



# VICTORIA GOVERNMENT GAZETTE

Published by Authority

[Registered at the General Post Office, Melbourne, for transmission by post as a newspaper.]

No. 61]

WEDNESDAY, AUGUST 17

[1966

## PROCLAMATIONS

*Land Act 1958.*

UNALIENATED CROWN LAND AVAILABLE FOR SETTLEMENT UNDER IMPROVEMENT PURCHASE LEASES.

### PROCLAMATION

By His Excellency the Governor of the State of Victoria and its Dependencies in the Commonwealth of Australia &c., &c., &c.

IN pursuance of the provisions of Section 153 of the *Land Act 1958*, I, the Governor of the State of Victoria, in the Commonwealth of Australia, by and with the advice of the Executive Council of the said State, do by this Proclamation declare the unalienated Crown lands mentioned in the subjoined schedule, to be available for settlement under improvement purchase leases.

### SCHEDULE.

County.	Parish.	Allotment.	Section.	Area.	Land Valuation.
				A. R. P.	
Delatite .. .. .	Tatong .. .. .	15, 15A, 15B, 15C	C	200 0 0±	\$7.00 per acre

Given under my Hand and the Seal of the State of Victoria aforesaid, at Melbourne this ninth day of August, in the year of Our Lord One thousand nine hundred and sixty-six and in the fifteenth year of the reign of Her Majesty Queen Elizabeth II.

(L.S.)

ROHAN DELACOMBE.

By His Excellency's Command,

JIM BALFOUR,  
Minister of Lands.

GOD SAVE THE QUEEN!

*Land Act 1958.*

AREA OF LAND COMPRISED IN CERTAIN CLASSES DIMINISHED OR INCREASED.

PROCLAMATION

By His Excellency the Governor of the State of Victoria and its Dependencies in the Commonwealth of Australia, &c., &c., &c.

WHEREAS by the *Land Act 1958* it is amongst other things enacted that the Governor in Council may, by Proclamation to be published in the *Government Gazette*, at any time diminish or increase the area of land comprised in any of the classes mentioned in Part I, Division 1, Section 5, of the said *Land Act 1958*, but that the area of lands which may be sold by auction (Class 6), shall not be increased except as in certain cases in the said Act provided: Now therefore I, the Governor of the State of Victoria, in the Commonwealth of Australia, by and with the advice of the Executive Council of the said State, and in accordance with the provisions of sections 94 and 117 of the *Land Act 1958* aforesaid, do hereby diminish or increase (as the case may be) the areas of Crown lands comprised in Classes 6 and 7 of the classes mentioned in section 5 of the *Land Act 1958* aforesaid to the extent set forth in the subjoined Schedule (that is to say):—

Schedule referred to.

CLASSES DIMINISHED OR INCREASED.

County.	Parish.	Allotment.	Section.	Area.	Diminished.	Increased.	Description.
					Class.	Class.	
				A. R. P.			
Bogong ..	Bright ..	16A	C	1 2 4	7	6	In the north of the Parish
" ..	" ..	17A	"	8 2 15	7	6	" " " " " "
" ..	" ..	17B	"	6 0 16	7	6	" " " " " "
Dalhousie ..	Heathcote ..	28H	"	3 3 13	..	6	In the north-west of the Parish

Given under my Hand and the Seal of the State of Victoria, aforesaid, at Melbourne, this ninth day of August, in the year of Our Lord One thousand nine hundred and sixty-six, and in the fifteenth year of the reign of Her Majesty Queen Elizabeth II.

ROHAN DELACOMBE.

(L.S.)

By His Excellency's Command,

JIM BALFOUR,

Minister of Lands.

GOD SAVE THE QUEEN!

PROROGUING PARLIAMENT AND FIXING THE TIME FOR HOLDING THE THIRD SESSION OF THE FORTY-THIRD PARLIAMENT OF VICTORIA.

PROCLAMATION

By the Lieutenant-Governor as Deputy for His Excellency the Governor of the State of Victoria and its Dependencies in the Commonwealth of Australia, &c., &c., &c.

WHEREAS the Parliament of Victoria stands adjourned until such day and hour as may be fixed by the President of the Legislative Council and the Deputy Speaker of the Legislative Assembly respectively: Now I, the Lieutenant-Governor as Deputy for the Governor of the State of Victoria, in the Commonwealth of Australia, do by this my Proclamation prorogue the said Parliament of Victoria until Wednesday, the seventh day of September, 1966, and I do hereby fix Wednesday, the seventh day of September, 1966, aforesaid, at the hour of half-past two o'clock in the afternoon, as the time for the commencement and holding of the next Session of the said Parliament of Victoria, for the despatch of business, in the Parliament Houses, situate in Spring-street, in the City of Melbourne: And the Honorable the Members of the Legislative Council and the Members of the Legislative Assembly are hereby required to give their attendance at the said time and place accordingly.

Given under my Hand and the Seal of the State of Victoria aforesaid, at Melbourne, the sixteenth day of August, in the year of our Lord, One thousand nine hundred and sixty-six, and in the fifteenth year of the reign of Her Majesty Queen Elizabeth II.

(L.S.)

E. F. HERRING.

By His Excellency's Command,

HENRY E. BOLTE,

Premier.

GOD SAVE THE QUEEN!

PUBLIC HOLIDAYS.

PROCLAMATION

By the Lieutenant-Governor as Deputy for His Excellency the Governor of the State of Victoria and its Dependencies in the Commonwealth of Australia, &c., &c., &c.

IN pursuance of the provisions contained in Part III of the *Public Service Act 1958*, I, the Lieutenant-Governor as Deputy for the Governor of the State of Victoria, in the Commonwealth of Australia, by and with the advice of the Executive Council of the said State, do by this my Proclamation appoint the days and dates hereunder mentioned to be observed as Public Holidays or Public Half-Holidays (as the case may be) at the places respectively specified, viz.:—

*Public Holidays:—*

WEDNESDAY, THE 21ST SEPTEMBER, 1966, throughout the Shire of Newham and Woodend.

MONDAY, THE 19TH SEPTEMBER, 1966, throughout the Shire of Kilmore.

SATURDAY, THE 22ND OCTOBER, 1966, throughout the Shire of Myrtleford.

MONDAY, THE 19TH SEPTEMBER, 1966, throughout the Shire of Phillip Island.

*Public Half-Holidays from the Hour of Twelve o'clock noon:—*

TUESDAY, THE 1ST NOVEMBER, 1966, throughout the Ouyen and Walpeup Ridings of the Shire of Walpeup.

TUESDAY, THE 4TH OCTOBER, 1966, throughout the Shire of Kilmore.

WEDNESDAY, THE 12TH OCTOBER, 1966, throughout the Tyrrell and North Ridings and the Township of Culgoa in the Central Riding within the Shire of Wycheproof.

WEDNESDAY, THE 19TH OCTOBER, 1966, throughout the South and Central Ridings, excluding the Township of Culgoa, in the Shire of Wycheproof.

Given under my Hand and the Seal of the State of Victoria aforesaid, at Melbourne, this sixteenth day of August, in the year of our Lord One thousand nine hundred and sixty-six, and in the fifteenth year of the reign of Her Majesty Queen Elizabeth II.

(L.S.) E. F. HERRING.

By His Excellency's Command,  
JAMES W. MANSON,  
Acting Chief Secretary.  
GOD SAVE THE QUEEN!

### BANK HOLIDAYS.

#### PROCLAMATION

By the Lieutenant-Governor as Deputy for His Excellency the Governor of the State of Victoria and its Dependencies in the Commonwealth of Australia, &c., &c., &c.

IN pursuance of the provisions of the *Bank Holidays Act 1958*, I, the Lieutenant-Governor as Deputy for the Governor of the State of Victoria, in the Commonwealth of Australia, do by this my Proclamation appoint the days and dates named hereunder special days to be observed as Bank Holidays or Bank Half-Holidays (as the case may be) at the places respectively mentioned, that is to say:—

#### *Bank Holidays:—*

WEDNESDAY, THE 21ST SEPTEMBER, 1966, at Healesville and Yarra Glen.

FRIDAY, THE 14TH OCTOBER, 1966, at Shepparton and Mooroopna.

#### *Bank Half-Holidays from the Hour of Eleven a.m.:—*

WEDNESDAY, THE 28TH SEPTEMBER, 1966, at Seymour.

Given under my Hand and the Seal of the State of Victoria aforesaid, at Melbourne, this sixteenth day of August, in the year of our Lord One thousand nine hundred and sixty-six, and in the fifteenth year of the reign of Her Majesty Queen Elizabeth II.

(L.S.) E. F. HERRING.

By His Excellency's Command,  
JAMES W. MANSON,  
Acting Chief Secretary.  
GOD SAVE THE QUEEN!

### BUNGAREE AND WALLACE WATERWORKS TRUST. PROCLAMATION OF URBAN DISTRICTS.

#### PROCLAMATION

By the Lieutenant-Governor as Deputy for His Excellency the Governor of the State of Victoria and its Dependencies in the Commonwealth of Australia, &c., &c., &c.

UNDER the powers conferred by the Water Act and all other powers enabling me in that behalf, I, the Lieutenant-Governor as Deputy for the Governor of the State of Victoria, in the Commonwealth of Australia, by and with the advice of the Executive Council of the said State, do hereby proclaim that on and from the date hereof portions of the Waterworks District of the Bungaree and Wallace Waterworks Trust within the boundaries described in the Schedule hereto shall be and become Urban Districts for the purpose of and within the meaning of the said Act.

#### SCHEDULE.

##### PORTION I.

##### *Bungaree Urban District.*

Commencing at the south-western angle of Crown allotment 1A, Section 2A, Parish of Warrenheip, County of Grant; thence generally easterly along the southern boundaries of the said Crown allotment 1A and of Crown allotment 2A a distance of 2,287 links; thence through the said Crown allotment 2A by lines bearing 343° 55' a distance of 175 links, 73° 55' a distance of 165 links and 163° 55' a distance of 175 links to an angle on the said southern boundary of Crown allotment 2A; thence easterly along the said southern boundary of Crown allotment 2A to its south-eastern angle; thence northerly and easterly along the eastern and southern boundaries of the said Crown allotment 2A to an angle on its eastern boundary; thence through Crown allotment

2B by lines bearing 181° 51' a distance of 90 links and 95° 31' a distance of 183.9 links to the north-western angle of Lot 1 on Lodged Plan of Subdivision No. 56815; thence easterly along the northern boundaries of the said Lot 1 and Lots 2 and 3 to the north-eastern angle of the said Lot 3; thence southerly along the eastern boundary of the said Lot 3 a distance of 25 links; thence through the said Crown allotment 2B by lines bearing 95° 31' a distance of 100 links and 186° 7' a distance of 250 links to a point on the northern boundary of the Western Highway; thence generally easterly along the said northern boundary of the Western Highway to a point 392.3 links westerly from the easternmost angle of the said Crown allotment 2B; thence through the said Crown allotment 2B by lines bearing 338° 56' a distance of 216 links and 68° 56' a distance of 354 links to a point on the north-eastern boundary of the said Crown allotment 2B; thence south-easterly along the said north-eastern boundary of Crown allotment 2B to its easternmost angle; thence north-easterly by a line across a road to the southernmost angle of Crown allotment 5, Section 7 and along the south-eastern boundary of the said Crown allotment 5 a distance of 2,094.5 links; thence through the said Crown allotment 5 by lines bearing 338° 52' a distance of 80.5 links, 68° 22' a distance of 45.5 links, 338° 52' a distance of 252.5 links and 68° 22' a distance of 300 links to the westernmost angle of Lot 1 on Lodged Plan of Subdivision No. 55230; thence north-easterly along the north-western boundaries of the said Lot 1 and Lots 2, 3, 4, and 5 to the northernmost angle of the said Lot 5; thence easterly along the northern boundary of Lodged Plan of Subdivision No. R678 to its north-eastern angle; thence north-easterly by a line through the said Crown allotment 5 and Crown allotment 4 to a point being the intersection of a line parallel to and distant 181 links easterly from the western boundary of the said Crown allotment 4 and a line parallel to and distant 530.1 links northerly from the southern boundary of the said Crown allotment 4; thence by a line bearing 159° 27' a distance of 530.3 links to a point on the said southern boundary of Crown allotment 4; thence north-easterly along the said southern boundary of Crown allotment 4 a distance of 665 links; thence southerly by a line across the said Western Highway a distance of approximately 300 links to a point on the northern boundary of Crown allotment 2, Section 8 distant 216 links westerly from an angle on the said northern boundary of Crown allotment 2; thence through the said Crown allotment 2 by lines bearing 179° 01' a distance of 729.9 links and 269° 01' a distance of 419.1 links to a point on the eastern boundary of a State School Reserve; thence southerly along the said eastern boundary of the State School Reserve to its south-eastern angle; thence westerly along the southern boundary of the said State School Reserve a distance of 11 links; thence through the said Crown allotment 2 and Crown allotment 1 by lines bearing 179° 13' a distance of 1,601 links, 270° 00' a distance of 800 links and 359° 13' a distance of 1,869 links to a point on the northern boundary of the said Crown allotment 1; thence south-westerly along the said northern boundary of Crown allotment 1 to its westernmost angle; thence south-easterly along the south-western boundary of the said Crown allotment 1 to a point in line with the southern boundary of Lot 5 on Lodged Plan of Subdivision No. 52755; thence westerly by a line across a road and along the said southern boundary of Lot 5 through Crown allotment 3A, Section 2A to a point on the eastern boundary of Crown allotment 3; thence northerly along the said eastern boundary of Crown allotment 3 to its intersection with a line parallel to and distant 215 links south-easterly from the north-western boundary of the said Crown allotment 3; thence south-westerly by the said parallel line through the said Crown allotment 3 to a point on its western boundary; thence northerly along the said western boundary of Crown allotment 3 to its north-western angle; thence generally westerly along the southern boundary of the said Western Highway to a point on the eastern boundary of Portion 2, Crown allotment 5, Section 2A; thence southerly along the said eastern boundary of Portion 2, Crown allotment 5 a distance of 279.4 links; thence through the said Portion 2, by a line bearing 266° 07' a distance of 752.1 links to a point on its western boundary; thence southerly along the said western boundary of Portion 2 a distance of 737.2 links; thence across a road and through Portion 1, Crown allotment 5 by lines bearing 275° 05' a distance of 355.4 links and 3° 23' a distance of 669.5 links to a point on the northern boundary of the said Portion 1; thence westerly along the said northern boundary of Portion 1 to the north-eastern angle of Lot 1 on Lodged Plan of Subdivision No. 63841; thence southerly, westerly and northerly along the eastern, southern and western boundaries of the said

Lot 1 to its north-western angle; thence northerly by a line across the said Western Highway to the point of commencement.

PORTION II.

Wallace Urban District.

Commencing at the south-western angle of Crown allotment 2, Section A, Parish of Warrenheip, County of Grant; thence north-easterly along the south-eastern boundary of the said Crown allotment 2 a distance of 1,900 links; thence southerly by a line across the Western Highway to the northernmost angle of Crown allotment 1A, Section 13; thence southerly along the eastern boundary of the said Crown allotment 1A and by a line being the continuation thereof across a road to a point on the northern boundary of Crown allotment 1G; thence generally north-westerly along the said northern boundary of Crown allotment 1G to the north-eastern angle of Crown allotment 1F; thence southerly and westerly along the eastern and southern boundaries of the said Crown allotment 1F to its south-western angle; thence southerly along the western boundaries of the said Crown allotment 1G and of Crown allotment 2A to a point on the centre line of the North Western Railway; thence generally north-westerly along the said centre line of the North Western Railway, across a road and through Crown allotment 3, Section 11 to a point on the north-western boundary of the said Crown allotment 3; thence south-westerly along the said north-western boundary of Crown allotment 3 a distance of 1,950 links; thence north-westerly by a line across the said Western Highway to a point on the south-eastern boundary of Crown allotment 4, Section 10 being distant 657.5 links north-easterly from the southernmost angle of the said Crown allotment 4; thence through the said Crown allotment 4 by lines bearing 358° 59' a distance of 744 links, 114° 39' a distance of 581.9 links, 24° 39' a distance of 250 links and 114° 39' a distance of 766 links to a point on the said south-eastern boundary of Crown allotment 4; thence north-easterly along the said south-eastern boundary of Crown allotment 4 to a point 798.6 links south-westerly from its south-eastern angle; thence through the said Crown allotment 4 by lines bearing 340° 41' a distance of 320 links, 74° 50' a distance of 542 links and 179° 00' a distance of 314 links to a point on the said south-eastern boundary of Crown allotment 4; thence north-easterly along the said south-eastern boundary of Crown allotment 4 a distance of 175 links; thence through the said Crown allotment 4 by lines bearing 344° 43' a distance of 297.7 links, 254° 51' a distance of 101 links, 357° 56' a distance of 376.1 links and 75° 55' a distance of 360.4 links to a point on the eastern boundary of the said Crown allotment 4 and by a line being the continuation thereof across a road to a point on the western boundary of the said Crown allotment 2, Section A; thence southerly along the said western boundary of Crown allotment 2 to the point of commencement.

All of which boundaries are shown on the plan deposited in the office of the State Rivers and Water Supply Commission, Melbourne.—(Corr. 61/1399/76).

Given under my Hand and the Seal of the State of Victoria aforesaid, at Melbourne, this sixteenth day of August, in the year of our Lord One thousand nine hundred and sixty six, and in the fifteenth year of the reign of Her Majesty Queen Elizabeth II.

(L.S.) E. F. HERRING.

By His Excellency's Command,  
T. A. DARCY,  
Minister of Water Supply.  
GOD SAVE THE QUEEN!

PUBLIC HIGHWAY.—SHIRE OF WINCHELSEA.

PROCLAMATION

By His Excellency the Governor of the State of Victoria and its Dependencies in the Commonwealth of Australia, &c., &c., &c.

WHEREAS by the Local Government Act 1958, as amended, Section 519 it is amongst other things enacted that it shall be lawful for the Governor in Council at any time and from time to time upon the request of the Council of any municipality by notice in the Government Gazette to proclaim any land reserved used or by purchase or exchange acquired for a street road highway thoroughfare bridge square court alley or right-of-way or any street road lane or passage made or laid out or proposed to be made or laid out on any land of which a plan of subdivision delineating that street road lane or passage

has been sealed with the seal of the municipality under subdivision (3) of Division 9 of Part XIX. of the Local Government Act 1958, as amended, or a corresponding previous enactment to be a public highway and that such land shall thereupon and thenceforth from the date of such proclamation become and be absolutely dedicated to the public as a public highway within the meaning of any law then and thereafter in force.

AND WHEREAS the Council of the Shire of Winchelsea has requested that the land hereinafter mentioned, used for a street, be so declared to be a public highway.

NOW THEREFORE I, the Governor of the State of Victoria in the Commonwealth of Australia, by and with the advice of the Executive Council of the said State, do by this Proclamation declare that Roadknight Street, Lorne, shown hatched on the plan hereunder, shall be a public highway within the meaning of the said Act.

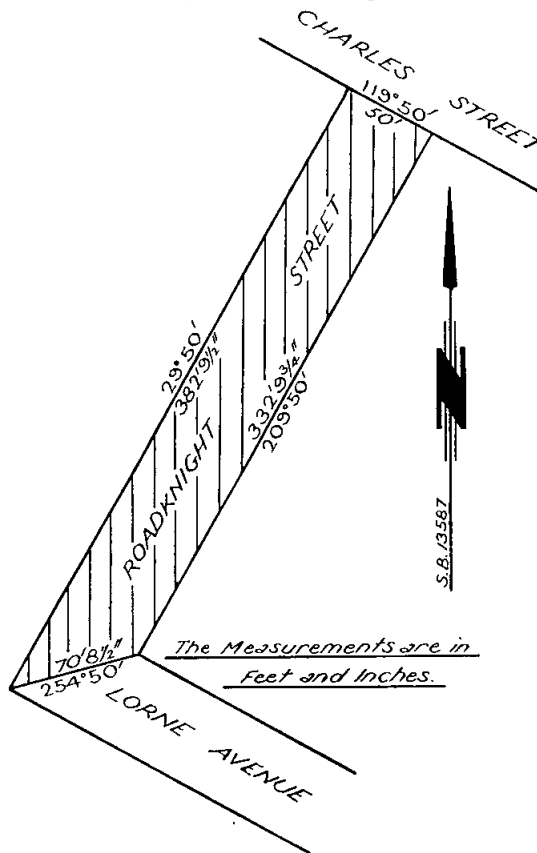

Given under my Hand and the Seal of the State of Victoria aforesaid, at Melbourne, this ninth day of August, in the year of our Lord One thousand nine hundred and sixty-six, and in the fifteenth year of the reign of Her Majesty Queen Elizabeth II.

(L.S.) ROHAN DELACOMBE.

By His Excellency's Command,  
R. J. HAMER,  
Minister for Local Government.  
GOD SAVE THE QUEEN!

PUBLIC HIGHWAY.—SHIRE OF FRANKSTON.

PROCLAMATION

By His Excellency the Governor of the State of Victoria and its Dependencies in the Commonwealth of Australia, &c., &c., &c.

WHEREAS by the Local Government Act 1958, as amended, Section 519 it is amongst other things enacted that it shall be lawful for the Governor in Council at any time and from time to time upon the request of the Council of any municipality by notice in the Government Gazette to proclaim any land reserved used or by

purchase or exchange acquired for a street road highway thoroughfare bridge square court alley or right-of-way or any street road lane or passage made or laid out or proposed to be made or laid out on any land of which a plan of subdivision delineating that street road lane or passage has been sealed with the seal of the municipality under subdivision (3) of Division 9 of Part XIX. of the *Local Government Act 1958*, as amended, or a corresponding previous enactment to be a public highway and that such land shall thereupon and thenceforth from the date of such proclamation become and be absolutely dedicated to the public as a public highway within the meaning of any law then and thereafter in force.

AND WHEREAS the Council of the Shire of Frankston has requested that the land hereinafter mentioned, being a street road lane or passage made or laid out or proposed to be made or laid out on any land of which a plan of subdivision delineating that street road lane or passage has been sealed with the seal of the municipality under subdivision (3) of Division 9 of Part XIX. of the *Local Government Act 1958*, as amended, or a corresponding previous enactment, be so declared to be a public highway.

NOW THEREFORE I, the Governor of the State of Victoria in the Commonwealth of Australia, by and with the advice of the Executive Council of the said State, do by this Proclamation declare that Plummer Avenue, Frankston, shown hatched on the plan hereunder, shall be a public highway within the meaning of the said

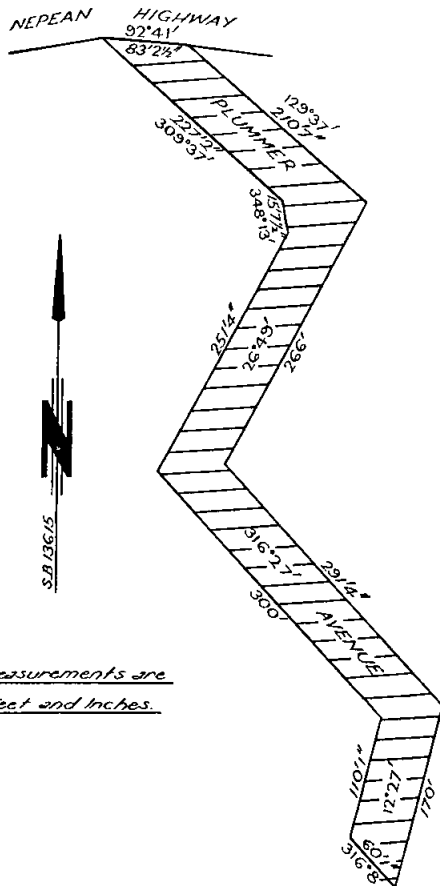

*The Measurements are  
in Feet and Inches.*

Given under my Hand and the Seal of the State of Victoria aforesaid, at Melbourne, this ninth day of August, in the year of our Lord One thousand nine hundred and sixty-six, and in the fifteenth year of the reign of Her Majesty Queen Elizabeth II.

(L.S.) ROHAN DELACOMBE.

By His Excellency's Command,  
R. J. HAMER,  
Minister for Local Government.

GOD SAVE THE QUEEN!

**GOVERNMENT NOTICES**

**PUBLIC TRUSTEE ACT 1958 (No. 6350).—SECTION 17.**

I HEREBY give notice that on the 27th July, 1966, the Public Trustee filed elections to administer the following deceased persons' estates, in accordance with section 17 of the *Public Trustee Act 1958*:—

- HAWKES, EDITH ANNIE, late of 26 Oberon-avenue, Hawthorn, spinster, died 8th June, 1966.
- HIGGS, EDWARD JAMES, late of Goulburn-street, Nagambie, general station hand, died 23rd April, 1966.
- PACE, STANLEY ARTHUR JOHN, also known as Stanley Arthur John Augustine Garfath, and Stanley Pace, late of 650 Elizabeth-street, Melbourne, cleaner, died 30th October, 1965.

A. D. DUNCAN,  
Public Trustee.

I HEREBY give notice that on the 3rd August, 1966, the Public Trustee filed elections to administer the following deceased persons' estates, in accordance with section 17 of the *Public Trustee Act 1958*:—

- DALY, MARGARET MARY, late of 134 Dryburgh-street, North Melbourne, widow, died 24th January, 1966.
- HOPLEY, WILLIAM EDWARD, late of 42 Bath-street, Chelsea retired piano-tuner, died 22nd December, 1965.
- HUNTER, THOMAS, late of 44 Kneen-street, North Fitzroy, pensioner, died 22nd April, 1966.
- JOHNSTON, ELIZABETH, also known as Lillian Johnston, late of 182 George-street, East Melbourne, pensioner, died 17th November, 1965.
- JONES, JOHN, late of Cheltenham Home and Hospital for the Aged, Cheltenham, pensioner, died 24th July, 1965.
- PUGLIELLI, FILIPPO, late of 16 Walter-street, Clifton Hill, labourer, died 3rd December, 1965.

A. D. DUNCAN,  
Public Trustee.

256 Flinders-street, Melbourne, C.1, 10th August, 1966.

**NOTICE.**

**CREDITORS**, next of kin and all others having claims against the estate of any of the under-mentioned deceased persons are required to send particulars of their claims to the Public Trustee, 256 Flinders-street, Melbourne, the personal representative, on or before the 21st October, 1966, after which date the Public Trustee may convey or distribute the assets, having regard only to the claims of which the Public Trustee then has notice:—

- DALY, MARGARET MARY, late of 134 Dryburgh-street, North Melbourne, widow, died 24th January, 1966.
- FARRAH, ETHEL JANE, late of 102 Dean-street, Moonee Ponds, widow, died 31st January, 1966.
- HAWKES, EDITH ANNIE, late of 26 Oberon-avenue, Hawthorn, spinster, died 8th June, 1966.
- HIGGS, EDWARD JAMES, late of Goulburn-street, Nagambie, general station hand, died 23rd April, 1966.
- HOPLEY, WILLIAM EDWARD, late of 42 Bath-street, Chelsea retired piano-tuner, died 22nd December, 1965.
- HUNTER, THOMAS, late of 44 Kneen-street, North Fitzroy, pensioner, died 22nd April, 1966.
- JOHNSTON, ELIZABETH, also known as Lillian Johnston, late of 182 George-street, East Melbourne, pensioner, died 17th November, 1965.
- JONES, JOHN, late of Cheltenham Home and Hospital for the Aged, Cheltenham, pensioner, died 24th July, 1965.
- MCKENZIE, FRANCIS DONALD, late of 52 Chatsworth-road, East Prahran, fitter, died 11th February, 1966.
- PACE, STANLEY ARTHUR JOHN, also known as Stanley Arthur John Augustine Garfath, and Stanley Pace, late of 650 Elizabeth-street, Melbourne, cleaner, died 30th October, 1965.
- PESAVENTO, JUNE MAY, late of 682 Canning-street, North Carlton, receptionist, died 19th May, 1965.
- PODWOJEWSKI, KAZIMIERZ, also known as Kazemez Podwojewski, late of 19 Percy-street, Newport, labourer, died 19th April, 1966.
- PUGLIELLI, FILIPPO, late of 16 Walter-street, Clifton Hill, labourer, died 3rd December, 1965.
- RODGERS, MARY, late of Kew, spinster, died 12th May, 1966.
- SWENSON, MARTIN, late of 6 Hilton-street, Clifton Hill, labourer, died 2nd March, 1931.
- TEHVER, JAAN, late of Collingwood-street, Apollo Bay, fisherman, died about 24th March, 1964.
- WATSON, JOHN, late of 44 Moubay-street, Albert Park, retired gas employee, died 15th September, 1962.

A. D. DUNCAN,  
Public Trustee.

Melbourne, 10th August, 1966.

## FARM PRODUCE AGENTS ACT (No. 6248).

LIST of persons to whom Farm Produce Agents' Licences have been issued for the year ending December, 1966, and each of whom has lodged a fidelity bond, in accordance with the requirements of the Act:—

*Name; Principal Place of Business.*

- Abidin, Besim, 48 Evans-street, Brunswick.  
 Acme Seed Store, Newham, via Woodend.  
 Adelaide and Local Tomato Supply, 51 Peel-street, West Melbourne.  
 Adgemis, Peter John, 8 Rae-street, Hawthorn.  
 Agosta, Frank, and Sons, 74 Clarendon-street, Thornbury.  
 Aidone, Sam., 122 Peel-street, North Melbourne.  
 Aitken, D. S., Pty. Ltd., 24 Walsh-street, Coburg.  
 Albioli, Vincenzo, 200 Pascoe Vale-road, Moonee Ponds.  
 Alexander, E., and Sons, Heathmere, Victoria.  
 Alexander, J. M., 39 Liverpool-street, West Coburg.  
 Alexander, N., 299 Plenty-road, Preston.  
 Alicaastro, Nicola, 21 Ferris-place, South Melbourne.  
 Allen, C. J., Station-street, Somerville.  
 Alltype Poultry Buyers, 24A Houston-street, Bendigo.  
 Aloï, Pasquale, 67 Bruce-street, Colac.  
 Amalfi, Frank, 30 Elizabeth-street, Fawkner.  
 Amalfi, Jim, 28 Elizabeth-street, Fawkner.  
 Amato Bros., 31 Lorne-street, Moonee Ponds.  
 Anderson, David, and Co., 76 Wilson-street, Horsham.  
 Andrews, Fruit and Vegetable Market, Lyttleton-terrace, Bendigo.  
 Angliss, W., and Co. (Aust.) Pty. Ltd., 42 Bourke-street, Melbourne.  
 Anguey, Robert Osborne, 51 Nungerner-street, Balwyn.  
 Ansell, Vernon, and Co. Pty. Ltd., 524 Collins-street, Melbourne.  
 Archibald Honey Co., Spring-road, Dingley.  
 Arena, Luigi, 191 Errol-street, North Melbourne.  
 Ashworth, K. P., Hay's-place, Geelong.  
 Augello, Matteo, 71 The Grove, Coburg.  
 Aumann, Edward Graham, 11 Yarra-road, Croydon.  
 Austral Fruit Agency, 147 Therry-street, Melbourne.  
 Austral Grain and Ambler Pty. Ltd., 46-52 King-street, Melbourne.  
 Australian Beeswax and Beeline Products of Daylesford (B. W. McCahon), Lake-road, Daylesford.  
 Australian Estates Co. Ltd., 114 William-street, Melbourne.  
 Australian Estates Company (Agencies) Pty. Ltd., 114 William-street, Melbourne.  
 Australian Mercantile Land and Finance Co. Ltd., 122 William-street, Melbourne.  
 Baker, L. F., Burwood-road, Wantirna.  
 Ballantyne, K. L., Pty. Ltd., 295 Grant-street, South Melbourne.  
 Bandias, A., Falconer-road, Warrandyte South.  
 Banson, George, and Son Pty. Ltd., 20 Wholesale Fruit Market, Melbourne.  
 Barbaro, A., 4 Murray-street, Brunswick West.  
 Barclay, David Alexander, Coolart-road, Hastings.  
 Barker and Staff Pty. Ltd., 294 Victoria-street, North Melbourne.  
 Barker, Green and Parke Pty. Ltd., 298 Victoria-street, North Melbourne.  
 Barker, Growers and Packers Pty. Ltd., 294 Victoria-street, North Melbourne.  
 Barker Produce (Vic.) Pty. Ltd., 298 Victoria-street, North Melbourne.  
 Barratt, W. H., Beenak-road, Seville.  
 Barrow, Alfred, Pty. Ltd., 47 King-street, Melbourne.  
 Barrow Bros. Commission Agency Pty. Ltd., 460-466 Flinders-lane, Melbourne.  
 Beckoff, T., 55 Brougham-street, North Melbourne.  
 Bellfair Purchasing Pty. Ltd., 225 Dundas-street, Preston.  
 Bellofiore, Michael, 173 Melville-road, West Brunswick.  
 Bendigo Quick Frozen Foods Pty. Ltd., Aspinall-street, Golden Square.  
 Bennett, J. F., and Co. Pty. Ltd., 404 Dana-street, Ballarat.  
 Bentleigh Poultry Auctions, Keys-road, Moorabbin.  
 Bertucci, Guisepppe, 7 Gunnedah-street, Sunshine.  
 Bickford, Alan Gilbert, Old Yarra-road, Wonga Park.  
 Black, H. R., Pty. Ltd., 395 Queen-street, Melbourne.  
 Black, Malcolm David, 14 Jellicoe-street, Noble Park.  
 Blooms Fruit Shop, 314 Wyndham-street, Shepparton.  
 Blue Moon Fruit Co-op. Ltd., 60 Railway-road, Blackburn.  
 B. and M. Fruit Agency, 462 Queen-street, Melbourne.  
 Bodley, H. H., and Son Pty. Ltd., Riverside-avenue, South Melbourne.  
 Bonney, Stan., 267 Punt-road, Richmond.  
 Booth, Frank, and Sons Pty. Ltd., 16 Wholesale Fruit Market, Melbourne.  
 Borgia Bros., 77 McKillop-street, Geelong.  
 Borwick, Thos., and Sons (Aust.) Ltd., 543 Little Collins-street, Melbourne.  
 Borwick, P. B. and R. W., 47 Bromfield-street, Colac.  
 Bourgazas, Nicholas, Pomona, via Wentworth, N.S.W.  
 Bourke, F. W., Pty. Ltd., 34-36 Doveton-street north, Ballarat.
- Name; Principal Place of Business.*  
 Bove, Antoine, 65 Capel-street, North Melbourne.  
 Bradbury, J. C., and Sons Pty. Ltd., 122 King-street, Melbourne.  
 Briggs, Neil John, 5 Allawarre-avenue, Croydon.  
 Brophy, Foley and Co., 204 Mair-street, Ballarat.  
 Brown and Dureau Ltd., cnr. Kavanagh and Ireland streets, South Melbourne.  
 Brown, G., 98 Myers-street, Bendigo.  
 Brunt, Arthur, Pty. Ltd., 385 Lygon-street, Brunswick.  
 Bryant and Gourley, 22 Peel-street north, Ballarat.  
 Buck, R. J. E., Anderson's Creek-road, Doncaster East.  
 Bunge (Aust) Pty. Ltd., 447 Collins-street, Melbourne.  
 Burgi, B. and E., Victoria-road, Wandin North.  
 Butler, T. E., and Co. Pty. Ltd., 64 Railway-road, Blackburn.  
 Cammaroto, Francesco, 33 Robertson-street, Kensington.  
 Cambridge, A. B., Pty. Ltd., 77 Whitehall-street, Footscray.  
 Captain Distributing Co. Ltd., 481 Flinders-lane, Melbourne.  
 Careri, Rocco, 43 Harding-street, Coburg.  
 Carrazza and Co., P.O. Box 43, Buronga, via Mildura.  
 Carrozza, Diego, 15 Birch-street, West Preston.  
 Caveny, William, Dennington.  
 Chambers, G. E., and Sons, Sheehans-road, Red Hill.  
 Chapman, Leslie Ernest, Charteris-road, Wandin East.  
 Chen, W. D., Fruit Co. Pty. Ltd., 9 Wholesale Fruit Market, Melbourne.  
 Chin, S. H., Bros. Pty. Ltd., 33 Wholesale Fruit Market, Melbourne.  
 Chinn, F. A., and Co., 40 Wholesale Fruit Market, Melbourne.  
 Chivers, Craig, & Co., Porter-street, Templestowe.  
 Christie, W. J., 30 Madden-avenue, Mildura.  
 Ciccone, V., 285 George-street, Fitzroy.  
 Clarke, G. S., Station-street, Somerville.  
 Clements, C. E., and Co. Pty. Ltd., 34 Queen-street, Melbourne.  
 Colling, G. A. and M., Hunter-road, Wandin North.  
 Collins, C. and S., 36 Thames-promenade, Chelsea.  
 Conaughton, J. P., and Co., corner of Doveton and Mair streets, Ballarat.  
 Cook, G. J., 91 Peel-street, North Melbourne.  
 Cooney, R. M., and Co., McLeod-street, Orbost.  
 Cooper, G. W., Main-road, Silvan.  
 Co-operated Dried Fruit Sales Pty. Ltd., 16-24 Jeffcott-street, Melbourne.  
 Corlass, Ian, Katunga.  
 Cornish, R., and Sons Pty. Ltd., 184 Franklin-street, Melbourne.  
 Corstorphan, James Francis, Morack-road, Vermont.  
 Courtney, Michael Edward, Daylesford.  
 Cousin, Ian, F. T., Meyers-road, Merricks North.  
 Cowin, W., 200 Brighton-street, Richmond.  
 Cowling, W., Market-square, Bendigo.  
 Cramer, E., and Sons Pty. Ltd., 54 Tuaggara-street, Maryborough.  
 Crema and Co., 31 Alice-street, Coburg.  
 Crickard, F. B., and Co., 443 Little Collins-street, Melbourne.  
 Cristofaro and Sons Pty. Ltd., 249 Franklin-street, Melbourne.  
 Croker, Arthur Edwin, 3 Sartre-court, Tally Ho.  
 Crossland, Alexander Cecil, Warburton-road, Wandin North.  
 Crowley, Thomas George, Kinglake West.  
 Croydon Market Auction and Real Estate Pty. Ltd., 13 Kent-avenue, Croydon.  
 Crystal Ice and Cool Stores Co., 123 Garsed-street, Bendigo.  
 Cunningham, D. and B., 7 Mile-road, Nar-Nar-Goon.  
 Curnow's (Bendigo), Queen-street, Bendigo.  
 Cutbush, G. C., and Co., Dean (Victoria).  
 Cutrale, Tony, 39 Mirams-street, Ascot Vale.  
 Daffy, Michael Joseph, Beeac, Victoria.  
 D'Agostino, Frank, and Son, 60 North-road, East Reservoir.  
 Dalgety and New Zealand Loan Ltd., 461 Bourke-street, Melbourne, C.I.  
 D'Aloisio, V. and D., Chapman-road, Silvan.  
 D'Aloisio, Panfilo, 7 Clyde-street, Lilydale.  
 Davis, J. L., Pty. Ltd., 7 Curdie-street, Camperdown.  
 Davis, J., Pty. Ltd., 8 Wholesale Fruit Market, Melbourne.  
 Davis, Lancaster, and Co., 601-611 Little Lonsdale-street, Melbourne.  
 De Bernardi, J. A. and E. L., Station-street, Somerville.  
 De Cicco, Carmine Pasquale, 110 O'Shannassy-street, North Melbourne.  
 De Julio, A., and Son, The Eyrie, Lilydale.  
 Demaria, Giovanni, 9 Shuter-street, Moonee Ponds.  
 Demaria, Domenico, 136 Reynards-road, Coburg.  
 Demarte, D., 80 Chapman-street, North Melbourne.  
 Dennys, Lascelles Ltd., Moorabool-street, Geelong.  
 D'Esposito, Gaspere, Moxham-road, Monbulk.  
 De Vincentiis, Domenico, Main-street, Lilydale.  
 Di Battista, A. and N., Beenak-road, Wandin.

*Name; Principal Place of Business.*

Di Benedetto, L., and Co., 86 Porter-street, West Heidelberg.  
 Dickson, D. S., Wonga-road, Ringwood North.  
 Dimattina, F., and Co. Pty. Ltd., 50 Wholesale Fruit Market, Melbourne.  
 Di Pietrantonio, Joseph, Queens-road, Silvan.  
 Divola, D., and Sons, 122 Eighth-street, Mildura.  
 Donga Meats Pty. Ltd., 4-12 Athol-street, Wodonga.  
 Donoghue, J. E., Pty. Ltd., 527 Collins-street, Melbourne.  
 Douglas, Harold, Pty. Ltd., 32 Peel-street, West Melbourne.  
 Dreyfus, Louis, and Co. Ltd., 505 St. Kilda-road, Melbourne.  
 Drouin Co-operative Butter Factory Co. Ltd., Lardner-road, Drouin.  
 Dunn, Neville Frederick, 12 Fleming-street, West Brunswick.  
 Duster, Stefan, and Co., 63 Peel-street, West Melbourne.  
 Dyer, W. and A., 601 Little Lonsdale-street, Melbourne.  
 Dykes, Mark, Pty. Ltd., 8 Oakhill-avenue, Regent.  
 Edgar, C. R., and Co. Pty. Ltd., 528 Lonsdale-street, Melbourne.  
 Edwards, M. T., Red Hill South.  
 Elder Smith Goldsbrough Mort Ltd., 499-501 Bourke-street, Melbourne.  
 Enbom, P. W., 56 Radovick-street, Korumburra.  
 Evans, C. W., 4 Gordon-street, Korumburra.  
 Everard, Jim, Wallace, Victoria.  
 Faba, Silvino, Lot 29b, off McBride-street, Fawkner.  
 Fairbairn, L. A., and Co., incorporating Youngusband Ltd., Main-street, Bacchus Marsh.  
 Fallow Products, 483 Collins-street, Melbourne.  
 Fankhauser, Ernest L. R., Stevens-road, Vermont.  
 Farquhar, Stan, Pty. Ltd., 610 Talbot-street, Ballarat.  
 Farquhar, J. T., and Sons, 19 Mair-street, Ballarat East.  
 Feeney, Ted, and Co. Pty. Ltd., 63 Peel-street, West Melbourne.  
 Feiglin, M., and Sons, Pty. Ltd., Station-street, Nunawading.  
 Ferlazzo, G., and Co. Pty. Ltd., 49 Wholesale Fruit Market, Melbourne.  
 Ferris, H., Pty. Ltd., Mollison-street, Kyneton.  
 Festival Packers Pty. Ltd., 723b Centre-road, East Bentleigh.  
 Fiesta, Fare Pty. Ltd., Main-road, Research.  
 Foley Bros. (London) Pty. Ltd., 213 King-street, Melbourne.  
 Forbes and Snell Pty. Ltd., 530 Collins-street, Melbourne.  
 Frankel, H. and S., 44 Wholesale Fruit Market, Melbourne.  
 Frazer, R. J. and A. M., 43 Fortuna-avenue, North Balwyn.  
 French, E. G., Victoria-street, Hastings.  
 Friedman, M., 286-288 Victoria-street, North Melbourne.  
 Gabriel, Kimon, 452 Albion-street, West Brunswick.  
 Gallo, G., 41 Miller-street, West Melbourne.  
 Gammaldi, G. and V., 116 Peel-street, North Melbourne.  
 Gangemi, Rosario, 27 Byron-street, Moonee Ponds.  
 Gaspari, Gabriele, 14 Sumner-avenue, Northcote.  
 Gatto, Antonio, 209 Cecil-street, South Melbourne.  
 Gauld, H. M. (Melbourne), 452 Queen-street, Melbourne.  
 Gavin, C. P. and L. M., Crossley.  
 Gaudin, P. G. and L. B., Beenak-road, Wandin.  
 Geelong Covent Garden, 174 Moorabool-street, Geelong.  
 Geelong and Cressy Trading Co. Ltd., 138 Malop-street, Geelong.  
 Gells Gippsland Honey Supply, McClure-street, Maryborough.  
 Gembrook Potato Growers Pty. Ltd., Main-road, Gembrook.  
 "Gem" Fruit Supply (Stephen John Adgemis), 260 Victoria-street, North Melbourne.  
 Geraldton Fruit Co., 57 Wholesale Fruit Market, Melbourne.  
 Giblin, Thomas John and Kathleen, 13 Mile-road, Garfield.  
 Gidley, John, 26 Milton-street, West Melbourne.  
 Gippsland and Northern Co-op. Co. Ltd., 492 Flinders-lane, Melbourne.  
 Glasshouse Tomato Growers of South Australia Co-operative Ltd., 11 Anders-avenue, Oaklands Park, South Australia.  
 Godfrey, Dan and Co. Pty. Ltd., 29 Clow-street, Dandenong.  
 Golden Poultry Farm Pty. Ltd., 51 Playne-street, Frankston.  
 Golden Valley Fruit Co. Pty. Ltd., 15 Wholesale Fruit Market, Melbourne.  
 Goodrich, Francis G., Shoreham-road, Red Hill South.  
 Goodwin, N. F., 40 High-street, Coburg.  
 Gormann, W. J., Pty. Ltd., 31 King-street, Melbourne.  
 Gould, R., Warrandyte-road, Baxter.  
 (The) Grain Handling Corporation Pty. Ltd., 528 Lonsdale-street, Melbourne.  
 Green, N., and Son Pty. Ltd., 113A Therry-street, Melbourne.  
 Groves, McVitty and Co. Pty. Ltd., Blackburn-road, Clayton.  
 Gugger, N. A., Hyland-street, Fyansford.  
 Guys Fruit Service Pty. Ltd., 228 Pascoe Vale-road, Essendon.  
 Haag, O. and S. G., School-street, Seville.

*Name; Principal Place of Business.*

Hancock, A. W., and Co. Pty. Ltd., 104 Armstrong-street north, Ballarat.  
 Hanger, H., Pty. Ltd., 1248 Burke-road, North Balwyn.  
 Hardidge, Herbert John, King-street, East Doncaster.  
 Harris, H. R., corner of Flinders-lane and Knight's-place, Melbourne.  
 Harrison, Neil J., Williamson's-road, Doncaster.  
 Harvey, Dann, and Co. Pty. Ltd., 118 Fyans-street, Geelong.  
 Harvey, G. R. and E. R., Wandin Yallock.  
 Harwood and Ahern Pty. Ltd., 1-3 Cobden-street, North Melbourne.  
 Haughton, William, and Co. Pty. Ltd., 545 Little Collins-street, Melbourne.  
 Hedditch, N. S. F., and Son Pty. Ltd., 85 Percy-street, Portland.  
 Hester Bros. Poultry Service, Powells-avenue, East Bendigo.  
 Hibbins, W. R., and Sons, 40 Talbot-avenue, East St. Kilda.  
 Hill, Frank A., and Co., Charing Cross, Bendigo.  
 Hockey's Bentleigh Hatchery, 41 Mawby-road, Bentleigh.  
 Holden, W. M., Hogan-street, Tatura.  
 Holland and Holland, Station-street, Cobram.  
 Holland, D. and G., Modella-road, Iona, via Bunyip.  
 Hoopell's Hardware, Timber and Fodder Store, Mollison-street, Malmsbury.  
 Horsfield, L., "Dalkeith", R.S.D., Thorpdale.  
 How, Keith Clifton, 16 Westminster-drive, Avondale Heights.  
 Howell, James (Jnr.), Victoria-road, Wandin North.  
 Huile Trading Co., 119 Therry-street, Melbourne.  
 Hunscha, A. R. and J. G., P.O. Box 10, Jeparit.  
 Hunter, W. B., Corio-street, Shepparton.  
 Hurst and Green, 11 Cobden-street, North Melbourne.  
 Hutchinson, Robert, Ltd., Hartington-street, Glenroy.  
 Hyland, David, and Sons Pty. Ltd., Salmon-street, Port Melbourne.  
 Hyman, J., and Sons Pty. Ltd., 51 Wholesale Fruit Market, Melbourne.  
 Ierianni, Antonio, 54 Fischer-street, Coburg.  
 Interlandi, G., 270 Victoria-street, North Melbourne.  
 International Fruit and Mercantile Co. Pty. Ltd., 60 Railway-road, Blackburn.  
 Interstate Fruit Supply Pty. Ltd., 264 Victoria-street, North Melbourne.  
 Inverno, S., and Co., Koo-Wee-Rup.  
 Italia, Salvatore, 40 Linda-street, Coburg.  
 Italiano, Leo., 391 Victoria-street, North Melbourne.  
 Iuele, M. and G., 396 Albert-street, West Brunswick.  
 Jackel, G. O., and Sons, Williams-road, Wangaratta.  
 Jackson, Shands, Pty. Ltd., 540 Little Collins-street, Melbourne.  
 James, H. K., 12-18 Northumberland-street, South Melbourne.  
 Johnston, H. and L., Birregurra, Victoria.  
 Johnston, Harold Vincent, Blackburn-road, Doncaster East.  
 Jonas Wholesale Pty. Ltd., 146 Dudley-street, Melbourne.  
 Kalamastrakis, George, 130A Eighth-street, Mildura.  
 Kapiris Bros., 290 Victoria-street, North Melbourne.  
 Kardos, J. I., 44 Anakie-road, Bell Park, Geelong.  
 Kelly, A. C. and I., 149 Therry-street, Melbourne.  
 Kelly, Maurice Thomas, Bungaree P.O.  
 Kilmore-Broadford Dairy Co., Sutherland-street, Kilmore.  
 Kington, W. S. and Sons, 143 Queen-street, Melbourne.  
 King, E. G. Pty. Ltd., 2 Wholesale Fruit Market, Melbourne.  
 King, J. L., and Co., 9 Queen-street, Bendigo.  
 Kitos, P. and D., Strathmerton, Victoria.  
 Knee, Alan Thomas, Dudley-road, Wonga Park.  
 Knee, F. J., Dudley-road, Wonga Park.  
 Kolmanic, Mirko, P.O. Box 59, Drysdale.  
 Kondopidis, Michael, 250 Victoria-street, North Melbourne.  
 Koroit and Tower Hill Farmers Co-op. Society Ltd., Koroit.  
 Kyneton Ice and Freezing Works (E. Portelli), 176 Mollison-street, Kyneton.  
 Lanera, P. G., 15 Spicer-street, Beaumaris.  
 Lanteri, M., and Son, 113 Wellington-street, Flemington.  
 Lanteri, Santi, 249 Brighton-road, Elwood.  
 Latorre, Francesco, 149 Sussex-street, Coburg.  
 Launceston Market Supplies Pty. Ltd., 7 William-street, Launceston, Tasmania.  
 Lauritz, W. G., and Sons Pty. Ltd., 21 Viaduct Buildings, Queens Bridge, Melbourne.  
 Lawless, T. J., and Co., 107-109 Lydiard-street, Ballarat.  
 Lee, Graeme Walter, 2 Violet-court, Blackburn.  
 Legg, F. J., and Son, 300 Burwood-road, Burwood.  
 Legudi, Francesco, 40 Borva-drive, East Keilor.  
 Leong Hoong Cheong Pty. Ltd., 16 Barnes-avenue, Burwood.  
 Lepre, Gerald, 80 Rose-street, Coburg West.  
 Licenti, Lorenzo, 1 Montgomery-street, Moonee Ponds.  
 Lindsay and Charteris, 7 Mt. Dandenong-road, Croydon.  
 Long, James, T. G., Kerang, Victoria.  
 Louey Pang, H., and Co. Pty. Ltd., 186 Franklin-street, Melbourne.

*Name; Principal Place of Business.*

Lovett, H. L. E., and Co., 23 Wholesale Fruit Market, Melbourne.  
 Lowan, H. W., 206 Edward-street, East Brunswick.  
 Lunt, G. and M., Rear 228 Dorcas-street, South Melbourne.  
 Lyndon and Jones Pty. Ltd., 40 Princess-street, Traralgon.  
 Mace, E. H., Pty. Ltd., 95 Cecil-street, South Melbourne.  
 Mackaness Produce, 11 Cobden-street, North Melbourne.  
 Madafferi, F., and Co., 110 Peel-street, North Melbourne.  
 Madden, P. F., "Sea View", Tower Hill.  
 Maffra Packing Co. Pty. Ltd., Rose-street, Heyfield.  
 Mandica, Domenico, 1 Ailsa-street, Ascot Vale, W.Z.  
 Marazita, G. and M., and Co., 298 Union-street, West Brunswick.  
 Market Distributors Pty. Ltd., 63 Peel-street, West Melbourne.  
 Marsh, E. G., Pty. Ltd., 522 Flinders-lane, Melbourne.  
 Marshall, R. and K. F., Neerim, Victoria.  
 Martakis, G., and Son Pty. Ltd., 390 Clarendon-street, South Melbourne.  
 Martinello and Pistrutto, 1 Chapman-street, North Melbourne.  
 Marvelli, Pasquale, 20 Dene-avenue, East Malvern.  
 Maryborough Flour Mills Pty. Ltd., 38 Albert-street, Maryborough.  
 Mason, G. F., 21 Leura-grove, Hawthorn.  
 Massaro, Guisepppe, 273 Mt. Alexander-road, Ascot Vale.  
 Mastromauro, A., 89 Suffolk-street, West Footscray.  
 Matthews, F. E., and Son, Korong Vale.  
 Mauri Brothers and Thomson (Aust.) Pty. Ltd., 35 Ainslie-avenue, Canberra City, A.C.T.  
 Maxwell, C. S., and Co., 8 Kathryn-street, Benalla.  
 Mazzetto and Valentino, 305 Cumberland-road, Pascoe Vale.  
 Mellor, F. R., and Son, 452 Queen-street, Melbourne.  
 Menta, Michelangelo, 36 Ascot Vale-road, Flemington.  
 Mentiplay, D., and Co. Pty. Ltd., 27 Wholesale Fruit Market, Melbourne.  
 Mentiplay, D., and Co. (Vegetables) Pty. Ltd., 624 Spencer-street, West Melbourne.  
 M.G.C. Pty. Ltd., 48 Capel-street, West Melbourne.  
 Micheli, J. and V., 70 Christmas-street, Northcote. N.16.  
 Michell and Son, Newlyn.  
 Midland Fruit Supply, 163 Hargreaves-street, Bendigo.  
 Mildura Leading Fruit Shop, 138 Eighth-street, Mildura.  
 Miller, A. F. and R. P., Church-street, Doncaster.  
 Millis, Alfred, and Sons Pty. Ltd., 438 Queen-street, Melbourne.  
 Mimmo and Ciavarello, 265 Albion-street, Brunswick.  
 Mirabella, Diego, McKurds-road, Tyabb.  
 Mirarchi, Nicodemo, 28 Leveson-street, North Melbourne.  
 Mobbs, N. and J., Knox-street, Daylesford.  
 Montague, W. F., Pty. Ltd., Horswood-road, Narre Warren North.  
 Morriss, G. N., and Co., Central Mart, Colac.  
 Mortimer, David Alexander, High-street, Drysdale.  
 Moss, J., and Sons Pty. Ltd., 11 Wholesale Fruit Market, Melbourne.  
 Motta, John, P.O., Dalmore, Victoria.  
 Moulden, E. T., and Sons Pty. Ltd., 561 Bell-street, Preston.  
 Mulholland, D. J., and Co. Pty. Ltd., 24 Arthurton-road, Northcote.  
 Mumford, J. G., Pty. Ltd., 35 Wholesale Fruit Market, Melbourne.  
 Muratore, Filomena, 15 Avondale-street, Hampton.  
 Murphy, W. T., Bros. Pty. Ltd., 594 Burwood-road, Auburn.  
 Murraydowns Grain Pty. Ltd., 52 McRae-street, Swan Hill.  
 Murray's Wholesale Fruit Supply, 187 Adderley-street, West Melbourne.  
 Murray Valley By-Products Pty. Ltd., Osboldstone-road, Wangaratta.  
 McBeth, J. P., 207 Neerim-road, Carnegie.  
 McCarthy, H., and Son, Mount Clear, via Ballarat.  
 McCraith, John A., and G., Pty. Ltd., 284 City-road, South Melbourne.  
 McCulloch Carrying Co. Pty. Ltd., 468 Collins-street, Melbourne.  
 McKeddie Orchards, Main Ridge, Victoria.  
 McKenzie, M. J., and Sons, Woorarra-avenue, East Doncaster.  
 McKinnon, C., Post Office, Box 3, St. Arnaud.  
 McKirdy, I. J. Queens-road, Wandin.  
 McPhail, Anderson, and Co. Pty. Ltd., 224 Queen-street, Melbourne.  
 McPhee, B. P., 31 Delaware-street, Reservoir.  
 McRae, John, and Son Pty. Ltd., Jung.  
 Nash, S., and Sons, Drysdale.  
 Natalizio, Emanuele, 201 Raleigh-street, Thornbury.  
 Neim, Petrit, 4 McLean-street, West Brunswick.  
 Newport Poultry Supply, 71 Junction-street, Newport.  
 Nichol, A., and Sons Pty. Ltd., 31 Wholesale Fruit Market, Melbourne.  
 Nicholas, Pat, 38 Lincoln-road, Essendon, W.5.

*Name; Principal Place of Business.*

Nolan, H. C., Pty. Ltd., 618 Queensberry-street, North Melbourne.  
 Nolan, T. J., Binney-street, Euroa.  
 Noonan, J. F., Pty. Ltd., 623 Collins-street, Melbourne.  
 North Eastern Co-op. Society Ltd., Reid-street, Wangaratta.  
 Nunn, G. P. and M. G., 13 Sturt-street, Ballarat.  
 Orlando, T., and Co. (Fruit) Pty. Ltd., 13 Wholesale Fruit Market, Melbourne.  
 Orlando, T., and Co. (Vegetables) Pty. Ltd., 13 Wholesale Fruit Market, Melbourne.  
 Or., G. K. and L. T., Bullarto South, Victoria.  
 O'Toole, H., Illowa.  
 Pack Kee, 55 Wholesale Fruit Market, Melbourne.  
 Pakenham Fruit Growers' and Producers' Co-operative Ltd., 38 James-street, Pakenham East.  
 Panton, M. J., 114 Chapel-street, Windsor.  
 Patchett Produce Distributors Pty. Ltd., 103 Victoria-street, West Melbourne.  
 Pays (Kerang) Pty. Ltd., 31 King-street, Melbourne.  
 Peachey, R. A., and Son Pty. Ltd., 623 Collins-street, Melbourne.  
 Pearce, George Arthur, 9 Winston-drive, South Caulfield.  
 Peck, Clive Donald, Ahern-road, Pakenham East.  
 Pellegrino, A., 43 Studley Park-road, Kew.  
 Pellegrino, C., and Co. Pty. Ltd., 280 Victoria-street, North Melbourne.  
 Penna, A. W., Pty. Ltd., 1 Canning-street, West Maribymong.  
 Permewans (Colac) Pty. Ltd., 31 King-street, Melbourne.  
 Permewans (Horsham) Pty. Ltd., 31 King-street, Melbourne.  
 Permewans (Wangaratta) Pty. Ltd., 31 King-street, Melbourne.  
 Permewans (Warragul) Pty. Ltd., 31 King-street, Melbourne.  
 Permewan Wright Ltd., 31 King-street, Melbourne.  
 Perry, William Anderson, Sunnycliffs P.O., Red Cliffs.  
 Pette, V. 20 Brougham-street, North Melbourne.  
 Petracca, Noe, 107 Anderson-street, Lilydale.  
 Pettolino, Angelo, 314 Gillies-street, Thornbury.  
 Pettolino, Phillip, 314 Gillies-street, Thornbury.  
 Petty, J. W., and Co., Myers-road, Balmarring.  
 Piccolo, Carmelo, 46 Moyangul-drive, East Keilor.  
 Piccolo, Francesco, 46 Moyangul-drive, East Keilor.  
 Picone, John, 2 Beatty-street, Reservoir, N.19.  
 Pignataro, Guisepppe, Monbulk-Seville road, Silvan.  
 Pignataro, Rocco, Seville-Monbulk road, Silvan.  
 Pirrie Bros., 136 Exhibition-street, Melbourne.  
 Pitt, A. E., 14 Wholesale Fruit Market, Melbourne.  
 Pizaro, Ronald J., 184 Kilgour-street, East Geelong.  
 Plant, C. S. and D. E., 22 Breed-street, Traralgon.  
 Ponte, Charles, 96 Weston-street, Brunswick.  
 Ponte, Frank, 24 Mitchell-street, Brunswick.  
 Ponte, V. and S., 450 Queensberry-street, North Melbourne.  
 Porter, L. M., Pty. Ltd., Stanley-street, Bendigo.  
 Potter Bros. Pty. Ltd., 219 Williamson-street, Bendigo.  
 Potter (Melb.) Pty. Ltd., 49 Wholesale Fruit Market, Melbourne.  
 Poultrymen and Farmers Trading Co. Pty. Ltd., 696 Queensberry-street, North Melbourne.  
 Poultrymen and Farmers Trading Co. (Frankston) Pty. Ltd., 696 Queensberry-street, North Melbourne.  
 Poultrymen and Farmers Trading Co. (Somerville) Pty. Ltd., 696 Queensberry-street, North Melbourne.  
 Pratt, David and Sons, 215-221 Mair-street, Ballarat.  
 Presti, Lorenzo, 92 Paisley-street, Footscray.  
 Prestia, Antonio, 16 James-street, Fawkner.  
 Producers Co-op. Distributing Society Ltd., 7 Wholesale Fruit Market, Melbourne.  
 Pullar, P., and Nephew, 59 Wholesale Fruit Market, Melbourne.  
 Pump, John William, Burwood-road, Wantirna South.  
 Pump, L. G., Manningham-road, Lower Templestowe.  
 P.W. Proprietary Limited, 31 King-street, Melbourne.  
 Quattrocchi, Antonio, 5 Nolan-street, North Essendon.  
 Quayle and Hutton, 23-25 Mair-street, Ballarat.  
 Quick, P. R., and Sons (Victoria), 458 Queen-street, Melbourne.  
 Quong, Hi Shing, Pty. Ltd., 407 Queen-street, Melbourne.  
 Quong, Hoong Wah, Pty. Ltd., 41 Wholesale Fruit Market, Melbourne.  
 Radatti, Saverio, 14 Thomson-street, Northcote.  
 Radeff, Sava, 57 Peel-street, West Melbourne.  
 Ralphs and Bravo Pty. Ltd., 24 Wholesale Fruit Market, Melbourne.  
 Rando, Steve Anthony, 17 Virginia-grove, Chadstone.  
 Rawson, Henry Claude, Moore-street, Erica.  
 Reid, Don, 81 Wyndham-street, Shepparton.  
 Richardson, H. F., and Co., Lonsdale-street, South Geelong.  
 Ridolfi, Antonio, 141 Albert-street, Brunswick.  
 Rigano, R. and D., 782 Centre-road, East Bentleigh.  
 River Farms Produce, Wallace, Victoria.  
 Riverina Voluntary Barley Pool Pty. Ltd., 528 Lonsdale-street, Melbourne.



*Name; Principal Place of Business.*

Rivervale Distributors, Box 214, P.O. Robinvale.  
 Rizza, S. and P., 101 Raymond-street, Sale.  
 Robertson, H. A. and H. D., 46 John-street, East Brunswick.  
 Robinvale Citrus Groves Pty. Ltd., 10-14 Leicester-street, Carlton.  
 Roderick, W., Hosie-street, Bairnsdale.  
 Rodriquez Bros., 156 Donald-street, Brunswick.  
 Rohr, George, Pty. Ltd., 9 Queen-street, Melbourne.  
 Rose, Arthur Thomas, 30 Lambeth-avenue, Armadale.  
 Rosenfield, R. J. and L. N., Pty. Ltd., 52 Wholesale Fruit Market, Melbourne.  
 Ross, J. W., Pty. Ltd., 13 Wholesale Fruit Market, Melbourne.  
 Rossin, G., and Sons, 75 Moreland-road, East Coburg.  
 Royle, William, and Son, 483 Flinders-lane, Melbourne.  
 Rullo, Pasquale, 9 Byron-street, Moonee Ponds.  
 Rural Distributing Co. Pty. Ltd., 20 Wholesale Fruit Market, Melbourne.  
 Rushan, Selim, 100 Union-street, Brunswick.  
 Russell, Frank, Box 150, P.O., Warrnambool.  
 Russo, Bros., 23 Evelyn-street, Frankston.  
 Sabatino, R., and Co. Pty. Ltd., 201 Peel-street, West Melbourne.  
 Sallmann, Jack, and Co., 123 Lloyd-street, Dimboola.  
 Samargis, George, 131 Gertrude-street, Fitzroy.  
 Sang Goon and Co., 56 Wholesale Fruit Market, Melbourne.  
 Sanitarium Health Food Co., 118 Union-street, Windsor.  
 Santalucia, A., and Sons Pty. Ltd., 47 Capel-street, North Melbourne.  
 Santarosa, Giacinto, 118 Peel-street, North Melbourne.  
 Scarff Bros. Pty. Ltd., 317 Collins-street, Melbourne.  
 Schultz, A. J., 20 Edgevale-road, Kew.  
 Schutt and Barrie Pty. Ltd., Geelong-road, West Footscray.  
 Schuyt, Johannes, Main-road, Silvan.  
 Sciarrone, Guiseppe, 10 Menzies-court, West Brunswick.  
 Scollo, Joe, 1420 Heather-ton-road, Dandenong.  
 Scott, Alex and Co. Pty. Ltd., 147 Lonsdale-street, Dandenong.  
 Scown and Standen Pty. Ltd., 1 Cobb-court, Swan Hill.  
 Seamer, A. F. and M. F., Mt. Pleasant-road, Monbulk.  
 Sesto, Geo., 104 Capel-street, North Melbourne.  
 Sfirro, L., and Co., 392A Brunswick-road, Brunswick.  
 Shea, Hood and Co. Pty. Ltd., 535 Flinders-lane, Melbourne.  
 Shue, D. Louey Bros. Pty. Ltd., 186 Franklin-street, Melbourne.  
 Sicura, Paola Guiseppe, 355 Brunswick-road, West Brunswick.  
 Silbert, Sharp and Davies Pty. Ltd., 17 Wholesale Fruit Market, Melbourne.  
 Silks Vegetables Pty. Ltd., 49 Peel-street, West Melbourne.  
 Simmonds, David George, Burwood-road, Wantirna South.  
 Simmons, S. F., Pty. Ltd., 9 Blackwood-street, North Melbourne.  
 Simos Bros., 33 Albert-road, Windsor.  
 Smith, David, Pty. Ltd., 3 Wholesale Fruit Market, Melbourne.  
 Smith, Gilbert E., Army-road, Pakenham East.  
 Smith, L. A., and Sons (Ballarat), 25 Doveton-street, Ballarat.  
 Smith, L. D. and L. M., Mangan's-road, Lilydale.  
 Smith and Milne, 1114 Howitt-street, Wendouree.  
 Smith, Robert, 21 Moorhouse-street, East Camberwell.  
 Smith, W. C., and Son, 14 Kendall-street, Syndal.  
 Smith, W. D., Main-road, Seville.  
 Smith, William John, 1116 Howitt-street, Ballarat.  
 Smorgons Rabbit and Poultry Packing Co. Pty. Ltd., Somerville-road, Brooklyn.  
 Smyth and Murphy, Gillies-street, Benalla.  
 Snowcap Products, 3 Teton-court, Moorabbin.  
 Soccio, Matteo, 42 McColl-street, Brunswick.  
 Soccio, S. and L., 450 Albion-street, West Brunswick.  
 Sortino, Mario, 45 Murray-street, West Brunswick.  
 Spence, J. G. and A. J., Stanley-road, Red Hill South.  
 Stabb, A. E., 10 Payne-street, West Caulfield.  
 Star Fruit Co. Pty. Ltd., 460 Queen-street, Melbourne.  
 Stellato, Louis, Pty. Ltd., 741 Nepean Highway, East Brighton.  
 Stott, T., and Sons, Pty. Ltd., 26 Wholesale Fruit Market, Melbourne.  
 Strachan and Co. Ltd, 25-43 Moorabool-street, Geelong.  
 Stuart, Ralph A., and Co. Pty. Ltd., 357-367 King-street, Melbourne.  
 Stuble, P., and Son Pty. Ltd., 45 Main-road, Greensborough.  
 Sun Loong, 46 Wholesale Fruit Market, Melbourne.  
 Sun Sui Wah Pty. Ltd., 58 Wholesale Fruit Market, Melbourne.  
 Sympag Pty. Ltd., 94 York-street, South Melbourne.  
 Tainton, K. and M., Burwood-road, East Burwood.  
 Tainton, Ray, and Sons, 28 Luba-street, Forest Hill.  
 Taralajkov, Petar, Settlement-road, Childers.  
 Tartaglia, Giuseppe, 207 Reynards-street, South Pascoe Vale.

*Name; Principal Place of Business.*

Taverna, Bruno, 2 Garden-court, Chadstone.  
 Taverna, V., 27 St. James-street, Moonee Ponds.  
 Taylor, E. J., and Son, "Somerset", Moorooduc.  
 Terang and District Fruit Supply, 76 Thomson-street, Terang.  
 Tesoriero and Natoli Pty. Ltd., 11 Station-street, Frankston.  
 Testarotta, Agostino, 22 Johnson-street, Sunshine.  
 The Committee of Direction of Fruit Marketing, 168 Franklin-street, Melbourne.  
 Thomas, I. H., 942 Canterbury-road, Box Hill.  
 Thompson Bros., Chaff and Produce, Cherry-street, Werribee.  
 Thompson, Geoffrey (Markets) Pty. Ltd., 40 Queen-street, Melbourne.  
 Till, H., and Son Pty. Ltd., 35 Peel-street, Melbourne.  
 Tinker, W. and W., 183 Fairy-street, Warrnambool.  
 Tocumwal Trading Co. Pty. Ltd., Meninya-street, Moama, New South Wales.  
 Tonkin Bros., Midland Apiaries, Talbot-road, Maryborough.  
 Torre, Charles, 440 Victoria-street, North Melbourne.  
 Torresi, U., and Sons, 30 Rathmines-street, Fairfield.  
 Tosto, Frank, 66 Moore-street, East Coburg.  
 Townley, Ronald George, Rossiter-road, Koo-Wee-Rup.  
 Trellis, John George, 41 Peel-street, West Melbourne.  
 Trethowan, J. V., and Sons, Brooklyn-road, Melton South.  
 Trew's Poultry Supplies, 126 Wilson-street, Colac.  
 Triplett, L. J., cnr. High-street and Mayfair-avenue, Lower Templestowe.  
 Tripodi, Serafino, 12 Combermere-street, Essendon.  
 Tripodi, Vincent, 12 Combermere-street, Essendon.  
 Tulloch, A., and Co., 114 King-street, Melbourne.  
 Tulloch, Jenkin, Pty Ltd., 33 Desailly-street, Sale.  
 Tully, L. J. and B. L., Victoria-street, Doncaster.  
 Tyabb Co-operative Trading & Cool Stores Ltd., The, Peacock-road, Tyabb.  
 Tyner, J. and R., 465 Collins-street, Melbourne.  
 Unthank, J. R., Flinders-road, Hastings.  
 Valley Potatoes, Warrenbayne, Victoria.  
 Valos Bros., 16 Fanny-street, Moonee Ponds.  
 Varano, Giovanni, 18 Davis-street, Moonee Ponds.  
 Varapodio, Amato, 303 Barkers-road, Kew.  
 Varapodio, R., and Sons, 303 Barkers-road, Kew.  
 Vear, F. W. (Fruit) Pty. Ltd., 28 Wholesale Fruit Market, Melbourne.  
 Vear, F. W., Overseas Pty. Ltd., 28 Wholesale Fruit Market, Melbourne.  
 Vear, F. W., Pty. Ltd., 28 Wholesale Fruit Market, Melbourne.  
 Vear, F. W. (Vegetables) Pty. Ltd., 28 Wholesale Fruit Market, Melbourne.  
 Venuto, A., 256 Victoria-street, North Melbourne.  
 Victorian Butter Factories Co-op. Ltd., 54-60 King-street, Melbourne.  
 Victorian Oat Growers' Pool and Marketing Co. Ltd., 528 Lonsdale-street, Melbourne.  
 Victorian Producers' Co-operative Co. Ltd., 578-584 Flinders-lane, Melbourne.  
 Victorian Wheatgrowers' Corporation Ltd., 296 Macaulay-road, North Melbourne.  
 Villani, Antonio, 39 Dundas-street, Preston.  
 Villani, Leonardo, 46-48 Erskine-street, North Melbourne.  
 Visalli, G., 261 Maribymong-road, Ascot Vale.  
 Wadson Bros., Grassy Flat-road, Diamond Creek.  
 Wake, H. J., 101 Pearson-street, Brunswick West.  
 Ward, H. S. K., Pty. Ltd., 24-38 Spencer-street, Melbourne.  
 Watkins Fruit Co. Pty. Ltd., 5 Wholesale Fruit Market, Melbourne.  
 Watson, J., and Co. Pty. Ltd., 3 Gordon-avenue, Geelong West.  
 Webber Bros. Pty. Ltd., 4 Courtney-street, North Melbourne.  
 Weddel and Co. (Aust.) Pty. Ltd., 43 King-street, Melbourne.  
 Weiss, Albert, 61 Peel-street, West Melbourne.  
 Westaway, H. J., Station-street, Somerville.  
 Westaway, William Oscar, Harcourt, Victoria.  
 Western District Co-op. Co. Ltd., 14-20 King-street, Melbourne.  
 Western District Fruit Supply, The, 281 Timor-street, Warrnambool.  
 Western Murray Fruit Supply Pty. Ltd., 147 Ninth-street, Mildura.  
 Westmore, M. R., 271 Canterbury-road, Heathmont.  
 Whaley Geo., and Sons, 9 Fitzgibbon-avenue, West Brunswick.  
 White, A. G., Queens-road, Silvan.  
 Wiffen, W. S., and Sons, Willis-street, Portarlington.  
 Wilco Honey Pty. Ltd., 13 Calder Highway, East Keilor.  
 Willey, Gilbert Thomas, Stevens-street, Portarlington.  
 Williams, A. E. and K. E., Queens-road, Silvan.  
 Williams, G. A., and Son, 53 Koonung-road, Blackburn.  
 Williams, G. R., 49 Welfare-parade, Burwood.

*Name; Principal Place of Business.*

Williams, Henry, E., and Sons Pty. Ltd., 3 High-street, Maryborough.  
 Willis, Bros. Pty. Ltd., Piper-street, Kyneton.  
 Wills, Ian Russell, 33 Hopetoun-street, Bendigo.  
 Wilson, Herbert, Pty. Ltd., 10 Wholesale Fruit Market, Melbourne.  
 Wilson and Sons, Produce Merchants Pty. Ltd., 407 Royal-parade, Parkville.  
 Wing, Hie, and Co. (Bananas) Pty. Ltd., 409 Queen-street, Melbourne.  
 Wing, Hie, and Co. Pty. Ltd., 53 Wholesale Fruit Market, Melbourne.  
 Wing, R. A., and Co. Pty. Ltd., 37 Wholesale Fruit Market, Melbourne.  
 Wing, Young, and Co. Pty. Ltd., 38 Wholesale Fruit Market, Melbourne.  
 Woodend Produce Store and Real Estate Agency, Woodend, Woods Bros., Devenish, Victoria.  
 Woodward, K. and V. F., Koo-Wee-Rup North.  
 Wright, N. H. and N. E., Robinvale, Victoria.  
 Wright Stephenson and Co. Ltd., 330 St. Kilda-road, Melbourne.  
 Yandell, John Richard, 47 Campbell-street, Castlemaine.  
 Yarrafarm Bulbs Pty. Ltd., 238 Elizabeth-street, Melbourne, C.I.  
 Yee Hop Loong Pty. Ltd., 32 Wholesale Fruit Market, Melbourne.  
 Yee Tong and Co. Pty. Ltd., 43 Wholesale Fruit Market, Melbourne.  
 Yick, Sam, and Co., 39 Wholesale Fruit Market, Melbourne.  
 Young, K., Auctions, 1 St. Andrews-avenue, Bendigo.  
 Young, Sang, 45 Wholesale Fruit Market, Melbourne.  
 Young, Tim, and Co. Pty. Ltd., 18 Wholesale Fruit Market, Melbourne.  
 Youngusband Ltd., 94 King-street, Melbourne.  
 Young's Market (Horsham), 34 Pynsent-street, Horsham.  
 Zammicheli, Umberto, 18 Moore-street, Coburg.  
 Zerbe, Leslie Herman, Anderson's Creek-road, East Doncaster.  
 Zissis, Nick, cnr. Waimarie-drive and Jarrah-court, Glen Waverley.  
 Zorro Produce, rear 280 Victoria-street, North Melbourne.

**L**IST of persons to whom Farm Produce Agents' Licences have been issued for the year ending December, 1966, all of whom are exempt from the provisions of paragraphs (a) and (b) of sub-section (1) of section 10 of Act 6248 in regard to lodging a fidelity bond:—

*Name; Principal Place of Business.*

Alexandra, G. R., Pty. Ltd., 109 Therry-street, Melbourne.  
 Anthony Bros., 34 Adelaide-street, Malvern.  
 Argentino, Aghito (Mrs.), 29 Sheddon-street, Pascoe Vale.  
 Australian Wholesale Grocery Pty. Ltd., 103 Victoria-street, Fitzroy.  
 Bellfair Poultry Supply Pty. Ltd., 225 Dundas-street, Preston.  
 Ben's Fruit Emporium, 37 Langford-street, Moe.  
 Borsumy Wehry (Aust.) Pty. Ltd., 311 King-street, Melbourne, C.I.  
 British United Dairies Pty. Ltd., 141 Osborne-street, South Yarra.  
 Bynon, John Arthur, Myrtle-street, Myrtleford.  
 Cannatelli Bros., 52 Bridge-street, Benalla.  
 Captain House Pty. Ltd., 479 Flinders-lane, Melbourne.  
 Casamento, J., 63 Japan-street, Warrnambool.  
 Cations and Garfield, 18 Church-street, Werribee.  
 Cleary, Michael, 33 Dudley-street, North Essendon.  
 Cole, A. H. and D. M., 93 Liebig-street, Warrnambool.  
 Collyvas Bros., 51 Napier-street, St. Arnaud.  
 Cooper, Neil Vinton, Commercial-road, Yarram.  
 Copolov, Myer, 6 Shelley-street, Elwood.  
 Country Fruit Distributors, 34 Teague-street, Niddrie.  
 Crosby, Frank, 8 Beauford-street, Huntingdale.  
 Davidson, K. W., and B., 46 Radovick-street, Korumburra.  
 Davies, N., 1 Odin-street, Strathmore.  
 Dickson, Leslie George, Second-street, Hepburn Springs.  
 Diggers' Fruit Stall, Little Malop-street, Geelong.  
 Ferguson, Archibald Thomas, Flat 7, 42 Burnett-street, St. Kilda.  
 Frantantaro, J. and M., Melbourne-road, Werribee.  
 Gazis, Zois, 114 Nolan-street, Maryborough.  
 Greaves, Arthur, 81 Capel-street, North Melbourne.  
 Greene, Owen, and Son, 36 Henty-street, Casterton.  
 Grigg, James, and Son, 14-16 South-street, Ascot Vale.  
 Grinham, Reginald Bruce, Whyte-street, Coleraine.  
 Hadwen, J. T., Pty. Ltd., 153 Princes-street, Port Melbourne.  
 Hall's Fruit Supply, 21 Victoria-street, Nhill.  
 Hamilton Fruit Company, 122 Gray-street, Hamilton.  
 Holloway, F. J., 62 Radovick-street, Korumburra.

*Name; Principal Place of Business.*

Jochinke, O. W., Pty. Ltd., 30 Wimmera-street, Dimboola.  
 Joosen, M. C. and A. M., 121 Edgar-street, Portland.  
 Kleeman, P. E., 26 Head-street, Elwood.  
 Lavery, David, and Son Pty. Ltd., 406 Lonsdale-street, Melbourne.  
 Layne, J. J., 69 Clausen-street, North Fitzroy.  
 Lazzaro Bros., 66 Raymond-street, Sale.  
 McCarty, Raymond James, 27 Leslie-street, Brunswick.  
 Marriott, A., 1161 Centre-road, South Oakleigh.  
 Martiniello, L., 73 Smythe-street, Benalla.  
 Maryvale Fruit Supply, 97 Argyle-street, Traralgon.  
 Materia Bros., 37 Bear-street, Leongatha.  
 Misuraca, M., and Co., 29 Smith-street, Warragul.  
 Myrtleford Fruit Palace, Myrtleford, Victoria.  
 Ogden's Poultry Supply, 131 Carlisle-street, Balaclava.  
 O'Hara, T., 315 Coventry-street, South Melbourne.  
 Paxinos, J., 161 Clarendon-street, South Melbourne.  
 Priestley, E. M. and F. R., 18 Melville-street, Numurkah.  
 Primrose Fruit Supply, Deniliquin (New South Wales).  
 Pritivelli, John, 149 Dundas-street, Preston.  
 Producers Packing Co. Pty. Ltd., 539 Flinders-lane, Melbourne.  
 Rankin, Edwin Douglas, 75 Preston-street, Geelong West.  
 Restuccia, Rosario, 43 Aikman-crescent, Chadstone.  
 Sau, Ignacij, 54 Lambie-street, Cooma, New South Wales.  
 Sciarro, Francesco, 35 Tyler-street, North Fitzroy.  
 Soumilas, H. and I., 170 Barker-street, Castlemaine.  
 South Western Fruit Supply, 43 Horner-street, Hamilton.  
 Stoneman, Mary Ellen, 10 Charles-street, Brunswick.  
 Thierry, J. C. and H. J., Chapel-street, Whittington.  
 Thomas, E. W., 119 Victoria-street, Melbourne.  
 Tripodi, Rocco, 148 Cooper-street, Essendon.  
 Wade, H. M., and Co. Pty. Ltd., 21 Wholesale Fruit Market, Melbourne.  
 Walker, Fred, 1167 Dandenong-road, East Malvern.  
 Walsh, E. J., Bros., 331 Latrobe-street, Melbourne.  
 Wangaratta Fruit Palace, 37 Reid-street, Wangaratta.  
 Webb, L. G. and M. M., Commercial-road, Yarram.  
 Westaway, N. E., 121 Waverley-street, Moonee Ponds.  
 Williams Bros., 8 Buckingham-avenue, Bentleigh.  
 Wilson, Donald Rex, 91 Valentine-street, Ivanhoe.  
 Wimmera and Mallee Fruit and Vegetable Distributors, 87 Firebrace-street, Horsham.  
 Young's Wholesale Supply, 39 Railway-street, Seymour.  
 Zagami, B., and Sons, 172 Main-street, Bairnsdale.

**L**IST of brokers to whom Farm Produce Agents' Licences have been issued for the year ending December, 1966, and each of whom is exempt from lodging a fidelity bond (in accordance with the provisions of section 10, sub-section (6) of Act 6248):—

*Name; Principal Place of Business.*

Box, A. D., 528 Collins-street, Melbourne.  
 Coutts, R. W., 422 Collins-street, Melbourne.  
 Fox, E. J., 120 King-street, Melbourne.  
 Jackett, Herbert, Pty. Ltd., 43 Elizabeth-street, Melbourne.  
 Kilgour, Douglas D., 479 Collins-street, Melbourne.  
 Leaver, C. H., (Aust.) Pty. Ltd., 540 Little Collins-street, Melbourne.  
 Moore, Robert, S. M., 90-92 William-street, Melbourne.  
 See, John, 1136 Malvern-road, Malvern.  
 Smith, E., and Son, 528 Collins-street, Melbourne.  
 Stephens, G. K., cnr. Dudley-street and Footscray-road, West Melbourne.  
 Wood, C. H., and Co., 75 Queens-road, Melbourne.

FRANK M. READ,  
 Director of Agriculture.

## WORKERS COMPENSATION ACT.

**N**OTICE is hereby given that pursuant to section 82 (7) of the *Workers Compensation Act 1958*, the Workers Compensation Board has fixed the under-mentioned days as the days upon which the respective quarterly instalments of the contributions to the Workers Compensation Board Fund for the financial year ending the 30th June, 1967, shall be paid:—

- 1st quarterly instalment.—22nd August, 1966.
- 2nd quarterly instalment.—1st October, 1966.
- 3rd quarterly instalment.—1st January, 1967.
- 4th quarterly instalment.—1st April, 1967.

By order of the Board,

GEO. T. SMITH, Registrar,  
 Workers Compensation Board.

Melbourne, 15th August, 1966.

Commercial Goods Vehicles Act.  
TRANSPORT REGULATION BOARD.

## HEARING OF APPLICATIONS.

NOTICE is hereby given that the following applications will be considered by the Transport Regulation Board at its offices at Rathdown-street, Carlton, at 10.15 a.m. on Wednesday, 7th September, 1966.

- ALLANS MUSIC (AUST.) PTY. LTD., 246 Collins-street, Melbourne. One commercial goods vehicle (L/C. 19 cwt.) to operate in the course of business as "Music Warehousemen". (a) Within a 50-mile radius from own premises in the City of Melbourne—own goods. (b) Throughout the State of Victoria—tools of trade and spare parts incidental to the installation, maintenance and repair of electronic organs, television sets and aerials, also musical instruments for demonstration purposes only.
- ANTONE, B. M., 282 Vickers-road, Lavington. One commercial goods vehicle (L/C. 311 cwt.) to operate from forest landings within a 25-mile radius of Stanley to consignees at Rutherglen, Wangaratta and Yackandandah—logs.
- ATHORN, A. T., Box 11, Beverford. One commercial goods vehicle (L/C. 79 cwt.) to operate: (a) Within a 20-mile radius of the post office at Beverford, in the course of business as "General Carrier"—general goods. (b) Within a 50-mile radius of the depot of Shell Company of Australia Ltd. at Swan Hill—petroleum products on behalf of the said company.
- AUTO REPLACEMENT CO., 25 Deakin-avenue, Mildura. One commercial goods vehicle (L/C. 10 cwt.) to operate within a 100-mile radius from the post office at Mildura and to and from the Township of Hopetoun in the course of business as "Automobile Engineers"—tools of trade, spare parts, motor car accessories, wet and dry batteries and engine blocks for repair or having been repaired.
- BARRY, N. U. & F. H., King-street, Yarra Glen. One commercial goods vehicle (L/C. approximately 110 cwt.) to operate in the course of business as "Garden Suppliers". (a) Within a 25-mile radius of own premises at Yarra Glen—own goods. (b) Within a 25-mile radius of own premises at Yarra Glen—road-making plant and materials.
- BOSCHEN, G. M., Austin-street, Stawell. One commercial goods vehicle (L/C. 200 cwt.) to operate within a 50-mile radius of the post office at Stawell in the course of business as "Earth-moving Contractors"—own earth-moving plant and equipment.
- BAYVIEW QUARRIES PTY. LTD., 602 St. Kilda-road, Melbourne. One commercial goods vehicle (L/C. 200 cwt.) to operate: (a) From sand pits situated within a 35-mile radius respectively from any one of own premises at Narre Warren, Berwick, Clayton, Springvale, Montrose, St. Helena, North Melbourne, Tullamarine, Lysterfield, Dandenong or Bulla to such premises only—sand. (b) From any one of own premises as defined in paragraph (a) above to consignees situated within a 35-mile radius thereof—screenings, stone dust, sand, hot asphalt and premix. (c) Within a 35-mile radius from any one of own premises as defined in paragraph (a) above—road-making plant and equipment.
- BELL, G. H., & SON PTY. LTD., P.O. Box 117, Mansfield. One commercial goods vehicle (L/C. 204 cwt.) to operate from forest landings in the Tolmie, Blue Range and King Basin areas to sawmills at Mansfield—logs. This application replaces licence No. T.T.D.468 held by the applicant.
- BERTACCHINI, P., 37 Mary-street, Heyfield. One commercial goods vehicle (L/C. 296 cwt.) to operate from forest landings in the Licola area to sawmills at Heyfield—logs. This application replaces licence No. T.T.D.129 held by the applicant.
- BLAKISTONS LTD., 78 Brovham-street, Geelong. One commercial goods vehicle (L/C. 70 cwt.) to operate: (a) Within a 25-mile radius from the chief post office in the City of Geelong for the purpose of towing a trailer for the carriage of heavy goods in conjunction with the use of the vehicle as a mobile crane. (b) Within a 50-mile radius of the post office aforesaid for the purpose of operating the vehicle as a mobile crane.
- CALLANDER, R. J., 76 Keon-street, Thornbury. One commercial goods vehicle (L/C. 60 cwt.) to operate throughout the State of Victoria in the course of business as "Marine Dealer" for the purpose of collecting second-hand uncleaned bags and scrap metals.
- CARLILE BROS. PTY. LTD., Strickland-road, East Bendigo. One commercial goods vehicle (L/C. 36 cwt.) to operate in the course of business as "Wool and Skin Merchants" within the areas as follows: (a) Within a 50-mile radius from the chief post office in the City of Bendigo—own goods. (b) From the Townships of Charlton, St. Arnaud, Kerang, Donald, Boort, Wyche-proof, Swan Hill and the Cities of Shepparton and Ballarat to own premises in the City of Bendigo—wet sheep skins and hides and a quantity, not exceeding five drums, of tallow on any one load.
- CLEELAND, W. R., 12 Royal-avenue, Benalla. One commercial goods vehicle (L/C. 271 cwt.) to operate from forest landings in the Bindiree area to Walkers' sawmill at Mansfield—logs. This application replaces licence No. T.T.D.545 held by the applicant.
- CROP AND ORCHARD CHEMICALS PTY. LTD., 4 Kintore-street, Springvale. One commercial goods vehicle (L/C. 8 cwt.) to operate throughout the State of Victoria in the course of business as "Agricultural Spraying Contractors"—tools of trade, spraying equipment and materials incidental to own contracts.
- DALE, C. W., View-street, Castlemaine. One commercial goods vehicle (L/C. 10 cwt.) to operate within a 50-mile radius of own premises at Castlemaine and to and from Melbourne in the course of business as "Second-hand Dealer"—second-hand goods.
- DE VRIES, W. R., 8 Albert-road, Drouin. One commercial goods vehicle (L/C. 95 cwt.) to operate from own premises at Drouin to places within a 50-mile radius thereof in the course of business as "Logging Contractor"—tools of trade, logging equipment and fuel for own tractor.
- DUNNING, G. & D., 40 Forest-road, Orbost. Two commercial goods vehicles (L/C. 261 and 272 cwt.) to operate: (a) Within a 20-mile radius of the Orbost Post Office—general goods. (b) From Errinundra Timber Co.'s sawmill at Club Terrace to the Orbost Railway Station—sawn timber. This application replaces licence Nos. T.T.D.184 and T.T.D.184/4 held by the applicant.
- EARL, L. R. & T. F., Box 7, Warrambool. Two commercial goods vehicles (L/C. 14 and 64 cwt.) to operate: (a) Within a 70-mile radius of own premises at Warrambool in the course of business as "Farm Machinery Distributor and Servicing Specialists"—tools of trade and spare parts incidental thereto, farm machinery for repair or having been repaired, second-hand traded-in machinery and new machinery for delivery and installation. (b) Within a 50-mile radius of the depot of Neptune Agency at Dennington—petroleum products in prescribed types of containers and empty return containers.
- FISHER, B. J., Badger Creek-road, Healesville. Application to vary the conditions of licence No. D.T.1125 (L/C. 265 cwt.) by adding after Molesworth—"area" and by adding after Healesville—"and to the sawmill of J. L. Barnes at Lilydale".
- FRANCOMBE, W. R., 65 Mt. Dandenong-road, Ringwood East. One commercial goods vehicle (L/C. 198 cwt.) to operate within a 50-mile radius of the premises of Bayview Quarries Pty. Ltd., at Montrose solely on behalf of the said company—pre-mixed concrete in a specially constructed agitator vehicle.
- FRANKLAND, G. H., 34 Moore-street, Traralgon. One commercial goods vehicle (L/C. 96 cwt.) to operate within the area east of a north/south line drawn through Pakenham and as far east as Orbost in the course of business as "Paving Contractor"—own plant and equipment, tools of trade and any materials incidental to the completion of any contract with the proviso that any bitumen carried shall be that initially consigned on rail to Traralgon or to the railway station nearest to the contract site.
- GENERAL MOTORS-HOLDEN'S PTY. LTD., Princes Highway, Dandenong. One commercial goods vehicle (L/C. 10 cwt.) to operate: (a) Within a 50-mile radius of own premises situated at Dandenong in the course of business as "Motor Vehicle Distributors"—own motor parts and chassis members. (b) Throughout the State of Victoria for the purpose of conducting instruction classes—tools of trade, spare parts and automotive equipment for demonstration.
- GRANDY, K. A., Box 159, Lakes Entrance. One commercial goods vehicle (L/C. 301 cwt.) to operate within a 50-mile radius from the post office at Lakes Entrance in the course of business as "Logging and Earth-moving Contractor"—own bulldozers, equipment, tools of trade and sufficient fuel for use in own machines.
- HALL, L., Box 320, Orbost. Application to vary the conditions of licence No. T.T.D.1138 (L/C. 250 cwt.) by deleting the existing conditions and adding in lieu—"within a 30-mile radius of the post office at Cann River—logs."
- HOSE, DAVID, PTY. LTD., Main-road, Elliminyt. One commercial goods vehicle (L/C. 240 cwt. approximately) to operate: (a) Within a 20-mile radius of the post office at Colac—general goods. (b) Within a 70-mile radius of the premises of Colac Brick Works Pty. Ltd.—bricks solely on behalf of the said company.

- CRUTE, A. H., (trading as J. & A. Wreckers), Princes Highway, Warrnambool. One commercial goods vehicle (L/C. 12 cwt.) to operate throughout the State of Victoria with special car carrying trailer for the purpose of carrying, repairing and/or disposing of disabled or wrecked motor vehicles from garage to garage or from premises to own premises in the course of business as a buyer and repairer of wrecked motor vehicles on behalf of insurance companies or other interested parties—disabled or wrecked motor vehicles, tools of trade, spare parts and materials incidental thereto, subject to the condition that the vehicle shall not be used to tow away any wrecked or damaged vehicle from the scene or area of collision or point of impact at which the damage was caused to any such vehicle and that all towing pursuant to this application be confirmed wholly to the subsequent disposal or repair of such vehicle after its initial towing to a garage by a properly authorized tow truck operator.
- LANSSELL & GRUMLEY, 62 Fitzroy-street, Sale. One commercial goods vehicle (L/C. 120 cwt.) to operate: (a) Within a 50-mile radius of the post office at Sale as a "Road Contractor"—road-making plant and materials. (b) Within a 20-mile radius of the post office at Dutton in the course of business as "Primary Producer"—own goods.
- LUCK, W. H. & N. B., Box 23, Benalla. One commercial goods vehicle (L/C. 78 cwt.) to operate: (a) Within a 50-mile radius of own branch premises at Mansfield in the course of business as "Commission Agents"—tires, tubes, batteries and farm storage tanks for sale and delivery and Cyclone gates on behalf of Cyclone Co. of Aust. Ltd. (b) Within a 50-mile radius of the post office at Mansfield—petroleum products in prescribed types of containers and empty return containers on behalf of Mobil Oil Aust. Ltd.
- MALONE, P. R., TRANSPORTS PTY. LTD., Grasmere Junction. Application to vary the conditions of licence No. D.A.35478/10 (L/C. 246 cwt.) by adding as an additional paragraph—"(g) Manufactured articles and products from Nestles Co. (Aust.) Ltd. (an approved Decentralized Industry) at Dennington to Portland and raw materials and goods being the property of the said company from Portland to Nestles Co. (Aust.) Ltd. manufacturing plant at Dennington."
- MAWSON, E. B., & SONS PTY. LTD., P.O. Box 66, Cohuna. One commercial goods vehicle (L/C. 18 cwt.) to operate throughout the State of Victoria in the course of business as "Contractors and Quarrymasters"—tools of trade, spare parts and materials incidental to the servicing and maintenance of own vehicles and earth-moving equipment.
- MEDREW & TEYCHENNE, 172 Franklin-street, Traralgon. One commercial goods vehicle (L/C. 7 cwt.) to operate within a 50-mile radius of Traralgon in the course of business as "Electrical Appliance and Sales Service"—tools of trade, spare parts, electrical appliances for sale or delivery for repair or having been repaired.
- MILES PAINT SERVICE PTY. LTD., 1032 Dandenong-road, Carnegie. Four commercial goods vehicles (L/C. 10 cwt. each) to operate throughout the State of Victoria in the course of business as "Signwriters and Maintenance Painters"—tools of trade, scaffolding, ladders and small quantities of materials incidental to the completion of own contracts.
- MODERN TOWING AND SALVAGE PTY. LTD., 380 Barkly-street, Footscray. One commercial goods vehicle (L/C. 16 cwt.) to operate throughout the State of Victoria in the course of business as "Crane Hirers and Tow Truck Operators" for the purpose of operating as a pilot vehicle for the purpose of servicing own vehicles and equipment incidental to any lifting or towing contract.
- MCERVALE, D. M., Wills-street, Beaufort. Application to vary the conditions of licence No. D.A.41368 (L/C. 77 cwt.) by deleting the existing conditions and adding in lieu—"(a) within a 20-mile radius from the post office at Beaufort—general goods. (b) To and from the City of Ballarat, from and to Beaufort—general goods."
- NEATE, R. R., 11 Maggs-street, Croydon. One commercial goods vehicle (L/C. 6 cwt.) to operate as a "Serviceman" solely on behalf of Turner Manufacturing Co. Pty. Ltd., as follows:—(a) Within a 50-mile radius of Nunawading for the delivery and installation of motor mowers, washing machines and appliances manufactured by the said company. (b) Within a 100-mile radius of Nunawading for the servicing and maintenance of motor mowers, washing machines and appliances manufactured by the said company—tools of trade, spare parts incidental thereto and motor mowers, and washing machines for repair or having been repaired.
- O'CONNOR, A. H., Jeeralang-road, Hazelwood. One commercial goods vehicle (L/C. 364 cwt.) to operate: (a) From landings situated within a 25-mile radius of the Australian Paper Manufacturers Ltd. mill at Maryvale to the said mill—pulpwood. (b) From landings in the Silver Creek area to own sawmill at Hazelwood and/or to Duff's sawmill at Morwell and/or to Andrew's sawmill at Longwarry—logs. This application replaces licence No. T.T.D.1070 held by the applicant.
- OSBORNE, W. & SONS, Anakie, via Geelong. One commercial goods vehicle (L/C. 206 cwt.) to operate: (a) Within a 20-mile radius of the post office at Anakie—general goods. (b) To or from places within a 5-mile radius of the post office at Anakie from or to petrol depots in the City of Melbourne—petroleum products in prescribed types of containers and empty return containers. (c) From and to places within the radius specified in part (a) above to or from places outside that radius but wholly within a 50-mile radius of the post office at Anakie—livestock.
- REYNOLDS, E. A., 96 Wilsons-road, Newcombe. One commercial goods vehicle (L/C. 253 cwt.) to operate: (a) Within a 50-mile radius from the chief post office in Geelong solely on behalf of Sou' West Frozen Food Packers Ltd.—market garden and orchard produce, frozen meat, frozen poultry, frozen fish, frozen vegetables, frozen pastries, frozen berries, frozen fruit juices, frozen pies, frozen chicken rolls, frozen prepared meals, frozen egg whites, ice-cream, empty return containers, plant and incidental equipment but excluding the carriage of any canned goods whatsoever. (b) From and to the premises of Sou' West Frozen Food Packers Ltd., at Geelong and their depot at Melbourne to the City of Bendigo and the Township of Traralgon—frozen meat, frozen poultry, frozen fish, frozen vegetables, frozen pastries, frozen berries, frozen fruit juices, frozen pies, frozen chicken rolls, frozen prepared meals, frozen egg whites and ice-cream, but excluding the carriage of any canned goods whatsoever.
- ROBERTS, O., 1 Young-street, Drouin. One commercial goods vehicle (L/C. 6 cwt.) to operate from the premises of Motor Spares Ltd., at Warragul to consignees at Yarragon, Trafalgar, Moe, Yallourn, Morwell and Traralgon on behalf of the said company—spare parts and accessories for motor vehicles.
- ROMANIN, A., & SONS, Neerim Junction. One commercial goods vehicle (L/C. 144 cwt.) to operate from forest landings in the Neerim South area to the A.P.M. at Maryvale—pulpwood.
- ROMEY, K. B., Glasgow-street, Rutherglen.—One commercial goods vehicle (L/C. 109 cwt.) to operate: (a) Within a 20-mile radius of the post office at Rutherglen—general goods. (b) Within a 50-mile radius from the post office at Rutherglen in the course of business as "Firewood Merchant"—own firewood.
- SAWYER, S. W., 12 Richardson-street, Portland. One commercial goods vehicle (L/C. 224 cwt.) to operate: (a) From Clay & Pitt's sawmill at Portland to yards and to building sites (in house lots only) within a 50-mile radius of such sawmill—sawn timber. (b) Within a 20-mile radius of the post office at Portland—general goods. This application replaces licence No. T.T.D.339/1 held by the applicant.
- SMEATH BROS. PTY. LTD., 173 Spring-street, Regent. One commercial goods vehicle (L/C. 138 cwt.) to operate within a 70-mile radius of the premises of the Northcote Brick Co. Ltd., at Northcote—bricks on behalf of the said company.
- SOUTH WANGARATTA SAWMILLING CO. PTY. LTD., Stanford-road, Wangaratta. One commercial goods vehicle (L/C. 211 cwt.) to operate: (a) From forest landings within a 50-mile radius of the post office at Wangaratta to own sawmill at Wangaratta—logs. (b) From own sawmill at Wangaratta to consignees within a 50-mile radius of the post office at Wangaratta—sawn timber. This application replaces licence No. T.T.D.450/1 held by the applicant.
- STACKHOUSE, C. R., MOTORS PTY. LTD., Clifton-street, Euroa. One commercial goods vehicle (L/C. 11 cwt.) to operate: (a) Within a 20-mile radius of the post office at Euroa in the course of business as "Garage Proprietor"—general goods. (b) With a specially constructed car carrying trailer in the course of business as "Garage Proprietors" (i) from General Motors-Holden's Pty. Ltd., at Dandenong to own premises at Euroa—own new motor vehicles; (ii) throughout the State of Victoria—used or wrecked motor vehicles.
- STOCKWELL, R. J., Davis-street, Corryong. One commercial goods vehicle (L/C. 127 cwt.) to operate: (a) Within a 50-mile radius from the post office at Corryong and to Wodonga in the course of business as "Scrap Metal Merchant"—own scrap metal. (b) Within a 20-mile radius from the post office at Corryong to the Cudgewa Dairy Company at Corryong—cream.

- VAN GENINDEN, W., 3 Breed-street, Traralgon. One commercial goods vehicle (L/C. 146 cwt.) to operate within a 25-mile radius of the A.P.M. Ltd. at Maryvale—pulpwood.
- WALKER, M. L., Box 124, Corryong. Application to vary the conditions of licence No. D.A.52280 (L/C. 92 cwt.) by deleting "Wodonga" from paragraphs (a) and (c) and adding in lieu—"Corryong".
- WALKER, W. S., & SON, Box 124, Corryong. One commercial goods vehicle (L/C. 264 cwt.) to operate: (a) From forest landings within a 40-mile radius from the post office at Corryong to own sawmill at Corryong—logs. (b) To customers and building sites situated within a 50-mile radius from own sawmill at Corryong—own sawn timber. This application replaces licence No. T.T.D.390/2 held by the applicant.
- WALLS, J. C., 38 Valerian-avenue, Altona North. One commercial goods vehicle (L/C. 9 cwt.) to operate throughout the State of Victoria in the course of business as "Refrigeration Engineer"—tools of trade, spare parts and materials incidental to the servicing and maintenance of refrigerators.
- FRANCIS, R. H. (trading as Wangaratta Sawmills & Timber Supplies), Greta-road, Wangaratta. One commercial goods vehicle (L/C. 250 cwt.) to operate: (1) Within a 20-mile radius from the post office at Wangaratta in the course of business as "Sawmiller and Timber Supplier"—own goods. (2) From any forest landings within a 50-mile radius from the post office at Wangaratta—logs only. This application replaces licence No. T.T.D.603 held by the applicant.
- NEWMAN, A. M. (trading as Wangaratta Steam Laundry), 72 Norton-street, Wangaratta. One commercial goods vehicle (L/C. 10 cwt.) to operate within a 50-mile radius of Wangaratta Post Office in the course of business as "Laundry Proprietor"—garments for cleaning and laundering and garments having been cleaned and laundered.
- WHITE, K., Post Office, Woodford. Application to vary the conditions of licence No. D.A.42892/1 (L/C. 107 cwt.) by adding as an additional paragraph "(c) from and to places situated within the radius as defined in paragraph (a) above, to and from places situated within a 50-mile radius from the post office at Woodford—livestock."
- YOUNG, V. J., Bruce-street, Heyfield. One commercial goods vehicle (L/C. 265 cwt.) to operate: (a) From forest landings in the Licola area to sawmills at Heyfield—logs. (b) From forest landings in the Licola area to pulp log dumps at Breakfast Creek, Licola and Heyfield and to the premises of A.P.M. Ltd. at Maryvale—pulpwood, logs and billets. This application replaces licence No. T.T.D.411/2 held by the applicant.

## TOW TRUCKS.

- KENNEDY, L. (trading as Ballarat Towing Service), 25 Main-road, Ballarat. One commercial goods vehicle (L/C. 20 cwt.) to operate throughout the State of Victoria as a "Tow Truck" for the purpose of lifting and carrying or towing and/or repairing wrecked or disabled vehicles—tools of trade, spare parts and materials incidental thereto.
- BASTIN, J. N., 101 Creswick-road, Ballarat. One commercial goods vehicle (L/C. 30 cwt.) to operate throughout the State of Victoria as a "Tow Truck" for the purpose of lifting and carrying or towing and/or repairing wrecked or disabled vehicles—tools of trade, spare parts and materials incidental thereto.
- COON, L. J., Waubra Garage, Waubra. One commercial goods vehicle (L/C. 47 cwt.) to operate throughout the State of Victoria as a "Tow Truck" for the purpose of lifting and carrying or towing and/or repairing wrecked or disabled vehicles—tools of trade, spare parts and materials thereto.
- DAVIDSON, K. R. & S. A. (trading as Davidson's Panel Works), 121 Argyle-street, Traralgon. One commercial goods vehicle (L/C. 31 cwt.) to operate within a 100-mile radius from the post office at Traralgon as a "Tow Truck" for the purpose of lifting and carrying or towing and/or repairing wrecked or disabled vehicles—tools of trade, spare parts and materials incidental thereto.
- KENNEDY, L., 25 Main-road, Ballarat. One commercial goods vehicle (L/C. 64 cwt.) to operate throughout the State of Victoria as a "Tow Truck" for the purpose of lifting and carrying or towing and/or repairing wrecked or disabled vehicles—tools of trade, spare parts and materials incidental thereto.
- ROSS, G. L., High-street, Drysdale. One commercial goods vehicle (L/C. 27 cwt.) to operate within a 25-mile radius of the post office at Drysdale as a "Tow Truck" for the purpose of lifting and carrying or towing and/or repairing wrecked or disabled vehicles—tools of trade, spare parts and materials incidental thereto.

TEMPLE TOWING & BODY WORKS PTY. LTD., 95 North-road, South Oakleigh. One commercial goods vehicle (L/C. 25 cwt.) to operate within a 20-mile radius of own premises at Oakleigh as a "Tow Truck" for the purpose of lifting and carrying or towing and/or repairing wrecked or disabled vehicles—tools of trade, spare parts and materials incidental thereto.

- APPLICATIONS for renewal of licences as shown by persons listed hereunder to operate under the same terms and conditions from the expiry shown in each case.
- ANDERSON, G. D. & D. J., "Iddyllwilde", Nirranda; D.A.5215; 17th September, 1966; 119 cwt.
- ATKINS, L. J., Princes Highway, Pakenham East; D.A.32366; 26th May, 1966; 138 cwt.
- BALLARAT DEEP FREEZE FOOD CO. PTY. LTD., 21 Grenville-street North, Ballarat; T.D.A.39041/3; 31st August, 1966; 35 cwt.
- BALLARAT & WESTERN VICTORIA TELEVISION LIMITED, Walker-street, Ballarat; D.A.47301; 17th September, 1966; 11 cwt.
- DAVIS, J. L., PTY. LTD., 7 Curdie-street, Camperdown; D.A.30402/1; 22nd September, 1966; 129 cwt.
- DEPELER, F., & SON, 217 Lexton-street, Ballarat; D.A.47268; 17th September, 1966; 111 cwt.
- DOOLAN, L. T., 35 Clanbrae-avenue, Burwood; D.A.12000; 6th September, 1966; 91 cwt.
- HARBIG, P. M. (Vic.) PTY. LTD., 1 Drill-street, Hawthorn; D.A.2762/1; 3rd September, 1966; 15 cwt.
- O'LOUGHLIN, B. A. & Y. M., 27 Baromia-road, Mirboo North; D.A.46958/1; 6th August, 1966; 133 cwt.
- PENTREATH, M. C., PTY. LTD., 58 Omar-street, Maidstone; D.A.31643/13; 19th February, 1966; 120 cwt. approximately.
- REYNOLDS, E. A., 96 Wilson-road, Newcomb; T.D.A.35694/2; 27th September, 1966; 211 cwt.
- SHEED, J. J., 11 Ligar-street, Bairsdale; D.A.33915; 22nd September, 1966; 48 cwt.
- SHIEL, J. K. & V. J., 25 Downey-street, Alexandra; D.A.2026; 22nd September, 1966; 10 cwt.
- SPITTY, N. J., Anakie-road, Lovely Banks; D.A.47383; 24th September, 1966; 143 cwt.
- TRANS-WEST HAULAGE PTY. LTD., 45 Ryrrie-street, Geelong; D.A.33968/4; 22nd September, 1966; 296 cwt.
- WITTICK, R. & N., 13 Millbank-street, Bacchus Marsh; D.A.16775; 22nd September, 1966; 120 cwt.

## RENEWALS WITH VARIATIONS.

- STEWART, K. D., 315 St. Georges-road, North Fitzroy; D.A.33326; 14th July, 1966; Application to renew and vary the conditions of licence No. D.A.33326 (L/C. 70 cwt.) by deleting . . . "within a 150-mile radius" and adding in lieu . . . "throughout the State of Victoria."
- VOSILAITIS, B. & M., 28 Berkshire-road, North Sunshine; D.A.28102/1; 3rd September, 1966; Application to renew and vary the conditions of licence No. D.A.28102/1 (L/C. 126 cwt.) by deleting paragraph (a) from the existing conditions.

Notice of any objections should be forwarded to reach the Secretary of the Board not later than Wednesday, 31st August, 1966.

Applicants are advised that it will not be necessary to appear on the hearing date specified above, unless advised in writing by the Board.

B. P. KAY,  
Secretary.

Exhibition Buildings, Rathdown-street, Carlton, N.3,  
17th August, 1966.

Transport Regulation Act.  
TRANSPORT REGULATION BOARD.

## HEARING OF APPLICATIONS.

NOTICE is hereby given that the following applications will be considered by the Transport Regulation Board at its offices at Rathdown-street, Carlton, at 10.15 a.m., on Wednesday, 7th September, 1966.

- ANNETT, B. E. & P. M., Ballarat-road, Hamilton. One commercial passenger vehicle (S/C. 9) to operate under the same terms and conditions as existing C.O. licences in the name of the applicants.
- WRIGHT, C. A., HALEY, W., BLAIR, D., TARANTO, B. (trading as Arbutnotts Bus Service), 25 Liverpool-street, Coburg. Application to operate metropolitan passenger service Route 8a part (A) (Brunswick—North Essendon) as at present operated under M.O. licences held by the applicants with the added ability to operate the service direct along Woodlands-street, from North-avenue to Bulla-road, between the hours of 9 a.m. and 3.30 p.m. on weekdays, Saturdays and Public Holidays and on all trips on Sundays.

**BEACH TRANSPORT SERVICE PTY. LTD.**, 1037 Centre-road, South Oakleigh. Application for variation of all C.O. licences, Route 200A (Mordialloc-Chelsea) to operate under charter conditions within a 50-mile radius of the General Post Office, Melbourne, provided that every journey commences within a 4-mile radius of the post office, Aspendale.

**BOLAND, R. & M. T.**, 43 High-street, Werribee. One commercial passenger vehicle (S/C. 5) to operate under the same terms and conditions as existing taxi-cabs at Werribee.

**DAVIS, H. A., MOTOR SERVICE PTY. LTD.**, 117 Doveton-street north, Ballarat. One commercial passenger vehicle (S/C. 45) to operate under the same terms and conditions as existing "U.O." licences in the name of the applicant company.

**DUNN, W. T.**, 42 Cornwall-street, West Brunswick, and **RTCHIE, W. K.**, 4 Tinning-street, Brunswick. Application to operate metropolitan passenger service Route 9A as at present operated between East Brunswick and the corner of Albion-street and Lawson-street, via Lawson-street, Salisbury-street, McPherson-street, Thomas-street, Pascoe Vale-road to a stand in Coates-street, Moonee Ponds, returning via Coates-street to McPherson-street and normal route—subject to cancellation of licence Nos. M.O.248, M.O.263 and substitute M.O.50, at present in the names of W. K. Ritchie and W. T. Dunn. (Sections, fares and time-tables to be determined.)

**FAIRFIELD-NORTHCOTE-BRUNSWICK-MOONEE PONDS BUS ASSOCIATION**, 252 St. Georges-road, Northcote. Application to operate metropolitan passenger service, Route 10A (Fairfield-Northcote-Brunswick-Moonee Ponds) as at present operated under licences held by the applicants with the following amendment to service:—With extension from the corner of Separation and Bennett streets, Alphington, via Bennett-street, Parklands-avenue, Yarrana-road to Wingrove-street and Alphington Railway Station, returning to normal route via Kelvin-road and Parklands-avenue, and Bennett-street.

**FRANKSTON PASSENGER SERVICES PTY. LTD.**, 120 Dandenong-road, Frankston. To operate extensions of the Beach-street, Karingal and Orwill-street, Skye-road services by extending services along Lester-drive to the corner of Lester-drive and Lindrum-road.

*Time-table.*—Nine trips, Monday to Friday and three trips Saturdays.

**MONSON, A. J.**, 284 Mount-street, Albury. Application to vary all "C.O." licences to include the ability to operate a passenger and parcels service between Corryong and Albury.

*Time-table.*

Depart Corryong—5.30 p.m.  
Depart Cudgewa—5.45 p.m.  
Depart Tallangatta—6.45 p.m.  
Arrive Wodonga—7.15 p.m.  
Arrive Albury—7.30 p.m.

**PHILLIPS, F. A.**, 8 Mereweather-avenue, Frankston. To operate an extension of the Cranbourne-Frankston service by extending operations to and from Frankston, along Lindrum-road, Lester-drive, to the corner of Boyong-avenue.

*Time-table.*—Four trips Monday to Thursday; six trips Friday; and three trips Saturday.

**POINT COOK-WERRIBEE PASSENGER SERVICE PTY. LTD.**, Railway-avenue, Laverton. Application for variation of permit No. 5442/1, which authorizes the carriage of school children between Laverton and/or Williamstown Girls' High School and Williamstown Technical School, to include the ability to convey pupils residing in Werribee to the two above-named schools.

**PRESTON COBURG BUS SERVICES PTY. LTD.**, 572 Murray-road, Preston. Application for authority to operate metropolitan passenger service Route 121A (Preston-West Coburg) as prescribed, from the existing Preston terminus to the corner of Murray-road and Elizabeth-street, Preston; thence via Murray-road, Gaffney and Champ streets and Sydney-road to the existing stand on the north side of Bell-street, Coburg, east of Sydney-road. Returning to normal route via Bell-street, Elm-grove, Urquhart-street and Sydney-road— with extension (a) from the corner of Murray and Newlands roads, via Newlands-road to the premises of John McIlwraith Industries and extension (b) from the corner of Bell and Elizabeth streets via Elizabeth-street, Murray and Newlands roads to the premises of J. S. Grey Industries Pty. Ltd. (one trip morning and evening).

*Sections on Route.*—

- (1) Corner Elizabeth and Kennedy streets—corner Gilbert-road and Regent-street.
- (2) Corner Gilbert-road and Regent-street—corner Jackson-parade and Boyne-street.
- (3) Corner Jackson-parade and Boyne-street—corner Murray-road and Connelly-avenue West.
- (4) Corner Murray-road and Connolly-avenue West—corner Bell-street and Sydney-road.

Fares to remain unchanged. Time-table to be determined (subject to the cancellation of licences authorizing operations on Route 121A as at present prescribed between Preston and West Coburg).

**PRESTON COBURG BUS SERVICE PTY. LTD.**, 572 Murray-road, Preston. One commercial passenger vehicle, to be purchased, to operate as an additional route omnibus on Route 69A (Preston-Coburg), under the same terms and conditions as licences already held in the applicant's name.

**PRESTON COBURG BUS SERVICES PTY. LTD.**, 572 Murray-road, Preston. Application for authority to operate metropolitan passenger service Route 69A (Preston-Coburg) as prescribed from the existing Preston terminus to the corner of Murray-road and Elizabeth-street, Preston; thence via Elizabeth, Main, Bell, Main, O'Hea, Sussex, Bell, Turner and Derby streets to Caringa-street with turning procedure at Caringa-street via Caringa, Sussex, South and Derby streets to normal route—With extension (a) from the corner of Gaffney and Derby streets to the Blessed Oliver Plunkett School (for the carriage of school children only).

*Sections on Route:*

- (1) Corner Tyler-street and Plenty-road — Corner Highview and Murray roads.
- (2) Corner Highview and Murray roads—Preston Railway Station.
- (3) Preston Railway Station—Corner Gilbert and Murray roads.
- (4) Corner Gilbert and Murray roads—Corner Bell and Elizabeth streets.
- (5) Corner Bell and Elizabeth streets—Corner Bell-street and Sydney-road.
- (6) Corner Bell-street and Sydney-road — Corner Sussex and O'Hea streets.
- (7) Corner Sussex and O'Hea streets — Corner Derby and Gaffney streets.
- (8) Corner Derby and Gaffney streets — Corner Derby-street and Kent-road.
- (9) Corner Derby-street and Kent-road—Corner Derby and Caringa streets.

Fares to remain unchanged. Time-table to be determined (subject to the cancellation of licences authorizing operations on Route 69A as at present prescribed between Preston and Coburg).

**SINCLAIR, W., & SONS PTY. LTD.**, 1081 Nepean Highway, Moorabbin. One commercial passenger vehicle with large seating capacity to be purchased to operate as an additional metropolitan special service omnibus within a 50-mile radius of the General Post Office, Melbourne.

**WEINBERG, A., PTY. LTD.**, Doherty's-road, Brooklyn. One commercial passenger vehicle (S/C. 29) to operate free of charge for the carriage of employees between the West Footscray Railway Station and the company's premises in Doherty's-road, Brooklyn.

**APPLICATION** for renewal of licences as shown, by persons listed hereunder to operate under the same terms and conditions:—

**ALEXANDER, E. B.**, Flat 11, 677 Toorak-road, Toorak; M.T.687.

**ASTORIA PTY. LTD.**, 214 Brunswick-street, Fitzroy; M.T.2407, M.T.2393, M.T.2410, M.T.2330, M.T.2392, M.T.2397, M.T.2417, M.T.2419, M.T.2395, M.T.2391, M.T.2394, M.T.2399, M.T.2242, M.T.2234, M.T.2245, M.T.2390, M.T.2408, M.T.2409, M.T.2411, M.T.2389, M.T.2398, M.T.2414, M.T.2416, M.T.2418, M.T.2402, M.T.2406, M.T.2405, M.T.2420, M.T.2244, M.T.2237, M.T.2233.

**AUSTRALIAN MOTOR INDUSTRIES**, Cook-street, Port Melbourne; T.P.69.

**BARNETT, S. J.**, 6 Brewer-road, Bentleigh; M.H.1865.

**BIVIANO, C.**, 42 Catherine-street, Geelong West; U.T.709.

**BRIGHTWELL, T. J.**, 186 Hope-street, Geelong West; U.T.706.

**IBRAHIM, J.**, 55 Bunbury-street, Newport; M.T.1742.

**LONEY, J. C.**, 17 Pevensey-crescent, Geelong; U.T.707.

**NAGEL, W. R.**, 9 Kipling-street, Moonee Ponds; M.H.1904.

**PEARCE, R. M.**, 18 Reading-avenue, North Balwyn; M.T.1991.

**ROBERTS, J. H.**, Main-street, Tallangatta; T.S.847.

**ROBERTSON, B. J.**, Tempy; T.S.291.

**SMITH, J. B.**, 52 Anderson-street, East Geelong; U.T.708.

## APPLICATION by—

ALTAVILLA, O., 6 Wheeler-street, Ormond; C.  
 AMATO, P., Sackville-street, Collingwood; G. and C.  
 ANDRICOPOULOS, P., 4 Margate-crescent, Glen Waverley; C.  
 ANGELINI, M., 21 Langham-street, Avondale Heights; G.  
 BAKER, G. T., 92 Ramu-parade, West Heidelberg; G.  
 BIANCHI, T., 204 Canning-street, Carlton; G.  
 CAMERON, R. A., 230 East Boundary-road, East Bentleigh; C.  
 CONDRON, M. R., 5 Princess-street, Merlynston; G.  
 COUROUZOS, S. G., 17 Elsa-street, Fawkner; G.  
 CRAKER, J. F. M., 34 Sussex-street, Preston; G.  
 CRONIN, L. G., 75 Pecham-street, Glenroy; G.  
 DAVIES, T. W., 47 Scotland-avenue, Greensborough; G.  
 DUNN, W. T., 44 Fulham-road, Alphington; G.  
 FORD, A. R., 4 Black-street, Watsonia; G.  
 FOTINIOTIS, P., 23 Avondale-street, Springvale; C.  
 FREEMAN, K. A., 25 Wadhams-street, Pascoe Vale South; G.  
 FULLARTON, R. C., 19 Manuka-street, South Oakleigh; C. and G.  
 GALEA, P., 569 Plenty-road, East Preston; G.  
 GARLICK, G. E. J., 60 Coorigil-road, Murrumbena; G. and C.  
 GARTH, R. N., 7 Una-street, Mount Waverley; C.  
 GRAY, R. W., 17 Payne-street, Caulfield; C.  
 HARPER, N. J., 8 Arbor-avenue, Reservoir; G.  
 HEIB, K. A., 8 Sunderland-avenue, Ashburton; C.  
 JILLY, B., Flat 7, 24 Acland-street, St. Kilda; G.  
 JONES, A. W. J., 35 Estelle-street, East Oakleigh; C.  
 JURMAN, A., 79 Neville-street, Carnegie; C.  
 KAYNE, V. A., Villa 2, 23 Hartington-street, Elsternwick; G. and C.  
 KING, J. A., lot 70, Walter-street, Glen Waverley; C.  
 KONING, P., 15 Denver-crescent, Elsternwick; C.  
 KOUKOUNAS, G., 73 Albion-road, Glen Iris; C.  
 KOUTLEMANIS, D., 59 Thea-grove, Doncaster East; C. and G.  
 KRASEY, L., 48 Pakington-street, Kew; C. and G.  
 LACEY, P., 38 Edward-street, McLeod; G.  
 LYONS, E. R., 24 Braidhill-road, McLeod; G.  
 MASON, B. L. A., 9 Watson-street, Dandenong; C.  
 MIRLOS, A. G., 120 St. Elmo-road, Ivanhoe; G.  
 MORGAN, E. B., 7 Inga-street, North Clayton; C.  
 MCINTYRE, J. R., 23 Waratah-street, West Footscray; G. and C.  
 O'NEILL, F. S., 6 Inez-avenue, Ringwood; C.  
 ORLICKI, K. L., 14 Ness-street, Diamond Creek; G.  
 PANDELOV, E., 213 Danks-street, Albert Park; G.  
 POLLARD, J. J., 55 Harold-street, Bulleen; G. and C.  
 RADCLIFFE, A. L., Flat 9, 31 Rosstown-road, Carnegie; C.  
 REBROVIC, A., 554 Huntingdale-road, East Bentleigh; C.  
 ROSEFIELD, H. K., 13 Frederick-street, South Caulfield; C.  
 ROY, W. H., 53 Tennyson-street, Sandringham; C.  
 SACCUZZO, P., 7 Massey-avenue, Reservoir; G.  
 SAMOLYK, A., 33 Sutton-street, North Carlton; G.  
 SANDERS, J. J., 14 Burroughs-road, Balwyn; G.  
 SAPOUNTZIS, K., 1 Hunter-street, Abbotsford; G. and C.  
 SHANAHAN, K. A., 11 Nyrang-street, Chadstone; C.  
 STAFFORD, G. H. E., Flat 1, 18 Clausen-street, North Fitzroy; G.  
 STICKLAND, W. B., 744 Burwood-road, Hawthorn; C.  
 TSAGARIS, C., 4 Gillman-street, East Hawthorn; G.  
 TUCKERMAN, B. T., 151 Bell-street, Coburg; G.  
 TZANEFF, N., 7 Ellesmere-road, Windsor; G.  
 WAHAB, S., 22 Ferguson-street, McLeod; G. and C.  
 WANZENB, G., Flat 2, 54 Southey-street, Elwood; C.  
 WATSON, C. R., 41 Saunders-street, West Coburg; G.  
 WILLIAMS, A. J., 48 Cleveland-road, Jordanville; C.  
 WILLIAMS, A. J. C., 6 Coventry-street, East Burwood; C.  
 WILLIAMS, L. A., 2 Lawson-parade, West Heidelberg; G.  
 WILSON, D. G., 13 Milloo-crescent, Mount Waverley; C.  
 WILSON, H. R., 13 Nicholls-road, Ormond; C.

each for Metropolitan Private Hire Car licence/s by the persons listed above in respect of commercial passenger vehicle/s with seating capacity for (5) five persons to operate under composite conditions from an approved depot in zone/s set out opposite their names.

Notice of any objection should be forwarded to reach the Secretary of the Board not later than Wednesday, 31st August, 1966.

Applicants are advised that it will not be necessary to appear on the hearing date specified above, unless advised in writing by the Board.

B. P. KAY,  
Secretary.

Exhibition Buildings, Rathdown-street, Carlton, N.3,  
Wednesday; 17th August, 1966.

## Police Regulation Act 1958, Section 122.

## SALE OF MOTOR VEHICLES.

AN owner is required for each of the following vehicles:—

1. Chrysler Royal sedan, ex-registered number HJC-713, engine number FE13285.
2. Wolseley sedan, ex-registered number US-745, engine number VC15WX8588.

These motor vehicles came into the possession of Police on the 4th April, 1966 and the 2nd May, 1966, respectively, and if not claimed will be sold by public auction at the Richmond Police Station, Bridge-road, Richmond, at 2 p.m. on Wednesday the 24th August, 1966.

R. H. ARNOLD,  
Chief Commissioner of Police.

## LOCAL GOVERNMENT DEPARTMENT.

## ORDER CONFIRMED.—SHIRE OF KYNETON.

THE Minister of the Crown administering the Local Government Act 1958, as amended, on the 5th day of August, 1966, confirmed the Order hereinafter referred to in pursuance of section 514 of the said Act, namely:

An Order of the Council of the Shire of Kyneton made on the 13th July, 1966, directing the compulsory taking of the land described hereunder for the provision of a landing ground for aircraft:

All that piece of land being part of Crown allotment 50, Parish of Lauriston, commencing at the north-eastern angle of the said Crown allotment; thence westerly by the northern boundary of the said Crown allotment for 450 links; due south for 2,460 links; due west for 450 links; due south for 810 links; due west for 3,080 links; south 13 deg. 39 min. east, 381 links; south 15 deg. 7 min. east, 374 links and thence easterly and northerly by the southern and eastern boundaries of the said Crown allotment 50 to the commencing point.

R. J. HAMER,  
Minister for Local Government.

## DEPARTMENT OF MINES.

SUBJECT to any necessary excisions, &c., it is proposed to grant the following mining lease:—

- 8208, Mineral; Cecil Gibson, John Ferris, William John Adey; 53a. 3r. 19p., Parish of Walwa.

## MINING LEASE GRANTED.

- 8405, Mineral; Mildura Brick and Pipe Works Proprietary Limited; 5 acres, Parish of Wedderburn.

## APPLICATION FOR LEASE DECLARED ABANDONED.

- 8234, Mineral; William John Steele; 300 acres, Parish of Willah.

## MINERAL SEARCH LICENCES EXPIRED.

- 616, Mineral Search Licence; Lindsay Gordon McRae and Keith McRae; 1,282 acres, Parishes of Mowamba, Tongara and Undowan.  
 625, Mineral Search Licence; Patrick Anthony Mackay; 50 acres, Parish of Tarrawarra North.  
 626, Mineral Search Licence; Patrick Anthony Mackay; 50 acres, Parish of Tarrawarra North.  
 627, Mineral Search Licence; Patrick Anthony Mackay; 50 acres, Parish of Tarrawarra North.  
 649, Mineral Search Licence; Nichilos Ramsay; 18 acres, Parish of Eldorado.  
 652, Mineral Search Licence; George Neville Connor and Francis John Farrell; 50 acres, Parish of Whanregarwen.  
 687, Mineral Search Licence; Brian McMahon, John Balmain Griffiths and Ron Whiting; 607 acres, Parish of Walhalla.

T. A. DARCY,  
Minister of Mines.

## EXPLORATION LICENCE DECLARED VOID.

- 30, Exploration Licence; Planet Mining Company Pty. Ltd.; 87 square miles, in the County of Poiwarth.

## MINING LEASE DECLARED VOID.

- 8396, Beechworth; Clarence George Henry Poole, Henry Higham Saw and Earl Hamilton Scott; 36a. 3r. 14p., Parish of Enochs Point.

E. CONDON,  
Secretary for Mines.

*Process Servers and Inquiry Agents Act 1958.*

## APPLICATIONS FOR LICENCES LODGED WITH CLERKS OF COURTS.

BY direction of the Chief Secretary, the subjoined lists of "new" applications for process servers and inquiry agents licences are published for general information.

Applicant.	Address.	Court.	Tentative Date of Hearing of Application.
<i>Process Servers—</i>			
Bye, Thomas Henry .. .. .	Checkmate P/L., 128 High-street, St. Kilda	Broadmeadows ..	8.9.66
Payne, Edward Alexander .. .. .	30 Golden-avenue, Werribee	Werribee ..	5.9.66
Pritchard, Reginald James Owen .. .. .	34 Patricia-street, South Oakleigh .. .. .	Cheltenham ..	30.8.66
Willis, Graham John .. .. .	329 Smith-street, Fitzroy .. .. .	Fitzroy ..	1.9.66
<i>Inquiry Agents—</i>			
Bye, Thomas Henry .. .. .	Checkmate P/L., 128 High-street, St. Kilda	Broadmeadows ..	8.9.66
Dawes, Harry Fuller .. .. .	Industrial Acceptance Corp. 48 Main-street, Box Hill	Box Hill ..	2.9.66
Murray, Geoffrey Edwin .. .. .	17 Richards-street, Yarraville .. .. .	Footscray ..	31.8.66
Willis, Graham John .. .. .	329 Smith-street, Fitzroy .. .. .	Fitzroy ..	1.9.66

Attention is directed to the provisions of the above Act and regulations thereunder relating to the lodgement of objections to applications

Chief Secretary's Office,

Melbourne, 16th August, 1966.

E. L. RICHARDSON, Registrar,

Process Servers and Inquiry Agents.

## STATE RIVERS AND WATER SUPPLY COMMISSION.

## LICENCES TO DIVERT WATER, PURSUANT TO THE PROVISIONS OF THE WATER ACT 1958.

THE Governor in Council has approved of the granting by the State Rivers and Water Supply Commission of licences as detailed hereunder for the term of years from the date specified in each case to the persons named in the following Schedule :—

## SCHEDULE.

Licence No.	Term of Licence and Commencing Date.	Name and Address of Person to Whom Licence is to be Granted.	Source of Supply.	Area Authorized to be Irrigated Per Annum.	Volume of Water Authorized to be Diverted Per Annum.
				acres.	ac. ft.
2139	Fifteen years from 1.7.65..	Ivy Alma Collins, Lindenow South ..	Mitchell River ..	25	50
2138	Four years from 1.7.66 ..	Giovanni Zanetti, Yarrowonga ..	River Murray ..	3	6
2140	Four years from 1.7.66 ..	Keith Mansfield Coombs, Mangalore	Goulburn River (Anabranche)	61	122
485	Four years from 1.7.66 ..	Francesco Gargiulo and Antonietta Gargiulo, Piangil	River Murray ..	40	120
486	Four years from 1.7.66 ..	Gerald Eshton Romaine Callender, Iraak	River Murray ..	26	78
533	Four years from 1.7.66 ..	Leonard Cecil Ferris, Mildura ..	River Murray ..	30	90
566	Four years from 1.7.66 ..	Richard Hurtle Palmer and Alison Elizabeth Palmer, "Overnewton" via Ivanhoe, N.S.W.	River Murray ..	50	150
582	Four years from 1.7.66 ..	Mick Szrenko and Maria Szrenko, Red Cliffs	River Murray ..	16	48
2137	Four years from 1.7.66 ..	Reginald Stanley Clarke, Vinifera ..	River Murray ..	100	200

Office of the State Rivers and Water Supply Commission,  
Melbourne, 16th August, 1966.

G. W. LEWIS, Secretary,  
State Rivers and Water Supply Commission.

## STATE RIVERS AND WATER SUPPLY COMMISSION.

## LICENCES TO DIVERT WATER AND CUT RACES, PURSUANT TO THE PROVISIONS OF THE WATER ACTS.

THE Licences as detailed hereunder to divert water and cut races have been revoked by the Governor in Council as from the date shown :—

Licence No.	Term of Licence and Commencing Date.	Name and Address of Person to Whom Licence Granted.	Source of Supply.	Date of Revocation.
65	Fifteen years from 1.7.57	Matthew John Bail, Torrumbarry .. .. .	Gunbower Creek ..	30.6.66
69	Fifteen years from 1.7.57	Arthur Edmond Besant and Jessie Besant, Cohuna (now held by Eric Christopher Roberts, Lillian Joyce Roberts and Barry James Roberts, Lyndhurst)	Gunbower Creek ..	30.6.66
76	Fifteen years from 1.7.57	Roy Garfield Tomlinson, Moama, N.S.W. (now held by Frederick George Williams and James Arthur Williams, Torrumbarry)	Gunbower Creek (National Channel)	30.6.66
175	Fifteen years from 1.7.58	Alan Henry Hall, Patho .. .. .	Gunbower Creek ..	30.6.66
267	Fifteen years from 1.7.58	Alan Henry Hall, Patho .. .. .	Gunbower Creek ..	30.6.66

Office of the State Rivers and Water Supply Commission,  
Melbourne, 16th August, 1966.

G. W. LEWIS, Secretary,  
State Rivers and Water Supply Commission.



## Water Act 1958.

## STATE RIVERS AND WATER SUPPLY COMMISSION.

ANGLESEA, BELLARINE, DANDENONG—SPRINGVALE, TORQUAY AND WESTERNPORT URBAN DISTRICTS.

NOTICE to owners of tenements in the under-mentioned streets in the abovementioned Urban Districts and the private streets, courts and alleys opening thereto:—

ANGLESEA URBAN DISTRICT.

## Anglesea.

Bachli-drive.  
Belton-street.  
Government-road, from Sunnymeade-road to Second-avenue.  
Noble-street, from end of existing main (opposite lot 145) to Pickworth-drive.  
Parker-street, from Sunnymeade-road to a point opposite lot 114, about  $\frac{1}{2}$  a chain north-easterly from Sparrow-avenue.  
Pickworth-drive.  
Second-avenue, from Government-road to a point opposite lot 74, about 17 chains north-easterly.  
Sunnymeade-road, from Government-road to—  
(i) a point opposite lot 31, about  $13\frac{1}{2}$  chains north-easterly, and  
(ii) a point opposite lot 31, about  $31\frac{1}{2}$  chains north-westerly.

BELLARINE URBAN DISTRICT.

## Point Lonsdale.

Victor-street, from end of existing main (opposite lot 8) to a point opposite lot 7, about  $9\frac{1}{2}$  chains north-westerly from Laker-drive.

## Queenscliff.

Swanston-street, from end of existing main (opposite lot 2) to The Esplanade.  
The Esplanade, from end of existing main (opposite lot 5) to Swanston-street.

## Ocean Grove.

Draper-street, from end of existing main (opposite lot 369) to a point opposite lot 360, about 8 chains easterly from Bramwell-street.  
Field-street, from end of existing main (opposite lot 2) to a point opposite lot 10 about 7 chains northerly from Madeley-street.  
Lelean-street, from end of existing main (opposite lot 191) to a point opposite lot 199, about  $12\frac{1}{2}$  chains easterly from Sweetmans-parade.  
Lowe-street, from end of existing main (opposite lot 65) to a point opposite lot 70, about 6 chains easterly from Presidents-avenue.  
Mann-street, from Ashbury-street to a point opposite lot 29, about 2 chains northerly.  
Osborne-street, from end of existing main (opposite lot 14) to a point opposite lot 11, about  $3\frac{1}{2}$  chains easterly from Field-street.  
Presidents-avenue, from Douburg-street to a point opposite lot 1, about  $3\frac{1}{2}$  chains northerly.  
Whitton-street, from end of existing main (opposite lot 31) to a point opposite lot 45 about  $9\frac{1}{2}$  chains south-westerly from Sweetmans-parade.  
Wyatt-street—  
(i) from Tuckfield-street to a point opposite lot 509, about  $2\frac{1}{2}$  chains westerly.  
(ii) from end of existing main (opposite lot 563) to Field-street.

DANDENONG—SPRINGVALE URBAN DISTRICT.

## Dandenong.

Francis-street, from Dalgety-street to a point opposite lot 63, about  $2\frac{1}{2}$  chains southerly.  
Grace-street, from Station-street to Greaves-street.  
Greaves-street, from Grace-street to a point opposite lot 50, about  $7\frac{1}{2}$  chains southerly.

## Keysborough.

Claremont-court.  
Claremont-road, from end of existing main (opposite lot 184) to Thurbro-drive.  
Thurbro-drive, from Chandler-road to a point opposite lot 31, about 6 chains easterly.

TORQUAY URBAN DISTRICT.

## Torquay.

Empire-avenue.  
Ocean-boulevard, from Sunset-strip to Princess-terrace.  
Princess-terrace, from Sunset-strip to Ocean-boulevard.

No. 61.—7351/66.—2

Regent-street, from Ocean-boulevard to a point opposite lot 37, about  $2\frac{1}{2}$  chains north-westerly from Sunset-strip.

Riverside-drive, from end of existing main (opposite lot 236) to existing main opposite lot 221, about  $8\frac{1}{2}$  chains westerly from Fischer-street.

Royal-court.

Sunset-strip, from Princess-terrace to a point opposite lot 22, about  $25\frac{1}{2}$  chains north-easterly.

WESTERNPORT URBAN DISTRICT.

## Crib Point.

Milne-street, from end of existing main (opposite lot 4) to a point opposite lot 5, about 5 chains south-easterly from Point-road.

## Hastings.

Ash-court.

Jacaranda-court.

Laurel-court.

William-street, from Douglas-street to—

(i) Martin-street, and

(ii) a point opposite lot 22, about  $\frac{1}{2}$  a chain northerly from Laurel-court.

## Somerville.

Guelph-street, from end of existing main (opposite lot 18) to a point opposite lot 11, about  $9\frac{1}{2}$  chains easterly from Alfred-street.

Park-lane, from Station-street to a point opposite lot 141, about 1 chain westerly from Clarinda-street.

Station-street, from end of existing main (opposite lot 110) to Park-lane.

## Tyabb.

Station-way, from end of existing main (opposite lot 38) to a point opposite lot 40, about  $4\frac{1}{2}$  chains westerly from Gerald-street.

The main pipe in the said streets being laid down, the owners of all tenements situated as above are hereby required, on or before the First day of October next to cause proper pipes and stop cocks to be laid, so as to supply water within such tenements from the main pipe.

G. W. LEWIS, Secretary,  
State Rivers and Water Supply Commission.

Melbourne, 10th August, 1966.

## STATE RIVERS AND WATER SUPPLY COMMISSION.

BY-LAW No. 5528—AMENDING BY-LAW No. 5396—SALE AND DISTRIBUTION OF WATER FOR IRRIGATION—WIMMERA WATERWORKS DISTRICT.

THE State Rivers and Water Supply Commission, in pursuance and exercise of the powers conferred by the Water Act, doth hereby make the By-law following:—

(1) This By-law shall apply to and have force in the Wimmera Waterworks District and shall come into operation as on and from the 1st day of September, 1966.

(2) Clause 5 of By-law No. 5396 is hereby amended to provide that the charge for the supply of water for irrigation of all lands in the Wimmera Waterworks District shall on and from the 1st day of September, 1966, be \$2 for each and every acre foot of water supplied; provided that the minimum annual charge shall be equal to \$2 an acre in respect of the total area authorized to be irrigated under permit or \$8 whichever is the greater.

The foregoing By-law was made by the State Rivers and Water Supply Commission on the 15th day of August, 1966, and the common seal of the said Commission was hereunto affixed on the 15th day of August 1966, in the presence of—

(SEAL) A. L. TISDALL, Commissioner.  
R. A. HORSFALL, Commissioner.

Approved by the Governor in Council, 16th August, 1966.  
—J. COLQUHOUN, Clerk of the Executive Council.

## ROSEDALE WATERWORKS TRUST.

## FIXING THE LIMIT OF A BANK OVERDRAFT.

THE Lieutenant-Governor as Deputy for His Excellency the Governor of the State of Victoria, by and with the advice of the Executive Council thereof, doth by Order made on the 16th day of August, 1966, in pursuance of the provisions of section 288 of the Water Act 1958 (No. 6413)

fix the limit of the overdraft to be obtained by the Rosedale Waterworks Trust from the Australia and New Zealand Bank Limited, Rosedale, at an amount not to exceed at any one time the sum of Twenty thousand dollars (\$20,000).

J. COLQUHOUN,  
Clerk of the Executive Council.

At the Executive Council Chamber,  
Melbourne, 16th August, 1966.

#### SEASPRAY WATERWORKS TRUST.

##### AUTHORITY TO OBTAIN BANK OVERDRAFT.

THE Lieutenant-Governor as Deputy for His Excellency the Governor of the State of Victoria, by and with the advice of the Executive Council thereof, doth by Order made on the 16th day of August, 1966, authorize the Seaspray Waterworks Trust to obtain in pursuance of the provisions of section 286 of the Water Act 1958 (No. 6413) an advance or advances during the year 1966 from the Australia and New Zealand Bank Limited, Rosedale, by overdraft of the Trust's current account thereat, such overdraft not to exceed at any one time the sum of Two thousand dollars (\$2,000).

J. COLQUHOUN,  
Clerk of the Executive Council.

At the Executive Council Chamber,  
Melbourne, 16th August, 1966.

#### FIRST MILDURA IRRIGATION TRUST.—MILDURA URBAN WATER TRUST.

##### PETITIONS UNDER THE MILDURA IRRIGATION AND WATER TRUSTS ACT.

IN pursuance of the provisions of the Mildura Irrigation and Water Trusts Act, the substance and prayer of petitions which have been presented to His Excellency the Governor in Council are published, viz.:—

Petitioners purporting to be the majority of the rate-payers in the areas described in the petitions such areas being described in the Schedule hereto.

Joint petitions from the First Mildura Irrigation Trust and the Mildura Urban Water Trust in respect of the above areas.

The petitioners pray that His Excellency the Governor in Council may be pleased to sever such area from the District of the First Mildura Irrigation Trust and annex the said area to the District of the Mildura Urban Water Trust in accordance with the provisions of the said Act.

Copies of such petitions together with plan showing the area proposed to be severed and annexed may be seen at the office of the Mildura Urban Water Trust, Seventh-street, Mildura.

##### SCHEDULE.

Parts of allotments 1, 2, 11 and 12, section 43, block F, on lodged plan of subdivision numbered 2637, Parish of Mildura, County of Karkaroc.

T. A. DARCY,  
Minister of Water Supply.

#### TOWN OF STAWELL WATER SUPPLY DISTRICT.

##### RATING BY-LAW FOR THE YEAR 1965/66.

THE Council of the Town of Stawell, in pursuance and exercise of the powers conferred by the Water Act, doth hereby make a rate for the supply of water for domestic purposes of five cents in \$1.00 of the annual municipal valuation of lands and tenements liable to be rated within the Town of Stawell Water Supply District.

Provided that in no case shall the amount payable per annum in respect of any tenement (other than land on which there is no buildings) be less than Sixteen dollars (\$16), and in respect of land on which there is no building be less than Ten dollars (\$10).

Such rates are made and shall be levied upon occupiers or owners of the said lands and tenements for the year commencing on the 1st day of October, 1965, and ending on the 30th day of September, 1966, and shall be payable on the 1st day of September 1966, at the office of the said Council.

The maximum quantity of water to be supplied in any one year without further charge to any property rated by the Council is hereby fixed at the quantity which, at a charge of Twenty five cents per 1,000 gallons, would produce an amount equal to the amount levied on such property for the said year.

The charge for water supplied by measure to any property rated by the Council in excess of such maximum quantity, computed as in the past preceding clause, is hereby fixed at Thirty cents per 1,000 gallons, with the exception of properties operated as market gardens, to the satisfaction of the Council, wherein the charge will be Ten cents per 1,000 gallons.

The charge for water supplied by measure to any property not rated by the Council is hereby fixed at Twenty-five cents for 1,000 gallons.

The charge for water supplied by measure shall be payable on demand at the office of the Council.

Dated this 3rd day of August, 1966.

(SEAL) H. L. SCHULTZ, Councillor.  
G. S. BENNETT, Councillor.  
L. L. SMITH, Secretary.

Approved, 11th August, 1966.—T. A. DARCY, Minister of Water Supply.

#### MILDURA URBAN WATER TRUST.

##### EXCESS BY-LAW 1966/67.

MILDURA Urban Water Trust, pursuant to and in exercise and execution of the powers conferred on it by Mildura Irrigation and Water Trusts Act and the Water Acts, doth hereby make the By-law following:—

“The maximum quantity of water to be supplied in any one year without further charge to any property rated by the Trust is hereby fixed at the quantity which at a charge of Eighteen Cents (18c) per thousand gallons would produce an amount equal to the amount of the rate levied on such a property for the said year.

The charge for water supplied by measure to any property rated by the Trust in excess of such maximum quantity, computed as in the last preceding clause, is hereby fixed at Ten Cents (10c) per thousand gallons which shall be payable on demand.”

The foregoing By-law was made and passed by the Mildura Urban Water Trust and its common seal was hereto affixed by direction of the said Trust on 14th July, 1966.

(SEAL) H. C. MCKENZIE, Secretary.

In the presence of—

C. G. EVANS, Commissioner.  
E. RISBEY, Commissioner.

Approved by the Governor in Council, 27th July, 1966.—  
J. COLQUHOUN, Clerk of the Executive Council.

#### MILDURA URBAN WATER TRUST.

##### RATING BY-LAW 1966/67.

ON the 14th day of July, 1966, in accordance with the approved estimates, the Mildura Urban Water Trust doth hereby make a rate for the supply of water for domestic purposes of Seven Cents (7c) in the Dollar (\$) on the municipal valuation of lands and tenements liable to be rated within its district.

Provided that in no cases shall the amount of rate payable per annum in respect of any Tenement (other than on land on which there is no building) be less than Eight Dollars (\$8.00) and in respect of any land on which there is no building be less than Four Dollars Fifty Cents (\$4.50).

The above rates are to be payable in one amount on the 30th September, 1966, and if not paid by 30th November, 1966, to bear interest at a rate of Six per cent (6%) per annum from 30th September, 1966 to date of payment.

The common seal of the Mildura Urban Water Trust was hereto affixed by the direction of the said Trust by—

(SEAL) H. C. MCKENZIE, Secretary.

In the presence of—

C. G. EVANS, Commissioner.  
E. RISBEY, Commissioner.

Approved by the Governor in Council, 27th July, 1966.—  
J. COLQUHOUN, Clerk of the Executive Council.

Melbourne and Metropolitan  
BOARD OF WORKS.

NOTICE is hereby given that after the publication of this advertisement in the *Government Gazette*, and once in not less than two daily newspapers published in the metropolis, the Melbourne and Metropolitan Board of Works will proceed to compulsorily take (unless the same is in the meantime acquired by the Board from the owner or owners or other person interested by mutual agreement) the land mentioned and described in the Schedule hereto.

The nature of the works in respect of which the land is proposed to be taken is for the purposes in connexion with the Truganina Purification Works.

A plan of the proposed works will be open for inspection at the offices of the Board, 110 Spencer-street, Melbourne, from the date hereof until the 9th September, 1966, during office hours.

The quantity of land which the Board requires for the purpose of such works and other particulars are set forth below.

The consent of the Governor in Council was duly obtained in terms of the Board's principal Act (No. 6310), on the 27th July, 1966.

SCHEDULE.

All that piece of land being part of Crown allotment 3, section 6, Parish of Truganina, commencing at a point in the southern boundary of the said allotment 3, 617 ft. 3 in. from the south-western corner thereof; thence northerly by a line bearing 0 deg. 36 min. for 1,095 ft. 11 in.; thence easterly by a line bearing 90 deg. 38 min. for 730 feet; thence northerly by a line bearing 341 deg. 8 min. for 318 ft. 3 in.; thence westerly by a line bearing 270 deg. 38 min. for 823 ft. 11½ in.; thence southerly by a line bearing 180 deg. 36 min. for 1,368 ft. 7½ in. to the southern boundary of the said allotment 3; thence easterly by the last mentioned boundary for 201 ft. 10½ in. to the commencing point and containing 11 acres 1 4/10 perches.

Dated the 12th day of August, 1966.

H. J. SNADDEN,  
Secretary.

Melbourne and Metropolitan  
BOARD OF WORKS.

GENERAL NOTICE.

THE Melbourne and Metropolitan Board of Works, having made sewers for carrying off the sewage from each and every property which, or any part of which, abuts on the streets or parts of streets in which such sewers are laid, and which are included within the sewerage areas hereinafter described, doth hereby declare that on and after the 17th September, 1966, each and every property which, or any part of which, abuts on the said streets or parts of streets, shall be deemed to be a seweraged property within the meaning of the *Melbourne and Metropolitan Board of Works Act 1958*.

The Sewerage Areas hereinbefore referred to are:—

*Sewerage Area No. 2048.*

*City of Box Hill.*—Commencing at the junction of Joy Hill-avenue and Nash-road; thence northerly along Nash-road, easterly along the northern boundary of lot 18 Nash-road, northerly along the western boundaries of lots 8 to 20 Penrose-street, easterly along the northern boundaries of lots 20 to 24 Penrose-street to the boundary of Sewerage Area No. 1693, southerly following the said area boundary to the south-eastern angle of lot 12 Eley-road, westerly along Eley-road to the boundary of Sewerage Area No. 1881, northerly, westerly and northerly following the said boundary to the commencing point.

*Sewerage Area No. 2049.*

*City of Waverley.*—Commencing at the junction of High Street-road and Raymond-street; thence northerly along Raymond-street, easterly along the northern boundaries of lots 124 to 119 and 104 to 101 Rocklands-road, southerly along Huntingdale-road, westerly along High Street-road to the commencing point.

*Sewerage Area No. 2050.*

*City of Nunawading.*—Commencing at the junction of Mitcham-road and Simpson-street; thence easterly along Simpson-street, southerly along Creek-road, easterly along Simpson-street, southerly along the eastern boundaries of lots 41 Simpson-street and 40 to 36 Ian-crescent, generally easterly along Ferris-avenue, southerly along Cochrane-street, westerly along the southern boundary of No. 7 Glenburnie-road, southerly along Glenburnie-road, westerly along the southern boundary of lot 4 Glenburnie-road, southerly along the eastern boundaries of lots 70 to 65

Halls-parade, westerly along the southern boundary of the said lot 65, southerly along Halls-parade, westerly along Premier-avenue, southerly along the eastern boundary of lot 48 Premier-avenue, westerly along the southern boundaries of lots 48 to 56 Premier-avenue, southerly and westerly along the eastern and southern boundaries of No. 275 Mitcham-road, northerly along Mitcham-road to the commencing point.

*Sewerage Area No. 2051.*

*City of Ringwood.*—Commencing at the junction of Bedford-road and Greenwood-avenue on the boundary of Sewerage Area No. 1872; thence north-westerly and northerly following the said boundary to Mullum Mullum Creek, generally north-easterly along the said creek, south-easterly along portion of the north-eastern boundary of lot 75 Leonard-street, north-easterly and easterly along the north-western and northern boundaries of lot 14 Wingrove-place, south-easterly along Wingrove-place, south-westerly along Maroondah Highway to the boundary of Sewerage Area No. 1971, further south-westerly and south-easterly following the said area boundary to the Lilydale railway line, westerly and south-westerly along the said railway line, easterly and south-easterly along the Belgrave railway line to Bedford-road, westerly along Bedford-road, southerly along Ford-street, westerly along the southern boundaries of lots 6 to 4 Bedford-road, southerly along the eastern boundaries of lots 48 to 43 Thomas-street, westerly along the southern boundary of the said lot 43, northerly along Thomas-street, westerly along the southern boundaries of lots 4 Thomas-street and 5 Wilana-street to the boundary of Sewerage Area No. 1872, further westerly and northerly following the said area boundary to the commencing point.

*Sewerage Area No. 2052.*

*City of Broadmeadows.*—Commencing at the junction of Lowson-street and Tyson-street; thence southerly along Tyson-street, easterly along the northern boundary of lot 12 Tyson-street, northerly along portion of the western boundary of lot 20 Lanigan-street, easterly along the northern boundary of the said lot 20, southerly along Lanigan-street, generally westerly along Jukes-road, southerly along the eastern boundary of lot 126 Jukes-road, westerly along the southern boundaries of lots 126 and 127 Jukes-road, northerly along William-street, easterly along Lowson-street to the commencing point.

*Sewerage Area No. 2053.*

*City of Waverley.*—Commencing at the junction of Grenfell-road and McLochlan-street; thence westerly along McLochlan-street to the boundary of Sewerage Area No. 1676, northerly and north-easterly following the said area boundary to the junction of Madison-court and Grenfell-road, south-easterly along Grenfell-road to the commencing point.

Further particulars regarding the streets or parts of streets in which sewers have been laid may be ascertained on inquiry at the Board's office.

By order of the Board,

H. J. SNADDEN,  
Secretary.

110 Spencer-street, Melbourne, C.1, 16th August, 1966.

*Country Roads Act 1958.*

COUNTRY ROADS BOARD.

NOTICE OF FIXING NEW ALIGNMENT OF PRINCES HIGHWAY  
IN THE CITY OF COLAC.

NOTICE is hereby given that the Country Roads Board under the powers conferred upon it by the *Country Roads Act 1958* (No. 6229) has fixed a new alignment for the south-side of Princes Highway in the City of Colac as described hereunder, that is to say:—

Commencing at a point on the eastern boundary of lot 5 on plan of subdivision numbered 11990, lodged in the Office of Titles and being part of allotment 7, section 9; Parish of Elliminyt, distant 180 deg. 2 min. 66 feet from the north-eastern angle of the said lot; thence by lines bearing respectively 180 deg. 2 min. 15 feet, 315 deg. 2 min. 2½ ft. 2½ in., 270 deg. 2 min. 834 ft. 9½ in., 224 deg. 47 min. 21 ft. 1½ in., 359 deg. 32 min. 15 feet, 270 deg. 2 min. 66 feet, 179 deg. 32 min. 15 feet, 314 deg. 47 min. 21 ft. 3½ in., 270 deg. 2 min. 1,669 ft. 1½ in., 225 deg. 0 min. 21 ft. 2½ in. and 359 deg. 59 min. 15 feet to a point on the western boundary of lot 1 on plan of subdivision numbered 3902, lodged in the Office of Titles and being part of the said allotment 7, distant 179 deg. 59 min. 66 feet from the north-western angle of the said lot 1— which said new alignment is shown on survey plan numbered 9891, lodged in the Office of the Country Roads Board.

Copies of the said survey plan are lodged in the offices of the Country Roads Board, the municipality of the City of Colac, the Registrar of Titles and the Registrar-General respectively, and may be inspected by any person without fee at any time at which such offices are open for business.

Dated the 10th day of August, 1966.

N. L. ALLANSON,  
Secretary.

Country Roads Board,  
60 Denmark-street, Kew, E.4.

*Cemeteries Act 1958.*

SCALE OF FEES OF THE WARRNAMBOOL PUBLIC CEMETERY.

IN pursuance of the powers conferred upon them by the Cemeteries Act, the trustees of the Warrnambool Public Cemetery hereby make the following scale of fees, which shall come into operation upon publication in the *Government Gazette*, and from and after such publication every scale of fees heretofore made by the said trustees shall be and is hereby rescinded to the extent to which it conflicts with this scale.

*Public Graves (Trustees' Selection).*

	\$
Single interment, adult .. .. .	30.00
Single interment, child under ten years .. .. .	16.00
Single interment, stillborn child .. .. .	8.00
<i>Applicant's Selection.</i>	
Single interment, adult .. .. .	30.00
Single interment, child under ten years .. .. .	16.00
Single interment, stillborn child .. .. .	8.00

*Private Graves.*

Land, 8 ft. x 4 ft., adjoining or abutting on a main road .. .. .	50.00
Land, 8 ft. x 8 ft., adjoining or abutting on a main road .. .. .	100.00
Land, 8 ft. x 4 ft., other than above .. .. .	37.50
Land, 8 ft. x 8 ft., other than above .. .. .	75.00
Land for family vaults (not exceeding 12 feet in width) 8 feet deep .. .. . per foot	6.00
Interment fee .. .. .	20.00
Removal and replace slab .. .. .	5.00

*Sinking Private Graves.*

Sinking grave 7 feet deep .. .. .	27.00
First additional foot .. .. .	4.00
Second additional foot .. .. .	4.50
Third additional foot .. .. .	5.00
Over 3 feet .. .. . per foot	11.50

*Reopening Charges.*

Reopening graves, vaults or tombs .. .. .	19.00
---	-------

*Miscellaneous.*

Exhumation of body (when authorized) .. .. .	19.00
Re-interment of body .. .. .	19.00
Interments on Sunday .. .. .	10.00 extra
Interments outside usual hours .. .. .	10.00 extra
Interments on public or proclaimed holidays .. .. .	10.00 extra
Permission to construct brick graves .. .. .	6.00
Permission to construct vaults .. .. .	20.00
Permission to erect tombstone (not exceeding 9 feet) .. .. .	5.00
Permission to erect tombstone (over 9 feet) .. .. .	9.50
Permission to erect monument .. .. .	11.50
Permission to erect ledger (single grave un-inscribed) .. .. .	4.00
Permission to erect ledger (double grave un-inscribed) .. .. .	7.50
Permission to erect kerb (single grave) .. .. .	4.00
Permission to erect kerb (each additional grave) .. .. .	2.00
Permission to inscribe ledger .. .. .	2.50
Permission to erect shield or tablet to railing .. .. .	2.50
Permission to inspect plan .. .. .	0.50
Copy of register .. .. .	0.50

D. G. COLLINS, Trustee.  
H. BEARDSLEY, Trustee.  
JOHN S. LARK, Trustee.

Approved by the Governor in Council, 9th August, 1966.  
—J. COLQUHOUN, Clerk of the Executive Council.

*Cemeteries Act 1958.*

SCALE OF FEES OF THE TARADALE PUBLIC CEMETERY.

IN pursuance of the powers conferred upon them by the Cemeteries Act, the trustees of the Taradale Public Cemetery hereby make the following scale of fees, which shall come into operation upon publication in the *Government Gazette*, and from and after such publication every scale of fees heretofore made by the said trustees shall be and is hereby rescinded to the extent to which it conflicts with this scale.

*Private Graves.*

	\$
Sinking grave 6 feet deep .. .. .	20.00
Each additional foot .. .. .	1.00
Reopening grave .. .. .	18.00
Sinking grave for child under twelve years .. .. .	7.00
Blasting rock—per foot .. .. .	0.50
Number peg .. .. .	1.50

JACK REILLY, Trustee.  
K. MCPHERSON, Trustee.  
J. G. DORMAN, Trustee.

Approved by the Governor in Council, 9th August, 1966.  
—J. COLQUHOUN, Clerk of the Executive Council.

*Cemeteries Act 1958.*

SCALE OF FEES OF THE POOWONG PUBLIC CEMETERY.

IN pursuance of the powers conferred upon them by the Cemeteries Act, the trustees of the Poowong Public Cemetery hereby make the following scale of fees, which shall come into operation upon publication in the *Government Gazette*, and from and after such publication every scale of fees heretofore made by the said trustees shall be and is hereby rescinded to the extent to which it conflicts with this scale.

*Private Graves.*

	\$
Land, 8 ft. x 4 feet .. .. .	13.00
Sinking charge .. .. .	20.00
Re-opening fee .. .. .	18.00

P. T. HALL, Trustee.  
W. J. McNALLY, Trustee.  
T. H. SLATER, Trustee.

Approved by the Governor in Council, 9th August, 1966.  
—J. COLQUHOUN, Clerk of the Executive Council.

*Cemeteries Act 1958.*

SCALE OF FEES OF THE ONDIT AND CUNDARE PUBLIC CEMETERY.

IN pursuance of the powers conferred upon them by the Cemeteries Act the trustees of the Oudit and Cundare Public Cemetery hereby make the following scale of fees, which shall come into operation upon publication in the *Government Gazette*, and from and after such publication every scale of fees heretofore made by the said trustees shall be and is hereby rescinded to the extent to which it conflicts with this scale.

*Private Graves.*

	\$
Land, 8 ft. x 4 ft. .. .. .	12.00
Own selection of land (extra) .. .. .	4.00
Sinking grave 6 feet deep .. .. .	20.00
Each additional foot .. .. .	2.00
Interment fee .. .. .	4.00
Permission to erect a headstone or monument— 2½ per cent. of cost, with a minimum of \$4.00	

B. WATSON, Trustee.  
S. MISSEN, Trustee.  
C. DARCY, Trustee.

Approved by the Governor in Council, 9th August, 1966.  
—J. COLQUHOUN, Clerk of the Executive Council.

*Cemeteries Act 1958.*

SCALE OF FEES OF THE BYADUK PUBLIC CEMETERY.

IN pursuance of the powers conferred upon them by the Cemeteries Act the trustees of the Byaduk Public Cemetery hereby make the following scale of fees, which shall come into operation upon publication in the *Government Gazette*, and from and after such publication every

scale of fees heretofore made by the said trustees shall be and is hereby rescinded to the extent to which it conflicts with this scale.

	\$
<i>Public Graves.</i>	
Interment in grave without exclusive right— stillborn child .. .. .	6.00
Interment in grave without exclusive right— others .. .. .	8.00
Number peg or label .. .. .	1.00
<i>Private Graves.</i>	
Land, 8 ft. x 4 ft. .. .. .	8.00
Own selection of land (extra) .. .. .	4.00
<i>Extra Charges.</i>	
Interment outside prescribed hours, or on Satur- days, Sundays or Public Holidays .. .. .	6.00
Interment in a private grave without due notice .. .. .	6.00
<i>Miscellaneous Charges.</i>	
Certificate of right of burial .. .. .	1.00
Number plate or brick .. .. .	1.00
Permission to erect a headstone or monument— 2½ per cent. of cost, with a minimum of \$4.00	
Permission to construct a brick grave or to erect any stone kerb, brick tilework or concrete .. .. .	2.00
Exhuming the remains of a body (when author- ized) .. .. .	25.00
Interment of ashes in a private grave .. .. .	6.00

J. CHRISTIE, Trustee.  
F. FALKENBURG, Trustee.  
F. HOLMES, Trustee.

Approved by the Governor in Council, 9th August, 1966.  
—J. COLQUHOUN, Clerk of the Executive Council.

*Cemeteries Act 1958.*  
**SCALE OF FEES OF THE BALLAARAT GENERAL  
CEMETERIES.**

IN pursuance of the powers conferred upon them by the Cemeteries Act the trustees of the Ballaarat General Cemeteries hereby make the following scale of fees, which shall come into operation upon publication in the *Government Gazette*, and from and after such publication every scale of fees heretofore made by the said trustees shall be and is hereby rescinded to the extent to which it conflicts with this scale.

	\$
<i>Lawn Graves.</i>	
Re-opening fee .. .. .	25.00

E. LUDBROOK, Trustee.  
F. PREST, Trustee.  
M. STONE, Trustee.

Approved by the Governor in Council, 9th August, 1966.  
—J. COLQUHOUN, Clerk of the Executive Council.

**FREE PLACES AT UNIVERSITY.**

APPLICATIONS are invited from persons (other than teachers) in the employment of the Government of Victoria for Free Places at the University of Melbourne, or Monash University, to be awarded from the beginning of 1967.

**Who Can Apply?**

Applicants must satisfy the following requirements:

- (a) They must be in the permanent service of the Government of Victoria, or be temporary employees of the Victorian Railways.
- (b) They must have matriculated or be otherwise qualified to commence a university course. (Candidates for the Matriculation examination this year may, however, apply).

Consideration will be given to age, suitability, qualifications, period of service of the applicant, and a report and recommendation of his permanent departmental head and a personal interview with the Selection Committee.

**Benefits.**

Free Places are tenable for the full length of an approved course for any degree, diploma or licence. A successful applicant will be granted such leave of absence on full pay as may be prescribed to enable him to attend essential lectures, practical and other work, and examinations. He will be admitted without fees to all lectures and examinations of his course.

**Bond.**

The holder of a Free Place will be required to enter into an agreement that he will remain in the service of the Government of Victoria for five years after the termination of his Free Place.

**Applications due 1st November.**

Applications must be submitted to the Permanent Head of the Department in which the applicant is employed, by the 1st November, 1966. Permanent heads of departments should ensure that such applications are forwarded to reach the Secretary, Education Department, Melbourne, C.2, not later than the 26th November, 1966.

W. A. CRELLIN, Secretary,  
Education Department.

**AERIAL PHOTOGRAPHY IN VICTORIA.**

QUOTATIONS will be received until Noon, 31st August, 1966, for aerial photography as required by the Department of Crown Lands and Survey during the period 1st October, 1966, to 30th September, 1967.

The lowest or any tender will not necessarily be accepted.

Full particulars may be obtained from—

The Surveyor-General,  
Department of Crown Lands and Survey,  
Treasury-place,  
Melbourne.

*Town and Country Planning Act 1961.*

**SHIRE OF BENALLA PLANNING SCHEME 1953.**

AMENDMENT NO. 2, 1966.

(CITY OF BENALLA.)

*Notice of Approval.*

IN pursuance of the powers conferred by the *Town and Country Planning Act 1961*, the Governor in Council on the 16th August, 1966, approved a planning scheme entitled the Shire of Benalla Planning Scheme 1953, Amendment No. 2, 1966 (City of Benalla), in respect of part of the municipal district of the City of Benalla.

A copy of the planning scheme as approved may be inspected during office hours at the office of the Town and Country Planning Board, 179 Queen-street, Melbourne; at the office of the Council of the City of Benalla, at Benalla; and when available, at the Office of Titles, Melbourne, and at the Central Plan Office of the Department of Crown Lands and Survey, Melbourne.

W. H. CRAIG, Secretary,  
Town and Country Planning Board.

**CONTRACTS ACCEPTED.—(Series 1966-67.)**

**PUBLIC WORKS.**

418. Clayton, Monash Teachers' College, supply racks and benches, \$1,120.80.—N. A. Stewart & Co.
419. Sunbury, Mental Hospital, supply mattresses and covers, \$1,360.00.—Seafoam Pty. Ltd.
420. Melbourne, Police Depot, supply refrigerators and grillers, \$2,362.00.—Ahearn Main & Stott Pty. Ltd.
421. South Yarra, Melbourne High School, supply tables, \$2,678.80.—Bera Cabinet Works Pty. Ltd.
422. South Yarra, Melbourne High School, supply chairs, \$1,967.10.—Ultra Stool & Chair Pty. Ltd.
423. Coorimungie, H.M. Prison Farm, supply wood-fired range, \$1,140.00.—Overseas Corporation (Aust.) Ltd.
424. Coorimungie, H.M. Prison Farm, supply refrigerator, \$2,022.00.—Ahearn Main & Stott Pty. Ltd.
425. Preston, Technical School, supply benches and cupboards, \$2,667.30.—Bera Cabinet Works Pty. Ltd.
426. Beechworth, Mental Hospital, supply hydraulic garbage trailer, \$1,085.00.—Freighter Industries (Vic.) Pty. Ltd.
427. North Melbourne, School of Printing and Graphic Arts, supply kitchen equipment, \$9,525.00.—Ahearn Main & Stott Pty. Ltd.
428. North Melbourne, School of Printing and Graphic Arts, supply gas range, \$1,392.75.—Waldorf Appliances Pty. Ltd.
429. Sebastopol, Technical School, supply benches, cupboards and bins, \$1,565.00.—Bera Cabinet Works Pty. Ltd.
430. Portsea, Marlborough House, supply and install curtains, \$1,017.47.—Fischer Furnishings Pty. Ltd.
431. Sunbury, Mental Hospital, supply hardwood kiln dried select, \$3,338.10.—Mordialloc Timber Co. Pty. Ltd.
432. Melbourne, William Angliss Trade School, remove and relay floor coverings, \$1,950.00.—Supa Grade Floors.

433. Royal Park, Psychiatric Hospital, supply dividers, \$1,080.00.—Westbury Timber Co. Pty. Ltd.

434. Royal Park, Psychiatric Hospital, supply furniture, \$2,057.00.—Myer Teale Pty. Ltd.

435. Port Melbourne, P.W.D. Storeyard, supply auto trays, science, \$1,277.60.—Ultra Stool & Chair Pty. Ltd.

436. Port Melbourne, P.W.D. Storeyard, supply stools, science, \$12,720.00.—D. F. Cowan Sales Pty. Ltd.

437. Parkville, University High School, supply and fix gymnasium equipment, \$3,049.00.—Laurion Pty. Ltd.

JIM BALFOUR, Commissioner of Public Works. 9.8.66.

#### GENERAL STORES.

Gazette No. 53, 19th July, 1966, Schedule No. 29, Cordage Lines, &c.:—Item No. 28 should read Twine, Sewing "A" line Flax, 3-ply, 6 lb. Standard pack 1 dozen 4 oz. reels.

Gazette No. 59, 10th August, 1966, Schedule No. 37, Electric Lamps, &c.:—Rate for item No. 28 should read \$2.71 each.

Gazette No. 53, 19th July, 1966, Schedule No. 64, Polishes, Dusters, &c.:—Item Nos. 24 and 25, Drums, \$8.00, credited on return.

Gazette No. 53, 19th July, 1966, Schedule No. 67, Soap Makers' Materials, &c.:—Item No. 8, Drums, \$4.00, credited on return.

H. COUTTS, Secretary to the Tender Board. 16.8.66.

#### ORDERS IN COUNCIL.—(Series 1966-67.)

##### PUBLIC WORKS.

397. Coburg, Pentridge Gaol, electrical installation, \$1,577.00.—C. J. Pearce and Coy.—(N.W.273889.)

398. Fitzroy, Education Department's Bulk Store, supply of timber pallets for shelving, \$3,515.00.—L. F. Hillyear.—(E.M.82003 "A".)

399. Mont Park, Mental Hospital, Ward M4, electrical installation, \$3,381.75.—Geo. Anderson.—(N.E.48403 "A".)

Approved by the Governor in Council, 9th August, 1966.—J. COLQUHOUN, Clerk of the Executive Council.

##### EDUCATION DEPARTMENT.

400. One only sound level measuring apparatus for Ballarat School of Mines, \$3,414.00.—National Instrument Co. Pty. Ltd.

401. One only microwave apparatus for Ballarat School of Mines, \$292.05.—H. B. Selby & Co. Pty. Ltd.

402. One only mains operated precision recording polarograph (\$2,305.00), and one only refractometer Abbe type (\$412.00), for Caulfield Technical College, \$2,717.00.—Watson Victor Ltd.

403. One only Oscilloscope camera for Caulfield Technical College for \$313.87.—Ronald J. T. Payne Pty. Ltd.

404. One only horizontal boring machine for Coburg Technical School, \$270.00.—A. & S. Wolfenden.

405. One only research type polarizing microscope for Royal Melbourne Institute of Technology, \$2,435.00.—Pyrox Limited.

406. One only Sheraton Diploma lathe and accessories for South Melbourne Technical School, \$3,492.00.—Demco Machinery Co. (Vic.) Pty. Ltd.

407. One only mechanism construction set for Swinburne Technical College, \$341.23.—Automat Service International.

408. One only hotel guest accounting machine for William Angliss Food Trades School, \$3,446.00.—The National Cash Register Co. Pty. Ltd.

409. One only itemizing cash register and two additional totals for William Angliss Food Trades School, \$1,500.98.—Anker Cash Registers Pty. Ltd.

410. One only continuous feed docket machine (\$95.00), and stationery (\$147.00) for William Angliss Food Trades School, \$242.00.—Lamson Paragon Ltd.

411. One only A.C. co-ordinate type potentiometer for Caulfield Technical College, \$720.00.—J. L. William.

412. One only photometer attachment Hitachi Perkin-Elmer for Caulfield Technical College, \$693.00.—Thomas Optical & Scientific Co. Pty. Ltd.

413. One only 12-in. circular saw bench, tilt arbor, sliding table for Caulfield Technical College, \$722.00.—J. R. Hall Machinery Pty. Ltd.

414. One only cramp folder and bender for Collingwood Technical School, \$480.00.—Frank Vial & Sons Pty. Ltd.

415. One only electric muffle furnace for Footscray Technical College, \$290.00.—H. B. Selby & Co. Pty. Ltd.

416. One only hand operated horizontal boring machine for Kangaroo Flat Technical School, \$273.90.—Charles Wolfenden & Co.

417. One only copying and duplicating machine for Royal Melbourne Institute of Technology, \$350.00.—S. E. L. Wilde.

Approved by the Governor in Council, 9th August, 1966.—J. COLQUHOUN, Clerk of the Executive Council.

#### FORESTS COMMISSION.

Loan Fund Act No. 7367, Item 6, Project PX.—

438. To the purchase of that allotment 8, section 5, and allotments 3, 4, 5 and 6, section 6, Parish of Mouzie, County of Normanby, containing 765 acres 9 perches for forest purposes, \$23,000.00.—Estate of Thompson Leslie Compton.

Approved by the Governor in Council, 12th July, 1966.—J. COLQUHOUN, Clerk of the Executive Council.

Loan Fund Act No. 7367, Item 6—

439. To the purchase of that lot 41 on plan of subdivision No. 26960, being part of allotment 126, Parish of Scoresby, County of Mornington for forest purposes, \$600.00.—Olive and Douglas Shelley.

Approved by the Governor in Council, 19th July, 1966.—J. COLQUHOUN, Clerk of the Executive Council.

#### APPOINTMENTS AND RESIGNATIONS

##### APPOINTMENTS.

HIS Excellency the Governor of the State of Victoria, by and with the advice of the Executive Council thereof, has, by Orders made on the 9th day of August, 1966, been pleased to make the under-mentioned appointments, viz.:—

##### CHIEF SECRETARY'S DEPARTMENT.

*Assistant to the Inspector of Fisheries.*

ROBERT WILLIAM JACKSON

to be an Assistant to the Inspector of Fisheries, pursuant to the provisions of section 6 of the Fisheries Act 1958.

*Chaplain to Prison.*

EMANUEL JOSEPH SPITERI (the Reverend)

to be Roman Catholic Chaplain (part-time) to Morwell River Reforestation Prison, vice Thomas O'Connell (the Reverend Father).

*Honorary Probation Officers.*

ROBERT WILLIAM BRAZENOR, 14 Meribah-court, Frankston,  
ELVA MARGARET HAYES (Mrs.), 76 Cuthbert-street, Broadmeadows,  
WILLIAM HAROLD PETERS (the Reverend), Methodist Parsonage, 6 Old-street, Robinvale,  
KENNETH DONALD ROWLANDS, 22 Anderson-street, War-racknabeal, and  
ALBERT EDWARD JOHN STRICKLAND (the Reverend), St. John's Vicarage, 81 Castella-street, Lilydale, pursuant to the provisions of section 507 (2) of the Crimes Act 1958, to be Honorary Probation Officers for all adult Courts in Victoria; and

GRAHAM NICHOLAS CALLAN, 8 Stephen-street, Newtown, Geelong,

HENRY JOHN DANSWICK, 3 Rotherham-street, Belmont, MARGARITA DEKONING (Mrs.), 77 Errington-road, St. Albans,

DONALD RHYS ELLIS (Salvation Army Captain), 24 Wilson-street, Orbost,

ELVA MARGARET HAYES (Mrs.), 76 Cuthbert-street, Broadmeadows,

EDWARD JOHN KEATING, 19 Boundary-road, Yallourn North,

FRANCIS DENIS KERLEY, 23 Stinton-avenue, Newtown, Geelong,

PAUL ANGUS McDONALD, 18 Coulter-street, Newcomb, Geelong,

DONALD LAWRENCE MATHIESON, 19 Cook-street, Newtown, Geelong,

WILLIAM HAROLD PETERS (the Reverend), Methodist Parsonage, 6 Old-street, Robinvale,

BEVERLEY JEANETTE PHILPOT (Mrs.), 180 High-street, Shepparton,

ROSS HOWARD QUARRELL, 14 Giddings-street, North Geelong,  
 CHARLES SAMUEL SHIRLEY (the Reverend Father), St. Augustine's Presbytery, Wodonga, and  
 GRAEME EVAN TRIMNELL, 4 Robinson-street, Moe.  
 pursuant to the provisions of section 10 (1) of the Children's Court Act 1958, to be Honorary Probation Officers for all Children's Courts in Victoria.

## DEPARTMENT OF CROWN LANDS AND SURVEY.

*Bailiffs of Crown Lands.*

CLARENCE CHARLES CURRAN and  
 CHESTER GULEY,  
 pursuant to section 30 of the Land Act 1958, to be Bailiffs of Crown lands without additional salary.

## MINISTRY OF HEALTH.

*Deputy Superintendent of Mental Hospital.*

JOSEPH HENRY PARKER DAVIES-SAGE, M.B., Ch.B.,  
 to be Deputy Superintendent of Mental Hospital, Beechworth and Training Centre, Beechworth, appointed on the recommendation of the Mental Health Authority, pursuant to section 56 of the Mental Health Act 1959, vice Dr. Z. B. Bozan, transferred.

*Members of Hospitals Committees of Management.*

ROBERT CHARLES BOWLER  
 to be a member of the Committee of Management of Yarram and District Hospital, pursuant to proviso (a) to section 48 (1) of the Hospitals and Charities Act 1958, for a period of three years ending 31st August, 1969, vice E. G. Griffiths, resigned; and

COUNCILLOR CLIFFORD HENRY CHAMPNESS  
 to be a member of the Committee of Management of Kaniva District Hospital, pursuant to proviso (b) to section 48 (1) of the Hospitals and Charities Act 1958, for a period of three years.

*Public Vaccinator.*

DUNCAN GORDON MACKELLAR, M.B., B.S.,  
 to be Public Vaccinator, Shire of Rodney.

*Trustees of Cemeteries.*

JOHN BRENNAN,  
 RONALD CRISP,  
 MELROSS DIXON,  
 DONALD McDougall,  
 KEITH McLENNAN and  
 FRANK WARDLE  
 to be Trustees of the Brim Public Cemetery, additional Trustees;

JAMES FREDERICK TONKIN  
 to be a Trustee of the Burwood General Cemetery, additional Trustee;

JOHN LEONARD IBBOTSON  
 to be a Trustee of the Portarlington Public Cemetery, vice L. Porritt, resigned;

WILLIAM SMITH  
 to be a Trustee of the Coburg General Cemetery, vice J. Lawless, resigned;

MICHAEL HALLEY  
 to be a Trustee of the Coburg General Cemetery, vice J. Smith, deceased;

HAROLD CLARENCE ALLEN  
 to be a Trustee of the Donald Public Cemetery, vice W. Lemon, resigned;

FREDERICK DAVID PENNO  
 to be a Trustee of the Taradale Public Cemetery, vice N. Miller, resigned;

ALFRED KEVIN MALTYB  
 to be a Trustee of the Taradale Public Cemetery, additional Trustee;

JOHN CAMPBELL  
 to be a Trustee of the Cheltenham General Cemetery, vice R. Fairbank, resigned; and

THOMAS BOREHAM HURREY  
 to be a Trustee of the Yan Yean Public Cemetery, additional Trustee.

## LAW DEPARTMENT.

*Commissioners for taking Declarations, &c.*

DAVID McINTOSH SUTTON, corner of High-street and Broadway, Reservoir,  
 to be a Commissioner for taking Declarations and Affidavits, pursuant to the provisions of the Evidence Act 1958, to resign upon ceasing to occupy his present position; and

SELWYN RUPERT KNIGHT, 61 Dinah-street, East Keilor, and

WESLEY FREDERICK MANN, Mincha,  
 to be Commissioners for taking Declarations and Affidavits, pursuant to the provisions of the Evidence Act 1958, to resign upon removing from the neighbourhood of the addresses stated.

*Justices of the Peace.*

LEONARD MAURICE BELL, Police Training Centre, St. Kilda-road, Melbourne,  
 to Keep the Peace in all bailiwicks of the State of Victoria;

ARCHIBALD COLIN CAMPBELL, Nepean Highway, Mornington, and

JOHN ANGUS McPHERSON, 618 Riversdale-road, Box Hill,  
 to Keep the Peace in the Central Bailiwick of the State of Victoria;

ARCHIBALD FRANCIS GOODMAN, 5 Camp-street, Daylesford,  
 to Keep the Peace in the Midland Bailiwick of the State of Victoria; and

CHARLES HENRY DE CLERCQ, "Greenlands", Maroona, and

DOUGLAS MAXWELL SCHNEIDER, Motel Thistle-dome, Calder Highway, Sea Lake.  
 to Keep the Peace in the Western Bailiwick of the State of Victoria.

## DEPARTMENT OF MINES.

KENNETH IAN MARTIN, First Constable of Police,  
 to be Warden's Clerk at Bendoc, vice First Constable D. B. Stuchbery, transferred.

J. COLQUHOUN,  
 Clerk of the Executive Council.

At Government House,  
 Melbourne, 9th August, 1966.

## EDUCATION DEPARTMENT.

## SUMMONING OFFICERS.

UNDER section 5 of the Education Act 1958, I hereby appoint—

Sergeant ROBERT NORMAN HOPE,  
 First Constable ALEXANDER WALTER MCEWAN,  
 First Constable JOHN WILLIAM GRIFFITHS,  
 First Constable KENNETH IAN MARTIN,

to summon parents within the State of Victoria.  
 4th August, 1966.

JOHN BLOOMFIELD,  
 Minister of Education.

## RESIGNATIONS.

HIS Excellency the Governor of the State of Victoria, by and with the advice of the Executive Council thereof, has, by Orders made on the 9th day of August, 1966, accepted the resignations of the persons named hereunder of the offices mentioned, viz.:—

## LAW DEPARTMENT.

WARWICK ALLAN COGHILL,  
 ALLAN RAYMOND LAMBDEN,  
 ALGIMANTAS HENRY VAISUTIS, and  
 CHARLES GILBERT WAUCHOPE,  
 as Commissioners for taking Declarations and affidavits, pursuant to the provisions of the Evidence Act 1958.

The persons named in the First column of the Schedule hereto, from the Commission of the Peace for the respective Bailiwicks of the State of Victoria set opposite their names in the Second column of the said Schedule.

## SCHEDULE.

Name.	SCHEDULE.	Bailiwick.
IAN ALEX ATKYNS . . . . .	.. .. .	Central
HAROLD WILLIAM BOLITHO . . . . .	.. .. .	Eastern
ARTHUR LESLIE NEWTON . . . . .	.. .. .	Western

J. COLQUHOUN,  
 Clerk of the Executive Council.

At Government House,  
 Melbourne, 9th August, 1966.

**ORDERS IN COUNCIL**

**LOCAL GOVERNMENT DEPARTMENT.**

At the Mercy Hospital, Melbourne, the second day of August, 1966.

PRESENT:

His Excellency the Governor of Victoria.  
Mr. Reid | Mr. Darcy.

**VESTING OF A RESERVE IN THE KNOX SHIRE COUNCIL.**

WHEREAS it is provided by section 569BA of the Local Government Act 1958, as amended, that where any map or plan has been lodged or deposited with the Registrar of Titles pursuant to section 97 of the Transfer of Land Act or any corresponding previous enactment (whether before or after the commencement of the Local Government Act 1963) and any allotment on that map or plan has been transferred the Governor in Council on the request of the council of the municipality may by Order published in the Government Gazette direct that the whole or any part of the land comprised in any reserve shown on that map or plan shall vest in the council whereupon such land shall so vest freed and discharged from any mortgage charge lease or sub-lease.

And whereas the Council of the Shire of Knox has requested that a reserve shown on a plan of subdivision be vested in the council and an allotment on that plan has been transferred:

Now therefore the Governor of the State of Victoria, by and with the advice of the Executive Council thereof, doth by this Order vest in the Council of the Shire of Knox certain land being the Drainage and Recreation Reserve on plan of subdivision No. 53086, lodged in the Office of Titles and being the land shown hatched on the plan hereunder.

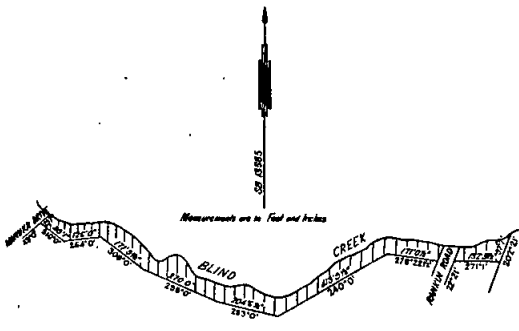

And the Honorable Rupert James Hamer, Her Majesty's Minister for Local Government for the State of Victoria, shall give the necessary directions herein accordingly.

J. COLQUHOUN,  
Clerk of the Executive Council.

**LOCAL GOVERNMENT DEPARTMENT.**

At Government House, Melbourne, the ninth day of August, 1966.

PRESENT:

His Excellency the Governor of Victoria.  
Mr. Bloomfield | Mr. Rossiter.

**ROAD DISCONTINUED.—SHIRE OF KNOX.**

WHEREAS it is provided in section 528 (2) of the Local Government Act 1958, as amended, that where a road (whether or not a public highway but not being a road set out on land of the Crown) or any part thereof is not required for public use, the Governor in Council, on the request of the Council of the municipality in which such road is situated made not less than one month after publishing in a newspaper generally circulating in the district and posting to the registered proprietor (if any) of the land and any person known to have an interest in the land, notice of intention to make such a request may by Order published in the Government Gazette, direct that such road or part shall be discontinued and thereupon such road or part shall be discontinued accordingly.

And whereas the Council of the Shire of Knox has requested that the Governor in Council direct that portion of a right-of-way be discontinued and not less than one month previously has published in a newspaper generally circulating in the district and posted to the registered proprietors of the land in the said road and to all persons known to have an interest in the said road, notice of intention to make such request.

Now therefore His Excellency the Governor of the State of Victoria, by and with the advice of the Executive Council thereof, hereby directs that the portion of the said road, which is shown hatched on the plan hereunder, shall be discontinued and that the land may be sold by the Council of the Shire of Knox by agreement.

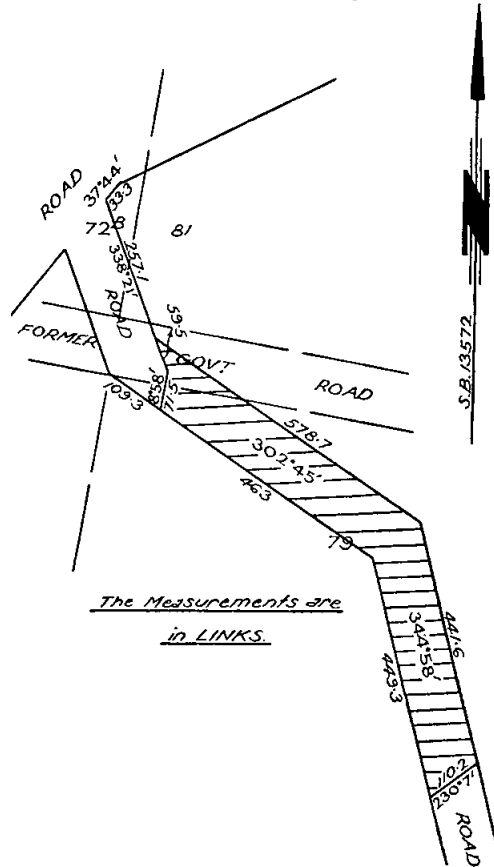

And the Honorable Rupert James Hamer, Her Majesty's Minister for Local Government for the State of Victoria, shall give the necessary directions herein accordingly.

J. COLQUHOUN,  
Clerk of the Executive Council.

**LOCAL GOVERNMENT DEPARTMENT.**

At Government House, Melbourne, the ninth day of August, 1966.

PRESENT:

His Excellency the Governor of Victoria.  
Mr. Bloomfield | Mr. Rossiter.

**ROAD DISCONTINUED.—SHIRE OF KNOX.**

WHEREAS it is provided in section 528 (2) of the Local Government Act 1958, as amended, that where a road (whether or not a public highway but not being a road set out on land of the Crown) or any part thereof is not required for public use, the Governor in Council, on the request of the Council of the municipality in which such road is situated made not less than one month after publishing in a newspaper generally circulating in the district and posting to the registered proprietor (if any) of the land and any person known to have an interest



in the land, notice of intention to make such a request may by Order published in the *Government Gazette*, direct that such road or part shall be discontinued and thereupon such road or part shall be discontinued accordingly.

And whereas the Council of the Shire of Knox has requested that the Governor in Council direct that portion of a right-of-way, off Lemon-grove, Bayswater, be discontinued and not less than one month previously, has published in a newspaper generally circulating in the district and posted to the registered proprietors of the land in the said road and to all persons known to have an interest in the said road, notice of intention to make such request.

Now therefore His Excellency the Governor of the State of Victoria, by and with the advice of the Executive Council thereof, hereby directs that the portion of the said road, which is shown hatched on the plan hereunder, shall be discontinued and that the land may be sold by the Council of the Shire of Knox by agreement.

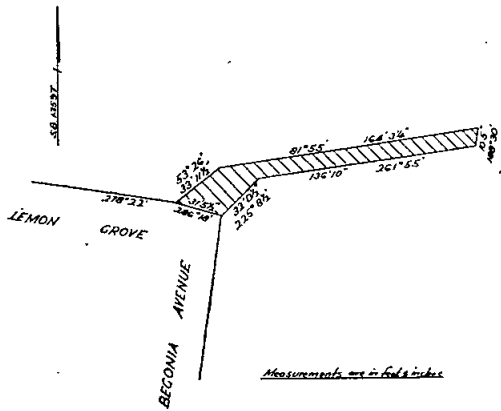

And the Honorable Rupert James Hamer, Her Majesty's Minister for Local Government for the State of Victoria, shall give the necessary directions herein accordingly.

J. COLQUHOUN,  
Clerk of the Executive Council.

LOCAL GOVERNMENT DEPARTMENT.

At Government House, Melbourne, the ninth day of August, 1966.

PRESENT:  
His Excellency the Governor of Victoria.  
Mr. Bloomfield | Mr. Rossiter.

ROAD DISCONTINUED.—CITY OF CAMBERWELL.

WHEREAS it is provided in section 528 (2) of the *Local Government Act 1958*, as amended, that where a road (whether or not a public highway but not being a road set out on land of the Crown) or any part thereof is not required for public use the Governor in Council on the request of the Council of the municipality in which such road is situated made not less than one month after publishing in a newspaper generally circulating in the district and posting to the registered proprietor (if any) of the land and any person known to have an interest in the land notice of intention to make such request may by Order published in the *Government Gazette* direct that such road or part shall be discontinued and thereupon such road or part shall be discontinued accordingly:

And whereas the Council of the City of Camberwell has requested that portion of a right-of-way, off Hazel-street, Camberwell, be discontinued and not less than one month previously has published in a newspaper generally circulating in the district and posted to the registered proprietor of the land in the road and to all persons known to have an interest in the said road notice of intention to make such request:

Now therefore His Excellency the Governor of the State of Victoria, by and with the advice of the Executive Council thereof, hereby directs:

- (a) that the portion of the said road, which is shown by hachure on the two plans hereunder, shall be discontinued.

- (b) that notwithstanding such discontinuance the Melbourne and Metropolitan Board of Works shall continue to have and possess the same right title power authority or interest in or in relation to the land shown by hachure on the said plans as it had or possessed prior to such discontinuance with respect to or in connexion with any sewers or drains laid or erected in on or over such land for the purposes of sewerage or drainage:
- (c) that, subject to any such right title power authority or interest, the land in the portion of the said road may be sold by the Council of the City of Camberwell by agreement.

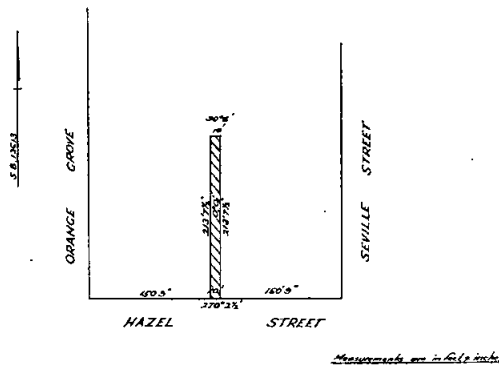
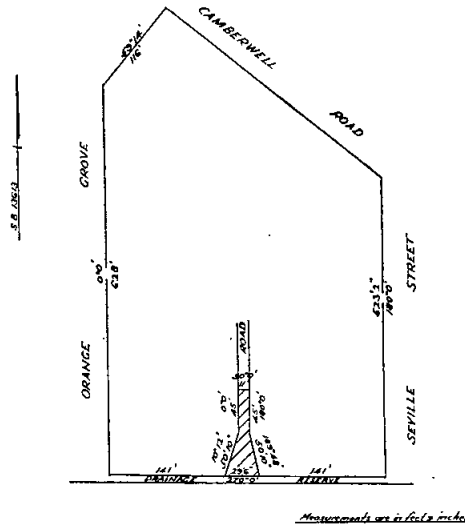

And the Honorable Rupert James Hamer, Her Majesty's Minister for Local Government for the State of Victoria, shall give the necessary directions herein accordingly.

J. COLQUHOUN,  
Clerk of the Executive Council.

LOCAL GOVERNMENT DEPARTMENT.

At Government House, Melbourne, the ninth day of August, 1966.

PRESENT:  
His Excellency the Governor of Victoria.  
Mr. Bloomfield | Mr. Rossiter.

VESTING OF A RESERVE IN THE BROADMEADOWS CITY COUNCIL.

WHEREAS it is provided by section 569BA of the *Local Government Act 1958*, as amended, that where any map or plan has been lodged or deposited with the Registrar of Titles, pursuant to section 97 of the *Transfer of Land Act* or any corresponding previous enactment (whether before or after the commencement of the *Local Government Act 1963*), and any allotment on that map

or plan has been transferred the Governor in Council on the request of the council of the municipality may by Order published in the *Government Gazette*, direct that the whole or any part of the land comprised in any reserve shown on that map or plan shall vest in the council whereupon such land shall so vest, freed and discharged from any mortgage, charge, lease or sub-lease:

And whereas the Council of the City of Broadmeadows has requested that a reserve shown on a plan of subdivision be vested in the council and an allotment on that plan has been transferred:

Now therefore the Governor of the State of Victoria, by and with the advice of the Executive Council thereof, doth by this Order vest in the Council of the City of Broadmeadows certain land being the Park and Drainage Reserve on plan of subdivision No. 12420, lodged in the Office of Titles, and being the land shown hatched on the plan hereunder.

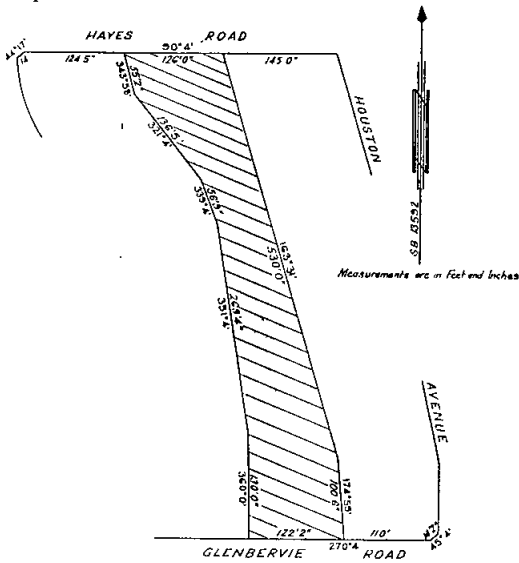

And the Honorable Rupert James Hamer, Her Majesty's Minister for Local Government for the State of Victoria, shall give the necessary directions herein accordingly.

J. COLQUHOUN,  
Clerk of the Executive Council.

LOCAL GOVERNMENT DEPARTMENT.

At Government House, Melbourne, the ninth day of August, 1966.

PRESENT:  
His Excellency the Governor of Victoria.  
Mr. Bloomfield | Mr. Rossiter.

VESTING OF A RESERVE IN THE BROADMEADOWS CITY COUNCIL.

WHEREAS it is provided by section 569BA of the *Local Government Act 1958*, as amended, that where any map or plan has been lodged or deposited with the Registrar of Titles, pursuant to section 97 of the *Transfer of Land Act* or any corresponding previous enactment (whether before or after the commencement of the *Local Government Act 1963*), and any allotment on that map or plan has been transferred the Governor in Council on the request of the council of the municipality may by Order published in the *Government Gazette*, direct that the whole or any part of the land comprised in any reserve shown on that map or plan shall vest in the council whereupon such land shall so vest, freed and discharged from any mortgage, charge, lease or sub-lease:

And whereas the Council of the City of Broadmeadows has requested that a reserve shown on a plan of subdivision be vested in the council and an allotment on that plan has been transferred:

Now therefore the Governor of the State of Victoria, by and with the advice of the Executive Council thereof, doth by this Order vest in the Council of the City of

Broadmeadows certain land being the Drainage and Sewerage Reserve on plan of subdivision No. 7506, lodged in the Office of Titles, and being the land shown hatched on the plan hereunder.

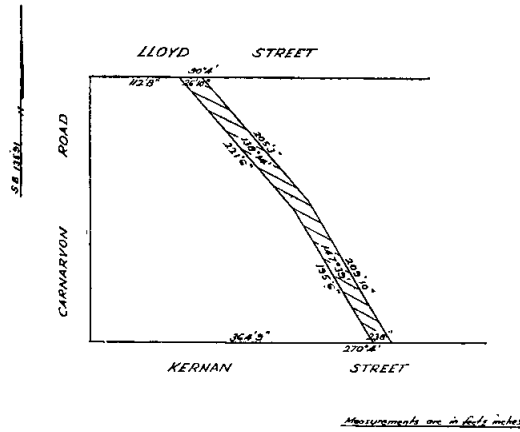

And the Honorable Rupert James Hamer, Her Majesty's Minister for Local Government for the State of Victoria, shall give the necessary directions herein accordingly.

J. COLQUHOUN,  
Clerk of the Executive Council.

LOCAL GOVERNMENT DEPARTMENT.

At Government House, Melbourne, the ninth day of August, 1966.

PRESENT:  
His Excellency the Governor of Victoria.  
Mr. Bloomfield | Mr. Rossiter.

CONSENT TO VARIATION OF USE OF RESERVE BY THE ELTHAM SHIRE COUNCIL.

WHEREAS, by an Order pursuant to section 569BA of the *Local Government Act 1958*, as amended, published in the *Government Gazette* of the 17th November, 1965, certain land being the Park Reserve on plan of subdivision No. 13612 was vested in the Council of the Shire of Eltham and the said Council is now of the opinion that the land is no longer required for the purpose for which it was reserved and has requested that consent be given to the use of the land for the purposes of an Infant Welfare and Pre-School Centre:

And whereas the said Council:

- (a) Has published in a newspaper generally circulating in the municipal district a notice describing the land and the proposal for the altered use thereof and stating that at the next ordinary meeting of the Council after the expiration of 40 days after publication of the notice the Council would consider any objection to the proposal and would receive any representations as to the disposal of any purchase money;
- (b) There being no registered mortgagee charge or lessee has served a copy of the said notice upon the registered proprietor of the land; and
- (c) Has posted a similar notice upon the land in question;

And whereas no objection to the proposal has been received.

Now therefore, the Governor of the State of Victoria, by and with the advice of the Executive Council thereof, doth hereby consent to the use of the land being the Park Reserve on plan of subdivision No. 13612 for the purposes of an Infant Welfare and Pre-School Centre.

And the Honorable Rupert James Hamer, Her Majesty's Minister for Local Government for the State of Victoria, shall give the necessary directions herein accordingly.

J. COLQUHOUN,  
Clerk of the Executive Council.

LOCAL GOVERNMENT DEPARTMENT.

At Government House, Melbourne, the ninth day of August, 1966.

PRESENT:

His Excellency the Governor of Victoria.  
 Mr. Bloomfield | Mr. Rossiter.

ROADS DISCONTINUED.—CITY OF HEIDELBERG.

WHEREAS it is provided in section 528 (2) of the Local Government Act as amended, that where a road (whether or not a public highway but not being a road set out on land of the Crown) or any part thereof is not required for public use the Governor in Council on the request of the council of the municipality in which such road is situated made not less than one month after publishing in a newspaper generally circulating in the district and posting to the registered proprietor (if any) of the land and any person known to have an interest in the land notice of intention to make such a request may by Order published in the *Government Gazette* direct that such road or part shall be discontinued and thereupon such road or part shall be discontinued accordingly.

And whereas the Council of the City of Heidelberg has requested that the Governor in Council direct that portions of Wungan-street, Dunvegan-crescent, Nicholls-street, Skye-street and Hooper-street, be discontinued and not less than one month previously has published in a newspaper generally circulating in the district notice of intention to make such request.

And whereas the Council of the City of Heidelberg is the registered proprietor or is entitled to be registered as the proprietor of the land in the roads:

Now therefore, His Excellency the Governor of the State of Victoria, by and with the advice of the Executive Council thereof, hereby directs that the portions of the said roads, which are shown by hachure on the plan hereunder, shall be discontinued and that the land shall be retained by the municipality for municipal purposes.

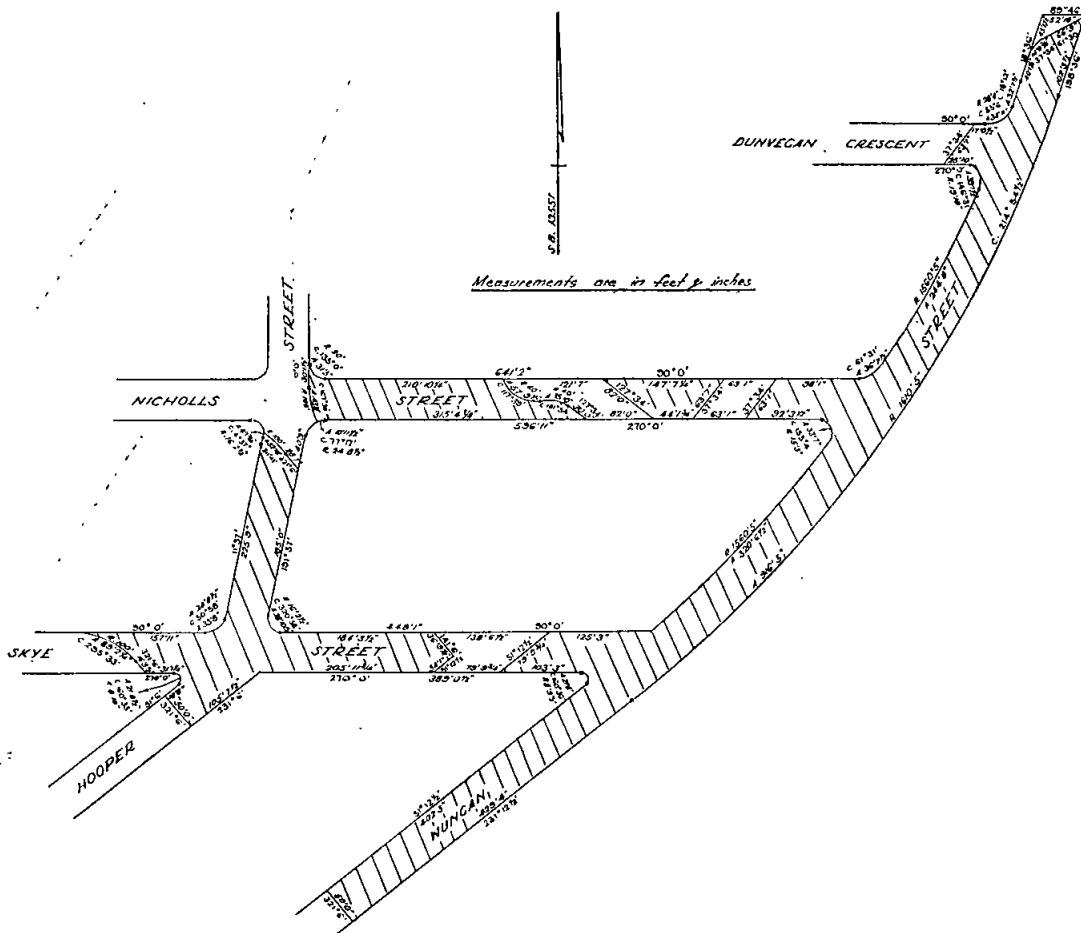

And the Honorable Rupert James Hamer, Her Majesty's Minister for Local Government for the State of Victoria, shall give the necessary directions herein accordingly.

J. COLQUHOUN,  
 Clerk of the Executive Council.

DEPARTMENT OF CROWN LANDS AND SURVEY.

At Government House, Melbourne, the ninth day of August, 1966.

PRESENT:

His Excellency the Governor of Victoria.  
Mr. Bloomfield | Mr. Rossiter.

UNUSED ROADS CLOSED.

HIS Excellency the Governor of the State of Victoria, by and with the advice of the Executive Council thereof, doth hereby direct that, in pursuance of the provisions of section 349 of the Land Act 1958, the unused roads referred to hereunder be closed, viz.:

Township of Clunes, Parish of Clunes, County of Talbot, being the portion of the width of the road indicated by hachure on plan hereunder.—(C.394<sup>(\*)</sup>) (J.31000).

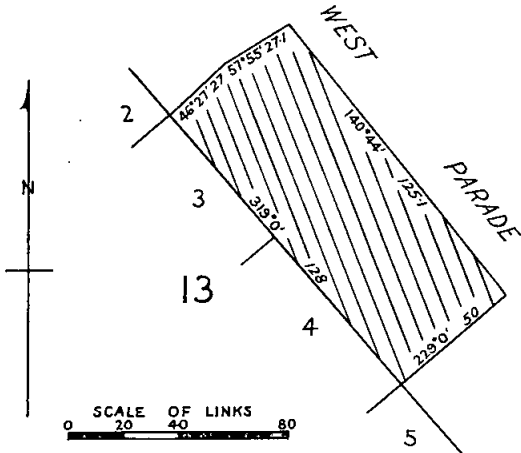

Township of Hamilton, Parish of South Hamilton, County of Normanby, being the portion of the width of the road indicated by hachure on plan hereunder.—(H.45<sup>(\*)</sup>) (J.31604).

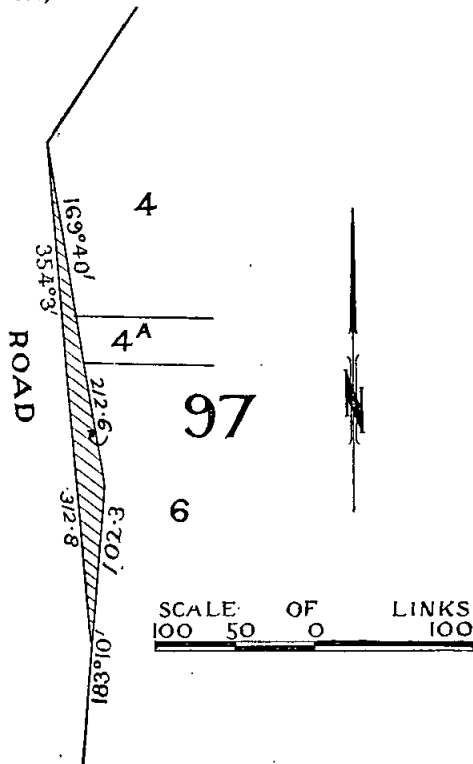

Parish of Maryvale, County of Buln Buln, being the road indicated by hachure on plan hereunder.—(M.481<sup>(\*)</sup>) (H.025074).

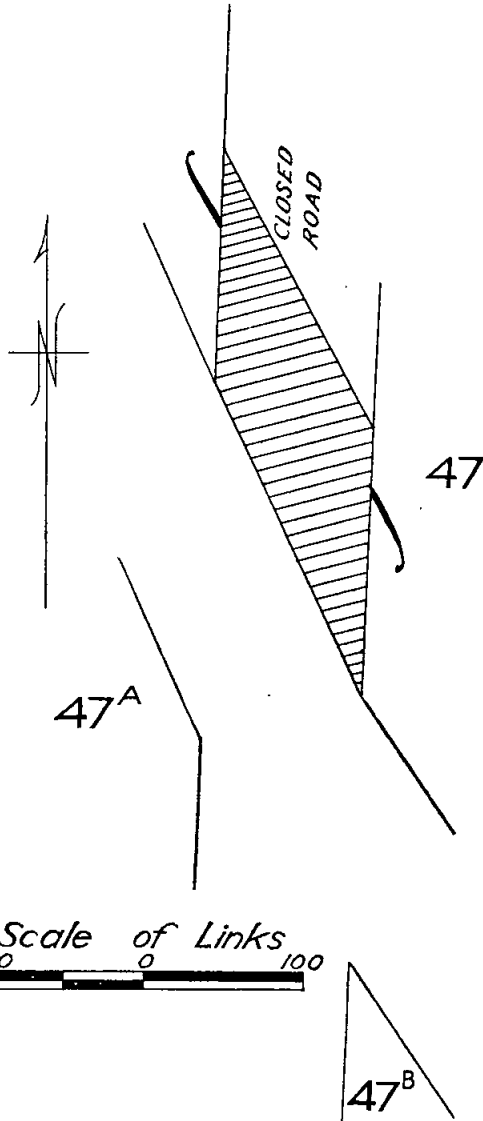

Parish of Yallakar, County of Lowan, being the road indicated by hachure on plan hereunder.—(Y.91<sup>(\*)</sup>) (J.31262).

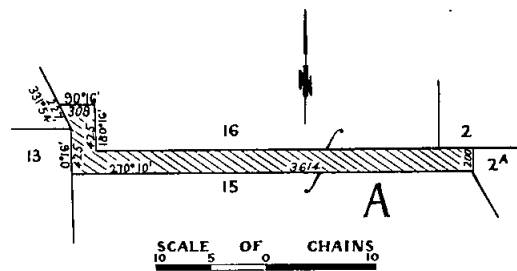

Parish of Sale, County of Tanjil, being the road indicated by hachure on plan hereunder.—(S.242<sup>(12)</sup>) (Rs.4096).

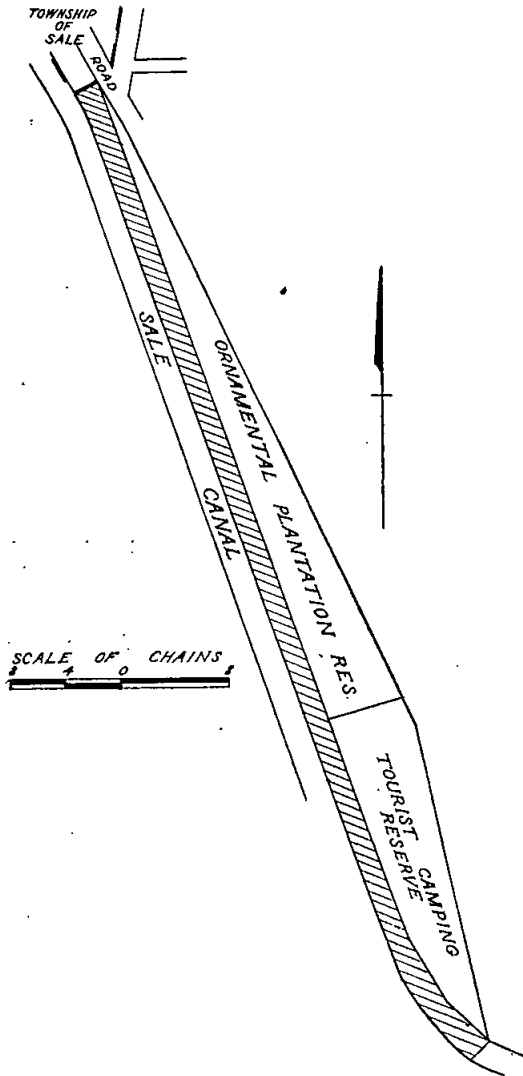

Township of Mia Mia, Parish of Spring Plains, County of Dalhousie, being the portion of the width of the road indicated by hachure on plan hereunder.—(M.110<sup>(2)</sup>) (Rs.3365).

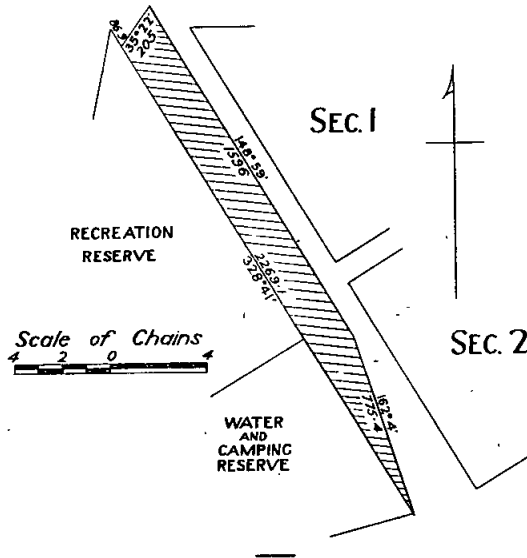

And the Honorable James Charles Murray Balfour, Her Majesty's Minister of Lands for the State of Victoria, shall give the necessary directions herein accordingly.

J. COLQUHOUN,  
Clerk of the Executive Council.

DEPARTMENT OF CROWN LANDS AND SURVEY.

At Government House, Melbourne, the ninth day of August, 1966.

PRESENT:

His Excellency the Governor of Victoria.  
Mr. Bloomfield | Mr. Rossiter.

LANDS TEMPORARILY RESERVED AS SITES.

HIS Excellency the Governor of the State of Victoria, by and with the advice of the Executive Council thereof, doth hereby, in pursuance of section 14 of the Land Act 1958, reserve temporarily from sale, from being leased and from having a licence granted in respect thereof, and also except from occupation for mining purposes under any miner's right, the lands hereinafter described:—

BOROONDARA (BALWYN).—Site for Public purposes (Social Welfare purposes), 3 roods 33 perches, Parish of Boroondara, County of Bourke, as indicated by hachure on plan hereunder.—(B.415<sup>(8)</sup>) (Rs.8657).

At Bendigo, Parish of Sandhurst, County of Bendigo, being the portion of the width of the road indicated by hachure on plan hereunder.—(S.372<sup>(110)</sup>) (W.82803).

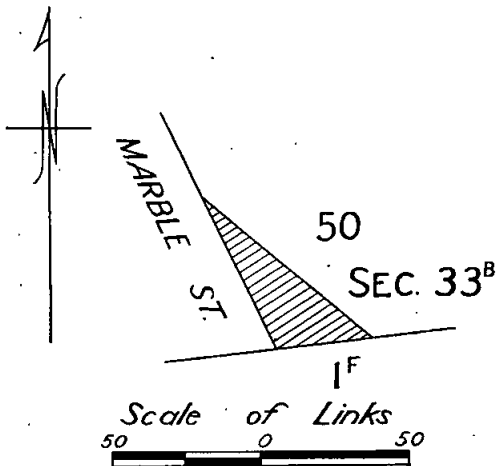

WHITE HORSE RP

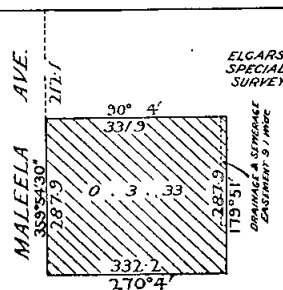

**BRIGHT.**—Site for the purposes of the Forests Commission, 17 perches, Township of Bright, Parish of Bright, County of Delatite, as indicated by hachure on plan hereunder.—(B.573<sup>(5)</sup>) (Rs.8031).

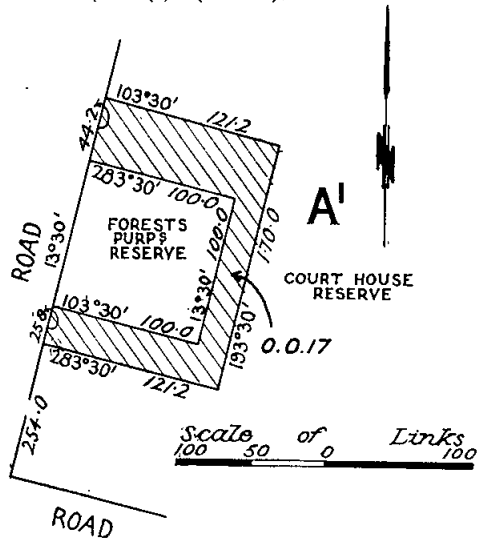

**NARRACAN.**—Site for Hospital Purposes, 4 acres 1 rood 3 perches, Parish of Narracan, County of Buln Buln, as indicated by hachure on plan hereunder.—(N.129<sup>(12)</sup>) (Rs.6912).

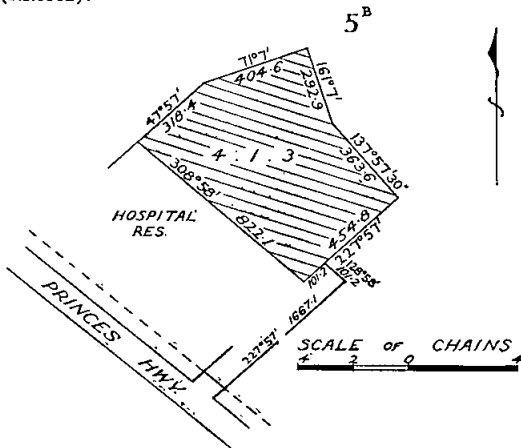

And the Honorable James Charles Murray Balfour, Her Majesty's Minister of Lands for the State of Victoria, shall give the necessary directions herein accordingly.

J. COLQUHOUN,  
Clerk of the Executive Council.

**COUNTRY ROADS BOARD.**

At Government House, Melbourne, the ninth day of August, 1966.

PRESENT:  
His Excellency the Governor of Victoria.  
Mr. Bloomfield | Mr. Rossiter.

**DECLARATION OF THE WIDENING OF THE CALDER HIGHWAY IN THE SHIRE OF KORONG.**

**WHEREAS** by sections 21 and 74 of the *Country Roads Act 1958* (No. 6229) it is amongst other things enacted that when the Country Roads Board under the provisions of the Country Roads Act has taken the land necessary for constructing the highway or deviation or widening it shall as soon as it thinks such highway or deviation or widening is fit to be used as a public highway by Resolution declare the highway or deviation or widening to be a State highway or part thereof and that upon

publication in the *Government Gazette* of the Order of the Governor in Council confirming such Resolution such highway or deviation or widening shall thereupon be a State highway or a part thereof within the meaning of the said Act: And whereas the said Board has by Resolution declared the highway on the land described in the Schedule to such Resolution to be part of a State highway: Now therefore His Excellency the Governor of the State of Victoria by and with the advice of the Executive Council thereof doth hereby confirm the said Resolution.

**Resolution for Declaration of the Widening of a State Highway under the Country Roads Act.**

Whereas the land the site of the highway the course of which is below set out was taken by the Board under the provisions of the Country Roads Act for the purpose of widening the State highway aforesaid which widening has now been laid out and formed on the same: And whereas the said Board (being the Country Roads Board incorporated under the said Act) thinks that the widening aforesaid is fit to be used as part of a public highway such Board at a meeting now holden doth by this Resolution hereby declare the same as described in the Schedule hereto with the commencing and terminating points thereof respectively specified to be part of the State highway within the meaning and for the purposes of the Country Roads Act.

**SCHEDULE.**

*Shire of Korong.*

3. *Calder Highway.*—All that piece of land in the Parish of Wedderburne, the boundaries of which are as follow:—Commencing at the western angle of allotment 16, section 5 of the said parish; thence by lines bearing respectively 333 deg. 10 min. 102.8 links, 0 deg. 0 min. 514.6 links, 171 deg. 39½ min. 502.6 links, 165 deg. 53 min. 100.0 links, 161 deg. 35 min. 347.8 links and 333 deg. 10 min. 356.2 links to the point of commencement—which said piece of land is particularly delineated and shown coloured red and yellow on survey plan numbered 7062, lodged in the office of the Country Roads Board.

The common seal of the Country Roads Board was hereto affixed at Kew this first day of August, One thousand nine hundred and sixty-six, in the presence of—

(SEAL) I. J. O'DONNELL, Chairman.  
F. WEST, Member.  
N. L. ALLANSON, Secretary.

And the Honorable Murray Victor Porter, Her Majesty's Minister of Public Works for the State of Victoria, shall give the necessary directions herein accordingly.

J. COLQUHOUN,  
Clerk of the Executive Council.

**COUNTRY ROADS BOARD.**

At Government House, Melbourne, the ninth day of August, 1966.

PRESENT:  
His Excellency the Governor of Victoria.  
Mr. Bloomfield | Mr. Rossiter.

**DECLARATION OF THE WIDENING OF THE MURRAY VALLEY HIGHWAY IN THE SHIRE OF UPPER MURRAY.**

**WHEREAS** by sections 21 and 74 of the *Country Roads Act 1958* (No. 6229) it is amongst other things enacted that when the Country Roads Board under the provisions of the Country Roads Act has taken the land necessary for constructing the highway or deviation or widening it shall as soon as it thinks such highway or deviation or widening is fit to be used as a public highway by Resolution declare the highway or deviation or widening to be a State highway or part thereof and that upon publication in the *Government Gazette* of the Order of the Governor in Council confirming such Resolution such highway or deviation or widening shall thereupon be a State highway or a part thereof within the meaning of the said Act: And whereas the said Board has by resolution declared the highway on the land described in the Schedule to such Resolution to be part of a State highway: Now therefore His Excellency the Governor of the State of Victoria by and with the advice of the Executive Council thereof doth hereby confirm the said Resolution.

*Resolution for Declaration of the Widening of a State Highway under the Country Roads Act.*

Whereas the land the site of the highway the course of which is below set out was taken by the Board under the provisions of the Country Roads Act for the purpose of widening the State highway aforesaid which widening has now been laid out and formed on the same: And whereas the said Board (being the Country Roads Board incorporated under the said Act) thinks that the widening aforesaid is fit to be used as part of a public highway such Board at a meeting now holden doth by this Resolution hereby declare the same as described in the Schedule hereto with the commencing and terminating points thereof respectively specified to be part of the State highway within the meaning and for the purposes of the Country Roads Act.

SCHEDULE.

*Shire of Upper Murray.*

7. *Murray Valley Highway.*—All that piece of land in the Parish of Tintalra, the boundaries of which are as follow:—

- (a) Commencing at a point on the southern boundary of allotment 1A, section 1A of the said parish, distant 122 deg. 40 min. 490.5 links from the south-western angle of the said allotment; thence by lines bearing respectively 90 deg. 43 min. 720.0 links, 241 deg. 48 min. 436.2 links and 302 deg. 40 min. 398.5 links to the point of commencement.
- (b) Commencing at a point on the northern boundary of allotment 21A, section 1A of the said parish, distant 61 deg. 49 min. 767.0 links from the north-western angle of the said allotment; thence by lines bearing respectively 61 deg. 49 min. 84.0 links, 132 deg. 27 min. 64.0 links and 271 deg. 39 min. 121.3 links to the point of commencement—

which said pieces of land are particularly delineated and shown coloured red on survey plan numbered 7991, lodged in the office of the Country Roads Board.

The common seal of the Country Roads Board was hereto affixed at Kew this first day of August. One thousand nine hundred and sixty-six, in the presence of—

(SEAL) I. J. O'DONNELL, Chairman.  
F. WEST, Member.  
N. L. ALLANSON, Secretary.

And the Honorable Murray Victor Porter, Her Majesty's Minister of Public Works for the State of Victoria, shall give the necessary directions herein accordingly.

J. COLQUHOUN,  
Clerk of the Executive Council.

COUNTRY ROADS BOARD.

At Government House, Melbourne, the  
ninth day of August, 1966.

PRESENT:

His Excellency the Governor of Victoria.  
Mr. Bloomfield | Mr. Rossiter.

DECLARATION OF A DEVIATION FROM THE SEA LAKE-ROBINVALE ROAD IN THE SHIRE OF WYCHEPROOF.

WHEREAS by sections 21 and 58 of the *Country Roads Act 1958* (No. 6229) it is amongst other things enacted that when the Country Roads Board under the provisions of the Country Roads Act has by Resolution declared a deviation to be a main road the said Board may also declare that such deviation shall be in lieu of any existing road or part thereof named in such Resolution and that on publication in the *Government Gazette* of the Order confirming such Resolution the existing road or part thereof shall cease to be a main road or be discontinued as provided in the Resolution: And whereas the said Board has by Resolution declared the deviation on the land described in the First Schedule to such Resolution to be a main road and has also declared that such deviation shall be in lieu of the part of the existing road being the land described in the Second Schedule to the said Resolution and that such part of the said existing road as is described in the Third Schedule shall be discontinued: Now therefore His Excellency the Governor of

the State of Victoria by and with the advice of the Executive Council thereof doth hereby confirm the said Resolution.

*Resolution for Declaration of a Deviation of a Main Road Under the Country Roads Act.*

Whereas the land the site of the road the course of which is below set out was taken by the Board under the provisions of the *Country Roads Act 1958* for the purpose of constructing such road deviation which road deviation has now been laid out and formed on the same: And whereas the said Board (being the Country Roads Board incorporated under the said Act) thinks that the road aforesaid is fit to be used as a public highway such Board at a meeting now holden acting under the authority conferred upon it by sections 21 and 58 of the said Act doth by this present Resolution hereby declare the said road deviation the course of which is described in the First Schedule hereto with the commencing and terminating points thereof respectively specified to be part of a main road within the meaning and for the purposes of the *Country Roads Act 1958*: And the said Board doth also declare that such deviation shall be in lieu of the existing road or part thereof described in the Second Schedule hereto and that such part of the said existing road shall be discontinued.

FIRST SCHEDULE.

*Shire of Wycheproof.*

11. *Sea Lake-Robinvale road (18711).*—All that piece of land in the Parishes of Burupga and Bourka, the boundaries of which are as follow:—

Commencing at the north-western angle of allotment 6, Parish of Burupga; thence by lines bearing respectively 12 deg. 17 min. 102.6 links, 33 deg. 42 min. 1,056.2 links, 206 deg. 58 min. 1,097.5 links, 186 deg. 5 min. 1,039.8 links and 0 deg. 0 min. 1,033 links to the point of commencement.

Also, all that piece of land in the Parish of Bourka, the boundaries of which are as follow:—

Commencing at a point on the western boundary of allotment 3A in the Parish of Bourka distant 33 deg. 42 min. 3,695 links from the south-western angle of the said allotment; thence by lines bearing respectively 358 deg. 9 min. 199.6 links, 28 deg. 12 min. 526.9 links, 13 deg. 49 min. 856.9 links, 9 deg. 23 min. 843.9 links, 28 deg. 57 min. 255.1 links, 323 deg. 9 min. 118.2 links, 9 deg. 30 min. 1,041.7 links, 18 deg. 43 min. 1,044.6 links, 89 deg. 33 min. 105.9 links, 198 deg. 43 min. 871.4 links, 194 deg. 6 min. 398.8 links, 189 deg. 30 min. 864.2 links, 189 deg. 23 min. 1,139.1 links, 193 deg. 49 min. 873.4 links and 208 deg. 12 min. 712.3 links to the point of commencement—

which said pieces of land are particularly delineated and shown coloured red and yellow on survey plan numbered 6272, lodged in the office of the Country Roads Board.

SECOND SCHEDULE.

*Shire of Wycheproof.*

11. *Sea Lake-Robinvale road (18711).*—All that piece of land in the Parish of Bourka, the boundaries of which are as follow:—Commencing at an angle in the eastern boundary of allotment 3, distant 33 deg. 42 min. 3,731 links from the southern boundary of the said allotment; thence by lines bearing respectively 358 deg. 9 min. 1,197.0 links, 28 deg. 57 min. 1,505 links, 323 deg. 9 min. 695 links, 1 deg. 19 min. 1,557 links, 89 deg. 33 min. 100.1 links, 181 deg. 19 min. 1,525.0 links, 143 deg. 9 min. 605.8 links, 189 deg. 30 min. 30.6 links, 189 deg. 23 min. 291.4 links, 208 deg. 57 min. 1,287.9 links, 178 deg. 9 min. 1,002.4 links and 209 deg. 0 min. 195.2 links to the point of commencement—which said piece of land is particularly delineated and shown coloured blue on survey plan numbered 6272, lodged in the office of the Country Roads Board.

The common seal of the Country Roads Board was hereto affixed at Kew this first day of August. One thousand nine hundred and sixty-six, in the presence of—

(SEAL) I. J. O'DONNELL, Chairman.  
F. WEST, Member.  
N. L. ALLANSON, Secretary.

And the Honorable Murray Victor Porter, Her Majesty's Minister of Public Works for the State of Victoria, shall give the necessary directions herein accordingly.

J. COLQUHOUN,  
Clerk of the Executive Council.

## COUNTRY ROADS BOARD.

At Government House, Melbourne, the ninth day of August, 1966.

PRESENT:

His Excellency the Governor of Victoria.  
Mr. Bloomfield | Mr. Rossiter.

## DECLARATION OF THE WIDENING OF COMBIENBAR-ROAD IN THE SHIRE OF ORBOST.

WHEREAS by section 21 of the *Country Roads Act 1958* (No. 6229) it is amongst other things enacted that when the Country Roads Board under the provisions of the Country Roads Act has taken the land necessary for constructing the road or deviation or widening it shall as soon as it thinks such road or deviation or widening is fit to be used as a public highway by Resolution declare the road or deviation or widening to be a main road or part thereof and that upon publication in the *Government Gazette* of the Order of the Governor in Council confirming such Resolution such road or deviation or widening shall thereupon be a main road or a part thereof within the meaning of the said Act: And whereas the said Board has by Resolution declared the road on the land described in the Schedule to such Resolution to be part of a main road: Now therefore His Excellency the Governor of the State of Victoria by and with the advice of the Executive Council thereof doth hereby confirm the said Resolution.

## Resolution for Declaration of the Widening of a Main Road under the Country Roads Act.

Whereas the land the site of the road the course of which is below set out was taken by the Board under the provisions of the Country Roads Act for the purpose of widening the main road aforesaid which widening has now been laid out and formed on the same: And whereas the said Board (being the Country Roads Board incorporated under the said Act) thinks that the widening aforesaid is fit to be used as part of a public highway such Board at a meeting now holden doth by this Resolution hereby declare the same as described in the Schedule hereto with the commencing and terminating points thereof respectively specified to be part of the main road within the meaning and for the purposes of the Country Roads Act.

## SCHEDULE.

## Shire of Orbost.

10. *Combienbar-road* (12710).—All that piece of land in the Parish of Goolengook, the boundaries of which are as follow:—Commencing at the southern angle of allotment 60, section A of the said parish; thence by lines bearing respectively 287 deg. 47 min. 25.6 links, 34 deg. 17 min. 267.1 links and 208 deg. 54 min. 261.0 links to the point of commencement—which said piece of land is particularly delineated and shown coloured red on survey plan numbered 9534, lodged in the office of the Country Roads Board.

The common seal of the Country Roads Board was hereto affixed, at Kew, this first day of August, One thousand nine hundred and sixty-six, in the presence of—

(SEAL) I. J. O'DONNELL, Chairman.  
F. WEST, Member.  
N. L. ALLANSON, Secretary.

And the Honorable Murray Victor Porter, Her Majesty's Minister of Public Works for the State of Victoria, shall give the necessary directions herein accordingly.

J. COLQUHOUN,  
Clerk of the Executive Council.

## COUNTRY ROADS BOARD.

At Government House, Melbourne, the ninth day of August, 1966.

PRESENT:

His Excellency the Governor of Victoria.  
Mr. Bloomfield | Mr. Rossiter.

## ORDER APPROVING OF A DEVIATION FROM A MAIN ROAD IN THE SHIRE OF BULN BULN.

WHEREAS the Country Roads Board constituted under the *Country Roads Act 1958* (No. 6229) has represented to His Excellency the Governor in Council that it appears to it desirable that the deviation hereinafter re-

ferred to from the existing Main South road in the Shire of Buln Buln (declared to be a main road under the said Act which declaration was confirmed by the Order in Council published in the *Government Gazette* of the 23rd December, 1925, on page 4328) should be made by the said Board: And whereas the said Board in accordance with the requirements of section 19 of the said cited Act has caused to be prepared a map plan and estimate showing the points between which and on and through what land the said deviation is proposed to be made and the cost of acquiring the land: And whereas on an inspection of the said map and plan and a consideration of the said estimate His Excellency the Governor in Council is satisfied that there are funds legally available for acquiring the land: Now therefore be it known by this present Order that His Excellency the Governor of the State of Victoria with the advice of the Executive Council thereof doth hereby approve of the said road being made, that is to say:—

All that piece of land in the Parish of Longwarry, the boundaries of which are as follow:—

Commencing at a point on the southern boundary of allotment 30 of the said parish distant 278 deg. 6 min. 365.2 links from the south-eastern angle of the said allotment; thence by lines bearing respectively 223 deg. 47 min. 954 links, 253 deg. 5 min. 306.5 links, 43 deg. 47 min. 1,558.1 links, 36 deg. 13 min. 417 links, 19 deg. 31 min. 423.4 links, 2 deg. 23 min. 548.8 links, 170 deg. 45 min. 647.7 links, 199 deg. 31 min. 402.1 links, 216 deg. 13 min. 448.9 links and 223 deg. 47 min. 346.7 links to the point of commencement—which said piece of land is particularly delineated and shown coloured red on survey plan numbered 10554, lodged in the office of the Country Roads Board.

And the Honorable Murray Victor Porter, Her Majesty's Minister of Public Works for the State of Victoria, shall give the necessary directions herein accordingly.

J. COLQUHOUN,  
Clerk of the Executive Council.

## COUNTRY ROADS BOARD.

At Government House, Melbourne, the ninth day of August, 1966.

PRESENT:

His Excellency the Governor of Victoria.  
Mr. Bloomfield | Mr. Rossiter.

## ORDER APPROVING OF A DEVIATION FROM A STATE HIGHWAY IN THE SHIRES OF ALBERTON AND SOUTH GIPPSLAND.

WHEREAS the Country Roads Board constituted under the *Country Roads Act 1958* (No. 6229) has represented to His Excellency the Governor in Council that it appears to it desirable that the deviation hereinafter referred to from the existing Midland Highway in the Shires of Alberton and South Gippsland (declared to be a State highway under the said Act which declaration was confirmed by the Order in Council published in the *Government Gazette* of the 24th August, 1938, on pages 2563 and 2564) should be made by the said Board: And whereas the said Board in accordance with the requirements of section 19 of the said cited Act has caused to be prepared a map, plan and estimate showing the points between which and on and through what land the said deviation is proposed to be made and the cost of acquiring the land: And whereas on an inspection of the said map and plan and a consideration of the said estimate His Excellency the Governor in Council is satisfied that there are funds legally available for acquiring the land: Now therefore be it known by this present Order that His Excellency the Governor of the State of Victoria with the advice of the Executive Council thereof doth hereby approve of the said highway being made, that is to say:—

All those pieces of land in the Parish of Woorarra, the boundaries of which are as follow:—

- (a) Commencing at the southern angle of allotment 11A, section D, of the said parish; thence by lines bearing respectively 343 deg. 42 min. 326 links, 318 deg. 16 min. 204 links, 340 deg. 46 min. 280 links, 89 deg. 47 min. 12.3 links, 140 deg. 9 min. 379.3 links, 161 deg. 25 min. 218.7 links, 178 deg. 13 min. 214 links and 215 deg. 19 min. 21 links to the point of commencement.



- (b) Commencing at an angle in the eastern boundary of allotment 11, section D, of the said parish, formed by the intersection of lines bearing 35 deg. 19 min. and 343 deg. 42 min.; thence by lines bearing respectively 215 deg. 19 min. 84.6 links, 356 deg. 48 min. 292.4 links and 163 deg. 42 min. 232.3 links to the point of commencement.
- (c) Commencing at the north-western angle of allotment 12, section D, of the said parish; thence by lines bearing respectively 106 deg. 19 min. 45.8 links, 213 deg. 58 min. 417.2 links, 202 deg. 55 min. 589.6 links, 352 deg. 19 min. 48.5 links, 20 deg. 14 min. 564 links and 35 deg. 20 min. 398 links to the point of commencement.
- (d) Commencing at an angle in the eastern boundary of allotment 11, section D, of the said parish, formed by the intersection of lines bearing 53 deg. 15 min. and 327 deg. 32 min.; thence by lines bearing respectively 233 deg. 15 min. 364.9 links, 14 deg. 53 min. 229.3 links, 28 deg. 32 min. 223.2 links and 147 deg. 32 min. 236.3 links to the point of commencement.
- (e) Commencing at an angle in the western boundary of allotment 12, section D, of the said parish, formed by the intersection of lines bearing 228 deg. 50 min. and 184 deg. 10 min.; thence by lines bearing respectively 48 deg. 50 min. 137.5 links, 201 deg. 21 min. 317.7 links, 161 deg. 20 min. 330.3 links, 318 deg. 33 min. 183.3 links and 4 deg. 10 min. 382 links to the point of commencement.
- (f) Commencing at the northern angle of allotment 12A, section D, of the said parish; thence by lines bearing respectively 135 deg. 40 min. 343 links, 145 deg. 6 min. 472 links, 178 deg. 29 min. 346 links, 125 deg. 53 min. 378 links, 189 deg. 3 min. 300 links, 175 deg. 29 min. 204.5 links 187 deg. 59 min. 26.5 links, 342 deg. 57 min. 460.9 links, 336 deg. 4 min. 336.1 links, 335 deg. 21 min. 803.2 links, 321 deg. 37 min. 260.8 links and 333 deg. 24 min. 49.1 links to the point of commencement.
- (g) Commencing at the south-western angle of allotment 12, section D, of the said parish; thence by lines bearing respectively 358 deg. 29 min. 324 links, 155 deg. 53 min. 517 links and 306 deg. 8 min. 251 links to the point of commencement.
- (h) Commencing at an angle in the eastern boundary of the existing Midland Highway through allotment 13, section D, of the said parish, formed by the intersection of lines bearing 175 deg. 29 min. and 143 deg. 28 min.; thence by lines bearing respectively 355 deg. 29 min. 489.4 links, 9 deg. 3 min. 159.3 links, 154 deg. 28 min. 59.4 links and 181 deg. 11 min. 591.7 links to the point of commencement—

which said pieces of land are particularly delineated and shown coloured red and yellow on survey plans numbered 10449 and 10450, lodged in the office of the Country Roads Board.

And the Honorable Murray Victor Porter, Her Majesty's Minister of Public Works for the State of Victoria, shall give the necessary directions herein accordingly.

J. COLQUHOUN,  
Clerk of the Executive Council.

#### COUNTRY ROADS BOARD.

At Government House, Melbourne, the ninth day of August, 1966.

PRESENT:

His Excellency the Governor of Victoria.  
Mr. Bloomfield | Mr. Rossiter.

#### DECLARATION OF A DEVIATION FROM KATANDRA ROAD IN THE SHIRE OF TUNGAMAH.

WHEREAS by sections 21 and 58 of the Country Roads Act 1958 (No. 6229) it is amongst other things enacted that when the Country Roads Board under the provisions of the Country Roads Act has by Resolution declared a deviation to be a main road the said Board

may also declare that such deviation shall be in lieu of any existing road or part thereof named in such Resolution and that on publication in the Government Gazette of the Order confirming such Resolution the existing road or part thereof shall cease to be a main road or be discontinued as provided in the Resolution: And whereas the said Board has by Resolution declared the deviation on the land described in the First Schedule to such Resolution to be a main road and has also declared that such deviation shall be in lieu of the part of the existing road being the land described in the Second Schedule to the said Resolution and that such part of the said existing road as is described in the Third Schedule shall be discontinued: Now therefore His Excellency the Governor of the State of Victoria by and with the advice of the Executive Council thereof doth hereby confirm the said Resolution.

#### Resolution for Declaration of a Deviation of a Main Road under the Country Roads Act.

Whereas the land the site of the road the course of which is below set out was taken by the Board under the provisions of the Country Roads Act 1958 for the purpose of constructing such road deviation which road deviation has now been laid out and formed on the same: And whereas the said Board (being the Country Roads Board incorporated under the said Act) thinks that the road aforesaid is fit to be used as a public highway such Board at a meeting now holden acting under the authority conferred upon it by sections 21 and 58 of the said Act doth by this present Resolution hereby declare the said road deviation the course of which is described in the First Schedule hereto with the commencing and terminating points thereof respectively specified to be part of a main road within the meaning and for the purposes of the Country Roads Act 1958: And the said Board doth also declare that such deviation shall be in lieu of the existing road or part thereof described in the Second Schedule hereto and that such part of the said existing road as is described in the Third Schedule shall be discontinued.

#### FIRST SCHEDULE.

##### Shire of Tungamah.

7. Katandra-road (16607).—All those pieces of land in the Parish of Waggarandall, the boundaries of which are as follow:—

- (a) Commencing at a point on the southern boundary of allotment 2, section B of the said parish, distant 90 deg. 0 min. 1,810.0 links from the south-western angle of the said allotment; thence by lines bearing respectively 302 deg. 12 min. 892.2 links, 299 deg. 25 min. 517.0 links, 283 deg. 37 min. 622.1 links, 360 deg. 0 min. 124.2 links, 100 deg. 43 min. 331.4 links, 108 deg. 38 min. 411.0 links, 122 deg. 5 min. 717.9 links, 119 deg. 21 min. 521.0 links, 106 deg. 3 min. 528.4 links, 92 deg. 39 min. 525.4 links and 270 deg. 0 min. 1,000 links to the point of commencement.
- (b) Commencing at a point on the southern boundary of allotment 7, section B of the said parish, distant 90 deg. 0 min. 1,253.5 links from the south-western angle of the said allotment; thence by lines bearing respectively 290 deg. 21½ min. 505.6 links, 315 deg. 3¼ min. 855.5 links, 339 deg. 32 min. 501.3 links, 360 deg. 0 min. 877.4 links, 177 deg. 12 min. 516.8 links, 159 deg. 32 min. 798.7 links, 135 deg. 3¼ min. 790.4 links, 110 deg. 21½ min. 804.9 links, 92 deg. 55 min. 485.0 links and 270 deg. 0 min. 848.1 links to the point of commencement.

Also, all those pieces of land in the Parish of Yabba Yabba, the boundaries of which are as follow:—

- (a) Commencing at a point on the northern boundary of allotment 4 section B of the said parish, distant 270 deg. 0 min. 1,256.8 links from the north-eastern angle of the said allotment; thence by lines bearing respectively 110 deg. 21½ min. 510.2 links, 135 deg. 3¼ min. 838.3 links, 159 deg. 14½ min. 525.6 links, 180 deg. 0 min. 838.3 links, 357 deg. 01½ min. 481.6 links, 339 deg. 14½ min. 818.7 links, 315 deg. 3¼ min. 773.3 links, 290 deg. 21½ min. 810.5 links, 272 deg. 41½ min. 525.1 links and 90 deg. 0 min. 889.0 links to the point of commencement.
- (b) Commencing at the north-western angle of allotment 48, section B of the said parish; thence by lines bearing respectively 62 deg. 40 min. 774.0

links, 90 deg. 0 min. 708.0 links, 265 deg. 19½ min. 694.4 links and 246 deg. 59½ min. 764.4 links to the point of commencement—

which said pieces of land are particularly delineated and shown coloured red on survey plans numbered 9757, 9758, 9759 and 9760, lodged in the office of the Country Roads Board.

SECOND SCHEDULE.

Shire of Tungamah.

7. *Katandra-road* (16607).—All that piece of land in the Parish of Waggarandall, the boundaries of which are as follow:—

Commencing at the south-western angle of allotment 7, section B of the said parish; thence by lines bearing respectively 90 deg. 0 min. 1,253.5 links, 110 deg. 21½ min. 287.4 links, 270 deg. 0 min. 1,623.0 links, 0 deg. 0 min. 1,618.9 links, 159 deg. 32 min. 286.0 links and 180 deg. 0 min. 1,251.0 links to the point of commencement.

Also, all that piece of land in the Parish of Yabba Yabba, the boundaries of which are as follow:—

Commencing at the north-eastern angle of allotment 4, section B of the said parish; thence by lines bearing respectively 270 deg. 0 min. 1,256.8 links, 290 deg. 21½ min. 287.4 links, 90 deg. 0 min. 1,626.3 links, 180 deg. 0 min. 1,626.1 links, 339 deg. 14½ min. 282.1 links and 0 deg. 0 min. 1,262.4 links to the point of commencement—

which said pieces of land are particularly delineated and shown coloured blue on survey plans numbered 9758 and 9759, lodged in the office of the Country Roads Board.

THIRD SCHEDULE.

Shire of Tungamah.

7. *Katandra-road* (16607).—All that piece of land in the Parish of Waggarandall, the boundaries of which are as follow:—Commencing at the south-western angle of allotment 2, section B of the said parish; thence by lines bearing respectively 90 deg. 0 min. 1,810.0 links, 122 deg. 12 min. 187.7 links, 270 deg. 0 min. 2,068.8 links, 0 deg. 0 min. 1,000.0 links, 103 deg. 37 min. 102.8 links and 180 deg. 0 min. 875.8 links to the point of commencement— which said piece of land is particularly delineated and shown coloured blue on survey plan numbered 9757, lodged in the office of the Country Roads Board.

The common seal of the Country Roads Board was hereto affixed, at Kew, this first day of August, One thousand nine hundred and sixty-six, in the presence of—

I. J. O'DONNELL, Chairman.  
(SEAL) F. WEST, Member.  
N. L. ALLANSON, Secretary.

And the Honorable Murray Victor Porter, Her Majesty's Minister of Public Works for the State of Victoria, shall give the necessary directions herein accordingly.

J. COLQUHOUN,  
Clerk of the Executive Council.

COUNTRY ROADS BOARD.

At Government House, Melbourne, the  
ninth day of August, 1966.

PRESENT:

His Excellency the Governor of Victoria.  
Mr. Bloomfield | Mr. Rossiter.

DECLARATION OF A DEVIATION FROM THE  
LEONGATHA-MIRBOO ROAD IN THE SHIRE OF  
WOORAYL.

WHEREAS by sections 21 and 58 of the *Country Roads Act 1958* (No. 6229) it is amongst other things enacted that when the Country Roads Board under the provisions of the *Country Roads Act* has by Resolution declared a deviation to be a main road the said Board may also declare that such deviation shall be in lieu of any existing road or part thereof named in such Resolution and that on publication in the *Government Gazette* of the Order confirming such Resolution the existing road or part thereof shall cease to be a main road or be discontinued as provided in the Resolution: And whereas the said Board has by Resolution declared the deviation

on the land described in the First Schedule to such Resolution to be a main road and has also declared that such deviation shall be in lieu of the part of the existing road being the land described in the Second Schedule to the said Resolution and that such part of the said existing road shall be discontinued: Now therefore His Excellency the Governor of the State of Victoria by and with the advice of the Executive Council thereof doth hereby confirm the said Resolution.

Resolution for Declaration of a Deviation of a Main Road  
Under the Country Roads Act.

Whereas the land the site of the road the course of which is below set out was taken by the Board under the provisions of the *Country Roads Act 1958* for the purpose of constructing such road deviation which road deviation has now been laid out and formed on the same: And whereas the said Board (being the Country Roads Board incorporated under the said Act) thinks that the road aforesaid is fit to be used as a public highway such Board at a meeting now holden acting under the authority conferred upon it by sections 21 and 58 of the said Act doth by this present Resolution hereby declare the said road deviation the course of which is described in the First Schedule hereto with the commencing and terminating points thereof respectively specified to be part of a main road within the meaning and for the purposes of the *Country Roads Act 1958*: And the said Board doth also declare that such deviation shall be in lieu of the existing road or part thereof described in the Second Schedule hereto and that such part of the said existing road shall be discontinued.

FIRST SCHEDULE.

Shire of Woorayl.

16. *Leongatha-Mirboo road* (18616).—All those pieces of land in the Parish of Koorooman, the boundaries of which are as follow:—

(a) Commencing at a point on the eastern boundary of allotment 96E of the said parish, distant 201 deg. 46 min. 103.0 links from the north-eastern angle of the said allotment; thence by lines bearing respectively 201 deg. 46 min. 4.5 links, 359 deg. 3½ min. 802.3 links, 169 deg. 17 min. 325.9 links and 185 deg. 31 min. 480.1 links to the point of commencement.

(b) Commencing at the south-western angle of allotment 95 of the said parish; thence by lines bearing respectively 21 deg. 46 min. 137.0 links, 189 deg. 44½ min. 648.0 links, 196 deg. 17 min. 591.2 links, 207 deg. 49 min. 241.7 links, 215 deg. 44 min. 763.7 links, 227 deg. 27 min. 462.9 links, 231 deg. 53½ min. 1,650.9 links, 308 deg. 29 min. 68.3 links, 38 deg. 35 min. 230.0 links, 57 deg. 1 min. 1,087.0 links, 43 deg. 14 min. 1,145.0 links, 21 deg. 46 min. 446.3 links, 31 deg. 13 min. 227.0 links, 16 deg. 17 min. 390.0 links and 21 deg. 46 min. 660.6 links to the point of commencement.

(c) Commencing at the south-western angle of allotment 98A of the said parish; thence by lines bearing respectively 268 deg. 52 min. 219.9 links, 82 deg. 11½ min. 745.0 links, 70 deg. 18½ min. 404.4 links, 59 deg. 8 min. 439.7 links, 52 deg. 37½ min. 1,117.7 links, 194 deg. 3 min. 266.0 links, 239 deg. 57 min. 1,732.0 links and 268 deg. 52 min. 601.0 links to the point of commencement—

which said pieces of land are particularly delineated and shown coloured red, yellow and green on survey plans numbered 10068 and 10069, lodged in the office of the Country Roads Board.

SECOND SCHEDULE.

Shire of Woorayl.

16. *Leongatha-Mirboo road* (18616).—All that piece of land in the Parish of Koorooman, the boundaries of which are as follow:—Commencing at a point on the eastern boundary of allotment 96E of the said parish, distant 201 deg. 46 min. 107.5 links from the north-eastern angle of the said allotment; thence by lines bearing respectively 190 deg. 45 min. 523.1 links, 201 deg. 46 min. 379.4 links, 125 deg. 5 min. 38.3 links, 211 deg. 13 min. 531.4 links, 223 deg. 14 min. 336.4 links, 32 deg. 30 min. 393.0 links and 21 deg. 46 min. 1,352.5 links to the point of commencement— which said piece of land is particularly delineated and shown coloured blue on survey plan numbered 10069, lodged in the office of the Country Roads Board.

The common seal of the Country Roads Board was hereto affixed at Kew this first day of August, One thousand nine hundred and sixty-six, in the presence of—

(SEAL) I. J. O'DONNELL, Chairman.  
F. WEST, Member.  
N. L. ALLANSON, Secretary.

And the Honorable Murray Victor Porter, Her Majesty's Minister of Public Works for the State of Victoria, shall give the necessary directions herein accordingly.

J. COLQUHOUN,  
Clerk of the Executive Council.

#### COUNTRY ROADS BOARD.

At Government House, Melbourne, the ninth day of August, 1966.

PRESENT:

His Excellency the Governor of Victoria.  
Mr. Bloomfield | Mr. Rossiter.

#### DECLARATION OF THE WIDENING OF RINGWOOD-WARRANTYTE ROAD IN THE CITY OF RINGWOOD.

WHEREAS by section 21 of the *Country Roads Act 1958* (No. 6229) it is amongst other things enacted that when the Country Roads Board under the provisions of the Country Roads Act has taken the land necessary for constructing the road or deviation or widening it shall as soon as it thinks such road or deviation or widening is fit to be used as a public highway by Resolution declare the road or deviation or widening to be a main road or part thereof and that upon publication in the *Government Gazette* of the Order of the Governor in Council confirming such Resolution such road or deviation or widening shall thereupon be a main road or a part thereof within the meaning of the said Act: And whereas the said Board has by Resolution declared the road on the land described in the Schedule to such Resolution to be part of a main road: Now therefore His Excellency the Governor of the State of Victoria by and with the advice of the Executive Council thereof doth hereby confirm the said Resolution.

#### Resolution for Declaration of the Widening of a Main Road under the Country Roads Act.

Whereas the land the site of the road the course of which is below set out was taken by the Board under the provisions of the Country Roads Act for the purpose of widening the main road aforesaid which widening has now been laid out and formed on the same: And whereas the said Board (being the Country Roads Board incorporated under the said Act) thinks that the widening aforesaid is fit to be used as part of a public highway such Board at a meeting now holden doth by this Resolution hereby declare the same as described in the Schedule hereto with the commencing and terminating points thereof respectively specified to be part of the main road within the meaning and for the purposes of the Country Roads Act.

SCHEDULE.

City of Ringwood.

5. *Ringwood-Warrandyte road* (14005).—All that piece of land in the Parish of Warrandyte, the boundaries of which are as follow:—Commencing at the southern angle of allotment 48 of the said parish; thence by lines bearing respectively 358 deg. 13½ min. 35 feet, 104 deg. 20 min. 19 ft. 5 in. and 210 deg. 26½ min. 35 feet to the point of commencement—which said piece of land is particularly delineated and shown coloured red on survey plan numbered 8243, lodged in the office of the Country Roads Board.

The common seal of the Country Roads Board was hereto affixed, at Kew, this first day of August, One thousand nine hundred and sixty-six, in the presence of—

(SEAL) I. J. O'DONNELL, Chairman.  
F. WEST, Member.  
N. L. ALLANSON, Secretary.

And the Honorable Murray Victor Porter, Her Majesty's Minister of Public Works for the State of Victoria, shall give the necessary directions herein accordingly.

J. COLQUHOUN,  
Clerk of the Executive Council.

#### COUNTRY ROADS BOARD.

At Government House, Melbourne, the ninth day of August, 1966.

PRESENT:

His Excellency the Governor of Victoria.  
Mr. Bloomfield | Mr. Rossiter.

#### DECLARATION OF THE WIDENING OF MICKLEHAM-ROAD IN THE SHIRE OF BULLA.

WHEREAS by section 21 of the *Country Roads Act 1958* (No. 6229) it is amongst other things enacted that when the Country Roads Board under the provisions of the Country Roads Act has taken the land necessary for constructing the road or deviation or widening it shall as soon as it thinks such road or deviation or widening is fit to be used as a public highway by Resolution declare the road or deviation or widening to be a main road or part thereof and that upon publication in the *Government Gazette* of the Order of the Governor in Council confirming such Resolution such road or deviation or widening shall thereupon be a main road or a part thereof within the meaning of the said Act: And whereas the said Board has by Resolution declared the road on the land described in the Schedule to such Resolution to be part of a main road: Now therefore His Excellency the Governor of the State of Victoria by and with the advice of the Executive Council thereof doth hereby confirm the said Resolution.

#### Resolution for Declaration of the Widening of a Main Road under the Country Roads Act.

Whereas the land the site of the road the course of which is below set out was taken by the Board under the provisions of the Country Roads Act for the purpose of widening the main road aforesaid which widening has now been laid out and formed on the same: And whereas the said Board (being the Country Roads Board incorporated under the said Act) thinks that the widening aforesaid is fit to be used as part of a public highway such Board at a meeting now holden doth by this Resolution hereby declare the same as described in the Schedule hereto with the commencing and terminating points thereof respectively specified to be part of a main road within the meaning and for the purposes of the Country Roads Act.

SCHEDULE.

Shire of Bulla.

5. *Mickleham-road* (2705).—All that piece of land in the Parishes of Yuroke and Will Will Rook, the boundaries of which are as follow:—Commencing at the south-western angle of Portion D, section 2, of the Parish of Yuroke; thence by lines bearing respectively 357 deg. 7 min. 525.8 links, 168 deg. 53 min. 534.2 links, 168 deg. 31 min. 32.8 links, 152 deg. 07 min. 494.7 links, 325 deg. 57 min. 526.2 links and 328 deg. 21 min. 38.2 links to the point of commencement—which said piece of land is particularly delineated and shown coloured red and yellow on survey plan numbered 9332, lodged in the office of the Country Roads Board.

The common seal of the Country Roads Board was hereto affixed, at Kew, this first day of August, One thousand nine hundred and sixty-six, in the presence of—

(SEAL) I. J. O'DONNELL, Chairman.  
F. WEST, Member.  
N. L. ALLANSON, Secretary.

And the Honorable Murray Victor Porter, Her Majesty's Minister of Public Works for the State of Victoria, shall give the necessary directions herein accordingly.

J. COLQUHOUN,  
Clerk of the Executive Council.

LABOUR AND INDUSTRY ACT 1958.

At Government House, Melbourne, the  
ninth day of August, 1966.

PRESENT:

His Excellency the Governor of Victoria.  
Mr. Bloomfield | Mr. Rossiter.

EXEMPTION OF A CLASS OF STEAM BOILERS FROM  
THE OPERATION OF DIVISION 2 OF PART IX. OF  
THE LABOUR AND INDUSTRY ACT 1958.

IN pursuance of the powers conferred by sub-section (1) of section 182 of the *Labour and Industry Act 1958*, His Excellency the Governor of the State of Victoria, by and with the advice of the Executive Council thereof, doth hereby exempt from the operation of Division 2 of Part IX. of the said Act the class of steam boilers known as the "Alliance Mark VIIB Steam Generator" having a capacity of not more than 8,625 pounds of steam per hour and manufactured by Alliance Engineering Proprietary Limited, of 18A Kilpa-road, Moorabbin, in accordance with drawing No. 200/250AB and attached specification, lodged with the Department of Labour and Industry by the said Alliance Engineering Proprietary Limited on the 25th day of July, 1966.

And the Honorable George Oswald Reid, Her Majesty's Acting Minister of Labour and Industry for the State of Victoria, shall give the necessary directions herein accordingly.

J. COLQUHOUN,  
Clerk of the Executive Council.

RAILWAYS ACT 1958.

At Government House, Melbourne, the  
ninth day of August, 1966.

PRESENT:

His Excellency the Governor of Victoria.  
Mr. Bloomfield | Mr. Rossiter.

TRANSFER OF SECTIONS OF RAILWAY.

HIS Excellency the Governor of the State of Victoria, by and with the advice of the executive council thereof, doth by this order in pursuance of the provisions of section 39 of the *Railways Act 1958*, transfer the following sections of railway to the Victorian Railway Commissioners, the requisite certificates having been given by the Railway Construction Board and the Chief Engineer of the Board:—

The reconstruction of the Fern Tree Gully and Gembrook Railway commencing at 22 miles 32 chains 83 links and terminating at 25 miles 56 chains 64 links from Melbourne.

And the Honorable Rupert James Hamer, Her Majesty's Acting Minister of Transport, shall give the necessary directions herein accordingly.

J. COLQUHOUN,  
Clerk of the Executive Council.

TATURA SEWERAGE AUTHORITY.

At the Executive Council Chamber, Melbourne, the  
sixteenth day of August, 1966.

PRESENT:

The Lieutenant-Governor as Deputy for His Excellency  
the Governor of Victoria.  
Mr. Balfour | Mr. Darcy.

EXTENT OF SEWERAGE DISTRICT INCREASED.

UNDER the powers conferred by the Sewerage Districts Act and all other powers enabling him in that behalf, the Lieutenant-Governor as Deputy for His Excellency the

Governor of the State of Victoria, by and with the advice of the Executive Council of the said State, doth hereby declare, order and direct as follows:—

That the extent of the Sewerage District of the Tatura Sewerage Authority be increased by adding to the same the lands comprised within the boundaries described in the Schedule hereto and as on and from the date hereof the extent of such District shall be deemed to be increased accordingly.

SCHEDULE.

Portion 1.

Commencing at the intersection of the northern boundary of William-street and the north-western boundary of Thomson-street, Parish of Toolamba West, County of Rodney, being a point on the boundary of the existing Sewerage District; thence generally north-easterly along the north-western boundary of Thomson-street and by a line being a continuation thereof across the said Thomson-street to a point on its north-eastern boundary; thence generally south-easterly along the north-eastern boundary of the said Thomson-street to the northernmost angle of lot 97 on lodged plan of subdivision No. 66677; thence south-easterly along the north-eastern boundary of the said lot 97 to the westernmost angle of lot 86; thence north-easterly, easterly and southerly along the north-western, northern and eastern boundaries of the said lot 86 and of lots 85, 84, 83, 82, 81, 80, 79 and 78 to the south-eastern angle of the said lot 78; thence southerly by a line to the north-western angle of lot 65; thence easterly along the northern boundaries of the said lot 65 and of lots 64 and 63 to the north-eastern angle of the said lot 63; thence generally south-easterly along the north-eastern boundaries of lots 62, 61, 60, 59 and 58 to the south-eastern angle of the said lot 58 being a point on the northern boundary of the lands shown on lodged plan of subdivision No. 62473, being a point on the northern boundary of the existing Sewerage District; thence westerly, southerly, westerly and generally northerly along the said boundary of the Sewerage District to the point of commencement.

Portion 2.

Commencing at the south-western angle of lot 42, on lodged plan of subdivision No. 66677, Parish of Toolamba West, County of Rodney, being a point on the boundary of the existing Sewerage District; thence generally northerly along the western boundaries of the said lot 42 and lots 43 to 57 inclusive to the north-western angle of the said lot 57; thence north-easterly along the north-western boundary of the said lot 57 to a point on the western boundary of Gowrie-street; thence northerly along the said western boundary of Gowrie-street to a point on the southern boundary of lot 2; thence westerly, northerly and easterly along the southern, western and northern boundaries of the said lot 2 to its north-eastern angle; thence southerly along the eastern boundary of the said lot 2 and continuing by the eastern boundary of Gowrie-street to the northernmost angle of lot 3; thence south-easterly along the north-eastern boundary of the said lot 3 to its north-eastern angle; thence southerly along the eastern boundaries of the said lot 3, and lots 4, 5, 6, 7, 8 and 9 to the north-western angle of lot 12; thence easterly along the northern boundaries of the said lot 12 and of lots 13 to 24 inclusive and southerly by the eastern boundaries of the said lot 24 and of lots 25, 26 and 27 to the south-eastern angle of the said lot 27; thence westerly along the southern boundaries of the said lot 27 and lots 28 to 39 inclusive to the south-western angle of the said lot 39; thence southerly by a line being a continuation of the western boundary of the said lot 39 through Crown allotments 28, 27 and 26 to a point on the southern boundary of the said Crown allotment 26, being a point on the boundary of the existing Sewerage District; thence westerly, northerly and westerly along the said boundary to the point of commencement.

All of which boundaries are shown on a plan approved by the Governor in Council and deposited in the office of the State Rivers and Water Supply Commission, Melbourne.—(Corres. 64/1453/12).

And the Honorable Thomas Anthony Darcy, Her Majesty's Minister of Water Supply for the State of Victoria, shall give the necessary directions herein accordingly

J. COLQUHOUN,  
Clerk of the Executive Council.

## MORNINGTON SEWERAGE AUTHORITY.

At the Executive Council Chamber, Melbourne, the  
sixteenth day of August, 1966.

PRESENT:

The Lieutenant-Governor as Deputy for His Excellency  
the Governor of Victoria.

Mr. Balfour | Mr. Darcy.

## EXTENT OF SEWERAGE DISTRICT INCREASED.

UNDER the powers conferred by the Sewerage Districts Act and all other powers enabling him in that behalf, the Lieutenant-Governor as Deputy for His Excellency the Governor of the State of Victoria, by and with the advice of the Executive Council of the said State, doth hereby declare, order and direct that the extent of the Sewerage District of the Mornington Sewerage Authority be increased by adding thereto the lands within the boundaries described in the Schedule hereto and as on and from the date hereof the extent of the said Sewerage District shall be and be deemed to be increased accordingly.

## SCHEDULE.

## Portion I.

Commencing at the westernmost angle of lot 13, section 6 on lodged plan of subdivision No. 3014, Crown section 36, Parish of Moorooduc, County of Mornington, being a point on the boundary of the existing Sewerage District; thence generally south-easterly and easterly along the north-eastern and northern boundaries of Dominion-road to its intersection with the northern prolongation of the eastern boundary of lot 1 on lodged plan of subdivision No. 71959; thence southerly by the said northern prolongation of the eastern boundary of lot 1 across the said Dominion-road and along the eastern boundaries of the said lot 1 and of lot 13 to an angle on the said eastern boundary of lot 13; thence south-westerly along the south-eastern boundary of the said lot 13 to its southernmost angle; thence north-westerly and westerly along the south-western and southern boundaries of the said lot 13 and of lots 12 and 11 to the westernmost angle of the said lot 11; thence southerly along the western boundaries of lots 1 and 2 on lodged plan of subdivision No. 25334 and by a line being the continuation thereof across a road and along the western boundaries of lots 7 and 8 to its intersection with the eastern prolongation of the southern boundary of lot 24 on lodged plan of subdivision No. 72782; thence westerly by the said eastern prolongation of the southern boundary of lot 1 across a road and along the southern boundaries of the said lot 24 and of lots 30, 31, 32, 33 and 34 and of lot 1 on lodged plan of subdivision No. 62602 and by a line being the continuation thereof across a road to a point on the boundary of the existing Sewerage District; thence northerly, easterly and north-westerly along the boundary of the existing Sewerage District to the point of commencement.

## Portion II.

Commencing at the westernmost angle of lot 31 on lodged plan of subdivision No. 19992, Crown section 35, Parish of Moorooduc, County of Mornington, being a point on the boundary of the existing Sewerage District; thence south-easterly along the south-western boundaries of the said lot 31 and of lots 32, 33 and 34 and a passageway on the said lodged plan of subdivision No. 19992 to the southernmost angle of the said passageway; thence northerly along the eastern boundary of the said passageway to a point on the boundary of the existing Sewerage District; thence generally north-westerly and south-westerly along the boundary of the existing Sewerage District to the point of commencement.

All of which boundaries are shown on a plan approved by the Governor in Council and deposited in the office of the State Rivers and Water Supply Commission, Melbourne.—(Corr. 63/935/140).

And the Honorable Thomas Anthony Darcy, Her Majesty's Minister of Water Supply for the State of Victoria, shall give the necessary directions herein accordingly.

J. COLQUHOUN,  
Clerk of the Executive Council.

## GEELONG WATERWORKS AND SEWERAGE TRUST.

At the Executive Council Chamber, Melbourne, the  
sixteenth day of August, 1966.

PRESENT:

The Lieutenant-Governor as Deputy for His Excellency  
the Governor of Victoria.

Mr. Balfour | Mr. Darcy.

## CONSENT TO BORROWING \$250,000.

UNDER the powers conferred by the Geelong Waterworks and Sewerage Act and all other powers enabling him in that behalf, the Lieutenant-Governor as Deputy for His Excellency the Governor of the State of Victoria, by and with the advice of the Executive Council of the said State, doth hereby consent to the Geelong Waterworks and Sewerage Trust borrowing at interest, subject to the Geelong Waterworks and Sewerage Act the sum of Two hundred and fifty thousand dollars (\$250,000) to meet the cost of sewerage works.

And the Honorable Thomas Anthony Darcy, Her Majesty's Minister of Water Supply for the State of Victoria, shall give the necessary directions herein accordingly.

J. COLQUHOUN,  
Clerk of the Executive Council.

## ROSEDALE WATERWORKS TRUST.

At the Executive Council Chamber, Melbourne, the  
sixteenth day of August, 1966.

PRESENT:

The Lieutenant-Governor as Deputy for His Excellency  
the Governor of Victoria.

Mr. Balfour | Mr. Darcy.

## REPEAL OF ORDER.

UNDER the powers conferred by the Water Act and all other powers, enabling him in that behalf, the Lieutenant-Governor as Deputy for His Excellency the Governor of the State of Victoria, by and with the advice of the Executive Council of the said State, doth hereby repeal the Order made by the Governor in Council on 3rd May, 1960, and published in the *Victoria Government Gazette* dated 11th May, 1960, as amended by Order in Council made on 21st March, 1961, and published in the *Victoria Government Gazette* dated 29th March, 1961, fixing the limit of the overdraft to be obtained by the Rosedale Waterworks Trust, pursuant to the provisions of section 288 of the *Water Act 1958*, and as on and from the date hereof the said Order of the Governor in Council shall be deemed to be repealed accordingly.

And the Honorable Thomas Anthony Darcy, Her Majesty's Minister of Water Supply for the State of Victoria, shall give the necessary directions herein accordingly.

J. COLQUHOUN,  
Clerk of the Executive Council.

## LANDLORD AND TENANT ACT 1958.

At the Executive Council Chamber, Melbourne, the  
sixteenth day of August, 1966.

PRESENT:

The Lieutenant-Governor as Deputy for His Excellency  
the Governor of Victoria.

Mr. Balfour | Mr. Darcy.

## ORDER EXTENDING APPLICATION OF PART V. OF THE LANDLORD AND TENANT ACT 1958 TO CERTAIN PREMISES.

IN pursuance of the powers conferred by section 44 of the *Landlord and Tenant Act 1958*, the Lieutenant-Governor as Deputy for His Excellency the Governor of Victoria, by and with the advice of the Executive Council, doth hereby declare that the application of Part V. of the *Landlord and Tenant Act 1958* shall extend to the following premises.

1. The premises known as Number 50 York-street, Richmond;

2. The premises known as Number 23 Iffla-street, South Melbourne.

And the Honorable George Oswald Reid, Her Majesty's Acting Attorney-General in and for the State of Victoria, shall give the necessary directions herein accordingly.

J. COLQUHOUN,  
Clerk of the Executive Council.

LOCAL GOVERNMENT DEPARTMENT.

At the Executive Council Chamber, Melbourne, the sixteenth day of August, 1966.

PRESENT:

The Lieutenant-Governor as Deputy for His Excellency the Governor of Victoria.

Mr. Balfour | Mr. Darcy.

APPLICATION TO ELECTIONS OF COUNCILLORS FOR THE BOROUGH OF KERANG OF REGULATIONS RELATING TO VOTING BY POST.

WHEREAS it is provided in section 149 of the *Local Government Act 1958*, as amended, that the Governor in Council on the petition of the Council of any municipality, may, by Order published in the *Government Gazette*, apply to elections of councillors, for such municipality, with any modifications provided for in such Order, all or any of the Regulations relating to voting by post made under section 149:

Now therefore, the Lieutenant-Governor as Deputy for His Excellency the Governor of the State of Victoria, by and with the advice of the Executive Council thereof, and in pursuance of a petition of the Council of the Borough of Kerang, doth hereby order that the Regulations relating to voting by post at municipal elections, made by the Governor in Council under the said section, shall apply to elections of councillors for the municipality of the Borough of Kerang.

And the Honorable Rupert James Hamer, Her Majesty's Minister for Local Government for the State of Victoria, shall give the necessary directions herein accordingly.

J. COLQUHOUN,  
Clerk of the Executive Council.

LOCAL GOVERNMENT DEPARTMENT.

At the Executive Council Chamber, Melbourne, the sixteenth day of August, 1966.

PRESENT:

The Lieutenant-Governor as Deputy for His Excellency the Governor of Victoria.

Mr. Balfour | Mr. Darcy.

APPLICATION TO ELECTIONS OF COUNCILLORS FOR THE BOROUGH OF KERANG OF REGULATIONS RELATING TO COMPULSORY VOTING.

WHEREAS it is provided in section 149 of the *Local Government Act 1958*, as amended, that the Governor in Council on the petition of the Council of any municipality, may, by Order published in the *Government Gazette*, apply to elections of councillors, for such municipality, with any modifications provided for in such Order, all or any of the Regulations relating to compulsory voting made under the said section 149:

Now therefore, the Lieutenant-Governor as Deputy for His Excellency the Governor of the State of Victoria, by and with the advice of the Executive Council thereof, and in pursuance of a petition of the Council of the Borough of Kerang, doth hereby order that the Regulations relating to the compulsory voting at municipal elections made pursuant to the provisions of the said section 149, shall apply to elections of councillors for the municipality of the Borough of Kerang.

And the Honorable Rupert James Hamer, Her Majesty's Minister for Local Government for the State of Victoria, shall give the necessary directions herein accordingly.

J. COLQUHOUN,  
Clerk of the Executive Council.

LOCAL GOVERNMENT DEPARTMENT.

At the Executive Council Chamber, Melbourne, the sixteenth day of August, 1966.

PRESENT:

The Lieutenant-Governor as Deputy for His Excellency the Governor of Victoria.

Mr. Balfour | Mr. Darcy.

ALTERATION OF TIME FOR CLOSING POLL AT MUNICIPAL ELECTIONS—BOROUGH OF KERANG.

THE Lieutenant-Governor as Deputy for His Excellency the Governor of the State of Victoria, by and with the advice of the Executive Council thereof, in pursuance of the powers conferred by section 134 of the *Local Government Act 1958*, as amended, and in compliance with the prayer of a petition presented by the Council of the Borough of Kerang, hereby declares that the hour for closing the poll at municipal elections for the said borough shall be Eight o'clock in the afternoon.

And the Honorable Rupert James Hamer, Her Majesty's Minister for Local Government for the State of Victoria, shall give the necessary directions herein accordingly.

J. COLQUHOUN,  
Clerk of the Executive Council.

LANDS DEPARTMENT NOTICES

APPROACHING LAND SALES.

SALES of Crown lands, in fee-simple, will be held at the under-mentioned places and dates, viz.:—

	No. of Gazette.
Ararat.—Wednesday, 31st August, 1966 ..	50
Ballarat.—Thursday, 18th August, 1966 ..	50
Natimuk.—Tuesday, 27th September, 1966 ..	61

SALE OF FREEHOLD LAND BY AUCTION.

Geelong.—Tuesday, 30th August, 1966 .. 50

SALE OF CROWN LAND BY AUCTION.

The land will be offered for sale in fee-simple, and subject to the provisions of the Land Act and Regulations thereunder.

The upset price is the sum at which bidding will start, and no bid below that sum can be accepted. The highest bidder at or above that sum shall be the purchaser, subject to signature of contract and any necessary payment.

TERMS:

A deposit of at least 12½% of the purchase price must be paid at the sale, either in cash or by cheque.

The residue is payable in half-yearly instalments, in accordance with the following scale, or may be paid off at any earlier time.

\$40 and under, 6 instalments.
Over \$40, and not exceeding \$100, 8 instalments.
Over \$100, and not exceeding \$200, 10 instalments.
Over \$200, and not exceeding \$400, 12 instalments.
Over \$400, and not exceeding \$600, 14 instalments.
Over \$600, and not exceeding \$800, 16 instalments.
Over \$800, and not exceeding \$1,000, 18 instalments.
Over \$1,000, 20 instalments.

Interest at the rate of 5% per annum is payable with all payments of residue, and is computed for each instalment from the date of sale to the date of such payment. Additional interest is charged if any instalment is not paid on or before the due date.

If paid off within 30 days of sale, no interest is payable.

FEES, ETC.:

Also payable at the sale, in addition to the deposit, are the survey fee and, if applicable, the valuation of improvements (if purchaser be not the owner thereof).

Payable with balance of purchase money—

Crown Grant fee—	
50 acres and under .. .. .	\$3
Over 50 acres .. .. .	\$4
Purchase money \$10 or under .. .. .	\$2

Assurance Fund contribution.—One cent in every Five dollars or part thereof of purchase price. (This is a fund established to guarantee the validity of freehold titles.)

Transfer of interest prior to completion of payment may be allowed on payment of \$2 fee and subject to stamp duty.

If unable to attend personally, a prospective purchaser may arrange for another person to bid as his agent.

Attention is drawn to section 95, *Land Act 1958*, which provides that the purchaser shall be deemed to be the owner for the purposes of other Acts; also to an amendment to the Local Government Act providing for Government roads in certain circumstances, to be declared "private streets" thus making the purchaser liable to contribute to the cost of street construction.

J. C. M. BALFOUR,  
Minister of Lands.

Office of Crown Lands and Survey,  
Melbourne, 17th August, 1966.

**NATIMUK.**—Sale (No. 11832) of Crown land in fee-simple by auction, will be held at the **MECHANICS' HALL, NATIMUK**, on **TUESDAY, 27th SEPTEMBER, 1966**, at **TEN o'clock a.m.** To be conducted by **E. M. FLOYD**, Land Officer, Horsham.

Lot 1.

TOWNSHIP OF NATIMUK, PARISH OF NATIMUK, COUNTY OF  
LOWAN.

Fronting the northern side of the Apsley-Horsham road, and being Education Department residence and site.

Upset price \$1,608 the lot. Survey fee \$13.

Area 1r. 22p., allotment F. Subject to drainage easement 10 links wide. One month allowed for removal of garage.

NOTES.—1. Improvements comprise an old weatherboard house of about 11 squares, septic sewerage and fencing.

2. The premises will be open for inspection from 3 p.m. to 5 p.m., on Monday, 19th September, 1966 and Monday, 26th September, 1966.

3. Buildings on adjacent freehold land owned by the Natimuk and District Gymnastic Club are connected to the effluent pipes of the septic tank system installed on this property.—(M.60908.)

#### COMMITTEES OF MANAGEMENT OF RESERVES.

##### APPOINTMENTS.

NOTICE is hereby given that, in pursuance of section 221 of the *Land Act 1958*, the following appointments of Committees of Management of reserved Crown lands have been made by the Minister of Lands:—

##### "BARKLY RECREATION RESERVE."

David Stewart, Donald G. Hart, Neil Emerson, Gordon Marland, Graham John Driscoll, Malcolm Herd, Kenneth Rex Stewart, Alan Driscoll, Benjamin Driscoll and Leslie Driscoll as a Committee of Management for a period of three (3) years from 22nd July, 1966, of the land temporarily reserved by Order in Council dated 26th May, 1902, as a site for Public Recreation purposes in the Parish of Barkly, and known as "Barkly Recreation Reserve".—(Corres. Rs.4800.)

##### "BENJEROOP PUBLIC HALL RESERVE."

Arthur Cyril Henry, Arthur Lindsay Morrow, Malcolm George Morton, R. Maxwell Waterson, George A. Vistarini, William Henry Binder, Alfred L. Nethercote and Douglas Walter Wells, as a Committee of Management for a period of three (3) years of the land temporarily reserved by Order in Council dated the 18th June, 1888, as a site for a Public Hall in the Township of Benjeroop and known as the "Benjeroop Public Hall Reserve".—(Corres. Rs.6664.)

##### "CASTERTON RACECOURSE RESERVE."

John Francis Gorman, Jeffrey Douglas Gordon, Wesley Allister McCombe, William John Donald Moffatt, Frederick Ernest Clode, Arthur Richard Young, William Henry Mitchell, Laurence Richard Hayden, Barry Michael Kent and Ivan Frederick McIlroy, as a Committee of Management for a period of three (3) years of the land permanently reserved by Order in Council dated the 17th September, 1883, as a site for a Racecourse in the Parish of Casterton and known as the "Casterton Racecourse Reserve".—(Corres. Rs.1771.)

##### "CATANI RECREATION RESERVE."

Leslie Albert Ashby, Laurie Kenneth Evans, Bruce Clement Mason, Allan Leslie Richards, Geoffrey Wardlaw Price, Robert Charles William Norton, Raymond Percy Fechner, Frank Jhon Williams and Stuart Maxwell Patullo, as a Committee of Management for a period of three (3) years of the remaining portion of the land temporarily reserved by Order in Council dated 20th December, 1900, as a site for Public Recreation in the Parish of Yallock and known as the "Catani Recreation Reserve".—(Corres. Rs.2133.)

##### "CHILTERN RACECOURSE RESERVE."

G. O'Neill, J. G. Byron, F. J. De Piazze, J. McInerney and J. Peake, as a Committee of Management for a period of three (3) years of the land reserved for a Racecourse in the Township and Parish of Chiltern and known as the "Chiltern Racecourse Reserve".—(Corres. Rs.2437.)

##### "CORRANDERRK ABORIGINAL CEMETERY."

Frank Endacott, Ronald Charles Mason, Patricia Lorraine Mason, Hendrick Joannes Swaan, Leonard Frank Foxcroft, Alan James McLaren, Sydney Ronald Gosling, Vernon Charles Mullett and Edward William J. Smith, as a Committee of Management for a period of three (3) years of the land in the Parish of Gracedale, temporarily reserved by Order in Council dated the 27th November, 1962, as a site for Public purposes (Protection of Aborigines' graves).—(Corres. Rs.8190.)

##### "DINGEE PUBLIC HALL RESERVE."

Raymond Victor Lawry, Hugh Campbell Wallace, Edward John Gately, Henry Bayden Rodgers, Thomas Alexander Thompson, Frank Gary Anset, Louis Ralph Vincent, and William Leslie Philips, as a Committee of Management for a period of three (3) years of the land in the Parish of Dingee, temporarily reserved as a site for a Public Hall by Order in Council of 5th February, 1957, and known as "Dingee Public Hall Reserve".—(Corres. Rs.7528.)

##### "LITCHFIELD RECREATION RESERVE."

Chas. Thomas Frank, Harold John Falla, Thomas Robert McConville, Allan Green, John Melican, John Leslie Arnel and Donald Andrew Newell, as a Committee of Management for a period of three (3) years of the land, temporarily reserved by Orders in Council dated 15th July, 1924, and 8th January, 1952, as a site for Recreation purposes in the Parish of Carron and known as the "Litchfield Recreation Reserve".—(Corres. Rs.2961.)

##### "MIRAM SOUTH PUBLIC HALL RESERVE."

William George Avelyn Coutts, Robert William McDonald and Murray Ellis Moar, as a Committee of Management for a period of three (3) years of the land in the Parish of Lawloit, temporarily reserved as a site for a Public Hall by Order in Council dated 1st June, 1914, and known as the "Miram South Public Hall Reserve".—(Corres. Rs.1265.)

##### "NATHALIA RACECOURSE RESERVE."

Royce Albert Ernest Hutchins, George Leaf, Peter Bernard Gallagher, Ernest Harold Lubke, Norman Frederick Smith, Roy William Swanton, Edward Parker Warren, Patrick John Maher, and John Rees Scolyer, as a Committee of Management for a period of three (3) years of the land temporarily reserved by Order in Council dated the 26th September, 1887, as a site for a Racecourse in the Parish of Barwo, and known as the "Nathalia Racecourse Reserve".—(Corres. Rs.4890.)

##### "NULLAWIL MECHANICS INSTITUTE RESERVE."

Jack Donald Cobham McLean, Frederick William Watson, Edwin Clive Townrow, John Ryan, Ian Ronald Poyner, Robert Lawrence Kelly and Herbert Adrian Clarke, as a Committee of Management for a period of three (3) years of the land, temporarily reserved by Order in Council of the 17th May, 1898, as a site for a Mechanics' Institute and Free Library in the Township of Nullawil and known as the "Nullawil Mechanics' Institute Reserve".—(Corres. Rs.352.)

“SCOTCHMAN’S LEAD RECREATION RESERVE.”

Peter John Nolan, Norman Goad, Alex. Douglas, Rupert Brown, and William Alphonsus Hayes, as a Committee of Management for a period of three (3) years of the land temporarily reserved by Order in Council dated 8th November, 1887, as a site for Public Recreation in the Parish of Buninyong and known as “Scotchman’s Lead Recreation Reserve”.—(Corres. Rs.5325.)

“SHEEP HILLS RECREATION RESERVE.”

John James Keogh, Archibald James Campbell, Laurence John Clonan, Alfred Robert Clark, Richard Geoffrey Quick, Roy Leslie Mills, Frank Dunstan Heath, Bruce Lancelot Peart, Ray George Parsons, Joseph James Stainthorpe, Roy Walter Krause and Andrew James Parsons, as a Committee of Management for a period of three (3) years of the land temporarily reserved by Order in Council dated 8th March, 1887, as a site for Public Recreation in the Parish of Kellalac and known as the “Sheep Hills Recreation Reserve”.—(Corres. Rs.17.)

“TARRAWINGEE PUBLIC HALL RESERVE.”

James Kenneth Stewart, Robert Francis Iskov, William James McCormack, Henry Charles Bradley, Stanley James Diffe, Harold Charles Stewart and Henry Peter Nolan, as a Committee of Management for a period of three (3) years of the land temporarily reserved by Order in Council dated 21st September, 1927, as a site for a Public Hall in the Parish of Tarrawingee and known as the “Tarrawingee Public Hall Reserve”.—(Corres. Rs.3524.)

“WILLOW GROVE RECREATION RESERVE.”

Cyril Harcourt Williams, Allan George Needham, Reginald Henry Riley, William Mervyn Erbs, Harold David Whittaker, William Allan Victor Horner, Eric Raymond Williams, Leonard Rowsell and William Henry Hunt, as a Committee of Management for a period of three (3) years of the land temporarily reserved by Orders in Council dated the 2nd May, 1906 and 16th March, 1951, as sites for Public Recreation in the Parish of Tanjil and known as the “Willow Grove Recreation Reserve”.—(Corres. Rs.4789.)

“PUBLIC PURPOSES (TOURIST PURPOSES) RESERVE”, PARISH OF MINDAL.

The Council of the Shire of Grenville as the Committee of Management of the land in the Parish of Mindal, temporarily reserved by Order in Council dated the 27th July, 1966, as a site for Public Purposes (Tourist Purposes).—(Corres. Rs.8616.)

“PUBLIC RECREATION RESERVE,” PARISH OF BALMORAL.

The Council of the Shire of Wannon as the Committee of Management of the land in the Parish of Balmoral, temporarily reserved by Order in Council dated the 27th July, 1966, as a site for Public Recreation.—(Corres. Rs.8567.)

“PUBLIC PURPOSES (CHILDREN’S PLAYGROUND) RESERVE” TOWNSHIP OF DROUIN.

The Council of the Shire of Buln-Buln as the Committee of Management of the land in the Township of Drouin, temporarily reserved by Order in Council dated the 19th July, 1966, as a site for Public Purposes (Children’s Playground).—(Corres. Rs.8604.)

“POWELLTOWN PICNIC GROUND RESERVE.”

G. C. Gribble, S. L. Cooper and F. J. May, as a Committee of Management for a period ending the 6th January, 1969, of the reserved Crown land in the Parish of Beenak, which is indicated by red colour on plan B/18.10.62 attached to Lands Department correspondence Rs.8176.—(Corres. Rs.8176.)

ALAN J. HOLT,  
Secretary for Lands.

16th August, 1966.

PROPOSED REVOCATIONS OF TEMPORARY RESERVATIONS OF LANDS BY ORDERS IN COUNCIL.

IN pursuance of the provisions of the Land Act 1958, notice is hereby given that it is the intention of the Governor in Council to revoke the temporary reservations of lands by Orders in Council hereunder referred to, viz.:—

The following Notices were published 1<sup>o</sup> on the 3rd August, 1966, pursuant to Orders of the 27th July, 1966.

AVOCA.—The temporary reservation by Order in Council of the 30th July, 1866, of 52 acres 2 roods 2½ perches, more or less, of land (in three separate portions) in the Township of Avoca as sites for Police purposes, revoked as to part by various Orders so far as the balance thereof containing 2 roods 1½ perches is concerned.—(A.86(\*) (Rs.7916).

NI NI.—The temporary reservation, by Order in Council of the 4th November, 1889, of 5 acres of land in the Parish of Ni Ni as a site for a State School.—(N.124(?) (Rs.5811).

CARLYLE.—The temporary reservation by Order in Council of 21st January, 1902, of 1 acre 2 roods 16 perches, of land in the Parish of Carlyle, as a site for Drainage purposes, so far only as the portion containing 2 perches, indicated by hachure on plan hereunder is concerned.—(C.187(?) (Rs.367).

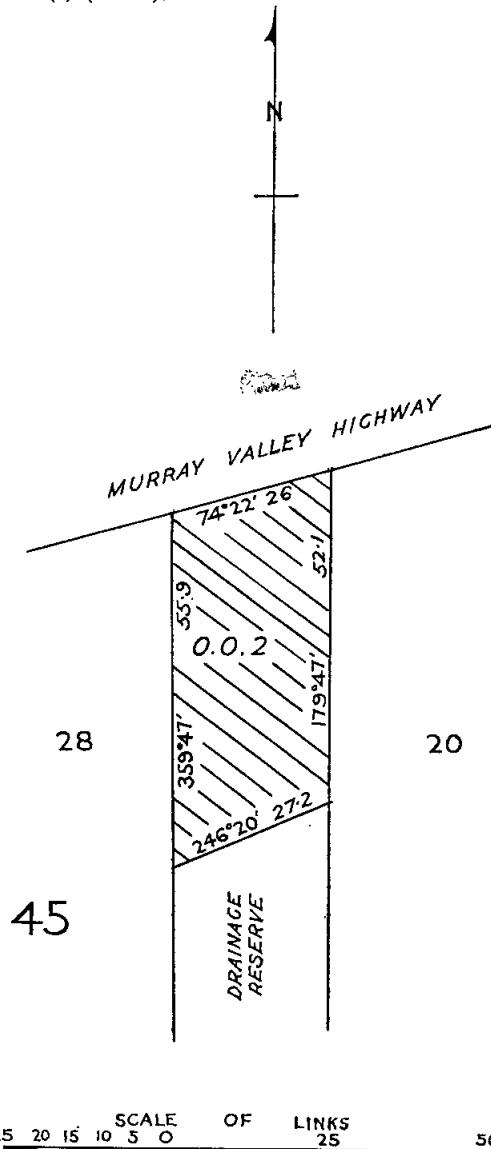

SCALE OF LINKS  
25 20 15 10 5 0 25 50



**KERANG.**—The temporary reservation by Order in Council of the 12th June, 1888, of 1 acre 2 roods of land in the Township of Kerang as a site for the Supply of Material for Road Making Purposes and the temporary reservation by Order in Council of the 10th March, 1891, of 1 rood 3 perches of land as an extension thereto.—(K.19<sup>(1)</sup>) (Rs.8578).

**KURTING.**—The temporary reservation, by Order in Council of the 30th June, 1896, of 6 acres 3 roods 23 perches of land in the Parish of Kurting as a site for Public Recreation.—(K.112<sup>(2)</sup>) (Rs.1977).

**MULLAGONG.**—The temporary reservation, by Order in Council of the 5th December, 1900, of 2 acres of land in the Parish of Mullagong as a site for a State School.—(M.545<sup>(4)</sup>) (Rs.5873).

**BALLARAT EAST.**—The temporary reservation by Order in Council of the 30th January, 1893, of 8 acres of land in the Township of Ballarat East, as a site for Supply of Gravel, revoked as to part by various Orders, so far as the balance thereof, containing 5 acres 1 rood 7 perches, more or less, is concerned.—(B.128<sup>(54)</sup>) (Rs.5349).

**WARRAQUIL.**—The withholding from sale, leasing and licensing by Order in Council of the 25th June, 1877, of 180 acres of land in the Parish of Warraquil, revoked as to part by Order of the 12th March, 1909, so far only as the portion containing 11 acres 32 perches, indicated by hachure on plan hereunder, is concerned.—(W.318<sup>(4)</sup>) (Rs.8098).

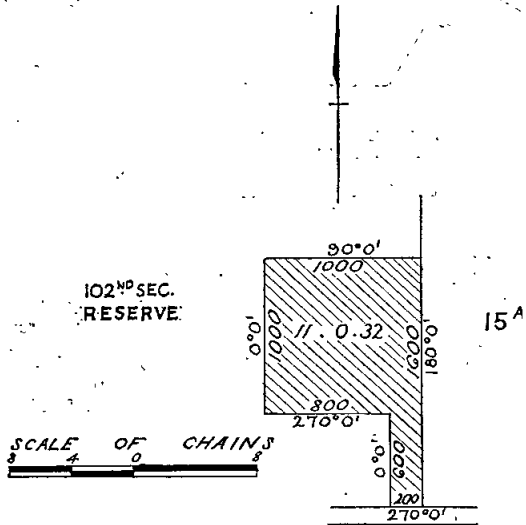

**YARRAGON (MOE).**—The temporary reservation, as a site for Racecourse and other purposes of Public Recreation and the withholding from sale, leasing and licensing by Order in Council of the 3rd November, 1884, of 118 acres 1 rood 24 perches of land in the Parish of Yarragon, revoked as to part by Order of the 20th February, 1902, so far only as the portion containing 1 acre 22 perches, indicated by hachure on plan hereunder, is concerned.—(Y.109<sup>(9)</sup>) (Rs.684).

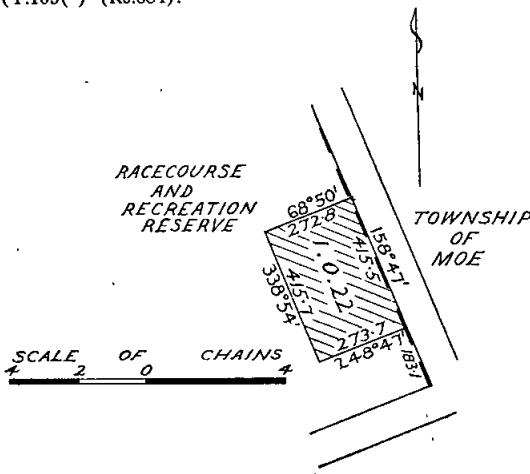

**DANDONGDALE (South Buffalo).**—The temporary reservation by Order in Council of the 18th September, 1956, of 3 acres, 2 roods, 30 perches, more or less, of land in the Parish of Dandongdale (formerly Dondangdale), as a site for Public Recreation.—(D.196<sup>(3)</sup>) (Rs.7497).

**GERANGAMETE.**—The temporary reservation, by Order in Council of the 5th November, 1941, of 14 acres 2 perches of land in the Parish of Gerangamete as a site for Watering purposes.—(G.170<sup>(c2)</sup>) (Rs.5286).

**JIL JIL.**—The temporary reservation, by Order in Council of the 25th May, 1937, of 1 acre of land in the Parish of Jil Jil as a site for a State school.—J.54<sup>(8)</sup> (Rs.4669).

J. C. M. BALFOUR,  
Minister of Lands

PROPOSED REVOCATIONS OF TEMPORARY RESERVATIONS OF LANDS BY ORDERS IN COUNCIL.

IN pursuance of the provisions of the Land Act 1958, notice is hereby given that it is the intention of the Governor in Council to revoke the temporary reservations of lands by Orders in Council hereunder referred to, viz.:

The following Notices were published 1<sup>o</sup> on the 10th August, 1966, pursuant to Orders of the 2nd August, 1966.

**BEECHWORTH.**—The temporary reservation, by Order in Council of the 17th June, 1935, of 13 acres 1 rood 34 perches of land in the Township of Beechworth as a site for Hospital Purposes, so far only as the portion containing 1 acre 2 roods 29 perches, indicated by hachure on plan hereunder, is concerned.—(B.348<sup>(9)</sup>) (Rs.770).

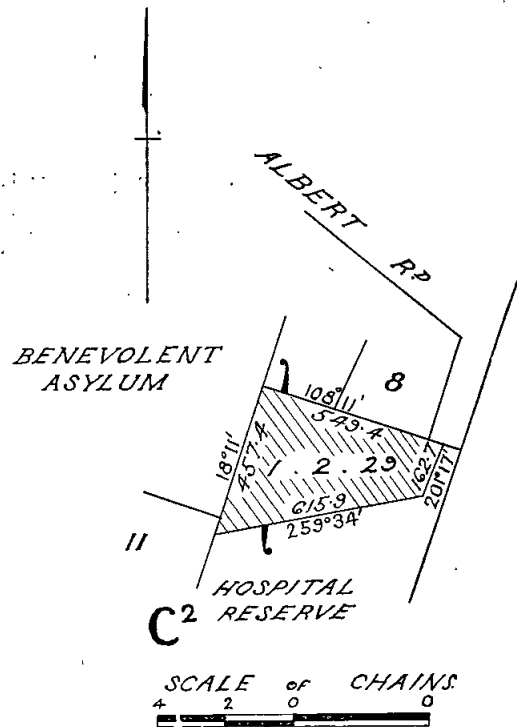

**KIRRAK.**—The temporary reservation, by Order in Council of the 18th June, 1888 (see Government Gazette of the 22nd June, 1888, page 2033) of 10 acres of land in the Parish of Kirrak as a site for a Cemetery so far only as the portion containing 2 roods 38 perches, indicated by hachure on plan hereunder, is concerned.—(K.148<sup>(2)</sup>) (C.99456).

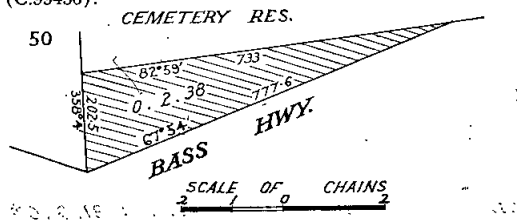

BOCHARA.—The temporary reservation, by Order in Council of the 4th November, 1953, of 1 acre 2 roods 20 perches, more or less, of land in the Parish of Bochara as a site for a Public Hall.—(B.423<sup>(2)</sup>) (Rs.6790).

FOOTSCRAY.—The temporary reservation, by Order in Council of the 9th December, 1902, of 21 3/10 perches of land in the City of Footscray as a site for an Ornamental Plantation.—(F.19<sup>(2)</sup>) (C.62029).

JOOP.—The temporary reservation, by Order in Council of the 24th April, 1923, of 6 acres 5 perches of land in the Parish of Joop as a site for Water Supply purposes.—(J.53<sup>(1)</sup>) (Rs.2552).

MARYBOROUGH.—The temporary reservation, by Order in Council of the 9th September, 1952, of 1 acre 1 perch of land in the Township of Maryborough as a site for Government and Municipal purposes, so far only as the portion containing 32 perches, indicated by hachure on plan hereunder, is concerned.—(M.66<sup>(16)</sup>) (Rs.5729).

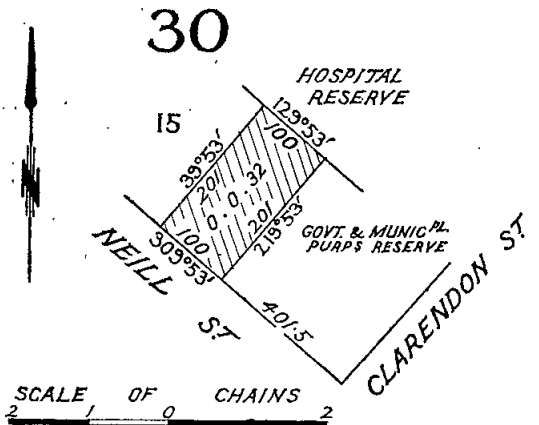

MARYSVILLE.—The temporary reservation, by Order in Council of the 27th December, 1865, of 3 roods 24 perches of land in the Township of Marysville as a site for Police purposes, revoked as to part by various Orders, so far as the balance thereof containing 2 roods 10 perches, more or less is concerned.—(M.431<sup>(3)</sup>) (Rs.5793).

TALLYGAROPNA.—The temporary reservation, as a site for Watering purposes and the withholding from sale, leasing and licensing by Order in Council of the 8th May, 1876 (see Government Gazette of the 12th May, 1876, page 894) of 39 acres of land in the Parish of Tallygaropna, so far only as the portions containing 31 acres 2 roods, more or less, indicated by hachure on plan hereunder, are concerned.—(T.234<sup>(3)</sup>) (C.99924).

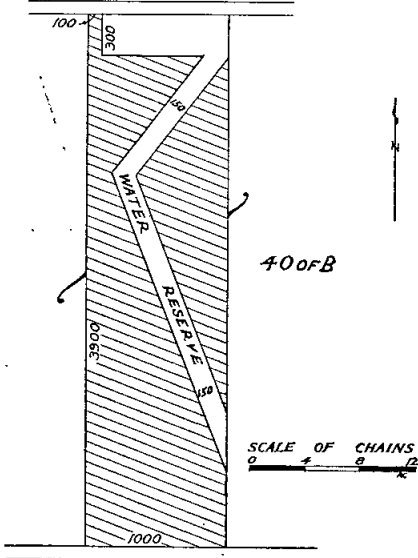

TOTAL AREA OF HACHURED PORTIONS:- 31. 2. 0±

BOCHARA.—The temporary reservation as a site for Camping and Watering and the withholding from sale, leasing and licensing by Order in Council of the 30th October, 1876, (see Government Gazette of the 3rd November, 1876, page 2030) of 12 acres 1 rood 20 perches, more or less, of land in the Parish of Bochara.—(B.423<sup>(2)</sup>) (Rs.8582).

WARRNAMBOOL.—The temporary reservation, by Order in Council of the 16th March, 1960, of 124 acres 18 perches of land in the Township of Warrnambool as a site for Public Park and Public Recreation, so far only as the portion containing 8 acres 1 rood 19 perches, indicated by hachure on plan hereunder, is concerned.—(W.99<sup>(6)</sup>) (Rs.283).

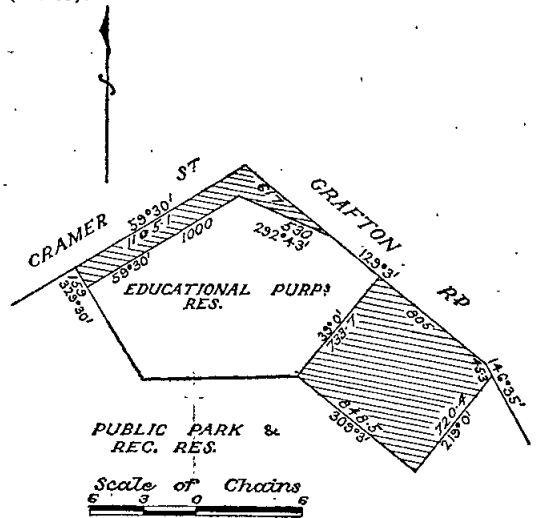

TOTAL AREA OF HACHURED PORTIONS:- 8. 1. 19±

WARRNAMBOOL.—The temporary reservation, by Order in Council of the 15th March, 1949, of 10 acres 1 rood 22 perches of land in the Township of Warrnambool as a site for Educational Purposes.—(W.99<sup>(6)</sup>) (Rs.6333).

J. C. M. BALFOUR, Minister of Lands.

PROPOSED REVOCATIONS OF TEMPORARY RESERVATIONS OF LANDS BY ORDERS IN COUNCIL.

IN pursuance of the provisions of the Land Act 1958, notice is hereby given that it is the intention of the Governor in Council to revoke the temporary reservations of lands by Orders in Council hereunder referred to, viz.:-

The following Notices were published 1° on the 17th August, 1966, pursuant to Orders of the 9th August, 1966.

BRIGHT.—The temporary reservation by Order in Council of the 10th August, 1874, of 2 acres 12 6/10 perches of land in the Township of Bright, as a site for Police purposes, revoked as to part by Order in Council of the 1st July, 1889, so far only as the portion containing 1 rood 32 perches, indicated by hachure on plan hereunder is concerned.—(B.573<sup>(5)</sup>) (Rs.4670).

SCALE OF CHAINS 3

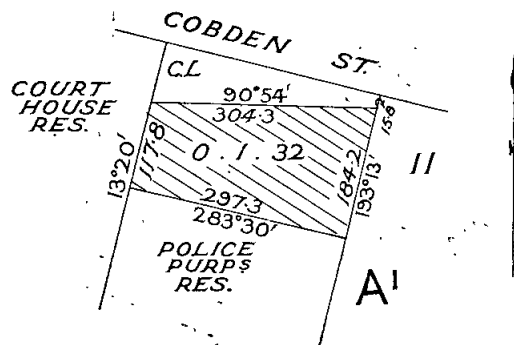

GEELONG.—The temporary reservation by Order in Council of the 30th July, 1963, of 111 acres 1 rood 19 perches of land in the City of Geelong, Parish of Corio, as a site for Public Racecourse and Recreation, so far only as the portion containing 8 perches, more or less, indicated by hachure on plan hereunder is concerned.—(C.272<sup>(5)</sup>) (Rs.519).

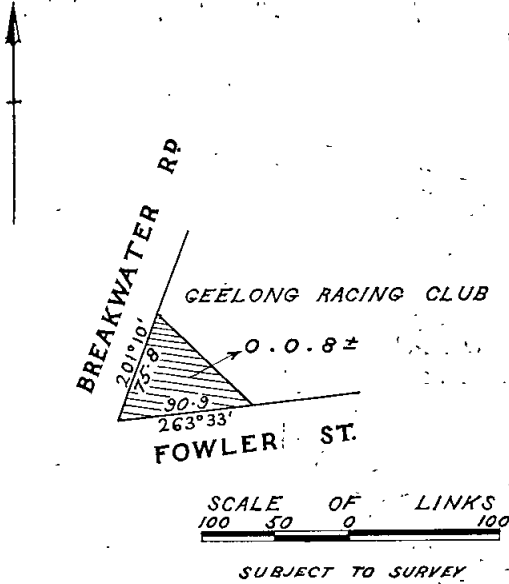

GEELONG.—The temporary reservation by Order in Council of the 24th February, 1885, of 3 acres 1 rood 20 perches, more or less, of land in the City of Geelong, Parish of Corio, as a site for a Quarry, so far only as the portion containing 14 perches, more or less, indicated by hachure on plan hereunder is concerned.—(C.272<sup>(5)</sup>) (Rs.1414).

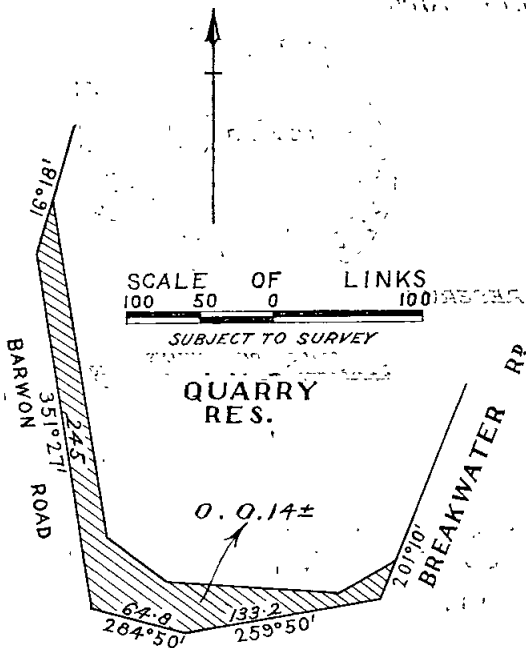

KEWELL EAST.—The temporary reservation by Order in Council of the 7th March, 1923, of 5 acres of land in the Parish of Kewell East, as a site for a State School.—(K.127<sup>(18)</sup>) (Rs.2702).

STAWELL.—The temporary reservation by Order in Council of the 17th April, 1956, of 3 roods 23 perches of land in the Parish of Stawell as a site for a Rubbish Depot.—(S.329<sup>(18)</sup>) (Rs.7444).

PATHO.—The temporary reservation as a site for Public Purposes (State School) and the withholding from sale, leasing and licensing by Order in Council of the 14th February, 1876, (see *Government Gazette* of 18th February, 1876, page 339) of 5 acres of land in the Parish of Patho (formerly Township of Turrumberry).—(P.152<sup>(10)</sup>) (Rs.8572).

TOOBOORAC.—The temporary reservation by Order in Council of the 24th December, 1889, (see *Government Gazette* of the 27th December, 1889, page 4537) of 26 acres 33 perches of land in the Parish of Tooborac as a site for the Supply of Material for Road-making.—(T.91<sup>(6)</sup>) (H.028766).

TUNART.—The temporary reservation by Order in Council of the 26th October, 1928, of 3 acres of land in the Parish of Tunart, as a site for State School.—(T.307<sup>(1)</sup>) (Rs.3773).

TYLDEN.—The temporary reservation by Order in Council of the 18th November, 1889, of 2 acres of land in the Parish of Tylden, as a site for Police purposes, revoked as to part by various Orders, so far only as the portion containing 1 acre 9 perches, indicated by hachure on plan hereunder, is concerned.—(T.132<sup>(3)</sup>) (Rs.8660).

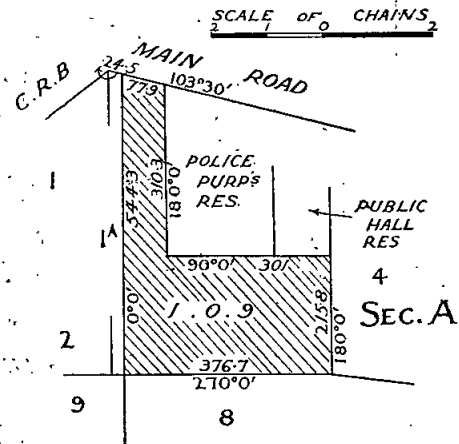

YANIPY.—The temporary reservation by Order in Council of the 22nd March, 1922, of 10 acres of land in the Parish of Yanipy, as a site for Recreation purposes.—(Y.90<sup>(A)</sup>) (Rs.2249).

J. C. M. BALFOUR,  
Minister of Lands.

PROPOSED PERMANENT RESERVATIONS OF LANDS AS SITES.

IN pursuance of the provisions of the *Land Act* 1958, notice is hereby given that it is the intention of the Governor in Council to permanently reserve as sites, and also except from occupation for mining purposes under any miner's right, the lands hereunder referred to:—

The following Notices were published 1<sup>o</sup> on the 3rd August, 1966, pursuant to Orders of the 27th July, 1966.

MOORPANYAL (GEELONG WEST).—Land proposed to be permanently reserved as a site for Public Park and Public Recreation, 9 acres 3 roods 10 perches more or less, Parish of Moorpanyal, County of Grant, being the remaining portion of the site temporarily reserved therefor by Order in Council of the 4th October, 1949, and known as "Western Oval".—(M.199<sup>(6)</sup>) (Rs.5533).

LAKE ROWAN.—Land proposed to be permanently reserved as a site for Public Recreation, 21 acres 3 roods 21 perches, Township of Lake Rowan (formerly Town of Karrabumet), Parish of Karrabumet, County of Moira, being the site temporarily reserved therefor by Order in Council of the 25th July, 1892, and known as "Lake Rowan Recreation Reserve".—(L.186<sup>(1)</sup>) (Rs.1971).

J. C. M. BALFOUR,  
Minister of Lands.

PROPOSED REVOCATIONS OF TEMPORARY RESERVATIONS OF LANDS BY ORDERS IN COUNCIL.

IN pursuance of the provisions of the *Land Act 1958*, notice is hereby given that it is the intention of the Governor in Council to revoke the temporary reservations of lands by Orders in Council hereunder referred to, viz.:

The following Notice was published 1° on the 10th August, 1966, pursuant to Orders of the 2nd August, 1966.

MULLROO (LAKE CULLULLERAINE).—The temporary reservation by Order in Council of the 12th December, 1930, of 1,435 acres 2 roods 36 perches of land in the Parish of Mullroo, as a site for Water Supply purposes, revoked as to part by various Orders, is about to be revoked so far only as the portion containing 383 acres 23 perches, indicated by hachure on plan hereunder, is concerned.—(M.499<sup>(1)</sup>) (Rs.4076).

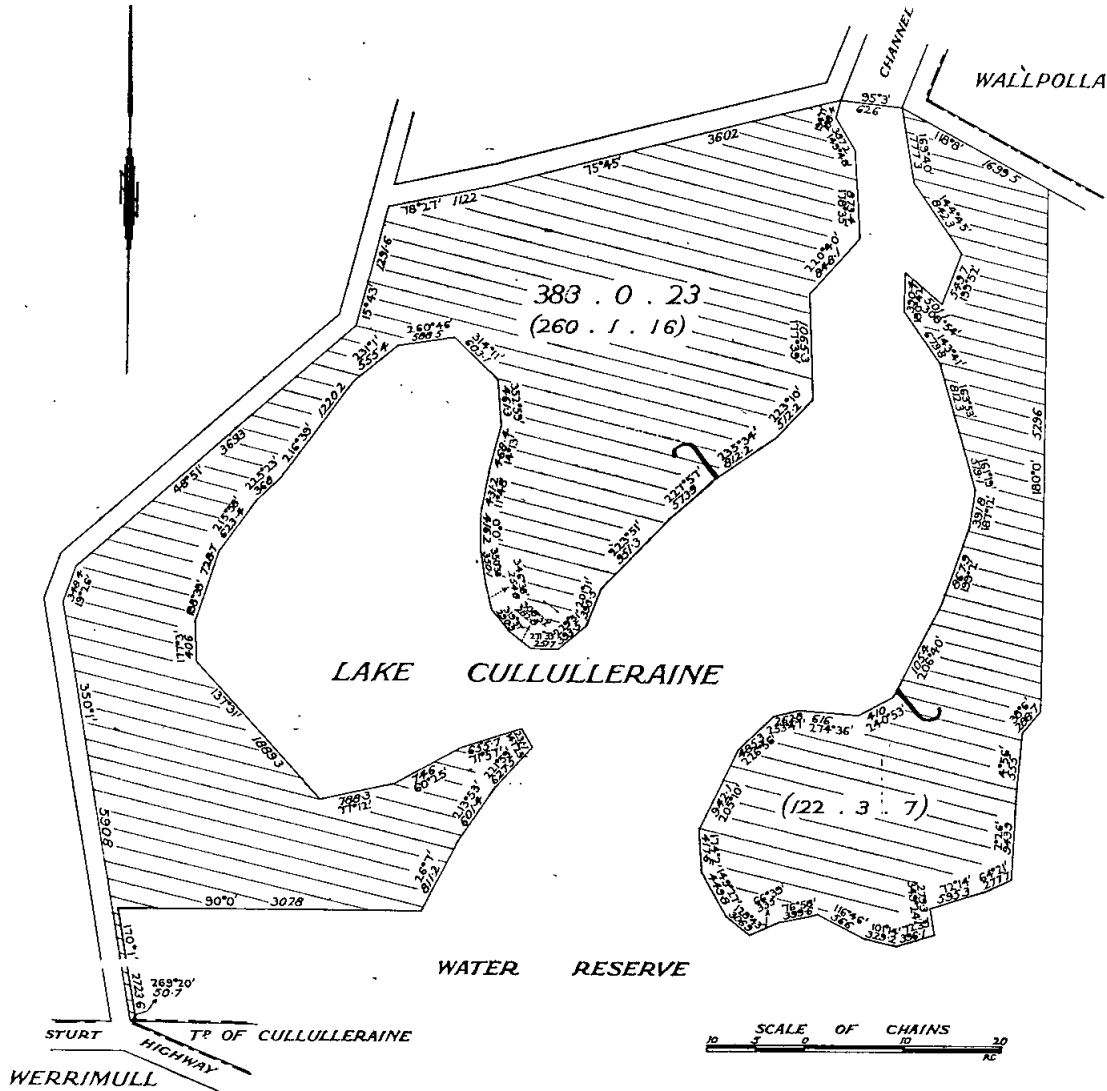

J. C. M. BALFOUR,  
Minister of Lands.

PROPOSED REVOCATION OF TEMPORARY RESERVATION OF LAND BY ORDER IN COUNCIL.

IN pursuance of the provisions of the *Land Act 1958*, notice is hereby given that it is the intention of the Governor in Council to revoke the temporary reservation of land by Order in Council hereunder referred to, viz.:

The following Notice was published 1° on the 27th July, 1966, pursuant to Order of the 19th July, 1966.

ARARAT.—The temporary reservation by Order in Council of the 10th February, 1953, of 20 perches of land in the Township of Ararat as a site for Government buildings and the temporary reservation by Order in Council of the 14th April, 1953, of 1 rood 20 perches, more or less, as an extension thereto.—(A.148<sup>(10)</sup>) (Rs.5724.)

J. C. M. BALFOUR,  
Minister of Lands.

LOCAL LAND BOARDS.

IN pursuance of the provisions of section 34 of the *Land Act 1958*, notice is hereby given that public hearings at the following places and times, will be conducted by the persons respectively mentioned, being duly appointed in that behalf.

J. C. M. BALFOUR,  
Minister of Lands.

Department of Crown Lands and Survey,  
Melbourne.

SCHEDULE.

LAND OFFICE, CAMP-STREET, BALLARAT, Tuesday, 13th September, 1966, at 9.30 a.m.—N. J. FITZGERALD and P. T. LEDGAR.

COURT HOUSE, NHILL, Tuesday, 11th October, 1966, at 10.15 a.m.—E. M. FLOYD.

**TENDERS****PUBLIC WORKS DEPARTMENT**

**TENDERS** will be received at Public Works Department, Treasury-place, Melbourne, until **TEN** a.m. on dates shown and for purposes mentioned hereunder.

Particulars and tender forms available at Contracts Office, Room 7, Building Division, Parliament-place and at places indicated in brackets hereunder.

Abbreviations in brackets mean:—W.O.—Inspector of Works Office; P.S.—Police Station; C.S.—Consolidated School; H.E.S.—Higher Elementary School; H.S.—High School; S.S.—State School; T.S.—Technical School.

Tenders to be submitted on the Department's printed Tender Form and will not be received by telephone. All tenders must be on a "Firm Tender" basis. The lowest or any tender will not necessarily be accepted.

Address tenders to the Minister of Public Works, and endorse the envelope containing the tender "Tender for closing Tuesday,".

No preliminary deposit is required with any tender, but a successful tenderer will be required to pay a deposit for any accepted tender of \$5,000 or over.

**Tuesday, 23rd August, 1966.****Building, Electrical and Mechanical Works.**

- Balmoral.—Repairs and painting, Consolidated School. (W.O., Hamilton; C.S., Balmoral).  
 Bentleigh West.—Renewal of urinals, pans, cisterns, &c., S.S., 4318.  
 Braybrook.—Demolition of slate urinal and renewal with stainless steel urinal, S.S. 1102.  
 Broadford.—Renovations, S.S. 1125. (W.O., Kyneton; S.S., Broadford).  
 Carnegie.—Renovations to Senior School, S.S. 2897.  
 Caulfield.—Renovations, additional toilet, &c., S.S. 773.  
 Dandenong.—External and internal renovations, High School. (Re-advertised.) (H.S., Dandenong).  
 Echuca.—Electrical installation in new L.T.C. Wing, High School. (W.O., Bendigo and Shepparton; H.S., Echuca).  
 Fairfield North.—External and internal repairs and painting, S.S. 4329.  
 Fawkner.—Repairs and painting, High School.  
 Footscray.—Electrical installation, reticulation of fluorescent lighting, &c., Technical College.  
 Footscray.—Sound-proofing of class-rooms, Technical College.  
 Footscray.—Supply and installation of plenum heating and modifications to boiler-room, Technical College.  
 Geelong.—Roof renewal, internal renovations to Davidson Hall, Gordon Institute of Technology. (Re-advertised.) (W.O., Geelong).  
 Glenormiston North.—Internal and external repairs and painting, S.S. 3207 and Residence. (Re-advertised.) (W.O., Camperdown; S.S. Glenormiston North).  
 Ivanhoe.—Electrical installation, Girls' Hostel, cnr. Maltravers and Marshall streets, Social Welfare Department.  
 Longford.—Repairs and painting, S.S. 1694 and Residence. (W.O., Traralgon; S.S. Longford).  
 Macleod.—Connexion to sewer, S.S. 4246.  
 Malvern East.—Repairs and painting, S.S. 4139 and residence.  
 Moomba Park.—Erection of four additional class-rooms, S.S. 4876.  
 Mount View.—Erection of paling fencing, S.S. 4923.  
 Nathalia.—New ceiling to Domestic Arts Wing, High School. (Re-advertised.) (W.O., Shepparton; H.S. Nathalia).  
 Olinda.—Fencing, S.S. 3494.  
 Orbost.—Chain mesh or weld mesh fencing, S.S. 2744. (W.O., Orbost and Bairnsdale; S.S. Orbost).  
 Osborne.—Internal and external renovations, S.S. 2655.  
 Point Lonsdale.—Renovations to toilet/store block, S.S. 3322. (W.O., Geelong; S.S. Point Lonsdale).  
 St. Albans.—External repairs and painting, High School.  
 Seymour.—Electrical installation in new school of eight (8) class-rooms, &c., S.S. 4957.  
 Seymour.—Erection of eight (8) class-room Primary School. S.S. 4957. (W.O., Alexandra; P.S., Seymour).  
 Seymour.—Plenum heating, S.S. 4957. (W.O., Alexandra).  
 South Yarra.—Internal repairs and painting, Melbourne Teachers' College Hostel, 24 Marne-street.

Sunny Creek.—General renovations to Residence, S.S. 2908. (W.O., Warragul; S.S. Sunny Creek.)

Swan Hill.—Extension of mechanical services, Technical School. (W.O., Swan Hill.)

Thornbury.—Repairs and painting, S.S. 3889 and residence.

Various.—Disconnexion, transportation and re-erection of approximately 200 (two hundred) existing timber framed pre-fabricated portable class-rooms to various school sites in Victoria.

Vermont.—Re-stumping of old building, S.S. 1022.

Warrnambool.—Electrical installation in Manual Arts Wing, &c., High School. (W.O., Warrnambool and Hamilton.)

Woods Point.—Repairs and painting, S.S. 789 and Residence. (W.O., Alexandra.)

**Furniture and Furnishings.**

Carlton.—Supply of steel desks, Motor Registration Branch, Lygon-street.

Melbourne.—Supply of executive chairs, Premiers Department, Cabinet Room, New State Offices, Treasury-place. (Yuncken, Freeman Architects Pty. Ltd., 411 King-street, Melbourne.)

Various.—Supply of furniture and furnishings for period 1st September, 1966, to 31st August, 1967, State Government Departments, Public Works Department.

**Site Works.**

Various.—Asphalting, asphalt repairs, gravelling, &c., Altona West, S.S. 4862, Altona East, S.S. 4805, Sunshine North, S.S. 4765 and St. Albans East, S.S. 4721.

**Miscellaneous.**

Ararat.—Supply of timber, Mental Hospital.

Beechworth.—Supply and delivery of thickening machine, Mental Hospital.

Melbourne.—Supply of bricks for Day Labour Organization, 1st October, 1966, to 30th September, 1967, Public Works Department.

**Tuesday, 30th August, 1966.****Building, Electrical and Mechanical Works.**

- Ararat.—External renovations to Nurses' Home, Mental Hospital. (W.O., Ararat).  
 Boroondara.—Internal repairs and painting, S.S. 4724.  
 Camperdown.—Internal and external repairs and painting, Residence, 56 Bowen-street, S.S. 114. (W.O., Camperdown; S.S., Camperdown).  
 Costerfield.—Erection of out-office and installation of septic tank, S.S. 1187. (Re-advertised.) (W.O., Bendigo; S.S., Costerfield).  
 Elwood.—External renovations, High School. (Re-advertised.)  
 Fairfield North.—Renewal of toilet pans, cisterns, urinal and drinking facilities, S.S. 4329.  
 Frankston.—Electrical installation in No. 1 glasshouse, Keith Turnbull Research Station.  
 Geelong.—Repairs and painting, Technical School (W.O., Geelong).  
 Gerangamete.—New toilet block and laying of drains, &c., S.S. 1243. (W.O., Camperdown; S.S., Gerangamete).  
 Hamilton.—Renovations, Residence, 3 Lewis-street, High School. (Re-advertised.) (W.O., Hamilton).  
 Hamilton.—Renovations, Residence, 28 Bree-road, Technical School. (Re-advertised.) (W.O., Hamilton).  
 Hawthorn.—Installation of electric heating, Burwood Teachers' College Hostel, 11 Paterson-street.  
 Heidelberg Heights.—External repairs and painting, S.S. 4774. (Amended Specification).  
 Leongatha.—Internal and external renovations, Residence, 38 A'Beckett-street, S.S. 2981. (W.O., Korumburra; S.S., Leongatha).  
 Melbourne.—Internal painting and renovations, School for Deaf Children, St. Kilda-road. (Re-advertised.)  
 Merri.—Repairs and painting, S.S. 3110.  
 Portland North.—Roof repairs and renovations, Residence, S.S. 1194. (W.O. Warrnambool; S.S., Portland North).  
 Preston East.—Erection of brick veneer Police Station (including electrical services).  
 Preston West.—Renewal of water service and drinking facilities, S.S. 3885.  
 Richmond.—External renovations and painting, Girls' Secondary School. (Re-advertised.)

Somers.—Additions and renewals to septic treatment plant, Children's School Camp No. 4647. (Re-advertised.)  
 South Melbourne.—Repairs and painting, J. H. Boyd Domestic College.

South Melbourne.—Repairs and painting, Caretaker's Residence, MacRobertson Girls' High School.

St. Albans.—External and internal repairs and painting, Technical School.

Strathdownie.—Repairs and painting, &c., S.S. 2883. (Re-advertised.) (W.O., Hamilton; S.S., Strathdownie.)

Victoria Park.—Roof repairs, erection of store, S.S. 2957.

Wallan Wallan.—Re-blocking, repairs and painting, Police Station and Residence. (Re-advertised.) (W.O., Alexandra; P.S., Wallan Wallan.)

Wangaratta.—Security lighting, Technical School. (W.O., Wangaratta and Benalla; T.S., Wangaratta.)

Warrnambool.—Connexion of toilet block to sewerage system, Mental Hospital. (W.O., Warrnambool.)

Watsonia Heights.—Erection of six (6) additional classrooms and toilet extensions, S.S. 4935.

Watsonia Heights.—Electrical installation in additional six (6) L.T.C. class-rooms, &c., S.S. 4935.

Watsonia Heights.—Extension of plenum heating, S.S. 4935.

#### Furniture and Furnishings.

Heidelberg.—Supply of furniture, Technical School.

#### Site Works.

Yarram.—Asphalt paving, grading and gravelling, lawns, &c., S.S. 693. (W.O., Traralgon.)

#### Miscellaneous.

Melbourne.—Maintenance cleaning, period 1st October, 1966, to 31st May, 1969, Old Treasury Building, Spring-street.

Mont Park.—Supply and installation of equipment in main kitchen, Mental Hospital.

Port Melbourne.—Supply and delivery of four tons capacity mobile slewing crane, Public Works Department, Depot, Salmon-street.

Port Melbourne.—Supply and delivery of three (3) pneumatic tyred tractor mounted 6 tons cranes, Public Works Department, Depot, Salmon-street.

Port Melbourne.—Supply and delivery of pneumatic tyred tractor mounted eight (8) tons crane, Public Works Department, Depot, Salmon-street.

### Tuesday, 6th September, 1966.

#### Building, Electrical and Mechanical Works.

Apollo Bay.—External and internal repairs and painting, residence, 2 Montrose-avenue, Consolidated School. (Amended Specification.) (Re-advertised.) (W.O., Camperdown.)

Banyule.—Sewer connexion and loop water supply, S.S. 4746.

Barwon Heads.—New roof and renovations, S.S. 1574 and residence. (Re-advertised.) (W.O., Geelong; S.S., Barwon Heads.)

Beechworth.—Re-roofing of flat roofs of cell block with steel decking, Training Prison. (W.O., Wangaratta; P.S., Beechworth.)

Black Rock.—Repairs and painting, S.S. 3631 and residence.

Buchan.—Renovations, Police Station. (Amended Specifications.) (Re-advertised.) (W.O., Orbost; P.S., Buchan.)

Cobains.—External repairs and painting, S.S., 4387. (W.O., Bairnsdale; S.S., Cobains.)

Collingwood.—Extension of heating, Technical School.

Echuca.—Mechanical service in new wing, High School. (W.O., Swan Hill, Shepparton and Bendigo.)

Frankston.—Internal toilet, &c., S.S. 1464. (S.S., Frankston.)

Garfield.—Erection of brick toilet block, Country Roads Board Rest Areas. (W.O., Warragul.) (Re-advertised.)

Geelong.—Repairs and painting to skylights and spouting, Prison. (W.O., Geelong.)

Gormandale East.—Internal and external repairs and painting, S.S. 2877. (W.O., Traralgon; S.S., Gormandale East.)

Healesville.—Erection of Police Residence. (W.O., Alexandra.) (Amended Specifications.)

Horsham West.—Repairs and renovations, S.S. 4691. (Re-advertised.) (W.O., Horsham.)

Koallah.—Erection of out-offices and installation of septic tank, S.S. 4225. (Re-advertised.) (W.O., Camperdown; S.S., Koallah.)

Malvern.—Installation of heating system in Therapy Building, Clinic, 321 Glenferrie-road.

Maryborough.—Installation of fire service, High School. (W.O., Maryborough.)

Maryborough East.—Erection of internal staff toilets, S.S. 2828. (W.O., Maryborough.)

Melbourne.—Supply and installation of an electric passenger lift, Crown Solicitors and Titles Office, 278-282 Queen-street.

Mont Park.—Supply and erection of steel framed hay shed, Janefield Mental Hospital. (Amended Specifications.)

Mont Park.—Installation of steam heating system, Nurses' Home, Mental Hospital.

Moonee Ponds West.—Internal and external renovations, S.S. 2901.

Morwell.—External repairs and painting, Technical School. (W.O., Traralgon; T.S., Morwell.)

Ormond.—Renewal of flooring, S.S. 3074.

Richmond.—Renewal of bicycle shed, Technical School.

Royal Park.—Erection of four (4) brick veneer residences, Psychiatric Hospital.

Royal Park.—Extension to Pathology Laboratory, Mental Hospital. (Re-advertised.) (Amended Specification.)

Sale.—External renovations, attention to toilets, S.S. 545. (Re-advertised.) (W.O., Traralgon; S.S., Sale.)

Shelley.—Erection of timber out-offices and water supply installation, S.S. 4538. (W.O., Wangaratta; S.S., Shelley.)

Shepparton.—Fifth form extensions, additions and alterations, Technical School. (W.O., Shepparton.)

Stawell.—Internal renovations to "Bristol" Ward, Pleasant Creek Special School. (W.O., Ararat; P.S., Stawell.)

Sunshine North.—Alternate water supply, Technical School.

Tatura.—Repairs and painting, Police Station and Residence. (Re-advertised.) (W.O., Shepparton; P.S., Tatura.)

Thornbury.—Erection of chain mesh fencing, High School.

Wangaratta.—Electrical installation for electrical engineering laboratory, &c., Technical School. (W.O., Wangaratta and Benalla.)

Wonthaggi.—New garage, repairs and painting, Technical School, Residence, 52 McKenzie-street. (W.O., Korumburra; T.S., Wonthaggi.)

Yinnar.—Repairs and painting, and re-blocking, S.S. 2419. (W.O., Traralgon; S.S., Yinnar.)

#### Furniture and Furnishings.

Carlton.—Supply of dining tables, Motor Registration Branch, Lygon-street.

Royal Park.—Supply and fix curtains, Psychiatric Hospital.

Warrnambool.—Joinery, Technical School.

#### Site Works.

Hamilton.—Construction of service road and associated works, S.S. 4777. (W.O., Warrnambool and Hamilton.)

Rochester.—Construction of concrete and asphalt paving, concrete kerbs and channels, beautification and associated works, High School. (Re-advertised.) (W.O., Bendigo; H.S., Rochester.)

Southwood.—Asphalting, concreting, drainage and associated work, S.S. 4857.

Tallangatta.—Drainage works, concrete and gravel pavements, &c., S.S. 1365 and Residence, High School, Residence and Soil Conservation Authority, Residence. (W.O., Wangaratta; P.S., Tallangatta.)

Terang.—Asphalt paving, asphalt repairs, drainage and associated works, High School. (W.O., Warrnambool and Camperdown.)

J. C. M. BALFOUR,  
 Acting Minister of Public Works.

Public Works Department,  
 Melbourne, C.2, 15th August, 1966.

#### TENDERS FOR GRAZING.

(Section 130, Land Act 1958.)

For the period 1st October, 1966, to 30th September, 1967, renewable annually for a further period where stated.

Tender forms and all particulars can be obtained on application to the Crown Lands Department, Melbourne, or any of the Land Offices in the country.

Tenders endorsed "Tender for Grazing" must reach the Secretary for Lands, Department of Crown Lands, Tender-box, State Treasury Buildings, Melbourne, C.2, at or before Noon on Wednesday, the 21st September, 1966.

TENDERS are invited and must be lodged at the Lands Department, Melbourne, at or before Noon on Wednesday, the 21st September, 1966, for the right to de-

pasture stock on the following unappropriated portions of lands, subject to the Regulations approved by the Governor in Council and also the subjoined conditions.

CONDITIONS.

1. The period of occupation will be from 1st October, 1966, to 30th September, 1967, renewable annually for a further period where stated.

2. The rent for twelve months—for which the licence will be issued, and the licence fee of 75 cents, must accompany the tender; otherwise the offer of the next highest tenderer who complies with this condition may be accepted.

3. The licensee shall pay shire rates and all other charges for the period of occupation.

4. Separate tenders must be lodged for each block.

5. Tenders to be addressed to the Secretary for Lands (Department of Crown Lands Tender-box), Melbourne, C.2, and endorsed Tender for Grazing.

6. The highest or any tender not necessarily accepted.

7. Tenderers must give their full name, occupation, and ordinary postal address.

8. Where permission to fence has been granted, the outgoing tenant has the option to remove any existing fencing owned by him within one month, or he may arrange with the incoming tenant to pay for it in accordance with the provisions of section 133, "Land Act 1958".

In all cases, the ingoing tenant will be held responsible for the care and maintenance of any improvements.

Licences issued will be for grazing only and will NOT authorize clearing or removal of timber or cultivation of the ground.

J. C. M. BALFOUR,  
Minister of Lands.

Department of Crown Lands and Survey,  
Melbourne, 17th August, 1966.

Lot 1 (B.2029). Area 41,000 acres—

Parish of Moonkan, County of Croajingolong, being Grazing Block 16. Formerly held by the Estate of C. H. West. Period of occupation, one year from 1st October, 1966, renewable annually for four years from 1st October, 1967.—(Bairnsdale 205/130.)

Lot 2 (B.2030). Area 15,820 acres—

Parishes of Suggan Buggan and Ingeegoodbee, County of Tambo, being Grazing Block 3. Formerly held by D. C. Rogers. Period of occupation, one year from 1st October, 1966, renewable annually for four years from 1st October, 1967.—(Bairnsdale 261/130.)

Lot 3 (B.2031). Area 11,700 acres, more or less—

Parish of Ingeegoodbee, County of Tambo, being Grazing Block 1. Formerly held by R. O. Harris. Period of occupation one year from 1st October, 1966, renewable annually for four years from 1st October, 1967.—(Bairnsdale 264/130.)

Lot 4 (B.2032). Area 10,720 acres—

Parish of Nungatta, County of Dargo, being Grazing Block 31. Formerly held by A. J. Treasure. Period of occupation one year from 1st October, 1966, renewable annually for four years from 1st October, 1967.—(Bairnsdale 81/130.)

Lot 5 (B.2033). Area 10,050 acres—

Parishes of Morekana and Doodwuk, County of Dargo, being Grazing Block 26. Formerly held by A. J. Treasure. Period of occupation, one year from 1st October, 1966, renewable annually for four years from 1st October, 1967.—(Bairnsdale 0723/130.)

Lot 6 (B.2034). Area 9,660 acres, more or less—

Parish of Windarra, County of Tambo, being Grazing Block 28. Formerly held by G. Hodge. Period of occupation, one year from 1st October, 1966, renewable annually for four years from 1st October, 1967.—(Bairnsdale 95/130.)

Lot 7 (B.2035). Area 8,600 acres, more or less—

Parishes of Coopracambra, Kowat and Weeragua, County of Croajingolong, being Grazing Block 48A. Formerly held by O. C. Petterson. Period of occupation, one year from 1st October, 1966, renewable annually for four years from 1st October, 1967.—(Bairnsdale 287/130.)

Lot 8 (B.2036). Area 8,600 acres, more or less—

Parishes of Morekana, Bullumwaal and Nungatta, County of Dargo, being Grazing Block 29. Formerly held by A. J. Treasure. Period of occupation, one year from 1st October, 1966, renewable annually for four years from 1st October, 1967.—(Bairnsdale 0717/130.)

Lot 9 (B.2037). Area 16,076 acres—

Parishes of Adjie and Canabore, County of Benambra, being Grazing Blocks 27 and 28. Formerly held by K. W. Coulston. Period of occupation, one year from 1st October, 1966, renewable annually for four years from 1st October, 1967.—(Beechworth 542/130.)

Lot 10 (B.2038). Area 14,500 acres—

Parishes of Panbulla, Buckland and Porepunkah, County of Delatite, being Grazing Block 24. Period of occupation, one year from 1st October, 1966, renewable annually for four years from 1st October, 1967.—(Beechworth 0263/130.)

Lot 11 (B.2039). Area 2,400 acres—

Parish of Wandiligong, County of Delatite, being southern portion of Grazing Block 26. Formerly held by N. Davidson. Period of occupation, one year from 1st October, 1966, renewable annually for four years from 1st October, 1967.—(Beechworth 247/130.)

Lot 12 (B.2040). Area 22,000 acres—

Parish of Butgalla, County of Tanjil, being Grazing Block 5. Period of occupation, one year from 1st October, 1966, renewable annually for four years from 1st October, 1967.—(Sale 030/130.)

Lot 13 (B.2041). Area 1,610 acres—

Parish of Sargood, County of Wonnangatta, being allotment 16 and that portion of allotment 17 not included in Grazing Block 23, County of Tanjil. Period of occupation, one year from 1st October, 1966, renewable annually for four years from 1st October, 1967.—(Sale H.O.30488.)

Lot 14 (B.2042). Area 28,800 acres—

Parishes of Boorolite and Changue, County of Wonnangatta, being Grazing Blocks 26, 27 and 31. Formerly held by L. J. Purcell. Period of occupation, one year from 1st October, 1966, renewable annually for four years from 1st October, 1967.—(Alexandra 97/130.)

Lot 15 (B.2043). Area 273 acres—

Parish of Yering, County of Evelyn, being allotment B2 of section 4. Formerly held by T. S. Turner. Period of occupation, one year from 1st October, 1966, renewable annually for four years from 1st October, 1967.

Permission to fence at licensee's risk will be given. One month allowed to outgoing licensee to remove fences erected by him.

The Department reserves the right to grant access to any person for the purpose of keeping existing drains clear.—(Melbourne 01645/130.)

Lot 16 (B.2044). Area 183 acres—

Parish of Telangatuk, County of Lowan, being allotment 142. Formerly held by H. J. Bloomfield. Period of occupation, one year from 1st October, 1966, renewable annually for four years from 1st October, 1967.

Permission to fence at licensee's risk will be given. One month allowed for removal of any improvement.—(Horsham 0615/130.)

Lot 17 (B.2045). Area 32 acres—

Parish of Nullan, County of Borung, being allotment 161B (Water Reserve). Formerly held by P. J. Tobin. Period of occupation, one year from 1st October, 1966, renewable annually for four years from 1st October, 1967. Any improvements to be protected and maintained. Fencing will be allowed at licensee's risk.—(Horsham 771/130.)

**PUBLIC SERVICE NOTICES**

No. 1648.

*Public Service Act 1958, Section 39.*

**REGULATIONS.—PART IV.—SALARIES AND INCREMENTS.**

THE Public Service Board, in pursuance of the powers conferred by the *Public Service Act 1958*, hereby amends its Regulations as shown below :—

**FIRST SCHEDULE.  
PROFESSIONAL DIVISION.**

*Amount of Salary Assigned to Offices in Class "A1".*

Office.	Yearly Rate of Salary.
<b>TREASURY.</b>	
	\$
<i>Delete—</i>	
Chief Technical Officer, Housing Commission	8,996
Chief Architect, Housing Commission	7,992
Senior Architect (Design and Research), Housing Commission	6,926
Senior Architect (Project), Housing Commission	6,926
Senior Architect (Design and Research), Housing Commission	6,550
Senior Architect (Project), Housing Commission	6,550
Senior Architect (Design and Research), Housing Commission	6,266
Senior Architect (Project), Housing Commission	6,266
Senior Architect (Design and Research), Housing Commission	5,982
Senior Architect (Project), Housing Commission	5,982
<i>Add—</i>	
Chief Technical Officer, Housing Commission	9,494
Chief Architect, Housing Commission	8,480
Superintending Architect (Construction), Housing Commission	7,484
Superintending Architect (Design and Research), Housing Commission	7,484
Superintending Architect (Construction), Housing Commission	7,200
Superintending Architect (Design and Research), Housing Commission	7,200

*This Regulation shall have effect as on and from the 24th December, 1965.*

F. E. CAHILL, Chairman.  
V. P. SCULLY, Secretary.

Office of the Public Service Board,  
Melbourne 4th August, 1966.

No. 1650.

*Public Service Act 1958, Section 50.*

**REGULATIONS.—PART IV.—SALARIES AND INCREMENTS.**

THE Public Service Board, in pursuance of the powers conferred by the *Public Service Act 1958*, hereby amends its Regulations as shown below :—

**SIXTH SCHEDULE.  
TEMPORARY EMPLOYEES.**

*Designations of Positions and Rates of Salaries.*

Department and Designation of Position.	Yearly Rate of Salary.		Increments (Annual).
	Minimum.	Maximum.	
<b>DEPARTMENT OF HEALTH. GENERAL HEALTH.</b>			
	\$	\$	
<i>Add—</i> Health Inspector, Industrial, Grade I.	3,018	3,440	1 of \$104 and 3 of \$106

F. E. CAHILL, Chairman.  
V. P. SCULLY, Secretary.

Office of the Public Service Board,  
Melbourne, 25th July, 1966.

No. 1649.

*Public Service Act 1958, Section 50.*

**REGULATIONS.—PART IV.—SALARIES AND INCREMENTS.**

THE Public Service Board, in pursuance of the powers conferred by the *Public Service Act 1958*, hereby amends its Regulations as shown below :—

**FIFTH SCHEDULE.  
TEMPORARY EMPLOYEES.  
DEPARTMENT OF HEALTH.  
MENTAL HYGIENE.**

*Designations of Positions and Rates of Salaries.*

Designation of Position.	Yearly Rate of Salary.Σ	
	Minimum.	Maximum.
	\$	\$
<i>Add—</i> Instructor (Female), Sheltered Workshop, Grade I.	1,832	1,904

Σ Annual increments shall be in accordance with those prescribed by Sub-Regulations 83 (2) and 83 (3), provided that in the case of the position of Assistant (Male), Administrative the annual increments shall be in accordance with those prescribed by Part D of the Third Schedule.

F. E. CAHILL, Chairman.  
V. P. SCULLY, Secretary.

Office of the Public Service Board,  
Melbourne, 1st August, 1966.

No. 1651.

*Public Service Act 1958, Section 50.*

**REGULATIONS.—PART IV.—SALARIES AND INCREMENTS.**

THE Public Service Board, in pursuance of the powers conferred by the *Public Service Act 1958*, hereby amends its Regulations as shown below :—

**FIFTH SCHEDULE.  
TEMPORARY EMPLOYEES.  
DEPARTMENT OF HEALTH.  
MENTAL HYGIENE.**

*Designation of Positions and Rates of Salaries.*

Designation of Position.	Yearly Rate of Salary.Σ	
	Minimum.	Maximum.
	\$	\$
<i>Add—</i> Dental Mechanic .. .. .	2,626	2,914

Σ Annual increments shall be in accordance with those prescribed by Sub-Regulations 83(2) and 83(3), provided that in the case of the position of Assistant (Male), Administrative, the annual increments shall be in accordance with those prescribed by Part D of the Third Schedule.

*This Regulation shall have effect as on and from the 13th April, 1966.*

F. E. CAHILL, Chairman.  
V. P. SCULLY, Secretary.

Office of the Public Service Board,  
Melbourne, 25th July, 1966.

**PUBLIC SERVICE OF VICTORIA.—VACANCIES.**

APPLICATIONS will be received by the Public Service Board up to Wednesday, the 31st August, 1966, from persons employed in the Public Service of Victoria, who are eligible and qualified for appointment to the under-mentioned positions:—

**ADMINISTRATIVE DIVISION.**

**Secretary, Class "A1", State Forests Department.**

*Yearly Salary.—\$8,500.*

*Duties.—Secretary, Department of State Forests and Chief of the Division of Administration.*

*Qualifications.—Sound administrative capacity and experience.*



**Class "C1", Milk Board, Department of Agriculture.**

*Yearly Salary.*—\$3,680, minimum; \$3,960, maximum.

*Duties.*—To assist in and be responsible for the collection of data by field officers engaged in the Board's wholemilk production cost survey; to supervise the recording and compilation of primary data (by such officers) and to assist in the preparation of reviews and summaries of the cost of wholemilk production.

*Qualifications.*—Preferably an accountancy student with experience in the interpretation and collation of information and data for costing and statistical purpose. Ability to conduct correspondence and to maintain good relations with producers. A knowledge of the Milk Board Act and agriculture in Victoria is desirable.

**Class "C", Milk Board, Department of Agriculture.**

*Yearly Salary.*—\$3,026, minimum; \$3,320, maximum.

*Duties.*—To maintain records relating to the Milk Board's wholemilk production cost survey; to assist in the collection of data from farmers in the Survey and to assist in the checking and compilation of costing surveys.

*Qualifications.*—To be an adult with at least three years' service; preferably a general knowledge of the Milk Board Act and experience in the recording of information for costing purposes.

**Class "C", Office of the Chief Commissioner of Police, Chief Secretary's Department.**

*Yearly Salary.*—\$3,026, minimum; \$3,320, maximum.

*Duties.*—To assist in the purchase of motor spirit, lubricants, parts and accessories for Police motor vehicles.

*Qualifications.*—To be an adult with at least three years' service; a knowledge of the organization of the Police Department and of Part V. of the Public Accounts and Stores Regulations.

**Class "C", Children's Cottages, Kew, Mental Hygiene Branch, Department of Health.**

*Yearly Salary.*—\$3,026, minimum; \$3,320, maximum.

*Duties.*—To be Deputy Secretary of the Hospital.

*Qualifications.*—To be an adult with at least three years' service; a good knowledge of the Mental Health Act and Public Service Acts and Regulations. Ability to control staff. Experience in institutional management including control of stores, &c., and artisan activities would be an advantage.

**Class "C", Public Works Department.**

*Yearly Salary.*—\$3,026, minimum; \$3,320, maximum.

*Duties.*—To be responsible for the direction and control of a District Records Section; to prepare submissions to the Minister of Public Works and requisitions to client Departments; to list minor tenders and quotations.

*Qualifications.*—To be an adult with at least three years' service; preferably familiar with the methods followed in handling requisitions, tenders, quotes, contracts and claims for works and supplies and correspondence relative thereto. Ability to control and direct staff.

**Class "C", Birchip, Water Supply Department.**

*Yearly Salary.*—\$3,026, minimum; \$3,320, maximum.

*Duties.*—To assist the District Accounting Officer in accounting matters, including revenue collection, costing and stores accounting.

*Qualifications.*—To be an adult with at least three years' service; a knowledge of the incidence of rating and of the Water Act, preferably some experience in rate collecting; a working knowledge of the Public Accounts and Stores Regulations and of the Commission's Stores Manual is desirable.

*NOTE.—Housing.*—The successful applicant will be required to occupy the official residence provided and vacation of the residence will not be permitted without the express approval of the Water Supply Department. A rental of 10 per cent. of total emolument inclusive of the amount payable under Regulation 74, less \$72.60 a year will be charged. Occupancy will be subject to a formal tenancy agreement being entered into. Particulars are available from the Water Supply Department.

**PROFESSIONAL DIVISION.****Deputy Chief Health Officer, Class "A1", General Health Branch, Department of Health.**

*Yearly Salary.*—\$10,600.

No. 61.—7351/66.—4

*Duties.*—To be Deputy Chief Health Officer; subject to the direction of the Chief Health Officer, to control and co-ordinate the administration of the General Health, Tuberculosis and Maternal and Child Welfare Branches.

*Qualifications.*—A legally qualified Medical Practitioner of Victoria, expert in sanitary science with a qualification in Public Health and satisfactory experience in public health administration.

**District Health Officer, Grade 1, Class "A1", General Health Branch, Department of Health.**

*Yearly Salary.*—\$9,000.

*Duties.*—To carry out duties under the Health Act, including inspection as to Public Health and Sanitary circumstances of the district; investigation and reporting on outbreaks of infectious diseases and other matters affecting Public Health.

*Qualifications.*—A legally qualified medical practitioner of Victoria with a degree or diploma of Public Health.

**District Health Officer, Grade II, Class "A1", General Health Branch, Department of Health.**

*Yearly Salary.*—\$8,480.

*Duties.*—To carry out duties under the Health Act, including inspection as to Public Health and Sanitary circumstances of the district; investigation and reporting on outbreaks of infectious diseases and other matters affecting Public Health.

*Qualifications.*—A legally qualified medical practitioner of Victoria; to have had approved experience in public health duties.

**Assistant Principal Legal Officer, Class "A1", Crown Solicitor's Office, Law Department.**

*Yearly Salary.*—\$7,200.

*Duties.*—To assist the Crown Solicitor generally and particularly in regard to advisory matters. If required, to exercise a supervisory control over such branches of the Crown Solicitor's Office as the Crown Solicitor directs.

*Qualifications.*—A barrister and solicitor of the Supreme Court with appropriate practical experience.

**Designing Engineer, Class 2, Kerang Regional Office, Water Supply Department.**

*Yearly Salary.*—\$5,074, minimum; \$5,714, maximum.

*Duties.*—In a Regional Designs Office to carry out field and office investigations of water supply works and to prepare designs and estimates of hydraulic structures, irrigation and drainage channels.

*Qualifications.*—A Degree or Diploma in Civil Engineering and considerable experience in the design of water supply works.

*NOTE.—Housing.*—A residence is available for the successful applicant, if married, for which a rental of 10 per cent. of total emolument inclusive of the amount payable under Regulation 74, less \$72.60 a year will be charged. Occupancy will be subject to a formal tenancy agreement being entered into. Particulars available from the Water Supply Department.

**District Engineer, Class 2, Nyah West Centre, Water Supply Department.**

*Yearly Salary.*—\$5,074, minimum; \$5,714, maximum.

*Duties.*—To supervise and control rural water supplies, works and expenditure within the Districts controlled from the Centre.

*Qualifications.*—A Degree or Diploma in Civil Engineering and qualifications as an Engineer of Water Supply; experience in the administration of irrigation districts or on other water supply works; versed in modern engineering practice and in design, construction and maintenance.

**Chemical Engineer, Class 2, or Scientific Officer (Chemist), Class "A", General Health Branch, Department of Health.**

*Yearly Salary.*—\$5,074, minimum; \$5,714, maximum—

Chemical Engineer.

\$4,912, minimum; \$5,714, maximum—

Scientific Officer (Chemist).

*Duties.*—To examine plans and specifications of new industrial plant for compliance with Clean Air legislation; to carry out and report on field and laboratory investigations into air pollution; to carry out and report on inspections into air pollution from industrial premises.

**Qualifications.—***Chemical Engineer.*

Appropriate Degree or Diploma in Chemical Engineering making the holder eligible for membership of the Institution of Engineers (Australia); industrial experience in combustion or allied fields.

*Scientific Officer (Chemist).*

A Degree or Diploma in Chemistry or Science with an approved Post Graduate Diploma in Chemical Engineering.

**Assistant Engineer, Class 1, Water Supply Department.**

*Yearly Salary.*—\$3,072, minimum; \$4,760, maximum. (Commencing salary will be determined according to qualifications and experience.)

*Duties.*—To assist the Plant Engineer in the work of the Plant and Equipment Section.

*Qualifications.*—A Degree or Diploma in Mechanical Engineering or other approved engineering qualifications. Experience in the operation, maintenance and repair of mechanical plant. A knowledge of modern construction methods on civil engineering works and costing methods applicable to the operation of modern construction equipment would be an advantage.

**NOTE.**—The successful applicant may be located at a Country Centre.

**Draughtsman Class "C", Office of the Housing Commission, Treasury.**

*Yearly Emolument.*—\$2,810, minimum; \$3,334, maximum.

*Duties.*—As directed by Chief Architect to prepare and check working drawings, details and specifications for houses and multi-storied flats; prepare site plans and layouts for housing estates.

*Qualifications.*—To be a competent draughtsman with at least five years' experience in an architectural drawing office and ability to control staff. A knowledge of mass housing schemes would be an advantage.

**TECHNICAL AND GENERAL DIVISION.****Dairy Supervisor, Senior, Department of Agriculture.**

*Yearly Salary.*—\$3,864, minimum; \$3,984, maximum.

*Duties.*—To assist in the administration of the Milk and Dairy Supervision Act in an allotted area and to control and co-ordinate the inspection and advisory work of dairy supervisors in that area.

*Qualifications.*—An experienced dairy supervisor with a good knowledge of the Milk and Dairy Supervision Act and Regulations and of modern dairy practice; ability to direct staff and deliver lectures.

**Farm Manager, Assistant, Dookie Agricultural College, Department of Agriculture.**

*Yearly Salary.*—\$3,122, minimum; \$3,546, maximum.

*Duties.*—To assist the Farm Manager in the supervision of the work of the Farm Branch and to take charge of the Branch in his absence; to supervise the practical farm work of students, and to perform such other duties as may be required.

*Qualifications.*—A diploma of an Agricultural College, experience in farming operations and ability to supervise the work of students and farm employees.

**NOTE—Housing.**—A house is available for the successful applicant, if married, for which a rental of 10 per cent. of total emolument, inclusive of the allowance payable under Regulation 74 less \$72.60 a year will be charged.

Accommodation is available for a single man at a charge of \$332 a year. Particulars are available from the Department of Agriculture.

**Technical Works Officer, Public Works Department.**

*Yearly Salary.*—\$3,122, minimum; \$3,334, maximum.

*Duties.*—To assist generally in the office in the handling of maintenance works and supply of mechanical equipment in Government buildings; to prepare estimates and minor specifications.

*Qualifications.*—Training in the theory and practice of a trade associated with mechanical services and equipment in buildings; a good knowledge of machine tools, also office experience in the supply, installation and maintenance of such services and equipment in large buildings; some association with the electrical trade would be an advantage.

**Technical Works Officer, Office of the Housing Commission, Treasury.**

The advertisement for this position (position No. 2) which appeared on page 3013 of *Government Gazette* No. 59, dated the 10th August, 1966, is withdrawn.

**Senior Works Inspector, Bendigo, Water Supply Department.**

*Yearly Salary.*—\$3,122, minimum; \$3,334, maximum.

*Duties.*—To regulate the supply of water in the City of Bendigo and adjoining Urban districts; to supervise the repair and maintenance of mains, valves, fire plugs and small service basins, and to undertake the supervision of reticulation construction works as required. Under the general direction of the District Inspector to relieve inspectors and control and relieve Turncocks within the Coliban district.

*Qualifications.*—A general knowledge of the location of all water mains and services within the district is desirable; ability to handle men engaged on the repair and maintenance and laying of water mains and to supervise associated field contract work; able to manipulate the various valves in the reticulation system; a practical knowledge of the relevant provisions of the Commission's By-laws. A Certificate of Registration by the Plumbers and Gasfitter's Board of Victoria would be an advantage.

**Machineman (Register), Stamp Duties Office, Treasury.**

*Yearly Salary.*—\$2,736, minimum; \$2,810, maximum.

*Duties.*—To impress stamp duty on the various classes of instruments chargeable under the Stamps Act.

*Qualifications.*—To be efficient with figures. Experience in the operation of cash register type machines and familiarity with the classes of instruments presented for stamping would be an advantage.

**Technical Assistant (Male), Grade I, Fisheries and Wildlife Branch, Chief Secretary's Department.**

*Yearly Salary.*—

Junior.—At 18 years of age, \$1,500.

At 19 years of age, \$1,710.

At 20 years of age, \$1,942.

Adult.—\$2,590, minimum; \$2,810, maximum.

*Duties.*—To assist Research Officers in fisheries investigations including underwater operations using S.C.U.B.A. equipment; other duties as required.

*Qualifications.*—To be educated to Leaving Certificate standard with Biology or Chemistry or Physics as a subject, or to possess equivalent qualifications; to possess a current motor driving licence, and to be of good physique and be willing and adaptable to living and working in field conditions.

**Water Bailiff, Swan Hill, Water Supply Department.**

*Yearly Salary.*—\$2,294, minimum; \$2,518, maximum.

*Qualifications.*—Ability to control and regulate the supply of water to irrigators and to keep the necessary records and make arithmetical computations; a knowledge of water requirements for crops and grasses grown under irrigation; the methods of preparation of land for irrigation and methods of channel and drain construction and maintenance.

**NOTE.**—The successful applicant will be required to occupy the official residence provided and vacation of the residence will not be permitted without the express approval of the Water Supply Department. A rental of 10 per cent. of total emolument inclusive of the amount payable under Regulation 74, less \$72.60 a year will be charged. Occupancy will be subject to a formal tenancy agreement being entered into. Particulars are available from the Water Supply Department.

**Storeman, Grade II., Orbost Forest Office, State Forests Department.**

*Yearly Salary.*—\$2,114, minimum; \$2,444, maximum.

*Duties.*—To be responsible at Orbost for the custody, handling and recording of transactions in general stores and spare parts as required.

*Qualifications.*—Good clerical capacity, preferably with experience in stores procedure. A knowledge of earthmoving equipment would be an advantage.

**Labourer, Bendigo Public Offices, Public Works Department.**

*Yearly Salary.*—\$1,838, minimum; \$2,078, maximum.

**NOTE.**—The salary rates quoted above do not include the additional amount which is payable under Regulation 74 of the Board's Regulations.

By order,

V. P. SCULLY,

Secretary.

Office of the Public Service Board,  
Melbourne, 16th August, 1966.

PUBLIC SERVICE OF VICTORIA.—VACANCIES.

DEPARTMENT OF HEALTH.  
MENTAL HYGIENE BRANCH.

TECHNICAL AND GENERAL DIVISION.

APPLICATIONS will be received by the Public Service Board up to Wednesday, the 7th September, 1966, from persons employed in the Public Service of Victoria, who are eligible and qualified for appointment to the under-mentioned positions:—

**Charge Nurse (Female), Kew.**

*Yearly Salary.*—\$2,564, minimum; \$2,772, maximum.  
*Duties.*—To take charge of a ward in a Mental Hospital and to assist in the training of Student Nurses and others.  
*Qualifications.*—A current practising Certificate for Mental Nursing.

**Kitchenman, Ararat.**

*Yearly Salary.*—\$1,940, minimum; \$2,186, maximum.  
*Duties.*—To assist cooks generally in preparation of vegetables and other foodstuffs. Attending to cleanliness of kitchen.  
*Qualifications.*—Some knowledge of cooking is desirable.

The salary rates quoted above do not include the additional amount which is payable under Regulation 74 of the Board's Regulations.

By order,  
V. P. SCULLY,  
Secretary.

Office of the Public Service Board,  
Melbourne, 16th August, 1966.

PUBLIC SERVICE OF VICTORIA.—VACANCY.

(TEMPORARY APPOINTMENT.)

APPLICATIONS will be received by the Public Service Board up to Wednesday, the 31st August, 1966, from persons who are qualified for appointment to the under-mentioned position:—

**Field Officer, S.S. Cameron Animal Research Laboratory, Werribee, Department of Agriculture.**

*Yearly Salary.*—  
Junior—at 18 years of age, \$1,704;  
at 19 years of age, \$1,912;  
at 20 years of age, \$2,146.  
Adult—\$2,914, minimum; \$3,228, maximum.

(Commencing salary will be determined within this initial range according to experience, but advancement is not limited to the maximum quoted.)

*Duties.*—To assist in beef cattle investigations as directed in the Animal Industry Division.

*Qualifications.*—A Diploma of an Australian Agricultural College or its equivalent; experience with beef cattle desirable.

*NOTE.*—Field Officers are eligible for progression to Field Officer, Senior, \$3,546–\$3,864 and, if they pass a qualifying examination, for appointment to the Professional Division, as Experimental Officer, \$3,734–\$4,466.

The salary rates quoted above do not include the additional amount which is payable under Regulation 74 of the Board's Regulations.

By order,  
V. P. SCULLY,  
Secretary.

Office of the Public Service Board,  
Melbourne, 16th August, 1966.

PUBLIC SERVICE OF VICTORIA.—VACANCY.

APPLICATIONS are invited from officers and employees of the Public Service up to Wednesday, the 31st August, 1966, for appointment to the position of—

**Private Secretary (Male or Female) to the Parliamentary Secretary of the Cabinet, Premier's Department.**

*Duties.*—To act as Private Secretary to the Parliamentary Secretary of the Cabinet.

*Qualifications.*—Preferably experience in secretarial duties, the recording and conducting of correspondence and the preparation of written material. Ability to conduct research and interviews. Ability to write shorthand is essential.

Applicants should furnish full particulars of their educational and other qualifications, and of their experience.

*NOTE.*—The successful applicant will be paid an allowance at the rate of \$200 a year for the first year, \$300 a year for the second year and \$400 a year for the third and subsequent years, providing that the total emolument received shall not exceed \$3,960 a year.

By order,  
V. P. SCULLY,  
Secretary.

Office of the Public Service Board,  
Melbourne, 16th August, 1966.

PUBLIC SERVICE (PUBLIC SERVICE BOARD) REGULATION 52.—VACANCY.

THE Permanent Head of the Department shown has recommended the officer named hereunder for appointment to the under-mentioned vacancy.

Office and Classification.	Duties.	Qualifications.	Officer Recommended for Appointment.		
			Name.	Classification.	Date of Classification.
<b>PROFESSIONAL DIVISION.</b>					
<b>WATER SUPPLY DEPARTMENT.</b>					
Chief Divisional Engineer, Class "A1" (\$10,000)	To direct the operation of all Divisions controlling irrigation districts and rural waterworks districts and of the Irrigation, Drainage Water Distribution and Farm Water Supplies Section; to co-ordinate with the Investigations and Designs Branches investigations into new irrigation and rural water supply projects and major extensions, including the allocation of water for expansion of existing districts and the development of new areas	To possess a Degree in Civil Engineering or other recognized engineering qualification and to hold qualification as an Engineer of Water Supply under the Water Acts, and to have had extensive experience as an engineer in charge of a Division, with demonstrated ability in administration and in the preparation of reports on major projects	Credlin, H. L.	Assistant Chief Divisional Engineer, Class 5	2.9.62

Appeals against such recommendation should be lodged with the Secretary to the Public Service Board not later than Saturday, the 27th August, 1966.

Office of the Public Service Board,  
Melbourne, 16th August, 1966.

By order,  
V. P. SCULLY,  
Secretary.

## PUBLIC SERVICE OF VICTORIA.—RECLASSIFICATIONS.

THE Public Service Board has raised the classification of the under-mentioned offices as shown, and appointed thereto the respective officers named hereunder.

Office and Former Classification.	Revised Classification.	Duties.	Qualifications.	Officer Appointed.
<b>ADMINISTRATIVE DIVISION.</b>				
<b>WATER SUPPLY DEPARTMENT.</b>				
Class "C"	Class "C1"	To be responsible for the preparation of reports and correspondence in connexion with the subdivision of land, the classification of land and the allocation of water in Irrigation Districts and the supervision of the preparation and revision of Registers of Lands in respect of such Districts	A good knowledge of the Commission's Irrigation Districts, the relevant provisions of the Water Act and cognate Acts and to be a competent correspondent with ability to prepare reports on complex matters	Simpson, R. I.
<b>TECHNICAL AND GENERAL DIVISION.</b>				
<b>CHIEF SECRETARY'S DEPARTMENT.</b>				
<i>Social Welfare Branch (Youth Welfare Division).</i>				
Hostel Manager, Sunshine Boys' Hostel, Grades 33-35 inclusive	Grades 35-37 inclusive	To manage Sunshine Boys' Hostel	Aptitude and ability for hostel management, including placement of youths in employment; a good knowledge of modern methods in youth care; ability to apply instructions relating to care and treatment of trainees	Hawkins, A. M.
<b>DEPARTMENT OF HEALTH.</b>				
<i>Maternal and Child Welfare Branch.</i>				
Sister, Infant Welfare, Grade F39	Inspector, Infant Welfare, Grade F41	Under the direction of the Director of Maternal, Infant and Pre-school Welfare, to arrange and supervise a programme of lecturing on mothercraft in State and registered schools. Such other duties as may be required	A current annual practising certificate issued by the Victorian Nursing Council in general nursing, midwifery and infant welfare; experience in teaching and/or possession of a teaching qualification would be an advantage	Rojo, Marjory
<b>DEPARTMENT OF LABOUR AND INDUSTRY.</b>				
Shortland Writer and Typist (Female), Grade II., Grades F24-F25 inclusive	Senior, Grades F30-F32 inclusive	To act as personal stenographer to the Chief Inspector of Factories and Shops and other Senior officers; to act as receptionist; other duties as required	A competent Shorthand Writer and Typist capable of writing shorthand at 100 words a minute	Williams, Lyla
<b>STATE FORESTS DEPARTMENT.</b>				
Artist and Display Designer, Grades 34-37 inclusive	Grades 36-39 inclusive	To design and prepare drawings, layouts, mockups and finished art work for posters, publicity pamphlets, film titles and other publications; plan, design and assemble all displays and exhibits; other duties as required	A good knowledge of drawing, design and layout for line, half-tone and lithographic reproduction and to have had substantial experience in design of displays and exhibits	Rawady, A. J.

Office of the Public Service Board,  
Melbourne, 16th August, 1966.

By order,  
V. P. SCULLY,  
Secretary.

**PRIVATE ADVERTISEMENTS**

NOTICE OF INTENTION TO APPLY FOR A LICENCE TO DIVERT WATER AND CUT RACE FROM THE RIVER MURRAY, AT WEMEN.

I HEREBY give notice that I intend to apply for a licence empowering me to divert water for a term of four years to the extent of 120 acre-feet per annum at a maximum rate of 5 acre-feet per day of 24 hours for the irrigation of pastures, being part of allotment 3, Parish of Wemen, and to occupy certain Crown lands for works of diversion, and to cut a race thereon.

Any objection to such application must be forwarded in writing to reach the State Rivers and Water Supply Commission, Melbourne, before 7th September, 1966, being 30 days from the first publication of this notice.

LINDSAY JOHN STORER.

Wemen via Robinvale.

3060

NOTICE OF INTENTION TO APPLY FOR A LICENCE TO DIVERT WATER AND CUT RACE FROM THE RIVER MURRAY, AT WHARPARILLA.

I HEREBY give notice that I intend to apply for a licence empowering me to divert water for a term of fifteen years to the extent of 200 acre-feet per annum at a maximum rate of 10 acre-feet per day of 24 hours for the irrigation of 100 acres of sub and rye grasses, being allotments 132-139 and 145, Parish of Wharparilla, and to occupy certain Crown lands for works of diversion, and to cut a race thereon.

Any objection to such application must be forwarded, in writing, to reach the State Rivers and Water Supply Commission, Melbourne, before 16th September, 1966, being 30 days from the first publication of this notice.

JOSEPH HENRY PIANTA.

Box 176, Echuca.

3066

## LAND ACT 1958, SECTION 134.

NOTICE is hereby given that the Pyramid Hill Golf Club has applied for a lease for a term of twenty-one (21) years under section 134 of the *Land Act 1958*, in respect of an area of Crown land containing approximately 80 acres in the Township of Pyramid Hill and the Parish of Mincha as a site for the purposes of Amusement and Recreation (Golf Links). 2846

## DIOCESAN SYNOD.

NOTICE is hereby given that the Archbishop of Melbourne has convened the Synod of the Church of England within the Diocese of Melbourne, Victoria, for Monday, the 10th day of October, A.D. 1966, at the Cathedral Church of St. Paul in the City of Melbourne, in the State of Victoria.

C. W. H. BARNES,  
Registrar of the Diocese of Melbourne.

3124

NOTICE is hereby given that White Crystal Chalet Pty. Ltd. has applied for a lease of an area of approximately 1 acre in the Parish of Yertoo, pursuant to section 134 of the *Land Act 1958*, for the purpose of accommodation and facilities for tourists, for a term of 45 years.

FREDERICK OWEN & ASSOCIATES, solicitors, 84  
William-street, Melbourne. 3098

## MOE SEWERAGE AUTHORITY.

PLANS have been prepared for the laying of a sewer main to serve No. 83 Shanahan-parade, Newborough.

Plans may be inspected during normal working hours at the office of the Authority, Albert-street, Moe.

3084 A. DEWAR, Secretary.

## STAWELL SEWERAGE AUTHORITY.

## GENERAL NOTICE.

*Sewerage Area No. 27.*

THE above-mentioned Sewerage Authority having made provision for carrying off the sewage from each and every property which or any part of which is within the Sewerage Area hereinafter described doth hereby declare that on and after the first day of October, 1966, each and every property which or any part of which is within the said Sewerage area shall be deemed to be a seweraged property within the meaning of the *Sewerage Districts Act 1958*.

The boundaries of the Sewerage Area hereinbefore referred to are:—Commencing at a point on the Western Highway, being the most easterly point of allotment 10, section 40, Parish and Township of Stawell; thence south-westerly, north-westerly and northerly around the boundary of the said allotment 10 to the Western Highway; thence westerly along the southerly boundary of the Western Highway to the point of commencement.

*Sewerage Area No. 28.*

The above-mentioned Sewerage Authority having made provision for carrying off the sewage from each and every property which or any part of which is within the Sewerage Area hereinafter described doth hereby declare that on and after the first day of October, 1966, each and every property which or any part of which is within the said Sewerage Area shall be deemed to be a seweraged property within the meaning of the *Sewerage Districts Act 1958*.

The boundaries of the Sewerage Area hereinbefore referred to are:—Commencing at the point being north-easterly corner of allotment 4, section 8, Parish and Township of Stawell; thence south-westerly along the westerly side of Foster-street to the intersection with the northerly side of Burgh-street; thence south-easterly along the northerly side of Burgh-street to the intersection with the westerly side of Sutherland-street; thence north-easterly along the westerly side of Sutherland-street to the intersection with the southerly side of the Western Highway; thence north-westerly along the southerly boundary of the Western Highway to the commencing point.

*Sewerage Area No. 29.*

The above-mentioned Sewerage Authority having made provision for carrying off the sewage from each and every property which or any part of which is within the Sewerage Area hereinafter described doth hereby declare that on and after the first day of October, 1966, each and every property which or any part of which is within the said Sewerage Area shall be deemed to be a seweraged property within the meaning of the *Sewerage Districts Act 1958*.

The boundaries of the Sewerage Area hereinbefore referred to are:—Commencing at a point where Declared Sewerage Area No. 9 intersects the easterly boundary of Main-street; thence northerly and easterly along the easterly boundary of Main-street to the northerly corner of allotment 11, section 85A, Parish and Township of Stawell; thence south-easterly along the north-easterly boundary of said allotment 11; thence south-westerly along the south-easterly boundaries of allotments 11, 12, 13, 14, and 15; thence continuing south-westerly in a line with the south-easterly boundary of said allotment 15 to intersect the boundary of Declared Sewerage Area No. 9; thence north-westerly along the boundary of Declared Sewerage Area No. 9 to the commencing point.

*Sewerage Area No. 30.*

The above-mentioned Sewerage Authority having made provision for carrying off the sewage from each and every property which or any part of which is within the Sewerage Area hereinafter described doth hereby declare that on and after the first day of October, 1966, each and every property which or any part of which is within the said Sewerage Area shall be deemed to be a seweraged property within the meaning of the *Sewerage Districts Act 1958*.

The boundaries of the Sewerage Area hereinbefore referred to are:—Commencing at the point being the south-easterly corner of allotment 2, section 10, Parish and Township of Stawell; thence southerly and westerly to the point being the easterly boundary of allotment 19, of said section 10; thence south-westerly along the south-easterly boundary of said allotment 19 to the most southerly point; thence south-easterly along the northern boundary of Longfield-street to the intersection with Sutherland-street; thence north-easterly along the western side of Sutherland-street to the most southerly point of allotment 10, of said section 10; thence north-easterly along the boundary of Declared Sewerage Area No. 26 to the commencing point.

*Sewerage Area No. 31.*

The above-mentioned Sewerage Authority having made provision for carrying off the sewage from each and every property which or any part of which is within the Sewerage Area hereinafter described doth hereby declare that on and after the first day of October, 1966, each and every property which or any part of which is within the said Sewerage Area shall be deemed to be a seweraged property within the meaning of the *Sewerage Districts Act 1958*.

The boundaries of the Sewerage Area hereinbefore referred to are:—Commencing at the point in Napier-street, being the south-east corner of allotment 7, section 51, Parish and Township of Stawell; thence easterly along the northern boundary of Napier-street to the south-easterly corner of allotment 48 as shown on plan of subdivision No. A688740, of parts Crown sections 50 and 51, Parish and Township of Stawell; thence northerly along the easterly boundary of allotments 48 and 65 to the north-easterly corner of allotment 65 at Sharpley-avenue as shown on said plan of subdivision; thence westerly along the southern side of Sharpley-avenue to a point being in line with the boundary between allotments 8 and 9 of said plan of subdivision; thence across Sharpley-avenue to the boundary of said allotment 8, and continuing along the easterly boundary and the northerly boundary of said allotment 8; thence southerly along the easterly boundaries of allotments 19 and 7, section 51 to the commencing point.

Dated 9th August, 1966.

3083 H. L. SCHULTZ, Chairman.  
LESLIE. L. SMITH, Secretary.

## GEELONG WATERWORKS AND SEWERAGE TRUST.

PURSUANT to section 60 (2) of the *Geelong Waterworks and Sewerage Act 1958* (No. 6263), notice is hereby given of the intention of the Trust to construct sewers to provide for properties in and adjacent to:—

Ruhamah-avenue, Bell Post Hill, Shire of Corio;

Cedar-grove, North Highton, Shire of South Barwon, and more particularly as shown on maps which are open for public inspection at the Trust's Offices, Rynie-street, Geelong, between the hours of 9 a.m. and 4 p.m. daily, from Monday to Friday.

. Dated this 12th day of August, 1966.

3085 B. C. HENSHAW, Secretary.

## PORT CAMPBELL WATERWORKS TRUST.

NOTICE to owners of tenements in the following streets and the private streets, lanes, courts, and alleys opening thereto:—

Tregea-street, Lord-street, Hennessy-street, Pitcher-street, Desailley-street, Ocean-road, Cairns-street, Morris-street, McCue-street.

The main pipe in the said streets being laid down, the owners of all tenements situated as above are hereby required to cause a proper pipe and stop cocks to be laid so as to supply water within such tenements from the main pipe.

3078

P. J. NORTHEAST, Secretary.

## TIMBOON WATERWORKS TRUST.

NOTICE to owners of tenements in the following street and the private streets, lanes, courts, and alleys opening thereto:—

Church-street.

The main pipe in the said street being laid down, the owners of all tenements situated as above are hereby required to cause a proper pipe and stop cocks to be laid so as to supply water within such tenements from the main pipe.

3077

F. A. ROBERTSON, Secretary.

## Town and Country Planning Act 1961.

## CITY OF CAMBERWELL PLANNING SCHEME, 1954.

NOTICE THAT A PLANNING SCHEME HAS BEEN PREPARED AND IS AVAILABLE FOR INSPECTION.

Amendment No. 32, 1965.

NOTICE is hereby given that the City of Camberwell, in pursuance of its powers under the *Town and Country Planning Act 1961*, has prepared a Planning Scheme for the whole of the municipality of the City of Camberwell for the purpose of amending the Ordinance of the Principal Scheme as it applies to special use Zones and re-zoning land at the west end of Vaughan-avenue from public open space to special use Zone "B".

A copy of the scheme has been deposited at the Municipal Offices, Civic Centre, Camberwell, and at the offices of the Town and Country Planning Board, 179 Queen-street, Melbourne, and will be open for inspection during office hours by any person, free of charge.

Any persons affected by the Planning Scheme are required to set forth, in writing, all objections they may have, addressed to the Chief Administrator, Civic Centre, Camberwell, on or before the 17th November, 1966, and to state whether they wish to be heard in respect of their objections.

3088

L. F. CHEFFERS, Chief Administrator.

## BOROUGH OF KERANG.

NOTICE is hereby given that Senior Constable Cyril Morton Oakes has been appointed Prosecuting Officer and Inspector of Nuisances for the Borough of Kerang.

3089

G. H. TATE, Town Clerk.

## BOROUGH OF KERANG.

## By-Law No. 1.

NOTICE is hereby given that a By-Law of the Borough of Kerang made under the Dog Acts, and numbered 1 for the purpose of fixing registration and other fees under the said Act was adopted by the Council on the 11th day of May, 1966, and confirmed on the 22nd day of June, 1966.

A true copy of the By-Law is open for inspection during normal office hours at the Municipal Chambers, Kerang.

3090

G. H. TATE, Town Clerk.

## SHIRE OF ALEXANDRA.

## LOAN No. 24.

Notice of Intention to Borrow the Sum of \$50,000 for Permanent Works and Undertakings.

NOTICE is hereby given that the Council of the Shire of Alexandra proposes to borrow the sum of Fifty thousand dollars on the credit of the municipal revenue of the President, Councillors and Ratepayers of the Shire of Alexandra, such sum to be raised by the grant of a mortgage, in accordance with the provisions of the Local Government Acts, and notice is hereby further given as follows:—

1. The maximum rate of interest that may be paid is 5½ per centum per annum.

2. The interest is to be payable half-yearly during the currency of the loan.

3. The period of the loan shall be 40 years.

4. The moneys borrowed shall be repayable at the Head Office of the National Bank of Australasia Ltd., Melbourne.

5. The loan shall be repaid by the creation of a sinking fund, and an appropriate amount, as determined by the Auditor-General, will be set aside annually out of the municipal fund for such purpose.

6. The purpose for which the loan is to be applied is for the construction of new municipal offices in Perkins-street, Alexandra.

The plans and specifications and an estimate of the cost of the proposed works, and a statement showing the proposed expenditure of the moneys to be borrowed, are open for inspection at the Shire Offices, Perkins-street, Alexandra, during office hours.

3094

R. G. HATFIELD, Shire Secretary.

## SHIRE OF CROYDON.

NOTICE is hereby given that the Council of the Shire of Croydon did, at a meeting held on 15th August, 1966, order that the street named Wendover-avenue as shown on lodged plan 53831, be now named Kirtain-drive.

3056

K. A. MCKAY, Shire Secretary.

## SHIRE OF DIAMOND VALLEY.

## LOAN No. 3.

Notice of Intention to Borrow the Sum of \$50,000 for Permanent Works and Undertakings.

NOTICE is hereby given that the Council of the Shire of Diamond Valley proposes to borrow the principal sum of \$50,000 secured by a charge over the general rates of the municipality, such sum to be raised by the grant of a mortgage in accordance with the provisions of the *Local Government Act 1958*.

1. The maximum rate of interest that may be paid is 5½ per cent. per annum.

2. The purposes for which the loan is to be applied are—

Purchase of plant—grader	.. ..	\$27,000
Extension to Shire Office	.. ..	13,000
Acquisition of land at rear of Main-street, Greensborough, for parking	.. ..	10,000
		<u>\$50,000</u>

3. The period of the loan shall be fifteen years.

4. The moneys borrowed shall be repayable by providing out of the municipal fund half-yearly instalments of approximately \$2,510 each, including principal and interest on the 1st day of November and the 1st day of May during the currency of the loan. The first instalment shall be payable on the 1st day of May, 1967.

5. Such moneys shall be repayable to the Commissioners of the State Savings Bank of Victoria at the office of the said Commissioners, corner Elizabeth and Bourke streets, Melbourne.

The plans and specifications and the estimate of the cost of the proposed works and a statement showing the proposed expenditure of the moneys to be borrowed are open for inspection at the office of the Council of the Shire of Diamond Valley, at Main-street, Greensborough.

12th August, 1966.

3072

B. J. MORGAN, Shire Secretary.

## SHIRE OF DONCASTER AND TEMPLESTOWE.

WHEREAS the Council of the Shire of Doncaster and Templestowe deems it expedient to exercise its powers of taking compulsorily the land described in the Schedule hereto for the purpose of providing pleasure grounds and places of public resort and recreation on land pursuant to section 799 of the *Local Government Act 1958* and acquiring the said land for that purpose: And whereas the Council has caused to be prepared a map and other papers setting out the general description of the work or undertaking for which the land proposed to be taken is to be used, the description of the land proposed to be taken and the names of the owners or reputed owners, lessees or reputed lessees mortgagees and occupiers of that land so far as those names are known to or can be ascertained by the Council: And whereas the said plan and other papers are deposited at the office of the said Council at Doncaster and are and shall be open for inspection by all persons interested at all reasonable hours for

the space of 40 clear days after the publication of this notice in the *Government Gazette*: Now notice is hereby given to all persons affected by the proposed taking of the said land to set forth, in writing, addressed to the Council or Shire Secretary within 40 clear days of the publication of this notice in the *Government Gazette* all objections which they may have to the taking of the said land.

THE SCHEDULE HEREINBEFORE REFERRED TO:

Land described in certificate of title, volume 8496, folio 854, having an area of 4 acres 1 rood 14.5 perches, at Estelle-street, Doncaster.

By order,  
3053 J. W. THOMSON, Shire Secretary,

SHIRE OF DONCASTER AND TEMPLESTOWE.

LOAN No. 87.

Notice of Intention to Borrow the Sum of \$60,000, for Permanent Works and Undertakings.

NOTICE is hereby given that the Council of the Shire of Doncaster and Templestowe proposes to borrow the principal sum of \$60,000 secured by a charge over the general rates of the municipality, such sum to be raised by the grant of a mortgage in accordance with the provisions of the *Local Government Act 1958*.

1. The maximum rate of interest that may be paid is 5½ per cent. per annum.
2. The purpose for which the loan is to be applied is the purchase of land in the Templestowe Riding for recreational purposes being the balance of cost of purchase of approximately 12 acres of land for a swimming pool site.
3. The period of the loan shall be fifteen years, the loan being repayable in one amount on the 1st September, 1981.
4. The loan is to be liquidated by the creation of a sinking fund pursuant to the provisions of section 428A of the *Local Government Act 1958*.
5. Such moneys shall be repayable to E.Z. Staff Funds Proprietary Limited, at 390 Lonsdale-street, Melbourne.

The plans and specifications and the estimate of the cost of the proposed works and a statement showing the proposed expenditure of the moneys to be borrowed are open for inspection at the office of the Council of the Shire of Doncaster and Templestowe, at the Municipal Offices, Doncaster-road, Doncaster.  
3054 J. W. THOMSON, Shire Secretary.

SHIRE OF FLINDERS.

LOAN No. 52.

Notice of Intention to Borrow the Sum of \$50,000, for Permanent Works and Undertakings.

NOTICE is hereby given that the Council of the Shire of Flinders proposes to borrow the principal sum of Fifty thousand dollars secured by a charge over the general rates of the municipality, such sum to be raised by the grant of a mortgage in accordance with the provisions of the *Local Government Act 1958*.

1. The maximum rate of interest that may be paid is 5½ per cent. per annum.
2. The purpose for which the loan is to be applied is—  
Construction of Buildings at Shire Depot, Rosebud . . . . . \$34,000  
Construction of Rye Hall, at Rye . . . . . \$16,000
3. The period of the loan shall be fifteen years.
4. The moneys borrowed shall be repayable by providing out of the municipal fund half-yearly instalments of approximately \$2,510 each, including principal and interest on the 1st day of May and the 1st day of November, during the currency of the loan. The first instalment shall be payable on the 1st day of May, 1967.
5. Such moneys shall be repayable to the Commissioners of the State Savings Bank of Victoria, at the office of the said Commissioners, corner Elizabeth and Bourke-streets, Melbourne.

The plans and specifications and the estimate of the cost of the proposed works and a statement showing the proposed expenditure of the moneys to be borrowed are open for inspection at the office of the Council of the Shire of Flinders at Shire Office, Dromana.  
Dated 17th August, 1966.

3065 S. WILLIAMS, Shire Secretary.

SHIRE OF KILMORE.

By-Law No. 23.

A By-Law of the Shire of Kilmore made under the provisions of the *Health Act 1958* for the purpose of prescribing the fees to be paid to the Council for the registration of certain premises and the renewal or transfer of such registrations.

IN pursuance of the powers conferred by the *Health Act 1958* and every other power enabling it in that behalf the President, Councillors and Ratepayers of the Shire of Kilmore doth hereby order as follows:—

1. That By-Law No. 12 of the Shire of Kilmore prescribing fees for the registration of premises and the renewal or transfer of such registration is hereby repealed.
2. The fees to be paid for registration or renewal of registration of the following premises within the Shire of Kilmore for any calendar year and the fees for transfer of registration shall be as follows:—

Piggeries	Six Dollars
Abattoirs	Ten "
Fat Rendering	Two "
Skin Stores	Four "
Cattle Sale Yards	Two "
Food Premises	Four "
Eating Houses	Four "
Hairdressers	Two "
Transfer of any Registration	Twenty Five Cents.

3. This By-Law shall apply to and have operation throughout the whole of the Municipal District of the Shire of Kilmore.

The Resolution to pass this By-law was agreed to by the Council on the sixth day of October, 1965, and confirmed on the first day of December, 1965.

The common seal of the President, Councillors and Ratepayers of the Shire of Kilmore was affixed hereto in our presence, this first day of December, 1965—

(SEAL) JOHN F. BUTLER, President,  
I. PARSONS, Councillor.  
BRIAN HOBAN, Secretary.

Approved by the Governor in Council, 3rd May, 1966.—  
J. COLQUHOUN, Clerk of the Executive Council. 3075

SHIRE OF KORONG.

LOAN No. 30.

Notice of Intention to Borrow the Sum of \$24,000 for Permanent Works and Undertakings.

NOTICE is hereby given that the Council of the Shire of Korong proposes to borrow the principal sum of \$24,000 secured by a charge over the general rates of the municipality, such sum to be raised by the grant of a mortgage in accordance with the provisions of the *Local Government Act 1958*.

1. The maximum rate of interest that may be paid is 5.5625 per cent. per annum.
2. The purpose for which the loan is to be applied is for purchase of a power grader and road-making plant.
3. The period of the loan shall be seven (7) years.
4. The moneys borrowed shall be repayable by providing out of the municipal fund fourteen half-yearly instalments of \$2,093.08 each, including principal and interest on the 1st days of May and November of each year during the currency of the loan. The first instalment shall be payable on the 1st day of May, 1967.
5. Such moneys shall be repayable to the Australia and New Zealand Bank Limited, Wedderburn.

A statement showing the proposed expenditure of the money to be borrowed is open for inspection at the Shire office, Wedderburn.

3068 R. G. STANLEY, Shire Secretary.

SHIRE OF MAFFRA.

LOAN No. 34—\$60,700.

Notice of Intention to Borrow the Sum of \$60,700 for Permanent Works and Undertakings.

NOTICE is hereby given that the Council of the Shire of Maffra proposes to borrow the sum of Sixty thousand seven hundred dollars (\$60,700) secured by a charge over the General Rates of the Municipality, such sum to be raised by the grant of a mortgage in accordance with the provisions of the *Local Government Act 1958*.

1. The maximum rate of interest that may be paid is 5.625 per cent. per annum.

2. The purposes for which the loan is to be applied are:—

(a) Purchase of Plant—			
Tip Truck .. .. .	\$	5,000	
Front End Loader .. .. .	\$	5,500	
			10,500
(b) Completion of Drainage Works—Heyfield Township .. .. .			4,000
(c) Construction of Pre-School Kindergarten—Heyfield .. .. .			4,000
(d) Conveniences Block, Heyfield Township (Shire contribution) .. .. .			1,200
(e) Street Construction, Maffra (completion of Johnson-street west) .. .. .			41,000
			<u>60,700</u>

3. The period of the loan shall be ten (10) years.

4. The moneys borrowed shall be repayable by providing out of the municipal fund twenty half-yearly instalments of \$4,009.60 each, including principal and interest, on the 1st day of November and the 1st day of May during the currency of the loan. The first instalment shall be payable on the 1st day of May, 1967.

5. Such moneys shall be repayable at the C.B.C. Savings Bank Limited, Melbourne.

The plans, specifications and the estimates of the cost of the proposed works and a statement showing the proposed expenditure of the moneys to be borrowed, are open for inspection at the Shire Office, Maffra.

Dated this 5th day of August, 1966.

3096 M. H. McMAHON, Shire Secretary.

#### SHIRE OF MANSFIELD.

LOAN No. 56.

*Notice of Intention to Borrow the Sum of \$3,000 for Permanent Works and Undertakings.*

NOTICE is hereby given that the Council of the Shire of Mansfield proposes to borrow the principal sum of Three thousand dollars secured by a charge over the general rates of the municipality, such sum to be raised by the grant of a mortgage in accordance with the provisions of the *Local Government Act 1958*.

1. The maximum rate of interest that may be paid is 5½ per cent. per annum.

2. The purpose for which the loan is to be applied is purchase of a motor truck.

3. The period of the loan shall be five years.

4. The moneys borrowed shall be repayable by providing out of the municipal fund half-yearly instalments of approximately \$347 each including principal and interest on the 1st day of June and the 1st day of December, during the currency of the loan. The first instalment shall be payable on the 1st day of June, 1967.

5. Such moneys shall be repayable to The Commissioners of the State Savings Bank of Victoria, at the office of the said Commissioners, corner of Elizabeth and Bourke streets, Melbourne.

The plans and specifications and the estimate of the cost of the proposed works and a statement showing the proposed expenditure of the moneys to be borrowed are open for inspection at the office of the Council of the Shire of Mansfield, at Mansfield.

Dated 8th August, 1966.

3064 R. WOMERSLEY, Shire Secretary.

#### SHIRE OF NEWHAM AND WOODEND.

APPOINTMENT OF POUNDKEEPER.

NOTICE is hereby given of the appointment by the Council, on 2nd August, 1966, of Frank Wright as Poundkeeper.

3069 N. M. SMITH, Shire Secretary.

#### SHIRE OF SEYMOUR.

By Law No. 60.

*Sale of Goods.*

A By Law of the Shire of Seymour made under Section 197 of the *Local Government Act 1958* and numbered 60 for the purpose of repealing By Law No. 43 and for the purpose of prohibiting without the written consent of Council previously obtained the sale of goods from stalls motor cars carts trucks barrows boxes baskets crates bags or other vehicles or receptacles standing or placed on any public place.

IN pursuance of the powers conferred by the *Local Government Act 1958* and all other powers enabling them in that behalf the President Councillors and Ratepayers of the Shire of Seymour order as follows:—

1. The By Law of the Shire of Seymour made and passed on the 13th day of February 1956 and confirmed on the 13th day of March 1956 and numbered 43 is hereby repealed.

2. Without the consent of Council previously obtained the sale of goods from stalls motor cars carts trucks barrows boxes baskets crates bags or other vehicles or receptacles standing or placed on any public place is prohibited.

3. "Public Place" includes and applies to every public highway road street footway footpath court alley passage thoroughfare park garden reserve or other place of public recreation or resort within the Shire of Seymour.

Resolution for the passing of this By Law agreed to by the Council on 9th May 1966.

Special Order advertisement published in the *Seymour Telegraph* on 17th May 1966 and 24th May 1966.

Copy of this By Law deposited at the Council Offices for inspection on 9th May, 1966.

Resolution confirmed by the Council on 14th June 1966.

The common seal of the President, Councillors and Ratepayers of the Shire of Seymour, was hereunto affixed on the 14th June, 1966, in the presence of—

(SEAL) MURRAY D. SMITH, President.  
J. W. ELLIOTT, Councillor.  
A. W. HALL, Secretary.

Approved by the Governor in Council, 2nd August, 1966.  
—J. COLQUHOUN, Clerk of the Executive Council. 3071

#### SHIRE OF SHEPPARTON.

LOAN No. 75.

*Notice of Intention to Borrow the Sum of \$100,000 for Permanent Works and Undertakings.*

NOTICE is hereby given that the Council of the Shire of Shepparton proposes to borrow the principal sum of One hundred thousand dollars secured by a charge over the income of the municipal abattoirs and by-products plant, such sum to be raised by the grant of a mortgage in accordance with the provisions of the *Local Government Act 1958*, section 397.

1. The maximum rate of interest that may be paid is 5½ per cent. per annum.

2. The purpose for which the loan is to be applied is Municipal Abattoir Development.

3. The period of the loan shall be two years based on a ten-year repayment table.

4. The moneys borrowed shall be repayable by providing out of the municipal abattoir and by-products plant fund three half-yearly instalments of approximately \$6,605 each, including principal and interest, and the fourth half-yearly payment of interest of approximately \$2,483 on the 1st day of May and the 1st day of November during the currency of the loan. The first instalment shall be payable on the 1st day of May, 1967. The fourth instalment of principal of \$84,176 shall be met by the raising of a further loan pursuant to section 394 of the *Local Government Act*.

5. Such moneys shall be repayable to the E. S. & A. Savings Bank Limited, Melbourne.

The plans and specifications and the estimate of the cost of the proposed works and a statement showing the proposed expenditure of the moneys to be borrowed are open for inspection at the office of the Council of the Shire of Shepparton at Nixon-street, Shepparton.

15th August, 1966.

3092 J. W. REED, Shire Secretary.

Sewerage Districts Acts.

SHIRE OF SOUTH BARWON.

PROPOSED TORQUAY SEWERAGE AUTHORITY.

NOTICE is hereby given that the Council of the Shire of South Barwon has made application to the Honorable, the Minister of Water Supply for the constitution of a Sewerage Authority and for the proclamation of a Sewerage District at Torquay and for the construction, maintenance and continuance of sewerage works within that district under the provisions of the Sewerage Districts Acts.



A general plan and description of the proposed works have been submitted with the application and copies of same may be seen at the office of the State Rivers and Water Supply Commission, 90 Orrong-road, Armidale, and at the offices of the Shire of South Barwon, Mt. Pleasant-road, Belmont, and the Shire of Barrabool, 441 Moorabool-street, Geelong.

Dated at Belmont the 8th day of August, 1966.

3063 E. T. CORNISH, Shire Secretary.

*Town and Country Planning Act 1961.*  
SHIRE OF SOUTH BARWON.—GEELONG PLANNING  
SCHEME 1959.

NOTICE THAT A PLANNING SCHEME HAS BEEN PREPARED  
AND IS AVAILABLE FOR INSPECTION.

Amendment No. 8, 1966.

NOTICE is hereby given that the Shire of South Barwon in pursuance of its powers under the *Town and Country Planning Act 1961* has prepared a Planning Scheme for the following area:—

Crown allotment 2 and parts of Crown allotments 4, 5 and 8, of section 16, Parish of Barrabool, County of Grant,

for the purpose of varying the zoning of the area from Agricultural "C" to Residential "A".

A copy of the scheme has been deposited at the Shire Office, Mt. Pleasant-road, Belmont, and at the office of the Town and Country Planning Board, 179 Queen-street, Melbourne, and will be open for inspection during office hours by any person free of charge.

Any persons affected by the Planning Scheme are required to set forth in writing all objections they may have, addressed to the Shire Secretary, Shire Office, Mt. Pleasant-road, Belmont, on or before the 19th day of September, 1966, and to state whether they wish to be heard in respect of their objections.

3055 E. T. CORNISH, Shire Secretary.

SHIRE OF WARRAGUL.

LOAN No. 48.

*Notice of Intention to Borrow the Sum of \$12,000 for  
Permanent Works and Undertakings.*

NOTICE is hereby given that the Council of the Shire of Warragul intends to borrow the principal sum hereinafter mentioned on the credit of the municipal revenues of the President, Councillors and Ratepayers of the Shire of Warragul by the grant of a mortgage in accordance with the provisions of the Local Government Acts, and notice is hereby further given:—

- (a) That the amount of the principal sum which it is proposed to borrow is \$12,000.
- (b) The maximum rate of interest that may be paid is 5.625 per centum per annum.
- (c) The moneys borrowed and interest thereon are to be repayable by twenty half-yearly instalments each of approximately \$792.67 on the 15th day of May, and the 15th day of November in each year, and the place at which such moneys are to be repayable is the A. & N. Z. Bank Ltd., Warragul. The first instalment shall be payable on the 15th day of May, 1967.
- (d) The purposes for which the loan is to be applied are:—  
Part cost of alterations and extensions to Club House, Warragul Bowling Club.
- (e) The loan is to be liquidated by appropriation out of the municipal fund.
- (f) The plans, specifications and estimate for the cost of such works, and the statement showing the proposed expenditure of the money to be borrowed, are open for inspection at the office of the Council, Civic-place, Warragul, during office hours.

Dated the 12th day of August, 1966.

3091 D. MCADIE, Shire Secretary.

NOTICE is hereby given that the partnership which existed between John Hartnell Potter, Gary Nessel and Brian John Woodhead of Moorabbin, carrying on the business of electronics under the business name of Strauss Sound, has been dissolved as from 8th August, 1966. John H. Potter and Gary Nessel will accept no responsibility or liability for any actions by Brian John Woodhead, after 8th August, 1966.

3061

JOHN H. POTTER.  
GARY NESSEL.

NOTICE OF DISSOLUTION.

NOTICE is hereby given that the partnership heretofore subsisting between Richard Thomas Geake and Judith Ann Geake, carrying on business as painters, at 12 Wellard-street, Box Hill South, under the style of R. & J. Geake has been dissolved, as from the 31st day of January, 1966.

Dated this 31st day of January, 1966.

3144

R. T. GEAKE.  
J. A. GEAKE.

PARTNERSHIP ACT 1958.

NOTICE is hereby given that the partnership formerly subsisting between Johannes Adrianus Antonius Van de Wiel, Mary Van de Wiel, and Stanislas Johannes Josephus Andrianus Van de Wiel, at Seaford, under the name of "John A. A. Van de Wiel & Sons", has been dissolved as from the 17th day of March, 1966. As from that date the business will be carried on by the said Stanislas Johannes Josephus Andrianus Van de Wiel, and all notices and accounts directed to the partnership should be sent to him at his address, 72 Ireland-street, Seaford.

Dated this 30th day of June, 1966.

Signed by the said Stanislas Johannes Josephus Andrianus Van de Wiel, in the presence of—

S. J. J. A. VAN DE WIEL.  
J. A. A. VAN DE WIEL.  
MARY VAN DE WIEL.

Witness—Mr. GRAHAM GEORGE FINCH.

3058

The *Companies Act 1961*.—In the matter of HALLMARK RENOVATIONS PTY. LTD.—Notice re Meeting of Creditors, pursuant to Section 260.

NOTICE is hereby given that a meeting of creditors of the above-named company will be held at the offices of Kennedy, Smail & Middlemiss, 296 Little Lonsdale-street, Melbourne, at 3 o'clock on the 25th day of August, 1966, the company having convened a meeting of its members for the same day for the purpose of considering a Resolution that the company be wound up voluntarily.

Dated this 16th day of August, 1966.

3138

EDWARD HALL, Director.

In the Supreme Court of Victoria.—No. C7244 of 1966.—In the matter of the *Companies Act 1961*; and in the matter of TRANSISTOR PARTS IMPORTS PROPRIETARY LIMITED.

NOTICE is hereby given that a petition for the winding up of the above-named company by the Supreme Court was on the 9th day of August, 1966, presented by Charles Valentine Taylor: And that the said petition is directed to be heard before the Court sitting at the Fourteenth Court, Law Courts, William-street, Melbourne, on the 9th day of September, 1966, at the hour of 10.30 o'clock in the forenoon; and any creditor or contributory of the said company desiring to support or oppose the making of an order on the said petition may appear at the time of hearing by himself or his counsel for that purpose; and a copy of the petition will be furnished to any creditor or contributory of the said company requiring the same by the undersigned on payment of the regulated charge for the same.

The petitioner's address is 567 Little Bourke-street, Melbourne.

The petitioner's solicitors are Messrs. Mahony, O'Brien & Duggan, of 37 Queen-street, Melbourne.

MAHONY, O'BRIEN & DUGGAN, solicitors for the petitioner.

NOTE.—Any person who intends to appear on the hearing of the said petition must serve on or send by post to the above-named solicitors, notice, in writing, of his intention so to do. The notice must state the name and address of the person, or, if a firm, the name and address of the firm and must be signed by the person or firm, or his or their solicitor (if any) and must be served, or if posted, must be sent by post in sufficient time to reach the above named not later than 4 o'clock in the afternoon of the 8th day of September, 1966.

3145

In the matter of CHOWILLA TIMBER SUPPLY CO. LIMITED.—Notice of Winding-up Order.

WINDING-UP Order made 5th August, 1966.

Name and address of official liquidator, Robert Charles Warne-Smith, of 440 Collins-street, Melbourne.

JAMES CANNY, Deputy Commissioner of Taxation of the Commonwealth of Australia, petitioner.

3146

## Unclaimed Moneys Act 1962.

## REGISTER of Unclaimed Moneys held by the—

Name of Owner on Books and Last Known Address.	Total Amount Due to Owner.	Description of Unclaimed Moneys.	Date when Amount first became Payable.
	\$ c		

## BRAMBLES INDUSTRIES LIMITED.

Young, John, Box 5, P.O., Mount Isa, Queensland 3147	15.00	Dividend on 100 shares	28.10.63
---	-------	------------------------	----------

The Companies Act 1961.—In the matter of FRANCIS ALAN GREEN PTY. LTD. (in Liquidation).

NOTICE is hereby given that at an Extraordinary Meeting of members of the above-named company held on 12th August, 1966, it was resolved that the company be wound up voluntarily and that Ralph Henry McNicol be appointed liquidator.

Dated 15th August, 1966.

3129

R. McNICOL, Liquidator.

IT is hereby advised that a Final Meeting of creditors and members of Jaydee Joinery Pty. Ltd. will be held on Monday, 18th September, 1966, for purpose of presenting the final accounts of the company prior to final liquidation, at the offices of J. Barry Reid & Co., company liquidators, at 2 p.m., at 469 King-street, Melbourne, pursuant to section 272 of the Companies Act 1961.

J. BARRY REID &amp; CO.

3132

The Companies Act 1961.

TOBINS FURNISHINGS PTY. LTD. (IN LIQUIDATION).

NOTICE is hereby given that a First and Final Dividend is intended to be declared in the above matter. Creditors who have not proved their debts by the 31st day of August, 1966, may be excluded from this dividend.

Dated this 12th day of August, 1966.

J. K. HALL, Liquidator.

Hall & Rose, chartered accountants, 260 Queen-street, Melbourne. 3134

Companies Act 1961.

TUCO PTY. LTD. (IN VOLUNTARY LIQUIDATION).

NOTICE is hereby given that a Final Meeting of members of TUCO PTY. LTD. (in Voluntary Liquidation) will be held on the 2nd Floor, 105 King-street, Melbourne, on Thursday, 22nd September, 1966, at 9.30 a.m. for the purpose of receiving an account showing how the winding-up has been conducted and the property of the company disposed of.

Dated this 10th day of August, 1966.

J. C. BENZIES, Liquidator.

Wilson, Danby &amp; Giddy, 105 King-street, Melbourne. 3135

Companies Act 1961.—In the matter of A. FRANKEL PTY. LIMITED.

TAKE notice that on the 2nd day of August, 1966, the Supreme Court made an Order confirming a Special Resolution of the above company reducing its capital from \$50,000 divided into 25,000 shares of \$2 each, to \$10,400 divided into 5,200 shares of \$2 each. Such reduction takes effect from the 12th day of August, 1966, when an office copy of the Court's Order was lodged with the Registrar of Companies.

McKEAN, PARK & COOPER, solicitors, 84 William-street, Melbourne. 3136

Companies Act 1961.—In the matter of HARVEST SALES PTY. LTD. (VICTORIA) (in Voluntary Liquidation)—Members Winding up.—Notice of Final Meeting.

NOTICE is hereby given, pursuant to section 272 of the Companies Act 1961 that the Final General Meeting of the members of the above-named company will be held at 44 Queen-street, Melbourne, on 15th day of September, 1966, at 9 a.m., when I shall lay before the meeting an account of how the winding up has been conducted and the property of the company disposed of.

Dated this 9th day of August, 1966.

3076

E. H. NIEMANN, Liquidator.

Companies Act 1961.—In the matter of LEFORD MOTORS PTY. LTD.—Notice of Meeting of Creditors, pursuant to section 260.

NOTICE is hereby given of a Meeting of Creditors of the above-named company to be held at the office of the Institute of Chartered Accountants in Australia, 23 McKillop-street, Melbourne, Thursday 25th August, 1966, at 11 o'clock in the forenoon, the company having convened a meeting of its members for the same day for the purpose of considering a Resolution that the company be wound up voluntarily.

Dated this 11th day of August, 1966.

G. S. EVANS, Director.

Norman, Cartledge & Holden, chartered accountants, 130 Commercial-road, Morwell. 3070

Companies Act 1961.

EBDEN INVESTMENTS PROPRIETARY LIMITED.

RESOLUTION TO WIND UP, PURSUANT TO SECTION 254 (2) (b).

AT an Extraordinary General Meeting of the above-named company, duly convened and held at Eighth Floor, 150 Queen-street, Melbourne, on Friday, 12th August, 1966, the following Resolution was duly passed as a Special Resolution:—

“That the company be wound up voluntarily.”

And at such last-mentioned meeting, Philip C. Simmons, of Eighth Floor, 150 Queen-street, Melbourne, was appointed liquidator for the purposes of the winding up.

Dated 12th August, 1966.

3148

P. C. SIMMONS, Liquidator.

Companies Act 1961.—BRUPAN PTY. LTD (in Voluntary Liquidation).—Notice of Meeting, Pursuant to Section 272 (2).

NOTICE is hereby given that the Final Meeting of members and creditors of Brupan Pty. Ltd., will be held at the office of A. Capper Moore & Sons, “Stanhill,” 34 Queens-road, Melbourne, on Friday, 23rd September, 1966, at 11.30 a.m., for the purpose of having an account laid before it showing how the winding up of the company has been conducted and the property of the company has been disposed of and to pass a Resolution to destroy the company's books and papers pursuant to section 284 (3) (b) of the Companies Act.

3097

GUY N. MOORE, Liquidator.

Companies Act 1961.

BRITISH THERMAL INSULATIONS (TAS.) PTY. LTD.

NOTICE PURSUANT TO SECTION 254 (2) (b) OF THE COMPANIES ACT 1961.

NOTICE is hereby given that at an Extraordinary General Meeting of the members of the above-named company held on Friday, the 29th July, 1966, it was resolved that the company be wound up voluntarily, and at a meeting of creditors held on the same day pursuant to section 260, it was resolved that for such purposes, Bruce Edward Fordham, of 170 Toorak-road, South Yarra, chartered accountant, be appointed liquidator.

Notice is also given that after 21 days from this date, I shall proceed to distribute the assets. All creditors having any claims against the company should furnish particulars of same by that date, otherwise I shall proceed to distribute the assets, without regard to their claim.

Dated this 8th day of August, 1966.

BRUCE FORDHAM, Liquidator.

Bruce Fordham, chartered accountant, 170 Toorak-road, South Yarra. 3099

## Companies Act 1961.

## CENTERCLIME PTY. LTD.

NOTICE PURSUANT TO SECTION 254 (2) (b) OF THE COMPANIES ACT 1961.

NOTICE is hereby given that at an Extraordinary General Meeting of the members of the above-named company held on Monday, the 8th day of August, 1966, it was resolved that the company be wound up voluntarily and at a meeting of creditors held on the same day, pursuant to section 260, it was resolved that for such purposes, Bruce Edward Fordham, of 170 Toorak-road, South Yarra, chartered accountant, be appointed liquidator.

Notice is also given that after twenty-one (21) days from this date, I shall proceed to distribute the assets. All creditors having any claims against the company should furnish particulars of same by that date, otherwise I shall proceed to distribute the assets, without regard to their claim.

Dated this 9th day of August, 1966.

BRUCE FORDHAM, Liquidator.

Bruce Fordham, chartered accountant, 170 Toorak-road, South Yarra. 3101

The Companies Act 1961.—COROROKE PROPRIETARY LIMITED (in Voluntary Liquidation).—Notice Convening Final Meeting of Members.

NOTICE is hereby given that pursuant to sub-section 1 of section 272 of the Companies Act 1961, a meeting of members of Cororooke Proprietary Limited (in voluntary liquidation) will be held at 143 Queen-street, Melbourne, on the 28th day of September, 1966, at 10 o'clock in the forenoon, for the purpose of laying before the meeting an account showing how the winding up has been conducted and the property of the company has been disposed of and to give any explanation of the account.

Dated this 11th day of August, 1966.

3109 A. S. McLAUGHLAN, Liquidator.

The Companies Act 1958.—In the matter of JACKSON'S PROPRIETARY LIMITED (in Liquidation).

NOTICE is hereby given that, pursuant to section 210 of the Companies Act, a Final Meeting of the creditors of the above company will be held at the offices of Kennedy, Smail & Middlemiss, 296-300 Little Lonsdale-street, Melbourne, on Wednesday, the 14th day of September, 1966, at 10.30 a.m.

Business.—To receive the liquidator's accounts.

Dated this 12th day of August, 1966.

NORMAN ERIC STRETTON, Liquidator.

Kennedy, Smail & Middlemiss, 296-300 Little Lonsdale-street, Melbourne. 3117

In the Supreme Court of Victoria.—1966, Co. No. 7234.—In the matter of the Companies Act 1961, and in the matter of WINONA PROPRIETARY LIMITED.

NOTICE is hereby given that an Order of the Supreme Court of Victoria made on the 2nd day of August, 1966, declared that the capital of the above company was reduced as follows:—

From.—\$200,000 divided into 40,000 ordinary shares of \$2.00 each, 10,000 "A" 6% Cumulative Preference Shares of \$2.00 each and 50,000 "B" 6% Cumulative Preference shares of \$2.00 each of which 17,777 ordinary shares of \$2.00 each, 10,000 "A" 6% Cumulative Preference Shares of \$2.00 each and 15,500 "B" 6% Cumulative Preference Shares of \$2.00 each have been issued and have been or are deemed to have been fully paid up, 22,223 ordinary shares of \$2.00 each and 34,500 "B" 6% Cumulative Preference Shares of \$2.00 each remain unissued.

To.—\$80,000 divided into 40,000 ordinary shares of \$2.00 each of which 17,777 ordinary shares of \$2.00 each have been issued and have been or are deemed to have been fully paid up and of which 22,223 ordinary shares of \$2.00 each remain unissued.

F. P. WILLIAMS.

Francis P. Williams, solicitor, 452 Lonsdale-street, Melbourne. 3125

The Companies Act 1961.

HENRY H. EILENBERG & SON PROPRIETARY LIMITED. PURSUANT TO SECTION 260 OF THE COMPANIES ACT 1961.

NOTICE is hereby given that a meeting of creditors of Henry H. Eilenberg & Son Proprietary Limited will, will be held at the Institute of Chartered Accountants, 23 McKillop-street, Melbourne, on Wednesday, the 31st day of August, 1966, at 11 o'clock in the forenoon, for the

purpose of considering the company's affairs, the company having convened an Extraordinary General Meeting of its members to be held on the same day and for the purpose of considering, and if thought fit, passing a Special Resolution that the company be wound up voluntarily.

Dated this 8th day of August, 1966.

A. H. EILENBERG, Director.

Hall & Rose, chartered accountants, 260 Queen-street, Melbourne, C.I. 3126

The Companies Act 1961.—In the matter of W. CROSS & SONS (CUSTOMS) PROPRIETARY LIMITED (in Voluntary Liquidation).

NOTICE is hereby given that after 21 days from this date I shall proceed to distribute the assets. All creditors having any claim against the company should furnish particulars of same by that date, otherwise I shall proceed to distribute the assets, without regard to their claims.

Dated this 17th day of August, 1966.

J. G. RYAN, Liquidator.

H. E. Ferris & Ryan, 422 Collins-street, Melbourne, C.I. 3113

CREDITORS, next of kin and others having claims in respect of the estate of Doris Irene Mary O'Neill, late of 60 Glen Orme-avenue, Ormond, in the State of Victoria, married woman, deceased (who died on the 23rd day of January, 1966), are required to send particulars of their claims to the administrator, Michael Hugh O'Neill, of 6 Grandview-grove, Moorabbin, in the State of Victoria, public servant, care of the under-mentioned solicitors, by the 28th day of October, 1966, after which date he will distribute the assets, having regard only to the claims of which he then has notice.

J. A. REDMOND & CO., solicitors, of 358 Collins-street, Melbourne. 3105

CREDITORS, next of kin and others having claims in respect of the estate of Mr. William Welsh, late of The Salvation Army Men's Eventide Home, Middleborough-road, Blackburn, single, (who died on the 9th June, 1966), are requested to send particulars of their claims to the executor, The Union-Fidelity Trustee Company of Australia Limited, 100 Exhibition-street, Melbourne, on or before the 19th October, 1966, after which date the said company will distribute the assets, having regard only to the claims of which it then has notice. 3110

MARY AGNES GOULD, late of 88 Henty-street Reservoir, widow, DECEASED.

CREDITORS, next of kin and others having claims in respect of the estate of the above-named deceased (who died on the 6th June 1966), are required to send the particulars of their claims to the executor, Alan Benjamin Gould, care of the undernamed solicitors, by the 18th day of October, 1966, after which date he will distribute the assets, having regard only to those claims of which he then has notice.

NORRIS, COATES & HEARLE, solicitors, of 422 Collins-street, Melbourne. 3111

CREDITORS, next of kin and others having claims in respect of the estate of Walter Irvine Jackson, late of 31 Elizabeth-street, Malvern, optometrist (who died on 2nd May, 1966), are to send particulars to the executor, Willis E. Teague of 66 Orrong-crescent, Caulfield, by 18th October, 1966, after which he will distribute the assets having regard to the claims of which he then has notice. 3123

CREDITORS, next of kin and others having claims in respect of the estate of Louis Howell, late of 157 Rupert-street, West Footscray, in the State of Victoria, suburban guard, deceased (who died on the 26th day of April, 1965), are required by the administratrix, Wendy Joy Kron, of 157 Rupert-street, West Footscray, aforesaid married woman, to send particulars in writing of such claims to the undersigned at their office hereunder mentioned by the 19th day of October, 1966, after which date the administratrix may convey or distribute the assets of the said estate, having regard only to the claims of which she then has notice.

Dated the 9th day of August, 1966.

SLATER AND GORDON, solicitors, 395 Collins-street, Melbourne. 3127

**CREDITORS**, next of kin and others having claims in respect of the estate of Harold Eastgate, late of 489 Brunswick-road, West Brunswick, manufacturer, deceased (who died on the 6th October, 1964), are to send particulars of their claims to the executors, Bruce William Laurence Doig, John Montague Eastgate and Ronald Stuart Doig care of the under-mentioned solicitors by the 20th October, 1966, after which date the said executors will distribute the assets of the said deceased, having regard only to the claims of which they then have notice.

R. WADHAM & DOIG, solicitors, of 383 Flinders-lane, Melbourne. 3114

PERCY AMIEL ALLEN, late of "Dendron", Wooralla-drive, Mount Eliza, gentleman, DECEASED.

**CREDITORS**, next of kin and others having claims in respect of the estate of the deceased (who died on the 27th day of June, 1966), are required by The Perpetual Executors and Trustees Association of Australia Limited, of 100-104 Queen-street, Melbourne to send particulars of their claims to the said company by the 20th day of October, 1966, after which date it will convey or distribute the assets having regard only to the claims of which the company then has notice.

W. H. FLOOD & PERMEZEL, solicitors, 388 Bourke-street, Melbourne. 3115

FRANCIS XAVIER MATTHEW EGAN, late of 443 Punt-road, South Richmond, in the State of Victoria, master butcher, DECEASED.

**CREDITORS**, next of kin and others having claims in respect of the estate of the above-named deceased (who died on the 6th day of May, 1966), are required by Eva Egan, of 443 Punt-road South Richmond, aforesaid widow the executrix of the will of the deceased to send particulars to her care of the undersigned, by the 12th day of November, 1966, after which date she will distribute the assets, having regard only to the claims of which she then has notice.

FAIRLIE GOLDENBERG & SULLIVAN, solicitors, of 317 Collins-street, Melbourne. 3116

**CREDITORS**, next of kin and others having claims in connexion with the estate of William Penson Bromley Read late of Flat 2, 22 Burwood-road, Hawthorn, in Victoria, bank officer, deceased, intestate (who died on the 24th day of April, 1966), are required by the administratrix Isabel Mary Read, of Flat 1, 2 Tivoli-place, South Yarra, in Victoria, widow, to send particulars of their claims to her, care of the under-mentioned solicitors, by the 18th day of October, 1966, after which date she may convey or distribute the assets, having regard only to the claims of which she then has notice.

AITKEN, WALKER & STRACHAN, 414 Collins-street, Melbourne, C.1. 3128

**THE** Equity Trustees, Executors and Agency Company Limited, of 472 Bourke-street, Melbourne, the executor of the will of Lucy Laidlay, late of 52 Mary-street, Hawthorn, widow, deceased (who died on the 6th June, 1966), requires creditors next of kin and others having claims against the property or estate of the said deceased, to send to the said executor, at 472 Bourke-street, Melbourne, on or before the 31st October, 1966, particulars, in writing, of such claim, after which date the said executor intends to convey or distribute such property or estate to or among the persons entitled thereto, having regard only to the claims of which it shall have notice.

Dated the 11th day of August, 1966.

G. F. PITCHER & CO., solicitors, 406 Lonsdale-street, Melbourne. 3108

**NOTICE** to Creditors.—Phyllis May Gowan, widow, Robin Byram Gowan, printer, and James McConnell Hambleton, solicitor, all care of Messrs. Darvall and Hambleton, solicitors, 147 Collins-street, Melbourne, the executors of the will of Byram Rutter Gowan, late of Flat 1, 4 Maple-grove, Toorak, printer, deceased (who died on the 10th day of November, 1965), requests all creditors next of kin and others having claims against the property or estate, of the said deceased; to send to them the said executors, at their address afore-mentioned, on or before the 18th day of October, 1966, particulars, in writing, of such claims, after which date the said executors intend to convey or distribute such property or estate to or among the persons entitled thereto, having regard only to the claims of which they shall have had notice.

DARVALL & HAMBLETON, solicitors, 147 Collins-street, Melbourne. 3112

ELVIRA ANNIE WALL, late of 30 Gladstone-road, Briar Hill, in the State of Victoria, widow, DECEASED.

**AFTER** fourteen clear days Colleen Rosemary Leslie, married woman, and Neville Leslie, driver, both of 90 Mountain View-road, Montmorency, the executrix and executor, appointed by the will of the deceased, dated the 4th day of May, 1966, will apply to the Supreme Court of Victoria for a grant of probate of the said will.

SETON WILLIAMS & HEATHFIELD, 230 Collins-street, Melbourne, solicitors for the applicants. 3086

**CREDITORS**, next of kin and all other persons having claims in respect of the estate of Mary Irene Thirlwell, late of 468 Burke-road, Camberwell, in the State of Victoria, spinster, deceased (who died on the 30th day of May, 1966), are required to send particulars of their claims to The Trustees Executors and Agency Company Limited, of 401 Collins-street, Melbourne, by 18th October, 1966, after which date it will distribute the assets, having regard only to the claims of which it then has notice.

JOHN D. MUSTOW & CO., solicitors, 89 Queen-street, Melbourne. 3107

**CREDITORS**, next of kin and all other persons having claims in respect of the estate of Hilda Ford, late of 8 Rangeview-grove, North Balwyn, in the State of Victoria, widow, deceased (who died on 20th day of May, 1966), are required to send particulars of their claims to The Trustees Executors and Agency Company Limited, of 401 Collins-street, Melbourne, by the 18th day of October, 1966, after which date it will distribute the assets, having regard only to the claims of which it then has notice.

JOHN D. MUSTOW & CO., solicitors, 89 Queen-street, Melbourne. 3106

LOUISA JANE MAY, late of 80 Harold-street, Thornbury, widow, DECEASED (who died on the 7th day of September, 1965).

**CREDITORS**, next of kin and all other persons having claims against the estate of the deceased are required by the executor, William Myles Wilson, to send particulars of their claims to the executor, care of the undersigned solicitors, on or before the 20th day of October, 1966, after which date he will distribute the assets, having regard only to the claims of which he then has notice.

HOME, WILKINSON & LOWRY, solicitors, 401 Collins-street, Melbourne. 3102

BERNARDINO LAZZARO (also known as Francis Bernard Lazzaro), late of 402 (formerly 352) Glen Eira-road, Caulfield, gentleman, DECEASED (who died on the 20th August, 1964).

**CREDITORS**, next of kin and all other persons having claims against the estate of the deceased are required by the executors, Maria Lazzaro, Joseph James Lazzaro and John Cowan Lowry, to send particulars of their claims to the executors, care of the undersigned solicitors, on or before the 20th day of October, 1966, after which date they will distribute the assets, having regard only to the claims of which they then have notice.

HOME, WILKINSON & LOWRY, solicitors, 401 Collins-street, Melbourne. 3140

CHRISTINA JANE HEALY, late of 39 Densham-road, Armadale, widow, DECEASED, intestate.

**CREDITORS**, next of kin and others having claims in respect of the estate of the above-named deceased (who died on 21st May, 1966), are required by the applicant for administration, Maureen Margaret Turner, of 7 Bailey-avenue, Armadale, married woman, to send particulars to her, care of the under-mentioned solicitors by 18th October, 1966, after which date the said applicant may convey or distribute the assets, having regard only to the claims of which she then has notice.

MCCRACKEN & MCCRACKEN, solicitors, 317 Collins-street, Melbourne. 3141

JANET LESLIE MADSEN, of 23 Centennial-avenue, West Brunswick, widow, DECEASED.

**CREDITORS**, next of kin and others having claims in respect of the estate of the above-mentioned deceased (who died on the 15th June, 1966), are required by the applicants for probate, Brian Darnton Bayston and John Harold McCracken, both of 317 Collins-street, Melbourne, solicitors, to send particulars to them by 18th October, 1966, after which date the said applicants may convey or distribute the assets, having regard only to the claims of which they then have notice.

MCCRACKEN & MCCRACKEN, solicitors, 317 Collins-street, Melbourne. 3142

**CREDITORS**, next of kin and others having claims in respect of the estate of George Allen Hornby, late of 10 Acacia-street, Dimboola, farmer, deceased (who died on the 16th day of May, 1966), are to send all particulars of their claims to the Trustees, Executors and Agency Company Limited, 401 Collins-street, Melbourne, by the 28th day of October, 1966, after which date it will distribute the assets, having regard only to the claims of which it then has notice.

Dated the 9th day of August, 1966.

STEWART F. BROWN & PROUDFOOT, solicitors for the said company. 3073

**CREDITORS**, next of kin and others having claims in respect of the estate of Ruth Eva Elizabeth Hornby, late of 10 Acacia-street, Dimboola, married woman, deceased (who died on the 13th day of July, 1961), are to send the particulars of their claims to the Trustees, Executors and Agency Company Limited, of 401 Collins-street, Melbourne, by the 28th day of October, 1966, after which date it will distribute the assets, having regard only to the claims of which it then has notice.

Dated the 9th day of August, 1966.

STEWART F. BROWN & PROUDFOOT, solicitors for the said company. 3074

SARAH LOUISA KENDALL, late of 17 Wattletree-road, Drumcondra, Geelong, widow, DECEASED.

**CREDITORS**, next of kin and others having claims in respect of the estate of the said deceased (who died 19th June, 1966, are required by the applicants for grant of probate of the will, Percy James Layfield, of 47 Fulton-street, Clayton, hairdresser, and James Findlay Field Frier, of 84 Darling-road, East Malvern, retired accountant), to send particulars to them, care of the undersigned solicitors by 19th October, 1966, after which date the said applicants may convey or distribute the assets, having regard only to the claims of which they then have notice.

WIGHTON & McDONALD, solicitors, 189-191 Moora-bool-street, Geelong. 3059

BLANCHE SMITH, late of 39 Fulton-street, East St. Kilda, in the State of Victoria, spinster, DECEASED.

**CREDITORS**, next of kin and others having claims in respect of the estate of the above-named deceased (who died on the 25th day of May, 1966), are required by the Trustees, Executors and Agency Company Limited, of 401 Collins-street, Melbourne, to send particulars to the company by the 18th day of October, 1966, after which date the company may convey or distribute the assets, having regard only to the claims of which it then has notice.

DAVID THOMAS & FRENKEL, of 104 Queen-street, Melbourne, solicitors for the said company. 3133

**ALL** persons having claims against the estate of Arthur Hull, late of 163 Exeter-road, Harrow, Middlesex, England, retired billiard hall proprietor, deceased (who died on the 26th April, 1965, and probate of whose will was on the 13th January, 1966, granted by the High Court of Justice, England, to Barclays Bank Limited, and application to the Supreme Court of Victoria (Probate Jurisdiction) by the Perpetual Executors and Trustees Association of Australia Limited, to seal such probate, having been granted on the 14th July, 1966), are hereby required to send particulars of such claims to the Perpetual Executors and Trustees Association of Australia Limited at its registered office, at 100-104 Queen-street, Melbourne, on or before 19th October, 1966, after which date the said company will proceed to transfer, convey or distribute the said estate to or among the persons entitled thereto, having regard only to the claims of which it shall then have had notice, and will not be liable for the assets so transferred, conveyed or distributed to any persons of whose claim it shall not then have had notice.

HEDDERWICK, FOKES & ALSTON, 103 William-street, Melbourne. 3137

**CREDITORS**, next of kin and others having claims in respect of the estate of Florence Jane Mossman, late of 360 New-street, North Brighton, spinster, deceased (who died on the 16th December, 1965), are required to send particulars of their claims to the Equity Trustees, Executors and Agency Company Limited, of 472 Bourke-street, Melbourne, by the 21st day of October, 1966, after which date it will distribute the assets, having regard only to the claims of which it then has notice.

Dated the 17th day of August, 1966.

MALLESONS, solicitors, 105 King-street, Melbourne. 3139

WILLIAM GEORGE MORRISON, late of 10 Sturt-street, Ballarat, clerk, DECEASED (who died on 16th June, 1966).

**CREDITORS**, next of kin and others having claims against the estate of the deceased are required by The Union-Fidelity Trustee Company of Australia Limited, of 101 Lydiard-street north, Ballarat, who has applied for probate of the will, to send particulars to the company, before the 18th day of October, 1966, after which date the said company will distribute the assets, having regard only to the claims of which it then has notice.

J. CURWEN-WALKER, solicitor, Ballarat. 3082

EVELYN LUCY TRENCHARD, late of Hestia Bruarong-avenue, Frankston, widow, DECEASED.

**CREDITORS**, next of kin and others having claims against the estate of the deceased (who died on 11th September, 1965) are required by the executors, Edward Russell Trenchard and Bernard Gore Brett, to send particulars to them, care of 120 William-street, Melbourne, by the 20th October, 1966, after which date they may convey and distribute the assets, having regard only to the claims of which they then have notice.

BLAKE & RIGGALL, solicitors, 120 William-street, Melbourne. 3095

ALBERT FRANK KINGSTON, late of 29 Embling-road, Malvern, retired manager, DECEASED.

**CREDITORS**, next of kin and others having claims against the estate of the said deceased (who died on 26th February, 1966) are to send particulars of their claims to The Union-Fidelity Trustee Company of Australia Limited, the registered office of which is situated at 100 Exhibition-street, Melbourne, by the 20th day of October, 1966, after which date it will distribute the assets, having regard only to the claims of which it then has notice.

BLAKE & RIGGALL, solicitors, 120 William-street, Melbourne 3100

**CREDITORS**, next of kin and others having claims against the estate of Mary Ross Purvis, late of 88 Tennyson-street, Essendon, widow, deceased (who died on the 25th day of May, 1966) are required by Sheila Isabella Johnson, the executrix of the will of deceased to send to her care of the undersigned solicitors, particulars thereof on or before the 17th day of October, 1966, after which date they will distribute the assets, having regard only to the claims of which they shall then have notice.

GAVIN DUFFY & KING, solicitors, 95 Queen-street, Melbourne. 3118

**CREDITORS**, next of kin and others having claims against the estate of Christos Yoanu Elias (in the will called Christo Yoanu Elias and also known as Christo Yoanu), late of 14 Lesney-street, Richmond, cook, deceased (who died on the 29th day of April, 1966) are required by James Loustas, the executor of the will of deceased, to send to him, care of the undersigned solicitors, particulars thereof on or before the 17th day of October, 1966, after which date they will distribute the assets, having regard only to the claims of which they shall then have notice.

GAVIN DUFFY & KING, solicitors, 95 Queen-street, Melbourne 3119

**CREDITORS**, next of kin and others having claims against the estate of Otto Ernst Venus, late of 24 Aubrey-grove, Boronia, carpenter, deceased (who died on the 10th day of February, 1966), are required by Bruno Ludwig Venus, the executor of the will of deceased, to send to him, care of the undersigned solicitors, particulars thereof, on or before the 31st day of October, 1966, after which date they will distribute the assets, having regard only to the claims of which they shall then have notice.

GAVIN DUFFY & KING, solicitors, 95 Queen-street, Melbourne. 3120

**CREDITORS**, next of kin and others having claims against the estate of Thomas McCarthy, late of "Tralee", Heathcote South, grazier, deceased (who died on the 12th day of January, 1966), are required by Patrick Francis Toohey and Mary Jane McCarthy, the executors of the will of deceased, to send to them, care of the undersigned solicitors, particulars thereof on or before the 31st day of October, 1966, after which date they will distribute the assets, having regard only to the claims of which they shall then have notice.

GAVIN DUFFY & KING, solicitors, 95 Queen-street, Melbourne. 3121

JOSEPH BENEDICT TROST, late of 330A Carlisle-street, East St. Kilda, hairdresser, DECEASED.

**CREDITORS**, next of kin and others having claims in respect of the estate of the above-named deceased (who died on 21st June, 1966), are required by the applicant for probate, Ivy Matilda Trost, of the same place, widow, to send particulars to her, care of the under-mentioned solicitors by 18th October, 1966, after which date the said applicant may convey or distribute the assets, having regard only to the claims of which she then has notice.

McCRACKEN & McCRACKEN, solicitors, 317 Collins-street, Melbourne. 3143

**CREDITORS**, next of kin and others having claims in respect of the estate of Irene Clara Couper, late of 36 Newman-street, West Brunswick, in the State of Victoria, married woman, deceased (who died on the 1st April, 1966), are required to send particulars of their claims to the trustee of the said estate, Equity Trustees, Executors and Agency Co. Ltd., of 472 Bourke-street, Melbourne, addressed to the manager of the said company by 26th October, 1966, after which date the said company will distribute the assets of the said deceased, having regard only to those claims of which it shall then have had notice.

ROWLAND P. HASSALL, 360 South-road, Moorabbin, solicitor for the said company. 3067

JANET WALTER, late of 26 Clydesdale-street, Box Hill, in the State of Victoria, widow, DECEASED.

**CREDITORS**, next of kin and others having claims in respect of the estate of the deceased (who died on 24th April, 1966), are required by the personal representative, The Trustees, Executors and Agency Company Limited, of 401 Collins-street, Melbourne, to send particulars to the said company by 19th October, 1966, after which date it may convey or distribute the assets, having regard only to the claims of which it then has notice.

HEDDERWICK, FOOKES & ALSTON, 103 William-street, Melbourne. 3104

WALTER GEORGE THORPE, late of 26 Hammerdale-avenue, East St. Kilda, gentleman, DECEASED.

**CREDITORS**, next of kin and others having claims in respect of the estate of the above-named deceased (who died on the 22nd day of April, 1966), are required by The Perpetual Executors and Trustees Association of Australia Limited, of 100-104 Queen-street, Melbourne, the applicant for a grant of administration, to send particulars of their claims to the said applicant by the 24th day of October, 1966, after which date it will convey or distribute the assets, having regard only to the claims of which it then has notice.

RUSSELL KENNEDY & COOK, solicitors, 401 Collins-street, Melbourne. 3103

HILDA MADELINE BOULTON, late of 16 Pearson-street, Sale, in the State of Victoria, home duties, DECEASED.

**CREDITORS**, next of kin and others having claims in respect of the estate of Hilda Madeline Boulton, late of 16 Pearson-street, Sale, in the State of Victoria, home duties, deceased (who died on the 30th day of October, 1964), are required to send particulars of their claims to The Union-Fidelity Trustee Company of Australia Limited, of 100 Exhibition-street, Melbourne, by the 25th day of October, 1966, after which date it will distribute the assets, having regard only to the claims of which it then has notice.

Dated the 10th day of August, 1966.

EUGENE M. ALLMAN Esq., solicitor, 49 Raymond-street, Sale. 3081

FOSTER LEONARD PRIESTLEY, late of 52 Breed-street, Traralgon, Electricity Commission employee, DECEASED.

**CREDITORS**, next of kin and others having claims in respect of the estate of Foster Leonard Priestley, formerly of 34 Market-street, Sale, but late of 52 Breed-street, Traralgon, Electricity Commission employee, deceased (who died on the 24th day of June, 1965), are required by the Trustees, Victoria Priestley and The Union-Fidelity Trustee Company of Australia Limited, of 100 Exhibition-street, Melbourne, to send particulars of their claims to it by the 25th day of October, 1966, after which date the trustees may convey and distribute the assets, having regard only to the claims of which they then have notice.

Dated the 10th day of August, 1966.

EUGENE M. ALLMAN Esq., solicitor, 49 Raymond-street, Sale. 3080

In the Supreme Court of the State of Victoria.

SALE BY THE SHERIFF.

ON Monday, the 19th of September, 1966, at Ten a.m., at the Police Station, Elsternwick (unless process be stayed or satisfied):—

All the estate and interest (if any) of I. Thomas, of 38 Downshire-road, Elsternwick, married woman, as proprietor of an estate in fee simple in the land described in certificate of title, volume 3467, folio 249, upon which is erected a six-room weatherboard dwelling house, known as No. 38 Downshire-road, Elsternwick.

Registered mortgage No. B.173840 and caveat No. C.479503 affects the said estate and interest.

Terms: Cash only.

DAVID J. JOHNSTON, Sheriff's Officer.

28th July, 1966.

3122

## IMPOUNDINGS

**ALEXANDRA**.—Impounded in Alexandra Pound, by Mr. J. Rahley, of Alexandra.

2 sheep (ewes), red markings on back, cannot be identified, notches on both ears

2 weaner lambs, red markings on back, cannot be identified, notches on both ears

If not claimed and expenses paid, to be sold on 2nd September, 1966.

G. MAUDOUT,

Poundkeeper.

3093—\$2.00

**BOX HILL**.—Impounded in Box Hill Pound, by Ranger.

1 skewbald gelding, cut mane, no visible brand

2 small lambs, long tails, no visible brand

If not claimed and expenses paid, to be sold on 1st September, 1966.

R. KENNEDY,

Poundkeeper.

3079—\$1.40

**DANDENONG**.—Impounded in Dandenong Pound, by G. Lambdon, from Moorabbin Airport.

1 bay mare, branded B near shoulder, off hind foot white, clipped, white star on forehead, white slit down nose, branded on off shoulder 2 over nought, green rug

1 chestnut mare, near hind foot white, star on forehead, shod, green rug, no visible brand

If not claimed and expenses paid, to be sold on 2nd September, 1966.

D. D. NAPIER,

Poundkeeper.

3087—\$2.20

**HEYWOOD**.—Impounded in Heywood Pound.

1 aged Merino sheep, red blotch on back.

If not claimed and expenses paid to be sold on 1st September, 1966.

C. SKIPWORTH,

Poundkeeper.

3031—\$1.20

**LEONGATHA**.—Impounded in Leongatha Pound by Ranger.

1 medium bay gelding, blaze on face, no visible brand

If not claimed and expenses paid to be sold on 1st September, 1966.

G. NELSON,

Poundkeeper.

3030—\$1.40

**MORWELL**.—Impounded in Morwell Pound.

1 ewe lamb, no visible brand

If not claimed and expenses paid, to be sold on 30th August, 1966.

S. HUGUENIN,

Poundkeeper.

3149—\$1.20

**YARRA JUNCTION.**—Impounded in Yarra Junction Pound.

1 grey mare, no visible brand, strap around neck  
 If not claimed and expenses paid, to be sold on 3rd September, 1966.  
 M. BERUDE,  
 Poundkeeper.  
 3062—\$1.40

**NOTICE OF MAKING OF STATUTORY RULES.**

*Subordinate Legislation Act 1962.*

IN pursuance of the provisions of the *Subordinate Legislation Act 1962* and the Regulations made thereunder, notice is given of the making of the following statutory rules:—

No.	Country Fire Authority Act 1958.	Price.
218/1966.	Country Fire Authority (General Regulations Amendment No. 1) Regulations 1966	8c
<i>Apprenticeship Act 1958.</i>		
219/1966.	Apprenticeship (Carpentry and Joinery Trades) (Amendment) Regulations 1966	8c
<i>Racing Act 1958.</i>		
220/1966.	Dog Racing Control Board (Fees) Regulations 1966	5c
<i>Education Act 1958.</i>		
221/1966.	Education Department Regulations 1962 (Amendment No. 12)	5c
<i>Game Act 1958.</i>		
222/1966.	Hog Deer on Wilson's Promontory National Park, and Nooramunga State Wildlife Reserve	5c
<i>Police Regulation Act 1958.</i>		
223/1966.	Police (Authorized Strength) Regulations 1966	5c

Copies of these statutory rules may be purchased at the Sale of Publications Section of the Government Printing Office, located off Parliament-place, Melbourne, C.2. If ordered by mail, remittance should be addressed to "The Government Printer, Box 203, P.O., North Melbourne, N.1", and should include 5c extra for postage. If a credit account is held at this Office, no remittance is required with the mail order.

A. C. BROOKS,  
 Government Printer.

**ACTS REPRINTED IN ACCORDANCE WITH THE AMENDMENTS INCORPORATION ACT 1958 (No. 6422), AND FOR SALE AT THE SALE OF PUBLICATIONS BRANCH OF THE GOVERNMENT PRINTING OFFICE, MACARTHUR-STREET, MELBOURNE.**

No.		Price.
6189.	Acts Interpretation (Incorporating amendments up to No. 7146)	\$0.15
6191.	Administration and Probate ( <i>Second Reprint</i> —Incorporating amendments up to No. 6920)	\$0.35
6194.	Agricultural Colleges Act ( <i>Reprint</i> (No. 1)—Incorporating Amendments up to Act No. 7302)	\$0.12
6199.	Apprenticeship ( <i>Reprint</i> No. 1, incorporating amendments up to No. 7312)	\$0.25
6209.	Boiler Inspection (Incorporating amendments up to No. 7072)	\$0.18
6210.	Building Societies Act 1958 (Incorporating Amendments up to No. 7125)	\$0.25
6218.	Children's Court (Incorporating amendments up to No. 7084)	\$0.20
6219.	Children's Welfare (Incorporating amendments up to No. 6812)	\$0.25
6220.	Clean Air (Incorporating amendments up to No. 6886)	\$0.10
6222.	Commercial Goods Vehicles (Incorporating amendments up to No. 6886)	\$0.18
6839.	Companies (Incorporating amendments up to No. 7142)	\$2.25
6839.	Companies Act 1961 ( <i>Second Reprint</i> —Incorporating amendments up to No. 7332)	\$2.32
6225.	Co-operation ( <i>Second Reprint</i> —Incorporating amendments up to No. 7083)	\$0.42

**ACTS REPRINTED IN ACCORDANCE WITH THE AMENDMENTS INCORPORATION ACT 1958 (No. 6422)—continued.**

No.		Price.
6226.	Co-operative Housing Societies (Incorporating amendments up to No. 7097)	\$0.40
6228.	Country Fire Authority (Incorporating amendments up to No. 7065)	\$0.40
6229.	Country Roads (Incorporating amendments up to No. 6943)	\$0.40
6231.	Crimes (Incorporating amendments up to No. 6958)	\$1.32
6236.	Dog ( <i>Second Reprint</i> —Incorporating amendments up to No. 7065)	\$0.15
6242.	Employers and Employés (Incorporating amendments up to No. 6740)	\$0.18
6245.	Estate Agents ( <i>Second Reprint</i> )—Incorporating amendments up to No. 7134)	\$0.38
6246.	Evidence (Incorporating amendments up to No. 6758)	\$0.35
6249.	Fences (Incorporating amendments up to No. 6550)	\$0.12
6250.	Fertilizers Act 1958 (Incorporating Amendments up to No. 7142)	\$0.18
6251.	Firearms (Incorporating amendments up to No. 6716)	\$0.22
6916.	Foreign Judgments Act 1962 ( <i>Reprint</i> No. 1, including amendments made by Act No. 7332)	\$0.12
6585.	Forests (Pulpwood Agreement) (Incorporating amendments up to No. 6886)	\$0.15
6259.	Gaols (Incorporating amendments up to No. 6651)	\$0.15
6265.	Goods ( <i>Third Reprint</i> —Incorporating amendments up to No. 7131)	\$0.28
6270.	Health (Incorporating amendments up to No. 6886)	\$1.45
6274.	Hospitals and Charities (Incorporating amendments up to No. 6716)	\$0.35
6279.	Instruments ( <i>Second Reprint</i> —Incorporating amendments up to No. 6886)	\$0.38
6282.	Justices (Incorporating amendments up to No. 6961)	\$1.12
6282.	Justices ( <i>Second Reprint</i> —Incorporating amendments up to Act No. 7369)	\$1.23
6283.	Labour and Industry ( <i>Second Reprint</i> —Incorporating amendments up to No. 7143)	\$0.75
6285.	Landlord and Tenant ( <i>Second Reprint</i> —Incorporating amendments up to No. 6996)	\$0.50
6289.	Land Tax (Incorporating amendments up to No. 7099)	\$0.32
6291.	Legal Profession Practice (Incorporating amendments up to No. 7065)	\$0.45
6293.	Licensing Act ( <i>Second Reprint</i> —Incorporating Amendments up to No. 7054)	\$0.95
6577.	Lifts and Cranes (Incorporating amendments up to No. 6886)	\$0.12
6295.	Limitation of Actions (Incorporating amendments up to No. 6845)	\$0.15
6298.	Local Authorities Superannuation (Incorporating amendments up to No. 6894)	\$0.25
6299.	Local Government (Incorporating amendments up to No. 7052)	\$3.50
6302.	Marine Act (Incorporating Amendments up to Act No. 7350)	\$0.72
6309.	Medical (Incorporating amendments up to No. 6837)	\$0.38
6310.	Melbourne and Metropolitan Board of Works Act 1958 (Incorporating amendments up to No. 7054)	\$0.85
6312.	Melbourne Harbor Trust Act 1958 ( <i>Reprint</i> No. 1, incorporating amendments up to Act No. 7356)	\$0.48
6605.	Mental Health (Incorporating amendments up to No. 7135)	\$0.45
6315.	Metropolitan Fire Brigades (Incorporating amendments up to No. 6886)	\$0.28
6317.	Milk and Dairy Supervision (Incorporating amendments up to No. 6964)	\$0.40
6318.	Milk Board Act (Incorporating amendments up to No. 7093)	\$0.22
6324.	Money Lenders (Incorporating amendments up to No. 6886)	\$0.25
6832.	Motor Boating (Incorporating amendments up to No. 6961)	\$0.15
6325.	Motor Car (Incorporating amendments up to No. 6867)	\$0.65
6325.	Motor Car ( <i>Second Reprint</i> —Incorporating amendments up to Act No. 7361)	\$0.82
6326.	National Parks Act 1958 (Incorporating Amendments up to No. 7275)	\$0.15
6328.	Nurses (Incorporating amendments up to No. 6716)	\$0.20
6330.	Partnership	\$0.15

ACTS REPRINTED IN ACCORDANCE WITH THE AMENDMENTS  
INCORPORATION ACT 1958 (No. 6422)—*continued*.

No.	Price.
6889. Poisons (Incorporating amendments up to No. 7065) .. .. .	\$0.35
6337. Police Offences (Incorporating amendments up to No. 7145) .. .. .	\$0.82
6338. Police Regulation (Incorporating amendments up to No. 7081) .. .. .	\$0.45
6890. Probate Duty (Incorporating amendments up to No. 6970) .. .. .	\$0.38
6343. Process Servers and Inquiry Agents (Incorporating amendments up to No. 7126) .. .. .	\$0.12
6344. Property Law (Incorporating amendments up to No. 6867) .. .. .	\$0.90
6349. Public Service (Incorporating amendments up to No. 6886) .. .. .	\$0.28
6350. Public Trustee (Incorporating amendments up to No. 6961) .. .. .	\$0.35
6359. Road Traffic (Incorporating amendments up to No. 6999) .. .. .	\$0.15
6359. Road Traffic ( <i>Second Reprint</i> —Incorporating amendments up to No. 7332) .. .. .	\$0.18
6360. Rural Finance Act ( <i>Reprint</i> (No. 1)—Incorporating Amendments up to Act No. 7328) .. .. .	\$0.12
6846. Rural Finance and Settlement Commission Act 1961 ( <i>Reprint</i> No. 1, incorporating amendments up to No. 7332) .. .. .	\$0.20
6975. Sale of Land Act 1962 ( <i>Reprint</i> No. 1, incorporating amendments up to No. 7332) .. .. .	\$0.18
6363. Second-Hand Dealers .. .. .	\$0.12
6367. Settled Land (Incorporating amendments up to No. 6505) .. .. .	\$0.40
6368. Sewerage Districts Act ( <i>Reprint</i> (No. 1)—Incorporating Amendments up to Act No. 7332) .. .. .	\$0.62
6651. Social Welfare ( <i>Second Reprint</i> —Incorporating amendments up to No. 7084) .. .. .	\$0.35
6372. Soil Conservation and Land Utilization Act 1958 (Incorporating amendments up to No. 6961) .. .. .	\$0.20
6375. Stamps ( <i>Second Reprint</i> —Incorporating amendments up to No. 7142) .. .. .	\$0.70
6375. Stamps ( <i>Third Reprint</i> —Incorporating amendments up to No. 7359) .. .. .	\$0.82
6377. State Electricity Commission (Incorporating amendments up to No. 7054) .. .. .	\$0.50
6379. State Savings Bank (Incorporating amendments up to No. 6886) .. .. .	\$0.42
6886. Subordinate Legislation (Incorporating amendments up to No. 6961) .. .. .	\$0.15
6849. Town and Country Planning Act ( <i>Reprint</i> (No. 1)—Incorporating Amendments up to Act No. 7276) .. .. .	\$0.35
6399. Transfer of Land ( <i>Second Reprint</i> —Incorporating amendments up to No. 7130) .. .. .	\$0.52
6401. Trustee ( <i>Second Reprint</i> —Incorporating amendments up to No. 6963) .. .. .	\$0.42
6879. Unclaimed Moneys (Incorporating amendments up to No. 6961) .. .. .	\$0.12
6653. Valuation of Land (Incorporating amendments up to No. 7019) .. .. .	\$0.15
6413. Water (Incorporating amendments up to No. 7228) .. .. .	\$1.42
6414. Weights and Measures (Including amendments up to No. 6918) .. .. .	\$0.32
6419. Workers Compensation (Incorporating amendments up to No. 7063) .. .. .	\$0.50
—	
FIRST NOTIFICATION OF REPRINT—	
6222. Commercial Goods Vehicles ( <i>Second Reprint</i> —Incorporating amendments up to Act No. 7358) .. .. .	\$0.22

ACTS REPRINTED IN ACCORDANCE WITH THE AMENDMENTS  
INCORPORATION ACT 1958 (No. 6422)—*continued*.

No.	Price.
6246. Evidence Act ( <i>Second Reprint</i> —Incorporating amendments up to Act No. 7366) .. .. .	\$0.42
6284. Land Act (Incorporating amendments up to Act No. 7360) .. .. .	\$1.53
6039. Medical Act ( <i>Second Reprint</i> —Incorporating amendments up to Act No. 7408) .. .. .	\$0.40
6353. Racing Act ( <i>First Reprint</i> —Incorporating amendments up to Act No. 7404) .. .. .	\$0.70
6373. Soldier Settlement Act ( <i>First Reprint</i> —Incorporating amendments up to Act No. 7328) .. .. .	\$0.42
6400. Transport Regulation Act ( <i>First Reprint</i> —Incorporating amendments up to Act No. 7358) .. .. .	\$0.22
6416. Weights and Measures Act ( <i>Second Reprint</i> —Incorporating amendments up to Act No. 7332) .. .. .	\$0.32
6419. Workers Compensation Act ( <i>Second Reprint</i> —Incorporating amendments up to Act No. 7332) .. .. .	\$0.52
6653. Valuation of Land Act 1960 ( <i>Second Reprint</i> —Incorporating amendments up to Act No. 7333) .. .. .	\$0.22
6191. Administration and Probate Act ( <i>Third Reprint</i> —Incorporating amendments up to Act No. 7332) .. .. .	\$0.38
6651. Social Welfare Act 1960 ( <i>Third Reprint</i> —Incorporating amendments up to Act No. 7332) .. .. .	\$0.20

A. C. BROOKS,  
Government Printer.

**CONTENTS**

	PAGE
Acts of Parliament on sale at the Government Printing Office .. .. .	3093
Appointments .. .. .	3052
Bank Holidays .. .. .	3033
Cemeteries—Scale of Fees .. .. .	3050
Contracts .. .. .	3051
Country Roads Board .. .. .	3049
Estates of Deceased Persons .. .. .	3035
Farm Produce Agents Act .. .. .	3036
Government Notices .. .. .	3035
Impoundings .. .. .	3092
Lands .. .. .	3068
Melbourne and Metropolitan Board of Works— Notices .. .. .	3049
Mining .. .. .	3045
Notice of Making of Statutory Rules .. .. .	3093
Orders in Council— Acts—Local Government; Land; Country Roads; Labour and Industry; Railways; Sewerage Districts; Geelong Waterworks and Sewerage; Water; Landlord and Tenant; Local Government. .. .. .	3054 et seq
Police Sale .. .. .	3045
Private Advertisements .. .. .	3082
Proclamations .. .. .	3031
Public Holidays .. .. .	3032
Public Service Notices .. .. .	3078
Resignations .. .. .	3053
State Rivers and Water Supply Commission .. .. .	3046
Tenders .. .. .	3075
Transport Regulation Board—Public Hearings .. .. .	3041
Waterworks Trusts .. .. .	3047