



VICTORIA
GOVERNMENT GAZETTE

Published by Authority

[Registered at the General Post Office, Melbourne, for transmission by post as a newspaper.]

No. 2]

FRIDAY, JANUARY 6

[1967

GOVERNMENT NOTICES

Government House,
Melbourne,
1st January, 1967.

THE QUEEN has been graciously pleased to signify Her Majesty's intention of conferring the following Honours, Decorations and Awards in the New Year Honours, 1967:—

TO BE KNIGHTS BACHELOR.

Harold Roy Fidge, Esquire, LL.B.
The Honourable Mr. Justice Robert Vincent Monahan, LL.B.

THE MOST DISTINGUISHED ORDER OF SAINT MICHAEL AND SAINT GEORGE.

To be a Companion of the said Most Distinguished Order:
Albert Edward Chadwick, Esquire, M.S.M.

THE MOST EXCELLENT ORDER OF THE BRITISH EMPIRE.

To be a Commander of the Civil Division of the said Most Excellent Order:

The Honourable Thomas Henry Grigg, M.L.C.

To be Officers of the Civil Division of the said Most Excellent Order:

The Reverend Christopher Thomas Frow Goy.
John Brisbane Harper, Esquire, M.A., LL.M.
George Lauder McCowan, Esquire, Dip.C.E.
Ainslie William Walker, Esquire.
The Reverend Alfred Harold Wood, D.D., M.A.

To be Members of the Civil Division of the said Most Excellent Order:

Councillor Kenneth Fox Adam.
Miss Eirene May Appleton.
Councillor Rupert Bassett.

Councillor Ernest Oliver Bidstrup.
Mrs. Helen Elizabeth Chandler.
Mrs. Maisie Carrothers Ewan.
Edward Noel Thomas Henry, Esquire.
Councillor Herbert David Mitchell.
Jabez Jagger Potts, Esquire.
Mrs. Mavis Prytz.
Fussell John Richardson, Esquire.

**AWARDS OF THE BRITISH EMPIRE MEDAL.
(Civil Division.)**

Arthur Ninian Cousland, Esquire.
Albert Edward Dawe, Esquire.
Percy Drummy, Esquire.
Edward Parry Taylor, Esquire.
Alan Hubert Tweney, Esquire.

J. COLQUHOUN,
Official Secretary to the Governor.

LOCAL GOVERNMENT DEPARTMENT.

ORDER CONFIRMED.—CITY OF MOORABBIN.

THE Minister of the Crown administering the *Local Government Act 1958*, as amended, on the 16th day of December, 1966, confirmed the Order hereinafter referred to in pursuance of section 514 of the said Act, namely:

An Order of the Council of the City of Moorabbin made on the 5th December, 1966, directing the compulsory taking of the land described in certificate of title, volume 2279, folio 761, for the purpose of providing a car parking area.

R. J. HAMER,
Minister for Local Government.

Local Government Department,
Melbourne.

LOCAL GOVERNMENT DEPARTMENT.

ORDER CONFIRMED.—SHIRE OF DONCASTER AND
TEMPLESTOWE.

THE Minister of the Crown administering the *Local Government Act 1958*, as amended, on the 16th day of December, 1966, confirmed the Order hereinafter referred to in pursuance of section 514 of the said Act, namely:

An Order of the Council of the Shire of Doncaster and Templestowe made on the 3rd October, 1966, directing the compulsory taking of the land described in certificate of title, volume 8496, folio 854, for the purpose of providing pleasure grounds and places of public resort and recreation.

R. J. HAMER,
Minister for Local Government.

Local Government Department,
Melbourne.

PUBLIC TRUSTEE ACT 1958 (No. 6350), SECTION 17.

I HEREBY give notice that on the 7th December, 1966, the Public Trustee filed elections to administer the following deceased persons' estates, in accordance with section 17 of the *Public Trustee Act 1958*:—

JONES, Frederick Walter, late of Cheltenham Home and Hospital for the Aged, Cheltenham, pensioner, died 20th November, 1965.

JONES, Gordon Robert, late of 26 Mary-street, St. Kilda, fibreglass worker, died 17th July, 1966.

MARRIAGE, Frederick Thomas, late of Ilex-street, Red Cliff, caretaker, died 16th January, 1966.

PLACE, William Thomas, late of 48 Malane-street, Ormond, gentleman, died 12th September, 1966.

SINNET, Charles, also known as Charles James Carter, late of 4 Commercial-road, Footscray, furnaceman, died 16th April, 1966.

SPRECKLEY, Charles Edward, also known as Charles Spreckly, late of 31 Bell-street, Fitzroy, pensioner, died 7th July, 1966.

VIGOR, Arthur James, late of 462 Little Lonsdale-street, Melbourne, cleaner, died 13th August, 1966.

WAH-AH-JUNG, Charlie, late of Cheltenham Home and Hospital for the Aged, Cheltenham, pensioner, died 7th August, 1966.

A. D. DUNCAN,
Public Trustee.

256 Flinders-street, Melbourne, C.1, 22nd December, 1966.

NOTICE.

CREDITORS, next of kin, and others having claims against the estate of any of the under-mentioned deceased persons are required to send particulars of their claims to the Public Trustee, 256 Flinders-street, Melbourne, the personal representative, on or before the 3rd March, 1967, after which date the Public Trustee may convey or distribute the assets, having regard only to the claims of which the Public Trustee then has notice:—

BELL, Thomas Blakeley, late of 68 Glen Orme-avenue, Ormond, retired, died 7th September, 1966.

BRAMLEY, George Frederick, late of Walwa, glazier, died 27th July, 1966.

BURKE, William James, late of 18 Douglas-street, Toorak, mercer, died 8th October, 1966.

ELLIS, Ethel May, 1 Webb-street, Coburg, widow, died 16th August, 1966.

FREEMAN, William George, late of Carnarvon-street, Lang Lang, farm labourer, died 18th May, 1966.

HANNEN, Doris May, late of 70 Leura-grove, Hawthorn, spinster, died 16th July, 1966.

HARRIS, Ethel Rosina Veronica, also known as Ethel Rose Harris, late of 87 Chomley-street, Prahran, married woman, died 29th April, 1966.

JONES, Frederick Walter, late of Cheltenham Home and Hospital for the Aged, Cheltenham, pensioner, died 20th November, 1965.

JONES, Gordon Robert, late of 26 Mary-street, St. Kilda, fibreglass worker, died 17th July, 1966.

LONG, Frederick Robert, late of 22 Ethel-street, Thornbury, retired storeman, died 1st October, 1966.

MARRIAGE, Frederick Thomas, late of Ilex-street, Red Cliff, caretaker, died 16th January, 1966.

MCGOWAN, Kelvin Herbert, late of 38 Nicholson-street, East Brunswick, accountant, died 19th August, 1966.

NULTY, Christopher Samuel Hampton, late of 50 Evelyn-street, Clayton, patrolman (S.E.C.), died 5th June, 1966.

PHILLIPS, Thomas David, late of 36 Main-street, Coburg, retired engineer, died 6th September, 1966.

PLACE, William Thomas, late of 48 Malane-street, Ormond, gentleman, died 12th September, 1966.

PRESTON, Hilda Dorothea, formerly of 129 Riversdale-road, Hawthorn, but late of 25 Kelmar-street, Cheltenham, widow, died 4th September, 1966.

PURNELL, Arthur Edward James, late of 8 de Carle-street, Coburg, clerk, died 1st September, 1966.

SINNET, Charles, also known as Charles James Carter, late of 4 Commercial-road, Footscray, furnaceman, died 16th April, 1966.

SMITH, Elsie Ida, late of Beach-road, Rhyll, Phillip Island, widow, died 8th July, 1966.

SPRECKLEY, Charles Edward, also known as Charles Spreckly, late of 31 Bell-street, Fitzroy, pensioner, died 22nd July, 1966.

SUMMERS, Reginald Edward, also known as Edward Summers, formerly of 185 Cubitt-street, Richmond, late of Greenvale Village, Broadmeadows, retired railway employee, died 12th August, 1966.

TRENGROVE, Edith Alice, late of 233 Shannon-avenue, Geelong West (formerly known as 183 West Melbourne-road, Geelong West), widow, died 29th August, 1966.

Tsingopoulos, Dionesia, late 219 Esplanade West, Port Melbourne, married woman, died 13th May, 1963.

TYRRELL, John Harold Leonard, also known as John Harold Tyrrell, late of 41 Chapman-street, North Melbourne, retired railway worker, died 28th June, 1966.

VIGOR, Arthur James, late of 462 Little Lonsdale-street, Melbourne, cleaner, died 13th August, 1966.

WAH-AH-JUNG, Charlie, late of Cheltenham Home and Hospital for the Aged, Cheltenham, pensioner, died 7th August, 1966.

WILSON, Charles George, formerly of 94 Leeds-road, Mount Waverley, late of 13 Investigator-street, Red Hills, A.C.T., retired accountant, died 18th July, 1966.

A. D. DUNCAN,
Public Trustee.

Melbourne, 22nd December, 1966.

FORESTS DEPARTMENT.

FOREST OFFICERS.

I LINDSAY HAMILTON SIMPSON, Her Majesty's Minister of Forests for the State of Victoria, in pursuance of the powers conferred by the Appointment of Forest Officers Regulations 1954-1957, upon the recommendation of the Forests Commission, do hereby revoke the declarations made on the 18th August, 1958, the 9th February, 1959 and the 22nd August, 1963.

And in further pursuance of such powers as aforesaid and upon the recommendation of the Forests Commission, do hereby now declare—

(1) the following officers or employees under the Commission to be forest officers under the *Forests Act 1958*:—

Chief of the Division of Forest Operations,
Chief of the Division of Forest Management,
Chief of the Division of Forest Protection,
Chief of the Division of Economics and Marketing,
Chief of the Division of Forestry Education and Research.

Chief Forest Research Officer,
Principal, School of Forestry,
Forest Resources Officer,
Officer in Charge, General Operations Branch,
Superintendent of Plantations and Nurseries,
Assistant Superintendent of Plantations and Nurseries,
Utilization Officer,
Senior Lecturer, School of Forestry,
Lecturer, School of Forestry,
Fire Protection Officer,
Sales and Marketing Officer,
Fire Research Officer,
Forest Assessor;

(2) the following classes of officers or employees to be forest officers under the said Act:—

Divisional Forester,
Assistant Divisional Forester,
District Forester,
Forester,
Working Plans Officer,
Research Officer,
Plantation Research Officer,
Cruiser,
Forest Supervisor,
Forest Overseer,
Herdsman,
Forest Foreman,
Fireguard,
Warden.

Dated at Melbourne the 3rd day of January, 1967.

L. H. S. THOMPSON,
Minister of Forests.

ORDERS IN COUNCIL.—(Series 1966-67.)**PUBLIC WORKS.**

1915. Geelong West, Technical School, laying of bituminous concrete surfacing, \$1,340.00.—Albion Reid Pty. Ltd.—(S.W.68196.)

1916. Langi Kal Kal, Youth Training Centre, urgent repairs and replacements to security locks, \$1,339.00.—W. Phelan & Sons Pty. Ltd.—(N.W.97933.)

1917. Melbourne, School of Hairdressing, supply of trolleys, \$1,373.50.—Leonardo Pty. Ltd.—(C.100428.)

1918. Mont Park, Mental Hospital, Ward M.3, electrical works urgently required to enable painting works to proceed, \$1,486.00.—S. F. Chanter Pty. Ltd.—(N.E. 93422 "A".)

1919. Mont Park, Mental Hospital, Ward M.5, electrical works urgently required to enable painting works to proceed, \$1,826.00.—S. F. Chanter Pty. Ltd.—(N.E.93421 "A".)

1920. Port Melbourne, Public Works Department's Storeyard, supply of pile shoes, \$1,750.00.—S. G. Sewell Pty. Ltd.—P. & H. 90169.

1921. Royal Park, Psychiatric Hospital, provision of Grand Master key system throughout the hospital, for security purposes, \$1,329.61.—Ogden Industries Sales Pty. Ltd.—(E.M.102284.)

1922. Toorak, Teachers' College, urgent installation of closed circuit television to avoid delays in building works, \$1,295.00.—National Television Engineering Pty. Ltd.—(E.M.245905 "A".)

1923. Warragul, High School, reconstruct an entrance road now badly deteriorated, \$14,500.00.—Shire of Warragul.—(S.E.103749.)

Approved by the Governor in Council, 20th December, 1966.—J. COLQUHOUN, Clerk of the Executive Council.

CONTRACTS ACCEPTED.—(Series 1966-67.)**PUBLIC WORKS.**

1924. Geelong, Gordon Institute of Technology, mechanical services in heat engines laboratory, \$35,976.00.—Mech Engineering Pty. Ltd.

1925. Harston, State School No. 1458, erection of residence and garage, \$10,600.00.—R. J. B. Milne.

1926. Frankston, State School No. 1464, internal toilet, &c., \$1,162.80.—W. McGown & Co.

1927. Essendon, High School, new toilet accommodation, \$1,590.00.—Nash Home Construction Co.

1928. Linton, State School No. 880, partial demolition, Room No. 4, \$1,605.00.—A. & B. Oswald Pty. Ltd.

1929. Melbourne, 278-282 Queen-street, supply and installation of an electric passenger lift, Crown Solicitors and Titles Office, \$20,124.00.—Otis Elevator Co. Pty. Ltd.

1930. Broadford, State School No. 1125, residence, Hamilton-street, repairs and painting, \$1,092.00.—Pyers Bros.

1931. Mansfield, Police Station, internal and external renovations, \$1,346.50.—Alf Richardson Constructions.

1932. Brunswick, Court House and Police Station, asphalt, concrete, drainage and associated works, \$6,584.00.—Rainbow Construction Company.

1933. Lakeside, High School, asphaltting and associated works, \$2,555.60.—Rainbow Construction Co.

1934. Horsham West, State School No. 4697, repairs and renovations, \$4,781.50.—W. Schipper Bros.

1935. Tottenham, Technical School, asphaltting, gravelling and associated works, \$13,590.60.—Roy Senior & Son Pty. Ltd.

1936. Traralgon, Day Training Centre, internal and external painting and repairs, \$2,298.00.—R. Shepherd & D. Davidson.

1937. Echuca, High School, mechanical service in new wing, \$31,324.00.—D. Smyth & Son Pty. Ltd.

1938. Netherby, State School No. 2651, renewal of non party fencing, \$1,037.95.—K. L. Templar.

1939. Ascot Vale, State School No. 2608, renewal of slate roof with concrete tiles and repair slate roof, \$8,770.58.—H. & A. Tinsley Pty. Ltd.

1940. Mildura, Reception Centre, Chaffey-street, supply and installation of Kelvinator room air conditioners as per alternative tender, \$1,382.00.—A.I. Industries.

1941. Wangaratta, Technical School, electrical installation for electrical engineering laboratory, &c., \$2,920.10.—Bartlett & Leggate.

1942. Benalla East, State School No. 2256, Residence, 8 Davey-street, repairs and painting, \$1,856.00.—Benalla Painting Service.

1943. Costerfield, State School No. 1187, erection of out-office and installation of septic tank, \$2,089.00.—B. R. Burns Pty. Ltd.

1944. Clayton, Monash High School, electrical installation in first and second sections, \$18,959.00.—P. Cave.

1945. Colac, State School No. 117, construction of new asphalt pavements and associated works, \$6,000.00.—Cavalieri Bros.

1946. Research, State School No. 2959, construction of earthworks, retaining wall, concreting asphaltting, drainage works and beautification, \$20,698.00.—W. J. Cody & Quinn Pty. Ltd.

1947. Upwey South, State School No. 4894, surface and underground drainage, asphalt, concrete gravel pavements, &c., \$9,172.00.—W. J. Cody & Quinn Pty. Ltd.

1948. Sunbury, Mental Hospital, alterations and additions to boiler house, \$22,063.00.—W. J. Cody & Quinn Pty. Ltd.

1949. Mont Park, Mental Hospitals, Mont Park, Plenty and Larundel, erection of five (5) proprietary type brick veneer residences, \$58,648.00.—Contemporary Homes Pty. Ltd.

1950. Collingwood, Technical School, electrical installation, &c., \$3,900.00.—D. J. Electrical.

1951. Pascoe Vale, Melbourne School of Textiles, Wool-classing School, electrical installation, &c., \$7,630.50.—D. J. Electrical.

1952. Echuca, High School, electrical installation in new L.T.C. wing, \$13,290.36.—K. J. Dupuy.

1953. Shepparton, Technical School, electrical installation in fifth form extensions, additions and alterations, \$28,949.29.—K. J. Dupuy.

1954. Won Wron, Reforestation Prison, mechanical services, \$15,985.00.—F.I.M.S. Heating.

1955. Ararat, Mental Hospital, external renovations to nurses' home, \$2,296.00.—A. Fiscalini.

1956. Timboon, High School, erection of residence and garage, \$11,750.00.—Fotheringham Constructions (Warrnambool) Pty. Ltd.

1957. Lilydale, High School, repairs and painting, \$21,440.00.—Gleeson & Grigg.

1958. Laburnum, State School No. 4863, erection of additional class-rooms, &c., \$18,310.00.—W. I. Hosie.

1959. Goroke, Consolidated School, erection of two (2) additional L.T.C. class-rooms, \$28,085.00.—A. V. Jennings Industries (Australia) Ltd.

1960. Kerang South, State School No. 4949, erection of new primary school of six class-rooms, \$78,383.00.—A. V. Jennings Industries (Australia) Ltd.

1961. Rushworth, High School, new wing and re-modelling, \$117,697.00.—A. V. Jennings Industries (Australia) Ltd.

1962. Diamond Creek, Police Station, renovations to office and residence, \$1,559.00.—L. J. Jessop.

1963. Swan Hill, High School, replacement of ceiling, \$5,714.00.—Kerang Plaster Sheet Co. Pty. Ltd.

1964. Welton, State School No. 4041, residence, new laundry and toilet, &c., \$1,850.00.—Kerang Plumbing Service.

1965. Kaniva, Consolidated School, residence, 33 Young-street, repairs and painting, \$1,383.75.—Laird Bros. Pty. Ltd.

1966. Dandenong, Police Station, alterations and additions, \$19,800.00.—W. B. Leed.

1967. Licola, State School No. 3748, erection of new out-offices and septic tank installation, \$2,359.00.—T. D. Logan & Co.

1968. Toolamba West, State School No. 1674, renovations to residence, \$1,514.50.—C. W. Le Sueur.

1969. Thomastown East, State School No. 4827, erection of four additional class-rooms, \$23,724.00.—Marshall Bros. Builders.

1970. Burnley, Agriculture Department, Burnley Gardens, electrical installation in two glasshouses, \$1,286.00.—H. C. Marshall & Co. Pty. Ltd.

1971. Caramut, State School No. 728 and Residence, conversion of toilets, \$3,124.00.—V. Turland & Sons.

1972. Koallah, State School No. 4225, erection of out-offices and installation of septic tank, \$3,210.00.—N. A. Wooding.

1973. Stawell, Pleasant Creek Special School, internal renovations to "Bristol" ward, \$1,201.70.—Wimmer & Wright.

1974. Various, State School No. 1365 and Residence, High School Residence, Soil Conservation Authority Residence, Tallangatta, drainage works, concrete and gravel pavements, &c., \$1,451.80.—I. M. Angel.

1975. Culgoa, State School No. 3246, erection of non-party fencing, \$1,309.57.—A. R. C. Engineering Pty. Ltd.

1976. Seymour, High School, non-party fencing, chain mesh fences and gates, &c., \$4,902.00.—A. R. C. Engineering Pty. Ltd.

1977. Mildura West, State School No. 3983, non-party fencing, \$1,642.79.—A. R. C. Engineering Pty. Ltd.

1978. Glenorchy, State School No. 263 and residence, new shelter shed and laundry, repairs and painting, \$3,200.00.—Azeus Painting & Decorating Co.

1979. Geelong, High School Residence, 3 Normanby-street, renovations and new garage, \$4,865.00.—I. Bulat.

1980. Black Rock, State School No. 3631 and Residence, repairs and painting, \$9,700.00.—A. Buljanovic & B. Bogdanovic.

1981. Bendigo North, State School No. 1267, internal and external repairs and painting, &c., \$5,120.00.—Bull & Guy.

1982. Monterey, State School No. 4939, sowing down and planting of trees and shrubs and water reticulation, \$9,714.00.—W. J. Cody & Quinn Pty. Ltd.

1983. Frankston, Keith Turnbull Research Station, electrical installation in No. 1 glasshouse, \$1,213.40.—David Crawford Pty. Ltd.

1984. Bairnsdale, Police Station, electrical installation, \$3,212.00.—J. Darby Pty. Ltd.

1985. Cobram, High School, electrical installation and additions, \$10,254.00.—Dixon & Gillespie.

1986. Traralgon, Hobson Park Hospital, installation of heaters, \$1,279.00.—Dunns Heating & Plumbing Service.

1987. Banyule, State School No. 4746, sewer connexion and loop water supply, \$1,263.00.—Egeberg Building & Plumbing Service.

1988. Hawthorn, Swinburne Technical College, conversion of store to class-room, \$4,452.00.—E. G. Constructions.

1989. Rochester, High School, construction of concrete and asphalt paving, concrete kerbs and channels, beautification and associated works, \$5,207.00.—R. T. Ford & Co.

1990. Pascoe Vale, Melbourne School of Textiles, air conditioning, hot-water system and alterations to heating system, \$6,580.00.—F. W. Heating & Sheetmetal Engineers.

1991. Sunbury, Mental Hospital, external painting of six residences, \$2,700.00.—Gary & Co.

1992. Macarthur, State School No. 1571, Residence, repairs and painting, \$2,375.00.—F. N. Hasell.

1993. Hawthorn, Swinburne Technical College, hydraulic pump test rig, \$1,468.00.—Harland Engineering (Aust.) Pty. Ltd.

1994. Amphitheatre, State School No. 1637 and Residence, internal and external painting and repairs, \$3,976.00.—H. A. Henderson.

1995. Garfield, Tourist Development Authority, Country Roads Board Rest Areas, erection of brick toilet block, \$2,926.90.—H. O. Johnson & Sons Pty. Ltd.

1996. Melbourne, Corner Lonsdale and William-streets, erection of new Civil and Criminal Court building, \$3,761,275.00.—Lewis Construction Co. Pty. Ltd.

1997. Shepparton, State School No. 4943, construction of concrete and asphalt paving, gravelled areas, drainage and associated works, \$1,745.60.—E. B. Mawson & Sons Pty. Ltd.

1998. Geelong, Gordon Institute of Technology, supply and installation of water turbine testing rig, \$3,640.00.—Mech Engineering Pty. Ltd.

1999. Melbourne, William-street, Cancer Institute Board, attention to stone facings on central block, \$6,092.00.—Melocco Bros. Pty. Ltd.

2000. Terang, High School, asphalt paving, asphalt repairs, drainage and associated works, \$6,446.60.—W. A. Molan.

2001. Elmore, State School No. 1515, improved heating, \$1,225.40.—L. J. Morey.

2002. Rochester, State School No. 795, improved heating facilities, \$1,896.50.—L. J. Morey.

2003. Preston East, Technical School, provision of water service, \$1,040.00.—J. H. Morris.

2004. Lilydale, High School, erection of residence and garage, \$11,600.00.—C. McCarthy.

2005. Kerang, High School Residence, 6 Vaughan-street, internal and external repairs and painting, \$1,795.00.—R. B. McDonald.

2006. Lake Bolac, High School, Teachers' Residences and Flats, external and internal renovations, \$3,127.00.—J. H. McEune.

2007. Rutherglen, Research Station, electrical installation, \$8,975.60.—I. D. McGuffie.

2008. Seymour, State School No. 4957, electrical installation in new school of eight (8) class-rooms, &c., \$3,382.00.—I. D. McGuffie.

2009. Braybrook, State School No. 1102, demolition of slate urinal and renewal with stainless steel urinal, \$1,119.00.—F. Norton Pty. Ltd.

2010. Melbourne, Spring-street, Old Treasury Building, maintenance cleaning period, 1.10.66 to 31.5.69, \$6,300.00 (per annum).—Palenti Dutch Cleaning Service.

2011. Kotupna, State School No. 1999 and Residence, reblocking, repairs and painting, \$6,023.00.—N. L. Pinder.

2012. Inglewood, Higher Elementary School No. 1052, erection of a weatherboard residence, \$9,500.00.—P. K. Builders.

2013. Nathalia, High School, Residence, Kosdaht-street, repairs and painting, new fence, \$2,299.00.—N. L. Pinder.

2014. Nathalia, High School, repairs and painting, \$4,697.00.—W. J. Pryde.

2015. Labertouche, State School No. 2471 and Residence, new toilet block, septic tank installation and water supply, \$2,487.00.—R. Rodgers & M. Perry.

2016. Point Wilson, Explosives Area, galvanized steel towers (lighting towers), \$1,215.00.—Southern Cross Machinery Pty. Ltd.

2017. Ararat, Mental Hospital, repairs and painting, Wards M.8, M.9, M.10 and M.11, \$6,880.80.—C. J. Stewart.

2018. Tallangatta Valley, State School No. 2337 and Residence, repairs and painting, \$3,575.20.—R. O. Tobias.

2019. Talgarno, State School No. 1954, erection of out-offices and installation of septic tank, \$2,172.00.—R. O. Tobias.

2020. Shepparton, Technical School, fifth form extensions, additions and alterations, \$276,534.00.—C. Van Meurs.

2021. Boronia, Police Station, renovations to office and residence, \$1,586.00.—N. Dalla Vecchia.

2022. Benalla East, State School No. 2256, provision of stainless steel urinal in boys' out offices, \$1,415.25.—A. W. Williams.

2023. Boorhaman, State School No. 1996, repairs and painting and provision of tank stands and drinking trough, \$1,197.00.—K. R. & N. M. Ward.

MURRAY PORTER, Minister of Public Works. 22.12.66.

SOIL CONSERVATION AUTHORITY.

WILBY ALMONDS.

Contract No. 6621.

2060. Erection of four reinforced concrete structures, \$2,640.00.—S. Juhasz, 7A Capella-street, North Balwyn.

SHELBOURNE HILLS.

Contract No. 6614.

2061. Erection of ten reinforced concrete structures, \$7,448.00.—F. A. & M. E. Negri, Birchip.

WILBY-ALMONDS GROUP CONSERVATION AREA.

Contract No. 6625.

2024. Hire of tractor and ancillary equipment at \$11 an hour.—McNulty Bros, Greta South.

2025. Hire of tractor and ancillary equipment at \$13 an hour.—J. F. Hanson, Wangaratta.

N. J. DENTON, Acting Secretary.

VICTORIAN RAILWAYS.

58. Manufacture, supply, delivery and installation of 2 No. Steam Raising Equipments for Mount Buffalo Chalet for an amount of \$18,720.00 (Contract 62995).—Presha Engineering Proprietary Limited. 59. Manufacture, supply, delivery and installation of 2 No. Fuel Oil Installations for Mount Buffalo Chalet for an amount of \$5,317.00 (Contract 62996).—Presha Engineering Proprietary Limited. 60. Manufacture, supply and delivery of Roller Bearing Axle Boxes at the rate of \$78.80 each (Contract 63043).—SKF Ball Bearing Company (Australia) Pty. Ltd. 61. Supply and delivery of 2,200 volt Cable at the rate of \$30,071.92 net for 10 miles (Contract 63048) Gilbert Lodge and Co. Ltd. as distributor for Olympic Cables Pty. Ltd. 62. Supply and delivery of wooden electric light poles at rates (Contract 63053).—A. Norman. 63. Supply and delivery of wooden electric light poles at rates (Contract 63080).—Hickson's Timber Impregnation Co. (Aust.) Pty. Ltd.

By order of the Victorian Railways Commissioners,

W. WALKER, Secretary. 22.12.66.

CONTRACTS ACCEPTED.—(Series 1966-67.)
PROVISIONS.—MEAT.

No. of Contract.	Particulars of Each Tender Accepted.	Amount.	Name of Contractor.	Charge Against Vote or Fund	
PROVISIONS—					
Supply of Meat, in such quantities as may be ordered, from 1st February, 1967 to 30th April, 1967.					
Schedule No. 1.—Melbourne District—					
2026	Kew Mental Hospital	Rates as per annex	F. Watkins Pty. Ltd. ..	General Expenses 1966-67	
2027	Children's Cottages, Kew	" "	Swift Australian Co. Pty. Ltd.		
2028	Pentridge Penal Establishment and "Fairlea" Female Prison, Fairfield	" "	J. H. Cooke Pty. Ltd. ..		
2029	"Turana" Youth Training Centre, Royal Park, and Travancore Developmental Centre, Flemington	" "	"		
2030	"Winlaton" Girls' Training Centre, 186 Springvale-road, Nunawading, and "Allambie", 70 Elgar-road, Burwood	" "	"		
2031	Royal Park Psychiatric Hospital	" "	"		
Schedule No. 2.—Mont Park, Bundoora, Larundel, Janefield, Gresswell, and Pleasant View, Wood-street, Preston—					
2032	Mont Park District	" "	W. Angliss and Co. (Aust.) Pty. Ltd.		
2033	Preston	" "	"		
2034	Gresswell Sanatorium	" "	"		
2035	Schedule No. 3.—SS. Rip and Dredges	" "	G. K. and M. Reynolds Bros. Pty. Ltd.		
2036	Schedule No. 4.—Teachers' College and Hostels at Grattan-street, 93 Drummond-street, Carlton; 470, 481 and 572 St. Kilda-road, Melbourne; 19 Queen's-road, Melbourne; 152 Toorak-road West, South Yarra; Frank Tate House, 373 Dandenong-road, Armadale; "Redcourt", No. 6, "Larnook", 13, and No. 10A Orrong-road, Armadale; 11 Patterson-street, Hawthorn; 174 Punt-road, Prahran; 221 Burwood-road, Burwood; John Cannon House, 32 Belmont-avenue, Kew, 17 Moule-avenue, Brighton, and Hastings-road, Frankston; and Police Hospital, St. Kilda-road, Melbourne; Mental Hygiene Clinic, 321 Glenferrie-road, Malvern, St. Nicholas Hospital	" "	Anderson Meat Packing Co. Pty. Ltd.		
2037	Schedule No. 5.—Heatherton Sanatorium, Cheltenham	" "	W. Angliss and Co. (Aust.) Pty. Ltd.		
2038	Schedule No. 6.—Ararat District	" "	"		
Schedule No. 7.—Ballarat District—					
2039	Gaol and Mental Hospital	" "	H. A. Morris		
2040	Teachers' Hostels	" "	"		
2041	Schedule No. 8.—Beechworth District	" "	E. Spencer		
Schedule No. 9.—Bendigo District—					
2042	Gaol	" "	Alan H. Gittins		
2043	Sandhurst Boys' Centre	" "	Alan H. Gittins		
2044	Teachers' Hostels	" "	Frank Wade		
2045	Schedule No. 10.—Castlemaine District	" "	McQueen Bros.		
2046	Schedule No. 11.—School of Forestry, Creswick	" "	H. J. Symons Pty. Ltd. ..		
2047	Schedule No. 13.—McLeod Settlement, French Island	" "	L. K. Jones		
Schedule No. 14.—Geelong District—					
2048	Gaol	" "	Jacksons Corio Meat Packing (1965) Pty. Ltd.		
2049	Teachers' Hostels	" "	"		
2050	Schedule No. 15.—Cooriemungle Prison Camp, Heytesbury Forest	" "	Thomas Borthwick and Sons (A/asia) Ltd.		
2051	Schedule No. 17.—Langi Kal Kal Training Centre	" "	H. A. Morris		
2052	Schedule No. 20.—Sale Gaol	" "	R. Schuback		
2053	Schedule No. 21.—Pleasant Creek Special School, Stawell	" "	Thos. Borthwick		
2054	Schedule No. 22.—Sunbury District	" "	Chas. T. Smitheram Pty. Ltd.		
2055	Schedule No. 23.—Warrnambool District	" "	Thomas Borthwick and Sons (A/asia) Ltd.		
2056	Schedule No. 24.—Hobson Park Hospital, Traralgon	" "	Stoddart Bros.		
2057	Schedule No. 25.—Morwell River Reforestation Prison	" "	Rogers Bros.		
2058	Schedule No. 26.—State Research Farm, Werribee	" "	Anderson Meat Packing Co. Pty. Ltd.		
2059	Schedule No. 27.—Hillside Boys' Home, Wheelers Hill	" "	"		

Approved H. E. Bolte, Treasurer—22.12.1966.

SCHEDULE No. 1.—MELBOURNE DISTRICT.

ANNEX TO CONTRACT No. 1967/2026.
F. Watkins Pty. Ltd., 256 Russell-street, Melbourne.

Sub-schedule No. 1.
MEAT FOR MENTAL HOSPITAL, KEW.
Security, \$40.

Fresh Beef—

1. Rolled Roast, boneless (Brisket excluded)	per lb.	cents
2. Buttocks	do.	32
3. Shin and Gravy Beef (boneless)	do.	26
4. Corned Beef—Rolled or Round, as ordered, without bone or cartilage	do.	28

SCHEDULE No. 1.—MELBOURNE DISTRICT—continued.

5. Fresh Mutton—(whole sheep) (Kidney fat to be removed)	per lb.	cents
6. Veal—boned	do.	30
7. Sausages—Mixed	do.	..
8. Sausage Meat	do.	15
9. Kidneys, Ox	do.	30
10. Tripe, Fresh	do.	..
11. Saveloys	per doz.	..
12. Fowls, First quality	per lb.	..
13. Bacon Sides	do.	50
14. Steak, Stewing	do.	..
15. Salad Loaf	do.	..
16. Luncheon Loaf	do.	28
17. Sausage, Strasburg	do.	35

SCHEDULE No. 1.—MELBOURNE DISTRICT—continued.

ANNEX TO CONTRACT No. 1967/2027.

F. Watkins Pty. Ltd., 256 Russell-street, Melbourne.

Sub-schedule No. 2.

MEAT FOR CHILDREN'S COTTAGES, KEW.

Security, \$30.

	cents.
1. Fresh Beef—Buttocks .. per lb.	27
2. Fresh Mutton (whole sheep) (Kidney fat to be removed) .. do.	20
3. Fresh Mutton—Legs .. do.	20
4. Sausages, mixed .. do.	20
5. Kidney—Sheep .. do.	30
6. Fresh Veal, boneless .. do.	9
7. Brains, Sheep .. per set	50
8. Bacon, Sides .. per lb.	40
9. Fowls, First quality .. do.	26
10. Fresh Beef, Shin, Gravy, and Stewing .. do.	19
11. Fresh Mutton Pumped Leg .. do.	28
12. Fresh Beef, Corned, Rolled, without bone or cartilage .. do.	28
13. Livers, Sheep .. do.	15
14. Sausage Meat .. do.	31
15. Fresh Beef, Rolled Roast, Brisket excluded .. do.	28
16. Beef Loaf .. do.	28
17. Beef Luncheon .. do.	28

ANNEX TO CONTRACT No. 1967/2028.

Swift Australian Co. (Pty.) Ltd., 37 Ascot Vale-road, Newport.

Sub-schedule No. 3.

MEAT FOR PENTRIDGE PENAL ESTABLISHMENT, COBURG; AND "FAIRLEA" FEMALE PRISON, FAIRFIELD.

Security, \$70.

	cents.
Fresh Beef—	
1. Forequarters .. per lb.	15
2. Minced .. do.	23
3. Corned Beef—Rolled or round, as ordered, without bone or cartilage .. do.	31
4. Fresh Mutton (whole sheep) .. do.	15
5. Sausages—Mixed—Thin .. do.	23
6. Fresh Suet—Kidney .. do.	10
7. Sausage—Beef, German .. do.	34
8. Sausage, Mince .. do.	18
9. Dripping, Beef .. do.	12
10. Frankfurts .. do.	24
11. Ham Loaf .. do.	35
12. Fresh Mutton, Legs .. do.	22
13. Fresh Beef Rolled Roast Boneless—Brisket Excluded .. do.	33

ANNEX TO CONTRACT No. 1967/2029.

J. H. Cooke, Pty. Ltd., 378 Queen's-parade, Clifton Hill.

Sub-schedule No. 4.

MEAT FOR "TURANA" YOUTH TRAINING CENTRE, ROYAL PARK, AND TRAVANCORE DEVELOPMENTAL CENTRE, FLEMINGTON.

Security, \$16.

	cents
1. Fresh Beef—Rolled Roast (Sirloin, per lb. Boneless) ..	35
2. Beef—Corned—Silverside .. do.	43
Fresh Mutton—	
3. Rib Chops as Cutlets .. do.	17
4. Legs .. do.	19
5. Legs (Two-tooth) .. do.	20
6. Chops—Mid. Loin (Two-tooth) .. do.	20
7. Chump Chops .. do.	30
8. Veal, Legs .. do.	30
Steak—	
9. Rump .. do.	38
10. Blade .. do.	36
11. Minced .. do.	27
12. Topside .. do.	43
13. Rissole .. do.	27
14. Veal—Fillet, boneless .. do.	36
15. Pork—Chops .. do.	38
16. Sausages—Mixed .. do.	21
17. Sausage—Strasbourg Pork .. do.	40
18. Frys—Lamb .. do.	20
19. Ox Kidney .. do.	30
20. Frankfurts .. do.	27
21. Rabbits—Fresh .. do.	28
22. Shanks—Sheep .. each,	35
23. Sausage—Beef-German .. per lb.	9
24. Steak—Stewing .. per set	9
25. Brains—Sheep ..	

SCHEDULE No. 1.—MELBOURNE DISTRICT—continued.

ANNEX TO CONTRACT No. 1967/2030.

J. H. Cooke Pty. Ltd., 378 Queen's-parade, Clifton Hill.

Sub-schedule No. 5.

MEAT FOR "WINLATON" GIRLS' TRAINING CENTRE, 186 SPRINGVALE-ROAD, NUNAWADING, AND "ALLAMBIE", 70 ELGAR-ROAD, BURWOOD.

Security, \$10.

	cents
1. Fresh Beef—Rolled Roast Sirloin, Boneless .. per lb.	35
2. Beef—Corned—Silverside .. do.	43
Mutton, Fresh—	
3. Chump Chops (two-tooth) .. per lb.	22
4. Legs .. do.	19
5. Chops—Mid. Loin .. do.	19
6. Chops—Forequarter .. do.	15
Steak—	
7. Topside .. do.	45
8. Rump .. do.	46
9. Stewing .. do.	34
10. Minced .. do.	28
11. Blade .. do.	38
12. Sausages—Mixed .. do.	21
13. Sausage Meat .. do.	13
14. Frys—Lamb .. do.	19
Veal—	
15. Fillet, Boneless .. do.	43
16. T-bone .. do.	49
17. Veal—Leg, Boned .. do.	35
18. Pork—Pickled (excluding legs) .. do.	20
19. Pressed Ham Loaf .. do.	36
20. Tongues—Ox .. do.	13
21. Dripping—Beef .. do.	12
22. Brains—Sheep .. per set	8
23. Sausage—Strasbourg, Pork .. per lb.	40
24. Frankfurts .. do.	28
25. Rabbits—Fresh .. do.	29
26. Kidneys—Sheep .. do.	15
27. " Ox .. do.	30
28. Sheep Shanks .. each	6

ANNEX TO CONTRACT No. 1967/2031.

J. H. Cooke Pty. Ltd., 378 Queen's-parade, Clifton Hill.

Sub-schedule No. 6.

MEAT FOR PSYCHIATRIC HOSPITAL, ROYAL PARK.

Security, \$20.

	cents
Fresh Beef—	
1. Rolled Roast, boneless (Brisket excluded) .. per lb.	35
2. Thick Flank .. do.	36
3. Fresh Mutton (legs) .. do.	19
4. Chops—Forequarter .. do.	16
5. Sausages—Mixed .. do.	21
6. Sausage—Meat .. do.	12
7. Saveloys .. per doz.	45
8. Corned Silverside .. per lb.	35
9. Sausage—Strasbourg .. do.	35
10. Luncheon Loaf .. do.	30
11. Sausage, Beef-German .. do.	30
12. Kidneys—Ox .. do.	30
13. Fowls, 1st Quality .. do.	30

SCHEDULE No. 2.—MONT PARK AND SANATORIUM GRESSWELL, ETC.

ANNEX TO CONTRACT No. 1967/2032.

W. Angliss and Co. (Aust.) Pty. Ltd., 42 Bourke-street, Melbourne.

Sub-schedule No. 1.

MEAT FOR MONT PARK MENTAL HOSPITAL, ETC.

Security, \$70.

	cents
Fresh Beef—	
1. Buttocks .. per lb.	27
2. Topside Pieces .. do.	..
3. Roast .. do.	..
Beef, Corned—	
4. Rolled or Round, as ordered, without bone or cartilage .. do.	..
5. Silverside .. do.	42
Mutton, Fresh—	
6. Carcass or Sides (Kidney fat to be removed) .. do.	12.75
7. Legs .. do.	25
Chops—	
8. Forequarter .. do.	15
9. Loin, Middle .. do.	..
10. Lamb, Loin .. do.	33
11. Lamb—Carcass .. do.	17
Steak—	
12. Topside .. do.	39
13. Stewing .. do.	25
14. Minced .. do.	25
15. Buttocks, sliced .. do.	39

SCHEDULE No. 2.—MONT PARK AND SANATORIUM GRESSWELL, ETC.—*continued.*

	cents
16. Saveloys	per doz. 58
17. Sausages—Mixed	per lb. 22
18. Shanks—Sheep	each 5
19. Tripe, Fresh	per lb. 10
20. Brains—Sheep	per set 8
21. Kidneys, Ox	per lb. 30
22. Lamb—Legs	do. 30
23. Beef, German	do. 25
24. Rabbits—Fresh	do. 33
25. Ham Loaf	do. 35
26. Veal—Minced	do. 30
27. Fillet—Veal	do. 42
28. Fowls—First quality	do. 38
29. Sausage, Strasburg, Pork	do. 35
30. Sausage, Pork German	do. do.
31. Beef, Rolled Roast—boneless, (Brisket excluded)	do. 33
32. Sausage—Meat	do. 13
33. Frankfurts	per doz. do.
34. Lamb Cutlets	per lb. 33
35. Loaf—Savoury	do. 35
36. Veal—Diced	do. 30

ANNEX TO CONTRACT No. 1967/2033.

W. Angliss and Co. (Aust.) Pty. Ltd., 42 Bourke-street, Melbourne.

Sub-schedule No. 2.

MEAT FOR PLEASANT VIEW RECEIVING HOUSE, WOOD-STREET, PRESTON.

	Security, \$10.	cents
1. Fresh Beef—Sirloin, boneless (Brisket per lb. excluded)	35
2. Corned Beef—Silverside	do. 42	
3. Fresh Lamb—Legs	do. 30	
Chops—		
4. Lamb—Forequarter	do. do.	
5. Lamb, Loin	do. 33	
6. Sausages—Pork	do. 23	
7. Dripping—Beef	do. 12	
8. Suet	do. 10	
9. Mutton, Legs, boiling	do. 22	
10. Tripe	do. 10	
11. Ham, tinned, 2-lb. tin	do. 112.5	
12. Pork—Fresh, Legs	do. 44	
Steak—		
13. Blade	do. 32	
14. Topside	do. 40	
15. Minced	do. 27	
16. Sausage—Strasburg, Pork	do. 35	
17. Tongues—Sheep	do. do.	
18. Brains—Sheep	per set do.	
19. Frankfurts	per doz. do.	
20. Rabbits—Fresh	per lb. do.	
21. Capons	do. do.	
22. Lambs Livers	do. do.	

ANNEX TO CONTRACT No. 1967/2034.

W. Angliss and Co. (Aust.) Pty. Ltd., 42 Bourke-street, Melbourne.

Sub-schedule No. 3.

MEAT FOR GRESSWELL SANATORIUM.

	Security, \$30.	cents
1. Fresh Beef—Rolled Roast Sirloin (boneless) per lb.	35
2. Beef—Corned, Silverside	do. 42	
Lamb—		
3. Fresh, Legs	do. 30	
4. Chops—Mid. Loin	do. 33	
5. Chump	do. 30	
6. Cutlets	do. 35	
Pork—		
7. Fresh, Legs	do. 44	
8. Chops	do. 45	
9. Pickled	do. 30	
10. Mutton—Leg Chops	do. 18	
Veal—		
11. Fresh, Shoulder	do. 15	
12. Cutlets	do. 40	
13. Fillet	do. 40	
Steak—		
14. Rump	do. 44	
15. Topside	do. 38	
16. Fillet	do. 68	
17. Minced	do. 25	
18. Brains—Sheep	per set 8	
19. Fowls—First quality	per lb. 38	
20. Frankfurts	do. 32	
21. Ham Loaf	do. 35	
22. Pressed Leg	do. 92	
23. Kidneys—Ox	do. 30	
24. Sheep	do. 27	
25. Livers—Lamb	do. 25	

SCHEDULE No. 2.—MONT PARK AND SANATORIUM GRESSWELL, ETC.—*continued.*

	cents
26. Rabbits—Fresh	per lb. 34
27. Sausages—Mixed	do. 22
28. Pork	do. 23
29. Sausage Meat	do. 13
30. Strasburg, Pork	do. 35
31. Tripe—Fresh	do. 10
32. Tongues—Ox	do. 15
33. Sheep	do. 12
34. Veal and Pork Loaf—Pressed	do. 35
35. Savoury Loaf—Pressed	do. 35
36. Ham—Leg, Raw	do. 75

SCHEDULE No. 3.—S.S. "Rip" AND DREDGES. ANNEX TO CONTRACT No. 1967/2035.

G. K. and M. Reynolds Bros. Pty. Ltd., 9 Villiers-street, North Melbourne.

Sub-schedule No. 1.

MEAT FOR DELIVERY AT YARRA RIVER WHARVES

	Security, \$10.	cents
1. Fresh Beef—Roast	per lb. 18
Beef Corned—		
2. Silverside	do. 41	
3. Rolled	do. 14	
Fresh Mutton—		
4. Forequarter	do. 5	
5. Legs	do. 20	
Chops—		
6. Forequarter	do. 5	
7. Loin	do. 9	
Steak—		
8. Rump	do. 45	
9. Stewing	do. 30	
10. Topside	do. 41	
11. Sausages—Mixed	do. 23	
12. Tripe—Fresh	do. 11	
13. Livers—Sheep	do. 20	
14. Suet—Kidney	do. 7	
15. Rabbits—Fresh	do. 29	
16. Ice	per cwt. 8	

SCHEDULE No. 4.—TEACHERS' COLLEGES, HOSTELS POLICE HOSPITAL, ETC. (Delivery at Institutions.)

TEACHERS' COLLEGE AND HOSTELS AT GRATTAN-STREET, 93 DRUMMOND-STREET, CARLTON; 470, 481 AND 572 ST. KILDA-ROAD, MELBOURNE; 19 QUEEN'S-ROAD, MELBOURNE; 152 TOORAK-ROAD WEST, SOUTH YARRA; FRANK TATE HOUSE, 373 DANDENONG-ROAD, ARMADALE; "REDCOURT", NO. 6, "LARNOOK", 13 AND NO. 10A ORRONG-ROAD, ARMADALE; 11 PATTERSON-STREET, HAWTHORN; 174 PUNT-ROAD, PRAHRAN; 221 BURWOOD-ROAD, BURWOOD; JOHN CANNON HOUSE, 32 BELMONT-AVENUE, KEW; 17 MOULE-AVENUE, BRIGHTON; AND HASTINGS-ROAD, FRANKSTON; POLICE HOSPITAL, ST. KILDA-ROAD, MELBOURNE; MENTAL HYGIENE CLINIC, GLENFERRIE-ROAD, MALVERN AND ST. NICHOLAS HOSPITAL.

ANNEX TO CONTRACT No. 1967/2036.

Anderson Meat Packing Co. Pty. Ltd., 613 Victoria-street, Abbotsford.

Sub-schedule No. 1.

	MEAT.	Security, \$30.	cents
Fresh Beef—			
1. Rolled Prime Ribs, boneless	per lb. 33	
2. Topside	do. 42		
3. Sirloin, boneless	do. 40		
Fresh Mutton—			
4. Legs	do. 20		
5. Legs, pickled	do. 18		
6. Sides, Two-tooth	do. 13		
7. Legs, Two-tooth	do. 21		
8. Cutlets	do. 24		
9. Chops, Mid. Loin	do. 18		
10. Chops, Forequarter	do. 16		
11. Chops, Chump	do. 19		
12. Beef—Corned, Silverside	do. 45		
Veal—			
13. Shoulder boned	do. 25		
14. Fillet, boneless	do. 46		
Steak—			
15. Blade	do. 39		
16. Minced	do. 27		
17. Stewing	do. 36		
18. Rump	do. 47		
19. Fillet	do. 72		
20. Sausages—Mixed	do. 20		
21. Sausage—Meat	do. 17		
22. Beef, German	do. 28		
23. Strasburg	do. 35		
24. Livers—Sheep	do. 21		

SCHEDULE No. 4.—TEACHERS' COLLEGES, HOSTELS, POLICE HOSPITAL, ETC.—continued.

	cents
25. Kidneys—Sheep per lb.	15
26. " Ox do.	30
27. Tongues—Ox do.	17
28. Ox Tails do.	12
29. Brains—Sheep per set	7
30. Tripe—Fresh per lb.	10
31. Frankfurts do.	30
32. Bones—Soup do.	2
33. Suet—Kidney do.	3
34. Rabbits—Fresh do.	35
35. Fowls—First quality do.	46
36. Pork—Legs do.	46
37. " Loin do.	44
38. Lamb, legs do.	33
39. Ham, pressed do.	85
40. Dripping do.	12

SCHEDULE No. 5.—HEATHERTON SANATORIUM. ANNEX TO CONTRACT No. 1967/2037.

W. Angliss and Co. (Aust.) Pty. Ltd., 42 Bourke-street, Melbourne.

Sub-schedule No. 1.

MEAT.		cents
Security, \$10.		
1. Beef, Fresh Roast—Sirloin, Rolled Roast	per lb.	28
2. " Corned—Silverside do.		42
Lamb, Fresh—		
3. Legs do.		30
4. Shoulder, Rolled do.		10
5. Chops, Mid. Loin do.		33
6. Chops, Chump do.		30
7. Chops, Forequarter do.		18
8. Cutlets do.		33
Pork, Fresh—		
9. Legs do.		44
10. Chops do.		40
11. Minced do.		16
Veal—		
12. Shoulder, Boned do.		15
13. Cutlets do.		33
14. Fillets do.		40
Steak—		
15. Rump do.		44
16. Blade do.		34
17. Topside do.		35
18. Minced do.		25
19. Porterhouse do.		36
20. Fillet do.		60
21. Mutton, Pumped, Leg do.		18
22. Tripe—Fresh do.		10
23. Brains—Sheep per set		8
24. Lamb's Fry per lb.		25
25. Tongues—Sheep do.		10
26. Kidneys—Ox do.		30
27. " Sheep do.		27
28. Tails—Ox do.		14
29. Sausages—Pork do.		23
30. Sausage Meat do.		10
31. Frankfurts—Vienna do.		35
32. Beef, German—Sausage do.		25
33. Ham—Loaf do.		35
34. " Pressed, Shoulder do.		75
35. Rabbits, Fresh do.		33
36. Dripping—Beef per tin		380

SCHEDULE No. 6.—ARARAT DISTRICT.

ANNEX TO CONTRACT No. 1967/2038.

H. A. Morris, 107 Victoria-street, Ballarat.

Sub-schedule No. 1.

MEAT.		cents
Security, \$60.		
1. Fresh Beef—		
Rolled Roast (Boneless, brisket excluded)	per lb.	25
2. Buttocks do.		24
Fresh Mutton—		
3. Kidney fat to be removed do.		12
4. Mid. Loin Chops do.		14
5. Corned Beef—Rolled or Round, as ordered, without bone or cartilage	do.	25
6. Sausage meat do.		15
7. Veal—Filletted do.		20
8. Sausages—Mixed do.		20
9. Steak—Topside do.		29
10. " Rump do.		43
11. " Porterhouse do.		43
12. Tripe—Fresh do.		19
13. Saveloys do.		20
14. Meat Loaf do.		20
15. Beef Luncheon Loaf do.		20

SCHEDULE No. 7.—BALLARAT DISTRICT.

ANNEX TO CONTRACT No. 1967/2039.

H. A. Morris, 107 Victoria-street, Ballarat.

Sub-schedule No. 1.

MEAT FOR MENTAL HOSPITAL.

Security, \$70.		cents
Fresh Beef—		
1. Buttocks per lb.		24
2. Roast—Rolled (Brisket excluded) do.		24
3. Beef, Corned, Rolled or Round, as ordered, without bone or cartilage	do.	24
Mutton, Fresh—		
4. Kidney fat removed (Mental Hospital)	do.	11
5. Veal—Boned do.		24
6. Sausages—Mixed do.		20
7. Sausage Meat do.		14
8. Kidney—Ox do.		18
9. Saveloys do.		19
10. Sausage, Beef German do.		19
11. Mince Meat do.		6
12. Tripe do.		6
13. Salad Loaf, Luncheon do.		..

ANNEX TO CONTRACT No. 1967/2040.

H. A. Morris, 107 Victoria-street, Ballarat.

Sub-schedule No. 2.

MEAT.

For delivery to Teachers' Hostels as under :—

Gillies-street, Ballarat.
Beaufort House, Beaufort-avenue, Ballarat.
1415 Sturt-street, Ballarat.
130 Victoria-street, Ballarat.
126 Webster-street, Ballarat.

Security, \$10.		cents
1. Fresh Beef—Sirloin, boneless per lb.		37
2. Beef—Corned, Silverside do.		40
Fresh Mutton—		
3. Legs do.		18
4. Forequarter Chops do.		12
5. Legs, Pickled do.		17
Two-tooth—		
6. Chump Chops do.		19
7. Mid. Loin Chops do.		13
Veal—		
8. Shoulder, Boned do.		30
9. Fillet, Boneless do.		36
Steak—		
10. Blade do.		25
11. Rump do.		49
12. Minced do.		24
13. Sausages—Mixed do.		20
14. Sausage Meat do.		15
15. Kidneys—Ox do.		18
16. Frankfurts do.		20
17. Dripping—Beef do.		8
18. Shanks—Sheep each		6
19. Beef Luncheon per lb.		23
20. Pork, Fresh, Legs do.		43
21. " " Loin do.		43

SCHEDULE No. 8.—BEECHWORTH DISTRICT.

ANNEX TO CONTRACT No. 1967/2041.

E. Spencer, Camp-street, Beechworth.

Sub-schedule No. 1.

MEAT.		cents
Security, \$60.		
1. Fresh Beef (Gaol) per lb.		33
2. Corned Beef, Rolled or Round as ordered, without bone or cartilage	do.	36
3. Mutton—Fresh (Kidney fat to be removed for Mental Hospitals)	do.	17
4. Beef Steak—Minced do.		34
5. Sausage Meat do.		18
6. Sausages—Mixed do.		23
7. Veal—Boned do.		34
8. Steak, Buttock do.		36
9. Sausage, German do.		35
10. Kidney—Ox do.		23
11. Fresh Beef, Rolled Roast, boneless, Brisket excluded	do.	36
12. Tripe—Fresh do.		18
13. Meat Loaf do.		..

SCHEDULE No. 9.—BENDIGO DISTRICT.

ANNEX TO CONTRACT No. 1967/2042.

Alan H. Gittins, 350 Hargreaves-street, Bendigo.

Sub-schedule No. 1.

MEAT FOR GAOL.		cents
Security, \$10.		
1. Fresh Beef per lb.		23
2. Fresh Mutton do.		14
3. Sausages—Mixed do.		20
4. Mincomeat do.		15
5. Saveloys do.		20

SCHEDULE No. 9.—BENDIGO DISTRICT—*continued.*

ANNEX TO CONTRACT No. 1967/2043.

Alan H. Gittins, 350 Hargreaves-street, Bendigo.

Sub-schedule No. 2.

MEAT FOR SANDHURST BOYS' CENTRE, BENDIGO.

	Security, \$10.	cents
1. Fresh Beef—Rolled Roast, boneless, brisket excluded	per lb.	32
2. Fresh Beef—Rib Roast	do.	32
3. Corned Beef—Rolled or Round, as ordered, without bone or cartilage	do.	28
4. Corned Silverside	do.	35
Fresh Mutton—		
5. Legs	do.	20
6. Legs, Boned	do.	22
7. Chops, Mid. Loin	do.	20
8. Chops, Forequarter	do.	20
9. Steak—Rump	do.	58
10. Steak, Stewing	do.	39
11. " Buttock	do.	40
12. Sausages—Mixed	do.	20
13. Sausage—Beef, German	per lb.	30
14. Bacon, Rashers, Shoulder	do.	75
15. Lamb—Legs	do.	35
16. Lamb Chops—Middle Loin	do.	39
17. Ham Loaf	do.	38
18. Kidney—Ox	do.	25
19. Pork, Leg	do.	50
20. Pork, Pickled Rolled Shoulder	do.	45
21. Saveloys	per doz.	..
22. Livers, Sheep	per lb.	..
23. Minced Meat	do.	15
24. Lambs Fry	do.	20

ANNEX TO CONTRACT No. 1967/2044.

Frank Wade, 193 Williamson-street, Bendigo.

Sub-schedule No. 3.

MEAT.

For Teachers' College Hostels as under—
Osborne-street, Pleasant Vale, Bendigo.
"Lancewood," McLaren-street, Bendigo.
"Comersdale," Pantom-street, Golden Square, Bendigo.

	Security, \$10.	cents
1. Fresh Beef—Topside	per lb.	65
2. Corned Beef—Rolled or Round, as ordered, without bone or cartilage	do.	25
3. Corned Silverside	do.	52
4. Fresh Mutton—Carcass	do.	10
Steak—		
5. Blade—Minced	do.	45
6. Chuck	do.	45
7. Rump	do.	70
8. Sausages—Mixed	do.	28
9. Sausage Meat	do.	18
10. Livers—Sheep	do.	12
11. Veal—Fillet, boneless	do.	65
12. Brains—Sheep	per set	3
13. Kidneys—Ox	per lb.	20
14. Pork—Fresh, Loin	do.	55
15. Sausage—Strasbourg	do.	38
16. Salad Loaf	do.	32
17. Bacon, Middle Rashers	do.	75

SCHEDULE No. 10.—CASTLEMAINE GAOL.

ANNEX TO CONTRACT No. 1967/2045.

McQueen Brothers, Hargreaves-street, Castlemaine.

Sub-schedule No. 1.

MEAT.

	Security, \$10.	cents
1. Fresh Beef	per lb.	24
2. Fresh Mutton	do.	16
3. Corned Beef—Rolled or Round, as ordered, without bone or cartilage	do.	26
4. Minced Meat—Beef	do.	24
5. Sausage Meat	do.	16
6. Saveloys	per doz.	50

SCHEDULE No. 11.—SCHOOL OF FORESTRY, CRESWICK.

ANNEX TO CONTRACT No. 1966/2046.

H. J. Symons Pty. Ltd., 1015 Macarthur-street, Ballarat.

Sub-schedule No. 1.

MEAT.

	Security, \$6.	cents
1. Fresh Beef—		
1. Topside	per lb.	52
2. Sirloin, boneless	do.	52
3. Corned. Silverside	do.	55
4. Mutton—Fresh, sides	do.	15
5. Pork—Fresh, leg	do.	50

SCHEDULE No. 11.—SCHOOL OF FORESTRY.

CRESWICK.—*continued.*

Steak—		
6. Stewing	do.	50
7. Minced	do.	38
8. Sausages—Mixed	do.	28
9. Sausage—Beef, German	do.	38
10. Kidney—Ox	do.	20
11. Liver—Sheep	do.	10
12. Saveloys	per doz.	40

SCHEDULE No. 13.—MCLEOD SETTLEMENT, FRENCH ISLAND.

ANNEX TO CONTRACT No. 1967/2047.

L. K. Jones, Main-street, Lang Lang.

Sub-schedule No. 1.

MEAT.

	Security, \$10.	cents
1. Fresh Beef	per lb.	29
2. Mutton	do.	17
3. Sausages—Mixed	do.	27

SCHEDULE No. 14.—GEELONG DISTRICT.

ANNEX TO CONTRACT No. 1967/2048.

Jacksons Corio Meat Packing (1965) Pty. Ltd. Corio Quay, Geelong.

Sub-schedule No. 1.

MEAT FOR GAOL.

	Security, \$10.	cents
1. Fresh Beef	per lb.	30
2. Corned Beef—Rolled or Round, without bone or cartilage	do.	25
Fresh Mutton—		
3. Forequarters	do.	10
4. Legs	do.	19
5. Beef—Minced	do.	20
6. Sausages—Mixed	do.	20
7. Sausage Meat	do.	10

ANNEX TO CONTRACT No. 1967/2049.

Jackson Corio Meat Packing (1965) Pty. Ltd., Corio Quay, Geelong.

Sub-schedule No. 2.

MEAT.

For delivery to Teachers' Hostels as under—
"Lauriston", 23 Aberdeen-street, Geelong.
"Forty-Five", The Esplanade, Western Beach, Geelong.
"Hawthorn", Aberdeen-street, Geelong.
"Ariston", Packington-street, Geelong.
"Warrain", 56 Western Beach, Geelong.

	Security, \$10.	cents
1. Fresh Beef—Sirloin, boneless	per lb.	30
2. Corned Beef—Rolled or Round, as ordered, without bone or cartilage	do.	30
Mutton—		
3. Legs, Two-tooth	do.	18
4. Forequarter, boned, rolled, and pickled	do.	10
5. Chops, Forequarter	do.	12
6. Chops, Cutlets	do.	19
Steak—		
7. Chuck	do.	25
8. Bladebone	do.	30
9. Minced	do.	19
10. Fillet—Veal	do.	10
11. Tongues—Ox	do.	15
12. Kidneys—Ox	do.	17
Sausages—		
13. Mixed, thin	do.	20
14. Pork, thick	do.	20
Sausage—		
15. Pork, German	do.	28
16. Mince	do.	10
17. Bacon—Shoulder	do.	49

SCHEDULE No. 15.—COORIEMUNGLE PRISON CAMP, HEYTESBURY FOREST.

ANNEX TO CONTRACT No. 1967/2050.

Thomas Borthwick and Sons (Asia) Ltd., P.O. Box 150, Portland.

Sub-schedule No. 1.

MEAT.

	Security, \$8.	cents
1. Fresh Beef	per lb.	48
2. Corned Beef—Rolled or Round, as ordered, without bone or cartilage	do.	37
3. Sausages—Mixed	do.	24
4. Sausage Mince	do.	18

SCHEDULE No. 17.—LANGI-KAL KAL TRAINING CENTRE.

ANNEX TO CONTRACT No. 1967/2051.
H. A. Morris, 105 Victoria-street, Ballarat.
Sub-schedule No. 1.

MEAT.		Security, \$10.	cents
1. Sausages—Mixed	per lb.	20	
2. Fresh Beef—Boneless	do.	33	

SCHEDULE No. 20.—SALE GAOL.

ANNEX TO CONTRACT No. 1967/2052.
R. Schuback, 99a Simpson-street, Sale.
Sub-schedule No. 1.

MEAT.		Security, \$6.	cents
1. Fresh Beef	per lb.	30	
Fresh Mutton—			
2. Chops, Forequarter	do.	19	
3. Corned Beef—Rolled or Round, as ordered, without bone or cartilage	do.	28	
4. Sausage Meat	do.	17	

SCHEDULE No. 21.—PLEASANT CREEK SPECIAL SCHOOL, STAWELL.

ANNEX TO CONTRACT No. 1967/2053.
Thomas Borthwick and Sons (Asia) Ltd., P.O. Box 150, Portland.

MEAT.		Security, \$6.	cents
1. Steak—Rump	per lb.	60	
2. Stewing (Minced when required)	do.	34	
3. Fresh Mutton Forequarter, Rolled	do.	20	
4. Chops—Leg	do.	23	
5. Sausages—Pork	do.	24	
6. Bacon Rashers, Shoulder	do.	78	
7. Beef—Corned, Silverside	do.	46	
8. Kidney—Ox	do.	27	
9. Sausage, Pork German	do.	49	
10. Forequarter Chops	do.	14	
11. Livers—Sheep	do.	44	
12. Meat Loaf	do.	40	
13. Mutton, Forequarter Chops	do.	22	
14. Beef, Rolled Roast, Brisket excluded	do.	22	
15. Tongues—Ox	do.	22	
16. Mutton Legs—Fresh, Two Tooth	do.	22	
17. Sausage Meat	do.	22	

SCHEDULE No. 22.—SUNBURY DISTRICT.

ANNEX TO CONTRACT No. 1967/2054.
Chas. T. Smitheram Pty. Ltd., 121 Westgarth-street, Fitzroy.
Sub-schedule No. 1.

MEAT.		Security, \$80.	cents
1. Fresh Beef—Rolled Roast, boneless (brisket excluded)	per lb.	31	
2. Buttocks	do.	28	
3. Fresh Mutton—Kidney fat to be removed	do.	12.75	
4. Corned Beef—Rolled or Round, as ordered, without bone or cartilage	do.	28	
5. Sausages—Mixed	do.	22	
6. Sausage Meat	do.	14	
7. Veal—Boneless	do.	30	
8. Sausage, Beef German	do.	27	
9. Ox—Kidney	do.	30	
10. Steak, Rump	do.	49	
11. " Topside	do.	42	
12. Tripe—Fresh	do.	12	
13. Beef Luncheon	do.	27	
14. Ham—Loaf	do.	29	

SCHEDULE No. 23.—WARRNAMBOOL DISTRICT.

ANNEX TO CONTRACT No. 1967/2055.
Thomas Borthwick and Sons (Asia) Ltd., P.O. Box 150, Portland.

MEAT.		Security, \$30.	cents
1. Fresh Beef—Rolled Roast (brisket per lb. excluded)	do.	36	
2. Corned Beef—Rolled or Round, as ordered	do.	36	
Fresh Mutton—			
3. Forequarters	do.	14	
4. Legs	do.	23	
5. Chops—Middle Loin	do.	24	
Steak—			
6. Stewing	do.	40	
7. Minced	do.	35	
8. Sausage Meat	do.	20	
Sausages—			
9. Beef	do.	26	
10. Pork	do.	28	
11. Kidneys—Ox	do.	28	
12. Steak—Topside	do.	48	
13. Saveloys	per doz.	70	
14. Sausage, Beef German	per lb.	39	

SCHEDULE No. 24.—HOBSON PARK HOSPITAL, TRARALGON.

ANNEX TO CONTRACT No. 1967/2056.
Stoddart Bros., 77 Franklin-street, Traralgon.
Sub-schedule No. 1.

MEAT.		Security, \$10.	cents
1. Rolled Roast Beef, boneless	per lb.	45	
2. Thick Flank (Minced when required)	do.	45	
3. Steak, Topside	do.	50	
4. Corned Silverside	do.	50	
5. Fresh Mutton, Legs (pickled, boned, and rolled)	do.	29	
6. Chops, Forequarter, Lamb	do.	29	
7. Lambs Fry	do.	20	
8. Shin Beef	do.	40	
9. Fresh Mutton, Legs, Two-tooth	do.	29	
10. Sausage Meat	do.	15	
11. Sausages, Beef German	do.	40	
12. Sausages, Mixed	do.	25	
13. Tripe fresh	do.	20	
14. Bacon, Middles	do.	72	
15. Pigs' Heads	do.	10	
16. Fowls, First quality	do.	..	
17. Sausage, Garlic	do.	..	
18. Brains	do.	..	
19. Ox, Kidney	do.	40	

SCHEDULE No. 25.—MORWELL RIVER REFORESTATION PRISON.

ANNEX TO CONTRACT No. 1967/2057.
Rogers Bros., Church-street, Boolarra.
Sub-schedule No. 1.

MEAT.		Security, \$10.	cents
1. Fresh Beef	per lb.	36	
2. Mutton	do.	15	

SCHEDULE No. 26.—STATE RESEARCH FARM, WERRIBEE.

ANNEX TO CONTRACT No. 1967/2058.
Anderson Meat Packing Co. Pty. Ltd., 613 Victoria-street, Abbotsford.

MEAT.		Security, \$10.	cents
1. Fresh Beef—Rolled Roast	per lb.	40	
2. Steak—Topside	do.	42	
3. " Thick Flank	do.	42	
4. " Mince	do.	30	
5. " Stewing	do.	38	
6. Beef, Corned Silverside	do.	45	
7. Pork, Legs	do.	48	
8. Beef—Shin	do.	40	
9. Mutton, Legs, Two-tooth	do.	24	
10. " " Pumped	do.	24	
11. Chops, Forequarter	do.	22	
12. " Cutlets	do.	28	
13. " Lamb	do.	35	
14. Frankfurts	per doz.	60	
15. Sausages	per lb.	20	
16. Sausage Meat	do.	17	
17. Veal Fillet	do.	43	
18. Bacon	do.	70	
19. Chops—Chump	do.	30	
20. Kidney—Ox	do.	33	
21. Tails—Ox	do.	25	
22. Pork, Strasburg	do.	35	
23. Beef	do.	21	
24. Dripping	do.	13	
25. Steak—Scotch, Fillet	do.	55	
26. Tripe	do.	12	
27. Tongues—Ox	do.	15	
28. Tongues—Sheep	do.	9	

SCHEDULE No. 27.—"HILLSIDE" BOYS' HOME, WHEELERS HILL.

ANNEX TO CONTRACT No. 1967/2059.
Anderson Meat Packing Co. Pty. Ltd., 613 Victoria-street, Abbotsford.

MEAT.		Security \$6.	cents
1. Legs, Lamb	per lb.	30	
2. Legs, Lamb, Seasoned	do.	33	
3. Legs, Pumped Mutton	do.	22	
4. Roast Beef	do.	36	
5. Corned Beef, Silverside	do.	45	
6. Chops, Barbecue	do.	28	
7. Cutlets, Crumbed	do.	30	
8. Steak—Topside	do.	43	
9. Steak—Stewing	do.	36	
10. Steak—Bladebone	do.	38	
11. Steak—Mince	do.	28	
12. Sausages	do.	20	
13. Sausage Mince	do.	18	
14. Frankfurts	do.	30	
15. Kidneys, Ox	do.	30	

Process Servers and Inquiry Agents Act 1958.

APPLICATIONS FOR LICENCES LODGED WITH CLERKS OF COURTS.

BY direction of the Chief Secretary, the subjoined lists of "new" applications for process servers and inquiry agents licences are published for general information.

Applicant.	Address.	Court.	Tentative Date of Hearing of Application.
<i>Process Servers Licences.</i>			
Baker, Barrie Lanham	1 Stuart-street, Korumburra	Korumburra	12.1.67
Bensley, Reginald Harold	7 Newby-street, Numurkah	Numurkah	3.1.67
Dimmitt, Graham Irving	17 Rothesay-avenue, Elwood	Elsternwick	10.1.67
Hubbard, Leslie John	E. S. Englander P/L., 533 Collins-street, Melbourne	Sandringham	24.1.67
Marriott, Helen Denise	16 Barnes-avenue, Burwood	Camberwell	19.1.67
Riedel, Walter Gerhard	Suite 105, M.L.C. Building, Victoria Square, Adelaide, South Australia (35 Como-street, Alphington)	Heidelberg	24.1.67
Rogalski, Edmond Peter	4 Hill-street, Wodonga	Wodonga	12.1.67
White, Robert Murray	Suite 4, Charnwood House, 128 High-street, St. Kilda	St. Kilda	13.1.67
Wishart, Leslie William	1 Dudley-street, West Preston	Preston	20.1.67
<i>Inquiry Agents Licences.</i>			
Bermingham, Alexander Leonard	Highway Car Sales P/L., 197 High-street, Bendigo	Bendigo	20.1.67
Edwards, Christian Thomas	24 Paterson-street, East Preston	Preston	19.1.67
Hansen, Peter John	Suite 20, 428 St. Kilda-road, Melbourne	Prahran	20.1.67
Riedel, Walter Gerhard	Suite 105, M.L.C. Building, Victoria Square, Adelaide, South Australia (35 Como-street, Alphington)	Heidelberg	24.1.67
White, Robert Murray	Suite 4, Charnwood House, 128 High-street, St. Kilda	St. Kilda	13.1.67

Attention is directed to the provisions of the above Act and regulations thereunder relating to the lodgement of objections to applications.

Chief Secretary's Office,
Melbourne, 4th January, 1967.

E. L. RICHARDSON, Registrar,
Process Servers and Inquiry Agents.

Cemeteries Act 1958.

SCALE OF FEES OF THE WYCHEPROOF PUBLIC CEMETERY.

IN pursuance of the powers conferred upon them by the Cemeteries Act, the trustees of the Wycheproof Public Cemetery hereby make the following scale of fees, which shall come into operation upon publication in the *Government Gazette*, and from and after such publication every scale of fees heretofore made by the said trustees shall be and is hereby rescinded to the extent to which it conflicts with this scale.

Private Graves.

Land, 8 ft. x 4 ft.	\$10.00
Sinking charge for adult graves	\$24.00
Sinking charge for children under twelve years	\$6.00
Sinking reopened grave	\$16.00
Sinking oversize grave	extra \$6.00
Reopening fee	\$1.50
Permission to erect a headstone or monument	\$1.50

F. CUMMINS, Trustee.
R. POLLARD, Trustee.
R. HARRISON, Trustee.
H. R. LOMAX, Secretary.

Approved by the Governor in Council, 20th December, 1966.—J. COLQUHOUN, Clerk of the Executive Council.

LAW DEPARTMENT.

COURT OF PETTY SESSIONS—ADDITIONAL DAYS APPOINTED.

HIS Excellency the Governor of the State of Victoria, by and with the advice of the Executive Council thereof, has, by Order made on the twentieth day of December, 1966, pursuant to the provisions of section 64 of the *Justices Act 1958*, appointed for the holding of Courts of Petty Sessions at the place named in the under-mentioned Schedule, in addition to the days and hours heretofore appointed.

SCHEDULE.

Place.	Days and Hours.
Richmond	Wednesday, the 18th January, 1967, at 10 a.m., and Wednesday, the 1st February, 1967, at 10 a.m.

J. COLQUHOUN,
Clerk of the Executive Council.

At the Executive Council Chamber,
Melbourne, 20th. December, 1966.

Licensing Acts.

REGISTRATION OF A BREWER.

THE Carlton and United Breweries Limited, of Armstrong-street, Ballarat, has this day registered its name and a particular description of its premises at the above address, wherein it proposes to carry on its business during the year 1967.

Dated this 28th day of December, 1966.

E. N. KINCHINGTON,
Clerk of the Licensing Court for
the Licensing Area of Ballarat.

MOTOR CAR ACTS.

REGISTRATION OFFICE.

IN pursuance of the powers conferred on me by section 5A (1) of the *Motor Car Act 1958*, I, Rupert Henry Arnold, the Chief Commissioner of Police, hereby appoint the Ocean Grove Police Station as a Registration Office.

R. H. ARNOLD,
Chief Commissioner of Police.

KYABRAM BOROUGH COUNCIL.

(WATER AUTHORITY.)

Rating By-Law for the Year Commencing 1st October, 1966, and ending 30th September, 1967.

THE Kyabram Borough Council (Water Authority), in pursuance and in exercise of the powers conferred by the Water Act, doth hereby make a rate for the supply of water for domestic purposes of 4 cents in the Dollar on the annual municipal valuation of the lands and tenements liable to be rated within the Kyabram Urban District.

Provided that in no case shall the amount of the rate payable per annum in respect of any tenement (other than land on which there is no building) be less than Six Dollars and in respect of any land on which there is no building less than Two Dollars.

Such rates are made and shall be levied upon the occupiers or owners of the said lands and tenements for the period commencing on 1st Day of October, 1966, and ending on the 30th Day of September, 1967, and shall be payable on the 9th Day of December, 1966, at the office of the said Council.

The maximum quantity of water to be supplied in any one year without further charge to any property rated by the Council is hereby fixed at the quantity which, at a charge of 15 cents per 1,000 gallons, would produce an amount equal to the amount of the rate levied on such property for the said year.

A charge for water supplied by measure to any property rated by the Council in excess of such maximum quantity, computed as in the last preceding clause, is hereby fixed at Fifteen Cents per 1,000 gallons.

The Charge for water supplied by measure to any property not rated by the Council is hereby fixed at Fifteen Cents per 1,000 gallons and the minimum quantity of water to be charged for in such cases where water is so supplied is hereby fixed at 40,000 gallons.

The charge for water supplied by measure shall be payable, on demand, at the office of the Council.

Passed this 6th Day of December, 1966.

(SEAL) L. J. SLATTERY, Chairman.
T. ATKINS, Commissioner.
J. A. CLAREY, Secretary.

Approved, 21st December, 1966.—T. A. DARCY, Minister of Water Supply.

KYNETON SHIRE WATERWORKS TRUST.

RATING BY-LAW FOR THE YEAR 1966-67.

THE Kyneton Shire Waterworks Trust, in pursuance and exercise of the powers conferred by the Water Act, doth hereby make a rate for the supply of water for domestic purposes of three cents in the \$1 on the annual municipal valuation of lands and tenements liable to be rated within the Kyneton Shire Waterworks Trust Urban District.

Provided that in no case shall the amount of rate payable per annum in respect of any tenements (other than land on which there is no building) be less than Nine dollars (\$9) and in respect of any land on which there is no building be less than Four dollars (\$4).

Such rates are made and shall be levied upon the occupiers or owners of the said lands and tenements for the year commencing on the 1st day of October, 1966 and shall be due and payable on the 17th day of January, 1967 at the Office of the said Trust.

The maximum quantity of water to be supplied in any one year without further charge to any property rated by the Trust is hereby fixed at the quantity which, at a charge of Fifteen cents (15c) per 1,000 gallons, would produce an amount equal to the amount of rate levied on such property for the said year.

The charge for water to be supplied by measure to any property rated by the Trust in excess of such maximum quantity computed as in the last preceding clause is hereby fixed at Fifteen cents (15c) per 1,000 gallons for the first 1,000,000 gallons Thirteen cents (13c) per 1,000 gallons for the next 500,000 gallons and Ten cents (10c) per 1,000 gallons for all consumption in excess of 1,500,000 gallons.

The charge for water supplied by measure shall be payable on demand at the Office of the Trust.

Passed this 7th day of December, 1966.

(SEAL) H. T. DETTMANN, Chairman.
S. G. PORTER, Secretary.

Approved, 21st December, 1966.—T. A. DARCY, Minister of Water Supply.

LEONGATHA WATERWORKS TRUST.

RATING BY-LAW FOR THE YEAR 1967 No. 67.

THE Leongatha Waterworks Trust, in pursuance and exercise of its powers conferred by the Water Act, doth hereby make a rate for the supply of water for domestic purposes of eight point five cents in the dollar on the net annual valuation of lands and tenements liable to be rated within the Leongatha Urban District.

Provided that in no case shall the amount of the rate payable per annum in respect of any tenement (other than land on which there is no buildings) be less than thirteen dollars, and in respect of any land on which there is no buildings less than three dollars.

Such rates are made and shall be levied upon the occupiers or owners of the said lands and tenements for the year commencing on the first day of January 1967 and shall be due and payable on the fifteenth day of June 1967 at the office of the Trust.

The maximum quantity of water to be supplied in any one year without further charge to any property rated by the Trust is hereby fixed at the quantity which at a charge of thirty cents per one thousand gallons for industrial and sporting use and forty cents per one thousand gallons for domestic use would produce an amount equal to the amount of rate levied on such property for the said year.

The charge for water supplied by measure to any property rated by the Trust in excess of such maximum quantity computed as in the last preceding clause, is hereby fixed at thirty cents per one thousand gallons for industrial and sporting use and forty cents per one thousand gallons for domestic use.

The charge for water supplied by measure to any property not rated by the Trust is hereby fixed at thirty cents per one thousand gallons for industrial and sporting use and forty cents per one thousand gallons for domestic use.

The charge for water supplied by measure shall be payable on demand at the office of the Trust.

The foregoing By-Law was made and passed by the Commissioners of the Leongatha Waterworks Trust on the fourteenth day of December, one thousand nine hundred and sixty-six and the seal of the Trust affixed hereto in the presence of—

(SEAL) W. P. GLEESON, Chairman.
R. J. HAGAN, Commissioner.
J. F. GEARY, Commissioner.
R. H. LESLIE, Secretary.

Approved, 21st December, 1966.—T. A. DARCY, Minister of Water Supply.

MURCHISON WATERWORKS TRUST

RATING BY-LAW FOR THE YEAR ENDING 31ST DECEMBER 1967 (No. 85)

THE Murchison Waterworks Trust, in pursuance and exercise of the powers conferred by the Water Act, doth hereby make a rate for the supply of water for domestic purposes of 11.5 cents in the Dollar on the annual municipal valuation of lands and tenements liable to be rated within the Murchison Urban District. Provided that in no case shall the amount of rate payable per annum in respect of any tenement (other than any land on which there is no building) be less than Ten Dollars, and in respect of any land on which there is no building be less than Six Dollars.

Such rates are made and levied on the occupiers or owners of the said lands and tenements for the year commencing on the 1st day of January 1967, and shall be payable on the 19th day of January, 1967, at the office of the Trust.

The maximum quantity of water to be supplied in any one year, without further charge to any property rated by the Trust, is hereby fixed at the quantity which, at a charge of 11.5 cents per 1,000 gallons would produce an amount equal to the amount of the rate levied on such property for the said year.

The charge for water supplied by measure to any property rated by the Trust in excess of such maximum quantity, computed as in the last preceding clause, is hereby fixed at 15 cents per 1,000 gallons. The charge for water supplied by measure shall be payable on demand at the office of the Trust.

Passed this 12th day of December, 1966.

(SEAL) T. K. GREGORY, Chairman.
A. HARRIS, Secretary.

Approved, 21st December, 1966.—T. A. DARCY, Minister of Water Supply.

MARYBOROUGH WATERWORKS TRUST.

RATING BY-LAW FOR 1966-67.

THE Maryborough Waterworks Trust, in pursuance and exercise of the powers conferred by the Water Act, doth hereby make a rate for the supply of water for domestic purposes of three and three tenths cents (3.3c) in the dollar on the net annual municipal valuation of lands and tenements liable to be rated within the Maryborough Urban District.

Provided that in no case shall the amount of rates payable per annum in respect of any tenement (other than land on which there is no building) be less than Eighteen dollars and in respect of land on which there is no building less than Twelve dollars.

Such rates are made and shall be levied upon the occupiers or owners of the said lands and tenements for the year commencing on the 1st day of October 1966 and shall be payable on the 10th day of January 1967 at the office of the Trust.

The maximum quantity of water to be supplied in any one year without further charge to any property rated by the Trust is hereby fixed at the quantity which at the charge or charges listed in the next following clause, would produce an amount equal to the amount of rate levied on such property for the said year.

The charge for water supplied by measure to any property rated by the Trust shall be as follows:—

Up to and including 500,000 gallons, twenty cents per 1,000 gallons.

Any quantity in excess of 500,000 gallons up to 1,500,000 gallons fifteen cents per 1,000 gallons.

Any quantity in excess of 1,500,000 gallons up to 3,500,000 gallons, twelve and one half cents per 1,000 gallons.

Any quantity in excess of 3,500,000 gallons, ten cents per 1,000 gallons.

The charge for water supplied by measure to any property not rated by the Trust shall be the same as set out in the last preceding clause, and the minimum quantity of water to be charged for in cases where water is so supplied is hereby fixed at 90,000 gallons.

The charge for water supplied by measure shall be payable, on demand, at the office of the Trust.

Passed this 15th day of December, 1966.

(SEAL) N. K. COLLINS, Chairman.
E. S. MOORE, Secretary.

Approved, 21st December, 1966.—T. A. DARCY, Minister of Water Supply.

SHIRE OF NUMURKAH WATERWORKS TRUST.

RATING BY-LAW FOR THE KATUNGA URBAN DISTRICT FOR THE YEAR 1966-67.

THE Shire of Numurkah Waterworks Trust, in pursuance and exercise of the powers conferred by the Water Act, doth hereby make a By-law and direct as follows:—

1. The said Shire of Numurkah Waterworks Trust doth hereby make a rate for the supply of water for domestic purposes of Twelve and one half cents in the dollar on an annual municipal valuation of lands and tenements liable to be rated within the Katunga Urban District.

Provided that in no case shall the amount of the rate payable per annum in respect of any tenement (other than land upon which there is no building) be less than Ten dollars and in respect of land on which there is no building less than Three dollars.

Such rates are made and shall be levied upon the occupiers or owners of the said lands and tenements for the year commencing on the 1st day of October, 1966, and shall be payable on the 28th day of January, 1967, at the office of the said Trust.

2. The maximum quantity of water to be supplied in any one year without further charge to any property rated by the Trust, is hereby fixed at the quantity which, at the charge of Fifty cents per 1,000 gallons would produce an amount equal to the amount of the rate levied on such property for the said year.

3. The charge for water supplied by measure to any property rated by the Trust in excess of such maximum quantity, as computed in the last preceding clause, is hereby fixed at Ten cents per 1,000 gallons.

4. The charge for water supplied by measure shall be payable, on demand, at the office of the Trust.

5. Such person or persons as the Commissioners of the Shire of Numurkah Waterworks Trust may from time to time appoint for the purpose, shall be authorized to demand and receive, collect and recover the rates and charges aforesaid, and each of them. And in the absence of such appointment the Secretary and/or Rate Collector of the Trust shall be deemed to have been appointed for the purpose aforesaid, and every and each of them.

Passed the 13th day of December, 1966.

The common seal of the Shire of Numurkah Waterworks Trust was hereto affixed, this 13th day of December, 1966, in the presence of—

(SEAL) RAY W. HODGE, Chairman.
A. M. FREESTONE, Commissioner.
L. G. MITCHELL, Secretary.

Approved, 21st December, 1966.—T. A. DARCY, Minister of Water Supply.

YALLOURN NORTH WATERWORKS TRUST.

RATING BY-LAW 1967.

THE Yallourn North Waterworks Trust, in pursuance and exercise of the powers conferred by the Water Act, doth hereby make a rate for the supply of water for domestic purposes of five cents in the dollar on the nett annual municipal valuation of lands and tenements liable to be rated within the Yallourn North Urban District.

Provided that in no case shall the amount of rate payable per annum in respect of any tenement (other than land on which there is no building) be less than eight dollars fifty cents, and in respect of any land on which there is no building less than three dollars and seventy-five cents.

Such rates are made and shall be levied upon the occupiers or owners of the said lands and tenements for the year commencing 1st January, 1967, and ending on the last day of December, 1967, and shall be payable on the 20th day of February, 1967, at the office of the said Trust.

The maximum quantity of water to be supplied in any one year, without further charge to any property rated by the Trust, is hereby fixed at the quantity which, at a charge of twenty-five cents per 1,000 gallons, would produce an amount equal to the amount of the rate levied on such property for the said year.

The charge for water supplied by measure to any property rated by the Trust in excess of such maximum quantity, computed as in the last preceding clause, is hereby fixed at twenty-five cents per 1,000 gallons.

The charge for water supplied by measure shall be payable, on demand, at the office of the said Trust.

Passed this 8th day of September, 1966.

(SEAL) C. E. LUCAS, Chairman.
W. J. C. PEACOCK, Commissioner.
J. F. BOAG, Secretary.

Approved, 21st December, 1966.—T. A. DARCY, Minister of Water Supply.

YARRAWONGA URBAN WATERWORKS TRUST.

RATING BY-LAW 1967.

THE Yarrawonga Urban Waterworks Trust in pursuance and exercise of the powers conferred by the Water Act doth hereby make the following rates for the supply of water on lands and tenements liable to be rated within the Yarrawonga Urban District.

On such lands and tenements a rate of Five Cents in the Dollar on the amount of the Annual Municipal Valuation.

Provided that in no case shall the amount of rate payable per annum in respect of any tenement (other than land on which there is no building) be less than Six Dollars, and in respect of land on which there is no building, less than Three Dollars.

Such rates are made and shall be levied upon the occupiers or owners of the said land and Tenements for the year commencing on the First day of January, 1967, and shall be payable on the First day of January, 1967, at the office of the above Trust.

The maximum quantity of water to be supplied in any one year without a further charge to any property rated by the Trust is hereby fixed at the quantity, which at a charge of Ten cents per 1,000 gallons would produce an amount equal to the amount of the rate levied for the said year.

The charge for water supplied by measure to any Property by the Trust in excess of such maximum quantity computed as in the last preceding clause, is hereby fixed at Ten Cents per 1,000 gallons.

The charge for water supplied by measure shall be payable, on demand, at the office of the said Trust.

Passed this 9th day of December, 1966.

(SEAL) FRANK KEENAN, Chairman.
DON C. FORBES, Secretary.

Approved, 21st December, 1966.—T. A. DARCY, Minister of Water Supply.

LINTON WATERWORKS TRUST.

RATING BY-LAW FOR THE YEAR 1967—No. 12.

THE Linton Waterworks Trust, in pursuance and exercise of its powers conferred by the Water Act, doth hereby make a rate for the supply of water for Domestic Purposes of Eight Cents in the Dollar on the Nett Annual Valuation of lands and tenements liable to be rated within the Linton Urban District.

Provided that in no case shall the amount of the rate payable per annum in respect of any tenement (other than the land on which there is no building) be less than Fourteen Dollars, and in respect of any land where there is no building, less than Two Dollars.

Such rates are made and shall be levied upon the occupiers or owners of the said lands and tenements for the year commencing on the 1st day of January, 1967, and shall be due and payable on the 1st day of February, 1967, at the Office of the said Trust.

The maximum quantity of water to be supplied in any one year without further charge to any property rated by the Trust is hereby fixed at the quantity which, at a charge of twenty cents per 1,000 gallons, would produce an amount equal to the amount of the rate levied on such property for the said year.

The charge for water supplied by measure to any property rated by the Trust in excess of such maximum quantity, computed as in the last preceding clause, is hereby fixed at Twenty Cents per 1,000 gallons.

The charge for water supplied by measure shall be payable, on demand, at the Office of the Trust.

Such person, or persons as the Trust may appoint for the purpose, are hereby authorised to demand, receive, collect and recover the said rates and charges.

Passed this 10th Day of November, 1966.

(SEAL) H. O'C. KENNEDY, Chairman.
S. E. MORGAN, Commissioner.
I. S. GRIGG, Commissioner.
L. OLDHAM, Secretary.

Approved, 21st December, 1966.—T. A. DARCY, Minister of Water Supply.

SHIRE OF KANIVA WATERWORKS TRUST.

RATING BY-LAW FOR 1967 IN THE URBAN DISTRICT OF KANIVA.

THE Chairman and Commissioners of the Shire of Kaniva Waterworks Trust, in pursuance of the powers conferred by the Water Act, do hereby make the following By-law:—

The following rate and charges are those which the occupiers or owners of lands and tenements liable to be rated shall pay for the year 1967 in respect of water supplied by the Trust within the Urban District of Kaniva as such district has been proclaimed and defined.

For the supply of water for domestic purposes, a rate is hereby made of Five and one-half cents in the Dollar on the annual municipal valuation of such lands and tenements. Provided that in no case shall the amount of the rate payable in respect of any tenement (other than land on which there is no building) be less than four Dollars and in respect of land on which there is no building less than one Dollar.

The maximum quantity of water to be supplied in any one year without further charge to any property rated by the Trust is hereby fixed at the quantity which, at a charge of fifteen cents per 1,000 gallons, would produce an amount equal to the amount of the rate levied on such property for the said year.

The charge for water supplied by measure to any property rated by the Trust in excess of such maximum quantity computed as in the last preceding clause is hereby fixed at twenty cents per 1,000 gallons.

The charge for water supplied by measure to any property not rated by the Trust shall be an amount equal to the district rate of Five and one half cents in the Dollar on the valuation of the property by the Trust, provided that such charge shall not be less than four Dollars. Allowance and excess water to be at district charge per 1,000 gallons.

The charge for water supplied by measure shall be payable, on demand, at the office of the Trust.

Public Institutions and Others—The charge for water supplied to all Government Departments shall be by special agreement, or shall be an amount equal to the district rate of five and one half cents in the Dollar on the valuation of the property by the Trust, provided that such charge shall not be less than four Dollars, meter to be installed if required by Trust; allowance and excess water to be at district charge per 1,000 gallons. Water supplied to churches and public hospitals shall be by measure at fifteen cents per 1,000 gallons. For water supplied to parks and recreations grounds and cricket, bowling or tennis clubs, the charge shall be subject to arrangement with the Trust.

Water Troughs—Private water troughs will be charged for at the rate of One dollar and forty cents per annum each, except where, in the opinion of the Trust, a meter shall be necessary, in which case the minimum charge shall be for 8,000 gallons per annum at Eighteen cents per 1,000 gallons. All water consumption in excess of such 8,000 gallons per annum will be charged at the rate of Eighteen cents per 1,000 gallons.

Period of Rate—That the above-mentioned rate is made for one year, commencing on the First day of January, 1967 and ending of the Thirty-first day of December, 1967, and shall be due and payable on the first day of February, 1967 at the office of the said Trust.

Such persons, as the Commissioners of the Trust may from time to time appoint for that purpose, shall be authorised to demand and receive and collect and recover the said rate and charges.

By-law passed and adopted this 15th day of November, 1966.

(SEAL) C. H. CHAMPNESS, Chairman.
G. J. WALKER, Secretary.

Approved, 21st December, 1966.—T. A. DARCY, Minister of Water Supply.

SHIRE OF KANIVA WATERWORKS TRUST.

RATING BY-LAW FOR 1967.

THE Chairman and Commissioners of the Shire of Kaniva Waterworks Trust, in pursuance of the powers conferred by the Water Act, do hereby make a rate for the supply of water for domestic and ordinary use and for watering stock of one-fifth of a cent in the Dollar on the annual municipal valuation of lands and tenements within the Waterworks District of the Trust, exclusive of the Urban District of Kaniva.

Such rate is made for one year commencing on the First day of January, 1967 and ending on the Thirty-first day of December, 1967 and shall be due and payable on the first day of February, 1967 at the office of the said Trust.

Such persons, as the Commissioners of the Trust may from time to time appoint for the purpose, shall be authorised to demand and receive and collect and recover the said rate.

By-law passed and adopted this 15th day of November, 1966.

(SEAL) C. H. CHAMPNESS, Chairman.
G. J. WALKER, Secretary.

Approved, 21st December, 1966.—T. A. DARCY, Minister of Water Supply.

THE BENDIGO SEWERAGE AUTHORITY.

RATING BY-LAW No. 13.

The Bendigo Sewerage District.

THE Bendigo Sewerage Authority, in pursuance and exercise of the powers conferred by the Sewerage Districts Acts, doth hereby make the following By-Law:

The following sewerage rate is hereby made under the provisions of the Sewerage Districts Acts, and shall be levied upon the nett annual value of the rateable sewerer properties within the Bendigo Sewerage District:

1. Of any land or tenements situate within the Bendigo Sewerage District, a sewerage rate of four and a half cents in the \$1.00 of the nett annual value of all rateable "sewerer property" within the said District.

2. In no case shall the amount of sewerage rate payable annually be less than \$9.00 in respect of any rateable seweraged property on which there is a building, and \$5.00 in respect of any rateable seweraged property on which there is no building.

3. Such rate is made and shall be levied for the year beginning with the first day of October, 1966 and ending with the thirtieth day of September, 1967 and shall be payable on the first day of February, 1967, at the office of the Authority, situate at the Civic Buildings, Bendigo.

4. If any rateable property which is unsewered at the time of the making of the aforesaid rate becomes during the said year a "sewered property", there shall be levied upon such property a proportionate part of the sewerage rate for the portion of the year after it has become a sewered property, and such property shall be deemed to have been lawfully rated accordingly.

5. For making and levying such rate the valuation for the time being of such lands and tenements for the municipal rate of the municipality in the municipal district of which such lands and tenements are situate shall be deemed and taken to be the valuation of such lands and tenements respectively; but if any such lands and tenements are not included in a valuation in force for the municipality in whose district they are situate, or if there is no such valuation, the nett annual value thereof may for all purposes of such rate be determined in the manner provided in the Sewerage Districts Acts.

6. Such person or persons as the Bendigo Sewerage Authority may from time to time appoint for that purpose shall be and is or are hereby authorized to demand, receive, collect and recover the said rates and charges.

The Resolution for passing the foregoing By-law was agreed to by the Bendigo Sewerage Authority on the twenty-fourth day of October, 1966, and was confirmed by the said Authority on the twenty-eighth day of November, 1966.

(SEAL)

T. R. FLOOD, Chairman.
K. HOULAHAN, Member.
H. A. MOORS, Secretary.

Approved by the Governor in Council, 20th December, 1966.—J. COLQUHOUN, Clerk of the Executive Council.

AVENEL WATERWORKS TRUST.

RATING BY-LAW 1967.

THE Avenel Waterworks Trust, in pursuance and exercise of the powers conferred by the Water Act, doth hereby make a Rate for the supply of Water for domestic purposes of Five Cents in the Dollar of the Annual Municipal Valuations of lands and tenements, liable to be rated within the Avenel Urban District.

Provided that in no case shall the amount of Rate payable per annum in respect of any tenement (Other than on land on which there is no building) be less than Sixteen Dollars and in respect of land on which there is no building less than Two Dollars.

Such rates are made and shall be levied on the Occupiers or Owners of the lands and tenements, for the year commencing on the 1st day of January 1967 and shall be payable on the 1st day of April 1967 at the office of the said Trust.

The Maximum quantity of Water to be supplied in any one year without further charge to any property rated by the Trust is hereby fixed at the quantity, which, at a charge of Fifteen Cents per 1000 Gallons, would produce an amount equal to the amount of rate levied on such property for the said year.

The Charge for Water supplied by measure to any property rated by the Trust, in excess of such maximum quantity computed as in the last preceding clause, is hereby fixed at Fifteen Cents per 1000 gallons as a minimum charge.

Water troughs will be supplied as follows:—For each trough in an allotment of 5 acres or under, Two Dollars Fifty Cents per annum; more than 5 acres, a charge of Two Dollars Fifty Cents for the first 5 acres and Twenty Cents for each additional acre.

The Charge for Water supplied by measure shall be payable on demand at the Office of the said Trust.

Passed on the 8th day of December 1966.

The common seal of the Avenel Waterworks Trust was hereunto affixed, in the presence of:—

(SEAL)

E. J. SAUNDERS, Chairman.
REG WHITFORT, Secretary.

Approved, 21st December, 1966.—T. A. DARCY, Minister of Water Supply.

CHARLTON WATERWORKS TRUST.

RATING BY-LAW FOR THE YEAR 1967—(No. 82)

THE Charlton Waterworks Trust, in pursuance and exercise of the powers conferred by the Water Act, doth hereby make a rate for the supply of water for domestic purposes of 6.50 cents in the dollar on the amount of the annual municipal valuation of the lands and tenements liable to be rated within the Charlton Urban District.

Provided that in no case shall the amount of rate payable per annum in respect of any tenement (other than land on which there is no building) be less than Six Dollars, and in respect of any land on which there is no building less than Three Dollars.

Such rates are made for the year commencing the 1st day of January, 1967 and ending on the 31st day of December 1967, and shall be payable on the 1st day of March 1967, at the office of the said Trust.

The maximum quantity of water to be supplied in any one year without further charge to any property rated by the Trust is hereby fixed at the quantity which, at a charge of Twenty-five cents per 1,000 gallons would produce an amount equal to the amount of rate levied on such property for the said year.

The charge of water supplied by measure to any property rated by the Trust in excess of such maximum quantity, computed as in the last preceding clause, is hereby fixed at Twenty-five cents per 1,000 gallons.

The charge for water supplied by measure shall be payable on demand, at the office of the said Trust.

The charge for water supplied from any standpipe on the Trust's mains is hereby fixed at Twenty-five cents per 1,000 gallons, and shall be payable on demand at the office of the said Trust.

The foregoing By-Law No. 82 was made by the Charlton Waterworks Trust on the 12th day of December, 1966, and the seal of the Trust was hereto affixed in our presence:—

(SEAL)

W. H. WOOD, Chairman.
V. J. RYAN, Commissioner.
A. F. HELYAR, Secretary.

Approved, 21st December, 1966.—T. A. DARCY, Minister of Water Supply.

HEALESVILLE WATERWORKS TRUST.

RATING BY-LAW 1967.

THE Healesville Waterworks Trust, in pursuance and exercise of the powers conferred by the Water Act, doth hereby make a rate for the supply of water for domestic purposes of Five cents in the dollar on the net annual valuation of lands and tenements liable to be rated within the Healesville Urban district.

Provided that in no case shall the amount of rate payable per annum in respect of any property be less than Ten dollars.

Such rates are made and shall be levied upon the occupiers or owners of the said lands and tenements for the year commencing on the 1st day of January, 1967 and shall be payable on the 31st day of January, 1967 at the office of the said Trust.

The maximum quantity of water to be supplied in any one year without further charge to any property rated by the Trust is hereby fixed at the quantity which, at a charge of Fifteen cents per 1,000 gallons would produce an amount equal to the amount of rate levied on such property for the said year.

The charge for water supplied by measure to any property rated by the Trust in excess of such maximum quantity, computed as in the last preceding clause, is hereby fixed at Ten cents per 1,000 gallons.

The charge for water supplied by measure to any property not rated by the Trust is hereby fixed at Ten cents per 1,000 gallons.

The charge for water supplied by measure shall be payable on demand, at the office of the Trust.

Passed this 12th day of December, 1966.

(SEAL)

E. R. FROGLEY, Chairman.
W. M. OLIVER, Secretary.

Approved, 21st December, 1966.—T. A. DARCY, Minister of Water Supply.

SHIRE OF NUMURKAH WATERWORKS TRUST.
RATING BY-LAW FOR THE NUMURKAH URBAN DISTRICT.
FOR THE YEAR 1966-67.

THE Shire of Numurkah Waterworks Trust, in pursuance and exercise of the powers conferred by the Water Act, doth hereby make a By-law and direct as follows:—

1. The said Shire of Numurkah Waterworks Trust doth hereby make a rate for the supply of water for domestic purposes of Six cents in the dollar on an annual municipal valuation of lands and tenements liable to be rated within the Numurkah Urban District.

Provided that in no case shall the amount of the rate payable per annum in respect of any tenement (other than land upon which there is no building) be less than Two dollars and in respect of land on which there is no building less than Two dollars.

Such rates are made and shall be levied upon the occupiers or owners of the said lands and tenements for the year commencing on the 1st day of October, 1966, and shall be payable on the 28th day of January, 1967, at the office of the said Trust.

2. The maximum quantity of water to be supplied in any one year without further charge to any property rated by the Trust, is hereby fixed at the quantity which, at the charge of Twenty-four cents per 1,000 gallons would produce an amount equal to the amount of the rate levied on such property for the said year.

3. The charge for water supplied by measure to any property rated by the Trust in excess of such maximum quantity, as computed in the last preceding clause, is hereby fixed at Ten cents per 1,000 gallons.

4. The charge for water supplied by measure shall be payable, on demand, at the office of the Trust.

5. Such person or persons as the Commissioners of the Shire of Numurkah Waterworks Trust may from time to time appoint for the purpose, shall be authorized to demand and receive, collect and recover the rates and charges aforesaid, and each of them. And in the absence of such appointment the Secretary and/or Rate Collector of the Trust shall be deemed to have been appointed for the purpose aforesaid, and every and each of them.

Passed the 13th day of December, 1966.

The common seal of the Shire of Numurkah Waterworks Trust was hereto affixed, this 13th day of December, 1966, in the presence of—

(SEAL) RAY W. HODGE, Chairman.
A. M. FREESTONE, Commissioner.
L. G. MITCHELL, Secretary.

Approved, 21st December, 1966.—T. A. DARCY, Minister of Water Supply.

SHIRE OF NUMURKAH WATERWORKS TRUST.
RATING BY-LAW FOR THE STRATHMERTON URBAN DISTRICT
FOR THE YEAR 1966-67.

THE Shire of Numurkah Waterworks Trust, in pursuance and exercise of the powers conferred by the Water Act, doth hereby make a By-law and direct as follows:—

1. The said Shire of Numurkah Waterworks Trust doth hereby make a rate for the supply of water for domestic purposes of Seven and one-half cents in the dollar on an annual municipal valuation of lands and tenements liable to be rated within the Strathmerton Urban District.

Provided that in no case shall the amount of the rate payable per annum in respect of any tenement (other than land upon which there is no building) be less than Six dollars and in respect of land on which there is no building less than Two dollars.

Such rates are made and shall be levied upon the occupiers or owners of the said lands and tenements for the year commencing on the 1st day of October, 1966, and shall be payable on the 28th day of January, 1967, at the office of the said Trust.

2. The maximum quantity of water to be supplied in any one year without further charge to any property rated by the Trust, is hereby fixed at the quantity which, at the charge of Thirty cents per 1,000 gallons would produce an amount equal to the amount of rate levied on such property for the said year.

3. The charge for water supplied by measure to any property rated by the Trust in excess of such maximum quantity, as computed in the last preceding clause, is hereby fixed at Ten cents per 1,000 gallons.

4. The charge for water supplied by measure shall be payable, on demand, at the office of the Trust.

5. Such person or persons as the Commissioners of the Shire of Numurkah Waterworks Trust may from time to time appoint for the purpose, shall be authorized to demand and receive, collect and recover the rates and charges aforesaid, and each of them. And in the absence of such appointment the Secretary and/or Rate Collector of the Trust shall be deemed to have been appointed for the purpose aforesaid, and every and each of them.

Passed on the 13th day of December, 1966.

The common seal of the Shire of Numurkah Waterworks Trust was hereto affixed, this 13th day of December, 1966, in the presence of—

(SEAL) RAY W. HODGE, Chairman.
A. M. FREESTONE, Commissioner.
L. G. MITCHELL, Secretary.

Approved, 21st December, 1966.—T. A. DARCY, Minister of Water Supply.

SHIRE OF NUMURKAH WATERWORKS TRUST.
RATING BY-LAW FOR THE WUNGHNU URBAN DISTRICT
FOR THE YEAR 1966-67.

THE Shire of Numurkah Waterworks Trust, in pursuance and exercise of the powers conferred by the Water Act, doth hereby make a By-law and direct as follows:—

1. The said Shire of Numurkah Waterworks Trust doth hereby make a rate for the supply of water for domestic purposes of seventeen and one-half cents in the dollar on an annual municipal valuation of lands and tenements liable to be rated within the Wunghnu Urban District.

Provided that in no case shall the amount of the rate payable per annum in respect of any tenement (other than land upon which there is no building) be less than Ten dollars and in respect of land on which there is no building less than Two dollars.

Such rates are made and shall be levied upon the occupiers or owners of the said lands and tenements for the year commencing on the 1st day of October, 1966, and shall be payable on the 28th day of January, 1967, at the office of the said Trust.

2. The maximum quantity of water to be supplied in any one year without further charge to any property rated by the Trust, is hereby fixed at the quantity which, at the charge of Thirty-five cents per 1,000 gallons would produce an amount equal to the amount of the rate levied on such property for the said year.

3. The charge for water supplied by measure to any property rated by the Trust in excess of such maximum quantity, as computed in the last preceding clause, is hereby fixed at Ten cents per 1,000 gallons.

4. The charge for water supplied by measure shall be payable, on demand, at the office of the Trust.

5. Such person or persons as the Commissioners of the Shire of Numurkah Waterworks Trust may from time to time appoint for the purpose, shall be authorized to demand and receive, collect and recover rates and charges aforesaid, and each of them. And in the absence of such appointment the Secretary and/or Rate Collector of the Trust shall be deemed to have been appointed for the purpose aforesaid, and every and each of them.

Passed the 13th day of December, 1966.

The common seal of the Shire of Numurkah Waterworks Trust was hereto affixed, this 13th day of December, 1966, in the presence of—

(SEAL) RAY W. HODGE, Chairman.
A. M. FREESTONE, Commissioner.
L. G. MITCHELL, Secretary.

Approved, 21st December, 1966.—T. A. DARCY, Minister of Water Supply.

LONGWOOD WATERWORKS TRUST.
RATING BY-LAW 1967.

THE Longwood Waterworks Trust, in pursuance and exercise of the powers conferred by the Water Act doth hereby make the following rates for the supply of water for domestic purposes on lands and tenements liable to be rated within the district of the Trust.

On such lands and tenements the rate of Fourteen cents in the dollar on the annual municipal valuation.

Provided that in no case shall the amount of rate payable per annum in respect of any tenement (other than land on which there is no building) be less than Ten Dollars, and in respect of any land on which there is no building be less than Four Dollars Fifty cents.

Such rates are made and shall be levied upon the occupiers or owners of the said lands or tenements for the year commencing the 1st day of January, 1967, and shall be payable on the 1st day of April, 1967, at the office of the said Trust.

Passed this 13th day of December, 1966.

(SEAL) P. J. CUMMINS, Chairman.
I. HOUSTON, Secretary.

Approved, 21st December, 1966.—T. A. DARCY, Minister of Water Supply.

PORTLAND WATERWORKS TRUST.

RATING BY-LAW FOR YEAR 1967.

THE Portland Waterworks Trust, in pursuance and exercise of the powers conferred by the Water Act, doth hereby make a rate for the supply of water for domestic purposes of 4 cents in the dollar (\$1) on the municipal valuation of all lands and tenements liable to be rated within the Portland Urban District.

Provided that in no case shall the amount of rate payable per annum in respect of any tenement (whether built on or vacant land) be less than 10 dollars—\$10.

Such rate is made for the year commencing on the 1st day of January, 1967, and shall be payable in one sum on the 18th January, 1967, at the office of the Trust.

The maximum quantity of water to be supplied in any one year without further charge to any property rated by the Trust is hereby fixed at the quantity which, at a charge of Fifteen cents per 1,000 gallons would produce an amount equal to the amount of the rate levied on such property for the said year.

The charges for water supplied by measure to any property rated by the Trust in excess of such maximum quantity computed as in the preceding clause, is hereby fixed at Fifteen cents per 1,000 gallons, except in cases of special agreement with the Trust.

The charge for water supplied by measure shall be payable, on demand, at the office of the Trust.

Dated this 13th day of December, 1966.

(SEAL) J. C. PATTERSON, Chairman.
E. T. NOEL HENRY, Secretary.

Approved, 21st December, 1966.—T. A. DARCY, Minister of Water Supply.

WODONGA WATERWORKS TRUST.

EASTERN URBAN DISTRICT.

Rating By-Law for the Year 1966-67.

THE Wodonga Waterworks Trust, in pursuance and exercise of the powers conferred by the Water Act, doth hereby make a rate for the supply of water for domestic purposes of point four five cents in the dollar (\$1) on the unimproved capital municipal valuation of lands and tenements liable to be rated within the Eastern Urban District of Wodonga Waterworks Trust.

Provided that in no case shall the amount of the rate payable in respect of any tenement (other than land on which there is no building) be less than Thirteen Dollars Fifty Cents (\$13.50) and in respect of land on which there is no building, less than Four Dollars (\$4.00).

Such rates are made and shall be levied upon the occupiers or owners of the said land and tenements for the year commencing on the 1st day of October, 1966, and shall be payable on the 9th day of January, 1967, at the office of the Trust.

The maximum quantity of water to be supplied in the year without further charge to any property rated by the Trust is hereby fixed at the quantity which, at the charge of Fifteen Cents per 1,000 gallons, would produce an amount equal to the amount of the rate levied on such property for the said year.

The charge for water supplied by measure to any property rated by the Trust in excess of such maximum quantity, computed as in the last preceding clause is hereby fixed at Ten Cents per 1,000 gallons.

The aforesaid charges shall be payable on demand.

Passed this 7th day of December, 1966.

Signed and sealed this 7th day of December, 1966—

(SEAL) A. TERRILL, Chairman.
R. H. HOWARD, Commissioner.
G. J. MORTON, Secretary.

Approved, 21st December, 1966.—T. A. DARCY, Minister of Water Supply.

No. 2.—11641/66.—2

WODONGA WATERWORKS TRUST.

WODONGA URBAN DISTRICT.

Rating By-Law for the Year 1966-67.

THE Wodonga Waterworks Trust, in pursuance and exercise of the powers conferred by the Water Act, doth hereby make a rate for the supply of water for domestic purposes of point four five cents in the dollar (\$1) on the unimproved capital municipal valuation of lands and tenements to be rated within the Wodonga Urban district.

Provided that in no case shall the amount of the rate payable in respect of any tenement (other than land on which there is no building) be less than four dollars (\$4.00) and in respect of any land on which there is no building less than One Dollar Fifty Cents (\$1.50).

Such rates are made and shall be levied upon the occupiers or owners of the said land and tenements for the year commencing on the 1st day of October, 1966, and shall be payable on the 9th day of January, 1967, at the office of the said Trust.

The maximum quantity of water to be supplied in any one year without further charge to any property rated by the Trust is hereby fixed at the quantity which, at the charge of Fifteen Cents per 1,000 gallons, would produce an amount equal to the amount of the rate levied on such property for the said year.

The charge for water supplied by measure to any property rated by the Trust in excess of such maximum quantity, computed as in the last preceding clause is hereby fixed at ten cents per 1,000 gallons up to 1,000,000 gallons, and excess at Eight Cents per 1,000 gallons.

The charges for water supplied by measure shall be payable on demand at the office of the Trust.

Passed this 7th day of December, 1966.

Signed and sealed this 7th day of December, 1966—

(SEAL) A. TERRILL, Chairman.
R. H. HOWARD, Commissioner.
G. J. MORTON, Secretary.

Approved, 21st December, 1966.—T. A. DARCY, Minister of Water Supply.

WOODEND WATERWORKS TRUST.

RATING BY-LAW FOR PERIOD COMMENCED 1ST OCTOBER, 1966, AND ENDING 30TH SEPTEMBER, 1967.

THE WOODEND WATERWORKS TRUST, in pursuance and exercise of the powers conferred by the Water Act, doth hereby make a rate for the supply of water for domestic purposes of six point five cents in the Dollar of the annual municipal valuation of lands and tenements liable to be rated within the Woodend Urban District.

PROVIDED that in no case shall the amount of rate payable in respect of any tenement (other than land on which there is no building) be less than six dollars, and in respect to any land on which there is no building, less than three dollars.

Such rates are made and shall be levied upon the occupiers or owners of the said lands and tenements for the period commenced the first day of October, 1966, and ending the 30th day of September, 1967, and shall be payable on the 10th day of January, 1967, at the office of the Trust.

The maximum quantity of water to be supplied in the period, without further charge to any property rated by the Trust, is hereby fixed at the quantity, which, at a charge of twenty cents per 1,000 gallons, would produce an amount equal to the amount of the rate levied on such property for the said period.

The charge for water supplied by measure to any property rated by the Trust in excess of such maximum quantity, computed as in the last preceding clause, is hereby fixed at twenty cents per 1,000 gallons.

The charge for water supplied to any property, by measure, not rated by the Trust is hereby fixed at twenty cents per 1,000 gallons and the minimum quantity of water to be charged for in cases where water is so supplied is hereby fixed at 30,000 gallons.

The charge for water supplied by measure shall be payable on demand at the office of the Trust.

Passed this 13th day of December, 1966.

(SEAL) A. C. ANDERSON, Commissioner.
R. MCKENZIE, Commissioner.
WILLIAM MCGARRY, Secretary.

Approved, 21st December, 1966.—T. A. DARCY, Minister of Water Supply.

Country Roads Act 1958.
COUNTRY ROADS BOARD.

NOTICE OF FIXING NEW ALIGNMENTS OF OVENS HIGHWAY IN THE SHIRE OF BEECHWORTH.

NOTICE is hereby given that the Country Roads Board under the powers conferred upon it by the Country Roads Act 1958 (No. 6229) has fixed an alignment for each side of Ovens Highway in the Shire of Beechworth as shown on plans numbered G.P.10690 and 10691 hereunder.—

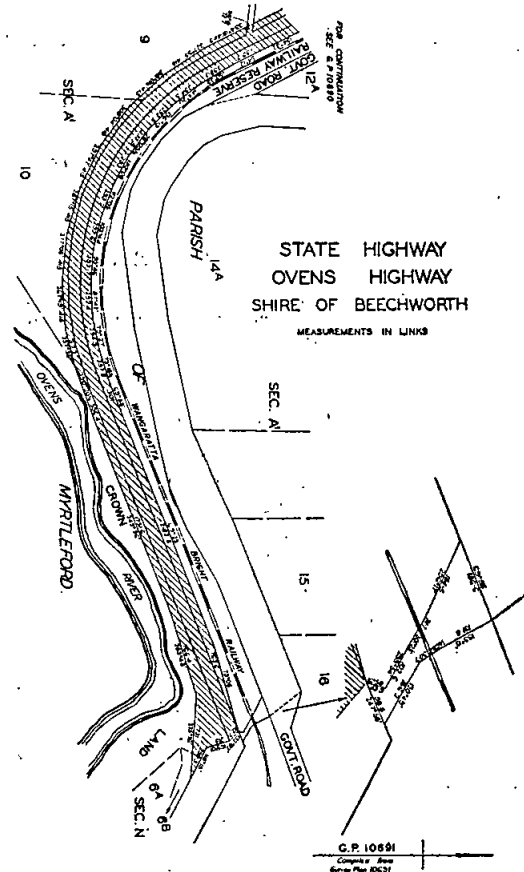
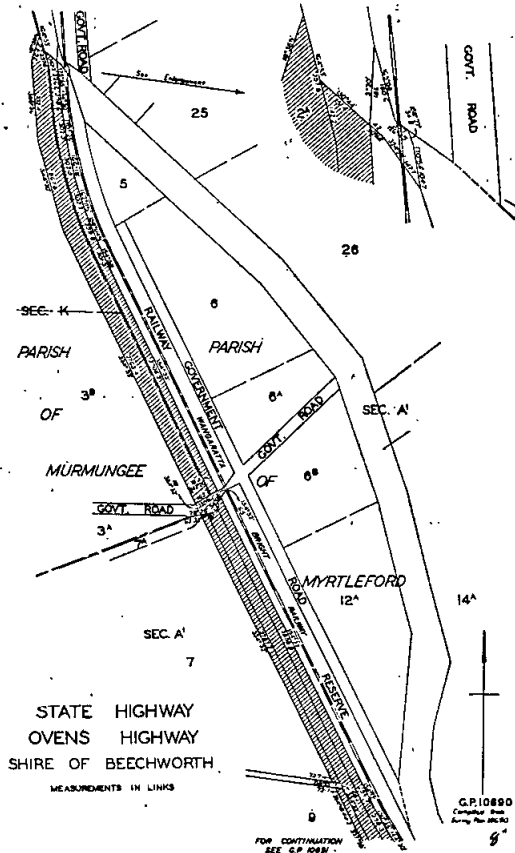

Copies of survey plans numbered 10690 and 10691 are lodged in the offices of the Country Roads Board, the municipality of the Shire of Beechworth, the Registrar of Titles and the Registrar-General, respectively and may be inspected by any person without a fee at any time at which such offices are open for business.

Dated the 19th day of December, 1966.

N. L. ALLANSON, Secretary.
Country Roads Board, 60 Denmark-street, Kew, E.A.

APPOINTMENTS AND RESIGNATIONS

APPOINTMENTS.

HIS Excellency the Governor of the State of Victoria, by and with the advice of the Executive Council thereof, has, by Orders made on the 20th day of December, 1966, been pleased to make the under-mentioned appointments, viz.:

CHIEF SECRETARY'S DEPARTMENT.

Governor (Acting) of Training Prison.

RAYMOND GEORGE SMITH, pursuant to the provisions of the Gaols Act 1958, to be Governor (Acting) of the Morwell River Reforestation Prison, from the 16th December, 1966, to the 26th December, 1966, both dates inclusive, during the absence on leave of George James Leslie Armstrong.

MINISTRY OF HEALTH.

Member of Committee of Management of Hospital.

Professor SYDNEY LANCE TOWNSEND, V.R.D., M.D., B.S., F.R.C.S. (Edin.), F.R.A.C.S., F.R.C.O.G., D.T.M. and H., to be a Member of the Committee of Management of Austin Hospital, Heidelberg, pursuant to proviso (c) to section 48 (1) of the Hospitals and Charities Act 1958, for a period of three years.

Trustees of Public Cemeteries.

IRVINE ATLEE WELSH to be a Trustee of the Benalla Public Cemetery, vice W Say, deceased;

JOHN HENRY RYAN to be a Trustee of the Mitiamo Public Cemetery, vice A. Maher, resigned;

KEITH PHELAN to be a Trustee of the Mitiamo Public Cemetery, vice W. Phillips, sen., deceased;

HENRY WILLIAM McERVALE, ALEXANDER ARCHIBALD McERVALE, and JOHN CHARLES WALTERS, to be Trustees of the Nandaly Public Cemetery, additional Trustees;

ALBERT VICTOR CARR to be a Trustee of the Tatura Public Cemetery, vice J. Webb, resigned;

JOHN HUMPHREY, ERIC NELSON, WILLIAM LONG, KEVIN HUMPHREY, and ERIC MURRELL, to be Trustees of the Cressy Public Cemetery, additional Trustees;

GORDON MCKAY to be a Trustee of the Eildon Public Cemetery, vice A. Sawers, deceased;

FREDERICK LEWIS MEAD
to be a Trustee of the Staffordshire Reef Public Cemetery,
vice R. Kitchen, resigned;

ROBERT MCLEAN
to be a Trustee of the Staffordshire Reef Public Cemetery,
vice C. Mitchell, resigned;

ALBERT EDWIN GUY
to be a Trustee of the Staffordshire Reef Public Cemetery,
vice H. Burr ridge, resigned;

ALAN VIVIAN GUY,
ALFRED ROY SCOTT, and
GLENTON DONALD MCKENZIE,
to be Trustees of the Staffordshire Reef Public Cemetery,
additional Trustees; and

EDWARD HUGH MCLEAN
to be a Trustee of the Staffordshire Reef Public Cemetery,
vice K. Halsted, resigned.

Public Vaccinator.

ALAN LANE, M.B., B.S., D. T. M. & H.,
to be a Public Vaccinator, Municipality of Waranga.

LAW DEPARTMENT.

Judge of the County Court, &c.

IVAN FRÉDERICK CHARLES FRANICH, B.A., LL.B., a
Barrister at Law who has practised as a Barrister
in Victoria for a period of seven years,
to be a Judge of the County Court and a Judge of Courts
of Mines, under the provisions of the County Court Acts,
to take effect from the date of commencement of duty.

Chairman of General Sessions.

IVAN FRÉDERICK CHARLES FRANICH, B.A., LL.B., a
Barrister at Law of Victoria who has practised for
a period of five years,
to be a Chairman of General Sessions under the provisions
of the Justices Act 1958, to take effect from the date of
commencement of duty.

Master of the Supreme Court.

GEORGE STAFFORD BRETT, Barrister at Law,
to be a Master of the Supreme Court of Victoria under
the provisions of section 185 of the Supreme Court Act
1958, to take effect from the date of commencement of
duty.

MINES DEPARTMENT.

Mining Registrar.

KENNETH BASIL SHUEY
to act as Mining Registrar for the St. Andrews Division
of the Castlemaine Mining District, vice Dennis Joseph
Darcy, transferred, fees received to be the only remunera-
tion.

DEPARTMENT OF THE TREASURER.

Receivers of Revenue (Acting).

JAMES COLIN MURRAY
to act temporarily as Receiver of Revenue, State Land
Tax and Probate Duties Office, Treasury, vice I. M. Green,
on leave; and

KEVIN GEORGE MCMAHON
to act temporarily as Receiver of Revenue, Colac, vice
A. R. Penfold.

J. COLQUHOUN,
Clerk of the Executive Council.

At the Executive Council Chamber,
Melbourne, 20th December, 1966.

FORESTS DEPARTMENT.

**APPOINTMENT OF ADVISORY COMMITTEE OF
"MOUNTAIN GALLERIES" RESERVE—MT.
DANDENONG.**

WHEREAS by section 50 of the Forests Act 1958 (No. 6254), it is provided that the Minister of Forests may, on the recommendation of the Forests Commission, appoint any number of persons, not less than three, to be an advisory committee of any land forming part of any reserved forest, such land being set aside and declared to be a reserve for the preservation of fauna and flora and the display of works of art, and may remove any of those persons: Now therefore, I, Lindsay Hamilton

Simpson Thompson, Her Majesty's Minister of Forests in the State of Victoria, on the recommendation of the Forests Commission, do hereby appoint—

Mrs. D. M. ATKINSON,
L. H. ATKINSON,
L. BAKACS,
R. WILSON, and
J. C. WESTCOTT,

as members of the Advisory Committee until the 17th day of February, 1970, of the land forming part of the reserved forest in the Parish of Mooroolbark, County of Evelyn, described in the accompanying Schedule, and known as "Mountain Galleries".

SCHEDULE ABOVE REFERRED TO.

Parish of Mooroolbark, County of Evelyn, comprising 4 acres 2 roods 10 perches, as shown on plan of survey No. S-766 on file of correspondence No. 62/763 in the Forests Department.

Dated at Melbourne, the 22nd day of December, 1966.

L. H. S. THOMPSON,
Minister of Forests.

RESIGNATION.

HIS Excellency the Governor of the State of Victoria, by and with the advice of the Executive Council thereof, has, by Orders made on the 20th day of December, 1966, accepted the resignation of the person named hereunder of the office mentioned, viz.:—

CHIEF SECRETARY'S DEPARTMENT.

JOHN EDMUND DE LANY, Superintendent of Police, Grade II., as a Licensing Inspector for the purposes of the Licensing Act 1958, to date from and inclusive of the 5th December, 1966.

J. COLQUHOUN,
Clerk of the Executive Council.

At the Executive Council Chamber,
Melbourne, 20th December, 1966.

ORDERS IN COUNCIL

RAILWAYS ACT 1958.

At the Executive Council Chamber, Melbourne, the
twentieth day of December, 1966.

PRESENT:

His Excellency the Governor of Victoria.
Mr. Rossiter Mr. Dickie.
Mr. Manson

**ORDER CLOSING CERTAIN RAILWAY LEVEL
CROSSINGS ON THE AVOCA AND ARARAT RAILWAY.**

WHEREAS pursuant to the provisions of the Railways Act 1958 No. 6355, The Victorian Railways Commissioners recommended to the Governor in Council that railway level crossings at 128M 07C 13L, 133M 63C 76L and 134M 45C 16L should be closed and gave the several notices required under the Act His Excellency the Governor of the State of Victoria with the advice of the Executive Council thereof and being satisfied—

- (a) that the requisite notices have been given;
- (b) that not less than two months have expired since the last of such notices was given;
- (c) that the level crossings are no longer required for the use of the public doth hereby order that the level crossings at 128M 07C 13L and 133M 63C 76L shall be closed on the provision of an occupation crossing at the sites, and that the level crossing at 134M 45C 16L be closed from 1st January, 1967.

And the Honorable Edward Raymond Meagher, Her Majesty's Minister of Transport for the State of Victoria shall give the necessary directions herein accordingly.

J. COLQUHOUN,
Clerk of the Executive Council.

COUNTRY ROADS BOARD.

At the Executive Council Chamber, Melbourne, the twentieth day of December, 1966.

PRESENT:

His Excellency the Governor of Victoria.
 Mr. Rossiter | Mr. Dickie.
 Mr. Manson |

ORDER APPROVING OF LAND BEING ACQUIRED AND ROADS, DEVIATIONS, OR WIDENINGS BEING MADE.

HIS Excellency the Governor of the State of Victoria, by and with the advice of the Executive Council thereof, being satisfied that there are funds legally available for acquiring the land, doth hereby approve the acquiring of the land described in the Schedule hereunder and the making of new roads and deviations from and widenings of existing roads referred to in the said Schedule.

SCHEDULE.

State Highways.

The land shown hatched on plan numbered G.P. 10739 hereunder required for the widening of the Midland Highway in the Shires of Corio and Bannockburn and making of the widening thereon.

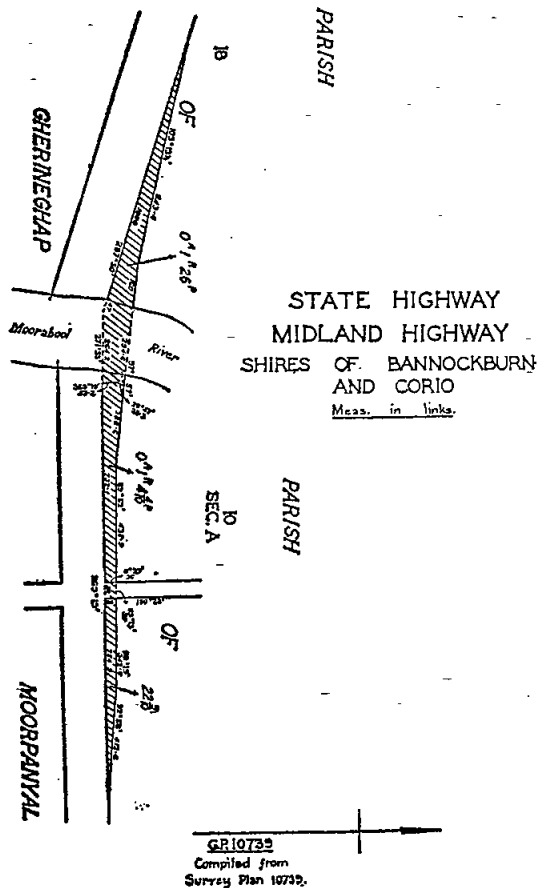

The land shown hatched on plan numbered G.P. 10613 hereunder required for the widening of the Princes Highway in the Shire of Hampden and making of the widening thereon.

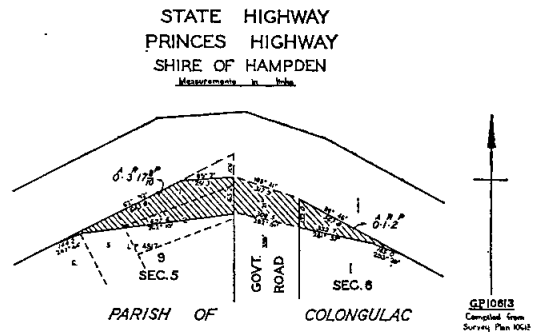

The land shown hatched on plans numbered G.P. 10631, G.P. 10632 and G.P. 10633 hereunder required for the deviation of the Cann Valley Highway in the Shire of Orbost and making of the deviation thereon.

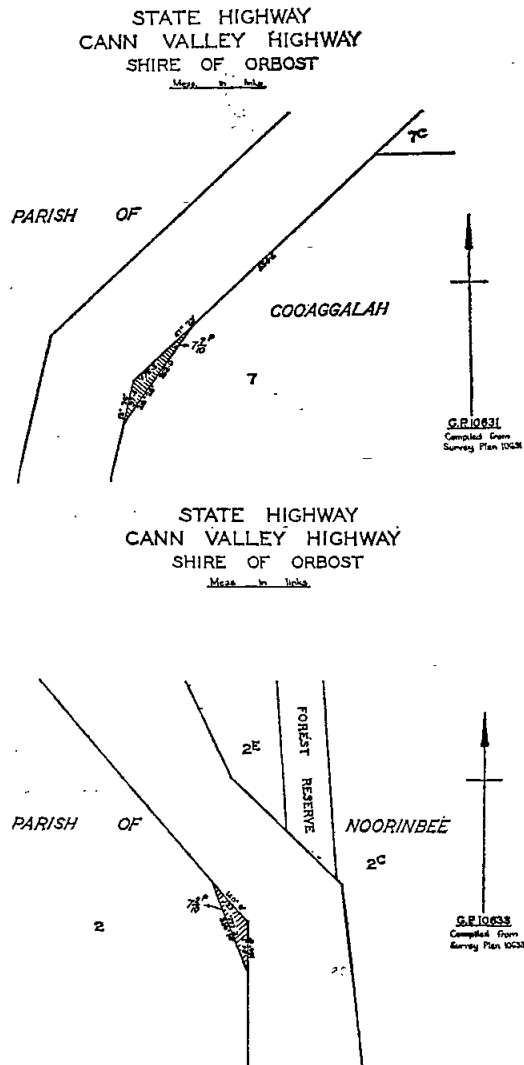

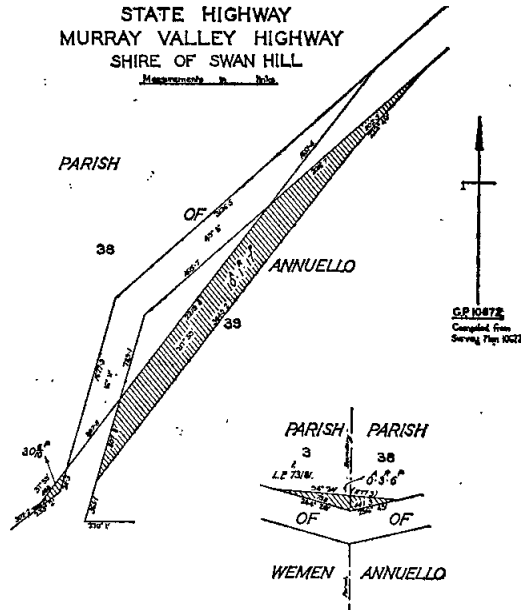
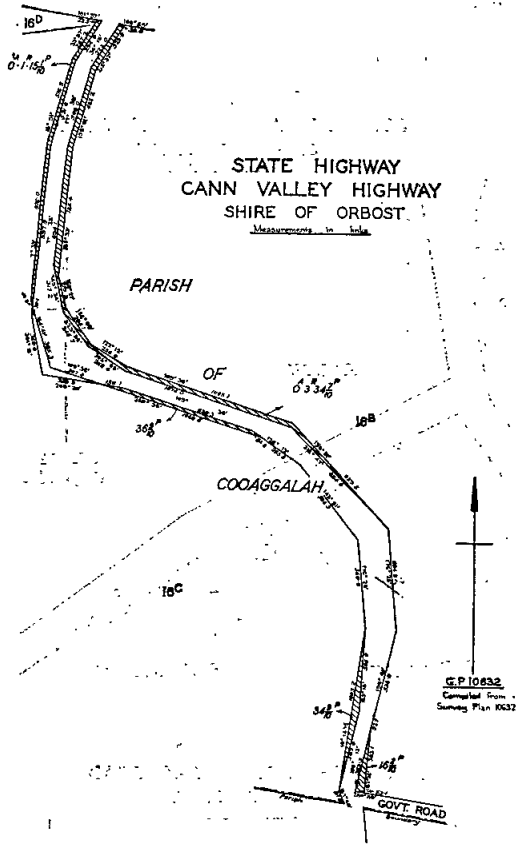

The land shown hatched on plans numbered G.P. 10671 and G.P. 10672 hereunder, required for the deviation of the Murray Valley Highway in the Shire of Swan Hill and making of the deviation thereon.

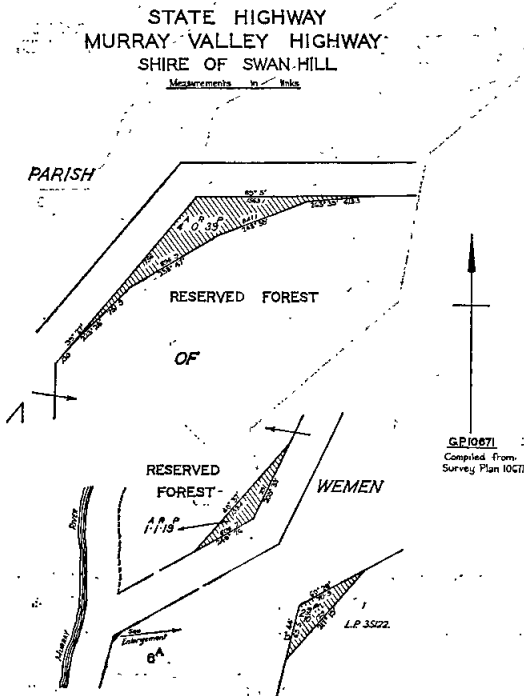

Unclassified Roads.

The land shown hatched on plan numbered G.P. 10757 hereunder, required for the making of the Latrobe Valley By-pass Access road in the Shire of Berwick.

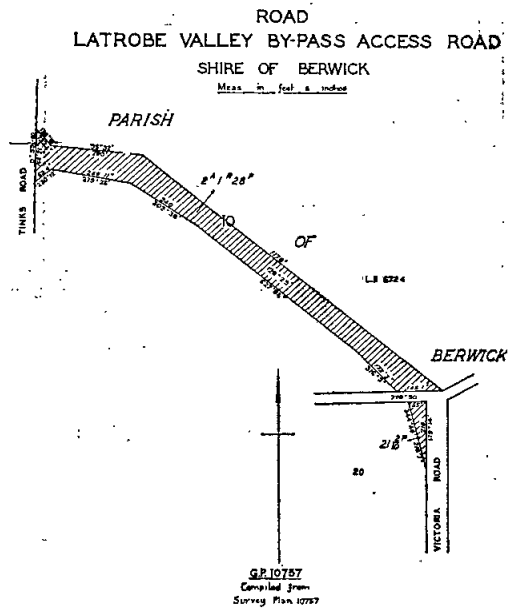

And the Honorable Murray Victor Porter, Her Majesty's Minister of Public Works for the State of Victoria, shall give the necessary directions herein accordingly.

J. COLQUHOUN,
Clerk of the Executive Council.

COUNTRY ROADS BOARD.

At the Executive Council Chamber, Melbourne, the twentieth day of December, 1966.

PRESENT:

His Excellency the Governor of Victoria.
 Mr. Rossiter
 Mr. Manson
 Mr. Dickie.

ORDER CONFIRMING RESOLUTIONS OF THE COUNTRY ROADS BOARD.

HIS Excellency the Governor of the State of Victoria, by and with the advice of the Executive Council thereof, doth hereby, in pursuance of the provisions of the Country Roads Act 1958, confirm the Resolutions of the Country Roads Board, the dates whereof and the terms of which are scheduled hereunder:—

SCHEDULE.

Main Roads.

Resolution dated 12th December, 1966, made pursuant to sections 21 and 58 of the Country Roads Act 1958 declaring the deviation from the Tyers-road in the Shire of Morwell as indicated by diagonal hatching on the plan numbered G.P. 7128 hereunder to be part of a main road within the meaning and for the purposes of the Country Roads Act 1958, and also declaring that such deviation shall be in lieu of the existing road or part thereof indicated by cross hatching on the said plan.

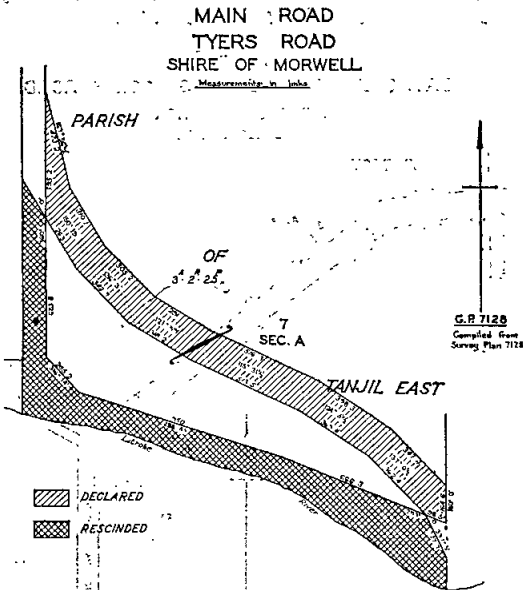

Forest Roads.

Resolution dated 12th December, 1966, made pursuant to sections 21, 58 and 94 of the Country Roads Act 1958, proclaiming the deviation from the Forrest-Apollo Bay road in the Shire of Otway as indicated by diagonal hatching on the plans numbered G.P. 9504 and G.P. 9505 attached to this Order to be part of a forest road within the meaning and for the purposes of the Country Roads Act 1958, and also proclaiming that such deviation shall be

in lieu of the existing road or part thereof indicated by cross hatching on the said plan and that such part of the said existing road shall be discontinued.

FOREST ROAD
 FORREST—APOLLO BAY ROAD
 SHIRE OF OTWAY

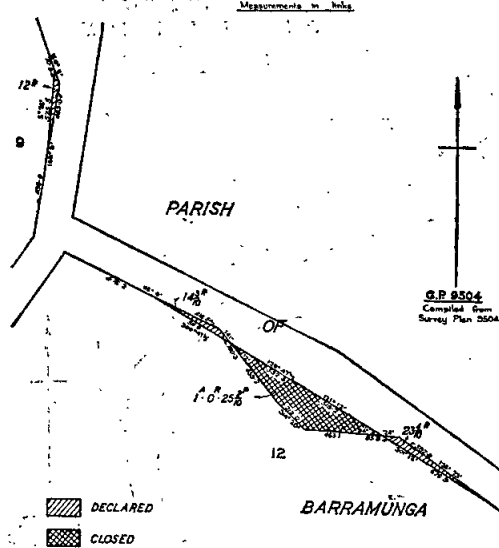

FOREST ROAD
 FORREST—APOLLO BAY ROAD
 SHIRE OF OTWAY

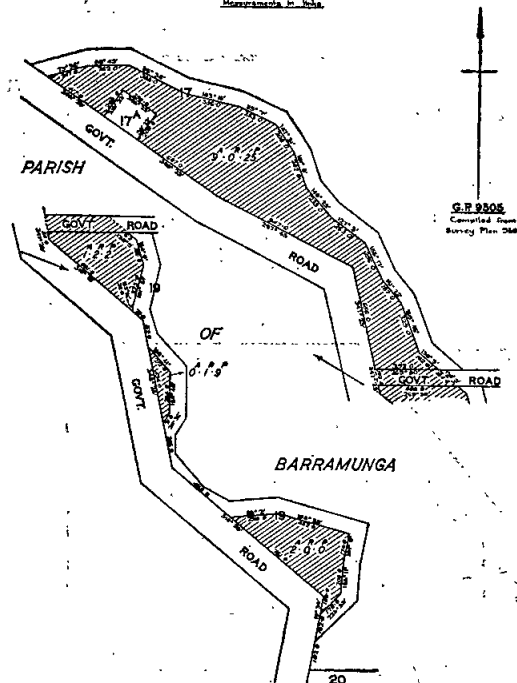

And the Honorable Murray Victor Porter, Her Majesty's Minister of Public Works for the State of Victoria, shall give the necessary directions herein accordingly.

J. COLQUHOUN,
 Clerk of the Executive Council.

ROAD TRAFFIC ACT 1958.

At the Executive Council Chamber, Melbourne, the twentieth day of December, 1966.

PRESENT:

His Excellency the Governor of Victoria.
Mr. Rossiter | Mr. Dickie.
Mr. Manson

ORDER EXTENDING THE APPLICATION OF THE ROAD TRAFFIC ACT 1958 TO CERTAIN LAND UNDER THE CONTROL OF THE CITY OF NUNAWADING.

IN pursuance of the powers conferred by the Road Traffic Act 1958, His Excellency the Governor of the State of Victoria, in the Commonwealth of Australia, by and with the advice of the Executive Council of the said State, and at the request in writing of the Council of the City of Nunawading doth by this Order extend the provisions of the said Act to the following land under the control of the City of Nunawading:—

All that piece of land shown delineated and hachured on the plan hereunder.

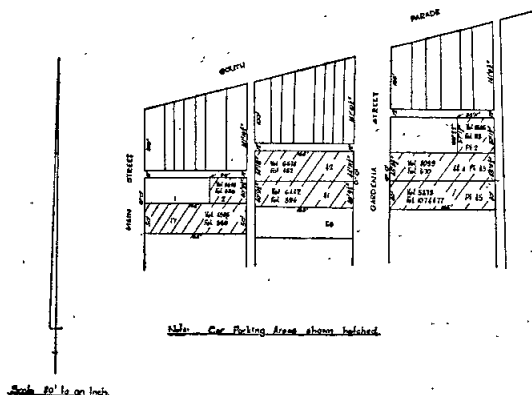

And the Honorable Arthur Gordon Rylah, Her Majesty's Chief Secretary for the State of Victoria, shall give the necessary directions herein accordingly.

J. COLQUHOUN,
Clerk of the Executive Council.

HOSPITALS SUPERANNUATION ACT 1965.—SECTION 3.

At the Executive Council Chamber, Melbourne, the twentieth day of December, 1966.

PRESENT:

His Excellency the Governor of Victoria.
Mr. Rossiter | Mr. Dickie.
Mr. Manson

WHEREAS it is provided in section 3 of the Hospitals Superannuation Act 1965 that "Institution" means, amongst other things, a body of persons corporate or unincorporate declared by Order of the Governor in Council to be an institution for the purposes of that Act:

Now therefore His Excellency the Governor of the State of Victoria, by and with the advice of the Executive Council of the said State, hereby declares Trade Union Clinic and Research Center Limited to be an institution for the purposes of the Hospitals Superannuation Act 1965.

And the Honorable Vance Oakley Dickie, Her Majesty's Minister of Health for the State of Victoria, shall give the necessary directions herein accordingly.

J. COLQUHOUN,
Clerk of the Executive Council.

DANDENONG VALLEY AUTHORITY ACT 1963.

At the Executive Council Chamber, Melbourne, the twentieth day of December, 1966.

PRESENT:

His Excellency the Governor of Victoria.
Mr. Rossiter | Mr. Dickie.
Mr. Manson

AGREEMENT BETWEEN DANDENONG VALLEY AUTHORITY AND THE SHIRE OF KNOX REGARDING THE REMODELLING OF FERNY CREEK AT THE GLENFERN ROAD BRIDGE, FERN TREE GULLY.

WHEREAS the Shire of Knox desires to carry out waterway improvements in the Ferny Creek in connexion with the replacement of a bridge at Glenfern-road, Fern Tree Gully:

And whereas, in pursuance of the provisions of section 20 (2) of the Dandenong Valley Authority Act 1963 the Authority may, with the consent of the Governor in Council, contract upon such terms and conditions as it sees fit with any public authority for or with respect to the construction of any works which the Authority is by law empowered to construct:

And whereas the Authority has agreed to make a contribution not exceeding \$9,340 towards the cost of the said waterway improvements:

Now therefore His Excellency the Governor of Victoria, acting by and with the advice of the Executive Council thereof and in pursuance of the said Act and all other powers thereunto him enabling, hereby consents to the Dandenong Valley Authority entering into an agreement with the Shire of Knox to contribute an amount not exceeding \$9,340 towards the cost of the said waterway improvements in the Ferny Creek.

And the Honorable Thomas Anthony Darcy, Her Majesty's Minister of Water Supply for the State of Victoria, shall give the necessary directions herein accordingly.

J. COLQUHOUN,
Clerk of the Executive Council.

LOCAL GOVERNMENT DEPARTMENT.

At the Executive Council Chamber, Melbourne, the twentieth day of December, 1966.

PRESENT:

His Excellency the Governor of Victoria.
Mr. Rossiter | Mr. Dickie.
Mr. Manson

VESTING OF A RESERVE IN THE ELTHAM SHIRE COUNCIL.

WHEREAS it is provided by section 569BA of the Local Government Act 1958, as amended, that where any map or plan has been lodged or deposited with the Registrar of Titles pursuant to section 97 of the Transfer of Land Act 1958 or any corresponding previous enactment (whether before or after the commencement of the Local Government Act 1963) and any allotment on that map or plan has been transferred the Governor in Council on the request of the Council of the municipality may by Order published in the Government Gazette direct that the whole or any part of the land comprised in any reserve shown on that map or plan shall vest in the council whereupon such land shall so vest freed and discharged from any mortgage charge lease or sub-lease:

And whereas the Council of the Shire of Eltham, has requested that a reserve shown on a plan of subdivision be vested in the Council and an allotment on that plan has been transferred:

Now therefore, His Excellency the Governor of the State of Victoria, by and with the advice of the Executive Council thereof, doth by this Order vest in the Council of the Shire of Eltham certain land being the Reserve on

plan of subdivision No. 7113, lodged in the Office of Titles and being the land shown hatched on the plan attached hereunder.

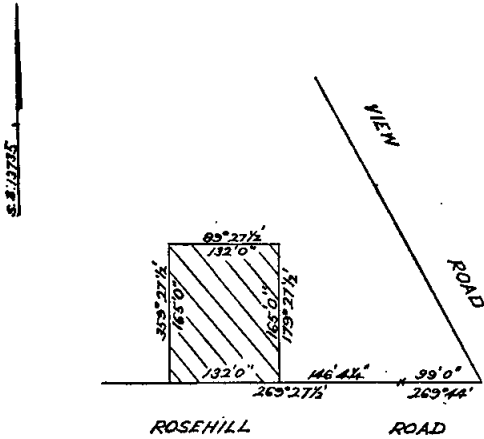

Measurements are in feet & inches

And the Honorable Rupert James Hamer, Her Majesty's Minister for Local Government for the State of Victoria, shall give the necessary directions herein accordingly.

J. COLQUHOUN,
Clerk of the Executive Council.

MARGARINE ACT 1958 (No. 6301).

At the Executive Council Chamber, Melbourne, the twentieth day of December, 1966.

PRESENT:

His Excellency the Governor of Victoria.
Mr. Rossiter | Mr. Dickie.
Mr. Manson |

IN pursuance of the powers conferred by section 15 of the Margarine Act 1958 (No. 6301) and all other powers him thereunto enabling, His Excellency the Governor of the State of Victoria by and with the advice of the Executive Council thereof, doth hereby appoint Norman Edward Richards, and Lorence George Whitehead, Dairy Produce Inspectors, to be Inspectors for the purposes of the said Act, without additional salary, and for the period during which the said Norman Edward Richards and Lorence George Whitehead shall continue to be employed in their present capacities.

And the Honorable Gilbert Lawrence Chandler, Her Majesty's Minister of Agriculture for the State of Victoria, shall give the necessary directions herein accordingly.

J. COLQUHOUN,
Clerk of the Executive Council.

LANDS DEPARTMENT NOTICES

APPROACHING LAND SALES.

SALES of Crown lands, in fee-simple, will be held at the under-mentioned places and dates, viz.:-

	No. of Gazette.
Blackwood.—Saturday, 11th February, 1967 ..	91
Melbourne, 15th February, 1967 ..	2

SALE OF CROWN LAND BY AUCTION.

The land will be offered for sale in fee-simple, and subject to the provisions of the Land Act and Regulations thereunder.

The upset price is the sum at which bidding will start, and no bid below that sum can be accepted. The highest bidder at or above that sum shall be the purchaser, subject to signature of contract and any necessary payment.

TERMS:

A deposit of at least 12½% of the purchase price must be paid at the sale, either in cash or by cheque.

The residue is payable in twenty half-yearly instalments.

Interest at the rate of 5% per annum is payable with all payments of residue, and is computed for each instalment from the date of sale to the date of such payment. Additional interest is charged if any instalment is not paid on or before the due date.

If paid off within 30 days of sale, no interest is payable. FEES, ETC.:

Also payable at the sale, in addition to the deposit, is the survey fee.

Payable with balance of purchase money—

Crown Grant fee \$3
Assurance Fund Contribution.—One cent in every Five dollars or part thereof of purchase price. (This is a fund established to guarantee the validity of freehold titles.)

Transfer of interest prior to completion of payment may be allowed on payment of \$2 fee and subject to stamp duty.

If unable to attend personally, a prospective purchaser may arrange for another person to bid as his agent.

J. C. M. BALFOUR,
Minister of Lands.

Office of Crown Lands and Survey,
Melbourne, 6th January, 1967.

MELBOURNE.—Sale (No. 11855) of Crown land in fee-simple, by auction, will be held in KELVIN HALL, 55 EXHIBITION-STREET, MELBOURNE, on WEDNESDAY, the 15th FEBRUARY, 1966, at half-past TEN o'clock a.m. To be conducted by Land Officer, Melbourne. Auctioneers: CAROLAN & CO. PTY. LTD., 243 Collins-street, Melbourne.

Lot 1.
AT ST. KILDA, PARISH OF MELBOURNE SOUTH, COUNTY OF BOURKE.

Having a frontage of 62 ft. 3 in. to the southern side of Acland-street about 129 yards south of Robe-street.

Upset price, \$12,150 the lot. Survey fee, \$100.

Area 19 perches, subject to survey, allotment 8B, together with a right of carriageway over the roadway 12 feet wide on the north-west boundary.

Subject to footway easement 5 feet wide along the south-eastern boundary in favour of adjoining land contained in Freehold Certificate of Title, Vol. 7057, Fol. 215.

NOTE.—The land is zoned Residential "A" under the Melbourne and Metropolitan Board of Works Planning Scheme.—(G.60511.)

Lot 2.
PARISH OF WILL-WILL-ROOK, COUNTY OF BOURKE.

Having a frontage of 200 feet to the western side of Sydney-road, Fawkner, about 722 yards north of Box Forest-road.

Upset price \$23,800 the lot. Survey fee \$60.

Area 2r. 36p., subject to survey, allotment 4B.

Subject to drainage easement 6 feet wide along the rear boundary.

The purchaser shall make arrangements acceptable to the City of Broadmeadows for the payment of kerb, channel and easement drain construction charges amounting to \$709.20.

A Crown Grant will not be issued until this condition has been complied with.

NOTE.—The land is zoned Light Industrial under the Melbourne and Metropolitan Board of Works Planning Scheme.—(G.60892.)

SALE OF CLOSER SETTLEMENT LAND BY AUCTION.

The land will be offered for sale in fee-simple, and subject to the provisions of the *Closer Settlement Act 1938*.

The **upset price** is the sum at which bidding will start, and no bid below that sum can be accepted. The highest bidder at or above that sum shall be the purchaser, subject to signature of contract and any necessary payment.

TERMS:

A **deposit of at least 12½%** of the purchase price must be paid at the sale, either in cash or by cheque.

The **residue** is payable in half-yearly instalments, in accordance with the following scale, or may be paid off at any earlier time.

- Over \$200, and not exceeding \$400, 12 instalments.
- Over \$400, and not exceeding \$600, 14 instalments.
- Over \$600, and not exceeding \$800, 16 instalments.
- Over \$800, and not exceeding \$1,000, 18 instalments.
- Over \$1,000, 20 instalments.

Interest at the rate of 5% per annum is payable with all payments of residue, and is computed on the unpaid balance. Additional interest is charged if any instalment is not paid on or before the due date.

If paid off within 30 days of sale, no interest is payable.

FEEs, ETC.:

Also payable at the sale, in addition to the deposit, are the survey fee and, if applicable, the valuation of improvements (if purchaser be not the owner thereof).

Payable with balance of purchase money—

Crown Grant fee—50 acres and under	.. \$3
Over 50 acres	.. \$4
Purchase money \$10 or under	\$2

Assurance Fund contribution.—One cent for each multiple of \$5. (This is a fund established to guarantee the validity of freehold titles.)

Transfer of interest prior to completion of payment may be allowed on payment of \$2 fee and subject to stamp duty.

If unable to attend personally, a prospective purchaser may arrange for another person to bid as his agent.

Attention is drawn to section 95, *Land Act 1958*, which provides that the purchaser shall be deemed to be the owner for the purposes of other Acts; also to an amendment to the *Local Government Act* providing for Government roads, in certain circumstances, to be declared "private streets", thus making the purchaser liable to contribute to the cost of street construction.

J. C. M. BALFOUR,
Minister of Lands.

Office of Crown Lands and Survey,
Melbourne, 6th January, 1967.

Lot 1.

PARISH OF MILDURA, COUNTY OF KARKAROO.

Fronting the eastern side of a Government road about 25 chains north of the Red Cliffs-Morkalla railway and about 2 miles south-west of Red Cliffs.

Upset price \$320 the lot. Survey fee \$19.25.

Area 7a.-1r. 16p., allotment 491D of section B.

One month allowed for removal of house and fencing.

NOTE.—The legal access to this allotment is by a road abuttal on its western boundary.

Any question of alternative access over the channel on the east of the allotment would be a matter for separate application to the State Rivers and Water Supply Commission, which has advised that this would be granted only at the purchasers expense.—(M.60977.)

PROPOSED REVOCATION OF TEMPORARY RESERVATION OF LAND BY ORDER IN COUNCIL.

IN pursuance of the provisions of the *Land Act 1958*, notice is hereby given that it is the intention of the Governor in Council to revoke the temporary reservation of land by Order in Council hereunder referred to, viz.:—

The following Notice was published 1° on the 7th December, 1966, pursuant to Order of the 29th November, 1966.

BEALIBA.—The temporary reservation, by Order in Council of the 24th July, 1893, of 18 acres 1 rood 8 perches of land in the Parish of Bealiba, as a site for a Rifle Range, revoked as to part by Order in Council of the 25th June,

1934, is about to be revoked so far as the balance thereof containing 15 acres 1 rood 23 perches, is concerned.—(B.588⁽⁵⁾) (C.78484).

BENDIGO.—The temporary reservation, by Order in Council of the 20th October, 1873, of 25 3/10 perches of land in the Parish of Sandhurst, at Bendigo, as a site for Recreation purposes.—(S.372⁽¹²³⁾) (Rs.8729).

WARRAQUIL.—The temporary reservation, by Order in Council of the 31st July, 1923, of 11 acres 3 roods 37 perches of land in the Parish of Warraquil, as a site for Recreation, revoked as to part by Order in Council of the 3rd August, 1954, is about to be revoked so far as the balance thereof, containing 11 acres 1 rood 19 perches, is concerned.—(W.318⁽⁴⁾) (Rs.2790).

J. C. M. BALFOUR,
Minister of Lands.

PROPOSED PERMANENT RESERVATIONS OF LANDS AS SITES.

IN pursuance of sections 14 and 21 of the *Land Act 1958*, notice is hereby given that it is the intention of the Governor in Council to reserve permanently from sale and from being leased and from having a licence granted in respect thereof, the land hereinafter described:—

The following notices were published 1° on the 7th December, 1966, pursuant to orders of the 29th November, 1966.

EAST CUNNINGHAME.—Land proposed to be permanently reserved as a site for Camping and Public Recreation, 10 acres 2 roods 10 perches, Township of East Cunninghame, Parish of Colquhoun, County of Tambo, being the site temporarily reserved therefor by Order in Council of the 12th February, 1935.—(C.486⁽⁴⁾) (Rs.5802).

KOO-WEE-RUP EAST.—Land proposed to be permanently reserved as a site for Public Recreation, 15 acres, Parish of Koo-wee-rup East, County of Mornington, being the site temporarily reserved therefor by Order in Council of the 4th July, 1899.—(K.118⁽¹²⁾) (Rs.2187).

PURNIM.—Land proposed to be permanently reserved as a site for Public Recreation, 4 acres 3 roods 39 perches, Parish of Purnim, County of Villiers, being the site temporarily reserved therefor by Order in Council of the 10th April, 1956.—(P.102⁽³⁾) (Rs.4418).

J. C. M. BALFOUR,
Minister of Lands.

COMMON ABOUT TO BE DIMINISHED.

IN pursuance of the provisions contained in the *Land Act 1958*, notice is hereby given that it is the intention of the Governor in Council to diminish the common hereinafter mentioned, viz.:—

The following Notice was published 1° on the 30th November, 1966, pursuant to Order of the 22nd November, 1966.

The Maldon Shire Common proclaimed as such by the Governor in Council on the 2nd April, 1889, and altered by Order in Council of the 23rd April, 1912, is about to be diminished by the excision therefrom of the following portions:

- (a) the portion in the Parish of Maldon containing 350 acres more or less, indicated by hachure, on plan hereunder.—(Rs.353.)

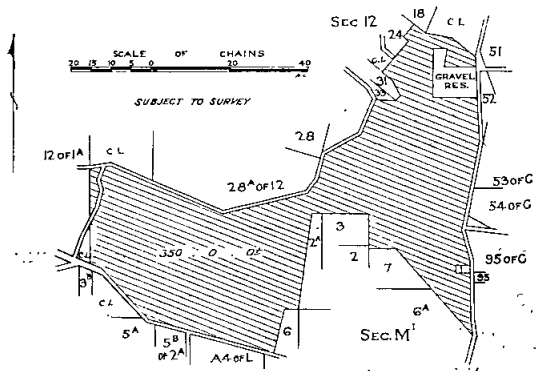

(b) the portion in the Township of Maldon containing 1 acre 2 roods, more or less, indicated by hachure on plan hereunder.—(Rs.353.)

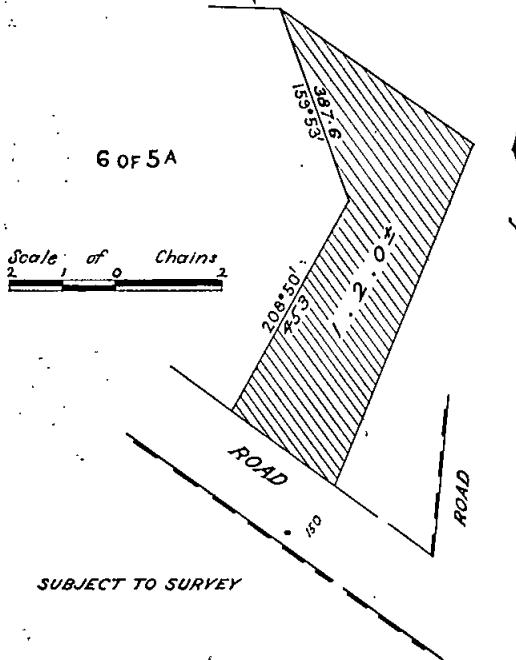

J. C. M. BALFOUR,
Minister of Lands.

COMMITTEES OF MANAGEMENT OF RESERVES.
APPOINTMENTS.

NOTICE is hereby given that, in pursuance of section 221 of the Land Act 1958, the following appointments of Committees of Management of reserved Crown lands have been made by the Minister of Lands:—

“ELSTER CREEK.”

The Melbourne and Metropolitan Board of Works as the Committee of Management of the land at Elsternwick temporarily reserved by Order in Council dated the 30th August, 1966, as a site for Public Purposes as shown hachured on plan hereunder.—(Corres. C.77698.)

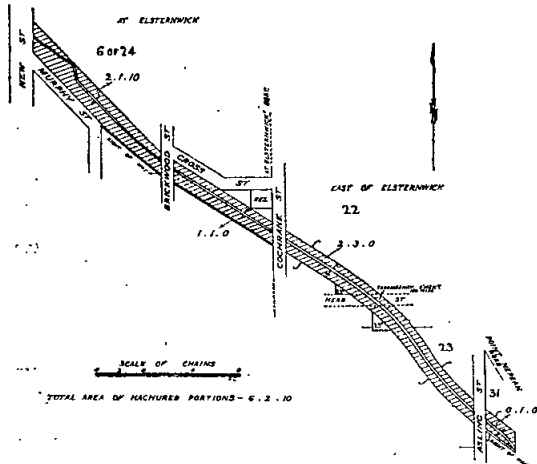

“PUBLIC PURPOSES AND LANDING SITES ON THE FRANKLIN RIVER, TOWNSHIP OF PORT FRANKLIN.”

Ralph Weston Cripps, Theo Avery, James Anderson Biggar, Donald Ross Cripps, Frederick Alexander Soderlund, William Batson, Leslie Mervyn Coghlan, Jeffrey Kelvin Cripps, Oscar Stewart Petterson and Ivan Staben Rathven as a Committee of Management for a period

ending the 3rd August, 1968 of the reserved land in Township of Port Franklin shown hatched on plan hereunder.—(Corres. Rs.5979.)

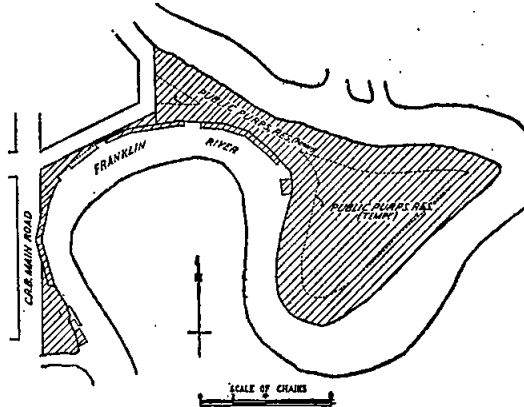

“HARRIETVILLE OVENS RIVER HISTORICAL SITE.”

Rupert Alfred Hosking, Eric M. Hoy and John Raymond Flinn as a Committee of Management for a period of three (3) years of the portion of the land in the Township of Harrierville permanently reserved as a site for Public Purposes as shown hachured on plan hereunder.—(Corres. C.98965.)

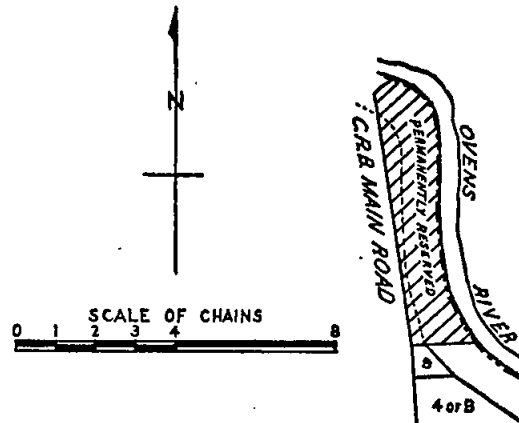

“BULLRUSH SWAMP RECREATION RESERVE.”

Edgar Harold Kruger, Walter Edward Tonissen, Vallance John Huf, Victor Uebergang, Charles S. Smith and Derryl Owen Huf as a Committee of Management for a period of three (3) years of the land in the Parish of Linlithgow temporarily reserved by Order in Council dated the 9th April, 1963, as a site for Public Recreation and known as the “Bullrush Swamp Recreation Reserve”.—(Corres. Rs.8215.)

“CASHMORE RECREATION RESERVE.”

Donald Wilmot, Edward Neil Alexander, Colin James Malcolm, John Allan Greig, Thomas James Alexander, Lawrence Stephen Rogers and Albert Wilmot as a Committee of Management for a period of three (3) years of the land temporarily reserved by Order in Council dated 16th October, 1934, as a site for Public Recreation in the Parish of Trewalla and known as the “Cashmore Recreation Reserve”.—(Corres. Rs.4408.)

“CHETWYND RECREATION RESERVE.”

Rolf Maxwell Waters, Gregory James Nolan, Alfred Edward Howlett, Francis Hubert George Sampey and Stanley Robert Crowhurst as a Committee of Management for a period of three (3) years of the land in the Parish of Ganoo Ganoo, temporarily reserved by Order in Council of the 6th December, 1955, as a site for Public Recreation and known as the “Chetwynd Recreation Reserve”.—(Corres. Rs.7404.)

"CHRISTMAS HILLS TOURIST RESERVE."

John James Stephenson, Thomas Leonard Holt, Trevor Davey, Charles Patrick Neander, Bruce Elliott, Douglas Lindsay LeBas, Stanley John Ashmore and Harold Raymond Muir as a Committee of Management for a period of three (3) years of the reserved Crown land in the Parish of Sutton indicated by red hachure on plan marked S over 4.12.59 with Lands Department Correspondence No. C.97709 and known as the "Christmas Hills Tourist Reserve".—(Corres. C.97709.)

"CORACK PARK RESERVE."

James Aloysius Brennan, Patrick James Brennan, Norval Keith Madder, William Bernard Harty, Steven Ralph Kittson, Clifford Arthur Madder and Alan John Sands, as a Committee of Management for a period of three (3) years of the lands temporarily reserved by Orders in Council dated the 13th November, 1912 and the 9th March, 1937, as sites for Public Recreation in the Township of Corack and Parish of Corack East and known as the Corrack Park.—(Corres. Rs.2230, Rs.4660.)

"DUNDONNELL PUBLIC HALL RESERVE."

Trevor Owen Smith, William Trevor Smith, Reg. Grant, Laurie William Grant, Laurence Nicholas Lamont, Christopher Griffith Luckcock, James Vickery Stansmore, Stanley Hugh McDonald, James Malcolm Small, Kenneth Grant, E. J. Turner, William Patrick Evans, Colin Ross Fletcher, Maurice Walter Goldsworthy, William John Cook, John William Doherty and Ronald Gordon Grant as a Committee of Management for a period of three (3) years of the land temporarily reserved by Order in Council dated 26th June, 1945, in the Parish of Terrinallum as a site for a Public Hall and known as the "Dundonnell Public Hall Reserve".—(Corres. Rs.5676.)

"GALLIPOLI PARK."

Geoffrey Gordon Cuzens, Kenneth Anthony Edward West, Frank Sylvester Keppel, Kenneth Carl McKenzie, Jack Haycraft, Albert William Halliday, Percy Phillips Barton, Frederick Kingsley Fiske, Ronald George Anderson and John Lloyd Gould as a Committee of Management for a period of three (3) years ending the 11th October, 1969 of the land in the Township of Marysville temporarily reserved by Order in Council dated the 28th July, 1953, as a site for Public Recreation and known as "Gallipoli Park".—(Corres. Rs.7134.)

"GORAE WEST PUBLIC HALL RESERVE."

Herbert Black, Ernest James Antony, Robert K. Firman, Russell James Hann, Robert John Beaglehole, Stanley John Dodson, Alfred John Hedditch, Robert Sefton Ryan and Wesley George Francis as a Committee of Management for a period of three (3) years of the land in the Parish of Mouzie temporarily reserved as a site for a Public Hall by Order in Council dated 22nd June, 1954, and known as the "Gorae West Public Hall Reserve".—(Corres. Rs.7273.)

"GORDON RECREATION RESERVE."

William Winter, William Henry Barry, Trevor Joseph Gleeson and James Winter as a Committee of Management for a period of three (3) years of the land temporarily reserved by Order in Council dated 21st April, 1870, as a site for Cricket and other Recreation purposes in the Parish of Moorarbool West and known as "Gordon Recreation Reserve".—(Corres. Rs.1532.)

"HEATHMERE PUBLIC HALL AND RECREATION RESERVE."

Norman Alexander Chapman, Robert John Alexander, Reginald Charles Alexander, Leslie John Carter, Samuel Atchinson W. Compton, Lindsay Gordon Finck, Stanley Edward Finck, Reginald Percy Finck, Doris Jean Alexander and Edwin Donald Alexander as a Committee of Management for a period of three (3) years of the land in the Parish of Gorae temporarily reserved by Orders in Council dated the 23rd October, 1952 and the 14th January, 1964, as a site for Public Hall and Public Recreation.—(Corres. Rs.7039.)

"HEYWOOD PUBLIC GARDENS RESERVE."

Ernest Heinrich Zeunert, Richard Peter Sibley, Herbert Edward Victor Sibley, Bruce Thomas Lasich and Cecil Claude Stevens as a Committee of Management for a

period ending the 30th August, 1967, of the land in the Township of Heywood temporarily reserved by Orders in Council dated the 11th November, 1919 and the 18th October, 1966, as sites for Public Gardens and known as the "Heywood Public Gardens Reserve".—(Corres. Rs.2045.)

"ILLABAROOK PUBLIC HALL RESERVE."

Frederick Harold Hall-Bentick, George Albert Terry, John William Pitman, Donald Alexander McKenzie, Leonard Aarons, John Harrison, Alfred Harrison, Eric Terry, Peter Chatham and Wallace Rizzoli as a Committee of Management for a period of three (3) years of the land temporarily reserved by Order in Council of the 19th June, 1951, as a site for a Public Hall in the Parish of Commeralghip and known as the "Illabarook Public Hall Reserve".—(Corres. Rs.6678.)

"JANCOURT EAST RECREATION RESERVE."

James Gilbert Nowell, Gilbert Henry Nowell, Leonard Stanley Clark, Leslie Rupert Sumner, Donald Benjamin Worland, William Alexander Finlayson, Arthur Matheson, Francis James Whiteside and William Kenneth Cairns as a Committee of Management for a period of three (3) years of the land temporarily reserved by Order in Council of 12th August, 1935, as a site for Public Recreation in the Parish of Jancourt and known as "Jancourt East Recreation Reserve".—(Corres. Rs.4469.)

"JARKLAN PUBLIC HALL RESERVE."

Kenneth Walter Toll, Edgar Thomas Bish, Leslie William Adams, Francis Ernest Tappe, Reginald Arthur Sinclair, Maxwell George Poyser and James Harvey Maxted as a Committee of Management for a period of three (3) years of the land temporarily reserved by Order in Council dated 20th May, 1959, as a site for a Public Hall in the Parish of Jarklan and known as the "Jarklan Public Hall Reserve".—(Corres. Rs.7809.)

"LAKES ENTRANCE RECREATION RESERVE."

Geoffrey Hobill Cole, Norman Gray, Norris A. Mitchellson, Wilfred Robert Davy, Clem Jones, Roy Henry Northrop and William Menzies as a Committee of Management for a period ending the 26th May, 1967, of the land in the Township of Lakes Entrance, temporarily reserved by Orders in Council dated the 18th November, 1889 and the 3rd November 1893, as sites for Public Recreation, together with the portion of the Public Purposes reserve shown by cross hachure on plan marked LE/2.11.1966 attached to Lands Department correspondence Rs.2251 and known as the Lakes Entrance Recreation Reserve.

This appointment is in lieu of all previous appointments in respect of the said lands which are hereby revoked.—(Corres. Rs.2251.)

"LORNE PUBLIC HALL AND FREE LIBRARY RESERVE."

Stanley Ernest Daw, Arthur Ronald Graham, Laurence Clifford Griffiths and Francis Richard Boney for a period ending the 30th September, 1969, together with Cyril George Crabbe, Reginald Clive Tune and M. McHugh for so long only as they continue to be Councillors for the Coast Riding of the Shire of Winchelsea and the elect of the Council of the Shire of Winchelsea, as a Committee of Management of the land permanently reserved by Order in Council dated the 19th December, 1893, as a site for a Public Hall and Free Library in the Township of Lorne and known as the "Lorne Public Hall and Free Library Reserve".—(Corres. Rs.1122.)

"MORKALLA RECREATION RESERVE."

Reginald Walter Gray, Leslie Ernest Gray, William Mortimer Mattschoss, Leslie Oscar Mattschoss as a Committee of Management for a period of three (3) years of the land temporarily reserved by Order in Council dated 2nd August, 1937, as a site for Public Recreation in the Parish of Morkalla.—(Corres. Rs.4708.)

"MYOLA PUBLIC HALL RESERVE"

Gerard Henry Tuohey, Dan Tuohey, Frank Nihill, Eugene Nihill, Patrick Tuohey, Joseph Tuohey, John E. Houlden, David James Roulston, Patrick E. McNamara, Joseph Carmody, Michael Joseph McNamara as a Committee of Management for a period of three (3) years of the land

in the Parish of Campaspe temporarily reserved as a site for Public Hall by Order in Council of the 19th June, 1951, and known as the "Myola Public Hall Reserve".—(Corres. Rs.6671.)

"PUBLIC PURPOSES RESERVE", TOWNSHIP OF NUMURKAH.

The Council of the Shire of Numurkah as the Committee of Management of the land in the Township of Numurkah temporarily reserved by Order in Council dated the 25th October, 1966, as a site for Public Purposes, together with the adjoining portion of the permanent reservation adjoining Broken Creek.—(Corres. Rs.8668.)

"OLINDA RECREATION RESERVE."

Trevor Billington, D. Jones, B. Brown, R. Hill, Ron Fowler, N. Wall, P. Chamberlain, T. Myers, L. Myers, J. Fowler and F. Fowler as a Committee of Management for a period of three (3) years of the land in the Parish of Monbulk temporarily reserved as a site for Public Recreation by Order in Council of the 16th July, 1957, in addition to the site temporarily reserved therefor by Order in Council of 15th July, 1913, both areas together known as "Olinda Recreation Reserve".—(Corres. Rs.984.)

"QUARRY STREET PLAYGROUND RESERVE."

Trevor Grant Stubbs, William Patrick Shea, Walter James Millar, Ian Price Wilson and Vic. Love as a Committee of Management for a period of three (3) years of the land in the Township of Leongatha temporarily reserved as a site for a Public Park and for Public Recreation by Order in Council of 19th June, 1957, and known as the "Quarry Street Playground Reserve".—(Corres. Rs.7571.)

"QUEENSTOWN RESERVE FOR THE PRESERVATION OF NATIVE FLORA."

Diana Joan Dyason, John James Woodward and Eric Dudley Butler as a Committee of Management for a period of three (3) years of the land in the Township of Queenstown, Parish of Queenstown temporarily reserved by Order in Council dated the 23rd June, 1959 as a site for the Preservation of Native Flora.—(Corres. Rs.7834.)

"ROMSEY PUBLIC PARK."

Christopher Sidney Johnston, Colin Alister Newnham, Thomas Edward McCarten, Kenneth Herbert Turner, Clifford Roy Shaw, Robert Claude Shaw and Leslie Argyle McIntyre as a Committee of Management for a period of three (3) years of the land in the Parish of Monegeetta reserved by Orders in Council dated the 15th October, 1883, and the 26th May, 1964, as a site for a Public Park and known as the "Romsey Public Park".—(Corres. Rs.1400.)

"RUPANYUP PUBLIC PARK RESERVE."

Jack David Johnston, Leonard James Bell, Leslie Irvine Gerditz and Desley Johns as a Committee of Management for a period of three (3) years of the land temporarily reserved by Order in Council dated 14th April, 1930, as a site for Public Park and Recreation in the Parish and Town of Rupanyup, and known as the "Rupanyup Public Park Reserve".—(Corres. Rs.3985.)

"SAILORS' FALLS RECREATION RESERVE."

Keith Cole, John Shanahan, Albert Burrows, John Muir, Andrew Rodoni, Peter Giacometti, Walter Pilmore and Robert Cooper as a Committee of Management for a period ending the 19th November, 1969, of the land in the Parish of Wombat temporarily reserved as a site for Public Recreation by Order in Council of the 23rd November, 1891, and known as the "Sailors' Falls Recreation Reserve".—(Corres. Rs.457.)

"SEA LAKE MECHANICS' INSTITUTE AND FREE LIBRARY RESERVE."

John Stanley Bailey, Andrew Carlyle McClelland, Leonard William Lloyd, George Edward Lazenby, Charles Joseph Bowd, Allan John Campbell, William George Butcher, John Allan James, Ian McDonald Templeton and John Henry Evans as a Committee of Management for a period of three (3) years of the land in the Township of Sea Lake permanently reserved by Order in Council of the 25th August, 1903, as a site for a Mechanics'

Institute and Free Library and known as the "Sea Lake Mechanics' Institute and Free Library" excluding the area occupied by the Boy Scouts Association.—(Corres. Rs.7670.)

"SEA LAKE RACECOURSE RESERVE."

John Stanley Bailey, Charles Joseph Bowd, Leonard Wilson Lloyd, George Edward Lazenby, Andrew Carlyle McClelland, John Henry Evans, Kenneth Samuel Lockhart, Richard George Jarry and Sidney Martin Smith as a Committee of Management for a period of three (3) years of the remaining portion of land in the Parish of Buruppa temporarily reserved by Order in Council dated the 21st August, 1916, as a site for Racecourse and Public Recreation and known as the "Sea Lake Racecourse Reserve".—(Corres. Rs.1181.)

"SPRING GULLY RECREATION AND PUBLIC HALL RESERVE."

Hurtle Sydney Nunn, Alan John Martin, Alfred William Carey, Edward Adrian Turner, Xavier Trevor Harrington, Eric Wastell and George Pendlebury as a Committee of Management for a period of three (3) years of the land temporarily reserved by Order in Council of the 13th July, 1942, as a site for Public Recreation and temporarily reserved for the additional purpose of a Public Hall by Order in Council of the 22nd August, 1956, and also of the land temporarily reserved by Order in Council of the 22nd May, 1945, as a site for Recreation purposes, both areas being in the Parish of Sandhurst, at Spring Gully, and known as the "Spring Gully Public Hall and Recreation Reserve".—(Corres. Rs.4599.)

"TOOLLEEN RECREATION RESERVE."

Patrick Thomas Sexton, Kenith John McFarlane, Arthur Edmund Tranter, Joseph Thomas Hamblin, Norman Arthur Hamblin, John Michael Conroy and William Alexander McRobert as a Committee of Management for a period of three (3) years of the land temporarily reserved by Orders in Council dated 13th August 1900, the 24th March, 1915, and the 21st May, 1966, for Public Recreation in the Township of Toolleen and known as the "Toolleen Recreation Reserve".—(Corres. Rs.2801.)

"TOORA RECREATION RESERVE."

Edward Everitt, Charles Victor Sagasser, Percy B. Martin, Cyril Meade Gratton, William Edward Cook, Thomas Raymond Morris, Ian Albert Nicholls, Raymond Henry Wheeler and Alfred Richard Hughes for a period of three (3) years as the Committee of Management of the land in the Township of Toora, Parish of Toora temporarily reserved by Order in Council dated the 3rd October, 1892, as a site for Public Recreation and known as the "Toora Recreation Reserve".—(Corres. Rs.1300.)

"VICTORIA PARK", YARRAWONGA.

William Joseph Ryan, Frank Keenan, Michael A. Lawless, John Morris Gardiner, John Joseph Lawless, Alexander V. Cameron and William George Hall as a Committee of Management for a period of three (3) years of the remaining portion of the land temporarily reserved by Order in Council dated 16th July, 1886, as a site for a Park for the Recreation and Convenience of the People in the Town of Yarrowonga and known as "Victoria Park".—(Corres. Rs.2055.)

"WILLOW GROVE PUBLIC HALL RESERVE."

Raymond James Arnott and Thomas Leslie Williams in the places of James William Marsden and Frank Donald Douglas Lamont (both resigned) as members of the Committee of Management for a period ending the 2nd August, 1968, of the land permanently reserved by Order in Council dated the 8th November, 1904, as a site for a Public Hall in the Township of Willow Grove and known as the "Willow Grove Public Hall Reserve".—(Corres. Rs.5365.)

"WOODS POINT PUBLIC HALL RESERVE."

Alan Louis Schumer, John Ernest Ryan, Sylvia May Bolton, Hector William Royston Stewart and John Henry Scott as a Committee of Management for a period of three (3) years of the land temporarily reserved by Order in Council dated the 23rd April, 1940, as a site for a Public Hall in the Parish of Goulburn, Township of Wood's Point, and known as the "Woods Point Public Hall".—(Corres. Rs.5034.)

"WYUNA RECREATION RESERVE."

Robert Quick Mitchell, Henry Holland Simm, John Hewitt, John Mervyn Lyle, John Graham, James Lennard Myers and Norman James McGregor as a Committee of Management for a period of three (3) years of the land temporarily reserved by Order in Council dated the 4th August, 1908, as a site for Public purposes in the Parish of Wyuna, and known as the "Wyuna Recreation Reserve".—(Corres. Rs.2177.)

"YALLOURN NORTH RECREATION RESERVE."

James Phillip Alcock, Richard John O'Donnell and Vivian Frank Gore in the places of William George Kempter, Brian Richardson and Maurice Gorman (resigned) as members of the Committee of Management for a period ending the 4th October, 1967, of the land in the Parish of Tanjil East, temporarily reserved by Order in Council dated the 30th June, 1964, as a site for Public Recreation and known as the "Yallourn North Recreation Reserve".—(Corres. Rs.8331.)

"YARRAGON RECREATION RESERVE."

Henry J. Bowers, Ian W. Best, Josiah C. Wheller, Lawrence W. Wheller, Bruce Chaproniere, Colin Handley and William J. Hay as a Committee of Management for a period of three (3) years of the land temporarily reserved by Order in Council dated 25th September, 1906, as a site for Public Recreation in the Township of Yarragon and known as the "Yarragon Recreation Reserve".—(Corres. Rs.936.)

JIM BALFOUR,
Minister of Lands.

2nd December, 1966.

TENDERS

PUBLIC WORKS DEPARTMENT

TENDERS will be received at Public Works Department, Treasury-place, Melbourne, until TEN a.m. on dates shown and for purposes mentioned hereunder.

Particulars and tender forms available at Contracts Office, Room 7, Building Division, Parliament-place and at places indicated in brackets hereunder.

Abbreviations in brackets mean:—W.O.—Inspector of Works Office; P.S.—Police Station; C.S.—Consolidated School; H.E.S.—Higher Elementary School; H.S.—High School; S.S.—State School; T.S.—Technical School.

Tenders to be submitted on the Department's printed Tender Form and will not be received by telephone. All tenders must be on a "Firm Tender" basis. The lowest or any tender will not necessarily be accepted.

Address tenders to the Minister of Public Works, and endorse the envelope containing the tender "Tender for closing Tuesday,

No preliminary deposit is required with any tender, but a successful tenderer will be required to pay a deposit for any accepted tender of \$5,000 or over.

Tuesday, 17th January, 1967.

Building, Electrical and Mechanical Works.

Ballarat.—Renewal of slate roof with terra cotta or concrete tiles, S.S. 695. (W.O., Ballarat.)

Balmoral.—Septic tank installation, Consolidated School. (W.O., Hamilton.) (Re-advertised.)

Bannockburn.—Erection of brick veneer residence, office and brick cell unit, Police Station. (W.O., Geelong.)

Beechworth.—Installation of water mains, Mental Hospital. (W.O., Wangaratta.)

Heywood.—Connexion to town water supply and fire service installations, Consolidated School. (W.O., Warrnambool.)

Murtoa.—Erection of weatherboard residence, High School. (W.O., Warracknabeal and Horsham; H.S., Murtoa.)

Poolajelo.—Erection of residence and garage, S.S. 2978. (W.O., Hamilton.) (Re-advertised.)

Site Works.

Ashwood.—Asphalting, concreting, drainage, &c., High School.

Echuca.—Drainage works, High School. (W.O., Shepparton.)

Flemington.—Earthworks, road construction, concrete paving, &c., High School.

Oakleigh.—Asphalting, concreting, drainage, retaining walls, &c., High School. (Re-advertised.)

Tuesday, 24th January, 1967.

Building, Electrical and Mechanical Works.

Berrybank.—New toilet block and proposed bore, S.S. 3639. (W.O., Camperdown.)

Don Valley.—Erection of residence and garage, S.S. 3956. (Re-advertised.)

Elwood.—Repairs to old toilets and additional staff facilities, S.S. 3942.

Hawksburn.—Renewal of urinal, cisterns, ablution and drinking troughs, S.S. 1467.

Keilor Heights.—Erection of six additional class-rooms, S.S. 4877.

Keilor Heights.—Electrical installation, S.S. 4877.

Keilor Heights.—Plenum heating, S.S. 4877.

Kew.—Tender "A", erection of brick veneer staff quarters, Tender "B", erection of brick children's play room, "The Gables".

Tallandoo.—Creek water supply installation, S.S. 2523 and Residence. (W.O., Wangaratta.)

Upfield.—Erection of first and second sections, High School.

Upfield.—Electrical installation, High School.

Upfield.—Mechanical services, High School.

Williamstown.—New class-room wing and conversion of existing class-rooms, High School. (Bills of Quantities Available.)

Williamstown.—Electrical installation, High School.

Williamstown.—Mechanical services, High School.

Furniture and Furnishings.

Essendon.—Supply of furniture, Technical School.

Miscellaneous.

Melbourne.—Supply of stoneware pipes and fittings, Public Works Department.

Mont Park.—Supply and installation of a portable cool room, Gresswell Sanatorium.

Tuesday, 31st January, 1967.

Building, Electrical and Mechanical Works.

Ballarat.—Alterations and renovations, Wards 1 and 2, Mental Hospital. (W.O., Ballarat.) (Bills of Quantities Available.)

Ballarat.—Electrical installation, Wards 1 and 2, Mental Hospital. (W.O., Ballarat.)

Ballarat.—Plenum heating and hot-water services, Wards 1 and 2, Mental Hospital. (W.O., Ballarat.)

Brighton.—Bathroom additions and alterations, Domestic Arts Teachers' College Hostel.

Caulfield.—New Diploma Block, Technical College. (Bills of Quantities Available.)

Caulfield.—Mechanical services, New Diploma Block, Technical College.

Caulfield.—Passenger/Goods Lift, New Diploma Block, Technical College.

Caulfield.—Experimental Steam Boiler, Technical College.

Deer Park.—Installation of stainless steel urinal and alter cisterns, S.S. 1434.

Jordanville South.—New Female Staff toilet, S.S. 4678.

Kerrimuir.—Fire re-instatement and additions, S.S. 4816.

Kerrimuir.—Electrical installation, S.S. 4816.

Kerrimuir.—Plenum heating, S.S. 4816.

Lurg.—Water supply installation, S.S. 2046. (W.O., Benalla.)

Port Fairy.—Renewal of water supply, Consolidated School. (W.O., Warrnambool.)

Preston East.—Extension to second and third sections, Composite Technical School.

Preston East.—Electrical installation, Composite Technical School.

Preston East.—Mechanical services, Composite Technical School.

Stawell.—Provision of storage space, &c., Technical School. (W.O., Ararat.) (Re-advertised.)

Site Works.

Highett.—Asphalt repairs, concreting, drainage works, &c., High School.

Mont Park.—Supply and delivery of electric sterilizer for Sick Hospital, Mental Hospital.

Stony Point.—Supply of a hydraulically actuated pneumatic tyred crane, Ports and Harbours Branch.

M. V. PORTER,

Minister of Public Works.

Public Works Department,

Melbourne, C.2, 19th December, 1966.

Teaching Service Act 1958.
TEACHING SERVICE (TEACHERS TRIBUNAL)
REGULATIONS.

AMENDMENT No. 112.

THE Teachers Tribunal, in pursuance of the powers conferred by the *Teaching Service Act 1958*, hereby amends Regulations 6 and 7 of the Teaching Service (Teachers Tribunal) Regulations in the manner following, that is to say:—

REGULATION 6.

Delete clause 1 (b) (iii) and substitute therefor the following:—

“(iii) three years of approved study including Trained Primary Teacher’s Certificate.”

REGULATION 7.

Delete clause 1 (b) (ii) and substitute therefor the following:—

“(ii) three years of approved study including Trained Primary Teacher’s Certificate.”

LOUIS F. C. GARLICK, Chairman.

G. FENNELL, Secretary.

Office of the Teachers Tribunal,
 Melbourne, 16th December, 1966.

PUBLIC SERVICE NOTICE

No. 1697.

Public Service Act 1958.

THE Public Service Board, in pursuance of the powers conferred by the *Public Service Act 1958*, hereby amends the Public Service (Public Service Board) Regulations as follows:—

PART V.—ALLOWANCES.

DIVISION I.—ALLOWANCES FOR QUALIFICATIONS OR EFFICIENCY, TECHNICAL AND GENERAL DIVISION.

After Regulation 100 the following heading and Regulation are inserted—

“*Education Department—Teachers’ Colleges and Schools.*”

100A. A Typist (Female), Grade I., Junior, who is performing the full duties of a Clerical Assistant (Female) shall, while engaged in the duties, be paid a total emolument in accordance with the following scale:—

Age.	Clerical Assistant (Female), Grade I.	Clerical Assistant (Female), Grade II.	Clerical Assistant (Female), Grade III.
	\$	\$	\$
Under 16 years	936	936	1,004
At 16 years	1,016	1,016	1,084
At 17 years	1,086	1,118	1,192
At 18 years	1,174	1,206	1,280
At 19 years	1,384	1,458	1,526
At 20 years	1,566	1,640	1,708

F. E. CAHILL, Chairman.

V. P. SCULLY, Secretary.

Office of the Public Service Board,
 Melbourne, 12th December, 1966.

PRIVATE ADVERTISEMENTS

Water Act 1958.

LANDSBOROUGH WATERWORKS TRUST.

EIGHTH SCHEDULE.

NOTICE to owners of tenements in the following streets or parts of streets:—

Bourke-street from a point south-east of section 6 to its junction with the Landsborough–Stawell road.

Ararat–St. Arnaud road from the Landsborough–Stawell road about 26 chains north-westerly to a point opposite Crown allotment 2, section 22.

Wills-street from Howitt-street to a point about 4 chains south-easterly.

Howitt-street from Bourke-street to the Malakoff Creek.

From the Malakoff Creek south-westerly through Crown allotments H and 2, section 20; thence southerly along a Government road to a point about 1 chain south of the northern boundary of Crown allotment 8, section 20.

Right-of-way between Crown allotments 1 and 3 of section 22.

McKinley-street from the south-western corner of section 15A to a point about 3.5 chains north of the south-west corner of the State School Reserve.

King-street from Crown allotment 3D, section 18, to Bourke-street.

Gray-street from Bourke-street about 4 chains south-westerly to a point south of Crown allotment 8, section 13.

From McKinley-street along the south side of the northern boundary of the Roman Catholic Church Reserve; thence along Brown’s-road for about 5 chains easterly from the south-western corner of Crown allotment 12A, section 15.

The main pipe in the said streets or parts of streets being laid down, the owners of all tenements situated as above, are hereby required on or before the 1st day of February, 1967, to cause a proper pipe and stop cock to be laid so as to supply water within such tenements from the main pipe.

F. C. S. EDWARDS, Secretary,

Landsborough Waterworks Trust.

Shire Office, Avoca.

4966

NOTICE OF INTENTION TO APPLY FOR A LICENCE TO DIVERT WATER AND CUT RACE FROM THE RIVER MURRAY, AT ROBINVALE.

WE hereby give notice that we intend to apply for a licence empowering us to divert water for a term of four years to the extent of 60 acre-feet per annum at a maximum rate of 4 acre-feet per day of 24 hours for the irrigation of 20 acres of vines and vegetables, being part of allotment 46c, Parish of Bumbang, and to occupy certain Crown lands for works of diversion, and to cut a race thereon.

Any objection to such application must be forwarded, in writing, to reach the State Rivers and Water Supply Commission, Melbourne, before 20th January, 1967, being 30 days from the first publication of this notice.

CHARLES OSCAR.
LORRAINE DOROTHY ERNY.

Box 450, Post Office, Robinvale, Victoria. 4963

NOTICE OF INTENTION TO APPLY FOR A LICENCE TO DIVERT WATER AND CUT RACE (RE-ISSUE) FROM THE RIVER MURRAY, AT NICHOLS POINT, MILDURA.

I HEREBY give notice that I intend to apply for a licence empowering me to divert water for a term of four years to the extent of 81 acre-feet per annum at a maximum rate of 2 acre-feet per day of 24 hours for the irrigation of 27 acres, being part of allotment A, section 6, block F, Parish of Mildura, and to occupy certain Crown lands for works of diversion, and to cut a race thereon.

Any objection to such application must be forwarded, in writing, to reach the State Rivers and Water Supply Commission, Melbourne, before 19th January, 1967, being 30 days from the first publication of this notice.

ELIAS MICHAEL SARROU.

Nichols Point. 4962

MOOROOPNA SEWERAGE AUTHORITY.

RATING BY-LAW FOR THE YEAR ENDING 31ST DECEMBER, 1967.

THE Mooroopna Sewerage Authority, in pursuance and exercise of powers enforced by the Sewerage Districts Acts, doth hereby make the following Rating By-Law:

The Mooroopna Sewerage Authority doth hereby make and levy a "Sewerage Rate" of 6 cents in the dollar on the net annual value of all rateable properties in its declared sewered areas one, two, three, four, five and six.

A "Special Rate" of 3 cents in the dollar on the net annual value of all rateable properties in the unsewered areas within its declared Sewerage District Boundaries. In no case shall the amount of the "Sewerage Rate" payable be less than Seventeen dollars in respect to any rateable "Sewered property" on which there is a building, and Nine Dollars in respect to any rateable "Sewered Property" on which there is no building.

A Cistern charge of Fifteen dollars is levied on all non rateable "Sewered Properties" of the Crown and Public bodies to be by agreement as provided by section 88 (2) of the Sewerage Districts Act 1958.

Such rates are made and shall be levied upon the occupiers or owners of the said rateable properties for the year commencing on the 1st day of January, 1966, and shall be payable on the 1st day of February, 1967, at the office of the Authority.

Resolution for the passing of this By-law was agreed to at a meeting held on the 29th day of December, 1966, by the said Authority and the common seal of the Mooroopna Sewerage Authority was hereunto fixed—

(SEAL) WILLIAM E. MALLOY, Chairman.
FRANCIS J. COOPER, Secretary.

5013

COLAC SEWERAGE AUTHORITY.

NOTICE OF INTENT TO COMPULSORILY ACQUIRE LAND UNDER THE SEWERAGE DISTRICTS ACT 1964—No. 7174 SECTION 6.

THE above Authority hereby gives notice of intent to take steps in accordance with the Sewerage Districts Act and the Land Compensation Act to compulsorily acquire land described hereunder for the purpose of constructing, operating and maintaining a sewage pumping station and ancillary works.

A general plan and description of the proposed works may be inspected at the office of the Authority, 2 Rae-street, Colac, during ordinary office hours from 9 a.m. to 5 p.m. on week days.

The following land is required for purchase:—

Approximately 23 perches being part of Crown Allotment 105, Town and Parish of Colac, County of Polwarth.

Dated 21st December, 1966.

4982

E. J. ROBBINS, Secretary.

BENDIGO SEWERAGE AUTHORITY.

THE Bendigo Sewerage Authority, having made provision for carrying off the sewage from each and every property which or any part of which is within the Sewerage Area hereinafter described, doth hereby declare that on and after the 1st day of January, 1967, each and every property which or any part of which is within the said Sewerage Area shall be deemed to be a sewered property within the meaning of the Sewerage Districts Acts.

The boundaries of the Sewerage Area hereinbefore referred to are:—

SEWERAGE AREA No. 243.

Commencing at the south-eastern corner of lot 8 of sub-division of Crown allotments 248, 249, 250 and 251, section O, Parish of Sandhurst; thence westerly along the southern boundary of the said lot 8 and northerly along the western boundaries of lots 8, 7, 6 and 5 of the said sub-division; thence easterly along the northern boundary of lot 5 and across Solomon-street; thence north-westerly along Solomon-street to Lloyd-street; thence easterly along Lloyd-street to a point 176 feet west of Harpin-street; thence northerly to a point 125 feet north of Lloyd-street; thence easterly to Harpin-street and southerly along Harpin-street to the northern boundary of Crown allotment 20, no section; thence easterly along the said Crown allotment boundary to Beischer-street; thence southerly along Beischer-street to the northern boundary of Crown allotment 26, no section; thence easterly and southerly along the northern and eastern boundaries of Crown allotment 26 and the eastern boundary of Crown allotment 25 to the northern boundary of lot 2 of sub-division of part of Crown allotments 25, 44 and 45, no section; thence easterly along the northern boundary of the said lot 2 and across a Government road to the eastern side thereof; thence southerly along the said Government road to a point 120 feet north of McIvor-road; thence easterly by a line parallel with McIvor-road and across a Government road and through Crown allotment 46 to the north-western corner of lot 16 of part of Crown allotment 46; thence easterly to the south-western corner of lot 3 of part of Crown allotment 46; thence northerly along the western boundary of lots 3, 2 and 1 easterly along the northern boundaries of lot 1 and southerly along the eastern boundaries of lots 1, 2, 3 and 4 of the said sub-division to McIvor-road; thence southerly across McIvor-road and westerly along McIvor-road to the north-eastern corner of Crown allotment 15A, section O; thence southerly, south-westerly and northerly along the eastern, south, eastern and western boundaries of Crown allotment 15A and western boundary of Crown allotment 15 to McIvor-road; thence westerly along McIvor-road to the north-eastern corner of lot 10 of sub-division of Crown allotments 165A, 166 and 167; thence southerly along the eastern boundary of the said lot 10 and westerly along the southern boundary of lot abutting on McIvor-road to Putman-avenue; thence northerly along Putman-avenue to McIvor-road and westerly along McIvor-road to the south-eastern corner of lot 1 of sub-division of Crown allotments 308 and 309; thence generally northerly and easterly along the boundaries of the said lot 1 to Harpin-street and northerly along Harpin-street to the point of commencement.

By order of the Bendigo Sewerage Authority,

T. R. FLOOD, Chairman.
H. A. MOORS, Secretary.

5008

LONGWARRY DRAINAGE TRUST.

BY-LAW No. 1.

By-law No. 1 for protecting Drains and the Banks thereof and Drainage improvement works under the control or management of the Longwarry Drainage Trust against interference or damage.

THE Longwarry Drainage Trust (hereinafter called "The Trust") in pursuance and exercise of the powers conferred by the River Improvement Acts doth hereby make the By-law following:—

1. This By-Law shall apply to all drains and the beds and banks thereof (hereinafter called "Trust Property") and to all Drainage Improvement works whether carried out constructed or in course of construction (hereinafter called "Trust Works") vested in or under the control or management of the Trust.

2. (a) No person shall (i) discharge any firearm on or from any Trust property or Trust works.
 (ii) Create a nuisance or disturbance thereon.
 (iii) Deposit rubbish or refuse thereon.
 (b) No person unless previously authorized in writing by an Officer of the Trust shall—
 (i) Operate or interfere with any Trust works.
 (ii) Cut down remove or destroy any trees shrubs or plants planted sown or maintained in connexion with any Trust works.
 (iii) Deposit in any drain any tree log rubbish soil carcass or any material likely to cause interference with the flow of water therein or the silting up or injury to or pollution thereof.
 (iv) Remove any soil gravel sand or rock from the bed or bank of any drain.
 (v) Erect any booth hut or other structure on any Trust property or any Trust Works.

3. Any person who contravenes or fails to comply with any provision of this By-Law shall be liable to a penalty of not more than Forty dollars and in the case of any offence which is continued or repeated after a conviction or order of any court in relation to the offence to a further penalty of not more than Four Dollars for each day on which the offence is so continued or repeated.

This By-law was made by the Longwarry Drainage Trust and the common seal of the said Trust was hereunto affixed on this 8th day of November, 1966, in the presence of—

(SEAL) T. R. EVANS, Chairman.
 P. E. EACOTT, Commissioner.
 K. A. PRETTY, Secretary.

Approved by the Governor in Council, at the Executive Council meeting held on 29th November, 1966. 4992

NOTICE is hereby given that the Lakes Entrance Fishermen's Co-operative Society Limited has applied for a lease under section 134 of the Land Act 1958 for a term of 21 years in respect of an area of one (1) acre in the Parish of Colquhoun as a site for fish processing works. 4812

NOTICE is hereby given that the Warmambool and District Gun Club has applied for a lease under section 134, Land Act 1958, for a term of 21 years, in respect of portion of the former Maam Water Reserve, Parish of Wangoom, as a site for Amusement and Recreation (Gun Club). 4886

THE VICTORIA RACING CLUB ACT 1871.

NOTICE is hereby given that on the nineteenth day of August, 1966, the Victoria Racing Club duly repealed its existing By-Law 22 and substituted in its place a new By-law 22 which reads as follows:—

“There shall be a General Meeting of the Club on the first Monday in September in each year, for the purpose of electing members of the Committee, discussing the general business of the Club, and receiving from the Committee an abstract of the state of the accounts of the receipts and expenditure with a report of the general concerns of the Club. At such meeting the accounts shall exhibit a true statement of the total receipts and expenditure of the Club during the year ending on the 30th of June last preceding such meeting, with a statement of the balance of such account.”

5003 Chairman,
 Victoria Racing Club.

LAND ACT 1958 (No. 6284 AS AMENDED BY ACT No. 7075).

WHEREAS:

I. Application has been made, pursuant to sub-section (1) of section 22c of the Land Act 1958, by Douglas George Grant, Ronald Francis Simpkin, Thomas Ford Daffy, Basil Augustine Kavenagh, Raymond Harry Evans and Bruce Watson, the trustees for the time being of the Beeac Recreation Reserve site, being the land described in the Schedule hereto for permission to surrender the said land to Her Majesty Queen Elizabeth the Second.

II. By the said sub-section (1) it is provided that the Attorney-General may by notice published in the Government Gazette grant permission to the trustees to surrender the land to Her Majesty, pursuant to the said section 22c and by sub-section (4) of the said section 22c, it is

further provided that the Attorney-General shall specify the purpose mentioned in section 14 of the Land Act 1958, for which the land was vested in the trustees or was used or to which the purpose for which it was vested in the trustees or was used is in his opinion substantially similar.

Now I, Arthur Gordon Rylah, in my capacity as Her Majesty's Attorney-General for the State of Victoria—

(a) grant permission to the said trustees to surrender the said land to Her Majesty, pursuant to section 22c of the Land Act 1958; and

(b) specify pursuant to sub-section (4) of section 22c aforesaid the following purpose mentioned in section 14 of the Land Act aforesaid, namely:—

“the recreation convenience or amusement of the people.”

SCHEDULE.

All those pieces of land being—

First.—Land containing 7 acres 2 roods and 16 perches or thereabouts being part of subdivision B of Crown allotment 86, Parish of Ondit, and being the land more particularly described in certificate of title, volume 3961, folio 112;

Secondly.—Land containing 37 acres 3 roods and 4 perches or thereabouts being part of subdivision A of Crown allotments 77 and 78, Parish of Ondit, and being the land now comprised in certificate of title, volume 5387, folio 286.

Given under my hand this 13th day of December, 1966.

5052 A. G. RYLAH,
 Attorney-General.

CITY OF BRIGHTON.

AN ORDER DECLARING A PUBLIC HIGHWAY OVER LAND ACQUIRED BY THE COUNCIL.

PURSUANT to the provisions of section 522 of the Local Government Act 1958, the Council of the City of Brighton hereby declares that all that land owned by the Council and used as a drainage reserve, and particularly described as that land having a width of 12 feet commencing at a point 324 ft. 8½ in. west of Cochrane-street and extending due north for a distance of 132 feet off the north side of Bay-street, be a public highway.

In witness whereof the common seal of the Mayor, Councillors and Citizens of the City of Brighton, was hereunto affixed pursuant to a Resolution of the Council made on the 19th December, 1966—

(SEAL) A. F. BOTTOMLEY, Mayor.
 GERARD GRANT, Councillor.
 A. C. G. DeGARIS, Town Clerk. 4979

CITY OF FRANKSTON.

ORDER CHANGING NAME OF STREET.

IN accordance with the powers conferred by the Local Government Act 1958, 15th Schedule, Part I, Clause 8, the Council of the City of Frankston does hereby make an Order changing the name of a street within the Municipal District.

Old Name; New Name; Location Referred to.

Lester-drive; Karingal-drive; from Ashleigh-avenue for its entire length as appearing on L.P. Nos. 54837; 55739; 57157; 57786; 57788; 57876; 63045; 63048; 63049; 63050; 63051; 64326; 68283; 74343; 74344; 75125.

G. C. PENTLAND, Town Clerk.

Civic Centre, Frankston, 19th December, 1966. 5005

CITY OF FRANKSTON.

ORDER CHANGING NAME OF STREET.

IN accordance with the powers conferred by the Local Government Act 1958, 15th Schedule, Part I, Clause 8, the Council of the City of Frankston does hereby make an Order changing the name of a street within the Municipal District.

Old Name; New Name; Location Referred to.

Glendale-avenue; Galway-street; from Belvédère-road to Austin-road as appearing on L.P. No. 50873.

G. C. PENTLAND, Town Clerk.

Civic Centre, Frankston, 19th December, 1966. 5006

Local Government Act 1958.

CITY OF FRANKSTON.

PUBLIC HIGHWAY DECLARATION—LANE BETWEEN WELLS-STREET AND BALMORAL PARK ACCESS ROAD.

IN pursuance of the provisions of section 522 of the Local Government Act 1958 the Council of the City of Frankston hereby orders and directs that as from the publication hereof in the Victoria Government Gazette the following land purchased or acquired by the said Council shall be a public highway, that is to say:—

All the piece of land in the Parish of Frankston the boundaries of which are as follow:—Commencing at a point on the southern boundary of Crown allotment 10, section B, Township of Frankston, in the said parish distant 109 deg. 15 min. 132 ft. 6 in., from the south-western corner of the said Crown allotment; thence by lines bearing respectively 20 deg. 54 min. 85 ft. 8½ in., 20 deg. 31 min. 45 ft. 7 in., 109 deg. 25 min. 107 ft. 3 in., 199 deg. 22 min. 10 feet, 289 deg. 25 min. 87 ft. 3¼ in., 245 deg. 10 min. 14 ft. 4 in., 200 deg. 54 min. 111 ft. 2½ in. and 289 deg. 15 min. 10 feet to the point of commencement.

Dated this 19th day of December, 1966.

The common seal of the Mayor, Councillors and Citizens of the City of Frankston was hereto affixed in the presence of—

(SEAL) L. WALKER, Mayor.
W. N. OATES, Councillor.
G. C. PENTLAND, Town Clerk.

5009

CITY OF FRANKSTON.

LOAN No. 111.

Notice of Intention to Borrow the Sum of \$100,000 for Permanent Works and Undertakings.

NOTICE is hereby given that the Council of the City of Frankston proposes to borrow the sum of One hundred thousand dollars (\$100,000) secured by a charge over the general rates of the municipality, such sum to be raised by the grant of a mortgage in accordance with the provisions of the Local Government Act 1958.

(i) The maximum rate of interest that may be paid is 5½ per centum per annum.

(ii) The purposes for which the loan will be applied are—

(a) Town Planning—Land Purchase .. \$60,000
(b) Outfall Drainage \$40,000

(iii) The period of the loan will be 40 years and one month.

(iv) The loan is to be liquidated by the creation of a sinking fund pursuant to the provisions of section 428A of the Local Government Act 1958.

(v) The moneys borrowed shall be repayable at the expiration of the loan at the office of the Local Authorities Superannuation Board, "Rigby House," 15 Queens-road, Melbourne, or such other place as the Board may require.

The plans, specifications and estimates of the cost of the proposed works and a statement showing the proposed expenditure of the moneys to be borrowed are open for inspection at the Civic Centre, Frankston.

G. C. PENTLAND, Town Clerk.

Civic Centre, Frankston. 5010

CITY OF HORSHAM.

LOAN No. 58.

Notice of Intention to Borrow the Sum of \$70,000 for Permanent Works and Undertakings.

NOTICE is hereby given that the Council of the City of Horsham intends to borrow the principal sum hereinafter mentioned on the credit of the municipal revenues of the Mayor, Councillors and Citizens of the City of Horsham by the grant of a mortgage in accordance with the provisions of the Local Government Acts, and notice is hereby further given:—

(a) That the amount of the principal sum which it is proposed to borrow is \$70,000.

(b) The maximum rate of interest that may be paid is 5½ per centum per annum.

(c) The moneys borrowed to be repayable in one sum on the 30th day of April, 2007, for which purpose a sinking fund will be provided to which payment of \$654.02 will be made on the 1st day of May in each year during the currency of the loan. The first payment to be made on the 1st day of May, 1968.

No. 2.—11641/66.—3

Interest at the rate of 5½ per centum per annum will be payable on the 1st day of May and the 1st day of November in each year during the currency of the loan at the office of the Local Authorities Superannuation Board, Rigby House, 15 Queens-road, Melbourne or the Council's Bankers for the time being in the City of Melbourne.

(d) The purposes for which the loan is to be applied are:—

To provide land, grounds and buildings to be used as a Library, Art Gallery, Meeting Room and generally for the purpose of public recreation and resort.

(e) The loan is to be liquidated by appropriation out of the municipal fund.

(f) Plans, specifications and estimate for the cost of such works and the statement showing the proposed expenditure of the money to be borrowed, are open for inspection at the office of the Council, Town Hall, Horsham, during office hours.

Dated the 20th day of December, 1966.

4972

A. R. CONN, Town Clerk.

CITY OF KEILOR.

LOAN No. 69.

Notice of Intention to Borrow the Sum of Thirty Thousand Dollars (\$30,000) for Permanent Works and Undertakings.

NOTICE is hereby given that the Council of the City of Keilor proposes to borrow the sum of Thirty thousand dollars (\$30,000) secured by a charge over the general rates of the municipality, such sum to be raised by the grant of a mortgage in accordance with the provisions of the Local Government Act 1958.

1. The maximum rate of interest that may be paid is 5.625 per centum per annum.

2. The purpose for which the loan is to be applied is as under:—

Part cost in connexion with the construction of a Swimming Pool on Council-owned land in Quinn-grove, Keilor East	\$30,000
Total:	\$30,000

3. The period of the loan shall be ten years.

4. The moneys borrowed shall be repayable by providing out of the municipal fund twenty equal half-yearly instalments of \$1,981.68 on the 1st day of September and the 1st day of March during the currency of the loan. The first instalment shall be payable on the 1st day of September, 1967.

5. Such money shall be repayable at the Australia and New Zealand Savings Bank Limited, 394 Collins-street, Melbourne.

The plans and specifications and the estimate of the cost of the proposed works and the statement showing the proposed expenditure of the money to be borrowed are open for inspection at the Municipal Offices, Calder Highway, Keilor, during office hours.

Dated this 16th day of December, 1966.

4968

N. A. WOODS, Town Clerk.

CITY OF KEILOR.

LOAN No. 67.

Notice of Intention to Borrow the Sum of Fifty Thousand Dollars (\$50,000) for Permanent Works and Undertakings.

NOTICE is hereby given that the Council of the City of Keilor proposes to borrow the principal sum of Fifty thousand dollars (\$50,000), secured by a charge over the general rates of the municipality, such sum to be raised by the grant of a mortgage in accordance with the provisions of the Local Government Act 1958.

1. The maximum rate of interest that may be paid is 5½ per cent. per annum.

2. The purpose for which the loan is to be applied is:—

Part cost of construction of a Swimming Pool on Council-owned land in Quinn-grove, at Keilor East	\$50,000
Total	\$50,000

3. The period of the loan shall be fifteen years.

4. The moneys borrowed shall be repayable by providing out of the municipal fund half-yearly instalments of approximately \$2,511 each including principal and interest on the 1st day of October and the 1st day of April during the currency of the loan. The first instalment shall be payable on the 1st day of October, 1967.

5. Such moneys shall be repayable to the Commissioners of The State Savings Bank of Victoria, at the office of the said Commissioners, corner Elizabeth and Bourke streets, Melbourne.

The plans and specifications and the estimate of the cost of the proposed works and a statement showing the proposed expenditure of the moneys to be borrowed are open for inspection at the office of the Council of the City of Keilor, at Calder Highway, Keilor, during office hours.

Dated this 16th day of December, 1966.

4969

N. A. WOODS, Town Clerk.

CITY OF KEILOR.

LOAN No. 68.

Notice of Intention to Borrow the Sum of One Hundred Thousand Dollars (\$100,000) for Permanent Works and Undertakings.

NOTICE is hereby given that the Council of the City of Keilor proposes to borrow the sum of One hundred thousand dollars (\$100,000) secured by a charge over the general rates of the municipality, such sum to be raised by the grant of a mortgage in accordance with the provisions of the *Local Government Act 1958*.

1. The amount of principal money which it is proposed to borrow is \$100,000.

2. The maximum rate of interest that may be paid is 5½ per centum per annum.

3. The interest is to be payable in equal half-yearly instalments at the Superannuation Board, Treasury-place, Melbourne.

4. The moneys borrowed shall be repayable at the State Superannuation Board, Treasury-place, Melbourne on the 1st April, 2007.

5. The purpose for which the loan is to be applied is:—

Part cost of construction of a swimming pool on Council-owned land in Quinn-grove, at Keilor East	\$100,000
Total	\$100,000

6. The loan is to be liquidated by the creation of a sinking fund, pursuant to the provisions of the *Local Government Act 1958*, and amendments by the investment annually of an amount of \$934.32 out of the municipal fund during the currency of the loan for such purpose.

The plans and specifications and the estimate of the cost of the proposed works and the statement showing the proposed expenditure of the money to be borrowed are open for inspection at the Municipal Offices, Keilor, during office hours.

Dated this 23rd day of December, 1966.

4996

N. A. WOODS, Town Clerk.

CITY OF KEILOR.

CHANGE OF STREET NAME.

NOTICE is hereby given that pursuant to the provisions of the *Local Government Act 1958*, the Council of the City of Keilor hereby orders that the name of a street within the municipality be changed as set out hereunder:—

Old Name; New Name; Location.

The Centre-way; Clough-street; between Intervale-drive and North-road (Milleara Gardens Estate), lodged plan 13096, Keilor East.

4970

N. A. WOODS, Town Clerk.

CITY OF MARYBOROUGH.

LOAN No. 24.

Notice of Intention to Borrow the Sum of \$15,000 for Permanent Works and Undertakings.

NOTICE is hereby given that the Council of the City of Maryborough proposes to borrow the principal sum of Fifteen thousand dollars secured by a charge over the general rates of the municipality, such sum to be raised by the grant of a mortgage in accordance with the provisions of the *Local Government Act 1958*.

1. The maximum rate of interest that may be paid is 5½ per cent. per annum.

2. The purpose for which the loan is to be applied is—

Purchase of band instruments	\$4,000
Purchase of seating for Town Hall	2,500
Purchase of plant and equipment, viz. motor tractor, gang mowers	2,400
Purchase of land, East Maryborough-road	1,250
Road and street Construction— Daly-street, Burke and Tuaggra streets	4,850
	\$15,000

3. The period of the loan shall be five years.

4. The moneys borrowed shall be repayable by providing out of the municipal fund half-yearly instalments of approximately \$1,736.00 each, including principal and interest on the 1st day of October and the 1st day of April, during the currency of the loan. The first instalment shall be payable on the 1st day of October, 1967.

5. Such moneys shall be repayable to the Commissioners of the State Savings Bank of Victoria at the office of the said Commissioners, corner Elizabeth and Bourke streets, Melbourne.

The plans and specifications and the estimate of the cost of the proposed works and a statement showing the proposed expenditure of the moneys to be borrowed are open for inspection at the office of the Council of the City of Maryborough, at Maryborough.

Dated 21st December, 1966.

4978

E. S. MOORE, Town Clerk.

CITY OF MILDURA.

LOAN No. 68.

Notice of Intention to Borrow the Sum of \$40,000 for Permanent Works and Undertakings.

NOTICE is hereby given that the Council of the City of Mildura intends to borrow the principal sum herein-after mentioned on the credit of the municipal revenues of the Mayor, Councillors and Citizens of the City of Mildura by the grant of a mortgage in accordance with the provisions of the *Local Government Acts*, and notice is hereby further given—

(a) That the amount of the principal sum which it is proposed to borrow is \$40,000.

(b) The maximum rate of interest that may be paid is 5.625 per cent. per annum.

(c) The moneys borrowed and interest thereon are to be repayable by twenty half-yearly instalments, each of approximately \$2,642.24 on the 1st day of April and the 1st day of October in each year, and the place at which such moneys are to be repayable is the National Bank Savings Bank Limited, Melbourne. The first instalment shall be payable on the 1st day of October, 1967.

(d) The purposes for which the loan is to be applied are:—

Purchase of plant and equipment.

(e) The loan is to be liquidated by appropriation out of the municipal fund.

(f) The plans, specification, and estimate for the cost of such works, and the statement showing the proposed expenditure of the money to be borrowed, are open for inspection at the office of the Council, Deakin-avenue, Mildura, during office hours.

Dated 6th day of January, 1967.

4988

W. J. DOWNIE, Town Clerk.

CITY OF PRESTON.

LOAN No. 74.

Notice of Intention to Borrow.

NOTICE is hereby given that the Council of the City of Preston intends to borrow the sum of \$70,000 (Seventy thousand dollars) by the grant of a mortgage secured by a charge over the general rates of the municipality in accordance with the provisions of the *Local Government Acts*.

In connexion therewith the following information is stated:—

(a) The amount of the principal moneys which it is proposed to borrow is Seventy thousand dollars (\$70,000).

(b) The maximum rate of interest that may be paid is \$5.75 per centum per annum.

- (c) The times which the moneys borrowed are to be repayable are the 1st day of October, 1967 and the 1st days of April and October during the years 1968 to 1981 inclusive and a final payment on the 1st day of April, 1982, and that the place such moneys shall be repayable is at the Bank of New South Wales, Preston.

- (d) The purposes for which the loan is to be applied are—

Capital works, Electricity Department	\$40,000
Street construction Mais-street and St. Vigeons-road	6,500
Construction of Murray-road (Council contribution)	18,000
Construction of toilets at the rear of the Town Hall (part cost)	5,500
	\$70,000

- (e) The manner in which the loan is to be liquidated is by provision out of the municipal fund in each half-year during the currency of the loan of the sum of \$3,513.88 which includes principal and interest.

The plans and specifications and estimate of the cost of the works and a statement showing the proposed expenditure of the moneys to be borrowed are open for inspection at the Town Hall, Preston, during office hours.

Dated this 3rd day of January, 1967.

4964 J. C. DONATH, F.I.M.A., Town Clerk.

CITY OF SUNSHINE.

LOAN No. 66.

Notice of Intention to Borrow the Sum of \$100,000 for Permanent Works and Undertakings.

NOTICE is hereby given that the Council of the City of Sunshine proposes to borrow the principal sum of One hundred thousand dollars (\$100,000) secured by a charge over the general rates of the municipality such sum to be raised by the grant of a mortgage in accordance with the provisions of the *Local Government Act 1958*.

- The maximum rate of interest that may be paid is 5½ per cent. per annum.
- The purposes for which the loan is to be applied are:—

(a) Balance for Billingham-road Construction	\$ 61,500
(b) Construction of Hortense-street	13,600
(c) Construction of service road—Geelong-road	24,900
	\$100,000

- The period of the loan shall be ten (10) years.

4. The moneys borrowed shall be repayable by providing out of the municipal fund twenty half-yearly instalments of approximately \$6,605.59 each, including principal and interest on the 1st day of March and the 1st day of September during the currency of the loan. The first instalment shall be repayable on the 1st day of September, 1967.

5. Such moneys shall be repayable at the National Bank Savings Bank, Sunshine.

The plans and specifications and the estimate of the cost of the proposed works, and a statement showing the proposed expenditure of the moneys to be borrowed, are open for inspection at the offices of the Council of the City of Sunshine at the Municipal Offices, Alexandra-avenue, Sunshine.

5004 T. W. DEUTSCHMANN, Town Clerk.

CITY OF SWAN HILL.

LOAN No. 41.

Notice of Intention to Borrow the Sum of \$20,000 for Permanent Works and Undertakings.

NOTICE is hereby given that the Council of the City of Swan Hill proposes to borrow the sum of Twenty thousand dollars (\$20,000) secured by a charge on the general rates of the municipality such sum to be raised by the grant of a mortgage, in accordance with the provisions of the *Local Government Act 1958*.

- The maximum rate of interest that may be paid is 5½ per cent. per annum.
- The interest is to be paid half-yearly during the currency of the loan.

- The period of the loan shall be fifteen years.

4. The moneys borrowed shall be repayable at the Commercial Savings Bank of Australia Limited, Melbourne.

5. Such moneys shall be repayable by providing out of the municipal fund 29 half-yearly instalments of approximately \$758.96, including principal and interest on the 1st days of April and October, and a final instalment of approximately \$12,182.17 on the 1st day of April, 1982. The first instalment shall be repayable on 1st October, 1967.

6. The purpose for which the loan is to be applied is to partly pay the cost of constructing a basketball stadium in Swan Hill.

The plans and estimates of the cost of the proposed work, and a statement showing the proposed expenditure of the moneys to be borrowed are open for inspection at the office of the Council of the City of Swan Hill at the Town Hall, Swan Hill, during office hours.

Dated 23rd December, 1966.

4987 R. J. PUGSLEY, Town Clerk.

CITY OF TRARALGON.

LOAN No. 21.

Notice of Intention to Borrow the Sum of \$50,000 for Permanent Works and Undertakings.

NOTICE is hereby given that the Council of the City of Traralgon intends to borrow the principal sum hereinafter mentioned on the credit of the municipal revenues of the Mayor, Councillors and Citizens of the City of Traralgon by the grant of a mortgage in accordance with the provisions of the *Local Government Acts*, and notice is hereby further given—

- That the amount of the principal sum which it is proposed to borrow is \$50,000.
- The maximum rate of interest that may be paid is 5.625 per centum per annum.
- The moneys borrowed and interest thereon are to be repayable by twenty half-yearly instalments, each of approximately \$3,312.80 on the 15th day of September, and the 15th day of March, in each year, and the place at which such moneys are to be repayable is the Australia and New Zealand Savings Bank Ltd., 38 Franklin-street, Traralgon. The first instalment shall be payable on the 15th day of September, 1967.
- The purposes for which the loan is to be applied are:—
The purchase of road-making plant and motor vehicles.
- The loan is to be liquidated by appropriation out of the municipal fund.
- The plans, specifications, and estimate for the cost of such works, and the statement showing the proposed expenditure of the money to be borrowed, are open for inspection at the office of the Council, Kay-street, Traralgon.

Dated the 22nd December, 1967.

4995 K. J. SAUNDERS, Town Clerk.

SHIRE OF AVOCA.

BY-LAW No. 31.

A By-law of the Shire of Avoca made under the provisions of section 197 (1) (xliia) of the *Local Government Act 1958* and numbered 31 prescribing areas within the municipal district within which the erection including the adaption for use of any building is prohibited unless the building is connected to a septic tank system.

IN pursuance of the powers contained in the *Local Government Act 1958* and of every other power enabling them in that behalf, the President, Councillors and Ratepayers of the Shire of Avoca do hereby order as follows:—

- In this By-law unless inconsistent with the context or subject matter—
 "Dwelling" means any building or portion of a building which is intended adapted or designed for use for living purposes.
 "Shop" means a shop as defined by Section 3 (1) of the *Labour and Industry Act 1958*.
 "Other Building" means any building or portion of a building which is intended adapted or designed for use for the purposes of any class of trade industry manufacture business public amusement or public utility.

2. No person shall erect or adapt for use any dwelling, shop or other building unless such dwelling, shop or other building is connected to a septic tank system in accordance with the requirements of the Septic Tank Regulations 1932 as amended.

3. This By-law shall apply to and have operation throughout those parts of the Municipal District as specified and set out in the Schedule hereto.

4. This By-law shall come into operation on its approval by the Governor-in-Council, and immediately after publication in the *Government Gazette*.

5. Any person guilty of any contravention of the provisions of this By-law shall be liable on conviction to a penalty not less than \$10 or more than \$40 and in the case of a continuing offence to a further daily penalty of not more than \$10.

SCHEDULE.

(a) The whole of the land within the boundaries of the following townships

Township of Avoca
Township of Crowlands
Township of Landsborough
Township of Moonambel
Township of Redbank.

(b) That portion of the land within the boundaries of the following townships that lies within the Municipal District of the Shire of Avoca—

Township of Navarre
Township of Natte Yallock.

(c) The whole of the land comprising Sections A and A3, Parish of Avoca.

Resolution for making and passing this By-law was agreed to by the Council of the Shire of Avoca on the 20th day of July, 1966, and confirmed on the 17th day of August, 1966.

The common seal of the President, Councillors and Ratepayers of the Shire of Avoca was hereunto affixed this 17th day of August, 1966, in the presence of—

M. W. DAWSON, President.
(SEAL) R. D. PECK, Councillor.
F. C. S. EDWARDS, Shire Secretary.

Approved by the Governor in Council, 13th December, 1966.—J. COLQUHOUN, Clerk of the Executive Council. 5012

SHIRE OF COHUNA.

LOAN No. 28.

Notice of Intention to Borrow the Sum of \$24,000.00 for Permanent Works and Undertakings.

NOTICE is hereby given that the Council of the Shire of Cohuna proposes to borrow the principal sum of \$24,000.00 secured by a charge over the general rates of the municipality, such sum to be raised by the grant of a mortgage in accordance with the provisions of the *Local Government Act 1958*.

1. The maximum rate of interest that may be paid is 5 9/16 per cent. per annum.
2. The purpose for which the loan is to be applied is—Purchase of grader.
3. The period of the loan shall be seven years.
4. The moneys borrowed shall be repayable by providing out of the municipal fund half-yearly instalments of approximately \$2,094.00 each including principal and interest on the 1st day of October and the 1st day of April during the currency of the loan. The first instalment shall be payable on the 1st day of October, 1967.

5. Such moneys shall be repayable to the Commissioners of the State Savings Bank of Victoria at the office of the said Commissioners, corner Elizabeth and Bourke streets, Melbourne.

The plans and specifications and the estimate of the cost of the proposed works and a statement showing the proposed expenditure of the moneys to be borrowed are open for inspection at the office of the Council of the Shire of Cohuna, at Cohuna.

4971

R. E. KNOWLES, Shire Secretary.

SHIRE OF DEAKIN.

Swimming Pool By-law.

BY-LAW No. 36.

A by-law of the Shire of Deakin made under the Local Government Acts and numbered 36 for regulating the use of and the conduct of persons using or being on the premises of the Tongala Swimming Pool situated at Tongala.

IN pursuance of the powers conferred by the Local Government Acts and of any and every power it thereunto enabling the President, Councillors and Ratepayers of the Shire of Deakin order as follows:—

1. In this By-law unless inconsistent with the subject-matter:—

“Attendant” means any employee of the Council or Committee of Management performing any duties on or in connexion with the swimming pool premises.

“Attendant in Charge” means any person by the authority of the Council or Committee of Management for the time being in charge or control of the swimming pool premises and of any attendant.

“Council” means the Council of the Shire of Deakin.

“Swimming Pool” means any pool or body of water provided on the swimming pool premises for the use of swimmers, including any wading or diving pool.

“Swimming Pool Premises” means the Tongala Swimming Pool, being the land more particularly described in (48) hereafter.

“Committee of Management” means the Committee of Management of the Tongala Swimming Pool as elected by public meeting from time to time and approved by Council.

2. The swimming pool premises shall be open to the public during such periods and such hours as the Council shall, by Resolution determine.

3. The Council or Committee of Management approved by the Council may at any time and from time to time close the pool premises or any part thereof for such period or periods as may be deemed necessary for the purpose of cleansing, repairing, rebuilding or reconstructing the same or for any other like purpose.

4. The attendant in charge of the pool premises may refuse admission thereto to any person.

5. No person shall enter the pool premises unless an attendant or authorized person is present.

6. Every person using any swimming pool, shall wear a suitable bathing costume and the Committee or its authorized officer shall be the sole judge of the suitability of any costume.

7. No person shall dress or undress or remove any part of his or her bathing costume in any part of the pool premises open to the public view or in or upon any part of the premises, except places specifically reserved for such purpose.

8. No person shall expectorate on the concourse of the pool or on any lawns or in the dressing rooms, compartments, passages or entrances thereto, or in the vicinity of the kiosk, on the walls or on any sealed surface within the pool premises.

9. No person shall spit, spout water or blow his or her nose in any of the pools.

10. No person shall roll or throw stones or other articles into any of the pools.

11. No person shall loiter, misconduct himself or herself or commit a nuisance in the pool premises or bring rubbish, filth or other offensive matter into the said premises or deposit any rubbish therein or leave therein any tins, bottles, broken glass, orange or other peel, papers, cast-off clothes or other litter, except in receptacles provided for such purpose.

12. No person shall interfere with the use and enjoyment of the pools by any other person and any person so acting or otherwise behaving in an unseemly or improper manner, shall immediately leave the pool when requested to do so by the attendant in charge. Only one person shall stand on or dive from any diving board at the one time, and no person other than the attendant in charge shall prevent any other person from using any diving board. No person shall use any diving board if the attendant in charge deems it dangerous for any such board to be used and so advises the person concerned either verbally or by a notice suitably displayed in the vicinity of such diving board or boards.

13. No person shall engage in boisterous or rough play or conduct within the pool premises.

14. Beach balls, motor tubes or other insulated rubber or plastic articles are not permitted in the main pool except by the permission of the attendant in charge. Toddlers may be permitted by the attendant in charge to take rubber toys into the wading pool. Water polo may only be practised or played at times and by teams approved by the Committee of Management. No other ball games of any kind shall be permitted in the pools or the pool premises.

15. No person shall obstruct, hinder or interfere with the attendant in charge or any person employed at the pool or any officer of the Council or Committee of Management or duty lifesaver or approved swimming instructor in the performance of his or her duty thereat.

16. An authorized attendant may require any person offending against any part of this By-law (but without prejudice to the imposition of any penalty in respect of such offence) to leave the pool premises and may eject such person therefrom if he or she fails to leave forthwith.

17. No person over the age of eight years shall use the wading pool, unless with the approval of the Attendant.

18. No person shall smoke within 15 feet of any pool in the premises.

19. No person shall at any time bring into or introduce into the pool premises or any part thereof any intoxicating liquors.

20. No person shall enter or remain in the pool premises whilst in a state of intoxication.

21. No person shall at any time while being in or upon the pool premises use indecent, offensive or abusive language or behave in an indecent or offensive manner.

22. No person shall occupy the shower baths for an unreasonable time or enter any shower or water closet occupied by another person.

23. No person shall bring into or cause or allow any dog or other animal under his or her control to remain in the pool premises.

24. No person shall bring any bicycle into the pool premises.

25. No person shall use the pools whilst in an unclean condition or who is suffering from any cutaneous, infectious or contagious disease and any person shall retire from the pools on being requested to do so by the attendant in charge.

26. No person shall enter a pool before first washing himself or herself in the shower bath and every bather after using the latrine or water closets shall wash under the showers without costume before entering or re-entering the pool.

27. No person unless authorized by the attendant in charge shall climb or attempt to climb over, into or upon or remain on or upon any fixture, fence, roof, building or structure.

28. No person shall use or interfere with any rope, raft, lifebuoy, or lifesaving appliance or apparatus in the premises except in the case of accident and danger occurring to a bather rendering their use necessary.

29. No person shall use any soap or other substance or preparation in any place or manner in the pool premises whereby any water in any pool may become discoloured or rendered turbid or unfit for the use of bathers. Approved soap is permitted for use in showers and at hand basins only.

30. No person shall damage, deface or remove any placard or notice board within the pool premises.

31. No person shall foul or pollute the water in any of the pools or the shower baths or wilfully or improperly soil or defile any towel or bathing costume or any shower, wall, closet or urinal or any bathroom, dressing room, compartment or any part of the pool premises or any furniture or articles therein.

32. No person shall at any time carelessly or negligently break injure or interfere with any lock, tap or fitting used in connexion with the pools nor carelessly, negligently or wilfully damage or injure any furniture or fitting, towel or any other article that may be in or upon the pools or write upon or deface the walls or partitions or any other part of the pool premises.

33. No boy or girl under the age of eight years who is unable to swim shall use the main pool without the permission of the attendant in charge unless accompanied by an adult or other person approved by the attendant in charge, and no adult non swimmer will enter the pool beyond his or her depth.

34. No child under the age of six years shall be permitted to enter the pool premises unless in the opinion of the attendant in charge such child is in the care of a responsible person.

35. No person other than a child under the age of four years under the care of a responsible person shall enter or use any dressing room, shower or convenience or passages leading thereto which have been appointed or appropriated to use of persons of the opposite sex.

36. No unauthorized person shall enter the plant room, its enclosure or any storeroom within the pool premises.

37. No person shall hawk or sell or offer for sale in the pool premises any goods or articles or services without having first obtained permission, in writing, from the Council or the Committee of Management.

38. Any person hiring any article from any attendant at the pool shall return the same to the attendant in charge prior to leaving the premises.

39. Every person shall before being furnished with any towel, bathing costume or locker pay to the authorized attendant, the price of payment for the use thereof and the deposit for same as fixed from time to time by the Council or the Committee of Management and after use shall return the same to the attendant who will return deposits lodged provided the said towel, bathing costume or locker has not been damaged in any way.

40. Neither the Council, the Committee of Management nor their officers or employees shall be responsible for any article lost by or stolen from any person admitted to the pool premises.

41. Any person finding any article in the pool premises shall immediately thereafter deliver the same to the attendant in charge who shall thereupon register a description of same and all particulars relating thereto in a book to be kept for that purpose, and upon any person losing such article giving satisfactory proof of loss, the attendant in charge shall deliver the same to such last mentioned person after entering the name and address of that person in the same book and obtaining therein his or her signature thereof.

42. Neither the Council nor the Committee of Management nor any of its officers or employees shall be responsible for any article lost by or stolen from any person whilst within the pool premises. Valuables may be handed to the attendant in charge for safe keeping.

43. Every person not being the holder of a seasonal or concession ticket shall before entering the pool premises pay to the person authorized for the purpose, the price fixed from time to time for admission thereto.

44. No seasonal or concession ticket shall be transferable and any holder of such ticket who allows any other person to use the same shall immediately forfeit such ticket and all moneys paid thereon and the rights and privileges given by such ticket.

45. The attendant in charge or other person duly authorized by the Committee of Management may charge every person entering the pool premises the proper fees as determined from time to time by Special Order of the Council.

46. In the event of the Council or the Committee of Management holding or authorizing a swimming carnival or other entertainment in the pool premises, the Council shall have power by Resolution to prohibit bathing in the pools whilst any such carnival or entertainment is being held, and to fix the fees chargeable to any organization conducting such carnival or entertainment, and to fix the prices that shall be charged for admission thereto. Seasonal or concession tickets shall not admit any person to the pool premises during the time fixed as the time for such carnival or entertainment.

47. Any person wilfully offending against any part of the provisions of this By-law, shall for every such offence, upon conviction forfeit and pay a penalty not exceeding \$40.

48. This By-law shall apply and have operation throughout the part of the Shire of Deakin known as the Tongala Swimming Pool and more particularly described in title Volume 3861, Folio 772196.

Resolution for passing for this By-law agreed to by the Council of the Shire of Deakin on the 21st day of November, 1966, and confirmed on the 19th day of December, 1966.

The common seal of the President, Councillors and Ratepayers of the Shire of Deakin was affixed hereto this 19th day of December, 1966, in the presence of—

(SEAL) A. GOOD, President.
C. P. MILLER, Councillor.
K. R. PITTS, Councillor.
B. PEARL, Shire Secretary.

SHIRE OF ELTHAM.

PROSECUTING OFFICER.

NOTICE is hereby given that Senior Constable Sidney Frederick Little, No. 9764, has been appointed Prosecuting Officer for the Eltham, West and North Ridings for the Shire of Eltham, vice Sergeant A. F. C. Glover, No. 10740, transferred.

4990 A. J. ROBERTS, Acting Shire Secretary.

SHIRE OF ELTHAM.

NOTICE OF INTENTION TO TAKE LAND COMPULSORILY.

NOTICE is hereby given that—

1. The Council of the Shire of Eltham deems it expedient to execute the work or undertaking of providing as a place of public resort and recreation all that land being part of Crown allotment 100 (formerly 14A), section E, Parish of Greensborough comprised in Crown grant, volume 1695, folio 979, situated in Main-road, Hurstbridge.

2. For the purpose of executing the same exercise of its power of taking land compulsorily will, in the opinion of the Council, be necessary.

3. The Council has caused to be prepared maps and other papers describing the proposed work or undertaking and the land proposed to be taken, together with the names of the owners or reputed owners, lessees or reputed lessees and the occupier thereof as far as such names can be ascertained by the Council.

4. Such maps and other papers are deposited at the Shire Offices, Main-road, Eltham, where they are and will remain open for inspection by all persons interested, at all reasonable hours, for the space of 40 clear days after publication of this notice in the *Government Gazette*.

5. All persons affected by the proposed work or undertaking are hereby called upon to set forth, in writing, addressed to the Council, or the Shire Secretary, of the Shire of Eltham, within 40 clear days from the publication of this notice in the *Government Gazette*, all objections which they may have to the said work or undertaking.

Dated this 6th day of January, 1967.

4989 A. J. ROBERTS, Acting Shire Secretary.

SHIRE OF FLINDERS.

NAMING OF STREETS AND ROADS.

NOTICE is hereby given that the Council of the Shire of Flinders, in pursuance of the provisions of the Local Government Acts, has named the previously un-named Government roads as shown:—

New Name; Location.

Andrews-lane; north off Red Hill-road forming western boundary of Crown allotment 13A, Parish of Kangerong.

Higgins-lane; continuation of Higgins-lane east of Hastings-Flinders road to Public Purpose Reserve, forming northern boundary of Crown allotment 2, Township of Balnarring.

Grasslands-road; between Marma Glen-road and Patterson-road along western boundaries of Crown allotments 30^a, 18A¹, 18A², 1, 2B, 3, 10^a, and 11, Parishes of Wannaeue and Fingal.

Rogers-road; between Limestone-road and Long Point Gully-road along eastern boundary of Crown allotments 2A, 3, 3A, 10A, 11, 13, 20B and 23, Parish of Fingal.

Hiscock-road; between Marma Glen-road and Truemans-road along northern boundary of Crown allotments 6, 4, 43 and 42, section A, Parish of Wannaeue.

Bowrings-road; off McIlroys-road forming western boundary of Crown allotment 20, Parish of Kangerong.

Nash's-lane; north and south off Red Hill-road forming western boundary of lots 2 and 5, lodged plan 6776, Parish of Kangerong.

Whites-road; off Purvis to Main Creek-road forming northern boundary of Crown allotments 24, 23A¹ and 23B, Parish of Wannaeue.

Wilson-road; off Purvis-road forming southern boundary of Crown allotment 24, Parish of Wannaeue.

Wannaeue-place; between Ninth-avenue and Rosebud-parade, Rosebud, Parish of Wannaeue.

The names of the following streets and roads have been changed as follows:—

Old Name; New Name; Location.

Browns-road; Old Main Creek-road; between Purvis-road and Shands-road, northern boundary of Crown allotments 10D, 10B, 19A, 19B, Parish of Wannaeue.

Boneo-road or Rosebud-Flinders road; Boneo-road; from Nepean Highway to southern boundary of Crown allotment 12, section A, Parish of Wannaeue.

Boneo-road or Rosebud-Flinders road; Rosebud-Flinders road; from northern boundary of Crown allotment 7, section A, Parish of Wannaeue to junction of Mornington-Flinders road, Parish of Flinders.

Banks-street; Riley-street; forming eastern boundary of lots 16-24 and western boundary of lots 32-41, lodged plan 21009, Parish of Wannaeue.

Mark-street; Kennington-road; forming eastern boundary of lots 61-64 and western boundary of lots 51, 50 and 49, lodged plan 43065, and eastern boundary of lots 166-181 and western boundary of lots 163-146, lodged plan 50228, Parish of Wannaeue.

Lawson-crescent; Leon-avenue; south from Murray Anderson-road forming northern boundary of lots 331-339, lodged plan 13140, Parish of Wannaeue.

York-street; Cowley-street; off Leichardt-street, lodged plan 50097, Parish of Wannaeue.

Forbes-street; Iluka-street; between Seaview-avenue and Rymer-street, lodged plan 11273, Parish of Kangerong.

Grace-street; Gibson-street; west of Gibson-street, southern boundary of lots 7 and 8, lodged plan 14644, Parish of Kangerong.

Flinders-road; Boundary-road; between Palmerston-avenue and Mornington-Flinders road, Parish of Kangerong.

Palmerston-avenue; Palmerston-avenue; between Nepean Highway and Burrell-road, Parish of Kangerong.

Bayview-road; Marma Glen-road; between Eastbourne-road and Rosebud-Flinders road, Parish of Wannaeue.

Cook-street; Cook-street; from junction of Rosebud-Flinders and Mornington-Flinders roads to Western-port Bay Foreshore, Parish of Flinders.

Wood-street; Wood-street; from Boyds-lane to Foreshore Public Park and Recreation Reserve, Parish of Flinders.

Mornington-Dromana road, Wills-road, Marine-parade, Marine-drive, Dromana-esplanade; Marine-drive; between Nepean Highway and Beach-road, Parish of Kangerong.

Wills-road; Bruce-road; from Marine-drive to Bruce-road, Parish of Kangerong.

Wills-road; Dromana-parade; from Bruce-road to Dromana-parade, Parish of Kangerong.

Lunts-lane; Arkwells-lane; from Red Hill-road to Mornington-Flinders road, Parish of Kangerong.

Bayview-road; Bayview-road; between Burrell-road and Eastbourne-road, Parish of Wannaeue.

4965 S. WILLIAMS, Shire Secretary.

SHIRE OF MORNINGTON.

By-Law No. 117.

Meeting Procedure Amendment By-Law.

NOTICE is hereby given that the Council of the Shire of Mornington has made a By-Law under the *Local Government Act 1958* as amended and all other powers it thereunto enabling Numbered 117 for the purpose of regulating the proceedings of Council meetings and for other purposes including provision for regular ordinary meetings of the Council to be held on the third Tuesday in each month in lieu of the last Wednesday in each month.

Notice is also hereby given that a copy of the above-mentioned By-Law is open for inspection, free of charge, during office hours, at the office of the said Council, Queen-street, Mornington.

Dated this 21st day of December, 1966

4882 D. G. COLLINGS, Shire Secretary.

NOTICE is hereby given that the partnership heretofore existing between Michael Ayres Webb, and Geoffrey Stuart Watson, carrying on business as public accountants, at 622 St. Kilda-road, Melbourne, under the firm name of "Watson Webb & Associates", has been dissolved as from the 30th day of June, 1966.

Dated this 23rd day of December, 1966.

MICHAEL AYRES WEBB,
GEOFFREY STUART WATSON.

Trevaks, Havyatt & Steward, solicitors, 472 Bourke-street, Melbourne. 4984

NOTICE is hereby given that the partnership heretofore subsisting between the undersigned, Yip Yuk Chun, and Jow Sang Fong, carrying on business as café proprietors, at 424 Hampton-street, Hampton, under the name of "Wah Yuon", has been dissolved by mutual consent as from the 20th day of October, 1966. All debts due to and owing by the said late firm will be received and paid by Jow Sang Fong, and Terry Sun Yip, who now carry on the business in partnership at the same place.

Dated the 15th day of December, 1966.

T. S. YEP.
J. S. FONG.
YIP YUK CHUN.

NOTICE is hereby given that the partnership heretofore subsisting between Frank Love Linay, of Sunningdale-avenue, Mornington, contractor, and Joseph Anthony Mansour, Junior, of "The Crest", Frankston, contractor, carrying on business as dance promoters, at Mechanics Hall, Frankston, under the style or firm of "Modville Dances", has been dissolved as from the 30th day of July, 1966. All debts due to and owing by the said firm will be received and paid respectively by the said Joseph Anthony Mansour, who will continue to carry on the said business under the style or firm of "Modville Dances".

Dated the 20th day of December, 1966.

JOSEPH ANTHONY MANŞOUR,

D. Condon & Co., solicitors, 83 William-street,
Melbourne. 5038

NOTICE OF DISSOLUTION OF PARTNERSHIPS.

NOTICE is hereby given that the assets and liabilities of the two partnerships carried on at 179 Scotchmer-street, North Fitzroy, by David Hewitt Bill, and Mervyn Ellis Bill, under style and titles of—

1. David H. Bill & Associates,
2. Format Furniture,

by agreement, dated the 26th day of October, 1965, and the 15th day of June, 1966, have respectively been purchased by David H. Bill & Associates Pty. Ltd., and Format Furniture Pty. Ltd., and that the two above-mentioned partnerships were then dissolved.

Dated at North Fitzroy this 1st day of December, 1966.

DAVID H. BILL.
MERVYN E. BILL.

4977

NOTICE is hereby given that the partnership heretofore subsisting between Raymond Charles Voutier, of 164 Wattle-tree-road, Malvern, and Edwin Adrian Vader, of 17 Gothic-road, Ascendale, carrying on business as suppliers of certain services to the textile industry in Melbourne, at 16 Flinders-lane, Melbourne, under the style or firm of "Associated Fashion Services", has been dissolved as from the 16th day of December, 1966. All debts due to and owing by the said firm will be received and paid respectively by Raymond Charles Voutier, who will continue to carry on the said business under the style or firm of "Associated Fashion Services".

Dated the 20th day of December, 1966.

ARNOLD, BLOCH & ASSOCIATES, of 167 Queen-street,
Melbourne, Victoria. 4974

The Companies Act 1961.—In the matter of COUNSEL'S CHAMBERS LIMITED.

NOTICE is hereby given that at an Extraordinary General Meeting of the above-named company duly convened and held at Owen Dixon Chambers, 205 William-street, Melbourne, at 1.15 o'clock in the afternoon, on the 15th day of December, 1966, the following Special Resolution was duly passed:—

"That Counsel's Chambers Limited be wound up voluntarily and that Douglas Stanley Anderson, chartered accountant, be appointed liquidator for the purposes of such winding up and that the remuneration of the liquidator be on an hourly basis in accordance with the scale of fees of the Institute of Chartered Accountants."

Dated the 21st day December, 1966.

X. CONNOR, Chairman.

Owen Dixon Chambers, 205 William-street Melbourne,
C.I. 4976

The Companies Act 1961.—In the matter of CAVALCADE RADIO & TELEVISION PROPRIETARY LIMITED (IN VOLUNTARY LIQUIDATION).—Members Winding up.

NOTICE is hereby given that at an Extraordinary General Meeting of the above company, duly convened and held at the registered office of the company, on 3rd January, 1967, the following Resolution was proposed and passed as a Special Resolution.—

"That the company be wound up voluntarily and that Ernest Harding Niemann, of 44 Queen-street, Melbourne, be appointed liquidator for the purpose of such winding up and that he be authorized to draw as remuneration for his services as liquidator his normal hourly charges in respect thereto."

3rd January, 1967.

5054

W. F. KRAUSS, Director.

The Companies Act 1961.—In the matter of A. G. KERR & SONS PROPRIETARY LIMITED (Provisional Liquidator Appointed).

NOTICE is hereby given that on the 7th day of July, 1966, Edward Ronald Smail, of 296 Little Lonsdale-street, Melbourne, chartered accountant, was appointed Provisional Liquidator of the above-named company pending the hearing of a petition for the winding up of the company which presently stands adjourned to the 22nd February, 1967.

It is intended that an application be made to the Court to permit the Provisional Liquidator to make an interim distribution to creditors.

Any persons having claims against this company are required to lodge a statement of claim to the Provisional Liquidator by not later than the 12th day of January, 1967.

Dated this 29th day of December, 1966.

E. R. SMAIL, Provisional Liquidator.

Kennedy, Smail and Middlemiss, 296 Little Lonsdale-street, Melbourne. 5020

The Companies Act 1961.

CALIFORNIA SHOES PROPRIETARY LIMITED.
(IN VOLUNTARY LIQUIDATION).

NOTICE is hereby given that at an Extraordinary Meeting of the members of the above-named company held on Friday, the 23rd day of December, 1966, it was resolved that the company be wound up voluntarily and at a meeting of creditors held on the same day it was resolved that for such purpose, Lewis Luckins, chartered accountant, of 289 Flinders-lane, Melbourne, be appointed liquidator.

Notice is also given that after 21 days from this date I shall proceed to distribute the assets. All creditors having any claim against the company should furnish particulars of same by that date; otherwise I shall proceed to distribute the assets without regard to their claim.

Dated this 23rd day of December, 1966.

LEWIS LUCKINS, Liquidator.

Lewis Luckins & Co., chartered accountants, 289
Flinders-lane, Melbourne, Telephone 63 8827. 5018

SEC. 254 (2)

Form 7.

Companies Act 1961.

SPACELINE INDUSTRIES (AUSTRALIA) PTY. LIMITED.

NOTICE OF RESOLUTION.

To the Registrar of Companies:

AT a General Meeting of the members of Spaceline Industries (Australia) Pty. Limited, duly convened and held at 414 Bourke-street, Melbourne, on the 22nd day of December, 1966, the Special Resolution set out below was duly passed:

"It was resolved that it has been proved to the satisfaction of this meeting, that the company cannot by reason of its liabilities continue its business and that it is advisable to wind up the same, and accordingly that the company be wound up voluntarily, and that Andrew Ian Sinclair, chartered accountant, be appointed the liquidator of the company."

Dated this 22nd day of December, 1966.

5037

R. ANDERSON, Director.

The Companies Act 1961.

KATHERINE TRADING COMPANY PROPRIETARY LIMITED (IN VOLUNTARY LIQUIDATION).

NOTICE is hereby given that at an Extraordinary Meeting of the members of the above-named company held on Thursday, the 22nd day of December, 1966, it was resolved that the company be wound up voluntarily and that for such purpose Walter Henry Germon, accountant, of 31 Queen-street, Melbourne, be appointed liquidator.

Notice is also given that after 21 days from this date I shall proceed to distribute the assets. All creditors having any claim against the company should furnish particulars of same by that date; otherwise I shall proceed to distribute the assets, without regard to their claim.

Dated this 23rd day of December, 1966.

4991

W. H. GERMON, Liquidator.

Companies Act.—In the matter of VASEY FARM PROPRIETARY LIMITED (in Voluntary Liquidation).

NOTICE is hereby given that at an Extraordinary General Meeting of the members of the above-mentioned company held on the 16th day of December, 1966, it was resolved that the company be wound up voluntarily and that John Bertrand McLarty, of 56 Thompson-street, Hamilton, be appointed liquidator for the purpose of such winding up and that the remuneration of the liquidator be fixed at \$700 in addition to his expenses and that the liquidator be hereby authorized to divide all or such part of the surplus assets of the company as he shall think fit among the members of the company in specie.

Dated the 16th day of December, 1966.

4997

J. B. MCLARTY, Secretary.

Companies Act 1961.

KLEER-VU PROPRIETARY LIMITED.

AT a General Meeting of the members of Kleer-Vu Proprietary Limited, duly convened and held at 340 Little Collins-street, Melbourne, on the 19th day of December, 1966, the Special Resolution set out below was duly passed:—

That the company be wound up voluntary and that Mr. Charles Thomas Goode, chartered accountant, of 340 Little Collins-street, Melbourne, be and is hereby appointed liquidator of the company.

Dated this 22nd day of December, 1966.

D. BIENCOURT, Secretary.

Goode, Morris and Toner, chartered accountants, 340 Little Collins-street, Melbourne. 4981

In the matter of WAKEFIELD WATERS PTY. LIMITED (in Liquidation); and in the matter of the *Companies Act 1962-1966*.—Notice to Creditors of Intention to Declare Dividend.

A FIRST Dividend is intended to be declared in the above matter.

Any creditor not proving his debt by the 2nd day of February, 1967, will be excluded from this dividend.

Dated this 3rd day of January, 1967.

J. I. N. WINTER, Liquidator, 134 Waymouth-street, Adelaide, S.A. 4975

The *Companies Act 1961*.—In the matter of I. G. THORNHILL PTY. LTD. (in Liquidation).

NOTICE is hereby given that a First Dividend is intended to be declared in this matter. Creditors who have not proved their debts by the 12th day of January, 1967, will be excluded from the dividend.

Dated this 22nd day of December, 1966.

E. R. SMAIL, Liquidator.

Kennedy, Smail & Middlemiss, 296-300 Little Lonsdale-street, Melbourne. 5032

DUPLEX TOTALIZATORS PROPRIETARY LIMITED.

NOTICE is hereby given that, pursuant to section 272 of the *Companies Act 1961*, a meeting of the members of the above-named company will be held at 440 Collins-street, Melbourne, on the 2nd day of February, 1967, at 10 o'clock in the forenoon, for the purpose of having an account laid before them showing how the winding up of the company has been conducted and the property of the company disposed of.

Dated the 6th day of January, 1967.

5023

P. W. HARVEY, Liquidator.

The *Companies Act 1961*.—In the matter of WRE福德 HOMES PTY. LTD. (in Liquidation).

NOTICE is hereby given that a First Dividend is intended to be declared in this matter. Creditors who have not proved their debts by the 12th day of January, 1967, will be excluded from the dividend.

Dated this 22nd day of December, 1966.

E. R. SMAIL, Liquidator.

Kennedy, Smail & Middlemiss, 296-300 Little Lonsdale-street, Melbourne. 5034

CREDITORS, next of kin and others having claims in respect of the estate of Hazel Pearl Wright, formerly of 12 Field-street, Caulfield, but late of Male-street Private Hospital, 161 Male-street, Brighton, widow, deceased (who died on the 31st day of August, 1966), are requested to send particulars of their claims to the National Trustees, Executors and Agency Company of Australasia Limited, of 95 Queen-street, Melbourne, the administrator of the will of the said deceased, in care of the said company by the 22nd day of March, 1967, after which date the administrator will distribute the assets, having regard only to the claims of which it has notice.

KENNETH J. CLEMENTS & SON, solicitors, 255 Glenhantly-road, Elsternwick. 5014

GEORGE TALBOT FARROLL, late of 409 Beach-road, Beaumaris, retired, DECEASED.

CREDITORS, next of kin and others having claims in respect of the estate of the above-named deceased (who died on the 1st September, 1965), are required to send the particulars of their claims to the executor, Lyonel Muntun Middows, care of the undernamed solicitors by the 6th day of March, 1967, after which date he will distribute the assets, having regard only to those claims of which he then has notice.

NORRIS, COATES & HEARLE, solicitors, of 422 Collins-street, Melbourne. 5016

MAY BEATRICE HOLDEN, late of 24 Ballantyne-street, Thornbury, widow, DECEASED.

CREDITORS, next of kin and others having claims in respect of the estate of the above-named deceased (who died on the 12th August, 1966), are required to send the particulars of their claims to the executrix, Muriel Emma Jones, care of the undernamed solicitors by the 6th day of March, 1967, after which date she will distribute the assets, having regard only to those claims of which she then has notice.

NORRIS, COATES & HEARLE, solicitors, of 422 Collins-street, Melbourne. 5017

ELSIE HANNAH MAXWELL-MOFFAT, late of 55 The Boulevard, Hawthorn, in the State of Victoria, widow, deceased INTTESTATE.

CREDITORS, next of kin and others having claims in respect of the estate of the deceased (who died on the 23rd day of February, 1966), are required by The Perpetual Executors and Trustees Association of Australia Limited, of 100-104 Queen-street, Melbourne, to send particulars of their claims to the said company by the 8th day of March, 1967, after which date it will convey or distribute the assets, having had regard only to the claims of which the company then has notice.

IVAN F. CROFT, solicitor, 108 Queen-street, Melbourne. 5019

FANNIE EVA BULLIVANT, late of "Gregadoo", Watts-road, Mount Eliza, in the State of Victoria, widow, DECEASED.

CREDITORS, next of kin and others having claims in respect of the estate of the deceased (who died on the 17th day of July, 1966), are required by The Perpetual Executors and Trustees Association of Australia Limited, of 100-104 Queen-street, Melbourne, the executor of the will of the deceased, to send particulars of their claims to the said company by the 9th day of March, 1967, after which it will convey or distribute the assets, having regard only to the claims of which it then has notice.

RAYNES, DICKSON & CO., solicitors, of 230 Collins-street, Melbourne. 5021

ELIZABETH MARY AGNES TREACEY, late of Flat 1, 566 Toorak-road, Toorak, Victoria, widow, DECEASED.

CREDITORS, next of kin and others having claims in respect of the estate of the deceased (who died on the 29th August, 1966), are required by the personal representative, National Trustees, Executors and Agency Company of Australasia Limited, of 95 Queen-street, Melbourne, to send particulars to the said company by 8th March, 1967, after which date it may convey or distribute the assets, having regard only to the claims of which it then has notice.

HEDDERWICK, FOOKES & ALSTON, 103 William-street, Melbourne. 5022

CREDITORS, next of kin and others having claims in respect of the estate of Ethel Millicent McKelvie, formerly of 32 Higinbotham-street, Coburg, but late of Flat 9, 31 Eildon-road, St. Kilda, widow (who died on the 14th day of September, 1966), are required by the trustee, Leslie Watson, to send particulars to him, care of the under-mentioned solicitors by the 17th March, 1967, after which date the trustee may convey or distribute the assets, having regard only to the claims of which he then has notice.

H. B. V. DIMELow, solicitors, 422 Collins-street, Melbourne. 5000

CREDITORS, next of kin and others having claims in respect of the estate of John Francis Farley, formerly of Cohuna, farmer, but late of 23 Rockaway-drive, Rosanna, retired (who died on the 31st day of October, 1966), are required by the trustee, Nora Agnes Farley, to send particulars to her, care of the under-mentioned solicitors by the 31st March, 1967, after which date the trustee may convey or distribute the assets, having regard only to the claims of which she then has notice.

H. B. V. DIMELow, solicitors, 422 Collins-street, Melbourne. 5001

FRANCIS THOMAS BELL HARRIS, late of Olinda Hotel Lilydale, manager, DECEASED.

CREDITORS, next of kin and others having claims in respect of the estate of the deceased (who died on 26th September, 1966), are required by the trustee, Roy Clive Hopetoun Beattie, of 61 Union-street, Armadale, solicitor, to send particulars to him by 15th March, 1967, after which date he may convey or distribute the assets, having regard only to the claims of which he then has notice.

R. C. H. BEATTIE, solicitor, 509 Collins-street, Melbourne. 5002

ERNEST EDWARD MILES, late of 2 Maryborough-avenue, Kingsbury, carrier, DECEASED (who died on the 5th November, 1965).

CREDITORS, next of kin and all other persons having claims against the estate of the deceased, are required by the administratrix, Lillian Mavis Miles, to send particulars of their claims to the administratrix, care of the undersigned solicitors, on or before the 9th March, 1967, after which date she will distribute the assets, having regard only to the claims of which she then has notice.

HOME, WILKINSON & LOWRY, solicitors, 401 Collins-street, Melbourne. 5024

MURDOCK HOCKNELL LONGMORE, late of 71 Broadway, East Camberwell, retired marine surveyor, DECEASED.

CREDITORS, next of kin and others having claims in respect of the estate of the deceased (who died on the 18th October, 1966), are required by The Perpetual Executors and Trustees Association of Australia Limited, of 100-104 Queen-street, Melbourne, to send particulars of their claims to the said company by the 8th day of March, 1967, after which date it will convey or distribute the assets, having had regard only to the claims of which the company then has notice.

TOLHURST DRUCE & EMMERSON, solicitors, 357 Little Collins-street, Melbourne. 5025

CREDITORS, next of kin and others having claims in respect of the estate of Jessie Alice Fredricksen, late of 4 Ascot-street, Malvern, widow, deceased (who died on the 10th day of August, 1966), are to send particulars of their claims to Royston T. Cahir & Martin, solicitors of 475 Collins-street, Melbourne, by the 2nd day of March, 1967, after which date the executor will distribute the assets of the said estate, having regard only to claims of which he then has notice.

ROYSTON T. CAHIR & MARTIN, solicitors, 475 Collins-street, Melbourne. 5051

CREDITORS, next of kin and others having claims in respect of the estate of George Arthur Russell, late of 38 Clarke-street, Northcote, dealer, deceased (who died on the 1st of October, 1966), are to send particulars of their claims to the executor, Mathew John Turner, care of the undersigned, by the 17th of March, 1967, after which date he will commence to distribute the assets, having regard only to the claims of which he then has notice.

RENNICK & GAYNOR, solicitors, 473 Bourke-street, Melbourne. 5033

WILLIAM HENRY RADFORD, late of Mercia-avenue, The Basin, retired gasfitter, DECEASED, intestate.

CREDITORS, next of kin and others having claims in respect of the estate of the deceased (who died on the 18th August, 1966), are required by the administratrix, Una Phoebe Elizabeth Radford, of Mercia-avenue, The Basin, widow, to send particulars to her care of the undersigned by the 12th March, 1967, after which date the administratrix may convey or distribute the assets, having regard only to the claims of which she then has notice.

W. B. & O. McCUTCHEON, solicitors 150 Queen-street, Melbourne. 5045

EMMELINE MELITA MURTON, late of 24 Loch-street, St. Kilda, in the State of Victoria, widow, DECEASED.

CREDITORS, next of kin and others having claims in respect of the estate of the deceased (who died on the 2nd day of February, 1966), are required by Basil Howard Barrand, of 113 Park-street, St. Kilda, the executor of the deceased, to send particulars to him by the 27th day of February, 1967, after which date the executor may convey or distribute the deceased's assets, having regard only to the claims of which he then has notice.

Dated the 19th day of December, 1966.

FRANCIS P. WILLIAMS, LL.B., 452 Lonsdale-street, Melbourne. 5046

CREDITORS, next of kin and others having claims in respect of the estate of Hilda Irene Turvey, late of 14 Anzac-avenue, North Coburg, married woman, deceased (who died on the 24th day of June, 1966), are to send particulars of their claims to Royston T. Cahir & Martin, solicitors, of 475 Collins-street, Melbourne, by the 2nd day of March, 1967, after which date the executrix will distribute the assets of the said estate, having regard only to claims of which she then has notice.

ROYSTON T. CAHIR & MARTIN, solicitors, 475 Collins-street, Melbourne. 5050

CREDITORS, next of kin and others having claims in respect of the estate of Ian Bryan Aird, late of 1010 Burke-road, Balwyn, in the State of Victoria, public relations consultant (who died on the 24th day of May, 1965), are to send particulars of their claims to Suzanne Mary Aird, the executrix appointed by the deceased's will, care of the under-mentioned solicitors, by the 14th day of March, 1967, after which date she will distribute the assets, having regard only to the claims of which she then has notice.

TREVAKS, HAVYATT & STEWARD, solicitors, 472 Bourke-street, Melbourne. 4980

CREDITORS, next of kin and others having claims against the estate of Samuel Joseph Mason, formerly of 106 Hawthorn-grove, Mildura, but late of 12 Dawn-street, Mildura, in the State of Victoria, retired council employee, deceased (who died on 17th October, 1966), are requested to send particulars of their claims to the executor, The Union-Fidelity Trustee Company of Australia Limited, 101 Lydiard-street north, Ballarat, by 1st day of March, 1967, after which date the said executor will distribute the assets, having regard only to the claims of which it then had notice. 4985

CREDITORS, next of kin and others having claims against the estate of Martha Jane Carr (also known as Jane Carr), late of 18 Ripon-street north, Ballarat, in the State of Victoria, widow, deceased (who died on the 9th day of September, 1966), are required to send particulars of their claim to The Union-Fidelity Trustee Company of Australia Limited, of 100 Exhibition-street, Melbourne, in the said State, the executor of the will of the said deceased, by the 1st day of March, 1967, after which date the said executor will distribute the assets, having regard only to the claims of which it then has notice.

BYRNE, JONES & TORNEY, solicitors, Ballarat. 4986

CREDITORS, next of kin and others having claims in respect of the estate of Alfred Francis Giles, late of 80 Dover-street, Flemington, gentleman, deceased (who died on the 28th day of August, 1966), are required to send particulars in writing of their claims to Harold Francis Giles, the executor, in care of the undersigned on or before the 7th day of March, 1967, after which date the executor will convey or distribute the assets, having regard only to the claims of which he then has notice.

IRVING S. PLOTKIN, SCOTT & OPAT, solicitors, 379 Bourke-street, Melbourne. 5026

In the intestate estate of LYALL CLYDE BUTLER, late of 36 Hakatere-street, Northcote, in the State of Victoria, storeman, DECEASED.

CREDITORS, next of kin and others having claims in respect of the estate of the deceased (who died on the 16th day of March, 1966), are required by Isla Maud Butler, of 36 Hakatere-street, Northcote, in the State of Victoria, widow, the administratrix of the estate of the said deceased, to send particulars of their claims to her, care of the under-mentioned solicitor, by the 6th day of March, 1967, after which date she will distribute the assets, having regard only to the claims of which she then has notice.

F. P. WALSH, solicitor, 452 High-street, Northcote. 4993

CREDITORS, next of kin and others having claims in respect of the estate of Ada Violet Jarman, late of 190 Buckley-street, Essendon, widow, deceased (who died on the 9th day of September, 1966), are required to send particulars of their claims to the executor, John Brian Jarman, care of the under-mentioned solicitors, on or before the 10th day of March, 1967, after which date he will distribute the assets, having regard only to the claims of which he then has notice.

O. R. BULKA & CO., solicitors, 103 Buckley-street, Essendon. 4994

FRANÇÈS BOWMAN, late of 2 Station-street, Hamilton, in the State of Victoria, widow, DECEASED.

CREDITORS, next of kin and others having claims in respect of the estate of the deceased (who died on the 16th September, 1966), are required by the executrix, Gertrude Carmel Bowman, of 2 Station-street, Hamilton aforesaid, spinster, to send particulars to her, care of the under-mentioned solicitors, by the 15th March, 1967, after which date the executrix may convey or distribute the assets, having regard only to the claims of which she then has notice.

CAMERON & LOWENSTERN, solicitors, Box 413, Hamilton. 4998

JESSIE BLACHRIE ANDERSON, late of 32 Grace-street, Malvern, widow, DECEASED.

CREDITORS, next of kin and others having claims in respect of the estate of the deceased (who died on 21st August, 1966), are required by the trustee, Roy Clive Hopetoun Beattie, of 61 Union-street, Malvern, solicitor, to send particulars to him by 15th March, 1967, after which date he may convey or distribute the assets, having regard only to the claims of which he then has notice.

R. C. H. BEATTIE, solicitor, 509 Collins-street, Melbourne. 4999

CREDITORS, next of kin and others having claims in respect of the estate of Ronald Henry Davis, formerly of 53 Sydney-road, Brunswick, newsagent, but late of 12 Evan-street, Box Hill, van salesman, deceased (who died on the 6th day of September, 1966), are requested to send particulars of their claims to the National Trustees, Executors and Agency Company of Australasia Limited, of 95 Queen-street, Melbourne, the administrator of the will of the said deceased, in care of the said company by the 10th day of March, 1967, after which date the administrator will distribute the assets, having regard only to the claims of which it has notice.

KENNETH J. CLEMENTS & SON, solicitors, 255 Glenhuntly-road, Elsternwick. 4973

WILLIAM LYTHILL WALTER FISHER, late of Modella, farmer, DECEASED.

CREDITORS, next of kin and others having claims in respect of the estate of the deceased (who died on 29th September, 1965), are required by the trustees, William Henry Walter Fisher, of Ballandalla, farmer, and Robert Lythil Fisher, of 44 Mudgee-street, East Burwood, car park attendant, to send particulars to them, care of the undersigned solicitors by the 15th day of March, 1966, after which date the trustees may convey or distribute the assets, having regard only to the claims of which they then have notice.

GRAY, FRIEND & LONG, solicitors, Warragul. 4967

CREDITORS, next of kin and others having claims in respect of the estate of Emily Theodora Donagher, late of 11A Third-avenue, West Brunswick, home duties, deceased (who died on the 1st day of April, 1966), are required to send particulars in writing of their claims to Robert William Brehaut, the executor, in care of the undersigned, on or before the 7th day of March, 1967, after which date the executor will convey or distribute the assets, having regard only to the claims of which he then has notice.

IRVING S. PLOTKIN, SCOTT & OPAT, solicitors, 379 Bourke-street, Melbourne. 5027

CREDITORS, next of kin and others having claims in respect of the estate of John Desmond Belot, late of 4 Milfay-court, North Balwyn, chartered engineer, deceased (who died on the 6th day of March, 1966), are required to send particulars in writing of their claims to Joan Loraine Belot, the executrix, in care of the undersigned, on or before the 7th day of March, 1967, after which date the executrix will convey or distribute the assets, having regard only to the claims of which she then has notice.

IRVING S. PLOTKIN, SCOTT & OPAT, solicitors, 379 Bourke-street, Melbourne. 5028

CREDITORS, next of kin and others having claims in respect of the estate of Isabel Jane Gidley, late of 96 Gatehouse-street, Parkville, widow, deceased (who died on the 13th day of July, 1966), are required to send particulars in writing of their claims to John Francis Curtain, and John Walter James Howard, the executors, in care of the undersigned, on or before the 7th day of March, 1967, after which date the executors will convey or distribute the assets, having regard only to the claims of which they then have notice.

IRVING S. PLOTKIN, SCOTT & OPAT, solicitors, 379 Bourke-street, Melbourne. 5029

CREDITORS, next of kin and others having claims in respect of the estate of William Martin Green, late of 24 Downes-avenue, Brighton, gentleman, deceased (who died on the 16th August, 1966), are to send particulars of their claims to The Equity Trustees Executors and Agency Company Limited, of 472 Bourke-street, Melbourne, by the 10th March, 1967, after which date it will distribute the assets, having regard only to the claims of which it then has notice.

MALLESONS, solicitors, 105 King-street, Melbourne. 5030

CREDITORS, next of kin and others having claims in respect of the estate of Mary Rose Prowse, late of 15 Harcourt-street, Hawthorn, widow, deceased (who died on the 12th May, 1965) are to send particulars of their claims to the personal representatives, Frank Wilson Bett, and Henry Francis Howden Selleck, both of 447 Collins-street, Melbourne, solicitors, care of the under-mentioned solicitors, by 17th March, 1967, after which date they will distribute the assets, having regard only to the claims of which they have notice.

ARTHUR ROBINSON & CO., solicitors, 447 Collins-street, Melbourne. 5031

HELEN MARGARET SANDELL, formerly of 10 The Crest, Surbiton, Surrey, England, but late of 11 Abbott-street, Sandringham, in the State of Victoria, widow, DECEASED.

CREDITORS, next of kin and others having claims in respect of the estate of the deceased (who died on the 6th day of July, 1966), are required by the Perpetual Executors and Trustees Association of Australia Limited, of 100-104 Queen-street, Melbourne, to send particulars of their claims to the said Company by the 13th day of March, 1967, after which date it will convey or distribute the assets, having had regard only to the claims of which the Company then has notice.

ELLISON, HEWISON & WHITEHEAD, solicitors, 421 Bourke-street, Melbourne. 5035

CREDITORS, next of kin and others having claims in respect of the estate of Margaret Milligan McBean, also known as Madge McBean, formerly of 78 Riversdale-road, Hawthorn, but late of 41 Royal-avenue, Essendon, widow, deceased (who died on the 11th day of September, 1966), are to send the particulars of their claims, to National Trustees Executors and Agency Company, of

Australasia Limited, of 95 Queen-street, Melbourne, C.I., by the 13th day of March, 1967, after which date it will distribute the assets, having regard only to the claims of which it then has notice.

JOHN W. ROBERTSON, RAMSAY & HYETT, solicitors,
11 Bank Place, Melbourne. 5036

CATHERINE HELEN MEAD (also known as Katherine Helen Walters), late of Stuart-court, Hastings, in the State of Victoria, widow, DECEASED.

CREDITORS, next of kin and others having claims in respect of the estate of the deceased (who died on the 26th June, 1965), are required by Vincent Morgan Mead, of 27 Bent-street, Caulfield, the executor of the deceased, to send particulars to him by the 27th day of February, 1967, after which date the executor may convey or distribute the deceased's assets, having regard only to the claims of which he then has notice.

Dated the 19th day of December, 1966.

FRANCIS P. WILLIAMS, LL.B., 452 Lonsdale-street,
Melbourne. 5040

CREDITORS, next of kin and others having claims against the estate of Norman Mackay, late of 57 Tuxen-street, North Balwyn, in the State of Victoria, gentleman, deceased (who died on the 7th day of November, 1966), are to send particulars of their claims to the executor, The Trustees, Executors and Agency Company Limited, at its registered office 401 Collins-street, Melbourne, in the said State, by the 22nd day of March, 1967, after which date the said company will convey or distribute the assets, having regard only to the claims of which it then has notice.

JOHN F. CARROLL, solicitor, 118 Queen-street, Melbourne. 5041

FRANCIS JAMES TEMPLETON, late of 16 Norris-street, Surrey Hills, gentleman, DECEASED.

CREDITORS, next of kin and others having claims in respect of the above-named deceased (who died on the 14th September, 1966), are required by the executor, National Trustees, Executors and Agency Company of Australasia Limited, of 95 Queen-street, Melbourne, to send particulars to the said company at its address aforesaid on or before the 20th day of March, 1967, after which date the said executor may convey or distribute the assets, having regard only to the claims of which it then has notice.

BERNARD NOLAN, solicitor, 595 Bourke-street, Melbourne. 5042

CREDITORS, next of kin and others having claims in respect of the estate of Walter Pett, late of 23 Tower Hill-road, Glen Iris, in the State of Victoria, gentleman, deceased (who died on the 15th day of June, 1966), are to send particulars of their claims to The Trustees, Executors and Agency Company Limited, of 401 Collins-street, Melbourne, in the said State, the executor of the will of the said deceased, by the 8th day of March, 1967, after which date the executor will distribute the assets, having regard only to the claims of which it shall then have had notice.

H. L. YUNCKEN & YUNCKEN, solicitors, of 443 Little Collins-street, Melbourne, C.I. 5043

RUBY DOROTHY PETSCHACK, late of 30 Flowerdale-road, Glen Iris.

CREDITORS, next of kin and others having claims in respect of the estate of the deceased (who died on the 11th day of October, 1966), are required by The Perpetual Executors and Trustees Association of Australia Limited, of 100-104 Queen-street, Melbourne, to send particulars of their claims to the said company by the 1st day of March, 1967, after which date it will convey or distribute the assets, having had regard only to the claims of which the company then has notice.

READ & READ, solicitors, of 422 Collins-street, Melbourne. 5044

JAMES EDWARD RYAN (also known as James Herbert Ryan), late of 336 St. Kilda-street, Brighton, gentleman, DECEASED.

CREDITORS, next of kin and others having claims in respect of the above-named deceased (who died on the 18th March, 1965), are required by the executor, National Trustees Executors and Agency Company of Australasia Limited, of 95 Queen-street, Melbourne, to send particulars to the said company at its address aforesaid

on or before the 15th day of March, 1967, after which date the said executor may convey or distribute the assets having regard only to the claims of which it then has notice.

BERNARD NOLAN, solicitor, 595 Bourke-street, Melbourne. 5039

In the Supreme Court of the State of Victoria.
SALE BY THE SHERIFF.

ON Monday, the 20th of February, 1967, at Ten a.m., at the Police Station, Newport (unless process be stayed or satisfied):—

All the estate and interest (if any) of Reginald William Oates of 9 Stephenson-street, Spotswood, motor body builder, as joint proprietor with Jessie Irene Oates, married woman, of an estate in fee simple in the land described in certificate of title, volume 7250, folio 903, upon which is erected a weatherboard dwelling house known as No. 9 Stephenson-street, Spotswood.

Terms: Cash only.

DAVID J. JOHNSTON, Sheriff's Officer.

29th December, 1966. 5047

In the Supreme Court of the State of Victoria.
SALE BY THE SHERIFF.

ON Tuesday, the 21st day of February, 1967, at Ten a.m. at the Police Station, Springvale (unless process be stayed or satisfied):—

All the estate and interest (if any) of Joyce Mary Horton, of 6 Thames-avenue, Springvale, as a tenant in common in equal shares with Michael Thomas Boyhan and Janet Elizabeth Brown, of an estate in fee simple in the land described in certificate of title, volume 8456, folio 663, upon which is erected a dwelling house known as No. 6 Thames-avenue, Springvale.

Registered mortgage Nos. C.106464 & C.283505, affects the said estate and interest.

Terms: Cash only.

N. FROGLEY, Sheriff's Officer.

28th December, 1966. 5048

In the Supreme Court of the State of Victoria.
SALE BY THE SHERIFF.

ON Tuesday, the 21st of February, 1967, at Two p.m., at the Police Station, North Carlton (unless process be stayed or satisfied):—

All the estate and interest (if any) of Fotios John Gerostathos, of 64 Amess-street, North Carlton, as proprietor of an estate in fee simple in the land described in certificate of title, volume 4696, folio 120, upon which is erected a brick shop and dwelling, known as No. 64 Amess-street, North Carlton.

Registered mortgage No. C.438681 affects the said estate and interest.

Terms: Cash only.

N. FROGLEY, Sheriff's Officer.

28th December, 1966. 5049

IMPOUNDINGS

HAMILTON.—Impounded in Hamilton Pound from sale-yards by Superintendent.

54 aged Merino sheep, mixed sexes

26 red Δ brand. 18 red S. 10 Blue S. Mixed ear marks

If not claimed and expenses paid to be sold on 7th January, 1967.

5011—\$2

I. FYFE,
Poundkeeper.

PORTLAND.—Impounded in Portland Pound, on the 20th December, 1966, by the Shire Ranger, from Bridge-water-road, approximately 6 miles west of Portland.

28 sheep, 14 ewes, 4 and 6 tooth, full wool, Comeback and Leicester, notch off ear, no visible brand

14 lambs, unshorn, about 5 months, no visible brand

If not claimed and expenses paid, to be sold on 21st January, 1967.

5053—\$2.50

P. A. LOOKER,
Poundkeeper.

WHITTLESEA.—Impounded in Epping Pound by Ranger.

- 1 Merino crossbred ewe, no visible brand
 - 3 Hereford steers, V cut right ear, no visible brand
 - 1 black and white Friesian steer, no visible brand.
 - 1 black Poll steer, VV cut left ear and V cut right ear, no visible brand
 - 1 black and white Poll steer, white tag on left ear, no visible brand
- If not claimed and expenses paid, to be sold on 20th January, 1967.
- W. HERD,
Poundkeeper.
- 4983—\$3

YARRA JUNCTION.—Impounded in Yarra Junction Pound.

- 2 Jersey steers, like club notch top right ear
 - 1 Jersey steer, ring around tail, club notch top right ear
- If not claimed and expenses paid, to be sold on 24th January, 1967.
- M. BERUDE,
Poundkeeper.
- 5055—\$2

Subordinate Legislation Act 1962.

NOTICE OF MAKING OF STATUTORY RULES.

IN pursuance of the provisions of the *Subordinate Legislation Act 1962* and the Regulations made thereunder, notice is given of the making of the following statutory rules:—

No.	National Parks Act 1958.	Price.
346/66.	Kinglake National Park (Fees) Regulations 1966	10c
	<i>Country Fire Authority Act 1958.</i>	
347/66.	Country Fire Authority (Loan No. 58) Regulations 1966	10c
	<i>Firearms Act 1958.</i>	
348/66.	Firearms (Gun Collector's Licence) Regulations 1966	10c
	<i>Protection of Animals Act 1966.</i>	
349/66.	Protection of Animals (Circus Licences) Regulations 1966	10c
	<i>Protection of Animals Act 1966.</i>	
350/66.	Protection of Animals (Experiments) Regulations 1966	10c
	<i>Fisheries Act 1958.</i>	
352/66.	Revocation of Proclamation Respecting the Terms and Conditions for the Sale of Trout during the Close Season	10c
	<i>Motor Boating Act 1961.</i>	
353/66.	Motor Boating (Gippsland Lakes Eastern Speed Restrictions) Regulations 1966	10c
	<i>Melbourne Harbor Trust Act 1958.</i>	
354/66.	Melbourne Harbor Trust Superannuation Regulations 1966 (Pension Supplementation Amendment)	25c

Copies of these statutory rules may be purchased at the Sale of Publications Section of the Government Printing Office, located at Macarthur-street, Melbourne, C.2. If ordered by mail, remittance should be addressed to "The Government Printer, Box 203, P.O., North Melbourne, N.1.", and should include 5c extra for postage. If a credit account is held at this office, no remittance is required with the mail order.

The annual subscription rate for Statutory Rules (including a Bound Volume) is \$15, payable in advance. The subscription year commences on 1st January.

A. C. BROOKS,
Government Printer.

STATE ACTS, 1964

COPIES of the following Acts of Parliament of Victoria may be obtained at the Government Printing Office or from any accredited agents, at the price set opposite to each (these prices do not include postage).

No.	Price.
7106.	Governor's Salary \$0.05
7107.	Gaols (Visiting Justices) \$0.05
7108.	Grain Elevators (Borrowing Powers) \$0.05
7109.	The Constitution Act Amendment (Conjoint Elections) \$0.08
7110.	Opticians Registration (Fees and Penalties) \$0.05
7111.	Railway Lands \$0.08
7112.	Revocation and Excision of Crown Reservations \$0.08
7113.	Balmoral Geelong and Balwyn Lands Exchange \$0.10
7114.	Transfer of Land (Service Agreements) \$0.05
7115.	R.S.L. Widows and Widowed Mothers' Trust Patriotic Fund \$0.10
7116.	Home Finance (Reconstitution of Trust) \$0.08
7117.	Appeal Costs Fund \$0.12
7118.	Maryborough Free Library and Literary Institute \$0.08
7119.	Wills (Formal Validity) \$0.08
7120.	Stamps (Exemptions) \$0.08
7121.	The Evangelical Lutheran Church of Australia (Victorian District) Incorporation \$0.15
7122.	Health (Child Minding) \$0.08
7123.	Wodonga Sewerage Authority (Acquisition of Land) \$0.08
7124.	Firearms (Interstate Transactions) \$0.08
7125.	Housing Advances and Loans (Improper Commissions) \$0.05
7126.	Process Servers and Inquiry Agents (Qualification) \$0.05
7127.	Supreme Court (Qualification of Judges) \$0.05
7128.	Monash University (Amendment) \$0.05
7129.	Athlone Mechanics' Institute Land \$0.05
7130.	Transfer of Land (Restrictive Covenants) \$0.05
7131.	Goods (Trading Stamps) \$0.05
7132.	Health (Amendment) \$0.08
7133.	Consolidated Revenue \$0.05
7134.	Estate Agents (Amendment) \$0.08
7135.	Public Service (Amendment) \$0.10
7136.	Sheep Owners Protection (Amendment) \$0.10
7137.	Motor Car (Indorsement of Licences) \$0.05
7138.	Racing (Interstate Totalizators) \$0.05
7139.	Police Offences (Animals) \$0.10
7140.	Education (Adult Education) \$0.05
7141.	University (Faculties) \$0.05
7142.	Statute Law Revision \$0.08
7143.	Labour and Industry (Chemists' Shops) \$0.05
7144.	Teaching Service (Amendment) \$0.05
7145.	Litter \$0.08
7146.	Acts Interpretation (Commencement) \$0.05
7147.	Adoption of Children \$0.20
7148.	National Parks \$0.08
7149.	The Constitution Act Amendment (Responsible Ministers) \$0.05
7150.	Consolidated Revenues \$0.05
7151.	Land (Special Grant) \$0.05
7152.	State Insurance Funds \$0.05
7153.	Local Government (Councillors' Declarations) \$0.05
7154.	Metropolitan Fire Brigades (Long Service Leave) \$0.05
7155.	Mildura (Rating on Unimproved Values) \$0.08
7156.	Country Fire Authority (Borrowing Powers) \$0.05
7157.	South Melbourne (Unimproved Rating Poll) \$0.05
7158.	Closer Settlement (Regulations) \$0.05
7159.	General Sessions (Pensions of Chairmen) \$0.05
7160.	Grain Elevators (Borrowing) \$0.05
7161.	Local Authorities Superannuation (Amendment) \$0.05
7162.	Children's Court (Amendment) \$0.05
7163.	Justices (Complaints and Summonses) \$0.05
7164.	Fisheries and Game (Reduced Licence Fees) \$0.05
7165.	Agricultural Colleges \$0.10
7166.	Motor Car (Amendment) \$0.05
7167.	Consolidated Revenue \$0.05
7168.	Administration and Probate (Small Estates) \$0.08
7169.	Game (Black Swans) \$0.05
7170.	Latrobe Valley (Amendment) \$0.05
7171.	Local Government (St. Kilda and Elwood Land Reclamation) \$0.05
7172.	State Forests Loan Application \$0.05
7173.	Portland Harbor Trust (Borrowing Powers) \$0.05
7174.	Sewerage Districts \$0.10
7175.	Consolidated Revenue \$0.05
7176.	Municipal Association (Accident Insurance) \$0.05
7177.	Railways (Long Service Leave) \$0.05
7178.	Country Roads (Amendment) \$0.08

STATE ACTS, 1964—continued.

No.	Description	Price
7179.	Revocation and Excision of Crown Reservations	\$0.10
7180.	Railway Loan Application	\$0.10
7181.	Disposal of Uncollected Goods (Damaged Motor Cars)	\$0.05
7182.	Trustee Companies (Affidavits)	\$0.05
7183.	Maintenance (Reciprocating State)	\$0.05
7184.	Crimes (Amendment)	\$0.10
7185.	Motor Car (Fines and Drivers' Licence Fees)	\$0.05
7186.	Public Works Loan Application	\$0.10
7187.	Juries (Women Jurors)	\$0.08
7188.	Pesticides	\$0.10
7189.	La Trobe University	\$0.18
7190.	National Parks (Amendment)	\$0.05
7191.	Motor Car (Carriers' Identification Marks)	\$0.05
7192.	Swine Compensation	\$0.05
7193.	Stamps (Motor Car)	\$0.10
7194.	Land Tax (Rates and Exemptions)	\$0.08
7195.	Estate Agents	\$0.05
7196.	Tattersall Consultations (Jackpot Consultations)	\$0.05
7197.	Labour and Industry (Fees)	\$0.05
7198.	Water	\$0.15
7199.	Superannuation (Time for Election)	\$0.05
7200.	Police Offences (Betting Information)	\$0.05
7201.	Marine (Amendment)	\$0.10
7202.	Labour and Industry (Long Service Leave)	\$0.08
7203.	Acquisition of Materials	\$0.10
7204.	Stamps	\$0.20
7205.	Forests (Amendment)	\$0.08
7206.	Boilers Inspection (Amendment)	\$0.05
7207.	State Electricity Commission (Contributions)	\$0.05
7208.	Theatres (Sunday Films)	\$0.05
7209.	Housing (Amendment)	\$0.10
7210.	Social Welfare (Trainees)	\$0.08
7211.	Health (Offensive Trades)	\$0.05
7212.	Medical (Amendment)	\$0.10
7213.	Stock Foods (Amendment)	\$0.10
7214.	Railways (Funds)	\$0.05
7215.	Licensing (Dining Permits)	\$0.05
7216.	Water (Recreational Areas)	\$0.05
7217.	Monash University (Amendment)	\$0.10
7218.	Water Supply Loan Application	\$0.15
7219.	Education (School Committees)	\$0.05
7220.	Cancer (Amendment)	\$0.05
7221.	Cadet Surveyors	\$0.05
7222.	Marine Stores and Old Metals (Welfare and Community Organizations)	\$0.05
7223.	Tomato Processing Industry (Uniform Agreement)	\$0.10
7224.	Melbourne Sailors' Home	\$0.05
7225.	Co-operative Housing Societies (Indemnities)	\$0.05
7226.	Legal Profession Practice (Amendment)	\$0.18
7227.	Parliamentary Salaries, Pensions and Superannuation	\$0.10
7228.	Public Lands and Works	\$0.35
7229.	Appropriation of Revenue	\$0.78
7230.	Racing (Amendment)	\$0.10
7231.	Friendly Societies (Assignment of Contracts)	\$0.08
7232.	The Decentralization Advisory Committee	\$0.08
7233.	Mines (Exploration Licences)	\$0.12
7234.	Motor Car (Hours of Driving)	\$0.10
7235.	Valuation of Land (Valuations)	\$0.10
7236.	Shell (Corio to Williamstown) Pipelines	\$0.10
7237.	Consumers Protection	\$0.08

Table of Acts and Enactments passed, date of operation, &c. \$0.02

A. C. BROOKS,
Government Printer.

STATE ACTS, 1965

COPIES of the following Acts of Parliament of Victoria may be obtained at the Government Printing Office, or from any accredited agents, at the price set opposite to each (these prices do not include postage).

No.	Description	Price
7238.	Wills (Minors')	\$0.05
7239.	Cattle Compensation (Amendment)	\$0.05
7240.	Swine (Amendment)	\$0.05
7241.	Social Welfare (Cadetships)	\$0.05
7242.	Appeal Costs Fund (Amendment)	\$0.05
7243.	Altona Railway Extension	\$0.08
7244.	Transfer of Land (Removal of Caveats)	\$0.05
7245.	Water Authorities Accident Insurance	\$0.08
7246.	Portland Harbor Trusts (Amendment)	\$0.10
7247.	Melbourne and Metropolitan Board of Works (Borrowing Powers)	\$0.05
7248.	Justices (Registration)	\$0.10

STATE ACTS, 1965—continued.

No.	Description	Price
7249.	Mildura Irrigation and Water Trusts (Amendment)	\$0.08
7250.	Health (Tuberculosis Arrangement)	\$0.08
7251.	Children's Court (Admission to Hearings)	\$0.05
7252.	Bendigo Land (Special Grant)	\$0.05
7253.	Werribee Waterworks District (Abolition)	\$0.05
7254.	Dandenong Valley Authority (Amendment)	\$0.05
7255.	Legal Aid (Costs)	\$0.05
7256.	Agricultural Education (Continuation)	\$0.05
7257.	Geelong (Kardinia Park) Land	\$0.05
7258.	Water (Amendment)	\$0.08
7259.	Victorian Inland Meat Authority (Amendment)	\$0.05
7260.	The Constitution Act Amendment (Subordinate Legislation Committee)	\$0.05
7261.	Country Fire Authority	\$0.08
7262.	Subordinate Legislation (Amendment)	\$0.05
7263.	Crimes (Illegal Use of Motor Cars)	\$0.08
7264.	Property Law (Loans to Minors)	\$0.08
7265.	Soil Conservation (Water Resources)	\$0.08
7266.	Grain Elevators (Borrowing Powers)	\$0.05
7267.	Aborigines (Amendment)	\$0.05
7268.	Stamps	\$0.10
7269.	Crimes (Parole)	\$0.05
7270.	Electoral Provinces and Districts	\$0.12
7271.	Mordialloc Public Hall and Court House	\$0.08
7272.	Sale of Land	\$0.15
7273.	Labour and Industry (Amendment)	\$0.10
7274.	Farm Produce Merchants and Commission Agents	\$0.30
7275.	National Parks (Amendment)	\$0.10
7276.	Valuation of Land (Appeals)	\$0.20
7277.	Medical (Foreign Practitioners)	\$0.05
7278.	Rural Finance and Settlement Commission	\$0.05
7279.	Home Finance (Amendment)	\$0.05
7280.	Road Traffic (Infringements)	\$0.10
7281.	Companies (Amendment)	\$0.10
7282.	Health (Household Insecticides)	\$0.08
7283.	Roads (Special Projects)	\$0.10
7284.	Consolidated Revenue	\$0.05
7285.	Consolidated Revenue	\$0.05
7286.	Local Government (Amendment)	\$0.15
7287.	Teaching Service (Amendment)	\$0.05
7288.	Marketing of Primary Products (Egg Marketing)	\$0.10
7289.	Maintenance	\$0.52
7290.	Veterinary Surgeons (Amendment)	\$0.10
7291.	Victoria Institute of Colleges	\$0.18
7292.	Workers Compensation (Amendment)	\$0.18
7293.	Petroleum Products Subsidy	\$0.10
7294.	Consolidated Revenue	\$0.05
7295.	Acts Interpretation	\$0.08
7296.	Administration and Probate (Surviving Actions)	\$0.05
7297.	Mines (Regulations)	\$0.05
7298.	Electric Light and Power (Interstate Supplies)	\$0.05
7299.	Supreme Court (Judges)	\$0.05
7300.	Local Government (Brighton Land Reclamation)	\$0.08
7301.	Racing (Totalizator Percentages)	\$0.05
7302.	Agricultural Colleges (Cadetships)	\$0.05
7303.	State Electricity Commission (Chairman)	\$0.08
7304.	Geelong Harbor Trust Lands	\$0.08
7305.	San Remo—Newhaven Land	\$0.08
7306.	Echuca Stockyards Railway Construction	\$0.08
7307.	Metropolitan Transportation Committee (Amendment)	\$0.05
7308.	Fuel and Power	\$0.08
7309.	Albert Park Lands	\$0.05
7310.	Presbyterian Trusts (Common Fund)	\$0.08
7311.	Melbourne Harbor Trust (Amendment)	\$0.10
7312.	Apprenticeship (Amendment)	\$0.10
7313.	Country Roads (Collection Costs)	\$0.05
7314.	Motor Car	\$0.10
7315.	Decimal Currency	\$0.20
7316.	Joint Select Committee (Drainage)	\$0.10
7317.	Stamps (Amendment)	\$0.08
7318.	Country Fire Authority (Service of Notices)	\$0.05
7319.	Licensing	\$0.15
7320.	Railway Loan Application	\$0.10
7321.	Water Licences and Permits	\$0.10
7322.	Railways (Amendment)	\$0.05
7323.	Local Government (Constitution of Municipalities)	\$0.20
7324.	Evidence (Reproductions)	\$0.12
7325.	Milk and Dairy Supervision (Cheese Factory Licences)	\$0.05
7326.	Water Supply Loan Application	\$0.15
7327.	Motor Car (Driving Offence)	\$0.08
7328.	Land Settlement and Rural Finance	\$0.08
7329.	Committees (Amendment)	\$0.05

STATE ACTS, 1965—continued.

No.	Price.
7330. Public Works Loan Application ..	\$0.10
7331. Weights and Measures (Amendment) ..	\$0.12
7332. Statute Law Revision ..	\$0.15
7333. Valuation of Land (General Amendment) ..	\$0.10
7334. Cul-de-sac Applications ..	\$0.05
7335. Tourist Resorts ..	\$0.05
7336. Gas Regulation (Amendment) ..	\$0.08
7337. Dried Fruits (Amendment) ..	\$0.05
7338. Patriotic Funds (Amendment) ..	\$0.10
7339. Flinders-lane Alignments ..	\$0.08
7340. Forests (Amendment) ..	\$0.08
7341. Poultry Levy (Collection Arrangement) ..	\$0.08
7342. Tomato Processing Industry (Amendment) ..	\$0.08
7343. Veterinary Surgeons (Further Amendment) ..	\$0.05
7344. Motor Car (Portable Speed-measuring Devices) ..	\$0.05
7345. Justices (Amendment) ..	\$0.05
7346. Judges' Salaries and Allowances ..	\$0.05
7347. Country Roads (Cadetships) ..	\$0.05
7348. St. Kilda Land ..	\$0.10
7349. Public Officers ..	\$0.08
7350. Marine (Amendment) ..	\$0.08
7351. Racing (Dog Racing) ..	\$0.08
7352. Land Tax (Rates) ..	\$0.08
7353. Collusive Practices ..	\$0.12
7354. Hospitals Superannuation ..	\$0.20
7355. Psychological Practices ..	\$0.15
7356. Public Officers Salaries and Allowances ..	\$0.10
7357. Superannuation ..	\$0.10
7358. Road Transport ..	\$0.15
7359. Stamps (Bills of Exchange) ..	\$0.05
7360. Survey Co-ordination (Place Names) ..	\$0.10
7361. Motor Car (Further Amendment) ..	\$0.05
7362. Universities (Amendment) ..	\$0.10
7363. Home Finance (Second Mortgages) ..	\$0.05
7364. Library Council of Victoria ..	\$0.10
7365. Lower Yarra Crossing Authority ..	\$0.10
7366. Evidence (Amendments) ..	\$0.08
7367. State Forests Loan Application ..	\$0.05
7368. Labour and Industry ..	\$0.10
7369. Justices (Sentencing) ..	\$0.05
7370. Consolidated Revenue ..	\$0.05
7371. Appropriation of Revenue ..	\$0.85

A. C. BROOKS,
Government Printer.

STATE ACTS, 1966

COPIES of the following Acts of Parliament of Victoria may be obtained at the Government Printing Office, or from any accredited agents, at the price set opposite to each (these prices do not include postage).

The annual subscription for State Acts 1967 et seq. is \$8, payable in advance.

Bound Volumes of State Acts are also available on a subscription basis at \$15 per annum.

No.	Price.
7372. Education (Council of Adult Education) ..	\$0.05
7373. Legal Profession Practice (Amendment) ..	\$0.05
7374. Co-operation (Amendment) ..	\$0.05
7375. Nurses (Amendment) ..	\$0.05
7376. Property Law (Loans to Minors) ..	\$0.05
7377. Audit (Amendment) ..	\$0.08
7378. Marketing of Primary Products (Tobacco Leaf Marketing Board) ..	\$0.05
7379. State Library National Gallery National Museum and Institute of Applied Science (Amendment) ..	\$0.05
7380. Reid Murray Acceptance Limited (Scheme of Arrangement) ..	\$0.12
7381. Lake Corangamite ..	\$0.10
7382. Tobacco Leaf Marketing Board (Appointment of Manager) ..	\$0.05
7383. Country Fire Authority (Borrowing Powers) ..	\$0.05
7384. Labour and Industry (Sheltered Workshops) ..	\$0.05
7385. Wombat Bonuses ..	\$0.05
7386. Country Fire Authority (Interstate Fire Brigades) ..	\$0.05
7387. Loch Public Hall Trust ..	\$0.12
7388. Co-operative Housing Societies (Amendment) ..	\$0.05
7389. Fisheries and Game (Amendment) ..	\$0.08
7390. Marine Stores and Old Metals (Collectors) ..	\$0.05
7391. Companies ..	\$0.22
7392. The Constitution Act Amendment ..	\$0.05

STATE ACTS, 1966—continued.

No.	Price.
7393. Vagrancy ..	\$0.12
7394. Consolidated Revenue ..	\$0.05
7395. Land (Plantation Areas) ..	\$0.10
7396. Daylesford Springs Land ..	\$0.05
7397. Barley Marketing (Amendment) ..	\$0.05
7398. Sheep Dipping (Repeal) ..	\$0.05
7399. Grain Elevators (Amendment) ..	\$0.05
7400. Seymour Racecourse Land ..	\$0.05
7401. Shepparton Abattoirs ..	\$0.05
7402. Paisley-Galvin Railway Land Exchange ..	\$0.08
7403. Aerial Spraying Control ..	\$0.12
7404. Racing (Amendment) ..	\$0.08
7405. Summary Offences ..	\$0.28
7406. Friendly Societies (Amendment) ..	\$0.05
7407. Crimes (Dangerous Driving) ..	\$0.05
7408. Medical (Foreign Practitioners Qualification Committee) ..	\$0.05
7409. Opticians Registration (Amendment) ..	\$0.05
7410. Labour and Industry (Petrol Shops) ..	\$0.08
7411. Melbourne and Metropolitan Board of Works (Amendment) ..	\$0.08
7412. Carlton (Recreation Ground) Land ..	\$0.08
7413. Boilers Inspection (Amendment) ..	\$0.05
7414. Warragul and Neerim Railway Lands ..	\$0.08
7415. Victoria Institute of Colleges (Council) ..	\$0.05
7416. Marketable Securities ..	\$0.18
7417. Pensions Supplementation ..	\$0.20
7418. Evidence (Medical Evidence) ..	\$0.05
7419. Water (Rating by Area) ..	\$0.05
7420. County Court (Common Law Jurisdiction) ..	\$0.05
7421. State Electricity Commission (Amendment) ..	\$0.05
7422. Gas and Fuel Corporation (Borrowing) ..	\$0.05
7423. Vegetation and Vine Diseases (Amendment) ..	\$0.05
7424. Motor Car ..	\$0.05
7425. Estate Agents (Amendment) ..	\$0.10
7426. Melbourne University (Chancellorship) ..	\$0.05
7427. Tobacco Leaf Industry Stabilization ..	\$0.15
7428. Consolidated Revenue ..	\$0.05
7429. Lotteries Gaming and Betting ..	\$0.35
7430. Stamps (Mortgages) ..	\$0.05
7431. Money Lenders (Exemption) ..	\$0.05
7432. Protection of Animals ..	\$0.12
7433. Marketing of Primary Products (Maize Marketing Board) ..	\$0.10
7434. Consolidated Revenue ..	\$0.10
7435. Firearms (Competition Weapons) ..	\$0.10
7436. Provincial Sewerage Authorities Association of Victoria ..	\$0.10
7437. Waterworks Trusts Association of Victoria ..	\$0.10
7438. Maffra Lands Exchange ..	\$0.10
7439. Trewalla Lands Exchange ..	\$0.10
7440. Tattersall Consultations ..	\$0.10
7441. Public Authorities (Contributions) ..	\$0.10
7442. Racing (Totalizator Percentages) ..	\$0.10
7443. Lower Yarra Crossing Authority (Guarantee) ..	\$0.10
7444. Stock and Share Brokers (Amendment) ..	\$0.15
7445. Moorpanyal Lands Exchange ..	\$0.10
7446. North Melbourne Lands ..	\$0.15
7447. Marine (Amendment) ..	\$0.10
7448. Mildura Irrigation and Water Trusts (Amendment) ..	\$0.10
7449. State Accident Insurance Office Land ..	\$0.10
7450. Public Account (Bona Vacantia) ..	\$0.10
7451. Motor Car (Hospital and Charities Contributions) ..	\$0.10
7452. Commonwealth and States Financial Agreement ..	\$0.15
7453. State Forests Loan Application ..	\$0.10
7454. Water (Amendment) ..	\$0.15
7455. Hospitals and Charities (Liability of Patients) ..	\$0.15
7456. Sewerage District's (Amendment) ..	\$0.10
7457. Limitation of Actions (Notice of Action) ..	\$0.10
7458. Long Island Country Club ..	\$0.10
7459. Country Roads (Level Crossings) (Amendment) ..	\$0.10
7460. Evidence (Foreign Tribunals) ..	\$0.10
7461. San Remo Lands ..	\$0.10
7462. The Constitution Act Amendment (Conjoint Elections) ..	\$0.10
7463. Vermin and Noxious Weeds (Financial) ..	\$0.10
7464. Co-operative Housing Societies (Financial) ..	\$0.10
7465. Morwell National Park ..	\$0.10
7466. Land Tax (Rates) ..	\$0.10
7467. Teaching Service (Married Women) ..	\$0.10
7468. Melbourne Cricket Ground (Guarantees) ..	\$0.10

A. C. BROOKS,
Government Printer.

ACTS REPRINTED IN ACCORDANCE WITH THE AMENDMENTS INCORPORATION ACT 1958 (No. 6422), AND FOR SALE AT THE SALE OF PUBLICATIONS BRANCH OF THE GOVERNMENT PRINTING OFFICE, MACARTHUR-STREET, MELBOURNE.

(These prices do not include postage.)

No.	Price.
6189. Acts Interpretation (Incorporating amendments up to No. 7146)	\$0.15
6191. Administration and Probate (Third Reprint—Incorporating amendments up to No. 7332)	\$0.38
6194. Agricultural Colleges (First Reprint—Incorporating amendments up to No. 7302)	\$0.12
6199. Apprenticeship (First Reprint—Incorporating amendments up to No. 7312)	\$0.25
6209. Boiler Inspection (Incorporating amendments up to No. 7072)	\$0.18
6210. Building Societies (Incorporating amendments up to No. 7125)	\$0.25
6218. Children's Court (Incorporating amendments up to No. 7084)	\$0.20
6219. Children's Welfare (Incorporating amendments up to No. 6812)	\$0.25
6220. Clean Air (Incorporating amendments up to No. 6886)	\$0.10
6222. Commercial Goods Vehicles (Second Reprint—Incorporating amendments up to No. 7358)	\$0.22
6839. Companies Act 1961 (Second Reprint—Incorporating amendments up to No. 7332)	\$2.32
6225. Co-operation (Second Reprint—Incorporating amendments up to No. 7083)	\$0.42
6226. Co-operative Housing Societies (Incorporating amendments up to No. 7097)	\$0.40
6228. Country Fire Authority (Incorporating amendments up to No. 7065)	\$0.40
6229. Country Roads (Incorporating amendments up to No. 6943)	\$0.40
6231. Crimes (Second Reprint—Incorporating amendments up to No. 7407)	\$1.33
6236. Dog (Second Reprint—Incorporating amendments up to No. 7065)	\$0.15
6242. Employers and Employés (Incorporating amendments up to No. 6740)	\$0.18
6245. Estate Agents (Second Reprint—Incorporating amendments up to No. 7134)	\$0.38
6246. Evidence (Second Reprint—Incorporating amendments up to No. 7366)	\$0.42
6249. Fences (Incorporating amendments up to No. 6550)	\$0.12
6250. Fertilizers (Incorporating amendments up to No. 7142)	\$0.18
ACTS REPRINTED IN ACCORDANCE WITH THE AMENDMENTS INCORPORATION ACT 1958 (No. 6422)—continued.	
6251. Firearms (Incorporating amendments up to No. 6716)	\$0.22
6916. Foreign Judgments Act 1962 (First Reprint—including amendments made by No. 7332)	\$0.12
6585. Forests (Pulpwood Agreement) (Incorporating amendments up to No. 6886)	\$0.15
6259. Gaols (Incorporating amendments up to No. 6651)	\$0.15
6258. Game—(First Reprint—Incorporating amendments up to No. 7389)	\$0.30
6265. Goods (Third Reprint—Incorporating amendments up to No. 7131)	\$0.28
6270. Health (Incorporating amendments up to No. 6886)	\$1.45
6933. Home Finance Act 1962 (First Reprint—Incorporating amendments up to No. 7363)	\$0.25
6274. Hospitals and Charities (Incorporating amendments up to No. 6716)	\$0.35
6279. Instruments (Third Reprint—Incorporating amendments up to No. 7315)	\$0.38
6282. Justices (Second Reprint—Incorporating amendments up to No. 7369)	\$1.23
6283. Labour and Industry (Second Reprint—Incorporating amendments up to No. 7143)	\$0.75
6284. Land (Incorporating amendments up to No. 7360)	\$1.53
6285. Landlord and Tenant (Second Reprint—Incorporating amendments up to No. 6996)	\$0.50
6534. Land Settlement Act 1959 (First Reprint—Incorporating amendments up to No. 7328)	\$0.30
6289. Land Tax (Incorporating amendments up to No. 7099)	\$0.32
6291. Legal Profession Practice (Incorporating amendments up to No. 7065)	\$0.45
6293. Licensing (Second Reprint—Incorporating amendments up to No. 7054)	\$0.95
6577. Lifts and Cranes (Incorporating amendments up to No. 6886)	\$0.12
6295. Limitation of Actions (Incorporating amendments up to No. 6845)	\$0.15

ACTS REPRINTED IN ACCORDANCE WITH THE AMENDMENTS INCORPORATION ACT 1958 (No. 6422)—continued.

No.	Price.
6298. Local Authorities Superannuation (Incorporating amendments up to No. 6894)	\$0.25
6299. Local Government (Incorporating amendments up to No. 7052)	\$3.50
6302. Marine (Incorporating amendments up to No. 7350)	\$0.72
6309. Medical (Second Reprint—Incorporating amendments up to No. 7408)	\$0.40
6310. Melbourne and Metropolitan Board of Works (Incorporating amendments up to No. 7054)	\$0.85
6312. Melbourne Harbor Trust (First Reprint—Incorporating amendments up to No. 7356)	\$0.48
6605. Mental Health (Incorporating amendments up to No. 7135)	\$0.45
6315. Metropolitan Fire Brigades (Incorporating amendments up to No. 6886)	\$0.28
6317. Milk and Dairy Supervision (Incorporating amendments up to No. 6964)	\$0.40
6318. Milk Board (Incorporating amendments up to No. 7093)	\$0.22
6324. Money Lenders (Incorporating amendments up to No. 6886)	\$0.25
6832. Motor Boating (Incorporating amendments up to No. 6961)	\$0.15
6325. Motor Car (Second Reprint—Incorporating amendments up to No. 7361)	\$0.82
6326. National Parks (Incorporating amendments up to No. 7275)	\$0.15
6328. Nurses (Incorporating amendments up to No. 6716)	\$0.20
6330. Partnership	\$0.15
6331. Patriotic Funds (First Reprint—Incorporating amendments up to No. 7338)	\$0.25
6889. Poisons (Incorporating amendments up to No. 7065)	\$0.35
6337. Police Offences (Incorporating amendments up to No. 7145)	\$0.82
6338. Police Regulation (Incorporating amendments up to No. 7081)	\$0.45
6341. Pounds (First Reprint—Incorporating amendments up to No. 7315)	\$0.25
6890. Probate Duty (Incorporating amendments up to No. 6970)	\$0.38
6343. Process Servers and Inquiry Agents (Incorporating amendments up to No. 7126)	\$0.12
6344. Property Law (Incorporating amendments up to No. 6867)	\$0.90
6349. Public Service (Second Reprint—Incorporating amendments up to No. 7356)	\$0.40
6350. Public Trustee (Incorporating amendments up to No. 6961)	\$0.35
6353. Racing (First Reprint—Incorporating amendments up to No. 7404)	\$0.70
6359. Road Traffic (Second Reprint—Incorporating amendments up to No. 7332)	\$0.18
6360. Rural Finance (First Reprint—Incorporating amendments up to No. 7328)	\$0.12
6846. Rural Finance and Settlement Commission Act 1961 (First Reprint—Incorporating amendments up to No. 7332)	\$0.20
6975. Sale of Land Act 1962 (First Reprint—Incorporating amendments up to No. 7332)	\$0.18
6363. Second-Hand Dealers	\$0.12
6367. Settled Land (Incorporating amendments up to No. 6505)	\$0.40
6368. Sewerage Districts (First Reprint—Incorporating amendments up to No. 7332)	\$0.62
6651. Social Welfare Act 1960 (Third Reprint—Incorporating amendments up to No. 7332)	\$0.20
6372. Soil Conservation and Land Utilization (Incorporating amendments up to No. 6961)	\$0.20
6373. Soldier Settlement (First Reprint—Incorporating amendments up to No. 7328)	\$0.42
6375. Stamps (Third Reprint—Incorporating amendments up to No. 7359)	\$0.82
6377. State Electricity Commission (Incorporating amendments up to No. 7054)	\$0.50
6379. State Savings Bank (Incorporating amendments up to No. 6886)	\$0.42
6395. Tourist (First Reprint—Incorporating amendments up to No. 7335)	\$0.15
6886. Subordinate Legislation (Incorporating amendments up to No. 7276)	\$0.35
6849. Town and Country Planning (First Reprint—Incorporating amendments up to No. 7276)	\$0.35
6399. Transfer of Land (Second Reprint—Incorporating amendments up to No. 7130)	\$0.52
6400. Transport Regulation (First Reprint—Incorporating amendments up to No. 7358)	\$0.22

ACTS REPRINTED IN ACCORDANCE WITH THE AMENDMENTS
INCORPORATION ACT 1958 (NO. 6422)—continued.

CONTENTS

No.	Price.		PAGE
6401. Trustee (<i>Second Reprint</i> —Incorporating amendments up to No. 6963)	\$0.42	Acts of Parliament on sale at the Government Printing Office	94
6879. Unclaimed Moneys (Incorporating amendments up to No. 6961)	\$0.12	Appointments	68
6653. Valuation of Land Act 1960 (<i>Second Reprint</i> —Incorporating amendments up to No. 7333)	\$0.22	Cemetery—Scale of Fees	61
6407. Vegetation and Vine Diseases (<i>First Reprint</i> —Incorporating amendments up to No. 7423)	\$0.30	Contracts	53
6410. Veterinary Surgeons (<i>First Reprint</i> —Incorporating amendments up to No. 7343)	\$0.15	Country Roads Board	68
6413. Water (Incorporating amendments up to No. 7228)	\$1.42	Courts	61
6414. Weights and Measures (<i>Second Reprint</i> —Incorporating amendments up to No. 7332)	\$0.32	Estates of Deceased Persons	52
6419. Workers Compensation (<i>Second Reprint</i> —Incorporating amendments up to No. 7332)	\$0.52	Government Notices	51
		Impoundings	93
		Lands	74
		Notice of Making of Statutory Rules	94
		Orders in Council—	
		Acts—Railways; Country Roads; Road Traffic; Hospitals Superannuation; Dandenong Valley Authority; Local Government; Margarine.	69 et seq
		Police—Motor Car Acts	61
		Private Advertisements	80
		Public Service Notice	80
		Regulations—	
		Acts—Teaching Service	80
		Resignation	69
		Tenders	79
		Waterworks Trusts	62
FIRST NOTIFICATION OF REPRINT.			
6203. Audit (<i>First Reprint</i> —incorporating amendments up to No. 7377)	\$0.35		
6256. Fruit and Vegetables (<i>First Reprint</i> —incorporating amendments up to No. 6944)	\$0.30		
6286. Lands Compensation—(<i>First Reprint</i> —incorporating amendments up to No. 7332)	\$0.25		
A. C. BROOKS, Government Printer.			