



VICTORIA GOVERNMENT GAZETTE

Published by Authority

[Registered at the General Post Office, Melbourne, for transmission by post as a newspaper.]

No. 33]

WEDNESDAY, APRIL 19

[1967

PROCLAMATIONS

BANK HOLIDAYS.

PROCLAMATION

By His Excellency the Governor of the State of Victoria and its Dependencies in the Commonwealth of Australia, &c., &c., &c.

IN pursuance of the provisions of the *Bank Holidays Act 1958*, I, the Governor of the State of Victoria, in the Commonwealth of Australia, do by this my Proclamation appoint the day and date named hereunder a special day to be observed as a Bank Half-Holiday at the place mentioned, that is to say:—

Bank Half-Holiday from the Hour of Eleven o'clock a.m.:—

THURSDAY, THE 4TH MAY, 1967, at Warrnambool and Koroit.

Given under my Hand and the Seal of the State of Victoria aforesaid, at Melbourne, this 18th day of April, in the year of our Lord One thousand nine hundred and sixty-seven, and in the 16th year of the reign of Her Majesty Queen Elizabeth II.

(L.S.) ROHAN DELACOMBE.

By His Excellency's Command,
JAMES W. MANSON,
for Chief Secretary.

GOD SAVE THE QUEEN !

PUBLIC HOLIDAYS.

PROCLAMATION

By His Excellency the Governor of the State of Victoria and its Dependencies in the Commonwealth of Australia, &c., &c., &c.

IN pursuance of the provisions contained in Part III. of the *Public Service Act 1958*, I, the Governor of the State of Victoria, in the Commonwealth of Australia, by and with the advice of the Executive Council of the said State, do by this my Proclamation appoint the days and dates hereunder mentioned to be observed as Public Half-Holidays at the places respectively specified, viz.:—

Public Half-Holidays from the Hour of Twelve o'clock noon:—

THURSDAY, THE 8TH JUNE, 1967, throughout the Shire of Myrtleford.

THURSDAY, THE 4TH MAY, 1967, throughout the City of Warrnambool.

Given under my Hand and the Seal of the State of Victoria aforesaid, at Melbourne, this 18th day of April, in the year of our Lord One thousand nine hundred and sixty-seven, and in the 16th year of the reign of Her Majesty Queen Elizabeth II.

(L.S.) ROHAN DELACOMBE.

By His Excellency's Command,
JAMES W. MANSON,
for Chief Secretary.

GOD SAVE THE QUEEN !

ROAD PROCLAIMED

PROCLAMATION

By His Excellency the Governor of the State of Victoria and its Dependencies in the Commonwealth of Australia, &c., &c., &c.

IN pursuance of the provisions of Section 25 of the Land Act 1958, the Governor of the State of Victoria, by and with the advice of the Executive Council of the said State, do hereby proclaim as a road the land in the Parish of Caralulup County of Talbot, as indicated by hatching on plan hereunder.—(C.356^(s)) (J.32229.)

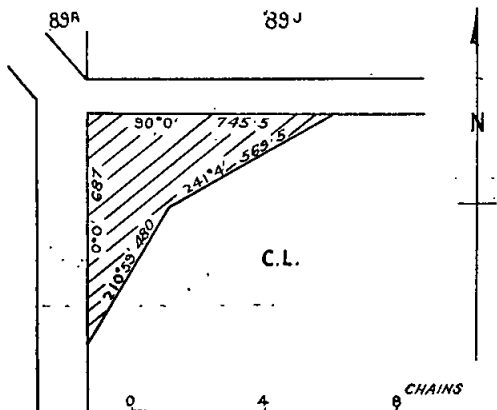

Given under my Hand and the Seal of the State of Victoria aforesaid, at Melbourne, this eleventh day of April in the year of Our Lord One thousand nine hundred and sixty-seven, and in the sixteenth year of the reign of Her Majesty Queen Elizabeth II.

(L.S.) ROHAN DELACOMBE.

By His Excellency's Command,
JIM BALFOUR,
Minister of Lands.

GOD SAVE THE QUEEN!

Marketing of Primary Products Act 1958 (No. 6304).
DECLARING THAT MAIZE SHALL BECOME THE PROPERTY OF THE MAIZE MARKETING BOARD FOR A FURTHER PERIOD OF TWO (2) YEARS.

PROCLAMATION

By His Excellency the Governor of the State of Victoria and its Dependencies in the Commonwealth of Australia, &c., &c., &c.

WHEREAS by sub-section (1) of section 17 of the Marketing of Primary Products Act 1958, it is enacted that where a product has been declared a commodity and a board has been appointed in relation thereto, the Governor in Council may by Proclamation—

- (a) provide and declare that the commodity shall forthwith, upon the date of publication of the Proclamation or on, from and after a later date specified in the Proclamation, be divested from the producers of the commodity and become vested in and be the absolute property of the Board as the owner thereof, and that upon any of the commodity coming into existence within a time specified in the same or a subsequent Proclamation it shall by virtue of this Act become vested in and be the absolute property of the Board as the owner thereof; and
- (b) make such further provision as will enable the Board effectively to obtain possession of the commodity as such owner and to deal with the same;

AND WHEREAS by a Proclamation made on the fifth day of May, 1936, under the provisions of section 7 of the said Act, the Governor in Council declared maize to be a commodity under and for the purposes of the said Act: AND WHEREAS by an Order made on the second day of November, 1936, the Governor in Council appointed a marketing Board in relation to maize and assigned to such Board the name of "The Maize Marketing Board": NOW THEREFORE, I, the Governor of the State of Victoria, in the Commonwealth of Australia, by and with the advice of the Executive Council of the said State, do

by this my Proclamation hereby PROVIDE AND DECLARE that on and from the second day of May, One thousand nine hundred and sixty-seven all maize shall subject to and in accordance with the Marketing of Primary Products Act 1958 be divested from the producers of maize and become vested in and be the absolute property of The Maize Marketing Board as the owner thereof and that upon any maize coming into existence within two (2) years from the second day of May, One thousand nine hundred and sixty-seven, it shall by virtue of and subject to and in accordance with the said Act become vested in and be the absolute property of The Maize Marketing Board as the owner thereof: AND to enable The Maize Marketing Board as owner of the above-mentioned commodity effectively to obtain possession thereof and to deal with the same I DO FURTHER PROVIDE that all such maize shall subject to and in accordance with the provisions of the said Act be delivered by the producers thereof to The Maize Marketing Board or its authorized agent within such times, at such places and in such manner as The Maize Marketing Board by public notice, or in a particular case in writing, directs or as are prescribed by Regulations made under the said Act.

Given under my Hand and the Seal of the State of Victoria aforesaid, at Melbourne, this eleventh day of April, in the year of our Lord One thousand nine hundred and sixty-seven, and in the sixteenth year of the reign of Her Majesty Queen Elizabeth II.

(L.S.) ROHAN DELACOMBE.

By His Excellency's Command,
G. L. CHANDLER,
Minister of Agriculture.

GOD SAVE THE QUEEN!

MOTOR BOATING ACT 1961.

PROCLAMATION

By His Excellency the Governor of the State of Victoria and its Dependencies in the Commonwealth of Australia, &c., &c., &c.

WHEREAS by Section 2, of the Motor Boating Act 1961, it is amongst other things enacted that the Governor in Council, by Proclamation published in the Government Gazette, may appoint an Authority over any Victorian waters for the purposes of the said Act:

NOW THEREFORE I, the Governor of the State of Victoria, in the Commonwealth of Australia, by and with the advice of the Executive Council of the said State, do by this my Proclamation appoint the State Rivers and Water Supply Commission to be the Authority over the waters of Rocklands Reservoir for the purposes of the said Act:

Given under my Hand and the Seal of the State of Victoria aforesaid, at Melbourne, this eleventh day of April, in the year of our Lord One thousand nine hundred and sixty-seven, and in the sixteenth year of the reign of Her Majesty Queen Elizabeth II.

(L.S.) ROHAN DELACOMBE.

By His Excellency's Command,
JAMES W. MANSON,
for Chief Secretary.

GOD SAVE THE QUEEN!

GOVERNMENT NOTICES

ANZAC DAY HOLIDAY.

IT is hereby notified that on—
TUESDAY, THE 25TH APRIL, 1967,
the Public Offices will be closed, such day having been appointed by the Public Service Act 1958, to be observed as a holiday in the Public Offices throughout the State of Victoria.

This notice relates only to the closing of the State Public Offices. All inquiries regarding the holiday in other offices and in shops and industry should be directed to the Department of Labour and Industry, 110 Exhibition-street, Melbourne, C.I. (Telephone 63 0321, Extension 6158 or 6721.)

A. G. RYLAH,
Chief Secretary.

Chief Secretary's Office,
Melbourne, C.I., 29th March, 1967.

Transport Regulation Act.

TRANSPORT REGULATION BOARD.

HEARING OF APPLICATIONS.

NOTICE is hereby given that the following applications will be considered by the Transport Regulation Board at its offices at corner Lygon and Princes streets, Carlton, at 10.15 a.m. on Wednesday, 10th May, 1967.

EELIS, F. C., 19 Viewpoint-road, North Balwyn. One commercial passenger vehicle (S/C. 5) to operate under country private hire conditions from Inverloch.

KASTORIA BUS LINES PTY. LTD., 3 Louis-street, Airport West. Application for variation of all M.O. licences, Route 39 (Moonee Ponds-Keilor) to delete deviation B and instead to operate a new deviation B as follows:—From the corner of Milleara-road and Dinah-parade, East Keilor via Milleara-road to the corner of North-road.

Section and fare.—Corner Milleara-road and Dinah-parade—North-road—2 cents.

MITCHELL, L. R., 87 Larch-crescent, Mt. Waverley. One commercial passenger vehicle (S/C. 4) to operate under country private hire conditions from Inverloch.

MCPHERSON, K. N., 52 Margaret-street, Werribee. One commercial passenger vehicle (S/C. 5) to operate under the same terms and conditions as existing taxi-cabs licensed at Werribee.

SITA, G., & F. BONO (trading as Avondale Heights-Footscray Bus Service), 81-83 Station-road, Deer Park. Application for variation of all M.O. licences, Route 142A (Avondale Heights—West Maribyrnong—Footscray) to extend service from the corner of Milleara-road and North-road via Milleara-road, The Crossway to the corner of Vista-drive.

Section and Fare.—Corner Milleara-road and North-road—Corner The Crossway and Vista-drive—2 cents.

APPLICATION for renewal of licences as shown, by persons listed hereunder to operate under the same terms and conditions.

DAVEY, R. H. W., Lot 48, Sesame-street, Syndal; M.H.2196.

FREYER, J. A., 5 Tandara-court, Chadstone; M.H.2197.

HEWISH, J., 23 Faussett-street, Albert Park; M.H.2615.

LANDER, P., 11 Eley-road, Blackburn South; M.H.2195.

LITTLE'S PTY. LTD., 214 Brunswick-street, Fitzroy;

M.T.2231, M.T.2243, M.T.2306, M.T.2354, M.T.2359,

M.T.2376, M.T.2381, M.T.2382, M.T.2383, M.T.2384,

M.T.2385, M.T.2386, M.T.2413.

O'HARE, R. B., 19 Richards-avenue, Croydon; M.H.2198.

PETERSON, T. B., 29 Argyll-street, Chadstone; M.H.2201.

PETRIK, L., 67 Millawa-avenue, St. Albans; M.H.2192.

PETTINELLA, M., 75 Pakington-street, Kew; M.T.4019.

TEFIK, R., 24 Prendergast-street, Pascoe Vale South; M.H.2199.

UBL, V., 10 Perry-street, St. Albans; M.H.2234.

ALTMANN, A. J., Albert-street, Rainbow; T.S.598.

BELL, R. G. (trading as Bell's Nurseryland), 7 Stella-

avenue, Noble Park; T.P.185.

BOLTON, A., 24 Sixth-street, Parkdale; C.T.280.

BONGIORNO BROS. PTY. LTD., Victoria-street, Nhill; T.S.601.

BRIGHTON GRAMMAR SCHOOL, 232 New-street, Brighton; T.P.166.

BRYANT MOTORS PTY. LTD., Main-road, Eltham; T.S.461,

T.S.640.

BRYCE, D. L. F. (Mrs.), and the estate of the late G. L.

BRYCE, Box 19, Beulah, T.S.629.

CINDERELLA DAY NURSERY, 74 Deakin-street, East Bent-

leigh; T.P.222.

COLLINGS, R. E., Box 5, Edenhope; T.S.603.

COOPER, A. S., PTY. LTD., 87 Lambeth-street, Kensington; T.P.212.

CROMPTON, P. M. (Mrs.), (trading as Airport West Day

Nursery), 77-79 McIntosh-street, Airport West; T.P.83.

CROUCH, F. J., and Son, 22 Main-street, Stawell; C.H.208.

DUBOIS, C. R., Youanmite; T.P.198.

EDDINGTON, P., (trading as Lesley's Day Nursery), 25

John-street, Oakleigh; T.P.218.

FORBES, R. G. and S. O., and J. C. and M. L. SUMMER,

Rochester-street, Giggarre; T.S.881.

GEELONG CHURCH OF ENGLAND GRAMMER SCHOOL, Corio; T.P.213.

HALL, F. R., 12 Hall-street, Mooroopna; T.S.599.

HAMILTON, A., and Son, 36 Alma-street, St. Arnaud, C.O.482.

LEE, C. W., 4 Parmee-street, Swan Hill; C.T.32.

MALONE, M. D., High-street, Lancefield; T.P.43.

MARSH, Z. (Mrs.), 28 Curtin-avenue, Lalar; T.P.271.

NESBIT, H. S. (Mr. and Mrs.), (trading as "Nurseryland" Children's Pre-School Centre), 53 Lane-crescent, Reservoir East; T.P.216.

RITCHIE, W. K., 3 Tinning-street, West Brunswick; M.O. Sub 53, M.O.263.

SURKITT, A., Gibson-street, Caramut; T.S.130, T.S.443, T.S.491.

TELFER, H. J., Lawrence-street, Beaufort; T.S.611.

TREWEEK, W. J. (Jnr.), 105 Evans-street, Sunbury; T.S.796.

U.S. MOTORS (TAXIS) PTY. LTD., 68 Monbulk-road, Bel-

grave; C.T.290.

WATSON CAMERON and Co., Whyte-street, Coleraine; T.S.606.

WEINBERG, A., PTY. LTD., P.O. Box 40, West Footscray; T.P.179.

ZAPPELLI, L. G., 16 Isabella-street, Shepparton; C.T.285.

Notice of any objection should be forwarded to reach the Secretary of the Board not later than Wednesday, 3rd May, 1967.

Applicants are advised that it will not be necessary to appear on the hearing date specified above, unless advised in writing by the Board.

B. P. KAY,

Secretary.

Corner Lygon and Princes streets, Carlton, Wednesday, 19th April, 1967.

Commercial Goods Vehicles Act.

TRANSPORT REGULATION BOARD.

HEARING OF APPLICATIONS.

NOTICE is hereby given that the following applications will be considered by the Transport Regulation Board at its offices at the corner Lygon and Princes streets, Carlton, at 10.15 a.m. on Wednesday, 10th May, 1967.

ALLEN, B. & E., Deakin-avenue, Mildura. One commercial goods vehicle (L/C. 136 cwt.) to operate: (a) Within a 25-mile radius of the post office at Mildura—general goods, with the proviso that no journey be more than 30 miles in length. (b) From pits at Hattah to the premises of Murray Valley Plaster Works at Mildura—gypsum in bulk. (c) Throughout the State of Victoria as a bulk tanker—bitumen and emulsion.

ANDERSON, E., & SONS PTY. LTD., Main-road, Monbulk. One commercial goods vehicle (L/C. not available) to operate: (a) From forest landings in the Cumberland and Gembrook areas to Anderson and Sons' sawmill at Monbulk—logs. (b) From Anderson and Sons' sawmill at Monbulk to consignees within a 25-mile radius of Melbourne—sawn timber. (c) From forest landings in the Alexandra and Yea areas to own sawmill at Monbulk—logs. (d) Within a 50-mile radius of own sawmill at Monbulk—own tractors and logging equipment.

ANSETT TRANSPORT INDUSTRY PTY. LTD., 489 Swanston-street, Melbourne. One commercial goods vehicle (L/C. 8 cwt.) to operate throughout the State of Victoria in the course of business as "Airline Operators" for the purpose of servicing and supervising the operations of helicopter services—tools of trade, spare parts, fuel, spraying chemicals and materials incidental thereto.

ASCOM PTY. LTD., 63 Queensbridge-street, South Melbourne. One commercial goods vehicle (L/C. 237 cwt. approximately) to operate in the course of business as "Civil Engineers"—(a) Within a 25-mile radius from the post office situated at the corner of Bourke-street and Elizabeth-street in the City of Melbourne—own goods. (b) Throughout the State of Victoria—own tools of trade and equipment. (c) Within a 20-mile radius from the site of any project currently engaged upon or from the railway station nearest thereto—materials for use on such project.

ASSOCIATED DIAMOND DRILLERS PTY. LTD., 64 Bell-street, Preston. One commercial goods vehicle (L/C. 20 cwt.) to operate throughout the State of Victoria in the course of business as "Boring and Drilling Contractors"—tools of trade, boring and drilling equipment and materials incidental thereto.

AVIA GUARD (Vic.), Ballarat Aerodrome. One commercial goods vehicle (Mobile Crane) to operate in the course of business as "Aerial Spraying Contractors" as follows:—(a) Throughout the State of Victoria—(i) Tools of trade and equipment only to own contracts. (ii) Aviation fuel and chemicals not exceeding a total aggregate weight of ten hundredweight (10 cwt.) at any one time. (b) Within a 20-mile radius of the site of any contract currently engaged upon or from the railway station nearest to such site—aviation fuel and chemicals.

- BALLARAT DEEP FREEZE FOOD COY. PTY. LTD.**, Grenville-street, Ballarat. One commercial goods vehicle (L/C. 16 cwt.) to operate as a specially constructed insulated and refrigerated vehicle within that part of the State of Victoria west of a north/south line drawn through the City of Melbourne—frozen fish and vegetables, in the course of business as "Frozen Food Distributors".
- BAMBROOK, K. A.**, Balfours-road, Granite Rock, via Bairnsdale. One commercial goods vehicle (L/C. 146 cwt.) to operate: (a) Within a 95-mile radius of the post office at Orbost (Bairnsdale Division of the Country Roads Board) and within a 70-mile radius of the Post office at Yarram (Traralgon Division of the Country Roads Board)—road contracting plant used in the construction or maintenance of a road, street, foot-path, bridge, wharf, pier, weir or channel. (b) Within a 20-mile radius from site of construction or maintenance work performed pursuant to paragraph (a) above, or from the railway station nearest thereto—metal, stones, screenings, ashes, gravel, sand, earth and any other materials required for such work. (c) Within a 20-mile radius of the post office at Bairnsdale—general goods.
- BANWELL, H. G.**, Bullarook. One commercial goods vehicle (L/C. 233 cwt.) to operate: (a) Within a 50-mile radius from the post office at Ballarat as a "Road Contractor"—road-making plant and materials. (b) Within a 25-mile radius from the post office at Ballarat—general goods, but excluding any plant and materials carried or to be carried pursuant to paragraphs (a) and (b) above, (no journey to exceed more than 30 road miles in distance).
- BIRKETT, R.**, 57 Surrey-road, South Yarra. One commercial goods vehicle (L/C. 11 cwt.) to operate throughout the State of Victoria in the course of business as "Electrical Contractor"—tools of trade, electrical equipment and surplus materials carried from contract to contract.
- BOND, H.**, 34 Guava-street, Red Cliffs. One commercial goods vehicle (L/C. 85 cwt.) to operate: (a) Within a 25-mile radius of the Red Cliffs Post Office—general goods. (b) Within a 70-mile radius of the Red Cliffs Post Office—for the carriage of own firewood for sale.
- BROADBENT, J. W. & J.**, 1 Gardenvale-road, South Caulfield. One commercial goods vehicle (L/C. 194 cwt.) to operate within a 50-mile radius from the premises of Bayview Quarries Pty. Ltd. at Springvale solely on behalf of the said company—premixed concrete in a specially constructed agitator vehicle.
- BROWN, R. M.**, Kotupna. One commercial goods vehicle (L/C. 15 cwt. approximately) to operate: (a) Within a 25-mile radius of the post office at Kotupna—general goods, provided that no journey be more than 30 miles in length. (b) Within a 50-mile radius of the post office at Kotupna in the course of business as "Primary Producer"—own goods. (c) Within a 50-mile radius of the depot of "H. C. Sleigh Ltd." at Kotupna on behalf of the said company—petroleum products in prescribed types of containers and empty return containers.
- CADD, N. W.**, 40 Holyrood-street, Hampton. One commercial goods vehicle (L/C. 12 cwt.) to operate within the State of Victoria as a "Scrap Metal Dealer and Motor Wrecker" for the purpose of collecting damaged cars for wrecking or selling as scrap.
- CANNY, W., & SONS PTY. LTD.**, Roy-street, Wangaratta. One commercial goods vehicle (L/C. 120 cwt.) to operate: (i) Within a 25-mile radius of own place of business at Wangaratta—general goods, with the proviso that no journey be more than 30 miles in length. (ii) Within a 50-mile radius of own business at Wangaratta and/or from railway sidings at Myrtleford, Ovens, Bright, Chiltern, Springhurst, Benalla, Glenrowan, Baddaginnie, Yarrowonga and Peechelba to nearest site of spreading to any such siding and also within a 20-mile radius of the post office at Peechelba—superphosphate and lime.
- CARRICK, R. E.**, 423 Olive-street, Albury, New South Wales. One commercial goods vehicle (L/C. 8 cwt.) to operate from Springhurst or Wodonga to Rutherglen, Wahgunyah and Yarrowonga—newspapers under contract to the "Age".
- SIMON CARVES (AUST.) PTY. LTD.**, Box 285, Morwell. Three commercial goods vehicles (L/C. 252, 11 and 11 cwt.) to operate: (a) Throughout the State of Victoria in the course of business as "Steel Fabrication and Erection Engineers"—being an approved decentralized secondary industry located at Morwell—raw materials to and own manufactured products from own premises at Morwell. (b) Within a 20-mile radius of Morwell—own goods.
- CLOHESY, F. J.**, care of H. Banwell, Bullarook, via Ballarat. One commercial goods vehicle (L/C. 140 cwt.) to operate: (a) Within a 50-mile radius of the chief post office in the City of Ballarat as a "Road Contractor"—road-making plant and materials. (b) Within a 25-mile radius of the chief post office at Ballarat—general goods, provided that no goods shall be carried whether by one stage or by more than one stage between places within the above radius, which are more than 30 road miles apart by the nearest practicable route.
- COOKE, B. P.**, Ferguson-street, Broadford. Application to vary the conditions of Licence No. D.A.60590 (L/C. 243 cwt.) by adding as additional paragraphs (b) and (c):—(b) From forest landings in the Broadford area to Melbourne—logs. (c) Within a 25-mile radius of Broadford—general goods, provided that no goods shall be carried whether by one stage or by more than one stage between places within the above radius, which are more than 30 road miles apart by the nearest practicable route".
- CHARLES, R. D.**, 284 Gray-street, Hamilton. One commercial goods vehicle (L/C. 60 cwt.) to operate: (a) Within a 25-mile radius of the post office at Hamilton—general goods, with the proviso that no journey to be more than 30 miles in length. (b) Within a 50-mile radius of the post office at Hamilton—firewood.
- CRAWFORD, W. S.**, Farm-road, Cheltenham. One commercial goods vehicle (L/C. 221 cwt.) to operate within a 35-mile radius of the premises of "Standard Quarries Pty. Ltd.", at Brooklyn on behalf of the said company—metal, screenings, stone dust and road-making materials.
- DIXON, J. T., & SON**, 125 Clarence-street, Geelong West. Application to vary the conditions of licence Nos. D.A.3704 and D.A.3704/1 (L/C. 113 and 55 cwt.) by adding as an additional paragraph:—(c) Within a 25-mile radius from the chief post office in the City of Geelong solely on behalf of Leonard Chemical Products Pty. Ltd.—chemicals and empty drums.
- DIXON, J. T. & SON**, 125 Clarence-street, Geelong West. One commercial goods vehicle (L/C. 10 cwt.) to operate: (a) Within a 50-mile radius of the Chief post office in the City of Geelong and also to and from places situated within that area contiguous to such radius south of a line drawn east and west through the City of Ballarat and east of a line drawn north and south through the township of Koroi in the course of business as "Second-hand Sack Dealers"—second-hand sacks for cleaning and repair on own premises at Geelong also cleaned and repaired second-hand sacks for sale and delivery. (b) From the Township of Daylesford to own premises at Geelong—second-hand sacks for cleaning and repair. (c) Within a 25-mile radius of the chief post office in the City of Geelong—chemicals and empty drums solely on behalf of Leonard Chemical Products Pty. Ltd.
- DODD, M. C.**, 1 Phippen-avenue, East Burwood. One commercial goods vehicle (L/C. 117 cwt.) to operate within a 70-mile radius from the premises of Brick Industries Pty. Ltd. at Burwood—bricks on behalf of the said company.
- DOOLAN, P. J.**, Lumsden-street, Kilmore. One commercial goods vehicle (L/C. 80 cwt.) to operate: (a) To and from the railway station at Kilmore from and to places situated within a 3-mile radius of the said railway station—general goods. (b) Within the area bounded on the north by an east/west line drawn through the junction of the Heathcote-road with the Hume Highway, on the west by a north/south line drawn through the Township of Darraweit Guim, on the south by an east/west line drawn through the Township of Craigieburn and on the east by a north/south line drawn through the Township of Whittlesea—agricultural machinery, earth moving equipment and farm produce—(c) To and from the area described in paragraph (b) above from and to Melbourne serving farm properties en route—farmers requisites and primary production, viz.: farm machinery including tractors, superphosphate, lime, seed, wool in season, and fencing materials. (d) From Kilmore to Melbourne—firewood, mill logs, hides, skins and tallow and empty aerated water bottles. (e) From Melbourne to Wallan and Kilmore—joinery, dressed timber, builders hardware and Coca Cola drinks.
- DUFF, A. R.**, 48 Kay-street, Traralgon. One commercial goods vehicle (L/C. 221 cwt.) to operate: (a) Within a 25-mile radius of the A.P.M. at Maryvale—pulpwood. (b) From forestry landings in the Licola—Neerim and Noojee areas to the A.P.M. at Maryvale—pulpwood.

- FIELD AIR (BENALLA) PTY. LTD.**, P.O. Box 228, Ballarat. One commercial goods vehicle (Mobile Crane) to operate: (a) Throughout the State of Victoria: (i) Tools of trade and equipment incidental only to own contracts. (ii) Aviation fuel and chemicals subject to the condition that the total weight of such goods so carried shall not exceed ten hundredweight (10 cwt.) at any one time. (b) Within a 20-mile radius from the railway station or railway siding nearest to the site of any contract currently engaged upon—aviation fuel and chemicals.
- FOLEY, M. J.**, 97 Jackson-street, Casterton. One commercial goods vehicle (L/C. 10 cwt.) to operate within a 50-mile radius from own premises at Casterton in the course of business as "Electrical Retailer" for the purpose of installing, servicing and maintaining electrical appliances and television sets—tools of trade, spare parts and materials incidental thereto, also electrical appliances, television sets and antennae for installation, for repair or having been repaired.
- FORD, K. C. & K. M.**, Chatsworth-road, Hexham. One commercial goods vehicle (L/C. 113 cwt.) to operate: (a) Within a 25-mile radius of the post office at Warrnambool—general goods, with the proviso that no journey be more than 30 miles in length. (b) Within a 50-mile radius of the aforesaid post office—firewood.
- GOUGE COUNTRY SERVICES PTY. LTD.**, 97 Brighton-road, Elwood. One commercial goods vehicle (L/C. 19 cwt.) to operate between Kerang and Swan Hill—soiled linen for cleaning and laundering and linen which has been cleaned and laundered.
- GRANT, D. J.**, 9 Boola-crescent, Yallourn. One commercial goods vehicle (L/C. 143 cwt.) to operate within a 20-mile radius of any current contract site in the State of Victoria on behalf of "Gemell and Hickey Pty. Ltd."—road-making plant, equipment and materials.
- HABERFIELD, R. F.**, Dennington. One commercial goods vehicle (L/C. 200 cwt.) to operate: (a) Within a 50-mile radius from the post office at Dennington as a "Road Contractor"—road-making plant and materials. (b) Within a 25-mile radius from the post office at Dennington—general goods, with the proviso that no journey to exceed more than 30 road miles in distance.
- HALLETT, C. E.**, 22 Hamilton-grove, Frankston. One commercial goods vehicle (L/C. 50 cwt.) to operate between the City of Melbourne and the Township of Wodonga and towns *en route* and adjacent to the Hume Highway in the course of business as "Cake Agent and Distributors"—own wedding, birthday, block cakes and shortbreads.
- VAN LISSUM, H. D.**, (trading as Hanks Steam Laundry), P.O. Box 250, Shepparton. One commercial goods vehicle (L/C. 8 cwt.) to operate within a 70-mile radius from the post office at Shepparton in the course of business as "Laundry Proprietor"—articles of clothing for laundering or dry cleaning or having been laundered or dry cleaned.
- HEMPHILL, D. B.**, Tucks-road, Main Ridge. One commercial goods vehicle (L/C. 182 cwt.) to operate within a 50-mile radius from the premises of "Victorian Quarries Limited" at Dromana, solely on behalf of the said company—premixed concrete in a specially constructed agitator vehicle.
- HENDERSON & LETTE & Co.**, 13 Ercil-street, Wendouree. One commercial goods vehicle (L/C. not available) to operate within the area west of a line drawn north and south through Geelong, Bacchus Marsh and Echuca in the course of trade as "Electrical Contractors"—tools of trade, spare parts and materials necessary to the completion of own contracts.
- CARMAN, L. R. & C. A.** (trading as Jays Laundry), 66 Kepler-street, Warrnambool. One commercial goods vehicle (L/C. 8 cwt.) to operate within a 50-mile radius from own premises at Warrnambool in the course of business as "Launderers"—articles for laundering or dry cleaning or having been laundered or dry cleaned.
- JECs, LES**, 20 Malcolm-crescent, Shepparton. One commercial goods vehicle (L/C. 10 cwt.) to operate within a 50-mile radius from the post office at Shepparton in the course of business as "Refrigeration and Washing Machine Engineers" for the sole purpose of repairing electrical appliances and refrigeration units—tools of trade, spare parts and appliances for repair or having been repaired.
- JECs, L.**, 20 Malcolm-crescent, Shepparton. Two commercial goods vehicles (L/C. 11 and 10 cwt.) to operate within a 50-mile radius of the post office at Shepparton in the course of business as "Washing Machines and Refrigeration Servicemen"—tools of trade, spare parts, materials, clients own equipment for repair or having been repaired.
- JOYNSON, G. W.**, 479 Kaitler-grove, Albury, New South Wales. One commercial goods vehicle (L/C. 170 cwt.) to operate: (a) Within a 25-mile radius of the post office at Wodonga—general goods, provided that no goods shall be carried whether by one stage or by more than one stage between places within the above radius, which are more than 30 road miles apart by the nearest practicable route. (b) Within a 50-mile radius of the post office at Wodonga—road-making plant and materials.
- KIENSROD, S. W.**, 4 Jackman-avenue, Warrnambool. One commercial goods vehicle (L/C. 10 cwt.) to operate within a 50-mile radius from the premises of "E. P. Gibbons Pty. Ltd." at Warrnambool in the course of business as "Television and Radio Technician" on behalf of the said company—television sets, radio sets and electrical appliances for installation, for repair or having been repaired, tools of trade, spare parts and materials incidental to servicing and installing such equipment.
- LANCASTER, D. R.**, 122 Lyons-street north, Ballarat. One commercial goods vehicle (L/C. 142 cwt.) to operate: (a) Within a 55-mile radius of Beaufort (Ballarat Division of the Country Roads Board) road contracting plant used in the construction or maintenance of a road, street, footpath, bridge, wharf, pier, weir or channel. (b) Within a 20-mile radius from the site of construction or maintenance work performed pursuant to paragraph (a) above or from a railway station nearest thereto—materials required for such work. (c) Within a 25-mile radius from the post office at Ballarat—general goods (with no journey to be more than 30 road miles in length by the nearest practicable route).
- MARTELLONI, W.**, 103 Davis-street, Warrnambool. Two commercial goods vehicles (L/C. 140 and 260 cwt.) to operate within a 50-mile radius of own premises at Warrnambool—premixed concrete in a specially constructed agitator vehicle.
- MILNE, J. O.**, 322 Swan-street, Richmond. One commercial goods vehicle (L/C. 78 cwt.) to operate throughout the State of Victoria in the course of business as "Marine Collector"—special wares, marine stores or old metals as designated in the *Marine Stores and Old Metals Act 1958* (No. 6303), Part 1, Section (3) but excluding the carriage of any such special wares, marine stores or old metals to wharves, docks or ships for shipment or export purposes, with the proviso that the combined load capacities of both prime mover and any trailer together shall not exceed 120 cwt.
- MORGAN, T. E.**, 346 Whitehorse-road, Croydon. One commercial goods vehicle (L/C. 79 cwt.) to operate within a 50-mile radius of the General Post Office situated at the corner of Bourke and Elizabeth streets in the City of Melbourne in the course of business as "Excavation Contractor"—tools of trade, excavation equipment and earth from excavation sites.
- YOUNGBERRY, J., & B. HOPFNER** (trading as Mountain District Carrying Service), Don-road, Healesville. One commercial goods vehicle (L/C. 102 cwt.) to operate within a 50-mile radius of own premises at Don-road Healesville for the purpose of emptying, cleaning and disposal of septic tanks in the course of business as "Septic Tank Cleaners".
- MURRAY VALLEY CONSTRUCTIONS**, 84 Tallangatta-road, Wodonga. One commercial goods vehicle (L/C. 124 cwt.) to operate: (a) Within a 50-mile radius of the post office at Wodonga—own road-making plant, materials and equipment. (b) Within a 25-mile radius of the post office at Wodonga—general goods, with the proviso that no journey be more than 30 miles in length.
- MYORS, E. W. J.**, 822 Mate-street, Albury, New South Wales. One commercial goods vehicle (L/C. 8 cwt.) to operate from Albury via Yackandandah to Beechworth and return, via Kiewa—Sun newspapers.
- MCCCLUSKEY, M. J.**, 195 Westblade-avenue, Terang. One commercial goods vehicle (L/C. 120 cwt.) to operate: (a) Within a 50-mile radius from the post office at Kerang as a "Road Contractor"—road-making plant and materials. (b) Within a 25-mile radius from the post office at Kerang—general goods, with the proviso that no journey be more than 30 miles in length.
- MACKENZIE, D., & R. VAUGHAN**, 23 Mackintosh-street, Echuca. One commercial goods vehicle (L/C. not available) to operate: (a) Within a 25-mile radius of the post office at Echuca—general goods with the proviso that no journey be more than 30 miles in length. (b) Within a 50-mile radius of the post office at Echuca—bulk gypsum.

- 600 OVERSEAS (AUSTRALIA) PTY. LTD., 19 Shirley-avenue, Glen Waverley. One commercial goods vehicle (L/C. 6 cwt.) to operate throughout the State of Victoria in the course of business as "Machinery Merchants" for the purpose of installing own machinery—tools of trade, spare parts and materials incidental to own installation contracts.
- PARK AVENUE LAUNDRY & DRY CLEANERS PTY. LTD., 8 Peace-avenue, Warragul. Application to vary the conditions of licence Nos. D.A.1775, D.A.1775/1, D.A.1775/2, D.A.1775/3, D.A.1775/4 and D.A.1775/5 (L/C. 18, 36, 16, 34, 18 and 36 cwt.) by adding after the word Warragul "and to Sale, Stratford and Maffra".
- POLIAKOW, L. & A., 133 Landers-road, Pascoe Vale. One commercial goods vehicle (L/C. 201 cwt.) to operate within a 50-mile radius from the premises of "Albion Reid Pty. Ltd." at North Melbourne, solely on behalf of the said company—premixed concrete in a specially constructed agitator vehicle.
- POULTON, J., Riddell. One commercial goods vehicle (L/C. 147 cwt.) to operate within a 3-mile radius of Riddell and to and from Melbourne—general goods.
- RICHARDSON, A. A., Briagolong-road, Stratford. One commercial goods vehicle (L/C. 145 cwt.) to operate: (a) Within a 25-mile radius of the post office at Stratford, but no journey to exceed 30 road miles within the said radius—general goods. (b) Within a 50-mile radius of the post office at Stratford—livestock.
- RICKEY, A. H., 8 Symons-street, Wendouree. One commercial goods vehicle (L/C. 244 cwt.) to operate in the course of business as "Bridge, Road and Earth-moving Contractor"—(a) Throughout the State of Victoria—own tools of trade and equipment incidental to own contracts. (b) Within a 20-mile radius from the site of any project currently engaged upon or from the railway station nearest thereto—materials required for such project.
- ROY, E. & W., 35 Dickinson-street, Glenroy. One commercial goods vehicle (L/C. 243 cwt.) to operate within a 50-mile radius from the premises of "Supermix Concrete Pty. Ltd." at Brooklyn, solely on behalf of the said company—premixed concrete in a specially constructed agitator vehicle.
- SBARZAGLIA, T., 22A Hewitt-street, Warracknabeal. One commercial goods vehicle (L/C. 129 cwt.) to operate: (a) Within a 50-mile radius of the post office at Warracknabeal as a "Road Contractor"—road-making plant and materials. (b) Within a 25-mile radius of the post office at Warracknabeal—general goods, with the proviso that no journey to exceed more than 30 road miles in distance.
- STEVENSON, G. R., Heyfield. Application to vary the conditions of licence No. D.T.423/2 (L/C. 240 cwt.) by deleting paragraphs (a) and (c) from the present conditions and by adding as paragraph (a) "from forest landings in the Dargo and Stockdale areas to sawmills at Stratford and Briagolong—logs".
- STEVENSON, G. R., Heyfield. Application to vary the conditions of licence No. D.T.423/1, D.T.423/3 and D.T.423/6 (L/C. 267, 136 and 274 cwt.) by deleting the present conditions and adding in lieu—"From Heyfield to the A.P.M. at Maryvale—pulpwood chips".
- SPATARO, O., Main-road, Powelltown. One commercial goods vehicle (L/C. not available) to operate from forest landings within a 10-mile radius of Noojee to the premises of the Australian Paper Manufacturers Ltd. at Maryvale—pulpwood.
- TAYLOR, L. J., 4 Carolin-street, Bendigo. One commercial goods vehicle (L/C. 10 cwt.) to operate within a 75-mile radius of the chief post office at Bendigo in the course of business as "Builder"—tools of trade, scaffolding and materials incidental to own contracts.
- VLAHOGÉORIS, A., 213 Park-street, South Melbourne. One commercial goods vehicle (L/C. 130 cwt.) to operate within a 35-mile radius of the premises of "Standard Quarries Pty. Ltd." at Brooklyn on behalf of the said company—sand, screenings and road-making materials.
- WRIGHT, J. L., 26 Lake-street, Wendouree. One commercial goods vehicle (L/C. 223 cwt.) to operate within a 50-mile radius from the chief post office in the City of Ballarat solely on behalf of "Ready Mixed Concrete (Vic.) Pty. Ltd."—premixed concrete in a specially constructed agitator vehicle.
- WATSON, G., PTY. LTD., 1-5 Dawn-street, Highett. One commercial goods vehicle (L/C. 237 cwt.) to operate: (a) Within a 25-mile radius of Melbourne—general goods. (b) From pits at Cranbourne to L.S.D. Brick Co. (Vic.) Pty. Ltd., at Bundoora—sand. (c) From Beveridge to L.S.D. Brick Co. (Vic.) Pty. Ltd., at Bundoora—scoria. (d) From Bacchus Marsh to L.S.D. Brick Co. (Vic.) Pty. Ltd., at Bundoora—river gravel.
- WIEDEMANN, A., 20 Clarinda-road, Clayton. One commercial goods vehicle (L/C. 11 cwt.) to operate throughout the State of Victoria in course of business as "Photographer"—own cameras and lighting equipment and materials incidental to own contracts.
- WILLIAMS, A., P.O. Box 3, Moe. One commercial goods vehicle (L/C. 80 cwt.) to operate within a 50-mile radius of Tanjil South in the course of business as "Septic Tank Cleaning Contractor"—own cleaning equipment necessary for completion of own contracts and waste materials from own contract sites.
- WILSON, W. D. & L. M., 3 Fairview-street, Traralgon. Application to vary the conditions of licence No. T.D.16461 (L/C. 16 cwt.) by deleting the present conditions and adding in lieu: (a) Mail from Traralgon Railway Station via Maffra to Lakes Entrance. (b) Milk from Bairnsdale Dairy Farmers Co-op. Ltd. to Lindenow and Stratford. (c) From the Fisherman's Co-op. Ltd. at Lakes Entrance to Caldwell Fish Processing Co. at Maffra—fresh fish, returning with empty boxes.
- YOUNGHUSBAND, I. B., Arnold. One commercial goods vehicle (L/C. 114 cwt.) to operate: (a) Within a 20-mile radius of the post office at Arnold—general goods, with the proviso that no journey is to exceed more than 30 miles in length either by one stage or by more than one stage. (b) Within a 50-mile radius of the post office at Arnold in the course of business as "Primary Producer"—own goods. (c) Within a 50-mile radius of the post office at Arnold—livestock. (d) Within a 50-mile radius of the post office at St. Arnaud—tomatoes.
- ZEC, S., 55 Wellington-street, Kerang. One commercial goods vehicle (L/C. 9 cwt.) to operate within a 50-mile radius of the post office at Kerang and to and from own premises at Robinvale in the course of business as "Hair Dressing Salon Operator"—own goods.

TOW TRUCKS.

- RAY, J. C. S. (trading as Local Towing Service), 67 Cecil-street, East Kew. One commercial goods vehicle (to be purchased) to operate throughout the State of Victoria as a "Tow Truck" for the purpose of lifting and carrying or towing and/or repairing wrecked or disabled vehicles—tools of trade, spare parts and materials incidental thereto.
- PARR & SPENCER PTY. LTD., 238-240 Murray-street, Colac. One commercial goods vehicle (L/C. 69 cwt.) to operate within a 50-mile radius of own premises at 238 Murray-street, Colac as a "Tow Truck" for the purpose of lifting and carrying or towing and/or repairing wrecked or disabled vehicles—tools of trade, spare parts and materials incidental thereto.
- RIGBY, N. E., High-street, Charlton. One commercial goods vehicle (L/C. 80 cwt.) to operate: (a) Within a 50-mile radius of the post office at Charlton as a "Tow Truck" for the purpose of lifting and carrying or towing and/or repairing wrecked or disabled vehicles—tools of trade, spare parts and materials incidental thereto. (b) Within a 50-mile radius of the post office at Charlton in the course of business as "Panel Beater"—own tools of trade.
- SMITH, I. L., 149 Mollison-street, Kyneton. One commercial goods vehicle (L/C. 65 cwt.) to operate throughout the State of Victoria as a "Tow Truck" for the purpose of lifting and carrying or towing and/or repairing wrecked or disabled vehicles—tools of trade, spare parts and materials incidental thereto.

- APPLICATIONS for renewal of licences as shown by persons listed hereunder to operate under the same terms and conditions from the expiry shown in each case.
- BARLING, L., Lyons-street, Cressy; D.A.12902/2; 20th May, 1967; 143 cwt.
- BENCE, E. J., 1 Price-place, Warrnambool; D.A.35833; 18th May, 1967; 132 cwt.
- CONDER, R. J. R., 73 Victoria-street, Eaglehawk; D.A.40127/1; 6th May, 1967; 16 cwt.
- DALGETY & NEW ZEALAND LOAN LTD., 1-7 Malop-street, Geelong; D.A.46170/24; 20th May, 1967; 10 cwt.
- DALGETY & NEW ZEALAND LOAN LTD., 1-7 Malop-street, Geelong; D.A.46170/28; 20th May, 1967; 9 cwt.
- DALGETY & NEW ZEALAND LOAN LTD., 1-7 Malop-street, Geelong; D.A.46170/25; 20th May, 1967; 16 cwt.
- DALGETY & NEW ZEALAND LOAN LTD., 1-7 Malop-street, Geelong; D.A.46170/27; 20th May, 1967; 11 cwt.
- DAVIDSON, R., 40 Plateau-road, Reservoir; D.A.38406/1; 27th May, 1967; 15 cwt.
- RILEY DODDS AUSTRALIA LTD., 636 Swanston-street, Carlton; D.A.1925/4; 16th June, 1967; 6 cwt.

- DOUBE, L., 26 Roberts-road, Belmont, Geelong; D.A.20490; 2nd May, 1967; 13 cwt.
- FARQUHAR, T. F., 715 Talbot-street, Ballarat; T.D.A.59300; 9th May, 1967; 51 cwt.
- FRANCOMBE, W. R., 65 Mount Dandenong-road, Ringwood East; D.A.49003; 6th May, 1967; 198 cwt.
- HALL, L., Box 320, Orbest; T.T.D.1138; 7th March, 1967; 262 cwt.
- JAMES, E. O., 80 Eleventh-street, Mildura; D.A.27031/2; 8th April, 1967; 10 cwt.
- JONES, D. W., PTY. LTD., 126 Cecil-street, Williamstown; D.A.1392; 23rd January, 1967; 146 cwt.
- LOWAN STAR DRY CLEANING & LAUNDRY SERVICE PTY. LTD., 113-115 Nelson-street, Nhill; D.A.35523; 25th May, 1967; 10 cwt.
- MCDONALD, M. J., 87 Douro-street, North Geelong; D.A.31771/1; 6th May, 1967; 51 cwt.
- OSBORNE, J. E., Anakie, via Geelong; D.A.32657; 4th May, 1967; 125 cwt.
- QUEEN'S BRIDGE MOTOR & ENGINEERING COMPANY PTY. LTD., corner Salmon and Plumber-streets, Port Melbourne; D.A.1783/39; 1st June, 1967; 11 cwt.
- REINFORCED CONCRETE & MONIER PIPE CONSTRUCTION CO. PTY. LTD., 9-13 King-street, Oakleigh; D.A.40771; 27th June, 1967; 46 cwt.
- REPLACEMENT PARTS PTY. LTD., 618 Elizabeth-street, Melbourne; D.A.1907/30; 8th April, 1967; 11 cwt.
- ROWLANDS PTY. LTD., "Airport", Ballarat; D.A.1958/5; 4th May, 1967; 68 cwt.
- SCOTT BONNAR AUST. PTY. LTD., 265 Huntingdale-road, Huntingdale; D.A.27445/3; 11th June, 1967; 11 cwt.
- SHEP-MIX PTY. LTD., 201 Corio-street, Shepparton; D.A.47457/2; 6th May, 1967; 206 cwt.
- SNELLINGS, A. J., Station-street, Rushworth; D.A.35514; 4th May, 1967; 186 cwt.
- SURREY, E., & SON, 36 Wells-road, Mordialloc; D.A.23907/3; 8th April, 1967; 175 cwt.
- SWEDA (VIC.) PTY. LTD., 34 Queens-road, Melbourne; D.A. 48310/1; 11th June, 1967; 11 cwt.
- WATSON, N. D., Darlington; D.A.9846; 29th April, 1967; 105 cwt.
- WILLIAMS, D. R., Sylvia-street, Orbest; T.D.A.2296/1; 2nd May, 1967; 200 cwt.
- WHITE, H. C., P.O. Box 40, Orford; D.A.2278/1; 6th May, 1967; 130 cwt.

TOW TRUCK RENEWALS.

- BAIRNSDALE G. P. MOTORS PTY. LTD., 115 Main-street, Bairnsdale; T.D.A.25954; 30th April, 1967; 39 cwt.
- KURRLE, R., PTY. LTD., Commercial-street, Korumburra; D.A.1459/3; 26th February, 1967; 70 cwt.

Notice of any objections should be forwarded to reach the Secretary of the Board not later than Wednesday, 3rd May, 1967.

Applicants are advised that it will not be necessary to appear on the hearing date specified above, unless advised in writing by the Board.

B. P. KAY,
Secretary.

Corner of Lygon and Princes streets, Carlton, N.3, 19th April, 1967.

Lower Yarra Crossing Authority Act 1965, No. 7365.

NOTICE OF APPROVAL OF PLANS AND SPECIFICATIONS OF THE LOWER YARRA CROSSING.

NOTICE is hereby given that at a meeting of the Executive Council on the 11th April, 1967, His Excellency the Governor in Council pursuant to section 3 of the Lower Yarra Crossing Authority Act 1965, approved the plans and specifications of the Lower Yarra Crossing proposed to be constructed by the said Authority.

J. COLQUHOUN,
Clerk of the Executive Council.

SHIRE OF CRANBOURNE.

ROAD DEVIATION ORDER.

Order of Cranbourne Shire Council Pursuant to Section 522 of the "Local Government Act 1958".

PURSUANT to the provisions of sections 522 and 526 of the Local Government Act 1958, the Council of the Shire of Cranbourne hereby orders and directs that the land being part of Crown allotment 54, Parish of Lang Lang East, County of Mornington, being part of the land described in certificate of title, volume 7148, folio 1429449, indicated by hatching on the diagram annexed hereto which has been purchased taken or acquired by it, shall be a public highway on and from the date of publication of this Order in the Government Gazette, and declares that such land shall be a public highway in lieu of the land indicated by cross-hatching on the diagram, such last-mentioned land being part of the land in the said Parish.

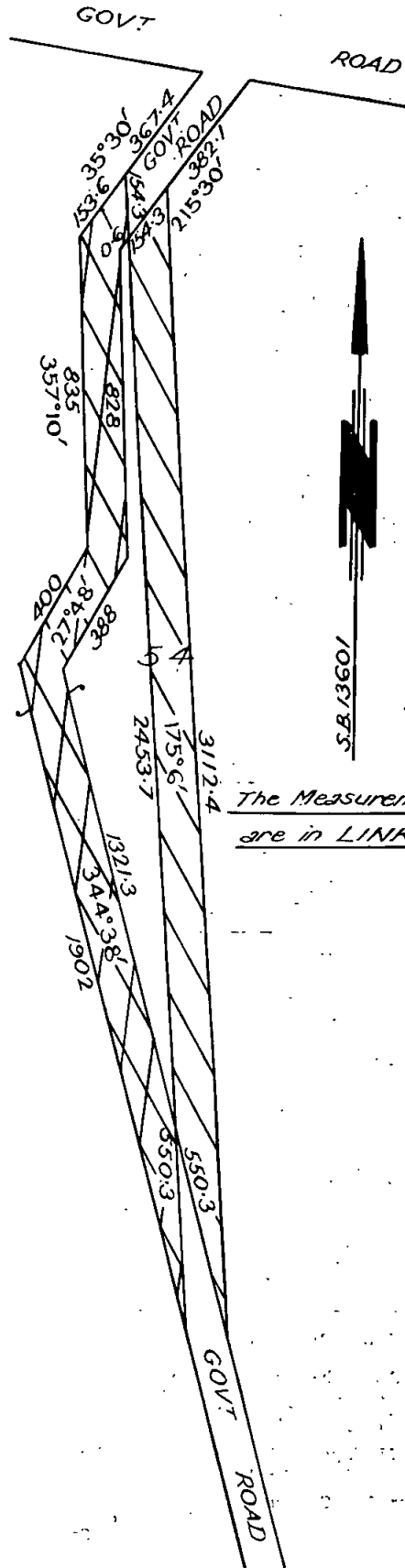

The common seal of the President, Councillors and Ratepayers of the Shire of Cranbourne was hereto affixed, this 7th day of October, 1966, in the presence of—

(SEAL) W. THWAITES, President.
W. B. CAMPBELL, Councillor.
T. W. GRANT, Shire Secretary.

Confirmed by the Governor in Council, 11th April, 1967.
—J. COLQUHOUN, Clerk of the Executive Council.

SHIRE OF COLAC.
ROAD DEVIATION ORDER.

IN pursuance of the powers conferred by sections 522 and 526 of the *Local Government Act 1958* the Council of the Shire of Colac doth hereby direct that the land in the Parish of Dreetite shown hatched on the plan annexed hereto which has been purchased by it shall be a public highway from and after the date of publication of this Order in the *Government Gazette* and doth declare that such land shall be a public highway in lieu of the land in the said parish shown cross-hatched on the said plan.

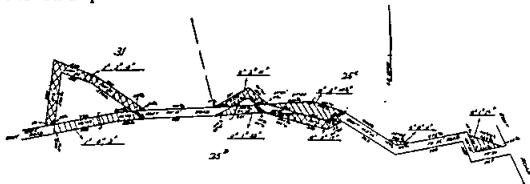

The common seal of the President, Councillors and Ratepayers of the Shire of Colac was hereto affixed, this 14th day of March, 1967, in the presence of—

(SEAL) J. CALVERT, President.
L. G. PARKER, Councillor.
J. W. TAYLOR, Secretary.

Confirmed by the Governor in Council, 11th April, 1967.
—J. COLQUHOUN, Clerk of the Executive Council.

NOTICE TO MARINERS.
[No. 4 of 1967] T.

AUSTRALIA.—VICTORIA.
PORT PHILLIP.
Sunken Vessel.

Position.—Gellibrand Pile Light, Lat. 37 deg. 53 min. S., Long. 144 deg. 55 min. E.

Details.—A sunken fishing vessel 38 feet in length lies in a position 210 deg. distant 1.34 miles from the above light.

Remarks.—The vessel lies in 43 feet of water and its position is marked by a 44-gallon drum painted green with a superimposed letter W in white. A further notice will be published when removal has been effected.

Charts Affected.—Aus. 153, B.A. 1171.

A. J. WAGGLEN,
Port Officer in Victoria.

Public Works Department,
Ports and Harbours Branch,
Melbourne, C.2, 13th April, 1967.

SURVEY CO-ORDINATION (PLACE NAMES) ACT
NO. 7360.

PURSUANT to the powers conferred under section 32 of the above Act, the Place Names Committee hereby gives notice that it has approved of the name of the under-mentioned Post Office:—

Municipality; Name of New Post Office.
City of Hamilton; Grangeburn.

By order of the Committee,
C. E. E. BARLOW,
Secretary.

SURVEY CO-ORDINATION (PLACE NAMES) ACT
NO. 7360.

PURSUANT to the powers conferred by section 28 of the above Act, the Place Names Committee hereby gives notice of intention to assign the following name to the feature mentioned hereunder:—

Shire; Feature and Location; Proposed Name.

Daylesford and Glenlyon; dam near the junction of the Wombat and Stewart Creeks; Wombat Creek Dam.

Any person who objects to the proposed name, may give such objection, in writing, stating the reasons therefor, to the Secretary of the Committee, not more than two months following the publication of this notice.

By order of the Committee,
C. E. E. BARLOW,
Secretary.

SURVEY CO-ORDINATION (PLACE NAMES) ACT
NO. 7360.

PURSUANT to the powers conferred under section 28 of the above Act, the Place Names Committee hereby gives notice of intention to assign the following name to the feature mentioned hereunder:—

Shire; Feature and Location; Proposed Name.

Omeo, Bright; Col at junction of Swindler's Creek and Diamantina River Watersheds. Approximate geographical co-ordinates Lat. 36 deg. 57 min. 45 sec. S., Long. 147 deg. 8 min. 51 sec. E., based on Australian National Datum; Derrick Col.

Any person who objects to the proposed name, may give such objections, in writing, stating the reasons therefor, to the Secretary of the Committee, not more than two months following the publication of this notice.

By order of the Committee,
C. E. E. BARLOW,
Secretary.

DEPARTMENT OF MINES.

APPLICATION FOR MINING LEASE REFUSED.

8330, Mineral; Alwyn John Todd, Edward Thomas Martin, Frank Leicester Young; 735 acres, Parishes of Woorarra, Toora.

MINING LEASES EXPIRED.

7261, Mineral; Joseph William Baker; 18a. 3r. 27p., Parish of Boulka.
7313, Mineral; Giovanni Mabilia, Mario Mabilia, Guerrino Mabilia; 87a. 2r. 29p., Parish of Woolamai.
7937, Mineral; A. G. Leech Proprietary Limited; 11a. 1r., Parish of Amherst.
8056, Mineral; Hercules Plaster Proprietary Limited; 41a. 3r. 21p., Parish of Boulka.

MINERAL SEARCH LICENCES EXPIRED.

707, Mineral Search Licence; Raymond Douglas McComb; 495 acres, Parish of Bullengarook.
708, Mineral Search Licence; Raymond Douglas McComb; 220 acres, Parish of Bullengarook.

TAILINGS LICENCE EXPIRED.

3451, Tailings Licence; Robert William Farrell; Oswalds Mine dump, Parish of Maldon.

T. A. DARCY,
Minister of Mines.

PUBLIC TRUSTEE ACT 1958 (No. 6350), SECTION 17.

I HEREBY give notice that on the 4th April, 1967, the Public Trustee filed elections to administer the following deceased persons' estates in accordance with section 17 of the *Public Trustee Act 1958*:—

CANE, Frank, late of 212 Pascoe Vale-road, Essendon, retired actor, died 21st January, 1967.

FOGGAN, George, late of 36 Royal-avenue, Glenhuntly, butcher, died 21st April, 1966.

FOORD, Annie Isabel, late of Kew, stenographer, died 1st December, 1966.

GELLION, Lillian Elizabeth, also known as Lillian Elizabeth Gellion, late of Flat 3, 20 Morobe-street, West Heidelberg, widow, died 7th February, 1967.

HALL, Francis, late of Lidcombe Hospital, Lidcombe, New South Wales, retired labourer, died 16th August, 1966.

HENDERSON, Ben Cook, late of Eventide Home, Charters Towers, Queensland, pensioner, died 7th August, 1965.

KRAMER, Henry, late of Table Hill, Daylesford, retired labourer, died 26th June, 1966.

RATHBONE, Barbara, late of Flat 10, 33A Byron-street, Elwood, nursing sister, died 2nd December, 1966.

ROACH, George Thomas, late of 4 (formerly 63) Bannerman-street, Bendigo, war pensioner, died 10th November, 1962.

WADE, Albert, late of Barnard-street, Bendigo, retired drover, died 18th November, 1966.

A. D. DUNCAN,
Public Trustee.

256 Flinders-street, Melbourne, 13th April, 1967.

NOTICE.

CREDITORS, next of kin, and others having claims against the estate of any of the under-mentioned deceased persons are required to send particulars of their claims to the Public Trustee, 256 Flinders-street, Melbourne, the personal representative, on or before the 23rd June, 1967, after which date the Public Trustee may convey or distribute the assets having regard only to the claims of which the Public Trustee then has notice:—

BONIWELL, Martin Charles, formerly of 9 Seacombe-grove, Brighton, late of 5 Newbay-crescent, Brighton, gentleman, died 6th January, 1967.

CANE, Frank, late of 212 Pascoe Vale-road, Essendon, retired actor, died 21st January, 1967.

CONSTANTINE, Charlotte Edith, late of 12 Charman-road Mentone, widow, died 9th January, 1967.

CULLEN, Richard Andrew, formerly of 275 Edwardes-street, East Brunswick, late of 135 Dundas-street, Preston, retired clicker, died 27th December, 1966.

DORGAN, Kathleen, late of 27 Verdon-street, Williamstown, married woman, died 17th December, 1966.

FOGGAN, George, late of 36 Royal-avenue, Glenhuntly, butcher, died 21st April, 1966.

FOORD, Annie Isabel, late of Kew, stenographer, died 1st December, 1966.

GELLION, Lillian Elizabeth, also known as Lillian Elizabeth Gellion, late of Flat 3, 20 Morobe-street, West Heidelberg, widow, died 7th February, 1967.

HALL, Francis, late of Lidcombe Hospital, Lidcombe, New South Wales, retired labourer, died 16th August, 1966.

HARRINGTON, Alice May, late of 69 Queen-street, Altona, married woman, died 5th December, 1966.

HENDERSON, Ben Cook, late of Eventide Home, Charters Towers, Queensland, pensioner, died 7th August, 1965.

KNIGHT, Dorothy Valentine, formerly of 12 Walter-street, Footscray, late of 13 Bayview-road, Footscray, married woman, died 17th December, 1966.

KRAMER, Henry, late of Table Hill, Daylesford, retired labourer, died 26th June, 1966.

KRUSE, Frederick Augustus, late of 152 Gordon-street, Footscray, retired carpenter, died 13th October, 1966.

LEWIS, John Frank, late of 42 Stead-street, South Melbourne, retired medical orderly, died 14th September, 1966.

MCCOLL, Ida Jane, late of 8 Anderson-street, Heidelberg, widow, died 2nd December, 1966.

MACPHERSON, Donald Alfred, also known as Donald Alfred Macpherson, late of 117 Bay-road, Sandringham, retired locksmith, carpenter and joiner, died 22nd January, 1967.

OGILVY, Ethel Louise, late of 58 Derby-street, Kew, widow, died 4th January, 1967.

PALMER, Robert Gordon, late of 45 Cameron-street, Coburg, retired traveller, died 12th November, 1966.

PIERSON, Dorothy May, late of Albert-road, Croydon, married woman, died 17th June, 1966.

PIGGOTT, Lydia Mabel, late of 4 Deakin-street, East Malvern, widow, died 30th November, 1966.

RATHBONE, Barbara, late of Flat 10, 33A Byron-street, Elwood, nursing sister, died 2nd December, 1966.

RILEY, Amy Victoria, late of 36 Stephenson-street, Springvale, widow, died 1st January, 1967.

ROACH, George Thomas, late of 4 (formerly 63) Bannerman-street, Bendigo, war pensioner, died 10th November, 1962.

SAVORY, Joseph Braithwaite, late of 14 Clyde-street, Berwick, retired clerk, died 21st August, 1966.

SIMMONS, Charles Cobham McLeod, late of 27 Abbey-gate-street, Oakleigh, retired fruiterer, died 6th September, 1966.

SKELLETT, Fanny Eveline Daisy, formerly of Athol-street, Moonee Ponds, late of Ballarat, spinster, died 25th July, 1966.

STEWART, Eunice Frances, in the will called Eunice Francis Stewart, late of 87 Aitken-street, Williamstown, married woman, died 29th September, 1966.

THOMAS, Stanley John, late of 13 Highview-road, East Preston, retired machinist, died 14th October, 1966.

WADE, Albert, late of Barnard-street, Bendigo, retired drover, died 18th November, 1966.

WINDUSS, Arthur Aubrey, late of 73 Heath-street, Port Melbourne, retired wharf carpenter, died 3rd January, 1967.

A. D. DUNCAN,
Public Trustee.

Melbourne, 13th April, 1967.

COMPANIES ACT 1961.

NOTICE is hereby given, in pursuance of sections 308 (2) and 308 (3) of the Companies Act 1961, that at the expiration of three months from the date hereof the names of the following Companies will, unless cause is shown to the contrary, be struck off the Register and the said Companies will be dissolved.

Dated this 14th day of April, 1967.

E. B. MITCHAM,
Assistant Registrar of Companies.

Companies Registration Office,
Melbourne.

COMPANIES ABOVE REFERRED TO.

Name of Company.	Number of Registration.
Star Picture Theatre Pty. Ltd.	8101
Alma Estates Pty. Ltd.	11468
Pinnacles Pty. Ltd.	11535
Toorak Motors Pty. Ltd.	12012
Publicity Press Pty. Ltd.	12405
T. H. Merson Pty. Ltd.	12543
Footgloves Pty. Ltd.	12745
Bakelite (Australia) Pty. Ltd.	14202
Dockerty & Buchanan Pty. Ltd.	14518
Viogen (Overseas) Pty. Ltd.	18103
Universal Providers Pty. Ltd.	18951
Jones Groom & Company Pty. Ltd.	20294
La Mart Modes Pty. Ltd.	20339
A. J. Humphreys Pty. Ltd.	20858
Rockman's (Brisbane) Pty. Ltd.	23596
Euston Chemical Industries Pty. Ltd.	24892
Benrow Agency Co. Pty. Ltd.	25229
Helvetia Smallgoods Pty. Ltd.	25539
R. C. Sandow Pty. Ltd.	27799
Winmarleigh Pty. Ltd.	28281
Associated Equipment Coy. Pty. Ltd.	29298
Guernsey Court Pty. Ltd.	29318
Brockman Engineering Coy. Pty. Ltd.	29987
Avonlea Holdings Pty. Ltd.	31418
Victorian Textile Waste Trades Association Ltd.	32419
Australian Exporting Tanners Association Pty. Ltd.	33768
McMann Trading Co. (A/sia.) Pty. Ltd.	34297
B.A.B. Constructions Pty. Ltd.	34965
Marell Investments Pty. Ltd.	35488
N. & S. Hardware Supplies Pty. Ltd.	35940
Winston Suits Pty. Ltd.	38303
Crosby Realty Pty. Ltd.	38631
Yarglen Property Disposals Pty. Ltd.	38664
W.A.H. Pty. Ltd.	40065
Merrie Park Pty. Ltd.	41307
Chatsworth Pty. Ltd.	41684
Balwyn Investments Pty. Ltd.	44171
Industrex International Pty. Ltd.	45124
V. P. Grant Pty. Ltd.	45680
Bravo Investments Pty. Ltd.	45766
Rees Estate & Business Agency Pty. Ltd.	45905
Cromwell Management and Accountancy Co. Pty. Ltd.	46692
Trousseau Creations (Vic.) Pty. Ltd.	47663
M. Halloran Cement Cartage Pty. Ltd.	48167
Wellesley Investments Pty. Ltd.	48239
Scoresby Timber Pty. Ltd.	49805
Dunbee (Australia) Pty. Ltd.	50004
N.T.J. Pty. Ltd.	50444
Sorrento Emporium Pty. Ltd.	51075
H. B. & J. V. Wharton Pty. Ltd.	53178
Pelmet Plaster Pty. Ltd.	53566
Casabella Pty. Ltd.	56148
I. & E. International Coy. Pty. Ltd.	56331
D. I. Hammill Pty. Ltd.	58909
Coupe's Broken Meats Pty. Ltd.	58987
Kool-Bright Refrigeration Engineers Pty. Ltd.	59884
J. & D. McKenzie Holding Coy. Pty. Ltd.	62605
Sun-Bright Homes Pty. Ltd.	62838
R. E. & P. T. Page Pty. Ltd.	63555
D. J. Smith Pty. Ltd.	64005
Davison Offshore Services Pty. Ltd.	66949
Sacur Tyre Service Pty. Ltd.	67438
Union and Dorrirt Gold Mining Coy. No Liability	M7475

Process Servers and Inquiry Agents Act 1958.

APPLICATIONS FOR LICENCES LODGED WITH CLERKS OF COURTS.

BY direction of the Chief Secretary, the subjoined lists of "new" applications for process servers and inquiry agents licences are published for general information.

Applicant.	Address.	Court.	Tentative Date of Hearing of Application.
<i>Process Servers Licence.</i>			
Plunkett, Ronald Lewis	65 Geelong-road, Ballarat	Ballarat	2.5.67
<i>Inquiry Agents Licence.</i>			
Soutar, Geoffrey John Ellis	3 Peace-street, Glen Iris	Malvern	2.5.67

Attention is directed to the provisions of the above Act and regulations thereunder relating to the lodgement of objections to applications.

Chief Secretary's Office,
Melbourne, 17th April, 1967.

E. L. RICHARDSON, Registrar,
Process Servers and Inquiry Agents.

THE LICENSING ACT.

BREWERS' LICENCE.

THE under-mentioned body corporate has this day registered with me its name and a particular description of the premises in which it intends to carry on the business of a brewer during the year 1967.

Name of Brewer; Situation of Premises; Licensing Area.
Courage Breweries Limited; corner of Lexton and Maffra streets, Broadmeadows; northern metropolitan.

Dated at Melbourne this 10th day of April, 1967.

W. E. McALLISTER,
Registrar of Victorian Licensing Court.

RULES UNDER THE JUSTICES ACT.

SELECTION BY A LAW OFFICER OF THE PLACES AND DAYS AND HOURS FOR HOLDING COURTS (WITHIN THE MEANING OF THE SAID RULES).

I, THE undersigned, Arthur Gordon Rylah, a Law Officer of the State of Victoria, in pursuance of the powers conferred upon me by Rule 2 of Chapter III. of the Justices Act Rules 1963, do hereby amend the days and hours selected on the 24th November, 1966, and published in the *Government Gazette* on the 7th December, 1966, as indicated in the Schedule hereto.

SCHEDULE.

Court.	Days and Hours.
Korumburra	Thursday the 15th June, 1967, at 10 a.m., in lieu of the 17th June, 1967.

Dated at Melbourne, this 17th day of April, 1967.

A. G. RYLAH,
Attorney-General.

Country Fire Authority Act 1958.

VARIATION OF SUMMER PERIOD IN RESPECT OF SPECIFIED PARTS OF THE COUNTRY AREAS OF VICTORIA.

WHEREAS by section 4 of the *Country Fire Authority Act 1958* it is enacted that the Chief Secretary of Victoria, after consultation with the Minister of Forests, may from time to time by declaration published in the *Government Gazette* declare any period to be the summer period in respect of the country area of Victoria, or any specified part or parts thereof and, without affecting the generality of the foregoing, may declare different periods to be the summer period in respect of different parts of the said country area:

And whereas by the said section it is further enacted that any declaration so published may be revoked, amended or varied by a subsequent declaration so published:

And whereas by declaration issued on the date stated in Schedule A annexed hereto, different summer periods expiring on the thirtieth day of April, 1967, were declared in respect of different parts of the country area of Victoria, including the parts of the said country area specified in Schedule B hereto:

And whereas the Chief Secretary and the Minister of Forests have consulted accordingly:

Now therefore I, the Chief Secretary of Victoria, do by this my declaration vary the aforesaid declaration by declaring that the summer period in respect of the parts of the country area of Victoria specified in Schedule B hereto shall end at midnight on the 21st day of April, 1967.

SCHEDULE A.

Date of Declaration; Date of Publication in "Government Gazette".

6th December, 1966; 7th December, 1966.
15th December, 1966; 16th December, 1966.
20th December, 1966; 21st December, 1966.

SCHEDULE B.

The Fourteenth Fire Control Region comprising the municipal districts of the Shires of Bacchus Marsh, Gisborne, Melton, Newham and Woodend and Romsey and those portions of the Cities of Broadmeadows, Keilor, Sunshine and the Shires of Bulla, Diamond Valley, Werribee and Whittlesea not included in the Metropolitan Fire District;
those portions of the Fifth Fire Control Region comprised by the municipal districts of the Shires of Belfast, Minhamite and Mortlake and those portions of the Shire of Warrambool comprised by the Parishes of Laang and Nullawarre; and
those portions of the Twelfth Fire Control Region comprised by the municipal districts of the Shires of Broadford, Kilmore, McIvor, Pyalong and Seymour.

JAMES W. MANSON,

for Chief Secretary.

Chief Secretary's Office,
Melbourne, 18th April, 1967.

CONTRACTS ACCEPTED.—(Series 1966-67.)

VICTORIAN RAILWAYS.

92. Manufacture, supply and delivery of diesel electric locomotives, at rates (Contract 62963).—The Clyde Engineering Co. Pty. Ltd. 93. Supply and completion of one Departmental Residence, outbuildings, fencing and services and demolition of Departmental Residence No. 581 at Yea for the amount of \$8,728.90 (Contract 63102).—W. Phelan and Sons Pty. Ltd. 94. Cartage services as required during the period from 1st July, 1967, to 30th June, 1969, at rates (Contract 63104).—Mayne Nickless Ltd. 95. Cartage services as required during the period from 1st July, 1967, to 30th June, 1969, at rates (Contract 63123).—Yellow Express Carriers Ltd.

By order of the Victorian Railways Commissioners,

W. WALKER, Secretary for Railways. 14.4.1967.

PRISONERS' MEALS IN LOCK-UPS.

CONTRACT CANCELLED.

Gazette No. 55, 7th July, 1966, Prisoners' Meals, Wodonga. Contract No. 326, is hereby cancelled.

CONTRACT ACCEPTED.

3139. For the supply of Prisoners' Meals at Wodonga, as from 1st April, 1967, Breakfast and Tea, 30 cents; Hot Dinner, 45 cents.—I. A. Weatherall.

CEREALS.

Requirements under Sub-Schedule No. 10 of Schedule No. 1 for the period 1st May, 1967, to 31st July, 1967, are to be purchased from the under-mentioned firms at the rates per cwt. respectively indicated, viz., Robert Harper & Co. Ltd., Oatmeal, plain, \$4.60; Oatmeal, flaked, \$4.80; Peas, split, yellow, \$7.50; Tapioca, seed, \$8.40; H. S. K. Ward (Melb.) Pty. Ltd., Barley, pearl, \$4.00; Rice, dressed, \$9.50.

H. COUTTS, Secretary to the Tender Board. 18.4.67.

CONTRACTS ACCEPTED.—(Series 1967-68).

GENERAL STORES.

Schedule No. 52.

TOOLS (GENERAL)

Contract from 1st April 1967, to 31st March, 1968.

1967/19—Briscoes Ltd.	Security, \$80.
1967/20—F. J. Clementson	Security, \$60
1967/21—Davis Gelatine Pty. Ltd.	Agreement
1967/22—Hardware Co. of Australia Pty. Ltd.	Security, \$100
1967/23—McPherson's Ltd.	Security, \$200
1967/24—Thos. Mitchell and Co. Pty. Ltd.	Security, \$20
1967/25—Precision Engineering Co. Pty. Ltd.	Agreement
1967/26—John Sharp and Sons Pty. Ltd.	Security, \$150
1967/27—James Walker	Security, \$20
1967/28—G. A. Williams Engineering Supplies Pty. Ltd.	Security, \$100.

ADJUSTMENT OF RATES, ETC.

Rates are subject to adjustment in accordance with the special conditions of the respective contracts. Supplies are subject to availability of stocks.

Item No.	Description of Articles.	Rate.	Name of Contractor.
SUB-SCHEDULE A			
TOOLS, WOODWORK AND METALWORK			
1	Adzes—Carpenters', square polled, "Cyclone" each	2.12	Hardware Co. of Australia Pty. Ltd.
2	" " Pin polled, 4-in. " "	"	Purchase (Clause 109)
3	Augers—Screw { 1/2-in. and 3/4-in. " Titan " } " "	0.92	McPherson's Ltd.
		1.19	
		1.23	
		1.39	
		1.68	
4	" " { 1 1/2-in. " Ridgway " } " "	2.00	Hardware Co. of Australia Pty. Ltd.
		2.39	
		2.82	
		3.93	
5	Aws—Brad, handled, all sizes per doz.	4.76	Briscoes Ltd.
6	Axes—American pattern 4-lb. each	1.55	Briscoes Ltd.
		3.08	
		3.22	
		3.70	
7	handles, "Hytest" Forrester 4-lb. " "	"	F. J. Clementson
		"	
8	with hickory handles 4 1/2-lb. " "	"	Purchase (Clause 109)
		"	
9	Bevels—Sliding, 10-in. "C & M." " "	1.02	
10	Bits—Brace, auger, 1/4-in. to 1-in. "Titan" " "	0.61	Briscoes Ltd.
		0.70	
		0.75	
		0.83	
		0.93	
		1.02	
11	" " "Titan" { 1 1/8-in. and 3/4-in. " " } " "	1.23	Briscoes Ltd.
		1.57	
		1.74	
		2.00	
12	expansion, 1/4-in. to 1 1/2-in. "Irwin" " "	0.31	McPherson's Ltd.
		0.32	
		0.35	
		0.37	
		0.40	
		0.42	
12	" " "centre" { 1 1/8-in. to 7/8-in. " " } " "	0.48	Briscoes Ltd.
		0.53	
		0.58	
		0.69	
		0.78	
		0.78	

CONTRACTS ACCEPTED—*continued.*

Item No.	Description of Articles.	Rate.	Name of Contractor.
	Bits— <i>continued.</i>	\$	
13.	Bits—Brace, nail, German pattern { Nos. 2 to 4 .. per doz.	..	Purchase (Clause 109)
	" " " " " 5 and 6 .. "	..	
	" " " " " 7 and 8 .. "	..	
14	" " Ridgway Type, $\frac{4}{32}$ -in. to $\frac{10}{32}$ -in. .. " Rose, $\frac{3}{8}$ -in. } "Jilton" .. "	..	
	" " " " " $\frac{1}{2}$ -in. } .. "	..	
15	" " countersinks { Snail, $\frac{1}{2}$ -in. to $\frac{3}{8}$ -in. " Ridgway" .. "	..	
16	" " gimlets, $\frac{3}{32}$ -in. to $\frac{8}{32}$ -in. " Boker" .. "	..	
17	Blades—Brad-awl, assorted sizes .. per doz.	..	P. J. Clemenston McPherson's Ltd. James Walker McPherson's Ltd.
18	" { Saw, bow, 10-in. .. each 0.18	0.18	
	" " " 12-in. .. " 0.25	0.25	
19	" " " 24-in. .. " 0.15	0.15	
	" Saw, coping, 6 $\frac{1}{2}$ -in., " Eclipse" .. per doz.	0.09	
20	" " fret, 6-in., " Eclipse" .. "	1.20	
21	" " keyhole, " Eclipse" .. "	0.71	
22	" " hack, 10-in. x $\frac{1}{2}$ -in., " Turner" .. "	0.79	
	" " " 12-in. x $\frac{1}{2}$ -in., " " .. "	6.75	
23	" " " power, 12-in. x 1-in. x .050 x 14 pitch " Turner" .. "	7.86	
24	" " " power, 14-in. x 1-in. x .050 x 14 pitch " Turner" .. "	1.11	
25	" Piercing saw, Jewellers, size 0 " Eclipse" per gross	1.11	
26	" " " " size 1 .. "	1.11	
27	" " " " size 2 .. "	1.11	
28	Blocks, lead, 8-in. x 6-in. x 1-in. .. each	3.70	
29	Braces—Iron, 10-in. sweep, " Stanley", No. 66 .. "	2.61	
30	" " 12-in. sweep .. "	3.27	
31	" " ratchet, ball-bearing, 10-in. sweep .. "	..	
32	" " ratchet, ball-bearing, 12-in. sweep .. "	..	
33	Buttons—Boxwood, wooden jack planes .. "	0.39	
	" 3-in. .. " 0.40	0.46	
	" 4-in. .. " 0.50	0.71	
	" 5-in. .. " 1.08	1.39	
34	Callipers—Steel, inside, firm joint " Moore & Wright" No. 330 { 6-in. .. " 0.39	0.40	
	" " " 8-in. .. " 0.46	0.50	
	" " " 10-in. .. " 0.71	1.94	
	" " " 12-in. .. " 2.19	0.25	
	" " " 3-in. .. " 0.25	0.27	
	" " " 4-in. .. " 0.31	0.35	
	" " " 5-in. .. " 0.37	0.80	
	" " " 6-in. .. " 0.80	0.80	
	" " " 8-in. .. " 0.80	0.82	
	" " " 10-in. .. " 0.87	0.87	
	" " " 12-in. .. " 0.92	0.92	
	" " " 1-in. .. " 0.96	0.96	
35	Chisels—Cold, all steel, " Loft" { $\frac{3}{8}$ -in. .. " 0.80	0.80	
	" " " $\frac{1}{2}$ -in. .. " 0.80	0.80	
	" " " $\frac{3}{4}$ -in. .. " 0.80	0.80	
	" " " 1-in. .. " 0.80	0.82	
	" " " $\frac{1}{8}$ -in. .. " 0.87	0.87	
	" " " $\frac{1}{4}$ -in. .. " 0.92	0.92	
	" " " $\frac{3}{8}$ -in. .. " 0.96	0.96	
36	" " Firmer, handled, " Titan" { $\frac{1}{8}$ -in. .. " 0.80	0.80	
	" " " $\frac{1}{4}$ -in. .. " 0.80	0.80	
	" " " $\frac{3}{8}$ -in. .. " 0.80	0.80	
	" " " $\frac{1}{2}$ -in. .. " 0.80	0.82	
	" " " $\frac{5}{8}$ -in. .. " 0.87	0.87	
	" " " $\frac{3}{4}$ -in. .. " 0.92	0.92	
	" " " 1-in. .. " 0.96	0.96	

CONTRACTS ACCEPTED—continued.

Item No.	Description of Articles.	Rate.	Name of Contractor.
	Chisels—continued.	\$	
38	Chisels—Firmer, handled, "Titan" { 1½-in. .. each	1.16	} Briscoes Ltd.
	1½-in. .. "	1.38	
	1½-in. .. "	1.60	
	2-in. .. "	1.79	
39	" " " } 1-in. .. "	0.86	
	" " " } 1½-in. .. "	0.86	
	" " " } 2-in. .. "	0.86	
	" " " } 2½-in. .. "	0.86	
40	" " " } Bevelled edge "Titan" { 3-in. .. "	0.90	
	" " " } " " { 3½-in. .. "	0.92	
	" " " } " " { 4-in. .. "	0.97	
	" " " } " " { 4½-in. .. "	1.03	
41	" " " } " " { 1-in. .. "	1.21	
	" " " } " " { 1½-in. .. "	1.43	
	" " " } " " { 1½-in. .. "	1.62	
	" " " } " " { 2-in. .. "	1.87	
42	" " Reg. Handled, "Titan" { ½-in. .. "	0.92	
	" " " " " { ¾-in. .. "	0.92	
43	" " " " " { 1-in. .. "	0.97	
	" " " " " { 1½-in. .. "	1.04	
	" " " " " { 2-in. .. "	1.20	
	" " " " " { 2½-in. .. "	1.26	
44	" " " " " { 1-in. .. "	1.50	
	" " " " " { 1½-in. .. "	1.67	
	" " " " " { 1½-in. .. "	1.89	
45	" Mortise, socket, handled, "Titan" { 1-in. .. "	2.08	
	" " " " " { 1½-in. .. "	1.15	
	" " " " " { 2-in. .. "	1.15	
46	" " " " " { 2½-in. .. "	1.21	
	" " " " " { 3-in. .. "	1.27	
	" " " " " { 3½-in. .. "	1.39	
47	" " " " " { 4-in. .. "	1.50	
	" " " " " { 4½-in. .. "	1.71	
48	Compasses—Carpenters' wing { 6-in. "Asbeck" .. "	1.87	} McPherson's Ltd.
	8-in. " " " " " .. "	1.16	
49	" Metalwork wing, "Marples" { 6-in. .. "	1.43	} Purchase (Clause 109)
	8-in. " " " " " .. "	..	
50	Countersinks, ¼-in. shanks "Jilton" .. "	0.18	McPherson's Ltd.
51	Cork rubbers, 4-in. x 2½-in x ¾-in. .. per doz.	..	Purchase (Clause 109)
	" " " " " { 2-ft. .. each	5.53	} John Sharp and Sons Pty. Ltd.
	" " " " " { 2-ft. 6-in. .. "	5.70	
	" " " " " { 3-ft. .. "	5.81	
52	Cramps—Joiners', "Dawn" { 3-ft. 6-in. .. "	5.92	
	" " " " " { 4-ft. .. "	6.03	
	" " " " " { 4-ft. 6-in. .. "	6.20	
	" " " " " { 5-ft. .. "	6.32	
	" " " " " { 5-ft. 6-in. .. "	6.45	
53	" Coach builders', G., 5-in., "Tudor" .. "	6.57	} Purchase (Clause 109)
54	Crampheds for ¾-in. GI pipe .. "	..	
55	Cutters—Pipe, steel, 3-wheel, No. 1 .. "	4.55	} F. J. Clementson
56	" " " " " No. 2 } "Record" .. "	5.68	
57	" " " " " No. 3 } " " " " " .. "	8.95	
58	Dividers, carpenters', winged, 8-in. .. "	1.43	} McPherson's Ltd.
59	Drills { Hand, "Ixion", No. 3 (Double pinion) .. "	3.25	
	{ Breast, "Ixion", ¾-in., No. 12 .. "	6.20	
	" —Twist, high-speed, steel—		
60	" Sets ⅜-in. to ½-in. in stands .. "		} G. A. Williams Engineering Supplies Pty. Ltd.
61	" Carbon sets ⅜-in. to ½-in. (set of 7) .. "		
62	" Taper shank per doz.	†	
63	" Jobbers' "		
64	" " sets ⅜-in. to ½-in. "		
65	" Longset or taper length "		} Purchase (Clause 109)
66	" Prentice short ½-in., round shank, carbon "		

† Patience and Nicholson Ltd. list price, less 25 per cent. net.

CONTRACTS ACCEPTED—continued.

Item No.	Description of Articles.	Rate.	Name of Contractor.	
	<i>Drills—continued.</i>	\$		
67	Drills, Coes, $\frac{1}{2}$ -in. round shank	per doz.	Purchase (Clause 109)	
68	" Bistock	each		
69	" Ratchet, $\frac{1}{2}$ -in. to $1\frac{1}{2}$ -in.	"	McPherson's Ltd.	
70	File carding "Taylor"	per ft.		
71	Files of every description, except watchmakers' and warding, "Wiltshire"	per doz.		John Sharp and Sons Pty. Ltd.
72	Files—Jewellers, needle cut, No. 2, 16 c.w. all types "Stubbs"	each		
73	" warding, sizes as ordered	"	Purchase (Clause 109)	
	{ 10-in. flat—Bast. cut	"		
	{ 10-in. flat—Fine cut	"		
	{ 12-in. flat—Bast. cut	"		
	{ 12-in. flat—Fine cut	"		
	{ 14-in. flat—Bast. cut	"		
74	" "Dreadnought"	"		
	{ 10-in. half-round—Bast. cut	"		
	{ 10-in. half-round—Fine cut	"		
	{ 12-in. half-round—Bast. cut	"		
	{ 12-in. half-round—Fine cut	"		
75	Gauges—Cutting, Beech or Rosewood, "Clay"	0.77	McPherson's Ltd.	
76	" Marking, plated, "Footprint" No. 2546	0.52	Hardware Co. of Australia Pty. Ltd.	
77	" Mortise, with brass thumbscrews, plated, "Footprint" No. 1876	1.01		
78	" Wire, S.W.G., "M & W."	1.33		F. J. Clementson
79	Gimlets, twist, large, medium, and small— Small Medium Large	"	Purchase (Clause 109)	
80	Gouges—handled—inside or outside ground— Firmer, $\frac{1}{4}$ -in. to $\frac{3}{8}$ -in.	0.86		
81	" " " " " " " " " " " " { $\frac{1}{4}$ -in. { $\frac{3}{8}$ -in. { $\frac{1}{2}$ -in. { $\frac{3}{4}$ -in. { 1-in. " " " " " " " " " " " " { "Titan"	0.93 0.96 1.03 1.07 1.12 3.90 4.90 6.00 7.00 7.60 9.00 10.30 12.00	Briscoes Ltd.	
82	Grindstones, unmounted— { 3-in. face { 4-in. face	14-in. diam. 16-in. diam. 18-in. diam. 20-in. diam. 18-in. diam. 20-in. diam. 22-in. diam. 24-in. diam.		McPherson's Ltd.
83	" Electric, 10-in. x 3-in., sandstone	"	Purchase (Clause 109)	
84	" Iron mountings, 17 $\frac{1}{2}$ -in. to 20-in.	"		
85	Hammers—Carpenters' claw, handled— 16-oz. 20-oz.	0.99 1.03	Hardware Co. of Australia Pty. Ltd.	
86	" "Warrington", steel-handled, 12-oz. " "Bestmore"	0.94		McPherson's Ltd.
87	" Light brad, 6-oz., "Cyclone"	0.83	Briscoes Ltd.	
88	" Engineers' ballpein, $\frac{1}{2}$ -lb. " " " " " " " " " " " " hickory-handled, 1-lb. " "Cyclone"	0.93 0.96 1.07		
89	" " " " " " " " " " " " " " " " " " " " " " " " " " " " " " " " " " " " " " " " " " " " " " " " " " " " " " " " " " " " " " " " " "	1.12 1.22 1.28 1.39	John Sharp and Sons Pty. Ltd.	
	" " " " " " " " " " " " " " " " " " " " " " " " " " " " " " " " "	1.54 1.88 2.58		
90	" Spalling, unhandled— 6-lb. 10-lb. 14-lb.	1.54 1.88 2.58 3.10		McPherson's Ltd.

CONTRACTS ACCEPTED—*continued.*

Item No.	Description of Articles.	Rate.	Name of Contractor.
	Hammers— <i>continued.</i>	\$	
91	Hammers, handled, repousse, 4-oz., "Whitehouse" No. 158	each	Purchase (Clause 109)
92	" " double face club, 4-lb. " " "Bestmore"	"	
93	" " collett, 8-oz. "Whitehouse" No. 138	2.45	McPherson's Ltd.
94	" " planishing, 4-oz., R/S ¼-in. "Whitehouse" No. 141	"	Purchase (Clause 109)
95	" " planishing, 10-oz., R/S 1½-in. "Whitehouse"	2.59	James Walker
96	" " paning, "Plumb"	"	Purchase (Clause 109)
97	" " creasing, "Whitehouse"	2.30	James Walker
98	Sledge, unhandled { 4-lb. } "Cyclone"	1.28	Briscoes Ltd.
		1.58	
		1.77	
		2.10	
		2.50	
	{ 10-lb. }	2.74	
	{ 12-lb. }		
	{ 14-lb. }		
99	Hatchets, "Challenge"	1.31	Briscoes Ltd.
100	Holdfasts, joiners' "Woden"	"	Purchase (Clause 109)
	Irons, cutting, with cover iron—		
101	1½-in. for wooden technical jack	per doz.	Briscoes Ltd.
102	2-in. for No. 4 iron, smooth, "Titan"	8.15	
103	2½-in. for 4½ iron, smooth, "Titan"	9.45	
104	2-in. for 5 iron, jack, "Titan"	8.15	
105	2½-in. for 6 iron, forc, "Titan"	10.12	
106	2½-in. for 7 iron, jointer, "Titan"	10.12	
	Irons—		
107	1½-in. for iron, block	"	Purchase (Clause 109)
108	1½-in. for rabbet and fillister	"	Purchase (Clause 109)
109	2-in. for spokeshave, "Stanley"	each	
110	2½-in. for spokeshave, "Stanley"	0.29	McPherson's Ltd.
111	Jigs, Dowelling, 5 guides, ¼-in. to ½-in. by 1/16-in.	"	Purchase (Clause 109)
112	Knives, drawing, 10-in.	"	
113	" joiners', striking 6-in., "Clay" No. 120	0.30	Briscoes Ltd.
	Levels, spirit, brass mounted, with brass tips—		
114	12-in., with plumb, "Varino 15"	2.05	Purchase (Clause 109)
115	24-in., with plumb, "Varino 15"	2.85	
116	30-in., with plumb, "Varino 15"	3.12	
117	Mallets, carpenters', square { 5-in. } "Armstrong"	0.63	Briscoes Ltd.
	head { 6-in. }	0.74	
118	" tinman's, hard rubber composition, { 2-in. diam. } "Dunlop"	0.85	Purchase (Clause 109)
	{ 2½-in. diam. }	0.98	
119	" tinman's, rawhide, renewable head, 1½-in. diam. "Thor"	1.30	McPherson's Ltd.
120	" tinman's, boxwood, 2½-in. diam. x 4½-in. diam.	0.67	F. J. Clementson
121	" tinman's, bossing, medium, 2½-in. diam. per doz. "Armstrong"	7.98	Purchase (Clause 109)
	" tinman's, bossing, small, 2-in. diam. "Armstrong"	7.28	
122	Oilstones, WB7, Washita (Norton)	each	Purchase (Clause 109)
123	" fine, India (al. oxide) A.A. F.B.6	2.02†	James Walker
124	" Arkansas (Norton) { S5B6 }	"	Purchase (Clause 109)
		{ S5B8 }	
125	" medium (silicon carb.), 7-in. x 2-in. x 1-in. Aust. Abrasives No. 134	1.83‡	Purchase (Clause 109)
126	" slips, medium, 4½-in. x 2½-in. x 1/8-in. x 1/8-in.—Aust. Abrasives No. 181	1.32‡	
127	" slips, fine, 4½-in. x 2½-in. x 1/8-in. x 1/8-in.—Aust. Abrasives No. 180	"	

† Less 30 per cent. ‡ Less 33½ per cent.

CONTRACTS ACCEPTED—continued.

Item No.	Description of Articles.	Rate.	Name of Contractor.	
		\$		
128	Pincers—Carpenters { 6-in. each 7-in. " 8-in. "	0.35 0.40 0.43	McPherson's Ltd.	
	Planes—adjustable, iron, complete—"Stanley" or "Turner"			
129	Iron, No. 4, smooth, 2-in. cutter, 9-in. "	4.98		
130	" " No. 4½, smooth, 2½-in cutter, 10-in. "	5.74		
131	" " No. 5, jack, 2-in. cutter, 14-in. .. "	5.95		
132	" " No. 6, fore, 2½-in. cutter, 18-in. .. "	8.05		
133	" " No. 7, jointer, 2½-in. cutter, 22-in. "	..		
134	" " router, with 3 cutters, 7½-in. .. "	..		
135	Quirk bead No. 130 "	..		
136	Ovolo "	4.20		
137	Ogee "	..		
138	Plough "	..	Purchase (Clause 109)	
139	Rabate, Shewmouth, ¼-in. to 7-in. .. "	..		
140	Trying No. 7 "	..		
	Pliers—			
141	" Cutting "Elliott Lucas" { 6-in. .. per pair 0.90 7-in. .. 0.96 8-in. .. 1.15		McPherson's Ltd.	
142	" Round nose "Elliott Lucas" A147. { 4-in. .. 0.58 5-in. .. 0.87 6-in. .. 0.90			
143	" Side cutting "Elliott Lucas" PW 77 { 5-in. .. 1.20 6-in. .. 1.25 7-in. .. 1.40			
144	" Long nose, snipe "Elliott Lucas" { 5½-in (A151) .. 0.75 6½-in (A151) .. 0.85 8-in. (PW106) .. 1.28			
145	" Flat, engineers', 6-in "Elliott Lucas" NOA161 0.85			
146	" Gas, 7-in. "Wilkinson" No. 86 4.41			Purchase (Clause 109)
	" " "Priory" .. Per doz. 4.41			
	{ 1½-in. .. 4.41 2-in. .. 4.41 2½-in. and ½-in. .. 4.92			Hardware Co. of Australia Pty. Ltd.
147	Punches, leather, engineers' { 2½-in. .. 5.56 3-in. .. 5.56 3½-in. .. 6.57 4-in. .. 8.00 5-in. .. 9.45			
148	Punches, nail, round, "Sidchrome" each 0.18			
149	" nail, A.B.C.D., 1/16-in. to 5/32-in. "Wall" .. 0.19			
150	" Centre, C.S. 3/8-in. x 4-in. "Sidchrome" .. 0.18			
151	" Hollow, tinsmiths', ¼-in. "Priory" 0.38		McPherson's Ltd.	
152	" Hollow, tinsmiths', ½-in. 0.48			
153	" Hollow, tinsmiths', ¾-in. 0.66			
154	" Hollow, tinsmiths', 1-in. 1.00		Hardware Co of Australia Pty. Ltd.	
155	" Grooving, tinsmiths', 3/16-in. "Greg Steel" .. 0.63			
156	" Grooving, tinsmiths', ¼-in. 0.63		McPherson's Ltd.	
158	" Pin, 1/8-in. "Sidchrome" 0.24			
159	" Pin, 3/16-in. 0.24			
160	" Pin, ¼-in. 0.24			
161	" Pin, 3/8-in. "M and W" 0.36			
162	" Pin, ½-in. 0.63			
163	" Letter, set 3/16-in. "Imperial" 3.75			
164	" Numeral, set, 3/16-in. "Imperial" 1.53			
165	Rasps—of any description ordered †		John Sharp and Sons Pty. Ltd.	
166	Rules—Brass, 2-ft., two-fold 0.67			
167	" Steel, stainless, 12-in. 0.68		Purchase (Clause 109)	
168	" Boxwood, four-fold, 1½-in. width, 2-ft.			

† Wiltshire List price less 35 per cent.

CONTRACTS ACCEPTED—continued

Item No.	Description of Articles.	Rate.	Name of Contractor.	
	Rules— <i>continued.</i>	\$		
169	Rules—Boxwood four-fold, 1½-in. width, 3-ft., each "Sybren"	0.55	Briscoes Ltd.	
170	" Steel, two-fold, "Rabone" No. 56 .. "	0.50	McPherson's Ltd.	
	Saws—			
171	" Butchers', 14-in. "	..	Purchase (Clause 109)	
172	" Bow, wood frame, 12-in. "Clay" .. "	2.00	McPherson's Ltd.	
173	" " " 16-in. to 24-in. .. "	..	Purchase (Clause 109)	
174	" Coping, 6½-in. "	0.24	McPherson's Ltd.	
175	" Crosscut { 5-ft. 5-ft. 6-in. " 6-ft. "	..	} Purchase (Clause 109)	
176	" Fret, 6-in., "Clay" "	0.39	McPherson's Ltd.	
177	" Hack, "Turner", T.100 "	1.75	James Walker	
178	" Hand, 26-in., hollow back, "Disston", D.8 .. "	4.46	McPherson's Ltd.	
179	" Jewellers' piercing, 2¼-in. P.S. 50, "Eclipse" .. "	0.88	McPherson's Ltd.	
180	" Keyhole, compass, and pruning, nest of 3 per nest .. "	1.05	Hardware Co. of Australia Pty. Ltd.	
181	" Dovetail 8-in. each	0.85	} F. J. Clementson	
182	" Panel, hollow or Straight back, "Disston" D.8 .. "	3.95		
183	" Pruning, D./Edge "	0.85		
184	" Rip, 28-in., hollow back, "Disston", D.8 .. "	4.35		
185	" Tenon, 10-in., steel back, "Disston", K.1 .. "	2.15		
186	" " 12-in., " " " " " " " " " " " "	2.25		
187	" " 14-in., " " " " " " " " " " " "	2.35		
188	" " 16-in., " " " " " " " " " " " "	..		
189	Scrapers, cabinet, rectangular { 4-in. x 2-in. " 5-in. x 3-in. " 6-in. x 4-in. "	0.15 0.16 0.22		} McPherson's Ltd.
190	Screwdrivers—Flat or spindle, plastic handled— 4-in. } " Pilot " { No. 117 .. per doz. 1.75 6-in. } " Pilot " { No. 117 .. " 1.85 8-in. } " Pilot " { No. 125 .. " 3.39 10-in. } " Pilot " { No. 131 .. " 4.59 12-in. " Cyclone " No. 132 .. " 7.70			} F. J. Clementson
191	" Ratchet "	..	} Purchase (Clause 109)	
192	Screws, bench, vice, wrought steel "	..		
193	Sets and headers, rivet, ½-in. "Gregsteel" "	4.79	} Hardware Co. of Australia Pty. Ltd.	
194	" " " " 5/32-in. "	4.79		
195	" " " " 7/32-in. "	4.79		
196	" Hot, 2-lb. 1¼-in. cutting edge "Loft" .. each	1.52	} McPherson's Ltd.	
197	" Cold, 2-lb. " " " " " " " " " " " "	1.52		
198	" saw, hand "	2.28		
199	" " crosscut "	2.28		
	Snips, tinsmiths'—			
200	" Cast steel, straight blade { 8-in., "Parex" per pair 1.03 10-in., " " " " 1.31 12-in., " " " " 1.90		} Briscoes Ltd.	
201	" Cast steel, bent blade { 8-in., " " " " 1.63 10-in., " " " " 1.88 12-in., " " " " 2.55			
202	Soldering irons, 12-oz., "Evro" per doz.	11.42		} McPherson's Ltd.
203	" " 16-oz., " " " " " " " " " " " "	13.90		
204	" " 8-oz., " " " " " " " " " " " "	..		
205	Spanners—Double ended, open, in sets of 6, ¼-in. to 1-in. "Sidchrome" No. S51 .. per set	3.69	} McPherson's Ltd.	
206	" Double ended, drop forged, in sets of 4, 1/16-in. to ½-in. "	1.75		

CONTRACTS ACCEPTED—continued.

Item No.	Description of Articles.	Rate.	Name of Contractor.
	Spanners—continued.	\$	
207	Spanners { 8-in. "Clyburn" each 10-in. " " " 12-in. " " " 14-in. " " " 16-in. " " " 18-in. " " "	1.30	McPherson's Ltd.
		1.80	
		2.20	
		2.60	
		3.20	
4.00			
208	Spokeshaves— 10-in. x 2½-in. { Adjustable, "Stanley" No. 151 Round-soled, "Stanley" No. 51R	1.01 0.79	Hardware Co. of Australia Pty. Ltd. Purchase (Clause 109)
209	Iron		
210	Squares, try— Rosewood—Brass plated { 6-in. "C and M" 8-in. all steel try	0.67 0.78	McPherson's Ltd. Purchase (Clause 109)
211	" " " { 10-in. 12-in.		
212	Straight-edges—Steel, polished, from { 2-ft. 3-ft. 2-ft. long and upwards, bevelled, { 4-ft. graduated, "Bodman" { 5-ft. 6-ft.	1.99 3.34 4.79 5.95 9.35	McPherson's Ltd.
213	Taps and dies, composite B.S.W., B.S.F., ¼-in to per set ¼-in by ⅜-in., button pattern set No. Com. 1, complete with stock and tap wrench	28.25†	G. A. Williams Engineering Supplies Pty. Ltd.
214	Tongs—Blacksmiths', 16-in., straight flat grooved, for ¼-in. round "Loft" each	1.53	McPherson's Ltd. Purchase (Clause 109) McPherson's Ltd. Purchase (Clause 109)
215	" " 16-in., straight hollow "Loft"	1.53	
216	" " 16-in., straight flat "Loft"	1.53	
217	" " 16-in. bent flat "Loft"	1.53	
218	" " 16-in. bolt "Loft"	1.53	
219	" " 16-in., rivet "Loft"	1.53	
220	" " 16-in., plier or pickups "Loft"		
221	Tomakawks, handled "Trojan/Hytest" No. 10062	0.92	Briscoes Ltd.
222	Trowels—Bricklayers' through tang capped, 13-in.	1.10	McPherson's Ltd.
223	" Pointing, 6-in.	0.72	
224	Vices—Hand, 2-in. "Rolls"	0.85	McPherson's Ltd.
225	" Pin, open jaw "Eclipse" No. 110	1.66	
226	" Pipe, to take ¼-in. to 2-in pipe "Dawn"	5.60	
227	" " to take ¼-in. to 4-in. pipe, "Dawn"	5.57	John Sharp and Sons Pty. Ltd.
228	" " Vulcan chain, ¼-in. to 4-in., "Dawn"	9.97	
229	Wedges—Splitting { 6-in. " Maul Head { 8-in. " " " { 10-in. "Hytest" " " " { 12-in.	0.58 0.76 1.24 1.79	Briscoes Ltd.
		1.26	
230	" Chain Saw, Plastic "Turner"	1.26	
231	Wheels—Pipe cutting { No. 1 No. 2 "Record" No. 3	0.25 0.30 0.38	McPherson's Ltd.
232	Wrenches—Pipe (Stillson pattern) "Dowidat", No. 252 { 8-in. 10-in. 12-in. 14-in. 18-in. 24-in. 36-in.	1.08 1.29 1.65 1.99 2.82 4.87 7.73	Briscoes Ltd.
233	" Screw (Crescent) { 6-in. 8-in. "Dowidat"	0.87 1.10	Briscoes Ltd.
234	" " " { 10-in. No. 91 12-in.	1.45 2.00	
235	" " " { 15-in. "Dowidat" No. 91	3.08	

† Less 25%

CONTRACTS ACCEPTED—continued.

Item No.	Description of Articles.	Rate.	Name of Contractor.
SUB-SCHEDULE B.			
AGRICULTURAL TOOLS			
236	Blades, Scythe, riveted, { 30-in. each	..	} Purchase (Clause 109)
	33-in. "	..	
237	" " bramble, 24-in. "	..	} McPherson's Ltd.
238	Cans, Watering, galv., 5 quart "	1.99	
239	" " " Willow " 8 quart "	..	} Purchase (Clause 109)
240	Cultivator—Hand { 3-prong, 4-ft., No. 62 "	1.25*	
	{ 5-prong, 4-ft., No. 63 "	1.57*	} F. J. Clementson
241	Forks—Digging, strapped, socket, 4 prongs, "Trojan", No. 14 "	2.43	
242	" " D.H., strapped, socket, 4 prongs Border, No. 82, "Trojan" "	1.12	McPherson's Ltd.
243	" " D.H., strapped, socket, 5 prongs, No. 15 "	3.12	Hardware Co. of Australia Pty. Ltd.
244	" Hay, 6-ft. length, 3 prongs { straight "	2.47	} McPherson's Ltd.
	"Trojan" bent "	2.52	
245	" Manure, D.H., strapped, socket, 4 prongs "	..	} Purchase (Clause 109)
246	" " D.H., strapped, socket, 5 prongs "	..	
247	" Spading, D.H., strapped, socket, 4 prongs "	..	
248	" " D.H., strapped, socket, 5 prongs "	..	
249	" Stone, 8 prongs, T.D.H. "	..	
	" " 10 prongs, T.D.H. "	..	} Hardware Co. of Australia Pty. Ltd.
250	" Weeding, twisted, 4 prong, 6½-in. handle, "Trojan" No. 375 "	0.43	
	" " twisted, 4 Prong, 14-in. handle, "Trojan" No. 376 "	0.54	
Hoes—			
251	" Burr forged steel, tapered eye, { 4-in. "	..	} Purchase (Clause 109)
	handled { 5-in. "	..	
	6-in. "	..	
	" Dutch, steel, riveted, blade, Heads only—	..	} John Sharp and Sons Pty. Ltd.
	1½-in. x 4-in., "Cyclone" "	0.34	
	1½-in. x 5-in. "	0.36	
	1½-in. x 6-in. "	0.39	
252	1½-in. x 7-in. "	0.42	
	Handled—	..	
	1½-in. x 4 in. "	0.78	
	1½-in. x 5-in. "	0.80	
	1½-in. x 6-in. "	0.83	
	1½-in. x 7-in. "	0.86	
253	" Dutch, steel, pressed, blade { Heads only "	..	}
	2½-in. x 7-in. { Handled "	..	
254	" Field, heavy, swan neck, 6-in., handled "	..	}
255	" Garden, light, swan neck, forged { 6-in. "	..	
	steel, handled, "Cyclone" { 7-in. "	..	
256	" Pickeye, grubbing, handled "	..	}
257	" Planters, forged steel, tapered eye, { 6-in. "	..	
	handled, "Trojan" { 7-in. "	..	
258	" Thistle, handled, 2½-in., "Trojan" "	..	} Purchase (Clause 109)
259	" Vine, 4 prong, handled "	..	
Hooks—			
260	" Bill, No. 1290, unhandled "	..	}
261	" Bagging, No. 143/5, unhandled "	..	
262	" Fern, No. 1010, unhandled "	..	
263	" " No. 1012, unhandled "	..	
264	" Furze, No. 249, unhandled "	..	
265	" Gippsland, No. 142, unhandled "	..	
266	" Sharp point, single cutter, unhandled, No. 87 "	..	
	" " "	..	
267	Mattocks, heads only { 4-lb. "Cyclone" or "	1.84	} John Sharp and Sons Pty. Ltd.
	{ 4½-lb. "Trojan" "	1.88	
	{ 5-lb. "	1.95	
	{ 4-lb. "	2.23	
	" with handles { 4½-in. "	2.27	
	{ 5-lb. "	2.34	

* Item 240—Standard pack 12. Broken pack plus 5 per cent.

CONTRACTS ACCEPTED—continued.

Item No.	Description of Articles.	Rate.	Name of Contractor.
		\$	
268	Picks—Single, miners', 4½-lb. { handled each	..	Purchase (Clause 109)
	unhandled "	
269	" Double, steel-end, 7-lb. { handled " 2.21		John Sharp and Sons Pty. Ltd
	" "Cyclone" { unhandled " 1.82		
270	Rakes, garden— Rakes, Iron, nail pattern, handled, { 10-tooth " 0.51		James Walker
	" "Cyclone" { 14-tooth " 0.53		
	{ 16-tooth " 0.57		
271	" Steel, light pattern, handled, { 10-tooth " 1.22		John Sharp and Sons Pty. Ltd.
	" "Trojan" or "Cyclone" { 12-tooth " 1.27		
	No. 66 { 14-tooth " 1.32		
	{ 16-tooth " 1.37		
	{ 18-tooth " 1.44		
272	" " heavy pattern, handled { 12-tooth " 1.32		John Sharp and Sons Pty. Ltd.
	" "Trojan" or { 14-tooth " 1.38		
	" "Cyclone" No. 66 { 16-tooth " 1.44		
273	" Cast steel, bow, handled	Purchased (Clause 109)
274	" Asphalt, handled, "Trojan" No. 311 ..	2.05*	F. J. Clementson
275	Secateurs "Rolcut"	Purchase (Clause 109)
276	Shears—Border, long-handled, without wheel, per pair	2.40	F. J. Clementson
	" "Brookfield"	
277	" Grass, 7-in.	0.70	McPherson's Ltd.
278	" Hedge, 10-in. "Brookfield"	1.60	F. J. Clementson
279	" " 12-in.	Purchase (Clause 109)
280	Shovels—D.H., R.M., socketed, No. 3 "Trojan" each	2.19	Briscoes Ltd.
281	" D.H. S.M., socketed, No. 3	2.17	
282	" L.H., R.M., socketed, No. 2	Purchase (Clause 109)
283	" L.H., R.M., socketed, No. 3 "Trojan" ..	2.06	Briscoes Ltd.
284	" L.H., S.M., socketed, No. 2	Purchase (Clause 109)
285	" L.H., S.M., socketed, No. 3 "Trojan" ..	2.03	Briscoes Ltd.
286	" Post hole, S.M.	
287	" " R.M.	
288	" Special rabbiters, L.H., with ring lock on handle, socket, No. 250, size No. 1	Purchase (Clause 109)
289	" Farmers Friend, No. 251, size No. 1	
290	" Stokers', D. H., riveted back, No. 4, S.M. ..	3.61	Briscoes Ltd.
291	" Stokers', D. H., riveted back, No. 5, S.M.	Purchase (Clause 109)
292	Slashers—Double-bladed, handled, 11-in. No. 213A ..	3.19	Briscoes Ltd.
293	" Single-bladed, handled, 11-in, No. 213Z, "Trojan"	Purchase (Clause 109)
294	" Mallee, fishtail, 10-in., unhandled	
295	Spades—D.H., black socket, treaded, No. 0 ..	1.98	McPherson's Ltd.
296	" D.H., black socket, treaded, No. 1	Purchase (Clause 109)
297	" D.H., black socket, treaded, No. 2, "Trojan" ..	2.03	Briscoes Ltd.
298	" D.H., black socket, treaded, No. 3	Purchase (Clause 109)
299	Trowels—Garden 6½-in. handle	0.38	McPherson's Ltd.
300	Weeders, Wonder, 15-in. "Trojan"	0.86	Briscoes Ltd.
301	" Wonder, 4-ft.	1.15*	F. J. Clementson
HANDLES			
302	Adze, hickory, No. 1, "Red Excell" .. per doz.	11.08	John Sharp and Sons Pty. Ltd.
303	" Commonwealth timber	Purchase (Clause 109)
304	Axe, hickory, No. 1, 32-in., "Echo"	8.69	John Sharp and Sons Pty. Ltd.
305	" Commonwealth timber	4.62†	F. J. Clementson
306	{ Broom, hardwood, 4-ft. 6-in. x ½-in.	1.39†	
	{ " " 4-ft. x 1-in.	Purchase (Clause 109)

* Item 274—Standard pack of 6 } Broken pack plus 5 per cent.
Item 301 " " " 12

† Standard packs of 6 dozen in one delivery and consisting of not less than 1 dozen of any one item—plus 7½ per cent. Standard packs of 6 dozen in one delivery, but consisting of less than 1 dozen of any one item, plus 33½ per cent., in respect of that item and quantities less than 6 dozen in one delivery—plus 33½ per cent., if ordered in less than ½ dozen lots—plus 2½ per cent.

CONTRACTS ACCEPTED—continued.

Item No.	Description of Articles.	Rate.	Name of Contractor.
	Handles—continued	\$	
307	Chisel, ferruled, firmer, any size, "Armstrong" per doz.	..	} Purchase (Clause 109)
308	" " " socket " " " " " " " "	..	
309	File, ferruled { 4-in. " " " " " " " "	0.45	} Briscoes Ltd.
	{ 5-in. " " " " " " " "	0.50	
	{ 6-in. " " " " " " " "	0.56	
310	Fork, bent, "D" top " " " " " " " "	..	} Purchase (Clause 109)
311	" straight, "D" top " " " " " " " "	..	
	{ straight { 5-ft. " " " " " " " "	..	
	{ 5-ft. 6-in. " " " " " " " "	..	
312	" hay { bent { 6-ft. " " " " " " " "	..	
	{ 6-ft. 6-in. " " " " " " " "	..	
313	Hammer, claw " " " " " " " "	1.28†	} F. J. Clementson
314	" hand { 14-in. } "Northgate" { " " " " " " " "	1.32†	
	{ 16-in. } "Northgate" { " " " " " " " "	1.45†	
315	" " light brad, 6-oz., "Cyclone" " " " " " " " "	1.80†	} McPherson's Ltd.
	" " " " " " " " " " " " " " " " " "	0.32	
316	Sledge, striking or spalling, 30-in. hickory, "Echo" " " " " " " " "	5.28	} John Sharp and Sons Pty. Ltd.
317	" striking or spalling, 36-in. hickory, "Echo" " " " " " " " "	6.16	
318	" striking or spalling, { Commonwealth } 30-in. timber " " " " " " " "	..	} Purchase (Clause 109)
319	" striking or spalling, 36-in. " " " " " " " "	3.85†	} F. J. Clementson
320	Hammer, for Warrington hammers, 12-in. "Northgate" " " " " " " " "	..	} Purchase (Clause 109)
321	Hoe, 4-ft. 6-in. { 1½-in. " " " " " " " "	..	}
	{ 2-in. " " " " " " " "	..	
322	Mop, ferruled " " " " " " " "	..	
323	Pick, or mattock hickory, "Echo" " " " " " " " "	11.08	} John Sharp and Sons Pty. Ltd.
324	Pick, Commonwealth timber, 36-in., "Challenge" " " " " " " " "	4.60	
325	Plane " " " " " " " "	..	} Purchase (Clause 109)
326	Rake, fire, 6-ft., "Bonser" " " " " " " " "	0.40	} Hardware Co. of Australia Pty. Ltd.
327	" garden { 5-ft. } "Northgate" { " " " " " " " "	1.98†	} F. J. Clementson
	{ 5-ft. 6-in. } "Northgate" { " " " " " " " "	2.42†	
	{ 6-ft. } "Northgate" { " " " " " " " "	2.64†	
	{ 6-ft. 6-in. } "Northgate" { " " " " " " " "	2.85†	
328	Scythe, complete, hickory each	..	} Purchase (Clause 109)
329	Slasher, 42-in., oval, "Northgate" per doz.	5.75†	} F. J. Clementson
330	" 36-in., oval " " " " " " " "	..	} Purchase (Clause 109)
331	" 42-in., round, "Northgate" " " " " " " " "	5.75†	} F. J. Clementson
332	" 36-in., round " " " " " " " "	..	} Purchase (Clause 109)
333	" 36-in., ring and bolt " " " " " " " "	..	
334	Shovel, "D", "Northgate" " " " " " " " "	7.70†	} F. J. Clementson
335	" long, "Challenge" " " " " " " " "	5.20†	
336	Spade, straight, "D" " " " " " " " "	7.70†	
337	" " long " " " " " " " "	..	} Purchase (Clause 109)
SUB-SCHEDULE C.			
MISCELLANEOUS AND HANDLES			
338	Brushes—Bench, round sash { ½-in. each	0.38	} Thos. Mitchell and Co. Pty. Ltd.
	{ 1-in. " " " " " " " "	0.79	
339	" Glue, round { ½-in. "Mitchells" No. 163 " " " " " " " "	0.38	}
	{ 1-in. " " " " " " " " " " " " " " " " " "	0.79	
340	" Spirit " " " " " " " "	0.15	} McPherson's Ltd.

† Standard Packs Clause.

CONTRACTS ACCEPTED—continued.

Item No.	Description of Articles.	Rate.	Name of Contractor.
		\$	
	Brushes— <i>continued.</i>		
341	Brushes, Tube, steel, wire, 1-in.	each	Purchase (Clause 109)
	" " " " 1½-in. and 1½-in.	" " " " " " " " " " " " "	
	" " " " 1½-in.	" " " " " " " " " " " "	
	" " " " 2-in.	" " " " " " " " " " " "	
	" " " " 2½-in.	" " " " " " " " " " " "	
	" " " " 2½-in.	" " " " " " " " " " " "	
	" " " " 3-in.	" " " " " " " " " " " "	
	" " " " 3½-in.	" " " " " " " " " " " "	
	" " " " 4-in.	" " " " " " " " " " " "	
342	Cans—Joiner's Oil, Valve spout, ¼-pint No. 4	per lb.	Hardware Co. of Australia Pty. Ltd.
343	Cotton Waste—coloured	per lb.	
344	Emery Cloth, Size "F" "Oakeys"	per 500 sh.	F. J. Clementson
345	" " " " 1	" " " " " " " " " " " "	
346	" " " " 1½	" " " " " " " " " " " "	
347	" " " " 2	" " " " " " " " " " " "	
348	Flux, Silver Soldering, lb. jars, C.I.G.	per lb.	Purchase (Clause 109)
349	Glue, best, fine joiners', pearl	per cwt.	
350	" best fine joiners', pearl, in 7-lb. packets	per doz.	Davis Gelatine Pty. Ltd.
351	" liquid, 4-oz. tins	per tin	
352	" cold water, in 1-lb. tins	each	Purchase (Clause 109)
353	Oil, Cutting, 1-gal. tins	per gal.	
354	Pencils, Carpenters'—Red and Black	per doz.	Purchase (Clause 109)
355	" Cedar, oval, 7½-in.	" " " " " " " " " " " "	
356	Polishing Compound, 1¼-lb. bars, "Zenith"	per bar	McPherson's Ltd.
357	Rega Knapsack Spray Pump, lead coated, fitted with auto-pop valve and special tail piece	Double	John Sharp and Sons Pty. Ltd.
		Cyclone	
		Nozzle	
358	Rega, continuous atomizer—Solid brass	" " " " " " " " " " " "	
359	Salamac, lb. blocks	per lb.	F. J. Clementson
360	Sandbags, leather, 10-in. diam., "Pizzey"	each	McPherson's Ltd.
361	Shovels—Fire, Tulip pattern, wood handle	" " " " " " " " " " " "	
362	Solder, Silver (¾-in. x .008) strip, No. 4 Hard	per oz.	F. J. Clementson
363	Soldering Fluid, "Baker", gallon tins	per gal.	
364	Spirit Pots, glazed, with lids	each	Precision Engineering Co. Pty. Ltd. (A)
365	Stones—Scythe, round	" " " " " " " " " " " "	Purchase (Clause 109)
366	" Carborundum, No. 190	" " " " " " " " " " " "	
367	Surface Plate, 12-in. x 12-in. x 2-in., C.1—"A" grade	" " " " " " " " " " " "	McPherson's Ltd.
	Tapes, measuring, leather cases, with flush handles, in links and feet, as ordered—		
368	Metallic, ¾-in. wide, 33-ft. } No. 291/14 {	" " " " " " " " " " " "	Purchase (Clause 109)
369	" ¾-in. wide, 66 ft. } "Fibron" {	" " " " " " " " " " " "	
370	" ¾-in. wide, 100-ft. } " " " " " " " " " " " "	" " " " " " " " " " " "	
	Tapes, measuring, steel, leather cases with flush handles—		
371	¾-in. wide, 33-ft. } feet and links "Rabone" {	" " " " " " " " " " " "	Purchase (Clause 109)
372	¾-in. wide, 66-ft. } No. 415 {	" " " " " " " " " " " "	
	Tapes, steel, measuring, in steel cases, detachable, "Rabones", No. 435/14		
373	¾-in. wide, 66-ft. } feet and links {	" " " " " " " " " " " "	Purchase (Clause 109)
374	¾-in. wide, 100-ft. } " " " " " " " " " " " "	" " " " " " " " " " " "	
	Tapes, measuring, on winding frame—		
375	Steel, links, ¾-in. wide, 66-ft., "Rabone's", No. 638	" " " " " " " " " " " "	Purchase (Clause 109)
376	" links, ¾-in. wide, 66-ft., "Rabone's"	" " " " " " " " " " " "	
377	" feet, ¾-in. wide, 100 ft. } No. 639 {	" " " " " " " " " " " "	

† Item 344-7, less 32½ per cent.

* In packs of 3 dozen, lesser quantities plus 10 per cent.

CONTRACTS ACCEPTED—*continued.*

NAMES AND ADDRESSES OF CONTRACTORS.

Briscoes Limited, 166 Roden-street, West Melbourne.
 F. J. Clementson, 109-111 Hawke-street, West Melbourne.
 Davis Gelatine Pty. Ltd., 324 William-street, Melbourne.
 Hardware Co. of Australia Pty. Ltd., P.O. Box 293, South Melbourne, S.C.4.
 McPherson's Ltd., 546 Collins-street, Melbourne, C.I.
 Thos. Mitchell and Co. Pty. Ltd., 417 Victoria-street, Brunswick, N.10.
 Precision Engineering Co. Pty. Ltd., 343 Lygon-street, East Brunswick.
 John Sharp and Sons Pty. Ltd., Lorimer-street, South Melbourne.
 James Walker, 378-380 Little Collins-street, Melbourne.
 G. A. Williams Engineering Supplies Pty. Ltd., 47 Wilson-street, South Yarra.

ORDERS IN COUNCIL.—(Series 1966-67.)

FORESTS COMMISSION.

Loan Fund Act No. 7453, Item 6, Project PX—

3125. To the purchase of lot 8 on plan of subdivision No. 26324, being part of allotment 22, section A, and allotment 6, section A, Parish of Trentham, County of Dalhousie, comprising 24 acres 3 roods 14 perches for forest purposes, \$6,457.75.—Robert James Douglas Davie & Rita Ada Davie.

Approved by the Governor in Council, 21st March, 1967.
 —J. COLQUHOUN, Clerk of the Executive Council.

Loan Fund Act No. 7432, Item 6—

3126. To the purchase of parts of allotments 9 and 10, section A, Township of Forrest, Parish of Yaughar, County of Polwarth, for forest purposes, \$350.00.—Albert Ernest Stephens.

Approved by the Governor in Council, 30th March, 1967.
 —J. COLQUHOUN, Clerk of the Executive Council.

PUBLIC WORKS.

3127. Ballarat, Mental Hospital, installation of expansion, pipe pits and trench drainage system, \$2,475.55.—George Stone & Sons.—(W.78117.)

3128. Langi Kal Kal, Social Welfare Training Centre, urgent replacement of dangerous and defective power poles condemned by the State Electricity Commission of Victoria, \$1,345.00.—Widgery and Wilson, Ballarat.—(N.W.105780.)

Approved by the Governor in Council, 11th April, 1967.
 —J. COLQUHOUN, Clerk of the Executive Council.

EDUCATION DEPARTMENT.

3129. Ten only metallurgical microscopes, bench type for Footscray Technical College, \$2,305.90.—Watson Victor Ltd.

3130. One only horizontal boring machine for Jordanville Technical School, \$270.00.—A. & S. Wolfenden Bros.

3131. One only bench folder for Noble Park Technical School, \$315.00.—McPhersons Ltd.

3132. One only cathode ray oscilloscope for Benalla Technical School, \$250.00.—B. W. D. Electronics Pty. Ltd.

3133. One only compound pendulum, \$34.75, one only fly-wheel, \$46.40, and one only spectrometer, \$320.00 for Brighton Technical School, \$401.15.—Townson & Mercer (Vic.) Pty. Ltd.

3134. Three only large metallographs for Footscray Technical College, \$14,831.46.—Nationwide Instrument Co.

3135. One only pottery wheel for Mooroolbark Technical School, \$375.50.—Orton & Burns Pty. Ltd.

3136. One only Heine bench folder for Sebastopol Technical School, \$319.00.—McPhersons Ltd.

3137. One only Heine bench folder for Williamstown Technical School, \$340.00.—McPhersons Ltd.

3138. One only Cupola melting equipment for Royal Melbourne Institute of Technology, \$34,268.00.—T. Main & Sons Pty. Ltd.

Approved by the Governor in Council, 11th April, 1967.
 —J. COLQUHOUN, Clerk of the Executive Council.

Town and Country Planning Act 1961.

SHIRE OF TRARALGON.—LATROBE VALLEY SUB-REGIONAL PLANNING SCHEME 1949.

AMENDMENT No. 12, 1967.

Notice of Amendment.

IN pursuance of the powers conferred by sub-section 6 of section 32 of the *Town and Country Planning Act 1961*, the Governor in Council, by and with the advice of the Executive Council thereof, on the 18th April, 1967, amended the Latrobe Valley Sub-Regional Planning Scheme 1949, in respect of a reclassification from major road to minor road of a road which traverses Crown allotment 51, section A, Parish of Traralgon.

A copy of the amendment may be inspected during office hours at the office of the Town and Country Planning Board, 179 Queen-street, Melbourne; at the office of the Council of the Shire of Traralgon; and when available, at the Office of Titles, Melbourne; and at the Central Plan Office of the Department of Crown Lands and Survey, Melbourne.

W. H. CRAIG, Secretary,
 Town and Country Planning Board.

Town and Country Planning Act 1961.

SHIRE OF KNOX PLANNING SCHEME 1965.

AMENDMENT No. 10.

Notice of Approval.

IN pursuance of the powers conferred by the *Town and Country Planning Act 1961*, the Governor in Council on the 18th April, 1967, approved a planning scheme entitled the Shire of Knox Planning Scheme 1965, Amendment No. 10, in respect of part of the municipal district of the Shire of Knox.

A copy of the planning scheme as approved may be inspected during office hours at the office of the Town and Country Planning Board, 179 Queen-street, Melbourne; at the office of the Shire of Knox at Fern Tree Gully; and when available, at the Office of Titles, Melbourne, and at the Central Plan Office of the Department of Crown Lands and Survey, Melbourne.

W. H. CRAIG, Secretary,
 Town and Country Planning Board.

Town and Country Planning Act 1961.

SHIRE OF NUMURKAH PLANNING SCHEME 1956.

AMENDMENT No. 2.

Notice of Approval.

IN pursuance of the powers conferred by the *Town and Country Planning Act 1961*, the Governor in Council on the 18th April, 1967, approved a planning scheme entitled the Shire of Numurkah Planning Scheme 1956, Amendment No. 2, in respect of part of the municipal district of the Shire of Numurkah.

A copy of the planning scheme as approved may be inspected during office hours at the office of the Town and Country Planning Board, 179 Queen-street, Melbourne; at the office of the Shire of Numurkah; and when available, at the Office of Titles, Melbourne, and at the Central Plan Office of the Department of Crown Lands and Survey, Melbourne.

W. H. CRAIG, Secretary,
 Town and Country Planning Board.

Town and Country Planning Act 1961.

SHIRE OF BARRABOOL.—OCEAN ROAD PLANNING SCHEME 1955.

AMENDMENT No. 5.

Notice of Approval.

IN pursuance of the powers conferred by the *Town and Country Planning Act 1961*, the Governor in Council on the 18th April, 1967, approved a Planning Scheme entitled the Ocean Road Planning Scheme 1955, Amendment No. 5 (Shire of Barrabool), in respect of part of the municipal district of the Shire of Barrabool.

A copy of the planning scheme as approved may be inspected during office hours at the office of the Town and Country Planning Board, 179 Queen-street, Melbourne; at the office of the Shire of Barrabool; and when available at the Office of Titles, Melbourne, and at the Central Plan Office of the Department of Crown Lands and Survey, Melbourne.

W. H. CRAIG, Secretary,
Town and Country Planning Board.

BOORT WATERWORKS TRUST.

RATING BY-LAW FOR THE YEAR 1967.

THE Boort Waterworks Trust, in pursuance and exercise of the Powers conferred by the Water Acts, doth hereby make a rate for the supply of water for domestic purposes of eight cents in the Dollar on the amount of the annual municipal valuation of the land and tenements liable to be rated within the Boort Urban District.

Provided that in no case shall the amount of the rate payable per annum in respect of any tenement (other than land on which there is no building) be less than Sixteen dollars and in respect of any land on which there is no building less than Five dollars.

Such rates are made and shall be levied upon the occupier or owner of the said lands and tenements for the year commencing on the 1st day of January 1967 and shall be payable on the 20th day of April 1967 at the office of the Trust.

The maximum quantity of water to be supplied in any one year without further charge to any property rated by the Trust, is hereby fixed at the quantity which at a charge of Twenty cents per 1,000 gallons would produce an amount equal to the amount of the rate levied on such property for the said year.

The charge for water supplied by measure to any property rated by the Trust in excess of such maximum quantity, computed as in the last preceding clause, is hereby fixed at Twenty dollars per 1,000 gallons.

The charge for water supplied by measure shall be payable on demand at the office of the Trust.

Passed this 4th day of November, 1966.

(SEAL) C. R. JAMES, Chairman.
H. M. JONES, Secretary.

Approved, 11th April, 1967.—T. A. DARCY, Minister of Water Supply.

LEARMONTH WATERWORKS TRUST.

RATING BY-LAW FOR THE YEAR 1967.

THE Learmonth Waterworks Trust, in pursuance and exercise of the powers conferred by the Water Acts, doth hereby make a rate for the supply of water for domestic purposes of, Fifteen Cents in the Dollar, on the annual municipal valuation of lands and tenements liable to be rated within the Learmonth Water Supply District.

Provided that in no case shall the amount of rate payable per annum in respect of any tenement (other than land on which there is no building) be less than Fourteen Dollars, and in respect of any land on which there is no building less than Four Dollars.

Such rates are made and shall be levied upon the occupiers or owners of the said lands and tenements for the period commencing on the 1st day of January, 1967, and ending on the 31st day of December 1967, and shall be payable on the 20th day of April 1967, at the office of the said Trust.

The maximum quantity of water to be supplied in any one year, without further charge to any property rated by the Trust, is hereby fixed at the quantity which, at a charge of Fifty Cents per 1,000 gallons, would produce an amount equal to the amount of the rate levied on such property for the said period.

The charge for water supplied by measure to any property rated by the Trust in excess of such maximum quantity, computed as in the last preceding clause, is hereby fixed at Fifty Cents per 1,000 gallons.

The charge for water supplied by measure to any property not rated by the Trust is hereby fixed at Fifty Cents per 1,000 gallons, and the minimum quantity of water to be charged for in cases where water is so supplied is hereby fixed at 28,000 gallons.

The charge for water supplied by measure shall be payable, on demand, at the office of the Trust.

Passed this 4th day of April, 1967.

(SEAL) J. B. DEAN, Chairman.
C. A. CRICK, Commissioner.
F. S. MCGRAW, Secretary.

Approved, 11th April, 1967.—T. A. DARCY, Minister of Water Supply.

RIDDELL'S CREEK WATERWORKS TRUST.

RATING BY-LAW FOR THE YEAR 1967.

THE Riddell's Creek Waterworks Trust, in pursuance and exercise of the powers conferred by the Water Act, doth hereby make a rate for the supply of Water for Domestic Purposes of Eleven cents (11c.) in the Dollar of the Annual Municipal Valuation of lands and tenements liable to be rated within the Riddell's Creek Urban District.

Provided that in no case shall the amount of rate payable per annum in respect of any tenement (other than land on which there is no building) be less than Four Dollars forty cents, (\$4.40), and in respect of land on which there is no building, less than Two Dollars (\$2.00).

Such rates are made and shall be levied upon the occupiers or owners of the said lands and tenements for the year commencing on the 1st day of January 1967, and shall be payable on the 20th day of April, 1967, at the office of the said Trust.

The maximum quantity of water to be supplied in any one year without further charge to any property rated by the Trust, is hereby fixed at the quantity which, at a charge of Twenty Cents (20c.) per 1,000 gallons, would produce an amount equal to the amount of rate levied on the property for the said year.

The charge for water supplied by measure to any property rated by the Trust, in excess of such maximum quantity computed as in the last preceding clause, is hereby fixed at twenty cents (20c) per 1,000 gallons.

The charge for water supplied by measure shall be payable on demand, at the office of the said Trust.

Passed this 6th day of December, 1966.

(SEAL) C. J. KNEWSTUB, Chairman.
UNA I. WRIGHT, Secretary.

Approved, 11th April, 1967.—T. A. DARCY, Minister of Water Supply.

WINCHELSEA WATERWORKS TRUST.

RATING BY-LAW No. 52.

THE Winchelsea Waterworks Trust, in pursuance and exercise of the powers conferred by the Water Act, doth hereby make a rate for the supply of water for domestic purposes of Six cents (6c) in the dollar on the net annual valuation of lands and tenements liable to be rated within the Winchelsea Waterworks Urban District.

Provided that in no case shall the amount of rate payable per annum in respect of any tenement (other than land on which there is no building) be less than Eight dollars and in respect of land on which there is no building less than Two dollars.

The maximum quantity of water to be supplied in any one year without further charge to any property rated by the Trust is hereby fixed at the quantity which at a charge of Twenty cents (20c) per 1,000 gallons, would produce an amount equal to the amount of rate levied on such property for the said year.

The charge for water supplied by measure to any property rated by the Trust in excess of such maximum quantity, computed as in the last preceding clause, is hereby fixed at Twenty cents per 1,000 gallons.

The charge for water supplied by measure shall be payable on demand.

Such rates are made and shall be levied upon the occupiers or owners of the said lands and tenements for the year commencing the 1st day of January, 1967, and ending on the 31st day of December, 1967, and shall be payable on the 1st May, 1967 at the office of the said Trust, Shire Hall, Winchelsea.

Passed this 3rd day of April, 1967.

(SEAL) CHARLES McDONALD, Chairman.
W. K. MATHISON, Secretary.

Approved, 11th April, 1967.—T. A. DARCY, Minister of Water Supply.

KYNETON SHIRE WATERWORKS TRUST.

FIXING THE LIMIT OF A BANK OVERDRAFT.

HIS Excellency the Governor of the State of Victoria, by and with the advice of the Executive Council thereof, doth, by Order made on the 18th day of April, 1967, and in pursuance of the provisions of section 288 of the Water Act 1958 (No. 6413) fix the limit of the overdraft to be obtained by the Kyneton Shire Waterworks Trust at an amount not to exceed at any one time the sum of Fifty thousand dollars (\$50,000).

J. COLQUHOUN,
Clerk of the Executive Council.

At the Executive Council Chamber,
Melbourne, 18th April, 1967.

BARNAWARTHA WATERWORKS TRUST.

AUTHORITY TO OBTAIN BANK OVERDRAFT.

HIS Excellency the Governor of the State of Victoria, by and with the advice of the Executive Council thereof, doth, by Order made on the 18th day of April, 1967, authorize the Barnawartha Waterworks Trust to obtain in pursuance of the provisions of section 286 of the Water Act 1958 (No. 6413) an advance or advances during the year ending 30th September, 1967, from the Bank of New South Wales, Chiltern, by overdraft of the Trust's current account thereat, such overdraft not to exceed at any one time the sum of Three thousand seven hundred dollars (\$3,700).

J. COLQUHOUN,
Clerk of the Executive Council.

At the Executive Council Chamber,
Melbourne, 18th April, 1967.

TALLANGATTA WATERWORKS TRUST.

RATING BY-LAW FOR THE YEAR 1967.

THE Tallangatta Waterworks Trust, in pursuance and exercise of the powers conferred by the Water Act, doth hereby make a rate for the supply of water for domestic purposes of 4½ (four and one fifth) cents in the dollar of the net Annual Value of the lands and tenements liable to be rated within the Tallangatta Urban District.

Provided that in no case shall the amount of the rate payable per annum in respect to any tenements (other than land on which there is no building) be less than fourteen dollars and in respect to any land on which there is no building less than ten dollars.

Such rates are made and shall be levied upon the occupiers or owners of the said lands and tenements for the year commencing on the 1st day of January 1967, and shall be payable on the 1st day of May, 1967, at the office of the Trust.

The maximum quantity of water to be supplied in any one year without further charge to any property rated by the Trust is hereby fixed at the quantity which, at a charge of Fifteen cents per 1,000 gallons, would produce an amount equal to the amount of the rate levied on such property for the said year.

The charge for water supplied by measure to any property rated by the Trust in excess of such maximum quantity computed as in the last preceding clause is hereby fixed at Fifteen cents per 1,000 gallons.

The charge for water supplied by measure shall be payable, on demand, at the office of the Trust.

Passed this 5th day of April, 1967.

(SEAL) J. RONAN, Chairman.
E. G. HAMILTON, Commissioner.
I. M. BOWMAN, Secretary.

Approved, 17th April, 1967.—T. A. DARCY, Minister of Water Supply.

SHEPPARTON URBAN WATERWORKS TRUST.

RATING BY-LAW FOR THE YEAR 1967.

THE Shepparton Urban Waterworks Trust, in pursuance and exercise of the powers conferred by the Water Act, doth hereby make a rate for the supply of water for domestic purposes of 4.3 cents in the Dollar of the annual municipal valuation of lands and tenements liable to be rated within the Shepparton Urban District.

Provided that in no case shall the amount of rate payable per annum in respect of any tenement (other than land on which there is no building) be less than Six dollars, and in respect of any land on which there is no building less than Three dollars.

Such rates are made and shall be levied upon the occupiers or owners of the said lands and tenements for the year commencing on the 1st day of January, 1967, and shall be payable on the 18th day of May, 1967, at the office of the said Trust.

The maximum quantity of water to be supplied in any one year without further charge to any property rated by the Trust is hereby fixed at the quantity which, at a charge of fourteen cents per 1,000 gallons, would produce an amount equal to the amount of the rate levied on such property for the said year.

The charge for water supplied by measure to any property rated by the Trust in excess of such maximum quantity, computed as in the last preceding clause, is hereby fixed at fourteen cents per 1,000 gallons.

The charge for water supplied by measure to any property not rated by the Trust is hereby fixed at fourteen cents per 1,000 gallons, and the minimum quantity of water to be charged for in cases where water is so supplied is fixed at 36,000 gallons.

The charge for water supplied by measure shall be payable, on demand at the office of the Trust.

Passed this 11th day of April, 1967.

(SEAL) A. G. ROSS, Acting Chairman.
NEIL P. HAYMES, Secretary.

Approved, 17th April, 1967.—T. A. DARCY, Minister of Water Supply.

THORPDALE WATERWORKS TRUST.

RATING BY-LAW 1967.

THE Thorpdale Waterworks Trust, in pursuance and exercise of the powers conferred by the Water Act doth hereby make a rate for the supply for domestic purposes of fifteen cents in the Dollar on the annual municipal valuation of lands and tenements liable to be rated within the Thorpdale Urban District.

Provided that in no case shall the amount of rate payable in respect of any tenement (other than land on which there is no building) be less than Twelve Dollars and in respect of any land on which there is no building less than three Dollars.

Such rates are made and shall be levied upon the occupiers or owners of the said lands and tenements for the year commencing the 1st day of January, 1967 and ending on the 31st day of December, 1967 and shall be payable on the 1st of May, 1967, at the Office of the said Trust.

The maximum quantity of water to be supplied in any one year without further charge to any property rated by the Trust is hereby fixed at the quantity which, at a charge of Fifteen Cents per 1,000 gallons, would produce an amount equal to the amount of the rate levied on such property for the said year.

The charge for water supplied by measure to any property rated by the Trust in excess of such maximum quantity, computed as in the last preceding clause, is hereby fixed at Fifteen Cents per 1,000 gallons.

The charge for water supplied by measure shall be payable on demand, at the office of the Trust.

(SEAL) ALAN F. GUNN, Chairman.
J. F. ROWLINGS, Commissioner.
W. F. NELSON, Secretary.

Approved, 17th April, 1967.—T. A. DARCY, Minister of Water Supply.

BUNINYONG WATERWORKS TRUST.

BUNINYONG URBAN DISTRICT.

Rating By-Law For The Year 1967.

THE Buninyong Waterworks Trust, in pursuance and exercise of the powers conferred by the Water Act, doth hereby make a rate for the supply of water for domestic purposes of Eight Cents in the dollar on the annual municipal valuation of lands and tenements liable to be rated within the Buninyong Urban District.

Provided that in no case shall the amount of rate payable per annum in respect of any tenement (other than land on which there is no building) be less than Ten dollars and in respect of any land on which there is no building less than Five dollars.

Such rates are made and shall be levied upon the occupiers or owners of the said lands and tenements for the year commencing on the 1st day of January, 1967, and shall be payable on the 1st day of May, 1967, at the office of the said Trust.

The maximum quantity of water to be supplied in any one year without further charge to any property rated by the Trust is hereby fixed at the quantity which, at a charge of Twenty Cents per 1,000 gallons, would produce an amount equal to the amount of the rate levied on such property for the said year.

The charge for water supplied by measure to any property rated by the Trust in excess of such maximum quantity, computed as in the last preceding clause, is hereby fixed at Twenty Cents per 1,000 gallons.

The charge for water supplied by measure to any property not rated by the Trust is hereby fixed at Twenty Cents per 1,000 gallons, and the minimum quantity of water to be charged for in cases where water is so supplied is hereby fixed at 50,000 gallons.

The charge for water supplied by measure shall be payable, on demand, at the office of the Trust.

Passed this 10th day of April, 1967.

(SEAL) A. A. DAVIS, Chairman.
A. C. LORD, Secretary.

Approved, 17th April, 1967.—T. A. DARCY, Minister of Water Supply.

SHIRE OF MOUNT ROUSE WATERWORKS TRUST.

RATING BY-LAW FOR THE YEAR 1967.

THE Shire of Mount Rouse Waterworks Trust, in pursuance and exercise of the powers conferred by the Water Acts, doth hereby make the under-mentioned rates on the annual municipal valuation of lands and tenements within the Urban Districts of Dunkeld, Glenthompson and Penshurst.

Dunkeld Urban District Eleven cents in the dollar
Glenthompson Urban District Ten cents in the dollar
Penshurst Urban District Twelve cents in the dollar

Provided that in no case shall the amount of rate payable in respect of any tenement (other than land on which there is no building) in the said urban districts be less than Seven dollars, and in respect of land on which there is no building less than One dollar Fifty cents.

Such rates are made and shall be levied upon the occupiers or owners of the said lands and tenements for the year commencing the 1st day of January, 1967, and shall be payable on the 1st day of June, 1967, at the office of the Trust.

The maximum quantity of water to be supplied in the year without further charge to any property rated by the Trust is hereby fixed at the quantity which at a charge of Thirty cents per 1,000 gallons would produce an amount equal to the amount of the rate levied on such property for the said year.

The charge for water supplied by measure to any property rated by the Trust in excess of such maximum quantity, computed as in the last preceding clause, is hereby fixed at Thirty cents per 1,000 gallons.

The charge for water supplied by measure shall be payable, on demand, at the office of the Trust.

Passed this 12th day of April, 1967.

(SEAL) PETER J. FRY, Chairman.
R. J. WOODBURN, Commissioner.
G. M. COMMONS, Secretary.

Approved, 17th April, 1967.—T. A. DARCY, Minister of Water Supply.

APPOINTMENTS AND RESIGNATIONS

APPOINTMENTS.

HIS Excellency the Governor of the State of Victoria, by and with the advice of the Executive Council thereof, has, by Orders made on 4th day of April, 1967, been pleased to make the under-mentioned appointments, viz.:

Land Officers.

JOHN REGINALD BUCK, and
PETER ROSS WARD,
Officers of the Department of Crown Lands and Survey,
to be Land Officers in and for the State of Victoria.

Officers Authorized to Grant a Right to Occupy Crown Lands.

JOHN REGINALD BUCK, and
PETER ROSS WARD,
Officers of the Department of Crown Lands and Survey,
to be duly authorized persons to grant to an applicant a right to occupy, as a residence area under the Land Act 1958, any Crown lands, as provided in section 165 of the Land Act 1958.

J. COLQUHOUN,
Clerk of the Executive Council.

At the Executive Council Chamber,
Melbourne, 4th April, 1967.

APPOINTMENTS.

HIS Excellency the Governor of the State of Victoria, by and with the advice of the Executive Council thereof, has, by Orders made on 11th day of April, 1967, been pleased to make the under-mentioned appointments, viz.:

MINISTRY OF HEALTH.

Member of Committee of Management of Hospital.

Cr. THOMAS JAMES HOWLETT
to be a Member of the Committee of Management of Casterton Memorial Hospital, pursuant to proviso (b) to section 48 (1) of the Hospitals and Charities Act 1958, for a period of three years ending the 1st May, 1970, vice Cr. H. D. Mitchell.

Deputy Superintendent, Mental Hospital.

TERESA GABRIELLE KENNY, M.B., B.S.,
to be Deputy Superintendent, Mental Hospital and Training Centre, Sunbury, pursuant to section 26 (1) of the Mental Health Act 1959, vice Dr. T. J. Leonard, promoted, as from 4th March, 1967.

DEPARTMENT OF CROWN LANDS AND SURVEY.

Managers of Commons.

The Honorable THOMAS HENRY GRIGG, M.L.C., C.B.E.,
ROBERT LANG,
FRANCIS BROWN,
NATAL MERLO,
ALFRED TRELOAR, and
HENRY SHEARER,
to be Managers of the Maldon Shire Common for the period ending 31st December, 1969; and

KEITH LESLIE BOWES,
PERCIVAL OTTO,
LYLE REX PARK, and
FREDERICK CHARLES PRUST,
to be Managers of the Wickliffe Common for the period ending 31st December, 1969.

LAW DEPARTMENT.

Commissioners for Taking Declarations, &c.

ALAN JAMES RUNDELL, Police Station, Nathalia,
RUSSELL GARNER FRENCH, care of Department of Crown Lands and Survey, Treasury-place, Melbourne, and
ERNEST JOHN LUFF, care of Victorian Railways, Spencer-street, Melbourne
to be Commissioners for taking Declarations and Affidavits, pursuant to the provisions of the Evidence Act 1958, to refrain from charging fees and to resign upon ceasing to occupy their present positions;

GEORGE BARNABUS SPOTTISWOOD, care of Commonwealth Hostels Limited, Williamson-road, Maribyrnong,
 RICHARD JOHN MACK, care of Town Hall, Broadmeadows, and
 JAMES KENNETH ARBUCKLE, care of Stramit Industries Limited, 96 Franklin-street, Melbourne,
 to be Commissioners for taking Declarations and Affidavits, pursuant to the provisions of the Evidence Act 1958, to resign upon ceasing to occupy their present positions; and
 LEONARDUS THEODORUS MARIA DE KONING, 77 Errington-road, St. Albans,
 JACK FRANCIS MADDOCK, 1 Doysal-avenue, Fern Tree Gully, and
 ALFRED GEORGE SHAW, Kangaroo Hotel, High-street, Maldon,
 to be Commissioners for taking Declarations and Affidavits, pursuant to the provisions of the Evidence Act 1958, to resign upon removing from the neighbourhood of the addresses stated.

Justices of the Peace.

KEVIN KEANEY, care of Catholic Schools Provident Fund, 359 Lonsdale-street, Melbourne,
 to keep the Peace in the Central Bailiwick of the State of Victoria; and

BRUCE ALEXANDER BURTON, 75 Binney-street, Euroa,
 to keep the Peace in the Northern Bailiwick of the State of Victoria.

DEPARTMENT OF THE TREASURER.

Collector of Imposts (Acting).

RAYMOND PERCIVAL WHITE
 to act temporarily as Collector of Imposts, Children's Court, Melbourne, vice K. J. Burgess on relieving duties; and

ROBERT ARTHUR SAUNDERS
 to act temporarily as Collector of Imposts, Education Department, vice B. H. H. Burville, on leave.

J. COLQUHOUN,
 Clerk of the Executive Council.

At the Executive Council Chamber,
 Melbourne, 11th April, 1967.

APPOINTMENT.

HIS Excellency the Governor of the State of Victoria, by and with the advice of the Executive Council thereof, has, by Order made on the 18th day of April, 1967, been pleased to make the under-mentioned appointment, viz.:

DEPARTMENT OF WATER SUPPLY.
Waterworks Trust Commissioner.

THEODORE BRUCE ANDERSON
 to be a Commissioner of the Thorpdale Waterworks Trust, to hold office as such for a period of four years from the date hereof, subject to the provisions of the Water Act.

J. COLQUHOUN,
 Clerk of the Executive Council.

At the Executive Council Chamber,
 Melbourne, 18th April, 1967.

FORESTS DEPARTMENT.

APPOINTMENT OF COMMITTEE OF MANAGEMENT OF PADDY'S RANGES SANCTUARY AND THE SPECIAL PURPOSES RESERVE FOR THE PRESERVATION OF NATIVE FLORA.

WHEREAS by section 50 of the Forests Act 1958 (No. 6254), it is provided that the Minister of Forests may, on the recommendation of the Forests Commission, appoint any number of persons, not less than three, to be a Committee of Management of any land forming part of any reserved forest, such land being set aside and declared to be reserves for the preservation of native flora, and may remove any of those persons: Now therefore, I, Lindsay Hamilton Simpson Thompson, Her Majesty's Minister of Forests in the State of Victoria, on the recommendation of the Forests Commission, do hereby appoint—

MRS. J. H. HERRING,
 MISS E. THOMPSON,
 J. ROGAN, and
 W. P. SHEEN,

as members of the Committee of Management until the 11th day of March, 1970, of the two areas of land being parts of the reserved forest in the Parish of Maryborough, County of Talbot, described in the accompanying Schedules A and B.

SCHEDULE A.

Parish of Maryborough, County of Talbot, comprising 84 acres of land, more or less, being the area shown by pink colour on the plan marked A.51/1599 over 12-3-58, on file of correspondence No. 58/1449 of the Forests Department.

SCHEDULE B.

Parish of Maryborough, County of Talbot, comprising 5 acres of land, more or less, being the area shown by pink colour on the plan marked 60/967 over 11.5.61, on file of correspondence No. 60/967 of the Forests Department.

Dated at Melbourne, the 13th day of April, 1967.

L. H. S. THOMPSON,
 Minister of Forests.

RESIGNATIONS.

HIS Excellency the Governor of the State of Victoria, by and with the advice of the Executive Council thereof, has, by Order made on the 11th day of April, 1967, accepted the resignations of the persons named hereunder of the office mentioned, viz.:

LAW DEPARTMENT.

JAMES WILLIAM SAMUEL JACOBS, and
 ERNEST OSBORNE NETTE,

as Commissioners for taking Declarations and Affidavits, pursuant to the provisions of the Evidence Act 1958.

J. COLQUHOUN,
 Clerk of the Executive Council.

At the Executive Council Chamber,
 Melbourne, 11th April, 1967.

ORDERS IN COUNCIL

LOCAL GOVERNMENT DEPARTMENT.

At the Executive Council Chamber, Melbourne, the eleventh day of April, 1967.

PRESENT:

His Excellency the Governor of Victoria.
 Mr. Thompson | Mr. Bloomfield.

ROAD DISCONTINUED.—CITY OF BRIGHTON.

WHEREAS it is provided in section 528 (2) of the Local Government Act 1958, that where a road (whether or not a public highway but not being a road set out on land of the Crown) or any part thereof is not required for public use the Governor in Council on the request of the Council of the municipality in which such road is situated made not less than one month after publishing in a newspaper generally circulating in the district and posting to the registered proprietor (if any) of the land and any person known to have an interest in the land notice of intention to make such a request may by Order published in the *Government Gazette* direct that such road or part shall be discontinued and thereupon such road or part shall be discontinued accordingly.

And whereas the Council of the City of Brighton has requested that the Governor in Council direct that a right-of-way off Centre-road, East Brighton, be discontinued and not less than one month previously has published in a newspaper generally circulating in the district and posted to the registered proprietor of the land in the road and to all persons known to have an interest in the said land notice of intention to make such request.

Now therefore His Excellency the Governor of the State of Victoria, by and with the advice of the Executive Council thereof, hereby directs:

- (a) that the said road, which is shown by hachure and cross-hachure on the plan hereunder, shall be discontinued.
- (b) that notwithstanding such discontinuance the Melbourne and Metropolitan Board of Works shall continue to have and possess the same right title power authority or interest in or in relation to the land shown by cross-hachure on the said plan as it had or possessed prior to such discontinuance with respect to or in connexion with any pipes laid or erected in or over such land for the purposes of drainage or sewerage.

(c) that, subject to any such right title power authority or interest, the land in the said road may be sold by the Council of the City of Brighton by agreement.

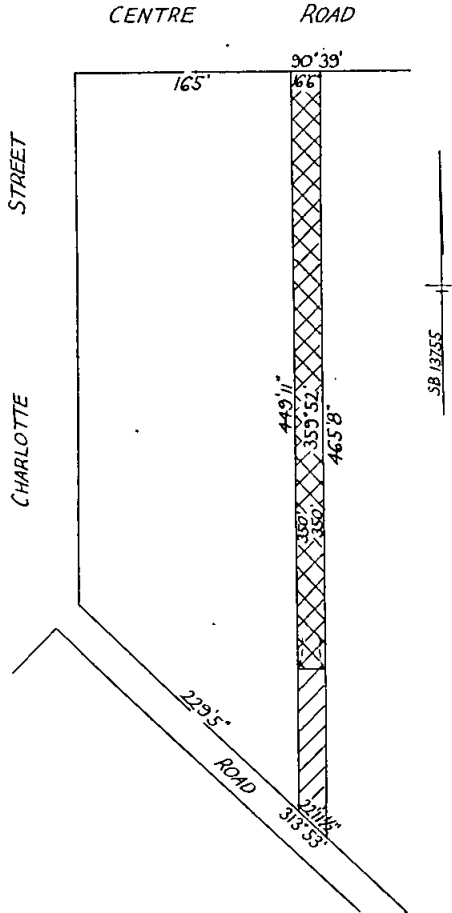

The measurements are in feet and inches

And the Honorable Rupert James Hamer, Her Majesty's Minister for Local Government for the State of Victoria, shall give the necessary directions herein accordingly.

J. COLQUHOUN,
Clerk of the Executive Council.

LOCAL GOVERNMENT DEPARTMENT.

At the Executive Council Chamber, Melbourne, the eleventh day of April, 1967.

PRESENT:

His Excellency the Governor of Victoria.
Mr. Thompson | Mr. Bloomfield.

ROAD DISCONTINUED.—CITY OF SOUTH MELBOURNE.

WHEREAS it is provided in section 528 (2) of the *Local Government Act 1958*, that where a road (whether or not a public highway but not being a road set out on land of the Crown) or any part thereof is not required for public use the Governor in Council on the request of the Council of the municipality in which such road is situated made not less than one month after publishing in a newspaper generally circulating in the district and posting to the registered proprietor (if any) of the land and any person known to have an interest in the land notice of intention to make such a request may by Order published in the *Government Gazette* direct that such road or part shall be discontinued and thereupon such road or part shall be discontinued accordingly.

And whereas the Council of the City of South Melbourne has requested that the Governor in Council direct that portion of a road off Albert-place, South Melbourne, be discontinued and not less than one month previously has published in a newspaper generally circulating in the district and posted to the registered proprietor of the land in the road and to all persons known to have an interest in the said land notice of intention to make such request.

Now therefore His Excellency the Governor of the State of Victoria, by and with the advice of the Executive Council thereof, hereby directs:

- (a) that the said road, which is shown by hachure on the plan hereunder, shall be discontinued.
- (b) that notwithstanding such discontinuance the Melbourne and Metropolitan Board of Works shall continue to have and possess the same right title power authority or interest in or in relation to the whole of the land shown by hachure on the said plan as it had or possessed prior to such discontinuance with respect to or in connexion with any pipes laid or erected in on or over such land for the purposes of drainage or sewerage.
- (c) that, subject to any such right title power authority or interest, the land in the said road may be sold by the Council of the City of South Melbourne by agreement.

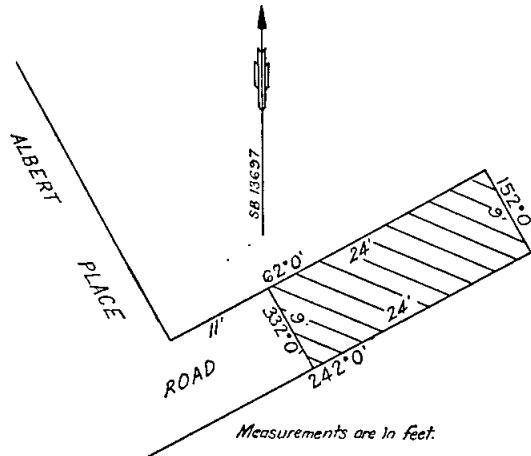

Measurements are in feet.

And the Honorable Rupert James Hamer, Her Majesty's Minister for Local Government for the State of Victoria, shall give the necessary directions herein accordingly.

J. COLQUHOUN,
Clerk of the Executive Council.

MARKETING OF PRIMARY PRODUCTS ACT 1958
(No. 6304).

At the Executive Council Chamber, Melbourne, the eleventh day of April, 1967.

PRESENT:

His Excellency the Governor of Victoria.
Mr. Thompson | Mr. Bloomfield.

APPOINTMENT OF A MEMBER OF THE MAIZE MARKETING BOARD.

IN pursuance of the powers conferred by the *Marketing of Primary Products Act 1958*, and all other powers him thereunto enabling, His Excellency the Governor of the State of Victoria, by and with the advice of the Executive Council thereof, doth by this Order hereby appoint CLAUDE JOHN FOUNTAIN, as a member of The Maize Marketing Board for a period of two (2) years from and inclusive of the 16th April, 1967.

And the Honorable Gilbert Lawrence Chandler, Her Majesty's Minister of Agriculture for the State of Victoria, shall give the necessary directions herein accordingly.

J. COLQUHOUN,
Clerk of the Executive Council.

DEPARTMENT OF CROWN LANDS AND SURVEY.

At the Executive Council Chamber, Melbourne, the eleventh day of April, 1967.

PRESENT:

His Excellency the Governor of Victoria.
Mr. Thompson | Mr. Bloomfield.

LAND TEMPORARILY RESERVED AS A SITE.

HIS Excellency the Governor of the State of Victoria, by and with the advice of the Executive Council thereof, doth hereby, in pursuance of section 14 of the Land Act 1958, reserve temporarily from sale, from being leased and from having a licence granted in respect thereof, and also except from occupation for mining purposes under any miner's right, the land hereinafter described:—

BALLARAT EAST (BLACK HILL).—Site for Water Supply purposes, 6 perches, Township of Ballarat East, Parish of Ballarat, County of Grenville, as indicated by hatching on plan hereunder.—(B.128⁽⁴²⁾) (Rs.8790.)

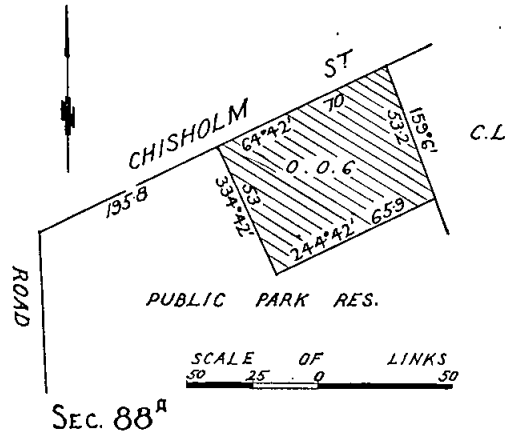

BEECHWORTH.—Site for Public purposes (Historical purposes), 5 acres 3 roods 30 perches, more or less, Parish of Beechworth, County of Bogong, as indicated by hatching on plan hereunder.—(B.349⁽²⁴⁾) (Rs.8801.)

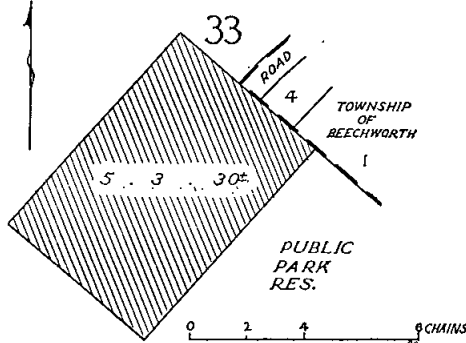

AT BENDIGO.—Site for a Public Park.—17 perches, more or less, at Bendigo, Parish of Sandhurst, County of Bendigo, as indicated by hatching on plan hereunder.—(S.372⁽¹²⁵⁾) (Rs.8729.)

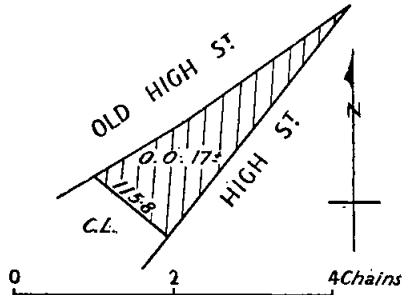

BRIGHT.—Site for Public purposes (Education Department purposes), 2 roods 15 perches, Township of Bright, Parish of Bright, County of Delatite, as indicated by hatching on plan hereunder.—(B.573⁽⁵⁾) (Rs.8808.)

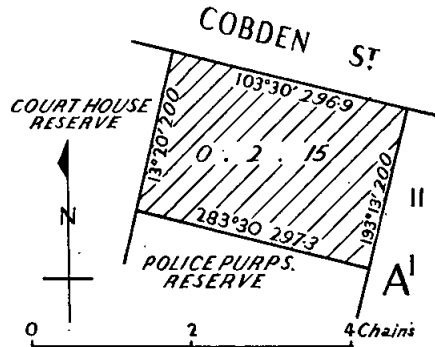

COLERAINE.—Site for State School purposes, 38 perches, Township of Coleraine, Parish of Coleraine, County of Dundas, as indicated by hatching on plan hereunder.—(C.301⁽⁸⁾) (Rs.8806.)

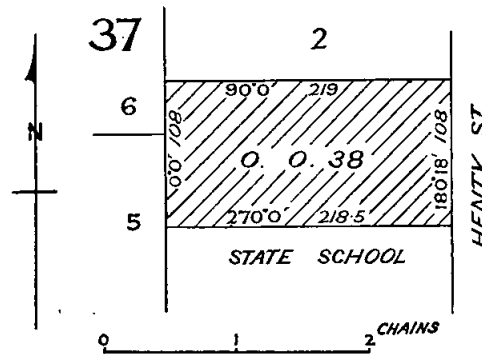

LAKES ENTRANCE.—Site for Public purposes (Municipal Depot), 2 roods 32 perches, Township of Lakes Entrance, Parish of Colquhoun, County of Tambo, as indicated by hatching on plan hereunder.—(C.383^(F5)) (Rs.8737.)

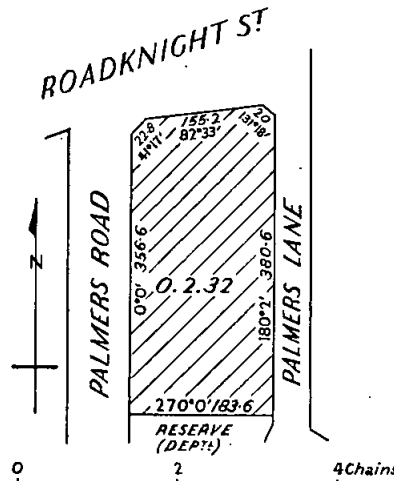

DANDONGADALE.—Site for Water Supply purposes, 60 acres, more or less, Parish of Dandongadale, County of Delatite, as indicated by hatching on plan hereunder.—(D.196⁽³⁾)—(Rs.8643.)

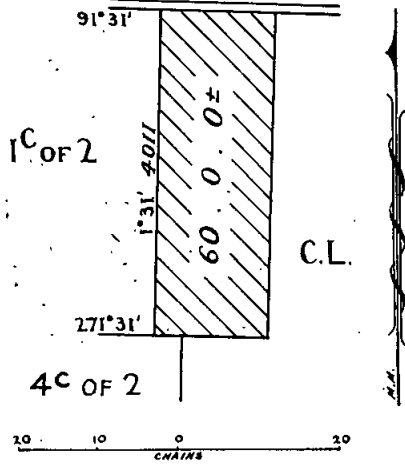

MARYBOROUGH.—Site for Public purposes (Government and Municipal purposes), 3 roods 9 perches, Township of Maryborough, Parish of Maryborough, County of Talbot, as indicated by hatching on plan hereunder.—(M.66⁽¹⁵⁾) (Rs.5729.)

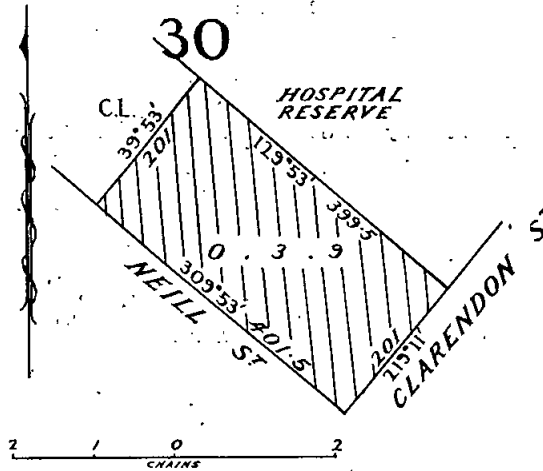

DUNBULBALANE.—Site for Public Recreation, 3 roods, Parish of Dunbulbalane, County of Moira, as indicated by hatching on plan hereunder.—(D.193F) (Rs.8426.)

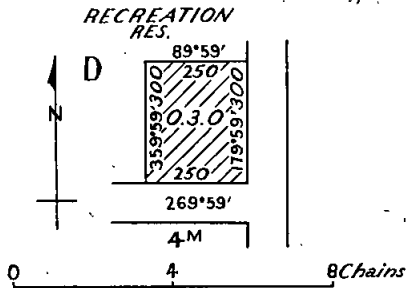

RUSHWORTH.—Site for State School purposes, 3 roods 30 perches, more or less, Township of Rushworth, Parish of Moora, County of Rodney, as indicated by hatching on plan hereunder.—(R.47⁽¹⁾) (Rs.2385.)

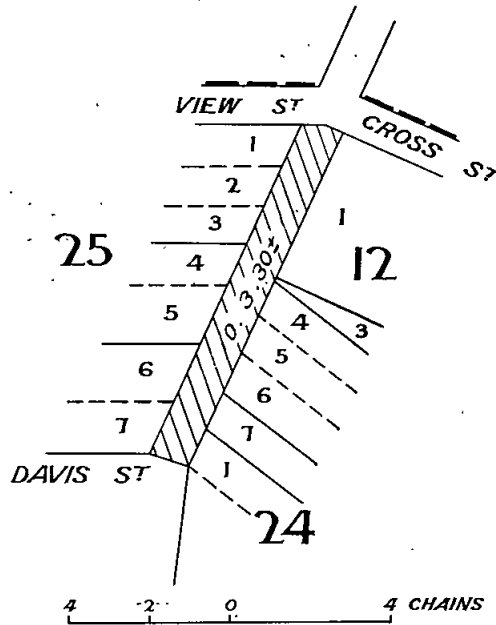

GOYURA.—Site for Public Recreation, 70 acres, more or less, Parish of Goyura, County of Karkaroc, as indicated by hatching on plan hereunder.—(G.202⁽¹⁾) (Rs.8810.)

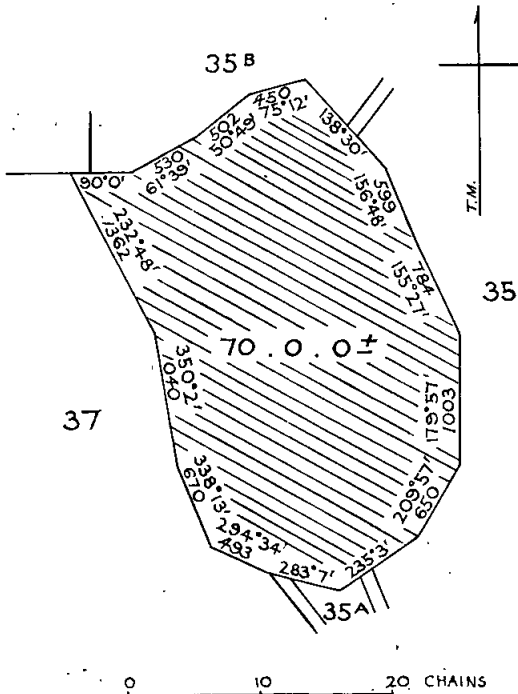

TAGGERTY.—Site for Public purposes (Forests Department purposes), 4 acres 3 roods 20 perches, more or less, Parish of Taggerty, County of Anglesey, as indicated by hatching on plan hereunder.—(T.188⁽⁶⁾) (Rs.8703.)

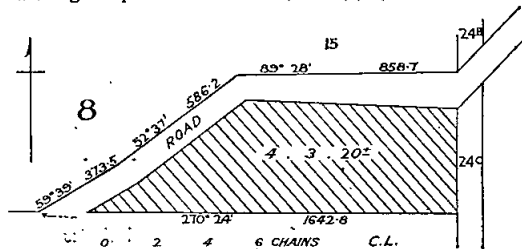

TARRAWINGEE (ELDORADO).—Site for Public Park, 16 acres 2 roods 20 perches, more or less, Parish of Tarrawingee, County of Bogong, as indicated by hatching on plan hereunder.—(T.61(k) (Rs.4972.)

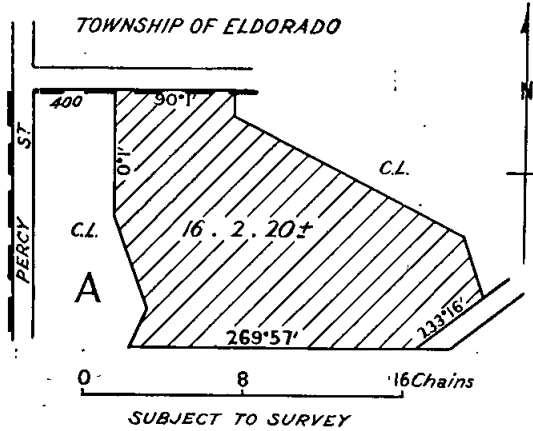

DEPARTMENT OF CROWN LANDS AND SURVEY.

At the Executive Council Chamber, Melbourne, the eleventh day of April, 1967.

PRESENT:
His Excellency the Governor of Victoria.
Mr. Thompson | Mr. Bloomfield.

UNUSED ROADS CLOSED.

HIS Excellency the Governor of the State of Victoria, by and with the advice of the Executive Council thereof, doth hereby direct that, in pursuance of the provisions of section 349 of the Land Act 1958, the unused roads referred to hereunder be closed, viz:—

Parish of Ballarat, Counties of Ripon and Grenville, being the roads indicated by hatching on plan hereunder.—(B.126⁽¹¹⁾ (J.31462.)

WARRA WARRA.—Site for Water Supply purposes, 9 acres 3 roods 6 perches, Parish of Warra Warra, County of Borung, as indicated by hatching on plan hereunder.—(W.261⁽⁴⁾ (Rs.580.)

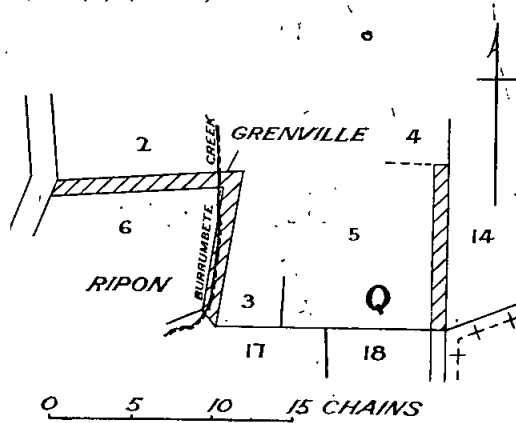
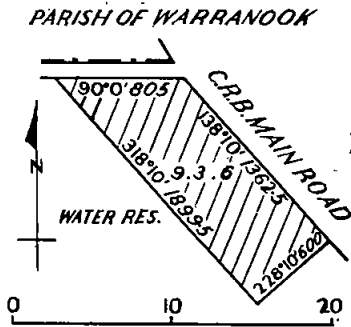

Parish of Coonoor West, County of Kara Kara, being the road between allotment 32 and allotments 50, 53.—(C.404⁽²⁾ (W.86532.)

WARRANTYTE (PARK ORCHARDS).—Site for Public purposes (Police purposes), 35 perches, Parish of Warrantyte, County of Evelyn, as indicated by hatching on plan hereunder.—(W.26⁽²⁾ (Rs.8804.)

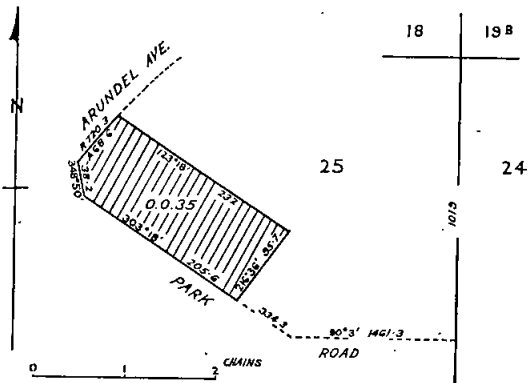

Parish of Korweinguboora, County of Grant, being the roads indicated by hatching on plan hereunder.—(K.133⁽⁶⁾ (J.29004.)

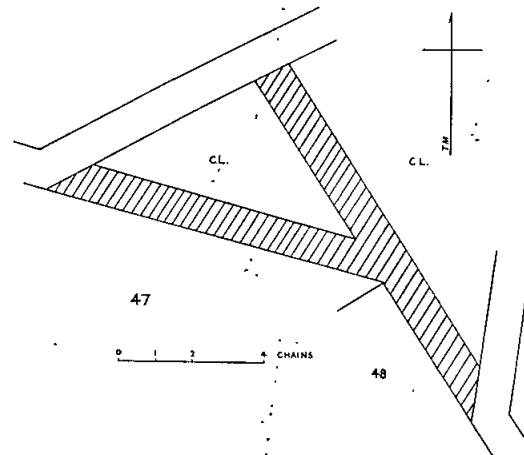

And the Honorable James Charles Murray Balfour, Her Majesty's Minister of Lands for the State of Victoria, shall give the necessary directions herein accordingly.

J. COLQUHOUN,
Clerk of the Executive Council.

Parish of Gooramadda, County of Bogong, being the road between allotment 8, section G1, Parish of Gooramadda, and allotments 12, 10, 9, 4, 8, section 4, Township of Gooramadda.—(G.114⁽⁴⁾ (H.030285.)

Township of Lorne, Parish of Lorne, County of Polwarth, being the portion of the width of the road indicated by hatching on plan hereunder.—(L.147(R1) (Misc.3719.)

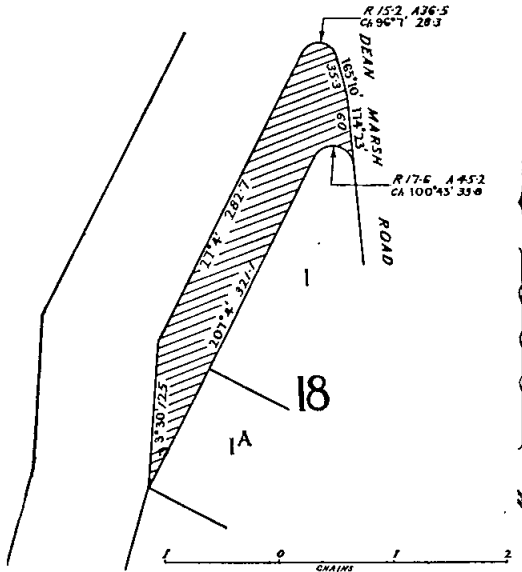

Parish of Narrung, County of Tatchera, being the portions of the width of the roads indicated by hatching on plan hereunder.—(N.128(D1) (M.60042.)

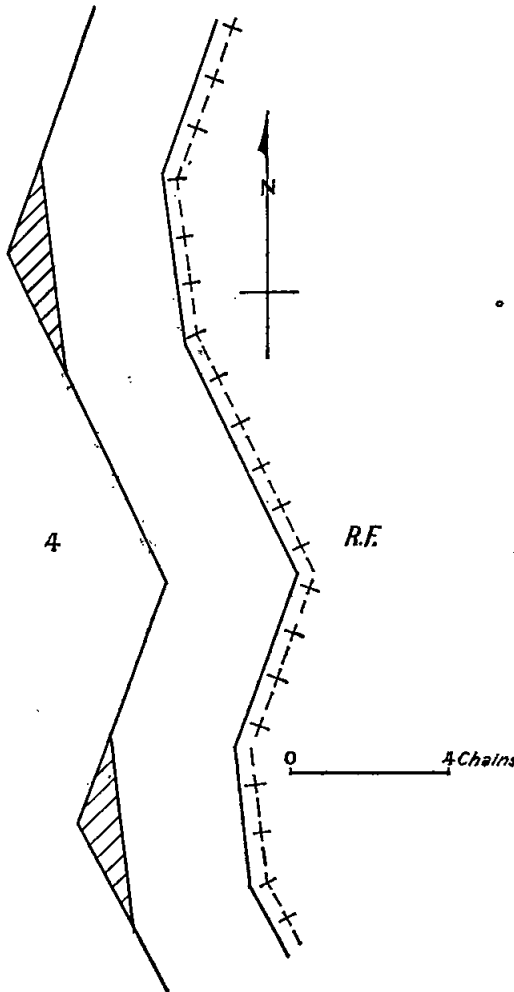

Parish of Franklin, County of Talbot, being the road indicated by hatching on plan hereunder.—(F.77(8) (W.88071.)

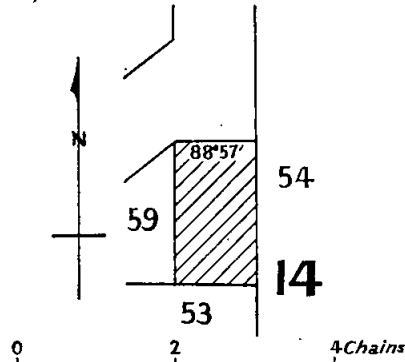

Parish of Tonghi, County of Croajingolong, being the road indicated by hatching on plan hereunder.—(T.271(3) (H.027997.)

PARISH OF NOORINBEE

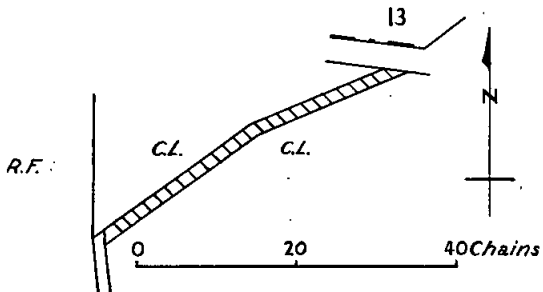

Parish of Wanwin, County of Follett, being the road indicated by hatching on plan hereunder.—(W.319(4) (J.31610.)

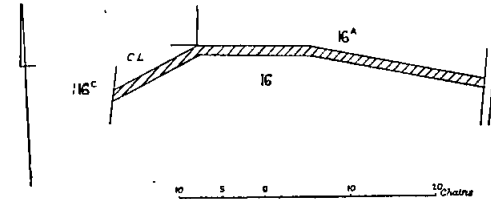

Township of Warracknabeal, Parish of Werrigar, County of Borung, being the road on the southern boundary of allotment 1, section 43.—(W.293(1) (M.51351.)

And the Honorable James Charles Murray Balfour, Her Majesty's Minister of Lands for the State of Victoria, shall give the necessary directions herein accordingly.

J. COLQUHOUN,
Clerk of the Executive Council.

DEPARTMENT OF CROWN LANDS AND SURVEY.

At the Executive Council Chamber, Melbourne, the eleventh day of April, 1967.

PRESENT:
His Excellency the Governor of Victoria.
Mr. Thompson | Mr. Bloomfield.

REVOCATION OF TEMPORARY RESERVATION OF LAND BY ORDER IN COUNCIL.

HIS Excellency the Governor of the State of Victoria, by and with the advice of the Executive Council thereof, doth hereby, in pursuance of the provisions of the Land Act 1958, revoke the temporary reservation of land by Order in Council hereinafter referred to, viz.:—

ARCHDALE.—Order in Council of 5th August, 1878, of 1 acre of land in the Township of Archdale, as a site for a Quarry.—(Rs.8764.)

BARWIDGEE.—Order in Council of 26th July, 1960, of 20 acres 1 rood 20 perches, more or less, of land in the Parish of Barwidgee, as a site for Travelling Stock purposes.—(Rs.7960.)

BLACKWOOD.—Order in Council of 24th April, 1871, of 3 roods 38 3/10 perches of land in the Township of Blackwood, as a site for Police purposes.—(Rs.2077.)

BOORT.—Order in Council of 6th March, 1876, of 2 acres of land in the Township of Boort, as a site for Public purposes (State School) and the temporary reservation by Order in Council of the 8th June, 1915, of 1 rood 8 perches of land as an extension thereto.—(Rs.8775.)

GALAH.—Order in Council of 20th November, 1939, of 2 roods 16 perches of land in the Township of Galah, as a site for a Public Hall.—(Rs.5135.)

INGLEWOOD.—Order in Council of 10th April, 1865, of 5 acres 3 roods 26 perches of land in the Township of Inglewood, as a site for a Pipeline in connexion with the public reservoir, and revoked as to part by various Orders.—(Rs.5354.)

LUDRIK-MUNJIE.—Order in Council of 1st March, 1949, of 1,300 acres, more or less, of land in the Parish of Ludrik-Munjie, as a site for the purpose of the manufacture or production of Eucalyptus Oil.—(73/141.)

SANDHURST.—Order in Council of 14th October, 1867, of 17 acres 2 roods 8 perches of land in the Parish of Sandhurst, as a site for Public purposes and revoked as to part by Order in Council of 22nd May, 1928.—(Rs.8799.)

WEDDERBURN.—Order in Council of 30th October, 1944, of 8 acres, more or less, of land in the Township of Wedderburn, as a site for Public Garden and Recreation so far only as regards the portion thereof comprised within the boundaries published in the *Government Gazette* of 1st March, 1967, and containing 1 acre 1 rood 30 perches, more or less.—(Rs.5523.)

YAUGHER.—Order in Council of 1st December, 1890, of 1 acre of land in the Parish of Yaugher, as a site for a State School.—(Rs.8788.)

And the Honorable James Charles Murray Balfour, Her Majesty's Minister of Lands for the State of Victoria, shall give the necessary directions herein accordingly.

J. COLQUHOUN,
Clerk of the Executive Council.

DEPARTMENT OF CROWN LANDS AND SURVEY.

At the Executive Council Chamber, Melbourne, the eleventh day of April, 1967.

PRESENT:

His Excellency the Governor of Victoria.
Mr. Thompson | Mr. Bloomfield.

LAND PERMANENTLY RESERVED AS A SITE.

HIS Excellency the Governor of the State of Victoria, by and with the advice of the Executive Council thereof, doth hereby, in pursuance of section 14 of the *Land Act* 1958, reserve permanently from sale and from being leased and from having a licence granted in respect thereof and also except from occupation for mining purposes under any miner's right, the land hereinafter described:—

WYUNA.—Twelve acres 3 roods 12 perches in the Parish of Wyuna, County of Rodney, as defined by the description published in the *Government Gazette* of 22nd February, 1967, which is required for Public Recreation and other Public purposes.—(Rs.2177.)

And the Honorable James Charles Murray Balfour, Her Majesty's Minister of Lands for the State of Victoria, shall give the necessary directions herein accordingly.

J. COLQUHOUN,
Clerk of the Executive Council.

MARINE STORES AND OLD METALS ACT 1958.

At the Executive Council Chamber, Melbourne, the eleventh day of April, 1967.

PRESENT:

His Excellency the Governor of Victoria.
Mr. Thompson | Mr. Bloomfield.

WHEREAS by section 4 of the *Marine Stores and Old Metals Act* 1958, it is enacted that the Governor in Council may from time to time upon the petition of any shire council within Victoria, make an Order directing that the provisions of Part II. of the said Act shall be extended to that shire:

And whereas the Council of the Shire of Swan Hill has petitioned the Governor in Council to extend the provisions of Part II. of the said Act to the Shire of Swan Hill:

Now therefore, His Excellency the Governor of the State of Victoria, in the Commonwealth of Australia, by and with the advice of the Executive Council of the said State, doth hereby direct that the provisions of Part II. of the *Marine Stores and Old Metals Act* 1958, shall be extended to and shall be in force from the first day of May, 1967, within and throughout the boundaries of the Shire of Swan Hill.

And the Honorable Arthur Gordon Rylah, Her Majesty's Chief Secretary for the State of Victoria, shall give the necessary directions herein accordingly.

J. COLQUHOUN,
Clerk of the Executive Council.

LOCAL GOVERNMENT DEPARTMENT.

At the Executive Council Chamber, Melbourne, the eighteenth day of April, 1967.

PRESENT:

His Excellency the Governor of Victoria.
Mr. Chandler | Mr. Porter.
Mr. Hamer

TOWN OF BAIRNSDALE.—FIRST ELECTION OF COUNCILLORS.

WHEREAS by the *Local Government Act* 1958, as amended, it is enacted that the Governor in Council may from time to time make Orders exercising certain powers therein set forth, amongst others to make provision for the election of councillors consequent upon the constitution of a new municipality, and that every such Order shall be published in the *Government Gazette*.

And whereas an Order constituting part of the Shire of Bairnsdale a town under the name of the Town of Bairnsdale is now being made.

Now therefore His Excellency the Governor of the State of Victoria, by and with the advice of the Executive Council thereof, doth hereby order that—

- (a) Edward Lloyd Brindley, Secretary of the Shire of Bairnsdale, shall prepare the voters' rolls and be the returning officer for the first election of councillors for the said Town.
- (b) The Regulations relating to voting by post and compulsory voting at elections of councillors made under the provisions of section 149 of the *Local Government Act* shall apply to such first election, which shall be held between the hours of 8 o'clock in the forenoon and 5 o'clock in the afternoon of the 3rd day of June, 1967; and
- (c) Notice of the elections shall be published in the "*Bairnsdale Advertiser*".

And the Honorable Rupert James Hamer, Her Majesty's Minister for Local Government for the State of Victoria, shall give the necessary directions herein accordingly.

J. COLQUHOUN,
Clerk of the Executive Council.

LOCAL GOVERNMENT DEPARTMENT.

At the Executive Council Chamber, Melbourne, the eighteenth day of April, 1967.

PRESENT:

His Excellency the Governor of Victoria. Mr. Chandler | Mr. Porter. Mr. Hamer

TOWN OF BAIRNSDALE CONSTITUTED.

WHEREAS it is provided by Part II. of the Local Government Act 1958, as amended, that the Governor in Council may after the receipt of a request to constitute any area of land in Victoria a municipality other than a Shire, signed by at least one-tenth of the persons whose names are inscribed on the municipal roll in respect of property in that area and upon being satisfied that the proposal set out in the request has been carried at a poll of such persons, and that the area is substantially urban in character, has a population of at least five thousand inhabitants and, in the year ended on the thirtieth day of September last passed, yielded a revenue from general and extra rates of not less than eighty thousand dollars, constitute that area a Town; and

Whereas every Order constituting a new Town shall assign a name to such Town, describe the boundaries thereof, determine of how many members the council shall consist and whether the municipal district is to be subdivided or not and in case it is to be subdivided, name and describe the subdivisions; and

Whereas it is further enacted that notwithstanding anything in the said Act any such Order may provide for any election of councillors necessary to be held consequent thereon to be held on a day appointed therein whether before or after the taking effect of any other provision of the Order;

And any such Order shall be published in the Government Gazette and shall take effect from the day or days specified therein and different days may be specified for different purposes.

And whereas a request pursuant to the said Act for the constitution as a Town of the Centre Riding, portion of the East Riding, and portion of the South Riding of the Shire of Bairnsdale has been received by the Governor in Council and the proposal set out in the request has been carried at a poll of ratepayers entitled to vote in respect of property in such ridings.

Now therefore, His Excellency the Governor of the State of Victoria, by and with the advice of the Executive Council thereof, doth by this Order grant such request and doth constitute a Town to be named the Town of Bairnsdale and doth further order that:—

- (i) The boundaries of the municipal district of the Town of Bairnsdale shall be those set forth in the Schedule hereto. (ii) The municipal district of the said Town shall be un-subdivided. (iii) The Council of the said Town shall consist of twelve Councillors. (iv) The first election of Councillors of the said Town shall be held on the third day of June, 1967.

This Order shall take effect on and from the 31st day of May, 1967.

SCHEDULE.

Town of Bairnsdale—(Constituted).

Commencing at the south-western angle of allotment 1; section A, Township of Bairnsdale; thence generally northerly by that township boundary to the Mitchell River; thence generally northerly and generally easterly by that river to a point in line with the western boundary of allotment 30C, Parish of Wy-Yung; thence northerly by a line and the western boundaries of that allotment and allotments 30B, 30A, 29A, 28 and 27B and easterly by a line (across the Bulumwaal-road), the northern boundary of allotment 27A, Township of Lucknow and a line to the Clifton Creek; thence generally south-easterly by that creek to the road on the northern boundary of allotment 34A; thence easterly by that road to the northern angle of allotment 36AB1; thence south-easterly and southerly by a road on the north-eastern and eastern boundaries of that allotment to the southern boundary thereof; thence easterly by a road to the road on the eastern boundary of the Township of Lucknow; thence southerly by that road to the road on the southern boundary of that township; thence westerly

by that road to the Mitchell River; thence generally south-easterly by that river to a point in line with the road on the southern boundary of allotment 6, section H, Township of Bairnsdale; thence south-westerly by a line, that road and a line to the eastern boundary of allotment 202A, Parish of Bairnsdale; thence northerly by that boundary and generally westerly by the northern boundaries of that allotment and allotments 200A, 199A, 74B and 74G to a point in line with the road on the eastern boundary of allotment 19A, section B, Township of Bairnsdale; thence northerly by a line and that road to the northern boundary of allotment 19; thence westerly by that boundary and northerly by the eastern boundary of allotment 18 to the road on the northern boundary of that allotment; thence westerly by that road to the Princes Highway; thence north-easterly by that highway to the road on the southern boundary of allotment 1, section A, and thence westerly by that road to the point of commencement. (Area 10.5 square miles).

And the Honorable Rupert James Hamer, Her Majesty's Minister for Local Government for the State of Victoria, shall give the necessary directions herein accordingly.

J. COLQUHOUN, Clerk of the Executive Council.

COUNTRY ROADS BOARD.

At the Executive Council Chamber, Melbourne, the eighteenth day of April, 1967.

PRESENT:

His Excellency the Governor of Victoria. Mr. Chandler | Mr. Porter. Mr. Hamer

ORDER APPROVING OF LAND BEING ACQUIRED AND ROADS, DEVIATIONS OR WIDENINGS BEING MADE.

HIS Excellency the Governor of the State of Victoria, by and with the advice of the Executive Council thereof, being satisfied that there are funds legally available for acquiring the land, doth hereby approve the acquiring of the land described in the Schedule hereunder and the making of new roads and deviations from and widenings of existing roads referred to in the said Schedule.

SCHEDULE.

Main Roads.

The land shown hatched on plan numbered G.P.10831 hereunder required for the widening of the Charlton-Durham Ox road in the Shire of Gordon and making of the widening thereon.

MAIN ROAD CHARLTON — DURHAM OX ROAD SHIRE OF GORDON Measurements in links

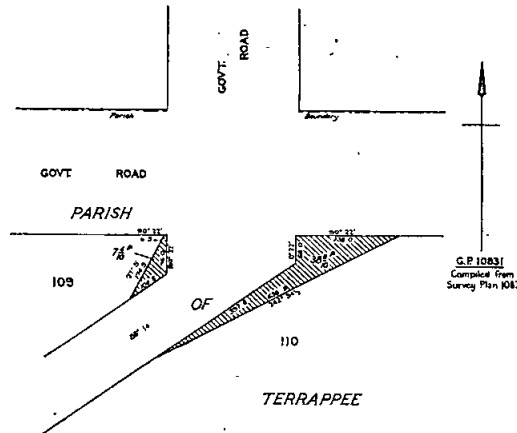

State Highways.

The land shown hatched on plan numbered G.P.10865 hereunder required for the widening of the Bellarine Highway in the Shire of Bellarine and making of the widening thereon.

STATE HIGHWAY
BELLARINE HIGHWAY
SHIRE OF BELLARINE
Measurements in feet and inches

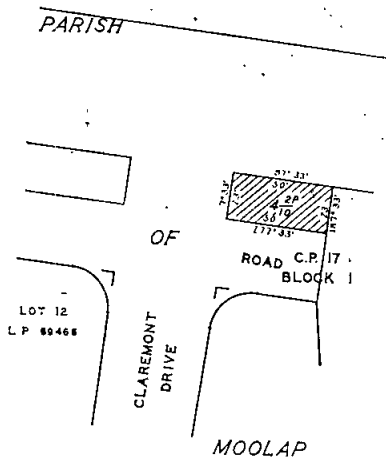

G.P. 10865
Compiled from
Survey Plan 10865

Tourists' Roads.

The land shown hatched on plans numbered G.P.10774, G.P.10777, G.P.10778, G.P.10779, G.P.10780, G.P.10781 and G.P.10782 hereunder required for the deviation of the Ocean-road in the Shire of Otway and making of the deviation thereon.

TOURISTS' ROAD
OCEAN ROAD
SHIRE OF OTWAY
Measurements in links

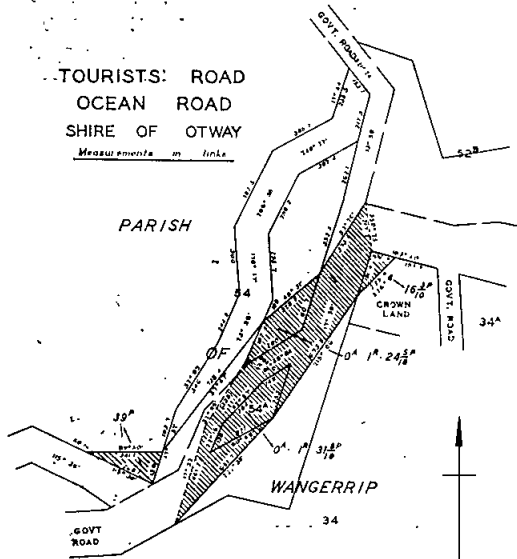

G.P. 10774
Compiled from
Survey Plan 10774

The land shown hatched on plan numbered G.P.10875 hereunder required for the widening of the Glenelg Highway in the Shire of Mount Rouse and making of the widening thereon.

STATE HIGHWAY
GLENELG HIGHWAY
SHIRE OF MOUNT ROUSE
Measurements in links

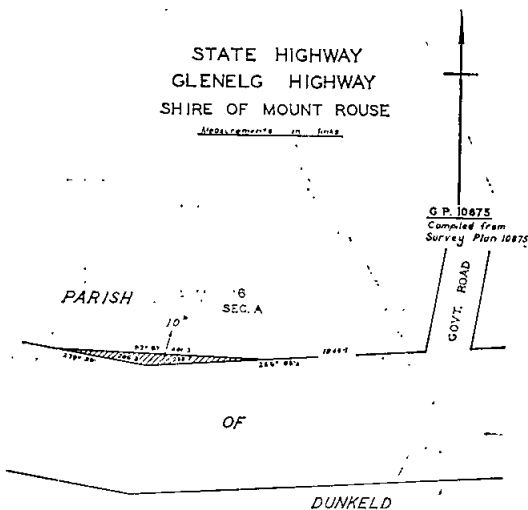

G.P. 10875
Compiled from
Survey Plan 10875

TOURISTS' ROAD
OCEAN ROAD
SHIRE OF OTWAY
Measurements in links

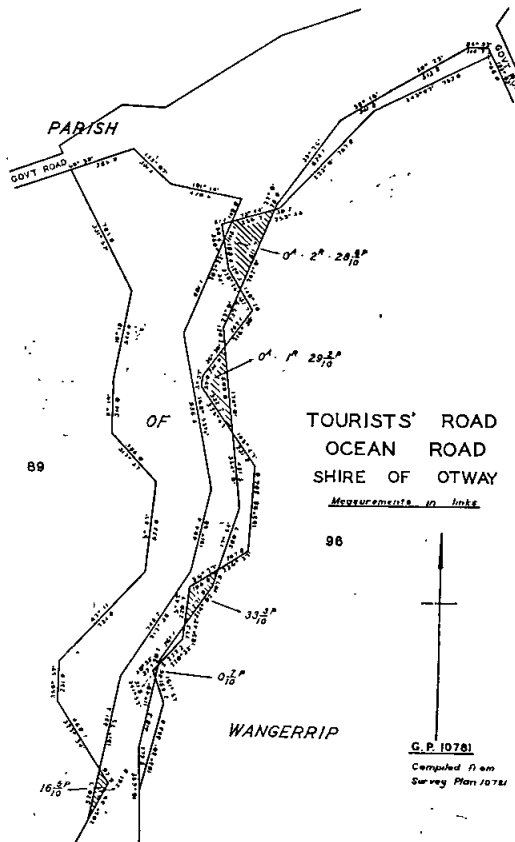

G.P. 10781
Compiled from
Survey Plan 10781

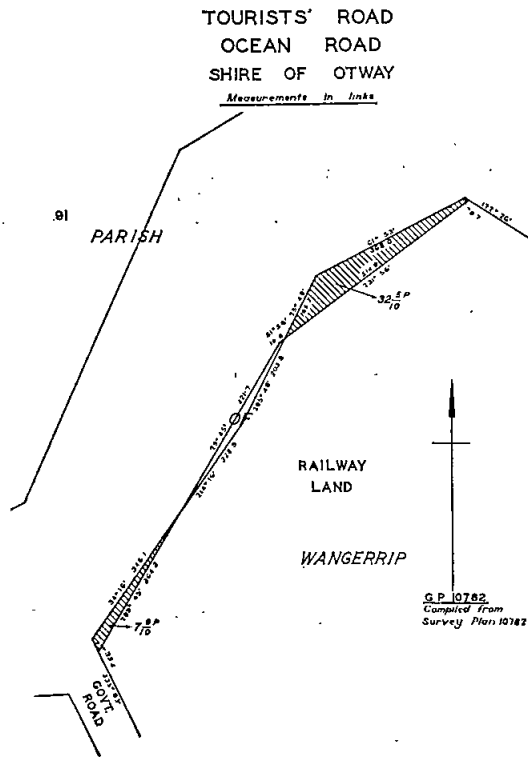
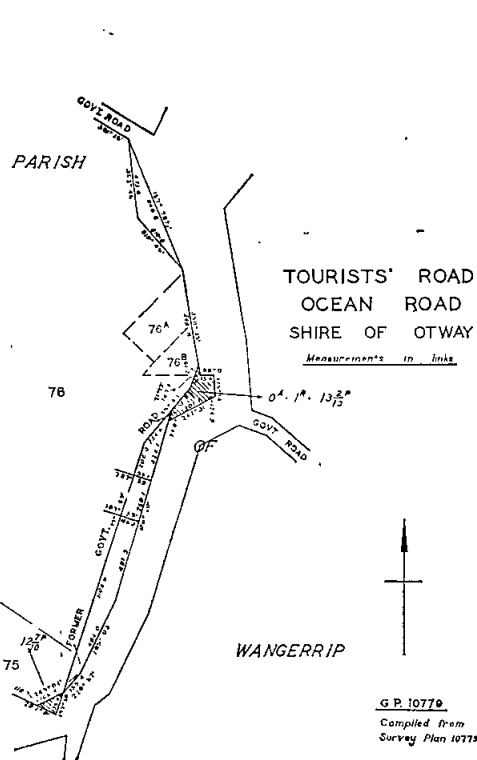
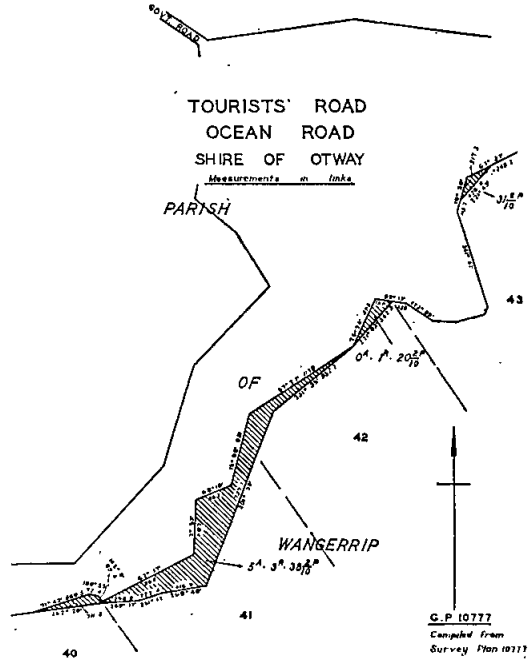
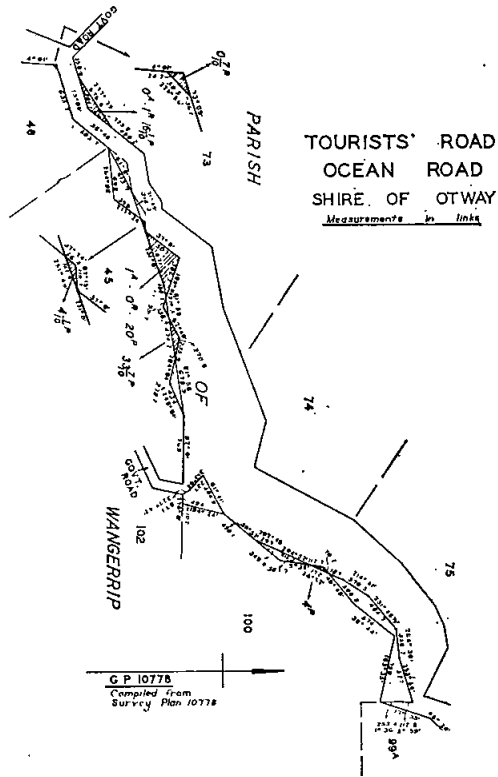

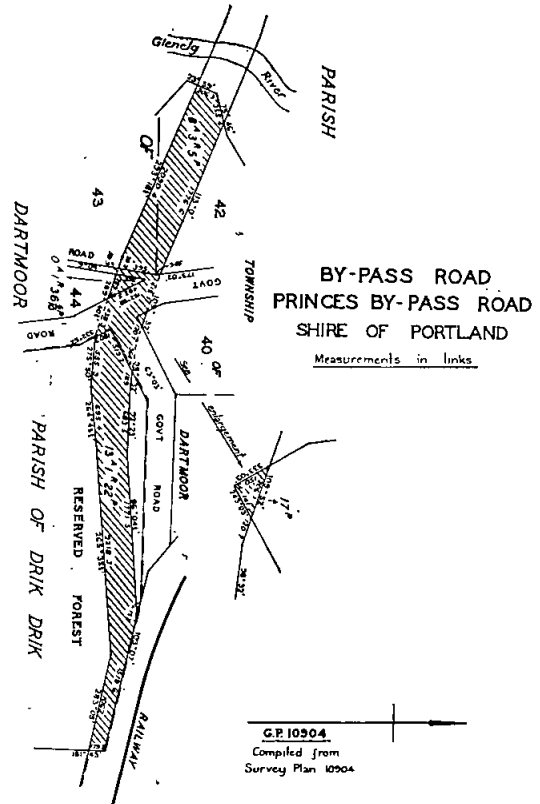
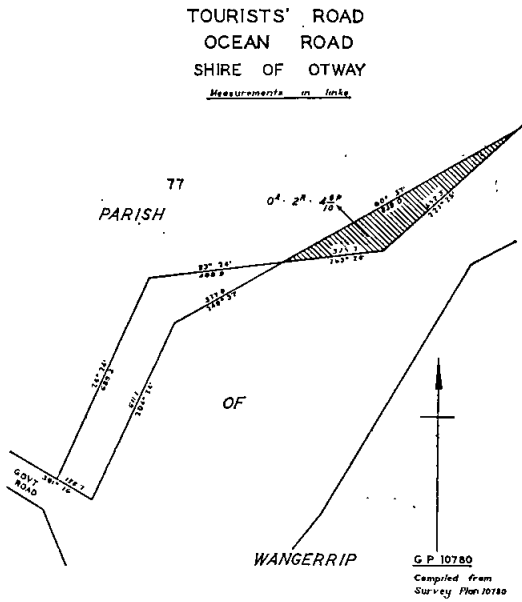

By-pass Roads.

The land shown hatched on plans numbered G.P.10903A and G.P.10904 hereunder required for the making of the Princes By-pass road in the Shire of Portland.

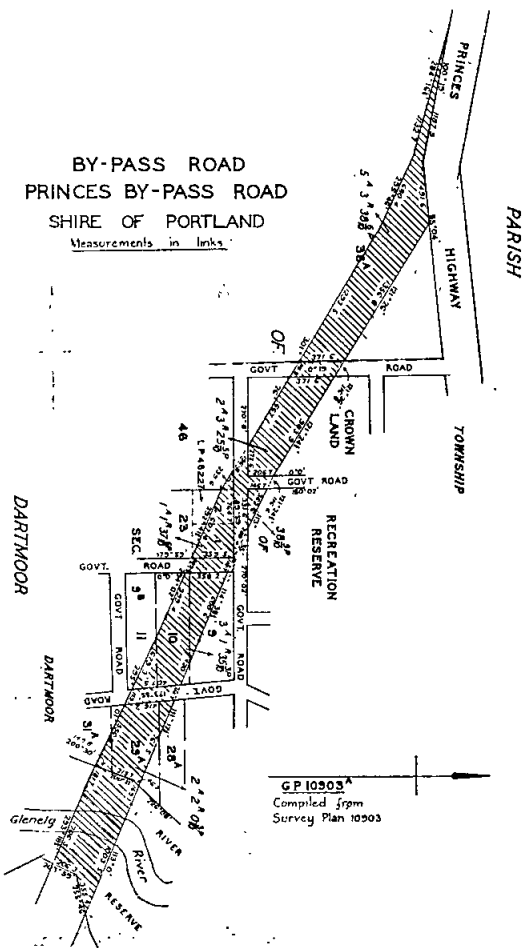

The land shown hatched on plan numbered G.P.9644 hereunder required for the making of the Mulgrave By-pass road in the City of Waverley.

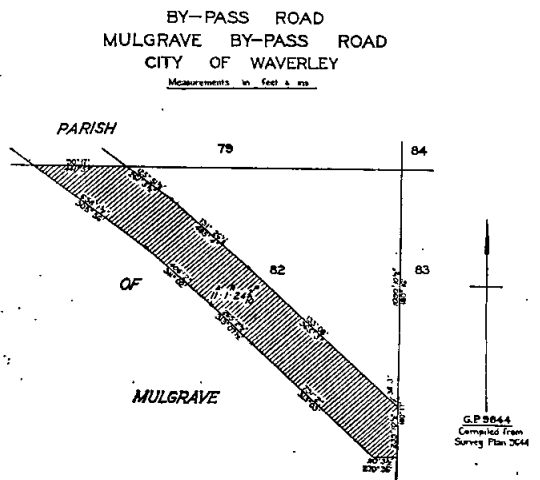

Unclassified Roads.

The land shown hatched on plan numbered G.P.10903B hereunder required for the making of the Princes By-pass Access road in the Shire of Portland.

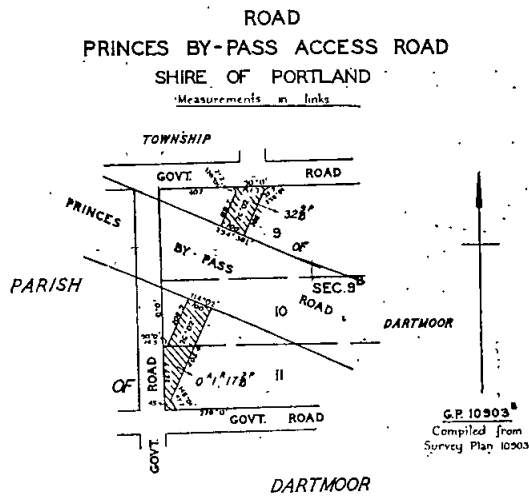

And the Honorable Murray Victor Porter, Her Majesty's Minister of Public Works for the State of Victoria, shall give the necessary directions herein accordingly.

J. COLQUHOUN,
Clerk of the Executive Council.

COUNTRY ROADS BOARD.

At the Executive Council Chamber, Melbourne, the
eighteenth day of April, 1967.

PRESENT:

His Excellency the Governor of Victoria.
Mr. Chandler Mr. Porter.
Mr. Hamer

ORDER CONFIRMING RESOLUTIONS OF THE COUNTRY
ROADS BOARD.

HIS Excellency the Governor of the State of Victoria, by and with the advice of the Executive Council thereof, doth hereby, in pursuance of the provisions of the Country Roads Act 1958, confirm the Resolutions of the Country Roads Board, the dates whereof, and the terms of which are scheduled hereunder:—

SCHEDULE.

State Highways.

Resolution dated 10th April, 1967, made, pursuant to sections 21, 58 and 74 of the Country Roads Act 1958, declaring the deviation from the Midland Highway in the Shires of Alberton and South Gippsland as indicated by diagonal hatching on the plans numbered G.P.10449 and G.P.10450 hereunder to be part of a State highway within the meaning and for the purposes of the Country Roads Act 1958, and also declaring that such deviation shall be in lieu of the existing road or part thereof indicated by cross-hatching on plan numbered G.P.10449 and that such part of the said existing road shall be discontinued.

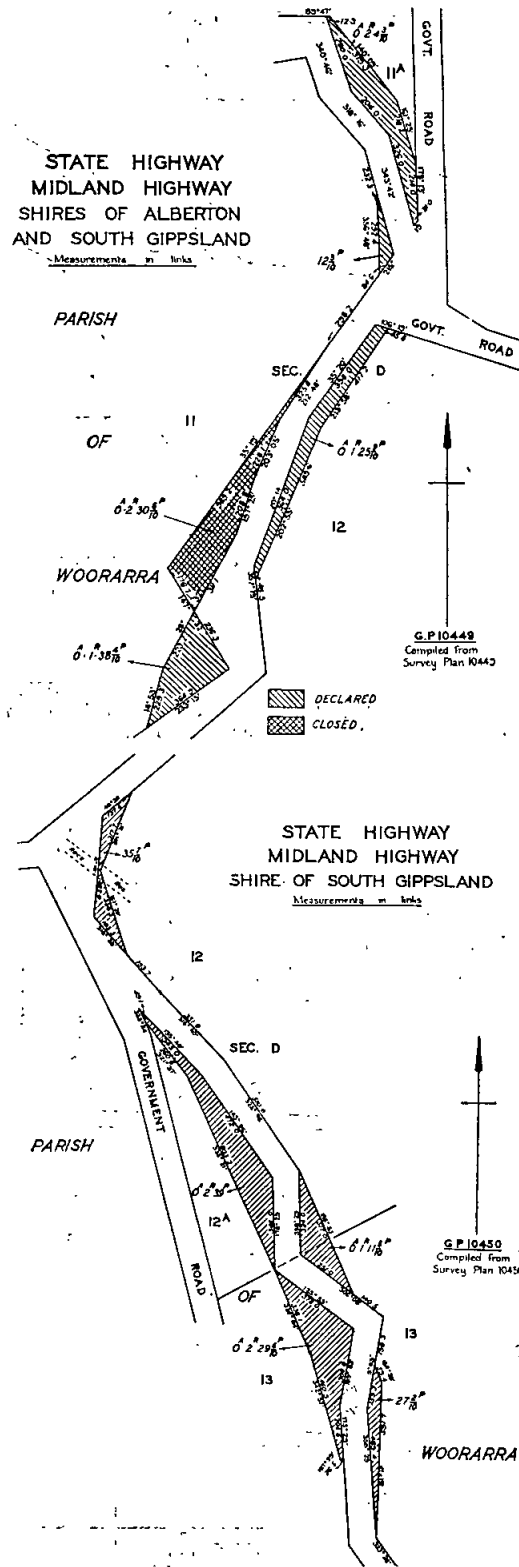

And the Honorable Murray Victor Porter, Her Majesty's Minister of Public Works for the State of Victoria, shall give the necessary directions herein accordingly.

J. COLQUHOUN,
Clerk of the Executive Council.

LANDLORD AND TENANT ACT 1958.

At the Executive Council Chamber, Melbourne, the eighteenth day of April, 1967.

PRESENT:

His Excellency the Governor of Victoria.
Mr. Chandler | Mr. Porter.
Mr. Hamer

ORDER EXTENDING APPLICATION OF PART V. OF THE LANDLORD AND TENANT ACT 1958 TO CERTAIN PREMISES.

IN pursuance of the powers conferred by section 44 of the *Landlord and Tenant Act 1958*, His Excellency the Governor of Victoria, by and with the advice of the Executive Council, doth hereby declare that the application of Part V. of the *Landlord and Tenant Act 1958* shall extend to the following premises—

1. The premises known as Number 8 Cooke-court, Richmond;
2. The premises known as Number 60 Whitehall-street, Footscray, and to all premises forming part of such premises.

And the Honorable Arthur Gordon Rylah, Her Majesty's Attorney-General in and for the State of Victoria, shall give the necessary directions herein accordingly.

J. COLQUHOUN,
Clerk of the Executive Council.

KYNETON SHIRE WATERWORKS TRUST.

At the Executive Council Chamber, Melbourne, the eighteenth day of April, 1967.

PRESENT:

His Excellency the Governor of Victoria.
Mr. Chandler | Mr. Porter.
Mr. Hamer

REPEAL OF ORDER.

UNDER the powers conferred by the Water Act and all other powers enabling him in that behalf, His Excellency the Governor of the State of Victoria, by and with the advice of the Executive Council of the said State, doth hereby repeal the Order in Council fixing the limit of the overdraft to be obtained by the Kyneton Shire Waterworks Trust made on 17th July, 1951 and published in the *Victoria Government Gazette* dated 25th July, 1951.

And the Honorable Thomas Anthony Darcy, Her Majesty's Minister of Water Supply for the State of Victoria, shall give the necessary directions herein accordingly.

J. COLQUHOUN,
Clerk of the Executive Council.

MOE WATERWORKS TRUST.

At the Executive Council Chamber, Melbourne, the eighteenth day of April, 1967.

PRESENT:

His Excellency the Governor of Victoria.
Mr. Chandler | Mr. Porter.
Mr. Hamer

CONSENT TO BORROWING \$7,000.

UNDER the powers conferred by the Water Act and all other powers enabling him in that behalf, His Excellency the Governor of the State of Victoria, by and with the advice of the Executive Council of the said State, doth hereby consent to the Moe Waterworks Trust borrowing at interest the sum of Seven thousand dollars (\$7,000) to meet the cost of water supply works.

And the Honorable Thomas Anthony Darcy, Her Majesty's Minister of Water Supply for the State of Victoria, shall give the necessary directions herein accordingly.

J. COLQUHOUN,
Clerk of the Executive Council.

MILDURA URBAN WATER TRUST.

At the Executive Council Chamber, Melbourne, the eighteenth day of April, 1967.

PRESENT:

His Excellency the Governor of Victoria.
Mr. Chandler | Mr. Porter.
Mr. Hamer

EXTENT OF URBAN DISTRICT INCREASED.

UNDER the powers conferred by the Mildura Irrigation and Water Trusts Act and all other powers enabling him in that behalf, His Excellency the Governor of the State of Victoria, by and with the advice of the Executive Council of the said State, doth hereby declare, order and direct as follows:—

That the extent of the Urban District of the Mildura Urban Water Trust be increased by adding to the same the lands comprised within the boundaries described in the Schedule hereto, and as on and from the date hereof, the extent of such District shall be deemed to be increased accordingly.

SCHEDULE.

Portion I.

Dyar-avenue (between Seventeenth-street and Dow-avenue).—Being all the road reservation in Dyar-avenue, Parish of Mildura, County of Karkaroc, between the south-western boundary of Seventeenth-street and the north-eastern boundary of Dow-avenue.

Portion II.

Riverside-avenue (between Seventeenth-street and Dow-avenue).—Being all the road reservation in Riverside-avenue, Parish of Mildura, County of Karkaroc, between the south-western boundary of Seventeenth-street and the north-eastern boundary of Dow-avenue.

Portion III.

Seventeenth-street (between Flora-avenue and Deakin-avenue).—Being all the road reservation in Seventeenth-street, Parish of Mildura, County of Karkaroc, between the south-eastern boundary of Flora-avenue and the north-western boundary of Deakin-avenue.

Portion IV.

Riverside-avenue (between Seventeenth-street and Sixteenth-street).—Being all the road reservation in Riverside-avenue, Parish of Mildura, County of Karkaroc, between the north-eastern boundary of Seventeenth-street and line parallel to and distant 460 feet north-easterly from the north-eastern boundary of Seventeenth-street.

Portion V.

Ontario-avenue (between Seventeenth-street and Sixteenth-street).—Being all the road reservation in Ontario-avenue, Parish of Mildura, County of Karkaroc, between the north-eastern boundary of Seventeenth-street and line parallel to and distant 2,175 feet north-easterly from the north-eastern boundary of Seventeenth-street.

Portion VI.

Seventeenth-street (between Etiwanda-avenue and Benetook-avenue).—Being all the road reservation in Seventeenth-street, Parish of Mildura, County of Karkaroc, between the south-eastern boundary of Etiwanda-avenue and the north-western boundary of Benetook-avenue.

Portion VII.

Dow-avenue (between Etiwanda-avenue and Benetook-avenue).—Being all the road reservation in Dow-avenue, Parish of Mildura, County of Karkaroc, between the south-eastern boundary of Etiwanda-avenue and the north-western boundary of Benetook-avenue.

Portion VIII.

Benetook-avenue (between Sixteenth-street and Dow-avenue).—Being all the road reservation in Benetook-avenue, Parish of Mildura, County of Karkaroc, between the north-eastern boundary of Sixteenth-street and the south-western boundary of Dow-avenue.

Portion IX.

Seventeenth-street (between Benetook-avenue and Cowra-avenue).—Being all the road reservation in Seventeenth-street, Parish of Mildura, County of Karkaroc, between the south-eastern boundary of Benetook-avenue and the north-western boundary of Cowra-avenue.

Portion X.

Plantation-street (off Deakin-avenue).—Being all the road reservation contained in the area commencing at a point on the north-western boundary of Deakin-avenue, being distant 927 ft. 7¼ in. north-east of Fifteenth-street; thence by lines bearing 315 deg. 16 min. a distance of 150 feet, 45 deg. 16 min. a distance of 50 feet, 135 deg. 16 min. a distance of 150 feet, and 225 deg. 16 min. a distance of 50 feet to the point of commencement.

Portion XI.

Walnut-avenue (between Seventeenth-street and Dow-avenue).—Being all the road reservation in Walnut-avenue between the south-western boundary of Seventeenth-street and the north-eastern boundary of Dow-avenue.

All of which boundaries are shown on a plan approved by the Governor in Council and deposited in the office of the State Rivers and Water Supply Commission, Melbourne.—(Corres. 63/4747/112.)

And the Honorable Thomas Anthony Darcy, Her Majesty's Minister of Water Supply for the State of Victoria, shall give the necessary directions herein accordingly.

J. COLQUHOUN,
Clerk of the Executive Council.

COBRAM SEWERAGE AUTHORITY.

At the Executive Council Chamber, Melbourne, the eighteenth day of April, 1967.

PRESENT:

His Excellency the Governor of Victoria.
Mr. Chandler | Mr. Porter.
Mr. Hamer

CONSENT TO BORROWING \$200,000.

UNDER the powers conferred by the Sewerage Districts Act and all other powers enabling him in that behalf, His Excellency the Governor of the State of Victoria, by and with the advice of the Executive Council of the said State, doth hereby consent to the Cobram Sewerage Authority borrowing at interest by the assignment of the General Fund the sum of Two hundred thousand dollars (\$200,000) to meet the cost of sewerage works as set forth in the detailed statement bearing date the 14th April, 1967.

And the Honorable Thomas Anthony Darcy, Her Majesty's Minister of Water Supply for the State of Victoria, shall give the necessary directions herein accordingly.

J. COLQUHOUN,
Clerk of the Executive Council.

MELBOURNE AND METROPOLITAN TRAMWAYS ACT 1958 No. 6311.

At the Executive Council Chamber, Melbourne, the eighteenth day of April, 1967.

PRESENT:

His Excellency the Governor of Victoria.
Mr. Chandler | Mr. Porter.
Mr. Hamer

WHEREAS His Excellency the Governor of the State of Victoria by and with the advice of the Executive Council thereof, has this day consented pursuant to the provisions of section 28 of the *Melbourne and Metropolitan Tramways Act 1958*, to the Melbourne and Metropolitan Tramways Board raising by way of loan an amount not exceeding Two hundred and fifty thousand dollars (\$250,000): And whereas His Excellency the Governor is satisfied that a sufficient proportion of the loan to be so raised will fall due and be repaid in each year during the currency of the proposed loan: Now therefore it is directed, pursuant to the provisions of section 28 (6) of the said Act, that it shall not be necessary to provide a sinking fund in connection with such loan.

And the Honorable Sir Henry Edward Bolte, Her Majesty's Treasurer for the State of Victoria, shall give the necessary directions herein accordingly.

J. COLQUHOUN,
Clerk of the Executive Council.

MELBOURNE AND METROPOLITAN TRAMWAYS ACT 1958 No. 6311.

At the Executive Council Chamber, Melbourne, the eighteenth day of April, 1967.

PRESENT:

His Excellency the Governor of Victoria.
Mr. Chandler | Mr. Porter.
Mr. Hamer

WHEREAS His Excellency the Governor of the State of Victoria by and with the advice of the Executive Council thereof, has this day consented pursuant to the provisions of section 28 of the *Melbourne and Metropolitan Tramways Act 1958*, to the Melbourne and Metropolitan Tramways Board raising by way of loan an amount not exceeding Eighty-seven thousand dollars (\$87,000): And whereas His Excellency the Governor is satisfied that a sufficient proportion of the loan to be so raised will fall due and be repaid in each year during the currency of the proposed loan: Now therefore it is directed, pursuant to the provisions of section 28 (6) of the said Act, that it shall not be necessary to provide a sinking fund in connection with such loan.

And the Honorable Sir Henry Edward Bolte, Her Majesty's Treasurer for the State of Victoria, shall give the necessary directions herein accordingly.

J. COLQUHOUN,
Clerk of the Executive Council.

STAMPS ACT 1958, No. 6375.

At the Executive Council Chamber, Melbourne, the eighteenth day of April, 1967.

PRESENT:

His Excellency the Governor of Victoria.
Mr. Chandler | Mr. Porter.
Mr. Hamer

DECLARATION OF APPROVED VENDOR.

HIS Excellency the Governor of the State of Victoria, by and with the advice of the Executive Council thereof, doth by this Order made pursuant to section 131c (1) of the *Stamps Act 1958*, declare the under-mentioned person carrying on business as a vendor of goods under instalment purchase agreements to be an "approved vendor" for the purposes of subdivision (14) of Division three of Part II. of the *Stamps Act 1958*:—

234. HEMBURROWS.

And the Honorable Sir Henry Edward Bolte, Her Majesty's Treasurer for the State of Victoria, shall give the necessary directions herein accordingly.

J. COLQUHOUN,
Clerk of the Executive Council.

LANDS DEPARTMENT NOTICES

APPROACHING LAND SALES.

SALES of Crown lands, in fee-simple, will be held at the under-mentioned places and dates, viz.:—

	No. of Gazette.
Dartmoor.—Tuesday, 30th May, 1967	.. 33
Maryborough.—Friday, 26th May, 1967	.. 33
Seymour.—Friday, 9th June, 1967	.. 33
Waihalla.—Saturday, 22nd April, 1967	.. 23
Warragul.—Wednesday, 26th April, 1967	.. 28

SALE OF FREEHOLD LAND BY AUCTION.

Hamilton.—Friday, 28th April, 1967	.. 23
------------------------------------	-------

AUCTION OF THE RIGHT TO LEASE CROWN LAND.

Meeniyan.—Wednesday, 26th April, 1967	.. 28
Melbourne.—Wednesday, 3rd May, 1967	.. 29
St. Arnaud.—Thursday, 25th May, 1967	.. 33

SALES OF CROWN LAND BY AUCTION.

The land will be offered for sale in fee-simple, and subject to the provisions of the Land Act and Regulations thereunder.

The upset price is the sum at which bidding will start, and no bid below that sum can be accepted. The highest bidder at or above that sum shall be the purchaser, subject to signature of contract and any necessary payment.

TERMS:

A deposit of at least 12½% of the purchase price must be paid at the sale, either in cash or by cheque.

The residue is payable in half-yearly instalments, in accordance with the following scale, or may be paid off at any earlier time.

\$40 and under, 6 instalments.	
Over \$40, and not exceeding \$100, 8 instalments.	
Over \$100, and not exceeding \$200, 10 instalments.	
Over \$200, and not exceeding \$400, 12 instalments.	
Over \$400, and not exceeding \$600, 14 instalments.	
Over \$600, and not exceeding \$800, 16 instalments.	
Over \$800, and not exceeding \$1,000, 18 instalments.	
Over \$1,000, 20 instalments.	

Interest at the rate of 5% per annum is payable with all payments of residue, and is computed for each instalment from the date of sale to the date of such payment. Additional interest is charged if any instalment is not paid on or before the due date.

If paid off within 30 days of sale, no interest is payable.

FEES, ETC.:

Also payable at the sale, in addition to the deposit, are the survey fee and, if applicable, the valuation of improvements (if purchaser be not the owner thereof).

Payable with balance of purchase money—

Crown Grant fee—	
50 acres and under	\$3
Over 50 acres	\$4
Purchase money \$10 or under	\$2

Assurance Fund contribution.—One cent in every Five dollars or part thereof of purchase price. (This is a fund established to guarantee the validity of freehold titles.)

Transfer of interest prior to completion of payment may be allowed on payment of \$2 fee and subject to stamp duty.

If unable to attend personally, a prospective purchaser may arrange for another person to bid as his agent.

Attention is drawn to section 95, Land Act 1958, which provides that the purchaser shall be deemed to be the owner for the purposes of other Acts; also to an amendment to the Local Government Act providing for Government roads, in certain circumstances, to be declared "private streets", thus making the purchaser liable to contribute to the cost of street construction.

J. C. M. BALFOUR,
Minister of Lands.

Office of Crown Lands and Survey,
Melbourne, 19th April, 1967.

DARTMOOR.—Sale (No. 11862) of Crown land in fee-simple, by auction, will be held at the LAND INSPECTORS OFFICE, DARTMOOR, on TUESDAY, 30th MAY, 1967, commencing at ELEVEN o'clock a.m. To be conducted by K. C. GITTENS, Land Officer, Hamilton.

Lot 1.

TOWNSHIP OF DARTMOOR, PARISH OF DARTMOOR, COUNTY OF FOLLETT.

A corner allotment fronting the southern side of Egan-street at its western end.

Upset price \$70 the lot. Survey fee \$12.

Area 2 roods, allotment 25 of section 9B.—(J.31474.)

Lot 2.

PARISH OF WANWIN, COUNTY OF FOLLETT.

In the north-west of the Parish.

Upset price \$480 the lot. Survey fee \$56.75.

Area 112a. 2r. 29p., allotment 16c.—(J.31611.)

Lot 3.

PARISH OF KINKELLA, COUNTY OF FOLLETT.

In the south of the Parish.

Upset price \$320 the lot. Survey fee \$26.25.

Area 37a. 0r. 32p., allotment 20. Valuation of improvements \$160 (fencing) (G. L. Bond).—(J.31355.)

SEYMOUR.—Sale (No. 11863) of Crown land in fee-simple, by auction, will be held at the LAND OFFICE, SEYMOUR, on FRIDAY, 9th JUNE, 1967, commencing at ELEVEN o'clock a.m. To be conducted by J. COX, Land Officer, Seymour.

Lot 1.

TOWNSHIP OF BROADFORD, PARISH OF BROADFORD, COUNTY OF DALHOUSIE.

Fronting the south-east side of First-street and the north-west side of Hawdon-street.

Upset price \$200 the lot. Survey fee \$15.

Area 3 roods, allotment 6, section 6A.—(H.O.24045.)

Lot 2.

TOWNSHIP OF TYAAK, PARISH OF KERRISDALE, COUNTY OF ANGLESEY.

On the west side of Township between a Government road and the eastern side of reservation to Dabyminga Creek.

Upset price \$40 the lot. Survey fee \$17.

Area 1a. 3r. 14p., allotment 4, section 1. One month allowed for removal of improvements.—(H.O.30726.)

Lot 3.

PARISH OF HEATHCOTE, COUNTY OF DALHOUSIE.

On the south side of a gravel road leading to the Eppalock Reservoir about 3 miles north-west of Heathcote.

Upset price \$100 the lot. Survey fee \$15.25.

Area 3a. 3r. 13p., allotment 28H.—(H.O.31299.)

ALSO THE FOLLOWING FREEHOLD LAND WILL BE OFFERED:—

NOTE.—This lot is not subject to the provisions of the Land Act as set out above, but comprises freehold land offered on behalf of the Education Department on the following conditions:—

- Deposit of at least 12½ per cent. payable at the sale and balance within 60 days.
- Purchaser to arrange for, and bear costs of, registration of transfer of title.

Lot 4.

PARISH OF TRAWOOL, COUNTY OF ANGLESEY.

Between Country Roads Board road and Railway about ¼ mile north of Falls Creek.

Upset price \$250 the lot.

Area 1a. 0r. 10p., part allotment 10A, and being the site together with improvements thereon of the former Traawool State School and being the land described in freehold certificate of title, volume 1711, folio 011.

NOTE.—Improvements consist of class-room, shelter-shed, toilets and fencing.—(H.O.30799.)

MARYBOROUGH.—Sale (No. 11865) of Crown land in fee-simple, by auction, will be held at the LAND OFFICE, MARYBOROUGH, on FRIDAY, 26th MAY, 1967, commencing at ELEVEN o'clock a.m. To be conducted by D. J. YURCINA, Land Officer, St. Arnaud.

Lot 1.

PARISH OF MARYBOROUGH, COUNTY OF TALBOT.

Fronting north-western side of Nelson-street about 14 chains north-east of Majorca-road.

Upset price \$600 the lot. Survey fee \$19.25.

Area 5 acres, subject to survey, allotment 28, section 5. Subject to drainage easement 25 links wide. One month allowed for removal of improvements.—(W.86454.)

Lot 2.

TOWNSHIP OF MARYBOROUGH, PARISH OF MARYBOROUGH, COUNTY OF TALBOT.

At the south-eastern corner of Spring and Outtrim streets.

Upset price \$200 the lot. Survey fee \$12.

Area 29 perches, allotment 3A, section 71C.—(W.70545.)

Lot 3.

TOWNSHIP OF GOLDSBOROUGH, PARISH OF PAINSWICK.

About ¼ mile south-west of Goldsborough Railway Station.

Upset price \$24 the lot. Survey fee \$17.

Area 2a. 3r. 25p., allotment 12 of section A. Subject to pipeline easement 15 links wide.—(W.86172.)

PARISH OF MARYBOROUGH, COUNTY OF TALBOT.

Lot 4.

At the north-eastern corner of Railway-crescent and Pyrenees Highway.

Upset price \$1,000 the lot. Survey fee \$200.

Area 31a. 3r. 20p., subject to survey, allotments 13, 14 and 15 of section 10.

NOTE.—There is no title road abuttal to the southern boundary of allotments 14 and 15. The eastern boundary of allotment 15 will be straight and at least one chain west of the adjacent gully.—(W.83579.)

Lot 5.

Fronting the northern side of Elgin-road about 19 chains west of Clarke-street.

Upset price \$310 the lot. Survey fee \$17.75.

Area 4a. 0r. 28p., subject to survey, allotment 19 of section 13.

Lot 6.

Fronting the northern side of Elgin-road about 23 chains west of Clarke-street.

Upset price \$250 the lot. Survey fee \$17.75.

Area 3a. 1r. 17p., subject to survey, allotment 20 of section 13.—(W.87271.)

Lot 7.

PARISH OF WARRENMANG, COUNTY OF KARA KARA.

Fronting the north-eastern side of the North-Western Highway about 5 chains north-west of Mountain Creek.

Upset price \$500 the lot. Survey fee \$34.25.

Area 51a. 1r., allotment 109 of section 1.—(W.85143.)

NOTE.—Lots 1, 2, 4, 5 and 6 are within the Planning Scheme area of the City of Maryborough.

AUCTION OF RIGHT TO LEASE CROWN LAND.

ST. ARNAUD.—A sale by auction of the right to lease Crown land will be held at the LAND OFFICE, ST. ARNAUD, on THURSDAY, 25th MAY, 1967, at TEN o'clock a.m. To be conducted by D. J. YURCINA, Land Officer, St. Arnaud.

The right to lease will be offered pursuant to section 134 of the *Land Act 1958*, for the purpose of offices only, subject to the provisions summarized hereunder:—

All mineral rights will be reserved under the provisions of the *Mines Act 1958* and all petroleum rights under the provisions of the *Petroleum Act 1958*.

The lease will commence on 26th May, 1967, the rent therefor will be the highest offer (not less than the upset rent) accepted at the sale, subject to re-appraisal at the end of each ten years' period if the lease be for a longer term than ten years. The rent will be payable quarterly in advance, and the first quarter's rent must be paid at the time of the sale.

The lessee shall pay all taxes, rates, duties, charges, assessments, &c., and discharge all obligations under any Act in respect of the leased premises.

Plans of all buildings proposed to be erected on the land shall be submitted to the Minister for his consideration, and work shall not be commenced until approval is given.

The buildings and other improvements shall be maintained throughout the term of the lease in good order and repair to the satisfaction of the Minister.

The lessee shall adopt such sanitary measures as the Minister requires and carry out all requirements of the Responsible Authority.

The Minister or his servants shall have the right of entry for inspection purposes, and in case of default with regard to maintenance, to make good any defects at lessee's expense.

Arrangements must be made for the prevention of nuisance.

No advertising matter or medium will be permitted on the land or premises or fencing, provided, however, that the Minister may permit a sign or other advertisement which refers solely to the purpose for which the lease is granted.

The site shall not be used for the storage of any explosive combustible or inflammable materials unless and until an application has been submitted and consented to by the Minister.

The lessee shall not assign, sublet, mortgage, or transfer the land, or any part thereof, without the consent of the Minister.

The lessee shall observe any other conditions and provisions agreed upon before the issue of the lease.

The lease shall be voidable for failure to use the land bona fide for the purpose for which it has been demised, or for non-payment of rent or interest on rent in arrear, or for breach of any condition, or if the affairs of the lessee be wound up, or in the event of bankruptcy of the lessee. In the event of the lease being declared void, it shall be lawful for the Crown to enter into and take full possession of the land and premises.

At the expiration or sooner determination of the term of the lease the land shall revert to the Crown.

The land is subject to resumption for mining purposes under section 205 of the *Land Act 1958*.

The Governor in Council has the right to resume the whole or any part of the land for public purposes, on payment of compensation for the lessee's interest in the unexpired term of the lease in respect of the resumed area.

The lessee shall contribute to the cost incurred by the local municipality for the construction of any roadway, footpath, and channel on any road abutting on the leased land, or in the drainage of such land, in the same way as if liable under the *Local Government Act 1958*.

Upon or at any time prior to the expiration or sooner determination of the said term it shall be lawful for the lessee to take down and remove from the said land all buildings, erections, extensions and improvements excepting all boundary fencing now or hereafter built, erected, constructed or made by the lessee on the demised premises doing as little injury as may be to the demised premises by the removal and making good such injury as may unavoidably be done.

If the purchaser covenants to erect substantial improvements the term of the lease may be fixed by the Minister for a longer term, to be determined by him within the provisions of the *Land Act*.

No buildings or other structures shall be erected at a level lower than that required for proper and effective drainage of the leased land.

Printed forms of the general conditions of the lease, in full, may be inspected at the Crown Lands Department, State Public Offices, Melbourne. (Phone 63 0321, Ext. 366) or the Land Office, St. Arnaud (Phone 115).

A. J. HOLT,
Secretary for Lands.

19th April, 1967.

TOWNSHIP OF ST. ARNAUD, PARISH OF ST. ARNAUD,
COUNTY OF KARA KARA.

Fronting the north-eastern side of McMahon-street about 2½ chains north-west of Sturt-street.

Upset rental \$75 per annum for the first ten years.

Survey fee \$100. Term of lease 21 years.

Area 1r. 20p., subject to survey, allotment 2 of section R1. Minimum expenditure for improvements \$5,000 within two years of date of lease. Subject to a condition allowing one month from date of sale for removal of fencing.—(W.87572).

PROPOSED PERMANENT RESERVATION OF LAND AS A SITE.

IN pursuance of sections 14 and 21 of the *Land Act 1958*, notice is hereby given that it is the intention of the Governor in Council to reserve permanently from sale, from being leased and from having a licence granted in respect thereof the land hereinafter described:—

The following Notice was published 1° on the 12th April, 1967, pursuant to Order of the 28th February, 1967.

TATURA.—Land proposed to be permanently reserved as a site for Racecourse and other purposes of Public Recreation, 94 acres 3 roods 27 perches, Township of Tatura, Parish of Toolamba West, County of Rodney, being the remaining portion of the site temporarily reserved therefor by Order in Council of the 21st February, 1881.—(T.252(°) (Rs.478).

JIM BALFOUR,
Minister of Lands.

PROPOSED PERMANENT RESERVATION OF LAND AS A SITE

IN pursuance of sections 14 and 21 of the *Land Act 1958*, notice is hereby given that it is the intention of the Governor in Council to reserve permanently from sale, from being leased and from having a licence granted in respect thereof the land hereinafter described:—

The following Notice was published 1° on the 31st March, 1967, pursuant to Order of the 21st March, 1967.

ELTHAM.—Land proposed to be permanently reserved as a site for a Cemetery, 12 acres 2 roods 30 perches, Township of Eltham, Parish of Nillumbik, County of Evelyn, as indicated by hatching on plan hereunder.—(E.41⁽¹⁾) (Rs.8403).

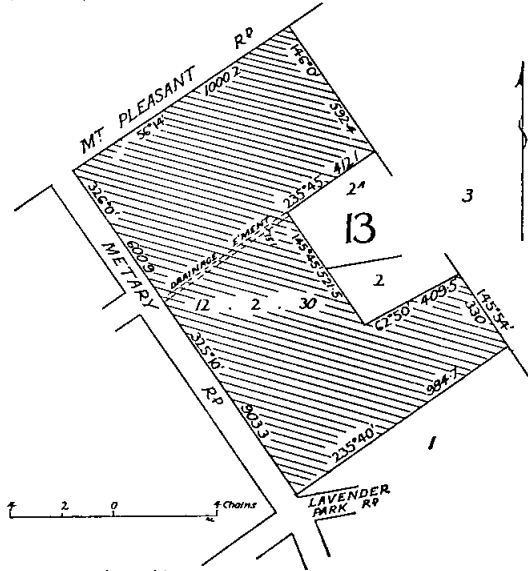

JIM BALFOUR,
Minister of Lands.

PROPOSED REVOCATIONS OF TEMPORARY RESERVATIONS OF LANDS BY ORDERS IN COUNCIL

IN pursuance of the provisions of the *Land Act 1958*, notice is hereby given that it is the intention of the Governor in Council to revoke the temporary reservations of lands by Orders in Council hereunder referred to, viz.:—

The following Notices were published 1° on the 31st March, 1967, pursuant to Orders of the 21st March, 1967.

BOULKA.—The temporary reservation, by Order in Council of the 22nd July, 1912, of 1 acre of land in the Parish of Boulka, as a site for a Public Hall.—(B.768⁽²⁾) (Rs.2947).

KIRKELLA.—The temporary reservation, by Order in Council of the 18th December, 1885, of 38 acres, more or less, of land in the Parish of Kirkella, as a site for Watering purposes, is about to be revoked so far only as the portion containing 33 perches, indicated by hatching on plan hereunder, is concerned.—(K.106⁽³⁾) (Rs.8670).

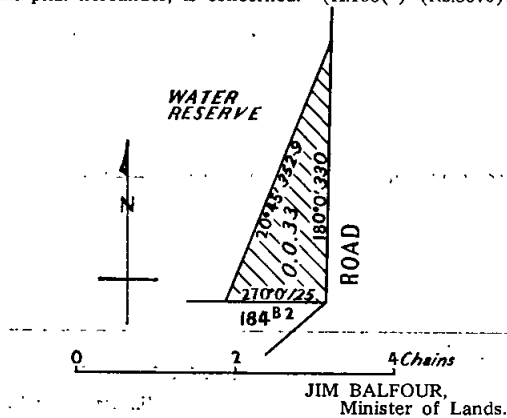

JIM BALFOUR,
Minister of Lands.

PROPOSED REVOCATIONS OF TEMPORARY RESERVATIONS OF LANDS BY ORDERS IN COUNCIL

IN pursuance of the provisions of the *Land Act 1958*, notice is hereby given that it is the intention of the Governor in Council to revoke the temporary reservations of lands by Orders in Council hereunder referred to, viz.:—

The following Notices were published 1° on the 19th April, 1967, pursuant to Orders of the 11th April, 1967.

LORNE.—The temporary reservation, by Order in Council of the 21st August, 1917, of 149 acres, more or less, of land in the Township of Lorne, as a site for Public purposes, revoked as to part by various Orders, is about to be revoked so far only as the portion containing 1 rood 10 perches, more or less, indicated by hatching on plan hereunder is concerned.—(L.147⁽⁷⁾) (Rs.1690).

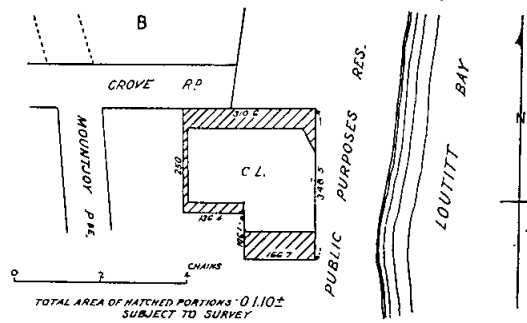

MOOROOLBARK.—The temporary reservation as a site for a Quarry and the withholding from sale, leasing and licensing by Order in Council of the 18th May, 1880, of 34 acres 3 roods 6 perches of land in the Parish of Mooroolbark, revoked as to part by Order in Council of the 19th October, 1915, are about to be revoked so far only as the portion containing 8 acres 2 roods 18 perches, indicated by hatching on plan hereunder, are concerned.—(M.152⁽⁵⁾) (Rs.1229).

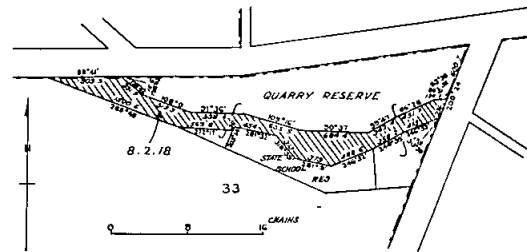

MOOROOLBARK.—The temporary reservation, by Order in Council of the 16th November, 1915, of 4 acres 3 roods 12 perches of land in the Parish of Mooroolbark, as a site for a State School, is about to be revoked so far only as the portion containing 1 rood 8 perches, indicated by hatching on plan hereunder, is concerned.—(M.152⁽⁵⁾) (Rs.1228).

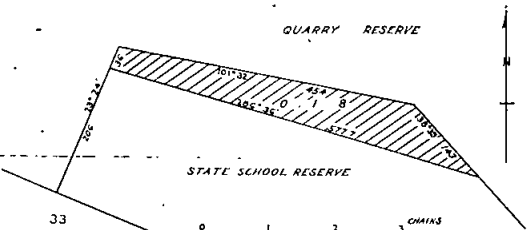

TEDDYWADDY.—The temporary reservation, as a site for Camping and Watering purposes and the withholding from sale, leasing and licensing by Order in Council of the 27th February, 1878 (see *Government Gazette* 1st March, 1878, page 477), of 66 acres 32 perches of land in the Parish of Teddywaddy, are about to be revoked so far only as the portions containing 1 acre 1 rood 32 perches, indicated by hatching on plan hereunder, are concerned.—(T.235^(a)) (Rs.8547).

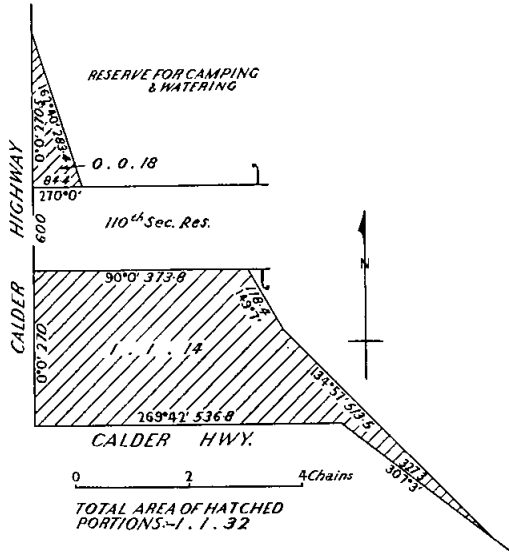

36 perches of land in the Parish of Tooborac, as a site for Railway purposes is about to be revoked so far only as the portion containing 2 roods 28 perches, indicated by hatching on plan hereunder, is concerned.—(T.91^(a)) (Rs.8792).

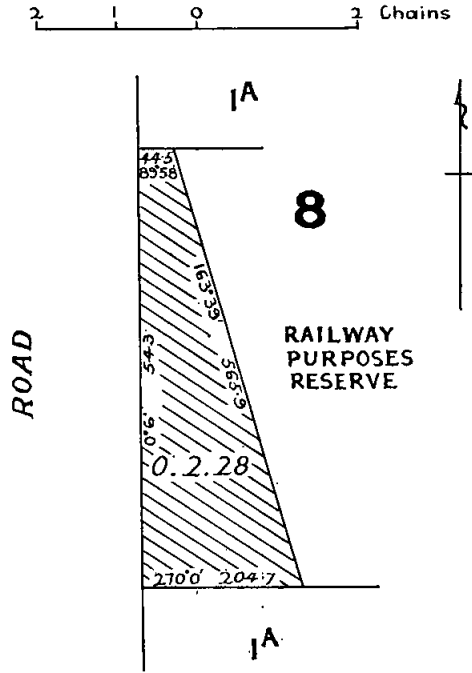

TOOBORAC.—The temporary reservation, by Order in Council of the 22nd January, 1889 (see *Government Gazette*, 25th January, 1889, page 255), of 3 acres 1 rood

J. C. M. BALFOUR,
Minister of Lands.

Land Act 1958.

LICENCES UNDER THE LAND ACTS DECLARED VOID.

NOTICE is hereby given that the Licences in the Schedule hereunder have been Declared Void for the reason specified in each case.

District.	Corr. No.	Name of Licensee.	Section of Land Act under which Licensed.	Parish.	Allotment.	Section.	Area.	Annual Rental	Reasons for Voiding.
Melbourne	01965/129	The Kauri Timber Company Limited	138	City of South Melbourne, Parish of Melbourne South	19	104	2 0 2 ¹⁰ / ₁₀₀	\$ 4,236.00	Surrendered
Melbourne	01454/129	The Kauri Timber Company Limited	138	City of South Melbourne, Parish of Melbourne South	16A & 17	104	1 1 3	\$ 2,920.00	Surrendered

Department of Crown Lands and Survey,
Melbourne, 11th April, 1967.

J. C. M. BALFOUR,
Minister of Lands.

Soldier Settlement Act.

LEASE SURRENDERED.

NOTICE is hereby given that the Rural Finance and Settlement Commission, pursuant to the powers conferred upon it by the Soldier Settlement Act, has accepted the surrender of the lease mentioned in the Schedule hereunder for the reason specified.

SCHEDULE.

Corr. No.	Name.	Section of Act No. 5179 under which leased.	Parish.	Allotment.	Area.	Reason.
2045/27	D. B. Druce	27	Enuc ..	Part 5 Section 28	A. R. P. 3 0 25	Surrendered for road purposes

Rural Finance and Settlement Commission,
13th April, 1967.

G. Mc G. BAKER,
Deputy Secretary.

PUBLIC SERVICE NOTICES

TENDERS

No. 1726.

Public Service Act 1958, Section 39.

REGULATIONS.—PART IV.—SALARIES AND INCREMENTS.

THE Public Service Board, in pursuance of the powers conferred by the Public Service Act 1958, hereby amends its Regulations as shown below :—

FIRST SCHEDULE.

PROFESSIONAL DIVISION.

Amount of Salary Assigned to Offices in "Special" Class.

Office.	Yearly Rate of Salary.
MINES DEPARTMENT.	
<i>Delete—</i> Director of Petroleum and Natural Gas ..	\$ 9,844
<i>Add—</i> Director, Petroleum and Natural Gas Branch	9,844

F. E. CAHILL, Chairman.
V. P. SCULLY, Secretary.

Office of the Public Service Board,
Melbourne, 7th April, 1967.

PUBLIC SERVICE OF PAPUA AND NEW GUINEA.

STENOGRAPHERS FOR NEW GUINEA.

STENOGRAPHERS are needed by the Public Service of Papua and New Guinea, mainly in Port Moresby, but appointment may be anywhere in the Territory.

Salary.—\$2,325—\$2,497 p.a. An additional \$86 p.a. is paid for 100 w.p.m. shorthand and \$172 p.a. for 120 w.p.m. Income tax in the Territory is at present about half that payable in Australia.

Qualifications.—A shorthand speed of 80 w.p.m. and typing speed of 40 w.p.m. Applicants must be adult, single women.

Engagement is by contract for a minimum of two years, longer if preferred. Applicants employed by a Government authority may be considered for secondment to the Territory Service with preservation of existing rights.

Leave.—Three months' after 21 months' service with assisted leave fares.

Details and application form from the Secretary, Department of Territories, Canberra, A.C.T., with whom applications close on 4th May, 1967. Please quote Advertisement No. 350.

PUBLIC WORKS DEPARTMENT

TENDERS will be received at Public Works Department, Treasury-place, Melbourne, until TEN a.m. on dates shown and for purposes mentioned hereunder.

Particulars and tender forms available at Contracts Office, Room 7, Building Division, Parliament-place and at places indicated in brackets hereunder.

Abbreviations in brackets mean:—W.O.—Inspector of Works Office; P.S.—Police Station; C.S.—Consolidated School; H.E.S.—Higher Elementary School; H.S.—High School; S.S.—State School; T.S.—Technical School.

Tenders to be submitted on the Department's printed Tender Form and will not be received by telephone. All tenders must be on a "Firm Tender" basis. The lowest or any tender will not necessarily be accepted.

Address tenders to the Minister of Public Works, and endorse the envelope containing the tender "Tender for , closing Tuesday, ".

No preliminary deposit is required with any tender, but a successful tenderer will be required to pay a deposit for any accepted tender of \$5,000 or over.

Wednesday, 26th April, 1967.

Building, Electrical and Mechanical Works.

Castlemaine.—Alterations and extensions, Lands and Survey Residence. (W.O., Kyneton.)

Coburg.—Repairs and painting, Court House.

Colac.—Repairs and painting, High School. (W.O., Camperdown.)

Drysdale.—Internal and external renovations, S.S. 1645. (W.O., Geelong.)

Frankston.—Aluminium partitions to glass-houses, Keith Turnbull Research Station. (Research Station.)

Geelong.—Repairs and painting, Teachers' College Hostel "Ariston", Pakington-street. (W.O., Geelong.)

Greta West.—Septic tank conversion and water supply installation, S.S. 2573 and Residence. (W.O., Benalla and S.S., Greta West.)

Highton.—Repairs and painting, S.S. 304 Residence. (W.O., Geelong.)

Kaniva.—Erection of residence and office, Police Station. (W.O., Horsham.)

Kew.—Mechanical services, new office block, Soil Conservation Authority. (Re-advertised.)

Kew.—Erection of an Occupational Therapy Building, Mental Hospital. (Specified Bills of Quantities Available.)

Kew.—Electrical services, Mental Hospital.

Kew.—Mechanical services, Mental Hospital.

Kyabram.—Electrical installation, High School. (W.O., Shepparton and Bendigo, High School, Kyabram.)

Lah Arum.—Repairs and painting, S.S. 2805 and Residence. (W.O., Horsham, S.S. 2805.)

Lilydale.—Repairs, renovations and painting, S.S. 876.

Lurg.—Repairs and painting, S.S. 2046 and Residence. (W.O., Benalla, S.S. 2046, Lurg.) (Re-advertised.)

Mitta Mitta.—Repairs and painting, S.S. 887 and Residence. (W.O., Wangaratta.)

Mont Park.—Erection of amenities block, Mental Hospital.

Mount Beauty.—Repairs and painting, High School Residence. (W.O., Benalla; High School Mount Beauty.) (Re-advertised.)

Newlyn.—New toilets, S.S. 453. (W.O., Ballarat, S.S., Newlyn.)

Parklands.—Repairs and painting, S.S. 4738.

Seymour.—Repairs and painting, High School. (W.O., Alexandra; High School, Seymour.) (Amended Specification.)

South Yarra.—Repairs and painting to Sports Pavilions, &c., Melbourne High School.

Stanley.—Repairs and painting, S.S. 550 and Residence. (W.O., Wangaratta; S.S., Stanley.)

Stawell.—Erection of a new three-storey class-room block, Technical School. (W.O., Ararat.) (Bills of Quantities Available.)

Stawell.—Electrical services, Technical School. (W.O., Horsham and Ararat; Technical School, Stawell.)

Stawell.—Mechanical services, Technical School. (W.O., Ararat, Bendigo and Ballarat.)

Tecoma.—Installation of town water supply, Melbourne Boys' High Forest School. (Belgrave Police Station.)

Willaura.—Connexion to town sewerage, Police Station.

Williamstown.—Erection and completion of Amenities Block, Ports and Harbours Dredging Depot.

Furniture and Furnishings.

Castlemaine.—Supply of general furniture, Technical School.

Dandenong.—Supply of easy chairs, Psychiatric Centre. Geelong West.—Supply of blackout curtains, Teachers' College.

Mont Park.—Supply of 70 mattresses and covers and 70 pillows with covers, Mental Hospital.

Port Melbourne.—Supply of 85 tables, cookery, to the Public Works Department Storeyard.

Royal Park.—Supply and fix curtains, Psychiatric Hospital.

Stawell.—Supply of combination sheet steel lockers, Pleasant Creek Special School.

Site Works.

Kerang South.—Site works, S.S. 4949. (W.O., Swan Hill & Bendigo.)

Monterey.—Drainage, asphalt, concrete, &c., S.S. 4939.

Miscellaneous.

Burnley.—Supply, delivery, &c., of Seed Germinating Cabinet, Seed Testing Laboratory, Burnley Gardens.

Kew.—Supply, delivery, &c., milk heating coils and hydraulic platform, Children's Cottages.

Melbourne.—Supply, delivery, &c., kitchen equipment, Police Depot, St. Kilda-road.

Port Melbourne.—Supply of 2,000 garbage bins, Public Works Department Storeyard.

Tuesday, 2nd May, 1967.

Building, Electrical and Mechanical Works.

Armada.—New students toilets, "Sebroff" Domestic Arts Teachers' College Hostel.

Armata.—Erection of new Primary School and Library, S.S. 4965.

Armata.—Electrical installation, S.S. 4965.

Armata.—Plenum heating, S.S. 4965.

Ballarat.—Installation of steam heating, Park Therapy Unit, Mental Hospital. (W.O., Ballarat.)

Ballarat.—Repairs and painting, &c., S.S. 33. (W.O., Ballarat.)

Beechworth.—Renovations and new laundry for District Inspector of Schools' Residence. (W.O., Wangaratta.)

Buckley's Swamp.—Repairs and painting, S.S. 1339. (W.O., Hamilton, S.S., Buckley's Swamp.)

Carlton.—External renovations, Melbourne Teachers' College.

Casterton.—External renovations, new doorway, High School. (W.O., Hamilton, H. S., Casterton.)

Casterton.—Water Supply, storm water drains and pump house, High School. (Amended Specification.) (W.O., Hamilton, H. S., Casterton.) (Re-advertised.)

Castlemaine.—Renovations, S.S. 119 Residence. (W.O., Kyneton.)

Coatesville.—Repairs, painting and extension of office, S.S. 4712. (Re-advertised.)

Cowes.—Repairs and painting, Police Station. (W.O., Korumburra, P.S., Cowes.) (Amended Specification.)

Cranbourne South.—Renovations, S.S. 4755.

Dandenong.—Renovations to toilet blocks, S.S. 1403.

Edenhope.—Renovations, Teachers' Fats, Consolidated School. (W.O., Horsham, C.S., Edenhope.)

Fifteen Mile Creek.—Renovations, &c., S.S. 2868. (W.O., Benalla.)

Flemington.—Alterations and renovations, Police Station.

Frankston.—Erection of fertilizer & machinery shed, ablation block & alterations, Vegetable Research Station. (Research Station, Frankston.)

Geelong West.—Repairs and painting, new porches, Technical School. (W.O., Geelong.)

Glengarry West.—Repairs and painting, re-blocking, S.S. 4426. (W.O., Traralgon, S.S., Glengarry West.)

Glenmore.—Septic tank and water supply installations, S.S. 3688. (W.O., Ballarat; S.S., Glenmore.)

Gravel Hill.—Renovations, S.S. 1566 Residence, 68 Neale-street. (W.O., Bendigo.)

Hampton.—Repairs and painting, S.S. 3754.

Heatherhill.—External repairs and painting, S.S. 4802. (Re-advertised.)

Kaniva.—Renew roofing, &c., Consolidated School. (W.O., Horsham, C.S., Kaniva.)

Kew.—Plenum heating, Ward 21, Children's Cottages.

Kew.—Installation of heating system, Male Therapy Buildings, Mental Hospital.

Lara.—Construction of 20,000 gal. water storage tank, "Pirra" Girls' Home. (W.O., Geelong.)

Mansfield.—Repairs and painting, S.S. 1112. (W.O., Alexandra.)

Mont Park.—Modifications to brickwork of boiler, Larundel Mental Hospital.

Murtoa.—Erection of residence, High School. (W.O., Warracknabeal, Horsham, H.S., Murtoa.) (Re-advertised.)

Myrtleford.—Alterations and additions to residence, Tobacco Research Station. (W.O., Benalla, Tobacco Research Station, Myrtleford.)

Northcote.—Repairs and painting, S.S. 3139.

Norwood.—Erection of Assembly Hall, High School.

Nunawading.—Electric service lift, "Winlton", Girls' Home.

Poowong.—Renovations, roof renewal, Consolidated School. (W.O., Korumburra, C.S., Poowong.)

Portland.—Repairs and painting, High School Residence. (W.O., Warrnambool, H.S., Portland.)

Sale.—External renovations, S.S. 545. (W.O., Traralgon, S.S., Sale.) (Amended Specification.)

Sandringham.—External repairs and painting, Technical School.

Strathmore.—Repairs and painting, High School.

Sunbury.—Fencing to tennis courts and swimming pool, Mental Hospital.

Timboon.—Renovations; attention to metal windows, High School. (W.O., Camperdown.)

Wallan.—Repairs and painting, S.S. 664. (W.O., Kyneton.)

Warrandyte.—Sewerage trickling filter installation, S.S. 12.

Werribee.—Repairs and painting, State Research Farm Residences.

Winchelsea.—Repairs and painting, Police Station and Residence. (W.O., Geelong, Police Station, Winchelsea.)

Woods Point.—Repairs and painting, S.S. 789 and Residence. (W.O., Alexandra.) (Re-advertised.)

Yannathan South.—External repairs and painting, S.S. 3225 Residence. (S.S., Yannathan South.) (Re-advertised.)

Furniture and Furnishings.

Kew.—Supply of 82 Hospital beds, Children's Cottages.

Kew.—Supply of 82 mattresses and waterproof covers, Children's Cottages.

Kew.—Supply and fix curtains to two hostels, Mental Hospital.

Site Works.

Moorabbin.—Site works, High School.

Royal Park.—Site works, "Turana", Boys' Home, Social Welfare Department.

Miscellaneous.

Jordanville.—Supply and delivery of universal tool and cutter grinder, Technical School.

Portarlington.—Supply and delivery of pre-cast reinforced concrete beams and flat slabs or U-slabs, Ports and Harbours. (W.O., Geelong.)

Preston East.—Supply and delivery of workshop equipment, Technical School.

Werribee.—Supply of galvanized fencing wire, &c., State Research Farm.

Tuesday, 9th May, 1967.

Building, Electrical and Mechanical Works.

Alexandra.—Renewal of internal water service, High School. (W.O., Alexandra; H.S., Alexandra.)

Archie's Creek.—Repairs and painting, S.S., 3135. (W.O., Korumburra; S.S., Archie's Creek.)

Ashwood.—External repairs and painting, High School.

Ballarat.—Electrical services, motor mechanics and wool sorting block, School of Mines. (W.O., Ballarat.)

Ballarat.—Erection of Motor Mechanics and Wool Clasing Building, School of Mines. (W.O., Ballarat.) (Bills of Quantities Available.)

Ballarat.—Mechanical services, motor mechanics and wool sorting block, School of Mines. (W.O., Ballarat.)

Baxter.—Renovations, &c., S.S. 3023. (S.S., Baxter.)

Beaumaris North.—Internal and external painting, S.S. 4803 and Residence.

Belle Vue.—External repairs and painting, S.S. 4733.

Bendigo.—Extension to Caretaker's Residence, Teachers' College. (W.O., Bendigo.)

Blackburn East.—Connexion to sewerage and demolition of sewerage treatment plant, S.S. 4800.

Camperdown.—Renovations and new garage, Residence, 60 Walls-street, High School. (W.O., Camperdown.)

Corryong.—Repairs and painting, Consolidated School. (W.O., Wangaratta.)

Doveton.—External renovations, &c., High School.

Geelong.—Alterations to male toilets, Gordon Institute of Technology. (W.O., Geelong.)

Hampton Park.—Internal and external renovations, S.S. 4062.

Hawkesdale.—External and internal repairs and painting, S.S. 766. (W.O., Warrambool; S.S., Hawkesdale.)

Hurstbridge.—Erection of 1st and 2nd sections, High School.

Hurstbridge.—Electrical installation, High School.

Hurstbridge.—Mechanical services, High School.

Ivanhoe East.—Provision of an additional bedroom or sleepout, Cleaner's Residence, S.S. 4836.

Koonung.—Extended 3rd section, High School.

Koonung.—Electrical installation, High School.

Koonung.—Mechanical services, High School.

Lockington.—External and internal repairs and painting, Consolidated School. (W.O., Bendigo.)

Malvern.—External repairs and painting, Girls' Secondary School.

Mansfield.—Internal and external painting, High School. (W.O., Alexandra; H.S., Mansfield.)

Milleara.—Erection of 10 classroom Primary School and Library in brick veneer, S.S. 4969.

Milleara.—Electrical installation, S.S. 4969.

Milleara.—Plenum heating, S.S. 4969.

Mitta Junction.—Renovations, S.S. 4080. (W.O. Wangaratta.) (Re-advertised.)

Morwell.—External repairs and painting, Technical School (W.O., Traralgon; T.S., Morwell.) (Re-advertised.)

Rosanna Golf Links.—Repairs and painting, S.S. 4753.

St. Germain's.—External and internal repairs and painting, S.S. 1555. (W.O. Shepparton.)

Strathbogie West.—Renovations, &c., S.S. 2267. (W.O., Alexandra; S.S., Strathbogie West.)

Tallangatta.—Repairs and painting, Residence, 2 Wonga Grove, S.S., 1365. (W.O. Wangaratta; S.S., Tallangatta.)

Toolangi.—Installation of pump, electric motor switch gear and erection of pump house foundations, Potato Research Station. (Potato Research Station, Toolangi.)

Toorak.—New steel fire escape stairs, Central School 3016.

Welshpool.—Internal and external repairs and painting, S.S. 3011 and Residence. (W.O. Korumburra.)

Werribee.—External and internal renovations, State Research Farm.

Site Works.

Beaumaris.—Asphalting, concreting and associated work, S.S. 3899.

Croydon North.—Asphalting, concreting, drainage and associated work, S.S. 1992.

Glen Waverley.—Asphalting, concreting, gravelling, drainage works, &c., High School.

Miscellaneous.

Mont Park.—Supply and delivery of 33 sanitary incinerators, Larundel Mental Hospital.

Various.—Supply of engineers lathes, Schools and other Government Buildings.

Various.—Supply of woodworking machines for the period 1st July, 1967 to 30th June, 1968, Schools and other Government Buildings.

M. V. PORTER,
Minister of Public Works.

Public Works Department;

Melbourne, C.2, 17th April, 1967.

PRIVATE ADVERTISEMENTS

ARARAT PISTOL CLUB.

NOTICE is hereby given that the Ararat Pistol Club has applied for a lease under section 134 of the Land Act 1958, for a term of 21 years, in respect of an area of approximately 3 acres in the Township of Ararat as a site for amusement and recreation (pistol range).

F. ALLENDER,

6092

Hon. Secretary, Ararat Pistol Club.

COHUNA SEWERAGE AUTHORITY.

THE Cohuna Sewerage Authority which proposes to compulsorily take the land hereinafter described and which has obtained the consent of the Governor in Council to such proposed compulsory taking hereby publishes the following advertisement in pursuance of section 111 of the Sewerage Districts Act 1958, as re-enacted by section 6 of the Sewerage Districts Act 1964, viz.:—

(a) The nature of the works in respect of which such land is proposed to be taken is the building or construction of all necessary and usual works for the operation of Sewerage Treatment Farm thereon and all things or matters appertaining to and incidental to such operation.

(b) A plan or description of the proposed works is open for inspection at the Municipal Office, Cohuna, between the hours of 9 a.m. and 12 noon and 1 p.m. and 4 p.m. on week days other than public holidays.

(c) The land which is required for the purpose of such works is lot 2 containing 183 acres and 3 roods or thereabouts on plan of subdivision dated the 18th day of January, 1967, by Mr. Surveyor John Laurence Dwyer being part of Crown allotment 12, section 2, Parish of Gunbower West, County of Gunbower and being part of the land described in C/T, volume 7547, folio No. 001, and being land commencing at the most south-eastern angle of Crown allotment 12, section 2, Parish of Gunbower West, County of Gunbower; thence westerly along the southern boundary of the said Crown allotment 12 for a distance of 4,466.4 links; thence by a line bearing north 7 deg. 57 min. east a distance of approximately 6,061.5 links to a point on the northern boundary of the Crown allotment 12; thence generally easterly and south-easterly along the northern and north-eastern boundaries of the said Crown allotment 12 to the point of commencement, all of which boundaries are shown on a plan approved by the Governor in Council and deposited in the office of the State Rivers and Water Supply Commission, Melbourne.—(Corres. No. 59/1530/15.)

The quantity of land required for the purpose of such works as aforesaid is the whole of the afore-mentioned land comprised in the said lot 2 and the particulars of the right power or privilege which the Cohuna Sewerage Authority requires for the purpose of such works is an unencumbered estate in fee-simple as owner of the said land.

Dated this 7th day of April, 1967.

For and on behalf of the Cohuna Sewerage Authority.
6386 R. E. KNOWLES, Secretary.

COLAC SEWERAGE AUTHORITY.

GENERAL NOTICE.

THE above-mentioned Sewerage Authority, having made provision for carrying off the sewage from each and every property which or any part of which is within the Sewerage Area hereinafter described doth hereby declare that on and after the 1st day of May, 1967, each and every property which or any part of which is within the said sewerage area shall be deemed to be a sewered property within the meaning of the Sewerage Districts Act 1958. The boundaries of the sewerage area hereinbefore referred to are:—

SEWERAGE AREA No. 33.

Commencing at a point being the north-eastern angle of lot 39 on lodged plan of subdivision No. 50940, Town and Parish of Colac, County of Polwarth, the said point being on the boundary of Sewerage Area No. 24 and also on the west side of Robertson-street distant 140 feet south of the south side of Bartlett-street; thence easterly by a line bearing north 89 deg. 54 min. east to a point on the east side of Robertson-street; thence southerly along the east side of Robertson-street to the north side of McLeod-street; thence easterly along the north side of McLeod-street to its intersection with the northerly prolongation of the east side of Hebb-court; thence southerly by a line across McLeod-street to its south side and

southerly along the east side of Hebb-court to the northern angle of lot 89 on lodged plan of subdivision No. 50940; thence south-easterly along the north-eastern boundary of the said lot 89 to its north-eastern angle; thence southerly along the eastern boundary of the said lot 89 to its south-eastern angle; thence westerly along the southern boundary of the said lot 89 to its intersection with the eastern boundary of lot 66, on lodged plan of subdivision No. 50940; thence southerly along the eastern boundary of the said lot 66 and its prolongation across Hearn-street to a point on the south side of Hearn-street; thence westerly along the south side of Hearn-street to its intersection with the eastern boundary of Crown allotment 116, Town and Parish of Colac; thence southerly along the eastern boundaries of Crown allotments 116, 115, 114 and 113 and their prolongation across Pound-road to a point on the south side of Pound-road; thence westerly along the south side of Pound-road and by a line across Armstrong-street to the south-western corner of the intersection of Pound-road and Armstrong-street; thence northerly by a line across Pound-road and along the west side of Armstrong-street to the south-eastern angle of lot 4 on lodged plan of subdivision No. 56286; thence westerly along the southern boundary of the said lot 4 to its south-western angle; thence northerly along the western boundaries of the said lot 4 and lots 3, 2 and 1 on lodged plan of subdivision No. 56286 and by a line being their prolongation to a point on the south side of Hearn-street distant 152 feet from the west side of Armstrong-street and by a line being a further prolongation to a point on the north side of Hearn-street; thence easterly along the north side of Hearn-street to the north-western corner of the intersection of Hearn and Armstrong streets; thence northerly along the west side of Armstrong-street to its intersection with the westerly prolongation of the north side of Bartlett-street; thence easterly by a line across Armstrong-street and along the north side of Bartlett-street for a distance of 244 feet; thence southerly by a line parallel to and distant 244 feet from the east side of Armstrong-street across Bartlett street to a point 140 feet south of the south side of Bartlett-street; thence easterly by a line parallel to and distant 140 feet south of the south side of Bartlett-street to the point of commencement.

By order of the said Sewerage Authority.

6498

W. J. HARRIS, Chairman.
E. J. ROBBINS, Secretary.

THE BALLARAT SEWERAGE AUTHORITY.

GENERAL NOTICE.

THE above-mentioned Sewerage Authority having made provision for carrying off the sewage from each and every property which or any part of which is within the Sewerage Area hereinafter described doth hereby declare that on and after the First day of May, 1967, each and every property which or any part of which is within the said Sewerage Area shall be deemed to be a seweraged property within the meaning of the *Sewerage Districts Act 1958*.

The boundaries of the Sewerage Area hereinbefore referred to are:—

Sewerage Area No. 273.

Borough of Sebastopol:—Commencing at the north-east corner of Whitta and Rowlands streets being a point on the boundary of Sewerage Area No. 261; thence south-easterly to the south-east corner of Whitta and Rowlands streets, southerly about 290 feet along the east building line of Rowlands-street to the north-east corner of Rowlands-street and Bruce-drive, westerly to the south-west corner of Rowlands-street and Sturrock-avenue, westerly to the south-east corner of Sturrock-avenue and Harbour-drive, northerly by a line along the east building line of Harbour-drive and the continuation thereof to the north building line of Hill-street, westerly about 570 feet along the north building line of Hill-street to the north-east corner of Hill and Alexandra streets, northerly along the east building line of Alexandra-street, such building line being the west boundary of the Sebastopol Technical School area, to the south-east corner of Alexandra and Hertford streets, north-easterly along the south building line of Hertford-street to the north-west corner of No. 51 Hertford-street being a point on the boundary of Sewerage Area No. 205; thence south-easterly, north-easterly, southerly, westerly, southerly, westerly, southerly, westerly and southerly along the boundaries of Sewerage Areas Nos. 205 and 261 to the point of commencement.

Further particulars regarding the streets or parts of streets in which sewers have been laid may be ascertained on enquiry at the Authority's Office.

By order of the said Sewerage Authority.

6532

A. W. NICHOLSON, Chairman.
CHAS. H. CLAMP, Secretary.

Water Act 1958.

BUNINYONG WATERWORKS TRUST.

EIGHTH SCHEDULE.

NOTICE to the owners of the tenements in the under-mentioned streets and roads and the private streets, lanes, courts and alleys opening thereto, within the Urban District of the Buninyong Waterworks Trust.

Cathcart-street east side in a southerly direction from the existing main in Learmonth-street to a point seven (7) feet south from the north-west corner of Crown allotment 1, section 50.

Scott-street north side in an easterly direction from the new main in Cathcart-street to a point twenty (20) feet east from the south-west corner of Crown allotment 13, section 17.

Palmerston-street south side in an easterly direction from the existing main in Warrenheip-street to a point fifteen (15) feet east of the north-west corner of Crown allotment 2, section 41.

The main pipe in the said streets and roads being laid down the owners of all tenements situated as above are hereby required on or before the 22nd day of May, 1967, to cause a proper pipe and stop cocks to be laid so as to supply water within such tenements from the main pipe.

A. C. LORD, Secretary of the Buninyong Waterworks Trust. 6567

Local Government Act 1958 (As Amended).

COMPULSORY TAKING OF THE WHOLE OF THE LAND DESCRIBED IN CERTIFICATE OF TITLE VOLUME 3123 FOLIO 525.

NOTICE THAT MAPS AND OTHER PAPERS ETC. ARE DEPOSITED FOR INSPECTION AND THE PLACE WHERE THEY ARE SO DEPOSITED.

NOTICE is hereby given that it is the intention of the Council of the City of Melbourne to compulsorily take the whole of the land described in Certificate of Title Volume 3123 Folio 525 and being the land and buildings generally known as No. 141 Miller Street, West Melbourne, situate within the municipality of the City of Melbourne.

This land and buildings are required for road making purposes in connection with the new Dynon Road Bridge at present being constructed adjacent to the North Melbourne Railway Station.

Such maps and other papers as may be necessary to show the general description of the work or undertaking for which the land and buildings proposed to be taken are to be used, the description of the land and buildings proposed to be taken and the names of the owners or reputed owners, lessees or reputed lessees, mortgagees and occupiers of those land and buildings so far as those names are known to or can be ascertained by the Council are deposited and will be OPEN FOR INSPECTION of all persons interested at the Office of the Town Clerk, First Floor, Town Hall, Swanston Street, Melbourne, for the space of forty clear days from the day of publication of this notice in the *Government Gazette*, within which time all persons affected by the proposed work or undertaking are hereby required to set forth in writing addressed to the Council or the Town Clerk, all objections which they may have to the work or undertaking.

Dated this 18th day of April, 1967.

6575

F. H. ROGAN, Town Clerk.

NOTICE OF INTENTION TO APPLY FOR A LICENCE TO DIVERT WATER AND CUT RACE FROM THE RIVER MURRAY AT NICHOLS POINT.

I HEREBY give notice that I intend to apply for a licence empowering me to divert water for a term of seven years to the extent of 45 acre-feet per annum at a maximum rate of 5 acre-feet per day of 24 hours for the purpose of irrigating 15 acres of citrus and vines, being part of allotment 12, section 5A, block F, parish of Mildura, and to occupy certain Crown lands for works of diversion, and to cut a race thereon.

Any objection to such application must be forwarded in writing to reach the State Rivers and Water Supply Commission, Melbourne, before the 19th May, 1967, being 30 days from the first publication of this notice.

PEITA MRIZIOU STOEVSKI.

Care of Post Office, Nichols Point.

6506

PRESTON AND DISTRICT NO. 1 CO-OPERATIVE HOUSING SOCIETY (IN LIQUIDATION).

SPECIAL RESOLUTION.

Passed 10th April, 1967.

AT a special general meeting of the above-named society duly convened and held at 28 Wilkinson-street, Reservoir, on the 10th day of April, 1967, at 8.00 p.m., the subjoined special resolution was duly passed:—

1. That the society having successfully completed its objectives 20 months ahead of its notional term, be wound up voluntarily, and that Hay Charles Holmes and Lindsay Arthur Stephenson, both of 475 Collins-street, Melbourne, be appointed liquidators for the purposes of the winding up.

2. That the remuneration of the liquidators be fixed at Five hundred dollars (\$500), or such lesser amount as is fixed by the Registrar of Co-operative Housing Societies.

3. That the liquidators be empowered to compromise with debtors and/or creditors and/or contributors.

C. T. BARLING, Chairman of Meeting.

6552

H. C. HOLMES, Secretary.

CITY OF BOX HILL.

BY-LAW NO. 125.

Sewerage By-Law.

A By-law of the City of Box Hill made under Section 197 of the *Local Government Act 1958*, and numbered 125 for:—

- (a) regulating sewerage and drainage
- (b) providing for the health of the residents in the municipal district and against the spreading of contagious or infectious diseases; and
- (c) suppressing nuisances.

IN pursuance of the powers conferred by the *Local Government Act, 1958*, the Mayor, Councillors and Citizens of the City of Box Hill order as follows:—

1. This By-law may be known as the Sewerage By-law.

2. In this By-law unless inconsistent with the context or subject matter:—

- “Board” means the Melbourne and Metropolitan Board of Works.
 “Council” means the Council of the City of Box Hill.
 “Property” includes any land upon which a house or other building is erected.
 “Sewer” means a sewer laid by the Board.
 “Sullage water” includes household waste water.

3. The owner of every property in respect of which a general notice has been given by the Board under Section 160 (1) of the *Melbourne and Metropolitan Board of Works Act, 1958*, shall—

- (a) Make provision to have the sewerage carried off from such property by the sewer laid by the Board; and
- (b) Provide such proper water closet or water closets and such drains, appliances, apparatus and connexion with such sewer as may be prescribed by Regulations of the Board:—

within six months or such further time as the Council may allow from the date of the coming into operation of this By-law where such a general notice has been given prior to the said date of within six months or such further time as aforesaid from the date of any such general notice given after the coming into operation of this By-law as the case may be.

4. All such sewerage works and the provision of all such water closet or water closets, drains, appliances, apparatus and connexions with a sewer shall be carried out, fitted and laid in accordance with Regulations prescribed by the Board.

5. Any owner desirous of an extension of time beyond the said period of six months shall:—

- (a) make application in writing, to the Council; and
- (b) in his application give:—
 - (i) his full name and address,
 - (ii) particulars of his property,
 - (iii) the reasons why he requires an extension; and
 - (iv) any other information the Council may require.

6. Any owner to whom this By-law applies who fails to provide for the sewerage from his property to be carried off by a sewer and to provide such water closet or water closets, drains, appliances, apparatus or connexions as may

be prescribed by the Regulations of the Board and cause the same to be connected to a sewer within the said period of six months or such further time as may be allowed by the Council shall be guilty of an offence against this By-law.

7. No person shall allow, permit or suffer, after the expiration of six months or such further time as the Council may allow from the date of the coming into operation of this By-law where a general notice under the said Section 160 (1) has been given prior to the said date or after the expiration of six months or such further time as aforesaid from the date of any such general notice given after the coming into operation of this By-law as the case may be, any sullage water to be discharged from any property affected by any such notice except into a sewer.

8. Any person guilty of a wilful act of default contrary to this By-law shall be liable to a penalty of not less than \$10 or more than \$40 and to a further penalty of not more than \$10 for each day on which such offence is continued after a conviction or order by any Court.

9. This By-Law shall apply to and have operation throughout the whole of the municipal district of the City of Box Hill but it shall not apply to any property in respect to which a general notice has been served by the Board under Section 160 (2) of the *Melbourne and Metropolitan Board of Works Act 1958*.

10. By-law No. 122 of the City of Box Hill and intitled the Sewerage By-law is hereby repealed.

Resolution for passing this By-law agreed to by the Council the sixth day of March 1967, and confirmed the Third day of April 1967.

The Common Seal of the Mayor, Councillors and Citizens of the City of Box Hill was hereto affixed in pursuance of a Resolution of the Council and in the presence of—

E. O. LUNGGREN, Mayor.
 D. M. YOUL, Councillor.
 A. N. WALLS, Town Clerk.

6518

CITY OF BOX HILL.

LOAN NO. 192.

Notice of Intention to Borrow the Sum of \$300,000 for Permanent Works and Undertakings in the City of Box Hill.

NOTICE is hereby given that the Council of the City of Box Hill proposes to borrow three hundred thousand dollars secured by a charge over the general rates of the municipality by the grant of a mortgage in accordance with the provisions of the *Local Government Act, 1958*.

The maximum rate of interest that may be paid is 5½ per centum per annum.

The money borrowed shall be repayable at the Australia and New Zealand Bank Limited, Melbourne, or at the Council's bankers for the time being in the City of Melbourne or at such place or places as the lender from time to time may require, in full at maturity.

The loan shall have a currency of forty five years and interest thereon shall be payable half-yearly on the 30th June and 31st December in each year, the first payment to be made on 31st December, 1967 and the final payment together with the repayment of principal (in full) on the 30th day of June, 2012.

The purpose for which the loan is to be applied shall be—

Capital Works in the Council's Electric Supply Undertaking.

The loan is to be liquidated by a sinking fund which shall be created in accordance with the provisions of the *Local Government Act* by the half-yearly investment of such amount, as the Auditor-General certifies within the currency of the loan, in such manner as the Treasurer of Victoria shall direct.

The plans specifications and estimates of cost of the works referred to above and statement showing the proposed expenditure of the money to be borrowed are open for inspection during office hours of the Council, Town Hall, Box Hill.

Dated this 17th day of April, 1967.

6519

A. N. WALLS, Town Clerk.

Local Government Act 1958.

CITY OF DANDENONG.

PART XVIII., DIVISION 4.

Notice of Intention to Take Land Compulsorily.

NOTICE is given that it is the intention of the Council of the City of Dandenong, in exercise of the powers conferred on it by the *Local Government Act 1958*, to take compulsorily all that piece of land being part of lot 19

on plan of subdivision No. 4924, Parish of Dandenong, and being part of the land described in certificate of title, volume 7394, folio 767, commencing at the north-west corner of the said lot at the intersection of Mason-street and a right-of-way; thence proceeding in a south-easterly direction on a bearing of 101 deg. 2 min. a distance of 8 ft. 6 in.; thence in a south-westerly direction on a bearing of 47 deg. 17 min. for a distance of 8 ft. 11½ in.; and thence along Mason-street on a bearing of 347 deg. for a distance of 7 ft. 10½ in. home to the commencing point.

1. The said land is required for, and it is intended to take compulsorily for the purpose of executing the work of providing the same for road purposes.

2. The said Council has caused to be prepared maps and other papers showing a general description of the said work or undertaking, a description of the land to be taken and that the owner of the said land is Gilbert George Benson Boileau.

3. The said maps and other papers have been approved by the said Council and are now deposited for inspection by all persons affected by the proposed taking of the said land at the office of the City of Dandenong, situate at the Municipal Offices, Lonsdale-street, Dandenong.

4. All persons affected by the proposed taking of the said land are hereby required to set forth, in writing, addressed to the said Council or the Municipal Clerk thereof within 40 clear days of the publication of this notice in the *Government Gazette* all objections which they may have to the taking of the said land.

Dated the 14th day of April, 1967.

By order of the Council,

6574 C. A. ELLIOTT, Municipal Clerk.

CITY OF DONCASTER AND TEMPLESTOWE.

LOAN No. 95.

Notice of Intention to Borrow the Sum of \$20,000 for Permanent Works and Undertakings.

NOTICE is hereby given that the Council of the City of Doncaster and Templestowe proposes to borrow the principal sum of Twenty thousand dollars, secured by a charge over the general rates of the municipality, such sum to be raised by the grant of a mortgage, in accordance with the provisions of the *Local Government Act 1958*.

1. The maximum rate of interest that may be paid is 5½ per cent. per annum.

2. The interest is to be payable half-yearly during the currency of the loan.

3. The purpose for which the loan is to be applied is—

Construction of combined infant welfare pre-school centre at Swanston-street, Lower Templestowe (part cost) .. \$20,000

4. The period of the loan shall be five years, the loan being repayable in one amount on the 1st July, 1972.

5. The loan shall be repayable by the creation of a sinking fund, pursuant to the provisions of section 428A of the *Local Government Act 1958*, and an amount of \$3,692.54 will be set aside annually out of the municipal fund for such purpose.

6. Such moneys shall be repayable to The South British Insurance Company Limited, 155-161 Queen-street, Melbourne.

The plans and specifications and the estimate of the cost of the proposed works and a statement showing the proposed expenditure of the moneys to be borrowed, are open for inspection at the office of the Council of the City of Doncaster and Templestowe, at the Municipal Offices, Doncaster-road, Doncaster.

6488 J. W. THOMSON, Town Clerk.

CITY OF DONCASTER AND TEMPLESTOWE.

WHEREAS the Council of the City of Doncaster and Templestowe deems it expedient to exercise its powers of taking compulsorily the lands described in the Schedule hereto for the purpose of providing pleasure grounds and places of public resort and recreation on lands pursuant to section 799 of the *Local Government Act 1958* and acquiring the said lands for that purpose: And whereas the Council has caused to be prepared maps and other papers setting out the general description of the work or undertaking for which the lands proposed to be taken are to be used, the description of the lands proposed to be taken, and the names of the owners or reputed owners, lessees or reputed lessees, mortgagees and occupiers of those lands so far as those names are known to or can be ascertained by the Council: And whereas the said plans and other papers are deposited at the office of the said Council at Doncaster and are and shall be open

for inspection by all persons interested at all reasonable hours for the space of 40 clear days after the publication of this notice in the *Government Gazette*: Now notice is hereby given to all persons affected by the proposed taking of the said lands, to set forth in writing addressed to the Council or Town Clerk within 40 clear days of the publication of this notice in the *Government Gazette* all objections which they may have to the taking of the said lands.

THE SCHEDULE HEREINBEFORE REFERRED TO.

Part of Crown portion 8, section 13, Parish of Bulleen, County of Bourke, and being the land commencing at a point bearing and distances respectively from the intersection of the east side of Clarke-street and the south side of Porter-street, Templestowe, easterly 1,226 ft. 1 in. and 179 deg. 42½ min. 439 ft. 6½ in.; thence by lines bearing and distance respectively 178 deg. 43 min. 408 ft. 10¼ in.; 282 deg. 36 min. 137 ft. 10¼ in., 2 deg. 2 min. 399 ft. 5¼ in., 100 deg. 25 min. 113 ft. 2¼ in. to the commencing point, and being the lands more particularly described as—

Part of land remaining in Book 321, Conveyance 424.
Lot 97 and part of lot 98, being part of Book 175, Conveyance 970.
Part of lots 87, 88 and 114, being part of Book 232, Conveyance 831.
Part of lots 79, 80 and 86, being part of Book 17, Conveyance 750.
Lots 81 and 82, Book 6, Conveyance 593.
Lot 84, Book 82, Conveyance 88.
Lot 85, Book 53, Conveyance 889.

By order,

6487 J. W. THOMSON, Town Clerk.

CITY OF DONCASTER AND TEMPLESTOWE.

LOAN No. 96.

Notice of Intention to Borrow the Sum of \$100,000 for Permanent Works and Undertakings.

NOTICE is hereby given that the Council of the City of Doncaster and Templestowe proposes to borrow the principal sum of \$100,000 secured by a charge over the general rates of the municipality, such sum to be raised by the grant of a mortgage in accordance with the provisions of the *Local Government Act 1958*.

The maximum rate of interest that may be paid is 5.875 per cent. per annum.

The interest is to be payable half-yearly during the currency of the loan.

The purpose for which the loan is to be applied is for capital works in the Electric Supply Undertaking as follows:—

Extension to mains and erection of sub-stations	\$39,000
Apparatus on Consumer premises (Meters, time switches and installation costs) ..	55,000
Plant and equipment	4,000
Street Lighting	2,000
	<u>\$100,000</u>

The period of the loan shall be 40 years, the loan being repayable in one amount on the 1st June, 2007.

The loan is to be liquidated by the creation of a sinking fund pursuant to the provisions of section 428A of the *Local Government Act, 1958*, and an amount of \$934.32 will be set aside annually out of the municipal fund for such purpose.

Such moneys shall be repayable to the Defence Forces Retirement Benefits Board, West Row, Canberra City, A.C.T.

The plans and specifications and the estimate of the cost of the proposed works and a statement showing the proposed expenditure of the moneys to be borrowed are open for inspection at the office of the Council of the City of Doncaster and Templestowe, at the Municipal Offices, Doncaster-road, Doncaster.

6496 J. W. THOMSON, Town Clerk.

CITY OF FITZROY.

LOAN No. 27—RE-ADVERTISED.

Notice of Intention to Borrow the Sum of \$40,000 for Permanent Works and Undertakings.

NOTICE is hereby given that the Council of the City of Fitzroy proposes to borrow the principal sum of \$40,000, secured by a charge over the general rates of the municipality, such sum to be raised by the grant of a mortgage, in accordance with the provisions of the *Local Government Act 1958*.

1. The amount of the principal moneys which it is proposed to borrow is \$40,000.

2. The maximum rate of interest that may be paid is 5½ per centum per annum.

3. The period of the loan shall be twenty years, and the times at which the moneys borrowed are to be repayable will be on the 1st day of March and September in each year during the currency of the loan, commencing on the 1st day of September, 1967. The place for repayment will be the Commonwealth Savings Bank of Australia, Melbourne.

4. The purpose for which the loan is to be applied is for the construction of an Infant Welfare, Pre-Natal and Dental Clinic Centres, Young-street, Fitzroy.

5. The manner in which the loan is to be liquidated is by provision out of the municipal fund in each half year during the currency of the loan of the sum of \$1,708.47, which includes principal and interest.

6. The plans and specifications and the estimated cost of such works, and the statement showing the proposed expenditure of the money to be borrowed, are open for inspection at the office of the Council, Town Hall, Fitzroy, during office hours.

Dated 12th April, 1967.

6489

J. O'HALLORAN, Town Clerk.

CITY OF FITZROY.

LOAN No. 28—RE-ADVERTISED.

Notice of Intention to Borrow the Sum of \$46,000 for Permanent Works and Undertakings.

NOTICE is hereby given that the Council of the City of Fitzroy proposes to borrow the principal sum of \$46,000, secured by a charge over the general rates of the municipality, such sum to be raised by the grant of a mortgage, in accordance with the provisions of the *Local Government Act 1958*.

1. The amount of the principal moneys which it is proposed to borrow is \$46,000.

2. The maximum rate of interest that may be paid is 5½ per centum per annum.

3. The period of the loan shall be ten years, and the times at which the moneys borrowed are to be repayable will be on the 1st day of March and September in each year during the currency of the loan, commencing on the 1st day of September, 1967. The place of repayment shall be the Commonwealth Savings Bank of Australia, Melbourne.

4. The purpose for which the loan is to be applied is for Road Works, reconstruction of Rushall-crescent.

5. The manner in which the loan is to be liquidated is by provision out of the municipal fund in each half year during the currency of the loan of the sum of \$3,056.30, which includes principal and interest.

6. The plans and specifications and the estimated cost of such works, and the statement showing the proposed expenditure of the money to be borrowed, are open for inspection at the office of the Council, Town Hall, Fitzroy, during office hours.

Dated 12th April, 1967.

6490

J. O'HALLORAN, Town Clerk.

CITY OF HEIDELBERG.

NOTICE OF INTENTION TO APPLY FOR AN ORDER-IN-COUNCIL UNDER THE ELECTRIC LIGHT AND POWER ACT 1958.

THE Mayor, Councillors and Citizens of the City of Heidelberg, acting by and through the Council of that municipality and herein called "the applicant", hereby gives notice that, for the purpose of enabling the applicant to supply consumers within the area of supply under the Shire of Heidelberg Electric Lighting Order No. 100-1914 with electricity to be taken in bulk from the State Electricity Commission substation "EP" situated in the City of Preston, the applicant intends to apply to the Governor in Council of the State of Victoria for an Order under Section 10 of the *Electric Light and Power Act 1958*, authorising the applicant to lay down or place and use and maintain electric lines for the above purpose along a twelve foot wide easement in the City of Preston comprising parts of Swanston-street and Bell-street as follows:—

Route "A"—Commencing from the south-eastern alignment of the State Electricity Commission substation "EP", thence in a south-westerly direction for approximately 70 feet to a pole situated at the south-eastern corner of Swanston-street and Quinn-street; thence in an easterly direction for approximately 85 feet to a pole located in Swanston-street adjacent to the south-eastern boundary of substation "EP".

Route "B"—Commencing from a point approximately 20 feet east of the south-western boundary of substation "EP", thence in a south-easterly direction along the northern side of Swanston-street for approximately 490 feet to a pole situated at the south-east corner of Bellvue-crescent and Swanston-street, thence in a southerly direction along the eastern side of Swanston-street for approximately 650 feet to a pole situated on the southern side of Bell-street, thence in an easterly direction along the southern side of Bell-street for approximately 185 feet to the centre of Darebin Creek (the common municipal boundary of the City of Preston and the City of Heidelberg).

Copies of the draft Order and of the Order when made can be obtained by any person at the price of One dollar each at the office of the applicant, Town Hall, Ivanhoe, and at the office of the State Electricity Commission of Victoria, at Nos. 15-27 William-street, Melbourne.

Notices of objection and other documents may be served at the office of the applicant as aforesaid.

Every council, company, person or persons desirous of bringing before the State Electricity Commission of Victoria, by whom the *Electric Light and Power Act, 1958*, is administered; any objection respecting the application must do so within three months from the date of the Government Gazette containing this advertisement, by notice addressed to the Secretary, State Electricity Commission of Victoria, 15-27 William-street, Melbourne, marked on the outside of the cover enclosing it: "*Electric Light and Power Act 1958*". A copy of every such notice must also be forwarded to the applicant for the Order.

Dated this 17th day of April, 1967.

6511

E. JACK, Town Clerk.

CITY OF HORSHAM.

LOAN No. 59.

Notice of Intention to Borrow the Sum of \$10,400 for Permanent Works and Undertakings.

NOTICE is hereby given that the Council of the City of Horsham proposes to borrow the principal sum of \$10,400 secured by a charge over the general rates of the municipality, such sum to be raised by the grant of a mortgage in accordance with the provisions of the *Local Government Act 1958*.

1. The maximum rate of interest that may be paid is 5½ per cent. per annum.

2. The purpose for which the loan is to be applied is—
The purchase of a Bookmobile.

3. The period of the loan shall be five years.

4. The moneys borrowed shall be repayable by providing out of the municipal fund half-yearly instalments of approximately \$1,204 each, including principal and interest, on the 1st day of July and the 1st day of January during the currency of the loan. The first instalment shall be payable on the 1st day of January, 1968.

5. Such moneys shall be repayable to the Commissioners of the State Savings Bank of Victoria at the office of the said Commissioners, corner Elizabeth and Bourke streets, Melbourne.

The plans and specifications and the estimate of the cost of the proposed works and a statement showing the proposed expenditure of the moneys to be borrowed are open for inspection at the office of the Council of the City of Horsham at the Town Hall, Wilson-street, Horsham.

18th April, 1967.

6521

A. R. CONN, Town Clerk.

CITY OF HORSHAM.

LOAN No. 60.

Notice of Intention to Borrow the Sum of \$17,500 for Permanent Works and Undertakings.

NOTICE is hereby given that the Council of the City of Horsham proposes to borrow the sum of \$17,500, on the credit of the municipal revenues of the Mayor, Councillors, and Citizens of the City of Horsham, such sum to be raised by the grant of a mortgage, in accordance with the provisions of the *Local Government Act*.

1. The maximum rate of interest that may be paid is 5½ per cent. per annum.

2. The purpose for which the Loan is to be applied is:

Road construction works	\$14,000
Town plan	2,000
Watering Racecourse Reserve	1,500
	<hr/>
	\$17,500

3. The period of the loan shall be ten years.

4. The moneys borrowed shall be repayable by providing out of the municipal fund twenty half-yearly instalments of approximately \$1,163 each, including principal and interest, on the 10th day of July and the 10th day of January during the currency of the loan. The first instalment shall be payable on the 10th day of January, 1968.

5. Such moneys shall be repayable at the Commercial Bank of Australia Limited, Melbourne, or at the Council's bankers for the time being in Melbourne.

The plans and specifications and the estimate of the cost of the proposed work, and a statement showing the proposed expenditure of the money to be borrowed, are open for inspection at the Town Hall, Horsham.

6522

A. R. CONN, Town Clerk.

CITY OF PRESTON.

By-Law No. 82.

NOTICE is hereby given that the Council of the City of Preston has made a By-law under the provisions of the *Local Government Act 1958*, as amended, and numbered 82, for the purposes of—

- (i) The adoption of certain of the provisions of the Fifteenth Schedule to the *Local Government Act 1958*, as amended;
- (ii) Making regulations for the proper maintenance and management of gardens under the management or control of the Council;
- (iii) Controlling and managing and preserving commons and public reserves of which the management is vested in the Council.

A copy of the By-law is open for inspection, free of charge during office hours at the offices of the Council, Town Hall, High-street, Preston.

Resolution for passing this By-law was agreed to by the Council on the 27th February, 1967, and confirmed on the 10th April, 1967.

6520

J. C. DONATH, Town Clerk.

CITY OF ST. KILDA.

By-Law No. 187.

Metropolitan Hawkers By-Law.

A By-Law of the City of St. Kilda made under the provisions of Section 36 of the *Hawkers and Pedlers Act 1958*, and numbered 187 for prescribing the limits whether as to time or place within which persons holding a Metropolitan Hawkers Licence may sell or offer or expose for sale any articles specified in their licences in any street road or public place.

IN pursuance of the powers conferred by the *Hawkers and Pedlers Act 1958*, and of any and every other power it thereto enabling the Mayor Councillors and Citizens of the City of St. Kilda order as follows:—

(1) This By-law may be known as the Metropolitan Hawkers' By-law.

(2) In this By-law the words "Metropolitan Hawker" mean the holder of a Metropolitan Hawkers licence under the *Hawkers and Pedlers Act 1958*.

(3) The limits as to time within which the selling or offering or exposing for sale by a Metropolitan Hawker of any articles specified in his licence issued under the *Hawkers and Pedlers Act 1958*, is permitted within the municipal district of the City of St. Kilda are hereby prescribed as between the hours of ten o'clock in the morning and three o'clock in the afternoon on any week day other than Saturday or a Public Holiday and no Metropolitan Hawker shall sell or offer or expose for sale any such articles at any other time or at any time on any Saturday Sunday or Public Holiday.

(4) Any person guilty of any wilful act or default contrary to this By-law shall be liable to a penalty of not less than \$10.00 nor more than \$40.00 and any person guilty of a continuing offence against this By-law shall be liable to a penalty of not more than \$10.00 for each day on which an offence against this By-law is continued after a conviction or order by any Court.

Resolution for passing this By-law agreed to by the Council of the City of St. Kilda on the 12th day of December, 1966, and confirmed on the 6th day of February, 1967.

The Corporate Seal of the Mayor Councillors and Citizens of the City of St. Kilda was hereunto affixed in the presence of:—

(SEAL) S. ALDAUS, Mayor.
A. C. WATSON, Councillor.
A. N. ISAAC, Town Clerk.

Approved by the Governor in Council on 15th March, 1967. 6507

CITY OF SWAN HILL.

LOAN No. 42.

Notice of Intention to Borrow the Sum of \$35,000 for Permanent Works and Undertakings.

NOTICE is hereby given that the Council of the City of Swan Hill proposes to borrow the sum of Thirty-five thousand dollars (\$35,000) secured by a charge on the general rates of the municipality such sum to be raised by the grant of a mortgage in accordance with the provisions of the *Local Government Act 1958*.

1. The maximum rate of interest that may be paid is 5½ per cent. per annum.

2. The interest is to be paid half yearly during the currency of the loan.

3. The period of the loan shall be fifteen years.

4. The moneys borrowed shall be repayable at the Commercial Savings Bank of Australia Limited, Melbourne.

5. Such moneys shall be repayable by providing out of the municipal fund 29 half yearly instalments of approximately \$1344.19, including principal and interest, on the 1st days of January and July and a final instalment of approximately \$21,458.38 on the 1st day of July, 1982. The first instalment shall be repayable on 1st January, 1968.

6. The purpose for which the loan is to be applied is to construct a Bowling Green Pavilion at Swan Hill.

The plans and estimates of the cost of the proposed work, and a statement showing the proposed expenditure of the monies to be borrowed are open for inspection at the office of the Council of the City of Swan Hill at the Town Hall, Swan Hill, during office hours.

6523

R. J. PUGSLEY, Town Clerk.

CITY OF WANGARATTA.

NOTICE is hereby given that Sergeant LAWRENCE JOSEPH RYAN, No. 8937, of Wangaratta, has been appointed Prosecuting Officer to the City of Wangaratta, in lieu of Sergeant Allan Bodey, resigned.

6491

W. R. FEATHERSTON, Town Clerk.

TOWN OF CAMPERDOWN.

LOAN No. 17.

Notice of Intention to Borrow the Sum of \$30,000 for Permanent Works and Undertakings.

NOTICE is hereby given that the Council of the Town of Camperdown proposes to borrow the principal sum of \$30,000 secured by a charge over the general rates of the municipality, such sum to be raised by the grant of a mortgage in accordance with the provisions of the *Local Government Act 1958*.

1. The maximum rate of interest that may be paid is 5½ per cent. per annum.

2. The purpose for which the loan is to be applied is for construction of:—

Kerb and Channel and Footpaths—

Walls, Bowen, Fergusson, Cole, Ower, Pike, Thornton, Harrison, Little, Brooke, Curdie, Errey, Wilson, Manifold, Henderson, Scott streets and Colac-road.

Contribution to C.R.B. Works—

Wright, Bowen, Cressy, Henderson, Cole, Manifold streets, Cemetery, Park, Ballarat, Cobden, Gnotuk, Mt. Leura and Depot roads.

3. The period of the loan shall be ten years.

4. The moneys borrowed shall be repayable by providing out of the municipal fund half-yearly instalments of approximately \$1,993 each, including principal and interest on the 1st day of June and the 1st day of December, during the currency of the loan. The first instalment shall be payable on the 1st day of December, 1967.

5. Such moneys shall be repayable to the Commissioners of the State Saving Bank of Victoria at the office of the said Commissioners, corner Elizabeth and Bourke streets, Melbourne.

The plans and specifications and the estimate of the cost of the proposed works and a statement showing the proposed expenditure of the moneys to be borrowed, are open for inspection at the office of the Council of the Town of Camperdown, at the Council Chambers, Manifold-street, Camperdown.

Dated 30th March, 1967.

6569

HUGH D. H. LEARMONTH, Town Clerk.

TOWN OF PORTLAND.

APPOINTMENT OF PROSECUTING OFFICER.

NOTICE is hereby given that the Council of the Town of Portland has appointed Sergeant Maxwell Allan Oakley, No. 10904, as Prosecuting Officer for the Town.
6524 L. FELL, Town Clerk.

Town and Country Planning Act 1961 (Twelfth Schedule).
SHIRE OF BELLARINE.—GEELONG AND DISTRICT
TOWN PLANNING SCHEME.

NOTICE THAT A PLANNING SCHEME HAS BEEN PREPARED AND IS AVAILABLE FOR INSPECTION.

Amendment No. 4.

NOTICE is hereby given that the Shire of Bellarine, in pursuance of its powers under the *Town and Country Planning Act 1961*, has prepared a Planning Scheme for the following areas:—

1. Land commencing at the corner of Collins-street and Wilsons-road, Whittington; thence northerly along Wilsons-road to the Queenscliff Railway Line; thence easterly along such railway line to Earl's-road; thence southerly along Earl's-road to a point in line with the continuation of Collins-street; thence westerly along such line to the point of commencement.

It is proposed that such land be rezoned from Agricultural "C" to Residential "A".

2. Land being part of the area bounded by the south side of Watsons-road, west side of Wilsons-road, north side of Dorward-avenue, and east side of Johnstone-avenue.

It is proposed that lot 5 of the Dorward No. 1 Estate, Watsons-road, Newcomb, be rezoned from Residential "A" to Commercial "C" to permit additional shops with provision for car parking areas at the rear of the shop sites.

3. Land fronting the east side of Helms-street between the Geelong-Portarlington road and the Bellarine Highway.

It is proposed to rezone the area concerned from Agricultural "C" to Residential "A".

Land fronting the west side of Helms-street, for approximately 75 per cent. of its total length is already zoned as Residential "A".

A copy of the scheme has been deposited at the Shire Offices, Drysdale, and at the office of the Town and Country Planning Board, 170 Queen-street, Melbourne, and will be open for inspection during the office hours by any person, free of charge.

Any persons affected by the Planning Scheme are required to set forth, in writing, all objections they may have, addressed to the Shire Secretary, Shire of Bellarine, Shire Offices, Drysdale, on or before the 31st July, 1967, and to state whether they wish to be heard in respect of their objections.

Dated this 14th day of April, 1967.

6572 H. A. WILLIAMS, Shire Secretary.

SHIRE OF BERWICK.

LOAN No. 34.

*Notice of Intention to Borrow the Sum of \$32,500 for
Permanent Works and Undertakings.*

NOTICE is hereby given that the Council of the Shire of Berwick proposes to borrow the principal sum of \$32,500 secured by a charge over the general rates of the municipality, such sum to be raised by the grant of a mortgage in accordance with the provisions of the *Local Government Act 1958*.

1. The maximum rate of interest that may be paid is 5½ per cent. per annum.

2. The purposes for which the loan is to be applied are—

Construction of Public Hall Extension, Doveton	\$26,000
Construction of Public Conveniences, Beacons- field Upper	\$1,000
Extension of main Outfall drain, Manuka-road, Berwick	\$5,500

3. The period of the loan shall be ten years.

4. The moneys borrowed shall be repayable by providing out of the municipal fund half-yearly instalments of approximately \$2,159.34 each including principal and interest on the 1st day of December and the 1st day of June, during the currency of the loan. The first instalment shall be payable on the 1st day of December, 1967.

5. Such moneys shall be repayable to the Commercial Bank of Australia Limited, Pakenham East, Victoria.

The plans and specifications and the estimate of the cost of the proposed works and a statement showing the proposed expenditure of the moneys to be borrowed are open for inspection at the office of the Council of the Shire of Berwick, at Main-street, Pakenham East.

Date, 7th April, 1967.

6482

B. J. WALLIS, Shire Secretary.

SHIRE OF BULLA.

LOAN No. 20.

Easement Drain Construction.

NOTICE is hereby given that at a meeting of the Council of the Shire of Bulla, held at the Municipal Offices, Sunbury, on the 6th March, 1967, the said Council did agree to adopt the following Resolution, that is to say:—

"That Council borrow \$20,000 on the municipal revenues of the President, Councillors and Ratepayers of the said Shire, such sum to be raised by the grant of a mortgage in accordance with the provisions of the *Local Government Act 1958*."

1. The maximum rate of interest that may be paid is 5.50 per cent. per annum.

2. The purpose for which the loan is to be applied is towards the cost of Easement Drain Construction.

3. The period of the loan shall be five years.

4. The moneys borrowed shall be repayable by twenty half-yearly instalments of \$2,314.79 including interest on the 1st November and 1st May, during the currency of the loan.

The first instalment shall be repayable on the 1st November.

5. Such moneys shall be repayable at the Head Office of the National Bank Savings Bank Ltd., Melbourne.

Notice is further given that at a meeting of the said Council held on the 3rd April, 1967, the said Resolution was confirmed.

6493

JOHN M. KELLY, Shire Secretary.

SHIRE OF CROYDON.

LOAN No. 68.

Private Street Construction.

NOTICE is hereby given that at the meeting of the Council of the Shire of Croydon, held at the Shire Hall, Croydon, on the 20th day of March, 1967, the said Council did agree to the following Resolution, that is to say:—

"That the Council do by Special Order and it does hereby resolve to borrow the sum of \$50,000 on the credit of the municipal revenues of the President, Councillors and Ratepayers of the said Shire, such sum to be raised by the grant of mortgage, in accordance with the provisions of the *Local Government Act 1958*."

The rate of interest to be paid shall be 5.75 per centum per annum and the said loan shall be liquidated by twenty half-yearly payments of principal and interest, at the National Bank Limited, Melbourne, on the several days and in the several amounts specified in the Schedule of payments.

The purposes for which the said loan shall be applied are for the construction of private streets under the provision of Division 10, Part XIX. of the *Local Government Act 1958* and the loan shall be liquidated from the receipts of money payable under scheme under the said Division."

Notice is hereby further given that at a meeting of the said Council held at the Shire Hall, Croydon, on the 17th day of April, 1967, the said Resolution was confirmed.

6481

K. A. MCKAY, Shire Secretary.

SHIRE OF DUNMUNKLE.

NOTICE is hereby given of the appointment of Mr. Albert Powell, Loats-street, Minyip, as Proper Officer under the *Dog Act 1958*.

6528

K. E. LIEBOLD, Shire Secretary.

SHIRE OF McIVOR.

NOTICE is hereby given that at the Meeting of the Council of the Shire of McIvor held on 14th March, 1967, the following Resolution was passed, viz.:—

"That this Council do by Special Order, and it does hereby resolve to borrow the principal sum of \$10,000 by the grant of a mortgage on the credit of the President, Councillors and Ratepayers of the Shire of McIvor, for

the purposes and upon the terms and conditions mentioned in the Notice of Intention to Borrow published in the *Victoria Government Gazette* on the 16th day of November, 1966."

And notice is further given that the above Resolution will be submitted for confirmation at a Meeting of the Council to be held on 11th May, 1967.

D. MAXWELL, Shire Secretary.
Shire Office, Heathcote. 6525

SHIRE OF MClVOR.

BY-LAW NO. 43 FOR THE PURPOSE OF DEFINING DISTANCES FROM BOUNDARIES TO OUTER WALLS OF DWELLINGS IN CERTAIN AREAS OF THE SHIRE.

NOTICE is hereby given that at the meeting of the Shire of Mclvor held on 13th April, 1967 the following resolution was passed, viz.:—

"That the Council of the Shire of Mclvor resolve and agree to make by Special Order, in accordance with the provisions of the *Local Government Act 1958* and the *Uniform Building Regulations, Victoria as amended* (hereinafter referred to as the Regulations), By-Law No. 43 as follows:—

"This By-Law shall apply to and have effect in the Central Riding of the Shire of Mclvor.

The minimum distances from boundaries to the outer walls of any building henceforth to be constructed in the above areas shall be those defined in Column 3 of Table 804 of the Regulations."

And further: That the confirmation of the resolution making such By-Law be made an Order of the Day for the meeting of the Council to be held at the Council Chambers, High Street, Heathcote, at 11 a.m. on 11th May, 1967."

D. MAXWELL, Shire Secretary.
Shire Office, Heathcote. 13th April, 1967. 6526

SHIRE OF MClVOR.

BY-LAW NO. 42 FOR THE PURPOSE OF DEFINING DISTANCES FROM BOUNDARIES TO OUTER WALLS OF DWELLINGS IN CERTAIN AREAS OF THE SHIRE.

NOTICE is hereby given that at the meeting of the Shire of Mclvor held on 13th April, 1967 the following resolution was passed, viz.:—

"That the Council of the Shire of Mclvor resolve and agree to make by Special Order, in accordance with the provisions of the *Local Government Act 1958* and the *Uniform Building Regulations, Victoria as amended* (hereinafter referred to as the Regulations), By-Law No. 42 as follows:—

"That By-Law shall apply to and have effect in those parts of the Shire of Mclvor being part of Crown allotment 3, Parish of Heathcote, Plan of Subdivision No. 68591, as shown on the Eppalock Planning Scheme as Residential "A" zone; and to any other areas which may be zoned subsequently as Residential "A" within that portion of the Eppalock Planning Scheme area falling within the boundaries of the Shire of Mclvor.

The minimum distances from boundaries to the outer walls of any buildings henceforth to be constructed in the above areas shall be those defined in Column 4 of Table 804 of the Regulations."

And further: That the confirmation of the resolution making such By-Law be made an Order of the Day for the meeting of the Council to be held at the Council Chambers, High Street, Heathcote, at 11 a.m. on 11th May, 1967."

D. MAXWELL, Shire Secretary.
Shire Office, Heathcote, 13th April, 1967. 6527

SHIRE OF MORNINGTON.

SPECIAL ORDER.

Loan No. 53, \$100,000.

NOTICE is hereby given that the Council of the Shire of Mornington did at its meeting on Tuesday, 21st February, 1967, for which notice of the making of a Special Order for borrowing had been given, agree to the following Resolution, that is to say:—

"That the Council of the Shire of Mornington does by Special Order, hereby resolve to borrow by the grant of a mortgage the sum of One hundred thousand dollars to be applied in the construction of private streets within the Municipality in accordance with schemes prepared under

the provisions of Division 10, Part XIX, of the *Local Government Act 1958*, such loan to be liquidated by the creation of a sinking fund pursuant to section 428A of the *Local Government Act 1958*; interest to be payable at the rate of 5½ per centum per annum during the period of the loan, viz.: 40 years, such loan to be secured by a charge over the general rates of the said Municipality."

Notice is further given that at a meeting of the said Council held on Tuesday, 21st March, 1967, the above Resolution was confirmed.

6480 D. G. COLLINGS, Shire Secretary.

SHIRE OF SWAN HILL.

LOAN No. 46.

Notice of Intention to Borrow the Sum of \$25,000 for Permanent Works and Undertakings.

NOTICE is hereby given that the Council of the Shire of Swan Hill proposes to borrow the principal sum of \$25,000 secured by a charge over the general rates of the municipality, such sum to be raised by the grant of a mortgage in accordance with the provisions of the *Local Government Act 1958*.

1. The maximum rate of interest that may be paid is 5.875 per cent. per annum.

2. The purposes for which the loan is to be applied are—

Robinvale Caravan Park Cottage and Kiosk	\$7,000
Staff Housing	13,000
Shire Office Alterations and Additions	5,000
	<hr/>
	\$25,000

3. The period of the loan shall be fifteen years.

4. The moneys borrowed shall be repayable by providing out of the municipal fund 30 half-yearly instalments of \$1,265.20 each, including principal and interest on the 1st day of August and the 1st day of February during the currency of the loan. The first instalment shall be payable on the 1st day of February, 1968.

5. Such moneys shall be repayable at the Commonwealth Savings Bank of Australia, Melbourne.

Plans and specifications and estimates of cost of the proposed works and a statement showing the proposed expenditure of the moneys to be borrowed are open for inspection at the Office of the Council of the Shire of Swan Hill, Beveridge-street, Swan Hill.

Dated this 11th day of April, 1967.

6497 J. D. LAURITZ, Shire Secretary.

SHIRE OF TOWONG.

LOAN No. 14.

Notice of Intention to Borrow the Sum of \$7,500 for Permanent Works and Undertakings.

NOTICE is hereby given that the Council of the Shire of Towong proposes to borrow the principal sum of \$7,500 secured by a charge over the general rates of the municipality, such sum to be raised by the grant of a mortgage in accordance with the provisions of the *Local Government Act 1958*.

1. The maximum rate of interest that may be paid is 5½ per cent. per annum.

2. The purpose for which the loan is to be applied is the purchase of road-making equipment.

3. The period of the loan shall be five years.

4. The moneys borrowed shall be repayable by providing out of the municipal fund half-yearly instalments of approximately \$868 each, including principal and interest on the 1st day of July and the 1st day of January, during the currency of the loan. The first instalment shall be payable on the 1st day of January, 1968.

5. Such moneys shall be repayable to the Commissioners of the State Savings Bank of Victoria, at the office of the said Commissioners, corner Elizabeth and Bourke streets, Melbourne.

The plans and specifications and the estimate of the cost of the proposed works and a statement showing the proposed expenditure of the moneys to be borrowed, are open for inspection at the office of the Council of the Shire of Towong, at Tallangatta.

6571 I. M. BOWMAN, Shire Secretary.

NOTICE is hereby given that the partnership heretofore subsisting between Frank Samuel Wilson, and Frederick William Wilson, carrying on business as monumental masons, at 27 Kent-street, Sebastopol, under the name of "F. Wilson Bros.", has been dissolved by mutual consent as and from the 31st March, 1967. All debts due to and owing by the said late firm will be received and paid by the said Frederick William Wilson. Hereafter the said Frank Samuel Wilson will carry on business as a monumental mason on his own behalf at 301 Rubicon-street, Sebastopol, under the name of "Frank S. Wilson", and the said Frederick William Wilson will carry on business as a monumental mason in partnership with Coral Maude Wilson at 27 Kent-street, Sebastopol, under the name of "Wilson's Memorials".

Dated the 4th day of April, 1967.

F. S. WILSON.

Witness—G. K. Sutton, solicitor, Ballarat.

F. W. WILSON.

Witness—A. Gavin Shaw, solicitor, Ballarat.

Dooley Sutton & A. W. Long, 43 Lydiard-street, South Ballarat, solicitors for the said Frank Samuel Wilson.

Cuthbert Morrow Must & Shaw, 102 Lydiard-street, South Ballarat, solicitors for the said Frederick William Wilson. 6531

NOTICE is hereby given that the partnership heretofore subsisting between RENNISON James Murray, and Harvey James Marshall, carrying on business as motor mechanics at Factory 4, 3 Levanswell-road, Moorabbin, under the style or firm of Speed Tuning and Equipment Co., has been dissolved as from the 1st day of May, so far as concerns the said Harvey James Marshall who retires from the said firm.

YELLAND & YELLAND, solicitors, 37 Swanston-street, Melbourne. 6542

NOTICE is hereby given that the partnership lately subsisting between Raymond William Slater Hall and Kenneth Neil Smith, carrying on the business of display artists at 14 Walter-street, Dandenong, in the State of Victoria, under the business or firm name of "Trent Promotions", was dissolved by mutual consent on the 14th day of April, 1967. The said Raymond William Slater Hall will continue to carry on business under the said name of Trent Promotions at the said address, where he will receive all debts owing to and pay all debts owing by the partnership.

Dated this 17th day of April, 1967.

6580

NOTICE is hereby given that the partnership heretofore subsisting between Ian Haynes and Thomas Edward Vaughan, carrying on business as building contractors, at lot 264 Armin-street, Scoresby, in the State of Victoria, under the firm of "Haynes & Vaughan", has been dissolved as from the 3rd day of April, 1967.

Dated this 13th day of April, 1967.

T. E. VAUGHAN.
IAN HAYNES.

6504

NOTICE is hereby given that the partnership hitherto existing between Paul Dodd, Valma June Dodd, Robert John Taylor and Valerie Taylor, trading as dealers in timber and hardware, at 116 Pier-street, Altona, under the name of Merritt Timber & Hardware Co., has been dissolved by mutual consent as from the 14th day of April, 1967. The business will hereafter be conducted by Robert John Taylor and Valerie Taylor at the same place and all debts due to and owing by the said firm will be received and paid by them.

Dated at Altona, the 14th day of April, 1967.

JUNE DODD.
P. DODD.
R. J. TAYLOR.
V. TAYLOR.

6597

The Companies Act 1961.—In the matter of MANNING SEPTICS PTY. LTD. (in Liquidation).

NOTICE is hereby given that pursuant to section 272 (1) of the Companies Act, a Final Meeting of creditors of the above company will be held at the office of Bruce Fordham, 170 Toorak-road, South Yarra, on Tuesday, the 23rd May, 1967, at 9 a.m.

Business: To receive the liquidator's accounts.

Dated this 14th day of April, 1967.

Bruce Fordham, liquidator, 170 Toorak-road, South Yarra. Telephone 24-7511. 6593

Form 92.

Companies Act 1961.

COLONY RESTAURANT PROPRIETARY LIMITED.

NOTICE OF MEETING OF CREDITORS PURSUANT TO S.260 (1).

NOTICE is hereby given that a meeting of the creditors of Colony Restaurant Proprietary Limited will be held at 57 Exhibition-street, Melbourne, on the 1st day of May, 1967, at 2.30 o'clock in the afternoon for the purposes set out in sections 260, 261 and 262 of the Companies Act 1961.

AGENDA.

1. To consider a statement of the position of the company's affairs, together with a list of creditors of the company and the estimated amounts of their claims.

2. To consider a special resolution for winding up passed by the above-named company.

3. To nominate a person to be liquidator for the purpose of winding up the affairs and distributing the assets of the above-named company.

4. If thought fit to appoint members of a committee of inspection.

5. To fix the remuneration of the proposed liquidator.

Dated the 17th day of April, 1967.

By Order of the Board,

J. SELBY, Secretary.

NOTE.—No person will be entitled to vote as a creditor at the meeting unless he shall have lodged with the chairman of the meeting details of the debt which he claims to be due to him from the company. Enclosed herewith, is a convenient form of proof of debt to be used for the purpose of this meeting only. These forms, duly completed, may be posted to the secretary of the company to reach him before the meeting or handed to the chairman at the commencement of the meeting.

Creditors unable to attend such meeting may vote by proxy; enclosed herewith is a form of proxy which may be used if desired. Proxies must be executed and forwarded to the Secretary of the Company, 57 Exhibition-street, Melbourne, so as to be delivered at that address not later than 2.00 p.m. on Friday 28th day of April, 1967.

6591

The Companies Act 1961.—In the matter of MANNING SEPTICS PTY. LTD. (in Liquidation).

NOTICE is hereby given that a Second and Final Dividend is intended to be declared in this matter.

Creditors who have not proved their debts by the 10th day of May, 1967, will be excluded from the dividend.

Dated this 14th day of April, 1967.

Bruce Fordham, liquidator, 170 Toorak-road, South Yarra. Telephone 24-7511. 6594

The Companies Act 1961.—In the matter of HALTON BROS. PROPRIETARY LIMITED.—Notice re Meeting of Creditors Pursuant to Section 260.

NOTICE is hereby given that a meeting of creditors of the above-named company will be held at the offices of Kennedy, Small and Middlemiss, 296 Little Lonsdale-street, Melbourne, at 11 a.m., on the 26th day of April, 1967, the company having convened a meeting of its members for the same day for the purpose of considering a Resolution that the company be wound up voluntarily.

Dated this 14th day of April, 1967.

M. B. HALTON, Director.

Kennedy, Small & Middlemiss, 296 Little Lonsdale-street, Melbourne. 6595

Companies Act 1961, Section 254 (2) (b).

GLAMOUR GIRL CASUALS PROPRIETARY LIMITED.

NOTICE is hereby given that at an Extraordinary General Meeting of the above-named company duly convened and held at the Institute of Chartered Accountants, 23 McKillop-street, Melbourne, on 13th April, 1967, the following Special Resolution was passed:—

"That the company be wound up voluntarily and that R. A. Waters, chartered accountant, 170 Queen-street, Melbourne, be appointed liquidator of such winding up."

Dated this 14th day of April, 1967.

6583 R. A. WATERS, Liquidator.

Unclaimed Moneys Act 1962.

REGISTER of Unclaimed Moneys held by the—

Name of Owner on Books and Last Known Address.	Total Amount Due to Owner.	Description of Unclaimed Moneys.	Date when Amount first became Payable.
THE BROKEN HILL PROPRIETARY COMPANY LIMITED.			
\$			
Alford, Robert G., 34 Wolseley-road, Mosman, N.S.W.	27.08	Dividend	{ 26.5.65 24.11.65
Atwood, Janette W. W. (estate of), c/o Bartier Perry and Purcell, 2 O'Connell-street, Sydney, N.S.W.	15.32	" " " " " "	" " " " " "
Barker, Sydney M., 26 Arnold-street, Killara, N.S.W.	15.32	" " " " " "	" " " " " "
Barnett, Ruby M., Pine Lodge, Duffield-street, Gawler, S.A.	17.92	" " " " " "	" " " " " "
Barnett, Ruby M., Pine Lodge, Duffield-street, Gawler, S.A.	63.00	Interest	1.10.65
Barnett, Ruby M., Pine Lodge, Duffield-street, Gawler, S.A.	137.41	Dividend	{ 26.5.65 24.11.65
Barney Smith and Co. Inc., 20 Broad-street, New York 5, N.Y., U.S.A.	23.37	" " " " " "	" " " " " "
Begg, John McQ., 4 R.D. Balclutha, Otago, N.Z.	26.78	" " " " " "	" " " " " "
Begg, Margaret J., c/o Mr. John M. Begg, 4 R.D. Balclutha, N.Z.	47.46	" " " " " "	" " " " " "
Brent, Evelyn M., c/o Hong Kong and Shanghai Banking Corp., 9 Gracechurch-street, London, EC3, U.K.	42.03	" " " " " "	" " " " " "
Caldwell, Tracy F., 177 West Coast Highway, Scarborough Beach, W.A.	64.17	" " " " " "	" " " " " "
Campbell, Donald McL. (estate of), c/o Box 219, Hastings, Hawkes Bay, N.Z.	81.04	" " " " " "	" " " " " "
Campbell, George A., 188 Main-road, Ballarat	16.54	" " " " " "	" " " " " "
Carson, William E., " Burraboranga ", Karara, Qld.	275.00	" " " " " "	" " " " " "
Carter, Wesley W., " Golambo ", Young, N.S.W.	14.58	" " " " " "	" " " " " "
Carter, Keith George, Davis, Russell Alton and Richards, May, 37-41 O'Riordan-street, Alexandria, N.S.W.	17.93	Dividend	{ 26.5.65 24.11.65
Chan, Vernon, 52 Waterloo-road, Lower Hutt, N.Z.	22.85	" " " " " "	" " " " " "
Chapman, Joan V. R., 194 Military-road, Dover Heights, N.S.W.	48.48	" " " " " "	" " " " " "
Cheong, Kai Swee, c/o Perak Traders and Co., Chartered Bank Chambers, Station-street, Ipoh, Malaysia	18.37	" " " " " "	" " " " " "
Colbourne, Ivan D., No. 9 R.D., Waimate, N.Z.	26.66	" " " " " "	" " " " " "
Collinson, Herbert, Linton War Veterans' Home, Yass, N.S.W.	29.56	" " " " " "	" " " " " "
Colman, Graeme R. (estate of), c/o G. F. Pitcher and Co., 406 Lonsdale-street, Melbourne	19.35	" " " " " "	" " " " " "
Colyer, Mary and Scott, Frank, 32 Austral-terrace, Malvern, S.A.	125.42	" " " " " "	" " " " " "
Cooke, Doris D., 3 Downcraig-road, Castlemilk, Glasgow S.5, U.K.	12.69	" " " " " "	" " " " " "
Davis, Antony, No. 1 Victoria Park Close, Singapore 10	29.24	" " " " " "	" " " " " "
de la Guerrande, Gaston, Chateau de Kerrozeu Marou, Pres Lamballe, France	12.41	" " " " " "	" " " " " "
Dickison, Hetty F., P.O., Box 992, Wellington, N.Z.	16.00	" " " " " "	" " " " " "
Dollimore Marie D., c/o Mr. A. G. Johnston, 19 Boden-avenue, Strathfield, N.S.W.	12.94	" " " " " "	" " " " " "
Dooley, David R. and Mollie J., 74 The Eyrie, Eaglemont, Victoria	112.87	" " " " " "	" " " " " "
Dummett, Cecil F. (estate of), 216-220 Sussex-street, Sydney, N.S.W.	36.58	" " " " " "	" " " " " "
Fisher, William R., Trafalgar Station, Bourke, N.S.W.	15.32	" " " " " "	" " " " " "
Fitzpatrick, Noel J., c/o H. A. Herborn and Son, 10 O'Connell-street, Sydney, N.S.W.	294.20	" " " " " "	" " " " " "
Fox, John F. A., c/o J. F. A. Fox and Co. Ltd., 4 Sefton-lane, Otemata, N.Z.	18.60	" " " " " "	" " " " " "
French, Stuyvesant L., 196 East 75th-street, New York, 25 NY, U.S.A.	15.23	" " " " " "	" " " " " "
Gilchrist, George, 2 Churchill-avenue, Te Avoha, N.Z.	38.08	" " " " " "	" " " " " "
Gill, Margaret J., 143 Queens-road, Connells Point, N.S.W.	10.27	" " " " " "	" " " " " "
Gillespie, John R., 2 Holloway-street, Ormond	13.75	" " " " " "	" " " " " "
Gordon, William H. L., 250 India Buildings, Liverpool 2, U.K.	43.38	" " " " " "	" " " " " "
Gundry, John H. B., c/o Bank of N.S.W., Head Office, 341 George- street, Sydney, N.S.W.	71.67	" " " " " "	" " " " " "
Gunn, William I., 17 Omahu-road, Remuera, Auckland, N.Z.	27.72	" " " " " "	" " " " " "
Hackett, Hugh, 39 Charleville-road, North Circular-road, Dublin, Eire	18.35	" " " " " "	" " " " " "
Hall, Clifford, T. R., 15 Mortlake-terrace, Port Lincoln, S.A.	17.50	" " " " " "	" " " " " "
Hanlon, Thomas M., 33 The Drive, Concord, N.S.W.	91.67	" " " " " "	" " " " " "
Harris, Valma J., 7 Kings-road, Vaucluse, N.S.W.	35.83	" " " " " "	" " " " " "
Hatherly, Peter W., Kokarrup, Arthur River, W.A.	10.08	" " " " " "	" " " " " "
Hatty, Edith Christian Guest Home, Atherton-road, Oakleigh	13.26	" " " " " "	" " " " " "
Hooper, Michael C., 182 Melville-street, Hobart, Tas.	10.45	" " " " " "	" " " " " "
Hussey, Eva M. (estate of), c/o Currie Jack and Davis, 12 Wicksteed- place, Wanganui, N.Z.	65.90	" " " " " "	" " " " " "
Irving, Florence C. (estate of), c/o F. C. Petrie and Son, 375-377 George-street, Sydney, N.S.W.	203.22	" " " " " "	" " " " " "
Jacques, Ernest P. (estate of), Glenorchy, Tas.	43.90	" " " " " "	" " " " " "
Jamison, Effie G. (estate of) and Hardie, James M., c/o Cooper Bros. and Co., G.P.O., Box 2650, Sydney, N.S.W.	117.90	" " " " " "	" " " " " "
Jones, Edwin J. and Anr., 96 High-road, East Finchley, London, N.2, U.K.	10.33	" " " " " "	" " " " " "
Jones, Margaret Claire, Flat 5, Cardigan Court, 16 Cardigan-street, East St. Kilda	21.88	" " " " " "	" " " " " "
Kilduff, Edward F. (estate of), and Kilduff, Arthur J., c/o National Bank Limited, Teremure, Dublin, Eire	117.93	" " " " " "	" " " " " "
Lancaster, Beatrice M., 1 Fredben-avenue, Cammeray, N.S.W.	70.00	Interest	{ 1.4.65 1.10.65
Lancaster, Beatrice M., 1 Fredben-avenue, Cammeray, N.S.W.	135.63	Dividend	{ 26.5.65 24.11.65
Le Couteur, Phillip F., Alexander, William H., McVicar, John J., Thompson, Harold B. and Vette, Alwyn G., c/o Manhattan Hotel, Greenknowe-avenue, Kings Cross, N.S.W.	17.92	" " " " " "	" " " " " "
Livingstone, Robert R., 11 Holmwood-road, Christchurch, N.Z.	15.58	" " " " " "	" " " " " "
Lunham, Winifred J. W., c/o A.N.Z. Bank Limited, 394 Collins-street, Melbourne	16.04	" " " " " "	" " " " " "
Lynch, Frederick J., Box 1860 G.P.O., Sydney, N.S.W.	16.28	" " " " " "	" " " " " "
Marcel, Joseph, St. Brieuc, France	16.40	" " " " " "	" " " " " "

Unclaimed Moneys Act 1962.

REGISTER of Unclaimed Moneys held by the—

Name of Owner on Books and Last Known Address.	Total Amount Due to Owner.	Description of Unclaimed Moneys.	Date when Amount first become Payable.
THE BROKEN HILL PROPRIETARY COMPANY LIMITED—continued.			
\$			
Marshall, George L., c/o Jardine Matheson and Co. Ltd., P.O. Box 70, Hong Kong	12.83	Dividend	} 26.5.65 24.11.65
Milton, Emma and Toovey, Geoffrey W., 102 Everton-street, Hamilton, N.S.W.	43.00	"	
Molloy, John M. (estate of), c/o F. C. Petrie and Son, 375 George-street, Sydney, N.S.W.	78.83	"	"
Morrissey, Bidelia (estate of), c/o Mr. B. Morrissey, 51 Pultney-street, Dandenong	226.83	"	"
Macaulay, Andrew I., Ribbonwood, Waikaka, Southland, N.Z. ..	15.58	"	"
McAuliffe, Peter C., 63 Telegraph-road, Pymble, N.S.W. ..	56.38	"	"
MacDonald, Angus M., Box 14, Apia, Samoa ..	21.44	"	"
MacDonald, Barbara M., c/o Mr. J. Nelson, 38 Fox Valley-road, Wahroonga, N.S.W.	13.12	"	"
MacDonald, Donald c/o Mr. J. Nelson, 38 Fox Valley Road, Wahroonga, N.S.W.	26.25	"	"
MacQueen, David B., 15 Gilmour-street, Paisley, Scotland ..	44.20	"	"
Naylor, Benjamin J., 63 Frederick-street, Dunedin, N.Z. ..	12.18	"	"
Ness, William J., 75 Grant-street, Cottesloe, W.A. ..	19.07	"	"
Newell, Bertha E. and Reginald M., 33 Montgomery-crescent, Cockle Bay, Howick, N.Z.	82.59	"	"
North, Lindesay S., c/o C.S.R. Co Ltd., 1 O'Connell-street, Sydney, N.S.W.	13.12	"	"
O'Brien, Thomas, 149 Highett-street, Richmond ..	143.46	"	"
Ogge, Marie L., 3 Barnato-grove, Armadale ..	64.17	"	"
Oldham, Dorothea C., 173 Mill Point-road, South Perth, W.A. ..	13.12	"	"
Pike, Kenneth H., John D., Florence D., and Cameron, Anne D., c/o Mr. J. D. Pike, Wittenburro, Eulo, via Cunnamulla, Qld.	21.88	"	"
Reeves, David W., P.O. Box 225, Tauranga, N.Z.	13.64	"	"
Romand, Emile (estate of), c/o Mme. Marie L. Romand, Chateau de Ja Villeneuve, St. Aaron, Pres. Lamballe, France	32.95	"	"
Rutter, Ivy F. L., 32 Kerr-street, Mayfield, N.S.W. ..	28.88	"	"
Rylands, David C. and Anr., The Uplands, Moore Warrington, Lancs., U.K.	50.61	"	"
St. Leger, Hugh (estate of), c/o Beechcroft and Co., 29 Bedford Square, London, C.1	176.52	"	"
Scannell, David P. and Carswell, Arthur S., P.O. Box 219, Hastings, N.Z.	26.66	"	"
Schaffer, Alwine (estate of), c/o Mrs. Boese, Manor House Boarding Establishment, Bewdley, U.K.	17.54	"	"
Scott, John F., c/o P.O. Box 420, Wanganui, N.Z. ..	15.58	"	"
Shawber, Susan A., 440 East 79th-street, New York 21, N.Y., U.S.A.	29.75	"	"
Shute, William H. (estate of), c/o R. Reynolds, 39 Martin-place, Sydney, N.S.W.	21.09	"	"
Sinclair, Peter M., 26 Derwentwater-avenue, Sandy Bay, Tas. ..	17.50	"	"
Sinclair-Smith, Robert C., c/o Gilchrist Watt and Sanderson Pty. Ltd., 5 O'Connell-street, Sydney, N.S.W.	17.75	"	"
Skinner, John K., P.O. Box 1205, Dunedin, N.Z. ..	32.16	"	"
Smith, Francis H., Marathon and Robert streets, Proserpine, Qld. ..	33.00	"	"
Smith, Nelly S., 13 Wentworth-road, Vaucluse, N.S.W. ..	65.09	"	"
Snodgrass, Vita M. (estate of), Cakobau-road, Suva, Fiji ..	140.00	Interest	} 1.4.65 1.10.65 26.5.65 24.11.65
Snook, Denen, c/o Mr. E. R. Snook, P.O. Box 14, Madang, Tpng. ..	17.50	Dividend	
Stewart, Richard B., 2206 Apache-street, St. Paul 18, Minn. U.S.A.	14.87	"	"
Stricke, David J., 15 March-street, Bellevue Hill, N.S.W. ..	11.38	"	"
Swan, Trevor W., c/o Australian National University, R.S.S.S. G.P.O. Box 4, Canberra, A.C.T.	171.46	"	"
Sweeney, Margaret G. (estate of), c/o 128 Chatsworth-road, Cricklewood, London, N.W.2, U.K.	75.42	"	"
Tanner, Peter (estate of), (address unknown) ..	11.13	"	"
Taylor, Mary (nee Hedworth), 5 Cranford View, Exmouth, Devon, U.K.	12.37	"	"
Torr, Bernice M., Flat 3, 120 Old South Head-road, Bellevue Hill, N.S.W.	11.83	"	"
Turner, Lucy A., 127 Carrington-avenue, Hurstville, N.S.W. ..	15.86	"	"
Vautier, Ray (estate of), c/o Mr. V. Benson, 160 Castlereagh-street, Sydney, N.S.W.	25.63	"	"
Ventura, Dorothy E., 14332 Martha-street, Van Nuys, California, U.S.A.	13.87	"	"
Vowels, John A. (estate of), c/o Norman J. Shankly and Shankly, 406 Lonsdale-street, Melbourne	17.50	"	"
W. and B. Nominee Corporation, c/o J. R. Williston and Beane Inc., P.O. Box 4, Bowling Green-street, New York, NY10004, U.S.A.	15.58	"	"
Waddington, John P. (estate of), c/o Girard Trust Bank, Trust Dept., P.O. Box 7334, Philadelphia, Penna, 19101, U.S.A.	175.30	"	"
Wagner, Erica M., Avonmore, Shawford, Hants, England, U.K. ..	37.19	"	"
Weisselberg, Marcell, 53 Grange-road, Toorak	35.83	"	"
Westenra, Fenton A., Craigieburn Private Bag, Christchurch, N.Z.	11.69	"	"
Wharton-Kirke, Clement, 10 Oxlade-drive, New Farm, Brisbane, Qld.	17.50	"	"
Williams, Edith M., 13 The Grove, Isleworth, Middlesex, U.K. ..	68.55	"	"
Wilson, Ian F. E., P.O. Box 17015, Green-lane, Auckland, N.Z. ..	12.04	"	"
Woods, William B., 46 Swinton-street, Invercargill, N.Z. ..	22.85	"	"

6289

D. AND W. MURRAY (AUSTRALIA) LIMITED.

Gracey, M. J., High Street-road, Glen Waverley	31.10	Balance Wages	—3.65
--	-------	-----------------------	-------

6349

Unclaimed Moneys Act 1962.

REGISTER of Unclaimed Moneys held by the—

Name of Owner on Books and Last Known Address.	Total Amount Due to Owner.	Description of Unclaimed Moneys.	Date when Amount first become Payable.
PHOSPHATE CO-OPERATIVE COMPANY OF AUSTRALIA LIMITED.			
\$			
Klaric, J., 14 Margaret-street, Newtown	20.50	Unclaimed Wages	19.5.65
Humm, P., 13 Eagle-parade, Norlane	12.20	" " " "	30.11.65
McCabe, C. (estate of), Camperdown	13.50	Interest	15.3.65
6232			
NOBEL (AUSTRALASIA) PTY. LTD.			
Jones, R., 30 Castley-crescent, Braybrook	11.69	Wages	8.5.65
Bird, F., 61 Chelsey-street, Deer Park	10.72	" " " "	27.11.65
Czeck, P., 67 Station-road, Deer Park	22.85	" " " "	8.1.66
6233			
CARLTON BREWERY LIMITED.			
Blaxland, Guy H. G., 6 Collings-street, Wahroonga, N.S.W.	96.98	Dividend	26.3.64 23.9.64
Bradley, Frederick S., 11 Luxton-road, South Yarra	13.00	" " " "	26.3.64 23.9.64
Graham, Eve (Mrs.), 39 Domain-street, South Yarra	19.50	" " " "	26.3.64 23.9.64
Holmes, Constance M. (Miss), Flat 4, 16 Canfield Gardens, London, N.W.6, England	14.69	" " " "	26.3.64 23.9.64
Riddell, Florence E. (Mrs.), Flat 10, 2 Collins-street, Melbourne	25.00	" " " "	23.9.64
Sunnymead Investments Pty. Ltd., c/o Hancock and Woodward, 143 Queen-street, Melbourne	32.00	" " " "	26.3.64
Wakelin, Vincent J., Motanau, North Canterbury, New Zealand.	10.27	" " " "	26.3.64 23.9.64
Blaxland, Guy, H. G., 6 Collings-street, Wahroonga, N.S.W.	63.41	" " " "	26.3.65
Bradley, Frederick S., 11 Luxton-road, South Yarra	14.50	" " " "	26.3.65 5.10.65
Cahill, Mary E., 93 New-street, Brighton	17.00	" " " "	26.3.65
Graham, Eve, 39 Domain-street, South Yarra	21.75	" " " "	26.3.65 5.10.65
Halls, John M., Unit 10, 22 Newworra-road, Northbridge, N.S.W.	15.96	" " " "	5.10.65
Holmes, Constance M., Flat 4, 16 Canfield Gardens, London, N.W.6, England	16.39	" " " "	26.3.65 5.10.65
Riddell, Florence E., Flat 10, 2 Collins-street, Melbourne	72.50	" " " "	26.3.65 5.10.65
6235.			
CARLTON AND UNITED BREWERIES LIMITED.			
McDonald, C. B., 156 Powlett-street, East Melbourne	14.40	Wages	1.6.65
Bambllett, D., 247 Bell-street, Coburg	63.08	" " " "	11.6.65
Stojanovski, M., 337 Napier-street, Fitzroy	13.18	" " " "	" " " "
Bambllett, D., 247 Bell-street, Coburg	28.04	" " " "	18.6.65
Politis, P., Mahoney-street, Fitzroy	21.32	" " " "	2.7.65
Bain, A. F. (estate of), Post Office, North Ballarat	38.02	" " " "	27.9.65
Ryan, J. J. (estate of), 19 Hamilton-street, East Kew	362.92	" " " "	13.10.65
Norden, A. C. (estate of), 40 Ramsay-avenue, Kew	91.10	" " " "	29.10.65
Pekaz, J., 32 Wolsey-parade, Kensington	32.40	" " " "	25.11.65
May, A., 11 Ludmilla-terrace, Fannie Bay, N.T.	31.09	" " " "	26.11.65
Walters, K. R. and S. J., Goroke Hotel, Goroke	64.78	Credit Balance	30.11.65
Geralopoulos, G., 63 Charles-street, Abbotsford	23.92	Wages	7.1.65
Hind, W. F., 21 Kenilworth-street, Reservoir	37.85	" " " "	20.1.66
Maher, B., 133 Miller-street, North Fitzroy	10.08	" " " "	" " " "
Simmons, F. M., 59 Ormond-road, Moonee Ponds	19.25	" " " "	25.1.66
Wysokier and Ritterman, 133 Carinish-road, Clayton	14.83	Credit Balance	31.1.66
Payne, B. G., 48 Pembroke-street, Surrey Hills	20.18	Wages	10.2.66
Haramis, K., 250 George-street, Fitzroy	12.90	" " " "	11.2.66
Cadee, L. A., 270 Pascoe Vale-road, Essendon	20.00	Debenture Interest	31.12.65
Greer, A. B., 435 Beaudesert-road, Moorooka, Qld.	25.00	" " " "	" " " "
Brown, M. (estate of), c/o Colman, Wyatt and Anderson, 578 Bourke-street, Melbourne	25.00	" " " "	" " " "
Manders, S., Green Valley, via Liverpool, N.S.W.	15.00	" " " "	" " " "
Quayle, J. H., Oakbank, Heywood	10.00	" " " "	" " " "
Bain, J. S., 22 Michael-street, Beaumaris	16.00	Dividends	6.10.65
Biggs, M. V., Beaumont-road, Berwick	80.00	" " " "	" " " "
Broome, N. S., R.M.B. 173, Griffith, N.S.W.	16.00	" " " "	" " " "
Brosnan, E., 13 Fortescue-street, Brisbane	45.30	" " " "	25.2.66
Campbell, N. J., 41 Lansell-road, Toorak	30.00	" " " "	" " " "
Coffey, F. A., Christian Brothers, Strathfield, N.S.W.	39.50	" " " "	" " " "
Cullen, M., 2 Perrott-street, Paddington, Qld.	26.20	" " " "	" " " "
Dawes, A., c/o Bank of N.S.W., Cloncurry, Qld.	50.00	" " " "	" " " "
Foden, D. R., 4 Hutchinson-avenue, Beaumaris	10.00	" " " "	" " " "
George Cripps Holdings Pty. Ltd., c/o R. D. Baker, 215 Lenah Valley-road, Lenah Valley, Tas.	100.00	" " " "	" " " "
Guest, D., 142 Kooyong-road, Toorak	20.00	" " " "	" " " "
Howard, L. W., Deputy Master in Lunacy, 697 George-street, Sydney, N.S.W.	44.00	" " " "	6.10.65
Kennedy, L. V. (estate of), c/o Barron and Allen, Mackay, Qld.	13.70	" " " "	25.2.66
Kuchmar, F., 14 Macartney-avenue, Kew	65.00	" " " "	6.10.65 25.2.66 25.2.66
Lamble, E. M., 14 Oriana-crescent, Yeronga West, Qld.	34.60	" " " "	25.2.66
Lamble, H. G., 14 Oriana-crescent, Yeronga West, Qld.	34.30	" " " "	" " " "
Lutana Investments Pty. Ltd., 308 Flinders-lane, Melbourne	20.00	" " " "	" " " "
McGovern, J., Land of Promise Hotel, Hindmarsh, S.A.	13.70	" " " "	" " " "

Unclaimed Moneys Act 1962.

REGISTER of Unclaimed Moneys held by the—

Name of Owner on Books and Last Known Address.	Total Amount Due to Owner.	Description of Unclaimed Moneys.	Date when Amount first became Payable.
CARLTON AND UNITED BREWERIES LIMITED—continued.			
	\$		
Mathers, R., 6 Bentley-street, Surrey Hills	10.00	Dividends	25.2.66
Morgan, F. A., 11 Sparkes-avenue, Ascot, Qld.	30.00	"	"
Moxham, L. M., 9 Croydon-street, Petersham, N.S.W.	24.00	"	6.10.65
Murray, G. N., 4 Landale-road, Toorak	30.00	"	25.2.66
Nixon, D., McQuillan-street, Tully, Qld.	28.40	"	"
Poppi, U. (estate of), c/o Feather, Walker and Delaney, 289 Queen-street, Brisbane, Qld.	32.00	"	6.10.65
Rickman, L., 88 Crosby-road, Albion, Qld.	10.00	"	25.2.66
Shelley, A. M., Remo-street, Isle of Capri, Surfers Paradise, Qld.	10.00	"	"
Shirley, A. D., 31 Howarth-street, Wyong, N.S.W.	16.00	"	6.10.65
Smith, F. H., 12 Robert-street, Proserpine, Qld.	10.00	"	25.2.66
Smith, N. D., Trincomalee, Church Point, N.S.W.	124.00	"	6.10.65
Strow, W. A., Adelaide Park-road, Yeppoon, Qld.	40.00	"	"
Sutherland, K., 54 Tarragindi-road, Tarragindi, Qld.	12.74	"	6.10.65
Wormell, T. F., Wongle, Meandarra, Qld.	48.00	"	25.2.66
6236			6.10.65
SIDDONS INDUSTRIES LIMITED.			
Johnston, P., 61 Sellers-street, Greensborough	10.80	Unclaimed wages	23.3.65
Smith, Basil, 14 Ramu-parade, West Heidelberg	18.00	"	19.3.65
Pabst, R., 1 Cohuna-street, West Brunswick	25.00	"	11.5.65
Butgen, H., 1 Cohuna-street, West Brunswick	26.00	"	11.5.65
Niblett, D., 20 Poplar-crescent, West Heidelberg	27.15	"	29.6.65
Lowe, E. R., 7 Lower Heidelberg-road, Ivanhoe	24.40	"	14.9.65
6285			
SIDDONS PTY. LIMITED.			
Maslin, A., 4 Boundary-street, North Coburg	0.50	Unclaimed wages	11.5.65
Johnston, P., 61 Sellers-street, Greensborough	10.80	"	23.3.65
Alexander, R., 252 Clarendon-street, Thornbury	6.20	"	10.3.65
Kolev, J., 49 Wilmoth-street, Thornbury	8.00	"	24.3.65
Smith, Basil, 14 Ramu-parade, West Heidelberg	18.00	"	19.3.65
Thompson, T., 31 Crevelli-street, East Reservoir	1.90	"	11.5.65
Pabst, R., 1 Cohuna-street, West Brunswick	25.00	"	11.5.65
Butgen, H., 1 Cohuna-street, West Brunswick	26.00	"	11.5.65
Niblett, D., 20 Poplar-crescent, West Heidelberg	27.15	"	29.6.65
Lowe, E. R., 7 Lower Heidelberg-road, Ivanhoe	24.40	"	14.9.65
Elkner, J., 33 Park-street, East Brunswick	7.40	"	14.9.65
6286			
WANGARATTA WOOLLEN MILLS LIMITED.			
Allan, Fanny (estate of), c/o Mr. P. Allan, 147 Ludstone-street, Hampton	23.45	Dividends	26.3.65
			1.10.65
			20.1.66
			26.3.65
Auckland, Harry L., c/o Mr. T. W. Keay, Royal-avenue, Springhill, Brisbane, Qld.	42.00	"	1.10.65
			20.1.66
Handley, Olive Mary (estate of), c/o J. W. Handley, 7 Park-street, Glenferrie	12.00	"	26.3.65
Burke, K., 29 Baker-street, Wangaratta	11.82	Wages	23.3.65
Nero, F., 13 Matheson-street, Wangaratta	24.25	"	23.3.65
Hasanovic, H., 168 Tone-road, Wangaratta	15.40	"	31.8.65
Shiels, B., 13 Lamont-street, Wangaratta	22.27	"	26.10.65
			22.12.65
Pauw, J., 12 Hallett-crescent, Wangaratta	66.87	"	22.12.65
6288			8.2.66
THOS. COOK AND SON (AUSTRALASIA) PTY. LTD.			
Hewitt, M. (Mrs.), Radium-street, Hepburn Springs	52.50	Unused sea passage money (A6/54433 part)	— 6.60
Collins, A. (Mr. and Mrs.), 56 St. George-road, Elsternwick	100.00	Steamship deposit not availed of (A3/24969)	— 2.60
Coleman, F., 415 Brunswick-road, West Brunswick	50.00	Steamship deposit not availed of (A4/680)	— 9.60
Pearce, R. W. and Kenny, J., c/o Bank of N.S.W., Sydney, N.S.W.	20.00	Hotel deposit receipt not availed of (A10/29393)	— 11.59
Manahan, Rudder, Green, Fairclough (Messrs.), c/o Nestles Ltd. Melbourne	40.00	Hotel deposit receipt not availed of (A10/29400)	— 12.59
Cameron, J. (Miss), Box 20, Surrey Hills	10.00	Unused sea passage money (part A1/79847)	— 2.60
Sloss, H. (Mrs.), 7 Winton-street, East Kew	20.00	Unused sea passage money (part A1/80048)	— 5.60
Anrime, H. J., 3 Bramerton-road, Caulfield	10.00	Unused sea passage money (part A6/53132)	— 11.59
Braunstein, A. (Mrs.), 11 Carlton-street, McKinnon	15.00	Unused sea passage money (part A6/54675)	— 6.60
De-Varney, J. L., 402 Albert-street, East Melbourne	50.00	Olympic Games tickets (A7/7793)	— 12.59
Bisziak, R. (Mrs.), c/o Thos. Cook and Son, Sydney, N.S.W.	100.00	Deposit on travel arrangements (A7/8852)	— 5.60
Moldrup, (Miss), c/o Thos. Cook and Son, Sydney, N.S.W.	25.00	Motor travel ticket unavailed of (A15/11704)	— 11.59
Name and address unknown	20.13	Motor travel ticket unavailed of (A20/93989)	— 12.59
6290			

Unclaimed Moneys Act 1962.

REGISTER of Unclaimed Moneys held by the—

Name of Owner on Books and Last Known Address.	Total Amount Due to Owner.	Description of Unclaimed Moneys.	Date when Amount first became Payable.
ROTHMANS OF PALL MALL (AUST.) LIMITED.			
\$			
Steel, M., 51 Ridgeway-parade, West Sunshine	11.64	Accrued holiday and sick pay on termination	26.3.65
Knofl, D (Miss), 61 Coronation-street, West Footscray	16.97	" " " "	7.10.65
Hancock, R., 73 Launder-street, Footscray 6311	32.90	" " " "	4.11.65
FOWLERS VACOLA MANUFACTURING COMPANY LIMITED.			
Adams, K. D., 4 View-street, Hawthorn	45.00	Ordinary Dividend of 900 shares	17.7.65
Manser, Robert W. E. (Dr.), 23 Studley-avenue, Kew 6312	32.10	Ordinary dividend of 642 shares	"
JAMES HARDIE AND COY. PTY. LIMITED.			
Jonsen, A., 73 Suspension-street, Ardeer 6313	19.90	Accumulated sick pay	13.2.66
ELDER SMITH GOLDSBROUGH MORT LIMITED.			
Andrews, C. F., Boort	24.40	N.S.W. 71 Melbourne div. No. 6 unrepresented	30.4.65
Gilchrist, G., New Zealand	10.20	N.S.W. 4313 Melbourne Div. No. 6 unrepresented	"
Lovering, J. E., London	40.80	N.S.W. 4396 Melbourne div. No. 6 unrepresented	"
Brain, O. (Mrs.), Willaura	48.00	N.S.W. 381 Melbourne div. No. 7 unrepresented	8.11.65
Fleming, Hilda N. (Mrs.), Broadbeach, Queensland	60.00	N.S.W. 1256 Melbourne div. No. 7 unrepresented	"
Nicholl, Elsie M. (Mrs.), Ashfield, N.S.W.	12.00	N.S.W. 2747 Melbourne div. No. 7 unrepresented	"
Tait, Anita J. (Mrs.), Baldick, George L. and Macpherson, Angus G., 14 Martin-place, Sydney, N.S.W.	120.00	N.S.W. 3594 Melbourne div. No. 7 unrepresented	"
Gilchrist, George, New Zealand	15.30	N.S.W. 4274 Melbourne div. No. 7 unrepresented	"
McCallum, B. L. R. (exors.), (address unknown)	10.20	N.S.W. 4393 Melbourne div. No. 7 unrepresented	"
Neville, H., Camperdown	111.51	National Melbourne 43045 unrepresented	20.5.65
Polocrosse Club, Casterton	22.80	National Melbourne 44453 unrepresented	30.6.65
Grover, J., Casterton	106.83	National Melbourne 44355 unrepresented	18.6.65
Clark, W. H., Stawell	15.90	National Melbourne 162139 unrepresented	12.11.64
Evans, J. N., Wangaratta	16.90	National Melbourne 21730 unrepresented	23.4.65
Howett, K., Wangaratta	22.77	National Melbourne 22047 unrepresented	18.5.65
Shanks, W. A., Casterton	18.00	National Melbourne 44571 unrepresented	5.7.65
Polocrosse Club, Casterton	65.20	National Melbourne 66964/71831 unrepresented	{ 12.8.65 3.9.65
Sloane, L., Corowa	66.60	National Melbourne 42120 unrepresented	27.8.65
Bentley, H., Echuca	99.92	National Melbourne 50080 unrepresented	17.7.65
Casterton Polo Club, Casterton	282.55	National Melbourne 39027/23549 unrepresented	{ 9.12.65 4.1.66
Drummond, Ivan (estate of), Corryong	13.73	National Melbourne 11332 unrepresented	8.2.66
Faulk, B., Dandenong	11.18	National Melbourne 26787 unrepresented	8.2.65
Wilson, K., Dandenong	18.46	National Melbourne 28081 unrepresented	6.2.66
Doucher, R. and H., Deniliquin	27.30	National Melbourne 33190 unrepresented	6.8.65
Nicklaus, A., Hamilton	42.98	National Melbourne 72546 unrepresented	4.8.65
Kirkwood, O., Hamilton	11.38	National Melbourne 74616 unrepresented	20.8.65
Kelly, Stan, Mortlake	257.25	National Melbourne 72757/74138/74230 unrepresented	{ 5.11.65 21.1.66 4.2.66
McCormack, B. and M. A., Shepparton	11.85	National Melbourne 37673 unrepresented	4.2.66
Evans, J. N., Wangaratta	28.41	National Melbourne 10388 unrepresented	25.10.65
Freeman Bros.	96.80	Commonwealth Melbourne 37943 unrepresented	18.5.65
Templeton, P. K., Chinkapook	16.00	Commonwealth Melbourne 44252 unrepresented	20.9.65
Webster, G. R.	94.46	National 431 Melbourne pcds. stock unrepresented	14.2.66

Unclaimed Moneys Act 1962.

REGISTER of Unclaimed Moneys held by—

Name of Owner on Books and Last Known Address.	Total Amount Due to Owner.	Description of Unclaimed Moneys.	Date when Amount first become Payable.
ELDER SMITH GOLDSBROUGH MORT LIMITED—continued.			
\$			
Waller, G. J., (address unknown)	118.97	N.S.W. Melbourne 23554 unrepresented	3.9.65
Greenhill, J. G., Corryong	65.00	Commonwealth 43427 Melbourne rent unrepresented	31.8.65
Gregory, J. G., Pyramid Hill	46.41	Commonwealth 43773 Melbourne garage a/c unrepresented	7.9.65
Nilon, R. I., Rocky Gully, W.A.	21.50	Commonwealth 46190 Melbourne insurance unrepresented	26.10.65
Kelly, B., Swan Hill	17.07	Commonwealth Melbourne 47471 comm. unrepresented	23.11.65
Trainer, J.	18.06	N.S.W. 8278 Geelong Pcds. sking unrepresented	12.2.66
Rowe, D.	10.48	N.S.W. 34912 Geelong pcds. wool unrepresented	15.10.65
Collins, R.	13.10	N.S.W. Geelong 1160 refund passage money unrepresented	13.10.65
Nelson, L. R.	467.50	N.S.W. 12456 Malop-street Pcds. cattle unrepresented	31.5.65
Lockstone, G. (estate of)	17.34	Pension unclaimed	18.3.65
Unknown	69.63	Pcds. 1 steer sold Horsham 11.5.65	11.5.65
.. .. .	66.45	Pcds. 10 calves	25.5.65
.. .. .	93.47	Pcds. 1 cow sold Dandenong	8.6.65
.. .. .	288.40	Pcds. 4 cows sold Kerang
.. .. .	75.20	Pcds. stock Dandenong
.. .. .	103.71	Pcds. 2 cattle sold Kerang	13.7.65
.. .. .	11.48	Pcds. 1 lamb sold Finley 8.7.65	8.7.65
.. .. .	88.64	Pcds. 1 cattle sold Shepparton	28.10.65
Doherty, J., (address unknown)	17.96	Wages unclaimed	22.2.66
6322			
AUSTRALIAN MARITIME INDUSTRY LIMITED.			
Ross, Peter, c/o Seamen's Union, Brisbane, Qld.	10.70	Attendance Money	16.8.65
Aitkin, Herbert K., Main-terrace, Deception Bay, Qld.	13.40	8.10.65
Burns, John, 2 Albert-street, Wickham, N.S.W.	13.40	3.12.65
Forsyth, James, 37 Bishopgate-street, Wickham, N.S.W.	10.70	16.8.65
Nyman, Martti, Booner-street, Hawks Nest, N.S.W.	10.80	28.9.65
Karteros, Evangelos, Marsters-street, North Belmont, N.S.W.	16.10	18.10.65
Heffernan, Barry M., 7 Wyal-street, Goulburn, N.S.W.	16.10	19.11.65
Davey, Frederick T., 10 Allison-street, West Hobart, Tas.	18.80	20.8.65
Devereux, Paul, 7 Pembroke-street, Stockton, N.S.W.	13.70	25.2.65
Gahagan, John W., 8 Block B, Parkway-avenue, The Junction, N.S.W.	18.80	22.11.65
Watt, Robert, 35 Girling-street, Islington, N.S.W.	18.80
Fotheringham, William J., 56 Oxford-street, Gateshead, N.S.W.	10.70	14.10.65
Brown, Adrian, 4 Yorston-street, Warners Bay, N.S.W.	18.80	20.8.65
Owens, Patrick, c/o Seamen's Union, Sydney, N.S.W.	13.40	16.8.65
Purcigo, Louis, c/o Seamen's Union, Sydney, N.S.W.	13.40
Zambelis, Constantine, Young-street, Redfern, N.S.W.	24.10
Edmonds, John, 4 Dixon-street, Port Macquarie, N.S.W.	18.80	1.10.65
Symonds, John, New Orleans Guest House, Port Kembla, N.S.W.	10.80	2.9.65
Graham, Wallace S., 13 Middleton-street, Petersham, N.S.W.	13.40	8.11.65
Johannisson, Lars, Sorento Guest House, Wollongong, N.S.W.	24.10	10.1.66
Cartwright, Patrick, 152 Lorne-street, Fawkner	13.40	16.8.65
6327			
THE GRASMERE BUTTER COMPANY LIMITED.			
Patison, A. C., Ellerslie	10.88	Dividend, 1965	1.9.65
6328			
MIRBOO AND MORWELL VALLEY FARMERS' CO-OPERATIVE COMPANY LTD.			
Patterson, William Reed, Longwarry-road, Drouin	18.00	Dividend on 120 shares	1.11.65
6329			
DAVIES, COOP AND CO. LIMITED.			
Gardiner, Adeline M. (Mrs.), 182 Park-terrace, Wayville West, S.A.	12.00	Dividend	30.9.65
6231			
FREIGHTERS LIMITED.			
Turner, I. S., 22 Godfrey-terrace, Leabrook, S.A.	23.73	Interest	31.5.65
McArthur, E. H. and R. E., 11 Walshs-road, Ashburton, N.Z.	21.00
Robertson, S. G., 42 Prince Albert-street, Mosman, N.S.W.	12.50	Dividend	29.10.65
Butler, C. W. H., Weerook Rokewood	62.50
Lyon, H. D., 23 Jervois-street, East St. Kilda	12.50
Tomlins, V. H., 15 Kingston-street, East Malvern	30.00
Twiss, N. A., 270 Waverley-road, East Malvern	12.50
Warne, A. M. and A. J., Flat 4, 4 Irwell-street, St. Kilda	25.00
McArthur, E. H. and R. E., 11 Walshs-road, Ashburton, N.Z.	53.55
Symes, P. M., 80 Russell-street, Westport, N.Z.	25.50
6234			

Unclaimed Moneys Act 1962.

REGISTER of Unclaimed Moneys held by the—

Name of Owner on Books and Last Known Address.	Total Amount Due to Owner.	Description of Unclaimed Moneys.	Date when Amount first become Payable.
THE PERPETUAL EXECUTORS AND TRUSTEES ASSOC. OF AUST. LTD.			
	\$		
Armstrong, B., 32 Frankland-street, Launceston, Tas.	56.33	Unit Trust Distributions	7.2.66
Brown, D., 39 Armstrong-street, Charlton	58.33	" " "	30.9.65
Courtney, S. G. (Mrs.), 6 Smith-road, Camberwell	23.58	" " "	30.10.65
Duggan, S. (Mrs.), 115 Dawson-street south, Ballarat	25.00	" " "	31.8.65
Evans, E. S., 3 Kiora-street, Essendon	15.60	" " "	6.8.65
Goldsburn, J., (estate of), c/o, J. K. Spark, Napier-street, St. Arnaud	22.92	" " "	30.11.65
Goldsmit, N. M., 59 Murray-street, Elsternwick	75.00	" " "	31.8.65
Hacking, E. S. and J. C. (Mrs.), 15 St. Leonards-avenue, St. Kilda	42.00	" " "	30.4.65
Hanks, E. G. and I. P. (Mrs.), 1 Second-street, Black Rock	18.75	" " "	31.5.65
Horton, E. B., 31 Redesdale-road, Ivanhoe	36.00	" " "	30.7.65
Kenealy, A. J. (Miss), 18 Alston-street, Thornbury	22.10	" " "	6.8.65
Kennedy, L. H. (Mrs.), 7 Alexander-street, Box Hill	105.00	" " "	30.4.65
Kenworthy, F., 7 Harrison-street, Ringwood	43.33	" " "	30.11.65
Kitchen, M. E. M., 23 Norwood-street, Sandringham	13.33	" " "	31.3.65
Landt, R. J., and A. E. (Mrs.), Box 96 Warracknabeal	70.00	" " "	30.4.65
Lucas, C. J. E., 114 Flinders-street, Thornbury	13.75	" " "	30.11.65
Martin, A. J. (Miss), Box 26 Deniliquin, N.S.W.	27.08	" " "	"
McKendry, R. H., 732 Inkerman-road, Caulfield	27.50	" " "	"
Miller, J. M. C. (Miss), 317 Collins-street, Melbourne	13.33	" " "	31.3.65
Murray, R. (Mrs.), 9 View-street, Reservoir	15.00	" " "	31.8.65
Oliver, D. H., 21 Bellevue-street, Lilydale	13.00	" " "	6.8.65
Rowe, J. (Mrs.), Flat 8, 472 St. Kilda-road, Melbourne	17.50	" " "	30.4.65
Schickert, G. M. and I. E. (Mrs.), 65 Lloyd-street, West Heidelberg	35.00	" " "	"
Shapcott, K. M. (estate of), c/o A. L. Anderson and Rice, 43 Queen-street, Melbourne	46.36	" " "	28.2.66
Skinner, A. H. W. (Miss), 30 Stephens-street, Yarraville	57.33	" " "	31.3.65
Shirra, S. C., 48 Lyons-street, Carnegie	45.83	" " "	30.11.65
Southern, M. D. (Mrs.), 76 Balaclava-road, Caulfield	13.75	" " "	"
Swift, R. A. (Miss), 109 Hoddle-street, Collingwood	21.67	" " "	"
Thyer, L. K., Henty-street, Casterton	25.00	" " "	31.8.65
Wallis, C. E. (Mrs.), 13 Carnegie-avenue, Kew	20.00	" " "	"
Watson, G. W., 12 Austen-avenue, Elwood	35.00	" " "	30.4.65
Wilkinson, E. M. (estate of), c/o Purves and Purves, 90 William-street, Melbourne	26.50	" " "	30.4.65
Williamson, E. V. (Mrs.), 752 Malvern-road, Armadale	108.33	" " "	31.5.65
			30.11.65
6352			
P. T. LIMITED.			
Armstrong, B., 32 Frankland-street, Launceston, Tas.	17.59	Unit Trust Distributions	20.8.65
Bailey, H. C. (Mrs.), 17 Hawthorn-avenue, Belmont, Geelong	21.33	" " "	7.5.65
Bonar, M. (Mrs.), 82 Argo-street, South Yarra	21.58	" " "	21.12.65
Box, P. F. (estate of) c/o Lawson and Jardine, 123 William-street, Melbourne	14.52	" " "	21.5.65
Breen, D. J., 271 Danks-street, Albert Park	59.85	" " "	22.3.65
Brummell, H. W., 2HS Zealandstr, Buitenveldert, Amsterdam, Holland	21.55	" " "	7.10.65
Burne, F. M. (Lady), 20 Rakingham-street, Kew	21.25	" " "	21.6.65
Campbell, G. A., 188 Main-road, Ballarat	169.57	" " "	21.12.65
Cartwright, N. R., Flat 1, 72 Campbell-road, Hawthorn	26.00	" " "	7.7.65
Chan, C. S., 106 Albert-street, Footscray	15.25	" " "	22.2.66
Cooper, E. M. (Miss), 8 Paddington-road, Oakleigh	18.10	" " "	7.4.65
Duggan, A. C., 203 Eyre-street, Ballarat	22.17	" " "	"
Keillor, A., 7 Wildwood-crescent, Warrnambool	399.29	" " "	21.12.65
Kissick, D. and F. M. (Mrs.), 11 Heron-avenue, Mildura	31.83	" " "	22.9.65
Lockhart, M. Milleu, Toolenbuc, N.S.W.	174.67	" " "	14.1.66
Lucas, A. J. R., 114 Flinders-street, Thornbury	34.28	" " "	7.10.65
Mazzon, A., Mount Burnett	251.88	" " "	"
McKay, J. A., 23 Patterson-street, Moonee Ponds	21.33	" " "	7.5.65
Miller, J. M. C., 317 Collins-street, Melbourne	10.04	" " "	7.7.65
Price, F. T., Flat 25, 311 Royal-parade, Parkville	25.31	" " "	"
Ray, N. J., 7 Tootal-road, Dingley	152.50	" " "	7.1.66
Robinson, M. S. (Mrs.), 46 Yuille-street, Frankston	20.08	" " "	7.7.65
Skinner, A. H. W. (Miss) 30 Stephen-street, Yarraville	19.06	" " "	7.10.65
Speedie, I. (Miss), 50 Eastern-road, South Melbourne	10.08	" " "	"
Tully, A. T., 496 Main-road, Doncaster	40.17	" " "	7.7.65
Weilandt, J. L. P.O. Box 10, Talbot	12.25	" " "	7.4.65
Wilkinson, E. M. (estate of), c/o Purves and Purves, 90 William-street Melbourne	10.90	" " "	22.2.66
Wilkinson, L. (estate of E. M. Wilkinson) 23 Alenbrook-avenue, East Malvern	42.00	" " "	7.10.65
Williamson, E. V. (Mrs.), 752 Malvern-road, Armadale	11.08	" " "	20.8.65
Wysham, D. A. and M. J. (Mrs.), 21 Banksia-street, Burwood	14.38	" " "	7.5.65
Vidler, L. E. (Mrs.), Springvale-road, Springvale South	65.00	" " "	7.7.65
Young, A. G., Fire Station, 220 Batman-avenue, West Melbourne	11.08	" " "	7.4.65
6353			
WILKE AND COMPANY LIMITED.			
Messiter, B., Mount Ousley-road, Woolongong, N.S.W.	2.50	Unclaimed Dividend	19.10.64
Jackson, D. E., Abbotsford-road, Mayne Junction, Brisbane, Qld.	1.70	" " "	26.3.65
Jackson, D. E., Abbotsford-road, Mayne Junction, Brisbane, Qld.	2.55	" " "	20.10.65
Mansell, R. E., 24 Central-avenue, Black Rock	12.10	Unclaimed Wages	11.3.65
Vellissarakos, J., 55 Fawkner-street, South Yarra	46.30	" " "	8.3.65
6350			

Unclaimed Moneys Act 1962.

REGISTER of Unclaimed Moneys held by the—

Name of Owner on Books and Last Known Address.	Total Amount Due to Owner.	Description of Unclaimed Moneys.	Date when Amount first became Payable.
ASSOCIATED PULP AND PAPER MILLS LIMITED.			
	\$		
Bailey, Leslie O. (estate of), c/o Cockburn Investments Pty. Ltd., 131 York-street, Sydney, N.S.W.	270.00	Dividends Nos. 48 and 49 on 1,500 shares	15.4.65 29.10.65
Banks, William C. (estate of), c/o 35 Gooch-street, Thornbury ..	16.00	Dividend No. 48 on 200 shares	15.4.65
Blayney, Mary L. (estate of), c/o Stuart McP. Chambers, 112 Glass-street, Essendon	30.24	Dividends Nos. 48 and 49 on 168 shares	15.4.65 29.10.65
Blayney, Thomas E. (estate of), c/o Stuart McP. Chambers, 112 Glass-street, Essendon	121.32	Dividends Nos. 48 and 49 on 674 shares	15.4.65 29.10.65
Coldham, Peter A., 382 Dandenong-road, North Caulfield ..	12.06	Dividends Nos. 48 and 49 on 67 shares	15.4.65 29.10.65
Curtis, Anthony, Butlers Court, Beaconsfield, Bucks, England ..	32.30	Dividend No. 48 on 475 shares	15.4.65
Donovan, Francis L., 3 Columban-avenue, Strathmore ..	20.00	Dividend No. 49 on 200 shares	29.10.65
Dowden, Kenneth F. (estate of), c/o H. R. Hoare, P.O. Box 3, Strathfield, N.S.W.	12.60	Dividends Nos. 48 and 49 on 70 shares	15.4.65 29.10.65
Dunlop, Joan I. (Mrs.), 43 Redwood-avenue, Tawa, N.Z. ..	22.95	Dividends Nos. 48 and 49 on 150 shares	15.4.65 29.10.65
Edwards, Phillip C. S., 18 Ebdon-avenue, Black Rock	10.26	Dividends Nos. 48 and 49 on 57 shares	15.4.65 29.10.65
Hancock, Harry E. (estate of), c/o Osborne Allen and Son, 75 Pitt-street, Sydney, N.S.W.	162.00	Dividends Nos. 48 and 49 on 900 shares	15.4.65 29.10.65
Huret, Pierre G. (estate of), c/o Perpetual Trustee Co. Ltd., 33 Hunter-street, Sydney, N.S.W.	182.16	Dividends Nos. 48 and 49 on 1,012 shares	15.4.65 29.10.65
Joyce, Emily A. (estate of), c/o C. Roberts Thomson, P.O. Box 89, Burnie, Tas.	43.20	Dividends Nos. 48 and 49 on 240 shares	15.4.65 29.10.65
Kennedy, Lance V. P. (estate of), c/o Barron and Allen, P.O. Box 116, Mackay, Qld.	22.50	Dividends Nos. 48 and 49 on 125 shares	15.4.65 29.10.65
Kirkham, William E., 30 Preston-street, Como, W.A.	10.00	Dividend No. 49 on 100 shares	29.10.65
Kraus, Marianne L., c/o Midland Bank Ltd., 501 Kingsbury-road, London, N.W.9, England	10.00	Dividend No. 48 on 125 shares	15.4.65
Lancaster, Beatrice M. (Mrs.), 1 Fredben-avenue, Cammeray, N.S.W.	48.60	Dividends Nos. 48 and 49 on 270 shares	15.4.65 29.10.65
Lew, William H. C., 65 Tooronga-road, East Hawthorn	10.00	Dividend No. 49 on 100 shares	29.10.65
Maddicks, Harry T., 102 Victoria-street, Daylesford	20.00	Dividend No. 49 on 200 shares	29.10.65
Moore, William B., Flat 6, 87 Alma-road, East St. Kilda ..	18.00	Dividends Nos. 48 and 49 on 100 shares	15.4.65 29.10.65
Morris, Gertrude E. (Mrs.), 22 Riverside-avenue, Balwyn ..	16.00	Dividend No. 48 on 200 shares	15.4.65
Murdoch, Ivon G. (estate of), c/o Garland Seaborn and Abbott, 9 Bligh-street, Sydney, N.S.W.	36.00	Dividends Nos. 48 and 49 on 200 shares	15.4.65 29.10.65
Fleming, Hilda N. (Mrs.), c/o A. E. Delany and Co., P.O. Box 15, Surfers Paradise, Qld.	18.00	Dividend No. 49 on 180 shares	29.10.65
McCutcheon, Wallace J., 34 Ward-crescent, Oyster Bay, N.S.W. ..	12.00	Dividend No. 48 on 150 shares	15.4.65
Naughton, Mary A. (estate of), c/o James L. Garvey, P.O. Box 27, Braidwood, N.S.W.	32.40	Dividends Nos. 48 and 49 on 180 shares	15.4.65 29.10.65
Neave, Patricia M. (estate of), c/o Allen Allen and Hemsley, G.P.O. Box 50, Sydney, N.S.W.	90.00	Dividends Nos. 48 and 49 on 500 shares	15.4.65 29.10.65
Neo, Mary T. J. (Madame), 6 Oxley-road, Singapore 9	22.50	Dividends Nos. 48 and 49 on 125 shares	15.4.65 29.10.65
O'Sullivan, John (estate of), c/o Miss Sarita O'Sullivan, 64 Mont Albert-road, Balwyn	18.80	Dividend No. 49 on 188 shares	29.10.65
Paxton, Ethel (estate of), c/o Perpetual E. and T. Asscn., 100 Queen-street, Melbourne, C.1	13.50	Dividends Nos. 48 and 49 on 75 shares	15.4.65 29.10.65
P.F.W. Investments Pty. Ltd., 83 William-street, Melbourne C.1 ..	30.20	Dividend No. 49 on 302 shares	29.10.65
Polley, Lucienne L. S. (Mrs.), 39 Windred-avenue, Apsley, Qld. ..	23.94	Dividends Nos. 48 and 49 on 133 shares	15.4.65 29.10.65
Potter, Caroline S. (Mrs.), 44 Fourth-avenue, St. Peters, S.A. ..	18.00	Dividends Nos. 48 and 49 on 100 shares	15.4.65 29.10.65
Reavey, Mary F. J. (Mrs.), Unit 5, 13 Pyne-street, South Caulfield	10.00	Dividend No. 49 on 100 shares	29.10.65
Rees, Harry, c/o King Edward Memorial Hospital, Bagot-avenue, Subiaco, W.A.	15.12	Dividends Nos. 48 and 49 on 84 shares	15.4.65 29.10.65
Ritchie, Alastair I. M., 38 Bellar-avenue, Gympie, N.S.W. ..	10.00	Dividend No. 49 on 100 shares	29.10.65
Robertson, Alan J., P.O. Box 9, Port Albert	36.00	Dividends Nos. 48 and 49 on 200 shares	15.4.65 29.10.65
Ross, Mabel C. (estate of), c/o Mortimer Griffin and Cameron, P.O. Box 25, Wagga Wagga, N.S.W.	27.06	Dividends Nos. 48 and 49 on 150 shares	15.4.65 29.10.65
Rudduck, Samuel A. (estate of), c/o Perpetual Executors T. and A. Co. (W.A.) Ltd., G.P.O. Box A3, Perth, W.A.	27.90	Dividends Nos. 48 and 49 on 155 shares	15.4.65 29.10.65
Ryan, Delia G. (Miss), 5 Mill-street, Mount Barker, S.A. ..	53.70	Dividend No. 49 on 537 shares	29.10.65
Shenstone, Frederick S., 8 Currawong-avenue, Normanhurst, N.S.W.	10.80	Dividends Nos. 48 and 49 on 60 shares	15.4.65 29.10.65
Smith, John S., Glenburn P.O., via Yea	16.70	Dividend No. 49 on 167 shares	29.10.65
Strugnell, Marilyn M. (Miss), Flat 3, 163 Male-street, North Brighton	12.00	Dividend No. 48 on 150 shares	15.4.65
Taylor, Laurence W., c/o Francis Taylor and Ferguson, 58 Margaret-street, Sydney, N.S.W.	40.50	Dividends Nos. 48 and 49 on 225 shares	15.4.65 29.10.65
Totenhofer, Francis M., 146 Western Highway, Blaxland, N.S.W. ..	10.00	Dividend No. 49 on 100 shares	29.10.65
Vicars, Thomas H. W., 10 Wedderburn-road, London, England ..	18.00	Dividends Nos. 48 and 49 on 100 shares	15.4.65 29.10.65
Will, Nancy M. (Miss), 321 South-road, Everard Park, S.A. ..	58.24	Dividend No. 48 on 728 shares	15.4.65
Woodrow, Daisy A. I., c/o Y. W. Armstrong, 249 St. Vincent-place, Port Adelaide, S.A.	21.78	Dividends Nos. 48 and 49 on 121 shares	15.4.65 20.10.65
Baugh, Elizabeth M. (estate of), c/o Tasmanian Permanent E. and T. Asscn. Ltd., P.O. Box 286c, Launceston, Tas.	25.00	Note Interest Nos. 19 and 20 on 200, 6½ per cent. Notes	30.7.65 31.1.66
Will, Nancy M. (Miss), 321 South-road, Everard Park, S.A. ..	12.50	Note Interest Nos. 19 and 20 on 100, 6½ per cent. Notes	30.7.65 31.1.66

The Companies Act 1961.—In the matter of VALET DRY CLEANERS PTY. LTD.—Notice re Meeting of Creditors, Pursuant to Section 260.

NOTICE is hereby given that a meeting of creditors of the above-named company will be held at Suite 18, 545 St. Kilda-road, Melbourne, on Wednesday, 26th April, 1967, at 11.30 a.m., the company having convened a meeting of its members for the same day for the purpose of considering a Resolution that the company be wound up voluntarily.

Dated this 17th day of April, 1967.

BENT & COUGLE, public accountants, Suite 18, 545 St. Kilda-road, Melbourne, S.C.3. 6568

Companies Act 1961.

BERNARD BUCKLEY AND SONS PROPRIETARY LIMITED (IN VOLUNTARY LIQUIDATION).

NOTICE is hereby given that, in pursuance of section 272 of the above Act, the Final General Meeting of the members of the company for the purpose of receiving the liquidator's account showing how the winding up has been conducted and how the property of the company has been disposed of will be held at the registered office of the company at 65 William-street, Melbourne (Fourth Floor), on Friday, 19th May, 1967, at 11 a.m.

Dated this 17th day of April, 1967.

6573 FRANK F. DIXON, Liquidator.

F. J. VINCENT AND SONS PROPRIETARY LIMITED.

NOTICE is hereby given that pursuant to section 272 of the Companies Act 1961, a meeting of the members of the above-named company will be held at 440 Collins-street, Melbourne, on the 22nd day of June, 1967, at 2 o'clock in the afternoon, for the purpose of having an account laid before them showing how the winding up of the company has been conducted and the property of the company disposed.

Dated this 13th day of April, 1967.

6600 P. W. HARVEY, Liquidator.

Companies Act 1961.

BENBURB PTY. LTD.

NOTICE PURSUANT TO SECTION 254 (2).

AT a general meeting of the members of Benburb Pty. Ltd. duly convened and held at 255 Castlereagh-street, Sydney, on the 12th April, 1967, the following special resolution was duly passed:—

That the company be wound up voluntarily.

Dated this 17th day of April, 1967.

ESMOND J. DOWNEY, Liquidator.

84 William-street, Melbourne, C.1. 6535

Companies Act 1961, Section 254 (2) (b).

YARRA CONSTRUCTIONS PROPRIETARY LIMITED.

AT a general meeting of the members of Yarra Constructions Proprietary Limited, duly convened and held at 9 Morton-avenue, Carnegie, on the 10th day of April, 1967, the following Resolutions were duly passed as Special Resolutions:—

1. That the company be wound up voluntarily and that William Philip Watson be hereby appointed liquidator for the purposes of such winding up.

2. That pursuant to section 269 of the Companies Act 1961 the liquidator be and is hereby authorized to exercise any of the powers given by paragraphs (b) (c) and (d) of section 236 of the Companies Act 1961 to a liquidator in a winding up by the court.

Dated this 10th day of April, 1967.

W. P. WATSON, Liquidator, 4 Bank-place, Melbourne, C.1. 6536

NOTICE is hereby given that an Extraordinary General Meeting of Astor Theatres Pty. Ltd., held at Melbourne on Monday, 10th April, 1967, the following Resolution was passed as a Special Resolution:—

"That the company be placed in voluntary liquidation."

Dated this 10th day of April, 1967.

Wilson, Bishop & Henderson, 191 Queen-street, Melbourne.

6544 J. B. HUTCHINS, Liquidator.

The Companies Act 1961.—In the matter of MOLYNEUX ALUMINIUM PROPRIETARY LIMITED.

ORDER for appointment of an official liquidator as provisional liquidator made 11th day of April, 1967.

Name and address of provisional liquidator—Robert Arthur Waters, a member of the firm of Orr, Martin, Murray and Waters, chartered accountants, of 170 Queen-street, Melbourne.

MOLOMBY & MOLOMBY, solicitors for the petitioner.

6545

The Companies Act 1961.—In the matter of MAYFAIR PTY. LTD. (in Voluntary Liquidation).

NOTICE is hereby given that, pursuant to section 272 of the Companies Act, a final meeting of the members of the above company will be held at Suite 2, 466 St. Kilda-road, Melbourne, on Thursday, 25th May, 1967, at 11 o'clock in the morning.

Business—To receive the liquidator's accounts.

V. N. MOGG, Liquidator.

Nixon, Watt & Company, chartered accountants, 466 St. Kilda-road, Melbourne, S.C.2. Telephone: 26-2481.

6548

The Companies Act 1961.—Section 272.

G. MEEHAN & CO. PTY. LTD.

NOTICE is hereby given that a Final Meeting of members will be held at the offices of the liquidator on Thursday, 11th May, 1967, at 10 a.m., for the purpose of laying before the meeting the liquidator's account and to give any explanation thereof.

7th April, 1967.

F. Y. RATTRAY, Liquidator, 24 Jeffcott-street, Melbourne. 6559

In the Supreme Court of Victoria.—1967 Co. No. 7339.—In the matter of the Companies Act 1961; and in the matter of SLOAN CONSTRUCTION PROPRIETARY LIMITED; and in the matter of a Petition dated the 17th day of March, 1967.

ADVERTISEMENT OF PETITION.

NOTICE is hereby given that a petition for the winding up of the above-named company by the Supreme Court was, on the 3rd day of April, 1967, presented by Windsor Sawmilling Co. Proprietary Limited, the registered office of which is situate at Windsor-road, Croydon, in the State of Victoria: And that the said petition is directed to be heard before the Court sitting in the Fourteenth Court, Supreme Courts, William-street, Melbourne, in the said State, at the hour of 10.30 o'clock on Tuesday, the 16th day of May, 1967; and any creditor or contributory of the said company desiring to support or oppose the making of an order on the said petition may appear at the time of hearing by himself or his counsel for that purpose; and a copy of the petition will be furnished to any creditor or contributory of the said company requiring the same by the undersigned on payment of the regulated charge for the same.

The petitioner's address is Windsor-road, Croydon.

The petitioner's solicitor is David Bristol, LL.B., of 549 Hampton-street, Hampton.

DAVID BRISTOL, Petitioner's Solicitor.

NOTE.—Any person who intends to appear on the hearing of the said petition must serve on or send by post to the above-named solicitor, notice in writing of his intention so to do. The notice must state the name and address of the persons, or if a firm, the name and address of the firm, and must be signed by the person or firm, or his or their solicitor (if any), and must be served or, if posted, must be sent by post in sufficient time to reach the above named not later than 4 o'clock in the afternoon of the 15th day of May, 1967. 6495

Companies Act 1961.—In the matter of MERSON ENGINEERING Co. PTY. LTD. (in Voluntary Liquidation), Members Winding Up.—Notice of Final Meeting.

NOTICE is hereby given that, pursuant to section 272 of the Companies Act 1961, that the Final Meeting of the members of the above-named company will be held at 44 Queen-street, Melbourne, on Monday, 22nd May, 1967, at 9 a.m., when I shall lay before the meeting an account of how the winding up has been conducted and the property of the company disposed of.

Dated this 13th day of April, 1967.

6500 E. H. NIEMANN, Liquidator.

State of Victoria.

COMPANIES ACT 1961-1966.

NOTICE OF MEETING OF CREDITORS.

Holdcroft Bros. Proprietary Limited.

NOTICE is hereby given that a meeting of the creditors of Holdcroft Bros. Proprietary Limited will be held at the M.T.P.A. Boardroom, 97 Currie-street, Adelaide, on Friday, the 21st day of April, 1967, at 12.00 noon for the following purposes:—

1. To receive a report from a Director and to receive the company's statement of affairs.

2. To receive a report upon general meeting of shareholders to be held at Adelaide on the 21st day of April, 1967, at which a Special Resolution will be proposed:

"That the company be wound up voluntarily and that a liquidator be nominated for the purpose of the winding up in view of the inability of the company by reason of its liabilities to continue its business."

and

3. In the event of the shareholders in the general meeting having resolved that the company go into voluntary liquidation and having nominated a liquidator to consider and confirm his appointment as such, or to appoint another liquidator.

4. If thought fit to appoint a committee of inspection pursuant to section 262 of the above act.

5. To fix the remuneration of the proposed liquidator or to delegate such power to the committee of inspection if appointed.

Dated this 11th day of April, 1967.

6505

W. J. HOLDCROFT,
Director.

Companies Act 1961.

SIDDONS (VICTORIA) PTY. LIMITED.

AT an Extraordinary General Meeting of the above-named company duly convened and held at 10-14 Leicester-street, Carlton, Victoria, on the 12th day of April, 1967, the following resolution was duly passed:—

"Resolved that the company be wound up voluntarily under section 254 (1) of the *Companies Act 1961* and that Mr. John David Balmford of the firm of Fitzgerald Gunn and Partners, chartered accountants, 390 Lonsdale-street, Melbourne, shall be appointed liquidator for the purposes of such winding up."

Dated the 12th day of April, 1967.

6513

J. D. BALMFORD, Liquidator.

Companies Act 1961.

SIDDONS LOCK & TOOL COMPANY PTY. LIMITED.

AT an Extraordinary General Meeting of the above-named company duly convened and held at 10-14 Leicester-street, Carlton, Victoria, on the 12th day of April, 1967, the following resolution was duly passed:—

"Resolved that the company be wound up voluntarily under section 254 (1) of the *Companies Act 1961* and that Mr. John David Balmford of the firm of Fitzgerald Gunn and Partners, chartered accountants, 390 Lonsdale-street, Melbourne, shall be appointed liquidator for the purposes of such winding up."

Dated the 12th day of April, 1967.

6514

J. D. BALMFORD, Liquidator.

Companies Act 1961.

SIDDONS STEEL SECTIONS PTY. LIMITED.

AT an Extraordinary General Meeting of the above-named company duly convened and held at 10-14 Leicester-street, Carlton, Victoria, on the 12th day of April, 1967, the following resolution was duly passed:—

"Resolved that the company be wound up voluntarily under section 254 (1) of the *Companies Act 1961* and that Mr. John David Balmford of the firm of Fitzgerald Gunn and Partners, chartered accountants, 390 Lonsdale-street, Melbourne, shall be appointed liquidator for the purposes of such winding up."

Dated the 12th day of April, 1967.

6515

J. D. BALMFORD, Liquidator.

FURS RENEE PTY. LTD. (IN VOLUNTARY LIQUIDATION).

NOTICE is hereby given, pursuant to section 272 (2) of the *Companies Act 1961*, that a General Meeting of the members of Furs Renee Pty. Ltd. (in Voluntary Liquidation), will be held on the 23rd May, 1967, at 10 a.m., at 10 Sherbrooke-avenue, Elsternwick, for the purpose of laying before the meeting an account, showing how the winding up has been conducted and the property of the company has been disposed of, and giving any explanations thereof.

Dated this 13th day of April, 1967.

6501

E. C. WINTER, Liquidator.

Companies Act 1961.

SIDDONS ABRASIVES PTY. LIMITED.

AT an Extraordinary General Meeting of the above-named company duly convened and held at 10-14 Leicester-street, Carlton, Victoria, on the 12th day of April, 1967, the following resolution was duly passed:—

"Resolved that the company be wound up voluntarily under section 254 (1) of the *Companies Act 1961* and that Mr. John David Balmford of the firm of Fitzgerald Gunn and Partners, chartered accountants, 390 Lonsdale-street, Melbourne, shall be appointed liquidator for the purposes of such winding up."

Dated the 12th day of April, 1967.

6516

J. D. BALMFORD, Liquidator.

Companies Act 1961.

SIDDONS ABRASIVES (SALES) PTY. LIMITED.

AT an Extraordinary General Meeting of the above-named company duly convened and held at 10-14 Leicester-street, Carlton, Victoria, on the 12th day of April, 1967, the following resolution was duly passed:—

"Resolved that the company be wound up voluntarily under section 254 (1) of the *Companies Act 1961* and that Mr. John David Balmford of the firm of Fitzgerald Gunn and Partners, chartered accountants, 390 Lonsdale-street, Melbourne, shall be appointed liquidator for the purposes of such winding up."

Dated the 12th day of April, 1967.

6517

J. D. BALMFORD, Liquidator.

CREDITORS, next of kin and others having claims in respect of the estate of Olive Elsie Rae Abson, late of 7 Webster-street, Ballarat, in the State of Victoria, married woman, deceased (who died on 4th July, 1966), are to send the particulars of their claims to the executors, Geoffrey Frederick Abson and Lois Yolande Fulford, in care of Colin Keon-Cohen, 472 Bourke-street, Melbourne, by the 26th June, 1967, after which date they will distribute the assets, having regard only to the claims of which they then have notice.

Dated the 18th April, 1967.

COLIN KEON-COHEN, solicitor, 472 Bourke-street,
Melbourne. 6576

CREDITORS, next of kin and others having claims in respect of the estate of Amy Dagmar Harding, formerly of Ingles-street, Port Melbourne, late of 25 Page-street, Albert Park, in the State of Victoria, married woman, deceased (who died on the 4th day of December, 1966), are to send the particulars of their claims to the executors, Norman Victor Morris and Bernard Russell Pettman, in care of Colin Keon-Cohen, 472 Bourke-street, Melbourne, by the 26th day of June, 1967, after which date they will distribute the assets, having regard only to the claims of which they then have notice.

Dated the 18th April, 1967.

COLIN KEON-COHEN, solicitor, 472 Bourke-street,
Melbourne. 6577

CREDITORS, next of kin and others having claims in respect of the estate of Sydney Hancock, late of 5 George-street, Sorrento, retired, deceased (who died on the 13th day of April, 1966), are to send particulars of their claims to Clarence Henry Puncher and Eric Airlie Ogilvy, care of the undersigned, by the 17th day of June, 1967, after which date they will distribute the assets, having regard only to the claims of which they then have notice.

BIRCH, ROSS & BARLOW, solicitors, Korumburra.

6582

CREDITORS, next of kin and others having claims in respect of the estate of William James Seale, late of 12 Hope-street, Camberwell, bachelor, deceased (who died on the 21st day of April, 1966, and probate of whose will has been granted to Ruby Snedden, of Flat 2; 10 Williams-road, Windsor, widow), are required to send particulars of their claims to the said executrix care of the under-mentioned solicitors, by the 15th day of June, 1967, after which date she will distribute the assets, having regard only to the claims of which she then has notice.

PEARCE & WEBSTER, solicitors, of 430 Little Collins-street, Melbourne. 6537

RACHEL LEBER, late of 340 Dandenong-road, St. Kilda, in the State of Victoria, widow, DECEASED.

CREDITORS, next of kin and others having claims in respect of the estate of the deceased (who died on the 28th day of March, 1965) are required by the personal representatives, Mabel Page, of 1170 Malvern-road, Malvern, married woman, and Thomas Michael Butler, of 358 Lonsdale-street, Melbourne, solicitor, to send particulars to them, care of the under-mentioned solicitors, by the 21st day of June, 1967, after which date the personal representatives may convey or distribute the assets, having regard only to the claims of which they then have notice.

HEFFEY & BUTLER, solicitors, 358 Lonsdale-street, Melbourne. 6560

CREDITORS, next of kin and others having claims in respect of the estate of Walter Spurr, formerly of 35 Merrin-crescent, Wonthaggi, in the State of Victoria, but late of 15 May-street, Hamilton, in the said State, retired miner, deceased (who died on the 1st January, 1967), are required by the executor, Walter Spurr, jun., of 15 May-street, Hamilton aforesaid, accountant, to send particulars of their claims to him, care of the under-mentioned solicitors, before the 21st June, 1967, after which date the executor may convey or distribute the assets, having regard only to the claims of which he then has notice.

CAMERON & LOWENSTERN, solicitors, 62 Thompson-street, Hamilton. 6581

CREDITORS, next of kin and others having claims in respect of the estate of William Ernest Harvey, late of 2 Tyndall-street, Surrey Hills, deceased, (who died on the 18th January, 1967), are to send particulars of their claims to the Trustees Executors and Agency Company Limited, of 401 Collins-street, Melbourne, the executor appointed by the will, of the said deceased, by the 23rd day of June, 1967, after which date the executor will distribute the assets, having regard only to the claims of which it then has notice.

WILLIAM HARRISON & SON, solicitors, 11 Bank-place, Melbourne. 6562

CREDITORS, next of kin and others having claims in respect of the estate of Bridget Brennan, late of 447 Gibert-road, West Preston, in the State of Victoria, widow, deceased, (who died on the 8th day of February, 1966), are required by Kevin Christopher Brennan, of 204 Patterson-road, Moorabbin, in the said State, public servant and Catherine Gertrude Brennan, of 447 Gibert-road, West Preston, in the said State, sales assistant, the executors of the will, of the said deceased, to send particulars of their claims to them care of Heffey and Butler, solicitors, 358 Lonsdale-street, Melbourne, by the 30th day of June, 1967, after which date they will distribute the assets, having regard only to the claims of which they then have been given notice.

Dated this 10th day of April, 1967.

HEFFEY & BUTLER, solicitors, 358 Lonsdale-street, Melbourne. 6564

Re EDITH EMILY LEMMON, late of 55 Walpole-street, Kew, gentlewoman, DECEASED.

CREDITORS, next of kin and others having claims in respect of the estate of the deceased, (who died on the 16th day of January, 1967), are required by the Trustee Winifred Edith Occo, of care of David Thomas & Frenkel, of 104 Queen-street, Melbourne, to send particulars to her by the 30th day of June, 1967, after which date the Trustee may convey or distribute the assets, having regard only to the claims of which she then has notice.

DAVID THOMAS & FRENKEL, of 104 Queen-street, Melbourne, solicitors for the Trustee. 6565

CREDITORS, next of kin and others having claims in respect of the estate of Isabella Carlyon Glenn, late of 40 Irving-avenue, Windsor, gentlewoman, deceased, (who died on the 17th August, 1966), are to send particulars of their claims to Robert Glenn Gillies, care of the under-mentioned solicitors, by the 30th June, 1967, after which date the said Robert Glenn Gillies will distribute the assets, having regard only to the claims of which he then has notice.

CORR & CORR, solicitors, 290 Latrobe-street, Melbourne. 6561

CREDITORS, next of kin and others having claims in respect of the estate of John Stewart McLaren, late of 9 Patterson-street, Preston, gentleman, deceased (who died on the 7th day of February, 1967), are to send particulars of their claims to Royston T. Cahir & Martin, solicitors, of 475 Collins-street, Melbourne, by the 21st day of June, 1967, after which date the executor will distribute the assets of the said estate, having regard only to claims of which he then has notice.

ROYSTON T. CAHIR & MARTIN, solicitors, 475 Collins-street, Melbourne. 6584

CREDITORS, next of kin and others having claims in respect of the estate of William Walter Brown, deceased, late of Yarrowonga, in the State of Victoria, (who died on the 28th day of November, 1966), are to send particulars of their claims to the executors of the estate of William Walter Brown, care of G. M. Castles & Middleton, solicitors, 38 Belmore-street, Yarrowonga, by the 30th day of June, 1967, after which date the said executors will distribute the estate of the said deceased, having regard only to the claims of which they then have notice.

G. M. CASTLES & MIDDLETON, solicitors, 38 Belmore-street, Yarrowonga. 6502

CREDITORS, next of kin and others having claims against the intestate estate of Minnie Frances Harris, late of 7 Bond-street, Preston, in the State of Victoria, widow, deceased, are requested by the administratrix, Martha Moles Kendall, of 7 Bond-street, Preston, in the said State, spinster, to send particulars of their claim, care of the undersigned, by the 20th day of June, 1967, after which date she will distribute the assets, having regard only to the claims of which she has notice.

JOHN D. MUSTOW & CO., 89 Queen street, Melbourne. 6538

CREDITORS, next of kin and others having claims in respect of the estate of Elsie Gladys Rowe, late of 12 Spehr-street, Mount Gambier, South Australia, but formerly of 22 Albert-street, Sebastopol, Victoria, widow, deceased (who died on the 7th day of August, 1966), are to send particulars of their claims to Royston T. Cahir and Martin, solicitors of 475 Collins-street, Melbourne, by the 21st day of June, 1967, after which date the executrix will distribute the assets of the said estate, having regard only to claims of which she then has notice.

ROYSTON T. CAHIR & MARTIN, solicitors, 475 Collins-street, Melbourne. 6585

AGNES FULTON LANNING, formerly of Moolap, but late of Flat 10, 10 Havelock-road, Hawthorn, Melbourne, home duties, DECEASED.

CREDITORS, next of kin and others having claims in respect of the estate of the deceased (who died on the 22nd day of October, 1966), are required by the personal representative, The Union-Fidelity Trustee Company of Australia Limited, of 100 Exhibition-street, Melbourne, to send particulars to their Geelong Branch, 8 Malop-street, Geelong, by the 28th day of June, 1967, after which date the personal representative may convey or distribute the assets, having regard only to the claims of which they then have notice.

WHYTE, JUST & MOORE, solicitors, 27 Malop-street, Geelong. 6566

CREDITORS, next of kin and all other persons having claims in respect of the estate of Paul Poulos, late of Kalkallo, in the State of Victoria, cafe proprietor, deceased, (who died on 24th December, 1965), are required to send particulars of their claims to John Duncan Mustow, of 89 Queen-street, Melbourne, solicitor, by the 20th day of June, 1967, after which date he will distribute the assets, having regard only to the claims of which he then has notice.

JOHN D. MUSTOW & CO., 89 Queen-street, Melbourne. 6541

JAMES ANDREW CANNY, (also known as JAMES CANNY), late of Swan Hill, in the State of Victoria, farmer, DECEASED, (who died on the 16th of November, 1966).

CREDITORS, next of kin and all other persons having claims against the estate of the deceased, are required by the executors of the will, Elsie Myra Canny, Raymond James Canny and John Edmund Ward, to send particulars to them, care of the undersigned on or before the 13th day of July, 1967, after which date they will distribute the assets, having regard only to the claims of which they then have notice.

GARDEN & GREEN, solicitors, 4 McCallum-street, Swan Hill. 6534

JESSIE ISABELLA LUND, formerly of 110 New-street, Middle Brighton, but late of 25A Latrobe-street, Caulfield, in the State of Victoria, spinster, DECEASED.

CREDITORS, next of kin and all others having claims in respect of the estate of the said deceased are requested by the executor, The Equity Trustees Executors and Agency Company Limited, of 472 Bourke-street, Melbourne, to send particulars of such claims to the said executor by the 24th day of June, 1967, after which date the said executors will distribute the assets, having regard only to the claims of which it then has notice.

E. L. VAIL & MCBAIN, solicitors, 472 Bourke-street, Melbourne. 6599

CREDITORS and next of kin and others having claims in respect of the estate of Patrick Jeremiah Cotter (usually known as Patrick Cotter), late of 156 Scotchmer-street, North Fitzroy, in the State of Victoria, retired labourer, deceased, (who died on the 9th day of November, 1966), are required to send particulars of all claims to National Trustees, Executors and Agency Company of Australasia Limited, of 95 Queen-street, Melbourne, on or before the 21st day of June, 1967, after which date the executors will distribute the assets of the estate, having regard only to the claims of which they have had notice.

NICHOLAS, O'DONOHUE & CO., solicitors, 493 Law Courts-place, Melbourne. 6503

CREDITORS, next of kin and others having claims in respect of the estate of Bessie Thompson, formerly of 10 Irlbarra-road, Canterbury, but late of Blind Association Home, 7 Mair-street, Brighton Beach, widow, deceased (who died on 15th November, 1966), are to send particulars of their claims to The Equity Trustees, Executors and Agency Company Limited, of 472 Bourke-street, Melbourne, by 20th June, 1967, after which date it will distribute the assets, having regard only to the claims of which it then has notice.

HALL & WILCOX, solicitors, 20 Queen-street, Melbourne. 6596

ENID MAY GRIFFITH, late of 41 Tramway-parade, Beaumaris, in the State of Victoria, home duties, DECEASED.

CREDITORS, next of kin and others having claims in respect of the estate of the deceased (who died on the 26th day of December, 1966), are required by The Equity Trustees, Executors and Agency Company Limited, of 472 Bourke-street, Melbourne, to send particulars of their claims to the said company by the 21st day of June, 1967, after which date it will convey or distribute the assets, having had regard only to the claims of which the company then has notice.

PURVES & PURVES, solicitors, 90 William-street, Melbourne, C.I. 6598

STATUTORY NOTICE TO CLAIMANTS.

THE PERPETUAL EXECUTORS AND TRUSTEES ASSOCIATION OF AUSTRALIA LIMITED, whose registered office is situated at 100-104 Queen-street, Melbourne, in the State of Victoria, the executor of the will of Frank Selwyn Horn, late of Charman Private Hospital, 200 Charman-road, Cheltenham, in the State of Victoria, retired master mariner, deceased (who died on the 24th day of December, 1966), requires all creditors, next of kin and others having claims against the property or estate of the said deceased to send to the said Association at its registered office on or before the 30th day of June, 1967, particulars in writing of such claims, after which date the said Association intends to convey or distribute this property or estate to or among the persons entitled thereto, having regard only to the claims of which it shall have had notice.

Dated the 17th day of April, 1967.

MALESONS, solicitors, 105 King-street, Melbourne, C.I. 6592

Trustee Act 1958.

NOTICE TO CLAIMANTS.

PURSUANT to the Trustee Act 1958, creditors, next of kin and all other persons having claims in respect of the estate of any deceased person named below are required to send particulars to the legal personal representative or representatives at the addresses stated, after which date the representative or representatives will distribute the assets, having regard only to the claims of which notice has been received:—

Alice Mary Gall, late of 48 Newcastle-street, Newport, widow, deceased, died on the 18th day of November, 1966.

—Claims to the executor, Thomas Joseph Gall, of 50 Newcastle-street, Newport, railway employee, care of John F. Carroll, of 4 Paisley-street, Footscray, solicitor, by the 21st day of June, 1967. John F. Carroll, LL.B., solicitor, 4 Paisley-street, Footscray. 6579

Rupert James Wallis, late of Port Fairy, plumber, deceased.—Claims to the trustees, Donald Bruce Wallis and Alma Ivy Wallis, care of J. W. Powling, solicitor, Port Fairy, by the 5th day of July, 1967. 6499

PURSUANT to the Trustee Act 1958, notice is hereby given that all persons having claims against the estate of Charles Ronald Joseph Hardy, late of 7 Erin-street, West Preston, in the State of Victoria, printer, deceased, intestate (who died on the 11th day of July, 1966, and administration of whose estate was granted by the Supreme Court of the said State in its probate Jurisdiction on the 16th day of September, 1966, to Nancy Margaret Hardy, of 7 Erin-street, West Preston, in the said State, widow), you are hereby required to send particulars in writing of such claims to the said Nancy Margaret Hardy, at her above-mentioned address or to the undersigned at her office, on or before the 20th day of June, 1967, after which date the said Nancy Margaret Hardy will proceed to distribute the assets of the said Charles Ronald Joseph Hardy, deceased, which shall have come to her hands amongst the persons entitled thereto, having regard only to the claims of which she shall then have had notice; and notice is hereby further given that the said Nancy Margaret Hardy will not be liable for the assets so distributed, or any part thereof, to any person of whose claim she shall not have had notice as aforesaid.

Dated this 17th day of April, 1967.

MARJORY C. COATES, solicitor, 422 Collins-street, Melbourne. 6540

CREDITORS, next of kin and others having claims against the estate of Edith Mary Thomas, late of Flat 1, 114 Kooyong-road, Armadale, in the State of Victoria, widow, deceased, are required by the executor, Michael Feerick, of 47 College-street, Elsternwick, in the said State, accounts clerk, to send particulars of their claim, care of the undersigned, by the 20th day of June, 1967, after which date he will distribute the assets, having regard only to the claims of which he has notice.

JOHN D. MUSTOW & CO., 89 Queen-street, Melbourne. 6547

CREDITORS, next of kin and other persons having claims against the estate of George Albert Jones, late of Flat 2, 1A Dickens-street, Elwood, in the State of Victoria, gentleman, deceased (who died on the 19th day of February, 1967), are to send particulars of their claims to the executors, William Henry Hardingham and Thomas Keith Burgin, care of the under-mentioned solicitors, by the 21st June, 1967, after which date the executors will distribute the assets having regard only for the claims of which they have notice.

JAMES P. OGGE & CO., solicitors, of 165 Greville-street, Prahran. 6550

HENRY O'KANE, formerly of 12 Kangaroo-road, Chelsea, but late of 16 Ilma-grove, Carrum, in the State of Victoria, gardener, DECEASED.

CREDITORS, next of kin and others having claims against the estate of the deceased (who died on the 1st day of November, 1966), are required to send particulars thereof to John Aloysius Collins, formerly of 16 Ilma-grove, Carrum, now of Flat 2, 18 Blanche-street, Elsternwick, in the said State, clerk, care of the undersigned solicitor, by the 16th day of June, 1967, after which date he will distribute the assets of the deceased, having regard only to the claims of which he then has notice.

E. K. O'DONNELL, solicitor, 173 Greville-street, Prahran. 6551

MARY ELIZABETH HUNT, formerly of Birchip, but late of Wycheproof, in the State of Victoria, spinster, DECEASED.

CREDITORS, next of kin and other persons having claims against the estate of the said deceased (who died on the 4th day of September, 1966), are required to send particulars of same to the executrices, Mary Brady and Marguerita McDougall, in care of the undersigned, on or before the 23rd day of June, 1967, after which date they will distribute the assets, having regard only to the claims of which they then have notice.

DELANY & DELANY, barristers and solicitors, 270 Campbell-street, Swan Hill. 6558

CREDITORS, next of kin and others having claims against the estate of Effie Wilkinson Lavender, late of 6 Thomas-street, Ringwood, in the State of Victoria, widow, deceased (who died on the 4th day of February, 1967), are required to send particulars of their claims to the executor, Charles Freeman Lavender, care of the undersigned solicitor, before the 30th day of June, 1967, after which date the said executor will distribute the assets having regard only to the claims of which he then has notice.

JOHN F. CARROLL, solicitor, 118 Queen-street, Melbourne. 6563

ELLEN MAUD BLACK, late of 49 Langford-street, Moe, in the State of Victoria, widow, DECEASED.

CREDITORS, next of kin and others having claims in respect of the estate of the deceased (who died on the 9th January, 1967), are required by the trustee, The Trustees Executors and Agency Company Limited, to send particulars to it care of the undersigned solicitors, by the 26th June, 1967, after which date the trustee may convey or distribute the assets, having regard only to the claims of which it then has notice.

GRAY, FRIEND & LONG, solicitors, Warragul. 6483

CREDITORS, next of kin and others having claims in respect of the estate of Elvie May Eckles, late of 433 Kooyong-road, Elsternwick, widow, deceased (who died on the 17th day of January, 1967), are requested to send particulars of their claims to The Equity Trustees, Executors and Agency Company Limited, of 472 Bourke-street, Melbourne, the executor of the will of the said deceased, in care of the said company by the 16th day of June, 1967, after which date the executor will distribute the assets, having regard only to the claims of which it has notice.

KENNETH J. CLEMENTS & SON, solicitors, 255 Glenhantly-road, Elsternwick. 6484

CREDITORS, next of kin and others having claims in respect of Charles John Styles, formerly of 51 Tennyson-street, Sandringham, in the State of Victoria, but late of 42 Nicholson-street, East Coburg, in the said State, gentleman, deceased (who died on the 18th day of January, 1967) are required to send particulars of their claims to The Union-Fidelity Trustee Company of Australia Limited, of 100 Exhibition-street, Melbourne, in the said State, by the 20th day of June, 1967, after which date, it may convey or distribute the assets having regard only to the claims of which it then has notice.

AITKEN WALKER & STRACHAN, solicitors, 414 Collins-street, Melbourne. 6549

GIROLAMO BONAGURO, formerly of 22 Brooks-street, North Fitzroy, but late of 143 Gillies-street, Fairfield, in the State of Victoria, carpenter, DECEASED.

CREDITORS, next of kin and others having claims in respect of the estate of the deceased (who died on the 25th day of October, 1966), are required by The Perpetual Executors and Trustees Association of Australia Limited, of 100-104 Queen-street, Melbourne, and Brian Patrick McCarthy, of 473 Bourke-street, Melbourne, solicitor, the applicants for a grant of administration to send particulars of their claims to the said applicants, in the care of the said company by the 26th day of June, 1967, after which date they will convey or distribute the assets having regard only to the claims of which they then have notice.

RENNICK & GAYNOR, solicitors, 473 Bourke-street, Melbourne. 6539

NEIL ROBERT McFARLANE, late of Park-street, Portarlington, retired farmer, DECEASED, intestate.

CREDITORS, next of kin and others having claims in respect of the estate of the said deceased (who died 22nd July, 1966), are required by the applicant for grant of letters of administration of the estate, Daisy Lillian Pickering, of 120 Willis-street, Portarlington, married woman, to send particulars to her, care of the undersigned solicitors, by 21st July, 1967, after which date the said applicant may convey or distribute the assets, having regard only to the claims of which she then has notice.

WIGHTON & McDONALD, solicitors, 189-191 Moorabool-street, Geelong. 6530

BEATRICE MAUD ZERCHO, late of 105 Grange-road, Toorak, Victoria, widow, DECEASED.

CREDITORS, next of kin and others having claims in respect of the estate of the deceased (who died on the 18th day of December, 1966) are required by The Perpetual Executors and Trustees Association of Australia Limited, of 100-104 Queen-street, Melbourne, and Beatrice Ina Zercho of 105 Grange-road aforesaid, the applicants for a grant of administration to send particulars of their claims to the said applicants, in the care of the said company, by the 21st day of June, 1967, after which date they will convey or distribute the assets, having regard only to the claims of which they then have notice.

HEDDERWICK FOOKES & ALSTON, 103 William-street, Melbourne. 6537

MARION BEATRICE NICOL, late of Beechworth, spinster.

CREDITORS, next of kin and others having claims in respect of the estate of the deceased (who died on the 23rd day of November, 1966), are required by The Perpetual Executors and Trustees Association of Australia Limited, of 100-104 Queen-street, Melbourne, to send particulars of their claims to the said company by the 21st day of June, 1967, after which date it will convey or distribute the assets having had regard only to the claims of which the company then has notice.

COLTMAN, WYATT & ANDERSON, solicitors, 578 Bourke-street, Melbourne. 6556

CREDITORS, next of kin and others having claims in respect of the estate of Lal Khan, late of Yarram, hawker, deceased (who died on the 11th day of November, 1966), are to send the particulars of their claims to George Daniel Speed and Edward James Moyes, in care of Davies and Vodicka, solicitors, of Commercial-road, Yarram, by the 20th day of June, 1967, after which date they will distribute the assets, having regard only to the claims of which they then have notice.

DAVIES & VODICKA, solicitors, of Commercial-road, Yarram. 6533

THOMAS GEORGE OATES, formerly of 116 Canterbury-road, Canterbury, in the State of Victoria, but late of 148 Swanston-street, Lower Templestowe, in the said State, gentleman, DECEASED.

CREDITORS, next of kin and others having claims in respect of the estate of the above-named deceased (who died on the 28th day of April, 1966), are required by the legal personal representative The Trustees Executors and Agency Company Limited, of 401 Collins-street, Melbourne, in the said State, to send particulars to it by the 22nd day of June, 1967, after which date it may convey or distribute the assets having regard only to the claims of which it then has notice.

E. P. JOHNSON & DAVIES, 339 Collins-street, Melbourne, solicitors for the Company. 6543

ALBERT LESLIE LANNING, late of 52 Kneen-street, North Fitzroy, Postman, DECEASED.

CREDITORS, next of kin and others having claims in respect of the estate of the deceased (who died on 11th September, 1966), are required by Dudley Ackerley Tregent, of 422 Collins-street, Melbourne, solicitor (the executor to whom probate was granted on 12th April, 1967), to send particulars to him by the 20th day of June, 1967, after which date the executor may convey or distribute the assets having regard only to the claims of which he then has notice.

DUDLEY A. TREGENT, B.A., LL.M., solicitor, 422 Collins-street, Melbourne. 6546

In the Supreme Court of the State of Victoria.

SALE BY THE SHERIFF.

ON Monday, the 29th of May, 1967, at Eleven a.m., at the Police Station, Mount Waverley (unless process be stayed or satisfied):—

All the estate and interest (if any) of Dale Andrew Code, of 47 Monomeith-crescent, Mount Waverley, business proprietor, as joint proprietor with Shirley Code, married woman, of an estate in fee-simple in the land described in certificate of title, volume 8449, folio 938, upon which is erected a brick veneer dwelling-house known as No. 47 Monomeith-crescent, Mount Waverley.

Registered mortgages Nos. B.825392 and B.835131 affect the said estate and interest.

Terms: Cash only.

DAVID J. JOHNSTON, Sheriff's Officer.

10th April, 1967.

6553

In the Supreme Court of the State of Victoria.

SALE BY THE SHERIFF.

ON Monday, the 29th of May, 1967, at Two p.m., at the Police Station, Eltham (unless process be stayed or satisfied):—

All the estate and interest (if any) of L. J. Steffan, of 97 Pitt-street, Eltham, mechanic, as joint proprietor with Diane Mary Harper, shop assistant, of an estate in fee-simple in the land described in certificate of title, volume 5389, folio 655, upon which is erected a weatherboard dwelling-house known as No. 97 Pitt-street, Eltham.

Registered mortgages Nos. B.442868 and B.493549 affect the said estate and interest.

Terms: Cash only.

DAVID J. JOHNSTON, Sheriff's Officer.

10th April, 1967.

6554

In the Supreme Court of the State of Victoria.

SALE BY THE SHERIFF.

ON Monday, the 22nd of May, 1967, at Eleven a.m., at the Police Station, Mount Evelyn (unless process be stayed or satisfied):—

All the estate and interest (if any) of Brian Dunn, of lot 64 Clancy-road, Mount Evelyn, truck driver, as proprietor of an estate in fee-simple in the land described in certificates of title, volume 6805, folios 852 and 853, the land known as lots 64, 78 and 79. Lot 64 is situated on the north side of Clancys-road, commencing 132 feet east of Spring-road, Mount Evelyn, and erected thereon is a weatherboard dwelling-house. Lot 78 is vacant land situated on the south side of Junction-road, Mount Evelyn, commencing 132 feet east of Spring-road and lot 79 is also vacant land situated on the south-eastern corner of Junction-road and Spring-road, Mount Evelyn.

Registered mortgage No. A.239510 affects the said estate and interest.

Terms: Cash only.

DAVID J. JOHNSTON, Sheriff's Officer.

12th April, 1967.

6555

In the Supreme Court of the State of Victoria.

SALE BY THE SHERIFF.

ON Monday, the 22nd of May, 1967, at Two-thirty p.m., at the Police Station, Coburg (unless process be stayed or satisfied):—

All the estate and interest (if any) of Giovanni Vadala, of 15 Audley-street, Coburg, cartage contractor, as tenant in common in equal shares with Rocco Vadala, labourer, of an estate in fee-simple in the land described in certificate of title, volume 6456, folio 156, upon which is erected a weatherboard dwelling house known as No. 15 Audley-street, Coburg.

Registered mortgage No. C.556308 affects the said estate and interest.

Terms: Cash only.

DAVID J. JOHNSTON, Sheriff's Officer.

6586

INSOLVENCY NOTICE

TAKE notice that a certificate under section 162 (2) of the *Bankruptcy Act 1924-1964* has been filed in the Bankruptcy Court declaring that at a meeting of the creditors of Jessie McTear, of Buln Buln, via Warragul, duly convened and held at Honorary Justices Room, 34 Queen-street, Melbourne, on the 31st day of March, 1967, a Special Resolution was duly carried that the said Jessie McTear execute a Deed of Assignment in pursuance of Part XI. of the *Bankruptcy Act 1924-1964* to Edward Peter Taylor, of 38 Smith-street, Warragul, public accountant as trustee.

The deed may be inspected at Messrs. Gleeson, Downie and Associates, of 38 Smith-street, Warragul.

Kiernan & Forrest, solicitors, 431 Bourke-street, Melbourne. 6494

IMPOUNDINGS

BOX HILL.—Impounded in Box Hill Pound by Ranger.

1 small Jersey heifer, no visible brand

If not claimed and expenses paid, to be sold on 4th May, 1967.

R. KENNEDY,

6512—\$1.50

Poundkeeper.

LAKE BENETOOK.—Impounded in Lake Benetook Pound.

1 white nanny goat, tip off side ear, no visible brand

If not claimed and expenses paid, to be sold on 27th April, 1967.

E. CURTIS,

6492—\$1.75

Poundkeeper.

LISMORE.—Impounded in Lismore Pound, by D. C. Oman.

1 wether, double back notch off ear, top notch and slit in near ear, no visible brand

1 ewe, front and double back off ear, front and quarter near ear, no visible brand

1 weaner, blue tag left ear, no visible brand

If not claimed and expenses paid, to be sold on 9th May, 1967.

J. A. SERGENT,

6570—\$2.50

Poundkeeper.

MELTON.—Impounded in Melton Pound by the Shire Ranger.

1 black mare, approximately 13 hands, no visible brand

If not claimed and expenses paid, to be sold on 5th May, 1967.

F. CHALLIS,

6529—\$1.75

Poundkeeper.

Subordinate Legislation Act 1962.

NOTICE OF MAKING OF STATUTORY RULES.

IN pursuance of the provisions of the *Subordinate Legislation Act 1962* and the Regulations made thereunder notice is given of the making of the following statutory rules:—

No.	Health Act 1958.	Price.
89/1967.	Registration (Health Acts) Amendment Regulations 1967	10c

Marketing of Primary Products Act 1958 (No. 6304).

90/1967.	The Tobacco Leaf Marketing Board (Charges) Regulations 1967	10c
----------	---	-----

Justices Act 1958.

91/1967.	Justices Act Rules 1967	15c
----------	-------------------------	-----

Health Act 1958.

92/1967. Private Hospitals (Registration Fees) Regulations 1967 10c

Fisheries Act 1958.

93/1967. Prohibition of Fishing in Lake Purrumbete 10c

Copies of these statutory rules may be purchased at the Sale of Publications Section of the Government Printing Office, located at Macarthur-street, Melbourne, C.2. If ordered by mail, remittance should be addressed to "The Government Printer, Box 203, P.O., North Melbourne, N.I.", and should include 5c extra for postage. If a credit account is held at this office, no remittance is required with the mail order.

The annual subscription rate for Statutory Rules (including a Bound Volume) is \$15, payable in advance. The subscription year commences on 1st January.

A. C. BROOKS,
Government Printer.

ACTS REPRINTED IN ACCORDANCE WITH THE AMENDMENTS INCORPORATION ACT 1958 (No. 6422), AND FOR SALE AT THE SALE OF PUBLICATIONS BRANCH OF THE GOVERNMENT PRINTING OFFICE, MACARTHUR-STREET, MELBOURNE.

(These prices do not include postage.)

No.	Description	Price.
6189.	Acts Interpretation (Incorporating amendments up to No. 7146)	\$0.15
6191.	Administration and Probate (Third Reprint—Incorporating amendments up to No. 7332)	\$0.38
6194.	Agricultural Colleges (First Reprint—Incorporating amendments up to No. 7302)	\$0.12
6199.	Apprenticeship (First Reprint—Incorporating amendments up to No. 7312)	\$0.25
6203.	Audit (First Reprint—incorporating amendments up to No. 7377)	\$0.35
6209.	Boiler Inspection (Incorporating amendments up to No. 7072)	\$0.18
6210.	Building Societies (Incorporating amendments up to No. 7125)	\$0.25
6218.	Children's Court (Incorporating amendments up to No. 7084)	\$0.20
6219.	Children's Welfare (Incorporating amendments up to No. 6812)	\$0.25
6220.	Clean Air (Incorporating amendments up to No. 6886)	\$0.10
6222.	Commercial Goods Vehicles (Second Reprint—Incorporating amendments up to No. 7358)	\$0.22
6839.	Companies Act 1961 (Second Reprint—Incorporating amendments up to No. 7332)	\$2.32
6225.	Co-operation (Second Reprint—Incorporating amendments up to No. 7083)	\$0.42
6226.	Co-operative Housing Societies (Incorporating amendments up to No. 7097)	\$0.40
6228.	Country Fire Authority (Incorporating amendments up to No. 7065)	\$0.40
6229.	Country Roads (Incorporating amendments up to No. 6943)	\$0.40
6230.	County Court Act (First Reprint—Incorporating amendments up to No. 7420)	\$0.35
6231.	Crimes (Second Reprint—Incorporating amendments up to No. 7407)	\$1.33
6236.	Dog (Second Reprint—Incorporating amendments up to No. 7065)	\$0.15
6242.	Employers and Employés (Incorporating amendments up to No. 6740)	\$0.18
6245.	Estate Agents (Second Reprint—Incorporating amendments up to No. 7134)	\$0.38
6246.	Evidence (Second Reprint—Incorporating amendments up to No. 7366)	\$0.42
6249.	Fences (Incorporating amendments up to No. 6550)	\$0.12
6250.	Fertilizers (Incorporating amendments up to No. 7142)	\$0.18
6251.	Firearms (Incorporating amendments up to No. 6716)	\$0.22
6252.	Fisheries Act (First Reprint—Incorporating amendments up to No. 7389)	\$0.35
6916.	Foreign Judgments Act 1962 (First Reprint—including amendments made by No. 7332)	\$0.12
6585.	Forests (Pulpwood Agreement) (Incorporating amendments up to No. 6886)	\$0.15
6256.	Fruit and Vegetables (First Reprint—incorporating amendments up to No. 6944)	\$0.30
6259.	Gaols (Incorporating amendments up to No. 6651)	\$0.15
6258.	Game—(First Reprint—Incorporating amendments up to No. 7389)	\$0.30

ACTS REPRINTED IN ACCORDANCE WITH THE AMENDMENTS INCORPORATION ACT 1958 (No. 6422)—continued.

No.	Description	Price.
6265.	Goods (Third Reprint—Incorporating amendments up to No. 7131)	\$0.28
6270.	Health (Incorporating amendments up to No. 6886)	\$1.45
6933.	Home Finance Act 1962 (First Reprint—Incorporating amendments up to No. 7363)	\$0.25
6274.	Hospitals and Charities (Incorporating amendments up to No. 6716)	\$0.35
6279.	Instruments (Third Reprint—Incorporating amendments up to No. 7315)	\$0.38
6282.	Justices (Second Reprint—Incorporating amendments up to No. 7369)	\$1.23
6283.	Labour and Industry (Third Reprint—Incorporating amendments up to No. 7410)	\$1.00
6284.	Land (Incorporating amendments up to No. 7360)	\$1.53
6534.	Land Settlement Act 1959 (First Reprint—Incorporating amendments up to No. 7328)	\$0.30
6289.	Land Tax (Incorporating amendments up to No. 7099)	\$0.32
6285.	Landlord and Tenant (Second Reprint—Incorporating amendments up to No. 6996)	\$0.50
6286.	Lands Compensation—(First Reprint—incorporating amendments up to No. 7332)	\$0.25
6290.	Latrobe Valley (First Reprint—Incorporating amendments up to No. 7332)	\$0.35
6291.	Legal Profession Practice (Incorporating amendments up to No. 7065)	\$0.45
6293.	Licensing (Second Reprint—Incorporating amendments up to No. 7054)	\$0.95
6577.	Lifts and Cranes (Incorporating amendments up to No. 6886)	\$0.12
6295.	Limitation of Actions (Incorporating amendments up to No. 6845)	\$0.15
6298.	Local Authorities Superannuation (Incorporating amendments up to No. 6894)	\$0.25
6299.	Local Government (Incorporating amendments up to No. 7052)	\$3.50
6302.	Marine (Incorporating amendments up to No. 7350)	\$0.72
6309.	Medical (Second Reprint—Incorporating amendments up to No. 7408)	\$0.40
6310.	Melbourne and Metropolitan Board of Works (Incorporating amendments up to No. 7054)	\$0.85
6312.	Melbourne Harbor Trust (First Reprint—Incorporating amendments up to No. 7356)	\$0.48
6605.	Mental Health (Incorporating amendments up to No. 7135)	\$0.45
6315.	Metropolitan Fire Brigades (Incorporating amendments up to No. 6886)	\$0.28
6317.	Milk and Dairy Supervision (Incorporating amendments up to No. 6964)	\$0.40
6318.	Milk Board (Incorporating amendments up to No. 7093)	\$0.22
6324.	Money Lenders (Incorporating amendments up to No. 6886)	\$0.25
6832.	Motor Boating (Incorporating amendments up to No. 6961)	\$0.15
6325.	Motor Car (Second Reprint—Incorporating amendments up to No. 7361)	\$0.82
6326.	National Parks (Incorporating amendments up to No. 7275)	\$0.15
6328.	Nurses (Incorporating amendments up to No. 6716)	\$0.20
6330.	Partnership	\$0.15
6331.	Patriotic Funds (First Reprint—Incorporating amendments up to No. 7338)	\$0.25
6889.	Poisons (Incorporating amendments up to No. 7065)	\$0.35
6337.	Police Offences (Incorporating amendments up to No. 7145)	\$0.82
6338.	Police Regulation (Incorporating amendments up to No. 7081)	\$0.45
6341.	Pounds (First Reprint—Incorporating amendments up to No. 7315)	\$0.25
6890.	Probate Duty (Incorporating amendments up to No. 3970)	\$0.38
6343.	Process Servers and Inquiry Agents (Incorporating amendments up to No. 7126)	\$0.12
6344.	Property Law (Incorporating amendments up to No. 6867)	\$0.90
6349.	Public Service (Second Reprint—Incorporating amendments up to No. 7356)	\$0.40
6350.	Public Trustee (Incorporating amendments up to No. 6961)	\$0.35
6353.	Racing (First Reprint—Incorporating amendments up to No. 7404)	\$0.70
6359.	Road Traffic (Second Reprint—Incorporating amendments up to No. 7332)	\$0.18

ACTS REPRINTED IN ACCORDANCE WITH THE AMENDMENTS INCORPORATION ACT 1958 (No. 6422)— <i>continued</i> .		STATE ACTS 1966— <i>continued</i> .	
No.	Price.	No.	Price.
6360. Rural Finance (<i>First Reprint</i> —Incorporating amendments up to No. 7328) ..	\$0.12	7377. Audit (Amendment) ..	\$0.08
6846. Rural Finance and Settlement Commission Act 1961 (<i>First Reprint</i> —Incorporating amendments up to No. 7332) ..	\$0.20	7378. Marketing of Primary Products (Tobacco Leaf Marketing Board) ..	\$0.05
6975. Sale of Land Act 1962 (<i>First Reprint</i> —Incorporating amendments up to No. 7332) ..	\$0.18	7379. State Library National Gallery National Museum and Institute of Applied Science (Amendment) ..	\$0.05
6363. Second-Hand Dealers ..	\$0.12	7380. Reid Murray Acceptance Limited (Scheme of Arrangement) ..	\$0.12
6367. Settled Land (Incorporating amendments up to No. 6505) ..	\$0.40	7381. Lake Corangamite ..	\$0.10
6368. Sewerage Districts (<i>First Reprint</i> —Incorporating amendments up to No. 7332) ..	\$0.62	7382. Tobacco Leaf Marketing Board (Appointment of Manager) ..	\$0.05
6651. Social Welfare Act 1960 (<i>Third Reprint</i> —Incorporating amendments up to No. 7332) ..	\$0.20	7383. Country Fire Authority (Borrowing Powers) ..	\$0.05
6372. Soil Conservation and Land Utilization (Incorporating amendments up to No. 6961) ..	\$0.20	7384. Labour and Industry (Sheltered Workshops) ..	\$0.05
6373. Soldier Settlement (<i>First Reprint</i> —Incorporating amendments up to No. 7328) ..	\$0.42	7385. Wombat Bonuses ..	\$0.05
6375. Stamps (<i>Third Reprint</i> —Incorporating amendments up to No. 7359) ..	\$0.82	7386. Country Fire Authority (Interstate Fire Brigades) ..	\$0.05
6377. State Electricity Commission (Incorporating amendments up to No. 7054) ..	\$0.50	7387. Loch Public Hall Trust ..	\$0.12
6379. State Savings Bank (Incorporating amendments up to No. 6886) ..	\$0.42	7388. Co-operative Housing Societies (Amendment) ..	\$0.05
6886. Subordinate Legislation (Incorporating amendments up to No. 6961) ..	\$0.15	7389. Fisheries and Game (Amendment) ..	\$0.08
6386. Superannuation (<i>First Reprint</i> —Incorporating amendments up to No. 7417) ..	\$0.60	7390. Marine Stores and Old Metals (Collectors) ..	\$0.05
6395. Tourist (<i>First Reprint</i> —Incorporating amendments up to No. 7335) ..	\$0.15	7391. Companies ..	\$0.22
6849. Town and Country Planning (<i>First Reprint</i> —Incorporating amendments up to No. 7276) ..	\$0.35	7392. The Constitution Act Amendment ..	\$0.05
6399. Transfer of Land (<i>Second Reprint</i> —Incorporating amendments up to No. 7130) ..	\$0.52	7393. Vagrancy ..	\$0.12
6400. Transport Regulation (<i>First Reprint</i> —Incorporating amendments up to No. 7358) ..	\$0.22	7394. Consolidated Revenue ..	\$0.05
6401. Trustee (<i>Second Reprint</i> —Incorporating amendments up to No. 6963) ..	\$0.42	7395. Land (Plantation Areas) ..	\$0.10
6879. Unclaimed Moneys (Incorporating amendments up to No. 6961) ..	\$0.12	7396. Daylesford Springs Land ..	\$0.05
6653. Valuation of Land Act 1960 (<i>Second Reprint</i> —Incorporating amendments up to No. 7333) ..	\$0.22	7397. Barley Marketing (Amendment) ..	\$0.05
6407. Vegetation and Vine Diseases (<i>First Reprint</i> —Incorporating amendments up to No. 7423) ..	\$0.30	7398. Sheep Dipping (Repeal) ..	\$0.05
6410. Veterinary Surgeons (<i>First Reprint</i> —Incorporating amendments up to No. 7343) ..	\$0.15	7399. Grain Elevators (Amendment) ..	\$0.05
6413. Water (Incorporating amendments up to No. 7228) ..	\$1.42	7400. Seymour Racecourse Land ..	\$0.05
6414. Weights and Measures (<i>Second Reprint</i> —Incorporating amendments up to No. 7332) ..	\$0.32	7401. Shepparton Abattoirs ..	\$0.05
6419. Workers Compensation (<i>Second Reprint</i> —Incorporating amendments up to No. 7332) ..	\$0.52	7402. Paisley-Galvin Railway Land Exchange ..	\$0.08
		7403. Aerial Spraying Control ..	\$0.12
		7404. Racing (Amendment) ..	\$0.08
		7405. Summary Offences ..	\$0.28
		7406. Friendly Societies (Amendment) ..	\$0.05
		7407. Crimes (Dangerous Driving) ..	\$0.05
		7408. Medical (Foreign Practitioners Qualification Committee) ..	\$0.05
		7409. Opticians Registration (Amendment) ..	\$0.05
		7410. Labour and Industry (Petrol Shops) ..	\$0.08
		7411. Melbourne and Metropolitan Board of Works (Amendment) ..	\$0.08
		7412. Carlton (Recreation Ground) Land ..	\$0.08
		7413. Boilers Inspection (Amendment) ..	\$0.05
		7414. Warragul and Neerim Railway Lands ..	\$0.08
		7415. Victoria Institute of Colleges (Council) ..	\$0.05
		7416. Marketable Securities ..	\$0.18
		7417. Pensions Supplementation ..	\$0.20
		7418. Evidence (Medical Evidence) ..	\$0.05
		7419. Water (Rating by Area) ..	\$0.05
		7420. County Court (Common Law Jurisdiction) ..	\$0.05
		7421. State Electricity Commission (Amendment) ..	\$0.05
		7422. Gas and Fuel Corporation (Borrowing) ..	\$0.05
		7423. Vegetation and Vine Diseases (Amendment) ..	\$0.05
		7424. Motor Car ..	\$0.05
		7425. Estate Agents (Amendment) ..	\$0.10
		7426. Melbourne University (Chancellorship) ..	\$0.05
		7427. Tobacco Leaf Industry Stabilization ..	\$0.15
		7428. Consolidated Revenue ..	\$0.05
		7429. Lotteries Gaming and Betting ..	\$0.35
		7430. Stamps (Mortgages) ..	\$0.05
		7431. Money Lenders (Exemption) ..	\$0.05
		7432. Protection of Animals ..	\$0.12
		7433. Marketing of Primary Products (Maize Marketing Board) ..	\$0.10
		7434. Consolidated Revenue ..	\$0.10
		7435. Firearms (Competition Weapons) ..	\$0.10
		7436. Provincial Sewerage Authorities Association of Victoria ..	\$0.10
		7437. Waterworks Trusts Association of Victoria ..	\$0.10
		7438. Maffra Lands Exchange ..	\$0.10
		7439. Trewalla Lands Exchange ..	\$0.10
		7440. Tattersall Consultations ..	\$0.10
		7441. Public Authorities (Contributions) ..	\$0.10
		7442. Racing (Totalizer Percentages) ..	\$0.10
		7443. Lower Yarra Crossing Authority (Guarantee) ..	\$0.10
		7444. Stock and Share Brokers (Amendment) ..	\$0.15
		7445. Moorpanyal Lands Exchange ..	\$0.10
		7446. North Melbourne Lands ..	\$0.15
		7447. Marine (Amendment) ..	\$0.10
		7448. Mildura Irrigation and Water Trusts (Amendment) ..	\$0.10
		7449. State Accident Insurance Office Land ..	\$0.10
		7450. Public Account (Bona Vacantia) ..	\$0.10
		7451. Motor Car (Hospital and Charities Contributions) ..	\$0.10
		7452. Commonwealth and States Financial Agreement ..	\$0.15
		7453. State Forests Loan Application ..	\$0.10
		7454. Water (Amendment) ..	\$0.15

FIRST NOTIFICATION OF REPRINT.

6330. Partnership (<i>Second Reprint</i> —Incorporating amendments up to No. 7315) ..	\$0.25
6289. Land Tax (<i>Second Reprint</i> —Incorporating amendments up to No. 7466) ..	\$0.40
6306. Marriage (<i>First Reprint</i> —Incorporating amendments up to No. 6959) ..	\$0.25
6254. Forests (<i>First Reprint</i> —Incorporating amendments up to No. 7356) ..	\$0.60

A. C. BROOKS,
Government Printer.

STATE ACTS, 1966

COPIES of the following Acts of Parliament of Victoria may be obtained at the Government Printing Office, or from any accredited agents, at the price set opposite to each (these prices do not include postage).

The annual subscription for State Acts 1967 et seq. is \$8, payable in advance.

Bound Volumes of State Acts are also available on a subscription basis at \$15 per annum.

No.	Price.
7372. Education (Council of Adult Education) ..	\$0.05
7373. Legal Profession Practice (Amendment) ..	\$0.05
7374. Co-operation (Amendment) ..	\$0.05
7375. Nurses (Amendment) ..	\$0.05
7376. Property Law (Loans to Minors) ..	\$0.05

STATE ACTS, 1966—continued.

No.		Price.
7455.	Hospitals and Charities (Liability of Patients)	\$0.15
7456.	Sewerage District's (Amendment)	\$0.10
7457.	Limitation of Actions (Notice of Action)	\$0.10
7458.	Long Island Country Club	\$0.10
7459.	Country Roads (Level Crossings) (Amendment)	\$0.10
7460.	Evidence (Foreign Tribunals)	\$0.10
7461.	San Remo Lands	\$0.10
7462.	The Constitution Act Amendment (Con-joint Elections)	\$0.10
7463.	Vermín and Noxious Weeds (Financial)	\$0.10
7464.	Co-operative Housing Societies (Financial)	\$0.10
7465.	Morwell National Park	\$0.10
7466.	Land Tax (Rates)	\$0.10
7467.	Teaching Service (Married Women)	\$0.10
7468.	Melbourne Cricket Ground (Guarantees)	\$0.10
7469.	Gaols (Commencement of Sentences)	\$0.10
7470.	Revocation and Excision of Crown Reservations	\$0.15
7471.	Soil Conservation and Land Utilization (Advisory Council)	\$0.10
7472.	Legal Profession Practice (Further Amend-ment)	\$0.10
7473.	Forests (Wood Pulp Agreement)	\$0.15
7474.	Companies (Amendment)	\$0.10
7475.	Portland Harbor Trust (Railways)	\$0.10
7476.	Country Fire Authority (Fire Prevention)	\$0.10
7477.	Victorian Pipelines Commission	\$0.15
7478.	Bees	\$0.15
7479.	Milk Board (Amendment)	\$0.10
7480.	Milk Pasteurization (Amendment)	\$0.10
7481.	State Insurance (Payments into Court)	\$0.10
7482.	National Gallery of Victoria	\$0.15
7483.	Building Societies (Amendment)	\$0.10
7484.	Firearms (Amendment)	\$0.15
7485.	Geelong Waterworks and Sewerage (Amend-ment)	\$0.10
7486.	Grain Elevators (Further Amendment)	\$0.10
7487.	Settlement Purchase Leases	\$0.10
7488.	Appeal Costs Fund (Amendment)	\$0.15
7489.	Geelong Harbor Trust (Amendment)	\$0.30
7490.	Health (Amendment)	\$0.15
7491.	Marketing of Primary Products (Onion Marketing Board)	\$0.10
7492.	State Coal Mine	\$0.10
7493.	Horse Breeding (Amendment)	\$0.10
7494.	Private Agents	\$0.30
7495.	Local Government	\$0.40
7496.	Wrongs (Assessment of Damages)	\$0.10
7497.	Melbourne and Metropolitan Board of Works (Reconstitution)	\$0.15
7498.	Port Phillip Authority	\$0.15
7499.	Extractive Industries	\$0.35
7500.	Stamps	\$0.25
7501.	Companies (Defaulting Officers)	\$0.15
7502.	Labour and Industry (Amendment)	\$0.15
7503.	Juries	\$0.10
7504.	Public Works Loan Application	\$0.15
7505.	Commercial Goods Vehicles (Tow Trucks)	\$0.10
7506.	Motor Car (Trailers)	\$0.15
7507.	Housing (Commonwealth and State Agree-ment)	\$0.10
7508.	Consolidated Revenue	\$0.10
7509.	Revenue Deficits Funding	\$0.10
7510.	The Constitution Act Amendment (Postal Voting)	\$0.25
7511.	Railway Loan Application	\$0.15
7512.	Inflammable Liquids	\$0.25
7513.	Water Supply Loan Application	\$0.25
7514.	Appropriation of Revenue	\$1.15

A. C. BROOKS,
Government Printer.

THE "VICTORIA GOVERNMENT GAZETTE".

SUBSCRIPTIONS.—The subscription, including postage, is \$10 per annum, or \$5 per half year, payable in advance.

Subscriptions are required for whole months, and must cover at least a half year.

Single copies are 20 cents, posted 25 cents. Subscribers do not receive the Acts of Parliament with the GAZETTE.

GAZETTES are held in stock for five years only.

PRIVATE ADVERTISEMENTS.—The charge for insertion is 25 cents per line single column, and 50 cents per line double column. The title forms one or more lines as a heading. On an average ten words make a line of single column. Every signature must likewise be counted as a line. The final words of a paragraph, though only portion of a line, must be counted as one line. Signatures (in particular) and proper names must be written very plainly in the text; ONE SIDE ONLY of each sheet of paper should be WRITTEN UPON.

All documents illegibly written will be returned un-published, and where brands occur unprovided for by the ordinary letters of the alphabet, a worded explanatory description must be furnished.

THE VICTORIA GOVERNMENT GAZETTE is published on WEDNESDAY EVENING in each week, and Notices for insertion will be received by the Government Printer at or before ONE p.m. at ordinary rates, and late advertisements between ONE p.m. and FOUR p.m. at double rates on the day preceding the day of publication.

PAYMENTS.—Unless the advertiser has a credit account, all payments are required in advance. Remittances should be made by cheque, postal order, or money order payable to "GOVERNMENT PRINTER".

ADDRESS.—All communications should be addressed to "The Government Printer, Box 203, P.O., North Melbourne".

CONTENTS

	PAGE
Acts of Parliament on sale at the Government Printing Office	1176
Anzac Day Holiday	1108
Appointments	1132
Bank Holidays	1107
Companies Act 1961—Notice	1115
Contracts	1116
Courts	1116
Estates of Deceased Persons	1114
Government Notices	1108
Impoundings	1175
Insolvency Notice	1175
Lands	1146
Mining	1114
Notice to Mariners	1114
Notice of Making of Statutory Rules	1175
Orders in Council—	
Acts—Local Government; Marketing of Primary Products; Land; Marine Stores and Old Metals; Local Government; Country Roads; Landlord and Tenant; Water; Mildura Irrigation and Water Trusts; Sewerage Districts; Melbourne and Metropolitan Tramways; Stamps.	1133 et seq
Private Advertisements	1153
Proclamations	1107
Public Holidays	1107
Public Service Notices	1151
Resignations	1133
Tenders	1151
Transport Regulation Board—Public Hearings	1109
Waterworks Trusts	1130