

[3659]



VICTORIA GOVERNMENT GAZETTE

Published by Authority

[Registered at the General Post Office, Melbourne, for transmission by post as a newspaper.]

No. 92]

WEDNESDAY, DECEMBER 6

[1967

PROCLAMATIONS

Land Act 1958.

UNALIENATED CROWN LAND AVAILABLE FOR SETTLEMENT UNDER IMPROVEMENT PURCHASE LEASES.

PROCLAMATION

By His Excellency the Governor of the State of Victoria and its Dependencies in the Commonwealth of Australia &c., &c., &c.

IN pursuance of the provisions of Section 153 of the *Land Act 1958*, 1, the Governor of the State of Victoria, in the Commonwealth of Australia, by and with the advice of the Executive Council of the said State, do by this Proclamation declare the unalienated Crown lands mentioned in the subjoined schedule, to be available for settlement under improvement purchase leases.

SCHEDULE.

| County. | Parish. | Allotment. | Section. | Area. | Land Valuation. |
|---------------|--------------------|------------|----------|-----------|-----------------|
| Lowan | Woraigworm | 41A | .. | 112 acres | \$4 per acre |

Given under my Hand and the Seal of the State of Victoria aforesaid, at Melbourne, this twenty-eighth day of November, in the year of Our Lord One thousand nine hundred and sixty seven and in the sixteenth year of the reign of Her Majesty Queen Elizabeth II.

(L.S.)

By His Excellency's Command,

ROHAN DELACOMBE.

W. J. F. McDONALD,
Minister of Lands.

GOD SAVE THE QUEEN !

PUBLIC HIGHWAYS.—SHIRE OF MANSFIELD.

PROCLAMATION

By His Excellency the Governor of the State of Victoria and its Dependencies in the Commonwealth of Australia, &c., &c., &c.

WHEREAS by the Local Government Act 1958, as amended, Section 519 it is amongst other things enacted that it shall be lawful for the Governor-in-Council at any time and from time to time upon the request of the Council of any municipality by notice in the Government Gazette to proclaim any land reserved used or by purchase or exchange acquired for a street road highway thoroughfare bridge square court alley or right-of-way or any street road lane or passage made or laid out or proposed to be made or laid out on any land of which a plan of subdivision delineating that street road lane or passage has been sealed with the seal of the municipality under subdivision (3) of Division 9 of Part XIX. of the Local Government Act 1958, or a corresponding previous enactment to be a public highway and that such land shall thereupon and thenceforth from the date of such proclamation become and be absolutely dedicated to the public as a public highway within the meaning of any law then or thereafter in force.

AND WHEREAS the Council of the Shire of Mansfield has requested that the lands hereinafter mentioned, being streets roads lanes or passages made or laid out or proposed to be made or laid out on land of which a plan of subdivision delineating those streets roads lanes or passages has been sealed with the seal of the municipality under subdivision (3) of Division 9 of Part XIX. of the Local Government Act 1958, as amended, or a corresponding previous enactment, be so declared to be public highways:

NOW THEREFORE I, the Governor of the State of Victoria in the Commonwealth of Australia, by and with the advice of the Executive Council of the said State, do by this Proclamation declare that Willow Lake Drive, Valley Fair Rise, Village Way, Trout Stream Way and River Bend Rise coloured brown on Plan of Subdivision No. 66337 lodged in the Office of Titles and the road shown hatched on the plan hereunder, shall be public highways within the meaning of the said Act:

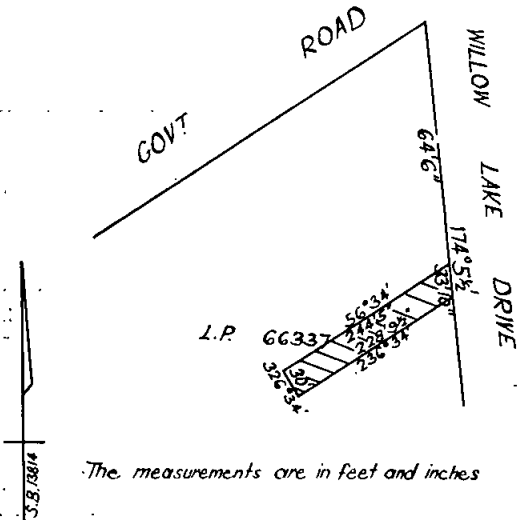

Given under my Hand and the Seal of the State of Victoria aforesaid, at Melbourne, this twenty-eighth day of November, in the year of our Lord One thousand nine hundred and sixty-seven, and in the sixteenth year of the reign of Her Majesty Queen Elizabeth II.

(L.S.) ROHAN DELACOMBE. By His Excellency's Command, R. J. HAMER, Minister for Local Government. GOD SAVE THE QUEEN!

PUBLIC HIGHWAY.—CITY OF NUNAWADING.

PROCLAMATION

By His Excellency the Governor of the State of Victoria and its Dependencies in the Commonwealth of Australia, &c., &c., &c.

WHEREAS by the Local Government Act 1958, as amended, Section 519 it is amongst other things enacted that it shall be lawful for the Governor-in-Council at any time and from time to time upon the request of the Council of any municipality by notice in the Government Gazette to proclaim any land reserved used or by purchase or exchange acquired for a street road highway thoroughfare bridge square court alley or right-of-way or any street road lane or passage made or laid out or proposed to be made or laid out on any land of which a plan of subdivision delineating that street road lane or passage has been sealed with the seal of the municipality under subdivision (3) of Division 9 of Part XIX. of the Local Government Act 1958, as amended, or a corresponding previous enactment to be a public highway and that such land shall thereupon and thenceforth from the date of such proclamation become and be absolutely dedicated to the public as a public highway within the meaning of any law then or thereafter in force.

AND WHEREAS the Council of the City of Nunawading has requested that the land herein after mentioned, being a street road lane or passage made or laid out or proposed to be made or laid out on land of which a plan of subdivision delineating that street road lane or passage has been sealed with the seal of the municipality under subdivision (3) of Division 9 of Part XIX. of the Local Government Act 1958, as amended, or a corresponding previous enactment, be so declared to be a public highway:

NOW THEREFORE I, the Governor of the State of Victoria in the Commonwealth of Australia, by and with the advice of the Executive Council of the said State, do by this Proclamation declare that Hylton-crescent, Forest Hill, shown hatched on the plan hereunder, shall be a public highway within the meaning of the said Act:

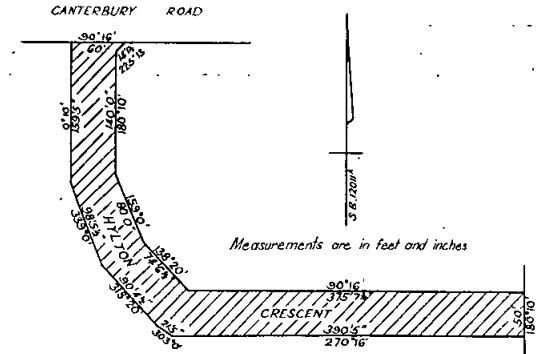

Given under my Hand and the Seal of the State of Victoria aforesaid, at Melbourne, this twenty-eighth day of November, in the year of our Lord One thousand nine hundred and sixty-seven, and in the sixteenth year of the reign of Her Majesty Queen Elizabeth II.

(L.S.) ROHAN DELACOMBE. By His Excellency's Command, R. J. HAMER, Minister for Local Government.

PUBLIC HIGHWAY.—SHIRE OF GISBORNE.

PROCLAMATION

By His Excellency the Governor of the State of Victoria and its Dependencies in the Commonwealth of Australia, &c., &c., &c.

WHEREAS by the Local Government Act 1958, as amended, Section 519 it is amongst other things enacted that it shall be lawful for the Governor-in-Council at any time and from time to time upon the request of the Council of any municipality by notice in the Government Gazette to proclaim any land reserved used or by purchase or exchange acquired for a street road highway thoroughfare bridge square court alley or right-of-way or any street road lane or passage made or laid out or proposed to be made or laid out on any land of which a

plan of subdivision delineating that street road lane or passage has been sealed with the seal of the municipality under subdivision (3) of Division 9 of Part XIX. of the *Local Government Act 1958*, as amended, or a corresponding previous enactment to be a public highway and that such land shall thereupon and thenceforth from the date of such proclamation become and be absolutely dedicated to the public as a public highway within the meaning of any law then or thereafter in force.

AND WHEREAS the Council of the Shire of Gisborne has requested that the land hereinafter mentioned, reserved for a street, be so declared to be a public highway.

NOW THEREFORE I, the Governor of the State of Victoria in the Commonwealth of Australia, by and with the advice of the Executive Council of the said State, do by this Proclamation declare that Sangster Road, delineated on the plan hereunder, shall be a public highway within the meaning of the said Act.

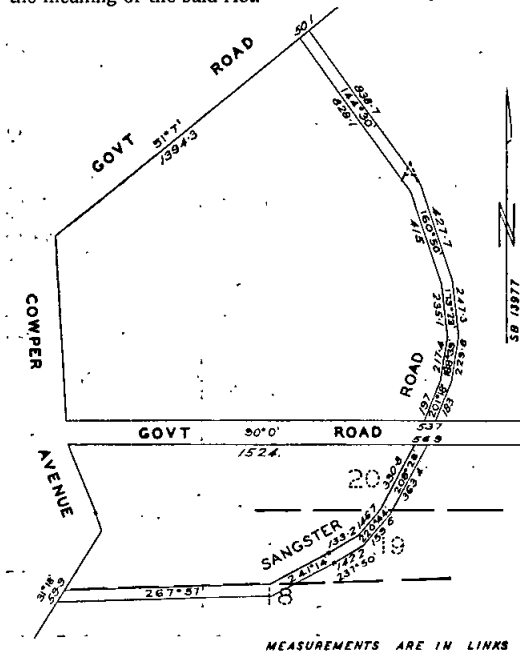

Given under my Hand and the Seal of the State of Victoria aforesaid, at Melbourne, this twenty-eighth day of November, in the year of our Lord One thousand nine hundred and sixty-seven, and in the sixteenth year of the reign of Her Majesty Queen Elizabeth II.

(L.S.) ROHAN DELACOMBE.
By His Excellency's Command,
R. J. HAMER,
Minister for Local Government.
GOD SAVE THE QUEEN!

ACTS OF PARLIAMENT.

PROCLAMATION

By His Excellency the Governor of the State of Victoria and its Dependencies in the Commonwealth of Australia, &c., &c., &c.

I, THE Governor of the State of Victoria, in the Commonwealth of Australia, do hereby declare that I have this day assented, in Her Majesty's name, to the Bills passed by the Parliament of the said State, the titles whereof are hereunder set forth, together with the short titles, that is to say:—

- No. 7586. "An Act to make Provision with respect to Financial Aid for Certain Registered Schools." (*Educational Grants Act 1967.*)
- No. 7587. "An Act to amend Division 3 of Part IV. of the *Motor Car Act 1958* and the Third Schedule thereto." (*Motor Car (Hours of Driving) Act 1967.*)
- No. 7588. "An Act to amend the *Poisons Act 1962.*" (*Poisons (Amendment) Act 1967.*)
- No. 7589. "An Act to amend the *Housing Act 1958.*" (*Housing (Amendment) Act 1967.*)

No. 7590. "An Act to amend the *Water Act 1958.*" (*Water (Further Amendment) Act 1967.*)

No. 7591. "An Act to make Provision with respect to the Exploration for, and the Exploitation of, the Petroleum Resources, and certain other Resources of certain Submerged Lands adjacent to the Coasts of the State, to amend the *Petroleum Act 1958* and the *Underseas Mineral Resources Act 1963*, to repeal the *Petroleum (Barracouta and Martin Fields Agreement) Act 1967* and the *Pipelines (Submerged Lands) Act 1967* and for other purposes." (*Petroleum (Submerged Lands) Act 1967.*)

Given under my Hand and the Seal of the State of Victoria aforesaid, at Melbourne, this twenty-eighth day of November, in the year of our Lord One thousand nine hundred and sixty-seven, and in the sixteenth year of the reign of Her Majesty Queen Elizabeth II.

(L.S.) ROHAN DELACOMBE.

By His Excellency's Command,
HENRY BOLTE,
Premier.

GOD SAVE THE QUEEN!

BANK HOLIDAYS.

PROCLAMATION

By His Excellency the Governor of the State of Victoria and its Dependencies in the Commonwealth of Australia, &c., &c., &c.

IN PURSUANCE of the provisions of the *Bank Holidays Act 1958*, I, the Governor of the State of Victoria, in the Commonwealth of Australia, do by this my Proclamation appoint the day and date named hereunder a special day to be observed as a Bank Half-Holiday at the place mentioned, that is to say:—

Bank Half-Holiday from Eleven a.m.:—

THURSDAY, THE 7TH DECEMBER, 1967, at Chiltern.

Given under my Hand and the Seal of the State of Victoria aforesaid, at Melbourne, this fifth day of December, in the year of our Lord One thousand nine hundred and sixty-seven, and in the sixteenth year of the reign of Her Majesty Queen Elizabeth II.

(L.S.) ROHAN DELACOMBE.

By His Excellency's Command,
A. G. RYLAH,
Chief Secretary.

GOD SAVE THE QUEEN!

Firearms Act 1958.

APPLICATION OF PROVISIONS OF PART IIIA OF THE FIREARMS ACT 1958 TO THE SHIRE OF CRESWICK.

PROCLAMATION

By His Excellency the Governor of the State of Victoria and its Dependencies in the Commonwealth of Australia, &c., &c., &c.

IN PURSUANCE of the powers conferred by the *Firearms Act 1958*, I, the Governor of the State of Victoria, in the Commonwealth of Australia, by and with the advice of the Executive Council of the said State and on the application of the Council of the Shire of Creswick, do by this my Proclamation declare the municipal district of the Shire of Creswick to be a district to which Part IIIA of the *Firearms Act 1958* applies.

Given under my Hand and the Seal of the State of Victoria aforesaid, at Melbourne, this fifth day of December, in the year of our Lord One thousand nine hundred and sixty-seven, and in the sixteenth year of the reign of Her Majesty Queen Elizabeth II.

(L.S.) ROHAN DELACOMBE.

By His Excellency's Command,
JAMES W. MANSON,
for Chief Secretary.

GOD SAVE THE QUEEN!

MALLACOOTA WATERWORKS TRUST.—
PROCLAMATION OF URBAN DISTRICT.

PROCLAMATION

By His Excellency the Governor of the State of Victoria and its Dependencies in the Commonwealth of Australia, &c., &c., &c.

UNDER the powers conferred by the Water Act and all other powers enabling me in that behalf, I, the Governor of the State of Victoria, in the Commonwealth of Australia, by and with the advice of the Executive Council of the said State, do hereby proclaim that on and from the date hereof, Portions IV, V and VI of the Waterworks District of the Mallee Waterworks Trust as defined in the Order in Council dated 28th November, 1967, and published in the *Victoria Government Gazette* dated 29th November, 1967, shall be and become an Urban District for the purpose of and within the meaning of the said Act, and be known as the Mallee Urban District.

Given under my Hand and the Seal of the State of Victoria, aforesaid, at Melbourne, this fifth day of December, in the year of our Lord One thousand nine hundred and sixty-seven, and in the sixteenth year of the reign of Her Majesty, Queen Elizabeth II.

(L.S.) ROHAN DELACOMBE.

By His Excellency's Command,
W. BORTHWICK,
Minister of Water Supply.

GOD SAVE THE QUEEN !

MOTOR BOATING ACT 1961, SECTION 4 (1).

PROCLAMATION

By His Excellency the Governor of the State of Victoria and its Dependencies in the Commonwealth of Australia, &c., &c., &c.

WHEREAS by Section 2 of the *Motor Boating Act 1961*, it is amongst other things enacted that the Governor in Council, by Proclamation published in the *Government Gazette*, may appoint an Authority in control over any Victorian waters:

AND WHEREAS by Section 4 of the *Motor Boating Act 1961* the Governor in Council, on the recommendation of an Authority having Control over any Victorian waters, may by Proclamation published in the *Government Gazette* set aside or prohibit or restrict the use of any specified part or parts of any waters under the control of the Authority for any specified class or classes of boating or similar activity:

AND WHEREAS the State Rivers and Water Supply Commission has been appointed the Authority in respect of Rocklands Reservoir:

AND WHEREAS the State Rivers and Water Supply Commission has recommended that the use of certain parts of the waters of Rocklands Reservoir be prohibited for certain classes of boating or similar activity:

NOW THEREFORE I, the Governor of the State of Victoria in the Commonwealth of Australia, by and with the advice of the Executive Council of the said State and in pursuance of the powers conferred by the *Motor Boating Act 1961*, do by this my Proclamation prohibit the use of the waters of Rocklands Reservoir 200 yards to the eastward of the dam to a line between two beacons on opposite shores of the reservoir marked "STOP" and "PROHIBITED WATER BEYOND THIS POINT" for all classes of boating.

Given under my Hand and the Seal of the State of Victoria aforesaid, at Melbourne, this fifth day of December, in the year of our Lord One thousand nine hundred and sixty-seven, and in the sixteenth year of the reign of Her Majesty Queen Elizabeth II.

(L.S.) ROHAN DELACOMBE.

By His Excellency's Command,
A. G. RYLAH,
Chief Secretary.

GOD SAVE THE QUEEN !

MOTOR BOATING ACT 1961, SECTION 4 (1).

PROCLAMATION

By His Excellency the Governor of the State of Victoria and its Dependencies in the Commonwealth of Australia, &c., &c., &c.

WHEREAS by Section 4 of the *Motor Boating Act 1961* the Governor in Council, on the recommendation of an Authority having control over any Victorian waters, may by Proclamation published in the *Government Gazette* set aside or prohibit or restrict the use of any specified part or parts of any waters under the control of the Authority for any specified class or classes of boating or similar activity:

AND WHEREAS the State Rivers and Water Supply Commission has been appointed the Authority over the waters of Lake Nillahcootie.

AND WHEREAS the State Rivers and Water Supply Commission has recommended that the use of certain parts of the waters of Lake Nillahcootie be prohibited for all classes of boating:

NOW THEREFORE I, the Governor of the State of Victoria in the Commonwealth of Australia, by and with the advice of the Executive Council of the said State and in pursuance of the powers conferred by the *Motor Boating Act 1961*, do by this my Proclamation prohibit the use of the waters of Lake Nillahcootie to the southward of the embankment to an imaginary line about 200 yards distant between two beacons on opposite shores of the Lake marked "STOP" and "PROHIBITED WATER BEYOND THIS POINT" for all classes of boating.

Given under my Hand and the Seal of the State of Victoria aforesaid, at Melbourne, this fifth day of December, in the year of our Lord One thousand nine hundred and sixty-seven, and in the sixteenth year of the reign of Her Majesty Queen Elizabeth II.

(L.S.) ROHAN DELACOMBE.

By His Excellency's Command,
A. G. RYLAH,
Chief Secretary.

GOD SAVE THE QUEEN !

GOVERNMENT NOTICES

PUBLICATION OF THE "VICTORIA GOVERNMENT GAZETTE".

IT is hereby notified that, owing to the Christmas and New Year Holidays, the last issue of the *Victoria Government Gazette* for the year 1967 will be published on Wednesday, the 20th December, except if special circumstances shall require otherwise.

The next *Gazette* after the 20th December, 1967, will be published on Friday, the 5th January, 1968, and thereafter on each Wednesday, as usual.

A. C. BROOKS,
Government Printer.

CHRISTMAS AND NEW YEAR HOLIDAYS.

IT is hereby notified that on—

MONDAY, THE 25TH DECEMBER, 1967,
TUESDAY, THE 26TH DECEMBER, 1967,
MONDAY, THE 1ST JANUARY, 1968 and
*TUESDAY, THE 2ND JANUARY, 1968,

the Public Offices will be closed, such days having been appointed by the *Public Service Act 1958* to be observed as holidays in the Public Offices throughout the State of Victoria.

This notice relates only to the closing of the State Public Offices. All inquiries regarding holidays in other offices and in shops and industry should be directed to the Department of Labour and Industry, 110 Exhibition-street, Melbourne (Telephone 63 0321, Extension 6158, 6721 or 6859).

A. G. RYLAH,
Chief Secretary.

* (Vide Proclamation published in the *Victoria Government Gazette* No. 43 of 17th May, 1967, page 1700.)
Chief Secretary's Office,
Melbourne, 3000, 24th November, 1967.

Transport Regulation Act.

TRANSPORT REGULATION BOARD.

HEARING OF APPLICATIONS.

NOTICE is hereby given that the following applications will be considered by the Transport Regulation Board at its offices at corner Lygon and Princes streets, Carlton, at 10.15 a.m. on Friday, 22nd December, 1967.

BELL STREET BUS CO. PTY. LTD., 324 Bell-street, Preston. Application for variation of all "M.O." licensed vehicles on Route 6A (West Breen-Pascoe Vale-Coburg-Heidelberg) (Part B) to include the ability to operate a turning procedure via Cumberland-road, Eddie-street, Wilna-street, Gaffney-street and Cumberland-road.

CAMDEN BUS SERVICE PTY. LTD., 1248 Glenhuntingly-road, Glenhuntingly. Application for variation of all "M.O." licences on Route 94A (Elsternwick-Ormond-Oakleigh) to delete the existing turning procedure and stand at Oakleigh and instead to operate a turning procedure via Carlisle-crescent, Earlstown-road, Kangaroo-road, Latrobe-street, Barkly-street, Warrigal-road, Davey-avenue and Johnson-street to a stand to be established on the west side of Johnson-street, returning via Mill-road, Warrigal-road, Barkly-street, Latrobe-street and Kangaroo-road to normal route.

DENDY OMNIBUSES AND L. T. & V. M. SUHR (trading as Landsford Motors), 559 Centre-road, Bentleigh. Application for variation of all "M.O." licences on Route 32A (Oakleigh-Bentleigh-Brighton) to delete the existing turning procedure and stand at Oakleigh and instead to operate a turning procedure via Kangaroo-road, Latrobe-street, Barkly-street, Warrigal-road, Davey-avenue and Johnson-street to a stand to be established on the west side of Johnson-street, returning via Mill-road, Warrigal-road, Barkly-street, Latrobe-street and Kangaroo-road to normal route.

GRENDA'S BUS SERVICE, 9 Foster-street, Dandenong. Three commercial passenger vehicles each with large seating capacity to be purchased to operate as additional country stage omnibuses under the same terms and conditions as existing "C.O." licences held by the applicant.

GRENDA'S BUS SERVICE, 9 Foster-street, Dandenong. Application for variation of "C.O." licences on Route 268A (Dandenong-Oakwood Park via Dandenong West) to delete existing route, sections and fares and instead to operate as follows:—Commencing at the Dandenong Railway Station via Foster, Thomas, Clow, Robinson and Hemmings streets, Benga-avenue, Ryland, Jones and Gladstone roads, Oakwood-avenue, Regency-street, Mollison-place, Heyington-place, Oakwood-avenue to the corner of Oakwood-avenue and Elonera-avenue.

Sections and Fares:

Dandenong Station to—

1. Corner of Benga-avenue and Hemmings-street, 6c adults, 4c children.
2. Corner of Princes Highway and Jones-road, 10c adults, 6c children.
3. Regency-street, 12c adults, 7c children.
4. Corner of Oakwood-avenue and Elonera-avenue, 15c adults, 8c children.

Time-table to remain unchanged.

RICCIARDI, P., 34 Bruce-street, North Geelong. One commercial passenger vehicle with seating capacity for eleven persons to operate for the carriage of bona fide harvesting workers from or to the Geelong urban district to or from their employment at properties in the following areas only, namely, within that part of the Shire of Werribee south of the Werribee River or within a 3-mile radius of the Werribee Post Office and within the Shire of Corio, Bellerine, South Barwon, Barrabool, Bannockburn, Winchelsea, Colac, Leigh and Otway.

Notice of any objection should be forwarded to reach the Secretary of the Board not later than Wednesday, 20th December, 1967.

Applicants are advised that it will not be necessary to appear on the hearing date specified above, unless advised in writing by the Board.

B. P. KAY,

Secretary.

Corner Lygon and Princes streets, Carlton, Wednesday, 6th December, 1967.

Commercial Goods Vehicles Act.

TRANSPORT REGULATION BOARD.

HEARING OF APPLICATIONS.

NOTICE is hereby given that the following applications will be considered by the Transport Regulation Board at its offices at the corner of Lygon and Princes streets, Carlton, at 10.15 a.m. on Friday, 22nd December, 1967.

ACROW (VICTORIA) PTY. LTD., 598 High-street, Thornbury, 3071. One commercial goods vehicle (L/C. 129 cwt.) to operate within a 50-mile radius from own premises at Thornbury in the course of business as "Builders Equipment Hirers and Distributors"—own concrete formwork and industrial storage racking.

ANDERSON, D. H., 14 Wynden-drive, Frankston, 3199. One commercial goods vehicle (L/C. 113 cwt.) to operate in the course of business as a "Landscape Gardener": (a) Within a 25-mile radius from the post office at Frankston with the proviso that no one journey shall exceed 30 miles in length—own goods. (b) From Bacchus Marsh to places within the radius as defined in paragraph (a) above—own river pebbles and honey-comb rock. (c) From Beveridge to places within the radius as defined in paragraph (a) above—own scoria gravel and scoria rock. (d) From Toolangi to places within the radius as defined in paragraph (a) above—own mountain soil.

ANDERSON, R. F., Diggers Rest, 3427. One commercial goods vehicle (L/C. 304 cwt.) to operate: (a) Within a 25-mile radius from own premises at Diggers Rest in the course of business as "Primary Producer and Earth-moving Contractor"—own goods and own earth-moving equipment and earth-moving equipment on behalf of other contractors. (b) Within a 50-mile radius from own premises at Quambatook in the course of business as "Primary Producer and Earth-moving Contractor"—own goods and own earth-moving equipment and earth-moving equipment on behalf of other contractors. (c) Between own premises at Diggers Rest and Quambatook—own earth-moving equipment and farm machinery in course of business as "Primary Producer and Earth-moving Contractor".

ASCOM PTY. LTD., 63 Queensbridge-street, South Melbourne, 3205. One commercial goods vehicle (L/C. 18 cwt. approximately) to operate throughout the State of Victoria for the purpose of supervising own contracts in the course of business as "Civil Engineers and Contractors"—tools of trade, spare parts and materials incidental to the completion of own contracts.

BARTEL, N. A., Box 19, Rutherglen, 3685. One commercial goods vehicle (L/C. 263 cwt.) to operate: (a) From own premises at Rutherglen to forest landings at Stanley and Mt. Cobbler in the course of business as "Earth-moving and Logging Contractor"—own earth-moving and logging equipment. (b) From forest landings at Stanley to Alstergren's sawmill at Stanley—logs. (c) From forest landings at Mt. Cobbler to the South Wangaratta sawmill at Wangaratta—logs.

BARTY, S. S., Sutton Grange, 3448. One commercial goods vehicle (L/C. 140 cwt. approximately) to operate: (a) Within a 25-mile radius of the post office at Sutton Grange with the proviso that no one journey shall exceed 30 miles in length—general goods. (b) Within a 50-mile radius of the post office at Sutton Grange in the course of business as "Stock Food Merchant"—own stock foods.

BASTOW, P. W., 42 Cromwell-street, Glenroy, 3046. One commercial goods vehicle (L/C. 246 cwt.) to operate: (a) Within a 25-mile radius from the post office situated at the corner of Bourke and Elizabeth streets in the City of Melbourne—general goods. (b) From Mt. Egerton to places situated within the radius as defined in paragraph (a) above—clay.

NOTE.—Subject to cancellation of licence No. D.A.34774/3 in the name of L. W. and E. M. Bastow.

BENNETT, J. G., 7 Stradbroke-avenue, Frankston, 3199. One commercial goods vehicle (L/C. 10 cwt.) to operate throughout the State of Victoria in course of business as "Drainage Contractor"—tools of trade, plant and equipment incidental to own contracts.

BIELBY, G. A., 28 Lake-street, Wendouree, 3355. One commercial goods vehicle (L/C. 75 cwt.) to operate: (a) Within a 40-mile radius from the post office at Ballarat in the course of business as "Confectionery Wholesaler"—own goods. (b) From the City of Ballarat to the Cities of Ararat, Horsham and the Township of Stawell in the course of business as "Confectionery Wholesaler" serving places *en route*—own goods.

PROVISO.—It is a special condition that all goods so carried shall only be those which have been initially consigned by rail to the aforesaid cities and town.

- BOURKE, T. M.**, 47 Gibney-street, Maffra, 3860. One commercial goods vehicle (L/C. 200 cwt. approximately) to operate from forest landings in the Conners Plains and Bennison Plains areas to sawmills at Heyfield—logs.
- BREEN, R. J.**, 204 Gooch-street, Thornbury, 3071. One commercial goods vehicle (L/C. 257 cwt.) to operate within a 50-mile radius of the premises of Albion Reid Pty. Ltd., at North Melbourne—road-making plant, materials, premix and hot asphalt on behalf of the said company; excluding the carriage of cement or lime from the Geelong Urban District.
- BURTON, T. A. (Mrs.) and A. N.**, Tyson-road, Heyfield, 3858. One commercial goods vehicle (L/C. 268 cwt.) to operate from forest landings in the Licola area to sawmills at Heyfield—logs.
- CARTWRIGHT, S. A.**, 17 Campbell-street, Birchip, 3483. One commercial goods vehicle (L/C. 248 cwt.) to operate: (a) Within a 50-mile radius from the post office at Birchip as a "Road Contractor"—road-making plant and materials. (b) Within a 25-mile radius of the post office at Birchip with the proviso that no one journey shall exceed 30 miles in length—general goods.
- CLEATOR, I. F.**, 6 Charter-street, Ringwood, 3134. One commercial goods vehicle (L/C. 10 cwt.) to operate within a 25-mile radius from the post office at Traralgon in the course of business as a "Dairy Herd Tester"—own tools of trade, equipment and materials.
- COOK, N. W.**, Nichol's-road, Leongatha, 3953. One commercial goods vehicle (L/C. 130 cwt.) to operate: (a) From the premises of the State Electricity Commission at Morwell and Yallourn to Leongatha and to places situated within a 20-mile radius of Leongatha—bagged and bulk briquettes. (b) Within a 20-mile radius of the post office at Mardan—road-making plant and equipment.
- DAWSON, T. H.**, 22 Wilson-street, Horsham, 3400. Eight commercial goods vehicles (L/C. 11, 13, 9, 50, 11, 11, 11, and 11 cwt.) to operate west of a line drawn north and south through the City of Ballarat in the course of business as a "Plumber, Sanitary Engineer and Hot Water Engineer"—tools of trade, material and equipment incidental to own contracts.
- DURAL LEEDS PTY. LTD.**, corner Calder Highway & Roberts-road, Niddrie, 3042. Three commercial goods vehicles (L/C. 10 cwt. each) to operate throughout the State of Victoria in course of business as "Blind and Awning Manufacturers" for the purpose of Sales Promotion, repairing and measuring contracts—samples, display materials, tools of trade, blinds and awnings for repair having been repaired and for specialized installation, and materials incidental thereto.
- EDWARDS, B. G.**, Flat 17, Brixton Court, Brixton-rise, Glen Iris, 3146. One commercial goods vehicle (L/C. 19 cwt.) to operate within a 50-mile radius of the post office situated at the corner of Bourke and Elizabeth streets in the City of Melbourne in the course of business as "Installation Contractor" solely on behalf of Dural Leeds Pty. Ltd.—tools of trade, blinds, awnings, insect screens and small quantities of materials incidental to the completion of contracts currently engaged upon.
- ELLIS, A. W.**, Pimpinio, 3415. One commercial goods vehicle (L/C. 241 cwt.) to operate: (a) Within a 80-mile radius from the post office at Dimboola (Horsham Division of the Country Roads Board)—road contracting plant used in the construction or maintenance of a road, street, footpath, bridge, wharf, pier, weir or channel. (b) Within a 20-mile radius from the site of construction or maintenance work performed pursuant to paragraph (a) above or from a railway station nearest thereto—materials required for such work. (c) Within a 25-mile radius of the post office at Pimpinio with the proviso that no one journey shall exceed 30 miles in length—general goods.
- FITZGIBBON, D. R.**, Molesworth, 3718. One commercial goods vehicle (L/C. 240 cwt. approximately) to operate from private landings at Molesworth to R. J. Richards sawmill at Healesville and to Ringwood Timber Co. at Ringwood—logs.
- FLICK, W. A., & Co. PTY. LTD.**, 73 Victoria-street, Chatswood, New South Wales, 2067. One commercial goods vehicle (L/C. 12 cwt.) to operate within that part of the State of Victoria north of a line drawn east and west through the Township of Bacchus Marsh in the course of business as "Pest Exterminators"—tools of trade, spraying equipment and small quantities of materials incidental to own contracts subject to the condition that all initial supplies of concentrated chemicals used in connexion therewith shall be forwarded by rail to railway stations at Ballarat, Horsham, Wedderburn and Shepparton.
- HARTLEY, ERN (WARRNAMBOOL) PTY. LTD.**, 223 Koroit-street, Warrnambool, 3280. One commercial goods vehicle (L/C. 31 cwt.) to operate within a 50-mile radius of the post office at Warrnambool and to the Township of Willaura, but excluding those towns on the Henty Highway between Portland and Hamilton—biscuit products on behalf of Nabisco Pty. Ltd.
- HARTLEY, ERN (WARRNAMBOOL) PTY. LTD.**, 223 Koroit-street, Warrnambool, 3280. Application to vary the conditions of licences numbered D.A.1266/1 and D.A.1266/3 (L/C. 75 and 74 cwt.) by adding to the existing conditions: "Within a 50-mile radius of the post office at Warrnambool and to the Township of Willaura, but excluding those towns on the Henty Highway between Portland and Hamilton—biscuit products on behalf of Nabisco Pty. Ltd."
- HARVEY, L. G.**, 89 Toole-street, Hopetoun, 3396. One commercial goods vehicle (L/C. 5 cwt.) to operate within a 50-mile radius from the post office at Wedderburn in the course of business as "Dry Cleaner"—clothing for dry-cleaning or having been dry-cleaned.
- HOMEWOOD, R. H.**, Whiteheads Creek, Seymour, 3660. One commercial goods vehicle (L/C. 140 cwt. approximately) to operate: (a) Within a 25-mile radius from the railway stations at Seymour, Nagambie, Tallarook, Kerrisdale, Homewood, Yea, Molesworth, York and Kanumbra—superphosphate in bulk tanks, for spreading purposes only; such superphosphate having been initially consigned by rail to the aforesaid railway stations. (b) Between Seymour and the sale-yards at Newmarket—livestock.
- JAMIESON, J. G.**, 8 Ireland-street, Ringwood, 3134. One commercial goods vehicle (L/C. 196 cwt.) to operate within a 50-mile radius from the premises of Ready Mixed Concrete (Vic.) Pty. Ltd., at Huntingdale solely on behalf of the said company—premixed concrete in a specially constructed agitator vehicle.
- LEHMANN, M. M.**, 72 Darlot-street, Horsham, 3400. One commercial goods vehicle (to be purchased) to operate: (a) Within a 50-mile radius from the post office at Horsham in the course of business as "Wholesale Distributor"—own agency lines. (b) Within that part of the State of Victoria bounded by and including the townships or cities as the case may be of Cavenish, Kaniva, Rainbow, Patchewollock, Woomelang, Donald, St. Arnaud and Ararat—biscuit products on behalf of Nabisco Pty. Ltd. provided that all such goods be initially consigned to Horsham by rail.
- LIESHOUT, L. & L.**, Longwarry, 3816. Application to vary the conditions of licence No. D.T.655 (L/C. 235 cwt.) by deleting paragraph (b) of the existing conditions and by adding in lieu: "(b) Within a 25-mile radius of the post office at Longwarry provided that no goods shall be carried whether by one stage or by more than one stage between places within the above radius which are more than 30 miles apart by the nearest practicable route—general goods."
- MARRICKVILLE HOLDINGS SALES PTY. LTD.**, Corner Ballarat-road and Lacy-street, Braybrook, 3019. One commercial goods vehicle (L/C. 7 cwt.) to operate throughout the State of Victoria as "Sales Supervisor" for the purpose of advertising and sales promotion—samples, advertising and display materials and small quantities of stock for replacement of unsaleable or damaged stock with the ability to carry unsaleable or damaged stock on return.
- MELBOURNE POTTERY PTY. LTD.**, 419 Victoria-street, Brunswick, 3056. One commercial goods vehicle (L/C. 225 cwt.) to operate in the course of business as "Pottery and Septic Tank Manufacturers"—(a) Within a 50-mile radius from own premises at Brunswick—own goods. (b) Within a 70-mile radius from own premises at Brunswick for the purpose of installing septic tanks—septic tanks for installation, tools of trade, excavation equipment and materials incidental thereto.
- HILLIER, F. A.** (trading as Mildura and Murray Valley Wholesale Confections), 159 Eleventh-street, Mildura, 3500. Application to vary the conditions of licence No. D.A.32239/4 (L/C. 17 cwt.) by adding to the existing conditions an additional paragraph (c)—"(c) Within a 65-mile radius from the post office at Mildura—biscuit products on behalf of Nabisco Pty. Ltd., provided that such goods be initially consigned by rail to Mildura."
- MIRIKLIS, D. H.**, 125 Kilby-road, East Kew, 3101. One commercial goods vehicle (L/C. 134 cwt.) to operate: (a) Within a 25-mile radius of the post office situate on the corner of Bourke and Elizabeth streets in the City of Melbourne—general goods. (b) From and to places within the radius as defined in paragraph (a)

- above to and from own premises at Officer in the course of business as "Primary Producer"—own goods.
- MITTON, E., 2 Young-street, Horsham, 3400. Two commercial goods vehicles (L/C. 241 and 127 cwt.) to operate within a 50-mile radius from the post office at Horsham or from any railway station within the said radius to farms nearest thereto—superphosphate for spreading purposes.
- MOLLISON MOTORS PTY. LTD., 167 Mollison-street, Kyneton, 3444. One commercial goods vehicle (L/C. 11 cwt. and 40 cwt. trailer) to operate: (a) Within a 25-mile radius of the post office at Kyneton in the course of business as "General Motors-Holden's Distributor and Garage Proprietor"—own goods. (b) From own premises at Kyneton to the City of Melbourne—own second-hand cars on a specially constructed car-carrying trailer. (c) From the premises of General Motors-Holden's Pty. Ltd. at Dandenong to own premises at Kyneton—own new cars on a specially constructed car-carrying trailer.
- MONBULK PRESERVES LIMITED, Camm's-road, Monbulk, 3793. One commercial goods vehicle (L/C. 149 cwt.) to operate within a 50-mile radius of own premises at Monbulk in the course of business as "Fruit Processors and Jam Manufacturers"—own goods.
- NABISCO PTY. LTD., 424 St. Kilda-road, Melbourne, 3004. One commercial goods vehicle (L/C. 60 cwt. approximately) to operate: (a) Within a 50-mile radius from the post office situated at the corner of Bourke and Elizabeth streets in the City of Melbourne—own biscuit products in the course of business as "Food Product Manufacturers". (b) From the railway station at Geelong to places within a 50-mile radius thereof—own biscuit products in the course of business as "Food Product Manufacturers" provided that such goods be initially consigned by rail to Geelong.
- NABISCO PTY. LTD., 424 St. Kilda-road, Melbourne, 3004. One commercial goods vehicle (L/C. 40 cwt. approximately) to operate within that part of the State of Victoria bounded on the east by a north/south line drawn through the Township of Orbost and on the west by a north/south line drawn through the Township of Drouin—own biscuit products in course of business as "Food Product Manufacturers" provided that all such goods be initially consigned by rail to Traralgon.
- NABISCO PTY. LTD., 424 St. Kilda-road, Melbourne, 3004. Two commercial goods vehicles (L/C. 40 and 60 cwt. approximately) to operate within a 50-mile radius of the post office at Shepparton and to the Townships of Wodonga, Tallangatta, Mitta Mitta, Mt. Beauty, Mansfield, Eildon, Seymour and the City of Bendigo—own biscuit products in course of business as "Food Product Manufacturer" provided that all such goods be initially consigned by rail to Shepparton.
- NILSEN, O. J., & Co. PTY. LTD., 45 Bourke-street, Melbourne, 3000. One commercial goods vehicle (L/C. 11 cwt.) to operate: (a) Within a 50-mile radius of own premises at Melbourne in the course of business as "Electrical Engineers"—own goods. (b) Throughout the State of Victoria—tools of trade and equipment incidental to own contracts. (c) Within a radius of 20-miles of any contract currently engaged upon—materials for use on such contract.
- NUNAWADING PLANT HIRE PTY. LTD., 10 Ashburn-place, Blackburn, 3130. Five commercial goods vehicles (L/C. 230; 204; 216; 130 and 213 cwt.) to operate: (a) Within a 25-mile radius of own premises at Blackburn in course of business as "Earth-moving Contractors and Plant Hirers"—own goods. (b) Throughout the State of Victoria as "Earth-moving Contractors"—own tools of trade, own plant and own equipment. (c) Within a 25-mile radius of any contract currently engaged upon or from the nearest railway station thereto—materials for use on such contract.
- PERKINS, C. C., PTY. LTD., 365 Bell-street, Heidelberg West, 3081. Two commercial goods vehicles (L/C. 240 and 270 cwt.) to operate throughout the State of Victoria as "House Remover"—houses, pre-fabricated houses, sheds and outbuildings for removal and re-erection together with tools of trade, removal equipment and materials incidental thereto.
- PHENIX BISCUIT CO. PTY. LTD., Grosvenor-street, Abbotsford, 3067. Application to vary the conditions of licence No. D.A.3949/14 (L/C. 17 cwt.) by adding to the existing conditions an additional paragraph (b)—"(b) Within a 50-mile radius from own premises at Abbotsford in the course of business as 'Biscuit and Cake Manufacturers'—own goods."
- PHENIX BISCUIT CO. PTY. LTD., Grosvenor-street, Abbotsford, 3067. One commercial goods vehicle (L/C. 60 cwt.) to operate within a 50-mile radius of own branch premises at Wangaratta in the course of business as "Biscuit and Cake Manufacturers"—own goods.
- PINKERTON, G., 45 Rundel-road, Park Orchards, 3114. One commercial goods vehicle (L/C. 9 cwt.) to operate within a 50-mile radius from the G.P.O., Melbourne, in the course of business as a "Venetian Blind Installer and Repairer"—new and second-hand venetian blinds for installation or repair or having been repaired.
- PISTEVOS, G., 1 Harper-street, Westgarth, 3070. One commercial goods vehicle (L/C. 137 cwt.) to operate within a 50-mile radius of the premises of Albion Reid Pty. Ltd., at North Melbourne—road-making plant, materials, premix and hot asphalt on behalf of the said company, but excluding the carriage of cement or lime from the Geelong urban district.
- POWER, R. L., 51 Honeysuckle-street, Bendigo, 3550. Application to vary the conditions of licence No. D.A.60948 (L/C. 5 cwt.) by deleting from the existing conditions "on behalf of H. G. Palmers Pty. Ltd."
- PROCESSED FOOD DISTRIBUTORS PTY. LTD., 8-10 Fishmarket Buildings, New Footscray-road, Footscray, 3011. One commercial goods vehicle (L/C. 33 cwt.) to operate: (a) Within a 50-mile radius of own premises at Footscray in course of business as "Frozen Food Distributors"—own goods. (b) Within that part of the State of Victoria east of a line drawn north and south through the City of Melbourne in a specially constructed refrigerated vehicle—frozen fish, frozen poultry, frozen processed vegetables, frozen chicken rolls, frozen dim sims, frozen hamburgers, ice-cream, frozen fruit juices, frozen egg whites and frozen pastries at a temperature of 0°F.
- RAYMOND, G. N., TIMBER PTY. LTD., Greens-road, Dandenong, 3175. One commercial goods vehicle (L/C. 145 cwt.) to operate within a 50-mile radius from own premises at Dandenong in the course of business as "Hardware and Timber Merchants"—own goods.
- ROUMELIOTIS, N. & O., 43 Ormond-road, Moonee Ponds, 3039. One commercial goods vehicle (L/C. 226 cwt.) to operate from the mine of Star Collieries Pty. Ltd., at Bacchus Marsh, to places within a 25-mile radius of the G.P.O., Melbourne—brown coal.
- SCANLON, B. R., Wood-street, Woodend, 3442. Two commercial goods vehicles (L/C. 136 and 157 cwt.) to operate from forest landings at Cobaw, Woodend, Bullengarook and Macedon to the hardwood mill of the Colonial Sugar Refining Co. Ltd., at Bacchus Marsh solely on behalf of the said company—pulpwood.
- SCOWN & STANDEN PTY. LTD., 1 Cobb-court, Swan Hill, 3585. Application to vary the conditions of licence No. D.A.55394/1 (L/C. 33 cwt.) by adding to the existing conditions an additional paragraph (b)—"(b) Within a 50-mile radius of the post office at Swan Hill and to the Townships of Charlton, Wyche-proof and Birchip—biscuits on behalf of Nabisco Pty. Ltd. provided such biscuits shall only be those initially consigned by rail to Swan Hill."
- SHKRELI, C. J., 5 Hillside-avenue, Dandenong, 3175. One commercial goods vehicle (L/C. 156 cwt.) to operate: (a) Within a 70-mile radius of the post office at Healesville (Dandenong Division of the C.R.B.)—road contracting plant used in the construction or maintenance of a road, street, footpath, bridge, wharf, pier, weir or channel. (b) Within a 20-mile radius from site of construction or maintenance work performed pursuant to paragraph (a) above or from a railway station nearest thereto—materials required for such work. (c) Within a 25-mile radius of the post office at Healesville with the proviso that no one journey shall exceed 30 miles in length—general goods.
- SKEEN, J., 20 Hudson-street, Coburg, 3058. One commercial goods vehicle (L/C. 59 and 30 cwt. trailer) to operate from the sawmill of J. W. Hill at Macedon to own premises at Coburg in the course of business as "Sawdust Supplier"—bulk sawdust.
- SUPER SPREAD AVIATION AUST. PTY. LTD., Hanger 7, Moorabbin Airport, Cheltenham, 3192. Two commercial goods vehicles (L/C. 11 cwt. each) to operate throughout the State of Victoria in the course of business as "Aerial Crop Dusters" for the purpose of supervising own contracts—tools of trade, equipment and small quantities of fuel for carriage from property to property for completion of own contracts.
- TOLEDO-BERKEL PTY. LTD., 59-63 Bourke-street, Melbourne, 3000. One commercial goods vehicle (L/C. 19 cwt.) to operate: (a) Throughout the State of Victoria in the course of business as "Scale Makers and Food Preparing Machinery Distributors"—weighing

machines, food preparing machinery, meat and food slicing machines. (b) Throughout the State of Victoria for the purpose of servicing and maintaining the aforesaid machines—tools of trade, spare parts and test weights.

TOTALIZATOR AGENCY BOARD OF VICTORIA, 2 Queens-road, Melbourne, 3004. One commercial goods vehicle (L/C. 32 cwt. and caravan) to operate throughout the State of Victoria in the course of business as "Totalizator Agency Board" for the purpose of operating the vehicle as a mobile totalizator with the ability to tow a specially constructed caravan—totalizator equipment and stationery.

TRANCO DELIVERY & CO. LTD., P.O. Box 27, Flemington, 3031. One commercial goods vehicle (L/C. 144 cwt.) to operate within a 50-mile radius from the post office situated at the corner of Bourke and Elizabeth streets in the City of Melbourne but excluding any operations to the City of Geelong—flour and stock feed solely on behalf of Jas. Minifie & Co. Pty. Ltd., and subsidiary companies.

TROTTER, R. F., Box 14, Jung, 3399. One commercial goods vehicle (L/C. 133 cwt.) to operate: (a) Within a 50-mile radius from the post office at Wychee—road-making plant and materials. (b) Within a 20-mile radius from own premises at Jung in course of business as "Primary Producer"—own goods.

VICTORIAN FISHERMEN'S CO-OPERATIVE SOCIETY LTD., Main Wharf Esplanade, Lakes Entrance, 3909. One commercial goods vehicle (L/C. 62 cwt.) to operate: (a) From Lakes Entrance to places within a 25-mile radius of chief post office at Melbourne and places en route—frozen fish fillets and fresh fish. (b) From the City of Melbourne to own premises at Lakes Entrance—solidified cooking fat for use in own fish frying shop at Lakes Entrance. (c) From the City of Melbourne and from the City of Moe to own premises at Lakes Entrance—wrapping paper for use in connexion with the marketing of own products. (d) From Melbourne to Lakes Entrance—boat fittings, engines and machinery and associated spare parts, fishing tackle, fishing nets, marker buoys for use in fishing operations, bottled butane gas, lubricating oil, hydraulic oils, coarse salt, hand tools, power operated tools provided that any of the aforementioned goods must be used on or in connexion with a fishing boat registered with the Marine Board of Victoria or a corresponding authority in other States of the Commonwealth for the purpose of commercial fishing.

WADE, P. F., 315 High-street, Bendigo, 3550. One commercial goods vehicle (L/C. 10 cwt.) to operate within a 100-mile radius from own premises at Bendigo but excluding any operations to or from the City of Melbourne—electrical appliances for installation, for repair or having been repaired, tools of trade, spare parts and materials incidental to installing and servicing such appliances.

WESTON, R. J. and E. M., 40 Power-street, Balwyn, 3103. One commercial goods vehicle (L/C. 190 cwt.) to operate within a 50-mile radius of the plant of Pioneer Concrete (Vic.) Pty. Ltd. at Croydon, solely on behalf of the said company—premixed concrete in a specially constructed agitator vehicle.

WILLIAMS, R., 43 Martin-street, Hamilton, 3300. One commercial goods vehicle (L/C. 140 cwt.) to operate within a 75-mile radius of the post office at Peshurst (Warmambool Division of the C.R.B.)—road-making plant and materials.

WITTINGSLOW, T. G., 4 Austin-street, Fairfield, 3078. One commercial goods vehicle (L/C. 30 cwt.) to operate throughout the State of Victoria in the course of business as "Travelling Showman"—tools of trade, own equipment and novelty prizes.

WOODALL, A. J., Private Bag 37, Heywood, 3304. One commercial goods vehicle (L/C. 120 cwt.) to operate: (a) Within a 75-mile radius of the post office at Peshurst as a "Road Contractor"—road-making plant and materials. (b) Within a 25-mile radius of the post office at Heywood with the proviso that no one journey shall exceed 30 miles in length—general goods.

TOW TRUCKS.

JAMIESON, L. J., 189 White-road, Wonthaggi, 3995. One commercial goods vehicle (to be constructed) to operate within a 75-mile radius of the post office at Wonthaggi as a "Tow Truck" for the purpose of lifting and carrying or towing and/or repairing wrecked or disabled vehicles—tools of trade, spare parts and materials incidental thereto.

MCINTOSH, A., 83 Mercer-street, Geelong, 3220. One commercial goods vehicle (L/C. 30 cwt.) to operate within a 100-mile radius from the chief post office in the City of Geelong as a "Tow Truck" for the

purpose of lifting and carrying or towing and/or repairing wrecked or disabled vehicles—tools of trade, spare parts and materials incidental thereto.

NOTE.—This application incorporates the rights construed in licence No. T.D.A.41361, expiring 20th December, 1967, and replaces the application for renewal of same licence as published in the Government Gazette, dated 29th November, 1967.

TAYLOR, G. F. (trading as Reservoir Towing), 927 High-street, Reservoir, 3073. One commercial goods vehicle (to be purchased) to operate throughout the State of Victoria as a "Tow Truck" for the purpose of lifting and carrying or towing and/or repairing wrecked or disabled vehicles—tools of trade, spare parts and materials incidental thereto.

RENEWALS.

APPLICATIONS for renewal of licences as shown by persons listed hereunder to operate under the same terms and conditions from the expiry shown in each case.

AUSTIN, R. E. W., Mirboo East via Boolarra, 3870; D.A.37770; 11th January, 1968; 36 cwt.

BARHAM CONSTRUCTION, 55 Edward-street, Shepparton, 3630; D.A.37342/1; 11th January, 1968; 11 cwt.

BLAKE, GEO., & SONS, Landsborough West, 3391; D.A.36787/1; 11th January, 1968; 63 cwt.

BRIGHT, R. G. and M. R., Dumbalk, 3956; D.A.37059/3; 16th December, 1967; 145 cwt.

CHAPMAN, J. H., & CO., 3 Floral-avenue, Mildura, 3500; D.A.37271; 14th December, 1967; 10 cwt.

CLOSE, A., Park-street, Trentham, 3350; D.A.51150; 27th January, 1968; 72 cwt.

COPI, F. and M., 23 Fisher-street, Wendouree, 3355; D.A.51028; 20th January, 1968; 143 cwt.

H.L.B. CONSTRUCTIONS PTY. LTD., 1 Raglan-street, St. Arnaud, 3478; D.A.1495/1; 11th January, 1968; 32 cwt.

HANLON & HISHON, Anderson-street, Skipton, 3361; D.A.60227; 16th January, 1968; 108 cwt.

HARRIS, A. W., 35 Devereux-street, Warracknabeal, 3393; D.A.38168; 21st December, 1967; 15 cwt.

HIGHLAND PLANT HIRE PTY. LTD., Box 254, Morwell, 3840; D.A.30224/1; 14th December, 1967; 8 cwt.

HIGHLAND PLANT HIRE PTY. LTD., Box 254, Morwell, 3840; D.A.30224/3; 21st December, 1967; 8 cwt.; D.A.30224/4; 21st December, 1967; 9 cwt.

JARRED, R. M., P.O. Box 30, Paynesville, 3875; D.A.50779; 16th December, 1967; 9 cwt.

JEFFREY, J., & SONS PTY. LTD., Wegner-street, Morwell, 3840; D.A.32735/7; 7th December, 1967; 32 cwt.

LITTLEWOOD, F. W. F., Soldiers-road, Bass, 3991; D.A.50735; 2nd December, 1967; 298 cwt.

QUEEN'S BRIDGE MOTORS PTY. LTD., 31-49 Queensbridge-street, South Melbourne, 3205; D.A.1783/44; 20th January, 1968; 10 cwt.

RABACH, P. W. & K. E., 237 Lava-street, Warmambool, 3280; D.A.37443; 7th December, 1967; 114 cwt.

RATHGEBER, A. R., & SONS, Hodges-street, Stawell, 3380; D.A.28173; 21st January, 1968; 79 cwt.

RAYMER, W., 78 High-street, Kyneton, 3444; D.A.1460/2; 27th January, 1968; 8 cwt.

REYNOLDS, A. A., & SON, Station-street, Cressy, 3322; D.A.1909/1; 1st December, 1967; 234 cwt.; D.A.1909/2; 1st December, 1967; 283 cwt.; D.A.1909/6; 1st December, 1967; 147 cwt.

SELL, K. D., Elliminyt, 3249; D.A.27172/3; 27th January, 1968; 133 cwt.

STEVENSON, D. L., 34 Portland-road, Heywood, 3304; D.A.37751; 7th December, 1967; 135 cwt.

TAYLOR, I. G. & L., Box 60, Apsley, 3319; D.A.29811/2; 11th January, 1968; 240 cwt.

WERNER, R., & CO. PTY. LTD., 80-86 Burnley-street, Richmond, 3121; D.A.2267/10; 2nd December, 1967; 17 cwt.

WINDY'S SALES & SERVICES PTY. LTD., Hume Highway, Euroa, 3666; D.A.50405; 20th January, 1968; 30 cwt.

TOW TRUCK RENEWALS.

SMITH, W. G. & C. H. (trading as Bendigo Motor Wreckers), 172 Mundy-street, Bendigo, 3550; D.A.49978; 3rd September, 1967; 30 cwt.

CHAPMAN, L. S., Kongwak, 3951; D.A.45884; 16th December, 1967; 74 cwt.

O'CONNELL MOTORS PTY. LTD., 19-25 McCrae-street, Swan Hill, 3585; T.D.A.46494; 10th December, 1967; 30 cwt.

OLSON, R. O. & J. A. EVANS, 93 Madden-avenue, Mildura, 3500; D.A.50767; 16th December, 1967; 70 cwt.

SWAN HILL MOTOR WRECKERS, Karanie-street, Swan Hill, 3585; T.D.A.46838/1; 1st December, 1967; 25 cwt.

TOW TRUCK RENEWALS WITH VARIATION.

APPPLICATION by the persons listed hereunder for renewal of the licences listed with variation of conditions in the manner set out opposite the names.

RANLEY PANELS PTY. LTD., 22 O'Callaghan-parade, Horsham, 3400; T.D.A.35033; 14th January, 1968; application to renew and vary the conditions of licence No. T.D.A.35033 (L/C. 25 cwt.) by deleting from the existing conditions: "Within a 50-mile radius from the post office in the City of Horsham" and by adding in lieu: "throughout the State of Victoria".

STANBIL MOTORS, Charing Cross, Bendigo, 3550; T.D.A.2092; 21st December, 1967; application to renew and vary the conditions of licence No. T.D.A.2092 (L/C. 16 cwt.) by adding to the existing conditions an additional paragraph (b)—"(b) Within a 50-mile radius from own premises in Bendigo in the course of business as 'Agricultural Distributors and Engineers'—tractors, agricultural machinery and farm implements."

WHITELEY, T. A., PTY. LTD., 32 Vincent-street, Daylesford, 3460; T.D.A.30100/1; 21st December, 1967; application to renew and vary the conditions of licence No. T.D.A.30100/1 (L/C. 50 cwt. approximately) by deleting from the existing conditions "within a 30-mile radius of the post office at Daylesford" and by adding in lieu: "throughout the State of Victoria".

Notice of any objections should be forwarded to reach the Secretary of the Board not later than Wednesday, 20th December, 1967.

Applicants are advised that it will not be necessary to appear on the hearing date specified above, unless advised in writing by the Board.

B. P. KAY,
Secretary.

Corner Lygon and Princes streets, Carlton, 3053,
Wednesday, 6th December, 1967.

Housing Act 1958. (Section 99 of Act No. 6275.)

GENERAL NOTICE TO PARTIES EMPOWERED BY THE "LANDS COMPENSATION ACT 1958" TO SELL AND CONVEY OR GRANT AND RELEASE PURSUANT TO SECTION 99 OF ACT 6275.

GENERAL NOTICE TO TREAT FOR LAND IN A RECLAMATION AREA AT SOUTH MELBOURNE.

IN pursuance of the provisions contained in the Housing Act 1958 and of the Lands Compensation Act 1958 Housing Commission (hereinafter referred to as "the Commission") hereby doth give notice that the lands tenements and hereditaments described in the Schedule hereto are required for the purpose of the Housing Act and that the Commission is authorized by the provisions of section 68 of the Housing Act to purchase or take compulsorily the said lands.

And the Commission accordingly hereby gives notice to all the parties interested in such land and to all persons empowered by the Lands Compensation Act 1958 to sell and convey or grant and release the land so required that it requires to take and purchase the land referred to in the said Schedule hereto and that it is willing to treat with such parties or persons for the purchase thereof and as to the compensation to be made and for the damage that may be sustained by reason of the execution of the works.

And further the Commission hereby requires such parties or persons on or before the expiration of twenty-one days from the Ninth day of December, 1967, to deliver to the Offices of the Commission at 179 Queen-street, Melbourne, a statement, in writing, of the particulars of the estate and interest in the said lands tenements and hereditaments and of the claims made in respect thereof.

Dated the twenty-first day of November, 1967.

By order of the Commission.

A. L. BOHN,
Secretary.

SCHEDULE.

First.—All that land being part of section 66, City of South Melbourne, Parish of Melbourne South bounded by a line as follows:—Commencing at a point on the south-eastern alignment of Park-street being the intersection thereof with the north-eastern alignment of Eastern-road; thence north-easterly by the said south-eastern alignment of Park-street to the intersection thereof with the south-western alignment of Stead-street; thence south-easterly by the said south-western alignment of Stead-street to the intersection thereof with the north-western alignment of Napier-street; thence south-westerly by the said north-western alignment of Napier-street to the intersection thereof with the north-eastern alignment of Eastern-road aforesaid; thence north-westerly by the said north-eastern alignment of Eastern-road to the point of commencement.

Secondly.—All that land being part of section 67, City of South Melbourne, Parish of Melbourne South bounded by a line as follows:—Commencing at a point on the south-eastern alignment of Park-street being the intersection thereof with the north-eastern alignment of Stead-street; thence north-easterly by the said south-eastern alignment of Park-street to the intersection thereof with the south-western alignment of Kingsway; thence south-easterly by the said south-western alignment of Kingsway to the intersection thereof with the north-western alignment of Napier-street; thence south-westerly by the said north-western alignment of Napier-street to the intersection thereof with the north-eastern alignment of Stead-street aforesaid; thence north-westerly by the said north-eastern alignment of Stead-street to the point of commencement.

Plans are available for inspection at the Estates Branch of the Housing Commission situated on the seventh floor at 179 Queen-street, Melbourne, and forms for the making of claims will also be available on application to the Commission.

DEPARTMENT OF MINES.

SUBJECT to any necessary excisions, &c., it is proposed to grant the following mining lease:—

8117, Mineral; Arbil Star Mining Co. Pty. Ltd., 49a. 0r. 10p., Parish of Byawatha.

MINING LEASES GRANTED.

5631, Gippsland; New Dawn Consolidated No Liability; 19a. 1r. 10p., Parish of Butgulla.

8475, Mineral; Nichilos John Ramsay; 17a. 0r. 20p., Parish of Eldorado.

8485, Mineral; State Electricity Commission of Victoria; 18a. 3r. 25p., Parish of Tanjil East.

8520, Mineral; The President, Councillors and Ratepayers of the Shire of Wannon; 10a. 1r. 78p., Parish of Dundas (previous notification of the grant of this lease, *Government Gazette* page 2602, dated 23rd August, 1967, is hereby cancelled).

8528, Mineral; Sulphates Chemical Company Pty. Limited; 14a., Parish of Narracan South (previous notification of the grant of this lease to Filtration and Water Softening Proprietary Limited is hereby cancelled).

8626, Mineral; A. G. Leech Proprietary Limited; 11a. 1r., Parish of Amherst.

APPLICATION FOR LEASE REFUSED.

8426, Beechworth; Edward Arthur Knox; 60 acres, Parish of Enoch's Point.

APPLICATIONS FOR LEASES DECLARED ABANDONED.

8389, Mineral; Roche Bros. Pty. Ltd.; 640 acres, Parishes of Jan Juc, Angahook.

8390, Mineral; Roche Bros. Pty. Ltd.; 640 acres, Parishes of Jan Juc, Angahook.

8391, Mineral; Roche Bros. Pty. Ltd.; 640 acres, Parishes of Jan Juc, Angahook.

8606, Mineral; Francis Johnson Bruhn; 40 acres, Parish of Shelbourne.

8607, Mineral; Frederick Noel Bruhn; 40 acres, Parish of Shelbourne.

EXPLORATION LICENCE GRANTED.

85, Exploration Licence; Eastern Prospectors Proprietary Limited; 218 square miles, Counties of Rodney and Dalhousie.

MINERAL SEARCH LICENCE GRANTED.

788, Mineral Search Licence; The Broken Hill Proprietary Company Limited; 10 square miles, Parishes of Murrindal West, Murrindal East and Buchan.

TAILINGS LICENCES GRANTED.

3558, Tailings Licence; B. Williams; "North Ajax" mine dump situated at Daylesford.

3566, Tailings Licence; Antonio Sist; "Waterloo" mine dump situated at Waterloo in the Parish of Raglan (in lieu of 3511 Tailings Licence expired).

J. C. M. BALFOUR,
Minister of Mines.

MINING LEASE DECLARED VOID.

7372, Mineral; Sterling Quarries Pty. Ltd.; 13a. 2r. 23p., Parish of Gheringhap.

E. CONDON,
Secretary for Mines.

Private Agents Act 1966.

NOTICE OF RECEIPT OF APPLICATIONS FOR LICENCES UNDER THE PROVISIONS OF THE PRIVATE AGENTS ACT 1966.

THE Clerks of the Courts of Petty Sessions as listed hereunder hereby give notice that applications, as under, have been lodged for hearing by the said Courts on the dates specified.

Any person desiring to object to any of such applications must—

- (a) lodge with the respective Clerk of Petty Sessions a notice in the prescribed form of his objection and of the grounds thereof;
- (b) cause a copy of such notice to be served personally or by post upon the applicant at least three days before the hearing of the application; and
- (c) send or deliver—
 - (i) where the objection is not made by the officer in charge of the police district in which the Court is situated—a copy of the notice to such officer; and
 - (ii) where the objection is not made by the Registrar or Deputy Registrar—a copy to the Registrar.

| Full Name of Applicant or in the case of a firm or Corporation, of the Nominee. | Place of Abode of Applicant or Nominee. | Name of Firm or Corporation. | Address for Registration. | Type of Licence. | Date of Hearing of Application. |
|---|---|------------------------------|---------------------------|------------------|---------------------------------|
|---|---|------------------------------|---------------------------|------------------|---------------------------------|

COURT OF PETTY SESSIONS, MOONEE PONDS.

| | | | | | |
|------------------------|----------------------------------|--|----------------------------|----------------|----------|
| Hartshorn, John Walter | 104 Hoffmans-road, Niddrie | | 104 Hoffmans-road, Niddrie | Process Server | 20.12.67 |
| Howden, Harold Thomas | 7 Market-street, Essendon | | 7 Market-street, Essendon | " " | " " |
| Kennedy, John David | 75 Margaret-street, Moonee Ponds | | P.O. Box 76, Moonee Ponds | " " | " " |

Dated at Moonee Ponds this 24th day of November, 1967.

D. A. THOMPSON,
Clerk of Petty Sessions.

COURT OF PETTY SESSIONS, RICHMOND.

| | | | | | |
|-------------------------|-----------------------------|--|-----------------------------|----------------------------|----------|
| Carroll, Dennis Malcolm | 10 Hazel-grove, Pascoe Vale | | 401 Church-street, Richmond | Inquiry Agent (Individual) | 19.12.67 |
| " " " | " " " | | " " " | Guard Agent (Individual) | " " |

Dated at Richmond this 23rd day of November, 1967.

J. F. PRESNELL,
Clerk of Petty Sessions.

COURT OF PETTY SESSIONS, SHEPPARTON.

| | | | | | |
|-----------------------|-------------------------------|--|--|----------|----------|
| Heenan, Alfred John | 30 Balaclava-road, Shepparton | Mayne Limited | 94 York-street, South Melbourne | Watchman | 14.12.67 |
| Paterson, John Philip | 10 Roberts-street, Shepparton | " " | " " | " " | " " |
| Doig, Charles | 12 Cameron-avenue, Shepparton | " " | " " | " " | " " |
| Elliot, Keith James | 10 Rule-street, Shepparton | M.S.S. Security Services Pty. Ltd. M.S.S. Guard Service Pty. Ltd. | 101-105 Clarke-street, South Melbourne | " " | " " |

Dated at Shepparton this 21st day of November, 1967.

R. N. HOLLIS,
Clerk of Petty Sessions.

COURT OF PETTY SESSIONS, BALLAN.

| | | | | | |
|------------------------|--------|--|--------|----------------------|----------|
| Ryan, Geoffrey Patrick | Gordon | | Gordon | Commercial Sub-agent | 22.12.67 |
|------------------------|--------|--|--------|----------------------|----------|

Dated at Ballan this 22nd day of November, 1967.

E. MCGOWAN,
Clerk of Petty Sessions.

COURT OF PETTY SESSIONS, BALLARAT.

| | | | | | |
|-----------------------|-----------------------------|--------------------------|-----------------------------|----------------------|----------|
| Till, Desmond Patrick | 11 Ercil-street, Wendouree | George Laurens Pty. Ltd. | 17 Doveton-street, Ballarat | Commercial Sub-agent | 19.12.67 |
| Wright, Robert George | 308 Larter-street, Ballarat | " " | " " | " " | " " |
| " " " | " " | " " | 308 Larter-street, Ballarat | Process Server | " " |

Dated at Ballarat this 23rd day of November, 1967.

E. N. KINCHINGTON,
Clerk of Petty Sessions.

COURT OF PETTY SESSIONS, COLAC.

| | | | | | |
|--------------------------|-----------------------------------|-----|-------------------------|----------------------|----------|
| Plunkett, Stanley Ernest | 47 Craddock-street, North Geelong | | 42 Murray-street, Colac | Commercial Sub-agent | 18.12.67 |
| " " " | " " | " " | " " | Process Server | " " |

Dated at Colac this 23rd day of November, 1967.

A. R. PENFOLD,
Clerk of Petty Sessions.

PRIVATE AGENTS—continued.

| Full Name of Applicant or in the case of a firm or Corporation, of the Nominee. | Place of Abode of Applicant or Nominee. | Name of Firm or Corporation. | Address for Registration. | Type of Licence. | Date of Hearing of Application. |
|---|---|------------------------------|---------------------------|------------------|---------------------------------|
|---|---|------------------------------|---------------------------|------------------|---------------------------------|

COURT OF PETTY SESSIONS, ELTHAM.

| | | | | | |
|-----------------------|----------------------------------|--|----------------------------------|----------------|----------|
| Paschall, Terry Chris | 10 Arthur-street, Eltham | | 10 Arthur-street, Eltham | Process Server | 20.12.67 |
| Collins, Colin Henry | 7 Flintoff-street, Greensborough | | 7 Flintoff-street, Greensborough | " " | " " |
| | " " | | " " | Inquiry Agent | " " |

Dated at Eltham this 22nd day of November, 1967.

J. E. DENNIS,
Clerk of Petty Sessions.

COURT OF PETTY SESSIONS, FERN TREE GULLY.

| | | | | | |
|-------------------------|------------------------------|--|------------------------------|----------------|----------|
| Remmer, Stanley Bernard | 8 Royston-avenue, Boronia | | 8 Royston-avenue, Boronia | Inquiry Agent | 18.12.67 |
| Swinden, Maxwell James | 12 The Glen, Fern Tree Gully | | 12 The Glen, Fern Tree Gully | Process Server | " " |
| Patterson, Frederick | 47 Griffiths-road, Upwey | | 47 Griffiths-road, Upwey | " " | " " |
| Davies, Walter Foulkes | 5 Bradman-street, Boronia | | 5 Bradman-street, Boronia | " " | " " |

Dated at Fern Tree Gully this 20th day of November, 1967.

F. J. DUTHIE,
Clerk of Petty Sessions.

COURT OF PETTY SESSIONS, FITZROY.

| | | | | | |
|---------------------------------------|--|---------------------------------------|-------------------------------------|--------------------------------|----------|
| Cohen, McCutcheon & Ryan Pty. Limited | 277 Smith-street, Fitzroy | | 277 Smith-street, Fitzroy | Commercial Agent (Corporation) | 20.12.67 |
| La Fontaine, Lionel Roy | 7 Lord-street, Bentleigh | Cohen, McCutcheon & Ryan Pty. Limited | " " | Commercial Sub-agent | " " |
| Dressler, Henry | Lavender Park-road, Eltham | "Inge" Detective Agency Pty. Ltd. | 220 Victoria-parade, East Melbourne | Inquiry Agent | " " |
| Longshaw, Elaine Iris | Flat 1, 211 Williams-road, South Yarra | " " | " " | Process Server | " " |
| " " | " " | " " | " " | Inquiry Agent | " " |
| " " | " " | " " | " " | Process Server | " " |

Dated at Fitzroy this 23rd day of November, 1967.

D. W. HAMMOND,
Clerk of Petty Sessions.

COURT OF PETTY SESSIONS, FOOTSCRAY.

| | | | | | |
|-------------------------------|---|--|---------------------------|----------|----------|
| Bury, Kevin Peter | 35 Cooper-street, North Altona | | 4 Cross-street, Footscray | Watchman | 18.12.67 |
| Draper, George Albert Kenneth | 64 Churchill-avenue, Braybrook | | " " | " " | " " |
| Hartley, Ronald Lawrence | Flat 10, 22 Empire-street, West Footscray | | " " | " " | " " |
| Monaghan, Michael Lawrence | 98 Trevelyan-street, South Caulfield | | " " | " " | " " |
| Organ, Robert Claude | 14 Herbert-street, Avondale Heights | | " " | " " | " " |
| Stewart, Robert Murray | 12 High-street, Sunshine | | " " | " " | " " |

Dated at Footscray this 23rd day of November, 1967.

J. CAVEN,
Clerk of Petty Sessions.

COURT OF PETTY SESSIONS, MELBOURNE.

| | | | | | |
|------------------------|---|--|--|------------------------------|----------|
| Begovic, Enver | Flat 14, 14 Chapel-street, East St. Kilda | "Inge" Detective Agency Pty. Ltd. | 220 Victoria-parade, East Melbourne | Inquiry Agent (Corporation) | 14.12.67 |
| Begovic, Ingeborg | 31 Howitt-street, Hawksburn | Federated Investigation Services (Aust.) Pty. Ltd. | " " | " " | " " |
| Begovic, Enver | Flat 14, 14 Chapel-street, East St. Kilda | "Inge" Detective Agency Pty. Ltd. | " " | Guard Agent (Corporation) | " " |
| " " | " " | " " | " " | Process Server (Corporation) | " " |
| Begovic, Ingeborg | 31 Howitt-street, Hawksburn | Federated Investigation Services (Aust.) Pty. Ltd. | " " | " " | " " |
| Lockhart, John Wright | "Koogon", 2 Phillip-street, Springvale | | 414 Lonsdale-street, Melbourne | Commercial Sub-agent | " " |
| Scott, James Allenby | 161 New-street, Brighton | | " " | " " | " " |
| Corbett, Kenneth James | 8 Wattle Valley-road, Mitcham | | 130 Abbotsford-street, North Melbourne | Inquiry Agent | " " |
| Kotros, George | 135 Flemington-road, North Melbourne | | 135 Flemington-road, North Melbourne | " " | " " |

PRIVATE AGENTS—*continued.*

| Full Name of Applicant or in the case of a firm or Corporation, of the Nominee. | Place of Abode of Applicant or Nominee. | Name of Firm or Corporation. | Address for Registration. | Type of Licence. | Date of Hearing of Application. |
|---|--|------------------------------|--|-------------------|---------------------------------|
| <i>COURT OF PETTY SESSIONS, MELBOURNE—continued.</i> | | | | | |
| Lockhart, John Wright .. | " Koogon ", 2 Phillip-street, Springvale | | 414 Lonsdale-street, Melbourne | Inquiry Agent .. | 14.12.67 |
| Kotros, George .. | 135 Flemington-road, North Melbourne | | 135 Flemington-road, North Melbourne | Guard Agent .. | " " |
| Sonnberger, Graeme Gordon | 1 Viewpoint-avenue, Glen Waverley | | 130 Abbotsford-street, North Melbourne | Inquiry Agent .. | " " |
| Lockhart, John Wright .. | " Koogon ", 2 Phillip-street, Springvale | | 414 Lonsdale-street, Melbourne | Process Server .. | " " |
| Allen, George .. | 81 Langton-street, Glenroy | | 130 Abbotsford-street, North Melbourne | Watchman .. | " " |
| Allan, Walter Crawford .. | 60 Queen-street, Altona | | 130 Abbotsford-street, North Melbourne | " .. | " " |
| Corbett, Kenneth James .. | 8 Wattle Valley-road, Mitcham | | " " | " .. | " " |
| Creswell, William James .. | 116 Brighton-road, Elsternwick | | " " | " .. | " " |
| Brighton, Cyril .. | 3 Regent-street, Mt. Waverley | | " " | " .. | " " |
| Edgerton, Ernest Albert Stanley | 19 Kendall-street, Essendon | | " " | " .. | " " |
| Ferguson, Felix John .. | 4 Andrew-street, Northcote | | " " | " .. | " " |
| Harle, Keith William .. | 420 Wellington-street, Clifton Hill | | " " | " .. | " " |
| Jones, Llewellyn .. | Flat 3, 8 Vasey-street, Ascot Vale | | " " | " .. | " " |
| Livingstone, Alexander Donald | 29 Frederick-street, Croydon | | " " | " .. | " " |
| McConnell, Lindsey Chester.. | 105 McPherson-street, Essendon | | " " | " .. | " " |
| McKeown, John Gerald .. | 45 Mundy-street, Mentone | | " " | " .. | " " |
| Raab, Erwin Michael .. | 51 Ginifer-avenue, North Altona | | " " | " .. | " " |
| Sonnberger, Graeme Gordon.. | 1 Viewpoint-avenue, Glen Waverley | | " " | " .. | " " |
| Spratling, Lindsay Gordon .. | 487 Dryburgh-street, North Melbourne | | " " | " .. | " " |
| Jackson, William James Benjamin | 53 Glenora-avenue, East Coburg | | " " | " .. | " " |
| Jansen, Willy .. | 3 Walkers-road, Frankston | | " " | " .. | " " |
| Jewell, John Peter .. | 32 Charlton-street, Blackburn | | " " | " .. | " " |
| Kimpton, Maurice Arthur .. | 1 Reynolds-parade, Pascoe Vale South | | " " | " .. | " " |
| Lindstrom, Alfred .. | 66 Langs-road, Ascot Vale | | " " | " .. | " " |
| Mackenzie, Alexander Matheson | 79 Britnells-road, Briar Hill | | " " | " .. | " " |
| McAlister, James Ross .. | 20 Callander-road, Pascoe Vale | | " " | " .. | " " |
| Morrison, William Anderson Burr | Flat 5, 269 Malvern-road, South Yarra | | " " | " .. | " " |
| Pisani, Anthony Joseph .. | 30 Kershaw-street, Mordialloc | | " " | " .. | " " |
| Russell, Norman George .. | 41 Barry-street, South Yarra | | " " | " .. | " " |
| Stephens, William James .. | 21 Pickett-street, Reservoir | | " " | " .. | " " |
| Tame, Roy Richard .. | 58 Wales-street, Thornbury | | " " | " .. | " " |
| Spruling, John Henry .. | 82 Ballarat-street, Yarraville | | " " | " .. | " " |
| Stoodley, Edward .. | 32 Millers-road, Altona | | " " | " .. | " " |
| Taubert, Harry .. | 48 Hawkhurst-street, Spotswood | | " " | " .. | " " |
| Tuckwell, Arthur Maxwell .. | 21 Castley-crescent, Braybrook | | " " | " .. | " " |
| Tunncliffe, Denis Patrick .. | 18 Boyd-crescent, East Coburg | | " " | " .. | " " |
| Vainoras, Kazys Antnas .. | 110 Hickford-street, Reservoir | | " " | " .. | " " |
| Warren, Thomas Frederick .. | 3 Perry-avenue, Seddon | | " " | " .. | " " |
| Allen, Charles Leslie .. | 148 Civic-parade, Altona | | " " | " .. | " " |
| Anthony, William Robert .. | 60 Crichton-avenue, Garden City | | " " | " .. | " " |
| Bloom, William Edward .. | 32 Lyons-street, Williamstown | | " " | " .. | " " |
| Dimsdale, Donald Henry .. | 1 Asquith-street, Box Hill South | | " " | " .. | " " |

PRIVATE AGENTS—*continued.*

| Full Name of Applicant or in the case of a firm or Corporation, of the Nominee. | Place of Abode of Applicant or Nominee. | Name of Firm or Corporation. | Address for Registration. | Type of Licence. | Date of Hearing of Application. |
|---|---|------------------------------|---------------------------|------------------|---------------------------------|
|---|---|------------------------------|---------------------------|------------------|---------------------------------|

COURT OF PETTY SESSIONS, MELBOURNE—*continued.*

| | | | | | |
|---------------------------------------|-----------------------------------|-------|--|-------------|----------|
| Dunn, Norman Thomas .. | 1 Bevis-street, East Bentleigh .. | | 130 Abbotsford-street, North Melbourne | Watchman .. | 14.12.67 |
| Dunstan, David John .. | 25 William-street, Morwell .. | | " " | " .. | " " |
| Hardiman, Patrick Thomas James Nelson | 8 Polo-parade, Caulfield .. | | " " | " .. | " " |

Dated at Melbourne this 21st day of November, 1967.

G. L. WEBSTER,
Clerk of Petty Sessions.

COURT OF PETTY SESSIONS, OAKLEIGH.

| | | | | | |
|-----------------------------|-------------------------------------|-------|----------------------------------|-------------------|----------|
| Ashfield, William Robert .. | 22 Raymond-street, Ashwood .. | | 22 Raymond-street, Ashwood | Process Server .. | 15.12.67 |
| Herrick, Clifford Gordon .. | 22 Donald-street, Mt. Waverley .. | | 22 Donald-street, Mt. Waverley | Inquiry Agent .. | " " |
| Hession, Ronald Brendon .. | 31 Closter-avenue, Ashwood .. | | 31 Closter-avenue, Ashwood | " .. | " " |
| Holmberg, Amelia Jane .. | 20 Manuka-street, South Oakleigh .. | | 20 Manuka-street, South Oakleigh | " .. | " " |
| " " " .. | " " " .. | | " " | Inquiry Agent .. | " " |

Dated at Oakleigh this 22nd day of November, 1967.

G. S. HOARE,
Clerk of Petty Sessions.

COURT OF PETTY SESSIONS, HEIDELBERG.

| | | | | | |
|------------------------------|----------------------------------|----------------------|-------------------------------|-------------------|----------------|
| Myszkowski, Edward Stanislaw | 9 Essex-court, Heidelberg | Ace Detective Agency | 9 Essex-court, Heidelberg | Guard Agent .. | 13.12.67 |
| " " | " " | " " | " " | Process Server .. | " " |
| Broadhurst, Joan .. | 122 " Graham-road, Rosanna .. | | 122 " Graham-road, Rosanna | Inquiry Agent .. | " " |
| Jenkin, Ronald Alston .. | 49 Plenty-lane, Greensborough .. | | 49 Plenty-lane, Greensborough | Process Server .. | " " |
| Smith, Ian Frederick .. | 128 " Graham-road, Rosanna .. | | 128 " Graham-road, Rosanna | " .. | " " |
| Thomas, John Russell .. | 53 Wilsons-road, Doncaster .. | T.S.S. Security | 53 Wilsons-road, Doncaster | Thomas Service | Guard Agent .. |

Dated at Heidelberg this 22nd day of November, 1967.

M. B. ROUND,
Clerk of Petty Sessions.

COURT OF PETTY SESSIONS, BENALLA.

| | | | | | |
|----------------------------|------------------------------|-------|---------------------------|----------------|----------|
| Randell, Barry Reginald .. | 25 Waller-street, Benalla .. | | 25 Waller-street, Benalla | Guard Agent .. | 13.12.67 |
| " " " .. | " " " .. | | " " | Watchman .. | " " |

Dated at Benalla this 22nd day of November, 1967.

R. F. FREEMAN,
Clerk of Petty Sessions.

COURT OF PETTY SESSIONS, PRESTON.

| | | | | | |
|------------------------------|-------------------------------------|-------|----------------------------------|----------------|----------|
| Edwards, Christian Thomas .. | 24 Paterson-street, East Preston .. | | 24 Paterson-street, East Preston | Guard Agent .. | 14.12.67 |
|------------------------------|-------------------------------------|-------|----------------------------------|----------------|----------|

Dated at Preston this 24th day of November, 1967.

P. C. CLOTHIER,
Clerk of Petty Sessions.

COURT OF PETTY SESSIONS, FRANKSTON.

| | | | | | |
|------------------------------|---------------------------------|-------|---|----------------------|----------|
| Nicholls, Reginald Alfred .. | 9 Jarrah-court, Frankston .. | | 9 Jarrah-court, Frankston | Guard Agent .. | 14.12.67 |
| Noy, Henry .. | North-road, Langwarrin .. | | Corner Wells and Young streets, Frankston | Process Server .. | " " |
| " " " .. | " " " .. | | " " | Commercial Sub-agent | " " |
| Noy, John .. | " " " .. | | North-road Langwarrin | Process Server .. | " " |
| Pitsillides, Theodore .. | 52 Orwill-street, Frankston .. | | 52 Orwill-street, Frankston | " .. | " " |
| Smith, James Claude .. | 8 " Overport-road, Frankston .. | | 8 " Overport-road, Frankston | Inquiry Agent .. | " " |
| Richards, William .. | 3 Phillips-street, Frankston .. | | 3 Phillips-street, Frankston | Guard Agent .. | " " |
| Brennan, Ronald William .. | 165 Kunyung-road, Mt. Eliza .. | | 165 Kunyung-road, Mt. Eliza | Process Server .. | 21.12.67 |
| " " " .. | " " " .. | | " " | Inquiry Agent .. | 14.12.67 |
| " " " .. | " " " .. | | " " | Commercial Sub-agent | " " |

PRIVATE AGENTS—continued.

| Full Name of Applicant or in the case of a firm or Corporation, of the Nominee. | Place of Abode of Applicant or Nominee. | Name of Firm or Corporation. | Address for Registration. | Type of Licence. | Date of Hearing of Application. |
|---|---|------------------------------|---------------------------|------------------|---------------------------------|
|---|---|------------------------------|---------------------------|------------------|---------------------------------|

COURT OF PETTY SESSIONS, FRANKSTON—continued.

| | | | | | |
|------------------------------------|------------------------------|--|------------------------------|----------------------|----------|
| Cartwright, Arthur Herbert Leonard | 8 Parer-street, Frankston | | 8 Parer-street, Frankston | Process Server | 14.12.67 |
| Cooper, Robert Fitzgerald | 33 Barmah-street, Mt. Eliza | | 33 Barmah-street, Mt. Eliza | " " " " | " " " " |
| Gray, Michael William | 8 Frome-avenue, Frankston | | 8 Frome-avenue, Frankston | " " " " | " " " " |
| Gunstone, Jack | 3 Addicott-street, Frankston | | 3 Addicott-street, Frankston | " " " " | " " " " |
| Moore, George Archibald Andrew | 9 Keerok-avenue, Seaford | | 9 Keerok-avenue, Seaford | Commercial Sub-agent | " " |
| " " " | " " " | | " " " | Process Server | " " |
| " " " | " " " | | " " " | Inquiry Agent | " " |
| Nettleton, Peter John | 38 Frome-avenue, Frankston | | 38 Frome-avenue, Frankston | Process Server | " " |
| " " " | " " " | | " " " | Commercial Sub-agent | " " |
| Nettleton, Robert Lindsay | " " " | | " " " | Process Server | " " |
| " " " | " " " | | " " " | Inquiry Agent | " " |
| " " " | " " " | | " " " | Commercial Agent | " " |

Dated at Frankston this 23rd day of November, 1967.

K. G. MASON,
Clerk of Petty Sessions.

COURT OF PETTY SESSIONS, DROMANA.

| | | | | | |
|-----------------------|-----------------------------|--|-----------------------------|----------------|----------|
| Cull, Joseph Aloysius | 448 Nepean Highway, Rosebud | | 448 Nepean Highway, Rosebud | Process Server | 18.12.67 |
| " " " | " " " | | " " " | Inquiry Agent | " " |
| " " " | " " " | | " " " | Guard Agent | " " |

Dated at Dromana this 23rd day of November, 1967.

K. G. MASON,
Clerk of Petty Sessions.

COURT OF PETTY SESSIONS, CASTERTON.

| | | | | | |
|-----------------------------|-----------------------------|--|---------------------------|---------------|----------|
| Williams, Anthony Llewellyn | 11 Webb-street, Mt. Gambier | | 65 Queens-road, Melbourne | Inquiry Agent | 14.12.67 |
|-----------------------------|-----------------------------|--|---------------------------|---------------|----------|

Dated at Casterton this 23rd day of November, 1967.

R. J. McALLISTER,
Clerk of Petty Sessions.

COURT OF PETTY SESSIONS, SPRINGVALE.

| | | | | | |
|-----------------------------|----------------------------------|--|---------------------------------|----------|----------|
| Adamson, Frederick George | 535 High-street, Mt. Waverley | | 94 York-street, South Melbourne | Watchman | 15.12.67 |
| Apostolidis, John | 2 Cooke-street, Clayton | | " " " | " " " | " " " |
| Boles, Donald Edward | 24 Vicki-street, Blackburn | | " " " | " " " | " " " |
| Conroy, George Thomas | 5 Culshaw-avenue, Clayton | | " " " | " " " | " " " |
| Creedon, Noel James | 15 Woodlea-drive, Glen Waverley | | " " " | " " " | " " " |
| Diender, Albert | 7 Essex-court, Bayswater | | " " " | " " " | " " " |
| Diggerson, Thomas George | 16 Kent-street, Windsor | | " " " | " " " | " " " |
| Dobbie, Jack Garth | 13 Rivette-street, Mordialloc | | " " " | " " " | " " " |
| Farrell, John Mathew | 30 Victory Boulevard, Ashburton | | " " " | " " " | " " " |
| Gogerley, Clive Maxival | 88 Worrell-street, Dandenong | | " " " | " " " | " " " |
| Greenwell, Frederick James | 16 Third-avenue, Ascendale | | " " " | " " " | " " " |
| Hall, Sidney Douglas | 23 Singleton-drive, Springvale | | " " " | " " " | " " " |
| Hodges, Stanley A. L. | 7 Standard-avenue, Box Hill | | " " " | " " " | " " " |
| Hyland, Charles Maurice | 18 Huntley-street, Elsternwick | | " " " | " " " | " " " |
| Hyland, Thomas Maurice | " " " | | " " " | " " " | " " " |
| James, Harry Cecil | 16 Swansea-road, Chelsea | | " " " | " " " | " " " |
| Kinghorn, Graham William | 34 Hiscock-street, Chadstone | | " " " | " " " | " " " |
| Mayne, Ronald L. C. | 64 Guinea-street, Carrum | | " " " | " " " | " " " |
| MacDonald, Mathew Morton | 48 Wonga-road, North Ringwood | | " " " | " " " | " " " |
| McGillivray, Robert William | 110 Sharon-road, Noble Park | | " " " | " " " | " " " |
| Mackenzie, Kenneth John | 4 Margot-street, Fern Tree Gully | | " " " | " " " | " " " |

PRIVATE AGENTS—continued.

| Full Name of Applicant or in the case of a Firm or Corporation, of the Nominee. | Place of Abode of Applicant or Nominee. | Name of Firm or Corporation. | Address for Registration. | Type of Licence. | Date of Hearing of Application. |
|---|---|------------------------------|---------------------------------|------------------|---------------------------------|
| COURT OF PETTY SESSIONS, SPRINGVALE—continued. | | | | | |
| Macniff, Thomas Leslie | 11 Thistle-street, Surrey Hills | | 94 York-street, South Melbourne | Watchman | 15.12.67 |
| Needle, Leslie | 21 Matilda-street, Moorabbin | | " " | " | " " |
| Rogers, Albert Edward | 69 Kirkwood-avenue, Seaford | | " " | " | " " |
| Rowland, Ernest Richard | 13 Laurina-court, Doveton | | " " | " | " " |
| Sanders, George Turner | 25 Wedd-street, Cheltenham | | " " | " | " " |
| Seymour, William George | 41 Gray-street, Springvale | | " " | " | " " |
| Varcoe, Robert Royal | 19 Third-street, Mentone | | " " | " | " " |
| Whitton, David Francis | 14 Hillside-parade, Glen Iris | | " " | " | " " |

Dated at Springvale this 24th day of November, 1967.

F. J. DUTHIE,
Clerk of Petty Sessions.

| | | | | | |
|------------------------------------|---------------------------------------|----------------------------|---------------------------------------|----------------|----------|
| COURT OF PETTY SESSIONS, BOX HILL. | | | | | |
| Adkins, Alan Bryce | 25 Banool Quadrant, East Doncaster | | 25 Banool Quadrant, East Doncaster | Process Server | 15.12.67 |
| Boyd, James Douglas | 3 Inverness-avenue, Burwood | | 3 Inverness-avenue, Burwood | " " | " " |
| Boyd, Marjorie Joyce | 21 Morinda-crescent, East Doncaster | | 21 Morinda-crescent, East Doncaster | " " | " " |
| Bucci, Mario Nicola | 21 Hillside-crescent, Blackburn | | 21 Hillside-crescent, Blackburn | " " | " " |
| Clark, Eric | 7 Linum-street, Blackburn | | 7 Linum-street, Blackburn | " " | " " |
| Harvie, Rosemary D'arcy | 101 Lake-road, Blackburn | | 101 Lake-road, Blackburn | " " | " " |
| Schmidt, Joseph | 25 Banool Quadrant, East Doncaster | | 25 Banool Quadrant, East Doncaster | Inquiry Agent | " " |
| Adkins, Alan Bryce | 21 Morinda-crescent, East Doncaster | | 21 Morinda-crescent, East Doncaster | " " | " " |
| Bucci, Mario Nicola | 7 Linum-street, Blackburn | | 7 Linum-street, Blackburn | " " | " " |
| Harvie, Rosemary D'arcy | 101 Lake-road, Blackburn | | 101 Lake-road, Blackburn | " " | " " |
| Schmidt, Joseph | 33 High-street, Nunawading | | 33 High-street, Nunawading | Process Server | " " |
| Edgar, Kenneth G. | 21 Balmoral-avenue, Lower Templestowe | Universal Security Systems | 21 Balmoral-avenue, Lower Templestowe | Inquiry Agent | " " |
| Lisle, Bobbie McVeigh | " " | " " | " " | Guard Agent | " " |

Dated at Box Hill this 24th day of November, 1967.

A. J. JOHNSON,
Clerk of Petty Sessions.

| | | | | | |
|-------------------------------------|--------------------------------|--|--------------------------------|------------------|----------|
| COURT OF PETTY SESSIONS, FOOTSCRAY. | | | | | |
| Massey, Alan William | 24 Smith-crescent, Footscray | | 24 Smith-crescent, Footscray | Commercial Agent | 18.12.67 |
| Murray, Geoffrey Edwin | 17 Richards-street, Yarraville | | 17 Richards-street, Yarraville | Process Server | " |
| " " " | " " | | " " | Guard Agent | " |
| " " " | " " | | " " | Inquiry Agent | " |

Dated at Footscray this 24th day of November, 1967.

J. CAVEN,
Clerk of Petty Sessions.

| | | | | | |
|------------------------------------|---------------------------------------|---------------------|---------------------------------|----------|----------|
| COURT OF PETTY SESSIONS, BALLARAT. | | | | | |
| Tait, Alick Vincent | 1008 Armstrong-street north, Ballarat | Mayne Nickless Ltd. | 94 York-street, South Melbourne | Watchman | 19.12.67 |
| Waight, Arthur James | 26 Salisbury-avenue, Ballarat | " " | " " | " | " |
| Burnside, Ian Clifford | 128 Raglan-street, Ballarat | " " | " " | " | " |
| Cox, Lesley Ernest | 1208 Mair-street, Ballarat | " " | " " | " | " |
| Richards, Kenneth George | Dean-road, Invermay | " " | " " | " | " |
| Mounier, Robert John | 49 Cambridge-street, Wendouree | " " | " " | " | " |
| Brown, Douglas | 5 Trethowan-street, Ballarat | " " | " " | " | " |
| Bennett, Charles Maxwell | 4 Hawthorn-grove, Wendouree | " " | " " | " | " |

Dated at Ballarat this 24th day of November, 1967.

E. N. KINCHINGTON,
Clerk of Petty Sessions.

PRIVATE AGENTS—*continued.*

| Full Name of Applicant or in the case of a Firm or Corporation, of the Nominee. | Place of Abode of Applicant or Nominee. | Name of Firm or Corporation. | Address for Registration. | Type of Licence. | Date of Hearing of Application. |
|---|---|------------------------------|---------------------------|------------------|---------------------------------|
|---|---|------------------------------|---------------------------|------------------|---------------------------------|

COURT OF PETTY SESSIONS, HEIDELBERG.

| | | | | | |
|---------------------------|---------------------------------|---------|---------------------------------|-------------------|----------|
| Prevot, Edward Michael .. | 22 Haig-street, West Heidelberg | | 22 Haig-street, West Heidelberg | Process Server .. | 29.12.67 |
|---------------------------|---------------------------------|---------|---------------------------------|-------------------|----------|

Dated at Heidelberg this 24th day of November, 1967.

M. ROUND,
Clerk of Petty Sessions.

COURT OF PETTY SESSIONS, BENALLA.

| | | | | | |
|-------------------------|-----------------------------|---------|-----------------------------|-------------|----------|
| Hurley, James Sydney .. | 36 McKellar-street, Benalla | | 36 McKellar-street, Benalla | Watchman .. | 13.12.67 |
|-------------------------|-----------------------------|---------|-----------------------------|-------------|----------|

Dated at Benalla this 23rd day of November, 1967.

R. F. FREEMAN,
Clerk of Petty Sessions.

COURT OF PETTY SESSIONS, WARRAGUL.

| | | | | | |
|-----------------------------|-------------------------------|-----------------------------|------------------------------|----------------------|----------|
| Caldecutt, Arthur Leslie .. | Forrest-road, Yannathan Lower | | 34 Williams-street, Warragul | Inquiry Agent .. | 22.12.67 |
| " " " .. | " " " | George W. Laurens Pty. Ltd. | " " | Process Server .. | " |
| " " " .. | " " " | " " " | " " | Commercial Sub-agent | " |

Dated at Warragul this 23rd day of November, 1967.

K. J. CRADDOCK,
Clerk of Petty Sessions.

COURT OF PETTY SESSIONS, OAKLEIGH.

| | | | | | |
|-----------------------------|----------------------------------|---------|----------------------------------|-------------------|----------|
| Bruinewoud, Frank Martin .. | 20 Manuka-street, South Oakleigh | | 20 Manuka-street, South Oakleigh | Process Server .. | 15.12.67 |
| " " " .. | " " " | " " " | " " " | Inquiry Agent .. | " |

Dated at Oakleigh this 24th day of November, 1967.

G. S. HOARE,
Clerk of Petty Sessions.

COURT OF PETTY SESSIONS, CHELSEA.

| | | | | | |
|-----------------------------|----------------------------------|---------|----------------------------------|-------------------|----------|
| Milicevic, Ante .. | 26 Church-street, Carrum | | 26 Church-street, Carrum | Inquiry Agent .. | 11.12.67 |
| Hocking, Maxwell Robert .. | 123 " Station-street, Aspendale | | 123 " Station-street, Aspendale | Process Server .. | " |
| Wilkinson, Royston Clive .. | 23 Fifth-avenue, Chelsea Heights | | 23 Fifth-avenue, Chelsea Heights | Inquiry Agent .. | " |
| | | | | Process Server .. | " |

Dated at Chelsea this 27th day of November, 1967.

G. F. MEEHAN,
Clerk of Petty Sessions.

COURT OF PETTY SESSIONS, DANDENONG.

| | | | | | |
|------------------------|------------------------------|---------|------------------------------|-------------------|----------|
| Carter, Joseph John .. | Lot 8, Monbulk-road, Emerald | | Lot 8, Monbulk-road, Emerald | Process Server .. | 13.12.67 |
| " " " .. | " " " | " " " | " " " | Inquiry Agent .. | " |

Dated at Dandenong this 22nd day of November, 1967.

C. F. LEWIS,
Clerk of Petty Sessions.

COURT OF PETTY SESSIONS, CHELTENHAM.

| | | | | | |
|---------------------------------------|--------------------------------------|------------------------------|---------------------------|-------------------|----------|
| Barnett, George Charles .. | 1337 Nepean Highway, Cheltenham | | | Process Server .. | 12.12.67 |
| Argus Night Patrol, Sheahan (nominee) | 217 Tucker-road, McKinnon | Argus Night Patrol Pty. Ltd. | 217 Tucker-road, McKinnon | Guard Agent | 15.12.67 |
| Neilson, Norman John .. | Flat 1, 4 Rowland-street, Kew | " " " | " " " | Watchman | " |
| Collins, Kenneth Royce .. | 17 Ellt-crescent, Noble Park | " " " | " " " | " | " |
| Phillips, Thomas Douglas .. | 72 Bruce-street, Mount Waverley | " " " | " " " | " | " |
| English, Cyril Stanley .. | 20 Lansell-avenue, Highett | " " " | " " " | " | " |
| Gleeson, Barrie Thomas .. | Lot 2, Harold-road, Springvale South | " " " | " " " | " | " |
| Adams, David Richard .. | 194 Surrey-road, Blackburn | " " " | " " " | " | " |
| Campos, Mario .. | 28 Marchiori-road, Blackburn | " " " | " " " | " | " |
| Rose, Kenneth Barry .. | Flat 4, 10 Markham-avenue, Ashburton | " " " | " " " | " | " |

PRIVATE AGENTS ACT—*continued.*

| Full Name of Applicant or in the case of a Firm or Corporation, of the Nominee. | Place of Abode of Applicant or Nominee. | Name of Firm or Corporation. | Address for Registration. | Type of Licence. | Date of Hearing of Application. |
|---|---|------------------------------|---------------------------|------------------|---------------------------------|
| COURT OF PETTY SESSIONS, CHELTENHAM—<i>continued.</i> | | | | | |
| Gillbee, Barry Raymond .. | 49 Botanic-drive, Glen Waverley | Argus Night Patrol Pty. Ltd. | 217 Tucker-road, McKinnon | Watchman .. | 15.12.67 |
| Moore, Mervyne Anthony .. | 26 Mallowa-street, Clayton | " " " | " " " | " .. | " |
| Le Plastrier, Michael Phillip .. | 26 Mallowa-street, Clayton | " " " | " " " | " .. | " |
| Walker, William Wilson .. | 5 Tibbles-street, North Beaumaris | " " " | " " " | " .. | " |

Dated at Cheltenham this 29th day of November, 1967.

G. F. MEEHAN,
Clerk of Petty Sessions.**COURT OF PETTY SESSIONS, SANDRINGHAM.**

| | | | | | |
|--------------------------|----------------------------------|---------|------------------------------|------------------|----------|
| Holmberg, Amelia Jane .. | 20 Manuka-street, South Oakleigh | | 253A Hampton-street, Hampton | Commercial Agent | 18.12.67 |
|--------------------------|----------------------------------|---------|------------------------------|------------------|----------|

Dated at Sandringham this 27th day of November, 1967.

J. A. BARNS,
Clerk of Petty Sessions.**COURT OF PETTY SESSIONS, MORNINGTON.**

| | | | | | |
|--------------------------|-----------------------------|---------|-----------------------------|-------------------|----------|
| Disher, David Russell .. | 34 Maude-street, Mt. Martha | | 34 Maude-street, Mt. Martha | Process Server .. | 11.12.67 |
|--------------------------|-----------------------------|---------|-----------------------------|-------------------|----------|

Dated at Mornington this 20th day of November, 1967.

B. J. HYAMS,
Clerk of Petty Sessions.**COURT OF PETTY SESSIONS, CHELTENHAM.**

| | | | | | |
|--------------------------|---------------------------------|---------|---------|-------------------|----------|
| Barnett, Dorothy Hope .. | 1337 Nepean Highway, Cheltenham | | | Process Server .. | 12.12.67 |
|--------------------------|---------------------------------|---------|---------|-------------------|----------|

Dated at Cheltenham this 30th day of November, 1967.

G. F. MEEHAN,
Clerk of Petty Sessions.**Police Regulation Act 1958.****POLICE FORCE OF VICTORIA.****DETERMINATION NO. 140 OF THE POLICE SERVICE BOARD.**

THE Police Service Board, in pursuance of the powers in that behalf conferred by the *Police Regulation Act 1958*, hereby makes the following Determination, that is to say:—

1. The Determination No. 107 of the Police Service Board of the 15th November, 1963, and published in the *Government Gazette* of the 4th February, 1964, as amended, is hereby further amended as follows:—

In paragraph 57—

At the end of sub-paragraph (1), by inserting the following proviso:—

“ Provided that no member shall receive any such allowance for a period longer than twelve calendar months.”

2. This Determination shall come into operation on the 3rd day of December, 1967.

Dated at Melbourne, this 30th day of November, 1967.

(Sgd.) BEN. J. DUNN,
A Judge of the County Court of Victoria,
Chairman and Member of the Police
Service Board.

(Sgd.) G. DAVIDSON,
Member of the Police Service Board.

RULES UNDER THE JUSTICES ACT.

SELECTION BY A LAW OFFICER OF THE PLACES AND DAYS AND HOURS FOR HOLDING COURTS (WITHIN THE MEANING OF THE SAID RULES).

I, THE undersigned, George Oswald Reid, a Law Officer of the State of Victoria, in pursuance of the powers conferred upon me by Rule 2 of Chapter III. of the Justices Act Rules 1963, do hereby select for the year 1968 from the places appointed by the Governor in Council for holding Courts of Petty Sessions the places named in the list hereto annexed as places for holding Courts within the meaning of the said Rule 2 of Chapter III: And I do hereby with respect to each place named in the said list from the days and hours appointed by the Governor in Council for holding Courts of Petty Sessions further select the days and hours set forth in the said list opposite the name and the said places respectively as the days and hours at which the said Courts shall be held.

Signed at Melbourne, this 27th day of November, 1967.

G. O. REID, Law Officer.

COURTS, DAYS AND HOURS FOR THE HEARING OF SPECIAL COMPLAINTS DURING 1968.

Table with columns: Court, Day, Hour, January, February, March, April, May, June, July, August, September, October, November, December. Rows list various courts like ALEXANDRA ARARAT, AVOCA, BACCHUS MARSH, etc., with their respective hearing days and hours for each month.

COURTS, DAYS AND HOURS FOR THE HEARING OF SPECIAL COMPLAINTS DURING 1968—continued.

Table with columns: Court, Day, Hour, and months from January to December. It lists 100 different courts and their respective hearing days and hours throughout the year 1968.

COURTS, DAYS AND HOURS FOR THE HEARING OF SPECIAL COMPLAINTS DURING 1968—continued.

| Court. | Day. | Hour. | January. | February. | March. | April. | May. | June. | July. | August. | September. | October. | November. | December. |
|---------------|-------|------------|---------------|---------------|-----------|--------------|--------------|-----------|-------------|-------------------|---------------|-----------|-----------|-----------|
| TALLANGATTA | Fri. | 10 a.m. | 19 | 16 | 15 | 10 | 7 | 5 | 2, 30 | 27 | 25 | 22 | 20 | |
| TATURA | Wed. | 10 a.m. | 24 | 21 | 20 | 17 | 15 | 12 | 10 | 7 | 4 | 2, 30 | 27 | |
| TERANG | Wed. | 10 a.m. | 17 | 14 | 13 | 10 | 8 | 5 | 3, 31 | 28 | 25 | 23 | 20 | |
| TRAFALGAR | Wed. | 10 a.m. | 17, 31 | 28 | 13 | 10, 24 | 8, 22 | 5 | 3, 17 | 14, 28 | 25 | 9 | 6, 20 | |
| TRARALGON | Mon. | 10 a.m. | 8, 15, 22, 26 | 5, 12, 19, 4 | 4, 18, 25 | 1, 8, 22, 27 | 6, 13, 20, 3 | 3, 17, 24 | 1, 8, 15, 5 | 12, 19, 2, 9, 16, | 7, 14, 21, 4, | 11, 18, | 2, 9, 16, | |
| TRENTAM | Wed. | 10 a.m. | 17 | 14 | 13 | 10 | 8 | 5 | 3, 31 | 28 | 25 | 23 | 20 | |
| TUNGAMAH | Thur. | 2.30 p.m. | .. | 8 | .. | 4 | 30 | .. | .. | .. | 19 | 14 | 18 | |
| VIOLET TOWN | Mon. | 10 a.m. | 15 | 12 | 4 | 8 | 6 | 3 | 1, 29 | 26 | 23 | 21 | 18 | |
| WALWA | Wed. | 11 a.m. | .. | 14 | .. | 10 | .. | .. | 31 | .. | 25 | 20 | .. | |
| WANGARATTA | Tues. | 10 a.m. | 9, 23 | 6, 20 | 5, 19 | 2, 30 | 14, 28 | 11, 25 | 9, 23 | 6, 20 | 3, 17 | 1, 15, 29 | 12, 26 | |
| WARBURTON | Wed. | 11 a.m. | 10, 24 | 7, 21 | 6, 20 | 3, 17 | 1, 15, 29 | 12, 26 | 10, 24 | 7, 21 | 4, 18 | 2, 16, 30 | 13, 27 | |
| WARRACKNABEAL | Thur. | 10 a.m. | 11, 25 | 8, 22 | 7, 21 | 4, 18 | 2, 16, 30 | 13, 27 | 11, 25 | 8, 22 | 5, 19 | 3, 17, 31 | 14, 28 | |
| WARRAGUL | Fri. | 10 a.m. | Every | Friday except | Public | Holidays, | and | Friday, | 26th | July | 1968. | .. | .. | |
| WARRNAMBOOL | Tues. | 10 a.m. | Every | Tuesday | except | Public | Holidays, | .. | .. | .. | .. | .. | .. | |
| WERRIBEE | Fri. | 10 a.m. | 8, 22 | 5, 19 | 4, 18 | 1, 29 | 13, 27 | 24 | 8, 22 | 5, 19 | 2, 16, 30 | 14, 28 | 11, 25 | |
| WHITTLESEA | Mon. | 11 a.m. | 8 | 5 | 1, 29 | 4 | 26 | 21 | 19 | 16 | 13 | 11 | 8 | |
| WILLIAMSTOWN | Wed. | 10 a.m. | Every | Wednesday | except | Public | Holidays, | .. | .. | .. | .. | .. | .. | |
| WODONGA | Tues. | 10 a.m. | 16, 30 | 13, 27 | 12, 26 | 9, 23 | 7, 21 | 4, 18 | 2, 16, 30 | 13, 27 | 10, 24 | 8, 22 | 5, 19 | |
| WONTHAGGI | Tues. | 10 a.m. | 9, 23 | 6, 20 | 5, 19 | 2, 30 | 14, 28 | 11, 25 | 9, 23 | 6, 20 | 3, 17 | 1, 15, 29 | 12, 26 | |
| WOODEND | Mon. | 10 a.m. | .. | 19 | .. | 18 | .. | .. | .. | .. | 12 | 7 | 4 | |
| WOOMELANG | Thur. | 2.30 p.m. | .. | 1 | .. | 28 | .. | .. | .. | .. | 18 | .. | .. | |
| WYCHEPROOF | Wed. | 10 a.m. | 3, 31 | 28 | 27 | 24 | 22 | 19 | 17 | 14 | 11 | 9 | 6 | |
| YACKANDANDAH | Fri. | 10 a.m. | 5 | .. | 1 | 26 | .. | .. | .. | .. | 16 | 11 | 8 | |
| YALLOURN | Mon. | 10.30 a.m. | 15 | 12, 26 | 25 | 8, 22 | 6, 20 | 3, 17 | 1, 15, 29 | 12, 26 | 9, 23 | 7, 21 | 4, 18 | |
| YARRAM | Wed. | 10 a.m. | 17 | 14 | 13 | 10 | 8 | 5 | 3, 31 | 28 | 25 | 23 | 20 | |
| YARRAWONGA | Thur. | 10 a.m. | 11 | 8 | 7 | 4 | 2, 30 | 27 | 24 | 22 | 19 | 17 | 14 | |
| YEA | Fri. | 10 a.m. | 19 | 16 | 15 | 10 | 7 | 5 | 2, 30 | 27 | 25 | 22 | 20 | |

POLICE OFFENCES ACT 1958.

IN pursuance of the powers conferred upon the Chief Secretary by sub-section (3) of section 184 of the Police Offences Act 1958, I do by this notice grant exemption from compliance with sub-sections (1) and (2) of section 184 of the said Act with respect to the publication Shooting Script distributed by Colorgravure Publications, 61 Flinders-lane, Melbourne.

JAMES W. MANSON,
for Chief Secretary.

Chief Secretary's Office,
Melbourne, 28th November, 1967.

Motor Car (Transfer and Roadworthiness) Regulations 1964.
APPROVAL OF BRAKE TESTING MACHINE.

NOTICE is hereby given that for the purposes of Part 4 of the Motor Car (Transfer and Roadworthiness) Regulations 1964 the under-mentioned device has been approved by me as a brake testing machine as defined in Regulation 102 (2) of the aforesaid Regulations.

"TRIANGLE" Brake Tester.

R. H. ARNOLD,
Chief Commissioner of Police.

LOCAL GOVERNMENT DEPARTMENT.

ORDER CONFIRMED.—SHIRE OF ALEXANDRA.

THE Minister of the Crown administering the Local Government Act 1958, as amended, on the twenty-eighth day of November, 1967, confirmed the Order hereinafter referred to, in pursuance of section 514 of the said Act, namely:

An Order made by the Council of the Shire of Alexandra on the twelfth July, 1967, directing the compulsory taking of the land described hereunder for road alignment purposes.

- (a) All that piece of land being part of Crown allotment 13B, section C, Parish of Gobur, commencing at a point being the north-west corner of the said allotment; thence by lines bearing 96 deg. 19 min. for 73.4 links, 114 deg. 42 min. for 209.7 links, 173 deg. 11 min. for 176 links, 294 deg. 42 min. for 267.9 links and 345 deg. 30 min. for 163.8 links to the commencing point.

- (b) All that piece of land being part of Crown allotment 13B, Section C, Parish of Gobur, commencing at a point distant 376.9 links bearing 257 deg. 29 min. from the south-eastern angle of the said allotment; thence by lines bearing 257 deg. 29 min. for 98.1 links, 274 deg. 46 min. for 266 links, 294 deg. 42 min. for 331.9 links, 74 deg. 19 min. for 46.1 links, 82 deg. 43 min. for 226.7 links and 114 deg. 42 min. for 432.2 links to the commencing point.

R. J. HAMER,
Minister for Local Government.

Local Government Department,
Melbourne.

LOCAL GOVERNMENT DEPARTMENT.

ORDER CONFIRMED.—SHIRE OF ROMSEY.

THE Minister of the Crown administering the Local Government Act 1958, as amended, on the first day of December, 1967, confirmed the Order hereinafter referred to, in pursuance of section 514 of the said Act, namely:

An Order of the Council of the Shire of Romsey, made on the sixth September, 1967, directing the compulsory taking of easements for drainage purposes over the land described hereunder.

- 1. All that piece of land commencing at a point on the northern boundary of Crown allotment 57, Township and Parish of Lancefield, distant 154 links easterly from the north-western corner of the said allotment; thence bearing 89 deg. 39 min. for 11 links, 153 deg. 51 min. for 626 links, 285 deg. 04 min. for 11 links; and thence by a line bearing 333 deg. 51 min. to the commencing point.

- 2. All that piece of land being part of the land described in certificate of title, volume 7784, folio 055, commencing at a point being the north-east corner of the land in the said certificate of title; thence by lines bearing 195 deg. 0 min. for 600 links, 285 deg. 0 min. for 10 links, 15 deg. 0 min. for 600 links, and 105 deg. 0 min. for 10 links to the commencing point.

- 3. All that piece of land being part of the land described in Crown grant, volume 313, folio 584, commencing at a point being the north-east angle of the land in the said Crown grant; thence by lines bearing 195 deg. 0 min. for 250 links, 285 deg. 0 min. for 10 links, 15 deg. 0 min. for 250 links, and 105 deg. 0 min. for 10 links to the commencing point.

- 4. All that piece of land being part of the land described in Crown grant, volume 187, folio 246, commencing at a point being the north-east angle of the land in the said Crown grant; thence by lines bearing 195 deg. 0 min. for 250 links, 285 deg. 0 min. for 10 links, 15 deg. 0 min. for 250 links, and 105 deg. 0 min. for 10 links to the commencing point.

R. J. HAMER,
Minister for Local Government.

Local Government Department,
Melbourne.

Co-operation Act 1958.

THOMSON CO-OPERATIVE COMMUNITY
ADVANCEMENT SOCIETY LIMITED.

NOTICE is hereby given in pursuance of section 78 (7) of the Co-operation Act 1958 and section 308 (2) of the Companies Act 1961 that, at the expiration of three months from the date hereof, the name of the aforementioned society will, unless cause is shown to the contrary, be struck off the register and the society will be dissolved.

Dated this twenty-seventh day of November, 1967.

J. W. JUNGWIRTH,
Deputy Registrar.

STATE RIVERS AND WATER SUPPLY COMMISSION.

LICENCES TO DIVERT WATER AND CUT RACES PURSUANT TO THE PROVISIONS OF SECTION 204 OF THE WATER ACT 1958 (AS AMENDED).

THE Governor in Council has approved of the granting by the State Rivers and Water Supply Commission of licences, as detailed hereunder for the term of years from the date specified in each case to the persons named in the following Schedule :—

SCHEDULE.

| Licence No. | Term of Licence and Commencing Date. | Name and Address of Person to Whom Licence is to be Granted. | Source of Supply. | Area Authorized to be Irrigated Per Annum. | Volume of Water Authorized to be Diverted Per Annum. |
|-------------|--------------------------------------|--|------------------------------|--|--|
| 2299 | Four years from 1.7.67 .. | Kevin Joseph Carroll, Wodonga .. | River Murray (Wodonga Creek) | 25 | 50 |
| 2300/305 | Five years from 1.7.66 .. | Margaret Wirk Heppell, Torrumbarry | River Murray .. | .. | 300 |

In each case, the annual fee payable in respect of each acre-foot of water authorized to be diverted is the equivalent of one-half of the irrigation charge per acre-foot fixed in the Goulburn-Murray Irrigation District for the preceding financial year.

Office of the State Rivers and Water Supply Commission,
Melbourne, 5th December, 1967.

J. N. MCAULEY, Acting Secretary,
State Rivers and Water Supply Commission.

STATE RIVERS AND WATER SUPPLY COMMISSION.

LICENCES TO DIVERT WATER AND CUT RACES PURSUANT TO THE PROVISIONS OF SECTION 204 OF THE WATER ACT 1958 (AS AMENDED).

THE Governor in Council has approved of the granting by the State Rivers and Water Supply Commission of the licence as detailed hereunder for the term of years from the date specified to the person named in the following Schedule :—

SCHEDULE.

| Licence No. | Term of Licence and Commencing Date. | Name and Address of Person to whom Licence is to be Granted. | Source of Supply. | Area Authorized to be Irrigated Per Annum. | Volume of Water Authorized to be Diverted Per Annum. | Annual Fee. |
|-------------|--------------------------------------|--|---------------------|--|--|-------------|
| 2301 | Four years from 1.7.66 | Swan Hill Lawn Tennis Club, Swan Hill | Little Murray River | 5 | 10 | \$ 10.00 |

Office of the State Rivers and Water Supply Commission,
Melbourne, 5th December, 1967.

J. N. MCAULEY, Acting Secretary,
State Rivers and Water Supply Commission.

STATE RIVERS AND WATER SUPPLY COMMISSION.

LICENCE TO DIVERT WATER PURSUANT TO THE PROVISIONS OF SECTION 204 OF THE WATER ACT 1958 (AS AMENDED).

THE Governor in Council has approved of the granting by the State Rivers and Water Supply Commission of the licence as detailed hereunder for the term of years from the date specified to the person named in the following Schedule :—

SCHEDULE.

| Licence No. | Term of Licence and Commencing Date. | Name and Address of Person to whom Licence is to be Granted. | Source of Supply. | Area Authorized to be Irrigated Per Annum. | Volume of Water Authorized to be Diverted Per Annum. |
|-------------|--------------------------------------|--|---------------------|--|--|
| 2302 | Fifteen years from 1.7.67 | Charles Lloyd, Rodborough | Tullaroop Reservoir | 15 | 30 |

The annual fee payable in respect of each acre-foot of water authorized to be diverted is the irrigation charge per acre-foot fixed in the Goulburn-Murray Irrigation District for the preceding financial year.

Office of the State Rivers and Water Supply Commission,
Melbourne, 5th December, 1967.

J. N. MCAULEY, Acting Secretary,
State Rivers and Water Supply Commission.

STATE RIVERS AND WATER SUPPLY COMMISSION.

LICENCE TO DIVERT WATER AND CUT RACE PURSUANT TO THE PROVISIONS OF SECTION 204 OF THE WATER ACT. (AS AMENDED).

THE Licence as detailed hereunder to divert water and cut race has been revoked by the Governor in Council.

SCHEDULE.

| Licence No. | Term of Licence and Commencing Date. | Name and Address of Person to whom Licence granted. | Source of Supply. |
|-------------|--------------------------------------|---|-------------------|
| 305 | Fifteen years from 1.7.57 | Thomas Henry Heppell, Torrumbarry | Gunbower Creek |

Office of the State Rivers and Water Supply Commission,
Melbourne, 5th December, 1967.

J. N. MCAULEY, Acting Secretary,
State Rivers and Water Supply Commission.

Water Act 1958.

STATE RIVERS AND WATER SUPPLY COMMISSION.

FRANKSTON—MORNINGTON URBAN DISTRICT.

NOTICE to owners of tenements in the under-mentioned streets in the Frankston—Mornington Urban District and the private streets, lanes, courts and alleys opening thereto:—

FRANKSTON.

Canning-street, from end of existing main opposite lot 4 to Hotham-street.
 Derinya-drive, from Overport-road to a point opposite lot 23 about 18 chains generally easterly.
 Ellis-street, from Kareela-road to a point opposite lot 34, about 7 chains easterly.
 Grosvenor-street, from Hotham-street to a point opposite lot 19, about 8½ chains north-easterly.
 Hotham-street, from Canning-street to Grosvenor-street.
 Kenilworth-avenue, from Gulwa-avenue to a point opposite lot 4, about 3 chains south-easterly.
 Leawarra-parade, from Lee-street to a point opposite lot 3, about 14½ chains north-westerly.
 Nursery-avenue, (i) from end of existing main (opposite lot 28), to a point opposite lot 2, about 9½ chains south-easterly from Craig-street; and (ii) from end of existing main (opposite lot 23), to a point opposite lot 24, about 1 chain north-westerly from Olympic-avenue.
 Sanders-road.
 Wangarra-road, from end of existing main (opposite lot 2) to a point opposite lot 1, about 2 chains north-westerly from Vermay-avenue.

MOUNT ELIZA.

Beluga-street, from end of existing main (opposite lot 331) to a point opposite lot 328, about 13½ chains generally north-westerly from Volitans-avenue.
 Berkeley-court.
 Como-court, from end of existing main (opposite lot 32) to a point opposite lot 29, about 7 chains westerly from Gillards-road.
 Ocean-grove, from end of existing main (opposite lot 29) to a point opposite lot 28, about 4½ chains generally south-easterly from Harleston-road.
 Sunset-crescent, from end of existing main (opposite lot 44) to a point opposite lot 41, about 12 chains generally south-westerly from Gillards-road.
 Wimbledon-avenue, from end of existing main (opposite lot 273) to existing main opposite lot 376.

The main pipe in the said streets being laid down, the owners of all tenements situated as above are hereby required, on or before the 1st day of February next, to cause proper pipes and stop cocks to be laid, so as to supply water within such tenements from the main pipe.

J. N. McAULEY, Acting Secretary,
 State Rivers and Water Supply Commission.
 Melbourne, 1st December, 1967.

PUBLIC TRUSTEE ACT 1958 (No. 6350), SECTION 17.

I HEREBY give notice that on the 20th November, 1967, the Public Trustee filed elections to administer the following deceased persons' estates in accordance with section 17 of the Public Trustee Act 1958:—

GARNERO, RODOLFO, also known as Rudy Garnero, late of 60 Hope-street, South Yarra, storeman, died 30th July, 1967.

LEWIS, RALPH, formerly of 32 Nicholson-street, Fitzroy, but late of Mount Royal, Parkville, retired linesman, died 16th April, 1967.

MANNING, AUGUSTINE FRANCIS, late of Mount Royal, Parkville, pensioner, died 23rd August, 1967.

MANUELE, SEBASTIANO, formerly of 446 Little Collins-street, Melbourne, but late of Daylesford, pensioner, died 28th June, 1967.

MCBEAN, FREDERICK, late of R.S.L. Burnewang House, Elmore, pensioner, died 7th September, 1967.

MCCANN, ANNE, late of 85 Budd-street, Collingwood, machinist, died 9th July, 1946.

MCCANN, MARY JANE, late of 85 Budd-street, Collingwood, machinist, died 1st February, 1942.

I HEREBY give notice that on the 22nd November, 1967, the Public Trustee filed elections to administer the following deceased persons' estates in accordance with section 17 of the Public Trustee Act 1958:—

BARTON, GLADYS MAUDE, late of 6 Drummond-street, Chadstone, married woman, died 3rd August, 1967.

FOSTER, CECIL EDWARD, late of Bundoora, pensioner, died 28th June, 1967.

PURDIE, ANNIE, formerly of 51 Carlyon-street, Ormond, but late of 58 Cochrane-street, North Brighton, widow, died 1st May, 1967.

REED, BRIDGET KATHLEEN, formerly of 72 Station-street, St. Albans, but late of 47 Rowena-parade, Richmond, pensioner, died 24th June, 1967.

A. D. DUNCAN,
 Public Trustee.

256 Flinders-street, Melbourne, 29th November, 1967.

NOTICE.

CREDITORS, next of kin, and others having claims against the estate of any of the under-mentioned deceased persons are required to send particulars of their claims to the Public Trustee, 256 Flinders-street, Melbourne, the personal representative, on or before the 13th February, 1968, after which date the Public Trustee may convey or distribute the assets, having regard only to the claims of which the Public Trustee then has notice:—

ANDERSON, MARK LESLIE, late of 107 Brunell-street, East Malvern, gentleman, died 9th May, 1967.

BARTON, GLADYS MAUDE, late of 6 Drummond-street, Chadstone, married woman, died 3rd August, 1967.

BRAYBROOKE, HENRY GEORGE, late of Kendalls-lane, Hurstbridge, pensioner, died 6th September, 1967.

BURNS, WILLIAM JOHN, late of 277 Dorcas-street, South Melbourne, labourer, died 10th August, 1967.

COLLINS, HENRY ERNEST, late of Hume Highway, Seymour, night watchman, died 9th April, 1967.

FOSTER, CECIL EDWARD, late of Bundoora, pensioner, died 28th June, 1967.

GARNERO, RODOLFO, also known as Rudy Garnero, late of 60 Hope-street, South Yarra, storeman, died 30th July, 1967.

LAWLOR, ADA, late of 140 Major-road, Fawkner, married woman, died 11th July, 1966.

LEWIS, RALPH, formerly of 32 Nicholson-street, Fitzroy, but late of Mount Royal, Parkville, retired linesman, died 16th April, 1967.

LOGAN, ALEXANDER DUNCAN, late of Orrvale, farmer, died 29th April, 1967.

MANNING, AUGUSTINE FRANCIS, late of Mount Royal, Parkville, pensioner, died 23rd August, 1967.

MANUELE, SEBASTIANO, formerly of 446 Little Collins-street, Melbourne, but late of Daylesford, pensioner, died 28th June, 1967.

MOORE, DONALD ALEXANDER, late of 582 Moreland-road, West Brunswick, retired telegraphist, died 19th June, 1967.

MCBEAN, FREDERICK, late of R.S.L. Burnewang House, Elmore, pensioner, died 7th September, 1967.

MCCANN, ANNE, late of 85 Budd-street, Collingwood, machinist, died 9th July, 1946.

MCCANN, MARY JANE, late of 85 Budd-street, Collingwood, machinist, died 1st February, 1942.

PHILPOT, EMILY MAY, formerly of 23 Erasmus-street, Surrey Hills, but late of 2 Beresford-street, Mont Albert, widow, died 16th August, 1967.

PURDIE, ANNIE, formerly of 51 Carlyon-street, Ormond, but late of 58 Cochrane-street, North Brighton, widow, died 1st May, 1967.

REED, BRIDGET KATHLEEN, formerly of 72 Station-street, St. Albans, but late of 47 Rowena-parade, Richmond, pensioner, died 24th June, 1967.

SCOTT, FREDERICK THOMAS, late of Main-road, St. Andrews, pensioner, died 18th June, 1967.

SCOTT, JOSEPH FREDERICK, late of Dannevirke, New Zealand, dental surgeon, died 12th October, 1966.

SMITH, THOMAS WILLIAM, formerly of "L'Allegro", 195 Burke-road, Glen Iris and 19 Vernon-street, Glen Iris, but late of 18 Heather-grove, Nunawading, retired public servant, died 28th August, 1967.

SQUIBB, ANN MARIA, late of The Old Rectory, Upton Scudamore, Warminster, Wiltshire, England, widow, died 8th November, 1965.

STEAD, ETHEL, formerly of 15 Hunter-street, Abbotsford, late of 4 Coral-avenue, Footscray, widow, died 25th August, 1967.

TECEY, MARSHALL, late of 23 Cunningham-street, South Yarra, retired liftman, died 28th June, 1967.

TEJCEK, VLADIMIR, also known as Ludvik Radvan and Vladimir, William Tejcek, late of 5 Orange-street, Braybrook, gentleman, died 15th March, 1967.

THOMAS, JAMES HENRY, late of 6 Derby-street, Northcote, retired boiler attendant, died 4th June, 1967.

THOMPSON, FRANCIS WINTERBURN, formerly of 75 Cameron-street, Launceston, Tasmania, late of Second A.I.F., real estate salesman, died 24th June, 1944.

A. D. DUNCAN,
 Public Trustee.

Melbourne, 29th November, 1967.

CONTRACTS ACCEPTED.—(Series 1967-68.)

PUBLIC WORKS.

1942. Williamstown, Technical School, mechanical services, \$9,980.00.—W. S. Atherton & Co. Pty. Ltd.
1943. Gardenvale, State School No. 3897 and Residence, renovations, \$3,512.00.—Azeus Painting & Decorating Co.
1944. Colac South West, State School No. 4775, renovations, \$1,550.00.—Ivan Bulat.
1945. Moonee Ponds West, State School No. 2901, renovations, \$10,253.00.—C. B. Bramich.
1946. Nunawading, High School, erection of a proprietary type residence and garage, \$10,650.00.—Contemporary Homes Pty. Ltd.
1947. Preston East, High School, mechanical services, \$11,951.18.—D. & N. Heating & Plumbing Services.
1948. Wangaratta, Fisheries & Wildlife Branch, Office and Residence, extensions and renovations, \$1,900.00.—M. J. Dore.
1949. Queenscliff, High School, mechanical services, \$19,958.00.—Ford-Swinton Industries Pty. Ltd.
1950. Timboon, High School, renovations, \$7,676.20.—Fotheringham Constructions Pty. Ltd.
1951. Brunswick, High School, erection of new second stage, \$295,642.00.—A. J. Galvin Pty. Ltd.
1952. Frankston, Technical School, extensions and alterations to trade block, \$122,639.00.—S. W. & J. Gardiner Pty. Ltd.
1953. Footscray North, State School No. 4160, renovations, \$1,670.00.—Gleeson & Grigg.
1954. Various, Schools, Zone A, erection of 60 standard primary class-rooms at rates within a 30-mile radius of Melbourne, at rates.—Contemporary Homes Pty. Ltd.
1955. Glenbrae, State School No. 3752, internal and external repairs and painting, enclosed porch and landing, \$1,083.00.—R. H. Hibbins & Sons.
1956. Kingston, State School No. 759, new toilet block and septic tank installation, \$2,267.00.—R. H. Hibbins & Sons.
1957. Laang, State School No. 1411, repairs and painting, \$1,290.00.—Hose & Schultz.
1958. Reservoir, High School, erection of two science rooms, \$43,521.00.—A. V. Jennings Industries (Aust.) Ltd.
1959. Various, Schools, Zone B, erection of 50 standard primary class-rooms at rates within a 30-mile radius of Melbourne, at rates.—A. V. Jennings Industries (Aust.) Ltd.
1960. Wallaloo East, State School No. 2698, erection of one replacement class-room and shelter pavilion, \$4,459.00.—A. V. Jennings Industries (Aust.) Ltd.
1961. Morningside, High School, erection of two-room science wing, \$45,585.00.—A. V. Jennings Industries (Aust.) Ltd.
1962. Kancoona, State School No. 3576, new shelter pavilion, &c., \$2,101.20.—F. K. Jensen.
1963. Ashwood, High School, electrical installation, \$7,132.00.—G. G. Kay & Co. Pty. Ltd.
1964. Warrnambool, High School, asphalt, concrete and gravel paving, &c., \$28,102.00.—J. Keen Proprietary Limited.
1965. Alvie, Consolidated School, asphalt, concrete and drainage works, &c., \$5,137.00.—J. Keen Proprietary Limited.
1966. Knox, Composite Technical School, electrical installation, \$36,373.00.—J. H. King Electrics.
1967. Croydon, High School, fire service installation, \$5,717.00.—Lewis Bros.
1968. Moorabbin, State School No. 1111, renewal of cisterns and troughs, \$2,249.50.—A. Liddell.
1969. Prahran, "Kuranda" Secondary Teachers' College Hostel, 174 Punt-road, renovations, \$1,600.00.—G. J. Little.
1970. Mont Albert, State School No. 3934, construction of asphalt, concrete and drainage works, &c., \$20,562.53.—Wm. Loud Pty. Ltd.
1971. Queenscliff, High School, erection of administration manual arts and science wings, \$74,484.00.—E. J. Lyons & Son Pty. Ltd.
1972. Brighton, Technical School, fire service installation, \$6,924.00.—F. J. & F. W. Maskell Pty. Ltd.
1973. Glen Forbes, State School No. 4008, external renovations, \$1,060.00.—L. C. Mott.
1974. Ashwood, High School, erection of assembly hall, type "800", \$81,743.00.—S. H. McCorkell Pty. Ltd.
1975. Huntingdale, High School, supply and erection of chain mesh fence and gates, \$1,456.60.—J. Otter Fencing Pty. Ltd.
1976. Heatherhill, State School No. 4802, renovations, \$1,336.00.—J. Podt.
1977. Pearcedale, State School No. 2962, renovations, \$2,358.00.—J. Podt.
1978. Laverton North, State School No. 4964, concrete and drainage works, &c., \$13,708.10.—Rainbow Construction Co. Pty. Ltd.

1979. Malvern, "Stonnington" Toorak Teachers' College, asphalt, concrete and drainage works, &c., \$43,703.50.—Rainbow Construction Co. Pty. Ltd.

1980. Hamilton, High School Residence, internal and external repairs and painting, \$1,328.15.—R. G. E. Radley.

1981. Granya, State School No. 2250, internal and external renovations and painting of residence, painting of school roof, \$1,580.00.—Rinius Bros. Painting Service.

1982. Hawthorn, Swinburne Technical College, supply and delivery of drafting machines, \$5,146.00.—Ray & Gilbert (Sales) Pty. Ltd.

1983. Beechworth, Mental Hospital, Administration Building, installation of steam heating, \$11,211.00.—Ross's Pty. Ltd.

1984. Burwood, Teachers' College, renovations, \$2,160.00.—Mick Sandic.

1985. Horsham, 36 Stewart-street, Lands and Survey Residence, renovations, \$1,180.00.—S. Saunders.

1986. Horsham West, State School No. 4697, residence, 34A Wawunna-road, painting and repairs, \$1,050.00.—S. Saunders.

1987. Pascoe Vale, Girls' Secondary School, paving drainage and asphalt repairs, \$11,183.00.—Roy Senior & Son Pty. Ltd.

1988. Woomelang, Group School No. 3373, asphalt and concrete works, \$1,038.00.—South West Bitumen Surfacing Co. Pty. Ltd.

1989. Kilmore, Court House, renovations, \$3,894.00.—Super Painting & Decorating Co. Pty. Ltd.

1990. Frankston, Technical School, mechanical services, \$17,685.00.—J. C. Thomson.

1991. Maribymong, High School, drainage, asphalt and road construction, \$16,800.20.—L. J. Towers.

1992. Coburg, Court House, repairs and painting, \$1,200.00.—Vasco Painter.

1993. Caulfield South, State School No. 4315, new toilet cubicle and roof over urinal, \$4,029.00.—B. J. Virtue.

1994. Frankston, Technical School, electrical installation, \$8,800.00.—W. A. D. Electrics Pty. Ltd.

G. SERPELL, Secretary for Public Works. 27.11.67.

SOIL CONSERVATION AUTHORITY.

CONTRACT 6721.

2014. Bulldozing earthworks including bank construction, gully battering and ripping, Parwan Valley Project, Bacchus Marsh.—W. R. and D. Altmann, Bannockburn.—Case 1000 D Terramatic and ancillary equipment, \$10.00 an hour.

P. J. McCALLUM, Secretary.

VICTORIAN RAILWAYS.

61. Erection and completion of a new multi-storey East Tower Building (excluding pile foundations), at the East Melbourne Goods Depot, for the amount of \$158,195.00 (Contract 63174).—D.A. Constructions Pty. Ltd. 62. Design of circuits and manufacture, supply, delivery, construction, erection and installation of an automatic boom barrier installation at Westgarth-street, Westgarth, and remote control of junction at Westgarth, for the amount of \$35,948.00 (Contract 63178).—McKenzie and Holland (Aust.) Pty. Ltd. 63. Design of circuits and manufacture, supply, delivery, construction, erection and installation of flashing light signals at thirteen locations, for the amount of \$97,680.00 (Contract 63188).—McKenzie and Holland (Aust.) Pty. Ltd.

By order of the Victorian Railways Commissioners,

W. WALKER, Secretary. 1.12.67.

GENERAL STORES.

Gazette No. 33, 19th April, 1967, Schedule No. 52, Tools (General). For rates shown opposite the following items, substitute the rates as set out hereunder:—Item No. 8, $\frac{1}{2}$ -in. to $\frac{1}{4}$ -in., \$0.64; Item No. 9, 9/16-in., \$0.73; $\frac{3}{8}$ -in., \$0.79, 11/16-in. to $\frac{1}{2}$ -in. \$0.89, 13/16-in. to $\frac{1}{2}$ -in., \$1.00, 15/16-in. to 1-in., \$1.09, $1\frac{1}{8}$ -in., \$1.31, $1\frac{1}{4}$ -in., \$1.60; Item No. 36, $\frac{1}{2}$ -in. to $\frac{1}{4}$ -in., \$0.84; Item No. 37, $\frac{3}{8}$ -in., \$0.88, $\frac{1}{2}$ -in., \$0.93, $\frac{5}{8}$ -in., \$0.98, 1-in., \$1.02; Item No. 38, $1\frac{1}{4}$ -in., \$1.23, $1\frac{1}{2}$ -in., \$1.47, $1\frac{3}{4}$ -in., \$1.71, 2-in., \$1.91; Item No. 39, $\frac{1}{2}$ -in. to $\frac{1}{4}$ -in., \$0.92; Item No. 40, $\frac{3}{8}$ -in., \$0.96, $\frac{1}{2}$ -in., \$0.98, $\frac{5}{8}$ -in., \$1.03, 1-in., \$1.10; Item No. 41, $1\frac{1}{4}$ -in., \$1.29, $1\frac{1}{2}$ -in., \$1.52, $1\frac{3}{4}$ -in., \$1.73, 2-in., \$2.00; Item No. 42, $\frac{1}{2}$ -in. to $\frac{1}{4}$ -in., \$0.98; Item No. 43, $\frac{3}{8}$ -in., \$1.03, $\frac{1}{2}$ -in., \$1.11, $\frac{5}{8}$ -in., \$1.28, 1-in., \$1.34; Item No. 44, $1\frac{1}{4}$ -in., \$1.49, $1\frac{1}{2}$ -in., \$1.67, $1\frac{3}{4}$ -in., \$1.90, 2-in., \$2.08; Item No. 45, $\frac{1}{2}$ -in. to $\frac{1}{4}$ -in., \$1.16; Item No. 46, $\frac{3}{8}$ -in., \$1.22, $\frac{1}{2}$ -in., \$1.28, $\frac{5}{8}$ -in., \$1.40, 1-in., \$1.51; Item No. 47, $1\frac{1}{4}$ -in., \$1.73, $1\frac{1}{2}$ -in., \$1.89; Item No. 80, $\frac{1}{2}$ -in. to $\frac{3}{8}$ -in., \$0.92; Item No. 81, $\frac{1}{2}$ -in., \$0.99, $\frac{3}{8}$ -in., \$1.02, $\frac{1}{4}$ -in., \$1.10, $\frac{1}{2}$ -in., \$1.14, 1-in., \$1.19, Item No. 102, \$10.51; Item No. 103, \$12.09; Item No. 104, \$10.51; Item No. 105, \$12.76; Item No. 106,

\$12.76 as from 1st November, 1967. Item No. 117, 5-in., \$0.68, 6-in., \$0.81 as from 2nd November, 1967. Item No. 272, 12T, \$1.40, 14T, \$1.44, 16T, \$1.50, as from 6th November, 1967. Item No. 302, \$11.91; Item No. 304, \$9.34; Item No. 316, \$5.68; Item No. 317, \$6.63; Item No. 323, \$11.84 as from 1st November, 1967.

Gazette No. 56, 17th July, 1967, Schedule No. 28, Coppers, Furnaces, &c. For rates shown opposite the following items, substitute the rates as set out hereunder:—Item No. 9, 24-in. Black, \$32.50, Enamel, \$38.00; Item No. 10, Black, \$44.00, Enamel, \$49.50; Item No. 13, Black, \$45.00, Enamel, \$52.50 each, as from 1st May, 1967.

Gazette No. 56, 17th July, 1967, Schedule No. 48, Iron (Galvanized). The rates for Item Nos. 1 to 5 have been increased by \$2.00 per ton as from 29th October, 1967.

Provisions.

Gazette No. 46, 26th May, 1967, Schedule No. 25, Milk—Malmesbury. The rate for Item No. 1 of Sub-schedule No. 3 has been increased by 3 cents per gallon, as from 1st November, 1967.

H. COUTTS, Secretary to the Tender Board. 5.12.67.

ORDERS IN COUNCIL.—(Series 1966-67.)

FORESTS COMMISSION.

Loan Fund Act No. 7453, Item 6—

4293. To the purchase of an area comprising 3 roods 39 perches, being portion of allotment 9, section 8, Parish of Macedon, County of Bourke, for forest purposes, \$20.—Denis R. Baker.

Approved by the Governor in Council, 1st February, 1967.—J. COLQUHOUN, Clerk of the Executive Council.

ORDERS IN COUNCIL.—(Series 1967-68.)

EDUCATION DEPARTMENT.

1995. Six (6) only engine turn over stands and trays, for Dandenong Technical School, \$636.00.—D.O.F. Steel Equipment.

1996. One (1) only leather finish rub resistance tester, one (1) only leather finish heat resistance tester, one (1) only laboratory press with heated platens, one (1) only upper-leather waterproof tester, one (1) only surface-water absorption apparatus, and one (1) only state of cure apparatus, for Collingwood Technical School, \$1,051.16.—Shoe and Allied Trades Research Association.

1997. One (1) only OCE66/407/printer/developer, for Dandenong Technical School, \$449.00.—Crosby Sensitizing Pty. Ltd.

1998. One (1) only horizontal boring machine, hand operated, for Echuca Technical School, \$315.00.—McPherson's Ltd.

1999. Four (4) only binocular microscopes, for White Hills Technical School, \$312.00.—H. B. Selby & Co. Pty. Ltd.

2000. Two (2) only 9-in. swing cone pulley lathes, for Wonthaggi Technical School, \$1,438.79.—Demco Machinery Co. Pty. Ltd. (This is in lieu of Order in Council published in the *Government Gazette*, dated 13th September, 1967, in respect of these items only.)

2001. One (1) only dry photocopier and off-set plate-making machine, and one (1) only copying machine for film-making unit, for Preston Technical College, \$1,260.00.—Atram Pty. Ltd.

2002. One (1) only tractor, for Wonthaggi Technical School, \$1,000.00.—Fiat Tractors.

2003. One (1) only 6-in. high speed heavy duty power hacksaw machine, for Warragul Technical School, \$400.00.—Scruttons Pty. Ltd.

Approved by the Governor in Council, 28th November, 1967.—J. ROSSITER, Clerk of the Executive Council.

PUBLIC WORKS.

2004. Boronia Heights, S.S. No. 4967, erection of two class-rooms, library, work room, &c., \$28,908.00.—J. P. & J. W. Wolbers Pty. Ltd.—(N.E.108888.)

2005. Dandenong, Psychiatric Centre, supply of special food trolleys, \$2,080.00.—K. G. Luke Australia.—(S.E.113583.)

2006. Echuca, High School, erection of a new woodwork room, machine room, and office, &c.—\$24,960.00.—E. Mills and Sons Pty. Ltd.—(N.E.16274.)

2007. Janefield, Mental Hospital, Ward F.1, supply and installation of evaporative coolers, \$2,992.00.—Ellis Air Conditioning Pty. Ltd.—(N.E.108436.)

2008. Larundel, Mental Hospital, supply of selected chairs, \$1,207.14.—Namco Products Pty. Ltd., and \$1,080.00.—Bera Furniture Pty. Ltd.—(N.E.86979.)

2009. North Melbourne, Melbourne School of Printing and Graphic Arts, supply of a reconditioned Linotype machine, \$5,000.00.—Gollin & Company Ltd.—(S.W.43937 "H".)

2010. Port Melbourne, Public Works Depot, supply of a Ditch Witch trenching machine, \$1,700.00.—Mole Engineering (Vic.) Pty. Ltd.—(S.W.124591.)

2011. Richmond, Technical School, provision of a staff room, store, &c., \$4,862.00.—Johns and Reid—(E.M.109894.)

Approved by the Governor in Council, 28th November, 1967.—J. ROSSITER, Clerk of the Executive Council.

FORESTS COMMISSION.

Loan Fund Act No. 7453, Item 6—

2012. To the purchase of that part of Crown allotment 24A, section B, Parish of Tallangalook, County of Delatite, comprising 5 acres 1 rood 52/10 perches be purchased for forest purposes, \$105.65.—Ernest Clarence and Roma Sinclair.

Approved by the Governor in Council, 12th September, 1967.—J. ROSSITER, Acting Clerk of the Executive Council.

Loan Fund Act No. 7453, Item 6—

2013. To the purchase of that lot 7 on plan of subdivision No. 26960, being part of Crown allotment 126, Parish of Scoresby, County of Mornington, for forest purposes, \$667.00.—Frances Lilian Moy.

Approved by the Governor in Council, 31st October, 1967.—J. ROSSITER, Clerk of the Executive Council.

AUCTION SALES ACT 1958.

HIS Excellency the Governor of the State of Victoria, by and with the advice of the Executive Council thereof, doth by Order made on fifth day of December, 1967, and under the powers conferred by section 16 of the Auction Sales Act 1958, No. 6202, the time for making payment of fees for Auctioneers' Licences granted at the General Meeting of Justices held on the fourth Tuesday in November, 1967, for the Licensing of Auctioneers, be extended to and inclusive of the eighth day of January, 1968.

F. R. KENNY,

Acting Clerk of the Executive Council.

At the Executive Council Chamber,
Melbourne, 5th December, 1967.

FARM PRODUCE MERCHANTS AND COMMISSION AGENTS ACT 1965, No. 7274.

BY virtue of the power conferred upon me by section 15 of the above Act, I hereby suspend the Farm Produce Merchants licence which was issued to John T. Lolbert, of 109 Albert-street, East Brunswick, for the period 1st July, 1967, to 30th June, 1968.

G. L. CHANDLER,
Minister of Agriculture.

SHIRE OF TAMBO.

ROAD DEVIATION ORDER.

PURSUANT to the provisions of sections 522 and 526 of the *Local Government Act 1958* the Council of the Shire of Tambo hereby directs that the land in the Parish of Gelantipy West indicated by hatching on the diagram hereunder which has been purchased taken or acquired by it shall be a public highway on and from the date of publication of this Order in the *Government Gazette* and declares that such land shall be a public highway in lieu of the land indicated by cross-hatching on the said diagram.

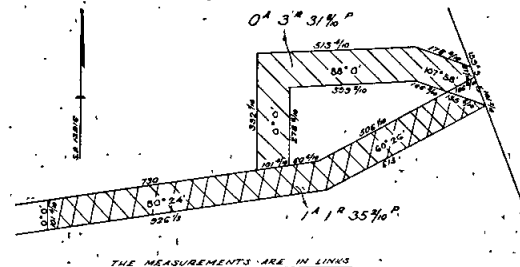

The common seal of the President, Councillors and Ratepayers of the Shire of Tambo was hereunto affixed this 19th day of September, 1967, in the presence of—

(SEAL) J. A. ARMSTRONG, President,
NEVILLE A. EVANS, Councillor,
G. W. RIDSDALE, Shire Secretary.

Confirmed by the Governor in Council, 28th November, 1967.—J. ROSSITER, Clerk of the Executive Council.

SHIRE OF NARRACAN.
ROAD DEVIATION ORDER.

PURSUANT to the provisions of sections 522 and 526 of the Local Government Act 1958 the Council of the Shire of Narracan hereby directs that the land in the Parish of Moe indicated by hatching on the diagram hereunder which has been purchased taken or acquired by it, shall be a public highway on and from the date of publication of this order in the Government Gazette and declares that such land shall be a public highway in lieu of the land indicated by cross-hatching on the said diagram.

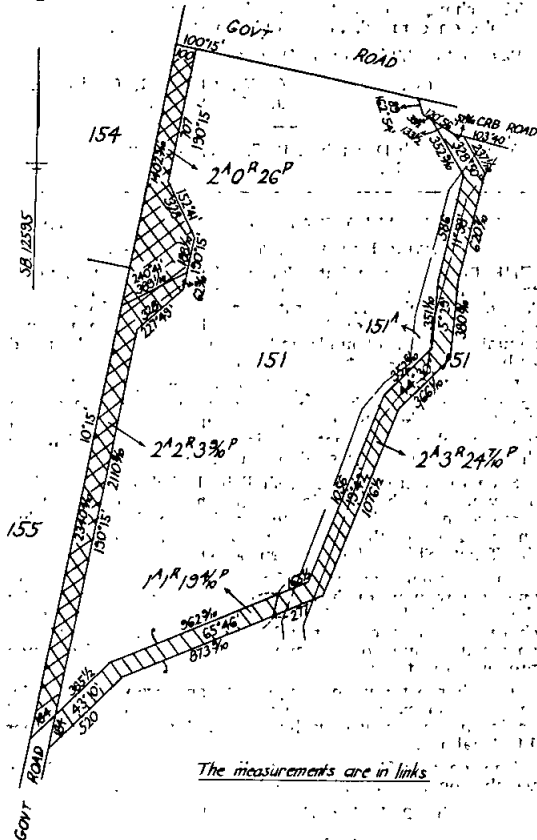

Dated this 10th day of November, 1967.

The common seal of the President, Councillors and Ratepayers of the Shire of Narracan was hereunto affixed in the presence of—

(SEAL) ALAN F. GUNN, President.
D. S. CLARKE, Councillor.
W. F. NELSON, Secretary.

Confirmed by the Governor in Council, 28th November, 1967.—J. ROSSITER, Clerk of the Executive Council.

SURVEY CO-ORDINATION (PLACE NAMES) ACT
No. 7360.

PURSUANT to the powers conferred under section 29 of the above Act, the Place Names Committee hereby gives notice of the assignment of the following name to the feature mentioned hereunder:—

Shire.—Omeo, Bright.

Feature and Location.—Col at junction of Swindler's Creek and Diamantina River Watersheds. Approximate geographical co-ordinates, lat. 36 deg. 57 min. 45 sec. S. Long. 147 deg. 8 min. 51 sec. E. based on Australian National Datum.

Name.—Derrick Col.

By order of the Committee,
C. E. E. BARLOW,
Secretary.

SURVEY CO-ORDINATION (PLACE NAMES) ACT
No. 7360.

PURSUANT to the powers conferred under section 29 of the above Act, the Place Names Committee hereby gives notice of the following alteration in the name of the township mentioned hereunder:—

Shire.—Swan Hill.

Present Name.—Woorinen.

New Name.—Woorinen South.

By order of the Committee,
C. E. E. BARLOW,
Secretary.

SURVEY CO-ORDINATION (PLACE NAMES) ACT
No. 7360.

PURSUANT to the powers conferred under section 29 of the above Act, the Place Names Committee hereby gives notice of the following alteration in the name of the creek mentioned hereunder:—

Shire.—Wannon.

Present Name.—Koroite Creek.

New Name.—Bryan Creek.

By order of the Committee,
C. E. E. BARLOW,
Secretary.

SURVEY CO-ORDINATION (PLACE NAMES) ACT
No. 7360.

PURSUANT to the powers conferred under section 29 of the above Act, the Place Names Committee hereby gives notice of the following alteration in the name of the under-mentioned township:—

Shire.—Shepparton.

Present Name.—Congupna Road.

New Name.—Congupna.

By order of the Committee,
C. E. E. BARLOW,
Secretary.

SURVEY CO-ORDINATION (PLACE NAMES) ACT
No. 7360.

PURSUANT to the powers conferred under section 29 of the above Act, the Place Names Committee hereby gives notice of the assignment of the following name to the feature mentioned hereunder:—

Shire.—Daylesford and Glenlyon.

Feature and Location.—Dam near the junction of the Wombat and Stewart Creeks.

Name.—Wombat Creek Dam.

By order of the Committee,
C. E. E. BARLOW,
Secretary.

State Savings Bank Act 1958.—Section 30.

THE STATE SAVINGS BANK OF VICTORIA.

ESTABLISHMENT OF BRANCH.

THE Commissioners of The State Savings Bank of Victoria hereby give notice of the establishment of Treasury-place branch of the Bank at State Government Offices, Treasury-place, East Melbourne, 3002, on Monday, 11th December, 1967.

T. E. HALL, General Manager.

SHEPPARTON SEWERAGE AUTHORITY.

By-Law No. 10.

THE Shepparton Sewerage Authority, in pursuance and exercise of powers conferred by the Sewerage Districts Acts, doth hereby make the By-Law following:—

1. By-Law No. 9 is hereby repealed.
2. The minimum amount of rate to be paid each year, commencing the first day of October, by the owner or occupier of any rateable sewer property on which there is a building shall be Twenty Dollars (\$20.00).
3. The minimum amount of rate to be paid each year, commencing the first day of October, by the owner or occupier of any rateable sewer property on which there is no building, shall be Fourteen Dollars (\$14.00).

THE RESOLUTION for passing this By-Law was adopted by the Shepparton Sewerage Authority on the sixteenth day of October, 1967.

CONFIRMED by the said Sewerage Authority on the thirteenth day of November, 1967.

The common seal of the Shepparton Sewerage Authority was hereto affixed on the seventeenth day of November, 1967, in the presence of—

(SEAL) V. E. VIBERT, Chairman.
R. L. TREVASKIS, Member.
R. O'BRIEN, Secretary.

Approved by the Governor in Council, 5th December, 1967.—F. R. KENNY, Acting Clerk of the Executive Council.

TRARALGON SEWERAGE AUTHORITY.
ANNUAL BALANCE.

HIS Excellency the Governor of the State of Victoria, by and with the advice of the Executive Council thereof doth by Order made on the 5th day of December, 1967, and in pursuance of the provisions of the Sewerage Districts Act fix the 30th day of September in each year as from 1st January, 1968, as the day to which the accounts of the Traralgon Sewerage Authority shall be balanced.

F. R. KENNY,
Acting Clerk of the Executive Council.
At the Executive Council Chamber,
Melbourne, 5th December, 1967.

YARRA JUNCTION WATERWORKS TRUST.
FIXING THE LIMIT OF BANK OVERDRAFT.

HIS Excellency the Governor of the State of Victoria, by and with the advice of the Executive Council thereof doth by Order made on the 5th day of December, 1967, fix the limit of the overdraft to be obtained by the Yarra Junction Waterworks Trust from the National Bank of Australasia, Warburton, pursuant to the provisions of Section 288 of the Water Act at Thirty-one thousand dollars (\$31,000).

F. R. KENNY,
Acting Clerk of the Executive Council.
At the Executive Council Chamber,
Melbourne, 5th December, 1967.

RUSHWORTH WATERWORKS TRUST.
AUTHORITY TO OBTAIN BANK OVERDRAFT.

HIS Excellency the Governor of the State of Victoria, by and with the advice of the Executive Council thereof doth by Order made on the 5th day of December, 1967, authorize the Rushworth Waterworks Trust to obtain in pursuance of the provisions of Section 286 of the Water Act 1958 (No. 6413) an advance or advances during the year 1968 from the Commercial Banking Company of Sydney Ltd., Rushworth, by overdraft of the Trust's current account thereat, such overdraft not to exceed at any one time the sum of Three thousand dollars (\$3,000).

F. R. KENNY,
Acting Clerk of the Executive Council.
At the Executive Council Chamber,
Melbourne, 5th December, 1967.

GOORAMBAT WATERWORKS TRUST.
RATING BY-LAW FOR THE YEAR 1967.

THE Goorambat Waterworks Trust, in pursuance and exercise of the powers conferred by the Water Act, doth hereby make a rate for the supply of water for domestic purposes, on lands and tenements liable to be rated within the Goorambat Urban District, of 22.5 cents in the dollar of the annual municipal valuation of lands and tenements not exceeding \$250, fifty-five dollars on each tenement having a Net Annual Value exceeding \$250 but not exceeding \$400, eighty dollars on each tenements having a Net Annual Value exceeding \$400 but not exceeding \$750, and one hundred dollars on each tenement having a Net Annual Value of more than \$750.

Provided that in no case shall the amount of rate payable per annum in respect of any tenement (other than land on which there is no building) be less than 22 dollars, and in respect of any land on which there is no building less than 5 dollars.

Such rates are made and shall be levied upon the occupiers or owners of the said lands and tenements for the year commencing on the 1st day of January, 1967, and shall be payable on the 13th day of December 1967, at the offices of the said Trust.

The maximum quantity of water to be supplied in any one year without further charge to any property rated by the Trust is hereby fixed at the quantity which, at a

charge of 40 cents per 1,000 gallons, would produce an amount equal to the amount of the rate levied on such property for the said year.

The charge for water supplied by measure to any property rated by the Trust in excess of such maximum quantity, computed as in the last preceding clause, is hereby fixed at 40 cents per 1,000 gallons.

The charge for water supplied by measure to any property not rated by the Trust is hereby fixed at 40 cents per 1,000 gallons, and the minimum quantity of water to be charged for in cases where water is so supplied is fixed at 50,000 gallons.

The charge for water supplied by measure shall be payable, on demand, at the office of the Trust.

Passed this 20th day of October, 1967.

(SEAL) C. W. COOPER, Chairman.
J. K. ASHTON, Secretary.

Approved, 4th December, 1967.—W. BORTHWICK, Minister of Water Supply.

PLENTY-YARRAMBAT WATERWORKS TRUST.
RATING BY-LAW FOR THE YEAR 1967-8.

THE Plenty Yarrambat Waterworks Trust, in pursuance and exercise of the powers conferred by the Water Act, doth hereby make a rate for the supply of water for domestic purposes of 13 cents in the dollar on the net annual valuation of lands and tenements liable to be rated with the Plenty-Yarrambat District.

Provided that in no case shall the amount of the rate payable per annum in respect of any tenement (other than the land on which there is no building) be less than thirteen dollars fifty cents and in respect of any land where there is no building less than four dollars.

Such rates are made and shall be levied upon occupiers or owners of the said land and tenements for the year commencing on the 1st October, 1967 and shall be due and payable on the 10th December, 1967 at the office of the Trust, Shire Office, Greensborough.

The maximum quantity of water to be supplied in any one year without further charge to any property rated by the Trust is hereby fixed at the quantity which, at a charge of forty cents per 1,000 gallons, would produce an amount equal to the amount of the rate levied on such property for the said year.

The charge for water supplied to any property rated by the Trust in excess of such maximum quantity, computed as in the last clause, is hereby fixed at forty cents per 1,000 gallons.

The charge for water supplied by measure shall be payable on demand at the office of the Trust.

Dated this 24th day of October, 1967.

(SEAL) G. T. UPTON, Chairman.
W. K. ROBERTSON, Commissioner.
F. PHILLIPS, Secretary.

Approved, 27th November, 1967.—W. BORTHWICK, Minister of Water Supply.

Melbourne and Metropolitan
BOARD OF WORKS.

NOTICE TO THE OWNERS OF TENEMENTS IN THE UNDERMENTIONED STREETS AND THE PRIVATE STREETS, LANES, COURTS AND ALLEYS OPENING THERETO.

THE main pipe in the said streets being laid down, the owners of all tenements situated as under are hereby required on or before the 8th January, 1968, to cause a proper pipe and stop cocks to be laid so as to supply water within such tenements from the main pipe.

H. J. SNADDEN,
28th November, 1967. Secretary.

STREET AND POSITION.

Broadmeadows.

Mascoma-street, from 60 feet east of Strathnaver-avenue south-eastwards 530 feet.

Camberwell.

Wandeen-street, from Gardenia-road to Arama-street.
Gardenia-road, from Wandeen-street to Oravel-street.
Arama-street, from Keon-court north-westwards 495 feet.
Keon-court, from Arama-street south-westwards 264 feet.

Diamond Valley.

Bent-street, from Monckton-street north-westwards 120 feet.
 Cambridge-way, from Bent-street to Oxford-drive.
 Yale-place, from Cambridge-way southwards 360 feet.
 Harvard-court, from Cambridge-way southwards 420 feet.
 Oxford-drive, from Cambridge-way to Grimshaw-street 600 feet.
 The Concord, from Grimshaw-street southwards, westwards and northwards 1,260 feet.
 The Concord, from 1,100 feet south of Grimshaw-street eastwards and northwards 120 feet.
 Bonnie Doone-street, from Eltham-road southwards 950 feet.
 Dixon-court, from Bonnie Doone-street south-westwards, northwards and southwards 670 feet.
 Brandon-court, from Bonnie Doone-street westwards 430 feet.

Doncaster and Templestowe.

Tasker-street, from Lakeview-terrace to Killarney-road.
 Lakeview-terrace, from Tasker-street southwards 60 feet.
 Rosebank-terrace, from Tasker-street southwards 230 feet.

Heidelberg.

Taree-place, from Tarcoola-drive southwards 270 feet.
 Moola-close, from Binowee-avenue northwards 490 feet.

Melbourne.

Penfold-place, from Little Collins-street northwards 200 feet.

Moorabbin.

Cavell-court, from 490 feet north of Balcombe-road northwards 120 feet.

Northcote.

Raleigh-street, from 940 feet east of Station-street eastwards 610 feet.

Nunawading.

Toomey-street, from Purches-street eastwards 550 feet.
 Lombard-road, from Toomey-street to Canterbury-road.
 Coady-court, from Lombard-road westwards 310 feet.
 Laidlaw-court, from Lombard-road westwards 270 feet.

Richmond.

Burnley-street, from Madden-grove southwards 570 feet.

Springvale.

Parker-street, from 340 feet south of Athol-road to Mackay-street.
 Mackay-street, from Parker-street eastwards 190 feet.
 Mackay-street, from Parker-street westwards 210 feet.

Sunshine.

Westmoreland-road, from Rufford-street to Craddock-court.
 Craddock-court, from Westmoreland-road eastwards 310 feet.

Waverley.

Bizley-street, from Gary-street westwards 66 feet.
 Academy-avenue, from 200 feet east of Brandon Park-drive eastwards 297 feet.
 Alumnus-court, from Academy-avenue southwards 660 feet.
 Salford-court, from Tiverton-drive north-westwards 346 feet.

Whittlesea.

Rochdale-square, from Sydney-crescent westwards 200 feet.
 Sydney-crescent, from Rochdale-square northwards 210 feet.
 Monash-street, from 140 feet east of Gibson-street to Kenna-drive.
 Kenna-drive, from Monash-street to Partridge-street.
 Edmondson-street, from Partridge-street southwards 110 feet.
 Partridge-street, from 200 feet east of Ballarat-street to Kenna-drive.

Town and Country Planning Act 1961.

SHIRE OF ELTHAM.

INTERIM DEVELOPMENT ORDER.

Notice of Approval.

IN pursuance of the powers conferred by the *Town and Country Planning Act 1961*, the Governor in Council on the 5th day of December, 1967, re-approved an Interim Development Order made by the Council of the Shire of Eltham for that portion of the municipal district of the Shire of Eltham known as the Eltham Business Centre.

The Interim Development Order provides that the use, subdivision or development of any land within the area described or the erection, construction or carrying out of

any buildings, roads or other works thereon is prohibited except that the Responsible Authority may permit such uses, subdivision, development, erection, constructions or other works as it thinks proper.

A copy of the Interim Development Order and the map showing the area affected may be inspected, free of charge, at the offices of the Council, Shire Offices, Main-road, Eltham, and at the offices of the Town and Country Planning Board, 179 Queen-street, Melbourne.

M. B. WATSON,
 Shire Secretary.

Town and Country Planning Act 1961.

SHIRE OF FLINDERS PLANNING SCHEME 1962.

AMENDMENT No. 6, 1967.

Notice of Approval.

IN pursuance of the powers conferred by the *Town and Country Planning Act 1961*, the Governor in Council on the 5th December, 1967, approved a planning scheme entitled the Shire of Flinders Planning Scheme 1962, Amendment No. 6, 1967, in respect of part of the municipal district of the Shire of Flinders and such planning scheme comes into operation on the date this notice of approval is published in the *Government Gazette*.

A copy of the planning scheme as approved may be inspected free of charge during office hours at the office of the Town and Country Planning Board, 179 Queen-street, Melbourne; at the office of the Flinders Shire Council at Dromana, and when available, at the Office of Titles, Melbourne, and at the Central Plan Office of the Department of Crown Lands and Survey, Melbourne.

W. H. CRAIG, Secretary,
 Town and Country Planning Board.

Town and Country Planning Act 1961.

SHIRE OF KNOX PLANNING SCHEME 1965.

AMENDMENT No. 2, 1966.

Notice of Approval.

IN pursuance of the powers conferred by the *Town and Country Planning Act 1961*, the Governor in Council on the 5th December, 1967, approved a planning scheme entitled the Shire of Knox Planning Scheme 1965, Amendment No. 2, 1966, in respect of part of the municipal district of the Shire of Knox and such planning scheme comes into operation on the date this notice of approval is published in the *Government Gazette*.

A copy of the planning scheme as approved may be inspected free of charge during office hours at the office of the Town and Country Planning Board, 179 Queen-street, Melbourne; at the office of the Knox Shire Council at Fern Tree Gully, and when available, at the Office of Titles, Melbourne, and at the Central Plan Office of the Department of Crown Lands and Survey, Melbourne.

W. H. CRAIG, Secretary,
 Town and Country Planning Board.

Town and Country Planning Act 1961.

SHIRE OF KNOX PLANNING SCHEME.

AMENDMENT No. 8, 1966.

Notice of Approval.

IN pursuance of the powers conferred by the *Town and Country Planning Act 1961*, the Governor in Council on the 5th December, 1967, approved a planning scheme entitled the Shire of Knox Planning Scheme, Amendment No. 8, 1966, in respect of part of the municipal district of the Shire of Knox and such planning scheme comes into operation on the date this notice of approval is published in the *Government Gazette*.

A copy of the planning scheme as approved may be inspected free of charge during office hours at the office of the Town and Country Planning Board, 179 Queen-street, Melbourne; at the office of the Knox Shire Council at Fern Tree Gully, and when available, at the Office of Titles, Melbourne, and at the Central Plan Office of the Department of Crown Lands and Survey, Melbourne.

W. H. CRAIG, Secretary,
 Town and Country Planning Board.

APPOINTMENTS AND RESIGNATIONS

APPOINTMENTS.

HIS Excellency the Governor of the State of Victoria, by and with the advice of the Executive Council thereof, has, by Orders made on the 28th day of November, 1967, been pleased to make the under-mentioned appointments, viz.:

CHIEF SECRETARY'S DEPARTMENT.

Chaplain of Prison (Part-time):

ALAN BAKER (the Reverend), pursuant to the provisions of the *Gaols Act 1958*, to be part-time Church of England Chaplain at Her Majesty's Prison, Pentridge, from 1st December, 1967, vice Edwin Thomas John Richardson (the Reverend), resigned; and

Chaplain of Rehabilitation Centre (Part-time):

WILLIAM FREDERICK MCKENZIE, C.B.E., B.A. (the Reverend), to be Methodist-Presbyterian Chaplain (part-time) at Dhurringile Rehabilitation Centre, from 9th December, 1967, to 5th April, 1968, vice Ian Silke (the Reverend), on leave.

MINISTRY OF HEALTH.

Official Visitor.

ALEXANDER REID McLACHLAN, to be an Official Visitor to the Mental Hospital, Warrnambool, pursuant to section 66 of the *Mental Health Act 1959*, for the further period ending 31st October, 1972.

LAW DEPARTMENT.

Clerk of Petty Sessions.

GEOFFREY JOHN WATERS, to be Clerk of Petty Sessions at Coburg, during the absence of F. J. Tenni, on annual leave, to take effect from the date of commencement of duty.

Commissioners for Taking Declarations, &c.

JACK VORWEG, Marine-parade, San Remo,
IAN CHARLES KEENAN, R.A.E.M.E. Training Centre, Bandiana,
ALBERT RICHARD O'BRIEN, 23 Thomas-street, Thomas-town,
VALERIE YVONNE LAMB, 16 Josephine-street, Oak Park,
ROY DESMOND PARKER, 12 Hudson-street, Hampton, and
NEVILLE FREDERICK JOHN DAVIS, 392 Middleborough-road, Blackburn,
to be Commissioners for taking Declarations and Affidavits, pursuant to the provisions of the *Evidence Act 1958*, to resign upon removing from the neighbourhood of the addresses stated; and

RONALD KEITH STREETER, care of Railways Workshops, Newport, and

GORDON JAMES HARLAND, care of Shire Office, Dalyston, to be Commissioners for taking Declarations and Affidavits, pursuant to the provisions of the *Evidence Act 1958*, to resign upon ceasing to occupy their present positions.

Justices of the Peace.

DOUGLAS ERIC MUIR, 7 Moralla-road, Kooyong, to keep the Peace in the Central Bailiwick of the State of Victoria;

WILLIAM FREDERICK PITTAWAY, 1 White-parade, Churchill, and

KEITH WHITE, Yinnar, to keep the Peace in the Eastern Bailiwick of the State of Victoria; and

HERBERT LOUÏE SCHULTZ, 35 Scallan-street, Stawell, to keep the Peace in the Western Bailiwick of the State of Victoria.

Queen's Counsel.

THOMAS ALFRED MILTON BOUTLER, Esquire (N.S.W.), to be one of Her Majesty's Counsel, under the Regulations of 11th October, 1955, to have precedence next after Ninian Martin Stephen, Esquire;

JOHN PHILIP SOMERVILLE, Esquire, to be one of Her Majesty's Counsel, under the Regulations of 11th October, 1955, to have precedence next after Thomas Alfred Milton Boulter, Esquire;

RICHARD GEORGE DE BURGH GRIFFITH, Esquire, to be one of Her Majesty's Counsel, under the Regulations of 11th October, 1955, to have precedence next after John Philip Somerville, Esquire;

KENNETH HENRY MARKS, Esquire, to be one of Her Majesty's Counsel, under the Regulations of 11th October, 1955, to have precedence next after Richard George de Burgh Griffith, Esquire; and

JACK THOMAS HIATT, Esquire (N.S.W.), to be one of Her Majesty's Counsel, under the Regulations of 11th October, 1955, to have precedence next after Kenneth Henry Marks, Esquire.

DEPARTMENT OF THE TREASURER.

Collector of Imposts (Acting):

RUBIN JOHN BULMAN, to act temporarily as Collector of Imposts, Country Roads Board, vice R. G. Cooper, on leave.

J. ROSSITER,

Clerk of the Executive Council.

At the Executive Council Chamber,
Melbourne, 28th November, 1967.

LAW DEPARTMENT.

CURATOR OF CONVICT'S PROPERTY.

HIS Excellency the Governor of the State of Victoria, by and with the advice of the Executive Council thereof, doth, by Order made on the 28th day of November, 1967, pursuant to the provisions of section 550 of the *Crimes Act 1958*, commit the custody and management of the property of the convict Luciano Capuano to Guiseppi Capuano, of 203 Military-road, Avondale Heights, as a curator hereby appointed in that behalf.

J. ROSSITER,

Clerk of the Executive Council.

At the Executive Council Chamber,
Melbourne, 28th November, 1967.

Vermin and Noxious Weeds Act 1958.

APPOINTMENT OF INSPECTOR.

IT is hereby notified that the Public Service Board in exercise of its powers has appointed, the under-mentioned person as an Inspector under the provisions of section 4 of the *Vermin and Noxious Weeds Act 1958* without additional salary:

LESLIE JAMES HARDING.

A. J. HOLT,

Secretary for Lands.

RESIGNATIONS.

HIS Excellency the Governor of the State of Victoria, by and with the advice of the Executive Council thereof, has, by Orders made on the 28th day of November, 1967, accepted the resignations of the persons named hereunder of the offices mentioned, viz.:

CHIEF SECRETARY'S DEPARTMENT.

Licensing Inspector.

JOHN EDWARD MATTHEWS, as a Licensing Inspector for the purposes of the *Licensing Act 1958*, from the 9th October, 1967.

LAW DEPARTMENT.

Justice of the Peace.

HENRY FREDERICK PROT, from the Commission of the Peace for the Central Bailiwick of the State of Victoria.

J. ROSSITER,

Clerk of the Executive Council.

At the Executive Council Chamber,
Melbourne, 28th November, 1967.

ORDERS IN COUNCIL

DEPARTMENT OF CROWN LANDS AND SURVEY.

At the Executive Council Chamber, Melbourne, the twenty-eighth day of November, 1967.

PRESENT:

His Excellency the Governor of Victoria.
 Mr. Rossiter | Mr. Dickie.
 Mr. Manson

PERMANENT RESERVATION AND REVOCATION AS TO PART OF ORDER IN COUNCIL.—PARISHES OF NARRACAN AND YARRAGON.

HIS Excellency the Governor of the State of Victoria, by and with the advice of the Executive Council thereof, and in pursuance of Section 15 of the Land Act 1958, doth hereby:—

(1) REVOKE the Order in Council of the 23rd May 1881 by which the beds of certain lakes, rivers and creeks specified therein, and crown lands on the margins and on the banks thereof respectively, were permanently reserved for Public Purposes so far as it relates to that portion of the Narracan Creek as shown by cross-hatching on the plan hereunder.

(2) PERMANENTLY RESERVE for Public Purposes the Crown lands forming the new bed of the Narracan Creek where the course of the said creek has become altered since the 23rd May 1881, and all Crown lands on the bank thereof as shown hatched on the plan hereunder.

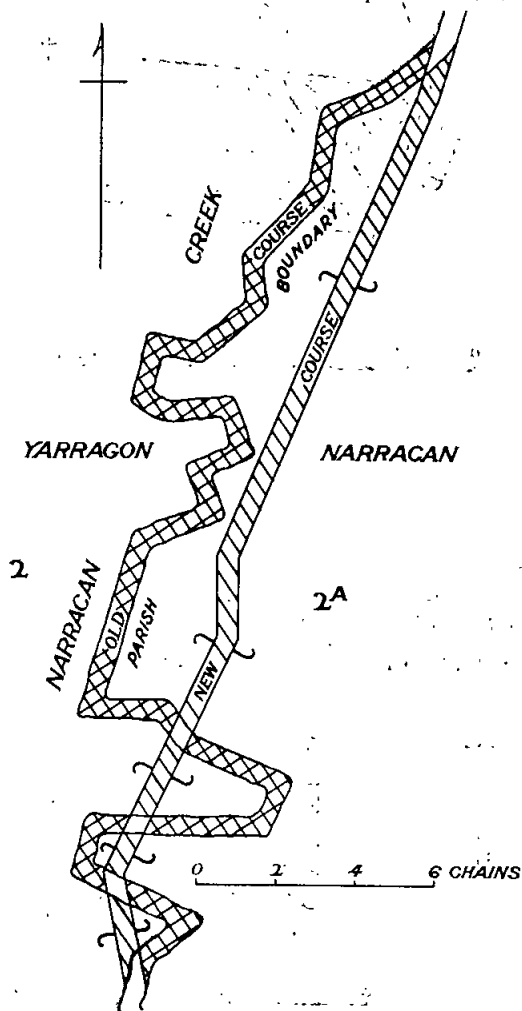

And the Honorable Sir William John Farquhar McDonald, Her Majesty's Minister of Lands for the State of Victoria, shall give the necessary directions herein accordingly.

J. ROSSITER,
 Clerk of the Executive Council.

DEPARTMENT OF CROWN LANDS AND SURVEY.

At the Executive Council Chamber, Melbourne, the twenty-eighth day of November, 1967.

PRESENT:

His Excellency the Governor of Victoria.
 Mr. Rossiter | Mr. Dickie.
 Mr. Manson

LAND ADOPTED BY THE CROWN FOR ROAD PURPOSES IN EXCHANGE FOR CROWN LAND AT EAGLEHAWK IN THE PARISH OF SANDHURST.

IN pursuance of the powers conferred by Section 208 of the Land Act 1958, His Excellency the Governor of the State of Victoria, by and with the advice of the Executive Council thereof, doth adopt the new road at Eaglehawk in the Parish of Sandhurst, County of Bendigo, being the land indicated by hatching in lieu of that portion of road indicated by cross hatching on the plan hereunder.—(S.371⁽²⁶⁾) (W.86932).

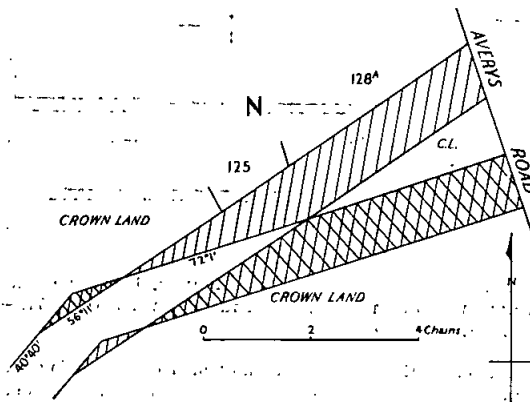

And the Honorable Sir William John Farquhar McDonald, Her Majesty's Minister of Lands for the State of Victoria, shall give the necessary directions herein accordingly.

J. ROSSITER,
 Clerk of the Executive Council.

DEPARTMENT OF CROWN LANDS AND SURVEY.

At the Executive Council Chamber, Melbourne, the twenty-eighth day of November, 1967.

PRESENT:

His Excellency the Governor of Victoria.
 Mr. Rossiter | Mr. Dickie.
 Mr. Manson

UNUSED ROADS CLOSED.

HIS Excellency the Governor of the State of Victoria, by and with the advice of the Executive Council thereof, doth hereby direct that, in pursuance of the provisions of section 349 of the Land Act 1958, the unused roads referred to hereunder be closed, viz.:—

Parish of Beechworth, County of Bogong, being the road between allotments 9, 10, 11, 12, 13, 14, 15, 16, section 3 and allotments 2, 1, section 2.—(B.349⁽²⁶⁾) (H.031122).

Township of Cohuna, Parish of Cohuna, County of Gunbower, being the portion of the road indicated by hatching on plan hereunder.—(C.424^(s)) (C.99757).

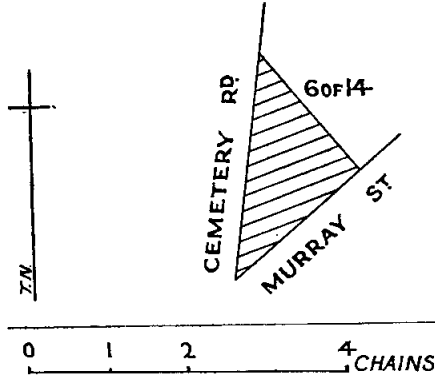

Parish of Eddington, County of Talbot, being the roads indicated by hatching on plan hereunder.—(E.16^(s)) (W.86034).

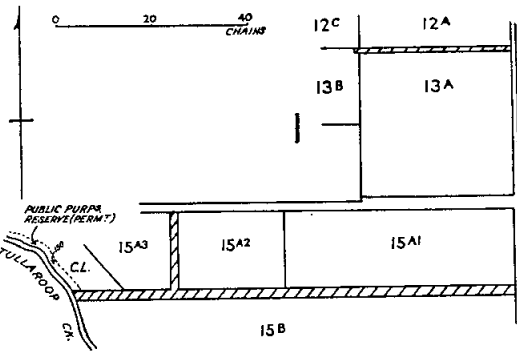

Parish of Kellalac, County of Borung, being the road between allotments 168, 169 and allotments 170, 171.—(K.154^{2A}) (M.60403).

Parish of Kunat Kunat, County of Tatchera, being the road between allotments 32 and 33, section 4, and the road between allotments 33 and 30, section 4.—(K.178^(s)) (M.61241).

Parish of Stanley, County of Bogong, being the road indicated by hatching on plan hereunder.—(S.339^(s)) (H.031354).

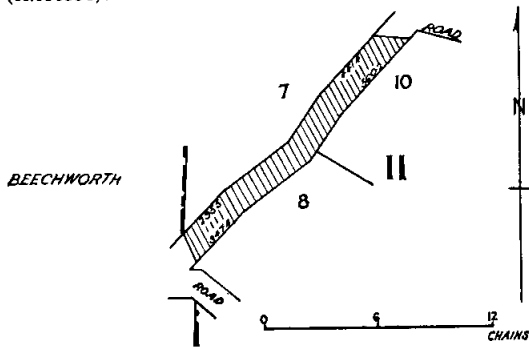

And the Honorable Sir William John Farquhar McDonald, Her Majesty's Minister of Lands for the State of Victoria, shall give the necessary directions herein accordingly.

J. ROSSITER,
Clerk of the Executive Council.

DEPARTMENT OF CROWN LANDS AND SURVEY.

At the Executive Council Chamber, Melbourne, the twenty-eighth day of November, 1967.

PRESENT:

His Excellency the Governor of Victoria.
Mr. Rossiter | Mr. Dickie.
Mr. Manson

LAND TEMPORARILY RESERVED AS SITES.

HIS Excellency the Governor of the State of Victoria, by and with the advice of the Executive Council thereof, doth hereby, in pursuance of section 14 of the Land Act 1958, reserve temporarily from sale, from being leased and from having a licence granted in respect thereof, and also except from occupation for mining purposes under any miner's right, the land hereinafter described:—

DARGO.—Site for Public purposes (Forests Department purposes), 2 roods, Township of Dargo, Parish of Dargo, County of Dargo, as indicated by hatching on plan hereunder.—(D.163^(s)) (Rs.8899).

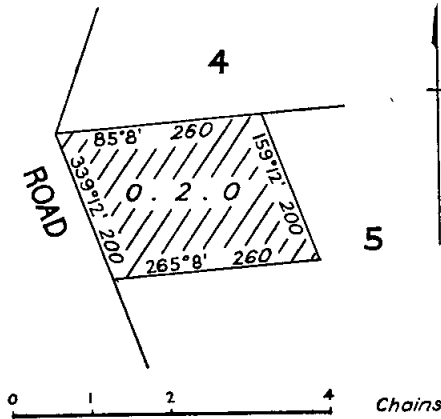

FORREST.—Site for Public purposes (Forests Department purposes), 1 rood 24 perches, Township of Forrest, Parish of Yaugher, County of Polwarth, as indicated by hatching on plan hereunder.—(F.104^(s)) (Rs.8850).

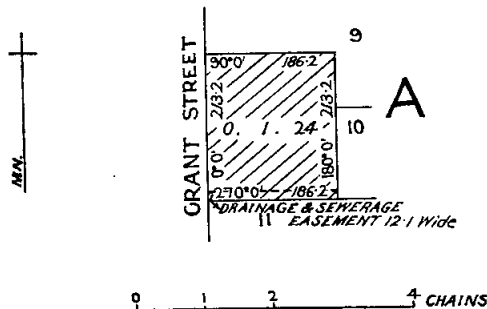

MERBEIN.—Site for Water Supply purposes, 2 roods, Township of Merbein, Parish of Merbein, County of Karkaroc, as indicated by hatching on plan hereunder.—(M.572A⁽³⁾) (Rs.8891).

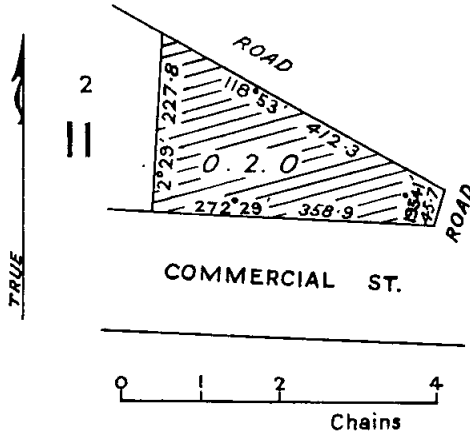

WORAIGWORM.—Site for a National Park, 2,870 acres, more or less, Parish of Woraigworm, County of Lowan, as indicated by hatching on plan hereunder.—(W.325⁽²⁾) (Rs.7401).

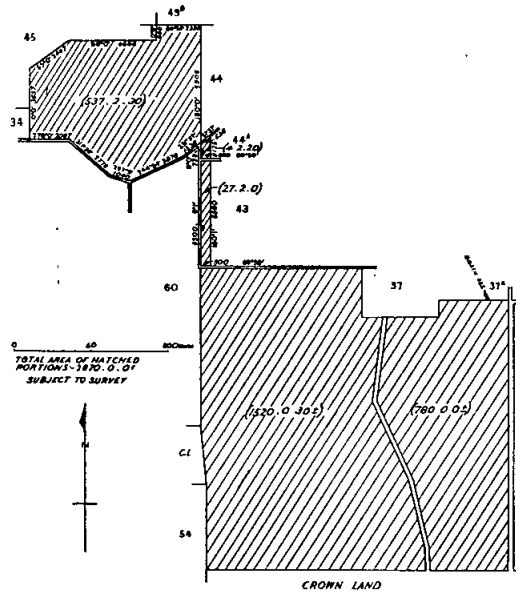

MOLOGA.—Site for Public Recreation, 7 acres 3 roods 16 perches, Parish of Mologa, County of Gunbower, as indicated by hatching on plan hereunder.—(M.506⁽³⁾) (Rs.8900).

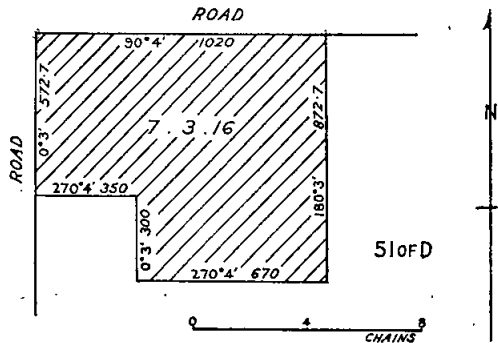

And the Honorable Sir William John Farquhar McDonald, Her Majesty's Minister of Lands for the State of Victoria, shall give the necessary directions herein accordingly.

J. ROSSITER,
Clerk of the Executive Council.

COUNTRY ROADS BOARD.

At the Executive Council Chamber, Melbourne, the twenty-eighth day of November, 1967.

PRESENT:

His Excellency the Governor of Victoria.
Mr. Rossiter | Mr. Dickie.
Mr. Manson

MONBULK.—Site for Ornamental Gardens, 6 acres 2 roods 6 perches, Parish of Monbulk, County of Mornington, as indicated by hatching on plan hereunder.—(M.555⁽¹²⁾) (Rs.474).

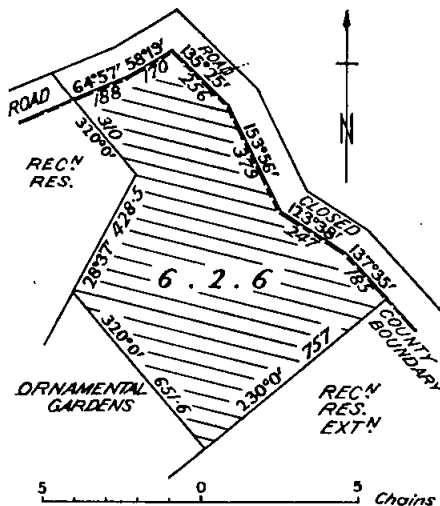

ORDER APPROVING OF LAND BEING ACQUIRED AND ROADS, DEVIATIONS OR WIDENINGS BEING MADE.

HIS Excellency the Governor of the State of Victoria, by and with the advice of the Executive Council thereof, being satisfied that there are funds legally available for acquiring the land, doth hereby approve the acquiring of the land described in the Schedule hereunder and the making of new roads and deviations from and widenings of existing roads referred to in the said Schedule.

SCHEDULE.

State Highways.

The land shown hatched on Plan numbered G.P. 10996 hereunder required for the widening of the South Gippsland Highway in the Shire of Cranbourne and making of the widening thereon.

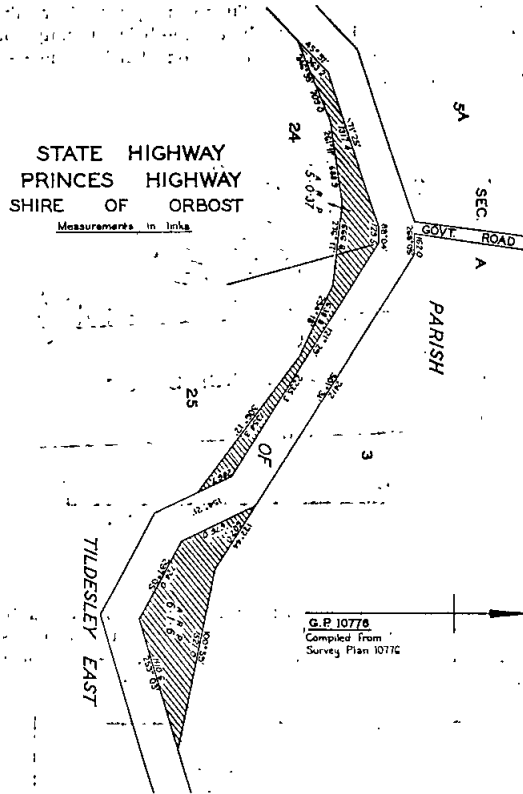
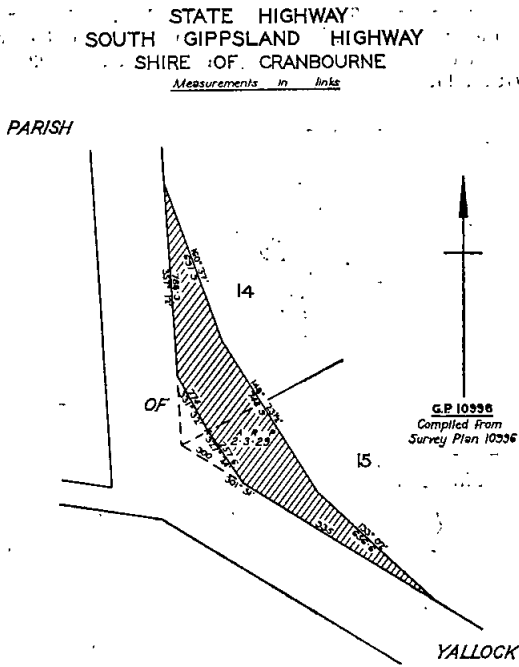

The land shown hatched on Plans numbered G.P. 10775 and G.P. 10776 hereunder required for the deviation of the Princes Highway in the Shire of Orbost and making of the deviation thereon.

The land shown hatched on Plan numbered G.P. 11037 hereunder required for the deviation of the Princes Highway in the Shire of Orbost and making of the deviation thereon.

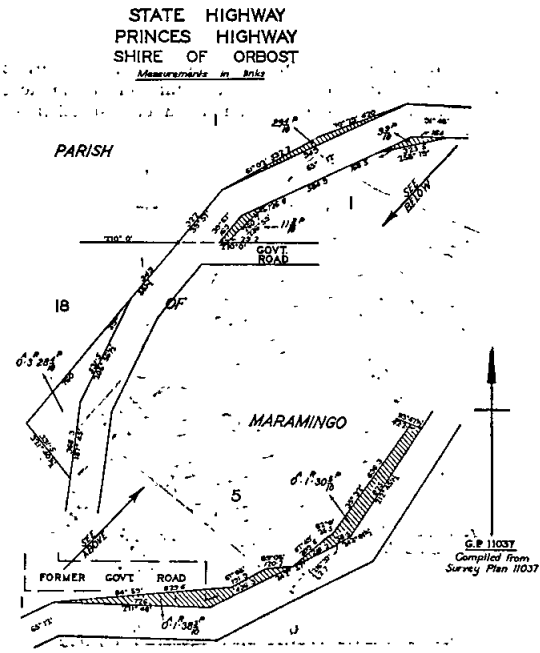
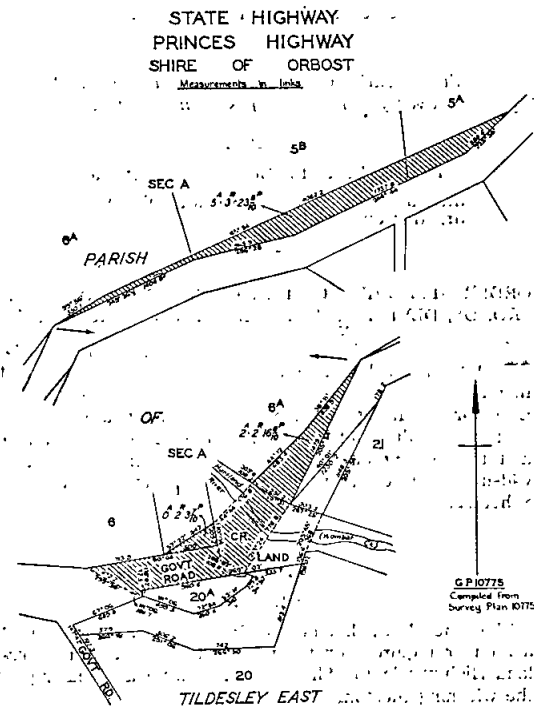

Main Roads.

The land shown hatched on Plan numbered G.P. 11001 hereunder required for the widening of the Hepburn-Newstead Road in the Shire of Daylesford and Glenlyon and making of the widening thereon.

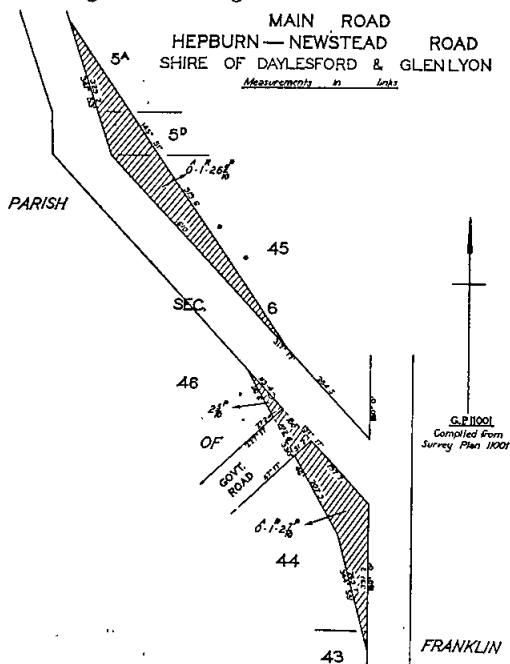

The land shown hatched on Plan numbered G.P. 11016 hereunder required for the widening of the Cobden-Scotts Creek Road in the Shire of Heytesbury and making of the widening thereon.

**MAIN ROAD
COBDEN-SCOTTS CREEK ROAD
SHIRE OF HEYTESBURY**

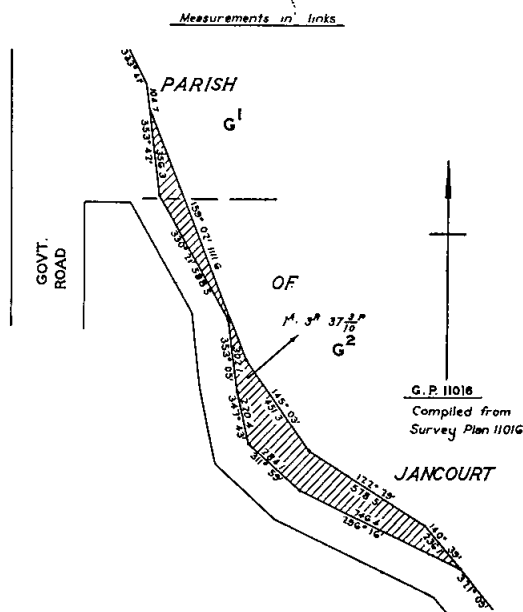

The land shown hatched on Plan numbered G.P. 11095 hereunder required for the widening of Marysville Road in the Shire of Healesville and making of the widening thereon.

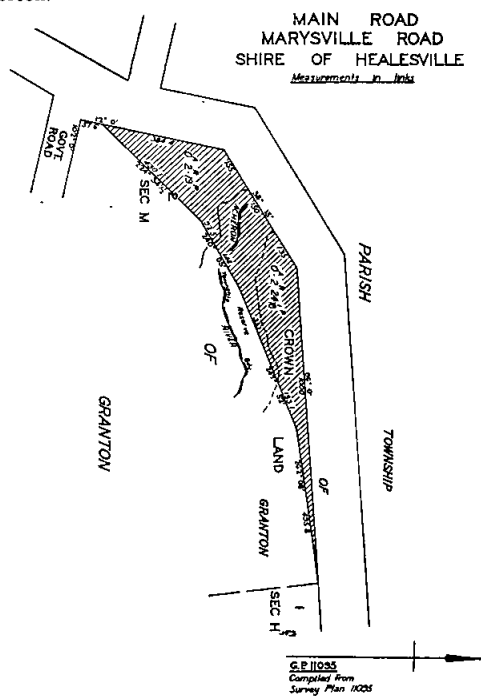

And the Honorable Murray Victor Porter, Her Majesty's Minister of Public Works for the State of Victoria, shall give the necessary directions herein accordingly.

J. ROSSITER,
Clerk of the Executive Council.

COUNTRY ROADS BOARD.

At the Executive Council Chamber, Melbourne, the twenty-eighth day of November, 1967.

PRESENT:

His Excellency the Governor of Victoria.
Mr. Rossiter | Mr. Dickie.
Mr. Manson

**ORDER CONFIRMING RESOLUTIONS OF THE
COUNTRY ROADS BOARD.**

HIS Excellency the Governor of the State of Victoria, by and with the advice of the Executive Council thereof, doth hereby, in pursuance of the provisions of the Country Roads Act 1958, confirm the resolutions of the Country Roads Board, the dates whereof and the terms of which are scheduled hereunder:—

SCHEDULE.

State Highways.

Resolution dated the Twentieth day of November, One Thousand Nine Hundred and Sixty-seven, made pursuant to Sections 21 and 74 of the Country Roads Act 1958 declaring the widening of the Princes Highway in the Shire of Berwick as shown hatched on Plan numbered G.P. 7351 hereunder to be part of a State highway within the meaning and for the purposes of the said Act.

STATE HIGHWAY
PRINCES HIGHWAY
SHIRE OF BERWICK

Measurements in links

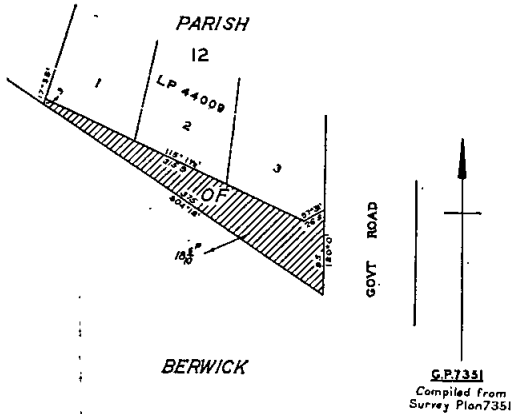

Resolution dated the Twentieth day of November, One Thousand Nine Hundred and Sixty-seven, made pursuant to Sections 21 and 74 of the Country Roads Act 1958 declaring the widening of the Maroondah Highway in the City of Nunawading as shown hatched on Plan numbered G.P. 7799 hereunder to be part of a State highway within the meaning and for the purposes of the said Act.

STATE HIGHWAY
MAROONDAH HIGHWAY
CITY OF NUNAWADING

Measurements in feet

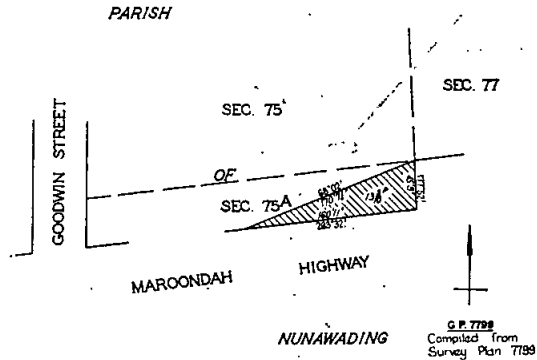

Resolution dated the Twentieth day of November, One Thousand Nine Hundred and Sixty-seven, made pursuant to Sections 21 and 74 of the Country Roads Act 1958 declaring the widening of the Burwood Highway in the City of Box Hill as shown hatched on Plan numbered G.P. 10648 hereunder to be part of a State highway within the meaning and for the purposes of the said Act.

STATE HIGHWAY
BURWOOD HIGHWAY
CITY OF BOX HILL

Measurements in feet

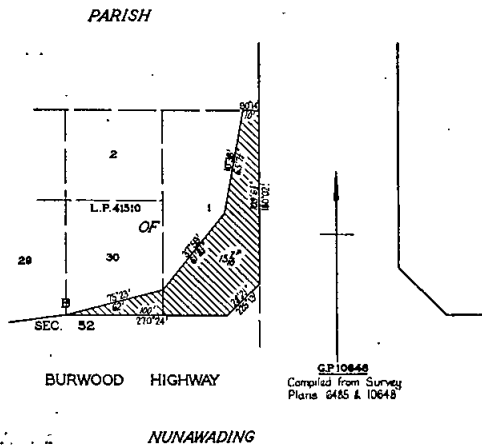

Resolution dated the Twentieth day of November, One Thousand Nine Hundred and Sixty-seven, made pursuant to Sections 21 and 74 of the Country Roads Act 1958 declaring the widening of the Ouyen Highway in the Shire of Walpeup as shown hatched on Plan numbered G.P. 8959 hereunder to be part of a State highway within the meaning and for the purposes of the said Act.

STATE HIGHWAY
OUYEN HIGHWAY
SHIRE OF WALPEUP

Measurements in links

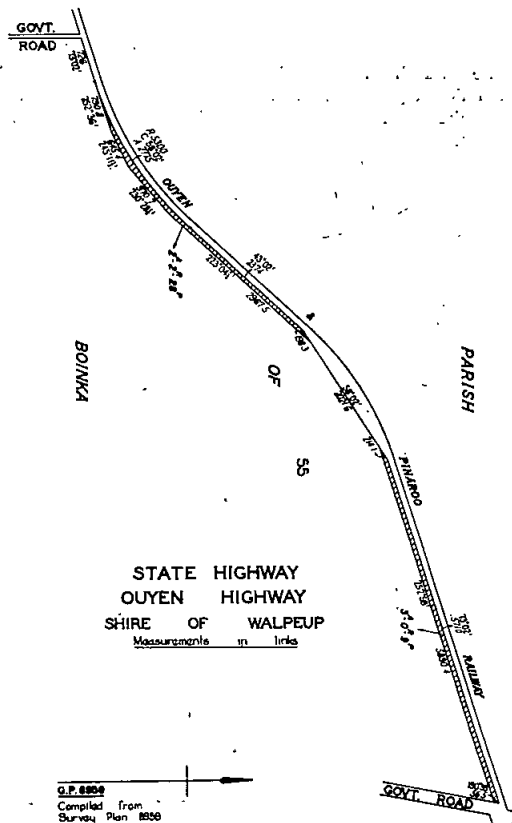

Main Roads.

Resolution dated the Twentieth day of November, One Thousand Nine Hundred and Sixty-seven, made pursuant to Section 21 of the Country Roads Act 1958 declaring the widening of the Bright-Tawonga Road, in the Shire of Bright as shown hatched on Plan numbered G.P. 8717 hereunder to be part of a main road within the meaning and for the purposes of the said Act.

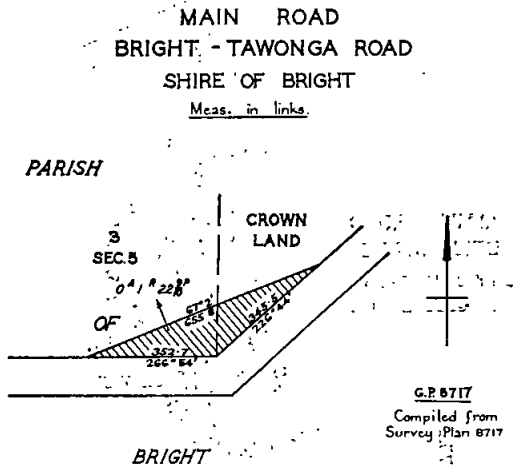

Resolution dated the Twentieth day of November, One Thousand Nine Hundred and Sixty-seven, made pursuant to Section 21 of the Country Roads Act 1958 declaring the widening of the Corangamite Lake Road in the Shire of Colac as shown hatched on Plan numbered G.P. 10764 hereunder to be part of a main road within the meaning and for the purposes of the said Act.

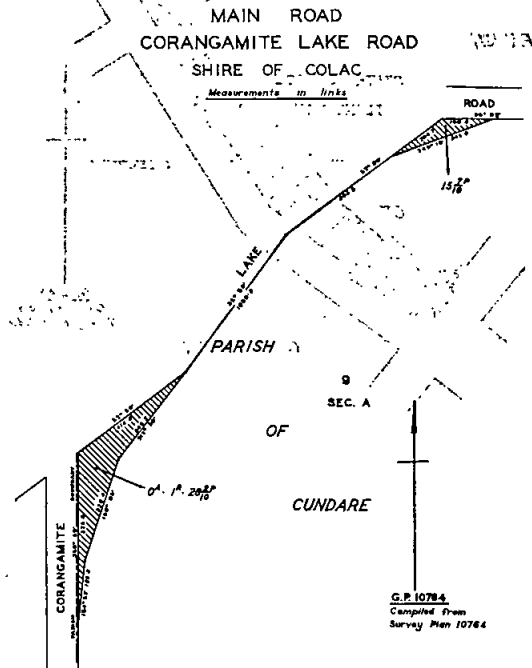

Resolution dated the Twentieth day of November, One Thousand Nine Hundred and Sixty-seven, made pursuant to Section 21 of the Country Roads Act 1958 declaring the widening of the Main Neerim Road in the Shire of Buln Buln as shown hatched on Plan numbered G.P. 10522 hereunder to be part of a main road within the meaning and for the purposes of the said Act.

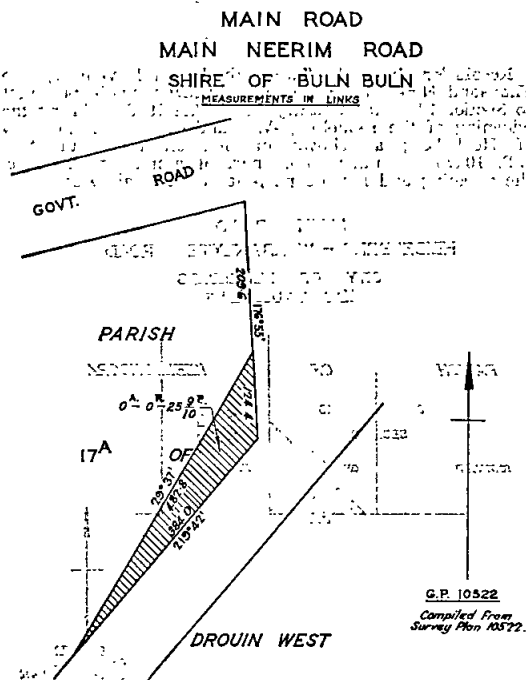

Resolution dated the Twentieth day of November, One Thousand Nine Hundred and Sixty-seven, made pursuant to Section 21 of the Country Roads Act 1958 declaring the widening of the Heidelberg-Kinglake Road in the Shire of Eltham as shown hatched on Plans, numbered G.P. 9148, G.P. 9149 and G.P. 9150, hereunder to be part of a main road within the meaning and for the purposes of the said Act.

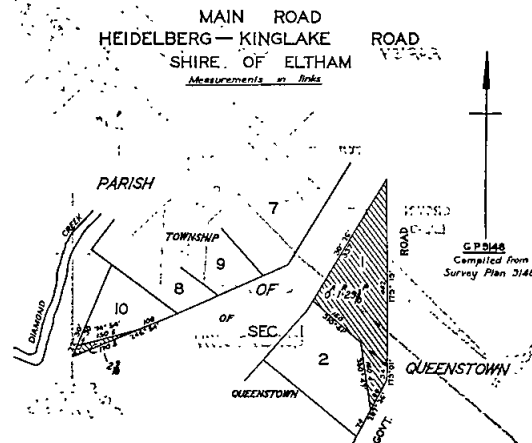

MAIN ROAD
HEIDELBERG—KINGLAKE ROAD
SHIRE OF ELTHAM
Measurements in links

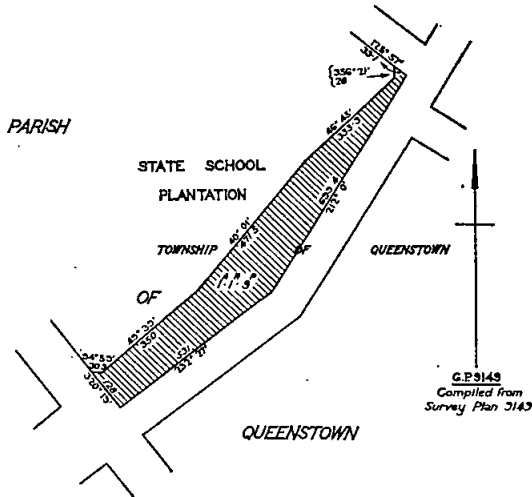

Resolution dated the Twentieth day of November, One Thousand Nine Hundred and Sixty-seven, made pursuant to Section 21 of the *Country Roads Act 1958* declaring the widening of Bell Street in the City of Heidelberg as shown hatched on Plan numbered G.P. 7467 hereunder to be part of a main road within the meaning and for the purposes of the said Act.

MAIN ROAD
BELL STREET
CITY OF HEIDELBERG
Measurements in feet

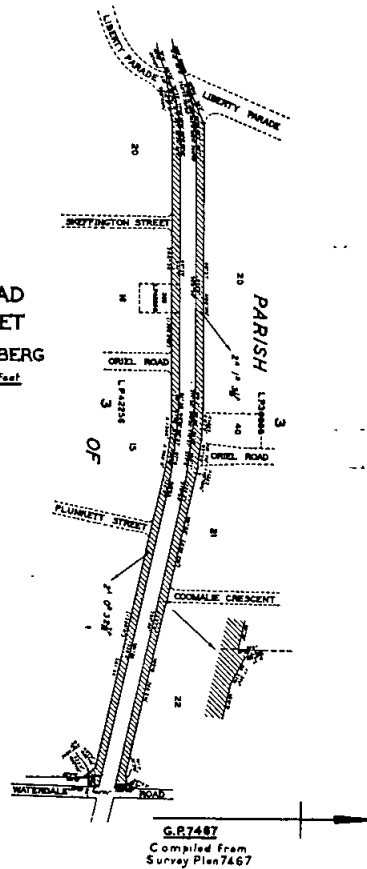

MAIN ROAD
HEIDELBERG—KINGLAKE ROAD
SHIRE OF ELTHAM
Measurements in links

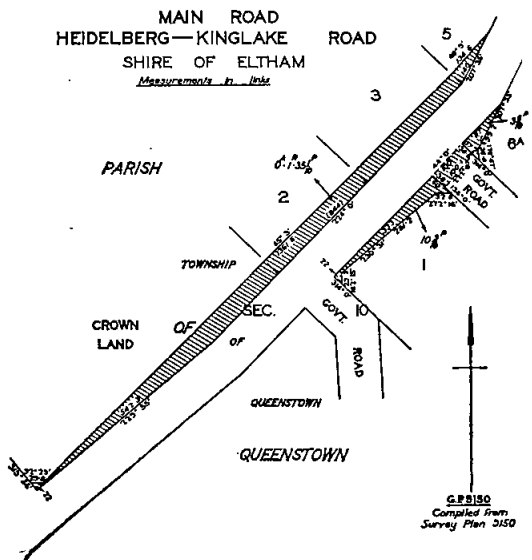

Resolution dated the Twentieth day of November, One Thousand Nine Hundred and Sixty-seven, made pursuant to Section 21 of the *Country Roads Act 1958* declaring the widening of the Heidelberg—Warrandyte Road in the City of Heidelberg as shown hatched on Plan numbered G.P. 10479 hereunder to be part of a main road within the meaning and for the purposes of the said Act.

MAIN ROAD
HEIDELBERG - WARRANDYTE ROAD
CITY OF HEIDELBERG
Measurements in feet

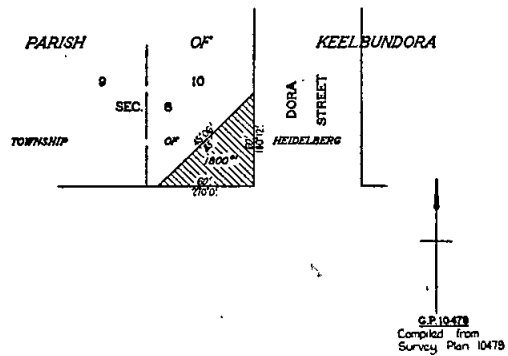

Resolution dated the Twentieth day of November, One Thousand Nine Hundred and Sixty-seven, made pursuant to Section 21 of the *Country Roads Act 1958* declaring the widening of the Mortlake-Framlingham Road in the Shire of Mortlake as shown hatched on Plans numbered G.P. 9061 and G.P. 9062 hereunder to be part of a main road within the meaning and for the purposes of the said Act.

Resolution dated the Twentieth day of November, One Thousand Nine Hundred and Sixty-seven, made pursuant to Section 21 of the *Country Roads Act 1958* declaring the widening of the Barwon Heads Road in the Shire of South Barwon as shown hatched on Plan numbered G.P. 7934 hereunder to be part of a main road within the meaning and for the purposes of the said Act.

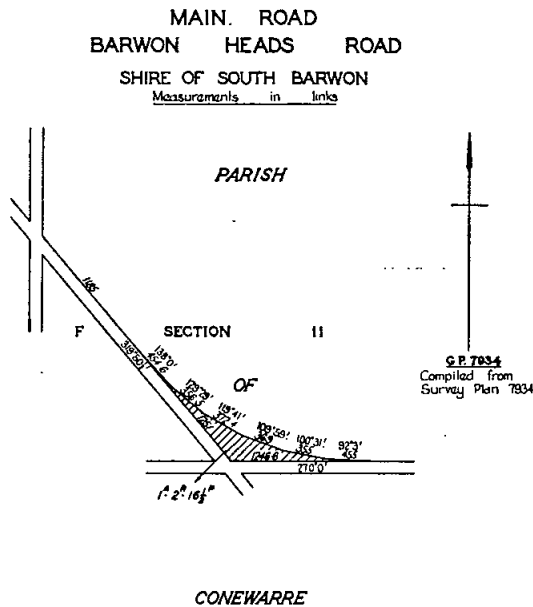
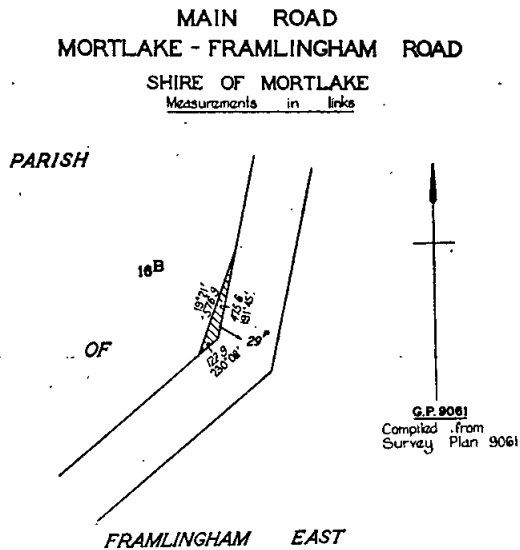

Resolution dated the Twentieth day of November, One Thousand Nine Hundred and Sixty-seven, made pursuant to Sections 21 and 58 of the *Country Roads Act 1958*, declaring the deviation from the Yabba Road in the Shire of Towong as indicated by diagonal hatching on Plan numbered G.P. 10784 hereunder to be part of a main road within the meaning and for the purposes of the said Act, and also declaring that such deviation shall be in lieu of the existing road or part thereof indicated by cross hatching on the said plan and that such part of the said existing road shall be discontinued.

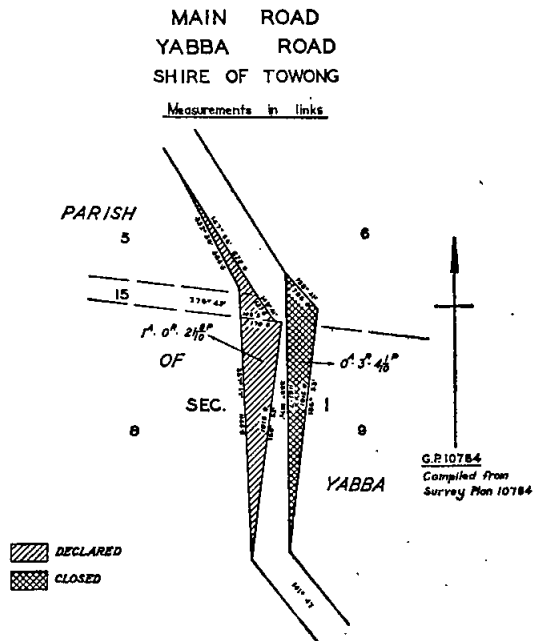
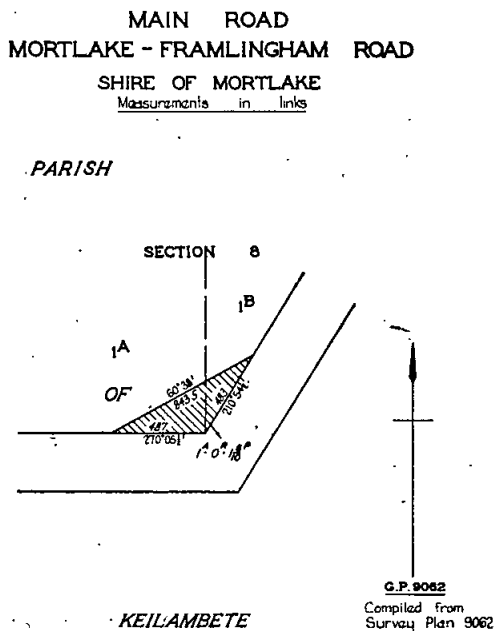

Unclassified Road.
 Resolution dated the Twentieth day of November, One Thousand Nine Hundred and Sixty-seven, made pursuant to Sections 21 and 110 of the Country Roads Act 1958, declaring the road in the Shire of Nathalia as shown hatched on Plan numbered G.P. 9902 hereunder, to be a road (Barmah Bridge Approach Road) within the meaning and for the purposes of the said Act.

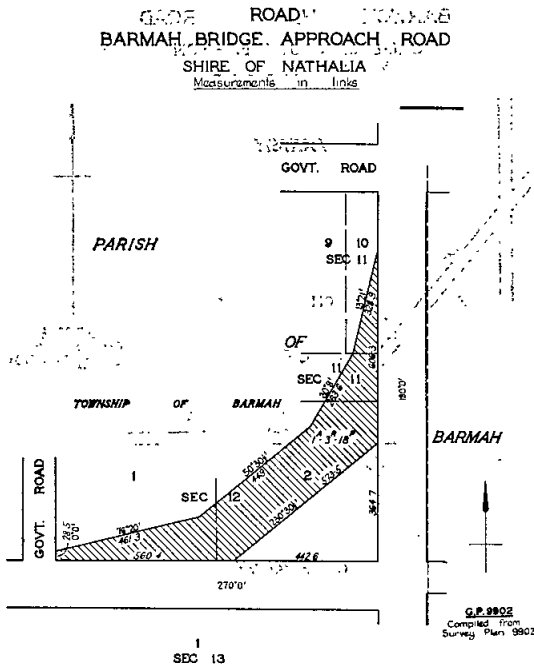

And the Honorable Murray Victor Porter, Her Majesty's Minister of Public Works for the State of Victoria, shall give the necessary directions herein accordingly.

J. ROSSITER,
 Clerk of the Executive Council.

LANDLORD AND TENANT ACT 1958.

At the Executive Council Chamber, Melbourne, the fifth day of December, 1967.

PRESENT:

His Excellency the Governor of Victoria.
 Mr. Reid | Mr. Thompson
 Mr. Meagher | Mr. Wilcox.

ORDER EXTENDING APPLICATION OF PART V. OF THE LANDLORD AND TENANT ACT 1958 TO CERTAIN PREMISES.

IN pursuance of the powers conferred by Section 44 of the Landlord and Tenant Act 1958, His Excellency the Governor of Victoria, by and with the advice of the Executive Council, doth hereby declare that the application of Part V. of the Landlord and Tenant Act 1958 shall extend to the following premises:—

1. The premises known as Number 66 Chandler Road, Noble Park; and
2. The premises known as Number 94 Fortesque Avenue, Seaford.

And the Honorable George Oswald Reid, Her Majesty's Attorney-General in and for the State of Victoria, shall give the necessary directions herein accordingly.

F. R. KENNY,
 Acting Clerk of the Executive Council.

LANDLORD AND TENANT ACT 1958.

At the Executive Council Chamber, Melbourne, the fifth day of December, 1967.

PRESENT:

His Excellency the Governor of Victoria.
 Mr. Reid | Mr. Thompson
 Mr. Meagher | Mr. Wilcox.

ORDER EXCLUDING CERTAIN PREMISES FROM THE OPERATION OF CERTAIN OF THE PROVISIONS CONTAINED IN PART V. OF THE LANDLORD AND TENANT ACT 1958.

IN pursuance of the powers conferred upon him by the Landlord and Tenant Act 1958, His Excellency the Governor of the State of Victoria, by and with the advice of the Executive Council thereof, doth hereby declare that the premises known as Number 15 Neill Street, Carlton, shall be excluded from the operation of the whole of the provisions contained in Divisions 2 and 3 of Part V. of the Landlord and Tenant Act 1958.

And the Honorable George Oswald Reid, Her Majesty's Attorney-General in and for the State of Victoria, shall give the necessary directions herein accordingly.

F. R. KENNY,
 Acting Clerk of the Executive Council.

TOWN AND COUNTRY PLANNING ACT 1961.

At the Executive Council Chamber, Melbourne, the fifth day of December, 1967.

PRESENT:

His Excellency the Governor of Victoria.
 Mr. Reid | Mr. Thompson
 Mr. Meagher | Mr. Wilcox.

REVOCATION IN PART OF THE SHIRE OF KNOX PLANNING SCHEME 1965.—REVOCATION No. 1.

WHEREAS it is provided under the Town and Country Planning Act 1961 that the Governor in Council, upon application of the Town and Country Planning Board or the responsible authority or of any other person or body of persons appearing to him to be interested, may revoke the whole or any part of any planning scheme if he thinks that, under the special circumstances of the case it should be so revoked:

AND WHEREAS it is provided under the Town and Country Planning Act 1961 that the Governor in Council may by notice of revocation thereof prohibit the use or development of any land to which the revoked scheme or part related except with the consent of the responsible authority which prepared the scheme, until such time as a further interim development order is made and any such prohibition shall be deemed to be an interim development order;

NOW THEREFORE, His Excellency the Governor of the State of Victoria, by and with the advice of the Executive Council and on the recommendation of the Town and Country Planning Board doth hereby:—

- (i) revoke the Shire of Knox Planning Scheme 1965, in so far as it applies to all that land being part of lot 1, on plan of subdivision 69539, Parish of Scoresby, County of Mornington, the boundaries of which are as follows:—Commencing at a point on the south-western alignment of Burwood Highway 348' 8" south-east of the south-eastern alignment of Kevin Avenue, thence by lines 222° 47' for a distance of 355' 7"; 165° 14' for a distance of 409' 3"; 48° 19' for a distance of 565' 4" to the south-western alignment of Burwood Highway, thence north-westerly by the said south-western alignment of Burwood Highway for a distance of 400' to the point of commencement; and
- (ii) prohibit the use or development of any land described in (i) above except with the consent of the Council of the Shire of Knox.

And the Honorable Rupert James Hamer, Her Majesty's Minister for Local Government for the State of Victoria, shall give the necessary directions herein accordingly.

F. R. KENNY,
 Acting Clerk of the Executive Council.

ROAD TRAFFIC ACT 1958.

At the Executive Council Chamber, Melbourne, the
fifth day of December, 1967.

PRESENT:

| | |
|--|--------------|
| His Excellency the Governor of Victoria. | |
| Mr. Reid | Mr. Thompson |
| Mr. Meagher | Mr. Wilcox. |

APPOINTMENT OF A MEMBER OF THE TRAFFIC COMMISSION.

HIS Excellency the Governor of the State of Victoria, in the Commonwealth of Australia, by and with the advice of the Executive Council of the said State, and in pursuance of the powers conferred by the Road Traffic Act 1958 and all other powers him thereunto enabling, doth by this Order approve the following person as a member of the Traffic Commission, as from and inclusive of the 6th December, 1967, in place of John Edward Matthews:—

RONALD KNIGHT, a member of the Police Force, nominated by the Chief Commissioner of Police.

And the Honorable Arthur Gordon Rylah, Her Majesty's Chief Secretary for the State of Victoria, shall give the necessary directions herein accordingly.

F. R. KENNY,
Acting Clerk of the Executive Council.

SUPERANNUATION ACT 1958.

At the Executive Council Chamber, Melbourne the
fifth day of December, 1967.

PRESENT:

| | |
|--|--------------|
| His Excellency the Governor of Victoria. | |
| Mr. Reid | Mr. Thompson |
| Mr. Meagher | Mr. Wilcox. |

PURSUANT to the powers conferred by the provisions of Subsection (1) of Section 3 of the Superannuation Act 1958, as amended by Paragraph (a) of Subsection 2 of Section 18 of the Pensions Supplementation Act 1966 No. 7417, His Excellency the Governor of the State of Victoria by and with the advice of the Executive Council thereof doth by this Order declare that the provisions of the Superannuation Act shall apply to THOMAS MURRAY AVARD of the Victoria Institute of Colleges constituted pursuant to the provisions of the Victoria Institute of Colleges Act 1965, No. 7291.

And the Honorable Sir Henry Edward Bolte, Her Majesty's Treasurer for the State of Victoria, shall give the necessary directions herein accordingly.

F. R. KENNY,
Acting Clerk of the Executive Council.

MOUNT ELIZA SEWERAGE AUTHORITY.

At the Executive Council Chamber, Melbourne, the
fifth day of December, 1967.

PRESENT:

| | |
|--|--------------|
| His Excellency the Governor of Victoria. | |
| Mr. Reid | Mr. Thompson |
| Mr. Meagher | Mr. Wilcox. |

CONSENT TO BORROWING \$30,000.

UNDER the powers conferred by the Sewerage Districts Act and all other powers enabling him in that behalf, His Excellency the Governor of the State of Victoria, by and with the advice of the Executive Council of the said State, doth hereby consent to the Mount Eliza Sewerage Authority borrowing at interest, by mortgage of the General Fund, the sum of Thirty thousand dollars (\$30,000) to meet the cost of sewerage works, as set forth in the detailed statement bearing date the 30th November, 1967.

And the Honorable William Archibald Borthwick, Her Majesty's Minister of Water Supply for the State of Victoria, shall give the necessary directions herein accordingly.

F. R. KENNY,
Acting Clerk of the Executive Council.

MANSFIELD SEWERAGE AUTHORITY.

At the Executive Council Chamber, Melbourne, the
fifth day of December, 1967.

PRESENT:

| | |
|--|--------------|
| His Excellency the Governor of Victoria. | |
| Mr. Reid | Mr. Thompson |
| Mr. Meagher | Mr. Wilcox. |

AMENDMENT OF ORDER.

UNDER the powers conferred by the Sewerage Districts Act and all other powers enabling him in that behalf, His Excellency the Governor of the State of Victoria, by and with the advice of the Executive Council of the said State, doth hereby amend as follows the Order in Council proclaiming the Sewerage District and constituting the Mansfield Sewerage Authority made on 23rd January, 1951, and published in the Government Gazette dated 31st January, 1951:—

In Clause (a) for the expression "Ninety thousand pounds (£90,000)" there shall be substituted the expression "Six hundred thousand dollars (\$600,000)".

And the Honorable William Archibald Borthwick, Her Majesty's Minister of Water Supply for the State of Victoria, shall give the necessary directions herein accordingly.

F. R. KENNY,
Acting Clerk of the Executive Council.

YARRA JUNCTION WATERWORKS TRUST.

At the Executive Council Chamber, Melbourne, the
fifth day of December, 1967.

PRESENT:

| | |
|--|--------------|
| His Excellency the Governor of Victoria. | |
| Mr. Reid | Mr. Thompson |
| Mr. Meagher | Mr. Wilcox. |

REPEAL OF ORDER.

UNDER the powers conferred by the Water Act and all other powers enabling him in that behalf, His Excellency the Governor of the State of Victoria, by and with the advice of the Executive Council of the said State, doth hereby repeal the Order in Council fixing the limit of the overdraft to be obtained by the Yarra Junction Waterworks Trust from the National Bank of Australasia Limited, Warburton, made on 21st December, 1954, and published in the Victoria Government Gazette dated 22nd December, 1954.

And the Honorable William Archibald Borthwick, Her Majesty's Minister of Water Supply for the State of Victoria, shall give the necessary directions herein accordingly.

F. R. KENNY,
Acting Clerk of the Executive Council.

LANDS DEPARTMENT NOTICES

APPROACHING LAND SALES.

SALES of Crown Lands, in fee-simple, will be held at the under-mentioned places and dates, viz.:

| | No. of Gazette. |
|---|--------------------|
| Beaufort.—Thursday, 7th December, 1967 .. | 85 |
| Daylesford.—Tuesday, 19th December, 1967 .. | 87 |
| Inglewood.—Tuesday, 12th December, 1967 .. | 86 |
| Pyramid Hill.—Wednesday, 13th December, 1967 .. | 86 |
| Sea Lake.—Tuesday, 12th December, 1967 .. | 86 |
| Stawell.—Friday, 8th December, 1967 .. | 85 |
| Swan Hill.—Wednesday, 13th December, 1967 .. | 86 |
| Wangaratta.—Thursday, 7th December, 1967 .. | 85 |

SALE OF FREEHOLD LAND BY AUCTION.

| | |
|---|----|
| Geelong.—Monday, 16th January, 1967 .. | 89 |
| Kerang.—Wednesday, 13th December, 1967 .. | 86 |

AUCTION OF RIGHT TO LEASE CROWN LAND.

Melbourne.—Wednesday, 20th December, 1967 .. 87

Land Act 1958.
PERMIT CANCELLED.

NOTICE is hereby given that the permit in the Schedule hereunder has been cancelled.

| District. | Corr. No. | Name of Permit Holder. | Parish. | Lot. | Section. | Area. |
|--------------|-----------|------------------------|---------------|------|----------|-----------------------|
| Mallee | C.21/8 | David Feiglin | Carwarp | 21 | .. | A. R. P. 4,998 0 0 |

Department of Crown Lands and Survey,
Melbourne, 30th November, 1967.

W. J. F. McDONALD,
Minister of Lands.

PROPOSED REVOCATIONS OF TEMPORARY RESERVATIONS OF LANDS BY ORDERS IN COUNCIL.

IN pursuance of the provisions of the Land Act 1958 notice is hereby given that it is the intention of the Governor in Council to revoke the temporary reservations of lands by Orders in Council hereunder referred to, viz.:

The following Notices were published 1° on the 6th December, 1967, pursuant to Orders of the 28th November, 1967.

ASHENS.—The temporary reservation, by Order in Council of the 31st October, 1922, of 10 acres (shown as 8 acres 3 roods 6 perches on Order) of land in the Parish of Ashens as sites for Supply of Loam is about to be revoked.—(A.168⁽⁸⁾) (Rs.2644).

SMYTHESDALE.—The temporary reservation, by Order in Council of the 6th November, 1865, of 815 acres 2 roods 15 perches of land in the Parish of Smythesdale as a site for Drainage Area of a Reservoir for supplying water to Smythesdale, revoked as to part by various Orders, is about to be revoked so far only as the portion containing 20 acres 30 perches, more or less, indicated by hatching on plan hereunder, is concerned.—(S.297⁽⁸⁾) (C.71778).

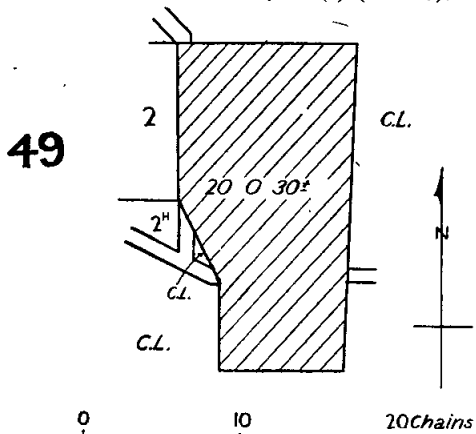

WARRANTYTE (ANDERSONS CREEK).—The temporary reservation, by Order in Council of the 17th September, 1866, of 14 acres 2 roods of land in the Township of Warrantyte as a site for Recreation purposes, revoked as to part by various Orders, is about to be revoked so far only as the portion containing 18 perches, indicated by hatching on plan hereunder, is concerned.—(W.25⁽⁴⁾) (Rs.653).

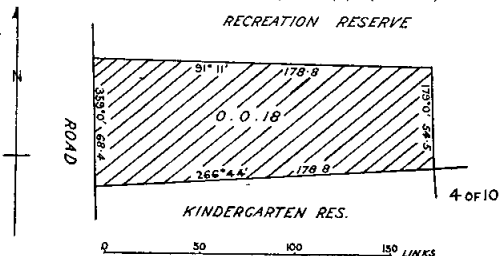

W. J. F. McDONALD,
Minister of Lands.

PROPOSED PERMANENT RESERVATION OF LAND AS A SITE.

IN pursuance of sections 14 and 21 of the Land Act 1958, notice is hereby given that it is the intention of the Governor in Council to reserve permanently from sale, from being leased and from having a licence granted in respect thereof the land hereinafter described:—

The following Notice was published 1° on the 15th November, 1967, pursuant to Order of the 8th November, 1967.

BELLARINE.—Land proposed to be permanently reserved as a site for Public Park, 200 acres, Parish of Bellarine, County of Grant, as indicated by hatching on plan hereunder.—(B.331⁽⁸⁾) (Rs.8895).

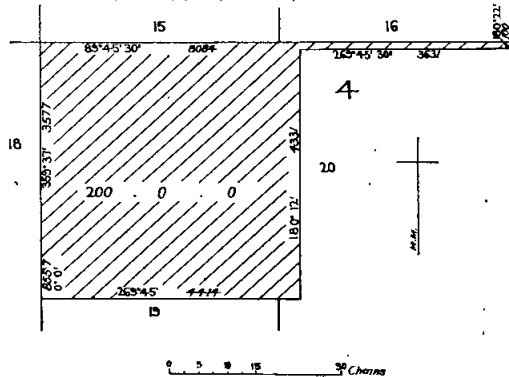

W. J. F. McDONALD,
Minister of Lands.

PROPOSED REVOCATIONS OF TEMPORARY RESERVATIONS OF LANDS BY ORDERS IN COUNCIL.

IN pursuance of the provisions of the Land Act 1958, notice is hereby given that it is the intention of the Governor in Council to revoke the temporary reservations of lands by Orders in Council hereunder referred to, viz.:

The following Notices were published 1° on the 22nd November, 1967, pursuant to Orders of the 14th November, 1967.

BEAUFORT.—The temporary reservation by Order in Council of the 7th August, 1871, of 5 acres of land in the Parish of Beaufort as a site for watering purposes, revoked as to part by various Orders, is about to be revoked so far only as the portion containing 3 roods 20 perches, more or less, indicated by hatching on plan hereunder, is concerned.—(B305⁽¹⁾) (Rs.4736).

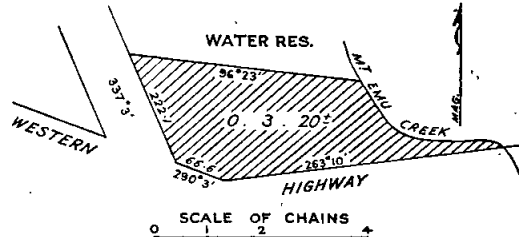

COONIMUR.—The temporary reservation, by Order in Council of the 22nd November, 1921, of 2 acres of land in the Parish of Coonimur as a site for a State School is about to be revoked.—(C.450⁽¹⁾) (Rs.2414).

MALMSBURY.—The temporary reservation, by Order in Council of the 18th April, 1961, of 83 acres, more or less, of land in the Township of Malmsbury as a site for the purposes of the Social Welfare Department is about to be revoked so far only as the portion containing 1 rood 14 perches, indicated by hatching on plan hereunder, is concerned.—(M.65⁽⁴⁾) (Rs.358).

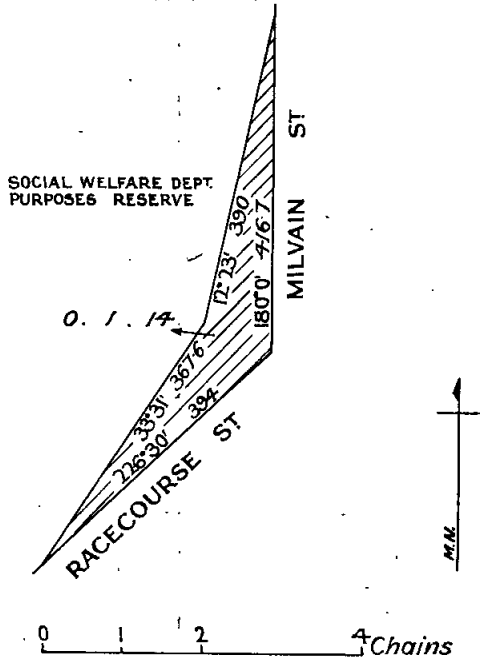

PALLARANG.—The temporary reservation, by Order in Council of the 11th November, 1919, of 2 acres 2 roods of land in the Parish of Pallarang as a site for a Public Hall is about to be revoked.—(P.176⁽³⁾) (Rs.1782).

POWELLTOWN.—The temporary reservation, by Order in Council of the 4th November, 1964, of 5 acres 2 roods 3 perches of land in the Township of Powelltown as a site for Public Recreation is about to be revoked.—(P.188⁽²⁾) (Rs.8367).

W. J. F. McDONALD,
Minister of Lands.

GARIBALDI.—The temporary reservation, by Order in Council of the 17th May, 1887, (see *Government Gazette* 20th May, 1887, page 1331) of 12 acres 5 perches of land in the Parish of Enfield (now in the Township of Garibaldi) as a site for supply of material for Road-making purposes, revoked as to part by Order in Council of the 12th July, 1909, (see *Government Gazette* 21st July, 1909, page 3322) is about to be revoked save and except the area of 6 acres 3 roods 30 perches, more or less, indicated by hatching on plan hereunder.—(E.52⁽⁴⁾) (Rs.8892).

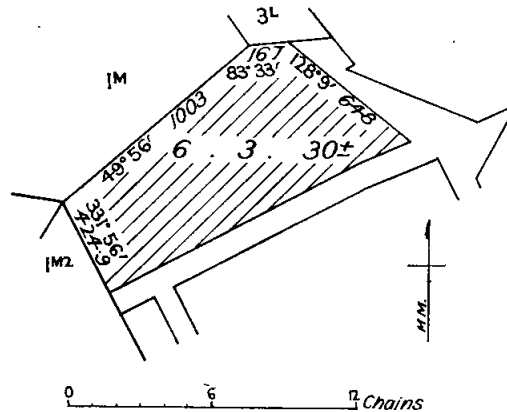

KALKEE.—The temporary reservation as a site for Public purposes and the withholding from sale, leasing and licensing by Order in Council of the 22nd November, 1875, of 60 acres 1 rood 26 perches of land in the Parish of Kalkee, revoked as to part by Order in Council of the 31st July, 1928, are about to be revoked so far as the balance thereof containing 10 acres 1 rood 38 perches is concerned.—(K.143⁽³⁾) (Rs.7261).

WILLAM.—The temporary reservation, by Order in Council of the 15th March, 1887, (see *Government Gazette* 18th March, 1887, page 785) of 6 acres 5 perches of land in the Parish of Willam as a site for Water Supply purposes and the temporary reservation by Order in Council of the 27th August, 1894 (see *Government Gazette* 31st August, 1894, page 3529) of 2 acres, more or less, of land as an extension thereto are about to be revoked.—(W.346⁽⁴⁾) (Rs.8883).

W. J. F. McDONALD,
Minister of Lands.

PROPOSED REVOCATIONS OF TEMPORARY RESERVATIONS OF LANDS BY ORDERS IN COUNCIL.

IN pursuance of the provisions of the *Land Act 1958*, notice is hereby given that it is the intention of the Governor in Council to revoke the temporary reservations of lands by Orders in Council hereunder referred to, viz.:—

The following Notices were published 1^o on the 29th November, 1967, pursuant to Orders of the 21st November, 1967.

OAKLEIGH.—The temporary reservation, by Order in Council of the 12th May, 1925, of 1 acre 1 rood 4 perches of land in the Township of Oakleigh as a site for Public Recreation Purposes is about to be revoked so far only as the portion containing 34 perches, indicated by hatching on plan hereunder, is concerned.—(O.1⁽²⁾) (Rs.470).

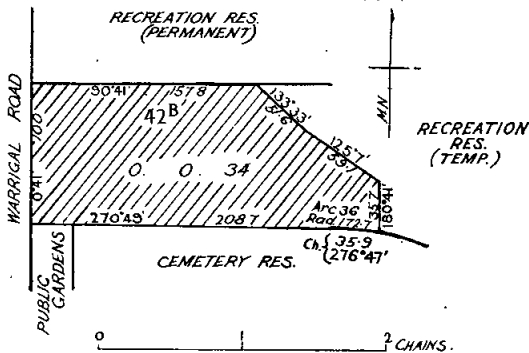

PROPOSED REVOCATION OF TEMPORARY RESERVATION OF LAND BY ORDER IN COUNCIL.

IN pursuance of the provisions of the *Land Act 1958*, notice is hereby given that it is the intention of the Governor in Council to revoke the temporary reservations of lands by Orders in Council hereunder referred to, viz.:—

The following Notices were published 1^o on the 29th November, 1967, pursuant to Orders of the 19th September, 1967.

WOMBAT (Blanket Flat).—The temporary reservation, by Order in Council of the 28th May, 1866, of 1 acre of land in the Parish of Wombat as a site for Presbyterian Church purposes is about to be revoked so far only as the portion containing 16 perches, indicated by hatching on plan hereunder, is concerned.—(W.179⁽³⁰⁾) (C.6803).

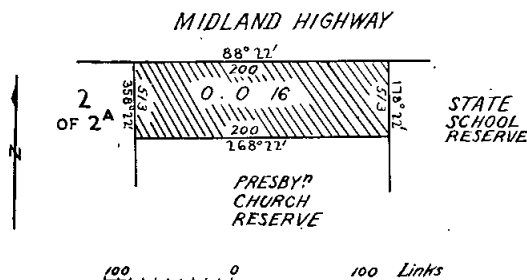

W. J. F. McDONALD,
Minister of Lands.

PROPOSED PERMANENT RESERVATION OF LAND AS A SITE.

IN pursuance of sections 14 and 21 of the *Land Act 1958*, notice is hereby given that it is the intention of the Governor in Council to reserve permanently from sale, from being leased and from having a licence granted in respect thereof the land hereinafter described:—

The following Notice was published 1° on the 22nd November, 1967, pursuant to Order of the 14th November, 1967.

NUNAWADING.—Land proposed to be permanently reserved as a site for Public Park, 9 acres, Parish of Nunawading, County of Bourke, as indicated by hatching on plan hereunder.—(N.79^(*)) (Rs.1564).

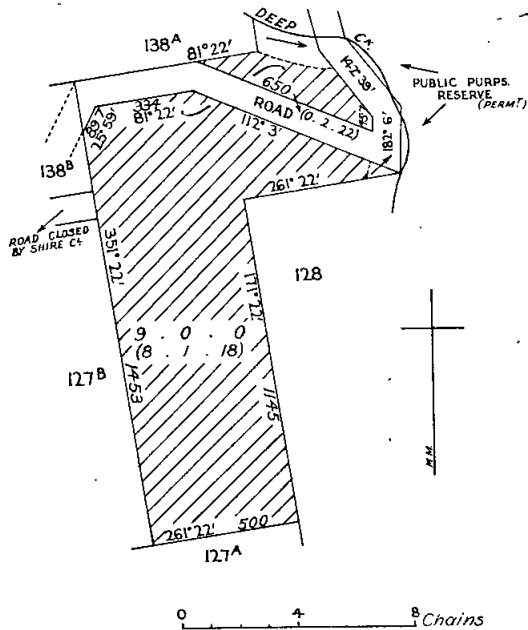

W. J. F. McDONALD,
Minister of Lands.

PROPOSED REVOCATIONS OF TEMPORARY RESERVATIONS OF LANDS BY ORDERS IN COUNCIL.

IN pursuance of the provisions of the *Land Act 1958*, notice is hereby given that it is the intention of the Governor in Council to revoke the temporary reservations of lands by Orders in Council hereunder referred to, viz.:—

The following Notices were published 1° on the 15th November, 1967, pursuant to Orders of the 8th November, 1967.

WARRION.—The temporary reservation as a site for Public Purposes (State School) and the withholding from sale, leasing and licensing by Order in Council of the 30th September, 1878, of 3 acres of land in the Parish of Warrion are about to be revoked.—(W.59⁽²⁾) (Rs.8505).

JIKA JIKA (AT CARLTON).—The temporary reservation, by Order in Council of the 31st October, 1922, of 1 acre 1 rood 14 perches of land, at Carlton, Parish of Jika Jika, as a site for State School purposes is about to be revoked so far only as the portion containing 1 acre 28 perches,

indicated by hatching on plan hereunder, is concerned.—(M.314⁽¹⁴⁾) (Rs.2528).

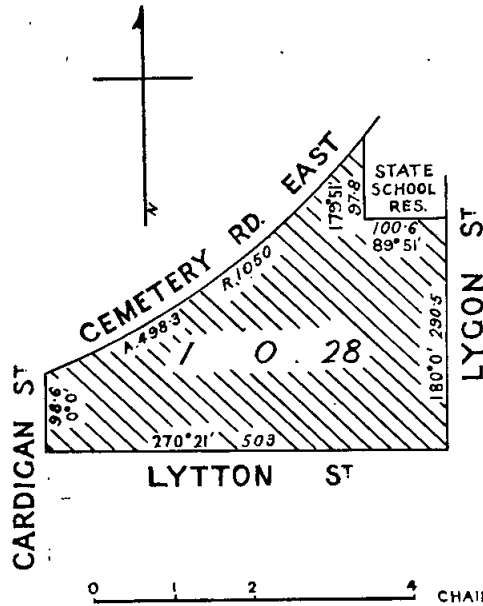

PORTARLINGTON.—The temporary reservation by Order in Council of the 28th November, 1938, of 10 acres 3 roods 3 perches of land in the Township of Portarlington as a site for Public Purposes is about to be revoked so far only as the portion containing 2 acres 1 rood, more or less, indicated by hatching on plan hereunder, is concerned.—(P.37⁽³⁾) (Rs.4899).

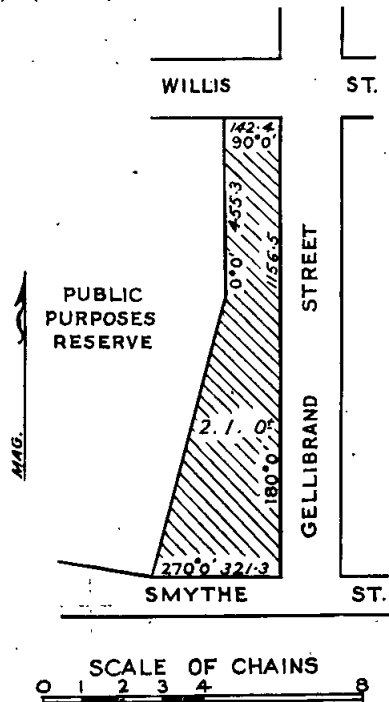

TARRAGUL AND TREWALLA.—The temporary reservation as a site for Public Recreation and the withholding from sale, leasing and licensing by Order in Council of the 27th February, 1878, (See *Government Gazette* 1st March, 1878, page 477) of 60 acres of land in the Parishes of Tarragal and Trewalla are about to be revoked.—(T.55⁽²⁾), T.114⁽⁴⁾) (C.95505).

W. J. F. McDONALD,
Minister of Lands.

PROPOSED PERMANENT RESERVATION OF LAND
AS A SITE.

IN pursuance of sections 14 and 21 of the *Land Act 1958*, notice is hereby given that it is the intention of the Governor in Council to reserve permanently from sale, from being leased and from having a licence granted in respect thereof the land hereinafter described:—

The following Notice was published 1° on the 6th December, 1967, pursuant to Order of the 28th November, 1967.

CUNNINGHAME.—Land proposed to be permanently reserved as a site for Public Recreation 7 acres, more or less, Township of Cunninghame, Parish of Colquhoun, County of Tambo, as indicated by hatching on plan hereunder.—(C.486(6) Rs.8888).

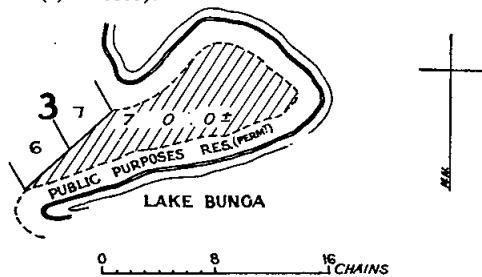

W. J. F. McDONALD,
Minister of Lands.

COMMITTEES OF MANAGEMENT OF RESERVES.
APPOINTMENTS.

NOTICE is hereby given that, in pursuance of section 221 of the *Land Act 1958*, the following appointments of Committees of Management of reserved Crown Lands have been made by the Minister of Lands:—

RESERVES FOR DRAINAGE PURPOSES IN THE TOWNSHIP OF
ARARAT.

The Council of the City of Ararat as the Committee of Management of the land in the Township of Ararat temporarily reserved by Order in Council dated the 16th April, 1962 as a site for Drainage Purposes and by Order in Council dated the 4th October, 1967 as a site for Public purposes (Drainage purposes).—(Corres. Rs.5773.)

QUARRY RESERVE IN THE CITY AND PARISH OF BALLARAT.

The Council of the City of Ballarat as the Committee of Management of the land in the City and Parish of Ballarat, temporarily reserved by an Order in Council dated the 17th October, 1967 as an extension to a site for a Quarry.—(Corres. Rs.3712.)

“BARMAH CAMPING RESERVE.”

The Council of the Shire of Nathalia as the Committee of Management of the land in the Township and Parish of Barmah temporarily reserved by Orders in Council dated 26th October, 1926 and 11th September, 1928 as a site for Public Recreation, together with the land in the Township and Parish of Barmah temporarily reserved by Orders in Council of the 9th July, 1957 and 16th August, 1966 as a site for Public purposes, and the land in the Township and Parish of Barmah permanently reserved by Order in Council dated 20th September, 1966, as a site for Public purposes, the whole known as the “Barmah Camping Reserve”.—(Corres. Rs.7641, Rs.3380.)

PUBLIC PURPOSES (CHILDREN'S PLAYGROUND) RESERVE AT
BENDIGO.

Council of the City of Bendigo as the Committee of Management of the land in the Parish of Sandhurst, at Bendigo temporarily reserved by Order in Council dated the 17th October, 1967, as a site for Public purposes (Children's Playground).—(Corres. Rs.8885.)

“BUCHAN RACECOURSE RESERVE.”

Oswald George Henham, Bernard James Manson, Lachiel Alexander Cameron, James David Harley, Cecil Gordon Matthews, Jack Darrawell Dalley, Horace Walter Carlyle, Sidney King and Edward Rupert King as a Committee of Management for a period of three (3) years of the land in the Parish of Nowa Nowa temporarily reserved by Order in Council dated the 7th March, 1961, as a site for a Racecourse and known as the “Buchan Racecourse Reserve”.—(Corres. Rs.1827.)

“BYADUK MECHANICS' INSTITUTE AND FREE LIBRARY
RESERVE.”

Russell Alexander Christie, Alexander Reeves, Charles Eric Kinghorn, Colin William Gibbins, Peter Stewart Kinghorn, Alan William Field, John Forsyth, John Christie Holcombe and Frederick Roland Falkenberg as the Committee of Management for a period of three (3) years of the land temporarily reserved by Orders in Council dated the 13th May, 1890, and 29th August, 1905, as a site for a Mechanics' Institute in the Parish of Byaduk, and known as the “Byaduk Mechanics' Institute and Free Library Reserve”.—(Corres. Rs.224.)

“CARISBROOK PUBLIC PARK RESERVE.”

Elizabeth Marjorie Dowie, Marjorie Olive Snow, Stanley Robert Hurse, Louis Frederick Koop, Ronald Raymond Hooper, George Wilfred Stewart and Arthur Thomas Gardiner Jennings as a Committee of Management for a period of three (3) years of the land in the Township and Parish of Carisbrook temporarily reserved by Order in Council dated 3rd October, 1932, as a site for Public Park, and of such portion of the Reserves along the Tullaroop Creek in the said Township and Parish as are indicated by blue colour on plan C.2/12/32 with Lands Department Correspondence Rs.4255 which areas are known as “Carisbrook Public Park”.—(Corres. Rs.4255.)

GRAVEL RESERVE (WESTERN PORTION) PARISH OF
DRUMDLEMARA.

The Council of the Shire of Woorayl as the Committee of Management of the land in the Parish of Drumdlemara shown by orange colour on plan D/10.5.1967 on Lands Department Correspondence Rs.4439, being portion of the land temporarily reserved by Order in Council dated the 28th February, 1935, as a site for the Supply of Gravel (Western Portion).—(Corres. Rs.4439.)

“CROWLANDS RECREATION RESERVE.”

Kevin William Lewis, Allen James Williams, Alexander Tucker, Albert Emile Wilkinson, Maxwell John Williams, Douglas John Hart and Arthur Noel Boatman as the Committee of Management for a period of three (3) years of the land in the Township and Parish of Crowlands temporarily reserved by Order in Council dated the 19th January, 1886, as a site for Public Recreation and known as the “Crowlands Recreation Reserve”.—(Corres. Rs.2864.)

“DARGALONG RACECOURSE AND RECREATION RESERVE.”

Bryan Denis Brady, Alan James Tweddle, Matthew Ewart, John Francis Burke and James Erskine Ewart as a Committee of Management for a period of three (3) years of the land temporarily reserved by Order in Council dated the 30th August, 1880, as a site for Racecourse and other purposes of Public Recreation in the Parish of Dargalong and known as the “Dargalong Racecourse and Recreation Reserve”.—(Corres. Rs.1961.)

“DARTMOOR PUBLIC HALL.”

John Vernon Spencer, Ronald Edward Dowling, Thomas Edward Melbourne, Lloyd Arthur Wapling, Joseph Charles Harris, Percy Clarence Little, Jack Russell Greenham, Ian William Spencer and Spencer William Ward, as a Committee of Management for a period of three (3) years of the land in the Township of Dartmoor, temporarily reserved by Order in Council of 2nd September, 1919, as a site for a Public Hall and known as the “Dartmoor Public Hall Reserve”.—(Corres. Rs.322.)

“ELLAM RECREATION RESERVE.”

Noel McIntosh, Lawrence George Solly, Harold Walter Smith, Alan William Werner, Thomas Lionel Smith, Clarence Allan McKenzie, Neil Leitch McKenzie, Christopher Bruce Newcombe, Barry Roderic McKenzie and Robert George McIntosh as the Committee of Management for a period of three (3) years of the land temporarily reserved by Order in Council dated the 24th October, 1932, as a site for Public Recreation in the Parish of Hindmarsh at Ellam and known as the “Ellam Recreation Reserve”.—(Corres. Rs.4268.)

“FLOWERDALE PUBLIC HALL RESERVE.”

Lily Mavis Rowe, Denis Anthony Hodge, Thomas Connell Byrne, John Moore, Phillip James George, Albert Maurice Edwards, Airlie Rose Collins and Keith Alexander Green as the Committee of Management for a period ending the 5th September, 1970, of the land in the Parish of Flowerdale temporarily reserved by Order in Council dated the 19th April, 1955, as a site for a Public Hall and known as the “Flowerdale Public Hall Reserve”.—(Corres. Rs.7343.)

"HAWKESDALE MEMORIAL HALL RESERVE."

John Anthony O'Brien, Albert George Marshall, Robert James Towler, Francis John Roache, Ronald Hausler, Laurence Emil Nagorcka, Francis Joseph Carlin and Douglas Williams as a Committee of Management for a period of three (3) years of the land temporarily reserved by Order in Council dated the 2nd November, 1896, as a site for a Mechanics' Institute and Free Library, and known as the "Hawkesdale Memorial Hall Reserve".—(Corres. Rs.2273.)

"JEERALANG NORTH PUBLIC HALL RESERVE."

William Mele, Zelma Mae Mildenhall, Robert Edward Mildenhall, Nelly Mele, Muriel Ann Martin, John Francis Touzel, Ross Mele, Thomas C. McKenzie, Wanda Heather Joan McKenzie and Hans Dortmans as the Committee of Management for a period of three (3) years of the remaining land in the Parish of Traralgon temporarily reserved by Order in Council dated the 20th July, 1954, as a site for a Public Hall and known as the "Jeeralang North Public Hall Reserve".—(Corres. Rs.7282.)

"KENNEDY'S CREEK PUBLIC RESERVE."

Sergio Giudici, Malcolm John Carter, Bernice Greenslade, Bianca Giudici, Maxwell Greenslade, Reg O'Callaghan, Joe Uwland, Jack Hinkley, Cyril Atwell and Peg Hinkley as a Committee of Management for a period of three (3) years, of the areas in the Parish of Wiridjil temporarily reserved by Orders in Council dated 28th December, 1906, and 25th July, 1950, as sites for a Public Hall and other Public Purposes, such areas being together known as the "Kennedy's Creek Public Reserve".—(Corres. Rs.4877.)

"LAKE GOLDSMITH PUBLIC HALL RESERVE."

William Archibald Kirkpatrick, Peter Henry Cushing, Donald Joseph George as the Committee of Management for a period of three (3) years of the land in the Parish of Yangerahwill temporarily reserved by Order in Council dated the 18th July, 1967, as a site for a Public Hall and known as the "Lake Goldsmith Public Hall Reserve".—(Corres. Rs.8844.)

"MANANGATANG RECREATION RESERVE."

Martin Patrick Walsh, Francis William Hughes, John Barry Cullen, Owen Thomas Jones, Garnet Craig Sutton, Sidney James Barnes, Eric Henry McCarroll, Peter David Carr, Stanley Morris, Keith Thompson and Frederick Arentz as a Committee of Management for a period of three (3) years of the land temporarily reserved by Order in Council of the 28th February, 1967, as a site for Public Recreation in the Parish of Manangatang and known as the "Manangatang Recreation Reserve".—(Corres. Rs.2469.)

"NATHALIA SHOW YARDS AND PUBLIC RECREATION RESERVE."

Stanley Charles Brown, Eric Thomas Frost, Frederick Grinter, Stanley John Vale, Bruce Schier, Robert Clarke Cocks, Thomas Francis Danaher, Jeffrey Leigh Arnel, William Clifford Thompson and Royce Albert Ernest Hutchins as a Committee of Management for a period of three (3) years of the land in the Township and Parish of Nathalia temporarily reserved by Order in Council as a site for Show Yards and Public Recreation together with the abutting reserve along the Broken River, both of which areas are shown by red and blue colours respectively on plan marked "N/30.4.52" attached to Lands Department Correspondence Rs.1094, and known as the "Nathalia Show Yards and Recreation Reserve".—(Corres. Rs.1094.)

"NAR-NAR-GOON PUBLIC HALL RESERVE."

Margaret Deering, Robert Deering Arnold, Euphemia Mary Edwards, Alexander Henry Anderson, James Edward Deering, Donald Sydney Gillard, William J. Harrop, Charles P. Abreheart, Daniel C. Cunningham, Patrick Gerard Kennelly, Graham Crichton Edwards, Bernard John Byrne, Maurice A. Kennelly and John Kinsey Mayson as the Committee of Management for a period of three (3) years of the land in the Parish of Nar-Nar-Goon temporarily reserved by Order in Council dated 7th June, 1955, as a site for a Public Hall and known as the "Nar-Nar-Goon Public Hall".—(Corres. Rs.7359.)

"NELSON PUBLIC PURPOSES AND RECREATION RESERVES."

Harry Huebner, Neville Pickernell Wilson, Mervyn Albert Miller, Frederick John Nash, Francis Henry Moore, David Cameron, Charles Frederick Johnson, Albert Stevens

and Rodney Treloar Hastings as the Committee of Management for a period of three (3) years of the lands in the Parish of Glenelg indicated by red colour on plans marked "G/173.49" and "G/14.4.54" with Lands Department Correspondence files Nos. Rs.4859 and Rs.4731 respectively and known as the "Nelson Public Purposes and Recreation Reserves".—(Corres. Rs.4859, Rs.4731, Rs.4730, Rs.4725.)

"PANMURE RECREATION RESERVE."

Ronald James McCrabb, Chas. Mooney, Lionel Herbert Monk, Patrick O'Shannessy, John Richard Walters, Raymond Goodwin, Graham George Rhode, William Bourke, Charles Henry Bond, Noel Frederick Wright, Harold Eric Welsford, Clive Robert Clark and David Harris as a Committee of Management for a period of three (3) years of the land in the Parish of Garvoc permanently reserved by Order in Council dated the 7th March, 1894, and temporarily reserved by Order in Council dated the 15th November, 1949, as sites for Public Recreation and known as the "Panmure Recreation Reserve".—(Corres. Rs.2916.)

"PATCHEWOLLOCK RECREATION RESERVE."

Peter John Kiely, Martin James Woollard, Lindsay Ronald Jackson, Malcolm Geoffrey Lynch, William Oliver Nicholl, Albert Francis Woollard, Kenneth Richard Jackson, Frederick Douglas William Hallan, Alexander William Blythman, Gerald Robert McLean, Gordon James Jolly, Frank William Woollard and Alan Edward Grigg as the Committee of Management for a period of three (3) years of the land in the Parish of Patchewollock temporarily reserved by Orders in Council dated the 7th June, 1953, and 15th January, 1959, as a site for Public Recreation and known as the "Patchewollock Recreation Reserve".—(Corres. Rs.7357.)

"POREPUNKAH RECREATION RESERVE."

William Neil Telford, Ian Stuart Wallace, Kenneth Lionel Simpson, Alan Willey, Henry Keith Armstrong, John Henry Wallace, Clifford James Coghill, Alexander John Armstrong, Stephen Henry Harris, John Robinette Chandler, Donald Hughes and Colin William MacGill as a Committee of Management for a period of three (3) years of the land temporarily reserved for Public Recreation in the Township of Porepunkah and known as the "Porepunkah Recreation Reserve".—(Corres. Rs.685.)

"ANZAC PARK", REDBANK.

Kevin Bernard Ryan, Kenneth Francis Grant, Kevin Cornelius Meagher and William Wolfe Irwin as a Committee of Management for a period of three (3) years of the land in the Township of Redbank permanently reserved by Order in Council of the 15th November, 1910, as a site for Public Recreation and Watering purposes, also the land in the Township of Redbank temporarily reserved by Order in Council of the 11th May, 1954, as a site for Public Recreation and together known as "Anzac Park".—(Corres. Rs.3856.)

"RUSHWORTH PUBLIC PARK RESERVE."

James Edgar Gleeson, Lyle Charles Parker, Reamond Alexander Cheatley, John Gordon Raglus, Alfred William Raglus, Graeme Johansen, Alan George Hammond, Hubert John Priston Elms, Walter Albert Locke, John Ellis Risstrom and Ronald Stewart Risstrom as a Committee of Management for a period of three (3) years of the land temporarily reserved as a site for a Public Park in the Township of Rushworth and known as the "Rushworth Public Park Reserve".—(Corres. Rs.767.)

"TAWONGA CAMPING SITE."

Murray Lawrence McVean, Sydney Herbert Drew, Steve Young, Albert Charles Callf, Samuel Keith Pearce and J. Smith as the Committee of Management for a period ending the 6th September, 1968, of so much of the reserved Crown land in the Parish of Mullindoolingong, as is indicated by red and blue colour on plan marked M/5.12.57 attached to Lands Department Correspondence Rs.7664 together with the land in the same parish reserved by Order in Council dated the 19th September, 1967, together known as the "Tawonga Camping Site".—(Corres. Rs.7664.)

"TIMBOON RECREATION RESERVE."

Clifford Sharp, John Wallace Donald McKenzie, Ian Daniel Thomas Bell, Herbert Vivian Tarrant, Donald Stephen McLeod and Ian MacGillivray McKenzie as the Committee of Management for a period of three (3)

years of the land in the Parish of Timboon temporarily reserved by Order in Council dated the 21st March, 1961, as a site for Public Recreation and known as the "Timboon Recreation Reserve".—(Corres. Rs.2617.)

"UNDERBOOL PUBLIC HALL RESERVE."

Raymond W. Gloster, Bernard W. Brown, Brendan V. Lynch, Alan G. Willsmore, James Arthur Willsmore, Elaine J. Lockett, Grace E. Gloster and Florence I. White as the Committee of Management for a period of three (3) years of the land in the Township of Underbool temporarily reserved by Order in Council dated the 22nd October, 1912, as a site for a Public Hall.—(Corres. Rs.7368.)

W. J. F. McDONALD,
Minister of Lands.

Department of Crown Lands and Survey,
Melbourne, 29th November, 1967.

AMENDMENT OF THE REGULATIONS FOR THE CARE PROTECTION AND MANAGEMENT OF "GOULBURN PARK RESERVE", SEYMOUR.

WHEREAS in pursuance of section 218 of the *Land Act 1958* as then enacted the Board of Land and Works on the 9th day of December, 1948, made Regulations for the care protection and management of certain Crown land, in the Township and Parish of Seymour, reserved as a site for Public Recreation: And whereas the said Board was dissolved by the *Public Lands and Works Act 1964*, which provided *inter alia* that all Regulations made by the Board shall remain in force subject to the *Land Act 1958*: And whereas the Minister of Lands is now empowered to make Regulations for or with respect to the said land (hereinafter called the Reserve) in pursuance of section 218 of the *Land Act 1958*: And whereas it is expedient that the Regulations made by the Board as aforesaid should be amended: Now therefore, I, William John Farquhar McDonald, Her Majesty's Minister of Lands in and for the State of Victoria do hereby rescind Regulation numbers 10 and 10A and substitute therefore under the same numbers the following Regulations:

10. The charges for camping in the area set apart as follows:—

A sum of not more than seventy cents (70c) for one night for a car party not exceeding six persons, for each additional person a sum of ten cents (10c) per night and for a party not exceeding six persons, four dollars (\$4) per week and for each additional person a sum of sixty cents (60c) per week.

10A. A sum of not more than thirty cents (30c) per night shall be charged for the use of a power point.—(Rs.4802.)

Given under my hand at Melbourne, on the 29th day of November, 1967.

W. J. F. McDONALD,
Minister of Lands.

Every person who contravenes or fails to comply with these Regulations shall, in accordance with the provisions of section 218 of the *Land Act 1958*, for each offence be liable to a penalty of not more than Fifty dollars, and every person who contravenes or fails to comply with any such Regulations, and who, after he has been warned by any bailiff of Crown lands or by any member of the Police Force, does not desist therefrom may be forthwith apprehended by such bailiff or member of the Police Force and taken before some justice to be dealt with according to law and shall be liable to a penalty of not more than One hundred dollars.

TENDERS

PUBLIC WORKS DEPARTMENT

TENDERS will be received at Public Works Department, Treasury-place, Melbourne, until TWO p.m. on dates shown and for purposes mentioned hereunder.

Particulars and tender forms available at Contracts Office, Room 7, Building Division, Parliament-place and at places indicated in brackets hereunder.

Abbreviations in brackets mean:—W.O.—Inspector of Works Office; P.S.—Police Station; C.S.—Consolidated School; H.E.S.—Higher Elementary School; H.S.—High School; S.S.—State School; T.S.—Technical School.

Tenders to be submitted on the Department's printed Tender Form and will not be received by telephone. All tenders must be on a "Firm Tender" basis. The lowest or any tender will not necessarily be accepted.

Address tenders to the Minister of Public Works, and endorse the envelope containing the tender "Tender for , closing Tuesday,

Hand delivered tenders to be placed in the Tender Box of the Public Works Department, located on the wall of the centre entrance foyer, Ground Floor, New Treasury Building, Treasury-place, Melbourne.

No preliminary deposit is required with any tender, but a successful tenderer will be required to pay a deposit for any accepted tender of \$5,000 or over.

Tuesday, 12th December, 1967.

Building, Electrical and Mechanical Works.

Aspendale.—Wire mesh fencing, Technical School.
Auburn South.—Erection of brick toilet block, S.S. 4183.
Bairwyn North.—Renovations, S.S. 4638.
Beaumaris North.—Renovations, S.S. 4803 and Residence. (Re-advertised.)
Blackburn.—Renovations, High School.
Brooklyn West.—Enclosing entrance, re-blocking, &c., S.S. 4825. (Amended Specification.)
Burnley Gardens.—Erection of Chemistry Laboratory and class-room, Horticultural College.
Burnley Gardens.—Electrical installation, Horticultural College.
Burnley Gardens.—Mechanical services, Horticultural College.
Dederang.—Renovations, S.S. 1772. (Amended Specification.) (W.O., Wangaratta; S.S., Dederang.)
East Melbourne.—Alterations to building, Council of Adult Education, 41-43 Gipps-street.
Flemington.—Remodelling of Building, &c., Travancore Developmental Centre. (Bills of Quantities available.)
Flemington.—Electrical installations, Travancore Developmental Centre.
Flemington.—Mechanical services, Travancore Developmental Centre.
Gnotuk.—Renovations, &c., Residence, S.S. 3392. (Re-advertised.) (W.O., Camperdown.)
Mont Park.—Supply and installation of 120 h.p. packaged steam boiler, Gresswell Sanatorium.
Portland.—Installation of fire service, S.S. 489. (W.O., Warmambool.)
Strathmerton.—Renovations, S.S. 2790. (Amended Specification.) (Re-advertised.) (W.O., Shepparton; S.S., Strathmerton.)
Tecoma.—Renovations, Melbourne Boys' High School, Forestry School. (Amended Specification.)
Toolangi.—Renovations, Residences, State Potato Research Station. (Re-advertised.)
Walwa.—Renovations, Residence, Police Station. (W.O., Wangaratta; P.S., Walwa.)
Williamstown North.—Renovations to toilet blocks, S.S. 1409.

Furniture and Furnishings.

Ringwood.—Supply and fix stage curtains, Technical School.

Site Works.

Solway.—Asphalt and gravel repairs, S.S. 4641.
Various.—Earthworks, asphalt, concrete and drainage works, &c., S.S. 2969, St. Albans; S.S. 2857, Laverton and Girls' Technical School, Sunshine.

Miscellaneous.

Coburg.—Supply of delivery van, Pentridge Prison.
Various.—Supply and delivery of AC/DC control cubicles and panels, Technical Schools, Colac, Frankston, Noble Park and Wodonga.

Tuesday, 19th December, 1967.

Building, Electrical and Mechanical Works.

Ballarat.—Wire mesh fencing, Girls' High School. (W.O., Ballarat.)
Bairwyn.—Erection of double brick garage, "Illoura" House.
Boronia.—Toilet repairs, &c., S.S. 4081.
Clarinda.—Fencing, S.S. 3336.
Colac West.—Renovations to toilet block, S.S. 4064. (W.O., Geelong.)
Delatite.—Renovations, S.S. 2829. (W.O., Alexandra.)
Ellinbank.—Erection of a brick petrol store, Research Station. (W.O., Warragul.) (Re-advertised.)
Footscray.—Mechanical services, Technical College.
Garfield.—Re-stumping and renovations, S.S. 2724. (Amended Specification.)
Geelong.—Electrical installation, Prison. (W.O., Geelong.)

Geelong.—Mechanical services, Prison. (W.O., Geelong.)
 Glenhuntly.—New brick toilet block, S.S. 3703.
 Heidelberg West.—Mechanical services, S.S. 4267.
 Horsham.—Erection of three glass-houses, Victorian Wheat Research Institute. (W.O., Horsham.)
 Horsham.—Electrical installation, Victorian Wheat Research Institute. (W.O., Horsham and Ballarat.)
 Horsham.—Supply and installation of evaporative cooling and heating, Victorian Wheat Research Institute.
 Kenmare.—Renovations, S.S. 3221 and Residence. (W.O., Warracknabeal.)
 Kiewa Valley.—Renovations, Residence, Consolidated School. (W.O., Wangaratta.)
 Middlefield.—Connexion to sewer, S.S. 4878.
 Moonee Ponds West.—Alterations and additions to toilets, S.S. 2901. (Amended Specification.)
 Newcomb.—Additional class-rooms, S.S. 4776. (W.O., Geelong.)
 Newcomb.—Electrical installation, S.S. 4776. (W.O., Geelong.)
 Newcomb.—Mechanical services, S.S. 4776. (W.O., Geelong.)
 Richmond.—Mechanical services, Technical School.
 Ripponlea.—Renovations, Residence, S.S. 4087 (Re-advertised.)
 Sebastopol.—Mechanical services, Technical School. (W.O., Ballarat.) (Re-advertised.)
 Stawell.—Internal painting, High School. (W.O., Ararat.)
 St. Kilda.—New bathroom and renovations, Residence, S.S. 1479.
 Tottenham.—External painting, S.S. 4707.
 Wonthaggi.—Mechanical services, Technical School. (W.O., Warragul and Korumburra.)

Site Works.

Altona.—Asphalt repairs, High School.
 Euroa.—Asphalt, drainage and gravel works, &c., S.S. 1706. (W.O., Benalla, Shepparton and Wangaratta.)
 Glenroy.—Asphalt, concrete and drainage works, &c., Technical School.
 Mont Park.—Construction of asphalt roadway, &c., Jane-field Training Centre.
 Sussex Heights.—Asphalt, concrete and drainage works, &c., S.S. 4832.
 Watsonia.—Earthworks, asphalt, concrete and drainage works, &c., Technical School.

Miscellaneous.

Geelong.—Supply and fix kitchen equipment, Gaol.
 Mooroolbark.—Supply of milling machine, Technical School.
 Noble Park.—Supply of arc and oxy-acetylene equipment, Technical School.
 Royal Park.—Supply and fix kitchen equipment, "Turana" Reception and Reclassification Centre.
 South Melbourne.—Supply and delivery of four-wheel-drive station wagon, complete with accessories, Public Works Department, Garage.
 Stony Point.—Re-charging, acetoneing and inspection of acetylene navigation light cylinders from 1st January, 1968, to 31st December, 1968, Buoy Depot, Ports and Harbours Branch.

Tuesday, 16th January, 1968.

Building, Electrical and Mechanical Works.

Ballarat.—New electrical sub-station, Mental Hospital. (W.O., Ballarat.)
 Blackburn.—Additions and modifications to Administration Block, High School.
 Blackburn.—Mechanical services, High School.
 Blackburn East.—Renovations, &c., S.S. 4800.
 Cobden.—Renovations, Residence, S.S. 864. (W.O., Camperdown.)
 Doon.—Erection of glass-house, Longerenong Agricultural College. (W.O., Horsham.)
 Ferntree Gully.—Erection of type "800C" Assembly Hall, Technical School.
 Ferntree Gully.—Electrical installation, Technical School.
 Ferntree Gully.—Mechanical services, Technical School.
 Melbourne.—Renovations, Victoria School for Deaf Children, No. 3774.
 Mont Park.—Steam and condensate reticulation, Mental Hospital.
 Sunbury.—Renovations to toilets, Mental Hospital.
 Werribee.—Erection of broiler test shed, State Research Farm. (W.O., Geelong.)
 Werribee.—Electrical installation, State Research Farm.
 Werribee.—Mechanical services, State Research Farm.
 Wodonga West.—Additional class-rooms, S.S. 4814. (W.O., Wangaratta.)
 Wodonga West.—Electrical installation, S.S. 4814. (W.O., Wangaratta.)

Wodonga West.—Mechanical services, S.S. 4814. (W.O., Wangaratta.)
 Wonthaggi.—Erection of a new High School. (W.O., Korumburra.)
 Wonthaggi.—Mechanical services, High School. (W.O., Korumburra and Warragul.)

Site Works.

Maribyrnong.—Asphalt repairs and retaining wall construction, S.S. 3736.
 Mitcham.—Asphalt, concrete and drainage works, &c., High School.
 St. Albans.—Asphalt repairs, High School.

Miscellaneous.

Variou.—Removal, lopping and pruning of trees, schools, South-Eastern District.
 Yallourn.—Supply and delivery of equipment, Technical College.

M. V. PORTER,
 Minister of Public Works.

Public Works Department,
 Melbourne, 3002, 4th December, 1967.

PUBLIC SERVICE NOTICES

No. 1795.

Public Service Act 1958, Section 39.

REGULATIONS.—PART IV.—SALARIES AND INCREMENTS.

THE Public Service Board, in pursuance of the powers conferred by the *Public Service Act 1958*, hereby amends its Regulations as shown below :—

FIRST SCHEDULE.

PROFESSIONAL DIVISION.

Amount of Salary Assigned to Offices in "Special" Class.

| Office. | Yearly Rate of Salary. |
|---|------------------------|
| MINES DEPARTMENT. | |
| | \$ |
| <i>Delete—</i> Director of Geological Survey | 9,844 |
| <i>Add—</i> Director of Geological Survey | 9,332 |

F. E. CAHILL, Chairman.
 V. P. SCULLY, Secretary.

Office of the Public Service Board,
 Melbourne, 17th November, 1967.

No. 1796.

Public Service Act 1958, Section 50.

REGULATIONS.—PART IV.—SALARIES AND INCREMENTS.

THE Public Service Board, in pursuance of the powers conferred by the *Public Service Act 1958*, hereby amends its Regulations as shown below :—

SIXTH SCHEDULE.

TEMPORARY EMPLOYEES.

Designations of Positions and Rates of Salaries.

| Department and Designation of Position. | Yearly Rate of Salary. | | Increments (Annual). |
|---|------------------------|----------|----------------------|
| | Minimum. | Maximum. | |
| TREASURY. | | | |
| <i>Government Printing Office.</i> | | | |
| Apprentices— | | | |
| <i>Delete—</i> Engineer | | † | |
| <i>Add—</i> Metal Trades | | † | |

† Rates in accordance with the Metal Trades award.

F. E. CAHILL, Chairman.
 V. P. SCULLY, Secretary.

Office of the Public Service Board,
 Melbourne, 20th November, 1967.

No. 1797.

Public Service Act 1958, Section 50.

REGULATIONS.—PART IV.—SALARIES AND INCREMENTS.

THE Public Service Board, in pursuance of the powers conferred by the Public Service Act 1958, hereby amends its Regulations as shown below :—

SIXTH SCHEDULE.
TEMPORARY EMPLOYEES.

Designations of Positions and Rates of Salaries.

| Department and Designation of Position. | Yearly Rate of Salary. | | Increments (Annual). |
|--|------------------------|----------|----------------------|
| | Minimum. | Maximum. | |
| | \$ | \$ | |
| GENERAL. | | | |
| <i>Delete—</i> General Assistant .. | 2,074 | 2,262 | Σ |
| <i>Add—</i> General Assistant— Junior— | | | |
| Under 16 years of age .. | | 943 | .. |
| At 16 years of age .. | | 1,026 | .. |
| At 17 years of age .. | | 1,198 | .. |
| At 18 years of age .. | | 1,354 | .. |
| At 19 years of age .. | | 1,603 | .. |
| At 20 years of age .. | | 1,853 | .. |
| Adult .. | 2,074 | 2,262 | Σ |
| Σ See Regulation 83 (2). | | | |

F. E. CAHILL, Chairman.
V. P. SCULLY, Secretary.

Office of the Public Service Board,
Melbourne, 22nd November, 1967.

No. 1798.

Public Service Act 1958, Section 39.

REGULATIONS.—PART IV.—SALARIES AND INCREMENTS.

THE Public Service Board, in pursuance of the powers conferred by the Public Service Act 1958, hereby amends its Regulations as shown below :—

FOURTH SCHEDULE.

ADMINISTRATIVE DIVISION.

Amount of Salary Assigned to Offices in Class "A1".

| Office. | Yearly Rate of Salary. |
|---|------------------------|
| | fstg. |
| PREMIER'S DEPARTMENT. | |
| <i>Delete—</i> Secretary, Office of the Agent-General .. | 3,641 |
| <i>Add—</i> Secretary, Office of the Agent-General .. | 3,641* |

*This rate is payable to a new appointee from the date of departure from Australia. The rate payable from the date of appointment until the date of departure shall be \$A7,282 a year.

This Regulation shall have effect as on and from the 20th October, 1967.

F. E. CAHILL, Chairman.
V. P. SCULLY, Secretary.

Office of the Public Service Board,
Melbourne, 27th November, 1967.

Teaching Service Act 1958.

TEACHING SERVICE (CLASSIFICATION, SALARIES & ALLOWANCES) REGULATIONS.

AMENDMENT No. 127.

THE Teachers Tribunal, in pursuance of the powers conferred by the Teaching Service Act 1958, hereby amends the Teaching Service (Classification, Salaries and Allowances) Regulations in the manner following, that is to say:—

PART V.—PROFESSIONAL OFFICERS.

In clause 12, under the sub-heading "(d) Other Positions"—

- (i) for the expression "Curriculum Officer; Research Officer" substitute the expression "Curriculum Officer, Grade I.; Research Officer, Grade I.";
- (ii) after the expression "Guidance Officer, Grade II." insert the expression "Curriculum Officer, Grade II.; Research Officer, Grade II."

A. McDONELL, Acting Chairman.
G. FENNELL, Secretary.

Office of the Teachers Tribunal,
Melbourne, 30th November, 1967.

PRIVATE ADVERTISEMENTS

NOTICE OF INTENTION TO APPLY FOR A LICENCE TO DIVERT WATER AND CUT RACE (RE-ISSUE) FROM THE GOULBURN RIVER, AT A HALF MILE ABOVE GOULBURN WEIR.

I HEREBY give notice that I intend to apply for a licence empowering me to divert water for a term of three years to the extent of 40 acre-feet per annum at a maximum rate of 6 acre-feet per day of 24 hours for the irrigation of 20 acres of pastures, being part of allotment 3, section Y, Parish of Noorlim, and to occupy certain Crown lands for works of diversion, and to cut a race thereon.

Any objection to such application must be forwarded, in writing, to reach the State Rivers and Water Supply Commission, Melbourne, before 28th December, 1967, being 30 days from the first publication of this notice.

JAMES ERNEST FROST.

Private Bag, Nagambie, Victoria, 3608.

NOTICE OF INTENTION TO APPLY FOR A LICENCE TO DIVERT WATER AND CUT RACE FROM THE RIVER MURRAY, AT WHARPARILLA.

WE hereby give notice that we intend to apply for a licence empowering us to divert water for a term of four years to the extent of 15 acre-feet per annum at a maximum rate of part 1 acre-feet per day of 24 hours for the irrigation of 6 acres for self-contained flats and domestic supply thereto, being part of allotment 130, Parish of Wharparilla, and to occupy certain Crown lands for works of diversion.

Any objection to such application must be forwarded, in writing, to reach the State Rivers and Water Supply Commission, Melbourne, before 10th January, 1968, being 30 days from the first publication of this notice.

THOMAS F. SLATER.
ALICE I. SLATER.

Box 15, Echuca P.O.

331

NOTICE OF INTENTION TO APPLY FOR A LICENCE TO DIVERT WATER AND CUT RACE (RE-ISSUE) FROM THE RIVER MURRAY AT COWANNA BEND.

I HEREBY give notice that I intend to apply for a licence empowering me to divert water for a term of four years to the extent of 63 acre-feet per annum at a maximum rate of 12 acre-feet per day of 24 hours for the irrigation of 21 acres of pastures, being part of allotments 4x and 4w, section G, Parish of Merbein, and to occupy certain Crown lands for works of diversion, and to cut a race thereon.

Any objection to such application must be forwarded, in writing, to reach the State Rivers and Water Supply Commission, Melbourne, before 5th January, 1968, being 30 days from the first publication of this notice.

BERNARD BANE.

Hattah.

332

NOTICE is hereby given that Johnsons Tyne Foundry Proprietary Limited has applied for a lease pursuant to section 134 of the Land Act 1958 for a term of 50 years in respect of allotment 81, City of South Melbourne, Parish of Melbourne South, containing 1 acre 3 roods 36 perches as a site for steel storage, engineering workshop, warehouse, service station, offices and amenities, showrooms and the garaging and servicing of vehicles.

GILLOTT, MOIR & WINNEKE, of 95 Queen-street, Melbourne. 9

WARRNAMBOOL SEWERAGE AUTHORITY.

GENERAL NOTICE.

THE above-mentioned Sewerage Authority having made sewers for carrying off the sewage from each and every property which or any part of which abuts on the streets or parts of streets in which such sewers are laid, and which are included within the sewerage areas hereinafter described, doth hereby declare that on and after the 1st day of January, 1968, each and every property which or any part of which abuts on the said streets or parts of streets shall be deemed to be seweraged property within the meaning of the Sewerage Districts Act 1958.

The boundaries of the sewerage areas hereinafter referred to are:—

Sewer Area No. 62.

That part of the Warrnambool Sewerage District which is bounded by a line which commences at the intersection of the east side of Rutledge-street with the north side of the Princes Highway which is also the south-west corner of Sewer Area No. 51, then proceeds in a clockwise direction around the north side of the Princes Highway and the east side of Caramut-road as far as its intersection with the north side of Fairfax-avenue, then along the north side of Fairfax-avenue to the south-west corner of lot 158 part of Crown allotments 68 and 69, Parish of Wangoom, County of Villiers, then around the west and north boundaries of said lot 158 and the north boundaries of lots 157 and 156, then diagonally across Exammer-crescent to the north-west corner of lot 102 which is a point at the north-west corner of Sewer Area No. 51, then south-westerly along the western boundary of Sewer Area No. 51 to the starting point.

(SEAL)

E. P. GIBBONS, Chairman.

K. L. ARNEL, Secretary.

260

GEELONG WATERWORKS AND SEWERAGE TRUST.

PURSUANT to section 60 (2) of the Geelong Waterworks and Sewerage Act 1958 (No. 6263), notice is hereby given of the intention of the Trust to construct sewers to provide for properties in and adjacent to:—

Valley-road South, Fryers-street, Madison-court, Konrads-crescent, Hendriks-court and Belle Vue-avenue, Highton—Shire of South Barwon;

Chester-street, Herne Hill—City of Newtown; Hennessy-parade and Bon View-avenue, Herne Hill—Shire of Corio;

Beulah-street, Hamlyn Heights—Shire of Corio;

Marathon-avenue, Bell Post Hill—Shire of Corio;

and more particularly as shown on maps which are open for public inspection at the Trust's Offices, Ryrie-street, Geelong, between the hours of 9 a.m. and 4 p.m. daily, from Monday to Friday.

286

B. C. HENSHAW, Secretary.

SPRINGVALE AND NOBLE PARK SEWERAGE AUTHORITY.

GENERAL NOTICE.

THE above-mentioned Sewerage Authority having made provision for carrying off the sewage from each and every property which, or any part of which is within the Sewerage Areas hereinafter described, doth hereby declare that on and after the 1st day of December, 1967, each and every property which or any part of which is within the said Sewerage Areas shall be deemed to be a seweraged property within the meaning of the Sewerage Districts Act 1958.

The boundaries of the Sewerage Areas hereinbefore referred to are:—

Sewerage Area No. 202—Springvale.

Commencing at a point being the intersection of the eastern side of Springvale-road and the northern side of MacKay-street; thence northerly along the eastern side of Springvale-road to its intersection with the southern side of Athol-road; thence easterly along the southern side of Athol-road a distance of approximately 484 feet; thence southerly by a line parallel to Springvale-road a distance of 230 feet; thence easterly by a line parallel to MacKay-street a distance of approximately 75 feet; thence southerly by a line parallel to Springvale-road a distance of 127 ft. 6 in.; thence easterly by a line parallel to MacKay-street a distance of 225 ft. 4 in.; thence northerly by a line parallel to Springvale-road a distance of 51 ft. 3 in.; thence easterly by a line parallel to MacKay-street to the western side of Coniston-drive; thence southerly along the western side of Coniston-drive and the southerly prolongation thereof to the southern side of MacKay-street; thence westerly along the southern side of MacKay-street a distance of approximately 643 feet; thence southerly by a line parallel to Springvale-road a distance of 120 ft. 2 in.; thence westerly by a line parallel to MacKay-street to the eastern side of Springvale-road; thence northerly along the eastern side of Springvale-road to the point of commencement.

Sewerage Area No. 203—Springvale.

All those pieces of land comprising lots 18 and 20 on lodged plan of subdivision No. 66,291.

For the purposes of these descriptions the lodged plans of subdivision herein referred to shall be taken as those lodged at the Office of Titles, Melbourne.

By order of the Springvale and Noble Park Sewerage Authority.

A. A. ERICKSEN, Chairman.

H. L. WILLIAMS, Secretary.

339

LITTLE RIVER WATERWORKS TRUST.

EIGHTH SCHEDULE.

NOTICE to the owners of tenements in the following streets and the private streets, lanes, courts and alleys opening thereto:—

Edgars-road, Little River-road, McLeans-road, Rothwell-road, You Yangs-road, Flinders-street, River-street, Rothwell-street and Boadles-lane.

The main pipe in the said streets being laid down, the owners of all tenements situated as above are hereby required on or before the 6th day of January, 1968, to cause a proper pipe and stop cocks to be laid so as to supply water within such tenements from the main pipe.

334

N. G. MINNS, Secretary.

CITY OF BROADMEADOWS.

LOAN No. 45.

Notice of Intention to Borrow the Sum of \$50,000 for Permanent Works and Undertakings.

NOTICE is hereby given that the Council of the City of Broadmeadows proposes to borrow the principal sum of \$50,000 secured by a charge over the general-rates of the Municipality, such sum to be raised by the grant of a mortgage in accordance with the provisions of the Local Government Act 1958.

1. The maximum rate of interest that may be paid is 5.75 per cent. per annum.

2. The purpose for which the loan is to be applied is:—

| | |
|---|----------|
| Elderly Citizens' Hall, Cromwell-street, Glenroy | \$12,000 |
| Hadfield Hall | 3,000 |
| Gibb Reserve Pavilion, Blair-street, Broadmeadows | 35,000 |

3. The period of the loan shall be Ten (10) years.

4. The moneys borrowed shall be repayable by providing out of the municipal fund Twenty (20) half-yearly instalments of approximately \$3,322 each, including principal

and interest, on the 1st day of April and the 1st day of October during the currency of the loan. The first payment shall be payable of the 1st day of October, 1968.

5. Such moneys shall be repayable to the Commissioners of the State Savings Bank of Victoria at the Office of the said Commissioners, corner Elizabeth and Bourke streets, Melbourne.

The plans and specifications and the estimate of the cost of the proposed works and a statement showing the proposed expenditure of the moneys to be borrowed are open for inspection at the Offices of the Council of the City of Broadmeadows, Municipal Offices, Broadmeadows.

242 E. F. SMILEY, Town Clerk.

CITY OF BROADMEADOWS.

LOAN No. 46.

Notice of Intention to Borrow the Sum of \$100,000 for Permanent Works and Undertakings.

NOTICE is hereby given that the Council of the City of Broadmeadows proposes to borrow the principal sum of \$100,000 secured by a charge over the general rates of the Municipality, such sum to be raised by the grant of a mortgage in accordance with the provisions of the Local Government Act 1958.

1. The maximum rate of interest that may be paid is 5½ per centum per annum.

2. The purpose for which the loan is to be applied is:—
Erection of Public Hall and Library in Fawkner.

3. The period of the loan shall be fifteen (15) years.

4. The moneys borrowed shall be repayable by providing out of the municipal fund Thirty (30) half-yearly instalments of approximately \$5,061 each, including principal and interest, on the 1st day of April and the 1st day of October during the currency of the loan. The first instalment shall be payable on the 1st day of October, 1968.

5. Such moneys shall be repayable to the Commonwealth Bank of Australia, Glenroy, Council's Bankers for the time being.

The plans and specifications and the estimate of the cost of the proposed works and a statement showing the proposed expenditure of the moneys to be borrowed are open for inspection at the Offices of the Council of the City of Broadmeadows, Municipal Offices, Broadmeadows.

243 E. F. SMILEY, Town Clerk.

Town and Country Planning Act 1961.

CITY OF COLAC.—CITY OF COLAC PLANNING SCHEME 1963.

NOTICE THAT A PLANNING SCHEME HAS BEEN PREPARED AND IS AVAILABLE FOR INSPECTION.

Amendment No. 1, 1967.

NOTICE is hereby given that the Council of the City of Colac, in pursuance of its powers under the Town and Country Planning Act 1961, has prepared a Planning Scheme for the City of Colac for the purpose of re-zoning several allotments of land from Residential Zone to Public Open Space Reserves Zone in order to permit the Council of the City of Colac to develop a Recreational Area within such zone.

A copy of the scheme has been deposited at the Municipal Offices, 4-6 Rae-street, Colac, and at the offices of the Town and Country Planning Board, 179 Queen-street, Melbourne, and will be open for inspection during office hours by any person, free of charge.

Any persons affected by the Planning Scheme are required to set forth, in writing, all objections they may have, addressed to the Town Clerk, City of Colac, Municipal Offices, 4-6 Rae-street, Colac, on or before the 18th day of March, 1968, and to state whether they wish to be heard in respect of their objections.

1st December, 1967.

274 F. M. KELLY, Town Clerk.

CITY OF DANDENONG.

BY-LAW No. 39.

A BY-LAW of the City of Dandenong made under Sections 368 and 394 of the Health Act 1958 and numbered 39 for prescribing the fees to be paid to the Council for registration and renewal and transfer of registration of certain premises and food vending machines.

IN pursuance of the powers conferred by the Health Act 1958, the Mayor, Councillors and Citizens of the City of Dandenong orders as follows:—

1. By-law No. 36 of the City of Dandenong is hereby repealed.

No. 92.—10842/67.—4

2. (a) The fees to be paid to the Council for each registration or renewal or transfer of registration and additional fees for late application for renewal of registration in respect of the several classes of premises and food vending machines hereunder specified shall be those set opposite to such classes of premises or food vending machines respectively, namely—

| Nature of Premises or Food Vending Machines. | Fees Payable for Registration or Renewal of Registration. |
|---|---|
| Offensive trades premises (being fat extracting or melting or rendering works which are conducted at premises occupied principally as a butcher's shop and at which fat is extracted melted or rendered only from materials derived from such shop) | \$ 5 |
| Offensive trades premises (being abattoirs in meat areas or piggeries) | 20 |
| Offensive trades premises (other than those referred to above)— | |
| (i) where not more than ten persons (including the proprietor and his family) are employed | 10 |
| (ii) where more than ten such persons but not more than twenty such persons are employed | 15 |
| (iii) where more than twenty such persons but not more than thirty such persons are employed | 20 |
| (iv) where more than thirty such persons are employed | 30 |
| Boarding Houses | 10 |
| Common lodging houses | 10 |
| Eating houses | 10 |
| Apartment houses— | |
| Containing not more than one apartment | 5 |
| Containing more than one apartment | 10 |
| Camping areas | 10 |
| Hairdresser's shop, beauty parlor or other like establishment or chiropodist's establishment | 5 |
| Food premises— | |
| (i) where not more than five persons (including the proprietor and his family) are employed | 5 |
| (ii) where more than five such persons are employed additional for each person in excess of five | 0.50 |
| (iii) provided that the maximum fees payable shall be | 100 |
| Premises at or in any part of which eggs for sale are received or stored for the purpose of being chilled | 5 |
| Food vending machines operated by— | |
| (i) one or two cents a sale | 0.50 |
| (ii) a coin or coins in excess of two cents in value but not exceeding five cents in value a sale | 2 |
| (iii) a coin or coins in excess of five cents in value a sale | 4 |

(b) For any transfer of registration—\$1 or fifty per cent. of the registration fee (whichever is the lesser amount).

(c) Where application for renewal of registration is not lodged with the Council until after the 15th day of November in each year, being the last day fixed for the lodging thereof, an additional fee of one quarter the foregoing registration fee shall be paid.

3. This By-Law shall apply to and have operation throughout the whole of the municipal district of the City of Dandenong.

Resolution for the passing of this By-Law agreed to by the Council on the 11th day of September, 1967 and confirmed on the 9th day of October, 1967.

The common seal of the Mayor, Councillors and Citizens of the City of Dandenong was hereunto affixed, this 9th day of October, 1967, in the presence of—

(SEAL) R. K. WAGSTAFF, Mayor.
A. C. DOWNARD, Councillor.
A. B. PEDDER, Councillor.
C. A. ELLIOTT, Town Clerk.

Submitted to the Commission of Public Health on the 24th day of October, 1967.—A. T. GARDNER, Secretary, Commission of Public Health.

Approved by the Governor in Council on the 21st day of November, 1967.—J. ROSSITER, Clerk of the Executive Council.

CITY OF HAWTHORN.

BY-LAW NO. 221.

A By-law of the City of Hawthorn made under the provisions of the Local Government Acts and numbered 221 for the purposes of controlling and regulating the use of premises with a view to preventing objectionable noises at unreasonable times.

IN pursuance of the powers conferred by the Local Government Acts and of every other power it thereunto enabling The Mayor, Councillors and Citizens of the City of Hawthorn order as follows:—

1. In this By-law "premises" shall be deemed to include vacant land.

2. This By-law shall apply to and have operation throughout the whole of the municipal district of the City of Hawthorn.

3. The owner or occupier of any premises used for industrial or trade purposes shall not use or permit such premises to be used between the hours of six o'clock in the afternoon and seven o'clock in the forenoon for any purposes or in any way which causes noise to be emitted from the premises which—

(a) harms or causes undue concern to or inconveniences any occupier or inmate of any dwelling situated within hearing of the noise or;

(b) is dangerous or likely to be dangerous to the health of any such occupier or inmate.

4. The owner or occupier of any premises not being premises used for industrial or trade purposes shall not use or permit such premises to be used in any way which causes noise to be emitted from the premises which—

(a) harms or causes undue concern to or inconveniences any occupier or inmate of any dwelling situated within hearing of the noise or;

(b) is dangerous or likely to be dangerous to the health of any such occupier or inmate.

5. Every person guilty of an offence against this By-law shall be liable to a penalty of not more than Forty dollars (\$40) and in the case of a continuing offence to a penalty of Ten dollars (\$10) for each day on which the offence against this By-law is continued after a conviction or order by any Court.

Resolution for passing this by-law agreed to by the Council of the City of Hawthorn on the 6th day of September, 1967, and confirmed on the 18th day of October, 1967.

The common seal of The Mayor, Councillors and Citizens of the City of Hawthorn was affixed hereto, this 23rd day of October, 1967, in the presence of—

W. P. BROWN, Mayor.
K. C. MILLER, Councillor.
J. R. JOHNSON, Town Clerk.

Approved by the Governor in Council the 21st day of November, 1967.—J. ROSSITER, Clerk of the Executive Council. 263

CITY OF KEILOR.

LOAN NO. 78.

Private Street Account.

NOTICE is hereby given that at a meeting of the Council of the City of Keilor, held at the Municipal Offices, Keilor, on Tuesday, the 17th day of October, 1967, at 7.15 o'clock p.m., the said Council did agree to the following Resolution, that is to say:—

Loan No. 78—Private Street Account.

1. That the Council of the City of Keilor do by special order and it does hereby resolve to borrow the sum of Ninety-three thousand eight hundred dollars (\$93,800) by the grant of a mortgage on the credit of the Mayor, Councillors and Citizens of the City of Keilor in accordance with the provisions of the Local Government Act 1958 and amendments.

2. That interest on such loan shall be at the rate of \$5.875 per centum per annum and shall be repayable half-yearly on the 1st days of June and December in each year, commencing on the 1st day of June, 1968, and ending on the 1st day of December, 1982, at the Commonwealth Savings Bank of Australia, Niddrie.

3. That the times at which moneys borrowed are to be repayable are the 1st days of June and December in each year, commencing on the 1st day of June, 1968, and ending on the 1st day of December, 1982, at the Commonwealth Savings Bank of Australia, Niddrie.

4. The loan is to be applied for the purpose of defraying part of the cost of the execution of schemes for the construction of private streets, pursuant to Division 10 of Part XIX. of the Local Government Act 1958 and amendments.

5. The loan shall be liquidated from the receipts of money payable under the schemes, in accordance with the provisions of the said division, by 30 half-yearly instalments of approximately \$4,747.03 each (including principal and interest).

Notice is further given that at a meeting of the said Council, held at the Municipal Offices, Keilor, on Tuesday, the 21st day of November, 1967, at 7.15 o'clock p.m., the said Resolution was confirmed.

Dated this 4th day of December, 1967.

329 R. F. B. KELLY, Acting Town Clerk.

CITY OF KEILOR.

LOAN NO. 79.

(Re-Advertised.)

Notice of Intention to Borrow the Sum of Twenty-nine thousand dollars for Permanent Works and Undertakings.

NOTICE is hereby given that the Council of the City of Keilor proposes to borrow the sum of Twenty-nine thousand dollars (\$29,000) secured by a charge over the general rates of the municipality, such sum to be raised by grant of a mortgage in accordance with the provisions of the Local Government Act 1958.

1. The maximum interest that may be paid is 5.75 per centum per annum.

2. The purposes for which the loan is to be applied are as under:—

| | | |
|---|----|----------|
| (a) Final council contribution to Prince-street reconstruction scheme | .. | \$18,000 |
| (b) Council contribution to the Keilor Infant Welfare and Pre-school Centre | .. | 11,000 |
| Total | .. | \$29,000 |

3. The period of the loan shall be ten years.

4. The moneys borrowed shall be repayable by providing out of the municipal fund twenty equal half-yearly instalments of \$1,926.80 on the 1st day of October and the 1st day of April during the currency of the loan. The first instalment shall be payable on the 1st day of October, 1968.

5. Such money shall be repayable at the National Bank of Australasia Limited, North Essendon.

Plans and specifications and the estimate of the cost of the proposed works and the statement showing the proposed expenditure of the money to be borrowed are open for inspection at the Municipal Offices, Calder Highway, Keilor, during office hours.

Dated this 5th day of December, 1967.

351 R. F. B. KELLY, Acting Town Clerk.

CITY OF KEW.

LOAN NO. 56.

Notice of Intention to Borrow the Sum of \$100,000 for Permanent Works and Undertakings.

NOTICE is hereby given that the Council of the City of Kew proposes to borrow the principal sum of \$100,000 secured by a charge over the general rates of the municipality such sum to be raised by the grant of a mortgage in accordance with the provisions of the Local Government Acts.

1. The maximum rate of interest that may be paid is 5½ per centum per annum.

2. The period of the loan shall be twenty years.

3. The moneys borrowed shall be repayable by providing out of the municipal fund 40 half-yearly instalments of \$4,282.64 each, including principal and interest, on the 1st day of April and the 1st day of October during the currency of the loan. The first instalment shall be payable on the 1st day of October, 1968.

4. Such moneys shall be repayable at the Office of the Local Authorities Superannuation Board, Rigby House, 15 Queens-road, Melbourne, or such other place or places as the said Board from time to time may require.

5. The purposes for which the loan is to be applied are:—

| | | |
|---|----|---------|
| Traffic Signals | .. | \$9,000 |
| Municipal Depot Improvements | .. | 5,000 |
| Places of Public Resort and Recreation Hyde Park Improvements | .. | 7,000 |

| | |
|--|------------------|
| Construction of Roads (C.R.B. Main) Studley Park-road | \$45,000 |
| Construction of Roads (C.R.B. Unclassified) Wellington-street | 17,000 |
| Reconstruction of Streets, Mount Victor-road, Burke and Kilby roads intersection | 17,000 |
| | <u>\$100,000</u> |

The plans and specifications and the estimate of the cost of the proposed works, and a statement showing the proposed expenditure of the moneys to be borrowed, are open for inspection at the Town Hall, Walpole-street, Kew.

Dated this 1st day of December, 1967.

244 J. L. JOHNSON, Town Clerk.

CITY OF KEW.

LOAN No. 55.

Notice of Intention to Borrow the Sum of \$30,000 for Permanent Works and Undertakings.

NOTICE is hereby given that the Council of the City of Kew proposes to borrow the principal sum of \$30,000 secured by a charge over the general rates of the municipality such sum to be raised by the grant of a mortgage in accordance with the provisions of the Local Government Acts.

1. The maximum rate of interest that may be paid is 5½ per centum per annum.

2. The period of the loan shall be fifteen years.

3. The moneys borrowed shall be repayable by providing out of the municipal fund 30 half-yearly instalments of approximately \$1,518 each, including principal and interest, on the 1st day of April and the 1st day of October during the currency of the loan. The first instalment shall be payable on the 1st day of October, 1968.

4. Such moneys shall be repayable to the Commissioners of the State Savings Bank of Victoria at the office of the said Commissioners corner Elizabeth and Bourke streets, Melbourne.

5. The purpose for which the loan is to be applied is—

Construction of Roads (C.R.B. Main) Barkers-road (part cost) .. \$30,000

The plans and specifications and the estimate of the cost of the proposed works, and a statement showing the proposed expenditure of the moneys to be borrowed, are open for inspection at the Town Hall, Walpole-street, Kew.

Dated this 1st day of December, 1967.

245 J. L. JOHNSON, Town Clerk.

CITY OF MALVERN.

By-Law No. 147.

NOTICE is hereby given that the Council of the City of Malvern has made a By-Law, under the *Health Act 1958* and the *Local Government Act 1958* and all other powers thereunto enabling it in that behalf, numbered 147 for the purposes of:—

(a) Repealing By-Laws numbered 138 and 144 of the City of Malvern;

(b) Prescribing fees to be paid to the Council of the City of Malvern for the Registration and Renewal and Transfers of Registration of certain premises and food vending machines.

Notice is also given that a copy of the above-mentioned By-Law is open for inspection, free of charge, during office hours, at the Office of the said Council, City Hall, Glenferrie Road, Malvern.

Dated this 4th day of December, 1967.

330 D. W. LUCAS, Town Clerk.

CITY OF NUNAWADING.

No. 1256.

By-Law No. 69.

A By-Law of the City of Nunawading made under Part XIX. of the *Health Act 1958* and numbered 69 for prescribing the fees payable for the registration of premises and renewal and transfer of such registration pursuant to the said Act.

IN pursuance of the powers conferred by the *Health Act 1958* and of any and every other Act or power enabling it in that behalf the Council of the City of Nunawading orders as follows:

1. By-Laws No. 45 and 56 of the City of Nunawading be and are hereby repealed.

2. From and after the date of the coming into operation of this By-Law the fees to be charged received and taken by the Council of the City of Nunawading for the registration or annual renewal of registration of—

- (a) Premises
(b) Food vending machines

shall be the respective fees set out in the second column of the Schedule hereto opposite to the description of such premises or food vending machines and the fee for any transfer of any such registration shall be the sum of \$1.00 or one half of the relevant registration fee for such premises or food vending machines (whichever is the lesser amount).

3. Where application for renewal of any such registration is not lodged with the Council until after the last day fixed for the lodging thereof an additional fee of one half of the relevant prescribed fee otherwise payable for renewal of registration shall be paid.

4. Such fees shall be paid to the Council of the City of Nunawading by any person making application for such registration renewal or transfer.

5. This By-Law shall apply to and have operation throughout the whole of the Municipal District of the City of Nunawading.

SCHEDULE.

| | |
|--|----------|
| (1) Offensive Trade Premises (being fat extracting or melting or rendering works which are conducted at premises occupied principally as a butcher's shop and at which fat is extracted melted or rendered only from materials derived from such shop) | \$5.00 |
| (2) Offensive Trade Premises (being abattoirs in meat areas or piggeries) | \$20.00 |
| (3) Offensive Trade Premises (other than those referred to above)— | |
| (i) where not more than ten persons (including the proprietor and his family) are employed | \$10.00 |
| not more than twenty such persons are employed | \$15.00 |
| (iii) where more than twenty such persons but not more than thirty such persons are employed | \$20.00 |
| (iv) where more than thirty such persons are employed | \$30.00 |
| (4) Boarding Houses | \$10.00 |
| (5) Common Lodging Houses | \$10.00 |
| (6) Eating Houses | \$10.00 |
| (7) Apartment Houses— | |
| (i) containing not more than one apartment | \$5.00 |
| (ii) containing more than one apartment | \$10.00 |
| (8) Camping Areas | \$10.00 |
| (9) Food Premises— | |
| (i) where not more than five persons (including the proprietor and his family) are employed | \$5.00 |
| (ii) where more than five such persons are employed—additional for each person in excess of five | \$0.50 |
| Provided that the maximum fee payable shall be | \$100.00 |
| (10) Premises at or in any part of which eggs for sale are received or stored for the purpose of being chilled | \$5.00 |
| (11) Food vending machines operated by— | |
| (i) a coin or coins of one or two cents in value a sale | \$0.50 |
| (ii) a coin or coins in excess of two cents in value but not exceeding five cents in value a sale | \$2.00 |
| (iii) a coin or coins in excess of five cents in value a sale | \$4.00 |

Resolution for passing this By-Law was agreed to by the Council of the City of Nunawading on the 14th day of August, 1967, and confirmed on the 11th day of September, 1967.

The corporate seal of the Mayor, Councillors and Citizens of the City of Nunawading was hereunto affixed, in the presence of—

(SEAL) C. R. T. MCCALL, Mayor.
C. L. WILLIS, Councillor.
J. H. BROWN, Town Clerk.

Submitted to the Commission of Public Health on the 24th day of October, 1967.—A. T. GARDNER, Secretary, Commission of Public Health.

Approved by the Governor in Council on the 21st November, 1967.—J. ROSSITER, Clerk of the Executive Council.

CITY OF SANDRINGHAM.
BEACH PARK REGULATIONS.

NOTICE is hereby given that the Municipal Council of the City of Sandringham, as the properly appointed Committee of Management under section 218 of the *Land Act 1958* of the Sandringham Beach Park, has appointed from the 29th day of November, 1967—

Senior Constable CYRIL STANLEY WILSON, 9901, Police Station, Hampton,

in lieu of Senior Constable Graham John Leslie-Glenn, 11242, retired, to be Prosecuting Officer; to take legal proceedings for and in connexion with breaches of non-observance of Rules and Regulations made by the Department of Crown Lands and Survey for the care, protection and management of such park.

273. J. L. ANDERSON, Town Clerk.

CITY OF SANDRINGHAM.

NOTICE is hereby given that the Council of the City of Sandringham has appointed—

Senior Constable CYRIL STANLEY WILSON, 9901, Police Station, Hampton,

in lieu of Senior Constable Graham John Leslie-Glenn, 11242, retired, to be Prosecuting Officer of the Council of the City of Sandringham for the municipality of Sandringham, as from the 29th day of November, 1967.

296 J. L. ANDERSON, Town Clerk.

Town and Country Planning Act 1961 (Twelfth Schedule).

TOWN OF PORTLAND.—PORTLAND PLANNING SCHEME 1957.

NOTICE THAT A PLANNING SCHEME HAS BEEN PREPARED AND IS AVAILABLE FOR INSPECTION.

Amendment No. 9, 1967.

NOTICE is hereby given that the Council of the Town of Portland, in pursuance of its powers under the *Town and Country Planning Act 1961*, has prepared a Planning Scheme for amending the original scheme as it applies to the Town of Portland.

A copy of the scheme has been deposited at the Town Hall, Portland, and at the office of the Town and Country Planning Board, 179 Queen-street, Melbourne, and will be open for inspection during office hours by any person, free of charge.

Any persons affected by the Planning Scheme are required to set forth, in writing, all objections they may have, addressed to the Town Clerk at the Town Hall, Portland, on or before the 8th day of January, 1968, and to state whether they wish to be heard in respect of their objections.

28th November, 1967.

285 L. FELL, Town Clerk.

Sewerage Districts Acts.
SHIRE OF BIRCHIP.

PROPOSED SEWERAGE AUTHORITY.

NOTICE is hereby given that the Council of the Shire of Birchip has made application to the Honorable the Minister of Water Supply for the constitution of a Sewerage Authority and for the Proclamation of a Sewerage District at Birchip, and for the construction, maintenance and continuance of sewerage works within that district under the provisions of the Sewerage Districts Acts.

A general plan and description of the proposed works have been submitted with the application and copies of same may be seen at Shire Office, Birchip.

Dated at Birchip the 14th day of November, 1967.

31 WALTER J. McQUILLEN, Shire Secretary.

SHIRE OF FLINDERS.

LOAN NO. 58.

Notice of Intention to Borrow.

NOTICE is hereby given that the Council of the Shire of Flinders intends to borrow the sum of Fifty thousand dollars (\$50,000) by a charge over the general rates of the municipality secured by the grant of a mortgage in accordance with the provisions of the Local Government Acts.

In connexion therewith the following information is stated:—

- (a) The amount of Principal moneys which it is proposed to borrow is \$50,000.
- (b) The maximum rate of interest that may be paid is \$5.875 per centum per annum.

(c) The times (which the moneys borrowed are to be repayable) are 1st September and 1st March of each year during the currency of the loan, the first repayment to be made on 1st September, 1968, and that the place such moneys shall be repayable is at the National Bank Savings Bank, Collins-street, Melbourne.

(d) The purpose for which the loan is to be applied is—

| | |
|--|-----------------|
| Construction of roads | \$27,741 |
| Purchase of lands | 16,259 |
| Parks, gardens and playgrounds | 6,000 |
| | <u>\$50,000</u> |

(e) The manner in which the loan is to be liquidated is by provision out of the municipal fund in each half-year, during the currency of the loan, the sum of \$2,530.40, which includes principal and interest.

The plans and specifications and estimate of the cost of the works and a statement showing the proposed expenditure of the moneys to be borrowed are open for inspection at the Shire Office.

Dated this 13th day of November, 1967.

259 S. WILLIAMS, Shire Secretary.

SHIRE OF KORONG.

NOTICE OF MAKING OF BY LAWS.

NOTICE is hereby given that the Council of the Shire of Korong has made the following By Laws.

By Law No. 32.

A By Law of the Shire of Korong made under Section 197 (1) (IV) of the Local Government Act and numbered 32 for regulating the supply and distribution of water from Waterworks under the management of the Council.

The By Law restricts the watering of gardens (other than commercial Market Gardens) and sporting areas, prohibits the use of water for private swimming pools and shall come into operation at such times and in such areas as the Council directs.

By Law No. 33.

A By Law of the Shire of Korong made under Section 197 (1) (IV) of the Local Government Act numbered 33 for regulating the supply and distribution of water from Waterworks under the management of the Council.

The By Law restricts the watering of gardens, lands and sporting areas, prohibits the use of water for private swimming pools and shall come into operation at such times and in such areas as the Council directs.

By Law No. 34.

A By Law of the Shire of Korong made under Section 197 (1) (IV) of the Local Government Act and numbered 34 for regulating the supply and distribution of water from Waterworks under the management of the Council.

The By Law restricts the watering of gardens, lands and sporting areas, prohibits the use of water for private swimming pools and shall come into operation at such times and in such areas as the Council directs.

By Law No. 35.

A By Law of the Shire of Korong made under Section 197 (1) (IV) of the Local Government Act and numbered 35 for regulating the supply and distribution of water from Waterworks under the management of the Council.

The By Law prohibits the use of water for private swimming pools, sporting areas, private gardens, lawns and lands and restricts the watering of commercial market gardens, nurseries and land used for the growing of feed for commercial poultry farms and shall come into operation at such times and in such areas as the Council directs.

Copies of the above By Laws are open for inspection; free of charge at the Shire Offices Wedderburn during office hours.

247 R. G. STANLEY, Shire Secretary.

SHIRE OF MAFFRA.

CHANGE OF STREET NAME.

NOTICE is hereby given that in pursuance of the powers conferred by the *Local Government Act 1958*, the Council of the Shire of Maffra at a meeting held on 10th October, 1967, did resolve to make the following alteration to a street name.

Old Name; New Name; Location.

Industrial-road, Maffra; McMahon-drive, Maffra; that section of Industrial-road adjoining the Macalister River between Thompson-street and Foster-street, Maffra.

279 J. RENNICK, Shire Secretary.

SHIRE OF MELTON.

BY-LAW No. 43.

NOTICE is hereby given that the Council of the Shire of Melton has made a By-Law under the provisions of Section 197 of the *Local Government Act, 1958*, and numbered 43 for the purpose of—

- (a) Prohibiting or regulating the use of private property situate at the junction of streets or roads for the growing of trees, shrubs, hedges, or other vegetation abutting on any such street or road or within 10 feet therefrom or within a distance of 30 feet from the junction of any street or road;
- (b) Requiring the reduction to a height not exceeding 3 feet 6 inches of any portion of a fence within 30 feet of the junction of any street or road;
- (c) Authorising the Council to reduce in height any portion of a fence which is not reduced in height as required by or under this By-Law at the expense of the owner and to recover the cost thereof as a civil debt recoverable summarily.

A copy of the said By-Law is open for inspection, free of charge, during office hours at the Shire Office, Melton.

Resolution for passing this By-Law was agreed to by the Council on the 23rd day of October, 1967, and confirmed on the 27th day of November, 1967.

277

D. J. R. DUNTON, Shire Secretary.

Town and Country Planning Act 1961 (Twelfth Schedule).

SHIRE OF MORNINGTON.—SHIRE OF MORNINGTON PLANNING SCHEME 1959.

NOTICE THAT A PLANNING SCHEME HAS BEEN PREPARED AND IS AVAILABLE FOR INSPECTION.

Amendment No. 27, 1967.

NOTICE is hereby given that the Council of the Shire of Mornington, in pursuance of its powers under the *Town and Country Planning Act 1961*, has prepared a Planning Scheme for:

Land abutting Tyabb-road near Derrill-road, Moorooduc, for the purpose of amending the zoning from Agricultural Zone to Public Purpose Reserve (9) (P.M.G. Reserve).

Land abutting Seppalt-avenue and Yalook-avenue, Mt. Martha, for the purpose of amending the zoning from Agricultural to Public Purpose Reserve (22) (Balcombe Military Camp).

Land abutting McLaren-place and Railway-grove, Mornington, for the purpose of amending the zoning from Commercial "A" Zone to Public Purpose Reserve (25) (Municipal Car Parking Area).

Land abutting Clendon-close, Grice-avenue, Tower-road and Wooralla-drive for the purpose of amending the zoning from Residential "D" Zone to Residential "G" Zone.

Land abutting Bradford-road for the purpose of amending the zoning from Public Open Space Reserve (C) (Public Park) to Public Purpose Reserve (11) (S.R. & W.S.C. Reserve).

Land in the Agricultural Zone, Commercial "A", "B" and "C" Zones, Industrial "A" and "B" Zones and Residential "A", "B", "C" and "D" Zones—Ordinance Amendment to include "Roads" as a permitted use.

Land in the Residential "D" Zone—Ordinance Amendment reducing the minimum requirements for subdivision and for other purposes.

Land in the Industrial "B" Zone—Ordinance Amendment exempting petrol bowser canopies from 30 feet building set back.

A copy of the scheme has been deposited at the Shire Office, at Mornington, and at the office of the Town and Country Planning Board, 179 Queen-street, Melbourne, and will be open for inspection during office hours by any person free of charge.

Any persons affected by the Planning Scheme are required to set forth, in writing, all objections they may have, addressed to the Shire Secretary, Shire of Mornington, Queen-street, Mornington, on or before the 6th day of March, 1968, and to state whether they wish to be heard in respect of their objections.

30th November, 1967.

283

D. G. COLLINGS, Shire Secretary.

Town and Country Planning Act 1961 (Twelfth Schedule).

SHIRE OF MORNINGTON.—SHIRE OF MORNINGTON PLANNING SCHEME 1959.

NOTICE THAT A PLANNING SCHEME HAS BEEN PREPARED AND IS AVAILABLE FOR INSPECTION.

Amendment No. 31, 1967.

NOTICE is hereby given that the Council of the Shire of Mornington, in pursuance of its powers under the *Town and Country Planning Act 1961*, has prepared a Planning Scheme for:

Land abutting Boundary-road and Nepean Highway (Mt. Eliza Way), Mt. Eliza, for the purpose of amending the zoning from Residential "C" Zone to Commercial "A" Zone.

Land in the Agricultural Zone—Ordinance amendment to permit boarding kennels including dressing of animal carcasses for food for boarded animals.

A copy of the scheme has been deposited at the Shire Office, at Mornington, and at the office of the Town and Country Planning Board, 179 Queen-street, Melbourne, and will be open for inspection during office hours by any person free of charge.

Any persons affected by the Planning Scheme are required to set forth, in writing, all objections they may have, addressed to the Shire Secretary, Shire of Mornington, Civic Centre, Queen-street, Mornington, on or before the 6th January, 1968, and to state whether they wish to be heard in respect of their objections.

30th November, 1967.

284

D. G. COLLINGS, Shire Secretary.

SHIRE OF MORNINGTON.

LOAN No. 58.

Notice of Intention to Borrow \$100,000.

NOTICE is hereby given that the Council of the Shire of Mornington proposes to borrow the principal sum of One hundred thousand dollars secured by a charge over the general rates of the municipality, such sum to be raised by the grant of a mortgage, in accordance with the provisions of the *Local Government Act 1958*.

(a) The principal moneys proposed to be borrowed—\$100,000.

(b) The maximum rate of interest which may be paid is 5.875 per cent. per annum, half-yearly rests.

(c) The moneys borrowed are to be repaid to the National Bank Savings Bank Ltd., 271 Collins-street, Melbourne, in half-yearly instalments on 1st October and 1st April for a period of fifteen years from 1st April, 1968.

(d) The loan is to be applied to the following purposes, viz.:—

| | | |
|--|----|-----------|
| (i) Kerbing and Channelling | .. | \$8,920 |
| (ii) Footpath Construction | .. | 2,150 |
| (iii) Construction of Sports Oval | .. | 2,600 |
| (iv) Building Construction | .. | 2,325 |
| (v) Land Acquisition and Minor Developmental Works | .. | 9,655 |
| (vi) Drainage Works | .. | 1,180 |
| (vii) Private Street Construction | .. | 55,150 |
| (viii) Road Construction | .. | 18,020 |
| | | \$100,000 |

(e) The loan is to be liquidated by payment of 30 approximately equal half-yearly instalments.

(f) That plans and specifications and an estimate of the cost of such works, and the statement of proposed expenditure of the money to be borrowed, are open for inspection at the Shire Offices, Queen-street, Mornington.

282

D. G. COLLINGS, Shire Secretary.

SHIRE OF OMEO.

LOAN No. 23.

Notice of Intention to Borrow the Sum of \$19,000 for Permanent Works and Undertakings.

NOTICE is hereby given that the Council of the Shire of Omeo proposes to borrow the principal sum of \$19,000 secured by a charge over the general rates of the municipality, such sum to be raised by the grant of a mortgage in accordance with the provisions of the *Local Government Act 1958*.

1. The maximum rate of interest that may be paid is 5½ per cent. per annum.

2. The purpose for which the loan is to be applied is:—

Purchase of a Power Grader.

3. The period of the loan shall be ten (10) years.

4. The moneys borrowed shall be repayable by providing out of the municipal fund twenty (20) half-yearly instalments of approximately \$1,262 each, including principal and interest, on the 1st day of September and the 1st day of March during the currency of the loan. The first instalment shall be payable on the 1st day of September, 1968.

5. Such moneys shall be repayable to the Commissioners of The State Savings Bank of Victoria at the office of the said Commissioners, corner Elizabeth and Bourke streets, Melbourne.

The plans and specifications and the estimate of the cost of the proposed works and a statement showing the proposed expenditure of the moneys to be borrowed are open for inspection at the office of the Council of the Shire of Omeo, Day-avenue, Omeo.

27th November, 1967.

280

G. R. DRYDEN, Shire Secretary.

SHIRE OF SHERBROOKE.

LOAN No. 113.

Notice of Intention to Borrow the Sum of \$50,000 for Permanent Works and Undertakings.

NOTICE is hereby given that the Council of the Shire of Sherbrooke proposes to borrow the principal sum of \$50,000 secured by a charge over the general rates of the municipality, such sum to be raised by the grant of a mortgage in accordance with the provisions of the *Local Government Act 1958*, for permanent works and undertakings within the municipality as follows:—

Part cost Shire Offices.

Purchase and development of C.A.47, Parish of Nangana.

Council proportion Station-street, Belgrave, construction.

Land acquisition, Belgrave, from Methodist Church Trustees.

Council proportion Private Street and Drainage Schemes.

Road construction as per Special Works Schedules.

1. That the amount of the principal sum which it is proposed to borrow be \$50,000.

2. That the maximum rate of interest that may be paid is 5½ per centum per annum.

3. That the moneys borrowed and interest thereon be repayable by twenty half-yearly instalments each on the 1st day of March and the 1st day of September in each year by appropriation of such amounts out of the municipal fund.

4. That such amounts be payable at the English, Scottish & Australian Bank Ltd., Melbourne.

The plans and specifications and the estimate of the cost of the proposed works and a statement showing the proposed expenditure of the moneys to be borrowed are open for inspection at the offices of the Council of the Shire of Sherbrooke, Glenfern-road, Upwey.

281

A. JONES, Shire Secretary.

SHIRE OF WARRAGUL.

LOAN No. 51.

Notice of Intention to Borrow the Sum of \$40,000 for Permanent Works and Undertakings.

NOTICE is hereby given that the Council of the Shire of Warragul proposes to borrow the principal sum of \$40,000, secured by a charge over the general rates of the municipality, such sum to be raised by the grant of a mortgage in accordance with the provisions of the *Local Government Act 1958*.

1. The maximum rate of interest that may be paid is 5½ per cent. per annum.

2. The purpose for which the loan is to be applied is—
Erection of Library Building.

3. The period of the loan shall be 40 years.

4. The loan shall be repaid by the establishment and accumulation of a sinking fund, pursuant to the provisions of section 428A of the *Local Government Act 1958*, by provision out of the municipal fund of an amount of \$182.55 in each half year during the period of the loan.

5. Interest shall be paid at the office of the Local Authorities Superannuation Board, Melbourne, on the 1st days of May and November in each year. The first interest payment shall be made on 1st November, 1968. Half-yearly interest payments will be \$1,175.00.

6. The plans and specifications and estimate of the cost of the works and a statement showing the proposed expenditure of the moneys to be borrowed are open for inspection at the Municipal Offices, Civic-place, Warragul.

Dated this 27th day of November, 1967.

255

D. McADIE Shire Secretary.

SHIRE OF WARRAGUL.

LOAN No. 52.

Notice of Intention to Borrow the Sum of \$20,000 for Permanent Works and Undertakings.

NOTICE is hereby given that the Council of the Shire of Warragul proposes to borrow the sum of \$20,000, secured by a charge over the general rates of the municipality, such sum to be raised by the grant of a mortgage in accordance with the provisions of the *Local Government Act 1958*.

1. The maximum rate of interest that may be paid is 5½ per cent. per annum.

2. The purpose for which the loan is to be applied is—
Part of cost of erection of Youth Club and Municipal Band Hall in Civic Centre, Warragul.

3. The period of the loan shall be twenty years.

4. The loan is to be liquidated over a period of twenty years by 39 equal half-yearly instalments of principal and interest of approximately \$651.80 calculated on a 40-year period with the balance of principal and interest thereon being repayable at the end of twenty years.

5. Such moneys shall be repayable at the Commercial Savings Bank of Australia Limited, Melbourne.

6. The plans and specifications and the estimate of the cost of the proposed works and a statement showing the proposed expenditure of moneys to be borrowed are open for inspection at the Municipal Offices, Warragul.

Dated this 27th day of November, 1967.

256

D. McADIE, Shire Secretary.

SHIRE OF WARRAGUL.

LOAN No. 53.

Notice of Intention to Borrow the Sum of \$6,000 for Permanent Works and Undertakings.

NOTICE is hereby given that the Council of the Shire of Warragul proposes to borrow the principal sum of \$6,000 secured by a charge over the general rates of the municipality, such sum to be raised by the grant of a mortgage in accordance with the provisions of the *Local Government Act 1958*.

1. The maximum rate of interest that may be paid is 5.75 per cent. per annum.

2. The purpose for which the loan is to be applied is for the purchase of an accounting machine.

3. The period of the loan shall be ten years.

4. The moneys borrowed shall be repayable by providing out of the municipal fund half-yearly instalments of approximately 398.65 each, including principal and interest, on the 15th day of September and the 15th day of March during the currency of the loan. The first instalment shall be payable on the 15th day of September, 1968.

5. Such moneys shall be repayable to the Australia and New Zealand Savings Bank Limited, Melbourne.

The plans and specifications of the cost of the proposed works and a statement showing the proposed expenditure of the moneys to be borrowed are open for inspection at the Municipal Offices, Warragul.

Dated this 27th day of November, 1967.

257

D. McADIE, Shire Secretary.

SHIRE OF WARRAGUL.

LOAN No. 54.

Notice of Intention to Borrow the Sum of \$22,000 for Permanent Works and Undertakings.

NOTICE is hereby given that the Council of the Shire of Warragul proposes to borrow the principal sum of \$22,000 secured by a charge over the general rates of the municipality, such sum to be raised by the grant of a mortgage in accordance with the provisions of the *Local Government Act 1958*.

1. The maximum rate of interest that may be paid is 5.75 per cent. per annum.

2. The purpose for which the loan is to be applied is for the purchase of a heavy grader.

3. The period of the loan shall be ten years.

4. The moneys borrowed shall be repayable by providing out of the municipal fund half-yearly instalments of approximately \$1,461.71 each, including principal and interest, on the 15th day of September and the 15th day of March during the currency of the loan. The first instalment shall be payable on the 15th day of September, 1968.

5. Such moneys shall be repayable to the Australia and New Zealand Savings Bank Limited, Melbourne.

The plans and specifications of the cost of the proposed works and a statement showing the proposed expenditure of the moneys to be borrowed are open for inspection at the Municipal Offices, Warragul.

Dated this 27th day of November, 1967.

258

D. McADIE, Shire Secretary.

Town and Country Planning Act 1961 (Twelfth Schedule).

SHIRE OF WERRIBEE PLANNING SCHEME 1963.

AMENDMENT No. 1.

NOTICE is hereby given that the Shire of Werribee, in pursuance of its powers under the Town and Country Planning Acts, has prepared a planning scheme for various portions of the municipal districts with the exception of that part of the municipal district already under the control of the Melbourne Metropolitan Planning Scheme for the purpose of amending the Shire of Werribee Planning Scheme 1963.

A copy of the scheme has been deposited at the Municipal Offices, Werribee, and at the office of the Town and Country Planning Board, 179 Queen-street, Melbourne, and will be open for inspection during office hours by any person, free of charge.

Any persons affected by the Planning Scheme are required to set forth, in writing, all objections they may have, addressed to the Shire Secretary, Shire of Werribee, Municipal Offices, Watton-street, Werribee, 3030, on or before the 6th March, 1968, and to state whether they wish to be heard in respect of their objections.

Dated the 4th day of December, 1967.

333

N. G. MINNS, Shire Secretary.

NOTICE is hereby given that the partnership heretofore subsisting between Francis James Phillips and Shirley Heather Phillips of the one part and James McCulloch of the other part, carrying on the business of farmers under their own names at Toolangi, has been dissolved as from the 1st day of July, 1966, so far as concerns the said James McCulloch, who retired from the said business on that date.

Dated this 27th day of November, 1967.

F. J. PHILLIPS.
S. H. PHILLIPS.

Signed by the said Francis James Phillips and Shirley Heather Phillips, in the presence of M. O. HENDERSON.

J. McCULLOCH.

Signed by the said James McCulloch in the presence of—
F. R. MONOTTI, of 13 Scott-street, Dandenong, solicitor for the said James McCulloch.

J. W. Glover, of 422 Collins-street, Melbourne, solicitor for the said Francis James Phillips and Shirley Heather Phillips. 311

NOTICE OF DISSOLUTION OF PARTNERSHIP.

NOTICE is hereby given that the partnership heretofore subsisting between the undersigned John Hedley Youngberry and Jean Mabel Youngberry, all of Don-road, Healesville, of the one part and Brian Elliott Hoppner and Gweneth Mary Hoppner, all of Rutter-avenue, Healesville, of the other part, carrying on business as general carriers and contractors at Healesville under the name of "Mountain District Carrying Service," has been dissolved by mutual consent as from the 30th day of November, 1967. All debts due and owing by the said firm will be received and paid by Brian Elliott Hoppner and Gweneth Mary Hoppner who will continue to carry on the business at the same place under the same business name.

Dated at Healesville the 30th day of November, 1967.

JOHN YOUNGBERRY.
JEAN M. YOUNGBERRY.
B. E. HOPPNER.
G. M. HOPPNER.

Witness—R. P. BAYLOR, solicitor, Healesville. 292

The Companies Act 1961.—In the matter of 65 WILLIAM STREET PTY. LTD. (in Voluntary Liquidation).—Notice of Special Resolution, Pursuant to Section 254.

NOTICE is hereby given that at an Extraordinary Meeting of the members of the above-named company duly convened and held in the Board Room, 2nd Floor, 401 Collins-street, Melbourne, on the 4th day of December, 1967, the following Resolution was passed:—

Special Resolution.

"That the company be voluntarily wound up."

Notice is also given that after 21 days from this date I shall proceed to distribute the assets. All creditors having any claims against the company should furnish particulars of same by that date, otherwise I shall proceed to distribute the assets, without regard to their claim.

Dated this 4th day of December, 1967.

R. E. CHANCELLOR, Liquidator.

Price Waterhouse & Co., chartered accountants, 447 Collins-street, Melbourne. 352

Companies Act 1961.

SUN VALLEY FEED CO. PROPRIETARY LIMITED.

NOTICE OF MEETING OF DIRECTORS.

NOTICE is hereby given that a meeting of creditors of Sun Valley Feed Co. Proprietary Limited, will be held at the offices of Mann, Judd, Roberts & Co., chartered accountants, 249 William-street, Melbourne, on 13th December, 1967, at 10 o'clock in the forenoon, the company having convened a meeting of its members for the same day for the purpose of considering a Resolution that the company be wound up voluntarily.

Dated this 4th day of December, 1967.

342

J. H. SHOOLBRED, Director.

Companies Act 1961.

A. & S. BUILDERS (VIC.) PROPRIETARY LIMITED.

NOTICE is hereby given that a meeting of creditors of the above-named company will be held at the Hawthorn Hall, 406 Burwood-road, Glenferrie, at 2 p.m., on Thursday, the 14th day of December, 1967, the company having convened a meeting of its members for the same day for the purpose of considering a Resolution that the company be wound up voluntarily.

Dated this 5th day of December, 1967.

IAN DAVID ANDERSON, Director.

NOTE.—A person shall not be entitled to vote as a creditor at the meeting unless he has lodged with the chairman of the meeting a proof of the debt which he claims to be due to him from the company. 348

Companies Act 1961.

A. & S. HOLDINGS PROPRIETARY LIMITED.

NOTICE is hereby given that a meeting of creditors of the above-named company will be held at the Waterloo Town Hall, 770 Elizabeth-street, Waterloo, New South Wales, at 11 a.m., on Friday, the 15th day of December, 1967, the company having convened a meeting of its members for the previous day for the purpose of considering a Resolution that the company be wound up voluntarily.

Dated this 5th day of December, 1967.

IAN DAVID ANDERSON, Director.

NOTE.—A person shall not be entitled to vote as a creditor at the meeting unless he has lodged with the chairman of the meeting a proof of the debt which he claims to be due to him from the company. 349

The Companies Act 1961.—In the matter of SWINDLERS VALLEY HOTEL PTY. LTD. (in Voluntary Liquidation).—Notice Convening Final Meeting, Pursuant to Section 272.

NOTICE is hereby given that pursuant to section 272 of the Companies Act 1961, a Final Meeting of the members and creditors of the above company will be held at the office of A. L. & J. S. Macgeorge, 8 Ely-street, Wangaratta, on Monday the 15th January, 1968, at 3 o'clock in the afternoon for the purpose of having an account laid before them showing the manner in which the winding up has been conducted and the property of the company disposed of and of hearing any explanations that may be given by the liquidator.

Dated this 28th day of November, 1967.

A. L. MACGEORGE, Liquidator.

A. L. & J. S. Macgeorge, 8 Ely-street, Wangaratta. 261

Pursuant to Section 272 (1) of the *Companies Act 1961*.
EAST KEW ACCEPTANCE CO. PTY. LTD.
(IN VOLUNTARY LIQUIDATION).

NOTICE is hereby given that a Final Meeting of Members and Creditors will be held at the offices of Edward Graham and Sons, 37 Queen-street, Melbourne, on Wednesday, 10th January, 1968, at 4.30 p.m. for the purpose of laying before it an account of the liquidation and giving any explanation thereof.

J. P. HOGAN, Liquidator.
Edward Graham & Sons, chartered accountants,
37 Queen-street, Melbourne. 253

THE MODERN HOME CO-OPERATIVE HOUSING
SOCIETY LIMITED (IN LIQUIDATION).

SPECIAL RESOLUTION.

Passed 30th November, 1967.

AT a Special General Meeting of the above-named society duly convened and held at 342A St. Kilda-road, Melbourne on the 30th day of November, 1967, at 5.30 p.m. the subjoined Special Resolution was duly passed:—

That the Society having successfully completed its objective sixteen months before its expected term, be wound up voluntarily and that Ivan Edward Byam-Wight be appointed liquidator for the purposes of winding up.

F. N. SECOMB, Chairman of Meeting.
271 K. SMITH, Secretary.

Companies Act 1961.

PLASTIC INSTALLATIONS PROPRIETARY LIMITED
(IN VOLUNTARY LIQUIDATION).

NOTICE TO CREDITORS OF INTENTION TO DECLARE A DIVIDEND.

A FIRST and Final dividend is intended to be declared in the above matter. Any creditor who does not prove his debt by the 20th day of December, 1967, will be excluded from the distribution.

The date of the liquidation was the 31st day of August, 1965.

264 E. JOHN BROWN, Liquidator.

Companies Act 1961.

P. A. CHEMICALS PROPRIETARY LIMITED.
(IN VOLUNTARY LIQUIDATION).

NOTICE TO CREDITORS OF INTENTION TO DECLARE A DIVIDEND.

A FIRST dividend is intended to be declared in the above matter. Any creditor who does not prove his debt by the 20th day of December, 1967, will be excluded from the distribution.

The date of the liquidation was the 8th day of June, 1967.

265 E. JOHN BROWN, Liquidator.

Companies Act 1961.

SIDDONS ABRASIVES PTY. LTD. (IN VOLUNTARY LIQUIDATION). SIDDONS ABRASIVES (SALES) PTY. LTD. (IN VOLUNTARY LIQUIDATION). SIDDONS LOCK AND TOOL COMPANY PTY. LTD. (IN VOLUNTARY LIQUIDATION). SIDDONS STEEL SECTIONS PTY. LTD. (IN VOLUNTARY LIQUIDATION). SIDDONS TOOLS PTY. LTD. (IN VOLUNTARY LIQUIDATION). SIDDONS (VICTORIA) PTY. LTD. (IN VOLUNTARY LIQUIDATION).

NOTICE CONVENING FINAL MEETING OF MEMBERS.

Pursuant to Section 272.

NOTICE is hereby given that general meetings of the members of the above companies will be held on Monday, 22nd January, 1968, at 10-12 Leicester-street, Carlton, Victoria, 3053, commencing at 12 noon, for the purpose in each case of having an account laid before the members, showing the manner in which the winding up has been conducted and the property disposed of, and of hearing any explanations which may be given by the liquidator.

1st December, 1967.

350 J. D. BALMFORD, Liquidator.

Companies Act 1961.

NOTICE TO CREDITORS OF INTENTION TO DECLARE A DIVIDEND.
DRAINEX PROPRIETARY LIMITED (IN VOLUNTARY LIQUIDATION).

A FIRST dividend is intended to be declared in the above matter. Any creditor who does not prove his debt by the 20th day of December, 1967, will be excluded from the distribution.

The date of the liquidation was the 17th day of August, 1965.

266 E. JOHN BROWN, Liquidator.

In the matter of the *Companies Act 1961*, and in the matter of ROCKMANS LIMITED (in voluntary liquidation).—Notice of Final Meeting of Members, pursuant to section 272.

NOTICE is hereby given in pursuance of section 272 of the *Companies Act 1961*, that a General Meeting of the members of the Company will be held at the office of Messrs. Cooper Brothers & Co., 360 Collins-street, Melbourne on the 29th day of January, 1968, at 10.00 o'clock in the forenoon for the purpose of having an account laid before it, showing the manner in which the winding up has been conducted and the property of the company disposed of, and hearing any explanation that may be given by the liquidator.

Dated this 1st day of December, 1967.

267 N. W. BUCKLEY, Liquidator.

In the matter of the *Companies Act 1961*, and in the matter of ROCKMANS STORES PTY. LIMITED (in voluntary liquidation).—Notice of Final Meeting of Members and Creditors, pursuant to section 272.

NOTICE is hereby given in pursuance of section 272 of the *Companies Act 1961*, that a General Meeting of the members and creditors of the Company will be held at the office of Messrs. Cooper Brothers & Co., 360 Collins-street, Melbourne, on the 29th day of January, 1968, at 10.15 o'clock in the forenoon, for the purpose of having an account laid before it, showing the manner in which the winding up has been conducted and the property of the company disposed of, and hearing any explanation that may be given by the liquidator.

Dated this 1st day of December, 1967.

268 N. W. BUCKLEY, Liquidator.

Companies Act 1961.—Section 254 (2) (b).

SPECTACLE CASES PROPRIETARY LIMITED.

NOTICE is hereby given that at an Extraordinary General Meeting of the above-named company, duly convened and held at the office of Australian Optical Holdings Limited, 16-22 Australia-street, Camperdown, N.S.W., on Friday, 17th November, 1967, the following Special Resolution was duly passed:

"That the company be wound up voluntarily and that Mr. Kenneth Harold Vial, of 330 Collins-street, Melbourne, be and is hereby appointed liquidator for the purpose of such winding up."

Dated this 29th day of November, 1967.

269 K. H. VIAL, Liquidator.

Companies Act 1961.—Section 254 (2) (b).

A. O. I. SUNGLASSES PROPRIETARY LIMITED.

NOTICE is hereby given that at an Extraordinary General Meeting of the above-named company, duly convened and held at the office of Australian Optical Holdings Limited, 16-22 Australia-street, Camperdown, N.S.W., on Friday, 17th November, 1967, the following Special Resolution was duly passed:

"That the company be wound up voluntarily and that Mr. Kenneth Harold Vial, of 330 Collins-street, Melbourne, be and is hereby appointed liquidator for the purpose of such winding up."

Dated this 29th day of November, 1967.

270 K. H. VIAL, Liquidator.

Companies Act 1961.

CAMORBEN (ORMOND) PTY. LIMITED.

NOTICE is hereby given, pursuant to section 254 (2) of the *Companies Act 1961*, that at an Extraordinary General Meeting of Members of the above company, held on the 29th day of November, 1967, the following Special Resolution was passed:—

"That the Company be wound up voluntarily."

Dated this 4th day of December, 1967.

309 ERIC E. FOOKES, Liquidator.

In the Supreme Court of Victoria.—Coy. No. 7442.—In the matter of the *Companies Act 1961*; and in the matter of WOLSTAN C. GINIES ENTERPRISES PTY. LTD.

WINDING up Order made the 24th day of November, 1967. Name and address of liquidator, Edward Ronald Small, of 296 Little Lonsdale-street, Melbourne.

LEWIS ORR & GIBSON, solicitors for the petitioner. 316

The Companies Act 1961.—In the matter of BELLARINE DISTRIBUTORS PTY. LTD.

NOTICE is hereby given that at an Extraordinary Meeting of the Members of the above-named Company, held on the 28th day of November, 1967, it was resolved that the company be wound up voluntarily, and at a meeting of creditors held on the same day, pursuant to section 260, it was resolved that for such purpose Everett Thomson Bent, of Suite 18, 545 St. Kilda-road, Melbourne, accountant, be appointed liquidator.

Notice is also given that after 21 days from this date, I shall proceed to distribute the assets. All creditors, having any claims against the company should furnish particulars of same by that date, otherwise I shall proceed to distribute the assets without regard to their claim.

Dated this 28th day of November, 1967.

E. T. BENT, Liquidator.

Bent & Cogle, public accountants, Suite 18, 545 St. Kilda-road, Melbourne, 3004. 289

The Companies Act 1961.—In the matter of INDUSTRIAL CONCRETE & TERRAZZO PTY. LTD.

NOTICE is hereby given that at an Extraordinary Meeting of the Members of the above-named Company, held on the 29th day of November, 1967, it was resolved that the company be wound up voluntarily, and at a meeting of creditors held on the same day, pursuant to section 260, it was resolved that for such purpose Everett Thomson Bent, of Suite 18, 545 St. Kilda-road, Melbourne, accountant, be appointed liquidator.

Notice is also given that after 21 days from this date, I shall proceed to distribute the assets. All creditors, having any claims against the company should furnish particulars of same by that date, otherwise I shall proceed to distribute the assets without regard to their claim.

Dated this 29th day of November, 1967.

E. T. BENT, Liquidator.

Bent & Cogle, public accountants, Suite 18, 545 St. Kilda-road, Melbourne, 3004. 290

The Companies Act 1961.

V. & C. FURNITURE INDUSTRIES PTY. LTD.

PURSUANT TO SECTION 260 OF THE COMPANIES ACT 1961.

NOTICE is hereby given that a Meeting of Creditors of V. & C. Furniture Industries Pty. Ltd. will be held at the Board Room, at the Institute of Chartered Accountants, 23 McKillop-street, Melbourne, on Monday, the 11th day of December, 1967, at 2.30 p.m., for the purpose of considering the company's affairs, the company having convened an Extraordinary General Meeting of its Members to be held on the same day, and for the purpose of considering and if thought fit passing a Special Resolution that the company be wound up voluntarily.

Dated this 28th day of November, 1967.

C. SGRO, Director.

Hall & Rose, chartered accountants, 260 Queen-street, Melbourne, Vic. 3000. 324

The Companies Act 1961.

NOTICE CONVENING FINAL MEETING OF SHAREHOLDERS, PURSUANT TO SECTION 272.

ENTERPRISE OF NEW GUINEA GOLD & PETROLEUM DEVELOPMENT NO LIABILITY (IN LIQUIDATION).

NOTICE is hereby given, in pursuance of section 272 of the Companies Act 1961, that a Meeting of the Shareholders of the above-named company will be held on the 3rd day of January, 1968, at 260 Queen-street, Melbourne, at 11 o'clock in the forenoon, for the purpose of having an account laid before them, showing the manner in which the winding up has been conducted and the property of the company disposed of, and of hearing any explanations that may be given by the liquidator.

Dated this 29th day of November, 1967.

S. M. NUNAN, Liquidator.

Hall & Rose, chartered accountants, 260 Queen-street, Melbourne, Vic. 3000. 325

NOTICE is hereby given that a meeting of shareholders of H. Keith Allen & Sons Pty. Ltd. (in Voluntary Liquidation), will be held on 12th January, 1968, at 3 p.m., at the office of Mortimer, Cox & Associates, 227 Collins-street, Melbourne, for the purposes set out in section 272 of the Companies Act 1961.

Dated this 28th day of November, 1967.

344

KENNETH M. COX, Liquidator.

In the matter of the Companies Act 1961; and in the matter of LUXOR FABRICS PTY. LTD.

Notice of Passing of Resolution for Voluntary winding up.

NOTICE is hereby given that at an Extraordinary General Meeting of the above-named company duly convened and held at 83 Orrong-road, Elsternwick, on Saturday the 25th day of November, 1967, at 2 o'clock in the afternoon, the following Special Resolutions were duly passed:—

1. "That the company be wound up voluntarily."

2. "That Mr. Paul Abram Juno is hereby appointed liquidator for the purpose of such winding up and that the remuneration for his duties be in accordance with the scale of fees set down by the Australian Society of Accountants."

Dated the 25th of November, 1967.

D. GROSLIK, Chairman.

Peter Barker, Harty & Co., solicitors, 400 Lonsdale-street, Melbourne, 3000. 326

Companies Act 1961.

NOTICE OF FINAL MEETING OF MEMBERS' VOLUNTARY WINDING UP.

NEW SOUTHPORT PTY. LTD.

NOTICE is hereby given, in pursuance of section 272 (1) that the Final General Meeting of the members of New Southport Pty. Ltd., will be held at 10.30 a.m., on Wednesday, 18th day of January, 1968, at the office of Fell & Starkey, 360 Collins-street, Melbourne, for the purpose of the liquidator laying before it an account, showing how the winding up has been conducted and the property disposed of and to give any explanation thereof.

328

K. V. HARRISON, Liquidator.

TRARALGON FURNITURE PROPRIETARY LIMITED.

NOTICE is hereby given that pursuant to section 272 of the Companies Act 1961, a meeting of the members and creditors of the above-named company will be held at the company's registered office, Matthews-avenue, Airport West, on the 13th of February, 1968, at 10.30 in the forenoon for the purpose of having an account laid before them, showing how the winding-up of the company has been conducted and the property of the company disposed of.

Dated this 29th day of November, 1967.

ROBERT RANKIN SMITH, Liquidator.

A. L. Royce and Warne-Smith, chartered accountants, 440 Collins-street, Melbourne. 300

In the matter of the Victorian Companies Act 1961; and H. A. C. SMITH INDUSTRIES PTY. LTD. (in liquidation).

NOTICE is hereby given that Creditors, having claims against the above-named company, should lodge Proofs of Debt with the official liquidator, Peter William Harvey, care of A. L. Royce and Warne-Smith, 440 Collins-street, Melbourne. Creditors, who have not lodged their claims by the 31st December, 1967, will be excluded from dividends.

Dated this 27th day of November, 1967.

P. W. HARVEY, official liquidator, 440 Collins-street, Melbourne. 305

Companies Act 1961.—In the matter of W. A. MILNE BUILDING & TRADING PTY. LTD. (in liquidation).

NOTICE is hereby given that a first dividend is intended to be declared in this matter. Creditors, who have not proved their debt by the 20th day of December, 1967, will be excluded from the dividend.

Dated this 4th day of December, 1967.

J. C. COUZENS, Liquidator.

J. C. Couzens & Associates, 527 Collins-street, Melbourne. 308

NEW DAWN CONSOLIDATED NO LIABILITY.

NOTICE is hereby given that a meeting of creditors of the above-named company will be held in the Board Room of the Institute of Chartered Accountants in Australia, 23 McKillop-street, Melbourne, on Thursday, 21st December, 1967, at 12 o'clock noon, the company having convened a meeting of its members for the same day for the purpose of considering a Special Resolution that the company be wound up voluntarily.

Dated this 6th day of December, 1967.

356

H. L. STEWART, Secretary.

In the matter of the *Companies Act 1961*; and in the matter of TRARALGON FURNITURE PTY. LTD.

AT an Extraordinary General Meeting of the above-named company, held at Matthews-avenue, Airport West, on the 28th November, 1967, the following Special Resolution was duly passed—

“That the Company be wound up voluntarily.”

And at such last mentioned meeting Robert Rankin Smith, of 343 Little Collins-street, Melbourne, was appointed liquidator for the purpose of the winding up.

R. M. BAYLEY, Secretary.

A. L. Royce and Warne-Smith, chartered accountants,
440 Collins-street, Melbourne. 299

In the matter of the *Companies Act 1961*; and in the matter of TRARALGON BUILDING SUPPLIES PTY. LTD.

AT an Extraordinary General Meeting of the above-named company, held at Matthews-avenue, Airport West, on the 28th November, 1967, the following Special Resolution was duly passed—

“That the Company be wound up voluntarily.”

And at such last mentioned meeting Robert Rankin Smith, of 343 Little Collins-street, Melbourne, was appointed liquidator for the purpose of the winding up.

R. M. BAYLEY, Secretary.

A. L. Royce and Warne-Smith, chartered accountants,
440 Collins-street, Melbourne. 301

TRARALGON BUILDING SUPPLIES PROPRIETARY LIMITED.

NOTICE is hereby given that pursuant to section 272 of the *Companies Act 1961*, a meeting of the members and creditors of the above-named company will be held at the company's registered office, Matthews-avenue, Airport West, on the 13th of February 1968, at 11 o'clock in the forenoon for the purpose of having an account laid before them, showing how the winding-up of the company has been conducted and the property of the company disposed of.

Dated this 29th day of November, 1967.

ROBERT RANKIN SMITH, Liquidator.

A. L. Royce and Warne-Smith, chartered accountants,
440 Collins-street, Melbourne. 302

The *Companies Act 1961*.—In the matter of ORIENTAL MOTORS PTY. LTD.

NOTICE re MEETING OF CREDITORS, PURSUANT TO SECTION 260.

NOTICE is hereby given that a Meeting of Creditors of the above-named company will be held at the offices of Kennedy, Smail & Middlemiss, 296 Little Lonsdale-street, Melbourne, at 11.00 a.m. on the 8th day of December, 1967, the Company having convened a Meeting of its Members for the same day for the purpose of considering a Resolution that the company be wound up voluntarily.

Dated this 30th day of November, 1967.

D. R. CAMERON, Director.

Kennedy, Smail & Middlemiss, 296 Little Lonsdale-street,
Melbourne. 298

NOTICE TO CREDITORS.

In the matter of the *Co-operative Housing Societies Act 1958* and the *Companies Act 1961*, and in the matter of THE MODERN HOME CO-OPERATIVE HOUSING SOCIETY LIMITED (in Liquidation).

NOTICE is hereby given that all persons having any claim against the above society are required on or before the 28th day of December, 1967, to send their names and addresses and particulars of their debts or claims to I. E. Byam-Wight, 342A St. Kilda-road, Melbourne, the liquidator of the said society, at his office and if so required by notice, in writing, from the said liquidator are personally, or by their solicitors, to come in and prove their said debts or claims at such time and place as shall be specified in such notice; or, in default thereof, they shall be excluded from the benefit of any distribution made before such debts or claims are so lodged or proved.

Dated at Melbourne this 4th day of December, 1967.

272 I. E. BYAM-WIGHT, Liquidator.

CREDITORS, next of kin and others having claims in respect of the estate of Arthur Reginald Bond, late of 96B Gould-street, Frankston, traveller, deceased (who died on the 12th day of July, 1967, and probate of whose will, has been granted to Alma May Bond, of 96B Gould-street, Frankston, widow), are required to send particulars of their claims to the said executrix, by the 10th day of

February, 1968, after which date she will distribute the assets, having regard only to the claims of which she then has notice.

PEARCE & WEBSTER, solicitors, 430 Little Collins-street, Melbourne. 335

Trustee Act 1958.

NOTICE TO CLAIMANTS.

PURSUANT to the *Trustee Act 1958*, creditors, next of kin and all other persons having claims in respect of the estate of any deceased person named below are required to send particulars to the legal personal representative or representatives at the addresses stated, after which date the representative or representatives will distribute the assets, having regard only to the claims of which notice has been received:—

Charlotte Lillian Sampson, late of 12 Temple-street, West Brunswick, widow, deceased, died on the 15th day of October, 1967.—Claims to the executrix, Betty Barbara Gephart, of 134 Warrigal-road, South Oakleigh, married woman, care of John F. Carroll, of 4 Paisley-street, Footscray, solicitor, by the 10th day of February, 1968. John F. Carroll, LL.B., solicitor, 4 Paisley-street, Footscray. 353

William Henry Bailey, late of 1 Soudan-road, West Footscray, retired clerk, deceased, died on the 28th day of September, 1967.—Claims to the executrix, Dorothy Mary Bailey, of 1 Soudan-road, West Footscray, widow, care of John F. Carroll, of 4 Paisley-street, Footscray, solicitor, by the 8th day of February, 1968. John F. Carroll, LL.B., solicitor, 4 Paisley-street, Footscray. 354

CECELIA OLIVIA POLLARD, late of Flat 2, 133 Alma-road, East St. Kilda, and of 5 Muir-street, Hawthorn, widow, DECEASED.

CREDITORS, next of kin and others having claims in respect of the estate of the deceased (who died on the 18th day of July, 1967), are required by the trustees, Rita Jean Magill, of 34 Christian-street, Clayfield, Brisbane, Queensland, and Mirriell Phyllis Atherton, of 24 Lilydale-grove, Auburn, married woman, to send particulars to them, care of the under-mentioned firm of Arthur Phillips & Just, by the 9th day of February, 1968, after which date the said trustees may convey or distribute the assets, having regard only to the claims of which they then have notice.

ARTHUR PHILLIPS & JUST, solicitors, 472 Bourke-street, Melbourne. 347

JESSIE MAUDE ELIZABETH ANDREWS, late of 45 Macleod-parade, Macleod West, widow, DECEASED.

CREDITORS, next of kin and others having claims in respect of the estate of the deceased (who died on the 13th day of September, 1967), are required by the trustee, Clyde Frederick Andrews, care of the under-mentioned solicitors to send particulars to him by the 15th day of February, 1968, after which date the trustee may convey or distribute the assets, having regard only to the claims of which he then has notice.

H. B. V. DIMELOW, solicitors, 129 Lower Plenty-road, Rosanna. 355

RUPERT FRANCIS LESLIE VICTOR HARVEY, late of “Navua”, 6 Whernside-avenue, Toorak, medical practitioner, DECEASED.

CREDITORS, next of kin and others having claims against the estate of the said deceased (who died on 21st October, 1967), are to send particulars of their claims to The Union-Fidelity Trustee Company of Australia Limited, care of 100 Exhibition-street, Melbourne by the 2nd day of February, 1968, after which date it will distribute the assets, having regard only to the claims of which it then has notice.

BLAKE & RIGGALL, solicitors, 120 William-street, Melbourne. 343

CREDITORS, next of kin and others having claims in respect of the estate of Edward Quinlan, late of 3 Merther-road, West Ivanhoe, engine driver, deceased (who died on 15th September, 1967), are requested by the executor, The Union-Fidelity Trustee Company of Australia Limited, of 100 Exhibition-street, Melbourne, to send particulars of their claims to the executor at the above address by the 15th day of February, 1968, after which date it will distribute the assets, having regard only to the claims of which it then has notice.

FREDERICK OWEN & ASSOCIATES, solicitors, 84 William-street, Melbourne. 346

DONALD LINDSAY MILDRED, formerly of 23 Queen-street, Melbourne, but late of 1034 Malvern-road, Malvern, formerly sales manager, but latterly company executive, DECEASED (who died on the 30th day of September, 1966).

CREDITORS, next of kin and others having claims against the estate of the deceased, are required by the executors, Susan Grace Mildred, of 36 Dunford-street, Paddington, New South Wales, widow, and Rodney Disney Davidson, of 401 Collins-street, Melbourne, solicitor, to send particulars of their claims to the executors, care of the undersigned solicitors on or before the 6th day of February, 1968, after which date they will distribute the assets, having regard only to the claims of which they then have notice.

HOME, WILKINSON & LOWRY, solicitors, of 401 Collins-street, Melbourne, 3000. 345

CREDITORS, next of kin and others having claims in respect of the estate of Griffith Blake Gaut, late of 5 Myrnong-crescent, Ascot Vale, in the State of Victoria, retired public servant, deceased, intestate (who died on the 26th day of December, 1966), are requested to send particulars of their claims to the administrator, George Abraham Gaut, care of the under-mentioned solicitor, by the 20th February, 1968, after which date he will distribute the assets, having regard only as to the claims to which he then has notice.

EDWARD CURMI, solicitor, of 440 Victoria-street, North Melbourne. 287

CREDITORS, next of kin and others having claims in respect of the estate of Elsie Maud Hall, late of 25 Davey-avenue, East Brighton, in the State of Victoria, married woman, deceased (who died on the 12th day of August, 1967), are to send particulars of their claims to The Equity Trustees Executors and Agency Company Limited, of 472 Bourke-street, Melbourne, by the 9th day of February, 1968, after which date the executors will distribute the assets, having regard only to the claims of which they then have notice.

DAVID BRISTOL, LL.B., solicitors, 549 Hampton-street, Hampton. 288

CREDITORS, next of kin and others having claims in respect of the estate of Preston Maggie Watkins, late of 3 Doona-avenue, Kew, widow, deceased (who died on the 3rd day of August, 1967), are required by the executors Annie Erica Smart and Donald Litchfield Watkins, to send particulars to them, care of the under-mentioned solicitor, by the 20th day of February, 1968, after which date the executors may convey or distribute the assets, having regard only to the claims of which they then have notice.

B. J. T. STONE, LL.B., solicitor, 221 High-street, Kew. 291

CREDITORS, next of kin and others having claims against the estate of Irene May Elizabeth Robinson, late of 1 Hill-street, Ballarat, widow, deceased (who died on the 17th day of October, 1967), are to send particulars of their claims to The Union-Fidelity Trustee Company of Australia Limited, of 101 Lydiard-street north, Ballarat, by the 1st day of February, 1968, after which date the Company will distribute the assets, having regard only to the claims of which it then has notice. 293

EDWARD GEORGE HAWKER, late of Kaniva, in the State of Victoria, farmer, DECEASED.

CREDITORS, next of kin and others having claims in respect of the estate of the said deceased (who died on 16th June, 1965), are required by the personal representatives, Kevin Hawker of Lillimur, in the said State, farmer, and Iris Gregory, of Kaniva, aforesaid, married woman, to send particulars to them, care of the under-mentioned solicitor, by the 15th day of February, 1968, after which date the personal representatives may convey or distribute the assets having regard only to the claims of which they then have notice.

J. C. WILLIAMS, solicitor, Kaniva. 295

CREDITORS, next of kin and others having claims in respect of the estate of Veronica Kathleen Carr, late of 476 Bell-street, Preston, retired clerk, deceased (who died on the 27th October, 1967), are to send particulars of their claims to the administrator, John Patrick Michael Carr, care of the undersigned solicitors, by the 8th February, 1968, after which date he will distribute the assets, having regard only to the claims of which he then has notice.

HALL & WILCOX, solicitors, 20 Queen-street, Melbourne. 297

CREDITORS, next of kin and others having claims in respect of the estate of Edith Marianne Hall, late of Hopetoun Private Hospital, 2 Hopetoun-street, Elsternwick, spinster, deceased (who died on the 13th July, 1967), are to send particulars of their claims to The Union-Fidelity Trustee Company of Australia Limited, of 100 Exhibition-street, Melbourne, the executor of the will, of the said deceased, by the 7th February, 1968, after which date the said company, will distribute the assets of the said deceased, having regard only to the claims of which it then has notice.

R. WADHAM & DOIG, solicitors, of 383 Flinders-lane, Melbourne. 303

CREDITORS, next of kin and other having claims against the estate of Mary Catherine McKie, late of 8 Somerville-street, Bendigo, spinster, deceased (who died on the 18th day of August, 1967), are required by the executor, Sandhurst and Northern District Trustees, Executors and Agency Company Limited, of View-street, Bendigo, to send particulars, in writing, of their claims to it on or before the 9th day of February, 1968, after which date the said company will distribute the assets of the said deceased, having regard only to the claims of which it then has notice.

WATSON, JAMES & ROGERS, solicitors, Bull-street, Bendigo. 248

ELINOR EDITH CLARK, late of 54 Aberdeen-street, Newtown, Geelong, spinster, DECEASED.

CREDITORS, next of kin and others having claims in respect of the estate of the said deceased (who died 18th August, 1967), are required by the applicants for grant of probate of the will, Margaret Trevenen, married woman and Frederick Harold Trevenen, retired public servant, both of Hempstead Cottage, Holmwood Common, North Holmwood, via Dorking, Surrey, England), to send particulars to them, care of the undersigned solicitors by 1st February, 1968, after which date the said applicants may convey or distribute the assets, having regard only to the claims of which they then have notice.

WIGHTON & McDONALD, solicitors, 89 Myers-street, Geelong. 249

CREDITORS, next of kin and others having claims against the estate of Bertie Washington Peake Solly, late of 46 Huntington-grove, East Coburg, salesman, deceased (who died on the 20th day of June, 1967), are required to send particulars of their claims to the executor, Albert Edward Solly, care of M. F. Hughes, solicitor, of 300 Barkly-street, Brunswick, by the 10th day of February, 1968, after which date he will distribute the assets of the deceased, having regard only to the claims of which he has notice.

M. F. HUGHES, LL.B., barrister and solicitor, 300 Barkly-street, Brunswick. 250

JOHN LANGTON MOONEY, formerly of Mooneys Gap, Ararat, grazier, late of Ararat, retired, DECEASED.

CREDITORS, next of kin and others having claims in respect of the estate of the above-mentioned deceased (who died on the 27th day of September, 1967), are required to send particulars of their claims to National Trustees, Executors and Agency Company of Australasia Limited and Beatrice Escombe Mooney, the executors of the will of the said deceased, care of 95 Queen-street, Melbourne, by the 14th day of February, 1968, after which date they will distribute the assets, having regard only to the claims of which they then have notice.

BRIGGS & O'DRISCOLL, solicitors, 94 Barkly-street, Ararat. 262

IVY JEAN QUINNELL, formerly of 257 McCrae-street, Bendigo, in the State of Victoria, but late of Deniliquin, in the State of New South Wales, married woman, DECEASED.

CREDITORS, next of kin and others having claims in respect of the estate of the deceased (who died on the 25th day of January, 1967), are required by the executors, Lester Bernard Quinnell, of Deniliquin, in the State of New South Wales, farmer, and Owen John Quinnell, of Deniliquin, in the State aforesaid, farmer, to send particulars to them, care of the undersigned, by the 13th day of February, 1968, after which date the executors may convey or distribute the assets, having regard only to the claims of which they then have notice.

Dated this 29th day of November, 1967.

ALEC M. HAYES, solicitor, 148 Campbell-street, Swan Hill. 252

FLORENCE MAY CHAPMAN, late of Filson-street, Nagambie, in the State of Victoria, spinster, DECEASED.

CREDITORS, next of kin and others having claims in respect of the estate of the deceased (who died on the 27th August, 1967), are required by the personal representative, The Equity Trustees, Executors and Agency Company Limited, of 472 Bourke-street, Melbourne, to send particulars to it by the 29th day of February, 1968, after which date the personal representative may convey or distribute the assets, having regard only to the claims of which it then has notice.

Dated the 29th day of November, 1967.

G. J. N. HOPKINS, solicitor, Nagambie.

254

DOUGLAS ERIC DAVIS, late of 40 Charteris-drive, East Ivanhoe, analytical chemist, DECEASED (who died on 5th August, 1967).

CREDITORS, next of kin and all other persons having claims against the estate of the deceased are required by the executrix of his will, Ethel Mary Davis, of 40 Charteris-drive, East Ivanhoe, widow, to send particulars thereof to her, care of the under-mentioned solicitors, before 6th February, 1967, after which date she may distribute the assets of the deceased, having regard only to the claims of which she then has notice.

COLTMAN, WYATT & ANDERSON, solicitors, of 578 Bourke-street, Melbourne.

319

CREDITORS, next of kin and others having claims in respect of the estate of Clifford Herman Andrewartha, late of 9 Kellett-grove, Kew, gentleman, deceased (who died on 3rd July, 1967), are to send particulars of their claims to Irma Corlass, of 9 Kellett-grove, Kew, married woman, the executrix appointed by the will of the said deceased by the 10th February, 1968, after which date the executrix will distribute the assets, having regard only to the claims of which she shall then have notice.

H. L. YUNCKEN & YUNCKEN, solicitors, 443 Little Collins-street, Melbourne.

320

ALL persons having claims against the estate of Albert Walter Richards, late of 15 Binnie-street, Brighton, retired builder, deceased (who died on the 27th June, 1965, and probate of whose will was, on the 7th June, 1966, granted by the Supreme Court of Victoria, to Ernest Sydney Middleton, of 224 Queen-street, Melbourne, solicitor), are hereby required to send particulars of such claims to Middletons, at 224 Queen-street, Melbourne, on or before the 6th February, 1968, after which date the executor will proceed to transfer, convey or distribute the said estate to or among the persons entitled thereto, having regard only to the claims of which he shall then have had notice, and will not be liable for the assets so transferred, conveyed or distributed to any person of whose claim he shall not then have had notice.

321

ALL persons having claims against the estate of Anna Mavis Cameron, late of 2 Melrose-avenue, East Malvern, widow, deceased (who died on the 1st August, 1966, and probate of whose will was, on the 23rd March, 1967, granted by the Supreme Court of Victoria to Leonard Clinton Shaw, of 224 Queen-street, Melbourne, solicitor), are hereby required to send particulars of such claims to Middletons, at 224 Queen-street, Melbourne, on or before the 6th February, 1968, after which date the executor will proceed to transfer, convey or distribute the said estate to or among the persons entitled thereto, having regard only to the claims of which he shall then have had notice, and will not be liable for the assets so transferred, conveyed or distributed to any person of whose claim he shall not then have had notice.

322

HERBERT FLUCK, late of 157 Banksia-street, Heidelberg, gentleman, DECEASED.

CREDITORS, next of kin and others having claims in respect of the estate of the deceased (who died on the 26th day of September, 1967), are required by The Perpetual Executors and Trustees Association of Australia Limited, of 100-104 Queen-street, Melbourne, and Otto Prouse Fluck, of 413 Burwood-road, Glenferrie, furniture dealer, the applicants for a grant of administration to send particulars of their claims to the said applicants in the care of the said company, by the 7th day of February, 1968, after which date they will convey or distribute the assets, having regard only to the claims of which they then have notice.

HENDERSON & BALL, solicitors, 430 Little Collins-street, Melbourne.

323

ALICE NORA NIVEN, late of Flat 6, 1328 High-street, Malvern, widow, DECEASED.

CREDITORS, next of kin and others having claims in respect of the estate of the deceased (who died on the 31st day of July, 1967), are required by The Perpetual Executors and Trustees Association of Australia Limited, of 100-104 Queen-street, Melbourne, to send particulars of their claims to the said company, by the 7th day of February, 1968, after which date it will convey or distribute the assets, having had regard only to the claims of which the company then has notice.

H. S. W. LAWSON, HUGHES & CO., 357 Little Collins-street, Melbourne, solicitors.

327

CREDITORS, next of kin and others having claims in respect of the estate of Florence Annie Taylor, formerly of 10 Gladstone-avenue, Malvern, but late of "Coimbra" Private Hospital, 5 Chaddesley-avenue, East St. Kilda, widow, deceased (who died on the 29th day of August, 1967, and probate of whose will has been granted to Ronald Harry Watkin Rimmer, of 36 Howie-street, Glen Iris, representative), are required to send particulars of their claims to the said executor, care of the under-mentioned solicitors, by the 10th day of February, 1968, after which date he will distribute the assets, having regard only to the claims of which he then has notice.

PEARCE & WEBSTER, solicitors, 430 Little Collins-street, Melbourne.

336

CREDITORS, next of kin and others having claims in respect of the estate of Christon Herbert Smith, formerly of 42 Roslyn-street, Middle Brighton, late of 211 Balcombe-road, Beaumaris, public servant, deceased (who died on the 28th day of June, 1967, and probate of whose will has been granted to Wallace Herbert Smith, of 10 Bundeera-road, South Caulfield, bank officer, and Glenda May Smith, of 211 Balcombe-road, Beaumaris, widow), are required to send particulars of their claims to the said executors, care of the under-mentioned solicitors by the 8th day of February, 1968, after which date they will distribute the assets, having regard only to the claims of which they then have notice.

PEARCE & WEBSTER, solicitors, 430 Little Collins-street, Melbourne.

337

JESSIE MCKAY, late of 20 Sutherland-street, Coburg, in the State of Victoria, spinster, DECEASED, intestate.

CREDITORS, next of kin and others having claims in respect of the estate of the deceased (who died on the 12th day of September, 1967), are required by the trustee, The Equity Trustees, Executors and Agency Company Limited, of 472 Bourke-street, Melbourne, to send particulars to it by the 28th day of February, 1968, after which date the trustee may convey or distribute the assets, having regard only to the claims of which it then has notice.

338

ADA CUMMIN, late of 32 Winter-street, Malvern, spinster, DECEASED.

CREDITORS, next of kin and others having claims in respect of the estate of the deceased (who died on the 7th August, 1967), are required by the executor, Ian William Cox, of 452 Lonsdale-street, Melbourne, solicitor, to send particulars to him, care of the under-mentioned solicitors, by the 9th February, 1968, after which date he will distribute the assets, having regard only to the claims of which he then has notice.

FREDERICK W. COX & SON, solicitors, 452 Lonsdale-street, Melbourne.

307

PURSUANT to the Trustee Act 1958, notice is hereby given that creditors, next of kin and all other persons having claims against the estate of Ernest Robert Manks, late of 213 Bluff-road, Sandringham, retired farmer, deceased (who died on the 23rd day of October, 1966), and probate of the will was on the 7th day of April, 1967, granted by the Supreme Court of Victoria, to Thomas Eli Manks, of 66 Victoria-street, Sandringham, pharmaceutical chemist, and Ronald Bell, of 34 Stuart-avenue, Cheltenham, accountant, are hereby required to send particulars, in writing, of such claims to the said executors, care of the under-mentioned solicitors, on or before the 17th day of February, 1968, after which date the executors will proceed to distribute the assets of the said deceased among the persons entitled thereto, having regard only to the claims of which they shall then have notice and will not be liable as regards the assets so distributed to any such person of whose claim they shall not then have had notice.

HERBERT, GEER & RUNDLE, 612-614 Balcombe-road, Black Rock, solicitors.

304

JOHN O'BRIEN, formerly of Lockington, but late of Swan Hill, in the State of Victoria, farmer, DECEASED.

CREDITORS, next of kin and other persons having claims against the estate of the said deceased (who died on the 27th day of May, 1967), are required to send particulars of same to the executors, Patricia Jean O'Brien, James Thomas O'Brien and Thomas O'Brien, in care of the undersigned, on or before the 3rd day of March, 1968, after which date they will distribute the assets, having regard only to the claims of which they then have notice.

DELANY & DWYER, barristers and solicitors, 270 Campbell-street, Swan Hill. 318

STATUTORY NOTICE TO CREDITORS.

PURSUANT to Trustee Act 1958, notice is hereby given that all persons having claims against the estate of Herbert Edward Watkins Mundy, formerly of 9 Winifred-crescent, Glen Iris, but late of Flat 11, 56 Sutherland-street, Armadale, in the State of Victoria, retired railways officer, deceased (who died on the 27th day of July, 1967), and probate of his will was granted by the Supreme Court of the said State, in its probate jurisdiction, on the 30th day of November, 1967, to Nigel Derwent Sinclair, of 401 Collins-street, Melbourne, in the said State, general manager of The Trustees, Executors and Agency Company Limited, are hereby required to send the particulars, in writing, of such claims to the undersigned, at his office hereunder mentioned, on or before the 15th day of March, 1968, after which date the said Nigel Derwent Sinclair will proceed to distribute the assets of the said Herbert Edward Watkins Mundy, deceased, which shall have come to his hands amongst the persons entitled thereto, having regard only to the claims of which he shall then have had notice. And notice is hereby further given that the said Nigel Derwent Sinclair will not be liable for the assets so distributed, or any part thereof, to any person of whose claim he shall not have had notice as aforesaid.

Dated the 6th day of December, 1967.

BARBOUR & ARNOLD, solicitors, of 405 Bourke-street, Melbourne. Proctors for the said Nigel Derwent Sinclair. 310

CREDITORS, next of kin and others having claims in respect of the estate of Hazel Violet Hogan, late of Kulwin, in the State of Victoria, married woman (who died on the 22nd November, 1967), are to send particulars of their claims to The Perpetual Executors and Trustees Association of Australia Limited, by the 4th of March, 1968, after which date they will distribute the assets, having regard only to the claims of which they then have notice.

PRICE & CHAMBERLIN, solicitors, 443 Little Collins-street, Melbourne. 315

CREDITORS, next of kin and others having claims in respect of the estate of Ernestine Frederica Caroline O'Connor, formerly of 105 Powell-street, Yarraville, but late of Keith House, 39 Armadale-street, Armadale, in the State of Victoria, widow, deceased (who died on the 28th July, 1967), are requested to send particulars of their claims to National Trustees Executors and Agency Company of Australasia Limited, of 95 Queen-street, Melbourne, the executor appointed by the will of the said deceased, by the 13th day of February, 1968, after which date it will distribute the assets of the said deceased, having regard only to the claims of which it shall then have had notice.

J. A. WILMOTH & SON, solicitors, 4 Bank-place, Melbourne. 306

In the Supreme Court of the State of Victoria.

SALE BY THE SHERIFF.

ON Monday, the 5th of February, 1968, at 10.30 a.m., at the Police Station, Werribee (unless process be stayed or satisfied):—

All the estate and interest (if any) of John Hamer, of Tower-road, Werribee, as proprietor with Stefan Milic, as tenants, in common in equal shares of an estate in fee-simple in the land described in certificate of title, volume 8682, folios 852 and 853, upon which is erected a dwelling-house and fowl pens, known as Hamers property, Tower-road, Werribee.

Registered mortgages Nos. C.224714, C.455986 and C.674890 affect the said estate and interest.

Terms: Cash only.

N. FROGLEY, Sheriff's Officer.

30th November, 1967.

317

In the Supreme Court of the State of Victoria:

SALE BY THE SHERIFF.

ON Monday, the 22nd of January, 1968, at 12.30 p.m., at the Police Station, Sorrento (unless process be stayed or satisfied):—

All the estate and interest (if any) of A. & S. Improvement & Finance Company Proprietary Limited, of 521 Burke-road, East Hawthorn; as proprietor of an estate in fee-simple in the land described in certificate of title, volume 8169, folio 611, upon which is erected a brick dwelling-house and garage, known as No. lot 1, Melbourne-road, Blairgowrie. The land is situated on the south-east corner of Melbourne-road and Hughes-road, Blairgowrie.

Registered mortgage No. C.538080 affects the said estate and interest.

Terms: Cash only.

DAVID J. JOHNSTON, Sheriff's Officer.

4th December, 1967.

312

In the Supreme Court of the State of Victoria.

SALE BY THE SHERIFF.

ON Monday, the 5th of February, 1968, at 1 p.m., at the Police Station, Mitcham (unless process be stayed or satisfied):—

All the estate and interest (if any) of Angus Gavin Cameron, of 5 Ashmore-road, Forest Hill; council employee, as proprietor of an estate in fee-simple in the land described in certificate of title, volume 8205, folio 257, upon which is erected a brick veneer dwelling-house, known as No. 5 Ashmore-road, Forest Hill.

Registered mortgage No. C.501990 affects the said estate and interest.

Terms: Cash only.

N. FROGLEY, Sheriff's Officer.

1st December, 1967.

313

In the Supreme Court of the State of Victoria.

SALE BY THE SHERIFF.

ON Monday, the 22nd of January, 1968, at 10 a.m., at the Police Station, Mentone (unless process be stayed or satisfied):—

All the estate and interest (if any) of Freda Ann Gaspero and Kenneth John Gaspero, both of 55 Riviera-street, Mentone, married woman and carpenter, respectively, as joint proprietors of an estate in fee-simple in the land described in certificate of title, volume 7180, folio 868, upon which is erected a weatherboard dwelling-house of three bedrooms and large garage, known as No. 55 Riviera-street, Mentone.

Registered mortgage No. B.797269 affects the said estate and interest.

Terms: Cash only.

DAVID J. JOHNSTON, Sheriff's Officer.

1st December, 1967.

314

IMPOUNDINGS.

BANNOCKBURN.—Impounded in Bannockburn Pound, found wandering at Fyansford.

4 lambs, no visible brand

If not claimed and expenses paid, to be sold on 23rd December, 1967.

340—\$1.75

T. PIKE,
Poundkeeper.

BUNINYONG.—Impounded in Buninyong Pound, from Yankee Flat:

1 black and white bull, no visible brand

If not claimed and expenses paid, to be sold on 18th December, 1967.

294—\$1.75

E. T. SUTHERLAND,
Poundkeeper.

HASTINGS.—Impounded at Shire Depot, Hastings, from South Boundary-road, Somerville, on 29th November.

1 red and white Hereford bull, approximately 18 months old, no visible brand

Impounded from Red Hill-road, on 30th November.

1 black Aberdeen Angus bull, ring in nose, approximately 12 months old, no visible brand

If not claimed and expenses paid, to be sold on 20th December, 1967.

278—\$2.75

L. A. WALKER,
Shire Secretary.

TATURA.—Impounded in Tatura Pound.

1 Corriedale wether, V tip right ear, no visible brand
If not claimed and expenses paid, to be sold on 20th December, 1967.

J. H. MACTIER,
Poundkeeper.

246—\$1.50

YARRAWONGA.—Impounded in Yarrowonga Pound.

2 Corriedale wethers in full wool, M out of top of left ear, no visible brand
1 Corriedale wether, recently shorn, M out of bottom of left ear, no visible brand

If not claimed and expenses paid, to be sold on 19th December, 1967.

R. K. SOULSBY,
Shire Secretary.

341—\$2.25

Subordinate Legislation Act 1962.

NOTICE OF MAKING OF STATUTORY RULES.

IN pursuance of the provisions of the *Subordinate Legislation Act 1962* and the Regulations made thereunder, notice is given of the making of the following statutory rules:—

| No. | Melbourne Harbor Trust Act 1958. | Price. |
|-----------|--|--------|
| 297/1967. | Melbourne Harbor Trust Regulations (Amendment No. 4/67, Alteration of Business Hours) | 10c |
| | <i>Apprenticeship Act 1958.</i> | |
| 300/1967. | Apprenticeship (Pastrycooking Trade) Regulations 1967 | 15c |
| | <i>Lifts and Cranes Act 1959.</i> | |
| 301/1967. | Lifts (Amendment) Regulations 1967 | 10c |
| | <i>Superannuation Act 1958.</i> | |
| 302/1967. | Superannuation (Conversion of Pension) Regulations 1967 | 10c |
| | <i>Superannuation Act 1958.</i> | |
| 303/1967. | Superannuation (Table B) Regulations 1967 | 10c |
| | <i>Stamps Act 1958.</i> | |
| 304/1967. | Stamps (Amendment) Regulations 1967 | 10c |
| | <i>Motor Boating Act 1961.</i> | |
| 305/1967. | Motor Boating (Pykes Creek Reservoir) Regulations 1967 | 10c |
| | <i>Motor Boating Act 1961.</i> | |
| 306/1967. | Motor Boating (Lake Glenmaggie) Regulations 1967 | 10c |
| | <i>Motor Boating Act 1961.</i> | |
| 307/1967. | Motor Boating (Lake Bellfield) Regulations 1967 | 10c |
| | <i>Motor Boating Act 1961.</i> | |
| 308/1967. | Motor Boating (Cairn Curran Reservoir) Regulations 1967 | 10c |
| | <i>Legal Profession Practice Act 1958.</i> | |
| 309/1967. | Rules of the Council of Legal Education.—Rules Relating to the Qualification and Admission of Candidates | 10c |
| | <i>Apprenticeship Act 1958.</i> | |
| 310/1967. | Apprenticeship (Watchmaking Trades) (Amendment No. 2) Regulations 1967 | 10c |
| | <i>State Savings Bank Act 1958.</i> | |
| 311/1967. | State Savings Bank (Interest Rates Amendment No. 1) General Orders 1967 | 10c |

Copies of these statutory rules may be purchased at the Sale of Publications Section of the Government Printing Office, located at Macarthur-street, Melbourne, C.2. If ordered by mail, remittance should be addressed to "The Government Printer, Box 203, P.O., North Melbourne, N.1.", and should include 5c extra for postage. If a credit account is held at this office, no remittance is required with the mail order.

The annual subscription rate for Statutory Rules (including a Bound Volume) is \$15, payable in advance. The subscription year commences on 1st January.

A. C. BROOKS,
Government Printer.

ACTS REPRINTED IN ACCORDANCE WITH THE AMENDMENTS INCORPORATION ACT 1958 (No. 6422), AND FOR SALE AT THE SALE OF PUBLICATIONS BRANCH OF THE GOVERNMENT PRINTING OFFICE, MACARTHUR-STREET, MELBOURNE, 3002.

(These prices do not include postage.)

| No. | | Price. |
|-------|---|--------|
| 6189. | Acts Interpretation (Incorporating amendments up to No. 7146) | \$0.15 |
| 6191. | Administration and Probate (Third Reprint—Incorporating amendments up to No. 7332) | \$0.38 |
| 6194. | Agricultural Colleges (First Reprint—Incorporating amendments up to No. 7302) | \$0.15 |
| 7117. | Appeal Costs Fund Act 1964 (First Reprint—Incorporating amendments up to No. 7488) | \$0.25 |
| 6199. | Apprenticeship (First Reprint—Incorporating amendments up to No. 7312) | \$0.25 |
| 6203. | Audit (First Reprint—Incorporating amendments up to No. 7377) | \$0.35 |
| 6209. | Boiler Inspection (Incorporating amendments up to No. 7072) | \$0.18 |
| 6210. | Building Societies (Incorporating amendments up to No. 7125) | \$0.25 |
| 6218. | Children's Court (Incorporating amendments up to No. 7084) | \$0.20 |
| 6219. | Children's Welfare (Second Reprint—Incorporating amendments up to No. 7084) | \$0.35 |
| 6220. | Clean Air (Incorporating amendments up to No. 6886) | \$0.10 |
| 6222. | Commercial Goods Vehicles (Second Reprint—Incorporating amendments up to No. 7358) | \$0.22 |
| 6839. | Companies Act 1961 (Second Reprint—Incorporating amendments up to No. 7332) | \$2.32 |
| 6225. | Co-operation (Second Reprint—Incorporating amendments up to No. 7083) | \$0.42 |
| 6226. | Co-operative Housing Societies (Incorporating amendments up to No. 7097) | \$0.40 |
| 6228. | Country Fire Authority (Second Reprint—Incorporating Amendments up to No. 7476) | \$0.50 |
| 6229. | Country Roads (Second Reprint—Incorporating Amendments up to No. 7506) | \$0.60 |
| 6230. | County Court Act (First Reprint—Incorporating amendments up to No. 7420) | \$0.35 |
| 6231. | Crimes (Second Reprint—Incorporating amendments up to No. 7407) | \$1.33 |
| 6236. | Dog (Second Reprint—Incorporating amendments up to No. 7065) | \$0.15 |
| 6240. | Education (First Reprint—Incorporating amendments up to No. 7533) | \$0.45 |
| 6242. | Employers and Employés (Incorporating amendments up to No. 6740) | \$0.18 |
| 6243. | Entertainments Tax (First Reprint—Incorporating amendments up to No. 7315) | \$0.25 |
| 6245. | Estate Agents (Second Reprint—Incorporating amendments up to No. 7134) | \$0.38 |
| 6246. | Evidence (Second Reprint—Incorporating amendments up to No. 7366) | \$0.42 |
| 6249. | Fences (Incorporating amendments up to No. 6550) | \$0.12 |
| 6250. | Fertilizers (Incorporating amendments up to No. 7142) | \$0.25 |
| 6251. | Firearms (Second Reprint—Incorporating amendments up to No. 7484) | \$0.40 |
| 6252. | Fisheries Act (First Reprint—Incorporating amendments up to No. 7389) | \$0.35 |
| 6916. | Foreign Judgments Act 1962 (First Reprint—including amendments made by No. 7332) | \$0.15 |
| 6585. | Forests (Pulpwood Agreement) (Incorporating amendments up to No. 6886) | \$0.15 |
| 6254. | Forests (First Reprint—Incorporating amendments up to No. 7356) | \$0.60 |
| 6256. | Fruit and Vegetables (First Reprint—Incorporating amendments up to No. 6944) | \$0.30 |
| 6258. | Game—(First Reprint—Incorporating amendments up to No. 7389) | \$0.30 |
| 6259. | Gaols (Incorporating amendments up to No. 6651) | \$0.15 |
| 6262. | Geelong Harbor Trust (First Reprint—Incorporating amendments up to No. 7547) | \$0.45 |
| 6263. | Geelong Waterworks and Sewerage (First Reprint—Incorporating amendments up to No. 7547) | \$0.75 |
| 6265. | Goods (Third Reprint—Incorporating amendments up to No. 7131) | \$0.35 |
| 6266. | Grain Elevators (First Reprint—Incorporating amendments up to No. 7486) | \$0.35 |
| 6270. | Health (Second Reprint—Incorporating amendments up to No. 7490) | \$1.65 |

ACTS REPRINTED IN ACCORDANCE WITH THE AMENDMENTS
INCORPORATION ACT 1958 (No. 6422)—continued.

| No. | Price. |
|---|--------|
| 6933. Home Finance Act 1962 (<i>First Reprint</i> —Incorporating amendments up to No. 7363) | \$0.25 |
| 6274. Hospitals and Charities (Incorporating amendments up to No. 6716) | \$0.35 |
| 6274. Hospitals and Charities (<i>Second Reprint</i> —Incorporating amendments up to No. 7455) | \$0.50 |
| 6275. Housing (<i>First Reprint</i> —Incorporating amendments up to No. 7507) | \$0.85 |
| 6279. Instruments (<i>Third Reprint</i> —Incorporating amendments up to No. 7315) | \$0.38 |
| 6282. Justices (<i>Second Reprint</i> —Incorporating amendments up to No. 7369) | \$1.23 |
| 6283. Labour and Industry (<i>Third Reprint</i> —Incorporating amendments up to No. 7410) | \$1.00 |
| 6284. Land (Incorporating amendments up to No. 7360) | \$1.53 |
| 6534. Land Settlement Act 1959 (<i>First Reprint</i> —Incorporating amendments up to No. 7328) | \$0.30 |
| 6289. Land Tax (<i>Second Reprint</i> —Incorporating amendments up to No. 7466) | \$0.40 |
| 6285. Landlord and Tenant (<i>Second Reprint</i> —Incorporating amendments up to No. 6996) | \$0.50 |
| 6286. Lands Compensation—(<i>First Reprint</i> —Incorporating amendments up to No. 7332) | \$0.25 |
| 6290. Latrobe Valley (<i>First Reprint</i> —Incorporating amendments up to No. 7332) | \$0.35 |
| 6291. Legal Profession Practice (Incorporating amendments up to No. 7065) | \$0.45 |
| 6293. Licensing (<i>Second Reprint</i> —Incorporating amendments up to No. 7054) | \$0.95 |
| 6577. Lifts and Cranes (Incorporating amendments up to No. 6886) | \$0.12 |
| 6295. Limitation of Actions (Incorporating amendments up to No. 6845) | \$0.15 |
| 6298. Local Authorities Superannuation (Incorporating amendments up to No. 6894) | \$0.25 |
| 6299. Local Government (Incorporating amendments up to No. 7052) | \$3.50 |
| 6302. Marine (Incorporating amendments up to No. 7350) | \$0.72 |
| 6304. Marketing of Primary Products (<i>First Reprint</i> —Incorporating amendments up to No. 7491) | \$0.45 |
| 6306. Marriage (<i>First Reprint</i> —Incorporating amendments up to No. 6959) | \$0.25 |
| 6309. Medical (<i>Second Reprint</i> —Incorporating amendments up to No. 7408) | \$0.40 |
| 6310. Melbourne and Metropolitan Board of Works (<i>Second Reprint</i> —Incorporating amendments up to No. 7547) | \$1.10 |
| 6312. Melbourne Harbor Trust (<i>First Reprint</i> —Incorporating amendments up to No. 7356) | \$0.48 |
| 6605. Mental Health (Incorporating amendments up to No. 7135) | \$0.45 |
| 6315. Metropolitan Fire Brigades (Incorporating amendments up to No. 6886) | \$0.28 |
| 6316. Mildura Irrigation and Water Trusts (<i>First Reprint</i> —Incorporating amendments up to No. 7448) | \$0.75 |
| 6317. Milk and Dairy Supervision (Incorporating amendments up to No. 6964) | \$0.40 |
| 6318. Milk Board (Incorporating amendments up to No. 7093) | \$0.22 |
| 6184. Monash University (<i>First Reprint</i> —Incorporating amendments up to No. 7533) | \$0.30 |
| 6324. Money Lenders (Incorporating amendments up to No. 6886) | \$0.25 |
| 6832. Motor Boating (Incorporating amendments up to No. 6961) | \$0.15 |
| 6325. Motor Car (<i>Second Reprint</i> —Incorporating amendments up to No. 7361) | \$0.82 |
| 6326. National Parks (Incorporating amendments up to No. 7275) | \$0.25 |
| 6328. Nurses (Incorporating amendments up to No. 6716) | \$0.20 |
| 6330. Partnership (<i>Second Reprint</i> —Incorporating amendments up to No. 7315) | \$0.25 |
| 6331. Patriotic Funds (<i>First Reprint</i> —Incorporating amendments up to No. 7338) | \$0.25 |
| 6889. Poisons (Incorporating amendments up to No. 7065) | \$0.35 |
| 6337. Police Offences (Incorporating amendments up to No. 7145) | \$0.82 |
| 6338. Police Regulation (Incorporating amendments up to No. 7081) | \$0.45 |
| 6340. Portland Harbor Trust (<i>First Reprint</i> —Incorporating amendments up to No. 7475) | \$0.35 |

ACTS REPRINTED IN ACCORDANCE WITH THE AMENDMENTS
INCORPORATION ACT 1958 (No. 6422)—continued.

| No. | Price. |
|--|--------|
| 6341. Pounds (<i>First Reprint</i> —Incorporating amendments up to No. 7315) | \$0.25 |
| 6890. Probate Duty (Incorporating amendments up to No. 6970) | \$0.38 |
| 6343. Process Servers and Inquiry Agents (Incorporating amendments up to No. 7126) | \$0.12 |
| 6344. Property Law (Incorporating amendments up to No. 6867) | \$0.90 |
| 6349. Public Service (<i>Second Reprint</i> —Incorporating amendments up to No. 7356) | \$0.40 |
| 6350. Public Trustee (Incorporating amendments up to No. 6961) | \$0.35 |
| 6353. Racing (<i>First Reprint</i> —Incorporating amendments up to No. 7404) | \$0.70 |
| 6355. Railways (<i>First Reprint</i> —Incorporating amendments up to No. 7475) | \$0.75 |
| 6359. Road Traffic (<i>Second Reprint</i> —Incorporating amendments up to No. 7332) | \$0.18 |
| 6360. Rural Finance (<i>First Reprint</i> —Incorporating amendments up to No. 7328) | \$0.12 |
| 6846. Rural Finance and Settlement Commission Act 1961 (<i>First Reprint</i> —Incorporating amendments up to No. 7332) | \$0.20 |
| 6975. Sale of Land Act 1962 (<i>First Reprint</i> —Incorporating amendments up to No. 7332) | \$0.18 |
| 6363. Second-Hand Dealers | \$0.12 |
| 6367. Settled Land (<i>Second Reprint</i> —Incorporating amendments up to No. 7065) | \$0.50 |
| 6368. Sewerage Districts (<i>First Reprint</i> —Incorporating amendments up to No. 7332) | \$0.62 |
| 6651. Social Welfare Act 1960 (<i>Third Reprint</i> —Incorporating amendments up to No. 7332) | \$0.20 |
| 6372. Soil Conservation and Land Utilization (Incorporating amendments up to No. 6961) | \$0.20 |
| 6373. Soldier Settlement (<i>First Reprint</i> —Incorporating amendments up to No. 7328) | \$0.42 |
| 6375. Stamps (<i>Third Reprint</i> —Incorporating amendments up to No. 7359) | \$0.82 |
| 6377. State Electricity Commission (<i>Second Reprint</i> —Incorporating Amendments up to No. 7421) | \$0.65 |
| 6379. State Savings Bank (Incorporating amendments up to No. 6886) | \$0.42 |
| 6381. Stock and Share Brokers (<i>First Reprint</i> —Incorporating amendments up to No. 7444) | \$0.15 |
| 6886. Subordinate Legislation (Incorporating amendments up to No. 6961) | \$0.15 |
| 6386. Superannuation (<i>First Reprint</i> —Incorporating amendments up to No. 7417) | \$0.60 |
| 6387. Supreme Court (<i>First Reprint</i> —Incorporating amendments up to No. 7522) | \$0.75 |
| 6391. Teaching Service (<i>First Reprint</i> —Incorporating amendments up to No. 7536) | \$0.35 |
| 7223. Tomato Processing Industry (Uniform Agreement) Act 1964 (<i>First Reprint</i> —Incorporating amendments up to No. 7342) | \$0.15 |
| 6395. Tourist (<i>First Reprint</i> —Incorporating amendments up to No. 7335) | \$0.15 |
| 6849. Town and Country Planning (<i>First Reprint</i> —Incorporating amendments up to No. 7276) | \$0.45 |
| 6399. Transfer of Land (<i>Second Reprint</i> —Incorporating amendments up to No. 7130) | \$0.52 |
| 6400. Transport Regulation (<i>First Reprint</i> —Incorporating amendments up to No. 7358) | \$0.22 |
| 6401. Trustee (<i>Second Reprint</i> —Incorporating amendments up to No. 6963) | \$0.42 |
| 6879. Unclaimed Moneys (Incorporating amendments up to No. 6961) | \$0.12 |
| 6653. Valuation of Land Act 1960 (<i>Second Reprint</i> —Incorporating amendments up to No. 7333) | \$0.22 |
| 6407. Vegetation and Vine Diseases (<i>First Reprint</i> —Incorporating amendments up to No. 7423) | \$0.30 |
| 6409. Vermin and Noxious Weeds (<i>First Reprint</i> —Incorporating amendments up to No. 7463) | \$0.35 |
| 6410. Veterinary Surgeons (<i>First Reprint</i> —Incorporating amendments up to No. 7343) | \$0.15 |
| 6413. Water (Incorporating amendments up to No. 7228) | \$1.42 |
| 6414. Weights and Measures (<i>Second Reprint</i> —Incorporating amendments up to No. 7332) | \$0.32 |
| 6419. Workers Compensation (<i>Second Reprint</i> —Incorporating amendments up to No. 7332) | \$0.52 |

A. C. BROOKS,
Government Printer.

THE "VICTORIA GOVERNMENT GAZETTE".

SUBSCRIPTIONS.—The subscription, including postage, is \$10 per annum, or \$5 per half year, payable in advance.

Subscriptions are required for whole months, and must cover at least a half year.

Single copies are 20 cents, posted 25 cents. Subscribers do not receive the Acts of Parliament with the GAZETTE.

GAZETTES are held in stock for five years only.

PRIVATE ADVERTISEMENTS.—The charge for insertion is 25 cents per line single column, and 50 cents per line double column. The title forms one or more lines as a heading. On an average ten words make a line of single column. Every signature must likewise be counted as a line. The final words of a paragraph, though only portion of a line, must be counted as one line. Signatures (in particular) and proper names must be written very plainly in the text; ONE SIDE ONLY of each sheet of paper should be WRITTEN UPON.

All documents illegibly written will be returned unpublished, and where brands occur unprovided for by the ordinary letters of the alphabet, a worded explanatory description must be furnished.

THE VICTORIA GOVERNMENT GAZETTE is published on WEDNESDAY EVENING in each week, and Notices for insertion will be received by the Government Printer at or before ONE p.m. at ordinary rates, and late advertisements between ONE p.m. and FOUR p.m. at double rates on the day preceding the day of publication.

PAYMENTS.—Unless the advertiser has a credit account, all payments are required in advance. Remittances should be made by cheque, postal order, or money order payable to "GOVERNMENT PRINTER".

ADDRESS.—All communications should be addressed to "The Government Printer, Box 203, P.O., North Melbourne", 3051.

PUBLICATION OF OFFICIAL MATTER.

ATTENTION is invited to the following procedure in relation to the publication of official matter in the Government Gazette:—

1. Matter submitted to the Executive Council.

Matters submitted to the Executive Council which requires gazettal will normally be published in the issue of the following week.

Where urgent gazettal is required, special arrangements should be made with the Gazette Officer, Room 9, first floor, Old Treasury Building.

Publication will be facilitated by the submission of carbon copies for the use of the Gazette Officer.

2. Other matter.

(a) All other matter duly certified by a responsible officer for publication should be lodged with the Gazette Officer not later than half-past Ten a.m. on Tuesday.

(b) Lengthy or involved notices should be forwarded several days before publication.

(c) Proofs, which will be supplied only when specifically requested or, at the direction of the Gazette Officer, should be returned promptly to avoid delay in publication.

(d) No additions or amendments to matter for publication will be accepted by telephone.

CONTENTS

| | PAGE |
|--|----------------|
| Acts of Parliament | 3661 |
| Acts of Parliament on sale at the Government Printing Office | 3720 |
| Appointments | 3686 |
| Auction Sales Act | 3682 |
| Bank Holidays | 3661 |
| Christmas and New Year Holidays | 3662 |
| Contracts | 3681 |
| Courts | 3676 |
| Estates of Deceased Persons | 3680 |
| Government Notices | 3662 |
| Impoundings | 3719 |
| Lands | 3697 |
| Melbourne and Metropolitan Board of Works— Notice | 3684 |
| Mining | 3667 |
| Notice of Making of Statutory Rules | 3720 |
| Orders in Council— Acts—Land; Country Roads; Landlord and Tenant; Town and Country Planning; Road Traffic; Superannuation; Sewerage Districts; Water. | 3687 et seq |
| Private Advertisements | 3705 |
| Proclamations | 3659 |
| Publication of the "Victoria Government Gazette" | 3662 |
| Public Service Notices | 3704 |
| Regulations— Acts—Police Regulation | 3675 |
| Teaching Service | 3705 |
| Resignations | 3686 |
| State Rivers and Water Supply Commission | 3679 |
| Tenders | 3703 |
| Transport Regulation Board—Public Hearings | 3663 |
| Waterworks Trusts | 3684 |