



VICTORIA GOVERNMENT GAZETTE

Published by Authority

[Registered at the General Post Office, Melbourne, for transmission by post as a newspaper.]

No. 96]

WEDNESDAY, DECEMBER 20

[1967

PROCLAMATIONS

Land Act 1958.

AREA OF LAND COMPRISED IN CERTAIN CLASSES DIMINISHED OR INCREASED.

PROCLAMATION

By His Excellency the Governor of the State of Victoria and its Dependencies in the Commonwealth of Australia, &c., &c., &c.

WHEREAS by the *Land Act 1958* it is amongst other things enacted that the Governor in Council may, by Proclamation to be published in the *Government Gazette*, at any time diminish or increase the area of land comprised in any of the classes mentioned in Part I., Division 1, section 5, of the said *Land Act 1958*, but that the area of lands which may be sold by auction (Class 6), shall not be increased except as in certain cases in the said Act provided: Now therefore I, the Governor of the State of Victoria, in the Commonwealth of Australia, by and with the advice of the Executive Council of the said State, and in accordance with the provisions of Sections 94 and 117 of the *Land Act 1958* aforesaid, do hereby diminish or increase (as the case may be) the areas of Crown Lands comprised in Class 6 of the classes mentioned in section 5 of the *Land Act 1958* aforesaid, to the extent set forth in the subjoined Schedule (that is to say):—

Schedule referred to.

CLASSES DIMINISHED OR INCREASED.

County.	Parish.	Allotment.	Section.	Area.	Diminished.	Increased.	Description.
					Class.	Class.	
				A. R. P.			
Follett	Langkoop ..	53A	..	42 1 33	3	6	In the east of the Parish
Follett	Mageppa ..	15A	..	40 1 33	3	6	In the west of the Parish

Given under my Hand and the Seal of the State of Victoria, aforesaid, at Melbourne, this twelfth day of December, in the year of our Lord One thousand nine hundred and sixty-seven, and in the sixteenth year of the reign of Her Majesty Queen Elizabeth II.

(L.S.)

By His Excellency's Command,

ROHAN DELACOMBE.

W. J. F. McDONALD,
Minister of Lands.

GOD SAVE THE QUEEN!

ACTS OF PARLIAMENT.

PROCLAMATION

By His Excellency the Governor of the State of Victoria and its Dependencies in the Commonwealth of Australia, &c., &c., &c.

I THE Governor of the State of Victoria, in the Commonwealth of Australia, do hereby declare that I have this day assented, in Her Majesty's name, to the Bills passed by the Parliament of the said State, the titles whereof are hereunder set forth, together with the short titles, that is to say:—

- No. 7619. "An Act to amend the *Justices Act 1958.*" (*Justices (Amendment) Act 1967.*)
- No. 7620. "An Act to amend the *Portland Harbor Trust Act 1958.*" (*Portland Harbor Trust (Amendment) Act 1967.*)
- No. 7621. "An Act to amend the *Racing Act 1958.*" (*Racing Act 1967.*)
- No. 7622. "An Act to amend the Ninth Schedule to the *Melbourne and Metropolitan Tramways Act 1958.*" (*Melbourne and Metropolitan Tramways (Detours) Act 1967.*)
- No. 7623. "An Act to amend the *Land Act 1958* and for other purposes." (*Land (Committees of Management) Act 1967.*)
- No. 7624. "An Act to amend the *Mildura Irrigation and Water Trusts Act 1958.*" (*Mildura Irrigation and Water Trusts (Amendment) Act 1967.*)
- No. 7625. "An Act to amend the *Apprenticeship Act 1958*, and for other purposes." (*Apprenticeship (Amendment) Act 1967.*)
- No. 7626. "An Act to amend Section 250 of the *Local Government Act 1958.*" (*Local Government (Municipalities Assistance Fund) Act 1967.*)
- No. 7627. "An Act relating to certain Lands at Fitzroy." (*Fitzroy (Edinburgh Gardens) Lands Act 1967.*)
- No. 7628. "An Act to amend Part III. of the *Coal Mines Act 1958* and for Purposes connected therewith." (*Coal Mines (Pensions) Act 1967.*)
- No. 7629. "An Act to make Provision with respect to the Safe Construction Installation and Use of Lifts Cranes Hoists and Conveyors, and for other purposes." (*Lifts and Cranes Act 1967.*)
- No. 7630. "An Act to amend Sections 8, 9A, and 256 of the *Licensing Act 1958.*" (*Licensing (Amendment) Act 1967.*)
- No. 7631. "An Act to make further Provision with respect to the Geelong Gas Company, to amend *The Geelong Gas Company's Act 1858* and for other purposes." (*The Geelong Gas Company's (Amendment) Act 1967.*)

Given under my Hand and the Seal of the State of Victoria aforesaid, at Melbourne, this twelfth day of December, in the year of our Lord One thousand nine hundred and sixty-seven, and in the sixteenth year of the reign of Her Majesty Queen Elizabeth II.

(L.S.) ROHAN DELACOMBE.

By His Excellency's Command,

H. E. BOLTE,
Premier.

GOD SAVE THE QUEEN!

ACTS OF PARLIAMENT.

PROCLAMATION

By His Excellency the Governor of the State of Victoria and its Dependencies in the Commonwealth of Australia, &c., &c., &c.

I THE Governor of the State of Victoria, in the Commonwealth of Australia, do hereby declare that I have this day assented, in Her Majesty's name, to the Bill passed by the Parliament of the said State, the title whereof is hereunder set forth together with the Short Titles, that is to say:—

- No. 7612. "An Act with respect to a Proposed Compromise between certain Contractors and Lenders and the Shire of Shepparton in relation to certain Contracts entered into and Borrowings made by the said Shire for the Purpose of the Construction and Enlargement of certain Abattoirs by the Shire and for other purposes." (*Shepparton Abattoirs Act 1967.*)

- No. 7613. "An Act relating to Certain Lands at Yarraville, in the City of Footscray, Parish of Cut-paw-paw, and to authorize the Granting of Leases of a Certain Part thereof, and for other purposes." (*Yarraville (Recreation Ground) Lands Act 1967.*)
- No. 7614. "An Act to consolidate and amend the Law relating to the Provision of Compensation for the Owners of certain Pigs, to repeal the Provisions relating to the Sale of Swine contained in Part II. of the *Swine Act 1958*, to amend the *Stamps Act 1958*, and for other purposes." (*Swine Compensation Act 1967.*)
- No. 7615. "An Act to consolidate and amend the Law relating to the Provision of Compensation for the Owners of certain Cattle, to amend the *Stamps Act 1958*, and for other purposes." (*Cattle Compensation Act 1967.*)
- No. 7616. "An Act relating to certain Lands in the Parishes of Ringwood and Warrandyte." (*Ringwood and Warrandyte Lands Act 1967.*)
- No. 7617. "An Act to amend the *Melbourne Harbor Trust Act 1958* the *Geelong Harbor Trust Act 1958* the *Portland Harbor Trust Act 1958* the *Harbor Boards Act 1958* and the *Marine Act 1958.*" (*Harbor Charges Act 1967.*)
- No. 7618. "An Act to vest certain unalienated Crown Land in the Melbourne Harbor Trust Commissioners and for other purposes." (*Melbourne Harbor Trust Land Act 1967.*)

Given under my Hand and the Seal of the State of Victoria aforesaid, at Melbourne, this twelfth day of December, in the year of our Lord One thousand nine hundred and sixty-seven, and in the sixteenth year of the reign of Her Majesty Queen Elizabeth II.

(L.S.) ROHAN DELACOMBE.

By His Excellency's Command,

H. E. BOLTE,
Premier.

GOD SAVE THE QUEEN!

MOTOR BOATING ACT 1961, Section 4 (1).

PROCLAMATION

By His Excellency the Governor of the State of Victoria and its Dependencies in the Commonwealth of Australia, &c., &c., &c.

WHEREAS by Section 2 of the *Motor Boating Act 1961* it is amongst other things enacted that the Governor in Council by Proclamation published in the *Government Gazette* may from time to time appoint an Authority in control over any Victorian waters:

AND WHEREAS by Section 4 of the *Motor Boating Act 1961* the Governor in Council, on the recommendation of an Authority having control over any Victorian waters, may by Proclamation published in the *Government Gazette* set aside or prohibit or restrict the use of any specified part or parts of any waters under the control of the Authority for any specified class or classes of boating or similar activity:

AND WHEREAS the Council of the Shire of Waranga has been proclaimed the Authority over the waters of Lake Cooper at Corop:

AND WHEREAS the Council of the Shire of Waranga has recommended the prohibition of the use of certain specified parts of the waters of Lake Cooper at Corop for all classes of boating:

NOW THEREFORE I, the Governor of the State of Victoria, in the Commonwealth of Australia, by and with the advice of the Executive Council of the said State, and in pursuance of the powers conferred by the *Motor Boating Act 1961*, do by this my Proclamation prohibit the use of those parts of the waters of Lake Cooper at Corop specified hereunder for all classes of boating:—

1. *Location*—on the western side of Lake Cooper one mile from Corop township: adjacent to Crown Allotment 156A, Parish of Corop, and commencing 150 feet north of the concrete launching ramp and extending northward along the shoreline for 1,200 feet and extending into the Lake for 150 feet.
2. *Location*—on the north-eastern corner of the shore of Lake Cooper: adjacent to Crown Allotments 111, 112, and 113 Township of Corop, and commencing at a point being the prolongation of the road between Crown Allotment 113, Township of Corop and Crown Allotment 140, Township of Corop and the shoreline and extending north-westerly for a distance of 1,200 feet and extending into the Lake for a distance of 150 feet.

3. Location—at the southern end of the Lake adjacent to Willoughby's Bridge.
Being an area 300 feet square immediately north of Willoughby's Bridge.
4. All boundaries shall be marked by beacons on the shore or by buoys.
5. The areas specified in this Proclamation are those delineated on drawing No. SWA2 hereunder.

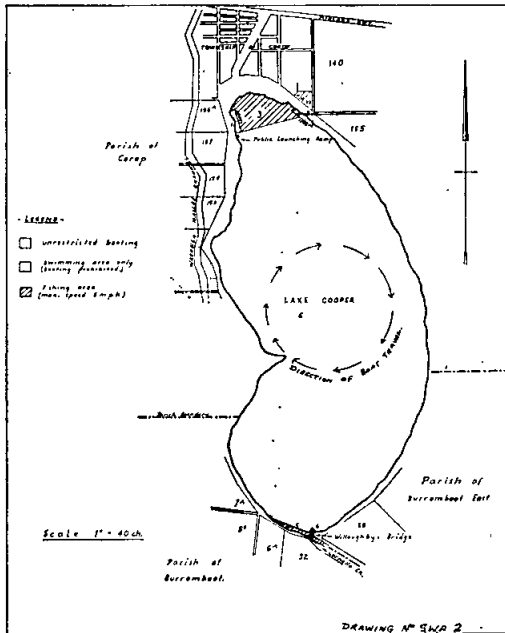

Given under my Hand and the Seal of the State of Victoria aforesaid, at Melbourne, this twelfth day of December, in the year of our Lord One thousand nine hundred and sixty-seven, and in the sixteenth year of the reign of Her Majesty Queen Elizabeth II.

(L.S.) ROHAN DELACOMBE.

By His Excellency's Command,

A. G. RYLAH,
Chief Secretary.

GOD SAVE THE QUEEN!

Milk Pasteurization Act 1958.

PROCLAMATION

DECLARING THE SHIRE OF PHILLIP ISLAND TO BE A PASTEURIZED MILK DISTRICT.

By His Excellency the Governor of the State of Victoria and its Dependencies in the Commonwealth of Australia, &c., &c., &c.

WHEREAS by section 4 of the Milk Pasteurization Act 1958 it is amongst other things enacted that the Governor in Council may by proclamation declare any area specified in such proclamation to be a pasteurized milk district on and after a date specified in the proclamation: NOW THEREFORE I, the Governor of the State of Victoria by and with the advice of the Executive Council thereof do by this my Proclamation hereby DECLARE the municipal district of the Shire of Phillip Island to be a pasteurized milk district on and after the twenty-second day of December, One thousand nine hundred and sixty-seven.

Given under my Hand and the Seal of the State of Victoria aforesaid, at Melbourne, this nineteenth day of December, in the year of our Lord One thousand nine hundred and sixty-seven, and in the sixteenth year of the reign of Her Majesty Queen Elizabeth II.

(L.S.) ROHAN DELACOMBE.

By His Excellency's Command,

G. L. CHANDLER,
Minister of Agriculture.

GOD SAVE THE QUEEN!

Milk Pasteurization Act 1958.
DECLARING AREAS TO BE PASTEURIZED MILK DISTRICTS.

PROCLAMATION

By His Excellency the Governor of the State of Victoria and its Dependencies in the Commonwealth of Australia, &c., &c., &c.

WHEREAS by section 4 of the Milk Pasteurization Act 1958 it is amongst other things enacted that the Governor in Council may by proclamation declare any area specified in such proclamation to be a pasteurized milk district on and after a date specified in the proclamation: NOW THEREFORE I, the Governor of the State of Victoria by and with the advice of the Executive Council thereof do by this my Proclamation hereby—

DECLARE the areas specified in the Schedule hereto to be pasteurized milk districts on and after the first day of February, One thousand nine hundred and sixty-eight.

SCHEDULE.

(1) The municipal districts of the—

- (a) City of Horsham.
- (b) Shire of Karkaroc.

(2) All that portion of the municipal district of the Shire of Maffra within the Parishes of Briagolong, Bundalaguah, Coongulla, Glenmaggie, Maffra, Tinamba, and Wa-de-Lock.

Given under my Hand and the Seal of the State of Victoria aforesaid, at Melbourne, this nineteenth day of December, in the year of our Lord One thousand nine hundred and sixty-seven, and in the sixteenth year of the reign of Her Majesty Queen Elizabeth II.

(L.S.) ROHAN DELACOMBE.

By His Excellency's Command,

G. L. CHANDLER,
Minister of Agriculture.

GOD SAVE THE QUEEN!

PUBLIC HIGHWAY—CITY OF FRANKSTON.

PROCLAMATION

By His Excellency the Governor of the State of Victoria and its Dependencies in the Commonwealth of Australia, &c., &c., &c.

WHEREAS by the Local Government Act 1958, as amended, Section 519 it is amongst other things enacted that it shall be lawful for the Governor-in-Council at any time and from time to time upon request of the Council of any municipality by notice in the Government Gazette to proclaim any land reserved used or by purchase or exchange acquired for a street road highway thoroughfare bridge square court alley or right-of-way or any street road lane or passage made or laid out or proposed to be made or laid out on land of which a plan of subdivision delineating that street road lane or passage has been sealed with the seal of the municipality under subdivision (3) of Division 9 of Part XIX of the Local Government Act 1958, or a corresponding previous enactment, to be a public highway and that such land shall thereupon and thenceforth from the date of such proclamation become and be absolutely dedicated to the public as a public highway within the meaning of any law then or thereafter in force:

AND WHEREAS the Council of the City of Frankston has requested that the land hereinafter mentioned, being a street road lane or passage made or laid out or proposed to be made or laid out on land of which a plan of subdivision delineating that street road lane or passage has been sealed with the seal of the municipality under subdivision (3) of Division 9 of Part XIX of the Local Government Act 1958, as amended, or a corresponding previous enactment, be so declared to be a public highway.

NOW THEREFORE I, the Governor of the State of Victoria in the Commonwealth of Australia, by and with the advice of the Executive Council of the said State, do by this Proclamation declare that Bunangib Court coloured brown on Plan of Subdivision No. 33562 lodged in the Office of Titles shall be a public highway within the meaning of the said Act.

Given under my Hand and the Seal of the State of Victoria aforesaid, at Melbourne, this twelfth day of December, in the year of our Lord One

thousand nine hundred and sixty-seven, and in the sixteenth year of the reign of Her Majesty Queen Elizabeth II.

(L.S.) ROHAN DELACOMBE.

By His Excellency's Command,

R. J. HAMER,
Minister for Local Government.

GOD SAVE THE QUEEN !

PUBLIC HIGHWAY.—SHIRE OF WOORAYL.

PROCLAMATION

By His Excellency the Governor of the State of Victoria and its Dependencies in the Commonwealth of Australia, &c., &c., &c.

WHEREAS by the *Local Government Act 1958*, as amended, Section 519 it is amongst other things enacted that it shall be lawful for the Governor-in-Council at any time and from time to time upon the request of the Council of any municipality by notice in the *Government Gazette* to proclaim any land reserved used or by purchase or exchange acquired for a street road highway thoroughfare bridge square court alley or right-of-way or any street road lane or passage made or laid out or proposed to be made or laid out on any land of which a plan of subdivision delineating that street road lane or passage has been sealed with the seal of the municipality under subdivision (3) of Division 9 of Part XIX of the *Local Government Act 1958*, as amended, or a corresponding previous enactment to be a public highway and that such land shall thereupon and thenceforth from the date of such proclamation become and be absolutely dedicated to the public as a public highway within the meaning of any law then or thereafter in force:

AND WHEREAS the Council of the Shire of Woorayl has requested that the land hereinafter mentioned, being a street road lane or passage made or laid out or proposed to be made or laid out on land of which a plan of subdivision delineating that street road lane or passage has been sealed with the seal of the municipality under subdivision (3) of Division 9 of Part XIX of the *Local Government Act 1958*, as amended, or a corresponding previous enactment, be so declared to be a public highway:

NOW THEREFORE I, the Governor of the State of Victoria in the Commonwealth of Australia, by and with the advice of the Executive Council of the said State, do by this Proclamation declare that Kathryn Close coloured brown on Plan of Subdivision No. 69529 lodged in the Office of Titles shall be a public highway within the meaning of the said Act:

Given under my Hand and the Seal of the State of Victoria aforesaid, at Melbourne, this twelfth day of December, in the year of our Lord One thousand nine hundred and sixty-seven, and in the sixteenth year of the reign of Her Majesty Queen Elizabeth II.

(L.S.) ROHAN DELACOMBE.

By His Excellency's Command,

R. J. HAMER,
Minister for Local Government.

GOD SAVE THE QUEEN !

ABORIGINAL AFFAIRS ACT 1967, No. 7574.

DATE OF COMING INTO OPERATION.

PROCLAMATION

By His Excellency the Governor of the State of Victoria and its Dependencies in the Commonwealth of Australia, &c., &c., &c.

WHEREAS by an Act of Parliament of the State of Victoria passed in the sixteenth year of the reign of Her Majesty Queen Elizabeth II, intituled the *Aboriginal Affairs Act 1967*, No. 7574, it is amongst other things enacted that the said Act shall come into operation on a day to be fixed by proclamation of the Governor in Council published in the *Government Gazette*:

NOW THEREFORE I, the Governor of the State of Victoria, in the Commonwealth of Australia, by and with the advice of the Executive Council of the said State do by this my proclamation fix Monday, the first day of January, One thousand nine hundred and sixty-eight, as the day on which the said *Aboriginal Affairs Act 1967*, No. 7574, shall come into operation.

Given under my Hand and the Seal of the State of Victoria aforesaid, at Melbourne, this nineteenth day of December, in the year of our Lord One

thousand nine hundred and sixty-seven and in the sixteenth year of the reign of Her Majesty Queen Elizabeth II.

(L.S.) ROHAN DELACOMBE.

By His Excellency's Command,

E. R. MEAGHER,
Minister for Aboriginal Affairs.

GOD SAVE THE QUEEN !

Dandenong Valley Authority Act 1963.

FLOOD-PRONE AREA NUMBER 6

PROCLAMATION

By His Excellency the Governor of the State of Victoria and its Dependencies in the Commonwealth of Australia, &c., &c., &c.

WHEREAS section 27 of the *Dandenong Valley Authority Act 1963* provides that the Governor in Council may, at the request of the Dandenong Valley Authority, declare by proclamation any specified area or areas of land within the district of the Authority to be within the flood plain of any river or group of rivers within that district:

AND WHEREAS the said Authority has complied with the provisions of section 27 of the afore-mentioned Act relative to the publication and service of notices in relation thereto;

NOW THEREFORE I, the Governor of the State of Victoria by and with the advice of the Executive Council thereof, do by this Proclamation declare that the areas shown coloured pink on plan number F14, approved by the Governor in Council and deposited in the office of the State Rivers and Water Supply Commission, Melbourne, are within the flood plain of the Eumemmerring Creek for the purposes of the said Act and shall be known as Flood-Prone Area Number 6.

Given under my Hand and the Seal of the State of Victoria aforesaid, at Melbourne, this nineteenth day of December, in the year of our Lord One thousand nine hundred and sixty-seven and in the sixteenth year of the reign of Her Majesty Queen Elizabeth II.

(L.S.) ROHAN DELACOMBE.

By His Excellency's Command,

W. A. BORTHWICK,
Minister of Water Supply.

GOD SAVE THE QUEEN !

Dandenong Valley Authority Act 1963.

FLOOD-PRONE AREA NUMBER 7

PROCLAMATION

By His Excellency the Governor of the State of Victoria and its Dependencies in the Commonwealth of Australia, &c., &c., &c.

WHEREAS section 27 of the *Dandenong Valley Authority Act 1963* provides that the Governor in Council may, at the request of the Dandenong Valley Authority, declare by proclamation any specified area or areas of land within the district of the Authority to be within the flood plain of any river or group of rivers within that district:

AND WHEREAS the said Authority has complied with the provisions of section 27 of the afore-mentioned Act relative to the publication and service of notices in relation thereto;

NOW THEREFORE I, the Governor of the State of Victoria by and with the advice of the Executive Council thereof, do by this Proclamation declare that the areas shown coloured pink on plans numbered F15 and F16, approved by the Governor in Council and deposited in the office of the State Rivers and Water Supply Commission, Melbourne, are within the flood plain of the Croydron Main Drain for the purposes of the said Act and shall be known as Flood-Prone Area Number 7.

Given under my Hand and the Seal of the State of Victoria aforesaid, at Melbourne, this nineteenth day of December, in the year of our Lord One thousand nine hundred and sixty-seven and in the sixteenth year of the reign of Her Majesty Queen Elizabeth II.

(L.S.) ROHAN DELACOMBE.

By His Excellency's Command,

W. A. BORTHWICK,
Minister of Water Supply.

GOD SAVE THE QUEEN !

SHIRE OF KANIVA WATERWORKS TRUST.

PROCLAMATION OF URBAN DISTRICTS AT LILLIMUR AND MIRAM

By His Excellency the Governor of the State of Victoria and its Dependencies in the Commonwealth of Australia, &c., &c., &c.

UNDER the powers conferred by the Water Act and all other powers enabling me in that behalf, I, the Governor of the State of Victoria, in the Commonwealth of Australia, by and with the advice of the Executive Council of the said State, do hereby proclaim that as on and from the date hereof portions of the Waterworks District of the Shire of Kaniva Waterworks Trust as shown on plans marked "A" and "B" deposited in the office of the State Rivers and Water Supply Commission, Melbourne (Corr. 65/3407/17) shall be and become Urban Districts for the purpose of and within the meaning of the said Act.

Given under my Hand and the Seal of the State of Victoria aforesaid, at Melbourne, this nineteenth day of December, in the year of our Lord One thousand nine hundred and sixty-seven and in the sixteenth year of the reign of Her Majesty Queen Elizabeth II.

(L.S.) ROHAN DELACOMBE.

By His Excellency's Command,
W. A. BORTHWICK,
Minister of Water Supply.

GOD SAVE THE QUEEN!

Metropolitan Fire Brigades Act 1958.
METROPOLITAN FIRE BRIGADES BOARD—
ENLARGEMENT OF FIRE DISTRICT.

PROCLAMATION

By His Excellency the Governor of the State of Victoria and its Dependencies in the Commonwealth of Australia, &c., &c., &c.

WHEREAS by the *Metropolitan Fire Brigades Act 1958* it is amongst other things enacted that on the request of the council of any municipal district and on receiving a certificate from the Metropolitan Fire Brigades Board that it is necessary so to do, the Governor in Council may by Proclamation published in the *Government Gazette* declare that that municipal district or a specified part thereof, shall be added to and shall form part of the Metropolitan Fire District:

AND WHEREAS the council of the municipal district of the Shire of Croydon has requested that the portion of such district enclosed within the boundaries set forth hereunder be added to and form part of the Metropolitan Fire District:

AND WHEREAS a certificate has been received from the Metropolitan Fire Brigades Board that it is desirable so to do:

NOW THEREFORE I, the Governor of the State of Victoria, in the Commonwealth of Australia, by and with the advice of the Executive Council of the said State, and in pursuance of the provisions of Section 5 (1) of the said Act, do by this my Proclamation declare that the portion of the municipal district of the Shire of Croydon enclosed within the boundaries set forth hereunder shall from the thirty-first day of December, 1967, be added to and form part of the Metropolitan Fire District, viz.:—

Shire of Croydon.

Commencing at the corner of Lusher Road and Ronald Road: thence southerly by a line to the corner of Eastfield Road and Lusher Road; thence southerly by Lusher Road and a line to the corner of Branch Road and Central Avenue; thence southerly by Branch Road to Bayfield Road; thence southerly by a line to the junction of Canterbury Road and Hamilton Road; thence generally southerly and westerly by Hamilton Road to the Dandenong Creek; thence generally westerly by that Creek to the existing boundary of the Metropolitan Fire District; thence generally northerly and easterly by that boundary to the point of commencement.

Given under my Hand and the Seal of the State of Victoria aforesaid, at Melbourne, this nineteenth day of December, in the year of our Lord One

thousand nine hundred and sixty-seven and in the sixteenth year of the reign of Her Majesty Queen Elizabeth II.

(L.S.) ROHAN DELACOMBE.

By His Excellency's Command,
A. G. RYLAH,
Chief Secretary.

GOD SAVE THE QUEEN!

PRIVATE AGENTS ACT 1966, No. 7494.

DATE OF COMING INTO OPERATION.

PROCLAMATION

By His Excellency the Governor of the State of Victoria and its Dependencies in the Commonwealth of Australia, &c., &c., &c.

WHEREAS by an Act of Parliament of the State of Victoria passed in the fifteenth year of the reign of Her Majesty Queen Elizabeth II, intituled the *Private Agents Act 1966*, No. 7494, it is amongst other things enacted that the several provisions of the said Act shall come into operation on a day or the respective days to be fixed by proclamation or a series of proclamations of the Governor in Council published in the *Government Gazette*:

AND WHEREAS by a Proclamation issued on the seventeenth day of October, One thousand nine hundred and sixty-seven, Wednesday the eighteenth day of October, One thousand nine hundred and sixty-seven was fixed as the day on which Sections 1 to 5 (inclusive), 7 to 14 (inclusive), 17, 18, 19, 31, 32, 40 to 44 (inclusive), 46 to 49 (inclusive) and 51 of the *Private Agents Act 1966*, No. 7494 shall come into operation.

NOW THEREFORE I, the Governor of the State of Victoria in the Commonwealth of Australia, by and with the advice of the Executive Council of the said State, do by this my proclamation fix Monday the first day of January, One thousand nine hundred and sixty-eight, as the day on which Sections 6, 15, 16, 20 to 30 (inclusive), 33 to 39 (inclusive), 45 and 50 of the *Private Agents Act 1966*, No. 7494 shall come into operation.

Given under my Hand and the Seal of the State of Victoria aforesaid, at Melbourne, this nineteenth day of December, in the year of our Lord One thousand nine hundred and sixty-seven and in the sixteenth year of the reign of Her Majesty Queen Elizabeth II.

(L.S.) ROHAN DELACOMBE.

By His Excellency's Command,
A. G. RYLAH,
Chief Secretary.

GOD SAVE THE QUEEN!

Private Agents Act 1966, No. 7494.

REPEAL OF THE PROCESS SERVERS AND INQUIRY AGENTS ACT 1958.

PROCLAMATION

By His Excellency the Governor of the State of Victoria and its Dependencies in the Commonwealth of Australia, &c., &c., &c.

WHEREAS by Section 2 of the *Private Agents Act 1966*, No. 7494, it is amongst other things enacted that on a day to be fixed by proclamation of the Governor in Council published in the *Government Gazette* the *Process Servers and Inquiry Agents Act 1958* shall be repealed:

NOW THEREFORE I, the Governor of the State of Victoria, in the Commonwealth of Australia, by and with the advice of the Executive Council of the said State, do by this my proclamation fix Monday, the first day of January, One thousand nine hundred and sixty-eight, as the day on which the *Process Servers and Inquiry Agents Act 1958*, No. 6343 shall be repealed.

Given under my Hand and the Seal of the State of Victoria aforesaid, at Melbourne, this nineteenth day of December, in the year of our Lord One thousand nine hundred and sixty-seven and in the sixteenth year of the reign of Her Majesty Queen Elizabeth II.

(L.S.) ROHAN DELACOMBE.

By His Excellency's Command,
A. G. RYLAH,
Chief Secretary.

GOD SAVE THE QUEEN!

GOVERNMENT NOTICES**DEPARTMENT OF MINES.**

SUBJECT to any necessary excisions, &c., it is proposed to grant the following mining leases:—

- 8206, Mineral; Roland Walton; 38a. 3r. 4p., Parish of Walwa.
 8231, Mineral; Roland Walton; 31a. 1r. 5p., Parish of Walwa.
 8235, Mineral; Shaw River Alluvials No Liability; 61a. 1r. 20p., Parishes of Burrowye, Walwa.
 8598, Mineral; Robert Henry Webb, Lloyd Owen Lehmann, Frank Leslie Boyle, James Robert Slatter; 89a. 1r. 36p., Parish of Boort.
 8625, Mineral; Albert William Strange, Leslie John Austin; 7a. 3r. 29p., Parish of Buninyong.
 8650, Mineral; Lindsay Gordon McRae, Keith McRae; 32a. 2r. 2p., Parish of Detarka.

MINING LEASE GRANTED.

- 8558, Mineral; Manata Proprietary Limited; 17a. 3r. 34p., Parish of Lara.

APPLICATION FOR LEASE REFUSED.

- 8671, Mineral; Norman William Clifton; 6 acres, Parish of Paraparap.

APPLICATIONS FOR LEASES DECLARED ABANDONED.

- 7943, Mineral; Henry Ailan Green; 315 acres; Parish of Ballarat.
 8575, Mineral; Nicholas John Ramsay, Derek Roy Hartley; 160 acres; Parish of Canabore.

TERM OF PETROLEUM EXPLORATION PERMIT EXTENDED.

- 26, Petroleum Exploration Permit; Planet Exploration Co. Pty. Ltd., 1,805 square miles; Counties of Follett and Lowan.

TAILINGS LICENCES GRANTED.

- 3567, Tailings Licence; Spencer Stewart; Oswalds Mine Dump at Maldon, Parish of Maldon.
 3568, Tailings Licence; The President, Councillors and Ratepayers of the Shire of Ballarat, "Albion" mine dump situated in the Parish of Smythesdale.
 3569, Tailings Licence; State Rivers and Water Supply Commission; "Victorian Proprietary Shaft" at Diamond Hill, Parish of Sandhurst.

MINERAL SEARCH LICENCES EXPIRED.

- 721, Mineral Search Licence; Roland Walton, 17.1 square miles, Parishes of Bogong North, Bogong South, Tongaro, Wollonaby, Ludrik-Munjie.
 756, Mineral Search Licence; John Wilson Kennedy; 40 acres, Parish of Warburton.
 757, Mineral Search Licence; Lindsay Walker; 40 acres, Parish of Warburton.
 758, Mineral Search Licence; Geoffrey Lindsay Kennedy; 40 acres, Parish of Warburton.
 759, Mineral Search Licence; Ian Hilton Danks; 40 acres, Parish of Warburton.
 760, Mineral Search Licence; Alan Ford Gerity; 245 acres, Parish of Bungil East.

J. C. M. BALFOUR,
 Minister of Mines.

PUBLIC NOTICE.

ALL persons who as producers of farm produce have any claim against John T. Lobbert, of 109 Albert-street, Brunswick, arising from any failure on his part to pay or account for any moneys payable to them by the said John T. Lobbert for farm produce are invited to forward particulars and proof of such claim to the Director of Agriculture, Public Offices, Melbourne, 3002, on or before, 22nd January, 1967.

D. S. WISHART,
 Director of Agriculture.

Labour and Industry Act 1958.**ORDER OF EXEMPTION UNDER SECTION 80A.**

WHEREAS pursuant to section 80A of the *Labour and Industry Act 1958* as amended by the *Labour and Industry (Amendment) Act 1965* the Council of the Shire of Maffra has applied to the Minister for an order exempting shopkeepers of shops in its municipal district from being required to close and keep closed their shops in accordance with the provisions of Part VI. of the said Act:

And whereas I have considered the report of the Tourist Development Authority obtained in accordance with the provisions of sub-section (4) of section 80A of the said Act:

Now therefore, I, John Frederick Rossiter, Her Majesty's Minister of Labour and Industry in the State of Victoria, do pursuant to the aforesaid section 80A of the *Labour and Industry Act 1958* make this Order granting exemption to any shopkeeper within the area mentioned in the First Schedule hereto from being required to close and keep closed his shop, at any time when he would but for this Order be required to close and keep closed that shop in accordance with Part VI. of the said Act on any day between the hours of 8 a.m. and 11 p.m. during the periods of the year mentioned in the Second Schedule hereto:

Provided that such exemption shall not apply to Christmas Day.

FIRST SCHEDULE.—THE AREA.

The Township of Maffra.

SECOND SCHEDULE.—THE PERIODS.

1. A period of seven consecutive weeks commencing on the 20th of December each year.
2. The second Monday in March each year and the two days immediately preceding that day.
3. A period of one week commencing on the day immediately preceding Good Friday, but excluding Good Friday and excluding Anzac Day if the latter should fall within that period.
4. A period of three consecutive weeks commencing on the 11th May each year.
5. The day observed as Queen's Birthday each year and the two days immediately preceding that day.
6. A period of three consecutive weeks commencing on the 24th of August each year.

Dated at Melbourne this 8th day of December, 1967.

JOHN ROSSITER,
 Minister of Labour and Industry.

Dried Fruits Act 1958.**STATE OF VICTORIA.****NOTICE.**

I GILBERT LAWRENCE CHANDLER, Minister of Agriculture, acting upon the recommendation of the Victorian Dried Fruits Board, hereby give notice that I have determined the maximum proportions of Dried Vine Fruits produced in Victoria in the year One thousand nine hundred and sixty-seven that may be marketed within Victoria are as follows:—

Dried Currants	45 per cent.
Dried Sultanas	17½ per cent.
Raisins	45 per cent.
Prunes	62 per cent.

G. L. CHANDLER,
 Minister of Agriculture.

Department of Agriculture,
 Melbourne, 4th December, 1967.

PRIVATE AGENTS ACT 1966.**APPROVED INSURANCE COMPANIES.**

PURSUANT to the provisions of Section 31 (2) of the *Private Agents Act 1966*, I, Her Majesty's Chief Secretary for the State of Victoria hereby approve of the following insurance company for the purposes of the said Act:—

Associated National Insurance Company Limited.

A. G. RYLAH,
 Chief Secretary,
 Chief Secretary's Office,
 Melbourne, 18th December, 1967.

Private Agents Act 1966.

NOTICE OF RECEIPT OF APPLICATIONS FOR LICENCES UNDER THE PROVISIONS OF THE PRIVATE AGENTS ACT 1966.

THE Clerk(s) of the Court(s) of Petty Sessions as listed hereunder hereby give notice that applications, as under, have been lodged for hearing by the said Court(s) on the date(s) specified.

Any person desiring to object to any of such applications must—

- (a) lodge with the respective Clerk of Petty Sessions a notice in the prescribed form of his objection and of the grounds thereof;
- (b) cause a copy of such notice to be served personally or by post upon the applicant at least three days before the hearing of the application; and
- (c) send or deliver—
 - (i) where the objection is not made by the officer in charge of the police district in which the Court is situated—a copy of the notice to such officer; and
 - (ii) where the objection is not made by the Registrar or Deputy Registrar—a copy to the Registrar.

Full Name of Applicant or in the case of a Firm or Corporation, of the Nominee.	Place of Abode of Applicant or Nominee.	Name of Firm or Corporation.	Address for Registration.	Type of Licence.	Date of Hearing of Application.
---	---	------------------------------	---------------------------	------------------	---------------------------------

COURT OF PETTY SESSIONS, SHEPPARTON.

Thomas, Louis Hamilton	27 Numurkah-road, Shepparton		27 Numurkah-road, Shepparton	Process Server	21.12.67
------------------------	------------------------------	--	------------------------------	----------------	----------

Dated at Shepparton this 1st day of December, 1967.

R. N. HOLLIS,
Clerk of Petty Sessions.

COURT OF PETTY SESSIONS, PRAHRAN.

Padur, Joseph Tibor	Flat 10, 8 Motherwell-street, South Yarra		Flat 10, 8 Motherwell-street, South Yarra	Inquiry Agent	9.1.68
---------------------	---	--	---	---------------	--------

Dated at Prahran this 6th day of December, 1967.

G. S. HOARE,
Clerk of Petty Sessions.

COURT OF PETTY SESSIONS, PRAHRAN.

Cox, Gerald Stewart	Flat 9, 37 Tintern-avenue, Toorak		Flat 9, 37 Tintern-avenue, Toorak	Process Server	4.1.68
---------------------	-----------------------------------	--	-----------------------------------	----------------	--------

Dated at Prahran this 5th day of December, 1967.

G. S. HOARE,
Clerk of Petty Sessions.

COURT OF PETTY SESSIONS, SWAN HILL.

Thomson, Allen Henry	49 Pritchard-street, Swan Hill	George Laurens Pty. Ltd.	5 Rutherford-street, Swan Hill	Commercial sub-agent	9.1.68
Beasy, Geoffrey Thomas	32 Mulbar-street, Swan Hill		32 Mulbar-street, Swan Hill	Process Server	"

Dated at Swan Hill this 4th day of December, 1967.

J. M. DUGAN,
Clerk of Petty Sessions.

COURT OF PETTY SESSIONS, SPRINGVALE.

Boyd, Denis	13 Barbara-avenue, Dandenong		9 Bowmore-road, Noble Park	Watchman	5.1.68
Young, Francis Henry	3 Cerat-court, Doveton		" "	"	"
Pickering, Rolland Westgarth	14 Koonalda-grove, Dandenong North		" "	"	"

Dated at Springvale this 6th day of December, 1967.

F. J. DUTHIE,
Clerk of Petty Sessions.

COURT OF PETTY SESSIONS, TOORA.

Ellis, Robert George	Townsend-street, Port Welshpool		130 Abbotsford-street, North Melbourne	Watchman	9.1.68
----------------------	---------------------------------	--	--	----------	--------

Dated at Toora this 1st day of December, 1967.

R. A. ISON,
Clerk of Petty Sessions.

COURT OF PETTY SESSIONS, HEIDELBERG.

Lynch, Kevin Francis	42 Forster-street, West Heidelberg		42 Forster-street, West Heidelberg	Inquiry Agent	29.12.67
----------------------	------------------------------------	--	------------------------------------	---------------	----------

Dated at Heidelberg this 7th day of December, 1967.

T. K. HASSARD,
Clerk of Petty Sessions.

PRIVATE AGENTS—*continued.*

Full Name of Applicant or in the case of a Firm or Corporation, of the Nominee.	Place of Abode of Applicant or Nominee.	Name of Firm or Corporation.	Address for Registration.	Type of Licence.	Date of Hearing of Application.
---	---	------------------------------	---------------------------	------------------	---------------------------------

COURT OF PETTY SESSIONS, BRUNSWICK.

Kibel, James Johnson ..	22 Austin-street, Balwyn	22 Austin-street, Balwyn	Guard Agent ..	8.1.68
-------------------------	--------------------------	---------	--------------------------	----------------	--------

Dated at Brunswick this 7th day of December, 1967.

G. H. SCHMIDT,
Clerk of Petty Sessions.

COURT OF PETTY SESSIONS, MARYBOROUGH.

Currie, Graham George ..	Harcourt	Ace Body Works	212 Railway-street, Maryborough	Commercial Agent	21.12.67
Hendrickson, Stanley Maxwell	273 Gladstone-street, Maryborough	273 Gladstone-street, Maryborough	Process Server

Dated at Maryborough this 30th day of November, 1967.

R. J. CANNING,
Clerk of Petty Sessions.

COURT OF PETTY SESSIONS, MORDIALLOC.

Read, William Eric ..	18 Sercombe-grove, Hawthorn	Max Hocking Night Patrol Service	123 Station-street, Aspendale	Watchman ..	21.12.68
Broome, George Frederick ..	8 Steedman-street, Mordialloc	Inquiry Agent

Dated at Mordialloc this 30th day of November, 1967.

G. F. MEEHAN,
Clerk of Petty Sessions.

COURT OF PETTY SESSIONS, CAMBERWELL.

Baldock, Clive Colin ..	319 Riversdale-road, Camberwell	319 Riversdale-road, Camberwell	Guard Agent ..	15.1.68
" " "	" " "	" " "	Process Server
Hooper, Walter Leslie ..	87 " Rochester-road, Balwyn	87 " Rochester-road, Balwyn	Inquiry Agent
Overend, Edward Arthur ..	77A Durham-road, Surrey Hills	77A Durham-road, Surrey Hills	Commercial sub-agent Process Server

Dated at Camberwell this 8th day of December, 1967.

J. C. TOBIN,
Clerk of Petty Sessions.

COURT OF PETTY SESSIONS, MELBOURNE.

McDonald, William St. Cyr...	64 Canora-street, Blackburn	414 Lonsdale-street, Melbourne	Process Server ..	27.12.67
Stafford, John Clyde ..	1 Wimport-street, Heidelberg	" " "	Inquiry Agent
Allan, Olliver James Rolland ..	30 Beaver's-road, Northcote	130 Abbotsford-street, North Melbourne	Watchman
Armstrong, Robert William ..	Preston Hostel, Water-road, Preston	" " "	"
Aron, Warren Harding ..	6 Taran-avenue, Ashburton	" " "	"
Bennett, Ronald William ..	870 Drummond-street, North Carlton	" " "	"
Buck, Harold Thomas Edward	43 Florey-crescent, North Springvale	" " "	"
Burrowes, Eric John ..	27 Willis-street, St. Albans	" " "	"
Byrnes, Nicholas Arthur ..	Cranbourne - road, Narre Warren	" " "	"
Carpenter, Harry ..	11 Graceburn-grove, St. Albans	" " "	"
Charles, Allen ..	27 Glencairn-avenue, Deer Park	" " "	"
Danaher, Kenneth John ..	136 Suffolk-street, Maidstone	" " "	"
Daniel, Alan Henry ..	7 Ballantyne-street, East Burwood	" " "	"
Disher, Brian ..	25 Graham-street, Broadmeadows	" " "	"
Dunlop, Matthew Howard ..	86 Murray-road, East Preston	" " "	"
Ellis, Frederick Richard ..	43 Dunlop-avenue, Ascot Vale	" " "	"
Fairy, Keith Merlin ..	7 Belgrave-street, East Preston	" " "	"
Finney, William Edgar ..	45 Errington-road, St. Albans	" " "	"
Fitzgerald, Charles John ..	43 Watt-street, South Kingsville	" " "	"
Flayman, Norman Clifford ..	4 Elliott-street, North Coburg	" " "	"

PRIVATE AGENTS—continued.

Full Name of Applicant or in the case of a Firm or Corporation, of the Nominee.	Place of Abode of Applicant or Nominee.	Name of Firm or Corporation.	Address for Registration.	Type of Licence.	Date of Hearing of Application.
COURT OF PETTY SESSIONS, MELBOURNE—continued.					
Foley, Denis Joseph	26 Murrumbeena-crescent, Murrumbeena		130 Abbotsford-street, North Melbourne	Watchman	27.12.67
Frost, Edward	Lot 8, Stanley-street, The Basin		" "	"	"
Glen, Joseph	31 Gordon-grove, Malvern		" "	"	"
Harrison, Norman Albert Love	43 Ormond-road, Clayton		" "	"	"
Hill, Francis Tremain	17 Gauntlet-road, Chadstone		" "	"	"
Horan, John Michael	5 St. Vincent-place, Albert Park		" "	"	"
Hunter, Reginald James	4 Beatrice-street, Yarraville		" "	"	"
Lockmond					
Ireland, Stanley Gordon	1 Lonsdale-street, West Coburg		" "	"	"
Jaskiewicz, Bronislaw	63 Barkly-street, St. Kilda		" "	"	"
Jordon, Francis James	3 Catalina-street, Heidelberg		" "	"	"
Kane, John	3 Salem-avenue, South Oakleigh		" "	"	"
Kilbride, John	4 Third-avenue, East Werribee		" "	"	"
Kilpatrick, Noel Francis	159 Cambridge-road, Mooroolbark		" "	"	"
Lorenzetti, Andrea	92 Hilton-street, Glenroy		" "	"	"
McCall, John	34 Laming-road, Deer Park		" "	"	"
McDonald, Alfred William	205 Arthur-street, Fairfield		" "	"	"
McFarlane, George Henry	42 Stanley-avenue, Eltham		" "	"	"
McLean, Norman Francis	117 Donald-street, Brunswick		" "	"	"
MacLean, Graham Bruce	13 Kincumber-drive, Glen Waverley		" "	"	"
Mahoney, John Ernest Robert	54 Park-road, Middle Park		" "	"	"
Mallia, Victor Paul	47 Walsh-street, West Melbourne		" "	"	"
Marlow, John Anthony	7 Cartledge-street, Laverton		" "	"	"
Mazou, Jules Merritt	26 Highgate-street, Spotswood		" "	"	"
Miller, Thomas James	23 Eirene-street, Yarraville		" "	"	"
Nicol, James Ballingal	22 Brook-drive, Altona		" "	"	"
Panter, William Norman	Flat 10, 188 Barkly-street, St. Kilda		" "	"	"
Oliver, Walter Richardson	64 Snell-grove, Oak Park		" "	"	"
Oram, Hugh	65 Cobden-street, South Melbourne		" "	"	"
Roderick, Donald	8 Taunton-street, Sunshine		" "	"	"
Shaw, John Keith	5 Bowen-road, East Doncaster		" "	"	"
Showell, Ernest William Henry	5 Cowra-road, Altona		" "	"	"
Smid, Meindert	124 Brougham-street, Eltham		" "	"	"
Soutar, Geoffrey John Ellis	3 Peace-street, Glen Iris		" "	"	"
Titter, John Charles	18 Giffard-street, Williamstown		" "	"	"
Van Dyke, Dick	194 Grange-road, Carnegie		" "	"	"
Walker, George Henry Arthur	48 Tennyson-street, Elwood		" "	"	"
Walker, Joseph	Lot 204, Monbulk-road, Emerald		" "	"	"
Walsh, Henry Alexander	24 Havelock-avenue, Bundoora		" "	"	"
Watson, Ernest Russell	66 Davis-street, East Burwood		" "	"	"
Whelan, William Francis	7 Milton-street, Glenroy		" "	"	"
Wilkinson, Clifford George	6 Mavho-street, Bentleigh		" "	"	"
Young, Andrew	12 Berl-court, Blackburn		" "	"	"

Dated at Melbourne this 7th day of December, 1967.

G. L. WEBSTER,
Clerk of Petty Sessions.

PRIVATE AGENTS—continued.

Full Name of Applicant or in the case of a Firm or Corporation, of the Nominee.	Place of Abode of Applicant or Nominee.	Name of Firm or Corporation.	Address for Registration.	Type of Licence.	Date of Hearing of Application.
---	---	------------------------------	---------------------------	------------------	---------------------------------

COURT OF PETTY SESSIONS, SHEPPARTON.

McTaggart, Ian William	Verney-road, North Shepparton		Verney-road, North Shepparton	Process Server Inquiry Agent	21.12.67 "
------------------------	-------------------------------	--	-------------------------------	---------------------------------	---------------

Dated at Shepparton this 1st day of December, 1967.

R. N. HOLLIS,
Clerk of Petty Sessions.

COURT OF PETTY SESSIONS, ST. KILDA.

Dickson, Patricia Mary	Flat 4, 55 Wickham-road, Moorabbin		Flat 4, 55 Wickham-road, Moorabbin	Process Server Inquiry Agent	29.12.67 "
Fox, Thomas Albert	8 Levanto-street, Mentone		8 Levanto-street, Mentone	Process Server Inquiry Agent	" "
Baker, David Miller	126 Inkerman-street, St. Kilda		Flat 2, 126 Inkerman-street, St. Kilda	Process Server Guard Agent Inquiry Agent	" " "

Dated at St. Kilda this 8th day of December, 1967.

J. E. REILLY,
Clerk of Petty Sessions.

COURT OF PETTY SESSIONS, WODONGA.

Levey, John McCallum	1014 Mate-street, Albury		6 Ely-street, Wangaratta	Process Server	28.12.67
----------------------	--------------------------	--	--------------------------	----------------	----------

Dated at Wodonga this 5th day of December, 1967.

J. T. KNIGHT,
Clerk of Petty Sessions.

COURT OF PETTY SESSIONS, BALLARAT.

Fithall, Grahame Norris	404 Armstrong-street north, Ballarat	Ballarat Guard Service	50 Lydiard-street south, Ballarat	Watchman	28.12.67
-------------------------	--------------------------------------	------------------------	-----------------------------------	----------	----------

Dated at Ballarat this 7th day of December, 1967.

E. N. KINCHINGTON,
Clerk of Petty Sessions.

COURT OF PETTY SESSIONS, COBURG.

Guy, Clarence William	5 Tiernan-street, East Preston	Mayne Nickless Ltd.	88 Baker's-road, Coburg	Watchman	11.1.68
-----------------------	--------------------------------	---------------------	-------------------------	----------	---------

Dated at Coburg this 8th day of December, 1967.

F. J. TENNI,
Clerk of Petty Sessions.

COURT OF PETTY SESSIONS, NORTHCOTE.

Doumtes, Jim	8 Lennox-street, Northcote		313 Smith-street, Collingwood	Inquiry Agent	22.12.67
Gidley, Thomas Henry	27 Mitchell-street, Northcote		27 Mitchell-street, Northcote	" Process Server	" "

Dated at Northcote this 30th day of November, 1967.

J. DENAHY,
Clerk of Petty Sessions.

COURT OF PETTY SESSIONS, HAMILTON.

McLaren, Douglas Morrison	137 Coleraine-road, Hamilton		137 Coleraine-road, Hamilton	Inquiry Agent	21.12.67
Loh, John Clement	4 Station-street, Hamilton		4 Station-street, Hamilton	Process Server	"
Rickey, Aubrey Harold	Cavendish-road, Hamilton		Cavendish-road, Hamilton	Inquiry Agent	"
Bennie, Lyle Edward	Flat 9, 40 Griffin-street, Hamilton	George Laurens	Thompson-street, Hamilton	Commercial Agent	"
" " "	" " "	" " "	" " "	Commercial Sub-agent	"
" " "	" " "	" " "	" " "	Process Server	"
Mirtschin, Conrad Erwin	5 Lonsdale-street, Hamilton	Grange Mercantile Agency	Thompson-street, Hamilton	Watchman	"

Dated at Hamilton this 7th day of December, 1967.

J. E. WALLACE,
Clerk of Petty Sessions.

PRIVATE AGENTS—continued.

Full Name of Applicant or in the case of a Firm or Corporation, of the Nominee.	Place of Abode of Applicant or Nominee.	Name of Firm or Corporation.	Address for Registration.	Type of Licence.	Date of Hearing of Application.
---	---	------------------------------	---------------------------	------------------	---------------------------------

COURT OF PETTY SESSIONS, PRESTON.

Watt, William Bromily ..	292 Oriel-road, West Heidelberg	Victorian Night Patrol Service	269 High-street, Preston	Guard Agent	21.12.67
Marsh, Allan Ralph ..	1 Ananda-court, Watsonia	"	"	Watchman	"
Appleton, John Garland ..	13 Bignell-street, Flemington	"	"	"	"
Walpole, Edward George ..	18 Landy-street, Reservoir	"	"	"	"
Pollard, Daniel James ..	16 Geddes-street, Ascot Vale	"	"	"	"
Watt, William Bromily (Jnr) ..	292 Oriel-road, West Heidelberg	"	"	"	"

Dated at Preston this 1st day of December, 1967.

P. C. CLOTHIER,
Clerk of Petty Sessions.

COURT OF PETTY SESSIONS, MILDURA.

Dawson, Ernest Edward ..	189 Walnut-avenue, Mildura	"	189 Walnut-avenue, Mildura	Commercial Agent	28.12.67
" " "	"	"	"	Process Server	"
Dick, Hugh William ..	15 Mimos-a-venue, Mildura	"	15 Mimos-a-venue, Mildura	Inquiry Agent Commercial Agent	"
" " "	"	"	"	Process Server	"
Staff, Roland ..	30 San Mateo-avenue, Mildura	"	30 San Mateo-avenue, Mildura	Inquiry Agent Commercial sub-agent	"
" " "	"	"	"	Process Server	"
" " "	"	"	"	Inquiry Agent	"

Dated at Mildura this sixth day of December, 1967.

J. KEARNEY,
Clerk of Petty Sessions.

COURT OF PETTY SESSIONS, SPRINGVALE.

Sewell, William Henry ..	8 Max-court, Noble Park	Mayne Nickless Ltd.	94 York-street, South Melbourne	Watchman	5.1.68
Lynch, John Robert ..	23 Edward-street, Noble Park	"	"	"	"
Richards, Leonard Ninnes ..	9 Rimmer-street, Mentone	"	"	"	"
Goodall, Leslie Thomas ..	24 Lincoln-avenue, Glen Waverley	"	"	"	"
Lang, Noel Roy ..	57 Hanleth-street, Springvale	"	"	"	"
Fowler, Charles ..	Flat 3, 35 Corrigan-road, Noble Park	T. J. Larkin, (Industrial and Commercial Investigation)	9 Bowmore-road, Noble Park	"	"

Dated at Springvale this 8th day of December, 1967.

F. J. DUTHIE,
Clerk of Petty Sessions.

COURT OF PETTY SESSIONS, OAKLEIGH.

Cook, Bruce Waldron ..	18 Wallace-avenue, Murrumbena	"	18 Wallace-avenue, Murrumbena	Process Server	12.1.68
------------------------	-------------------------------	---	-------------------------------	----------------	---------

Dated at Oakleigh this 8th day of December, 1967.

F. McSWEENEY,
Clerk of Petty Sessions.

COURT OF PETTY SESSIONS, SWAN HILL.

Gray, Leon Allan ..	35 Palaroo-street, Swan Hill	"	35 Palaroo-street, Swan Hill	Commercial Agent	9.1.68
" " "	"	"	"	Inquiry Agent	"
" " "	"	"	"	Process Server	"
" " "	"	"	"	Guard Agent	"

Dated at Swan Hill this 6th day of December, 1967.

J. M. DUGAN,
Clerk of Petty Sessions.

COURT OF PETTY SESSIONS, RINGWOOD.

Hibbert, Anthony ..	26 Faraday-road, Croydon	"	42 Sherbrooke-avenue, Ringwood	Watchman	9.1.68
---------------------	--------------------------	---	--------------------------------	----------	--------

Dated at Ringwood this 11th day of December, 1967.

L. T. GOULD,
Clerk of Petty Sessions.

PRIVATE AGENTS—continued.

Full Name of Applicant or in the case of a Firm or Corporation, of the Nominee.	Place of Abode of Applicant or Nominee.	Name of Firm or Corporation.	Address for Registration.	Type of Licence.	Date of Hearing of Application.
COURT OF PETTY SESSIONS, PRAHRAN.					
Copeland, James Maitland ..	15 Charlesworth-street, Laverton	C/o Melbourne Night Patrol Service, Suite 18, 614 St. Kilda-road, Melbourne	Watchman ..	12.1.68
Dalton, Patrick John ..	54 Heywood-street, Ringwood	" "	" ..	8.1.68
Garvie, Douglas Frederick ..	32 Cropley-crescent, Laverton	" "	" ..	4.1.68
Hodgkinson, Michael John ..	Flat 5, 95 Aitken-street, Williamstown	" "	" ..	8.1.68
Kearns, John Desmond ..	8 Colac-street, Dallas	" "	" ..	12.1.68
Thurlow, Benjamin James ..	58 Husband-road, Forest Hill	" "	" ..	4.1.68
Young, Byas Maxwell ..	10 McNamara-street, Laverton	" "	" ..	12.1.68
Harrex, Maxwell James ..	5 Mell-street, Toorak	5 Mell-street, Toorak	Process Server ..	12.1.68
Morrison, Michael Evan ..	93 Ormond-esplanade, Elwood	C/o Melbourne Night Patrol Service, Suite 18, 614 St. Kilda-road Melbourne	Watchman ..	4.1.68
Morrison, Jean ..	" "	" "	Guard Agent ..	"
" ..	" "	" "	Inquiry Agent ..	"

Dated at Prahran this 8th day of December, 1967.

G. S. HOARE,
Clerk of Petty Sessions.

COURT OF PETTY SESSIONS, PRAHRAN.

Kecley, Robert Leslie ..	25 Cooper-avenue, North Altona	C/o Melbourne night Patrol Service, Suite 18, 614 St. Kilda-road Melbourne	Watchman ..	12.1.68
--------------------------	--------------------------------	---------	--	-------------	---------

Dated at Prahran this 12th day of December, 1967.

G. S. HOARE,
Clerk of Petty Sessions.

COURT OF PETTY SESSIONS, GEELONG.

Capstick, Joan Margaret ..	252 Mt. Pleasant-road, Highton	2A James-street, Geelong	Process Server	29.12.67
Casey, William James ..	274 Pakington-street, Newtown	George Laurens Pty. Ltd.	65 " Gheringhap-street, Geelong	Commercial Sub-agent	"
Major, John ..	173 Roslyn-road, Belmont	Torquay-Road, Grovedale	Individual Commercial Agent	"
Capstick, Edmund ..	22 Cuthbert-avenue, Highton	2A James-street, Geelong	Commercial Sub-agent	"
Capstick, Joan Margaret ..	252 Mt. Pleasant-road, Highton	2A James-street, Geelong	Guard Agent ..	"
Martinac, Ante ..	25 Granault-parade, Corio	" "	" "	"
Capstick, Joan Margaret ..	252 Mt. Pleasant-road, Highton	" "	Inquiry Agent ..	"
Capstick, Edmund ..	22 Cuthbert-avenue, Highton	" "	" "	"
Major, John ..	173 Roslyn-road, Belmont	Torquay-road, Grovedale	" "	"
Martinac, Ante ..	25 Granault-parade, Corio	2A James-street, Geelong	" "	"
Major, John ..	173 Roslyn-road, Belmont	Torquay-road, Grovedale	Process Server ..	"
Capstick, Edmund ..	22 Cuthbert-avenue, Highton	2A James-street, Geelong	" "	"
Cross, Kenneth William ..	8 McIntyre-street, East Geelong	Mayne Ltd.	94 York-street, South Melbourne	Watchman ..	"
Bruce, William ..	59 Moreton Bay-drive, Highton	" "	" "	" "	"
Dunbar, Wilfred ..	28 Seabeach-parade, North Shore	" "	" "	" "	"
Freeman, Kenneth Charles Spiller	106 Settlement-road, Belmont	" "	" "	" "	"
Lanyon, William Thomas ..	2 Lunan-avenue, Drumcondra	" "	" "	" "	"
Pearce, Louis Murray ..	1 Holden-avenue, North Geelong	" "	" "	" "	"
Roll, Victor Norman ..	19 Skene-street, Newtown	" "	" "	" "	"
Scott, Donald Gordon ..	264 Latrobe-terrace, Geelong	" "	" "	" "	"
Szymczak, Ward Oswald ..	22 Kalimna-street, Hamlyn Heights	" "	" "	" "	"
West, Huxley Francis ..	Cresta-street, Leopold	" "	" "	" "	"

Dated at Geelong this 8th day of December, 1967.

J. R. AITKEN,
Clerk of Petty Sessions.

PRIVATE AGENTS—continued.

Full Name of Applicant or in the case of a Firm or Corporation, of the Nominee.	Place of Abode of Applicant or Nominee.	Name of Firm or Corporation.	Address for Registration.	Type of Licence.	Date of Hearing of Application.
COURT OF PETTY SESSIONS, MELBOURNE.					
Scammell, Walter Ingram ..	7 Glyn-court, Cheltenham	W. I. Scammell P/L, trading as Geronimo Investigation Service	148 Roden-street, West Melbourne	Process Server ..	28.12.67
" " " ..	" " " ..	" " " ..	" " " ..	Inquiry Agent ..	" "
" " " ..	" " " ..	" " " ..	" " " ..	Guard Agent ..	" "
Batis, Gloria Betty ..	Flat 4, 1761 Dandenong-road, Oakleigh	" " " ..	130 Abbotsford-street, North Melbourne	Inquiry Agent ..	" "
Metz, Adolph Joseph ..	29 Larnook-street, East Prahran	" " " ..	Suite 401, 4th Floor, 46 Elizabeth-street, Melbourne	Commercial Agent	" "
Perkins, Norman James ..	27 Monomeath-avenue, Canterbury	Accounts Recovery Pty. Ltd.	100 Collins-street, Melbourne	" " "	" "
" " " ..	" " " ..	" " " ..	" " " ..	Commercial Sub-agent	" "
Humphreys, Francis George Marland	70 Somerlayton-crescent, Moomba Park, Fawkner	Secure Accident Investigators Pty. Ltd.	128 Chetwynd-street, North Melbourne	" " "	" "
" " " ..	" " " ..	" " " ..	" " " ..	Process Server ..	" "
" " " ..	" " " ..	" " " ..	" " " ..	Inquiry Agent ..	" "
" " " ..	" " " ..	" " " ..	" " " ..	Commercial Sub-agent	" "
Bell, Barry Keith ..	52 Gipps-street, East Melbourne	" " " ..	148 Roden-street, West Melbourne	Process Server ..	" "
" " " ..	" " " ..	" " " ..	" " " ..	Inquiry Agent ..	" "
" " " ..	" " " ..	" " " ..	" " " ..	Watchman ..	" "
Capewell, Charles Brian ..	Flat 2, 56 Rathmines-road, Hawthorn	" " " ..	Suite 3, 106 Wellington-place, East Melbourne	Commercial Agent	" "
Nash, George Henry Eagles ..	445 Canterbury-road, Surrey Hills	" " " ..	148 Roden-street, West Melbourne	Inquiry Agent ..	" "
Foster, Alan Francis Walter	Flat 11, 109 Weatherall-road, Cheltenham	" " " ..	" " " ..	Process Server ..	" "
" " " ..	" " " ..	" " " ..	" " " ..	" " " ..	" "
" " " ..	" " " ..	" " " ..	" " " ..	Inquiry Agent ..	" "
Mather, Graeme Francis ..	79 Daley-street, Glenroy	" " " ..	" " " ..	Watchman ..	" "
" " " ..	" " " ..	" " " ..	" " " ..	Inquiry Agent ..	" "
Capewell, Charles Brian ..	Flat 2, 56 Rathmines-road, Hawthorn	" " " ..	Suite 3, 106 Wellington-place, East Melbourne	" " " ..	" "
Connolly, John Edward ..	18 Blenheim-road, Newport	" " " ..	414 Lonsdale-street, Melbourne	Process Server ..	" "
Runting, Alan Lindsay ..	26 Coreen-avenue, Beaumaris	" " " ..	123 Queen-street, Melbourne	" " " ..	" "
Wishart, Leslie William ..	1 Dudley-street, West Preston	" " " ..	533 Collins-street, Melbourne	" " " ..	" "
Bristow, Victor Francis ..	49 Union-road, Ascot Vale	" " " ..	220 Victoria-parade, East Melbourne	Inquiry Agent ..	" "
Yvill, Donald Cameron ..	Flat 4, 224 Inkerman-street, East St. Kilda	" " " ..	128 Chetwynd-street, North Melbourne	Process Server ..	" "
" " " ..	" " " ..	" " " ..	" " " ..	Inquiry Agent ..	" "
" " " ..	" " " ..	" " " ..	" " " ..	Commercial Sub-agent	" "
Levy, Gordon Hermann ..	97 Liberty-parade, West Heidelberg	" " " ..	100 Collins-street, Melbourne	" " " ..	" "
Aldersea, Charles Francis ..	2 Griffiths-street, Werribee	" " " ..	130 Abbotsford-street, North Melbourne	Watchman ..	" "
Allen, Arthur George ..	14 Goulburn-street, Cheltenham	" " " ..	" " " ..	" " " ..	" "
Anderson, George Maxwell ..	17 Jenner-street, Blackburn South	" " " ..	" " " ..	" " " ..	" "
Anderson, William Preston ..	36 Daff-avenue, Moorabbin	" " " ..	" " " ..	" " " ..	" "
Armstrong, William Gordon ..	27 Market-road, Sunshine	" " " ..	" " " ..	" " " ..	" "
Baker, Robert Lane ..	12 Wackett-street, Laverton	" " " ..	" " " ..	" " " ..	" "
Beckett, Barry Thomas ..	Flat 1, 183 Moreland-road, Moreland	" " " ..	" " " ..	" " " ..	" "
Bengtsson, Sydney Robert ..	35 Union-street, West Preston	" " " ..	" " " ..	" " " ..	" "
Blacket, Terence Bernard ..	Flat 1, 15 Lennox-street, North Richmond	" " " ..	" " " ..	" " " ..	" "
Boxshall, Bruce ..	17 Samuel-road, Blackburn South	" " " ..	" " " ..	" " " ..	" "
Bragg, Ronald Thomas ..	29A Finchley-avenue, Glenroy	" " " ..	" " " ..	" " " ..	" "
Brimfield, Raymond ..	67 Devereaux-street, Oak Park	" " " ..	" " " ..	" " " ..	" "
Broadway, Raymond George ..	92 Misten-avenue, North Altona	" " " ..	" " " ..	" " " ..	" "
Broad, Denis ..	37 Baird-street, Springvale North	" " " ..	" " " ..	" " " ..	" "

PRIVATE AGENTS—*continued.*

Full Name of Applicant or in the case of a firm or Corporation, of the Nominee.	Place of Abode of Applicant or Nominee.	Name of Firm or Corporation.	Address for Registration.	Type of Licence.	Date of Hearing of Application.
<i>COURT OF PETTY SESSIONS, MELBOURNE—continued.</i>					
Butterworth, Joseph ..	13 Kinane-crescent, Sunshine	104 Wellington-parade, East Melbourne	Watchman ..	28.12.67
Bye, Frederick Charles ..	20 Dennis-avenue, East Keilor	130 Abbotsford-street, North Melbourne	" ..	"
Belt, Robert Neale Carlton ..	83 Napier-crescent, Montmorency South	130 Abbotsford-street, North Melbourne	" ..	"
Carr, William Neil ..	13 Smith-street, Bentleigh	104 Wellington-parade, East Melbourne	" ..	"
Chambers, Gordon Lester Trent	17 Fifth-avenue, Aspendale	" "	" ..	"
Clarkson, Henry Roy James ..	37 Belgrove-street, East Preston	130 Abbotsford-street, North Melbourne	" ..	"
Coe, Alexander Campbell ..	101 Jenkins-street, Northcote	" "	" ..	"
Comley, Geoffrey Robert ..	5 Hazel-court, Ashwood	" "	" ..	"
Condon, Richard George ..	22 Charles-street, Hadfield	" "	" ..	"
Croft, Edward Maxwell ..	26 Clarence-street, Elsternwick	104 Wellington-parade, East Melbourne	" ..	"
Dalsasso, Leonardo ..	4 Wattle-street, Thomastown	130 Abbotsford-street, North Melbourne	" ..	"
Dean, Charles Albert ..	10A Thompson-street, Abbotsford	104 Wellington-parade, East Melbourne	" ..	"
Dundas, Mervyn Lyndhurst ..	1 Devon-court, Mount Waverley	130 Abbotsford-street, North Melbourne	" ..	"
Dunlop, Bruce Victory ..	Flat 107, 480 Lygon-street, Carlton	104 Wellington-parade, East Melbourne	" ..	"
Dunstan, James Gullan ..	307 Poath-road, Hughesdale	" "	" ..	"
Dupoy, Augustus ..	13 Clark-street, Williamstown	130 Abbotsford-street, North Melbourne	" ..	"
Elmore, Anthony Gordon ..	Flat 8, 66 Canning-street, North Melbourne	104 Wellington-parade, East Melbourne	" ..	"
Evans, John ..	30 Sandringham-road, Sandringham	130 Abbotsford-street, North Melbourne	" ..	"
Fisher, Harold Ray ..	62 Clematis-avenue, North Altona	" "	" ..	"
Frawley, Bernard Thomas ..	29 Beatrice-street, East Preston	" "	" ..	"
Garnett, Ernest Maxwell ..	3 Wellington-street, Middle Brighton	" "	" ..	"
Ginn, Charles Edward ..	1065 Heidelberg-road, Ivanhoe	" "	" ..	"
Goding, Arthur Leslie ..	43 Champion-road, North Williamstown	" "	" ..	"
Gothard, Raymond ..	11 Bent-street, Moonee Ponds	" "	" ..	"
Graham, George William ..	35 Grosvenor-street, Balaclava	" "	" ..	"
Green, Ronald William ..	16 Cobby-street, Laverton	104 Wellington-parade, East Melbourne	" ..	"
Guy, Noel ..	8 Stevenston-street, Deer Park	130 Abbotsford-street, North Melbourne	" ..	"
Hainsworth, Charles ..	85 Doncaster-road, North Balwyn	" "	" ..	"
Hardiman, Graeme ..	11 McNamara-street, Laverton	104 Wellington-parade, East Melbourne	" ..	"
Hedger, Leonard ..	76 Cecil-street, East Kew	130 Abbotsford-street, North Melbourne	" ..	"
Hiscock, Oswald William ..	8 Goode-street, Chadstone	" "	" ..	"
Howson, Reginald Maurice ..	1 Kilmore-avenue, East Reservoir	" "	" ..	"
Hurlston, Gordon Keith ..	6 Godfrey-avenue, North Sunshine	" "	" ..	"
Jacobson, Norman Joseph ..	35 Riverside-avenue, Avondale Heights	" "	" ..	"
Jones, Ronald Sidney ..	4 Miller-street, Fawkner	" "	" ..	"

PRIVATE AGENTS—continued.

Full Name of Applicant or in the case of a firm or Corporation, of the Nominee.	Place of Abode of Applicant or Nominee.	Name of Firm or Corporation.	Address for Registration.	Type of Licence.	Date of Hearing of Application.
COURT OF PETTY SESSIONS, MELBOURNE—continued.					
Jordan, Ronald Francis	17 North-crescent, Heidelberg		130 Abbotsford-street, North Melbourne	Watchman	28.12.67
Kelso, Stanley Alex Charles	55 Mitta-street, Box Hill		" "	" "	" "
Kelly, John Lester	16 Grandview-road, West Preston		" "	" "	" "
Kuhn, Colin Douglas	18 Julian-street, Kingsville		" "	" "	" "
Kupsch, William Henry	Flat 2, 25 Marine-parade, St. Kilda		" "	" "	" "
Leahy, Matthew Roy	17 James-avenue, Highett		" "	" "	" "
Lynas, Mark	18 Garrett-crescent, West Heidelberg		" "	" "	" "
McCabe, Arthur William	98 Carlton-street, Carlton		" "	" "	" "
McCull, Daniel George	4 Edgar-street, North Brighton		" "	" "	" "
McEwan, William Denovan	Flat 5, 86 Canning-street, North Melbourne		" "	" "	" "
MacFarlane, John Douglas Stewart	39 Lansdowne-road, East St. Kilda		" "	" "	" "
McIntosh, Noel Robert	120 Ford-street, Ivanhoe		" "	" "	" "
McKeown, Leo Michael	60 Churchill-avenue, Braybrook		" "	" "	" "
Maher, William Laurence	35 Cuthbert-street, Bulleen		" "	" "	" "
Malley, Ernest Richard	28 Westwood-drive, Bulleen		" "	" "	" "
Meaney, William Geoffrey	8 Llewellyn-grove, Carrum		" "	" "	" "
Moore, Arnold Huntley	45 Renshaw-street, East Doncaster		" "	" "	" "
Müller, Josef	8 Prince-street, North Sunshine		" "	" "	" "
Murphy, Roy James	16 Forrest-street, Spotswood		" "	" "	" "
O'Halloran, Terence Leton	170 Separation-street, Northcote		" "	" "	" "
Kelly, Henry Michael	566 Morwell-avenue, Bundoora		" "	" "	" "
Osborne, Richard Joseph	25 Dickens-street, Elwood		" "	" "	" "
Pearson, William Thomas	501 Pascoe Vale-road, Oak Park		" "	" "	" "
Philpots, Harris Purdie	22 Lucille-avenue, Keon Park		" "	" "	" "
Neilson, William James	56 Board-street, Doncaster		" "	" "	" "
O'Shea, Francis Raymond	19 Biscop-road, Moorabbin		" "	" "	" "
Pilgrim, Rupert John Marcuis	91 Carlisle-street, St. Kilda		" "	" "	" "
Pursell, Noel Edward	20 Highbury-avenue, Moorabbin		" "	" "	" "
Puttyfoot, Royce Edward	39 Ashton-street, Reservoir		" "	" "	" "
Reed, Gordon Maxwell Norman	43 Ross-road, North Altona		" "	" "	" "
Redford, William James	60 Blake-street, East Reservoir		" "	" "	" "
Rigby, Frederick William	12 Bunting-court, Altona North		" "	" "	" "
Rogers, Francis James	390 Huntingdale-road, Oakleigh South		" "	" "	" "
Rohan, Francis Xavier	7 Hebb-street, Braybrook		" "	" "	" "
Ryan, Edward James	20 William-avenue, Hallam		" "	" "	" "
Saintsbury, Michael Timothy	55 Rayner-street, Altona		" "	" "	" "
Shanahan, George James	14 Tarneit-road, Werribee		" "	" "	" "
Shanks, Henry Terence	50 Augustine-terrace, Glenroy		" "	" "	" "
Shirley, Victor John	3 Drina-street, Strathmore		" "	" "	" "
Smith, Kenneth George	Flat 172, 76 Canning-street, North Melbourne		" "	" "	" "
Sturgess, John Albert Edward	2 Dempster-street, Tottenham		" "	" "	" "
Sullivan, Michael Joseph	4 Fenton-street, Ascot Vale		" "	" "	" "

PRIVATE AGENTS—*continued.*

Full Name of Applicant or in the case of a Firm or Corporation, of the Nominee.	Place of Abode of Applicant or Nominee.	Name of Firm or Corporation.	Address for Registration.	Type of Licence.	Date of Hearing of Application.
COURT OF PETTY SESSIONS, MELBOURNE—<i>continued.</i>					
Taylor, Albers Richard ..	136 Devonshire-road, Sunshine	130 Abbotsford-street, North Melbourne	Watchman ..	28.12.67
Thomas, David George ..	Lot 11, Vaughan-avenue, Boronia	" "	" ..	"
Weeks, William Anthony ..	10 William-street, Seddon	" "	" ..	"
Weiland, Edwin Frederick ..	64 Canning-street, Avondale Heights	" "	" ..	"
Welch, William Henry ..	46 Westerfield-drive, North Clayton	" "	" ..	"
Weymouth, Lawrence ..	41 Piperita-road, Ferntree Gully	" "	" ..	"
Wilkinson, Edward ..	20 Kathryn-street, Doveton	" "	" ..	"
Williams, Owen Thomas ..	Flat 10, 203 Gold-street, Clifton Hill	" "	" ..	"
Woods, Ian Charles ..	30 Grandview-road, North Brighton	" "	" ..	"
Woolrich, Harold Robert James	34 Leigh-street, Huntingdale	" "	" ..	"

Dated at Melbourne, this 8th day of December, 1967.

G. L. WEBSTER,
Clerk of Petty Sessions.

COURT OF PETTY SESSIONS, SANDRINGHAM.

Coombes, Walter Thomas ..	257 Bluff-road, Sandringham	257 Bluff-road, Sandringham	Inquiry Agent ..	8.1.68
---------------------------	-----------------------------	---------	-----------------------------	------------------	--------

Dated at Sandringham this 11th day of December, 1967.

J. A. BARNS,
Clerk of Petty Sessions.

COURT OF PETTY SESSIONS, FERNTREE GULLY.

Novak, William ..	Hollis-road, Burleigh	Hollis-road, Burleigh	Process Server ..	8.1.68
" ..	"	" ..	Guard Agent ..	"
" ..	"	" ..	Inquiry Agent ..	"

Dated at Ferntree Gully this 11th day of December, 1967.

F. J. DUTHRIE,
Clerk of Petty Sessions.

COURT OF PETTY SESSIONS, SUNSHINE.

Johnston, Laurence Francis ..	56 Fehon-street, Yarraville	13 Victoria-crescent, St. Albans	Watchman ..	29.12.67
Bowers, Barrie James ..	195 Taylors-road, St. Albans	" "	" ..	"
Aitken, Gavin George ..	13 Victoria-crescent, St. Albans	" "	Guard Agent ..	"
" ..	"	" "	Inquiry Agent ..	"

Dated at Sunshine this 8th day of December, 1967.

BERN J. COBURN,
Clerk of Petty Sessions.

COURT OF PETTY SESSIONS, MELBOURNE.

Lister, Charles Bodem ..	4 Ballinamona-street, Fairfield	130 Abbotsford-street, North Melbourne	Watchman ..	28.12.67
Wells, Ronald Godfrey ..	9 Darbyshire-road, Mt. Waverley	" "	" ..	"

Dated at Melbourne this 11th day of December, 1967.

G. L. WEBSTER,
Clerk of Petty Sessions.

COURT OF PETTY SESSIONS, MELBOURNE.

Nancarrow, William Francis ..	2 Royal-avenue, Sandringham	Cnr. Arden and Lothian streets, North Melbourne	Watchman ..	29.12.67
Rossi, Pasquale ..	248 Hope-street, West Brunswick	" "	" ..	"
Evans, Warren Leonard ..	31 Tarella-road, Chelsea	" "	" ..	"
Kenneth, Keith Maxwell ..	Flat 7, 3 Avoca-avenue, Elwood	" "	" ..	"

Dated at Melbourne this 12th day of December, 1967.

G. L. WEBSTER,
Clerk of Petty Sessions.

PRIVATE AGENTS—continued.

Full Name of Applicant or in the case of a Firm or Corporation, of the Nominee.	Place of Abode of Applicant or Nominee.	Name of Firm or Corporation.	Address for Registration.	Type of Licence.	Date of Hearing of Application.
---	---	------------------------------	---------------------------	------------------	---------------------------------

COURT OF PETTY SESSIONS, SPRINGVALE.

Starvaggi, Antonio	20A Princess-avenue, Springvale	20A Princess-avenue, Springvale	Guard Agent ..	5.1.68
--------------------------	---------------------------------	-------	---------------------------------	----------------	--------

Dated at Springvale this 12th day of December, 1967.

F. J. DUTHIE,
Clerk of Petty Sessions.

COURT OF PETTY SESSIONS, WODONGA.

Rogalski, Edmund Peter ..	4 Hill-street, Wodonga	4 Hill-street, Wodonga	Process Server ..	28.12.67
Morley, Reginald Stanley ..	10 Church-street, Wodonga	Border Night Patrol Service	10 Church-street, Wodonga	Guard Agent ..	"
" " " ..	" " "	" "	" "	Process Server ..	"
" " " ..	" " "	" "	" "	Inquiry Agent ..	"

Dated at Wodonga this 8th day of December, 1967.

J. T. KNIGHT,
Clerk of Petty Sessions.

COURT OF PETTY SESSIONS, HEIDELBERG.

Niland, Margaret Joan ..	120 Beverley-road, Rosanna	120 Beverley-road, Rosanna	Inquiry Agent ..	16.1.68
Riedel, Walter Gerhard ..	4 Cobham-avenue, Parkholme, S.A.	35 Como-street, Alphington	Process Server .. Inquiry Agent ..	29.12.67

Dated at Heidelberg this 12th day of December, 1967.

T. K. HASSARD,
Clerk of Petty Sessions.

COURT OF PETTY SESSIONS, BRIGHTON.

Burns, William James ..	1092 Nepean Highway, Hightett	c/o Argus Night Patrol Pty. Ltd.	Watchman ..	29.12.67
-------------------------	-------------------------------	-------	----------------------------------	-------------	----------

Dated at Brighton this 12th day of December, 1967.

J. A. BARNS,
Clerk of Petty Sessions.

COURT OF PETTY SESSIONS, PRAHRAN.

Stephenson, Paul Gray ..	69 Green-street, Ivanhoe	c/o Melbourne Night Patrol Service, Suite 18, 614 St. Kilda-road, Melbourne	Watchman ..	9.1.68
Wright, Robin Lyall ..	5 Chave-court, Laver-ton	" "	" ..	"
Cartner, Derrick Ivan Austin	51 Aviation-road, Point Cook	" "	" ..	8.1.68
Read, Eric Francis Norman	52 Brook-drive, Altona	Flat 6, 47 Marne-street, South Yarra	Process Server ..	"
File, Steven	" "	Inquiry Agent ..	"

Dated at Prahran this 12th day of December, 1967.

G. S. HOARE,
Clerk of Petty Sessions.

COURT OF PETTY SESSIONS, PRAHRAN.

Harrey, Maxwell James ..	5 Mell-street, Toorak	5 Mell-street, Toorak	Inquiry Agent ..	12.1.68
--------------------------	-----------------------	-------	-----------------------	------------------	---------

Dated at Prahran this 13th day of December, 1967.

G. S. HOARE,
Clerk of Petty Sessions.

COURT OF PETTY SESSIONS, ELTHAM.

Clinnick, Gary James ..	Lot 66, Old Warrandyte-road, Research	Lot 66, Old Warrandyte-road, Research	Process Server ..	3.1.68
-------------------------	---------------------------------------	-------	---------------------------------------	-------------------	--------

Dated at Eltham this 13th day of December, 1967.

J. B. DENNIS,
Clerk of Petty Sessions.

COURT OF PETTY SESSIONS, MALVERN.

Churches, Clifford John ..	Flat 7, 95 Wilson-street, Brighton	116 Glenferrie-road, Malvern	Commercial Sub-agent	5.1.68
" " " ..	" " "	" "	Inquiry Agent ..	"

Dated at Malvern this 14th day of December, 1967.

P. J. RODDA,
Clerk of Petty Sessions.

PRIVATE AGENTS—continued.

Full Name of Applicant or in the case of a Firm or Corporation, of the Nominee.	Place of Abode of Applicant or Nominee.	Name of Firm or Corporation.	Address for Registration.	Type of Licence.	Date of Hearing of Application.
COURT OF PETTY SESSIONS, MELBOURNE.					
Healy, Peter John	155 Royal-parade, Parkville	155 Royal-parade, Parkville	Process Server ..	3.1.68
Robinson, Dennis Lloyd ..	Flat 15, 3 Struan-street, Toorak	414 Lonsdale-street, Melbourne	" " ..	"
Ahearn, James Joseph ..	24 Roy-street, Donvale	130 Abbotsford-street, North Melbourne	Watchman ..	"
Allen, Stanley Sperry ..	24 Canterbury-street, Moonee Ponds	" ..	"
Bartlett, Albert Joseph ..	341 Blackburn-road, East Burwood	" "	" ..	"
Bradbrook, Ronald Bertram ..	11 Seagull-avenue, Altona West	" "	" ..	"
Byrnes, Nicholas James ..	Sunning Hill, Cranbourne-road, Narre Warren	" "	" ..	"
Cochrane, Reginald William ..	10 Marlborough-road, Bayswater	" "	" ..	"
Cole, Leslie William ..	348 Beaconsfield-parade, St. Kilda	" "	" ..	"
Crook, John	5 Kelvin-avenue, Springvale	" "	" ..	"
Dalton, Brian Francis ..	Flat 6, 11 Maroona-road, Glenhuntly	" "	" ..	"
Daniel, Richard Leslie ..	86 Alexandra-street, East St. Kilda	" "	" ..	"
Davies, Michael Noel ..	17 Harcourt-street, Hawthorn East	" "	" ..	"
Davis, Carl Anthony ..	14 Bowen-street, Chadstone	" "	" ..	"
Deegan, Frederick Ambrose ..	17 Bruce-street, West Coburg	" "	" ..	"
Dennis, Barry Joseph ..	9 Morton-grove, Chelsea	" "	" ..	"
Doornbusch, Corry ..	5 Newton-street, Glenroy	" "	" ..	"
Douglas, Leonard Joseph ..	2 Bethune-street, East Hawthorn	" "	" ..	"
Doyle, Anthony ..	4 Hurtle-street, Lalor	" "	" ..	"
Fenech, Lawrence ..	16 Box-road, Briar Hill	" "	" ..	"
Finn, William Edward ..	Flat 203, 12 Holland-court, Flemington	" "	" ..	"
Fisher, William Frederick ..	19 Rooney-street, Maidstone	" "	" ..	"
Goldsworthy, Geoffrey Leonard	1 Taylor-street, Burwood	" "	" ..	"
Gook, Kevin Frederick ..	118 Sunset-boulevard, Jacana	" "	" ..	"
Griffin, Kevin Roy ..	Flat 12, 133 Clarke-street, Northcote	" "	" ..	"
Hewat, Robert John ..	147 Railway-avenue, Laverton	" "	" ..	"
Hieks, Roy Dundas ..	Olympic - avenue, Springvale	" "	" ..	"
James, Clifford Wellman ..	Old Gippsland-road, Lilydale	" "	" ..	"
Jesser, Roy Maxwell ..	16 Highfield-avenue, Springvale North	" "	" ..	"
Mensgens, Henry Joseph ..	50 Kanooka-road, Wantirna	" "	" ..	"
Milner, Stuart Michael ..	Flat 12, 18 Churchill-avenue, Ascot Vale	" "	" ..	"
Moore, Frederick Keith ..	13 Miller-street, Fawkner	" "	" ..	"
Moore, Leo Joseph ..	8 Stock-street, Coburg	" "	" ..	"
Murray, David ..	58 Spencer-street, Essendon	" "	" ..	"
Oakley, George Patrick ..	39 Regent-street, Prahran	" "	" ..	"
O'Regan, Denis Anthony ..	Rockbank, Victoria	" "	" ..	"
O'Sullivan, John ..	59 Millawa-avenue, St. Albans	" "	" ..	"
Philpots, Nelson James ..	4 German-court, Thomastown	" "	" ..	"
Porteous, Donald Alexander	10 Pentathlon-street, Bundoora	" "	" ..	"
William
Provost, Max ..	501 Dalzell-road, RAAF Base, Point Cook	" "	" ..	"
Savage, Graham Alexander ..	10 Settlement-road, Bundoora	" "	" ..	"
Skarratt, John ..	30 Bungay-street, Fawkner	" "	" ..	"
Fawkner, Arthur Robert ..	3 Flintoff-street, Greensborough	" "	" ..	"
Venon, Arthur Benjamin ..	687 Barkly-street, West Footscray	" "	" ..	"
Watts, Richard Pemberton ..	54 Oberon-avenue, St. Albans	" "	" ..	"

PRIVATE AGENTS—*continued.*

Full Name of Applicant or in the case of a Firm or Corporation, of the Nominee.	Place of Abode of Applicant or Nominee.	Name of Firm or Corporation.	Address for Registration.	Type of Licence.	Date of Hearing of Application.
COURT OF PETTY SESSIONS, MELBOURNE— <i>continued.</i>					
Wells, Robert William John ..	1 Mitchell-road, Box Hill North	130 Abbotsford-street, North Melbourne	Watchman ..	3.1.68
West, Harold Robert ..	38 Mollison-street, Abbotsford	" "	" ..	"
Wilson, Jack ..	72 Armstrong-street, Middle Park	" "	" ..	"
Wilson, Thomas ..	Lot 1, 4 Fisherman's Bend Hostel, Port Melbourne	" "	" ..	"
Young, Norman Arthur ..	51 Couch-street, Sunshine	" "	" ..	"

Dated at Melbourne this 14th day of December, 1967.

G. L. WEBSTER,
Clerk of Petty Sessions.

COURT OF PETTY SESSIONS, BOX HILL.

Williamson, Roger Gilbert ..	18 Boondara-road, North Box Hill	18 Boondara-road, North Box Hill	Process Server ..	15.1.68
------------------------------	----------------------------------	---------	----------------------------------	-------------------	---------

Dated at Box Hill this 15th day of December, 1967.

A. J. JOHNSON,
Clerk of Petty Sessions.

COURT OF PETTY SESSIONS, ST. KILDA.

Kellick, Raymond ..	1 Mimosa-road, Carnegie	1 Mimosa-road, Carnegie	Process Server ..	9.1.68
Stevens, Charles James ..	15 Avenza-street, Mentone	15 "Avenza-street, Mentone	Inquiry Agent ..	"
" " " ..	" " "	" " "	Process Server ..	"
" " " ..	" " "	" " "	Inquiry Agent ..	"

Dated at St. Kilda this 15th day of December, 1967.

J. E. REILLY,
Clerk of Petty Sessions.

COURT OF PETTY SESSIONS, LILYDALE.

Clavant, Isabell Ann ..	Lot 4, Taylor-road, Mooroolbark	Dorset Night Patrol Service	Lot 4, Taylor-road, Mooroolbark	Inquiry Agent ..	22.12.67
" " " ..	" " "	" "	" "	Guard Agent ..	"
Clavant, Willem " ..	" " "	" "	" "	Inquiry Agent ..	"
Humphries, Terrence ..	24 "Victoria-road, Lilydale	" "	" "	Guard Agent ..	"
				Watchman ..	"

Dated at Lilydale this 8th day of December, 1967.

J. A. GIDLEY,
Clerk of Petty Sessions.

COURT OF PETTY SESSIONS, WARRNAMBOOL.

Greaves, Reginald Clifford ..	48 Princes Highway West, Warrnambool	182 Lava-street, Warrnambool	Inquiry Agent ..	9.1.68
-------------------------------	--------------------------------------	---------	------------------------------	------------------	--------

Dated at Warrnambool this 13th day of December, 1967.

V. G. STAFFORD,
Clerk of Petty Sessions.

COURT OF PETTY SESSIONS, BALLARAT.

Till, Desmond Patrick ..	11 Ercil-street, Wendouree	17 Doveton-street North, Ballarat	Inquiry Agent ..	4.1.68
--------------------------	----------------------------	---------	-----------------------------------	------------------	--------

Dated at Ballarat this 18th day of December, 1967.

E. W. KINCHINGTON,
Clerk of Petty Sessions.

Apprenticeship Act 1958.

APPRENTICESHIP COMMISSION OF VICTORIA.

NOTICE OF INTENTION TO RECOMMEND THAT THE WAITING TRADE BE PROCLAIMED AN APPRENTICESHIP TRADE.

NOTICE is hereby given, in pursuance of the provisions of the *Apprenticeship Act 1958*, that it is the intention of the Apprenticeship Commission of Victoria to make a recommendation to the Minister of Labour and Industry that the trade of *waiting* be proclaimed an apprenticeship trade under the said Act insofar as it is carried on in any hotel, club, restaurant, eating house or boarding house anywhere in the State of Victoria in which three or more adult persons are permanently employed in the said trade.

(For the purpose of this Notice a person shall be deemed to be permanently employed if engaged to work a week of not less than 40 hours).

It is also notified that the 13th February, 1968, has been fixed as the date before which representations may be made to the said Commission, by or on behalf of employers or employees in the said trade, whether for or against the said trade being so proclaimed.

By Order of the Commission,

L. R. BROWN,
Secretary to the Commission.

Transport Regulation Act.
TRANSPORT REGULATION BOARD.
HEARING OF APPLICATIONS.

NOTICE is hereby given that the following applications will be considered by the Transport Regulation Board at its offices at corner Lygon and Princes streets, Carlton, at 10.15 a.m., on Wednesday, 10th January, 1968.

CROYDON BUS SERVICE PTY. LTD., Maroondah Highway, Croydon. Application to vary C.O. licences as follows:—(a) To delete that part of the Lilydale-Silvan South route from Parkers Corner, via Wiseman and Link roads and Seville-road to Silvan South. (b) To extend the Lilydale-Parkers Corner service to Monbulk, via Lilydale-Monbulk road.

GEELONG ROAD BUS SERVICE PTY. LTD., 307 Geelong-road, West Footscray. Application for variation of all M.O. licences, Route 20A (Footscray-Brooklyn) to operate an extension of service from the corner of Little Boundary and Geelong roads, via Little Boundary-road to Pipe-road.

GRENDAS BUS SERVICE, 9 Foster-street, Dandenong. Application for permit authority to operate vehicle licensed No. M.C.353 under contract to Simpson's Manufacturing Pty. Ltd., for the carriage of personnel between the present factory in Burnley-street, Burnley, and the new factory premises in Heatherton-road, Springvale South via Burnley-street, South Eastern Freeway, Grange, Toorak, Ororong, Dandenong, Springvale and Heatherton roads—Permit is required for an experimental period of 1 month commencing from 17th January, 1968.

Time-table:

Depart Burnley—6.45 a.m.

Depart Springvale South—4.15 p.m.

IVANHOE BUS CO. PTY. LTD., 56 Bell-street, West Heidelberg. Application for permit authority to operate any three M.O. licensed vehicles under contract to Christian Brothers College, Bundoora, for the carriage of school children on the following routes: 1. From the corner of Burke and Cotham roads, Kew, via Burke-road, Burke-road North, McArthur and Lower Heidelberg roads, Marshall, Norman and Noel streets, Upper Heidelberg and Waiora roads, Kingsbury-drive and Plenty-road to school. 2. From the corner of Bell and Edwin streets, West Heidelberg, via Edwin and Altona streets, Waterdale, Southern and Waiora-roads, Kingsbury-drive and Plenty-road to school. 3. From the corner of Bond-street, and Waterdale-road, Ivanhoe, via Bond-street, Oriol-road, Ramu-parade, Waterdale-road, Kingsbury-drive and Plenty-road to school. Until such time as Kingsbury-drive is completed each route will be via Waiora-road and through the grounds of Mont Park Mental Hospital to Plenty-road.

Time-table (School Days Only).

Route 1.—Depart corner Burke and Cotham roads, Kew, 8.00 a.m.; Depart school, 4.00 p.m.

Route 2.—Depart corner Bell and Edwin streets, West Heidelberg, 8.10 a.m.; Depart school 4.00 p.m.

Route 3.—Depart corner Bond-street and Waterdale-road, Ivanhoe, 8.10 a.m.; Depart school, 4.00 p.m.

NORTHERN BUS LINES PTY. LTD., Walter-street, Glenroy. One commercial passenger vehicle (S/C. 34) to operate as an additional metropolitan stage omnibus on Route 147A (Broadmeadows Military Camp-Broadmeadows-Upfield).

PHILLIPS, F. A., 8 Mereweather-avenue, Frankston. One commercial passenger vehicle (S/C. 35) to operate under the same terms and conditions as existing C.O. licences in the name of the applicant.

Notice of any objection should be forwarded to reach the Secretary of the Board not later than Wednesday, 3rd January, 1968.

Applicants are advised that it will not be necessary to appear on the hearing date specified above, unless advised, in writing, by the Board.

B. P. KAY,

Secretary.

Corner Lygon and Princes streets, Carlton, Wednesday, 20th December, 1967.

Commercial Goods Vehicles Act.
TRANSPORT REGULATION BOARD.
HEARING OF APPLICATIONS.

NOTICE is hereby given that the following applications will be considered by the Transport Regulation Board at its offices at the cnr. Lygon and Princes Streets, Carlton, at 10.15 a.m. on Wednesday, 10th January, 1968.

ALLEN, A., 17 Kinnaird-street, Jacana, 3047. One commercial goods vehicle (L/C. 18 cwt.) to operate: (a) Within a 50-mile radius of own premises at

Broadmeadows in the course of business as "Builder and Carpenter"—own goods. (b) Within a 50-mile radius of the premises of Alpha Blinds Co. Pty. Ltd., at Brunswick solely on behalf of the said Company—tools of trade, equipment, blinds and awnings for installation purposes.

ANDERSEN, R. W. K., 23 Elizabeth-street, Moe, 3825. One commercial goods vehicle (L/C. 10 cwt.) to operate within that part of the State of Victoria east of a line drawn due north and south through the City of Melbourne to merchants yards in the Metropolitan Area in the course of business as "Marine Collector"—special wares, marine stores or old metals as designated in the *Marine Stores and Old Metals Act 1958* (No. 6303), Part I, (3) but excluding the carriage of any such special wares, marine stores or old metals to wharves, docks or ships for shipment or export purposes, with the proviso that the combined load capacities of both prime mover and any trailer together shall not exceed 120 cwt.

ANGOVE, T. A., Private Bag, Echuca, 3625. One commercial goods vehicle (L/C. 11 cwt.) to operate within a 50-mile radius from the premises of D. H. Loader at Rochester in the course of business as "Bulldozer Operator"—tools of trade, spare parts and materials incidental to the repair and maintenance of equipment on behalf of D. H. Loader.

ARTHUR'S DAIRY PTY. LTD., 146 Beach-street, Frankston, 3199. One commercial goods vehicle (L/C. 95 cwt.) to operate within a 50-mile radius of own premises at Frankston in the course of business as "Dairymen"—fresh milk, cream and a small quantity limited to a maximum of three hundredweight (3 cwt.) at any one time of butter, yoghurt, cheese, eggs and ice.

AVERY, W. & T., (AUST.) PTY. LTD., 255 William-street, Melbourne, 3000. One commercial goods vehicle (L/C. 11 cwt.) to operate: in the course of business as "Retailers and Repairers of Weighing and Testing Equipment": (a) Within a 50-mile radius of the post office situated at the corner of Bourke and Elizabeth streets in the City of Melbourne—own goods. (b) Throughout the State of Victoria—weighing and testing machines for installation, for repair and for return when repaired, also tools of trade, spare parts and materials incidental to the installation, testing and servicing of weighing machines.

BELL, G. D., 31 Temple-court, Noble Park, 3174. One commercial goods vehicle (L/C. 198 cwt.) to operate within a 50-mile radius of the premises of Consolidated Quarries Limited at Oakleigh, solely on behalf of the said company—premixed concrete in a specially constructed agitator vehicle.

BROWN, J. R., 40 Princes Highway, Warrnambool, 3280. One commercial goods vehicle (L/C. 123 cwt.) to operate within a 75-mile radius of the post office at Penhurst (Warrnambool Division of the C.R.B.) as a "Water Tanker" for road-making purposes.

BURGESS, J. B., 30 Tucker-street, Horsham, 3400. One commercial goods vehicle (L/C. 290 cwt.) to operate: (a) Within a 25-mile radius from the G.P.O., Melbourne, solely on behalf of Rowlands Quarries Pty. Ltd.—sand, screenings and soil. (b) From the Rowlands Quarries Pty. Ltd., quarry at Broadford to the plants of Pioneer Concrete Pty. Ltd., at Brunswick, Bundoora and Collingwood—screenings.

GREEN, M. F., (trading as C.N.G. Plant Hire), Flaxman-street, Warrnambool, 3280. One commercial goods vehicle (L/C. 7 cwt.) to operate: (a) Within that part of the State of Victoria west of a line drawn due north and south, through the City of Colac and south of a line drawn due east and west through the township of Ararat for the purposes of servicing own plant and equipment under hire in the field only—tools of trade and spare parts incidental to servicing such plant and equipment and also own plant and equipment for delivery to or return from hirer. (b) Within a 50-mile radius of the Caltex Depot at Warrnambool—petroleum products in prescribed types of containers and empty containers for return. (c) Within a 20-mile radius of the post office at Warrnambool—general goods.

CADBY, C. R., 153 Sutton-street, Warragul, 3820. One commercial goods vehicle (L/C. 40 cwt.) to operate in the course of business as "Building Contractor": (a) Within a 50-mile radius of Warragul—own goods. (b) Throughout the State of Victoria—own tools of trade and equipment when being moved from site to site. (c) Within a 20-mile radius of any contract site currently engaged upon or from the railway station nearest thereto—materials required for the completion of such contract.

CLARKE, A. E., Box 91, Mansfield, 3722. One commercial goods vehicle (L/C. 271 cwt.) to operate from the Forest Commission logging areas at King, Sixteen Mile, Howitt and Bluff to the premises of Burwood Timber Mills Pty. Ltd., at Mansfield—logs.

- CONSOLIDATED QUARRIES LTD.**, Centre-road, South Oakleigh, 3167. Nine commercial goods vehicles (L/C. 263, 263, 264, 267, 268, 265, 265, 266 and 264 cwt.) to operate: (a) Within a 25-mile radius from the G.P.O., Melbourne, in the course of business as "Quarry Masters"—own goods. (b) Within a 35-mile radius from the G.P.O., Melbourne, in the course of business as "Quarry Masters"—own screenings, own sand and own quarry products.
- COOPER, R. B.**, Musk, 3456. One commercial goods vehicle (L/C. 122 cwt.) to operate: (a) Within a 25-mile radius from the post office at Musk with the proviso that no one journey shall exceed 30 miles in length—general goods. (b) From and to places situated within the radius as defined in paragraph (a) above to and from places outside that radius but wholly within a 50-mile radius from the post office at Musk—livestock; (c) from and to the Ampol Petroleum (Vic.) Pty. Ltd. depot at Ballarat to and from own premises at Musk—petroleum products in prescribed types of containers and empty return containers.
- CRESKO FERTILIZERS LTD.**, 38 Fenewick-street, Geelong 3220. One commercial goods vehicle (L/C. 119 cwt.) to operate: (a) Throughout the State of Victoria in the course of business as "Fertilizer Manufacturers"—own agricultural plant and equipment incidental to the maintenance and harvesting of crops grown in experimental plots on primary producers' properties; (b) from railway stations throughout the State of Victoria nearest to the site of own experimental plots—superphosphate incidental only to the fertilizing of such plots.
- CURTHOYS, J. S.**, Lalbert, 3542. One commercial goods vehicle (L/C. 122 cwt.) to operate: (a) Within a 50-mile radius from the post office at Lalbert as a "Road Contractor"—road-making plant and materials (b) Within a 25-mile radius from the post office at Lalbert with the proviso that no one journey shall exceed 30 miles in length—general goods.
- DAY, W. A. & J. H.**, 76 Kemp-street, Springvale, 3171. One commercial goods vehicle (L/C. 129 cwt.) to operate within a radius of 70 miles from the premises of "Atlas Industries Australia Ltd." at Springvale solely on behalf of the said company—concrete roofing tiles, roof battens and tile fixing materials.
- EVANS, A. J.**, 54 Beverley-street, East Doncaster, 3109. Two commercial goods vehicles (L/C. 156 and 249 cwt.) to operate: (a) Within a 25-mile radius from the post office at the corner of Bourke and Elizabeth streets in the City of Melbourne in the course of business as "Sand, Soil and Screening Supplier"—own goods. (b) From Toolangi to places within the radius as defined in paragraph (a) above—own mountain soil. (c) From Bacchus Marsh to places within the radius as defined in paragraph (a) above—own river pebbles.
- FOODLAND STORES PTY. LTD.**, 619 Springvale-road, Glen Waverley, 3150. Six commercial goods vehicles (L/C. 8 cwt. each) to operate: (a) Within a 50-mile radius of own premises at Glen Waverley in the course of business as "Wholesale Grocers"—own goods. (b) Throughout the State of Victoria for the purpose of sales promotion of own goods and agency lines—samples and advertising and display materials.
- FREGON SAND PTY. LTD.**, Centre-road, South Oakleigh, 3167. One commercial goods vehicle (L/C. 200 cwt.) to operate: (a) Within a 25-mile radius from the G.P.O. Melbourne in the course of business as "Quarry Masters"—own goods. (b) Within a 35-mile radius from the G.P.O., Melbourne in the course of business as "Quarry Masters"—own screenings, own sand and own quarry products.
- GARDNER, J. W.**, 417 Princes Highway, Morwell, 3840. Two commercial goods vehicles (L/C. 120 and 123 cwt.) to operate within a 50-mile radius from the premises of "Coast Contractors Pty. Ltd." at Yallourn, solely on behalf of the said company—premixed concrete in a specially constructed agitator vehicle.
- GIRGARRE CHEESE CO. PTY. LTD.**, 177 Victoria-parade, Collingwood, 3066. Application to vary the conditions of licence No. D.A.14433/5 (L/C. 6 cwt.) by deleting from paragraph (a) of the existing conditions "Collingwood" and by adding in lieu: "Girgarre."
- GLADMAN, G. J.**, Serpentine, 3517. One commercial goods vehicle (L/C. 120 cwt. approximately) to operate to properties within a 50-mile radius of the post office at Serpentine, from the railway station nearest thereto in the course of business as "Bulk Superphosphate Spreader"—bulk superphosphate for spreading purposes only.
- GRATON, N. L.**, Coombs-street, Taggerty, 3779. One commercial goods vehicle (L/C. 68 cwt.) to operate within a 50-mile radius from the post office at Taggerty and to and from the City of Melbourne in the course of business as "Secondhand Dealer"—own goods.
- GREENWAY, R. S. & A., PTY. LTD.**, Grand-road, Somerville, 3912. One commercial goods vehicle (L/C. 137 cwt.) to operate throughout the State of Victoria in a specially constructed refrigerated vehicle—frozen poultry, frozen processed vegetables and frozen fish.
- GRIL, F.**, 13 Austral-avenue, West Preston, 3072. One commercial goods vehicle (L/C. 138 cwt.) to operate: (a) Within a 35-mile radius of the premises of "Bayview Quarries Pty. Ltd." at Tullamarine—screenings, stone dust and premix on behalf of the said company; (b) From pits within a 35-mile radius of Tullamarine to the plant of "Bayview Quarries Pty. Ltd." at Tullamarine—sand.
- HAMMOND, E. H., & SON**, 899 Canterbury-road, Box Hill South, 3128. Application to vary the conditions of licences No. D.A.51727 and D.A.51727/1 (L/C. 130 and 112 cwt.) by adding to the existing conditions additional paragraphs (c), (d), (e), (f) and (g): (c) From pits at Tooradin and Cranbourne to places within the radius as defined in paragraph (a) above—own sand and soil. (d) From Bacchus Marsh to places within the radius as defined in paragraph (a) above—own river pebbles. (e) From quarries at Castlemaine and Chewton to places within the radius as defined in paragraph (a) above—own paving slate. (f) From pits at Hoddles Creek to places within the radius as defined in paragraph (a) above—own soil. (g) From private properties at Werribee to places within the radius as defined in paragraph (a) above—own honeycomb rock.
- HAMMOND, E. H., & SON**, 899 Canterbury-road, Box Hill South, 3128. One commercial goods vehicle (L/C. 129 cwt.) to operate: (a) Within a 20-mile radius of the post office at Box Hill in the course of business as "Soil, Screenings and Gravel Supplier"—own goods. (b) From Toolangi to places within the radius as defined in paragraph (a) above—own mountain soil. (c) From pits at Tooradin and Cranbourne to places within the radius as defined in paragraph (a) above—own sand and soil. (d) From Bacchus Marsh to places within the radius as defined in paragraph (a) above—own river pebbles. (e) From quarries at Castlemaine and Chewton to places within the radius as defined in paragraph (a) above—own paving slate. (f) From pits at Hoddles Creek to places within the radius as defined in paragraph (a) above—own soil. (g) From private properties at Werribee to places within the radius as defined in paragraph (a) above—own honeycomb rock.
- HAMMOND, L. G.**, 899 Canterbury-road, Box Hill South, 3128. One commercial goods vehicle (L/C. 112 cwt.) to operate: (a) Within a 20-mile radius of the post office at Box Hill in the course of business as "Soil, Screenings and Gravel Supplier"—own goods. (b) From Toolangi to places within the radius as defined in paragraph (a) above—own mountain soil. (c) From pits at Tooradin and Cranbourne to places within the radius as defined in paragraph (a) above—own sand and soil. (d) From Bacchus Marsh to places within the radius as defined in paragraph (a) above—own river pebbles. (e) From quarries at Castlemaine and Chewton to places within the radius as defined in paragraph (a) above—own paving slate. (f) From pits at Hoddles Creek to places within the radius as defined in paragraph (a) above—own soil. (g) From private properties at Werribee to places within the radius as defined in paragraph (a) above—own honeycomb rock.
- HARDWARE, W. A. & K., PTY. LTD.**, corner Whiteside and Clayton roads, Clayton, 3168. One commercial goods vehicle (L/C. 17 cwt.) to operate throughout the State of Victoria: (a) For the purpose of servicing and installing petrol pumps and petrol dispensing equipment in the course of business as "Mechanical Engineers"—tools of trade, spare parts and materials incidental thereto and also petrol pumps and equipment for installation and repair or having been repaired. (b) In the course of business as "Heating, Ventilating and Air-Conditioning Engineers"—own equipment and ductwork.
- HOSE, DAVID, PTY. LTD.**, Main-road, Elliminyt, 3249. One commercial goods vehicle (L/C. 244 cwt.) to operate: (a) Within a 25-mile radius of the post office at Colac with the proviso that no one journey shall exceed 30 miles in length—general goods. (b) Within a 70-mile radius of the brickworks of "Colac Brick Works Pty. Ltd." at Colac—bricks solely on behalf of the said company.

- HOUGHTON & BYRNE (VIC.) PTY. LTD.**, 20A Nicholson-street, East Brunswick, 3057. One commercial goods vehicle (L/C. 6 cwt.) to operate throughout the State of Victoria in the course of business as "Pest Control Specialists"—tools of trade, spraying equipment and materials incidental to the completion of own contracts.
- HUNT, L.**, care of Drouin West Sawmill, Drouin West, 3818. One commercial goods vehicle (L/C. 320 cwt.) to operate: (a) From private landings situated within a 35-mile radius of the post office at Drouin to own sawmill at Drouin West—mill logs. (b) Within a 25-mile radius of the post office at Drouin—own sawn timber and own new pallets. (c) From own sawmill at Drouin West to places within a 25-mile radius of the post office situated at the corner of Bourke and Elizabeth streets in the City of Melbourne and to places *en route*—own sawn timber and own new pallets.
- JAMES, E.**, 62 Mookarri-street, Cobram, 3644. One commercial goods vehicle (L/C. 18 cwt.) to operate throughout the State of Victoria in the course of business as "Painter"—tools of trade, materials and equipment incidental to own contracts.
- JOHNSTON, M. J.**, Flat 8, 25 Lillimur-road, Ormond, 3204. One commercial goods vehicle (L/C. 120 cwt.) to operate within a 70-mile radius of the premises of "Evans Brothers (Bricks) Pty. Ltd." at Scoresby, solely on behalf of the said company—bricks.
- JONES, R. J.**, 16 Murphy-street, Mansfield, 3722. One commercial goods vehicle (L/C. 267 cwt.) to operate: (a) From forest landings in the Jamieson area to sawmills at Mansfield and Benalla—logs. (b) From private landings in the Mansfield area to sawmills at Yarra Glen and Ringwood—logs.
- JUDD, N. F. & (Mrs.) S. R.**, 2 Neal-court, North Altona, 3025. One commercial goods vehicle (L/C. 206 cwt.) to operate within a 50-mile radius of the premises of "Consolidated Quarries Limited" at Newport, solely on behalf of the said company—premixed concrete in a specially constructed agitator vehicle.
- KEATH, ROBIN, PTY. LTD.**, Hamilton-road, Horsham, 3400. One commercial goods vehicle (L/C. 149 cwt.) to operate throughout that part of the State of Victoria west of a north/south line drawn through the City of Melbourne in the course of business as a "Contractor" for the purpose of operating the vehicle as a "Water Tanker".
- KEEN, J.**, 22 Botanic-road, Warrnambool, 3280. One commercial goods vehicle (L/C. 46 cwt.) to operate within a 75-mile radius of the post office at Warrnambool as a "Road Contractor"—road-making plant and materials.
- KEEN, J., PTY. LTD.**, 22 Botanic-road, Warrnambool, 3280. One commercial goods vehicle (L/C. 58 cwt.) to operate within a 75-mile radius from the post office at Warrnambool as a "Road Contractor"—road-making plant and materials.
- KENNEDY, P., PTY. LTD.**, 27 Oak-street, Wendouree, 3355. One commercial goods vehicle (L/C. 264 cwt.) to operate throughout the State of Victoria in the course of business as "Earthmoving Contractors"—own tools of trade, own plant and own equipment incidental to own contracts.
- KENNEDY, P., PTY. LTD.**, 27 Oak-street, Wendouree, 3355. One commercial goods vehicle (L/C. 212 cwt.) to operate: (a) Within a 50-mile radius from the post office at Ballarat as a "Road Contractor"—road-making plant and materials. (b) Within a 25-mile radius of the post office at Ballarat—general goods.
- KINNERSLY, T.**, 31 Anderson-street, Horsham, 3400. One commercial goods vehicle (L/C. 14 cwt.) to operate: (a) Within a 25-mile radius from the post office at Horsham with the proviso that no one journey shall exceed 30 miles in length—general goods. (b) Within a 50-mile radius from the post office at Horsham—firewood.
- LEMING, J. N.**, Reynolds-street, Mansfield, 3722. One commercial goods vehicle (L/C. 261 cwt.) to operate from forest landings in the Mt. Buller area to Barry's Sawmill at Mansfield—logs.
- MAO, F.**, 357 Barkly-street, Ararat, 3377. One commercial goods vehicle (L/C. 101 cwt.) to operate: (a) Within a 50-mile radius from the post office at Ararat as a "Road Contractor"—roadmaking plant and materials. (b) Within a 25-mile radius of the post office at Ararat with the proviso that no one journey shall exceed 30 miles in length—general goods.
- MANN, W. L. J.**, Box 275, Ballarat, 3350. One commercial goods vehicle (L/C. 100 cwt. approximately) to operate: (a) Within a 50-mile radius of own premises at Ballarat in the course of business as "Distributor"—own aerated waters. (b) Within a 50-mile radius from the post office at Ballarat—petroleum products in prescribed types of containers and empty return containers.
- MAXWELL, H. E.**, Maroondah Highway, Buxton, 3711. One commercial goods vehicle (L/C. 141 cwt.) to operate from Dry Creek to Ruok's sawmills at Alexandra—logs.
- MIDGLEY, O. R. & C. F.**, 9 Bank-street, Port Fairy, 3284. One commercial goods vehicle (L/C. 6 cwt. and 20-cwt. trailer) to operate within that part of the State of Victoria west of a north/south line drawn through Camperdown and south of an east/west line drawn through Cavendish in the course of business as "Hotel-keeper and Caterer"—own catering equipment and victuals with the proviso that wine, spirits and beer are initially consigned by rail to Port Fairy.
- MOOROODUC CO-OP. TRADING SOCIETY LTD.**, Moorooduc, 3933. Application to vary the conditions of licence No. D.A.9889 (L/C. 146 cwt.) by adding to the existing conditions, after the City of Melbourne, "and within a radius of 8 miles thereof".
- MURRAY VALLEY SAWMILLS PTY. LTD.**, North-street, Nathalia, 3638. One commercial goods vehicle (L/C. 248 cwt.) to operate: (a) From own sawmills at Nathalia and Picola to consignees within a 50-mile radius of such mills—sawn timber. (b) From own sawmills at Mansfield to consignees within a 20-mile radius from the post office at Mansfield—sawn timber. (c) From own sawmills at Mansfield to own premises at Nathalia—sawn timber. (d) From own sawmills at Mansfield to consignees in the Shepparton, Nathalia, Numurkah, Kyabram, Echuca, Yarrowonga, Kerang and Cobram areas—sawn timber.
- MYER SOUTHERN STORES LTD.**, 295 Lonsdale-street, Melbourne, 3000. One commercial goods vehicle (L/C. 26 cwt.) to operate: (a) Within a 50-mile radius of the chief post office in the City of Geelong in the course of business as "General Merchants"—own goods (excluding operations to or from the City of Melbourne). (b) Within a 100-mile radius of the chief post office in the City of Geelong (excluding operations to or from Melbourne) for the purpose of installing and/or servicing electrical appliances, floor coverings, curtains and blinds—tools of trade, items for installation, for repair or having been repaired and materials incidental thereto.
- MCCANN, R.**, Barmah, 3639. One commercial goods vehicle (L/C. 43 cwt.) to operate: (1) Within a 20-mile radius of Picola in the course of business as a "Sleeper Cutter"—sleepers. (2) Within a 50-mile radius of Barmah in the course of business as "French Polisher"—articles for french polishing or having been french polished.
- MCGILL, J. B.**, Garfield, 3814. Application to vary the conditions of licence No. D.T.1170 (L/C. 139 cwt.) by deleting from the existing conditions "within a 35-mile radius thereof" and by adding in lieu: "within a 50-mile radius thereof".
- MCMAHON, D. G.**, 22 MacLagan-crescent, Reservoir, 3073. One commercial goods vehicle (L/C. 118 cwt.) to operate within a 70-mile radius from the premises of "Clifton Brick Holdings Ltd." solely on behalf of the said company—bricks.
- MCTAGGARTS OF HAMILTON**, Ballarat-road, Hamilton, 3300. One commercial goods vehicle (L/C. 120 cwt. approximately) to operate: (a) Within a 50-mile radius from the depot of the "Shell Co. of Australia Ltd." at Hamilton in the course of business as "Petroleum Agents"—petroleum products in prescribed types of containers and empty return containers. (b) Within a radius of 30 miles from the post office at Hamilton and to and from the Township of Balmoral serving places *en route*—farm storage tanks and stands subject to the condition that such goods so carried shall only be those having been initially consigned to Hamilton by rail.
- NIUWLAND, S.**, 7 Plunkett-road, Dandenong, 3175. One commercial goods vehicle (L/C. 140 cwt.) to operate within a 50-mile radius of the premises of "Albion Reid Pty. Ltd.", at North Melbourne—road-making plant, materials, premix and hot asphalt on behalf of the said company; excluding the carriage of cement or lime from the Geelong Urban District.
- O'CALLAGHAN, W.**, Box 12, Rutherglen, 3685. One commercial goods vehicle (L/C. 92 cwt.) to operate: (a) Within a 90-mile radius of the post office at Wangaratta (Benalla Division of the C.R.B.)—road contracting plant used in the construction or maintenance of a road, street, footpath, bridge, wharf, pier, weir or channel. (b) Within a 20-mile radius from site of construction or maintenance work performed pursuant to paragraph (a) above or from the railway station nearest thereto—materials required for

- such work. (c) Within a 25-mile radius of the post office at Rutherglen with the proviso that no one journey shall exceed 30 miles in length—general goods.
- O'CONNOR, A. B., 125 Lime-avenue, Mildura, 3500. One commercial goods vehicle (L/C. 8 cwt.) to operate throughout the State of Victoria for the purpose of operating the vehicle as a mortuary unit in the course of business as "Funeral Directors".
- PANAGIOTAKIS, K. & A., 7 Ryland-avenue, Croydon, 3132. One commercial goods vehicle (L/C. 220 cwt.) to operate within a 50-mile radius from the premises of "Albion Reid Pty. Ltd.", at North Melbourne—road-making plant, materials, premix and hot asphalt on behalf of the said company; excluding the carriage of cement or lime from the Geelong Urban District.
- PETERSON, R., 10 Anzac-street, Moe, 3825. One commercial goods vehicle (L/C. 151 cwt.) to operate: (a) From landings within a 20-mile radius of Moe to Ron Andrew's sawmill at Longwarry and Ward's sawmill at Drouin West—logs. (b) Within a 20-mile radius of Moe—own tractor when being moved from logging site to logging site and fuel for operational purposes only.
- PETERSVILLE AUSTRALIA LTD., Wellington-road, Clayton, 3168. One commercial goods vehicle (L/C. 78 cwt.) to operate throughout the State of Victoria as a specially constructed insulated and refrigerated van for the purpose of supplying own distributors with ice-cream, frozen vegetables, frozen fish and frozen poultry at a temperature not exceeding 10 degrees F.
- POWELL'S PEST CONTROL PTY. LTD., 420 St. Kilda-road, Melbourne, 3004. One commercial goods vehicle (L/C. 10 cwt.) to operate throughout the State of Victoria in the course of business as "Pest Control Specialists"—tools of trade, spraying equipment and materials incidental to the completion of own contracts.
- PROPOSCH, V. A. & A. C. (trading as Proposch Bros.), Longwarry, 3816. Application to vary the conditions of licences No. D.A.635, D.A.635/1 and D.A.635/2 (L/C. 279, 260 and 267 cwt.) by deleting from paragraph (a) of the existing conditions: "within a 20-mile radius of the post office at Longwarry" and by adding in lieu: "within a 30-mile radius of the post office at Longwarry" and by adding to paragraph (c) of the existing conditions, after the word "Melbourne" "and within a 30-mile radius of the post office at Longwarry".
- RAITT, L. J., 4 Oliver-avenue, Stawell, 3380. Two commercial goods vehicles (L/C. 7 and 8 cwt.) to operate within a 50-mile radius from the post office at Stawell in the course of business as "Dry Cleaners"—articles for dry-cleaning or having been dry-cleaned.
- READ, H. L., corner Warrigal-road and Fairchild-street, Moorabbin, 3189. Four commercial goods vehicles (L/C. 258, 79, 234 and 133 cwt.) to operate within a 25-mile radius from the chief post office in the cities or towns as the case may be of Melbourne, Geelong, Ballarat, Ballan, Sale and Traralgon in the course of business as "Waste Disposal Contractor"—septic tank effluent and liquid industrial waste.
- REES, F. G. & D. A. (trading as Rees T.V. Service and Sales), 27 King-street, Boort, 3537. One commercial goods vehicle (L/C. 11 cwt.) to operate within a radius of 75 miles from the post office at Boort in the course of business as "Electrical Retailer"—uncrated refrigerators, uncrated washing machines, uncrated television sets, television aeriels and electrical appliances for specialized installation, for repair or having been repaired, also tools of trade, spare parts and materials incidental to installing, servicing and maintaining such appliances and equipment.
- RUSSELL, J. A. & M. A., Campbell-street, Garfield, 3814. One commercial goods vehicle (L/C. 139 cwt.) to operate within a 50-mile radius from the post office at Garfield as a "Road Contractor"—road-making plant and materials.
- RYAN EQUIPMENT CO. PTY. LTD., Box 148, Shepparton, 3630. One commercial goods vehicle (L/C. 110 cwt. approximately) to operate: (a) Within a 50-mile radius of own premises at Shepparton in course of business as "Primary Producer"—own goods. (b) Within a 50-mile radius from the post office at Shepparton in course of business as "Machinery Dealer"—used farm and earthmoving machinery. (c) Within a 25-mile radius from the post office at Shepparton with the proviso that no one journey shall exceed 30 miles in length—general goods.
- SAND SUPPLY CO. PTY. LTD., Centre-road, South Oakleigh, 3167. One commercial goods vehicle (L/C. 151 cwt.) to operate: (a) Within a 25-mile radius of the G.P.O. Melbourne in course of business as "Quarry Masters"—own goods. (b) Within a 35-mile radius of the G.P.O. Melbourne in course of business as "Quarry Masters"—own screenings, own sand and own quarry products.
- SAUNDERS, N., 106 Hume-street, Mulwala, N.S.W., 2647. Two commercial goods vehicles (L/C. 10 cwt. each) to operate within a 50-mile radius of the post office at Yarrowonga in the course of business as "Painter and Signwriter"—tools of trade, equipment and a small quantity of paint and materials incidental to own contracts.
- SCHULTZ, R. L., Warracknabeal-road, Dimboola, 3414. One commercial goods vehicle (L/C. 10 cwt.) to operate within a 75-mile radius from the post office at Dimboola in the course of business as "Pest Exterminator"—tools of trade, equipment and a small quantity of materials incidental to the completion of own contracts, with the proviso that all supplies of concentrated chemicals be initially consigned by rail to Dimboola.
- SINGER (AUST.) LTD., 45 Pall Mall, Bendigo, 3550. One commercial goods vehicle (L/C. 10 cwt.) to operate within a 70-mile radius from the chief post office in the City of Bendigo, for the purpose of delivering and servicing sewing machines—sewing machines, tools of trade, spare parts and materials incidental thereto.
- SKYFARMERS PTY. LTD., 42 George-street, Morwell, 3840. One commercial goods vehicle (L/C. 121 cwt.) to operate within a 50-mile radius from the post office at Morwell and to and from places situated on the Mornington Peninsula south of a line drawn east and west through the Township of Frankston in the course of business as "Aerial Spraying Contractor"—tools of trade, equipment, spare parts for servicing, fuel for operational purposes and small quantities of materials incidental to own spraying contracts.
- SLATER, A. M., 29 Caledonia-crescent, Springvale North, 3170. One commercial goods vehicle (L/C. 140 cwt.) to operate within a 35-mile radius from the G.P.O., Melbourne, solely on behalf of "Consolidated Quarries Limited"—screenings, sand and quarry products.
- STOCKDALE EXPLORATION LTD., Suite 1309, 447 Collins-street, Melbourne, 3000. One commercial goods vehicle (L/C. 18 cwt.) to operate throughout the State of Victoria in the course of mineral exploration—tools of trade, equipment and allied exploration materials and samples of minerals or earth excavated.
- TETLEY, F. E., Golden Fleece Road House, Buxton, 3711. Application to vary the conditions of licence number D.A.60257 (L/C. 134 cwt.) by deleting the existing conditions and by adding in lieu: "From the sawmill of M. Fieglin & Son Pty. Ltd., at Mansfield to the premises of the above named at Nunawading—sawn timber."
- THOMSON, B. G., Verney-road, Shepparton, 3630. One commercial goods (vehicle to be purchased) to operate: (a) From distributors in Melbourne to car dealers within a 25-mile radius from the post office at Shepparton—new cars. (b) From garages within a 25-mile radius from the post office at Shepparton to used car dealers in Melbourne—used cars.
- THOR INDUSTRIES PTY. LTD., Slater-parade, East. Keilor, 3042. One commercial goods vehicle (L/C. 30 cwt.) to operate: (a) Within a 50-mile radius from the post office at East Keilor in the course of business as "Septic Tank Manufacturers"—own goods. (b) Within a 70-mile radius of the post office at Keilor East for the purpose of preparing sites for the installation of septic tanks—tools of trade, digging equipment and materials incidental thereto.
- TOMASIC, J. & M., 38 Granthome-street, Shepparton, 3630. One commercial goods vehicle (L/C. 134 cwt.) to operate: (a) Within a 50-mile radius of the post office at Shepparton as a Road Contractor—road-making plant and materials. (b) Within a 25-mile radius of the post office at Shepparton with the proviso that no one journey shall exceed 30 miles in length—general goods.
- TOORALAC MILK PRODUCTS PTY. LTD., Beach-road, Toora, 3962. One commercial goods vehicle (L/C. 208 cwt.) to operate solely on behalf of the applicant's wholly owned subsidiary company Tooralac Milk Products Pty. Ltd. at Toora being an approved decentralized secondary industry: (a) Bulk milk and cream to the said factory at Toora and concentrated milk from Toora to Melbourne. (b) From the premises of the said company at Toora to the premises of primary producers from which milk or cream is collected—empty milk and cream cans and general goods. (c) Between Toora and Melbourne and Toora and South Gippsland areas—goods and material associated with the manufacture of milk products and manufactured milk products.

TRANSVIC CONTRACTORS PTY. LTD., 185 Lygon-street, Carlton, 3053. One commercial goods vehicle (L/C. 11 cwt.) to operate throughout the State of Victoria for the purpose of servicing and maintaining own earth-moving equipment in the course of business as "Earth-moving Contractor"—tools of trade, spare parts and materials incidental thereto.

TULLOCH, W. K., & J. S., PTY. LTD., 36 St. Georges-crescent, Ashburton, 3147. One commercial goods vehicle (L/C. 11 cwt.) to operate throughout the State of Victoria for the purpose of installing and maintaining petrol pumps, tanks and bowsers on behalf of "Caltex Oil Co. Pty. Ltd."—fittings, tools of trade, spare parts and equipment incidental to such installation and maintenance.

VALENCIC, S. & V., 52 Grange-road, Alphington, 3078. One commercial goods vehicle (L/C. 232 cwt.) to operate within a 50-mile radius from the premises of "Albion Reid Pty. Ltd.", at North Melbourne—roadmaking plant, materials, premix and hot asphalt on behalf of the said company; excluding the carriage of cement or lime from the Geelong Urban District.

VICKERS, E. M. (MRS.), & C. E., Curdie Vale, 3277. One commercial goods vehicle (L/C. 266 cwt.) to operate: (a) Within a 50-mile radius from the post office at Curdie Vale as a Road Contractor—roadmaking plant and materials. (b) Within a 25-mile radius from the post office at Curdie Vale with the proviso that no one journey shall exceed 30 miles in length—general goods.

WESTERN DISTRICT TYRE SERVICE, High-street, Lismore, 3324. Two commercial goods vehicles (L/C. 10 and 18 cwt.) to operate within a 50-mile radius of own premises in the Township of Lismore in the course of business as "Tyre Distributors and Repairers"—tyres for repair or having been repaired, tyres for retreading or having been retreaded, tubes for repair or having been repaired, new tyres, batteries and motor car accessories.

WILLIAMS, W. J., 2 Cranwell-court, North Springvale, 3170. One commercial goods vehicle (L/C. 13 cwt.) to operate from and to the City of Melbourne and from the coastal areas of the State of Victoria in the course of business as a "Professional Diver and Fisherman"—tools of trade and equipment, fish, shellfish, crayfish, shells and seaweed.

WILSON, W. D., & L. M., 3 Fairview-street, Traralgon, 3844. Application to vary the conditions of licence number T.D.A.47237/6 (L/C. 16 cwt.) by adding to the existing conditions an additional paragraph (e): "(e) From Lakes Entrance to Bairnsdale and from Bairnsdale to Sale—fish bait."

WIZEL, M., Flat 4, 29 Spencers-street, St. Kilda, 3182. One commercial goods vehicle (L/C. 9 cwt.) to operate throughout the State of Victoria in the course of business as "Hawker"—own drapery subject to the condition that any goods so carried shall not be supplied to retail stores for resale.

WRIGHT STEPHENSON & CO. LTD., 330 St. Kilda-road, Melbourne, 3004. One commercial goods vehicle (L/C. 77 cwt.) to operate within a 50-mile radius from own branch premises at Heywood in the course of business as "Wholesale and Retail Merchants"—own goods.

YARRA VALLEY TYRE CO. PTY. LTD., 50 Maroondah Highway, Ringwood, 3134. One commercial goods vehicle (L/C. 20 cwt.) to operate within a 50-mile radius of own premises at Ringwood in the course of business as "Tyre Retreaders and Distributors" new and second-hand tyres and tubes, used tyres and tubes for repair and/or retread or having been repaired or retreaded, batteries, oil and motor car accessories.

YOUNG & WRIGHT, 63 Whatley-street, Carrum, 3197. Application to vary the conditions of licence number D.A.61081 (L/C. 50 cwt.) by adding to the existing conditions, after the words "new and second-hand furniture"—"lino, underfelt and carpets".

YOUNG, W. H. & SONS (PLANT HIRE) PTY. LTD., 182 High-street, Shepparton, 3630. One commercial goods vehicle (L/C. 120 cwt. approx.) to operate: (a) Within a 50-mile radius from the post office at Shepparton as a "Road Contractor"—roadmaking plant and materials. (b) Within a 25-mile radius from the post office at Shepparton with the proviso that no one journey shall exceed 30 miles in length—general goods.

TOW TRUCKS.

PIERA, V. L. (trading as Donald Panel Service), 11 Aitken-avenue, Donald, 3480. One commercial goods vehicle (to be constructed) to operate throughout the State of Victoria as a Tow Truck solely: (a) For the

purpose of lifting and carrying or towing motor cars and the carriage of tools and equipment necessary for such purposes only. (b) The carriage of spare parts necessary for repair of a disabled motor to and from the place at which such disablement has occurred.

GLOBE MOTOR BODY WORKS AND ENGINEERING, cnr. Albion and Harrison streets, East Brunswick, 3057. One commercial goods vehicle (to be purchased) to operate within a 50-mile radius from own premises at East Brunswick as a Tow Truck: (a) For the purpose of lifting and carrying or towing motor cars and the carriage of tools and equipment necessary for such purposes only. (b) The carriage of spare parts necessary for the repair of a disabled motor to and from the place at which such disablement has occurred.

RENEWALS.

APPLICATIONS for renewal of licences as shown by persons listed hereunder to operate under the same terms and conditions from the expiry shown in each case.

ADAMS, WILLIAM, TRACTORS PTY. LTD., Nantilla-road, Clayton North, 3168; D.A.512/9; 12th February, 1968; 11 cwt.

ADDRESSOGRAPH MULTIGRAPH OF AUST. PTY. LTD., 411 Swanston-street, Melbourne, 3000; D.A.2118; 12th February, 1968; 9 cwt.

ALLAN, J. & D., 12 Chicago-street, Maribyrnong, 3032; D.A.48900, D.A.48900/1, D.A.48900/2; 29th April, 1967; 68 cwt.

AUSTRALIAN GYPSUM LTD., 340 Queen-street, Melbourne, 3000; D.A.46341/3; 1st June, 1967; 198 cwt.

BALLARAT DEEP FREEZE FOOD CO. PTY. LTD., 21 Grenville-street north, Ballarat, 3350; T.D.A.39041/5; 21st December, 1967; 76 cwt.

BALTIC SIMPLEX MACHINERY CO. PTY. LTD., 210 Hall-street, Spotswood, 3015; D.A.37341/6; 22nd February, 1967; 11 cwt.

BASINSKI, O. E., 8 Ailsa-court, Greythorn, 3104; D.A.38337; 2nd February, 1968; 209 cwt.

BAYVIEW QUARRIES PTY. LTD., 83 Riversdale-road, Hawthorn, 3122; D.A.44014/146; 3rd February, 1968; 132 cwt.

BELL, C. G., 32 Ivan-avenue, Edithvale, 3196; D.A.38498; 22nd February, 1968; 10 cwt.

BIGGER, D. A. & J. I., 20 Drummond-street, Chadstone, 3148; D.A.38554; 22nd February, 1968; 16 cwt.

BISHOP, R. A., 9 Victory-boulevard, Ashburton, 3147; D.A.51168; 3rd February, 1968; 134 cwt.

BRIDGES, H. J., 37 Bishop-street, Box Hill, 3128; D.A.50810; 17th February, 1968; 20 cwt.

CHASEMORE, G. F., 110 Greythorn-road, North Balwyn, 3104; D.A.38526; 22nd February, 1968; 140 cwt.

E.I.L. SERVICE PTY. LTD., 161 Sturt-street, South Melbourne, 3205; D.A.30374/18; 2nd February, 1967; 11 cwt.

F.M.C. (AUSTRALIA) LTD., 58 Whiteside-road, Clayton, 3168; D.A.50816/3; 12th February, 1968; 73 cwt.

FEIGLIN, M., & SON PTY. LTD., Station-street, Nunawading, 3131; D.A.1066/2; 2nd February, 1968; 10 cwt.

FRIGRITE MANUFACTURING PTY. LTD., 525 Graham-street, Port Melbourne, 3207; D.A.28162/17; 17th February, 1968; 80 cwt.

GARNAR & SON PTY. LTD., 28 Walker-street, Dandenong, 3175; D.A.38131/2; 22nd February, 1967; 10 cwt.

GENERAL MOTORS-HOLDEN'S PTY. LTD., Princes Highway, Dandenong, 3175; D.A.27925/53; 17th February, 1968; 11 cwt.

GRILLO, R., 58 Maxweld-street, Ardeer, 3022; D.A.38549; 22nd February, 1968; 15 cwt.

HILL, C. H., "Upalong", Ridge-road, Mt. Dandenong, 3767; D.A.24637; 13th February, 1968; 10 cwt.

HOADLEY'S CHOCOLATES LTD., 99 Coventry-street, South Melbourne, 3205; D.A.1308/8; 3rd February, 1968; 48 cwt.

HOGAN, (M/s) A. K., 31 Chifley-drive, Maribyrnong, 3032; D.A.28205/1; 2nd February, 1968; 13 cwt.; D.A.28205/2; 17th February, 1968; 10 cwt.

INSTRUMENT ENGINEERING SERVICE PTY. LTD., 111-113 George-street, Fitzroy, 3065; D.A.8168/1; 2nd February, 1968; 10 cwt.

JENNINGS, C. J. & C. G., Box 21, Rye, 3941; D.A.1375/5; 17th February, 1968; 130 cwt.

JONES, D. W., PTY. LTD., 126 Cecil-street, Williamstown, 3016; D.A.1392/16; 17th February, 1968; 147 cwt.

JOSEPH, K. M., & CO. PTY. LTD., Box 36, Prahran, 3181; D.A.38452; 2nd February, 1968; mobile crane.

JOSEPH, K. M., & CO. PTY. LTD., Box 36, Prahran, 3181; D.A.38452/1; 2nd February, 1968; 7 cwt.

JOSEPH, K. M., & Co. PTY. LTD., Box 36, Prahran, 3181; D.A.38452/2; 2nd February, 1968; 40 cwt.; D.A.38452/3; 2nd February, 1968; 35 cwt.; D.A.38452/4; 2nd February, 1968; 60 cwt. approximately.

JOSEPH, K. M., & Co. PTY. LTD., Box 36, Prahran, 3181; D.A.38452/5; 2nd February, 1968; post hole digger.

KELVINATOR AUSTRALIA LTD., 487 Williamstown-road, Port Melbourne, 3207; D.A.1420/6; 3rd February, 1968; 24 cwt.; D.A.1420/7; 3rd February, 1968; 15 cwt.; D.A.1420/8; 3rd February, 1968; 14 cwt.; D.A.1420/9; 3rd February, 1968; 15 cwt.; D.A.1420/10; 3rd February, 1968; 24 cwt.; D.A.1420/11; 10th February, 1968; 14 cwt.; D.A.1420/12; 10th February, 1968; 23 cwt.

KIMPTON, W. S., & SONS PTY. LTD., 143 Queen-street, Melbourne, 3000; D.A.6317/2; 22nd February, 1968; 113 cwt.

MALKIN TRANSPORT PTY. LTD., Yuilles-road, Mornington, 3931; D.A.61046/4; 3rd February, 1968; 77 cwt.

MASONRY VENEER PTY. LTD., 263 North-road, Huntingdale, 3166; D.A.51505; 3rd February, 1968; 130 cwt.

MILES PAINT SERVICE PTY. LTD., 1032 Dandenong-road, Carnegie, 3163; D.A.41523/32; 3rd February, 1968; 10 cwt.

MULQUEEN & SONS PTY. LTD., 170 Sydney-road, Brunswick, 3056; D.A.3594/4; 17th February, 1968; 8 cwt.

N. & C. TRANSPORT CO. PTY. LTD., Ocean Beach-road, Sorrento, 3943; D.A.35734/1; 8th December, 1967; 71 cwt.

PEATEY, A. H., PTY. LTD., 429 Albert-street, Brunswick, 3056; D.A.37963; 22nd February, 1968; 125 cwt.

PEGORARO, F., & B. CERVI, 83 Palmerston-street, Carlton, 3053; D.A.10231/4; 17th February, 1968; 119 cwt.

PHOENIX BISCUIT CO. PTY. LTD., Grosvenor-street, Abbotsford, 3067; D.A.39491/6; 17th February, 1968; 6 cwt.

REPLACEMENT PARTS PTY. LTD., 618 Elizabeth-street, Melbourne, 3000; D.A.1907/19; 22nd February, 1968; 11 cwt.

RODGERS, R. L., 4 Harry-street, Thornbury, 3071; D.A.27484/3; 22nd February, 1968; 25 cwt.

RODKIN, G., 69 Russell-crescent, Doncaster East, 3109; D.A.51347; 10th February, 1968; 149 cwt.

STEVENSON, H. F., PTY. LTD., 10 Duffy-street, Burwood, 3125; T.D.A.2111/6; 11th February, 1968; 78 cwt.

TOWNLEY, R. G., Rossiter-road, Koo-Wee-Rup, 3981; D.A.43295/4; 17th February, 1968; 234 cwt.

UNDERWOOD, R., Caramut, 3274; D.A.51144; 27th January, 1968; 123 cwt.

VICTORIAN OATGROWERS POOL & MARKETING CO. LTD., 528 Lonsdale-street, Melbourne, 3000; D.A.37995/4; 17th February, 1968; 11 cwt.; D.A.37995/5; 17th February, 1968; 10 cwt.

TOW TRUCK RENEWALS.

ZUKANOVIC, R. (trading as Opslan Motors), Duncans-road, Werribee South, 3030; D.A.50195; 5th November, 1967; 32 cwt.

SERVIS PANEL WORKS, 282 South-road, Moorabbin, 3189; D.A.47362/2; 17th December, 1967; 40 cwt.

STRATHMORE MOTOR BODY & ENG. CO., 981 Mt. Alexander-road, Essendon, 3040; D.A.46475/2; 3rd February, 1968; 70 cwt.

TOWN & COUNTRY TOWING SERVICE, 378 Mt. Alexander-road, Ascot Vale, 3032; D.A.35191/5; 3rd February, 1968; 70 cwt.

UNITED USED VEHICLES PTY. LTD., 517 Bridge-road, Richmond, 3121; D.A.38568; 22nd February, 1968; 75 cwt.

RENEWALS WITH VARIATION.

APPLICATION by the persons listed hereunder for renewal of the licences listed with variation of conditions in the manner set out opposite the names.

PEARSE BROS., 2 Marks-street, Bendigo, 3550; D.A.38064/1; 11th January, 1968; application to renew and vary the conditions of licence No. D.A.38064/1 (L/C. 80 cwt.) by adding to the existing conditions, after the words "plaster sheets", plaster board.

BYRDEN, P., 236 North-road, Huntingdale, 3166; D.A.38563; 22nd February, 1968; application to renew and vary the conditions of licence No. D.A.38563 (L/C. 198 cwt.) by deleting from the existing conditions "Moorabbin" and by adding in lieu: "Oakleigh".

BYRDEN, P. & M., 236 North-road, Huntingdale, 3166; D.A.38563/1; 17th February, 1968; application to renew and vary the conditions of licence No. D.A.38563/1 (L/C. 200 cwt.) by deleting from the existing conditions "the premises of Specified Concrete (Vic.) Pty. Ltd. at Moorabbin" and by adding in lieu: "the premises of Specified Concrete (Vic.) Pty. Ltd. at Oakleigh".

TOW TRUCK RENEWAL WITH VARIATION.

A.S.A. TOWING PTY. LTD. (trading as A.A.A. Towing Service), 46 Connell-road, Oakleigh, 3166; T.D.A.46939/3; 18th February, 1968; application to renew and vary the conditions of licence No. T.D.A.46939/3 (L/C. 32 cwt.) by deleting from the existing conditions; "within a radius of 20 miles from the post office at Hughesdale" and by adding in lieu: "throughout the State of Victoria".

Notice of any objections should be forwarded to reach the Secretary of the Board not later than Wednesday, 3rd January, 1968.

Applicants are advised that it will not be necessary to appear on the hearing date specified above, unless advised in writing by the Board.

B. P. KAY,
Secretary.

Corner Lygon and Princes streets, Carlton, 3053,
20th December, 1967.

Dairy Products Act.

QUOTAS FOR BUTTER AND CHEESE.

BUTTER QUOTA.

I, GILBERT LAWRENCE CHANDLER, Minister of Agriculture in the State of Victoria, after consultation with the Victorian Dairy Products Board, and after ascertaining that the supply and distribution of butter at reasonable prices to consumers thereof in Victoria will be ensured, hereby determine a quota for butter as follows:—

The proportion shall be Fifty point one four per centum.

The period for which this quota is to operate shall be the month of January, 1968.

CHEESE QUOTA.

I, GILBERT LAWRENCE CHANDLER, Minister of Agriculture in the State of Victoria, after consultation with the Victorian Dairy Products Board, and after ascertaining that the supply and distribution of cheese at reasonable prices to consumers thereof in Victoria will be ensured, hereby determine a quota for cheese as follows:—

The proportion shall be Forty-four point five five per centum.

The period for which this quota is to operate shall be the month of January, 1968.

G. L. CHANDLER,
Minister of Agriculture.

Marketing of Primary Products Act 1958.

ELECTION NOTICE—THE EGG AND EGG PULP MARKETING BOARD.

PURSUANT to the provisions of section 38 of the *Marketing of Primary Products Act 1958*, I hereby give notice that I have appointed Saturday the 9th March, 1968 as the date for the purpose of calculating eligibility of producers to vote at an election of one producers' representative on The Egg and Egg Pulp Marketing Board, to be held during the month of May 1968.

G. L. CHANDLER,
Minister of Agriculture.

12th December, 1967.

LOCAL GOVERNMENT DEPARTMENT.

ORDER CONFIRMED.—SHIRE OF ARARAT.

THE Minister of the Crown administering the *Local Government Act 1958*, as amended, on the 14th day of December, 1967, confirmed the Order hereinafter referred to in pursuance of Section 514 of the said Act, namely:

An Order of the Council of the Shire of Ararat made on the 20th November, 1967, directing the compulsory taking of the land described in certificate of title, volume 3071, folio 052, as a place of public resort or recreation.

R. J. HAMER,
Minister for Local Government.

Local Government Department,
Melbourne. (1061311).

MELBOURNE AND METROPOLITAN BOARD OF WORKS
ACT 1958.

BY-LAW NO. 93—WATER SUPPLY RESTRICTIONS.

THE Melbourne and Metropolitan Board of Works (hereinafter called "the Board"), pursuant to and in exercise and execution of the powers and authorities conferred on such Board by the *Melbourne and Metropolitan Board of Works Act 1958* and in exercise and execution of any other powers and authorities in any way enabling the Board in that behalf, doth make the By-law following:—

1. By-law No. 61 made and passed by the Board on the 21st day of September, 1954, and gazetted on the 29th day of September, 1954, and By-law No. 85 made and passed by the Board on the 11th day of December, 1962, and gazetted on the 12th day of December, 1962, are hereby repealed as from the date of the coming into operation of this By-law.

2. In this By-law unless inconsistent with the subject matter or context—

(a) "The Act" means the *Melbourne and Metropolitan Board of Works Act 1958* and any Act amending the same.

"The Chairman" means the Chairman of the Board for the time being.

"The Secretary" means the Secretary of the Board for the time being or the Acting Secretary of the Board for the time being and shall also mean and include any other Officer or person appointed by the Board for the purpose of exercising the powers of the Secretary under this By-law.

"Municipal District" means a municipal district or so much thereof as lies within the metropolis.

"Daily Newspaper" means "The Age" "Herald" "Sun" or other daily newspaper circulating in the metropolis.

"Period" means a succession of days whether broken or not commencing at a specified hour of a specified day and concluding at a specified hour of a specified day or at such hour of such day as shall subsequently be declared.

"Period of Restriction" means a period of control of peak use of water, a period of controlled use of water, a period of restricted use of water, a period of limited use of water, a period of reduced use of water, a period of severely reduced use of water or a period of more severely reduced use of water whichever be declared in terms of this By-law.

"Garden" means any ground used for the cultivation of or in which are situate trees shrubs flowers vegetables lawns or vegetation of any kind but shall not include a market garden or a nursery.

"Private Garden" means a garden appurtenant to a building used for domestic, commercial or industrial purposes and shall include any part of the curtilage in which the private garden is situate which is used or adapted for use for the purposes of any sport game or other form of recreation and any nature strip appurtenant to such curtilage.

"Market Garden" means any ground used wholly for the growing for sale any vegetables fruit seedlings seeds or flowers.

"Nursery" means any land devoted to the cultivation of trees shrubs flowers seeds and seedlings either for sale or for use or distribution by some body (whether corporate or not) other than for profit.

"Sports Ground" means any ground used or adapted for use for the purpose of any sport game contest or other form of recreation by any club school institution or like organization or by any person normally conducting any sport game contest or other form of recreation upon such ground for gain or reward.

"Vehicle" includes a motor car and a trailer as defined in the *Motor Car Act 1958* and a caravan and for the purposes of this By-law shall include a boat.

(b) The expression "person" shall include a corporation unless there is something repugnant to or inconsistent with that interpretation.

(c) Words importing the masculine gender shall be deemed and taken to include females, and the singular to include the plural, and the plural the singular, unless the contrary as to gender or number is expressly provided.

3. If in the opinion of the Chairman or in his absence of the Secretary it is necessary to reduce the consumption of water supplied by the Board within the whole of the metropolis or within any municipal district or municipal districts comprised therein the Chairman or the Secretary (as the case may be) may at any time and from time to time declare that in respect to the metropolis or in respect to such municipal district or municipal districts as are specified in the declaration—

- (a) any period to be a period of control of peak use of water;
- (b) any period to be a period of controlled use of water;
- (c) any period to be a period of restricted use of water;
- (d) any period to be a period of limited use of water;
- (e) any period to be a period of reduced use of water;
- (f) any period to be a period of severely reduced use of water; or
- (g) any period to be a period of more severely reduced use of water.

4. If during any period of restriction the Chairman or in his absence the Secretary is of the opinion that (having regard to the water supply then available) less severe or more severe (as the case may be) restrictions upon the use of water supplied by the Board should be imposed within the whole of the metropolis or within any municipal district or municipal districts specified in a declaration made pursuant to Clause 3 hereof he may in respect to the metropolis or with respect to any municipal district or municipal districts—

- (a) Terminate such period of restriction and may declare that the period from the time of termination to be a period of restriction other than that terminated.
- (b) Without terminating such period of restriction may declare any immediately ensuing period to be a period of restriction.

5. (1) Any declaration made pursuant to Clause 3 or Clause 4 hereof shall be in the form or to the effect set forth in the Schedule hereto and where made during the currency of any period of restriction an appropriate reference to the termination or effluxion of such period of restriction shall be contained in such declaration and such declaration shall be signed by the Chairman or the Secretary (as the case may be) and shall be published in a daily newspaper and subject to such publication shall take effect as provided in the declaration.

(2) To each declaration published in a daily newspaper pursuant to sub-clause (1) hereof there shall be appended such portion of Clause 6 hereof as shall be applicable having regard to such declaration.

6. Water supplied by the Board—

(1) During any period declared to be a period of control of peak use of water shall between the hours of 5 p.m. and 9 p.m. of each day be used for the watering of any garden or sports ground only by means of a hose or a watering can or other similar container held in the hand.

(2) During any period declared to be a period of controlled use of water shall be used for the watering of gardens and of sports grounds only by means of a watering can or hose held in the hand except between the hours of 7 a.m. and 10 a.m. on each day during which period water may be used for any such purpose by means of a hose not held in the hand.

(3) During any period declared to be a period of restricted use of water—

(a) Shall be used for the watering of gardens or sports grounds only by means of a watering can or other similar container held in the hand except between the hours of 6 a.m. and 9 a.m. and 5.30 p.m. and 8.30 p.m. each day during which periods water may be used for any such purpose by means of a hose held in the hand.

(b) Shall be used for the washing of a vehicle only by means of a bucket or other similar container unless—

(i) the cleaning of the vehicle is necessary for the purpose of public health and it has been established to the satisfaction of the Board that such vehicle can only be properly cleaned by the means of a hose; or

- (ii) the washing of vehicles is carried out for fee or reward by a vehicle cleaning establishment which has made provision for the recirculation of the cleaning water.
- (c) Shall not be used for filling or adding to or replacing water in any swimming pool or wading pool or other than a pool to which members of the public are admitted unless the Board having regard to considerations of health or of the structural safety of the pool has given prior consent in writing to such use.
- (d) Shall be used for the washing of drives, paths, walks, paved surfaces or buildings only by means of a watering can or other similar container held in the hand unless the washing is such as is necessary in the interests of public health or is required for the construction of any buildings or works.
- (e) Shall not be used for filling tankers unless such water is required for flushing of streets gutters or drains for public health purposes, for watering public gardens, and trees situate in or along any thoroughfare during the hours prescribed in paragraph (a) hereof or for construction purposes on buildings or other works.
- (f) Shall not be used for the operation of any fountains, whether public or private, whether recirculated or not.
- (4) During any period declared to be a period of limited use of water—
- (a) Shall be used for the watering of a private garden only by means of a watering can or other similar container held in the hand except between the hours of 7 p.m. and 8 p.m. each day during which period water may be used for such purpose by means of a hose held in the hand.
- (b) Shall be used for the watering of any garden (other than a private garden) or any sports grounds only by means of a watering can or other similar container held in the hand except between the hours of 7 a.m. and 9 a.m. each day during which period water may be used for any such purpose by means of a hose held in the hand.
- (c) Shall be used for the washing of a vehicle only by means of a bucket or other similar container unless—
- (i) the cleaning of the vehicle is necessary for the purpose of public health and it has been established to the satisfaction of the Board that such vehicle can only be properly cleansed by the means of a hose; or
- (ii) the washing of vehicles is carried out for fee or reward by a vehicle cleaning establishment which has made provision for the recirculation of the cleaning water.
- (d) Shall not be used for filling or adding to or replacing water in any swimming pool or wading pool or other than a pool to which members of the public are admitted unless the Board having regard to considerations of health or of the structural safety of the pool has given prior consent in writing to such use.
- (e) Shall be used for the washing of drives, paths, walks, paved surfaces or buildings only by means of a watering can or other similar container held in the hand unless the washing is such as is necessary in the interests of public health or is required for the construction of any buildings or works.
- (f) Shall not be used for filling tankers unless such water is required for flushing of streets gutters or drains for public health purposes, for watering public gardens, and trees situate in or along any thoroughfare during the hours prescribed in paragraph (a) hereof or for construction purposes on buildings or other works.
- (g) Shall not be used for the operation of any fountains whether public or private and whether recirculated or not.
- (5) During any period declared to be a period of reduced use of water—
- (a) Shall not be used for the watering by any means whatsoever of lawns or other grass areas wheresoever the same may be situate unless such water shall have first been used for some domestic commercial or industrial purpose and cannot again be so used.
- (b) Shall be used for the watering of garden beds shrubs and trees within a private garden only by means of a watering can or other similar container held in the hand except that between the hours of 7 p.m. and 8 p.m. on such of the days prescribed hereunder as may be applicable having regard to the numbering to the frontage or to the situation of the premises in which a private garden is situate water supplied by the Board may be used for the watering of garden beds shrubs and trees within such private garden by means of a hose held in the hand provided that not more than one hose is at any time used within such garden—
- (i) Sunday, Tuesday and Thursday of each week—
Where houses and buildings are numbered such houses or buildings as have odd numbers—
Where houses and buildings are not numbered such houses or buildings as are situate in a court, cul-de-sac, crescent, or quadrant, or where not so situate, have a frontage generally facing north or a frontage generally east;
- (ii) Monday, Wednesday and Saturday of each week—
Where houses and buildings are numbered such houses or buildings as have even numbers—
Where houses and buildings are not numbered such houses or buildings as have a frontage generally facing south or a frontage generally facing west.
- (c) May be used for the watering by means of a hose held in the hand of garden beds shrubs and trees situate in a garden other than a private garden between the hours of 7 a.m. and 9 a.m. on Monday, Wednesday and Friday of each week provided that trees and shrubs situate in The Royal Botanic Gardens may be watered by means of a hose held in the hand during the hours of 7 a.m. and 10 a.m. any day other than Saturday or Sunday.
- (d) Shall be used for the watering of any sports grounds only by means of a watering can or other similar container held in the hand except that to the extent hereinafter prescribed water may be used by means of a hose or hoses held in the hand between the hours of 7 a.m. and 8 a.m. on each day other than Tuesday and Saturday of each week for—
- (i) Trees and shrubs comprised in any sports ground;
- (ii) Cricket grounds—wicket area only;
- (iii) Golf courses—greens only;
- (iv) Bowling clubs, Trugo and Croquet clubs—greens only;

- (v) Tennis courts other than courts situate in a private garden—play surface only;
- (vi) Athletic grounds—running tracks and surfaces used for field games only.
- (e) For watering the running tracks of a race course within the metropolitan area by means of a hose or hoses held in the hand only between the hours of 7 a.m. and 8 a.m. on each day other than Tuesday and Saturday of each week.
- (f) For watering of market gardens and nurseries by means of existing reticulation or a hose or hoses not held in the hand only between the hours of 5 a.m. and 8 p.m. each day.
- (g) For watering land used for the growing of green feed by a commercial poultryman or for the cooling of a building in which poultry is kept for commercial purposes by means of existing reticulation or a hose or hoses not held in the hand only between the hours of 5 a.m. and 8 p.m. each day.
- (h) Shall not be used for filling or adding to the contents of any dam tank or like container situate upon premises used for any agricultural, horticultural commercial or industrial purpose unless the prior written authority of the Board is first obtained.
- (i) Shall be used for the washing of a vehicle only by means of a bucket or other similar container unless—
- (i) the cleaning of the vehicle is necessary for the purpose of public health and it has been established to the satisfaction of the Board that such vehicle can only be properly cleaned by the means of a hose; or
 - (ii) the washing of vehicles is carried out for fee or reward by a vehicle cleaning establishment which has made provision for the recirculation of the cleaning water.
- (j) Shall not be used for filling or adding to or replacing water in any swimming pool or wading pool other than a pool to which members of the public are admitted unless the Board having regard to considerations of health or of the structural safety of the pool has given prior consent in writing to such use.
- (k) Shall be used for the washing of drives, paths, walks, paved surfaces or buildings only by means of a watering can or other similar container held in the hand unless the washing is such as is necessary in the interests of public health or is required for the construction of any buildings or works.
- (l) Shall not be used for filling tankers unless such water is required for flushing of streets gutters or drains for public health purposes, for watering public gardens, and trees situate in or along any thoroughfare during the hours prescribed in paragraph (b) hereof or for construction purposes on buildings or other works.
- (m) Shall not be used for the operation of any fountains whether public or private and whether recirculated or not.
- (6) During any period declared to be a period of severely reduced use of water—
- (a) Shall not be used for the watering by any means whatsoever of lawns or other grass areas wheresoever the same may be situate unless such water shall have first been used for some domestic, commercial or industrial purpose and cannot again be so used.
 - (b) Shall be used for watering garden beds shrubs and trees situate within any garden only by means of a watering can or other similar container held in the hand except that garden beds shrubs and trees situate in any garden not being a private garden may be watered by means of a hose held in the hand between the hours of 7 a.m. and 9 a.m. on Monday, Wednesday and Friday of each week.
- (c) Notwithstanding anything hereinbefore contained trees and shrubs situate in The Royal Botanic Gardens may be watered by means of a hose or hoses held in the hand between the hours of 7 a.m. and 10 a.m. any day other than Saturday or Sunday.
- (d) Shall be used for the watering of any sports grounds only by means of a watering can or other similar container held in the hand except that to the extent hereinafter prescribed water may be used by means of a hose or hoses held in the hand between the hours of 7 a.m. and 8 a.m. each day other than Tuesday and Saturday for—
- (i) Trees and shrubs comprised in any sports ground;
 - (ii) Cricket grounds—wicket area only;
 - (iii) Golf courses—greens only;
 - (iv) Bowling clubs Trugo and Croquet Clubs—greens only;
 - (v) Tennis Courts other than courts situate in a private garden—play surface only;
 - (vi) Athletic grounds—running tracks and surfaces used for field games only.
- (e) For watering the running tracks of a race course within the metropolitan area by means of a hose or hoses held in the hand only between the hours of 7 a.m. and 8 a.m. on each day other than Tuesday and Saturday of each week.
- (f) For watering of market gardens and nurseries by means of existing reticulation or a hose or hoses not held in the hand only between the hours of 5 a.m. and 8 p.m. each day.
- (g) For watering land used for the growing of green feed by a commercial poultryman or for the cooling of a building in which poultry is kept for commercial purposes by means of existing reticulation or a hose or hoses not held in the hand only between the hours of 5 a.m. and 8 p.m. each day.
- (h) Shall not be used for filling or adding to the contents of any dam tank or like container situate upon premises used for any agricultural, horticultural, commercial or industrial purpose unless the prior written authority of the Board is first obtained.
- (i) Shall be used for the washing of a vehicle only by means of a bucket or other similar container on the Tuesday or Saturday of each week unless—
- (i) the cleaning of the vehicle is necessary for the purpose of public health and it has been established to the satisfaction of the Board that such vehicle can only be properly cleaned by the means of a hose; or
 - (ii) the washing of vehicles is carried out for fee or reward by a vehicle cleaning establishment which has made provision for the recirculation of the cleaning water.
- (j) Shall not be used for filling or adding to or replacing water in any swimming pool or wading pool other than a pool to which members of the public are admitted unless the Board having regard to considerations of health or of the structural safety of the pool has given prior consent in writing to such use.
- (k) Shall be used for the washing of drives, paths, walks, paved surfaces or buildings only by means of a watering can

or other similar container held in the hand unless the washing is such as is necessary in the interests of public health or is required for the construction of any buildings or works.

- (l) Shall not be used for filling tankers unless such water is required for flushing of streets gutters or drains for public health purposes or for watering shrubs and trees in public gardens and shrubs and trees situate in or along any thoroughfare during the hours prescribed in paragraph (b) hereof or for construction purposes on buildings or other works.
- (m) Shall not be used for the operation of any fountains whether public or private and whether recirculated or not.
- (7) During any period declared to be a period of more severely reduced use of water—
 - (a) Shall not be used for the watering by any means whatsoever of lawns or other grass areas wheresoever the same may be situate unless such water shall first have been used for some domestic commercial or industrial purposes and cannot again be so used.
 - (b) Shall be used for watering garden beds shrubs and trees situate within any garden only by means of a watering can or other similar container held in the hand except that garden beds shrubs and trees situate in any garden not being a private garden may be watered by means of a hose held in the hand between the hours of 8 a.m. and 9 a.m. on Tuesday and Friday of each week.
 - (c) Notwithstanding anything hereinbefore contained trees and shrubs situate in the Royal Botanic Gardens may be watered by means of a hose or hoses held in the hand between the hours of 7 a.m. and 10 a.m. on any day other than Saturday or Sunday.
 - (d) Shall not be used for the watering of any sports grounds including a race-course unless such water shall have first been used for some domestic commercial or industrial purpose and cannot again be so used.
 - (e) For watering of market gardens and nurseries by means of existing reticulation or a hose or hoses not held in the hand only between the hours of 5 a.m. and 8 p.m. each day.
 - (f) For watering land used for the growing of green feed by a commercial poultryman or for the cooling of a building in which poultry is kept for commercial purposes by means of existing reticulation or a hose or hoses not held in the hand only between the hours of 5 a.m. and 8 p.m. each day.
 - (g) Shall not be used for filling or adding to the contents of any dam tank or like container situate upon premises used for any agricultural, horticultural, commercial or industrial purpose unless the prior written authority of the Board is first obtained.
 - (h) Shall be used for the washing of a vehicle only by means of a bucket or other similar container on the Tuesday and Saturday of each week unless—
 - (i) the cleaning of the vehicle is necessary for the purpose of public health and it has been established to the satisfaction of the Board that such vehicle can only be properly cleansed by the means of a hose; or
 - (ii) the washing of vehicles is carried out for fee or reward by a vehicle cleaning establishment which has made provision for the recirculation of the cleaning water.
 - (i) Shall not be used for filling or adding to or replacing water in any swimming pool or wading pool other than a pool to which members of the public are

admitted unless the Board having regard to considerations of health or of the structural safety of the pool has given prior consent in writing to such use.

- (j) Shall be used for the washing of drives, paths, walks, paved surfaces or buildings only by means of a watering can or other similar container held in the hand unless the washing is such as is necessary in the interests of public health or is required for the construction of any buildings or works.
- (k) Shall not be used for filling tankers unless such water is required for flushing of streets gutters or drains for public health purposes or for watering shrubs and trees in public gardens, and shrubs and trees situate in or along any thoroughfare during the hours prescribed in paragraph (b) hereof or for construction purposes on buildings or other works.
- (l) Shall not be used for the operation of any fountains whether public or private and whether recirculated or not.

7. Any person who uses or causes or permits to be used water supplied by the Board contrary to the provisions of this By-law shall be guilty of an offence against this By-law and shall upon conviction be liable to a penalty not exceeding One hundred dollars.

8. The Chairman or in his absence the Secretary having regard to the water supply then available may by declaration published in a daily newspaper—

- (a) Specify the hour and day of the conclusion of a period of restriction where such conclusion was not specified when the period of restriction was declared;
- (b) Specify an earlier conclusion where the hour and day of the conclusion of the period of restriction was specified when the period of restriction was declared.

SCHEDULE REFERRED TO.

I, the Chairman of Melbourne and Metropolitan Board of Works Secretary of Melbourne and Metropolitan Board of Works in pursuance of the powers conferred by By-law No. of the said Board:

Hereby declare that in respect of the period commencing at _____ o'clock in the noon of the _____ the _____ day of _____ 19 _____ and concluding at _____ o'clock in the _____ noon of the _____ day of _____ 19 _____ or at such hour of such day as shall subsequently be specified (as the case may be) shall be a use of water.

SIGNED by the said _____ }
in the presence of: _____ }

APPENDIX.

Restrictions Applicable During a Period of _____ use of water.

The foregoing By-law was made and passed by the Melbourne and Metropolitan Board of Works and the common seal of the said Board was hereunto affixed the 12th day of December One thousand nine hundred and sixty-seven in the presence of:

(SEAL) ALAN H. CROXFORD, Chairman.
JOHN McCONNELL, Member.
H. SNADDEN, Secretary.

MELBOURNE AND METROPOLITAN BOARD OF WORKS ACT 1958.

By-LAW No. 94.

Water Supply—Industrial—Commercial Restriction.

MELBOURNE AND METROPOLITAN BOARD OF WORKS (hereinafter called "the Board") pursuant to and in exercise and execution of the powers and authorities conferred on the Board by the Melbourne and Metropolitan Board of Works Act 1958, and in exercise and execution of any powers and authorities in any way enabling the Board in that behalf doth make the By-law following that is to say:—

1. Water supplied by the Board otherwise than for domestic purposes shall in addition to the conditions contained in any By-law of the Board be and be deemed to be supplied subject to and upon the conditions herein prescribed.

2. During any period of restriction declared in terms of By-law No. 93 of the Board other than a period of control of peak demand use of water, a period of controlled use of water or a period of restricted use of water;

(1) Any person using water supplied by the Board otherwise than for domestic purposes shall adopt such methods or processes and shall take all such measures (including where practicable the recirculation of water and the use of waste water) as may reduce his consumption of water so supplied.

(2) The Board may make such investigation as in the circumstances may be necessary or desirable in order to ascertain whether the amount of water supplied by the Board to any person otherwise than for domestic purposes can be reduced and any person using water so supplied otherwise than for domestic purposes shall furnish to the Board such information as it may properly require for the purpose of such investigation and shall permit such inspections and tests as may be required for such purposes.

(3) (a) If as a result of any such investigation as aforesaid it would appear that the consumption of water by any person otherwise than for domestic purposes can be reduced by the adoption of any system control method or process the Board (after consideration of the cost of the adoption of such method or process the effect thereof on the carrying on of industrial or commercial operations and the amount by which the quantity of water used is likely to be reduced) may by order under the hand of its Secretary require such person or may require all persons carrying on any industrial or commercial activity which is the same as or similar to the industry or commercial activity which was the subject of such investigation to adopt such system form of control method or process generally or particularly described in such order.

(b) Should any person supplied by the Board with water otherwise than for domestic purposes fail to observe any order made as hereinbefore provided which is applicable to him the Board may by further order under the hand of its Secretary direct that the water supplied to and consumed by such person at such premises during any period of such duration as is specified in the order shall not exceed the quantity specified therein and during the operation of such last mentioned order the Board may limit the quantity of water supplied so that the quantity specified in the order is not exceeded.

(4) Any person failing to observe any order made pursuant to sub-clause (b) of Clause (3) hereof shall be guilty of an offence against this By-law and shall be liable to a penalty not exceeding \$100 and in case of a continuing offence shall be liable to a further penalty not exceeding \$10 for each day the offence continues after notice of the offence from the Board.

The foregoing By-law was made and passed by the Melbourne and Metropolitan Board of Works and the common seal of the said Board was hereunto affixed the 12th day of December, 1967.

(SEAL) ALAN H. CROXFORD, Chairman.
JOHN McCONNELL, Member.
H. SNADDEN, Secretary.

MELBOURNE AND METROPOLITAN BOARD OF WORKS
ACT 1958.

BY-LAW No. 95.

Water Supply—Industrial—Commercial Surcharge.

MELBOURNE AND METROPOLITAN BOARD OF WORKS (hereinafter called "the Board"), pursuant to and in exercise and execution of the powers and authorities conferred upon the Board by the *Melbourne and Metropolitan Board of Works Act 1958*, and in exercise and execution of any powers and authorities in any way enabling the Board in that behalf doth make the By-law following, that is to say:—

1. This By-law shall be read and construed as one with By-law No. 81 duly made and passed by the Board on the 18th day of September 1962 and published in the *Government Gazette* on the 3rd day of October 1962 (which By-law by virtue of a Declaration made by the Attorney General pursuant to the *Subordinate Legislation Act 1962* is a Statutory Rule within the meaning of the said Act) as amended by By-law No. 89 (Statutory Rule No. 192/1965) duly made and passed by the Board on the 14th day of September 1965 and published in the *Government Gazette* on the 20th day of October 1965 as further amended by Decimal Currency (Melbourne and Metropolitan Board of Works) Order 1966 (Statutory Rule No. 141/1966) and as further amended by By-law No. 91 (Statutory Rule No.

165/1967) duly made and passed by the Board on the 7th day of February 1967 notice of which was published in the *Government Gazette* on 30th day of June, 1967.

2. The said By-law No. 81 as so amended (being hereinafter referred to as "the said By-law") is hereby further amended by inserting after Clause 7 thereof the following new Clause, that is to say:—

"7A. In the event of the Board making any order under sub-clause (a) of Clause 3 of By-law No. 94 whereby it is directed that the water supplied to and consumed by any person at the premises and during the period specified in such order shall not exceed the quantity specified therein then whether or not the quantity of water supplied may be limited and whether or not any proceedings may be commenced in respect of any breach of the said By-law No. 94 the supply of water to the person named in the order at the premises and during the period specified therein shall as to such quantity as exceeds the quantity specified in such order be upon and subject to a surcharge calculated at the rate per thousand gallons of four times the rate prescribed in sub-clause (a) of Clause 7 of this By-law."

The foregoing By-law was made and passed by the Melbourne and Metropolitan Board of Works and the common seal of the said Board was hereunto affixed the 12th day of December, 1967.

(SEAL) ALAN H. CROXFORD, Chairman.
JOHN McCONNELL, Member.
H. SNADDEN, Secretary.

MELBOURNE AND METROPOLITAN BOARD OF WORKS
ACT 1958.

BY-LAW No. 96—WATER SUPPLY (AMENDING
BY-LAW No. 42).

MELBOURNE AND METROPOLITAN BOARD OF WORKS (hereinafter called "the Board") pursuant to and in exercise and execution of the powers and authorities conferred on the Board by the *Melbourne and Metropolitan Board of Works Act 1958* and in exercise and execution of any other powers and authorities in anywise enabling the Board in that behalf doth hereby make the By-law following that is to say:—

1. This By-law shall be read and construed as one with By-law No. 42 duly made and passed by the Board on the 22nd day of July, 1947 and published in the *Government Gazette* on the 8th day of October 1947 (which By-law by virtue of a Declaration made by the Attorney General pursuant to the *Subordinate Legislation Act 1962* is a Statutory Rule within the meaning of the said Act) as amended by Decimal Currency (Melbourne and Metropolitan Board of Works) Order 1966 (Statutory Rule No. 141/1966).

2. In Clause 3 of the said By-law No. 42 as so amended for the expression "\$40" there shall be substituted the expression "\$100".

The foregoing By-law was made and passed by the Melbourne and Metropolitan Board of Works and the common seal of the said Board was hereunto affixed the 12th day of December, 1967.

(SEAL) ALAN H. CROXFORD, Chairman.
JOHN McCONNELL, Member.
H. SNADDEN, Secretary.

Melbourne and Metropolitan
BOARD OF WORKS.

NOTICE TO THE OWNERS OF TENEMENTS IN THE UNDER-MENTIONED STREETS AND THE PRIVATE STREETS, LANES, COURTS AND ALLEYS OPENING THERETO.

THE main pipe in the said streets being laid down, the owners of all tenements situated as under are hereby required on or before the 22nd January, 1968, to cause a proper pipe and stop cocks to be laid so as to supply water within such tenements from the main pipe.

H. J. SNADDEN,
Secretary.

12th December, 1967.

STREET AND POSITION.
Broadmeadows.

Railway-crescent, from 130 feet north of Nicholas-street northwards 190 feet.

Dandenong.

Elonera-road, from Oakwood-avenue to Titcher-road.
Titcher-road, from Hampstead-road westwards 280 feet.
Edden-road, from Oakwood-avenue to Titcher-road.

Kingswood-crescent, from Ebdon-road eastwards 760 feet.
 Rubina-court, from Kingswood-crescent northwards 330 feet.
 Albany-court, from Kingswood-crescent northwards and eastwards 478 feet.

Diamond Valley.

Greenwood-drive, from 1,126 feet west of Thornton-avenue to Noorong-avenue.
 Lea-crescent, from 90 feet north of Nola-court northwards and eastwards 880 feet.
 Lea-crescent, from Greenwood-drive northwards 420 feet.
 Nola-court, from Lea-crescent eastwards 650 feet.
 Marie-court, from Nola-court northwards 220 feet.

Doncaster and Templestowe.

Stanlake-rise, from Airds-road to Thompsons-road.
 Airds-road, from Heather-grove southwards 280 feet.
 Newbury-close, from Stanlake-rise to Cavendish-drive.
 Thompsons-road, from Birchwood-avenue to Templestowe-road.
 Templestowe-road, from Thompsons-road westwards 300 feet.
 Randolph-court, from Stanlake-rise northwards 450 feet.
 Cavendish-drive, from Stanlake-rise to Birchwood-drive.

Essendon.

Vida-street, from Tilba-street to Morgan-street.
 Janfred-street, from Vida-street eastwards 230 feet.
 Morgan-street, from Vida-street westwards 50 feet.
 Woodvale-court, from Woodvale-grove southwards 340 feet.
 Hesleden-street, from 140 feet south of Alfred-road southwards 60 feet.

Keilor.

Churchill-avenue, from Dawson-street northwestwards and northwards 1,210 feet.
 Churchill-avenue, from Dawson-street southeastwards 710 feet.
 Janus-street, from Churchill-avenue eastwards 430 feet.
 Dawson-street, from Churchill-avenue northeastwards 310 feet.
 Burgess-street, from Janus-street to Dawson-street.
 Spring-street, from 260 feet south of Dorothy-street southwards 310 feet.

Moorabbin.

Jedda-court, from Silver-street northwards 264 feet.
 Lincoln-drive, from Farm-road southwards 700 feet.

Nunawading.

Jilmax-court, from Boyle-street westwards 264 feet.
 Ballantyne-street, from Mahony's-road westwards 924 feet.
 Dawayne-street, from 1,020 feet east of Robinlee-avenue eastwards 165 feet.
 Kipling-court, from Ballantyne-street northwestwards 380 feet.
 Florida-court, from Scott-street eastwards 370 feet.

Springvale.

Corrigan-road, from Ardgow-avenue northwards 495 feet.
 Edith-street, from Walter-street eastwards 570 feet.
 Walter-street, from 60 feet south of Gordon-street southwards 530 feet.
 Edith-street, from Walter-street westwards 140 feet.

Waverley.

Buller-drive, from Rowitta-drive northwards 630 feet.
 Springvale-road, from 430 feet north of Rowitta-drive northwards 610 feet.
 Therese-avenue, from 280 feet west of Cremin-court westwards 220 feet.
 Long Beach-crescent, from Therese-avenue to Catherine-avenue.
 Dai-court, from Long Beach-crescent eastwards 220 feet.
 Rees-court, from Long Beach-crescent eastwards 310 feet.
 Catherine-avenue, from 170 feet west of Woodlands-avenue westwards 850 feet.

Whittlesea.

Kiama-drive, from Epping-road westwards 1,060 feet.
 Linoak-avenue, from Kiama-drive southwards 148 feet.
 Winslow-avenue, from Kiama-drive southwards 182 feet.
 Avondale-road, from Kiama-drive southwards 247 feet.
 Teal-crescent, from Kiama-drive northwards 200 feet.
 Epping-road, from Kiama-drive northwards 230 feet.
 Epping-road, from Kiama-drive southwards 314 feet.
 Linoak-avenue, from Kingsway-drive northwards 974 feet.
 Tandarra-crescent, from Kingsway-drive to Linoak-avenue.
 Settlement-road, from 130 feet west of Latrobe-avenue westwards 1,140 feet.

PUBLIC TRUSTEE ACT 1958 (No. 6350), SECTION 17.

I HEREBY give notice that on the 4th December, 1967, the Public Trustee fled elections to administer the following deceased persons' estates, in accordance with section 17 of the *Public Trustee Act 1958*:—

BAYLISS, CYRIL THOMAS, late of Clare Castle Hotel, 168 Exhibition-street, Melbourne, jeweller, died 4th August, 1967.

SCHONDORFER, ANTON, late of 197 Victoria-parade, Fitzroy, storeman, died 17th December, 1966.

STANFORD, ALICE MAUD, late of 28 Berry-street, East Melbourne, spinster, died 15th July, 1967.

A. D. DUNCAN,

Public Trustee.

256 Flinders-street, Melbourne, 3000, 13th December, 1967.

NOTICE.

CREDITORS, next of kin and others having claims against the estate of any of the under-mentioned deceased persons are required to send particulars of their claims to the Public Trustee, 256 Flinders-street, Melbourne, 3000, the personal representative, on or before the 27th February, 1968, after which date the Public Trustee may convey or distribute the assets, having regard only to the claims of which the Public Trustee then has notice:—

ANDREWS, WALTER STANLEY, formerly of 12 Ivy-street, Prahran, but late of 9 Bayview-street, East Prahran, retired process worker, died 18th October, 1967.

ASSER, SARAH, late of 21 Dudley-street, Ivanhoe, widow, died 3rd October, 1967.

AUSTEN, LINDSAY OLIVER, late of 621 Whitehorse-road, Mitcham, business executive, died 26th September, 1967.

BASTOW, LEO WILLIAM, late of 42 Cromwell-street, Glenroy, cartage contractor, died 18th September, 1967.

BAYLISS, CYRIL THOMAS, late of Clare Castle Hotel, 168 Exhibition-street, Melbourne, jeweller, died 4th August, 1967.

BORBEBY, MARIA ROSA, in the will called Rosa Borboby, late of St. Vincent, Province of Aosta, Italy, widow, died 9th December, 1937.

BRADY, PATRICK WILLIAM, late of 323 Gaffney-street, Pascoe Vale, retired typewriter mechanic, died 9th August, 1967.

CAMPBELL, EDITH GRACE, late of 24 Tooronga-road, East Malvern, widow, died 3rd October, 1967.

CHILDS, WILLIAM, late of 22 Spring-road, Highett, tool-maker, died 30th September, 1967.

CLARK, GORDON JAMES, late of 60 Moore-street, Footscray, retired night watchman, died 11th October, 1967.

COLLINS, WILFRED, late of 11 Preston-street, Fawkner, engineer's assistant, died 4th August, 1967.

COUTTIE, VERNON JOHN GORDON, late of 10 Beryl-avenue, South Oakleigh, retired sales representative, died 12th August, 1967.

CRAIG, FREDERICK, late of 4 Marriott-street, Caulfield, retired accountant, died 27th September, 1967.

GRAY, WILLIAM CHARLES, late of 8 Phillip-street, Bentleigh, retired railway employee, died 20th September, 1967.

KENSLEY, JOHN MARTIN, late of 70 Mahoney-street, Upwey, retired accountant, died 31st October, 1966.

MARTAIN, JOHN DOUGLAS, late of State Rivers and Water Supply Commission Camp, Kerang, foreman, died 22nd June, 1967.

MACLAREN, LOUISA, late of Liscombe House, St. Helena-road, North Eltham, widow, died 18th September, 1967.

MACMILLAN, HARRY, late of 5 Ardyne-street, Murrumbena, retired cooper, died 29th August, 1967.

OGLE, ARTHUR GORDON, late of 1 Second-avenue, Brunswick, retired railway employee, died 26th September, 1967.

PATTISON, HERBERT JOHN, late of 47 Cecil-street, Fitzroy, retired wood machinist, died 17th July, 1967.

PULLIN, MYRTLE AMELIA, late of 68 Power-street, Williamstown, widow, died 4th July, 1967.

RANDLE, LEONARD GEORGE, formerly of 14 Mashoobra-street, Merlynston, but late of 446 Waterdale-road, West Heidelberg, retired clerk, died between 24th April and 27th April, 1967.

SCHONDORFER, ANTON, late of 197 Victoria-parade, Fitzroy, storeman, died 17th December, 1966.

STANFORD, ALICE MAUD, late of 28 Berry-street, East Melbourne, spinster, died 15th July, 1967.

WHEATLEY, REGINALD, late of 7 Victoria-road, Camberwell, retired postman, died 10th August, 1967.

A. D. DUNCAN,

Public Trustee.

Melbourne, 13th December, 1967.

RULES UNDER THE JUSTICES ACT.

SELECTION BY A LAW OFFICER OF THE PLACES AND DAYS FOR HOLDING COURTS (WITHIN THE MEANING OF THE SAID RULES).

I, THE undersigned, George Oswald Reid, a Law Officer of the State of Victoria, in pursuance of the powers conferred upon me by Rule 2 of Chapter III. of the Justices Act 1963, do hereby amend the days and hours selected on the 27th November, 1967 and published in the *Government Gazette* on the 6th December, 1967, as indicated in the Schedule hereto.

SCHEDULE.

Court.	Day.	Hour.	January.	February.	March.	April.	May.	June.	July.	August.	September.	October.	November.	December.
PORTLAND ..	Mon.	10 a.m.	..	26 in addition	25 to the days	22 and	20 hours he	17 retofore	15 appointe	12 d.	9	8	4	2
MURTOA ..	Tues.	2 p.m.	9	6 in lieu	5 of the	2, 30 days and	28 hours he	25 retofore	23 appointe	20 d.	24	22	19	17

Dated at Melbourne, this 13th day of December, 1967.

G. O. REID, Law Officer.

Justices Act 1958.

REVOCATION OF THE APPOINTMENT OF A PLACE FOR HOLDING COURTS OF PETTY SESSIONS.

HIS Excellency the Governor of the State of Victoria by and with the advice of the Executive Council thereof doth by Order made on the 19th day of December, 1967, pursuant to the provisions of Section 65 of the *Justices Act 1958*, revoke the appointment of Nagambie as a place for holding Courts of Petty Sessions and that such Court be directed to be closed as from and including the 1st March, 1968, and that the books and other records of the said Court and of the Clerk thereof be directed to be delivered to the Clerk of Petty Sessions at Seymour.

J. ROSSITER,
Clerk of the Executive Council.

At the Executive Council Chamber,
Melbourne, 19th December, 1967.

LAW DEPARTMENT.

CURATOR OF CONVICT'S PROPERTY.

HIS Excellency the Governor of the State of Victoria by and with the advice of the Executive Council thereof doth by Order made on the 19th day of December, 1967, pursuant to the provisions of Section 550 of the *Crimes Act 1958*, commit the custody and management of the property of the convict Alwyn Apted to Vida Elaine O'Brien of 8 Glenora-street, Chadstone, as a curator hereby appointed in that behalf.

J. ROSSITER,
Clerk of the Executive Council.

At the Executive Council Chamber,
Melbourne, 19th December, 1967.

Administration and Probate Act 1958.

INSURANCE COMPANY APPROVED.

HIS Excellency the Governor of the State of Victoria by and with the advice of the Executive Council thereof doth by Order made on the 19th day of December, 1967, approve "Guardian Assurance Company Limited" under the provisions of section 57 (4) of the *Administration and Probate Act 1958*.

J. ROSSITER,
Clerk of the Executive Council.

At the Executive Council Chamber,
Melbourne, 19th December, 1967.

COUNTRY ROADS BOARD.

NOTICE is hereby given that the Board has decided to lift the prohibition of the use of the Beech Forest-Lavers Hill-road between Ferguson and Lavers Hill in the Shire of Otway of motor cars, the weight of which and of the load (if any) carried thereon exceeds five (5) tons on any one axle thereof.

Dated at Melbourne this Thirteenth day of December, 1967.

By Order,
C. C. LIDDELL, Acting Secretary.

Town and Country Planning Act 1961.

SHIRE OF MORNINGTON PLANNING SCHEME 1959.

NOTICE OF APPROVAL.

Amendment No. 19, 1966.

IN pursuance of the powers conferred by the *Town and Country Planning Act 1961*, the Governor in Council on the 19th December, 1967, approved a planning scheme entitled the Shire of Mornington Planning Scheme 1959, Amendment No. 19, 1966, in respect of part of the municipal district of the Shire of Mornington and such planning scheme comes into operation on the date this notice of approval is published in the *Government Gazette*.

A copy of the planning scheme as approved may be inspected free of charge during office hours at the office of the Town and Country Planning Board, 179 Queen-street, Melbourne; at the office of the Council of the Shire of Mornington, at Mornington; and when available, at the Office of Titles, Melbourne; and at the Central Plan Office of the Department of Crown Lands and Survey, Melbourne.

W. H. CRAIG, Secretary.
Town and Country Planning Board.

Town and Country Planning Act 1961.

TOWN OF PORTLAND.—PORTLAND PLANNING SCHEME 1957.

NOTICE OF AMENDMENT.

Amendment No. 10, 1967.

IN pursuance of the powers conferred by sub-section 6 of section 32 of the *Town and Country Planning Act 1961*, the Governor in Council, by and with the advice of the Executive Council thereof, on the 19th December, 1967, amended the Portland Planning Scheme in respect of part of the municipality of the Town of Portland and such amendment comes into effect the date this notice of amendment is published in the *Government Gazette*.

A copy of the amendment may be inspected during office hours at the office of the Town and Country Planning Board, 179 Queen-street, Melbourne; at the office of the council of the Town of Portland at Portland; and when available, at the Office of Titles, Melbourne; and at the Central Plan Office of the Department of Crown Lands and Survey, Melbourne.

W. H. CRAIG, Secretary.
Town and Country Planning Board.

CONTRACTS ACCEPTED.—(Series 1967-68.)

PUBLIC WORKS.

2028. Clayton, Technical School, supply lathes and equipment, \$2,086.83.—Demco Machinery Co. (Vic.) Pty. Ltd.

2029. North Clayton, Monash, High School, supply and install venetian blinds, \$1,698.00.—G. P. Blinds Repairs & Sales.

2030. Rushworth, High School, supply woodworking equipment, \$1,064.20.—Frank Vial & Sons Pty. Ltd.

2031. Wodonga, Technical School, supply shaping machine, \$1,386.00.—Elgar Machinery (A'Asia) Pty. Ltd.

2032. Springvale, High School, supply and install curtains, \$4,063.00.—Hoed Manufacturing Pty. Ltd.

2033. Preston, Preston East Technical School, supply drilling machine and grinder, \$1,207.25.—Waldown Pty. Ltd.

2034. Preston, Preston East Technical School, supply lathes and equipment, \$10,164.85.—Demco Machinery Co. Pty. Ltd.

2035. Preston, Preston East Technical School, supply shaping machines, \$1,880.00.—Marweight Equipment Pty. Ltd.

2036. Wodonga, Technical School, supply furniture, \$7,679.00.—Bera Furniture Pty. Ltd.

2037. Euroa, High School, supply woodworking machinery, \$1,064.60.—Frank Vial & Sons Pty. Ltd.

2038. Kew, Children's Cottages, supply mattresses and covers, \$1,203.00.—Storey Davies (Sales) Pty. Ltd.

2039. Parkville, "Turana", supply and lay vinyl flooring, \$1,020.60.—Laminex Industries.

2040. Warrambool, Warrambool Foreshore, supply and deliver stone, \$3,222.00.—Tip-Truck Operators Association of Vic. Ltd.

2041. Bendigo, Mental Hospital, supply, deliver and place in position food trollies in convalescent and administration ward, \$1,264.00.—Ahearn Main & Stott Pty. Ltd.

2042. Bendigo, Mental Hospital, supply kitchen equipment, convalescent and administration ward, \$2,631.70.—E.G.A. (S. Cunningham) Pty. Ltd.

2043. Rosebud, High School, supply and install curtains, \$1,772.36.—Fischer Furnishings Pty. Ltd.

2044. Bendigo, Mental Hospital, supply, deliver and place in position, kitchen equipment, main kitchen, \$3,416.00.—E.G.A. (S. Cunningham) Pty. Ltd.

2045. Bendigo, Mental Hospital, supply steam cookers, \$4,163.00.—Anderson and Ritchie Pty. Ltd.

2046. Bendigo, Mental Hospital, supply, deliver and place in position tilting kettles, main kitchen, \$4,872.00.—J. Curtain & Son Pty. Ltd.

2047. Bendigo, Mental Hospital, supply, deliver and place in position, electric ovens, main kitchen, \$3,520.00.—Thermo Radiant Oven Sales Pty. Ltd.

2048. Bendigo, Mental Hospital, supply, deliver and place in position, kitchen equipment, main kitchen, \$14,905.00.—Ahearn Main & Stott Pty. Ltd.

2049. Bendigo, Mental Hospital, supply, deliver and place in position, deep fat fryer, main kitchen, \$1,128.00.—L. J. Morgan Pty. Ltd.

2050. Bendigo, Mental Hospital, supply, deliver and place in position, double oven ranges, \$3,508.50.—Waldorf Appliances Pty. Ltd.

2051. Bendigo, Mental Hospital, supply kitchen equipment, main kitchen, \$1,460.07.—Hobart Manufacturing Co. Pty. Ltd.

2052. Bendigo, Mental Hospital, supply kitchen equipment, main kitchen, \$1,447.50.—Brice Equipment Pty. Ltd.

2053. Bendigo, Mental Hospital, supply kitchen equipment, main kitchen, \$1,140.65.—T. S. Nettlefold Sales Pty. Ltd.

2054. Bendigo, Mental Hospital, supply kitchen equipment, main kitchen, \$2,251.40.—Henry Berry & Co. (Australasia) Ltd.

2055. Corio, Technical School, supply lathes and equipment, \$2,674.00.—Demco Machinery Co. (Vic.) Pty. Ltd.

2056. Ballarat, Mental Hospital, supply hot press and refrigerator, \$2,769.55.—Ahearn Main & Stott Pty. Ltd.

2057. Ballarat, Mental Hospital, supply gas oven range, \$1,976.00.—Waldorf Appliance Dist.

2058. Ballarat, Mental Hospital, supply kitchen equipment, \$1,313.50.—Brice Equipment Pty. Ltd.

2059. Geelong East, Technical School, supply lathe and equipment, \$1,431.22.—Demco Machinery Pty. Ltd.

2060. Geelong East, Technical School, supply shaping machine, \$1,386.00.—Elgar Machinery (A'Asia) Pty. Ltd.

2061. Bentleigh, High School, supply and install curtains, \$1,695.00.—Hoad Manufacturing Pty. Ltd.

2062. Bundoora, Janefield Training Centre, supply beds, \$4,046.40.—Bendix Consolidated Ind. Pty. Ltd.

2063. Bundoora, Janefield Training Centre, supply and fit curtains, \$2,139.00.—Frances Burke Fabrics Pty. Ltd.

2064. Bundoora, Janefield Training Centre, supply chairs, \$1,600.00.—Ultra Stool & Chair Pty. Ltd.

2065. Bundoora, Repatriation Hospital, supply beds, hospital, \$1,152.10.—Bendix Consolidated Ind. Pty. Ltd.

2066. Bundoora, Repatriation Hospital, supply and install robe unit, \$3,398.00.—Bera Furniture Pty. Ltd.

2067. Williamstown, P.W.D. Dredging Depot, supply rubber suction hose, \$1,307.58.—Dunlop Rubber Australia Ltd.

2068. Hamilton, Technical School, supply electrical fittings, \$1,918.41.—Australian Electrical Industries Pty. Ltd.

2069. Ballarat, Mental Hospital, supply and fix curtains, \$3,990.00.—Myer Teale Pty. Ltd.

2070. Mont Park, Mental Hospital, supply wheelchairs, \$1,080.00.—Denyers Pty. Ltd.

2071. Belmont, Oberon High School, supply woodworking equipment, \$1,199.60.—Frank Vial & Sons Pty. Ltd.

2072. Port Melbourne, P.W.D. Storeyard, supply suspension frames and folders, \$3,350.00.—Namco Products Pty. Ltd.

2073. Noble Park, Technical School, supply welding equipment, \$3,765.99.—Aston sales Pty. Ltd.

2074. Noble Park, Technical School, supply welding equipment, \$6,491.00.—Commonwealth Industrial Gases Ltd.

2075. Port Melbourne, P.W.D. Storeyard, supply balancing forms, \$1,650.00.—Laurion Pty. Ltd.

2076. Port Melbourne, P.W.D. Storeyard, supply vaulting horses, \$2,050.00.—Lorbach & Rye Pty. Ltd.

2077. Ballarat North, Technical School, supply staple machine, shaping, \$1,900.00.—Marweight Equipment Pty. Ltd.

2078. Ballarat North, Technical School, supply lathe and equipment, \$7,140.00.—Demco Machinery Co. (Vic.) Pty. Ltd.

2079. Port Melbourne P.W.D. Depot, supply crawler tractor, \$6,939.24.—International Harvester Co. of Aust. Pty. Ltd.

2080. St. Alban's, Technical School, supply lathes and equipment, \$6,930.00.—Demco Machinery Co. (Vic.) Pty. Ltd.

2081. Bendigo, Teachers' College, supply washing machines, \$1,242.50.—Lightburn & Co. Ltd.

2082. Swan Hill, Court House, supply, make and locate in position, court furniture, \$1,545.00.—Bera Furniture Pty. Ltd.

2083. Sunshine, Technical School, supply cupboards, \$1,413.00.—Bera Cabinet Works Pty. Ltd.

G. SERPELL, Secretary for Public Works. 4.12.67.

VICTORIAN RAILWAYS.

64. Manufacture, supply and delivery of 3 circuit carrier telephone, plus 4 circuit duplex carrier telegraph terminals, at rates (Contract 63181).—G.E.C. (Aust.) Pty. Ltd. 65. Renovations to and rehabilitation of the Swanston-street concourse, outer concourse and booking hall at the eastern end of the Flinders-street Station Buildings, Melbourne, for the amount of \$33,015.00 (Contract 63203).—McDonald Constructions Pty. Ltd. 66. Supply and delivery of bridge beams, at rates (Contract 63210).—M. & P. G. Donchi.

By order of the Victorian Railways Commissioners.

W. WALKER, Secretary. 8.12.67.

PROVISIONS.

Gazette No. 46, 26th May, 1967, Schedule No. 1, Sub-schedule No. 6, Bread.—For the rates shown opposite the following items substitute the rates as set out hereunder:—Item No. 1, \$5.72-8 per cental; Item No. 2, \$6.02-8 per cental; Item No. 3, \$4.41 per cental as from 1st December, 1967.

Gazette No. 46, 26th May, 1967, Schedule No. 1, Sub-schedule No. 4, Milk.—Rates for bulk milk have increased to 56-02 cents per gallon, bottled pints, 65-20 cents per gallon as from 1st November, 1967.

GENERAL STORES.

Gazette No. 33, 19th April, 1967, Schedule No. 52, Tools (General).—For rates shown opposite the following items, substitute the rates as set out hereunder:—Item No. 3, $\frac{1}{2}$ -in. to $\frac{3}{4}$ -in., \$0.96, $\frac{7}{16}$ -in. to $\frac{1}{2}$ -in., \$0.97, $\frac{9}{16}$ -in. to $\frac{3}{4}$ -in., \$1.02, $\frac{13}{16}$ -in., \$1.27, $\frac{1}{2}$ -in., \$1.28, $\frac{15}{16}$ -in., \$1.42, 1-in., \$1.43; Item No. 31, \$3.31; Item No. 129, \$5.25; Item No. 130, \$6.06; Item No. 131, \$6.28; Item No. 132, \$8.49; Item No. 244, Straight, \$2.54, Bent, \$2.58; Item No. 295, \$2.00, each as from 13th December, 1967.

Gazette No. 56, 17th July, 1967, Schedule No. 37, Electric Lamps, &c.—For rates for cable supplied under Sub-schedule "E", apply Tender Board.

Gazette No. 73, 27th September, 1967, Schedule No. 2, Education Requisites.—For rates shown opposite the following items, substitute the rates as set out hereunder:—Item No. 28, \$147.24 per thousand; Item No. 30, \$241.00 per thousand, as from 14th December, 1967.

H. COUTTS, Secretary to the Tender Board. 19.12.67.

GENERAL STORES.

Gazette No. 61, 9th August, 1967, Schedule No. 1, Printing Paper, &c.—For Item No. S37 substitute \$3.33 per thousand, as from 29th November, 1967.

PROVISIONS.

Gazette No. 46, 26th May, 1967, Schedule No. 1, Sub-schedule No. 6, Flour.—The rate for flour has increased by 16 cents per cental, as from 1st December, 1967.

H. COUTTS, Secretary to the Tender Board. 12.12.67.

SOIL CONSERVATION AUTHORITY.

CONTRACT No. 6720.

2088.—Erection of round treated post-driven fencing at Birregurra Project.—A. E. & C. M. Dakin, Winchelsea.—\$1.90 a chain, \$1.60 for each end assembly.

CONTRACT No. 6722.

2089. Supply of treated pine fence posts, strainers and stays for period 1st November to 30th October, 1968, inclusive.—Grant and Crocker, Beaufort:—

6 ft. x 3 in.—4 in. diameter Posts ..	\$55 per 100
6 ft. x 4 in.—5 in. diameter Posts ..	\$66 per 100
7 ft. 6 in. x 5 in.—6 in. diameter Strainers	\$1.75 each
10 ft. x 3 in. diameter Stays ..	\$1.25 each
Extra price for post pointed ..	5c each
All less 15 per cent. paid 30 days.	

P. J. McCALLUM,
Secretary.

ORDERS IN COUNCIL.—(Series 1967-68.)

EDUCATION DEPARTMENT.

2015. One (1) only refrigerator, for Emily McPherson College, \$1,080.00.—G.E.C. (Aust.) Pty. Ltd.

2016. One (1) only powderless etching machine, for Melbourne School of Printing and Graphic Arts, \$3,000.00.—Middows Pty. Ltd.

2017. One (1) only foot-operated 230-volt electric spot-welding machine, for Ferntree Gully Technical School, \$340.00.—E.M.F.

2018. One (1) only neutron source Americium Beryllium, for Gordon Institute of Technology, \$280.00.—Australian Atomic Energy Commission.

2019. One (1) only valve refacer, "W. & B." model, 2 x 10, for Swan Hill Technical School, \$594.75.—McPherson's Ltd.

Approved by the Governor in Council, 5th December, 1967.—F. R. KENNY, Acting Clerk of the Executive Council.

PUBLIC WORKS.

2020. Ballarat, Mental Hospital, supply of filling, sand and top soil, \$1,710.00 estimated.—R. Coffield.—(W.120751.)

2021. Collingwood, Girls High School, alterations to toilets, &c., \$1,236.00.—Lewton Plumbing Services.—(E.M.105314.)

2022. Heatherton Sanatorium, Staff residences, urgently required fencing, \$1,126.00.—R. W. Lee.—(E.M.73177.)

2023. Melbourne, Government House, supply of a bottle storage cabinet, \$1,330.00.—Ahearn Main and Stott Pty. Ltd.—(C.119740.)

2024. Melbourne, 200 Little Collins-street, reimbursement of partitioning and ancillary works to premises, \$31,277.00.—K. D. H. Trading Co. Pty. Ltd.—(C.115046.)

2025. Melbourne, Supreme Court, supply of stone to match existing, \$1,640.00.—Gosford Quarries Pty. Ltd.—(C.10575 "B".)

2026. Melbourne, for docking, scraping and painting the dredge, "Matthew Flinders", \$1,691.89.—Duke's and Orr's Amalgamated Dry Docks Ltd.—(P. & H. 119404.)

2027. Sea Lake, High School, asphalt repairs to roadway, \$2,196.00.—Allen Bros. (Asphalting Contractors Pty. Ltd.).—(N.W.88899.)

Approved by the Governor in Council, 5th December, 1967.—F. R. KENNY, Acting Clerk of the Executive Council.

FORESTS COMMISSION.

Loan Fund Act No. 7453, Item 6—

2084. To the purchase of that lot 116, on plan of subdivision No. 12973, being part of Crown allotment 87, Parish of Scoresby, County of Mornington, for forest purposes, \$325.00.—Eileen Elizabeth Fisher.

2085. To the purchase of that lot 117 on plan of subdivision No. 12973, being part of Crown allotment 87, Parish of Scoresby, County of Mornington, for forest purposes, \$325.00.—Una May Kathleen Wilkinson.

2086. To the purchase of those lots 280 and 281, on plan of subdivision No. 12973, being parts of Crown allotment 86, Parish of Scoresby, County of Mornington, for forest purposes, \$800.00.—John Charles Such.

2087. To the purchase of that lot 11 on plan of subdivision No. 26960, being part of Crown allotment 126, Parish of Scoresby, County of Mornington, for forest purposes, \$750.00.—Douglas Arthur McBean.

Approved by the Governor in Council, 14th November, 1967.—J. ROSSITER, Clerk of the Executive Council.

Loan Fund Act No. 7453, Item 6—

2139. To the purchase of that lot 1 and part of lot 2, on plan of subdivision No. 16960, being parts of Crown allotment 13, section 2, Parish of Mooroolbark, County of Evelyn, and comprising 1 acre 2 roods 28 perches, for forest purposes, \$2,600.00.—J. P. & P. J. Hogan.

Approved by the Governor in Council, 26th September, 1967.—J. ROSSITER, Clerk of the Executive Council.

Loan Fund Act No. 7453, Item 6—

2140. To the purchase of those lots 291 and 292, on plan of subdivision No. 12973, being parts of Crown allotments 86 and 87, Parish of Scoresby, County of Mornington, for forest purposes, \$1,000.00.—Thomas William Stagg and Ida Hazel Stagg.

Approved by the Governor in Council, 28th November, 1967.—J. ROSSITER, Clerk of the Executive Council.

STATE ELECTRICITY COMMISSION.

2090. For the supply and erection of two self-propelled rail mounted hoppers with auxiliary equipment for movable conveyors, Morwell open cut, to Specification No. 67/5, \$57,088.—Deer Park Engineering Pty. Ltd.

Approved by the Governor in Council, 31st October, 1967.—J. ROSSITER, Clerk of the Executive Council.

2091. For supply of fifteen 35-ft. elevating work platforms for construction and maintenance works on transmission and distribution lines, to Specification No. 67/106, \$119,190.—Marweight Equipment Pty. Ltd.

2092. For hire of steel form material and equipment for construction and maintenance works for a period of two years with optional three months' extension, to Specification No. 67/35, at Schedule rates.—Acrow Pty. Ltd.

2093. For hire of tubular scaffolding material and equipment for construction and maintenance works, for a period of two years with optional three months' extension, to Specification No. 67/35, at Schedule rates.—Cyclone Double Grip Scaffolding Pty. Ltd.

Approved by the Governor in Council, 8th November, 1967.—J. ROSSITER, Clerk of the Executive Council.

2094. For supply of eight cast steel 18-in. gate valves for fire and water services reticulation system, Latrobe Valley, to Specification No. 67/74, \$11,838.—C. A. Burgmann Pty. Ltd.

2095. For supply of electrical appliances and spare parts for merchandising in Commission showrooms for a period of three years, to Quotation No. 1465, at Schedule rates.—Draffin Everhot Ltd.

2096. For supply of 500-kV station post insulators for Hazelwood and Keilor Terminal Stations, to Specification No. 67/11, \$76,134.—R. M. Hall Pty. Ltd.

2097. For supply of 137 sets of parts for modification of rack soot blowers on Nos. 1 to 4 boilers, Hazelwood Power Station, Stages 1 and 2, to Quotation No. 1788, \$98,894.62.—Halley & Mellowes Pty. Ltd.

Approved by the Governor in Council, 14th November, 1967.—J. ROSSITER, Clerk of the Executive Council.

2098. For supply of six soot blowers for stages 1 and 2, Hazelwood Power Station, to Quotation No. 1829, \$14,984.70.—Diamond Power Speciality Ltd., care of Halley & Mellowes Pty. Ltd.

2099. For supply of electrical appliances and spare parts for merchandising in Commission showrooms for a period of three years, to Quotation No. 1463, at Schedule rates.—General Motors-Holdens Pty. Ltd.

2100. For supply of 45 amp. fused overhead line connector boxes for consumers' services for a period of one year with optional three months' extension, to Specification No. 67/113, at Schedule rates.—Henry Marlow.

2101. For undergrounding of supervisory control cables and telephone cables at Yallourn Power Station and Morwell Open Cut, to Specification No. 67/112, at Schedule rates.—Oliver J. Nilsen & Co. Pty. Ltd.

2102. For supply of 78 miles of steel reinforced aluminium conductor for extension of the 22-kV distribution system at Omeo, to Quotation No. 1858, at Schedule rates.—Olympic Cables Pty. Ltd.

2103. For supply of electrical appliances and spare parts for merchandising in Commission showrooms for a period of three years, to Quotation No. 1469, at Schedule rates.—Simpson Pope Ltd.

Approved by the Governor in Council, 21st November, 1967.—J. ROSSITER, Clerk of the Executive Council.

STATE ELECTRICITY COMMISSION.

2104. For earthing of plant and equipment, Yallourn "W" Power Station, to Specification No. 67/2, at Schedule rates.—A.E.I. Engineering Pty. Ltd.

Approved by the Governor in Council, 14th November, 1967.—J. ROSSITER, Clerk of the Executive Council.

2105. For supply of sixty 22-kV automatic oil circuit reclosers for protection of the distribution system, to Specification No. 67/77, \$30,132.—A.E. Supplies Pty. Ltd.

2106. For supply of control equipment for public lighting electric discharge lamps for a period of two years with optional three months' extension, to Specification No. 66-67/382, at Schedule rates.—Australian Electrical Industries Pty. Ltd.

2107. For supply of steel pipes and reducing pieces for fire and water services, Yallourn and Morwell open cuts, to Specification No. 66-67/404, \$44,715.—Humes Ltd.

2108. For supply of 30 kits for conversion of tray top trucks to light construction trucks, to Specification No. 67/119, \$10,350.—R.S. Metal Products (Sales) Pty. Ltd.

2109. For provision of cleaning services at the Commission's premises, Lyle House, 22-32 William-street, Melbourne, for a period of approximately 2½ years, to Quotation No. 1637, at Schedule rates.—Utility Cleaning Co. (Vic.) Pty. Ltd.

2110. For supply of valve type lightning arresters for the distribution system for a period of one year with optional twelve months' extension, to Specification No. 66-67/370, at Schedule rates.—A.S.E.A. Electric Pty. Ltd.

2111. For supply of valve type lightning arresters for the distribution system for a period of one year with optional three months' extension, to Specification No. 66-67/370, at Schedule rates.—Bowthorpe Australia Pty. Ltd.

Approved by the Governor in Council, 21st November, 1967.—J. ROSSITER, Clerk of the Executive Council.

2112. For reblading of E2 turbine H.P. rotor, Yallourn "E" Power Station, to Quotation No. 1388, \$13,590.—A.E.I. Engineering Pty. Ltd.

2113. For supply of 22-kV intermediate class valve type surge diverters for protection of the distribution system against lightning for a period of two years with optional three months' extension, to Specification No. 67/26, at Schedule rates.—A.S.E.A. Electric (Aust.) Pty. Ltd.

2114. For supply and erection of one 10-ton electrically-operated overhead travelling crane for Boilermakers' Workshop, Hazelwood Power Station, to Specification No. 67/72, \$15,560.—Deer Park Engineering Pty. Ltd.

2115. For supply of electrical winding wire for a period of two years with an optional three months' extension, to Specification No. 65-66/229A, at Schedule rates.—Fairfield Electric Wire Co. Pty. Ltd.

2116. For the supply of galvanized structural steelwork for 22-kV switchyard structures for a period of seventeen months with an optional three months' extension, to Specification No. 67/12, at Schedule rates.—Frankwil Engineering Industries Pty. Ltd.

2117. For extensions to Chemical Laboratory and Amenities Building, Hazelwood Power Station, to Specification No. 67/100, \$112,500.—A. Gathercole & Co. (Gippsland) Pty. Ltd.

2118. For the construction of ancillary workshops and offices between stages 2 and 3, Hazelwood Power Station, to Specification No. 67/105, \$192,850.—A. Gathercole & Co. (Gippsland) Pty. Ltd.

2119. For earthworks and construction of roads and associated drains for Hazelwood Terminal Station, to Specification No. 67/149, at Schedule rates.—Gemell & Hickey Pty. Ltd.

2120. For supply and erection of auxiliary 415-volt switchgear and associated apparatus for Hazelwood Terminal Station, to Specification No. 67/42, \$25,968.—H. H. Green and Co. Pty. Ltd.

2121. For supply of replacement parts for various vehicles marketed by General Motors Holdens Pty. Ltd. in the Latrobe Valley area for a period of three years with an optional three months' extension, to Specification Nos. 65-66/34, at Schedule rates.—Kelly Bros. Motors Morwell Pty. Ltd.

2122. For the manufacture and supply of four mobile belt conveyors for bulk storage of briquettes, Morwell Briquette Works, to Specification No. 67/118, \$11,729.—V. M. Medley & Co.

2123. For supply and erection of plastic coated chain wire mesh fencing for substation and regulator sites and supply of chain wire mesh fencing for capacitor banks for a period of two years with optional three months' extension, to Specification No. 67/31, at Schedule rates.—Melbourne Wire Works Pty. Ltd.

2124. For civil engineering works and building for Frankston Terminal Station, to Specification No. 67/143, \$132,428.—Williamson Constructions Pty. Ltd.

Approved by the Governor in Council, 28th November, 1967.—J. ROSSITER, Clerk of the Executive Council.

FORESTS COMMISSION.

Loan Fund Act No. 7453, Item 6—

2125. To the purchase of that lot 95 on plan of subdivision No. 6142, being part of Crown allotment 63, Parish of Mooroolbark, County of Mornington, for forest purposes, \$590.00.—Helena Schild.

Loan Fund Act No. 7453, Item 6, Project PX—

2126. To the purchase of those allotments 12 and 101, Parish of Narbethong, County of Anglesey, containing 306 acres 1 rood 29 perches, for forest purposes, \$9,000.00.—J. L. Tremewen.

Approved by the Governor in Council, 21st November, 1967.—J. ROSSITER, Clerk of the Executive Council.

EDUCATION DEPARTMENT.

2127. Stawell Technical School, one (1) only vertical drilling machine, two hundred dollars (\$200). One (1) only woodturning lathe, two hundred and seventy-three dollars (\$273).—Scruttons Pty. Ltd.

2128. Stawell Technical School, one (1) only horizontal borer, two hundred and seventy dollars (\$270).—A. & S. Wolfenden.

2129. Ballarat School of Mines and Industries, six (6) only hand calculating machines, eight hundred and forty dollars (\$840).—Sydney Pincombe Pty. Ltd.

2130. Caulfield Technical College, two (2) only 13 inch carriage typewriters, three hundred and fifty dollars (\$350).—Sydney Pincombe Pty. Ltd.

2131. Horsham Technical School, one (1) only planing and thicknessing machine, one thousand five hundred and seventy-five dollars (\$1,575).—A. & S. Wolfenden.

Approved by the Governor in Council, 12th December, 1967.—J. ROSSITER, Clerk of the Executive Council.

PUBLIC WORKS.

2132. State Fauna Reserve, Wathe, hire of dozer to construct a fire break at the rate of \$20.00 per hour, total estimated cost, one thousand eight hundred dollars (\$1,800).—Thompson Plant Hire Agency Pty. Ltd.—(W.87358.)

2133. H.M. Gaol Pentridge, granolithic work, one thousand and seventy-one dollars (\$1,071).—Cement Flooring Co.—(N.W.37712 "6".)

2134. Family Cottages, Burwood Social Welfare Department, supply and installation of curtains, one thousand three hundred and forty-five dollars, eleven cents (\$1,345.11).—Fischer Furnishings Pty. Ltd.—(E.M.44840 "D".)

2135. Mental Hospital, Ballarat, supply of specially selected chairs, three thousand one hundred and eighty-three dollars (\$3,183).—Aristoc Industries Pty. Ltd.—(W.120207.)

2136. Maryvale High School, erection of portable administration building, eleven thousand nine hundred and ninety dollars (\$11,990).—Willcroft Terradin Pty. Ltd.—(S.E.108409 "E".)

2137. Swan Hill Technical School, mechanical services to woolclassing room, one thousand seven hundred and forty dollars (\$1,740).—F. A. Petzke & Co. Pty. Ltd.—(N.W.121252 "B".)

2138. Mental Hospital, Ballarat, installation of security grills, one thousand and ninety-seven dollars (\$1,097).—Charles Marshall Pty. Ltd.—(W.231950.)

Approved by the Governor in Council, 12th December, 1967.—J. ROSSITER, Clerk of the Executive Council.

CITY OF PRESTON.

TOWN AND COUNTRY PLANNING ACTS.

Interim Development Order.

BY virtue of the powers conferred by the Town and Country Planning Acts and of every other power enabling it in that behalf, the City of Preston (hereinafter referred to as the Responsible Authority), having commenced the preparation of a planning scheme in accordance with the said Act on the eighteenth day of February, 1952, hereby makes the following Interim Development Order for the purpose of regulating, restricting, restraining or prohibiting the use or development of any land or the erection, construction or carrying out of any buildings or works on any land within the area described or shown on the map as the Schedule hereto:—

1. After the coming into operation of this Interim Development Order no person shall use or develop any land or erect, construct or carry out any buildings or works on any land within the area included in the Schedule, except in accordance with the provisions of a permit issued by the Responsible Authority.

2. Any application for a permit to use or develop any land or to erect, construct or carry out any buildings or works, shall be accompanied by a sketch, plan or copy of certificate of title of the land, and a description of the proposed use or development, and type and construction of any buildings or works proposed to be erected, constructed or carried out and such other particulars relating to the application as the Responsible Authority may require.

3. This Interim Development Order shall not prevent the continuance of the use of any land or buildings for the purpose for which such land or buildings were lawfully used immediately before the coming into operation of this order.

4. *Schedule.*—The whole of the municipal district of the City of Preston.

C. P. W. KIRBY, Mayor.
A. H. CAPP, Councillor.
J. C. DONATH, Town Clerk.

(SEAL)

Report by the Town and Country Planning Board on the twelfth day of September, 1957. Recommended for approval.—FRED C. COOK, Chairman.

Approved by the Governor in Council on the seventeenth day of September, 1957.—A. MAHLSTEDT, Clerk of the Executive Council.

Report by the Town and Country Planning Board on the fourth day of September, 1958. Recommended for approval, pursuant to section 5 of the *Town and Country Planning (Metropolitan Area) Act 1954* (No. 5834).—FRED C. COOK, Chairman.

Approved by the Governor in Council, pursuant to section 5 of the *Town and Country Planning (Metropolitan Area) Act 1954* (No. 5834). Dated this seventeenth day of September, 1958.—N. G. WISHART, Acting Clerk of the Executive Council.

Report by the Town and Country Planning Board on the twenty-sixth day of August, 1959. Recommended for approval, pursuant to section 34 of the *Town and Country Planning Act 1958*.—FRED C. COOK, Chairman.

Approved by the Governor in Council, pursuant to section 34 of the *Town and Country Planning Act 1958*. Dated this fifteenth day of September, 1959.—A. MAHLSTEDT, Clerk of the Executive Council.

Report by the Town and Country Planning Board on the ninth day of September, 1960. Recommended for approval, pursuant to section 34 of the *Town and Country Planning Act 1958* (as amended).—FRED C. COOK, Chairman.

Approved by the Governor in Council, pursuant to section 34 of the *Town and Country Planning Act 1958* (as amended). Dated this twentieth day of September, 1960.—A. MAHLSTEDT, Clerk of the Executive Council.

Report by the Town and Country Planning Board on the fourth day of September, 1961. Recommended for approval, pursuant to section 34 of the *Town and Country Planning Act 1958* (as amended).—FRED C. COOK, Chairman.

Approved by the Governor in Council, pursuant to section 34 of the *Town and Country Planning Act 1958* (as amended). Dated this eighteenth day of September, 1961.—N. G. WISHART, Acting Clerk of the Executive Council.

Report by the Town and Country Planning Board on the nineteenth day of September, 1962. Recommended for approval, pursuant to section 55 of the *Town and Country Planning Act 1961*.—FRED C. COOK, Chairman.

Approved by the Governor in Council, pursuant to section 55 of the *Town and Country Planning Act 1961*. Dated this ninth day of October, 1962.—N. G. WISHART, Clerk of the Executive Council.

Report by the Town and Country Planning Board on the 9th day of October, 1963. Recommended for approval.—FRED C. COOK, Chairman.

Approved by the Governor in Council on the twenty-ninth day of October, 1963.—J. ROSSITER, Acting Clerk of the Executive Council.

Report by the Town and Country Planning Board on the twenty-eighth day of October, 1964. Recommended for approval.—FRED C. COOK, Chairman.

Approved by the Governor in Council on the twenty-fourth day of November, 1964.—J. COLQUHOUN, Clerk of the Executive Council.

Report by the Town and Country Planning Board on the twentieth day of October, 1965. Recommended for approval.—FRED C. COOK, Chairman.

Approved by the Governor in Council on the sixteenth day of November, 1965.—J. COLQUHOUN, Clerk of the Executive Council.

Report by the Town and Country Planning Board on the ninth day of November, 1966. Recommended for approval.—R. D. L. FRASER, Chairman.

Approved by the Governor in Council on the twenty-second day of November, 1966.—J. ROSSITER, Acting Clerk of the Executive Council.

Report by the Town and Country Planning Board on the twenty-first day of November, 1967. Recommended for approval.—R. D. L. FRASER, Chairman.

Approved by the Governor in Council on the fifth day of December, 1967.—F. KENNY, Acting Clerk of the Executive Council.

CITY OF BOX HILL.

TOWN AND COUNTRY PLANNING ACTS.

Interim Development Order.

BY virtue of the powers conferred by the *Town and Country Planning Act 1961* (as amended), and of every other power enabling it in that behalf, the Council of the City of Box Hill (hereinafter referred to as the Responsible Authority), having commenced the preparation of a planning scheme on the fourteenth day of August, 1961, in accordance with the *Town and Country Planning Acts* then in force, hereby makes the following Interim Development Order for the purpose of regulating, restricting, restraining or prohibiting the use of development of any land or the erection, construction or carrying out of any buildings or works on any land within the area described in the Schedule hereto.

1. After the coming into operation of this Interim Development Order no person shall use or develop any land or erect, construct or carry out any buildings or works on any land within the area included in the Schedule, except in accordance with the provision of a permit issued by the Responsible Authority.

2. Every application for a permit under the provisions of this Order shall be made on the prescribed form, copies of which may be obtained from the office of the Responsible Authority of Box Hill.

3. This Interim Development Order shall not prevent—

(a) the continuance of the use of any land or buildings or works for the purposes for which such land or buildings or works were lawfully used immediately before the coming into operation of this Order;

(b) any dealing or the registration of any dealing with any land in a subdivision of which a plan has been sealed by the Council of the City of Box Hill and lodged with the Registrar of Titles, pursuant to section 569 of the *Local Government Act 1958*, before the coming into operation of this Order.

4. *Schedule.*—The whole of the land within the following boundaries:—

Commencing at the south-west corner of Whitehorse-road and Market-street; thence westerly, northerly and westerly along the southern boundary of Whitehorse-road to the south-west corner of Nelson-road and Whitehorse-road; thence southerly along the western boundary of Nelson-road to the north-west corner of Prospect-street and Nelson-road; thence diagonally across Prospect-street to the north-west corner of lot 51 on plan of subdivision lodged in the Titles Office and numbered 6554; thence southerly

along the western boundary of the said lot 51 to its boundary with the Railway Reserve; thence south 87 degrees east a distance of 845 feet; thence north to the north-west corner of Market-street and Main-street; thence northerly along the western boundary of Market-street to the point of commencement.

The common seal of the Mayor, Councillors and Citizens of the City of Box Hill was hereunto affixed this 25th day of October, 1965, in the presence of—

(SEAL) S. G. DEWAR, Councillor.
W. G. HOSIE, Councillor.
A. N. WALLS, Town Clerk.

Report by the Town and Country Planning Board on the tenth day of November, 1965.—FRED C. COOK, Chairman.

Approved by the Governor in Council on the twenty-third day of November, 1965.—J. COLQUHOUN, Clerk of the Executive Council.

Report by the Town and Country Planning Board on the twenty-third day of November, 1966. Recommended for approval.—R. D. L. FRASER, Chairman.

Approved by the Governor in Council on the thirteenth day of December, 1966.—J. COLQUHOUN, Clerk of the Executive Council.

Report by the Town and Country Planning Board on the twenty-eighth day of November, 1967. Recommended for approval.—R. D. L. FRASER, Chairman.

Approved by the Governor in Council on the twelfth day of December, 1967.—J. ROSSITER, Clerk of the Executive Council.

CITY OF SALE.

RATING BY-LAW FOR THE YEAR ENDING 1967-68.

By-law No. 54.

THE Municipal Council of the City of Sale, in pursuance and exercise of the powers conferred by the Water Acts, doth make a rate for the supply of water for domestic purposes of Four cents in the dollar on the Net Annual Valuation of lands and tenements liable to be rated within the Sale Water Supply District.

Provided that in no case shall the amount of the rate payable per annum in respect of any tenement (other than land on which there is no building) be less than Six dollars and in respect of any land on which there is no building less than Two dollars.

Such rates are made and shall be levied upon the Occupiers or Owners of the said lands and tenements for the year commencing on the 1st day of October, 1967 and shall be payable on the 20th day of December, 1967, at the office of the said Local Governing Body, Council Chambers, Sale.

The maximum quantity of water to be supplied in any one year without further charge to any property rated by the Council is hereby fixed at the quantity which, at a charge of Fifteen cents per 1000 gallons, would produce an amount equal to the amount of the rate levied on such property for the said year.

The charge for water supplied by measure to any property rated by the Council in excess of such maximum quantity, computed as in the last preceding clause is hereby fixed at Twenty Five cents for 1000 gallons.

The charge for water supplied by measure to any property not rated by the Council is hereby fixed at Twenty Five cents per 1000 gallons and the minimum quantity of water to be charged in cases where water is so supplied is hereby fixed at 48,000 gallons.

Such person or persons as the Council may appoint from time to time for the purpose shall be authorised to demand, receive and collect the said rates and charges.

The foregoing was made and adopted by the Municipal Council of the City of Sale on the 2nd day of October, 1967, and the common seal of the City of Sale was hereto affixed by order of the said Council, in the presence of—

(SEAL) W. J. STEPHENSON, Mayor.
O. A. RUFF, Councillor.
J. R. RAY, Town Clerk.

Approved, 15th December, 1967.—W. BORTHWICK, Minister of Water Supply.

THE BALLARAT WATER COMMISSIONERS.

BY-LAW NO. 19.

THE Ballarat Water Commissioners in pursuance of and in exercise of the powers conferred by the Water Act 1958 and of any and every other power it thereunto enabling doth hereby make a By-law as follows:—

1. The meter or meters measuring the supply of water to any land or tenement shall be read as near as practicable to twelve months from the date that it was read previously and the quantity of water so measured as having been supplied during the period between any two successive such readings (hereinafter called "the meter year") shall be the basis of the calculating of charges payable under this By-law provided always that where a meter has been installed on any land or tenement during the course of a meter year the quantity of water measured as having been supplied during the period between the date of such installation and the date of the reading shall be the basis of calculating such charges.

2. Subject as is hereinafter provided in respect of any land or tenement rated by the Commissioners—

(a) The maximum quantity of water to be supplied in any meter year without charge is hereby fixed as a quantity which if charged at Fourteen cents per thousand gallons for any meter year would give an amount equal to the amount of the rate payable in respect of the land or tenement for the said meter year.

(b) For all water supplied in any meter year in excess of the maximum quantity referred to in paragraph (a) of this clause the charge is hereby fixed at Fourteen cents per thousand gallons for any meter year.

3. Subject as is hereinafter provided the charge for water supplied by measure to any property not rated by the Commissioners is hereby fixed at Fourteen cents per thousand gallons.

4. The minimum charge for water supplied by measure to any property not rated by the Commissioners is hereby fixed at Four dollars.

5. The aforesaid charges shall be payable within seven days of demand upon the owner or occupier at the office of the Commissioners during normal business hours.

6. The provisions of Clauses 2, 3 and 4 of this By-law shall not apply to any land tenement or property supplied with water by the Commissioners under a special agreement pursuant to Section 215 of the Water Act 1958.

Passed this sixteenth day of November, One thousand nine hundred and sixty-seven.

(SEAL) A. W. NICHOLSON, Chairman.
A. GUYE, Commissioner.
CHAS. H. CLAMP, Secretary.

Approved, 8th December, 1967.—W. BORTHWICK, Minister of Water Supply.

THE BALLARAT WATER COMMISSIONERS.

BY-LAW NO. 71.

THE Ballarat Water Commissioners in pursuance of and in exercise of the powers conferred by the Water Act 1958 and of any and every other power it thereunto enabling doth hereby make a By-law as follows:—

1. The Ballarat Water Commissioners hereby makes and levies a rate in respect of all the lands and tenements within the Ballarat Water Supply District of 3.2 cents in the dollar on the net annual value set out in the valuation at present in force of such lands and tenements for the purposes of the municipal rate which is hereby adopted as the valuation of such lands and tenements respectively.

2. Such rate shall be made and levied upon the occupiers and owners of such lands and tenements for the year commencing on the 1st day of January, 1968 and shall be payable on the 31st day of March, 1968 at the office of the said Commissioners.

3. In no case shall the rate payable hereunder in respect of any land on which there is a building be less than Four dollars and in respect of land on which there is no building be less than Four dollars.

Passed this Sixteenth day of November, One thousand nine hundred and sixty-seven.

(SEAL) A. W. NICHOLSON, Chairman.
A. GUYE, Commissioner.
CHAS. H. CLAMP, Secretary.

Approved, 8th December, 1967.—W. BORTHWICK, Minister of Water Supply.

WARRAGUL WATERWORKS TRUST.

RATING BY-LAW FOR THE YEAR 1968.

THE Warragul Waterworks Trust, in pursuance of the powers conferred by the Water Act, doth hereby make the By-Law following :—

1. The following rates for the supply of water for domestic purposes are hereby made and shall be levied upon the occupiers or owners of lands and tenements within the respective urban districts as set out hereunder :—

Lands and tenements liable to be rated—a rate of such amount in the dollar of the annual municipal valuation of such lands or tenements as is set down in column 2 opposite the names of the respective urban districts in column 1 of the Schedule hereto : Provided that the total amount of the rate payable annually in respect of any such lands or tenements (other than land on which there is no building) shall be not less than the sum set down in column 3 opposite the name of the respective urban districts in column 1 of the said schedule, and in respect of any such lands or tenements on which there is no building shall be not less than the sum set down in column 4 opposite the name of the respective urban districts in column 1 of the said schedule.

2. Such rates are made and shall be levied upon the occupiers or owners of the said lands and tenements for the year commencing the 1st January, 1968, and shall be payable on the 11th day of January, 1968, at the Office of the Trust, Civic Place, Warragul.

SCHEDULE.

Name of Respective Urban District. Column 1.	Amount of Rate in the Municipal Valuation of Tenements (Subject to the Minimum Amount of Rates as set out in Columns 3 and 4). Column 2.	Minimum Amount of Rate per Year in Respect of Tenements (Other than Lands on which there is no building). Column 3.	Minimum Amount of Rate per Year in Respect of Land on which there is no building. Column 4.
	c	\$	\$
Darnum	15	15.00	10.00
Nilma	14	15.00	10.00
Rokeyby	17.5	17.00	10.00
Warragul	5	15.00	10.00

Passed this 6th day of December, 1967.

A. W. RANDALL, Chairman.
L. J. BAXTER, Commissioner.
J. C. GRAEME APLIN, Secretary.

Approved, 12th December, 1967.—W. Borthwick, Minister of Water Supply.

AXEDALE WATERWORKS TRUST.

RATING BY-LAW FOR THE YEAR 1968.

THE Axedale Waterworks Trust, in pursuance and exercise of the powers conferred by the Water Act, doth hereby make a rate for the supply of water for domestic purposes of Thirteen cents in the Dollar on the annual municipal valuation of lands and tenements liable to be rated within the Axedale Urban District.

Provided that in no case shall the amount of rate payable per annum in respect of any tenement (other than land on which there is not a building) be less than Fourteen dollars and in respect of land on which there is no building less than Six dollars.

Such rates are made and shall be levied upon the occupiers or owners of the said lands and tenements for the year commencing 1st January, and ending 31st December, 1968, and shall be payable in one amount on the 1st March, 1968 at the office of the said Trust.

The maximum quantity of water to be supplied for the year without further charge to any property rated by the Trust or in respect of which payments are made to the Trust ex gratia or by agreement is hereby fixed at the quantity which, at a charge of Thirty cents per 1,000 gallons on a quantity up to 40,000 gallons and Twenty cents per 1,000 on any further quantity, would produce an amount equal to the amount of the rate levied on or payment received in respect of such property for the said year.

The charge for water supplied by measure to any such property in excess of such maximum quantity, computed as in the last preceding clause, is hereby fixed at Twenty cents per 1,000 gallons.

The charge for water supplied by measure shall be payable, on demand, at the office of the Trust.

The seal of the Axedale Waterworks Trust was hereto affixed this 30th day of November, 1967, in the presence of—

(SEAL) JOHN ELLISON, Chairman.
JOHN A. COLVIN, Commissioner.
THOMAS H. BOWLES, Secretary.

Approved, 14th December, 1967.—W. BORTHWICK, Minister of Water Supply.

GISBORNE WATERWORKS TRUST.

RATING BY-LAW FOR THE YEAR 1968.

THE Gisborne Waterworks Trust, in pursuance and exercise of the powers conferred by the Water Act, doth hereby make a rate for the supply of water for domestic purposes of Six Cents in the Dollar (6 cents in the \$1) of the annual municipal valuation of lands and tenements liable to be rated within the Gisborne Urban District.

Provided that in no case shall the amount of rate payable per annum in respect of any tenement (other than land on which there is no building) be less than (\$6) and in respect of any land on which there is no building less than (\$3).

Such rate is made for the year commencing the 1st day of January, 1968, and shall be payable on the 1st day of February, 1968, at the office of the said Trust.

The maximum quantity of water to be supplied in any one year, without further charge on any property rated by the Trust, is hereby fixed at the quantity which, at a charge of 15 cents per 1,000 gallons, would produce an amount equal to the amount of rate levied on such property for the said year.

The charge for water supplied by measure to any property rated by the Trust in excess of such maximum quantity, computed as in the last preceding clause, is hereby fixed at 15 cents per 1,000 gallons.

The charge for water supplied by measure shall be payable, on demand, at the office of the Trust.

Passed this 5th day of December, 1967.

(SEAL) H. G. GRUMONT, Commissioner.
ALAN J. PEAVEY, Commissioner.
F. V. ROBINSON, Secretary.

Approved, 13th December, 1967.—W. BORTHWICK, Minister of Water Supply.

TRARALGON WATERWORKS TRUST.

RATING BY-LAW.—PERIOD 1ST JANUARY, 1968, TO 30TH SEPTEMBER, 1968.

THE Traralgon Waterworks Trust, in pursuance and exercise of the powers conferred by the Water Act, doth hereby make a rate for the supply of water for domestic purposes of point four two cents (.42 cents) in the dollar on Unimproved Capital Valuation of lands and tenements liable to be rated within the Traralgon Urban District.

1. Provided that in no case shall the amount of rate payable in respect of any tenement other than land on which there is no building be less than eleven dollars twenty-five cents (\$11.25) and in respect of any land on which there is no building, be less than six dollars (\$6.00).
2. Such rates are made and shall be levied upon the occupiers or owners of the said land and tenements for the period commencing on the first day of January, 1968, and ending on the thirtieth day of September, 1968, and shall become due and payable on the second day of January, 1968, at the office of the said Trust.
3. The maximum quantity of water to be supplied during the period, without further charge, to any property rated by the Trust is hereby fixed at a quantity which, at a charge of twenty-five cents (25 cents) per 1,000 gallons, would produce an amount equal to the amount of rate levied on such property for the said period.
4. The charge for water supplied by measure to any property rated by the Trust in excess of such maximum quantity, computed as in the last preceding clause is hereby fixed at twenty cents (20 cents) per 1,000 gallons.
5. The charge for water supplied by measure to any property not rated by the Trust will be fixed by special agreement with the Trust provided that in no case shall the amount payable be less than ten dollars (\$10.00).
6. The charge for water supplied by measure and by special agreement shall be payable on demand at the office of the said Trust.

Passed this 6th day of December, 1967.

(SEAL) DONALD DUNBAR, Acting Chairman.
C. E. STAMMERS, Commissioner.
K. J. SAUNDERS, Secretary.

Approved, 14th December, 1967.—W. BORTHWICK, Minister of Water Supply.

ALEXANDRA WATERWORKS TRUST.

RATING BY-LAW FOR THE YEAR 1968.

THE Alexandra Waterworks Trust, in pursuance and exercise of the powers conferred by the Water Act, doth hereby make a rate for the supply of water of six cents in the dollar, on the annual municipal valuation of lands and tenements liable to be rated within the Alexandra Urban District.

Provided that in no case shall the amount of rate payable per annum in respect of any tenement (other than land on which there is no building) be less than six dollars, and in respect of land on which there is no building be less than two dollars.

Such rates are made and shall be levied upon the occupiers or owners of the said lands and tenements for the year commencing on the 1st January, 1968, and shall be due and payable on the 4th day of January, 1968, at the Office of the said Trust, and if unpaid by the 4th day of May, 1968, shall bear interest at 6 per cent. per annum from the day on which they become payable.

The maximum quantity of water to be supplied in any one year without any further charge to any property rated by the Trust is hereby fixed at the quantity which at a charge of eighteen cents per 1,000 gallons would produce the amount equal to the amount of rates levied on such property for the said year.

The charge for water supplied by measure to any property rated by the Trust in excess of such maximum quantity, computed as in the last preceding clause, is hereby fixed at eighteen cents per 1,000 gallons.

The charge for water supplied by measure to any property not rated by the Trust is hereby fixed at nineteen cents per 1,000 gallons, and the minimum quantity of water to be charged for in any case where water is not supplied is hereby fixed at 30,000 gallons.

The charge for water supplied by measure shall be payable on demand at the Office of the Trust.

Passed by the Alexandra Waterworks Trust this 30th day of October, 1967.

(SEAL) B. J. O'BRIEN, Chairman.
T. COOKE, Commissioner.
L. H. THOMPSON, Secretary.

Approved 19th December, 1967.—W. A. BORTHWICK, Minister of Water Supply.

LANDSBOROUGH WATERWORKS TRUST.

RATING BY-LAW FOR THE YEAR 1968.

THE Landsborough Waterworks Trust, in pursuance and exercise of the powers conferred by the Water Act, doth hereby make a rate for the supply of water for domestic purposes of 17.5 cents in the dollar on the annual municipal valuation of lands and tenements liable to be rated within the Landsborough Waterworks Trust Urban District.

Provided that in no case shall the amount of the rate payable per annum in respect of any tenement (other than land on which there is no building) be less than Seventeen dollars, and in respect of any land on which there is no building less than Five dollars.

Such rates are made and shall be levied upon the occupiers or owners of the said lands and tenements for the year commencing on the first day of January, 1968, and shall be payable on the fifth day of January, 1968, at the office of the said Trust.

The maximum quantity of water to be supplied in any one year, without further charge to any property rated by the Trust, is hereby fixed at the quantity which, at a charge of Forty cents per 1,000 gallons, would produce an amount equal to the amount of the rate levied on such property for the said year.

The charge for water supplied by measure to any property rated by the Trust in excess of such maximum quantity, computed as in the preceding clause, is hereby fixed at Forty cents per 1,000 gallons.

The charge for water supplied by measure to any property not rated by the Trust is hereby fixed at Fifty cents per 1,000 gallons for a supply up to 60,000 gallons, and Forty cents per 1,000 gallons thereafter, and the minimum quantity of water to be charged for in cases where water is so supplied is hereby fixed at 30,000 gallons.

The charge for water supplied by measure shall be payable, on demand, at the office of the said Trust.

Passed this 28th day of November, 1967.

The corporate seal of the Landsborough Waterworks Trust was hereunto affixed, this 28th day of November, 1967, in the presence of—

(SEAL) ARTHUR J. VANCE, Chairman.
RAY BIBBY, Commissioner.
J. FFRENCH, Commissioner.
F. C. S. EDWARDS, Secretary.

Approved, 8th December, 1967.—W. BORTHWICK, Minister of Water Supply.

THE BENDIGO SEWERAGE AUTHORITY.

RATING BY-LAW No. 14.

The Bendigo Sewerage District.

THE Bendigo Sewerage Authority, in pursuance and exercise of the powers conferred by the Sewerage Districts Acts, doth hereby make the following By-Law:—

The following sewerage rate is hereby made under the provision of the Sewerage Districts Acts, and shall be levied upon the nett annual value of the rateable sewerer properties within the Bendigo Sewerage District:—

1. Of any land or tenements situate within the Bendigo Sewerage District, a sewerage rate of four and a half cents in the \$1.00 of the nett annual value of all rateable "sewerer property" within the said District.

2. In no case shall the amount of sewerage rate payable annually be less than \$9.00 in respect of any rateable sewerer property on which there is a building, and \$5.00 in respect of any rateable sewerer property on which there is no building.

3. Such rate is made and shall be levied for the year beginning with the first day of October, 1967 and ending with the thirtieth day of September, 1968 and shall be payable on the first day of February, 1968 at the office of the Authority, situate at the Civic Buildings, Bendigo.

4. If any rateable property which is unsewered at the time of the making of the aforesaid rate becomes during the said year a "sewered property", there shall be levied upon such property a proportionate part of the sewerage rate for the portion of the year after it has become a sewered property, and such property shall be deemed to have been lawfully rated accordingly.

5. For making and levying such rate the valuation for the time being of such lands and tenements for the municipal rate of the municipality in the municipal district of which such lands and tenements are situate shall be deemed and taken to be the valuation of such lands and tenements respectively; but if any such lands and tenements are not included in a valuation in force for the municipality in whose district they are situate, or if there is no such valuation, the nett annual value thereof may for all purposes of such rate be determined in the manner provided in the Sewerage Districts Acts.

6. Such person or persons as the Bendigo Sewerage Authority may from time to time appoint for that purpose shall be and is or are hereby authorized to demand, receive, collect and recover the said rates and charges.

The resolution for passing the foregoing By-Law was agreed to by the Bendigo Sewerage Authority on the twenty-third day of October, 1967, and was confirmed by the said Authority on the twenty-seventh day of November, 1967.

(SEAL) T. R. FLOOD, Chairman.
ROY M. SHADFORTH, Member.
H. A. MOORS, Secretary.

Approved by the Governor in Council, 12th December, 1967.—J. ROSSITER, Clerk of the Executive Council.

FRANKSTON SEWERAGE AUTHORITY.

BY-LAW No. 6.

A By-law of the Frankston Sewerage Authority, made under the Sewerage Districts Act and every other Act or Regulation enabling it in that behalf, and numbered 6 for the purpose of fixing minimum sewerage rates.

IN pursuance of the powers conferred by the foregoing Act and every other Act or Regulation enabling it in that behalf, the Chairman and Members of the Frankston Sewerage Authority order as follows:—

In no case shall the amount of sewerage rate payable annually be less than Twenty Dollars (\$20) in respect of any rateable sewered property on which there is a building and Fourteen Dollars (\$14) in respect of any rateable sewered property on which there is no building.

Resolution for the passing of this By-law was agreed to by the Frankston Sewerage Authority at a Meeting held on the 6th day of November 1967, and confirmed at a Meeting held on the 4th day of December 1967.

The common seal of the Frankston Sewerage Authority was hereunto affixed in the presence of—

(SEAL) V. S. McCOMB, Chairman.
G. W. PAYNE, Member.
G. C. PENTLAND, Secretary.

Approved by the Governor in Council, on the 19th day of December, 1967.—J. ROSSITER, Clerk of the Executive Council.

ORBOST SEWERAGE AUTHORITY

RATING BY-LAW FOR THE YEAR COMMENCING 1ST JANUARY, 1968.

THE Orbost Sewerage Authority, in pursuance and exercise of the powers conferred by the Sewerage Districts Act, doth hereby make and levy a sewerage rate of fifteen cents in the dollar on the Net Annual Valuation of all rateable sewered property and a Special Rate of ten cents in the dollar on the Net Annual Valuation of all rateable unsewered property within the Orbost Sewerage District, provided that the minimum amount of Sewerage Rate shall be Fifteen Dollars in respect of any rateable sewered property on which there is a building and Ten Dollars in respect of any rateable sewered property on which there is no building.

Such rates are made for the year commencing 1st January, 1968, and shall be payable on 31st January, 1968, at the Office of the Authority, Clarke Street, Orbost, provided that the Sewerage Rate in respect of any property which becomes sewered property after the thirty-first day of January, 1968, shall be payable one month after the date on which such property becomes sewered property.

A resolution for the passing of this By-Law was agreed to at a Special Meeting held on 23rd day of November, 1967, by the said Authority and the Common Seal of the Orbost Sewerage Authority was thereunto fixed.

(SEAL) K. E. G. MOORE, Chairman.
J. D. TORLEY, Member.
L. SPINK, Secretary.

Approved by the Governor in Council, 19th December, 1967.—J. ROSSITER, Clerk of the Executive Council.

APPOINTMENTS

APPOINTMENTS.

HIS Excellency the Governor of the State of Victoria, by and with the advice of the Executive Council thereof, has, by Orders made on the 12th day of December, 1967, been pleased to make the under-mentioned appointments, viz.:—

CHIEF SECRETARY'S DEPARTMENT.

Chaplain of a Prison (Part-time).

CYRIL LONSDALE CHATHAM, B.A. (the Reverend), to be Church of England Chaplain (part-time) to Bendigo Training Prison, from the 1st December, 1967.

MINISTRY OF HEALTH.

Members of Committees of Management of Hospitals.

BRYAN RAYMOND DAHLSSEN to be a member of the Committee of Management of Bairnsdale District Hospital, pursuant to proviso (a) to section 48 (1) of the *Hospitals and Charities Act 1958*, for a further period of three years ending 21st December, 1970; and

NEIL CHARLES BELL to be a member of the Committee of Management of Morwell and District Community Hospital, pursuant to proviso (a) to section 48 (1) of the *Hospitals and Charities Act 1958*, for a period of three years.

Superintendents.

JACK LEWIS EVANS, M.B., B.S., D.P.M., to be Superintendent of the Children's Cottages, Kew, pursuant to section 26 (1) of the *Mental Health Act 1959*, as from and inclusive of the 1st December, 1967, vice Dr. D. B. Pitt; and

MARCUS KINGSLEY BENJAMIN, M.B., B.S., M.R.A.C.P., D.P.M., to be Superintendent of the Larundel Mental Hospital, pursuant to section 26 (1) of the *Mental Health Act 1959*, vice Dr. D. H. Barlow.

Deputy Superintendents.

DAVID BUXTON PITT, M.B., B.S., M.D., to be Deputy Superintendent of the Children's Cottages, Kew, pursuant to section 26 (1) of the *Mental Health Act 1959*, as from and inclusive of the 1st December, 1967, vice Dr. F. W. Lustig; and

LANCE MERVYN BROWN, M.B., B.S., D.P.M., to be Deputy Superintendent of the Larundel Mental Hospital, pursuant to section 26 (1) of the *Mental Health Act 1959*, vice Dr. M. K. Benjamin.

LAW DEPARTMENT.

Commissioners for Taking Declarations, &c.

GEORGE WILLIAM GRIFFIN, care of V.A.C.C. Insurance Company, 200 Queen-street, Melbourne.
LEIGH FOSTER MUMFORD, care of The Commercial Bank of Australia Limited, Lygon-street, East Brunswick,
JAMES ALLISON KING, care of McWilliams Wines Pty. Ltd., 27-31 Munster-terrace, North Melbourne, and
WILLIAM JOHN GOUDGE, care of Trotting Control Board, Royal Melbourne Showgrounds, Ascot Vale,
to be Commissioners for taking Declarations and Affidavits, pursuant to the provisions of the *Evidence Act 1958*, to resign upon ceasing to occupy their present positions;

DOROTHY PATRICIA GRIMMER, care of Housing Commission, Victoria, 179 Queen-street, Melbourne, to be a Commissioner for taking Declarations and Affidavits, pursuant to the provisions of the Evidence Act 1958, to refrain from charging fees and to resign upon ceasing to occupy her present position; and

GEORGE HENRY LYLE TREYVAUD, 56A Morris-street, Williamstown,
DOUGLAS ALBERT WYSHAM, 130 Swan-street, Richmond,
and
ROY JAMES HARVEY, 609 Balcombe-road, Black Rock, to be Commissioners for taking Declarations and Affidavits, pursuant to the provisions of the Evidence Act 1958, to resign upon removing from the neighbourhood of the addresses stated.

Justice of the Peace.

DAWN JOAN TURNER, 51 Korumburra-road, Wonthaggi, to Keep the Peace in the Central Bailiwick of the State of Victoria.

PUBLIC WORKS DEPARTMENT.

President of the Marine Board of Victoria.

ALBERT JOHN WAGGLEN
to be President of the Marine Board of Victoria, for a period of three years from the 19th December, 1967.

Members of the Marine Board of Victoria.

ALBERT JOHN WAGGLEN,
JOHN HENRY COLES, and
PERCY WILLIAM MERRETT
to be Members of the Marine Board of Victoria, for a period of three years from the 19th December, 1967.

DEPARTMENT OF THE TREASURER.

Receiver of Revenue (Acting).

IAN JOHN COLLARD
to act temporarily as Receiver of Revenue, Yarram, vice A. R. Ison, on leave.

DEPARTMENT OF WATER SUPPLY.

Waterworks Trusts Commissioners.

ROBERT SWEETNAM KREBS and
HARRY LADD SOUTER
to be Commissioners of the Mallacoota Waterworks Trust for a period of four years from the date hereof; and

PERCY BOWEN MARTIN
to be a Commissioner of the Toora Waterworks Trust, to hold office as such for a period of two years from the date hereof, subject to the provisions of the Water Act.

Members of Sewerage Authorities.

LEO PATRICK McMAHON
to be a Member of the Anglesea Sewerage Authority, to hold office as such for a period of four years from the date hereof, subject to the provisions of the Sewerage Districts Act; and

RALPH BENJAMIN WILSON and
DAVID ANTHONY WYLES
to be Members of the Dromana-Rosebud Sewerage Authority, to hold office as such for a period of four years from the date hereof, subject to the provisions of the Sewerage Districts Act.

J. ROSSITER,
Clerk of the Executive Council.

At the Executive Council Chamber,
Melbourne, 12th December, 1967.

CORRIGENDUM.

AGRICULTURE DEPARTMENT.

Appointment of Inspectors.

IN Government Gazette No. 89 of 22nd November, 1967, page 3456. Appointments Fruit and Vegetables Act 1958—

"CLARENCE ERNEST DAVIS, TREVOR JAMES DINEEN, and HAROLD MARSHALL, Orchard Inspectors."

should read

"CLARENCE ERNEST DAVIS, and TREVOR JAMES DINEEN, Orchard Inspectors."

HAROLD MARSHALL, Horticultural Adviser."

D. S. WISHART,
Director of Agriculture.

ORDER IN COUNCIL

LOCAL GOVERNMENT DEPARTMENT.

At the Executive Council Chamber, Melbourne, the twelfth day of December, 1967.

PRESENT:

His Excellency the Governor of Victoria.
Mr. Chandler | Mr. Rossiter.
Mr. Borthwick

ROAD DISCONTINUED.— SHIRE OF FLINDERS.

WHEREAS it is provided in Section 528 (2) of the Local Government Act, as amended, that where a road (whether or not a public highway but not being a road set out on land of the Crown) or any part thereof is not required for public use the Governor-in-Council on the request of the Council of the municipality in which such road is situated made not less than one month after publishing in a newspaper generally circulating in the district and posting to the registered proprietor (if any) of the land and any person known to have an interest in the land notice of intention to make such a request may by Order published in the *Government Gazette* direct that such road or part shall be discontinued and thereupon such road or part shall be discontinued accordingly.

AND WHEREAS the Council of the Shire of Flinders has requested that the Governor-in-Council direct that a right-of-way off Dromana Parade, be discontinued and not less than one month previously has published in a newspaper generally circulating in the district and posted to the registered proprietor of the land in the said road and to all persons known to have an interest in the said land notice of intention to make such request.

NOW THEREFORE, His Excellency the Governor of the State of Victoria, by and with the advice of the Executive Council thereof, hereby directs that the said road, which is shown hatched on the plan hereunder, shall be discontinued and that the land may be sold by the Council of the Shire of Flinders by agreement.

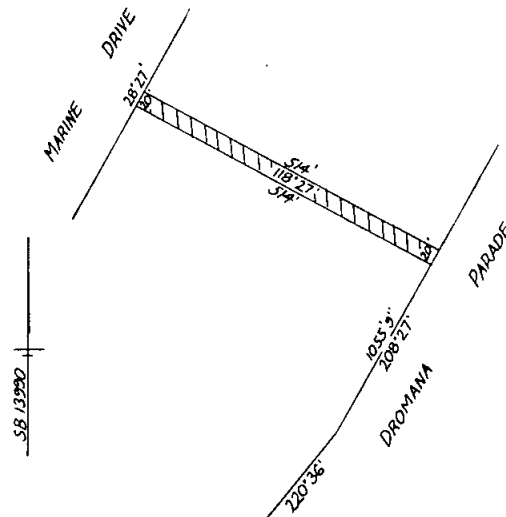

The fee of the land was on 10-11-67 comprised in Certificate of Title Vol 3281 F-003.

The measurements are in feet and inches

And the Honorable Rupert James Hamer, Her Majesty's Minister for Local Government for the State of Victoria, shall give the necessary directions herein accordingly.

J. ROSSITER,
Clerk of the Executive Council.

LOCAL GOVERNMENT DEPARTMENT.

At the Executive Council Chamber, Melbourne, the twelfth day of December, 1967.

PRESENT:

His Excellency the Governor of Victoria.
Mr. Chandler | Mr. Rossiter.
Mr. Borthwick

CONSENT TO SALE OF RESERVE BY THE SUNSHINE CITY COUNCIL.

WHEREAS, by an Order pursuant to Section 569BA of the *Local Government Act 1958*, as amended, published in the *Government Gazette* of the 20th October, 1965, certain land being a reserve on Plan of Subdivision No. 11263 lodged in the Office of Titles was vested in the Council of the City of Sunshine and the said Council is now of the opinion that the land is no longer required for the purpose for which it was reserved and has requested that consent be given to the sale of the land:

AND WHEREAS the said Council:

- (a) Has published in a newspaper generally circulating in the municipal district a notice describing the land and the proposal for the sale of the land and stating that at the next ordinary meeting of the Council after the expiration of forty days after publication of the notice the Council would consider any objection to the proposal and would receive any representations as to the disposal of any purchase money;
- (b) Has served a copy of the said notice upon the registered proprietor of the land and upon those other persons upon whom the Council considered such notice should be served;
- (c) Has posted a similar notice upon the land in question:

AND WHEREAS no person has objected to the proposed sale of the land.

NOW THEREFORE, His Excellency the Governor of the State of Victoria, by and with the advice of the Executive Council thereof, doth hereby consent to the Council of the City of Sunshine selling by private treaty the Reserve for Plantation Drainage and Sewerage coloured green on Plan of Subdivision No. 11263 lodged in the Office of Titles.

And the Honorable Rupert James Hamer, Her Majesty's Minister for Local Government for the State of Victoria, shall give the necessary directions herein accordingly.

J. ROSSITER,
Clerk of the Executive Council.

LOCAL GOVERNMENT DEPARTMENT.

At the Executive Council Chamber, Melbourne, the twelfth day of December, 1967.

PRESENT:

His Excellency the Governor of Victoria.
Mr. Chandler | Mr. Rossiter.
Mr. Borthwick

APPLICATION TO ELECTIONS OF COUNCILLORS FOR THE SHIRE OF CROYDON OF REGULATIONS RELATING TO COMPULSORY VOTING.

WHEREAS it is provided in Section 149 of the *Local Government Act 1958*, as amended, that the Governor-in-Council on the petition of the Council of any municipality, may by Order published in the *Government Gazette*, apply to elections of councillors for such municipality with any modifications provided for in such Order, all or any of the Regulations relating to compulsory voting made under the said Section 149.

NOW THEREFORE His Excellency the Governor of the State of Victoria, by and with the advice of the Executive Council thereof, and in pursuance of a petition of the Council of the Shire of Croydon, doth hereby order that the Regulations relating to the compulsory voting at municipal elections made pursuant to the provisions of the said Section 149 shall apply to elections of councillors for the municipality of the Shire of Croydon.

And the Honorable Rupert James Hamer, Her Majesty's Minister for Local Government for the State of Victoria, shall give the necessary directions herein accordingly.

J. ROSSITER,
Clerk of the Executive Council.

LOCAL GOVERNMENT DEPARTMENT.

At the Executive Council Chamber, Melbourne, the twelfth day of December, 1967.

PRESENT:

His Excellency the Governor of Victoria.
Mr. Chandler | Mr. Rossiter.
Mr. Borthwick

CONFIRMATION OF SEPARATE RATE—CITY OF COBURG.

IN pursuance of the provisions of Section 287 of the *Local Government Act 1958*, as amended, His Excellency the Governor of the State of Victoria, by and with the advice of the Executive Council thereof, hereby confirms a separate rate of one-quarter of one cent in the dollar on the unimproved capital value of the properties described hereunder, which rate was made by the Council of the City of Coburg on the 20th November 1967, for the purpose of permanently paving, draining, beautifying and carrying out ancillary works on the land provided and to be provided for off-street car parking purposes for the Sydney Road Shopping Centre by means of a separate rate confirmed by the Governor-in-Council by notice published in the *Government Gazette* on the 14th February, 1962.

Properties to be rated

- (a) The properties situate at and fronting the east side of that portion of Sydney Road, bounded on the south by Harding Street and on the north by Bell Street and numbered from 368 to 502 Sydney Road inclusive.
- (b) The properties situate at and fronting the west side of that portion of Sydney Road, between a point 187 ft. 6 in. south of Munro Street and a point 215 ft. 5 in. north of Bell Street and numbered 347 to 517 Sydney Road inclusive.
- (c) The properties situate at and fronting the north side of that portion of Bell Street bounded on the east by Sydney Road and on the west by Lobb Street and numbered 100 to 114 Bell Street inclusive.
- (d) The properties situate at and fronting the south side of that portion of Bell Street bounded on the east by Sydney Road and on the west by Mary Street and numbered 83 to 121 Bell Street inclusive.
- (e) The properties situate at and fronting the south side of that portion of Victoria Street bounded on the east by Sydney Road, and on the west by Louisa Street and numbered 1 to 17 Victoria Street inclusive.
- (f) The property situate at and numbered 12 Victoria Street and having a frontage of 40 feet.
- (g) The properties situate at and fronting the north side of that portion of Munro Street between Sydney Road and a point 149 feet west thereof and numbered 2 to 8 Munro Street inclusive.
- (h) The properties situate at and fronting the north side of Harding Street and numbered 1 to 9 Harding Street inclusive.
- (i) The property situate at and numbered 51 Waterfield Street and having a frontage of 60 feet.

And the Honorable Rupert James Hamer, Her Majesty's Minister for Local Government for the State of Victoria, shall give the necessary directions herein accordingly.

J. ROSSITER,
Clerk of the Executive Council.

GAS REGULATION ACT 1958.

At the Executive Council Chamber, Melbourne, the twelfth day of December, 1967.

PRESENT:

His Excellency the Governor of Victoria.
Mr. Chandler | Mr. Rossiter.
Mr. Borthwick

CALORIFIC VALUE OF GAS SUPPLIED BY THE GAS AND FUEL CORPORATION OF VICTORIA IN THE ALTONA PORTION OF ITS UNDERTAKING.

WHEREAS it is provided in sub-section (1) of section 15 of the *Gas Regulation Act 1958*, that gas supplied by an undertaker, with respect to calorific value, shall

be as prescribed in the Second Schedule to the said Act, or, in respect of all or a specified part of the undertaking of such standard as is prescribed from time to time by Order of the Governor in Council:

Now therefore, His Excellency the Governor of the State of Victoria, in the Commonwealth of Australia, by and with the advice of the Executive Council of the said State, and in pursuance of the powers conferred by the Gas Regulation Act 1958, doth by this Order prescribe 2460 British thermal units (gross) per cubic foot as the standard of calorific value of gas supplied by the Gas and Fuel Corporation of Victoria in the Altona portion of its undertaking from the 1st day of January, 1968.

And the Honorable James Charles Murray Balfour, Her Majesty's Minister of Mines for the State of Victoria, shall give the necessary directions herein accordingly.

J. ROSSITER,
Clerk of the Executive Council.

MONASH UNIVERSITY ACT 1958.

At the Executive Council Chamber, Melbourne, the twelfth day of December, 1967.

PRESENT:

His Excellency the Governor of Victoria.
Mr. Chandler | Mr. Rossiter.
Mr. Borthwick |

APPOINTMENT OF MEMBERS OF THE COUNCIL OF THE MONASH UNIVERSITY.

HIS Excellency the Governor of the State of Victoria, by and with the advice of the Executive Council and in pursuance of the powers conferred by Section 7 of the Monash University Act 1958 doth by this Order hereby appoint the under-mentioned persons as members of the Council of the Monash University for a period of four years such persons being members of the Parliament of Victoria recommended for appointment by a joint sitting of the members of the Legislative Council and the Legislative Assembly.

- (1) The Honorable William Raymond Garrett, A.F.C., A.E.A., M.L.C.
- (2) Dr. Henry Alfred Jenkins, M.L.A.
- (3) The Honorable Stuart Richard McDonald, M.L.C.

J. ROSSITER,
Clerk of the Executive Council.

UNIVERSITY ACT 1958.

At the Executive Council Chamber, Melbourne, the twelfth day of December, 1967.

PRESENT:

His Excellency the Governor of Victoria.
Mr. Chandler | Mr. Rossiter.
Mr. Borthwick |

APPOINTMENT OF MEMBERS OF THE COUNCIL OF THE UNIVERSITY OF MELBOURNE.

HIS Excellency the Governor of the State of Victoria, by and with the advice of the Executive Council thereof and in pursuance of the powers conferred by the Melbourne University Act 1958, doth by this Order hereby appoint the under-mentioned persons to be members of the Council of the University of Melbourne for the period of four years from and including the 17th December, 1967:—

- (i) The Honorable Rupert James Hamer, M.L.C. (as being a member of the Legislative Council);
- (ii) The Honorable Sir John Stoughton Bloomfield, Q.C., M.L.A., and Allan Clyde Holding, Esq., M.L.A. (as being members of the Legislative Assembly);
- (iii) Donald James Hibberd, Esq., O.B.E. (as representing manufacturing and commercial interests);
- (iv) David Sutcliffe Wishart, Esq. (as representing agricultural interests);

- (v) Norman Edward Thomas Jones, Esq., and Alexander Leslie Cahill, Esq. (as representing industrial interests);
- (vi) Neil Bannatyne Lewis, Esq. (as representing technical education).

The Honorable Lindsay Hamilton Simpson Thompson, M.L.C., Her Majesty's Minister of Education for the State of Victoria, shall give the necessary directions herein accordingly.

J. ROSSITER,
Clerk of the Executive Council.

DAIRY PRODUCTS ACT 1958.

At the Executive Council Chamber, Melbourne, the nineteenth day of December, 1967.

PRESENT:

His Excellency the Governor of Victoria.
Mr. Porter | Mr. Hamer.

APPOINTMENT OF MEMBER OF THE VICTORIAN DAIRY PRODUCTS BOARD.

IN pursuance of the powers conferred by section 4 of the Dairy Products Act 1958 and all other powers him thereunto enabling, His Excellency the Governor of the State of Victoria, by and with the advice of the Executive Council thereof, doth by this Order hereby appoint KENNETH ROYDEN KENT, nominated by the Co-operative Dairy Factories' Association of Victoria, as a member of the Victorian Dairy Products Board for the period from the 19th December 1967 to the 14th February 1970, both dates inclusive.

And the Honorable Gilbert Lawrence Chandler, Her Majesty's Minister of Agriculture for the State of Victoria, shall give the necessary directions herein accordingly.

J. ROSSITER,
Clerk of the Executive Council.

RAILWAYS ACT 1958.

At the Executive Council Chamber, Melbourne, the twelfth day of December, 1967.

PRESENT:

His Excellency the Governor of Victoria.
Mr. Chandler | Mr. Rossiter.
Mr. Borthwick |

ORDER CLOSING RAILWAY LEVEL CROSSING AT 135M 07C 68L AT TARNAGULLA.

WHEREAS pursuant to the provisions of the Railways Act 1958 No. 6355 THE VICTORIAN RAILWAYS COMMISSIONERS recommended to the Governor-in-Council that the railway level crossing at 135M 07C 68L on the Bendigo—St. Arnaud Road at Tarnagulla, should be closed and gave the several notices required—under that Act and there having been no objections to the said recommendation, His Excellency the Governor of the State of Victoria with the advice of the Executive Council thereof and being satisfied—

- (a) that the requisite notices have been given
 - (b) that not less than two months have expired since the last of such notices was given
 - (c) that satisfactory provision for diverting the road which crosses the railway line can be provided
- doth hereby order that the said level crossing shall be closed upon opening of the road deviation for traffic.

And the Honorable Vernon Francis Wilcox, Her Majesty's Minister of Transport for the State of Victoria, shall give the necessary directions herein accordingly.

J. ROSSITER,
Clerk of the Executive Council.

COUNTRY ROADS BOARD.

At the Executive Council Chamber, Melbourne, the twelfth day of December, 1967.

PRESENT:

His Excellency the Governor of Victoria.
 Mr. Chandler | Mr. Rossiter.
 Mr. Borthwick |

ORDER CONFIRMING RESOLUTIONS OF THE COUNTRY ROADS BOARD.

HIS Excellency the Governor of the State of Victoria, by and with the advice of the Executive Council thereof, doth hereby, in pursuance of the provisions of the Country Roads Act 1958, confirm the resolutions of the Country Roads Board, the dates whereof and the terms of which are scheduled hereunder:—

SCHEDULE.

State highways

Resolution dated the Fourth day of December One Thousand Nine Hundred and Sixty-seven, made pursuant to Sections 21 and 74 of the Country Roads Act 1958 declaring the widening of the Hamilton Highway in the Shire of Bannockburn as shown hatched on Plans numbered G.P.10157 and G.P.10158 hereunder to be part of a State highway within the meaning and for the purposes of the said Act.

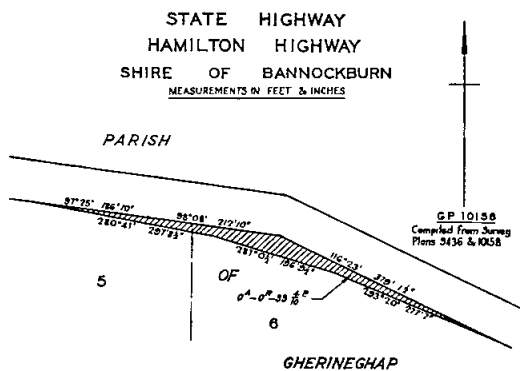
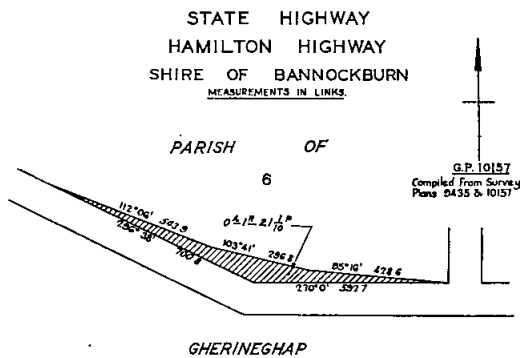

Resolution dated the Fourth day of December One Thousand Nine Hundred and Sixty-seven, made pursuant to Sections 21 and 74 of the Country Roads Act 1958

declaring the widening of the Princes Highway in the Shire of Morwell as shown hatched on Plan numbered G.P.10546 hereunder to be part of a State highway within the meaning and for the purposes of the said Act.

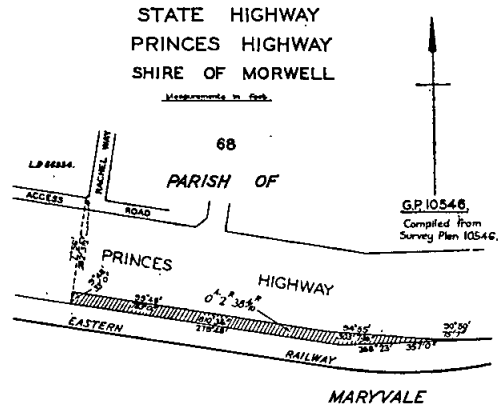

Main roads.

Resolution dated the Fourth day of December One Thousand Nine Hundred and Sixty-seven, made pursuant to Section 21 of the Country Roads Act 1958, declaring the widening of the Bacchus Marsh-Balliang Road in the Shire of Bacchus Marsh as shown hatched on Plan numbered G.P.8652 hereunder to be part of a main road within the meaning and for the purposes of the said Act.

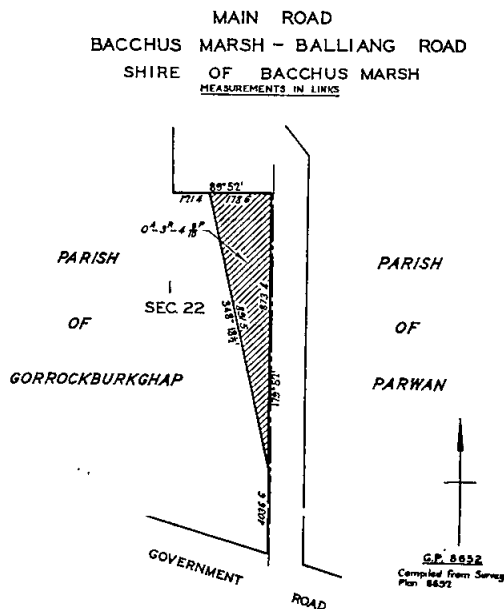

Resolution dated the Fourth day of December One Thousand Nine Hundred and Sixty-seven, made pursuant to Section 21 of the Country Roads Act 1958, declaring the widening of the Heidelberg-Warrandyte Road in the

City of Doncaster and Templestowe as shown hatched on Plan numbered G.P.8539 hereunder to be part of a main road within the meaning and for the purposes of the said Act.

MAIN ROAD
HEIDELBERG WARRANDYTE ROAD
CITY OF DONCASTER AND TEMPLESTOWE
Measurements in feet

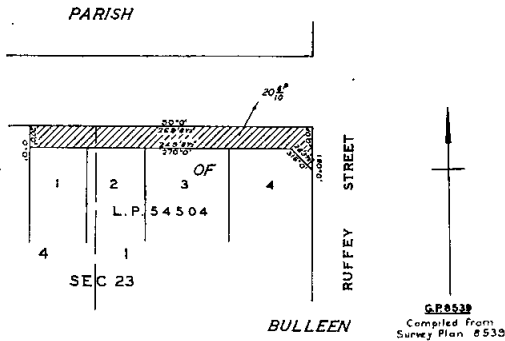

bered G.P.9221 and G.P.9265 hereunder to be part of a main road within the meaning and for the purposes of the said Act.

MAIN ROAD
PENSHURST-WARRNAMBOOL ROAD
SHIRE OF MOUNT ROUSE
MEASUREMENTS IN LINKS

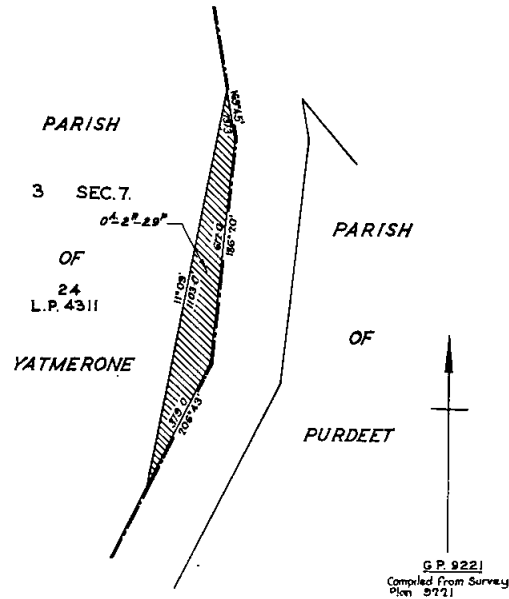

Resolution dated the Fourth day of December One Thousand Nine Hundred and Sixty-seven, made pursuant to Section 21 of the Country Roads Act 1958, declaring the widening of the Mansfield-Whitfield Road in the Shire of Mansfield as shown hatched on Plan numbered G.P.10087 hereunder to be part of a main road within the meaning and for the purposes of the said Act.

MAIN ROAD
MANSFIELD-WHITFIELD ROAD
SHIRE OF MANSFIELD
MEASUREMENTS IN LINKS

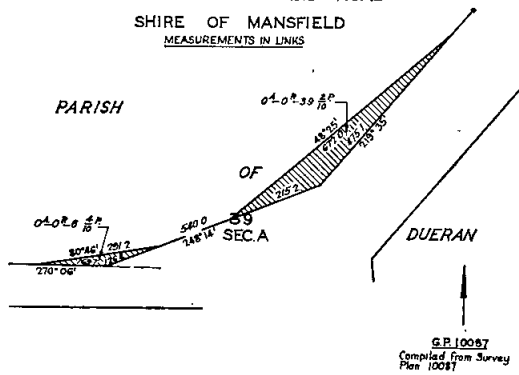

Resolution dated the Fourth day of December One Thousand Nine Hundred and Sixty-seven, made pursuant to Section 21 of the Country Roads Act 1958, declaring the widening of the Peshurst-Warrnambool Road in the Shire of Mount Rouse as shown hatched on Plans num-

MAIN ROAD
PENSHURST-WARRNAMBOOL ROAD
SHIRE OF MOUNT ROUSE
MEASUREMENTS IN LINKS

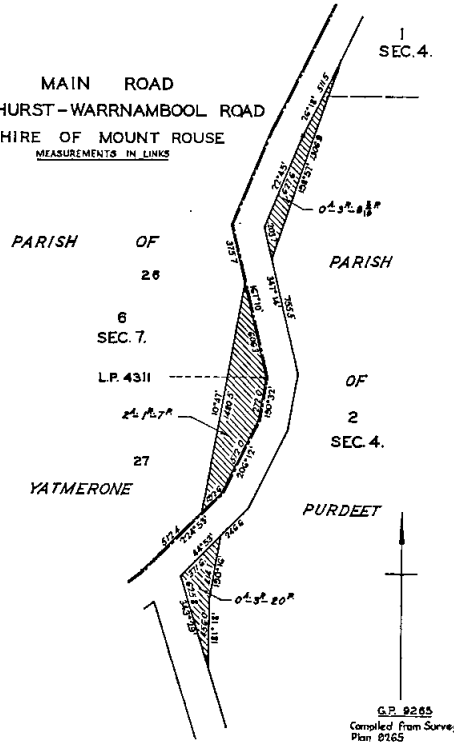

Resolution dated the Fourth day of December One Thousand Nine Hundred and Sixty-seven, made pursuant to Section 21 of the Country Roads Act 1958, declaring the widening of Buffalo River Road in the Shire of Oxley

as shown hatched on Plan numbered G.P.8084 hereunder to be part of a main road within the meaning and for the purposes of the said Act.

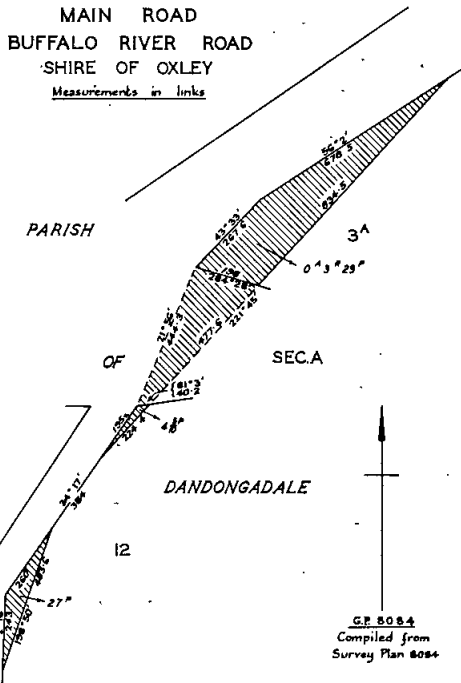

Unclassified road.

Resolution dated the Fourth day of December One Thousand Nine Hundred and Sixty-seven, made pursuant to Sections 21, 58 and 110 of the Country Roads Act 1958, declaring the deviation from the Clear Lake-Sherwoods Dam Road in the Shire of Arapiles as indicated by diagonal hatching on Plan numbered G.P.10815 hereunder to be part of a road within the meaning and for the purposes of the said Act and also declaring that such deviation shall be in lieu of the existing road or part thereof indicated by cross hatching on the said plan and that such part of the said existing road shall be discontinued.

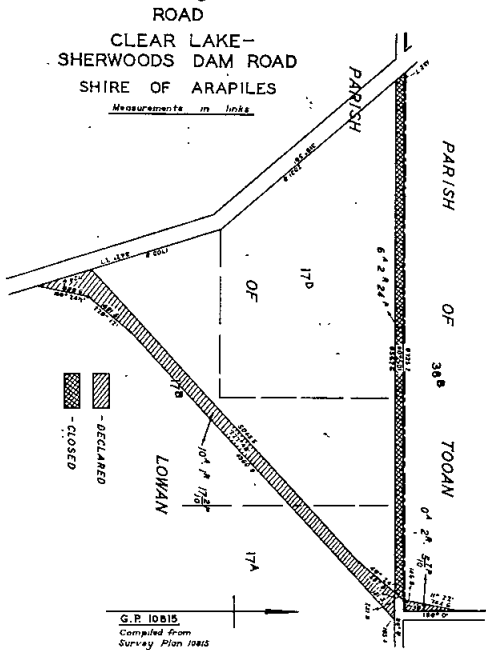

And the Honorable Murray Victor Porter, Her Majesty's Minister of Public Works for the State of Victoria, shall give the necessary directions herein accordingly.

J. ROSSITER,
Clerk of the Executive Council.

COUNTRY ROADS BOARD.

At the Executive Council Chamber, Melbourne, the twelfth day of December, 1967.

PRESENT:

His Excellency the Governor of Victoria.
Mr. Chandler | Mr. Rossiter.
Mr. Borthwick

ORDER APPROVING OF LAND BEING ACQUIRED AND ROADS DEVIATIONS OR WIDENINGS BEING MADE.

HIS Excellency the Governor of the State of Victoria, by and with the advice of the Executive Council thereof, being satisfied that there are funds legally available for acquiring the land, doth hereby approve the acquiring of the land described in the schedule hereunder and the making of new roads and deviations from and widenings of existing roads referred to in the said schedule.

SCHEDULE.

State highway.

The land shown hatched on Plan numbered G.P.10693 hereunder required for the widening of the Murray Valley Highway in the City of Echuca and making of the widening thereon.

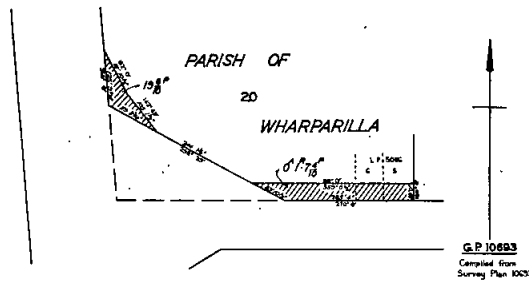

STATE HIGHWAY
MURRAY VALLEY HIGHWAY
CITY OF ECHUCA
Measurements in links

Main Roads.

The land shown hatched on Plan numbered G.P.10733 hereunder required for the widening of the Port Fairy Road in the City of Hamilton and making of the widening thereon.

MAIN ROAD
PORT FAIRY ROAD
CITY OF HAMILTON
Measurements in links

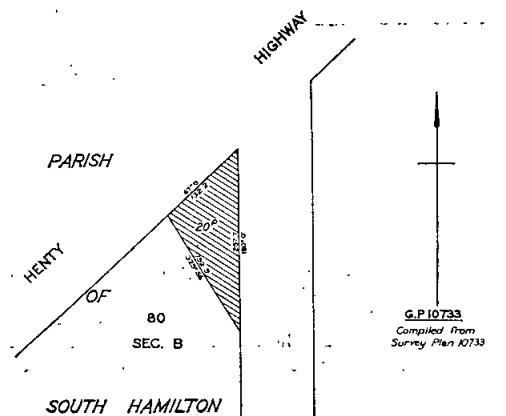

The land shown hatched on Plan numbered G.P.11073 hereunder required for the deviation from the Nar Nar Goon—Longwarry Road in the Shire of Berwick and making of the deviation thereon.

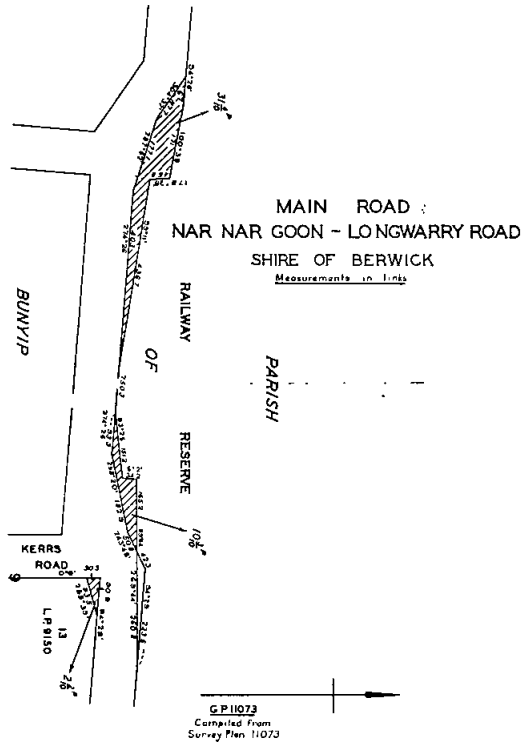

The land shown hatched on Plan numbered G.P.11090 hereunder required for the widening of the Portland—Nelson Road in the Shire of Portland and making of the widening thereon.

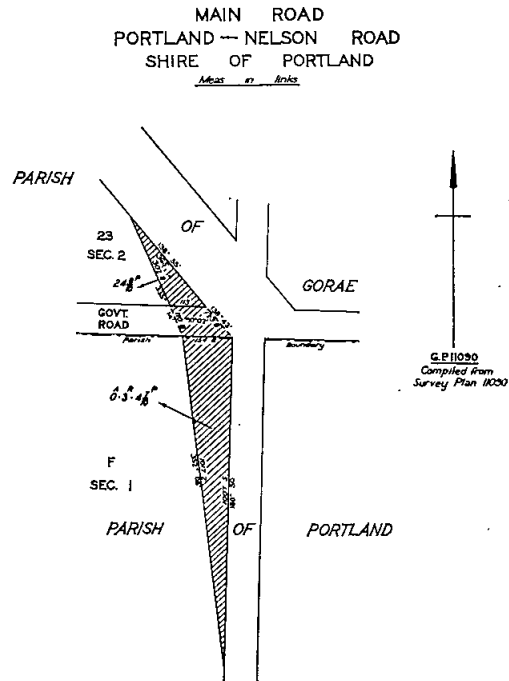

The land shown hatched on Plan numbered G.P.11138 hereunder required for the making of the Worthing Road Pedestrian Overpass in the City of Moorabbin.

**ROAD
WORTHING ROAD PEDESTRIAN OVERPASS
CITY OF MOORABBIN**
Measurements in feet

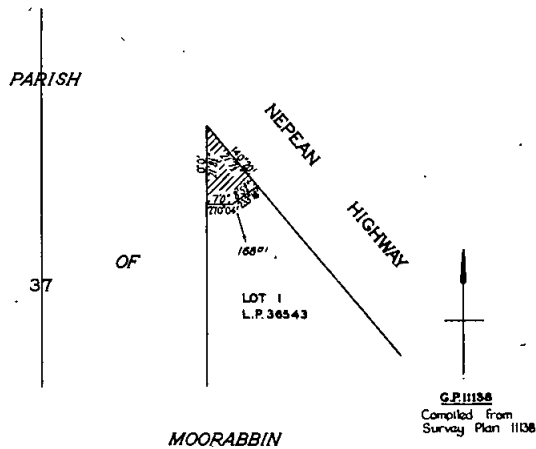

The land shown hatched on Plan numbered G.P.11091 hereunder required for the widening of Heath Road in the Shire of Portland and making of the widening thereon.

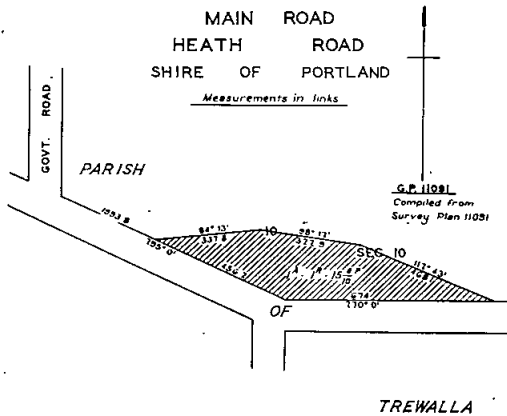

And the Honorable Murray Victor Porter, Her Majesty's Minister of Public Works for the State of Victoria, shall give the necessary directions herein accordingly.

J. ROSSITER,
Clerk of the Executive Council.

DEPARTMENT OF CROWN LANDS AND SURVEY.

Parish of Timboon, County of Heytesbury, being the road indicated by hatching on plan hereunder.—(T.182⁽¹⁰⁾) (Misc.3770.)

At the Executive Council Chamber, Melbourne, the twelfth day of December, 1967.

PRESENT:

His Excellency the Governor of Victoria.
Mr. Chandler | Mr. Rossiter.
Mr. Borthwick |

UNUSED ROADS CLOSED.

HIS Excellency the Governor of the State of Victoria, by and with the advice of the Executive Council thereof, doth hereby direct that, in pursuance of the provisions of section 349 of the Land Act 1958, the unused roads referred to hereunder be closed, viz.:-

Parish of Bruarong, County of Bogong, being the roads indicated by hatching on plan hereunder.—(H.119⁽¹⁾) (H.029455.)

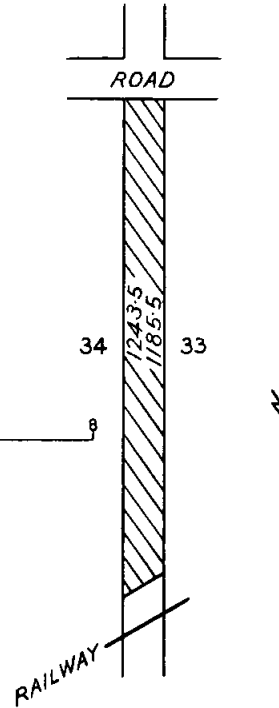
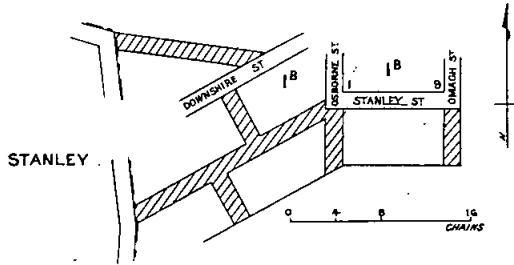

Parish of Narrung, County of Tatchera, being the road indicated by hatching on plan hereunder.—(N.128⁽¹⁾) (171/264B.)

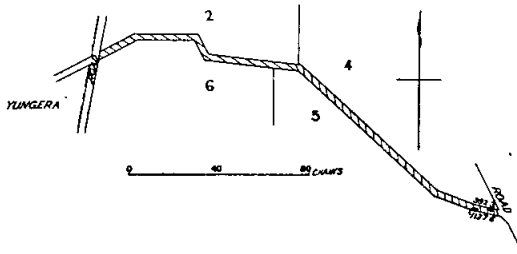

Parish of Narracan, County of Buln Buln, being the roads indicated by hatching on plan hereunder.—(N.129⁽¹²⁾) (Misc.3643.)

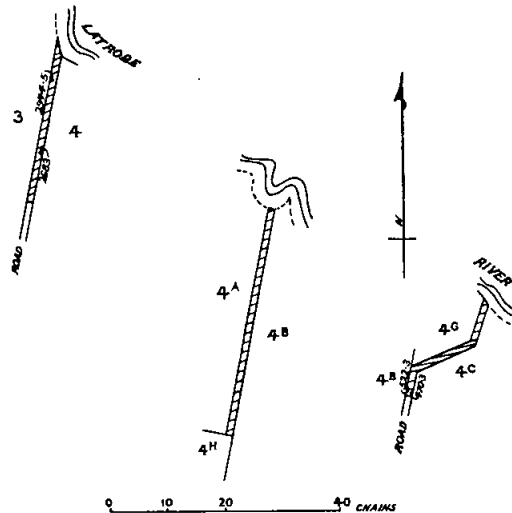

Township of Toolern Vale, Parish of Yangardook, County of Bourke, being the portion of the width of the road indicated by hatching on plan hereunder.—(Y.24C⁽¹⁾) (Misc.3784.)

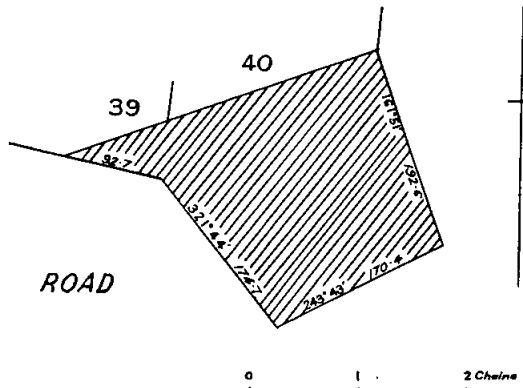

Parish of Buangor, County of Ripon, being the road indicated by hatching on plan hereunder.—(B.472⁽²⁾) (Rs.5808.)

DEPARTMENT OF CROWN LANDS AND SURVEY.

At the Executive Council Chamber, Melbourne, the twelfth day of December, 1967.

PRESENT:

His Excellency the Governor of Victoria.
 Mr. Chandler | Mr. Rossiter.
 Mr. Borthwick |

LAND TEMPORARILY RESERVED AS A SITE.

HIS Excellency the Governor of the State of Victoria, by and with the advice of the Executive Council thereof, doth hereby, in pursuance of section 14 of the Land Act 1958, reserve temporarily from sale, from being leased and from having a licence granted in respect thereof, and also except from occupation for mining purposes under any miner's right, the land hereinafter described:—

CARLYLE.—Site for Public Purposes (Tourist Camping) and Recreation, 2 roods, more or less, Parish of Carlyle, County of Bogong, as indicated by hatching on plan hereunder.—(C.187⁽⁹⁾) (Rs.4517.)

WONTHAGGI.—Site for State school purposes, 19 acres, 7 perches, Township of Wonthaggi, Parish of Wonthaggi, County of Mornington, as indicated by hatching on plan hereunder.—(W.345⁽¹⁰⁾) (Rs.8907.)

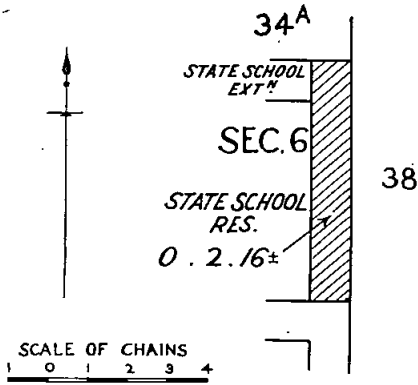

Township of Beechworth, Parish of Beechworth, County of Bogong, being the roads indicated by hatching on plan hereunder.—(B.348⁽⁹⁾) (Rs.770.)

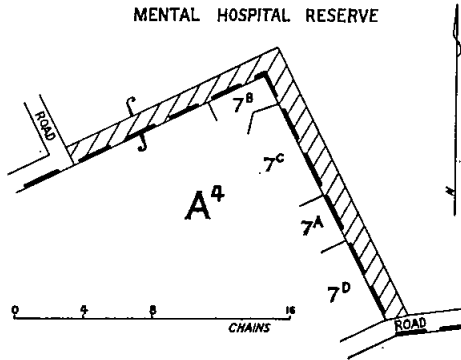

Township of Tyers, Parish of Boola Boola, County of Tanjil, being the road between the land temporarily reserved as a site for Public Purposes (State School) by Order in Council of the 20th May, 1878, and allotment 2, section B.—(B.687⁽⁹⁾) (H.031081.)

Township of Winchelsea, Parish of Mirree, County of Grenville, being the portion of the width of the road indicated by hatching on plan hereunder.—(W.168⁽²⁾) (Rs.5446.)

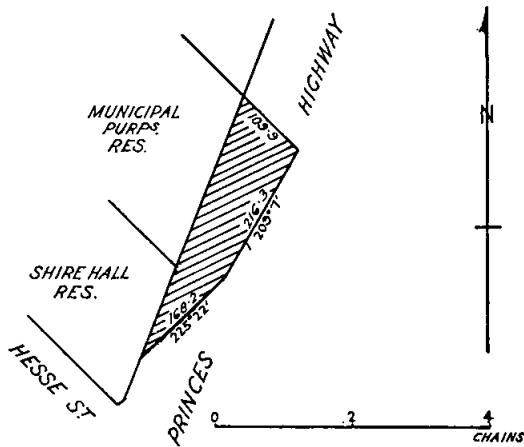

And the Honorable Sir William John Farquhar McDonald, Her Majesty's Minister of Lands for the State of Victoria, shall give the necessary directions herein accordingly.

J. ROSSITER,
 Clerk of the Executive Council.

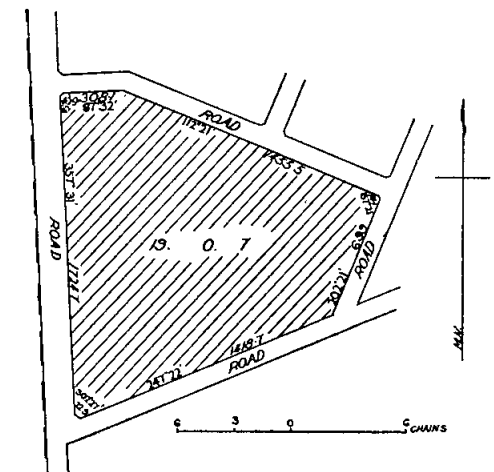
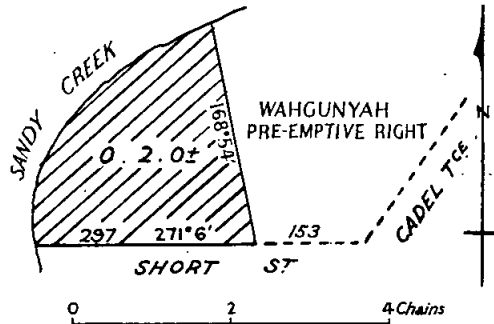

SOUTH MELBOURNE.—Site for Public Purposes (Mental Health Authority), 2 roods, 1 perch, City of South Melbourne, Parish of Melbourne South, County of Bourke, as indicated by hatching on plan hereunder.—(M.333⁽²⁹⁾) (Rs.8905.)

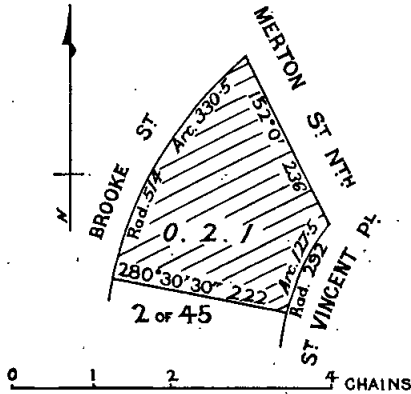

NYAH AND TYNTYNDER NORTH.—Site for Water Supply purposes, 1 acre 3 roods 20 perches, more or less, Township of Nyah and Parish of Tyntynder North, County of Tatchera, as indicated by hatching on plan hereunder.—(N.161⁽²⁾) (Rs.8863.)

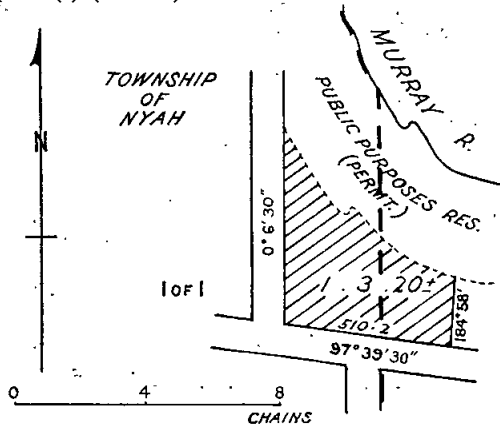

And the Honorable Sir William John Farquhar McDonald, Her Majesty's Minister of Lands for the State of Victoria, shall give the necessary directions herein accordingly.

J. ROSSITER,
Clerk of the Executive Council.

TOBACCO LEAF INDUSTRY STABILIZATION ACT 1966.

At the Executive Council Chamber, Melbourne, the twelfth day of December, 1967.

PRESENT:
His Excellency the Governor of Victoria.
Mr. Chandler | Mr. Rossiter.
Mr. Borthwick

APPOINTMENT OF SECRETARY TO THE TOBACCO QUOTA APPEALS TRIBUNAL.

IN pursuance of the powers conferred by section 19 of the Tobacco Leaf Industry Stabilization Act 1966, His Excellency the Governor of the State of Victoria, by and with the advice of the Executive Council thereof, DOETH by this Order hereby APPOINT GARY JAMES SHEPPARD, an officer of the Department of Agriculture, as Secretary to the Tobacco Quota Appeals Tribunal from and inclusive of the 12th December, 1967.

And the Honorable Gilbert Lawrence Chandler, Her Majesty's Minister of Agriculture for the State of Victoria, shall give the necessary directions herein accordingly.

J. ROSSITER,
Clerk of the Executive Council.

TOBACCO LEAF INDUSTRY STABILIZATION ACT 1966.

At the Executive Council Chamber, Melbourne, the twelfth day of December, 1967.

PRESENT:
His Excellency the Governor of Victoria.
Mr. Chandler | Mr. Rossiter.
Mr. Borthwick

CANCELLATION OF APPOINTMENT OF SECRETARY TO THE TOBACCO QUOTA APPEALS TRIBUNAL.

IN pursuance of the powers conferred by section 19 of the Tobacco Leaf Industry Stabilization Act 1966, His Excellency the Governor of the State of Victoria, by and with the advice of the Executive Council thereof, DOETH by this Order hereby CANCEL the appointment of JAMES MCKANE, an officer of the Department of Agriculture, as Secretary to the Tobacco Quota Appeals Tribunal from and inclusive of the 12th December, 1967.

And the Honorable Gilbert Lawrence Chandler, Her Majesty's Minister of Agriculture for the State of Victoria, shall give the necessary directions herein accordingly.

J. ROSSITER,
Clerk of the Executive Council.

GEELONG HARBOR TRUST ACT 1958.

At the Executive Council Chamber, Melbourne, the twelfth day of December, 1967.

PRESENT:
His Excellency the Governor of Victoria.
Mr. Chandler | Mr. Rossiter.
Mr. Borthwick

APPOINTMENT OF A COMMISSIONER AND CHAIRMAN, A COMMISSIONER AND DEPUTY CHAIRMAN AND A COMMISSIONER OF THE GEELONG HARBOR TRUST COMMISSIONERS.

IN accordance with the provisions of the Geelong Harbor Trust Act 1958, His Excellency the Governor of the State of Victoria, by and with the advice of the Executive Council thereof, doth by this Order appoint Sir ROY FIDGE, LL.B., a Commissioner and Chairman of the Geelong Harbor Trust Commissioners for the period from 1st January, 1968 to 31st December, 1970, at a salary of \$4,700.00 per annum, and ERNEST WESLEY McCANN, O.B.E., a Commissioner and Deputy Chairman of the said Geelong Harbor Trust Commissioners, for the period from 1st January, 1968 to 31st December, 1969, at a salary of \$1,900.00 per annum, and GORDON DAVID MURRAY, a Commissioner of the said Geelong Harbor Trust Commissioners, for the period from 1st January, 1968 to 31st December, 1968, at a salary of \$1,900.00 per annum.

And the Honorable Murray Victor Porter, Her Majesty's Minister of Public Works for the State of Victoria, shall give the necessary directions herein accordingly.

J. ROSSITER,
Clerk of the Executive Council.

FRANKSTON SEWERAGE AUTHORITY.

At the Executive Council Chamber, Melbourne, the nineteenth day of December, 1967.

PRESENT:
His Excellency the Governor of Victoria.
Mr. Porter | Mr. Hamer.

CONSENT TO BORROWING \$100,000.

UNDER the powers conferred by the Sewerage Districts Act and all other powers enabling him in that behalf, His Excellency the Governor of the State of Victoria, by and with the advice of the Executive Council of the said State doth hereby consent to the Frankston Sewerage Authority borrowing by mortgage of the General Fund the sum of One hundred thousand dollars (\$100,000) to meet the cost of sewerage works as set forth in the detailed statement bearing date 14th December, 1967.

And the Honorable William Archibald Borthwick, Her Majesty's Minister of Water Supply for the State of Victoria, shall give the necessary directions herein accordingly.

J. ROSSITER,
Clerk of the Executive Council.

FRANKSTON SEWERAGE AUTHORITY.

At the Executive Council Chamber, Melbourne, the nineteenth day of December, 1967.

PRESENT:

His Excellency the Governor of Victoria.
Mr. Porter | Mr. Hamer.

CONSENT TO BORROWING \$100,000.

UNDER the powers conferred by the Sewerage Districts Act and all other powers enabling him in that behalf, His Excellency the Governor of the State of Victoria, by and with the advice of the Executive Council of the said State, doth hereby consent to the Frankston Sewerage Authority borrowing at interest, by mortgage of the General Fund, the sum of One hundred thousand dollars (\$100,000) to meet the cost of sewerage works, as set forth in the detailed statement bearing date the 14th December, 1967.

And the Honorable William Archibald Borthwick, Her Majesty's Minister of Water Supply for the State of Victoria, shall give the necessary directions herein accordingly.

J. ROSSITER,
Clerk of the Executive Council.

MARYBOROUGH SEWERAGE AUTHORITY.

At the Executive Council Chamber, Melbourne, the nineteenth day of December, 1967.

PRESENT:

His Excellency the Governor of Victoria.
Mr. Porter | Mr. Hamer.

REPEAL OF ORDER.

UNDER the powers conferred by the Sewerage Districts Act and all other powers enabling him in that behalf, His Excellency the Governor of the State of Victoria, by and with the advice of the Executive Council of the said State, doth hereby repeal the Order in Council made on 23rd May, 1967, and published in the *Victoria Government Gazette* dated 24th May, 1967, approving of the Maryborough Sewerage Authority borrowing Twenty thousand dollars (\$20,000) for the conversion of Loan No. 10.

And the Honorable William Archibald Borthwick, Her Majesty's Minister of Water Supply for the State of Victoria, shall give the necessary directions herein accordingly.

J. ROSSITER,
Clerk of the Executive Council.

MARYBOROUGH SEWERAGE AUTHORITY.

At the Executive Council Chamber, Melbourne, the nineteenth day of December, 1967.

PRESENT:

His Excellency the Governor of Victoria.
Mr. Porter | Mr. Hamer.

CONSENT TO BORROWING \$40,000.

UNDER the powers conferred by the Sewerage Districts Act and all other powers enabling him in that behalf, His Excellency the Governor of the State of Victoria, by and with the advice of the Executive Council of the said State, doth hereby consent to the Maryborough Sewerage Authority borrowing at interest the sum of Forty thousand dollars (\$40,000) for the conversion of Loans Nos. 10 and 14.

And the Honorable William Archibald Borthwick, Her Majesty's Minister of Water Supply for the State of Victoria, shall give the necessary directions herein accordingly.

J. ROSSITER,
Clerk of the Executive Council.

ARARAT SEWERAGE AUTHORITY.

At the Executive Council Chamber, Melbourne, the nineteenth day of December, 1967.

PRESENT:

His Excellency the Governor of Victoria.
Mr. Porter | Mr. Hamer.

CONSENT TO BORROWING \$15,000.

UNDER the powers conferred by the Sewerage Districts Act and all other powers enabling him in that behalf, His Excellency the Governor of the State of Victoria, by and with the advice of the Executive Council of the said State, doth hereby consent to the Ararat Sewerage Authority borrowing by mortgage of the General Fund the sum of Fifteen thousand dollars (\$15,000) to meet the cost of Sewerage works as set forth in the detailed statement bearing date the 14th December, 1967.

And the Honorable William Archibald Borthwick, Her Majesty's Minister of Water Supply for the State of Victoria, shall give the necessary directions herein accordingly.

J. ROSSITER,
Clerk of the Executive Council.

COBRAM SEWERAGE AUTHORITY.

At the Executive Council Chamber, Melbourne, the nineteenth day of December, 1967.

PRESENT:

His Excellency the Governor of Victoria.
Mr. Porter | Mr. Hamer.

CONSENT TO BORROWING \$100,000.

UNDER the powers conferred by the Sewerage Districts Act and all other powers enabling him in that behalf, His Excellency the Governor of the State of Victoria, by and with the advice of the Executive Council of the said State, doth hereby consent to the Cobram Sewerage Authority borrowing by assignment of the General Fund the sum of One hundred thousand dollars (\$100,000) to meet the cost of sewerage works as set forth in the detailed statement bearing date 14th December, 1967.

And the Honorable William Archibald Borthwick, Her Majesty's Minister of Water Supply for the State of Victoria, shall give the necessary directions herein accordingly.

J. ROSSITER,
Clerk of the Executive Council.

EUROA WATERWORKS TRUST.

At the Executive Council Chamber, Melbourne, the nineteenth day of December, 1967.

PRESENT:

His Excellency the Governor of Victoria.
Mr. Porter | Mr. Hamer.

AMENDMENT OF ORDER.

UNDER the powers conferred by the Water Act, and all other powers enabling him in that behalf, His Excellency the Governor of the State of Victoria, by and with the advice of the Executive Council of the said State, doth hereby amend as follows the Order made by the Governor in Council on 12th May, 1959, and published in the *Victoria Government Gazette*, dated 13th May, 1959, fixing the limit of the overdraft to be obtained by the Euroa Waterworks Trust.

For the expression "at an amount, not to exceed at any one time the sum of Five thousand pounds (£5,000)" there shall be substituted the expression "at an amount not to exceed at any one time the sum of One hundred thousand dollars (\$100,000)".

And the Honorable William Archibald Borthwick, Her Majesty's Minister of Water Supply for the State of Victoria, shall give the necessary directions herein accordingly.

J. ROSSITER,
Clerk of the Executive Council.

DANDENONG VALLEY AUTHORITY.

At the Executive Council Chamber, Melbourne, the nineteenth day of December, 1967.

PRESENT:

His Excellency the Governor of Victoria.
Mr. Porter | Mr. Hamer.

CONSENT TO BORROWING \$50,000.

UNDER the powers conferred by the Dandenong Valley Authority Act and all other powers enabling him in that behalf, His Excellency the Governor of the State of Victoria, by and with the advice of the Executive Council of the said State, doth hereby consent to the Dandenong Valley Authority borrowing at interest the sum of Fifty thousand dollars (\$50,000) to meet the cost of river improvement and drainage works.

And the Honorable William Archibald Borthwick, Her Majesty's Minister of Water Supply for the State of Victoria, shall give the necessary directions herein accordingly.

J. ROSSITER,
Clerk of the Executive Council.

GEELONG WATERWORKS AND SEWERAGE TRUST.

At the Executive Council Chamber, Melbourne, the nineteenth day of December, 1967.

PRESENT:

His Excellency the Governor of Victoria.
Mr. Porter | Mr. Hamer.

APPROVAL OF PLAN SHOWING SITE OF PUMPING STATION.

HIS Excellency the Governor of the State of Victoria, by and with the advice of the Executive Council thereof, doth hereby approve, in accordance with the provisions of the Water Act—

(a) The work comprising a pumping station and associated water purification works situated on the right bank of the Barwon River within Section XV. (Queen's Gardens), Crown allotment 3A, Section XVI. and adjacent Crown lands in the Parish of Barrabool, County of Grant, as shown on a plan deposited in the office of the State Rivers and Water Supply Commission, Melbourne (Corr. 67/4853/2), and of the acquisition of lands necessary for the construction of that work by the Geelong Waterworks and Sewerage Trust.

(b) That the amount of water which may be diverted from the said Barwon River by the Geelong Waterworks and Sewerage Trust shall not exceed 40 per centum of the total flow of the river at the point of diversion.

And the Honorable William Archibald Borthwick, Her Majesty's Minister of Water Supply for the State of Victoria, shall give the necessary directions herein accordingly.

J. ROSSITER,
Clerk of the Executive Council.

WATER ACT 1958.

At the Executive Council Chamber, Melbourne, the nineteenth day of December, 1967.

PRESENT:

His Excellency the Governor of Victoria.
Mr. Porter | Mr. Hamer.

STATE RIVERS AND WATER SUPPLY COMMISSION
LAKE HUME (SHIRE OF WODONGA) RECREATIONAL AREA—DECLARATION.

WHEREAS it is provided by section 206A of the Water Act 1958 (as amended) that the Governor in Council may by Order declare any area of land owned or controlled by the State Rivers and Water Supply Commission to be a recreational area.

Now therefore, His Excellency the Governor of the State of Victoria, by and with the advice of the Executive Council thereof, hereby declares that the area of land shown within a red border on plan numbered 6125, and

lodged in the Plan Room of the State Rivers and Water Supply Commission at 90 Orrong Road, Armadale, shall be a recreational area to be known as the Lake Hume (Shire of Wodonga) Recreational Area except that any of such land inundated from time to time by the waters stored in Lake Hume shall not while so inundated be deemed to be within the Lake Hume (Shire of Wodonga) Recreational Area.

And the Honorable William Archibald Borthwick, Her Majesty's Minister of Water Supply for the State of Victoria, shall give the necessary directions herein accordingly.

J. ROSSITER,
Clerk of the Executive Council.

Water Act 1958.

STATE RIVERS AND WATER SUPPLY COMMISSION.

At the Executive Council Chamber, Melbourne, the nineteenth day of December, 1967.

PRESENT:

His Excellency the Governor of Victoria.
Mr. Porter | Mr. Hamer.

FRANKSTON-MORNINGTON URBAN DISTRICT.—AREA OF DISTRICT INCREASED.

UNDER the powers conferred by the Water Act 1958 and all other powers enabling him in that behalf, His Excellency the Governor of the State of Victoria, with the advice of the Executive Council of the said State, on the recommendation of the State Rivers and Water Supply Commission, doth hereby declare, order and direct as follows:

That the area of the Frankston-Mornington Urban District be increased by adding to the same the lands set out and described in the Schedule hereto, and as on and from the 1st day of January, 1968, the area of such district shall be deemed to be so increased.

SCHEDULE.

Commencing at the most westerly angle of lot 2 on lodged plan of subdivision No. 6505, being part of allotment 13, Parish of Moorooduc, County of Mornington; thence south-easterly by the south-western boundaries of lots 2 and 3 to the north-western boundary of the Frankston and Mornington railway reserve; thence south-westerly by that reserve boundary to a point in line with the south-western boundary of the land described in certificate of title, volume 8158, folio 974, being part of said allotment 13; thence north-westerly by a line to the most southern angle of the land described in the last-mentioned certificate of title; thence north-westerly by a line to the point of commencement.

The lands set out and described in the foregoing Schedule are shown on a plan approved by the Governor in Council, and deposited in the office of the State Rivers and Water Supply Commission, Melbourne.—(Corres. No. 62/5760.)

And the Honorable William Archibald Borthwick, Her Majesty's Minister of Water Supply for the State of Victoria, shall give the necessary directions herein accordingly.

J. ROSSITER,
Clerk of the Executive Council.

LANDLORD AND TENANT ACT 1958.

At the Executive Council Chamber, Melbourne, the nineteenth day of December, 1967.

PRESENT:

His Excellency the Governor of Victoria.
Mr. Porter | Mr. Hamer.

ORDER EXCLUDING CERTAIN PREMISES FROM THE OPERATION OF CERTAIN OF THE PROVISIONS CONTAINED IN PART V. OF THE LANDLORD AND TENANT ACT 1958.

IN pursuance of the powers conferred upon him by the Landlord and Tenant Act 1958, His Excellency the Governor of the State of Victoria, by and with the advice of the Executive Council thereof, doth hereby declare that the premises known as Number 66 Waterloo Road,

Northcote, shall be excluded from the operation of the whole of the provisions contained in Divisions 2 and 3 of Part V. of the *Landlord and Tenant Act 1958*.

And the Honorable George Oswald Reid, Her Majesty's Attorney-General in and for the State of Victoria, shall give the necessary directions herein accordingly.

J. ROSSITER,
Clerk of the Executive Council.

PATRIOTIC FUNDS ACT.

At the Executive Council Chamber, Melbourne, the nineteenth day of December, 1967.

PRESENT:

His Excellency the Governor of Victoria.
Mr. Porter | Mr. Hamer.

APPOINTMENT OF MEMBERS FOR THE PATRIOTIC FUNDS COUNCIL OF VICTORIA.

IN pursuance of the provisions of the *Patriotic Funds Act 1958* (No. 6331), His Excellency the Governor of the State of Victoria, by and with the advice of the Executive Council thereof, doth by this Order—

1. Appoint the under-mentioned persons to be members of the Patriotic Funds Council of Victoria for a period of three years as from and including the 22nd day of December, 1967:—

The Right Honorable the Lord Mayor of Melbourne for the time being.

Arthur Grahame TAYLOR, being a representative nominated by the Chairman of the Australian Red Cross Society (Victorian Division) for the time being.

Sir William John JUNGWIRTH, C.M.G.

The Honorable Sir Archie MICHAELIS.

Frederick George Robotham CLAYTON.

Francis James Eric GYNGELL, M.B.E.

Group Captain Hans HAMILTON, C.B.E., R.A.A.F. (retired).

Matthew HARRISON, C.B.E., J.P.

Cuthbert Oswald HARRY.

Dr. John Henry LINDELL, M.D., M.S.

George MARCHANT.

Roy Warwick NEVILLE, C.B.E.

William Andrews PERRIN, O.B.E.

Robert Fitzroy SANDERSON, C.B.E.

Lewis Grant WILSON.

Norman David WILSON, C.B.E.

2. Appoint Robert Fitzroy Sanderson, C.B.E., to be Chairman of the said Council, and Cuthbert Oswald Harry to be Vice-Chairman of the said Council.

And the Honorable George Oswald Reid, Her Majesty's Attorney-General for the State of Victoria, shall give the necessary directions herein accordingly.

J. ROSSITER,
Clerk of the Executive Council.

POLICE REGULATION ACT 1958.

At the Executive Council Chamber, Melbourne, the nineteenth day of December, 1967.

PRESENT:

His Excellency the Governor of Victoria.
Mr. Porter | Mr. Hamer.

APPOINTMENT OF A SUPERINTENDENT OF POLICE AS A DEPUTY MEMBER OF THE BOARD.

WHEREAS John Edmund De Lany, a Superintendent of Police who is a member of the Police Discipline Board, is unable to carry out his duties as a member of the said Board:

AND WHEREAS the Chief Commissioner of Police has nominated Gilbert Trainor, a Superintendent of Police to act as the Deputy of the said member of the said Board:

NOW THEREFORE His Excellency the Governor of the State of Victoria in the Commonwealth of Australia, by and with the advice of the Executive Council of the said State, and in pursuance of the powers conferred by the *Police Regulation Act 1958* doth by this Order appoint the said Gilbert Trainor to act as the Deputy of the said John

Edmund De Lany from the nineteenth day of December, 1967, during the incapacity of the said John Edmund De Lany.

And the Honorable Arthur Gordon Rylah, Her Majesty's Chief Secretary for the State of Victoria, shall give the necessary directions herein accordingly.

J. ROSSITER,
Clerk of the Executive Council.

LICENSING ACT 1958.

At the Executive Council Chamber, Melbourne, the nineteenth day of December, 1967.

PRESENT:

His Excellency the Governor of Victoria.
Mr. Porter | Mr. Hamer.

EXTENSION OF THE ANNUAL SITTING OF THE VICTORIAN LICENSING COURT.

IN PURSUANCE of the powers conferred by the *Licensing Act 1958*, His Excellency the Governor of the State of Victoria, in the Commonwealth of Australia, by and with the advice of the Executive Council of the said State, doth by this Order extend the time for holding the Annual Sitting of the Victorian Licensing Court for the Licensing Areas set out in the Schedule hereunder to a date not later than 29th February, 1968—

SCHEDULE.

Central Metropolitan.
Eastern Metropolitan.
Northern Metropolitan.
Shepparton.
Southern Metropolitan.
Warragul.
Western Metropolitan.

And the Honorable Arthur Gordon Rylah, Her Majesty's Chief Secretary for the State of Victoria, shall give the necessary directions herein accordingly.

J. ROSSITER,
Clerk of the Executive Council.

HOUSING ACT 1958.

At the Executive Council Chamber, Melbourne, the nineteenth day of December, 1967.

PRESENT:

His Excellency the Governor of Victoria.
Mr. Porter | Mr. Hamer.

CLOSING OF ROADS AND EXTINGUISHMENT OF EASEMENTS AND RESTRICTIVE COVENANTS.—CITY OF COLAC.

WHEREAS by virtue and in exercise of the powers contained in the *Housing Act 1958* (No. 6275) Housing Commission has recommended to the Governor-in-Council that the roads, easements and restrictive covenants described in the Schedule hereto be closed and extinguished.

NOW THEREFORE His Excellency the Governor of the State of Victoria in the Commonwealth of Australia by and with the advice of the Executive Council of the said State, doth in pursuance of the powers conferred by the said Act and upon such recommendation, consent and by this Order hereby close and extinguish such roads, easements and restrictive covenants.

SCHEDULE.

Any easements and restrictive covenants affecting the whole of the land comprised in Certificate of Title, Volume 8495, Folio 842, and all roads within the said land save and except that portion of road abutting the western boundary of Lot 5 on Plan of Subdivision, Number 10978 lodged in the Office of Titles which lies south of the westerly prolongation of the northern boundary of the said Lot 5.

And the Honorable James Williamson Manson, Her Majesty's Acting Minister of Housing for the State of Victoria, shall give the necessary directions herein accordingly.

J. ROSSITER,
Clerk of the Executive Council.

STATE SAVINGS BANK ACT 1958, No. 6379.

At the Executive Council Chamber, Melbourne, the nineteenth day of December, 1967.

PRESENT:

His Excellency the Governor of Victoria.
Mr. Porter | Mr. Hamer.

IN accordance with the provisions of the State Savings Bank Act 1958, No. 6379, His Excellency the Governor of the State of Victoria by and with the advice of the Executive Council thereof doth by this Order hereby appoint

WILLIAM LIONEL MOSS, C.B.E.
to be Chairman of the Commissioners of the State Savings Bank of Victoria for the year commencing on the 1st January, 1968.

And the Honorable Sir Henry Edward Bolte, Her Majesty's Treasurer for the State of Victoria, shall give the necessary directions herein accordingly.

J. ROSSITER,
Clerk of the Executive Council.

REMISSION OF SENTENCE OF IMPRISONMENT.

At the Executive Council Chamber, Melbourne, the nineteenth day of December, 1967.

PRESENT:

His Excellency the Governor of Victoria.
Mr. Porter | Mr. Hamer.

WHEREAS at the Court of Petty Sessions at Melbourne on the 27th September, 1966, one NOLA ELIZABETH REEVES was convicted on a charge of having insufficient means of support and was sentenced to be imprisoned for one month: NOW THEREFORE I, the Governor of the State of Victoria, by and with the advice of the Executive Council thereof, DO, under and by virtue of the powers conferred upon me by Letters Patent dated the 29th October, 1900, passed under the Great Seal of the United Kingdom constituting the office of Governor of the State of Victoria, remit the sentence of imprisonment for one month imposed on the said NOLA ELIZABETH REEVES at the Court of Petty Sessions held at Melbourne on the 27th day of September, 1966.

And the Honorable George Oswald Reid, Her Majesty's Attorney-General for the State of Victoria, shall give the necessary directions herein accordingly.

J. ROSSITER,
Clerk of the Executive Council.

LANDS DEPARTMENT NOTICES

APPROACHING LAND SALES.

SALES of Crown Lands, in fee-simple, will be held at the under-mentioned places and dates, viz.:

Sale	No. of Gazette.
Sale.—Saturday, 20th January, 1968	94

SALE OF FREEHOLD LAND BY AUCTION.

Geelong.—Monday, 16th January, 1968	89
-------------------------------------	----

PROPOSED REVOCATIONS OF TEMPORARY RESERVATIONS OF LANDS BY ORDERS IN COUNCIL.

IN pursuance of the provisions of the Land Act 1958, notice is hereby given that it is the intention of the Governor in Council to revoke the temporary reservations of lands by Orders in Council hereunder referred to, viz.:

The following Notices were published 1° on the 6th December, 1967, pursuant to Orders of the 28th November, 1967.

ASHENS.—The temporary reservation, by Order in Council of the 31st October, 1922, of 10 acres (shown as 8 acres 3 roods 6 perches on Order) of land in the Parish of Ashens as sites for Supply of Loam is about to be revoked.—(A.168(*) (Rs.2644).

SMYTHESDALE.—The temporary reservation, by Order in Council of the 6th November, 1865, of 815 acres 2 roods 15 perches of land in the Parish of Smythesdale as a site for Drainage Area of a Reservoir for supplying water to Smythesdale, revoked as to part by various Orders, is about to be revoked so far only as the portion containing 20 acres 30 perches; more or less, indicated by hatching on plan hereunder, is concerned.—(S.297(*) (C.71778).

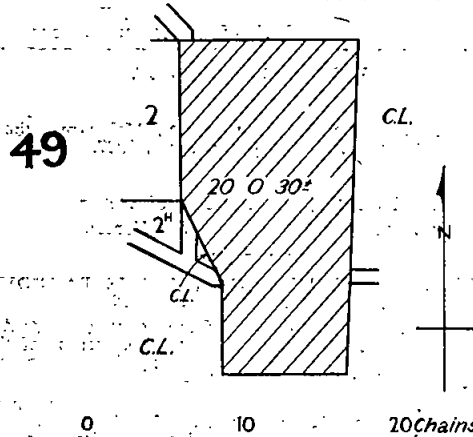

WARRANTYTE (ANDERSONS CREEK).—The temporary reservation, by Order in Council of the 17th September, 1866, of 14 acres 2 roods of land in the Township of Warrandyte as a site for Recreation purposes, revoked as to part by various Orders, is about to be revoked so far only as the portion containing 18 perches, indicated by hatching on plan hereunder, is concerned.—(W.25(*) (Rs.653).

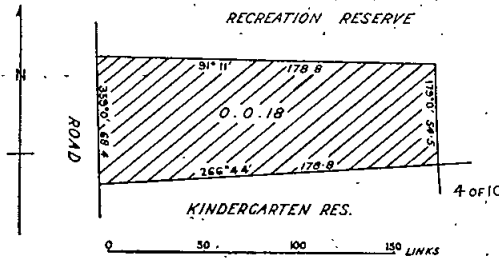

W. J. F. McDONALD,
Minister of Lands.

PROPOSED REVOCATIONS OF TEMPORARY RESERVATIONS OF LANDS BY ORDERS IN COUNCIL.

IN pursuance of the provisions of the Land Act 1958, notice is hereby given that it is the intention of the Governor in Council to revoke the temporary reservations of lands by Orders in Council hereunder referred to, viz.:

The following Notices were published 1° on the 29th November, 1967, pursuant to Orders of the 21st November, 1967.

OAKLEIGH.—The temporary reservation, by Order in Council of the 12th May, 1925, of 1 acre 1 rood 4 perches of land in the Township of Oakleigh as a site for Public Recreation Purposes is about to be revoked so far only as the portion containing 34 perches, indicated by hatching on plan hereunder, is concerned.—(O.1(*) (Rs.470).

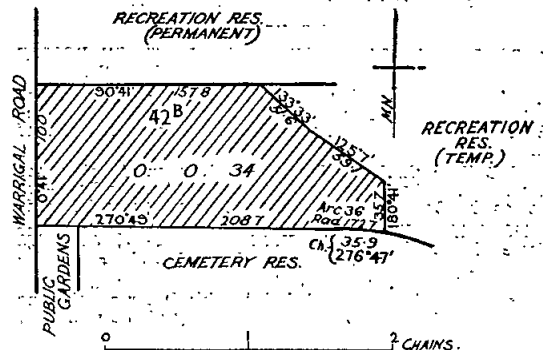

GARIBALDI.—The temporary reservation, by Order in Council of the 17th May, 1887, (see *Government Gazette* 20th May, 1887, page 1331) of 12 acres 5 perches of land in the Parish of Enfield (now in the Township of Garibaldi) as a site for supply of material for Road-making purposes, revoked as to part by Order in Council of the 12th July, 1909, (see *Government Gazette* 21st July, 1909, page 3322) is about to be revoked save and except the area of 6 acres 3 roods 30 perches, more or less, indicated by hatching on plan hereunder.—(E.52⁽⁴⁾) (Rs.8892).

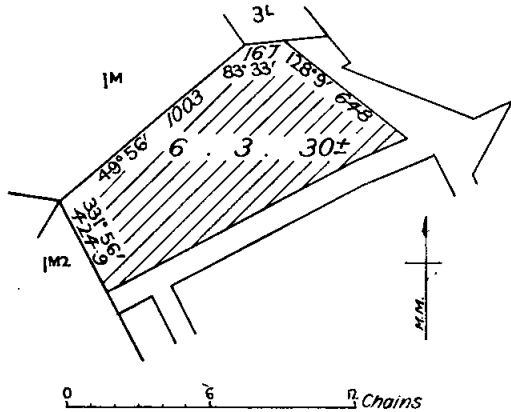

KALKEE.—The temporary reservation as a site for Public purposes and the withholding from sale, leasing and licensing by Order in Council of the 22nd November, 1875, of 60 acres 1 rood 26 perches of land in the Parish of Kalkee, revoked as to part by Order in Council of the 31st July, 1928, are about to be revoked so far as the balance thereof containing 10 acres 1 rood 38 perches is concerned.—(K.143⁽⁸⁾) (Rs.7261).

WILLAM.—The temporary reservation, by Order in Council of the 15th March, 1887, (see *Government Gazette* 18th March, 1887, page 785) of 6 acres 5 perches of land in the Parish of Willam as a site for Water Supply purposes and the temporary reservation by Order in Council of the 27th August, 1894 (see *Government Gazette* 31st August, 1894, page 3529) of 2 acres, more or less, of land as an extension thereto are about to be revoked.—(W.346⁽⁴⁾) (Rs.8883).

W. J. F. McDONALD,
Minister of Lands.

PROPOSED REVOCATION OF TEMPORARY RESERVATION OF LAND BY ORDER IN COUNCIL.

IN pursuance of the provisions of the *Land Act* 1958, notice is hereby given that it is the intention of the Governor in Council to revoke the temporary reservations of lands by Orders in Council hereunder referred to, viz.:—

The following Notices were published 1° on the 29th November, 1967, pursuant to Orders of the 19th September, 1967.

WOMBAT (Blanket Flat).—The temporary reservation, by Order in Council of the 28th May, 1866, of 1 acre of land in the Parish of Wombat as a site for Presbyterian Church purposes is about to be revoked so far only as the portion containing 16 perches, indicated by hatching on plan hereunder, is concerned.—(W.179⁽³⁶⁾) (C.6803).

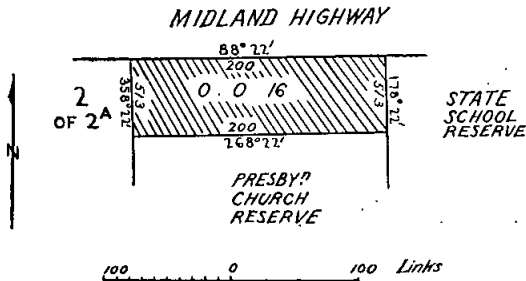

W. J. F. McDONALD,
Minister of Lands.

PROPOSED PERMANENT RESERVATION OF LAND AS A SITE.

IN pursuance of sections 14 and 21 of the *Land Act* 1958, notice is hereby given that it is the intention of the Governor in Council to reserve permanently from sale, from being leased and from having a licence granted in respect thereof the land hereinafter described:—

The following Notice was published 1° on the 6th December, 1967, pursuant to Order of the 28th November, 1967.

CUNNINGHAME.—Land proposed to be permanently reserved as a site for Public Recreation 7 acres, more or less, Township of Cunninghame, Parish of Colquhoun, County of Tambo, as indicated by hatching on plan hereunder.—(C.486⁽²⁾) (Rs.8888).

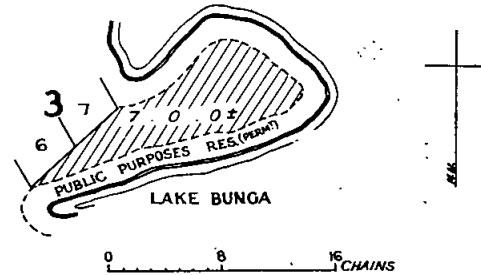

W. J. F. McDONALD,
Minister of Lands.

PROPOSED REVOCATIONS OF TEMPORARY RESERVATIONS OF LANDS BY ORDERS IN COUNCIL.

IN pursuance of the provisions of the *Land Act* 1958, notice is hereby given that it is the intention of the Governor in Council to revoke the temporary reservations of lands by Orders in Council hereunder referred to, viz.:—

The following Notices were published 1° on the 20th December, 1967, pursuant to Orders of the 12th December, 1967.

NUNAWADING.—The temporary reservation as a site for Public purposes (State School) and the withholding from sale, leasing and licensing by Order in Council of the 14th February, 1876, of 2 acres of land in the Parish of Nunawading are about to be revoked so far only as the portion containing 7 perches, indicated by hatching on plan hereunder, is concerned.—(N.79⁽⁶⁾) (Rs.5471).

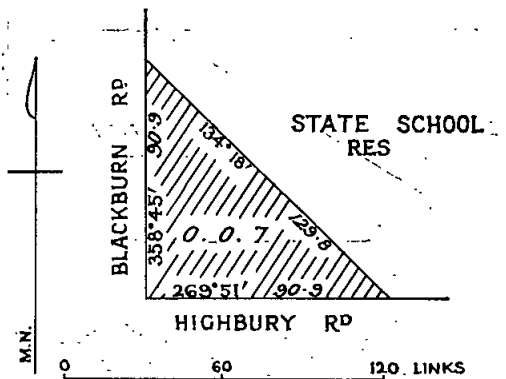

SANDHURST (BENDIGO).—The temporary reservation, by Order in Council of the 26th May, 1925, of several portions of land at Bendigo in the Parish of Sandhurst as sites for Public purposes (Sewerage), revoked as to part by Order

of the 30th June, 1964, is about to be revoked so far only as the portion containing 12 perches, indicated by hatching on plan hereunder, is concerned.—(S.372⁽¹¹³⁾ (C.73802).

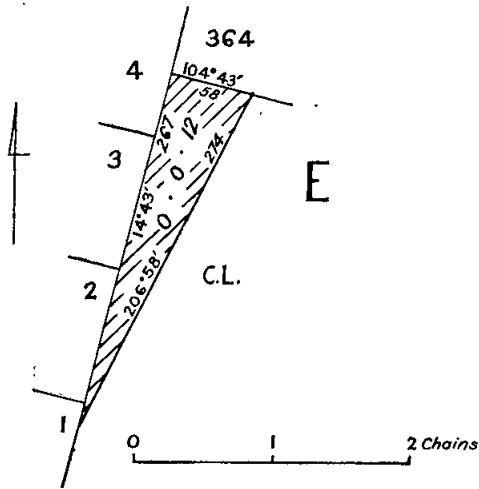

BRUARONG.—The temporary reservation, by Order in Council of the 11th November, 1867 (see *Government Gazette* 19th November, 1867, page 2232), of 3 roods 4 perches of land in the Township of Hillsborough (now in the Parish of Bruarong), as a site for Common School purposes is about to be revoked.—(H.119⁽¹⁾) (Rs.8913).

W. J. F. McDONALD,
Minister of Lands.

COMMITTEES OF MANAGEMENT OF RESERVES.

APPOINTMENTS.

NOTICE is hereby given that in pursuance of section 221 of the *Land Act* 1958, the following appointments of Committees of Management of reserved Crown Land has been made by the Minister of Lands:—

“BAKER RECREATION RESERVE.”

Harold Chandler, Mervyn Harold Marra, Alan Walter Smith, George Arnold Golder, Herbert John Wilksch, Alfred John McMartin, Edgar Alfred Rethus, Samuel William Chandler and Clifford Henry Sanders as a Committee of Management for a period of three (3) years of the land temporarily reserved by Order in Council dated the 29th August, 1967, as a site for Public Recreation in the Township of Baker, Parish of Warraquil, and known as the “Baker Recreation Reserve”.—(Corres. Rs.8834.)

“BLACKWOOD MECHANICS’ INSTITUTE RESERVE.”

Margaret Matheson, William Alexander Matheson, James Allison, Elizabeth Sweet, Mark Eugene Walker, Dorothy Williamson, Eleanor Rebecca Matheson, Kenneth Kendall Matheson, John Peter Simmonds and John Joseph Cann as a Committee of Management for a period of three (3) years of the land temporarily reserved by Orders in Council dated the 7th March, 1870 and 27th April, 1880 as a site for a Mechanics’ Institute at Blackwood, and known as the “Blackwood Mechanics’ Institute Reserve”.—(Corres. Rs.4711.)

“DOREEN HALL AND RECREATION RESERVE.”

Arthur James Christian, Laurence Patrick Mitchell, Leslie Ernest Kemp, Hector Rogers, Daphne Louise Reid and Russell Hamilton Smith as a Committee of Management for a period of three (3) years of the land temporarily reserved by Order in Council dated the 5th January, 1909, as a site for Public Recreation in the Parish of Yan Yean, and known as the “Doreen Hall and Recreation Reserve”.—(Corres. Rs.2607.)

“ENSAY MECHANICS’ INSTITUTE RESERVE.”

Bernie Kenneth Duggan, Hugh Thomas Fraser, George Cannon Taylor, Neville Davis, John Phillip Maberly Margetts, Edward John Kennedy and Thomas Macknight Langtree as a Committee of Management for a period of three (3) years of the land in the Township of Ensay, Parish of Numbie-Munjie temporarily reserved by Order in Council dated the 16th November, 1891, as a site for a Mechanics’ Institute Reserve.—(Corres. Rs.7744.)

“ENSAY RECREATION RESERVE.”

Finley Angus, Maisie Caroline Duggan, Peter Frederick Duggan, Hugh Thomas Fraser, Robert Burden Taylor, Thomas Macknight Langtree and James Flynn as a Committee of Management for a period of three (3) years of the land temporarily reserved by Order in Council dated the 30th August, 1955, as a site for Recreation purposes in the Parish of Angora.—(Corres. Rs.5750.)

“KINGLAKE TOWNSHIP RECREATION RESERVE.”

Avon Frederick Schultz, William Alan Fairlie, Maurice Gordon Hawkins, William Thomas Golder, Stanley Arthur Reeves, Frederick Weatherley, Robert Wilson and Terry Thomas Toohey as a Committee of Management for a period of three (3) years of the land temporarily reserved by Order in Council dated the 16th August, 1910, as a site for Public Recreation in the Parish of Kinglake, and known as the “Kinglake Township Recreation Reserve”.—(Corres. Rs.4814.)

“KOOREH MEMORIAL HALL RESERVE.”

William Henry Howard, James Percival Wandel, Cecil Charles Cole, Leon John Proctor and Ronald McNally as a Committee of Management for a period of three (3) years of the land in the Parish of Kooreh temporarily reserved by Order in Council dated the 20th January, 1923 as a site for a Public Hall, and known as the “Kooreh Memorial Hall Reserve”.—(Corres. Rs.2679.)

BANNOCKBURN.—The temporary reservation, by Order in Council of the 26th June, 1962, of 2 roods of land in the Township of Bannockburn as a site for Public Hall is about to be revoked so far only as the portion containing 24 perches, indicated by hatching on plan hereunder, is concerned.—(B.35⁽¹⁾) (Rs.2121).

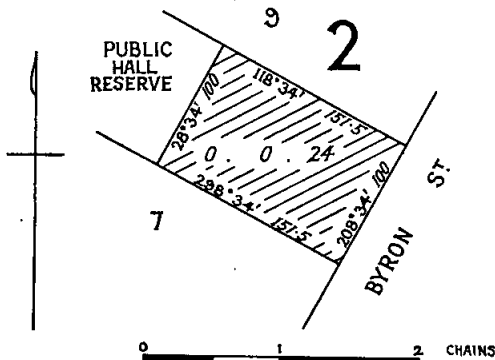

BOORT.—The temporary reservation, by Order in Council of the 20th March, 1946, of 14 acres 1 rood, more or less, of land in the Township of Boort as a site for Plantation purposes is about to be revoked so far only as the portion containing 5 perches, indicated by hatching on plan hereunder, is concerned.—(B.654⁽¹⁰⁾) (Rs.5764).

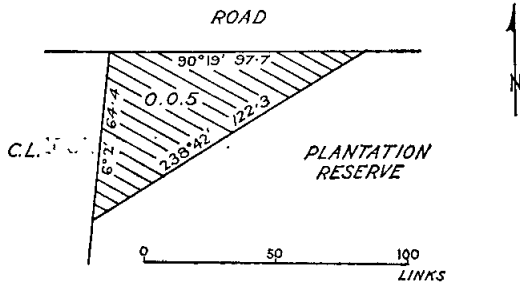

HEYWOOD.—The temporary reservation as a site for Public purposes (State School) and the withholding from sale, leasing and licensing by Order in Council of the 21st May, 1877, of 1 acre 2 roods 34 8/10 perches of land in the Township of Heywood, revoked as to part by Order in Council of the 24th April, 1939, are about to be revoked so far as the balance thereof, containing 1 acre 2 roods, is concerned.—(H.86⁽³⁾) (Rs.5267).

DUNKELD.—The temporary reservation, by Order in Council of the 15th August, 1893, of 1 acre 1 rood 30 perches of land in the Township of Dunkeld as a site for Public Gardens is about to be revoked.—(D.143⁽²⁾) (C.81449).

"MEENIYAN RECREATION RESERVE."

David Patrick McKitterick, Walter Alfred Mihan, John Meikle, Brendan Jackson Hanily, Morton Fulton Hewett, Leonard John Taylor, John Neville Meikle and Dudley Harold John Douglas as a Committee of Management for a period of three (3) years of the land temporarily reserved by Order in Council dated the 11th December, 1894 and of the lands temporarily reserved by Orders in Council dated the 2nd July, 1912 and 8th August, 1922, for Public Recreation in the Parish of Nerrena and Township of Meeniyau, and known as the "Meeniyau Recreation Reserve".—(Corres. Rs.153.)

"MOONAMBEEL RECREATION RESERVE."

Joseph Micheal Slater, Thomas William Hope, Jack Lawrence Howard, Keith John Farnsworth, James Allen Farnsworth, George William Driscoll, Joseph William Summerfield and Patrick Cudmore as a Committee of Management for a period of three (3) years of the land in the Township of Moonambeel, temporarily reserved by Order in Council dated the 6th February, 1865, for Public Recreation purposes, and known as the "Moonambeel Recreation Reserve".—(Corres. Rs.1127.)

"NARRAWONG CAMPING AND RECREATION RESERVE."

Owen Leonard Roberts, Alfred Ernest Saunders, Robert Edwin Gerdtz, Robert Keith McIntyre, Lindsay Meyer Trigg, Douglas Sidney May, Peter D. Jenz, Gavin James Adamson, Eric A. Barber and Thomas Campbell Walder as a Committee of Management for a period of three (3) years of the land in the Township of Narrawong temporarily reserved as a site for Camping and Public Recreation by Order in Council dated the 14th September, 1948, together with that portion of the permanent reservation for Public purposes along the Surry River abutting such land and known as the "Narrawong Camping and Recreation Reserve" and also in respect of that portion of land in the said township fronting the Surry River and Portland Bay as is indicated by red colour on plan marked "N"/1.12.53 attached to Lands Department correspondence Rs.6212.—(Corres. Rs.6212.)

"NAMBROK HALL AND RECREATION RESERVE."

Norman David Medew, Vernon John Bermingham, William Henry Wheeler, Henry Cull, John Joseph Killert, John Bruce Mathieson, William John Gurling, Robert Joseph Barr Mason, Kevin Jeremiah Gray and Ronald Sydney Pietersen as a Committee of Management for a period of three (3) years of the land in the Parish of Denison temporarily reserved by Order in Council dated the 11th February, 1958, as a site for a Public Hall and Public Recreation, and known as the "Nambrok Hall and Recreation Reserve".—(Corres. Rs.7700.)

"NORTH BOORHAMAN RECREATION RESERVE."

William Joseph Jones, William Leslie Sandford, Graham John Woods, John Fenley McInness, Keith Charles Wienert, Charles Creighton Phillis, Edwin Alfred Robinson, Brian Thomas Jones and Michael George Colvin as a Committee of Management for a period of three (3) years of the land in the Parish of Boorhaman temporarily reserved by Order in Council dated the 20th April, 1886, as a site for Public Recreation, and known as the "North Boorhaman Recreation Reserve".—(Corres. Rs.2791.)

"SOUTH LILLIMUR RECREATION RESERVE."

John Henson Kennett, David Edwin Hawker, Geoffrey Robert Black, Francis William Kuchel, Sydney Roy Goodwin, William Robert Black, Noel William Nash, Douglas Rex Thompson and Neville Ian Goodwin as a Committee of Management for a period of three (3) years of the land temporarily reserved by Order in Council dated the 21st September, 1927 as a site for Public Recreation in the Township of Lillimur South, Parish of Lillimur, and known as the "South Lillimur Recreation Reserve".—(Corres. Rs.3525.)

"YEA SHOWYARDS AND RECREATION RESERVE."

Albert Edward Robinson, Ronald Douglas Drysdale, Errol Rodney Simon, Donald Scott McLeish, Frederick Rothwell Pilfoot, Leslie Noel Moore, Thomas Michael Dignam and Gordon Kenneth McPhee as a Committee of Management for a period of three (3) years of the land temporarily reserved by Orders in Council dated the 20th July, 1891 and 31st July, 1917, as a site for Public Recreation and Agricultural Show Yards in the Township of Yea, and known as the "Yea Show Yards and Recreation Reserve".—(Corres. Rs.146.)

"WARRNAMBOOL CRICKET GROUND RESERVE."

Trevor Graeme Ryan and Neil Arthur Fisher in the places of Russell John Pink and Desmond David Thompson (resigned) as members of the Committee of Management for a period ending the 15th December, 1968, of the land temporarily reserved by Order in Council dated the 27th May, 1903, as a site for Cricket and other purposes of Public Recreation in the Township of Warrnambool, and known as the "Warrnambool Cricket Ground Reserve".—(Corres. Rs.1825.)

SITE FOR WATERING PURPOSES, TOWNSHIP OF BUNINYONG.

Council of the Shire of Buninyong as the Committee of Management of the land in the Township of Buninyong temporarily reserved by an Order in Council dated the 14th October, 1872, as a site for Watering Purposes.—(Corres. Rs.8909.)

SITE FOR WATERING PURPOSES, TOWNSHIP OF BUNINYONG.

Council of the Shire of Buninyong as the Committee of Management of the land by the township of Buninyong temporarily reserved by an Order in Council dated the 8th July, 1978, as a site for Watering Purposes.—(Corres. Rs.8910.)

SITE FOR THE SUPPLY OF GRAVEL, PARISH OF GUILDFORD.

Council of the Shire of Newstead as the Committee of Management of the land temporarily reserved by Order in Council dated the 19th February, 1913, as a site for the supply of gravel in the Parish of Guildford.—(Corres. Rs. 3500.)

SITE FOR THE SUPPLY OF GRAVEL, PARISH OF GUILDFORD.

Council of the Shire of Newstead as the Committee of Management of the land temporarily reserved by Order in Council dated the 21st October, 1902, as a site for the Supply of Gravel in the Parish of Guildford.—(Corres. Rs.3502.)

SAND HILL GRAVEL RESERVE, PARISH OF SARSFIELD.

The Council of the Shire of Bairnsdale as the Committee of Management of the land in the Parish of Sarsfield temporarily reserved by Order in Council dated the 19th October, 1891, as a site for the Supply of Gravel.—(Corres. 7082.)

SITE FOR TOURIST CAMPING PURPOSES, TOWNSHIP OF SEYMOUR.

Council of the Shire of Seymour as the Committee of Management of the land in the Township of Seymour temporarily reserved by Order in Council dated the 31st October, 1967, as a site for Tourist Camping Purposes, together with the adjoining portion of land in the Township of Seymour, being part of the Goulburn River reserve as shown coloured red on plan "S/12-10-1967" attached to Lands Department correspondence Rs.2235.—(Corres. Rs.2235.)

ALAN J. HOLT,
Secretary for Lands.

8th December, 1967.

Land Act 1958.
LEASE SURRENDERED.

NOTICE is hereby given that the Governor in Council has accepted the surrender of the Lease mentioned in the schedule hereunder for the reason specified.

District.	Corr. No.	Name.	Section of Land Act under which Leased.	Parish.	Allotment.	Section.	Area.	Reason.
Melbourne	0447/134	G. Vaccari & Co. (Travel Service) Proprietary Limited	134	City of Melbourne, Parish of Melbourne North	13A	32	A. R. P. 0 0 5 $\frac{1}{16}$	Surrendered

Department of Crown Lands and Survey,
Melbourne, 13th December, 1967.

W. J. F. McDONALD,
Minister of Lands.

PUBLIC SERVICE NOTICES

No. 1803.

Public Service Act 1958.

THE Public Service Board, in pursuance of the powers conferred by the *Public Service Act 1958*, hereby amends the Public Service (Public Service Board) Regulations as shown below :—

PART V.—ALLOWANCES.

DIVISION II.—OVERTIME AND STAND-BY ALLOWANCES.

WATER SUPPLY DEPARTMENT.

Regulation 107 (1).

Office or Position.	Stand-by per Annum.		Commuted Overtime Percentage.
	\$	%	
<i>District Superintendent, Supervisor, Waranga Western Channel, Senior District Inspectors, Works Superintendents, District Inspectors, Senior Works Inspectors, Works Inspectors, Inspectors and Inspector, Loddon Weir</i>			
Paragraphs (a) and (b) are deleted and the following paragraphs are substituted therefor—			
(a) Goulburn Division—			
(i) Stanhope Irrigation area and Murchison	132	28	
(ii) All others	106	12.5	
(b) Loddon Division—			
(i) Waranga Western Channel, Rushworth and Dingee Irrigation area	132	28	
(ii) District Inspector, Kerang	132	28	
(iii) Inspector, Loddon Weir	106	18	
(iv) All others	106	12.5	

F. E. CAHILL, Chairman.
V. P. SCULLY, Secretary.

Office of the Public Service Board,
Melbourne, 1st December, 1967.

No. 1802.

Public Service Act 1958, Section 50.

REGULATIONS.—PART IV.—SALARIES AND INCREMENTS.

THE Public Service Board, in pursuance of the powers conferred by the *Public Service Act 1958*, hereby amends its Regulations as shown below :—

SIXTH SCHEDULE.

TEMPORARY EMPLOYEES.

Designations of Positions and Rates of Salaries.

Department and Designation of Position.	Yearly Rate of Salary.		Increments (Annual).
	Minimum.	Maximum.	
GENERAL.	\$	\$	
<i>Delete—</i> Engineer Assistant ≠	3,255	4,986	f(i)
<i>Add—</i> Engineer ≠	3,255	4,986	f(i)
≠ To apply to employees who are qualified engineers. f(i) Increments in accordance with the scale of rates of salaries as set out for Engineer, Class "E-1" in Part B of the Third Schedule			

F. E. CAHILL, Chairman.
V. P. SCULLY, Secretary.

Office of the Public Service Board,
Melbourne, 6th December, 1967.

No. 1800.

Public Service Act 1958, Section 50.

REGULATIONS.—PART IV.—SALARIES AND INCREMENTS.

THE Public Service Board, in pursuance of the powers conferred by the *Public Service Act 1958*, hereby amends its Regulations as shown below :—

SIXTH SCHEDULE.

TEMPORARY EMPLOYEES.

Designations of Positions and Rates of Salaries.

Department and Designation of Position.	Yearly Rate of Salary.		Increments (Annual).
	Minimum.	Maximum.	
<i>Immediately prior to the heading "DEPARTMENT OF AGRICULTURE"</i>	\$	\$	
<i>add—</i> MINISTRY OF ABORIGINAL AFFAIRS. Aborigines Welfare Officer (Female)	2,559	2,633	Σ
CHIEF SECRETARY'S DEPARTMENT			
<i>Delete—</i> Aborigines Welfare Officer (Female), Aborigines Welfare Board	2,559	2,633	Σ
Farm Foreman, Aboriginal Station, Lake Tyers	2,534	2,572	Σ
Nurse, Aboriginal Station, Lake Tyers	2,521	2,559	Σ
Σ See Regulation 83 (2).			

This Regulation shall have effect as on and from the 1st January, 1968.

F. E. CAHILL, Chairman.
V. P. SCULLY, Secretary.

Office of the Public Service Board,
Melbourne, 13th December, 1967.

No. 1801.

Public Service Act 1958, Section 50.

REGULATIONS.—PART IV.—SALARIES AND INCREMENTS.

THE Public Service Board, in pursuance of the powers conferred by the *Public Service Act 1958*, hereby amends its Regulations as shown below :—

SIXTH SCHEDULE.

TEMPORARY EMPLOYEES.

Designations of Positions and Rates of Salaries.

Department and Designation of Position.	Yearly Rate of Salary.		Increments (Annual).
	Minimum.	Maximum.	
CHIEF SECRETARY'S DEPARTMENT. SOCIAL WELFARE. <i>Youth Welfare Division.</i>	\$	\$	
<i>Add—</i> Trade Instructor (Female), (Cookery and Home Management), "Winlaton"	3,027	3,244	Σ
Σ See Regulation 83 (2).			

F. E. CAHILL, Chairman.
V. P. SCULLY, Secretary.

Office of the Public Service Board,
Melbourne, 4th December, 1967.

No. 1804.

Public Service Act 1958.

REGULATIONS.—PART IV.—SALARIES AND INCREMENTS.

THE Public Service Board, in pursuance of the powers conferred by the Public Service Act 1958, hereby amends its Regulations as shown below:—

THIRD SCHEDULE.

PART B.

PROFESSIONAL DIVISION.

Scale of Rates of Annual Salaries.

PSYCHOLOGISTS.

The Salary scale shown is deleted and the following salary scale is inserted in lieu thereof:—

Class.	Annual Salary of Each Subdivision of Each Class.						
	1.	2.	3.	4.	5.	6.	7.
P-1	\$ 3,343	\$ 3,571	\$ 3,768	\$ 4,184	\$ 4,434	\$ 4,684	\$ 5,141
P-2	5,475	5,652	5,963	6,238
P-3	6,529	6,820	7,206
P-4	7,487	7,778	8,298

SIXTH SCHEDULE.

TEMPORARY EMPLOYEES.

Designations of Positions and Rates of Salaries.

Department and Designation of Position.	Yearly Rate of Salary.		Increments (Annual).
	Minimum.	Maximum.	
DEPARTMENT OF HEALTH. Mental Hygiene.	\$	\$	
<i>Delete the existing yearly rates of salary for the following positions and insert the rates shown hereunder in lieu thereof:—</i>			
Psychologist (Male), Senior Clinical	6,529	7,206	σ (i)
Psychologist (Male), Clinical	5,475	6,238	σ (ii)
Psychologist (Male), Clinical	3,343	5,141	σ (iii)
Psychologist (Female), Senior Clinical	6,103	6,780	1 of \$291 and 1 of \$386
Psychologist (Female), Senior Research	6,103	6,780	1 of \$291 and 1 of \$386
Psychologist (Female), Clinical	5,049	5,812	1 of \$177, 1 of \$311 and 1 of \$275
Psychologist (Female)	2,917	4,715	1 of \$228, 1 of \$197, 1 of \$416, 2 of \$250 and 1 of \$457.
σ (i) Increments in accordance with the scale of rates of salaries as set out for Psychologist, Class "P-3" in Part B of the Third Schedule.			
σ (ii) Increments in accordance with the scale of rates of salaries as set out for Psychologist, Class "P-2" in Part B of the Third Schedule.			
σ (iii) Increments in accordance with the scale of rates of salaries as set out for Psychologist, Class "P-1" in Part B of the Third Schedule.			

F. E. CAHILL, Chairman.
V. P. SCULLY, Secretary.

Office of the Public Service Board,
Melbourne, 1st December, 1967.

PUBLIC SERVICE OF PAPUA AND NEW GUINEA.

DIRECTORATE OF TRANSPORT IN NEW GUINEA.

TRANSPORT is a challenge in New Guinea. The people and the country have been divided by vast mountain ranges, broad rivers, swampy plains, and thousands of islands.

The Directorate of Transport, nucleus of a Department of Transport to be set up at an early date, has recently been established to formulate integrated plans and policies for the development of all modes of transport—land, sea and air. About 35 per cent of the Capital Budget is devoted to transport facilities and increasing emphasis is being placed in the Territory on economic development.

Interdisciplinary methods will be used and work will concentrate on the investigation and appraisal of major road and wharf projects and programmes, the relation of transport investment plans to Territory-wide and regional development, and policies for the efficient development and financing of the rapidly growing transport industries.

Vacancies exist for—

Principal Transport Engineer.

\$8,742—\$9,290 per annum.

Qualifications.—Eligibility for A.M.I.E. (Aust.). Wide experience in civil engineering construction and estimating. Sound knowledge of road and wharf surveys and construction costs. Experience in transport planning and materials handling techniques.

Duties.—Direction of investigations into technical and cost aspects of transport development programmes. Co-ordinate technical investigations by executive agencies and consultants into road, port and aerodrome surveys and designs.

Senior Transport Engineer.

\$7,920—\$8,428 per annum.

Qualifications.—Eligibility for A.M.I.E. (Aust.). Substantial experience in major construction, especially roads and wharves, with sound knowledge of modern methods of financial and project control and planning. Background in transportation planning desirable.

Duties.—Assist in the co-ordination of road transport development programmes and expenditures, and the development of planning controls. Investigate road and vehicle operating standards.

Transport Engineer (Marine).

\$6,844—\$7,606 per annum.

Qualifications.—Degree in Civil or Mechanical Engineering or equivalent professional qualification in shipping and port operations. Wide experience in maritime operations, especially of port design and handling cargo developments. Knowledge of technical aspects of shipping operations desirable.

Duties.—Liaise with and advise Port authorities and other bodies on development of ports. Undertake studies on materials handling. Assist in proposals for development of coastal and overseas shipping.

Transport Engineer (Planning).

\$6,844—\$7,606 per annum.

Qualifications.—Degree in Engineering or other appropriate qualification. Extensive experience in municipal and urban planning and transportation problems. Qualifications in urban development and experience in underdeveloped countries desirable.

Duties.—Assist in planning urban and associated development and transportation, formulation of policy proposals relating to urban and associated transport. Supervise urban transport surveys.

Senior Transport Economist (Investigations).

\$8,111—\$8,418 per annum.

Qualifications.—Post-graduate degree in Transport Economics or location studies desirable. Considerable experience in academic research or industry of transportation projects and programmes. Sound statistical knowledge.

Duties.—Direct investigations into economic conditions in the land, sea and air transport industries, transport development projects and programmes, and economic implications of proposed policy measures.

Senior Transport Planner (Development).
\$8,111—\$8,418 per annum.

Qualifications.—Degree in Economics or other appropriate qualifications. Post-graduate qualifications desirable. Wide experience in public or private development planning and programming. Sound statistical knowledge. Experience in an under-developed country at the policy and planning level most desirable.

Duties.—Advise on and assist in formulation of policy proposals for economic and other regulations in the transport industries. Assist in co-ordination of transport development programmes and development of planning criteria.

Salaries and Allowances.—Salaries quoted are for single men and include allowances. Married men receive an additional allowance of \$360 per annum.

Income Tax is at present about half that payable in Australia.

Leave.—Three months' leave after each 21 months of service with assisted leave fares paid to Australia. After each six years of service an additional three months' leave is granted in conjunction with the regular leave, giving a "long leave" of six months.

Engagement is by contract—term to be negotiated.

Applicants employed by a Government authority may be considered for secondment to the Territory Service with preservation of existing rights.

Education facilities range from pre-school to tertiary level. An education allowance and an annual return air fare as far as Sydney is paid for children who receive a secondary education in Australia.

Accommodation.—Furnished married accommodation at nominal rates is guaranteed.

Details and application form from—

The Secretary, Department of Territories, Hobart-place, Canberra, A.C.T., 2601 'phone 4 0477
The Official Representative, Department of Territories, 46 Market-street, Sydney, N.S.W., 2001 29 5151

188 Queen-street, Melbourne, Vic., 3000 67 6159
145 Eagle-street, Brisbane, Qld., 4000 33 5100
Applications close in Canberra on 13th January, 1968.

PUBLIC SERVICE OF PAPUA AND NEW GUINEA.
AGRICULTURAL CHEMIST FOR NEW GUINEA.

AN Agricultural Chemist possessing a degree in Agricultural Science or Science, with a major in Chemistry is needed in the Department of Agriculture, Stock and Fisheries, to undertake and supervise investigations into plant nutritional problems in Territory crops. He will be required to organize and supervise the work of a staff of chemists and assistants. The appointee should have considerable research experience in plant nutrition.

Commencing salary (including allowances) will be within the range \$6,580—\$8,027 per annum depending on qualifications and experience. A married appointee will receive an additional \$360 per annum. (Income tax in the Territory is at present about half that payable in Australia).

Engagement is by contract for a minimum of two years, longer if preferred. Applicants employed by a Government Authority may be considered for secondment to the Territory Service for an initial period of two years with preservation of existing rights.

Leave.—Three months' leave after 21 months' service with assisted leave fares to Australia.

Education.—Facilities in the Territory range from pre-school to tertiary level. An education allowance plus an annual return airfare, is paid for children attending secondary school in Australia.

Accommodation.—Requirements will be discussed at interview.

Details and application form from—

Recruitment Officer, Department of Territories, Hobart-place, Canberra, A.C.T., 2601 4 0477
46 Market-street, Sydney, N.S.W., 2001 29 5151
188 Queen-street, Melbourne, Vic., 3000 67 6159
145 Eagle-street, Brisbane, Qld., 4000 33 5100

Applications, quoting advertisement No. 408 should reach the Canberra address by 20th January.

Teaching Service Act 1958.

TEACHING SERVICE (TEACHERS TRIBUNAL) REGULATIONS.

AMENDMENT No. 128.

THE Teachers Tribunal, in pursuance of the powers conferred by the Teaching Service Act 1958, hereby rescinds Regulations 19 and 21 of the Teaching Service (Teachers Tribunal) Regulations, as from and including the 1st January, 1968, and substitutes therefor the following Regulations:—

REGULATION 19.

Relative Numbers of Positions for Teachers in each Class of the Secondary Schools Division.

The relative numbers of positions for teachers in each class of the Secondary Schools Division from the 1st January, 1968, shall be as follows:—

Class.	Men.	Women.
Special	159	71
I.	377	179
II.	820	460
III.	1300	860
IV.	2250	2250

REGULATION 21.

Relative Numbers of Positions for Teachers in each Class of the Technical Schools Division.

The relative numbers of positions for teachers in each class of the Technical Schools Division from the 1st January, 1968, shall be as follows:—

Class.	Men.	Women.
Special	109	10
I.	254	29
II.	715	74
III.	980	223
IV.	1050	350

A. McDONELL, Acting Chairman.
G. FENNELL, Secretary.

Office of the Teachers Tribunal,
Melbourne, 15th December, 1967.

Teaching Service Act 1958.

TEACHING SERVICE (CLASSIFICATION, SALARIES AND ALLOWANCES) REGULATIONS.

AMENDMENT No. 129.

THE Teachers Tribunal, in pursuance of the powers conferred by the *Teaching Service Act 1958*, hereby amends the Teaching Service (Classification, Salaries and Allowances) Regulations in the manner following, that is to say:—

PART XII.—ALLOWANCES.

In paragraph (d) of clause 31 (B), after the word "Richmond" insert the word "Yallourn" and after the words "Melbourne School of Printing and Graphic Arts" insert the words "Melbourne School of Textiles".

(To take effect from and including the 1st January, 1968.)

A. McDONELL, Acting Chairman.

G. FENNELL, Secretary.

Office of the Teachers Tribunal,
Melbourne, 15th December, 1967.

Teaching Service Act 1958.

TEACHING SERVICE (CLASSIFICATION, SALARIES AND ALLOWANCES) REGULATIONS.

AMENDMENT No. 130.

THE Teachers Tribunal, in pursuance of the powers conferred by the *Teaching Service Act 1958*, hereby amends the Teaching Service (Classification, Salaries and Allowances) Regulations in the manner following, that is to say:—

PART V.—PROFESSIONAL OFFICERS.

In clause 12, under the sub-heading "(b) Principals and Staffs of Teachers' Colleges and Training Institutions"—

- (i) for the expression "Principal, Burwood, Frankston, Melbourne, Monash, Toorak and Secondary Teachers' Colleges" substitute the expression "Principal, Burwood, Frankston, Geelong, Melbourne, Monash, Toorak and Secondary Teachers' Colleges";
- (ii) for the expression "Principal, Ballarat, Bendigo, Coburg, Geelong and Technical Teachers' Colleges, and Training Centre for Teachers of the Deaf and 'Glendonald' School for Deaf Children" substitute the expression "Principal, Ballarat, Bendigo, Coburg, Domestic Arts and Technical Teachers' Colleges, and Training Centre for Teachers of the Deaf and 'Glendonald' School for Deaf Children";
- (iii) for the expression "Vice-Principal, Burwood, Coburg, Frankston, Melbourne, Toorak and Secondary Teachers' Colleges" substitute the expression "Vice-Principal, Burwood, Coburg, Frankston, Geelong, Melbourne, Monash, Secondary, Technical and Toorak Teachers' Colleges, and Training Centre for Teachers of the Deaf and 'Glendonald' School for Deaf Children";
- (iv) delete the expression "Principal, Domestic Arts Teachers' College (Woman) 6,974".

(To take effect from and including the 1st January, 1968.)

A. McDONELL, Acting Chairman.

G. FENNELL, Secretary.

Office of the Teachers Tribunal,
Melbourne, 15th December, 1967.

TENDERS**PUBLIC WORKS DEPARTMENT**

TENDERS will be received at Public Works Department, Treasury-place, Melbourne, until **TWO** p.m. on dates shown and for purposes mentioned hereunder.

Particulars and tender forms available at Contracts Office, Room 7, Building Division, Parliament-place and at places indicated in brackets hereunder.

Abbreviations in brackets mean:—W.O.—Inspector of Works Office; P.S.—Police Station; C.S.—Consolidated School; H.E.S.—Higher Elementary School; H.S.—High School; S.S.—State School; T.S.—Technical School.

Tenders to be submitted on the Department's printed Tender Form and will not be received by telephone. All tenders must be on a "Firm Tender" basis. The lowest or any tender will not necessarily be accepted.

Address tenders to the Minister of Public Works, and endorse the envelope containing the tender "Tender for closing Tuesday,

Hand delivered tenders to be placed in the Tender Box of the Public Works Department, located on the wall of the centre entrance foyer, Ground Floor, New Treasury Building, Treasury-place, Melbourne.

No preliminary deposit is required with any tender, but a successful tenderer will be required to pay a deposit for any accepted tender of \$5,000 or over.

Tuesday, 16th January, 1968.**Building, Electrical and Mechanical Works.**

Ballarat.—New electrical sub-station, Mental Hospital. (W.O., Ballarat.)

Blackburn.—Additions and modifications to Administration Block, High School.

Blackburn.—Mechanical services, High School.

Blackburn.—Electrical installation, High School.

Blackburn East.—Renovations, &c., S.S. 4800.

Burwood.—Renovations, S.S. 461.

Cobden.—Renovations, Residence, S.S. 864. (W.O., Camperdown.)

Dooen.—Erection of glass-house, Longerenong Agricultural College. (W.O., Horsham.)

Ferntree Gully.—Erection of type "800C" Assembly Hall, Technical School.

Ferntree Gully.—Electrical installation, Technical School.

Ferntree Gully.—Mechanical services, Technical School.

Melbourne.—Renovations, Victoria School for Deaf Children, No. 3774.

Melton South.—Installation of sewerage treatment unit, S.S. 3717. (P.S., Bacchus Marsh.)

Mont Park.—Steam and condensate reticulation, Mental Hospital.

Sunbury.—Renovations to toilets, Mental Hospital.

Various.—Erection of 22 proprietary type residences, Various Departments.

Warrnambool.—Renovations, Residence, 30 Merri-street; Technical School. (W.O., Warrnambool.)

Werribee.—Erection of broiler test shed, State Research Farm. (W.O., Geelong.)

Werribee.—Electrical installation, State Research Farm.

Werribee.—Mechanical services, State Research Farm.

Wodonga West.—Additional class-rooms, S.S. 4814. (W.O., Wangaratta.)

Wodonga West.—Electrical installation, S.S. 4814. (W.O., Wangaratta.)

Wodonga West.—Mechanical services, S.S. 4814. (W.O., Wangaratta.)

Wonthaggi.—Erection of a new High School. (W.O., Korumburra.)

Wonthaggi.—Mechanical services, High School. (W.O., Korumburra and Warragul.)

Wonthaggi.—Electrical installation, High School. (W.O., Korumburra; P.S., Wonthaggi.)

Furniture and Furnishings.

Ballarat.—Supply and fix curtains, Mental Hospital.

Malvern.—Supply and fix curtains, "Stonnington", Toorak Teachers' College.

Site Works.

Maribyrnong.—Asphalt repairs and retaining wall construction, S.S. 3736.

Mitcham.—Asphalt, concrete and drainage works, &c., High School.

St. Albans.—Asphalt repairs, High School.

Miscellaneous.

Clayton.—Supply and delivery of milling machine, Technical School.

Melbourne.—Maintenance cleaning for the period, 22nd January, 1968, to 31st May, 1970, 200 Little Collins-street, Department of Labour and Industry.

Various.—Removal, lopping and pruning of trees, schools, South-Eastern District.

Yallourn.—Supply and delivery of equipment, Technical College.

Tuesday, 23rd January, 1968.**Building, Electrical and Mechanical Works.**

Beechworth.—Supply and fix handrail, Mental Hospital. (W.O., Wangaratta; P.S., Beechworth.)

Boolarra.—Erection of six class-rooms, S.S. 2617, (W.O., Traralgon.)

Boolarra.—Electrical installation, S.S. 2617. (W.O., Korumburra and Traralgon; P.S., Boolarra.)

Boolarra.—Mechanical services, S.S. 2617. (W.O., Traralgon and Warragul.)

Burnley Gardens.—Mechanical services, Victorian Plant Research Institute. (Amended Specification.)

Caulfield.—Chain mesh fence, &c., High School.

Glen Waverley.—Extensions to toilet, &c., S.S. 2219.

Mont Park.—Erection of offices, potting shed and cold frames, Larundel Mental Hospital. (Amended Specification.)

Mont Park.—Electrical installation, Larundel Mental Hospital.

Mont Park.—Mechanical services, Larundel Mental Hospital.

Mont Park.—Mechanical services, Larundel Mental Hospital.

Mont Park.—Mechanical services, Mental Hospital.

Mont Pellier.—Erection of six class-rooms, &c., S.S. 4972. (W.O., Geelong.)

Mont Pellier.—Electrical installation, S.S. 4972. (W.O., Geelong.)

Mont Pellier.—Mechanical services, S.S. 4972. (W.O., Geelong.)

Norlane.—Renovations, S.S. 4734. (W.O., Geelong.)

Norwood.—Renovations, High School.

Traralgon.—Erection of School of Nursing, Hobson Park Hospital. (W.O., Traralgon.)

Traralgon.—Electrical installation, Hobson Park Hospital. (W.O., Traralgon.)

Traralgon.—Mechanical services, Hobson Park Hospital. (W.O., Traralgon.)

Furniture and Furnishings.

St. Albans.—Supply and fix stage curtains, High School.

Shepparton South.—Supply of furniture, Technical School.

Sunshine.—Supply and fix curtains, High School.

Site Works.

Bairnsdale.—Asphalt repairs, High School. (W.O., Bairnsdale, Traralgon and Warragul.)

Boisdale.—Asphalt repairs, &c., Consolidated School. (W.O., Traralgon and Warragul.)

Drouin.—Asphalt repairs, High School. (W.O., Traralgon and Warragul.)

Mildura.—Asphalt and concrete works, S.S. 2915. (W.O., Mildura.)

Parkdale.—Asphalt, concrete and drainage works, &c., High School.

Richmond.—Asphalt and drainage works, S.S. 2084.

Wonthaggi North.—Asphalt repairs and gravelling, S.S. 3716. (W.O., Korumburra, Traralgon and Warragul.)

Tuesday, 30th January, 1968.**Building, Electrical and Mechanical Works.**

Alvie.—Renovations, &c., Consolidated School. (W.O., Camperdown.) (Amended Specification.)

Bairnsdale.—Roof repairs, Technical School. (W.O., Bairnsdale.)

Ballarat.—Erection of six class-rooms, S.S. 4936. (W.O., Ballarat.)

Ballarat.—Electrical installation, S.S. 4936. (W.O., Ballarat.)

Ballarat.—Mechanical services, S.S. 4936. (W.O., Ballarat.)

Brooklyn West.—Enclosing entrance, re-blocking, &c., S.S. 4825. (Re-advertised.) (Amended Specification.)

Buninyong.—Renewal of slate roof with terra cotta or concrete tiles, S.S. 1270. (W.O., Ballarat; P.S., Buninyong.)

Colac.—Renovations, High School. (W.O., Geelong.) (Amended Specification.)

Dooen.—Additional floor to Dormitory, &c., Longerenong Agricultural College. (W.O., Horsham and Ballarat.)

. Dooen.—Electrical installation, Agricultural College. (W.O., Ballarat and Horsham.)

. Dooen.—Mechanical services, Agricultural College. (W.O., Ballarat, Bendigo and Horsham.)

. Dookie.—Erection of new kitchen and dining hall, Agricultural College. (Bills of Quantities Available.) (W.O., Shepparton.)

. Footscray West.—Re-blocking of class-rooms, S.S. 3890.

. Heatherton.—Erection of store, Sanatorium.

. Kingsbury.—Renovations, Technical School.

. Millbrook.—Conversion of septic closets, &c., S.S. 1972. (W.O., Ballarat.)

. Oakleigh.—Extensions and alterations, Police Station.

. Warncoort.—Renovations, S.S. 2218 and Residence. (W.O., Geelong.)

. Wendouree.—Renovations, Bristol Building, S.S. 1813. (W.O., Ballarat.)

. Williamstown North.—Renovations to toilet blocks, S.S. 1409. (Re-advertised.)

Site Works.

. Casterton.—Asphalt, concrete and gravel works, &c., High School. (W.O., Warrnambool.)

M. V. PORTER,
Minister of Public Works.

Public Works Department,
Melbourne, 3002, 18th December, 1967.

PRIVATE ADVERTISEMENTS

NOTICE OF INTENTION TO APPLY FOR A LICENCE TO DIVERT WATER AND CUT RACE (RE-ISSUE) FROM THE BUFFALO RIVER AT UPPER MERRIANG BRIDGE.

I HEREBY give notice that I intend to apply for a licence empowering me to divert water for a term of eight years to the extent of 100 acre-feet per annum at a maximum rate of 3 acre-feet per day of 24 hours for the irrigation of tobacco and pasture, being part of allotments 1, 1A, 2, 3, 21 and 22, section P, Parish of Myrtleford, and to occupy certain Crown lands for works of diversion, and to cut a race thereon.

Any objection to such application must be forwarded, in writing, to reach the State Rivers and Water Supply Commission, Melbourne, before the 18th January, 1968, being 30 days from the first publication of this notice.

COLIN MACDONALD.
SYLVIA LILLIAN MACDONALD.

P.O. Box 89, Myrtleford, Victoria, 3737. 538

NOTICE OF INTENTION TO APPLY FOR A LICENCE TO DIVERT WATER AND CUT RACE FROM THE GOULBURN RIVER AT BAILLESTON EAST.

I HEREBY give notice that I intend to apply for a licence empowering me to divert water for a term of three years to the extent of 40 acre-feet per annum at a maximum rate of 5 acre-feet per day of 24 hours for the irrigation of 20 acres, being part of allotment 48A, section Y, Parish of Bailestion, and to occupy certain Crown lands for works of diversion, and to cut a race thereon.

Any objection to such application must be forwarded in writing to reach the State Rivers and Water Supply Commission, Melbourne, before 16th January, 1968, being 30 days from the first publication of this notice.

REGINALD G. ANDERSON.

Bailestion East, via Nagambie, 3608. 516

NOTICE OF INTENTION TO APPLY FOR A LICENCE TO DIVERT WATER AND CUT RACE (RE-ISSUE) FROM THE RIVER MURRAY AT COLIGNAN.

WE hereby give notice that we intend to apply for a licence empowering us to divert water for a term of four years to the extent of 300 acre-feet per annum at a maximum rate of 10 acre-feet per day of 24 hours for the irrigation of 100 acres of vegetables, citrus and vines, being part of allotment lot 2, P/S. 78588, Parish of Colignan, and to occupy certain Crown lands for works of diversion, and to cut a race thereon.

Any objection to such application must be forwarded in writing to reach the State Rivers and Water Supply Commission, Melbourne, before 20th January, 1968, being 30 days from the first publication of this notice.

M. & D. BRIGGS & CO.

Colignan. 517

NOTICE OF INTENTION TO APPLY FOR A LICENCE TO DIVERT WATER AND CUT RACE (RE-ISSUE) FROM THE GOULBURN RIVER, AT YAMBUNA.

I HEREBY give notice that I intend to apply for a licence empowering me to divert water for a term of three years to the extent of 24 acre-feet per annum at a maximum rate of 3 acre-feet per day of 24 hours for the irrigation of 12 acres of pasture, being part of allotments 21 and 21A, Parish of Moira, and to occupy certain Crown lands for works of diversion, and to cut a race thereon.

Any objection to such application must be forwarded, in writing, to reach the State Rivers and Water Supply Commission, Melbourne, before 13th January, 1968, being 30 days from the first publication of this notice.

WILLIAM JAMES POWER.
Yambuna. 618

I, JOY BERNICE McDONALD, of Heywood-road, Portland, in the State of Victoria, bookkeeper, heretofore called and known by the name of Bonnie Jean Walker, hereby give public notice that by a deed poll dated the 15th day of November, 1967, duly executed and attested and deposited with the Registrar General of the said State of Victoria, on the 21st day of November, 1967, I formally and absolutely renounced and abandoned the said name of Bonnie Jean Walker and declared that I had assumed and adopted and intended thenceforth upon all occasions whatsoever to use and subscribe the name of Joy Bernice McDonald instead of the said name of Bonnie Jean Walker and so as to be at all times thereafter called, known and described by the name of Joy Bernice McDonald.

Dated the 8th day of December, 1967.

JOY B. McDONALD.

Witness—D. PARKER. 577

LAND ACT 1958 (No. 6284 AS AMENDED BY ACT No. 7075).

WHEREAS:

I. Application has been made pursuant to sub-section (1) of section 22c, of the *Land Act 1958*, by Lawrence O'Brien and Hugh Allman, both of Cowwarr, farmers, and Arthur Lenz, of 15 Younger-street, Wangaratta, salesman, being the trustees for the time being of the Cowwarr Tennis Club site, being the land described in the schedule hereto, for permission to surrender the said land to Her Majesty Queen Elizabeth II.

II. By the said sub-section (1) it is provided that the Attorney-General may by notice published in the *Government Gazette* grant permission to the trustees to surrender the land to Her Majesty pursuant to the said section 22c, and by sub-section (4) of the said section 22c it is further provided that the Attorney-General shall specify the purpose mentioned in section 14 of the *Land Act 1958* for which the land was vested in the trustees or was used is in his opinion substantially similar.

NOW I, the Honorable George Oswald Reid, in my capacity as Her Majesty's Attorney-General for the State of Victoria—

- (a) grant permission to the said trustees to surrender the said land to Her Majesty pursuant to section 22c of the *Land Act 1958*; and
- (b) specify pursuant to sub-section (4) of section 22c aforesaid the following purpose mentioned in section 14 of the *Land Act* aforesaid namely—
"the recreation convenience or amusement of the people."

SCHEDULE.

All that piece of land being lot 18 and part of lot 17 on plan of subdivision number 9309 lodged in the Office of Titles being part of Crown allotment F, Parish of Toongabbie North and being the land more particularly described in certificate of title, volume 6280, folio 971.

Given under my hand this 10th day of November, 1967.
539 G. O. REID, Attorney-General.

FRANKSTON SEWERAGE AUTHORITY.

BY-LAW No. 5.

NOTICE is hereby given that By-law No. 5 relating to Consents, Licences, Fees, Trade Waste and other matters not included in the Uniform Building Regulations relating to House Connections and repealing previous By-laws on these matters, as passed by the Authority on October 2, 1967 and confirmed on November 6, 1967, has now been approved by the Governor in Council.

A copy of the said By-law No. 5 may be inspected free of charge at the office of the Authority, Civic Centre, Frankston between the hours of 10 a.m. and noon on those days during which the Civic Centre is open for transacting the business of the City of Frankston.

511

G. C. PENTLAND, Secretary.

GEELONG WATERWORKS AND SEWERAGE TRUST.

THE above-mentioned Trust having made provision for carrying off the sewage from each and every property which or any part of which is within the sewerage area hereinafter described doth hereby declare that on and after the 1st day of January, 1968, each and every property which or any part of which is within the said sewerage area shall be deemed and taken to be deemed property within the meaning of the *Geelong Waterworks and Sewerage Act 1958*.

SEWERAGE AREA No. 374.

Shire of Bellarine, Parish of Moolap, County of Grant.

Commencing at a point being on the west side of Wilsons-road, Whittington, the said point being also on the prolongation of the north side of Hickey-street and also on the boundary of Sewerage Area No. 245; thence due easterly on a straight line across Wilsons-road to the east side of Wilsons-road; thence southerly along the east side of Wilsons-road to a point being 235 feet north from the north-east corner of the intersection of Wilsons and Townsend roads; thence easterly by a line bearing 90 degrees for a distance of 440 feet; thence southerly by a line bearing 180 degrees and crossing Townsend-road, to the south side of Townsend-road; thence westerly along the south side of Townsend-road to the south-east corner of the intersection of Townsend and Wilsons roads; thence southerly along the east side of Wilsons-road for a distance of 320 feet; thence easterly by a line bearing 90 degrees for a distance of 160 feet; thence southerly by a line bearing 180 degrees for a distance of 130 feet; thence westerly by a line bearing 270 degrees to the east side of Wilsons-road; thence southerly along the east side of Wilsons-road for a distance of 410 feet; thence easterly by a line bearing 90 degrees for a distance of 145 feet; thence southerly by a line bearing 180 degrees for a distance of 418 feet; thence westerly by a line bearing 270 degrees to the east side of Wilsons-road; thence southerly along the east side of Wilsons-road to the prolongation of the north side of Collins-street; thence westerly across Wilsons-road and continuing westerly along the north side of Collins-street to the north-east corner of the intersection of Collins and Buckingham streets; thence northerly along the east side of Buckingham-street and crossing St. Albans-street to the north-east corner of the intersection of Buckingham and St. Albans streets; thence easterly along the north side of St. Albans-street for a distance of 530 feet; thence northerly by a line bearing 0 degrees and crossing Chandos-street to the north side of Chandos-street; thence easterly along the north side of Chandos-street for a distance of 360 feet; thence northerly by a line bearing 0 degrees and crossing Grafton-street to the north side of Grafton-street; thence westerly along the north side of Grafton-street for a distance of 205 feet; thence northerly by a line bearing 0 degrees and crossing St. James-street to the north side of St. James-street; thence westerly along the north side of St. James-street for a distance of approximately 1,150 feet to a point on the prolongation of the west side of Hotham-street; thence southerly along the said prolongation and along the west side of Hotham-street and crossing St. James-street, Grafton-street, Chandos-street and St. Albans-street to the south side of St. Albans-street; thence easterly along the south side of St. Albans-street to the south-west corner of the intersection of St. Albans-street and Buckingham-street; thence southerly along the west side of Buckingham-street to the north-west corner of the intersection of Buckingham and Durran-streets; thence westerly along the north side of Durran-street to the north-east corner of the intersection of Durran-street and Boundary-road; thence northerly along the east side of Boundary-road to the south-east corner of the intersection of Boundary-road and St. Albans-street; thence easterly along the south side of St. Albans-street for a distance of 350 feet; thence northerly by a line bearing 0 degrees and crossing St. Albans and Grafton streets to the north side of Grafton-street; thence westerly along the north side of Grafton-street to the north-east corner of the intersection of Grafton-street and Boundary-road; thence northerly along the east side of Boundary-road to the south-east corner of the intersection of Boundary-road and St. James-street; thence easterly along the south side of St. James-

street for a distance of 323 feet; thence northerly by a line bearing 0 degrees and crossing St. James-street to the south side of Westmoreland-street; thence easterly along the south side of Westmoreland-street for a distance of 115 ft. 10 in.; thence northerly by a line bearing 0 deg. and crossing Westmoreland-street to the south side of Townsend-road; thence westerly along the south side of Townsend-road to the south-east corner of the intersection of Townsend and Boundary-roads; thence northerly across Townsend-road and continuing northerly along the east side of Boundary-road for a distance of 171 ft. 2 in. to the north-west corner of lot No. 9 Boundary-road which is also on the boundary of Sewerage Area No. 365; thence easterly along the northern boundary of the said lot No. 9 by a line bearing 90 deg. 20 min. for a distance of 111 ft. 7 in.; thence easterly across lot No. 18A to the north-west corner of lot No. 17 Chapel-street; thence north-easterly by a line bearing 81 deg. 31 min. to the west side of Chapel-street; thence northerly along the west side of Chapel-street for a distance of 351 ft. 1 in.; thence easterly by a line bearing 90 deg. 20 min. across Chapel-street and continuing easterly along the northern boundary of lot No. 1 Chapel-street to the north-east corner of the said lot No. 1; thence southerly along the eastern boundaries of lots Nos. 1 to 5 inclusive Chapel-street for a distance of 300 feet; thence easterly by a line bearing 90 deg. 20 min. to the west side of Thompson-street; thence northerly along the west side of Thompson-street for a distance of 483 feet; thence easterly by a line bearing 90 degrees and crossing Thompson-street for a distance of 460 feet; thence northerly by a line bearing 0 deg. to the southern boundary of Sewerage Area No. 245; thence easterly following the southern boundary of Sewerage Area No. 245 to the point of commencement.

SEWERAGE AREA No. 375.

Shire of Corio, Parish of Moorpanyal, County of Grant.

Commencing at a point being the south-east corner of the intersection of Tahara and Hamlyn streets, Hamlyn Heights, which is also on the boundary of Sewerage Area No. 330; thence southerly along the east side of Tahara-street to the prolongation of the southern boundary of lot No. 40 Tahara-street; thence westerly across Tahara-street and continuing westerly along the southern boundary of the said lot No. 40 to the south-west corner of the said lot No. 40; thence northerly along the western boundaries of lots No. 40 to 25 inclusive Tahara-street to the north-west corner of the said lot No. 25; thence north-easterly along the northern boundary of the said lot No. 25 and its prolongation and across Tahara-street to a point on the east side of Tahara-street, which is also on the boundary of Sewerage Area No. 330; thence south-easterly and southerly following the boundary of Sewerage Area No. 330 and across Hamlyn-street to the point of commencement.

SEWERAGE AREA No. 376.

Shire of South Barwon, Parish of Barrabool, County of Grant.

Commencing at a point being the north-east corner of lot No. 13 St. Elmo-crescent, Highton, the said point being also on the south side of St. Elmo-crescent and on the boundary of Sewerage Area No. 340; thence south-westerly, north-westerly and northerly following the boundaries of Sewerage Areas No. 340 and 323 to the north-west corner of lot No. 15 St. Elmo-crescent; thence easterly along the northern boundary of the said lot No. 15 to the west side of St. Elmo-crescent; thence south-easterly and easterly along the west and south side of St. Elmo-crescent to the point of commencement.

SEWERAGE AREA No. 377.

Shire of Corio, Parish of Moorpanyal, County of Grant.

Commencing at a point being the north-west corner of lot No. 3 Thompson-road, North Geelong, which is 619 feet south from the south-west corner of the intersection of Thompson-road and Braund-avenue, the said point being also on the west side of Thompson-road, and on the boundary of Sewerage Area No. 284; thence southerly along the west side of Thompson-road to the north side of Geelong-Ballarat Railway Reserve; thence north-westerly following the boundary of Geelong-Ballarat Railway Reserve by a line bearing 325 deg. 57½ min. for a distance of approximately 921 feet to the north-west corner of lot No. 1 Blakistons Subdivision Thompson-road; thence easterly along the northern boundary of the said lot No. 1 to the south-west corner of lot No. 2 of Blakistons subdivision Thompson-road; thence northerly along the western boundaries of lots Nos. 2 and 3 Thompson-road to the north-west corner of the said lot No. 3; thence easterly along the northern boundary of the said lot No. 3 to the point of commencement.

SEWERAGE AREA NO. 378.

Shire of Corio, Parish of Moranghurk, County of Grant.

Commencing at a point being the south-east corner of lot No. 58 Talpa-crescent, Corio, the said point being also on the west side of Talpa-crescent, and on the boundary of Sewerage Area No. 285; thence westerly along the southern boundary of the said lot No. 58 to the south-west corner of the said lot No. 58; thence northerly along the western boundaries of lots No. 58 to 60 inclusive Talpa-crescent to the south-east corner of lot No. 8 Rodbrough-crescent; thence westerly along the southern boundary of the said lot No. 8 to a point on the east side of Rodbrough-crescent, which is also on the boundary of Sewerage Area No. 285; thence northerly along the east side of Rodbrough-crescent to the north-west corner of lot No. 8 Rodbrough-crescent; thence easterly along the northern boundary of the said lot No. 8 to the south-west corner of lot No. 62 Talpa-crescent; thence northerly along the western boundaries of lots No. 62 to 64 inclusive Talpa-crescent to the south side of Raymond-street; thence easterly along the south side of Raymond-street and crossing Talpa-crescent to the north-east corner of lot No. 49 Raymond-street; thence southerly along the eastern boundary of the said lot No. 49 to the north-west corner of lot No. 52 Kalver-street; thence easterly along the northern boundary of the said lot No. 52 to the west side of Kalver-street; thence southerly along the west side of Kalver-street to the south-east corner of lot No. 52 Kalver-street; thence westerly along the southern boundary of the said lot No. 52 to the eastern boundary of lot No. 55 Hague-street; thence southerly along the eastern boundary of the said lot No. 55 and crossing Hague-street to a point on the south side of Hague-street, which is also on the boundary of Sewerage Area No. 285; thence westerly along the south side of Hague-street to the north-east corner of lot No. 42 Talpa-crescent; thence southerly along the eastern boundary of the said lot No. 42 to the south-east corner of lot No. 42; thence westerly along the southern boundary of the said lot No. 42 and crossing Talpa-crescent to the point of commencement.

Signed under Seal of the Trust this 14th day of December, 1967—

(SEAL) J. W. CARR, Chairman.
595 B. C. HENSHAW, Secretary.

THE BALLARAT SEWERAGE AUTHORITY.

GENERAL NOTICE.

THE above-mentioned Sewerage Authority having made provision for carrying off the sewage from each and every property which or any part of which is within the Sewerage Areas hereinafter described doth hereby declare that on and after the 1st day of January, 1968, each and every property which or any part of which is within the said Sewerage Areas shall be deemed to be a sewered property within the meaning of the *Sewerage Districts Act 1958*.

The boundaries of the Sewerage Areas hereinbefore referred to are:—

Sewerage Area No. 281.

City of Ballarat.—Commencing at the south-west corner of No. 88 Cobden-street, being a point on the boundary of Sewerage Area No. 123; thence south-westerly to a point on the south building line of Fraser-street, about 203 feet west of Brittain-street, southerly about 233 feet to a point on the northern boundary of a Government road about 204 feet from Brittain-street, easterly about 204 feet along the northern boundary of the said Government road to the west building line of Brittain-street, northerly to the south-west corner of Brittain and Fraser streets, north-westerly to most easterly corner of No. 88 Cobden-street being a point on the boundary of Sewerage Area No. 123; thence south-westerly and westerly along the boundaries of Sewerage Area No. 123 to the point of commencement.

Sewerage Area No. 282.

City of Ballarat.—Commencing at the south-east corner of No. 3 Ida-street, being a point on the boundary of Sewerage Area No. 137; thence north-easterly across Ida-street to the south-west corner of a vacant allotment being about 170 feet from Chisholm-street, easterly about 317 feet along the southern boundary of the said vacant allotment and prolongation thereof to a point on a fence, north-easterly about 355 feet to the south-east corner of No. 728 Chisholm-street, northerly about 211 feet to the north-east corner of the said No. 728, generally westerly along the south building line of Chisholm-street to the south-west corner of Chisholm and Ida streets being a point on the boundary of Sewerage Area No. 137; thence southerly along the boundary of Sewerage Area No. 137 to the point of commencement.

No. 96.—11334/67.—5

Further particulars regarding the streets or parts of streets in which sewers have been laid may be ascertained on inquiry at the Authority's Office.

By order of the said Sewerage Authority,

A. W. NICHOLSON, Chairman.
CHAS. H. CLAMP, Secretary.

563

MOE SEWERAGE AUTHORITY.

GENERAL NOTICE.

THE above-mentioned Sewerage Authority having made provision for carrying off the sewage from each and every property which or any part of which is within the sewerage areas hereinafter described doth hereby declare that on and after the 1st day of January, 1968, each and every property which or any part of which is within the said sewerage area shall be deemed to be a sewered property within the meaning of the *Sewerage Districts Act 1958*.

The boundaries of the sewerage areas hereinbefore referred to are:—

Sewerage Area No. 54.

Commencing at the north-east corner of lot 16, pt. 14 of 13, Moe, 1 York-street, being a point on the existing boundary of sewerage area No. 14; thence east along the northern boundaries of lots 1 and 10, pt. 9 of 13, Moe, to the north-east corner of the said lot 10; thence south along the western building line of Gibson-street to the southern building line of Albert-street, East, Moe; thence easterly along the said building line to the most easterly corner of lot 25, Sec. 12, Moe; thence southerly along the eastern boundary of the said lot 25 and lot 8 to the northern building line of Somerville-street; thence west along the said building line to and across Bennett-street to an existing point on the boundary of Sewerage Area No. 14; thence north along the said boundary to the point of commencement.

Sewerage Area No. 55.

Commencing at the southern corner of lot 39, pt. C/A. 5c, Narracan, being the junction of Glads-street and Princes Highway and the boundary of Sewerage Area No. 38; thence across Glads-street and along the south-west and south-east boundaries of lot 43, pt. C/A. 5c, Narracan, to the boundary of Sewerage Area No. 38; thence back to point of commencement.

Sewerage Area No. 56.

All the area being lot 1, pt. 3c, Narracan, containing a Drive-in Theatre in Thompsons-road.

Sewerage Area No. 57.

All of C/A. 5, 5A and 5c, Narracan, contained by farm bounded by Princes Highway on the south and Narracan Creek on the west.

By order of the said Sewerage Authority,

J. S. TABUTEAU, Chairman.
A. DEWAR, Secretary.

530

CITY OF BALLAARAT.

NOTICE OF MAKING OF BY-LAW NO. 167.

NOTICE is hereby given that the Council of the City of Ballarat has made and passed a By-law under the Local Government Acts and Uniform Building Regulations of Victoria and numbered 167 for the purpose of repealing Clause Number 5 of By-law Number 154 of the said City.

Such By-law has been approved by the Governor-in-Council.

A copy of the above-mentioned By-law has been deposited at the office of the City Council, Town Hall, Ballarat, and is open for inspection free of charge during office hours.

Dated the 15th day of December, 1967.

555

H. R. MADDERN, Town Clerk.

CITY OF BRIGHTON.

NOTICE is hereby given that the Municipality of the City of Brighton in its capacity as Committees of Management of various Crown reserves hereby appoints

Sergeant FREDERICK GORDON JONES, No. 9955,
Sergeant JOHN BELL, No. 10359

as prosecuting officers to take legal proceedings for and in connexion with breaches and non-observance of rules and regulations made by the Minister of Crown Lands for the care, protection and management of such reserves.

Municipal Offices, Boxshall-street, Brighton.

19th December, 1967.

562

A. C. G. De GARIS, Town Clerk.

CITY OF BRIGHTON.

NOTICE is hereby given that the City of Brighton has appointed

Sergeant FREDERICK GORDON JONES, No. 9955,
Sergeant JOHN BELL, No. 10359

as prosecuting officers to take legal proceedings on behalf of the Council for and in connexion with breaches and non-observance of the Local Government Act or any other Act which the Council from time to time is empowered to enforce and any By-laws, rules and regulations made under such Acts.

Municipal Offices, Boxshall-street, Brighton.

19th December, 1967.

561 A. C. G. De GARIS, Town Clerk.

CITY OF BROADMEADOWS.

PRIVATE STREETS LOAN No. 51.

Construction of Private Streets and Drains.

NOTICE is hereby given that at the Meeting of Council of the City of Broadmeadows, held at the Council Chambers, Broadmeadows, on 6th November, 1967, the said Council did agree to the following Resolution, that is to say:—

"That this Council, by Special Order, resolves to borrow on the credit of the Mayor, Councillors and Citizens of the City of Broadmeadows the sum of One hundred thousand dollars (\$100,000), such sum to be secured by grant of a mortgage in accordance with the provisions of the Local Government Act.

The rate of interest to be paid is \$5.75 per centum per annum and the said loan shall be liquidated by twenty half-yearly instalments of approximately \$6,644.14, including principal and interest.

The time which the moneys borrowed are to be repayable are on the 1st day of January and the 1st day of July in each year during the period of ten years. The first payment shall be on 1st July, 1968.

The moneys shall be repayable at the Commonwealth Savings Bank, Glenroy.

The purposes for which the said loan shall be applied are for:—

Construction of Private Streets and Drains under the provisions of Division 10 of Part XIX. of the Local Government Act 1958, and amendments, and the loan shall be liquidated from the receipts of money payable under schemes under the said Division."

Notice is further given that at a meeting of the said Council held at the Council Chambers, Broadmeadows, on 11th December, 1967, the said Resolution was confirmed.

Dated at Broadmeadows this 15th day of December, 1967.

556 E. F. SMILEY, Town Clerk.

CITY OF CASTLEMAINE.

LOAN No. 43.

Notice of Intention to Borrow the Sum of \$7,050 for Permanent Works and Undertakings.

NOTICE is hereby given that the Council of the City of Castlemaine proposes to borrow the principal sum of \$7,050 secured by a charge over the general rates of the municipality, such sum to be raised by grant of a mortgage in accordance with the provisions of the Local Government Act 1958.

1. The maximum rate of interest that may be paid is 5.5625 per cent. per annum.

2. The purpose for which the loan is to be applied is purchase of plant and equipment as follows:—

- Utility.
- 30-cwt. tray truck.
- 3-ton truck.

3. The period of the loan shall be seven years.

4. The moneys borrowed shall be repayable by providing out of the municipal fund fourteen half-yearly instalments of approximately \$614.85 each including principal and interest on the 1st day of September and the 1st day of March each year during the currency of the loan. The first instalment shall be payable on the 1st day of September, 1968.

5. Such moneys shall be payable at the Commonwealth Savings Bank, Castlemaine.

The plans and specifications and the estimate of the cost of the proposed works and a statement showing the proposed expenditure of the moneys to be borrowed are open for inspection at the office of the Council, Town Hall, Castlemaine.

12th December, 1967.

494

I. C. SMITH, Town Clerk.

CITY OF CAULFIELD.

LOAN No. 48.

Notice of Intention to Borrow the Sum of \$150,000 for Permanent Works and Undertakings.

NOTICE is hereby given that the Council of the City of Caulfield proposes to borrow the sum of \$150,000 on the credit of the municipal revenues of the Mayor, Councillors and Citizens of the said City, such sum to be raised by the grant of a mortgage in accordance with the provisions of the Local Government Act.

1. The maximum rate of interest that may be paid is 5.75 per centum per annum.

2. The purposes for which the loan is to be applied are—

Erection of pavilions at Princes Park and Murrumbeena Park \$150,000

3. The period of the loan shall be ten years.

4. The moneys borrowed shall be repayable by providing out of the municipal fund twenty half-yearly instalments of \$9,966.20, including principal and interest, on the 12th day of March and the 12th day of September during the currency of the loan. The first instalment shall be payable on the 12th day of September, 1968.

5. Such moneys shall be repayable at the Commonwealth Savings Bank of Australia, Melbourne.

The plans and specifications and the estimate of the cost of the proposed works and a statement showing the proposed expenditure of the moneys to be borrowed are open for inspection at the Town Hall, corner Glen Eira and Hawthorn roads, Caulfield.

B. MORAN, Town Clerk.

Town Hall, Caulfield, 15th December, 1967.

554

CITY OF DONCASTER AND TEMPLESTOWE.

LOAN No. 109.

Notice of Intention to Borrow the Sum of \$100,000 for Permanent Works and Undertakings.

NOTICE is hereby given that the Council of the City of Doncaster and Templestowe proposes to borrow the principal sum of One hundred thousand dollars secured by a charge over the general rates of the municipality, such sum to be raised by the grant of a mortgage in accordance with the provisions of the Local Government Act 1958.

1. The maximum rate of interest that may be paid is 5½ per cent. per annum.

2. The purpose for which the loan is to be applied is:—
Road and Drainage Works

Intersection treatment of Doncaster and Wetherby roads, Doncaster	\$12,000
Intersection treatment of Manningham and Bulleen roads, Bulleen	11,500
Construction of road to Doncaster Infant Welfare Centre and Pre-School Centre, off Doncaster-road, Doncaster, including provision of car parking area ..	12,900
Earthworks and Drainage Works—George-street, Doncaster	8,900
Construction of main drain culvert, road and drainage construction works—Sheahans-road/Warrigal-street	14,400
Construction of outlet drain through East Doncaster Reserve, East Doncaster. Council's proportion	2,000
Construction of outlet drain from Doncaster Infant Welfare Centre, Doncaster. Council's proportion	3,800
	65,500

Construction of Tennis Courts

Lower Templestowe Reserve, Lower Templestowe	4,000
Athenaeum Hall, Doncaster	4,000
Donvale Reserve, Donvale	1,800
Koonung Park, Bulleen	2,300
	12,100

Athenaeum Hall—Doncaster-road, Doncaster

Provision of Parking Area	5,000
---------------------------------	-------

Reserves

Construction of Conveniences at Dome- ney Reserve, Park Orchards ..	5,400	
Provision of Caretaker's House—Council Nursery, Templestowe ..	12,000	
		17,400
		\$100,000

3. The period of the loan shall be ten years.

4. The moneys borrowed shall be repayable by providing out of the municipal fund twenty half-yearly instalments of approximately \$6,644 each including principal and interest on the 1st day of March and the 1st day of September during the currency of the loan. The first instalment shall be payable on the 1st day of September, 1968.

5. Such moneys shall be repayable to the Commissioners of the State Savings Bank of Victoria, at the office of the said Commissioners, corner Elizabeth and Bourke streets, Melbourne.

The plans and specifications and the estimate of the cost of the proposed works and a statement showing the proposed expenditure of the moneys to be borrowed are open for inspection at the office of the Council of the City of Doncaster and Templestowe at the Municipal Offices, Doncaster-road, Doncaster.

493 J. W. THOMPSON, Town Clerk.

CITY OF FRANKSTON.

LOAN No. 121.

Notice of Intention to Borrow the Sum of \$100,000 for Permanent Works and Undertakings.

NOTICE is hereby given that the Council of the City of Frankston proposes to borrow the principal sum of \$100,000 secured by a charge over the general rates of the municipality, such sum to be raised by the grant of a mortgage in accordance with the provisions of the *Local Government Act 1958*.

(i) The maximum rate of interest that may be paid is 5½ per centum per annum.

(ii) The purposes for which the loan will be applied are:—

(a) Outfall drainage	\$60,000
(b) Town planning—land purchase ..	\$40,000

(iii) The period of the loan will be 40 years and 2 months.

(iv) The loan is to be liquidated by the creation of a sinking fund, pursuant to the provisions of section 428A of the *Local Government Act 1958*.

(v) The moneys borrowed shall be repayable at the expiration of the loan at the office of the Local Authorities Superannuation Board, "Rigby House", 15 Queens-road, Melbourne, or such other place as the Board may require.

The plans, specifications and estimates of the cost of the proposed works and a statement showing the proposed expenditure of the moneys to be borrowed, are open for inspection at the Civic Centre, Frankston.

G. C. PENTLAND, Town Clerk.
Civic Centre, Frankston. 560

CITY OF FRANKSTON.

DOG ACT 1958.

THE Council of the City of Frankston hereby orders in accordance with the powers conferred on it by the Dog Acts that the following bathing beaches in the Municipal district of the said Council be and are hereby specified for the purposes of section 17, 1 (b) (i) of the said Acts, that is to say:—

Every bathing beach on the foreshore of Port Phillip extending from the boundary of the City of Frankston with the City of Chelsea to the boundary of the City of Frankston with the Shire of Mornington.

Civic Centre, Frankston.
1518 G. C. PENTLAND, Town Clerk.

CITY OF KEILOR.

LOAN No. 80.

Notice of Intention to Borrow.

NOTICE is hereby given that the Council of the City of Keilor intends to borrow Fifty Thousand Dollars (\$50,000) secured by a charge over the general rates of the Municipality by the grant of a Mortgage in accordance with the provisions of the *Local Government Acts*.

In connexion therewith the following information is stated:—

(a) The amount of the principal moneys which it is proposed to borrow is \$50,000.

(b) The maximum rate of interest that may be paid is \$5.875 per centum per annum.

(c) The times which the moneys borrowed are to be repayable are the first day of November, 1968, and the first days of May and November during the years 1969–2007 inclusive and the first day of May, 2008, and that the place such moneys shall be repayable is the Australian Mutual Provident Society, 425 Collins-street, Melbourne.

(d) The purpose for which the loan is to be applied is:—

(1) Part Council's contribution Eliza-street Group Private Street Construction Scheme	\$22,000
(2) Part Council's liability for Private Street Construction	7,000
(3) Keilor East Community Centre Building ..	21,000
	Total .. \$50,000

(e) The manner in which the loan is to be liquidated is by provision out of the municipal fund in each half-year during the currency of the loan the sum of \$1,629.51 which includes principal and interest.

The plans and specifications and the estimate of the cost of the works and a statement showing the proposed expenditure of the moneys to be borrowed are open for inspection at the Town Hall.

Dated this 13th day of December, 1967.
495 R. F. B. KELLY, Acting Town Clerk.

CITY OF KEILOR.

LOAN No. 81.

Notice of Intention to Borrow.

NOTICE is hereby given that the Council of the City of Keilor intends to borrow Fifty Thousand Dollars (\$50,000) secured by a charge over the general rates of the Municipality by the grant of a Mortgage in accordance with the provisions of the *Local Government Acts*.

In connexion therewith the following information is stated:—

(a) The amount of the principal moneys which it is proposed to borrow is \$50,000.

(b) The maximum rate of interest that may be paid is \$5.875 per centum per annum.

(c) The times which the moneys borrowed are to be repayable are the 1st day of October, 1968, and the 1st days of April and October during the years 1969–1982 inclusive and the 1st day of April, 1983, and that the place such moneys shall be repayable is the Bank of New South Wales, Niddrie.

(d) The purpose for which the loan is to be applied is:—

(1) St. Albans West Infant Welfare and Pre-School Centre, and	\$19,000
(2) Part of Councils proportion of Private Street Schemes	31,000
	Total .. \$50,000

(e) The manner in which the loan is to be liquidated is by provision out of the municipal fund in each half-year during the currency of the loan the sum of \$2,530.40 which includes principal and interest.

The plans and specifications and the estimate of the cost of the works and a statement showing the proposed expenditure of the moneys to be borrowed are open for inspection at the Town Hall.

Dated this 11th day of December, 1967.
496 R. F. B. KELLY, Acting Town Clerk.

CITY OF MILDURA.

LOAN No. 72.

Notice of Intention to Borrow the Sum of \$100,000 for Permanent Works and Undertakings.

NOTICE is hereby given that the Council of the City of Mildura proposes to borrow the principal sum of \$100,000 secured by a charge over the general rates of the municipality of the said City of Mildura, such sum to be raised by way of mortgage in accordance with the provisions of the *Local Government Act 1958*.

1. The maximum rate of interest that may be paid is 5½ per centum per annum.

2. The purpose for which the loan is to be applied is:—
Construction of basketball stadium and other recreational facilities.

3. The period of the loan shall be 40 years and 2 months.

4. The moneys borrowed shall be repayable in one sum on the 31st day of May, 2008. The loan shall be liquidated by the creation of a sinking fund, pursuant to section 428A of the *Local Government Act 1958*.

5. Interest at the rate of 5½ per centum per annum will be payable on the 1st day of June and the 1st day of December in each year, during the currency of the loan at the office of the Local Authorities Superannuation Board, Queens-road, Melbourne.

6. The plans and specifications and estimate of the cost of the proposed works and a statement showing the proposed expenditure of the money to be borrowed, are open for inspection at the Municipal Offices, Deakin-avenue, Mildura.

Dated this 20th day of December, 1967.

558 W. J. DOWNIE, Town Clerk.

CITY OF MORDIALLOC.

NOTICE is hereby given that the Council of the City of Mordialloc did, on the 11th day of December, 1967, appoint—

Sergeant Thomas Condon, No. 8657, and
Sergeant Darrell Keith Downie, No. 9447,

Prosecuting Officers for the municipality of the City of Mordialloc.

559 J. GRUT, Town Clerk.

CITY OF NUNAWADING.

LOAN No. 104.

Notice of Intention to Borrow the Amount of \$150,000 for Permanent Works and Undertakings.

NOTICE is hereby given that the Council of the City of Nunawading proposes to borrow the sum of One hundred and fifty thousand dollars (\$150,000) secured by a charge over the general rates of the municipality, such sum to be raised by the grant of a mortgage, in accordance with the provisions of the *Local Government Act 1958*.

1. The maximum rate of interest to be paid is 5½ per centum per annum. Two months' interest shall be payable on 1st June, 1968, and thereafter interest shall be payable half-yearly on the 1st December and the 1st June in each year during the currency of the loan.

2. The purpose for which the loan is to be applied is provision of places of public resort and recreation.

3. The period of the loan shall be 40 years and 2 months. The principal amount of the loan will be repayable on 31st May, 2008.

4. The loan is to be liquidated by the creation of a sinking fund, pursuant to the provisions of section 428A of the *Local Government Act 1958*.

5. Such moneys shall be repayable at the office of the Local Authorities Superannuation Board, 15 Queens-road, Melbourne, or at such other place or places as the lender may from time to time direct.

The plans and specifications and the estimate of the cost of the proposed works, and a statement showing the proposed expenditure of the moneys to be borrowed, are open for inspection at the Municipal Offices, Nunawading.

Dated 13th December, 1967.

610 J. H. BROWN, Town Clerk.

CITY OF NUNAWADING.

WHEREAS the Council of the City of Nunawading deems it expedient to exercise its power of taking compulsorily the land described in the Schedule at the foot hereof for the work or undertaking of providing a footway to connect Bond-avenue and Hearty-street: And whereas the Council has caused to be prepared a map and other papers setting out the general description of the work or undertaking, for which the land proposed to be taken is to be used, the description of the land proposed to be taken, and the names of the owners or reputed owners, lessees or reputed lessees, mortgagees and occupiers of that land so far as those names are known to or can be ascertained by the Council: And whereas the said map and other papers are deposited at the office of the said Council at Nunawading and are and shall be open for inspection by all persons interested at all reasonable hours for the space of 40 clear days after the publication of this notice in the *Government Gazette*: Now notice is hereby given to all persons affected by the proposed

taking of the said land to set forth in writing, addressed to the Council or the Town Clerk within 40 clear days of the publication of this notice in the *Government Gazette*, all objections which they may have to the taking of the said land.

SCHEDULE HEREINBEFORE REFERRED TO.

All that piece of land being part of Crown portion 96, Parish of Nunawading, County of Bourke, and being part of the land described as allotment 17, on a general law plan of subdivision numbered H.294, lodged in the Office of the Registrar-General, Melbourne, and being part of the land more particularly described in a memorial of conveyance, registered in Book 621, No. 649, in the Office of the Registrar-General, Melbourne, and being the land contained within a boundary line commencing at a point being the north-east corner of the land described in the said conveyance; thence on a bearing of 179 deg. 58 min. for a distance of 4 ft. 9½ in.; thence on a bearing of 282 deg. 24 min. for a distance of 4 ft. 11½ in.; thence on a bearing of 359 deg. 58 min. for a distance of 3 ft. 10 in.; thence on a bearing of 91 deg. 16 min. for a distance of 4 ft. 10 in. to the point of commencement.

Dated the 18th day of December, 1967.

By order of the Council,

611 J. H. BROWN, Town Clerk.

CITY OF PRESTON.

LOAN No. 78.

Notice of Intention to Borrow.

NOTICE is hereby given that the Council of the City of Preston intends to borrow Two hundred thousand dollars (\$200,000) secured by a charge over the general rates of the municipality, such sum to be raised by the grant of a mortgage in accordance with the provisions of the *Local Government Act 1958*.

In connexion therewith, the following information is stated:—

1. The amount of the principal moneys which it is proposed to borrow is \$200,000.
2. The maximum rate of interest that may be paid is 5.875 per centum per annum.
3. The purposes for which the loan is to be applied are as follows:—

Electricity Department—

Capital works \$130,000

Municipal Fund—

Construction of—	
Turf store, Preston oval	\$1,850
Boiler and storage enclosure, Preston oval	1,240
Chair store, "T. W. Blake" park	700
Tool store, "T. W. Blake" park	895
Tool store, "William Ruthven V.C." Reserve	700
Toilet block, Kingsbury Youth Club hall	1,400
Toilet block, Keon Park Youth Club hall	2,500
Public conveniences, Edwardes Park	7,500
Public conveniences, "J. E. Moore" Park	7,500
Public conveniences, Crispe Park	7,500
Pavilion, "T. W. Blake" Park (balance)	3,800
Pavilion, hockey ground, Plenty-road	3,370
Nursery roof extension	1,320
Elderly Citizens' Club, Wright-street	8,000
Elderly Citizens' Club, "William Ruthven V.C." Reserve	8,000
Bus shelters	1,425
Development of sports oval, Dunne-street	6,600
Water reticulation, "C. T. Barling" Park	3,100
Reconstruction pavilion floors, Preston oval	1,100
Erection of signs in parks and municipal boundaries	1,500
	70,000
	\$200,000

4. The period of the loan shall be forty (40) years.
5. The loan shall be repaid by the establishment and accumulation of a sinking fund, pursuant to the provisions of section 428A of the *Local Government Act 1958*, by provision out of the municipal fund of an appropriate amount in each half-year during the period of the loan.

6. The loan shall be repaid in one amount at maturity at the office of the State Superannuation Board, Treasury-place, Melbourne, or at such other place as the Board may require.

7. Interest shall be payable at the office of the Board or such other place as the Board may require in half-yearly payments of \$5,875.00 each, on the 1st day of April and the 1st day of October in each year, during the currency of the loan, the first of such payments being made on the 1st day of October, 1968.

Plans and specifications and estimate of the cost of the works and a statement showing the proposed expenditure of the moneys to be borrowed are open for inspection at the Town Hall, Preston, during office hours.

11th December, 1967.

557

J. C. DONATH, Town Clerk.

CITY OF SHEPPARTON.

LOAN No. 51.

NOTICE is hereby given that the Council of the City of Shepparton proposes to borrow the sum of \$80,000 secured by a charge over the general rates of the municipality, such sum to be raised by the grant of a mortgage in accordance with the provisions of the Local Government Acts.

1. The amount of principle to be \$80,000.
2. The maximum rate of interest to be paid is 5½ per centum per annum.

3. The purposes for which the loan is to be applied are:—

- (a) Land and buildings for public purposes;
- (b) Increasing the width of streets;
- (c) Construction of drains.

4. The period of the loan shall be forty (40) years.

5. The loan shall be repaid by the creation of a sinking fund and an appropriate amount, as determined by the State Auditor-General, will be set aside annually out of the general account for such purposes.

6. The moneys borrowed shall be repayable at the office of the Local Authorities Superannuation Board, "Rigby House", 15 Queens-road, Melbourne, or at such other place as the Board may require.

7. The plans, specifications and estimate of the cost of the proposed works and undertakings and a statement showing the proposed expenditure of the moneys to be borrowed, are open for inspection at the Municipal Offices, Civic Centre, Welsford-street, Shepparton, during office hours.

Dated this 15th day of December, 1967.

568

R. O'BRIEN, Town Clerk.

CITY OF TRARALGON.

SPECIAL ORDER.—LOAN No. 26.

NOTICE is hereby given that the Council of the City of Traralgon did at a meeting held on Wednesday, 1st November, 1967, agree to the following Resolution:—

(a) That the Council of the City of Traralgon resolve to borrow from the State Savings Bank of Victoria the sum of \$30,000 secured on the general rates of the municipality, such sum to be raised by the grant of a mortgage in accordance with the provisions of section 585 of the Local Government Act 1958, as amended.

(b) That the maximum rate of interest that may be paid be 5.875 per centum per annum.

(c) That the period of the loan be fifteen (15) years.

(d) That the moneys borrowed, and interest thereon, be repayable by thirty (30) half-yearly instalments each of approximately \$1,519 on the 1st day of August and the 1st day of February in each year during the currency of the loan, the first instalment being repayable on the 1st day of August, 1968.

(e) That such money be repayable to the Commissioners of the State Savings Bank of Victoria, Melbourne.

(f) That the loan be applied for the purpose of constructing private streets within the City of Traralgon in pursuance and in accordance with the provisions of Division 10 of Part XIX. of the Local Government Act 1958.

Notice is hereby further given that the said Council did at a meeting held on 12th December, 1967, confirm such Resolution.

497

K. J. SAUNDERS, Town Clerk.

CITY OF WARRNAMBOOL.

LOAN No. 75.

Notice of Intention to Borrow the Sum of \$25,000 for Permanent Works and Undertakings.

NOTICE is hereby given, that the Council of the City of Warrnambool proposes to borrow the sum of Twenty-five thousand dollars (\$25,000) secured by a charge over the general rates of the municipality, such sum to be raised by the grant of a mortgage in accordance with the provisions of the Local Government Act 1958.

1. The maximum rate of interest that may be paid is 5.875 per cent. per annum.

2. The purpose for which the loan is to be applied, is for the following works:—

Council Contribution—Main Roads	..	\$4,640
Jamieson-street—Kerb and Channel	..	2,160
Ward-street Extension	..	750
Purchase Micro Film Equipment	..	4,000
Purchase New Road Making Plant	..	13,450
		\$25,000

3. The period of the loan shall be fifteen years.

4. The money borrowed, shall be repayable by providing out of municipal fund, 30 half-yearly instalments of \$1,265.20, each including principal and interest, on the 1st day of April and the 1st day of October, during the currency of the loan. The first instalment shall be payable on the 1st day of October, 1968.

5. Such moneys shall be repayable to the National Bank Savings Bank Ltd., 271-285 Collins-street, Melbourne.

A Statement showing the proposed expenditure of the moneys to be borrowed, is open for inspection at the Municipal Office, Timor-street, Warrnambool.

498

K. L. ARNEL, Town Clerk.

CITY OF WAVERLEY.

LOAN No. 81.

Notice of Intention to Borrow.

NOTICE is hereby given that the Council of the City of Waverley intends to borrow \$100,000 secured by a charge over the general rates of the municipality by the grant of a mortgage in accordance with the provisions of the Local Government Acts.

In connexion therewith the following information is stated:—

(a) The amount of the principal moneys which it is proposed to borrow is \$100,000.

(b) The maximum rate of interest that may be paid is \$5.75 per centum per annum.

(c) The times which the moneys borrowed are to be repayable are the 28th day of August, 1968 and the 28th day of February, and 28th day of August during the years 1969 and 1977 inclusive with a final payment on 28th day of February, 1978 and that the place such moneys shall be repayable is at the Bank of New South Wales, Glen Waverley.

(d) The purpose for which the loan is to be applied is:—

Reconstruction of Waverley-road	..	\$20,000
Reconstruction of Gallaghers-road	..	45,000
Extensions—Syndal Infant Welfare Centre	..	2,500
Fencing various Ovals	..	7,500
Part Construction Lum-road Outfall Drain	..	6,600
Concrete Footpath Construction—sundry	..	18,400
		\$100,000

(e) The manner in which the loan is to be liquidated is by provision out of the municipal fund in each half-year during the currency of the loan of the sum of \$6,664.13 which includes principal and interest.

The plans and specifications and estimate of the cost of the works and a statement showing the proposed expenditure of the moneys to be borrowed are open for inspection at the Municipal Offices, Springvale-road, Glen Waverley.

Dated this 20th day of December, 1967.

569

F. S. BALES, Town Clerk.

TOWN OF CAMPERDOWN.

LOAN No. 16.

Notice of Intention to Borrow the Sum of Forty Thousand Dollars (\$40,000) for Permanent Works and Undertakings.

NOTICE is hereby given that the Council of the Town of Camperdown proposes to borrow the sum of Forty thousand dollars (\$40,000), secured by a charge over the general rates of the municipality, such sum to be raised by the grant of a mortgage in accordance with the provisions of the *Local Government Act 1958*.

1. The maximum rate of interest that may be paid is $5\frac{1}{2}$ per cent. per annum.
2. The purpose for which the loan is to be applied is:—
For part cost of Civic Centre.
3. The period of the loan shall be twenty years.
4. The moneys borrowed shall be repayable by providing out of the municipal fund 39 half-yearly payments of \$1,303.61 and a final payment of \$31,742.51 on 1st February and 1st August each year, the first such payment to be on 1st August, 1968.
5. Such moneys shall be repayable at the Commonwealth Savings Bank, Melbourne.

The plans and specifications and the estimate of the cost of the proposed works, and the statement showing the proposed expenditure of the money to be borrowed are open for inspection at the Council Offices, Fergusson-street, Camperdown, during office hours.

Dated this 5th day of December, 1967.

519 HUGH D. H. LEARMONTH, Town Clerk.

Town and Country Planning Act 1961 (Twelfth Schedule).

UNITED SHIRE OF BEECHWORTH.

LOAN No. 16.

Notice of Intention to Borrow.

NOTICE is hereby given that the Council of the United Shire of Beechworth intends to borrow Twelve thousand dollars (\$12,000) on the credit of the President, Councillors and Ratepayers of the said Shire by the grant of a mortgage in accordance with the provisions of the *Local Government Acts*.

In connexion therewith the following information is stated:—

- (a) The amount of the principal moneys which it is proposed to borrow is \$12,000.00.
- (b) The maximum rate of interest that may be paid is 5 per centum per annum.
- (c) The times which the moneys borrowed are to be repayable are the 1st day of September, 1968, and the 1st days of March and September during the years 1968 to 1990 inclusive, and that the place such moneys shall be repayable is at the office of the Tourist Development Authority, Melbourne, or at such other place as the Authority may require.
- (d) The purpose for which the loan is to be applied is for—
the erection of a Kiosk and Caretaker's Residence at Lake Sambell Reserve, Beechworth.
- (e) The manner in which the loan is to be liquidated is by provision out of the municipal fund in each half year, during the currency of the loan of the sum of \$447.22 which includes principal and interest.

The specifications and estimate of the cost and a statement showing the proposed expenditure of the moneys to be borrowed are open for inspection at the Shire Office, Beechworth.

Dated this 4th day of December, 1967.

505 G. T. GRAY, Shire Secretary.

SHIRE OF BULLA.

LOAN No. 18.

Private Street Construction.

NOTICE is hereby given, that at the meeting of the Council of the Shire of Bulla held at the Municipal Offices, Sunbury, on the 6th November, 1967, the said Council did agree to the following Resolution, that is to say—

That Council borrow \$50,000 on the credit of the Municipal Revenues of the President, Councillors and Ratepayers of the Shire of Bulla; such sum to be raised by the grant of a mortgage in accordance with the provisions of the *Local Government Act 1958*.

- (a) The maximum rate of interest that may be paid is 5.75 per cent. per annum.

- (b) The purpose for which the loan is to be applied is towards the cost of a Private Street Construction Scheme known as the Hume Street Group Construction Scheme, Sunbury, under the provisions of Division 10 of Part XIX. of the *Local Government Act 1958*.
- (c) The moneys borrowed shall be repayable by twenty half-yearly instalments of approximately \$3,322 each including interest on the 1st September and 1st March during the currency of the loan. The first instalment shall be payable on the 1st September, 1968.
- (d) Such moneys shall be repayable at the Head Office, National Bank Savings Bank Ltd., Melbourne.
- (e) The period of the loan shall be ten years.

Notice is hereby further given, that at a meeting of the said Council held at the Municipal Offices, Sunbury, on the 4th December, 1967, the said Resolution was confirmed.

520 JOHN M. KELLY, Shire Secretary.

SHIRE OF BULLA.

LOAN No. 19.

Private Street Construction.

NOTICE is hereby given, that at the meeting of the Council of the Shire of Bulla held at the Municipal Offices, Sunbury, on the 6th November, 1967, the said Council did agree to the following Resolution, that is to say—

That Council borrow \$30,000 on the credit of the Municipal Revenues of the President, Councillors and Ratepayers of the Shire of Bulla; such sum to be raised by the grant of a mortgage in accordance with the provisions of the *Local Government Act 1958*.

- (a) The maximum rate of interest that may be paid is 5.75 per cent. per annum.
- (b) The purpose for which the loan is to be applied is towards the cost of a Private Street Construction Scheme known as the Hume Street Group Construction Scheme, Sunbury, under the provisions of Division 10 of Part XIX. of the *Local Government Act 1958*.
- (c) The moneys borrowed shall be repayable by twenty half-yearly instalments of approximately \$1,993 each including interest on the 1st July and 1st January during the currency of the loan. The first instalment shall be payable on the 1st July, 1968.
- (d) Such moneys shall be repayable at the Head Office, State Savings Bank of Victoria, Melbourne.
- (e) The period of the loan shall be ten years.

Notice is hereby further given, that at a meeting of the said Council held at the Municipal Offices, Sunbury, on the 4th December, 1967, the said Resolution was confirmed.

521 JOHN M. KELLY, Shire Secretary.

Town and Country Planning Act 1961 (Twelfth Schedule).

SHIRE OF BULLA.—SHIRE OF BULLA PLANNING SCHEME 1959.

NOTICE THAT A PLANNING SCHEME HAS BEEN PREPARED AND IS AVAILABLE FOR INSPECTION.

Amendment No. 2, 1967.

NOTICE is hereby given that the Shire of Bulla, in pursuance of its powers under the *Town and Country Planning Act 1961*, has prepared a Planning Scheme for—

- (a) Greenvale—area bounded by Mickleham, Somerton and Section roads and Providence-lane;
- (b) Sunbury—
 - (a) area included in lodged plan No. 5392, plus
 - (b) balance of Mr. Sambell's property fronting Riddell-road between the existing 5-acre subdivision to the north and the residential subdivision to the south,
 - (c) balance of "Kismet Park" area fronting Racecourse-road, being lots 1 and 4 of lodged plan No. 55058 (with the exception of lodged plan Nos. 55059 and 55060, already residential subdivision),
- (c) Yuroke—
 - (a) area covered by lodged plan No. 3554, plus
 - (b) Crown allotments A and E of section XX., Parish of Yuroke,

for the purpose of creating a new zone to be known as Residential B based on a minimum subdivisional area of 5 acres instead of the existing Rural Zone based on a minimum subdivisional area of 15 acres.

A copy of the scheme has been deposited at the Municipal Offices, Macedon-street, Sunbury, and at the office of the Town and Country Planning Board, 61 Spring-street, Melbourne, and will be open for inspection during office hours by any person, free of charge.

Any persons affected by the Planning Scheme are required to set forth, in writing, all objections they may have addressed to the Shire Secretary, Shire of Bulla, Municipal Offices, Macedon-street, Sunbury, on or before the 31st day of January, 1968, and to state whether they wish to be heard in respect of their objections.

18th December, 1967.

617 JOHN M. KELLY, Shire Secretary.

Town and Country Planning Act 1961 (Twelfth Schedule).
SHIRE OF BULLA.—SHIRE OF BULLA PLANNING SCHEME 1959.

NOTICE THAT A PLANNING SCHEME HAS BEEN PREPARED AND IS AVAILABLE FOR INSPECTION.

Amendment No. 3, 1967.

NOTICE is hereby given that the Shire of Bulla, in pursuance of its powers under the *Town and Country Planning Act 1961*, has prepared a Planning Scheme for—

Part of allotment 20 and part of allotment 23 of lodged plan No. 5393 within the Parish of Buttlejorrk, each having a frontage to Riddell-road, for the purpose of altering the above areas from Rural Zoning to Offensive Trades Zoning.

A copy of the scheme has been deposited at the Municipal Offices, Macedon-street, Sunbury, and at the office of the Town and Country Planning Board, 61 Spring-street, Melbourne, and will be open for inspection during office hours by any person, free of charge.

Any persons affected by the Planning Scheme are required to set forth, in writing, all objections they may have addressed to the Shire Secretary, Shire of Bulla, Municipal Offices, Macedon-street, Sunbury, on or before the 31st day of January, 1968, and to state whether they wish to be heard in respect of their objections.

18th December, 1967.

627 JOHN M. KELLY, Shire Secretary.

Town and Country Planning Act 1961 (Twelfth Schedule).
SHIRE OF BULLA.—SHIRE OF BULLA PLANNING SCHEME 1959.

NOTICE THAT A PLANNING SCHEME HAS BEEN PREPARED AND IS AVAILABLE FOR INSPECTION.

Amendment No. 4, 1967.

NOTICE is hereby given that the Shire of Bulla, in pursuance of its powers under the *Town and Country Planning Act 1961*, has prepared a Planning Scheme for—

Lot 566 of lodged plan No. 66779, being part of Crown allotment A3, section XXIII., Parish of Yuroke, for the purpose of giving to the Responsible Authority power to vary the setback of shops in the Craigieburn Central Business Zone if it considers that development may be more appropriately and conveniently carried out.

A copy of the scheme has been deposited at the Municipal Offices, Macedon-street, Sunbury, and at the office of the Town and Country Planning Board, 61 Spring-street, Melbourne, and will be open for inspection during office hours by any person, free of charge.

Any persons affected by the Planning Scheme are required to set forth, in writing, all objections they may have addressed to the Shire Secretary, Shire of Bulla, Municipal Offices, Macedon-street, Sunbury, on or before the 31st day of January, 1968, and to state whether they wish to be heard in respect of their objections.

18th December, 1967.

628 JOHN M. KELLY, Shire Secretary.

Town and Country Planning Act 1961 (Twelfth Schedule).
SHIRE OF BULLA.—SHIRE OF BULLA PLANNING SCHEME 1959.

NOTICE THAT A PLANNING SCHEME HAS BEEN PREPARED AND IS AVAILABLE FOR INSPECTION.

Amendment No. 5, 1967.

NOTICE is hereby given that the Shire of Bulla, in pursuance of its powers under the *Town and Country Planning Act 1961*, has prepared a Planning Scheme for portions of the Township of Sunbury, being—

- (a) Crown allotments 17 to 24 inclusive, section 16,
- (b) Crown allotments 4 to 7 inclusive, section 10,

- (c) Portion of land owned by the Victorian Railways fronting Evans-street and being the area occupied by Frank Ulm Motors Pty. Ltd., under Railways Lease No. 16613,

for the purpose of altering the above areas to Commercial Zoning.

A copy of the scheme has been deposited at the Municipal Offices, Macedon-street, Sunbury, and at the office of the Town and Country Planning Board, 61 Spring-street, Melbourne, and will be open for inspection during office hours by any person, free of charge.

Any persons affected by the Planning Scheme are required to set forth, in writing, all objections they may have addressed to the Shire Secretary, Shire of Bulla, Municipal Offices, Macedon-street, Sunbury, on or before the 31st day of January, 1968, and to state whether they wish to be heard in respect of their objections.

18th December, 1967.

629 JOHN M. KELLY, Shire Secretary.

Town and Country Planning Act 1961 (Twelfth Schedule).
SHIRE OF BULLA.—SHIRE OF BULLA PLANNING SCHEME 1959.

NOTICE THAT A PLANNING SCHEME HAS BEEN PREPARED AND IS AVAILABLE FOR INSPECTION.

Amendment No. 6, 1967.

NOTICE is hereby given that the Shire of Bulla, in pursuance of its powers under the *Town and Country Planning Act 1961*, has prepared a Planning Scheme for—

- (a) Part of section VIII., Parish of Will Will Rook, being south of the Victoria Police Horse Depot, having a frontage to Mickleham-road and extending westerly from Mickleham-road along its northern boundary approximately 28½ chains,

(b) That part of section IX., Parish of Will Will Rook, south-west of the present Mickleham-road, for the purpose of altering the above areas from Rural Zoning to Residential Zoning.

A copy of the scheme has been deposited at the Municipal Offices, Macedon-street, Sunbury, and at the office of the Town and Country Planning Board, 61 Spring-street, Melbourne, and will be open for inspection during office hours by any person, free of charge.

Any persons affected by the Planning Scheme are required to set forth, in writing, all objections they may have addressed to the Shire Secretary, Shire of Bulla, Municipal Offices, Macedon-street, Sunbury, on or before the 31st day of January, 1968, and to state whether they wish to be heard in respect of their objections.

18th December, 1967.

630 JOHN M. KELLY, Shire Secretary.

SHIRE OF BULN BULN.

LOAN No. 32.

Notice of Intention to Borrow the Sum of \$30,000 for Permanent Works and Undertakings.

NOTICE is hereby given that the Council of the Shire of Buln Buln proposes to borrow the principal sum of Thirty thousand dollars secured by a charge over the general rates of the municipality, such sum to be raised by the grant of a mortgage in accordance with the provisions of the *Local Government Act 1958*.

1. The maximum rate of interest that may be paid is 5½ per cent., per annum.

2. The purposes for which the loan is to be applied are:—

- (a) Purchase of Roadmaking Plant .. \$14,200
- (b) Construction of Depot (Part Cost) .. 700
- (c) Street Construction (including Foot-paths, Kerb and Channelling)—Hearn, Victoria, Bennett, Ramsden, Bertram, Young, Church, Grant, Sinclair, Kennedy, Mackey and McCrae streets; Hopetoun, Albert, Main Neerim, Long-warry, Main South, Lardner and Weebar roads; Railway-avenue; Armstrong-avenue; Princes-avenue; and Princes Highway. (Council's Proportion) 15,100

\$30,000

3. The period of the loan shall be ten years.

4. The moneys borrowed shall be repayable by providing out of the municipal fund, twenty half-yearly instalments of approximately \$1,993 each including principal and interest on the 1st day of April and the 1st day of October during the currency of the loan. The first instalment shall be payable on the 1st day of October, 1968.

5. Such moneys shall be repayable to the Commissioners of The State Savings Bank of Victoria at the office of the said Commissioners, corner Elizabeth and Bourke streets, Melbourne.

The plans and specifications and the estimate of the cost of the proposed works and a statement showing the proposed expenditure of the moneys to be borrowed are open for inspection at the office of the Council of the Shire of Buln Buln, at Drouin.

Dated the 12th day of December, 1967.

504 K. A. PRETTY, Shire Secretary.

SHIRE OF BUNINYONG.

By-Law No. 25.

A BY-LAW of the SHIRE OF BUNINYONG made under Section 93 of the *Health Act 1958*, and numbered 25, for fixing the limits within which it shall be unlawful to keep swine or pig-sties.

IN pursuance of the powers conferred by the *Health Act 1958* and all other powers it thereunto enabling, the President, Councillors, and Ratepayers of the Shire of Buninyong order as follows:—

1. No person shall keep or permit or suffer to be kept any swine or any pig-sty within the limits of the areas prescribed by this By-Law.

2. This By-Law shall apply to and have operation within the following parts of the Municipal District of the Shire of Buninyong:—

- (a) The Township of Warrenheip.
- (b) That part of the Water District of the Bungaree and Wallace Waterworks Trust, which is south of the Western Highway.
- (c) That part of the Buninyong, Mt. Helen, Mt. Clear, and Canadian districts within the area defined in the first schedule hereto.

3. The proper officer of the Council shall have the power to enter into or upon any premises, yards or lands at any reasonable hour for the purpose of carrying out the provisions of this By-Law.

4. If any person by wilful act or default contravenes any of the provisions of this By-Law he shall be guilty of an offence against this By-Law, and liable, on conviction, to a penalty not exceeding Forty Dollars (\$40) and in the case of a continuing offence after conviction or order by any Court to a further penalty of Ten Dollars (\$10) for each day on which an offence against this By-Law is continued.

FIRST SCHEDULE.

Commencing in the Parish of Ballarat at the intersection of the northern boundary of the Shire of Buninyong and the western boundary of the Midland Highway (Geelong Road); thence westerly a distance of 1,000 links along the Shire boundary; thence southerly to the north western corner of crown allotment 8A section 14 Parish of Ballarat; thence southerly along the western boundary of crown allotment 8A to the north western corner of crown allotment 4b section 14 Parish of Ballarat; thence southerly, and 532 links easterly by the western and southern boundaries of crown allotment 4b to a Government Road; thence southerly by the western boundary of the Government Road to the Mt. Clear Sebastopol Road; thence south westerly across the Mt. Clear Sebastopol Road to the north eastern corner of a Permissive Occupancy to the Forests Department; thence southerly along the eastern boundary of the said Permissive Occupancy to the south eastern corner of the said Permissive Occupancy; thence south easterly across a Government Road to the north east corner of crown allotment 22 section 17A Parish of Ballarat; thence by the eastern boundaries of the said crown allotment southerly and easterly; thence across a Government Road to the north easterly corner of a Permissive Occupancy to the Forests Department; thence southerly, easterly, and southerly by the eastern boundaries of the said Permissive Occupancy to Boak Avenue and the south west corner of crown allotment 12 Parish of Ballarat; thence south easterly across Boak Avenue to the north easterly corner of a Permanent Forest Reservation in the Parish of Buninyong; thence southerly, easterly, and southerly by the eastern boundaries of the said Reservation to the north eastern corner of crown allotment 51E Parish of Buninyong; thence westerly by the northern boundaries of crown allotments 51E and 51F to the north western corner of crown allotment 51F; thence southerly

along the western boundary of crown allotment 51F to the south western corner of crown allotment 51F; thence across a Government Road to the north western corner of crown allotment 116B; thence southerly along the western boundary of crown allotment 116B to a Government Road; thence south-westerly across the Government Road to the north western corner of crown allotment 119B; thence southerly along the western boundary of crown allotment 119B to a Government Road; thence south easterly across the Government Road to the north western corner of crown allotment 121A; thence southerly along the western boundary of crown allotment 121A, across the Buninyong Sebastopol Road to the north western corner of crown allotment 125 (Recreation Reserve); thence southerly along the western boundary of the said Reserve to the south western corner of the said Reserve; thence across a road to the north west corner of crown allotment 128 A1; thence southerly and south westerly along a Government Road to the south west corner of crown allotment 129F; thence south easterly across a road to the north western corner of crown allotment 118A; thence southerly along the western boundary of crown allotment 118A to the south western corner of crown allotment 118A; thence easterly by the northern boundary of a Government Road to the south east corner of crown allotment 102; thence northerly by the eastern boundaries of crown allotments 102, 93, 88, 79, and 75; thence across the Midland Highway to the south eastern corner of crown allotment 68; thence northerly along the eastern boundary of crown allotment 68 to the north eastern corner of crown allotment 68; thence by a line northerly to the north-western corner of crown allotment M section 24 Parish of Buninyong; thence northerly along the western boundary of a Government Road to the south east corner of crown allotment 5 section 21 Parish of Warrenheip; thence westerly and northerly by the southern and western boundaries of crown allotment 5 to the south east corner of crown allotment Z2 Parish of Ballarat; thence westerly along the south boundaries of crown allotments Z2 and Z5 across a Government Road to the south east corner of crown allotment 13; thence westerly and northerly along the southern and western boundaries of crown allotment 13 to the north western corner of crown allotment 13; thence across a Government Road and westerly along the northern boundary of the Government Road to the south eastern corner of crown allotment 2 section 4 A1 Parish of Ballarat; thence northerly along the eastern boundary of crown allotment 2 to the north eastern corner of crown allotment 2; thence by a line northerly to the south eastern corner of crown allotment 15, section Y¹ Parish of Ballarat; thence north westerly along the eastern boundary of crown allotment 15 to the Shire boundary at Elsworth Street; thence westerly along the said boundary of the Shire of Buninyong to the commencing point.

RESOLUTION for passing this By-Law agreed to by the Council of the Shire of Buninyong on the fifth day of October 1967.

CONFIRMED this second day of November 1967.

IN WITNESS whereof the Common Seal of the President, Councillors and Ratepayers of the Shire of Buninyong was hereunto affixed this second day of November 1967 in the presence of—

(SEAL) A. P. TURNER, President.
D. L. COXALL, Councillor.
A. C. LORD, Shire Secretary.

Submitted to the Commission of Public Health on the 21st day of November, 1967.—A. T. GARDNER, Secretary to the Commission.

Approved by the Governor in Council this 28th day of November, 1967.—J. ROSSITER, Clerk of the Executive Council. 500

Town and Country Planning Act 1961 (Twelfth Schedule).

SHIRE OF CROYDON PLANNING SCHEME 1961.

NOTICE THAT A PLANNING SCHEME HAS BEEN PREPARED AND IS AVAILABLE FOR INSPECTION.

Amendment No. 4, 1967.

NOTICE is hereby given that the Shire of Croydon in pursuance of its powers under the *Town and Country Planning Act 1961*, has prepared a Planning Scheme for:—

1. Lot 2, L.P.39218, Lusher-road, for the purpose of rezoning from Proposed Public Open Space to Light Industrial.

2. Lot 1, L.P.33232, Taylors-road, for the purpose of rezoning from Proposed Public Open Space to Light Industrial.

3. Lots 1, 2 and 3, L.P.54583, Jesmond-road, for the purpose of rezoning part from Proposed Public Open Space to Light Industrial.

4. Lot 1, L.P.46634, Jesmond-road, for the purpose of rezoning part from Proposed Public Open Space to Light Industrial.

5. Lot 20, L.P.9560, Jesmond-road, for the purpose of rezoning part from Proposed Public Open Space to Light Industrial.

6. Lot 1, L.P.39842, Lusher-road, for the purpose of rezoning from Light Industrial to Residential.

7. Lot 2, L.P.39842, Lusher-road, for the purpose of rezoning part from Proposed Public Open Space and Light Industrial to Residential.

8. Lot 25, L.P.8854, Lusher-road, for the purpose of rezoning part from Proposed Public Open Space and Light Industrial to Residential.

9. Lot 27, L.P.8854, Lusher-road, for the purpose of rezoning part from Proposed Public Open Space to Light Industrial and part from Light Industrial to Proposed Public Open Space.

A copy of the scheme has been deposited at the Shire of Croydon, Shire Office, Railway-crescent, Croydon; and at the office of the Town and Country Planning Board, 179 Queen-street, Melbourne, and will be open for inspection during office hours by any person, free of charge.

Any persons affected by the planning scheme are required to set forth, in writing, all objections they may have, addressed to the Shire Secretary, Shire of Croydon, Shire Offices, Railway-crescent, Croydon, on or before the 29th day of March, 1968, and to state whether they wish to be heard in respect of their objections.

508

K. A. McKAY, Shire Secretary.

SHIRE OF DAYLESFORD AND GLENLYON.

LOAN NO. 3.

Notice of Intention to Borrow the Sum of \$19,900 for Permanent Works and Undertakings.

NOTICE is hereby given that the Council of the Shire of Daylesford and Glenlyon proposes to borrow the principal sum of Nineteen thousand nine hundred dollars secured by a charge over the general rates of the municipality, such sum to be raised by the grant of a mortgage in accordance with the provisions of the *Local Government Act 1958*.

1. The maximum rate of interest that may be paid is 5 9/16 per cent. per annum.

2. The purpose for which the loan is to be applied is:—
Purchase of road-making equipment.

3. The period of the loan shall be nine years.

4. The moneys borrowed shall be repayable by providing out of the municipal fund half-yearly instalments of approximately \$1,420 each including principal and interest on the 1st day of September and the 1st day of March during the currency of the loan. The first instalment shall be payable on the 1st day of September, 1968.

5. Such moneys shall be repayable to the Commissioners of the State Savings Bank of Victoria, at the office of the said Commissioners, corner Elizabeth and Bourke streets, Melbourne.

The plans and specifications and the estimate of the cost of the proposed works and a statement showing the proposed expenditure of the moneys to be borrowed are open for inspection at the office of the Council of the Shire of Daylesford and Glenlyon, at Shire Office, Town Hall, Daylesford.

Dated the 15th December, 1967.

593

S. HAUSER, Shire Secretary.

SHIRE OF DIAMOND VALLEY.

LOAN NO. 9.

Notice of Intention to Borrow the Sum of \$100,000 for Permanent Works and Undertakings.

NOTICE is hereby given that the Council of the Shire of Diamond Valley proposes to borrow the principal sum of \$100,000 secured by a charge over the general rates of the municipality, such sum to be raised by the grant of a mortgage in accordance with the provisions of the *Local Government Act 1958*.

1. The maximum rate of interest that may be paid is 5 1/4 per cent. per annum.

2. The purposes for which the loan is to be applied are:—
Public works—

C.R.B. works—Council proportion 1967/8, Grimshaw-street, reconstruction and widening	\$25,000
Grimshaw-street—construction of paths, kerb and channel, Council proportion	20,000
Grimshaw-street—reconstruction—Carter to Main streets	20,000
Clyde-street—initial treatment, prime and seal	4,000
	<hr/>
	\$69,000

Buildings—

A. K. Lines Reserve—pavilion (part provision)	6,000
Diamond Creek Elderly Citizens' Centre (part provision)	1,000
N. J. Telfer Reserve—pavilion and toilet block (part provision)	12,000
Partington's Flat—pavilion (part provision)	12,000
	<hr/>
	\$31,000

\$100,000

3. The period of the loan shall be fifteen years.

4. The moneys borrowed shall be repayable by providing out of the municipal fund half-yearly instalments of approximately \$5,060 each, including principal and interest on the 1st day of April and the 1st day of October, during the currency of the loan. The first instalment shall be payable on the 1st day of October, 1968.

4. Such moneys shall be repayable to the Commissioners of the State Savings Bank of Victoria, at the office of the said Commissioners, corner Elizabeth and Bourke streets, Melbourne.

The plans and specifications and the estimate of the cost of the proposed works and a statement showing the proposed expenditure of the moneys to be borrowed are open for inspection at the office of the Council of the Shire of Diamond Valley, at Main-street, Greensborough.

Dated the 15th December, 1967.

565

B. J. MORGAN, Shire Secretary.

SHIRE OF DONALD.

BY-LAW NO. 42.

A By-law of the Shire of Donald made under parts XIX. and XX. of the *Health Act 1958*, as amended, and numbered 42 for the purpose of prescribing the fees to be charged for registration of premises and food vending machines and for the renewal and/or transfer of registration of premises and food vending machines pursuant to the said Act as amended.

IN PURSUANCE of the powers conferred by the *Health Acts*, the President, Councillors and Ratepayers of the Shire of Donald ORDER as follows:—

1. All former By-laws in so far as they relate to the purport of this By-law are hereby repealed.

2. This By-law shall apply to and have effect throughout the Shire of Donald.

3. The fees to be charged received and taken by the Shire of Donald for the registration of premises and food vending machines and for the annual renewals and transfers thereof pursuant to the *Health Act 1958* as amended shall be those specified in the Schedule hereto.

4. Such fees shall be paid to the Shire Secretary of the said Shire or other Authorised officer, by every person making application for such registration, renewal or transfer.

SCHEDULE REFERRED TO IN THIS BY-LAW.

(a) For the granting or annual renewal of Registration of premises:—

<i>Nature of Premises.</i>	<i>Fees payable.</i>
Offensive Trade Premises (other than those referred to below)	\$10.00
Offensive Trade Premises (being fat extracting or melting or rendering works which are conducted at premises occupied principally as a butchers shop and at which fat is extracted melted or rendered only from materials derived from such shop)	\$5.00
Cattle Sale Yards	\$10.00
Boarding Houses	\$10.00
Common Lodging Houses	\$10.00
Eating Houses	\$10.00

Apartment Houses containing not more than one (1) apartment	\$5.00
Apartment Houses containing more than one (1) apartment	\$10.00
Camping Areas	\$10.00
Food Premises—	
(i) where not more than five persons (including the proprietor and his family) are employed	\$5.00
(ii) where more than five (5) such persons are employed additional for each person in excess of five (5)	\$0.50c
Provided that the maximum fee payable shall be \$100.00	\$100.00
Premises at or in any part of which eggs for sale are received or stored for the purpose of being chilled	\$5.00
Hairdressers, Beauty Parlours and Chiropodists	\$5.00
Food Vending Machines—operated by—	
(1) One or Two Cents a sale	\$0.50c
(2) A coin or coins in excess of two cents in value but not exceeding five cents in value a sale	\$2.00
(3) A coin or coins in excess of five cents in value a sale	\$4.00
(b) For any transfer of registration—one Dollar (\$1) or fifty per cent. of the registration fee (whichever is the lesser amount).	

Resolution for passing this By-law was carried by the Council of the Shire of Donald on the 20th day of September, 1967, and confirmed on the 18th day of October, 1967.

The common seal of the President, Councillors and Ratepayers of the Shire of Donald was hereunto affixed this 18th day of October, 1967, in the presence of—

(SEAL) H. J. FALLA, Shire President.
C. P. WHELAN, Councillor.
H. C. SMALE, Shire Secretary.

Submitted to the Commission of Public Health on the 8th day of November, 1967.—A. T. GARDNER, Secretary, Commission of Public Health.

Approved by the Governor in Council, 21st November, 1967.—J. P. ROSSITER, Clerk of the Executive Council. 499

SHIRE OF FLINDERS.
BY-LAW No. 63.

A BY-LAW of the Shire of Flinders made pursuant to Section 197 of the *Local Government Act 1958*, and numbered 63 for suppressing nuisances controlling and regulating the use of premises with a view to preventing objectionable noises, prohibiting or minimizing noises in any public highway.

1. By-Law No. 51 of the Shire of Flinders is hereby repealed.

2. No person shall in or upon any land or premises make cause or permit or suffer to be made or cause such volume or amount of sound or noise as to be objectionable or an annoyance or nuisance to any other person being in or upon any other land or premises or in or upon any public highway:—

- (a) by shouting calling out haranguing or singing or;
- (b) by using operating controlling sounding or playing any wireless set amplifying equipment gramophone piano piano-player or any other instrument or contrivance.

3. No person shall in any public highway cause or permit or suffer to be caused without justifiable cause any loud or objectionable noise by shouting calling out haranguing or singing.

4. (i) No person shall in any public highway cause or permit or suffer to be caused any noise by using operating controlling sounding or playing any wireless set amplifying equipment gramophone piano piano-player or any other instrument or contrivance without the consent in writing of the Council of the Shire of Flinders and in the event of such consent being granted except in accordance with the conditions (if any) attached thereto.

- (ii) Any person applying for such consent shall:—
 - (a) make application in writing to the Council of the Shire of Flinders and
 - (b) in such application state:
 - (i) his full name and address;
 - (ii) the date and times between which he proposes to use such wireless set amplifying equipment gramophone piano piano-player or any other instrument or contrivance;

- (iii) the purpose for which he desires to use such electrical wireless set amplifying equipment gramophone piano piano-player or any other instrument or contrivance;
- (iv) the name of the public highway involved; and

(c) supply any other information the Council of the Shire of Flinders may desire.

5. The Council of the Shire of Flinders may grant the application either subject to conditions or not or refuse the same as it sees fit.

6. Any person guilty of wilful act or default contrary to this By-Law shall be liable to a penalty of not less than Twenty Dollars (\$20) or more than Forty Dollars (\$40) and to a further penalty of not more than Ten Dollars (\$10) for each day on which such offence is continued after a conviction or order is made by the Court.

7. This By-Law shall apply to and have operation throughout the whole of the municipal district of the Shire of Flinders.

Resolution for passing this By-Law agreed to by the Council on the 4th day of October, 1967, and confirmed the 1st day of November, 1967.

The common seal of the President, Councillors and Ratepayers of the Shire of Flinders was hereto affixed in the presence of—

(SEAL) P. W. STYNES, President.
G. BISHOP, Councillor.
S. WILLIAMS, Shire Secretary.

Approved by the Governor in Council the 28th day of November, 1967.—J. ROSSITER, Clerk of the Executive Council. 529

SHIRE OF FLINDERS.

NOTICE is hereby given that in pursuance of the powers conferred by the *Local Government Act 1958*, the Council of the Shire of Flinders did resolve on 6th December, 1967, to make the following alterations in street names and to name streets as set out hereunder not previously named.

COLLINS RIDING.

Old Name; New Name; Location.

- Agnes-court; Fiona-court; runs north-west off Samuel-street, lodged plan 31239, Parish of Nepean, part Crown allotment 61A.
- Allan-street; Golf-road; runs west off Hemston-avenue, lodged plan 8909, Parish of Nepean, part Crown allotment 108.
- Beach-avenue; Terry-avenue; runs south-west off Nepean Highway, lodged plans 10208, 48546, 10574, Parish of Nepean, part Crown allotment 77.
- Cain-court; Weir-street; runs south off Nepean Highway, lodged plan 43067, Parish of Nepean, part Crown allotment 29.
- Cain-street; Newton-avenue; runs north-west off St. Pauls-road to Coppin-road, part Crown allotment 82 and Township of Sorrento, Parish of Nepean.
- Cain-street; Revell-street; runs south-west off Nepean Highway to Melbourne-road, Parish of Nepean, part Crown allotments 38, 39, 41.
- Campbell-avenue; Macgregor-avenue; runs south off Nepean Highway to the north boundary of Crown allotment 123, Parish of Nepean, part Crown allotment 124.
- Charles-street; Godfrey-street; the continuation of Godfrey-street running north-west off St. Johns Wood-road to The Loop, lodged plans 11328, 24714, Parish of Nepean.
- Clerk-street; Penman-street; runs north-east off Melbourne-road to Melibee-street, lodged plans 30064, 30065, Parish of Nepean, part Crown allotment 33.
- Collins-parade; Hiscock-parade; runs south-west off Nepean Highway to north boundary of Crown allotment 69, lodged plans 11774, 40712, Parish of Nepean.
- Collins-street; Cecil-street; runs north-west off Salonika-street, lodged plans 1137, 6909, Parish of Nepean, part Crown allotment 77.
- Carslake-street; Carslake-avenue; continuation to the South-east of Carslake-avenue to Canterbury Jetty-road, lodged plan 43634, Parish of Nepean.
- David-grove; Keating-avenue; runs from Mission-street to the Ocean Beach Reserve, lodged plans 25452, 45075, Parish of Nepean, part of Crown allotment 67.
- Elizabeth-street; Betty-street; runs south from Peter-street to Percy-street, lodged plans 50981, 50985, Parish of Nepean, part Crown allotment 6.
- Elizabeth-avenue; Eliza-street; runs north-west from Spray Point-road to Koonya-avenue, lodged plan 17893, Parish of Nepean.

- Elizabeth-grove; Winifred-grove; runs west off Macfarlan-avenue to Ocean-road, lodged plan 13609, Parish of Nepean.
- Elizabeth-grove; Ocean-road; forming south-east boundaries of lots 264-268, lodged plan 13609, Parish of Nepean.
- Ellesmere-street; Scott-street; running north-west from Caxton-street to William-road, lodged plans 26944, 30061, 30062, Parish of Nepean.
- Francis-road; Elaine-road; runs south-west from Marcia-avenue, previously Shirley-avenue, to Tasman-drive, lodged plan 42209, Parish of Nepean.
- Franklin-street; Kennedy-street; runs south from William-road to Garden-street, lodged plans 1445, 26139, 52025, 14770, 26139, 160, Parish of Nepean.
- George-street; Richard-street; runs south-east off St. Pauls-road, lodged plan 2290, Parish of Nepean, part Crown allotment 77.
- Gavan-street; Judge-street; runs east off Campbells-road forming southern boundaries of lots 29, 30 and part 31 and northern boundaries of lots 28 and 33.
- Government-road; French-street; runs south off Melbourne-road to Sanitary Reserve, lodged plan 60358, Parish of Nepean.
- Grange-road; Becket-street; the westerly continuation of Becket-street to Canterbury Jetty-road, lodged plans 34524, 34523, 41472, Parish of Nepean.
- Heather-street; Bruce-street; runs west off Gray-street to Marcia-avenue, lodged plans 44559, 44560, Parish of Nepean.
- Hilltop-avenue; Ritchie-avenue; runs south-east off Dana-avenue, forming south-west boundaries of lots 1989, 1990-1997, lodged plan 43380, lots 2232-2223, lodged plan 43382, lots 11-2, lodged plan 25073 and north-east boundaries of lots 1998, lodged plan 43380, lots 12-23, lodged plan 25073, Parish of Nepean.
- Koonya-grove; McMahon-street; runs south-west off Samuel-street to Ocean Reserve, lodged plan 17893, Parish of Nepean.
- Latham-court; Lambert-court; runs west off Canterbury Jetty-road, lodged plans 60289, 57394, Parish of Nepean.
- Lind-avenue; Molloy-street; runs east off Lucien-road forming northern boundaries of lots 45-49, lodged plan 51350 and southern boundaries of lot 34, lodged plan 42667 and lot 18, lodged plan 42666, Parish of Nepean.
- Lucien-road; Moody-street; runs east off Dunham-street forming northern boundaries of lots 59-61, lodged plan 32757 and 11-13, lodged plan 51349, and southern boundaries of lots 62, lodged plan 32757 and 10, lodged plan 42395, Parish of Nepean, part Crown allotment 8.
- Lawes-street; Court-street; runs south-west from Garden-street to Lansdowne-street, lodged plans 30058, 30059, Parish of Nepean.
- Martin-street; Doe-street; runs north from Melbourne-road to Becket-street, lodged plans 41471, 41472, 41473 and 41474, Parish of Nepean.
- Mendes-parade; Erlandsen-avenue; south-west continuation of the existing Erlandsen-avenue, Parish of Nepean.
- Morgan-avenue; Albert-avenue; runs west off Neville-drive to Michael-street, lodged plans 41888, 51858, 51405, 57878, Parish of Nepean.
- Nepean-grove; Ossett-street; south-west continuation of Ossett-street to the Ocean Reserve, Parish of Nepean.
- Nepean-avenue; Farnsworth-avenue; runs east off Back Beach-road forming northern boundaries lots 1-4, lodged plan 57957 and southern boundaries lots 5-6, lodged plan 57957, Parish of Nepean.
- Ocean-avenue; Foam-avenue; runs south-west off Melbourne-road to the Ocean Beach Reserve, lodged plan 11454, Parish of Nepean.
- Ocean-drive; Tasman-drive; runs south-east from Canterbury Jetty-road to Browns-road, Parish of Nepean.
- Ocean-street; Sullivan-street; runs from Park-road to the Ocean Reserve, lodged plans 206, 9578, 73226, Parish of Nepean.
- Ocean Amphitheatre-road; Ocean Beach-road; runs from Nepean Highway to the Ocean Reserve, Parish of Nepean.
- Omar-court; Clematis-court; runs north off Landra-street, lodged plan 50973, Parish of Nepean.
- Peter-court; Peta-court; runs north-east off Archer-street, lodged plan 31239, Parish of Nepean.
- Patricia-street; Gladwell-street; runs west off Felecia-street to Pasadena-street, lodged plans 50977, 50978, Parish of Nepean.
- Petrel-avenue; Tallant-avenue; the continuation of Tallant-avenue running south-west off Rosetta-avenue, forming north-west boundaries of lots 39-43, lodged plan 50772 and south-east boundaries of lots 89-94, lodged plan 11774, Parish of Nepean.
- Phyllis-street; Edward-street; runs west off Dunham-street to Neville-drive, lodged plan 43068, Parish of Nepean.
- Proposch-street/Adelaide-street; Adelaide-street; runs south off Nepean Highway to Garden-street, Parish of Nepean.
- Shirley-grove; Samuel-street; runs north-west off Spray Point-road forming the continuation of the existing Samuel-street, lodged plan 17893, Parish of Nepean.
- Shirley-avenue; Marcia-avenue, runs east from Canterbury Jetty-road to Tasman-drive, part Crown allotment 14, Parish of Nepean.
- Stephen-street; Dark-parade; south-west continuation of Dark-parade to Watson-street, lodged plans 206, 34647, 43889, 71677, Parish of Nepean.
- St. Pauls-avenue; Diamond Bay-road; runs south-west off Melbourne-road to the Ocean Reserve, lodged plans 4612, 54892, Parish of Nepean.
- Tallant-avenue; Rosetta-avenue; north-west continuation of Rosetta-avenue to Westmore-avenue, lodged plan 11774, Parish of Nepean, north-east boundary lots 94-98, south-west boundary lot 99 and lot 1, lodged plan 56527.
- Tallant-avenue; Vision-avenue; north-west continuation of Vision-avenue to Westmore-avenue, south-west boundary lots 106-111, lodged plan 11774, and north-east boundary lots 105, 112, lodged plan 11774, Parish of Nepean.
- Watts-road; Ruth-street; runs north-east off Nepean Highway, part Crown allotment 6, section 2, Township of Sorrento, Parish of Nepean.
- Watts-street; Killarney-street; runs west off Murray-street to Canterbury Jetty-road, lodged plan 72743, Parish of Nepean.
- William-street; Armott-street; runs north-west off Ivanhoe-street to Waverly-street, lodged plan 4612, Parish of Nepean.
- William-street; Austin-avenue; runs south-east off Hotham-road to the Esplanade, lodged plans 20772, 60506, Parish of Nepean.
- William-street; Coker-crescent; runs east from Crown-avenue, forming south boundary of lots 1 and 3, lodged plan 34987 and lot 2, lodged plan 47466, part Crown allotment 151, Parish of Nepean.
- William-street; Cooper-grove; runs east off Nepean Highway to Austin-avenue, lodged plans 63499, 20772, Parish of Nepean.
- William-street; Croad-street; runs east off Hemston-avenue to Hurstwood-road, lodged plan 155, Parish of Nepean.
- William-street; Dickson-lane; runs north off Nepean Highway to Port Phillip Bay, lodged plans 23280, 34357, 55659, part Crown allotment 137, Parish of Nepean.
- William-street; Dunes; forming south-west boundary lots 11-13, section D, lodged plan 200, Parish of Nepean.
- William-street; Dorell-lane; runs north off Nepean Highway to Port Phillip Bay, lodged plans 41289, 37794.
- William-street; Hayes-avenue; runs south-east off Kerferd-avenue, lodged plan 5952, Township of Sorrento, Parish of Nepean.
- William-street; Leggett Way; runs east off Nepean Highway, lodged plan 66826, part Crown allotment 65A, Parish of Nepean.
- William-street; Primrose-lane; runs south-east off Park-road, forming north-east boundary lots 1-4, lodged plan 51703, south-west boundary lots 15-19, lodged plan 206, lot 2, lodged plan 58544, and lot 4, lodged plan 61080, Parish of Nepean.
- William-street; Riley-grove; runs north-west off Lentell-avenue, forming north-east boundary lots 47, lodged plan 2369, and west boundary lots 1-2, lodged plan 15343, lots 4-5, lodged plan 35931, lot 42, lodged plan 2369, Parish of Nepean.
- William-street; Stewart-street; runs south-west off Grange-road, part Crown allotment 2, section 2, Township of Sorrento, Parish of Nepean.
- William-street; Tayton-street; runs south off Nepean Highway to Relph-avenue, lodged plans 3133, 11573, Parish of Nepean.
- William-street; The Cutting; runs north off Nepean Highway to Port Phillip Bay, forming west boundary lots 2-3, lodged plan 31543, and east boundary lots 1-2, lodged plan 56465, lot 1, lodged plan 13637, Parish of Nepean.
- William-street; Watts-road; runs north-east off Nepean Highway, part Crown allotment 6, section 2, Township of Sorrento, Parish of Nepean.
- William-street; Weeroona-avenue; runs north off Nepean Highway, lodged plan 43325, part Crown allotment 149, Parish of Nepean.

Drainage Areas Act 1958.

SHIRE OF GOULBURN.

NOTICE is hereby given in accordance with section 5, sub-section (4) of the above Act, that the petition to constitute certain lands within the Parishes of Bailleston and Noorilim a Drainage Area within the meaning of the above Act is open for inspection at the Shire Office, Nagambie, from 21st December, 1967, until 18th February, 1968.

The plan of the proposed area, together with the Local Government Department's Report will also be open for examination during the period specified between the hours of 9 a.m. to 5 p.m., holidays excepted.

Any person may inspect the documents and within 28 days from 18th February, 1968, lodge a counter petition or objection to the proposal.

H. R. LOMAX, Shire Secretary.

Shire Office, Nagambie, 8th December, 1967. 509

SHIRE OF HASTINGS.

ORDER CHANGING NAME OF STREET.

IN accordance with the powers conferred by the *Local Government Act 1958*, 15th Schedule, the Council of the Shire of Hastings has made an Order changing the names of streets within the municipality.

Old Name—Government-road.

New Name—Colin-parade.

Location—The road running in a general east-west direction being south of allotments 2, 3, 4, 5, 6. Section 2, the Recreation Reserve, allotments 17 and 16. Section 3 and allotments 6 and 7, Section 10, Township of Morradoo (Crib Point).

Old Name—Morrington—Merricks road.

New Name—Tubbarubba-road.

Location—The road between the Bittern—Dromana road at Fenton Hall and Balnarring-road at Foxey's Hangout.

528 L. A. WALKER, Shire Secretary.

SHIRE OF HEYTESBURY.

LOAN No. 23.

Notice of Intention to Borrow the Sum of \$100,000 for Permanent Works and Undertakings.

NOTICE is hereby given that the Council of the Shire of Heytesbury proposes to borrow the principal sum of \$100,000 secured by a charge over the general rates of the municipality; such sum to be raised by the grant of a mortgage in accordance with the provisions of the *Local Government Act 1958*.

1. The maximum rate of interest to be paid is 5½ per centum per annum.

2. The purpose for which the loan is to be applied is the construction of a Public Hall in the Township of Timboon.

3. The period of the loan shall be 40 years 2 months.

4. The loan shall be liquidated by the establishment and accumulation of a sinking fund, pursuant to the provisions of section 428A of the *Local Government Act 1958*, by provision out of the Municipal Fund of an amount of \$934.32 each year, during the period of the loan.

5. Interest shall be payable to the Local Authorities Superannuation Board, Melbourne on the 1st days of June and December in each year during the period of the loan. The first interest payment shall be made on the 1st day of June, 1968.

6. Such moneys borrowed shall be repayable to the Local Authorities Superannuation Board at Melbourne.

The plans and specifications and the estimate of the cost of the proposed works and a statement showing the proposed expenditure of the moneys to be borrowed are open for inspection at the Municipal Offices, Cobden. Dated this 14th day of December, 1967.

523 P. J. NORTHEAST, Shire Secretary.

SHIRE OF KANIVA.

BY-LAW No. 20.

A By-Law of the Shire of Kaniva made under the *Health Act 1958* and numbered 20 for the purpose of prescribing the fees to be charged for the registration of premises and for the renewal and transfer of registration thereof.

THE President, Councillors and Ratepayers of the Shire of Kaniva, in pursuance of the powers conferred by the *Health Act 1958* and every other power enabling it in that behalf, does hereby order as follows:—

1. That By-Law No. 14 of the Shire of Kaniva is hereby repealed, provided that such repeal shall not prejudice or affect any right accrued or liability incurred prior to the commencement of this By-Law.

2. The fees to be charged, received and taken by the Council of the Shire of Kaniva for the registration or the renewal or transfer of the registration of premises, pursuant to the provisions of the *Health Act 1958*, shall be as set out in the Schedule hereto.

3. Where application for the renewal of registration is not lodged with the Council until after the last day fixed for the lodging thereof, an additional fee equal to one-half of the relevant prescribed fee otherwise payable for renewal of registration shall be paid.

4. Such fees shall be paid to the Shire Secretary by any person making application for such registration, renewal or transfer, respectively.

5. This By-Law shall apply to and have force throughout the whole of the municipal district of the Shire of Kaniva and shall come into operation on the day after its publication in the *Victorian Government Gazette*, after the approval of the Commission of Public Health and the Governor in Council has been obtained.

THE SCHEDULE REFERRED TO IN THIS BY-LAW.

(a) For every registration and for every annual renewal of registration of premises:—

Nature of Premises.	Fee Payable.
Offensive trades premises (other than those referred to below)	\$10.00
Offensive trades premises (being fat extracting or melting, or rendering works which are conducted at premises occupied principally as a butcher's shop and at which fat is extracted, melted or rendered only from materials derived from such shop)	2.00
Offensive trades premises being piggeries	2.00
Offensive trades premises being poultry killing or cleaning or dressing premises	2.00
Cattle sale-yards	2.00
Boarding Houses	4.00
Common lodging houses	4.00
Eating houses	4.00
Apartment houses—	
Containing not more than one apartment	2.00
Containing more than one apartment	4.00
Camping areas	4.00
Food Premises—	
(i) Where not more than five persons (including the proprietor and his family) are employed	4.00
(ii) where more than five such persons are employed additional for each person in excess of five	25c
Provided that the maximum fee payable shall be	50.00
Premises at or in any part of which eggs for sale are received or stored for the purpose of being chilled	4.00
(b) For every transfer of registration	25c

Resolution for the passing of this By-Law agreed to by the Council of the Shire of Kaniva on the 15th day of August, 1967, and confirmed on the 19th day of September, 1967.

The common seal of the President, Councillors and Ratepayers of the Shire of Kaniva was hereunto affixed, in the presence of—

(SEAL) R. J. MITCHELL, President.
J. C. GRANT, Councillor.
T. SHEPHERD, Secretary.

Submitted to the Commission of Public Health on the 24th day of October, 1967.—A. T. GARDNER, Secretary, Commission of Public Health.

Approved by the Governor in Council, 21st November, 1967.—J. ROSSITER, Clerk of the Executive Council. 502

Town and Country Planning Act 1961.

SHIRE OF KNOX.—SHIRE OF KNOX PLANNING SCHEME 1965.

NOTICE THAT A PLANNING SCHEME HAS BEEN PREPARED AND IS AVAILABLE FOR INSPECTION.

Amendments Numbers 29, 30 and 31, 1967.

NOTICE is hereby given that the Council of the Shire of Knox in pursuance of its powers under the *Town and Country Planning Act 1961*, has prepared Planning Schemes for portions of the Shire of Knox for the purpose of amending the Principal Scheme by re-zoning part of Crown allotment 38B, lots 1-6 (inclusive) on lodged plan 23323, lots 1-5 (inclusive) and balance of title on lodged plan 18446,

from Stream Residential and Rural to Commercial (Drive-In), part of lot 23 on lodged plan 3761 from Reserved Residential to Existing Public Purposes 2, lot 2 on lodged plan 39246 from Commercial General to Residential (General) and part of Crown allotment 1, section 10, Parish of Narree Worran from Rural to Residential (General) as shown on the maps comprising the Schedules to the schemes.

A copy of each scheme has been deposited at the Office of the Shire of Knox, Spring-street, Fern Tree Gully and at the Office of the Town and Country Planning Board, 179 Queen-street, Melbourne, and will be open for inspection during office hours by any person free of charge.

Any persons affected by the Planning Schemes are required to set forth, in writing, all objections they may have, addressed to the Shire Secretary, Shire of Knox, Spring-street, Fern Tree Gully, on or before the 20th day of January, 1968, for Amendments 29 and 31, and the 20th day of March, 1968, for Amendment number 30, and state whether they wish to be heard in respect of their objections.

564

N. G. HAYNES, Shire Secretary.

SHIRE OF KNOX.

LOAN No. 36.

Notice of Intention to Borrow the Sum of \$19,300 for Permanent Works and Undertakings.

NOTICE is hereby given that the Council of the Shire of Knox in pursuance of powers conferred by the Local Government Acts, intends to borrow the sum of \$19,300 secured by a charge over the general rates of the municipality, such sum to be raised by the grant of a mortgage, in accordance with the said Acts and states:

(a) The amount of principal moneys it is proposed to borrow is \$19,300.

(b) The maximum rate of interest that may be paid is 5½ per cent. per annum.

(c) The period of the loan will be ten years and the time or times at which the moneys borrowed are to be repayable is on the 1st day of March and the 1st day of September in each year, during the currency of the loan, commencing on the 1st day of September, 1968, until the final payment on 1st March, 1978.

(d) The purpose for which the loan is to be applied is for permanent works and undertakings, viz.:-

- (i) Scoresby Recreation Reserve—additional tennis court and fencing \$1,990
- (ii) Wantirna South Recreation Reserve—additional tennis court \$1,700
- (iii) Benedikt Park—toilet block \$1,800
- (iv) Johnson Park—fencing extension \$400
- (v) H. V. Jones Reserve—basketball court .. \$1,500
- (vi) Concrete footpaths, Boronia—Council contribution \$4,000
- (vii) Toilet Block—Boronia Off-street Parking Area \$6,000
- (viii) Pavilion Scoresby Reserve—part cost .. \$1,910

(e) The loan is to be liquidated by half-yearly payments of approximately \$1,283 including principal and interest, payable out of the municipal fund.

(f) The place of repayment will be the E. S. & A. Bank Ltd., 206 Dorset-road, Boronia.

Plans and specifications and an estimate of the cost of such works and undertakings, and a statement showing the proposed expenditure of the money to be borrowed, are open for inspection by ratepayers, during office hours, at the Shire Offices, Fern Tree Gully, for one month after the publication of this Notice.

Dated at Fern Tree Gully this 12th day of December, 1967.

594

N. G. HAYNES, Shire Secretary.

SHIRE OF KORUMBURRA.

ROAD DEVIATION ORDER.

PURSUANT to the provisions of section 522 of the Local Government Act 1958, the Council of the Shire of Korumburra hereby directs that the land in the Parish of Poowong indicated by hatching on the diagram annexed

hereto, which has been purchased, taken or acquired by it shall be a public highway on and from the date of publication of this order in the Government Gazette.

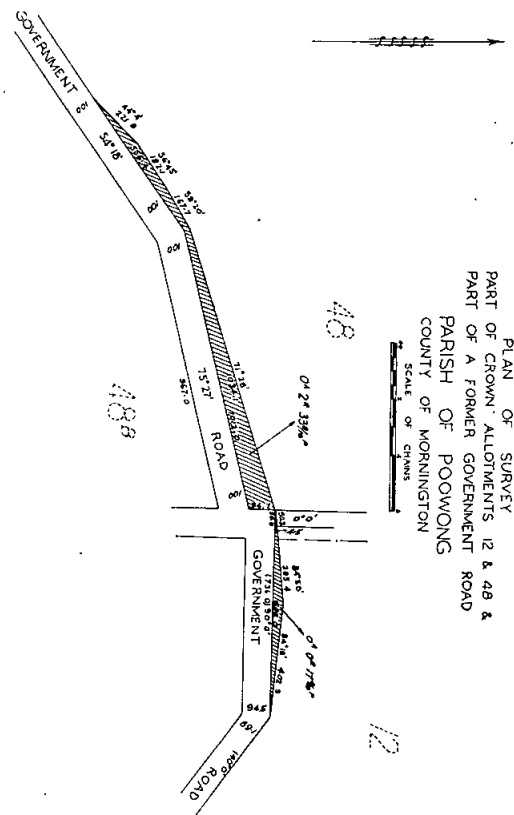

The common seal of the President, Councillors and Ratepayers of the Shire of Korumburra was hereunto affixed—

(SEAL) R. ATTENBOROUGH, President.
J. W. GRUNDY, Councillor.
W. O. CLARK, Secretary.

Dated this 15th day of November, 1967. 515

SHIRE OF McIVOR.

LOAN No. 26.

Notice of Intention to Borrow the Sum of \$23,000 for Permanent Works and Undertakings.

NOTICE is hereby given that it is the intention of the Council of the Shire of McIvor to proceed by Special Order to borrow the sum of \$23,000 by a charge over the General Rates of the Municipality in accordance with the provisions of the Local Government Act 1958, as amended.

1. The maximum rate of interest that may be paid is 5½ per cent. per annum.

2. The purpose for which the loan is to be applied is renovation and extension of Shire Offices and renovation of Mechanics' Institute.

3. The period of the loan shall be fifteen years.

4. The moneys borrowed shall be repaid by providing out of the municipal fund thirty (30) half-yearly instalments of approximately \$1,163.98 each, including interest and principal, the first instalment being repayable on 10th September, 1968.

5. Such moneys shall be repayable at the Commercial Bank of Australia Ltd., Heathcote, or at the Council's banker for the time being in Melbourne.

Plans and specifications and estimates of the cost of such works together with a statement showing the proposed expenditure of the money to be borrowed are open for inspection at the Office of the Council, High-street, Heathcote.

506

D. MAXWELL, Shire Secretary.

SHIRE OF MILDURA.

LOAN No. 47.

Notice of Intention to Borrow the Sum of Forty Thousand Dollars (\$40,000) for Permanent Works and Undertakings.

NOTICE is hereby given that the Council of the Shire of Mildura proposes to borrow the principal sum of Forty thousand dollars (\$40,000), secured by a charge over the general rates of the Municipality, such sum to be raised by the grant of a mortgage in accordance with the provisions of the *Local Government Act 1958*.

(1) The maximum rate of interest that may be paid, is 5½ per centum per annum.

(2) The purpose for which the loan is to be applied is purchase of a heavy duty bulldozer (130-150 horse power).

(3) The period of the loan shall be fifteen (15) years.

(4) The moneys borrowed shall be repayable by providing out of the municipal fund, half-yearly instalments of approximately \$2,024 each, including principal and interest, on the first day of April and the first day of October during the currency of the loan. The first instalment shall be payable on the first day of October in the year One thousand nine hundred and sixty-eight.

(5) Such moneys shall be repayable at the office of the Local Authorities Superannuation Board, Rigby House, 15 Queens-road, Melbourne, or such other place as the Board may require.

(6) The plans and specifications and the estimate of the cost of the proposed works and the statement showing the proposed expenditure of the moneys to be borrowed, are open for inspection at the office of the Council of the Shire of Mildura, at 70 Deakin-avenue, Mildura, during normal office hours.

Dated 13th December, 1967.

526 A. D. HARVEY, Shire Secretary.

SHIRE OF MILDURA.

BY-LAW No. 105.

A By-law of the Shire of Mildura, made under the provisions of the *Local Government Act 1958* and numbered 105, for regulating charges of admission to and the care, protection and management of Quandong Park, Red Cliffs, including Lots 467 and 468, Parish of Mildura and, Kenny Park, within the Township of Merbein (both Parks hereinafter referred to as the "Reserves").

IN pursuance of the powers conferred by the *Local Government Act 1958* and by every other Act or power enabling them in that behalf, the President, Councillors and Ratepayers of the Shire of Mildura, order as follows:—

(1) No person shall use a caravan within the Reserves for a period of more than eighty-four (84) days at any one time, unless with the special consent in writing of the Council and no person shall use a caravan within the Reserves for more than one period of eighty-four (84) days in any one calendar year.

(2) The Council shall have the power to hold entertainments or performances in the Reserves and to make a charge for admission thereto, such charge being that fixed by the Council from time to time, not exceeding One Dollar (\$1.00) for every adult person.

(3) The Council shall have the power to let with or without the payment of a fee, the Reserves, except that portion or those portions set apart as and for the purposes of a caravan park, to any club, association or person, for the purpose of holding entertainments, performances or sports, the fee to be charged for the letting of the Reserves shall be that deemed by the Council to be reasonable and consistent with these regulations and shall not exceed Forty Dollars (\$40.00) for any one day and the Council may authorize such club, association or person to make a charge for admission thereto, such charge not to exceed One Dollar (\$1.00) for each adult person.

(4) Sections 18, 22 and 23 of the By-law No. 97, are hereby repealed.

The resolution for passing this By-law was agreed to by the Council on the Fifth day of October, One thousand nine hundred and sixty-seven, and confirmed on the Second day of November, One thousand nine hundred and sixty-seven.

(SEAL) V. R. HEWETT, President.
A. G. SMART, Councillor.
A. D. HARVEY, Secretary.

Approved by the Governor in Council the 28th day of November, 1967.—J. ROSSITER, Clerk of the Executive Council. 501

SHIRE OF MORNINGTON.

SPECIAL ORDER.

Loan No. 56, \$200,000.

NOTICE is hereby given that the Council of the Shire of Mornington did at its meeting on 21st November, 1967, for which notice of the making of a Special Order for borrowing had been given, agree to the following Resolution, that is to say:—

"That the Council of the Shire of Mornington by Special Order hereby resolves to borrow money by the grant of a mortgage secured on the general rates of the municipality the required particulars whereof are as follows:—

(i) Amount of principal sum to be borrowed—\$200,000.

(ii) Rate of interest—5.875 per cent. per annum, half-yearly rests.

(iii) The money borrowed is to be repaid to the Local Authorities Superannuation Board, 15 Queens-road, Melbourne, or such other place as the said Board may require, in half-yearly instalments on 1st June and 1st January, for a period of fifteen years from 1st January, 1968.

(iv) The money is to be borrowed for the purpose of defraying the cost of the execution of schemes for the construction of private streets, pursuant to Division 10 of Part XIX. of the *Local Government Act 1958* (as amended).

(v) The loan is to be liquidated by the payment of 30 equal half-yearly instalments."

Notice is further given that at a meeting of the said Council held on 19th December, 1967, the above Resolution was confirmed.

524 D. G. COLLINGS, Shire Secretary.

SHIRE OF MORNINGTON.

SPECIAL ORDER.

Loan No. 57, \$100,000.

NOTICE is hereby given that the Council of the Shire of Mornington did at its meeting on 17th October, 1967, for which notice of the making of a Special Order for borrowing had been given, agree to the following Resolution, that is to say:—

"That the Council of the Shire of Mornington by Special Order hereby resolves to borrow money by the grant of a mortgage secured on the general rates of the municipality the required particulars whereof are as follows:—

(i) Amount of principal sum to be borrowed—\$100,000.

(ii) Rate of interest—5.875 per cent. per annum, half-yearly rests.

(iii) The money borrowed is to be repaid to the State Savings Bank of Victoria, 139 Elizabeth-street, Melbourne, in half-yearly instalments on 1st August and 1st February, for a period of fifteen years from 1st February, 1958.

(iv) The money is to be borrowed for the purpose of defraying the cost of the execution of schemes for the construction of private streets, pursuant to Division 10 of Part XIX. of the *Local Government Act 1958* (as amended).

(v) The loan is to be liquidated by the payment of 30 approximately equal half-yearly instalments."

Notice is further given that at a meeting of the said Council held on 21st November, 1967, the above Resolution was confirmed.

525 D. G. COLLINGS, Shire Secretary.

SHIRE OF NEWSTEAD.

LOAN No. 9.

Notice of Intention to Borrow the Sum of \$20,000 for Permanent Works and Undertakings.

NOTICE is hereby given that the Council of the Shire of Newstead proposes to borrow the principal sum of \$20,000 secured by a charge over the general rates of the municipality, such sum to be raised by the grant of a mortgage in accordance with the provisions of the *Local Government Act 1958*.

1. The maximum rate of interest that may be paid is 5½ per cent. per annum.

2. The purpose for which the loan is to be applied is the purchase of roadmaking plant—1 Power Grader.

3. The period of the loan is ten years.

4. The moneys borrowed and interest thereon are to be repayable by twenty half-yearly instalments each of \$1,329 approximately, on the 1st day of April and the 1st day of October, in each year, and the place at which such moneys are to be repayable is the National Bank Savings Bank Limited, 271 Collins-street, Melbourne. The first instalment shall be payable on the 1st day of October, 1968.

5. The loan is to be liquidated by appropriation out of the Municipal Fund.

Plans and specifications and an estimate of the cost of the proposed works and a statement showing the proposed expenditure of the moneys to be borrowed are open for inspection at the Shire Office, Newstead, during office hours.

507

D. H. HUTTON, Shire Secretary.

SHIRE OF ORBOST.

LOAN No. 41.

Notice of Intention to Borrow the Sum of \$40,000 for Permanent Works and Undertakings.

NOTICE is hereby given that the Council of the Shire of Orbost proposes to borrow the sum of forty thousand dollars (\$40,000) secured by a charge on the general rate of the municipality, such sum to be raised by the grant of a mortgage in accordance with the provisions of the *Local Government Act 1958*, and states:—

1. That the amount of principal money it is proposed to borrow is \$40,000.

2. The maximum rate of interest that may be paid is 5.875 per cent. per annum.

3. The period of the loan shall be forty (40) years and the time at which the moneys borrowed shall be repayable is the 1st day of June, 2008. The place of payment will be at the office of the Local Authorities Superannuation Board, 15 Queens-road, Melbourne.

4. The purposes for which the loan is to be applied are the following Permanent Works and Undertakings:—

Completion of erection and furnishing of new Municipal Offices at Orbost (part cost) .. \$40,000

5. (a) The loan is to be liquidated by a half-yearly investment of \$182.55 in a Sinking Fund, bearing interest at not less than 4.5 per cent. compounded, in accordance with section 428A (2) of the *Local Government Act 1958*.

(b) Interest on the principal amount shall be payable half yearly out of the municipal fund. The first payment (pro rata) to be made on 1st June, 1968.

Plans and specifications and estimate of the cost of such works and undertakings, and a statement showing the proposed expenditure of the money to be borrowed, are open for inspection by ratepayers during office hours, at the Shire Office, Orbost, for one month after publication of this notice.

Dated this 13th day of December, 1967.

527

R. G. HEWSON, Shire Secretary.

SHIRE OF ROCHESTER.

LOAN No. 25.

Notice of Intention to Borrow the Sum of \$25,000 for Permanent Works and Undertakings.

NOTICE is hereby given that the Council of the Shire of Rochester proposes to borrow the principal sum of Twenty-five thousand dollars (\$25,000) secured by a charge over the general rates of the municipality, such sum to be raised by the grant of a mortgage in accordance with the provisions of the *Local Government Act 1958*.

1. The maximum rate of interest that may be paid is 5.9/16 per cent. per annum.

2. The purpose for which the loan is to be applied is street construction and drainage in Moore, Elizabeth and Mackay streets, Rochester Township.

3. The period of the loan shall be nine years.

4. The moneys borrowed shall be repayable by providing out of the municipal fund eighteen half-yearly instalments of approximately \$1,784 each, including principal and interest on the 1st day of October and the 1st day of April, during the currency of the loan. The first instalment shall be payable on the 1st day of October, 1968.

5. Such moneys shall be repayable to The Commissioners of the State Savings Bank of Victoria at the office of the said Commissioners, corner Elizabeth and Bourke streets, Melbourne.

The plans and specifications and the estimate of the cost of the proposed works and a statement showing the proposed expenditure of the moneys to be borrowed, are open for inspection at the office of the Council of the Shire of Rochester, at Mackay-street, Rochester.

Dated 12th December, 1967.

503

H. R. WESTCOTT, Shire Secretary.

SHIRE OF ROMSEY.

LOAN No. 27.

TAKE notice that the Council of the Shire of Romsey proposes to borrow on the credit of the President, Councillors and Ratepayers of the said Shire, the sum of Twenty thousand dollars (\$20,000), such sum to be raised by the granting of a mortgage in accordance with the provisions of the *Local Government Act 1958*.

The rate of interest to be paid shall not exceed 5.875 per cent. per annum.

The period of the loan shall be twenty years.

Such moneys shall be repayable by 40 half-yearly instalments of \$856.53 each, including principal and interest, by providing out of the municipal fund such amounts on the 1st day of April and the 1st day of October in each respective year during the currency of the loan. The first instalment shall be repayable on the 1st day of October, 1968.

Such moneys shall be repayable at Melbourne at the National Bank of Australasia Ltd. or at the Council's Bankers for the time being in Melbourne.

The purposes for which the loan is to be applied are:—

Depot Improvements	\$9,000
Drainage Works	\$9,000
Town Planning (Part Cost)	\$2,000

\$20,000

The plans, specifications and estimate of the cost of the works referred to above and a statement showing the proposed expenditure of money to be borrowed are open for inspection at the Shire Office, Romsey.

Dated this 12th day of December, 1967.

591

BRIAN F. CARNE, Shire Secretary.

SHIRE OF ROMSEY.

LOAN No. 28.

TAKE notice that the Council of the Shire of Romsey proposes to borrow on the credit of the President, Councillors and Ratepayers of the said Shire the sum of Eight thousand dollars (\$8,000) such sum to be raised by the granting of a mortgage in accordance with the provisions of the *Local Government Act 1958*.

The rate of interest to be paid shall not exceed 5.5 per centum per annum.

The period of the loan shall be five years.

Such moneys shall be repayable by ten equal half-yearly instalments of \$925.92 each, including principal and interest by providing out of the municipal fund such amounts on the 1st day of April and the 1st day of October, in each respective year during the currency of the loan. The first instalment shall be repayable on the 1st day of October, 1968.

Such moneys shall be repayable at Melbourne at the National Bank of Australasia Ltd., or at the Council's Bankers for the time being at Melbourne.

The purposes for which the loan is to be applied are purchase of road-making machinery—\$8,000.

The plans, specifications and estimate of the cost of the works referred to above and a statement showing the proposed expenditure of money to be borrowed are open for inspection at the Shire Office, Romsey.

Dated this 12th day of December, 1967.

592

BRIAN F. CARNE, Shire Secretary.

SHIRE OF SHEPPARTON.

LOAN No. 77.

Notice of Intention to Borrow the Sum of \$128,000 for Permanent Works and Undertakings pursuant to the Provisions of the "Shepparton Abattoirs Act" 1967.

NOTICE is hereby given that the Council of the Shire of Shepparton proposes to borrow the principal sum of One hundred and twenty-eight thousand dollars secured by a charge over the general rates of the municipality and on the guarantee of the Government of the State of Victoria, such sum to be raised by the grant of a mortgage in accordance with the provisions of the *Local Government Act 1958*.

1. The maximum rate of interest that may be paid is 5.875 per cent. per annum.

2. The purpose for which the loan is to be applied is to pay contractors for reconstruction and enlargement of the Shepparton Abattoir Project.

3. The period of the loan shall be 40 years.

4. The moneys borrowed shall be repayable by providing out of the municipal fund—

(a) payments of interest on the first day of April, 1968, and thereafter half-yearly up to and including the first day of April, 1972.

(b) payments of approximately \$4,171.54 each inclusive of principal and interest on the first day of October, 1972, and thereafter half-yearly during the currency of the loan.

5. Such moneys shall be repayable to The Commissioners of the State Savings Bank of Victoria at the office of the said Commissioners, corner Elizabeth and Bourke streets, Melbourne.

Details of the proposed expenditure of the moneys to be borrowed, which is authorized by the *Shepparton Abattoirs Act 1967*, are open for inspection at the Office of the Council of the Shire of Shepparton, at Nixon-street, Shepparton.

567

J. W. REED, Shire Secretary.

Town and Country Planning Act 1961 (Twelfth Schedule).

SHIRE OF SWAN HILL.—CASTLE DONNINGTON
PLANNING SCHEME.

NOTICE THAT A PLANNING SCHEME HAS BEEN PREPARED AND IS AVAILABLE FOR INSPECTION.

Amendment No. 1.

NOTICE is hereby given that the Council of the Shire of Swan Hill, in pursuance of its powers under the *Town and Country Planning Act 1961*, has prepared a planning scheme for the rural zone of such scheme for the purpose of permitting the establishment of motels in such zone subject to certain conditions.

A copy of the scheme has been deposited at the Shire Office, Beveridge-street, Swan Hill, and at the office of the Town and Country Planning Board, Melbourne, and will be open for inspection during office hours by any person free of charge.

Any persons affected by the planning scheme are required to set forth, in writing, all objections they may have, addressed to the Shire Secretary, Shire Office, Swan Hill, on or before the 20th day of January, 1968, and to state whether they wish to be heard in respect of their objections.

Dated the 5th day of December, 1967.

612

J. D. LAURITZ, Shire Secretary.

SHIRE OF WARRACKNABEAL.

LOAN No. 30.

Notice of Intention to Borrow the Sum of \$15,250 for Permanent Works and Undertakings.

NOTICE is hereby given that the Council of the Shire of Warracknabeal proposes to borrow the principal sum of \$15,250, secured by a charge over the general rates of the municipality, such charge to be raised by the grant of a mortgage, in accordance with the provisions of the *Local Government Act 1958*.

1. The maximum rate of interest that may be paid is 5½ per cent. per annum.

2. The purpose for which the loan is to be applied is—
Drainage Construction, Warracknabeal Township.

3. The period of the loan shall be twenty years.

4. The moneys borrowed shall be repayable by providing out of the municipal fund half-yearly instalments of approximately \$653.10 each, including principal and interest, on the 10th day of March and the 10th day of September, during the currency of the loan. The first instalment shall be payable on the 10th day of September, 1968.

5. Such moneys shall be repayable at the office of the Commercial Savings Bank of Australia Limited, Scott-street, Warracknabeal.

6. The plans and specifications and the estimate of cost of the proposed works, and a statement showing the proposed expenditure of the moneys to be borrowed, are open for inspection at the Shire Office, Scott-street, Warracknabeal.

579

S. FELL, Shire Secretary.

SHIRE OF WARRACKNABEAL.

LOAN No. 29.

Notice of Intention to Borrow the Sum of \$33,750 for Permanent Works and Undertakings.

NOTICE is hereby given that the Council of the Shire of Warracknabeal proposes to borrow the principal sum of \$33,750, secured by a charge over the general rates of the municipality, such charge to be raised by the grant of a mortgage in accordance with the provisions of the *Local Government Act 1958*.

1. The maximum rate of interest that may be paid is 5½ per cent. per annum.

2. The purpose for which the loan is to be applied is drainage construction, Warracknabeal Township.

3. The period of the loan shall be six years.

4. The moneys borrowed shall be repayable by providing out of the municipal fund half-yearly instalments of approximately \$3,340.19 each, including principal and interest on the 10th day of March and the 10th day of September, during the currency of the loan. The first instalment shall be payable on the 10th day of September, 1968.

5. Such moneys shall be repayable at the office of the Commercial Savings Bank of Australia Limited, Scott-street, Warracknabeal.

6. The plans and specifications and the estimate of cost of the proposed works and a statement showing the proposed expenditure of the moneys to be borrowed, are open for inspection at the Shire Office, Scott-street, Warracknabeal.

578

S. FELL, Shire Secretary.

NOTICE OF DISSOLUTION OF PARTNERSHIP.

TAKE notice that the partnership of Doctor Arthur King and Doctor Alan Leslie Nicholson, heretofore conducted at 1010 Sturt-street, Ballarat, was dissolved on the 7th day of December, 1967.

Signed for and on behalf of Dr. Arthur King,

A. L. NICHOLSON.

Signed by the said Dr. Alan Leslie Nicholson,

A. L. NICHOLSON.

Dated this 13th day of December, 1967.

546

NOTICE is hereby given that the partnership heretofore subsisting between Wilfred George Powling and Robert William Powling both of Tesbury carrying on the business of farmers and graziers under the firm name of "W. G. & R. W. Powling" has been dissolved by mutual consent as from the 30th day of September, 1967.

Dated the 14th day of December, 1967.

BUCKLAND & NEVETT, solicitors, Camperdown.

513

Companies Act 1961, Section 254.

SUN VALLEY FEED CO. PTY. LTD.

MEMBERS' VOLUNTARY WINDING UP.

NOTICE is hereby given that at an Extraordinary General Meeting of the members of the above-named company, held on the 13th December, 1967, the following Resolution was passed:—

"That the company be wound up voluntarily, and that Andrew Ian Sinclair be appointed liquidator for the purpose of such winding up, and that the remuneration of Mr. Sinclair be in accordance with the scale of fees laid down by the Institute of Chartered Accountants in Australia."

Dated this 13th day of December, 1967.

A. I. SINCLAIR, Liquidator.

Mann, Judd, Roberts & Co., 249 William-street, Melbourne.

622

A. & S. (HOLDINGS) PROPRIETARY LIMITED.

SPECIAL RESOLUTION TO WIND UP, PURSUANT TO SECTION 254 OF THE COMPANIES ACT 1961.

AT an Extraordinary General Meeting of the above-named company, duly convened and held at 521 Burke-road, Hawthorn East, on the 14th day of December, 1967, the following Resolution was duly passed as a Special Resolution:—

(a) "That the company be wound up voluntarily.

(b) That Howard John Hinde, having consented to act, be and is hereby appointed liquidator, and that he be remunerated at the rates recommended by the Institute of Chartered Accountants in Australia for special and investigation work."

Dated this 14th day of December, 1967.

624

H. J. HINDE, Liquidator.

The Companies Act 1961.—In the matter of MALVERN COLOUR CENTRE PROPRIETARY LIMITED (in Liquidation).

NOTICE is hereby given that a Fourth and Final Dividend is intended to be declared in this matter. Creditors who have not proved their debts by the 4th day of January, 1968, will be excluded from the dividend.

Dated this 14th day of December, 1967.

A. M. HORSBURGH, Liquidator.

Kennedy, Small & Middlemiss, 296 Little Lonsdale-street, Melbourne, 3000. 583

The Companies Act 1961.—In the matter of HILLSTAN FROZEN FOODS PROPRIETARY LIMITED (in Liquidation).

NOTICE is hereby given that a First and Final Dividend is intended to be declared in this matter. Creditors who have not proved their debts by the 4th day of January, 1968, will be excluded from the dividend.

Dated this 14th day of December, 1967.

E. R. SMAIL, Liquidator.

Kennedy, Small & Middlemiss, 296 Little Lonsdale-street, Melbourne, 3000. 584

In the matter of the Co-operative Housing Societies Act 1958 and the Companies Act 1961, and in the matter of DENDY CO-OPERATIVE HOUSING SOCIETY LIMITED (in Liquidation).—Notice to Creditors.

NOTICE is hereby given that all persons having any claim against the above society are required, on or before the 31st day of January, 1968, to send their names and addresses and particulars of their debts or claims to Clive Thornton White the liquidator of the said society, at his office and if so required, by notice in writing from the said liquidator are personally, or by their solicitors, to come in and prove their said debts or claims at such time and place as shall be specified in such notice; or, in default thereof, they shall be excluded from the benefit of any distribution made before such debts or claims are so lodged or proved.

Dated at Brighton, this 14th day of December, 1967.

550

C. T. WHITE, Liquidator.

The Companies Act 1961.—In the matter of BETTA BUILT HOMES PTY. LTD. (in Liquidation).

NOTICE is hereby given that pursuant to section 272 of the Companies Act a Final Meeting of the creditors of the above company will be held at the offices of Bent & Cogle, on Thursday, 25th January, 1968, at 9.30 a.m.

Business.—To receive the Liquidator's accounts.

Dated this 12th day of December, 1967.

E. T. BENT, Liquidator.

Bent & Cogle, public accountants, Suite 18, 545 St. Kilda-road, Melbourne, 3004. 512

DENDY CO-OPERATIVE HOUSING SOCIETY LIMITED (IN LIQUIDATION).

SPECIAL RESOLUTION.

Passed 14th December, 1967.

AT a Special General Meeting of the above-named society duly convened and held at 381-383 Bay-street, North Brighton, on the 14th day of December, 1967, at 8 p.m. the subjoined Special Resolution was duly passed:—

"That the society having successfully completed its objectives sixteen (16) months ahead of its expected term be wound up voluntarily, and that Clive Thornton White, Secretary, of 381-383 Bay-street, North Brighton, be appointed liquidator for the purposes of the winding up."

K. J. SCADDAN, Chairman of Meeting.
C. T. WHITE, Secretary.

549

In the matter of the Companies Act 1961 and in the matter of BENDIGO ROYAL PRINCESS THEATRE CO. PTY. LTD.—Notice of Passing of Resolution for Voluntary Winding Up.

NOTICE is hereby given that at an Extraordinary General Meeting of the above-named company, duly convened and held at 18 View-street, Bendigo, on Monday, 11th December, 1967, the following Special Resolutions were duly passed:—

1. That the company be wound up voluntarily.

2. That Byron Sydney Andrew be appointed liquidator for the purpose of winding up and is hereby authorized to divide all the assets of the company among the members of the company in proportion to number of shares held.

Dated this 11th day of December, 1967.

619

A. V. GRAY, Chairman.

No. 96.—11334/67.—6

Companies Act 1961.

CONSOLIDATED THEATRES LIMITED.

AT an Extraordinary General Meeting of the above-named company duly convened and held at the registered office of the company, 5th Floor, E.Z. Building, 390 Lonsdale-street, Melbourne, Victoria, 3000, on the fifteenth day of December, 1967, the following Resolution was duly passed:—

1. That it is hereby resolved pursuant to section 254 of the Companies Act 1961 that the company be wound up voluntarily.

2. That John Royden Ballantyne, a registered liquidator and a director of the company be and he is hereby appointed liquidator for the purpose of winding up the affairs and distributing the assets of the company.

3. That the remuneration of the liquidator shall be in accordance with the scale recommended by the Institute of Chartered Accountants upon a time basis.

Dated this 15th day of December, 1967.

580

J. R. BALLANTYNE, Chairman.

NOTICE OF RESOLUTION.

FLOR LYFE PROPRIETARY LIMITED hereby gives notice that a meeting of creditors of Flor Lyfe Pty. Ltd., duly convened and held at 312 Pascoe Vale-road, Essendon, on the 8th day of December, 1967, the Special Resolution set out below was duly passed:—

"It was resolved that the company should be placed into liquidation as a creditors' voluntary winding up under the provisions of section 260 of the Companies Act."

"It was further resolved that Alan Bruce McMullin be appointed liquidator."

Dated this 15th day of December, 1967.

A. B. McMULLIN, Liquidator.

In accordance with Regulation 56 of the Companies Act 1961, I hereby give notice that all creditors of Flor Lyfe Pty. Ltd., should forward Statutory Declaration as to Proof of Debt Forms to 39 Little Collins-street, Melbourne, by 31st January, 1968.

Dated this 15th day of December, 1967.

537

A. B. McMULLIN, Liquidator.

A. & S. BUILDERS (VIC.) PROPRIETARY LIMITED.
SPECIAL RESOLUTION TO WIND UP, PURSUANT TO SECTION 254 OF THE COMPANIES ACT 1961.

AT an Extraordinary General Meeting of the above-named company, duly convened and held at 521 Burke-road, Hawthorn East, on the 14th day of December, 1967, the following Resolution was duly passed as a Special Resolution:—

(a) "That the company be wound up voluntarily.

(b) That Howard John Hinde, having consented to act, be and is hereby appointed liquidator, and that he be remunerated at the rates recommended by the Institute of Chartered Accountants in Australia for special and investigation work."

Dated this 14th day of December, 1967.

625

H. J. HINDE, Liquidator.

In the Supreme Court of Victoria.—Co. No. 7458 of 1967.—In the matter of the Companies Act 1961; and in the matter of THE GEELONG ADVERTISER PROPRIETARY LIMITED.

TAKE notice that on 12th December, 1967, it was ordered by the Supreme Court of Victoria that the reduction of capital of The Geelong Advertiser Proprietary Limited, proposed by Special Resolution duly passed at an Extraordinary General Meeting of the said company duly held on 15th May, 1967, at 191-197 Ryrie-street, Geelong, Victoria, be approved and that the capital of the said company be reduced from \$180,000, divided into 90,000 ordinary shares of \$2 each (all of which have been issued and are fully paid) to and should upon the lodging in the office of the Registrar of Companies of a copy of the said order be \$900 divided into 90,000 ordinary shares of 1 cent each (all of which are issued and fully paid).

JOHN McDONALD MORWOOD,

Secretary of The Geelong Advertiser Proprietary Limited.

626

Companies Act 1961.

NEWMARKET SEED & GRAIN PTY. LTD.

NOTICE OF RESOLUTION, PURSUANT TO SECTION 254 (2).

NOTICE is hereby given that at an Extraordinary General Meeting of the above-named company, duly convened and held at 249 William-street, Melbourne, Victoria, on the 8th day of December, 1967, the following Resolution was proposed and passed as a Special Resolution:—

"That the company be wound up voluntarily, and that Mr. Leslie William Edward Charlton be appointed liquidator of the company at a sum to be affixed in accordance with the scale of fees laid down by the Institute of Chartered Accountants in Australia."

620 J. H. SHOOLBRED, Director.

The *Companies Act 1961*.—In the matter of BERWIN PROPRIETARY LIMITED (in Liquidation).

NOTICE is hereby given that a First and Final Dividend is intended to be declared in this matter. Creditors who have not proved their debts by the 11th day of January, 1968, will be excluded from the dividend.

Dated this 21st day of December, 1967.

N. E. STRETTON, Liquidator.

Kennedy, Smail and Middlemiss, 296 Little Lonsdale-street, Melbourne, 3000. 621

OAKLEIGH CO-OPERATIVE HOUSING SOCIETY LIMITED (IN LIQUIDATION).

SPECIAL RESOLUTION.

AT a Special General Meeting of the above-named society duly convened and held at the Library Room (downstairs), Oakleigh Town Hall, Drummond-street, Oakleigh, at 8 p.m., on Thursday, 14th December, 1967, the subjoined Special Resolution was duly passed:—

That the society, having successfully completed its objectives thirteen months ahead of the notional period, be wound up voluntarily and that Ernest Alfred Best Graham, of 63 Atherton-road, Oakleigh, be appointed liquidator for the purposes of the winding up.

Passed 14th December, 1967.

541 E. A. B. GRAHAM, Liquidator.

STRATA DEVELOPMENT PTY. LTD. (IN LIQUIDATION).
PURSUANT TO SECTION 254 (2) (b) OF THE COMPANIES ACT 1961.

AT an Extraordinary General Meeting of the members of Strata Development Pty. Ltd. duly convened and held at 4 Brennan-street, McKinnon on the 11th day of December, 1967, the following Special Resolution was duly passed:—

"That the company, being able to pay its debts in full, be wound up voluntarily forthwith and that Reginald Robert William Fox, whose office is situated at 112 Patterson-road, Moorabbin, be appointed liquidator."

Dated this 14th day of December, 1967.

542 R. R. W. FOX, Liquidator.

Companies Act 1961.

CHROME INVESTMENTS PROPRIETARY LIMITED.

NOTICE is hereby given that at a General Meeting of members of the above-named company duly convened and held at 98 Bourke-street, Melbourne, on the 11th day of December, 1967, the following Special Resolution was duly passed:—

"That the company be wound up voluntarily."

Dated this 11th day of December, 1967.

544 M. B. GREEN, Liquidator.

In the Supreme Court of Victoria (No. Co. 7436 of 1967).—In the matter of the *Companies Act 1961*; and in the matter of DENWELL HOMES PROPRIETARY LIMITED.—Notice of Winding-up Order.

WINDING-UP ORDER made 12th day of December, 1967.

Name and address of liquidator: John Charles Couzens, of 527 Collins-street, Melbourne

JOHN J. CANTWELL & CO., Solicitors for the Petitioner. 603

The Companies Act 1961, Section 272 (1).

A. B. SMITH & SONS PTY. LIMITED (IN LIQUIDATION).

NOTICE is hereby given that a Final Meeting of members and creditors of A. B. Smith & Sons Pty. Limited (in Liquidation), will be held at the registered office of the company, 4th Floor, 403 Bourke-street, Melbourne, on the 24th day of January, 1968, at 11 a.m., for the purpose of laying before the meeting an account showing how the winding up has been conducted and the property of the company has been disposed of, and of giving any explanation thereof.

Dated this 14th day of December, 1967.

E. H. NIEMANN, Liquidator.

Messrs. Hungerford, Spooner & Kirkhope, 44 Queen-street, Melbourne. 547

The Companies Act 1961, Section 272 (1).

LOUISIANA BUILDING ENTERPRISES PTY. LIMITED (IN LIQUIDATION).

NOTICE is hereby given that a Final Meeting of members and creditors of Louisiana Building Enterprises Pty. Limited (in Liquidation), will be held at the registered office of the company, 4th Floor, 403 Bourke-street, Melbourne, on the 24th day of January, 1968, at 11.15 a.m. for the purpose of laying before the meeting an account showing how the winding up has been conducted and the property of the company has been disposed of, and of giving any explanation thereof.

Dated this 14th day of December, 1967.

E. H. NIEMANN, Liquidator.

Messrs. Hungerford, Spooner & Kirkhope, 44 Queen-street, Melbourne. 548

In the matter of the *Companies Act 1961* and in the matter of FEAM PTY. LTD.

NOTICE is hereby given that at an Extraordinary General Meeting of the above-named company, duly convened and held at Melbourne at 12 in the forenoon, on the 14th day of December, 1967, the following Special Resolution was duly passed:—

"That the company be wound up voluntarily and that Gordon Thomas Quinn, of Gordon Quinn & Co., 325 Collins-street, Melbourne, be appointed liquidator for the purposes of such winding up, and that the remuneration of Gordon Thomas Quinn be fixed in accordance with the scale of fees of the Institute of Chartered Accountants."

Dated the 14th day of December, 1967.

608 E. H. MEYER, Chairman.

No. of Company—22559.

In the matter of the *Companies Act 1961* and in the matter of BARWON CLUB HOTEL PROPRIETARY LIMITED.

NOTICE is hereby given pursuant to section 272 of the *Companies Act 1961*, that a General Meeting of the members of the above-named company will be held at 16 James-street, Geelong, on 31st January, 1968, at 3.30 p.m., for the purpose of having an account laid before them showing the manner in which this voluntary winding up has been conducted and the property of the company disposed of and of hearing any explanation that may be given by the liquidator.

Dated this 13th day of December, 1967.

604 R. G. FARROW, Liquidator.

RE FRANCIS ROTHERHAM, late of St. Arnaud, in the State of Victoria, farmer and grazier, DECEASED.

CHARLOTTE THEODORA VICTORIA ROTHERHAM, widow, and Mavis Isabel Simpson, widow, both of St. Arnaud aforesaid, the executors to whom probate of the will of the abovenamed deceased (who died on the 18th day of June, 1967), was granted by the Supreme Court of Victoria, on the 14th day of August, 1967, require all creditors and others having claims against the said deceased or the estate of the said deceased to send to them, care of the undersigned on or before the 13th day of March, 1968, particulars in writing of such claims after which date they intend to convey or distribute the assets of the said deceased to or amongst the persons entitled thereto, having regard only to the claims of which they shall then have had notice.

H. L. DUNKLEY & KELLY, solicitors, 78 Napier-street, St. Arnaud. 600

CREDITORS, next of kin and others having claims in respect of the estate of Richard Harold Jones, late of 141 Marshall-street, Ivanhoe, company director, deceased (who died on the 26th day of May, 1967), are required to send particulars of their claims to the executors, Eileen Grace Jones, and George Thomas Ramsay Wilby, care of the under-mentioned solicitors, by the 26th day of February, 1968, after which date they will distribute the assets, having regard only to the claims of which they then have notice.

MAHONY O'BRIEN & DUGGAN, solicitors, 37 Queen-street, Melbourne. 623

FREDERICK CHARLES TAYLOR, late of 40 Tennyson-street, Sandringham in the State of Victoria, gentleman, DECEASED.

CREDITORS, next of kin and others having claims in respect of the estate of the above-named deceased (who died on the 9th July, 1967), are required by the executrix of the said deceased's will, Doris Nellie Cassie Taberner, of 40 Tennyson-street, Sandringham, widow, to send particulars to her by the 21st February, 1968, after which date the executrix may convey or distribute the assets of the estate, having regard only to the claims of which she may have notice.

KEITH A. NESS & SON, solicitors, 411 Collins-street, Melbourne. 585

CREDITORS, next of kin and others having claims in respect of the estate of Ernest Albert Denman, formerly of 241 Church-street, Richmond, but late of Crombie-road, Lilydale, in the State of Victoria, company director, deceased (who died on the 3rd day of June, 1967), are to send particulars of their claims to the executrix of the will of deceased, Alma Gladys Denman, of Crombie-road, Lilydale, care of the under-mentioned solicitors of 388 Bourke-street, Melbourne, by the 24th day of March, 1968, after which date she will distribute the assets, having regard only to the claims of which she then has notice.

LLOYD P. GOODE & CO., solicitors, 388 Bourke-street, Melbourne. 586

RALPH MITCHELL, late of 518 Murray-road, Preston, in the State of Victoria, retired, DECEASED.

CREDITORS, next of kin and others having claims in respect of the estate of the deceased (who died on the 26th day of January, 1967), are required by the personal representatives, Ralph Mitchell, the younger, of 518 Murray-road, Preston, and Alan Thomas Mitchell, of 8 George-street, Frankston, to send particulars to them by the 28th day of February, 1968, after which date the personal representatives may convey or distribute the assets, having regard only to the claims of which they then have notice.

Dated 15th day of December, 1967.

MARJORY C. COATES, solicitor, 422 Collins-street, Melbourne. 587

ANDRE ARTHUR NAUMANN HERMAN, also known and styled ANDRE HERMAN, formerly of Avoncourt, Avoca-street, South Yarra, but late of 86 Normanby-road, Kew, gentleman, DECEASED.

CREDITORS, next of kin and others having claims in respect of the estate of the deceased (who died on the 22nd December, 1963), are required by Judith Ann Blenkinsop, of Huntly Park, Morawa, Western Australia, married woman, the administrator to whom letters of administration with the will, dated 21st December, 1948, annexed was granted on the 13th July, 1967, to send particulars to her in care of the undersigned solicitor by the 23rd day of February, 1968, after which date the administrator may convey or distribute the assets, having regard only to the claims of which she then has notice.

DUDLEY A. TREGENT, B.A., LL.M., solicitor, of 422 Collins-street, Melbourne. 589

CREDITORS, next of kin and others having claims in respect of the estate of William James Rooney, late of 17 Albion-road, Surrey Hills, gentleman, deceased (who died on the 23rd day of January, 1967), are required to send particulars of their claim to the executors, George Wilfred Munro and Victor Alexander Robinson Chapple, care of the under-mentioned solicitors by the 23rd day of February, 1968, after which date they will distribute the assets, having regard only to the claims of which they then have notice.

KIDDLE, BRIGGS & WILLOX, solicitors, of 400 Collins-street, Melbourne. 590

ANGUS GEORGE MURRAY, late of Telangatuk East, grazier, DECEASED.

CREDITORS, next of kin and others having claims in respect to the estate of the deceased (who died on the 24th day of October, 1966), are required by the personal representatives, John Alexander Murray, of 1 Elm-grove, Brighton, retired, Maxwell Edward Murray, of Telangatuk East, farmer, and Ian David Murray, of 2 Almer-avenue, Nunawading, contractor, to send particulars to them, care of the under-mentioned solicitors, by the 15th March, 1968, after which date the personal representatives may convey or distribute the assets, having regard only to the claims of which they then have notice.

STEWART F. BROWN & PROUDFOOT, Horsham, solicitors for the personal representatives. 597

CREDITORS, next of kin and others having claims against the estate of Jane Barrett, formerly of Bridge-street, Bendigo, but late of Hightt-street, West Richmond, spinster, deceased (who died on the 30th day of May, 1966), are required by the administrator of her estate to send particulars in writing of their claims to Watson James & Rogers, of Bull-street, Bendigo, on or before the 1st day of March, 1968, after which date the said administrator will distribute the assets of the estate, having regard only to the claims of which notice has been received.

WATSON JAMES & ROGERS, solicitors, Bull-street, Bendigo. 551

CREDITORS, next of kin and others having claims against the estate of Albert Keith Secombe, late of 4 Royal-avenue, Bendigo, departmental manager, deceased (who died on the 4th day of May, 1967), are required by the administrator of his estate to send particulars, in writing, of their claims to Watson James & Rogers, of Bull-street, Bendigo, on or before the 1st day of March, 1968, after which date the assets of the estate will be distributed, having regard only to the claims of which notice has been received.

WATSON JAMES & ROGERS, solicitors, Bull-street, Bendigo. 552

CREDITORS, and next of kin having claims against the estate of Charles Edward Holland, formerly of 41 Guilford-road, Surrey Hills, but late of Surrey-road, Warburton, retired tramway engineer, deceased (who died on the 5th September, 1967), are requested to send particulars in writing of such claims to National Trustees, Executors and Agency Company of Australasia Limited, of 95 Queen-street, Melbourne (the executor of the will of the said deceased), on or before the 22nd February, 1968, after which date the said company will distribute the estate to or amongst the persons entitled thereto, having regard only to the claims of which it shall then have had notice.

GERALD E. DELANY & CO., solicitors, of 452 Lonsdale-street, Melbourne. 571

CREDITORS, next of kin and others having claims against the estate of David William Evans, late of 19 Royal-avenue, Glenhuntly, in the State of Victoria, retired railway employee, deceased, are required by the executors, Stella Lacey, of 44 Frederick-street, Caulfield, in the said State, married woman, and Robert John Evans, of 12 Mimosa-road, Carnegie, in the said State, retired, to send particulars of their claim, care of the undersigned, by the 21st day of February, 1968, after which date they will distribute the assets, having regard only to the claims of which they have notice.

JOHN D. MUSTOW & CO., solicitors, 89 Queen-street, Melbourne. 582

RE ROBERT ALEXANDER MARTIN, late of Bowen-street, St. Arnaud, in the State of Victoria, farmer, DECEASED.

AGNES WHITE MARTIN, of St. Arnaud aforesaid, widow, the sole executrix to whom probate of the will of the abovenamed deceased (who died on the 14th day of October, 1967), was granted by the Supreme Court of Victoria, on the 22nd day of November, 1967, requires all creditors and others having claims against the said deceased or the estate of the said deceased to send to her, care of the undersigned on or before the 13th day of March, 1968, particulars in writing of such claims after which date she intends to convey or distribute the assets of the said deceased to or amongst the persons entitled thereto, having regard only to the claims of which she shall then have had notice.

H. L. DUNKLEY & KELLY, solicitors, 78 Napier-street, St. Arnaud. 601

COLIN ISAAC MILLER FROWD, late of 75 Charleston-road, Bendigo, retired agent, DECEASED.

CREDITORS, next of kin and others having claims against the estate of the abovenamed deceased are required by the executor therein, Reginald Arthur Pollard, of Leitchville, welding engineer, to forward particulars thereof to him, care of the under-mentioned solicitors on or before the 20th day of February, 1968, after which date he will distribute the assets of the said estate, having regard only to the claims of which he then has notice.

Dated the 20th day of December, 1967.

HYETT & HYETT, solicitors, 51 Bull-street, Bendigo. 596

THE TRUSTEES, EXECUTORS AND AGENCY COMPANY LIMITED, of 401 Collins-street, Melbourne, the executor of the will of William Pike, late of 50 Bowmore-road, Noble Park, retired farmer, deceased (who died on the 7th day of June, 1967), requests all creditors next of kin and others having claims against the property or estate of the said deceased to send to it the said executor at its afore-mentioned address on or before the 19th day of February, 1968, particulars in writing of such claims after which date the said executor intends to convey or distribute such property or estate to or among the persons entitled thereto, having regard only to the claims of which it shall have had notice.

DARVALL & HAMBLETON, solicitors, 7th Floor, T. & G. Building, 147 Collins-street, Melbourne. 581

BRIAN LAWRENCE MARKS, late of 376 Glenferrie-road, Malvern, medical practitioner, DECEASED (who died on 11th August, 1967).

CREDITORS, next of kin and all other persons having claims against the estate of the deceased, are required by the executors of his will, James Noel Marks, of 9 Haverbrack-avenue, Malvern, solicitor, and Angela Stuart Donaldson Marks, of 376 Glenferrie-road, Malvern, widow, to send particulars thereof to them care of the under-mentioned solicitors before 20th February, 1968, after which date they may distribute the assets of the deceased, having regard only to the claims of which they then have notice.

COLTMAN, WYATT & ANDERSON, solicitors, of 578 Bourke-street, Melbourne. 572

CREDITORS, next of kin and other persons having claims against the estate of Mary Josephin McCaughy, late of Woodleigh Hospital, 10 Collins-street, West Preston, widow, deceased (who died on the 12th day of September, 1967), are to send particulars of their claims to the executor, National Trustees, Executors and Agency Co. of Australasia Limited, of 95 Queen-street, Melbourne, by the 29th day of February, 1968, after which date the company will distribute the assets, having regard only for the claims of which it then has notice.

MAURICE J. BROPHY, O'DEA & CO., of 281 Sydney-road, Coburg, solicitors. 540

RE IDA MARY STEWART, late of Swanwater, in the State of Victoria, widow, DECEASED.

WILLIAM COLIN STEWART, of Swanwater, aforesaid farmer, the sole executor to whom probate of the will of the abovenamed deceased (who died on the 5th day of October, 1967), was granted by the Supreme Court of Victoria, on the 22nd day of November, 1967, requires all creditors and others having claims against the said deceased or the estate of the said deceased to send to him, care of the undersigned on or before the 13th day of March, 1968, particulars in writing of such claims after which date he intends to convey or distribute the assets of the said deceased to or amongst the persons entitled thereto, having regard only to the claims of which he shall then have had notice.

H. L. DUNKLEY & KELLY, solicitors, 78 Napier-street, St. Arnaud. 598

CREDITORS, next of kin and others having claims in respect of the estate of Edward Bill Gowdie, late of 69 Reynard-road Coburg, in the State of Victoria, gentleman, deceased (who died on 21st March, 1967), are to send the particulars of their claims to the executor, Alfred William Graham Harding, in care of Colin Keon-Cohen, 472 Bourke-street, Melbourne, by the 27th February, 1968, after which date he will distribute the assets, having regard only to the claims of which he then has notice.

Dated the 21st December, 1967.

COLIN KEON-COHEN, solicitors, 472 Bourke-street, Melbourne. 613

RE URSULA MARY ANN COOMBE, late of St. Arnaud, in the State of Victoria, widow, DECEASED.

COLIN CHRISTOPHER COOMBE and Graham Thomas Coombe, both of St. Arnaud aforesaid, Flour Mill Employees, the executors to whom probate of the will of the abovenamed deceased (who died on the 2nd of October, 1967), was granted by the Supreme Court of Victoria, on the 22nd day of November, 1967, require all creditors and others having claims against the said deceased, or the estate of the said deceased to send to them, care of the undersigned on or before the 13th day of March, 1968, particulars in writing of such claims after which date they intend to convey or distribute the assets of the said deceased to or amongst the persons entitled thereto, having regard only to the claims of which they shall then have had notice.

H. L. DUNKLEY & KELLY, solicitors, 78 Napier-street, St. Arnaud. 599

CREDITORS, next of kin and others having claims against the estate of Eleanor Rose Grant (sometimes called Rose Eleanor Grant), formerly of 52 Maud-street, North Balwyn, but late of 34 Sweetland-road, Box Hill, married woman, deceased, are required to send particulars of their claims to The Trustees, Executors and Agency Company Limited, of 401 Collins-street, Melbourne, by the 21st February, 1968, after which date it will distribute the assets, having regard only to the claims of which it then has notice.

JOHN D. MUSTOW & CO., solicitors, 89 Queen-street, Melbourne. 588

ROBINA GILCHRIST MCGOWAN, formerly of 30 Brewster-street, Essendon, but late of 101 Mahoneys-road, Forest Hill, spinster, DECEASED.

CREDITORS, next of kin and others having claims in respect of the estate of the deceased (who died on the 8th day of September, 1967), are required by The Perpetual Executors and Trustees Association of Australia Limited, of 100-104 Queen-street, Melbourne, to send particulars of their claims to the said company, by the 21st day of February, 1968, after which date it will convey or distribute the assets, having had regard only to the claims of which the company then has notice.

H. S. W. LAWSON, HUGHES & CO., 357 Little Collins-street, Melbourne, solicitors. 576

KENNETH ERNEST CAMERON, late of Condah, retired farmer, DECEASED.

CREDITORS, next of kin and others having claims in respect of the estate of the deceased (who died on the 5th October, 1967), are required by the executor, Kenneth Norman McLeod, to send particulars of their claims to the executor, care of the under-mentioned solicitors on or before the 28th February, 1968, after which date he will distribute the assets, having regard only to the claims of which they then have notice.

MELVILLE ORTON & LEWIS, solicitors, 66 Thompson-street, Hamilton. 533

RE OLIVER CLAUDE WINES, late of Woodford, in the State of Victoria, retired master baker, DECEASED.

CREDITORS, next of kin and others having claims in respect of the estate of the deceased (who died on the 15th day of October, 1966), are required by the Perpetual Executors and Trustees Association of Australia Limited of 100-104 Queen-street, Melbourne, the executor of and to whom probate of the will of the said deceased was granted by the Supreme Court of the said State on the 18th day of October, 1967, to send particulars of their claims to the said company at its above-mentioned address by the 29th day of February, 1968, after which date it will convey or distribute the assets, having regard only to the claims of which it then has notice.

J. S. TAIT & CO., solicitors, Warrnambool. 534

CREDITORS, next of kin and others having claims against the estate of Charles Roy Wright, formerly of East Shelbourne, but late of 129 Windsor-crescent, Mont Albert, in the State of Victoria, retired council employee, deceased (who died on the 18th day of September, 1967), are required by the executor, Sandhurst and Northern District Trustees Executors and Agency Company Limited, of View-street, Bendigo, to send particulars thereof in writing to it on or before the 1st day of March, 1968, after which date the said company will distribute the assets of the said deceased, having regard only to the claims of which it then has notice.

WATSON JAMES & ROGERS, solicitors, Bull-street, Bendigo. 535

CREDITORS, next of kin and others having claims in respect of the estate of Jean Marie Gowdie, late of 69 Reynard-road, Coburg, in the State of Victoria, pensioner, deceased (who died on 24th February, 1958), are to send the particulars of their claims to the executor, Richard William Gordon Smith, in care of Colin Keon-Cohen, 472 Bourke-street, Melbourne, by the 27th February, 1968, after which date he will distribute the assets, having regard only to the claims of which he then has notice.

Dated the 21st December, 1967.

COLIN KEON-COHEN, solicitors, 472 Bourke-street, Melbourne. 614

LESLIE JAMES MERRYFULL, late of Balmoral, in the State of Victoria, apiarist, DECEASED, intestate.

CREDITORS, next of kin and others having claims in respect of the estate of the deceased (who died on the 11th September, 1967), are required by the administratrix, Florence Lilia Merryfull, of Balmoral aforesaid, widow, to send particulars to her, care of the under-mentioned solicitors, by the 8th March, 1968, after which date she may convey or distribute the assets, having regard only to the claims of which she then has notice.

CAMERON & LOWENSTERN, solicitors, 62 Thompson-street, Hamilton. 605

KENNETH NAGORCKA, late of Tarrington, in the State of Victoria, grazier, DECEASED.

CREDITORS, next of kin and others having claims in respect of the estate of the deceased (who died on the 14th March, 1967), are required by the executors, Olga Elizabeth Nagorcka, formerly of Tarrington aforesaid, but now of 220 Rippon-road, Hamilton, in the said State, widow, and Percy Carl Nagorcka, of Tarrington aforesaid, grazier, to send particulars to them, care of the under-mentioned solicitors, by the 8th March, 1968, after which they may convey or distribute the assets, having regard only to the claims of which they then have notice.

CAMERON & LOWENSTERN, solicitors, 62 Thompson-street, Hamilton. 606

CATHERINE MARGARET McMAHON (usually known as Katherine Margaret McMahon), late of Hamilton, in the State of Victoria, married woman, DECEASED.

CREDITORS, next of kin and others having claims in respect of the estate of the deceased (who died on the 1st July, 1967); are required by the executors, Matthew Lawrence McMahon, of Hamilton aforesaid, retired baker, and Michael John McMahon, of Hamilton aforesaid, baker, to send particulars to them, care of the under-mentioned solicitors, by the 8th March, 1968, after which date they may convey or distribute the assets, having regard only to the claims of which they then have notice.

CAMERON & LOWENSTERN, solicitors, 62 Thompson-street, Hamilton. 607

CREDITORS, next of kin and others having claims in respect of the estate of Leo Peter O'Sullivan, formerly of 2 Park-street, Moonee Ponds, in the State of Victoria, hotelkeeper, but late of "Minora Lodge", Olivers Hill, Frankston, in the said State, retired, deceased (who died on the 16th day of August, 1967), are required to send particulars of their claims to the executor, National Trustees, Executors & Agency Company of Australasia Limited, of 95 Queen-street, Melbourne, in the said State, on or before the 25th day of February, 1968, after which date the executor will distribute the assets of the said estate, having regard only to the claims of which it then has notice.

BRENDAN McGUINNESS & CO., solicitors, 118 Queen-street, Melbourne. 609

CREDITORS, next of kin and others having claims against the estate of Thomas George Hunt, formerly No. V 19365, Bendigo Detention Barracks, Inglewood-street, Golden Square, Bendigo, but late of 31 Neale-street, Bendigo, in the State of Victoria, drainer, deceased (who died on the 6th day of September, 1966), are required by his executor, Myra Emily Hunt, of 31 Neale-street, Bendigo, widow, to send particulars thereof in writing to her, care of Watson James & Rogers, of Bull-street, Bendigo, solicitors, on or before the 1st day of March, 1968, after which date the assets of the said deceased will be distributed, having regard only to the claims of which notice has then been received.

WATSON JAMES & ROGERS, solicitors, Bull-street, Bendigo. 536

RE FRANK GORDON SANDERSON, formerly of Coonoor Bridge and Drysdale, both in the State of Victoria, but late of Coonoor Bridge aforesaid, formerly farmer, but lately retired farmer, DECEASED.

FRANK OSWALD SANDERSON, of Coonoor Bridge aforesaid, farmer, and Roy Joseph Sanderson, of Donald, in the said State, farmer, the executors to whom probate of the will of the abovenamed deceased (who died on the 19th day of April, 1967), was granted by the Supreme Court of Victoria, on the 8th day of June, 1967, require all creditors and others having claims against the said deceased or the estate of the said deceased, to send to them, care of the undersigned, on or before the 13th day of March, 1968, particulars in writing of such claims after which date they intend to convey or distribute the assets of the said deceased to or amongst the persons entitled thereto, having regard only to the claims of which they shall then have had notice.

H. L. DUNKLEY & KELLY, solicitors, 78 Napier-street, St. Arnaud. 602

CREDITORS, next of kin and others having claims in respect of the estate of George Sakkas, late of 11 Oak-avenue, Mentone, in the State of Victoria, labourer, deceased (who died on the 21st January, 1966), are required to send particulars of their claims to Eric Sakkas, care of the under-mentioned solicitor by the 21st February, 1968, after which date he will distribute the assets of the said deceased, having regard only to those claims of which he then has notice.

ROWLAND P. HASSALL, solicitor, 360 South-road, Moorabbin. 514

ALEXANDER WALKER, late of 32 John-street, Pakenham East, gentleman, DECEASED.

CREDITORS, next of kin and others having claims in respect of the estate of the above-named deceased (who died on the sixth day of September, 1967), are required by the executors of the will of the said deceased, Ada Agnes Walker, of 32 John-street, Pakenham East, widow, and Cedric Ronald Lambert, of 46 Reserve-road, Beaumaris, solicitor, to send particulars to them in the care of the under-mentioned solicitors by the eighth day of March, 1968, after which date the said executors may convey or distribute the assets, having regard only to the claims of which they then have notice.

MACPHERSON & KELLEY, solicitors, 264 Lonsdale-street, Dandenong. 531

NOTICE TO CLAIMANTS.

CREDITORS, next of kin and others having claims in respect of the estate of Mary McQueen, late of Cudgewa, married woman, deceased (who died on the 23rd day of August, 1967), are to send particulars of their claims to the executor, Kevin Ellery Carkeek, care of the under-mentioned solicitors on or before the 29th day of February, 1968, after which date the said executor will distribute the assets, having regard only to the claims of which notice has been received.

HOOD & BRAHAM, solicitors, Corryong. 532

HENRY BONFIELD BAYLIS, late of 22 Templeton-street, Euroa, retired grazier, DECEASED.

CREDITORS, next of kin and others having claims in respect of the estate of the deceased (who died on the 14th September, 1967, at Euroa), are required by the executor, The Trustees, Executors and Agency Co. Ltd., of 401 Collins-street, Melbourne, in the said State, to send particulars of their claims to the said company on or before the 20th March, 1968, after which date the executor will distribute the assets, having regard only to the claims of which it then has notice.

F. KIERCE O'LOUGHLIN, solicitor, Euroa. 545

RUTH ELLWOOD ADAMS, late of Swan Hill, in the State of Victoria, widow, DECEASED.

CREDITORS, next of kin and others having claims in respect of the estate of the deceased (who died on the 20th day of December, 1963), are required by the executor, Francis James Adams, of Swan Hill, farmer, to send particulars to him, care of the undersigned, by the 4th day of March, 1968, after which date the executor may convey or distribute the assets, having regard only to the claims of which he then has notice.

Dated this 15th day of December, 1967.

ALEC M. HAYES, solicitor, 148 Campbell-street, Swan Hill. 543

JAMES MARTIN, late of 38 Hazel-grove, Tecoma, in the State of Victoria, gentleman, DECEASED.

CREDITORS, next of kin and others having claims in respect of the estate of the deceased (who died on the 22nd day of October, 1967), are required by The Perpetual Executors and Trustees Association of Australia Limited, of 100-104 Queen-street, Melbourne, to send particulars of their claims to the said company by the 28th day of February, 1968, after which date it will convey or distribute the assets, having had regard only to the claims of which the company then has notice.

L'ESTRANGE & KENNEDY, solicitors, of 291 Bridge-road, Richmond. 553

CREDITORS, next of kin and others having claims in respect of the estate of William Gibson, deceased, late of 283 Upper Heidelberg-road, Ivanhoe, gentleman (who died on the 31st July, 1967) are to send particulars of their claims to the executrix, Joyce Gibson, care of the under-mentioned solicitors, by the 28th day of February, 1968, after which date she will distribute the estate, having regard only to the claims of which she then has notice.

W. A. PRENDERGAST & ROBINSON, solicitors, 406 Lonsdale-street, Melbourne. 570

ADA MAY SIMPSON, late of 47 Redesdale-road, Ivanhoe, widow, DECEASED.

CREDITORS, next of kin and others having claims in respect of the estate of the deceased (who died on the 24th day of September, 1967), are required by The Perpetual Executors and Trustees Association of Australia Limited, of 100-104 Queen-street, Melbourne, to send particulars of their claims to the said company by the 21st day of February, 1968, after which date it will convey or distribute the assets, having had regard only to the claims of which the company then has notice.

H. S. W. LAWSON HUGHES & CO., solicitors, 357 Little Collins-street, Melbourne. 573

VICTORIA MAY MITCHELL, late of 6A Bowen-crescent, Melbourne, widow, DECEASED.

CREDITORS, next of kin and others having claims in respect of the estate of the deceased (who died on the 30th day of July, 1967), are required by The Perpetual Executors and Trustees Association of Australia Limited, of 100-104 Queen-street, Melbourne, to send particulars of their claims to the company by 21st day of February, 1968, after which date it will convey or distribute the assets, having had regard only to the claims of which the company then has notice.

H. S. W. LAWSON HUGHES & CO., solicitors, 357 Little Collins-street, Melbourne. 574

FRANK MITCHELL, late of 6A Bowen-crescent, Melbourne, superannuated Commonwealth public servant, DECEASED.

CREDITORS, next of kin and others having claims in respect of the estate of the deceased (who died on the 13th day of July, 1967), are required by The Perpetual Executors and Trustees Association of Australia Limited, of 100-104 Queen-street, Melbourne, to send particulars of their claims to the said company by the 21st day of February, 1968, after which date it will convey or distribute the assets, having had regard only to the claims of which the company then has notice.

H. S. W. LAWSON HUGHES & CO., solicitors, 357 Little Collins-street, Melbourne. 575

In the Supreme Court of the State of Victoria.
SALE BY THE SHERIFF.

ON Monday, the 5th of February, 1968, at Two-thirty p.m., at the Police Station, Doncaster (unless process be stayed or satisfied):—

All the estate and interest (if any) of Kenneth Roy Studd, refrigeration engineer, of 8 Renshaw-street, East Doncaster, as joint proprietor with Catherine Ann Studd, married woman, of an estate in fee simple in the land described in certificate of title, volume 8253, folio 489, upon which is erected a dwelling house known as No. 8 Renshaw-street, East Doncaster.

Registered mortgage No. A.972669 affects the said estate and interest.

Terms: Cash only.

N. FROGLEY, Sheriff's Officer.

19th December, 1967.

616

IMPOUNDINGS

COLERAINE.—Impounded in Coleraine Pound by Miss L. Cornish from Austral Park.

No. 23. Crossbred weaner, V tip near ear, indistinct green brand on rump

No. 24. Corriedale 2-tooth wether, V tip and front notch off ear, no visible brand

If not claimed and expenses paid to be sold on 23rd December, 1967.

GEO. SPONG,
Poundkeeper.

510—\$2.50

LAKE BENETOOK.—Impounded in Lake Benetook Pound.

3 ewes, cut in back of right ear, no visible brand
3 young unmarked lambs

If not claimed and expenses paid, to be sold on 4th January, 1968.

E. CURTIS,
Poundkeeper.

566—\$1.75

HAMILTON.—Impounded in Hamilton Pound, by City Ranger, from Monivae-street.

1 Corriedale ram, notch near ear, no visible brand

If not claimed and expenses paid, to be sold on 22nd December, 1967.

Impounded from Lewis-street.

1 Jersey heifer, 2 years old, notch near ear, no visible brand

If not claimed and expenses paid, to be sold on 23rd December, 1967.

I. FYFE,
Poundkeeper.

615—\$3

RUTHERGLEN.—Impounded in Rutherglen Shire Pound, from Wahgunyah Riding, by A. J. Prentice.

1 aged ewe, with wether lamb at foot, ewe earmarked double notch right ear, no visible brand, lamb no earmark, no visible brand

If not claimed and expenses paid, to be sold on 6th January, 1968.

ERIC MILLAR,
Poundkeeper.

632—\$2.25

UPWEY.—Impounded in Upwey Pound, on 14th December, 1967, from Engelke-road, Belgrave Heights.

1 black bull calf, no visible brand

Impounded from Pauline-avenue, Tecoma.

1 sheep, no visible brand

If not claimed and expenses paid, to be sold on 2nd January, 1968.

K. McMAHON,
Poundkeeper.

631—\$2.25

Subordinate Legislation Act 1962.

NOTICE OF MAKING OF STATUTORY RULES.

IN pursuance of the provisions of the Subordinate Legislation Act 1962 and the Regulations made thereunder, notice is given of the making of the following statutory rules:—

No.	Motor Boating Act 1961.	Price.
315/1967.	Motor Boating (Shire of Waranga, Lake Cooper) Regulations 1967	10c
	Health Act 1958 (No. 6270).	
316/1967.	Analyses (Health Act) Regulations 1967	10c
	Health Act 1958 (No. 6270).	
317/1967.	Plumbers and Gas-fitters Regulations 1967	25c
	Seeds Act 1958.	
318/1967.	Seeds (French Bean Seed Certification) (Amendment) Regulations 1967	10c
	Health Act 1958.	
319/1967.	Child Minding Centres (Health Act) Amendment Regulations 1967	10c
	Motor Boating Act 1961.	
320/1967.	Motor Boating (Shire of Flinders Speed Restrictions) Regulations 1967	10c

No.	Act	Price.
321/1967.	Racing (Designation of Totalizer Windows No. 2) Regulations 1967	10c
	<i>Nurses Act 1958.</i>	
322/1967.	Nursing Council (Fees) Regulations 1967	10c
	<i>Estate Agents Act 1958.</i>	
323/1967.	Estate Agents (Fees) Rules 1967	10c
	<i>Agricultural Education Act 1958.</i>	
324/1967.	Agricultural Education (Cadets in Training) Regulations 1967	15c
	<i>Agricultural Colleges Act 1958.</i>	
325/1967.	Agricultural Colleges (Cadets in Training) Regulations 1967	15c
	<i>Cadet Surveyors Act 1964.</i>	
326/1967.	Cadet Surveyors (Department of Crown Lands and Survey) Regulations 1967	10c
	<i>Educational Grants Act 1967.</i>	
327/1967.	Educational Grants Regulations 1967	10c
	<i>Masseurs Registration Act 1958.</i>	
328/1967.	Masseurs (Fees) Regulations 1967	10c
	<i>Aboriginal Affairs Act 1967.</i>	
329/1967.	Aboriginal Affairs (General) Regulations 1967	10c
	<i>Workers Compensation Act 1958.</i>	
330/1967.	Workers Compensation Board (Amendment) Regulations 1967	10c
	<i>State Electricity Commission Act 1958.</i>	
331/1967.	State Electricity Commission Falls Creek Tourist Area (Additional Amendment) Regulations 1967	10c
	<i>Town and Country Planning Act 1961.</i>	
332/1967.	Town and Country Planning Board (Staff) Regulations 1964, Amendment No. 23	10c

Copies of these statutory rules may be purchased at the Sale of Publications Section of the Government Printing Office, located at Macarthur-street, Melbourne, C.2. If ordered by mail, remittance should be addressed to "The Government Printer, Box 203, P.O., North Melbourne, N.1.", and should include 5c extra for postage. If a credit account is held at this office, no remittance is required with the mail order.

The annual subscription rate for Statutory Rules (including a Bound Volume) is \$15, payable in advance. The subscription year commences on 1st January.

A. C. BROOKS,
Government Printer.

STATE ACTS, 1966

COPIES of the following Acts of Parliament of Victoria may be obtained at the Government Printing Office, or from any accredited agents, at the price set opposite to each (these prices do not include postage).

The annual subscription for State Acts 1967 et seq. is \$8 payable in advance.

Bound Volumes of State Acts are also available on a subscription basis at \$15 per annum.

No.	Act	Price.
7372.	Education (Council of Adult Education)	\$0.05
7373.	Legal Profession Practice (Amendment)	\$0.05
7374.	Co-operation (Amendment)	\$0.05
7375.	Nurses (Amendment)	\$0.05
7376.	Property Law (Loans to Minors)	\$0.05
7377.	Audit (Amendment)	\$0.08
7378.	Marketing of Primary Products (Tobacco Leaf Marketing Board)	\$0.05
7379.	State Library National Gallery National Museum and Institute of Applied Science (Amendment)	\$0.05
7380.	Reid Murray Acceptance Limited (Scheme of Arrangement)	\$0.12
7381.	Lake Corangamite	\$0.10
7382.	Tobacco Leaf Marketing Board (Appointment of Manager)	\$0.05
7383.	Country Fire Authority (Borrowing Powers)	\$0.05
7384.	Labour and Industry (Sheltered Workshops)	\$0.05
7385.	Wombat Bonuses	\$0.05

No.	Act	Price
7386.	Country Fire Authority (Interstate Fire Brigades)	\$0.05
7387.	Loch Public Hall Trust	\$0.12
7388.	Co-operative Housing Societies (Amendment)	\$0.05
7389.	Fisheries and Game (Amendment)	\$0.08
7390.	Marine Stores and Old Metals (Collectors)	\$0.05
7391.	Companies	\$0.22
7392.	The Constitution Act Amendment	\$0.05
7393.	Vagrancy	\$0.12
7394.	Consolidated Revenue	\$0.05
7395.	Land (Plantation Areas)	\$0.10
7396.	Daylesford Springs Land	\$0.05
7397.	Barley Marketing (Amendment)	\$0.05
7398.	Sheep Dipping (Repeal)	\$0.05
7399.	Grain Elevators (Amendment)	\$0.05
7400.	Seymour Racecourse Land	\$0.05
7401.	Shepparton Abattoirs	\$0.05
7402.	Paisley-Galvin Railway Land Exchange	\$0.08
7403.	Aerial Spraying Control	\$0.12
7404.	Racing (Amendment)	\$0.08
7405.	Summary Offences	\$0.28
7406.	Friendly Societies (Amendment)	\$0.05
7407.	Crimes (Dangerous Driving)	\$0.05
7408.	Medical (Foreign Practitioners Qualification Committee)	\$0.05
7409.	Opticians Registration (Amendment)	\$0.05
7410.	Labour and Industry (Petrol Shops)	\$0.08
7411.	Melbourne and Metropolitan Board of Works (Amendment)	\$0.08
7412.	Carlton (Recreation Ground) Land	\$0.08
7413.	Boilers Inspection (Amendment)	\$0.05
7414.	Warragul and Neerim Railway Lands	\$0.08
7415.	Victoria Institute of Colleges (Council)	\$0.05
7416.	Marketable Securities	\$0.18
7417.	Pensions Supplementation	\$0.20
7418.	Evidence (Medical Evidence)	\$0.05
7419.	Water (Rating by Area)	\$0.05
7420.	County Court (Common Law Jurisdiction)	\$0.05
7421.	State Electricity Commission (Amendment)	\$0.05
7422.	Gas and Fuel Corporation (Borrowing)	\$0.05
7423.	Vegetation and Vine Diseases (Amendment)	\$0.05
7424.	Motor Car	\$0.05
7425.	Estate Agents (Amendment)	\$0.10
7426.	Melbourne University (Chancellorship)	\$0.05
7427.	Tobacco Leaf Industry Stabilization	\$0.15
7428.	Consolidated Revenue	\$0.05
7429.	Lotteries Gaming and Betting	\$0.35
7430.	Stamps (Mortgages)	\$0.05
7431.	Money Lenders (Exemption)	\$0.05
7432.	Protection of Animals	\$0.12
7433.	Marketing of Primary Products (Maize Marketing Board)	\$0.10
7434.	Consolidated Revenue	\$0.10
7435.	Firearms (Competition Weapons)	\$0.10
7436.	Provincial Sewerage Authorities Association of Victoria	\$0.10
7437.	Waterworks Trusts Association of Victoria	\$0.10
7438.	Maffra Lands Exchange	\$0.10
7439.	Trewalla Lands Exchange	\$0.10
7440.	Tattersall Consultations	\$0.10
7441.	Public Authorities (Contributions)	\$0.10
7442.	Racing (Totalizer Percentages)	\$0.10
7443.	Lower Yarra Crossing Authority (Guarantee)	\$0.10
7444.	Stock and Share Brokers (Amendment)	\$0.15
7445.	Moorpanyal Lands Exchange	\$0.10
7446.	North Melbourne Lands	\$0.15
7447.	Marine (Amendment)	\$0.10
7448.	Mildura Irrigation and Water Trusts (Amendment)	\$0.10
7449.	State Accident Insurance Office Land	\$0.10
7450.	Public Account (Bona Vacantia)	\$0.10
7451.	Motor Car (Hospital and Charities Contributions)	\$0.10
7452.	Commonwealth and States Financial Agreement	\$0.15
7453.	State Forests Loan Application	\$0.10
7454.	Water (Amendment)	\$0.15
7455.	Hospitals and Charities (Liability of Patients)	\$0.15
7456.	Sewerage District's (Amendment)	\$0.10
7457.	Limitation of Actions (Notice of Action)	\$0.10
7458.	Long Island Country Club	\$0.10
7459.	Country Roads (Level Crossings) (Amendment)	\$0.10
7460.	Evidence (Foreign Tribunals)	\$0.10
7461.	San Remo Lands	\$0.10
7462.	The Constitution Act Amendment (Conjoint Elections)	\$0.10
7463.	Vermin and Noxious Weeds (Financial)	\$0.10
7464.	Co-operative Housing Societies (Financial)	\$0.10
7465.	Morwell National Park	\$0.10
7466.	Land Tax (Rates)	\$0.10

STATE ACTS 1966—continued.

No.	Price.
7467. Teaching Service (Married Women) ..	\$0.10
7468. Melbourne Cricket Ground (Guarantees) ..	\$0.10
7469. Gaols (Commencement of Sentences) ..	\$0.10
7470. Revocation and Excision of Crown Reservations ..	\$0.15
7471. Soil Conservation and Land Utilization (Advisory Council) ..	\$0.10
7472. Legal Profession Practice (Further Amendment) ..	\$0.10
7473. Forests (Wood Pulp Agreement) ..	\$0.15
7474. Companies (Amendment) ..	\$0.10
7475. Portland Harbor Trust (Railways) ..	\$0.10
7476. Country Fire Authority (Fire Prevention) ..	\$0.10
7477. Victorian Pipelines Commission ..	\$0.15
7478. Bees ..	\$0.15
7479. Milk Board (Amendment) ..	\$0.10
7480. Milk Pasteurization (Amendment) ..	\$0.10
7481. State Insurance (Payments into Court) ..	\$0.10
7482. National Gallery of Victoria ..	\$0.15
7483. Building Societies (Amendment) ..	\$0.10
7484. Firearms (Amendment) ..	\$0.15
7485. Geelong Waterworks and Sewerage (Amendment) ..	\$0.10
7486. Grain Elevators (Further Amendment) ..	\$0.10
7487. Settlement Purchase Leases ..	\$0.10
7488. Appeal Costs Fund (Amendment) ..	\$0.15
7489. Geelong Harbor Trust (Amendment) ..	\$0.30
7490. Health (Amendment) ..	\$0.15
7491. Marketing of Primary Products (Onion Marketing Board) ..	\$0.10
7492. State Coal Mine ..	\$0.10
7493. Horse Breeding (Amendment) ..	\$0.10
7494. Private Agents ..	\$0.30
7495. Local Government ..	\$0.40
7496. Wrongs (Assessment of Damages) ..	\$0.10
7497. Melbourne and Metropolitan Board of Works (Reconstitution) ..	\$0.15
7498. Port Phillip Authority ..	\$0.15
7499. Extractive Industries ..	\$0.35
7500. Stamps ..	\$0.25
7501. Companies (Defaulting Officers) ..	\$0.15
7502. Labour and Industry (Amendment) ..	\$0.15
7503. Juries ..	\$0.10
7504. Public Works Loan Application ..	\$0.15
7505. Commercial Goods Vehicles (Tow Trucks) ..	\$0.10
7506. Motor Car (Trailers) ..	\$0.15
7507. Housing (Commonwealth and State Agreement) ..	\$0.10
7508. Consolidated Revenue ..	\$0.10
7509. Revenue Deficits Funding ..	\$0.10
7510. The Constitution Act Amendment (Postal Voting) ..	\$0.25
7511. Railway Loan Application ..	\$0.15
7512. Inflammable Liquids ..	\$0.25
7513. Water Supply Loan Application ..	\$0.25
7514. Appropriation of Revenue ..	\$1.15

A. C. BROOKS,
Government Printer.

STATE ACTS, 1967

COPIES of the following Acts of Parliament of Victoria may be obtained at the Government Printing Office, or from any accredited agents, at the price set opposite to each (these prices do not include postage).

The annual subscription for State Acts 1967 et seq. is \$8 payable in advance.

Bound Volumes of State Acts are also available on a subscription basis at \$15 per annum.

No.	Price.
7515. New Melbourne Cemetery Lands ..	\$0.10
7516. Country Fire Authority (Prosecutions) ..	\$0.10
7517. Social Welfare (Detention) ..	\$0.10
7518. Zoological Gardens ..	\$0.15
7519. Richmond (South-Eastern Freeway) Lands ..	\$0.10
7520. The Geelong Gas Company's ..	\$0.10
7521. Co-operative Housing Societies (Indemnities) ..	\$0.10
7522. Supreme and County Courts (Sittings) ..	\$0.10
7523. Dandenong Valley Authority (Amendment) ..	\$0.15
7524. State Savings Bank (Amendment) ..	\$0.10
7525. Land (Surf Life Saving Association) ..	\$0.10
7526. Warragul (Public Park) Lands ..	\$0.10

STATE ACTS, 1967—continued.

No.	Price.
7527. Tobacco Leaf Marketing Board (Appointment of Manager) (Amendment) ..	\$0.10
7528. Stock Artificial Breeding (Amendment) ..	\$0.10
7529. Second-hand Dealers (Amendment) ..	\$0.10
7530. Legal Aid (Amendment) ..	\$0.10
7531. Weights and Measures (Amendment) ..	\$0.25
7532. The Constitution Act Amendment (Electoral) ..	\$0.10
7533. Education and Teaching Service (Amendment) ..	\$0.15
7534. Public Officers Salaries and Allowances ..	\$0.10
7535. Railways (State Coal Mine Officers) ..	\$0.10
7536. Public Officers (Long Service Leave) ..	\$0.15
7537. Pipelines (Submerged Lands) ..	\$0.30
7538. Police Regulation (Pensions) ..	\$0.10
7539. Legal Profession Practice (Victoria Law Foundation) ..	\$0.10
7540. Petroleum (Barracouta and Marlin Fields Agreement) ..	\$0.25
7541. Pipelines ..	\$0.25
7542. Local Government (Amendment) ..	\$0.15
7543. Stamps (Amendment) ..	\$0.10
7544. Police Offences (Obscene Publications) ..	\$0.10
7545. Melbourne University (Amendment) ..	\$0.10
7546. Crimes ..	\$0.15
7547. Instruments (Corporate Bodies Contracts) ..	\$0.10
7548. Land (Amendment) ..	\$0.25
7549. Water (Amendment) ..	\$0.10
7550. Dowling Forest Racecourse Lands ..	\$0.15
7551. Strata Titles ..	\$0.40
7552. Revocation and Excision of Crown Reservations ..	\$0.15
7553. Tullamarine Freeway Lands ..	\$0.15
7554. Friendly Societies Investment ..	\$0.10
7555. Victoria Institute of Colleges (Board of Studies) ..	\$0.10

A. C. BROOKS,
Government Printer.

CONTENTS

	PAGE
Acts of Parliament ..	3842
Acts of Parliament on sale at the Government Printing Office ..	3927
Appointments ..	3880
Contracts ..	3872
Country Roads Board ..	3872
Courts ..	3872
Estates of Deceased Persons ..	3871
Government Notices ..	3846
Impoundings ..	3926
Lands ..	3894
Melbourne and Metropolitan Board of Works—Notices ..	3866
Mining ..	3846
Notice of Making of Statutory Rules ..	3926
Orders in Council—	
Acts—Local Government; Gas Regulation; Monash University; Melbourne University; Dairy Products; Railways; Country Roads; Land; Tobacco Leaf Industry Stabilization; Geelong Harbor Trust; Sewerage Districts; Water; Dandenong Valley Authority; Landlord and Tenant; Patriotic Funds; Police Regulation; Licensing; Housing; State Savings Bank; Courts.	3881 et seq
Private Advertisements ..	3903
Private Agents ..	3847
Proclamations ..	3841
Public Service Notices ..	3898
Regulations—	
Acts—Teaching Service ..	3900
Tenders ..	3902
Transport Regulation Board—Public Hearings ..	3860
Waterworks Trusts ..	3878

[3929]



VICTORIA
GOVERNMENT GAZETTE

Published by Authority

[Registered at the General Post Office, Melbourne, for transmission by post as a newspaper.]

No. 971

FRIDAY, DECEMBER 22

[1967

CONTRACTS ACCEPTED

(Series 1967-68.)

PROVISIONS.—MEAT.

CONTRACTS ACCEPTED.—(Series 1967-68.)
PROVISIONS.—MEAT.

No. of Contract.	Particulars of Each Tender Accepted.	Amount.	Name of Contractor.	Charge Against Vote or Fund.	
PROVISIONS—					
Supply of Meat, in such quantities as may be ordered, from 1st February, 1968 to 30th April 1968.					
Schedule No. 1.—Melbourne District—					
2142	Kew Mental Hospital	Rates as per annex	F. Watkins Pty. Ltd. ..	General Expenses 1967-68	
2143	Children's Cottages, Kew	" "	" "		
2144	Pentridge Penal Establishment and "Fairlea" Female Prison, Fairfield	" "	Swift Australian Co. Pty. Ltd.		
2145	"Turana" Youth Training Centre, Royal Park, and Travancore Developmental Centre, Flemington	" "	" "		
2146	"Winlaton" Girls' Training Centre, 186 Springvale-road, Nunawading, and "Allambie", 70 Elgar-road, Burwood	" "	J. H. Cooke Pty. Ltd. ..		
2147	Royal Park Psychiatric Hospital	" "	" "		
Schedule No. 2.—Mont Park, Bundoora, Larundel, Janefield, Gresswell, and Pleasant View, Wood-street, Preston—					
2148	Mont Park District	" "	W. Angliss and Co. (Aust.) Pty. Ltd.		
2149	Preston	" "	" "		
2150	Gresswell Sanatorium	" "	" "		
2151	Schedule No. 3.—SS. Rip and Dredges	" "	" "		
2152	Schedule No. 4.—Teachers' College and Hostels at Grattan-street, 93 Drummond-street, Carlton; 470, 481 and 572 St. Kilda-road, Melbourne; 19 Queen's-road, Melbourne; 152 Toorak-road West, South Yarra; Frank Tate House, 373 Dandenong-road, Armadale; "Redcourt", No. 6, "Larnook", 13, and No. 10A Orrong-road, Armadale; 11 Patterson-street, Hawthorn; 174 Punt-road, Prahran; 221 Burwood-road, Burwood; John Cannon House, 32 Belmont-avenue, Kew, 23 Moule-avenue, Brighton, and Hastings-road, Frankston; and Police Hospital, St. Kilda-road, Melbourne; Mental Hygiene Clinic, 321 Glenferrie-road, Malvern, St. Nicholas Hospital	" "	J. H. Cooke Pty. Ltd. .. W. Angliss and Co. (Aust.) Pty. Ltd.		
2153	Schedule No. 5.—Heatherton Sanatorium, Cheltenham	" "	" "		
2154	Schedule No. 6.—Ararat District	" "	" "		
Schedule No. 7.—Ballarat District—					
2155	Mental Hospital	" "	H. A. Morris		
2156	Teachers' Hostels	" "	" "		
2157	Schedule No. 8.—Beechworth District	" "	E. Spencer		
Schedule No. 9.—Bendigo District—					
2158	Gaol	" "	A. K. Gittins		
2159	Sandhurst Boys' Centre	" "	" "		
2160	Teachers' Hostels	" "	Frank Wade		
2161	Schedule No. 10.—Castlemaine District	" "	McQueen Bros.		
2162	Schedule No. 11.—School of Forestry, Creswick	" "	H. J. Symons Pty. Ltd. ..		
2163	Schedule No. 13.—McLeod Settlement, French Island	" "	L. K. and H. M. Jones ..		
Schedule No. 14.—Geelong District—					
2164	Gaol	" "	Jackson's Corio Meat Packing (1965) Pty. Ltd. W. Angliss and Co. (Aust.) Pty. Ltd.		
2165	Teachers' Hostels	" "	" "		
2166	Schedule No. 15.—Cooriemungie Prison Camp, Heytesbury Forest	" "	Thomas Borthwick and Sons (Aust.) Ltd.		
2167	Schedule No. 17.—Langi Kal Kal Training Centre	" "	H. A. Morris		
2168	Schedule No. 20.—Sale Gaol	" "	R. Schuback		
2169	Schedule No. 21.—Pleasant Creek Special School, Stawell	" "	H. A. Morris		
2170	Schedule No. 22.—Sunbury District	" "	F. Watkins Pty. Ltd. ..		
2171	Schedule No. 23.—Warrnambool District	" "	O'Connor Bros.		
2172	Schedule No. 24.—Hobson Park Hospital, Traralgon	" "	Stoddart Bros.		
2173	Schedule No. 25.—Morwell River Reforestation Prison	" "	Rogers Bros.		
2174	Schedule No. 26.—State Research Farm, Werribee	" "	W. Angliss and Co. (Aust.) Pty. Ltd.		
2175	Schedule No. 27.—Hillside Boys' Home, Wheelers Hill	" "	J. H. Cooke Pty. Ltd. ..		
2176	Schedule No. 28.—Malmsbury Youth Training Centre	" "	R. W. and L. J. Blomeley		

Approved H. E. Bolte, Treasurer—19.12.1967.

SCHEDULE No. 1.—MELBOURNE DISTRICT.

ANNEX TO CONTRACT No. 1967/2142.

F. Watkins Pty. Ltd., 256 Russell-street, Melbourne.

Sub-schedule No. 1.

MEAT FOR MENTAL HOSPITAL, KEW.

Security, \$40.

Fresh Beef—		cents
1. Rolled Roast, boneless (Brisket excluded)	per lb.	35
2. Buttocks	do.	29
3. Shin and Gravy Beef (boneless)	do.	29
4. Corned Beef—Rolled or Round, as ordered, without bone or cartilage	do.	30

SCHEDULE No. 1.—MELBOURNE DISTRICT—continued.

5. Fresh Mutton—(whole sheep) (Kidney fat to be removed)	per lb.	13.5
6. Veal—boned	do.	32
7. Sausages—Mixed	do.	23
8. Sausage Meat	do.	17
9. Kidneys, Ox	do.	32
10. Tripe, Fresh	do.	..
11. Saveloys	per doz.	..
12. Fowls, First quality	per lb.	..
13. Bacon Sides	do.	58
14. Steak, Stewing	do.	..
15. Salad Loaf	do.	30
16. Luncheon Loaf	do.	30
17. Sausage, Beef German	do.	30

SCHEDULE No. 1.—MELBOURNE DISTRICT—continued.

ANNEX TO CONTRACT No. 1967/2143.

F. Watkins Pty. Ltd., 256 Russell-street, Melbourne.

Sub-schedule No. 2.

MEAT FOR CHILDREN'S COTTAGES, KEW.

Security, \$30.

	cents.
1. Fresh Beef—Buttocks per lb.	29
2. Fresh Mutton (whole sheep) (Kidney fat to be removed) do.	22
3. Fresh Mutton—Legs do.	22
4. Sausages, Thin do.	24
5. Kidney—Sheep do.	..
6. Fresh Veal, boneless do.	32
7. Brains, Sheep per set	9
8. Bacon, Sides per lb.	58
9. Fowls, First quality do.	40
10. Fresh Beef, Shin, Gravy, and Stewing do.	29
11. Fresh Mutton Pumped Leg do.	22
12. Fresh Beef, Corned, Rolled, without bone or cartilage do.	30
13. Sausage Meat do.	17
14. Beef Loaf do.	30
15. Fresh Beef, Rolled Roast, Brisket excluded do.	35
16. Beef Luncheon do.	30

ANNEX TO CONTRACT No. 1967/2144.

Swift Australian Co. Pty. Ltd., 37 Ascot Vale-road, Flemington.

Sub-schedule No. 3.

MEAT FOR PENRIDGE PENAL ESTABLISHMENT, COBURG; AND "FAIRLEA" FEMALE PRISON, FAIRFIELD.

Security, \$70.

	cents.
Fresh Beef—	
1. Forequarters per lb.	16.5
2. Minced do.	25
3. Corned Beef—Rolled or round, as ordered, without bone or cartilage do.	34
4. Fresh Mutton (whole sheep) do.	13.5
5. Sausages—Mixed—Thin do.	25
6. Fresh Suet—Kidney do.	10
7. Sausage—Beef, German do.	37
8. Sausage, Mince do.	18
9. Dripping, Beef do.	12
10. Frankfurts do.	30.5
11. Ham Loaf do.	35
12. Fresh Mutton, Legs do.	22
13. Fresh Beef Rolled Roast Boneless—Brisket Excluded do.	33

ANNEX TO CONTRACT No. 1967/2145.

J. H. Cooke Pty. Ltd., 378 Queen's-parade, Clifton Hill.

Sub-schedule No. 4.

MEAT FOR "TURANA" YOUTH TRAINING CENTRE, ROYAL PARK, AND TRAVANCORE DEVELOPMENTAL CENTRE, FLEMINGTON.

Security, \$16.

	cents
1. Fresh Beef—Rolled Roast (Sirloin, per lb. Boneless) do.	52
2. Beef—Corned—Silverside do.	49
Fresh Mutton—	
3. Rib Chops as Cutlets do.	20
4. Legs do.	21
5. Legs (Two-tooth) do.	22
6. Chops—Mid. Loin (Two-tooth) do.	22
7. Chump Chops do.	..
8. Steak—Stewing do.	42
9. Rump do.	48
10. Blade do.	42
11. Minced do.	33
12. Topside do.	47
13. Rissole do.	..
14. Veal—Fillet, boneless do.	52
15. Veal—Legs do.	40
16. Sausages—Mixed do.	26
17. Sausage—Strasburg Pork do.	40
18. Sausage Meat do.	15
19. Ox Kidney do.	33
20. Frankfurts do.	33
21. Rabbits—Fresh do.	32
22. Shanks—Sheep each	..
23. Brains—Sheep per set	6

SCHEDULE No. 1.—MELBOURNE DISTRICT—continued.

ANNEX TO CONTRACT No. 1967/2146.

J. H. Cooke Pty. Ltd., 378 Queen's-parade, Clifton Hill.

Sub-schedule No. 5.

MEAT FOR "WINLATON" GIRLS' TRAINING CENTRE, 186 SPRINGVALE-ROAD, NUNAWADING, AND "ALLAMBIE", 70 ELGAR-ROAD, BURWOOD. Security, \$10.

	cents
1. Fresh Beef—Rolled Roast Sirloin, Boneless per lb.	52
2. Beef—Corned—Silverside do.	50
Mutton, Fresh—	
3. Chump Chops (two-tooth) per lb.	20
4. Legs do.	23
5. Chops—Mid. Loin do.	22
6. Chops—Forequarter do.	18
Steak—	
7. Topside do.	47
8. Rump do.	55
9. Stewing do.	43
10. Minced do.	36
11. Blade do.	44
12. Sausages—Mixed do.	26
13. Sausage Meat do.	14
14. Frys—Lamb do.	24
Veal—	
15. Fillet, Boneless do.	53
16. T-bone do.	50
17. Veal—Leg, Boned do.	42
18. Pork—Pickled (excluding legs) do.	20
19. Pressed Ham Loaf do.	39
20. Tongues—Ox do.	21
21. Dripping—Beef do.	12
22. Brains—Sheep per set	9
23. Sausage—Strasburg, Pork per lb.	40
24. Frankfurts do.	33
25. Rabbits—Fresh do.	32
26. Kidneys—Sheep do.	15
27. " Ox do.	33
28. Sheep Shanks each	4
29. Pork Leg per lb.	55
30. Pork Loin do.	50
31. Lamb Leg do.	34
32. Ham Pressed do.	90
33. Fowls—1st Quality do.	55
34. Fowls—boiling do.	45

ANNEX TO CONTRACT No. 1967/2147.

J. H. Cooke Pty. Ltd., 378 Queen's-parade, Clifton Hill.

Sub-schedule No. 6.

MEAT FOR PSYCHIATRIC HOSPITAL, ROYAL PARK. Security, \$20.

	cents
Fresh Beef—	
1. Rolled Roast, boneless (Brisket excluded) per lb.	..
2. Thick Flank do.	42
3. Fresh Mutton (legs) do.	23
4. Chops—Forequarter do.	18
5. Sausages—Mixed do.	26
6. Sausage—Meat do.	15
7. Saveloys per doz.	..
8. Corned Silverside per lb.	48
9. Sausage—Strasburg do.	40
10. Luncheon Loaf do.	40
11. Kidneys—Ox do.	33
12. Lambs Fry do.	25
13. Mutton—Forequarter do.	11

SCHEDULE No. 2.—MONT PARK AND SANATORIUM GRESSWELL, ETC.

ANNEX TO CONTRACT No. 1967/2148.

W. Angliss and Co. (Aust.) Pty. Ltd., 42 Bourke-street, Melbourne.

Sub-schedule No. 1.

MEAT FOR MONT PARK MENTAL HOSPITAL, ETC. Security, \$70.

	cents
Fresh Beef—	
1. Buttocks per lb.	29½
2. Topside Pieces do.	..
3. Roast do.	..
Beef, Corned—	
4. Rolled or Round, as ordered, without bone or cartilage do.	33
5. Silverside do.	50
Mutton, Fresh—	
6. Carcass or Sides (Kidney fat to be removed) do.	12.375
7. Legs do.	25
Chops—	
8. Forequarter do.	20
9. Loin do.	25
10. Lamb, Loin do.	..
11. Lamb—Carcass do.	25
Steak—	
12. Topside do.	48
13. Stewing do.	43
14. Minced do.	35
15. Buttocks, sliced do.	48

SCHEDULE No. 2.—MONT PARK AND SANATORIUM GRESSWELL, ETC.—*continued.*

	cents
16. Saveloys per doz.	26
17. Sausages—Mixed per lb.	9
18. Shanks—Sheep each	22
19. Tongues—Ox per lb.	9
20. Brains—Sheep per set	33
21. Kidneys, Ox per lb.	35
22. Lamb—Legs do.	25
23. Mutton—Fresh Legs—Pumped do.	34
24. Rabbits—Fresh do.	40
25. Ham Loaf do.	40
26. Veal—Minced do.	50
27. Fillet—Veal do.	38
28. Fowls—First quality do.	45
29. Veal, Diced do.	34
30. Sausage, German, Beef do.	39
31. Beef, Rolled Roast—boneless, (Brisket excluded)	40
32. Sausage—Strasburg Pork do.	30
33. Mutton—Diced do.	25
34. Lambs Fry do.	40
35. Loaf—Savoury do.	51
36. Lamb Cutlets do.	17
37. Sausage Meat do.	

ANNEX TO CONTRACT No. 1967/2149.

W. Angliss and Co. (Aust.) Pty. Ltd., 42 Bourke-street, Melbourne.

Sub-schedule No. 2.

MEAT FOR PLEASANT VIEW RECEIVING HOUSE, WOOD-STREET PRESTON.

	cents
Security, \$10.	
1. Fresh Beef—Sirloin, boneless (Brisket per lb. excluded)	52
2. Corned Beef—Silverside do.	36
3. Fresh Lamb—Legs do.	
4. Chops—	
Lamb—Forequarter do.	
Lamb, Loin—Mid do.	
5. Sausages—Pork do.	26
6. Tongues—Ox do.	22
7. Capons do.	45
8. Suet do.	9
9. Bacon Pieces do.	
10. Bacon Rashers do.	
11. Bacon Rashers do.	
12. Fresh, Legs, two-tooth, pumped Steak—	25
13. Topside do.	
14. Stewing do.	43
15. Minced do.	35
16. Sausage—Strasburg, Pork do.	40
17. Mutton Legs—Boiling do.	
18. Brains—Sheep per set	
19. Frankfurts per doz.	68

ANNEX TO CONTRACT No. 1967/2150.

W. Angliss and Co. (Aust.) Pty. Ltd., 42 Bourke-street, Melbourne.

Sub-schedule No. 3.

MEAT FOR GRESSWELL SANATORIUM.

	cents
Security, \$30.	
1. Fresh Beef—Rolled Roast Sirloin (boneless) per lb.	37
2. Beef—Corned, Silverside do.	50
Lamb—	
3. Fresh, Legs do.	36
4. Chops—Mid. Loin do.	40
5. " Chump do.	30
6. Cutlets do.	40
Pork—	
7. Fresh, Legs do.	55
8. Chops do.	55
9. Pickled do.	35
10. Mutton—Leg Chops do.	26
Veal—	
11. Fresh, Shoulder do.	26
12. Cutlets do.	45
13. Fillet do.	55
Steak—	
14. Rump do.	55
15. Topside do.	49
16. Fillet do.	98
17. Minced do.	35
18. Brains—Sheep per set	9
19. Fowls—First quality per lb.	38
20. Frankfurts do.	35
21. Ham Loaf do.	40
22. " Pressed Leg do.	112
23. Kidneys—Ox do.	33
24. " Sheep do.	30
25. Livers—Lamb do.	25

SCHEDULE No. 2.—MONT PARK AND SANATORIUM GRESSWELL, ETC.—*continued.*

	cents
26. Rabbits—Fresh per lb.	37
27. Sausages—Mixed do.	25
28. " Pork do.	26
29. Sausage Meat do.	17
30. " Strasburg, Pork do.	40
31. Tripe—Fresh do.	13
32. Tongues—Ox do.	22
33. " Sheep do.	18
34. Veal and Pork Loaf—Pressed do.	40
35. Savoury Loaf—Pressed do.	40
36. Ham—Leg, Raw do.	79

SCHEDULE No. 3.—S.S. "Rip" AND DREDGES.

ANNEX TO CONTRACT No. 1967/2151.

W. Angliss and Co. (Aust.) Pty. Ltd., 42 Bourke-street, Melbourne.

Sub-schedule No. 1.

MEAT FOR DELIVERY AT YARRA RIVER WHARVES

Security, \$10.

	cents
1. Fresh Beef—Roast per lb.	37
Beef Corned—	
2. Silverside do.	52
3. Rolled do.	46
Fresh Mutton—	
4. Forequarter do.	19
5. Legs do.	24
Chops—	
6. Forequarter do.	21
7. Loin do.	26
Steak—	
8. Rump do.	55
9. Stewing do.	35
10. Topside do.	47
11. Sausages—Mixed do.	25
12. Tripe—Fresh do.	13
13. Livers—Sheep do.	26
14. Suet—Kidney do.	9
15. Rabbits—Fresh do.	37
16. Ice per cwt.	50

SCHEDULE No. 4.—TEACHERS' COLLEGES, HOSTELS, POLICE HOSPITAL, ETC.

(Delivery at Institutions.)

TEACHERS' COLLEGE AND HOSTELS AT GRATTAN-STREET, 93 DRUMMOND-STREET, CARLTON; 470, 481 AND 572 ST. KILDA ROAD, MELBOURNE; 19 QUEEN'S-ROAD, MELBOURNE; 152 TOORAK-ROAD WEST, SOUTH YARRA; FRANK TATE HOUSE, 373 DANDENONG-ROAD, ARMADALE; "REDCOURT", NO. 6, "LARNOOK", 13 AND NO. 10A ORRONG-ROAD, ARMADALE; 11 PATTERSON-STREET, HAWTHORN; 174 PUNT-ROAD, PRAHRAN; 221 BURWOOD-ROAD, BURWOOD; JOHN CANNON HOUSE, 32 BELMONT-AVENUE, KEW; 23 MOULE-AVENUE, BRIGHTON; AND HASTINGS-ROAD, FRANKSTON; POLICE HOSPITAL, ST. KILDA ROAD, MELBOURNE; MENTAL HYGIENE CLINIC, GLENFERRIE ROAD, MALVERN AND ST. NICHOLAS HOSPITAL.

ANNEX TO CONTRACT No. 1967/2152.

J. H. Cooke Pty. Ltd., 378 Queen's-parade, Clifton Hill.

Sub-schedule No. 1.

MEAT.

	cents
Security, \$30.	
Fresh Beef—	
1. Rolled Prime Ribs, boneless per lb.	40
2. Topside do.	47
3. Sirloin, boneless do.	55
Fresh Mutton—	
4. Legs do.	23
5. Legs, pickled do.	23
6. Sides, Two-tooth do.	13
7. Legs, Two-tooth do.	24
8. Cutlets do.	26
9. Chops, Mid. Loin do.	22
10. Chops, Forequarter do.	20
11. Chops, Chump do.	23
12. Beef—Corned, Silverside do.	50
Veal—	
13. Shoulder boned do.	26
14. Fillet, boneless do.	55
Steak—	
15. Blade do.	43
16. Minced do.	36
17. Stewing do.	42
18. Rump do.	55
19. Fillet do.	96
20. Sausages—Mixed do.	26
21. Sausage—Meat do.	17
22. " Beef, German do.	33
23. " Strasburg do.	40
24. Livers—Sheep do.	25

SCHEDULE No. 4.—TEACHERS' COLLEGES, HOSTELS, POLICE HOSPITAL, ETC.—continued.

	cents
25. Kidneys—Sheep per lb.	15
26. " Ox do.	33
27. Tongues—Ox do.	20
28. Ox Tails do.	18
29. Brains—Sheep per set	9
30. Tripe—Fresh per lb.	12
31. Frankfurts do.	33
32. Bones—Soup do.	2
33. Suet—Kidney do.	5
34. Rabbits—Fresh do.	32
35. Fowls—First quality do.	50
36. Pork—Legs do.	55
37. " Loin do.	45
38. Lamb, legs do.	35
39. Ham, pressed do.	93
40. Dripping do.	12

SCHEDULE No. 5.—HEATHERTON SANATORIUM.

ANNEX TO CONTRACT No. 1967/2153.
W. Angliss and Co. (Aust.) Pty. Ltd., 42 Bourke-street, Melbourne.

Sub-schedule No. 1.

MEAT.			cents
Security, \$10.			
1. Beef, Fresh Roast—Sirloin, Rolled Roast	per lb.	32	
2. " Corned—Silverside do.		50	
Lamb, Fresh—			
3. Legs do.		36	
4. Shoulder, Rolled do.		17	
5. Chops, Mid. Loin do.		40	
6. Chops, Chump do.		40	
7. Chops, Forequarter do.		20	
8. Cutlets do.		40	
Pork, Fresh—			
9. Legs do.		55	
10. Chops do.		55	
11. Minced do.		18	
Veal—			
12. Shoulder, Boned do.		30	
13. Cutlets do.		45	
14. Fillets do.		55	
Steak—			
15. Rump do.		55	
16. Blade do.		43	
17. Topside do.		49	
18. Minced do.		35	
19. Porterhouse do.		55	
20. Fillet do.		98	
21. Mutton, Pumped, Leg do.		25	
22. Tripe—Fresh do.		13	
23. Brains—Sheep per set		9	
24. Lamb's Fry per lb.		25	
25. Tongues—Sheep do.		16	
26. Kidneys—Ox do.		33	
27. " Sheep do.		30	
28. Tails—Ox do.		18	
29. Sausages—Pork do.		25	
30. Sausage Meat do.		17	
31. Frankfurts—Vienna do.		37	
32. Beef, German—Sausage do.		30	
33. Ham—Loaf do.		40	
34. " Pressed, Shoulder do.		85	
35. Rabbits, Fresh do.		39	
36. Dripping—Beef per tin		3.80	

SCHEDULE No. 6.—ARARAT DISTRICT.

ANNEX TO CONTRACT No. 1967/2154.
H. A. Morris, 107 Victoria-street, Ballarat.

Sub-schedule No. 1.

MEAT.			cents
Security, \$60.			
1. Fresh Beef—			
Rolled Roast (Boneless, brisket excluded)	per lb.	26	
2. Buttocks do.		26	
Fresh Mutton—			
3. Kidney fat to be removed do.		14	
4. Chops, Two-tooth do.		15	
5. Corned Beef—Rolled or Round, as ordered, without bone or cartilage do.		26	
6. Kidneys—Ox do.		20	
7. Veal—Filletted do.		25	
8. Sausages—Mixed do.		20	
9. Steak—Minced do.		25	
10. " Rump do.		..	
11. " Porterhouse do.		..	
12. Sausage Meat do.		15	
13. Lambs Fry do.		20	
14. Pie Meat do.		25	
15. Beef Luncheon Loaf do.		20	
16. Saveloys do.		20	
17. Steak—Topside do.		29	

SCHEDULE No. 7.—BALLARAT DISTRICT.

ANNEX TO CONTRACT No. 1967/2155.
H. A. Morris, 107 Victoria-street, Ballarat.

Sub-schedule No. 1.

MEAT FOR MENTAL HOSPITAL.
Security, \$70.

		cents
Fresh Beef—		
1. Buttocks per lb.		26
2. Roast—Rolled (Brisket excluded) do.		..
3. Beef, Corned, Rolled or Round, as ordered, without bone or cartilage do.		25
Mutton, Fresh—		
4. Kidney fat removed (Mental Hospital) do.		13.5
5. Veal—Boned do.		25
6. Sausages—Mixed do.		20
7. Sausage Meat do.		15
8. Kidney—Ox do.		20
9. Saveloys do.		..
10. Sausage, Beef German do.		20
11. Sausage—Strasburg do.		..
12. Salad Luncheon Loaf do.		20
13. Ox—Tongue do.		..
14. Lambs Fry do.		20

ANNEX TO CONTRACT No. 1967/2156.

H. A. Morris, 107 Victoria-street, Ballarat.

Sub-schedule No. 2.

MEAT.

For delivery to Teachers' Hostels as under :—
Gillies-street, Ballarat.

Beaufort House, Beaufort-avenue, Ballarat.
1415 Sturt-street, Ballarat.
130 Victoria-street, Ballarat.
126 Webster-street, Ballarat.

Security, \$10.			cents
1. Fresh Beef—Sirloin, boneless per lb.		39	
2. Beef—Corned, Silverside do.		44	
Fresh Mutton—			
3. Legs do.		20	
4. Forequarter Chops do.		14	
5. Legs, Pickled do.		19	
Two-tooth—			
6. Chump Chops do.		20	
7. Mid. Loin Chops do.		15	
Veal—			
8. Shoulder, Boned do.		30	
9. Fillet, Boneless do.		36	
Steak—			
10. Blade do.		26	
11. Rump do.		52	
12. Minced do.		25	
13. Sausages—Mixed do.		21	
14. Sausage Meat do.		15	
15. Kidneys—Ox do.		20	
16. Frankfurts do.		20	
17. Dripping—Beef do.		8	
18. Shanks—Sheep each		6	
19. Beef Luncheon per lb.		23	
20. Pork, Fresh, Legs do.		50	
21. " " Loin do.		50	

SCHEDULE No. 8.—BEECHWORTH DISTRICT.

ANNEX TO CONTRACT No. 1967/2157.

E. Spencer, Camp-street, Beechworth.

Sub-schedule No. 1.

MEAT.

Security, \$60.			cents
1. Fresh Beef (Gaol) per lb.		34	
2. Corned Beef, Rolled or Round as ordered, without bone or cartilage do.		38	
3. Mutton—Fresh (Kidney fat to be removed for Mental Hospitals) do.		16	
4. Beef Steak—Minced do.		34	
5. Sausage Meat do.		18	
6. Sausages—Mixed do.		23	
7. Veal—Boned do.		34	
8. Steak, Buttock do.		37	
9. Sausage, German do.		36	
10. Kidney—Ox do.		22	
11. Fresh Beef, Rolled Roast, boneless, Brisket excluded do.		..	
12. Steak Minced do.		35	
13. Meat Loaf do.		39	

SCHEDULE No. 9.—BENDIGO DISTRICT.

ANNEX TO CONTRACT No. 1967/2158.

A. K. Gittins, 350 Hargreaves-street, Bendigo.

Sub-schedule No. 1.

MEAT FOR GAOL.
Security, \$10.

		cents
1. Fresh Beef per lb.		26
2. Fresh Mutton do.		14
3. Sausages—Mixed do.		25
4. Mincedmeat do.		16
5. Saveloys do.		25

SCHEDULE No. 9.—BENDIGO DISTRICT—continued.

ANNEX TO CONTRACT No. 1967/2159.

A. K. Gittins, 350 Hargreaves-street, Bendigo.
Sub-schedule No. 2.

MEAT FOR SANDHURST BOYS' CENTRE, BENDIGO.

	Security, \$10.	cents
1. Fresh Beef—Rolled Roast, boneless, brisket excluded, per lb.		39
2. Fresh Beef—Rib Roast do.		39
3. Corned Beef—Rolled or Round, as ordered, without bone or cartilage do.		40
4. Corned Silverside do.		45
5. Fresh Mutton—		
6. Legs do.		20
7. Legs, Boned do.		22
8. Chops, Mid. Loin do.		22
9. Chops, Forequarter do.		22
10. Steak—Rump do.		60
11. Steak, Stewing do.		39
12. " Buttock do.		40
13. Sausages—Mixed do.		25
14. Sausage—Beef, German do.		30
15. Bacon, Rashers, Shoulder do.		78
16. Lamb—Legs do.		35
17. Lamb Chops—Middle Loin do.		39
18. Ham Loaf do.		38
19. Kidney—Ox do.		..
20. Pork, Leg do.		50
21. Pork, Pickled Rolled Shoulder do.		..
22. Saveloys per doz.		..
23. Lambs Fry per lb.		20
24. Minced Meat do.		16

ANNEX TO CONTRACT No. 1967/2160.

Frank Wade, 193 Williamson-street, Bendigo.

Sub-schedule No. 3.

MEAT.

For Teachers' College Hostels as under—
Osborne-street, Pleasant Vale, Bendigo.
"Lancewood," McLaren-street, Bendigo.
"Comersdale," Pantom-street, Golden Square, Bendigo.

	Security, \$10.	cents
1. Fresh Beef—Topside per lb.		65
2. Corned Beef—Rolled or Round, as ordered, without bone or cartilage do.		25
3. Corned Silverside do.		52
4. Fresh Mutton—Carcass do.		10
5. Steak—		
6. Blade—Minced do.		45
7. Chuck do.		45
8. Rump do.		70
9. Sausages—Mixed do.		28
10. Sausage Meat do.		18
11. Livers—Sheep do.		10
12. Veal—Fillet, boneless do.		65
13. Brains—Sheep per set		3
14. Kidneys—Ox per lb.		15
15. Pork—Fresh, Loin do.		55
16. Sausage—Strasburg do.		38
17. Salad Loaf do.		32
18. Bacon, Middle Rashers do.		75

SCHEDULE No. 10.—CASTLEMAINE GAOL.

ANNEX TO CONTRACT No. 1967/2161.

McQueen Brothers, Hargreaves-street, Castlemaine.

Sub-schedule No. 1.

MEAT.

	Security, \$10.	cents
1. Fresh Beef per lb.		24
2. Fresh Mutton do.		16
3. Corned Beef—Rolled or Round, as ordered, without bone or cartilage do.		26
4. Minced Meat—Beef do.		23
5. Sausage Meat do.		16
6. Saveloys per doz.		50

SCHEDULE No. 11.—SCHOOL OF FORESTRY, CRESWICK.

ANNEX TO CONTRACT No. 1967/2162.

H. J. Symons Pty. Ltd., 1015 Macarthur-street, Ballarat

Sub-schedule No. 1.

MEAT.

	Security, \$6.	cents
1. Fresh Beef—		
2. Topside per lb.		55
3. Sirloin, boneless do.		52
4. Corned. Silverside do.		55
5. Mutton—Fresh, sides do.		17
6. Pork—Fresh, leg do.		55

SCHEDULE No. 11.—SCHOOL OF FORESTRY, CRESWICK.—continued.

	cents
Steak—	
6. Stewing do.	50
7. Minced do.	38
8. Sausages—Mixed do.	28
9. Sausage—Beef, German do.	38
10. Kidney—Ox do.	20
11. Liver—Sheep do.	10
12. Saveloys per doz.	40

SCHEDULE No. 13.—MCLEOD SETTLEMENT, FRENCH ISLAND.

ANNEX TO CONTRACT No. 1967/2163.

L. K. and H. M. Jones, Main-street, Lang Lang.

Sub-schedule No. 1.

MEAT.

	Security, \$10.	cents
1. Fresh Beef per lb.		30
2. Mutton do.		20
3. Sausages—Mixed do.		27

SCHEDULE No. 14.—GEELONG DISTRICT.

ANNEX TO CONTRACT No. 1967/2164.

Jacksons Corio Meat Packing (1965) Pty. Ltd., Corio Quay, North Geelong.

Sub-schedule No. 1.

MEAT FOR GAOL.

	Security, \$10.	cents
1. Fresh Beef per lb.		30
2. Corned Beef—Rolled or Round, without bone or cartilage do.		25
3. Fresh Mutton—		
4. Forequarters do.		10
5. Legs do.		20
6. Beef—Minced do.		19
7. Sausages—Mixed do.		23
8. Sausage Meat do.		10

ANNEX TO CONTRACT No. 1967/2165.

W. Angliss and Co. (Aust.) Pty. Ltd., 42 Bourke-street, Melbourne.

Sub-schedule No. 2.

MEAT.

For delivery to Teachers' Hostels as under—
"Lauriston", 23 Aberdeen-street, Geelong.
"Forty-Five", The Esplanade, Western Beach, Geelong.
"Hawthorn", Aberdeen-street, Geelong.
"Ariston", Packington-street, Geelong.
"Warrain", 56 Western Beach, Geelong.

	Security, \$10.	cents
1. Fresh Beef—Sirloin, boneless per lb.		30
2. Corned Beef—Rolled or Round, as ordered, without bone or cartilage do.		30
3. Mutton—		
4. Legs, Two-tooth do.		20
5. Forequarter, boned, rolled, and pickled do.		10
6. Chops, Forequarter do.		12
7. Chops, Cutlets do.		19
8. Steak—		
9. Chuck do.		28
10. Bladebone do.		30
11. Minced do.		19
12. Fillet—Veal do.		15
13. Tongues—Ox do.		15
14. Kidneys—Ox do.		17
15. Sausages—		
16. Mixed, thin do.		23
17. Pork, thick do.		22
18. Sausage—		
19. Pork, German do.		31
20. Mince do.		10
21. Bacon—Shoulder do.		49

SCHEDULE No. 15.—COORIEMUNGLE PRISON CAMP HEYTESBURY FOREST.

ANNEX TO CONTRACT No. 1967/2166.

Thomas Borthwick and Sons (Aust.) Ltd., P.O. Box 150, Portland.

Sub-schedule No. 1.

MEAT.

	Security, \$8.	cents
1. Fresh Beef per lb.		56
2. Corned Beef—Rolled or Round, as ordered, without bone or cartilage do.		40
3. Sausages—Mixed do.		28
4. Sausage Mince do.		20
5. Fresh Mutton do.		17

SCHEDULE No. 17.—LANGI KAL KAL TRAINING CENTRE.

ANNEX TO CONTRACT No. 1967/2167.

H. A. Morris, 105 Victoria-street, Ballarat.

Sub-schedule No. 1.

MEAT.			
Security, \$10.			cents
1. Sausages—Mixed	per lb.	20
2. Fresh Beef—Boneless	do.	33

SCHEDULE No. 20.—SALE GAOL.

ANNEX TO CONTRACT No. 1967/2168.

R. Schuback, 99B Raymond-street, Sale.

Sub-schedule No. 1.

MEAT.			
Security, \$6.			cents
1. Fresh Beef	per lb.	30
Fresh Mutton—			
2. Chops, Forequarter	do.	14
3. Corned Beef—Rolled or Round, as ordered, without bone or cartilage	do.	32
4. Sausage Meat	do.	15

SCHEDULE No. 21.—PLEASANT CREEK SPECIAL SCHOOL, STAWELL.

ANNEX TO CONTRACT No. 1967/2169.

H. A. Morris, 105 Victoria-street, Ballarat

Sub-schedule No. 1.

MEAT.			
Security, \$6.			cents
Steak—			
1. Rump	per lb.	60
2. Stewing (Minced when required)	do.	33
3. Fresh Mutton Forequarter, Rolled	do.	18
4. Chops—Mid-loin	do.	23
5. Sausages—Thin	do.	26
6. Bacon Rashers, Shoulder	do.	75
7. Beef—Corned, Silverside	do.	52
8. Kidney—Ox	do.	26
9. Sausage Meat	do.	18
10. Chops—Leg	do.	28
11. Lambs Fry	do.	23
12. Meat Loaf	do.	26
13. Mutton, Forequarter Chops	do.	..
14. Beef, Rolled Roast, Brisket excluded	do.	40
15. Tongues—Ox	do.	24
16. Mutton Legs—Two-Tooth	do.	26
17. Sausage, Pork, German	do.	40

SCHEDULE No. 22.—SUNBURY DISTRICT.

ANNEX TO CONTRACT No. 1967/2170.

F. Watkins Pty. Ltd., 256 Russell-street, Melbourne.

Sub-schedule No. 1.

MEAT.			
Security, \$80.			cents
Fresh Beef—			
1. Rolled Roast, boneless (brisket excluded)	per lb.
2. Buttocks	do.	29
3. Fresh Mutton—Kidney fat to be removed	do.	13.5	
4. Corned Beef—Rolled or Round, as ordered, without bone or cartilage	do.	30	
5. Sausages—Mixed	do.	24
6. Sausage Meat	do.	15
7. Veal—Boneless	do.	33
8. Sausage, Beef German	do.	27
9. Ox—Kidney	do.	32
10. Steak, Rump	do.	49
11. " Topside	do.	44
12. Lambs Fry	do.	25
13. Beef Luncheon Loaf	do.	30
14. Ham Loaf	do.	40
15. Corned Beef—Silverside	do.	48

SCHEDULE No. 23.—WARRNAMBOOL DISTRICT.

ANNEX TO CONTRACT No. 1967/2171.

O'Connor Bros., Box 313, Warrnambool.

Sub-schedule No. 1.

MEAT.			
Security, \$30.			cents
1. Fresh Beef—Rolled Roast (brisket excluded)	per lb.
2. Corned Beef—Rolled or Round, as ordered	do.	36	
Fresh Mutton—			
3. Forequarters	do.	11
4. Legs	do.	22
5. Chops—Middle Loin	do.	23
Steak—			
6. Stewing	do.	38
7. Minced	do.	33
8. Sausage Meat	do.	18
Sausages—			
9. Beef	do.	24
10. Pork	do.	..
11. Kidneys—Ox	do.	28
12. Steak—Topside	do.	48
13. Corned Silverside	do.	45
14. Sausage, Beef German	do.	35
15. Ham Loaf	do.	45
16. Strasburg Loaf	do.	45
17. Frankfurts	per doz.	..

SCHEDULE No. 24.—HOBSON PARK HOSPITAL, TRARALGON.

ANNEX TO CONTRACT No. 1967/2172.

Stoddart Bros., 77 Franklin-street, Traralgon.

Sub-schedule No. 1.

MEAT.			
Security, \$10.			cents
1. Rolled Prime Ribs, boneless	per lb.	50
2. Thick Flank (Minced when required)	do.	50
3. Steak, Topside	do.	50
4. Corned Silverside	do.	50
5. Fresh Mutton, Legs (pickled, boned, and rolled)	do.	29
6. Chops, Forequarter, Lamb	do.	35
7. Lambs Fry	do.	30
8. Kidneys—Ox	do.	40
9. Fresh Mutton, Legs, Two-tooth	do.	29
10. Sausage Meat	do.	..
11. Sausages, Beef German	do.	50
12. Sausages, Mixed	do.	30
13. Pigs Heads	do.	10
14. Bacon, Middles	do.	74
15. Shin Beef—Bone in	do.	20
16. Rabbits, First quality	per pair	..
17. Meat Loaf	per lb.	59
18. Sausage Mince	per set	18
19. Tripe, Fresh	per lb.	20

SCHEDULE No. 25.—MORWELL RIVER REFORESTATION PRISON.

ANNEX TO CONTRACT No. 1967/2173.

Rogers Bros., Church-street, Boolarra.

Sub-schedule No. 1.

MEAT.			
Security, \$10.			cents
1. Fresh Beef	per lb.	38
2. Mutton	do.	18

SCHEDULE No. 26.—STATE RESEARCH FARM,
WERRIBEE.

ANNEX TO CONTRACT No. 1967/2174.
W. Angliss and Co. (Aust.) Pty. Ltd., 42 Bourke-street,
Melbourne.

Sub-schedule No. 1.

MEAT.		Security, \$10.	cents
1. Fresh Beef—Rolled Roast per lb.	..	38
2. Steak—Topside do.	..	45
3. " Thick Flank do.	..	40
4. " Mince do.	..	30
5. " Stewing do.	..	39
6. Beef, Corned Silverside do.	..	48
7. Pork, Legs do.	..	55
8. Beef—Shin do.	..	20
9. Mutton, Legs, Two-tooth do.	..	23
10. " " Pumped do.	..	23
11. Chops, Forequarter do.	..	20
12. " Cutlets do.	..	26
13. " Lamb do.	..	36
14. Frankfurts do.	..	33
15. Sausages do.	..	25
16. Sausage Meat do.	..	12
17. Veal Fillet do.	..	49
18. Bacon do.	..	78
19. Chops—Chump do.	..	24
20. Kidney—Ox do.	..	30
21. Tails—Ox do.	..	20
22. Pork, Strasburg do.	..	42
23. Beef " do.	..	30
24. Dripping do.	..	14
25. Steak—Scotch-fillet do.	..	55
26. Tripe do.	..	10
27. Tongues—Ox—Trimmed do.	..	12
28. Tongues—Sheep do.	..	12

SCHEDULE NO. 27.—"HILLSIDE" BOYS' HOME,
WHEELERS HILL.

ANNEX TO CONTRACT No. 1967/2175.
J. H. Cooke Pty. Ltd., 37 Queens Parade, Clifton Hill.
Sub-Schedule No. 1.

MEAT.		Security \$6.	cents
1. Legs, Lamb per lb.	..	34
2. Legs, Lamb, Seasoned do.	..	34
3. Legs, Pumped Mutton do.	..	23
4. Roast Beef do.	..	40
5. Corned Beef, Silverside do.	..	50
6. Chops, Barbecue do.	..	25
7. Cutlets, Crumbed do.	..	30
8. Steak—Topside do.	..	47
9. Steak—Stewing do.	..	43
10. Steak—Bladebone do.	..	44
11. Steak—Mince do.	..	33
12. Sausages do.	..	26
13. Sausage Mince do.	..	16
14. Frankfurts do.	..	33
15. Kidneys, Ox do.	..	33

SCHEDULE No. 28—MALMSBURY YOUTH TRAINING
CENTRE

ANNEX TO CONTRACT No. 1967/2176.
R. W. and L. J. Blomeley, Mollison-street, Malmsbury.
Sub-Schedule No. 1.

MEAT.		Security \$6.	cents
1. Roast Beef per lb.	..	50
2. Corned Beef do.	..	42
3. Pork, Legs do.	..	48
4. Sausages, Thin do.	..	25
5. Beef, German do.	..	34
6. Sausage Meat do.	..	18
7. Steak—Stewing do.	..	42
8. " Minced do.	..	38
9. Saveloys per doz.	..	56