



# VICTORIA GOVERNMENT GAZETTE

Published by Authority

[Registered at the General Post Office, Melbourne, for transmission by post as a newspaper.]

No. 1]

FRIDAY, JANUARY 5

[1968

Government House,  
Melbourne, Vic., 3004,  
1st January, 1968.

THE Queen has been graciously pleased to signify Her Majesty's intention of conferring the following Honours in the New Year Honours, 1968:—

**TO BE KNIGHTS BACHELOR.**

Brigadier William Henry Hall, C.B.E., D.S.O., E.D.  
The Honourable Mr. Justice George Augustus Pape, LL.B.

**THE MOST DISTINGUISHED ORDER OF SAINT MICHAEL AND SAINT GEORGE.**

To be a Companion of the said Most Distinguished Order:  
Thomas Symington Carlyon, Esquire, O.B.E.

**THE MOST EXCELLENT ORDER OF THE BRITISH EMPIRE.**

To be a Dame Commander of the Civil Division of the said Most Excellent Order:

Mrs. Hilda Mabel Stevenson, C.B.E.

To be Commanders of the Civil Division of the said Most Excellent Order:

Rupert Henry Arnold, Esquire, Q.P.M.  
John Miller Rodd, Esquire, LL.B.

To be Officers of the Civil Division of the said Most Excellent Order:

Hector William Crawford, Esquire.  
Councillor William Lawrence Kraft.  
Doctor Lorna Lloyd-Green, M.B., B.S., D.G.O.  
Mrs. Helena Catherine Marfell.  
Councillor Leslie Fielding Payne.  
George Roy Schintler, Esquire.  
Mrs. Mary Torney.

To be Members of the Civil Division of the said Most Excellent Order:

Richard Jacob Attrill, Esquire.  
Mrs. Ruby Robertson Barclay.  
Councillor Ullick Lord Daly.  
Councillor Frederick William Dods.  
Councillor Walter Albert Fordham.  
Charles Henry Gould, Esquire, M.M.  
Frank Reginald Harrison, Esquire.  
Councillor Isaac Roy Humphrys.  
Arthur Ernest Ireland, Esquire.  
Mrs. Edna Mavis Jackson, B.Sc.  
Councillor Kenneth Nelson King.  
John Oakley Parker, Esquire, B.C.E.  
Arthur Mervyn Pearson, Esquire.  
Mrs. Margaret Elizabeth Tucker.

F. R. KENNY,  
Acting Official Secretary to the Governor.

**PROCLAMATIONS**

ACTS OF PARLIAMENT.

PROCLAMATION

By His Excellency the Governor of the State of Victoria and its Dependencies in the Commonwealth of Australia, &c., &c., &c.

I, THE Governor of the State of Victoria, in the Commonwealth of Australia, do hereby declare that I have this day assented, in Her Majesty's name, to the Bills passed by the Parliament of the said State, the titles whereof are hereunder set forth, together with the short titles, that is to say:—

- No. 7632. "An Act to amend the *Extractive Industries Act 1966* with respect to the Ownership of Stone, and for other purposes." (*Extractive Industries (Amendment) Act 1967.*)
- No. 7633. "An Act to declare the Rates of Land Tax for the year ending the Thirty-first day of December One Thousand nine hundred and sixty-eight." (*Land Tax (Rates) Act 1967.*)
- No. 7634. "An Act to make Provision with respect to the Holding or Conduction of Public Entertainments on Sundays and for Purposes connected therewith." (*Sunday Entertainment Act 1967.*)
- No. 7635. "An Act to amend Part I. of the *Summary Offences Act 1966.*" (*Summary Offences Act 1967.*)
- No. 7636. "An Act to amend Section 131AC and the Third Schedule of the *Stamps Act 1958* and to amend Section 6 of the *Stamps Act 1967.*" (*Stamps (Exemptions) Act 1967.*)
- No. 7637. "An Act to regulate certain Rain-making and other Cloud-modification Processes, to make Provision with respect to Claims for Damages against Persons lawfully engaged therein and for other purposes." (*Rain-making Control Act 1967.*)
- No. 7638. "An Act to amend Part III. of the *Cemeteries Act 1958.*" (*Cemeteries (St. Kilda Public Cemetery) Act 1967.*)
- No. 7639. "An Act to amend the *Weights and Measures Act 1958* with respect to the Regulation and Control of Packaging and Sale of Pre-packed Articles, the Marking of Packages containing such Articles, the Prohibition or Restriction of the Use of certain Expressions on such Packages, and for other purposes." (*Weights and Measures (Pre-packed Articles) Act 1967.*)

No. 7640. "An Act to sanction the Issue and Application of Loan Money for Works and other Purposes relating to State Forests." (*State Forests Loan Application Act 1967.*)

No. 7641. "An Act to amend the Fisheries Act 1967." (*Fisheries (Amendment) Act 1967.*)

Given under my Hand and the Seal of the State of Victoria aforesaid, at Melbourne, this nineteenth day of December, in the year of our Lord One thousand nine hundred and sixty-seven, and in the sixteenth year of the reign of Her Majesty Queen Elizabeth II.

(L.S.) ROHAN DELACOMBE.

By His Excellency's Command,  
HENRY BOLTE,  
Premier.

GOD SAVE THE QUEEN !

ACTS OF PARLIAMENT.

PROCLAMATION

By His Excellency the Governor of the State of Victoria and its Dependencies in the Commonwealth of Australia, &c., &c., &c.

I, THE Governor of the State of Victoria, in the Commonwealth of Australia, do hereby declare that I have this day assented, in Her Majesty's name, to the Bills passed by the Parliament of the said State, the titles whereof are hereunder set forth, together with the short titles, that is to say:—

No. 7642. "An Act to authorize the Construction of a Line of Railway to connect the Railway from Leongatha to Port Albert with Barry Beach and for other purposes." (*Barry Beach Railway Construction Act 1967.*)

No. 7643. "An Act to clarify the Persons who may Vote at Polls and Elections held pursuant to the *Marketing of Primary Products Act 1958*, to enable Managers to be appointed for Marketing Boards in certain circumstances, and for other purposes." (*Marketing of Primary Products (Amendment) Act 1967.*)

No. 7644. "An Act to amend the *Victoria Institute of Colleges Act 1965* and the *Education Act 1958* and for other purposes." (*Victoria Institute of Colleges Act 1967.*)

No. 7645. "An Act to amend the *Crimes Act 1958* with respect to certain Driving Offences connected with Motor Cars, to amend Part VI. of the *Motor Car Act 1958* and for Purposes connected therewith." (*Crimes (Driving Offences) Act 1967.*)

No. 7646. "An Act to amend the *Private Agents Act 1966.*" (*Private Agents Act 1967.*)

No. 7647. "An Act to amend the *Teaching Service Act 1958* with regard to the Members to be elected to the Teachers Tribunal and Committees of Classifiers and for other purposes." (*Teaching Service (Teachers Tribunal) Act 1967.*)

No. 7648. "An Act to declare the Extent of the Liability of Authorized Insurers under Contracts of Insurance deemed to have been made under Division 1 of Part V. of the *Motor Car Act 1958* and under Corresponding Previous Enactments." (*Motor Car (Compulsory Third Party Insurance) Act 1967.*)

No. 7649. "An Act to sanction the Issue and Application of Loan Money for Public Works, and for other purposes." (*Public Works Loan Application Act 1967.*)

No. 7650. "An Act to sanction the Issue and Application of Loan Money for Works and Purposes relating to Railways and other purposes." (*Railway Loan Application Act 1967.*)

Given under my Hand and the Seal of the State of Victoria aforesaid, at Melbourne, this nineteenth day of December, in the year of our Lord One thousand nine hundred and sixty-seven, and in the sixteenth year of the reign of Her Majesty Queen Elizabeth II.

(L.S.) ROHAN DELACOMBE.

By His Excellency's Command,  
HENRY BOLTE,  
Premier.

GOD SAVE THE QUEEN !

Land Act 1958.

UNALIENATED CROWN LAND AVAILABLE FOR SETTLEMENT UNDER IMPROVEMENT PURCHASE LEASES.

PROCLAMATION

By His Excellency the Governor of the State of Victoria and its Dependencies in the Commonwealth of Australia, &c., &c., &c.

IN pursuance of the provisions of Section 153 of the *Land Act 1958*, I, the Governor of the State of Victoria, in the Commonwealth of Australia, by and with the advice of the Executive Council of the said State, do by this Proclamation declare the unalienated Crown lands mentioned in the subjoined schedule, to be available for settlement under improvement purchase leases.

SCHEDULE.

County.	Parish.	Allotment.	Section.	Area.	Land Valuation.
Lowan .. .. .	Carchap .. .. .	134A	..	A. R. P. 82 0 0 (Subject to Survey)	\$4 per acre

Given under my Hand and the Seal of the State of Victoria aforesaid, at Melbourne this nineteenth day of December in the year of our Lord One thousand nine hundred and sixty-seven and in the sixteenth year of the reign of Her Majesty Queen Elizabeth II.

ROHAN DELACOMBE.

(L.S.)

By His Excellency's Command,  
W. J. F. McDONALD,  
Minister of Lands.

GOD SAVE THE QUEEN !

ACTS OF PARLIAMENT.

PROCLAMATION

By His Excellency the Governor of the State of Victoria and its Dependencies in the Commonwealth of Australia, &c., &c., &c.

I, THE Governor of the State of Victoria, in the Commonwealth of Australia, do hereby declare that I have this day assented, in Her Majesty's name, to the Bills passed by the Parliament of the said State, the titles whereof are hereunder set forth, together with the short titles, that is to say:—

- No. 7651. "An Act to consolidate and amend the Law relating to Juries, to amend the Coroners Act 1958, the County Court Act 1958, the Crimes Act 1958 and the Evidence Act 1958, and for other purposes." (Juries Act 1967.)
- No. 7652. "An Act to ratify validate approve and otherwise give Effect to an Agreement between the Premier for and on behalf of the State of Victoria and Hematite Petroleum Proprietary Limited and Esso Exploration and Production Australia Inc. to authorize the Construction of Additional Port Facilities in Westernport to make Provision with respect to the Reclamation of Certain Land at Old Tyabb and for other purposes." (Westernport Development Act 1967.)
- No. 7653. "An Act to amend the North Melbourne Lands Act 1966 and for other purposes." (North Melbourne Lands (Amendment) Act 1967.)
- No. 7654. "An Act to sanction the Issue and Application of Loan Money for Works and other Purposes relating to Irrigation Water Supply Drainage Sewerage Flood Protection and River Improvement, and other purposes." (Water Supply Loan Application Act 1967.)
- No. 7655. "An Act to apply a sum out of the Consolidated Revenue to the service of the Year ending on the thirtieth day of June One thousand nine hundred and sixty-eight and to appropriate the Supplies granted in this Session of Parliament."

Given under my Hand and the Seal of the State of Victoria aforesaid, at Melbourne, this nineteenth day of December, in the year of our Lord One thousand nine hundred and sixty-seven, and in the sixteenth year of the reign of Her Majesty Queen Elizabeth II.

(L.S.) ROHAN DELACOMBE.  
By His Excellency's Command,  
HENRY BOLTE,  
Premier.  
GOD SAVE THE QUEEN!

PUBLIC HIGHWAYS.—SHIRE OF MILDURA.

PROCLAMATION

By His Excellency the Governor of the State of Victoria and its Dependencies in the Commonwealth of Australia, &c., &c., &c.

WHEREAS by the Local Government Act 1958, as amended, Section 519 it is amongst other things enacted that it shall be lawful for the Governor-in-Council at any time and from time to time upon the request of the Council of any municipality by notice in the Government Gazette to proclaim any land reserved used or by purchase or exchange acquired for a street road highway thoroughfare bridge square court alley or right-of-way or any street road lane or passage made or laid out or proposed to be made or laid out on any land of which a plan of subdivision delineating that street road lane or passage has been sealed with the seal of the municipality under subdivision (3) of Division 9 of Part XIX. of the Local Government Act 1958, as amended, or a corresponding previous enactment to be a public highway and that such land shall thereupon and thenceforth from the date of such proclamation become and be absolutely dedicated to the public as a public highway within the meaning of any law then or thereafter in force:

AND WHEREAS the Council of the Shire of Mildura has requested that the lands hereinafter mentioned, being streets roads lanes or passages made or laid out or proposed to be made or laid out on land of which a plan of subdivision delineating those streets roads lanes or passages has been sealed with the seal of the municipality under subdivision (3) of Division 9 of Part

XIX. of the Local Government Act 1958, as amended, or a corresponding previous enactment, be so declared to be public highways:

NOW THEREFORE I, the Governor of the State of Victoria in the Commonwealth of Australia, by and with the advice of the Executive Council of the said State, do by this Proclamation declare that Hassell and Elms Streets, Irymple, shown hatched on the plan hereunder, shall be public highways within the meaning of the said Act:

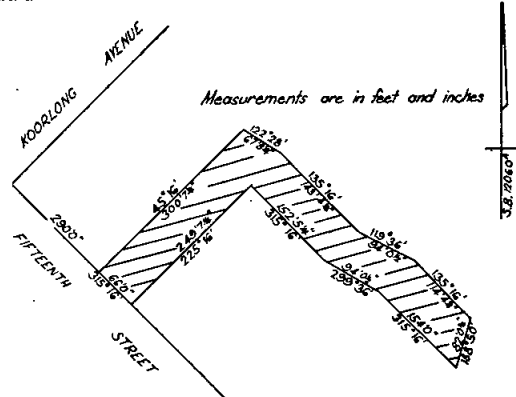

Given under my Hand and the Seal of the State of Victoria aforesaid, at Melbourne, this nineteenth day of December, in the year of our Lord One thousand nine hundred and sixty-seven and in the sixteenth year of the reign of Her Majesty Queen Elizabeth II.

(L.S.) ROHAN DELACOMBE.  
By His Excellency's Command,  
R. J. HAMER,  
Minister for Local Government.  
GOD SAVE THE QUEEN!

GOVERNMENT NOTICES

ERRATUM.

RULES UNDER THE JUSTICES ACT.

Courts, Days and Hours for the Hearing of Special Complaints during 1968.

IN Government Gazette, No. 92, of 6th December, 1967, pages 3676-3678—Mortlake.

"Wednesday, at 2 p.m., on 20th October, 1968" should read "Wednesday, at 2 p.m., on 23rd October, 1968".

Marine Act 1958.

AMENDMENT OF PILOTAGE RATES.

IN pursuance of the powers conferred by section 79 of the Marine Act 1958, the Marine Board of Victoria, with the approval of the Governor in Council, doth ordain and determine as follows:—

That on and after the 1st day of January, 1968:—

The Pilotage Rate for ships from without Port Phillip Heads to an anchorage or pier in Hobson's Bay or Corio Bay, or vice versa, shall be \$0.0265 per ton, calculated on the ship's gross tonnage, subject in any case to a maximum charge of Four hundred and thirty dollars (\$430) and a minimum charge of Fifty dollars (\$50).

The Pilotage Rate for ships from without Westernport Bay to an anchorage or the Refinery Pier within Westernport Bay, or vice versa, shall be \$0.0265 per ton, calculated on the ship's gross tonnage, subject in any case to a maximum charge of Four hundred and thirty dollars (\$430) and a minimum charge of Fifty dollars (\$50).

The foregoing ordinance and determination was passed at a meeting of the Marine Board of Victoria held on the 24th day of November, 1967.

(SEAL) A. T. SMITHERS, President.  
K. W. BLUE, Member.  
K. T. MANALLACK, Secretary.

Approved by the Governor in Council, 19th December, 1967.—J. ROSSITER, Clerk of the Executive Council.

**LEXTON WATERWORKS TRUST.**

**RATING BY-LAW FOR THE YEAR 1967-1968.**

THE Lexton Waterworks Trust, in pursuance and exercise of the powers conferred by the Water Act, doth hereby make a rate for the supply of water for domestic purposes of Seventeen and one half cents in the dollar of the Net Annual Value of lands and tenements liable to be rated within the Lexton Urban District.

Provided that in no case shall the amount of rate payable per annum in respect of any tenement (other than land on which there is no building) be less than Seventeen dollars, and in respect of any land on which there is no building less than Five dollars.

Such rates are made and shall be levied upon the occupiers or owners of the said lands and tenements for the year commencing the 1st day of October, 1967, and shall be due and payable on the 8th day of January, 1968, at the office of the said Trust.

The maximum quantity of water to be supplied in any one year without further charge to any property rated by the Trust is hereby fixed at a quantity which, at a charge of Thirty four cents per 1,000 gallons, would produce an amount equal to the amount of the rate levied on such properties for the said year.

The charge for water supplied by measure to any property rated by the Trust in excess of such maximum quantity, computed as in the last preceding clause, is hereby fixed at Thirty four cents per 1,000 gallons.

The charge for water supplied by measure shall be payable, on demand, at the Office of the Trust.

The foregoing By-law was made and passed by the Commissioners of the Lexton Waterworks Trust on the 13th day of December, 1967, and the seal of the Trust affixed hereto, in the presence of—

(SEAL) K. SEVERINO, Chairman.  
J. J. BORRIDGE, Commissioner.  
H. L. TEAGUE, Secretary.

Approved, 27th December, 1967.—W. A. BORTHWICK, Minister of Water Supply.

**THORNTON WATERWORKS TRUST.**

**RATING BY-LAW FOR THE YEAR 1968.**

THE Thornton Waterworks Trust, in pursuance and exercise of the powers conferred by the Water Act, doth hereby make a rate for the supply of water of six cents in the dollar, on the annual municipal valuation of land and tenements liable to be rated within the Thornton Urban District.

Provided that in no case shall the amount of rate payable per annum in respect of any tenement (other than land on which there is no building) be less than fifteen dollars, and in respect of land on which there is no building be less than four dollars.

Such rates are made and shall be levied upon the occupiers or owners of the said lands and tenements for the year commencing on the 1st day of January, 1968, and shall be due and payable on the 5th day of January, 1968, at the office of the said Trust, and if unpaid by the 5th day of May, 1968, shall bear interest at 6% per annum from the day on which they became payable.

The maximum quantity of water to be supplied in any one year without further charge to any property rated by the Trust is hereby fixed at the quantity which at a charge of eighteen cents per 1,000 gallons would produce the amount equal to the amount of rate levied on such property for the said year.

The charge for water supplied by measure to any property rated by the Trust in excess of such maximum quantity computed as in the last preceding clause, is hereby fixed at eighteen cents per 1,000 gallons.

The charge for water supplied by measure to any property not rated by Trust is hereby fixed at nineteen cents per 1,000 gallons, and the minimum quantity of water to be charged for in any case where water is so supplied is hereby fixed at 30,000 gallons.

The charge for water supplied by measure shall be payable on demand at the office of the Trust.

Passed by the Thornton Waterworks Trust this 1st day of December, 1967.

(SEAL) REG. B. SPARKE, Chairman.  
R. D. MILES, Commissioner.  
L. H. THOMPSON, Acting Secretary.

Approved, 27th December, 1967.—W. A. BORTHWICK, Minister of Water Supply.

**PUBLIC HOLIDAY.—AUSTRALIA DAY.**

IT is hereby notified that on—

MONDAY, THE 29TH JANUARY, 1968,

the Public Offices will be closed, such day having been appointed by the Public Service Act 1958, to be observed as a holiday in the Public Offices throughout the State of Victoria.

This notice relates only to the closing of the State Public Offices. All inquiries regarding the holiday in other offices and in shops and industry should be directed to the Department of Labour and Industry, 110 Exhibition-street, Melbourne, 3000. (Telephone 63 0321, Extension 6158, 6721 or 6859.)

A. G. RYLAH,  
Chief Secretary.

Chief Secretary's Office,  
Melbourne, 3rd January, 1968.

**SHIRE OF SOUTH GIPPSLAND.**

**ROAD DEVIATION ORDER.**

PURSUANT to the provisions of sections 522 and 526 of the Local Government Act 1958, the Council of the Shire of South Gippsland hereby directs that the land in the Parish of Meeniyah indicated by hatching in the diagram hereunder, which has been purchased, taken or acquired by it, shall be a public highway on and from the date of publication of this order in the Government Gazette and declares that such land shall be a public highway in lieu of the land indicated by cross-hatching on the said diagram.

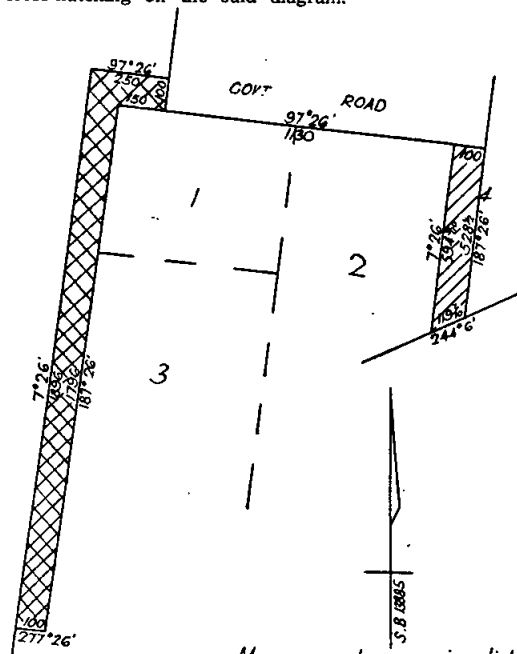

Measurements are in links

The Common Seal of the President, Councillors and Ratepayers of the Shire of South Gippsland was hereunto affixed this 10th day of August, 1967.

(SEAL) V. W. B. WOOD, President.  
J. LESTER, Councillor.  
J. RENNICK, Shire Secretary.

Confirmed by the Governor in Council, 19th December, 1967.—J. ROSSITER, Clerk of the Executive Council.

**Private Agents Act 1966.**

**APPROVED INSURANCE COMPANIES.**

PURSUANT to the provisions of section 31 (2) of the Private Agents Act 1966, I, Her Majesty's Chief Secretary for the State of Victoria, hereby approve of the following insurance company for the purposes of the said Act:—

The Dominion Insurance Company Limited.

A. G. RYLAH,  
Chief Secretary.

Chief Secretary's Office,  
Melbourne, 29th December, 1967.

## Private Agents Act 1966.

## NOTICE OF RECEIPT OF APPLICATIONS FOR LICENCES UNDER THE PROVISIONS OF THE PRIVATE AGENTS ACT 1966.

THE Clerk(s) of the Court(s) of Petty Sessions as listed hereunder hereby give notice that applications, as under, have been lodged for hearing by the said Court(s) on the date(s) specified.

Any person desiring to object to any of such applications must—

- (a) lodge with the respective Clerk of Petty Sessions a notice in the prescribed form of his objection and of the grounds thereof;
- (b) cause a copy of such notice to be served personally or by post upon the applicant at least three days before the hearing of the application; and
- (c) send or deliver—
  - (i) where the objection is not made by the officer in charge of the police district in which the Court is situated—a copy of the notice to such officer; and
  - (ii) where the objection is not made by the Registrar or Deputy Registrar—a copy to the Registrar.

Full Name of Applicant or in the case of a Firm or Corporation, of the Nominee.	Place of Abode of Applicant or Nominee.	Name of Firm or Corporation.	Address for Registration.	Type of Licence.	Date of Hearing of Application.
COURT OF PETTY SESSIONS, PRAHRAN.					
Martin, Kenneth John ..	3 Grout-street, Mentone ..	.. .. .	C/o Melbourne Night Patrol Service, Suite 18, 614 St. Kilda-road, Melbourne	Watchman ..	8.1.68
Schillaci, John ..	586 Rae-street, North Fitzroy ..	.. .. .	157 Dandenong-road, Windsor	Process Server ..	12.1.68
Voltz, William Francis ..	33 " Williams-road, Laverton ..	.. .. .	C/o " Melbourne Night Patrol Service, Suite 18, 614 St. Kilda-road, Melbourne	Inquiry Agent ..	9.1.68
" Winduss, " Frederick " Robert ..	55 " Poolman-street, Port Melbourne ..	.. .. .	" " " " " "	Watchman ..	" "
Carter, James Franklin ..	71 Ardoyne-street, Black Rock ..	Trans Continental Credit Pty. Ltd.	154 Greville-street, Prahran	Commercial Agent (Corporation)	8.1.68
" " " ..	" " " " " "	" " " "	" " " "	Commercial Sub-agent	" "

Dated at Prahran this 15th day of December, 1967.

G. S. HOARE,  
Clerk of Petty Sessions.

## COURT OF PETTY SESSIONS, SOUTH MELBOURNE.

Advice, Marie Joseph Henri ..	Flat 1, 22 Esplanade, St. Kilda ..	.. .. .	101-105 Clarke-street, South Melbourne	Watchman ..	10.1.68
Brooks, Herbert Leslie ..	1 Moore-crescent, Reservoir ..	.. .. .	" " " "	" ..	" "
Fraser, Clifford Henry ..	Flat 7, 160 Napier-street, Essendon ..	.. .. .	" " " "	" ..	" "
Gration, Thomas ..	2 Guildford-avenue, Broadmeadows ..	.. .. .	" " " "	" ..	" "
Hornby, Claude Weston ..	108 Blackshaws-road, Spotswood ..	.. .. .	" " " "	" ..	" "
Kidd, Stanley Herbert ..	52 Tudor-street, South Oakleigh ..	.. .. .	" " " "	" ..	" "
Mennie, George Howitt ..	55 Hillview-drive, Kilsyth ..	.. .. .	" " " "	" ..	" "
Payet, Sybert C. J. ..	47 Osborne-street, South Yarra ..	.. .. .	" " " "	" ..	" "
Perrins, Ernest John ..	21 Leston-avenue, Dandenong West ..	.. .. .	" " " "	" ..	" "
Ransom, Edward Andrew James ..	7 Eve-court, Springvale North ..	.. .. .	" " " "	" ..	" "
Stevens, Allen Edward ..	Flat 10, 70 The Boulevard, Chadstone ..	.. .. .	" " " "	" ..	" "
Weston, Leslie Richard ..	6 Lulworth-street, Blackburn ..	.. .. .	" " " "	" ..	" "
Yates, Horace Gideon ..	26 Rathmullen-road, Boronia ..	.. .. .	" " " "	" ..	" "

Dated at South Melbourne this 18th day of December, 1967.

G. MILLER,  
Clerk of Petty Sessions.

## COURT OF PETTY SESSIONS, DANDENONG.

Crossley, Harry ..	57 Railway-parade, Seaford ..	.. .. .	22 McCrae-street, Dandenong	Inquiry Agent ..	10.1.68
--------------------	-------------------------------	---------	-----------------------------	------------------	---------

Dated at Dandenong this 19th day of December, 1967.

C. F. LEWIS,  
Clerk of Petty Sessions.

PRIVATE AGENTS—continued.

Full Name of Applicant or in the case of a Firm or Corporation, of the Nominee.	Place of Abode of Applicant or Nominee.	Name of Firm or Corporation.	Address for Registration.	Type of Licence.	Date of Hearing of Application.
---	---	------------------------------	---------------------------	------------------	---------------------------------

COURT OF PETTY SESSIONS, KEW.

Hutcheon, Jeffrey ..	44 Eglinton-street, Kew		44 Eglinton-street, Kew	Watchman	1.8.68
----------------------	-------------------------	--	-------------------------	----------	--------

Dated at Kew this 19th day of December, 1967.

D. M. CRANE,  
Clerk of Petty Sessions.

COURT OF PETTY SESSIONS, LAKES ENTRANCE.

Neal, William Richard ..	Hunter-street, Lakes Entrance	Neal & Maben ..	Hunter-street, Lakes Entrance	Process Server (Individual)	9.1.68
Maben, Geoffrey Gustav ..	Jemmeson - street, Lakes Entrance	" "	" "	" "	"
" " "	" "	" "	" "	Process Server (Firm)	"

Dated at Lakes Entrance this 18th day of December, 1967.

S. G. MACKIE,  
Clerk of Petty Sessions.

COURT OF PETTY SESSIONS, ORBOST.

Dominey, Hector Wakefield ..	52 Salisbury-street, Orbost		52 Salisbury-street, Orbost	Process Server (Individual)	10.1.68
------------------------------	-----------------------------	--	-----------------------------	-----------------------------	---------

Dated at Orbost this 18th day of December, 1967.

S. G. MACKIE,  
Clerk of Petty Sessions.

COURT OF PETTY SESSIONS, OAKLEIGH.

Austin, Robert Ronald ..	86 South-parade, Blackburn	Waverley Watching Co.	310 Stephenson's-road, Mt. Waverley	Watchman	19.1.68
Elsun, William Henry ..	Glenbrook-road, Clematis	" "	" "	" "	"
French, Reginald William ..	10 Cleve-grove, Heidelberg	Mulgrave Security Service Pty. Ltd.	" "	" "	"
Hughes, Harold George ..	34 Surrey-street, Box Hill	Waverley Watching Co.	" "	" "	"
Jones, Leonard William ..	10 Alice-street, Mt. Waverley	" "	" "	" "	"
Matthews, Douglas ..	Glenbrook-road, Clematis	" "	" "	" "	"
Powell, Baden James ..	Lot 7, Canterbury-road, Bayswater	" "	" "	" "	"
Rice, Cyril Edward ..	14 Mimosa-avenue, Oakleigh	Mulgrave Security Service Pty. Ltd.	" "	" "	"
Savage, John ..	36 Deakin-street, Mitcham	" "	" "	" "	"
Simmonds, Eric Stratford ..	26 Woodville-street, North Balwyn	Waverley Watching Co.	" "	" "	"
Yendle, Victor Ernest ..	383 Albion-street, Brunswick	" "	" "	" "	"

Dated at Oakleigh this 18th day of December, 1967.

F. McSWEENEY,  
Clerk of Petty Sessions.

COURT OF PETTY SESSIONS, GEELONG.

Ricketts, Donald Henry ..	17 Colorado-drive, Corio	Australian Watching Co. Pty. Ltd.	130 Abbotsford-street, North Melbourne	Watchman	10.1.68
---------------------------	--------------------------	-----------------------------------	--	----------	---------

Dated at Geelong this 20th day of December, 1967.

J. R. AITKEN  
Clerk of Petty Sessions.

COURT OF PETTY SESSIONS, HEIDELBERG.

Smith, Arthur Herbert ..	35 Como-street, Alphington		35 Como-street, Alphington	Commercial Agent	16.1.68
--------------------------	----------------------------	--	----------------------------	------------------	---------

Dated at Heidelberg this 20th day of December, 1967.

T. K. HASSARD,  
Clerk of Petty Sessions.

COURT OF PETTY SESSIONS, SPRINGVALE.

Casey, John Gerald ..	14 Pheasant-street, Burwood	T. G. Larkin ..	9 Bowmore-road, Noble Park	Watchman	12.1.68
-----------------------	-----------------------------	-----------------	----------------------------	----------	---------

Dated at Springvale this 19th day of December, 1967.

F. J. DUTHIE,  
Clerk of Petty Sessions.

PRIVATE AGENTS—continued.

Full Name of Applicant or in the case of a Firm or Corporation, of the Nominee.	Place of Abode of Applicant or Nominee.	Name of Firm or Corporation.	Address for Registration.	Type of Licence.	Date of Hearing of Application.
---	---	------------------------------	---------------------------	------------------	---------------------------------

COURT OF PETTY SESSIONS, WANGARATTA.

Brauman, Donald Lindsay ..	20 Brodie-street, Wangaratta	.. .. .	6 Ely-street, Wangaratta	Inquiry Agent ..	9.1.68
Constable, Claude Wallace ..	16 Crammond-avenue, Wangaratta	.. .. .	16 Crammond-avenue, Wangaratta	Process Server ..	"

Dated at Wangaratta this 18th day of December, 1967.

A. VALE,  
Clerk of Petty Sessions.

COURT OF PETTY SESSIONS, FOOTSCRAY.

Ebert, Stanford Lloyd ..	30 Pecham-street, Glenroy	.. .. .	130 Abbotsford-street, North Melbourne	Watchman ..	11.1.68
Guthrie, Geoffrey Alan ..	53 Woods-street, Ascot Vale	.. .. .	79 Nicholson-street, Footscray	Commercial Sub-agent	"
Collier, Roger Treyhern ..	2/271 Malvern-road, South Yarra	.. .. .	" "	Inquiry Agent ..	"
			" "	" "	"

Dated at Footscray this 20th day of December, 1967.

J. CAVEN,  
Clerk of Petty Sessions.

COURT OF PETTY SESSIONS, COLAC.

Plunkett, Stanley Ernest ..	47 Craddock-street, North Geelong	.. .. .	42 Murray-street, Colac	Inquiry Agent ..	15.1.68
-----------------------------	-----------------------------------	---------	-------------------------	------------------	---------

Dated at Colac this 20th day of December, 1967

A. R. PENFOLD,  
Clerk of Petty Sessions.

COURT OF PETTY SESSIONS, MOONEE PONDS.

Hodge, Lindsay Ronald ..	5 Churchill-avenue, Maidstone	Consolidated Security Services	53 Daisy-street, Essendon	Watchman ..	9.1.68
Michalski, Wieslaw-Jan ..	5 Carol-grove, Tullamarine	.. .. .	5 Carol-grove, Tullamarine	Inquiry Agent ..	"
Pooles, Robert Harold Francis	9 Morphett-avenue, Ascot Vale	.. .. .	9 Morphett-avenue, Ascot Vale	" "	"
Whiteside, John Siggins ..	8 Sandown-road, Ascot Vale	.. .. .	8 Sandown-road, Ascot Vale	Process Server ..	"
" " "	" " "	.. .. .	" " "	" "	"
" " "	" " "	.. .. .	" " "	Guard Agent ..	"
" " "	" " "	.. .. .	" " "	Inquiry Agent ..	"

Dated at Moonee Ponds this 18th day of December, 1967.

D. A. THOMPSON,  
Clerk of Petty Sessions.

COURT OF PETTY SESSIONS, MORWELL.

Whelan, Geoffrey ..	71 Wirraway-street, Moe	Latrobe Security Services	Room 5, 176 Commercial-road, Morwell	Guard Agent ..	10.1.68
" " "	" " "	" " "	" " "	Watchman ..	"
" " "	" " "	" " "	" " "	Process Server ..	"
" " "	" " "	" " "	" " "	Inquiry Agent ..	"
Whelan, David John ..	71 Wirraway-street, Moe	.. .. .	" "	Watchman ..	"

Dated at Morwell this 22nd day of December, 1967.

D. L. CROFT,  
Clerk of Petty Sessions.

COURT OF PETTY SESSIONS, PRAHRAN.

Duncan, Charles ..	2 Wood-street, Laverton	.. .. .	Suite 18, 614 St. Kilda-road, Melbourne	Watchman ..	9.1.68
Miscamble, Clive Owen ..	240 York-street, South Melbourne	.. .. .	" "	" "	"
Winderlich, Arthur Geoffrey ..	22 Epsom-street, Laverton	.. .. .	" "	" "	"

Dated at Prahran this 19th day of December, 1967.

G. S. HOARE,  
Clerk of Petty Sessions.

## PRIVATE AGENTS—continued.

Full Name of Applicant or in the case of a Firm or Corporation, of the Nominee.	Place of Abode of Applicant or Nominee.	Name of Firm or Corporation.	Address for Registration.	Type of Licence.	Date of Hearing of Application.
COURT OF PETTY SESSIONS, MELBOURNE.					
Bishop, Geoffrey Adrian ..	1013 North-road, Murrumbeena	.. .. .	1st Floor 390 Lonsdale-street, Melbourne	Commercial Agent	8.1.68
Bishop, Gregory Owen ..	406 Warrigal-road, South Oakleigh	.. .. .	390 Lonsdale-street, Melbourne	" "	"
Mitchell, Malcolm Wallace ..	10 Manor-street, Brighton	.. .. .	23 McKillop-street, Melbourne	" "	"
Mitchell, Malcolm Wallace ..	10 Manor-street, Brighton	.. .. .	23 McKillop-street, Melbourne	Process Server ..	"
Mitchell, Malcolm Wallace ..	10 Manor-street, Brighton	.. .. .	23 McKillop-street, Melbourne	Inquiry Agent ..	"
Breguet, Alan Howard ..	42 Cameron-street, Niddrie	.. .. .	130 Abbotsford-street, North Melbourne	Watchman ..	"
Brunner, Alexander Rowan ..	3 Riversdale-avenue, Carrum	.. .. .	" "	" "	"
Cole, John Sandry ..	14 Edgecombe-street, Kew	.. .. .	" "	" "	"
Gowen, James Alexander ..	7 Craddock-avenue, Caulfield	.. .. .	" "	" "	"
Hedrick, Bruce Norman ..	1 Dunlop-avenue, Ascot Vale	.. .. .	" "	" "	"
Howie, James ..	90 Moreland-street, Footscray	.. .. .	" "	" "	"
Jenkins, Lawrence John ..	6 Vernon-street, South Kingsville	.. .. .	" "	" "	"
Jones, Edgar Roy ..	16 Laronga-court, Nunawading	.. .. .	" "	" "	"
Maguire, Victor Patrick ..	30 Brett-street, Murrumbeena	.. .. .	" "	" "	"
Marmo, Ronald John ..	124 Dunne-street, Kingsbury	.. .. .	" "	" "	"
Mathews, Kevin William ..	61 Baratta-street, Blackburn South	.. .. .	" "	" "	"
Smith, Kenneth Francis ..	6 Jacaranda-street, Doveton	.. .. .	" "	" "	"
Stokes, Dennis Robert ..	18 Chestnut-street, Campbellfield	.. .. .	" "	" "	"
Styling, Kenneth ..	25 Sussex-street, Seaholme	.. .. .	" "	" "	"

Dated at Melbourne this 22nd day of December, 1967.

G. L. WEBSTER,  
Clerk of Petty Sessions.

## COURT OF PETTY SESSIONS, MELBOURNE.

Kitchen, Kevin Barry ..	94 Hilton-street, Glenroy	.. .. .	130 Abbotsford-street, North Melbourne	Watchman ..	8.1.68
Legood, William Frederick Thomas	22 Wharton-street, Surrey Hills	.. .. .	Wrightcel Ltd., Cato-street, Auburn	" "	"
Macleay, Robin Alexander ..	25 Normadale-road, East Bentleigh	.. .. .	130 Abbotsford-street, North Melbourne	" "	"
O'Callaghan, William Daniel	93 Holland-road, Blackburn South	.. .. .	" "	" "	"
Palfreman, Brian Harrison ..	23 Kingston-street, Hampton	.. .. .	" "	" "	"
Peters, Benno ..	72 Stanhope-street, West Footscray	.. .. .	" "	" "	"
Sencek, Martin Emil ..	52 Borna-grove, East Doncaster	.. .. .	" "	" "	"
Sims, Frederick Norman ..	14 Wales-street, West Footscray	.. .. .	" "	" "	"
Smith, Brian Joseph ..	41 Gabonia-street, Watsonia	.. .. .	" "	" "	"
Stokes, Leslie Clive ..	32 Greenwood-drive, Bundoora	.. .. .	" "	" "	"
Taylor, Clarenc ..	Flat 19, 37 Vale-street, St. Kilda	.. .. .	" "	" "	"
Tisdale, Donald Cottell ..	7 Charles-street, North Coburg	.. .. .	" "	" "	"
Wallace, Meric Leopold Arnold	Flat 1, 7 Wickham-road, Moorabbin	.. .. .	" "	" "	"
Walle, John Michael ..	33 Denman-street, Brunswick	.. .. .	" "	" "	"
Wood, Roy ..	188 Kororoit Creek-road, Williamstown	.. .. .	" "	" "	"
Yates, Noel William ..	24 Vernal-avenue, Mitcham	.. .. .	" "	" "	"
Blashki, Eugenie ..	44a Clendon-road, Toorak	.. .. .	104 Wellington-parade, East Melbourne	Commercial Agent	"
Blashki, Eugenie ..	44a Clendon-road, Toorak	.. .. .	" "	Commercial Sub-agent	"



PRIVATE AGENTS—continued.

Full Name of Applicant or in the case of a Firm or Corporation, of the Nominee.	Place of Abode of Applicant or Nominee.	Name of Firm or Corporation.	Address for Registration.	Type of Licence.	Date of Hearing of Application.
COURT OF PETTY SESSIONS, MELBOURNE—continued.					
Arrandale Brian Edward ..	9 Karri-court, Frankston	.. .. .	130 Abbotsford-street, North Melbourne	Watchman ..	8.1.68
Atkinson, Sydney David ..	24 Skeffington-street, West Heidelberg	.. .. .	" "	" "	" "
Barfoot, George Duncan Bowman	432 Williamstown-road, Port Melbourne	.. .. .	" "	" "	" "
Bond, John ..	197 The Esplanade, Altona	.. .. .	" "	" "	" "
Brady, James Cavan ..	9 Mansfield-court, Bundoora	.. .. .	" "	" "	" "
Cantwell, Francis Lawrence ..	19 Dixon-road, Boronia West	.. .. .	" "	" "	" "
Castles, Ian Albert ..	77 Ridgeway-parade, West Sunshine	.. .. .	" "	" "	" "
Chisholm, Murray Montgomery	48 Josephine-avenue, Mt. Waverley	.. .. .	" "	" "	" "
Cumming, John Sidney Angus	90 Liston-avenue, Keon Park	.. .. .	" "	" "	" "
Darlington, John Ronald Ogier	16 Harold-street, Middle Park	.. .. .	" "	" "	" "
Day, Maxwell Martin ..	36 Heath-avenue, Oakleigh	.. .. .	" "	" "	" "
Facer, Andrew ..	9 Arthur-street, Preston	.. .. .	" "	" "	" "
Giles, Derek Edward ..	2a Gillies-street, Fairfield	.. .. .	" "	" "	" "
Glanville, George Bernard ..	Flat 4, 1761 Dandenong-road, Oakleigh	.. .. .	" "	" "	" "
Hanlin, Michael Russell ..	96 Thomas-street, Hampton	.. .. .	" "	" "	" "
Harding, Ronald Peter ..	27 Ashmore-road, Forest Hill	.. .. .	" "	" "	" "
Hobbs, William Richard John	9 Corris-street, Yarraville	.. .. .	" "	" "	" "
Kirsch, Erwin Johann ..	27 Sonia-street, Donvale	.. .. .	" "	" "	" "

Dated at Melbourne this 3rd day of January, 1968.

G. L. WEBSTER,  
Clerk of Petty Sessions.

COURT OF PETTY SESSIONS, SWAN HILL.

Thomson, Allen Henry ..	49 Pritchard-street, Swan Hill	.. .. .	5 Rutherford-street, Swan Hill	Inquiry Agent ..	9.1.68
-------------------------	--------------------------------	---------	--------------------------------	------------------	--------

Dated at Swan Hill this 19th day of December, 1967.

B. MEEHAN,  
Clerk of Petty Sessions.

PUBLIC TRUSTEE ACT 1958 (No. 6350), SECTION 17.

I HEREBY give notice that on the 8th December, 1967, the Public Trustee filed elections to administer the following deceased persons' estates, in accordance with section 17 of the Public Trustee Act 1958:—

AMBLER, LEONARD LESLIE JOHN, also known as Leonard Leslie Ambler, late of 263 Dorcas-street, South Melbourne, storeman, died 18th October, 1967.

BLAKELEY, ROSE, formerly of 432 Punt-road, South Yarra, but late of Caulfield Hospital, 294 Kooyong-road, Caulfield, spinster, died 30th October, 1967.

GAMBLE, ROBERT, late of 1 Fisher-street, Forest Hill, retired storeman, died 29th August, 1967.

HOUGHTON, ALFRED JAMES, late of 1 Christmas-street, Northcote, retired labourer, died 18th August, 1967.

LUBERA, ZYGMUNT, late of 29 Pine-avenue, North Shore, Victoria, laboratory assistant, died 24th January, 1967.

LUSCOMBE, FLORENCE ELLEN, formerly of 14 Tyrrell-avenue, Blackburn, and 259 Mitcham-road, Mitcham, but late of Warrigal-road, Cheltenham, widow, died 29th August, 1967.

ROCHE, ETHEL JANE, late of Princes Hill Village, Pigdon-street, North Carlton, spinster, died 6th October, 1967.

SOBczyk, ADM, late of Railway Hostel, Jolimont, cleaner, died 17th July, 1967.

A. D. DUNCAN,  
Public Trustee.

256 Flinders-street, Melbourne, 3000, 21st December, 1967.

NOTICE.

CREDITORS, next of kin and others having claims against the estate of any of the under-mentioned deceased persons are required to send particulars of their claims to the Public Trustee, 256 Flinders-street, Melbourne, 3000, the personal representative, on or before the 5th March, 1968, after which date the Public Trustee may convey or distribute the assets, having regard only to the claims of which the Public Trustee then has notice:—

AMBLER, LEONARD LESLIE JOHN, also known as Leonard Leslie Ambler, late of 263 Dorcas-street, South Melbourne, storeman, died 18th October, 1967.

BLAKELEY, ROSE, formerly of 432 Punt-road, South Yarra, but late of Caulfield Hospital, 294 Kooyong-road, Caulfield, spinster, died 30th October, 1967.

FENNESSY, DAVID FREDERICK, late of 20A Teak-street, Caulfield South, retired farmer, died 19th August, 1967.

GAMBLE, ROBERT, late of 1 Fisher-street, Forest Hill, retired storeman, died 29th August, 1967.

HOUGHTON, ALFRED JAMES, late of 1 Christmas-street, Northcote, retired labourer, died 18th August, 1967.

JONES, THOMAS HENRY, late of 2 Union-place, Carlton, retired labourer, died 14th October, 1966.

LAWSON, WILLIAM CHARLES, late of 19 Raglan-street, Port Melbourne, sheetmetal worker, died 29th August, 1967.

LUBERA, ZYGMUNT, late of 29 Pine-avenue, North Shore, Victoria, laboratory assistant, died 24th January, 1967.

LUSCOMBE, FLORENCE ELLEN, formerly of 14 Tyrrell-avenue, Blackburn, and 259 Mitcham-road, Mitcham, but late of Warrigal-road, Cheltenham, widow, died 29th August, 1967.

ROCHE, ETHEL JANE, late of Princes Hill Village, Pigdon-street, North Carlton, spinster, died 6th October, 1967.

SIMPSON, ELIZABETH IRENE, late of 6 The Crofts, Richmond, spinster, died 2nd August, 1967.

SOBCZYK, ANM, late of Railway Hostel, Jolimont, cleaner, died 17th July, 1967.

A. D. DUNCAN,  
Public Trustee.

Melbourne, 21st December, 1967.

#### HONORARY CONSUL.

NOTICE is given that provisional recognition has been accorded to Mr. Eric Nugent Avery, as Honorary Consul for Brazil, in Melbourne, with effect from 3rd November, 1967.

A. G. COULTHARD, Secretary,  
Premier's Department.

Premier's Office, Melbourne, 3002, 14th December, 1967.

In the Supreme Court of Victoria.—In the matter of the *Licensing Act 1958*, and in the matter of the *Lotteries Gaming and Betting Act 1966*, and in the matter of an application by COLIN RAFFAELLE SHARP to have the house or place situate at 276-278 Lonsdale-street, Melbourne, in the State of Victoria, and known as the "Paris Cabaret", declared a house or place where liquor is sold without a licence authorizing such sale.

BEFORE HIS HONOUR MR. JUSTICE STARKE IN CHAMBERS, MONDAY, THE 18TH DAY OF DECEMBER, 1967.

THIS Application coming on to be heard before me the 15th day of December 1967 and this day: And upon hearing Mr. Nettlefold of Counsel for the applicant and Mr. O'Callaghan of Counsel for the occupier Paulette Giret there being no appearance of the owner: And upon reading the affidavits with their respective exhibits of Colin Raffaele Sharp sworn the 8th day of December 1967 and of John Xavier Smith sworn the 18th day of December 1967: And having ordered that this application be disposed of in Chambers: I declare pursuant to the provisions of Section 48 of the *Licensing Act 1958* and Section 51 of the *Lotteries Gaming and Betting Act 1966* that the house or place situate at 276-278 Lonsdale Street, Melbourne and known as the Paris Cabaret is a house or place which is used as a house or place for the selling of liquor without a licence authorizing such sale: And I do order that this declaration shall not extend to the Barber's shop situate on the ground floor of the said house and known as 278 Lonsdale Street, Melbourne: And I do further order that the costs of the applicant of this application which are hereby fixed at \$120 be paid by the Respondent Paulette Giret.

JOHN STARKE, J.

This Order was taken out by Thomas Francis Mornane, Crown Solicitor and Solicitor for the Applicant.

#### NOTICE TO MARINERS.

[No. 21 of 1967]T.

#### AUSTRALIA.—VICTORIA.

##### WESTERNPORT.—BUOYS ESTABLISHED.

Position.—Tortoise Head Light, Latitude 38 deg. 24 min. 39 sec. South, Longitude 145 deg. 16 min. 23 sec. East (approximately).

Details.—Buoys have been established in the following positions:—

- (a) 7.45 miles, 132 deg. from the above position.
- (b) 1.25 miles, 128 deg. from (a).
- (c) 1.25 miles 188 deg. from (a).

Character.—The buoys are 44 gallon drums, carrying a wooden staff surmounted by orange coloured discs, standing 8 feet above water level.

The buoys will be withdrawn at the end of April, 1968.

Charts Affected.—B.A. No. 1707, Aust. 144.

D. P. BARKLEY,  
Deputy Port Officer.

Public Works Department,  
Ports and Harbours Branch,  
Treasury-place, Melbourne, 3002,  
28th December, 1967.

## APPOINTMENTS AND RESIGNATIONS

### APPOINTMENTS.

HIS Excellency the Governor of the State of Victoria, by and with the advice of the Executive Council thereof, has, by Orders made on the 19th day of December, 1967, been pleased to make the under-mentioned appointments, viz.:—

#### CHIEF SECRETARY'S DEPARTMENT.

##### Electoral Registrars (Acting).

##### RAE STOKLAY MCDOWELL

to be Electoral Registrar (Acting) for the Armadale Sub-division of the Electoral District of Caulfield; the Toorak Subdivision of the Electoral District of Malvern; and the Prahran and South Yarra Subdivisions of the Electoral District of Prahran; to take effect on and from the 2nd January, 1968, during the absence on leave of John Joseph Ireland; and

##### VICTOR ERNEST SPARK

to be Electoral Registrar (Acting) for the Footscray, Footscray North and Yarraville Subdivisions of the Electoral District of Footscray; the Kingsville Subdivision of the Electoral District of Sunshine, and the Newport subdivision of the Electoral District of Williamstown; to take effect on and from the 28th December, 1967, during the absence on leave of Douglas Stampler Taylor.

##### Licensing Inspector.

JAMES PATRICK RYAN, Inspector Grade I, to be a Licensing Inspector for the purposes of the *Licensing Act 1958*, vice Superintendent J. E. Matthews, resigned.

##### Honorary Probation Officers.

ALFRED GEORGE AUSTIN, (The Reverend), St. Mary's Rectory, Owen-street, Woodend,  
CATHERINE ELIZABETH BLEGG, (Mrs.), (Salvation Army Officer), 4 Wimmera-street, Stawell,  
MARGARET COATES BROWNING (Mrs.), "Riverslea", Box 43, Yarrowonga,  
VALERIE GILLES CROMIE, (Mrs.), 95 Wellington-street, Kew,  
SUSAN CURWOOD, (Mrs.), Flat 3, 127 Devonshire-road, Sunshine,  
THOMAS HENRY DONOHUE, 28 Hotham-street, Ballarat,  
CEDRIC COLIN GARRICK, 45 Heathwood-street, Ringwood,  
ELIZABETH MAITLAND McDONALD (Mrs.), Lorne-road, Winchelsea,  
KATHLEEN NANCY MARSHALL (Miss), care of High School, Epping-street, Kyneton,  
KEITH OTTO DOUGLAS NAGEL, (The Reverend), 108 Baillie-street, Horsham,  
CLIVE RANDOLPH SPEED, 33 Gummon-street, Swan Hill,  
DAVID LEWIS STOKES, care of Patterson, Riverside-drive, Warburton,  
JOHN DAVID TIPPING, Main-road, Sassafras,  
AALTJE CORNALIA WIERENGA, (Mrs.), 20 Epping-street, Kyneton,  
RAYMOND CANT, View-street, Lakes Entrance,  
KATHLEEN SARA COLBERT (Mrs.), Wayside Delivery, Nhill,  
ALAN HOWARD COULSON, (The Reverend), 12 Warringa-road, Frankston,  
GRAEME MACAULAY HINDSON, 108 Cranbourne-road, Frankston,  
JOHN DAVID MCCONCHIE, 10 Bowden-street, Wendouree, Victoria; and  
RAYMOND CHARLES OUTHRED, (The Reverend), 10 Pynsent-street, Horsham,  
pursuant to the provisions of Section 10 (1) of the *Children's Court Act 1958*, to be Honorary Probation Officers for all Children's Courts in Victoria.

#### MINISTRY OF HEALTH.

##### Committee of Management of a Hospital.

JOHN MCGANN to be a Member of the Committee of Management of the Kilmore Hospital, pursuant to proviso (a) to Section 48 (1) of the *Hospitals and Charities Act 1958* for a further period ending 18th January, 1971.

##### Superintendent of a Mental Hospital.

PHILIP ROBERT WOOD, M.B., Ch.B., D.P.M., to be Superintendent, Mental Hospital Warrambool, pursuant to Section 26 (1) of the *Mental Health Act 1959* for the period from 4th January, 1968, to 18th January, 1968, both dates inclusive, vice Dr. T. R. Leonard, on leave.

*Deputy Superintendent of a Mental Hospital.*

MICHAEL DOCKETT YOUNGS, M.B., B.S.,  
to be Deputy Superintendent, Beechworth Mental Hospital  
and Training Centre, pursuant to Section 26 (1) of the  
*Mental Health Act 1959* as from and including the 29th  
December, 1967, vice Dr. E. (Yu Kuen) Chiu.

## LAW DEPARTMENT.

*Justices of the Peace.*

JOHN ALBERT LUCAS, Town Hall, Chapel-street,  
Prahran,  
ERIC CLARENCE WHITE, 464 Upper Heidelberg-road,  
Heidelberg; and  
THOMAS FREDERICK RICH, 7 Eden-street, Heidelberg  
West,

to Keep the Peace in the Central Bailiwick of the State of  
Victoria.

GEOFFREY REGINALD CLARKE, "Linden Park", Long-  
wood; and

FREDERICK HENRY TUBB, "Trevallyn", Longwood,  
to Keep the Peace in the Northern Bailiwick of the State  
of Victoria.

LEONARD ALFRED GLOSTER, 88 Edgecombe-street,  
Kyneton,  
to Keep the Peace in the Midland Bailiwick of the State  
of Victoria.

*Commissioners for Taking Declarations, &c.*

ALMA MARY WILSON, care of Housing Commission,  
Victoria, 179 Queen-street, Melbourne; and  
LESLIE JAMES HARDING, care of Department of Crown  
Lands and Survey, State Public Offices, Treasury-  
place, Melbourne,  
to be Commissioners for taking Declarations and Affidavits,  
pursuant to the provisions of the *Evidence Act 1958*, to  
refrain from charging fees and to resign upon ceasing to  
occupy their present positions.

WILLIAM ARTHUR KELLOW, care of Imperial Chemical  
Industries of Australia and New Zealand Limited,  
Pigments Plant, Old Geelong-road, Laverton; and  
LAURENCE WILLIAM DAVISON, care of Sidney Cooke  
Chemicals Pty. Ltd., 3 Millers-road, Brooklyn,  
to be Commissioners for taking Declarations and Affidavits,  
pursuant to the provisions of the *Evidence Act 1958*, to  
resign upon ceasing to occupy their present positions.

NEIL FREDERICK TAYLOR, 5 Bluff-road, Black Rock,  
to be a Commissioner for taking Declarations and Affi-  
davits, pursuant to the provisions of the *Evidence Act*  
1958, to resign upon removing from the neighbourhood of  
the address stated.

*Deputy Prothonotary.*

GRAHAM JOSEPH COLLINS, Clerk of Courts,  
to be Deputy Prothonotary at Ararat, Registrar of the  
County Court at Ararat and Deputy Clerk of the Peace  
for the Western Bailiwick during the absence of J. L.  
Thompson on recreation leave, to take effect from the  
date of commencement of duty.

*Clerk of the Children's Court.*

GEOFFREY JOHN WATERS, Clerk of Courts,  
to be Clerk of the Children's Court at Beechworth, Bright,  
Myrtleford and Yackandandah and Assistant Registrar of  
the County Court at Wangaratta, during the absence of  
A. Spencer on recreation leave, to take effect from the date  
of commencement of duty.

*Clerk of Petty Sessions.*

GEOFFREY MELVILLE PHILPOTT, Clerk of Courts,  
to be Clerk of Petty Sessions at Healesville in the place of  
L. T. Gould, relieved, to take effect from the date of  
commencement of duty.

## PUBLIC WORKS DEPARTMENT.

*Members of Marine Board of Victoria.*

VAIBEN LOUIS SOLOMON  
to be a Member of the Marine Board for a period of three  
years from the 21st December, 1967; and

RICHARD PERCIVAL FRIEND  
to be a Member of the Marine Board for a period of three  
years from the 12th January, 1968, pursuant to the provi-  
sions of the Marine Acts.

*Vice President of the Marine Board of Victoria.*

PERCY WILLIAM MERRETT  
to be Vice President of the Marine Board for a period of  
three years from 19th December, 1967, pursuant to the  
provisions of the Marine Acts.

*Wharf Manager.*

Constable ARCHIBALD ANDREW LOGAN, No. 10191,  
to be Wharf Manager at Lorne, to carry out that portion  
of Part II. of the *Marine Act 1958*, which relates to the  
Management of Public Wharfs, and to be an officer under  
Section 19 of such Act to levy and collect wharfage rates  
thereat, vice Senior Constable Glen Sydney Wilmot Croft,  
No. 11510, transferred.

## DEPARTMENT OF THE TREASURER.

RONALD FRANCIS SCOLLARD  
to act temporarily as Collector of Imposts, Registry of  
Co-operative Housing Societies and Co-operative Societies,  
vice M. V. Hammond, on recreation leave.

MAURICE JAMES FAREY  
to act temporarily as Collector of Imposts, Fisheries and  
Wildlife Department, vice R. G. P. Uhd on recreation leave.

IAN JAMES BENNETT  
to act temporarily as Receiver of Revenue, Korumburra,  
vice L. E. Breen, on recreation leave.

J. ROSSITER,  
Clerk of the Executive Council.

At the Executive Council Chamber,  
Melbourne, 19th December, 1967.

## RESIGNATIONS.

HIS Excellency the Governor of the State of Victoria,  
by and with the advice of the Executive Council  
thereof, has, by Orders made on the 19th day of December,  
1967, accepted the resignations of the persons named  
hereunder of the offices mentioned, viz.:—

## CHIEF SECRETARY'S DEPARTMENT.

*Licensing Inspector.*

JOHN BROWN SKEA, as a Licensing Inspector for the  
purposes of the *Licensing Act 1958*.

## LAW DEPARTMENT.

*Justices of the Peace.*

The persons named in the first column of the Schedule  
hereto, from the Commission of the Peace for the respec-  
tive Bailiwicks of the State of Victoria set opposite their  
names in the second column of the said Schedule, be  
accepted.

## SCHEDULE.

Name.	Bailiwick.
PHYLLIS JEAN ORAM	Midland
ERIC CLARENCE WHITE	Southern

J. ROSSITER,  
Clerk of the Executive Council.

At the Executive Council Chamber,  
Melbourne, 19th December, 1967.

## ORDERS IN COUNCIL

## LOCAL GOVERNMENT DEPARTMENT.

At the Executive Council Chamber, Melbourne, the  
nineteenth day of December, 1967.

## PRESENT:

His Excellency the Governor of Victoria.  
Mr. Porter | Mr. Hamer.

## ROAD DISCONTINUED.—CITY OF MELBOURNE.

WHEREAS it is provided in Section 528 (2) of the *Local  
Government Act 1958*, as amended, that where a road  
(whether or not a public highway but not being a road  
set out on land of the Crown) or any part thereof is not  
required for public use, the Governor-in-Council, on the  
request of the Council of the municipality in which such  
road is situated made not less than one month after pub-  
lishing in a newspaper generally circulating in the district  
and posting to the registered proprietor (if any) of the  
land and any person known to have an interest in the land  
notice of intention to make such a request may by Order  
published in the *Government Gazette* direct that such road  
or part shall be discontinued and thereupon such road or  
part shall be discontinued accordingly.

AND WHEREAS the Council of the City of Melbourne has requested that the Governor-in-Council direct that a right-of-way, off Little Dryburgh Street South, North Melbourne, be discontinued and not less than one month previously, has published in a newspaper generally circulating in the district and posted to the proprietor of the land in the said road and to all persons known to have an interest in the said land notice of intention to make such request.

NOW THEREFORE, His Excellency the Governor of the State of Victoria, by and with the advice of the Executive Council thereof, hereby directs that the said road, which is shown hatched on the plan hereunder, shall be discontinued and that the land may be sold by the Council of the City of Melbourne by agreement.

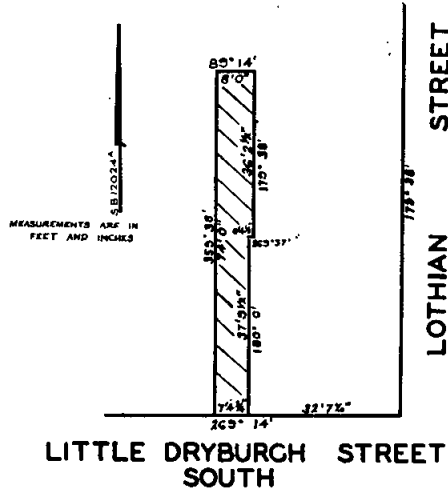

**LITTLE DRYBURGH STREET SOUTH**

**THE FEE OF THE LAND WAS, ON THE 27-11-1967, UNDER THE OLD LAW.**

And the Honorable Rupert James Hamer, Her Majesty's Minister for Local Government for the State of Victoria, shall give the necessary directions herein accordingly.

J. ROSSITER,  
Clerk of the Executive Council.

**LOCAL GOVERNMENT DEPARTMENT.**

*At the Executive Council Chamber, Melbourne, the nineteenth day of December, 1967.*

PRESENT:  
His Excellency the Governor of Victoria.  
Mr. Porter | Mr. Hamer.

**ROAD DISCONTINUED.—CITY OF FITZROY.**

WHEREAS it is provided in Section 528 (2) of the *Local Government Act 1958*, as amended, that where a road (whether or not a public highway but not being a road set out on land of the Crown) or any part thereof is not required for public use, the Governor-in-Council, on the request of the Council of the municipality in which such road is situated made not less than one month after publishing in a newspaper generally circulating in the district and posting to the registered proprietor (if any) of the land and any person known to have an interest in the land notice of intention to make such a request may by Order published in the *Government Gazette* direct that such road or part shall be discontinued and thereupon such road or part shall be discontinued accordingly.

AND WHEREAS the Council of the City of Fitzroy has requested that the Governor-in-Council direct that a right-of-way off Napier Street, Fitzroy be discontinued and not less than one month previously has published in a newspaper generally circulating in the district and posted to the registered proprietor of the land in the said road and to all persons known to have an interest in the said land notice of intention to make such request.

NOW THEREFORE, His Excellency the Governor of the State of Victoria, by and with the advice of the Executive Council thereof, hereby directs that the said road, which is shown hatched on the plan hereunder, shall be discontinued and that the land may be sold by the Council of the City of Fitzroy by agreement.

**LITTLE VICTORIA STREET**

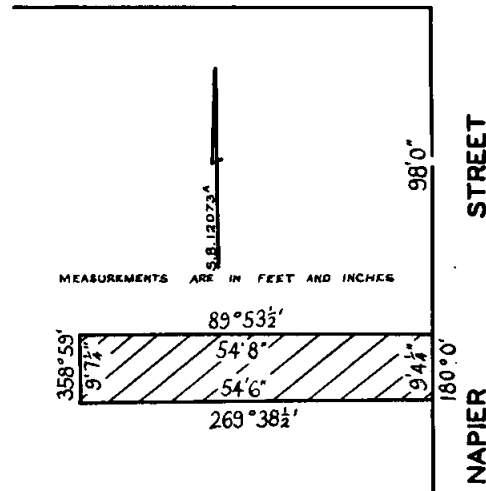

**THE FEE OF THE LAND WAS, ON THE 30-11-1967, UNDER OLD LAW**

And the Honorable Rupert James Hamer, Her Majesty's Minister for Local Government for the State of Victoria, shall give the necessary directions herein accordingly.

J. ROSSITER,  
Clerk of the Executive Council.

**LOCAL GOVERNMENT DEPARTMENT.**

*At the Executive Council Chamber, Melbourne, the nineteenth day of December, 1967.*

PRESENT:  
His Excellency the Governor of Victoria.  
Mr. Porter | Mr. Hamer.

**ROAD DISCONTINUED.—SHIRE OF ELTHAM.**

WHEREAS it is provided in Section 528 (2) of the *Local Government Act 1958*, as amended, that where a road (whether or not a public highway but not being a road set out on land of the Crown) or any part thereof is not required for public use, the Governor-in-Council, on the request of the Council of the municipality in which such road is situated made not less than one month after publishing in a newspaper generally circulating in the district and posting to the registered proprietor (if any) of the land and any person known to have an interest in the land notice of intention to make such a request may by Order published in the *Government Gazette* direct that such road or part shall be discontinued and thereupon such road or part shall be discontinued accordingly.

AND WHEREAS the Council of the Shire of Eltham has requested that the Governor-in-Council direct that York Street, Eltham, be discontinued and not less than one month previously has published in a newspaper generally circulating in the district and posted to the registered proprietor of the land in the said road and to all persons known to have an interest in the said land notice of intention to make such request.

NOW THEREFORE, His Excellency the Governor of the State of Victoria, by and with the advice of the Executive Council thereof, hereby directs that the said road, which

is shown hatched on the plan hereunder, shall be discontinued and that the land shall be retained by the municipality for municipal purposes.

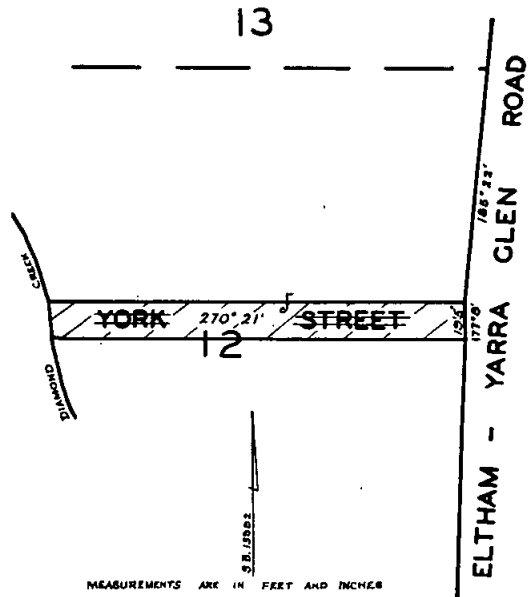

**THE FEE OF THE LAND WAS, ON THE 29-11-1967, UNDER OLD LAW**

And the Honorable Rupert James Hamer, Her Majesty's Minister for Local Government for the State of Victoria, shall give the necessary directions herein accordingly.

J. ROSSITER,  
Clerk of the Executive Council.

DEPARTMENT OF CROWN LANDS AND SURVEY.

At the Executive Council Chamber, Melbourne, the nineteenth day of December, 1967.

PRESENT:  
His Excellency the Governor of Victoria.  
Mr. Porter | Mr. Hamer.

REVOCATION OF TEMPORARY RESERVATION OF LAND BY ORDER IN COUNCIL.

HIS Excellency the Governor of the State of Victoria, by and with the advice of the Executive Council thereof, doth hereby, in pursuance of the provisions of the Land Act 1958, revoke the temporary reservation of land by Order in Council hereinafter referred to, viz.:—

CARLTON.—Order in Council of 31st October, 1922, of 1 acre 1 rood 14 perches of land at Carlton, in the Parish of Jika Jika, as a site for State School purposes, so far only as regards the portion thereof comprised within the boundaries published in the Government Gazette of 15th November, 1967, and containing 1 acre 0 roods 28 perches.—(Rs.2528.)

CORRYONG.—Order in Council of 20th August, 1888, of 137 acres 1 rood of land in the Township of Corryong, as a site for a Racecourse and other purposes of Public Recreation, revoked as to part by Order in Council of the 24th August, 1909, and the temporary reservation for the additional purpose of Show Yards of the balance by Order in Council of the 12th October, 1909, so far only as regards the portion thereof comprised within the boundaries published in the Government Gazette of 8th November, 1967, and containing 1 acre 2 roods 32 perches.—(Rs.1930.)

EDENHOPE.—Order in Council of the 6th November, 1907, of 6 acres of land in the Township of Edenhope as a site for Public Park and Gardens, revoked as to part by Order in Council of the 12th August, 1940, and the temporary reservations by Orders in Council of the 12th

August, 1940, 3rd September, 1946 and 8th November, 1949, of 3 acres 0 roods 17 perches, 7 acres 2 roods, more or less and 29 perches respectively, as additions thereto and the temporary reservation by Order in Council of the 23rd September, 1952, for the additional purpose of Public Recreation.—(Rs.2468.)

KAANGLANG.—Order in Council of 19th March, 1883, of 20 acres, more or less of land in the Parish of Kaanglang, revoked as to part by Order in Council of 16th August, 1955.—(Rs.4936.)

MOCKINYA.—Order in Council of 12th December, 1881, of 34 acres 3 roods 38 perches of land in the Parish of Mockinya, as a site for affording access to water, and revoked as to part by various Orders, so far only as regards the portion thereof comprised within the boundaries published in the Government Gazette of 8th November, 1967, and containing 1 acre 2 roods 15 perches, more or less.—(Rs.2833.)

PORTARLINGTON.—Order in Council of 28th November, 1938, of 10 acres 3 roods 3 perches of land in the Township of Portarlinton, as a site for Public purposes, so far only as regards the portion thereof comprised within the boundaries published in the Government Gazette of 15th November, 1967, and containing 2 acres 1 rood, more or less.—(Rs.4899.)

RUPANYUP.—Order in Council of 28th October, 1889, of 265 acres, more or less of land in the Parish of Rupanyup, as a site for Water Supply purposes and the temporary reservation by Order in Council of the 18th April, 1902, of 22 acres 3 roods 22 perches of land as an extension thereto.—(Rs.8882.)

TARRAGAL AND TREWALLA.—Order in Council of 27th February, 1878, of 60 acres of land in the Parishes of Tarragal and Trewalla, as a site for Public Recreation.—(C.95505.)

WARRION.—Order in Council of 30th September, 1878, of 3 acres of land in the Parish of Warrion, as a site for Public purposes (State School).—(Rs.8505.)

And the Honorable Sir William John Farquhar McDonald, Her Majesty's Minister of Lands for the State of Victoria, shall give the necessary directions herein accordingly.

J. ROSSITER,  
Clerk of the Executive Council.

DEPARTMENT OF CROWN LANDS AND SURVEY.

At the Executive Council Chamber, Melbourne, the nineteenth day of December, 1967.

PRESENT:  
His Excellency the Governor of Victoria.  
Mr. Porter | Mr. Hamer.

LANDS PERMANENTLY RESERVED AS SITES.

HIS Excellency the Governor of the State of Victoria, by and with the advice of the Executive Council thereof, doth hereby, in pursuance of section 14 of the Land Act 1958, reserve permanently from sale and from being leased and from having a licence granted in respect thereof and also except from occupation for mining purposes under any miner's right, the lands hereinafter described:—

BELLARINE.—200 acres in the Parish of Bellarine, County of Grant, as defined by the description published in the Government Gazette, of 15th November, 1967, which is required for Public Park.—(Rs.8895.)

DOWLING FOREST.—41 acres 3 roods 20 perches more or less in the Parish of Dowling Forest, County of Ripon, as defined by the description published in the Government Gazette, of 12th July, 1967, which is required for Public Recreation.—(Rs.6805.)

And the Honorable Sir William John Farquhar McDonald, Her Majesty's Minister of Lands for the State of Victoria, shall give the necessary directions herein accordingly.

J. ROSSITER,  
Clerk of the Executive Council.

**LANDS DEPARTMENT NOTICES**

**APPROACHING LAND SALES.**

**S**ALES of Crown Lands, in fee-simple, will be held at the under-mentioned places and dates, viz.:—

Sale.—Saturday, 20th January, 1968	No. of Gazette. 94
------------------------------------	--------------------

**SALE OF FREEHOLD LAND BY AUCTION.**

Geelong.—Monday, 16th January, 1968	89
-------------------------------------	----

**PROPOSED REVOCATIONS OF TEMPORARY RESERVATIONS OF LANDS BY ORDERS IN COUNCIL.**

**I**N pursuance of the provisions of the Land Act 1958, notice is hereby given that it is the intention of the Governor in Council to revoke the temporary reservations of lands by Orders in Council hereunder referred to, viz.:—

The following Notices were published 1° on the 6th December, 1967, pursuant to Orders of the 28th November, 1967.

**ASHENS.**—The temporary reservation, by Order in Council of the 31st October, 1922, of 10 acres (shown as 8 acres 3 roods 6 perches on Order) of land in the Parish of Ashens as sites for Supply of Loam is about to be revoked.—(A.168<sup>(8)</sup>) (Rs.2644).

**SMYTHESDALE.**—The temporary reservation, by Order in Council of the 6th November, 1865, of 815 acres 2 roods 15 perches of land in the Parish of Smythesdale as a site for Drainage Area of a Reservoir for supplying water to Smythesdale, revoked as to part by various Orders, is about to be revoked so far only as the portion containing 20 acres 30 perches, more or less, indicated by hatching on plan hereunder, is concerned.—(S.297<sup>(8)</sup>) (C.71778).

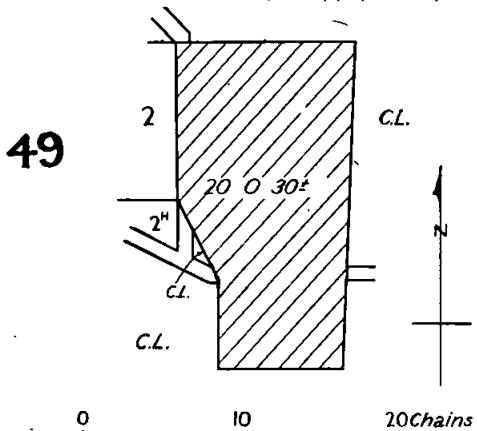

**WARRANTYTE (ANDERSONS CREEK).**—The temporary reservation, by Order in Council of the 17th September, 1866, of 14 acres 2 roods of land in the Township of Warrandyte as a site for Recreation purposes, revoked as to part by various Orders, is about to be revoked so far only as the portion containing 18 perches, indicated by hatching on plan hereunder, is concerned.—(W.25<sup>(4)</sup>) (Rs.653).

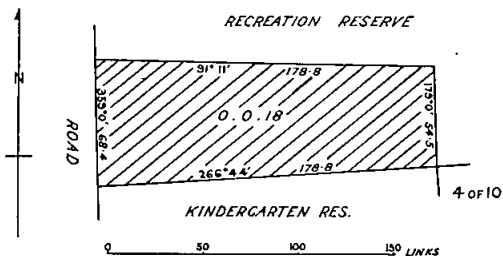

W. J. F. McDONALD,  
Minister of Lands.

**PROPOSED PERMANENT RESERVATION OF LAND AS A SITE.**

**I**N pursuance of sections 14 and 21 of the Land Act 1958, notice is hereby given that it is the intention of the Governor in Council to reserve permanently from sale, from being leased and from having a licence granted in respect thereof the land hereinafter described:—

The following Notice was published 1° on the 6th December, 1967, pursuant to Order of the 28th November, 1967.

**CUNNINGHAME.**—Land proposed to be permanently reserved as a site for Public Recreation 7 acres, more or less, Township of Cunninghame, Parish of Colquhoun, County of Tambo, as indicated by hatching on plan hereunder.—(C.486<sup>(9)</sup>) (Rs.8888).

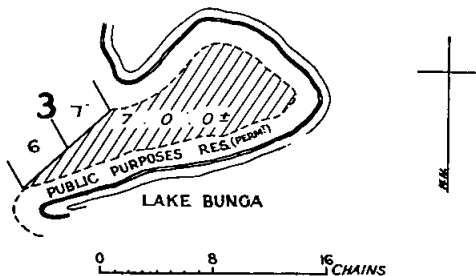

W. J. F. McDONALD,  
Minister of Lands.

**PROPOSED REVOCATIONS OF TEMPORARY RESERVATIONS OF LANDS BY ORDERS IN COUNCIL.**

**I**N pursuance of the provisions of the Land Act 1958, notice is hereby given that it is the intention of the Governor in Council to revoke the temporary reservations of lands by Orders in Council hereunder referred to, viz.:—

The following Notices were published 1° on the 20th December, 1967, pursuant to Orders of the 12th December, 1967.

**SANDHURST (BENDIGO).**—The temporary reservation, by Order in Council of the 26th May, 1925, of several portions of land at Bendigo in the Parish of Sandhurst as sites for Public purposes (Sewerage), revoked as to part by Order of the 30th June, 1964, is about to be revoked so far only as the portion containing 12 perches, indicated by hatching on plan hereunder, is concerned.—(S.372<sup>(113)</sup>) (C.73802).

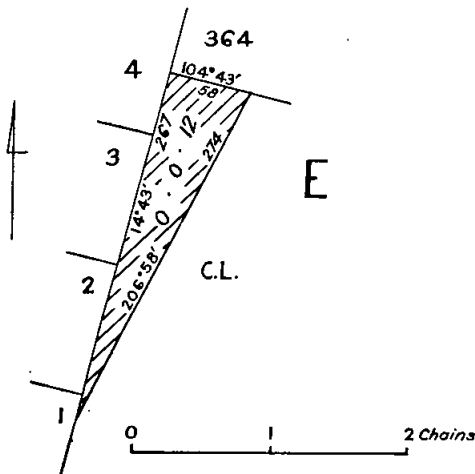

**NUNAWADING.**—The temporary reservation as a site for Public purposes (State School) and the withholding from sale, leasing and licensing by Order in Council of the 14th February, 1876, of 2 acres of land in the Parish of Nunawading are about to be revoked so far only as the portion containing 7 perches, indicated by hatching on plan hereunder, is concerned.—(N.79<sup>(6)</sup>) (Rs.5471).

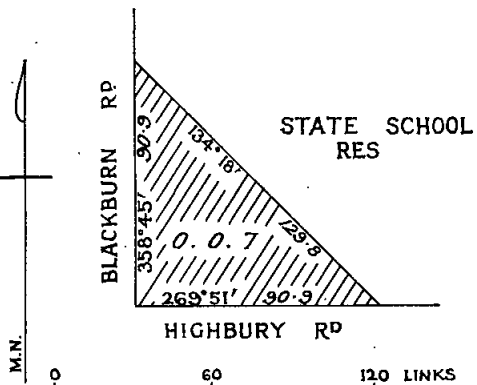

**BANNOCKBURN.**—The temporary reservation, by Order in Council of the 26th June, 1962, of 2 roods of land in the Township of Bannockburn as a site for Public Hall is about to be revoked so far only as the portion containing 24 perches, indicated by hatching on plan hereunder, is concerned.—(B.35<sup>(1)</sup>) (Rs.2121).

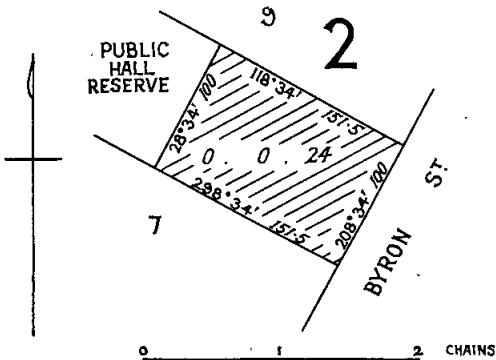

**BOORT.**—The temporary reservation, by Order in Council of the 20th March, 1946, of 14 acres 1 rood, more or less, of land in the Township of Boort as a site for Plantation purposes is about to be revoked so far only as the portion containing 5 perches, indicated by hatching on plan hereunder, is concerned.—(B.654<sup>(10)</sup>) (Rs.5764).

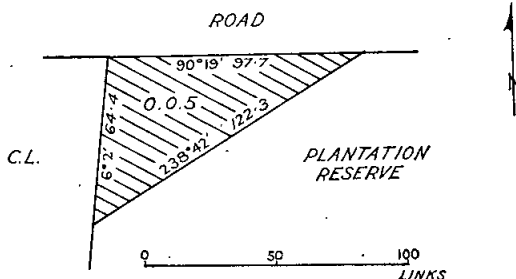

**HEYWOOD.**—The temporary reservation as a site for Public purposes (State School) and the withholding from sale, leasing and licensing by Order in Council of the 21st May, 1877, of 1 acre 2 roods 34 8/10 perches of land in the Township of Heywood, revoked as to part by Order in Council of the 24th April, 1939, are about to be revoked so far as the balance thereof, containing 1 acre 2 roods, is concerned.—(H.86<sup>(3)</sup>) (Rs.5267).

**DUNKELD.**—The temporary reservation, by Order in Council of the 15th August, 1898, of 1 acre 1 rood 30 perches of land in the Township of Dunkeld as a site for Public Gardens is about to be revoked.—(D.143<sup>(3)</sup>) (C.81449).

**BRUARONG.**—The temporary reservation, by Order in Council of the 11th November, 1867 (see *Government Gazette* 19th November, 1867, page 2232), of 3 roods 4 perches of land in the Township of Hillsborough (now in the Parish of Bruarong), as a site for Common School purposes is about to be revoked.—(H.119<sup>(1)</sup>) (Rs.8913).

W. J. F. McDONALD,  
Minister of Lands.

**PUBLIC SERVICE NOTICE**

No. 1805.

*Public Service Act 1958.*

**REGULATIONS.—PART IV.—SALARIES AND INCREMENTS.**

THE Public Service Board, in pursuance of the powers conferred by the *Public Service Act 1958*, hereby amends its Regulations as shown below—

**FIRST SCHEDULE.**

**PROFESSIONAL DIVISION.**

*Amount of Salary Assigned to Offices in "Special" Class.*

Office.	Yearly Rate of Salary.
<b>LAW DEPARTMENT.</b>	
<i>Delete the existing yearly rates of salary for the following offices and insert the rates shown hereunder in lieu thereof—</i>	
Crown Solicitor .. .. .	13,340
Parliamentary Draftsman .. .. .	13,340
Registrar-General and Registrar of Titles .. .. .	11,640
Assistant Crown Solicitor .. .. .	10,350
Assistant Parliamentary Draftsman .. .. .	10,350

**THIRD SCHEDULE.**

**PART B.**

**PROFESSIONAL DIVISION.**

*Scale of Rates of Annual Salaries.*

**OFFICERS CLASSIFIED IN "SPECIAL" CLASS.**

The amount "\$12,458" is deleted and the amount "\$13,340" is inserted in lieu thereof.

**LEGAL OFFICERS.**

The salary scale shown is deleted and the following salary scale is inserted in lieu thereof—

Class.	Annual Salary of Each Subdivision of Each Class.						
	1.	2.	3.	4.	5.	6.	7.
LO-1 ..	2,884	2,999	3,114	3,229	..	..	..
LO-2 ..	3,456	3,571	3,686	..	..	..	..
LO-3 ..	3,571	3,686	3,768	3,934	4,309	4,684	4,986
LO-4 ..	5,475	5,652	5,963	6,238	..	..	..
LO-5 ..	6,529	..	..	..	..	..	..
LO-6 ..	6,820	..	..	..	..	..	..
LO-7 ..	7,487	..	..	..	..	..	..
LO-8 ..	7,778	..	..	..	..	..	..
LO-9 ..	8,298	..	..	..	..	..	..
LO-10 ..	8,799	..	..	..	..	..	..

*This Regulation shall have effect as on and from the 17th December, 1967.*

F. E. CAHILL, Chairman.

V. P. SCULLY, Secretary.

Office of the Public Service Board,  
Melbourne, 15th December, 1967.

**PRIVATE ADVERTISEMENTS****NOTICE OF INTENTION TO APPLY FOR A LICENCE TO DIVERT WATER AND CUT RACE (RE-ISSUE) FROM THE RIVER MURRAY, AT ROBINVALE.**

I HEREBY give notice that I intend to apply for a licence empowering me to divert water for a term of three years to the extent of 45 acre-feet per annum at a maximum rate of 4 acre-feet per day of 24 hours for the irrigation of grass fairways, being part of allotment 8n, section A, Parish of Bumbang, and to occupy certain Crown lands for works of diversion, and to cut a race thereon.

Any objection to such application must be forwarded, in writing, to reach the State Rivers and Water Supply Commission, Melbourne, before 5th February, 1968, being 30 days from the first publication of this notice.

ROBINVALE GOLF CLUB.  
(per G. L. Lackman, Manager.)

P.O. Box 436, Robinvale. 661

**NOTICE OF INTENTION TO APPLY FOR A LICENCE TO DIVERT WATER AND CUT RACE (RE-ISSUE) FROM THE RIVER MURRAY, AT THOLOGOLONG.**

I HEREBY give notice that I intend to apply for a licence empowering me to divert water for a term of four years to the extent of 100 acre-feet per annum at a maximum rate of 2 acre-feet per day of 24 hours for the irrigation of 50 acres for pastures and crops, being part of allotment 11, section 2, Parish of Thologolong, and to occupy certain Crown lands for works of diversion, and to cut a race thereon.

Any objection to such application must be forwarded, in writing, to reach the State Rivers and Water Supply Commission, Melbourne, before 1st February, 1968, being 30 days from the first publication of this notice.

RONALD JAMES CONIBEAR.

"Clovelly", Private Bag, Wodonga. 658

**NOTICE OF INTENTION TO APPLY FOR A LICENCE TO DIVERT WATER AND CUT RACE FROM THE RIVER MURRAY, ANA-BRANCH, AT GOORAMADDA.**

I HEREBY give notice that I intend to apply for a licence empowering me to divert water for a term of four years to the extent of 60 acre-feet per annum at a maximum rate of 1 acre-foot per day of 24 hours for the irrigation of summer crops, being part of allotment 1, section B.1, Parish of Gooramadda, and to occupy certain Crown lands for works of diversion, and to cut a race thereon.

Any objection to such application must be forwarded, in writing, to reach the State Rivers and Water Supply Commission, Melbourne, before 5th February, 1968, being 30 days from the first publication of this notice.

WILLIAM THOMAS NORMAN.

"Stretton," Gooramadda, Vic. 633

**Water Acts.****PROPOSED WATERWORKS TRUST.**

NOTICE is hereby given that the Mansfield Shire Council has made application to the Honorable the Minister of Water Supply for the constitution of a Waterworks Trust, and for the proclamation of a Waterworks District at and the construction, maintenance, and continuance of Water Supply Works within that District under the provisions of the Water Acts.

A general plan and description of the proposed works have been submitted with the application, and copies of same may be seen at the Shire Office at Mansfield and at the General Store at Woods Point.

Any objections should be forwarded to the undersigned.

Dated at Mansfield the 20th day of December, 1967.

660 R. WOMERSLEY, Secretary.

**COBRAM SEWERAGE AUTHORITY.**

PURSUANT to the Sewerage Districts Act, the Cobram Sewerage Authority gives notice:—

(a) That the nature of the works in respect of which the land hereafter described is proposed to be taken is to construct a sewerage pumping station.

(b) A plan or description of the proposed works will be open for inspection at the Offices of the Shire of Cobram from 6th December, 1967 to 6th January, 1968, both inclusive, from 9 a.m. to 5.15 p.m. each day.

(c) The quantity of the land the Sewerage Authority requires for the purpose described above is 750 square feet or thereabouts; and

(d) The land proposed to be taken is part of lot 19 of lodged plan 13529 in Crown allotment 43, Parish of Cobram, County of Moira and commences at the north-western angle of the said lot 19; thence by lines bearing 89 deg. 56 min. a distance of 15 feet, 179 deg. 56 min. a distance of 50 feet, 269 deg. 56 min. a distance of 15 feet and 359 deg. 56 min. a distance of 50 feet to the point of commencement, being an area within the existing Sewerage District.

Dated this 27th day of November, 1967.

The common seal of the Chairman, Members and Ratepayers of the Cobram Sewerage Authority was hereunto affixed this 25th day of November, 1967, in the presence of—

(SEAL) JAMES COX, Chairman.  
ROBERT HOSIE, Member.  
RONALD CUTTS, Secretary.

657

**ROCHESTER SEWERAGE AUTHORITY.**

THE Rochester Sewerage Authority which proposes to compulsorily take the land hereinafter described and which has obtained the consent of the Governor in Council to such proposed compulsory taking hereby publishes the following advertisement in pursuance of section 111 of the Sewerage Districts Act 1958, viz.:—

(a) The nature of the works in respect of which such land is proposed to be taken is the building or construction of all necessary and usual works for the operation of Sewerage Treatment Farm thereon and all things or matters appertaining to and incidental to such operation.

(b) A plan or description of the proposed works is open for inspection at the Municipal Offices, Rochester, between the hours of 9 a.m. and 12 noon and 1.30 p.m. and 4.30 p.m. on week days other than public holidays.

(c) The land which is required for the purpose of such works is Crown allotment 71, Parish of Rochester West, County of Bendigo, containing 100 acres or thereabouts being the land described in certificate of title volume 1016, folio 133, and Crown allotment 72, Parish of Rochester West, County of Bendigo, containing 96 acres or thereabouts being part of the land described in certificate of title volume 4100, folio 882. The boundaries of which are shown on a plan approved by the Governor in Council and deposited in the office of the State Rivers and Water Supply Commission, Melbourne.—(Corr. 61/1601/34.)

The quantity of land required for the purpose of such works as aforesaid is the whole of the afore-mentioned land comprised in the said allotments 71 and 72 and the particulars of the right power or privilege which the Rochester Sewerage Authority requires for the purpose of such works is an unencumbered estate in fee simple as owner of the said land.

For and on behalf of the Rochester Sewerage Authority.

H. R. WESTCOTT, Secretary.

Dated this 27th day of December, 1967. 692

**WANGARATTA WATERWORKS TRUST.****POLLUTION OF WATER.**

IN pursuance of the powers conferred by Division 4 of Part V. of Water Act 1958, notice is given that bathing is prohibited in the Ovens River between the confluence with the King River and the bridge over the Ovens River carrying the north bound lane of the Hume Highway.

672 W. R. FEATHERSTON, Town Clerk.

**MOE WATERWORKS TRUST.****EIGHTH SCHEDULE.**

NOTICE to owners of tenements in the under-mentioned streets and private streets, lanes, courts and alleys opening thereto.

Jubilee-street  
Desmond-street, No. 13.

The main pipe in the said streets being laid down the owners of all tenements situated as above are hereby required on or before the 1st day of January, 1968 next, to cause a proper pipe and stop cocks to be laid so as to supply water within such tenements from the main pipe.

A. DEWAR,  
682 Secretary of the Moe Waterworks Trust.



## CHARLTON WATERWORKS TRUST.

BY-LAW No. 88.

*Water Restrictions: Stage Five.*

1. This By-Law shall come into operation at such time as the Trust from time to time directs by notice published in a newspaper circulating generally within the District and cease to have operation at such time as the Trust from time to time directs by a notice so published.

2. Subject to provisions of Clauses 3 and 4 of this stage, no person shall, with water supplied by the Trust—

(a) Water any garden, lawn or other land (other than commercial market gardens, commercial nurseries or land used for growing of green feed for commercial poultry farms) within the specified area except by means of a hose held in the hand or by means of a can or other vessel held in the hand, between the hours of 5.30 p.m. and 8 p.m. of each day.

(b) Fill, add to, or cleanse any private swimming pool within the specified area.

3. No person shall, with water supplied by the Trust, water any commercial market gardens, commercial nurseries or land used for growing green feed for commercial poultry farms within the specified area by means of fixed sprinklers between the hours of 5.30 p.m. and 8 p.m. each day.

4. No person shall, with water supplied by the Trust, water any land comprising sports grounds, golf courses, race courses, public and club tennis courts and public and club bowling and croquet grounds within the specified area by means of fixed sprinklers, except during the maximum period of 14 hours a week at times and under conditions to be determined by the Trust.

5. Every person who uses or permits or suffers water supplied by the Trust to be used contrary to the provisions of this By-Law shall be guilty of an offence, and shall be liable to a penalty not exceeding One Hundred Dollars.

6. No person shall wash a car within the specified area by means of a hose held in the hand.

7. If any person supplied with water from the Trust, wrongfully does, or causes or permits to be done, anything in contravention of this By-Law, the Trust may (without prejudice to any remedy in respect thereof) close or cut off any of the pipes by or through which water is supplied to that person for that persons use and may cease to supply that person with water as provided by the *Water Act 1958*.

The foregoing By-Law was made by the Charlton Waterworks Trust on the 13th day of November, 1967, and the common seal of the said Trust was hereunto affixed, the 13th day of November, 1967, in the presence of—

(SEAL) V. J. RYAN, Commissioner.  
W. H. WOOD, Commissioner.  
A. F. HELYAR, Secretary.

This is a certified copy of By-law No. 88, approved by the Governor in Council at the Executive Council meeting held on 5th December, 1967.—G. W. LEWIS, Secretary, State Rivers and Water Supply Commission. 728

## CITY OF BROADMEADOWS.

NOTICE is hereby given that the Council of the City of Broadmeadows appointed First Constable Donald Matthies, No. 9823 as Prosecuting Officer for the City of Broadmeadows, in place of First Constable John Raymond Causer, No. 11222, who has resigned.

J. T. SMITH, Acting Town Clerk.

Municipal Offices, Broadmeadows. 649

## CITY OF CAULFIELD.

LOAN No. 49.

*Notice of Intention to Borrow the Sum of \$114,000 for Permanent Works and Undertakings.*

NOTICE is hereby given that the Council of the City of Caulfield proposes to borrow the sum of \$114,000 on the credit of the municipal revenues of the Mayor, Councillors and Citizens of the said city, such sum to be raised by the grant of a mortgage in accordance with the provisions of the *Local Government Acts*.

1. The maximum rate of interest that may be paid is 5.75 per centum per annum.

No. 1.—81/68.—2

2. The purposes for which the loan is to be applied are:—

(a) Erection of buildings at Glenhuntly Depot, Ormond Park, and 15 Truganini-road . . . . .	\$48,000
(b) Purchase of properties for public resort and car parking purposes . . . . .	40,000
(c) Construction of car park, Glen Eira-road adjacent to Town Hall . . . . .	26,000
	\$114,000

3. The period of the loan shall be ten years.

4. The moneys borrowed shall be repayable by providing out of the municipal fund twenty half-yearly instalments of \$7,574.31, including principal and interest, on the 15th day of March and the 15th day of September during the currency of the loan. The first instalment shall be payable on the 15th day of September, 1968.

5. Such moneys shall be repayable at the Commonwealth Savings Bank of Australia, Melbourne.

The plans, specifications and the estimate of the cost of the proposed works and a statement showing the proposed expenditure of the moneys to be borrowed are open for inspection at the Town Hall, corner Glen Eira and Hawthorn roads, Caulfield.

Town Hall, Caulfield, 22nd December, 1967.

684

B. MORAN, Town Clerk.

## CITY OF FRANKSTON.

ORDER CHANGING NAME OF STREET.

THAT in accordance with the powers conferred by the *Local Government Act 1958*, 15th Schedule, Part 1, Clause 8, the Council of the City of Frankston does hereby make an Order changing the name of a street within the Municipal District.

*Old Name; New Name; Location Referred To.*

Barwon-place; Winton-avenue; as appearing on Plan of Subdivision No. 41406 (between Towerhill-road and Verner-avenue).

G. C. PENTLAND, Town Clerk.

Civic Centre, Frankston. 641

## CITY OF MALVERN.

LOAN No. 42.

*Notice of Intention to Borrow the Sum of \$45,000 for Permanent Works and Undertakings.*

NOTICE is hereby given that the Council of the Municipality of the City of Malvern intends to borrow the principal sum of Forty-five thousand dollars on the security of the general rates of the said Municipality, such principal sum to be raised by the grant of a mortgage in accordance with the provisions of the *Local Government Act 1958*.

1. The maximum rate of interest that may be paid is 5½ per centum per annum.

2. The moneys borrowed are to be repayable on 1st November and 1st May each year at the National Bank of Australasia Ltd., Melbourne, or at the council's bankers for the time being in Melbourne.

3. The purpose for which the loan is to be applied is—

Reconstruction of the Malvern Municipal Baths (part) . . . . .	\$45,000
--	----------

4. The loan is to be liquidated by providing out of the municipal fund 40 half-yearly instalments of approximately \$1,927 (which instalments shall comprise principal and interest) each on the dates hereinbefore mentioned.

The plans and specifications and the estimate of the cost of the proposed works and a statement showing the proposed expenditure of the moneys to be borrowed are open for inspection at the City Hall, Malvern, during office hours.

D. W. LUCAS, Town Clerk.

City Hall, Malvern. 642

## CITY OF MOORABBIN.

BY-LAW No. 274.

A By-law of the City of Moorabbin made under Section 197 (1) (xxi) of the *Local Government Act 1958*, and numbered 274 for the purpose of prohibiting or minimising noises in any public highway within the municipal district of the City of Moorabbin.

IN pursuance of the powers conferred by the *Local Government Act 1958*, the Mayor Councillors and Citizens of the City of Moorabbin order as follows:—

1. In this By-law, unless repugnant to or inconsistent with the context or subject matter—

"Council" means the Council of the City of Moorabbin.

"Municipal District" means the municipal district of the City of Moorabbin.

2. No person shall in any public highway within the municipal district cause or permit or suffer to be caused any noise:

- (a) by shouting, calling out, haranguing or singing; or
- (b) by using operating controlling sounding or playing any device or instrument;

without having first obtained the written consent of the Council.

3. Any person guilty of any wilful act of default contrary to this By-law shall be liable to a penalty of not less than \$10.00 nor more than \$40.00, and any person guilty of a continuing offence against this By-law shall be liable to a penalty of not more than \$10.00 for each day on which an offence against this By-law is continued after a conviction or order by any Court.

4. This By-law shall have operation in all public highways throughout the whole of the municipal district.

The resolution for making and passing this By-law was agreed to by the Council at a meeting held on the 20th day of November, 1967, and confirmed at a meeting held on the 18th day of December, 1967.

The common seal of the Mayor, Councillors and Citizens of the City of Moorabbin was hereto affixed in the presence of—

(SEAL) G. BRICKER, Mayor.  
L. R. COATES, Councillor.  
V. A. SMITH, Town Clerk.

643

CITY OF SWAN HILL.

LOAN No. 46.

Notice of Intention to Borrow the Sum of \$100,000 for Permanent Works and Undertakings.

NOTICE is hereby given that the Council of the City of Swan Hill proposes to borrow the sum of One hundred thousand dollars (\$100,000) on the credit of the general rates of the Mayor, Councillors and Citizens of the said City, such sum to be raised by the grant of a mortgage, in accordance with the provisions of the Local Government Act 1958.

1. The maximum rate of interest that may be paid is 5½ per cent. per annum.
2. The interest is to be payable half-yearly during the currency of the loan.
3. The period of the loan shall be forty years and two months.
4. The moneys borrowed shall be repayable to the Local Authorities Superannuation Board, "Rigby House", 15 Queens-road, Melbourne.
5. The loan shall be repaid by the creation of a sinking fund and an appropriate amount, as determined by the Auditor-General, will be set aside annually out of the municipal fund for such purpose.
6. The purposes to which the loan is to be applied are construction of drains \$25,770, improvements to Library building \$830, playground improvements \$3,400 and construction of Race and Golf Course Pavilion \$70,000.

The plans and specifications and estimate of the cost of the proposed works and a statement showing the proposed expenditure of the moneys to be borrowed, are open for inspection at the office of the Council of the City of Swan Hill at the Town Hall, Swan Hill, during office hours.

644

R. J. PUGSLEY, Town Clerk.

CITY OF TRARALGON.

NOTICE OF THE MAKING OF BY-LAWS.

NOTICE is hereby given that the Council of the City of Traralgon has made the following By-laws:—

By-law Number 13.

A By-law of the City of Traralgon made under the provisions of the Local Government Act 1958, the Health Act 1958 and all other powers it thereunto enabling and numbered thirteen for the purposes of repealing By-laws of the Shire of Traralgon (as scheduled) to the extent to which they are at present in force within the Municipal District of the City of Traralgon.

By-law Number 14.

A By-law of the City of Traralgon, made under the provisions of the Local Government Act 1958, and all other powers it thereunto enabling and numbered fourteen for the purposes of:

- (a) regulating the use of streets, roads and public places by street hawkers and itinerant traders.

- (b) prohibiting or regulating the sale of goods from stalls, motor cars, carts, trucks, barrows and other receptacles, standing or placed on any street, road or public place or vacant land.

- (c) prohibiting or regulating the erection or use on any land of tents or other temporary structures or buildings.

- (d) prescribing penalties for breaches of this By-law: and for other purposes.

Copies of the above By-laws are open for inspection free of charge during office hours at the Municipal Offices, Kay-street, Traralgon.

676

K. J. SAUNDERS, Town Clerk.

BOROUGH OF EAGLEHAWK.

CHANGE OF STREET NAME.

NOTICE is hereby given that pursuant to the provisions of the Local Government Act 1958, the Council of the Borough of Eaglehawk, doth Order that the name of a street within the municipality be changed as set out here-with:—

Old name; New name; Location.

—; Hocking-court; commencing at McGowan-street, running north-west into council reclamation scheme from a point 40 feet from the south-western corner of C.A.537, Parish of Sandhurst.

640

J. K. GIOVANETTI, Town Clerk.

BOROUGH OF WONTHAGGI.

BY-LAW No. 40.

A By-Law of the Borough of Wonthaggi, made under the provisions of the Health Act 1958, as amended by the Health Act 1959, and numbered 40 for prescribing the fees to be charged for the registration of premises and for the renewal or transfer of such registration.

IN pursuance of the powers conferred by the Health Act 1958 and every other power enabling it in that behalf, the Mayor, Councillors and Burgesses of the Borough of Wonthaggi order as follows:—

1. By-Law No. 29 of the Borough of Wonthaggi shall be and is hereby repealed.
2. The Fees payable to the Borough of Wonthaggi for the registration of premises, the annual renewal thereof and for any transfers of such registration shall be the fees as set out in the schedule hereto.
3. Any application for re-registration made after the last day for making such application shall be liable to an additional fee of one half of the prescribed fee.

SCHEDULE REFERRED TO.

Nature of Premises.	Fee.
1. Offensive trades premises (being fat extracting or melting or rendering works which are conducted at premises occupied principally as a butcher's shop and at which fat is extracted melted or rendered only from materials derived from such shop) . . . . .	\$5.00
2. Offensive trades premises (being abattoirs in meat areas or piggeries) . . . . .	\$20.00
3. Offensive trades premises (other than those referred to above)—	
(i) where not more than 10 persons (including the proprietor and his family) are employed . . . . .	\$10.00
(ii) where more than 10 such persons but not more than 20 such persons are employed . . . . .	\$15.00
(iii) where more than 20 such persons but not more than 30 such persons are employed . . . . .	\$20.00
(iv) where more than 30 such persons are employed . . . . .	\$30.00
4. Cattle saleyards . . . . .	\$10.00
5. Boarding-houses . . . . .	\$10.00
6. Common lodging-houses . . . . .	\$10.00
7. Eating-houses . . . . .	\$10.00
8. Apartment-houses—	
containing not more than one apartment . . . . .	\$5.00
containing more than one apartment . . . . .	\$10.00
9. Camping areas . . . . .	\$10.00
10. Food premises—	
(i) where not more than 5 persons (including the proprietor and his family) are employed . . . . .	\$5.00

- (ii) where more than 5 such persons are employed additional for each person in excess of 5 .. \$0.50  
Provided that the maximum fee payable shall be .. \$100.00
- 11. Premises at or in any part of which eggs for sale are received or stored for the purpose of being chilled .. \$5.00
- 12. Food vending machines operated by—
  - (i) one or two cents a sale .. \$0.50
  - (ii) a coin or coins in excess of 2 cents in value but not exceeding 5 cents in value a sale .. \$2.00
  - (iii) a coin or coins in excess of 5 cents in value a sale .. \$4.00
- 13. For an transfer of registration—\$1.00 or one half of the registration fee (whichever is the lesser amount).

Provided that in respect to any registration granted after the 31st day of March in any year the fee shall be calculated at the rate of one-quarter of the fee prescribed by these Regulations for each full three months or part thereof between the date of such registration and the 31st day of December following.

This By-Law shall apply to and have operation throughout the whole of the Municipal district of the Borough of Wonthaggi.

Resolution for passing this By-Law was agreed to by the Council of the Borough of Wonthaggi on the 21st day of August, 1967, and was confirmed on the 18th day of September, 1967.

The common seal of the Mayor, Councillors and Burgesses of the Borough of Wonthaggi was hereto affixed by order of the Council, in the presence of—

(SEAL) J. R. ELKIN, Mayor.  
C. OSBORNE, Councillor.  
F. R. DUNN, Acting Town Clerk.

Submitted to the Commission of Public Health on the 8th day of November, 1967.—A. T. GARDNER, Secretary, Commission of Public Health.

Approved by the Governor in Council, 21st November, 1967.—J. ROSSITER, Clerk of the Executive Council. 650

SHIRE OF BELLARINE.

WHEREAS the Council of the Shire of Bellarine deems it expedient to exercise its power of taking compulsorily the land delineated and hatched on the map at the foot hereof for the work or undertaking of providing and constructing a car parking area at Ocean Grove: And whereas the Council has caused to be prepared a map and other papers setting out the general description of the work or undertaking for which the land proposed to be taken is to be used the description of the land proposed to be taken and the names of the owners or reputed owners, lessees, or reputed lessees, mortgagees and occupiers of that land so far as those names are known to or can be ascertained by the Council: And whereas the said map and other papers are deposited at the office of the said Council at Drysdale and are and shall be open for inspection by all persons interested at all reasonable hours for the space of forty clear days after the publication of this notice in the *Government Gazette*: Now notice is hereby given to all persons affected by the proposed taking of the said land to set forth, in writing, addressed to the Council or the Shire Secretary within forty clear days of the publication of this notice in the *Government Gazette* all objections which they may have to the taking of the said land.

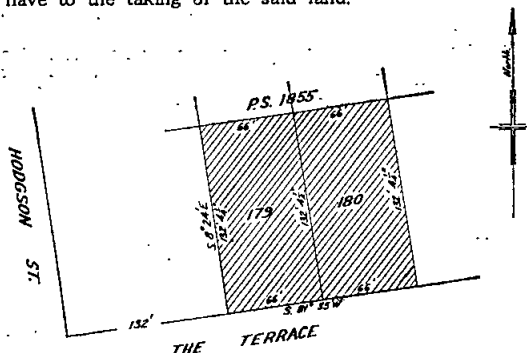

Dated the 22nd day of December, 1967.  
By order of the Council,  
H. A. WILLIAMS, Shire Secretary.

SHIRE OF CROYDON.

BY-LAW No. 23.

A BY-LAW of the Shire of Croydon made under the provisions of Sections 197 and 198 of the *Local Government Act 1958*, and numbered 23, a By-Law to amend By-Law No. 19—Crossings and Roads of Limited Access—by adding the following words to Section 15(1) of By-Law No. 19:

“except when an application is made in writing to Council for a crossing greater in width than 12 ft., upon receipt of a report by the Engineer, Council may grant a crossing larger in width than 12 ft. but not more than 16 ft.”

This By-Law shall apply to and have operation throughout the whole of the Municipal District.

Resolution for the passing of this By-Law agreed to by the Council on 3rd July, 1967.

Resolution confirmed on 7th August, 1967.

The common seal of the President, Councillors and Ratepayers of the Shire of Croydon was hereto affixed on the 18th day of December, 1967, in the presence of—

(SEAL) G. L. PILE, J.P., Councillor.  
G. L. RAISBECK, Councillor.  
K. A. MCKAY, Shire Secretary.

SHIRE OF CROYDON.

BY-LAW No. 24.

A BY-LAW of the Shire of Croydon made under the provisions of Sections 197 and 198 of the *Local Government Act 1958*, and numbered 24, a By-Law to amend By-Law No. 16—Meetings Procedure By-Law—by adding the following words to Section 21(a) of By-Law No. 16:

(vi) A Councillor may only speak to a motion or amendment for a maximum of 5 minutes unless he receives the vote of the Council for an extension over each 5 minutes.

This By-Law shall apply to and have operation throughout the whole of the Municipal District.

Resolution for the passing of this By-Law agreed to by the Council on 21st July, 1967.

Resolution confirmed on 21st August, 1967.

The common seal of the President, Councillors and Ratepayers of the Shire of Croydon was hereto affixed on the 18th day of December, 1967, in the presence of—

(SEAL) G. L. PILE, J.P., Councillor.  
G. S. BEANLAND, Councillor.  
K. A. MCKAY, Shire Secretary.

SHIRE OF DONALD.

LOAN No. 41.

Notice of Intention to Borrow the Sum of \$24,000 for Permanent Works and Undertakings.

NOTICE is hereby given that the Council of the Shire of Donald proposes to borrow the sum of Twenty-four thousand dollars (\$24,000) secured by a first charge under the *Local Government Act* upon the general rates of the Shire, such sum to be raised by the grant of mortgage in accordance with the provisions of the *Local Government Act 1958*.

1. The maximum rate of interest that may be paid is 5.625 per cent. per annum.

2. The purpose for which the loan is to be applied, is/are:—

- Purchase of heavy road grader .. \$2,500
- Purchase of motor truck .. 2,000
- Purchase of mechanical rammer .. 500

3. The period of the loan shall be eight years.

4. The moneys borrowed shall be repayable by providing out of the municipal fund sixteen half-yearly instalments of approximately \$1,878.86 each, including principal and interest, on the 1st days of March and of September in each year during the currency of the loan. The first instalment shall be payable on the 1st day of September, 1968.

5. Such moneys shall be repayable at the C.B.C. Savings Bank Limited, Melbourne.

The plans, specifications and the estimate of the cost of the works and a statement showing the proposed expenditure of the moneys to be borrowed are open for inspection at the Shire Offices, Donald.

H. C. SMALE, Shire Secretary.

Dated at Donald this 21st day of December, 1967. 674

## SHIRE OF GOULBURN.

## LOAN No. 14.

*Notice of Intention to Borrow the Sum of \$18,000 for Permanent Works and Undertakings.*

NOTICE is hereby given that the Council of the Shire of Goulburn proposes to borrow the principal sum of \$18,000 secured by a charge over the general rates of the municipality, such sum to be raised by the grant of a mortgage in accordance with the provisions of the *Local Government Act 1958*.

1. The maximum rate of interest that may be paid is \$5.75 per centum per annum.

2. The purposes for which the loan is to be applied are:—

(a) Balance of furnishing and surround development of Shire Offices and Council Chamber .. .. .	\$12,500
(b) Purchase of Plant .. .. .	5,500
	\$18,000

3. The period of the loan shall be ten years.

4. The loan shall be repaid by providing out of the municipal fund twenty half-yearly instalments of approximately \$1,195.94 each, including principal and interest, on the 10th day of April and October during the currency of the loan. The first instalment shall be payable on the 10th day of October, 1968.

5. Such money shall be repayable at the office of the Commercial Savings Bank, High-street, Nagambie.

6. The plans and specifications and the estimate of cost of the proposed works and a statement showing the proposed expenditure of the moneys to be borrowed are open for inspection at the Shire Office, High-street, Nagambie.

638

H. R. LOMAX, Shire Secretary.

## SHIRE OF HAMPDEN.

## LOAN No. 14.

*Notice of Intention to Borrow the Sum of \$50,000 for Permanent Works and Undertakings.*

NOTICE is hereby given that the Council of the Shire of Hampden proposes to borrow the sum of Fifty thousand dollars (\$50,000) on the credit of the municipal revenues of the President, Councillors and Ratepayers of the said Shire, such sum to be raised by the grant of a mortgage in accordance with the provisions of the *Local Government Act 1958*.

1. The maximum rate of interest that may be paid is 5½ per cent. per annum.

2. The purpose for which the loan is to be applied is:—  
Construction and Furnishing of Branch Library Building at Terang .. .. . \$50,000

3. The period of the loan shall be fifteen (15) years.

4. The moneys shall be repayable by providing out of the municipal fund thirty half-yearly instalments of approximately \$2,530.40 each, including principal and interest, on the 1st day of April and the 1st day of October, during the currency of the loan.

5. Such moneys shall be payable at the National Bank of Australasia Limited, Melbourne, or at the Council's bankers for the time being in Melbourne.

The plans and specifications and estimates of the costs of the proposed works and a statement showing the proposed expenditure of the moneys to be borrowed, are open for inspection at the Shire Office, Camperdown.

18th December, 1967.

639

S. J. GRIMMER, Shire Secretary.

## SHIRE OF HEALESVILLE.

## BYLAW No. 50.

A bylaw of the Shire of Healesville made under Sections 197(1) (xxxiii), 197(1) (xxxiv) and 197(1) (xlv) of the *Local Government Act 1958* and all other powers it thereunto enabling passed by a special order by the Shire of Healesville sealed with the common seal of the Shire of Healesville advertised in accordance with the provisions of the *Local Government Acts* approved by the Governor in Council and numbered 50 for the purposes of:—

(a) Prohibiting or regulating the sale of goods from stalls motor cars carts trucks barrows boxes baskets crates bags or other vehicles or receptacles standing or placed on any street road or public place within the areas within the said municipality set forth in this bylaw.

(b) Prohibiting or regulating the sale of goods from stalls motor cars carts trucks barrows or any other vehicles boxes baskets crates bags or other receptacles standing or placed on vacant land (not being Crown land or land under the care and management of the municipality or a public place within the meaning of Section three of the *Summary Offences Act 1966*) within the area within the said municipality set forth in the bylaw.

IN pursuance of the powers conferred by the above-mentioned parts of the *Local Government Act 1958* as amended and of any and every other power it thereunto enabling, the President Councillors and Ratepayers of the Shire of Healesville orders as follows:—

1. Save as is herein otherwise provided no person shall within the municipal district of the Shire of Healesville sell any goods from any stall motor car cart truck barrow box basket crate bag or other vehicle or receptacle standing on or placed on:—

(a) Any street road or public place within the said municipal district or,

(b) On vacant land (not being Crown land or land under the care and management of the said municipality or a public place within the meaning of Section three of the *Summary Offences Act 1966*) within the said municipal district.

2. Any person may lodge with the Shire Secretary of the said Shire an application substantially in the form set out in the First Schedule hereto for a permit to sell goods from any stall motor car cart truck barrow box basket crate bag or other vehicle or receptacle standing or placed on any street road public place or vacant land as aforesaid. Such application shall be signed by the applicant and by at least five ratepayers of the Shire of Healesville.

3. Subject to the provisions of paragraph 4 hereof the Council may in its discretion grant or refuse to grant the said application and any grant of a permit may be made for such period and subject to such terms and conditions as the Council may cause to be endorsed on the permit. Any such permit shall be substantially in the form in the Second Schedule hereto together with such additions or alterations as the Council may require and shall be given under the hand of the Shire Secretary.

4. No permit shall be issued pursuant to the foregoing provisions of this by law for the sale of goods from any stall within the areas set forth in the first part of the Third Schedule hereto unless the following conditions (in addition to any conditions imposed by the said Council) are complied with:—

(i) sales of goods from the stall are made only on behalf of a church or on behalf of a youth organisation festival or charity registered by the Council as a church organisation festival or charity for the purposes of this bylaw;

(ii) the whole of the proceeds of the sale of those goods (save only for so much of the proceeds as is necessary to meet the cost of those goods) must be paid to the church the youth organisation festival or the charity concerned; and

(iii) the stall must be so located as not to create any undue congestion either for vehicles or for pedestrians.

5. Any person selling goods from a stall that is permitted by Clause 4 must ensure that no box cardboard carton crate glass package paper plastic straw tin or vegetable matter is deposited on any part of any street road or public place by any person selling goods from the stall.

6. When a stall is removed any person who was selling any goods from that stall must ensure that no box cardboard crate glass package paper plastic straw tin or vegetable matter is left on any part of any street road or public place within 10' of where the stall stood.

7. Any person who is the holder of a current permit hereunder when engaged in the business of selling goods within the Shire of Healesville shall carry the said permit and produce the same on demand to any authorized officer of the Council.

8. If at any time in the opinion of the Council the holder of any permit issued hereunder shall fail to comply with all the terms and conditions thereof or if at any time in the opinion of the Council any obstruction shall be caused or traffic shall be interfered with by the exercise of any rights granted by such permit or any assemblage of persons caused thereby the Council may revoke or vary such permit and the same shall thereupon become void and of no effect or varied accordingly.

9. With the exception of permits issued under Clause 4 hereof no permit shall be issued pursuant to the provisions of this bylaw until a permit fee shall first be paid to the Council of the said Shire being a fee of Two dollars in respect of each day (or part thereof) of sale of such goods in the areas set forth in the second part of the third schedule hereto and a fee of one dollar in respect of each day (or part thereof) of sale of such goods in other parts of the municipal district of the said Shire.

10. Any person guilty of any wilful act or default contrary to this bylaw shall be liable to a penalty of not more than Forty dollars and any person guilty of a continuing offence against this bylaw shall be liable to a penalty of not more than Ten dollars for each day on which an offence against this bylaw is continued after notice has been given to the offender by the Council of the commission of the offence or after a conviction or order of any Court.

11. Save as is otherwise herein provided this bylaw shall apply to and have operation throughout the whole of the municipal district of the said Shire.

12. This bylaw shall come into operation on the publication thereof or of notice of the making thereof in the *Victoria Government Gazette*.

FIRST SCHEDULE.  
APPLICATION FOR PERMIT.

SECOND SCHEDULE.  
PERMIT.

THIRD SCHEDULE.

AREAS REFERRED TO IN PARAGRAPHS 4 AND 9 THEREOF.

*First Part:* Areas in which permits are limited to Youth Organizations, Charitable Organizations, Festivals or Church Organizations:—

Maroondah Highway throughout the Shire; Green Street, Healesville, Murchison Street, Marysville; Bell Street, Yarra Glen between Yarra River and Irvine Crescent; Anzac Avenue, Yarra Glen; King Street, Yarra Glen.

*Second Part:* Areas in which a permit fee of \$2 per day shall apply:—

Any street or road within the Township of Marysville or the Township of Healesville and the following streets or roads Badger Creek Road, Old Fernshaw Road, St. Leonards Road, McKenzie Avenue, Glen Eadie Avenue.

Resolution for the passing of this bylaw agreed to by the Council on Tuesday, 31st of October, 1967.

Copy of this bylaw deposited at the Council Office for inspection on Tuesday, 31st of October, 1967.

Special order advertisement published in the *Yarra Valley News* newspaper on Tuesday, 7th and 14th of November, 1967.

Resolution confirmed on Tuesday, 28th of November, 1967.

The common seal of the President, Councillors and Ratepayers of the Shire of Healesville was hereunto affixed on 28th November, 1967, in the presence of—

(SEAL) G. G. CUZENS, President.  
E. R. FROGLEY, Councillor.  
W. M. OLIVER, Shire Secretary.

Approved by the Governor in Council on 19th December, 1967.—J. ROSSITER, Clerk of the Executive Council.

Notice of making of this bylaw published in the *Government Gazette* on 5th January, 1968, at page 20. 729

SHIRE OF KERANG.

LOAN No. 56.

*Notice of Intention to Borrow the Sum of \$25,000 for Permanent Works and Undertakings.*

NOTICE is hereby given that the Council of the Shire of Kerang proposes to borrow the principal sum of \$25,000 secured by a charge over the general rates of the municipality, such sum to be raised by the grant of a mortgage in accordance with the provisions of the *Local Government Act 1958*.

1. The maximum rate of interest that may be paid is 5½ per cent. per annum.

2. The purposes for which the loan is to be applied are:—

	\$
Council proportion Drainage, Quambatook ..	2,000
Council proportion Drainage, Koondrook ..	4,000
Bridge Construction, Bannagher Creek—Appin-road ..	12,000
Bridge Construction, Avoca River, Quambatook ..	2,000
Water Supply, Mystic Park Township ..	3,000
Council proportion, Koondrook Caravan Park ..	2,000

3. The period of the loan shall be twenty years.

4. The moneys borrowed shall be repayable by providing out of the municipal fund half-yearly instalments of \$1,070.66 each, including principal and interest, on the 1st day of December and 1st day of June during the currency of the loan. The first instalment shall be payable on the 1st day of December, 1968.

5. Such moneys shall be repayable at the Commercial Banking Co. of Sydney Limited, Melbourne.

6. The plans and specifications and the estimate of the cost of the proposed works and a statement showing the proposed expenditure of the moneys to be borrowed are open for inspection at the Municipal Offices, Kerang.

Dated this 22nd day of December, 1967.

725

L. R. RUNDLE, Shire Secretary.

SHIRE OF KORUMBURRA.

ROAD DEVIATION ORDER—HENRYS ROAD.

PURSUANT to the provisions of section 522 of the *Local Government Act 1958*, the Council of the Shire of Korumburra hereby directs that the land in the Parish of Lang Lang East, indicated by hatching on the diagram annexed hereto, which has been purchased, taken or acquired by it, shall be a public highway on and from the date of publication of this Order in the *Government Gazette*.

PLAN OF SURVEY  
PART OF CROWN ALLOTMENT 89  
PARISH OF LANG LANG EAST  
COUNTY OF MORNINGTON  
SCALE OF CHAINS

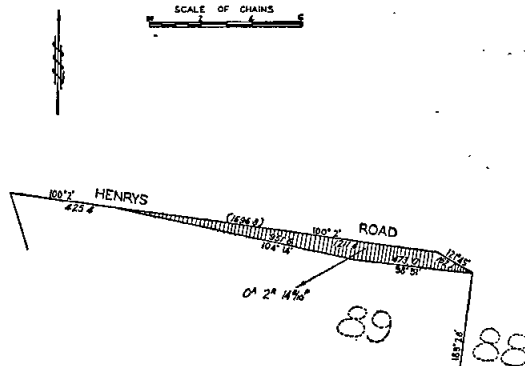

The Common Seal of the President, Councillors and Ratepayers of the Shire of Korumburra was hereunto affixed this 20th day of December, 1967, in the presence of—

(SEAL) R. ATTENBOROUGH, President.  
S. A. GREAVES, Councillor.  
W. O. CLARK, Secretary.

663

SHIRE OF KORUMBURRA.

ROAD DEVIATION ORDER—OLD LEONGATHA ROAD.

PURSUANT to the provisions of section 522 of the *Local Government Act 1958*, the Council of the Shire of Korumburra hereby directs that the land in the Parish of Korumburra, indicated by hatching on the diagram annexed hereto, which has been purchased, taken or

acquired by it, shall be a public highway on and from the date of publication of this Order in the *Government Gazette*.

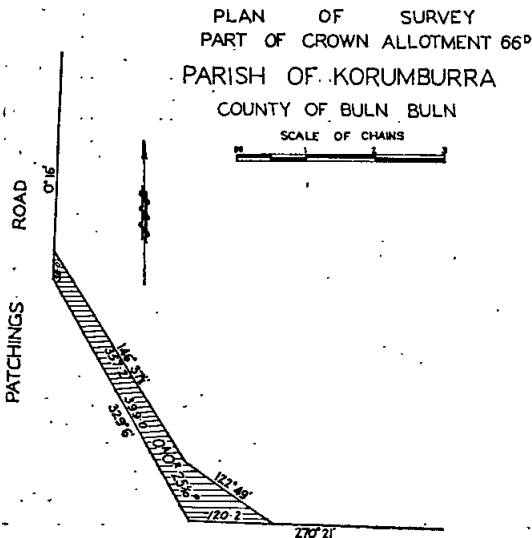

OLD LEONGATHA ROAD  
The Common Seal of the President, Councillors and Ratepayers of the Shire of Korumburra was hereunto affixed this 20th day of December, 1967, in the presence of—  
R. ATTENBOROUGH, President.  
S. A. GREAVES, Councillor.  
W. O. CLARK, Secretary.

SHIRE OF MORNINGTON.  
SPECIAL ORDER.  
Loan No. 57, \$100,000.

NOTICE is hereby given that the Council of the Shire of Mornington did at its meeting on 17th October, 1967, for which notice of the making of a Special Order for borrowing had been given, agree to the following Resolution, that is to say:—

“That the Council of the Shire of Mornington by Special Order hereby resolves to borrow money by the grant of a mortgage secured on the general rates of the municipality the required particulars whereof are as follows:—

- (i) Amount of principal sum to be borrowed—\$100,000.
- (ii) Rate of interest—5.875 per cent. per annum, half-yearly rests.
- (iii) The money borrowed is to be repaid to the State Savings Bank of Victoria, 139 Elizabeth-street, Melbourne, in half-yearly instalments on 1st August and 1st February, for a period of fifteen years from 1st February, 1968.
- (iv) The money is to be borrowed for the purpose of defraying the cost of the execution of schemes for the construction of private streets, pursuant to Division 10 of Part XIX. of the *Local Government Act 1958* (as amended).
- (v) The loan is to be liquidated by the payment of 30 approximately equal half-yearly instalments.”

Notice is further given that at a meeting of the said Council held on 21st November, 1967, the above Resolution was confirmed.  
D. G. COLLINGS, Shire Secretary.

SHIRE OF NARRACAN.  
LOAN No. 34.  
*Notice of Intention to Borrow the Sum of \$60,000 for Permanent Works and Undertakings.*

NOTICE is hereby given that the Council of the Shire of Narracan proposes to borrow the sum of Sixty thousand dollars, secured by a charge over the general rates of the municipality, such sum to be raised by the grant of a mortgage, in accordance with the provisions of the *Local Government Act 1958*.

- 1. The maximum rate of interest that may be paid is 5½ per cent. per annum.

2. The purpose for which the loan is to be applied is the construction of Private Streets pursuant to Division 10 of Part XIX. of the *Local Government Act 1958* as amended.

3. The period of the loan shall be fifteen years.

4. The moneys borrowed shall be repayable by providing out of the receipts of money payable under schemes under the said Division, thirty equal half-yearly payments of \$3,036.48, including principal and interest, on the 1st day of May and the 1st day of November during the currency of the loan. The first instalment shall be payable on the 1st day of November, 1968.

5. Such moneys shall be repayable at the C.B.C. Savings Bank Limited, Melbourne.

The plans, specifications and estimates of the cost of the proposed works and a statement showing the proposed expenditure of the moneys to be borrowed, are open for inspection at the Shire Office, Trafalgar.

W. F. NELSON, Shire Secretary.

SHIRE OF NARRACAN.  
LOAN No. 35.

*Notice of Intention to Borrow the Sum of \$30,000 for Permanent Works and Undertakings.*

NOTICE is hereby given that the Council of the Shire of Narracan proposes to borrow the sum of Thirty thousand dollars, secured by a charge over the general rates of the municipality, such sum to be raised by the grant of a mortgage, in accordance with the provisions of the *Local Government Act 1958*.

1. The maximum rate of interest that may be paid is 5½ per cent. per annum.

2. The purpose for which the loan is to be applied is the purchase of Road-making Plant.

3. The period of the loan shall be ten years.

4. The moneys borrowed shall be repayable by providing out of the municipal fund twenty half-yearly instalments of \$1,993.24, including principal and interest, on the 1st day of May and the 1st day of November during the currency of the loan. The first instalment shall be payable on the 1st day of November, 1968.

5. Such moneys shall be repayable at the C.B.C. Savings Bank Limited, Melbourne.

The plans, specifications and estimates of the cost of the proposed works and a statement showing the proposed expenditure of the moneys to be borrowed, are open for inspection at the Shire Office, Trafalgar.

W. F. NELSON, Shire Secretary.

SHIRE OF NARRACAN.  
LOAN No. 36.

*Notice of Intention to Borrow the Sum of \$40,000 for Permanent Works and Undertakings.*

NOTICE is hereby given that the Council of the Shire of Narracan proposes to borrow the sum of Forty thousand dollars, secured by a charge over the general rates of the municipality, such sum to be raised by the grant of a mortgage, in accordance with the provisions of the *Local Government Act 1958*.

1. The maximum rate of interest that may be paid is 5½ per cent. per annum.

2. The purpose for which the loan is to be applied is:—

- Drainage Works—Trafalgar Township . . . \$20,000
- Town Planning—Land Purchase . . . \$20,000

3. The period of the loan shall be fifteen years.

4. The moneys borrowed shall be repayable by providing out of the municipal fund thirty half-yearly instalments of \$2,024.32, including principal and interest, on the 1st day of May and the 1st day of November during the currency of the loan. The first instalment shall be payable on the 1st day of November, 1968.

5. Such moneys shall be repayable at the C.B.C. Savings Bank Limited, Melbourne.

The plans, specifications and estimates of the cost of the proposed works and a statement showing the proposed expenditure of the moneys to be borrowed, are open for inspection at the Shire Office, Trafalgar.

W. F. NELSON, Shire Secretary.

SHIRE OF NUMURKAH.

LOAN No. 39.

*Notice of Intention to Borrow the Sum of \$35,000 for Permanent Works and Undertakings.*

NOTICE is hereby given that the Council of the Shire of Numurkah proposes to borrow the principal sum of \$35,000 secured by a charge over the general rates of the Municipality, such sum to be raised by the grant of a mortgage in accordance with the provisions of the *Local Government Act 1958*.

1. The maximum rate of interest that may be paid is five and one-half per centum per annum.
2. The purpose for which the loan is to be applied is purchase of road grader, bulldozer and tractor, \$35,000.
3. The period of the loan shall be five years.
4. The moneys borrowed shall be repayable by providing out of the municipal fund half-yearly instalments of approximately \$4,050.89 each, including principal and interest, on the 1st day of April and the 1st day of October during the currency of the loan. The first instalment shall be payable on the 1st day of October, 1968.
5. Such moneys shall be repayable to the Australia and New Zealand Bank Limited, Melbourne.

The plans and specifications and the estimate of the cost of the proposed works and a statement showing the proposed expenditure of the moneys to be borrowed are open for inspection at the office of the Council of the Shire of Numurkah, at Melville-street, Numurkah.

677 L. G. MITCHELL, Shire Secretary.

SHIRE OF ORBOST.

LOAN No. 43.

*Notice of Intention to Borrow the Sum of \$30,000 for Permanent Works and Undertakings.*

NOTICE is hereby given that the Council of the Shire of Orbost proposes to borrow the sum of Thirty thousand dollars (\$30,000) secured by a charge over the general rate of the Municipality, such sum to be raised by the grant of a mortgage, in accordance with the provisions of the *Local Government Act 1958*.

1. The maximum rate of interest that may be paid is 5.75 per cent. per annum.
2. The purpose for which the loan is to be applied is—
 

Underground drains, Orbost .. .. .	\$ 25,000
Kerbs and channels, Mallacoota .. .. .	5,000
	\$30,000
3. The period of the loan shall be ten (10) years.
4. The moneys borrowed shall be repayable by providing out of the municipal fund twenty half-yearly instalments of \$1,993.24 each, including principal and interest, on the 10th day of March and the 10th day of September in each year during the currency of the loan.

The first instalment shall be payable on the 10th day of September, 1968.

5. Such moneys shall be repayable to the Commercial Savings Bank of Australia Limited, Melbourne.

The plans and specifications and the estimated cost of the works and a statement showing the proposed expenditure of the moneys to be borrowed are open for inspection at the Shire Office, Orbost.

Dated this 19th day of December, 1967.  
683 R. G. HEWSON, Shire Secretary.

SHIRE OF ORBOST.

ORDER OF CHANGING NAME OF STREET.

IN accordance with the powers conferred by the *Local Government Act 1958*, the Council of the Shire of Orbost does hereby make an Order changing the name of a street within the Municipality.

*Old Name.*—Kimba-court.  
*New Name.*—Ralston-court.  
*Location.*—Off Reed-street, Orbost.

652 R. G. HEWSON, Shire Secretary.

SHIRE OF WHITTLESEA.

LOAN No. P.S.19.

*Private Streets Account.*

NOTICE is hereby given that at the Meeting of the Council of the Shire of Whittlesea, held at the Shire Office, Epping, on Monday, 20th November, 1967, the said Council did agree to the following Resolution, that is to say:—

- “That—
- (a) This Council borrow moneys by the grant of a mortgage secured on the general rates of the Municipality, pursuant to section 585 of the *Local Government Acts*.
  - (b) The amount of the principal moneys to be borrowed be \$50,000.
  - (c) The rate of interest to be paid be 5½ per cent. per annum.
  - (d) The moneys borrowed be repayable by 30 instalments of \$2,530.40 each payable respectively on the 1st day of April and on the 1st day of October of each year, the first such instalment being repayable on the 1st day of October, 1968.
  - (e) The moneys borrowed be repayable to the Australian Mutual Provident Society, Melbourne.
  - (f) The loan be applied for the purpose of defraying part of the cost of the execution of schemes for the construction of private streets pursuant to Division 10 of Part XIX. of the *Local Government Acts*.
  - (g) The loan be liquidated by providing out of the receipts from owners made liable under the schemes, or, in case such receipts are insufficient, then by providing from the municipal fund, in each half year during the currency of the loan the sum of \$2,530.40 which sum includes principal and interest.”

And notice is hereby further given that, at the meeting of the said Council held at the Shire Office, Epping, on Monday, 18th December, 1967, the said Resolution was confirmed.

666 R. G. C. COOK, Shire Secretary.

SHIRE OF WINCHELSEA.

NOTICE is hereby given that Senior Constable Archibald Andrew Logan has been appointed as Prosecuting Officer for the Shire vice Senior Constable C. G. W. Croft, resigned.

651 W. K. MATHISON, Shire Secretary.

SHIRE OF WYCHEPROOF.

LOAN No. 47.

*Notice of Intention to Borrow the Sum of \$30,000 for Permanent Works and Undertakings.*

NOTICE is hereby given that the Council of the Shire of Wycheproof proposes to borrow the principal sum of \$30,000 secured by a charge over the general rates of the municipality, such sum to be raised by the grant of a mortgage in accordance with the provisions of the *Local Government Act 1958*.

1. The maximum-rate of interest that may be paid is 5½ per cent. per annum.
2. The purpose for which the loan is to be applied is:—
 

Purchase of Road-making Plant and Equipment	\$21,000
Council contribution (balance) towards Sea Lake Pre-School Centre	2,000
Shire Office Extensions and Air-conditioning	7,000
	\$30,000
3. The period of the loan shall be ten years.
4. The moneys borrowed shall be repayable by providing out of the municipal fund twenty half-yearly instalments of approximately \$1,993 each, including principal and interest, on the 1st day of March and the 1st day of September during the currency of the loan. The first instalment shall be payable on the 1st day of September, 1968.
5. Such moneys shall be repayable to the Commissioners of the State Savings Bank of Victoria at the office of the said Commissioners, corner Elizabeth and Bourke streets, Melbourne.

The plans and specifications and the estimate of the cost of the proposed works and a statement showing the proposed expenditure of the moneys to be borrowed are open for inspection at the office of the Council of the Shire of Wycheproof, Broadway, Wycheproof.

Dated 11th December, 1967.  
671 ALAN J. BOWES, Shire Secretary.

NOTICE is hereby given that the partnership heretofore subsisting between John Michael Connolly and Edna Patricia Connolly, carrying on the business of a garage and service station at premises at the corner of Raleigh-road and Navigator-street, Maribyrnong, under the registered business name of "Amoco Service Station, Maribyrnong" has been dissolved as from 30th day of November, 1967, by the retirement of Edna Patricia Connolly from the said business. All debts due and owing by the said business will be received and paid respectively by John Michael Connolly, who will continue to carry on the said business. 701

NOTICE is hereby given that the partnership heretofore subsisting between Ronald John McLean, garage proprietor, of 59 Bignell-road, East Bentleigh, and Victor Edwards, garage proprietor, of 4 Chalmers-avenue, Sandringham, carrying on business as service station proprietors at 307 New-street, Brighton, under the style or firm of Pindar Neptune Service Station, has been dissolved as from the 28th day of February, 1967, so far as concerns the said Ronald John McLean, who retires from the said firm.

Dated the 13th day of December, 1967. 646

NOTICE is hereby given that the partnership heretofore subsisting between the undersigned Alfred Thomas Battisson and John Alfred Battisson, carrying on business as electrical contractors at 26 Peacock-street, Burwood, under the name of Battisson Electrical Service, has been dissolved by mutual consent as from the 30th day of June, 1967. All debts due to and owing by the said late firm will be received and paid by John Alfred Battisson, who will continue to carry on the business in partnership with Joan Mabel Battisson under the same name and at the same address.

Dated the 4th day of October, 1967.

ALFRED THOMAS BATTISSON.  
JOHN ALFRED BATTISSON.

636

NOTICE is hereby given that the partnership lately subsisting between Ethel Irene Notton Gill (now deceased), Victor Arnold Lambeth and Vincent Raymond Lambeth, carrying on the business of nurserymen at Centre-road, Brighton, under the style or firm name of Gills Grendon Nursery, was dissolved by mutual consent on the 13th day of December, 1967, by the retirement therefrom of the estate of the said Ethel Irene Notton Gill. The said Victor Arnold Lambeth and Vincent Raymond Lambeth will continue to carry on business under the name of Gills Grendon Nursery at the said address, where they will receive all debts owing to and pay all debts owing by the partnership.

Dated this 13th day of December, 1967. 680

*Companies Act 1961.—Section 272 (1).*

ROYAL OAK PTY. LTD. (IN VOLUNTARY LIQUIDATION).

NOTICE is hereby given that a Final Meeting of members will be held at the registered office, 547 Collins-street, Melbourne, on the 22nd day of January, 1968, at 10 a.m. for the purpose of laying before the meeting an account and statement of the winding up of the company and an explanation thereof.

19th December, 1967.

I. DUNCAN, liquidator, 547 Collins-street, Melbourne.

637

In the matter of FOUNDRY EQUIPMENT (AUSTRALIA) PTY. LIMITED (in Liquidation); and of the *Companies Act 1961*.

NOTICE is hereby given that a Meeting of Shareholders of Foundry Equipment (Australia) Pty. Limited (in Liquidation) will be held at the offices of Hungerford, Spooner and Kirkhope, 44 Queen-street, Melbourne, on the 19th day of January, 1968, at 11 o'clock in the forenoon, for the purpose of the liquidator laying an account and report before the meeting, showing how the winding up has been conducted and the assets of the company disposed of.

Dated this 13th day of December, 1967.

653

E. H. NIEMANN, Liquidator.

*Companies Act 1961.*

DARTMOOR PINE MILLS (VIC.) PROPRIETARY LIMITED.

NOTICE is hereby given that at an Extraordinary Meeting of the members of the above-named company, held on the 20th day of December, 1967, it was resolved that the company be wound up voluntarily and that

on the winding up of the company, subject to the payments of the debts and liabilities and the costs of the liquidation, all assets of the company be distributed among the members in whole or in part according to their rights and interest in the company and that Joseph Ian Norman Winter, chartered accountant, of 134 Waymouth-street, Adelaide, be appointed liquidator for the purpose of such winding up.

Dated this 21st day of December, 1967.

ARTHUR ROBINSON & CO., solicitors, 447 Collins-street, Melbourne, solicitors for the company. 714

*Companies Act 1961.*

CORNUCOPIA PROPRIETARY LIMITED.

AT an Extraordinary Meeting of the above-named Company duly convened and held at 19 Watt-avenue, Pascoe Vale, Victoria, on Tuesday, 19th December, 1967, the following Resolution was duly passed as a Special Resolution:—

*Resolution.*

That the Company be wound up voluntarily and that Mr. John Wootton Danby of 33 Queens-road, Melbourne, be appointed liquidator for the purpose of such winding up.

Dated the 19th day of December, 1967.

635 RICHARD MACDONALD BLAND, Secretary.

*Companies Act 1961.*

DENTON HATS LIMITED.

AT an Extraordinary General Meeting of the above-named Company duly convened and held at 191 Queen-street, Melbourne, Victoria, held on Thursday, 21st December, 1967, the following Special and Ordinary Resolutions were duly passed.

*Special Resolution.*

That the Company be wound up voluntarily.

*Ordinary Resolution.*

That Mr. Barrie Alexander Provan, of 33 Queens-road, Melbourne, be appointed liquidator for the purposes of the winding up of the company at a fee not to exceed \$1,000.

Dated the 22nd day of December, 1967.

665 BARRIE ALEXANDER PROVAN, Secretary.

In the matter of the *Companies Act 1961*, as amended, and in the matter of EILBECK AND COMPANY PTY. LIMITED, EILBECK DISTRIBUTORS PTY. LIMITED, EILBECK DISTRIBUTORS (VIC.) PTY. LIMITED, EILBECK ELECTRICS PTY. LIMITED, EILBECK SALES PTY. LIMITED, and EILBECK SOLENOIDS PTY. LIMITED.

AT Extraordinary General Meetings of shareholders of each of the above companies, each duly convened and held at 22 Carlotta-street, Artarmon, New South Wales, on 20th December, 1967, the following Resolution was duly passed as a Special Resolution:—

"That the companies be wound up voluntarily and that Vere Gordon Thorn be and is hereby appointed liquidator for the purposes of the winding up."

Dated this 20th day of December, 1967.

G. E. EILBECK, Chairman.

Vere Gordon Thorn, liquidator, of 50 Miller-street, North Sydney, New South Wales. 718

*The Companies Act 1961.*

In the matter of ROBERTS TRANSPORT PTY. LTD. (in Liquidation).

NOTICE is hereby given that at an Extraordinary General Meeting of the Members of the above-named company held on the 11th day of December, 1967, it was resolved that the company be wound up voluntarily, and at a meeting of creditors held on the same day, pursuant to section 260, it was resolved that for such purpose Norman Eric Stretton of 296 Little Lonsdale-street, Melbourne, accountant, be appointed liquidator.

Notice is also given that after 21 days from this date I shall proceed to distribute the assets. All creditors having any claims against the company should furnish particulars of same by that date, otherwise I shall proceed to distribute the assets without regard to their claim.

Dated this 21st day of December, 1967.

N. E. STRETTON, Liquidator.

Kennedy, Smail & Middlemiss, 296 Little Lonsdale-street, Melbourne, 3000. 713



Subordinate Legislation Act 1962.

**NOTICE OF MAKING OF STATUTORY RULES.**

IN pursuance of the provisions of the Subordinate Legislation Act 1962 and the Regulations made thereunder, notice is given of the making of the following statutory rules:—

No.	Motor Boating Act 1961.	Price.
333/1967.	Motor Boating (Bellarine and Queenscliffe Speed Restrictions) Regulations 1967 ..	10c
	<i>Motor Boating Act 1961.</i>	
334/1967.	Motor Boating (Gippsland Lakes Western Speed Restrictions) Regulations 1967 ..	10c
	<i>Motor Boating Act 1961.</i>	
335/1967.	Motor Boating (Gippsland Lakes Central Speed Restrictions) Regulations 1967 ..	10c
	<i>Social Welfare Act 1960.</i>	
336/1967.	Social Welfare (Health Services) Regulations 1967 ..	10c
	<i>Second Hand Dealers Act 1958.</i>	
337/1967.	Second-hand Dealers (Exemption No. 11) Regulations 1967 ..	10c
	<i>Racing Act 1958.</i>	
338/1967.	Trotting Control Board (Fees) Regulations 1967 ..	10c
	<i>Racing Act 1958.</i>	
339/1967.	Licensing of Dog Racing Grounds (Amendment) Regulations 1967 ..	10c
	<i>Private Agents Act 1966.</i>	
340/1967.	Private Agents (Amendment) Regulations 1967 ..	10c
	<i>Melbourne Harbor Trust Act 1958.</i>	
341/1967.	Melbourne Harbor Trust Regulations (Amendment No. 3/67 Export Wharfage Charges and other matters) ..	15c

Copies of these statutory rules may be purchased at the Sale of Publications Section of the Government Printing Office, located at Macarthur-street, Melbourne, C.2. If ordered by mail, remittance should be addressed to "The Government Printer, Box 203, P.O., North Melbourne, N.1.", and should include 5c extra for postage. If a credit account is held at this office, no remittance is required with the mail order.

The annual subscription rate for Statutory Rules (including a Bound Volume) is \$15, payable in advance. The subscription year commences on 1st January.

A. C. BROOKS,  
Government Printer.

**STATE ACTS, 1966**

COPIES of the following Acts of Parliament of Victoria may be obtained at the Government Printing Office, or from any accredited agents, at the price set opposite to each (these prices do not include postage).

The annual subscription for State Acts 1967 et seq. is \$8 payable in advance.

Bound Volumes of State Acts are also available on a subscription basis at \$15 per annum.

No.		Price.
7372.	Education (Council of Adult Education) ..	\$0.05
7373.	Legal Profession Practice (Amendment) ..	\$0.05
7374.	Co-operation (Amendment) ..	\$0.05
7375.	Nurses (Amendment) ..	\$0.05
7376.	Property Law (Loans to Minors) ..	\$0.05
7377.	Audit (Amendment) ..	\$0.08
7378.	Marketing of Primary Products (Tobacco Leaf Marketing Board) ..	\$0.05
7379.	State Library National Gallery National Museum and Institute of Applied Science (Amendment) ..	\$0.05
7380.	Reid Murray Acceptance Limited (Scheme of Arrangement) ..	\$0.12
7381.	Lake Corangamite ..	\$0.10
7382.	Tobacco Leaf Marketing Board (Appointment of Manager) ..	\$0.05
7383.	Country Fire Authority (Borrowing Powers) ..	\$0.05
7384.	Labour and Industry (Sheltered Workshops) ..	\$0.05
7385.	Wombat Bonuses ..	\$0.05

STATE ACTS, 1966—continued.

No.		Price
7386.	Country Fire Authority (Interstate Fire Brigades) ..	\$0.05
7387.	Loch Public Hall Trust ..	\$0.12
7388.	Co-operative Housing Societies (Amendment) ..	\$0.05
7389.	Fisheries and Game (Amendment) ..	\$0.08
7390.	Marine Stores and Old Metals (Collectors) ..	\$0.05
7391.	Companies ..	\$0.22
7392.	The Constitution Act Amendment ..	\$0.05
7393.	Vagrancy ..	\$0.12
7394.	Consolidated Revenue ..	\$0.05
7395.	Land (Plantation Areas) ..	\$0.10
7396.	Daylesford Springs Land ..	\$0.05
7397.	Barley Marketing (Amendment) ..	\$0.05
7398.	Sheep Dipping (Repeal) ..	\$0.05
7399.	Grain Elevators (Amendment) ..	\$0.05
7400.	Seymour Racecourse Land ..	\$0.05
7401.	Shepparton Abattoirs ..	\$0.05
7402.	Paisley-Galvin Railway Land Exchange ..	\$0.08
7403.	Aerial Spraying Control ..	\$0.12
7404.	Racing (Amendment) ..	\$0.08
7405.	Summary Offences ..	\$0.28
7406.	Friendly Societies (Amendment) ..	\$0.05
7407.	Crimes (Dangerous Driving) ..	\$0.05
7408.	Medical (Foreign Practitioners Qualification Committee) ..	\$0.05
7409.	Opticians Registration (Amendment) ..	\$0.05
7410.	Labour and Industry (Petrol Shops) ..	\$0.08
7411.	Melbourne and Metropolitan Board of Works (Amendment) ..	\$0.08
7412.	Carlton (Recreation Ground) Land ..	\$0.08
7413.	Boilers Inspection (Amendment) ..	\$0.05
7414.	Warragul and Neerim Railway Lands ..	\$0.08
7415.	Victoria Institute of Colleges (Council) ..	\$0.05
7416.	Marketable Securities ..	\$0.18
7417.	Pensions Supplementation ..	\$0.20
7418.	Evidence (Medical Evidence) ..	\$0.05
7419.	Water (Rating by Area) ..	\$0.05
7420.	County Court (Common Law Jurisdiction) ..	\$0.05
7421.	State Electricity Commission (Amendment) ..	\$0.05
7422.	Gas and Fuel Corporation (Borrowing) ..	\$0.05
7423.	Vegetation and Vine Diseases (Amendment) ..	\$0.05
7424.	Motor Car ..	\$0.05
7425.	Estate Agents (Amendment) ..	\$0.10
7426.	Melbourne University (Chancellorship) ..	\$0.05
7427.	Tobacco Leaf Industry Stabilization ..	\$0.15
7428.	Consolidated Revenue ..	\$0.05
7429.	Lotteries Gaming and Betting ..	\$0.35
7430.	Stamps (Mortgages) ..	\$0.05
7431.	Money Lenders (Exemption) ..	\$0.05
7432.	Protection of Animals ..	\$0.12
7433.	Marketing of Primary Products (Maize Marketing Board) ..	\$0.10
7434.	Consolidated Revenue ..	\$0.10
7435.	Firearms (Competition Weapons) ..	\$0.10
7436.	Provincial Sewerage Authorities Association of Victoria ..	\$0.10
7437.	Waterworks Trusts Association of Victoria ..	\$0.10
7438.	Maffra Lands Exchange ..	\$0.10
7439.	Trewalla Lands Exchange ..	\$0.10
7440.	Tattersall Consultations ..	\$0.10
7441.	Public Authorities (Contributions) ..	\$0.10
7442.	Racing (Totalizator Percentages) ..	\$0.10
7443.	Lower Yarra Crossing Authority (Guarantee) ..	\$0.10
7444.	Stock and Share Brokers (Amendment) ..	\$0.15
7445.	Moorpanyal Lands Exchange ..	\$0.10
7446.	North Melbourne Lands ..	\$0.15
7447.	Marine (Amendment) ..	\$0.10
7448.	Mildura Irrigation and Water Trusts (Amendment) ..	\$0.10
7449.	State Accident Insurance Office Land ..	\$0.10
7450.	Public Account (Bona Vacantia) ..	\$0.10
7451.	Motor Car (Hospital and Charities Contributions) ..	\$0.10
7452.	Commonwealth and States Financial Agreement ..	\$0.15
7453.	State Forests Loan Application ..	\$0.10
7454.	Water (Amendment) ..	\$0.15
7455.	Hospitals and Charities (Liability of Patients) ..	\$0.15
7456.	Sewerage District's (Amendment) ..	\$0.10
7457.	Limitation of Actions (Notice of Action) ..	\$0.10
7458.	Long Island Country Club ..	\$0.10
7459.	Country Roads (Level Crossings) (Amendment) ..	\$0.10
7460.	Evidence (Foreign Tribunals) ..	\$0.10
7461.	San Remo Lands ..	\$0.10
7462.	The Constitution Act Amendment (Conjoint Elections) ..	\$0.10
7463.	Vermin and Noxious Weeds (Financial) ..	\$0.10
7464.	Co-operative Housing Societies (Financial) ..	\$0.10
7465.	Morwell National Park ..	\$0.10
7466.	Land Tax (Rates) ..	\$0.10

STATE ACTS 1966—continued.

No.		Price.
7467.	Teaching Service (Married Women) ..	\$0.10
7468.	Melbourne Cricket Ground (Guarantees) ..	\$0.10
7469.	Gaols (Commencement of Sentences) ..	\$0.10
7470.	Revocation and Excision of Crown Reservations ..	\$0.15
7471.	Soil Conservation and Land Utilization (Advisory Council) ..	\$0.10
7472.	Legal Profession Practice (Further Amendment) ..	\$0.10
7473.	Forests (Wood Pulp Agreement) ..	\$0.15
7474.	Companies (Amendment) ..	\$0.10
7475.	Portland Harbor Trust (Railways) ..	\$0.10
7476.	Country Fire Authority (Fire Prevention) ..	\$0.10
7477.	Victorian Pipelines Commission ..	\$0.15
7478.	Bees ..	\$0.15
7479.	Milk Board (Amendment) ..	\$0.10
7480.	Milk Pasteurization (Amendment) ..	\$0.10
7481.	State Insurance (Payments into Court) ..	\$0.10
7482.	National Gallery of Victoria ..	\$0.15
7483.	Building Societies (Amendment) ..	\$0.10
7484.	Firearms (Amendment) ..	\$0.15
7485.	Geelong Waterworks and Sewerage (Amendment) ..	\$0.10
7486.	Grain Elevators (Further Amendment) ..	\$0.10
7487.	Settlement Purchase Leases ..	\$0.10
7488.	Appeal Costs Fund (Amendment) ..	\$0.15
7489.	Geelong Harbor Trust (Amendment) ..	\$0.30
7490.	Health (Amendment) ..	\$0.15
7491.	Marketing of Primary Products (Onion Marketing Board) ..	\$0.10
7492.	State Coal Mine ..	\$0.10
7493.	Horse Breeding (Amendment) ..	\$0.10
7494.	Private Agents ..	\$0.30
7495.	Local Government ..	\$0.40
7496.	Wrongs (Assessment of Damages) ..	\$0.10
7497.	Melbourne and Metropolitan Board of Works (Reconstitution) ..	\$0.15
7498.	Port Phillip Authority ..	\$0.15
7499.	Extractive Industries ..	\$0.35
7500.	Stamps ..	\$0.25
7501.	Companies (Defaulting Officers) ..	\$0.15
7502.	Labour and Industry (Amendment) ..	\$0.15
7503.	Juries ..	\$0.10
7504.	Public Works Loan Application ..	\$0.15
7505.	Commercial Goods Vehicles (Tow Trucks) ..	\$0.10
7506.	Motor Car (Trailers) ..	\$0.15
7507.	Housing (Commonwealth and State Agreement) ..	\$0.10
7508.	Consolidated Revenue ..	\$0.10
7509.	Revenue Deficits Funding ..	\$0.10
7510.	The Constitution Act Amendment (Postal Voting) ..	\$0.25
7511.	Railway Loan Application ..	\$0.15
7512.	Inflammable Liquids ..	\$0.25
7513.	Water Supply Loan Application ..	\$0.25
7514.	Appropriation of Revenue ..	\$1.15

A. C. BROOKS,  
Government Printer.

**STATE ACTS, 1967**

COPIES of the following Acts of Parliament of Victoria may be obtained at the Government Printing Office, or from any accredited agents, at the price set opposite to each (these prices do not include postage).

The annual subscription for State Acts 1967 et seq. is \$8 payable in advance.

Bound Volumes of State Acts are also available on a subscription basis at \$15 per annum.

No.		Price.
7515.	New Melbourne Cemetery Lands ..	\$0.10
7516.	Country Fire Authority (Prosecutions) ..	\$0.10
7517.	Social Welfare (Detention) ..	\$0.10
7518.	Zoological Gardens ..	\$0.15
7519.	Richmond (South-Eastern Freeway) Lands ..	\$0.10
7520.	The Geelong Gas Company's ..	\$0.10
7521.	Co-operative Housing Societies (Indemnities) ..	\$0.10
7522.	Supreme and County Courts (Sittings) ..	\$0.10
7523.	Dandenong Valley Authority (Amendment) ..	\$0.15
7524.	State Savings Bank (Amendment) ..	\$0.10
7525.	Land (Surf Life Saving Association) ..	\$0.10
7526.	Warragul (Public Park) Lands ..	\$0.10
7527.	Tobacco Leaf Marketing Board (Appointment of Manager) (Amendment) ..	\$0.10
7528.	Stock Artificial Breeding (Amendment) ..	\$0.10
7529.	Second-hand Dealers (Amendment) ..	\$0.10
7530.	Legal Aid (Amendment) ..	\$0.10
7531.	Weights and Measures (Amendment) ..	\$0.25
7532.	The Constitution Act Amendment (Electoral) ..	\$0.10

STATE ACTS, 1967—continued.

No.		Price.
7533.	Education and Teaching Service (Amendment) ..	\$0.15
7534.	Public Officers Salaries and Allowances ..	\$0.10
7535.	Railways (State Coal Mine Officers) ..	\$0.10
7536.	Public Officers (Long Service Leave) ..	\$0.15
7537.	Pipelines (Submerged Lands) ..	\$0.30
7538.	Police Regulation (Pensions) ..	\$0.10
7539.	Legal Profession Practice (Victoria Law Foundation) ..	\$0.10
7540.	Petroleum (Barracouta and Marlin Fields Agreement) ..	\$0.25
7541.	Pipelines ..	\$0.25
7542.	Local Government (Amendment) ..	\$0.15
7543.	Stamps (Amendment) ..	\$0.10
7544.	Police Offences (Obscene Publications) ..	\$0.10
7545.	Melbourne University (Amendment) ..	\$0.10
7546.	Crimes ..	\$0.15
7547.	Instruments (Corporate Bodies Contracts) ..	\$0.10
7548.	Land (Amendment) ..	\$0.25
7549.	Water (Amendment) ..	\$0.10
7550.	Dowling Forest Racecourse Lands ..	\$0.15
7551.	Strata Titles ..	\$0.40
7552.	Revocation and Excision of Crown Reservations ..	\$0.15
7553.	Tullamarine Freeway Lands ..	\$0.15
7554.	Friendly Societies Investment ..	\$0.10
7555.	Victoria Institute of Colleges (Board of Studies) ..	\$0.10

A. C. BROOKS,  
Government Printer.

ACTS REPRINTED IN ACCORDANCE WITH THE AMENDMENTS INCORPORATION ACT 1958 (No. 6422), AND FOR SALE AT THE SALE OF PUBLICATIONS BRANCH OF THE GOVERNMENT PRINTING OFFICE, MACARTHUR-STREET, MELBOURNE, 3002.

(These prices do not include postage.)

No.		Price.
6189.	Acts Interpretation (Incorporating amendments up to No. 7146) ..	\$0.15
6191.	Administration and Probate (Third Reprint—Incorporating amendments up to No. 7332) ..	\$0.38
6194.	Agricultural Colleges (First Reprint—Incorporating amendments up to No. 7302) ..	\$0.15
7117.	Appeal Costs Fund Act 1964 (First Reprint—Incorporating amendments up to No. 7488) ..	\$0.25
6199.	Apprenticeship (First Reprint—Incorporating amendments up to No. 7312) ..	\$0.25
6203.	Audit (First Reprint—Incorporating amendments up to No. 7377) ..	\$0.35
6209.	Boiler Inspection (Incorporating amendments up to No. 7072) ..	\$0.18
6210.	Building Societies (Incorporating amendments up to No. 7125) ..	\$0.25
6218.	Children's Court (Incorporating amendments up to No. 7084) ..	\$0.20
6219.	Children's Welfare (Second Reprint—Incorporating amendments up to No. 7084) ..	\$0.35
6220.	Clean Air (Incorporating amendments up to No. 6886) ..	\$0.10
6222.	Commercial Goods Vehicles (Second Reprint—Incorporating amendments up to No. 7358) ..	\$0.22
6839.	Companies Act 1961 (Second Reprint—Incorporating amendments up to No. 7332) ..	\$2.32
6225.	Co-operation (Second Reprint—Incorporating amendments up to No. 7083) ..	\$0.42
6226.	Co-operative Housing Societies (Incorporating amendments up to No. 7097) ..	\$0.40
6228.	Country Fire Authority (Second Reprint—Incorporating Amendments up to No. 7476) ..	\$0.50
6229.	Country Roads (Second Reprint—Incorporating Amendments up to No. 7506) ..	\$0.60
6230.	County Court Act (First Reprint—Incorporating amendments up to No. 7420) ..	\$0.35
6231.	Crimes (Second Reprint—Incorporating amendments up to No. 7407) ..	\$1.33
6236.	Dog (Second Reprint—Incorporating amendments up to No. 7065) ..	\$0.15
6240.	Education (First Reprint—Incorporating amendments up to No. 7533) ..	\$0.45
6242.	Employers and Employés (Incorporating amendments up to No. 6740) ..	\$0.18
6243.	Entertainments Tax (First Reprint—Incorporating amendments up to No. 7315) ..	\$0.25
6245.	Estate Agents (Second Reprint—Incorporating amendments up to No. 7134) ..	\$0.38

ACTS REPRINTED IN ACCORDANCE WITH THE AMENDMENTS  
INCORPORATION ACT 1958 (No. 6422)—*continued*.

No.	Price.
6249. Fences (Incorporating amendments up to No. 6550) ..	\$0.12
6246. Evidence (Second Reprint—Incorporating amendments up to No. 7366) ..	\$0.42
6250. Fertilizers (Incorporating amendments up to No. 7142) ..	\$0.25
6251. Firearms (Second Reprint—Incorporating amendments up to No. 7484) ..	\$0.40
6252. Fisheries Act (First Reprint—Incorporating amendments up to No. 7389) ..	\$0.35
6916. Foreign Judgments Act 1962 (First Reprint— including amendments made by No. 7332) ..	\$0.15
6585. Forests (Pulpwood Agreement) (Incorporating amendments up to No. 6886) ..	\$0.15
6254. Forests (First Reprint—Incorporating amendments up to No. 7356) ..	\$0.60
6256. Fruit and Vegetables (First Reprint—incorporating amendments up to No. 6944) ..	\$0.30
6258. Game—(First Reprint—Incorporating amendments up to No. 7389) ..	\$0.30
6259. Gaols (Incorporating amendments up to No. 6651) ..	\$0.15
6262. Geelong Harbor Trust (First Reprint—Incorporating amendments up to No. 7547) ..	\$0.45
6263. Geelong Waterworks and Sewerage (First Reprint—Incorporating amendments up to No. 7547) ..	\$0.75
6265. Goods (Third Reprint—Incorporating amendments up to No. 7131) ..	\$0.35
6266. Grain Elevators (First Reprint—Incorporating amendments up to No. 7486) ..	\$0.35
6270. Health (Second Reprint—Incorporating amendments up to No. 7490) ..	\$1.65
6933. Home Finance Act 1962 (First Reprint—Incorporating amendments up to No. 7363) ..	\$0.25
6274. Hospitals and Charities (Incorporating amendments up to No. 6716) ..	\$0.35
6274. Hospitals and Charities (Second Reprint—Incorporating amendments up to No. 7455) ..	\$0.50
6275. Housing (First Reprint—Incorporating amendments up to No. 7507) ..	\$0.85
6279. Instruments (Third Reprint—Incorporating amendments up to No. 7315) ..	\$0.38
6282. Justices (Second Reprint—Incorporating amendments up to No. 7369) ..	\$1.23
6283. Labour and Industry (Third Reprint—Incorporating amendments up to No. 7410) ..	\$1.00
6284. Land (Incorporating amendments up to No. 7360) ..	\$1.53
6534. Land Settlement Act 1959 (First Reprint—Incorporating amendments up to No. 7328) ..	\$0.30
6289. Land Tax (Second Reprint—Incorporating amendments up to No. 7466) ..	\$0.40
6285. Landlord and Tenant (Second Reprint—Incorporating amendments up to No. 6996) ..	\$0.50
6286. Lands Compensation—(First Reprint—incorporating amendments up to No. 7332) ..	\$0.25
6290. Latrobe Valley (First Reprint—Incorporating amendments up to No. 7332) ..	\$0.35
6291. Legal Profession Practice (Incorporating amendments up to No. 7065) ..	\$0.45
6293. Licensing (Second Reprint—Incorporating amendments up to No. 7054) ..	\$0.95
6577. Lifts and Cranes (Incorporating amendments up to No. 6886) ..	\$0.12
6295. Limitation of Actions (Incorporating amendments up to No. 6845) ..	\$0.15
6298. Local Authorities Superannuation (Incorporating amendments up to No. 6894) ..	\$0.25
6299. Local Government (Incorporating amendments up to No. 7052) ..	\$3.50
6302. Marine (Incorporating amendments up to No. 7350) ..	\$0.72
6304. Marketing of Primary Products (First Reprint—Incorporating amendments up to No. 7491) ..	\$0.45
6306. Marriage (First Reprint—Incorporating amendments up to No. 6959) ..	\$0.25
3309. Medical (Second Reprint—Incorporating amendments up to No. 7408) ..	\$0.40
3310. Melbourne and Metropolitan Board of Works (Second Reprint—Incorporating amendments up to No. 7547) ..	\$1.10
3312. Melbourne Harbor Trust (First Reprint—Incorporating amendments up to No. 7356) ..	\$0.48
6605. Mental Health (Incorporating amendments up to No. 7135) ..	\$0.45
6315. Metropolitan Fire Brigades (Incorporating amendments up to No. 6886) ..	\$0.28

ACTS REPRINTED IN ACCORDANCE WITH THE AMENDMENTS  
INCORPORATION ACT 1958 (No. 6422)—*continued*.

No.	Price.
6316. Mildura Irrigation and Water Trusts (First Reprint—Incorporating amendments up to No. 7448) ..	\$0.75
6317. Milk and Dairy Supervision (Incorporating amendments up to No. 6964) ..	\$0.40
6318. Milk Board (Incorporating amendments up to No. 7093) ..	\$0.22
6184. Monash University (First Reprint—Incorporating amendments up to No. 7533) ..	\$0.30
6324. Money Lenders (Incorporating amendments up to No. 6886) ..	\$0.25
6832. Motor Boating (Incorporating amendments up to No. 6961) ..	\$0.15
6325. Motor Car (Second Reprint—Incorporating amendments up to No. 7361) ..	\$0.82
6326. National Parks (Incorporating amendments up to No. 7275) ..	\$0.25
6328. Nurses (Incorporating amendments up to No. 6716) ..	\$0.20
6330. Partnership (Second Reprint—Incorporating amendments up to No. 7315) ..	\$0.25
6331. Patriotic Funds (First Reprint—Incorporating amendments up to No. 7338) ..	\$0.25
6889. Poisons (Incorporating amendments up to No. 7065) ..	\$0.35
6337. Police Offences (Incorporating amendments up to No. 7145) ..	\$0.82
6338. Police Regulation (Incorporating amendments up to No. 7081) ..	\$0.45
6340. Portland Harbor Trust (First Reprint—Incorporating amendments up to No. 7475) ..	\$0.35
6341. Pounds (First Reprint—Incorporating amendments up to No. 7315) ..	\$0.25
6890. Probate Duty (Incorporating amendments up to No. 6970) ..	\$0.38
6343. Process Servers and Inquiry Agents (Incorporating amendments up to No. 7126) ..	\$0.12
6344. Property Law (Incorporating amendments up to No. 6867) ..	\$0.90
6349. Public Service (Second Reprint—Incorporating amendments up to No. 7356) ..	\$0.40
6350. Public Trustee (Incorporating amendments up to No. 6961) ..	\$0.35
6353. Racing (First Reprint—Incorporating amendments up to No. 7404) ..	\$0.70
6355. Railways (First Reprint—Incorporating amendments up to No. 7475) ..	\$0.75
6359. Road Traffic (Second Reprint—Incorporating amendments up to No. 7332) ..	\$0.18
6360. Rural Finance (First Reprint—Incorporating amendments up to No. 7328) ..	\$0.12
6846. Rural Finance and Settlement Commission Act 1961 (First Reprint—Incorporating amendments up to No. 7332) ..	\$0.20
6975. Sale of Land Act 1962 (First Reprint—Incorporating amendments up to No. 7332) ..	\$0.18
6363. Second-Hand Dealers ..	\$0.12
6367. Settled Land (Second Reprint—Incorporating amendments up to No. 7065) ..	\$0.50
6368. Sewerage Districts (First Reprint—Incorporating amendments up to No. 7332) ..	\$0.62
6651. Social Welfare Act 1960 (Third Reprint—Incorporating amendments up to No. 7332) ..	\$0.20
6372. Soil Conservation and Land Utilization (Incorporating amendments up to No. 6961) ..	\$0.20
6373. Soldier Settlement (First Reprint—Incorporating amendments up to No. 7328) ..	\$0.42
6375. Stamps (Third Reprint—Incorporating amendments up to No. 7359) ..	\$0.82
6377. State Electricity Commission (Second Reprint—Incorporating Amendments up to No. 7421) ..	\$0.65
6379. State Savings Bank (Incorporating amendments up to No. 6886) ..	\$0.42
6381. Stock and Share Brokers (First Reprint—Incorporating amendments up to No. 7444) ..	\$0.15
6886. Subordinate Legislation (Incorporating amendments up to No. 6961) ..	\$0.15
6386. Superannuation (First Reprint—Incorporating amendments up to No. 7417) ..	\$0.60
6387. Supreme Court (First Reprint—Incorporating amendments up to No. 7522) ..	\$0.75
6391. Teaching Service (First Reprint—Incorporating amendments up to No. 7536) ..	\$0.35
7223. Tomato Processing Industry (Uniform Agreement) Act 1964 (First Reprint—Incorporating amendments up to No. 7342) ..	\$0.15
6395. Tourist (First Reprint—Incorporating amendments up to No. 7335) ..	\$0.15

ACTS REPRINTED IN ACCORDANCE WITH THE AMENDMENTS INCORPORATION ACT 1958 (No. 6422)—*continued*.

No.	Price.
6849. Town and Country Planning ( <i>First Reprint</i> —Incorporating amendments up to No. 7276) ..	\$0.45
6399. Transfer of Land ( <i>Second Reprint</i> —Incorporating amendments up to No. 7130) ..	\$0.52
6400. Transport Regulation ( <i>First Reprint</i> —Incorporating amendments up to No. 7358) ..	\$0.22
6401. Trustee ( <i>Second Reprint</i> —Incorporating amendments up to No. 6963) ..	\$0.42
6879. Unclaimed Moneys (Incorporating amendments up to No. 6961) ..	\$0.12
6653. Valuation of Land Act 1960 ( <i>Second Reprint</i> —Incorporating amendments up to No. 7333) ..	\$0.22
6407. Vegetation and Vine Diseases ( <i>First Reprint</i> —Incorporating amendments up to No. 7423) ..	\$0.30
6409. Vermin and Noxious Weeds ( <i>First Reprint</i> —Incorporating amendments up to No. 7463) ..	\$0.35
6410. Veterinary Surgeons ( <i>First Reprint</i> —Incorporating amendments up to No. 7343) ..	\$0.15
6413. Water (Incorporating amendments up to No. 7228) ..	\$1.42
6414. Weights and Measures ( <i>Second Reprint</i> —Incorporating amendments up to No. 7332) ..	\$0.32
6419. Workers Compensation ( <i>Second Reprint</i> —Incorporating amendments up to No. 7332) ..	\$0.52

A. C. BROOKS,  
Government Printer.

AGENTS FOR THE "VICTORIA GOVERNMENT GAZETTE".

THE following have been appointed agents to receive Advertisements and Subscriptions for the *Victoria Government Gazette*:—

- ARMSTRONG'S AGENCY, 205 Queen-street, Melbourne, Victoria 3000.
- ARNALL & JACKSON, 390 Barkly-street, Brunswick, Victoria 3056.
- BAIRNSDALE AUTHORIZED NEWSAGENCY, 132 Main-street, Bairnsdale, Victoria 3875.
- BICKNELL, M. J., Authorized Newsagent, 196 Timor-street, Warrnambool, Victoria 3280.
- R. G. CARTER ADVERTISING SERVICE PTY. LTD., 26-32 King-street, Melbourne, Victoria 3000.
- DAVIES, G. & M. V., 112 Gray-street, Hamilton, Victoria 3300
- DAVIS, WM. (MILDURA) PTY. LTD., 126 Eighth-street, Mildura, Victoria 3500.
- DIXON'S NEWSAGENCY, 89 Firebrace-street, Horsham, Victoria 3400.
- EDGAR'S NEWSAGENCY PTY. LTD., 293 Hargreaves-street, Bendigo, Victoria 3550.
- EDGARS' AUTHORIZED NEWSAGENCY, 45 Bridge-street, Benalla, Victoria 3672.
- FRANKS, H., & CO., 184 Ryrie-street, Geelong, Victoria 3220.
- GORDON & GOTCH AUSTRALASIA LTD., 511 Little Collins-street, Melbourne, Victoria 3000.
- GULLAN'S NEWSAGENCY, 88 Bridge-street, Ballarat, Victoria 3350.
- HAMPTON, A. C., 243 Mitchell-street, Bendigo, Victoria 3550.
- HARSTON, PARTRIDGE & CO. PTY. LTD., 455 Little Collins-street, Melbourne, Victoria 3000.
- KYNETON GUARDIAN PTY. LTD., P.O. Box 18, Kyneton, Victoria 3444.
- LATIMER'S, Newsagents, 45 Station-street, Malvern, Victoria 3144.
- LIVINGSTON'S SHEPPARTON NEWSAGENCY, 246 Wyndham-street, Shepparton, Victoria 3630.
- THE MERCANTILE EXCHANGE, 90 Queen-street, Melbourne, Victoria 3000.
- McGILL'S AUTHORIZED NEWSAGENCY, 183-5 Elizabeth-street, Melbourne, Victoria 3000.

PHILLIPS AUTHORIZED AGENCY, 83 Murphy-street, Wangaratta, Victoria 3677.  
Victoria 3220.

PURDIE, J., & CO., 138 Moorabool-street, Geelong, SALE AUTHORIZED NEWSAGENCY, 142 Raymond-street, Sale, Victoria 3850.

SKINNER'S AUTHORIZED NEWSAGENCY, 49-51 Franklin-street, Traralgon, Victoria 3844.

STEVENSON, A. C. & M., NEWSAGENTS, 132 Henty-street, Casterton, Victoria 3311.

VERNON, C. F. & H. J., 162 Bridge-road, Richmond, Victoria 3121.

VIEW POINT AUTHORIZED NEWSAGENCY, 4 View-Point, Bendigo, Victoria 3550.

A copy of the *Gazette* filed at each place for public reference.

THE "VICTORIA GOVERNMENT GAZETTE".

SUBSCRIPTIONS.—The subscription, including postage, is \$10 per annum, or \$5 per half year, payable in advance.

Subscriptions are required for whole months, and must cover at least a half year.

Single copies are 20 cents, posted 25 cents. Subscribers do not receive the Acts of Parliament with the GAZETTE.

GAZETTES are held in stock for five years only.

PRIVATE ADVERTISEMENTS.—The charge for insertion is 25 cents per line single column, and 50 cents per line double column. The title forms one or more lines as a heading. On an average ten words make a line of single column. Every signature must likewise be counted as a line. The final words of a paragraph, though only portion of a line, must be counted as one line. Signatures (in particular) and proper names must be written very plainly in the text; ONE SIDE ONLY of each sheet of paper should be WRITTEN UPON.

All documents illegibly written will be returned unpublished, and where brands occur unprovided for by the ordinary letters of the alphabet, a worded explanatory description must be furnished.

THE VICTORIA GOVERNMENT GAZETTE is published on WEDNESDAY EVENING in each week, and Notices for insertion will be received by the Government Printer at or before ONE p.m. at ordinary rates, and late advertisements between ONE p.m. and FOUR p.m. at double rates on the day preceding the day of publication.

PAYMENTS.—Unless the advertiser has a credit account, all payments are required in advance. Remittances should be made by cheque, postal order, or money order payable to "GOVERNMENT PRINTER".

ADDRESS.—All communications should be addressed to "The Government Printer, Box 203, P.O., North Melbourne", 3051.

CONTENTS

	PAGE
Acts of Parliament .. .. .	1
Acts of Parliament on sale at the Government Printing Office .. .. .	25
Appointments .. .. .	10
Courts .. .. .	3
Estates of Deceased Persons .. .. .	9
Government Notices .. .. .	3
Lands .. .. .	14
New Year Honours .. .. .	1
Notice to Mariners .. .. .	10
Notice of Making of Statutory Rules .. .. .	25
Orders in Council—	
Acts—Local Government; Land .. .. .	11
Private Advertisements .. .. .	16
Private Agents .. .. .	5
Proclamations .. .. .	1
Public Holiday—Australia Day .. .. .	4
Public Service Notices .. .. .	15
Resignations .. .. .	11
Waterworks Trusts .. .. .	4