

[2883]



VICTORIA GOVERNMENT GAZETTE

Published by Authority

[Registered at the General Post Office, Melbourne, for transmission by post as a newspaper.]

No. 701

WEDNESDAY, AUGUST 14

[1968

PROCLAMATIONS

Land Act 1958.

AREA OF LAND COMPRISED IN CERTAIN CLASSES DIMINISHED OR INCREASED.

PROCLAMATION

By His Excellency the Lieutenant-Governor of the State of Victoria and its Dependencies in the Commonwealth of Australia, &c., &c., &c.

WHEREAS by the *Land Act 1958* it is amongst other things enacted that the Governor in Council may, by Proclamation to be published in the *Government Gazette*, at any time diminish or increase the area of land comprised in any of the classes mentioned in Part I., Division 1, Section 5, of the said *Land Act 1958*, but that the area of lands which may be sold by auction (Class 6), shall not be increased except as in certain cases in the said Act provided: Now therefore I, the Lieutenant-Governor of the State of Victoria, in the Commonwealth of Australia, by and with the advice of the Executive Council of the said State, and in accordance with the provisions of Sections 94 and 117 of the *Land Act 1958* aforesaid, do hereby diminish or increase (as the case may be) the areas of Crown lands comprised in Classes 7 and 6 of the classes mentioned in Section 5 of the *Land Act 1958* aforesaid, to the extent set forth in the subjoined Schedule (that is to say):—

Schedule referred to.

CLASSES DIMINISHED OR INCREASED.

County.	Parish.	Allotment.	Section.	Area.	Diminished.	Increased.	Description.
					Class.	Class.	
				A. R. P.			
Borong	Illawarra ..	219B	..	79 3 34	7	6	In the middle of the Parish
Tambo	Newmerella ..	22A	C	3 0 0	..	6	In the north of Parish

Given under my Hand and the Seal of the State of Victoria, aforesaid, at Melbourne, this 6th day of August, in the year of our Lord One thousand nine hundred and sixty-eight, and in the seventeenth year of the reign of Her Majesty Queen Elizabeth II.

E. F. HERRING,

(L.S.)

By His Excellency's Command,

W. J. F. McDONALD,
Minister of Lands.

GOD SAVE THE QUEEN !

PUBLIC HIGHWAYS.—SHIRE OF FRANKSTON.

PROCLAMATION

By His Excellency the Lieutenant-Governor of the State of Victoria and its Dependencies in the Commonwealth of Australia, &c., &c., &c.

WHEREAS by the *Local Government Act 1958*, Section 519 it is amongst other things enacted that it shall be lawful for the Governor-in-Council at any time and from time to time upon request of the Council of any municipality by notice in the *Government Gazette* to proclaim any land reserved used or by purchase or exchange acquired for a street road highway thoroughfare bridge square court alley or right-of-way or any street road lane or passage made or laid out or proposed to be made or laid out on land of which a plan of subdivision delineating that street road lane or passage has been sealed with the seal of the municipality under subdivision (3) of Division 9 of Part XIX. of the *Local Government Act 1958*, or a corresponding previous enactment, to be a public highway and that such land shall thereupon and thenceforth from the date of such proclamation become and be absolutely dedicated to the public as a public highway within the meaning of any law then or thereafter in force:

AND WHEREAS the Council of the City of Frankston has requested that the lands hereinafter mentioned, being streets roads lanes or passages made or laid out or proposed to be made or laid out on land of which a plan of subdivision delineating those streets roads lanes or passages has been sealed with the seal of the municipality under subdivision (3) of Division 9 of Part XIX. of the *Local Government Act 1958*, or a corresponding previous enactment, be so declared to be public highways:

NOW THEREFORE I, the Lieutenant-Governor of the State of Victoria in the Commonwealth of Australia, by and with the advice of the Executive Council of the said State, do by this Proclamation declare that Allen Drive, Richard Court and Kingsley Court coloured brown on Plan of Subdivision No. 79017 lodged in the Office of Titles, shall be public highways within the meaning of the said Act.

Given under my Hand and the Seal of the State of Victoria aforesaid, at Melbourne, this thirtieth day of July, in the year of our Lord One thousand nine hundred and sixty-eight and in the seventeenth year of the reign of Her Majesty Queen Elizabeth II.

(L.S.) E. F. HERRING.

By His Excellency's Command,
JIM BALFOUR,
for Minister for Local Government.
GOD SAVE THE QUEEN!

PUBLIC HIGHWAY.—SHIRE OF MORNINGTON.

PROCLAMATION

By His Excellency the Lieutenant-Governor of the State of Victoria and its Dependencies in the Commonwealth of Australia, &c., &c., &c.

WHEREAS by the *Local Government Act 1958*, as amended, section 519 it is amongst other things enacted that it shall be lawful for the Governor-in-Council at any time and from time to time upon the request of the Council of any municipality by notice in the *Government Gazette* to proclaim any land reserved used or by purchase or exchange acquired for a street road highway thoroughfare bridge square court alley or right-of-way or any street road lane or passage made or laid out or proposed to be made or laid out on any land of which a plan of subdivision delineating that street road lane or passage has been sealed with the seal of the municipality under subdivision (3) of Division 9 of Part XIX. of the *Local Government Act 1958*, as amended, or a corresponding previous enactment to be a public highway and that such land shall thereupon and thenceforth from the date of such proclamation become and be absolutely dedicated to the public as a public highway within the meaning of any law then or thereafter in force.

AND WHEREAS the Council of the Shire of Mornington has requested that the land hereinafter mentioned, used for a street be so declared to be a public highway.

NOW THEREFORE I, the Lieutenant-Governor of the State of Victoria in the Commonwealth of Australia, by and with the advice of the Executive Council of the State, do by this Proclamation declare that so much of Watt Road, Mornington, being a Road under the General Law contained within Crown Portion 12 Parish of Moorooduc as lies between Yuilles Road and that Portion of the said Watt Road previously proclaimed a Public Highway—*vide Government Gazette* No. 7, 1966, Page 396, shall be a public highway.

Given under my Hand and the Seal of the State of Victoria aforesaid, at Melbourne, this sixth day of August, in the year of our Lord One thousand nine hundred and sixty-eight and in the seventeenth year of the reign of Her Majesty Queen Elizabeth II.

(L.S.) E. F. HERRING.

By His Excellency's Command,
JIM BALFOUR,
for Minister for Local Government.
GOD SAVE THE QUEEN!

Land Settlement Act 1959 (No. 6534).
ROADS CLOSED.

PROCLAMATION

By His Excellency the Lieutenant-Governor of the State of Victoria and its Dependencies in the Commonwealth of Australia, &c., &c., &c.

WHEREAS section 5 (1) of the *Land Settlement Act 1959* (No. 6534) so far as the said section 5 extends and applies section 40 (1) of the *Soldier Settlement Act 1958* (No. 6373) prescribes that where any road (whether used or unused and whether formed or unformed) forms part of or intersects any estate and the Rural Finance and Settlement Commission, after consultation with the council or councils of the municipality or municipalities concerned, certifies that the said road is unsuited to the proper subdivision of the estate:

And whereas the Rural Finance and Settlement Commission, after consultation with the council of the municipality concerned, has so certified:

Now therefore I, the Lieutenant-Governor of the State of Victoria, in the Commonwealth of Australia, by and with the advice of the Executive Council of the said State and in pursuance of the said section 5 of the *Land Settlement Act 1959* (No. 6534), do by this my Proclamation direct that the roads, as described hereunder be closed, that is to say:—

Parish of La Trobe, County of Heytesbury, being the road indicated by hachure on plan hereunder.—(L.143^(*)) (1116L/26).

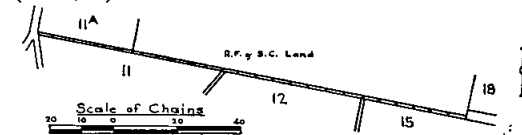

Parish of La Trobe, County of Heytesbury, being the roads indicated by hachure on plan hereunder.—(L.143^(*)) (1116N/26).

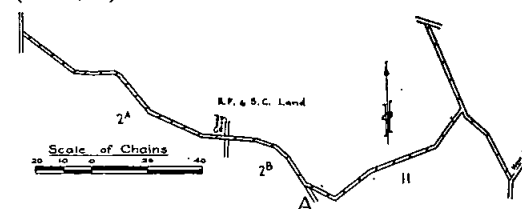

Given under my Hand and the Seal of the State of Victoria aforesaid, at Melbourne, this sixth day of August, in the year of our Lord One thousand nine hundred and sixty-eight and in the seventeenth year of the reign of Her Majesty Queen Elizabeth II.

(L.S.) E. F. HERRING.

By His Excellency's Command,
W. J. F. McDONALD,
Minister of Soldier Settlement.
GOD SAVE THE QUEEN!

ROAD PROCLAIMED.

PROCLAMATION

By His Excellency the Lieutenant-Governor of the State of Victoria and its Dependencies in the Commonwealth of Australia, &c., &c., &c.

IN pursuance of the provisions of Section 25 of the Land Act 1958, the Lieutenant-Governor of the State of Victoria, by and with the advice of the Executive Council of the said State, do hereby proclaim as a road the land in the Parish of Beechworth, County of Bogong as indicated by hatching on plan hereunder.—(B.349⁽²⁵⁾) (H.031122).

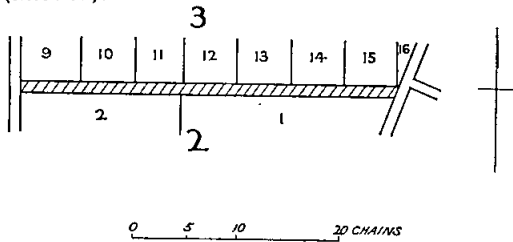

Given under my Hand and the Seal of the State of Victoria aforesaid, at Melbourne, this sixth day of August, in the year of our Lord One thousand nine hundred and sixty-eight and in the seventeenth year of the reign of Her Majesty Queen Elizabeth II.

(L.S.) E. F. HERRING.

By His Excellency's Command,
W. J. F. McDONALD,
Minister of Lands.

GOD SAVE THE QUEEN!

GOVERNMENT NOTICES

LAW DEPARTMENT.

CURATOR OF CONVICT'S PROPERTY.

HIS Excellency the Lieutenant-Governor of the State of Victoria, by and with the advice of the Executive Council thereof, doth by Order made on the 6th day of August, 1968, and pursuant to the provisions of section 550 of the Crimes Act 1958, commit the custody and management of the property of the convict JAMES DUNWOODIE to LAURETTE JEAN ALFORD, of 4 Crocker-street, Ballarat, as a Curator hereby appointed in that behalf.

J. ROSSITER,
Clerk of the Executive Council.

At the Executive Council Chamber,
Melbourne, 6th August, 1968.

The Constitution Act Amendment Act 1958.

REVOCATION OF APPOINTMENTS OF POLLING PLACES.

HIS Excellency the Lieutenant-Governor of the State of Victoria, by and with the advice of the Executive Council thereof, doth by Order made on the 6th day of August, 1968, and pursuant to the provisions of The Constitution Act Amendment Act 1958, revoke the appointments of—

KULWIN
as a Polling Place within and for the Robinvale Sub-division of the North-Western Province and the Electoral District of Swan Hill;

NARRUNG
as a Polling Place within and for the Nyah West Sub-division of the North-Western Province and the Electoral District of Swan Hill;

THALIA
as a Polling Place within and for the Wycheproof Sub-division of the North-Western Province and the Electoral District of Swan Hill; and

SANDHILL LAKE
as a Polling Place within and for the Kerang Sub-division of the Northern Province and the Electoral District of Swan Hill.

J. ROSSITER,
Clerk of the Executive Council.

At the Executive Council Chamber,
Melbourne, 6th August, 1968.

SHIRE OF HEYTESBURY.

ROAD DEVIATION ORDER.

PURSUANT to the provisions of sections 522 and 526 of the Local Government Act 1958 the Council of the Shire of Heytesbury hereby directs that the land in the Parish of Paaratte indicated by hatching on the diagram hereunder which has been purchased taken or acquired by it shall be a public highway on and from the date of the publication of this order in the Government Gazette and declares that such land shall be a public highway in lieu of the land indicated by cross-hatching on the said diagram.

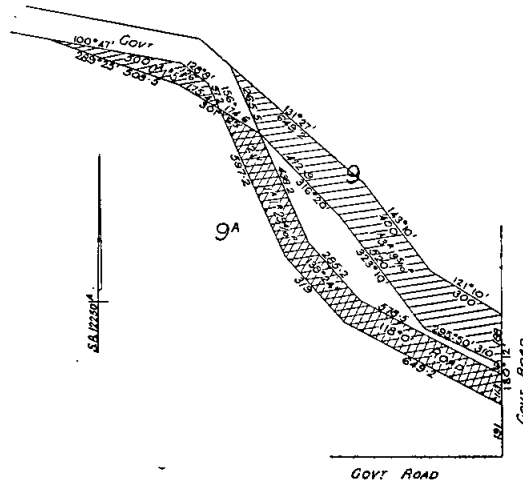

MEASUREMENTS ARE IN LINKS

The common seal of the President, Councillors and Ratepayers of the Shire of Heytesbury was hereunto affixed, this 14th day of March, 1968, in the presence of—

JOHN C. McCUE, President.
J. F. YOUNIS, Councillor.
P. J. NORTHEAST, Shire Secretary.

Confirmed by the Governor in Council, this 6th day of August, 1968.—J. ROSSITER, Clerk of the Executive Council.

Town and Country Planning Act 1961.

CITY OF SHEPPARTON PLANNING SCHEME 1953.

AMENDMENT No. 16, 1967.

Notice of Approval.

IN pursuance of the powers conferred by the Town and Country Planning Act 1961 the Governor in Council on the 6th August, 1968, approved a Planning Scheme entitled the City of Shepparton Planning Scheme 1953, Amendment No. 16, 1967, in respect of part of the municipal district of the City of Shepparton and such Planning Scheme comes into operation on the date this notice of approval is published in the Government Gazette.

A copy of the Planning Scheme as approved may be inspected free of charge during office hours at the office of the Town and Country Planning Board, 179 Queen-street, Melbourne; at the office of the Shepparton City Council at Shepparton, and when available, at the Office of Titles, Melbourne, and at the Central Plan Office of the Department of Crown Lands and Survey, Melbourne.

W. H. CRAIG, Secretary,
Town and Country Planning Board.

Town and Country Planning Act 1961.

SHIRE OF WOORAYL PLANNING SCHEME.

NOTICE OF AMENDMENT TO INTERIM DEVELOPMENT ORDER.

IN pursuance of the powers conferred by section 26 of the Town and Country Planning Act 1961, the Governor in Council, by and with the advice of the Executive Council on the 13th August, 1968, amended the interim development order made by the Shire of Woorayl in connexion with the Shire of Woorayl Planning Scheme.

A copy of the amendment may be inspected during office hours at the office of the Town and Country Planning Board, 179 Queen-street, Melbourne; and at the office of the Council of the Shire of Woorayl at Leongatha.

W. H. CRAIG, Secretary,
Town and Country Planning Board.

Transport Regulation Act.

TRANSPORT REGULATION BOARD.

HEARING OF APPLICATIONS.

NOTICE is hereby given that the following applications will be considered by the Transport Regulation Board at its offices at the corner of Lygon and Princes streets, Carlton, at 10.15 a.m. on Wednesday, 4th September, 1968.

GRENDAS BUS SERVICES, 9 Foster-street, Dandenong. One commercial passenger vehicle (S/C. 36) to be purchased to operate as an additional country stage omnibus on Route 211A (Mordialloc-Mentone-Springvale).

GRENDAS BUS SERVICES, 9 Foster-street, Dandenong. One commercial passenger vehicle (S/C. 36) to be purchased to operate as an additional country stage omnibus on Route 219A (Cheltenham-Dandenong).

GRENDAS BUS SERVICES, 9 Foster-street, Dandenong. One commercial passenger vehicle (S/C. 36) to be purchased to operate as an additional country stage omnibus on Route 213A (Dandenong-Springvale).

GRENDAS BUS SERVICES, 9 Foster-street, Dandenong. Applications have been received from the above operator to provide 13 school bus services to Haileybury College, Keysborough for the 1969 school year. The applicant at present operates eight special bus services to the College which service the following areas:—East Brighton, Brighton Beach, Hampton, Sandringham, Black Rock, Beaumaris, Mentone, Cheltenham, Highett, Moorabbin and Heatherton. The proposed services will cater for those areas at present being served and in addition the following new areas:—Middle Brighton, Bentleigh and East Bentleigh.

KARAKATSANIS, M., 48 Leicester-street, West Preston. Application to operate a required number of commercial passenger vehicles with large seating capacity to operate as metropolitan stage omnibuses on a route as follows: (City-Fairfield)—Commencing at the corner of Dudley-street and William-street; thence via William-street, Howard-street, Courtney-street, Gatehouse-street, College-crescent, Cemetery-road, Princes-street, Alexandra-parade, Gray-street, Yambala-street, Dwyer-street, Heidelberg-road, Station-street, Wingrove-street and Grange-road to Darebin-road.

TIME-TABLE TO BE OPERATED.

Monday-Saturday.

15 minutes—5.30 a.m.—12.10 a.m.

Sunday.

8.30 a.m.—11.50 p.m., frequency to be determined.

POINT COOK-WERRIBEE PASSENGER SERVICE PTY. LTD., Railway-avenue, Laverton. One commercial passenger vehicle (S/C. 36) to operate as an additional country stage omnibus under the same terms and conditions as existing C.O. licences held by the applicant.

VENTURA MOTORS PTY. LTD., 1037 Centre-road, South Oakleigh. Application for permit authority to operate any one M.C. licensed vehicle held by the applicant for the carriage of school children from the corner of Burwood and Warrigal roads, Burwood, via Burwood-road, Middleborough-road, Canterbury-road, Blackburn-road, Whitehorse-road, Station-street, Williamson-road, Manningham-road, High-street, Doncaster-road, Balwyn-road, and Mont Albert-road to Camberwell Grammar School, Mont Albert, under contract to the school.

TIME-TABLE (School Days Only).

Depart Burwood	8.00 a.m.
Depart School	4.05 p.m.

Notice of any objection should be forwarded to reach the Secretary of the Board not later than Wednesday, 28th August, 1968.

Applicants are advised that it will not be necessary to appear on the hearing date specified above, unless advised in writing by the Board.

B. P. KAY,
Secretary.

Corner Lygon and Princes streets, Carlton, Wednesday, 14th August, 1968.

Commercial Goods Vehicles Act.

TRANSPORT REGULATION BOARD.

HEARING OF APPLICATIONS.

NOTICE is hereby given that the following applications will be considered by the Transport Regulation Board at its offices at the corner Lygon and Princes streets, Carlton, at 10.15 a.m., on Wednesday, 4th September, 1968.

BALMER & JONES PTY. LTD., Scott-street, Orbost, 3888. One commercial goods vehicle (L/C. 70 cwt.) to operate: (1) From and to the depot of Mobil Oil (Aust.) Pty. Ltd., at Bairnsdale to and from own depot at Orbost, in course of business as "Agents" of the above company—petroleum products in prescribed types of containers and empty return containers. (2) From and to the Mobil Oil (Aust.) Pty. Ltd., depot at Orbost to and from consignees situated within a 50-mile radius of Orbost in the course of business as "Agent" on behalf of the said company—petroleum products in bulk and in prescribed types of containers and empty return containers, also tools of trade, spare parts and dispensing equipment.

BELLS SOFT DRINKS PTY. LTD., Railway-street, Wagga Wagga, 2650. One commercial goods vehicle (L/C. 79 cwt.) to operate within a 50-mile radius of own premises at Wodonga and to and from Corryong in the course of business as "Cordial and Soft Drink Manufacturers and Distributors"—straws, cordials, soft drinks and empty return containers.

COBDEN & DISTRICT CO-OPERATIVE PIONEER CHEESE & BUTTER FACTORY CO. LTD., THE, 229 Curdie-street, Cobden, 3266. One commercial goods vehicle (L/C. 202 cwt.) to operate: (a) In the course of business as an approved decentralized secondary industry (manufacture and processing of milk products) carried on at own factory premises at Cobden and Timboon as follows: (i) To such factory premises from points within a 50-mile radius respectively of each premises and/or from the Cities of Melbourne or Geelong—goods and raw materials for use solely in the manufacturing or processing of milk products in such decentralized industry. (ii) From such factory premises at Cobden and Timboon to points within a 50-mile radius respectively of each premises and/or to the Cities of Melbourne or Geelong—own manufactured products of such decentralized industry. (b) From the said factory premises at Cobden or Timboon to the farms of primary producers from whom milk and cream is collected within a 50-mile radius respectively of each factory premises—own goods. (c) From the said factory premises at Cobden or Timboon to the Township of Portland for delivery to cool stores or to ship's side—own manufactured products and articles.

CONCRETE TESTING PTY. LTD., 184 Kings-way, South Melbourne, 3205. Two commercial goods vehicles (L/C. 11 cwt. each) to operate: (a) Within a 50-mile radius of own premises at South Melbourne in the course of business as "Concrete Testers"—own goods. (b) Throughout the State of Victoria—tools of trade and equipment, samples of concrete to be tested and sufficient fuels and lubricants for the operation of own equipment only.

CULLEN, R. N., Fischen-street, Ballan, 3342. One commercial goods vehicle (L/C. 145 cwt.) to operate: (a) Within a 50-mile radius from the post office at Ballan as a "Road Contractor"—road-making plant and materials. (b) Within a 25-mile radius of the post office at Ballan—general goods provided that no goods shall be carried whether by one stage or by more than one stage between places within the above radius which are more than 30 road miles apart by the nearest practicable route.

CROWN CONTROLS AUSTRALIA PTY. LTD., corner Balmain and Chestnut streets, Richmond, 3121. One commercial goods vehicle (L/C. 6 cwt.) to operate throughout the State of Victoria in the course of business as "Manufacturers of Mechanical Handling Equipment" for the purpose of servicing such equipment—tools of trade, spare parts and materials incidental to servicing.

DALGETY NEW ZEALAND LOAN LTD., 1 Malop-street, Geelong, 3220. One commercial goods vehicle (L/C. 24 cwt.) to operate within a 50-mile radius of the Terang Post Office in the course of business as "Stock and Station Agents"—own goods subject to the condition that all goods so carried shall have been initially consigned by rail to Terang.

DURAL LEEDS PTY. LTD., cnr. Calder Highway and Roberts-road, Niddrie, 3042. One commercial goods vehicle (L/C. 11 cwt.) to operate throughout the State of Victoria in the course of business as "Blind and Awning Manufacturers" for the purpose of sales promotion, repairing and measuring contracts; samples, display materials, tools of trade, blinds and

- awnings for repair, having been repaired and for specialized installation and materials incidental thereto.
- EDWARDS, G. R., AUTO ELECTRICAL SERVICE PTY. LTD.,** 207 Dana-street, Ballarat, 3350. Two commercial goods vehicles (L/C. 17 and 19 cwt.) to operate in the course of business as "Automotive Electrical Spare Parts and Accessories Distributor"—(a) Within a 50-mile radius of own premises at Ballarat and to and from Ararat—own goods. (b) From own premises at Ballarat to the following places only:—(i) The City of Bendigo and return serving places *en route*. (ii) Camperdown and Mortlake and return serving places *en route*. (iii) The City of Hamilton and return serving places *en route*. (iv) The Town of Stawell and return serving places *en route*. (v) The Towns of St. Arnaud, Warracknabeal, Hopetoun, Lascelles, Woomelang, Birchip and return serving places *en route*; own automotive electrical spare parts and accessories having been railed to Ballarat for display with the ability to make incidental deliveries whilst taking orders, such orders subsequently to be railed from Ballarat.
- Special Conditions.*—That records of the consignment of goods by rail be kept and the load capacity of the licensed vehicle shall not be altered without permission from the Board.
- ELLIS, G. E.,** Main-street, Mallacoota, 3889. One commercial goods vehicle (L/C. 32 cwt.) to operate within a 50-mile radius of own premises at Mallacoota and to and from the Township of Orbost to own premises at Mallacoota in the course of business as "Retail Butcher"—own goods.
- GENERAL CONSTRUCTIONS PTY. LTD.,** 62 Mandoon-road, Girraween, 2145. One commercial goods vehicle (L/C. 20 cwt.) to operate in the course of business as "General Construction Engineers"—(a) Throughout the State of Victoria—own tools of trade and own equipment incidental to own contracts. (b) Within a 20-mile radius of any current contract site or from the nearest railway station thereto—materials for use on own contracts. (c) From the site of any contract to the site of disposal—overburden.
- GILBARCO AUST. LTD.,** 11 Anderson-road, Thornbury, 3071. Six commercial goods vehicles (L/C. 38, 39, 24, 23, 23 and 38 cwt.) to operate throughout the State of Victoria—petrol pumps for installation, also tools of trade and materials incidental to the installation, servicing and maintenance of petrol and oil pumping equipment, heating equipment and water engineering equipment.
- GRANT, C. W.,** 41 Lambert-street, Ararat, 3377. One commercial goods vehicle (L/C. 142 cwt.) to operate: (a) Within a 25-mile radius of the post office at Ararat—general goods, provided that no goods shall be carried whether by one stage or by more than one stage between places within the above radius which are more than thirty road miles apart by the nearest practicable route—(b) In course of business as "Wholesale Agent"—(1) From Ararat to the Townships of Willaura, Dunkeld, Lake Bolac, Skipton, Beaufort and return to Ararat and towns *en route*—aerated waters, groceries, confectionery and empty return containers. (2) From Ararat to the Townships of Moyston, Halls Gap, Stawell and return to Ararat and towns *en route*—aerated waters, groceries, confectionery and empty return containers. (3) From Ararat to the Townships of Glenthompson, Hamilton, Peshurst, Caramut, Wickcliffe and return to Ararat and towns *en route*—aerated waters, groceries, confectionery and empty return containers.
- HAEBICH, O.,** 78 Upper Regions-street, Dimboola, 3414. One commercial goods vehicle (L/C. 7 cwt.) to operate within that part of the State of Victoria east of a north/south line through Kiata, west of a north/south line through Birchip, south of an east/west line through Woomelang and north of an east/west line through Pimpino in the course of business as "Sales Representative" on behalf of W. T. Rawleigh Co. Ltd.—medicines, toilet articles, food products and other sales lines of the said company.
- HAMILTON, D. K. & Y.,** 4 Bellevue-court, Springvale, 3171. One commercial goods vehicle (L/C. 195 cwt.) to operate within a 50-mile radius of the premises of "Ready Mixed Concrete (Vic.) Pty. Ltd.," at Oakleigh solely on behalf of the said company—pre-mixed concrete in a specially constructed agitator vehicle.
- HARTLEY, P. & B. F., & T. J. F. & F. MURRAY** (trading as Hartley and Murray Van Lines, Shepparton), 71 McDonald-street, Shepparton, 3630. One commercial goods vehicle (L/C. 54 cwt.) to operate: (a) Within a 25-mile radius of the post office at Shepparton—general goods provided that no goods shall be carried whether by one stage or by more than one stage between places within the above radius which are more than thirty miles apart by the nearest practicable route. (b) Within a 50-mile radius of own premises at Shepparton—secondhand or used furniture. (c) Within a 40-mile radius of the post office at Shepparton on behalf of James Fairley Pty. Ltd., Patersons Pty. Ltd., Clausens (Sales) Pty. Ltd., and Piero's Home Furnishings, all of Shepparton—furniture, furnishings, electrical goods and ornamental furnishings.
- HODGES, R. H.,** Church-street, Kangaroo Flat, 3555. One commercial goods vehicle (L/C. 8 cwt.) to operate within that part of the State of Victoria bounded by the Cities or Towns as the case may be of Castlemaine, Maldon, Dunolly, Charlton, Quambatook, Kerang, Koondrook, Echuca, Colbinabbin and Kilmore in the course of business as "Builder" under contract to the Public Works Department—tools of trade and small quantity of materials incidental to the completion of own contracts.
- INSULATION & SPECIALITIES PTY. LTD.,** 39 Roberna-street, Moorabbin, 3189. One commercial goods vehicle (L/C. 231 cwt.) to operate within a 25-mile radius of the G.P.O., Melbourne, and to places on the Mornington Peninsula in course of business as "Insulation Contractors"—own goods.
- JEFFREY, J., & SONS PTY. LTD.,** Wegner-street, Morwell, 3840. One commercial goods vehicle (L/C. 180 cwt.) to operate: (a) Within a 70-mile radius of the post office at Yarram (Traralgon Division of the Country Roads Board)—road-making plant. (b) Within a 20-mile radius of any current construction site or from the nearest railway station thereto—materials. (c) Within a 25-mile radius of the post office at Morwell—general goods provided that no goods shall be carried whether by one stage or by more than one stage between places within the above radius which are more than thirty road miles apart by the nearest practicable route.
- JOBLING, L. W.,** 12 Logie-street, Oakleigh, 3166. One commercial goods vehicle (L/C. 148 cwt.) to operate within a 70-mile radius of the premises of Monier Besser Blocks at Dandenong solely on behalf of the said company—bricks.
- JOHNS, D. S.** (trading as D. S. and M. A. Johns), Proctor-street, Woomelang, 3485. One commercial goods vehicle (L/C. 116 cwt.) to operate within a 50-mile radius of the post office at Woomelang in the course of business as "Superphosphate Spreader"—bulk superphosphate.
- QUINN, T.** (trading as Keilor Garden Supplies), 18 Royal-avenue, North Essendon, 3041. One commercial goods vehicle (L/C. 142 cwt.) to operate: (a) Within a 25-mile radius of the G.P.O., Melbourne in the course of business as "Garden Supplier"—own goods. (b) From Bacchus Marsh to own premises at Keilor East—own river pebbles. (c) From pits at Toolangi to own premises at Keilor East—own mountain soil. (d) From Harcourt to own premises at Keilor East—own paving slate.
- KENNEDY, P., PTY. LTD.,** 27 Oak-street, Wendouree, 3355. One commercial goods vehicle (L/C. 14 cwt.) to operate in the course of business as "Earth-moving and Excavation Contractors" as follows:—(a) Throughout the State of Victoria—tools of trade, spare parts and a quantity of fuel sufficient only for the operation of machinery on site but excluding the carriage of any spare parts from the Metropolitan Area (as defined in the *Transport Regulation Act 1958*) to the Ballarat Urban District (as similarly defined). (b) Within a 20-mile radius of the site of any contract currently engaged upon—materials for use in such contract.
- LEURY, D. P.,** 13 Daley-street, Pascoe Vale, 3044. One commercial goods vehicle (L/C. 150 cwt.) to operate: (a) Within a 25-mile radius of the post office situated at the corner of Bourke and Elizabeth streets in the City of Melbourne—general goods. (b) Within a 70-mile radius of the brickworks of Clifton Brick Holdings Ltd., at Brunswick—bricks on behalf of the said company.
- MACKRELL, L. C.,** Strathbogie, 3666. One commercial goods vehicle (L/C. 100 cwt.) to operate: (a) Within a 25-mile radius of the post office at Strathbogie—general goods provided no goods shall be carried whether by one stage or by more than one stage between places within the above radius which are more than thirty miles apart by the nearest practicable route. (b) Within a 50-mile radius of own premises at Strathbogie in the course of business as "Agricultural Contractor"—tools of trade and agricultural equipment for use in connection with own contracts.
- MALONE, P. R.,** Grassmere Junction, 3279. One commercial goods vehicle (L/C. 10 cwt.) to operate: (a) Within a 25-mile radius of the post office at Grassmere

- Junction—general goods provided that no goods shall be carried whether by one stage or by more than one stage between places within the above radius which are more than thirty road miles apart by the nearest practicable route. (b) Throughout the State of Victoria as a "Service Vehicle" for the purpose of servicing and repairing vehicles on behalf of P.R. Malone Transports Pty. Ltd., and Super Agencies Pty. Ltd.—tools of trade and spare parts but excluding the carriage of spare parts from Melbourne.
- MARRONE, D.**, 43 Hillside-parade, Glen Iris, 3146. One commercial goods vehicle (L/C. 193 cwt.) to operate within a 50-mile radius of the premises of Pronto Mixed Concrete Co. Pty. Ltd., at Ringwood solely on behalf of the said company premixed concrete in a specially constructed agitator vehicle.
- MATHRICK, W. R. & V.**, 13A Hall-street, Eaglehawk, 3556. One commercial goods vehicle (L/C. 30 cwt.) to operate: (a) Throughout the State of Victoria in the course of business as "Builder"—tools of trade and equipment and a small quantity of materials for use in own contracts. (b) Within a 25-mile radius of any current contract site or from the railway station nearest thereto—materials incidental to the completion of such contract.
- WARD, K. R.** (trading as Midland Brick Works), P.O. Box 663, Shepparton, 3630. Three commercial goods vehicles (L/C. 79, 252 and 22 cwt.) to operate: (a) Within the area east of a north/south line drawn through Elmore and north of an east/west line drawn through Kilmore as an approved decentralized secondary industry (brickmaking)—own manufactured bricks and small quantity of bricks manufactured by Clifton Brick Holdings Ltd. (b) To and from Melbourne from and to own decentralized industry at Shepparton—goods for use in connexion with such industry.
- MILGATE, F. A.**, 28 Victoria-street, Rochester, 3561. One commercial goods vehicle (L/C. 120 cwt.) to operate: (a) Within a 50-mile radius of the post office at Rochester as a "Road Contractor"—road-making plant and materials. (b) Within a 25-mile radius of the post office at Rochester—general goods provided that no goods shall be carried whether by one stage or by more than one stage between places within the above radius which are more than thirty road miles apart by the nearest practicable route.
- NOLAN, E. J.**, 34 Carrington-street, East Geelong, 3219. Two commercial goods vehicles (L/C. 68 and 15 cwt.) to operate: (a) Throughout the State of Victoria in the course of business as "Bridge Building Contractors"—own tools of trade, plant and equipment incidental to own contracts. (b) Within a 20-mile radius of any current contract site or from the nearest railway station thereto—materials for use on such contract.
- PERRY, W. C. L.**, Buxton, 3711. Application to vary conditions of licence No. D.A.58537 (L/C. 88 cwt.) by adding to paragraph (b) of the existing conditions after "Spotswood" the word "Dandenong".
- PORTER, D. W.**, P.O. Box 203, Ballarat, 3350. One commercial goods vehicle (L/C. 16 cwt.) to operate throughout the State of Victoria in the course of business as "Earthmoving and Excavation Contractor"—tools of trade, spare parts and fuel for the operation and maintenance of own equipment only but excluding the carriage of spare parts from the Melbourne Metropolitan Area to the Ballarat Urban District as defined in the *Transport Regulation Act 1958*.
- REID (ASPHALTING CONTRACTORS) PTY. LTD.**, 29 Metropolitan-avenue, Nunawading, 3131. One commercial goods vehicle (L/C. 63 cwt.) to operate throughout the State of Victoria for the purpose of operating the vehicle as a specially constructed road spraying unit—bitumen and tar in bulk for road spraying.
- SAVVA, A.**, 4 Butters-street, Morwell, 3840. One commercial goods vehicle (L/C. 135 cwt.) to operate: (a) From forest landings situated within a 5-mile radius of Allambee to the premises of Australian Paper Manufacturers Ltd., at Maryvale—pulpwood. (b) From forest landings situated within a 5-mile radius of Allambee to the premises of Drouin West Sawmills at Drouin West—mill logs.
- BUTLER, J. J.** (trading as A. R. Scoones and Co.), 108 Allen-street, Kyabram, 3620. One commercial goods vehicle (L/C. 97 cwt.) to operate: (a) Within a 25-mile radius of own branch premises at Shepparton—general goods provided that no goods shall be carried whether by one stage or by more than one stage between places within the above radius which are more than thirty road miles apart by the nearest practicable route. (b) Within a 20-mile radius from own depot at Kyabram in the course of business as "Petroleum Agents" on behalf of the Shell Co. of Aust. Ltd.—petroleum products in prescribed types of containers and empty return containers.
- SMYTH, N. R. & E. M.** (trading as Seymour Trading Company), 52 Emily-street, Seymour, 3660. Two commercial goods vehicles (L/C. 236 cwt. and 137 cwt.) to operate: (a) In the course of business as "Manufacturers of Farm Gates and Farm Equipment" from places within the Melbourne Metropolitan Area to the Township of Seymour—piping, angle iron, sheet steel, wire, galvanized iron and steel. (b) In course of business as "Hardware Merchant, Furniture and Drapery Reseller" from the Melbourne Metropolitan area to Seymour—piping, angle iron, sheet steel, wire, galvanized iron, steel, furniture, carpet, bedding, paint, hardware and clothing. (c) Throughout the State of Victoria in course of business as "Marine Collector" special wares, marine stores and old metals as designated in the *Marine Stores and Old Metals Act 1958* (No. 6303), Part 1, Section 3, but excluding the carriage of any such marine stores and old metals to wharves, docks or ships for shipment or export purposes.
- SPOKES, C. J.**, McKenzie-street, Cowes, 3922. Two commercial goods vehicles (L/C. 209 and 80 cwt.) to operate: (a) From the Township of San Remo to the City of Melbourne—fish and fisherman's gear for repair. (b) From Melbourne to San Remo—life boats, boat fittings, timber for boat building and repair, engines and machinery and associated spare parts, fishing tackle, fishing nets, marker buoys for use in fishing operations, bottled Butane gas, lubricating oil, hydraulic oils, coarse salt, empty fish boxes, cartons and other packaging materials for uncooked fresh or frozen fish, hand tools, power operated tools provided that any of the aforementioned goods must be used on or in connexion with a fishing boat registered with the Marine Board of Victoria or a corresponding authority in other States of the Commonwealth for the purpose of commercial fishing. (c) From the City of Melbourne to the Township of San Remo—potatoes solely on behalf of the San Remo Fishermans Co-operative Society Ltd. (d) From Melbourne to the premises of the San Remo Fishermans Co-operative Society Ltd., at San Remo—frozen dim sims, frozen chicken rolls, frozen packs of chinese food, frozen hamburgers, frozen scallops, frozen oysters, frozen prawns, frozen fish and up to 6 cwt. of cooking oil and up to 20 lb. of bottled pickled onions and bottled mussels on any one trip. (e) From the depot of Ampol Petroleum Aust. Ltd. at Spotswood to our depot at Cowes—petroleum products in prescribed types of containers and empty return containers. (f) Within a 25-mile radius of the post office at Cowes—general goods provided that no goods shall be carried whether by one stage or by more than one stage between places within the above radius which are more than thirty road miles apart by the nearest practicable route.
- STAMOULIS, S. & N.**, 20 Cozens-street, Brunswick, 3056. One commercial goods vehicle (L/C. 240 cwt.) to operate: Within a 35-mile radius from the G.P.O., Melbourne solely on behalf of Consolidated Quarries Ltd.—sand, screenings and quarry products.
- WILLIAM STEPHEN PTY. LTD.**, Railway-parade, Glen Waverley, 3150. One commercial goods vehicle (L/C. 13 cwt.) to operate: Throughout the State of Victoria in course of business as "Veterinary and Agricultural Chemical and Equipment Distributors" for the purpose of promoting sales and booking orders with poultry, pig, and dairy farmers and resellers—display materials, samples and incidental delivery of urgently required medicines and related equipment only to a primary producer.
- NOTE.—Goods for resellers and non-urgent goods consigned by rail.

RENEWALS.

- APPLICATIONS for renewal of licences as shown by persons listed hereunder to operate under the same terms and conditions from the expiry shown in each case.
- ASHCROFT, H. E.**, 11 High-street, Beechworth, 3747; D.A.41541; 12th September, 1968; 10 cwt.
- AVON QUARRIES PTY. LTD.**, P.O. Box 41, Stratford, 3862; D.A.40522; 26th September, 1968; 229 cwt.
- BRITTON, L. W.**, 609 Lydiard-street, Ballarat, 3350; D.A.40531; 26th September, 1968; 30 cwt.
- CARRACHER, C. P.**, Minimay, 3413; D.A.40517; 26th September, 1968; 131 cwt.
- COLGATE, E. R.**, Apsley-road, Edenhope, 3318; D.A.868; 6th September, 1968; 125 cwt.
- DE BORTOLI, J.**, P.O., Wandong, 3656; D.A.31097/1; 12th September, 1968; 139 cwt.

- DEVERALL, P., Hamilton-street, Gisborne, 3437; D.A.53063; 31st August, 1968; 157 cwt.
 DUNN, D. W. & H. F., 2 Crowlands-road, Stawell, 3380; D.A.53258; 21st September, 1968; 26 cwt.
 EVANS, H., & SONS PTY. LTD., 19 Main-street, Ballarat, 3350; D.A.3518/3; 26th September, 1968; 10 cwt.
 FOX, V. L. (trading as V. & M. Fox), 61 Templeton-street, Euroa, 3666; D.A.52653/1; 21st September, 1968; 9 cwt.
 HOUGHTON & BYRNE (VIC.) PTY. LTD., 22 Nicholson-street, East Brunswick, 3056; D.A.43077/8; 31st August, 1968; 11 cwt.; D.A.43077/9; 31st August, 1968; 11 cwt.
 IERACI, N., & SONS PTY. LTD., 76 McLlwraith-street, Princes Hill, 3054; D.A.40019/3; 31st August, 1968; 13 cwt.
 JENNINGS, H., Frankston-road, Cranbourne, 3977; D.A.53215; 31st August, 1968; 140 cwt. approximately.
 KEUTMANN, LEO (trading as Leo Keutmann & Co.), 36 Carver-street, East Burwood, 3151; D.A.51387; 17th February, 1968; 196 cwt.
 KIZELIS, G., 131 Fawkes-street, Essendon, 3040; D.A.52666; 7th July, 1968; 228 cwt.
 KOVACS, E., 95-99 Mornington-street, North Geelong, 3215; D.A.33993/1; 26th September, 1968; 251 cwt.
 MATTHEWS, F., 9 Munro-street, Orbost, 3888; D.A.53094; 31st August, 1968; 17 cwt.
 MEDWELL, W. C., 21 Ophir-street, Sebastopol, 3350; D.A.1585; 5th September, 1968; 118 cwt.
 NEEDS, T. W., 17 Bourke-street, Kyneton, 3444; D.A.1708; 1st August, 1968; 105 cwt.
 NOTT & DREW PTY. LTD., 31-33 Ryrie-street, Geelong, 3220; D.A.49888/1; 31st August, 1968; 38 cwt.
 ORENSHAW, K. A. & D. M., King-street, Yarra Glen, 3775; D.A.52940; 31st August, 1968; 135 cwt.
 PEACH, R. J. (trading as Peach's Transport), High-street, Macarthur, 3286; T.D.A.1788; 1st September, 1968; 159 cwt.
 PHILLIPS, W. D., 12 Dundas-street, St. Arnaud, 3478; D.A.39632; 27th June, 1968; 247 cwt.
 RAFTERY, J. W., 60 Chum-street, Bendigo, 3550; D.A.53119; 31st August, 1968; 63 cwt.
 RHODES, L. J. (trading as Rhodes Bros.), Tomkies-road, Castlemaine, 3450; D.A.4246/2; 31st August, 1968; 12 cwt.
 SELL, K. D., Elliminyt, 3249; D.A.27172; 24th September, 1968; 161 cwt.
 THOMPSONS (CASTLEMAINE) LTD., 5 Parker-street, Castlemaine, 3450; D.A.2156/5; 26th September, 1968; 78 cwt.
 WILSON ELECTRIC TRANSFORMER CO. PTY. LTD., 310 Springvale-road, Glen Waverley, 3150; D.A.34340/1; 25th July, 1968; 11 cwt.
 WITTICK, R. & N., 13 Millbank-street, Bacchus March, 3340; D.A.36427/1; 8th August, 1968; 90 cwt.

RENEWALS WITH VARIATION.

APPLICATION by the persons listed hereunder for renewal of the licences listed with variation of conditions in the manner set out opposite their names.

- BANKS, J. J., Glenaladale, via Lindenow, 3875; D.A.53088; 31st August, 1968; Application to renew and vary conditions of licence No. D.A.53088 (L/C. 121 cwt.) by deleting "85 miles" from paragraph (a) of the existing conditions and adding in lieu "95 miles" and also deleting paragraph (c) and adding in lieu— "(c) Within a 25-mile radius of the post office at Lindenow—general goods, provided that no goods shall be carried whether by one stage or by more than one stage between places within the above radius, which are more than 30 miles apart by the nearest practicable route."
 COCA-COLA BOTTLERS (GEELOG) PTY. LTD., Corio Quay-road, North Geelong, 3215; D.A.27356; 10th September, 1968; Application to renew and vary conditions of licence No. D.A.27356 (L/C. 136 cwt.) by adding to paragraph (b) of the existing conditions after "own soft drinks in glass containers" the words "canned soft drinks, not exceeding ten (10) cartons on any one load."

Notice of any objection should be forwarded to reach the Secretary of the Board not later than 28th August, 1968.

Applicants are advised that it will not be necessary to appear on the hearing date specified above, unless advised in writing by the Board.

B. P. KAY,
Secretary.

Corner Lygon and Princes streets, Carlton, 3053, 9th August, 1968.

Pounds Act 1958.

SHIRE OF KORUMBURRA.

TABLE of Rates to be charged for the trespass of cattle and their sustenance while impounded in the Korumburra and oowong Pounds fixed by the Council of the Shire of Korumburra.

Description of Cattle Trespassing.	Trespass Rates.		Sustenance Fees.
	Upon Land other than Tillage Land Enclosed by a Substantial Fence.	Upon Tillage Land Enclosed by a Substantial Fence.	Amount to be Charged Daily for Sustenance while Impounded.
	\$	\$	\$
For every sheep ..	0.03	0.10	0.10
For every goat ..	1.00	2.00	0.50
For every pig ..	1.00	2.00	1.00
For every head of other cattle ..	1.00	2.00	1.00
<i>Additional rates payable in respect of entire animals.</i>			
For every entire horse bull or ram ..	20.00	20.00	..

By Order of the Council,
W. O. CLARK,
Shire Secretary.

Approved by the Governor in Council, 6th August, 1968.—
J. ROSSITER, Clerk of the Executive Council.

Pounds Act 1958.

SHIRE OF DEAKIN.

TABLE of Rates to be charged for the trespass of cattle and their sustenance while impounded, fixed by the Council of the Shire of Deakin.

Description of Cattle Trespassing.	Trespass Rates.		Sustenance Fees.
	Upon Land other than Tillage Land Enclosed by a Substantial Fence.	Upon Tillage Land Enclosed by a Substantial Fence.	Amount to be Charged Daily for Sustenance while Impounded.
	\$	\$	\$
For every sheep ..	0.03	0.06	0.10
For every goat ..	1.00	2.00	0.20
For every pig ..	1.00	2.00	0.20
For every head of other cattle ..	1.00	2.00	1.00

By Order of the Council,
B. PEARL,
Shire Secretary.

Approved by the Governor in Council, 6th August, 1968.—
J. ROSSITER, Clerk of the Executive Council.

PUBLIC NOTICE.

ALL persons who as producers of farm produce have any claims against Francesco Cammaroto, of 33 Robertson-street, Kensington, arising from any failure on his part to pay or account for any moneys payable to them by the said Francesco Cammaroto are invited to forward particulars and proof of such claim to the Director of Agriculture, Treasury Place, Melbourne, 3002 on or before 21st August, 1968.

D. S. WISHART,
Director of Agriculture.

State Savings Bank Act 1958, Section 30.
THE STATE SAVINGS BANK OF VICTORIA.

CLOSURE OF BRANCH.

THE Commissioners of the State Savings Bank of Victoria hereby give notice of the closure of the Flinders-street Sub-branch of the Bank, on 28th August, 1968.

T. E. HALL,
General Manager.

Private Agents Act 1966.

NOTICE OF RECEIPT OF APPLICATIONS FOR LICENCES UNDER THE PROVISIONS OF THE PRIVATE AGENTS ACT 1966.

THE Clerk(s) of the Court(s) of Petty Sessions as listed hereunder hereby give notice that applications, as under, have been lodged for hearing by the said Court(s) on the date(s) specified.

Any person desiring to object to any of such applications must—

(a) lodge with the respective Clerk of Petty Sessions a notice in the prescribed form of his objection and of the grounds thereof;

(b) cause a copy of such notice to be served personally or by post upon the applicant at least three days before the hearing of the application; and

(c) send or deliver—

(i) where the objection is not made by the officer in charge of the police district in which the Court is situated—a copy of the notice to such officer; and

(ii) where the objection is not made by the Registrar or Deputy Registrar—a copy to the Registrar.

Full Name of Applicant or in the case of a Firm or Corporation, of the Nominee.	Place of Abode of Applicant or Nominee.	Name of Firm or Corporation.	Address for Registration.	Type of Licence.	Date of Hearing of Application.
---	---	------------------------------	---------------------------	------------------	---------------------------------

COURT OF PETTY SESSIONS, HEIDELBERG.

Paterson, Malcolm McGregor	61 Hume-street, Greensborough	Malan Private Detective Agency	61 Hume-street, Greensborough	Inquiry Agent	30.8.68
----------------------------	-------------------------------	--------------------------------	-------------------------------	---------------	---------

Dated at Heidelberg this 5th day of August, 1968.

T. K. HASSARD, Clerk of Petty Sessions.

COURT OF PETTY SESSIONS, ST. KILDA.

O'Neill, Allan Terence	42 Dalgety-street, St. Kilda		42 Dalgety-street, St. Kilda	Process Server	29.8.68
" " "	" " "		" " "	Inquiry Agent	"

Dated at St. Kilda this 7th day of August, 1968.

J. E. REILLY, Clerk of Petty Sessions.

COURT OF PETTY SESSIONS, COBURG.

Fellows, Lawrence	Flat 10, 21 Cohuna-street, West Brunswick	Mayne Nickless Ltd.	88 Bakers-road, North Coburg	Watchman	27.8.68
-------------------	---	---------------------	------------------------------	----------	---------

Dated at Coburg this 7th day of August, 1968.

F. J. TENNI, Clerk of Petty Sessions.

COURT OF PETTY SESSIONS, SOUTH MELBOURNE.

Elsom, Robert Louis	34 Brunswick-road, East Brunswick		101-105 Clarke-street, South Melbourne	Watchman	4.9.68
Forsdick, Thomas Curry	2 Fitzroy-street, St. Kilda		" " "	"	"

Dated at South Melbourne this 7th day of August, 1968.

G. MILLER, Clerk of Petty Sessions.

COURT OF PETTY SESSIONS, COLLINGWOOD.

Morris, Esther Jean	56 Gold-street, Collingwood	Charles P. Morris Detective Agency	56 Gold-street, Collingwood	Process Server	2.9.68
" " "	" " "	" " "	" " "	Inquiry Agent	"

Dated at Collingwood this 8th day of August, 1968.

H. KING, Clerk of Petty Sessions.

COURT OF PETTY SESSIONS, SALE.

Stubbe, Gerrit	28 Overend-crescent, Sale	Sale Security Patrol	26 Overend-crescent, Sale	Watchman	3.9.68
Hornby, Walter Stanley	75 MacAlester-street, Sale	Australian Watching Co.	340 Abbotsford-street, North Melbourne	"	10.9.68

Dated at Sale this 7th day of August, 1968.

D. R. WORKER, Clerk of Petty Sessions.

COURT OF PETTY SESSIONS, SOUTH MELBOURNE.

Bradman, Alfred Dennis	22 Daly-street, Frankston		101-105 Clarke-street, South Melbourne	Watchman	4.9.68
Cooper, Geoffrey Arthur	17 Byron-road, Kilsyth		" " "	"	"
Hancock, Kenneth Geoffrey	50 Craig-street, Spotswood		" " "	"	"
Harman, Kevin Allan	15 Janet-street, Boronia		" " "	"	"
Wade, Walter	Fisherman's Bend Hostel, Lorimer-street, Port Melbourne		" " "	"	"
Grose, Lionel Stephen	166 Danks-street, Albert Park		" " "	"	"

Dated at South Melbourne this 8th day of August, 1968.

G. MILLER, Clerk of Petty Sessions.

PRIVATE AGENTS—continued.

Full Name of Applicant or in the case of a Firm or Corporation, of the Nominee.	Place of Abode of Applicant or Nominee.	Name of Firm or Corporation.	Address for Registration.	Type of Licence.	Date of Hearing of Application.
COURT OF PETTY SESSIONS, MELBOURNE.					
Laurens, Peter John George ..	49 Irving-road, Toorak	Laurens Reports Pty. Ltd.	414 Lonsdale-street, Melbourne	Inquiry Agent (Corporation)	28.8.68
English, John Berchmans ..	14 Lesley-grove, Noble Park	" "	14 Lesley-grove, Noble Park	Inquiry Agent (Individual)	"
Julyan, Finlay Munro ..	23 Primrose-crescent, East Brighton	" "	23 Primrose-crescent, East Brighton	Process Server (Individual)	"
Englander, Eric Simon ..	Flat 4, 416 Dandenong road, North Caulfield	" "	533 Collins-street, Melbourne	Guard Agent (Individual)	"
Campbell, Ian ..	93 Alamein-road, West Heidelberg	Australian Watching Co. Pty. Ltd.	340 Abbotsford-Street, North Melbourne	Watchman	"
Cree, Kenneth David ..	11 Mitchell-street, North Footscray	" "	" "	" "	"
Feureau, Edgar ..	5 Olive Bank-road, Ferntree Gully	" "	" "	" "	"
Hanson, George Raymond ..	515 Waterdale-road, West Heidelberg	" "	" "	" "	"
Probyn, Dudley Charles ..	"Two Hills", Glenburn	" "	" "	" "	"
Raymer, Charles Wesley ..	56 Adam-street, Burnley	" "	" "	" "	"
Stidworthy, Peter ..	Flat 304, 100 Altona-street, Kensington	" "	" "	" "	"
Taylor, Keith Maxwell ..	Flat 9, 25 Brighton-road, St. Kilda	" "	" "	" "	"
Tyrrrell, Alan James ..	26 Coolstore-road, Hastings	" "	" "	" "	"

Dated at Melbourne this 7th day of August, 1968.

G. L. WEBSTER, Clerk of Petty Sessions.

COURT OF PETTY SESSIONS, SPRINGVALE.

Cook, William James ..	Emerald-road, Grey's Hill, Beaconsfield	" "	Emerald road, Grey's Hill, Beaconsfield	Watchman	30.8.68
------------------------	---	-----	---	----------	---------

Dated at Springvale this 9th day of August, 1968.

F. J. DUTHIE, Clerk of Petty Sessions.

COMPANIES ACT 1961.

NOTICE is hereby given, in pursuance of section 308 (2) and 308 (3) of the Companies Act 1961, that at the expiration of three months from the date hereof the names of the following companies will, unless cause is shown to the contrary, be struck off the Register and the said companies will be dissolved.

Dated this 8th day of August, 1968.

E. B. MITCHAM,
Assistant Registrar of Companies.

Companies Office,
Melbourne.

COMPANIES ABOVE REFERRED TO.

Name of Company.	Number of Registration.	Name of Company.	Number of Registration.
Laurence B. Fitch Pty. Ltd. ..	45312	Sam's Supermarket Pty. Ltd. ..	55770
Tresmor Investments Pty. Ltd. ..	46106	Associated Egg Packers & Distributors Pty. Ltd. ..	55922
Somerton Development Pty. Ltd. ..	49033	Quality Typing Service Pty. Ltd. ..	56453
Daveheath Pty. Ltd. ..	49855	American Modern Pleating Co. Pty. Ltd. ..	56640
Danina Pty. Ltd. ..	49856	Peter Boyd Squires (Burwood) Pty. Ltd. ..	56860
Marvis Pty. Ltd. ..	49857	Peter Boyd Squires (Auburn) Pty. Ltd. ..	56861
Dom Realty Pty. Ltd. ..	51000	116 Brougham Street Pty. Ltd. ..	57618
Adams Haulage Pty. Ltd. ..	51867	Golden Key Restaurant Pty. Ltd. ..	58650
Nargoth (Holdings) Pty. Ltd. ..	52323	John R. McKenzie (Builders) Pty. Ltd. ..	58980
Agate Publishing Co. Pty. Ltd. ..	52723	Variable Drives & Couplings Pty. Ltd. ..	59199
John R. McKenzie (Holdings) Pty. Ltd. ..	52938	T. O. P. Secretaries (Victoria) Pty. Ltd. ..	59506
Nicholls & Utting Pty. Ltd. ..	53017	Top Press Dry Cleaners Pty. Ltd. ..	60518
Jeimar Pty. Ltd. ..	53080	Visser Engineering Pty. Ltd. ..	61087
Eden Meat Supplies Pty. Ltd. ..	53097	Skals Transport Pty. Ltd. ..	62215
Pittard's of Horsham Pty. Ltd. ..	53671	Richmond Development Pty. Ltd. ..	62283
Henry Homes Pty. Ltd. ..	53844	Bayswater Continental Butchers Pty. Ltd. ..	62498
Dinra Construction Pty. Ltd. ..	53969	Emgo Equipment Pty. Ltd. ..	62513
Pittard's of Colac Pty. Ltd. ..	54430	Attica Importers Pty. Ltd. ..	62734
Petmar Pty. Ltd. ..	54995	Northern Licensed Grocers Pty. Ltd. ..	63092
Wanda Constructions Pty. Ltd. ..	55453	Westall Heating & Air Conditioning Engineers Pty. Ltd. ..	63635
Cellinco Pty. Ltd. ..	55682	Hi-Test Fabrications Pty. Ltd. ..	63673
		Chalet International (Victoria) Pty. Ltd. ..	64038
		35 Edgcombe Street Pty. Ltd. ..	64076
		Divertafon Holdings Pty. Ltd. ..	64330
		Civic Transport Pty. Ltd. ..	64609
		Mercer Motors Pty. Ltd. ..	64733
		Miden Creations Pty. Ltd. ..	65737
		Black Rock Meat Supply Pty. Ltd. ..	66066
		Travel Credit & Finance Co. (Australia) Pty. Ltd. ..	66221
		Holant Investments Pty. Ltd. ..	66326
		Wannon Milk Trading Pty. Ltd. ..	66452
		Cortina Paving Co. Pty. Ltd. ..	66798
		Australian Gas Conversion Co. Pty. Ltd. ..	66912
		Camden Finance Pty. Ltd. ..	67087
		Baranbali Pty. Ltd. ..	67617
		393 Gilbert Road, Preston Pty. Ltd. ..	69156
		Thirty Seven Northcote Avenue Pty. Ltd. ..	69211

ORDERS IN COUNCIL.—(Series 1968-69.)**STATE ELECTRICITY COMMISSION.**

549. For earthworks and site preparation, for Horsham Terminal Station, to Specification No. 68/165A, at Schedule rates.—Robin Keath Pty. Ltd.

Approved by the Governor in Council, 2nd July, 1968.—J. ROSSITER, Clerk of the Executive Council.

550. For the construction of high and/or low voltage distribution lines and substations for a period of two years, to Specification No. 68/137, at Schedule rates.—Alan Davis.

551. For the construction of high and/or low voltage distribution lines and substations for a period of one year, to Specification No. 68/137, at Schedule rates.—C. J. Robertson & Co. (Horsham).

552. For the construction of high and/or low voltage distribution lines and substations for a period of two years, to Specification No. 68/137, at Schedule rates.—Construction Line Electrics Pty. Ltd.

553. For the construction of high and/or low voltage distribution lines and substations for a period of two years, to Specification No. 68/137, at Schedule rates.—Eastern Power Lines Pty. Ltd.

554. For the construction of high and/or low voltage distribution lines and substations for a period of two years, to Specification No. 68/137, at Schedule rates.—F. J. & S. Wintle.

555. For the construction of high and/or low voltage distribution lines and substations for a period of two years, to Specification No. 68/137, at Schedule rates.—G. M. & P. A. Duncan.

556. For the construction of high and/or low voltage distribution lines and substations for a period of two years, to Specification No. 68/137, at Schedule rates.—Ian Taylor Construction Pty. Ltd.

557. For the construction of high and/or low voltage distribution lines and substations for a period of two years, to Specification No. 68/137, at Schedule rates.—J. E. & J. Griffiths.

558. For the construction of high and/or low voltage distribution lines and substations for a period of two years, to Specification No. 68/137, at Schedule rates.—J. J. Clark.

559. For the construction of high and/or low voltage distribution lines and substations for a period of two years, to Specification No. 68/137, at Schedule rates.—James E. Spooner.

560. For the construction of high and/or low voltage distribution lines and substations for a period of two years, to Specification No. 68/137, at Schedule rates.—K. M. Joseph Co. Pty. Ltd.

561. For the construction of high and/or low voltage distribution lines and substations for a period of two years, to Specification No. 68/137, at Schedule rates.—M. A. Saunders and Son.

Approved by the Governor in Council, 9th July, 1968.—J. ROSSITER, Clerk of the Executive Council.

562. For the supply of street lighting lanterns for a period of two years, with optional extension of three months, to Specification No. 68/62A, at Schedule rates.—A. J. Ferguson & Co. Pty. Ltd.

Approved by the Governor in Council, 16th July, 1968.—J. ROSSITER, Clerk of the Executive Council.

563. For the supply of creosote oil for timber preservation for a period of two years, with optional extension of three months, to Specification No. 68/199, at Schedule rates.—Duratar Pty. Ltd.

564. For the supply of refractory cement for maintenance of boiler furnace walls, Latrobe Valley Power Stations, for a period of two years, with optional extension of three months, to Specification No. 68/155, at Schedule rates.—Morganite Australia Pty. Ltd.

Approved by the Governor in Council, 23rd July, 1968.—J. ROSSITER, Clerk of the Executive Council.

PUBLIC WORKS.

565. Brunswick, Police Traffic Centre, replacement of aluminium windows, \$5,737.20.—Ullin Engineering Co. Pty. Ltd.—(N.W.46386.)

566. Coburg, H.M. Gaol, Pentridge, replacement of steam line, \$2,062.00.—Mech Engineering Pty. Ltd.—(N.W.133407.)

567. Coburg, H.M. Gaol, Pentridge, replacement of telephone switchboard, \$7,201.00.—Standard Telephones and Cables Pty. Ltd.—(N.W.106542.)

568. Heatherton, Sanatorium, remodelling of bathrooms, \$1,662.70.—Ford Swinton Industries Pty. Ltd.—(E.M.109075 "B".)

569. Horsham, High School, supply and installation of blackout blinds and screens, \$1,702.45.—Dural Leeds Pty. Ltd.—(W.105510 "D".)

570. Longerenong, Agricultural College, supply and delivery of ready-mixed concrete, \$1,368.90.—McKenzie Creek Quarrying Co. Pty. Ltd.—(W.137268.)

571. St. Arnaud, High School, urgent repairs to hot-water boiler, \$1,615.00.—D. Smyth & Son Pty. Ltd.—(N.W.136853.)

572. South Melbourne, MacRobertson Girls' High School, repairs to steel windows, \$1,679.00.—Alfred H. Wall.—(E.M.89127.)

573. Tatura, S.S. No. 1441, urgent works to fire-damaged class-room, \$1,123.82.—N. Pinder.—(V.308514.)

Approved by the Governor in Council, 6th August, 1968.—J. ROSSITER, Clerk of the Executive Council.

CONTRACTS ACCEPTED.—(Series 1968-69.)**PUBLIC WORKS.**

574. Frankston, Teachers College Hostel, supply and install washing machines, \$1,747.56.—John W. Stamp Pty. Ltd.

575. Shepparton South, Technical School, supply and install Audio venetian blinds and P.V.C. screens, \$1,181.30.—G.P. Blinds Repairs & Sales.

576. Parkville, "Turana", supply timber, \$1,098.92.—Alex Sturrock & Sons Ltd.

577. Warracknabeal, High School, supply and fix stage curtains, \$1,484.89.—Fischer Furnishings Pty. Ltd.

578. Traralgon, Hobson Park Mental Hospital, supply chairs and settee, \$1,075.30.—Aristoc Industries Pty. Ltd.

579. Traralgon, Hobson Park Mental Hospital, supply and install curtains and bedspreads, \$2,894.55.—Fischer Furnishings Pty. Ltd.

580. Prahran, Technical School, supply tables and benches, \$3,162.90.—Lloyd Industries.

581. Frankston, Monterey Technical School, supply steel shelving units, \$1,410.41.—Brownbuilt Ltd.

582. Sandringham, Technical School, supply furniture, \$2,459.20.—Bera Furniture Pty. Ltd.

583. Frankston, Technical School, supply furniture, \$1,678.80.—Westbury Timber Co. Pty. Ltd.

584. Beechworth, Mental Hospital, supply timber, \$1,729.18.—Mordialloc Timber Co. Pty. Ltd.

585. Port Melbourne, P.W.D. Storeyard, supply bolts and nuts, \$1,035.70.—Ajax Fastener Co.

586. Caulfield, Institute of Technology, supply furniture, \$1,132.00.—D. F. Cowan Sales Pty. Ltd.

587. Shepparton, Technical School, supply of school furniture, \$2,486.00.—D. F. Cowan Sales Pty. Ltd.

588. Warrnambool, Technical School, supply timber cupboards and benches, \$2,478.00.—Fotheringham Bros. Pty. Ltd.

589. Warrnambool, Technical School, supply steel framed furniture, \$1,026.60.—C. Macrae.

G. SERPELL, Secretary for Public Works. 6.8.68.

TOOLS.

Gazette No. 30, 5th April, 1968, Schedule No. 52, Tools (General).—For rates shown opposite the following items, substitute the rates as set out hereunder, as from 6th August, 1968:—Item No. 202, \$12.48 per doz.; Item No. 203, \$15.00 per doz.; Item No. 204, \$9.12 per doz.; Item No. 226, \$5.95 each; Item No. 227, \$10.63 each; Item No. 250, 6½-in., \$0.46 each, 14-in., \$0.58 each; Item No. 258, \$1.81 each; Item No. 268, handled, \$2.72 each, unhandled, \$2.20 each.

GENERAL STORES.

Gazette No. 58, 1st July, 1968, Schedule No. 27, Cocks and Fittings.—For rates shown opposite the following items, substitute the rates as set out hereunder, as from 5th August, 1968:—Item No. 22, \$5.20 per doz.; Item No. 25, \$7.20 per doz.; Item No. 26, \$7.20 per doz.

Gazette No. 58, 1st July, 1968, Schedule No. 57, Nails, Screws, Rivets, &c.—For rates shown opposite the following items, substitute the rates as set out hereunder, as from 5th August, 1968:—Item No. 19, List Price less 27½ per cent.; Item No. 20, List Price less 27½ per cent; Item No. 21, List Price less 27½ per cent; Item No. 22, List Price less 27½ per cent.

PROVISIONS.

Gazette No. 60, 4th July, 1968, Schedule No. 2, Sub-schedule No. 1, Meat.—Rate for Item No. 31, should read 22 cents per lb., as from 1st August, 1968.

J. M. PAWSON, Acting Secretary to the Tender Board. 13.8.68.

MILK BOARD ACT 1958.

IN accordance with the provisions of Section 4b of the Milk Board Act 1958, the Milk Board hereby exempts from the provisions of the said Act, all sterilized milk processed by Tongala Milk Products Pty. Ltd., of Tongala for sale to—

- (a) Commonwealth authorities, for consumption by Australian defence services personnel in areas outside Board Milk Districts, or
- (b) Ships' provedores for consumption on ships at sea.

Such exemption shall be effective from the date of publication of this notice until 30th June, 1969, and shall be subject to the following conditions—

- (1) The said sterilized milk shall be packed only in hermetically sealed metal cans of a capacity of seven pints.
- (2) Tongala Milk Products Pty. Ltd., shall lodge with the Board, not later than the tenth day of the months of January, April, July and October, a return in respect of the three preceding calendar months, setting out the following information in relation to all sales of milk so exempted:
 - (i) Name of purchaser or purchasers.
 - (ii) Quantity sold to each purchaser.
 - (iii) Price charged in each case.
 - (iv) Point of delivery in each case.

W. DOBINSON, Secretary.
Milk Board.

LOCAL GOVERNMENT ACT 1958.

IN pursuance of the powers conferred by sub-section 3A of section 575 of the Local Government Act 1958, I, William John Farquhar McDonald, Her Majesty's Minister of Lands in the State of Victoria hereby declare that the road set out on Crown land in the Township of Wonthaggi, Parish of Wonthaggi, County of Mornington, as delineated and indicated by hachure on the plan hereunder be a private street within the meaning of and for the purposes of Division 10, Part XIX of the said Act.—(Corres. No. O.1344/121.)

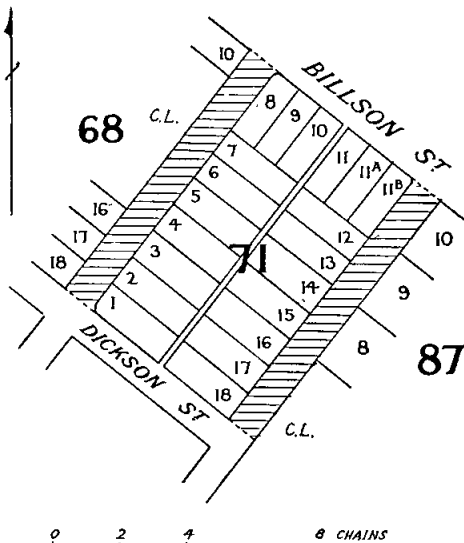

Dated at Melbourne, this 2nd day of August, 1968.

W. J. F. McDONALD,
Minister of Lands.

LOCAL GOVERNMENT ACT 1958.

IN pursuance of the powers conferred by sub-section 3A of section 575 of the Local Government Act 1958, I, William John Farquhar McDonald, Her Majesty's Minister of Lands in the State of Victoria hereby declare that the road set out on Crown land in the Parish of Kevington, County of Wonnangatta, as delineated and indicated by hachure on the plan hereunder be a private street within the meaning of and for the purposes of Division 10 Part XIX. of the said Act.—(Corres. No. H.027231.)

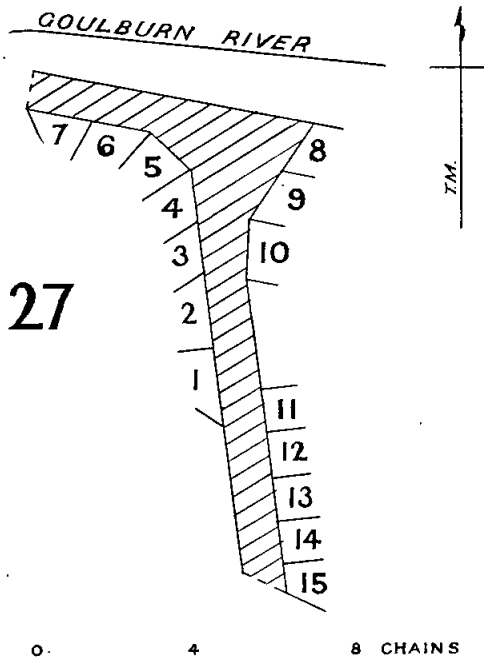

Dated at Melbourne, this 23rd day of July, 1968.

W. J. F. McDONALD,
Minister of Lands.

Victoria.

LOCAL GOVERNMENT DEPARTMENT.

ORDER CONFIRMED.—CITY OF DONCASTER AND TEMPLESTOWE.

THE Minister of the Crown administering the Local Government Act 1958, on the 7th day of August, 1968, confirmed the Order hereinafter referred to in pursuance of section 514 of the said Act namely:

An Order of the Council of the City of Doncaster and Templestowe, made on the 20th May, 1968, directing the compulsory taking of the land described hereunder for the purpose of widening Elgar-road, Doncaster.

- (a) All that piece of land being part of the land described in certificate of title, volume 7534, folio 057, commencing at a point distant 65 ft. 0 in., bearing 212 deg. 16 min. from the south-eastern corner of the intersection of Elgar-road and Malcolm-crescent, Doncaster; thence by lines bearing 108 deg. 0 min. for 3 ft. 2 in., 208 deg. 49 min. for 64 ft. 1½ in., 288 deg. 0 min. for 7 ft. 1½ in., and 32 deg. 16 min. for 65 ft. 0 in. to the point of commencement.
- (b) All that piece of land being part of the land described in certificate of title, volume 8368, folio 893, commencing at a point distant 336 ft. 0 in. bearing 21 deg. 28 min. from the north-eastern corner of the intersection of Elgar-road and Boyd-street, Doncaster; thence by lines bearing 21 deg. 28 min. for 55 ft. 2 in., 89 deg. 20½ min. for 13 ft. 7½ in., 202 deg. 24½ min. for 55 ft. 8 in., and 269 deg. 53 min. for 12 ft. 7 in. to the point of commencement.
- (c) All that piece of land being part of the land described in certificate of title, volume 8433, folio 483, commencing at a point distant 41 ft. 5 in. bearing 181 deg. 12 min. and 15 ft. 8¼ in. bearing 186 deg. 04 min. from the south-western corner of the intersection of Elgar-road and Briar-court, Doncaster; thence by lines bearing 186 deg. 04 min. for 55 ft. 5 in., 269 deg. 05 min. for 13 ft. 1½ in., 10 deg. 09 min. for 56 ft. 0¼ in. and 89 deg. 05 min. for 9 ft. 1 in. to the point of commencement.

- (d) All that piece of land being part of the land described in certificate of title, volume 2154, folio 796, commencing at a point distant 620 ft. 1 in. bearing 205 deg. 48 min. and 583 ft. 7 in. bearing 195 deg. 25 min. from the south-western corner of the intersection of Elgar-road and Doncaster-road, Doncaster; thence by lines bearing 195 deg. 25 min. for 20 ft. 10 in., 270 deg. 42 min. for 8 ft. 0 in., 15 deg. 25 min. for 20 ft. 10 in., and 90 deg. 42 min. for 8 ft. 0 in. to the point of commencement.
- (e) All that piece of land being part of the land described in certificate of title volume 4339, folio 682, commencing at a point distant 620 ft. 1 in. bearing 205 deg. 48 min. and 472 ft. 11 in. bearing 195 deg. 25 min. from the south-western corner of Elgar-road and Doncaster-road, Doncaster; thence by lines bearing 195 deg. 25 min. for 110 ft. 8 in., 270 deg. 42 min. for 16 ft. 8 in., 15 deg. 22 min. for 110 ft. 9½ in. and 91 deg. 08 min. for 16 ft. 8½ in. to the point of commencement.
- (f) All that piece of land being part of the land described in certificate of title, volume 8464, folio 142, commencing at a point distant 620 ft. 1 in. bearing 205 deg. 48 min. and 583 ft. 7 in. bearing 195 deg. 25 min. and 8 ft. 0 in. bearing 270 deg. 42 min. from the south-western corner of the intersection of Elgar-road and Doncaster-road, Doncaster; thence by lines bearing 195 deg. 25 min. for 20 ft. 10 in., 270 deg. 42 min. for 8 ft. 7½ in., 15 deg. 22 min. for 20 ft. 10 in., and 90 deg. 42 min. for 8 ft. 8 in. to the point of commencement.
- (g) All that piece of land being part of the land described under General Law in book 490, memorial 191, commencing at a point distant 804 ft. 5 in. bearing 15 deg. 41½ min. and 6 ft. 8½ in. bearing 89 deg. 26 min. from the north-western corner of the intersection of Elgar-road and Wilson's-road, Doncaster; thence by lines bearing 89 deg. 26 min. for 9 ft. 10½ in., 195 deg. 44½ min. for 9 ft. 10½ in. and 323 deg. 04 min. for 12 ft. 0 in. to the point of commencement.

JIM BALFOUR,

for Minister for Local Government.

Local Government Department,
Melbourne.

PUBLIC TRUSTEE ACT 1958 (No. 6350).—SECTION 17.

I HEREBY give notice that on the 24th July, 1968, the Public Trustee filed elections to administer the following deceased persons' estates, in accordance with section 17 of the *Public Trustee Act 1958*:—

HENDRIE, JOSEPHINE ANN, formerly of 19 Little Grey-street, St. Kilda, but late of 187 Page-street, Middle Park, married woman, died 26th May, 1968.

MOAR, JESSIE ROBINA, formerly of 17 Gladstone-road, Armadale, but late of Kingston-road, Heatherton, spinster, died 24th April, 1968.

MCDONALD, ALEXANDER, formerly of 9 Murrumbeena-road, Murrumbeena, but late of 64 Euston-road, Oakleigh, military pensioner, died 9th March, 1968.

I HEREBY give notice that on the 31st July, 1968, the Public Trustee filed elections to administer the following deceased persons' estates, in accordance with section 17 of the *Public Trustee Act 1958*:—

BROWN, WILLIAM LESLIE, late of 48 North-avenue, Moorabbin, retired plumber, died 30th May, 1968.

CHENERY, LENA AMELIA, late of Cheltenham Home and Hospital for the Aged, Cheltenham, pensioner, died 4th May, 1968.

HUNNAN, WILLIAM, late of Inglewood Hospital, Inglewood, Victoria, invalid pensioner, died 15th May, 1968.

JOHNSON, EDWARD HANS, late of Beechworth, pensioner, died 17th October, 1967.

MYALL, ELIZABETH CATHERINE, late of 3 Elizabeth-street, East Doncaster, widow, died 20th May, 1968.

WALKINSHAW, FLORENCE, late of 15 The Greenway, Heathmont, retired florist, died 28th February, 1968.

WEIR, FRANK ALEXANDER, "Sandown", Jallukar, Victoria, pensioner, died between 10th and 17th November, 1967.

D. HOOKEY,
Acting Public Trustee.

256 Flinders-street, Melbourne, 3000, 7th August, 1968.

NOTICE.

CREDITORS, next of kin and others having claims against the estate of any of the under-mentioned deceased persons are required to send particulars of their claims to the Public Trustee, 256 Flinders-street, Melbourne, the personal representative, on or before the 22nd October, 1968, after which date the Public Trustee may convey or distribute the assets, having regard only to the claims of which the Public Trustee then has notice:—

BAKA, ANASTASIA MATVEEVNA, late of Konukhi, Ternopol District, Ukrainian Soviet Socialist Republic, married woman, died 17th December, 1958.

BENNETT, FREDERICK WILLIAM, late of Fewtrell-street, Palmwoods, Queensland, salesman, died 21st November, 1965.

BLACK, WILFRED, late of 7 Belford-avenue, Kew, retired printer, died 13th June, 1968.

BOWMAN, EVA, late of 2 Beach-grove, Mentone, widow, died 21st June, 1967.

EBBROOKE, AGNES LOUISA, late of 9 Ross-street, Bentleigh, widow, died 5th January, 1968.

DICKSON, MARGARET DORIS, also known as Margherite Doris Dickson, late of 17 Warrak-road, Balwyn, widow, died 26th January, 1968.

HAMILTON, MARY ANN, late of 41 Linacre-road, Hampton, home duties, died 24th March, 1968.

JAMES, DOROTHY LOETITIA, late of 17 Mangorei-road, New Plymouth, New Zealand, spinster, died 17th February, 1967.

LINACRE, GEORGE EDWARD ALFRED, also known as George Edward Linacre, late of 240 Ross-street, Port Melbourne, clerk, died 8th March, 1968.

LITTLEFIELD, IDA JOYCE, late of 105 Derby-street, Kew, spinster, died 6th May, 1968.

LOFT, PERCY CLARENCE OWEN, late of 73 Webb-street, Fitzroy, retired fitter, died 29th April, 1968.

MAXWELL, MARY, late of Oamaru, New Zealand, widow, died 17th December, 1967.

MYERS, REGINALD NORMAN, late of 35 David-street, Hampton, public servant, died 16th January, 1968.

PATCHETT, LILY, late of 2 Hendra-court, Elsterwick, widow, died 26th May, 1968.

SCHLITZ, VIOLET RISTORI, late of 25 Balmoral-avenue, East Brunswick, spinster, died 29th January, 1968.

UNTHANK, ALICE JANE, formerly of Victoria-street, Hastings, but late of Frankston Private Hospital, 20 Overton-road, Frankston, widow, died 8th April, 1967.

URQUHART, VERNON JAMES, formerly of 7 Queens-avenue, Oakleigh, but late of 645 High-street, Armadale, war pensioner, died 25th March, 1968.

WALKLING, LESLIE WILLIAM HERRETT, late of Ward 7, Melbourne Home and Hospital for the Aged, Warrigal-road, Cheltenham, retired estate agent, died 27th April, 1968.

BROWN, WILLIAM LESLIE, late of 48 North-avenue, Moorabbin, retired plumber, died 30th May, 1968.

CHENERY, LENA AMELIA, late of Cheltenham Home and Hospital for the Aged, Cheltenham, pensioner, died 4th May, 1968.

HENDRIE, JOSEPHINE ANN, formerly of 19 Little Grey-street, St. Kilda, but late of 187 Page-street, Middle Park, married woman, died 26th May, 1968.

HUNNAN, WILLIAM, late of Inglewood Hospital, Inglewood, Victoria, invalid pensioner, died 15th May, 1968.

JOHNSON, EDWARD HANS, late of Beechworth, pensioner, died 17th October, 1967.

MOAR, JESSIE ROBINA, formerly of 17 Gladstone-road, Armadale, but late of Kingston-road, Heatherton, spinster, died 24th April, 1968.

MCDONALD, ALEXANDER, formerly of 9 Murrumbeena-road, Murrumbeena, but late of 64 Euston-road, Oakleigh, military pensioner, died 9th March, 1968.

MYALL, ELIZABETH CATHERINE, late of 3 Elizabeth-street, East Doncaster, widow, died 20th May, 1968.

WALKINSHAW, FLORENCE, late of 15 The Greenway, Heathmont, retired florist, died 28th February, 1968.

WEIR, FRANK ALEXANDER, late of "Sandown", Jallukar, Victoria, pensioner, died between 10th and 17th November, 1967.

D. HOOKEY,
Acting Public Trustee.

Melbourne, 7th August, 1968.

Police Regulation Act 1958, Section 122.

SALE OF UNCLAIMED MOTOR VEHICLE.

AN owner is required for a 1954 model, blue Holden Panel Van, ex-registered No. (VIC) JCF-781, engine No. 280317.

The vehicle came into the possession of Police on the 22nd June, 1967, and if not claimed, will be sold by public auction at the Police Traffic Control Branch, Dawson-street, Brunswick, at 2 p.m., on the 28th August, 1968.

R. H. ARNOLD,
Chief Commissioner of Police.

Police Regulation Act 1958, Section 122.
SALE OF UNCLAIMED MOTOR VEHICLE.

AN owner is required for a 1950 model, khaki Ford Custom Utility motor vehicle, ex-registered No. (VIC) YK 472, engine No. CB 49700.

The vehicle came into the possession of Police on the 18th March, 1968, and if not claimed, will be sold by public auction at the Yarra Junction Police Station, Main-road, Yarra Junction, at 2 p.m., on the 26th August, 1968.

R. H. ARNOLD,
Chief Commissioner of Police.

FORREST WATERWORKS TRUST.

AUTHORITY TO OBTAIN BANK OVERDRAFT.

HIS Excellency the Lieutenant-Governor of the State of Victoria, by and with the advice of the Executive Council thereof, doth by Order made on the 13th day of August, 1968, authorize the Forrest Waterworks Trust to obtain in pursuance of the provisions of section 286 of the Water Act 1958 (No. 6413) an advance or advances during the year ending 30th September, 1968, by overdraft of the Trust's current account, such overdraft not to exceed at any one time the sum of Two thousand dollars (\$2,000).

J. ROSSITER,
Clerk of the Executive Council.

At the Executive Council Chamber,
Melbourne, 13th August, 1968.

NOTICE TO MARINERS.
[No. 18 of 1968.]

AUSTRALIA.—VICTORIA.

ANDERSONS INLET.

Light to be Established.

Date.—On or about 20th August, 1968.

Position of Light.—Lat. 38 deg. 38 min. S. Long. 145 deg. 44 min. E. (approximately).

Details.—A flashing red light every 5 seconds; flash 0.5 second, eclipse 4.5 seconds, will be shown from a post 15 feet high, at the head of Inverloch Jetty at an elevation of 28 feet. Visibility 3 miles.

Abridged Description.—Fl. R.5 sec., 3 M.

Remarks.—The above light replaces the flashing white light shown on Chart AUS. 144, which has been discontinued.

Chart Affected.—AUS. 144.

A. J. WAGGLEN,
Port Officer in Victoria.

Public Works Department,
Ports and Harbours Branch,
Treasury-place,
Melbourne, Vic., 3002, 6th August, 1968.

NOTICE TO MARINERS.
[No. 17 of 1968.]

AUSTRALIA.—VICTORIA.

BASS STRAIT—PORT ALBERT.

Light Buoy Established.

Position.—Front main leading light Lat. 38 deg. 44 min. S., Long. 146 deg. 39.5 min. E. (approximately).

Position of buoy.—142 degrees distant 2.3 miles from the above position. This buoy marks the south-western extremity of Outer Clonmel Sand.

Description.—A 3 feet diameter black conical light buoy showing a flashing white light every 2.0 seconds; flash 0.5 second, eclipse 1.5 seconds. Elevation 7 feet. Visibility 2 miles.

Abridged Description.—Fl. 2 secs.

Remarks.—The above sand spit is subject to considerable movement and the buoy may be moved accordingly without notice.

Charts Affected.—AUS. 145, 199.

A. J. WAGGLEN,
Port Officer in Victoria.

Public Works Department,
Ports and Harbours Branch,
Treasury-place,
Melbourne, Vic., 3002, 6th August, 1968.

Melbourne and Metropolitan
BOARD OF WORKS.

NOTICE TO THE OWNERS OF TENEMENTS IN THE UNDERMENTIONED STREETS AND THE PRIVATE STREETS, LANES, COURTS AND ALLEYS OPENING THERETO.

THE main pipe in the said streets being laid down, the owners of all tenements situated as under are hereby required, on or before the 16th September, 1968, to cause a proper pipe and stop cocks to be laid so as to supply water within such tenements from the main pipe.

W. K. Y. BROMLEY,
Acting Secretary.

6th August, 1968.

STREET AND POSITION.

Berwick.

Kidds-road, from Marie-street eastwards 2,237 feet.
Marie-street, from Kidds-road to Dorothy-street.
Dorothy-street, from Kidds-road to Marie-street.

Broadmeadows.

Connell-street, from Hilton-street southwards 1,060 feet.
Brooklyn-court, from Hume Highway eastwards 1,050 feet.
Palagia-court, from Access-road eastwards and southwards 676 feet.

Camberwell.

Karwarren-street, from Kelvinside-street northwards 400 feet.

Doncaster.

Banksia-street, from 200 feet west of Sybilla-street westwards 110 feet.
Greenaway-street north, from Banksia-street to Sybilla-street.
Lindsay-street, from Ayr-street to Vera-street.
Vera-street, from Lindsay-street northwards 390 feet.

Footscray.

Catherine-street, from Herbert-street eastwards 89 feet.

Heidelberg.

Helen-street, from Dougharty-road to Vernon-avenue.
McEwan-road, from Dougharty-road northwards 820 feet.

Moorabbin.

Grandview-grove, from Barilla-road southwards 300 feet.

Nunawading.

Burwood-road (north side), from Stanley-road eastwards 1,180 feet.
Fankhauser-drive, from Burwood-road northwards 310 feet.
Ritz-street, from Fankhauser-drive to Beacon-street.
Beacon-street, from Burwood-road northwards 310 feet.
Burwood-road (north side), from Stanley-road westwards 1,090 feet.

Stanley-road, from Burwood-road northwards 840 feet.
Consort-avenue, from Burwood-road northwards 860 feet.
Dalroy-crescent, from Burwood-road to Stanley-road.
Parvin-court, from Dalroy-crescent eastwards 290 feet.
Bolyn-court, from Dalroy-crescent northwards 300 feet.
Burwood-road, from Blackburn-road eastwards 250 feet.
Primrose-street, from Springfield-road to Shafer-road.
Begonia-court, from Primrose-street eastwards 528 feet.
Iris-court, from Primrose-street eastwards 528 feet.
Shasta-street, from Shafer-road to Lantana-street.
Shafer-road, from Katrina-street to Primrose-street.
Shafer-road, from Primrose-street westwards 734 feet.
Hibiscus-road, from Shafer-road westwards 1,070 feet.
Lilac-street, from Shafer-road westwards 570 feet.
Erica-street, from Shafer-road westwards 570 feet.
Lantana-street, from Shasta-street to Katrina-street.
Camelia-street, from Lantana-street to Koonung-road.
Morrie-crescent, from Katrina-street southwards and westwards 1,347 feet.

Primula-street, from Morrie-crescent westwards 320 feet.
Kingsley-avenue, from Stevens-road to Ferncroft-street.
Lexington-street, from Kingsley-avenue southwards 600 feet.
Ferncroft-street, from Kingsley-avenue southwards 630 feet.
Bradley-avenue, from Ferncroft-street eastwards 130 feet.

Oakleigh.

Princes Highway, from 170 feet east of Arnott-street, south-eastwards 230 feet.
Normanby-road, from Blackburn-road to Howley's-road.

Ringwood.

Hammond-street, from Maidstone-street westwards and northwards 560 feet.

Sunshine.

Beech-court, from Sanders-avenue eastwards 720 feet.
Sanders-avenue, from 130 feet north-east of Beech-court further north-eastwards 920 feet.
Berwick-court, from Sanders-avenue westwards 210 feet.
Calder-court, from Sanders-avenue eastwards 250 feet.

Waverley.

Wirth-street, from Wadham-parade to Bowman-street.
Kinnoull-grove, from Coleman-parade southwards 1,579 feet.
Willow-avenue, from M.M.B.W. pipe track to Clivejay-street.
High Street-road, from Mimosa-street eastwards 620 feet.
High Street-road, from Glen Tower-drive eastwards 90 feet.
High Street-road, from Glen Tower-drive westwards 130 feet.
Brynor-crescent, from 170 feet west of Glen Tower-drive westwards 620 feet.
Normanby-road, from Blackburn-road to Howley's-road.
Donald-road, from Ferntree Gully-road northwards 540 feet.
Highwood-drive, from 400 feet west of Lum-road further westwards 560 feet.
Karjen-place, from Highwood-drive south-eastwards 490 feet.
Kauri-grove, from Fraser-street westwards and northwards 1,260 feet.
Marcia-court, from Kauri-grove northwards 390 feet.
Boriska-court, from Kauri-grove northwards 360 feet.
Fraser-street, from Windella-crescent northwards 850 feet.
Johnson-drive, from Fraser-street eastwards 210 feet.
Vermont-street, from Fraser-street eastwards 200 feet.

Whittlesea.

Spring-street, from Simpson-street westwards 470 feet.

Williamstown.

Johnston-street, from Newcastle-street to Mason-street.
Elizabeth-street, from Newcastle-street southwards 330 feet.

DEPARTMENT OF MINES.

SUBJECT to any necessary excisions, &c., it is proposed to grant the following lease:—

9246, Ballarat; Albert William Strange, Leslie John Austin; 7a. 3r. 29p., Parish of Buninyong.

APPLICATION FOR LEASE DECLARED ABANDONED.
8810, Mineral; Leslie Albert Wallman, Kenneth John Wallman; 16 acres, Parish of Whanregarwen.

TERM OF EXPLORATION LICENCE EXTENDED.

50, Exploration Licence; George Milton; 410 square miles, Counties of Tambo and Croajingalong.

MINING LEASE EXPIRED.

7090, Maryborough; Clyde Wolfenden; 6a. 0r. 4p., Parish of Eglinton.

MINERAL SEARCH LICENCE GRANTED.

837, Mineral Search Licence; George Milton; 5 square miles, Parishes of Deddick, Moonkan.

J. C. M. BALFOUR,
Minister of Mines.

MINING LEASE DECLARED VOID AS TO PART.

In pursuance of the powers conferred by sections 56 and 79 of the *Mines Act 1958*, the Governor in Council has, by Order made on the 13th August, 1968, declared void Mining Lease No. 8634 Mineral as to such part of the land demised and indicated by red colour on the plan hereunto annexed to the said order. The said lease is entered in the Register book at the Office of Titles, volume 334, folio 649.

MINING LEASE DECLARED VOID.

8588, Mineral; Rail and Road Metals Proprietary Limited; 2a. 0r. 34p., Parish of Cut-Paw-Paw.

E. CONDON,
Secretary for Mines.

APPOINTMENTS AND RESIGNATIONS

APPOINTMENTS.

HIS Excellency the Lieutenant-Governor of the State of Victoria, by and with the advice of the Executive Council thereof, has, by Orders made on the 6th day of August, 1968, been pleased to make the under-mentioned appointments, viz.:—

CHIEF SECRETARY'S DEPARTMENT.

Electoral Registrars (Acting).

MAURICE PATRICK DWYER
to be Electoral Registrar (Acting) for the Canterbury and Deepdene Subdivisions of the Electoral District of Balwyn; the Camberwell North Subdivision of the Electoral District of Camberwell; and for the Balwyn North, Kew and Kew North Subdivisions of the Electoral District of Kew, to take effect on and from the 22nd July, 1968, during the absence on leave of William John Millett Bailey; and

VICTOR ERNEST SPARK
to be Electoral Registrar (Acting) for the Footscray, Footscray North and Yarraville Subdivisions of the Electoral District of Footscray; the Kingsville Subdivision of the Electoral District of Sunshine; and the Newport Subdivision of the Electoral District of Williamstown, to take effect on and from the 22nd July, 1968, during the absence on leave of Douglas Stamler Taylor.

Honorary Probation Officers.

DOROTHY ALICE BAILEY (Mrs.), 3 Ash-grove, Dandenong,
JOAN LEESON BARTLE (Mrs.), 34 Victoria-street, Hastings,
ROGER HOWARD COOK, Flat 6, 20A Fordholm-road, Hawthorn,
JOHN BOOTH CORBY (The Reverend), 7 Elliott-avenue, Broadmeadows,
DOROTHY NOELLE DAVIDSON (Mrs.), Bayview-road, Hastings,
ANNE ROSEMARY DESALVO (Mrs.), 7 Errey-street, Camperdown,
NORMAN GEORGE FARY, 39 Monomeith-crescent, Mount Waverley,
BARRY GARNHAM, 18 Monomeith-crescent, Mount Waverley,
ROY KENNETH LAWN, "Harrison House", Presbyterian Boys' Hostel, 50 Power-street, Hawthorn,
HAROLD DAVID LEWELLIN, 15 Henry-street, Ringwood,
REITA JOSEPHINE MAYS, 14 Cooper-street, Sunshine,
MABEL WINIFRED RHODES (Mrs.), 46A Barkly-street, Camperdown,
ALBERT EDWARD JOHN STRICKLAND, St. John's Vicarage, Lilydale, and
DALE MARGARET VAGG (Mrs.), 51 Lord-street, Cobden, pursuant to the provisions of section 10 (1) of the *Children's Court Act 1958*, for all Children's Courts in Victoria, to be Honorary Probation Officers; and
PAUL MICHAEL GARDNER, "Holy Cross", Serpells-road, Templestowe,
LAURENCE JOHN LANG, Flat 1, 55 Stewart-street, Colac,
DENIS GEORGE LORIMER, 56 Timor-street, Warrnambool,
GARY EDWARD O'CONNOR, 4 Neptune-avenue, Newcomb,
KEITH ALBERT SULLIVAN, "Corio", Donald-road, Langwarrin, and
JOHN DESMOND RUSSELL, 15 Dunoon-street, Colac, pursuant to the provisions of section 507 (2) of the *Crimes Act 1958*, to be Honorary Probation Officers for all Adult Courts in Victoria.

Stipendiary Probation Officer, &c.

AGNES CATHERINE O'DWYER, pursuant to the provisions of section 9 (2) of the *Children's Court Act 1958*, section 507 (1) and section 533 (3) of the *Crimes Act 1958* and section 36 (1) of the *Social Welfare Act 1960*, to be a Stipendiary Probation Officer for every Children's Court, Stipendiary Probation Officer and Stipendiary Parole Officer and Stipendiary Youth Parole Officer, respectively.

CROWN LANDS AND SURVEY DEPARTMENT.

Trustees of Site—Show Grounds.

NORMAN FREDERICK MITCHELL (His Honour Judge),
ARCHIBALD CLYDE WANLISS FISKEN,
GEORGE PRITCHARD HARVEY WILSON, and
WILLIAM JOHN FARQUHAR McDONALD (Sir), in the places of Charles Edward Merritt, George Thomas Chirnside, Arthur Ernest Tyndall Payne, and Samuel Sherwen Cameron, all deceased, to be Trustees of the land permanently reserved on the 5th August, 1913, as a site for Agricultural Show purposes at Flemington.

Trustees of Site—Show Yards.

NORMAN FREDERICK MITCHELL (His Honour Judge),
ARCHIBALD CLYDE WANLISS FISKEN, and
GEORGE PRITCHARD HARVEY WILSON,
in the places of Charles Edward Merritt, George Thomas Chirnside, and Arthur Ernest Tyndall Payne, all deceased; and

WILLIAM JOHN FARQUHAR McDONALD (Sir), as an additional Trustee,
to be Trustees of the land permanently reserved on the 15th May, 1882, as a site for the use of the National Agricultural Society of Victoria as a site for Show Yards and other purposes at Flemington.

MINISTRY OF HEALTH.

Members of Committees of Management of Hospitals.

DONALD McLEAN LINDSAY
to be a Member of the Committee of Management of The Creswick District Hospital, pursuant to proviso (a) to section 48 (1) of the *Hospitals and Charities Act 1958*, for a further period ending 21st August, 1971; and

FREDERICK CHARLES HORNSBY
to be a Member of the Committee of Management of Minyip and District Hospital, pursuant to proviso (a) to section 48 (1) of the *Hospitals and Charities Act 1958*, for a period of three years, *vice* R. G. Evans, resigned.

LAW DEPARTMENT.

Commissioners for Taking Declarations, &c.

GEORGE RODNEY MORGAN, 56 Rosanna-road, Murtumbeena,
JOHN RALPH JOPLING, 10 Elliott-street, Ballarat, and
JOHN DOUGLAS NEAL, Flat 7, 37 Sycamore-grove, Balaclava,

to be Commissioners for taking Declarations and Affidavits, pursuant to the provisions of the *Evidence Act 1958*, to resign upon removing from the neighbourhood of the addresses stated; and

COLIN KING, care of Federal Woollen Mills Limited, Mackey-street, North Geelong, and
JOHN DAVID COCHRANE, care of New Oakleigh Motors Pty. Ltd., Ferntree Gully-road, Notting Hill,
to be Commissioners for taking Declarations and Affidavits, pursuant to the provisions of the *Evidence Act 1958*, to resign upon ceasing to occupy their present positions.

Justices of the Peace.

ERIC MUSGRAVE ERICSSON, 6 Bethell-avenue, Parkdale, and
DONALD McCRAE BARTY, 17 Nepean Highway, Elsternwick,
to keep the Peace in the Central Bailiwick of the State of Victoria.

Deputy Prothonotaries, &c.

JOHN JOSEPH CAVEN
to be Deputy Prothonotary at Hamilton and Deputy Clerk of the Peace for the Western Bailiwick during the absence of J. E. Wallace on annual leave, to take effect from the date of commencement of duty; and

JOHN MILTON DUGAN
to be Deputy Prothonotary at Shepparton and Clerk of the Peace for the Northern Bailiwick during the absence of R. N. Hollis on annual leave, to take effect from the date of commencement of duty.

Clerk of Petty Sessions (Acting).

JOHN DOUGLAS BOLSTER
to be Clerk of Petty Sessions and Clerk of the Children's Court at Beech Forest, Birregurra, Cressy and Rokewood, during the absence of K. G. McMahon on annual leave, to take effect from the date of commencement of duty.

DEPARTMENT OF WATER SUPPLY.

Waterworks Trust Commissioners.

JAMES THOMAS PARKIN and
ARTHUR MALONE
to be Commissioners of the Rutherglen Waterworks Trust for a period of four years from the date hereof, subject to the provisions of the *Water Act 1958*.

J. ROSSITER,
Clerk of the Executive Council.

At the Executive Council Chamber,
Melbourne, 6th August, 1968.

*Vegetation and Vine Diseases Act 1958.**Fruit and Vegetation Act 1958.*

APPOINTMENT OF INSPECTORS.

IN exercise of its powers the Public Service Board, by certificates dated 9th July, 1968, has appointed the under-mentioned officers and employees, Department of Agriculture, as Inspectors under the provisions of the *Vegetation and Vine Diseases Act 1958* and the *Fruit and Vegetation Act 1958*, without additional salary:—

RONALD ARTHUR MULLETT—Deputy Chief of Division of Horticulture.

JOHN ERNEST COLLYER—Senior Field Officer.

REGINALD JAMES NANCARROW—Field Officer.

NOEL WILLIAM ALLAN—Orchard Inspector.

LINDSAY WALLACE ANDREW MACKIESON—Orchard Inspector.

RICHARD GEORGE SHANNON—Orchard Inspector.

LINDSAY TREVOR SINCLAIR—Orchard Inspector.

PETER SPONG—Orchard Inspector.

D. S. WISHART,
Director of Agriculture.

RESIGNATIONS.

HIS Excellency the Lieutenant-Governor of the State of Victoria, by and with the advice of the Executive Council thereof, has, by Orders made on the 6th day of August, 1968, accepted the resignations of the persons named hereunder of the offices mentioned, *viz.*—

LAW DEPARTMENT.

Justices of the Peace.

The persons named in the first column of the Schedule hereto, from the Commission of the Peace for the respective Bailiwicks of the State of Victoria set opposite their names in the second column of the said Schedule.

Name.	SCHEDULE.	Bailiwick.
HAROLD RAY FIRMAN	Northern.
REGINALD LOGAN	Central.

J. ROSSITER,

Clerk of the Executive Council.

At the Executive Council Chamber,
Melbourne, 6th August, 1968.

ORDERS IN COUNCIL

DRAINAGE AREAS ACT 1958.

At the Executive Council Chamber, Melbourne, the sixth day of August, 1968.

PRESENT:

His Excellency the Lieutenant-Governor of Victoria.

Mr. Reid | Mr. Thompson.

EXTENSION OF LIMITS OF YAMBUK DRAINAGE AREA, SHIRE OF BELFAST.

PURSUANT to the provisions of the *Drainage Areas Act 1958* and in compliance with the prayer of a petition presented by the President Councillors and Ratepayers of the Shire of Belfast, His Excellency the Lieutenant-Governor of the State of Victoria, by and with the advice of the Executive Council thereof, by this Order hereby extends the limits of the Yambuk Drainage Area, within the Shire of Belfast, to include the land described hereunder:

All that piece of land commencing at a point, being the south-eastern corner of Crown allotment 10, Section A, in the Parish of Yambuk; thence northerly along the eastern boundary, of said allotment 10; thence across a 3 chain Government Road Reserve, to the south-western corner of Crown allotment 4, Section C, of the said Parish; thence northerly along the western boundaries of Crown allotments 4, 5, and 7, Section C, of the said Parish, to the north-western corner of Crown allotment 7; thence across a Government Road Reserve to the south-western corner of Crown allotment 6b, Section B, of the said Parish; thence by the western boundary of Crown allotments 6b, 7a, 7, and 9, to the south-western corner of Crown allotment 10, Section B, in the said Parish; thence north-easterly along the western boundary of Crown allotment 10, for a distance of 110.4 links; thence by lines bearing S. 37 deg. 48 min. E. for 4,178.7 links; N. 71 deg.

53 min. E. for 2732.2 links; N. 67 deg. 3 min. E. for 1611.8 links; S. 8 deg. 12 min. E. for 475.5 links; S. 16 deg. 52 min. E. for 801.8 links; S. 40 deg. 32 min. E. for 493.2 links; S. 11 deg. 27 min. E. for 343.9 links; S. 25 deg. 39 min. E. for 517.5 links; S. 2 deg. 47 min. W. for 2067.5 links; N. 88 deg. 40 min. W. for 1065.5 links; S. 69 deg. 33 min. W. for 421.1 links; S. 89 deg. 24 min. W. for 53.5 links; S. 0 deg. 15 min. W. for 8,359.9 links; to the northern boundary of a subdivisional road; thence by the northern boundary of the said road, by lines bearing N. 77 deg. 51 min. W. for 1,690 links; N. 89 deg. 4 min. W. for 643 links; N. 39 deg. 27 min. W. for 489.5 links; N. 83 deg. 17 min. W. for 1944.4 links; S. 78 deg. 20 min. W. for 3474.6 links to the eastern boundary of a 3 chain Government Road Reserve; thence across the said 3 chain road, by a line bearing S. 78 deg. 20 min. W. to the western boundary of the said 3 chain Government Road; thence by the eastern boundary of Crown allotment 7 Section C, Parish of Yambuk, to the south-eastern corner thereof; thence by the northern boundary of Crown allotment 5, Section C, by a line bearing west for 4133 links; thence through Crown allotment 5, Section C, by a line bearing south for 4000 links; thence along the northern boundary of Crown allotment 4 to the north-eastern corner thereof; thence along the eastern boundary of Crown allotment 4, Section C, to the south-eastern corner thereof, at the 3 chain Government Road Reserve; thence across this 3 chain Road Reserve to the north-eastern corner of Crown allotment 9b of Section A, Parish of Yambuk; thence along the northern boundary of said Crown allotment 9b, to the north-western corner thereof; thence southerly along the western boundary of said Crown allotment 9b, for a distance of 3359 links; thence westerly through Crown allotment 9c to the point of commencement.

And the Honorable James Charles Murray Balfour, for and on behalf of Her Majesty's Minister for Local Government for the State of Victoria, shall give the necessary directions herein accordingly.

J. ROSSITER,
Clerk of the Executive Council.

SOIL CONSERVATION AND LAND UTILIZATION ACT 1958.

At the Executive Council Chamber, Melbourne, the sixth day of August, 1968.

PRESENT:

His Excellency the Lieutenant-Governor of Victoria.
Mr. Reid | Mr. Thompson.

DISTRICT ADVISORY COMMITTEE.—NORTHERN WIMMERA SOIL CONSERVATION DISTRICT.

IN pursuance of the powers conferred by Section 15 of the Soil Conservation and Land Utilization Act, His Excellency the Lieutenant-Governor of the State of Victoria by and with the advice of the Executive Council thereof doth hereby appoint the following persons to be members of the District Advisory Committee of the Northern Wimmera Soil Conservation District for a term of three years as from 3rd July, 1968.

- VICTOR GEORGE CHAMPNESS, being a person elected to represent grazing, agricultural and other relevant interests in the District.
- ALEXANDER HENRY LAVERTY, being a person elected to represent grazing, agricultural and other relevant interests in the District.
- LLOYD GEORGE ATKIN, being a person elected to represent grazing, agricultural and other relevant interests in the District.
- NEIL GEORGE WATT, being a person elected to represent grazing, agricultural and other relevant interests in the District.
- OSWALD CARL PIETSCH, being a person elected to represent grazing, agricultural and other relevant interests in the District.
- CHARLES LAWRENCE TUOHEY, being the person representing the Department of Agriculture.
- GERALD EDWIN COGHLAN, being the person representing the Soil Conservation Authority.

And the Honorable Sir William John Farquhar McDonald, Her Majesty's Minister for Conservation for the State of Victoria, shall give the necessary directions herein accordingly.

J. ROSSITER,
Clerk of the Executive Council.

COUNTRY ROADS BOARD.

At the Executive Council Chamber, Melbourne, the sixth day of August, 1968.

PRESENT:

His Excellency the Lieutenant-Governor of Victoria.
Mr. Reid | Mr. Thompson.

ORDER CONFIRMING RESOLUTIONS OF THE COUNTRY ROADS BOARD.

HIS Excellency the Lieutenant-Governor of the State of Victoria, by and with the advice of the Executive Council thereof doth hereby, in pursuance of the provisions of the Country Roads Act 1958, confirm the resolutions of the Country Roads Board, the dates whereof and the terms of which are scheduled hereunder:—

SCHEDULE.

State highways

Resolution dated the Twenty-ninth day of July, One Thousand Nine Hundred and Sixty-eight, made pursuant to Sections 21 and 74 of the Country Roads Act 1958, declaring the widening of the Princes Highway in the Cities of Malvern and Caulfield as shown hatched on Plan numbered G.P.9215 hereunder to be part of a State highway within the meaning and for the purposes of the said Act.

STATE HIGHWAY PRINCES HIGHWAY

CITIES OF MALVERN & CAULFIELD

Measurements in Feet & ins.

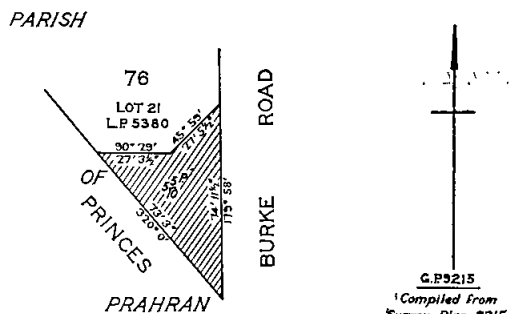

Resolution dated the Twenty-ninth day of July, One Thousand Nine Hundred and Sixty-eight, made pursuant to Sections 21 and 74 of the Country Roads Act 1958, declaring the widening of the Pyrenees Highway in the Shire of Tullaroop as shown hatched on Plan numbered G.P.10642 hereunder to be part of a State highway within the meaning and for the purposes of the said Act.

STATE HIGHWAY PYRENEES HIGHWAY
SHIRE OF TULLAROOP

Measurements in Links.

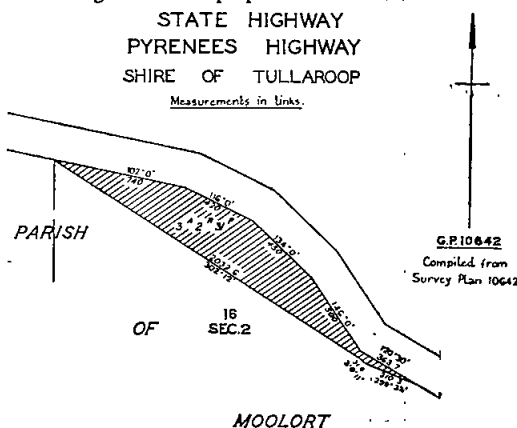

Main roads

Resolution dated the Twenty-ninth day of July, One Thousand Nine Hundred and Sixty-eight, made pursuant to Sections 21 and 58 of the Country Roads Act 1958 declaring the deviation from the Bendigo-Pyramid Road in the Shire of East Loddon as indicated by diagonal hatching on Plan numbered G.P.9952b hereunder to be part of a main road within the meaning and for the purposes of the said Act, and also declaring that such deviation shall be in lieu of the existing road or part thereof indicated by cross hatching and horizontal hatching on the said plan which part indicated by cross hatching on the said plan shall be discontinued.

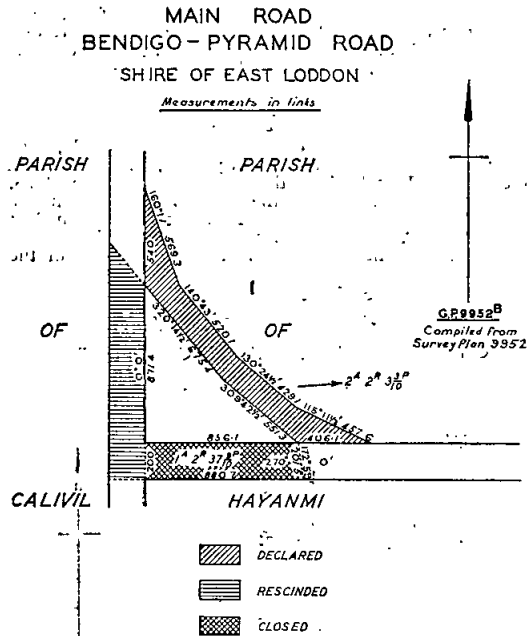

Resolution dated the Twenty-ninth day of July, One Thousand Nine Hundred and Sixty-eight, made pursuant to Sections 21 and 58 of the Country Roads Act 1958 declaring the deviation from the Mitiamo-Boort Road in the Shire of East Loddon as indicated by diagonal hatching on Plan numbered G.P.9952a hereunder to be part of a main road within the meaning and for the purposes of the said Act, and also declaring that such deviation shall be in lieu of the existing road or part thereof indicated by horizontal hatching on the said plan.

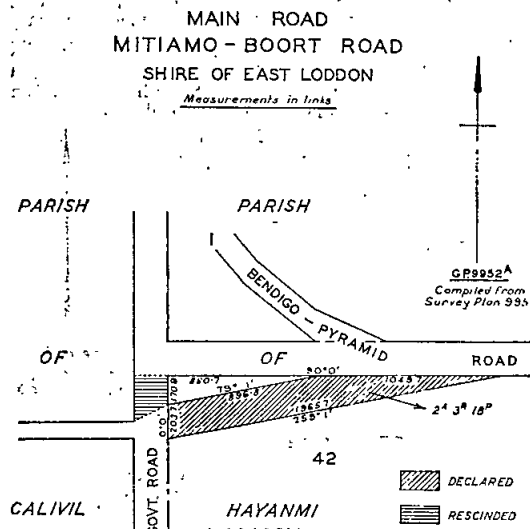

Resolution dated the Twenty-ninth day of July, One Thousand Nine Hundred and Sixty-eight, made pursuant to Section 21 of the Country Roads Act 1958 declaring the widening of Lismore Road in the Shire of Grenville as shown hatched on Plan numbered G.P.10884 hereunder to be part of a main road within the meaning and for the purposes of the said Act.

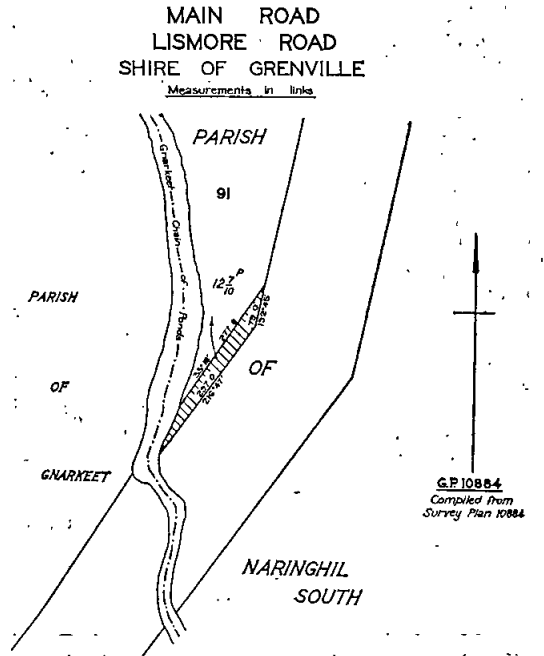

Resolution dated the Twenty-ninth day of July, One Thousand Nine Hundred and Sixty-eight, made pursuant to Section 21 of the Country Roads Act 1958 declaring the widening of the Rokewood-Shelford Road in the Shire of Leigh as shown hatched on Plan numbered G.P.10188 hereunder to be part of a main road within the meaning and for the purposes of the said Act.

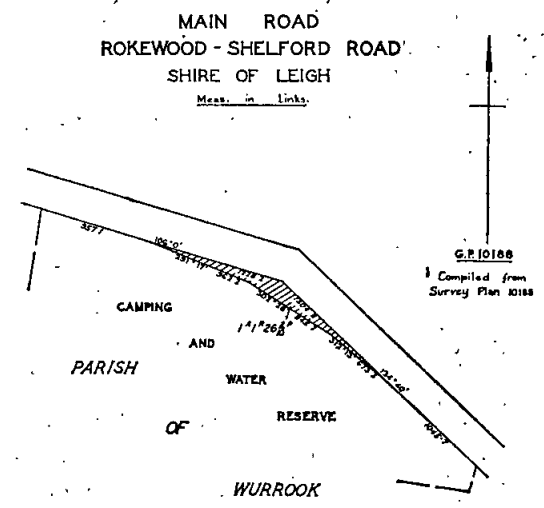

Resolution dated the Twenty-ninth day of July, One Thousand Nine Hundred and Sixty-eight, made pursuant to Section 21 of the Country Roads Act 1958 declaring the widening of Vaughan Springs Road in the Shire of

Newstead as shown hatched on Plan numbered G.P.9946 hereunder to be part of a main road within the meaning and for the purposes of the said Act.

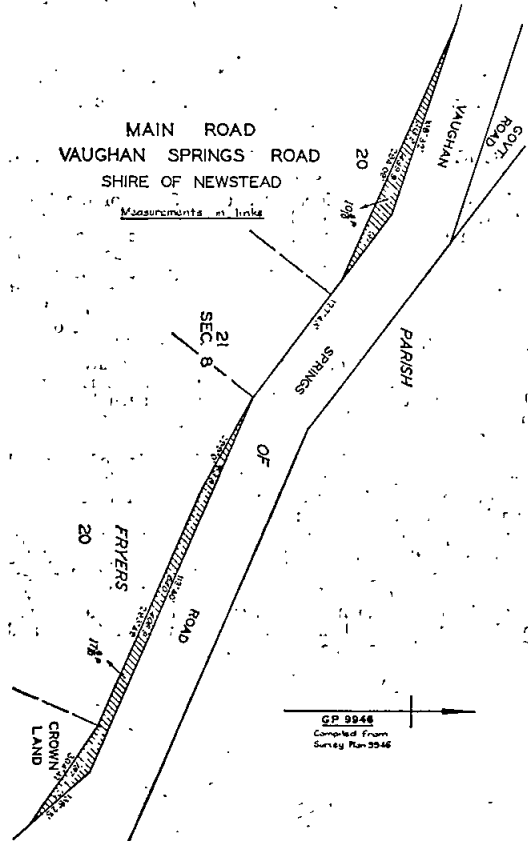

Resolution dated the Twenty-ninth day of July, One Thousand Nine Hundred and Sixty-eight, made pursuant to Section 21 of the Country Roads Act 1958 declaring the widening of the Echuca-Mitiamo Road in the Shire of Rochester as shown hatched on Plan numbered G.P.9536 hereunder to be part of a main road within the meaning and for the purposes of the said Act.

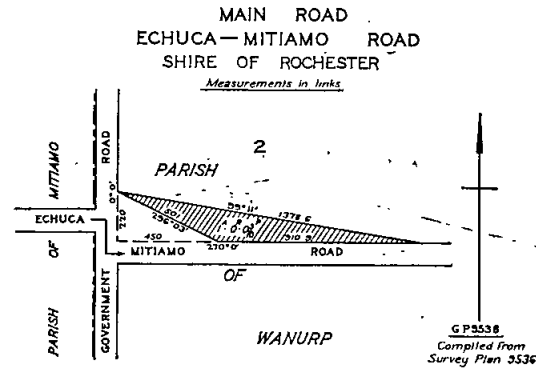

Resolution dated the Twenty-ninth day of July, One Thousand Nine Hundred and Sixty-eight, made pursuant to Sections 21 and 58 of the Country Roads Act 1958 declaring the deviation from Nerrena Road in the Shire of Woorayl as indicated by diagonal hatching on Plan numbered G.P.10790 hereunder to be part of a main road within the meaning and for the purposes of the said Act, and also declaring that such deviation shall be in lieu of the existing road or part thereof indicated by vertical hatching on the said plan.

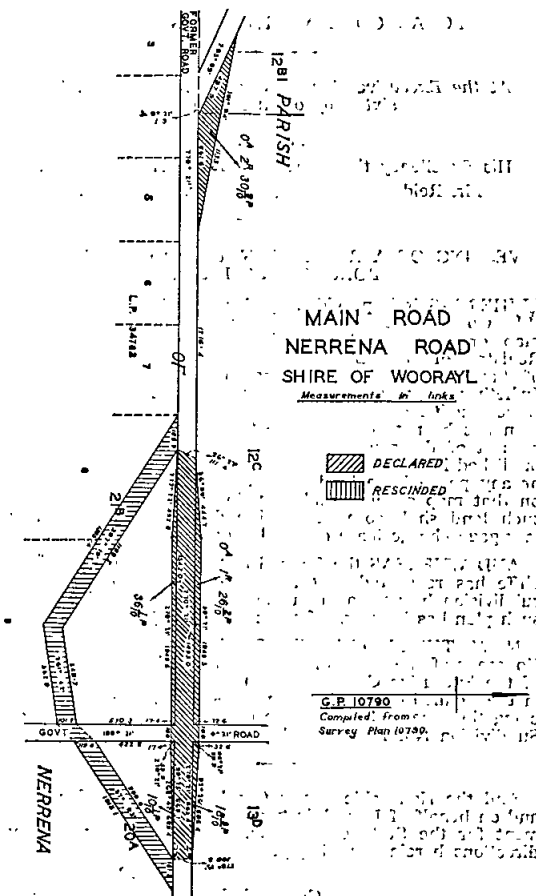

Resolution dated the Twenty-ninth day of July, One Thousand Nine Hundred and Sixty-eight, made pursuant to Section 21 of the Country Roads Act 1958 declaring the widening of Gelantipy Road in the Shire of Tambo as shown hatched on Plan numbered G.P.10699 hereunder to be part of a main road within the meaning and for the purposes of the said Act.

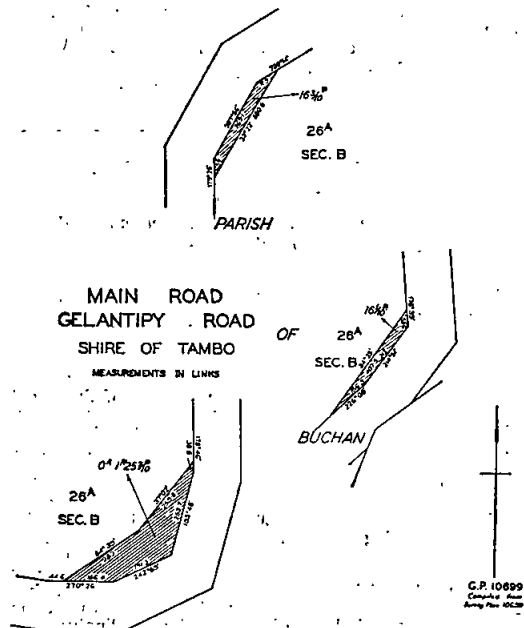

Resolution dated the Twenty-ninth day of July, One Thousand Nine Hundred and Sixty-eight, made pursuant to Section 21 of the *Country Roads Act 1958* declaring the widening of Dederang Road in the Shire of Yackandandah as shown hatched on Plan numbered G.P.10868 hereunder to be part of a main road within the meaning and for the purposes of the said Act.

MAIN ROAD
 DEDERANG ROAD
 SHIRE OF YACKANDANDAH
 Measurements in links

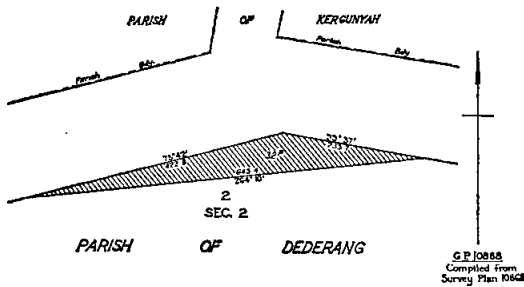

And the Honorable Murray Victor Porter, Her Majesty's Minister of Public Works for the State of Victoria, shall give the necessary directions herein accordingly.

J. ROSSITER,
 Clerk of the Executive Council.

LOCAL GOVERNMENT DEPARTMENT.

At the Executive Council Chamber, Melbourne, the sixth day of August, 1968.

PRESENT:

His Excellency the Lieutenant-Governor of Victoria.
 Mr. Reid | Mr. Thompson.

VESTING OF A RESERVE IN THE QUEENSLIFFE BOROUGH COUNCIL.

WHEREAS it is provided by Section 569BA of the *Local Government Act 1958*, as amended, that where any map or plan has been lodged or deposited with the Registrar of Titles pursuant to Section 97 of the *Transfer of Land Act* or any corresponding previous enactment (whether before or after the commencement of the *Local Government Act 1963*) and any allotment on that map or plan has been transferred the Governor-in-Council on the request of the council of the municipality may by Order published in the *Government Gazette* direct that the whole or any part of the land comprised in any reserve shown on that map or plan shall vest in the council whereupon such land shall so vest freed and discharged from any mortgage charge lease or sub-lease:

AND WHEREAS the Council of the Borough of Queenscliffe has requested that a reserve shown on a plan of subdivision be vested in the Council and an allotment on such plan has been transferred:

NOW THEREFORE, His Excellency the Lieutenant-Governor of the State of Victoria, by and with the advice of the Executive Council thereof, doth by this Order vest in the Council of the Borough of Queenscliffe certain land being the reserve 3 links wide coloured yellow on Plan of Subdivision No. 1554 lodged in the Office of Titles.

And the Honorable James Charles Murray Balfour, for and on behalf of Her Majesty's Minister for Local Government for the State of Victoria, shall give the necessary directions herein accordingly.

J. ROSSITER,
 Clerk of the Executive Council.

LOCAL GOVERNMENT DEPARTMENT.

At the Executive Council Chamber, Melbourne, the sixth day of August, 1968.

PRESENT:

His Excellency the Lieutenant-Governor of Victoria.
 Mr. Reid | Mr. Thompson.

VESTING OF A RESERVE IN THE MORWELL SHIRE COUNCIL.

WHEREAS it is provided by Section 569BA of the *Local Government Act 1958* that where any map or plan has been lodged or deposited with the Registrar of Titles pursuant to Section 97 of the *Transfer of Land Act* or any corresponding previous enactment (whether before or after the commencement of the *Local Government Act 1963*) and any allotment on that map or plan has been transferred the Governor-in-Council on the request of the Council of the municipality may by Order published in the *Government Gazette* direct that the whole or any part of the land comprised in any reserve shown on that map or plan shall vest in the council whereupon such land shall so vest freed and discharged from any mortgage charge lease or sub-lease:

AND WHEREAS the Council of the Shire of Morwell has requested that a reserve shown on a plan of subdivision be vested in the council and an allotment on that plan has been transferred:

NOW THEREFORE, His Excellency the Lieutenant-Governor of the State of Victoria, by and with the advice of the Executive Council thereof, doth by this Order vest in the Council of the Shire of Morwell the land shown hatched on the plan hereunder, such land being a Reserve for Plantation on Plans of Subdivision Nos. 30034 and 30035 lodged in the Office of Titles.

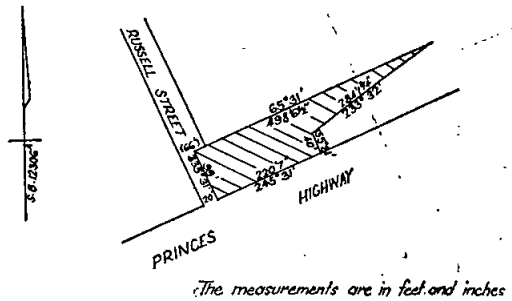

And the Honorable James Charles Murray Balfour, for and on behalf of Her Majesty's Minister for Local Government for the State of Victoria, shall give the necessary directions herein accordingly.

J. ROSSITER,
 Clerk of the Executive Council.

LOCAL GOVERNMENT DEPARTMENT.

At the Executive Council Chamber, Melbourne, the sixth day of August, 1968.

PRESENT:

His Excellency the Lieutenant-Governor of Victoria.
 Mr. Reid | Mr. Thompson.

ROADS DISCONTINUED—SHIRE OF CROYDON.

WHEREAS it is provided in Section 528 (2) of the *Local Government Act 1958*, as amended, that where a road (whether or not a public highway but not being a road set out on land of the Crown) or any part thereof is not required for public use, the Governor-in-Council, on the request of the Council of the municipality in which such road is situated made not less than one month after publishing in a newspaper generally circulating in the district and posting to the registered proprietor (if any) of the land and any person known to have an interest in the land notice of intention to make such a request may by Order published in the *Government Gazette* direct that such road or part shall be discontinued and thereupon such road or part shall be discontinued accordingly:

AND WHEREAS the Council of the Shire of Croydon has requested that the Governor-in-Council direct that portions of Fairview Avenue and Palmer Avenue, Croydon, be discontinued and not less than one month previously, has published in a newspaper generally circulating in the district and posted to the registered proprietor of the land in the said roads and to all persons known to have an interest in the said land notice of intention to make such request:

NOW THEREFORE, His Excellency the Lieutenant-Governor of the State of Victoria, by and with the advice of the Executive Council thereof, hereby directs that the said roads which are shown hatched on the plan hereunder, shall be discontinued and that the land may be sold by the Council of the Shire of Croydon by-agreement.

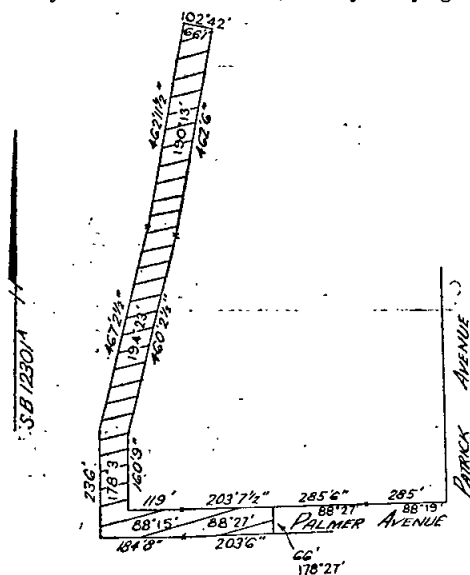

The measurements are in feet and inches

The fee of the land shown hatched was comprised in Certificate of Title Vol 421 Fol 139 on 10th July 1968

And the Honorable James Charles Murray Balfour, for and on behalf of Her Majesty's Minister for Local Government for the State of Victoria, shall give the necessary directions herein accordingly.

J. ROSSITER,
Clerk of the Executive Council.

LOCAL GOVERNMENT DEPARTMENT.

At the Executive Council Chamber, Melbourne, the sixth day of August, 1968.

PRESENT:

His Excellency the Lieutenant-Governor of Victoria.
Mr. Reid | Mr. Thompson.

OPERATION OF CERTAIN PROVISIONS OF THE LOCAL GOVERNMENT ACT 1958 RELATING TO SITE VALUE.

WHEREAS by an Order published in the *Government Gazette* on the 26th June 1968 the 15th July 1968 was fixed as the date after which the councils of certain municipalities should, in certain circumstances, assess site value in respect of each rateable property in the municipality:

AND WHEREAS it is provided by Section 315A of the *Local Government Act 1958* that the Governor-in-Council may by Order or by successive Orders fix the date or dates when certain sub-sections of that section shall come into operation generally or with respect, to any rating authority or authorities:

NOW THEREFORE, I, the Lieutenant-Governor of the State of Victoria, by and with the advice of the Executive Council thereof, hereby fix the 15th August 1968 as the date when sub-sections (3), (4), (5) and (6) of the said section 315A shall come into operation generally.

And the Honorable James Charles Murray Balfour, for and on behalf of Her Majesty's Minister for Local Government for the State of Victoria, shall give the necessary directions herein accordingly.

J. ROSSITER,
Clerk of the Executive Council.

Land Act 1958, Section 15.

DEPARTMENT OF CROWN LANDS AND SURVEY.

At the Executive Council Chamber, Melbourne, the sixth day of August, 1968.

PRESENT:

His Excellency the Lieutenant-Governor of Victoria.
Mr. Reid | Mr. Thompson.

PERMANENT RESERVATION OF CERTAIN LAND AND REVOCATION AS TO PART OF ORDER IN COUNCIL DATED 23RD MAY, 1881.—TOWNSHIP OF HARRIETVILLE, PARISH OF HARRIETVILLE.

HIS Excellency the Lieutenant-Governor of the State of Victoria, by and with the advice of the Executive Council thereof and in pursuance of the provisions of the Land Act and all other powers him thereunto enabling, doth, by this Order—

- (1) revoke the Order in Council of the 23rd May, 1881, by which the beds of certain lakes, rivers, and creeks specified therein, and Crown lands on the margins and on the banks thereof respectively were permanently reserved for public purposes so far only as it relates to that portion of the Ovens River (East Branch) as indicated by description and plan published in the *Victoria Government Gazette* on the 5th June, 1968; and
- (2) permanently reserve for public purposes and except from occupation under any Miner's Right the Crown lands forming the new bed of the Ovens River (East Branch) where the course of the said river has become altered since the 23rd May, 1881, together with the Crown lands on the banks thereof as indicated by description and hatching on the plan published in the aforesaid *Government Gazette* of the 5th June, 1968.

And the Honorable Sir William John Farquhar McDonald, Her Majesty's Minister of Lands for the State of Victoria, shall give the necessary directions herein accordingly.

J. ROSSITER,
Clerk of the Executive Council.

DEPARTMENT OF CROWN LANDS AND SURVEY.

At the Executive Council Chamber, Melbourne, the sixth day of August, 1968.

PRESENT:

His Excellency the Lieutenant-Governor of Victoria.
Mr. Reid | Mr. Thompson.

REVOCATION OF TEMPORARY RESERVATIONS OF LANDS BY ORDERS IN COUNCIL.

HIS Excellency the Lieutenant-Governor of the State of Victoria, by and with the advice of the Executive Council thereof, doth hereby, in pursuance of the provisions of the Land Act 1958, revoke the temporary reservations of lands by Orders in Council hereinafter referred to, viz.:—

CASTLEMAINE.—Order in Council of 10th February, 1947, of 10 acres 1 rood 12 perches of land in the Township of Castlemaine as a site for Benevolent Home and Hospital for the Aged and Infirm and the temporary reservation by Order in Council of the 5th February, 1957, of 2 acres 2 roods 30 perches, more or less, of land as an extension thereto.—(Rs.5800.)

MOKOAN.—Order in Council of 8th April, 1878, of 5 acres of land in the Parish of Mokoan (now in the Township of Bungeet) as a site for Public purposes (State School).—(H.031718.)

NYORA.—Order in Council of 31st July, 1900, of 2 roods of land in the Township of Nyora as a site for a Mechanics' Institute.—(Rs.774.)

TALBOT.—Order in Council of 10th August, 1868, of 3 roods 32 perches of land in the Township of Talbot as a site for Police purposes.—(C.50558.)

And the Honorable Sir William John Farquhar McDonald, Her Majesty's Minister of Lands for the State of Victoria, shall give the necessary directions herein accordingly.

J. ROSSITER,
Clerk of the Executive Council.

DEPARTMENT OF CROWN LANDS AND SURVEY.

At the Executive Council Chamber, Melbourne, the sixth day of August, 1968.

PRESENT:

His Excellency the Lieutenant-Governor of Victoria.
Mr. Reid | Mr. Thompson.

UNUSED ROADS CLOSED.

HIS Excellency the Lieutenant-Governor of the State of Victoria, by and with the advice of the Executive Council thereof, doth hereby direct that, in pursuance of the provisions of section 349 of the Land Act 1958, the unused roads referred to hereunder be closed, viz:—

Township of Moliagul, Parish of Moliagul, County of Gladstone, being the road between allotment 2 and allotments 7, 6, 5, section H.—(M.131^(*)) (W.88323).

Township of Freeburgh and Parish of Freeburgh, County of Delatite, being the roads indicated by hatching on plan hereunder.—(F.95^(*)) (H.030025).

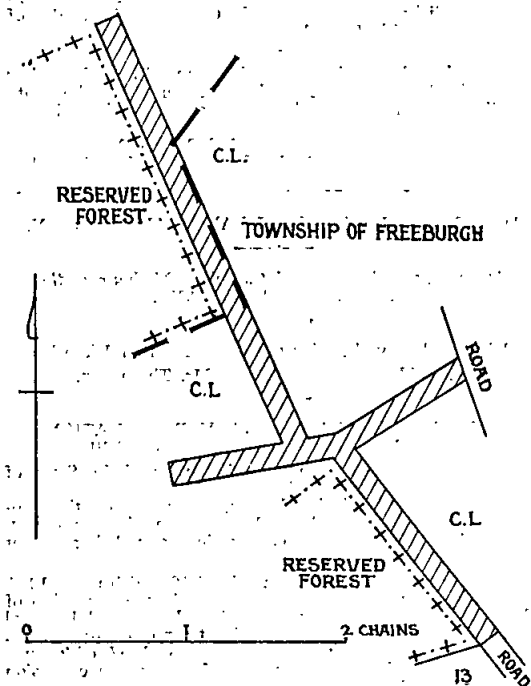

Parish of Bruarong, County of Bogong, being the road indicated by hatching on plan hereunder.—(B.639^(*)) (H.030399).

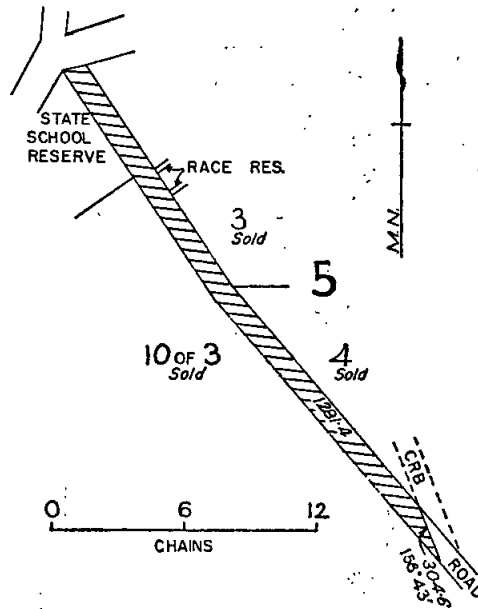

And the Honorable Sir William John Farquhar McDonald, Her Majesty's Minister of Lands for the State of Victoria, shall give the necessary directions herein accordingly.

J. ROSSITER,
Clerk of the Executive Council.

DEPARTMENT OF CROWN LANDS AND SURVEY.

At the Executive Council Chamber, Melbourne, the sixth day of August, 1968.

PRESENT:

His Excellency the Lieutenant-Governor of Victoria.
Mr. Reid | Mr. Thompson.

LANDS TEMPORARILY RESERVED AS SITES.

HIS Excellency the Lieutenant-Governor of the State of Victoria, by and with the advice of the Executive Council thereof, doth hereby, in pursuance of section 14 of the Land Act 1958, reserve temporarily from sale, from being leased, and from having a licence granted in respect thereof, and also except from occupation for mining purposes under any miner's right, the land hereinafter described:—

FOSTER.—Site for a Public Park, 21 acres 3 roods, more or less, Township of Foster, Parish of Wonga Wonga South, County of Buln Buln, as indicated by hatching on plan hereunder.—(F.100^(*)) (Rs.9035).

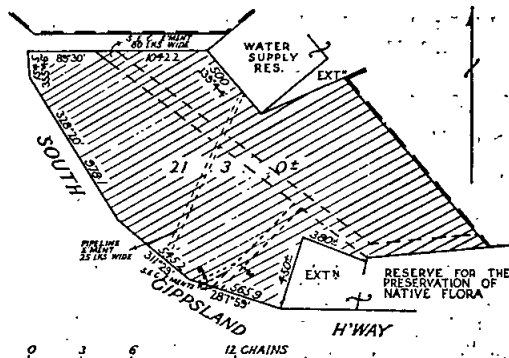

AVENEL.—Site for a Cricket Ground and other purposes of Public Recreation, 1 acre 2 roods, Township of Avenel, Parish of Avenel, County of Delatite, as indicated by hatching on plan hereunder.—(A.74(*) (Rs.1920).

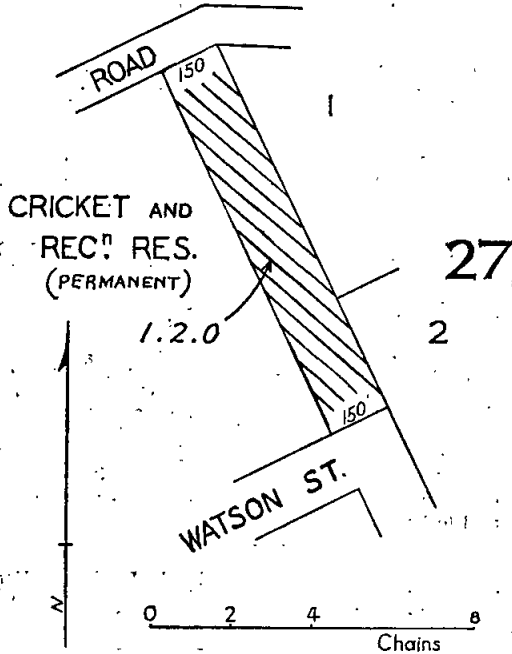

SWAN HILL.—Site for Public Recreation, 2 acres, more or less, Township of Swan Hill, Parish of Castle Donnington, County of Tatchera, as indicated by hatching on plan hereunder.—(S.464(*) (Rs.2601).

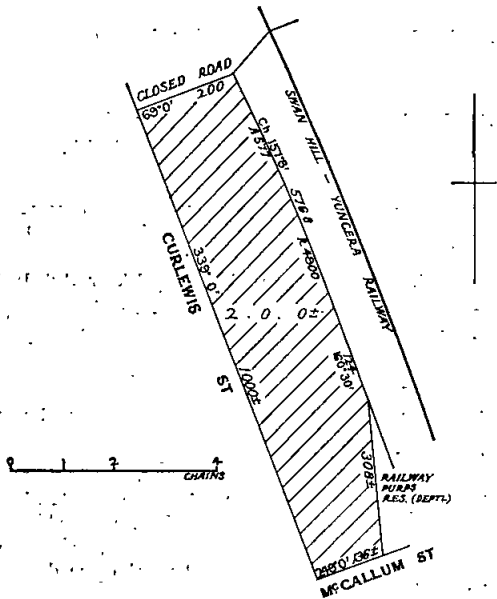

And the Honorable Sir William John Farquhar McDonald, Her Majesty's Minister of Lands for the State of Victoria, shall give the necessary directions herein accordingly.

J. ROSSITER,
Clerk of the Executive Council.

FORESTS DEPARTMENT.

At the Executive Council Chamber, Melbourne, the sixth day of August, 1968.

PRESENT:

His Excellency the Lieutenant-Governor of Victoria,
Mr. Reid | Mr. Thompson.

ALIENATED LAND ACQUIRED BY EXCHANGE, ETC., AND DEDICATED AS RESERVED FOREST.

WHEREAS by section 42, sub-section 8, of the Forests Act 1958, it is prescribed that the Governor in Council may acquire by exchange of land dedicated as reserved forest—

- (a) any alienated land or Crown land licensed or leased with an inchoate right of purchase; or
- (b) any land, public or private, and whether vested in trustees or otherwise,

and may by Order published in the Government Gazette dedicate the same as reserved forest:

Now, therefore, His Excellency the Lieutenant-Governor of the State of Victoria, by and with the advice of the Executive Council of the said State, and in pursuance of the provisions of section 42, sub-section 8, of the Forests Act 1958, doth by this Order—

- (1) acquire the alienated land described in Schedule "A" hereto by exchange of land dedicated as reserved forest described in Schedule "B" hereto;
- (2) excise from the reserved forest the area described in the aforesaid Schedule "B", such excision to take effect 30 days from date hereof;
- (3) dedicate the land described in Schedule "A" aforementioned as reserved forest, such dedication to take effect 30 days from date hereof.

THE SCHEDULE ABOVE REFERRED TO.

Schedule "A"—Dedication Schedule No. 200.

Alienated land acquired from George Walter Symons, of 63 Lily-street, Bendigo, being allotment 2A, section A, Parish of Whirrakee, County of Bendigo, comprising 10 acres more or less.

Schedule "B"—Excision Schedule No. 161.

Land excised from reserved forest for George Walter Symons, of 63 Lily-street, Bendigo, being allotments 53K, 53L and 53M, Parish of Marong, County of Bendigo, and comprising 10 acres 3 roods 5 perches.

And the Honorable Edward Raymond Meagher, Her Majesty's Minister of Forests for the State of Victoria, shall give the necessary directions herein accordingly.

J. ROSSITER,
Clerk of the Executive Council.

HOUSING ACT 1958.

At the Executive Council Chamber, Melbourne, the thirteenth day of August, 1968.

PRESENT:

His Excellency the Lieutenant-Governor of Victoria,
Sir William McDonald | Mr. Borthwick.

CLOSING OF ROADS AND EXTINGUISHMENT OF EASEMENTS—CITY OF WAVERLEY.

WHEREAS by virtue and in exercise of the powers contained in the Housing Act 1958 (No. 6275) Housing Commission has recommended to the Governor in Council that the roads and easements described in the Schedule hereto be closed and extinguished:

NOW THEREFORE His Excellency the Lieutenant-Governor of the State of Victoria in the Commonwealth of Australia by and with the advice of the Executive Council of the said State, doth in pursuance of the powers conferred by the said Act and upon such recommendation; consent and by this Order hereby close and extinguish such roads and easements.

SCHEDULE.

First.—So much of the roads coloured brown on Plan of Subdivision Number 30039 lodged in the Office of Titles as is delineated and hachured on the plan hereunder.

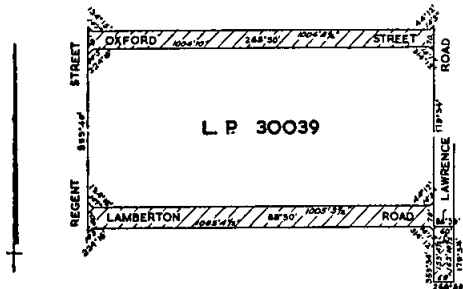

PART CROWN PORTION 68
PARISH OF MULGRAVE

Secondly.—Any easements affecting Lots 74 to 94 (both inclusive) and Lots 100 to 140 (both inclusive) all on Plan of Subdivision Number 30039 lodged in the Office of Titles.

And the Honorable Edward Raymond Meagher, Her Majesty's Minister of Housing for the State of Victoria, shall give the necessary directions herein accordingly.

J. ROSSITER,
Clerk of the Executive Council.

WATER ACT 1958.

At the Executive Council Chamber, Melbourne, the thirteenth day of August, 1968.

PRESENT:
His Excellency the Lieutenant-Governor of Victoria.
Sir William McDonald | Mr. Borthwick.

WOORI YALLOCK—LAUNCHING PLACE WATERWORKS TRUST CONSTITUTED.

HIS Excellency the Lieutenant-Governor of the State of Victoria, by and with the advice of the Executive Council thereof, doth hereby approve, in accordance with the provisions of the Water Act, of the construction of works for the water supply of Woori Yallock and Launching Place as set out in the application of the Councillors of the Shire of Upper Yarra for the constitution of a Waterworks Trust to construct, manage and maintain the said works in accordance with the provisions of the said Act and doth hereby order and appoint as follows:—

1. That a Waterworks Trust is hereby constituted and its corporate name shall be Woori Yallock—Launching Place Waterworks Trust.
2. That the Commissioners of the Trust shall comprise the Councillors for the time being of the West and Central Ridings of the Shire of Upper Yarra together with one Government Nominee.
3. That the estimated cost of carrying out the proposed waterworks is One hundred and seventy-two thousand dollars (\$172,000).
4. The principal works to be constructed or carried out by the said Trust shall comprise a diversion weir on the Don River, a combined break-pressure and settling tank, a supply pipeline, a service basin, an elevated tank, and reticulation works.
5. That the lands within the boundary, indicated in blue colour on the plan, shall be the Waterworks District (to be known as the Woori Yallock—Launching Place Waterworks District) of the said Trust, such lands being within the municipal district of the Shire of Upper Yarra.

The location of the said works and the boundary of the said Woori Yallock—Launching Place Waterworks District are shown on a plan approved by the Governor in Council by and with this Order and deposited in the office of the State Rivers and Water Supply Commission, Melbourne.—(Corres. No. 66/1457/38.)

And the Honorable William Archibald Borthwick, Her Majesty's Minister of Water Supply for the State of Victoria, shall give the necessary directions herein accordingly.

J. ROSSITER,
Clerk of the Executive Council.

WATER ACT 1958.

At the Executive Council Chamber, Melbourne, the thirteenth day of August, 1968.

PRESENT:
His Excellency the Lieutenant-Governor of Victoria.
Sir William McDonald | Mr. Borthwick.

SHIRE OF TUNGAMAH WATERWORKS TRUST—
EXTENT OF WATERWORKS DISTRICT INCREASED.
—AREA OF KATANDRA WEST URBAN DISTRICT INCREASED.

UNDER the powers conferred by the Water Act 1958 and all other powers enabling him in that behalf, His Excellency the Lieutenant-Governor of the State of Victoria, with the advice of the Executive Council of the said State doth hereby declare, order, and direct that the extent of the Waterworks District of the Shire of Tungamah Waterworks Trust and the area of the Katandra West Urban District be increased by adding to such Districts the land (being part of Allotment 15, Section A, Parish of Katandra) shown on a plan approved by the Governor in Council and deposited in the office of the State Rivers and Water Supply Commission, Melbourne (Corr. No. 68/3031) and as from the 1st day of September, 1968 the extent of the said Waterworks District and the area of the said Urban District shall be deemed to be so increased.

And the Honorable William Archibald Borthwick, Her Majesty's Minister of Water Supply for the State of Victoria, shall give the necessary directions herein accordingly.

J. ROSSITER,
Clerk of the Executive Council.

Water Act 1958.

STATE RIVERS AND WATER SUPPLY COMMISSION:

At the Executive Council Chamber, Melbourne, the thirteenth day of August, 1968.

PRESENT:
His Excellency the Lieutenant-Governor of Victoria.
Sir William McDonald | Mr. Borthwick.

GOULBURN—MURRAY IRRIGATION DISTRICT—
PORTION EXCISED.—SHEPPARTON IRRIGATION
AREA—BOUNDARIES VARIED.

UNDER the powers conferred by the Water Act 1958 and all other powers enabling him in that behalf, His Excellency the Lieutenant-Governor of the State of Victoria with the advice of the Executive Council of the said State, on the recommendation of the State Rivers and Water Supply Commission, doth hereby declare, order and direct:—

1. That there be excised from the Goulburn—Murray Irrigation District; and
2. That the boundaries of the Shepparton Irrigation Area be varied to excise therefrom

the land (being part of Allotment 15, Section A, Parish of Katandra) shown by green colour on a plan approved by the Governor in Council and deposited in the office of the State Rivers and Water Supply Commission, Melbourne (Corr. No. 68/3031) which land shall be deemed to be excised from the said Irrigation District and Irrigation Area as from the 31st day of August, 1968.

And the Honorable William Archibald Borthwick, Her Majesty's Minister of Water Supply for the State of Victoria, shall give the necessary directions herein accordingly.

J. ROSSITER,
Clerk of the Executive Council.

ALEXANDRA SEWERAGE AUTHORITY.

At the Executive Council Chamber, Melbourne, the
thirteenth day of August, 1968.

PRESENT:

His Excellency the Lieutenant-Governor of Victoria.
Sir William McDonald | Mr. Borthwick.

CONSENT TO BORROWING \$100,000.

UNDER the powers conferred by the Sewerage Districts Act and all other powers enabling him in that behalf, His Excellency the Lieutenant-Governor of the State of Victoria, by and with the advice of the Executive Council of the said State, doth hereby consent to the Alexandra Sewerage Authority borrowing by mortgage of the General Fund the sum of One hundred thousand dollars (\$100,000) to meet the cost of sewerage works as set forth in the detailed statement bearing date the 8th August, 1968.

And the Honorable William Archibald Borthwick, Her Majesty's Minister of Water Supply for the State of Victoria, shall give the necessary directions herein accordingly.

J. ROSSITER,
Clerk of the Executive Council.

KYNETON SEWERAGE AUTHORITY.

At the Executive Council Chamber, Melbourne, the
thirteenth day of August, 1968.

PRESENT:

His Excellency the Lieutenant-Governor of Victoria.
Sir William McDonald | Mr. Borthwick.

CONSENT TO BORROWING \$68,000.

UNDER the powers conferred by the Sewerage Districts Act and all other powers enabling him in that behalf, His Excellency the Lieutenant-Governor of the State of Victoria, by and with the advice of the Executive Council of the said State, doth hereby consent to the Kyneton Sewerage Authority borrowing at interest by mortgage of the General Fund the sum of Sixty-eight thousand dollars (\$68,000) for the conversion of Loan No. 1.

And the Honorable William Archibald Borthwick, Her Majesty's Minister of Water Supply for the State of Victoria, shall give the necessary directions herein accordingly.

J. ROSSITER,
Clerk of the Executive Council.

BENDIGO SEWERAGE AUTHORITY.

At the Executive Council Chamber, Melbourne, the
thirteenth day of August, 1968.

PRESENT:

His Excellency the Lieutenant-Governor of Victoria.
Sir William McDonald | Mr. Borthwick.

EXTENT OF SEWERAGE DISTRICT INCREASED.

UNDER the powers conferred by the Sewerage Districts Act and all other powers enabling him in that behalf, His Excellency the Lieutenant-Governor of the State of Victoria, by and with the advice of the Executive Council of the said State doth hereby declare, order and direct that the extent of the Sewerage District of the Bendigo Sewerage Authority be increased by adding thereto the lands comprised within the boundaries described in the Schedule hereto and as on and from the date hereof the extent of such District shall be and be deemed to be increased accordingly.

SCHEDULE.

Commencing at a point on the boundary of the existing Sewerage District at its intersection with the Axe Creek Race at McIvor Road, Parish of Sandhurst; thence generally southerly along the Axe Creek Race to its confluence with Spencers Race within the land reserved for the Bendigo Institute of Technology; thence generally north-westerly along Spencers Race to its intersection with the existing Sewerage District boundary; thence generally north-easterly along the existing Sewerage District boundary to the point of commencement.

All of which boundaries are shown on a plan approved by the Governor in Council by and with this Order and deposited in the office of the State Rivers and Water Supply Commission, Melbourne.—(Corres. 63/3747/113.)

And the Honorable William Archibald Borthwick, Her Majesty's Minister of Water Supply for the State of Victoria, shall give the necessary directions herein accordingly.

J. ROSSITER,
Clerk of the Executive Council.

SUPERANNUATION ACT 1958.

At the Executive Council Chamber, Melbourne, the
thirteenth day of August, 1968.

PRESENT:

His Excellency the Lieutenant-Governor of Victoria.
Sir William McDonald | Mr. Borthwick.

PURSUANT to the powers conferred by the provisions of Subsection (1) of Section 3 of the Superannuation Act 1958, as amended by Paragraph (a) of Subsection 2 of Section 18 of the Pensions Supplement Act 1966 No. 7417, His Excellency the Lieutenant-Governor of the State of Victoria by and with the advice of the Executive Council thereof doth by this Order declare that the provisions of the Superannuation Act shall apply to Kenneth Arthur Doyle, an officer of the Victorian Pipelines Commission constituted pursuant to the provisions of the Victorian Pipelines Commission Act 1966 No. 7477.

And the Honorable Sir Henry Edward Bolte, Her Majesty's Treasurer for the State of Victoria, shall give the necessary directions herein accordingly.

J. ROSSITER,
Clerk of the Executive Council.

LANDS DEPARTMENT NOTICES

APPROACHING LAND SALES.

SALES of Crown Lands, in fee-simple, will be held at the under-mentioned places and dates, viz.:

	No. of Gazette.
Ararat.—Thursday, 29th August, 1968	53
Avoca.—Friday, 13th September, 1968	67
Balmoral.—Friday, 6th September, 1968	59
Beaufort.—Thursday, 29th August, 1968	53
Bright.—Wednesday, 14th August, 1968	61
Dunolly.—Friday, 13th September, 1968	67
Edenhope.—Friday, 6th September, 1968	59
Maryborough.—Friday, 13th September, 1968	67
Myrtleford.—Wednesday, 14th August, 1968	61
Red Cliffs.—Wednesday, 21st August, 1968	55
St. Arnaud.—Thursday, 12th September, 1968	67

CORRIGENDUM.

IN the Victoria Government Gazette, No. 67, of the 7th August, 1968, page 2827, the notice under the heading "MARYBOROUGH.—Sale (No. 11953)" should read "to be held at the LAND OFFICE, NEILL-STREET, MARYBOROUGH, on FRIDAY, the 13th SEPTEMBER, 1968, at ELEVEN o'clock a.m."

PROPOSED REVOCATIONS OF TEMPORARY RESERVATIONS OF LANDS BY ORDERS IN COUNCIL.

IN pursuance of the provisions of the Land Act 1958, notice is hereby given that it is the intention of the Governor in Council to revoke the temporary reservations of lands by Orders in Council hereunder referred to, viz.:

The following Notices were published 1° on the 24th July, 1968, pursuant to Orders of the 16th July, 1968.

BRAYBROOK.—The temporary reservation, by Order in Council of the 1st February, 1961, of 3 acres 1 rood 10 perches of land in the Township of Braybrook as a site for State School purposes, revoked as to part by Order of the 14th August, 1963, is about to be revoked so far only as the portion containing 6 perches, indicated by hatching on plan hereunder, is concerned.—(B.439⁽²⁾) (Rs.4425.)

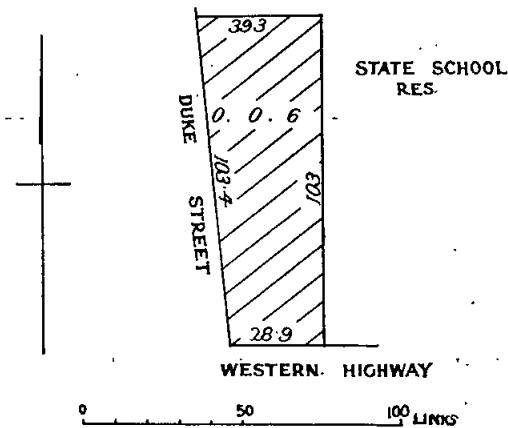

BUNGAREE.—The temporary reservation by Order in Council of the 26th May, 1873 (see Government Gazette, 30th May, 1873, page 964) of 5 acres 3 roods 15 perches of land in the Parish of Bungaree as a site for Cemetery Purposes is about to be revoked so far only as the portion containing 1 acre 2 roods 4 perches, indicated by hatching on plan hereunder, is concerned.—(B.507⁽⁸⁾) (C.98690.)

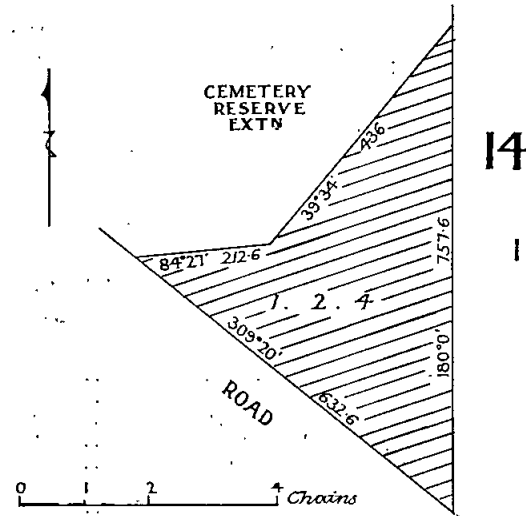

BUNGAREE.—The temporary reservation by Order in Council of the 30th September, 1872 (see Government Gazette, 4th October, 1872, page 1837) of 5 acres 3 roods 15 perches of land in the Parish of Bungaree as a site for Public Purposes is about to be revoked.—(B.507⁽⁸⁾) (C.98690.)

DATTUCK.—The temporary reservation, by Order in Council of the 26th August, 1947, of 1393 acres 2 roods 16 perches of land in the Parish of Dattuck as a site for Growth of Timber for the purpose of the production or manufacture of eucalyptus oil is about to be revoked.—(D.220⁽²⁾) (M.37036.)

TARRAWINGEE.—The temporary reservation, by Order in Council of the 2nd September, 1902 (see Government Gazette, 10th September, 1902, page 3750) of 4 acres 3 roods 21 perches of land in the Parish of Tarrawingee as a site for a Night-soil Depot is about to be revoked.—(T.61⁽³⁾) (C.16396.)

W. J. F. McDONALD,
Minister of Lands.

PROPOSED REVOCATIONS OF TEMPORARY RESERVATIONS OF LANDS BY ORDERS IN COUNCIL.

IN pursuance of the provisions of the Land Act 1958, notice is hereby given that it is the intention of the Governor in Council to revoke the temporary reservations of lands by Orders in Council hereunder referred to, viz.:

The following Notices were published 1° on the 7th August, 1968, pursuant to Orders of the 30th July, 1968.

SANDHURST.—The temporary reservation, by Order in Council of the 2nd March, 1892, of 127 acres 3 roods 20 perches of land in the Parish of Sandhurst as a site for a Sewage Farm and Manure Depot, revoked as to part by Order of the 12th May, 1959, and the temporary reservation by Order of the 19th March, 1894, of 221 acres 1 rood 12 perches of land as an extension thereto are about to be revoked so far as the balance thereof containing 341 acres 2 roods 32 perches, more or less, is concerned.—(S.371⁽²¹⁾) (Rs.1741.)

CASTLEMAINE.—The temporary reservation, by Order in Council of the 23rd March, 1954, of 79 acres 11 perches of land in the Township of Castlemaine as a site for Public Recreation, Tourist Camping and Public Park purposes, revoked as to part by Order of the 13th November, 1956, is about to be revoked so far only as the portion containing 6 acres 3 roods 13 perches, indicated by hatching on plan hereunder, is concerned.—(C.99⁽¹⁾) (Rs.177.)

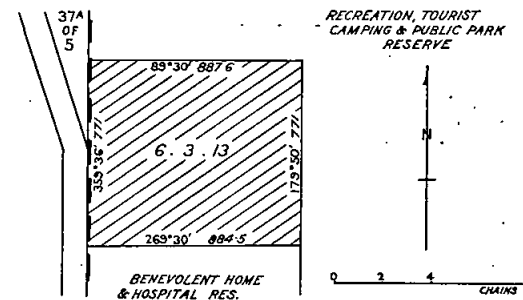

WEDDERBURN.—The temporary reservation as a site for Public Garden and other purposes of Recreation and the withholding from sale, leasing and licensing by Order in Council of the 14th July, 1884 of 4 acres 3 roods 16 perches of land in the Township of Wedderburn are about to be revoked so far only as the portion containing 24 perches, indicated by hatching on plan hereunder, is concerned.—(W.116⁽⁸⁾) (Rs.2604.)

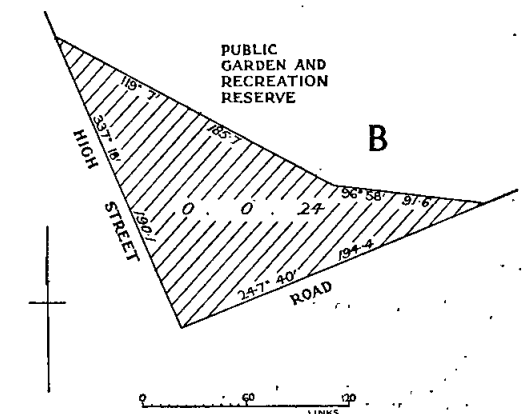

PROPOSED REVOCATIONS OF TEMPORARY RESERVATIONS OF LANDS BY ORDERS IN COUNCIL.

IN pursuance of the provisions of the Land Act 1958, notice is hereby given that it is the intention of the Governor in Council to revoke the temporary reservations of lands by Orders in Council hereunder referred to, viz.:—

The following Notices were published 1° on the 14th August, 1968, pursuant to Orders of the 6th August, 1968.

GLENALBYN.—The temporary reservation, by Order in Council of the 26th March, 1901, of 10,700 acres of unappropriated Crown land in the Parishes of Kurting, Salisbury West, Glenalbyn, Inglewood and Tarnagulla as a site for the Growth of Timber for the purpose of the manufacture or production of Eucalyptus Oil, revoked as to part by various Orders, is about to be revoked so far only as the portion in the Parish of Glenalbyn containing 43 acres 2 roods 20 perches, more or less, indicated by hatching on plan hereunder, is concerned.—(G.161⁽³⁾) (Rs.1614.)

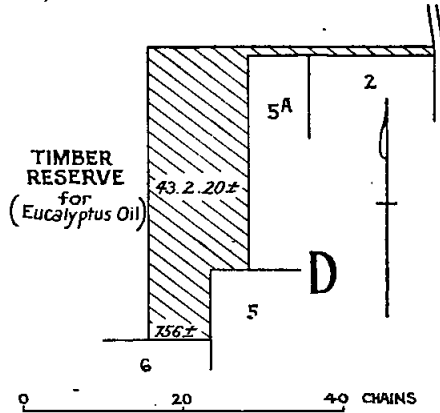

CARINA.—The temporary reservation, by Order in Council of the 21st December, 1910, of 4 acres of land in the Parish of Carina as a site for a State School is about to be revoked.—(C.477⁽²⁾) (Rs.7022.)

SALE.—The temporary reservation, by Order in Council of the 14th December, 1874 (see Government Gazette 18th December, 1874, page 2215) of 1 acre of land in the Parish of Sale as a site for State School purposes is about to be revoked.—(S.242⁽¹⁰⁾) (H.028894.)

BOORONGIE.—The temporary reservation, by Order in Council of the 17th February, 1916, of 42 acres of land in the Parish of Boorongie as a site for Water Supply purposes is about to be revoked.—(B.772⁽²⁾) (Rs.903.)

SCORESBY.—The temporary reservation, by Order in Council of the 27th March, 1956, of 25 acres 3 roods 37 perches of land in the Parish of Scoresby as a site for Horticultural Research Station is about to be revoked.—(S.250A⁽⁶⁾) (Rs.5885.)

FLINDERS.—The temporary reservation, by Order in Council of the 23rd March, 1874, of 2 acres of land in the Township of Flinders as a site for State School purposes, revoked as to part by Order of the 25th March, 1958, is about to be revoked so far as the balance thereof containing 2 roods 16 perches, more or less, is concerned.—(F.16A⁽¹⁾) (Rs.6971.)

FLINDERS.—The temporary reservation, by Order in Council of the 2nd July, 1958, of 1 acre 1 rood 24 perches, more or less, of land in the Township of Flinders as a site for Public Park, revoked as to part by Order of the 2nd December, 1958, is about to be revoked so far as the balance thereof containing 3 roods 34 perches, more or less, is concerned.—(F.16A⁽¹⁾) (Rs.7696.)

OMEQ.—The temporary reservation, by Order in Council of the 29th April, 1958, of 4 acres 1 rood 36 perches, more or less, of land in the Township of Omeo as a site for Court House and Police purposes is about to be revoked so far only as the portion containing 1 rood 25 perches, more or less, indicated by hatching on plan hereunder, is concerned.—(O.19⁽²⁾) (Rs.7367.)

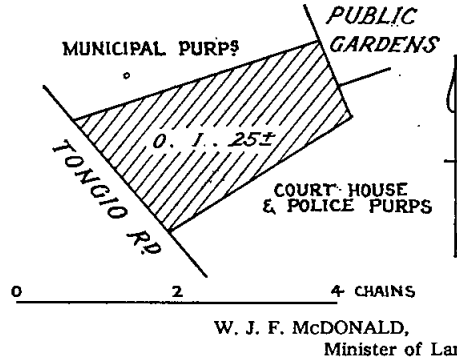

W. J. F. McDONALD,
Minister of Lands.

LOCAL LAND BOARDS.

IN pursuance of the provisions of section 34 of the Land Act 1958, notice is hereby given that public hearings at the following places and times, will be conducted by the persons respectively mentioned, being duly appointed in that behalf.

W. J. F. McDONALD,
Minister of Lands.

Department of Crown Lands and Survey,
Melbourne.

SCHEDULE.

- KOWREE SHIRE OFFICE, EDENHOPE, Tuesday, 27th August, 1968, at 10 a.m.—E. Kennedy and K. C. Gittins.
- HORSHAM LAND OFFICE, Monday, 26th August, 1968, 2 p.m.—E. Kennedy and E. M. Floyd.
- ARARAT LAND OFFICE, Thursday, 29th August, 1968, at 11 a.m.—N. J. Fitzgerald.

Land Act 1958.

LEASE DECLARED VOID.

NOTICE is hereby given that the Governor in Council has declared void the Lease mentioned in the schedule hereunder for the reason specified.

District.	Corr. No.	Name.	Section of Land Act under which Leased.	Parish.	Allotment.	Section.	Area.	Reason.
Melbourne	0513/134	Autobody Repairs Pty. Limited	134	Melbourne South	59J3	..	A. R. P. 0 0 27	Lease expired. New lease to issue

Department of Crown Lands and Survey,
Melbourne, 6th August, 1968.

W. J. F. McDONALD,
Minister of Lands.

PUBLIC SERVICE NOTICES

No. 56.

Public Service Act 1958, Section 50.

REGULATIONS.—PART IV.—SALARIES AND INCREMENTS.

THE Public Service Board, in pursuance of the powers conferred by the *Public Service Act 1958*, hereby amends its Regulations as shown below :—

SIXTH SCHEDULE.

TEMPORARY EMPLOYEES.

Designations of Positions and Rates of Salaries.

Department and Designation of Position.	Yearly Rate of Salary.		Increments (Annual).
	Minimum.	Maximum.	
MINISTRY OF ABORIGINAL AFFAIRS	\$	\$	
<i>Delete—</i> Aborigines Welfare Officer (Female)	2,559	2,633	£
<i>Add—</i> Field Officer, Assistant	2,559	2,633	£
£ See Regulation 97 (2).			

F. E. CAHILL, Chairman.
V. P. SCULLY, Secretary.

Office of the Public Service Board,
Melbourne, 26th July, 1968.

PUBLIC SERVICE OF PAPUA AND NEW GUINEA.

DEPARTMENT OF LANDS SURVEYS AND MINES.

Surveyor Class 2.

Salary.—\$6,678–\$7,327 per annum single male, including allowances.

Qualifications.—Licensed as a surveyor in Australia or New Zealand. Must have extensive experience.

Duties.—Variety of responsible survey work within a region.

Land Development Officers.

Salary.—

Grade 1—\$3,475–\$4,645 per annum.

Grade 2—\$4,851–\$5,263 per annum, single male including allowances.

Qualifications.—Grades 1 and 2 full pass, including English, in Victorian Leaving Certificate examination or equivalent. Extensive experience in rural land development and farm management.

Grade 2—Diploma in Agriculture.

Duties.—Reconnaissance surveys prior to land development.

Valuer Grade 1.

Salary.—\$4,369–\$5,601 per annum, single male, including allowances.

Qualifications.—Eligible for Associate Membership of the Commonwealth Institute of Valuers.

Duties.—Valuing and appraising duties within the Valuation Branch.

Drafting Officers.

Salary.—

Grade 1—\$4,000–\$4,416 per annum.

Grade 2—\$4,521–\$4,833 per annum, single male, including allowances.

Qualifications.—Diploma, Technical College Certificate, or equivalent, in Survey Drafting or Cartography. Five years' experience including cadetship, is acceptable equivalent for Grade 1 position. Applicants for Grade 2 position must have wide experience.

Married Men.—Married men receive an additional \$360 per annum.

Term of Engagement.—Engagement is by contract for a minimum period of two years, longer if preferred. Applicants employed by a Government authority may be considered for secondment to the Territory Service for a period of two years in the first instance with preservation of existing rights.

Accommodation.—Requirements will be discussed at interview.

Fares.—Fares and, for a married appointee, removal expenses for up to two tons weight of personal effects will be paid from Australia to the Territory on engagement, and to Australia on satisfactory completion of the contract.

Leave.—Three months' leave after each 21 months' service and an additional three months after each six years. Assistance with leave fares to Australia is provided and this assistance may be used for travel overseas.

Taxation.—Income tax in the Territory is at present less than half that payable in Australia for the same net taxable income.

Retirement Benefits Scheme.—Contract officers, other than seconded or transferred appointees, may from the date of engagement contribute 5 per cent. of actual salary for "retirement", invalidity and death benefits under the Provident Fund Scheme. There is a right of election not to contribute under the scheme and benefits payable on resignation, retrenchment or completion of contract vary according to length of service.

Education Subsidy Scheme.—There are high schools following the full New South Wales Higher School Certificate syllabus at Port Moresby, Lae and Rabaul and the Administration grants a special secondary education allowance to Territory residents whose children attend secondary schools in Australia, plus an annual return airfare for each child as far as Sydney or a nearer suitable airport.

An education allowance and an annual return airfare are also paid for children who have to go away to secondary school within the Territory.

For further information and application forms, contact the Department of External Territories,

Hobart-place, Canberra, A.C.T., 2601. Phone 4 0477
46 Market-street, Sydney, N.S.W., 2000. Phone 29 5151
188 Queen-street, Melbourne, Vic., 3000. Phone 67 6159
145 Eagle-street, Brisbane, Qld., 4000. Phone 33 7575

Please state the job in which you are interested. Applications must be received by 28th August, and should refer to advertisement No. 450A.

By order of the Secretary,

DEPARTMENT OF EXTERNAL TERRITORIES,
CANBERRA, A.C.T.

TENDERS

PUBLIC WORKS DEPARTMENT

TENDERS will be received at Public Works Department, Treasury-place, Melbourne, until TWO p.m. on dates shown and for purposes mentioned hereunder.

Particulars and tender forms available at Contracts Office, Room 7, Building Division, Parliament-place and at places indicated in brackets hereunder.

Abbreviations in brackets mean:—W.O.—Inspector of Works Office; P.S.—Police Station; C.S.—Consolidated School; H.E.S.—Higher Elementary School; H.S.—High School; S.S.—State School; T.S.—Technical School.

Tenders to be submitted on the Department's printed Tender Form and will not be received by telephone. All tenders must be on a "Firm Tender" basis. The lowest or any tender will not necessarily be accepted.

Address tenders to the Minister of Public Works, and endorse the envelope containing the tender "Tender for , closing Tuesday,

Hand delivered tenders to be placed in the Tender Box of the Public Works Department, located on the wall of the centre entrance foyer, Ground Floor, New Treasury Building, Treasury-place, Melbourne.

No preliminary deposit is required with any tender, but a successful tenderer will be required to pay a deposit for any accepted tender of \$4,000 or over.

Tuesday, 20th August, 1968.

Building, Electrical and Mechanical Works.

- Box Hill.—Electrical installation, S.S. 2838.
- Camberwell.—Erection of Assembly Hall and new Classroom Block, High School. (Specified Bills of Quantities Available.)
- Camberwell.—Electrical installation, High School.
- Camberwell.—Mechanical services, High School.
- Collingwood.—Electrical installation, Technical School.
- Heidelberg.—Electrical installation, High School.
- Jacana.—Renovations, S.S. 4839.
- Malvern.—Erection of Arts and Craft Block, Toorak Teachers' College, "Stonnington".
- Malvern.—Electrical installation, Toorak Teachers' College, "Stonnington".
- Malvern.—Mechanical services, Toorak Teachers' College, "Stonnington".
- Melbourne.—Fire service installation, Titles Office, 272-282 Queen-street. (Amended specification.)
- Moorleigh.—Erection of mesh fencing, High School.
- Myrtleford.—Renovations, Residence, Tobacco Research Station. (W.O., Wangaratta; Tobacco Research Station, Myrtleford.)
- Stawell.—Erection of Trades Wing, Second Stage, Technical School. (W.O., Ararat.) (Bills of Quantities Available.)
- Stawell.—Electrical installation, Technical School. (W.O., Ballarat and Horsham; T.S., Stawell.)
- Stawell.—Mechanical services, Technical School. (W.O., Ballarat.)
- Williamstown.—Supply and erection of mesh fencing and gates, &c., Dredging Depot, Ports and Harbours Branch.

Furniture and Furnishings.

- Melbourne.—Supply of steel furniture, Public Works Department.

Site Works.

- Bentleigh.—Asphalt, concrete and drainage works, &c., High School.
- South Yarra.—Asphalt, drainage and gravel works, &c., Melbourne Boys' High School.
- Various.—Asphalt, concrete, drainage and gravel works, &c., S.S. 4865, Eastmeadows, and S.S. 4811, St. Albans North.

Miscellaneous.

- Springvale North.—Removal of trees, S.S. 1658.

Tuesday, 27th August, 1968.

Building, Electrical and Mechanical Works.

- Beechworth.—Replacement of section of 8-in. woodstave main with 8-in. A.C. pipe, Mental Hospital. (W.O., Wangaratta.)
- Ellinbank.—Erection of a brick petrol store, Research Station. (W.O., Warragul.) (Re-advertised.)
- Heatherton.—Heating of Wing 2, Sanatorium.
- Richmond North.—Renovations, &c., Toilet Blocks, S.S. 2798.
- South Melbourne.—Repairs to roof, J. H. Boyd Domestic College.
- Sunbury.—Heating and hot water extensions, Mental Hospital.
- West Preston.—Renovations, Residence, 48 Jessie-street. S.S. 3885.

Furniture and Furnishings.

- Ballarat.—Supply and fix curtains, Mental Hospital.
- Flemington.—Supply and fix curtains, Travancore Developmental Centre.
- Parkville.—Floor treatment to ground floor, Melbourne Teachers' College Hostel. (Re-advertised.)

Site Works.

- Kew.—Asphalt roads and drainage works, &c., Mental Hospital.

Miscellaneous.

- Mildura.—Supply and delivery of electric fork lift truck, 3,000 lb. capacity, Research Station.
- Port Melbourne.—Supply and delivery of twelve (12) only trailer type concrete mixers, 3½ cubic-ft. capacity, Plant Depot, Public Works Department.

Tuesday, 3rd September, 1968.

Building, Electrical and Mechanical Works.

- Balwyn North.—Modifications and additions to heating-system, S.S. 4638.
- Braybrook.—Replacement of water service and cisterns, S.S. 1102.
- Burnley Gardens.—Underpinning of walls, Victorian Plant Research Institute, Horticultural College.
- Carlton.—Erection of Motor Registration and Licence Testing Station. (Specifications and Bills of Quantities Available.)
- Carlton.—Electrical installation and telephone conduits, Motor Registration and Licence Testing Station.
- Carlton.—Mechanical services, Motor Registration and Licence Testing Station.
- Carlton.—Fire alarm installation, Motor Registration and Licence Testing Station.
- Geelong.—Re-building of urinal, &c., Gordon Institute of Technology. (W.O., Geelong.)
- Hamilton.—Renovations, &c., S.S. 295. (W.O., Hamilton.) (Amended specification.)
- Melbourne.—Dust extraction system, Gold and Silver-smiths Department, Royal Melbourne Institute of Technology.
- Mount Evelyn.—Renovations, S.S. 3642.
- Portland.—New toilet and renovations, S.S. 489. (W.O., Warrnambool.)
- Portland.—Electrical installation, S.S. 489. (W.O., Warrnambool; S.S., Portland.)
- Sunvale.—Renovations, S.S. 4818.
- Wangaratta.—Renovations, &c., High School. (W.O., Wangaratta.) (Amended specification.)
- Williamstown.—Alternate fire and domestic water service installation, High School. (Re-advertised.)
- Wonthaggi.—Supply and installation of sawdust extraction system, High School. (W.O., Traralgon and Warragul.)

Site Works.

- Port Melbourne.—Reinforced concrete floor between stores Nos. 33 and 34, Storeyard, Public Works Department.
- Sandown Park.—Asphalt, concrete, drainage and gravel works, &c., S.S. 4901.
- Upper Ferntree Gully.—Asphalt, concrete, drainage and gravel works, &c., S.S. 3926.

Miscellaneous.

- Malmsbury.—Supply and delivery of bricks, Youth Training Centre.

Tuesday, 10th September, 1968.

Miscellaneous.

- Melbourne.—Supply of bricks, 1st October, 1968, to 30th September, 1969, Public Works Department.

M. V. PORTER,
Minister of Public Works.

Public Works Department,
Melbourne, 3002, 12th August, 1968.

TENDERS FOR THE SERVICE, 1968-69.

PROVISIONS—MEAT.

TENDERS will be received until Eleven o'clock a.m. on Friday, 6th September, 1968, from persons willing to furnish the under-mentioned supplies, in such quantities as may be ordered by the Victorian Government—delivery to be made at the under-mentioned places—during the three months commencing on 1st November, 1968.

In all cases the total cost of each item must be extended in the columns provided.

The places for which tenders will be received and the amount of the security required for the due fulfilment of each contract, are as follows:—

Schedule No. 1.—Melbourne District—	Security.
Meat—Kew Mental Hospital	40
Children's Cottages, Kew	30
Meat—Pentridge Penal Establishment, Coburg, and "Fairlea" Female Prison, Fairfield	70
"Turana" Youth Training Centre, Royal Park; and Travancore Developmental Centre, Flemington	16
"Winlaton" Girls' Training Centre, Nunawading, and "Allambie" Reception Centre, 70, Elgar-road, Burwood	10
Psychiatric Hospital, Royal Park	20

	Security
Schedule No. 2.—Mont Park, Bundoora, Larundel, Janefield, Gresswell, and Pleasant View, Wood-street, Preston—	\$
Meat—Mont Park	70
" Preston	10
" Gresswell	30
Schedule No. 3.—S.S. Rip and Dredges—	
Meat	10
Schedule No. 4.—Teachers' College and Hostels at Grattan-street, 93 Drummond-street, Carlton; 470, 481 and 572 St. Kilda-road, Melbourne; 19 Queen's-road, Melbourne; 152 Toorak-road west, South Yarra; Frank Tate House, 373 Dandenong-road, Armadale; "Redcourt", 6, "Larnook", 13 and No. 10A Orrong-road, Armadale; 11 Patterson-street, Hawthorn; 174 Punt-road, Prahran; 221 Burwood-road, Burwood; John Cannon House, 32 Belmont-avenue, Kew; 23 Moule-avenue, Brighton; and Hastings-road, Frankston; and Police Hospital, St. Kilda-road, Melbourne; Mental Hygiene Clinic, 321 Glenferrie-road, Malvern, St. Nicholas Hospital—	
Meat	30
Schedule No. 5.—Heatherton Sanatorium, Cheltenham—	
Meat	10
Schedule No. 6.—Ararat District—	
Meat	60
Schedule No. 7.—Ballarat District—	
Meat—Mental Hospital	70
" Teachers' Hostels	10
Schedule No. 8.—Beechworth District—	
Meat	60
Schedule No. 9.—Bendigo District—	
Meat—Gaal	10
" Teachers' Hostels	10
" Sandhurst Boys' Centre, Mental Hygiene	10
Schedule No. 10.—Castlemaine District—	
Meat	10
Schedule No. 11.—School of Forestry, Creswick—	
Meat	6
Schedule No. 13.—McLeod Settlement, French Island—	
Meat	10
Schedule No. 14.—Geelong District—	
Meat—Gaal	10
" Teachers' Hostels	10
Schedule No. 15.—Cooriemungle Prison Camp, Heytesbury Forest—	
Meat	8
Schedule No. 17.—Langi Kal Kal Training Centre—	
Meat	10
Schedule No. 20.—Sale Gaol—	
Meat	6
Schedule No. 21.—Pleasant Creek Special School, Stawell—	
Meat	6
Schedule No. 22.—Sunbury District—	
Meat	80
Schedule No. 23.—Warrnambool District—	
Meat	30
Schedule No. 24.—Hobson Park Hospital, Traralgon—	
Meat	10
Schedule No. 25.—Morwell River Reforestation Prison—	
Meat	10
Schedule No. 26.—State Research Farm, Werribee—	
Meat	10
Schedule No. 27.—"Hillside" Boys' Home, Wheelers Hill—	
Meat	6
Schedule No. 28.—Malmsbury Youth Training Centre—	
Meat	6
Schedule No. 29.—Won Wron Reforestation Prison—	
Meat	10
Schedule No. 30.—Dhurringile Rehabilitation Centre—	
Meat	10

Printed forms of tender and the conditions of contract may, in all cases, be obtained from the Secretary to the Tender Board, 2nd Floor, South Building, New State Public Offices, Treasury-place, Melbourne, 3002, by whom also any information or explanation will be afforded to persons tendering.

Security will be acquired either in Commonwealth Treasury Bonds, or approved bank guarantee, fixed deposit receipt, Savings Bank deposit book, or non-negotiable cheque in favour of the Secretary to the Tender Board, as the tenderer may elect.

The security must be completed and the contract signed within five days of acceptance of the tender, failing which the service may be again advertised, or another tender accepted.

The lowest or any tender will not necessarily be accepted.

In the event of tenderers withdrawing or attempting to withdraw their tenders before notification of acceptance of same, or failing to take up their accepted tenders within the prescribed period after notification of acceptance they may be disqualified from tendering or holding any future contracts for Government supplies for a period of twelve months, such disqualification to date from the notification of acceptance of tender. It is also stipulated that, if a tenderer be a member of a firm and such firm be interested in the contract, the tender shall be in the name of the firm and not in that of the individual and that, for a breach of this condition, the tender will be declared informal.

Tenders enclosed in a separate envelope, and having the words "Tender for at" (as the case may be) written thereon, must be deposited in the Tender Box at the Tender Board Offices, 2nd Floor, South Building, New State Public Offices, Treasury-place, Melbourne, 3002, or, if sent by post, postage must be prepaid, and the tenders addressed to the Chairman of the Tender Board, Tender Board Offices, 2nd Floor, South Building, New State Public Offices, Treasury-place, Melbourne, 3002, which office they must reach not later than by first post on the date of closing of tenders.

CONDITIONS OF CONTRACT.

The conditions of contract are those published in the *Victoria Government Gazette*, No. 23, dated 13th March, 1968, pages 755 to 757.

H. E. BOLTE,
Treasurer.

The Treasury,
Melbourne, 12th August, 1968.

TENDERS FOR THE SERVICE.

PROVISIONS.

BUTTER AND CHEESE.

TENDERS will be received until Eleven o'clock a.m. on Friday, 6th September, 1968, from persons willing to furnish the under-mentioned supplies, in such quantities as may be ordered by the Victorian Government during the twelve months commencing on 1st October, 1968, as per Schedule No. 26—delivery to be made at the institutions at the under-mentioned places.

The places and supplies for which tenders will be received are as follows:—

Melbourne, Mont Park, Ararat, Ballarat, Beechworth, Pleasant Creek Special School, Stawell, Sunbury, and Warrnambool Districts—Butter and Cheese.

The prices tendered must not include sales tax.

Printed Forms of tender and the conditions of contract may, in all cases, be obtained from the Secretary to the Tender Board, 2nd Floor, South Building, New State Public Offices, Treasury-place, Melbourne, 3002, by whom also any information or explanation will be afforded to persons tendering.

Security will be required either in Commonwealth Treasury Bonds, or approved bank guarantee, fixed deposit receipt, Savings Bank deposit book, or non-negotiable cheque in favour of the Secretary to the Tender Board as the tenderer may elect.

The security must be completed and the contract signed within ten days of acceptance of the tender, failing which the contract may be again advertised, or another tender accepted.

The lowest or any tender will not necessarily be accepted.

In the event of tenderers withdrawing or attempting to withdraw their tenders before notification of acceptance of same, or failing to take up their accepted tenders within the prescribed period after notification of acceptance, they may be disqualified from tendering or holding any future contracts for Government supplies for a period of twelve months, such disqualification to date from the notification of acceptance of tender. It is also stipulated that, if a tenderer be a member of a firm and such firm be interested in the contract, the tender shall be in the name of the firm and not in that of the individual and that, for a breach of this condition, the tender will be declared informal.

Tenders enclosed in a separate envelope, and having the words "Tender for _____ at _____" (as the case may be) written thereon, must be deposited in the Tender Box at the Tender Board Offices, 2nd Floor, South Building, New State Public Offices, Treasury-place, Melbourne, 3002, or, if sent by post, postage must be prepaid, and the tenders addressed to the Chairman of the Tender Board, Tender Board Offices, 2nd Floor, South Building, New State Public Offices, Treasury-place, Melbourne, 3002, which office they must reach not later than by first post on the date of closing of tenders.

The conditions of contract are those published in the *Victoria Government Gazette*, No. 23, dated 13th March, 1968, pages 755 to 757.

H. E. BOLTE,
Treasurer.

The Treasury,
Melbourne, 12th August, 1968.

PRIVATE ADVERTISEMENTS

NOTICE is hereby given that the Victorian Association of Youth Clubs has applied for a lease under section 134 of the *Land Act 1958* for a term of 21 years in respect of an area of 1 rood and 20 perches (0.120) at Grant-street in the Township of Bairnsdale as a site for Amusement and Recreation (Youth Club).—(H.027511.)
3946 J. W. GEARING, General Secretary.

NOTICE is hereby given that Kenneth Willis Copland, of Mystic Park, and George Arthur Gillingham, of Lake Charm, have applied for a lease under section 134 of the *Land Act 1958* for a term of nine years from 1st December, 1968, of an area being Little Lake, in the Parish of Benjeroop, as a site for the manufacture of salt. 3922

L ANITA GRACE ROACH, of Fish Point, in the State of Victoria, married woman, give public notice that by deed poll dated the 10th day of July, 1968, duly executed and attested and deposited with the Registrar-General in the said State on the 2nd day of August, 1968, on behalf of my daughter Deborah Kay Hanson and my son Robert Guy Hanson respectively, who are infants, I formally absolutely renounced and abandoned the names of Deborah Kay Hanson and Robert Guy Hanson, and declared that my said daughter and my said son had assumed and adopted and intended thenceforth upon all occasions whatsoever to use and subscribe the names of Deborah Kay Roach and Robert Guy Roach respectively so as to be at all times thereafter called, named and described by the said names of Deborah Kay Roach and Robert Guy Roach.

DELANY & DWYER, barristers and solicitors, 201
Campbell-street, Swan Hill. 4216

LILYDALE SEWERAGE AUTHORITY.

TAKE notice that the Lilydale Sewerage Authority proposes to construct a sewerage treatment works on all that piece of land contained in certificate of title, volume 8505, folio 374, being part of Crown section 24, Parish of Yering, County of Evelyn, and for the purpose of those works the said Authority requires the above-mentioned land and proposes to compulsorily take all those pieces of land being contained in certificate of title, volume 8505, folio 374, being part Crown section 24, Parish of Yering, County of Evelyn.

A plan or description of the proposed works will be open for inspection at the Shire Office, Lilydale, during ordinary office hours between the 12th day of August and 20th day of September, 1968.

Dated this 12th day of August, 1968.

T. H. COWLEY, Secretary,
Lilydale Sewerage Authority.
4193

CITY OF DONCASTER AND TEMPLESTOWE.

BY-LAW No. 52.

Metropolitan Hawkers By-law.

A By-law of the City of Doncaster and Templestowe made under the provisions of Section 36 of the *Hawkers and Pedlars Act 1958* and numbered 52 for prescribing the limits whether as to time or place within which a person holding a Metropolitan Hawkers Licence may sell or offer or expose for sale any articles specified in their licences in any street, road or public place.

PURSUANT to the powers conferred by the *Hawkers and Pedlars Act 1958* and of any and every other power it thereunto enabling the Mayor Councillors and Citizens of the City of Doncaster and Templestowe orders as follows:—

1. This By-law may be known as the Metropolitan Hawkers By-law.

2. In this By-law the words "Metropolitan Hawker" means the holder of a Metropolitan Hawkers Licence under the *Hawkers and Pedlars Act 1958*.

3. The limits as to time within which the selling or offering or exposing for sale by a Metropolitan Hawker of any article specified in his licence issued under the *Hawkers and Pedlars Act 1958* is permitted within any street, road or public place within the Municipal District of the City of Doncaster and Templestowe are hereby prescribed as between the hours of ten o'clock in the forenoon and five o'clock in the afternoon on any week-day other than a Sunday or a Public Holiday and between the hours of ten o'clock in the forenoon and one o'clock in the afternoon on any Saturday.

4. No Metropolitan Hawker shall so sell or offer or expose for sale any articles specified in his licence issued under the *Hawkers and Pedlars Act 1958* at any time other than a time permitted by the last preceding clause.

5. Any person guilty of any wilful act or default contrary to this By-law shall be liable to a penalty of not less than Ten Dollars nor more than Forty Dollars and any person guilty of a continuing offence against this By-law shall be liable to a penalty of not more than Ten Dollars for each day on which an offence against this By-law is continued after a conviction or order by any Court.

Resolution for passing this By-law agreed to by the Council of the City of Doncaster and Templestowe on the 6th day of May, 1968, and confirmed on the 3rd day of June, 1968.

The corporate seal of the Mayor, Councillors and Citizens of the City of Doncaster and Templestowe was hereunto affixed, in the presence of—

B. S. ELMS, Mayor.
I. E. PETER-BUDGE, Councillor.
J. W. THOMSON, Town Clerk.

Approved by the Governor in Council, 30th July, 1968.—
J. ROSSITER, Clerk of the Executive Council. 4181

CITY OF ESSENDON.

NAME OF STREET CHANGED.

NOTICE is hereby given that in accordance with the provisions of Clause 8 of Part 1 of the Fifteenth Schedule of the *Local Government Act 1958*, the following change of street name has been ordered by the Council of the City of Essendon.

Old Name; New Name; Location.

Janfred-court; Aroona-court; off east side of Vida-street, between Tilba-street and The Boulevard.

By order of the Council,

4236 A. E. O'NEILL, Acting Town Clerk.

Town and Country Planning Act 1961.

CITY OF GEELONG.—GEELONG PLANNING SCHEME 1959.

NOTICE THAT A PLANNING SCHEME HAS BEEN PREPARED AND IS AVAILABLE FOR INSPECTION.

Amendment No. 6.

NOTICE is hereby given that the City of Geelong, in pursuance of its powers under the *Town and Country Planning Act 1961*, has prepared a Planning Scheme for the following area:—

Land within the City of Geelong, being allotment 79, Parish of Moorpanyal, for the purpose of rezoning such area of land from Agricultural "E" to Industrial "A".

A copy of the scheme has been deposited at the Temporary Council Offices, 147 Malop-street, Geelong, and at the office of the Town and Country Planning Board, 179 Queen-street, Melbourne, and will be open for inspection during office hours by any person, free of charge.

Any persons affected by the Planning Scheme are required to set forth, in writing, all objections they may have, addressed to the Town Clerk, City of Geelong, Temporary Council Offices, 147 Malop-street, Geelong, on or before the 14th September, 1968, and to state whether they wish to be heard in respect of their objections.

Dated 14th August, 1968.

4192

L. L. WALTER, Town Clerk.

CITY OF HAWTHORN.

LOAN No. 44.

Notice of Intention to Borrow the Sum of \$100,000 for Permanent Works and Undertakings.

NOTICE is hereby given that the Council of the City of Hawthorn proposes to borrow the sum of One hundred thousand dollars, secured by a charge over the general rates of the municipality, such sum to be raised by the grant of a mortgage, in accordance with the provisions of the Local Government Act.

1. The amount of the principal moneys which it is proposed to borrow is \$100,000.
2. The maximum rate of interest that may be paid is 5½ per centum per annum.
3. The period of the loan shall be fifteen years.
4. The moneys borrowed shall be repayable by providing out of the municipal fund 30 half yearly instalments of approximately \$5,060 each, including principal and interest on the 1st day of June and the 1st day of December during the currency of the loan. The first instalment shall be payable on the 1st day of June, 1969.
5. Such moneys shall be repayable at the E.S. and A. Savings Bank Ltd., Melbourne or at the Council's bankers for the time being in Hawthorn.

6. The purpose for which the loan is to be applied is—
Acquisition of properties for the provision
of car parking areas \$100,000

The plans and specifications and the estimate of the cost of the proposed works and a statement showing the proposed expenditure of the money to be borrowed are open for inspection at the Municipal Offices, Town Hall, Hawthorn, during office hours.

Dated this 12th day of August, 1968.

4195

J. R. JOHNSON, Town Clerk.

CITY OF NORTHCOTE.

BY-LAW No. 174.

Metropolitan Hawkers By-law.

A By-law of the City of Northcote made under the provisions of section 36 of the *Hawkers and Pedlers' Act 1958* and numbered 174 for prescribing the limits whether as to time or place within which a person holding a Metropolitan Hawkers' Licence may sell or offer or expose for sale any articles specified in their licences in any street road or public place.

IN pursuance of the powers conferred by the *Hawkers and Pedlers' Act 1958* and of any and every other power it thereunto enabling, the Mayor Councillors and Citizens of the City of Northcote order as follows:

1. This By-law may be known as the Metropolitan Hawkers By-law.
2. By-law No. 168 of the City of Northcote is hereby repealed.
3. In this By-law the words "Metropolitan Hawker" mean the holder of a Metropolitan Hawkers' Licence under the *Hawkers and Pedlers' Act 1958*.
4. The limits as to time within which the selling or offering or exposing for sale by a Metropolitan Hawker of any article specified in his licence issued under the *Hawkers and Pedlers' Act 1958* is permitted within any street road or public place within the Municipal District of the City of Northcote are hereby prescribed as between the hours of 9 o'clock in the morning and 5 o'clock in the afternoon on any day other than Saturday, Sunday or a public holiday and between the hours of 9 o'clock in the morning and 1 o'clock in the afternoon on any Saturday.
5. No Metropolitan Hawker shall so sell or offer or expose for sale any such articles at any time other than a time permitted by the last preceding clause.

No. 70.—7378/68.—3

6. Any person guilty of any wilful act or default contrary to this By-law shall be liable to a penalty of not less than \$10.00 nor more than \$30.00 and any person guilty of a continuing offence against this By-law shall be liable to a penalty of not more than \$10.00 for each day in which an offence against this By-law is continued after a conviction or order by any Court.

Resolution for passing this By-law agreed to by the Council of the City of Northcote on the 26th day of February, 1968, and confirmed on the 1st day of April, 1968.

The common seal of the Mayor, Councillors and Citizens of the City of Northcote was hereunto affixed in the presence of—

(SEAL) A. R. CADDY, Mayor.
J. A. HOWES, Councillor.
A. J. HILL, Town Clerk.

Approved by the Governor in Council on the 30th day of July, 1968.—J. ROSSITER, Clerk of the Executive Council. 4169

TOWN OF BAIRNSDALE.

LOAN No. 2.

Notice of Intention to Borrow the Sum of \$50,000 for Permanent Works and Undertakings.

NOTICE is hereby given that the Council of the Town of Bairnsdale proposes to borrow the principal sum of Fifty thousand dollars (\$50,000) secured by a charge over the general rates of the municipality, such sum to be raised by the grant of a mortgage, in accordance with the provisions of the *Local Government Act 1958*.

1. The maximum rate of interest that may be paid is 5.75 per centum per annum.
2. The purpose for which the loan is to be applied is for Drainage Works.
3. The period of the loan shall be ten years.
4. The moneys borrowed shall be repayable by providing out of the municipal fund twenty half-yearly instalments of \$3,322.07, each including principal and interest, on the 15th day of April and the 15th day of October, during the currency of the loan. The first instalment shall be payable on the 15th day of April, 1969.
5. Such moneys shall be repayable at the Australia and New Zealand Savings Bank Limited, Melbourne.

The plans and specifications and the estimate of the cost of the proposed works, and a statement showing the proposed expenditure of the moneys to be borrowed, are open for inspection at the offices of the Council, at Main-street, Bairnsdale, during office hours.

4186

T. N. MUNTZ, Town Clerk.

SHIRE OF ARARAT WATERWORKS TRUST.

LAKE BOLAC URBAN WATER SUPPLY DISTRICT.

NOTICE is hereby given that the Shire of Ararat Waterworks Trust has made application to the Honorable the Minister of Water Supply for the proclamation of an Urban Waterworks District at Lake Bolac, and the construction, maintenance and continuance of Water Supply Works within that District under the provisions of the Water Acts. A general plan and description of the proposed works have been submitted with the application and copies of same may be seen at the Shire Office, Ararat.

Dated 3rd July, 1968.

4066

K. N. BISHOP, Secretary.

SHIRE OF BERWICK.

NOTICE is hereby given that pursuant to the provisions of the *Local Government Act 1958*, the Council of the Shire of Berwick doth order that the name of the following road within the municipality be changed as set out hereunder:—

Old Name.—Ingram-road.

New Name.—O'Brien-road.

Location.—A 1-chain wide Government road in the Parish of Nar-Nar-Goon, County of Mornington, running north-easterly between Crown allotments 2 and 3, section B, from the Nar-Nar-Goon-Gembrook road to the Ararat Creek.

4182

B. J. WALLIS, Shire Secretary.

SHIRE OF BULN BULN.

BY-LAW No. 78.

A By-law of the Shire of Buln Buln, made under Section 800 of the *Local Government Act 1958*, and numbered 78 for the purpose of repealing By-law No. 77 and of further amending By-law No. 43.

IN pursuance of the powers conferred by the *Local Government Act 1958*, the President, Councillors and Ratepayers of the Shire of Buln Buln orders as follows:—

1. Clause 2 of By-law No. 77 of the Shire of Buln Buln is hereby repealed.

2. Clause 7 of By-law No. 43 shall be and is hereby repealed, and the following clause substituted therefor:—

"7. (a) Unless the Council is satisfied that special circumstances exist in any particular case; (i) no person shall engage or take part in sport in organised competition on the Reserve on any Sunday before the hour of 1.00 p.m.; (ii) no club, association or person shall conduct any sport in organised competition on the Reserve on any Sunday before the hour of 1.00 p.m.

(b) The Council may delegate authority to make a decision under this Clause to a Committee appointed by the Council for the purpose."

3. This By-law shall apply to and have operation throughout that part of the Shire of Buln Buln consisting of the Drouin Recreation Reserve as described in By-law No. 43.

Resolution for passing this By-law agreed to by the Council of the Shire of Buln Buln on the 18th day of March, 1968, and confirmed the 22nd day of April, 1968.

The common seal of the President, Councillors and Ratepayers of the Shire of Buln Buln was hereunto affixed in the presence of—

N. E. NICHOLSON, Shire President.
(SEAL) J. E. DELZOPPO, Councillor.
K. A. PRETTY, Shire Secretary.

Approved by the Governor in Council, 30th July, 1968.—
J. ROSSITER, Clerk of the Executive Council. 4184

SHIRE OF BULN BULN.

BY-LAW No. 79.

A By-law of the Shire of Buln Buln, made under Section 800 of the *Local Government Act 1958*, and numbered 79 for the purpose of amending By-law No. 76.

IN pursuance of the powers conferred by the *Local Government Act 1958*, the President, Councillors and Ratepayers of the Shire of Buln Buln orders as follows:—

1. Clause 6 of By-law No. 76 shall be and is hereby repealed, and the following clause substituted therefor:—

"6. (a) Unless the Council is satisfied that special circumstances exist in any particular case; (i) no person shall engage or take part in sport in organised competition on the Park on any Sunday before the hour of 1.00 p.m.; (ii) no club, association or person shall conduct any sport in organised competition on the Park on any Sunday before the hour of 1.00 p.m.

(b) The Council may delegate authority to make a decision under this Clause to a Committee appointed by the Council for the purpose."

2. This By-law shall apply to and have operation throughout that part of the Shire of Buln Buln consisting of Bellbird Park as described in By-law No. 76.

Resolution for passing this By-law agreed to by the Council of the Shire of Buln Buln on the 18th day of March, 1968, and confirmed the 22nd day of April, 1968.

The common seal of the President, Councillors and Ratepayers of the Shire of Buln Buln was hereunto affixed in the presence of—

N. E. NICHOLSON, Shire President.
(SEAL) J. E. DELZOPPO, Councillor.
K. A. PRETTY, Shire Secretary.

Approved by the Governor in Council, 30th July, 1968.—
J. ROSSITER, Clerk of the Executive Council. 4185

Town and Country Planning Act 1961 (Twelfth Schedule).

SHIRE OF KNOX.—SHIRE OF KNOX PLANNING SCHEME 1965.

NOTICE THAT A PLANNING SCHEME HAS BEEN PREPARED AND IS AVAILABLE FOR INSPECTION.

Amendment No. 41, 1968.

NOTICE is hereby given that the Council of the Shire of Knox in pursuance of its powers under the *Town and Country Planning Act 1961*, has prepared a planning scheme for portions of the Shire of Knox for the purpose of amending the Principal Scheme by the widening of Jersey-road by 16 feet on the east side and Malvern-street by 16 feet on the north side.

A copy of the scheme has been deposited at the Office of the Shire of Knox, Spring-street, Fern Tree Gully, and at the office of the Town and Country Planning Board, 179 Queen-street, Melbourne, and will be open for inspection during office hours by any person free of charge.

Any persons affected by the Planning Scheme are required to set forth, in writing, all objections they may have, addressed to the Shire Secretary, Shire of Knox, Spring-street, Fern Tree Gully, on or before the 14th day of November, 1968, and to state whether they wish to be heard in respect of their objections.

4196. N. G. HAYNES, Shire Secretary.

SHIRE OF KNOX.

NOTICE OF INTENTION TO TAKE LAND COMPULSORILY.

Drainage, Sewerage and Recreation Reserve.

WHEREAS the Council of the Shire of Knox deems it expedient to execute the work or undertaking of providing the land described hereunder for a drainage, sewerage and recreation reserve: And whereas for the purpose thereof the exercise of the power of taking land compulsorily will in the opinion of the Council be necessary and desirable: And whereas the Council has caused to be prepared maps and other papers showing a general description of the work or undertaking for which the land proposed to be taken is to be used, a description of the lands proposed to be taken and the names of the owners or reputed owners lessees reputed lessees mortgagees occupiers of such lands so far as those names are known to or can be ascertained by the Council: And whereas such maps and other papers are deposited at the office of the said Council situate at Fern Tree Gully and are open for inspection by all persons affected by the proposed taking of lands during normal office hours: And whereas the notice referred to in Section 513 (1) of the *Local Government Act* was published in the *Government Gazette* on the 14th August, 1968, now therefore take notice that under the provisions of sub-section (2) of the said Section 513 you are hereby required to answer this notice within 40 days of the date of the said publication in the *Government Gazette* stating whether you assent, dissent or are neutral in respect of the taking of the said land.

THE LAND REFERRED TO:

Lot 47, lodged plan 52355, Parish of Scoresby.
4191 N. G. HAYNES, Shire Secretary.

SHIRE OF MALDON.

POUNDKEEPER.

NOTICE is hereby given that James Lacey, Chapel-street, Maldon has been appointed Poundkeeper for the Shire of Maldon, vice William Bowen, resigned.

4188 S. R. BEACH, Shire Secretary.

SHIRE OF MELTON.

LOAN No. 32.

Notice of Intention to Borrow the Sum of \$30,000 for Permanent Works and Undertakings.

NOTICE is hereby given that the Council of the Shire of Melton proposes to borrow the principal sum of \$30,000 secured by a charge over the general rates of the municipality, such sum to be raised by the grant of a mortgage in accordance with the provisions of the *Local Government Act 1958*.

1. The maximum rate of interest that may be paid is 5.75 per centum per annum.

2. The purpose for which the loan is to be applied is part construction of Township Drainage Scheme No. 7 (Kendale and Overs Estates).

3. The period of the loan shall be ten years.

4. The moneys borrowed shall be repayable by providing out of the municipal fund half-yearly instalments of approximately \$1,993 each, including principal and interest on the first day of May and the first day of November, during the currency of the loan. The first instalment shall be payable on the first day of May, 1969.

5. Such moneys shall be repayable to The Commissioners of The State Savings Bank of Victoria at the office of the said Commissioners, corner Elizabeth and Bourke streets, Melbourne.

The plans and specifications and the estimate of the cost of the proposed works and a statement showing the proposed expenditure of the moneys to be borrowed are open for inspection at the office of the Council of the Shire of Melton, at Melton.

4235

D. J. R. DUNTON, Shire Secretary.

SHIRE OF MORNINGTON.

LOAN No. 59.

Notice of Intention to Borrow the Sum of \$50,000 for Permanent Works and Undertakings.

NOTICE is hereby given that the Council of the Shire of Mornington proposes to borrow the principal sum of \$50,000 secured by a charge over the general rates of the municipality, such sum to be raised by the grant of a mortgage in accordance with the provisions of the *Local Government Act 1958*.

1. The maximum rate of interest that may be paid is 5.875 per cent. per annum.

2. The purposes for which the loan is to be applied are—

(a) *Construction of Roads* \$17,000

1. Nepean Highway (Wooralla to Tower).
2. Nepean Highway (Culvert—Tanti Creek).
3. Mt. Eliza-way—Boundary-road.
4. Moomba-street.

(b) *Construction of Kerbing and Channelling* 3,400

1. Mt. Eliza-way (Service-road—west side).
2. Moomba-street (Nepean Highway to Tyabb-road).

(c) *Construction of Footpaths* 900

1. Mt. Eliza-way (Service-road—west side).

(d) *Land Acquisition* 28,700

The purchase price or compensation paid (as the case may be) for any lands purchased or taken for the purposes of:—

Opening new streets or roads (including the extension of existing streets or roads) (Cromwell-street, Spray-street and Waterloo-place).

Providing car parking areas (Empire-street, Mornington).

3. The period of the loan shall be 15 years. \$50,000

4. The moneys borrowed shall be repayable by providing out of the municipal fund half-yearly instalments of approximately \$2,530.40 each, including principal and interest on the first day of April and the first day of October during the currency of the loan. The first instalment shall be payable on the first day of October, 1968.

5. Such moneys shall be repayable to The Commissioners of The State Savings Bank of Victoria at the office of the said Commissioners, corner Elizabeth and Bourke streets, Melbourne.

The plans and specifications and the estimate of the cost of the proposed works and a statement showing the proposed expenditure of the moneys to be borrowed are open for inspection at the office of the Council of the Shire of Mornington, at Queen-street, Mornington.

D. G. COLLINGS, Shire Secretary.

14th August, 1968.

4194

SHIRE OF OTWAY.

LOAN No. 17.

Notice of Intention to Borrow.

NOTICE is hereby given that the Council of the Shire of Otway intends to borrow the sum of \$12,000 (Twelve thousand dollars) on the credit of the municipal revenues of the President, Councillors and Ratepayers of the said Shire, such sum to be raised by grant of mortgage, in accordance with the said Acts and states:—

1. The amount of principal moneys it is proposed to borrow is \$12,000.

2. The maximum rate of interest that may be paid is 5.75 per cent. per annum.

3. The period of the loan shall be for ten years and the time or times at which the moneys borrowed are to be repayable are on the 10th day of November and 10th day of May in each year during the currency of the loan, commencing on the 10th day of May, 1969. The place of repayment will be the Commercial Bank of Australia Ltd., Melbourne.

4. The purpose for which the loan is to be applied is for permanent works and undertakings, viz.:—

Purchase of land (where necessary), legal costs, removal and re-erection of buildings, surveys, in widening of laneways through sections 13 and 15 in the Apollo Bay Township, and the construction and surfacing of the streets and footpaths.

5. The loan is to be liquidated by half-yearly payments of \$797.30 including principal and interest, payable out of the Municipal Fund.

Plans and specifications and an estimate of the cost of such works and undertakings, and a statement showing the proposed expenditure of the moneys to be borrowed, are open for inspection by ratepayers during office hours, at the Shire Offices, Beech Forest, for one month after publication of this notice.

Dated at Beech Forest, this 5th day of August, 1968.

4162

T. J. FRY,
Shire Secretary.

SHIRE OF ROSEDALE.

LOAN No. 26.

Notice of Intention to Borrow the Sum of \$35,000 for Permanent Works and Undertakings.

NOTICE is hereby given that the Council of the Shire of Rosedale proposes to borrow the principal sum of \$35,000 secured by a charge over the general rates of the municipality, such sum to be raised by the grant of a mortgage, in accordance with the provisions of the *Local Government Act 1958*.

1. The maximum rate of interest that may be paid is 5.875 per cent. per annum.

2. The purpose for which the loan is to be applied is as follows:—

(a) Concrete kerb and channel, drainage works, and road works in the Township of Rosedale—Prince, Duke, Mackay, Hood and Cansick streets.

(b) Land purchase.

3. The period of the loan shall be fifteen years.

4. The moneys borrowed shall be repayable by providing out of the municipal fund half-yearly instalments of approximately \$1,771.28 each, including principal and interest, on the 22nd day of April and October during the currency of the loan. The first instalment shall be payable on the 22nd day of April, 1969.

5. Such moneys shall be repayable to the Australia and New Zealand Savings Bank Limited, Melbourne.

The plans and specifications and the estimate of the cost of the proposed work and a statement showing the proposed expenditure of the moneys to be borrowed are open for inspection at the office of the Council of the Shire of Rosedale, at Rosedale.

Dated this 7th day of August, 1968.

4180

G. W. THOMSON, Shire Secretary.

*Town and Country Planning Act 1961.*SHIRE OF SHERBROOKE.—SHIRE OF SHERBROOKE
PLANNING SCHEME.

AMENDMENT No. 14, 1968.

NOTICE is hereby given that the Council of the Shire of Sherbrooke, in pursuance of its powers under the *Town and Country Planning Act 1961*, has prepared a Planning Scheme for portions of the Shire of Sherbrooke for the purpose of amending the principal scheme.

A copy of the scheme has been deposited at the Shire Office, Glenfern-road, Upwey, and at the Office of the Town and Country Planning Board, 179 Queen-street, Melbourne, and will be open for inspection during office hours by any person, free of charge.

Any persons affected by the Planning Scheme are required to set forth, in writing, all objections they may have, addressed to the Shire Secretary, Shire of Sherbrooke, Glenfern-road, Upwey, 3158, on or before the 16th September, 1968, in respect of Amendment No. 14, 1968, and to state whether they wish to be heard in respect of their objections.

4165

A. JONES,
Shire Secretary.

SHIRE OF UPPER MURRAY.

LOAN No. 24.

Notice of Intention to Borrow the Sum of \$10,000 for Permanent Works and Undertakings.

NOTICE is hereby given that the Council of the Shire of Upper Murray proposes to borrow the principal sum of Ten thousand dollars secured by a charge over the general rates of the municipality, such sum to be raised by the grant of a mortgage in accordance with the provisions of the *Local Government Act 1958*.

1. No interest shall be paid on moneys borrowed.
2. The purpose for which the loan is to be applied is the acquisition of a site and the erection of Municipal Saleyards—\$10,000.
3. The period of the loan shall be ten years.
4. The sum borrowed shall be repayable by providing out of the municipal fund annual instalments of One thousand dollars each, being principal on the 30th day of September, during the currency of the loan. The first instalment shall be payable on the 30th day of September, 1969.

5. Such amount shall be repayable to the office of Gippsland and Northern Company Limited at Corryong, or at such other place or places as the lenders may require.

The plans and specifications of the estimate of the cost of the works and a statement showing the expenditure of the moneys to be borrowed are open for inspection at the office of the Council of the Shire of Upper Murray at 103-105 Hansen-street, Corryong, Victoria.

4234 R. C. McDIARMID, Shire Secretary.

SHIRE OF WODONGA.

BYLAWS.

NOTICE is hereby given that the Council of the Shire of Wodonga has made the following Bylaws for the purposes as stated:—

BYLAW No. 60.

Title: Repealing Bylaws.

Contents: Repealing Bylaws Nos. 1-47 inclusive, 49-55 inclusive, and Bylaw No. 57.

BYLAW No. 61.

Title: For determining, applying, dispensing with or regulating such matters or things as are left to be determined, applied, dispensed with or regulated by the Council of the said Shire of Wodonga under the Uniform Building Regulations, Victoria.

Contents: (1) Describing brick areas.

(2) Fixing minimum area, depth and width of frontages and minimum distance of outer walls of any building from the frontage of any land of buildings of Class I and Class II occupancy.

BYLAW No. 62.

Title: Prohibiting the driving of cattle in or along any specified street in the municipal district.

Contents: Prohibiting the driving of cattle in or along certain streets within the Shire of Wodonga.

BYLAW No. 63.

Title: Regulating the use of private property situate at the junction of streets or roads for the growing of trees, shrubs or hedges abutting on any such street or road or within 10 ft. therefrom or within a distance of 30 ft. from the junction of any streets or roads requiring the reduction to a height not exceeding 3 ft. 6 in. of any portion of a fence within 30 ft. of the junction of any streets or roads.

Contents: Prohibiting the use of private property situate at the junction of streets or roads for the growing of trees, shrubs or hedges abutting on any such street or road or within 10 ft. therefrom or within a distance of 30 ft. from the junction of any streets or roads requiring the reduction to a height not exceeding 3 ft. 6 in. of any portion of a fence within 30 ft. of the junction of any streets or roads.

BYLAW No. 64.

Title: For controlling the construction of crossings over gutters and footways.

Contents: Prohibiting the driving of any vehicle across any footway or any water channel or gutter except at some properly constructed crossing.

Requiring landowners to obtain Council's consent to the construction of crossings over footpaths and gutters.

BYLAW No. 65.

Title: Regulating the proceedings of meetings of the Council of the Shire of Wodonga.

Contents: Procedures to be followed at meetings of the Council of the Shire of Wodonga.

BYLAW No. 66.

Title: Fixing registration and other fees under the Dog Act 1958.

Contents: Fixing dog registration fees and release fees for impounded dogs.

BYLAW No. 67.

Title: Fixing the fee for the examination of plans, specifications, particulars and descriptions of proposed septic tank systems and any inspection of these and installations.

Contents: Fixing the fee for the examination of plans, specifications, particulars and descriptions of proposed septic tank systems and any inspection of these and installations.

BYLAW No. 68.

Title: Fixing of fees to be paid in respect to the registration or renewal or transfer of registration of certain premises under the Health Act.

Contents: Fixing various amounts to be paid in respect of registration or renewal or transfer of registration of certain premises under the Health Act.

BYLAW No. 69.

Title: For the provision, use and control of receptacles for the deposit and collection of refuse and rubbish and describing the size and shape of the materials to be used in the construction of such receptacles, and preventing or regulating the deposit of rubbish or refuse upon streets and other lands and places under the control of the Council of the Shire of Wodonga.

Contents: Regulating the use and control of receptacles for the deposit and collection of refuse and rubbish and describing the size and shape of the materials to be used in the construction of such receptacles and preventing or regulating the deposit of rubbish or refuse upon streets and other lands and places under the control of the Council of the Shire of Wodonga.

4183

G. J. MORTON, Shire Secretary.

NOTICE OF DISSOLUTION OF PARTNERSHIP.

NOTICE is hereby given that the partnership previously subsisting among John Classon, of 31 Frater-street, Kew, Herbert Barras, of 14 Peveril-street, Glen Waverley, and Albert Houghton, of 3 Lister-street, East Kew, and carried on by them as trade slitters, at 7 Carinish-road, Huntingdale, under the business name of "Trans Cel", has been dissolved by mutual consent, such dissolution relating back to the 30th June, 1968, and the said Herbert Barras has since the said date and will in the future continue the said business under the said business name at the said address.

Dated the 8th day of August, 1968.

4231

HERBERT BARRAS.

NOTICE is hereby given that the partnership heretofore subsisting between Colin Edward Hunter, of 83 Morris-road, Upwey, and Leslie Robert Kerr, of 8 Morris-road, Upwey, carrying on business as pharmaceutical chemists at Nos. 320 and 350 Main-street, Upwey, under the style or firm of L. R. Kerr and C. E. Hunter, has been dissolved by mutual consent as from the 2nd day of June, 1968. The said business shall be thereafter carried on by the said Leslie Robert Kerr.

Dated the 7th day of August, 1968.

COLIN E. HUNTER.

Signed by the said Colin Edward Hunter, in the presence of—M. BAILEY.

L. R. KERR.

Signed by the said Leslie Robert Kerr, in the presence of—P. KERR. 4229

NOTICE is hereby given that the partnership heretofore subsisting between Douglas William Phillips, Rebina Rita Phillips, Alexander William Boyle and Patricia Helen Boyle, carrying on the business of a milk and sandwich bar and mixed business, at 350 Bay-road, Cheltenham, has been dissolved as from the 31st day of July, 1968.

Dated this 5th day of August, 1968.

D. W. PHILLIPS.

R. R. PHILLIPS.

ALEXANDER W. BOYLE.

P. H. BOYLE.

4168

NOTICE is hereby given that the partnership heretofore subsisting between Nicolas Tiligadis and Emmanuel Dretakis, carrying on business of service station, at 554 High-street, Thornbury, under the style or firm name of "B.P. Highbin Service Station", has been dissolved as from 1st August, 1968.

Dated the 9th day of August, 1968.

NICOLAS TILIGADIS.
EMMANUEL DRETAKIS.

Todd & Todesco, solicitors, 618 High-street, Thornbury,
3071. 4190

NOTICE is hereby given that the partnership heretofore subsisting between Moniek Sambor and Susanne Sambor and Herc Gottlieb and Mela Gottlieb, carrying on business as builders' suppliers, at 178 Neerim-road, Carnegie, under the style or firm name of "Gottlieb and Sambor", has been dissolved by mutual consent as from the 22nd day of July, 1968.

The said business is being carried on by Gottlieb's Building Supply Proprietary Limited (of which the said Herc Gottlieb and Mela Gottlieb are the only directors), at the same address, i.e., 178 Neerim-road, Carnegie.

Dated this 6th day of August, 1968.

STERLING & SHEINK, solicitors, 154 Chapel-street,
Windsor. 4197

TAKE notice that as from the 1st day of July, 1968, Mr. Andrew Sharp Peacock has retired from the firm of solicitors Messrs. Rigby & Fielding and Holt, Newman & Holt, carrying on business at 331 Collins-street, Melbourne. Mr. Charles Allen Moir Hider and Mr. Sam James Sydney Holt remain as partners in the said firm.
4210

I, NOEL STEEN, of Flat 6, 45 Williams-road, Windsor, who was formerly associated with Mr. Derek Palmer, of Palmer Air-Conditioning, of 2 Anderson-street, Caulfield, ceased that association on the 21st day of February, 1968.

I was not at any time a partner with Mr. Palmer in the firm of Palmer Air-Conditioning.

4208 (Signed) NOEL STEEN.

Companies Act 1961.

NATIONAL SOCIETY OF CHIROPODISTS
(IN VOLUNTARY LIQUIDATION).

NOTICE CONVENING FINAL MEETING OF MEMBERS, PURSUANT TO SECTION 272.

NOTICE is hereby given in pursuance of section 272 of the Companies Act 1961, that a General Meeting of the members of the above-named company will be held at the offices of J. D. Curtain, public accountant, 486 Sydney-road, Coburg, on Monday, the 16th day of September, 1968, at 10 o'clock in the forenoon for the purpose of having an account laid before them, showing the manner in which the winding up has been conducted and the property of the association disposed of and of hearing any explanations that may be given by the liquidator.

Dated this 5th day of August, 1968.

4164 J. D. CURTAIN, Liquidator.

Companies Act 1961.

SUPERIOR EQUIPMENT PTY. LTD. (IN LIQUIDATION).
GENERAL MEETING.

NOTICE is given of a General Meeting of Superior Equipment Pty. Ltd. (in Liquidation) to be held on Thursday, 26th September, 1968, at 143 Queen-street, Melbourne, for the purpose of considering the liquidator's account of how the winding up has been conducted.

J. McINTOSH, Liquidator, 8 Victor-avenue, Cheltenham,
10th August, 1968. 4167

The Companies Act 1961.—In the matter of WOLTAC PTY. LTD. (in Liquidation).

NOTICE is hereby given that pursuant to section 272 of the Companies Act, a Final Meeting of the contributors and the creditors of the above company will be held at Suite 18, 545 St. Kilda-road, Melbourne, on the 21st August, 1968, at 11 a.m.

Business.—To receive the Liquidator's accounts.

Dated this 1st day of August, 1968.

E. T. BENT, Liquidator.

Bent & Cogle, public accountants, Suite 18, 545 St.
Kilda-road, Melbourne. 4171

The Companies Act 1961.—In the matter of GRANTS SALES PTY. LTD.

NOTICE is hereby given that pursuant to section 272 of the Companies Act a Final Meeting of the creditors of the above company will be held at the offices of Bent & Cogle, on Tuesday, the 10th day of September, 1968, at 10.30 a.m.

Business.—To receive the Liquidator's accounts.

Dated this 31st day of July, 1968.

D. J. COUGLE, Liquidator.

Bent & Cogle, public accountants, Suite 18, 545 St.
Kilda-road, Melbourne, 3004. 4172

The Companies Act 1961.

FRASER & BOWES PTY. LTD. (IN VOLUNTARY LIQUIDATION).

MEMBERS VOLUNTARY WINDING UP UNDER SECTION 258.

NOTICE is hereby given that pursuant to section 272 of the Companies Act 1961, a meeting of the members of the above-named company will be held at the offices of Goode & Toner, chartered accountants, 340 Little Collins-street, Melbourne, on the 16th day of September, 1968, at 11 o'clock in the forenoon, for the purpose of having an account laid before them showing how the winding up of the company has been conducted, and the property of the company disposed.

Dated this 7th day of August, 1968.

C. T. GOODE, Liquidator.

Goode & Toner, chartered accountants, 340 Little Collins-street, Melbourne. 4173

In the matter of the Companies Act 1961; and in the matter of THE REGENT ESTATES PTY. LTD., and INVESTORS REALTY PTY. LTD., pursuant to Section 254 (2).

NOTICE is hereby given that at Extraordinary General Meetings of the Shareholders of—

THE REGENT ESTATES PTY. LTD., and
INVESTORS REALTY PTY. LTD.,

held on the 30th July, 1968, the following Resolution was carried as a Special Resolution at the meeting of each company.

"That the company be wound up voluntarily."

Dated this 2nd day of August, 1968.

Liquidators.—V. G. H. HARRISON, chartered accountant, 360 Collins-street, Melbourne, and P. M. WOOD, chartered accountant, 346 Little Collins-street, Melbourne. 4174

The Companies Act 1961.—In the matter of D. R. P. (HOLDINGS) PTY. LTD. under the business names of—Doug. R. Penberthy—Plumbers, Brett's Plumbing Supplies, and Plumbers & Engineering Hire Equipment.—Notice Re Meeting of Creditors, pursuant to Section 260.

NOTICE is hereby given that a Meeting of Creditors of the above-named company will be held at the offices of Kennedy, Smail & Middlemiss, 296 Little Lonsdale-street, Melbourne, at 11.30 a.m., on the 20th day of August, 1968, the company having convened a meeting of its members for the same day for the purpose of considering a Resolution that the company be wound up voluntarily.

Dated this 13th day of August, 1968.

D. R. PENBERTHY, Director.

Kennedy, Smail & Middlemiss, 296 Little Lonsdale-street,
Melbourne. 4212

The Companies Act 1961.—In the matter of OLIVE STREET MOTORS PROPRIETARY LIMITED.—Notice Re Meeting of Creditors, pursuant to section 260.

NOTICE is hereby given that a Meeting of Creditors of the above-named company will be held at the offices of Kennedy, Smail & Middlemiss, 296-304 Little Lonsdale-street, Melbourne, on Tuesday, the 20th day of August, 1968, at 10.30 o'clock in the forenoon, the company having convened a meeting of its members for the same day for the purpose of considering a Resolution that the company be wound up voluntarily.

Dated this 12th day of August, 1968.

F. ROSS, Director.

Kennedy, Smail & Middlemiss, 296-304 Little Lonsdale-street, Melbourne, 3000. 4213

Unclaimed Moneys Act 1962.

REGISTER of Unclaimed Moneys held by the—

Name of Owner on Books and Last Known Address.	Total Amount Due to Owner.	Description of Unclaimed Moneys.	Date when Amount first became Payable.
§			
MACROBERTSON (AUSTRALIA) LIMITED.			
Franklin, Margaret, Flat 3, 145-Gore-street, Fitzroy	12.60	Wages	28.3.66
Bissiotis, George, 84 Easey-street, Collingwood	14.88	"	11.4.66
Dokas, Helen, 57 Napier-street, Fitzroy	11.02	"	18.4.66
Hutchison, Eddie Donald, Flat 5, 106 Campbell-street, Collingwood	19.03	"	25.4.66
Sawczuk, Roberta Dianne, 26 York-street, Reservoir	10.35	"	16.5.66
Kopelis, George, 416 George-street, Fitzroy	12.47	"	23.5.66
Dowling, Marese, 34 Nicholson-street, Fitzroy	19.55	"	"
Campbell, Ada Patricia, 6 Barce-place, West Heidelberg	11.22	"	"
Contoyianopoulos, Anastasia, 116 Edward-street, East Brunswick	23.12	"	6.6.66
Sagos, George, 5 David-street, Carlton	15.44	"	4.7.66
Ball, Ernest William, 1064 Malvern-road, Armadale	42.49	"	14.11.66
Sinclair, Ronald George, 65 Cecil-street, Fitzroy	11.70	"	23.1.67
McLean, Archibald, 36 Cardigan-street, Mooroolbark	23.21	"	13.2.67
Bryant, Carol Diane, Flat 2, ½ Hales-street, Northcote	12.42	"	27.2.67
Alma Investments Pty. Ltd., Flat 4, Parkview, 124 Alma-road, East St. Kilda	10.98	Dividend	29.4.66
Curdie, Laura J. C., 8 Glenervie-road, Toorak	26.00	"	16.6.66
4175			
ROCHESTER CO-OPERATIVE BUTTER AND CANNING CO. LIMITED.			
Hocking, Gerald, Moama	11.52	Dividend	—12.65
4176			
MIRBOO AND MORWELL VALLEY FARMERS' CO-OPERATIVE CO. LIMITED.			
Cox, L. G. and V. A., Mirboo North	11.21	Suppliers Pay	15.7.66
Kubale, N. F., Mirboo North	39.55	"	15.3.66
Mayer Bros., Boolarra	15.00	Dividend	1.11.66
Patterson, William R., Drouin	18.00	"	"
4177			
GRASMERE BUTTER CO. LIMITED.			
Galerio, Salvatore, Carlisle River	22.27	Suppliers Pay	—9.66
Knights, Donald, Warrnambool	35.87	"	"
Hackett, John (estate of), Koroot	12.16	Dividend	—12.66
Logan, Douglas J., Allansford	27.52	"	"
4178			
MURRAY GOULBURN CO-OPERATIVE CO. LIMITED.			
Clark, Ian, Yarroweyah	14.56	Dividend	—12.66
Growse, Alan Brampton, 1 Neil-street, Heathmont	12.80	"	"
Hocking, Philip Douglas, Lockington	12.48	"	"
Jarvis, John Thomas, Box 59, Albany, W.A.	10.08	"	"
McNair, Edward James (deceased), and Edward Barry, 794 Pascoe Vale-road, Glenroy	16.00	"	"
Smith, Arthur Leslie and Son, Dunnstown, via Ballarat	13.60	"	"
Horner, Brian Henry, Box 31c, Nathalia	18.88	"	—12.6?
4179			

Companies Act 1961.

IMPACT PUBLICATIONS PROPRIETARY LIMITED.

PURSUANT TO SECTION 260 OF THE COMPANIES ACT 1961.

NOTICE is hereby given that a Meeting of Creditors of Impact Publications Proprietary Limited will be held at the office of the Institute of Chartered Accountants, 23 McKillop-street, Melbourne, on Friday, the 30th August, 1968, at 2.30 p.m. for the purpose of considering the company's affairs, the company having convened an Extraordinary General Meeting of its Members to be held on the same day and for the purpose of considering and if thought fit passing the following Special Resolution:—

"That it has been proved to the satisfaction of this meeting that the company cannot, by reason of its liabilities, continue its business, and that it is advisable to wind up the company and accordingly that the same be wound up voluntarily."

Upon appointment of a liquidator it will then be necessary to fix the remuneration of the proposed liquidator.

An individual or a member of a partnership may attend and vote personally whilst a company may be represented personally by a Director, the Manager or Secretary, but in all other cases the proxy must be completed and lodged with the company prior to the meeting.

A form of proxy is attached.

Dated this 6th day of August, 1968.

By order of the Board,

4230

C. EDGE, Director.

In the Supreme Court of Victoria, 1968, Coy. No. 7556.—

In the matter of the Companies Act 1961, and in the matter of AUTOPRINT PROPRIETARY LIMITED.

NOTICE is hereby given that a petition for the winding up of the above-named company by the Supreme Court was, on the 5th day of August, 1968, presented by Mojzis Jakubovic. And that the said petition is directed to be heard before the Court sitting at Melbourne, at the hour of 10.30 o'clock in the forenoon on the 2nd day of September, 1968; and any creditor or contributory of the said company desiring to support or oppose the making of an order on the said petition may appear at the time of the hearing by himself or his counsel for that purpose; and a copy of the petition will be furnished to any creditor or contributory of the said company requiring the same by the undersigned on payment of the regulated charge for same.

The petitioner's address is 18 Ellesmere-road, Windsor.

The petitioner's solicitors are Messrs. Jack Cohen, Marks & Co., of 224 Queen-street, Melbourne.

JACK COHEN, MARKS & CO.

NOTE.—Any person who intends to appear on the hearing of the said petition must serve on or send by post to the above-named solicitors notice, in writing, of his intention so to do. The notice must state the name and address of the person, or, if a firm, the name and address of the firm, and must be signed by the person or firm, or his or their solicitor (if any) and must be served, or, if posted, must be sent by post in sufficient time to reach the above named not later than 4 o'clock in the afternoon of the 30th day of August, 1968.

4242

THE NORTHCOTE THEATRE COMPANY PTY. LTD. (IN VOLUNTARY LIQUIDATION).

NOTICE is hereby given, in pursuance of section 272 of the Companies Act 1961, that a Final General Meeting of the members of the above-named company will be held at the Rivoli Theatre, 200 Camberwell-road, Hawthorn East, Victoria, on Thursday, 19th September, 1968, at 11 a.m., for the purpose of having an account laid before them showing the manner in which the winding up has been conducted and the property of the company disposed of.

4209

F. H. TADGELL, Liquidator.

THE MODERN HOME CO-OPERATIVE HOUSING SOCIETY LIMITED (IN LIQUIDATION).

TAKE notice that the affairs of the above-named society are now fully wound up and that, in pursuance of section 272 (1) of the Companies Act 1961 and of the Co-operative Housing Societies Act 1958, a General Meeting of the society will be held at 342A St. Kilda-road, Melbourne, on the 19th day of September, 1968, at 5.30 p.m. for the purpose of—

- (1) Laying before it an account showing how the winding up has been granted and the property of the society disposed of and giving explanations thereof; and
- (2) Passing a Resolution that the books and papers of the said and of the liquidator relevant to the affairs of the society be destroyed after a period of twelve months from the date of the meeting.

Dated the 12th day of August, 1968.

4198

I. E. BYAM-WIGHT, Liquidator.

In the Supreme Court of Victoria 1968—C.O.7537.—In the matter of the Companies Act 1961 and in the matter of TRIACAS' PTY. LIMITED.

NOTICE is hereby given that a petition for the winding up of the above-named company by the Supreme Court was, on the 4th day of July, 1968, presented by James Canny, Deputy Commissioner of Taxation of the Commonwealth of Australia, and that the said petition is directed to be heard before the Court sitting at the Fourteenth Court, Law Courts, William-street, Melbourne, at the hour of 10.30 o'clock in the forenoon on the 26th day of August, 1968, and any creditor or contributory of the said company desiring to support or oppose the making of an order on the said petition may appear at the time of hearing by himself or his counsel for that purpose; and a copy of the said petition will be furnished to any creditor or contributory of the said company requiring the same by the undersigned on payment of the regulated charge for the same.

The petitioner's official address is 436 Lonsdale-street, Melbourne.

The petitioner's solicitor is Harold Edward Renfree, Crown Solicitor for the Commonwealth, of 99 Queen-street, Melbourne.

H. E. RENFREE.

NOTE.—Any person who intends to appear on the hearing of the said petition must serve on or send by post to the above-named H. E. Renfree notice in writing of his intention so to do. The notice must state the name and address of the person, or, if a firm, the name and address of the firm, and must be signed by the person or firm, or his or their solicitor (if any), and must be served or, if posted, must be sent by post in sufficient time to reach the above named not later than 4 o'clock in the afternoon of the 23rd day of August, 1968. 4241

Companies Act 1961, Section 254 (2) (b).

HUME HOLDINGS PROPRIETARY LIMITED.

NOTICE is hereby given that at an Extraordinary General Meeting of the above-named company duly convened and held at 29 Canterbury-road, Canterbury, on Thursday, 8th August, 1968, the following Special Resolution was duly passed:—

"That the company be wound up as a members' voluntary winding up and that Rex Stanley Prime, of 330 Collins-street, Melbourne, be appointed liquidator for such purpose, and that the liquidator be authorized to distribute in specie the whole or part of the assets of the company."

Dated this 12th day of August, 1968.

4233

R. S. PRIME, Liquidator.

The Companies Act 1961.—In the matter of AJAX CONSTRUCTIONS PTY. LTD.

NOTICE is hereby given that at an Extraordinary General Meeting of the members of the above-named company, held on the 31st day of July, 1968, it was resolved that the company be wound up voluntarily, and at a meeting of creditors held on the same day, pursuant to section 260, it was resolved that for such purpose Mr. Alex Neville Bird, of 289 Flinders-lane, Melbourne, accountant, be appointed liquidator.

Notice is also given that after 21 days from this date I shall proceed to distribute the assets. All creditors having any claims against the company should furnish particulars of same by that date otherwise I shall proceed to distribute the assets without regard to their claim.

Dated this 12th day of August, 1968.

A. NEVILLE BIRD, Liquidator.

A. Neville Bird & Co., chartered accountants, 289 Flinders-lane, Melbourne, 3000. 4239

The Companies Act 1961.

PETER GREENLAW PROPRIETARY LIMITED (IN LIQUIDATION).

NOTICE CONVENING FINAL MEETING OF MEMBERS AND CREDITORS, PURSUANT TO SECTION 272.

NOTICE is hereby given, pursuant to section 272 of the Companies Act 1961, that a General Meeting of the members and creditors of the above-named company will be held in the offices of Kennedy, Smail & Middlemiss, 296-304 Little Lonsdale-street, Melbourne, on Wednesday, the 11th day of September, 1968, at 10.30 a.m., for the purpose of having an account laid before them showing the manner in which the winding up has been conducted and the property of the company disposed of, and of hearing any explanations that may be given by the liquidator.

Dated this 7th day of August, 1968.

NORMAN ERIC STRETTON, Liquidator.

Kennedy, Smail & Middlemiss, 296-304 Little Lonsdale-street, Melbourne, 3000. 4211

In the matter of MONTBELL INVESTMENTS PROPRIETARY LIMITED.—Notice of Winding-up Order.

WINDING-UP Order made 9th August, 1968.

Name and address of official liquidator: Mr. Everett Thomson Bent, of Suite 18, 545 St. Kilda-road, Melbourne.

JAMES CANNY, Deputy Commissioner of Taxation of the Commonwealth of Australia, Petitioner. 4238

In the matter of FINCH ESTATES PROPRIETARY LIMITED.—Notice of Winding-up Order.

WINDING-UP Order made 9th August, 1968.

Name and address of official liquidator: Mr. Everett Thomson Bent, of Suite 18, 545 St. Kilda-road, Melbourne.

JAMES CANNY, Deputy Commissioner of Taxation of the Commonwealth of Australia, Petitioner. 4240

TOINETTE HUGO AIRD HOUGHTON, late of Flat 2, 123 Domain-road, South Yarra, widow, DECEASED.

CREDITORS, next of kin and others having claims in respect of the estate of the deceased (who died on the 16th day of June, 1968) are required by The Trustees, Executors and Agency Company Limited, of 401 Collins-street, Melbourne, to send particulars of their claims to the said company, by the 18th day of October, 1968, after which date it will convey or distribute the assets, having regard only to the claims of which it then has notice.

RUSSELL, KENNEDY & COOK, solicitors, 401 Collins-street, Melbourne. 4207

HAROLD JENKINS, late of Derrinallum, labourer, DECEASED.

CREDITORS, next of kin and others having claims in respect of the estate of the above-named deceased (who died on the 9th day of June, 1968), are required by the executor, William Oman Oman, of 32 Aphrasia-street, Newtown, Geelong, retired grazier, to send particulars to him, care of the under-mentioned solicitors, by the 18th day of October, 1968, after which date he may convey or distribute the assets, having regard only to the claims of which he shall then have had notice.

ARTHUR E. GEORGE & SONS, solicitors; 202 Manifold-street, Camperdown. 4163

ELSIE GORDON CHALLIS, late of 83 Valley-road,
Highton, widow, DECEASED.

CREDITORS, next of kin and others having claims in respect of the estate of the said deceased (who died 2nd June, 1968) are required by the applicants for grant of probate of the will, Patricia Ling, of Barwon Heads, married woman, and Nancy Margaret Challis, of Connewarre, widow, to send particulars to them, care of the undersigned solicitors, by 23rd October, 1968, after which date the said applicants may convey or distribute the assets, having regard only to the claims of which they then have notice.

WIGHTON & McDONALD, solicitors, 89 Myers-street,
Geelong. 4189

CREDITORS, next of kin and others having claims in respect of the estate of Bertha Augusta Jones, formerly of 25 Finlayson-street, Malvern, in the State of Victoria, but late of The Queen Elizabeth Home, 102 Ascot-street, Ballarat, in the said State, widow, deceased (who died on the 11th day of April, 1968), are to send the particulars of their claims to The Equity Trustees, Executors and Agency Company Limited, of 472 Bourke-street, Melbourne, in the said State, by the 25th day of October, 1968, after which date it will distribute the assets, having regard only to the claims of which it then has notice.

Dated the 9th day of August, 1968.

BOOTHBY & BOOTHBY, solicitors, 883 Dandenong-
road, Caulfield East. 4199

CREDITORS, next of kin and others having claims in respect of the estate of Millicent Florence Chapple, formerly of 29 Rowell-avenue, but late of "Broughton Hall", Camberwell, saleswoman, deceased (who died on the 14th day of May, 1968), are to send particulars of their claims to The Union-Fidelity Trustee Company of Australia Limited, of 100 Exhibition-street, Melbourne, by the 15th day of October, 1968, after which date the said executor will distribute the assets in the said estate, having regard only to the claims of which it then has notice.

FENTON, DUNN & BRUCE, solicitors, 422 Collins-street,
Melbourne. 4200

CREDITORS, next of kin and others having claims in respect of the estate of John McGill Carson, late of 30 Stephen-street, Newtown, Geelong, in the State of Victoria, grazier, deceased (who died on the 5th day of June, 1968), are required by the executors, Alexander Herbert McMillan, of "The Falls", Inverleigh, in the said State, and John Leslie Parker, of Sutherlands Creek, Bannockburn, in the said State, graziers, to send particulars of their claims to them, care of the under-mentioned solicitors, by the 15th day of October, 1968, after which date they may convey or distribute the assets, having regard only to the claims of which they then have notice.

AITKEN, WALKER & STRACHAN, solicitors, 414
Collins-street, Melbourne. 4201

CREDITORS, next of kin and others having claims in respect of the estate of Hazel Alice Macfarlan, formerly of "Avon Court", 55 Alma Road-street, St. Kilda, but late of Flat 9, 21 Florence-street, Mentone, in the State of Victoria, spinster (who died on the 22nd day of April, 1968), are to send particulars of their claims to the Equity Trustees, Executors and Agency Company Limited, at their registered office, at 472 Bourke-street, Melbourne, in the said State, the trustee of the will of the said Hazel Alice Macfarlan, by the 10th day of October, 1968, after which date it will distribute the assets, having regard only to the claims of which it then has notice.

PRICE & CHAMBERLIN, solicitors, 443 Little Collins-
street, Melbourne. 4202

CREDITORS, next of kin and others having claims in respect of the estate of Catherine Jessie Wright, formerly of 289 but late of 282 Springfield-road, Blackburn, widow, deceased (who died on the 8th November, 1967), are to send particulars of their claims to the executors, Geoffrey James Wright and David William Wright, care of the undersigned solicitors, by the 5th October, 1968, after which date they will distribute the assets, having regard only to the claims of which they then have notice.

HALL & WILCOX, solicitors, 20 Queen-street, Melbourne.
4204

CREDITORS, next of kin and others having claims in respect of the estate of Clement Mary Larcher, formerly of 36 The Esplanade, Mornington, late of 60 Liberty-parade, West Ivanhoe, widow, deceased (who died on the 3rd May, 1968), are to send particulars of their claims to the executor, Vincent Leonard Cox, care of the undersigned solicitors, by the 5th October, 1968, after which date he will distribute the assets, having regard only to the claims of which he then has notice.

HALL & WILCOX, solicitors, 20 Queen-street, Melbourne.
4205

CREDITORS, next of kin and others having claims in respect of the estate of Agnes Valerie Mason, late of "Strathdon", Jolimont-road, Forest Hill, spinster, deceased (who died on the 9th December, 1967), are to send particulars of their claims to the executors, Frank Gavin Mason, James Valentine Mason and Edgar Mervyn Harris, care of the undersigned solicitors, by the 5th October, 1968, after which date they will distribute the assets, having regard only to the claims of which they then have notice.

HALL & WILCOX, solicitors, 20 Queen-street, Melbourne.
4206

CREDITORS, next of kin and all other persons having any claims in respect of the estate of Doris Leith, late of Flat 2, 7 Park-avenue, Glenhuntly, married woman, deceased (who died on the 17th day of May, 1968), are required to send particulars of their claims to the executor, The Trustees, Executors and Agency Company Limited, of 401 Collins-street, Melbourne, by the 23rd day of October, 1968, after which date the said executor will distribute the assets of the said deceased, having regard to the claims of which it shall then have had notice.

HULBERT A. GREENING & BENNETT, of 422 Collins-
street, Melbourne, solicitors. 4237

HAROLD DONALD PUGH, late of 156 Kerferd-road,
Albert Park, retired postmaster, DECEASED.

CREDITORS, next of kin and others having claims in respect of the estate of the deceased (who died on the 17th day of May, 1968), are required by the executor of his will, Victor Albert Pugh, of 51 Tibrockney-street, Highett, to send particulars thereof to him, care of the under-mentioned solicitor, by the 15th day of October, 1968, after which date he will distribute the assets, having regard only to the claims of which he then has notice.

L. G. EGAN, solicitor, 20 Bendigo-avenue, Elwood. 4215

STELLA HOLMES, formerly of 18 Westgarth-street, East Malvern, and 109 Hotham-street, East St. Kilda, but late of 88 Middlesex-road, Surrey Hills, in the State of Victoria, married woman, DECEASED.

CREDITORS, next of kin and others having claims in respect of the estate of the above-named deceased (who died on the 29th April, 1968), are required by the executor of the said deceased's will, Ernest Henry Holmes, of 88 Middlesex-road, Surrey Hills, gentleman, to send particulars to him by the 16th October, 1968, after which date the executor may convey or distribute the assets of the estate, having regard only to the claims of which they may have notice.

KEITH A. NESS & SON, solicitors, 411 Collins-street,
Melbourne. 4214

WALTER COOK, late of Nandaly in the State of Victoria,
farmer, DECEASED.

CREDITORS, next of kin and other persons having claims against the estate of the said deceased (who died on the 19th day of May, 1968), are required to send particulars of same to the executor, Walter John Francis Cook, in care of the undersigned, on or before the 25th day of October, 1968, after which date they will distribute the assets, having regard only to the claims of which they then have notice.

DELANY & DWYER, barristers and solicitors, 201
Campbell-street, Swan Hill. 4219

CREDITORS, next of kin and others having claims in respect of the estate of Ruby Berry Wilson, late of 3 Arthur-street, Dromana, widow, deceased (who died on the 6th of August, 1967), are to send particulars of their claims to Godfrey Nelson Wilson and Miriam Berry Bendix, the executors, in care of the undersigned, on or before the 15th day of October, 1968, after which date they will distribute the assets, having regard only to the claims of which they then have notice.

EVANS, GUSS & HOLT, solicitors, 421 Bourke-street,
Melbourne, 3000. 4228

MARJORY RAFF, late of 131A Dalgetty-road, Beaumaris, widow, DECEASED.

CREDITORS, next of kin and others having claims in respect of the estate of the deceased (who died on the 24th day of May, 1968), are required by The Trustees, Executors and Agency Company Limited, of 401 Collins-street, Melbourne, to send particulars of their claims to the said company by the 21st day of October, 1968, after which date it may convey or distribute the assets, having regard only to the claims of which it shall then have had notice.

DUGDALE, DIMMICK & STEVENS, solicitors, 37 Queen-street, Melbourne. 4220

WILLIAM JAMES TRURAN, late of 416 Queens-parade, North Fitzroy, gentleman, DECEASED.

CREDITORS, next of kin and others having claims in respect of the estate of the deceased (who died on the 24th day of May, 1968), are required by Dulcie Maud Soler, of 10 Railway-place, Preston, and Valerie Bell, of 42 Primula-street, Blackburn, married woman, to send particulars of their claims to the said executors, care of Dugdale, Dimmick & Stevens, 37 Queen-street, Melbourne, solicitors, by the 21st day of October, 1968, after which date they may convey or distribute the assets, having regard only to the claims of which they shall then have had notice.

DUGDALE, DIMMICK & STEVENS, solicitors, 37 Queen-street, Melbourne. 4221

CYRIL CAHILL ROBINSON, late of Tarneit, farmer and grazier, DECEASED.

CREDITORS, next of kin and others having claims in respect of the estate of the deceased (who died on the 24th day of April, 1968), are required by Henry Parkes Robinson, of East-street, Woodend, investor, and Douglas Ernest Robinson, of Mahoney-road, Woodend, farmer, to send particulars of their claims to the said executors, care of Dugdale, Dimmick & Stevens, 37 Queen-street, Melbourne, solicitors, by the 21st day of October, 1968, after which date they may convey or distribute the assets, having regard only to the claims of which they shall then have had notice.

DUGDALE, DIMMICK & STEVENS, solicitors, 37 Queen-street, Melbourne. 4222

EDWARD ERNEST ROBERTSON, late of 6 Macedon-street, Sunbury, retired grazier, DECEASED, intestate.

CREDITORS, next of kin and others having claims in respect of the estate of the deceased (who died on the 2nd day of March, 1968), are required by Elsie Myrtle May Robertson, of 6 Macedon-street, Sunbury, widow, to send particulars of their claims to the said administrator, Elsie Myrtle May Robertson, care of Dugdale, Dimmick & Stevens, 37 Queen-street, Melbourne, solicitors, by the 21st day of October, 1968, after which date she may convey or distribute the assets, having regard only to the claims of which she shall then have had notice.

DUGDALE, DIMMICK & STEVENS, solicitors, 37 Queen-street, Melbourne. 4223

CREDITORS, next of kin and others having claims in respect of the estate of Reuben Arthur Maguire, late of 36 Reed-street, Albert Park, clerk, deceased, intestate (who died on 18th day of December, 1967), are to send particulars of their claims to Norma Bennett, care of the under-mentioned solicitors, by 14th day of October, 1968, after which date she will distribute the assets, having regard only to the claims of which she then has notice.

W. CAREW & CO., solicitors, 224 Queen-street, Melbourne. 4224

OSCAR LEONARD KELLER, formerly of Peake in the State of South Australia, but late of Swan Hill in the State of Victoria, farmer, DECEASED.

CREDITORS, next of kin and other persons having claims against the estate of the said deceased (who died on the 31st day of May, 1967), are required to send particulars of same to the administrator, Herbert Frederick Keller, in care of the undersigned, on or before the 18th day of October, 1968, after which date they will distribute the assets, having regard only to the claims of which they then have notice.

DELANY & DWYER, barristers and solicitors, 201 Campbell-street, Swan Hill. 4217

No. 70.—7378/68.—4

CREDITORS, next of kin and others having claims in respect of the estate of Robert Clark, late of 4 Connor-street, East Brighton, retired gentleman (who died on the 26th October, 1967), are required by the administrator, Joseph Clark, of 12 Charlton-street, East Bentleigh, gentleman, to send particulars of their claims to him, care of the under-mentioned solicitors, by the 14th November, 1968, after which date the administrator will distribute the assets, having regard only to the claims of which he then will have notice.

ARCHER SHULMAN & CO., solicitors, 406 Lonsdale-street, Melbourne. 4166

CREDITORS, next of kin and other persons having claims against the estate of Clarence James Royle, late of 24 Pyke-street, Bairnsdale, gentleman, deceased (who died on the 23rd day of October, 1967), are required to send particulars of their claims to the administrator, The Union-Fidelity Trustee Company of Australia Limited, whose registered office is situated at 100 Exhibition-street, Melbourne, by the 21st day of October, 1968, after which date the administrator will distribute the assets, having regard only for the claims of which it then has had notice.

WARREN, GRAHAM & MURPHY, 96 Main-street, Bairnsdale. 4170

JOHN CLARENCE LOONEY, late of Meatian, in the State of Victoria, railway employee, DECEASED.

CREDITORS, next of kin and other persons having claims against the estate of the said deceased (who died on the 24th day of February, 1968), are required to send particulars of same to the administratrix, Lillian May Daphne Looney, in care of undersigned, on or before the 11th day of October, 1968, after which date they will distribute the assets, having regard only to the claims of which they then have notice.

DELANY & DWYER, barristers and solicitors, 201 Campbell-street, Swan Hill. 4218

CREDITORS, next of kin and others having claims in respect of the estate of Newton Allen, late of 94 Stanhill-drive, Chevron Island, Surfers Paradise, in the State of Queensland, gentleman, deceased (who died on the 7th day of May, 1967), are required to send particulars of their claims to the executor, National Trustees, Executors and Agency Company of Australasia Limited, of 95 Queen-street, Melbourne, before the 21st day of October, 1968, after which date the executor will distribute the assets, having regard only to the claims of which it then has had notice.

BRENDAN MCGUINNESS & CO., solicitors, 118 Queen-street, Melbourne. 4226

CREDITORS, next of kin and others having claims in respect of the estate of Constance Eva Cooney, late of 4 Park-street, South Melbourne, widow, deceased (who died on the 4th day of January, 1968), are to send particulars of their claims to the executor, the Public Trustee, of 256 Flinders-street, Melbourne, by the 16th day of October, 1968, after which date the executor will distribute the estate, having regard only to the claims of which he then has notice.

VIRGIL B. GILL, KANE & CO., of 450 Little Collins-street, Melbourne, solicitors. 4227

CREDITORS, next of kin and others having claims in respect of the estate of Albert Edward Smith, late of 293 Oxford-road, Croydon, company director, deceased (who died on the 1st July, 1967), are required to send particulars of their claims to the executors, Edmund Lloyd Smith and Albert Howard Smith, care of the under-mentioned solicitors, not later than 21st October, 1968, after which date the executors will distribute the assets, having regard only to the claims of which they then have notice.

KIDDLE, BRIGGS & WILLOX, 400 Collins-street, Melbourne, solicitors. 4243

ELFIE MAY GUENTHER, late of 6 Allenby-road, Canterbury, in the State of Victoria, widow, DECEASED (died 19th May, 1968).

CREDITORS, next of kin and others having claims against the estate specified above are required to send particulars in writing of such claims to the personal representatives of such estate, in care of Messrs. Morrison & Teare, solicitors, Numurkah, on or before the 6th of November, 1968, after which date the assets of the estate will be conveyed or distributed among the persons entitled thereto, having regard only to the claims to which the representatives shall then have had notice.

4161

CREDITORS, next of kin and others having claims in respect of the estate of Benjamin James Finch, late of 6 Bertha-street, Springvale, retired inspector (who died on the 30th June, 1968), are to send particulars of their claims to Robert Andrew Pitt, care of R. P. Barrett & Son, solicitors, 473 Bourke-street, Melbourne, on or before, the 14th day of October, 1968, after which date he will distribute the assets, having regard only to the claims of which he then has notice.

R. P. BARRETT & SON, solicitors, 473 Bourke-street, Melbourne. 4244

IVY ROBINS, late of 5 Rosamond-street, Balaclava, in the State of Victoria, widow, DECEASED.

CREDITORS, next of kin and others having claims in respect of the estate of the deceased (who died on the 17th day of February, 1968) are to send particulars of their claims to the executor, Ronald William Edwards, care of the undersigned solicitors, by the 18th day of October, 1968, after which date he will proceed to distribute the estate, having regard only to the claims of which he then has notice.

HADEN SMITH & FITCHETT, solicitors, 405 Collins-street, Melbourne. 4203

NOTICE TO CLAIMANTS.

(WHERE COMPANY IS SOLELY CONCERNED.)

FANNY AGNES COURTNEY, late of 4 Moore-street, South Caulfield, in the State of Victoria, home duties, DECEASED.

CREDITORS, next of kin and others having claims in respect of the estate of the deceased (who died on the 18th day of April, 1968), are required by The Perpetual Executors and Trustees Association of Australia Limited, of 100-104 Queen-street, Melbourne, to send particulars of their claims to the said company, by the 23rd day of October, 1968, after which date it will convey or distribute the assets, having regard only to the claims of which the company then has notice.

NORMAN LANDAU & FRANKEL, 415 Bourke-street, Melbourne. 4245

CREDITORS, next of kin and others having claims in respect of the estate of Mary Agar Richardson, formerly of Mayfair, Marne-street, South Yarra, 18 Malvern-road, Malvern, and 11 Fairlie-court, South Yarra, married woman, but late of 20 Fairlie-court, South Yarra, widow, deceased (who died on the 7th day of April, 1968), are to send the particulars of their claims to Geoffrey Agar Richardson, and James Nicholson Richardson, and the Union-Fidelity Trustee Company of Australia Limited, in care of the said company, at 100 Exhibition-street, Melbourne, by the 17th October, 1968, after which date they will distribute the assets, having regard only to the claims of which they then have notice.

MIDDLETONS, solicitors, 224 Queen-street, Melbourne. 4225

IMPOUNDINGS

FOSTER.—Impounded in Foster Pound from Agnes, on 7th August, 1968.

23 crossbred wethers, no visible brands

If not claimed and expenses paid, to be sold on 30th August, 1968.

4246—\$1.75 I. MORRIS, Poundkeeper.

SHEPPARTON.—Impounded in Shepparton Pound.

1 large white sow, no visible brand

If not claimed and expenses paid to be sold on 28th August, 1968.

4247—\$1.50 C. L. MANSELL, Poundkeeper.

SWAN HILL.—Impounded in Swan Hill Pound, from the Swan Hill Saleyards on the 1st August, 1968.

1 Friesian heifer, no visible brand
1 roan and white steer, nick from left ear, no visible brand
1 red and white heifer, nick from right ear, no visible brand
1 red and white steer, nick from right ear, no visible brand
1 red and white heifer, no visible brand
1 red and white heifer, nicks from both ears, no visible brand

If not claimed and expenses paid, to be sold on 26th August, 1968.

4187—\$3.25 F. G. BLAIR, Poundkeeper.

WHITTLESEA.—Impounded in Epping Pound by Ranger.

1 black and white Friesian bull, no visible brand

If not claimed and expenses paid, to be sold on 30th August, 1968.

4232—\$1.50 W. HERD, Poundkeeper.

Subordinate Legislation Act 1962.

NOTICE OF MAKING OF STATUTORY RULES.

IN pursuance of the provisions of the *Subordinate Legislation Act 1962* and the Regulations made thereunder, notice is given of the making of the following statutory rules:—

No.		Price.
	<i>Adoption of Children Act 1964;</i>	
	<i>Supreme Court Act 1958.</i>	
157/1968.	Adoption of Children Rules 1968	15c
	<i>Second-hand Dealers Act 1958.</i>	
190/1968.	Second-hand Dealers (Exemption No. 7) Regulations 1968	10c
	<i>Motor Boating Act 1961.</i>	
191/1968.	Motor Boating (Altona and Williamstown Speed Restrictions) Regulations 1968	10c
	<i>Inflammable Liquids Act 1966.</i>	
192/1968.	Inflammable Liquids (Amendment No. 1) Regulations 1968	10c
	<i>Liquified Petroleum Gas Act 1958.</i>	
193/1968.	Liquified Petroleum Gas (Amendment No. 1) Regulations 1968	15c
	<i>Seeds Act 1958.</i>	
194/1968.	Seeds (Pasture Seed Certification) (Amendment) Regulations 1968	10c
	<i>Drought Relief Act 1968.</i>	
195/1968.	Drought Relief Act (Additional Drought Relief Areas) Regulations 1968	10c

Copies of these statutory rules may be purchased at the Sale of Publications Section of the Government Printing Office, located at Macarthur-street, Melbourne, 3002. If ordered by mail, remittance should be addressed to "The Government Printer, Box 203, P.O., North Melbourne, 3051", and should include 5c extra for postage. If a credit account is held at this office, no remittance is required with the mail order.

The annual subscription rate for Statutory Rules (including a Bound Volume) is \$15, payable in advance. The subscription year commences on 1st January.

A. C. BROOKS,
Government Printer.

ACTS REPRINTED IN ACCORDANCE WITH THE AMENDMENTS INCORPORATION ACT 1958 (No. 6422), AND FOR SALE AT THE SALE OF PUBLICATIONS BRANCH OF THE GOVERNMENT PRINTING OFFICE, MACARTHUR-STREET, MELBOURNE, 3002.

(These prices do not include postage.)

No		Price
6189.	Acts Interpretation (Incorporating amendments up to No. 7146)	\$0.15
6191.	Administration and Probate (Third Reprint—Incorporating amendments up to No. 7332)	\$0.38
6194.	Agricultural Colleges (First Reprint—Incorporating amendments up to No. 7302)	\$0.15
7117.	Appeal Costs Fund Act 1964 (First Reprint—Incorporating amendments up to No. 7488)	\$0.25
6199.	Apprenticeship (First Reprint—Incorporating amendments up to No. 7312)	\$0.25
6203.	Audit (First Reprint—incorporating amendments up to No. 7377)	\$0.35
6209.	Boiler Inspection (Incorporating amendments up to No. 7072)	\$0.18
6210.	Building Societies (Incorporating amendments up to No. 7125)	\$0.25
6218.	Children's Court (Incorporating amendments up to No. 7084)	\$0.20
6219.	Children's Welfare (Second Reprint—Incorporating amendments up to No. 7084)	\$0.35

ACTS REPRINTED IN ACCORDANCE WITH THE AMENDMENTS
INCORPORATION ACT 1958 (No. 6422)—*continued*.

No.	Price.
6220. Clean Air (Incorporating amendments up to No. 6886)	\$0.10
6222. Commercial Goods Vehicles (<i>Second Reprint</i> —Incorporating amendments up to No. 7358)	\$0.22
6839. Companies Act 1961 (<i>Second Reprint</i> —Incorporating amendments up to No. 7332)	\$2.32
6225. Co-operation (<i>Second Reprint</i> —Incorporating amendments up to No. 7083)	\$0.42
6226. Co-operative Housing Societies (Incorporating amendments up to No. 7097)	\$0.40
6228. Country Fire Authority (<i>Second Reprint</i> —Incorporating Amendments up to No. 7476)	\$0.50
6229. Country Roads (<i>Second Reprint</i> —Incorporating Amendments up to No. 7506)	\$0.60
6230. County Court Act (<i>First Reprint</i> —Incorporating amendments up to No. 7420)	\$0.35
6231. Crimes (<i>Second Reprint</i> —Incorporating amendments up to No. 7407)	\$1.33
7060. Dandenong Valley Authority Act 1963 (<i>First Reprint</i> —Incorporating amendments up to No. 7523)	\$0.35
6236. Dog (<i>Second Reprint</i> —Incorporating amendments up to No. 7065)	\$0.15
6239. Dried Fruits Act 1968 (<i>First Reprint</i> —Incorporating amendments up to No. 7337)	\$0.25
6240. Education (<i>First Reprint</i> —Incorporating amendments up to No. 7533)	\$0.45
6241. Electric Light and Power (<i>First Reprint</i> —Incorporating amendments up to No. 7315)	\$0.30
6242. Employers and Employés (Incorporating amendments up to No. 6740)	\$0.18
6243. Entertainments Tax (<i>First Reprint</i> —Incorporating amendments up to No. 7315)	\$0.25
6245. Estate Agents Act (<i>Third Reprint</i> —Incorporating amendments up to No. 7425)	\$0.50
6246. Evidence (<i>Second Reprint</i> —Incorporating amendments up to No. 7366)	\$0.42
6249. Fences (Incorporating amendments up to No. 6550)	\$0.12
6250. Fertilizers (Incorporating amendments up to No. 7142)	\$0.25
6251. Firearms (<i>Second Reprint</i> —Incorporating amendments up to No. 7484)	\$0.40
6252. Fisheries Act (<i>First Reprint</i> —Incorporating amendments up to No. 7389)	\$0.35
6916. Foreign Judgments Act 1962 (<i>First Reprint</i> —including amendments made by No. 7332)	\$0.15
6585. Forests (Pulpwood Agreement) (Incorporating amendments up to No. 6886)	\$0.15
6254. Forests (<i>First Reprint</i> —Incorporating amendments up to No. 7356)	\$0.60
6256. Fruit and Vegetables (<i>First Reprint</i> —incorporating amendments up to No. 6944)	\$0.30
6258. Game—(<i>First Reprint</i> —Incorporating amendments up to No. 7389)	\$0.30
6259. Gaols (Incorporating amendments up to No. 6651)	\$0.15
6261. Gas Regulation (<i>First Reprint</i> —Incorporating amendments up to No. 7580)	\$0.30
6262. Geelong Harbor Trust (<i>First Reprint</i> —Incorporating amendments up to No. 7547)	\$0.45
6263. Geelong Waterworks and Sewerage (<i>First Reprint</i> —Incorporating amendments up to No. 7547)	\$0.75
6265. Goods (<i>Third Reprint</i> —Incorporating amendments up to No. 7131)	\$0.35
6266. Grain Elevators (<i>First Reprint</i> —Incorporating amendments up to No. 7486)	\$0.35
6270. Health (<i>Second Reprint</i> —Incorporating amendments up to No. 7490)	\$1.65
6933. Home Finance Act 1962 (<i>First Reprint</i> —Incorporating amendments up to No. 7363)	\$0.25
6274. Hospitals and Charities (<i>Second Reprint</i> —Incorporating amendments up to No. 7455)	\$0.50
6275. Housing (<i>First Reprint</i> —Incorporating amendments up to No. 7507)	\$0.85
6279. Instruments (<i>Third Reprint</i> —Incorporating amendments up to No. 7315)	\$0.38
6282. Justices (<i>Second Reprint</i> —Incorporating amendments up to No. 7369)	\$1.23
6283. Labour and Industry (<i>Third Reprint</i> —Incorporating amendments up to No. 7410)	\$1.00
6284. Land (Incorporating amendments up to No. 7360)	\$1.53
6534. Land Settlement Act 1959 (<i>First Reprint</i> —Incorporating amendments up to No. 7328)	\$0.30
6289. Land Tax (<i>Second Reprint</i> —Incorporating amendments up to No. 7466)	\$0.40

ACTS REPRINTED IN ACCORDANCE WITH THE AMENDMENTS
INCORPORATION ACT 1958 (No. 6422)—*continued*.

No.	Price.
6285. Landlord and Tenant (<i>Second Reprint</i> —Incorporating amendments up to No. 6996)	\$0.50
6286. Lands Compensation—(<i>First Reprint</i> —incorporating amendments up to No. 7332)	\$0.25
6290. Latrobe Valley (<i>First Reprint</i> —Incorporating amendments up to No. 7332)	\$0.35
6291. Legal Profession Practice (<i>Second Reprint</i> —Incorporating amendments up to No. 7539)	\$0.70
6295. Limitation of Actions (<i>Second Reprint</i> —Incorporating amendments up to No. 7457)	\$0.25
6298. Local Authorities Superannuation (Incorporating amendments up to No. 6894)	\$0.25
6299. Local Government (Incorporating amendments up to No. 7052)	\$3.50
6302. Marine (Incorporating amendments up to No. 7350)	\$0.72
6304. Marketing of Primary Products (<i>First Reprint</i> —Incorporating amendments up to No. 7491)	\$0.45
6306. Marriage (<i>First Reprint</i> —Incorporating amendments up to No. 6959)	\$0.25
6309. Medical (<i>Second Reprint</i> —Incorporating amendments up to No. 7408)	\$0.40
6310. Melbourne and Metropolitan Board of Works (<i>Second Reprint</i> —Incorporating amendments up to No. 7547)	\$1.10
6312. Melbourne Harbor Trust (<i>First Reprint</i> —Incorporating amendments up to No. 7356)	\$0.48
6605. Mental Health (Incorporating amendments up to No. 7135)	\$0.45
6315. Metropolitan Fire Brigades (Incorporating amendments up to No. 6886)	\$0.28
6316. Mildura Irrigation and Water Trusts (<i>First Reprint</i> —Incorporating amendments up to No. 7448)	\$0.75
6317. Milk and Dairy Supervision (Incorporating amendments up to No. 6964)	\$0.40
6318. Milk Board (Incorporating amendments up to No. 7093)	\$0.22
6320. Mines (<i>First Reprint</i> —Incorporating amendments up to No. 7499)	\$1.90
6184. Monash University (<i>First Reprint</i> —Incorporating amendments up to No. 7533)	\$0.30
6324. Money Lenders (Incorporating amendments up to No. 6886)	\$0.25
6832. Motor Boating (Incorporating amendments up to No. 6961)	\$0.15
6325. Motor Car (<i>Second Reprint</i> —Incorporating amendments up to No. 7361)	\$0.82
6326. National Parks (Incorporating amendments up to No. 7275)	\$0.25
6328. Nurses (Incorporating amendments up to No. 6716)	\$0.20
6330. Partnership (<i>Second Reprint</i> —Incorporating amendments up to No. 7315)	\$0.25
6331. Patriotic Funds (<i>First Reprint</i> —Incorporating amendments up to No. 7338)	\$0.25
6257. Pesticides Act 1968 (<i>First Reprint</i> —Incorporating amendments up to No. 7595)	\$0.15
6889. Poisons Act 1962 (<i>Second Reprint</i> —Incorporating amendments up to No. 7588)	\$0.50
6337. Police Offences (Incorporating amendments up to No. 7145)	\$0.82
6338. Police Regulation (Incorporating amendments up to No. 7081)	\$0.45
6340. Portland Harbor Trust (<i>First Reprint</i> —Incorporating amendments up to No. 7475)	\$0.35
6341. Pounds (<i>First Reprint</i> —Incorporating amendments up to No. 7315)	\$0.25
6890. Probate Duty (Incorporating amendments up to No. 6970)	\$0.38
6344. Property Law (Incorporating amendments up to No. 6867)	\$0.90
6349. Public Service (<i>Second Reprint</i> —Incorporating amendments up to No. 7356)	\$0.40
6350. Public Trustee (Incorporating amendments up to No. 6961)	\$0.35
6353. Racing (<i>First Reprint</i> —Incorporating amendments up to No. 7404)	\$0.70
6355. Railways (<i>First Reprint</i> —Incorporating amendments up to No. 7475)	\$0.75
6564. Registration of Births Deaths and Marriages Act 1959 (<i>First Reprint</i> —Incorporating amendments up to No. 7332)	\$0.25
6359. Road Traffic (<i>Second Reprint</i> —Incorporating amendments up to No. 7332)	\$0.18
6360. Rural Finance (<i>First Reprint</i> —Incorporating amendments up to No. 7328)	\$0.12

ACTS REPRINTED IN ACCORDANCE WITH THE AMENDMENTS
INCORPORATION ACT 1958 (No. 6422)—continued.

No.	Price.
6846. Rural Finance and Settlement Commission Act 1961 (<i>First Reprint</i> —Incorporating amendments up to No. 7332) ..	\$0.20
6975. Sale of Land Act 1962 (<i>First Reprint</i> —Incorporating amendments up to No. 7332) ..	\$0.18
6363. Second-hand Dealers (<i>First Reprint</i> —Incorporating amendments up to No. 7529) ..	\$0.25
6367. Settled Land (<i>Second Reprint</i> —Incorporating amendments up to No. 7065) ..	\$0.50
6368. Sewerage Districts (<i>First Reprint</i> —Incorporating amendments up to No. 7332) ..	\$0.62
6651. Social Welfare Act 1960 (<i>Third Reprint</i> —Incorporating amendments up to No. 7332) ..	\$0.20
6372. Soil Conservation and Land Utilization (Incorporating amendments up to No. 6961) ..	\$0.20
6373. Soldier Settlement (<i>First Reprint</i> —Incorporating amendments up to No. 7328) ..	\$0.42
6375. Stamps (<i>Third Reprint</i> —Incorporating amendments up to No. 7359) ..	\$0.82
6377. State Electricity Commission (<i>Second Reprint</i> —Incorporating Amendments up to No. 7421) ..	\$0.65
6379. State Savings Bank (Incorporating amendments up to No. 6886) ..	\$0.42
6381. Stock and Share Brokers (<i>First Reprint</i> —Incorporating amendments up to No. 7444) ..	\$0.15
6886. Subordinate Legislation (Incorporating amendments up to No. 6961) ..	\$0.15
6386. Superannuation (<i>First Reprint</i> —Incorporating amendments up to No. 7417) ..	\$0.60
6387. Supreme Court (<i>First Reprint</i> —Incorporating amendments up to No. 7522) ..	\$0.75
6391. Teaching Service (<i>First Reprint</i> —Incorporating amendments up to No. 7536) ..	\$0.35
7223. Tomato Processing Industry (Uniform Agreement) Act 1964 (<i>First Reprint</i> —Incorporating amendments up to No. 7342) ..	\$0.15
6395. Tourist (<i>First Reprint</i> —Incorporating amendments up to No. 7335) ..	\$0.15
6849. Town and Country Planning (<i>First Reprint</i> —Incorporating amendments up to No. 7276) ..	\$0.45
6399. Transfer of Land Act (<i>Third Reprint</i> —Incorporating amendments up to No. 7551) ..	\$0.65
6400. Transport Regulation (<i>First Reprint</i> —Incorporating amendments up to No. 7358) ..	\$0.22
6401. Trustee (<i>Second Reprint</i> —Incorporating amendments up to No. 6963) ..	\$0.42
6879. Unclaimed Moneys (Incorporating amendments up to No. 6961) ..	\$0.12
6653. Valuation of Land Act 1960 (<i>Second Reprint</i> —Incorporating amendments up to No. 7333) ..	\$0.22
6407. Vegetation and Vine Diseases (<i>First Reprint</i> —Incorporating amendments up to No. 7423) ..	\$0.30
6409. Vermin and Noxious Weeds (<i>First Reprint</i> —Incorporating amendments up to No. 7463) ..	\$0.35

ACTS REPRINTED IN ACCORDANCE WITH THE AMENDMENTS
INCORPORATION ACT 1958 (No. 6422)—continued.

No.	Price.
6410. Veterinary Surgeons (<i>First Reprint</i> —Incorporating amendments up to No. 7343) ..	\$0.15
7291. Victoria Institute of Colleges Act 1965 (<i>First Reprint</i> —Incorporating amendments up to No. 7644) ..	\$0.25
6413. Water (<i>Second Reprint</i> —Incorporating amendments up to No. 7590) ..	\$1.95
6414. Weights and Measures (<i>Second Reprint</i> —Incorporating amendments up to No. 7332) ..	\$0.32
6416. Wills (<i>First Reprint</i> —Incorporating amendments up to No. 7238) ..	\$0.25
6419. Workers Compensation (<i>Second Reprint</i> —Incorporating amendments up to No. 7332) ..	\$0.52

CONTENTS

	PAGE
Acts of Parliament on sale at the Government Printing Office	2924
Appointments	2897
Companies Act 1961—Notice	2892
Contracts	2893
Estates of Deceased Persons	2895
Government Notices	2886
Impoundings	2924
Lands	2907
Melbourne and Metropolitan Board of Works—Notice	2896
Mining	2897
Notices to Mariners	2896
Notice of Making of Statutory Rules	2924
Orders in Council— Acts—Drainage; Soil Conservation and Land Utilization; Country Roads; Local Government; Land; Forests; Housing; Water; Sewerage Districts; Superannuation.	2898
Police Sales	2895
Private Advertisements	2914
Proclamations	2883
Public Notice	2890
Public Service Notices	2911
Resignations	2898
Tenders	2911
Transport Regulation Board—Public Hearings	2887
Waterworks Trust	2896