



# VICTORIA GOVERNMENT GAZETTE

Published by Authority

[Registered at the General Post Office, Melbourne, for transmission by post as a newspaper.]

No. 75]

WEDNESDAY, AUGUST 28

[1968

## PROCLAMATIONS

*Land Act 1958.*

UNALIENATED CROWN LAND AVAILABLE FOR SETTLEMENT UNDER IMPROVEMENT PURCHASE LEASES.

### PROCLAMATION

By His Excellency the Lieutenant-Governor of the State of Victoria and its Dependencies in the Commonwealth of Australia, &c., &c., &c.

IN pursuance of the provisions of Section 153 of the *Land Act 1958*, I, the Lieutenant-Governor of the State of Victoria in the Commonwealth of Australia, by and with the advice of the Executive Council of the said State, do by this Proclamation declare the unalienated Crown lands mentioned in the sub-joined schedule, to be available for settlement under improvement purchase leases.

### SCHEDULE.

County.	Parish.	Allotment.	Section.	Area.			Land Valuation.
				A.	R.	P.	
Delatite .. .. .	Myrtleford .. .. .	21	24	46	0	0±	\$8 per acre
Follett .. .. .	Nangeela .. .. .	15A	5	96	0	0±	\$4 per acre
Follett .. .. .	Nangeela .. .. .	17	5	669	0	0±	\$4 per acre
Buln Buln .. .. .	Fumina .. .. .	99	..	80	0	0	\$1,200 per acre
Lowan .. .. .	Durong .. .. .	35, 36	..	1,008	0	0±	\$5 per acre

Given under my Hand and the Seal of the State of Victoria aforesaid, at Melbourne this twentieth day of August, in the year of our Lord One thousand nine hundred and sixty-eight and in the seventeenth year of the reign of Her Majesty Queen Elizabeth II.

(L.S.)

By His Excellency's Command,

E. F. HERRING.

W. J. F. McDONALD,  
Minister of Lands.

GOD SAVE THE QUEEN !

*Land Act 1958.*

## AREA OF LAND COMPRISED IN CERTAIN CLASSES DIMINISHED OR INCREASED.

## PROCLAMATION

By His Excellency the Lieutenant Governor of the State of Victoria and its Dependencies in the Commonwealth of Australia, &c., &c., &c.

WHEREAS by the *Land Act 1958* it is amongst other things enacted that the Governor in Council may, by Proclamation to be published in the *Government Gazette*, at any time diminish or increase the area of land comprised in any of the classes mentioned in Part I., Division 1, Section 5, of the said *Land Act 1958*, but that the area of lands which may be sold by auction (Class 6), shall not be increased except as in certain cases in the said Act provided: Now therefore I, the Lieutenant-Governor of the State of Victoria, in the Commonwealth of Australia, by and with the advice of the Executive Council of the said State, and in accordance with the provisions of Sections 94 and 117 of the *Land Act 1958* aforesaid, do hereby diminish or increase (as the case may be) the areas of Crown lands comprised in Classes 7 and 6 of the classes mentioned in Section 5 of the *Land Act 1958* aforesaid, to the extent set forth in the subjoined Schedule (that is to say):—

Schedule referred to  
CLASSES DIMINISHED OR INCREASED.

County.	Parish.	Allotment.	Section.	Area.	Diminished.	Increased.	Description.
					Class.	Class.	
Ripon	Ararat	134A	14	A. R. P. 2 2 14	7	6	North of the Township of Ararat

Given under my Hand and the Seal of the State of Victoria, aforesaid, at Melbourne, this twentieth day of August, in the year of our Lord One thousand nine hundred and sixty-eight, and in the seventeenth year of the reign of Her Majesty Queen Elizabeth II.

(L.S.)

By His Excellency's Command,

W. J. F. McDONALD,

Minister of Lands.

GOD SAVE THE QUEEN!

*Apprenticeship Act 1958.*

## STONEMASONRY TRADE PROCLAIMED TO BE AN APPRENTICESHIP TRADE.

## PROCLAMATION

By His Excellency the Lieutenant-Governor of the State of Victoria and its Dependencies in the Commonwealth of Australia, &c., &c., &c.

WHEREAS Section 13 of the *Apprenticeship Act 1958* provides, *inter alia*, that after the Minister has taken into consideration any recommendation made by the Apprenticeship Commission the Governor in Council, for the purposes of the said Act, may from time to time by Proclamation, proclaim any trades to be apprenticeship trades:

AND WHEREAS the Apprenticeship Commission having notified in the manner prescribed by the said Act its intention to recommend that the trade of stonemasonry, in so far as it is carried on anywhere in the State of Victoria, be proclaimed an apprenticeship trade under the said Act, and having considered the representations made on behalf of the employers and employees in the said trade, has recommended to the Minister that the said trade be so proclaimed:

AND WHEREAS the Minister has taken the said recommendation into consideration:

NOW THEREFORE I, the Lieutenant-Governor of the State of Victoria, in the Commonwealth of Australia, by and with the advice of the Executive Council of the said State, do by this my Proclamation proclaim the trade of Stonemasonry, in so far as it is carried on anywhere in the State of Victoria, to be an apprenticeship trade.

Given under my Hand and the Seal of the State of Victoria aforesaid, at Melbourne, this twentieth day of August, in the year of our Lord One thousand nine hundred and sixty-eight, and in the seventeenth year of the reign of Her Majesty Queen Elizabeth II.

(L.S.)

E. F. HERRING.

By His Excellency's Command,

J. F. ROSSITER,  
Minister of Labour and Industry.

GOD SAVE THE QUEEN!

## BANK HOLIDAYS.

## PROCLAMATION

By His Excellency the Lieutenant-Governor of the State of Victoria and its Dependencies in the Commonwealth of Australia, &c., &c., &c.

IN pursuance of the provisions of the *Bank Holidays Act 1958*, I, the Lieutenant-Governor of the State of Victoria, in the Commonwealth of Australia, do by this my Proclamation appoint the days and dates named hereunder special days to be observed as Bank Holidays or Bank Half-Holidays (as the case may be) at the places respectively mentioned, that is to say:—

*Bank Holidays:—*

THURSDAY, THE 19TH SEPTEMBER, 1968, at Kilmore.

MONDAY, THE 23RD SEPTEMBER, 1968, at Cowes.

MONDAY, THE 23RD SEPTEMBER, 1968, at Bacchus Marsh.

WEDNESDAY, THE 25TH SEPTEMBER, 1968, at Healesville and Yarra Glen.

FRIDAY, THE 11TH OCTOBER, 1968, at Shepparton and Mooroopna.

FRIDAY, THE 11TH OCTOBER, 1968, at Dookie.

FRIDAY, THE 11TH OCTOBER, 1968, at Yarrowonga.

TUESDAY, THE 5TH NOVEMBER, 1968, at Ouyen.

*Bank Half-Holidays from the Hour of Eleven a.m.:—*

TUESDAY, THE 8TH OCTOBER, 1968, at Kilmore.

TUESDAY, THE 3RD SEPTEMBER, 1968, at Natimuk.

WEDNESDAY, THE 11TH SEPTEMBER, 1968, at Seymour.

TUESDAY, THE 8TH OCTOBER, 1968, at Cobram, Katamatite, and Strathmerton.

THURSDAY, THE 10TH OCTOBER, 1968, at Warracknabeal.

TUESDAY, THE 15TH OCTOBER, 1968, at Birchip.

WEDNESDAY, THE 16TH OCTOBER, 1968, at Murrayville.

TUESDAY, THE 5TH NOVEMBER, 1968, at Mildura, Red Cliffs and Merbein.

Given under my Hand and the Seal of the State of Victoria aforesaid, at Melbourne, this twenty-seventh day of August, in the year of our Lord One thousand nine hundred and sixty-eight, and in the seventeenth year of the reign of Her Majesty Queen Elizabeth II.

(L.S.)

E. F. HERRING.

By His Excellency's Command,

A. G. RYLAH,  
Chief Secretary.

GOD SAVE THE QUEEN!

ROADS PROCLAIMED.

PROCLAMATION

By His Excellency the Lieutenant-Governor of the State of Victoria and its Dependencies in the Commonwealth of Australia, &c., &c., &c.

IN pursuance of the provisions of Section 25 of the Land Act 1958, the Lieutenant-Governor of the State of Victoria, by and with the advice of the Executive Council of the said State, doth hereby proclaim as roads the under-mentioned lands:

Parish of Heathcote, County of Dalhousie, being the land indicated by hatching on plan hereunder.—(H.75(1<sup>st</sup>)) (H.030840.)

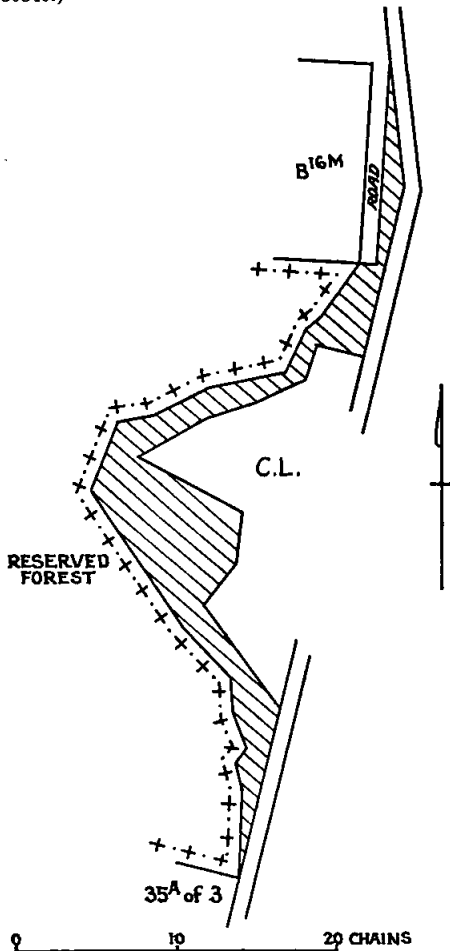

Parish of Noorilim, County of Rodney, being the land indicated by hatching on plan hereunder.—(N.73(4)) (H.032198.)

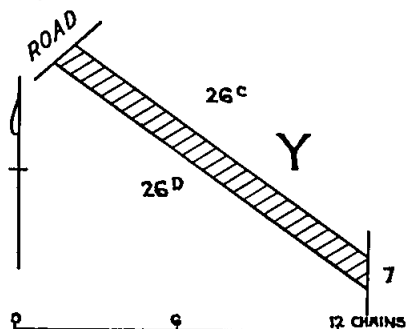

Given under my Hand and the Seal of the State of Victoria aforesaid, at Melbourne, this twentieth day of August, in the year of our Lord One thousand nine hundred and sixty-eight, and in the seventeenth year of the reign of Her Majesty Queen Elizabeth II.

(L.S.)

E. F. HERRING.

By His Excellency's Command,

W. J. F. McDONALD,  
Minister of Lands.

GOD SAVE THE QUEEN!

PUBLIC HOLIDAYS.

PROCLAMATION

By His Excellency the Lieutenant-Governor of the State of Victoria and its Dependencies in the Commonwealth of Australia, &c., &c., &c.

IN pursuance of the provisions contained in Part III. of the Public Service Act 1958, I, the Lieutenant-Governor of the State of Victoria, in the Commonwealth of Australia, by and with the advice of the Executive Council of the said State, do by this my Proclamation appoint the days and dates hereunder mentioned to be observed as Public Holidays or Public Half-Holidays (as the case may be) at the places respectively specified, viz.:

Public Holidays:—

- MONDAY, THE 23RD SEPTEMBER, 1968, throughout the Shire of Bacchus Marsh.
- MONDAY, THE 23RD SEPTEMBER, 1968, throughout the Shire of Romsey.
- WEDNESDAY, THE 25TH SEPTEMBER, 1968, throughout the Shire of Newham and Woodend.
- WEDNESDAY, THE 25TH SEPTEMBER, 1968, throughout the Shire of Gisborne.
- WEDNESDAY, THE 2ND OCTOBER, 1968, at Donald, Litchfield and Corack East within the Shire of Donald.
- SATURDAY, THE 26TH OCTOBER, 1968, throughout the Shire of Myrtleford.
- SATURDAY, THE 8TH FEBRUARY, 1969, throughout the Central Riding of the Shire of Kowree.
- MONDAY, THE 23RD SEPTEMBER, 1968, throughout the Shire of Pyalong.
- SATURDAY, THE 2ND NOVEMBER, 1968, throughout the Borough of Kerang.

Public Half-Holidays from the Hour of Twelve o'clock noon:—

- FRIDAY, THE 4TH OCTOBER, 1968, throughout the West Riding of the Shire of Dunmunkle.
- TUESDAY, THE 8TH OCTOBER, 1968, throughout the North Riding of the Shire of Dunmunkle.
- WEDNESDAY, THE 9TH OCTOBER, 1968, throughout the East Riding of the Shire of Dunmunkle.
- WEDNESDAY, THE 16TH OCTOBER, 1968, throughout the Murrayville Riding of the Shire of Walpeup.
- WEDNESDAY, THE 13TH NOVEMBER, 1968, throughout the City of Bendigo.
- THURSDAY, THE 10TH OCTOBER, 1968, in the North Riding of the Shire of Wimmera.

Given under my Hand and the Seal of the State of Victoria aforesaid, at Melbourne, this twenty-seventh day of August, in the year of our Lord One thousand nine hundred and sixty-eight, and in the seventeenth year of the reign of Her Majesty Queen Elizabeth II.

(L.S.)

E. F. HERRING.

By His Excellency's Command,

A. G. RYLAH,  
Chief Secretary.

GOD SAVE THE QUEEN!

MOTOR CAR ACT 1967, No. 7593.

DATE OF COMING INTO OPERATION.

PROCLAMATION

By His Excellency the Lieutenant-Governor of the State of Victoria and its Dependencies in the Commonwealth of Australia, &c., &c., &c.

WHEREAS by an Act of Parliament of the State of Victoria passed in the sixteenth year of the reign of Her Majesty Queen Elizabeth II entitled the Motor Car Act 1967, No. 7593, it is amongst other things enacted that the several provisions of the said Act shall come into operation on a day or the respective days to be fixed by proclamation or successive proclamations of the Governor in Council published in the Government Gazette:

AND WHEREAS by proclamations issued on the sixth day of February, One thousand nine hundred and sixty-eight, and published in the *Government Gazette* of the seventh day of February, One thousand nine hundred and sixty-eight, the nineteenth day of February, One thousand nine hundred and sixty-eight, was fixed as the day on which Sections 1, 2, and 5 to 11, inclusive, of the said *Motor Car Act 1967*, shall come into operation; and the first day of March, One thousand nine hundred and sixty-eight was fixed as the day on which Sections 3 and 15 of the said Act shall come into operation:

AND WHEREAS by proclamations issued on the twenty-seventh day of February, One thousand nine hundred and sixty-eight, and published in the *Government Gazette* of the twenty-eighth day of February, One thousand nine hundred and sixty-eight, the twenty-eighth day of February, One thousand nine hundred and sixty-eight was fixed as the day on which Section 12 of the said *Motor Car Act 1967*, shall come into operation; and the first day of March, One thousand nine hundred and sixty-eight was fixed as the day on which Sections 13, 14 and 16 of the said Act shall come into operation:

NOW THEREFORE, I, the Lieutenant-Governor of the State of Victoria in the Commonwealth of Australia, by and with the advice of the Executive Council of the said State, do by this my proclamation fix Friday, the first day of November, One thousand nine hundred and sixty-eight, as the day on which Section 4 of the said *Motor Car Act 1967*, No. 7593, shall come into operation.

Given under my Hand and the Seal of the State of Victoria, aforesaid at Melbourne, this twenty-seventh day of August, in the year of Our Lord, One thousand nine hundred and sixty-eight, and in the seventeenth year of the reign of Her Majesty Queen Elizabeth II.

(L.S.) E. F. HERRING.

By His Excellency's Command,  
JAMES W. MANSON,  
for Chief Secretary.  
GOD SAVE THE QUEEN!

## GOVERNMENT NOTICES

Victoria.

### ACT No. 391.—SECOND SCHEDULE.

A STATEMENT of Trusts having been submitted by the head or authorized representative of the denomination of The Ballarat Diocesan Trustees (Church of England) under the provisions of the "Act to provide for the Abolition of State Aid to Religion," for allowance by the Governor, the same was allowed by him on the 20th day of August, 1968, and the following is the form in which such statement of trusts has been allowed:—

#### STATEMENT OF TRUSTS.

*Description of Land.*—2 acres temporarily reserved for Church of England purposes by Order in Council of the 5th March, 1866: 2 acres, Parish of Kerrit Bareet, County of Grant, being allotment 3A, section 12: Commencing at the most northerly angle of allotment 3, section 12; bounded thence by roads bearing 73 deg. 11 feet 400 links and 180 deg. 0 feet 583 links; and thence by allotment 3 bearing 270 deg. 0 feet 383 links and 0 deg. 0 feet 467 links to the point of commencement.

*Name of Trustees.*—The Ballarat Diocesan Trustees of Cathedral Buildings, Dana-street, Ballarat.

*Powers of Disposition.*—To permit and suffer so much of the land as shall not be disposed of under the powers hereinafter specified to be used for the purposes for which it was promised or permanently reserved from sale by the Crown. To let, lease, sell, mortgage or exchange if concurred in by the said Head or Authorized Representative for the time being, the said land or any portion thereof or any buildings thereon on such terms and conditions as shall be specified by such Head or Representative.

*Purposes to which Proceeds of Disposition are to be Applied.*—Moneys obtained from sale, leases, mortgages or exchanges to be paid to the Bishop to be dealt with for Church of England purposes as shall be directed by the said Trustees but to be subject nevertheless to the payment or deduction therefrom of all costs, charges and expenses incurred by the Trustee or for which it shall be liable in respect of the trust estate.

Cuthbert, Morrow, Must & Shaw, Lydiard-street, Ballarat, solicitors for the applicant.

As witness the hand of the Lieutenant-Governor of the State of Victoria, this twentieth day of August, 1968.

E. F. HERRING,  
Lieutenant-Governor of the State of Victoria.

## SHIRE OF ARARAT.

### TOWN AND COUNTRY PLANNING ACTS.

#### Interim Development Order.

BY virtue of the powers conferred by the *Town and Country Planning Act 1961*, as amended, and of every other power enabling it in that behalf, the Council of the Shire of Ararat (hereinafter referred to as the Responsible Authority) having commenced the preparation of the planning scheme on the Twentieth day of May, 1968, in accordance with the Town and Country Planning Acts then in force, hereby makes the following Interim Development Order for the purpose of regulating, restricting, restraining or prohibiting the use or development of any land or the erection, construction or carrying out of any buildings or works on any land within the area described in the Schedule hereto.

1. After the coming into operation of this Interim Development Order no person shall use or develop any land or erect, construct or carry out any buildings or works on any land within the area included in the Schedule, except in accordance with the provision of a permit issued by the Responsible Authority.

2. Every application for a permit under the provisions of this Order shall be made on the prescribed form, copies of which may be obtained from the office of the Responsible Authority at Ararat.

3. This Interim Development Order shall not prevent—

(a) the continuance of the use of any land or buildings or works for the purposes for which such land or buildings or works were lawfully used immediately before the coming into operation of this Order;

(b) any dealing or the registration of any dealing with any land in a subdivision of which a plan has been sealed by the Council of the Shire of Ararat and lodged with the Registrar of Titles, pursuant to section 569 of the *Local Government Act 1958*, before the coming into operation of this Order.

4. *Schedule.*—The whole of the land within the following boundaries:—Commencing at the north-western angle of lot 16BA, Parish of Willaura, County of Ripon; thence easterly by the northern boundary of the said allotment; thence due east by a line across a road and the Ararat-Hamilton Railway Reserve to a point on the said Railway Reserve on its eastern boundary; thence south-westerly along the said boundary of the Ararat-Hamilton Railway Reserve to the north-western angle of allotment 15B, Parish of Willaura; thence easterly by the northern boundary of the said allotment to its easternmost angle; thence southerly by the eastern boundary of the said lot and of lots 34A, 34B, 39A2, 39A1 and 60A to the south-eastern angle of the said lot 60A; thence westerly and northerly along the southern and western boundary of the said lot 60A to the south-eastern angle of lot 59A; thence westerly by the southern boundary of the said lot 59A to its western angle; thence south-easterly to a point due east of the south-eastern angle of lot 58A; thence due west across a road and along the southern boundary of the said lot 58A; thence due west across a road to a point on the eastern boundary of lot 57B; thence northerly by the eastern boundaries of the said lot 57B and lot 57A to the north-eastern angle of the said lot 57A; thence west along the northern boundary of that lot to its north-western angle; thence due north across a road to the south-western angle of lot 42AB; thence northerly by the western boundary of the said lot 42AB and lot 42AA; thence due north across a road and lot 43B and a road to the south-western angle of lot 30A; thence northerly by the western boundary of the said lot 30A and lot 17B to the north-western angle of the said lot 17B; thence easterly by the northern boundary of the said lot 17B to its north-eastern angle; thence northerly along the eastern boundary of lot 17A to a point due west of the north-western angle of lot 16BA; thence due east across a road to the said north-western angle of lot 16BA being the point of commencement.

The common seal of the President, Councillors and Ratepayers of the Shire of Ararat was hereunto affixed this fifteenth day of July, 1968, in the presence of—

(SEAL) THOMAS FORD, President.  
J. K. PICKFORD, Councillor.  
K. N. BISHOP, Municipal Clerk.

Approved by the Governor in Council on the 20th day of August, 1968.—J. ROSSITER, Clerk of the Executive Council.

Transport Regulation Act.  
TRANSPORT REGULATION BOARD.

## HEARING OF APPLICATIONS.

NOTICE is hereby given that the following applications will be considered by the Transport Regulation Board at its offices at the corner of Lygon and Princes streets, Carlton, at 10.15 a.m. on Wednesday, 18th September, 1968.

DAVIS, M. (Mrs.), 134 Blackshaw-road, South Kingsville. One commercial passenger vehicle (S/C. 4) to operate for the carriage of pre-school children between their homes and the applicant's child-minding centre situated at 134 Blackshaw-road, South Kingsville. No direct fare is to be charged for the service.

HOLMES, D. E. & H. J., Box 30, Numurkah. One commercial passenger vehicle (S/C. 33) to operate in substitution for but not in addition to T.S. licences in the names of the applicant.

LAWLER, J. W., Fairview-avenue, Yarram. Application to vary licence T.S.389 to include the ability to operate as a country special service omnibus with a pick-up radius of ten (10) miles from the post office at Yarram.

APPLICATION for renewal of licences as shown, by persons listed hereunder to operate under the same terms and conditions.

BARKER, J. S., 378 High-street, Lower Templestowe; M.H.2290.

BIBBY, R. S., 25 Tasman-road, East Bentleigh; M.H.2283.

BLYTHE, A. J., 11 Cusdin-street, Glen Iris; M.H.2288.

CHOUSSOS, S., 51 Lewisham-road, Windsor; M.T.1847.

CIVITELLA, B., 21 Middleborough-road, Burwood; M.H.2281.

DJANKOVIC, A., 149 Drummond-street, Carlton; M.H.2295.

LOCKE, V., Flat 3, 71 Queens-road, Melbourne; M.H.2280.

MANDEMAKER, W. J., 1 Amboina-avenue, Mitcham; M.H.2289.

MCVEIGH, W. W., 13 Byron-street, Box Hill South; M.H.2279.

REID, R. A. J., 25 Union-street, West Preston; M.H.2278.

SCOBIE, L. J., 25 May-street, Balwyn; M.H.2285.

SEIKAS, A., 54 Davison-street, North Richmond; M.H.2286.

TAIT, K. K., 20 Winbirra-parade, Ashwood; M.H.2276.

VITZDAMM-JONES, A. U., 32 Yackatooon-avenue, Aspendale; M.H.2287.

WAY, N. D., 40 Adeny-street, Yarraville; M.H.2277.

ZELTNER, H., 19 Sunburst-avenue, North Balwyn; M.H.1854.

Notice of any objection should be forwarded to reach the Secretary of the Board not later than Wednesday, 11th September, 1968.

Applicants are advised that it will not be necessary to appear on the hearing date specified above, unless advised in writing by the Board.

B. P. KAY,  
Secretary.

Corner Lygon and Princes streets, Carlton, Wednesday, 28th August, 1968.

Commercial Goods Vehicles Act.  
TRANSPORT REGULATION BOARD.

## HEARING OF APPLICATIONS.

NOTICE is hereby given that the following applications will be considered by the Transport Regulation Board at its offices at the corner of Lygon and Princes streets, Carlton, at 10.15 a.m. on Wednesday, 18th September, 1968.

BROADBENT, H. A., 324 Centre-road, Bentleigh, 3204. Two commercial goods vehicles (L/C. 128, 141 cwt.) to operate: (a) Within a 25-mile radius of G.P.O., Melbourne, in course of business as "Sand, Screenings, and Garden Supplies"—own goods. (b) From Bacchus Marsh to own yard at Bentleigh—own river pebbles. (c) From Toolangi to own yard at Bentleigh—own mountain soil. (d) From pits at Cranbourne to own yard at Bentleigh—own sand.

BROWN, C. O., 17 Canterbury-road, Kilsyth, 3137. One commercial goods vehicle (198 cwt.) to operate within a 50-mile radius of the premises of Pronto Mixed Concrete Co. Pty. Ltd., at Ringwood, solely on behalf of the said company—premixed concrete in a specially constructed agitator vehicle.

BRUHNS QUARRY PTY. LTD., Murray Valley Highway, Cohuna, 3568. Application to vary conditions of licences numbered D.A.61184/1 and D.A.61184/2 (L/C. 136, and 211 cwt.) by deleting paragraphs (a) (b) (c) (d) of the existing conditions.

CAMPBELL, COLIN (CHEMICALS) PTY. LTD., 61 Weddell-street, Shepparton, 3630. Two commercial goods vehicles (L/C. 8 and 10 cwt.) to operate within a 50-mile radius of own branch agency at Shepparton in the course of business as "Agricultural Chemical Distributor"—own goods.

CORBIN, W. O., Catani, 3981. One commercial goods vehicle (L/C. 92 cwt.) to operate: (a) Within a 20-mile radius of the post office at Catani—general goods. (b) From and to places situated within a 20-mile radius of Catani and to and from Dandenong—livestock. (c) Within an 8-mile radius of Catani to and from Melbourne for the carriage of general goods.

DEWAR, J. A., 7 Julia-street, Portland, 3305. One commercial goods vehicle (L/C. 14 cwt.) to operate: (a) Throughout the State of Victoria in course of business as "Antique and Second-hand Furniture Dealer" for the purpose of collecting antique articles and secondhand furniture from auctions for return to own premises at Portland. (b) From own place of business at Portland to purchasers within the State of Victoria—antique articles and second-hand furniture.

ELLIOTT, J. H., PTY. LTD., 131 Myers-street, Geelong, 3220. One commercial goods vehicle (L/C. 121 cwt.) to operate within a 50-mile radius of the chief post office in the City of Geelong in the course of business as "Mobile Crane Operators"—crane jibs, hooks, counter weights and tools of trade incidental to own contracts.

FIELD AIR (BENALLA) PTY. LTD., Municipal Airport, Ballarat, 3350. One commercial goods vehicle (L/C. 11 cwt.) to operate: (a) Throughout the State of Victoria—(i) Tools of trade and equipment incidental to own contracts only. (ii) Aviation fuel and chemicals incidental to own spraying contracts subject to the condition that the total weight of all goods so carried shall not exceed 10 cwt. at any one time. (b) Within a 20-mile radius of the railway station or railway siding nearest to the site of any contract currently engaged upon—aviation fuel and chemicals.

FINK, W. A., 44 Picket-street, Dandenong, 3175. One commercial goods vehicle (L/C. 10 cwt.) to operate throughout the State of Victoria in the course of business as "General Engineering Installation and Maintenance Contractor"—tools of trade, spare parts, machinery for repair, having been repaired and for specialized installation and materials incidental thereto.

FLICK, W. A., & Co. PTY. LTD., 1008 Sturt-street, Ballarat, 3350. One commercial goods vehicle (L/C. 15 cwt.) to operate within a 50-mile radius of the Township of Seymour in course of business as "Pest Exterminators"—tools of trade, spraying equipment and small quantities of materials incidental to own contracts, provided that all initial supplies of concentrated chemicals are forwarded to Seymour by rail from Ballarat.

FLICK, W. A., & Co. PTY. LTD., 1008 Sturt-street, Ballarat, 3350. One commercial goods vehicle (L/C. 10 cwt.) to operate within that part of the State of Victoria west of a north/south line drawn through the City of Bendigo in course of business as "Pest Exterminators"—tools of trade, spraying equipment and small quantities of materials incidental to own contracts provided that all initial supplies of concentrated chemicals are forwarded to Kerang by rail from Ballarat.

NOTE.—This application replaces previous application made by the company above which appeared in the *Government Gazette* dated 6th December, 1967.

GALLAGHER, S., 11 Ulm-street, Laverton, 3028. One commercial goods vehicle (L/C. 209 cwt.) to operate within a 50-mile radius of the premises of Supermix Concrete Pty. Ltd. at Brooklyn solely on behalf of the said company—premixed concrete in a specially constructed agitator vehicle.

MEADOWS, F. R. (trading as Gippsland Frozen Foods), Church-street, Morwell, 3840. One commercial goods vehicle (L/C. 10 cwt.) to operate: (a) From the City of Melbourne to own premises at Morwell in the course of business as "Frozen Food Distributor"—own pre-packed frozen meats. (b) Within a 50-mile radius of own premises at Morwell—own frozen foodstuffs.

GLARE, L. H., 167 Murlong-street, Swan Hill, 3585. One commercial goods vehicle (L/C. 256 cwt.) to operate: (a) Within a 50-mile radius of the post office at Swan Hill as a "Road Contractor"—road-making plant and materials. (b) Within a 25-mile radius of the post office at Swan Hill—general goods provided that no goods shall be carried whether by one stage or by more than one stage between places within the above radius which are more than thirty road miles apart by the nearest practicable route.

- GLEN IRIS BRICK TILE & TERRA COTTA CO. PTY. LTD.**, Templestowe-road, Bulleen, 3105. One commercial goods vehicle (L/C. 155 cwt.) to operate within a 70-mile radius of own brickworks at Bulleen in the course of business as "Brick Manufacturers"—own bricks.
- GREGORY, H. P. (VIC.) PTY. LTD.**, 615 Bridge-road, Richmond, 3121. One commercial goods vehicle (L/C. 14 cwt.) to operate throughout the State of Victoria in the course of business as "Engineers and Machinery Manufacturers" for the purpose of servicing of own sewerage units, compressors, electric supply plant and general production machinery—tools of trade, servicing equipment, spare parts and materials incidental to servicing.
- HILL, L. A.**, Eldorado, 3746. One commercial goods vehicle (L/C. 153 cwt.) to operate solely on behalf of Whitelaw Monier Pty. Ltd., an approved decentralized secondary industry (manufacture of concrete roofing tiles) carried on by such company at its factory premises at Wangaratta: (a) Within a 100-mile radius of the post office at Wangaratta—roofing tiles. (b) From the premises of Whitelaw Monier Pty. Ltd., at Melbourne and Ballarat, to the premises of Whitelaw Monier Pty. Ltd., at Wangaratta—ridges, shell-ends, apexes, oxide colour, roman tiles and shingle tiles.
- HUTTON, J. C., PTY. LTD.**, 65 High-street, Preston, 3072. One commercial goods vehicle (L/C. 85 cwt.) to operate throughout the State of Victoria in the course of business as "Bacon and Smallgoods Manufacturers" in a specially constructed refrigerated vehicle—fresh meat, cooked meat, sausages and small goods with the ability to carry also up to a maximum load of three (3) cwt. at any one time of dripping, lard, cheese, canned hams and margarine.
- INGWERSEN, A. G.**, 81 McLeod-street, Bairnsdale, 3875. One commercial goods vehicle (L/C. 120 cwt.) to operate within a 50-mile radius of the post office at Bairnsdale in the course of business as "Engineer"—own tools of trade, machinery, equipment and materials incidental to the completion of own contracts and machinery and equipment for repair or having been repaired.
- JENNINGS, N.**, 7 Douglas-crescent, Castlemaine, 3450. One commercial goods vehicle (L/C. 200 cwt. approximately) to operate within a 50-mile radius of the post office at Castlemaine in the course of business as "Earth-moving Contractor"—tools of trade, earth-moving plant and equipment incidental only to own contracts.
- KELLAWAY, S.**, Mary-street, East Bairnsdale, 3875. One commercial goods vehicle (L/C. 8 cwt.) to operate within a 70-mile radius from the post office at Bairnsdale in the course of business as "Service Agent" for the purpose of servicing and repairing washing machines, television sets, vacuum cleaners, floor polishers, radio sets and lawn mowers—tools of trade, spare parts and materials incidental thereto, also articles and appliances for repair or having been repaired.
- KELVINATOR AUSTRALIA LTD.**, 487 Williamstown-road, Port Melbourne, 3207. One commercial goods vehicle (L/C. 17 cwt.) to operate throughout the State of Victoria for the purpose of servicing and installing petrol pumps and petroleum dispensing equipment solely on behalf of Wayne Pumps Australia Ltd.—tools of trade, spare parts and materials incidental thereto, pumps and equipment for repair, having been repaired and for installation.
- KYABRAM NEWSPAPERS PTY. LTD.**, 287-291 Allan-street, Kyabram, 3620. One commercial goods vehicle (L/C. 14 cwt.) to operate within a 50-mile radius of own premises at Kyabram in the course of business as "Newspaper Publishers and Commercial Printers"—newspaper, commercial printing, stationery and materials for use in connexion with own newspaper publishing and commercial printing and goods the property of own associated companies.
- LACEY, S. H. I.**, 13 Lacey-street, Croydon, 3136. Two commercial goods vehicles (L/C. 101 and 121 cwt.) to operate within a 50-mile radius of own premises at Croydon in the course of business as "Produce Merchant"—own livestock produce.
- LIESHOUT, L.**, Mackie-street, Longwarry, 3816. One commercial goods vehicle (L/C. 143 cwt.) to operate: (a) Within a 25-mile radius of the post office situated at Longwarry—general goods provided that no goods shall be carried whether by one stage or by more than one stage between places within the above radius which are more than thirty (30) miles apart by the nearest practicable route. (b) From consignees situated within a 30-mile radius of the post office at Longwarry to the premises of Longwarry and District Dairymen's Co-op. Ltd., at Longwarry—milk in cans.
- MAHER, L. A.**, 18 Coalville-road, Moe, 3825. One commercial goods vehicle (L/C. 140 cwt.) to operate: (a) Within a 25-mile radius of the post office at Moe—general goods provided that no goods shall be carried whether by one stage or by more than one stage between places within the above radius which are more than thirty (30) miles apart by the nearest practicable route. (b) From forest landings within a 20-mile radius of the post office at Moe to sawmills situated within the above radius and to Andrews Sawmill and Russells Sawmill at Longwarry—mill logs.
- MARSHALL, R. & K. F.**, Neerim, 3821. Application to vary conditions of licence No. D.A.18834/1 (L/C. 164 cwt.) by adding to paragraph (b) of the existing conditions after "Glen Waverley" "and from the premises of F.M.C. (Aust.) Ltd., at Clayton, Thermal Traders (Vic.) Pty. Ltd., at Dandenong, and David Mitchell Estate Ltd., at Lilydale".
- MENDELSON, N. R.**, Lot 26, Scots Angle-road, Wattle Glen, 3096. One commercial goods vehicle (L/C. 106 cwt.) to operate: (a) Within a 25-mile radius of the G.P.O., Melbourne—general goods, (b) Within a 70-mile radius of the premises of Co-operative Brick Company Pty. Ltd., at Mitcham, solely on behalf of the said company—roofing tiles, tile-fixing materials and roof battens.
- MILLER, G. W.**, 14 Acacia-avenue, Huntingdale, 3166. One commercial goods vehicle (L/C. 145 cwt.) to operate within a 35-mile radius of the plant of Rowlands Quarries Pty. Ltd., at Narre Warren North, solely on behalf of the said company—screenings, stone dust and quarry products.
- MCQUALTER, N.**, 29-31 Carrier-street, Benalla, 3672. One commercial goods vehicle (L/C. 20 cwt.) to operate: (a) Within a 50-mile radius from own premises at Benalla in the course of business as "Garage Proprietors"—own goods. (b) Within a 150-mile radius from the post office at Benalla as agent for International Harvester Co. Pty. Ltd.—agricultural equipment for display and demonstration purposes with the ability also to make an urgent incidental delivery subject to the condition that such goods so carried shall have been initially consigned to Benalla by rail.
- PANTSELIAS, A.**, 2 Wordsworth-avenue, Clayton, 3168. One commercial goods vehicle (L/C. 200 cwt. approximately) to operate within a 50-mile radius of the premises of Consolidated Quarries Ltd., at Clayton solely on behalf of the said company—premixed concrete in a specially constructed agitator vehicle.
- PERKINS, C. C., PTY. LTD.**, 365 Bell-street, Heidelberg West, 3081. One commercial goods vehicle (L/C. 16 cwt.) to operate throughout the State of Victoria in course of business as "House Remover" as a pilot vehicle for the purpose of escorting house removing floats—tools of trade, house removing equipment and a small quantity of material for the purpose of re-siting houses.
- PERMEWAN WRIGHT LTD.**, 147-179 Alexandra-parade, Abbotsford, 3067. Four commercial goods vehicles (L/C. 138, 19, 78, and 125 cwt.) to operate within a 50-mile radius of own branch premises at Warragul in the course of business as "General and Produce Merchants"—own goods.
- PICTON HOPKINS & SON PTY. LTD.**, 130 Church-street, Richmond, 3121. One commercial goods vehicle (L/C. 9 cwt.) to operate in the course of business as "Plaster Craftsmen"—(a) Within a 25-mile radius of the post office at Richmond—own goods. (b) (1) Throughout the State of Victoria—fibrous plaster sheeting, mouldings, sisal and plaster sufficient only for the fixing of the said sheets and mouldings also battens nails, insulating materials, viz.: insulwool and rockwool suspended ceilings component parts, associated acoustic tiles and sprayed finishes. (2) Terrazzo slabs and/or materials incidental to fixing of same, stone dust, sand, cement sufficient only for floating and/or concrete floor finishing purposes, expanded metal, plaster sufficient only for setting purposes and associated materials necessary to carry out solid plastering contracts, vinyl and lino tiles and adhesives, scaffolding plant, tools of trade for use in connexion with own building contracts. (c) Within a 20-mile radius of own branch premises at Herne's Oak—own goods. (d) Within a 20-mile radius of any contract currently engaged upon or from the nearest railway station thereto—materials for use on such contract.

PULLEN, P., Box 157, Casterton, 3311. One commercial goods vehicle (L/C. 8 cwt.) to operate within a 70-mile radius of the post office at Casterton in the course of business as "Cartage Contractors"—tools of trade, equipment and fuels and lubricants incidental to the operation and maintenance of own vehicles.

ROBERTSON, C. J., & Co. (HORSHAM) PTY. LTD., 21 Stawell-road, Horsham, 3400. Two commercial goods vehicles (L/C. 12 cwt.) to operate within that part of the State of Victoria west of a line drawn due north and south through the City of Melbourne in the course of business as "Auto Wrecking Contractor" but excluding the carriage of goods from the Metropolitan Area (as defined in the *Transport Regulation Act 1958*)—tools of trade, equipment and materials incidental to the repair and servicing of own plant and equipment.

ROTHMANS OF PALL MALL (AUSTRALIA) LTD., Lorimer-street, Port Melbourne, 3207. One commercial goods vehicle (L/C. 10 cwt.) to operate throughout the State of Victoria as a Traveller's Vehicle for display and sales promotion of own products and agency lines in the course of business as "Manufacturers and Distributors"—samples of own products and agency lines, together with display materials relating to goods for sale and also together with sufficient quantity of stocks of the various lines for sale to enable a sample to be left with a customer when required or an interim supply of any product to be left with a retailer pending despatch by rail of normal supplies to such retailer.

SAWTELL, F., 61 Cadorna-street, Box Hill, 3128. One commercial goods vehicle (L/C. 140 cwt. approximately) to operate within a 35-mile radius of the G.P.O., Melbourne, solely on behalf of Consolidated Quarries Ltd.—screenings, stone-dust and quarry products.

TERZINI, A., 51 Royal-parade, Reservoir, 3073. One commercial goods vehicle (L/C. 196 cwt.) to operate within a 50-mile radius of the plant of Albion Reid Pty. Ltd., at North Melbourne solely on behalf of the said company—premixed concrete in a specially constructed agitator vehicle.

TOMSIK, P., 6 Whites-lane, Glen Waverley, 3150. Application to vary conditions of licence No. D.A.61883 (L/C. 193 cwt.) by deleting "Blue Metal Quarries Pty. Ltd., at Epping" and adding in lieu—"Pronto Mixed Concrete Co. Pty. Ltd., at Springvale."

SAXTON, C., A. GRAY & J. ELLIS (trading as Trio Carpet Service), 2A Power-street, North Williamstown, 3016. Two commercial goods vehicles (L/C. 13 and 8 cwt.) to operate within a 50-mile radius of own premises at Williamstown in the course of business as "Carpet Laying Contractors"—tools of trade carpet and underfelt for laying purposes only and materials incidental to the completion of own carpet laying contracts.

TRUPACKERS PTY. LTD., Benalla-road, Shepparton, 3630. One commercial goods vehicle (L/C. 53 cwt.) to operate from own packing sheds at Shepparton to the Townships of Wodonga, Yea, Seymour, Elmore, Rochester, Cohuna and places within the area bounded by a line drawn through the said towns and the River Murray in the course of business as "Fruit Packers"—pre-packed and cased fruit and also pre-packed potatoes in bags.

WADE, R. G., 178 Barkly-street, East Brunswick, 3057. One commercial goods vehicle (L/C. 16 cwt.) to operate throughout the State of Victoria as a "Roof Tiling Contractor"—tools of trade, ladders, and up to 30 roofing tiles, three (3) bags of cement and 30 lb. of oxide colour incidental to the completion of a contract.

#### RENEWALS.

APPLICATIONS for renewal of licences as shown by persons listed hereunder to operate under the same terms and conditions from the expiry shown in each case.

A.C.I. OPERATIONS PTY. LTD., Booker-street, Spotswood, 3015; D.A.29952/1; 19th October, 1968; 178 cwt.; D.A.29952/2; 19th October, 1968; 180 cwt.

ALBION REID PTY. LTD., 83 Riversdale-road, Hawthorn, 3122; D.A.520/126; 26th October, 1968; 129 cwt.

BAYER LEVERKUSEN LTD., 1087 High-street, Armadale, 3143; D.A.48044/4; 5th October, 1968; 12 cwt.

BEAUREPAIRE TYRE SERVICE PTY. LTD., 102 Victoria-street, Carlton, 3053; D.A.629/20; 13th October, 1968; 16 cwt.

BEAUREPAIRE TYRE SERVICE PTY. LTD., 102 Victoria-street, Carlton, 3053; D.A.629/105; 19th October, 1968; 11 cwt.

BEAUREPAIRE TYRE SERVICE PTY. LTD., 102 Victoria-street, Carlton, 3053; D.A.629/106; 19th October, 1968; 11 cwt.

BROWN, C. J., 17 James-street, Ascendale, 3195; D.A.53348; 5th October, 1968; 80 cwt.

CERAMIC TRANSPORT PTY. LTD., cnr. Princes Highway and Smith-road, Springvale, 3171; D.A.50824/21; 5th October, 1968; 262 cwt.

CHRISTEYS MOTOR AUCTIONS PTY. LTD., 334 William-street, Melbourne, 3000; D.A.40914/1; 4th October, 1968; 81 cwt.

COLGATE-PALMOLIVE PTY. LTD., 660 Footscray-road, West Melbourne, 3003; D.A.41727/30; 5th October, 1968; 10 cwt.; D.A.41727/31; 5th October, 1968; 10 cwt.

COLONIAL GAS ASSOCIATION LTD., THE, 480 St. Kilda-road, Melbourne, 3004; D.A.25112/7; 8th October, 1968; 52 cwt.

DAIRYMASTER MILKING MACHINES PTY. LTD., cnr. Lygon-street and Brunswick-road, East Brunswick, 3057; D.A.53608; 19th October, 1968; 11 cwt.

DARLING, JOHN, & SON PTY. LTD., 324-328 William-street, Melbourne, 3000; D.A.44587/4; 5th October, 1968; 148 cwt.; D.A.44587/5; 5th October, 1968; 169 cwt.

EASTMOND, R. M., HOLDINGS PTY. LTD., Box 558, Renmark, 5341; D.A.23084/8; 12th September, 1968; 190 cwt.

FALKENBERG, A. F., PTY. LTD., 6 Shaftesbury-parade, Thornbury, 3071; D.A.27416/2; 1st October, 1968; 123 cwt.; D.A.27416/3; 1st October, 1968; 113 cwt.

GARDNER & TAYLOR PTY. LTD., 192 Burwood-road, Hawthorn, 3122; D.A.1128/2; 1st October, 1968; 11 cwt.

GLENMIX PTY. LTD., Beaconsfield-parade, Glenrowan, 3675; D.A.53997; 31st August, 1968; 184 cwt.

HILL, V. J., 55 Somerset-street, Richmond, 3121; D.A.53758; 26th October, 1968; 39 cwt.

HUTTON, J. C., PTY. LTD., 65 High-street, Preston, 3072; T.D.A.48355; 4th October, 1968; 123 cwt.; T.D.A.48355/1; 4th October, 1968; 125 cwt.

HUTTON, J. C., PTY. LTD., 65 High-street, Preston, 3072; T.D.A.48355/2; 4th October, 1968; 44 cwt.; T.D.A.48355/3; 4th October, 1968; 58 cwt.; T.D.A.48355/5; 4th October, 1968; 50 cwt.; T.D.A.48355/6; 4th October, 1968; 27 cwt.; T.D.A.48355/9; 4th October, 1968; 97 cwt.; T.D.A.48355/10; 4th October, 1968; 96 cwt.

JACKSON, E., 194 Napier-street, Essendon, 3040; D.A.53036; 5th October, 1968; 164 cwt.

JACKSON, J. F., 194 Napier-street, Essendon, 3040; D.A.53033; 5th October, 1968; 133 cwt.

MALONE, P. R., TRANSPORTS PTY. LTD., Grasmere Junction, 3279; D.A.35478/14; 21st September, 1968; 200 cwt.

#### TOW TRUCK:

HUSSEY, J. H. (trading as Allied Towing Service), 493 Spencer-street, West Melbourne, 3003; D.A.53177; 5th October, 1968; 42 cwt.; D.A.53177/1; 5th October, 1968; 79 cwt.

#### RENEWALS WITH VARIATION.

APPLICATIONS by the persons listed hereunder for renewal of the licence listed with variation of conditions in the manner set out opposite the names:

CORNWALL, R. C., 2 Duffy-street, Reservoir, 3073; D.A.53707; 5th October, 1968; Application to renew and vary conditions of licence No. D.A.53707. (L/C. 142 cwt.) by deleting "Albion Quarrying Co. Pty. Ltd." from the existing conditions and adding in lieu "Albion Reid Pty. Ltd."

FOOD GUARD PTY. LTD., 99 Bell-street, Preston, 3072; D.A.48195/1; 24th October, 1968; Application to renew and vary conditions of licence No. D.A.48195/1 (L/C. 19 cwt.) by deleting "East Brunswick" from the existing conditions and adding in lieu "Preston".

HATTY, W. J., 165 Raglan-street, Preston, 3072; D.A.38788; 9th May, 1968; Application to vary and renew conditions of licence No. D.A.38788 (L/C. 60 cwt.) by adding to the existing conditions after "Braybrook" the words "and on behalf of Crittall Manufacturing Co. (Aust.) Pty. Ltd. and M.T.M. (Vic.) Pty. Ltd."

Notice of any objection should be forwarded to reach the Secretary of the Board not later than 11th September, 1968.

Applicants are advised that it will not be necessary to appear on the hearing date specified above, unless advised in writing by the Board.

B. P. KAY,

Secretary.

Cnr. Lygon and Princes streets, Carlton, 3053, 23rd August, 1968.

## Private Agents Act 1966.

## NOTICE OF RECEIPT OF APPLICATIONS FOR LICENCES UNDER THE PROVISIONS OF THE PRIVATE AGENTS ACT 1966.

THE Clerk(s) of the Court(s) of Petty Sessions as listed hereunder hereby give notice that applications, as under, have been lodged for hearing by the said Court(s) on the date(s) specified.

Any person desiring to object to any of such applications must—

- (a) lodge with the respective Clerk of Petty Sessions a notice in the prescribed form of his objection and of the grounds thereof;
- (b) cause a copy of such notice to be served personally or by post upon the applicant at least three days before the hearing of the application; and
- (c) send or deliver—
  - (i) where the objection is not made by the officer in charge of the police district in which the Court is situated—a copy of the notice to such officer; and
  - (ii) where the objection is not made by the Registrar or Deputy Registrar—a copy to the Registrar.

Full Name of Applicant or in the case of a Firm or Corporation, of the Nominee.	Place of Abode of Applicant or Nominee.	Name of Firm or Corporation.	Address for Registration.	Type of Licence.	Date of Hearing of Application.
---	---	------------------------------	---------------------------	------------------	---------------------------------

## COURT OF PETTY SESSIONS, SHEPPARTON.

Senior, Raymond .. ..	8 Hill-street, Shepparton	George Laurens Pty. Ltd.	23 Fraser-street, Shepparton	Process Server ..	12.9.68
" " .. ..	" " .. ..	" " .. ..	" " .. ..	Commercial Sub-Agent	"

Dated at Shepparton this 20th day of August, 1968.

J. M. DUGAN, Clerk of Petty Sessions.

## COURT OF PETTY SESSIONS, HAMILTON.

Plummer, Stanley Edward ..	Caramut .. ..	" .. ..	47 Thompson-street, Hamilton	Commercial Sub-Agent	12.9.68
----------------------------	---------------	---------	------------------------------	----------------------	---------

Dated at Hamilton this 21st day of August, 1968.

J. CAVEN, Clerk of Petty Sessions.

## COURT OF PETTY SESSIONS, SHEPPARTON.

Willett, William Leonard ..	6 Wyndham-street, Shepparton	" .. ..	211 Corio-street, Shepparton	Process Server ..	12.9.68
-----------------------------	------------------------------	---------	------------------------------	-------------------	---------

Dated at Shepparton this 21st day of August, 1968.

J. M. DUGAN, Clerk of Petty Sessions.

## COURT OF PETTY SESSIONS, SOUTH MELBOURNE.

Drake, Achilles Sperry ..	Mt. Slide-road, Kinglake	" .. ..	101-105 Clarke-street, South Melbourne	Watchman ..	18.9.68
Miller, Frederick Alexander ..	14 Darbyshire-road, Mt. Waverley	" .. ..	" " .. ..	" .. ..	"

Dated at South Melbourne this 21st day of August, 1968.

G. MILLER, Clerk of Petty Sessions.

## COURT OF PETTY SESSIONS, MELBOURNE.

Ronan, Robert Joseph as nominee for Perrys Collection Services Proprietary Limited	Flat 12A, 51 Chapel-street, St. Kilda, 3182	Perrys Collection Proprietary Limited	403 Bourke-street, Melbourne, 3000	Commercial Agent (Corporation)	11.9.68
Lockwood, Ernest William as nominee for Integrity Collection Pty. Ltd.	54 Keith-street, Parkdale, 3194	Integrity Collection Pty. Ltd.	4 Dudley-street, West Melbourne, 3003	" "	"
Farnell, Thomas Kitchiner ..	377 Station-street, Box Hill, 3128	Australian Watching Co. Pty. Ltd.	340 Abbotsford-street, North Melbourne, 3051	Watchman ..	"
Gilmour, Clive Douglas ..	10 Cooke-street, Essendon, 3040	" "	" "	" ..	"
Holmes, Francis Oliver ..	22 Green-avenue, Kingsbury, 3083	" "	" "	" ..	"
Humar, Oscar .. ..	77 McArthur-avenue, St. Albans, 3021	" "	" "	" ..	"
Kolp, Otto .. ..	8 McKay-street, Sunshine, 3020	" "	" "	" ..	"
Lovatt, James .. ..	Flat 17, 47 Robinson-road, Hawthorn, 3122	" "	" "	" ..	"
March, Edward Francis ..	Flat 8, 11 Palmer-street, Collingwood, 3066	" "	" "	" ..	"
Marion, George .. ..	142 Hyde-street, Yarraville, 3013	" "	" "	" ..	"
Ramaekers, Joseph .. ..	195 Brunswick-road, East Brunswick, 3056	" "	" "	" ..	"
Roff, Arthur Derek .. ..	568 North-road, Ormond, 3204	" "	" "	" ..	"
Williams, Raymond Edmund ..	Flat 22, 83 Albert-street, East Melbourne, 3002	" "	" "	" ..	"

Dated at Melbourne this 21st day of August, 1968.

G. L. WEBSTER, Clerk of Petty Sessions.

## COURT OF PETTY SESSIONS, HORSHAM.

Williams, Charles Henry ..	26 Bradshaw-street, Horsham	" .. ..	26 Bradshaw-street, Horsham	Process Server ..	4.9.68
----------------------------	-----------------------------	---------	-----------------------------	-------------------	--------

Dated at Horsham this 19th day of August, 1968.

J. M. DUFFY, Clerk of Petty Sessions.



Health Act 1958.

VICTORIA—DEPARTMENT OF HEALTH.

**NOTICE TO ATTEND FOR RADIOLOGICAL EXAMINATION.**

To all persons aged twenty-one years and over enrolled or resident in the Subdivisions specified hereunder in the State Electoral District of Geelong.

**T**AKE notice that you are required to attend at a Department of Health X-ray unit sited in the public street at or as near as possible to the main entrance to the premises specified in this notice, at any time between the hours specified on one of the days specified and during the period specified in respect of those premises, and thereat to submit yourself to radiological examination of the chest for the purpose of ascertaining whether you may be suffering from pulmonary tuberculosis. If you have had a Chest X-ray within the last twelve months and for that reason do not wish to be examined now, you should attend the unit as directed and submit particulars of the previous examination.

SPECIFIED SUBDIVISIONS, PREMISES, PERIODS, DAYS AND HOURS.

Subdivision.	Premises.	Period.	Days.	Hours.
Belmont North	Dickins New World Supermarket, High-street, Belmont	Monday, 16th September, 1968, to Thursday, 19th September, 1968, (inclusive)	Monday, 16th September, 1968 All other days during the period except Public Holidays	From 2 p.m. to 6 p.m. and 7.30 p.m. to 9 p.m. From 10 a.m. to 6 p.m. and 7.30 p.m. to 9 p.m.
	Highton Pharmacy, Bellevue-avenue, Highton	Monday, 16th September, 1968, to Wednesday, 18th September, 1968 (inclusive)	Monday, 16th September, 1968 All other days during the period except Public Holidays	From 2 p.m. to 6 p.m. and 7.30 p.m. to 9 p.m. From 10 a.m. to 6 p.m. and 7.30 p.m. to 9 p.m.
	Shopping Centre, cnr. Araluen-parade and Mt. Pleasant-road, Belmont	Wednesday, 18th September, 1968, and Thursday, 19th September, 1968	Wednesday, 18th September, 1968 Thursday, 19th September, 1968	From 11 a.m. to 6 p.m. and 7.30 p.m. to 9 p.m. From 10 a.m. to 6 p.m. and 7.30 p.m. to 9 p.m.
Newtown and Chilwell	Town Hall, cnr. Pakington-street and Retreat-road, Newtown	Thursday, 19th September, 1968, to Wednesday, 25th September, 1968 (inclusive)	Thursday, 19th September, 1968 All other days during the period except Saturday, Sunday and Public Holidays	From 11 a.m. to 6 p.m. and 7.30 p.m. to 9 p.m. From 10 a.m. to 6 p.m. and 7.30 p.m. to 9 p.m.
	Cnr. Holyrood-avenue and Fyans-street, Chilwell	Friday, 20th September, 1968	Friday, 20th September, 1968	From 11 a.m. to 6 p.m. and 7.30 p.m. to 9 p.m.
	Wood's Foodland Store, Stinton-avenue, Chilwell	Friday, 20th September, 1968, and Monday, 23rd September, 1968	Friday 20th September, 1968 Monday, 23rd September, 1968	From 11 a.m. to 6 p.m. and 7.30 p.m. to 9 p.m. From 10 a.m. to 6 p.m. and 7.30 p.m. to 9 p.m.
	Malkin's Pharmacy, cnr. Shannon-avenue and Aberdeen-street, Newtown	Monday, 23rd September, 1968, to Friday, 27th September, 1968 (inclusive)	Monday, 23rd September, 1968 All other days during the period except Public Holidays	From 11 a.m. to 6 p.m. and 7.30 p.m. to 9 p.m. From 10 a.m. to 6 p.m. and 7.30 p.m. to 9 p.m.
Geelong	Infant Welfare Centre, Russell-street, Newtown	Tuesday, 24th September, 1968, to Friday, 27th September, 1968 (inclusive)	Tuesday, 24th September, 1968 All other days during the period except Public Holidays	From 11 a.m. to 6 p.m. and 7.30 p.m. to 9 p.m. From 10 a.m. to 6 p.m. and 7.30 p.m. to 9 p.m.
	Milk Bar, cnr. Foster and Yarra streets, Geelong South	Thursday, 26th September, 1968, to Monday, 30th September, 1968 (inclusive)	Thursday, 26th September, 1968 All other days during the period except Saturday, Sunday and Public Holidays	From 11 a.m. to 6 p.m. and 7.30 p.m. to 9 p.m. From 10 a.m. to 6 p.m. and 7.30 p.m. to 9 p.m.
	Gilmore Service Station, cnr. McKillop-street and Ormond-road, Geelong	Monday, 30th September, 1968, to Tuesday, 8th October, 1968 (inclusive)	Monday, 30th September, 1968 All other days during the period except Saturday, Sunday and Public Holidays	From 2 p.m. to 6 p.m. and 7.30 p.m. to 9 p.m. From 10 a.m. to 6 p.m. and 7.30 p.m. to 9 p.m.
	Fenwick Memorial Hall, cnr. Breakwater and St. Albans roads, Geelong	Monday, 30th September, 1968, to Thursday, 3rd October, 1968 (inclusive)	Monday, 30th September, 1968 All other days during the period except Public Holidays	From 2 p.m. to 6 p.m. and 7.30 p.m. to 9 p.m. From 10 a.m. to 6 p.m. and 7.30 p.m. to 9 p.m.
	Library, rear City Hall, Little Malop-street, Geelong	Tuesday, 1st October, 1968, to Monday, 7th October, 1968 (inclusive)	Tuesday, 1st October, 1968 All other days during the period except Saturday, Sunday and Public Holidays	From 11 a.m. to 6 p.m. and 7.30 p.m. to 9 p.m. From 10 a.m. to 6 p.m. and 7.30 p.m. to 9 p.m.
	Cnr. Malop and Bellarine streets, Geelong	Friday, 4th October, 1968, to Tuesday, 8th October, 1968 (inclusive)	Friday, 4th October, 1968 All other days during the period except Saturday, Sunday and Public Holidays	From 11 a.m. to 6 p.m. and 7.30 p.m. to 9 p.m. From 10 a.m. to 6 p.m. and 7.30 p.m. to 9 p.m.

NOTE.—Any person to whom this notice applies and who without reasonable excuse fails to comply with the requirements of the notice shall be guilty of an offence, and shall be liable to a penalty of not more than Forty dollars  
Dated this 19th day of August, One thousand nine hundred and sixty-eight.

R. J. FARNBACH, Chief Health Officer.

LOCAL GOVERNMENT DEPARTMENT.

ORDER CONFIRMED.—SHIRE OF BELLARINE.

**T**HE Minister of the Crown administering the Local Government Act 1958, on the 21st day of August, 1968, confirmed the Order hereinafter referred to in pursuance of section 514 of the said Act namely:

An Order of the Council of the Shire of Bellarine made on the 3rd July, 1968, directing the compulsory taking of

certain land being lot 20, on plan of subdivision No. 11151, lodged in the Office of Titles, for the provision of a recreation reserve at Newcomb.

R. J. HAMER,  
Minister for Local Government.

Local Government Department,  
Melbourne.

Melbourne and Metropolitan  
BOARD OF WORKS.

NOTICE TO THE OWNERS OF TENEMENTS IN THE UNDER-  
MENTIONED STREETS, AND THE PRIVATE STREETS, LANES,  
COURTS AND ALLEYS OPENING THERETO.

THE main pipe in the said streets being laid down, the  
owners of all tenements situated as under are hereby  
required, on or before the 30th September, 1968, to cause  
a proper pipe and stop cocks to be laid so as to supply  
water within such tenements from the main pipe.

H. J. SNADDEN,  
Secretary.

20th August, 1968.

STREET AND POSITION.

*Altona.*

Simmons-drive, from Noordenne-avenue, southwards, south-  
easterly and northwards to Noordenne-avenue.  
James-avenue, from Noordenne-avenue to Simmons-drive.  
Jurga-court, from Noordenne-avenue southwards 590 feet.  
Martin-court, from Noordenne-avenue southwards 480 feet.  
McIntyre-drive, from Lugg-street south-eastwards 890 feet.  
Kim-court, from McIntyre-drive south-westwards 340 feet.  
Chorley-avenue, from Hammond-street to McIntyre-drive.

*Broadmeadows.*

Andrew-street, from Ward-street eastwards 150 feet.  
Ward-street, from Andrew-street south-eastwards 990 feet.  
John-street, from May-street north-westwards 1,570 feet.  
Sadie-street, from John-street to Gowrie-street.  
Evell-street, from May-street to Ogden-street.  
Morell-street, from May-street north-westwards 630 feet.  
Everard-street, from Hilton-street north-westwards 820  
feet.  
Hilton-street, from Eucra-street eastwards 530 feet.

*Dandenong.*

Patrona-street, from 180 feet east of Plunkett-street east-  
wards 250 feet.  
Dennis-street, from Patrona-street southwards 80 feet.

*Doncaster.*

Grasmere-avenue, from George-street to Saxonwood-drive.  
Saxonwood-drive, from Grasmere-avenue eastwards 808  
feet.  
Romford-court, from Saxonwood-drive southwards 297  
feet.  
Woodstock-court, from Saxonwood-drive southwards 380  
feet.  
Retford-court, from Saxonwood-drive northwards 346 feet.  
Maldon-crescent, from Saxonwood-drive northwards 230  
feet.

*Keilor.*

York-street, from 907 feet east of Bowes-avenue eastwards  
99 feet.

*Moorabbin.*

Washington-drive, from Old Dandenong-road westwards  
1,000 feet.  
Norwood-street, from Washington-drive to Old Dandenong-  
road.  
Roche-court, from Old Dandenong-road southwards 370  
feet.  
Beatrice-street, from Farm-road northwards and westwards  
1,960 feet.  
Barkley-drive, from Beatrice-street southwards 420 feet.  
Hermitage-street, from Beatrice-street southwards 430  
feet.

*Nunawading.*

Paranda-court, from Culbara-drive south-westwards 490  
feet.  
Culbara-drive, from Centre-road southwards 460 feet.

*Springvale.*

Clarke-road, from 640 feet south of Heatherton-road  
southwards 250 feet.  
Springfield-road, from Clarke-road eastwards 390 feet.  
Frances-street, from Springfield-road to Heatherton-road.  
Ruth-court, from Frances-street westwards 260 feet.  
Judith-court, from Frances-street westwards 360 feet.

*Sunshine.*

Hilma-street, from 20 feet west of Alexander-street west-  
wards 1,200 feet.

*Waverley.*

Ferntree Gully-road, from Moores-road westwards 940  
feet.  
Cootamundra-drive, from Ferntree Gully-road southwards  
120 feet.

*Whittlesea.*

Partridge-street, from Tobruk-court north-eastwards 880  
feet.  
Coral-court, from Partridge-street north-westwards 380  
feet.  
Kokoda-court, from Partridge-street north-westwards 530  
feet.  
Tobruk-court, from Partridge-street south-eastwards 370  
feet.  
Derna-crescent, from Partridge-street south-eastwards 650  
feet.  
Manus-court, from Derna-crescent westwards 520 feet.

*Labour and Industry Act 1958, Section 45b.*

REFERENCE OF A MATTER TO THE INDUSTRIAL  
APPEALS COURT.

NOTICE is hereby given that pursuant to the provisions  
of section 45b of the *Labour and Industry Act 1958*  
the Minister of Labour and Industry has referred to the  
Industrial Appeals Court for determination by it the  
following matter, viz.:-

An application to each of the Wages Boards mentioned  
in the Schedule hereto to amend its Determination by  
altering the prices and/or rates thereby determined having  
regard to the order of the Commonwealth Conciliation and  
Arbitration Commission made on the 6th day of August,  
1968, in the Metal Trades Cases (C No. 839 of 1968 and  
C No. 840 of 1968).

SCHEDULE.

Agricultural Implements; Bedsteadmakers; Boilermakers;  
Cycle Trade; Draughtsmen; Electrical Trade; Electro-  
platers; Engineers and Brassworkers (Skilled); Engineers  
and Brassworkers (Unskilled); Engravers; Gas Meter; Iron-  
moulders; Jewellers; Nailmakers; Nickelware; Opticians;  
Ovenmakers; Production Planning; Radio; Road Patrol-  
men's; Tinsmiths; Watch Cases; Watchmakers; Wire Fence  
and Tubular Gate; Wireworkers.

Notice is also given that the Industrial Appeals Court  
will deal with the aforesaid matter on Tuesday, the 3rd day  
of September, 1968, at No. 1 Boardroom, Workers Com-  
pensation Board Offices, 160 Queen-street, Melbourne, at  
10 a.m.

Dated at Melbourne, this 23rd day of August, 1968.

P. F. FENNESSY, Registrar,  
Industrial Appeals Court.

DEPARTMENT OF LABOUR AND INDUSTRY.  
DETERMINATION OF THE HOSPITAL AND  
BENEVOLENT HOMES BOARD.

ATTENTION is drawn to the fact that a notice of appeal  
to the Industrial Appeals Court has been lodged  
against Clause 31 of the Determination of the Hospital and  
Benevolent Homes Board made on the 29th July, 1968.

Section 45 (1) (b) of Act 6283 provides that when an  
appeal is made in accordance with that Act, the parts of  
the Determination appealed against shall not come into  
operation until the appeal has been dealt with by the Court.

M. S. JEANS, Acting Secretary.

DEPARTMENT OF LABOUR AND INDUSTRY.  
DETERMINATION OF THE TEACHERS (DAY TRAINING  
CENTRES) BOARD.

ATTENTION is drawn to the fact that a notice of appeal  
to the Industrial Appeals Court has been lodged  
against Clause 2 (Wages) of the Determination of the  
Teachers (Day Training Centres) Board made on the 30th  
July, 1968.

Section 45 (1) (b) of Act 6283 provides that when an  
appeal is made in accordance with that Act, the parts of  
the Determination appealed against shall not come into  
operation until the appeal has been dealt with by the  
Court.

M. S. JEANS, Acting Secretary.

*Co-operation Act 1958.*

CHANGE OF NAME OF A SOCIETY.

NOTICE is hereby given that Mildura Parish Co-operative  
Credit Society Limited which was incorporated as a  
Credit Society under the above-named Act on the twenty-  
eighth day of October, 1964, has registered a change of its  
name and is now incorporated under the name of Mildura  
Co-operative Credit Society Limited under the said Act.

Dated at Melbourne, this twentieth day of August, 1968.

M. V. HAMMOND,  
Deputy Registrar of Co-operative Societies.

## Co-operation Act 1958.

## MITCHAM HIGH SCHOOL CO-OPERATIVE LIMITED.

## NOTICE OF DISSOLUTION OF SOCIETY.

NOTICE is hereby given that I have this day registered the dissolution of the above-named society and cancelled its registration under the above-named Act.

Dated at Melbourne, this nineteenth day of August, 1968.

M. V. HAMMOND,  
Deputy Registrar of Co-operative Societies.

## Police Regulation Act 1958, Section 122.

## SALE OF UNCLAIMED LAMB.

AN owner is required for a crossbred lamb, approximately eleven months old, which came into the possession of Police on the 13th September, 1967.

If not claimed, the lamb will be sold by public auction at the Police Stud Depot, "Attwood", Mickleham-road, Westmeadows, at 10 a.m., on the 30th August, 1968.

R. H. ARNOLD,  
Chief Commissioner of Police.

## Police Regulation Act 1958, Section 122.

## SALE OF UNCLAIMED MOTOR VEHICLE.

AN owner is required for a 1952 model black Wolseley sedan motor vehicle, ex-registered No. (Vic.) HGE-284, engine No. 7538.

The vehicle came into the possession of Police on the 17th November, 1967, and if not claimed, will be sold by public auction at the Dandenong Police Station, Langthorpe-street, Dandenong, at 2 p.m., on the 10th September, 1968.

R. H. ARNOLD,  
Chief Commissioner of Police.

## State Savings Bank Act 1958, Section 30.

## THE STATE SAVINGS BANK OF VICTORIA.

## ESTABLISHMENT OF BRANCH.

THE Commissioners of the State Savings Bank of Victoria hereby give notice of the establishment of a branch of the bank at Southland Centre, Cheltenham, on 3rd September, 1968.

T. E. HALL,  
General Manager.

## Dairy Products Act.

## QUOTAS FOR BUTTER AND CHEESE.

## BUTTER QUOTA.

I, GILBERT LAWRENCE CHANDLER, Minister of Agriculture in the State of Victoria, after consultation with the Victorian Dairy Products Board, and after ascertaining that the supply and distribution of butter at reasonable prices to consumers thereof in Victoria will be ensured, hereby determine a quota for butter as follows:—

The proportion shall be Forty point four three per centum.

The period for which this quota is to operate shall be the month of September, 1968.

## CHEESE QUOTA.

I, GILBERT LAWRENCE CHANDLER, Minister of Agriculture in the State of Victoria, after consultation with the Victorian Dairy Products Board, and after ascertaining that the supply and distribution of cheese at reasonable prices to consumers thereof in Victoria will be ensured, hereby determine a quota for cheese as follows:—

The proportion shall be Thirty-three point eight eight per centum.

The period for which this quota is to operate shall be the month of September, 1968.

G. L. CHANDLER,  
Minister of Agriculture.

## PUBLIC TRUSTEE ACT 1958 (No. 6350), SECTION 17.

I HEREBY give notice that on the 7th August, 1968, the Public Trustee filed elections to administer the following deceased persons' estates, in accordance with section 17 of the Public Trustee Act 1958:—

HUGHES, WILLIAM, formerly of Lot 95, Scenic-crescent, Eltham, late of Greenvale Village, Greenvale, retired metal worker, died 5th May, 1968.

JONES, FRANCIS, late of Kew, no occupation, died 21st August, 1965.

JORGENSEN, ELIZABETH ESTELLE, late of 65 Talbot-avenue, Balwyn, married woman, died 28th May, 1968.

PERRY, EMILY RUBECCA, late of 3 Hamel-street, Sunshine, married woman, died 7th May, 1968.

SMITH, ARTHUR JAMES, formerly known as Singh, Arthur James, late of 62 McIndoe-parade, Parkdale, gardener, died 22nd June, 1968.

I HEREBY give notice that on the 14th August, 1968, the Public Trustee filed elections to administer the following deceased persons' estates, in accordance with section 17 of the Public Trustee Act 1958:—

ARNOLD, KATE, late of 33 Grey-street, St. Kilda, spinster, died 6th June, 1968.

JOHNSON, EVELYN ANGIER, late of 143 Cranbourne-road, Frankston, married woman, died 6th June, 1968.

JOHNSTONE, MARY BARBARA, formerly of Ventnor, Phillip Island, but late of Manchester Unity Aged Members' Centre, Glen Waverley, widow, died 3rd June, 1968.

LEAHY, ALICE FRANCES, formerly of 2 Grattan-street, Carlton, but late of St. Georges-road, Northcote, retired seamstress, died 7th June, 1968.

LINDGREN, GEORGE LEONARD, late of 192 Neerim-road, Carnegie, pensioner, died 8th December, 1966.

LOPEZ, JUAN RAMIREZ, formerly of Electric Power Transmission Pty. Ltd. Camp, Tomago, New South Wales, but late of Electric Power Transmission Pty. Ltd. Camp, Barwidgee Creek, via Myrtleford, Victoria, rigger, died 22nd March, 1968.

PLENTY, GEORGE JAMES CORBET, also known as George Parker, formerly of 19 Avenue-road, Payneham, South Australia, and 50 Nicholson-street, Fitzroy, Victoria, but late of 44 Gertrude-street, Fitzroy, canvasser, formerly tailor, died 2nd April, 1967.

WHEELER, ETHEL FLORENCE, late of Queen Elizabeth Home, Ballarat, spinster, died 14th May, 1968.

D. HOOKEY,  
Acting Public Trustee.

256 Flinders-street, Melbourne, 21st August, 1968.

## NOTICE.

CREDITORS, next of kin and others having claims in against the estate of any of the under-mentioned deceased persons are required to send particulars of their claims to the Public Trustee, 256 Flinders-street, Melbourne, 3000, the personal representative, on or before the 6th November, 1968, after which date the Public Trustee may convey or distribute the assets, having regard only to the claims of which the Public Trustee then has notice:—

ANDREWS, FLOSSIETTE LAVENA MAY, late of 4 Vega-street, North Balwyn, married woman, died 13th June, 1968.

ARNOLD, KATE, late of 33 Grey-street, St. Kilda, spinster, died 6th June, 1968.

BLUNDY, HILDA MAY, formerly of 10 Lempriere-avenue, East St. Kilda, and Wesley House, 148 Lonsdale-street Melbourne, but late of Cheltenham Home and Hospital for Aged, Cheltenham, spister, died 12th June, 1968.

BOWLER, MICHAEL, late of 23 Mount Pleasant-road, Nunawading, retired taxi truck driver, died 11th June, 1968.

BURT, AMELIA, late of Kal Kallo, spinster, died 15th August, 1951.

FORD, ELIZABETH MARY, late of Pleasant View Hospital, 131 Wood-street, Preston, pensioner, died 16th May, 1968.

FULTON, ANNA MARIA, late of 30 Edsall-street, Malvern, widow, died 16th July, 1946.

GRIMWOOD, JOHN STANLEY, formerly of 5 Rupert-street, Gardenvale, but late of "Overton" 17 Packington-street, Kew, retired civil servant, died 6th May, 1968.

HOOGENBOOM, PETRUS BARTHOLOMEUS, also known as Petrus Hoogenboom, late of Lot 2, Clayton-road, Clayton South, poultry farmer, died 17th July, 1967.

HOUGHIN, CATHERINE, also known as Catherine Houchan, late of 23 Mitchell-street, Seaford, widow, died 9th May, 1968.

HUGHES, WILLIAM, formerly of Lot 95, Scenic-crescent, Eltham, late of Greenvale Village, Greenvale, retired metal worker, died 5th May, 1968.

JOHNSON, EVELYN ANGIER, late of 143 Cranbourne-road, Frankston, married woman, died 6th June, 1968.

JOHNSTONE, MARY BARBARA, formerly of Ventnor, Phillip Island, but late of Manchester Unity Aged Members' Centre, Glen Waverley, widow, died 3rd June, 1968.

JONES, FRANCIS late of Kew, no occupation, died 21st August, 1965.

JORGENSEN, ELIZABETH ESTELLE, late of 65 Talbot-avenue, Balwyn, married woman, died 28th May, 1968.

KELLEHER, ROSEANNE CONSTANCE, also known as Roseann Kelleher, Roseanne Kelleher, Rose Kelleher, Rosie Kelleher, late of 283 Abbotsford-street, North Melbourne, buyer, died 15th November, 1967.

LEAHY, ALICE FRANCES, formerly of 2 Grattan-street, Carlton, but late of St. Georges-road, Northcote, retired seamstress, died 7th June, 1968.

LINDGREN, GEORGE LEONARD, late of 192 Neerim-road, Carnegie, pensioner, died 8th December, 1966.

LOPEZ, JUAN RAMIREZ, formerly of Electric Power Transmission Pty. Ltd. Camp, Tomago, New South Wales, but late of Electric Power Transmission Pty. Ltd. Camp, Barwidgee Creek, via Myrtleford, Victoria, rigger, died 22nd March, 1968.

MOELLER, LEONARD JOHANNES FRENCH, also known as Leonard Johannes French Moeller, formerly of 40 Dorritt-street, Carlton, but late of Warrigal-road, Cheltenham, retired railways employee, died 9th January, 1968.

MCEVOY, WILLIAM HENRY, late of 129 Head-street, Elsternwick, retired senior clerk, died 13th May, 1968.

O'BRIEN, ALFRED CLIFTON, late of 10 Powell-street, Reservoir, clerk, died 21st May, 1968.

O'SULLIVAN, TERENCE MICHAEL, late of Flat E2-1 Hotham Gardens, 140 Arden-street, North Melbourne, traveller, died 18th June, 1967.

PERRY, EMILY RUBECCA, late of 3 Hamel-street, Sunshine, married woman, died 7th May, 1968.

PLENTY, GEORGE JAMES CORBET, also known as George Parker, formerly of 19 Avenue-road, Payneham, South Australia, and 50 Nicholson-street, Fitzroy, Victoria, but late of 44 Gertrude-street, Fitzroy, canvasser, formerly tailor, died 2nd April, 1967.

SMITH, ARTHUR JAMES, formerly known as Singh Arthur James, late of 62 McIndoe-parade, Parkdale, gardener, died 22nd June, 1968.

SMITH, MAY CHARLOTTE, late of St. Michael's Hospital, Omama-road, Murrumbidgee, widow, died 1st June, 1968.

TREVEN, STANISLAV, also known as Stanislaw Treven, late of 237 William-road, South Yarra, carpenter, died 11th April, 1968.

TYNAN, LEO JOSEPH, late of 2 Phillis-street, Elwood, retired male nurse, died 27th May, 1968.

WHEELER, ETHEL FLORENCE, late of Queen Elizabeth Home, Ballarat, spinster, died 14th May, 1968.

D. HOOKEY,  
Acting Public Trustee.

Melbourne, 21st August, 1968.

#### ORDERS IN COUNCIL.—(Series 1968-69.)

##### PUBLIC WORKS DEPARTMENT.

651. Dookie, Agricultural College, supply of "Steelbilt" shelving, \$1,110.44.—Steelbilt (Aust.) Pty. Ltd.—(N.E.132012.)

652. Geelong, Teachers' College, supply of gymnasium equipment, \$1,066.00.—Laurion Pty. Ltd.—(S.W.107125.)

653. Heidelberg Heights, State School No. 4774, repairs to storm damaged shelter sheds, \$1,207.00.—Laurie Jessop.—(N.E.135321.)

654. Maryvale, High School, supply of class-room seating, \$2,583.30.—Namco Furniture Contract Division.—(S.E.108409 "F")

655. Melbourne, Royal Melbourne Institute of Technology, urgent replacement of roofing, \$5,654.00.—Building Plastics (Vic.) Pty. Ltd.—(C.95507.)

656. Melbourne, School of Hairdressing, supply and erection of partitions, \$3,619.00.—G.K.N. Building & Engineering.—(C.133924.)

657. Melbourne, Victorian Government Tourist Bureau, supply and installation of new air conditioning plant, \$9,476.00.—Email Ltd.—(C.78532.)

658. Olympic Village, State School No. 4713, repair and replacement of storm damaged shelter sheds, \$1,599.00.—Laurie Jessop.—(N.E.135320.)

659. Richmond, Technical School, improved lighting in panel-beating shop, \$1,087.00.—J. Newall Pty. Ltd.—(E.M.129470.)

660. Toolangi, Potato Research Farm, glazing works required to glasshouse, \$1,540.00.—Specialty Engineering Pty. Ltd.—(N.E.110053.)

Approved by the Governor in Council, 20th August, 1968.—J. ROSSITER, Clerk of the Executive Council.

#### STATE ELECTRICITY COMMISSION.

662. For the construction of civil engineering works and building for South Melbourne Substation, to Specification No. 68/157, \$123,819.—Ararat Concrete Paving Co. Pty. Ltd.

663. For the supply of three power system disturbance recorders for Keilor and Hazelwood Terminal Stations, to Specification No. 68/178, \$60,885.—Automatic Accessories Pty. Ltd.

664. For the supply of natural round wooden poles for preservative treatment at Brooklyn for a period of twelve months, to Specification No. 68/151, at Schedule rates.—R. J. Curtis.

665. For the supply of natural round wooden poles for preservative treatment at Brooklyn for a period of twelve months, to Specification No. 68/151, at Schedule rates.—W. R. & M. De Vries.

666. For the supply of natural round wooden poles for preservative treatment at Brooklyn for a period of twelve months, to Specification No. 68/151, at Schedule rates.—Duncan Innes Pty. Ltd.

667. For the supply of natural round wooden poles for preservative treatment at Brooklyn for a period of twelve months, to Specification No. 68/151, at Schedule rates.—Gippsland Pole Supply.

668. For the supply of lubricants for automotive, tractor and associated plant, for a period of two years, with optional extension of three months, to Specification No. 68/108, at Schedule rates.—Golden Fleece Petroleum.

669. For the supply of natural round wooden poles for preservative treatment at Brooklyn for a period of twelve months, to Specification No. 68/151, at Schedule rates.—N. A. Keogh.

670. For the supply of natural round wooden poles for preservative treatment at Brooklyn for a period of twelve months, to Specification No. 68/151, at Schedule rates.—R. & L. McLeod.

671. For the supply of natural round wooden poles for preservative treatment at Brooklyn for a period of twelve months, to Specification No. 68/151, at Schedule rates.—A. Sturrock & Sons Pty. Ltd.

Approved by the Governor in Council, 6th August, 1968.—J. ROSSITER, Clerk of the Executive Council.

672. For the supply of fourteen International vehicles for replacement of high mileage vehicles, to Quotation No. 4731, \$56,802.—International Harvester Co. of Aust. Pty. Ltd.

Approved by the Governor in Council, 13th August, 1968.—J. ROSSITER, Clerk of the Executive Council.

#### CONTRACTS ACCEPTED.—(Series 1968-69.)

##### VICTORIAN RAILWAYS.

19. Supply and delivery of combination turret lathe for Ballarat Workshops (f.o.r., Melbourne), at rates (Contract 63269).—Demco Machinery Co. (Vic.) Pty. Ltd. 20. Supply and delivery of mobile crane for Traffic Branch, at rates f.o.b. U.K. Port (Contract 63270).—Colex Cranes Limited. 21. Manufacture, supply and delivery of twelve circuit carrier telephone, terminals, repeaters and associated equipment (Melbourne to Ararat) at rates (Contract 63277).—Siemens Industries Ltd. 22. Supply and delivery of wooden electric light poles, at rates (Contract 63289).—A Norman. 23. Supply and delivery of wooden electric light poles, at rates (Contract 63331).—W. J. & J. P. McKenzie. 24. Supply and delivery of wooden electric light poles, at rates (Contract 63332).—Hickson's Timber Impregnation Co. (Aust.) Pty. Ltd.

By order of the Victorian Railways Commissioners,  
W. WALKER, Secretary. 23.8.68.

#### SOIL CONSERVATION AUTHORITY.

No. 16802.

661. Gully battering and waterway construction in Jeffcott Co-operative Project.—K. J. & M. J. Pritchard, St. Arnaud.—Fiat AD12 Dozer—\$15.75 per hour.

No. 96802.

650. Earthwork construction, Wilby-Almonds Project.—F. W. Stilo, Benalla.—Cat. 12 Grader, at \$8.00 per hour; Ramage Bros., Wangaratta.—Cat. 12 Grader, at \$8.00 per hour.

P. J. MCCALLUM, Secretary.

#### Town and Country Planning Act 1961.

##### GEELONG PLANNING SCHEME 1959.

AMENDMENT No. 4, 1967.

(CITY OF GEELONG.)

Notice of Approval.

IN pursuance of the powers conferred by the Town and Country Planning Act 1961, the Governor in Council, on the 20th August, 1968, approved a planning scheme entitled the Geelong Planning Scheme 1959, Amendment No. 4, 1967 (City of Geelong), in respect of part of the municipal district of the City of Geelong and such planning scheme comes into operation on the date this notice of approval is published in the *Government Gazette*.

A copy of the planning scheme as approved may be inspected free of charge during office hours at the office of the Town and Country Planning Board, 179 Queen-street, Melbourne; at the office of the Geelong City Council at Geelong, and when available, at the Office of Titles, Melbourne, and at the Central Plan Office of the Department of Crown Lands and Survey, Melbourne.

W. H. CRAIG, Secretary,  
Town and Country Planning Board.

Town and Country Planning Act 1961 (As amended).  
GEELONG PLANNING SCHEME 1959.

AMENDMENT No. 7, 1967.

(CITY OF NEWTOWN.)

Notice of Approval.

IN pursuance of the powers conferred by the Town and Country Planning Act 1961, as amended, the Governor in Council on the 20th August, 1968, approved a planning scheme entitled the Geelong Planning Scheme 1959, Amendment No. 7, 1967, (City of Newtown) in respect of the municipal district of the City of Newtown and such planning scheme comes into operation on the date this notice of approval is published in the *Government Gazette*.

A copy of the planning scheme as approved may be inspected free of charge during office hours at the office of the Town and Country Planning Board, 179 Queen-street, Melbourne; at the office of the Newtown City Council at Newtown, and when available, at the Office of Titles, Melbourne, and at the Central Plan Office of the Department of Crown Lands and Survey, Melbourne.

W. H. CRAIG, Secretary,  
Town and Country Planning Board.

Town and Country Planning Act 1961 (As amended).  
GEELONG PLANNING SCHEME 1959.

AMENDMENT No. 7, 1966.

(SHIRE OF SOUTH BARWON.)

Notice of Approval.

IN pursuance of the powers conferred by the Town and Country Planning Act 1961, as amended, the Governor in Council on the 20th August, 1968, approved a planning scheme entitled the Geelong Planning Scheme 1959, Amendment No. 7, 1966 (Shire of South Barwon) in respect of part of the municipal district of the Shire of South Barwon and such planning scheme comes into operation on the date this notice of approval is published in the *Government Gazette*.

A copy of the planning scheme as approved may be inspected free of charge during office hours at the office of the Town and Country Planning Board, 179 Queen-street, Melbourne; at the office of the South Barwon Shire Council at Belmont, and when available, at the Office of Titles, Melbourne, and at the Central Plan Office of the Department of Crown Lands and Survey, Melbourne.

W. H. CRAIG, Secretary,  
Town and Country Planning Board.

DEPARTMENT OF MINES.

SUBJECT to any necessary excisions, &c., it is proposed to grant the following leases:—

- 8226, Mineral; Roland Walton; 101a. 0r. 0p., Parish of Burrowye.  
8227, Mineral; Roland Walton; 134a. 3r. 0p., Parish of Burrowye.

MINING LEASES GRANTED.

- 8429, Mineral; Robert Frederick Fitzgerald Harbison, Clive Stephen McAuliffe, Harry James McAuliffe, John Allan Feild Showels, William John Chisholm; 14a. 1r. 2p., Parish of Kosciusko.  
8546, Mineral; Dandenong Quarries Pty. Limited; 89a. 1r. 14p., Parish of Narree Worrان.  
8635, Mineral; Martin Stoneware Pipe Proprietary Limited; 4a. 0r. 39p., Parish of Lynchfield.  
8744, Mineral; Albion Reid Pty. Limited; 24a. 0r. 17p., Parish of Narree Worrان.

TAILINGS LICENCES GRANTED.

- 3585, Tailings Licence; The President, Councillors and Ratepayers of the Shire of Daylesford and Glenlyon; "North Ajax Mine", dump situated in the Parish of Wombat (in lieu of 3361 Tailings Licence expired).  
3589, Tailings Licence; The President, Councillors and Ratepayers of the Shire of Alexandra; "The Gobur Mine" dump situated in the Township of Gobur (in lieu of 3378 Tailings Licence expired).

TERMS OF EXPLORATION LICENCES EXTENDED.

- 3, Exploration Licence; Western Mining Corporation Limited.  
4, Exploration Licence; Western Mining Corporation Limited.

- 5, Exploration Licence; Western Mining Corporation Limited.

J. C. M. BALFOUR,  
Minister of Mines.

MINING LEASE DECLARED VOID.

8165, Mineral; North East Tin Mines Proprietary Limited; 33a. 1r. 31p., Parish of Everton.

E. CONDON,  
Secretary for Mines.

BARNAWARTHA WATERWORKS TRUST.

RATING BY-LAW 1968/69.

THE Barnawartha Waterworks Trust in pursuance of and in exercise of the powers conferred by the *Water Act 1958* and of any and every other power it thereunto enabling doth hereby make a By-Law as follows—

1. The Trust hereby makes and levies a rate in respect of all the lands and tenements within the Barnawartha Urban District of seventeen and one half cents in the dollar on the net annual value set out in the valuation at present in force of such lands and tenements for the purposes of the municipal rate of the Shire of Chiltern which is hereby adopted as the valuations of such lands and tenements respectively.

2. Such rate shall be made and levied upon the occupiers and owners of such lands and tenements for the year commencing on the 1st day of October 1968 and shall be payable on the 28th day of February 1969 at the office of the said Trust at Chiltern.

3. In no case shall the rate payable hereunder in respect of any land on which there is a building be less than seventeen dollars and in respect of land on which there is no building be less than five dollars.

The common seal of the Barnawartha Waterworks Trust was hereby affixed, the 8th day of August, 1968, in the presence of—

(SEAL) T. M. RYAN, Chairman.  
R. DOUGLAS, Commissioner.  
G. G. McWHINNEY, Secretary.

Approved, 22nd August, 1968.—W. BORTHWICK, Minister of Water Supply.

BARNAWARTHA WATERWORKS TRUST.

EXCESS WATER BY-LAW 1968-69.

THE Barnawartha Waterworks Trust in pursuance of and in exercise of the powers conferred by the *Water Act 1958* and of any and every other power it thereunto enabling doth hereby make a By-Law as follows:—

1. The meter or meters measuring the supply of water to any land or tenements shall be read as near as practicable to twelve months from the date that it was read previously and the quantity of water so measured as having been supplied during the period between any two successive such readings (hereinafter called "the meter year") shall be the basis of the calculating of charges payable under this By-Law provided always that where a meter has been installed on any land or tenement during the course of a meter year the quantity of water measured as having been supplied during the period between the date of such installation and the date of the reading shall be the basis of calculating such charges.

2. Subject as is hereinafter provided in respect of any land or tenement rated by the Trust—

(a) The maximum quantity of water to be supplied in any meter year without charge is hereby fixed as a quantity which if charged at thirty four (34) cents per thousand gallons for any meter year would give an amount equal to the amount of the rate payable in respect of the land or tenement for the financial year in which the said meter year ended.

(b) For all water supplied in any meter year in excess of the maximum quantity referred to in paragraph (a) of this clause the charge is hereby fixed at thirty four (34) cents per thousand gallons for any meter year.

3. Subject as is hereinafter provided the charge for water supplied by measure to any property not rated by the Trust is hereby fixed at thirty four (34) cents per thousand gallons.

4. The minimum charge for water supplied by measure to any property not rated by the Trust is hereby fixed at Twenty Dollars (\$20).

5. The aforesaid charges shall be payable within seven days of demand upon the owner or occupier at the office of the Trust during normal business hours.

6. The provisions of Clauses 2, 3 and 4 of this By-Law shall not apply to any land tenement or property supplied with water by the Trust under a special agreement pursuant to Section 215 of the *Water Act 1958*.

The common seal of the Barnawartha Waterworks Trust was hereby affixed, the 8th day of August, 1968, in the presence of—

(SEAL) T. M. RYAN, Chairman.  
R. DOUGLAS, Commissioner.  
G. G. McWHINNEY, Secretary.

Approved, 22nd August, 1968.—W. BORTHWICK, Minister of Water Supply.

#### WURRUK WATERWORKS TRUST.

##### RATING BY-LAW FOR YEAR 1968.

THE Wurruk Waterworks Trust in pursuance of and in exercise of the powers conferred by the *Water Act 1958* and of any and every other power it thereunto enabling doth hereby make a By-law as follows:—

1. The Trust hereby makes and levies a rate in respect of all the lands and tenements within the Wurruk Urban District, of 11.25 cents in the dollar on the net annual value set out in the valuation at present in force of such lands and tenements for the purposes of the Municipal rate of the Shire of Rosedale, which is hereby adopted as the valuation of such lands and tenements respectively.

2. Such rate shall be made and levied upon the occupiers and owners of such lands and tenements for the year commencing on the 1st day of January, 1968 and shall be payable on the 1st day of September, 1968 at the office of the said Trust.

3. In no case shall the rate payable hereunder in respect of any land on which there is a building be less than thirteen dollars and fifty cents and in respect of land on which there is no building be less than four dollars.

Passed this 13th day of August 1968.

(SEAL) ROBERT J. GRAHAM, Chairman.  
K. T. HOWARD, Commissioner.  
G. W. THOMSON, Secretary.

Approved, 16th August, 1968.—W. BORTHWICK, Minister of Water Supply.

#### WURRUK WATERWORKS TRUST.

##### BY-LAW No. 1.

THE Wurruk Waterworks Trust in pursuance of and in exercise of the powers conferred by the *Water Act 1958*, and of any and every other power it thereunto enabling, doth hereby make a By-law as follows:

1. The meter or meters measuring the supply of water to any land or tenement shall be read as near as practicable to twelve months from the date that it was read previously and the quantity of water so measured as having been supplied during the period between any two successive such readings (hereinafter called "the meter year") shall be the basis of the calculating of charges payable under this By-law provided always that where a meter has been installed on any land or tenement during the course of a meter year, the quantity of water measured as having been supplied during the period between the date of such installation and the date of the reading shall be the basis of calculating such charges.

2. Subject as is hereinafter provided in respect of any land or tenement rated by the Trust—

(a) The maximum quantity of water to be supplied in any meter year without charge is hereby fixed as a quantity which if charged at 25 cents per thousand gallons for any meter year, would give an amount equal to the amount of the rate payable in respect of the land or tenement for the financial year in which the said meter year ended.

(b) For all water supplied in any meter year in excess of the maximum quantity referred to in paragraph (a) of this clause, the charge is hereby fixed at 20 cents per thousand gallons for any meter year.

3. Subject as is hereinafter provided the charge for water supplied by measure to any property not rated by the Trust is hereby fixed at 25 cents per thousand gallons.

4. The minimum charge for water supplied by measure to any property not rated by the Trust is hereby fixed at \$20.00.

5. The aforesaid charges shall be payable within seven days of demand upon the owner or occupier at the office of the Trust during normal business hours.

6. The provisions of Clauses 3, 4 and 5 of this By-law shall not apply to any land tenement or property supplied with water by the Trust under a special agreement pursuant to Section 215 of the *Water Act 1958*.

Passed this 13th day of August 1968.

(SEAL) ROBERT J. GRAHAM, Chairman.  
K. T. HOWARD, Commissioner.  
G. W. THOMSON, Secretary.

Approved, 16th August, 1968.—W. BORTHWICK, Minister of Water Supply.

#### WARRACKNABEAL WATERWORKS TRUST.

##### AUTHORITY TO OBTAIN BANK OVERDRAFT.

HIS Excellency the Lieutenant-Governor of the State of Victoria by and with the advice of the Executive Council thereof doth by Order made on the 27th day of August, 1968, authorize the Warracknabeal Waterworks Trust to obtain in pursuance of the provisions of Section 286 of the *Water Act 1958* (No. 6413) an advance or advances during the year ending 30th September, 1969, by overdraft of the Trust's current account, such overdraft not to exceed at any one time the sum of Ten thousand dollars (\$10,000).

J. ROSSITER,  
Clerk of the Executive Council.

At the Executive Council Chamber,  
Melbourne, 27th August, 1968.

#### WODONGA WATERWORKS TRUST.

##### AUTHORITY TO OBTAIN BANK OVERDRAFT.

HIS Excellency the Lieutenant-Governor of the State of Victoria by and with the advice of the Executive Council thereof doth by Order made on the 27th day of August, 1968, authorize the Wodonga Waterworks Trust to obtain in pursuance of the provisions of Section 286 of the *Water Act 1958* (No. 6413) an advance or advances during the year ending 30th September, 1969, by overdraft of the Trust's current account, such overdraft not to exceed at any one time the sum of Fifteen thousand dollars (\$15,000).

J. ROSSITER,  
Clerk of the Executive Council.

At the Executive Council Chamber,  
Melbourne, 27th August, 1968.

#### ORBOST SEWERAGE AUTHORITY.

##### FIXING THE LIMIT OF BANK OVERDRAFT.

HIS Excellency the Lieutenant-Governor of the State of Victoria by and with the advice of the Executive Council thereof doth by Order made on the 27th day of August, 1968, fix the limit of the bank overdraft to be obtained by the Orbost Sewerage Authority, pursuant to the provisions of Section 78 of the *Sewerage Districts Act* at Fifteen thousand dollars (\$15,000).

J. ROSSITER,  
Clerk of the Executive Council.

At the Executive Council Chamber,  
Melbourne, 27th August, 1968.

#### COBRAM SEWERAGE AUTHORITY.

##### AUDIT OF ACCOUNTS.

##### Fee payable to Auditor.

HIS Excellency the Lieutenant-Governor of the State of Victoria by and with the advice of the Executive Council thereof doth by Order made on the 27th day of August, 1968, and in pursuance of the provisions of the *Sewerage Districts Act 1958* (No. 6368) approve the payment to H. W. McCutcheon of the sum of Thirty dollars (\$30) as remuneration for making an audit of the accounts of the Cobram Sewerage Authority for the period from 15th July, 1964, to 30th September, 1967, he having been duly appointed by Order in Council made 3rd October, 1967, to make such an audit.

J. ROSSITER,  
Clerk of the Executive Council.

At the Executive Council Chamber,  
Melbourne, 27th August, 1968.

## APPOINTMENTS AND RESIGNATIONS

### SEWERAGE AUTHORITIES.

#### APPOINTMENT OF AUDITORS.

HIS Excellency the Lieutenant-Governor of the State of Victoria by and with the advice of the Executive Council thereof doth by Order made on the 27th day of August, 1968, and, in pursuance of the provisions of the *Sewerage Districts Act 1958* (No. 6368), appoint the persons whose names appear hereunder, being Auditors holding certificates of competency from the Municipal Auditors' Board under the *Local Government Act 1958*, to audit and report on the accounts of the Sewerage Authorities set opposite their respective names, for the years shown, and to approve the payment out of the general fund of each of the respective authorities for such audit the remuneration shown opposite the name of each person, and the payment to the Auditor of an amount for expenses and allowances not exceeding the following:—

1. (a) Fares incurred by himself and assistants employed on the audit, or  
(b) An allowance of ten cents per mile if he travels by car;
2. An amount of \$9.00 per day for himself and each assistant when the work of the audit makes it impracticable to return home daily; and
3. An amount equal to the cost of postage incurred in connexion with the work of the audit.

### SEWERAGE AUTHORITY AUDITS.

*Auditors appointed to conduct an audit of the Accounts of Sewerage Authorities for the years shown hereunder.*

Authority.	Year Ending.	Name and Address of Auditor.	Remuneration Excluding Transport, Maintenance Expenses and Postage.
(1).	(2).	(3).	(4).
			\$
Ararat .. .. .	30th September, 1969 ..	J. Crowther, 6 Albany-road, Toorak, 3142 ..	180
Bacchus Marsh .. .. .	30th September, 1968 ..	R. W. Wade, 346 Little Collins-street, Melbourne, 3000 ..	120
Bairnsdale .. .. .	31st December, 1969 ..	K. W. Steedman, Goodman-street, Bairnsdale, 3875 ..	225
Ballarat .. .. .	31st December, 1969 ..	J. N. Morey, c/o E. N. Morey and Sons, 141 High-street, Prahran, 3181 ..	405
Benalla .. .. .	30th September, 1968 ..	N. F. Horsburgh, c/o Hatch and Horsburgh, 100 Collins-street, Melbourne, 3000 ..	150
Bendigo .. .. .	30th September, 1969 ..	G. T. Quinn, 150 Queen-street, Melbourne, 3000 ..	590
Camperdown .. .. .	30th September, 1968 ..	I. E. Lohrey, Box 48, Warrnambool, 3280 ..	90
Casterton .. .. .	30th September, 1968 ..	L. P. Smart, c/o G. Marquand and Son, 51 Queen-street, Melbourne, 3000 ..	120
Castlemaine .. .. .	30th September, 1968 ..	Miss P. Stewart, Kyneton, 3444 ..	200
Charlton .. .. .	30th September, 1968 ..	J. B. Fox, c/o Hancock, Woodward and Hollick, Box 82, Robinvale, 3549 ..	120
Chelsea .. .. .	30th September, 1969 ..	S. B. W. Cooke, 343 Little Collins-street, Melbourne, 3000 ..	To be determined
Cobram .. .. .	30th September, 1968 ..	S. S. Macgeorge, 456 Little Collins-street, Melbourne, 3000 ..	To be determined
Cohuna .. .. .	30th September, 1968 ..	L. S. Eva, 306 Little Collins-street, Melbourne, 3000 ..	To be determined
Colac .. .. .	30th September, 1968 ..	L. W. Gilbert, Box 179, Colac, 3250 ..	180
Coleraine .. .. .	30th September, 1968 ..	L. P. Smart, c/o G. Marquand and Son, 51 Queen-street, Melbourne, 3000 ..	To be determined
Corryong .. .. .	31st December, 1968 ..	F. A. Ballantine, Box 124, Wangaratta, 3677 ..	200
Croydon .. .. .	30th September, 1969 ..	H. K. Cartledge, c/o Norman, Cartledge and Brown, 1 Palmerston-crescent, South Melbourne, 3205 ..	To be determined
Dandenong .. .. .	30th September, 1969 ..	A. D. Foreshew, 172 Bouverie-street, Carlton, 3053 ..	430
Dimboola .. .. .	30th September, 1968 ..	D. E. Beasy, c/o Hancock, Woodward and Hollick, Box 82, Robinvale, 3549 ..	80
Drouin .. .. .	31st December, 1968 ..	L. R. Shepherd, 411 Collins-street, Melbourne, 3000 ..	To be determined
Echuca .. .. .	30th September, 1968 ..	G. F. Cumming, 6 Albany-road, Toorak, 3142 ..	225
Euroa .. .. .	31st December, 1968 ..	B. H. McKenzie, c/o Harris and McLaren, 340 Little Collins-street, Melbourne, 3000 ..	120
Frankston .. .. .	30th September, 1969 ..	F. G. Foster, 411 Little Collins-street, Melbourne, 3000 ..	To be determined
Hamilton .. .. .	30th September, 1969 ..	I. E. Lohrey, Box 48, Warrnambool, 3280 ..	270
Horsham .. .. .	30th September, 1969 ..	V. Clayton, Box 247, Hamilton, 3300 ..	225
Kaniva .. .. .	30th September, 1968 ..	F. E. Iredale, Box 114, Bendigo, 3550 ..	135
Kerang .. .. .	31st December, 1968 ..	L. R. Williams, 319 Maroondah Highway, Ringwood, 3134 ..	140
Korumburra .. .. .	31st December, 1968 ..	F. G. Foster, 411 Little Collins-street, Melbourne, 3000 ..	200
Kyabram .. .. .	30th September, 1968 ..	R. G. Ham, National Bank Chambers, Pall Mall, Bendigo, 3550 ..	180
Kyneton .. .. .	30th September, 1968 ..	J. T. Coutts, Box 13, Belgrave, 3160 ..	110
Lang Lang .. .. .	30th September, 1969 ..	E. A. Faulkner, Box 47, Yarram, 3971 ..	135
Leongatha .. .. .	31st December, 1968 ..	E. A. Faulkner, Box 47, Yarram, 3971 ..	200
Lorne .. .. .	31st December, 1968 ..	L. W. Gilbert, Box 179, Colac, 3250 ..	95
Maffra .. .. .	31st December, 1968 ..	E. W. McKenzie, c/o Norman, Cartledge and Brown, 1 Palmerston-crescent, South Melbourne, 3205 ..	250
Maryborough .. .. .	30th September, 1968 ..	V. Clayton, Box 247, Hamilton, 3300 ..	145
Mildura .. .. .	30th September, 1969 ..	T. C. Bignell, c/o Warnock, Wharton and Bignell, 20 Collins-street, Melbourne, 3000 ..	360
Moe .. .. .	31st December, 1969 ..	T. E. Osborn, 42A Albert-street, Footscray, 3011 ..	290
Mooroopna .. .. .	31st December, 1968 ..	R. G. Ham, National Bank Chambers, Pall Mall, Bendigo, 3550 ..	160
Mornington .. .. .	30th September, 1969 ..	Miss H. Crozier, c/o Leane and Crozier, 64 Elizabeth-street, Melbourne, 3000 ..	250
Morwell .. .. .	31st December, 1969 ..	R. L. Summers, Box 47, Yarram, 3971 ..	315
Mount Beauty .. .. .	31st December, 1968 ..	F. A. Ballantine, Box 124, Wangaratta, 3677 ..	160

SEWERAGE AUTHORITIES—continued.

Authority.	Year Ending.	Name and Address of Auditor.	Remuneration Excluding Transport, Maintenance Expenses and Postage.
(1).	(2).	(3).	(4).
			\$
Mount Eliza .. ..	30th September, 1969 ..	Miss H. Crozier, c/o Leane and Crozier, 64 Elizabeth-street, Melbourne, 3000	To be determined
Murtoa .. ..	31st December, 1968 ..	G. J. Officer, Baillie-street, Horsham, 3400	60
Nhill .. ..	31st December, 1968 ..	G. J. Officer, Baillie-street, Horsham, 3400	60
Orbost .. ..	31st December, 1968 ..	K. W. Steedman, Goodman-street, Bairnsdale, 3875	180
Portland .. ..	30th September, 1968 ..	M. B. Wellington, 482 Nepean Highway, Frankston, 3199	220
Red Cliffs .. ..	30th September, 1969 ..	T. C. Bignell, c/o Warnock, Wharton and Bignell, 20 Collins-street, Melbourne, 3000	200
St. Arnaud .. ..	31st December, 1968 ..	J. F. Nixon, c/o David Fell and Co., 360 Collins-street, Melbourne, 3000	200
Sale .. ..	30th September, 1969 ..	R. L. Summers, Box 47, Yarram, 3971	125
Seymour .. ..	31st December, 1968 ..	W. G. Thornhill, 19A Burwood-road, Burwood, 3125	135
Shepparton .. ..	30th September, 1969 ..	L. S. Eva, 306 Little Collins-street, Melbourne, 3000	290
Springvale and Noble Park	30th September, 1969 ..	W. A. Betheras, c/o William Buck and Co., 422 Collins-street, Melbourne, 3000	540
Stawell .. ..	30th September, 1969 ..	G. J. Officer, Baillie-street, Horsham, 3400	250
Swan Hill .. ..	31st December, 1969 ..	A. D. Foreshew, 172 Bouverie-street, Carlton, 3053	290
Tallangatta .. ..	31st December, 1968 ..	F. A. Ballantine, Box 124, Wangaratta, 3677	120
Tatura .. ..	31st December, 1968 ..	R. G. Ham, National Bank Chambers, Pall Mall, Bendigo, 3550	225
Terang .. ..	30th September, 1968 ..	M. Bourke, Koroit, 3282	100
Toora .. ..	31st December, 1968 ..	C. H. Atkins, P.O. Box 31, Foster, 3960	To be determined
Traralgon .. ..	31st December, 1969 ..	E. W. McKenzie, c/o Norman, Cartledge and Brown, 1 Palmerston-crescent, South Melbourne, 3205	270
Wangaratta .. ..	30th September, 1969 ..	N. F. Horsburgh, c/o Hatch and Horsburgh, 100 Collins-street, Melbourne, 3000	270
Warracknabeal .. ..	30th September, 1968 ..	F. E. Iredale, Box 114, Bendigo, 3550	100
Warragul .. ..	31st December, 1968 ..	R. H. Sullivan, 42 Berry-street, East Melbourne, 3002	200
Warrnambool .. ..	30th September, 1968 ..	M. B. Wellington, 482 Nepean Highway, Frankston, 3199	200
Werribee .. ..	30th September, 1969 ..	B. Pescod, c/o G. Marquand and Son, 51 Queen-street, Melbourne, 3000	180
Willaura .. ..	30th September, 1968 ..	J. Crowther, 6 Albany-road, Toorak, 3142	60
Wodonga .. ..	30th September, 1968 ..	D. P. Rankin, c/o V. S. Rankin and Sons, 358 Collins-street, Melbourne, 3000	200
Yallourn North .. ..	31st December, 1968 ..	T. E. Osborn, 42A Albert-street, Footscray, 3011	To be determined
Yarram .. ..	30th September, 1968 ..	R. L. Summers, Box 47, Yarram, 3971	225
Yarrowonga .. ..	30th September, 1968 ..	D. H. McDonald, c/o Troup, Horwood and Co., 422 Collins-street, Melbourne, 3000	110

At the Executive Council Chamber,  
Melbourne, 27th August, 1968.

J. ROSSITER,  
Clerk of the Executive Council.

APPOINTMENTS.

HIS Excellency the Lieutenant-Governor of the State of Victoria, by and with the advice of the Executive Council thereof, has, by Orders made on the 20th day of August, 1968, been pleased to make the under-mentioned appointments, viz.:—

CHIEF SECRETARY'S DEPARTMENT.

Honorary Probation Officers.

- ARTHUR ROBERT MAWSON (Captain), 36 Henty-street, Portland,
- JOAN LEESON BARTLE (Mrs.), 34 Victoria-street, Hastings,
- DOROTHY NOELLE DAVIDSON (Mrs.), Bayview-road, Hastings,
- ANNE ROSEMARY DESALVO (Mrs.), 7 Errey-street, Camperdown,
- REITA JOSEPHINE MAYS (Mrs.), 14 Cooper-street, Sunshine,
- MIMA ELIZABETH MITCHELL (Mrs.), P.O. Box 25, Rosebery,
- MABEL WINIFRED RHODES (Mrs.), 64A Barkly-street, Camperdown,
- ERIN SATCHWELL (Mrs.), 32 Jeffery-street, Blackburn,
- JOYCE THELMA SKEELS (Mrs.), 1022 Burke-road, Balwyn, and
- DALE MARGARET VAGG (Mrs.), 51 Lord-street, Cobden, pursuant to the provisions of section 507 of the Crimes Act 1958, to be Honorary Probation Officers for all Adult Courts in Victoria; and
- LESLIE NANKERVILLE BACON, Barretts-road, Baxter,
- LAURENCE JOHN LANG, Flat 1, 55 Stewart-street, Colac,

- GEORGE SYLVESTER LEAHY, 10 Fry-street, Eaglehawk,
  - DENIS GEORGE LORIMER (Captain, Salvation Army), 56 Timor-street, Warrnambool,
  - MIMA ELIZABETH MITCHELL (Mrs.), P.O. Box 25, Rosebery,
  - GARY EDWARD O'CONNOR, 4 Neptune-avenue, Newcomb,
  - ERIN SATCHWELL (Mrs.), 32 Jeffery-street, Blackburn,
  - JOYCE THELMA SKEELS (Mrs.), 1022 Burke-road, Balwyn,
  - KEITH ALBERT SULLIVAN, "Corio", Donald-road, Langwarrin,
  - PETER JOSEPH TAFFE (Reverend Father), Catholic Presbytery, Mildura, and
  - MATHEW JOHN TURNER (The Reverend), Church of Christ Manse, Main-road, Red Hill,
- pursuant to the provisions of section 10 (1) of the Children's Court Act 1958 to be Honorary Probation Officers in all Children's Courts in Victoria.

Member and Chairman of the Totalizator Agency Board.

HILTON JOHN NICHOLAS  
to be a Member and Chairman of the Totalizator Agency Board, pursuant to the provisions of the Racing Act 1958, from 13th September, 1968, to 1st June, 1969, vice Thomas Chester Manifold.

Trustee of the Institute of Applied Science.

PHILLIP GARTH LAW  
pursuant to the provisions of the State Library National Gallery National Museum and Institute of Applied Science Act 1960, to be a Trustee of the Institute of Applied Science, for the period ending 15th March, 1971.



MINISTRY OF HEALTH.

Member of Committee of Management of Hospital.

**LAWRENCE NEWITT**  
to be a Member of the Committee of Management of The Dunolly District Hospital, pursuant to proviso (a) to section 48 (1) of the *Hospitals and Charities Act 1958*, for a further period of three years ending 7th September, 1971.

Deputy Superintendent of Mental Hospital.

**ROBERT KELLY ARTHUR, B.A., M.B., B.S., D.P.M.,**  
to be Deputy Superintendent, Plenty Mental Hospital, pursuant to section 26 of the *Mental Health Act 1959*, as from and inclusive of 1st August, 1968, vice Dr. W. F. Gordon, resigned.

LAW DEPARTMENT.

Commissioners for Taking Declarations, &c.

**JAMES MURRAY GAVIN, 20 Somali-street, Pascoe Vale South, and**  
**RAYMOND HASWELL WITHERDEN, 9 Vista-avenue, Mount Waverley,**  
to be Commissioners for taking Declarations and Affidavits, pursuant to the provisions of the *Evidence Act 1958*, to resign upon removing from the neighbourhood of the addresses stated.

**ERIC YOUNG LOGAN, care of Australian Mutual Provident Society, 425 Collins-street, Melbourne, and**  
**VICTOR WEISS, care of Caird, Chandler & Co. Ltd., 100 Denmark-street, Kew,**  
to be Commissioners for taking Declarations and Affidavits, pursuant to the provisions of the *Evidence Act 1958*, to resign upon ceasing to occupy their present positions.

Justices of the Peace.

**CYRIL RICHARD NEWMAN, 17 Adamson-street, Heidelberg,**  
**ROBERT LANCELOT ROFE, 90 Outer-crescent, Brighton,**  
**JOHN BRUCE HOWIE, 1 Dunblane-avenue, Ascot Vale,**  
**NATHAN JACOBS, 3 Ian-street, Noble Park,**  
**KEVIN ARTHUR DOWLING, 15 Argyle-street, Moonee Ponds,**  
**LEONARD JOHN COOK, "Rochford Hall", Romsey,**  
**WILLIAM AFFLECK ADAMS, 74 Spring-street, Sandringham, and**  
**KEITH JOHN WATKINS, 50 Moncur-avenue, Springvale,**  
to Keep the Peace in the Central Bailiwick of the State of Victoria; and  
**ROBERT GEORGE SINGM, 21 Vines-road, Geelong; and**  
**BERT EDWIN MINCHINTON, Beech Forest,**  
to Keep the Peace in the Southern Bailiwick of the State of Victoria.

DEPARTMENT OF THE TREASURER.

Receivers of Revenue (Acting).

**JOHN JOSEPH CAVEN**  
to act temporarily as Receiver of Revenue, Hamilton, vice J. E. Wallace, on leave.

**IAN JOHN COLLARD**  
to act temporarily as Receiver of Revenue, Camperdown, vice M. W. Gerken, on leave.

**GEOFFREY JOHN WATERS**  
to act temporarily as Receiver of Revenue, Echuca, vice M. M. Saunders, on leave.

**GEOFFREY GORDON MOON**  
to act temporarily as Receiver of Revenue, Geelong, vice J. R. Aitken, on leave.

Collectors of Imposts.

**KEVIN PATRICK PULBROOK**  
to be Collector of Imposts, National Gallery of Victoria, vice Accountant, Chief Secretary's Department.

**RONALD FREDERICK SCOLLARD**  
to be Collector of Imposts, Registry of Co-operative Housing Societies, Treasury, vice M. V. Hammond, promoted.

DEPARTMENT OF WATER SUPPLY.

Waterworks Trust Commissioner.

**KEITH RICHARD DOHERTY**  
to be a Commissioner of the Koo-Wee-Rup Waterworks Trust for a period of four years from the date hereof, subject to the provisions of the *Water Act 1958*.

**J. ROSSITER,**  
Clerk of the Executive Council.

At the Executive Council Chamber,  
Melbourne, 20th August, 1968.

Liquor Control Act 1968.

APPOINTMENT OF LICENSING INSPECTORS.

IN accordance with the authority conferred upon me by sub-section (1) of Section 22 of the *Liquor Control Act 1968*, I, Rupert Henry Arnold, Chief Commissioner of Police, hereby appoint the following Officers of Police as Licensing Inspectors in respect of the under-mentioned Divisions of the Police Districts as shown herein :—

Division Number.	Police District.	Rank and Name.
1	Barwon ..	Superintendent John Gilbert Brown
"	" ..	Inspector Michael Clifford
2	" ..	Inspector Francis Clive Beattie
1	Bourke ..	Superintendent James Ronald Milner
"	" ..	Inspector Allan Henry Absalom
2	" ..	Chief Inspector Joseph Stanislaus Hannabery
"	" ..	Inspector Lindsay Neil Patterson
3	" ..	Inspector Walter Gordon Perry
4	" ..	Inspector John William Tobin
1	Central Highlands	Superintendent Alfred William John Simmons
"	" ..	Inspector Francis Raymond Kelly
2	" ..	Inspector Sidney Glanville
3	" ..	Inspector Albert Edgar Hope
1	Corangamite ..	Superintendent George Henry Carter
"	" ..	Chief Inspector John Harrison
2	" ..	Inspector Sidney John Olsen
1	East Gippsland ..	Superintendent William Robert Farrell
"	" ..	Inspector Robert Maxwell Condie
2	" ..	Inspector John Charles White
1	Flinders ..	Superintendent Leonard Maurice Bell
"	" ..	Inspector Arthur John Slater
2	" ..	Chief Inspector Thomas James Trueman
3	" ..	Inspector Michael Hanley
1	Gippsland ..	Superintendent James Daniel Moore
"	" ..	Inspector Cornelius John Crowe
2	" ..	Inspector William Craig Caldwell
3	" ..	Inspector William Leonard Job
1	Glenelg ..	Superintendent George Ernest Warren
2	" ..	Inspector William Joseph McBride
3	" ..	Inspector Joseph Reuben Sellwood
1	Goulburn ..	Superintendent Victor Thomas Sheather
2	" ..	Inspector George Russell Hildebrand
1	Henty ..	Superintendent Gilbert Trainor
2	" ..	Inspector Norman Harold Hume
"	" ..	Chief Inspector Michael Francis Sharkey
"	" ..	Inspector Alexander Leslie Buckler
3	" ..	Inspector Frederick Taylor Kennedy
1	Loddon ..	Superintendent Edmond Cornelius Coady
"	" ..	Inspector William Condie
2	" ..	Inspector Alan Findley Stock
3	" ..	Inspector Norman Jones
1	Mallee ..	Superintendent Keith McTier McLeod
"	" ..	Inspector James Patrick Ryan
2	" ..	Inspector Patrick Francis Cashin
1	Melbourne ..	Inspector Martin Hubert Vereker
"	" ..	Inspector Henry Robert Hutchins
2	" ..	Inspector John McPartland
"	" ..	Inspector Norman Sydney Sumpter
3	" ..	Inspector Albert Verdun Thomson
4	" ..	Inspector Reginald Barrie Clowes
1	Upper Goulburn	Superintendent John Hynes
"	" ..	Inspector Ewan Leslie Howlett
1	Upper Murray ..	Superintendent Allan Peach
1	" ..	Inspector Reginald Gordon Peters
2	" ..	Inspector Gordon Albert North
1	Wimmera ..	Superintendent Campbell George Thomas Payne
2	" ..	Inspector Gerald James Sheehan
1	Yarra ..	Superintendent John Edmund DeLany
"	" ..	Inspector Harry Michael Duffy
2	" ..	Chief Inspector Harry Parker
3	" ..	Inspector Leslie James Britton
3	" ..	Inspector Andrew George Pattison
4	" ..	Inspector Hugh Laurence Hookey

**R. H. ARNOLD,**  
Chief Commissioner of Police.

## RESIGNATIONS.

HIS Excellency the Lieutenant-Governor of the State of Victoria, by and with the advice of the Executive Council thereof, has, by Orders made on the 20th day of August, 1968, accepted the resignations of the persons named hereunder of the offices mentioned, viz.:—

## CROWN LANDS AND SURVEY DEPARTMENT.

*Trustee of Yarra Bend Park.*

JOHN LESLIE EABRY, as a Trustee of the land permanently reserved on the 26th March, 1935, as a site for Public Park and Recreation in the parishes of Boroondara and Jika Jika.

## LAW DEPARTMENT.

*Commissioners for Taking Declarations, &c.*

ALFRED COLLINS and RICHARD RANDALL GREEN, as Commissioners for taking Declarations and Affidavits, pursuant to the provisions of the Evidence Act 1958.

*Justice of the Peace.*

FREDERICK WILLIAM DODS, from the Commission of the Peace for the Central Bailiwick of the State of Victoria.

J. ROSSITER,

Clerk of the Executive Council.

At the Executive Council Chamber,  
Melbourne, 20th August, 1968.

## ORDERS IN COUNCIL

## DEPARTMENT OF CROWN LANDS AND SURVEY.

At the Executive Council Chamber, Melbourne, the sixth day of August, 1968.

## PRESENT:

His Excellency the Lieutenant-Governor of Victoria.

Mr. Reid | Mr. Thompson.

## LAND EXCEPTED FROM OCCUPATION.—ORDER REVOKED.

HIS Excellency the Lieutenant-Governor of the State of Victoria, by and with the advice of the Executive Council thereof doth hereby revoke the Order in Council of the 31st August, 1920, excepting from occupation for mining purposes under any miner's right the land comprising 1,190 acres more or less in the Parishes of Castlemaine and Faraday described in the said Order.—(C.100<sup>(21)</sup>)(<sup>22</sup>) and F.7<sup>(5)</sup> (C.71027).

And the Honorable Sir William John Farquhar McDonald, Her Majesty's Minister of Lands for the State of Victoria, shall give the necessary directions herein accordingly.

J. ROSSITER,

Clerk of the Executive Council.

## HOSPITALS AND CHARITIES ACT 1958.—SECTION 53.

At the Executive Council Chamber, Melbourne, the twentieth day of August, 1968.

## PRESENT:

His Excellency the Lieutenant-Governor of Victoria.

Mr. Porter | Mr. Meagher  
Mr. Hamer | Mr. Balfour.

## ANNUAL GENERAL MEETING OF CONTRIBUTORS TO BURWOOD BOYS' HOME.

PURSUANT to the powers conferred by Section 53 of the Hospitals and Charities Act 1958, and all other powers enabling him in that behalf, His Excellency the Lieutenant-Governor of the State of Victoria, by and with the advice of the Executive Council of the said State, hereby fixes the thirtieth day of November 1968 as the day prior to which the annual general meeting for 1968 of contributors to Burwood Boys' Home shall be held.

And the Honorable Vance Oakley Dickie, Her Majesty's Minister of Health for the State of Victoria, shall give the necessary directions herein accordingly.

J. ROSSITER,

Clerk of the Executive Council.

## HOSPITALS AND CHARITIES ACT 1958.—SECTION 65.

At the Executive Council Chamber, Melbourne, the twentieth day of August, 1968.

## PRESENT:

His Excellency the Lieutenant-Governor of Victoria.

Mr. Porter | Mr. Meagher  
Mr. Hamer | Mr. Balfour.

## AUTHORITY FOR SALE OF LAND BY CENTRAL VICTORIA DISTRICT AMBULANCE SERVICE.

WHEREAS the Central Victoria District Ambulance Service a benevolent society incorporated under the Hospitals and Charities Act 1958 and hereinafter called "the Service" is the owner of land at Kyneton, more accurately described in the schedule hereto:

AND WHEREAS no part of the said land is reserved or set apart for the purposes of the institution:

AND WHEREAS the majority of the Committee of Management of the Society desire that the said land be sold:

AND WHEREAS the Hospitals and Charities Commission reports that the said land is now surplus to requirements:

NOW THEREFORE His Excellency the Lieutenant-Governor of the State of Victoria by and with the advice of the Executive Council of the said State, by virtue of the powers conferred on him by Section 65 of the Hospitals and Charities Act 1958 and all other powers enabling him in that behalf, hereby consents to the sale of the said land freed and discharged from all trusts affecting the same to James O'Callaghan of Kyneton, for the sum of \$9,000 cash.

And His Excellency, by and with the advice aforesaid hereby directs that of the proceeds of the sale the sum of \$4,850 be paid into Government Building Trust Funds held by the society for use as directed.

## SCHEDULE.

All that piece of land being part of Crown Allotment 4 Section 25 Township of Kyneton, Parish of Lauriston, and being the whole of the land comprised in Certificate of Title Volume 8407 Folio 710.

And the Honorable Vance Oakley Dickie, Her Majesty's Minister of Health for the State of Victoria, shall give the necessary directions herein accordingly.

J. ROSSITER,

Clerk of the Executive Council.

## ELECTRIC LIGHT AND POWER ACT 1958 AND STATE ELECTRICITY COMMISSION ACTS.

At the Executive Council Chamber, Melbourne, the twentieth day of August, 1968.

## PRESENT:

His Excellency the Lieutenant-Governor of Victoria.

Mr. Porter | Mr. Meagher  
Mr. Hamer | Mr. Balfour.

## MULTIPLE EARTHED NEUTRAL SYSTEMS OF DISTRIBUTION.—EXTENSION OF TIME FOR PERFORMANCE OF WORK BY THE STATE ELECTRICITY COMMISSION OF VICTORIA.

WHEREAS, by an Order-in-Council made the 2nd day of July, 1963, the Governor-in-Council further postponed the date for performance of work by the State Electricity Commission of Victoria to complete multiple earthed neutral systems of distribution until the 30th day of September, 1968, AND WHEREAS the Commission is not able to carry out the said requirements by the said date. NOW THEREFORE His Excellency the Lieutenant-Governor of the State of Victoria by and with the advice of the Executive Council thereof, doth hereby further postpone the date upon which the aforementioned requirements are to be complied with to the 30th day of September, 1975.

And the Honorable James Charles Murray Balfour, Her Majesty's Minister for Fuel and Power for the State of Victoria, shall give the necessary directions herein accordingly.

J. ROSSITER,

Clerk of the Executive Council.

COUNTRY ROADS BOARD.

At the Executive Council Chamber, Melbourne, the twentieth day of August, 1968.

PRESENT:

His Excellency the Lieutenant-Governor of Victoria.

Mr. Porter	Mr. Meagher
Mr. Hamer	Mr. Balfour.

ORDER CONFIRMING RESOLUTIONS OF THE COUNTRY ROADS BOARD.

HIS Excellency the Lieutenant-Governor of the State of Victoria, by and with the advice of the Executive Council thereof, doth hereby, in pursuance of the provisions of the Country Roads Act 1958, confirm the resolutions of the Country Roads Board, the dates whereof and the terms of which are scheduled hereunder—

SCHEDULE.

State highways.

Resolution dated the Twelfth day of August, One Thousand Nine Hundred and Sixty-eight, made pursuant to Section 70 of the Country Roads Act 1958 rescinding part of the resolution passed by the Country Roads Board on the First day of December One Thousand Nine Hundred and Forty-seven and confirmed by an Order in Council published in the Government Gazette of the Seventeenth day of December One Thousand Nine Hundred and Forty-seven on page 6176, declaring the highway to be a State highway (Northern Highway) in the Shire of Huntly so far as it relates to the part of the said road as shown hatched on Plan numbered G.P.7687b hereunder.

STATE HIGHWAY  
NORTHERN HIGHWAY  
SHIRE OF HUNTLY  
Measurements in links

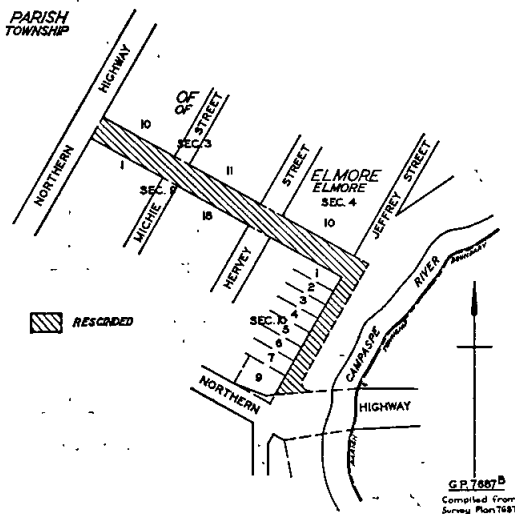

Resolution dated the Twelfth day of August, One Thousand Nine Hundred and Sixty-eight, made pursuant to Sections 21 and 74 of the Country Roads Act 1958 declaring the widening of the Midland Highway in the

Shire of Huntly as shown hatched on Plan numbered G.P.11299a hereunder to be part of a State highway within the meaning and for the purposes of the said Act.

STATE HIGHWAY  
MIDLAND HIGHWAY  
SHIRE OF HUNTLY  
Measurements in links

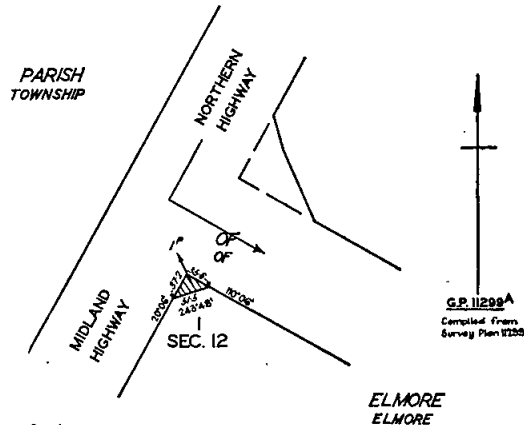

Resolution dated the Twelfth day of August, One Thousand Nine Hundred and Sixty-eight, made pursuant to Section 70 of the Country Roads Act 1958, declaring the highway in the Shire of Huntly as shown hatched on Plan numbered G.P.7687a hereunder to be a State highway (Northern Highway) within the meaning and for the purposes of the said Act.

STATE HIGHWAY  
NORTHERN HIGHWAY  
SHIRE OF HUNTLY  
Measurements in links

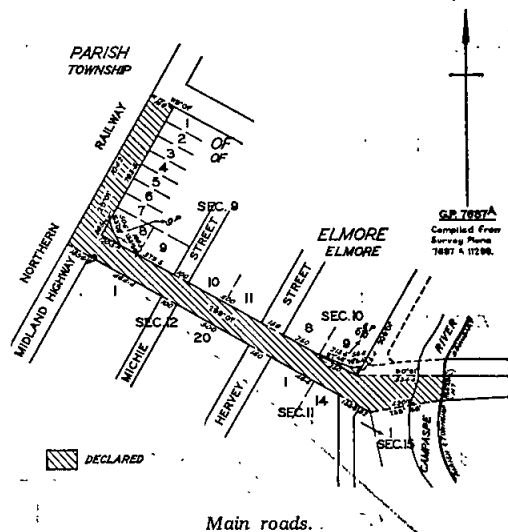

Resolution dated the Twelfth day of August, One Thousand Nine Hundred and Sixty-eight, made pursuant to Sections 21 and 58 of the Country Roads Act 1958 declaring the deviation from the Inverleigh-Winchelsea Road in the Shire of Bannockburn as indicated by diagonal hatching on Plan numbered G.P.8262 hereunder to be part of a main road within the meaning and for the

purposes of the said Act, and also declaring that such deviation shall be in lieu of the existing road or part thereof indicated by cross hatching on the said plan.

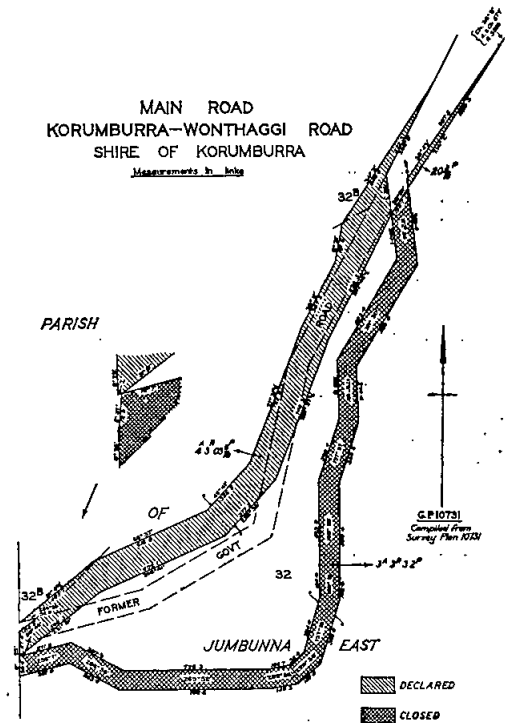
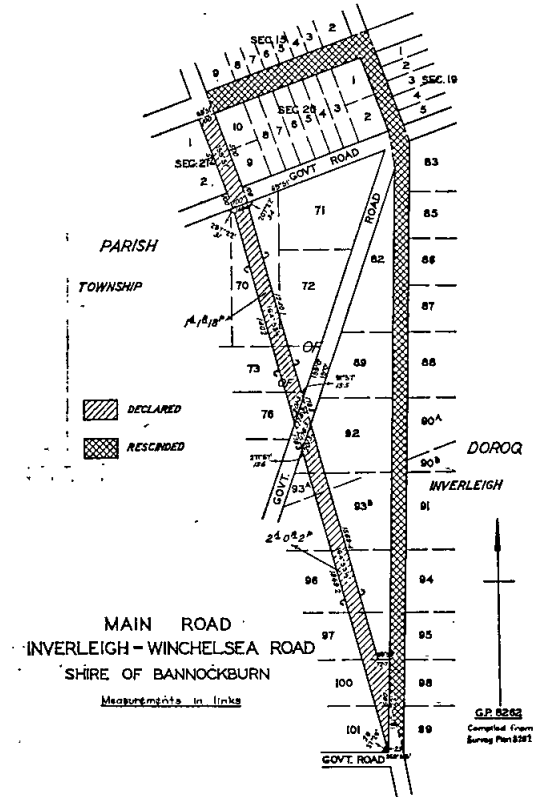

Resolution dated the Fifth day of August, One Thousand Nine Hundred and Sixty-eight, made pursuant to Sections 21 and 58 of the Country Roads Act 1958 declaring the deviation from the Korumburra—Wonthaggi Road in the Shire of Korumburra as indicated by diagonal hatching on Plans numbered G.P.10730, G.P.10731 and G.P.10732 hereunder to be part of a main road within the meaning and for the purposes of the said Act, and also declaring that such deviation shall be in lieu of the existing road or part thereof indicated by cross hatching on Plan numbered G.P.10731 and that such part of the said existing road shall be discontinued.

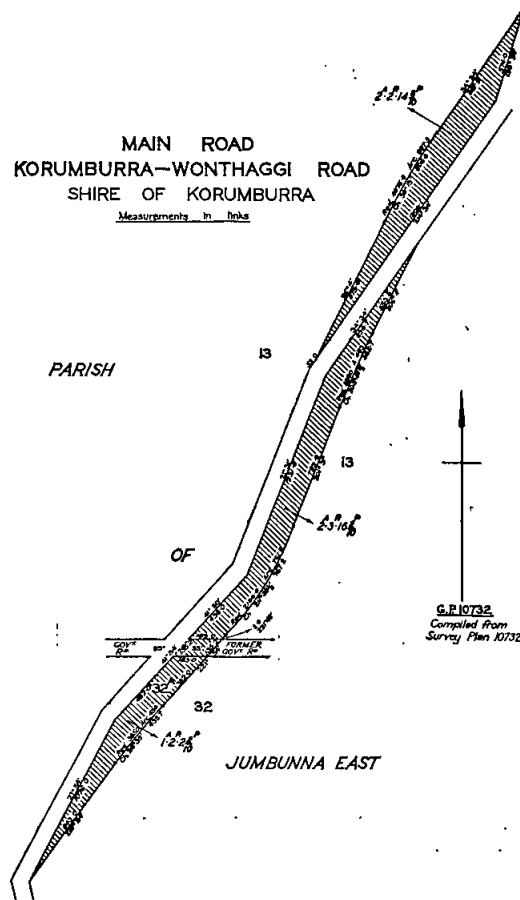
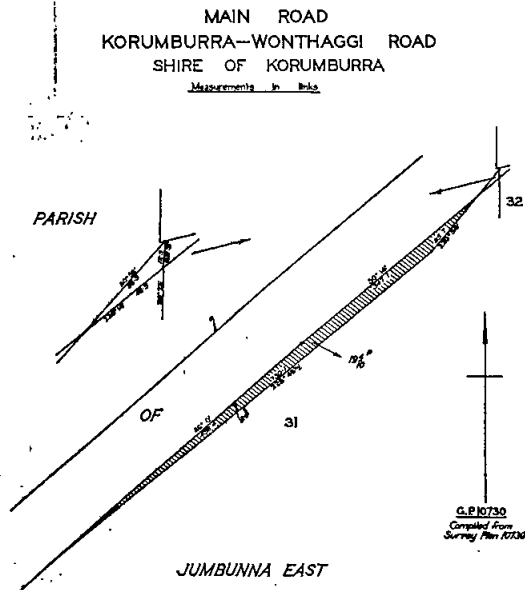

Resolution dated the Twelfth day of August, One Thousand Nine Hundred and Sixty-eight, made pursuant to Section 21 of the Country Roads Act 1958, declaring the widening of the Traralgon-Maffra Road in the Shire of Maffra as shown hatched on Plan numbered G.P.6722 hereunder to be part of a main road within the meaning and for the purposes of the said Act.

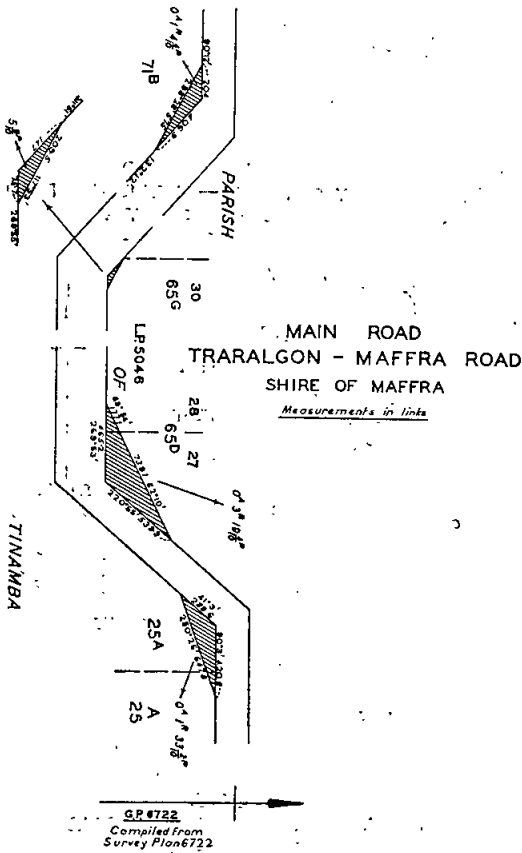

Resolution dated the Twelfth day of August, One Thousand Nine Hundred and Sixty-eight, made pursuant to Sections 21 and 58 of the Country Roads Act 1958 declaring the deviation from Lardners Track in the Shires of Warragul and Buln Buln as indicated by diagonal hatching on Plans numbered G.P.10907A and G.P.10908 hereunder to be part of a main road within the meaning and for the purposes of the said Act, and also declaring that such deviation shall be in lieu of the existing road or part thereof indicated by cross hatching on the said plans and that such part of the said existing road shall be discontinued.

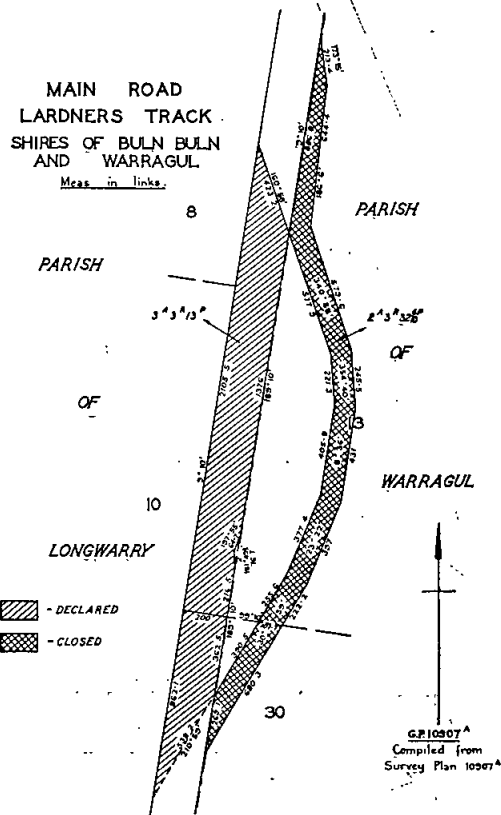

Resolution dated the Twelfth day of August, One Thousand Nine Hundred and Sixty-eight, made pursuant to Section 21 of the Country Roads Act 1958, declaring the widening of Gundowring Road in the Shire of Yackandandah as shown hatched on Plan numbered G.P.8312 hereunder to be part of a main road within the meaning and for the purposes of the said Act.

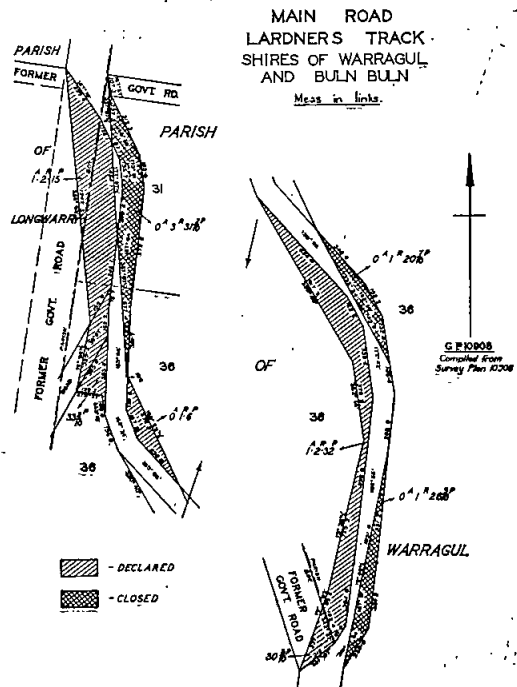
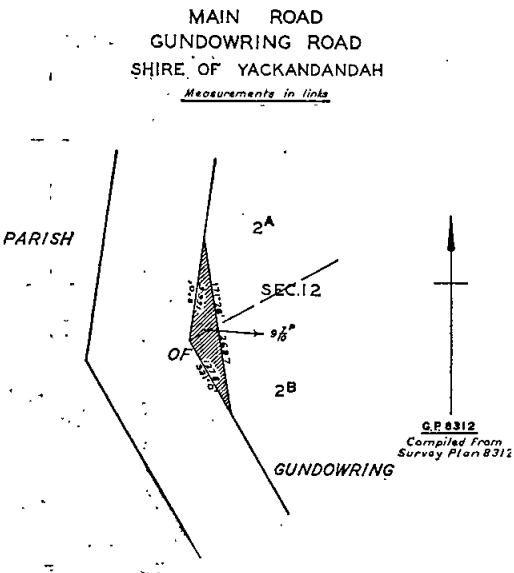

Resolution dated the Twelfth day of August, One Thousand Nine Hundred and Sixty-eight, made pursuant to Sections 21 and 58 of the Country Roads Act 1958 declaring the deviation from the Yarra Glen—Glenburn Road in the Shire of Yea as indicated by diagonal hatching on Plans numbered G.P.10830 and G.P.11284 hereunder to be part of a main road within the meaning and for the purposes of the said Act, and also declaring that such deviation shall be in lieu of the existing road or part thereof indicated by cross hatching on Plan numbered G.P.11284.

Road in the Shire of Yea as indicated by diagonal hatching on Plans numbered G.P.11088 and G.P.11089 hereunder to be part of a main road within the meaning and for the purposes of the said Act, and also declaring that such deviation shall be in lieu of the existing road or part thereof indicated by cross hatching on the said plans.

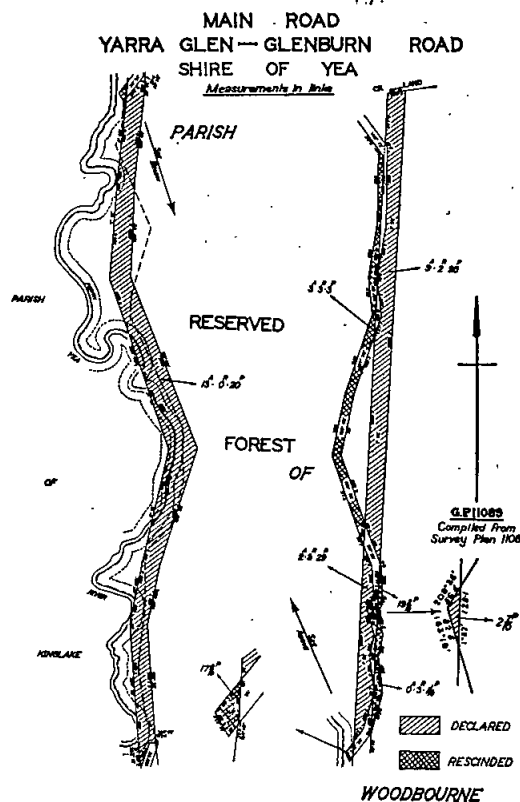
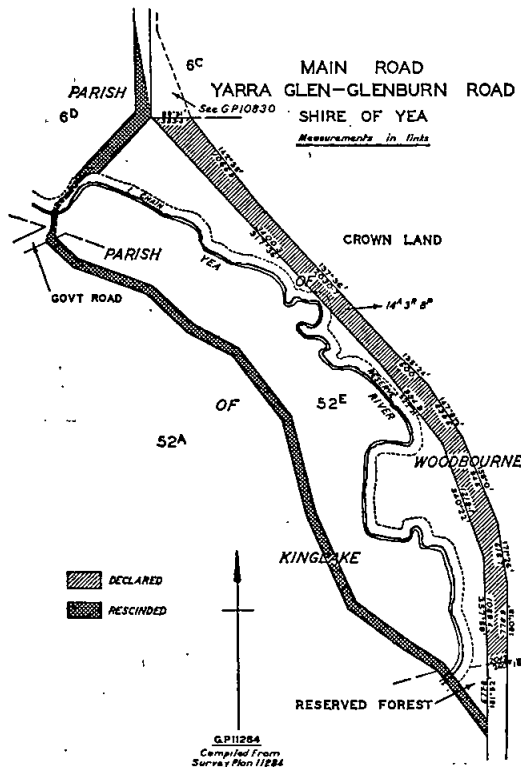
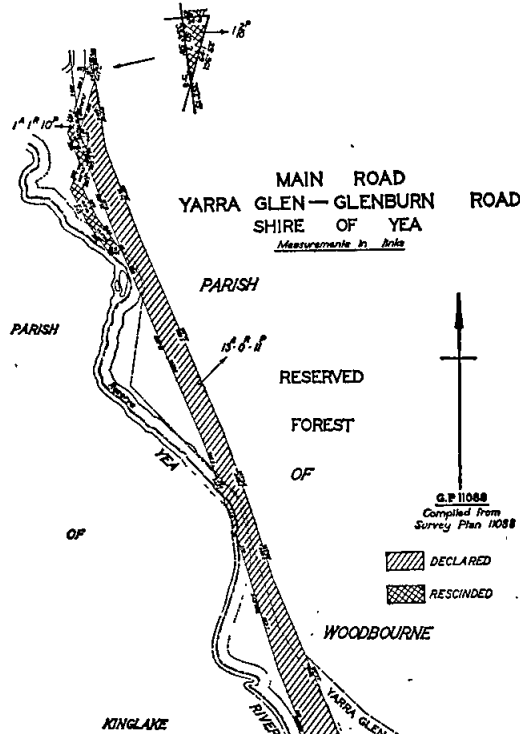
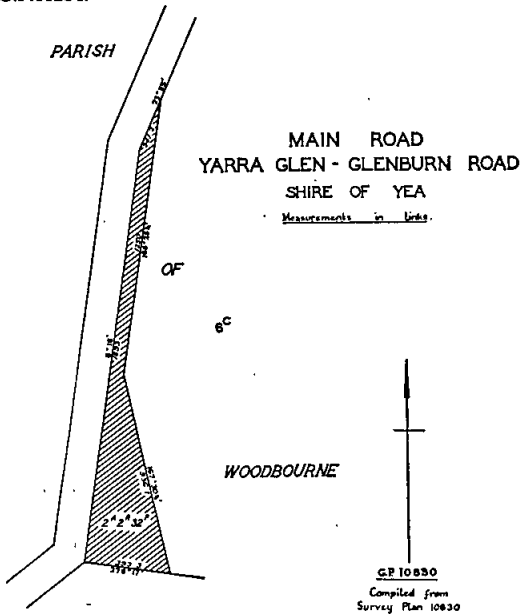

Resolution dated the Twelfth day of August, One Thousand Nine Hundred and Sixty-eight, made pursuant to Sections 21 and 58 of the Country Roads Act 1958 declaring the deviation from the Yarra Glen—Glenburn

And the Honorable Murray Victor Porter, Her Majesty's Minister of Public Works for the State of Victoria, shall give the necessary directions herein accordingly.

J. ROSSITER,  
Clerk of the Executive Council.

COUNTRY ROADS BOARD.

At the Executive Council Chamber, Melbourne, the twentieth day of August, 1968.

PRESENT:

His Excellency the Lieutenant-Governor of Victoria.

Mr. Porter | Mr. Meagher  
Mr. Hamer | Mr. Balfour.

ORDER APPROVING OF LAND BEING ACQUIRED AND ROADS, DEVIATIONS OR WIDENINGS BEING MADE.

HIS Excellency the Lieutenant-Governor of the State of Victoria, by and with the advice of the Executive Council thereof, being satisfied that there are funds legally available for acquiring the land, doth hereby approve the acquiring of the land described in the schedule hereunder and the making of new roads and deviations from and widenings of existing roads referred to in the said schedule.

SCHEDULE.

State highway.

The land shown hatched on Plan numbered G.P.11403 hereunder required for the widening of the Midland Highway in the Shire of Creswick and making of the widening thereon.

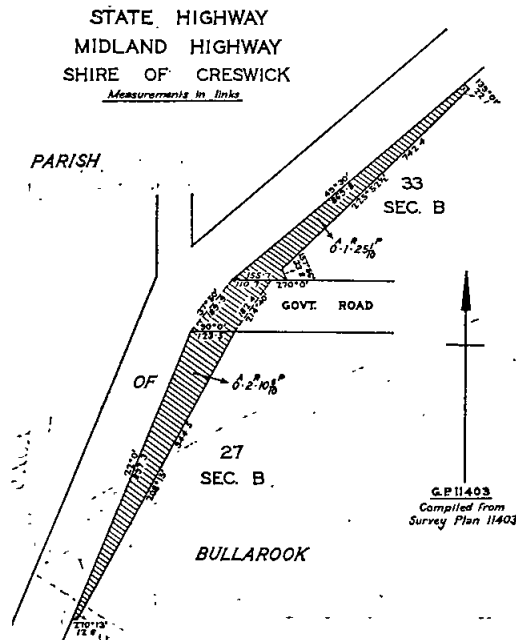

Main roads.

The land shown hatched on Plan numbered G.P.11391 hereunder required for the widening of the Keilor-Melton Road in the Shire of Melton and making of the widening thereon.

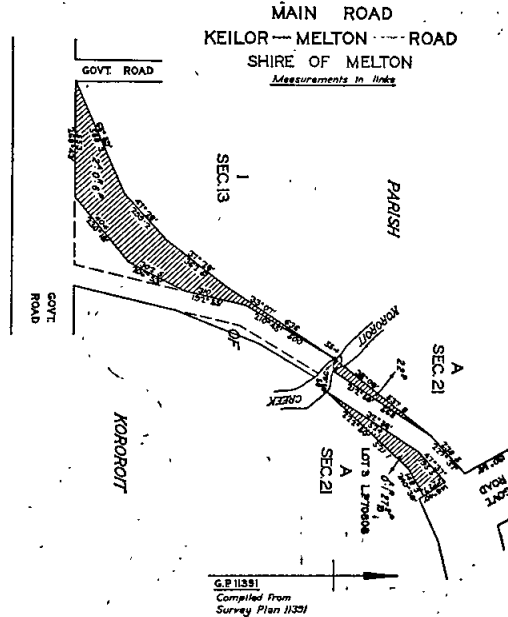

The land shown hatched on Plans numbered G.P.11172 and G.P.11173 hereunder required for the deviation from the Colac-Forrest Road in the Shire of Otway and making of the deviation thereon.

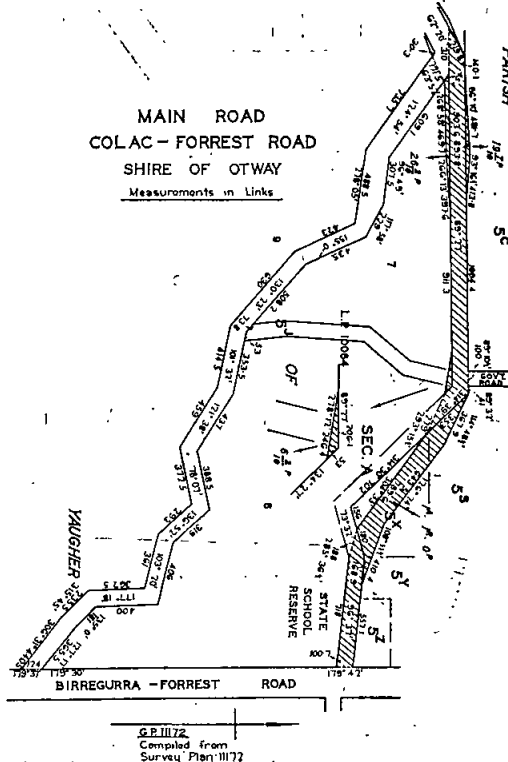

MAIN ROAD  
COLAC - FORREST ROAD

SHIRE OF OTWAY

Measurements in Links

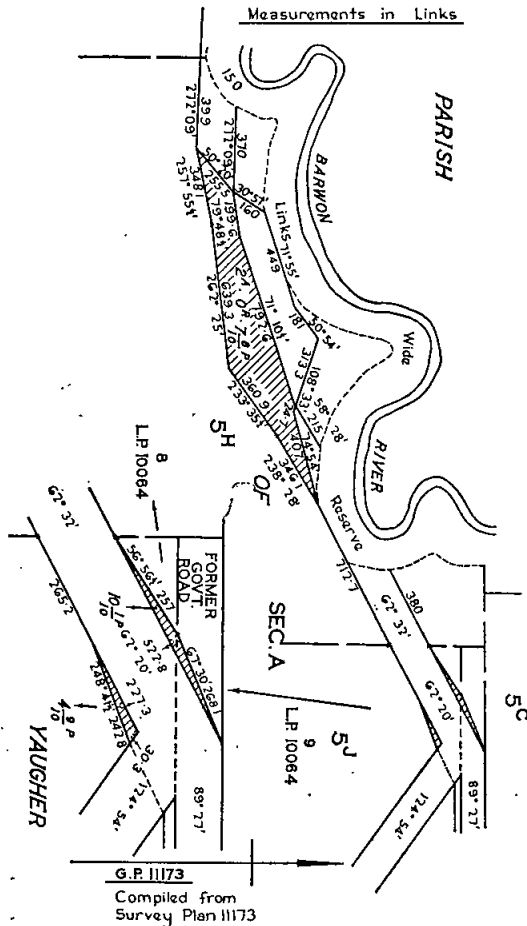

Unclassified road.

The land shown hatched on Plan numbered G.P.11431 hereunder required for the widening of Mahoney's Road in the City of Broadmeadows and making of the widening thereon.

ROAD  
MAHONEY'S ROAD  
CITY OF BROADMEADOWS

Measurements in Feet & Inches

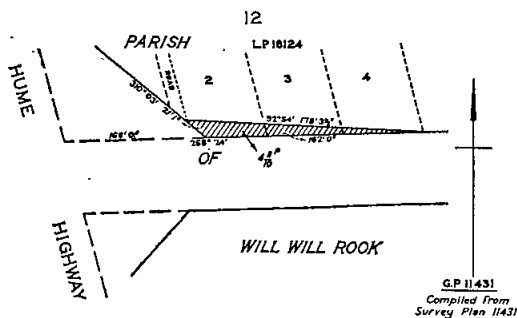

And the Honorable Murray Victor Porter, Her Majesty's Minister of Public Works for the State of Victoria, shall give the necessary directions herein accordingly.

J. ROSSITER,  
Clerk of the Executive Council.

DEPARTMENT OF CROWN LANDS AND SURVEY.

At the Executive Council Chamber, Melbourne, the twentieth day of August, 1968.

PRESENT:

His Excellency the Lieutenant-Governor of Victoria.

Mr. Porter | Mr. Meagher  
Mr. Hamer | Mr. Balfour.

UNUSED ROADS CLOSED.

HIS Excellency the Lieutenant-Governor of the State of Victoria, by and with the advice of the Executive Council thereof, doth hereby direct that, in pursuance of the provisions of section 349 of the Land Act 1958, the unused roads referred to hereunder be closed, viz.:-

At Eaglehawk, Parish of Sandhurst, County of Bendigo, being the portion of the width of the road indicated by hatching on plan hereunder.—(S.371<sup>(21)</sup>) (W.88256).

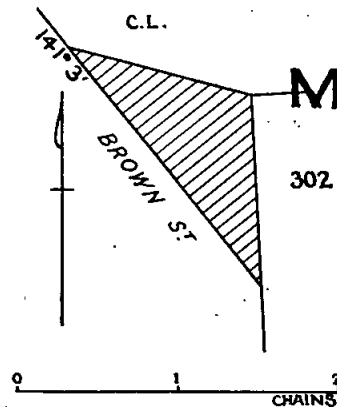

Township of Harrietville, Parish of Harrietville, County of Delatite, being the road indicated by hatching on plan hereunder.—(H.125<sup>(6)</sup>) (H.030267).

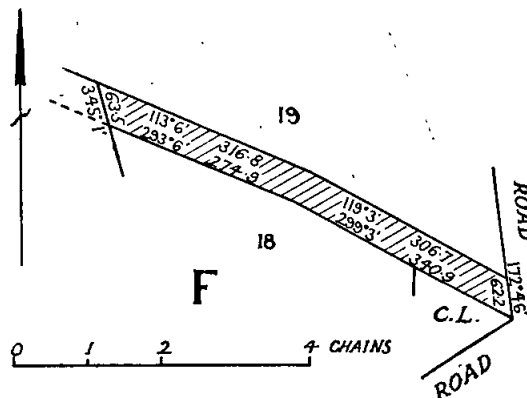



Township of Hotspur, Parish of Hotspur, County of Normanby, being the road indicated by hatching on plan hereunder.—(H.103(\*) (J.32514).

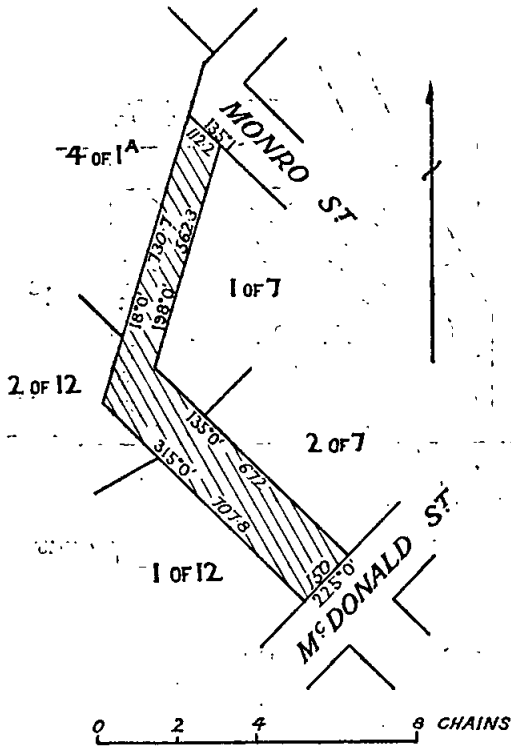

Parish of Mildura, County of Karkaroc, being the road and the portions of roads indicated by hatching on plan hereunder.—(M.533(\*) (M.41536).

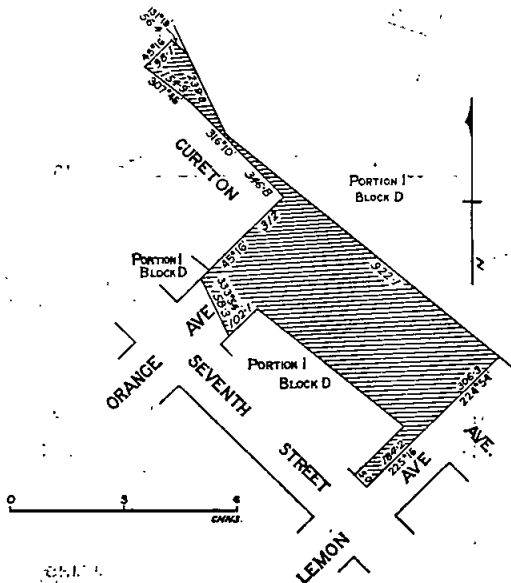

Parish of Magorra, County of Bogong, being the roads indicated by hatching on plan hereunder.—(M.529(\*) (H.030653).

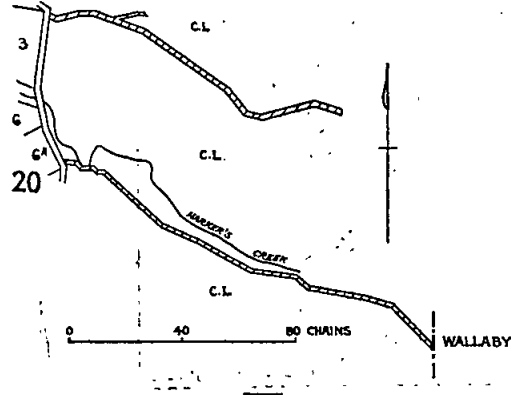

And the Honorable Sir William John Farquhar McDonald, Her Majesty's Minister of Lands for the State of Victoria, shall give the necessary directions herein accordingly.

J. ROSSITER,  
Clerk of the Executive Council.

DEPARTMENT OF CROWN LANDS AND SURVEY.

At the Executive Council Chamber, Melbourne, the twentieth day of August, 1968.

PRESENT:

His Excellency the Lieutenant-Governor of Victoria.

Mr. Porter                      Mr. Meagher  
Mr. Hamer                      Mr. Balfour.

LANDS TEMPORARILY RESERVED AS SITES.

HIS Excellency the Lieutenant-Governor of the State of Victoria, by and with the advice of the Executive Council thereof, doth hereby, in pursuance of section 14 of the Land Act 1958, reserve temporarily from sale, from being leased, and from having a licence granted in respect thereof, and also except from occupation for mining purposes under any miner's right, the land hereinafter described:—

BARWO.—Site for Public Recreation Purposes, 89 acres 2 roods 35 perches, Parish of Barwo, County of Moira, as indicated by hatching on plan hereunder.—(B.690A<sup>(3)</sup>) (Rs.4890).

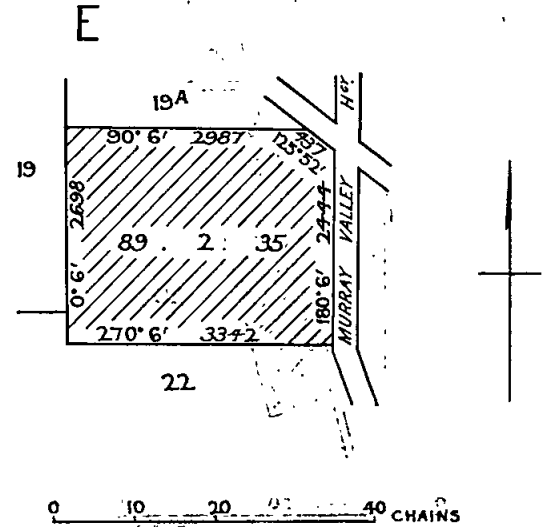

**BALLARAT (WENDOUREE).**—Site for Public Purposes (Government Buildings), 23 perches, Parish of Ballarat, County of Grenville, as indicated by hatching on plan hereunder.—(B.126<sup>(11)</sup>) (Rs.9034).

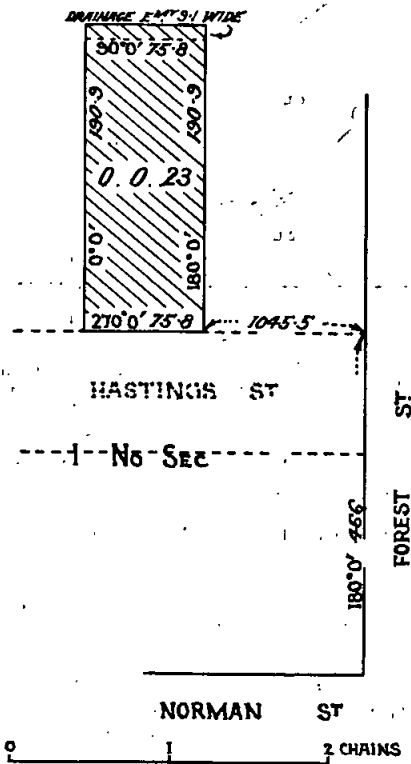

**COMBIENBAR.**—Site for State School purposes, 5 acres, Parish of Combiensbar, County of Croajingolong, as indicated by hatching on plan hereunder.—(C.449<sup>(6)</sup>) (Rs.3149).

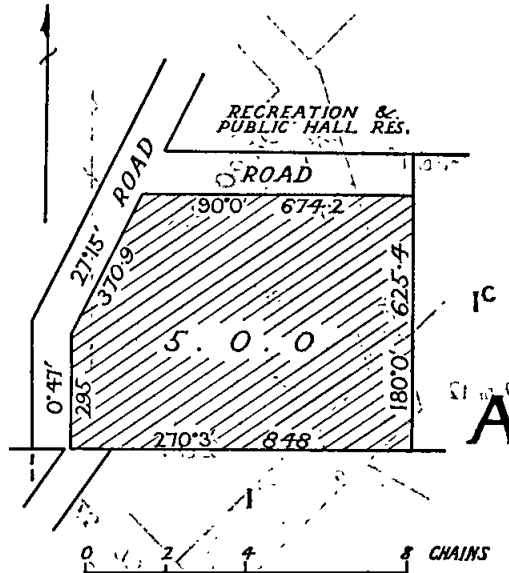

**CRIB POINT.**—Site for Public Purposes (Hall), 2 roods 16 perches, Township of Crib Point, Parish of Bittern, County of Mornington, as indicated by hatching on plan hereunder.—(M.531<sup>(2)</sup>) (Rs.9011).

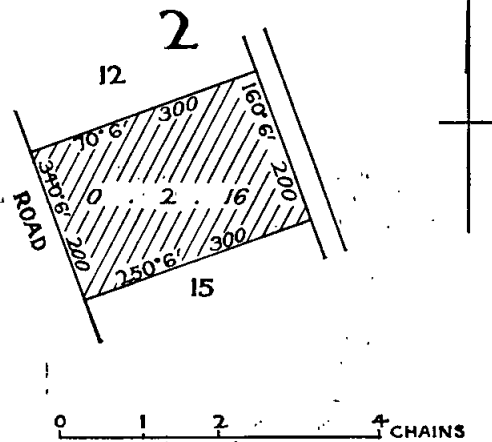

**CATIABRIM.**—Site for Public Purposes (Removal of Stone), 20 acres, Parish of Catiabrim, County of Lowan, as indicated by hatching on plan hereunder.—(C.481<sup>(2)</sup>) (Rs.9010).

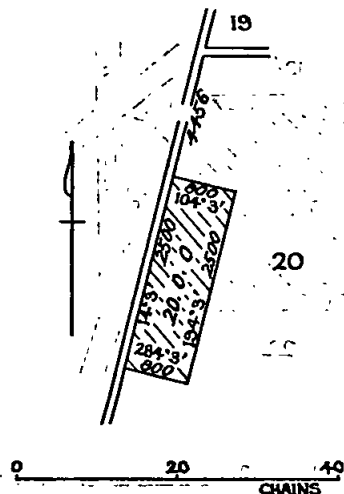

**FRYERSTOWN.**—Site for State School purposes, 1 acre 17 perches, Township of Fryerstown, Parish of Fryers, County of Talbot, as indicated by hatching on plan hereunder.—(F.47<sup>(6)</sup>) (Rs.8699).

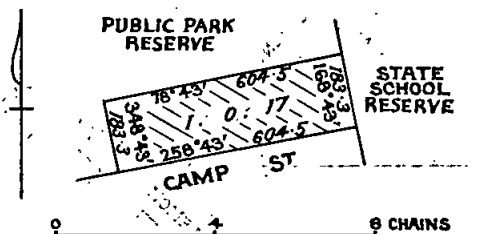

PRAHRAN (ELWOOD).—Site for State School purposes, 1 rood 36 perches, Parish of Prahran, County of Bourke, as indicated by hatching on plan hereunder.—(P.81<sup>(13)</sup>) (Rs.1633A).

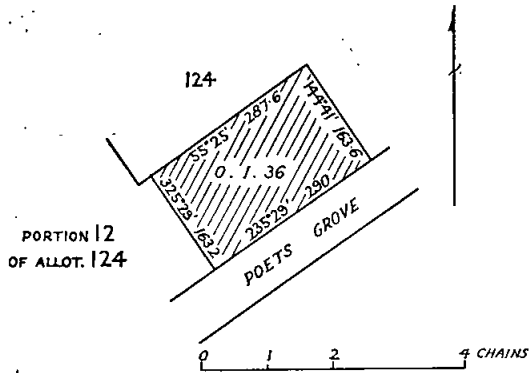

WOMBAT.—Site for Public Recreation, 3 roods 28 perches, Parish of Wombat, County of Talbot, as indicated by hatching on plan hereunder.—(W.179<sup>(38)</sup>) (Rs.457).

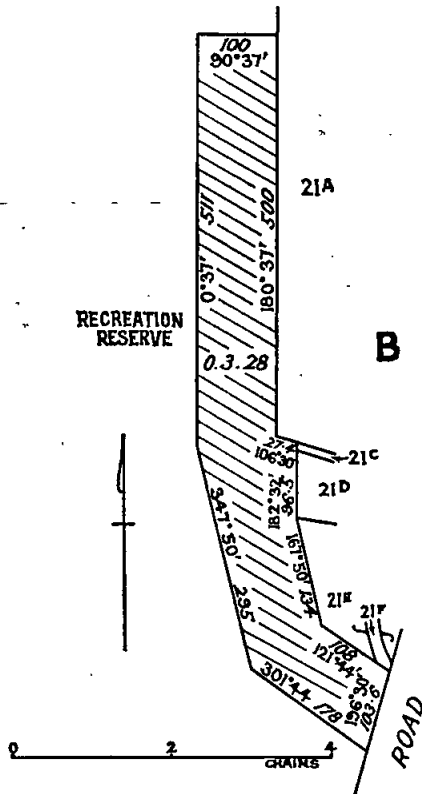

SEVILLE.—Site for State School purposes, 1 rood 4 perches, Township of Seville, Parish of Wandin Yallock, County of Evelyn, as indicated by hatching on plan hereunder.—(S.457<sup>(1)</sup>) (Rs.9040.)

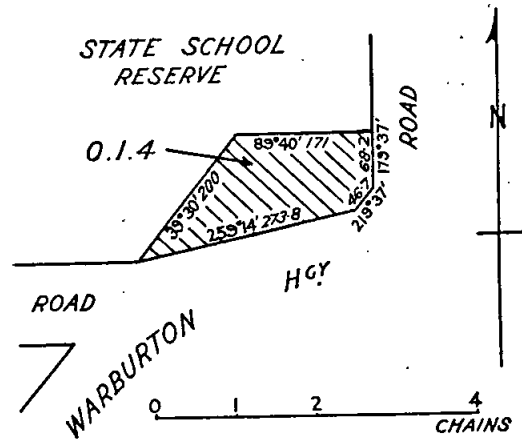

YACKANDANDAH.—Site for State School Purposes (Water Supply), 2 acres 3 roods, Parish of Yackandandah, County of Bogong, as indicated by hatching on plan hereunder.—(Y.45<sup>(15)</sup>) (Rs.2721).

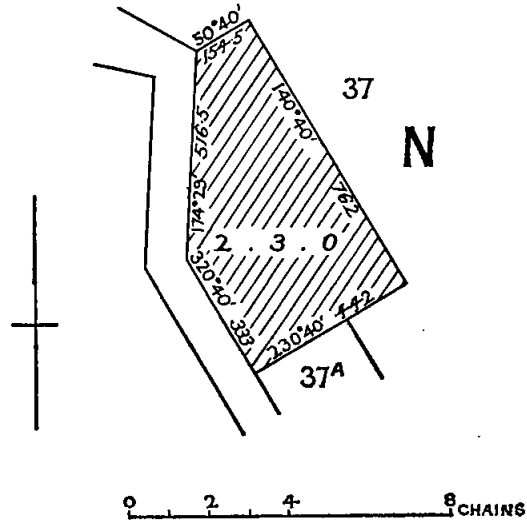

And the Honorable Sir William John Farquhar McDonald, Her Majesty's Minister of Lands for the State of Victoria, shall give the necessary directions herein accordingly.

J. ROSSITER,  
Clerk of the Executive Council.

DEPARTMENT OF CROWN LANDS AND SURVEY.

At the Executive Council Chamber, Melbourne, the twentieth day of August, 1968.

PRESENT:

His Excellency the Lieutenant-Governor of Victoria.  
Mr. Porter | Mr. Meagher  
Mr. Hamer | Mr. Balfour.

REVOCATION OF TEMPORARY RESERVATIONS OF LANDS BY ORDERS IN COUNCIL.

HIS Excellency the Lieutenant-Governor of the State of Victoria, by and with the advice of the Executive Council thereof, doth hereby, in pursuance of the provisions of the Land Act 1958, revoke the temporary reservations of lands by Orders in Council hereinafter referred to, viz.:

BRAYBROOK.—Order in Council of 1st February, 1961, of 3 acres 1 rood 10 perches of land in the Township of Braybrook as a site for State School Purposes so far only

as regards the portion thereof comprised within the boundaries published in the *Government Gazette* of 24th July, 1968, and containing 6 perches.—(Rs.4425.)

**BUNGAREE.**—Order in Council of 26th May, 1873, of 5 acres 3 roods 15 perches of land in the Parish of Bungaree as a site for Cemetery Purposes so far only as regards the portion thereof comprised within the boundaries published in the *Government Gazette* of 24th July, 1968, and containing 1 acre 2 roods 4 perches.—(C.98690).

**BUNGAREE.**—Order in Council of 30th September, 1872, of 5 acres 3 roods 15 perches of land in the Parish of Bungaree as a site for Public Purposes.—(C.98690).

**DATTUCK.**—Order in Council of 26th August, 1947, of 1,393 acres 2 roods 16 perches of land in the Parish of Dattuck as a site for Growth of Timber for the purpose of the production or manufacture of eucalyptus oil.—(M.37036).

**DONALD.**—Order in Council of 10th October, 1898, of 60 acres, more or less, of land in the Township of Donald as a site for Water Supply Purposes save and except the portion thereof comprised within the boundaries published in the *Government Gazette* of 24th July, 1968, and containing 41 acres, more or less.—(C.74453).

**DRUMBORG.**—Order in Council of 21st January, 1878, of 4 acres 3 roods 39 perches of land in the Parish of Drumborg as a site for Public Purposes (State School).—(C.91886).

**GOWAR.**—Order in Council of 15th January, 1877, of 5 acres of land in the Parish of Gowar as a site for Public Purposes (State School).—(C.100201).

**HAMILTON.**—Order in Council of 25th May, 1954, of 1 rood and 2 perches of land in the Township of Hamilton as a site for State School so far only as regards the portion thereof comprised within the boundaries published in the *Government Gazette* of 17th July, 1968, and containing 5 perches.—(Rs.7259).

**PINE LODGE.**—Order in Council of 24th August, 1880, of 2 acres of land in the Parish of Pine Lodge as a site for Public Purposes (State School).—(C.100200).

**SHEPPARTON.**—Order in Council of 8th October, 1940, of 32 5/10 perches, more or less, of land in the Township of Shepparton as a site for Public Buildings.—(Rs.5100).

**TARRAWINGEE.**—Order in Council of 2nd September, 1902, of 4 acres 3 roods 21 perches of land in the Parish of Tarrawingee as a site for a Night-soil Depot.—(C.16396).

**YALLOCK.**—Order in Council of 12th March, 1889, of 16 acres, more or less, of land in the Parish of Yallock as a site for Camping purposes.—(Rs.6049).

And the Honorable Sir William John Farquhar McDonald, Her Majesty's Minister of Lands for the State of Victoria, shall give the necessary directions herein accordingly.

J. ROSSITER,  
Clerk of the Executive Council.

LOCAL GOVERNMENT DEPARTMENT.

At the Executive Council Chamber, Melbourne, the twentieth day of August, 1968.

PRESENT:

His Excellency the Lieutenant-Governor of Victoria.  
Mr. Porter | Mr. Meagher  
Mr. Hamer | Mr. Balfour.

ROADS DISCONTINUED.—CITY OF SUNSHINE.

WHEREAS it is provided in Section 528 (2) of the *Local Government Act 1958*, that where a road (whether or not a public highway but not being a road set out on land of the Crown) or any part thereof is not required for public use the Governor-in-Council on the request of the Council of the municipality in which such road is situated made not less than one month after publishing in a newspaper generally circulating in the district and posting to the registered proprietor (if any) of the land and any person known to have an interest in the land notice of intention to make such a request may by Order published in the *Government Gazette* direct that such road or part shall be discontinued and thereupon such road or part shall be discontinued accordingly.

AND WHEREAS the Council of the City of Sunshine has requested that the Governor-in-Council direct that two rights-of-way off Dawson and George Streets, Sunshine, be discontinued and not less than one month previously has published in a newspaper generally circulating in the

district and posted to the registered proprietor of the land in the roads and to all persons known to have an interest in the said land notice of intention to make such request.

NOW THEREFORE, His Excellency the Lieutenant-Governor of the State of Victoria, by and with the advice of the Executive Council thereof, hereby directs:

- (a) that the said roads, which are shown by hachure and cross-hachure on the plan hereunder, shall be discontinued;
- (b) that notwithstanding such discontinuance the Melbourne and Metropolitan Board of Works shall continue to have and possess the same right title power authority or interest in or in relation to the whole of the land shown by cross-hachure on the said plan as it had or possessed prior to such discontinuance with respect to or in connection with any drains or pipes laid or erected in on or over such land for the purposes for drainage or sewerage;
- (c) that, subject to any such right title power authority or interest, the land in the portion of the said road shown cross-hatched on the said plan shall be retained by the municipality for municipal purposes; and
- (d) that the land in the portion of the road shown hatched on the said plan may be sold by the Council of the City of Sunshine by agreement.

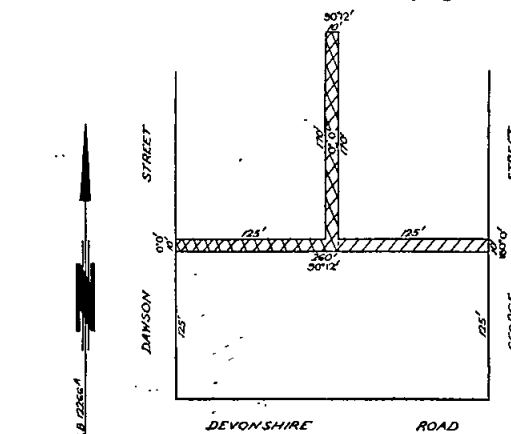

The Measurements  
are in Feet.

The fee of the land shown hatched and  
cross hatched was, on the 17th June 1868,  
comprised in Certificate of Title  
Vol 8035 Folio 650.

And the Honorable Rupert James Hamer, Her Majesty's Minister for Local Government for the State of Victoria shall give the necessary directions herein accordingly.

J. ROSSITER,  
Clerk of the Executive Council.

FORESTS DEPARTMENT.

At the Executive Council Chamber, Melbourne, the twentieth day of August, 1968.

PRESENT:

His Excellency the Lieutenant-Governor of Victoria.  
Mr. Porter | Mr. Meagher  
Mr. Hamer | Mr. Balfour.

ALIENATED LAND ACQUIRED BY EXCHANGE, ETC., AND DEDICATED AS RESERVED FOREST.

WHEREAS by section 42, sub-section 8, of the *Forests Act 1958*, it is prescribed that the Lieutenant-Governor in Council may acquire by exchange of land dedicated as reserved forest—

- (a) any alienated land or Crown land licensed or leased with an inchoate right of purchase; or
- (b) any land, public or private, and whether vested in trustees or otherwise,

and may by Order published in the *Government Gazette* dedicate the same as reserved forest:

Now, therefore, His Excellency the Lieutenant-Governor of the State of Victoria, by and with the advice of the Executive Council of the said State, and in pursuance of the provisions of section 42, sub-section 8, of the Forests Act 1958, doth by this Order—

- (1) acquire the alienated land described in Schedule "A" hereto by exchange of land dedicated as reserved forest described in Schedule "B" hereto;
- (2) excise from the reserved forest the area described in the aforesaid Schedule "B", such excision to take effect 30 days from date hereof;
- (3) dedicate the land described in Schedule "A" aforementioned as reserved forest, such dedication to take effect 30 days from date hereof.

THE SCHEDULE ABOVE REFERRED TO.

SCHEDULE "A"—DEDICATION SCHEDULE No. 201.

Alienated land acquired from Harold Alfred Holmes of Private Bag 3, Traralgon, being part of Allotment 18, Section B, Parish of Callignee, County of Buln Buln, comprising 52 acres 0 roods 34 perches.

SCHEDULE "B"—EXCISION SCHEDULE No. 162.

Land excised from reserved forest for Harold Alfred Holmes of Private Bag 3, Traralgon, being Allotment 18A, Parish of Callignee, County of Buln Buln, and comprising 8 acres 1 rood 35 perches.

And the Honorable Edward Raymond Meagher, Her Majesty's Minister of Forests for the State of Victoria, shall give the necessary directions herein accordingly.

J. ROSSITER,  
Clerk of the Executive Council.

SOIL CONSERVATION AND LAND UTILIZATION ACT 1958.

At the Executive Council Chamber, Melbourne, the twentieth day of August, 1968.

PRESENT:

His Excellency the Lieutenant-Governor of Victoria.  
Mr. Porter | Mr. Meagher  
Mr. Hamer | Mr. Balfour.

DISTRICT ADVISORY COMMITTEE.—WESTERN GIPPSLAND SOIL CONSERVATION DISTRICT.

IN pursuance of the powers conferred by Section 15 of the Soil Conservation and Land Utilization Act, His Excellency the Lieutenant-Governor of the State of Victoria by and with the advice of the Executive Council thereof doth hereby appoint the following persons to be members of the District Advisory Committee of the Western Gippsland Soil Conservation District for a term of three years.

IAN MAXWELL GIBSON—being a person elected to represent grazing, agricultural and other relevant interests in the District.

HAROLD DONALD ENGLISH—being a person elected to represent grazing, agricultural and other relevant interests in the District.

TEGWYN DAVID KELLY—being a person elected to represent grazing, agricultural and other interests in the District.

DESMOND McCRAE—being a person elected to represent grazing, agricultural and other relevant interests in the District.

JOHN BARRIE BARDSLEY—being the person representing the Department of Agriculture.

STANLEY CHARLES BUTLER—being the person representing the Forests Commission.

DONALD RANDALL PATERSON—being the person representing the Soil Conservation Authority.

And the Honorable Sir William John Farquhar McDonald, Her Majesty's Minister for Conservation for the State of Victoria shall give the necessary directions herein accordingly.

J. ROSSITER,  
Clerk of the Executive Council.

SOIL CONSERVATION AND LAND UTILIZATION ACT 1958.

At the Executive Council Chamber, Melbourne, the twentieth day of August, 1968.

PRESENT:

His Excellency the Lieutenant-Governor of Victoria.  
Mr. Porter | Mr. Meagher  
Mr. Hamer | Mr. Balfour.

DISTRICT ADVISORY COMMITTEE.—AVON SOIL CONSERVATION DISTRICT.

WHEREAS a vacancy exists on the Avon Soil Conservation District Advisory Committee due to the death of FRANCIS ROBERTS DRAKE, being the person representing the Department of Agriculture, now, therefore, I, the Lieutenant-Governor of the State of Victoria, by and with the advice of the Executive Council thereof, and in pursuance of the provisions of Section 15 of the Soil Conservation and Land Utilization Act, do hereby remove the said FRANCIS ROBERTS DRAKE from office and appoint the following person to such vacancy for a period up to and including the twentieth day of November, 1970:—

MALCOLM JOHN LEE—being the person representing the Department of Agriculture.

And the Honorable Sir William John Farquhar McDonald, Her Majesty's Minister for Conservation for the State of Victoria shall give the necessary directions herein accordingly.

J. ROSSITER,  
Clerk of the Executive Council.

PUBLIC SERVICE ACT 1958.

At the Executive Council Chamber, Melbourne, the twentieth day of August, 1968.

PRESENT:

His Excellency the Lieutenant-Governor of Victoria.  
Mr. Porter | Mr. Meagher  
Mr. Hamer | Mr. Balfour.

APPOINTMENT OF A DEPUTY OF A MEMBER OF THE PUBLIC SERVICE BOARD.

WHEREAS in the manner prescribed by the Regulations and at an election held in conjunction with the election of Kevin John Tutty as a member of the Public Service Board, EDWIN JOHN BENNETT was elected to be his deputy in the case of his suspension, illness or absence:

NOW THEREFORE, in pursuance of the powers conferred by the Public Service Act 1958, His Excellency the Lieutenant-Governor of the State of Victoria, by and with the advice of the Executive Council thereof, doth hereby appoint the said

EDWIN JOHN BENNETT

to act as the deputy of Kevin John Tutty for the period from the 26th August, 1968, to the 6th September, 1968, both dates inclusive.

And the Honorable Sir Henry Edward Bolte, K.C.M.G., Her Majesty's Premier for the State of Victoria, shall give the necessary directions herein accordingly.

J. ROSSITER,  
Clerk of the Executive Council.

RAILWAYS ACT 1958.

At the Executive Council Chamber, Melbourne, the twentieth day of August, 1968.

PRESENT:

His Excellency the Lieutenant-Governor of Victoria.  
Mr. Porter | Mr. Meagher  
Mr. Hamer | Mr. Balfour.

ORDER CLOSING RAILWAY LEVEL CROSSING AT 209M 15c 67L AT KYUP.

WHEREAS pursuant to the provisions of the Railways Act 1958 No. 6355 THE VICTORIAN RAILWAYS COMMISSIONERS recommended to the Governor-in-Council that the railway level crossing at 209M 15c 67L situated

at the northern end of Kyup railway station, should be closed and gave the several notices required under that Act and there being no objections to the said recommendation, His Excellency the Lieutenant-Governor of the State of Victoria with the advice of the Executive Council thereof and being satisfied—

- (a) that the requisite notices have been given
- (b) that not less than two months have expired since the last of such notices was given
- (c) that the level crossing is no longer required for the use of the public

doth hereby order that the said level crossing shall be closed upon the opening of a proposed new crossing at 209M 10c 28L.

And the Honorable Vernon Francis Wilcox, Her Majesty's Minister of Transport for the State of Victoria shall give the necessary directions herein accordingly.

J. ROSSITER,  
Clerk of the Executive Council.

*Water Act 1958.*

WERRIBEE WATER SUPPLY DISTRICT.

*At the Executive Council Chamber, Melbourne, the twenty-seventh day of August, 1968.*

PRESENT:

His Excellency the Lieutenant-Governor of Victoria.

Mr. Balfour		Mr. Dickie.
Mr. Manson		

LOCAL GOVERNING BODY, WERRIBEE SHIRE COUNCIL—AREA OF DISTRICT INCREASED.

UNDER the powers conferred by the *Water Act 1958* and all other powers enabling him in that behalf, His Excellency the Lieutenant-Governor of the State of Victoria, with the advice of the Executive Council of the said State, doth hereby declare, order and direct that the area of the Werribee Water Supply District, under the control of the Werribee Shire Council, as a Local Governing Body, be increased by adding thereto the lands shown on a plan approved by the Governor in Council and deposited in the office of the State Rivers and Water Supply Commission, Melbourne (Corr. No. 60/7672) and as on and from the 1st day of September, 1968, the area of such District shall be deemed to be so increased.

And the Honorable William Archibald Borthwick, Her Majesty's Minister of Water Supply for the State of Victoria, shall give the necessary directions herein accordingly.

J. ROSSITER,  
Clerk of the Executive Council.

*Water Act 1958.*

STATE RIVERS AND WATER SUPPLY COMMISSION.

*At the Executive Council Chamber, Melbourne, the twenty-seventh day of August, 1968.*

PRESENT:

His Excellency the Lieutenant-Governor of Victoria.

Mr. Balfour		Mr. Dickie.
Mr. Manson		

WERRIBEE WATERWORKS DISTRICT ABOLISHED.

UNDER the powers conferred by Section 2 of the *Werribee Waterworks District (Abolition) Act 1965* and all other powers enabling him in that behalf, His Excellency the Lieutenant-Governor of the State of Victoria, with the advice of the Executive Council of the said State, on the recommendation of the State Rivers and Water Supply Commission, doth hereby declare, order and direct as follows:—

That as on and from the 1st day of September, 1968, the Werribee Waterworks District be abolished and that the amount of liability of \$5,790.36 (being the amount of loss standing in the name of the Werribee Waterworks

District at that date) be transferred to the Account in the books of the State Rivers and Water Supply Commission called the "Revenue Expenditure Chargeable to the State Account".

And the Honorable William Archibald Borthwick, Her Majesty's Minister of Water Supply for the State of Victoria, shall give the necessary directions herein accordingly.

J. ROSSITER,  
Clerk of the Executive Council.

WATER ACT 1958.

*At the Executive Council Chamber, Melbourne, the twenty-seventh day of August, 1968.*

PRESENT:

His Excellency the Lieutenant-Governor of Victoria.

Mr. Balfour		Mr. Dickie.
Mr. Manson		

EXTENDING APPOINTMENT OF ACTING COMMISSIONER OF THE STATE RIVERS AND WATER SUPPLY COMMISSION.

PURSUANT to the provisions of the *Water Act 1958* His Excellency the Lieutenant-Governor of the State of Victoria by and with the advice of the Executive Council thereof doth by this Order appoint

CECIL LANCELOT SANDERS

Chief Engineer, Major Works of the State Rivers and Water Supply Commission to be an Acting Commissioner of the State Rivers and Water Supply Commission under the *Water Act 1958* for a further period from the second day of September, 1968, to the twenty-second day of September, 1968, inclusive, during the absence from Victoria of Kenneth David Green, a Commissioner of the said State Rivers and Water Supply Commission who on account of such absence from Victoria will not be available for the transaction of business during the said absence.

And the Honorable William Archibald Borthwick, Her Majesty's Minister of Water Supply for the State of Victoria, shall give the necessary directions herein accordingly.

J. ROSSITER,  
Clerk of the Executive Council.

LANDLORD AND TENANT ACT 1958.

*At the Executive Council Chamber, Melbourne, the twenty-seventh day of August, 1968.*

PRESENT:

His Excellency the Lieutenant-Governor of Victoria.

Mr. Balfour		Mr. Dickie.
Mr. Manson		

ORDER EXTENDING APPLICATION OF PART V. OF THE LANDLORD AND TENANT ACT 1958 TO CERTAIN PREMISES.

IN pursuance of the powers conferred by Section 44 of the *Landlord and Tenant Act 1958*, His Excellency the Lieutenant-Governor of the State of Victoria, by and with the advice of the Executive Council thereof, doth hereby declare that the application of Part V. of the *Landlord and Tenant Act 1958* shall extend to the following premises—

The premises known as Number 493 St. Kilda Street, Elwood.

And the Honorable George Oswald Reid, Her Majesty's Attorney-General in and for the State of Victoria, shall give the necessary directions herein accordingly.

J. ROSSITER,  
Clerk of the Executive Council.

COUNTRY ROADS BOARD.

At the Executive Council Chamber, Melbourne, the twenty-seventh day of August, 1968.

PRESENT:

His Excellency the Lieutenant-Governor of Victoria.

Mr. Balfour Mr. Dickie.  
Mr. Manson

ORDER APPROVING OF LAND BEING ACQUIRED AND ROADS, DEVIATIONS OR WIDENINGS BEING MADE.

HIS Excellency the Lieutenant-Governor of the State of Victoria, by and with the advice of the Executive Council thereof, being satisfied that there are funds legally available for acquiring the land, doth hereby approve the acquiring of the land described in the schedule hereunder and the making of new roads and deviations from and widenings of existing roads referred to in the said schedule.

SCHEDULE.

State highways.

The land shown hatched on Plan numbered G.P.11404 hereunder required for the widening of the Pyrenees Highway in the Shire of Ararat and making of the widening thereon.

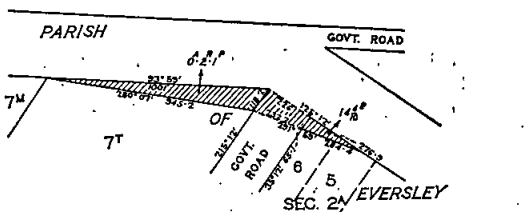
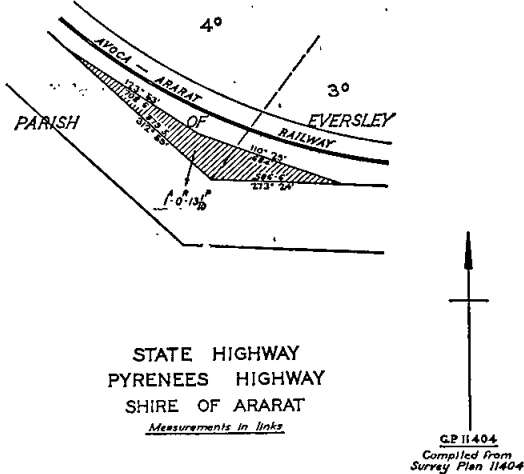

The land shown hatched on Plan numbered G.P.11072 hereunder required for the deviation from the Hamilton Highway in the Shire of Bannockburn and making of the deviation thereon.

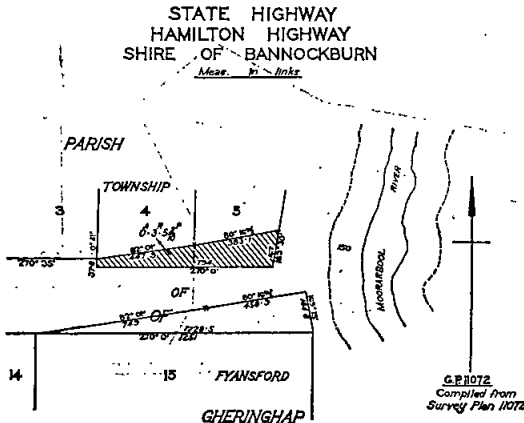

Main roads.

The land shown hatched on Plan numbered G.P.11370 hereunder required for the widening of the Clunes-Creswick Road in the Shire of Ballarat and making of the widening thereon.

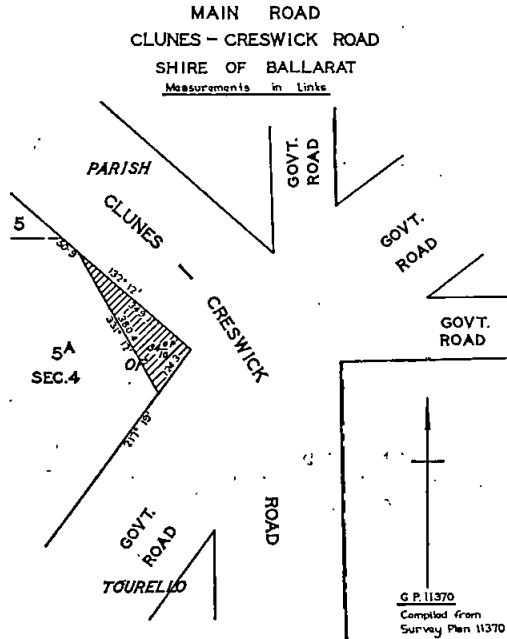

The land shown hatched on Plan numbered G.P.11314 hereunder required for the deviation from the Buckland Valley Road in the Shire of Bright and making of the deviation thereon.

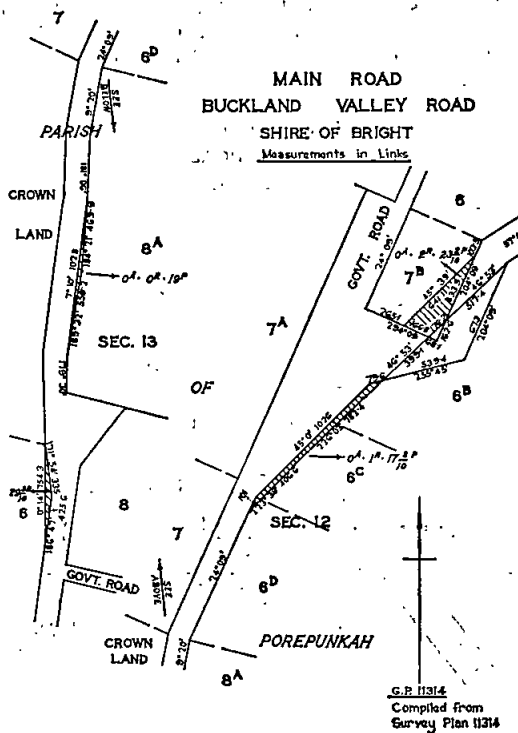

The land shown hatched on Plan numbered G.P.11347 hereunder required for the deviation from the Cohuna-McMillans Road in the Shire of Cohuna and making of the deviation thereon.

The land shown hatched on plan numbered G.P.11466 hereunder required for the widening of the Doncaster-Mordialloc Road in the City of Springvale and making of the widening thereon.

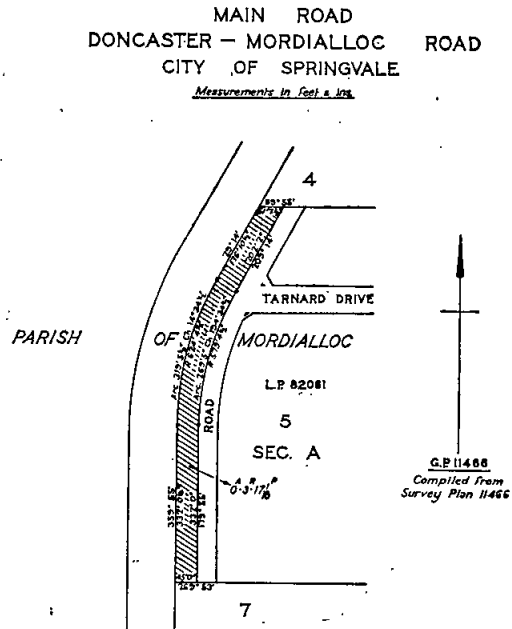
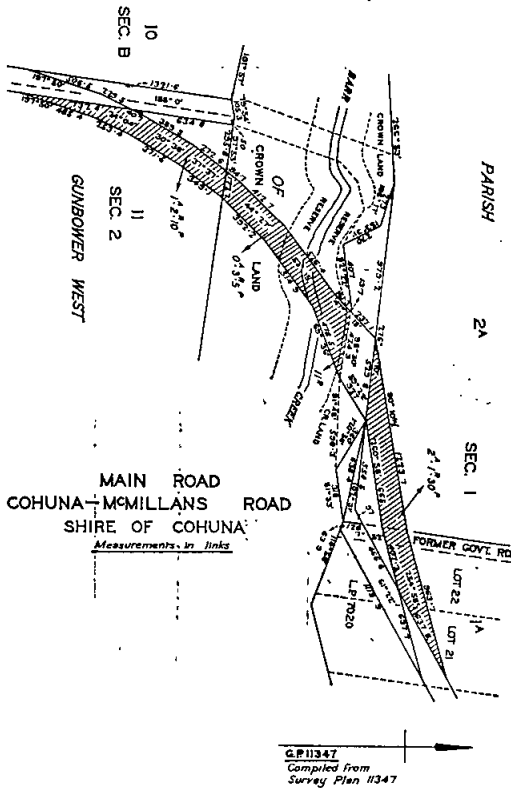

The land shown hatched on Plan numbered G.P.11283 hereunder required for the deviation from the Irrewillipe Road in the Shire of Colac and making of the deviation thereon.

The land shown hatched on Plan numbered G.P.11443 hereunder required for the widening of the Don Road in the Shire of Upper Yarra and making of the widening thereon.

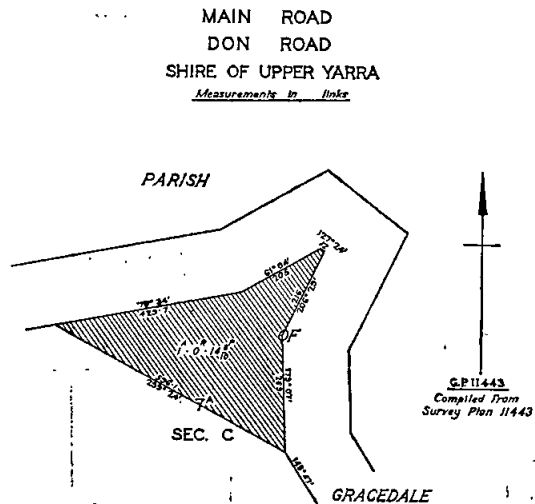
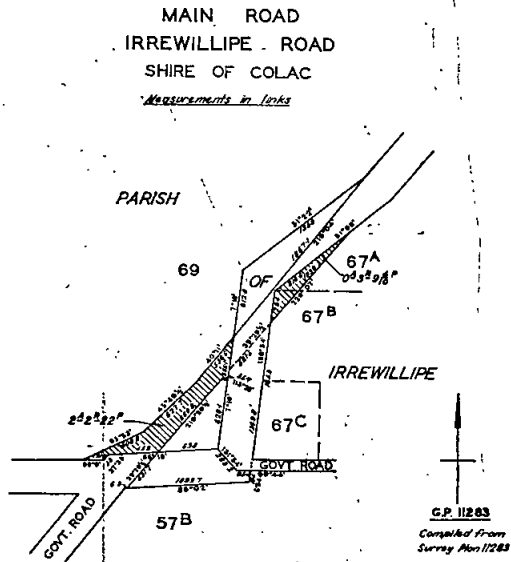



The land shown hatched on Plan numbered G.P.11396 hereunder required for the widening of the Birchip—Sea Lake Road in the Shire of Wycheproof and making of the widening thereon.

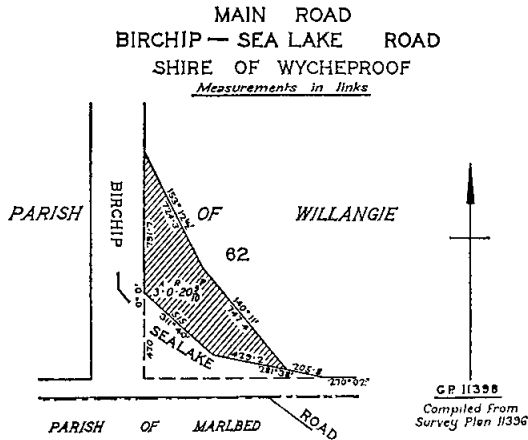

**By-pass roads.**

The land shown hatched on Plans numbered G.P.11419A, G.P.11420A and G.P.11421A hereunder required for the making of part of the Lower Yarra Freeway By-pass Road in the City of Footscray.

**BY-PASS ROAD  
LOWER YARRA FREEWAY BY-PASS ROAD  
CITY OF FOOTSCRAY**  
*Measurements in feet & inches*

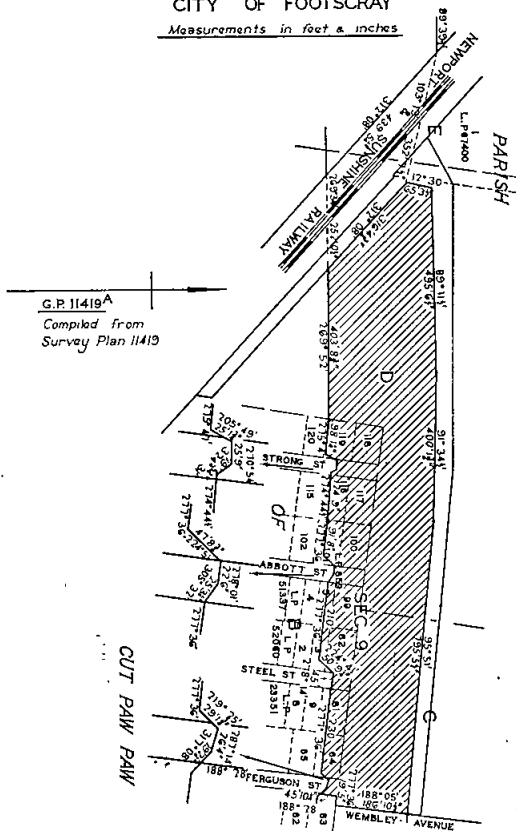

**BY-PASS ROAD  
LOWER YARRA FREEWAY BY-PASS ROAD  
CITY OF FOOTSCRAY**  
*Measurements in feet & inches*

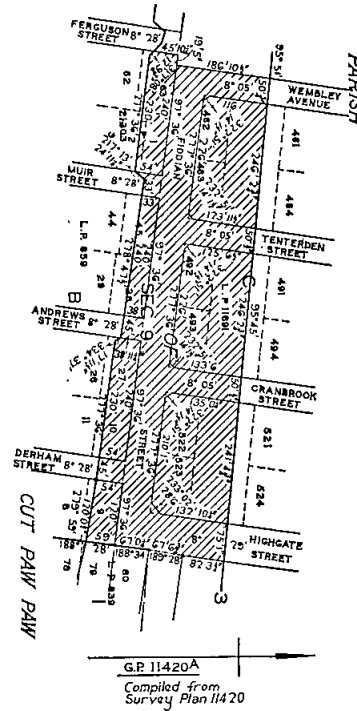

**BY-PASS ROAD  
LOWER YARRA FREEWAY BY-PASS ROAD  
CITY OF FOOTSCRAY**  
*Measurements in feet & inches*

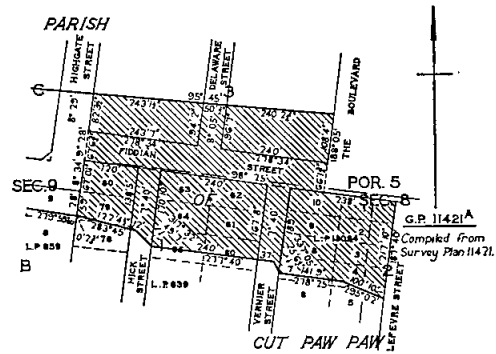

NOTE:—This Order is in lieu of part of the Order published in the Government Gazette dated the Twentieth day of September, One Thousand Nine Hundred and Sixty-seven, on pages 2899-2900.

The land shown hatched on Plans numbered G.P.11055, G.P.11056, G.P.11100A, G.P.11101, G.P.11102, G.P.11111, G.P.11163 and G.P.11164 hereunder required for the making of part of the Healesville Freeway By-pass Road in the City of Nunawading.

BY-PASS ROAD  
HEALESVILLE FREEWAY BY-PASS ROAD  
CITY OF NUNAWADING

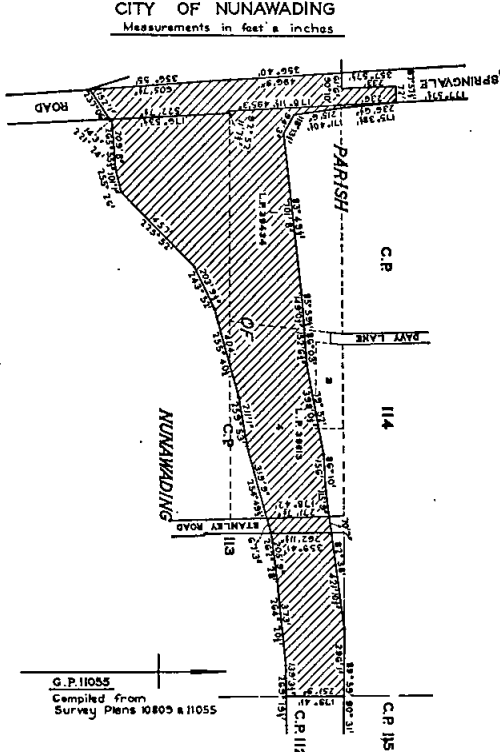

BY-PASS ROAD  
HEALESVILLE FREEWAY BY-PASS ROAD  
CITY OF NUNAWADING

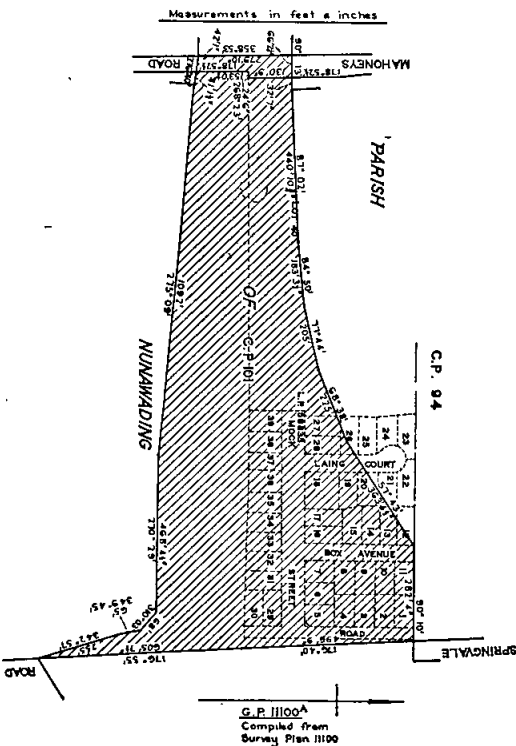

BY-PASS ROAD  
HEALESVILLE FREEWAY BY-PASS ROAD  
CITY OF NUNAWADING

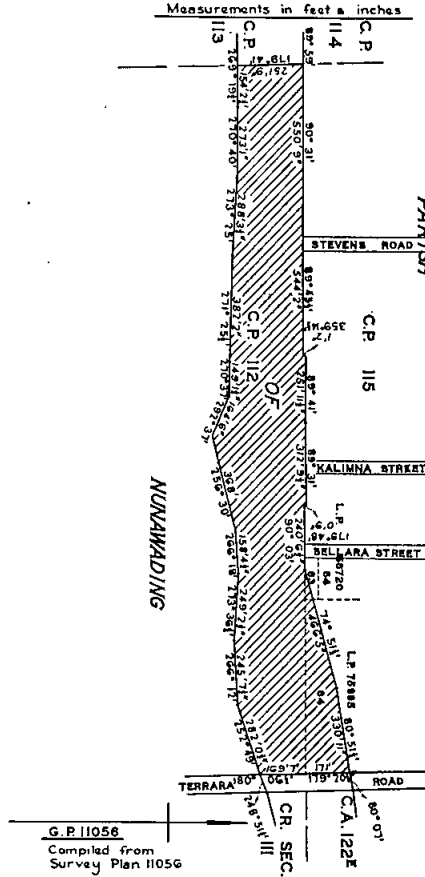

BY-PASS ROAD  
HEALESVILLE FREEWAY BY-PASS ROAD  
CITY OF NUNAWADING

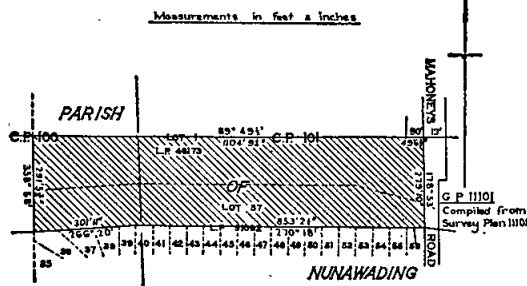

BY-PASS ROAD  
HEALESVILLE FREEWAY BY-PASS ROAD  
CITY OF NUNAWADING

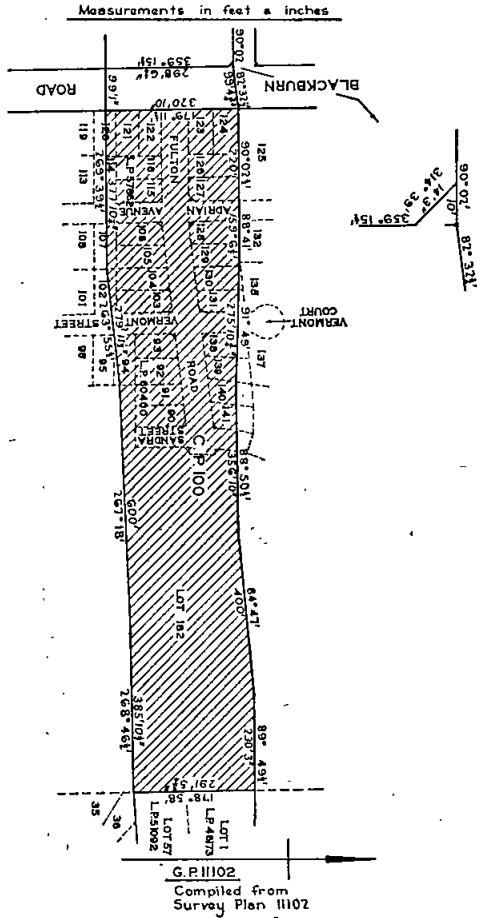

BY-PASS ROAD  
HEALESVILLE FREEWAY BY-PASS ROAD  
CITY OF NUNAWADING

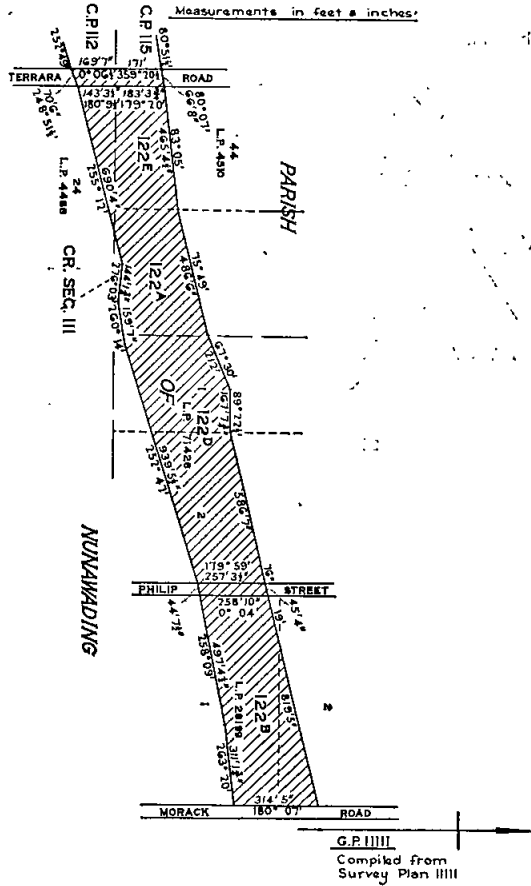

BY-PASS ROAD  
HEALESVILLE FREEWAY BY-PASS ROAD  
CITY OF NUNAWADING

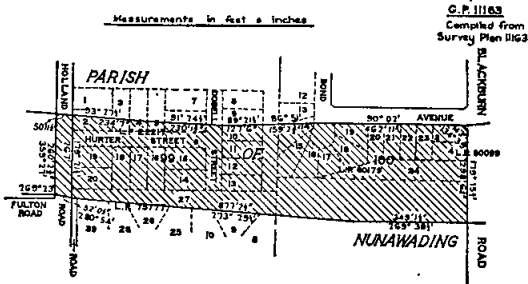

BY-PASS ROAD  
HEALESVILLE FREEWAY BY-PASS ROAD  
CITY OF NUNAWADING

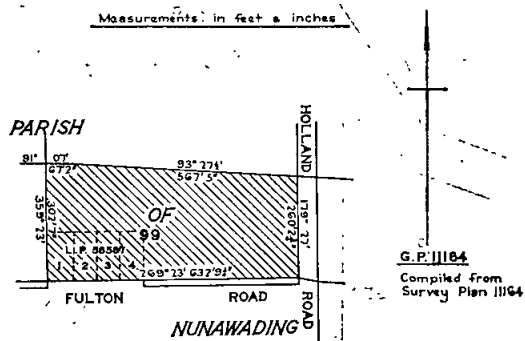

Tourists' roads.

The land shown hatched on Plan numbered G.P.11392 hereunder required for the deviation from the Mallocoota Road in the Shire of Orbost and making of the deviation thereon.

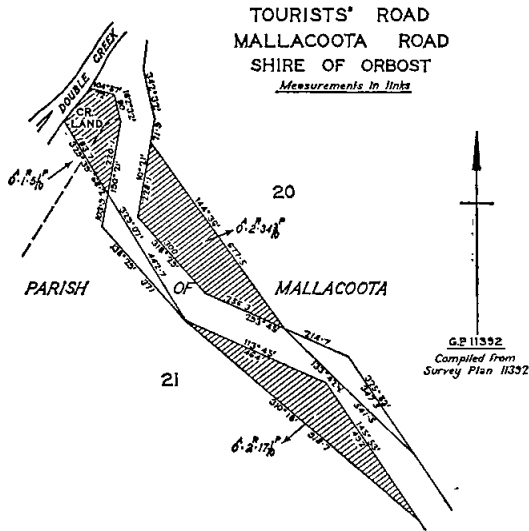

Unclassified road.

The land shown hatched on Plans numbered G.P.11419a, G.P.11420b and G.P.11421b hereunder required for the making of a new road in the City of Footscray.

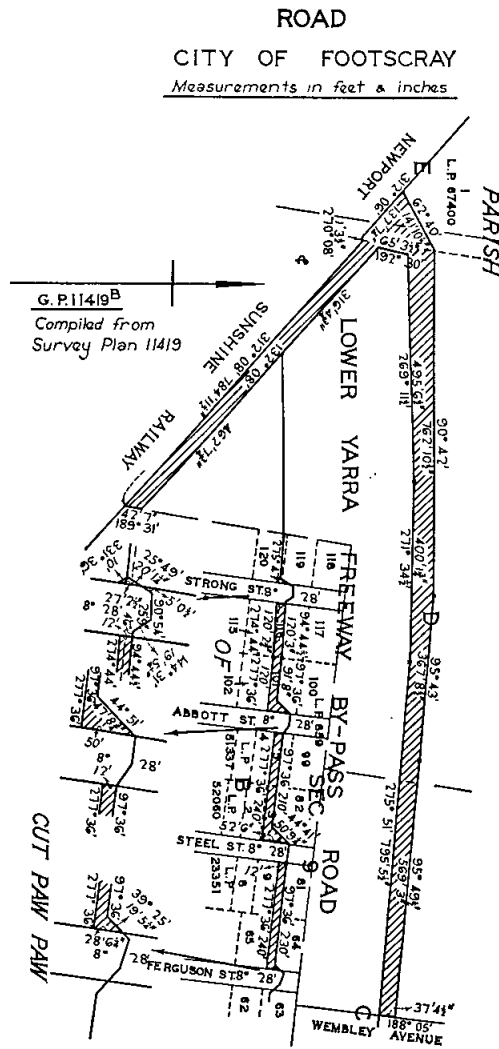

The land shown hatched on Plan numbered G.P.11411 hereunder required for the deviation from the Ocean Road in the Shire of Otway and making of the deviation thereon.

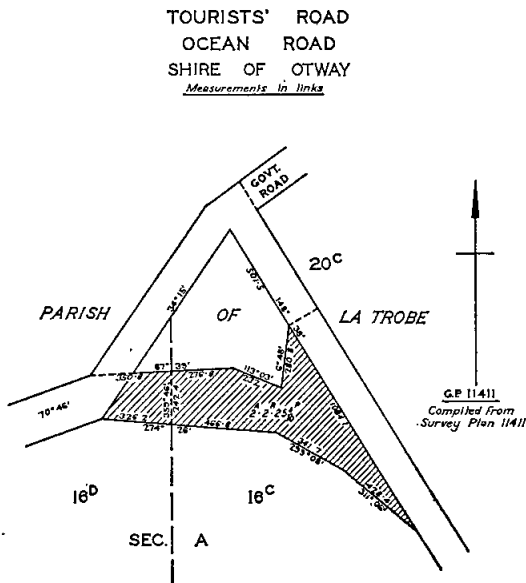

ROAD  
CITY OF FOOTSCRAY

Measurements in feet & inches

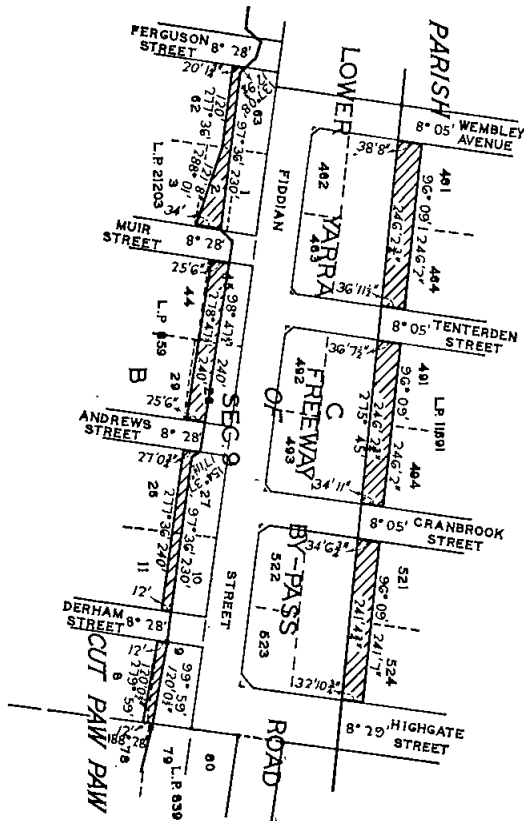

G.P. 11420<sup>B</sup>  
Compiled from  
Survey Plan 11420

ROAD  
CITY OF FOOTSCRAY

Measurements in feet & inches

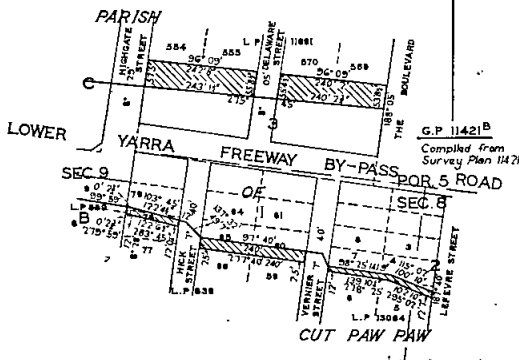

G.P. 11421<sup>B</sup>  
Compiled from  
Survey Plan 11421

Forest road.

The land shown hatched on Plan numbered G.P.11437 hereunder required for the widening of the Dean Marsh-Lorne Road in the Shire of Winchelsea and making of the widening thereon.

FOREST ROAD  
DEAN MARSH — LORNE ROAD  
SHIRE OF WINCHELSEA

Measurements in links

PARISH

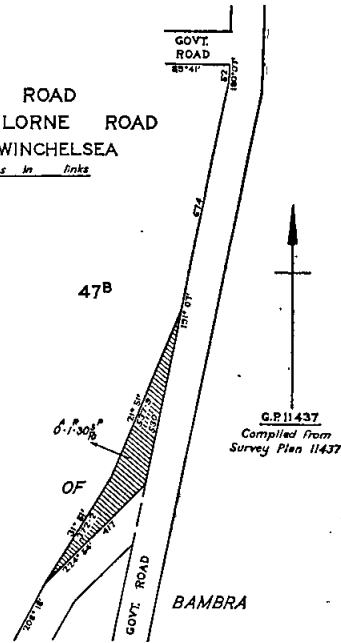

G.P. 11437  
Compiled from  
Survey Plan 11437

And the Honorable Murray Victor Porter, Her Majesty's Minister of Public Works for the State of Victoria, shall give the necessary directions herein accordingly.

J. ROSSITER,  
Clerk of the Executive Council.

HOUSING ACT 1958.

At the Executive Council Chamber, Melbourne, the twenty-seventh day of August, 1968.

PRESENT:

His Excellency the Lieutenant-Governor of Victoria.  
Mr. Balfour  
Mr. Manson  
Mr. Dickie.

DECLARATION OF PRIVATE STREETS AS PUBLIC HIGHWAYS WITHIN THE SHIRE OF GORDON.

WHEREAS pursuant to Section 107 of the Housing Act 1958 it is among other things enacted that where works have been carried out in accordance with an Agreement for the full construction of any roads, pavements, culverts or drains made pursuant to the provisions of the said Section 107 such roads, pavements, culverts or drains shall be under the care and management of the Municipality which shall be liable for the cost of any maintenance, repair, alteration or reconstruction thereof and the Governor-in-Council may by order published in the Government Gazette declare any road so constructed to be a public highway.

AND WHEREAS by Order dated the Thirtieth day of May, 1967, the Governor-in-Council consented to an agreement between the Housing Commission and the Shire of Gordon regarding street and drainage construction in Wait Street in the Boort Estate situate in the Municipality of the Shire of Gordon and the carrying out of the works enumerated in the said Agreement.

AND WHEREAS the works of road pavements, culvert and drainage construction have now been carried out in accordance with the said Agreement between the Housing Commission and the Shire of Gordon.

NOW THEREFORE His Excellency the Lieutenant-Governor of the State of Victoria by and with the advice of the Executive Council of the said State and in pursuance of the powers conferred by Section 107 of the Housing Act and upon recommendation of the Housing Commission DOETH by this order declare the streets more particularly delineated and shown hatched on the plan hereunder to

be absolutely dedicated to the public as Public Highways within the meaning of any law now or hereafter in force AND THAT the Council of the Municipality in which the streets are situate shall hereafter be liable for all cost of any maintenance, repair, alteration or reconstruction thereof.

PART OF CROWN ALLOTMENT 15B SECTION F  
**PARISH OF BOORT**

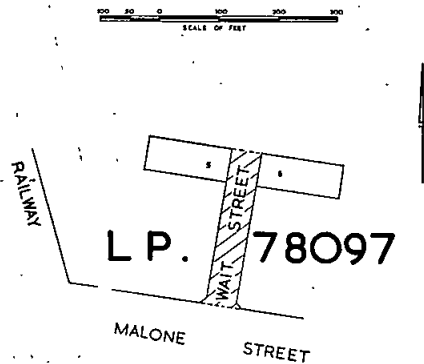

And the Honorable Edward Raymond Meagher, Her Majesty's Minister of Housing for the State of Victoria, shall give the necessary directions herein accordingly.

J. ROSSITER,  
Clerk of the Executive Council.

HOUSING ACT 1958.

At the Executive Council Chamber, Melbourne, the twenty-seventh day of August, 1968.

PRESENT:

His Excellency the Lieutenant-Governor of Victoria.  
Mr. Balfour | Mr. Dickie.  
Mr. Manson

DECLARATION OF PRIVATE STREETS AS PUBLIC HIGHWAYS WITHIN THE CITY OF WAVERLEY.

WHEREAS pursuant to Section 107 of the Housing Act 1958 it is among other things enacted that where works have been carried out in accordance with an agreement for the full construction of any roads, pavements, culverts or drains made pursuant to the provisions of the said Section 107 such roads, pavements, culverts or drains shall be under the care and management of the Municipality which shall be liable for the cost of any maintenance, repair, alteration or reconstruction thereof and the Governor-in-Council may by order published in the Government Gazette declare any road so constructed to be a public highway.

AND WHEREAS by Order dated the Fifteenth day of December, 1964, the Governor-in-Council consented to an agreement between the Housing Commission and the City of Waverley regarding street and drainage construction in Gordon Road, Lechte Road, Bicton Street, Beaufort Street, Roe Court, Hovea Court and Dart Court in the Mt. Waverley Estate situate in the municipality of the City of Waverley and the carrying out of the works enumerated in the said Agreement.

AND WHEREAS the works of road, pavements, culvert and drainage construction have now been carried out in accordance with the said agreement between the Housing Commission and the City of Waverley.

NOW THEREFORE His Excellency the Lieutenant-Governor of the State of Victoria by and with the advice of the Executive Council of the said State and in pursuance of the powers conferred by Section 107 of the Housing Act and upon recommendation of the Housing Commission DOTH by this order declare the streets more particularly delineated and shown hatched on the plan hereunder to be absolutely dedicated to the public as Public Highways within the meaning of any law now or hereafter in force AND THAT the Council of the Municipality in which the streets are situate shall hereafter be liable for all cost of any maintenance, repair, alteration or reconstruction thereof.

PART OF CROWN PORTION 63  
**PARISH OF MULGRAVE**

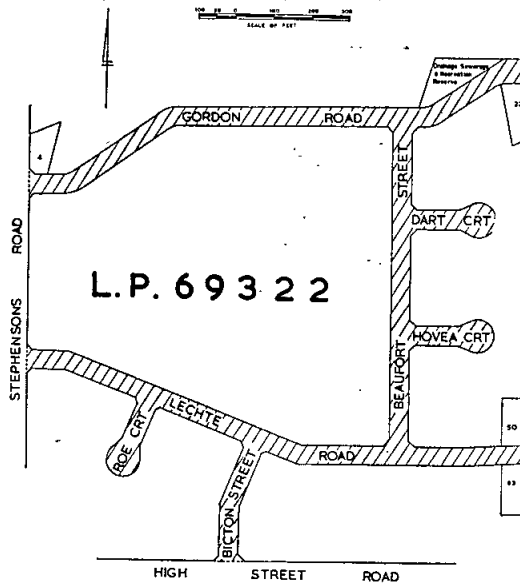

And the Honorable Edward Raymond Meagher, Her Majesty's Minister of Housing for the State of Victoria, shall give the necessary directions herein accordingly.

J. ROSSITER,  
Clerk of the Executive Council.

YATCHAW DRAINAGE TRUST.

At the Executive Council Chamber, Melbourne, the twenty-seventh day of August, 1968.

PRESENT:

His Excellency the Lieutenant-Governor of Victoria.  
Mr. Balfour | Mr. Dickie.  
Mr. Manson

AMENDMENT OF ORDER.

UNDER the powers conferred by the River Improvement Act and all other powers enabling him in that behalf, His Excellency the Lieutenant-Governor of the State of Victoria, by and with the advice of the Executive Council of the said State, doth hereby amend as follows the Order in Council made on 7th February, 1967, and published in the Victoria Government Gazette dated 8th February, 1967, appointing Allan Raymond Lewis a Commissioner of the Yatchaw Drainage Trust.

For the expression "for a period of four years from the date hereof" there shall be substituted the expression "from the date hereof until the date of the election of Commissioners to be held in July 1969".

And the Honorable William Archibald Borthwick, Her Majesty's Minister of Water Supply for the State of Victoria, shall give the necessary directions herein accordingly.

J. ROSSITER,  
Clerk of the Executive Council.

LEONGATHA SEWERAGE AUTHORITY.

At the Executive Council Chamber, Melbourne, the twenty-seventh day of August, 1968.

PRESENT:

His Excellency the Lieutenant-Governor of Victoria.  
Mr. Balfour | Mr. Dickie.  
Mr. Manson

COMPULSORY ACQUISITION OF LANDS.

UNDER the powers conferred by the Sewerage Districts Act and other powers enabling him in that behalf, His Excellency the Lieutenant-Governor of the State of Victoria, by and with the advice of the Executive Council

of the said State, doth hereby consent to the compulsory acquisition by the Leongatha Sewerage Authority of the lands shown in red colour on the plans numbered Twelve A, Fifty-five C and Fifty-five B which comprise part of the site for works of the Leongatha Sewerage Authority which were approved by Order published in the Gazette No. 59 of 10th August, 1966, Pages 3004 and 3005.

ALL of which lands are shown in the aforesaid plans approved by the Governor in Council and deposited in the office of The State Rivers and Water Supply Commission, Melbourne.—(Corr. 64/5496/146).

And the Honorable William Archibald Borthwick, Her Majesty's Minister of Water Supply for the State of Victoria, shall give the necessary directions herein accordingly.

J. ROSSITER,  
Clerk of the Executive Council.

#### WERRIBEE SEWERAGE AUTHORITY.

At the Executive Council Chamber, Melbourne, the twenty-seventh day of August, 1968.

PRESENT:

His Excellency the Lieutenant-Governor of Victoria.  
Mr. Balfour | Mr. Dickie.  
Mr. Manson

#### EXTENT OF SEWERAGE DISTRICT INCREASED.

UNDER the powers conferred by the Sewerage Districts Act and all other powers enabling him in that behalf, His Excellency the Lieutenant-Governor of the State of Victoria, by and with the advice of the Executive Council of the said State, doth hereby declare, order and direct that the extent of the Sewerage District of the Werribee Sewerage Authority be increased by adding to the same the lands comprised within the boundaries described in the Schedule hereto and as on and from the date hereof the extent of such District shall be deemed to be increased accordingly.

#### SCHEDULE.

Commencing at a point being the north-western corner of Crown allotment 17, Parish of Deutgam, County of Bourke, being also a point on the boundary of the existing Sewerage District, thence by a line south-easterly along the north-eastern boundaries of the said Crown allotment 17, and Crown allotment 16 to the easternmost angle of Crown allotment 16; thence south-westerly along the south-eastern boundary of the said Crown allotment 16 to its southernmost angle and by the continuation thereof across Tower Road and across a channel to the north-eastern boundary of Crown allotment 19; thence north-westerly along the north-eastern boundary of the said Crown allotment 19 and of Crown allotment 18 to the northernmost angle of Crown allotment 18; being also a point on the boundary of the existing Sewerage District; thence north-easterly along the said boundary of the existing Sewerage District to the point of commencement.

All of which boundaries are shown on a plan approved by the Governor in Council and deposited in the office of the State Rivers and Water Supply Commission, Melbourne.—(Corres. No. 68/3914/1).

And the Honorable William Archibald Borthwick, Her Majesty's Minister of Water Supply for the State of Victoria, shall give the necessary directions herein accordingly.

J. ROSSITER,  
Clerk of the Executive Council.

#### PORTLAND SEWERAGE AUTHORITY.

At the Executive Council Chamber, Melbourne, the twenty-seventh day of August, 1968.

PRESENT:

His Excellency the Lieutenant-Governor of Victoria.  
Mr. Balfour | Mr. Dickie.  
Mr. Manson

#### EXTENT OF SEWERAGE DISTRICT INCREASED.

UNDER the powers conferred by the Sewerage Districts Act and all other powers enabling him in that behalf, His Excellency the Lieutenant-Governor of the State of Victoria, by and with the advice of the Executive Council of the said State, doth hereby declare, order and direct that the extent of the Sewerage District of the Portland Sewerage Authority be increased by adding thereto land

reclaimed from Portland Bay being a strip of reclaimed land of maximum width of approximately 9 chains adjoining the existing Sewerage District boundary (being the natural shoreline of Portland Bay) and commencing at the right bank of Salt Creek and continuing generally south-easterly for a distance of approximately 72 chains to the end of the said strip of reclaimed land generally in line with the north-easterly continuation of Hughes-street as shown on a plan approved by the Governor in Council by and with this Order and deposited in the office of the State Rivers and Water Supply Commission, Melbourne (Corr. 59/915/216), and as on and from the date hereof the extent of such District shall be and be deemed to be increased accordingly.

And the Honorable William Archibald Borthwick, Her Majesty's Minister of Water Supply for the State of Victoria, shall give the necessary directions herein accordingly.

J. ROSSITER,  
Clerk of the Executive Council.

#### PORTLAND WATERWORKS TRUST.

At the Executive Council Chamber, Melbourne, the twenty-seventh day of August, 1968.

PRESENT:

His Excellency the Lieutenant-Governor of Victoria.  
Mr. Balfour | Mr. Dickie.  
Mr. Manson

#### EXTENT OF WATERWORKS AND URBAN DISTRICTS INCREASED.

UNDER the powers conferred by the Water Act and all other powers enabling him in that behalf, His Excellency the Lieutenant-Governor of the State of Victoria, by and with the advice of the Executive Council of the said State, doth hereby declare, order and direct that the extent of the Waterworks and Urban Districts of the Portland Waterworks Trust be increased by adding to the same land reclaimed from Portland Bay being a strip of reclaimed land of maximum width of approximately 9 chains adjoining the existing Waterworks District and Urban District boundary (being the natural shoreline of Portland Bay) and commencing at the right bank of Salt Creek and continuing generally south-easterly for a distance of approximately 72 chains to the end of the said strip of reclaimed land generally in line with the north-easterly continuation of Hughes-street as shown on a plan approved by the Governor in Council and deposited in the office of the State Rivers and Water Supply Commission, Melbourne (Corr. 62/3573/238) and as on and from the date hereof, the extent of such Districts shall be and be deemed to be increased accordingly.

And the Honorable William Archibald Borthwick, Her Majesty's Minister of Water Supply for the State of Victoria, shall give the necessary directions herein accordingly.

J. ROSSITER,  
Clerk of the Executive Council.

#### Water Act 1958.

#### STATE RIVERS AND WATER SUPPLY COMMISSION.

At the Executive Council Chamber, Melbourne, the twenty-seventh day of August, 1968.

PRESENT:

His Excellency the Lieutenant-Governor of Victoria.  
Mr. Balfour | Mr. Dickie.  
Mr. Manson

#### TOOLONDO RESERVOIR RECREATIONAL AREA— DECLARATION.

WHEREAS it is provided by section 206A of the Water Act 1958 (as amended) that the Governor in Council may by Order declare any area of land owned or controlled by the State Rivers and Water Supply Commission to be a recreational area.

Now therefore, His Excellency the Lieutenant-Governor of the State of Victoria, by and with the advice of the Executive Council thereof, hereby declares that the area of land shown by red colour on plan numbered 6126, and lodged in the Plan Room of the State Rivers and Water

Supply Commission at 90 Orrong Road, Armadale, shall be a recreational area to be known as the Toolondo Reservoir Recreational Area except that any of such land inundated from time to time by the waters stored in the Toolondo Reservoir, shall not while so inundated be deemed to be within the Toolondo Reservoir Recreational Area.

And the Honorable William Archibald Borthwick, Her Majesty's Minister of Water Supply for the State of Victoria, shall give the necessary directions herein accordingly.

J. ROSSITER,  
Clerk of the Executive Council.

If unable to attend personally, a prospective purchaser may arrange for another person to bid as his agent.

Attention is drawn to section 95, Land Act 1958, which provides that the purchaser shall be deemed to be the owner for the purposes of other Acts; also to an amendment to the Local Government Act providing for Government roads, in certain circumstances, to be declared "private streets", thus making the purchaser liable to contribute to the cost of street construction.

W. J. F. McDONALD,  
Minister of Lands.

Office of Crown Lands and Survey,  
Melbourne 28th August, 1968.

**LANDS DEPARTMENT NOTICES**

**APPROACHING LAND SALES.**

SALES of Crown Lands, in fee-simple, will be held at the under-mentioned places and dates, viz.:-

	No. of Gazette.
Alexandra.—Friday, 27th September, 1968	71
Ararat.—Thursday, 29th August, 1968	53
Avoca.—Friday, 13th September, 1968	67
Balmoral.—Friday, 6th September, 1968	59
Beaufort.—Thursday, 29th August, 1968	53
Chiltern.—Monday, 30th September, 1968	75
Dunolly.—Friday, 13th September, 1968	67
Edenhope.—Friday, 6th September, 1968	59
Heathcote.—Friday, 4th October, 1968	71
Kilmore.—Friday, 4th October, 1968	71
Maryborough.—Friday, 13th September, 1968	67
Mitta Mitta.—Monday, 30th September, 1968	75
Rushworth.—Friday, 4th October, 1968	71
St. Arnaud.—Thursday, 12th September, 1968	67
Stawell.—Friday, 11th October, 1968	75

**SALE OF FREEHOLD LAND BY AUCTION.**

Tallangatta.—Monday, 30th September, 1968 75

**SALES OF CROWN LAND BY AUCTION.**

The land will be offered for sale in fee-simple, and subject to the provisions of the Land Act and Regulations thereunder.

The upset price is the sum at which bidding will start, and no bid below that sum can be accepted. The highest bidder at or above that sum shall be the purchaser, subject to signature of contract and any necessary payment.

**TERMS:—**

A deposit of at least 12½% of the purchase price must be paid at the sale, either in cash or by cheque.

The residue is payable in half-yearly instalments, in accordance with the following scale, or may be paid off at any earlier time.

\$40 and under, 6 instalments.
Over \$40, and not exceeding \$100, 8 instalments.
Over \$100, and not exceeding \$200, 10 instalments.
Over \$200, and not exceeding \$400, 12 instalments.
Over \$400, and not exceeding \$600, 14 instalments.
Over \$600, and not exceeding \$800, 16 instalments.
Over \$800, and not exceeding \$1,000, 18 instalments.
Over \$1,000, 20 instalments.

Interest at the rate of 5% per annum is payable with all payments of residue, and is computed for each instalment from the date of sale to the date of such payment. Additional interest is charged if any instalment is not paid on or before the due date.

If paid off within 30 days of sale, no interest is payable.

**FEEs, ETC.:**

Also payable at the sale, in addition to the deposit, are the survey fee and, if applicable, the valuation of improvements (if purchaser be not the owner thereof).

**Payable with balance of purchase money—**

Crown Grant fee—	
50 acres and under .. .. .	\$3
Over 50 acres .. .. .	\$4
Purchase money \$10 or under .. .. .	\$2

Assurance Fund contribution.—One cent in every Five dollars or part thereof of purchase price. (This is a fund established to guarantee the validity of freehold titles.)

Transfer of interest prior to completion of payment may be allowed on payment of \$2 fee and subject to stamp duty.

**STAWELL.**—Sale (No. 11959) of Crown Land in fee-simple, by auction will be held at the COURT HOUSE, PATRICK-STREET, STAWELL, on FRIDAY, the 11th OCTOBER, 1968, at ELEVEN o'clock a.m. To be conducted by E. M. FLOYD, Land Officer, Horsham.

**Lot 1.**

TOWNSHIP OF STAWELL, PARISH OF STAWELL, COUNTY OF BORUNG.

Fronting the south side of Pickering-road about 3½ chains west of Racecourse-road.

Upset price \$700 the lot. Survey fee \$16.

Area 1a. 1r. 22p. Subject to survey, allotment 7 of section 6A. Valuation of improvements \$7,000. (R. S. Fisher). (Loose boxes, horse yard, stables, &c.)—(M.60500.)

**Lot 2.**

PARISH OF ILLAWARRA, COUNTY OF BORUNG.

Fronting south side of Government-road about ¼ mile west of the Western Highway and about 4½ miles north-west of the Township of Stawell.

Upset price \$800 the lot. Survey fee \$42.

Area 79a. 3r. 34p., allotment 219B. Subject to State Rivers and Water Supply Commission Flooding indemnity condition.—(M.60461.)

**CHILTERN.**—Sale (No. 11960) of Crown Land in fee-simple, by auction, will be held at the LAND INSPECTOR'S OFFICE, CHILTERN, on MONDAY, the 30th SEPTEMBER, 1968, at half-past NINE o'clock a.m. To be conducted by F. F. HOLT, Land Officer, Beechworth.

TOWNSHIP OF CHILTERN, PARISH OF CHILTERN, COUNTY OF BOGONG.

**Lot 1.**

Situated on the south-west corner of the junction of Makay and Smythe streets.

Upset price \$60 the lot. Survey fee \$6.

Area 3r. 31p., allotment 1 of section F. Subject to State Electricity Commission easement. One month allowed for removal of improvements.

**Lot 2.**

Situated on the north-west corner of the junction of Makay and Smythe streets.

Upset price \$100 the lot. Survey fee \$8.

Area 2r. 0p., allotment 1A of section F. Subject to State Electricity Commission easement. One month allowed for removal of improvements.—(H.017159.)

**Lot 3.**

PARISH OF LILLIPUT, COUNTY OF BOGONG.

About 1½ miles south of the Township of Rutherglen.

Upset price \$120 the lot. Survey fee \$19.25.

Area 5a. 0r. 12p., allotment 5A of section 9. One month allowed for removal of improvements.—(H.032382.)

**MITTA MITTA.**—Sale (No. 11961) of Crown Land in fee-simple by auction will be held at the LAND INSPECTOR'S OFFICE, MITTA MITTA, on MONDAY, the 30th SEPTEMBER, 1968, at TWO o'clock p.m. To be conducted by F. F. HOLT, Land Officer, Beechworth.

TOWNSHIP OF MITTA MITTA, PARISH OF MAGORRA, COUNTY OF BOGONG.

In the south-west of the Township, on the southern side of the Omeo Highway.

**Lot 1.**

Upset price \$80 the lot. Survey fee \$15.

Area 2r. 16p., allotment 2 of section L.



- Lot 2. Upset price \$80 the lot. Survey fee \$15.  
Area 2r. 18p., allotment 3 of section L.
- Lot 3. Upset price \$80 the lot. Survey fee \$15.  
Area 2r. 14p., allotment 4 of section L.
- Lot 4. Upset price \$80 the lot. Survey fee \$13.  
Area 1r. 11p., allotment 5 of section L.
- Lot 5. Upset price \$80 the lot. Survey fee \$13.  
Area 1r. 17p., allotment 6 of section L.
- Lot 6. Upset price \$80 the lot. Survey fee \$15.  
Area 2r. 12p., allotment 7 of section L.
- Lot 7. Upset price \$100 the lot. Survey fee \$15.  
Area 1r. 24p., allotment A<sup>32</sup>.
- Lot 8. Upset price \$120 the lot. Survey fee \$16.  
Area 1a. 0r. 5p., allotment A<sup>34</sup>.

NOTE.—The roads abutting above allotments (Nos. 1 to 8) have been declared private streets in pursuance to section 575 (3a) *Local Government Act 1958*.—(H.030456.)

**SALE OF FREEHOLD LAND BY AUCTION.**

**TALLANGATTA.**—A sale of freehold land, by auction for and on behalf of the Minister of Education, will be held at the LAND INSPECTOR'S OFFICE, TALLANGATTA, on MONDAY, 30th SEPTEMBER, 1968, at ELEVEN o'clock a.m. To be conducted by F. F. HOLT, Land Officer, Beechworth.

Conditions.—Deposit of at least 12½ per cent. of purchase price payable at sale and balance within 60 days. Purchaser to arrange for and bear costs of registration of transfer of title.

Lot 1. PARISH OF TANGAMBALANGA, COUNTY OF BOGONG.  
Being site and buildings of former State School residence at Red Bluff.

Upset price \$2,363 the lot.

Area 3r. 20p., part of allotment 15 of section 2, being the whole of the land described in freehold certificate of title, volume 3157, folio 241.

NOTE.—Improvements consist of timber residence, tanks, outbuildings and fencing valuation of which is included in upset.—(H.032507.)

**PROPOSED REVOCATIONS OF TEMPORARY RESERVATIONS OF LANDS BY ORDERS IN COUNCIL.**

IN pursuance of the provisions of the *Land Act 1958*, notice is hereby given that it is the intention of the Governor in Council to revoke the temporary reservations of lands by Orders in Council hereunder referred to, viz.:

The following Notices were published 1° on the 14th August, 1968, pursuant to Orders of the 6th August, 1968.

CARINA.—The temporary reservation, by Order in Council of the 21st December, 1910, of 4 acres of land in the Parish of Carina as a site for a State School is about to be revoked.—(C.477<sup>(5)</sup>) (Rs.7022.)

SALE.—The temporary reservation, by Order in Council of the 14th December, 1874 (see *Government Gazette* 18th December, 1874, page 2215) of 1 acre of land in the Parish of Sale as a site for State School purposes is about to be revoked.—(S.242<sup>(10)</sup>) (H.028894.)

BOORONGIE.—The temporary reservation, by Order in Council of the 17th February, 1916, of 42 acres of land in the Parish of Boorongie as a site for Water Supply purposes is about to be revoked.—(B.772<sup>(5)</sup>) (Rs.903.)

SCORESBY.—The temporary reservation, by Order in Council of the 27th March, 1956, of 25 acres 3 roods 37 perches of land in the Parish of Scoresby as a site for Horticultural Research Station is about to be revoked.—(S.250A<sup>(6)</sup>) (Rs.5885.)

GLENALBYN.—The temporary reservation, by Order in Council of the 26th March, 1901, of 10,700 acres of unappropriated Crown land in the Parishes of Kurting, Salisbury West, Glenalbyn, Inglewood and Tarnagulla as a site for the Growth of Timber for the purpose of the manufacture or production of Eucalyptus Oil, revoked as to part by various Orders, is about to be revoked so far only as the portion in the Parish of Glenalbyn containing 43 acres 2 roods 20 perches, more or less, indicated by hatching on plan hereunder, is concerned.—(G.161<sup>(8)</sup>) (Rs.1614.)

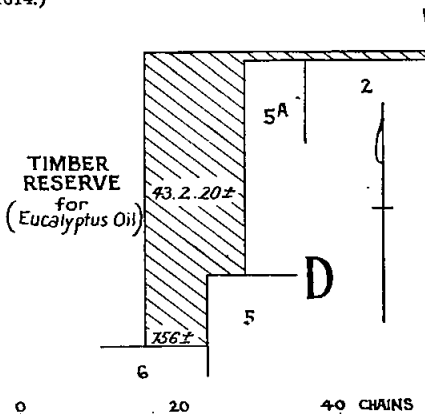

FLINDERS.—The temporary reservation, by Order in Council of the 23rd March, 1874, of 2 acres of land in the Township of Flinders as a site for State School purposes, revoked as to part by Order of the 25th March, 1958, is about to be revoked so far as the balance thereof containing 2 roods 16 perches, more or less, is concerned.—(F.16A<sup>(1)</sup>) (Rs.6971.)

FLINDERS.—The temporary reservation, by Order in Council of the 2nd July, 1958, of 1 acre 1 rood 24 perches, more or less, of land in the Township of Flinders as a site for Public Park, revoked as to part by Order of the 2nd December, 1958, is about to be revoked so far as the balance thereof containing 3 roods 34 perches, more or less, is concerned.—(F.16A<sup>(1)</sup>) (Rs.7696.)

OMEQ.—The temporary reservation, by Order in Council of the 29th April, 1958, of 4 acres 1 rood 36 perches, more or less, of land in the Township of Omeo as a site for Court House and Police purposes is about to be revoked so far only as the portion containing 1 rood 25 perches, more or less, indicated by hatching on plan hereunder, is concerned.—(O.19<sup>(8)</sup>) (Rs.7367.)

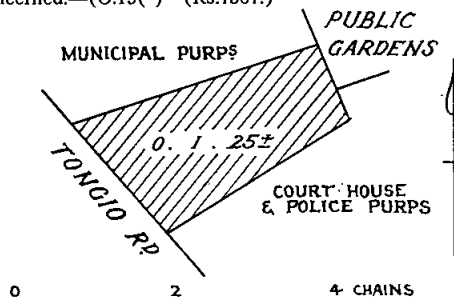

W. J. F. McDONALD,  
Minister of Lands.

**PROPOSED REVOCATIONS OF TEMPORARY RESERVATIONS OF LANDS BY ORDERS IN COUNCIL.**

IN pursuance of the provisions of the *Land Act 1958*, notice is hereby given that it is the intention of the Governor in Council to revoke the temporary reservations of lands by Orders in Council hereunder referred to, viz.:

The following Notices were published 1° on the 21st August, 1968, pursuant to Orders of the 13th August, 1968.

BUDGEREE.—The temporary reservation as a site for a Quarry and the withholding from sale, leasing and licensing by Order in Council of the 21st July, 1884 (see

Government Gazette of the 25th July, 1884, page 2151) of 11 acres 0 roods 3 perches of land in the Parish of Budgerie are about to be revoked.—(B.713(\*) (C.52758).

GAVAN DUFFY.—The temporary reservation, by Order in Council of the 1st December, 1873, of 3 acres 2 roods 39 perches of land in the Township of Gavan Duffy as a site for State School purposes is about to be revoked.—(G.195(\*) (Rs.5239).

W. J. F. McDONALD,  
Minister of Lands.

PROPOSED REVOCATIONS OF TEMPORARY RESERVATIONS OF LANDS BY ORDERS IN COUNCIL.

IN pursuance of the provisions of the Land Act 1958, notice is hereby given that it is the intention of the Governor in Council to revoke the temporary reservations of lands by Orders in Council hereunder referred to, viz.:

The following Notices were published 1<sup>o</sup> on the 7th August, 1968, pursuant to Orders of the 30th July, 1968.

SANDHURST.—The temporary reservation, by Order in Council of the 2nd March, 1892, of 127 acres 3 roods 20 perches of land in the Parish of Sandhurst as a site for a Sewage Farm and Manure Depot, revoked as to part by Order of the 12th May, 1959, and the temporary reservation by Order of the 19th March, 1894, of 221 acres 1 rood 12 perches of land as an extension thereto are about to be revoked so far as the balance thereof containing 341 acres 2 roods 32 perches, more or less, is concerned.—(S.371(\*) (Rs.1741).

CASTLEMAINE.—The temporary reservation, by Order in Council of the 23rd March, 1954, of 79 acres 11 perches of land in the Township of Castlemaire as a site for Public Recreation, Tourist Camping and Public Park purposes, revoked as to part by Order of the 13th November, 1956, is about to be revoked so far only as the portion containing 6 acres 3 roods 13 perches, indicated by hatching on plan hereunder, is concerned.—(C.99(\*) (Rs.177).

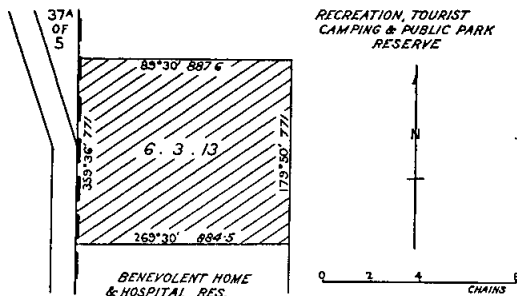

WEDDERBURN.—The temporary reservation as a site for Public Garden and other purposes of Recreation and the withholding from sale, leasing and licensing by Order in Council of the 14th July, 1884 of 4 acres 3 roods 16 perches of land in the Township of Wedderburn are about to be revoked so far only as the portion containing 24 perches, indicated by hatching on plan hereunder, is concerned.—(W.116(\*) (Rs.2604).

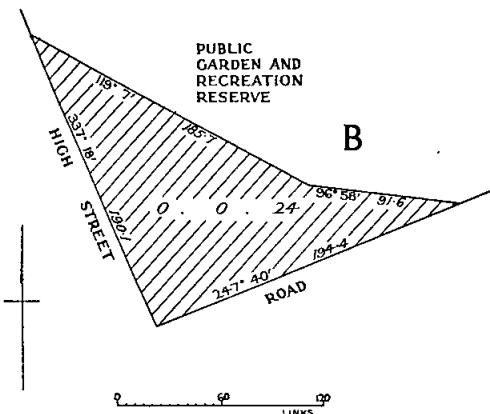

INVERLOCH.—The temporary reservation, by Order in Council of the 12th May, 1891, of 2 acres 1 rood 12 perches of land in the Township of Inverloch (formerly Anderson's Inlet) as a site for Police purposes is about to be revoked so far only as the portion containing 1 rood 38 perches, indicated by hatching on plan hereunder, is concerned.—(I.17(\*) (Rs.1686).

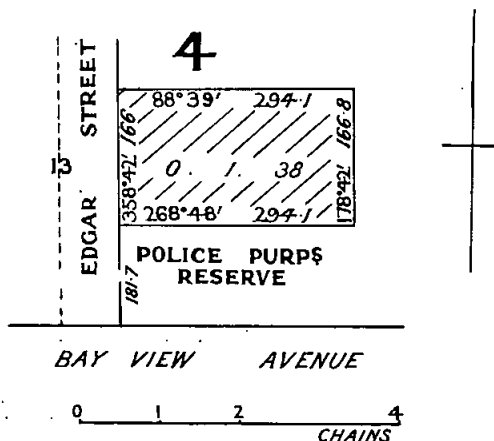

LAKES ENTRANCE.—The temporary reservation, by Order in Council of the 15th November, 1966, of 26 acres 2 roods of land in the Townships of Cunninghame and Lakes Entrance as a site for Public purposes is about to be revoked so far only as the portion in the Township of Lakes Entrance containing 7 acres 1 rood 34 perches, indicated by hatching on plan hereunder, is concerned.—(C.383F(\*) (Rs.3353).

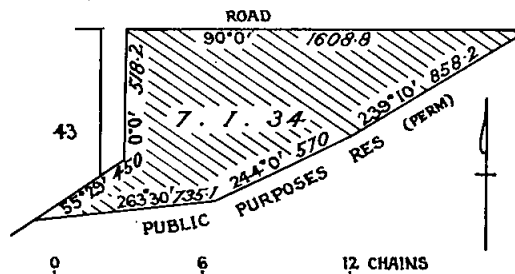

HAMILTON.—The temporary reservation, by Order in Council of the 31st May, 1938, of 4 acres 1 rood, more or less, of land in the Township of Hamilton as a site for Public Purposes (Swimming Pool) is about to be revoked so far only as the portion containing 1 rood 2 perches, indicated by hatching on plan hereunder, is concerned.—(H.45(\*) (Rs.4822).

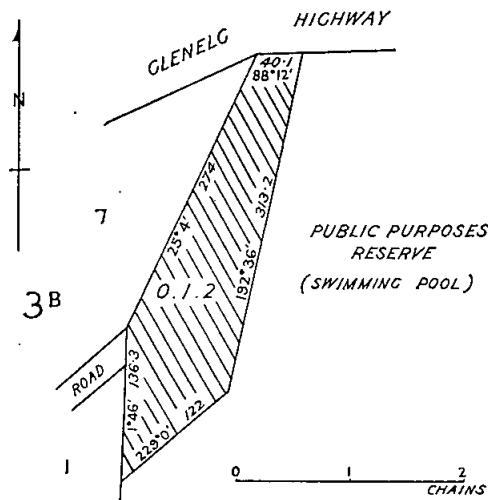

STRATFORD.—The temporary reservation, by Order in Council of the 31st July, 1899, of 40 acres of land in the Parish of Stratford as a site for Watering purposes and the withholding from leasing and licensing by Order in Council of the 13th May, 1890, of the same land are about to be revoked.—(S.346<sup>(9)</sup>) (Rs.9030).

**BOW-WORRUNG**

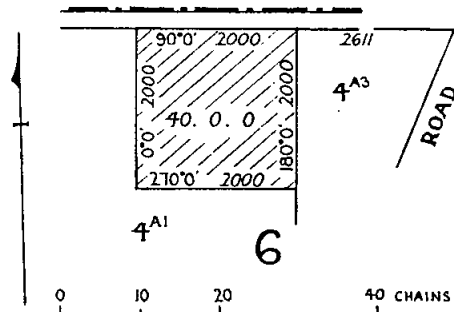

STEIGLITZ.—The temporary reservation, by Order in Council of the 30th December, 1867, of 67 acres 2 roods 30 perches of land in the Township of Steiglitz as a site for Racecourse and Recreative purposes is about to be revoked.—(S.337<sup>(2)</sup>) (Rs.8094).

W. J. F. McDONALD,  
Minister of Lands.

**PROPOSED PERMANENT RESERVATION OF LAND AS A SITE.**

IN pursuance of sections 14 and 21 of the Land Act 1958, notice is hereby given that it is the intention of the Governor in Council to reserve permanently from sale, from being leased and from having a licence granted in respect thereof the land hereinafter described:—

The following Notice was published 1° on the 28th August, 1968, pursuant to Order of the 20th August, 1968.

WARRANTYTE (RINGWOOD).—Land proposed to be permanently reserved as a site for Public Recreation, 8 acres 0 roods 3 perches, Parish of Warrantyte, County of Evelyn, as indicated by hatching on plan hereunder.—(W.26<sup>(5)</sup>) (Rs.9037).

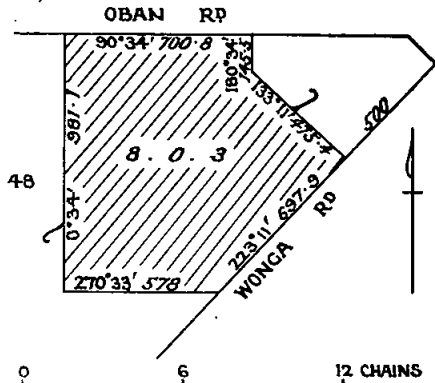

W. J. F. McDONALD,  
Minister of Lands.

**PROPOSED REVOCATIONS OF TEMPORARY RESERVATIONS OF LANDS BY ORDERS IN COUNCIL.**

IN pursuance of the provisions of the Land Act 1958, notice is hereby given that it is the intention of the Governor in Council to revoke the temporary reservations of lands by Orders in Council hereunder referred to, viz.:—

The following Notices were published 1° on the 28th August, 1968, pursuant to Orders of the 20th August, 1968.

ASHENS.—The temporary reservation as a site for Public purposes (State School) and the withholding from sale, leasing and licensing by Order in Council of the 2nd July, 1883 (see Government Gazette, 6th July, 1883, page 1585) of 1 acre of land in the Parish of Ashens are about to be revoked.—(A.168<sup>(8)</sup>) (Rs.9039).

CASTLEMAINE.—The temporary reservation, by Order in Council of the 20th September, 1955, of 1 acre 12 perches, more or less, of land in the Township of Castlemaine as a site for a Market and Comfort Station is about to be revoked.—(C.99<sup>(8)</sup>) (Rs.2341).

DOOLAM.—The temporary reservation, by Order in Council of the 19th August, 1902 (see Government Gazette 27th August, 1902, page 3595), of 16 acres 2 roods 9 perches of land in the Parish of Doolam as a site for Camping and Watering purposes is about to be revoked so far only as the portion containing 1 acre 3 roods 17 perches, indicated by hatching on plan hereunder, is concerned.—(D.154<sup>(3)</sup>) (C.100140).

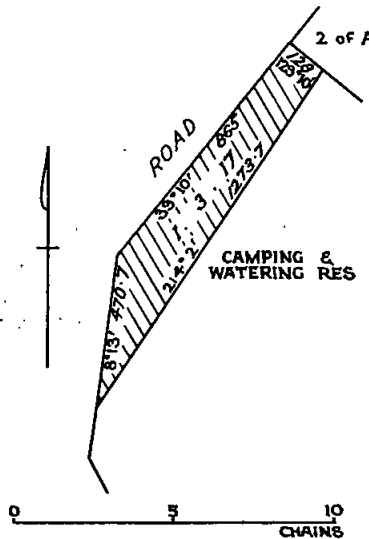

LA TROBE.—The temporary reservation, by Order in Council of the 6th July, 1891, of 2 acres of land in the Parish of La Trobe as a site for a State School, revoked as to part by Order of the 31st October, 1967, is about to be revoked so far as the balance thereof containing 1 acre 3 roods 27 perches, is concerned.—(L.143<sup>(8)</sup>) (Rs.2697).

POREPUNKAH.—The Temporary reservation, by Order in Council of the 14th August, 1928, of 40 acres 2 roods 23 perches of land in the Parish of Porepukah as a site for Public purposes (State School Forest Plantation) is about to be revoked so far only as the portion containing 9 acres 3 roods 38 perches, more or less, indicated by hatching on plan hereunder, is concerned.—(P.70<sup>(A8)</sup>) (Rs.3728).

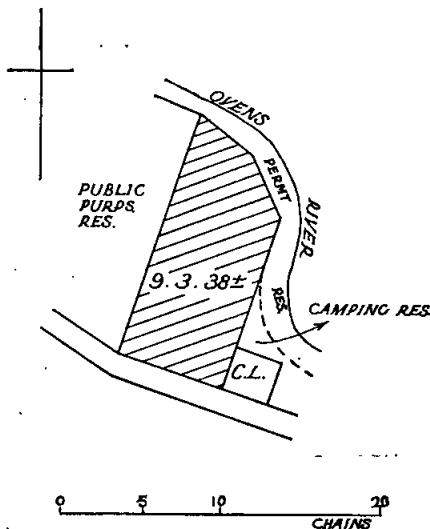

HINNO-MUNJIE.—The temporary reservation, by Order in Council of the 2nd July, 1919, of 4 acres 3 roods 39 perches of land in the Parish of Hinnō-Munjie as a site for a State School is about to be revoked so far only as the portion containing 3 roods 10 perches, indicated by hatching on plan hereunder, is concerned.—(H.108<sup>(9)</sup>) (Rs.1937).

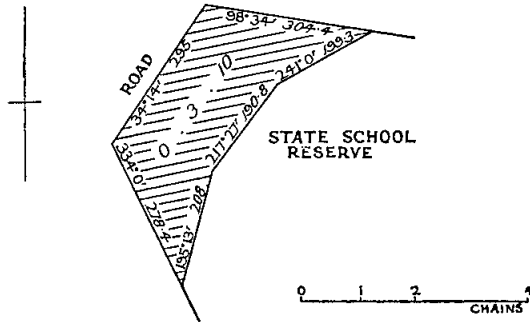

SANDHURST.—The temporary reservation, by Order in Council of the 13th August, 1946, of 272 acres, more or less, of land in the Parish of Sandhurst as a site for the growth of Timber for the purpose of the manufacture or production of eucalyptus oil and revoked as to part by various Orders, is about to be revoked so far only as the portion containing 1 acre 2 roods 30 perches, more or less, indicated by hatching on plan hereunder, is concerned.—(S.371<sup>(17)</sup>) (Rs.5844).

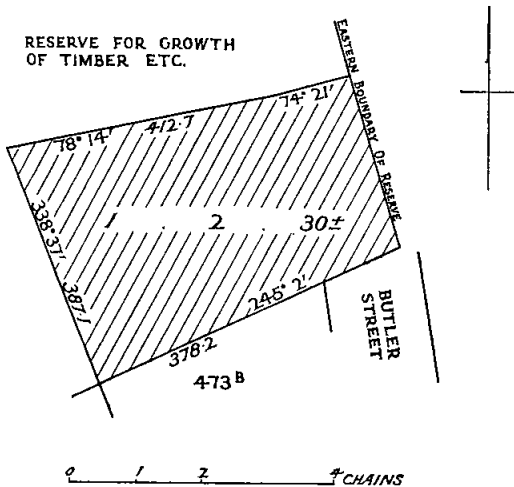

SOUTH MELBOURNE.—The temporary reservation, by Order in Council of the 23rd July, 1934, of 3 roods 34 8/10 perches of land in the City of South Melbourne as a site for Public Gardens and Plantation Purposes is about to be revoked so far only as the portion containing 25 perches, indicated by hatching on plan hereunder, is concerned.—(M.333<sup>(83)</sup>) (Rs.4394).

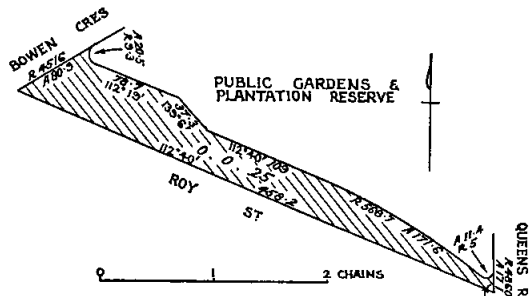

W. J. F. McDONALD,  
Minister of Lands.

COMMITTEES OF MANAGEMENT OF RESERVES.

APPOINTMENTS.

NOTICE is hereby given that in pursuance of section 221 of the Land Act 1958, the following appointments of Committees of Management of reserved Crown lands have been made by the Minister of Lands:—

“CAMPERDOWN RACECOURSE AND RECREATION RESERVE.”  
Laurence Albert Hateley, Robert Edward Manifold, Claude Wade, David Carstairs Bell and Patrick Joseph Sinnott as a Committee of Management for a period of three (3) years of the land in the Parish of Colongiac, Township of Camperdown, permanently reserved by Orders in Council dated the 12th January, 1900, as a site for Racecourse and Public Recreation purposes, and known as the “Camperdown Racecourse and Recreation Reserve.”—(Corres. No. Rs.1763.)

“DOUGLAS MECHANICS INSTITUTE RESERVE.”  
Oliver Leslie Shrive, Maxwell Owen Penny, James William Shields, Arthur John Hicks, Ivan Reginald Hair, Thomas Gordon Penny, Albert Clive Hobbs, Neville Howard Hobbs and John David Ross as a Committee of Management for a period of three (3) years of the land in the Township of Kerrareek (Douglas) temporarily reserved by Order in Council dated the 6th February, 1903, as a site for a Mechanics Institute, and known as “Douglas Mechanics Institute Reserve.”—(Corres. No. Rs.3070.)

“FISHER RESERVE”, AT FOSTER BEACH.  
The Corporation of the Shire of South Gippsland as the Committee of Management of the lands in the Parish of Wonga Wonga South, at Foster Beach, temporarily reserved by Order in Council dated the 20th January, 1914, as a site for Public Purposes, and by Order in Council dated the 11th October, 1943, as a site for Public Recreation, respectively, both of which are known together as “Fisher Reserve.”—(Corres. No. Rs.5330.)

“QUAMBATOOK PARK FRONTAGE RESERVE.”  
Allan Joseph Free, Thomas Vincent Hogan, Victor William Hahnel, Edmond Francis Doyle and Edmund Alfred Adamthwaite as a Committee of Management for a period of three (3) years of the reserved Crown lands in the Parish of Quambatook, as are indicated by pink, yellow and green colour on plan marked “Q/22.7.1942” attached to Lands Department correspondence Rs.2439, and known as “Quambatook Park Frontage Reserve.”—(Corres. No. Rs.2439.)

“SANDY POINT RECREATION RESERVE.”  
Alwyn John Todd, Lachlan McInnes, John Overton Bowron, John Edward Dennis Lane, Michael Redmond Maloney, Allen Bruce Worcester, John S. Pilkington, Frederick Keane Pilkington, Hugh Henderson, Lindsay McBain Bistrup and Graeme Dell for a period ending the 13th March, 1971, and William Augustus Gale, Turwald Ernest Thorson and John McKenzie Luckie (for so long only as they shall continue to be Councillors and the elect of the Council of the Shire of South Gippsland) as the Committee of Management of the land in the Township of Sandy Point, Parish of Waratah North, temporarily reserved by Order in Council dated the 9th July, 1968, as a site for the Recreation, Convenience and Amusement of the People, and known as the “Sandy Point Recreation Reserve.”—(Corres. No. Rs.8998.)

“SPRINGDALE RECREATION RESERVE.”  
Mervyn George Packer, John Wilson Davies, Maxwell James Mitchell, Leo John Packer, William P. Nichol, Ian Goldsworthy Sirl and Norman Kenneth Nichol as a Committee of Management for a period of three (3) years of the remaining portion of the land, in the Parish of Tatonga, temporarily reserved by Order in Council dated the 30th September, 1958, as a site for Public Recreation, and known as the “Springdale Recreation Reserve.”—(Corres. No. Rs.4176.)

“UPPER BEACONSFIELD PUBLIC HALL AND CHILDREN’S PLAYGROUND RESERVES.”  
Kenneth Boulton Hudson, Keith Ewenson, John Eldred Royle, Doris Eileen Jack, Joan Trumper, Brenda J. Hopkins, Selina Lavinia Royle, Irene Joan Rogers and Frederick John Webb as a Committee of Management of a period of one (1) year of the land in the Parish of

Gembrook, at Upper Beaconsfield, temporarily reserved by Orders in Council dated the 29th July, 1940, and 23rd September, 1940, as sites for a Children's Playground and Public Hall, respectively, and known as the "Upper Beaconsfield Public Hall and Children's Playground Reserves".—(Corres. Nos. Rs.5102, Rs.5066.)

"VICTORIA PARK RESERVE", BANNOCKBURN.

Keith Henry Parker, William Frederick Adams, Colin Ernest Baker, Herbert John Lemaitre, Raymond Joseph Coles, Stuart William Moodie, Ronald Henry Moreillon, John Ross Dow and George Joseph Cocks as a Committee of Management for a period of three (3) years of the land in the Parish of Wabdallah, temporarily reserved by Order in Council dated the 9th August, 1881, as a site for Cricket and other purpose of Public Recreation, and known as "Victoria Park Reserve", at Bannockburn.—(Corres. No. Rs.584.)

"WATCHUPGA PUBLIC HALL RESERVE."

Robert Alexander McPhee, Eric James Neville, Allan Percival Michael, Arthur Dale Boxall, Maurice Robert Cossens, Leslie Victor Sanford, Herbert Arnold Pohlner, Thomas Gordon Cossens and Norman Thomas Rinaldi as a Committee of Management for a period of three (3) years of the land in the Parish of Watchupga, temporarily reserved by Order in Council dated the 23rd September, 1935, as a site for a Public Hall, and known as the "Watchupga Public Hall Reserve".—(Corres. No. Rs.4480.)

"WARRNAMBOOL AGRICULTURAL SHOW GROUNDS RESERVE."

Gordon Robert Parsons, Bruce McMeekin Jones, Vernon Maxwell Burleigh, James Lindsay Charles Henderson, Charles Archibald Rogers, Edwin Russell Northeast, Richard Ainslie Crothers, Albert Wilson Rienzi Dawson, Leslie Clyde Ludeman and Ian Askew (for so long only as they continue to be representatives of the Warrnambool Agricultural Society) as the Committee of Management of the land in the Township of Warrnambool temporarily reserved by Orders in Council dated the 24th January, 1876, and 26th April, 1887, as sites for the use of the Villiers and Heytesbury Agricultural Association and the Western Caledonian Society, and known as the "Warrnambool Agricultural Show Grounds Reserve".

This appointment is made in lieu of all previous appointments, which are hereby revoked.—(Corres. No. Rs.2184.)

"WILLOW PARK," TOWNSHIP OF KOONDROOK.

Audrey Doreen Price, Audrey Joan Carter, William Thomas James Reaper, David Colin Mooring, Keith Raymond Bell, William Richard Bray, Robert Bray and Stephen Williams as a Committee of Management for a period of three (3) years of the land in the Township of Koondrook, Parish of Murrabit temporarily reserved by Order in Council dated the 16th December, 1958, as a site for Public Recreation, and known as "Willow Park".—(Corres. No. Rs.1510.)

"WILLUNG RECREATION RESERVE."

Ernest Douglas Mowat, Thomas James Fleming, Carl Frederick Wilson, Percy Edward Macreadie, Charles Henry Attenborough, Alfred Ernest Macreadie, Henry Thomas Attenborough and William Eric Mowat as a Committee of Management for a period of three (3) years of the land in the Township of Willung temporarily reserved by Order in Council dated the 7th February, 1950, as a site for Public Recreation, and known as the "Willung Recreation Reserve".—(Corres. No. Rs.6512.)

"WONWONDALH RECREATION RESERVE."

D. Bell, William E. McGennisken, Hector Douglas Hallam, Alan Jackman McGennisken, Roy Trevor Curtis, James Bromell Heard, Alfred George Hoskins and Carl Alfred Brawer as a Committee of Management for a period ending the 10th July, 1969, of the land in the Township of Wonwondah temporarily reserved by Orders in Council dated the 21st October, 1947, and the 18th June, 1968, as a site for Public Recreation, together with the adjoining portion of the permanent reservation to Norton Creek, and known as the "Wonwondah Recreation Reserve".—(Corres. No. Rs.6059.)

"WONGA WONGA PUBLIC HALL RESERVE."

Prince Victor Pridham, Roderick Thomas McKenzie, Nola Emily Richardson, Fremlin William Richardson jnr., Edith Perchase Pridham, Lawrence Victor Pridham and

William Charles Kershaw as a Committee of Management for a period of three (3) years of the land in the Parish of Wonga Wonga, temporarily reserved by Order in Council dated the 24th March, 1904, as a site for a Public Hall, and known as the "Wonga Wonga Public Hall Reserve".—(Corres. No. Rs.5863.)

W. J. F. McDONALD,  
Minister of Lands.

Department of Crown Lands and Survey,  
Melbourne, 22nd August, 1968.

REGULATIONS FOR THE CARE, PROTECTION AND MANAGEMENT OF THE MACARTHUR MARKET SQUARE RESERVE.

WHEREAS by section 218 of the Land Act 1958 the Minister of Lands is empowered to make Regulations as to any land which under the provisions of that Act or of any other Act relating to Crown lands has been reserved for any public purpose whatsoever and which has not been conveyed to or vested in trustees: And whereas certain Crown lands in the Township and Parish of Macarthur and described in a notice published in the Gazette of the 22nd day of October, 1924, were reserved as a site for Recreation and other public purposes: And whereas such lands (hereinafter called "the Reserve") have not been conveyed to or vested in trustees: And whereas it is expedient that Regulations for the care, protection and management of the Reserve and for other purposes connected therewith should be made: Now Therefore I, William John Farquhar McDonald Her Majesty's Minister of Lands in and for the State of Victoria, in pursuance of the powers aforesaid, do hereby make the following Regulations for or with respect to the Reserve:—

The Reserve has been placed under the control of a Committee of Management with power and authority to enforce the following Regulations.

REGULATIONS.

1. The Reserve shall be open to the public from sunrise to sunset.
2. No person shall enter or remain in the Reserve who may offend against decency as regards dress language or conduct.
3. No person shall damage in any way any trees shrubs or flowers in the Reserve, nor shall fires be lighted therein without permission in writing of the Committee first obtained.
4. No person shall climb or jump over gates in or around the Reserve, nor post bills thereon, or cut names on, or in any way damage or injure any of the buildings, erections, gates, fences, seats, or trees, nor leave or deposit any glass, paper or rubbish nor roll or throw stones or any missiles of any kind therein.
5. No person shall bring or put into the Reserve any dog, cattle, or other animals without permission in writing of the Committee of Management.
6. No person shall camp in the Reserve, without permission of the Committee of Management.
7. No person shall erect any structure therein without the permission, in writing of the Committee of Management first obtained.
8. No person shall take part in any public entertainment of any sort in the Reserve without the permission, in writing of the Committee of Management first obtained.
9. Persons renting or hiring the Reserve or any portion thereof for any purpose whatsoever and who make any charge to the public for admission to the Reserve shall pay to the Committee a fee for the use thereof which shall be fixed by the Committee.
10. No person shall remove or displace any board, plate or tablet or any support, fastening, or fitting used or constructed or adapted to be used for the exhibition of any Regulation or notice and fixed or set up by the Committee of Management in the Reserve.
11. No person shall behave in a disorderly manner, or create or take part in any disturbance, or use indecent or abusive language, or commit any nuisance, or in any way offend against decency in the Reserve or the buildings therein, and any persons found in a state of intoxication or otherwise offending against these Regulations, shall be liable to be forthwith removed from the Reserve, notwithstanding that such a person shall have purchased a ticket for the admission thereto, and shall also be liable to the penalty hereinafter provided.
12. All papers, fruit peel, and other litter shall be placed in the receptacles provided by the Committee of Management for that purpose.

13. Every person in the Reserve shall obey the lawful directions of any member of the Committee of Management in respect of his or her conduct therein.

14. Public betting in any part of the Reserve shall not be permitted without the consent of the Committee of Management first obtained and every person infringing this Regulation shall be liable to expulsion from the Reserve.

15. No person other than the players and officials of the game and other than any competitor at any sports gathering, shall intrude upon the playground or oval during the course of such games and sport.

16. No person shall be entitled to play any game or practice or take part in practice on the Reserve unless:—

(a) He or she is a financial member of one of the clubs that have been granted permission, in writing by the Committee to play or practice any game on the Reserve; or

(b) He or she is an invited guest of one of the clubs; or

(c) Provided always that no organized or competitive sport or organized practice for any sport or game shall be permitted on any part of the Reserve on any Sunday, Christmas Day, Good Friday or Anzac Day;

(c) Provided further that no intoxicating liquor shall be brought or consumed on any portion of the Reserve without the permission of the Committee, in writing, first had and obtained.

17. Any bailiff of Crown lands, a member of the Police Force, or duly appointed officer or servant of the Committee of Management shall have the right (in addition to any other penalty provided under these Regulations) to remove or exclude from the Reserve any person who commits a breach of these Regulations, or who wilfully damages any of the swings or other appliances or property in the Reserve.

Given under my hand at Melbourne on the 22nd day of August, 1968.

W. J. F. McDONALD,  
Minister of Lands.

Every person who contravenes or fails to comply with these Regulations shall, in accordance with the provisions of section 218 of the *Land Act 1958*, for each offence be liable to a penalty of not more than Fifty dollars, and every person who contravenes or fails to comply with any such Regulations, and who, after he has been warned by any bailiff of Crown lands or by any member of the Police Force, does not desist therefrom may be forthwith apprehended by such bailiff or member of the Police Force and taken before some justice to be dealt with according to law and shall be liable to a penalty of not more than One hundred dollars.

**AMENDMENT OF THE REGULATIONS FOR THE CARE, PROTECTION AND MANAGEMENT OF THE EUREKA STOCKADE RESERVE, BALLARAT EAST.**

WHEREAS in pursuance of section 218 of the *Land Act 1958* as then enacted by the Board of Land and Works on the 26th August, 1935, and amended on the 9th November, 1961, made Regulations for the care,

protection and management of the land in the Township of Ballarat East, temporarily reserved by Order in Council dated the 7th May, 1935, as a site for a Public Park and Recreation: And whereas the said Board was dissolved by the *Public Lands and Works Act 1964* which provided *inter alia* that all Regulations made by the Board shall remain in force subject to the *Land Act 1958*: And whereas the Minister of Lands is now empowered to make Regulations for or with respect to the said land (hereinafter called "the Reserve") in pursuance of section 218 of the *Land Act 1958*: And whereas it is expedient that the Regulations made by the Board as aforesaid should be amended: Now therefore I, William John Farquhar McDonald Her Majesty's Minister of Lands in and for the State of Victoria do hereby make the following Regulations by rescinding Regulation No. 1 and substituting therefor under the same number the following Regulation:

1. "The Reserve shall be open to the public from sunrise to sunset, free of charge except on such days (not exceeding twenty-four in any one year) as the Reserve may be set apart for fêtes, swimming carnivals, sports, or holiday amusements, on any of which occasions a sum not exceeding Twenty cents may be charged and taken for the admission of each adult person to the Reserve, provided however that on four of such days in any one year a sum not exceeding Forty cents may be charged and taken as aforesaid."—(Rs.89).

Given under my hand at Melbourne on the 22nd day of August, 1968.

W. J. F. McDONALD,  
Minister of Lands.

Every person who contravenes or fails to comply with these Regulations shall, in accordance with the provisions of section 218 of the *Land Act 1958*, for each offence be liable to a penalty of not more than Fifty dollars, and every person who contravenes or fails to comply with any such Regulations, and who, after he has been warned by any bailiff of Crown lands or by any member of the Police Force, does not desist therefrom may be forthwith apprehended by such bailiff or member of the Police Force and taken before some justice to be dealt with according to law and shall be liable to a penalty of not more than One hundred dollars.

**LOCAL LAND BOARDS.**

IN pursuance of the provisions of section 34 of the *Land Act 1958*, notice is hereby given that public hearings at the following places and times, will be conducted by the persons respectively mentioned, being duly appointed in that behalf.

W. J. F. McDONALD,  
Minister of Lands.

Department of Crown Lands and Survey,  
Melbourne.

**SCHEDULE.**

BALLARAT LAND OFFICE, Friday, 11th October, 1968, at 9.00 a.m.—E. Kennedy and N. J. Fitzgerald.

BALLARAT LAND OFFICE, Monday 9th September, 1968, at 9.00 a.m.—N. J. Fitzgerald and P. T. Ledger.

*Land Act 1958.*

**LEASES SURRENDERED.**

NOTICE is hereby given that the Governor in Council has accepted the surrender of the Leases mentioned in the schedule hereunder for the reason specified in each case.

District.	Corr. No.	Name.	Section of Land Act under which Leased.	City or Parish.	Allotment.	Section.	Area.	Reason.
Melbourne	0699/134	Commonwealth Aircraft Corporation Pty. Ltd.	134	City of Port Melbourne, Parish of Melbourne South	6	57	A. R. P. 5 1 36	Surrendered as to part only (1a. 0r. 8p.) as at 1st December, 1966
Beechworth	10/155	Edwin Sydney Jephcott ..	155	Thowgla ..	20b	2	247 0 0	New lease to issue

Department of Crown Lands and Survey,  
Melbourne, 20th August, 1968.

W. J. F. McDONALD,  
Minister of Lands.

## Land Act 1958.

## LEASE DECLARED VOID.

NOTICE is hereby given that the Governor in Council has declared void the Lease mentioned in the schedule hereunder for the reason specified.

District.	Corr. No.	Name.	—	Parish.	Allotment.	Section.	Area.	Reason.
Melbourne	2019/5	John Thomas Cavill	Section 5 of the Land (Improvement Purchase Lease) Act 1958	Tarrawarra North	4	..	A. R. P. 97 2 28	New lease to issue

Department of Crown Lands and Survey,  
Melbourne, 20th August, 1968.

W. J. F. McDONALD,  
Minister of Lands.

## Land Act 1958.

## LICENCE UNDER THE LAND ACT DECLARED VOID.

NOTICE is hereby given that the Licence in the Schedule hereunder has been Declared Void for the reason specified.

District.	Corr. No.	Name of Licensee.	Section of Land Act 1958 under which Licensed.	Parish.	Allotment.	Section.	Area.	Annual Rental.	Reason for Voiding.
Bairnsdale	197/138	R. G. Gray	138	Mallacoota	6	12	A. R. P. 0 0 39 $\frac{3}{4}$	\$18.00	Non-compliance with conditions of Licence

Department of Crown Lands and Survey,  
Melbourne, 20th August, 1968.

W. J. F. McDONALD,  
Minister of Lands.

## TENDERS

## PUBLIC WORKS DEPARTMENT

TENDERS will be received at Public Works Department, Treasury-place, Melbourne, until TWO p.m. on dates shown and for purposes mentioned hereunder.

Particulars and tender forms available at Contracts Office, Room 7, Building Division, Parliament-place and at places indicated in brackets hereunder.

Abbreviations in brackets mean:—W.O.—Inspector of Works Office; P.S.—Police Station; C.S.—Consolidated School; H.E.S.—Higher Elementary School; H.S.—High School; S.S.—State School; T.S.—Technical School.

Tenders to be submitted on the Department's printed Tender Form and will not be received by telephone. All tenders must be on a "Firm Tender" basis. The lowest or any tender will not necessarily be accepted.

Address tenders to the Minister of Public Works, and endorse the envelope containing the tender "Tender for , closing Tuesday,

Hand delivered tenders to be placed in the Tender Box of the Public Works Department, located on the wall of the centre entrance foyer, Ground Floor, New Treasury Building, Treasury-place, Melbourne.

No preliminary deposit is required with any tender, but a successful tenderer will be required to pay a deposit for any accepted tender of \$4,000 or over.

Tuesday, 3rd September, 1968.

## Building, Electrical and Mechanical Works.

Balwyn North.—Modifications and additions to heating system, S.S. 4638.

Braybrook.—Replacement of water service and cisterns, S.S. 1102.

Burnley Gardens.—Underpinning of walls, Victorian Plant Research Institute, Horticultural College.

Carlton.—Erection of Motor Registration and Licence Testing Station. (Specifications and Bills of Quantities Available.)

Carlton.—Electrical installation and telephone conduits, Motor Registration and Licence Testing Station.

Carlton.—Mechanical services, Motor Registration and Licence Testing Station.

Carlton.—Fire alarm installation, Motor Registration and Licence Testing Station.

Geelong.—Re-building of urinal, &c., Gordon Institute of Technology. (W.O., Geelong.)

Hamilton.—Renovations, &c., S.S. 295. (W.O., Hamilton.) (Amended specification.)

Melbourne.—Dust extraction system, Gold and Silver-smiths Department, Royal Melbourne Institute of Technology.

Mount Evelyn.—Renovations, S.S. 3642.

Portland.—New toilet and renovations, S.S. 489. (W.O., Warrnambool.)

Portland.—Electrical installation, S.S. 489. (W.O., Warrnambool; S.S., Portland.)

Sunvale.—Renovations, S.S. 4818.

Wangaratta.—Renovations, &c., High School. (W.O., Wangaratta.) (Amended specification.)

Williamstown.—Alternate fire and domestic water service installation, High School. (Re-advertised.)

Wonthaggi.—Supply and installation of sawdust extraction system, High School. (W.O., Traralgon and Warragul.)

## Furniture and Furnishings.

Ararat.—Supply of bedspreads, Mental Hospital.

## Site Works.

Port Melbourne.—Reinforced concrete floor between stores Nos. 33 and 34, Storeyard, Public Works Department.

Sandown Park.—Asphalt, concrete, drainage and gravel works, &c., S.S. 4901.

Upper Ferntree Gully.—Asphalt, concrete, drainage and gravel works, &c., S.S. 3926.

## Miscellaneous.

French Island.—Supply and delivery of pneumatic tired wheeled tractor, McLeod Training Prison.

Malmesbury.—Supply and delivery of bricks, Youth Training Centre.

Melbourne.—Maintenance cleaning for the period 1st October, 1968, to 31st May, 1971, Public Offices, New Treasury Buildings.

Tuesday, 10th September, 1968.

**Building, Electrical and Mechanical Works.**

Beaumaris.—Erection of type 992 Assembly Hall, High School.

Beaumaris.—Electrical installation, High School.

Beaumaris.—Mechanical services, High School.

Benalla.—Renovations, Residence, 2 Hope-street, S.S. 31. (W.O., Benalla.)

Colac.—Erection of fifth form extensions, Technical School. (W.O., Geelong.)

Colac.—Electrical installation, Technical School. (W.O., Geelong and Warrnambool; T.S., Colac.)

Colac.—Mechanical services, Technical School. (W.O., Ballarat and Geelong.)

Meringur.—Installation of fire service and water supply, S.S. 4357. (W.O., Mildura.)

Olinda.—Renovations, S.S. 3494, and Residence.

Parkville.—Renovations, &c., two residences, "Turana", Youth Training Centre.

Pascoe Vale.—Renovations, Girls' High School.

Rutherglen.—Renovations, Residence, Police Station. (W.O., Wangaratta.)

Toora.—Renovations, S.S. 2253. (W.O., Korumburra; S.S., Toora.)

Tungamah.—Renovations, Residence, S.S. 2225. (W.O., Benalla; S.S., Tungamah.)

**Furniture and Furnishings.**

Ashwood.—Supply and fix stage and auditorium curtains, High School.

Ballarat.—Supply of furniture, School of Mines. (W.O., Ballarat.)

Kew.—Supply of Polyurethane foam mattresses and foam rubber pillows, Children's Cottages.

McKinnon.—Supply and fix auditorium curtains, High School.

Melbourne.—Supply of steel lockers, Melbourne Teachers' College, 449 Swanston-street.

Melbourne.—Supply of steel cabinets, Visual Education Centre, 405 Swanston-street.

Traralgon.—Supply of tables, Hobson Park Hospital.

**Site Works.**

Blackburn.—Concreting, drainage works, &c., High School.

Blackburn.—Asphalt and gravel works, &c., S.S. 2923.

Fairhills.—Asphalt, concrete and drainage works, &c., S.S. 4906. (Amended Specification.)

Lyndale.—Asphalt, concrete and drainage works, &c., S.S. 4771.

**Miscellaneous.**

Melbourne.—Supply of bricks, 1st October, 1968, to 30th September, 1969, Public Works Department.

Tuesday, 17th September, 1968.

**Building, Electrical and Mechanical Works.**

Buchan.—Electrical distribution and switchboards, Caves Reserve. (W.O., Bairnsdale.)

Bullioh.—Completion of renovations, &c., S.S. 2495 and residence. (W.O., Wangaratta; S.S., Bullioh.)

Buxton.—Hot and cold water services, Youth Camp. (W.O., Alexandra.)

Laverton.—Renovations, S.S. 4765. (W.O., Geelong.)

Toolondo.—Supply and installation of an elevated tank system on water supply, S.S. 3051 and residence. (W.O., Horsham.)

Various.—Erection of 80 timber class-rooms, &c., Schools. (W.O., Alexandra, Ballarat, Bairnsdale, Bendigo, Benalla, Camperdown, Geelong, Hamilton, Horsham, Mornington, Shepparton, Traralgon and Warrnambool.)

**Site Works.**

Footscray.—Paving and drainage works, &c., Technical School.

**Miscellaneous.**

Castlemaine.—Supply and fix kitchen equipment, Gaol.

M. V. PORTER,  
Minister of Public Works.

Public Works Department,  
Melbourne, 3002, 26th August, 1968.

**PUBLIC SERVICE NOTICE****PUBLIC SERVICE OF PAPUA AND NEW GUINEA.****DEPUTY COMMISSIONER OF POLICE.**

*Salary.*—\$8,657 per annum single male, including allowances. Additional \$360 per annum for a married man.

*Qualifications.*—Executive and administrative ability of a high order. Applicants should have experience in administration in a developing country or high level administrative experience in a recognized police force.

*Nature of Appointment.*—Contract engagement for two years, longer if preferred. Government employees may be considered for secondment for a period of two years in the first instance with preservation of existing rights.

*Conditions.*—Furnished married or single accommodation available, 3 months' leave after 21 months' service, assisted leave fares to Australia, fares to the Territory paid for appointee and family, education allowances for children receiving secondary education in Australia. Income tax in the Territory is currently less than half that payable in Australia.

*Apply to—*

The Department of External Territories,  
Hobart-place, Canberra, A.C.T., 2601. Phone 4 0477  
46 Market-street, Sydney, N.S.W., 2000. Phone 29 5151  
188 Queen-street, Melbourne, Vic., 3000. Phone 67 6159  
145 Eagle-street, Brisbane, Qld., 4000. Phone 33 7575

for application forms and further information. Applications must reach Canberra by 7th September and should quote advertisement No. 455A.

By order of the Secretary,

DEPARTMENT OF EXTERNAL TERRITORIES,  
CANBERRA, A.C.T.

**PRIVATE ADVERTISEMENTS**

NOTICE is hereby given that The Boy Scouts Association (Wannon Scout District) has applied for a lease of approximately 10 acres situated in the south-east corner of allotment 1, Parish of Panyabyr, pursuant to section 134, Land Act 1958, for the purpose of amusement and recreation, for a term of 21 years. 4263

I, JUDITH LORRAINE BERRY, of 12 Cross-road, Chelsea, in the State of Victoria, machinist, heretofore called and known by the name of Judith Lorraine Duffy hereby give public notice that by a Deed Poll, dated the 21st day of August, 1968, duly executed and attested and deposited with the Registrar-General of the said State, on the 22nd day of August, 1968, I formally and absolutely renounced and abandoned the said surname of Duffy and declared that I had assumed and adopted and intended thenceforth upon all occasions whatsoever to use and subscribe the surname of Berry instead of the said surname of Duffy and so as to be at all times thereafter called known and described by the said surname of Berry.

Dated this 22nd day of August, 1968.

JUDITH LORRAINE BERRY.

Witness—G. M. RANDALL.

Russell, Kennedy & Cook, solicitors, 401 Collins-street, Melbourne. 4409

NOTICE OF INTENTION TO APPLY FOR A LICENCE TO DIVERT WATER AND CUT RACE FROM THE RIVER MURRAY, AT ROBINVALE.

WE hereby give notice that we intend to apply for a licence empowering us to divert water for a term of four years to the extent of 9 acre-feet per annum, at a maximum rate of  $\frac{1}{2}$  acre-foot per day of 24 hours for the irrigation of 3 acres of vegetables, being part of allotment 70, Township of Bumbang, Parish of Bumbang, and to occupy certain Crown lands for works of diversion, and to cut a race thereon.

Any objection to such application must be forwarded, in writing, to reach the State Rivers and Water Supply Commission, Melbourne, before 28th September, 1968, being 30 days from the first publication of this notice.

ALBERT ARTHUR RATTEN.  
MYRA LILLIAN RATTEN.

Box 477, P.O. Robinvale, 3549.

4410



## Sewerage Districts Act.

## PROPOSED SEWERAGE AUTHORITY.

NOTICE is hereby given that the Shire of Numurkah has made application to the Honorable the Minister of Water Supply for the constitution of a Sewerage Authority and for the proclamation of a Sewerage District at Numurkah and for the construction, maintenance and continuance of sewerage works within that District under the provisions of the Sewerage Districts Act.

A general plan and description of the proposed works have been submitted with the application and copies of same may be seen at the Shire Office, Numurkah.

Dated at Numurkah the 26th day of August, 1968.

L. G. MITCHELL, Secretary.

The Act requires that this notice be published weekly for three weeks in a newspaper circulating locally and the *Government Gazette* and provides that within one month of the third notice in the *Government Gazette*, any person having an interest therein, who is likely to be injuriously affected by the proposed sewerage works, may forward to the Minister of Water Supply a petition, seeking refusal or amendment to the application.

In this case the period for objections will expire on 11th October, 1968. 4353

## GEELONG WATERWORKS AND SEWERAGE TRUST.

THE above-mentioned Trust having made provision for carrying off the sewage from each and every property which or any part of which is within the sewerage area hereinafter described doth hereby declare that on and after the 1st day of September, 1968, each and every property which or any part of which is within the said sewerage area shall be deemed and taken to be deemed property within the meaning of the *Geelong Waterworks and Sewerage Act 1958*.

## SEWERAGE AREA No. 397.

*Shire of Corio, Parish of Moorpanyal,  
County of Grant.*

Commencing at a point being the south-west corner of the intersection of Thompson-road and Braund-avenue, North Geelong, the said point being also on the boundary of Sewerage Area No. 284; thence southerly along the west side of Thompson-road for a distance of 200 feet to the south-east corner of lot No. 9 Thompson-road; thence westerly along the southern boundary of the said lot No. 9 and the southern boundaries of lots Nos. 13 to 18 inclusive Braund-avenue to the south-west corner of the said lot No. 18; thence northerly by a line bearing 359 deg. 40 min. for a distance of 233 feet; thence easterly by a line bearing 89 deg. 45 min. for a distance of 450 feet to a point which is on the boundary of Sewerage Area No. 284; thence southerly following the boundary of Sewerage Area No. 284 to the point of commencement.

## SEWERAGE AREA No. 398.

*Shire of South Barwon, Parish of Barrarbool,  
County of Grant.*

Commencing at a point being the south-west corner of lot No. 142 Montpellier-drive, North Highton, the said point being also on the east side of Montpellier-drive and on the boundary of Sewerage Area No. 328; thence north-easterly and northerly along the east side of Montpellier-drive to the north-west corner of lot No. 146 Montpellier-drive; thence easterly along the northern boundary of the said lot No. 146 to the north-east corner of lot No. 146, which is on the boundary of Sewerage Area No. 328; thence southerly and south-westerly following the boundary of Sewerage Area No. 328 to the southernmost corner of lot No. 142 Montpellier-drive; thence north-westerly along the south-western boundary of lot No. 142 to the point of commencement.

## SEWERAGE AREA No. 400.

*Shire of South Barwon, Parish of Barrarbool,  
County of Grant.*

Commencing at a point on the east side of South Valley-road, Highton, 247 ft. 6 in. north from the north-east corner of the intersection of South Valley-road and Elliott-avenue, which is also the north-west corner of lot No. 1 South Valley-road and is on the boundary of Sewerage Area No. 282; thence easterly along the northern boundary of the said lot No. 1 and continuing easterly along the northern boundaries of lots Nos. 9 and 10 Berry-court, lots Nos. 18 and 19 Lund-court, lots Nos. 27 and 28 Mason-court, lot No. 34 Belle Vue-avenue and crossing Belle Vue-avenue and continuing easterly along the northern boundaries of lot No. 35 Belle Vue-avenue and lots 63 to 72 inclusive Roycroft-avenue to the north-east corner of the said lot No. 72; thence southerly along the eastern boundary of lot No. 72 to the north side of Roycroft-avenue; thence easterly

along the north side of Roycroft-avenue to the prolongation of the eastern boundary of lot No. 73 Roycroft-avenue; thence southerly across Roycroft-avenue and continuing southerly along the eastern boundary of lot No. 73 Roycroft-avenue and the eastern boundaries of lots Nos. 75 to 86 inclusive Roycroft-avenue to the north side of Fryers-street; thence westerly along the north side of Fryers-street and crossing Amoore and Northam avenues to the north-east corner of the intersection of Fryers-street and Belle Vue-avenue; thence northerly along the east side of Belle Vue-avenue to the prolongation of the southern boundary of lot No. 41 Belle Vue-avenue; thence westerly across Belle Vue-avenue and continuing westerly along the southern boundary of the said lot No. 41 and southern boundaries of lots Nos. 43 to 60 inclusive Elliott-avenue and the southern boundary of lot No. 62 South Valley-road and crossing South Valley-road to a point on the west side of South Valley-road, which is also on the boundary of Sewerage Area No. 358, and easterly following the boundaries of Sewerage Areas No. 358 and 282 to the point of commencement.

## SEWERAGE AREA No. 401.

*Shire of South Barwon, Parish of Barrarbool,  
County of Grant.*

Commencing at a point being the north-east corner of the intersection of Bonsey and Thornhill roads, Highton, which is also on the boundary of Sewerage Area No. 280, the said point being also the south-west corner of lot No. 7 Bonsey-road; thence northerly along the east side of Thornhill-road to the north-west corner of the said lot No. 7; thence easterly along the northern boundaries of lots Nos. 7 and 6 Bonsey-road to the south-west corner of lot No. 21 Cemaloma-court; thence northerly along the western boundaries of lots Nos. 21 and 20 Cemaloma-court to the north-west corner of the said lot No. 20; thence easterly along the northern boundaries of lots Nos. 20 to 18 inclusive Cemaloma-court and crossing Cedmar-avenue to the east side of Cedmar-avenue; thence southerly along the east side of Cedmar-avenue to the north-west corner of lot No. 27 Cedmar-avenue; thence easterly along the northern boundary of the said lot No. 27 to the boundary of Sewerage Area No. 280; thence southerly and westerly following the boundary of Sewerage Area No. 280 and crossing Cedmar-avenue to the point of commencement.

Signed under seal of the trust, this 22nd day of August, 1968.

4370 J. W. CARR, Chairman.  
B. C. HENSHAW, Secretary.

## CITY OF DANDENONG.

## CHANGING OF STREET NAME.

NOTICE is hereby given that the Council of the City of Dandenong, at a meeting held on the 22nd July, 1968, passed a Resolution changing the name of the street as set out hereunder:—

*Old Name; New Name.*

York-street; Jacana-street.

4413 C. A. ELLIOTT, Town Clerk.

## CITY OF DONCASTER AND TEMPLESTOWE.

## BYLAW No. 51.

*Camping and Caravan Bylaw.*

A Bylaw of the City of Doncaster and Templestowe made under the provisions of Sections 197 and 198 of the *Local Government Act 1958* and numbered 51 for the purpose of:—

- (i) Prohibiting or regulating camping on Roads.
- (ii) Prohibiting or regulating the placing of caravans on private property.
- (iii) Regulating, restricting or prohibiting the use of caravan or camping parks or sites and regulating the conduct or management thereof.
- (iv) Regulating, restricting, restraining or prohibiting the erection, construction, use, occupation, conversion and alteration of and any addition to buildings or erections.
- (v) Suppressing nuisances.

PURSUANT to the powers conferred by the *Local Government Act 1958* and of any and every other power it thereunto enabling the Mayor Councillors and Citizens of the City of Doncaster and Templestowe orders as follows:—

1. This Bylaw may be known as the *Camping and Caravan Bylaw*.

2. This Bylaw shall apply to and have operation throughout the whole of the Municipal District of the City of Doncaster and Templestowe.

3. No person shall camp on any road.

4. Subject as is hereinafter provided no person shall without the prior consent in writing of the Council place any caravan on any private property which is not a camping area in respect of which a current permit issued by the Council under the Camping Regulations 1958 or any amendment or alteration thereof is in existence Provided Always that nothing in this clause shall prevent:

- (a) The placing by the owner of any land of not more than one caravan belonging to him on such land where such caravan is not without the prior consent in writing of the Council used by any person for the purpose of sleeping or living therein.
- (b) The placing of caravans for sale, or hire on any land the use of which for the purposes of the business of selling or hiring caravans is permitted by or under any Interim Development Order or Planning Scheme made under the *Town and Country Planning Act 1961* or any statutory amendment, modification or re-enactment thereof for the time being in force or by or under any Bylaw or Regulation.

5. No person shall without the prior consent in writing of the Council erect, construct or occupy on any land any tent or similar structure.

6. Every person who is guilty of any wilful act or default contrary to any of the provisions of this Bylaw shall be liable to a penalty of not less than Ten Dollars nor more than Forty Dollars and any person guilty of a continuing offence contrary to this Bylaw shall be liable to a penalty of Ten Dollars for each day on which an offence against this Bylaw shall be continued after a conviction or order by any Court.

Resolution for passing this Bylaw agreed to by the Council of the City of Doncaster and Templestowe on the 1st day of April, 1968, and confirmed on the 6th day of May, 1968.

The corporate seal of the Mayor, Councillors and Citizens of the City of Doncaster and Templestowe was hereunto affixed in the presence of—

(SEAL) B. S. ELMS, Mayor.  
ROY A. HARLE, Councillor.  
J. W. THOMSON, Town Clerk.

Approved by the Governor in Council on the 13th day of August, 1968.—J. ROSSITER, Clerk of the Executive Council. 4367

#### CITY OF TRARALGON.

##### CONFIRMATION OF APPOINTMENT OF POUNDKEEPER.

NOTICE is hereby given that the Council of the City of Traralgon has appointed Edmund Krutop, as Poundkeeper in charge of the City of Traralgon Pound. 4356

K. J. SAUNDERS, Town Clerk.

#### CITY OF TRARALGON.

##### CONFIRMATION OF APPOINTMENT OF POUND

NOTICE is hereby given that the Council of the City of Traralgon has, pursuant to section 4 (3) of the *Pounds Act 1958*, appointed the following place as the City of Traralgon Pound:

The area of land situate corner corner Rose-avenue and Hickox-street, Traralgon, comprising 3 roads, 14½ perches, with a frontage of 235 ft. 8 in. to Rose-avenue and 155 ft. 2 in. to Hickox-street.

4355 K. J. SAUNDERS, Town Clerk.

#### SHIRE OF AVOCA.

##### NOTICE OF INTENTION TO TAKE LAND COMPULSORILY.

WHEREAS the Council of the Shire of Avoca deems it expedient to provide the land described in the Schedule hereto as a place of public resort and recreation and whereas for the purposes thereof the exercise of the compulsory power of taking the land described in the Schedule hereto will in the Council's opinion be necessary and desirable and whereas the Council has caused to be prepared maps and other papers showing—

- (a) the general description of the work or undertaking for which the land proposed to be taken is to be used;
- (b) the description of the lands proposed to be taken; and
- (c) the names of the owners or reputed owners lessees or reputed lessees mortgagees and occupiers of those lands so far as those names are known to or can be ascertained by the council;

and whereas such maps and other papers are deposited at the office of the said Council in Rutherford-street, Avoca, and are and shall be open for inspection by all persons interested at all reasonable hours for the space of 40 clear days after publication of this notice in the *Government Gazette*: Now notice is hereby given to all persons affected by the proposed taking of the land described in the Schedule hereto and they are hereby called upon to set forth in writing, addressed to the said Council or the Shire Secretary of the Shire of Avoca within 40 clear days from the publication of this notice in the *Government Gazette* all objections which they may have to the taking of the land described in the Schedule hereto.

#### THE SCHEDULE HEREINBEFORE REFERRED TO.

All that piece of land having an area of 26 4/10 perches or thereabouts, being Crown allotments 13, 14, 15 and 16, section 8, Township of Landsborough, County of Kara Kara, contained in four unregistered Crown grants.

Dated the 21st day of August, 1968.

By order of the Council,

4381 F. C. S. EDWARDS, Shire Secretary.

#### SHIRE OF AVOCA.

##### PROPOSED REDBANK WATERWORKS TRUST.

NOTICE is hereby given that the Avoca Shire Council has made application to the Honorable the Minister of Water Supply for the constitution of a Waterworks Trust, and for the proclamation of a Waterworks District at Redbank and the construction, maintenance, and continuance of Water Supply Works within that District under the provisions of the Water Acts.

A general plan and description of the proposed works have been submitted with the application, and copies of same may be seen at the Shire Office, Rutherford-street, Avoca.

Dated at Avoca, the 23rd day of August, 1968.

4380 F. C. S. EDWARDS, Shire Secretary.

#### SHIRE OF AVOCA.

##### ORDER CHANGING NAME OF STREET.

NOTICE is hereby given that, in pursuance of the powers conferred by the Local Government Act, the Council of the Shire of Avoca did, at a meeting held on the 21st August, 1968, order that the road running generally easterly off Homebush-road from the north-western corner of Crown allotment 1, section A2, Township of Avoca, to the north-eastern corner of Crown allotment B1, section A2, Township of Avoca, for a distance of approximately 26 chains and now known as a Government road, be named Rowe-street.

4379 F. C. S. EDWARDS, Shire Secretary.

#### SHIRE OF KNOX.

##### NOTICE OF CHANGES IN STREET NAMES.

NOTICE is hereby given that in pursuance of the powers conferred by the *Local Government Act 1958*, the Council of the Shire of Knox at a meeting held on 3rd July, 1968, resolved to make the following changes in street names:

##### Old Name; Location; New Name.

Brown-street; Fern Tree Gully; Cathay-street.  
Chandler-court; Fern Tree Gully; Callemondah-court.  
High-street; Fern Tree Gully; Clyde-street.  
Francis-court; Knoxfield; Carrabin-court.  
Gearon-parade; Rowville; Heany Park-road.  
Graham-road, Lysterfield; Karoo-road.  
Major-road; Lysterfield; Major-crescent.  
New-street; The Basin; Walker-street.  
Burton-road; The Basin; Burston-road.  
Wattle-tree-road West; Boronia; Western-road.  
Aubrey-road (north of Sutton-avenue); Boronia; Aubrey-grove.  
Buda-street; Wantirna; Gresford-road.  
Orchard-street (easterly end); Bayswater; Orchard-road.

4378 N. G. HAYNES, Shire Secretary.

Town and Country Planning Act 1961 (Twelfth Schedule).

#### SHIRE OF KNOX PLANNING SCHEME.

NOTICE THAT A PLANNING SCHEME HAS BEEN PREPARED AND IS AVAILABLE FOR INSPECTION.

Amendment No. 42, 1968.

NOTICE is hereby given that the Council of the Shire of Knox, in pursuance of its powers under the *Town and Country Planning Act 1961*, has prepared a Planning Scheme for portions of the Shire of Knox for the purpose

of amending the Principal Scheme by introducing discretionary control over the development of nonconforming uses in respect of Clause 24 of the Planning Scheme Ordinance.

A copy of the scheme has been deposited at the office of the Shire of Knox, Spring-street, Fern Tree Gully, and at the office of the Town and Country Planning Board, 179 Queen-street, Melbourne, and will be open for inspection during office hours by any person free of charge.

Any persons affected by the Planning Scheme are required to set forth, in writing, all objections they may have addressed to the Shire Secretary, Shire of Knox, Spring-street, Fern Tree Gully, on or before the 28th day of September, 1968, and to state whether they wish to be heard in respect of their objections.

4369 N. G. HAYNES, Shire Secretary.

## SHIRE OF MALDON.

## LOAN NO. 21.

*Notice of Intention to Borrow the Sum of \$21,250 for Permanent Works and Undertakings.*

NOTICE is hereby given that the Council of the Shire of Maldon proposes to borrow the principal sum of Twenty one thousand, two hundred and fifty dollars, secured by a charge over the general rates of the municipality, such sum to be raised by the grant of a mortgage in accordance with the provisions of the *Local Government Act 1958*.

1. The maximum rate of interest that may be paid is 5½ per cent. per annum.

2. The purpose for which the loan is to be applied is for purchase of road making plant.

3. The period of the loan shall be ten years.

4. The moneys borrowed shall be repayable by providing out of the municipal fund half-yearly instalments of approximately \$1,412.00 each including principal and interest, on the 1st day of June and the 1st day of December, during the currency of the loan. The first instalment shall be payable on the 1st day of June, 1969.

5. Such moneys shall be repayable to the Commissioners of the State Savings Bank of Victoria, at the office of the said Commissioners, corner Elizabeth and Bourke streets, Melbourne.

The plans and specifications and the estimate of the cost of the proposed works and a statement showing the proposed expenditure of the moneys to be borrowed, are open for inspection at the office of the Council of the Shire of Maldon, at Maldon.

4360 S. R. BEACH, Shire Secretary.

## SHIRE OF VIOLET TOWN.

## LOAN NO. 23.

*Notice of Intention to Borrow the Sum of \$23,000 for Permanent Works and Undertakings.*

NOTICE is hereby given that the Council of the Shire of Violet Town proposes to borrow the principal sum of Twenty-three thousand dollars secured by a charge over the general rates of the municipality, such sum to be raised by the grant of a mortgage in accordance with the provisions of the *Local Government Act 1958*.

1. The maximum rate of interest that may be paid is 5.5 per centum per annum.

2. The purpose for which the loan is to be applied is the purchase of a Grader—\$23,000.

3. The period of the loan shall be five years.

4. The moneys borrowed shall be repayable by providing out of the municipal fund half-yearly instalments of \$2,662.01 each, including principal and interest on the 1st day of May and the 1st day of October, during the currency of the loan. The first instalment shall be payable on the 1st day of May, 1969.

5. Such moneys shall be repayable at the National Bank Savings Bank Limited, Melbourne.

The plans and specifications and the estimate of the cost of the proposed works and a statement showing the proposed expenditure of the moneys to be borrowed are open for inspection at the office of the Council of the Shire of Violet Town at the Shire Office, Lily-street, Violet Town.

4374 T. R. RICHARDSON, Shire Secretary.

NOTICE is hereby given that the partnership heretofore subsisting between Antonio Schiavello, of 35 Fifth-avenue, Brunswick, Giuseppe Schiavello, of 49 Camberra-street, Brunswick, and Antonio Cipollone, of 561 Station-street, North Carlton, carrying on business as "Shop Fitters", at 35 Fifth-avenue, Brunswick, under the style or firm of "T. T. & G. Partition Contractors and General Fitting", has been dissolved as from the 21st day of July, 1968.

Dated this 19th day of August, 1968.

4349 A. SCHIAVELLO.  
G. SCHIAVELLO.

NOTICE is hereby given that the partnership heretofore subsisting between Orestis Roumeliotis and Nafsika Roumeliotis, of 43 Ormond-road, Moonee Ponds, Demetre Christopoulos and Efthalia Christopoulos, of 55 Craighton-avenue, Port Melbourne and Kostas Didelis and Sophia Didelis, of 3 Donald-avenue, Essendon, carrying on business as coal carriers under the firm name of "Deer Transport Company", at 8 Gilbert-street, Braybrook, has been dissolved as from the 19th day of August, 1968.

Dated the 19th day of August, 1968.

4365 O. R. BULKA & CO., Solicitors.

NOTICE is hereby given that on the 31st day of July, 1968, Brian James Shimmen, retired as a partner in the firm of Davies and Dalziel, members of the stock exchange of Melbourne, whose place of business is at 408 Collins-street, Melbourne. The remaining partners, John Dowell Davies, James Grimaldi Perry, Richard Cobden, Robert Frank Griffiths, and John Edward Barry will continue to carry on business under the same name at the above-mentioned address.

4408

NOTICE is hereby given that the partnership heretofore subsisting between Frederick William Robert Deppeler, of 208 Creswick-road, Ballarat, contractor, and Maxwell Frederick Deppeler, of 217 Lexton-street, Ballarat, cartage contractor, carrying on business as contractors, at 208 Creswick-road, Ballarat, under the name of F. Deppeler & Son, has been dissolved by mutual consent, as from the 1st day of July, 1968, and the business will henceforth be carried on by the said Maxwell Frederick Deppeler, and all debts due and owing by the said firm will be received and paid by the said Maxwell Frederick Deppeler, who will continue to carry on the said business, at 217 Lexton-street, Ballarat, under the name of M. F. Deppeler.

Dated this 20th day of August, 1968.

4387 FREDERICK WILLIAM ROBERT DEPPELER.  
MAXWELL FREDERICK DEPPELER.

NOTICE is hereby given that the partnership of William Rothwell Johnston, of Flat 5, 558 Toorak-road, Toorak, and Gordon Robert Bernard Peace, of 91 Hammer-street, Williamstown, who have traded under the style or firm name of Wertheim Musical Instruments, at 153 Canterbury-road, Toorak, has been dissolved and the business conducted by such partnership shall be continued by the said William Rothwell Johnston, at the same address under the same style or firm name.

4398

NOTICE is hereby given that the partnership heretofore subsisting between Peter Gerald Phillips, of River-street, Whittlesea, and Charles Frederick Read, of 320 Danks-street, Middle Park, and carrying on the business of poultry farming and shopkeeping in River-street, Whittlesea, and High-street, Whittlesea, respectively has been dissolved by mutual consent, as from the 21st day of June, 1968. The said business will be continued by Peter Gerald Phillips, who will be solely responsible for all debts.

Dated the 21st day of August, 1968.

OSWALD BURT & CO., solicitors, 178 William-street, Melbourne, 3000.

4405

NOTICE is hereby given that the partnership heretofore subsisting between Brian Cyril Flight, of 17 Dunoon-street, Mooroolbark, and Carol Vivienne Flight, of 17 Dunoon-street, Mooroolbark, carrying on business as taxi proprietors, at 17 Dunoon-street, Mooroolbark, under the style or firm of B. C. & C. B. Flight, has been dissolved, as from the 29th day of January, 1968.

Dated this 21st day of August, 1968.

CAROL V. FLIGHT.  
John P. Rhoden, solicitor, 376 Collins-street, Melbourne.

4400

Unclaimed Moneys Act 1962.

**R**EGISTER of Unclaimed Moneys held by the—

Name of Owner on Books and Last Known Address.	Total Amount Due to Owner.	Description of Unclaimed Moneys.	Date when Amount first became Payable.
<b>5</b>			
<b>PORTLAND CO-OPERATIVE DAIRY CO. LIMITED.</b>			
Hickleton, C. S., Portland 4371	15.74	Cream/Milk Proceeds	—12.66
<b>B.X. PLASTICS (AUSTRALIA) PTY. LIMITED.</b>			
Halt, Kenneth Roland, 16 Hornby-street, East Brighton	21.05	Wages	10.3.66
Mitchell, Robyn, 4 Small-street, Hampton	15.95	"	20.3.66
Roberts, Christine Anne, 31 Earlsfield-road, Hampton	13.90	"	3.4.66
Ryan, Sandra, 4 Small-street, Hampton	13.95	"	"
Smart, D., 26 Sylverly-grove, Caulfield	17.65	"	1.5.66
Pearce, F., 116 Nepean Highway, Gardenvale	15.05	"	22.5.66
Talarico, T., 345 Lygon-street, East Brunswick	15.18	"	22.6.66
Lawrence, J. T., 6 Barrisford-street, Mascot, N.S.W.	16.37	"	6.7.66
Russo, A., 10 Abbott-street, Sandringham	19.70	"	20.7.66
Hill, L. J., 17 Ritchie-street, Frankston	10.80	"	28.8.66
Lawson, J., 471 Bluff-road, Hampton	15.90	"	23.10.66
Cramer, B., 235A Bamba-road, Caulfield	10.20	"	30.10.66
Fulland, J., 3 Maskell-street, North Brighton	20.35	"	25.12.66
Watson, I., 10 Carrington-grove, East Brighton	15.85	"	1.1.67
4372			

Companies Act 1961, Section 272 (2).  
TOULEMONDE (AUSTRALIA) PROPRIETARY LIMITED  
(IN LIQUIDATION).

NOTICE OF FINAL MEETING AND DISSOLUTION.

NOTICE is hereby given that a General Meeting of the Members of Toulemonde (Australia) Proprietary Limited will be held at 409 Lonsdale-street, Melbourne, on the 30th day of September, 1968, at 9.30 a.m. in the forenoon, for the purpose of laying before the meeting an account showing how the winding up has been conducted and the property of the company has been disposed of and of giving any explanation of the account and also of determining by extraordinary resolution the manner in which the books, accounts and documents of the company and of the liquidator thereof shall be disposed of.

Dated this 26th day of August, 1968.

4414 J. C. HOUGH, Liquidator.

Companies Act 1961, Section 272 (2).  
GOLDSAND (SALES) PROPRIETARY LIMITED  
(IN LIQUIDATION).

NOTICE OF FINAL MEETING AND DISSOLUTION.

NOTICE is hereby given that a General Meeting of the Members of Goldsand (Sales) Proprietary Limited, will be held at 409 Lonsdale-street, Melbourne, on the 30th day of September, 1968, at 10 a.m. in the forenoon, for the purpose of laying before the meeting an account showing how the winding up has been conducted and the property of the company has been disposed of and of giving any explanation of the account and also of determining by extraordinary resolution the manner in which the books, accounts and documents of the company and of the liquidator thereof shall be disposed of.

Dated this 26th day of August, 1968.

4415 J. C. HOUGH, Liquidator.

Companies Act 1961, Section 272 (2).  
HELBRO FASHIONS (SALES) PROPRIETARY LIMITED  
(IN LIQUIDATION).

NOTICE OF FINAL MEETING AND DISSOLUTION.

NOTICE is hereby given that a General Meeting of the Members of Helbro Fashions (Sales) Proprietary Limited, will be held at 409 Lonsdale-street, Melbourne, on the 30th day of September, 1968, at 10.30 a.m., in the forenoon, for the purpose of laying before the meeting an account showing how the winding up has been conducted and the property of the company has been disposed of and of giving any explanation of the account and also of determining by extraordinary resolution the manner in which the books, accounts and documents of the company and of the liquidator thereof shall be disposed of.

Dated this 26th day of August, 1968.

4416 J. C. HOUGH, Liquidator.

Companies Act 1961, Section 272 (2).  
L. A. NEALE (SALES) PROPRIETARY LIMITED  
(IN LIQUIDATION).

NOTICE OF FINAL MEETING AND DISSOLUTION.

NOTICE is hereby given that a General Meeting of the Members of L. A. Neale (Sales) Proprietary Limited will be held at 409 Lonsdale-street, Melbourne, on the 30th day of September, 1968, at 11 a.m. in the forenoon, for the purpose of laying before the meeting an account showing how the winding up has been conducted and the property of the company has been disposed of and of giving any explanation of the account and also of determining by extraordinary resolution the manner in which the books, accounts and documents of the company and of the liquidator thereof shall be disposed of.

Dated this 26th day of August, 1968.

4417 J. C. HOUGH, Liquidator.

In the matter of INDESCO PROPRIETARY LIMITED.  
WINDING-UP Order made the 23rd day of August, 1968.

Name and address of liquidator: Reginald Wilfrid Ellis, of 360 Collins-street, Melbourne.

K. S. FIZELLE, solicitor for the petitioner. 4422

Notice of Winding-up Order.—In the matter of  
BENNETTSWOOD PLUMBING SERVICES PTY. LTD.

WINDING-UP Order made 23rd August, 1968.

Name and address of official liquidator: Mr. Philip Douglas George, 440 Collins-street, Melbourne.

JAMES CANNY, Deputy Commissioner of Taxation of the Commonwealth of Australia, Petitioner. 4426

The Companies Act 1961.—In the matter of WOLTAC PTY. LTD.

NOTICE is hereby given that at an Extraordinary Meeting of the members of the above-named company held on the 21st August, 1968, it was resolved that the company be wound up voluntarily and at a meeting of creditors held on the same day, pursuant to section 260, it was resolved that for such purpose Everett Thomson Bent, of Suite, 18, 545 St. Kilda-road Melbourne, accountant, be appointed liquidator.

Notice is also given that after 21 days from this date I shall proceed to distribute the assets. All creditors having any claims against the company should furnish particulars of same by that date, otherwise I shall proceed to distribute the assets, without regard to their claims.

Dated this 21st day of August, 1968.

E. T. BENT, Liquidator.

Bent & Cougle, public accountants, Suite 18, 545 St. Kilda-road, Melbourne, 3004. 4357

The Companies Act 1961.—In the matter of FLORHEAT PTY. LTD. (in Liquidation).

NOTICE is hereby given that, pursuant to section 272 (1) of the Companies Act 1961, a Final Meeting of creditors and contributories of the above company will be held at 170 Toorak-road, South Yarra, on Monday, the 23rd day of September, 1968, at 11.45 a.m.

*Business.*

To receive the liquidator's account of the winding up and his report thereon.

Dated this 28th day of August, 1968.

BRUCE FORDHAM, Liquidator.

170 Toorak-road, South Yarra, Vic., 3141. Telephone: 24 7511. 4428

The Companies Act 1961.—In the matter of FLORHEAT SERVICES PTY. LTD. (in Liquidation).

NOTICE is hereby given that, pursuant to section 272 (1) of the Companies Act 1961, a Final Meeting of creditors and contributories of the above company will be held at 170 Toorak-road, South Yarra, on Monday, the 23rd day of September, 1968, at 11.30 a.m.

*Business.*

To receive the liquidator's account of the winding up and his report thereon.

Dated this 28th day of August, 1968.

BRUCE FORDHAM, Liquidator.

170 Toorak-road, South Yarra, Vic., 3141. Telephone: 24 7511. 4427

Co-operative Housing Societies Act 1958.

ADVERTISING WINDING UP RESOLUTION.

PORTLAND CO-OPERATIVE HOUSING SOCIETY LIMITED (IN LIQUIDATION).

*Special Resolution.*

Passed.—16th August, 1968.

AT a Special General Meeting of the above-named Society duly convened and held at Portland Free Library Hall Committee Room, on the 16th August, 1968, at 8.15 p.m., the subjoined Special Resolution was duly passed:—

"That the society having successfully completed its objectives fourteen months ahead of its expected term be wound up voluntarily, and that Francis Donald Stewart, of 97A Percy-street, Portland, be appointed liquidator for the purposes of the winding up."

R. J. STUCHBERY, Chairman of Meeting.

4350 F. D. STEWART, Secretary.

Companies Act 1961.—In the matter of SPEED TOOLS AND EQUIPMENT CO. PTY. LTD.

NOTICE is hereby given that at an Extraordinary General Meeting of the Members of the above-mentioned company held on the 13th day of August, 1968, it was resolved that the company be wound up voluntarily and that Ronald Dennis Widdows, of 6 Marilyn-court, East Bentleigh, be appointed liquidator for the purpose of such winding up.

Notice is also hereby given that after 21 days from this date the above-named liquidator shall proceed to distribute the assets. All creditors having any claim against the company should furnish particulars of the same by that date otherwise the liquidator shall proceed to distribute the assets without regard to their claim.

Dated this 13th day of August, 1968.

R. D. WIDDOWS, 6 Marilyn-court, East Bentleigh. 4399

Co-operative Housing Societies Act 1958 and Companies Act 1961.

FRANKSTON CO-OPERATIVE HOUSING SOCIETY LIMITED (IN LIQUIDATION).

*SPECIAL RESOLUTION.*

AT a Special General Meeting of the above-named society duly convened and held at 3A Wells-street, Frankston, on 21st August, 1968, the subjoined Special Resolution was duly passed:—

"That the Society having successfully completed its objectives twelve months ahead of its expected term be wound up voluntarily and that Mr. E. E. Shepard and Mr. A. A. B. Webster, of 3A Wells-street, Frankston, be appointed liquidators for the purposes of the winding up."

4366 J. A. WHYTE, Chairman of Meeting.  
E. E. SHEPARD, Secretary.

C.T.C. TRANSPORT AND CARRYING PTY. LTD. (IN VOLUNTARY LIQUIDATION).

NOTICE is hereby given in pursuance of section 272 (2) of the Companies Act 1961, that a Final Meeting of the Members of the above-named company will be held at the offices of Alex. W. Price, chartered accountant, of 973 Whitehorse-road, Box Hill, on Monday, 30th September, 1968, at 2.00 p.m. for the purpose of having an account laid before them showing the manner in which the winding up has been conducted and the property of the company disposed of, and of hearing any explanation that may be given by the liquidator.

Dated the 23rd day of August, 1968.

4382 ALEX. W. PRICE, Liquidator.

Companies Act 1961.

RE C. F. WOODS CONSTRUCTIONS PTY. LTD. (IN LIQUIDATION).

NOTICE is hereby given that a Final Dividend is to be declared in the above matter. Creditors who do not lodge proof of debt in the prescribed form by 13th September, 1968, will be excluded.

The date of the winding up order was 30th September, 1966.

Dated this 20th day of August, 1968.

E. T. BENT, Liquidator.

Bent & Cogle, public accountants, Suite 18, 545 St. Kilda-road, Melbourne. 4368

The Companies Act 1961.—In the matter of D. R. P. (HOLDINGS) PTY. LTD.

NOTICE is hereby given that at an Extraordinary General Meeting of the members of the above-named company, held on the 20th day of August, 1968, it was resolved that the company be wound up voluntarily, and at a meeting of creditors held on the same day, pursuant to section 260, it was resolved that for such purpose Edward Ronald Smail, of 296 Little Lonsdale-street, Melbourne, chartered accountant, be appointed liquidator.

Notice is also given that after 21 days from this date I shall proceed to distribute the assets. All creditors having any claims against the company should furnish particulars of same by that date, otherwise I shall proceed to distribute the assets, without regard to their claim.

Dated this 26th day of August, 1968.

E. R. SMAIL, Liquidator.

Kennedy, Smail & Middlemiss, 296 Little Lonsdale-street, Melbourne, 3000. 4407

BLACKBURN CO-OPERATIVE HOUSING SOCIETY LIMITED (IN VOLUNTARY LIQUIDATION).

TAKE notice that the affairs of the above-named society are now fully wound-up and that in pursuance of section 272 (1) of the Companies Act 1961 and of the Co-operative Housing Societies Act 1958, a General Meeting of the society will be held at 973 Whitehorse-road, Box Hill, on the 30th September, 1968, at 8 p.m. for the purposes of—

(i) laying before it an account showing how the winding-up has been conducted and the property of the society disposed of and giving any explanations thereof; and

(ii) passing a resolution that the books and papers of the said society and of the liquidator relevant to the affairs of the society be destroyed after a period of three months from the date of the meeting.

Dated the 23rd day of August, 1968.

ALEX. W. PRICE, liquidator, 973 Whitehorse-road, Box Hill. 4385

Companies Act 1961.—Section 254 (2).

SWAN SEWING COTTON COMPANY PTY. LIMITED.

AT an Extraordinary General Meeting of Swan Sewing Cotton Company Pty. Limited and held at Ferntree Gully-road, Mount Waverley, Victoria, on the 16th August, 1968, the following Special Resolution was passed.

"That the company be wound up voluntarily and that Philip Douglas George, of Edwin V. Nixon & Partners, chartered accountants, of 440 Collins-street, Melbourne, be appointed liquidator."

Dated the 20th August, 1968.

4348 F. T. DOCKING, Chairman.

**HODDLE CO-OPERATIVE HOUSING SOCIETY  
LIMITED (IN VOLUNTARY LIQUIDATION).**

**TAKE** notice that the affairs of the above-named society are now fully wound up and that in pursuance of section 272 (1) of the *Companies Act 1961* and of the *Co-operative Housing Societies Act 1958*, a General Meeting of the Society will be held at Scots Hall, ground floor, 99 Russell-street, Melbourne, on Monday, 30th September, 1968, at 8 p.m., for the purpose of—

- (1) laying before it an account showing how the winding up has been conducted and the property of the society disposed of and giving any explanations thereof; and
- (2) passing a resolution that the books and papers of the said society and of the liquidator relevant to the affairs of the society be destroyed after a period of twelve months from the date of the meeting.

Dated the 26th day of August, 1968.

4373 A. C. DOWNARD, Liquidator.

**The Companies Act 1961.—In the matter of OLIVE STREET  
MOTORS PROPRIETARY LIMITED.**

**NOTICE** is hereby given that at an Extraordinary General Meeting of the members of the above-named company, held on the 20th day of August, 1968, it was resolved that the company be wound up voluntarily, and at a meeting of creditors held on the same day, pursuant to section 260, it was resolved that for such purpose Norman Eric Stretton, of 296 Little Lonsdale-street, Melbourne, accountant, be appointed liquidator.

Notice is also given that after 21 days from this date I shall proceed to distribute the assets. All creditors having any claims against the company should furnish particulars of same by that date, otherwise I shall proceed to distribute the assets, without regard to their claim.

Dated this 22nd day of August, 1968.

N. E. STRETTON, Liquidator.  
Kennedy, Small & Middlemiss, 296 Little Lonsdale-street, Melbourne, 3000. 4406

**BOX HILL (No. 1) CO-OPERATIVE HOUSING SOCIETY  
LIMITED (IN VOLUNTARY LIQUIDATION).**

**TAKE** notice that the affairs of the above-named society are now fully wound-up and that in pursuance of section 272 (1) of the *Companies Act 1961* and of the *Co-operative Housing Societies Act 1958*, a General Meeting of the society will be held at 973 Whitehorse-road, Box Hill, on the 30th September, 1968, at 8 p.m. for the purposes of—

- (i) laying before it an account showing how the winding-up has been conducted and the property of the society disposed of and giving any explanations thereof; and
- (ii) passing a resolution that the books and papers of the said society and of the liquidator relevant to the affairs of the society be destroyed after a period of three months from the date of the meeting.

Dated the 23rd day of August, 1968.

ALEX. W. PRICE, liquidator, 973 Whitehorse-road, Box Hill. 4383

**BOX HILL (No. 2) CO-OPERATIVE HOUSING SOCIETY  
LIMITED (IN VOLUNTARY LIQUIDATION).**

**TAKE** notice that the affairs of the above-named society are now fully wound-up and that in pursuance of section 272 (1) of the *Companies Act 1961* and of the *Co-operative Housing Societies Act 1958*, a General Meeting of the society will be held at 973 Whitehorse-road, Box Hill, on the 30th September, 1968, at 8 p.m. for the purposes of—

- (i) laying before it an account showing how the winding-up has been conducted and the property of the society disposed of and giving any explanations thereof; and
- (ii) passing a resolution that the books and papers of the said society and of the liquidator relevant to the affairs of the society be destroyed after a period of three months from the date of the meeting.

Dated the 23rd day of August, 1968.

ALEX. W. PRICE, liquidator, 973 Whitehorse-road, Box Hill. 4384

**CREDITORS**, next of kin and others having claims in respect of the estate of Lancelot Henry Rosel, late of 10 Ridge-avenue, Moorabbin, dairy worker, deceased (who died on the 18th August, 1967), are required to send particulars of their claims to the administrator of the said estate, William Kenneth Rosel, care of the under-mentioned solicitor, by the 31st October, 1968, after which date he will distribute the assets, having regard only to those claims of which he then has notice.

ROWLAND P. HASSALL, solicitor, 360 South-road, Moorabbin. 4375

**CREDITORS**, next of kin and others having claims against the estate of Graeme Reginald Ebsworth, late of 9 Douglas-street, Kangaroo Flat, in the State of Victoria, salesman, deceased (who died on the 28th day of March, 1968), are required to send particulars thereof to National Trustees, Executors and Agency Company of Australasia Limited, of 95 Queen-street, Melbourne, and 46 Queen-street, Bendigo, in the said State, by the 22nd day of October, 1968, after which date the said company will distribute the assets of the said deceased, having regard only to the claims of which it then has notice.

WATSON JAMES & ROGERS, solicitors, 61 Bull-street, Bendigo. 4345

**CREDITORS**, next of kin and others having claims against the estate of Dorothy Sara McNair, late of 76 Hargreaves-street, Bendigo, in the State of Victoria, gentlewoman, deceased (who died on the 15th day of May, 1968), are required to send particulars thereof to Sandhurst and Northern District Trustees, Executors and Agency Company Limited, of 18 View-street, Bendigo aforesaid, David Kippen, of 76 Hargreaves-street, Bendigo aforesaid, driver, and Kevin Kippen, of Stewart-street, Warragul, in the said State, clerk, by the 22nd day of October, 1968, after which date the said company will distribute the assets of the said deceased, having regard only to the claims of which it then has notice.

WATSON JAMES & ROGERS, solicitors, 61 Bull-street, Bendigo. 4346

**CREDITORS**, next of kin and others having claims in respect of the estate of Olivia Elizabeth Mallard Stubber, late of View-street, Croydon, in the State of Victoria, spinster, deceased (who died on the 24th day of May, 1968), are to send the particulars of their claims to The Trustees, Executors and Agency Company Limited, of 401 Collins-street, Melbourne, by the 6th day of November, 1968, after which date it will distribute the assets, having regard only to the claims of which it then has notice.

BRAHAM & PIRANI, solicitors, 53 Queen-street, Melbourne. 4347

**CREDITORS**, next of kin and others having claims in respect of the estate of David Gordon Dean, late of Hall's Gap, in Victoria, retired, deceased (who died on 16th April, 1968), are to send particulars of their claims to The Trustees, Executors and Agency Company Limited, of 401 Collins-street, Melbourne, by the 12th day of November, 1968, after which date it will distribute the assets, having regard only to the claims of which it then has notice.

DAVID THOMAS & FRENKEL, of 104 Queen-street, Melbourne, solicitors to the said company. 4352

**CREDITORS**, next of kin and others having claims in respect of the estate of Marie Jeanne Quinn, late of 5 Hillcrest-avenue, Ferntree Gully, married woman, and grocer, deceased (who died on the 23rd day of February, 1968), are to send their claims to the administrator Christopher Joseph Quinn, care of Luke Murphy & Co., solicitors, 422 Bourke-street, Melbourne, on or before the 30th day of October, 1968, after which date he will distribute the assets, having regard only to the claims of which he has notice.

LUKE MURPHY & CO., solicitors, 422 Bourke-street, Melbourne. 4354

Re the Estate of D. A. L. BOWMAN, DECEASED.

**CREDITORS**, next of kin and others having claims in respect of the estate of Dorothy Ada Livingstone Bowman, late of 104 Browns-road, Clayton, Victoria, widow (who died on the 12th day of June, 1968), are to send the particulars of their claims to the Trustees, Executors and Agency Company Limited, of 401 Collins-street, Melbourne, Victoria, by the 29th day of October, 1968, after which date it will distribute the assets, having regard only to the claims of which it then has notice.

HERBERT TURNER & SON, solicitors, 411 Collins-street, Melbourne. 4358

CLARENCE EDWIN DICKASON, late of "The Rest", Stephens-road, Healesville, gentleman, DECEASED.

CREDITORS, next of kin and others having claims in respect of the estate of the deceased (who died on the 7th day of April, 1968), are required by the executors, Hilda Mary Lavinia Dickason, of "The Rest", Stephens-road, Healesville, widow, and Oswald Robert Dickason, of 11 Field-street, McKinnon, accountant, to send particulars to them, care of the undersigned, on or before the 10th day of November, 1968, after which date they will distribute the assets, having regard only to the claims of which they then have notice.

R. P. BAYLOR & CO., solicitors, Healesville. 4361

CREDITORS, next of kin and others having claims in respect of the will of Johanna Mary O'Brien, formerly of 22 Railway-crescent, Moonee Ponds, in the State of Victoria, but late of 58 Beatty-avenue, Glenroy, in the said State, pensioner, deceased (who died on the 1st day of July, 1968), are requested to send particulars of their claims to the executor, Peter Mario Albertin, care of the under-mentioned solicitor, by the 10th day of November, 1968, after which date he will distribute the assets, having regard only as to the claims of which he then has notice.

JOHN STEWART, solicitor, of 290 Racecourse-road, Newmarket. 4362

CREDITORS, next of kin and others having claims in respect of the will of Albert Edward Jordan, formerly of 155 Abbotsford-street, North Melbourne, in the State of Victoria, but late of Mount Royal, Poplar-road, Parkville, in the said State, retired transport driver, deceased (who died on the 20th day of July, 1968), are requested to send particulars of their claims to the executrix, Grace Sylvia Ashman, care of the under-mentioned solicitor, by the 10th day of November, 1968, after which date she will distribute the assets, having regard only as to the claims of which she then has notice.

JOHN STEWART, solicitor, of 290 Racecourse-road, Newmarket. 4363

CREDITORS, next of kin and others having claims in respect of the estate of Gertrude Gerda Mathew, late of 93 Kambrook-road, Caulfield, in the State of Victoria, widow (who died on the 19th day of October, 1967), are required by the executor, Keith Archibald Balstrup, of 17 Redan-road, Caulfield, engineer, to send particulars to him, care of Arthur Edward Cutler, LL.B., at 221 Balaclava-road, Caulfield, by the 31st day of October, 1968, after which date the executor may convey or distribute the assets, having regard only to the claims of which he then has notice.

A. E. CUTLER, LL.B., solicitor, 221 Balaclava-road, Caulfield. 4377

CREDITORS, next of kin and others having claims in respect of the estate of Keith Watmere Burns, late of 166 Gower-street, Preston, deceased (who died on the 19th day of January, 1968), are to send particulars of their claims to Royston T. Cahir & Martin, solicitors, of 475 Collins-street, Melbourne, by the 31st day of October, 1968, after which date the executor will distribute the assets of the estate, having regard only to claims of which he then has notice.

ROYSTON T. CAHIR & MARTIN, 475 Collins-street, Melbourne, 3000. 4388

CREDITORS, next of kin and others having claims in respect of the estate of Bernard Murray Botterill, late of No. 525 The Boulevard, Ivanhoe, medical practitioner, deceased (who died on the 7th day of April, 1968), are required to send particulars of their claims to Margaret Marcelle Botterill, widow, and Harold Murray Hamilton, accountant, the executors of the will and codicil of the said deceased, care of the undersigned solicitors, by the 1st day of November, 1968, after which date the executors will distribute the assets, having regard only to the claims of which they then have notice.

SEWELL & SEWELL, solicitors, 422 Collins-street, Melbourne. 4389

COLIN BROWN, late of 72 Roden-street, West Melbourne, gentleman, DECEASED.

CREDITORS, next of kin and others having claims in respect of the estate of the deceased (who died on the 28th day of October, 1967), are required by The Equity Trustees, Executors and Agency Company Limited, of 472 Bourke-street, Melbourne, to send particulars of their claims to the said company, at the above address, by the 30th day of October, 1968, after which date the said

company may convey or distribute the assets, having regard only to the claims of which it shall then have had notice.

DUGDALE, DIMMICK & STEVENS, solicitors, 37 Queen-street, Melbourne. 4390

CREDITORS, next of kin and others having claims in respect of the estate of Vera Emily Donohue, formerly of 14 Slater-street, Northcote, but late of 31 Palm-street, Fairfield, widow, deceased (who died on the 9th day of October, 1967), are required to send particulars of their claims to the executor, The Perpetual Executors and Trustees Association of Australia Limited, care of the under-mentioned solicitor, by the 28th day of October, 1968, after which date the executor will distribute the assets, having regard only to the claims of which he then has notice.

McLAUGHLIN, EAVES & JOHNSTON, solicitors, 331 Collins-street, Melbourne, 3000. 4393

OLIVIA WILSON, late of 1 Surgey-street, Merbein, widow, DECEASED.

CREDITORS, next of kin and others having claims in respect of the estate of the deceased (who died on the 30th April, 1968), are requested by The Union-Fidelity Trustee Company of Australia Limited, of 100 Exhibition-street, Melbourne, to send particulars of their claims to the said company, by the 30th October, 1968, after which date it will convey or distribute the assets, having regard only to the claims of which the company then has notice.

CORR & CORR, solicitors, 290 Latrobe-street, Melbourne. 4394

CREDITORS, next of kin and others having claims in respect of the estate of Elizabeth Martha Sullivan, late of 42 Ridgeway-avenue, Kew, spinster, deceased (who died on the 29th day of February, 1968), are required by the executors to send particulars of their claims to the National Trustees, Executors and Agency Company of Australasia Limited, of 95 Queen-street, Melbourne, by the 30th day of October, 1968, after which date the executors will distribute the assets, having regard only to the claims of which they then have notice.

F. E. O'BRIEN & CO., solicitors, of 470 Bourke-street, Melbourne. 4396

CREDITORS, next of kin and others having claims in respect of the estate of John Hartley Waterhouse, late of 8 Larkspur-avenue, Doncaster, motor mechanic (who died on the 14th April, 1968), are required to send written notice of their claims to the administratrix, Adele Lorraine O'Neill, care of the undersigned solicitors, by the 29th October, 1968, after which date the administratrix will distribute the assets, having regard only to the claims of which she then has notice.

PROUDFOOT, HORTON & COOKE, solicitors, of 452 Lonsdale-street, Melbourne. 4397

CREDITORS, next of kin and others having claims in respect of the estate of Dorothy Blanche Porter, late of 54 Ludstone-street, Hampton, in the State of Victoria, widow (who died on the 20th day of April, 1967), are required by the trustees, John Stanley Burgess Davis and Darvell Martin Hutchinson, both of 191 Queen-street, Melbourne, chartered accountants, to send particulars to them, care of Messieurs Wilson, Bishop & Henderson, at 191 Queen-street, Melbourne, by the 31st day of October, 1968, after which date the trustees may convey or distribute the assets, having regard only to the claims of which they then have notice.

PURVES & PURVES, solicitors, 90 William-street, Melbourne. 4401

CREDITORS, next of kin and others having claims in respect of the estate of Caroline Moran, late of 20 Hughendon-road, East St. Kilda, widow, deceased (who died on the 16th day of March, 1968), are required to send particulars of their claims to the executor, The Trustees, Executors and Agency Company Limited, of 401 Collins-street, Melbourne, by the 31st day of October, 1968, after which date the company will distribute the assets, having regard only to the claims of which it then has notice.

MAHONY, O'BRIEN & DUGGAN, solicitors, 37 Queen-street, Melbourne. 4403

CREDITORS, next of kin and others having claims in respect of the estate of Eileen Rosa Rossiter, late of the Brotherhood of St. Laurence, Carrum Downs Settlement, Carrum Downs, widow, deceased (who died on the 16th day of May, 1968), are to send particulars of their

claims to National Trustees, Executors and Agency Company of Australasia Limited, of 95 Queen-street, Melbourne, by the 6th day of November, 1968, after which date it will distribute the assets, having regard only to the claims of which it then has notice.

Dated the 27th day of August, 1968.

MADDEN, BUTLER, ELDER & GRAHAM, solicitors, 31 Queen-street, Melbourne. 4404

ELLEN JANET MITCHELL, formerly of Bonnie Doon, in the State of Victoria, but late of Ancona, in the said State, widow, DECEASED.

CREDITORS, next of kin and others having claims in respect of the deceased (who died on the 1st day of April, 1968), are required by her trustees, Alfred John Mitchell, grazier, and Ursula Mary Mitchell, married woman, both of Ancona aforesaid, to send particulars to them, care of the under-mentioned firm of solicitors, by the 6th day of November, 1968, after which date the trustees may convey and distribute the assets, having regard only to the claims of which they then have notice.

MAL. RYAN & GLEN, High-street, Mansfield, solicitors for the trustees. 4344

IDA LOUISA RAE WILSON, late of 72 Bowen-street, Camberwell, married woman, DECEASED, intestate.

CREDITORS, next of kin and all others having claims in respect of the estate of the above-named deceased (who died on the 5th day of June, 1968), are requested to send particulars, in writing, of their claim to Patricia Wilson, the administrator of the estate of the said deceased, care of her solicitors, at their address set out hereunder, on or before the 31st day of October, 1968, after which date she will distribute the assets of the said deceased, having regard only to the claims of which she then has notice.

JOHN MORAN & HAYES, 422 Collins-street, Melbourne, solicitors for the said administrator. 4391

IRENE DOROTHY MAHAR, formerly of Woodend, and Flat 5, 21 Grange-road, Toorak, but late of Maras Creek, via Macksville, New South Wales, married woman, DECEASED (who died on 6th May, 1968).

CREDITORS, next of kin and all other persons having claims against the estate of the deceased, are required by the executor of her will, The Equity Trustees, Executors and Agency Company Limited, of 472 Bourke-street, Melbourne, to send particulars thereof to the said company before 28th October, 1968, after which date the company may distribute the assets of the deceased, having regard only to the claims of which it then has notice.

CREDITORS, next of kin and others having claims against the estate of Sylvia May Gibson, late of 32 Anderson-street, Ballarat, in the State of Victoria, hospital employee, deceased (who died on the 24th day of March, 1968), are required by the executors, Hilda May Starr, of 26 Adams-street, Castlemaine, married woman, and Desmond Clive Gaunt, of 41 Lydiard-street south, Ballarat, solicitor, to send particulars of their claims to the under-mentioned firm by the 28th day of October, 1968, after which date the said executors will distribute the assets, having regard only to the claims of which they then have notice.

RAMSAY, GAUNT & FRASER, solicitors, of 41 Lydiard-street south, Ballarat. 4386

CREDITORS, next of kin and others having claims in respect of the estate of Joseph James Herman Engelbrecht, formerly of Apollo Bay, but late of Hall's-road, Myrtleford, dentist, deceased (who died on the 29th April, 1968), are to send particulars of their claims to The Trustees, Executors and Agency Company Limited, at 401 Collins-street, Melbourne, by the 14th day of November, 1968, after which date it will distribute the assets, having regard only to the claims of which it then has notice.

LEACH & THOMSON, solicitors, 472 Bourke-street, Melbourne. 4412

CREDITORS, next of kin and others having claims in respect of the estate of Maud Matilda Dainty, late of Yannathan-road, Nyora, widow, deceased (who died on the 8th May, 1968), are to send particulars of their claims to The Trustees, Executors and Agency Company Limited, at 401 Collins-street, Melbourne, by the 28th November, 1968, after which date it will distribute the assets, having regard only to the claims of which it then has notice.

BARKER & PEILE, solicitors, 358 Lonsdale-street, Melbourne. 4419

CREDITORS, next of kin and others having claims against the estate of James Colin Marshall, formerly of Flat 3, 15 Pevensey-crescent, East Geelong, but late of 15 Iona-avenue, Belmont, in the State of Victoria, retired manager, deceased (who died on 6th July, 1967, and probate of whose will was granted by the Supreme Court of the said State in its probate jurisdiction on 8th August, 1968, to Cyril Brooks, of 411 Collins-street, Melbourne, in the said State, solicitor), are hereby required by the said Cyril Brooks, to send particulars to him at his said address by 31st October, 1968, after which date the said Cyril Brooks may convey or distribute the assets of the said deceased, having regard only to the claims of which he then has notice.

Dated this 22nd day of August, 1968. 4402

CREDITORS, next of kin and others having claims against the estate of William Henry Stewart, late of 44 Bell-avenue, Altona West, retired public servant (who died on the 31st day of May, 1968), are required to send particulars of their claims to the executors, William Henry Stewart, and Lesbia Margaret Davis, care of the undersigned solicitor before the 6th day of November, 1968, after which date the said executors will distribute the assets, having regard only to the claims of which they then have notice.

JOHN F. CARROLL, solicitor, 118 Queen-street, Melbourne. 4395

Trustee Act 1958.

NOTICE TO CLAIMANTS.

PURSUANT to the Trustee Act 1958, creditors, next of kin and all other persons having claims in respect of the estate of any deceased person named below are required to send particulars to the legal personal representative or representatives at the addresses stated, after which date the representative or representatives will distribute the assets, having regard only to the claims of which notice has been received:—

Edward Albert Adams, late of 9 Horton-street, Reservoir, investor, deceased, who died on the 11th of May, 1968.—Claims to the executor, Alan Howard Gray, care of Gray and Gray, solicitors, 188 High-street, Northcote, by the 10th day of November, 1968. 4418

MERLE THOMPSON, late of 408 North-road, Ormond, in the State of Victoria, nurse, DECEASED.

CREDITORS, next of kin and others having claims in respect of the estate of the deceased (who died on the 27th day of July, 1968), are required by the trustee, the Equity Trustees, Executors and Agency Company Limited, of 472 Bourke-street, Melbourne, in the said State, to send particulars to it by the 30th day of October, 1968, after which date the trustees may convey or distribute the assets, having regard only to the claims of which it then has notice.

Dated this 26th day of August, 1968.

EGGLESTON CLIFTON-JONES & CO., solicitors, 578 Bourke-street, Melbourne. 4420

CREDITORS, next of kin and others having claims against the estate of Szajna Glikman, late of 5 Trevascus-street, South Caulfield, in the State of Victoria, widow, deceased (who died on the 5th day of June, 1968), are required to send particulars of their claims to the executors of her will, Mendal Smerling and Elliott Lindell, care of the under-mentioned solicitors, before the 5th day of November, 1968, after which date the said executors will distribute the estate of the said deceased, having regard only to the claims of which they then have notice.

J. OKNO & CO., solicitors, of 390 Lonsdale-street, Melbourne. 4421

CREDITORS, next of kin and others having claims in respect of the estate of Richard Charles Billings Wilkinson, formerly of 95 Chomley-street, East Prahran, in the State of Victoria, but late of 85 Chapman-avenue, Glenroy, in the said State, gentleman, deceased (who died on the 18th day of June, 1968), are to send particulars of their claims to the executor, Roy Walter Rudolph Wilkinson, care of the under-signed solicitors, on or before the 31st day of October, 1968, after which date he will proceed to distribute the said estate, having regard only to the claims of which he then has notice.

F. J. ORAMES & DOWNING, solicitors, 84 William-street, Melbourne. 4424



**CREDITORS**, next of kin and others having claims in respect of the estate of William James Easton, late of 14 Alice-street, Sunshine, retired, deceased (who died on the 31st day of May, 1968), are to send particulars of their claims to the executor, Harold Edward Easton, care of the under-mentioned solicitors, on or before the 30th day of October, 1968, after which date the executor will distribute the assets, having regard only to the claims of which he then has notice.

MARTIN & MARTIN, solicitors, 37 Queen-street, Melbourne. 4423

**CREDITORS**, next of kin and others having claims in respect of the estate of Alice Maud Willett, formerly of 33 Adrian-street, Burwood, in the State of Victoria, but late of Karinyah Private Hospital, 69 Broadway, East Camberwell, in the State of Victoria, widow, deceased (who died on the 13th day of August, 1967), are to send particulars of their claims to the executor, Arthur James Downing, care of the under-signed solicitors, on or before the 31st day of October, 1968, after which date he will proceed to distribute the said estate, having regard only to the claims of which he then has notice.

F. J. ORAMES & DOWNING, solicitors, 84 William-street, Melbourne. 4425

**IMPOUNDINGS**

**ECHUCA**.—Impounded in Echuca Pound by A. B. Burtchell, Impounding Officer.

1 ewe with notch out of left ear, in full wool, no visible brand

Impounded from Campaspe River.

1 lamb, no visible brand

If not claimed and expenses paid, to be sold on 11th September, 1968.

4364—\$2.50 B. CLEE, Poundkeeper.

**LILYDALE**.—Impounded in Lilydale Pound.

1 black heifer, approximately 18 months, no visible brand

1 brindle heifer, approximately 18 months, no visible brand

1 black heifer with white face, approximately 18 months, no visible brand

If not claimed and expenses paid, to be sold on 13th September, 1968.

4376—\$2.25 M. STEWART, Poundkeeper.

**MAFFRA**.—Impounded in Maffra Pound.

2 lamb wethers, like V out of top near ear, no visible brand

If not claimed and expenses paid, to be sold on 6th September, 1968.

4351—\$1.75 F. GIESCHEN, Poundkeeper.

**PAKENHAM**.—Impounded in Pakenham Pound from Bailey-road, Narre Warren North.

1 Hereford crossbred bull calf, about 9 months, no visible brand

If not claimed and expenses paid, to be sold on 9th September, 1968.

4359—\$2.00 H. SMITH, Poundkeeper.

**UPWEY**.—Impounded in Upwey Pound, from Lysterfield-road, Fern Tree Gully, 16th August, 1968.

1 steer, no visible brand

Impounded from Engelke-road, Belgrave South, 19th August, 1968.

3 yearling bulls, 1 calf no visible brand

If not claimed and expenses paid, to be sold on 10th September, 1968.

4411—\$2.50 K. McMAHON, Poundkeeper.

Subordinate Legislation Act 1962.

**NOTICE OF MAKING OF STATUTORY RULES.**

IN pursuance of the provisions of the Subordinate Legislation Act 1962 and the Regulations made thereunder, notice is given of the making of the following statutory rules:—

No.	Motor Boating Act 1961.	Price.
200/1968.	Motor Boating (Little Lake Boort) Regulations 1968 .. .. .	10c
	<i>Racing Act 1958.</i>	
201/1968.	Racing (Racecourses Licences Board Amendment) Regulations 1968 .. .. .	10c
	<i>Local Government Act 1958.</i>	
202/1968.	Long Service Leave (Municipal Employés) Amendment Regulation No. 1, 1968 .. .. .	10c
	<i>Firearms Act 1958.</i>	
203/1968.	Firearms (Orbost Historical Society Museum Exemption) Regulations 1968 .. .. .	10c
	<i>Cadet Surveyors Act 1964.</i>	
204/1968.	Cadet Surveyors (Water Supply Department) Amendment Regulations 1968 .. .. .	10c
	<i>Explosives Act 1960.</i>	
205/1968.	Explosives (Fireworks Prohibition) Order 1968 .. .. .	10c
	<i>Health Act 1958 (No. 6270).</i>	
206/1968.	Registration (Health Acts) Amendment Regulations 1968 .. .. .	10c
	<i>Drought Relief Act 1968.</i>	
207/1968.	Drought Relief Act (Ending of the Drought Period) Regulations 1968 .. .. .	10c

Copies of these statutory rules may be purchased at the Sale of Publications Section of the Government Printing Office, located at Macarthur-street, Melbourne, 3002. If ordered by mail, remittance should be addressed to "The Government Printer, Box 203, P.O., North Melbourne, 3051"; and should include 5c extra for postage. If a credit account is held at this office, no remittance is required with the mail order.

The annual subscription rate for Statutory Rules (including a Bound Volume) is \$15, payable in advance. The subscription year commences on 1st January.

A. C. BROOKS,  
Government Printer.

ACTS REPRINTED IN ACCORDANCE WITH THE AMENDMENTS INCORPORATION ACT 1958 (No. 6422), AND FOR SALE AT THE SALE OF PUBLICATIONS BRANCH OF THE GOVERNMENT PRINTING OFFICE, MACARTHUR-STREET, MELBOURNE, 3002.

(These prices do not include postage.)

No.		Price.
6189.	Acts Interpretation (Incorporating amendments up to No. 7146) .. .. .	\$0.15
6191.	Administration and Probate (Third Reprint—Incorporating amendments up to No. 7332) .. .. .	\$0.38
6194.	Agricultural Colleges (First Reprint—Incorporating amendments up to No. 7302) .. .. .	\$0.15
7117.	Appeal Costs Fund Act 1964 (First Reprint—Incorporating amendments up to No. 7488) .. .. .	\$0.25
6199.	Apprenticeship (First Reprint—Incorporating amendments up to No. 7312) .. .. .	\$0.25
6203.	Audit (First Reprint—Incorporating amendments up to No. 7377) .. .. .	\$0.35
6209.	Boiler Inspection (Incorporating amendments up to No. 7072) .. .. .	\$0.18
6210.	Building Societies (Incorporating amendments up to No. 7125) .. .. .	\$0.25
6218.	Children's Court (Incorporating amendments up to No. 7084) .. .. .	\$0.20
6219.	Children's Welfare (Second Reprint—Incorporating amendments up to No. 7084) .. .. .	\$0.35
6220.	Clean Air (Incorporating amendments up to No. 6886) .. .. .	\$0.10
6222.	Commercial Goods Vehicles (Second Reprint—Incorporating amendments up to No. 7358) .. .. .	\$0.22
6839.	Companies Act 1961 (Second Reprint—Incorporating amendments up to No. 7332) .. .. .	\$2.32
6225.	Co-operation (Second Reprint—Incorporating amendments up to No. 7083) .. .. .	\$0.42

ACTS REPRINTED IN ACCORDANCE WITH THE AMENDMENTS  
INCORPORATION ACT 1958 (No. 6422)—*continued*.

No.	Price.
6226. Co-operative Housing Societies (Incorporating amendments up to No. 7097) ..	\$0.40
6228. Country Fire Authority ( <i>Second Reprint</i> —Incorporating Amendments up to No. 7476) ..	\$0.50
6229. Country Roads ( <i>Second Reprint</i> —Incorporating Amendments up to No. 7506) ..	\$0.60
6230. County Court Act ( <i>First Reprint</i> —Incorporating amendments up to No. 7420) ..	\$0.35
6231. Crimes ( <i>Second Reprint</i> —Incorporating amendments up to No. 7407) ..	\$1.33
7060. Dandenong Valley Authority Act 1963 ( <i>First Reprint</i> —Incorporating amendments up to No. 7523) ..	\$0.35
6236. Dog ( <i>Second Reprint</i> —Incorporating amendments up to No. 7065) ..	\$0.15
6239. Dried Fruits Act 1968 ( <i>First Reprint</i> —Incorporating amendments up to No. 7337) ..	\$0.25
6240. Education ( <i>First Reprint</i> —Incorporating amendments up to No. 7533) ..	\$0.45
6241. Electric Light and Power ( <i>First Reprint</i> —Incorporating amendments up to No. 7315) ..	\$0.30
6242. Employers and Employés (Incorporating amendments up to No. 6740) ..	\$0.18
6243. Entertainments Tax ( <i>First Reprint</i> —Incorporating amendments up to No. 7315) ..	\$0.25
6245. Estate Agents Act ( <i>Third Reprint</i> —Incorporating amendments up to No. 7425) ..	\$0.50
6246. Evidence ( <i>Second Reprint</i> —Incorporating amendments up to No. 7366) ..	\$0.42
6249. Fences (Incorporating amendments up to No. 6550) ..	\$0.12
6250. Fertilizers (Incorporating amendments up to No. 7142) ..	\$0.25
6251. Firearms ( <i>Second Reprint</i> —Incorporating amendments up to No. 7484) ..	\$0.40
6252. Fisheries Act ( <i>First Reprint</i> —Incorporating amendments up to No. 7389) ..	\$0.35
6916. Foreign Judgments Act 1962 ( <i>First Reprint</i> —including amendments made by No. 7332) ..	\$0.15
6585. Forests (Pulpwood Agreement) (Incorporating amendments up to No. 6886) ..	\$0.15
6254. Forests ( <i>First Reprint</i> —Incorporating amendments up to No. 7356) ..	\$0.60
6256. Fruit and Vegetables ( <i>First Reprint</i> —incorporating amendments up to No. 6944) ..	\$0.30
6258. Game—( <i>First Reprint</i> —Incorporating amendments up to No. 7389) ..	\$0.30
6259. Goals (Incorporating amendments up to No. 6651) ..	\$0.15
6261. Gas Regulation ( <i>First Reprint</i> —Incorporating amendments up to No. 7580) ..	\$0.30
6262. Geelong Harbor Trust ( <i>First Reprint</i> —Incorporating amendments up to No. 7547) ..	\$0.45
6263. Geelong Waterworks and Sewerage ( <i>First Reprint</i> —Incorporating amendments up to No. 7547) ..	\$0.75
6265. Goods ( <i>Third Reprint</i> —Incorporating amendments up to No. 7131) ..	\$0.35
6266. Grain Elevators ( <i>First Reprint</i> —Incorporating amendments up to No. 7486) ..	\$0.35
6270. Health ( <i>Second Reprint</i> —Incorporating amendments up to No. 7490) ..	\$1.65
6933. Home Finance Act 1962 ( <i>First Reprint</i> —Incorporating amendments up to No. 7363) ..	\$0.25
6274. Hospitals and Charities ( <i>Second Reprint</i> —Incorporating amendments up to No. 7455) ..	\$0.50
6275. Housing ( <i>First Reprint</i> —Incorporating amendments up to No. 7507) ..	\$0.85
6279. Instruments ( <i>Third Reprint</i> —Incorporating amendments up to No. 7315) ..	\$0.38
6282. Justices ( <i>Second Reprint</i> —Incorporating amendments up to No. 7369) ..	\$1.23
6283. Labour and Industry ( <i>Third Reprint</i> —Incorporating amendments up to No. 7410) ..	\$1.00
6284. Land (Incorporating amendments up to No. 7360) ..	\$1.53
6534. Land Settlement Act 1959 ( <i>First Reprint</i> —Incorporating amendments up to No. 7328) ..	\$0.30
6289. Land Tax ( <i>Second Reprint</i> —Incorporating amendments up to No. 7466) ..	\$0.40
6285. Landlord and Tenant ( <i>Second Reprint</i> —Incorporating amendments up to No. 6996) ..	\$0.50
6286. Lands Compensation—( <i>First Reprint</i> —incorporating amendments up to No. 7332) ..	\$0.25
6290. Latrobe Valley ( <i>First Reprint</i> —Incorporating amendments up to No. 7332) ..	\$0.35
6291. Legal Profession Practice ( <i>Second Reprint</i> —Incorporating amendments up to No. 7539) ..	\$0.70
6295. Limitation of Actions ( <i>Second Reprint</i> —Incorporating amendments up to No. 7457) ..	\$0.25

ACTS REPRINTED IN ACCORDANCE WITH THE AMENDMENTS  
INCORPORATION ACT 1958 (No. 6422)—*continued*.

No.	Price.
6298. Local Authorities Superannuation (Incorporating amendments up to No. 6894) ..	\$0.25
6299. Local Government (Incorporating amendments up to No. 7052) ..	\$3.50
6302. Marine (Incorporating amendments up to No. 7350) ..	\$0.72
6304. Marketing of Primary Products ( <i>First Reprint</i> —Incorporating amendments up to No. 7491) ..	\$0.45
6306. Marriage ( <i>First Reprint</i> —Incorporating amendments up to No. 6959) ..	\$0.25
6309. Medical ( <i>Second Reprint</i> —Incorporating amendments up to No. 7408) ..	\$0.40
6310. Melbourne and Metropolitan Board of Works ( <i>Second Reprint</i> —Incorporating amendments up to No. 7547) ..	\$1.10
6312. Melbourne Harbor Trust ( <i>First Reprint</i> —Incorporating amendments up to No. 7356) ..	\$0.48
6605. Mental Health (Incorporating amendments up to No. 7135) ..	\$0.45
6315. Metropolitan Fire Brigades (Incorporating amendments up to No. 6886) ..	\$0.28
6316. Mildura Irrigation and Water Trusts ( <i>First Reprint</i> —Incorporating amendments up to No. 7448) ..	\$0.75
6317. Milk and Dairy Supervision (Incorporating amendments up to No. 6964) ..	\$0.40
6318. Milk Board (Incorporating amendments up to No. 7093) ..	\$0.22
6320. Mines ( <i>First Reprint</i> —Incorporating amendments up to No. 7499) ..	\$1.90
6184. Monash University ( <i>First Reprint</i> —Incorporating amendments up to No. 7533) ..	\$0.30
6324. Money Lenders (Incorporating amendments up to No. 6886) ..	\$0.25
6832. Motor Boating (Incorporating amendments up to No. 6961) ..	\$0.15
6325. Motor Car ( <i>Second Reprint</i> —Incorporating amendments up to No. 7361) ..	\$0.82
6326. National Parks (Incorporating amendments up to No. 7275) ..	\$0.25
6328. Nurses (Incorporating amendments up to No. 6716) ..	\$0.20
6330. Partnership ( <i>Second Reprint</i> —Incorporating amendments up to No. 7315) ..	\$0.25
6331. Patriotic Funds ( <i>First Reprint</i> —Incorporating amendments up to No. 7338) ..	\$0.25
6257. Pesticides Act 1968 ( <i>First Reprint</i> —Incorporating amendments up to No. 7595) ..	\$0.15
6889. Poisons Act 1962 ( <i>Second Reprint</i> —Incorporating amendments up to No. 7588) ..	\$0.50
6337. Police Offences (Incorporating amendments up to No. 7145) ..	\$0.82
6338. Police Regulation (Incorporating amendments up to No. 7081) ..	\$0.45
6340. Portland Harbor Trust ( <i>First Reprint</i> —Incorporating amendments up to No. 7475) ..	\$0.35
6341. Pounds ( <i>First Reprint</i> —Incorporating amendments up to No. 7315) ..	\$0.25
6890. Probate Duty (Incorporating amendments up to No. 6970) ..	\$0.38
6344. Property Law (Incorporating amendments up to No. 6867) ..	\$0.90
6349. Public Service ( <i>Second Reprint</i> —Incorporating amendments up to No. 7356) ..	\$0.40
6350. Public Trustee (Incorporating amendments up to No. 6961) ..	\$0.35
6353. Racing ( <i>First Reprint</i> —Incorporating amendments up to No. 7404) ..	\$0.70
6355. Railways ( <i>First Reprint</i> —Incorporating amendments up to No. 7475) ..	\$0.75
6564. Registration of Births Deaths and Marriages Act 1959 ( <i>First Reprint</i> —Incorporating amendments up to No. 7332) ..	\$0.25
6359. Road Traffic ( <i>Second Reprint</i> —Incorporating amendments up to No. 7332) ..	\$0.18
6360. Rural Finance ( <i>First Reprint</i> —Incorporating amendments up to No. 7328) ..	\$0.12
6846. Rural Finance and Settlement Commission Act 1961 ( <i>First Reprint</i> —Incorporating amendments up to No. 7332) ..	\$0.20
6975. Sale of Land Act 1962 ( <i>First Reprint</i> —Incorporating amendments up to No. 7332) ..	\$0.18
6363. Second-hand Dealers ( <i>First Reprint</i> —Incorporating amendments up to No. 7529) ..	\$0.25
6367. Settled Land ( <i>Second Reprint</i> —Incorporating amendments up to No. 7065) ..	\$0.50
6368. Sewerage Districts ( <i>First Reprint</i> —Incorporating amendments up to No. 7332) ..	\$0.62
6651. Social Welfare Act 1960 ( <i>Third Reprint</i> —Incorporating amendments up to No. 7332) ..	\$0.20

ACTS REPRINTED IN ACCORDANCE WITH THE AMENDMENTS  
INCORPORATION ACT 1958 (No. 6422)—*continued.*

No.	Price.
6372. Soil Conservation and Land Utilization (Incorporating amendments up to No. 6961)	\$0.20
6373. Soldier Settlement ( <i>First Reprint</i> —Incorporating amendments up to No. 7328)	\$0.42
6375. Stamps ( <i>Third Reprint</i> —Incorporating amendments up to No. 7359)	\$0.82
6377. State Electricity Commission ( <i>Second Reprint</i> —Incorporating Amendments up to No. 7421)	\$0.65
6379. State Savings Bank (Incorporating amendments up to No. 6886)	\$0.42
6381. Stock and Share Brokers ( <i>First Reprint</i> —Incorporating amendments up to No. 7444)	\$0.15
6886. Subordinate Legislation (Incorporating amendments up to No. 6961)	\$0.15
6386. Superannuation ( <i>First Reprint</i> —Incorporating amendments up to No. 7417)	\$0.60
6387. Supreme Court ( <i>First Reprint</i> —Incorporating amendments up to No. 7522)	\$0.75
6391. Teaching Service ( <i>First Reprint</i> —Incorporating amendments up to No. 7536)	\$0.35
7223. Tomato Processing Industry (Uniform Agreement) Act 1964 ( <i>First Reprint</i> —Incorporating amendments up to No. 7342)	\$0.15
6395. Tourist ( <i>First Reprint</i> —Incorporating amendments up to No. 7335)	\$0.15
6849. Town and Country Planning ( <i>First Reprint</i> —Incorporating amendments up to No. 7276)	\$0.45
6399. Transfer of Land Act ( <i>Third Reprint</i> —Incorporating amendments up to No. 7551)	\$0.65
6400. Transport Regulation ( <i>First Reprint</i> —Incorporating amendments up to No. 7358)	\$0.22
6401. Trustee ( <i>Second Reprint</i> —Incorporating amendments up to No. 6963)	\$0.42
6879. Unclaimed Moneys (Incorporating amendments up to No. 6961)	\$0.12
6653. Valuation of Land Act 1960 ( <i>Second Reprint</i> —Incorporating amendments up to No. 7333)	\$0.22
6407. Vegetation and Vine Diseases ( <i>First Reprint</i> —Incorporating amendments up to No. 7423)	\$0.30
6409. Vermin and Noxious Weeds ( <i>First Reprint</i> —Incorporating amendments up to No. 7463)	\$0.35
6410. Veterinary Surgeons ( <i>First Reprint</i> —Incorporating amendments up to No. 7343)	\$0.15
7291. Victoria Institute of Colleges Act 1965 ( <i>First Reprint</i> —Incorporating amendments up to No. 7644)	\$0.25
6413. Water ( <i>Second Reprint</i> —Incorporating amendments up to No. 7590)	\$1.95
6414. Weights and Measures ( <i>Second Reprint</i> —Incorporating amendments up to No. 7332)	\$0.32
6416. Wills ( <i>First Reprint</i> —Incorporating amendments up to No. 7238)	\$0.25
6419. Workers Compensation ( <i>Second Reprint</i> —Incorporating amendments up to No. 7332)	\$0.52

## FIRST NOTIFICATION OF REPRINT.

7499. Extractive Industries Act 1966 ( <i>First Reprint</i> —Incorporating amendments up to No. 7632)	\$0.35
6353. Racing ( <i>Second Reprint</i> —Incorporating amendments up to No. 7691)	\$0.85
6368. Sewerage Districts ( <i>Second Reprint</i> —Incorporating amendments up to No. 7547)	\$0.75

## STATE ACTS, 1968

COPIES of the following Acts of Parliament of Victoria may be obtained at the Government Printing Office, or from any accredited agents, at the price set opposite to each (these prices do not include postage).

The annual subscription for State Acts 1968 et seq. is \$8 payable in advance.

Bound Volumes of State Acts are also available on a subscription basis of \$15 per annum.

No.	Price.
7656. The Constitution Act Amendment (Governor's Salary)	\$0.10
7657. Victorian Limbless Soldiers' Provident Fund (Closing)	\$0.15
7658. Country Roads (Borrowing Powers)	\$0.10
7659. Hairdressers Registration (Amendment)	\$0.10

STATE ACTS, 1968—*continued.*

No.	Price.
7660. Evidence (Attestations)	\$0.10
7661. Melbourne Harbor Trust (Borrowing Powers)	\$0.10
7662. Cheltenham Cemetery Lands Exchange	\$0.10
7663. Administration and Probate (Amendment)	\$0.10
7664. Road Traffic (Infringements)	\$0.10
7665. Transport Regulation (Amendment)	\$0.10
7666. Commercial Goods Vehicles (Amendment)	\$0.10
7667. Tyabb to Long Island Railway Construction	\$0.10
7668. Marriage (Liability in Tort)	\$0.10
7669. La Trobe University (Amendment)	\$0.10
7670. Children's Court (Procedure)	\$0.10
7671. Labour and Industry (Amendment)	\$0.15
7672. Cemeteries (Exhumation Licences)	\$0.10
7673. Consolidated Revenue	\$0.10
7674. Forests (Amendment)	\$0.10
7675. Drought Relief	\$0.15
7676. Town and Country Planning (Amendment)	\$0.35
7677. Sunday Entertainment (Amendment)	\$0.10
7678. Police Offences (Publications)	\$0.10
7679. The Constitution Act Amendment	\$0.10
7680. Portland Harbor Trust (Borrowing Powers)	\$0.10
7681. Acts Interpretation (Prior Convictions)	\$0.10
7682. Aerial Spraying Control (Amendment)	\$0.10
7683. Shearers Accommodation (Amendment)	\$0.15
7684. Racing (Amendment)	\$0.15
7685. Health (Amendment)	\$0.10
7686. State Electricity Commission (Amendment)	\$0.15
7687. Kyneton Cattle Market Lands Exchange	\$0.15
7688. Swine (Application of Fund)	\$0.10
7689. Local Government (Amendment)	\$0.40
7690. Royal Society for the Prevention of Cruelty to Animals	\$0.15
7691. Racing (Trotting Meetings)	\$0.10
7692. Labour and Industry (Shop Trading Hours)	\$0.10
7693. Justices (General Sessions Jurisdiction)	\$0.10
7694. Latrobe Valley (Amendment)	\$0.10
7695. Liquor Control	\$0.75
7696. Crimes (Amendment)	\$0.10
7697. Country Roads (Amendment)	\$0.10
7698. West Moorabool Water Board	\$0.35
7699. Melbourne and Metropolitan Board of Works (Borrowing Powers)	\$0.10
7700. Teaching Service (Amendment)	\$0.10
7701. Children's Welfare (Amendment)	\$0.10

A. C. BROOKS,  
Government Printer.

## PUBLICATION OF OFFICIAL MATTER.

ATTENTION is invited to the following procedure in relation to the publication of official matter in the *Government Gazette*:—

1. *Matter submitted to the Executive Council.*

Matters submitted to the Executive Council which requires gazettal will normally be published in the issue of the following week.

Where urgent gazettal is required, special arrangements should be made with the *Gazette Officer*, Room 9, first floor, Old Treasury Building.

Publication will be facilitated by the submission of carbon copies for the use of the *Gazette Officer*.

2. *Other matter.*

(a) All other matter duly certified by a responsible officer for publication should be lodged with the *Gazette Officer* not later than half-past Nine a.m. on Tuesday.

(b) Lengthy or involved notices should be forwarded several days before publication.

(c) Proofs, which will be supplied only when specifically requested or, at the direction of the *Gazette Officer*, should be returned promptly to avoid delay in publication.

(d) No additions or amendments to matter for publication will be accepted by telephone.

## THE "VICTORIA GOVERNMENT GAZETTE".

SUBSCRIPTIONS.—*The subscription, including postage, is \$10 per annum, or \$5 per half year, payable in advance.*

*Subscriptions are required for whole months, and must cover at least a half year.*

*Single copies are 20 cents, posted 25 cents. Subscribers do not receive the Acts of Parliament with the GAZETTE.*

*GAZETTES are held in stock for five years only.*

PRIVATE ADVERTISEMENTS.—The charge for insertion is 25 cents per line single column, and 50 cents per line double column. The title forms one or more lines as a heading. On an average ten words make a line of single column. Every signature must likewise be counted as a line. The final words of a paragraph, though only portion of a line, must be counted as one line. Signatures (in particular) and proper names must be written very plainly in the text; ONE SIDE ONLY of each sheet of paper should be WRITTEN UPON.

All documents illegibly written will be returned unpublished, and where brands occur unprovided for by the ordinary letters of the alphabet, a worded explanatory description must be furnished.

THE VICTORIA GOVERNMENT GAZETTE is published on WEDNESDAY EVENING in each week, and Notices for insertion will be received by the Government Printer at or before ONE p.m. at ordinary rates, and late advertisements between ONE p.m. and FOUR p.m. at double rates on the day preceding the day of publication.

PAYMENTS.—Unless the advertiser has a credit account, all payments are required in advance. Remittances should be made by cheque, postal order, or money order payable to "GOVERNMENT PRINTER".

ADDRESS.—All communications should be addressed to "The Government Printer, Box 203, P.O., North Melbourne".

AGENTS FOR THE "VICTORIA GOVERNMENT GAZETTE".

THE following have been appointed agents to receive Advertisements and Subscriptions for the Victoria Government Gazette:—

- ARMSTRONG'S AGENCY, 205 Queen-street, Melbourne, Victoria 3000.
- ARNALL & JACKSON, 390 Barkly-street, Brunswick, Victoria 3056
- BAIRNSDALE AUTHORIZED NEWSAGENCY, 132 Main-street, Bairnsdale, Victoria 3875.
- BICKNELL, M. J., Authorized Newsagent, 196 Timor-street, Warrnambool, Victoria 3280.
- BLANE'S AUTHORIZED NEWSAGENTS, 162 Murray-street, Colac, Victoria 3250.
- CARTER, R. G., ADVERTISING SERVICE PTY. LTD., 26-32 King-street, Melbourne, Victoria 3000.
- DAVIES, G. & M. V., 112 Gray-street, Hamilton, Victoria 3300
- DAVIS, WM. (MILDURA) PTY. LTD., 126 Eighth-street, Mildura, Victoria 3500.
- DIXON'S NEWSAGENCY, 89 Firebrace-street, Horsham, Victoria 3400.
- EDGAR'S NEWSAGENCY PTY. LTD., 293 Hargreaves-street, Bendigo, Victoria 3550.
- EDGARS' AUTHORIZED NEWSAGENCY, 45 Bridge-street, Benalla, Victoria 3672.
- FRANKS, H., & CO., 184 Ryrie-street, Geelong, Victoria 3220.
- GORDON & GOTCH AUSTRALASIA LTD., 511 Little Collins-street, Melbourne, Victoria 3000.
- GULLAN'S NEWSAGENCY, 88 Bridge-street, Ballarat, Victoria 3350.
- HAMPTON, A. C., 243 Mitchell-street, Bendigo, Victoria 3550.
- HARSTON, PARTRIDGE & CO. PTY. LTD., 455 Little Collins-street, Melbourne, Victoria 3000.

- KYNETON GUARDIAN PTY. LTD., P.O. Box 18, Kyneton, Victoria 3444.
- LATIMER'S, Newsagents, 45 Station-street, Malvern, Victoria 3144.
- LIVINGSTON'S SHEPPARTON NEWSAGENCY, 246 Wyndham-street, Shepparton, Victoria 3630.
- THE MERCANTILE EXCHANGE, 67 Queen-street, Melbourne, Victoria, 3000.
- MCGILL'S AUTHORIZED NEWSAGENCY, 183-5 Elizabeth-street, Melbourne, Victoria 3000.
- PHILLIPS AUTHORIZED AGENCY, 83 Murphy-street, Wangaratta, Victoria 3677.
- PURDIE, J., & CO., 138 Moorabool-street, Geelong, Victoria 3220.
- SALE AUTHORIZED NEWSAGENCY, 142 Raymond-street, Sale, Victoria 3850.
- SKINNER'S AUTHORIZED NEWSAGENCY, 49-51 Franklin-street, Traralgon, Victoria 3844.
- STEVENSON, A. C. & M., NEWSAGENTS, 132 Henty-street, Casterton, Victoria 3311.
- VERNON, C. F. & H. J., 162 Bridge-road, Richmond, Victoria 3121.
- VIEW POINT AUTHORIZED NEWSAGENCY, 4 View-Point, Bendigo, Victoria 3550.

A copy of the Gazette filed at each place for public reference.

CONTENTS

	PAGE
Acts of Parliament on sale at the Government Printing Office .. .. .	3107
Appointments .. .. .	3065
Bank Holidays .. .. .	3052
Contracts .. .. .	3062
Estates of Deceased Persons .. .. .	3061
Government Notices .. .. .	3054
Impoundings .. .. .	3107
Lands .. .. .	3090
Melbourne and Metropolitan Board of Works— Notice .. .. .	3060
Mining .. .. .	3063
Notice to attend for Radiological Examination ..	3059
Notice of Making of Statutory Rules .. .. .	3107
Orders in Council—	
Acts—Land; Hospitals and Charities; Electric Light and Power; Country Roads; Land; Local Government; Forests; Soil Conservation and Land Utiliza- tion; Public Service; Railways; Water; Landlord and Tenant; Country Roads; Housing; River Improvement; Sewerage Districts.	3068 et seq
Police Sales .. .. .	3061
Private Advertisements .. .. .	3098
Proclamations .. .. .	3051
Public Holidays .. .. .	3053
Public Service Notice .. .. .	3098
Resignations .. .. .	3068
Tenders .. .. .	3097
Transport Regulation Board—Public Hearings ..	3055
Waterworks Trusts .. .. .	3063