

[3335]



VICTORIA GOVERNMENT GAZETTE

Published by Authority

[Registered at the General Post Office, Melbourne, for transmission by post as a newspaper.]

No. 82]

WEDNESDAY, OCTOBER 2

[1968

PROCLAMATIONS

Land Act 1958.

UNALIENATED CROWN LAND AVAILABLE FOR SETTLEMENT UNDER IMPROVEMENT PURCHASE LEASES.

PROCLAMATION

By His Excellency the Lieutenant-Governor of the State of Victoria and its Dependencies in the Commonwealth of Australia, &c., &c., &c.

IN pursuance of the provisions of Section 153 of the *Land Act 1958*, I, the Lieutenant-Governor of the State of Victoria, in the Commonwealth of Australia, by and with the advice of the Executive Council of the said State, do by this Proclamation declare the unalienated Crown lands mentioned in the sub-joined schedule, to be available for settlement under improvement purchase leases.

SCHEDULE.

County.	Parish.	Allotment.	Section.	Area.	Land Valuation.
				A. R. P.	
Tanjil	Nindoo	53D	E	59 0 33	\$10.00 per acre
Delatite	Too-rour	5C & 5D	A	50 0 0	\$10.00 per acre
Croajingalong	Bendock	54	A	150 acres±	} \$5.00 per acre
		55	A	205 acres±	
		56	A	315 acres±	
		57	A	95 acres±	
Buln Buln	Carrajung	61	..	60 acres	} \$10 per acre
		61A	..	150 acres	
		61B	..	160 acres	
Lowan	Awonga	105	..	102 acres±	\$7.00 per acre
Tambo	Tildesley West	37B & 37C	..	40 acres±	\$10.00 per acre
Tambo	Ensay	9B, 9C & 9D	2	450 acres	\$5.00 per acre

Given under my Hand and the Seal of the State of Victoria aforesaid, at Melbourne this twenty-fourth day of September in the year of our Lord One thousand nine hundred and sixty-eight and in the seventeenth year of the reign of Her Majesty Queen Elizabeth II.

E. F. HERRING.

(L.S.)

By His Excellency's Command,

W. J. F. McDONALD,
Minister of Lands.

GOD SAVE THE QUEEN!

Land Act 1958.

AREA OF LAND COMPRISED IN CERTAIN CLASSES DIMINISHED OR INCREASED.

PROCLAMATION

By His Excellency the Lieutenant-Governor of the State of Victoria, and its Dependencies in the Commonwealth of Australia, &c., &c., &c.

WHEREAS by the *Land Act 1958* it is amongst other things enacted that the Governor in Council may, by Proclamation to be published in the *Government Gazette*, at any time diminish or increase the area of land comprised in any of the classes mentioned in Part I., Division 1, Section 5, of the said *Land Act 1958*, but that the area of lands which may be sold by auction (Class 6), shall not be increased except as in certain cases in the said Act provided: Now therefore I, the Lieutenant-Governor of the State of Victoria, in the Commonwealth of Australia, by and with the advice of the Executive Council of the said State, and in accordance with the provisions of Sections 94 and 117 of the *Land Act 1958* aforesaid, do hereby diminish or increase (as the case may be) the areas of Crown lands comprised in Classes 1, 6 and 7 of the classes mentioned in Section 5 of the *Land Act 1958* aforesaid, to the extent set forth in the subjoined Schedule (that is to say):—

Schedule referred to

CLASSES DIMINISHED OR INCREASED.

County.	Parish.	Allotment.	Section.	Area.	Diminished.	Increased.	Description.
					Class.	Class.	
				A. R. P.			
Delatite ..	Bright ..	S27a	..	2 1 9	..	6	West of Township of Wandiligong
Grant ..	Buninyong ..	7D8	..	8 0 3	7	6	In the north-east of the Parish
Grant ..	Buninyong ..	E20	27	22 3 22	..	6	In the west of the Parish
Grant ..	Buninyong ..	E21	27	19 2 0	1	6	In the west of the Parish
Grant ..	Ballarat ..	16N	11	1 1 16	7	6	At Mount Clear—in the south of the Parish
Grant ..	Ballarat ..	21B	4	1 0 1	..	6	In the south of the Parish
Delatite ..	Bright ..	12	H	19 2 11	7	1	In the north of the Parish
Grant ..	Kerrit Barcet ..	2a	14	15 2 8	7	1	In the north-east of the Parish

Given under my Hand and the Seal of the State of Victoria, aforesaid, at Melbourne, this twenty-fourth day of September, in the year of our Lord One thousand nine hundred and sixty-eight, and in the seventeenth year of the reign of Her Majesty Queen Elizabeth II.

E. F. HERRING.

(L.S.)

By His Excellency's Command,

W. J. F. McDONALD,
Minister of Lands.

GOD SAVE THE QUEEN !

PUBLIC HOLIDAYS.

PROCLAMATION

By His Excellency the Lieutenant-Governor of the State of Victoria and its Dependencies in the Commonwealth of Australia, &c., &c., &c.

IN pursuance of the provisions contained in Part III. of the *Public Service Act 1958*, I, the Lieutenant-Governor of the State of Victoria, in the Commonwealth of Australia, by and with the advice of the Executive Council of the said State, do by this my Proclamation appoint the days and dates hereunder mentioned to be observed as Public Half-Holidays at the places respectively specified, viz.:—

Public Half-Holidays from the Hour of Twelve o'clock noon:—

WEDNESDAY, THE 13TH NOVEMBER, 1968, in the West and South Ridings of the Shire of Huntly.

WEDNESDAY, THE 23RD OCTOBER, 1968, throughout the City of Geelong.

THURSDAY, THE 14TH NOVEMBER, 1968, throughout the City of Hamilton.

FRIDAY, THE 11TH OCTOBER, 1968, throughout the Shire of Orbost.

Given under my Hand and the Seal of the State of Victoria aforesaid, at Melbourne, this first day of October, in the year of our Lord One thousand nine hundred and sixty-eight, and in the seventeenth year of the reign of Her Majesty Queen Elizabeth II.

(L.S.)

E. F. HERRING.

By His Excellency's Command,

A. G. RYLAH,
Chief Secretary.

GOD SAVE THE QUEEN!

PUBLIC HOLIDAYS.

PROCLAMATION

By His Excellency the Lieutenant-Governor of the State of Victoria and its Dependencies in the Commonwealth of Australia, &c., &c., &c.

IN pursuance of the provisions contained in Part III. of the *Public Service Act 1958*, I, the Lieutenant-Governor of the State of Victoria, in the Commonwealth of Australia, by and with the advice of the Executive Council of the said State, do by this my Proclamation appoint the days and dates hereunder mentioned to be observed as Public Half-Holidays at the places respectively specified, viz.:—

Public Half-Holidays from the Hour of Twelve o'clock noon:—

WEDNESDAY, THE 9TH OCTOBER, 1968, within the Municipality of Kerang.

THURSDAY, THE 17TH OCTOBER, 1968, throughout the municipal district of the Shire of Lowan.

WEDNESDAY, THE 20TH NOVEMBER, 1968, throughout the City of Ballarat.

Given under my Hand and the Seal of the State of Victoria aforesaid, at Melbourne, this first day of October, in the year of our Lord One thousand nine hundred and sixty-eight, and in the seventeenth year of the reign of Her Majesty Queen Elizabeth II.

(L.S.)

E. F. HERRING.

By His Excellency's Command,

A. G. RYLAH,
Chief Secretary.

GOD SAVE THE QUEEN !

BANK HOLIDAYS.

PROCLAMATION

By His Excellency the Lieutenant-Governor of the State of Victoria and its Dependencies in the Commonwealth of Australia, &c., &c., &c.

IN pursuance of the provisions of the Bank Holidays Act 1958, I, the Lieutenant-Governor of the State of Victoria, in the Commonwealth of Australia, do by this my Proclamation appoint the days and dates named hereunder special days to be observed as Bank Holidays or Bank Half-Holidays (as the case may be) at the places respectively mentioned, that is to say:—

Bank Holiday:—

- TUESDAY, 5TH NOVEMBER, 1968, at Queenscliff.
Bank Half-Holidays from the Hour of Eleven a.m.:—
THURSDAY, 14TH NOVEMBER, 1968, at Hamilton and Dunkeld.
WEDNESDAY, 20TH NOVEMBER, 1968, at Clunes.
WEDNESDAY, 9TH OCTOBER, 1968, at Lalbert.
WEDNESDAY, 9TH OCTOBER, 1968, at Quambatook.
MONDAY, 14TH OCTOBER, 1968, at Hamilton.
WEDNESDAY, 16TH OCTOBER, 1968, at Rochester and Lockington.
WEDNESDAY, 30TH OCTOBER, 1968, at Swan Hill.

Given under my Hand and the Seal of the State of Victoria aforesaid, at Melbourne, this first day of October, in the year of our Lord One thousand nine hundred and sixty-eight, and in the seventeenth year of the reign of Her Majesty Queen Elizabeth II.

(L.S.) E. F. HERRING.

By His Excellency's Command, A. G. RYLAH, Chief Secretary.

GOD SAVE THE QUEEN!

ALBERTON-PORT ALBERT WATERWORKS TRUST.

PROCLAMATION OF URBAN DISTRICTS AT ALBERTON AND PORT ALBERT

By His Excellency the Lieutenant-Governor of the State of Victoria and its Dependencies in the Commonwealth of Australia, &c., &c., &c.

UNDER the powers conferred by the Water Act and all other powers enabling me in that behalf, I, the Lieutenant-Governor of the State of Victoria, in the Commonwealth of Australia, by and with the advice of the Executive Council of the said State, do hereby proclaim that on and from the date hereof Portions II. and IV. of the Waterworks District of the Alberton-Port Albert Waterworks Trust as defined in the Order in Council dated 23rd August, 1966, and published in the Victoria Government Gazette dated 24th August, 1966, shall be and become Urban Districts for the purposes of and within the meaning of the said Act and shall be known as the Alberton Urban District and the Port Albert Urban District respectively.

Given under my Hand and the Seal of the State of Victoria aforesaid, at Melbourne, this first day of October, in the year of our Lord One thousand nine hundred and sixty-eight, and in the seventeenth year of the reign of Her Majesty Queen Elizabeth II.

(L.S.) E. F. HERRING.

By His Excellency's Command, W. BORTHWICK, Minister of Water Supply.

GOD SAVE THE QUEEN!

Survey Co-ordination Act 1958. PROCLAIMED SURVEY AREA (No. 15).

PROCLAMATION

By His Excellency the Lieutenant-Governor of the State of Victoria and its Dependencies in the Commonwealth of Australia, &c., &c., &c.

WHEREAS it is provided by section 12, sub-section 2 (b) of the Survey Co-ordination Act 1968 that upon a report of the Surveyor-General in writing to the effect that there are in existence in any area within Victoria sufficient permanent marks for the establishment of a local traverse for such area, the Governor in Council may proclaim such area to be a "proclaimed survey area" for the purposes of the said Act: Now therefore, I, the

Lieutenant-Governor of the State of Victoria, in the Commonwealth of Australia, by and with the advice of the Executive Council thereof, do by this my Proclamation proclaim approximately 708 acres, being part of the Township of Korumburra in the Parish of Korumburra, Counties of Buln Buln and Mornington, as indicated by hatching on plan hereunder, a "proclaimed survey area" for the purposes of the Survey Co-ordination Act 1958—(Proclaimed Survey Area No. 15—K 172(12); K 173(13); C.O.S. 3214; X.107).

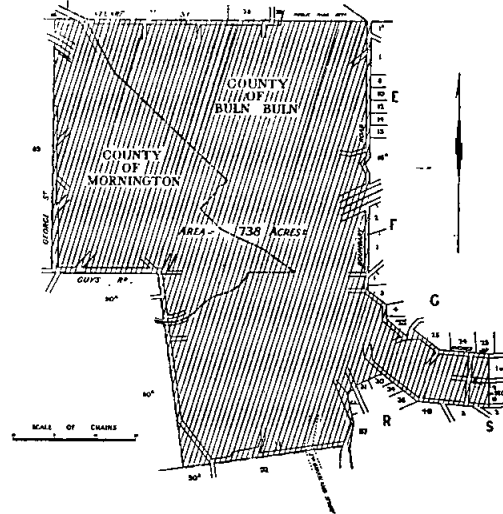

Given under my Hand and the Seal of the State of Victoria aforesaid, at Melbourne, this twenty-fourth day of September, in the year of our Lord One thousand nine hundred and sixty-eight, and in the seventeenth year of the reign of Her Majesty Queen Elizabeth II.

(L.S.) E. F. HERRING.

By His Excellency's Command, W. J. F. McDONALD, Minister of Lands.

GOD SAVE THE QUEEN!

ROADS PROCLAIMED.

PROCLAMATION

By His Excellency the Lieutenant-Governor of the State of Victoria and its Dependencies in the Commonwealth of Australia, &c., &c., &c.

IN pursuance of the provisions of Section 25 of the Land Act 1958, the Lieutenant-Governor of the State of Victoria, by and with the advice of the Executive Council of the said State, do hereby proclaim as roads the under-mentioned lands:

Township of Queenstown, Parish of Queenstown, County of Evelyn, being the land indicated by hatching on plan hereunder.—(Q.22(6) (C.77505.)

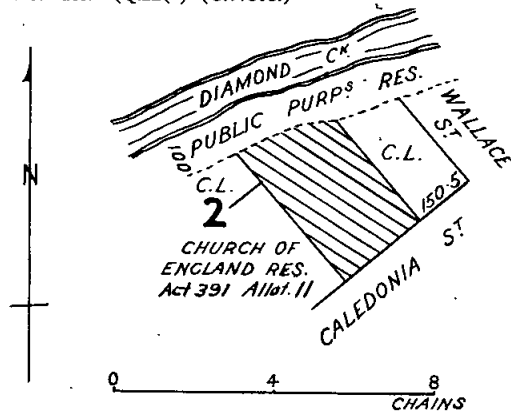

Parish of Dollin, County of Borung, being the land indicated by hatching on plan hereunder.—(D.195^(*)) (M.61427.)

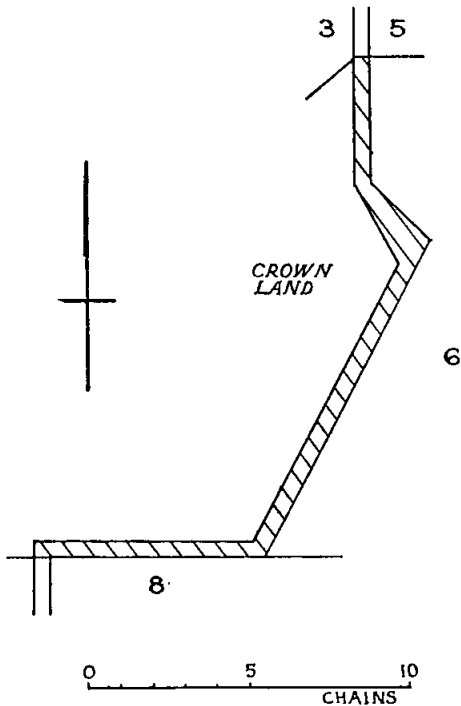

Township of Whittlesea, Parish of Toorourrong, County of Bourke, being the land indicated by hatching on plan hereunder.—(W.133^(*)) (C.99883.)

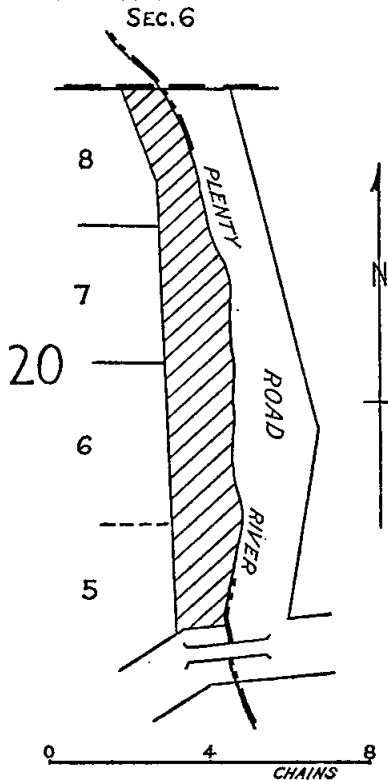

Given under my Hand and the Seal of the State of Victoria aforesaid, at Melbourne, this twenty-fourth day of September, in the year of Our Lord

One thousand nine hundred and sixty-eight, and in the seventeenth year of the reign of Her Majesty Queen Elizabeth II.

(L.S.) E. F. HERRING.

By His Excellency's Command,
W. J. F. McDONALD,
Minister of Lands.
GOD SAVE THE QUEEN !

LOCAL AUTHORITIES SUPERANNUATION ACT 1958.

PROCLAMATION

By His Excellency the Lieutenant-Governor of the State of Victoria and its Dependencies in the Commonwealth of Australia, &c., &c., &c.

WHEREAS the *Local Authorities Superannuation Act 1958*, Section 3, it is among other things enacted that it shall be lawful for the Governor-in-Council to declare any body constituted for a joint purpose by two or more authorities within the meaning of the said Act to be an authority for the purposes of the Act:

AND WHEREAS the Essendon-Broadmeadows Regional Library Service has requested that it be declared to be an Authority:

NOW THEREFORE, I, the Lieutenant-Governor of the State of Victoria in the Commonwealth of Australia, by and with the advice of the Executive Council of the said State, do by this Proclamation declare that the Essendon-Broadmeadows Regional Library Service, being an authority constituted for a joint purpose by the municipalities of the City of Essendon and the City of Broadmeadows, shall be an authority for the purposes of the said Act.

Given under my Hand and the Seal of the State of Victoria aforesaid, at Melbourne, this twenty-fourth day of September, in the year of our Lord One thousand nine hundred and sixty-eight, and in the seventeenth year of the reign of Her Majesty Queen Elizabeth II.

(L.S.) E. F. HERRING.

By His Excellency's Command,
R. J. HAMER,
Minister for Local Government.
GOD SAVE THE QUEEN !

Latrobe Valley (Amendment) Act 1968.

DATE OF COMMENCEMENT.

PROCLAMATION

By His Excellency the Lieutenant-Governor of the State of Victoria and its Dependencies in the Commonwealth of Australia, &c., &c., &c.

WHEREAS by an Act of Parliament of the State of Victoria passed in the seventeenth year of the reign of Her Majesty Queen Elizabeth II., intituled the *Latrobe Valley (Amendment) Act 1968*, it is amongst other things enacted that the provisions of the said Act shall come into operation on a day to be fixed by Proclamation of the Governor-in-Council published in the *Government Gazette*.

NOW THEREFORE I, the Lieutenant-Governor of the State of Victoria in the Commonwealth of Australia acting by, and with the advice of the Executive Council of the said State do by this my Proclamation fix Tuesday, the fifteenth day of October One thousand nine hundred and sixty-eight as the day upon which the *Latrobe Valley (Amendment) Act 1968* shall come into operation.

Given under my Hand and the Seal of the State of Victoria aforesaid, at Melbourne, this twenty-fourth day of September, One thousand nine hundred and sixty-eight, and in the seventeenth year of the reign of Her Majesty Queen Elizabeth II.

(L.S.) E. F. HERRING.

By His Excellency's Command,
HENRY BOLTE,
Premier.
GOD SAVE THE QUEEN !

GOVERNMENT NOTICES

Transport Regulation Act.
TRANSPORT REGULATION BOARD.

HEARING OF APPLICATIONS.

NOTICE is hereby given that the following applications will be considered by the Transport Regulation Board at its offices at the corner Lygon and Princes streets, Carlton, at 10.15 a.m., on Wednesday, 23rd October, 1968.

HAOUST, V. (Estate of Late), 15 Bonnie Doonee-street, Briar Hill. Application for variation of all M.O. licensed vehicles on Route 10 (Hawthorn Bridge—Camberwell Junction) to include the ability to deviate from Burwood-road, via Yarra-street, Isabella-grove and Coppin-grove on trips to Richmond as and when required by traffic conditions.

APPLICATION for renewal of licences as shown, by persons listed hereunder to operate under the same terms and conditions.

AMPOL PETROLEUM (VIC.) PTY. LTD., 792 Elizabeth-street, Melbourne; T.P.39.

BOGDANOVIC, R., 119 Ballarat-road, Bell Park, North Geelong; T.P.53.

CONNELLY, M. M., 6 Dorothy-avenue, Thomastown; T.P.183.

CULLEN, J. M. & J. E., 9 Raymond-street, Wangaratta; T.P.199.

ELDER—SMITH GOLDSBOROUGH—MORT LTD., 499 Bourke-street, Melbourne; T.P.194.

FREEMAN, A. S., 12 Rosslyn-street, East Hawthorn; T.P.133.

GOLDSACK, R. J., 81 Princes Highway, Pakenham East; T.S.942.

GODDARD, LES, MOTORS, High-street, Beaufort; T.S.726.

OLYMPIC TYRE & RUBBER CO. PTY. LTD., Cross-street, P.O. Box 1, Footscray; T.P.45.

QANTAS EMPIRE AIRWAYS LTD., Beach-road, Avalon; T.P.97, T.P.204.

REVELL, A., 90 Punt-road, Prahran; T.P.27.

SAWYER, L. L. & G. J., Eskdale; T.S.723.

SIDNEY COOKE (PRINTING INKS) PTY. LTD., 225 Queen-street, Melbourne; T.P.135, T.P.136.

Notice of any objection should be forwarded to reach the Secretary of the Board not later than Wednesday, 16th October, 1968.

Applicants are advised that it will not be necessary to appear on the hearing date specified above, unless advised, in writing, by the Board.

B. P. KAY,
 Secretary.

Corner Lygon and Princes streets, Carlton, Wednesday, 2nd October, 1968.

Commercial Goods Vehicles Act.

TRANSPORT REGULATION BOARD.

HEARING OF APPLICATIONS.

NOTICE is hereby given that the following applications will be considered by the Transport Regulation Board at its offices at the corner Lygon and Princes streets, Carlton, at 10.15 a.m., on Wednesday, 23rd October, 1968.

DAVIES, J. J. (Trading as Bendigo Disposals), 371 Hargreaves-street, Bendigo, 3550. One commercial goods vehicle (L/C. 10 cwt.) to operate within that part of the State of Victoria north of an east/west line drawn through Seymour, west of a north/south line drawn through Shepparton and east of a north/south line drawn through Sea Lake in the course of business as "Automotive Parts Wholesaler"—automotive parts and accessories within a 50-mile radius of the railway stations at Bendigo, Shepparton, Koondrook, Swan Hill or Wycheproof provided that all such goods have been initially consigned by rail to the said station.

Special Condition.—It is a special condition of this licence that quarterly returns showing details of all consignments by rail to the railway stations specified above be furnished to the Board.

BIRCH, E. C., PTY. LTD., 84 Flinders-lane, Melbourne, 3000. One commercial goods vehicle (L/C. 8 cwt.) to operate in the course of business as "Wholesale Softgoods Merchants": (a) Within a 50-mile radius from own premises in the City of Melbourne—own goods. (b) Throughout the State of Victoria—own softgoods for display and advertising purposes only.

BREMNER, R. J., 221 Westblade-avenue, Kerang, 3579. One commercial goods vehicle (L/C. 246 cwt.) to operate: (a) Within a 50-mile radius of the post office at Kerang as a "Road Contractor"—road-making plant and materials. (b) Within a 25-mile radius from the post office at Kerang—general goods provided that no goods shall be carried whether by one stage or by more than one stage between places within the above radius which are more than 30 road miles apart by the nearest practicable route.

BRIGGS, D., P.O. Box 136, Warragul, 3820. One commercial goods vehicle (L/C. 140 cwt.) to operate: (a) Within a 25-mile radius of the post office at Warragul—general goods, provided that no goods shall be carried whether by one stage or by more than one stage between places within the above radius which are more than thirty (30) miles apart by the nearest practicable route. (b) Throughout the State of Victoria in the course of own business as a "Road Making Contractor"—own tools of trade and equipment, and fuel necessary for operation of own equipment. (c) Within a 20-mile radius of any contract site currently engaged upon or from the railway station nearest thereto—materials necessary for completion of said contract and waste materials for disposal.

CAIRNS, J. J., Private Bag 50, Hamilton, 3300. Two commercial goods vehicles (L/C. 11 and 41 cwt., and trailer 10 cwt.) to operate: (a) Within a 50-mile radius of own premises at Yulecart in the course of business as "Electrical Construction Contractor"—own goods. (b) Within a 50-mile radius of the G.P.O., Melbourne for the purpose of operating throughout the Eastern Metropolitan Branch of the S.E.C. for the maintenance of S.E.C. power lines—tools of trade and materials on behalf of the S.E.C. for power line maintenance. (c) Between the areas as defined in paragraphs (a) and (b) above—own tools of trade.

CLARK, J. H., 19 Hindmarsh-street, Dimboola, 3414. One commercial goods vehicle (L/C. 245 cwt.) to operate: (a) Within a 50-mile radius from the post office at Horsham as a "Road Contractor"—road-making plant and materials. (b) Within a 25-mile radius from the post office at Dimboola—general goods provided that no goods shall be carried whether by one stage or by more than one stage between places within the above radius which are more than thirty road miles apart by the nearest practicable route.

CLEAN AIR PTY. LTD., 19 Park-road, Cheltenham, 3192. One commercial goods vehicle (L/C. 14 cwt.) to operate: (a) Within a 50-mile radius from own premises at Cheltenham in course of business as "Air Conditioning Contractors"—own goods. (b) Throughout the State of Victoria for the purpose of installing and servicing heating and air conditioning units—tools of trade, spare parts, ductwork and fittings incidental thereto and equipment for repair or having been repaired.

DEHNE, G. W. Weir-road, Kerang, 3579. One commercial goods vehicle (L/C. 113 cwt.) to operate: (a) Within a 20-mile radius of Kerang—general goods. (b) Throughout the State of Victoria—livestock. (c) Within a 30-mile radius of Kerang—stock fodder to a railway siding providing such stock fodder is consigned from the railway siding.

DENSLEY, A. N. & N. G. (trading as A. Densley & Co.), 4 Patrica-street, Warrnambool, 3280. One commercial goods vehicle (L/C. 8 cwt.) to operate: (a) Within a 50-mile radius of the post office at Warrnambool in the course of business as "Plumber"—own goods. (b) Throughout the State of Victoria on behalf of the Public Works Department—tools of trade and spare parts incidental to the repair, maintenance and installation of furnace equipment.

FIAT OF AUSTRALIA PTY. LTD., 5 Warrigal-road, Moorabbin, 3189. One commercial goods vehicle (L/C. 30 cwt.) to operate throughout the State of Victoria in the course of business as "Tractor and Implement Importers and Distributors": (a) Tools of trade, spare parts and materials incidental to the servicing and maintenance of tractors and implements in the field only. (b) Implements and accessories for demonstration purposes only.

FOSTER, J. C., 30 Pyke-street, Bairnsdale, 3875. One commercial goods vehicle (L/C. 79 cwt.) to operate throughout the State of Victoria in the course of business as "Marine Collector"—special wares, marine stores and old metals as designated in the *Marine Stores and Old Metals Act 1958* (No. 6303) Part (1), Section (3), but excluding the carriage of any such marine stores or old metals to wharves, docks or ships for shipment or export purposes with the proviso that the combined load capacity of both prime mover and any trailer attached thereto shall not exceed 120 cwt.

- RAWSON, R. (trading as Glenrowan Quarrying Co.), Beaconsfield-parade, Glenrowan, 3675. One commercial goods vehicle (L/C. 209 cwt.) to operate within a 50-mile radius of own premises at Glenrowan in the course of business as "Quarrymasters"—own screenings and quarry products.
- GREGORY, H. P. (VIC.) PTY. LTD., 615 Bridge-road, Richmond, 3121. One commercial goods vehicle (L/C. 11 cwt.) to operate throughout the State of Victoria in the course of business as "Engineers and Machinery Manufacturers" for the purposes of servicing of own sewerage units, compressors, electric supply plant and general production machinery—tools of trade, servicing equipment, spare parts and materials incidental to servicing.
- GUILMARTIN, T. W. & M. L., 119 Panton-street, Golden Square, 3555. One commercial goods vehicle (L/C. 220 cwt.) to operate: (a) Within a 50-mile radius from the post office at Pyramid Hill as a "Road Contractor"—road-making plant and materials. (b) Within a 25-mile radius from the post office at Pyramid Hill—general goods provided that no goods shall be carried whether by one stage or by more than one stage between places within the above radius which are more than thirty road miles apart by the nearest practicable route.
- JASPERSE, A., Rowe-street, Shepparton, 3630. One commercial goods vehicle (L/C. 8 cwt.) to operate within a 50-mile radius of the post office at Shepparton in the course of business as "Electrical Serviceman"—tools of trade, servicing equipment and spare parts incidental to the servicing and repair of electrical goods, and electrical goods for repair or having been repaired.
- JENKS, S. J. (trading as Ray Jenks Radio and Television Service), 120 High-street, Shepparton, 3630. One commercial goods vehicle (L/C. 14 cwt.) to operate within a 50-mile radius of the post office at Shepparton in the course of business as "Electrical Contractor"—electrical goods for sale and/or repair or having been repaired and/or for hire also own tools of trade and equipment incidental to the servicing of such electrical appliances.
- JOBSON, A. I., 16 Jacqueline-street, Mt. Waverley, 3149. One commercial goods vehicle (L/C. 202 cwt.) to operate within a 50-mile radius of the premises of Pioneer Concrete (Vic.) Pty. Ltd., at Croydon, solely on behalf of the said company—premixed concrete in a specially constructed agitator vehicle.
- LARSEN, N., 37 Cambro-road, Clayton, 3168. One commercial goods vehicle (L/C. 150 cwt.) to operate within a 35-mile radius of the G.P.O., Melbourne, solely on behalf of Consolidated Quarries Ltd.—screenings, stone dust and quarry materials.
- LOVELL, P. J. & G. B., 17 Barry-street, Reservoir, 3073. One commercial goods vehicle (L/C. 199 cwt.) to operate within a 50-mile radius of the premises of Boulders Pty. Ltd., at Bundoora, solely on behalf of the said company—premixed concrete in a specially-constructed agitator vehicle.
- MAUDE, J. H., 109 Haldane-road, Niddrie, 3042. One commercial goods vehicle (L/C. 220 cwt.) to operate within a 50-mile radius of the plant of Albion Reid Pty. Ltd., at North Melbourne, solely on behalf of the said company—road-making materials, premix and hot asphalt but excluding the carriage of cement or lime from Geelong.
- MEAD, A. W., 279 Lara-street, Warrnambool, 3280. One commercial goods vehicle (L/C. 77 cwt.) to operate throughout the State of Victoria in the course of business as "Marine Collector"—special wares, marine stores and old metals as designated in the *Marine Stores and Old Metals Act 1958* (No. 6303), Part 1, Section 3, but excluding the carriage of any such marine stores or old metals to wharves, docks or ships for shipment or export purposes with the proviso that the combined load capacity of both prime mover and any trailer attached thereto shall not exceed 120 cwt.
- MILLER, G. W., 14 Acacia-street, Huntingdale, 3166. One commercial goods vehicle (L/C. 146 cwt.) to operate within a 35-mile radius of the G.P.O., Melbourne, solely on behalf of Consolidated Quarries Ltd.—screenings, stone dust and quarry products.
- MOOROOPNA SAWMILLS PTY. LTD., P.O. Box 48, Mooroopna, 3629. One commercial goods vehicle (L/C. 240 cwt.) to operate: (a) From forest landings in the Barmah and Undera areas to own sawmill at Mooroopna—red gum logs. (b) From own sawmill at Mooroopna to the Mooroopna Railway Station and/or the Shepparton Railway Station and direct to consignees within a 20-mile radius of the Mooroopna Post Office—sawn timber.
- PASCO, G. R., Albert-street, Creswick, 3363. One commercial goods vehicle (L/C. 10 cwt.) to operate throughout the State of Victoria in the course of business as "Funeral Directors" as a mortuary vehicle.
- PASSIONA BOTTLING CO. (MELBOURNE) LTD., 215 Chester-ville-road, Moorabbin, 3189. Two commercial goods vehicles (L/C. 129 cwt. each) to operate within a 50-mile radius of the G.P.O., Melbourne, in course of business as "Aerated Water Manufacturers"—own aerated waters and empty containers for return.
- PEDYN, B., 9 Goode-street, Chadstone, 3148. One commercial goods vehicle (L/C. 20 cwt.) to operate within a 50-mile radius of the premises of Four'n Twenty Pies Pty. Ltd., at Ascot Vale, as a sales agent—pies and pasties, sausage rolls and fruit drinks in paper containers solely on behalf of the said company.
- PERMEWAN WRIGHT LTD., 147-179 Alexandra-parade, Abbotsford, 3067. One commercial goods vehicle (L/C. 33 cwt.) to operate within a 50-mile radius of own branch premises at Leongatha in course of business as "General and Produce Merchants"—own goods.
- PRESHA ENGINEERING PTY. LTD., Ferntree Gully-road, Notting Hill, 3168. Two commercial goods vehicles (L/C. 14 cwt. each) to operate: (a) Within a 50-mile radius of the G.P.O., Melbourne, in the course of business as "Manufacturers of Steam Generators"—own goods. (b) Throughout the State of Victoria for the purposes of servicing and repairing steam generators—tools of trade, spare parts and materials incidental to such servicing and repair.
- PRICE, K. A., 5 Tatiara-avenue, Croydon, 3136. One commercial goods vehicle (L/C. 9 cwt.) to operate within a 50-mile radius of G.P.O., Melbourne, as a "Service Mechanic" on behalf of Turner Manufacturing Co. Pty. Ltd.—tools of trade, spare parts, appliances for repair and having been repaired and for installation.
- REILLY, K. A., Bayfield-road, Bayswater, 3153. One commercial goods vehicle (L/C. 189 cwt.) to operate within a 50-mile radius of the premises of Pioneer Concrete (Vic.) Pty. Ltd., at Croydon, solely on behalf of the said company—premixed concrete in a specially-constructed agitator vehicle.
- ROBERTSON, A. R., Station-street, Nunawading, 3131. One commercial goods vehicle (L/C. 201 cwt.) to operate: (a) Within a 25-mile radius from the post office situated at the corner of Bourke and Elizabeth streets in the City of Melbourne in course of business as "Tile Manufacturers"—own goods. (b) Within a 70-mile radius of the premises of Daniel Robertson, at Nunawading—own terra cotta roofing tiles, own battens, tile-fixing materials and bricks.
- SKINNER, R. E., Carlisle River, 3239. One commercial goods vehicle (L/C. 157 cwt.) to operate: (a) Within a 50-mile radius of the post office at Carlisle River as a "Road Contractor"—road-making plant and materials. (b) Within a 25-mile radius of the post office at Carlisle River—general goods provided that no goods shall be carried whether by one stage or by more than one stage between places within the above radius which are more than thirty road miles apart by the nearest practicable route.
- STEPHENS-ADAMSON AUST. PTY. LTD., P.O. Box 137, Oakleigh, 3166. One commercial goods vehicle (L/C. 11 cwt.) to operate throughout the State of Victoria for the purpose of servicing materials handling equipment—tools of trade, spare parts and materials incidental to servicing.
- STUART, JACK, PTY. LTD., 29 Mostyn-street, Castlemaine, 3450. One commercial goods vehicle (L/C. 11 cwt.) to operate within a 50-mile radius of own premises at Castlemaine in course of business as "Electrical Retailer and T.V. Technician"—tools of trade, spare parts, own electrical appliances, electrical appliances for repair, having been repaired and for specialized installation.
- TARAX DRINKS (ALBURY) PTY. LTD., 26 High-street, Wodonga, 3690. One commercial goods vehicle (L/C. 129 cwt.) to operate within a 50-mile radius of own approved decentralized secondary industry premises at Wodonga and from and to Wodonga, to and from the township of Corryong, in the course of business as "Cordial and Aerated Water Manufacturers and Distributors"—cordials and aerated waters and empty return containers.
- TARAX DRINKS (SHEPPARTON) PTY. LTD., 19 Old Dookie-road, Shepparton, 3630. One commercial goods vehicle (L/C. 120 cwt.) to operate: (a) Within a 50-mile radius of own approved decentralized secondary industries premises at Shepparton and from and to such premises to and from the towns of Swan Hill and Wodonga serving places *en route*—own soft drinks and

cordials in bottles and cans together with drinking straws and associated lines. (b) Within a 50-mile radius of own premises at Shepparton—cordials on behalf of Cottee's Ltd.

Special Conditions.

It is a condition of this licence that all goods not manufactured at Shepparton carried on the vehicle shall have been initially consigned by rail to the Shepparton Railway Station.

TOORALAC MILK PRODUCTS PTY. LTD., 141 Osborne-street, South Yarra, 3141. Five commercial goods vehicles (L/C. 62, 232, 221, 239, and 118 cwt.) to operate: (a) From the farms of primary producers situated within a 50-mile radius of the post office at Toora to our own milk factory at Toora—milk and cream in cans. (b) From our own milk factory at Toora to the farms of primary producers from whom milk and cream is collected—empty milk and cream cans, also general goods for delivery to any such primary producer when required. (c) Goods associated with our own approved decentralized secondary industry (Milk Products Manufacture) carried on at the premises at Toora as follows: (1) To the said premises from the City of Melbourne and/or from South Gippsland district of the State of Victoria, goods and materials required solely in the manufacturing process of such decentralized industry. (2) From the said premises at Toora to the City of Melbourne and/or to the points within the said Gippsland District—own manufactured milk products.

UNILEVER AUSTRALIA PTY. LTD., 164-220 Inglis-street, Port Melbourne, 3207. One commercial goods vehicle (L/C. 112 cwt.) to operate within a 25-mile radius of the G.P.O., Melbourne and to and from places on the Mornington Peninsula in course of business as "Soap and Food Stuff Manufacturers"—own margarine, own fats and own edible oils in an insulated van.

WALSH, P. E., Pound Creek-road, Navigator, 3352. One commercial goods vehicle (L/C. 211 cwt.) to operate: (a) Within a 50-mile radius of the post office at Navigator—as a "Road Contractor"—road-making plant and materials. (b) Within a 25-mile radius of the post office at Navigator—general goods provided that no goods shall be carried whether by one stage or by more than one stage between places within the above radius which are more than thirty road miles apart by the nearest practicable route.

WHITELAW-MONIER PTY. LTD., Smith-road, Springvale, 3171. One commercial goods vehicle (L/C. 145 cwt.) to operate: (a) From own factory at Springvale to places within a 70-mile radius from such factory for the carriage of own cement tiles, cement capping, battens and the tile-fixing materials. (b) Between own factory at Springvale and own decentralized factories at Ballarat and Wangaratta for the carriage of oxides (tile colouring), glazing compounds (for glazing tiles), concrete releasing oil (occasionally), pallets, moulds, spare parts, machinery for repair, or having been repaired, cement tiles and cement capping.

WILLIAMS, B. H., Collis-street, Foster, 3960. One commercial goods vehicle (L/C. 200 cwt.) to operate: (a) Within a 50-mile radius of Foster—road-making materials—plant and equipment. (b) From the S.E.C. at Morwell to own premises at Foster and for distribution within a 20-mile radius thereof—briquettes. (c) Within a 25-mile radius of Foster—general goods provided no journey shall exceed more than thirty road miles in distance.

WRIGHT STEPHENSON & CO. LTD., 330 St. Kilda-road, Melbourne, 3004. One commercial goods vehicle (L/C. 64 cwt.) to operate: (a) Within a 25-mile radius of the post office at Heywood—general goods provided that no goods shall be carried whether by one stage or by more than one stage between places within the above radius which are more than thirty road miles apart by the nearest practicable route. (b) Within a 50-mile radius of the depot of Ampol Petroleum (Vic.) Pty. Ltd., at Portland—petroleum products in prescribed types of containers and empty return containers.

WRIGHT STEPHENSON & CO. LTD., 330 St. Kilda-road, Melbourne, 3004. One commercial goods vehicle (L/C. 11 cwt.) to operate within a 100-mile radius of own premises at Heywood in course of business as "General Merchants"—stoves and heating equipment for installation or for repair or having been repaired, tools of trade and spare parts incidental to the repair or installation of such stoves and equipment provided that all such stoves and equipment have been initially consigned by rail to Heywood.

RENEWALS.

APPLICATIONS by persons listed hereunder for renewal of the licences listed hereunder to operate under the same terms and conditions from the expiry date shown in each case.

BENDIGO DE LUXE CATERING SERVICE PTY. LTD., 27 Queen-street, Bendigo, 3550; D.A.30962/4; 14th November, 1968; 43 cwt.

BLACKNEY'S FROZEN FOODS PTY. LTD., 34-36 Smythe-street, Geelong, 3220; T.D.A.36140/4; 14th October, 1968; 72 cwt.

BLENNERHASSETT, J. & L. C., 18 Horn-street, Leongatha, 3953; D.A.60463/2; 14th November, 1968; 252 cwt.

CAMPBELL, J. J., Glenrowan, 3675; D.A.40984; 14th November, 1968; 90 cwt.

CARLILE BROS. PTY. LTD., Strickland-road, Bendigo, 3550; D.A.807; 25th July, 1968; 61 cwt.

CHIVELL, F. H. M., 1 Jamboree-avenue, Frankston, 3199; D.A.53554; 5th October, 1968; 102 cwt.

CIGARETTE SERVICE PTY. LTD., 171 Bridge-street, Bendigo, 3550; D.A.40870; 7th November, 1968; 19 cwt.; D.A.40870/3; 7th November, 1968; 26 cwt.; D.A.40870/4; 7th November, 1968; 17 cwt.

CIGARETTE SERVICE PTY. LTD., 171 Bridge-street, Bendigo, 3550; D.A.40870/6; 21st November, 1968; 20 cwt.

COX, R. E., Garfield-road, Garfield, 3814; T.D.A.37206; 23rd November, 1968; 118 cwt.

DARLEY FIREBRICK CO. PTY. LTD., THE, 422 Swan-street, Richmond, 3121; D.A.947; 3rd November, 1968; 250 cwt.

DINSDALE, F. H. & G., Station-street, Ferntree Gully, 3156; D.A.33629/3; 28th November, 1968; 95 cwt.

DIXON, R. H., 22 Roslyn-road, Belmont, 3216; D.A.53309; 5th October, 1968; 11 cwt.

DRUG HOUSES OF AUSTRALIA LTD., 504 Bourke-street, Melbourne, 3000; D.A.2414/11; 9th November, 1968; 19 cwt.

ELLIS, P., 4 Pearce-street, Shepparton, 3630; T.D.A.61276; 20th November, 1968; 35 cwt.

FOORD, N. W. J., 107-109 Lydiard-street north, Ballarat, 3350; D.A.31347/1; 15th November, 1968; 21 cwt.

GALLAGHER, DON, PTY. LTD., 52 Mackie-road, East Bentleigh, 3165; D.A.53588; 9th November, 1968; 148 cwt.

GENERAL MOTORS-HOLDEN'S PTY. LTD., Princes Highway, Dandenong, 3175; D.A.27925/60; 9th November, 1968; 11 cwt.

GISSING, L. H., Cromie-street, Rupanyup, 3388; D.A.27478; 1st October, 1968; 99 cwt.

RAWSON, D. & R. (trading as Glenrowan Quarrying Co.), Beaconsfield-parade, Glenrowan, 3675; D.A.40976; 14th November, 1968; 106 cwt.

H.L.B. CONSTRUCTIONS PTY. LTD., 1 Raglan-street, St. Arnaud, 3478; D.A.1495/2; 7th November, 1968; 16 cwt.

HARTWICH, A. R., & R. M. COOPER, Wild-street, Ararat, 3377; D.A.53156; 26th October, 1968; 108 cwt.

JENNINGS, A. V., INDUSTRIES (AUSTRALIA) LTD., 690 Springvale-road, Mulgrave, 3170; D.A.37756/15; 26th October, 1968; 11 cwt.

LUCAS, K. J., 166 Murdoch-road, Wangaratta, 3677; D.A.53388; 5th October, 1968; 278 cwt.

LUDBROOK, J. H., 59 Melbourne-road, Ballarat East, 3350; D.A.40863; 17th November, 1968; 11 cwt.

FLAHERTY, J. M. (trading as M. & J. Distributors), 52 Kepler-street, Warrambbool, 3280; T.D.A.44613; 27th November, 1968; 16 cwt.

MASKELL & GRIBBEN PTY. LTD., 201 Corio-street, Shepparton, 3630; D.A.1566/1; 18th November, 1968; 230 cwt.; D.A.1566/2; 18th November, 1968; 239 cwt.; D.A.1566/3; 18th November, 1968; 155 cwt.

MATHESON & O'CALLAGHAN PTY. LTD., 25 Ely-street, Wangaratta, 3677; D.A.40896; 14th November, 1968; 157 cwt.

MILDURA QUARRIES & READY MIXED PTY. LTD., Box 273, Mildura, 3500; D.A.40758/1; 14th November, 1968; 224 cwt.

MCCULLAGH (VICTORIA) PTY. LTD., 14 Alex-avenue, Moorabbin, 3189; D.A.53808; 9th November, 1968; 11 cwt.

PIGDON, J. A., Box 19, Yarrowonga, 3730; D.A.47514/1; 26th October, 1968; 100 cwt.

PITTS, J. W. (trading as Narbethong Service Station), Maroondah Highway, Narbethong, 3778; D.A.45599/2; 5th October, 1968; 20 cwt.

OATES, P. S., 37A Moore-street, Traralgon, 3844; D.A.40892; 28th November, 1968; 164 cwt.

OVERY, F. J., Bull-street, Bairnsdale, 3875; D.A.53683; 26th October, 1968; 8 cwt.

POTTER, H. J. M. & I. A., 3 Childe-street, Stawell, 3380; D.A.40020/20; 19th October, 1968; 226 cwt.

POULTRYMEN & FARMERS TRADING CO. PTY. LTD., 696-710 Queensberry-street, North Melbourne, 3051; D.A.1847/5; 21st November, 1968; 114 cwt.; D.A.1847/6; 21st November, 1968; 114 cwt.

ROBERTS, D. A. (BENDIGO), 11 Forest-street, Bendigo, 3550; D.A.45590/1; 26th October, 1968; 11 cwt.
 SANDERS, J. W., 39 Madden-street, Kaniva, 3419; D.A.53279; 9th November, 1968; 11 cwt.
 SHERLOCK, E. J., 62 Edinburgh-street, Clayton, 3168; D.A.18447; 28th November, 1968; 138 cwt.
 SHIELS, J. M., 112 Mackenzie-street west, Bendigo, 3555; D.A.2027; 15th November, 1968; 10 cwt.
 STONE, R., 5 Beischer-street, Bendigo, 3550; D.A.31249/1; 17th November, 1968; 233 cwt.
 SUNKIST FOODS PTY. LTD., 50 Nott-street, Port Melbourne, 3207; T.D.A.47865/10; 31st August, 1968; 79 cwt.
 SUNKIST FOODS PTY. LTD., 50 Nott-street, Port Melbourne, 3207; T.D.A.47865/11; 19th October, 1968; 80 cwt.; T.D.A.47865/12; 19th October, 1968; 79 cwt.; T.D.A.47865/13; 19th October, 1968; 71 cwt.
 TRENFIELD, SETH, & SONS, 5 Dumosa-avenue, Croydon, 3136; D.A.2181; 12th November, 1968; 231 cwt.
 TREVOR BOILER & ENGINEERING Co. PTY. LTD., Steel-street, North Melbourne, 3051; D.A.28850; 12th November, 1968; 54 cwt.
 WIGGS, W. T., PTY. LTD., 60 Little Ryrie-street, Geelong, 3220; D.A.40407/1; 10th October, 1968; 42 cwt.
 WIGGS, W. T., PTY. LTD., 60 Little Ryrie-street, Geelong, 3220; D.A.40407/2; 17th October, 1968; 44 cwt.
 WITLOX, A. J., 100 Fryers-street, Shepparton, 3630; D.A.53802; 9th November, 1968; 11 cwt.

TOW TRUCK RENEWALS.

BUNYIP MOTORS, Old Princes Highway, Bunyip, 3815; D.A.40746; 17th October, 1968; 64 cwt.
 CARROLL, J. P., Mountjoy-parade, Lorne, 3232; D.A.53370; 5th October, 1968; 60 cwt.
 GRANT MOTORS, 66 Grant-street, Bacchus Marsh, 3340; T.D.A.31078; 5th November, 1968; 28 cwt.
 MARYSVILLE GARAGE, Marysville, 3779; D.A.53374; 26th October, 1968; 79 cwt.
 WILSON, R. S., Bristol-road, Torquay, 3228; D.A.45724/2; 20th October, 1968; 30 cwt.

RENEWALS WITH VARIATION.

APPLICATIONS by the persons listed hereunder for renewal of the licences listed with variation of conditions in the manner set out opposite the names.

CHAMBERS, B. M., 79 Moroney-street, Bairnsdale, 3875; D.A.53372; 5th October, 1968; Application to renew and vary the conditions of licence No. D.A.53372 (L/C. 67 cwt.) by deleting the existing conditions and by adding in lieu: "In course of business of the licensee as 'Produce Merchant, General Hardware Dealer, Building Materials Supplier, and Distributor of Petroleum Products':—(a) Between the Townships of Bairnsdale and Swifts Creek—own goods, liquified petroleum gas in cylinders and empty return cylinders, and petroleum products in prescribed types of containers and empty return containers on behalf of B.P. Australia Ltd. (b) Within a 20-mile radius of own premises at Bairnsdale in the course of business of 'Pump Specialist'—pumps and pumping equipment. (c) From own premises at Swifts Creek to—(i) Points situated within a 20-mile radius of the post office at Swifts Creek—goods as designated in part (a) above. (ii) To points situated within a 50-mile radius of the post office at Swifts Creek, but excluding any part of the said radius situated within a 10-mile radius of the post office at Glen Valley—petroleum products in prescribed types of containers and empty containers for return on behalf of B.P. Australia Ltd."

CORNTHWAITE, R. I., 91 Chapman-street, Swan Hill, 3585; Application to renew and vary the conditions of licence No. D.A.53290 (L/C. 10 cwt.) by deleting from the present conditions the word "Charlton" and by adding in lieu the words "Swan Hill"

EDDY, ELLIS C., PTY. LTD., Cyril-street, Lilydale, 3140; Application to renew and vary the conditions of licence No. D.A.52956 (L/C. 132 cwt.) by deleting from the present conditions paragraph (b) and by adding in lieu as a new paragraph (b) "Within a 25-mile radius of own premises at Lilydale in the course of business as 'Petroleum Agent'—tanks and stands on behalf of Caltex Oil Pty. Ltd., and own goods".

Notice of any objection should be forwarded to reach the Secretary of the Board not later than 16th October, 1968.

Applicants are advised that it will not be necessary to appear on the hearing date specified above, unless advised in writing by the Board.

B. P. KAY,
Secretary.

Corner Lygon and Princes streets, Carlton, 3053, 27th September, 1968.

PUBLIC TRUSTEE ACT 1958 (No. 6350), SECTION 17.

I HEREBY give notice that on the 11th September, 1968, the Public Trustee filed elections to administer the following deceased persons' estates, in accordance with section 17 of the Public Trustee Act 1958:—

BROWN, ALLAN JOHN, late of Ward 11, Gresswell Sanatorium, Mont Park, pensioner, died 1st August, 1968.
 KAY, EMMA, late of 7 York-street, Mont Albert, retired kitchen hand, died 17th July, 1968.

KING, WILLIAM CHARLES, formerly of 252 Raleigh-street, Thornbury, but late of 133 Edinburgh-street, Flemington, transport driver, died 27th December, 1964.

PUSZTAY, GEORGE, late of Flat 6, 188 Barkly-street, St. Kilda, bricklayer, died 4th June, 1968.

RUTKOWSKI, STANISLAW, late of 405 Nott-street, Port Melbourne, electrical fitter, died 28th June, 1968.

D. HOOKEY,
Acting Public Trustee.

256 Flinders-street, Melbourne, 25th September, 1968.

NOTICE.

CREDITORS, next of kin and others having claims against the estate of any of the under-mentioned deceased persons are required to send particulars of their claims to the Public Trustee, 256 Flinders-street, Melbourne, 3000, the personal representative, on or before the 10th December, 1968, after which date the Public Trustee may convey or distribute the assets, having regard only to the claims of which the Public Trustee then has notice:—

ALLAN, ALICE MARIA, formerly Alice Maria Beaver, known as Alice Beaver, late of 54 Whitby-street, West Brunswick, widow, died 20th July, 1968.

BAKER, DONALD, formerly of Warwick Farm-road, Olinda, but late of 3 Berwick-street, Camberwell, bishop, died 19th June, 1968.

BANFIELD, CHARLES ARTHUR, late of 57 Gold-street, Collingwood, retired storeman, died 5th August, 1968.

BRODIE, ISABEL ROSA, also known as Isabell Rosa Brodie, late of 23 Erskine-street, Albert Park, widow, died 8th July, 1968.

BROOKES, NORMAN STEWART, late of 1 Thomas-street, Port Melbourne, contractor, died 10th June, 1968.

BROWN, ALLAN JOHN, late of Ward 11, Gresswell Sanatorium, Mont Park, pensioner, died 1st August, 1968.

JOHNSTON, EVA ANNA, late of 11 Maxwell-grove, Caulfield, widow, died 21st July, 1968.

KAY, EMMA, late of 7 York-street, Mont Albert, retired kitchen hand, died 17th July, 1968.

KERR, VIRGINIA LILLIAN MARIA, also known as Virginia Maria Kerr and Virginia Kerr, formerly of Brighton-street, Richmond, but late of 15 Deakin-street, Malvern, retired teacher, died 2nd November, 1967.

KING, WILLIAM CHARLES, formerly of 252 Raleigh-street, Thornbury, but late of 133 Edinburgh-street, Flemington, transport driver, died 27th December, 1964.

MEREDITH, PERCIVAL PHILLIP HAROLD, also known as Phillip Meredith, formerly of Monbulk-road, Lilydale, but late of 13 Webb-street, Margate, Queensland, pensioner, died 24th November, 1967.

MCGANN, WILLIAM GEORGE, late of 16 Rogers-street, Coburg, retired storeman, died 14th September, 1967.

MCLEAN, ARCHIBALD, late of 35 Macgowan-avenue, Glenhuntly, track repairer, died 25th August, 1967.

MCNELLAN, LESLIE WARD, also known as Leslie Ward, formerly of 61 Kerford-street, Albert Park, but late of 105 Great Ryrie-street, Heathmont, retired railway employee, died 22nd May, 1968.

PIPER, ISABEL HARRIET, formerly of 18 Fraser-street, Brunswick, but late of Lot 3, Macedon-street, Keilor, Victoria, widow, died 27th July, 1968.

POWELL, JOHN BRADFORD, late of 16 Leoni-avenue, Heathmont, retired clerk, died 5th July, 1968.

PUSZTAY, GEORGE, late of Flat 6, 188 Barkly-street, St. Kilda, bricklayer, died 4th June, 1968.

ROBERTSON, ELIZABETH ADA, formerly of 167 Nelson-road, South Melbourne, but late of 7 Mair-street, Brighton Beach, widow, died 20th July, 1968.

RUTKOWSKI, STANISLAW, late of 405 Nott-street, Port Melbourne, electrical fitter, died 28th June, 1968.

SPINK, EVELINE, late of 63 William-street, Newport, pensioner, died 8th June, 1968.

BOFFEY, MARGARET ELIZABETH, late of 25 Vincent-street, Sandringham, widow, died 3rd August, 1968.

D. HOOKEY,
Acting Public Trustee.

Melbourne, 25th September, 1968.

Private Agents Act 1966.

NOTICE OF RECEIPT OF APPLICATIONS FOR LICENCES UNDER THE PROVISIONS OF THE PRIVATE AGENTS ACT 1966.

THE Clerk(s) of the Court(s) of Petty Sessions as listed hereunder hereby give notice that applications, as under, have been lodged for hearing by the said Court(s) on the date(s) specified.

Any person desiring to object to any of such applications must—

- (a) lodge with the respective Clerk of Petty Sessions a notice in the prescribed form of his objection and of the grounds thereof;
- (b) cause a copy of such notice to be served personally or by post upon the applicant at least three days before the hearing of the application; and
- (c) send or deliver—
 - (i) where the objection is not made by the officer in charge of the police district in which the Court is situated—a copy of the notice to such officer; and
 - (ii) where the objection is not made by the Registrar or Deputy Registrar—a copy to the Registrar.

Full Name of Applicant or in the case of a Firm or Corporation, of the Nominee.	Place of Abode of Applicant or Nominee.	Name of Firm or Corporation.	Address for Registration.	Type of Licence.	Date of Hearing of Application.
COURT OF PETTY SESSIONS, PRAHRAN.					
Spek, Nico	15 Kendall-street, Canterbury	Factory Guard Service	Suite 17, 562 St. Kilda-road, Melbourne	Watchman ..	18.10.68
Dated at Prahran this 27th day of September, 1968.					
G. T. WHEELHOUSE, Clerk of Petty Sessions.					
COURT OF PETTY SESSIONS, SALE.					
Ruff, Oswald Abraham ..	56 Pearson-street, Sale	Australian Watching Co.	340 Abbotsford-street, North Melbourne	Watchman ..	22.10.68
Dated at Sale this 27th day of September, 1968.					
D. R. WALKER, Clerk of Petty Sessions.					
COURT OF PETTY SESSIONS, SPRINGVALE.					
Giddings, John Edward ..	10 Woodlea-drive, Glen Waverley	Mayne Nickless Ltd.	Fairview - street, Springvale	Watchman ..	18.10.68
Dated at Springvale this 27th day of September, 1968.					
F. J. DUTHIE, Clerk of Petty Sessions.					
COURT OF PETTY SESSIONS, MELBOURNE.					
Keating, Brian Lawrence ..	2 Broad Oak-street, Noble Park	Australian Watching Co. Pty. Ltd.	340 Abbotsford-street, North Melbourne	Watchman ..	16.10.68
McFarlane, Frank Edward ..	1 Esper-avenue, South Oakleigh	" "	" "	" ..	"
McNamara, Thomas Raymond	82 Civic-parade, Altona	Mayne Nickless Ltd.	94 York-street, South Melbourne	" ..	"
Platt, Raymond Leonard ..	9 William-street, Cranbourne	Australian Watching Co. Pty. Ltd.	340 Abbotsford-street, North Melbourne	" ..	"
Walker, Eric Lindsay ..	39 Hilda-street, Glenroy	" "	" "	" ..	"
Wood, John Stanton ..	2 Beckwith-street, Coburg	" "	" "	" ..	"
Elgar, William Winston ..	149 Glen Eira-road, East St. Kilda	" "	414 Lonsdale-street, Melbourne	Process Server (Individual)	"
Bolger, Claude John ..	33 Jellicoe-street, Ivanhoe	Australian Watching Co. Pty. Ltd.	340 Abbotsford-street, North Melbourne	Watchman ..	"
Bullimore, George Arthur ..	14 Westmere-crescent, Coolaroo	" "	" "	" ..	"
Caple, Robert Harvey ..	32 Albany-crescent, Aspendale	" "	" "	" ..	"
Davies, Frederick Roy ..	26 Gale-street, East Brunswick	" "	" "	" ..	"
Hansford, William Elgin Frank	Broadmeadows Hostel, Camp-road, Broadmeadows	" "	" "	" ..	"
Dated at Melbourne this 25th day of September, 1968.					
G. L. WEBSTER, Clerk of Petty Sessions.					
COURT OF PETTY SESSIONS, MORWELL.					
Seehusen, Stanley Garrelt ..	40 Vincent-road, Morwell	" "	40 Vincent-road, Morwell	Process Server ..	22.10.68
" " " " ..	" " " "	" "	" " " "	Inquiry Agent ..	"
Dated at Morwell this 27th day of September, 1968.					
D. L. CROFT, Clerk of Petty Sessions.					
COURT OF PETTY SESSIONS, CAMBERWELL.					
Haughton-Wyatt, Thomas Francis Lewis William	5 Kingsley-street, East Camberwell	" "	5 Kingsley-street, East Camberwell	Process Server ..	17.10.68
Dated at Camberwell this 27th day of September, 1968.					
J. C. TOBIN, Clerk of Petty Sessions.					
COURT OF PETTY SESSIONS, SOUTH MELBOURNE.					
Webb, William John ..	27 Waters-drive, Bay-side Village, Altona	" "	101-105 Clarke-street, South Melbourne	Watchman ..	21.10.68
Dated at South Melbourne this 23rd day of September, 1968.					
G. MILLER, Clerk of Petty Sessions.					

PRIVATE AGENTS—continued.

Full Name of Applicant or in the case of a Firm or Corporation, of the Nominee.	Place of Abode of Applicant or Nominee.	Name of Firm or Corporation.	Address for Registration.	Type of Licence.	Date of Hearing of Application.
COURT OF PETTY SESSIONS, MELBOURNE.					
Cleary, Thomas Joseph	11 Shelley-street, East Keilor	Mayne Nickless Ltd.	94 York-street, South Melbourne	Watchman	9.10.68
Diamond, Ian Maxwell	11 Poulter-avenue, Greensborough	Australian Watching Co. Pty. Ltd.	340 Abbotsford-street, North Melbourne	"	"
Hanafin, Sean Francis	25 Lewis-road, Wantirna South	" "	" "	"	"
Harvey, Cecil William	188 Mt. Pleasant-road, Eltham	Mayne Nickless Ltd.	94 York-street, South Melbourne	"	"
King, Gene Frank	Hollywood Guest House, 348 Beaconsfield-parade, St. Kilda	Australian Watching Co. Pty. Ltd.	340 Abbotsford-street, North Melbourne	"	"
Long, Brian Francis	11 Dunn-street, Watsonia	Mayne Nickless Ltd.	94 York-street, South Melbourne	"	"
O'Donnell, Reginald Arthur	232 Gilbert-road, West Preston	" "	" "	"	"
Phillips, Brian	40 Lorikeet-street, Nunawading	Australian Watching Co. Pty. Ltd.	340 Abbotsford-street, North Melbourne	"	"
Stanley, James Joseph	2 Alder-street, South Caulfield	" "	" "	"	"

Dated at Melbourne this 18th day of September, 1968.

G. L. WEBSTER, Clerk of Petty Sessions.

COURT OF PETTY SESSIONS, COBURG.

Barrett, Donald Jack	11 Maher-street, Fawkner	"	978 Sydney-road, North Coburg	Watchman	10.10.68
Ryan, Robert James	72 Hawdon-street, Heidelberg	"	"	"	"

Dated at Coburg this 19th day of September, 1968.

F. J. TENNI, Clerk of Petty Sessions.

COURT OF PETTY SESSIONS, SOUTH MELBOURNE.

Roberts, Leonard George	Flat 10, 23 Hotham-street, East Melbourne	"	101-105 Clarke-street, South Melbourne	Watchman	11.10.68
-------------------------	---	---	--	----------	----------

Dated at South Melbourne this 20th day of September, 1968.

G. MILLER, Clerk of Petty Sessions.

COURT OF PETTY SESSIONS, SPRINGVALE.

Hough, Clifford Frederick	4 Tulip-grove, Cheltenham	Mayne Nickless Ltd.	94 York-street, South Melbourne	Guard Agent	11.10.68
---------------------------	---------------------------	---------------------	---------------------------------	-------------	----------

Dated at Springvale this 20th day of September, 1968.

F. J. DUTHIE, Clerk of Petty Sessions.

COURT OF PETTY SESSIONS, OAKLEIGH.

Morgan, Cyril Alfred Murray	28 Argyll-street, Chadstone	"	28 Argyll-street, Chadstone	Guard Agent	11.10.68
-----------------------------	-----------------------------	---	-----------------------------	-------------	----------

Dated at Oakleigh this 19th day of September, 1968.

F. McSWEENEY, Clerk of Petty Sessions.

COURT OF PETTY SESSIONS, CHELSEA.

Jeffrey, Rex Isherwood	4 Beardsworth-avenue, Chelsea	"	4 Beardsworth-avenue, Chelsea	Process Server	15.10.68
------------------------	-------------------------------	---	-------------------------------	----------------	----------

Dated at Chelsea this 24th day of September, 1968.

G. MEEHAN, Clerk of Petty Sessions.

COURT OF PETTY SESSIONS, BOX HILL.

Perkins, Gordon Francis	12 Richard-street, East Doncaster	"	12 Richard-street, East Doncaster	Guard Agent	18.10.68
-------------------------	-----------------------------------	---	-----------------------------------	-------------	----------

Dated at Box Hill this 24th day of September, 1968.

A. J. JOHNSON, Clerk of Petty Sessions.

STATE RIVERS AND WATER SUPPLY COMMISSION.

LICENCES TO DIVERT WATER AND CUT RACES PURSUANT TO THE PROVISIONS OF SECTION 204 OF THE WATER ACT (AS AMENDED).

THE Schedule of Licences as detailed hereunder to divert water and cut races have been revoked by the Governor in Council.

SCHEDULE.

Licence No.	Term of Licence and Commencing Date.	Name and Address of Person to whom Licence Granted.	Source of Supply.
550	Five years from 1.7.65	Hans Cohrs and Bette Cohrs, Mildura	River Murray
1707	Seven years from 1.7.63	Hans Cohrs and Bette Cohrs, Mildura	River Murray

Office of the State Rivers and Water Supply Commission, Melbourne, 1st October, 1968.

G. W. LEWIS, Secretary,
State Rivers and Water Supply Commission.

STATE RIVERS AND WATER SUPPLY COMMISSION.

LICENCE TO DIVERT WATER PURSUANT TO THE PROVISIONS OF SECTION 204 OF THE WATER ACT 1958 (AS AMENDED).

THE Governor in Council has approved of the granting by the State Rivers and Water Supply Commission of the licence as detailed hereunder for the term of years from the date specified to the persons named in the following Schedule :—

SCHEDULE.

Licence No.	Term of Licence and Commencing Date.	Name and Address of Persons to whom Licence is to be Granted.	Source of Supply	Area Authorized to be Irrigated Per Annum.	Volume of Water Authorized to be Diverted Per Annum.
2440	Five years from 1.7.68	James O'Sullivan and Partners, Ovens ..	Ovens River ..	acres. 30	ac. ft. 45

The annual fee payable in respect of each acre-foot of water authorized to be diverted is the equivalent of one-half of the irrigation charge per acre-foot fixed in the Goulburn-Murray Irrigation District for the preceding financial year.

Office of the State Rivers and Water Supply Commission,
Melbourne, 1st October, 1968.

G. W. LEWIS, Secretary,
State Rivers and Water Supply Commission.

STATE RIVERS AND WATER SUPPLY COMMISSION.

LICENCES TO DIVERT WATER AND CUT RACES PURSUANT TO THE PROVISIONS OF SECTION 204 OF THE WATER ACT 1958 (AS AMENDED).

THE Governor in Council has approved of the granting by the State Rivers and Water Supply Commission of licences as detailed hereunder for the term of years from the date specified in each case to the persons named in the following Schedule :—

SCHEDULE.

Licence No.	Term of Licence and Commencing Date.	Name and Address of Person to whom Licence is to be Granted.	Source of Supply.	Area Authorized to be Irrigated Per Annum.	Volume of Water Authorized to be Diverted Per Annum.
				acres.	ac. ft.
2424	Five years from 1.7.68	William Brooke Boothby and Michael Brooke Boothby, Peechelba East	Ovens River ..	50	100
2425	Five years from 1.7.68	Carlton and United Breweries Ltd., Carlton	Ovens River ..	20	30
2426	Five years from 1.7.68	John Robinette Chandler, Porepunkah ..	Ovens River ..	12	18
2427	Five years from 1.7.68	Carmine De Grazia, Ovens ..	Ovens River ..	8	12
2428	Five years from 1.7.68	Giovanni Fota, Guiseppe Vescio and Paola Vaccaro, Whorouly North	Ovens River ..	40	60
2429	Five years from 1.7.68	Ronald Charles Kneebone, Whorouly East	Ovens River ..	8	12
2430	Five years from 1.7.68	Salvatore La Spina and Francesco La Spina, Whorouly	Ovens River ..	55	82½
2431	Five years from 1.7.68	Angelina Marasco, Gapsted ..	Ovens River ..	7	10½
2432	Five years from 1.7.68	Giovanni Marotta, Pietro Marotta and Raffaolina Marrotta, Myrtleford ..	Ovens River ..	18	27
2433	Five years from 1.7.68	John Patrick McCormack, Ovens ..	Ovens River ..	20	30
2434	Five years from 1.7.68	Frederick John Minney, Gapsted ..	Ovens River ..	20	30
2435	Five years from 1.7.68	Pietro Scalzo, Ovens ..	Ovens River ..	8	12
2436	Five years from 1.7.68	W. R. Selzer and Son, Ovens ..	Ovens River ..	36	54
2437	Five years from 1.7.68	Edward George Walkear, Eurobin ..	Ovens River ..	13	19½
2438	Five years from 1.7.68	Thomas Wallace and Norman John Wallace, Gapsted	Ovens River ..	20	30
2439	Five years from 1.7.68	C. F. and J. M. Woodward, Gapsted ..	Ovens River ..	20	30
417	Four years from 1.7.68	Giuseppe Manna, Antonio Manna and Vincenzo Manna, Robinvale	River Murray ..	50	150
550/1707	Two years from 1.7.68	Hans Cohrs and Bette Cohrs, Mildura ..	River Murray ..	8½	25½
2032/1662	Four years from 1.7.68	Audrey Helen Young, Wemen ..	River Murray ..	30	90

In each case, the annual fee payable in respect of each acre-foot of water authorized to be diverted is the equivalent of one-half of the irrigation charge per acre-foot fixed in the Goulburn-Murray Irrigation District for the preceding financial year.

Licence No.	Term of Licence and Commencing Date.	Name and Address of Person to whom Licence is to be Granted.	Source of Supply.	Area Authorized to be Irrigated Per Annum.	Volume of Water Authorized to be Diverted Per Annum.	Annual Fee.
				acres.	ac. ft.	\$
2441/2404	Four years from 1.7.68	William James Crichton and Silvie Jane Crichton, Lietchville	Kow Swamp ..	36½	73	36.50
2442/2404	Four years from 1.7.68	Francis Charles Hawken, Lietchville	Kow Swamp ..	37	74	37.00

Office of the State Rivers and Water Supply Commission,
Melbourne, 1st October, 1968.

G. W. LEWIS, Secretary,
State Rivers and Water Supply Commission.

Melbourne and Metropolitan
BOARD OF WORKS.

GENERAL NOTICE.

THE Melbourne and Metropolitan Board of Works having made provision for carrying off the sewage of each and every property which or any part of which is situate in the Sewerage Areas hereinafter described, doth hereby declare that on and after the 2nd day of November, 1968, each and every property so situate shall be deemed to be a seweraged property within the meaning of the *Melbourne and Metropolitan Board of Works Act 1958*.

The Sewerage Areas hereinbefore referred to are:—

Sewerage Area No. 2215.

City of Broadmeadows.—Commencing at the junction of Taylor-drive and Parnell-crescent; thence northerly along Parnell-crescent, south-easterly along the north-eastern boundary of lot 757, Parnell-crescent, northerly and north-easterly along the western and north-western boundaries of lot 760, Abbey-court, south-easterly by a line to and along the north-eastern boundary of lot 762, Abbey-court, southerly along portion of the eastern boundary of the said lot 762, north-easterly along the north-western boundary of lot 768, Power-close, easterly by a line to the northern angle of lot 770, Power-close, south-easterly and southerly along the north-eastern and eastern boundaries of the said lot 770, easterly along the northern boundary of lot 823, Baxter-close, north-easterly by a line to the north-western angle of lot 810, Baxter-close, easterly and southerly along the northern and eastern boundaries of the said lot 810, south-easterly by a line to the western angle of lot 799, Cosdown-close, north-easterly along the north-western boundary of the said lot 799, easterly along Cosdown-close, south-easterly and south-westerly along the north-eastern and portion of the south-eastern boundaries of lot 802, Cosdown-close, south-easterly along the north-eastern boundary of lot 611, Carrick-drive, further south-easterly by a line to and along the north-eastern boundary of lot 848, Carrick-drive, south-westerly along the south-eastern boundary of the said lot 848, south-easterly along the north-eastern boundary of lot 907, Midway-close, southerly by a line to the eastern angle of lot 908, Midway-close, south-westerly along the south-eastern boundary of the said lot 908, south-easterly along portion of the north-eastern boundary of lot 931, Avondale-court, southerly along the eastern boundary of the said lot 931, further southerly along Avondale-court, westerly along portion of the southern boundary of lot 938, Avondale-court, southerly along the eastern boundary of lot 940, Katrina-drive, easterly along Katrina-drive, southerly along the eastern boundary of lot 949, Katrina-drive, westerly along the southern boundaries of lots 949 to 941, Katrina-drive, 628 and 629, Carrick-drive, 636 to 638, Warrah-court, and 646 and 647, Ashwood-close, south-westerly along the south-eastern boundary of lot 33, Koonalda-road, westerly along Koonalda-road, north-westerly along the south-western boundary of lot 16, Koonalda-road, westerly by a line to and along the southern boundary of lot 296, Elmhurst-road, northerly along Elmhurst-road, easterly along Burnleigh-drive, northerly along the western boundary of lot 537, Burnleigh-drive, to the boundary of Sewerage Area No. 2111, generally northerly, north-easterly and generally north-westerly following the said area boundary and the boundary of Sewerage Area No. 2116 to the north-eastern angle of lot 239, Taylor-drive, generally south-easterly along Taylor-drive to the commencing point.

Sewerage Area No. 2216.

City of Heidelberg.—Commencing at the junction of Dougharty-road and Sheehan-road; thence northerly along Sheehan-road, easterly along the northern boundary of lot 83, Sheehan-road, southerly along the eastern boundaries of the said lot 83 and lot 84, Sheehan-road, easterly by a line to the south-western angle of lot 89, Kylta-road, northerly along the western boundaries of the said lot 89 and lot 90, Kylta-road, easterly along the northern boundaries of lot 90 and lot 134, Kylta-road, southerly along the eastern boundaries of lots 134 to 147, Kylta-road, easterly, southerly and westerly along the boundaries of lot 155, Kolora-road, southerly along the eastern boundaries of lots 149 to 151, Kylta-road, westerly along Dougharty-road to the commencing point.

Sewerage Area No. 2217.

City of Oakleigh.—Commencing at the junction of Warrigal-road and Pitt-street; thence easterly along Pitt-street, northerly along the western boundary of lot 6, Pitt-street, easterly along the northern boundaries of lots 6 to 17 and 36 to 38, Pitt-street, and a line in continuation to Cameron-avenue, southerly along Cameron-avenue, westerly along Pitt-street, southerly along the eastern boundary of lot 39, Pitt-street, westerly along the southern

boundaries of lots 39 to 41 and 18 to 32, Pitt-street, southerly and westerly along the eastern and southern boundaries of lot 33, Warrigal-road, northerly along Warrigal-road to the commencing point.

Sewerage Area No. 2218.

City of Heidelberg.—Commencing at the junction of Korong-road and Dougharty-road; thence westerly along Dougharty-road, northerly along the western boundaries of lots 216 to 232, Korong-road, easterly along the northern boundary of the said lot 232, northerly along Korong-road, easterly along the northern boundary of lot 262, Korong-road, southerly along the eastern boundaries of lots 262 to 274, Korong-road, westerly along the southern boundary of the said lot 274, southerly along Korong-road to the commencing point.

Sewerage Area No. 2219.

City of Oakleigh.—Commencing at the junction of Centre-road and Pullyn-street on the boundary of Sewerage Area No. 1914; thence northerly, westerly, north-westerly and northerly following the said area boundary and the boundary of Sewerage Area No. 1923 to the junction of Mary-street and Carinish-road, south-easterly along Carinish-road to the boundary of Sewerage Area No. 1739, further south-easterly, westerly, southerly, easterly and generally southerly following this area boundary to the south-eastern angle of lot 49, Mallawa-street, westerly along Mallawa-street, southerly along the eastern boundary of lot 187, Mallawa-street, westerly along the southern boundaries of lots 187 to 180, Mallawa-street, to the boundary of Sewerage Area No. 1914 in Alward-avenue, further westerly and generally northerly following the last-mentioned area boundary to the commencing point.

Sewerage Area No. 2220.

City of Oakleigh.—Commencing at the junction of Haughton-road and Tennyson-avenue; thence southerly along Tennyson-avenue, westerly along the southern boundaries of lots 49, Tennyson-avenue, and 26, Bevan-avenue, southerly along Bevan-avenue, westerly along the southern boundaries of lots 52, Bevan-avenue, and 31, Main-road, northerly along Main-road, south-easterly along Haughton-road to the commencing point.

By order of the Board,

H. J. SNADDEN,
Secretary.

110 Spencer-street, Melbourne, 3001, 1st October, 1968.

Co-operation Act 1958.

CHANGE OF NAME OF A SOCIETY.

NOTICE is hereby given that Allansford & District Artificial Breeders Co-operative Society Limited which was incorporated as a Producers Society under the above-named Act on the thirtieth day of March, 1960, has registered a change of its name and is now incorporated under the name of Warrnambool & District Artificial Breeders Co-operative Society Limited under the said Act.

Dated at Melbourne, this nineteenth day of September, 1968.

M. V. HAMMOND,
Deputy Registrar of Co-operative Societies.

Co-operation Act 1958.

CHANGE OF NAME OF A SOCIETY.

NOTICE is hereby given that St. Mary's (Dandenong) Credit Co-operative Limited which was incorporated as a credit society under the above-named Act on the fourth day of January, 1968, has registered a change of its name and is now incorporated under the name of Dandenong Credit Co-operative Limited under the said Act.

Dated at Melbourne this twentieth day of September, 1968.

M. V. HAMMOND,
Deputy Registrar of Co-operative Societies.

Co-operation Act 1958.

CHANGE OF NAME OF A SOCIETY.

NOTICE is hereby given that I.C.I.A.N.Z. Employees (Vic.) Credit Co-operative Limited which was incorporated as a credit society under the above-named Act on the twenty-fifth day of November, 1963, has registered a change of its name and is now incorporated under the name of Derrimut Credit Co-operative Limited under the said Act.

Dated at Melbourne this nineteenth day of September, 1968.

M. V. HAMMOND,
Deputy Registrar of Co-operative Societies.

Town and Country Planning Act 1961.
SHIRE OF MORNINGTON PLANNING SCHEME 1959.
AMENDMENT No. 36, 1968.

Notice of Approval.

IN pursuance of the powers conferred by the *Town and Country Planning Act 1961*, the Governor in Council, on the 24th September, 1968, approved a planning scheme entitled the Shire of Mornington Planning Scheme 1959, Amendment No. 36, 1968, in respect of part of the municipal district of the Shire of Mornington and such planning scheme comes into operation on the date this notice of approval is published in the *Government Gazette*.

A copy of the planning scheme as approved may be inspected free of charge during office hours at the office of the Town and Country Planning Board, 179 Queen-street, Melbourne; at the office of the Mornington Shire Council at Mornington, and when available, at the Office of Titles, Melbourne; and at the Central Plan Office of the Department of Crown Lands and Survey, Melbourne.

W. H. CRAIG, Secretary,
Town and Country Planning Board.

Town and Country Planning Act 1961.
SHIRE OF KNOX PLANNING SCHEME 1965.
AMENDMENT No. 32, 1968.

Notice of Approval.

IN pursuance of the powers conferred by the *Town and Country Planning Act 1961*, the Governor in Council, on the 24th September, 1968, approved a planning scheme entitled the Shire of Knox Planning Scheme 1965, Amendment No. 32, 1968, in respect of part of the municipal district of the Shire of Knox and such planning scheme comes into operation on the date this notice of approval is published in the *Government Gazette*.

A copy of the planning scheme as approved may be inspected free of charge during office hours at the office of the Town and Country Planning Board, 179 Queen-street, Melbourne; at the office of the Knox Shire Council at Fern Tree Gully, and when available, at the Office of Titles, Melbourne; and at the Central Plan Office of the Department of Crown Lands and Survey, Melbourne.

W. H. CRAIG, Secretary,
Town and Country Planning Board.

Town and Country Planning Act 1961.
SHIRE OF KNOX PLANNING SCHEME 1965.
AMENDMENT No. 36, 1968.

Notice of Approval.

IN pursuance of the powers conferred by the *Town and Country Planning Act 1961*, as amended, the Governor in Council, on the 24th September, 1968, approved a planning scheme entitled the Shire of Knox Planning Scheme 1965, Amendment No. 36, 1968, in respect of part of the municipal district of the Shire of Knox and such planning scheme comes into operation on the date this notice of approval is published in the *Government Gazette*.

A copy of the planning scheme as approved may be inspected free of charge during office hours at the office of the Town and Country Planning Board, 179 Queen-street, Melbourne; at the office of the Knox Shire Council at Fern Tree Gully, and when available, at the Office of Titles, Melbourne; and at the Central Plan Office of the Department of Crown Lands and Survey, Melbourne.

W. H. CRAIG, Secretary,
Town and Country Planning Board.

Town and Country Planning Act 1961.
CITY OF SANDRINGHAM PLANNING SCHEME 1948.
AMENDMENT No. 6, 1967.

Notice of Amendment.

IN pursuance of the powers conferred by sub-section 6 of section 32 of the *Town and Country Planning Act 1961*, the Governor in Council, by and with the advice of the Executive Council, on the 24th September, 1968, amended the City of Sandringham Planning Scheme 1948, to permit the establishment of paint factory in the Industrial Zone.

A copy of the amendment may be inspected during office hours at the office of the Town and Country Planning Board, 179 Queen-street, Melbourne; at the office of the Council of the City of Sandringham, at Sandringham; and when available, at the Office of Titles, Melbourne; and at the Central Plan Office of the Department of Crown Lands and Survey, Melbourne.

W. H. CRAIG, Secretary,
Town and Country Planning Board.

Town and Country Planning Act 1961.
CITY OF FOOTSCRAY PLANNING SCHEME.
INTERIM DEVELOPMENT ORDER.

(Apartment-houses, Flats and Residential Buildings.)

BY virtue of the powers conferred by the *Town and Country Planning Act 1961* and of every other power enabling it in that behalf, the Council of the City of Footscray (hereinafter referred to as the Responsible Authority) having commenced the preparation of a planning scheme on the 21st day of August, 1967, in accordance with the *Town and Country Planning Act 1961*, hereby makes the following Interim Development Order for the purpose of regulating, restricting, restraining or prohibiting the use or development of any land for the erection or construction of apartment-houses, flats and residential buildings within the area described in the Schedule hereto.

For the purpose of this Interim Development Order, the following definitions apply:—

“Apartment-house” means a building (not being a residential building as hereinafter defined) used for human habitation not providing self-contained living accommodation for individual families or facilities for persons other than residents or their guests, but does not include such accommodation where it forms part of an educational establishment, a hospital, an hotel, an institutional home, a mental institution, a reformatory institution, a tourist establishment or a motel.

“Flat” means that portion of a building which is used or intended, adapted or designed to be used as a dwelling and is a self-contained unit, but does not include a “caretaker’s house”.

“Residential building” means a boarding-house or a common lodging-house (as such terms are defined in the *Health Act 1958*) or a residential club, but does not include a restaurant, dining-room or café available to persons other than residents or their guests or a motel.

1. After the coming into operation of this Interim Development Order, no person shall use or develop any land for the purpose of the erection or construction of apartment-houses, flats and residential buildings within the area included in the Schedule, except in accordance with the provisions of a permit issued by the Responsible Authority.

2. Every application for a permit under the provisions of this Order shall be made on the prescribed form, copies of which may be obtained from the office of the Responsible Authority at the Municipal Offices, Napier-street, Footscray.

3. Nothing in this Interim Development Order shall prevent—

(a) the continuance of the use of any land for the purposes for which it was being lawfully used immediately before the coming into operation of this Order or the use of any building or works for any purpose for which it was being lawfully erected or carried out immediately before that time;

(b) any dealing or the registration of any dealing with any land in a subdivision of which a plan has been sealed by the Council of the City of Footscray or confirmed by the arbitrator pursuant to sections 569B and 570 respectively of the *Local Government Act 1958*, before the coming into operation of this Order.

4. *Schedule*.—The whole of the municipal district of the City of Footscray.

The common seal of the Mayor, Councillors and Citizens of the City of Footscray was hereunto affixed on the twenty-second day of July, 1968, in the presence of—

(SEAL) G. J. CRUICKSHANK, Mayor.
F. J. MADDERN, Councillor.
W. H. SWABY, Town Clerk.

Approved by the Governor in Council, 1st October, 1968.
—J. ROSSITER, Clerk of the Executive Council.

DRAWING OF TOPOGRAPHIC MAPS.

QUOTATIONS will be received until noon 28th October, 1968, for the plotting of cadastral information and the scribe drawing of Base Maps at a scale of 1:5,000. The lowest or any tender will not necessarily be accepted.

Full particulars may be obtained from the Surveyor-General, Department of Crown Lands and Survey, 2 Treasury-place, Melbourne, 3002.

DEPARTMENT OF MINES.

SUBJECT to any necessary excisions, &c., it is proposed to grant the following lease:—

8602, Mineral; William Alexander Beaumont, George Lightfoot, Maxwell Kevin Kirwan, Kevin Heffernan, Harley James Mehegan, Warren Smith; 50 acres; Parish of Redcastle.

APPLICATION FOR LEASE DECLARED ABANDONED.

8695, Mineral; Eric Dahlstrom, B. Dahlstrom; 100 acres, Parish of Wooragee.

APPLICATIONS FOR LEASES REFUSED.

8805, Mineral; Robert Albert McDonough, Ray Owen; 39 acres, Parish of Warrambat.

8827, Mineral; Stanley Ivan Clark, Stewart Keith Beattie; 240 acres, Parishes of Dookie, Devenish.

EXPLORATION LICENCE GRANTED.

92, Exploration Licence; Victorian Refining and Smelting Company Proprietary Limited; 206 square miles, Counties of Croajingolong, Tambo.

MINERAL SEARCH LICENCE GRANTED.

801, Mineral Search Licence; A. C. Stead, W. A. Grebert, S. G. Porch, R. Nibbs, 425 acres, Parish of Neerim East.

EXPLORATION LICENCE EXTENDED.

34, Exploration Licence; Western Mining Corporation Limited; 115 square miles; Counties of Ripon and Talbot.

PETROLEUM EXPLORATION PERMITS EXTENDED.

59, Petroleum Exploration Permit; Woodside (Lakes Entrance) Oil Company No Liability; 1,022 square miles, Counties of Buln Buln and Tanjil.

60, Petroleum Exploration Permit; Woodside (Lakes Entrance) Oil Company No Liability; 463 square miles, County of Tanjil.

MINING LEASES TRANSFERRED.

8053, Mineral; from Brian Arthur McMahon to Coopers Creek Mines Pty. Limited.

8085, Mineral; from Brian Arthur McMahon to Coopers Creek Mines Pty. Limited.

8195, Mineral; from Brian Arthur McMahon to Coopers Creek Mines Pty. Limited.

MINING LEASE EXPIRED.

8133, Mineral; James Theo Madden; 3a. Or. 26p., Parish of Parwan.

TAILINGS LICENCE EXPIRED.

3388, Tailings Licence; The President, Councillors and Ratepayers of the Shire of Bet Bet; "The Grand Duke No. 4" mine dump situated at Timor.

J. C. M. BALFOUR,
Minister of Mines.

Country Fire Authority Act.

PERMISSION TO HOLD FIRE BRIGADE DEMONSTRATIONS.

IN pursuance with the provisions of section 103 of the Country Fire Authority Act 1958, the Country Fire Authority has granted permission for the holding of fire brigade demonstrations as under:—

URBAN FIRE BRIGADES.

At Mildura, on Sunday 2nd, Monday 3rd, Tuesday 4th, and Wednesday, 5th March, 1969.

RURAL FIRE BRIGADES.

At Hamilton, on Saturday, 26th October, 1968.
At Lilydale, on Saturday, 7th December, 1968.
At Geelong, on Saturday, 19th April, 1969.

J. L. ALLEN,
Secretary.

24th September, 1968.

SHIRE OF CHARLTON.

Cemeteries Act 1958.

SCALE OF FEES OF CHARLTON PUBLIC CEMETERY.

IN pursuance of powers conferred upon them by the Cemeteries Act 1958, the trustees of the Charlton Public Cemetery hereby make the following scale of fees, which shall come into operation upon publication in the Government Gazette, and from and after such publication every scale of fees heretofore made by the said trustees shall be and is hereby rescinded:—

Public Graves.

Interment in grave without exclusive right—	
Stillborn child	\$6.00
Interment in grave without exclusive right—	
Others	\$12.00
Number peg or label	\$1.00

Private Graves.

Land—purchase 8 ft. x 4 ft.	\$15.00
Selection of own site—additional	\$5.00

Sinking Charges for Private Graves.

Sinking grave 6 feet depth	\$28.00
Each additional foot in depth	\$6.00
Sinking over-size casket grave 6 feet depth	\$40.00
Each additional foot in depth therefor	\$6.00
Cancellation of order to sink (if commenced)	\$5.00

Reopening Charges.

Reopening grave (no cover)	\$24.00
Reopening grave—over-size casket (no cover)	\$28.00
Reopening any grave with cover—	
Other than concrete of 2 inches—extra fee	\$4.00
Other than concrete of 3 inches—extra fee	\$6.00
Other than concrete of 4 inches—extra fee	\$8.00
Concrete	\$4.00

Extra Charges.

Interment outside prescribed hours or on public holidays	\$10.00
Interment in grave without due notice	\$10.00

Miscellaneous Charges.

Interment fee	\$10.00
Certificate of right of burial	\$1.00
Number plate or brick	\$1.00
Permission to erect a headstone or monument	\$6.00
Permission to erect brick grave or stone kerb, brick tilework or concrete kerb	\$4.00
Permission to exhume remains of body—authorized	\$25.00
Interment of ashes in a private grave	\$10.00

F. X. DONNELLON, Trustee.

W. H. WOOD, Trustee.

A. E. JUDD, Trustee.

A. F. HELYAR, Secretary.

Approved by the Governor in Council, 24th September, 1968.—J. ROSSITER, Clerk of the Executive Council.

LAW DEPARTMENT.

CHILDREN'S COURT, TRARALGON—DAYS AND HOURS ALTERED.

HIS Excellency the Lieutenant-Governor of the State of Victoria, by and with the advice of the Executive Council thereof, doth by Order made on the 1st day of October, 1968, and pursuant to the provisions of the Children's Court Act 1958, appoint every Monday at 9.45 a.m., except Public Holidays, as from and inclusive of the 7th October, 1968, for the holding of the Children's Court at Traralgon, in lieu of the days and hours heretofore appointed.

J. ROSSITER,

Clerk of the Executive Council.

At the Executive Council Chamber,
Melbourne, 1st October, 1968.

LAW DEPARTMENT.

CURATOR OF CONVICT'S PROPERTY.

HIS Excellency the Lieutenant-Governor of the State of Victoria, by and with the advice of the Executive Council thereof, doth by Order made on the 24th day of September, 1968, and pursuant to the provisions of section 550 of the Crimes Act 1958, commit the custody and management of the property of the convict Alfred Herbert Wright to Linda Edna Wright, of 457 Keilor-road, Niddrie, as a Curator hereby appointed in that behalf.

J. ROSSITER,

Clerk of the Executive Council.

At the Executive Council Chamber,
Melbourne, 24th September, 1968.

YARRAM SEWERAGE AUTHORITY.

RATING BY-LAW FOR THE YEAR 1969.

THE Yarram Sewerage Authority, in pursuance and exercise of the powers conferred by the Sewerage Districts Acts, doth hereby make the following By-Law.

The following sewerage rates are hereby made under the provisions of the Sewerage Districts Act and shall be levied upon the municipal valuations of the rateable properties within the Yarram Sewerage District:—

1. Of any lands and tenements within the declared Yarram Sewerage Area a sewerage rate of Eleven cents (11 cents) in the Dollar of the municipal value of all rateable "Sewered Property" within the said area.

2. In no case shall the amount of sewerage rate payable annually be less than Fifteen Dollars (\$15.00) in respect of any rateable property sewered on which there is a building, and Six Dollars (\$6.00) in respect of any rateable property on which there is no building.

3. Of any lands and tenements within the Yarram Sewerage District a special sewerage rate of One cent in the Dollar of the municipal value of all rateable "Unsewered Property" within the said District.

4. Such rate is made and shall be levied for the year beginning on the 1st day of October, 1968 and ending on the 30th September, 1969 and shall be payable on the 28th day of October, 1968 at the office of the Authority, Commercial Road, Yarram.

5. For making and levying such rates the valuations for the time being of such lands and tenements for the municipal rate of the municipality in the municipal districts of which lands and tenements are situated shall be deemed and taken to be the valuations of such lands and tenements respectively; but if any such lands and tenements are not included in a valuation in force for the municipality in whose district they are situated or if there is no such valuation, the municipal value thereof may for all purposes of such rates be determined in the manner provided in the Sewerage Districts Acts.

6. Such person or persons as the Yarram Sewerage Authority may from time to time appoint for that purpose shall be and is or are hereby authorized to demand, receive, collect, and recover the said rates and charges.

The Resolution for passing the foregoing By-Law was agreed to by the Yarram Sewerage Authority on the 8th day of August, 1968, and was confirmed by the said Authority on the 27th day of August, 1968.

The common seal of the Yarram Sewerage Authority was affixed on the 27th day of August, 1968, in the presence of:—

(SEAL) S. A. WALPOLE, Chairman.
J. F. KINGCHURCH, Member.
S. PONSFORD, Secretary.

Approved by the Governor in Council, 10th September, 1968.—J. ROSSITER, Clerk of the Executive Council.

CONSUL.

NOTICE is given that provisional recognition has been accorded Mr. David Hakim as Consul of the United States of America in Melbourne, with jurisdiction throughout the State of Victoria, as from 23rd August, 1968.

A. G. COULTHARD,
Secretary.

Premier's Office, Melbourne, Vic., 3002, 24th September, 1968.

AUCTION SALES ACT 1958.

MORWELL.—Notice is hereby given that the Annual Meeting of Justices for the Licensing of Auctioneers will be held at the Court House, Morwell, on Tuesday, the 26th day of November, 1968, at the hour of Ten o'clock in the forenoon. Dated this 24th day of September, 1968.—D. L. CROFT, Clerk of Petty Sessions.

TRARALGON.—Notice is hereby given that the Annual Meeting of Justices for the Licensing of Auctioneers will be held at the Court House, Traralgon, on Tuesday, the 26th day of November, 1968, at the hour of Ten o'clock in the forenoon. Dated this 24th day of September, 1968.—D. A. DRUMMOND, Clerk of Petty Sessions.

CONTRACTS ACCEPTED.—(Series 1968-69.)

VICTORIAN RAILWAYS.

35. Design, manufacture, supply, delivery, installation and testing of a compressed air system to be located in a compressor house adjacent to the "West Tower", Melbourne Yard, for the amount of \$63,457.40 (Contract 63318).—Knox Schlapp Pty. Ltd. 36. Structural works in the alteration to and provision of sanitary conveniences the connexion of fixtures and the laying of house connexion sewerage drains to the Station Buildings and Departmental Residences at Eaglehawk for the amount of \$2,255.00 (Contract 63320).—P. Dunstan. 37. Erection and completion of three brick and concrete buildings, stage 8, part 3, Melbourne Yard Re-arrangement, for the amount of \$64,000.00 (Contract 63325).—K. G. Hooker Builders Pty. Ltd. 38. Erection and completion of a 50-cycle Electrical Sub station and Switch Yard at Hampton for the amount of \$7,558.00 (Contract 63341).—G. Harris (Builders) Pty. Ltd. 39. Supply and delivery of vertical boring machine for Newport Workshops for the amount of \$12,275.00 f.o.b. U.K. Port (Contract 63314).—Wickman (Aust.) Pty. Ltd.

By order of the Victorian Railways Commissioners,
W. WALKER, Secretary. 27.9.68.

PRISONERS' MEALS IN LOCK-UPS.

CONTRACT CANCELLED.

Gazette No. 59, 3rd July, 1968, Prisoners' Meals, Carlton.—Contract is hereby cancelled.

CONTRACT ACCEPTED.

958. For the supply of Prisoners' Meals, at Carlton, as from 13th September, 1968.—Breakfast and Tea, 45 cents; Hot Dinner, 55 cents.—J. T. Clancy.

GENERAL STORES.

Gazette No. 58, 1st July, 1968, Schedule No. 37, Electric Lamps, &c.—Contract in respect of Item No. 39, Torches, 3 cells, non-focussing, has been cancelled. Supplies to be purchased under Regulation 109.

E. P. WATSON, Secretary to the Tender Board. 30.9.68.

ORDERS IN COUNCIL.—(Series 1968-69.)

PUBLIC WORKS.

952. Hattah Lakes, National Parks Authority, erection of a Park Assistant's Residence, \$11,161.00.—W. Phelan & Sons Pty. Ltd.—(N.W.120252.)

953. Janefield, Mental Health Training Centre, supply of special seating to various wards, \$1,345.00.—Aristoc Industries Pty. Ltd.—(N.E.136405.)

954. Melbourne, Teachers' College, Arts and Crafts Centre, supply of various items of furniture and equipment, \$1,354.99.—Bera Furniture Pty. Ltd.—(C.132568.)

955. Mitcham, S.S. No. 2904, supply and installation of gas heating, \$3,580.31.—The Colonial Gas Association Ltd.—(E.M.125668.)

956. Rutherglen, Agricultural Research Station, supply and installation of sun-control louvres to laboratory building, \$1,740.00.—N. V. Appleton.—(N.E.65682.)

957. Turana, Boys' Home, alterations to telephone cables, \$2,872.87.—Postmaster-General's Department.—(E.M.57181.)

Approved by the Governor in Council, 24th September, 1968.—J. ROSSITER, Clerk of the Executive Council.

BENDIGO REGIONAL LIBRARY SERVICE.

NOTICE OF APPROVAL OF AGREEMENT.

THE agreement made between the Mayor, Councillors and Citizens of the City of Bendigo, the Mayor, Councillors and Citizens of the City of Castlemaine, the President, Councillors and Ratepayers of the Shire of Huntly, the President, Councillors and Ratepayers of the Shire of Kyneton, the President, Councillors and Ratepayers of the Shire of Marong and the President, Councillors and Ratepayers of the Shire of Strathfieldsaye for the provision of a joint library service in the municipal districts of the said municipalities was approved by the Governor in Council pursuant to the provisions of Section 799 of the Local Government Act 1958 on the twenty-fourth day of September, 1968.

J. ROSSITER,
Clerk of the Executive Council.

At the Executive Council Chamber,
Melbourne, 24th September, 1968.

GLENELG REGIONAL LIBRARY SERVICE.

NOTICE OF APPROVAL OF AGREEMENT.

THE agreement made between the Mayor, Councillors and Citizens of the City of Hamilton, the Mayor, Councillors and Burgesses of the Town of Portland, the President, Councillors and Ratepayers of the Shire of Dundas, the President, Councillors and Ratepayers of the Shire of Glenelg and the President, Councillors and Ratepayers of the Shire of Wannan for the provision of a joint library service in the municipal districts of the said municipalities was approved by the Governor in Council pursuant to the provisions of section 799 of the *Local Government Act 1958* on the twenty-fourth day of September, 1968.

J. ROSSITER,

Clerk of the Executive Council.

At the Executive Council Chamber,
Melbourne, 24th September, 1968.

LOCAL GOVERNMENT DEPARTMENT.

ORDER CONFIRMED.—SHIRE OF BAIRNSDALE.

THE Minister of the Crown administering the *Local Government Act 1958*, on the 25th day of September, 1968, confirmed the Order hereinafter referred to in pursuance of section 514 of the said Act namely:

An Order of the Council of the Shire of Bairnsdale made on the 8th May, 1968, directing the compulsory taking of certain land being Lot 63 on Plan of Subdivision No. 21059 lodged at the Office of Titles for the purpose of providing a place of public resort and recreation.

R. J. HAMER,

Minister for Local Government.

Local Government Department,
Melbourne.

LOCAL GOVERNMENT DEPARTMENT.

ORDER CONFIRMED.—CITY OF WAVERLEY.

THE Minister of the Crown administering the *Local Government Act 1958*, as amended, on the 24th day of September, 1968, confirmed the Order hereinafter referred to, in pursuance of section 514 of the said Act, namely:

An Order of the Council of the City of Waverley made on the 23rd July, 1968, directing the compulsory taking of the land described hereunder for the purpose of providing a place for public resort or recreation.

All that piece of land being part of Crown portion 62, Parish of Mulgrave, County of Bourke, commencing at a point being the south-eastern corner of the intersection of Charles-street and Portsmouth-street; thence by the eastern alignment of Charles-street for 176 feet to Burgundy-street; thence by the northern alignment of Burgundy-street for 182 feet; thence on a bearing 0 deg. 30 min. for 176 feet to Portsmouth-street; and thence by the southern alignment of Portsmouth-street for 182 feet to the point of commencement.

R. J. HAMER,

Minister for Local Government.

Local Government Department,
Melbourne.

APPOINTMENTS AND RESIGNATION

APPOINTMENTS.

HIS Excellency the Lieutenant-Governor of the State of Victoria, by and with the advice of the Executive Council thereof, has by Orders made on the 24th day of September, 1968, been pleased to make the under-mentioned appointments, viz.:

CHIEF SECRETARY'S DEPARTMENT.

Governor of Prison (Acting).

EDWARD O'SULLIVAN,

pursuant to the provisions of the *Goals Act 1958*, to be Governor (Acting) of Her Majesty's Prison, Bendigo, from the 20th September, 1968, to the 4th October, 1968, both dates inclusive, during the absence on leave of John Nicholas Riley.

Honorary Probation Officers.

JOHN WILLIAM C. MORAN, 32 Cantala-street, Pascoe Vale South,

pursuant to the provisions of Section 507 (2) of the *Crimes Act 1958*, to be an Honorary Probation Officer for all Adult Courts in Victoria; and

DOUGLAS S. BEGBIE, "Molloy House", 19 Maling-road, Canterbury,

ADRIAN DANAHER, 28 Harrison-street, Box Hill North, and

NEIL ROBERT McMILLAN, 24 Middleborough-road, Burwood,

pursuant to the provisions of Section 10 (1) of the *Children's Court Act 1958*, to be Honorary Probation Officers for all Children's Courts in Victoria.

Public Auditor.

FRANCIS KEVIN FORBES,

pursuant to the provisions of the *Friendly Societies Act 1958*, to be a Public Auditor for the purposes of the said Act.

CROWN LANDS AND SURVEY DEPARTMENT.

Trustee of Land.

The Honorable Mr. Justice CLIFFORD INCH MENCHENITT, LL.M., Q.C.,

to be a trustee of the land permanently reserved on the 2nd April, 1883, as a site for a Hall for the use of the Royal Society of Victoria, at Melbourne, in the place of Sir Arthur Dean, resigned.

MINISTRY OF HEALTH.

Members of Committees of Management of Hospitals.

WILLIAM HERBERT HERDMAN

to be a Member of the Committee of Management of Kaniva District Hospital, pursuant to proviso (a) to section 48 (1) of the *Hospitals and Charities Act 1958*, for a further period of three years ending 6th October, 1971;

Councillor LESLIE ROBERT ERWIN, J.P.,

to be a Member of the Committee of Management of Stawell District Hospital, pursuant to proviso (b) to section 48 (1) of the *Hospitals and Charities Act 1958*, for a further period of three years ending 6th October, 1971; and

LAWRENCE DEAN

to be a Member of the Committee of Management of Birregurra and District Community Hospital, pursuant to proviso (a) to section 48 (1) of the *Hospitals and Charities Act 1958*, for a period of three years, vice R. G. Carey, resigned.

LAW DEPARTMENT.

Clerk of Petty Sessions.

WILLIAM EDWARD BYRNE

to be Clerk of Petty Sessions at Chelsea, to take effect from the date of commencement of duty.

Assistant Registrar of County Court.

GRAEME JOSEPH COLLINS

to be an Assistant Registrar at Tallangatta for the County Court at Wangaratta, to take effect from the date of commencement of duty.

Deputy Clerk of Peace.

IAN JOHN COLLARD

to be Deputy Clerk of the Peace for the Midland Bailiwick, to take effect from the date of commencement of duty.

Commissioners for Taking Declarations, &c.

JAN CHARLES BALLEK, care of Department of Agriculture, Victoria, Treasury-place, Melbourne, to be a Commissioner for taking Declarations and Affidavits, pursuant to the provisions of the *Evidence Act 1958*, to refrain from charging fees and to resign upon ceasing to occupy his present position;

IRME PATRICK LELE, care of A. V. Wehl Industries Limited, 22-26 Webb-road, Niddrie,

to be a Commissioner for taking Declarations and Affidavits, pursuant to the provisions of the *Evidence Act 1958*, to resign upon ceasing to occupy his present position; and

MATTHEW EDWARD COUGHLIN, Prince of Wales Hotel, Seymour,

WALTER HARRISON, 105 Neville-street, Middle Park,

UGO VITO LO IACONO, Upper Fraser-street, Clunes,

ARTHUR JAMES HUNT, 2 Hampstead-road, Noble Park, and

GEORGE SALUSINSZKY SELBY, Howey-court, Room 704, 234 Collins-street, Melbourne,

to be Commissioners for taking Declarations and Affidavits, pursuant to the provisions of the *Evidence Act 1958*, to resign upon removing from the neighbourhood of the addresses stated.

Judges of the Supreme Court (Acting).

His Honour Judge JOHN GERALD NORRIS, and
His Honour Judge BENJAMIN JAMES DUNN,
Judges of the County Court of the State of Victoria,
to be Acting Judges of the Supreme Court of the State of
Victoria for the period commencing on the 1st day of
October, 1968 and concluding on the 30th day of Novem-
ber, 1968, both dates inclusive, pursuant to section 11 (2)
of the *Supreme Court Act 1958*, as amended by section 3
of the *Supreme Court (Judges) Act 1967*.

Public Trustee (Acting).

JOHN KENNETH COOK, solicitor to the Public Trustee,
to be Acting Public Trustee, to take effect from the 1st
October, 1968.

DEPARTMENT OF THE TREASURER.

Collector of Imposts (Acting).

BERNARD NEVILLE BENEDICT
to act temporarily as Collector of Imposts, Chief Secre-
tary's Office, vice D. H. McDermott, on leave.

Receiver of Revenue (Acting).

ALAN JOHN MATFIN
to act temporarily as Receiver of Revenue, Yarram, vice
R. A. Ison, on leave.

Collector of Imposts.

ERIC PERCIVAL WATSON
to be Collector of Imposts, Tender Board, Treasury, vice
J. M. Pawson, relieved.

DEPARTMENT OF WATER SUPPLY.

Sewerage Authority Members.

ALLAN NEIL LYONS,
DAVID SNEDDON and
LLOYD TRICKEY
to be Members of the Beaufort Sewerage Authority, to
hold such position for a period of four years from date
hereof, subject to the provisions of the Sewerage Districts
Act.

Waterworks and Sewerage Trust Commissioner.

JOHN WILFRED CARR
to be a Commissioner of the Geelong Waterworks and
Sewerage Trust and also Chairman thereof, for a period of
two years from 26th September, 1968, his present term of
office expiring on 25th September, 1968, in pursuance of
the provisions of the Geelong Waterworks and Sewerage
Act.

Waterworks Trust Commissioners.

BERNARD JOSEPH RINALDI
to be a Commissioner of the Bealiba Waterworks Trust,
to hold such position for a period of four years from the
date hereof, subject to the provisions of the Water Act;

ALBERT JAMES BRUMBY and
RAYMOND ROYCE KENNEBURY
to be Commissioners of the Shire of Heytesbury Water-
works Trust, to hold such position for a period of four
years from the date hereof, subject to the provisions of
the Water Act;

WILLIAM JOHN CROTHERS
to be a Commissioner of the Kiewa Waterworks Trust, to
hold such position for a period from the date hereof until
14th June, 1970, subject to the provisions of the Water
Act;

FREDERICK WILLIAM BENJAMIN RAYNER
to be a Commissioner of the Myrtleford Waterworks
Trust, to hold such position for a period of four years
from the date hereof, subject to the provisions of the
Water Act;

WALTER ROBERT TRICKEY
to be a Commissioner of the Yarragon Waterworks Trust,
to hold such position for a period of four years from the
date hereof, subject to the provisions of the Water Act;

CLARENCE ERIC ALDOUS
to be a Commissioner of the Yea Waterworks Trust for a
period of four years from the date hereof, subject to the
provisions of the Water Act; and

ROYDEN BERESFORD GERRAND
to be a Commissioner of the Seaspray Waterworks Trust,
to hold such position for a period of four years from the
date hereof, subject to the provisions of the Water Act.

J. ROSSITER,
Clerk of the Executive Council.

At the Executive Council Chamber,
Melbourne, 24th September, 1968.

No. 82.—8959/68.—2

Liquor Control Act 1968.

APPOINTMENT OF LICENSING INSPECTORS.

IN accordance with the authority conferred upon me by
Sub-section (1) of Section 22 of the *Liquor Control Act 1968*,
I, Rupert Henry Arnold, Chief Commissioner of Police, hereby
appoint the following Officers of Police as Licensing Inspectors
for the Divisions of the Police Districts as shown :

Division No.	Police District.	Rank and Name.
3	Flinders ..	Inspector Andrew George Pattison
2	Henty ..	Chief Inspector Harry Parker
1	Goulburn ..	Chief Inspector John Harrison

R. H. ARNOLD,
Chief Commissioner of Police.

RESIGNATION.

HIS Excellency the Lieutenant-Governor of the State of
Victoria, by and with the advice of the Executive
Council thereof, has, by Order made on the 24th day of
September, 1968, accepted the resignation of the person
named hereunder of the office mentioned, viz.:—

LAW DEPARTMENT.

Commissioner for Taking Declarations, &c.

ORMOND NEIL YEO, as a Commissioner for taking
Declarations and Affidavits, pursuant to the pro-
visions of the *Evidence Act 1958*.

J. ROSSITER,
Clerk of the Executive Council.

At the Executive Council Chamber,
Melbourne, 24th September, 1968.

ORDERS IN COUNCIL

LOCAL GOVERNMENT DEPARTMENT.

At the Executive Council Chamber, Melbourne, the
twenty-fourth day of September, 1968.

PRESENT:

His Excellency the Lieutenant-Governor of Victoria.
Mr. Reid | Mr. Meagher
Mr. Rossiter | Mr. Dickie.

VESTING OF A RESERVE IN THE PRESTON CITY COUNCIL.

WHEREAS it is provided by Section 569BA of the *Local
Government Act 1958*, as amended, that where any
map or plan has been lodged or deposited with the Regis-
trar of Titles pursuant to Section 97 of the Transfer of
Land Act or any corresponding previous enactment
(whether before or after the commencement of the *Local
Government Act 1963*) and any allotment on that map or
plan has been transferred the Governor-in-Council on the
request of the council of the municipality may by Order
published in the *Government Gazette* direct that the whole
or any part of the land comprised in any reserve shown
on that map or plan shall vest in the council whereupon
such land shall so vest freed and discharged from any
mortgage charge lease or sub-lease:

AND WHEREAS the Council of the City of Preston has
requested that a reserve shown on a plan of subdivision be
vested in the Council and an allotment on such plan has
been transferred:

NOW THEREFORE, His Excellency the Lieutenant-
Governor of the State of Victoria, by and with the advice
of the Executive Council thereof, doth by this Order vest
in the Council of the City of Preston certain land being the
Park Reserve coloured blue and green on Plan of Sub-
division No. 10498 lodged in the Office of Titles.

And the Honorable Rupert James Hamer, Her Majesty's
Minister for Local Government for the State of Victoria,
shall give the necessary directions herein accordingly.

J. ROSSITER,
Clerk of the Executive Council.

COUNTRY ROADS BOARD.

At the Executive Council Chamber, Melbourne, the twenty-fourth day of September, 1968.

PRESENT:

His Excellency the Lieutenant-Governor of Victoria. Mr. Reid Mr. Meagher Mr. Rossiter Mr. Dickie.

ORDER APPROVING OF LAND BEING ACQUIRED AND ROADS, DEVIATIONS OR WIDENINGS BEING MADE.

HIS Excellency the Lieutenant-Governor of the State of Victoria, by and with the advice of the Executive Council thereof, being satisfied that there are funds legally available for acquiring the land, doth hereby approve the acquiring of the land described in the schedule hereunder and the making of new roads and deviations from and widenings of existing roads referred to in the said schedule.

SCHEDULE.

State highway.

The land shown hatched on Plan numbered G.P.11389 hereunder required for the widening of the Western Highway in the Town of Stawell and making of the widening thereon.

STATE HIGHWAY WESTERN HIGHWAY TOWN OF STAWELL Measurements in links

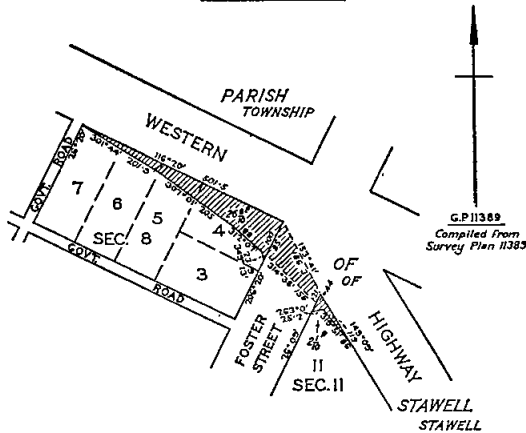

Main roads.

The land shown hatched on Plan numbered G.P.11463 hereunder required for the widening of the Dalyston-Glen Forbes Road in the Shire of Bass and making of the widening thereon.

MAIN ROAD DALYSTON - GLEN FORBES ROAD SHIRE OF BASS Measurements in links

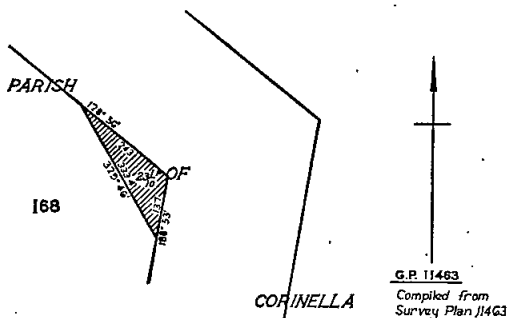

The land shown hatched on Plan numbered G.P.11058 hereunder required for the widening of the Whittlesea-Yea Road in the Shire of Yea and making of the widening thereon.

MAIN ROAD WHITTLESEA - YEA ROAD SHIRE OF YEA Measurements in links

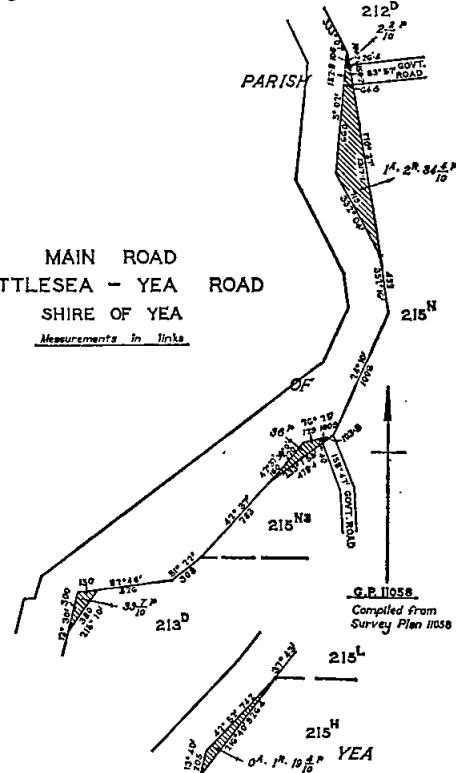

The land shown hatched on Plan numbered G.P.11335 hereunder required for the widening of the King Parrot Creek Road in the Shire of Yea and making of the widening thereon.

MAIN ROAD KING PARROT CREEK ROAD SHIRE OF YEA Measurements in links

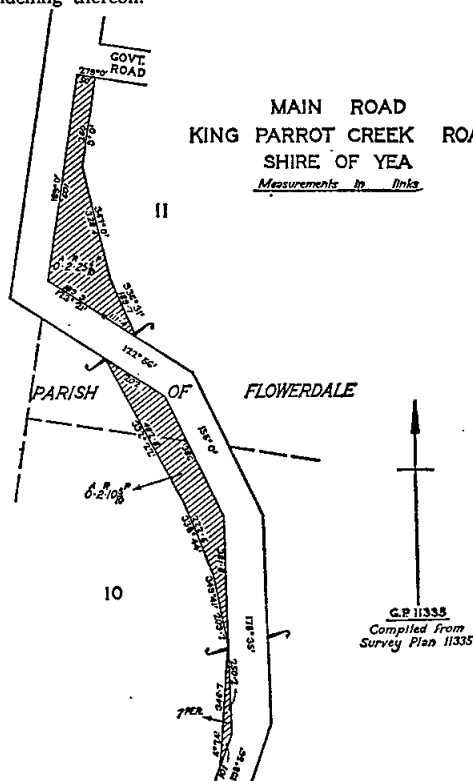

Unclassified road.

Resolution dated the Sixteenth day of September, One Thousand Nine Hundred and Sixty-eight, made pursuant to Sections 21 and 110 of the Country Roads Act 1958 declaring the widening of Blackburn Road in the City of Doncaster and Templestowe as shown hatched on Plan numbered G.P.8930 hereunder to be part of a road within the meaning and for the purposes of the said Act.

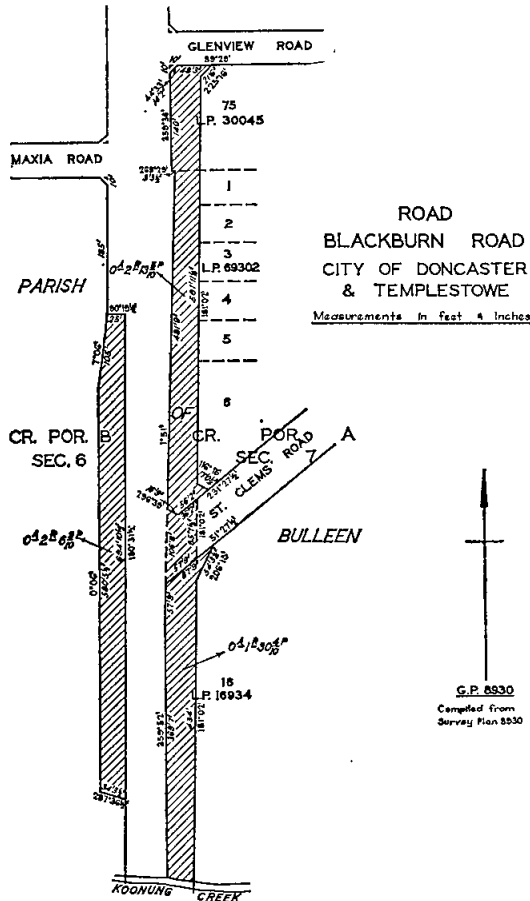

G.P. 8930
Compiled from
Survey Plan 8530

And the Honorable Murray Victor Porter, Her Majesty's Minister of Public Works for the State of Victoria, shall give the necessary directions herein accordingly.

J. ROSSITER,
Clerk of the Executive Council.

DEPARTMENT OF CROWN LANDS AND SURVEY.

At the Executive Council Chamber, Melbourne, the
twenty-fourth day of September, 1968.

PRESENT:

His Excellency the Lieutenant-Governor of Victoria.
Mr. Reid | Mr. Meagher
Mr. Rossiter | Mr. Dickie.

LANDS TEMPORARILY RESERVED AS SITES.

HIS Excellency the Lieutenant-Governor of the State of Victoria, by and with the advice of the Executive Council thereof, doth hereby, in pursuance of section 14 of the Land Act 1958, reserve temporarily from sale, from being leased and from having a licence granted in respect thereof, and also except from occupation for mining purposes under any miner's right, the land hereinafter described:—

EUMEMMERRING (DOVETON).—Site for Public purposes (Police purposes), 27 perches, Parish of Eumemmerring, County of Mornington, as indicated by hatching on plan hereunder.—(E.78^(s)) (Rs.9033).

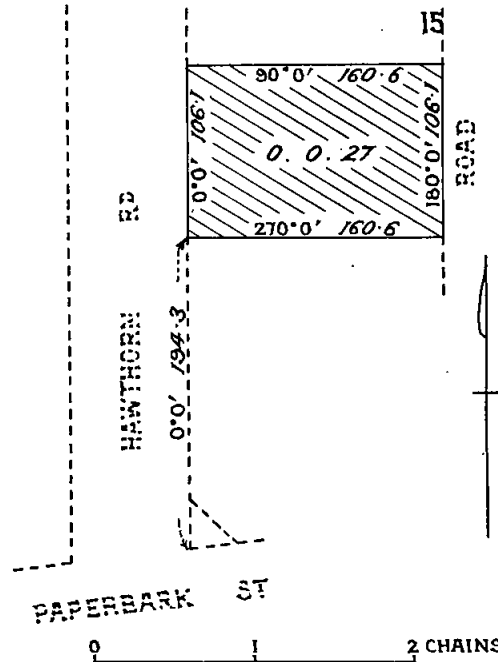

MALLACOOTA.—Site for Public purposes (Trigonometrical Station), 1 acre 1 rood, more or less, Parish of Mallacoota, County of Croajingolong, as indicated by hatching on plan hereunder.—(M.550^(s)) (Rs.9036).

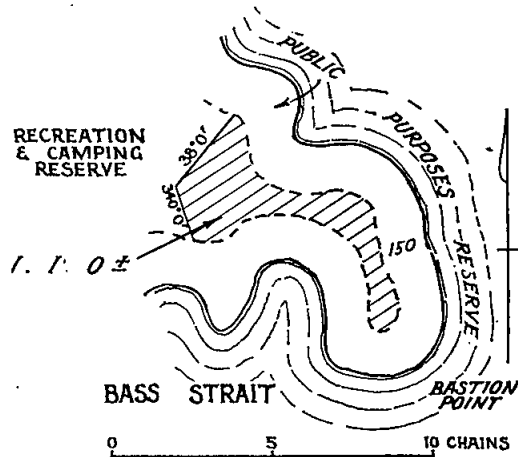

YAUGHER.—Site for Public purposes (Forests Department purposes), 4 acres 10 perches, more or less, Parish of Yaugher, County of Polwarth, as indicated by hatching on plan hereunder.—(Y.115^(r)) (Rs.7773).

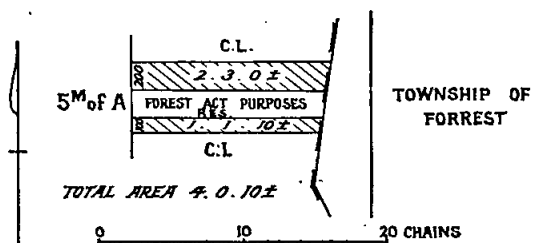

MONBULK.—Site for a Public Park, 9 acres 28 perches, Parish of Monbulk, County of Evelyn, as indicated by hatching on plan hereunder.—(M.555⁽¹²⁾) (Rs.9062).

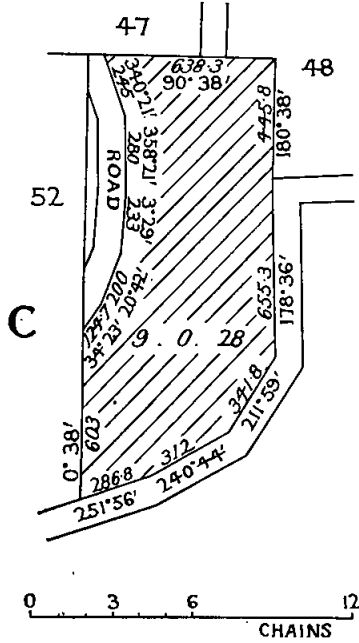

EPSOM.—Site for Public purposes (Regional Agricultural Centre), 16 acres 31 perches, Township of Epsom, Parish of Sandhurst, County of Bendigo, as indicated by hatching on plan hereunder.—(S.371⁽²¹⁾) (Rs.9066).

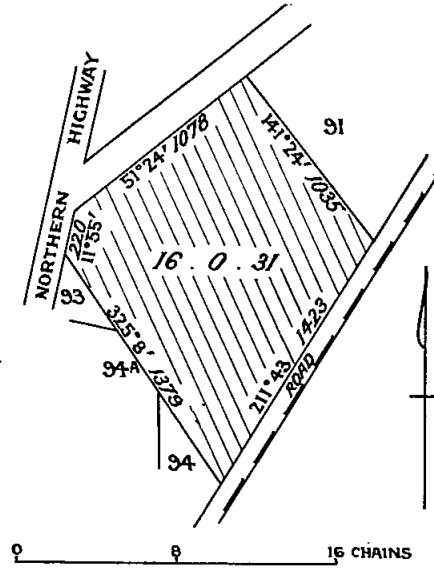

STRATFORD.—Site for Public purposes (Supply of Gravel), 40 acres, Parish of Stratford, County of Tanjil, as indicated by hatching on plan hereunder.—(S.346⁽⁹⁾) (Rs.9030).

BOW-WORRUNG

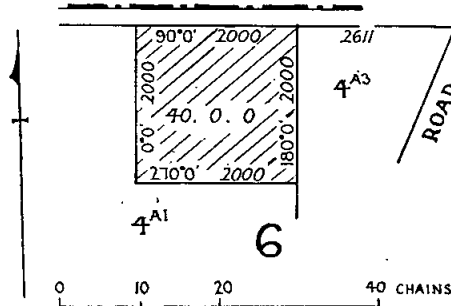

BETKA AND MALLACOOTA.—Site for Recreation and Camping purposes, 87 acres 2 roods, more or less, Parishes of Betka and Mallacoota, County of Croajingolong, as indicated by hatching on plan hereunder.—(M.550⁽⁶⁾) (Rs.2419).

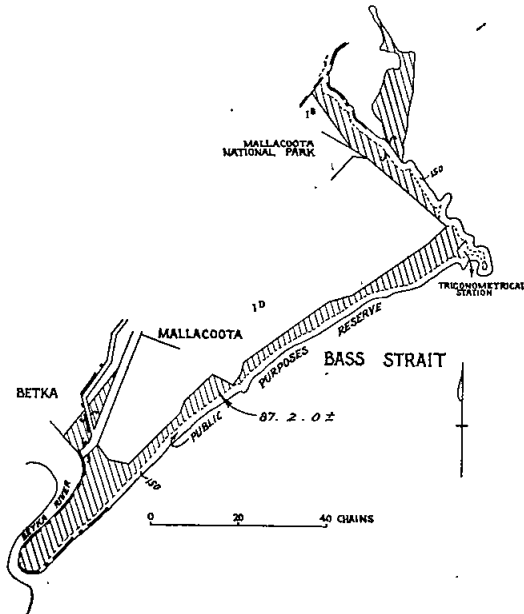

NEERIM.—Site for Public purposes (Forests Department purposes), 39 perches, Parish of Neerim, County of Buln Buln, as indicated by hatching on plan hereunder.—(N.121⁽²³⁾) (Rs.9050).

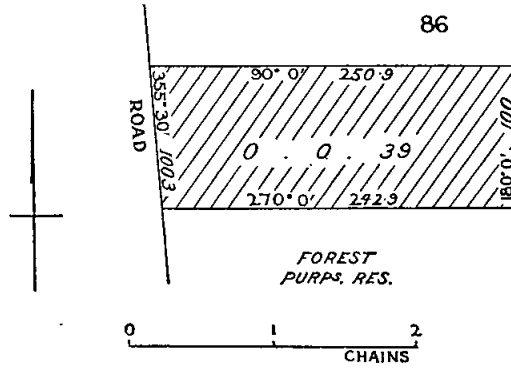

And the Honorable Sir William John Farquhar McDonald, Her Majesty's Minister of Lands for the State of Victoria, shall give the necessary directions herein accordingly.

J. ROSSITER,
Clerk of the Executive Council.

Township of Queenstown, Parish of Queenstown, County of Evelyn, being the road indicated by hatching on plan hereunder.—(Q.22^(*) (Rs.6730).

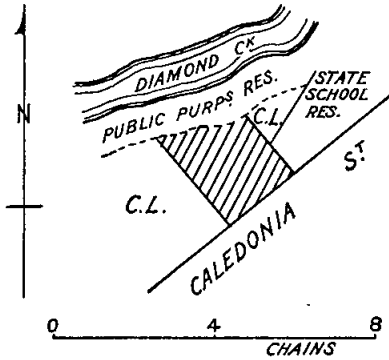

Parish of Wareek, Counties of Gladstone and Talbot, being the roads indicated by hatching on plan hereunder.—(W.36^(*) (W.81259).

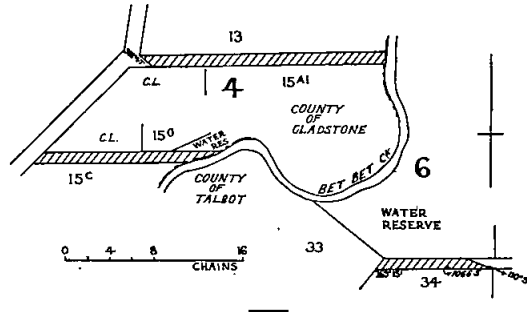

Township of Trentham, Parish of Trentham, County of Dalhousie, being the portion of the width of the road indicated by hatching on plan hereunder.—(T.168^(*) (W.88214).

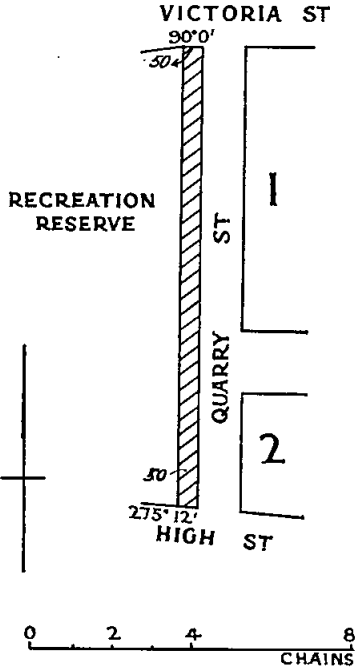

And the Honorable Sir William John Farquhar McDonald, Her Majesty's Minister of Lands for the State of Victoria, shall give the necessary directions herein accordingly.
J. ROSSITER,
 Clerk of the Executive Council.

ROAD TRAFFIC ACT 1958.

At the Executive Council Chamber, Melbourne, the twenty-fourth day of September, 1968.

PRESENT:

His Excellency the Lieutenant-Governor of Victoria.

Mr. Reid | Mr. Meagher
 Mr. Rossiter | Mr. Dickie.

IN pursuance of the powers conferred by the Road Traffic Act 1958, His Excellency the Lieutenant-Governor of the State of Victoria, in the Commonwealth of Australia, by and with the advice of the Executive Council of the said State, and at the request in writing of the Council of the City of Melbourne doth by this Order extend the provisions of the said Act to the land under the control of the City of Melbourne:—

All that land shown delineated and hachured on the plan hereunder.

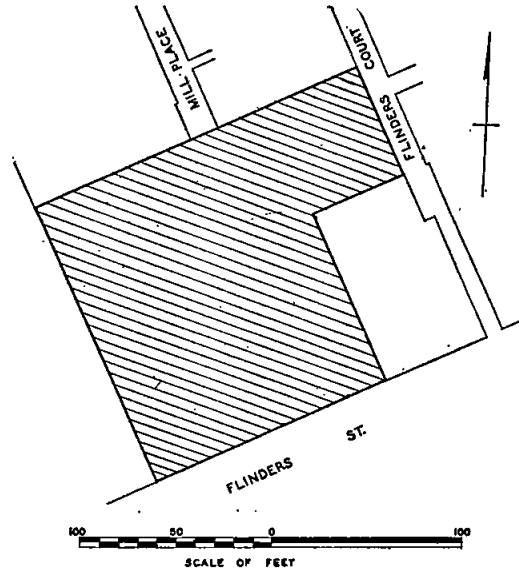

Parish of Waranga, County of Rodney, being the road indicated by hatching on plan hereunder.—(W.37^(*) (C.98695).

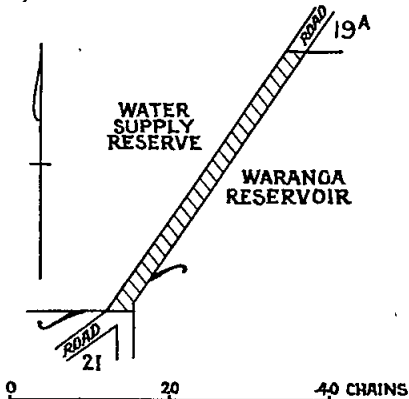

And the Honorable Sir Arthur Gordon Rylah, Her Majesty's Chief Secretary for the State of Victoria, shall give the necessary directions herein accordingly.

J. ROSSITER,
 Clerk of the Executive Council.

NURSES ACT 1958 (No. 6328).

At the Executive Council Chamber, Melbourne, the twenty-fourth day of September, 1968.

PRESENT:

His Excellency the Lieutenant-Governor of Victoria.

Mr. Reid		Mr. Meagher
Mr. Rossiter		Mr. Dickie.

APPOINTMENT OF THE VICTORIAN NURSING COUNCIL.

BY virtue of the powers conferred by Sections 4 and 5 of the Nurses Act 1958 (No. 6328) and all other powers enabling him in that behalf, His Excellency the Lieutenant-Governor of the State of Victoria, by and with the advice of the Executive Council of the said State, hereby appoints as members of the Victorian Nursing Council for the period of three years ending the 28th September, 1971, the persons named hereunder each such person having been nominated elected or selected (as the case may be) pursuant to the particular provision of subsection (2) of the said Section 4 set forth opposite his or her name:—

Name of Appointee; Statutory Provision of Act No. 6328.

WINIFRED MAVIS GREENWOOD; S.4 (2) (a) (i).
 MURIEL HARPER GILCHRIST; S.4 (2) (a) (ii).
 DULCIE MAY TRETHERWIE; S.4 (2) (a) (ii).
 KEVIN WILLIAM MCMAHON; S.4 (2) (a) (iii).
 EDITH HUGHES-JONES; S.4 (2) (a) (iv).
 JEAN GLEN MURRAY; S.4 (2) (a) (v).
 PATRICIA VIOLET SLATER; S.4 (2) (a) (vi).
 NANCY SEWELL; S.4 (2) (a) (vi).
 ELAINE PHILLIPA ORR; S.4 (2) (a) (vi).
 ERNA MARGARET BEGG; S.4 (2) (a) (vi).
 FAY BATHGATE; S.4 (2) (a) (vi).
 LYNLY SHEILA AITKEN; S.4 (2) (a) (vi).
 BETTY CONSTANCE LAWSON; S.4 (2) (b).
 THOMAS ALFRED NESBITT; S.4 (2) (c).
 WILMA GABRIELLE HOGBEN; S.4 (2) (c).
 VALERIE LOUISE SMITH; S.4 (2) (d) (i).
 NGARIE SMITH; S.4 (2) (d) (ii).
 EVA JOHNSON; S.4 (2) (e) (i).
 WINIFRED MURIEL RIDE; S.4 (2) (e) (ii).
 DR. ERIC CUNNINGHAM DAX; S.4 (2) (e) (iii).
 Professor SYDNEY LANCE TOWNSEND; S.4 (2) (e) (iv).
 DR. JOHN LEWTAS FREW; S.4 (2) (e) (iv).
 JAMES FINLAY PATRICK; S.4 (2) (e) (v).
 ROBERT JAMES LEES; S.4 (2) (e) (vi).
 MAVIS AMY PRYTZ; S.4 (2) (e) (vii).
 GEOFFREY NICE; S.4 (2) (e) (viii).
 LORNA JESSIE GORDON; S.4 (2) (e) (ix).
 JOAN MARGARET PESCOTT; S.4 (2) (e) (x).

And the Honorable Vance Oakley Dickie, Her Majesty's Minister of Health for the State of Victoria, shall give the necessary directions herein accordingly.

J. ROSSITER,
 Clerk of the Executive Council.

DANDENONG VALLEY AUTHORITY.

At the Executive Council Chamber, Melbourne, the first day of October, 1968.

PRESENT:

His Excellency the Lieutenant-Governor of Victoria.

Mr. Thompson		Mr. Wilcox.
--------------	--	-------------

CONSENT TO BORROWING \$50,000.

UNDER the powers conferred by the Dandenong Valley Authority Act and all other powers enabling him in that behalf, His Excellency the Lieutenant-Governor of the State of Victoria, by and with the advice of the Executive Council of the said State, doth hereby consent to the Dandenong Valley Authority borrowing at interest by mortgage of the General Fund the sum of Fifty thousand dollars (\$50,000) to meet the cost of river improvement and drainage works.

And the Honorable William Archibald Borthwick, Her Majesty's Minister of Water Supply for the State of Victoria, shall give the necessary directions herein accordingly.

J. ROSSITER,
 Clerk of the Executive Council.

WARRAGUL WATERWORKS TRUST.

At the Executive Council Chamber, Melbourne, the first day of October, 1968.

PRESENT:

His Excellency the Lieutenant-Governor of Victoria.

Mr. Thompson		Mr. Wilcox.
--------------	--	-------------

CONSENT TO BORROWING \$8,000.

UNDER the powers conferred by the Water Act and all other powers enabling him in that behalf, His Excellency the Lieutenant-Governor of the State of Victoria, by and with the advice of the Executive Council of the said State, doth hereby consent to the Warragul Waterworks Trust borrowing at interest by mortgage of the General Fund the sum of Eight thousand dollars (\$8,000) for the conversion of Loan No. 1.

And the Honorable William Archibald Borthwick, Her Majesty's Minister of Water Supply for the State of Victoria, shall give the necessary directions herein accordingly.

J. ROSSITER,
 Clerk of the Executive Council.

MILDURA URBAN WATER TRUST.

At the Executive Council Chamber, Melbourne, the first day of October, 1968.

PRESENT:

His Excellency the Lieutenant-Governor of Victoria.

Mr. Thompson		Mr. Wilcox.
--------------	--	-------------

EXTENT OF URBAN DISTRICT INCREASED.

UNDER the powers conferred by the Mildura Irrigation and Water Trusts Act and all other powers enabling him in that behalf, His Excellency the Lieutenant-Governor of the State of Victoria, by and with the advice of the Executive Council of the said State, doth hereby declare, order and direct that the extent of the Urban District of the Mildura Urban Water Trust be increased by adding to the same the lands comprised within the boundaries shown on a plan approved by the Governor in Council and deposited in the office of the State Rivers and Water Supply Commission, Melbourne, (Corr. No. 59/2164/45) and as on and from the date hereof, the extent of such District shall be deemed to be increased accordingly.

And the Honorable William Archibald Borthwick, Her Majesty's Minister of Water Supply for the State of Victoria, shall give the necessary directions herein accordingly.

J. ROSSITER,
 Clerk of the Executive Council.

LEONGATHA SEWERAGE AUTHORITY.

At the Executive Council Chamber, Melbourne, the first day of October, 1968.

PRESENT:

His Excellency the Lieutenant-Governor of Victoria.

Mr. Thompson		Mr. Wilcox.
--------------	--	-------------

CONSENT TO BORROWING \$90,000.

UNDER the powers conferred by the Sewerage Districts Act and all other powers enabling him in that behalf, His Excellency the Lieutenant-Governor of the State of Victoria, by and with the advice of the Executive Council of the said State, doth hereby consent to the Leongatha Sewerage Authority borrowing at interest by mortgage of the General Fund the sum of Ninety thousand dollars (\$90,000) to meet the cost of sewerage works as set forth in the detailed statement bearing date 25th September, 1968.

And the Honorable William Archibald Borthwick, Her Majesty's Minister of Water Supply for the State of Victoria, shall give the necessary directions herein accordingly.

J. ROSSITER,
 Clerk of the Executive Council.

FRANKSTON SEWERAGE AUTHORITY.

At the Executive Council Chamber, Melbourne, the first day of October, 1968.

PRESENT:

His Excellency the Lieutenant-Governor of Victoria.
Mr. Thompson | Mr. Wilcox.

CONSENT TO BORROWING \$20,000.

UNDER the powers conferred by the Sewerage Districts Act and all other powers enabling him in that behalf, His Excellency the Lieutenant-Governor of the State of Victoria, by and with the advice of the Executive Council of the said State, doth hereby consent to the Frankston Sewerage Authority borrowing at interest by mortgage of the General Fund the sum of Twenty thousand dollars (\$20,000) to meet the cost of sewerage works as set forth in the detailed statement bearing date 25th September, 1968.

And the Honorable William Archibald Borthwick, Her Majesty's Minister of Water Supply for the State of Victoria, shall give the necessary directions herein accordingly.

J. ROSSITER,
Clerk of the Executive Council.

DANDENONG SEWERAGE AUTHORITY.

At the Executive Council Chamber, Melbourne, the first day of October, 1968.

PRESENT:

His Excellency the Lieutenant-Governor of Victoria.
Mr. Thompson | Mr. Wilcox.

CONSENT TO BORROWING \$50,000.

UNDER the powers conferred by the Sewerage Districts Act and all other powers enabling him in that behalf, His Excellency the Lieutenant-Governor of the State of Victoria, by and with the advice of the Executive Council of the said State, doth hereby consent to the Dandenong Sewerage Authority borrowing at interest by mortgage of the General Fund the sum of Fifty thousand dollars (\$50,000) to meet the cost of sewerage works as set forth in the detailed statement bearing date 25th September, 1968.

And the Honorable William Archibald Borthwick, Her Majesty's Minister of Water Supply for the State of Victoria, shall give the necessary directions herein accordingly.

J. ROSSITER,
Clerk of the Executive Council.

BAIRNSDALE SEWERAGE AUTHORITY.

At the Executive Council Chamber, Melbourne, the first day of October, 1968.

PRESENT:

His Excellency the Lieutenant-Governor of Victoria.
Mr. Thompson | Mr. Wilcox.

CONSENT TO BORROWING \$35,000.

UNDER the powers conferred by the Sewerage Districts Act and all other powers enabling him in that behalf, His Excellency the Lieutenant-Governor of the State of Victoria, by and with the advice of the Executive Council of the said State, doth hereby consent to the Bairnsdale Sewerage Authority borrowing at interest by mortgage of the General Fund the sum of Thirty-five thousand dollars (\$35,000) to meet the cost of sewerage works as set forth in the detailed statement bearing date 25th September, 1968.

And the Honorable William Archibald Borthwick, Her Majesty's Minister of Water Supply for the State of Victoria, shall give the necessary directions herein accordingly.

J. ROSSITER,
Clerk of the Executive Council.

CHELSEA SEWERAGE AUTHORITY.

At the Executive Council Chamber, Melbourne, the first day of October, 1968.

PRESENT:

His Excellency the Lieutenant-Governor of Victoria.
Mr. Thompson | Mr. Wilcox.

COMPULSORY ACQUISITION OF EASEMENT.

UNDER the powers conferred by the Sewerage Districts Act and all other powers enabling him in that behalf, His Excellency the Lieutenant-Governor of the State of Victoria, by and with the advice of the Executive Council of the said State, doth hereby consent to the compulsory acquisition by the Chelsea Sewerage Authority of an easement over the land described in the Schedule hereto.

SCHEDULE

Commencing at the northernmost angle of Lot 51 on Lodged plan of Subdivision No. 9312, Crown allotment 145, Parish of Lyndhurst, County of Mornington; thence south-easterly along the north-eastern boundary of the said Lot 51 a distance of 9.1 links; thence through the said Lot 51 by a line bearing 237° 58' to a point on its south-western boundary; thence north-westerly and north-easterly along the said south-western and the north-western boundaries of the said Lot 51 to the point of commencement.

All of which lands are shown on a plan approved by the Governor in Council by and with this Order and deposited in the office of the State Rivers and Water Supply Commission, Melbourne (Corr. No. 68/2661/11).

And the Honorable William Archibald Borthwick, Her Majesty's Minister of Water Supply for the State of Victoria, shall give the necessary directions herein accordingly.

J. ROSSITER,
Clerk of the Executive Council.

SEYMOUR SEWERAGE AUTHORITY.

At the Executive Council Chamber, Melbourne, the first day of October, 1968.

PRESENT:

His Excellency the Lieutenant-Governor of Victoria.
Mr. Thompson | Mr. Wilcox.

CONSENT TO BORROWING \$25,000.

UNDER the powers conferred by the Sewerage Districts Act and all other powers enabling him in that behalf, His Excellency the Lieutenant-Governor of the State of Victoria, by and with the advice of the Executive Council of the said State, doth hereby consent to the Seymour Sewerage Authority borrowing at interest by mortgage of the General Fund the sum of Twenty five thousand dollars (\$25,000) to meet the cost of sewerage works as set forth in the detailed statement bearing date the 25th September, 1968.

And the Honorable William Archibald Borthwick, Her Majesty's Minister of Water Supply for the State of Victoria, shall give the necessary directions herein accordingly.

J. ROSSITER,
Clerk of the Executive Council.

SPRINGVALE AND NOBLE PARK SEWERAGE AUTHORITY.

At the Executive Council Chamber, Melbourne, the first day of October, 1968.

PRESENT:

His Excellency the Lieutenant-Governor of Victoria.
Mr. Thompson | Mr. Wilcox.

CONSENT TO BORROWING \$150,000.

UNDER the powers conferred by the Sewerage Districts Act and all other powers enabling him in that behalf, His Excellency the Lieutenant-Governor of the State of

Victoria, by and with the advice of the Executive Council of the said State, doth hereby consent to the Springvale and Noble Park Sewerage Authority borrowing at interest, by mortgage of the General Fund, the sum of One hundred and fifty thousand dollars (\$150,000) in two amounts of One hundred thousand dollars (\$100,000) and Fifty thousand dollars (\$50,000) respectively to meet the cost of sewerage works as set forth in the detailed statement bearing date 25th September, 1968.

And the Honorable William Archibald Borthwick, Her Majesty's Minister of Water Supply for the State of Victoria, shall give the necessary directions herein accordingly.

J. ROSSITER,
Clerk of the Executive Council.

ORBOST SEWERAGE AUTHORITY.

At the Executive Council Chamber, Melbourne, the first day of October, 1968.

PRESENT:

His Excellency the Lieutenant-Governor of Victoria.
Mr. Thompson | Mr. Wilcox.

CONSENT TO BORROWING \$45,000.

UNDER the powers conferred by the Sewerage Districts Act and all other powers enabling him in that behalf, His Excellency the Lieutenant-Governor of the State of Victoria, by and with the advice of the Executive Council of the said State, doth hereby consent to the Orbst Sewerage Authority borrowing at interest by mortgage of the General Fund the sum of Forty-five thousand dollars (\$45,000) to meet the cost of sewerage works as set forth in the detailed statement bearing date 25th September, 1968.

And the Honorable William Archibald Borthwick, Her Majesty's Minister of Water Supply for the State of Victoria, shall give the necessary directions herein accordingly.

J. ROSSITER,
Clerk of the Executive Council.

METROPOLITAN FIRE BRIGADES ACT 1958.

At the Executive Council Chamber, Melbourne, the first day of October, 1968.

PRESENT:

His Excellency the Lieutenant-Governor of Victoria.
Mr. Thompson | Mr. Wilcox.

PERIODICAL ELECTION OF MEMBERS OF THE METROPOLITAN FIRE BRIGADES BOARD.

WHEREAS amongst other things it is enacted by the *Metropolitan Fire Brigades Act 1958* that all elections of members of the Metropolitan Fire Brigades Board shall be conducted in all respects whatsoever in such manner as is prescribed by the Regulations and every such election shall be held at such times and under the direction of such returning officers as the Governor in Council from time to time appoints:

AND WHEREAS the manner of conducting such elections is prescribed in the *Metropolitan Fire Brigades General Regulations 1951*:

AND WHEREAS pursuant to the said Act and the said Regulations it is necessary to conduct in the month of December, 1968, a periodical election of members of the said Board:

NOW THEREFORE His Excellency the Lieutenant-Governor of the State of Victoria, by and with the advice of the Executive Council thereof, and in pursuance of the *Metropolitan Fire Brigades Act 1958* and all other powers him thereunto enabling, doth by this Order appoint—

1. FRANCIS HENRY ROGAN, the Town Clerk of the City of Melbourne, to be the Returning Officer for the election of a member by the Council of the City of Melbourne.

2. (a) WEDNESDAY, THE 4th DECEMBER, 1968, to be the day for holding the election of one member by the Councils of the North Yarra Group and of one member by the Councils of the South Yarra Group of municipalities; and

(b) CHARLES WALTER PHILLIPS, the Chief Electoral Officer for Victoria, to be the Returning Officer for such elections.

3. (a) WEDNESDAY, THE 4th DECEMBER, 1968, to be the day for holding the election of members by the insurance companies carrying on business and insuring property within Victoria; and

(b) HENRY FRANCIS HOLLOWAY, the Secretary of the Fire and Accident Underwriters' Association of Victoria, to be the Returning Officer for such election.

4. (a) WEDNESDAY, THE 4th DECEMBER, 1968, to be the day for holding the election of one member by the officers and employees of the said Board; and

(b) CHARLES WALTER PHILLIPS, the Chief Electoral Officer for Victoria, to be the Returning Officer for such election.

And the Honorable Sir Arthur Gordon Rylah, Her Majesty's Chief Secretary for the State of Victoria, shall give the necessary directions herein accordingly.

J. ROSSITER,
Clerk of the Executive Council.

LANDLORD AND TENANT ACT 1958.

At the Executive Council Chamber, Melbourne, the first day of October, 1968.

PRESENT:

His Excellency the Lieutenant-Governor of Victoria.
Mr. Thompson | Mr. Wilcox.

ORDER EXTENDING APPLICATION OF PART V. OF THE LANDLORD AND TENANT ACT 1958 TO CERTAIN PREMISES.

IN pursuance of the powers conferred by Section 44 of the *Landlord and Tenant Act 1958*, His Excellency the Lieutenant-Governor of the State of Victoria, by and with the advice of the Executive Council thereof, doth hereby declare that the application of Part V. of the *Landlord and Tenant Act 1958* shall extend to the following premises—

1. The premises known as Number 14 Derby Street, Collingwood; and
2. The premises known as Number 50 Bryant Street, Flemington.

And the Honorable George Oswald Reid, Her Majesty's Attorney-General in and for the State of Victoria, shall give the necessary directions herein accordingly.

J. ROSSITER,
Clerk of the Executive Council.

LANDLORD AND TENANT ACT 1958.

At the Executive Council Chamber, Melbourne, the first day of October, 1968.

PRESENT:

His Excellency the Lieutenant-Governor of Victoria.
Mr. Thompson | Mr. Wilcox.

ORDER EXCLUDING CERTAIN PREMISES FROM THE OPERATION OF CERTAIN OF THE PROVISIONS CONTAINED IN PART V. OF THE LANDLORD AND TENANT ACT 1958.

IN pursuance of the powers conferred upon him by the *Landlord and Tenant Act 1958*, His Excellency the Lieutenant-Governor of the State of Victoria, by and with the advice of the Executive Council thereof, doth hereby declare that the premises known as Number 33 Haines Street, Hawthorn, shall be excluded from the operation of the whole of the provisions contained in Divisions 2 and 3 of Part V. of the *Landlord and Tenant Act 1958*.

And the Honorable George Oswald Reid, Her Majesty's Attorney-General in and for the State of Victoria, shall give the necessary directions herein accordingly.

J. ROSSITER,
Clerk of the Executive Council.

POLICE REGULATION ACT 1958.

At the Executive Council Chamber, Melbourne, the first day of October, 1968.

PRESENT:

His Excellency the Lieutenant-Governor of Victoria.
Mr. Thompson | Mr. Wilcox.

APPOINTMENT OF A DEPUTY MEMBER OF THE POLICE DISCIPLINE BOARD.

WHEREAS James Ronald Milner, a Superintendent of Police, who is a member of the Police Discipline Board, is unavailable, on account of illness, to carry out the duties of a member of the said Board:

NOW THEREFORE His Excellency the Lieutenant-Governor of the State of Victoria, in the Commonwealth of Australia, by and with the advice of the Executive Council of the said State, and in pursuance of the powers conferred by the Police Regulation Act 1958, doth by this Order appoint—

GILBERT TRAINOR.

a Superintendent of Police, to act as the Deputy of James Ronald Milner, while the said member is unavailable.

And the Honorable Sir Arthur Gordon Rylah, Her Majesty's Chief Secretary for the State of Victoria, shall give the necessary directions herein accordingly.

J. ROSSITER,
Clerk of the Executive Council.

LANDS DEPARTMENT NOTICES

APPROACHING LAND SALES.

SALES of Crown Lands, in fee-simple, will be held at the under-mentioned places and dates, viz.:-

	No. of Gazette.
Ballarat.—Tuesday, 12th November, 1968	80
Boort.—Thursday, 10th October, 1968	76
Castlemaine.—Tuesday, 29th October, 1968	78
Heathcote.—Friday, 4th October, 1968	71
Inglewood.—Thursday, 10th October, 1968	76
Kilmore.—Friday, 4th October, 1968	71
Kyneton.—Tuesday, 29th October, 1968	78
Mortlake.—Thursday, 17th October, 1968	77
Rushworth.—Friday, 4th October, 1968	71
Sea Lake.—Thursday, 10th October, 1968	76
Stawell.—Friday, 11th October, 1968	75
Wonthaggi.—Friday, 1st November, 1968	80

SALE OF FREEHOLD LAND BY AUCTION.

Timboon.—Thursday, 17th October, 1968 .. 77

SALE BY AUCTION OF THE RIGHT TO LEASE CROWN LAND.

Wonthaggi.—Friday, 1st November, 1968 .. 80

LOCAL LAND BOARDS.

IN pursuance of the provisions of section 34 of the Land Act 1958, notice is hereby given that public hearings at the following places and times, will be conducted by the persons respectively mentioned, being duly appointed in that behalf.

W. J. F. McDONALD,
Minister of Lands.

Department of Crown Lands and Survey,
Melbourne.

SCHEDULE.

LAND INSPECTOR'S OFFICE, OUYEN, Monday, 18th November, 1968, at 1 p.m., and Tuesday, 19th November, 1968, at 8.45 a.m.—N. J. Fitzgerald and E. Kennedy.

LAND OFFICE, RED CLIFFS, Tuesday, 22nd October, 1968, at 9 a.m.—N. J. Fitzgerald.

LAND OFFICE, RED CLIFFS, Thursday, 21st November, 1968, at 8.45 a.m.—N. J. Fitzgerald and E. Kennedy.

PROPOSED REVOCATIONS OF TEMPORARY RESERVATIONS OF LANDS BY ORDERS IN COUNCIL.

IN pursuance of the provisions of the Land Act 1958, notice is hereby given that it is the intention of the Governor in Council to revoke the temporary reservations of lands by Orders in Council hereunder referred to, viz.:-

The following Notices were published 1^o on the 11th September, 1968, pursuant to Orders of the 3rd September, 1968.

BAYNTON.—The temporary reservation as a site for Public Purposes (State School) and the withholding from sale, leasing and licensing by Order in Council of the 26th March, 1877, of 1 acre 16 perches of land in the Parish of Baynton, are about to be revoked.—(B.24⁽²⁾) (76E608).

BOROKA (HALL'S GAP).—The temporary reservation, by Order in Council of the 29th June, 1953, of 3 acres 1 rood 20 perches, more or less, of land in the Parish of Boroka as a site for State School purposes, is about to be revoked so far only as the portion containing 1 rood, indicated by hatching on plan hereunder, is concerned.—(B.678⁽⁶⁾) (Rs.3550).

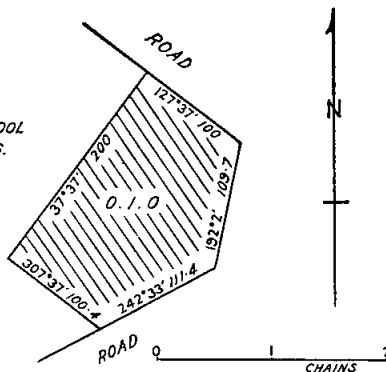

GREENSBOROUGH (QUEENSTOWN).—The temporary reservation, by Order in Council of the 14th May, 1866, of 5 acres of land in the Parish of Greensborough as a site for a Cricket Ground, revoked as to part by Order of the 19th December, 1961, is about to be revoked so far as the balance thereof, containing 4 acres 2 roods 13 perches, is concerned.—(G.179⁽⁷⁾) (Rs.1460).

LORNE.—The temporary reservation as a site for Cricket and other purposes of Public Recreation and the withholding from sale, leasing and licensing by Order in Council of the 31st May, 1880, of 6 acres 1 rood 12 perches of land in the Township of Lorne, revoked as to part by various Orders, is about to be revoked, so far only as the portion containing 8 perches, more or less, indicated by hatching on plan hereunder, is concerned.—(L.147⁽⁷⁾) (Rs.90).

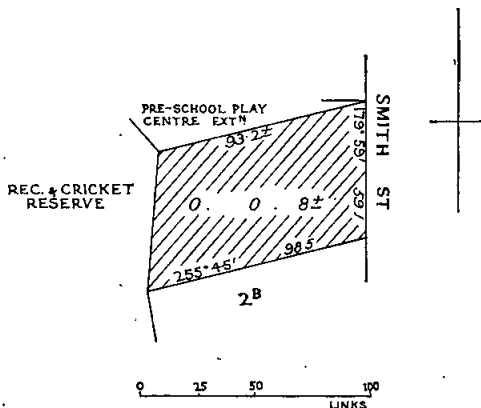

W. J. F. McDONALD,
Minister of Lands.

PROPOSED REVOCATIONS OF TEMPORARY RESERVATIONS OF LANDS BY ORDERS IN COUNCIL.

IN pursuance of the provisions of the *Land Act 1958*, notice is hereby given that it is the intention of the Governor in Council to revoke the temporary reservations of lands by Orders in Council hereunder referred to, viz.:

The following Notices were published 1° on the 18th September, 1968, pursuant to Orders of the 10th September, 1968.

MOORABBIN.—The temporary reservation, by Order in Council of the 15th April, 1958, of 17 acres 1 rood 27 perches of land in the Parish of Moorabbin as a site for Hospital purposes, is about to be revoked save and except the area of 7 acres 2 roods 1 perch, indicated by hatching on plan hereunder.—(M.164⁽³⁾) (Rs.7716).

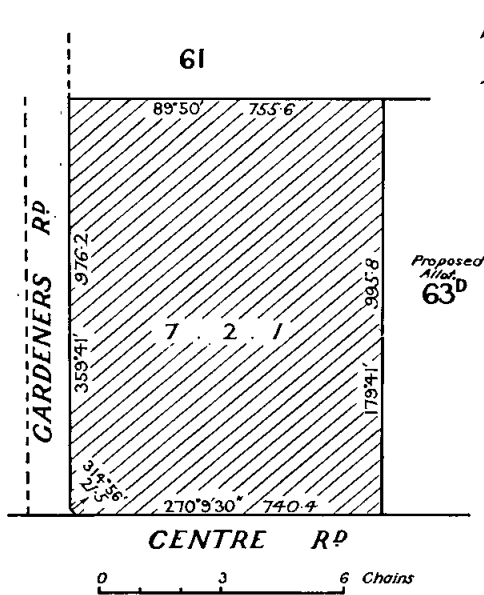

WONTHAGGI.—The temporary reservation, by Order in Council of the 27th October, 1953, of 2 roods 38 perches, more or less, of land in the Township of Wonthaggi as a site for Police purposes, is about to be revoked so far only as the portion containing 1 rood, indicated by hatching on plan hereunder, is concerned.—(W.345⁽¹⁸⁾) (Rs.7174).

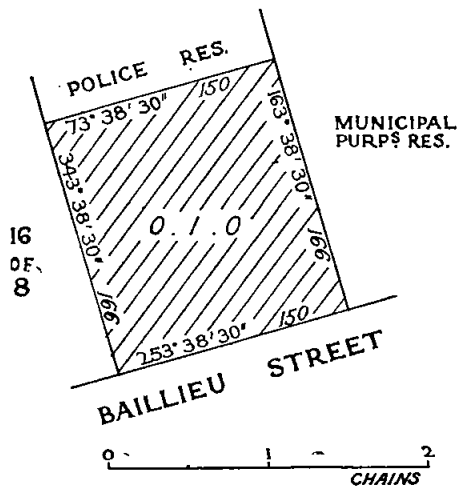

TATURA.—The temporary reservation, by Order in Council of the 25th September, 1903, of 35 acres 3 roods 46/10 perches of land in the Township of Tatura as a site for Ornamental Lake, and for Public Recreation and the temporary reservation by Order of the 20th March, 1917, of the same land for the additional purpose of Public Baths, are about to be revoked so far only as the portions containing 20 acres 16 perches, indicated by hatching on plan hereunder, are concerned.—(T.252⁽³⁾) (Rs.1319).

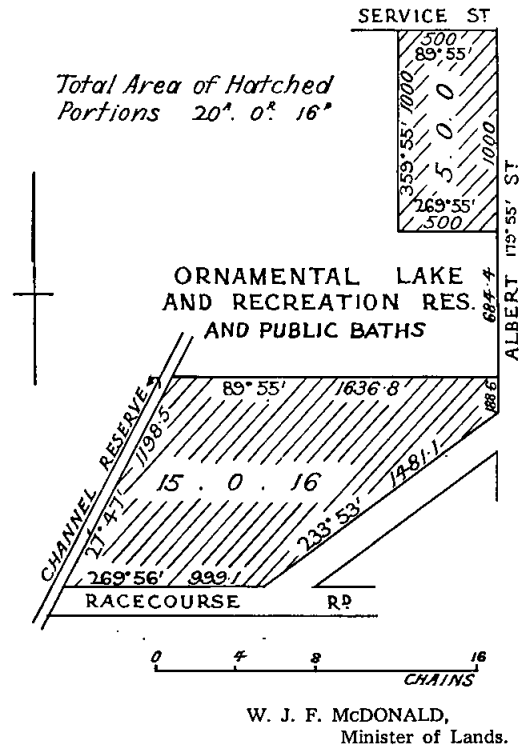

PROPOSED REVOCATIONS OF TEMPORARY RESERVATIONS OF LANDS BY ORDERS IN COUNCIL.

IN pursuance of the provisions of the *Land Act 1958*, notice is hereby given that it is the intention of the Governor in Council to revoke the temporary reservations of lands by Orders in Council hereunder referred to, viz.:

The following Notices were published 1° on the 2nd October, 1968, pursuant to Orders of the 24th September, 1968.

CANN RIVER.—The temporary reservation, by Order in Council of the 30th July, 1968, of 3 roods of land in the Township of Cann River as a site for the Use and Benefits of the Aboriginal Inhabitants is about to be revoked, so far only as the portion containing 1 rood, indicated by hatching on plan hereunder, is concerned.—(N.156J) (Rs.9031).

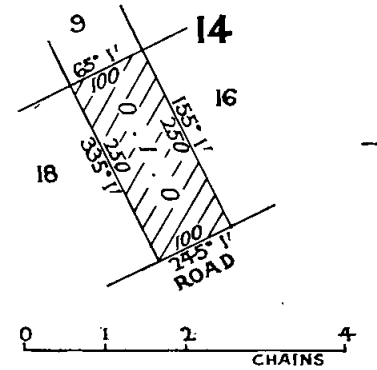

COHUNA.—The temporary reservation, by Order in Council of the 18th January, 1909, of 1 acre of land in the Township of Cohuna as a site for Police purposes is about to be revoked, so far only as the portion containing 2 roads, indicated by hatching on plan hereunder, is concerned.—(C.424⁽⁶⁾) (C.41704).

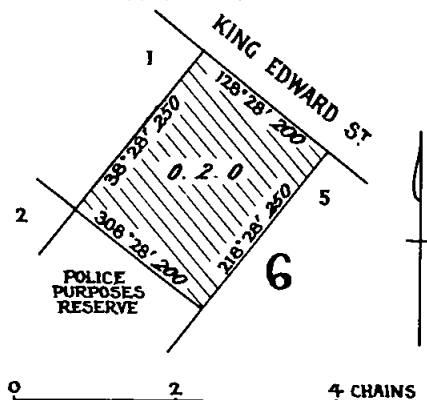

W. J. F. McDONALD,
Minister of Lands.

COMMON ABOUT TO BE DIMINISHED.

IN pursuance of the provisions contained in the Land Act 1958, notice is hereby given that it is the intention of the Governor in Council to diminish the common herein-after mentioned, viz.:-

The following Notice was published 1° on the 4th September, 1968, pursuant to Order of the 27th August, 1968.

The Ballarat West Town Common, proclaimed as such by the Governor in Council on the 28th January, 1861 (see Government Gazette, 6th February, 1861, page 256) is about to be diminished by the excision therefrom of the portion in the Parish of Dowling Forest containing 1 acre, indicated by hatching on plan hereunder.—(C.91998.)

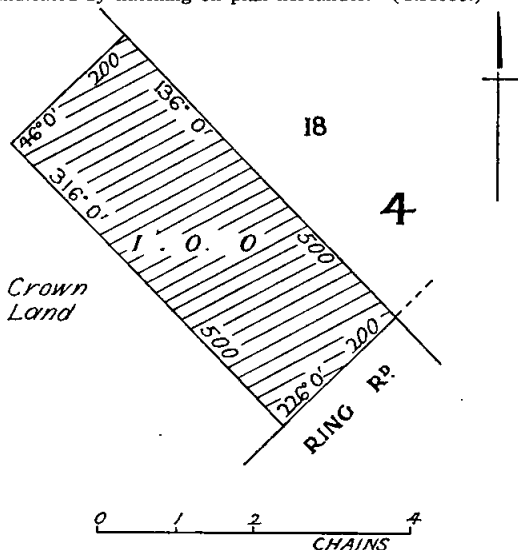

W. J. F. McDONALD,
Minister of Lands.

COMMITTEES OF MANAGEMENT OF RESERVES.
APPOINTMENTS.

NOTICE is hereby given that, in pursuance of section 221 of the Land Act 1958, the following appointments of Committees of Management of reserved Crown lands have been made by the Minister of Lands:-

"ALBERT PARK", IN THE MUNICIPAL DISTRICTS OF THE CITIES OF SOUTH MELBOURNE AND ST. KILDA.

Harry Eric Charles Hall-Kenney (for so long only as he continues to be a councillor and the elect of the Council of the City of St. Kilda) in the place of J. Macartney, as a member of the Committee of Management of the land

permanently reserved as a site for a Public Park in the Municipal Districts of the Cities of South Melbourne and St. Kilda, and known as "Albert Park".—(Corres. No. Rs.3321.)

"BAW BAW ALPINE RESERVE."

Kenneth Edgar Nicholls in the place of William James Edgar (resigned) as a member of the Committee of Management, for a period ending the 22nd April, 1969, of the land in the County of Tanjil, temporarily reserved by Orders in Council dated the 30th October, 1962 and 1st April, 1964, as a site for an Alpine Resort.—(Corres. No. Rs.8171.)

"BORUNG PUBLIC HALL RESERVE."

Joseph Evan Perryman, William Perryman, David James Roberts, James Lesley Bell, George William Bremner, James Lesley Coghill, Howard Perryman, Aubrey Alexander Bell and Maxwell Perryman as a Committee of Management for a period of three (3) years of the land in the Parish of Kinypanial, permanently reserved by Order in Council dated the 25th February, 1941, as a site for a Public Hall, and known as the "Borong Public Hall Reserve".—(Corres. No. Rs.5162.)

"CAPE PATERSON BEACH RESERVE."

John McKenzie Fleming (for so long only as he shall continue to be a councillor and the elect of the Council of the Borough of Wonthaggi) in the place of Peter Frederick McRae (retired) as a member of the Committee of Management of that portion of the reserved Crown lands in the Parish of Wonthaggi as is indicated by red colour on plan marked "W/16.8.44" attached to Lands Department correspondence Rs.4057, together with the land in the same parish temporarily reserved by Order in Council dated the 5th March, 1968, for Public Recreation, the whole known as the "Cape Paterson Beach Reserve".—(Corres. No. Rs.4057.)

PUBLIC PURPOSES (REMOVAL OF STONE), PARISH OF CATIABRIM.

The Corporation of the Shire of Lowan as the Committee of Management of the land in the Parish of Catiabrim, temporarily reserved by Order in Council dated the 20th August, 1968, as a site for Public purposes (Removal of Stone).—(Corres. No. Rs.9010.)

COWWARR RECREATION RESERVE (TENNIS CLUB SITE).

Herman Floyd Sundumann, Barret John Houston, Leo John Harkin, William Kelly, Francis Joseph Harkin, Edward Jones, Noel James Murphy, Robert J. Donaldson, John Phelan and Hector Baxter as a Committee of Management for a period ending the 22nd October, 1970, of the land in the Parish of Toongabbie North deemed permanently reserved for the recreation, convenience or amusement of the people.—(Corres. No. Rs.9045.)

"DARRIMAN RECREATION RESERVE."

Raymond Charles Jago, Frank Edwin Jago, David William Pearson Borthwick, Colin Anderson Mactier, John Robert Brown, John Irvins Mactier, Geoffrey David Gooding, Peter Alan Gooding and Raymond Graeme Lacey as a Committee of Management for a period of three (3) years of the land in the Parish of Darriman, temporarily reserved by Order in Council dated the 31st July, 1956, as a site for Public Recreation, in addition to and adjoining the land temporarily reserved therefor by Order in Council dated the 2nd September, 1895, and together known as "Darriman Recreation Reserve".—(Corres. No. Rs.3113.)

"DUMOSA PUBLIC HALL."

Thomas Hugh Trewin, Michael Vincent Dillon, Vincent Joseph Sheahan, William James Keith White, Donald James McNaughton, Murray Douglas Morrison, Graeme Alexander Morrison, James Vincent McNicol and Norman Stanley Turnbull as a Committee of Management for a period of three (3) years of the land in the Parish of Cooroojerrup, temporarily reserved by Order in Council dated the 6th December, 1955, as a site for a Public Hall, and known as the "Dumosa Public Hall".—(Corres. No. Rs.7406.)

"GOON NURE PUBLIC HALL AND RECREATION RESERVE."

Alistair Malcolm Scott, Gordon David Hallett, Donald Musgrove, Henry James Mitchell, Keith Leslie Gullickson, Richard James Kyle and George Lindsay McDonald as a Committee of Management for a period of three (3) years of the land in the Parish of Goon Nure, temporarily reserved by Order in Council dated the 30th September, 1958,

as a site for Public Hall and Public Recreation purposes and known as the "Goon Nure Public Hall and Recreation Reserve".—(Corres. No. Rs.7770.)

"LAWLOIT PUBLIC HALL RESERVE."

Harold Walter Krause, Gerald John Meagher, Rees David Morgan, William Henry Morgan, David James Hicks, John Powell Morgan, Graeme Walter Krause, Ronnie Welesley Warner and Garnet Victor Ralph Merrett as a Committee of Management for a period of three (3) years of the land in the Parish of Lawloit temporarily reserved by Order in Council dated the 18th January, 1955, as a site for a Public Hall and known as the "Lawloit Public Hall Reserve".—(Corres. No. Rs.7327.)

"MIRBOO RECREATION RESERVE."

George William Smith, Ronald Gregory Peart, John Thomas Jacka, John Allerdine Hankinson, Maurice William Pyle, George Brockley Riches and William Percival Kirk as a Committee of Management for a period of three (3) years of the land in the Township of Mirboo, temporarily reserved by Order in Council dated the 21st March, 1934, as a site for the Recreation and Amusement of the People, and known as the "Mirboo Recreation Reserve".—(Corres. No. Rs.4196.)

"QUEENSCLIFF RECREATION RESERVE."

Vasile Pantea and James Lindsey Jordan (for so long only as they shall continue to be councillors and the elect of the Council of the Borough of Queenscliff) in the places of Roy Lachlan Fairbairn and Frederick Robert St. John (resigned) as members of the Committee of Management of the land in the Township of Queenscliff, Parish of Paywit, permanently reserved by Order in Council dated the 30th March, 1931, as a site for the Recreation of the People, and known as the "Queenscliff Recreation Reserve".—(Corres. No. Rs.4111.)

"SHELFORD RECREATION RESERVE" (ADDITIONAL AREA).

John Richard Heard, Robert Thomas Meek, John Wayne Honeyman, Brian Lawrence Parker, Frederick William Butcher, Ronald Thomas Robertson, Douglas Andrew Simpson, Dennis Elliott Smith, Leslie Samuel Parker and Roy Gillett as a Committee of Management for a period ending the 17th November, 1968 of the land in the Township of Shelford, Parish of Dorog, temporarily reserved by Order in Council dated the 13th August, 1968, as a site for Public Recreation, and being an addition to the existing reservation in the same parish known as the "Shelford Recreation Reserve".—(Corres. No. Rs.4830.)

"TATONG PUBLIC HALL AND RECREATION RESERVE."

Robert Keith Hughan, John Wilfred Mitchell, Howard Henry Lewis, Hughan Walter Lewis, Albie Henderson, Peter George Fairbairn, Allan Evan Lewis, Duncan Harrison and Evan William James as a Committee of Management for a period of three (3) years of the land in the Township of Tatong temporarily reserved by Order in Council dated the 6th January, 1953, as a site for a Public Hall and Public Recreation, and known as the "Tatong Public Hall and Recreation Reserve".—(Corres. No. Rs.7062.)

"WYCHEPROOF SCOUT HALL RESERVE."

Leo O'Laughlin, Maxwell Ian Pym, Robert Douglas Thompson, James Milburn, Ernest Edward Nicholls, and Allan Pym as a Committee of Management for a period of three (3) years of the land in the Parish of Bunguluke, Township of Wycheproof, temporarily reserved by Order in Council dated the 20th July, 1925, as a site for a Public Hall, and known as the "Wycheproof Scout Hall Reserve".—(Corres. No. Rs.3138.)

W. J. F. McDONALD,
Minister of Lands.

Department of Crown Lands and Survey,
Melbourne, 25th September, 1968.

COMMITTEES OF MANAGEMENT OF RESERVES.

APPOINTMENTS.

NOTICE is hereby given that, in pursuance of section 221 of the Land Act 1958, the following appointments of Committees of Management of reserved Crown lands have been made by the Minister of Lands:—

"ALBERTON MECHANICS INSTITUTE AND FREE LIBRARY RESERVE."

Jack St. Ledger Kay, Laurence George Moorfield, Stanley Johnstone Finlay, John Ronald May and Harold Douglas Mowat as a Committee of Management for a period of

three (3) years of the land in the Township of Alberton, permanently reserved by Order in Council dated the 25th November, 1889, as a site for a Mechanics Institute and Free Library, and known as the "Alberton Mechanics Institute and Free Library Reserve".—(Corres. No. Rs.4077.)

"ONE TREE HILL RESERVE," BENDIGO.

Bernard Maxwell Walker (for so long only as he shall continue to be a councillor and the elect of the Council of the Shire of Strathfieldsaye) in the place of Hurtle Sydney Nunn (no longer a councillor) as a member of the Committee of Management of the remaining portion of land in the Parish of Sandhurst, near Bendigo, temporarily reserved by Order in Council dated the 23rd January, 1895, as a site for a Public Park and known as the "One Tree Hill Reserve".—(Corres. No. Rs.3581.)

"BRIGHT RECREATION RESERVE."

Ewan D. Lowe, Geoffrey W. Irvine, John Mills, Anthony D. Jack, Ian G. Huggins, Albert N. Smith, David M. Roberts, Edward James Lester and Ronald N. Dennis as a Committee of Management for a period ending the 15th August, 1971, of the land in the Parish of Bright temporarily reserved by Orders in Council dated the 29th June, 1891, 6th May, 1913, 10th January, 1924, and 16th November, 1936, as sites for Public Recreation and Show Yards, and known as the "Bright Recreation Reserve".—(Corres. No. Rs.790.)

"BULLARTO PUBLIC HALL RESERVE."

William Arthur Orr, Arthur Robert Botheras, Graeme Keith Orr, Harold Roy Douglas Olson, John Muir Black, Thomas John Thornbury, Colin William Mossop, Norman Henry Maxwell, Percy Reuben Pearce and Leonard Thomas Orr as a Committee of Management for a period of three (3) years of the land in the Parish of Bullarto, temporarily reserved by Order in Council dated the 15th October, 1957, as a site for a Public Hall, and known as the "Bullarto Public Hall Reserve".—(Corres. No. Rs.7661.)

"DARNUM RECREATION RESERVE."

Leslie James Davidson, Stanley Walter Wellings, Thomas Wright Adkins, Henry James Sargeant, Raymond Searle Croyley, Frederick Charles Brooker, Walter John Carson, Daniel James Young and Harold Charles Coster as a Committee of Management for a period of three (3) years of the land in the Township of Darnum, temporarily reserved by Orders in Council dated the 30th August, 1886, 27th May, 1947, and 16th May, 1961, as sites for Public Recreation, and known as the "Darnum Recreation Reserve".—(Corres. No. Rs.2493.)

"HAPPY VALLEY PUBLIC HALL RESERVE."

Alma Victoria Crosier, Leslie Joseph Crosier and James T. Thomas as a Committee of Management for a period of three (3) years of the land in the Parish of Clarkesdale, temporarily reserved by Orders in Council dated the 18th November, 1935, and 1st June, 1937, as sites for Public Hall and Recreation purposes, and known as the "Happy Valley Public Hall Reserve".—(Corres. No. Rs.4494.)

"PUBLIC PURPOSES (CARAVAN PARK) RESERVE," HOPETOUN.

The Corporation of the Shire of Karkaroc as the Committee of Management of the land in the Parish of Wiall, temporarily reserved by Order in Council dated the 13th August, 1968, as a site for Public Purposes (Caravan Park).—(Corres. No. Rs.9038.)

"JERUK RECREATION (TENNIS COURTS) RESERVE" AND THE "JERUK PUBLIC HALL AND PLANTATION RESERVE."

Francis William James Miller, Lloyd George Bailey, Oliver William Peter Judd, Francis George Tunstall and Ronald Lloyd Bailey as a Committee of Management for a period of three (3) years of the land in the Parish of Jeruk temporarily reserved by Orders in Council dated the 30th April, 1957, and 17th April, 1956, as sites for Public Recreation and Public Hall and Plantation respectively.—(Corres. Nos. Rs.7445, Rs.7538.)

"LANGKOOP MEMORIAL HALL AND RECREATION RESERVE."

Brian Geoffrey Maddern, Sankey Roydon Badman, George Athol Grummett, Robert Nairn Harkness, Ronald Clarence Case, Neil Reginald Smith and Kenneth Alfred Rowntree as a Committee of Management for a period of three (3) years of the land in the Parish of Meereek, temporarily reserved by Order in Council dated the 23rd September, 1958 as a site for a Public Hall, and by Order in Council dated the 7th April, 1959, for the additional purpose of Public Recreation, and known as the "Langkoop Memorial Hall and Recreation Reserve".—(Corres. No. Rs.7764.)

"PUBLIC PURPOSES (CARAVAN AND CAMPING PARK AND PUBLIC RECREATION) RESERVE," PARISH OF SEACOMBE.

The Corporation of the Shire of Rosedale as the Committee of Management of the land in the Parish of Seacombe, temporarily reserved by Order in Council dated the 30th July, 1968, for Public Purposes (Caravan and Camping Park and Public Recreation), together with the portion of the permanent Public Purposes Reserve as is shown hatched green on plan "S/15.2.66" attached to Lands Department correspondence Rs.9014.—(Corres. No. Rs.9014.)

"UPPER BEACONSFIELD RECREATION RESERVE."

Keith Donald Ferguson, James Alexander Foster Robson, Robert Walter Trumper, Ronald Aaron Murphy, Thomas Vincent Griffin, Rodney William Meredith and Hendrik Jan Pikel as a Committee of Management for a period of three (3) years of the land in the Parish of Gembrook, at Upper Beaconsfield, temporarily reserved by Order in Council dated the 17th June, 1941, as a site for Public Recreation, and known as the "Upper Beaconsfield Recreation Reserve".—(Corres. No. Rs.5219.)

"WOORNDOO RECREATION RESERVE."

William John Ilott, Royce Walter Brooks, Ross Garfield Flanders, Claude Wilson, Samuel Edward Gamble, Raymond Abel Wade and Ross David Barr as a Committee of Management for a period of three (3) years of the land in the Parish of Woorndoo, temporarily reserved by Order in Council dated the 8th November, 1937, as a site for Public Recreation, and known as the "Woorndoo Recreation Reserve".—(Corres. No. Rs.4740.)

W. J. F. McDONALD,

Minister of Lands.

Department of Crown Lands and Survey,
Melbourne, 12th September, 1968.

Land Act 1958.

LEASE SURRENDERED.

NOTICE is hereby given that the Governor in Council has declared void the Lease mentioned in the schedule hereunder for the reason specified.

District.	Corr. No.	Name.	Section of Land Act under which Leased.	Parish.	Allotment.	Section.	Area.	Reason.
Eastern ..	42/155	William Leonard Curtis ..	155	Everton ..	10	7	A. R. P. 97 0 4	Non-compliance with conditions

Department of Crown Lands and Survey,
Melbourne, 24th September, 1968.

W. J. F. McDONALD,
Minister of Lands.

TENDERS

PUBLIC WORKS DEPARTMENT

TENDERS will be received at Public Works Department, Treasury-place, Melbourne, until TWO p.m. on dates shown and for purposes mentioned hereunder.

Particulars and tender forms available at Contracts Office, Room 7, Building Division, Parliament-place and at places indicated in brackets hereunder.

Abbreviations in brackets mean:—W.O.—Inspector of Works Office; P.S.—Police Station; C.S.—Consolidated School; H.E.S.—Higher Elementary School; H.S.—High School; S.S.—State School; T.S.—Technical School.

Tenders to be submitted on the Department's printed Tender Form and will not be received by telephone. All tenders must be on a "Firm Tender" basis. The lowest or any tender will not necessarily be accepted.

Address tenders to the Minister of Public Works, and endorse the envelope containing the tender "Tender for .. closing Tuesday, .."

Hand delivered tenders to be placed in the Tender Box of the Public Works Department, located on the wall of the centre entrance foyer, Ground Floor, New Treasury Building, Treasury-place, Melbourne.

No preliminary deposit is required with any tender, but a successful tenderer will be required to pay a deposit for any accepted tender of \$4,000 or over.

Tuesday, 8th October, 1968.

Building, Electrical and Mechanical Works.

Beaufort.—External painting, S.S. 60 (W.O., Ballarat; S.S., Beaufort.)

Dookie.—Erection of brick office, assembly room, &c., Agricultural College (W.O., Shepparton.)

Fawkner.—Connection to sewer, Technical School.

Harcourt North.—Installation of water supply, S.S. 4043 and residence (W.O., Kyneton.)

Hawthorn.—Erection of office extensions, Milk Board.

Hawthorn.—Electrical services, Milk Board.

Hawthorn.—Mechanical services, Milk Board.

Hawthorn West.—Completion of terra cotta tile roof, S.S. 293.

Numurkah.—Mechanical services, High School. (W.O., Bendigo and Wangaratta.)

Various.—Erection of forty portable class-rooms, three portable kitchens and three portable toilet blocks, Schools.

Various.—Supply and installation of L.P. Gas service in 43 Portable Class-rooms, Schools.

Warrnambool.—Alterations and new fire escape stairs, Police Station. (W.O., Warrnambool.)

Werribee.—Supply and erection of a proprietary type Implement Shed, State Research Farm.

Werribee.—Provision and installation of louvred vents &c., State Research Farm. (W.O., Geelong.)

Williamstown.—Alternate fire and domestic water service installation, High School. (Re-advertised.)

Furniture and Furnishings.

Blackburn.—Supply of office desk/book shelf units, High School.

Box Hill.—Supply of furniture, Court House.

Fern Tree Gully.—Supply of metal framed tables, High School.

Heatherhill.—Supply of tables and trolleys, High School.

Warmambool.—Supply and fix stage and assembly hall curtains, High School.

Site Works.

Bayswater.—Asphalt, concrete and drainage works, &c., S.S. 2163.

Lyndale.—Asphalt and drainage works, &c., High School.

Preston East.—Asphalt, concrete, gravel and drainage works, &c., Technical School.

Miscellaneous.

Various.—Supply and installation of woodwork machine safety guards, Public Works Department.

Tuesday, 15th October, 1968.

Building, Electrical and Mechanical Works.

Ballarat.—Supply and installation of insulated flues for two steam boilers, Mental Hospital. (W.O., Ballarat.)

Balwyn North.—Modifications and additions to heating system, S.S. 4638. (Re-advertised.)

Croydon West.—Erection of Third section with Physical Education Wing, High School.

Croydon West.—Electrical installation, High School.

Croydon West.—Mechanical services, High School.

Ellinbank.—Supply and erection of a proprietary type Implement Shed, Dairy Research Station. (W.O., Warragul.)

Karingal.—Completion of heating services, High School.

La Trobe.—Renovations, High School and Residence.

Mildura.—Electrical services, Technical School. (W.O., Mildura and Swan Hill.)

Newtown.—Electrical services, S.S. 1887. (W.O., Geelong.)

Werribee.—Additional room, Residence, State Research Farm. (W.O., Geelong.)

Furniture and Furnishings.

Kew.—Supply and lay vinyl floor coverings, Children's Cottages.

Site Works.

Jordanville.—Asphalt and concrete works, &c., Technical School.

Noble Park.—Paving and drainage works, &c., Technical School.

Miscellaneous.

Stawell.—Supply of aluminium roof decking, Pleasant Creek Special School.

Williamstown.—Supply and delivery of one only 8-in. sand and gravel pump, Dredging Depot, Port and Harbours Branch.

Tuesday, 22nd October, 1968.

Building, Electrical and Mechanical Works.

Alexandra.—Renovations, &c., S.S. 912. (Re-advertised.) (W.O., Alexandra.)

Ballarat East.—Replacement of slate roof with terra cotta or concrete tiles, S.S. 1998. (W.O., Ballarat.)

Beechworth.—Renovations, &c., Residence, Mental Hospital. (W.O., Wangaratta.)

Carlton North.—Renovations and re-blocking, &c., S.S. 1252.

Cropton.—Renovations, Special School No. 4679.

Merlynston.—Renovations, &c., S.S. 4328.

Stawell.—Extensions to roadway lighting, Pleasant Creek Special School. (W.O., Horsham.)

Tallangatta.—Renovations, Residence, High School. (W.O., Wangaratta.)

Various.—Erection of 30 proprietary type residences, Schools.

Site Works.

Overport.—General ground improvements, S.S. 4780.

St. Kilda.—Asphalt, concrete and drainage works, S.S. 1479.

Upper Ferntree Gully.—Asphalt, concrete and drainage works, &c., S.S. 3926. (Amended specification.)

M. V. PORTER,

Minister of Public Works.

Public Works Department,

Melbourne, 3002, 30th September, 1968.

PUBLIC SERVICE NOTICES

PUBLIC SERVICE FREE PLACES.

APPLICATIONS are invited from persons (other than teachers) in the employment of the Government of Victoria for a maximum of twenty Free Places to be awarded from the beginning of 1969.

Who Can Apply?

Applicants must satisfy the following requirements:

- They must be in the permanent service of the Government of Victoria, or be temporary employees of the Victorian Railways.
- They must be qualified or hope to qualify this year to commence a university course. Those who have commenced a university course are also eligible.
- Those wishing to commence a university course, for the first time, must have made application to the Victorian Universities Admissions Committee by 1st November, 1968.

Those who have applied previously but have been unsuccessful are eligible to reapply.

Application Forms.

These may be obtained from an applicant's organization or from the Training Section, Office of the Public Service Board of Victoria.

Basis of Award.

Consideration will be given to academic record, age, suitability of the course, period of service, and the report and recommendation of the Permanent Head.

Benefits.

Free Places are tenable for the full length of an approved part-time or full-time university course. A successful applicant will be granted such leave of absence on full pay as may be prescribed to enable him to attend essential lectures, practical and other work, and examinations. He will be admitted without fees to all the lectures and examinations of his course. A part-time Free Place Holder is also eligible for five days pre-examination leave with pay.

Bond.

The holder of a Free Place will be required to enter into an agreement that he will remain in the service of the Government of Victoria for five years after the termination of his Free Place.

Closing Date for Applications.

Applications must be submitted to the Permanent Head of the department in which the applicant is employed, by the 1st November, 1968. Permanent Heads of departments should ensure that such applications are forwarded to reach the Secretary, Public Service Board of Victoria, New Public Offices, Treasury-place, Melbourne, 3002, not later than the 25th November, 1968.

R. H. DURRANT,

Acting Secretary.

Public Service Board,

27th September, 1968.

No. 79.

Public Service Act 1958, Section 50.
REGULATIONS.—PART IV.—SALARIES AND INCREMENTS.

THE Public Service Board, in pursuance of the powers conferred by the *Public Service Act 1958*, hereby amends its Regulations as follows :—

SECOND SCHEDULE.

TECHNICAL AND GENERAL DIVISION.

GRADES AND SALARY SCALES.

JUNIOR GRADES.

The existing Grades and Salary Scales are deleted and the following Grades and Salary Scales are substituted therefor—

Males.

Grade.	Yearly Rate of Salary at Each Age in Years.					
	Under 16.	16.	17.	18.	19.	20.
	\$	\$	\$	\$	\$	\$
A ..	889	947	1,109	1,292	1,486	1,743
B ..	943	1,026	1,198	1,354	1,603	1,853
C ..	996	1,063	1,252	1,445	1,676	1,906
D	1,289	1,597	1,829	2,077
E ..	996	1,063	1,252	1,479	1,702	1,971
F	1,597	1,829	2,247*
G	2,275	2,507	2,758
H ..	1,039	1,106	1,346	1,576	1,832	2,087
I ..	1,044	1,092	1,311	1,529	1,769	1,988
J ..	1,000	1,059	1,270	1,482	1,715	1,927
K	1,769	2,047	2,300
L ..	1,053	1,096	1,324	1,603	1,814	2,405
M ..	992	1,050	1,235	1,465	1,697	1,890

* Equivalent to adult rate in the Carters and Drivers Determination.

Females.

Grade.	Yearly Rate of Salary at Each Age in Years.					
	Under 16.	16.	17.	18.	19.	20.
	\$	\$	\$	\$	\$	\$
A ..	889	921	984	1,043	1,204	1,368
B ..	915	976	1,010	1,108	1,295	1,492
C ..	943	1,028	1,073	1,176	1,364	1,557
D ..	996	1,065	1,143	1,268	1,463	1,644
E ..	1,034	1,075	1,141	1,274	1,450	1,632
F ..	1,201	1,217	1,356	1,535	1,710	1,866
G ..	1,010	1,041	1,246	1,335	1,496	1,639
H	1,292	1,389	1,484
I ..	915	976	1,080	1,222	1,363	1,492
J ..	1,096	1,130	1,269	1,448	1,623	1,779
K ..	1,279	1,295	1,372	1,565	1,754	1,922
L ..	1,174	1,201	1,331	1,513	1,691	1,844
M ..	992	1,023	1,149	1,311	1,470	1,610

SEVENTH SCHEDULE.

TECHNICAL AND GENERAL DIVISION.

DEPARTMENT OF HEALTH.

MENTAL HYGIENE.

Grades and Salary Scales.

JUNIOR GRADES.

The existing Grades and Salary Scales are deleted and the following Grades and Salary Scales are substituted therefor—

Males.

Grade.	Yearly Rate of Salary at Each Age in Years.					
	Under 16.	16.	17.	18.	19.	20.
	\$	\$	\$	\$	\$	\$
A ..	889	947	1,109	1,292	1,486	1,743
B ..	943	1,026	1,198	1,354	1,603	1,853
C ..	996	1,063	1,252	1,445	1,676	1,906
D	1,289	1,597	1,829	2,077
E ..	1,044	1,092	1,311	1,529	1,769	1,988
F	1,597	1,829	2,247*
G	1,063	1,289	1,572	1,702	1,833
H ..	1,000	1,059	1,270	1,482	1,715	1,927

* Equivalent to adult rate in the Carters and Drivers Determination.

Females.

Grade.	Yearly Rate of Salary at Each Age in Years.					
	Under 16.	16.	17.	18.	19.	20.
	\$	\$	\$	\$	\$	\$
A ..	889	921	984	1,043	1,204	1,368
B ..	915	976	1,010	1,108	1,295	1,492
C ..	943	1,028	1,073	1,176	1,364	1,557
D ..	996	1,065	1,143	1,268	1,463	1,644
E ..	1,034	1,075	1,141	1,274	1,450	1,632
F ..	1,201	1,217	1,356	1,535	1,710	1,866
G	1,002	1,143	1,370	1,465	1,555
H ..	1,279	1,295	1,372	1,565	1,754	1,922
I ..	992	1,023	1,149	1,311	1,470	1,610
J ..	1,096	1,130	1,269	1,448	1,623	1,779

This Regulation shall have effect as on and from the 8th September, 1968.

F. E. CAHILL, Chairman.

V. P. SCULLY, Secretary.

Office of the Public Service Board,
Melbourne, 9th September, 1968.

No. 80.

Public Service Act 1958, Section 50.
REGULATIONS.—PART IV.—SALARIES AND INCREMENTS.

THE Public Service Board, in pursuance of the powers conferred by the *Public Service Act 1958*, hereby amends its Regulations as shown below :—

FIFTH SCHEDULE.

TEMPORARY EMPLOYEES.

DEPARTMENT OF HEALTH.

MENTAL HYGIENE.

Designations of Positions and Rates of Salaries.

Designation of Position.	Yearly Rate of Salary. £	
	Minimum.	Maximum.
	\$	\$
<i>Delete—</i>		
Shorthand Writer and Typist (Female), Senior*	2,483	2,559
Shorthand Writer and Typist (Female), Grade II.*	2,255	2,293
Shorthand Writer and Typist (Female), Grade I.*—		
Junior—		
Under 16 years of age	1,119
At 16 years of age	1,167
At 17 years of age	1,226
At 18 years of age	1,366
At 19 years of age	1,536
At 20 years of age	1,802
Adult	2,106	2,180
<i>Add—</i>		
Stenographer, Grade IV.	2,707	2,920
Stenographer, Grade III.*	2,483	2,559
Stenographer, Grade II.*	2,255	2,293
Stenographer, Grade I.*—		
Junior—		
Under 16 years of age	1,201
At 16 years of age	1,217
At 17 years of age	1,356
At 18 years of age	1,535
At 19 years of age	1,710
At 20 years of age	1,866
Adult	2,106	2,180

* See Regulation 114.

Delete the existing yearly rates of salary for the following positions and substitute the rates shown hereunder in lieu thereof—

Designation of Position.	Yearly Rate of Salary. £	
	Minimum.	Maximum.
	\$	\$
<i>Assistant (Male), Grade I.—</i>		
Junior—		
Under 16 years of age	1,044
At 16 years of age	1,092
At 17 years of age	1,311
At 18 years of age	1,529
At 19 years of age	1,769
At 20 years of age	1,988
Adult	2,458	2,648

FIFTH SCHEDULE—continued.

Designation of Position.	Yearly Rate of Salary. £	
	Minimum.	Maximum.
	\$	\$
Assistant (Female), Grade I.—		
Junior—		
Under 16 years of age	992
At 16 years of age	1,023
At 17 years of age	1,149
At 18 years of age	1,311
At 19 years of age	1,470
At 20 years of age	1,610
Adult	1,840	1,995
Inquiry Officer—		
Junior—		
At 19 years of age	1,769
At 20 years of age	1,988
Adult	2,458	2,648
Laboratory Assistant (Male)—		
Junior—		
Under 16 years of age	1,000
At 16 years of age	1,059
At 17 years of age	1,270
At 18 years of age	1,482
At 19 years of age	1,715
At 20 years of age	1,927
Adult	2,458	2,686
Laboratory Assistant (Female),		
Grade II	2,255	2,331
Laboratory Assistant (Female), Grade I		
Junior—		
Under 16 years of age	1,279
At 16 years of age	1,295
At 17 years of age	1,372
At 18 years of age	1,565
At 19 years of age	1,754
At 20 years of age	1,922
Adult	1,958	2,180
Machinist (Female), Grade III	2,331	2,369
Machinist (Female), Grade II	2,143	2,293
Machinist (Female), Grade I.—		
Junior*—		
Under 16 years of age	1,096
At 16 years of age	1,130
At 17 years of age	1,269
At 18 years of age	1,448
At 19 years of age	1,623
At 20 years of age	1,779
Adult	1,995	2,106
Typist (Female), Supervising		
Typist (Female), Grade I.†—		
Junior—		
Under 16 years of age	1,096
At 16 years of age	1,130
At 17 years of age	1,269
At 18 years of age	1,448
At 19 years of age	1,623
At 20 years of age	1,779
Adult	1,995	2,106
Typist (Female), Supervising		
Typist (Female), Grade I.†—		
Junior—		
Under 16 years of age	1,096
At 16 years of age	1,130
At 17 years of age	1,269
At 18 years of age	1,448
At 19 years of age	1,623
At 20 years of age	1,779
Adult	1,921	2,069

* See Regulation 112.
 † See Regulation 115.
 £ Annual increments shall be in accordance with those prescribed by Sub-Regulations 97 (2) and 97 (3), provided that in the case of the position of Assistant (Male), Administrative the annual increments shall be in accordance with those prescribed by Part A of the Third Schedule.

SIXTH SCHEDULE—continued.

Department and Designation of Position.	Yearly Rate of Salary.		Increments (Annual)
	Minimum.	Maximum.	
	\$	\$	
Junior—			
Under 16 years of age	1,119	..
At 16 years of age	1,167	..
At 17 years of age	1,226	..
At 18 years of age	1,366	..
At 19 years of age	1,536	..
At 20 years of age	1,802	..
Adult	2,106	2,180	£
Add—			
Stenographer, Grade IV	2,707	2,920	£
Stenographer, Grade III.ϕ	2,483	2,559	£
Stenographer, Grade II.ϕ	2,255	2,293	£
Stenographer, Grade I.ϕ—			
Junior—			
Under 16 years of age	1,201	..
At 16 years of age	1,217	..
At 17 years of age	1,356	..
At 18 years of age	1,535	..
At 19 years of age	1,710	..
At 20 years of age	1,866	..
Adult	2,106	2,180	£
ϕ See Regulation 114.			
Delete the existing yearly rates of salary for the following positions and substitute the rates shown hereunder in lieu thereof—			
Assistant (Male), Grade I.—			
Junior—			
Under 16 years of age	1,044	..
At 16 years of age	1,092	..
At 17 years of age	1,311	..
At 18 years of age	1,529	..
At 19 years of age	1,769	..
At 20 years of age	1,988	..
Adult	2,458	2,648	£
Assistant (Female), Grade I.—			
Junior—			
Under 16 years of age	992	..
At 16 years of age	1,023	..
At 17 years of age	1,149	..
At 18 years of age	1,311	..
At 19 years of age	1,470	..
At 20 years of age	1,610	..
Adult	1,840	1,995	£
Laboratory Assistant (Male)—			
Junior—			
Under 16 years of age	1,000	..
At 16 years of age	1,059	..
At 17 years of age	1,270	..
At 18 years of age	1,482	..
At 19 years of age	1,715	..
At 20 years of age	1,927	..
Adult	2,496	2,686	£
Laboratory Assistant (Female), Grade I.—			
Junior—			
Under 16 years of age	1,279	..
At 16 years of age	1,295	..
At 17 years of age	1,372	..
At 18 years of age	1,565	..
At 19 years of age	1,754	..
At 20 years of age	1,922	..
Adult	1,958	2,180	£
Laboratory Attendant—			
Junior—			
At 18 years of age	1,482	..
At 19 years of age	1,715	..
At 20 years of age	1,927	..
Adult	2,074	2,262	£
Machinist (Data Processing) (Female), Supervising	2,483	2,559	£
Machinist (Data Processing) (Female), in Charge	2,407	..
Machinist (Data Processing) (Female), Grade II	2,293	..
Machinist (Data Processing) (Female), Grade I.ϕ—			

SIXTH SCHEDULE.
 TEMPORARY EMPLOYEES.

Designations of Positions and Rates of Salaries.

Department and Designation of Position.	Yearly Rate of Salary.		Increments (Annual)
	Minimum.	Maximum.	
	\$	\$	
GENERAL.			
Delete—			
Shorthand Writer and Typist (Female), Senior ϕ	2,483	2,559	£
Shorthand Writer and Typist (Female), Grade II.ϕ	2,255	2,293	£
Shorthand Writer and Typist (Female), Grade I.ϕ—			

SIXTH SCHEDULE—continued.

SIXTH SCHEDULE—continued.

Department and Designation of Position.	Yearly Rate of Salary.		Increments (Annual)
	Minimum.	Maximum.	
	\$	\$	
Junior—			
Under 16 years of age	..	1,174	..
At 16 years of age..	..	1,201	..
At 17 years of age..	..	1,331	..
At 18 years of age..	..	1,513	..
At 19 years of age..	..	1,691	..
At 20 years of age..	..	1,844	..
Adult	1,995	2,106	Σ
Machinist (Female), Grade III.	2,331	2,369	Σ
Machinist (Female), Grade II.	2,143	2,293	Σ
Machinist (Female), Grade I.—			
Junior**—			
Under 16 years of age	..	1,096	..
At 16 years of age..	..	1,130	..
At 17 years of age..	..	1,269	..
At 18 years of age..	..	1,448	..
At 19 years of age..	..	1,623	..
At 20 years of age..	..	1,779	..
Adult	1,995	2,106	Σ
Photographic Assistant (Male)—			
Junior—			
Under 16 years of age	..	992	..
At 16 years of age..	..	1,050	..
At 17 years of age..	..	1,235	..
At 18 years of age..	..	1,465	..
At 19 years of age..	..	1,697	..
At 20 years of age..	..	1,890	..
Adult	2,334	2,610	Σ
Photographic Assistant (Female)—			
Junior—			
Under 16 years of age	..	915	..
At 16 years of age	..	976	..
At 17 years of age	..	1,080	..
At 18 years of age	..	1,222	..
At 19 years of age	..	1,363	..
At 20 years of age	..	1,492	..
Adult	1,768	2,069	Σ
Typist (Female), Supervising	2,369	2,407	Σ
Typist (Female), Grade I. ††—			
Junior—			
Under 16 years of age	..	1,096	..
At 16 years of age	..	1,130	..
At 17 years of age	..	1,269	..
At 18 years of age	..	1,448	..
At 19 years of age	..	1,623	..
At 20 years of age	..	1,779	..
Adult	1,921	2,069	Σ

* See Regulation 113.
 ** See Regulation 112.
 †† See Regulation 115.

CHIEF SECRETARY'S DEPARTMENT.

FISHERIES AND WILDLIFE.

Delete the existing yearly rates of salary for the following position and substitute the rates shown hereunder in lieu thereof—

Technical Assistant (Male)—			
Junior—			
At 18 years of age	..	1,769	..
At 19 years of age	..	2,047	..
At 20 years of age	..	2,300	..
Adult	2,762	2,986	Σ

Department and Designation of Position.	Yearly Rate of Salary.		Increments (Annual)
	Minimum.	Maximum.	
	\$	\$	
DEPARTMENT OF CROWN LANDS AND SURVEY.			
Delete the existing yearly rates of salary for the following position and substitute the rates shown hereunder in lieu thereof—			
Technical Assistant (Male)—			
Junior—			
At 18 years of age	..	1,769	..
At 19 years of age	..	2,047	..
At 20 years of age	..	2,300	..
Adult	2,762	2,986	Σ
EDUCATION DEPARTMENT.			
Delete the existing yearly rates of salary for the following positions and substitute the rates shown hereunder in lieu thereof—			
Laboratory Assistant (Male), Schools—			
Junior—			
Under 16 years of age	..	1,053	..
At 16 years of age	..	1,096	..
At 17 years of age	..	1,324	..
At 18 years of age	..	1,603	..
At 19 years of age	..	1,814	..
At 20 years of age	..	2,405	..
Adult	2,686	2,911	Σ
TEACHERS' COLLEGES AND SCHOOLS.*			
Typist (Female), Grade I. †—			
Junior—			
Under 16 years of age	..	1,010	..
At 16 years of age	..	1,041	..
At 17 years of age	..	1,246	..
At 18 years of age	..	1,335	..
At 19 years of age	..	1,496	..
At 20 years of age	..	1,639	..
Adult	1,876	2,032	Σ
* Excluding Colleges and Schools approved by the Board. † See Regulations 115 and 119.			
PREMIER'S DEPARTMENT.			
TOURIST DEVELOPMENT AUTHORITY.†			
Delete the existing yearly rates of salary for the following position and substitute the rates shown hereunder in lieu thereof—			
Inquiry Clerk (Female), Victorian Government Tourist Bureau—			
Junior—			
Under 16 years of age	..	1,201	..
At 16 years of age	..	1,217	..
At 17 years of age	..	1,356	..
At 18 years of age	..	1,535	..
At 19 years of age	..	1,710	..
At 20 years of age	..	1,866	..
Adult	2,069	2,707	Σ
† See Regulation 158. Σ See Regulation 97 (2).			

This Regulation shall have effect as on and from the 8th September, 1968.

F. E. CAHILL, Chairman.
 V. P. SCULLY, Secretary.

Office of the Public Service Board,
 Melbourne, 9th September, 1968.

No. 81.

PUBLIC SERVICE ACT 1958.

THE Public Service Board, in pursuance of the powers conferred by the Public Service Act 1958, hereby amends the Public Service (Public Service Board) Regulations as shown below:—

PART II.—APPOINTMENTS TO THE PUBLIC SERVICE.

DIVISION IV.—TECHNICAL AND GENERAL DIVISION.

Regulation 35 is revoked and the following Regulation is substituted therefor:—

“General—Stenographers.

35. (1) No person shall be eligible to be appointed to the office of Stenographer, Grade IV., unless she has satisfied the Board, by test, of her ability to write shorthand at the rate of 120 words a minute: Provided that any person appointed as a Shorthand Writer and Typist (Female), Senior, prior to 13th October, 1963, shall be regarded as being so qualified.

(2) No person shall be eligible to be appointed to the office of Stenographer, Grade III., or Stenographer, Grade II., unless she has satisfied the Board, by test, of her ability to write shorthand at the rate of 100 words a minute.

(3) No person shall be appointed as a Shorthand Writer (Female), Licensed, unless she is licensed under the provisions of the Evidence Act 1958 as a shorthand writer.”

PART V.—ALLOWANCES.

TECHNICAL AND GENERAL DIVISION.

General—Machinists (Female).

Regulation 112 is revoked and the following Regulation is substituted therefor:—

“112. (a) A Machinist (Female), Grade I., Junior, who is performing the duties of a Machinist (Female), Grade II., shall, while engaged in the duties, be paid an allowance at the rate of \$174 a year.

(b) A Machinist (Female), Grade I., Junior, who is performing the duties of a Machinist (Female), Grade III., shall, while engaged in the duties, be paid an allowance at the rate of \$283 a year.”

General—Machinists (Data Processing) (Female).

Regulation 113 is revoked and the following Regulation is substituted therefor:—

“113. (1) (a) A Machinist (Data Processing) (Female), Grade I., who has attained a standard of output and accuracy which has been approved by the Board shall be paid an allowance at the rate of \$46 a year.

(b) A Machinist (Data Processing) (Female), Grade I., who has attained an advanced standard of output and accuracy which has been approved by the Board and who is in receipt of an allowance under the provisions of sub-clause (a) of this sub-regulation shall be paid an additional allowance at the rate of \$52 a year.

(2) A Machinist (Data Processing) (Female), Grade I., Junior, who is performing the duties of a Machinist (Data Processing) (Female), Grade II., shall, while engaged in the duties, be paid an allowance at the rate of \$109 a year in addition to any allowance or allowances that may be payable to her under the provisions of sub-regulation (1) of this Regulation.”

Regulation 114 is revoked and the following Regulation is substituted therefor:—

“General—Stenographers.

114. (1) Any person who satisfies the Board, by test, of her ability to write shorthand at the rate of 100 words a minute shall, from the date of the test and while engaged on shorthand and typing duties—

(a) if an adult, be reclassified or redesignated to Stenographer, Grade II.; or

(b) if a minor, be paid a total emolument in accordance with the following scale:—

Age	Annual Rate of Total Emolument
	\$
Under 16 years	1,288
At 16 years	1,304
At 17 years	1,443
At 18 years	1,622
At 19 years	1,797
At 20 years	1,953

and, on attaining the age of 21 years, be reclassified or redesignated to Stenographer, Grade II.

(2) Any person who satisfies the Board, by test, of her ability to write shorthand at the rate of 120 words a minute shall, from the date of the test and while engaged on shorthand and typing duties—

(a) if a Stenographer, Grade III., or Stenographer, Grade II., be paid an allowance at the rate of \$88 a year; or

(b) if a Stenographer, Grade I., Junior, be paid an allowance at the rate of \$88 a year, in addition to the total emolument payable under the provisions of sub-regulation (1) (b) of this Regulation.”

General—Typists (Female) and Education Department—Typists (Female) in Teachers' Colleges and Schools.

Regulation 115 is revoked and the following Regulation is substituted therefor:—

“115. Any person who satisfies the Board, by test, of her ability to type at the rate of 42 words a minute shall, from the date of the test—

(a) if an adult, be reclassified or redesignated to Typist (Female), Grade II.; or

(b) if a minor, be paid a total emolument in accordance with the following scales:—

Age	Annual Rate of Total Emolument	
	General—Typists (Female)	Education Department Typists (Female) in Teachers' Colleges and Schools
	\$	\$
Under 16 years	1,174	1,082
At 16 years	1,201	1,107
At 17 years	1,331	1,227
At 18 years	1,513	1,395
At 19 years	1,691	1,559
At 20 years	1,844	1,700

and, on attaining the age of 21 years, be reclassified or redesignated to Typist (Female), Grade II.”

Education Department—Teachers' Colleges and Schools.

Regulation 119 is revoked and the following Regulation is substituted therefor:—

“119. A Typist (Female), Grade I., Junior, who is performing the full duties of a Clerical Assistant (Female), shall, while engaged in the duties, be paid a total emolument in accordance with the following scale:—

Age	Clerical Assistant (Female), Grade I.	Clerical Assistant (Female), Grade II.	Clerical Assistant (Female), Grade III.
	\$	\$	\$
Under 16 years	1,201	1,288	1,376
At 16 years	1,217	1,304	1,392
At 17 years	1,356	1,443	1,531
At 18 years	1,535	1,622	1,710
At 19 years	1,710	1,797	1,885
At 20 years	1,866	1,953	2,041 ”

This Regulation shall have effect as on and from the 8th September, 1968.

F. E. CAHILL, Chairman.
V. P. SCULLY, Secretary.

Office of the Public Service Board,
Melbourne, 9th September, 1968.

No. 82.

Public Service Act 1958, Section 50.

REGULATIONS.—PART IV.—SALARIES AND INCREMENTS.

THE Public Service Board, in pursuance of the powers conferred by the *Public Service Act 1958*, hereby amends its Regulations as shown below :—

**SIXTH SCHEDULE.
TEMPORARY EMPLOYEES.**

Designations of Positions and Rates of Salaries.

Department and Designation of Position.	Yearly Rate of Salary.		Increments (Annual).
	Minimum.	Maximum.	
GENERAL.	\$	\$	
Add— Typist and Assistant (Male)	2,762	2,838	Σ
Σ See Regulation 97 (2).			

F. E. CAHILL, Chairman.
V. P. SCULLY, Secretary.

Office of the Public Service Board,
Melbourne, 20th September, 1968.

No. 83.

Public Service Act 1958, Section 50.

REGULATIONS.—PART IV.—SALARIES AND INCREMENTS.

THE Public Service Board, in pursuance of the powers conferred by the *Public Service Act 1958*, hereby amends its Regulations as shown below :—

**SIXTH SCHEDULE.
TEMPORARY EMPLOYEES.**

Designations of Positions and Rates of Salaries.

Department and Designation of Position.	Yearly Rate of Salary.		Increments (Annual).
	Minimum.	Maximum.	
STATE FORESTS DEPARTMENT.	\$	\$	
Delete— Radio Technician ..	2,911	3,199	Σ
Add— Radio Technician ..	3,288	3,576	Σ
Σ See Regulation 97 (2).			

F. E. CAHILL, Chairman.
V. P. SCULLY, Secretary.

Office of the Public Service Board,
Melbourne, 13th September, 1968

ADMINISTRATION OF CHRISTMAS ISLAND.

ACCOUNTANT.
CHIEF CLERK.

CHRISTMAS ISLAND is the summit of a submarine mountain, 52 miles square and rising to almost 1,200 feet above the sea.

The climate is exhilaratingly healthy, with an average annual temperature between 70 and 95 degrees.

We are looking for two men to work for the Administration of Christmas Island as Accountant and Chief Clerk. Applicants will need a Victorian Leaving Certificate, or equivalent, and broad clerical and administrative experience. The Accountant should preferably have some experience in government accounting.

Salaries, including basic allowances, will be within the range \$4,112–\$5,344 per annum single, \$4,362–\$5,594 per annum married for the Accountant, and \$3,221–\$4,112 per annum single, \$3,471–\$4,362 per annum married, for the Chief Clerk.

General conditions are good. Fares and removal expenses for the appointees and families will be paid. Engagement is by contract for an initial period of two years, with 10 weeks' recreation leave in Australia on completion of the contract. There are generous allowances for children. Accommodation will be provided at low rates and power, light and water are provided free.

For further information and application forms, contact the Department of External Territories—

Hobart-place, Canberra, A.C.T., 2601. Phone 4 0477
46 Market-street, Sydney, N.S.W., 2000. Phone 29 5151
188 Queen-street, Melbourne, Vic., 3000. Phone 67 6159
145 Eagle-street, Brisbane, Qld., 4000. Phone 33 7575

Applications must reach Canberra by 16th October, and should quote advertisement No. 463A.

By order of the Secretary,

DEPARTMENT OF EXTERNAL TERRITORIES,
CANBERRA, A.C.T.

PUBLIC SERVICE OF PAPUA AND NEW GUINEA.

DEPARTMENT OF PUBLIC HEALTH.

Pre-School Teachers.

Remuneration.—\$2,800–\$3,745, per annum, including allowances.

Duties.—Teacher in charge of a pre-school centre based on the Australian pattern.

Qualifications.—Diploma from an approved Kindergarten Training College.

Assistant Pre-School Officer.

Remuneration.—\$3,880–\$4,285, per annum, including allowances.

Duties.—Co-ordinate and supervise the pre-school teacher training course and lecture in certain subjects to Papuan and New Guinean Pre-school Assistants.

Qualifications.—Diploma from an approved Kindergarten Training College, teaching experience, and preferably some supervisory and lecturing experience.

CONDITIONS OF SERVICE.

Term of Engagement.—Engagement is by contract for a minimum period of two years, longer if preferred.

Applicants employed by a Government authority may be considered for secondment to the Territory Service for a period of two years in the first instance with preservation of existing rights.

Accommodation.—Requirements will be discussed at interview.

Fares.—Fares will be paid from Australia to the Territory on engagement, and to Australia on satisfactory completion of the contract.

Leave.—Three months' leave after each 21 months' service and an additional three months after each six years. Assistance with leave fares to Australia is provided and this assistance may be used for travel overseas.

Taxation.—Income tax in the Territory is at present less than half that payable in Australia for the same net taxable income.

Retirement Benefits Scheme.—Contract officers, other than seconded or transferred appointees, may from the date of engagement contribute five per cent. of actual pay for "retirement", invalidity and death benefits under the Provident Fund Scheme. There is a right of election not to contribute under the scheme and benefits payable on resignation, retrenchment or completion of contract vary according to length of service.

Further Information.—Further information and applications forms are available from the Department of External Territories—

Hobart-place, Canberra, A.C.T., 2601. Phone 4 0477
46 Market-street, Sydney, N.S.W., 2000. Phone 29 5151
188 Queen-street, Melbourne, Vic., 3000. Phone 67 6159
145 Eagle-street, Brisbane, Qld., 4000. Phone 33 7575

Applications should reach Canberra by 12th October, and should refer to advertisement No. 443A.

By order of the Secretary,

DEPARTMENT OF EXTERNAL TERRITORIES,
CANBERRA, A.C.T.

PRIVATE ADVERTISEMENTS

NOTICE is hereby given that the St. Leonards Bowling Club has applied for a lease under section 134 *Land Act* 1958, of allotment 3, section A, Township of St. Leonards, containing 2 acres 24 perches, for a term of twenty years, as a site for amusement and recreation (Bowling Club). 4550

SEWERAGE DISTRICT ACT.**PROPOSED SEWERAGE AUTHORITY.**

NOTICE is hereby given that the Shire of Heytesbury has made application to the Honorable the Minister of Water Supply for the constitution of a Sewerage Authority and for the Proclamation of a Sewerage District at Simpson and for the construction, maintenance and continuance of sewerage works within that District under the provisions of the Sewerage Districts Act.

A general plan and description of the proposed works have been submitted with the application and copies of same may be seen at the Shire Office, Cobden.

Dated at Cobden, the 13th day of September, 1968.

P. J. NORTHEAST, Shire Secretary.

The Act requires that this Notice be published weekly for three weeks in a newspaper circulating locally and the *Government Gazette* and provides that within one month of the third Notice in the *Government Gazette* any person having an interest therein, who is likely to be injuriously affected by the proposed sewerage works, may forward to the Minister of Water Supply a petition, seeking refusal or amendment to the application.

In this case the period for objections will expire on 9th November, 1968. 4761

DANDENONG SEWERAGE AUTHORITY.**GENERAL NOTICE.**

THE above-mentioned Sewerage Authority, having made provision for carrying off the sewage from each and every property which or any part of which is within the Sewerage Areas hereinafter described doth hereby declare that on and after the 1st day of October, 1968, each and every property which or any part of which is within the said Sewerage Areas shall be deemed to be a sewered property within the meaning of the *Sewerage Districts Act* 1958.

The boundaries of the Sewerage Areas hereinbefore referred to are:—

Sewerage Area No. 181.

Commencing at a point being the south-western angle of lot 140 on lodged plan of subdivision No. 58890; thence westerly a distance of 300 feet by a line being the westerly prolongation of the southern boundary of the said lot 140; thence northerly by a line parallel to the western boundary of the said lot 140 a distance of 200 feet; thence easterly by a line to the north-western angle of lot 143 on the said lodged plan; thence southerly along the western boundaries of the said lot 143 and lots 142 and 141 on the said lodged plan and the said lot 140 to the point of commencement.

Sewerage Area No. 182.

All those pieces of land comprising lots 16, 20, 21, 22 and 23 on lodged plan of subdivision No. 40769.

Sewerage Area No. 183.

All that piece of land comprising lots 7 and 8 on lodged plan of subdivision No. 60201 and lot 5 on lodged plan of subdivision No. 57914.

Sewerage Area No. 184.

All that piece of land comprising Crown allotments 20 to 23 inclusive section 26, Town of Dandenong, Parish of Eumemmerring, County of Mornington.

Sewerage Area No. 185.

All that piece of land being lot 17 on lodged plan of subdivision No. 53101.

Sewerage Area No. 186.

All that piece of land comprising lots 44 and 45 on lodged plan of subdivision No. 53102.

For the purposes of these descriptions the lodged plans of subdivision herein referred to shall be taken as those lodged at the Office of Titles, Melbourne.

By order of the Dandenong Sewerage Authority,

I. A. FOTHERINGHAM, Chairman.
A. R. EDWARDS, Secretary.

4848

GEE LONG WATERWORKS AND SEWERAGE TRUST.

The above-mentioned Trust having made provision for carrying off the sewage from each and every property which or any part of which is within the sewerage area hereinafter described, doth hereby declare that on and after the first day of October, 1968, each and every property which or any part of which is within the said sewerage area shall be deemed and taken to be deemed property within the meaning of the *Geelong Waterworks and Sewerage Act* 1958.

SEWERAGE AREA No. 396.**Shire of Corio.—Parish of Moorpanyal.—County of Grant.**

Commencing at a point being the north-east corner of the intersection of Rollins-road and Ballarat-road, Bell Post Hill, the said point being also on the boundary of Sewerage Area No. 298; thence northerly along the east side of Rollins-road and crossing Neil-street, Corinella-street, and Ruhamah-avenue to the north-east corner of the intersection of Rollins-road and Ruhamah-avenue; thence easterly along the north side of Ruhamah-avenue and following boundaries of Sewerage Areas No. 394 and 352 and crossing Ward-street to the north-east corner of the intersection of Ruhamah-avenue and Ward-street, which is on the boundary of Sewerage Areas Nos. 352 and 392; thence southerly across Ruhamah-avenue and continuing southerly along the east side of Ward-street, following the boundaries of Sewerage Areas Nos. 392, 335, 355 and crossing Corinella and Neil streets to the prolongation of the southern boundary of lot No. 265, Neil-street; thence westerly across Ward-street and continuing westerly along the southern boundaries of lots No. 265 to 277, Neil-street and lot No. 278, Rollins-road, following the northern boundary of Sewerage Area No. 298 to the point of commencement.

SEWERAGE AREA No. 399.**Shire of Corio.—Parish of Moorpanyal.—County of Grant.**

Commencing at a point being the north-west corner of lot No. 6, Cox-road, Norlane, the said point being also on the east side of Como-road and on the boundary of Sewerage Area No. 312; thence easterly along the northern boundaries of lots Nos. 6 and 7, Cox-road, to the north-east corner of the said lot No. 7; thence southerly along the eastern boundaries of the said lot No. 7 and on a straight line across Cox-road to the south-east corner of the intersection of Cox-road and Allowah-avenue, which is on the boundary of Sewerage Areas Nos. 205 and 312; thence westerly across Allowah-avenue and continuing westerly along the south side of Cox-road and crossing Korumburra-avenue to the prolongation of western boundary of lot No. 138, Cox-road; thence northerly across Cox-road and continuing northerly along the western boundary of the said lot No. 138 to the southern boundary of lot No. 137, Epsom-road; thence westerly along the southern boundaries of the said lot No. 137 and lot No. 143, Stapledon-road to the east side of Stapledon-road; thence northerly along the east side of Stapledon-road to the north-west corner of lot No. 145, Stapledon-road; thence easterly along the northern boundaries of the said lot No. 145 and lot No. 135, Epsom-road and crossing Epsom-road to the east side of Epsom-road; thence southerly along the east side of Epsom-road to the north-west corner of lot No. 50, Epsom-road; thence easterly along the northern boundaries of the said lot No. 50 and lot No. 32, Como-road and crossing Como-road to a point on the east side of Como-road, which is on the boundary of Sewerage Area No. 312; thence southerly along the east side of Como-road to the point of commencement.

SEWERAGE AREA No. 402.**Shire of Corio.—Parish of Moranghurk.—County of Grant.**

Commencing at a point being the south-west corner of the intersection of Princes Highway (Melbourne-road) and Purnell-road, Corio, the said point being also on the boundaries of Sewerage Areas Nos. 216 and 319; thence westerly along the south side of Purnell-road and crossing Michigan-avenue to the prolongation of the west side of Hendy-street; thence northerly across Purnell-road to the north-west corner of the intersection of Purnell-road and Hendy-street, which is on the boundary of Sewerage Area No. 216; thence northerly along the west side of Hendy-street for a distance of 1,622 ft. 6 in., and crossing Rotella-avenue and Rimula-road; thence easterly across Hendy-street by a line bearing 89 deg. 58 min. 40 sec. to the east side of Hendy-street; thence easterly by a line having the same bearing for the distance of 600 ft. 5 in.; thence southerly by a line bearing 179 deg. 58 min. 40 sec. to the prolongation of the north side of Gambier-grove; thence north-easterly along the said prolongation across Education Department land (Primary School Extension) and continuing north-easterly along the north side of Gambier-grove to the north-west corner of the intersection of

Gambier-grove and Kosciusko-avenue; thence south-easterly across Gambier-grove and continuing south-easterly along the south-west side of Kosciusko-avenue and crossing Bogong-street to the south-west corner of the intersection of Princes Highway (Melbourne-road) and Kosciusko-avenue; thence south-easterly by a line bearing 125 deg. 8 min. across Princes Highway to the south-east side of Princes Highway (Melbourne-road); thence south-westerly along the south-east side of Princes Highway and crossing Refinery-road and Station-road to the south-west corner of the intersection of Princes Highway (Melbourne-road) and Station-road, which is on the boundary of Sewerage Area No. 319; thence north-westerly across Princes Highway (Melbourne-road) to the point of commencement.

SEWERAGE AREA No. 403.

Shire of South Barwon.—Parish of Barrarbool.—County of Grant

Commencing at a point being the south-west corner of the intersection of Thornbury-lane and Ewrick-crescent, North Highton, the said point being also on the boundary of Sewerage Area No. 366; thence westerly, northerly, easterly and northerly following the boundaries of Sewerage Areas No. 336 and 328 to the south side of Melrose-avenue; thence easterly along the south side of Melrose-avenue to the north-east corner of lot No. 44, Melrose-avenue; thence southerly along the eastern boundary of the said lot No. 44 to the northern boundary of lot No. 78, Thornbury-lane; thence easterly along the northern boundary of the said lot No. 78 to the north-east corner of lot No. 78; thence southerly along the eastern boundary of lot No. 78 and across Thornbury-lane to the south side of Thornbury-lane; thence westerly along the south side of Thornbury-lane and crossing Ewrick-crescent to the point of commencement.

SEWERAGE AREA No. 404.

Shire of Corio.—Parish of Moranghurk.—County of Grant.

Commencing at a point being the south-west corner of lot No. 16, Donax-road, Corio, the said point being also on the boundaries of Sewerage Areas Nos. 216 and 285; thence northerly following the boundary of Sewerage Area No. 285 and crossing Raymond-grove to the north-west corner of lot No. 21, Raymond-grove; thence easterly along the northern boundaries of lots Nos. 21 and 22, Raymond-grove to the west side of Donax-road; thence southerly along the west side of Donax-road and crossing Raymond-grove to the south-east corner of lot No. 16, Donax-road, which is on the boundary of Sewerage Area No. 216; thence westerly along the southern boundary of the said lot No. 16 to the point of commencement.

Signed under seal of the Trust, this 26th day of September, 1968.

J. W. CARR, Chairman.

4841

B. C. HENSHAW, Secretary.

PORTLAND SEWERAGE AUTHORITY.

GENERAL NOTICE.

THE above-mentioned Sewerage Authority, having made provision for carrying off the sewage from each and every property which or any part of which, is within the Sewerage Area hereinafter described, doth hereby declare that on and after the 3rd day of October, 1968, each and every property which, or any part of which, is within the said Sewerage Area shall be deemed to be a Sewered Property within the meaning of the Sewerage Districts Act 1958.

The boundaries of the Sewerage Area hereinbefore referred to are:—

Sewerage Area No. 15.

The existing declared area to be extended by adding to the same land reclaimed from Portland Bay. Commencing at the intersection of the northern boundary of Bancroft-street and the western boundary of Victoria-parade being a point on the existing Sewered Area 6; thence by a line in continuation of the northern boundary of Bancroft-street to a point on the north-eastern boundary of the said reclaimed land; thence south-easterly and south-westerly along the boundary of reclaimed land to a point opposite the projection of the southern boundary of Edgar-street; thence westerly by a line to the intersection of the southern boundary of Edgar-street and Victoria-parade; thence north-westerly along the western boundary of Victoria-parade to the point of commencement.

By order of the said Sewerage Authority,

(SEAL)

K. D. WILSON, Chairman.

4865

L. FELL, Secretary.

FRANKSTON SEWERAGE AUTHORITY.

CONSTRUCTION OF SEWERS—AMENDED LOCATIONS.

NOTICE is hereby given that the above Authority has amended the design of its sewers for the Bentick-street, Frankston area.

A map showing the original and amended sewer design may be inspected at the office of the Authority in the Civic Centre, Frankston.

4832

G. C. PENTLAND, Secretary.

NOTICE OF INTENTION TO APPLY FOR A LICENCE TO DIVERT WATER AND CUT RACE (RE-ISSUE) FROM THE BROKEN RIVER, AT BENALLA.

WE hereby give notice that we intend to apply for a licence empowering us to divert water for a term of four years to the extent of 16 acre-feet per annum at a maximum rate of 5 acre-feet per day of 24 hours for the irrigation of a market garden, being allotments 4, 5, 6, 7, 8, 9, 10 and 11, section A, Parish of Benalla, and to occupy certain Crown lands for works of diversion, and to cut a race thereon.

Any objection to such application must be forwarded, in writing, to reach the State Rivers and Water Supply Commission, Melbourne, before 23rd October, 1968, being 30 days from the first publication of this notice.

LUIGI MARTINIELLO.

VALENTINA MARTINIELLO.

73 Smythe-street, Benalla.

4856

NOTICE OF INTENTION TO APPLY FOR A LICENCE TO DIVERT WATER AND CUT RACE (RE-ISSUE) FROM THE RIVER MURRAY, AT KOONDROOK.

I HEREBY give notice that I intend to apply for a licence empowering me to divert water for a term of four years to the extent of 12 acre-feet per annum at a maximum rate of $\frac{1}{2}$ acre-foot per day of 24 hours for the irrigation of 1 acre of Orchard, being part of allotment 22, section E, Town of Koondrook, Parish of Murrabit, and to occupy certain Crown lands for works of diversion, and to cut a race thereon.

Any objection to such application must be forwarded, in writing, to reach the State Rivers and Water Supply Commission, Melbourne, before 1st November, 1968, being 30 days from the first publication of this notice.

WILLIAM HENRY FULTON.

Myall-road, Koondrook.

4857

NOTICE OF INTENTION TO APPLY FOR A LICENCE TO DIVERT WATER AND CUT RACE FROM THE BROKEN RIVER, AT SWANPOOL.

I HEREBY give notice that I intend to apply for a licence empowering me to divert water for a term of four years to the extent of 80 acre-feet per annum at a maximum rate of 10 acre-feet per day of 24 hours for the irrigation of 40 acres of lucerne and summer pasture, being part of allotment 117, Parish of Moorngag.

Any objection to such application must be forwarded, in writing, to reach the State Rivers and Water Supply Commission, Melbourne, before 30th October, 1968, being 30 days from the first publication of this notice.

STEWART LEONARD DOBSON.

"Swansea", Swanpool, 3673.

4858

NOTICE OF INTENTION TO APPLY FOR A LICENCE TO DIVERT WATER AND CUT RACE (RE-ISSUE) FROM THE RIVER MURRAY, AT COLIGNAN.

I HEREBY give notice that I intend to apply for a licence empowering me to divert water for a term of four years to the extent of 300 acre-feet per annum at a maximum rate of 6 acre-feet per day of 24 hours for the irrigation of 100 acres, being part of allotment 25, section 2, Parish of Colignan, and to occupy certain Crown lands for works of diversion, and to cut a race thereon.

Any objection to such application must be forwarded, in writing, to reach the State Rivers and Water Supply Commission, Melbourne, before 26th October, 1968, being 30 days from the first publication of this notice.

DONALD BRUCE MATTHEWS.

Block 228, Dareton, N.S.W.

4859

NOTICE OF INTENTION TO APPLY FOR A LICENCE TO DIVERT WATER AND CUT RACE FROM THE BROKEN RIVER, AT BOOROMI.

I HEREBY give notice that I intend to apply for a licence empowering me to divert water for a term of four years to the extent of 80 acre-feet per annum at a maximum rate of 8 acre-feet per day of 24 hours for the irrigation of pasture, being part of allotments 72, 73 and 74A, Parish of Upotipotpon, and to occupy certain Crown lands for works of diversion, and to cut a race thereon.

Any objection to such application must be forwarded, in writing, to reach the State Rivers and Water Supply Commission, Melbourne, before 26th October, 1968, being 30 days from the first publication of this notice.

ARCHIBELLE CAMERON MURCH.

Booromi, Benalla.

4860

Victoria.

ACT No. 391.—FIRST SCHEDULE.

I, THE RIGHT REVEREND WILLIAM AUCHTERLONIE HARDIE, of Cathedral Buildings, Ballarat, Bishop of Ballarat, head or authorized representative of the denomination known as the Church of England in the Diocese of Ballarat in Victoria, with the consent of the corporation styled The Ballarat Diocesan Trustees, of Cathedral Buildings, Dana-street, Ballarat, the Trustees of the land described in the subjoined statement of trusts and of the Reverend Thomas Joseph O'Brien, being the person entitled to minister in or occupy a building or buildings upon the said land, hereby apply to the Governor of the State of Victoria for leave to dispose of the said land by the means and for the purposes mentioned in the said statement of trusts: And I hereby certify that the said land hereinafter mentioned was reserved from sale by the Governor in Council as a site for Church of England purposes by Order in Council dated the 21st day of February, 1870: That the only trustee of the said land is the said corporation styled The Ballarat Diocesan Trustees: That there are no buildings upon the said land and that the only person entitled to minister in or occupy the same (if any) is the above-named Thomas Joseph O'Brien.

Dated the 13th day of March, 1968.

Signature of head or authorized representative—WILLIAM BALLARAT.

The corporation styled The Ballarat Diocesan Trustees hereby consents to this application.

The common seal of the corporation styled The Ballarat Diocesan Trustees was affixed hereto, in the presence of us, being three of the Trustees authorized to attest the affixing of such seal—

(SEAL) WILLIAM BALLARAT, Trustee.
ROBERT G. PORTER, Trustee.
P. ROWLANDS, Trustee.

Signature of person entitled to minister in or occupy building or buildings—T. J. O'BRIEN.

STATEMENT OF TRUSTS.

Description of Land.—Kolara Church of England, Parish of Glenormiston: 1 acre 2 roods, temporarily reserved for Church of England by Order in Council of the 21st February, 1870 (*Government Gazette*, 25th February, 1870, page 379).

1 acre 2 roods, Parish of Glenormiston, County of Hampden, being subdivision 14 of allotment 4, section 28: Commencing at the south-western angle of subdivision 13; bounded thence by the southern boundary of subdivision 13 bearing 90 deg. 0 min. 400 links, and thence by roads bearing 180 deg. 0 min. 375 links, 270 deg. 0 min. 400 links, and 0 deg. 0 min. 375 links to the point of commencement.

Name of Trustees.—The Ballarat Diocesan Trustees, of Cathedral Buildings, Dana-street, Ballarat.

Powers of Disposition.—To permit and suffer so much of the land as shall not be disposed of under the powers hereinafter specified to be used for the purposes for which it was promised or permanently reserved from sale by the Crown. To let, lease, sell, mortgage or exchange if concurred in by the said head or authorized representative for the time being, the said land, or any portion thereof, or any buildings thereon on such terms and conditions as shall be specified by such head or representative.

Purposes to which Proceeds of Disposition are to be Applied.—Moneys obtained from sale, leases, mortgages or exchanges to be paid to the Bishop to be dealt with for Church of England purposes as shall be directed by the said Trustees, but to be subject nevertheless to the

payment or deduction therefrom of all costs, charges and expenses incurred by the Trustee or for which it shall be liable in respect of the trust estate.

CUTHBERT, MORROW, MUST & SHAW, Lydiard-street, Ballarat, solicitors for the applicant. 4870

CITY OF CASTLEMAINE.

By-Law No. 129.

NOTICE is given that the Council of the City of Castlemaine has made the following By-Law:—

Number.—129.

Short Title.—Meeting Procedure.

Purpose.—Repeals By-Law No. 87 and regulates proceedings of Council and Committee meetings conducted by the City of Castlemaine.

Copies of the By-Law are available for inspection at the Town Hall, Castlemaine.

4861

I. C. SMITH, Town Clerk.

CITY OF COBURG.

LOAN No. 114.

Notice of Intention to Borrow the Sum of \$50,000 for Permanent Works and Undertakings.

NOTICE is hereby given that the Council of the City of Coburg proposes to borrow the sum of Fifty thousand dollars (\$50,000) secured by a charge over the general rates of the municipality, such sum to be raised by the grant of a mortgage in accordance with the provisions of the *Local Government Act 1958*.

1. The maximum rate of interest that may be paid is 5.875 per centum per annum.

2. The purpose for which the loan is to be applied is Electric Supply Capital Expenditure.

3. The period of the loan shall be 40 years.

4. The moneys borrowed shall be repayable to State Superannuation Board, Treasury Place, Melbourne, 3002, on 1st January, 2009.

5. The loan is to be liquidated by the creation of a sinking fund pursuant to section 428A of the *Local Government Act 1958*.

The plans and specifications and the estimate of the cost of the proposed works and a statement showing the proposed expenditure of the moneys to be borrowed are open for inspection at the Town Hall, Coburg, during office hours.

Dated 30th September, 1968.

4903

G. A. BRIDGES, Town Clerk.

CITY OF COLAC.

IN pursuance of the powers conferred on it by section 522 of the *Local Government Act 1958*, the Council of the City of Colac hereby directs that the following lands which have been taken, purchased or acquired by it shall be Public Highways from and after the date of publication of this Order in the *Government Gazette*:—

All of the lands described in certificates of title, volume 8475, folio 350, volume 8525, folio 676.

By order made by the Council of the City of Colac, this 25th day of September, 1968.

(SEAL)
4826

D. MATHEWS, Mayor.
J. C. MCLENNAN, Councillor.
F. M. KELLY, Town Clerk.

CITY OF MALVERN.

LOAN No. 45.

Notice of Intention to Borrow the Sum of \$30,000 for Permanent Works and Undertakings.

NOTICE is hereby given that the Council of the municipality of the City of Malvern intends to borrow the principal sum of Thirty thousand dollars on the security of the general rates of the said municipality, such principal sum to be raised by the grant of a mortgage, in accordance with the provisions of the *Local Government Act 1958*.

1. The maximum rate of interest that may be paid is 5.875 per centum per annum.

2. The moneys borrowed are to be repayable on 1st July and 1st January each year to the Commissioners of the State Savings Bank of Victoria at the office of the said Commissioners, corner Elizabeth and Bourke streets, Melbourne.

3. The purpose for which the loan is to be applied is—

Reconstruction of the Malvern Municipal Baths (part) \$30,000

4. The loan is to be liquidated by providing out of the municipal fund 30 half-yearly instalments of approximately \$1,518.00 (which instalments shall comprise principal and interest) each on the appropriate date.

The plans and specifications and the estimate of the cost of the proposed works, and a statement showing the proposed expenditure of the moneys to be borrowed, are open for inspection at the City Hall, Malvern, during office hours.

4838

D. W. LUCAS, Town Clerk.

CITY OF MOORABBIN.

LOAN No. 159.

Notice of Intention to Borrow the Sum of One Hundred Thousand Dollars for Permanent Works and Undertakings.

NOTICE is hereby given that the Council of the City of Moorabbin proposes to borrow the sum of One hundred thousand dollars secured by a charge over the general rates of the municipality, such sum to be raised by the grant of a mortgage, in accordance with the provisions of the *Local Government Act 1958*.

1. The maximum rate of interest that may be paid is 5.75 per centum per annum.

2. The purposes for which the loan is to be applied are—

Purchase of land for recreation purposes ..	\$16,000
Construction and widening of roads, including channelling works	43,920
Construction of drains	18,000
Construction of footpaths and channels ..	17,030
Improvements to Reserves	5,050
	\$100,000

3. The period of the loan shall be 40 years.

4. The loan shall be repaid by the creation of a sinking fund, and an amount of \$934.32 will be set aside annually out of the municipal fund for such purpose.

5. The moneys borrowed shall be repayable at the offices of the State Superannuation Board, Treasury-place, Melbourne, or at such other place as the Board may require.

6. The plans, specifications and estimate of the cost of the proposed works and undertakings, and a statement showing the proposed expenditure of the moneys to be borrowed, are open for inspection at the Municipal Offices, Nepean Highway, Moorabbin, during office hours.

Dated this 27th day of September, 1968.

4843

V. A. SMITH, Town Clerk.

CITY OF WAVERLEY.

NOTICE is hereby given that, in pursuance of the powers conferred by the *Local Government Act*, the Council of the City of Waverley did, at a meeting, held on 24th September, 1968, order that the following alteration be made to the under-mentioned streets and that such order take effect from the date of this publication in the *Victoria Government Gazette*:

Old name; New name.

Durward-street, as shown on lodged plan of subdivision No. 79700; Durward-avenue.

Lemont-avenue, as shown on lodged plan of subdivision No. 67190; Sampson-drive.

Lum-road, as shown on lodged plan of subdivision No. 79345; Remington-drive.

4866

R. S. BALES, Town Clerk.

BOROUGH OF QUEENSCLIFFE.

LOAN No. 22.

Notice of Intention to Borrow the Sum of \$13,500 for Permanent Works and Undertakings.

NOTICE is hereby given that the Council of the Borough of Queenscliffe proposes to borrow the sum of Thirteen thousand five hundred dollars secured by a charge over the general rates of the municipality, such sum to be raised by the grant of a mortgage in accordance with the provisions of the *Local Government Act 1958*.

1. The maximum rate of interest that may be paid is 5.75 per centum per annum.

2. The purpose for which the loan is to be applied is:

Paving Works	\$10,000
Municipal Depot	\$3,500
	\$13,500

3. The period of the loan shall be ten years.

4. The moneys borrowed shall be repayable by providing out of the municipal fund twenty half-yearly instalments of \$896.96 each, including principal and interest, on the 1st day of May and the 1st day of November during the currency of the loan. The first instalment shall be repayable on 1st May, 1968.

5. Such moneys shall be repayable at the C.B.C. Savings Bank Ltd., Melbourne.

The plans and specifications and the estimate of the cost of the proposed works and a statement showing the proposed expenditure of the moneys to be borrowed are open for inspection at the Town Hall, Queenscliff.

Dated the 24th September, 1968.

4868

D. F. DREW, Town Clerk.

SHIRE OF BET BET.

COMPULSORY ACQUISITION OF LAND.

TO Ernest James Theodore Bock, of Ballarat-road, Maryborough, owner according to Crown Grant, and Gwenda Knight, of Commercial-road, Tarnagulla, occupier, according to ratebook of the Shire of Bet Bet, as persons, having interest(s) in allotment 7 of section 16, Township and Parish of Tarnagulla, County of Gladstone.

Take notice that the Council of the above-named Shire, for purpose of providing public conveniences in the Township of Tarnagulla, deems it advisable to compulsorily acquire all of the allotment of land hereabove described and contained in Crown Grant No. 941 in Book No. 454 and delineated on plan lodged at the Shire Office, Dunolly.

Take further notice that you are hereby required to respond, in writing, addressed to the undersigned at the Shire Office, Dunolly, on or before Wednesday, the 20th day of November, 1968, whether you assent, dissent or are neutral to such acquisition.

Dated this 1st day of October, 1968.

4869

N. MCCARTNEY, Shire Secretary.

SHIRE OF ELTHAM.

By-Law No. 56.

Regulating sewerage and drainage.

A By-Law of the Shire of Eltham made under Section 197 of the *Local Government Act 1958* and numbered 56 for—

- (a) regulating sewerage and drainage;
- (b) providing for the health of the residents in the municipal district and against the spreading of contagious or infectious diseases; and
- (c) suppressing nuisances.

IN pursuance of the powers conferred by the *Local Government Act 1958* the President, Councillors and Ratepayers of the Shire of Eltham order as follows—

1. In this By-Law unless inconsistent with the context or subject matter—

- “Board” means the Melbourne & Metropolitan Board of Works.
 “Council” means the Council of the Shire of Eltham.
 “Property” includes any land upon which a house or other building is erected.
 “Sewer” means a sewer laid by the Board.
 “Sullage water” includes household waste water.

2. (1) The owner of every property in respect of which a general notice has been given by the Board under Section 160 (1) of the *Melbourne and Metropolitan Board of Works Act 1958* shall—

- (a) make provision to have the sewerage carried off from such property by the sewer laid by the Board; and
- (b) provide such proper water closet or water closets and such drains, appliances, apparatus and connexions with such sewer as may be prescribed by Regulations of the Board—

within twelve months or such further time as the Council may allow from the date of the coming into operation of this By-Law where such a general notice has been given prior to the said date or within twelve months or such further time as aforesaid from the date of any such general notice given after the coming into operation of this By-law as the case may be.

(2) All such sewerage works and the provision of such water closet or water closets, drains, appliances, apparatus and connexions with a sewer shall be carried out, fitted and laid in accordance with Regulations prescribed by the Board.

(3) Any owner desirous of an extension of time beyond the said period of twelve months shall—

- (a) make application, in writing, to the Council; and

- (b) in his application give—
 (i) his full name and address;
 (ii) particulars of his property;
 (iii) the reasons why he requires an extension,
 and
 (iv) any other information the Council may require.

(4) Any owner to whom this By-law applies who fails to provide for the sewerage from his property to be carried off by a sewer and to provide such water closet or water closets, drains, appliances, apparatus or connexions as may be prescribed by the Regulations of the Board and cause the same to be connected to a sewer within the said period of twelve months or such further time as may be allowed by the Council shall be guilty of an offence against this By-Law.

3. No person shall allow, permit or suffer, after the expiration of twelve months or such further time as the Council may allow from the date of the coming into operation of this By-Law, where a general notice under the said Section 160 (1) has been given prior to the said date, or after the expiration of twelve months or such further time as aforesaid from the date of any such general notice given after the coming into operation of this By-Law as the case may be, any sullage water to be discharged from any property affected by any such notice except into a sewer.

4. Any person guilty of a wilful act or default contrary to this By-law shall be liable to a penalty of not less than \$10 or more than \$40, and to a further penalty of not more than \$10 for each day on which such offence is continued after a conviction or order by any Court.

5. This By-Law shall apply to and have operation throughout the whole of the municipal district of the Shire of Eltham but it shall not apply to any property in respect of which a further general notice has been served by the Board under Section 160 (2) of the *Melbourne and Metropolitan Board of Works Act 1958*.

6. This By-law shall come into operation on the first day of January, 1969.

The Resolution for passing this By-Law was agreed to by the Council of the Shire of Eltham on the 12th day of August, 1968, and confirmed on the 9th day of September, 1968.

The common seal of the President, Councillors and Ratepayers of the Shire of Eltham was hereto affixed this 9th day of September, 1968, in the presence of—

(SEAL) JOHN V. McCONNELL, Shire President.
 J. A. LEWIS, Councillor.
 4844 M. B. WATSON, Shire Secretary.

SHIRE OF KNOX.

LOAN No. 44.

Notice of Intention to Borrow the Sum of \$100,000 for Permanent Works and Undertakings.

NOTICE is hereby given that the Council of the Shire of Knox, in pursuance of powers conferred by the Local Government Acts, intends to borrow the sum of \$100,000, secured by a charge over the general rates of the municipality, such sum to be raised by the grant of a mortgage, in accordance with the said Acts and states:

- (a) The amount of principal moneys it is proposed to borrow is \$100,000.
- (b) The maximum rate of interest that may be paid is 5.875 per cent. per annum.
- (c) The period of the loan will be 40 years and the money borrowed is to be repayable in full at the expiration of the loan on 1st January, 2009.
- (d) The purpose for which the loan is to be applied is for permanent works and undertakings, viz.:
Purchase of land.
- (e) The loan is to be liquidated by the establishment of a sinking fund pursuant to Section 428A (1) of the Local Government Act with an annual appropriation of \$934.32.
- (f) The place of repayment will be: State Superannuation Board, Treasury-place, Melbourne, 3002.

Plans and specifications and an estimate of the cost of such works and undertakings, and a statement showing the proposed expenditure of the money to be borrowed, are open for inspection by ratepayers, during office hours, at the Shire Offices, Fern Tree Gully, for one month after the publication of this notice.

Dated at Fern Tree Gully this 27th day of September, 1968.

4845 N. G. HAYNES, Shire Secretary.

SHIRE OF MILDURA.

LOAN No. 48.

Notice of Intention to Borrow the Sum of \$40,000 for Permanent Works and Undertakings.

NOTICE is hereby given that the Council of the Shire of Mildura proposes to borrow the principal sum of \$40,000, secured by a charge over the general rates of the municipality, such sum to be raised by the grant of a mortgage, in accordance with the provisions of the *Local Government Act 1958*.

1. The maximum rate of interest that may be paid is \$5.875 per cent. per annum.
2. The purpose for which the loan is to be applied is—
Drainage Works at Irymple, Mildura South
and Red Cliffs \$40,000
3. The period of the loan shall be forty (40) years.
4. The loan shall be repaid by the creation of a sinking fund, and an appropriate amount will be set aside annually out of the municipal fund for such purposes as determined by the State Auditor-General.
5. The moneys borrowed shall be repayable at the office of the State Superannuation Board, Melbourne, or such other place as the Board shall require.
6. The plans and specifications and estimate of the costs of the proposed works and undertakings, and a statement showing the proposed expenditure of the moneys to be borrowed, are open for inspection at the office of the Council of the Shire of Mildura, at Deakin-avenue, Mildura, during office hours.

Dated 25th September, 1968.

4851 A. D. HARVEY, Shire Secretary.

SHIRE OF SOUTH BARWON.

BY-LAW No. 58.

A By-Law of the Shire of South Barwon made under the Dog Acts and numbered 58 for fixing registration and other fees thereunder.

IN pursuance of the powers conferred by the Dog Acts and of every other power it thereunto enabling the President, Councillors and Ratepayers of the Shire of South Barwon, orders as follows:—

1. The By-Law No. 45 for fixing the dog registration and other fees is repealed and revoked as from the date of the coming into operation of this By-Law.
2. The following fees and sums are hereby fixed pursuant to the Dog Act 1958 (as amended)—

(a) For registration pursuant to Section 5 of the Dog Act 1958 as amended by an Act	\$1.50
(b) For particulars of any dog or for name of the registered owners thereof or for a certified copy of the Dog Act 1958 as amended by any Act	25c
(c) Sum payable to the Registration Officer pursuant to Section 15 of the Dog Act 1958 as amended by any Act (to reclaim a registered dog seized after being found wandering at large and having a registration collar around its neck)	\$2.50
(d) Sum payable to the Registration Officer pursuant to Section 16 of the Dog Act 1958 as amended by any Act (to reclaim a dog seized after being found wandering at large with or without a registration collar around its neck whether registered or not)	\$2.50

3. This By-Law shall apply to and have operation throughout the whole of the municipal district.

Resolution for passing this By-Law was agreed to by the Council of the Shire of South Barwon on the 20th day of August, 1968, and confirmed at a meeting of the said Council held on the 17th September, 1968.

In witness whereof the common seal of the President, Councillors and Ratepayers of the Shire of South Barwon was hereto affixed this 17th September, 1968, in the presence of—

(SEAL) R. J. REYNOLDS, Shire President.
 M. A. DRAYTON, Councillor.
 4842 A. A. N. DEED, Shire Secretary.

SHIRE OF STAWELL.

LOAN No. 10.

Notice of Intention to Borrow the Sum of \$40,000 for Permanent Works and Undertakings.

NOTICE is hereby given that the Council of the Shire of Stawell proposes to borrow the sum of Forty thousand dollars secured by a charge over the general rates of the municipality, such sum to be raised by the grant of a mortgage in accordance with the provisions of the *Local Government Act 1958*.

1. The maximum rate of interest that may be paid is 5½ per cent. per annum.
2. The purpose for which the loan is to be applied is the purchase of two power graders.
3. The period of the loan shall be ten years.
4. The moneys borrowed shall be repayable by providing out of the municipal fund half-yearly instalments of approximately \$2,657.65 each, including principal and interest on the 10th day of May and the 10th day of November, during the currency of the loan. The first instalment shall be payable on the 10th day of May, 1969.
5. Such moneys shall be repayable at the Commercial Savings Bank of Australia Limited, Melbourne.

Dated 1st October, 1968.

4825 V. C. NIELSEN, Shire Secretary.

SHIRE OF WHITTLESEA.

BY-LAW No. 63.

A By-Law of the Shire of Whittlesea made under the provisions of the *Local Government Act, 1958*, as amended, and numbered 63 for the purpose of regulating the supply and distribution of water and other purposes ancillary thereto.

IN pursuance of the powers conferred by the *Local Government Act, 1958*, as amended, and in further pursuance of the provisions of agreements under the seals of the Melbourne and Metropolitan Board of Works of the one part and the President, Councillors and Ratepayers of the Shire of Whittlesea of the other part THE PRESIDENT, COUNCILLORS AND RATEPAYERS OF THE SHIRE OF WHITTLESEA (hereinafter called the Council) do hereby make and prescribe the following By-Law, that is to say:—

1. This By-Law is to be read and construed as one with By-Law No. 18 duly passed by the Council on the 11th day of November, 1936, and confirmed on the 9th day of December, 1936, as amended by By-Laws numbered 22, 27, 46 and 62 all of which have also been duly passed and confirmed (the said By-Law as so amended being hereinafter referred to as "the said By-Law").

2. The said By-Law is hereby further amended as follows:—

A. For Clause 4 (b) there shall be substituted the following:—

"4 (b) Water supplied by the Council by measure shall be charged for

- (i) at the rate of Thirty cents per thousand gallons supplied to lands and tenements primarily used for any industrial, commercial or like purposes, and
- (ii) at the rate of Twenty-five cents per thousand gallons supplied to lands and tenements primarily used otherwise than for any industrial, commercial or like purposes."

B. Clause 34 (a) shall be amended as follows:—

For the words "For each such private fire service there shall be paid a sum of Ten Shillings upon the fixing thereof, and a sum of Ten Shillings per annum thereafter." there shall be substituted "For each such private fire service there shall, as from the 1st October, 1968, be paid a sum of Three Dollars upon the fixing thereof and an annual fee of Three Dollars thereafter. When, with the approval of the Engineer, a fire service is extended from one tenement to one or more abutting tenements, under separate valuations, there shall, as from the 1st October, 1968, be paid an annual fee of Three Dollars in respect of each extension."

The Resolution adopting this By-Law No. 63 was agreed to at the meeting of the Council held on the 5th day of August, 1968, and confirmed on the 2nd day of September, 1968.

As witness, the common seal of the President, Councillors and Ratepayers of the Shire of Whittlesea was hereunto affixed this 2nd day of September, 1968, in the presence of—

(SEAL) K. N. BALHARRIE, President.
JOHN W. TOWT, Councillor.
R. G. C. COOK, Shire Secretary.

Approved by the Melbourne and Metropolitan Board of Works on the 20th day of September, 1968.

The common seal of the Melbourne and Metropolitan Board of Works was affixed hereto in the presence of—

(SEAL) ALAN H. CROXFORD, Chairman.
A. P. DONNELLY, Member.
H. J. SNADDEN, Secretary.

SHIRE OF WODONGA.

NOTICE OF CHANGE IN NAME OF ROAD.

NOTICE is hereby given that in pursuance of the powers conferred by the *Local Government Act 1958* the Council of the Shire of Wodonga resolved that the following road be renamed:—

Old Name.—Mann's-lane Extension.

New Name.—Pressnell-lane.

4840 G. J. MORTON, Shire Secretary.

Town and Country Planning Act 1961 (Twelfth Schedule).

SHIRE OF WOORAYL.—SHIRE OF WOORAYL PLANNING SCHEME.

NOTICE THAT A PLANNING SCHEME HAS BEEN PREPARED AND IS AVAILABLE FOR INSPECTION.

NOTICE is hereby given that the Shire of Woorayl in pursuance of its powers under the *Town and Country Planning Act 1961*, has prepared an Amending Planning Scheme for Crown allotments 18, 19 and 20, section 28, Township and Parish of Leongatha, for the purpose of amending the Shire of Woorayl Planning Scheme, 1963.

A copy of the scheme has been deposited at the Shire Office, Leongatha, and at the office of the Town and Country Planning Board, 179 Queen-street, Melbourne, 3000, and will be open for inspection during office hours by any person free of charge.

Any persons affected by the Planning Scheme are required to set forth, in writing, all objections they may have, addressed to the Shire Secretary, Shire of Woorayl, Post Office Box 21, Leongatha, 3953, on or before the 6th day of November, 1968, and state whether they wish to be heard in respect of their objections.

Date the 26th day of September, 1968.

4872 K. G. BRYDON, Shire Secretary.

NOTICE is hereby given that the partnership previously existing between John Stanley Coon, of 71 Cornella-street, North Geelong, and Ronald James McDonough, of 47 Yarra-street, Geelong, was dissolved on Monday, 2nd September, 1968.

4839 R. J. McDONOUGH.

Companies Act 1961. Section 272.

THE BENDIGO TIMBER COMPANY (JOINERY) PTY. LTD. (IN LIQUIDATION).

NOTICE is hereby given that a meeting of members will be held at National Bank Chambers, Pall Mall, Bendigo, at 10 a.m., Monday, 4th November, 1968. The object of the meeting is to submit the liquidator's account, showing how the winding up has been conducted and the property of the company has been disposed of and giving any explanation thereof.

Dated this 25th day of September, 1968.

4827 WARWICK N. JOHANSON, Liquidator.

Companies Act 1961. Section 272.

THE BENDIGO TIMBER COMPANY (PAINTS) PTY. LTD. (IN LIQUIDATION).

NOTICE is hereby given that a meeting of members will be held at National Bank Chambers, Pall Mall, Bendigo, at 10 a.m., Monday, 4th November, 1968. The object of the meeting is to submit the liquidator's account, showing how the winding up has been conducted and the property of the company has been disposed of and giving any explanation thereof.

Dated this 25th day of September, 1968.

4828 WARWICK N. JOHANSON, Liquidator.

Companies Act 1961. Section 272.

**THE BENDIGO TIMBER COMPANY (MERCHANTS)
PTY. LTD. (IN LIQUIDATION).**

NOTICE is hereby given that a meeting of members will be held at National Bank Chambers, Pall Mall, Bendigo, at 10 a.m., Monday, 4th November, 1968. The object of the meeting is to submit the liquidator's account, showing how the winding up has been conducted and the property of the company has been disposed of and giving any explanation thereof.

Dated this 25th day of September, 1968.

4829 WARWICK N. JOHANSON, Liquidator.

**KING BROS. & DOIG PROPRIETARY LIMITED
(IN VOLUNTARY LIQUIDATION).**

NOTICE is hereby given that at an Extraordinary General Meeting of the company, held at the Registered Office of the company, at the residence of Mrs. T. E. King, 46 Prince-street, Gisborne, Victoria, on the 25th day of September, 1968, in the forenoon a special resolution was duly passed that the company be wound up voluntarily, and at the same meeting an ordinary resolution was duly passed that Peter Addenbrook Walker, of 357 Little Collins-street, Melbourne, Victoria, be appointed as liquidator for the purpose of such winding up.

4850 J. D. HARVEY, Secretary.

The *Companies Act 1961*.—In the matter of **CRAIG FORD
MOTORS PTY. LTD.**

NOTICE is hereby given that at a meeting of the members of the above-named company, held on 24th day of September, 1968, it was resolved that the company be wound up voluntarily and at a meeting of the creditors, held on the same day, pursuant to section 260, it was resolved that for such purpose Dennis John Cogle, of 545 St. Kilda-road, Melbourne, public accountant, be appointed liquidator.

BENT & COUGLE, public accountants, Suite 18, 545 St. Kilda-road, Melbourne. 4837

The *Companies Act 1961*.—In the matter of **J. HEWITT
PTY. LTD.**—Notice of Final Meeting.

NOTICE is hereby given that, in pursuance to section 272 of the *Companies Act 1961*, a General Meeting of the members of the above-named company will be held, at 39 Nepean Highway, Aspendale, on Wednesday, the 30th day of October, 1968, at 10 o'clock in the forenoon, for the purpose of having an account laid before them, showing the manner in which the winding up has been conducted and the property of the company disposed of, and of hearing any explanation that may be given by the liquidator.

Dated the 23rd day of September, 1968.

4830 J. A. FARMER, Liquidator.

Companies Act 1961.

KANAB PTY. LTD. (IN VOLUNTARY LIQUIDATION).

**NOTICE CONVENING FINAL MEETING OF MEMBERS, PURSUANT
TO SECTION 272.**

NOTICE is hereby given in pursuance to section 272 of the *Companies Act 1961*, that a General Meeting of the members of the above-named company will be held at 207b Balaclava-road, Caulfield, on Wednesday, 6th November, 1968, at 9 a.m., for the purpose of having an account laid before them showing the manner in which the winding up has been conducted and the property of the company disposed of.

Dated this 30th day of September, 1968.

H. GUEST, Liquidator.

H. GUEST & ASSOCIATES, public accountants, 207b Balaclava-road, Caulfield. 4904

In the matter of the *Companies Act 1961*, and in the matter of **N. N. MCLEAN PTY. LIMITED (IN LIQUIDATION).**

NOTICE is hereby given that at an Extraordinary General meeting of the above-named company, duly convened and held at Northam-avenue, Bankstown, New South Wales, on the 18th day of September, 1968, the following Special Resolution set out below was duly passed:—

"That the company be wound up voluntarily, and that Mr. J. A. Pringle, chartered accountant, be appointed liquidator for the purposes of the winding up."

Dated this 18th day of September, 1968.

4852 J. A. PRINGLE, Liquidator.

In the matter of the *Companies Act 1961*, and in the matter of **LANE'S (VICTORIA) PTY. LIMITED (IN LIQUIDATION).**

NOTICE is hereby given that at an Extraordinary General meeting of the above-named company, duly convened and held at Northam-avenue, Bankstown, New South Wales, on the 18th day of September, 1968, the following Special Resolution set out below was duly passed:—

"That the company be wound up voluntarily, and that Mr. J. A. Pringle, chartered accountant, be appointed liquidator for the purposes of the winding up."

Dated this 18th day of September, 1968.

4853 J. A. PRINGLE, Liquidator.

In the matter of the *Companies Act 1961*, and in the matter of **VICTOR LEGGO CHEMICAL COMPANY PTY. LIMITED (IN LIQUIDATION).**

NOTICE is hereby given that at an Extraordinary General meeting of the above-named company, duly convened and held at Northam-avenue, Bankstown, New South Wales, on the 18th day of September, 1968, the following Special Resolution set out below was duly passed:—

"That the company be wound up voluntarily, and that Mr. J. A. Pringle, chartered accountant, be appointed liquidator for the purposes of the winding up."

Dated this 18th day of September, 1968.

4854 J. A. PRINGLE, Liquidator.

In the matter of the *Companies Act 1961*, and in the matter of **JAQUES PTY. LIMITED (IN LIQUIDATION).**

NOTICE is hereby given that at an Extraordinary General meeting of the above-named company, duly convened and held at Northam-avenue, Bankstown, New South Wales, on the 18th day of September, 1968, the following Special Resolution set out below was duly passed:—

"That the company be wound up voluntarily, and that Mr. J. A. Pringle, chartered accountant, be appointed liquidator for the purposes of the winding up."

Dated this 18th day of September, 1968.

4855 J. A. PRINGLE, Liquidator.

The Companies Act 1961.
WIMMERA INVESTMENTS PTY. LTD.

PURSUANT TO SECTION 260 OF THE COMPANIES ACT 1961.

NOTICE is hereby given that a meeting of creditors of Wimmera Investments Pty. Ltd. will be held at the offices of Hall & Rose, chartered accountants, 260 Queen-street, Melbourne, on Tuesday, the 22nd day of October, 1968, at 10.45 in the forenoon, for the purpose of considering the company's affairs, the company having convened an Extraordinary General Meeting of its members to be held on the same day and for the purpose of considering and if thought fit passing a Special Resolution that the company be wound up voluntarily.

Dated this 27th day of September, 1968.

R. R. BUXTON, Director.

Hall & Rose, chartered accountants, 260 Queen-street, Melbourne, 3000. 4881

Companies Act 1961.

W. R. HUGHES PROPRIETARY LIMITED (IN LIQUIDATION).

NOTICE TO CREDITORS OF INTENTION TO DECLARE DIVIDEND.

A SECOND Dividend is intended to be declared in the above matter. Creditors who have not proved their debt by the 7th day of October, 1968, will be excluded from this dividend. The date of liquidation was the 3rd day of January, 1968.

Dated this 23rd day of September, 1968.

LEWIS LUCKINS, F.C.A., Liquidator.

Lewis Luckins & Co., chartered accountants, 289 Flinders-lane, Melbourne, 3000. 4895

**VICTORIAN APIARISTS CO-OPERATIVE LTD. (IN
LIQUIDATION).**

NOTICE is hereby given that pursuant to section 272 of the *Companies Act 1961*, a meeting of the Victorian Apiarists Co-operative Ltd. and its creditors will be held at the 3rd Floor, 430 Little Collins-street, Melbourne, on Wednesday, 6th November, 1968, at 3 o'clock in the afternoon, for the purpose of receiving the liquidator's account, showing how the winding up has been conducted and the property of the company has been disposed of and any explanation thereof.

4897 N. H. MUNDAY, Liquidator.

The Companies Act 1961.—In the matter of W.L.B. & Co. PTY. LTD.

NOTICE is hereby given that at an Extraordinary General Meeting of the members of the above-named company, held on the 23rd day of September, 1968, it was resolved that the company be wound up voluntarily and at a meeting of creditors held on the same day pursuant to section 260, it was resolved that for such purpose Mr. Norman Eric Stretton, of 296 Little Lonsdale-street, Melbourne, accountant, be appointed liquidator.

Notice is also given that after 21 days from this date I shall proceed to distribute the assets. All creditors having any claims against the company should furnish particulars of same by that date, otherwise I shall proceed to distribute the assets, without regard to their claim.

Dated this 30th day of September, 1968.

N. E. STRETTON, Liquidator.

Kennedy, Smail & Middlemiss, 296 Little Lonsdale-street, Melbourne, 3000. 4896

The Companies Act 1961.

MARRIOTT TRANSPORT PROPRIETARY LIMITED
(IN LIQUIDATION).

NOTICE CONVENING FINAL MEETING OF MEMBERS AND CREDITORS PURSUANT TO SECTION 272.

NOTICE is hereby given that pursuant to section 272 of the Companies Act 1961, that a General Meeting of the members and creditors of the above-named company will be held in the offices of Kennedy, Smail & Middlemiss, 296-304 Little Lonsdale-street, Melbourne, on Wednesday, the 30th day of October, 1968, at 10.30 a.m., for the purpose of having an account laid before them showing the manner in which the winding up has been conducted and the property of the company disposed of and of hearing any explanation that may be given by the liquidator.

Dated this 30th day of September, 1968.

A. M. HORSBURGH, Liquidator.

Kennedy, Smail & Middlemiss, 296-304 Little Lonsdale-street, Melbourne, 3000. 4898

Companies Act 1961.

ROUCH & KENNEDY PTY. LTD.

NOTICE is hereby given pursuant to section 254 (2) (b) of the Companies Act 1961, that Rouch and Kennedy Pty. Ltd., by a Special Resolution passed at an Extraordinary General Meeting of the members duly convened and held on the 25th September, 1968, agreed that the company be wound up voluntarily.

Dated this 25th day of September, 1968.

W. A. BETHERAS, Liquidator.

William Buck & Co., chartered accountants, 422 Collins-street, Melbourne, Victoria, 3000. 4900

In the Supreme Court of Victoria.—1968 No. 7591.—In the matter of the Companies Act 1961; and in the matter of MCCALLUM PROPERTIES PTY. LTD.

NOTICE is hereby given that a petition for the winding up of the above-named company by the Supreme Court was on the 27th day of September, 1968, presented by Leslie Kaye Proprietary Limited, a creditor of the said company. And that the said petition is directed to be heard before the Court sitting at Melbourne, at the hour of 10.30 o'clock in the forenoon, on the 1st day of November, 1968, and any creditor or contributor of the said company desiring to support or oppose the making of an order on the said petition may appear at the time of the hearing by himself or his counsel for that purpose, and a copy of the petition will be furnished to any creditor or contributor of the said company requiring the same by the undersigned on payment of the regulated charge for same.

The petitioner's address is 205 Greville-street, Prahran.

The petitioner's solicitors are Messrs. O'Phelan & Company, of 380 Lonsdale-street, Melbourne.

O'PHELAN & COMPANY.

NOTE.—Any person who intends to appear on the hearing of the said petition must serve or send by post to the above-named solicitors, Messrs. O'Phelan & Company, notice, in writing, of his intention to do so. This notice must state the name and address of the person, or if a firm, the name and address of the firm or his or their solicitor (if any), and must be served or if posted must be sent by post in sufficient time to reach the above-named not later than 4 o'clock in the afternoon of this 31st day of October, 1968. 4901

In the Supreme Court of Victoria.—1968 No. Co. 7584.—In the matter of the Companies Act 1961; and in the matter of J. G. ROUDA & ASSOCIATES PTY. LTD.

NOTICE is hereby given that a petition for the winding up of the above-named company by the Supreme Court was on the 16th day of September, 1968, presented by the said John H. Kinnear & Co.: And that the said petition is directed to be heard before the Court sitting at the Fourteenth Court, Law Courts, William-street, Melbourne, at the hour of 2.45 p.m. on the 22nd day of October, 1968; and any creditor or contributory of the said company desiring to support or oppose the making of an order on the said petition may appear at the time of hearing by himself or his counsel for that purpose; and a copy of the petition will be furnished to any creditor or contributory of the said company requiring the same by the undersigned on payment of the regulated charge for the same.

The petitioner's address is 51 Riversdale-road, Camberwell.

The petitioner's solicitors are Messrs. Abbott, Stillman & Wilson, of 406 Lonsdale-street, Melbourne.

ABBOTT, STILLMAN & WILSON.

NOTE.—Any person who intends to appear on the hearing of the said petition must serve or send by post to the above-named Abbott, Stillman & Wilson, notice, in writing, of his intention to do so. The notice must state the name and address of the person, or if a firm, the name and address of the firm, and must be signed by the person or firm, or his or their solicitor (if any), and must be served, or, if posted, must be sent by post in sufficient time to reach the above named not later than Four o'clock in the afternoon of the 21st day of October, 1968 (the day before the day appointed for the hearing of the petition or the Friday preceding the day appointed for the hearing of the petition if such day is a Monday or a Tuesday following a public holiday).

ABBOTT, STILLMAN & WILSON, solicitors, of 406 Lonsdale-street, Melbourne. 4915

The Companies Act 1961.

30 WASHINGTON STREET PTY. LTD. (IN VOLUNTARY LIQUIDATION).

NOTICE OF FINAL MEETING.

NOTICE is hereby given that pursuant to section 272 of the Companies Act 1961 a general meeting of members of 30 Washington Street Pty. Ltd. will be held at the office of Spry Walker & Co., 339 Collins-street, Melbourne, on Wednesday, 6th November, 1968, at 10 a.m., for the purpose of laying before the meeting accounts showing how the winding-up has been conducted, and the property of the company has been disposed of, and of hearing any explanation that may be given by the liquidators.

R. MOORE & E. M. HUGGARD, joint and several liquidators. 4912

Companies Act 1961.—In the matter of LIPSON & ROGERS MANUFACTURING PTY. LTD.—Notice Re Meeting of Creditors, pursuant to Section 260.

NOTICE is hereby given that a meeting of creditors of the above-named company will be held at Room 314, 3rd Floor, Princes Gate, East Par, 151 Flinders-street, Melbourne, at 10.30 a.m., on Friday the 11th day of October, 1968, the company having convened a meeting of its members for the same day for the purpose of considering a Resolution that the company be wound up voluntarily.

Dated the 27th day of September, 1968.

J. ESTRY, Director.

A. Neville Bird & Co., chartered accountants, 289 Flinders-lane, Melbourne. 4913

Companies Act 1961, Section 254 (2).

J. E. DONOGHUE PROPRIETARY LIMITED (IN VOLUNTARY LIQUIDATION).

NOTICE OF RESOLUTION.

AT an Extraordinary Meeting of the members of the above-named company held on the 20th day of September, 1968, the Special Resolution set out below was duly passed:—

"That the company having successfully completed its objectives be voluntarily wound up pursuant to section 254 of the Companies Act 1961 and that John Charles Couzens be appointed liquidator."

JOHN C. COUZENS, liquidator, 527 Collins-street, Melbourne, 3000. 4914

The Companies Act 1961.

FITZHERBERT GENERAL ELECTRIC PTY. LTD.

NOTICE is hereby given that a First Dividend is intended to be declared in the above matter. Creditors, who have not proved their debts by the 15th day of October, 1968, may be excluded from this dividend.

Dated this 25th day of September, 1968.

G. O. HARRISON, Liquidator.

Hall & Rose, chartered accountants, 260 Queen-street, Melbourne, 3000. 4882

Form 7.

Companies Act 1961.

C. & R. GORDON PROPRIETARY LIMITED.

NOTICE OF RESOLUTION.

To the Registrar of Companies.

AT a general meeting of the members of C. & R. Gordon Proprietary Limited, duly convened and held at 52 Eastmont-street, Northcote, on the 23rd day of September, 1968, the special resolution set out below was duly passed.

That the company be wound up voluntarily.

That Robert Joseph Glover be and is hereby appointed liquidator at a remuneration in accordance with the scale of fees laid down by Australian Society of Accountants.

Dated this 23rd day of September, 1968.

4863 R. J. GLOVER, Secretary.

Form 69

Companies Act 1961.

C. & R. GORDON PROPRIETARY LIMITED.

NOTICE OF APPOINTMENT AND SITUATION OF OFFICE OF LIQUIDATOR (MEMBERS VOLUNTARY WINDING UP).

To the Registrar of Companies.

I, ROBERT JOSEPH GLOVER, of 143 Wells-street, South Melbourne give notice that:

(a) I was appointed liquidator of C. & R. Gordon Proprietary Limited by resolution passed on 23rd day of September, 1968.

(b) My office is situated at 143 Wells-street, South Melbourne, 3205.

Dated this 23rd day of September, 1968.

4862 R. J. GLOVER, Liquidator.

MARGARET FLANAGAN, late of 249 McKean-street, North Fitzroy, in the State of Victoria, gentlewoman, DECEASED.

CREDITORS, next of kin and others having claims against the estate of the above-named deceased (who died on the 24th day of August, 1968), are to send in particulars of their claim to the executor, National Trustees, Executors and Agency Company of Australasia Limited, 95 Queen-street, Melbourne, by the 9th day of December, 1968, after which day it will distribute the assets, having regard only to the claims of which it then has notice.

MICHAEL R. NOLAN, 62 Jackson-court, East Doncaster. 4833

ADA ANN ASHBY, late of 3 Antibes-street, Parkdale, in the State of Victoria, spinster, DECEASED.

CREDITORS, next of kin and others having claims in respect of the estate of the deceased (who died on the 3rd day of December, 1967), are required by the executrix, Alice Myrtle Kennedy, of 27 Vale-street, Moe, married woman, to send particulars to her solicitors, Messrs. F. X. O'Halloran, Davis & Co., Kirk-street, Moe, by the 2nd day of December, 1968, after which date the executrix may convey or distribute the assets, having regard only to the claims of which they then have notice.

Dated the 30th day of September, 1968.

F. X. O'HALLORAN, DAVIS & CO., solicitors, Moe. 4834

CREDITORS, next of kin and others having claims in respect of the estate of Lucy Maude Mapiestone, late of Hamilton, spinster, deceased (who died on the 7th day of July, 1968), are to send the particulars of their claims to National Trustees, Executors and Agency Company of Australasia Limited, of 95 Queen-street, Melbourne, by the 5th day of December, 1968, after which date it will distribute the assets, having regard only to the claims of which it then has notice.

HULL, NEWNS & LORD, solicitors, 58 Gray-street, Hamilton. 4835

WALTER POWELL ARMSTRONG DAVEY, late of 45 Roberts-avenue, Horsham, retired, DECEASED.

CREDITORS, next of kin and others having claims in respect of the estate of the deceased (who died on the 6th day of October, 1967), are required by the deceased's personal representative, Norman Stanley Davey, of 41 Cockle-street, O'Connor, Australian Capital Territory, auditor, to send particulars to him care of his solicitors, B. J. McGrath & Gaskell, of 52 Wilson-street, Horsham, by the 29th day of November, 1968, after which date they may convey or distribute the assets, having regard only to the claims of which they then have notice.

Dated the 23rd day of September, 1968.

B. J. McGRATH & GASKELL, solicitors, 52 Wilson-street, Horsham. 4824

HERBERT KAY, late of Beverford in the State of Victoria, farmer, DECEASED (who died on the 3rd day of March, 1968).

CREDITORS, next of kin and all other persons having claims against the estate of the deceased are required by the executors of the will, Emily Kay and Peter James Kay, to send particulars to them care of the undersigned on or before the 24th day of December, 1968, after which date they will distribute the assets, having regard only to the claims of which they then have notice.

GARDEN & GREEN, solicitors, 4 McCallum-street, Swan Hill. 4836

WILLIAM HERBERT EDWARDS, late of "The Moorlands", Acheron, grazier, DECEASED.

CREDITORS, next of kin and others having claims in respect of the deceased (who died on the 16th day of May, 1968), are required by his trustees, Leonard William Edwards, logging contractor, Thelma Edith Edwards, spinster, and Clara Isabel Edwards, widow, all of "The Moorlands", Acheron, to send particulars to them care of the under-mentioned firm of solicitors by the 11th day of November, 1968, after which date the trustees may convey and distribute the assets, having regard only to the claims of which they then have notice.

MAL. RYAN & GLEN, High-street, Mansfield, solicitors for the trustees. 4846

CREDITORS, next of kin and others having claims in respect of the estate of John Bowring O'Brien, late of "Inala Village", 208 Middleborough-road, South Blackburn, in the State of Victoria, retired musician, deceased (who died on the 22nd day of July, 1968), are required by the executor, National Trustees, Executors and Agency Company of Australasia Limited, to send particulars to it at 95 Queen-street, Melbourne, by the 13th day of December, 1968, after which date it will distribute the assets, having regard only to the claims of which it then has notice.

KENNETH J. CLEMENTS & SON, solicitors, 255 Glenhuntly-road, Elsternwick. 4867

CREDITORS, next of kin and others having claims in respect of the estate of Elsie Ellen Bell, formerly of 147 Springfield-road, Blackburn, but late of 120 Springfield-road, Blackburn, both in the State of Victoria, widow deceased (who died on the 24th March, 1968), are to send particulars of their claims to The Equity Trustees, Executors and Agency Company Limited, of 472 Bourke-street, Melbourne, in the State of Victoria, the executor appointed by the will of the said deceased, by the 4th December, 1968, after which date the executor will distribute the assets, having regard only to the claims of which it shall then have notice.

H. L. YUNCKEN & YUNCKEN, solicitors, of 443 Little Collins-street, Melbourne, 3000. 4876

CREDITORS, next of kin and others having claims in respect of the estate of Rose May Ludlow, formerly of 36 Alexander-street, Collingwood, but late of 45 Rosanna-road, Heidelberg, both in the State of Victoria, aged pensioner, deceased (who died on the 1st July, 1968), are to send particulars of their claims to Alfred William Ludlow, of 45 Rosanna-road, Heidelberg, in the State of Victoria, the executor appointed by the will of the said deceased by the 4th December, 1968, after which date the executor will distribute the assets having regard only to the claims of which it shall then have notice.

H. L. YUNCKEN & YUNCKEN, solicitors, of 443 Little Collins-street, Melbourne, 3000. 4877

CREDITORS, next of kin and others having claims in respect of the estate of Klaas Renooy, late of Boggy Creek-road, Tinamba, in Victoria, farmer, deceased (who died on 29th June, 1968), are to send particulars of their claims to the executor, The Union-Fidelity Trustee Company of Australia Limited, at its office at 100 Hotham-street, Traralgon, by 1st December, 1968, after which date the said company will distribute the assets, having regard only to the claims of which it then has notice.

C. H. FORD, LL.M., solicitor, Traralgon. 4849

WILLIAM ALEXANDER CARLAND, late of Neerim South, retired farmer, DECEASED.

CREDITORS, next of kin and others having claims in respect of the estate of the deceased (who died on 5th July, 1968), are required by the trustee, Harold Grenville Skewes, formerly of Craig-street, Warragul, but now of Clifford-street, Warragul, to send particulars to him, care of the undersigned solicitors, by the 4th day of December, 1968, after which date the trustee may convey or distribute the assets, having regard only to the claims of which he then has notice.

GRAY, FRIEND & LONG, solicitors, Warragul. 4874

CREDITORS, next of kin and others having claims in respect of the estate of Robert Henry Sword, late of 3 Carlyle-crescent, Mont Albert, in the State of Victoria, gentleman, deceased (who died on the 16th June, 1968), are to send particulars of their claims to Bernard Vere Sword, of 1A Western Beach, Geelong, in the State of Victoria, the executor appointed by the will of the said deceased, by the 4th December, 1968, after which date the executor will distribute the assets, having regard only to the claims of which he shall then have notice.

H. L. YUNCKEN & YUNCKEN, solicitors, of 443 Little Collins-street, Melbourne, 3000. 4875

CREDITORS, next of kin and others having claims in respect of the estate of Effie Kerr McDonald, late of 72 Rose-street, Armadale, spinster, deceased (who died on the 16th day of July, 1968), are to send particulars of their claims to The Equity Trustees, Executors and Agency Company Limited, of 472 Bourke-street, Melbourne, by the 20th day of December, 1968, after which date it will distribute the assets, having regard only to claims of which it then has notice.

LYNCH & MACDONALD, of 118 Queen-street, Melbourne. 4889

CREDITORS, next of kin and others having claims against the estate of Elizabeth Austin, formerly of 211 Royal-parade, Parkville, but late of 2 Sheffield-street, Brunswick, widow, deceased, are required to send particulars of their claims to the administratrix, Shirley Young, of 501 Park-road, Park Orchards, married woman, care of the undersigned by the 3rd day of December, 1968, after which date she will distribute the assets, having regard only to the claims of which she then has notice.

JOHN D. MUSTOW & CO., solicitors, of 89 Queen-street, Melbourne. 4890

IVOR JAMES PAHL, late of Apsley, grazier, DECEASED.

CREDITORS, next of kin and others having claims in respect of the estate of the deceased (who died on the 25th day of April, 1968), are required by The Union-Fidelity Trustee Company of Australia Limited, of 100 Exhibition-street, Melbourne, and Eleanor Emily Jean Pahl, of Apsley, widow, the applicants for a grant of probate to send particulars of their claims to the said applicants in the care of the said company by the 20th day of December, 1968, after which date they will convey or distribute the assets, having regard only to the claims of which they then have notice.

Dated the 25th day of September, 1968.

MADDEN, BUTLER, ELDER & GRAHAM, solicitors, 31 Queen-street, Melbourne. 4891

CREDITORS, next of kin and others having claims in respect of the estate of Mabel Adeline Riley, late of 227 North-road, East Oakleigh, widow, deceased (who died on the 25th day of July, 1968), are to send particulars of their claims to the executor, George Creswell Riley, of 69 Alice-street, Clayton, care of the under-mentioned solicitors by the 11th day of December, 1968, after which date he will distribute the assets, having regard only to the claims of which he then has notice.

LLOYD P. GOODE & CO., solicitors, 388 Bourke-street, Melbourne. 4892

CREDITORS, next of kin and others having claims in respect of the estate of Antonios Antonopoulos, (commonly known as Tony Tonopoulos), late of Traralgon, in the State of Victoria, retired, deceased (who died on the 17th day of March, 1968, and probate of whose will was granted by the Supreme Court of the State of Victoria, on the 10th day of September, 1968), are to send particulars of their claims to the Union Fidelity Trustee Company of Australia Limited, of 100 Exhibition-street, Melbourne, in the said State by the 30th November, 1968, after which date it will distribute the assets of the deceased, having regard only to the claims of which it then has notice.

Dated the 23rd September, 1968.

BRUCE & LITTLETON, solicitors, Traralgon. 4899

PURSUANT to the Trustee Act 1958 notice is hereby given that all persons having claims against the estate of Myrtle Annie Eileen Andrew, late of 59 Tooronga-road, East Malvern, spinster, deceased (who died on the 30th July, 1968, and probate of whose will was granted by the Supreme Court of the said state, in its Probate Jurisdiction, on the 17th day of September, 1968, to Lyndhurst Thomas Mullett, of 470 Bourke-street, Melbourne, solicitor), are hereby required to send particulars in writing of such claims to the said Lyndhurst Thomas Mullett, at his above-mentioned address on or before the 7th day of December, 1968, after which date the said Lyndhurst Thomas Mullett, will proceed to distribute the assets of the said Myrtle Annie Eileen Andrew, deceased, which shall have come to his hands amongst the persons entitled thereto, having regard only to the claims of which he shall then have had notice. And notice is hereby further given that the said Lyndhurst Thomas Mullett, will not be liable for the assets so distributed or any part thereof to any person of whose claim he shall not have had notice as aforesaid.

Dated this 25th day of September, 1968.

MULLETT & LANGFORD, of 470 Bourke-street, Melbourne, solicitors for the said Lyndhurst Thomas Mullett. 4893

ETHEL FLORENCE WATSON, late of Flat 2, 161 Alexandra-avenue, Toorak, widow, DECEASED.

CREDITORS, next of kin and others having claims in respect of the estate of the above-named deceased (who died on the 25th day of July, 1968), are required by the applicants for probate, Brian Darnton Bayston, of 317 Collins-street, Melbourne, and the Public Trustee, of 256 Flinders-street, Melbourne, to send particulars to them, care of the under-mentioned solicitors by 3rd day of December, 1968, after which date the applicants may convey or distribute the assets, having regard only to the claims of which they then have notice.

MCCRACKEN & MCCRACKEN, 317 Collins-street, Melbourne, solicitors. 4894

CREDITORS, next of kin and others having claims against the estate of Helen Leura Ware Dowling, late of 15 Alleyne-avenue, Armadale, in the State of Victoria, gentlewoman, deceased (who died on the 26th day of June, 1968), are required by The Trustees Executors and Agency Company Limited, of 401 Collins-street, Melbourne, in the said State, and Colin Brandon Villiers, of 9 Alleyne-avenue, Armadale, in the said State, company secretary, the executors of the will of the said deceased, to send particulars of their claims to the said executors, in the care of the said company, by the 5th day of December, 1968, after which date the executors will convey or distribute the estate of the said deceased, having regard only to the claims of which they then have notice.

MELVILLE & MELVILLE, solicitors, of 224 Glenferrie-road, Malvern. 4883

IVY MARION MARY MATHIESON, late of the Kerang Hotel, Kerang, widow, DECEASED.

CREDITORS, next of kin and others having claims in respect of the estate of the deceased (who died on the 21st day of July, 1968), are required by The Perpetual Executors and Trustees Association of Australia Limited, of 100-104 Queen-street, Melbourne, and John Joseph Forrest, of "Barjarg", Mansfield, grazier, the applicants for a grant of administration, to send particulars of their claims to the said applicants, in the care of the said company, by the 4th day of December, 1968, after which date they will convey or distribute the assets, having regard only to the claims of which they then have notice.

WHITING & BYRNE, solicitors, 166 Queen-street, Melbourne. 4884

CREDITORS, next of kin and others having claims in respect of the estate of Mary Hopetoun Ford, late of Flat 10, 530 Toorak-road, Toorak, spinster, deceased (who died on 8th May, 1968), are to send particulars of their claims to The Union-Fidelity Trustee Company of Australia Limited and Bessie Edith George, at 100 Exhibition-street, Melbourne, by the 3rd December, 1968, after which date it and she will distribute the assets, having regard only to the claims of which it and she then have notice.

HENDERSON & BALL, solicitors, 430 Little Collins-street, Melbourne. 4878

CREDITORS, next of kin and others having claims against the estate of Minnie Sedgman, late of 78 Parer-street, Burwood, in the State of Victoria, widow, deceased (who died on the 30th day of April, 1968), are required to send particulars of their claims to the executrix, Joyce Thelma Burton, care of the undersigned solicitor, before the 12th day of December, 1968, after which date she will distribute the assets, having regard only to the claims of which she then has notice.

JOHN F. CARROLL, solicitor, 118 Queen-street, Melbourne. 4879

CREDITORS, next of kin and other persons having claims against the estate of Irene Gladys Robertson, late of 40 Garfield-avenue, Ormond, in the State of Victoria, spinster, deceased (who died on the 28th day of January, 1968), are required to send particulars of their claims to the executor, James Patrick Ogge, care of the undersigned solicitors, by the 12th December, 1968, after which date the executor will distribute the assets, having regard only for the claims of which he then has had notice.

JAMES P. OGGE & CO., solicitors, of 165 Greville-street, Prahran. 4888

CREDITORS, next of kin and others having claims in respect of the estate of Miriam May Page, late of 12 Bangalore-street, Kensington, widow, deceased (who died on the 19th day of June, 1968), are required to send particulars, in writing, of their claims to John Victor Page and Barbara Joan Urch, the executors, in care of the undersigned, on or before the 3rd December, 1968, after which date the executors will convey or distribute the assets, having regard only to the claims of which they then have notice.

IRVING S. PLOTKIN, SCOTT & OPAT, 379 Bourke-street, Melbourne. 4907

CREDITORS, next of kin and others having claims in respect of the estate of Charles Tanner Davis, late of 3 Lonie-street, North Melbourne, retired iron worker, deceased (who died on the 4th day of June, 1968), are required to send particulars, in writing, of their claims to Irving Samuel Plotkin, the executor, in care of the undersigned, on or before the 3rd December, 1968, after which date the executor will convey or distribute the assets, having regard only to the claims of which he then has notice.

IRVING S. PLOTKIN, SCOTT & OPAT, 379 Bourke-street, Melbourne, solicitors. 4908

JOSEF SWIECONEK, late of 27 Orvieto-street, Merlynston, machinist, DECEASED (who died on the 19th April, 1968).

CREDITORS, next of kin and others having claims against the estate of the deceased are required by the executor, William Myles Wilson, of 401 Collins-street, Melbourne, solicitor, to send particulars of their claims to the executor, care of the undersigned solicitors, on or before the 6th December, 1968, after which date he will distribute the assets, having regard only to the claims of which he then has notice.

HOME, WILKINSON & LOWRY, solicitors, of 401 Collins-street, Melbourne. 4910

CREDITORS, next of kin and others having claims in respect of the estate of John Bradbury Sparkes, late of 9 Tyndall-street, Surrey Hills, gentleman, deceased (who died on the 24th July, 1968), are to send particulars of their claims to The Trustees, Executors and Agency Company Limited, of 401 Collins-street, Melbourne, by the 6th December, 1968, after which date it will distribute the assets, having regard only to the claims of which it then has notice.

MOULE, HAMILTON & DERHAM, solicitors, 224 Queen-street, Melbourne. 4911

JANET ISABELLE WHYTE, late of 29 Toorak-road, South Camberwell, gentlewoman, DECEASED.

CREDITORS, next of kin and others having claims in respect of the estate of the deceased (who died on 4th day of August, 1968), are required by The Perpetual Executors and Trustees Association of Australia Limited, of 100-104 Queen-street, Melbourne, to send particulars of their claims to the said company, by the 6th day of December, 1968, after which date it will convey or distribute the assets, having had regard only to the claims of which the company then has notice.

UPTON & ETTTELSON, solicitors, 100 Queen-street, Melbourne. 4909

CREDITORS, next of kin and others having claims in respect of the estate of William Stephen Rumble, late of 172 Whitehorse-road, Balwyn, gentleman, deceased (who died on 6th February, 1968), are to send particulars of their claims to Elsie Barbara Rumble, of 172 Whitehorse-road, Balwyn, widow, and Jean Mary Stevenson, married woman, and Douglas Arthur Stevenson, sales supervisor, both of 7 Norbert-street, Balwyn, the executors appointed by the will of the said deceased, by the 3rd December, 1968, after which date the executor will distribute the assets, having regard only to the claims of which it shall then have notice.

H. L. YUNCKEN & YUNCKEN, solicitors, 443 Little Collins-street, Melbourne. 4880

CREDITORS, next of kin and others having claims in respect of the estate of Jane Goodlet Sutherland (also known as Jean Goodlet Sutherland) late of 24 Normanby-street, Middle Brighton, in the State of Victoria, spinster, deceased (who died on the 12th day of June, 1968), are to send the particulars of their claims to The Equity Trustees, Executors and Agency Company Limited, of 472 Bourke-street, Melbourne, in the said State, by the 5th day of December, 1968, after which date it will distribute the assets, having regard only to the claims of which it then has notice.

ABBOTT, STILLMAN & WILSON, solicitors, of 406 Lonsdale-street, Melbourne. 4902

CREDITORS, next of kin and others having claims in respect of the estate of Mary Nankivell Russell, late of "Lynn", 11 Elgin-avenue, Armadale, in Victoria, widow, deceased (who died on the 16th day of July, 1968), are required to send particulars of their claims to the executor, George Kincaid Russell, of "Barunah Plains", Hesse, in Victoria, grazier, care of the under-mentioned solicitors, by the 3rd day of December, 1968, after which date he may convey or distribute the assets, having regard only to the claims of which he then has notice.

AITKEN, WALKER & STRACHAN, solicitors, 414 Collins-street, Melbourne. 4886

CREDITORS, next of kin and other persons having claims against the estate of Norah Nolan, sometimes known as Nora Nolan, formerly of 302 Johnston-street, Abbotsford, in the State of Victoria, but late of 23 Yeo-street, Neutral Bay, in the State of New South Wales, widow, deceased (who died on the 19th October, 1967), are required to send particulars of their claims to National Trustees, Executors and Agency Company of Australasia Limited, whose registered office is situated at 95 Queen-street, Melbourne, by the 12th December, 1968, after which date the executor will distribute the assets, having regard only for the claims of which it then has had notice.

JAMES P. OGGE & CO., solicitors, of 165 Greville-street, Prahran. 4887

CREDITORS, next of kin and others having claims in respect of the estate of Walter St. George Sproule, late of 292 Tooronga-road, Glen Iris, in Victoria, gentleman, deceased (who died on the 17th day of March, 1968), are required to send particulars of their claims to the executors, James Edward St. George Sproule, of Tucks-road, Shoreham, in Victoria, retired, and The Equity Trustees, Executors and Agency Company Limited, of 472 Bourke-street, Melbourne, in Victoria, care of the said company, by the 3rd day of December, 1968, after which date they may convey or distribute the assets, having regard only to the claims of which they then have notice.

AITKEN, WALKER & STRACHAN, solicitors, 414 Collins-street, Melbourne. 4885

In the Supreme Court of the State of Victoria.
SALE BY THE SHERIFF.

ON Thursday, the 14th of November, 1968, at 10 a.m. at the Police Station, Lilydale, (unless process be stayed or satisfied):—

All the estate and interest (if any) of Hendrik Paas, of 32 Haig-street, Croydon, bricklayer, as proprietor of an estate in fee-simple in the land described in certificate of title, volume 8285, folio 617. The property, which is vacant land is lot 2 on plan of subdivision No. 51181, Parish of Mooroolbark, has a frontage of 120 feet, and is known as lot 2, Patterson-road, Lilydale.

Terms—Cash only.

N. FROGLEY, Sheriff's Officer.

1st October, 1968.

4906

IMPOUNDINGS

BROADMEADOWS.—Impounded in Campbellfield Pound.

1 donkey, no visible brand

If not claimed and expenses paid, to be sold on 17th October, 1968.

G. SCHNEIDER,
 Poundkeeper.

4831—\$1.50

KERANG.—Impounded in Kerang Pound, from Lower Loddon, on 26th September, 1968.

1 Friesian crossbred bull, 15 months, no visible brand
 1 Jersey crossbred bull, 15 months, no visible brand

If not claimed and expenses paid, to be sold on 19th October, 1968.

F. F. HASTIE,
 Poundkeeper.

4873—\$2.00

PAKENHAM.—Impounded in Pakenham Pound, from Langs-road, Dewhurst.

1 Poll Hereford bull, no visible brand

If not claimed and expenses paid to be sold on 14th October, 1968.

H. SMITH,
 Poundkeeper.

4871—\$1.75

RUTHERGLEN.—Impounded in Rutherglen Shire Pound, from Norong Riding, by D. Stanton, herdsman.

1 full mouth woolly crossbred wether, earmark notch right ear, no visible brand

If not claimed and expenses paid, to be sold on 19th October, 1968.

ERIC MILLER,
 Poundkeeper.

4916—\$2.00

TRARALGON.—Impounded in Traralgon Pound.

1 ewe, short tail, full ears, no visible brand

If not claimed and expenses paid, to be sold on 15th October, 1968.

E. KRUTOP,
 Poundkeeper.

4905—\$1.50

Subordinate Legislation Act 1962.

NOTICE OF MAKING OF STATUTORY RULES.

IN pursuance of the provisions of the *Subordinate Legislation Act 1962* and the Regulations made thereunder, notice is given of the making of the following statutory rules:—

No.	Drought Relief Act 1968.	Price.
234/1968.	Drought Relief Act (Ending of the Drought Period Amendment No. 1) Regulations 1968	10c
	<i>Drought Relief Act 1968.</i>	
235/1968.	Drought Relief Act (Amendment No. 3) Regulations 1968	10c
	<i>Legal Profession Practice Act 1958.</i>	
236/1968.	Rules Relating to the Qualification and Admission of Candidates	10c

No. 82.—8959/68.—4

No.	Melbourne Harbor Trust Act 1958 (No. 6312).	Price.
237/1968.	Melbourne Harbor Trust Long Service Leave Regulations (Amendment No. 1/68)	10c

Copies of these statutory rules may be purchased at the Sale of Publications Section of the Government Printing Office, located at Macarthur-street, Melbourne, 3002. If ordered by mail, remittance should be addressed to "The Government Printer, Box 203, P.O., North Melbourne, 3051", and should include 5c extra for postage. If a credit account is held at this office, no remittance is required with the mail order.

The annual subscription rate for Statutory Rules (including a Bound Volume) is \$15, payable in advance. The subscription year commences on 1st January.

A. C. BROOKS,
 Government Printer.

STATE ACTS, 1968

COPIES of the following Acts of Parliament of Victoria may be obtained at the Government Printing Office, or from any accredited agents, at the price set opposite to each (these prices do not include postage).

The annual subscription for State Acts 1968 et seq. is \$8 payable in advance.

Bound Volumes of State Acts are also available on a subscription basis of \$15 per annum.

No.		Price.
7656.	The Constitution Act Amendment (Governor's Salary)	\$0.10
7657.	Victorian Limbless Soldiers' Provident Fund (Closing)	\$0.15
7658.	Country Roads (Borrowing Powers)	\$0.10
7659.	Hairdressers Registration (Amendment)	\$0.10
7660.	Evidence (Attestations)	\$0.10
7661.	Melbourne Harbor Trust (Borrowing Powers)	\$0.10
7662.	Cheltenham Cemetery Lands Exchange	\$0.10
7663.	Administration and Probate (Amendment)	\$0.10
7664.	Road Traffic (Infringements)	\$0.10
7665.	Transport Regulation (Amendment)	\$0.10
7666.	Commercial Goods Vehicles (Amendment)	\$0.10
7667.	Tyabb to Long Island Railway Construction	\$0.10
7668.	Marriage (Liability in Tort)	\$0.10
7669.	La Trobe University (Amendment)	\$0.10
7670.	Children's Court (Procedure)	\$0.10
7671.	Labour and Industry (Amendment)	\$0.15
7672.	Cemeteries (Exhumation Licences)	\$0.10
7673.	Consolidated Revenue	\$0.10
7674.	Forests (Amendment)	\$0.10
7675.	Drought Relief	\$0.15
7676.	Town and Country Planning (Amendment)	\$0.35
7677.	Sunday Entertainment (Amendment)	\$0.10
7678.	Police Offences (Publications)	\$0.10
7679.	The Constitution Act Amendment	\$0.10
7680.	Portland Harbor Trust (Borrowing Powers)	\$0.10
7681.	Acts Interpretation (Prior Convictions)	\$0.10
7682.	Aerial Spraying Control (Amendment)	\$0.10
7683.	Shearers Accommodation (Amendment)	\$0.15
7684.	Racing (Amendment)	\$0.15
7685.	Health (Amendment)	\$0.10
7686.	State Electricity Commission (Amendment)	\$0.15
7687.	Kyneton Cattle Market Lands Exchange	\$0.15
7688.	Swine (Application of Fund)	\$0.10
7689.	Local Government (Amendment)	\$0.40
7690.	Royal Society for the Prevention of Cruelty to Animals	\$0.15
7691.	Racing (Trotting Meetings)	\$0.10
7692.	Labour and Industry (Shop Trading Hours)	\$0.10
7693.	Justices (General Sessions Jurisdiction)	\$0.10
7694.	Latrobe Valley (Amendment)	\$0.10
7695.	Liquor Control	\$0.75
7696.	Crimes (Amendment)	\$0.10
7697.	Country Roads (Amendment)	\$0.10
7698.	West Moorabool Water Board	\$0.35
7699.	Melbourne and Metropolitan Board of Works (Borrowing Powers)	\$0.10
7700.	Teaching Service (Amendment)	\$0.10
7701.	Children's Welfare (Amendment)	\$0.10

A. C. BROOKS,
 Government Printer.

ACTS REPRINTED IN ACCORDANCE WITH THE AMENDMENTS INCORPORATION ACT 1958 (No. 6422), AND FOR SALE AT THE SALE OF PUBLICATIONS BRANCH OF THE GOVERNMENT PRINTING OFFICE, MACARTHUR STREET, MELBOURNE, 3002.

(These prices do not include postage.)

No.	Price.
6189. Acts Interpretation (Incorporating amendments up to No. 7146)	\$0.15
6191. Administration and Probate (Third Reprint—Incorporating amendments up to No. 7332)	\$0.38
6194. Agricultural Colleges (First Reprint—Incorporating amendments up to No. 7302)	\$0.15
7117. Appeal Costs Fund Act 1964 (First Reprint—Incorporating amendments up to No. 7488)	\$0.25
6199. Apprenticeship (First Reprint—Incorporating amendments up to No. 7312)	\$0.25
6203. Audit (First Reprint—Incorporating amendments up to No. 7377)	\$0.35
6209. Boiler Inspection (Incorporating amendments up to No. 7072)	\$0.18
6210. Building Societies (Incorporating amendments up to No. 7125)	\$0.25
6218. Children's Court (Incorporating amendments up to No. 7084)	\$0.20
6219. Children's Welfare (Second Reprint—Incorporating amendments up to No. 7084)	\$0.35
6220. Clean Air (Incorporating amendments up to No. 6886)	\$0.10
6221. Coal Mines (First Reprint—Incorporating amendments up to No. 7628)	\$1.05
6222. Commercial Goods Vehicles (Second Reprint—Incorporating amendments up to No. 7358)	\$0.22
6839. Companies Act 1961 (Second Reprint—Incorporating amendments up to No. 7332)	\$2.32
6225. Co-operation (Second Reprint—Incorporating amendments up to No. 7083)	\$0.42
6226. Co-operative Housing Societies (Incorporating amendments up to No. 7097)	\$0.40
6228. Country Fire Authority (Second Reprint—Incorporating Amendments up to No. 7476)	\$0.50
6229. Country Roads (Second Reprint—Incorporating Amendments up to No. 7506)	\$0.60
6230. County Court Act (First Reprint—Incorporating amendments up to No. 7420)	\$0.35
6231. Crimes (Second Reprint—Incorporating amendments up to No. 7407)	\$1.33
7060. Dandenong Valley Authority Act 1963 (First Reprint—Incorporating amendments up to No. 7523)	\$0.35
6236. Dog (Second Reprint—Incorporating amendments up to No. 7065)	\$0.15
6239. Dried Fruits Act 1968 (First Reprint—Incorporating amendments up to No. 7337)	\$0.25
6240. Education (First Reprint—Incorporating amendments up to No. 7533)	\$0.45
6241. Electric Light and Power (First Reprint—Incorporating amendments up to No. 7315)	\$0.30
6242. Employers and Employés (Incorporating amendments up to No. 6740)	\$0.18
6243. Entertainments Tax (First Reprint—Incorporating amendments up to No. 7315)	\$0.25
6245. Estate Agents Act (Third Reprint—Incorporating amendments up to No. 7425)	\$0.50
6246. Evidence (Second Reprint—Incorporating amendments up to No. 7366)	\$0.42
7499. Extractive Industries Act 1966 (First Reprint—Incorporating amendments up to No. 7632)	\$0.35
6249. Fences (Incorporating amendments up to No. 6550)	\$0.12
6250. Fertilizers (Incorporating amendments up to No. 7142)	\$0.25
6251. Firearms (Second Reprint—Incorporating amendments up to No. 7484)	\$0.40
6252. Fisheries Act (First Reprint—Incorporating amendments up to No. 7389)	\$0.35
6916. Foreign Judgments Act 1962 (First Reprint—including amendments made by No. 7332)	\$0.15
6585. Forests (Pulpwood Agreement) (Incorporating amendments up to No. 6886)	\$0.15
6254. Forests (First Reprint—Incorporating amendments up to No. 7356)	\$0.60
6256. Fruit and Vegetables (First Reprint—Incorporating amendments up to No. 6944)	\$0.30
6258. Game—(First Reprint—Incorporating amendments up to No. 7389)	\$0.30
6259. Gaols (Incorporating amendments up to No. 6651)	\$0.15
6261. Gas Regulation (First Reprint—Incorporating amendments up to No. 7580)	\$0.30

ACTS REPRINTED IN ACCORDANCE WITH THE AMENDMENTS INCORPORATION ACT 1958 (No. 6422)—continued.

No.	Price.
6262. Geelong Harbor Trust (First Reprint—Incorporating amendments up to No. 7547)	\$0.45
6263. Geelong Waterworks and Sewerage (First Reprint—Incorporating amendments up to No. 7547)	\$0.75
6265. Goods (Third Reprint—Incorporating amendments up to No. 7131)	\$0.35
6266. Grain Elevators (First Reprint—Incorporating amendments up to No. 7486)	\$0.35
6270. Health (Second Reprint—Incorporating amendments up to No. 7490)	\$1.65
6933. Home Finance Act 1962 (First Reprint—Incorporating amendments up to No. 7363)	\$0.25
6274. Hospitals and Charities (Second Reprint—Incorporating amendments up to No. 7455)	\$0.50
6275. Housing (First Reprint—Incorporating amendments up to No. 7507)	\$0.85
6279. Instruments (Third Reprint—Incorporating amendments up to No. 7315)	\$0.38
6282. Justices (Second Reprint—Incorporating amendments up to No. 7369)	\$1.23
6283. Labour and Industry (Third Reprint—Incorporating amendments up to No. 7410)	\$1.00
6284. Land (Incorporating amendments up to No. 7360)	\$1.53
6534. Land Settlement Act 1959 (First Reprint—Incorporating amendments up to No. 7328)	\$0.30
6289. Land Tax (Second Reprint—Incorporating amendments up to No. 7466)	\$0.40
6285. Landlord and Tenant (Second Reprint—Incorporating amendments up to No. 6996)	\$0.50
6286. Lands Compensation—(First Reprint—Incorporating amendments up to No. 7332)	\$0.25
6290. Latrobe Valley (First Reprint—Incorporating amendments up to No. 7332)	\$0.35
6291. Legal Profession Practice (Second Reprint—Incorporating amendments up to No. 7539)	\$0.70
6295. Limitation of Actions (Second Reprint—Incorporating amendments up to No. 7457)	\$0.25
6298. Local Authorities Superannuation (Incorporating amendments up to No. 6894)	\$0.25
6299. Local Government (Second Reprint—Incorporating amendments up to No. 7689)	\$4.00
6302. Marine (Incorporating amendments up to No. 7350)	\$0.72
6304. Marketing of Primary Products (First Reprint—Incorporating amendments up to No. 7491)	\$0.45
6306. Marriage (First Reprint—Incorporating amendments up to No. 6959)	\$0.25
6309. Medical (Second Reprint—Incorporating amendments up to No. 7408)	\$0.40
6310. Melbourne and Metropolitan Board of Works (Second Reprint—Incorporating amendments up to No. 7547)	\$1.10
6312. Melbourne Harbor Trust (First Reprint—Incorporating amendments up to No. 7356)	\$0.48
6605. Mental Health (Incorporating amendments up to No. 7135)	\$0.45
6315. Metropolitan Fire Brigades (Incorporating amendments up to No. 6886)	\$0.28
6316. Mildura Irrigation and Water Trusts (First Reprint—Incorporating amendments up to No. 7448)	\$0.75
6317. Milk and Dairy Supervision (Incorporating amendments up to No. 6964)	\$0.40
6318. Milk Board (Incorporating amendments up to No. 7093)	\$0.22
6320. Mines (First Reprint—Incorporating amendments up to No. 7499)	\$1.90
6184. Monash University (First Reprint—Incorporating amendments up to No. 7533)	\$0.30
6324. Money Lenders (Incorporating amendments up to No. 6886)	\$0.25
6832. Motor Boating (Incorporating amendments up to No. 6961)	\$0.15
6325. Motor Car (Second Reprint—Incorporating amendments up to No. 7361)	\$0.82
6326. National Parks (Incorporating amendments up to No. 7275)	\$0.25
6328. Nurses (Incorporating amendments up to No. 6716)	\$0.20
6330. Partnership (Second Reprint—Incorporating amendments up to No. 7315)	\$0.25
6331. Patriotic Funds (First Reprint—Incorporating amendments up to No. 7338)	\$0.25
6257. Pesticides Act 1968 (First Reprint—Incorporating amendments up to No. 7595)	\$0.15
6889. Poisons Act 1962 (Second Reprint—Incorporating amendments up to No. 7588)	\$0.50

ACTS REPRINTED IN ACCORDANCE WITH THE AMENDMENTS INCORPORATION ACT 1958 (No. 6422)—continued.

No.	Price.
6337. Police Offences (Incorporating amendments up to No. 7145)	\$0.82
6338. Police Regulation (Incorporating amendments up to No. 7081)	\$0.45
6340. Portland Harbor Trust (First Reprint—Incorporating amendments up to No. 7475)	\$0.35
6341. Pounds (First Reprint—Incorporating amendments up to No. 7315)	\$0.25
6890. Probate Duty (Incorporating amendments up to No. 6970)	\$0.38
6344. Property Law (Incorporating amendments up to No. 6867)	\$0.90
6349. Public Service (Second Reprint—Incorporating amendments up to No. 7356)	\$0.40
6350. Public Trustee (Incorporating amendments up to No. 6961)	\$0.35
6353. Racing (Second Reprint—Incorporating amendments up to No. 7691)	\$0.85
6355. Railways (First Reprint—Incorporating amendments up to No. 7475)	\$0.75
6564. Registration of Births Deaths and Marriages Act 1959 (First Reprint—Incorporating amendments up to No. 7332)	\$0.25
6359. Road Traffic (Second Reprint—Incorporating amendments up to No. 7332)	\$0.18
6360. Rural Finance (First Reprint—Incorporating amendments up to No. 7328)	\$0.12
6846. Rural Finance and Settlement Commission Act 1961 (First Reprint—Incorporating amendments up to No. 7332)	\$0.20
6975. Sale of Land Act 1962 (First Reprint—Incorporating amendments up to No. 7332)	\$0.18
6363. Second-hand Dealers (First Reprint—Incorporating amendments up to No. 7529)	\$0.25
6367. Settled Land (Second Reprint—Incorporating amendments up to No. 7065)	\$0.50
6368. Sewerage Districts (Second Reprint—Incorporating amendments up to No. 7547)	\$0.75
6651. Social Welfare Act 1960 (Third Reprint—Incorporating amendments up to No. 7332)	\$0.20
6372. Soil Conservation and Land Utilization (Incorporating amendments up to No. 6961)	\$0.20
6373. Soldier Settlement (First Reprint—Incorporating amendments up to No. 7328)	\$0.42
6375. Stamps (Third Reprint—Incorporating amendments up to No. 7359)	\$0.82
6377. State Electricity Commission (Second Reprint—Incorporating Amendments up to No. 7421)	\$0.65
6379. State Savings Bank (Incorporating amendments up to No. 6886)	\$0.42
6381. Stock and Share Brokers (First Reprint—Incorporating amendments up to No. 7444)	\$0.15
6886. Subordinate Legislation (Incorporating amendments up to No. 6961)	\$0.15
6386. Superannuation (First Reprint—Incorporating amendments up to No. 7417)	\$0.60
6387. Supreme Court (First Reprint—Incorporating amendments up to No. 7522)	\$0.75
6391. Teaching Service (First Reprint—Incorporating amendments up to No. 7536)	\$0.35
7223. Tomato Processing Industry (Uniform Agreement) Act 1964 (First Reprint—Incorporating amendments up to No. 7342)	\$0.15
6395. Tourist (First Reprint—Incorporating amendments up to No. 7335)	\$0.15
6849. Town and Country Planning (First Reprint—Incorporating amendments up to No. 7276)	\$0.45
6399. Transfer of Land Act (Third Reprint—Incorporating amendments up to No. 7551)	\$0.65
6400. Transport Regulation (First Reprint—Incorporating amendments up to No. 7358)	\$0.22
6401. Trustee (Second Reprint—Incorporating amendments up to No. 6963)	\$0.42
6879. Unclaimed Moneys (Incorporating amendments up to No. 6961)	\$0.12
6653. Valuation of Land Act 1960 (Second Reprint—Incorporating amendments up to No. 7333)	\$0.22
6407. Vegetation and Vine Diseases (First Reprint—Incorporating amendments up to No. 7423)	\$0.30
6409. Vermin and Noxious Weeds (First Reprint—Incorporating amendments up to No. 7463)	\$0.35
6410. Veterinary Surgeons (First Reprint—Incorporating amendments up to No. 7343)	\$0.15
7291. Victoria Institute of Colleges Act 1965 (First Reprint—Incorporating amendments up to No. 7644)	\$0.25

ACTS REPRINTED IN ACCORDANCE WITH THE AMENDMENTS INCORPORATION ACT 1958 (No. 6422)—continued.

No.	Price.
6413. Water (Second Reprint—Incorporating amendments up to No. 7590)	\$1.95
6414. Weights and Measures (Second Reprint—Incorporating amendments up to No. 7332)	\$0.32
6416. Wills (First Reprint—Incorporating amendments up to No. 7238)	\$0.25
6419. Workers Compensation (Second Reprint—Incorporating amendments up to No. 7332)	\$0.52

FIRST NOTIFICATION OF REPRINT.

6255. Friendly Societies (First Reprint—Incorporating amendments up to No. 7554)	\$0.60
6260. Gas and Fuel Corporation (First Reprint—Incorporating amendments up to No. 7422)	\$0.70

THE "VICTORIA GOVERNMENT GAZETTE".

SUBSCRIPTIONS.—The subscription, including postage, is \$10 per annum, or \$5 per half year, payable in advance.

Subscriptions are required for whole months, and must cover at least a half year.

Single copies are 20 cents, posted 25 cents. Subscribers do not receive the Acts of Parliament with the GAZETTE.

GAZETTES are held in stock for five years only.

PRIVATE ADVERTISEMENTS.—The charge for insertion is 25 cents per line single column, and 50 cents per line double column. The title forms one or more lines as a heading. On an average ten words make a line of single column. Every signature must likewise be counted as a line. The final words of a paragraph, though only portion of a line, must be counted as one line. Signatures (in particular) and proper names must be written very plainly in the text; ONE SIDE ONLY of each sheet of paper should be WRITTEN UPON.

All documents illegibly written will be returned unpublished, and where brands occur unprovided for by the ordinary letters of the alphabet, a worded explanatory description must be furnished.

THE VICTORIA GOVERNMENT GAZETTE is published on WEDNESDAY EVENING in each week, and Notices for insertion will be received by the Government Printer at or before ONE p.m. at ordinary rates, and late advertisements between ONE p.m. and FOUR p.m. at double rates on the day preceding the day of publication.

PAYMENTS.—Unless the advertiser has a credit account, all payments are required in advance. Remittances should be made by cheque, postal order, or money order payable to "GOVERNMENT PRINTER".

ADDRESS.—All communications should be addressed to "The Government Printer, Box 203, P.O., North Melbourne", 3051.

PUBLICATION OF OFFICIAL MATTER.

ATTENTION is invited to the following procedure in relation to the publication of official matter in the Government Gazette:—

Publication will be facilitated by the submission of carbon copies for the use of the Gazette Officer.

1. Matter submitted to the Executive Council.

Matters submitted to the Executive Council which requires gazettal will normally be published in the issue of the following week.

Where urgent gazettal is required, special arrangements should be made with the Gazette Officer, Room 9, first floor, Old Treasury Building.

2. Other matter.

(a) All other matter duly certified by a responsible officer for publication should be lodged with the Gazette Officer not later than half-past Nine a.m. on Tuesday.

(b) Lengthy or involved notices should be forwarded several days before publication.

(c) Proofs, which will be supplied only when specifically requested or, at the direction of the Gazette Officer, should be returned promptly to avoid delay in publication.

(d) No additions or amendments to matter for publication will be accepted by telephone.

AGENTS FOR THE "VICTORIA GOVERNMENT GAZETTE".

THE following have been appointed agents to receive Advertisements and Subscriptions for the *Victoria Government Gazette*:—

- ARMSTRONG'S AGENCY, 205 Queen-street, Melbourne, Victoria 3000.
- ARNALL & JACKSON, 390 Barkly-street, Brunswick, Victoria 3056.
- BAIRNSDALE AUTHORIZED NEWSAGENCY, 132 Main-street, Bairnsdale, Victoria 3875.
- BICKNELL, M. J., Authorized Newsagent, 196 Timor-street, Warrnambool, Victoria 3280.
- BLANE'S AUTHORIZED NEWSAGENTS, 162 Murray-street, Colac, Victoria 3250.
- R. G. CARTER ADVERTISING SERVICE PTY. LTD., Suite 24, 65 Queens-road, Melbourne, Victoria 3004.
- DAVIES, G. & M. V., 112 Gray-street, Hamilton, Victoria 3300.
- DAVIS, WM. (MILDURA) PTY. LTD., 126 Eighth-street, Mildura, Victoria 3500.
- DIXON'S NEWSAGENCY, 89 Firebrace-street, Horsham, Victoria 3400.
- EDGAR'S NEWSAGENCY PTY. LTD., 293 Hargreaves-street, Bendigo, Victoria 3550.
- EDGARS' AUTHORIZED NEWSAGENCY, 45 Bridge-street, Benalla, Victoria 3672.
- FRANKS, H. & CO., 184 Ryrie-street, Geelong, Victoria 3220.
- GORDON & GOTCH AUSTRALASIA LTD., 511 Little Collins-street, Melbourne, Victoria 3000.
- GULLAN'S NEWSAGENCY, 88 Bridge-street, Ballarat, Victoria 3350.
- HAMPTON, A. C., 243 Mitchell-street, Bendigo, Victoria 3550.
- HARSTON, PARTRIDGE & CO. PTY. LTD., 455 Little Collins-street, Melbourne, Victoria 3000.
- KYNETON GUARDIAN PTY. LTD., P.O. Box 18, Kyneton, Victoria 3444.
- LATIMER'S, Newsagents, 45 Station-street, Malvern, Victoria 3144.
- LIVINGSTON'S SHEPPARTON NEWSAGENCY, 246 Wyndham-street, Shepparton, Victoria 3630.
- THE MERCANTILE EXCHANGE, 67 Queen-street, Melbourne, Victoria, 3000.
- MCGILL'S AUTHORIZED NEWSAGENCY, 183-5 Elizabeth-street, Melbourne, Victoria 3000.
- PHILLIPS AUTHORIZED AGENCY, 83 Murphy-street, Wangaratta, Victoria 3677.
- PURDIE, J., & CO., 138 Moorabool-street, Geelong, Victoria 3220.
- SALE AUTHORIZED NEWSAGENCY, 142 Raymond-street, Sale, Victoria 3850.
- SKINNER'S AUTHORIZED NEWSAGENCY, 49-51 Franklin-street, Traralgon, Victoria 3844.

STEVENSON, A. C. & M., NEWSAGENTS, 132 Henty-street, Casterton, Victoria 3311.

VERNON, C. F. & H. J., 162 Bridge-road, Richmond, Victoria 3121.

VIEW POINT AUTHORIZED NEWSAGENCY, 4 View-Point, Bendigo, Victoria 3550.

A copy of the *Gazette* filed at each place for public reference.

CONTENTS

	PAGE
Acts of Parliament on sale at the Government Printing Office	3383
Appointments	3350
Auction Sales Act	3349
Bank Holidays	3337
Cemetery—Scale of Fees	3348
Contracts	3349
Courts	3348
Estates of Deceased Persons	3342
Government Notices	3339
Impoundings	3383
Lands	3361
Melbourne and Metropolitan Board of Works— Notice	3346
Mining	3348
Notice of Making of Statutory Rules	3383
Orders in Council— Acts—Local Government; Country Roads Board; Land; Road Traffic; Nurses; Dandenong Valley Authority; Water; Mildura Irrigation and Water Trusts; Sewerage Districts; Metropolitan Fire Brigades; Landlord and Tenant; Police Regulation.	3351 et seq
Private Advertisements	3372
Proclamations	3335
Public Holidays	3336
Public Service Notices	3366
Resignation	3351
State Rivers and Water Supply Commission	3344
Tenders	3365
Transport Regulation Board—Public Hearings	3339