



VICTORIA  
GOVERNMENT GAZETTE

Published by Authority

[Registered at the General Post Office, Melbourne, for transmission by post as a newspaper.]

No. 88]

WEDNESDAY, OCTOBER 23

[1968

PROCLAMATIONS

*Land Act 1958.*

UNALIENATED CROWN LAND AVAILABLE FOR SETTLEMENT UNDER IMPROVEMENT PURCHASE LEASES.

PROCLAMATION

By His Excellency the Lieutenant-Governor of the State of Victoria and its Dependencies in the Commonwealth of Australia, &c., &c., &c.

IN pursuance of the provisions of Section 153 of the *Land Act 1958*, I, the Lieutenant-Governor of the State of Victoria, in the Commonwealth of Australia, by and with the advice of the Executive Council of the said State, do by this Proclamation declare the unalienated Crown lands mentioned in the sub-joined schedule, to be available for settlement under improvement purchase leases.

SCHEDULE.

County.	Parish.	Allotment.	Section.	Area.			Land Valuation.
				A.	R.	P.	
Bogong .. .. .	Byawatha .. .. .	3B	10	50	0	0±	\$10 per acre
Dargo .. .. .	Bullumwaal .. .. .	10A	A	150	0	0	\$12 per acre
Anglesey .. .. .	Yea .. .. .	215M3	..	37	0	0	\$12 per acre
Polwarth .. .. .	Yaughter .. .. .	9A	A	135	0	0	\$4.00 per acre

Given under my Hand and the Seal of the State of Victoria aforesaid, at Melbourne this fifteenth day of October, in the year of our Lord One thousand nine hundred and sixty-eight and in the seventeenth year of the reign of Her Majesty Queen Elizabeth II.

E. F. HERRING.

(L.S.)

By His Excellency's Command,

W. J. F. McDONALD,

Minister of Lands.

GOD SAVE THE QUEEN !

ACTS OF PARLIAMENT.

PROCLAMATION

By His Excellency the Lieutenant-Governor of the State of Victoria and its Dependencies in the Commonwealth of Australia, &c., &c., &c.

I, THE Lieutenant-Governor of the State of Victoria, in the Commonwealth of Australia, do hereby declare that I have this day assented, in Her Majesty's name, to the Bills passed by the Parliament of the said State, the titles whereof are hereunder set forth, together with the short titles, that is to say:—

- No. 7703. An Act to abolish Bailiwicks. (*Abolition of Bailiwicks Act 1968.*)
- No. 7704. An Act relating to Certain Lands in the City of Footscray, Parish of Cut-paw-paw, and to Authorize the Granting of Leases of a Certain Part thereof and for other purposes. (*Footscray (Recreation Ground) Lands Act 1968.*)
- No. 7705. An Act to abolish Courts of General Sessions of the Peace, to vest the Jurisdiction thereof in the County Court and for other purposes. (*County Court (Jurisdiction) Act 1968.*)
- No. 7706. An Act to extend the Powers of the Shrine of Remembrance Trustees. (*Shrine of Remembrance Trustees (Powers) Act 1968.*)

Given under my Hand and the Seal of the State of Victoria aforesaid, at Melbourne, this fifteenth day of October, in the year of our Lord One thousand nine hundred and sixty-eight and in the seventeenth year of the reign of Her Majesty Queen Elizabeth II.

(L.S.) E. F. HERRING.

By His Excellency's Command,  
HENRY BOLTE,  
Premier.

GOD SAVE THE QUEEN!

BALLARAT WEST TOWN COMMON.

PROCLAMATION

By His Excellency the Lieutenant-Governor of the State of Victoria and its Dependencies in the Commonwealth of Australia, &c., &c., &c.

WHEREAS by Division 12 of Part I of the *Land Act 1958* it is amongst other things enacted that the Governor in Council may from time to time increase, and, after one month's notice in the *Government Gazette*, diminish, alter or abolish any common, and may from time to time re-proclaim the whole or any part of any such common for any of the purposes and subject to the provisions of the said Part of the said Act, and that nothing therein contained shall prevent the exercise of the powers conferred by the said Part of the said Act with respect to the leasing or licensing of any land comprised in any common: And whereas notice of the intention to diminish the Ballarat West Town Common has been duly published in the *Government Gazette* for one month: Now therefore, I, the Lieutenant-Governor of the State of Victoria in the Commonwealth of Australia, by and with the advice of the Executive Council of the said State, do hereby diminish the Ballarat West Town Common, proclaimed as such on the 28th January, 1861 by deducting therefrom 1 acre comprised within the boundaries as defined by description published in the *Government Gazette* of 4th September, 1968.—(C.91998.)

Given under my Hand and the Seal of the State of Victoria aforesaid, at Melbourne, this fifteenth day of October, in the year of our Lord One thousand nine hundred and sixty-eight, and in the seventeenth year of the reign of Her Majesty Queen Elizabeth II.

(L.S.) E. F. HERRING.

By His Excellency's Command,  
W. J. F. McDONALD,  
Minister of Lands.

GOD SAVE THE QUEEN!

ROADS PROCLAIMED.

PROCLAMATION

By His Excellency the Lieutenant-Governor of the State of Victoria and its Dependencies in the Commonwealth of Australia, &c., &c., &c.

IN pursuance of the provisions of section 25 of the *Land Act 1958*, the Lieutenant-Governor of the State of Victoria, by and with the advice of the Executive Council of the said State, do hereby proclaim as roads the land in the Parish of Illawarra, County of Borung, as indicated by hatching on plan hereunder.—(L13<sup>(c)</sup>) (M.53569).

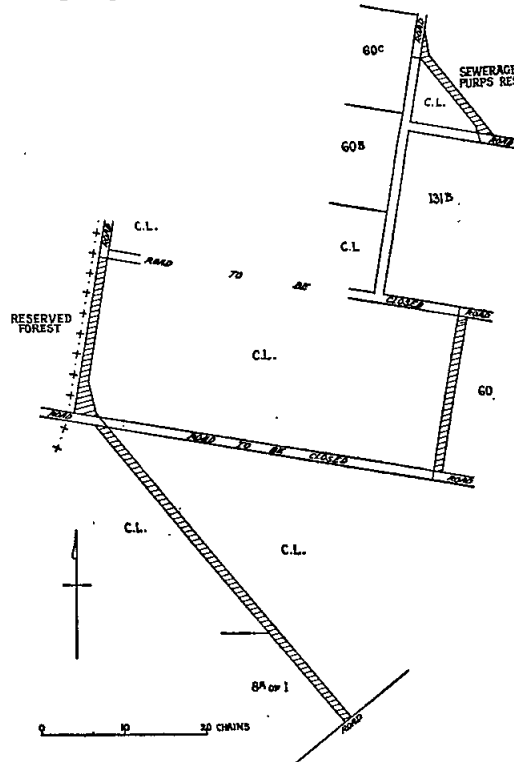

Given under my Hand and the Seal of the State of Victoria aforesaid, at Melbourne, this fifteenth day of October, in the year of our Lord One thousand nine hundred and sixty-eight, and in the seventeenth year of the reign of Her Majesty Queen Elizabeth II.

(L.S.) E. F. HERRING.

By His Excellency's Command,  
W. J. F. McDONALD,  
Minister of Lands.

GOD SAVE THE QUEEN!

MOTOR BOATING ACT 1961, SECTION 4 (1).

PROCLAMATION

By His Excellency the Lieutenant-Governor of the State of Victoria and its Dependencies in the Commonwealth of Australia, &c., &c., &c.

WHEREAS by Section 4 of the *Motor Boating Act 1961* the Governor in Council, on the recommendation of an Authority having control over any Victorian waters, may by Proclamation published in the *Government Gazette*, set aside or prohibit or restrict the use of any specified part or parts of any waters under the control of the Authority for any specified class or classes of boating or similar activity:

AND WHEREAS the State Rivers and Water Supply Commission has been appointed the Authority in respect of the waters of Lake Eppalock:

AND WHEREAS the said Authority has recommended that the use of certain parts of the waters of Lake Eppalock be prohibited for all classes of motor boating:

NOW THEREFORE I, the Lieutenant-Governor of the State of Victoria, in the Commonwealth of Australia, by and with the advice of the Executive Council of the said State, and in pursuance of the powers conferred by the *Motor Boating Act 1961*, do by this my Proclamation prohibit the use of those parts of the waters of Lake Eppalock specified hereunder for all classes of motor boating:—

*Strath Bay*—The northern waters of Strath Bay, northward of a line between two beacons marked "No motor boats" on opposing shores.

Given under my Hand and the Seal of the State of Victoria aforesaid, at Melbourne, this twenty-second day of October, in the year of our Lord, One thousand nine hundred and sixty-eight, and in the seventeenth year of the reign of Her Majesty Queen Elizabeth II.

(L.S.) E. F. HERRING.

By His Excellency's Command,  
JAMES W. MANSON,  
for Chief Secretary.

GOD SAVE THE QUEEN!

*Motor Boating Act 1961.*  
CAIRN CURRAN RESERVOIR.

PROCLAMATION

By His Excellency the Lieutenant-Governor of the State of Victoria and its Dependencies in the Commonwealth of Australia, &c., &c., &c.

WHEREAS by Section 4 of the *Motor Boating Act 1961* the Governor in Council, on the recommendation of an Authority having control over any Victorian waters, may by Proclamation published in the *Government Gazette* set aside, prohibit or restrict the use of any specified part or parts of any waters under the control of the Authority for any specified class or classes of boating or similar activity:

AND WHEREAS the State Rivers and Water Supply Commission has been appointed the Authority over the waters of Cairn Curran Reservoir:

AND WHEREAS the State Rivers and Water Supply Commission has recommended that the use of certain parts of the waters of Cairn Curran Reservoir be set aside for boating (except the anchoring or mooring of boats):

NOW THEREFORE, I, the Lieutenant-Governor of the State of Victoria, in the Commonwealth of Australia, by and with the advice of the Executive Council of the said State, and in pursuance of the powers conferred by the said Act, do hereby set aside the waters of Cairn Curran Reservoir specified hereunder for boating except the anchoring or mooring of boats (that is to say):—

*Woolshed Bay*—

(a) The waters within an off-shore distance of 200 feet around the point at the northern limit of Woolshed Bay for a distance of about 100 yards between beacons along the shore.

(b) The waters within an off-shore distance of 200 feet on the south side of Woolshed Bay between a beacon situated on the shore approximately 200 yards easterly from the point where the shoreline meets the western end of the unused road in Allotment I, Section IIIA, Parish of Baringhup, and a beacon situated on the shore approximately 200 yards distant in an easterly direction.

*Upstream of Dam*—

The waters within an off-shore distance of 200 feet between a beacon on the western shore of the Reservoir approximately 25 chains upstream of the Dam and a beacon a further 200 yards along that shore.

*Lethbridge's Bay*—

The waters within an off-shore distance of 200 feet between beacons about 200 yards apart on the northern side of Lethbridge's Bay, about a mile and a quarter northward of the Maryborough—Castlemaine railway line.

Given under my Hand and the Seal of the State of Victoria aforesaid, at Melbourne, this twenty-second day of October, in the year of our Lord, One thousand nine hundred and sixty-eight, and in the seventeenth year of the reign of Her Majesty Queen Elizabeth II.

(L.S.) E. F. HERRING.

By His Excellency's Command,  
JAMES W. MANSON,  
for Chief Secretary.

GOD SAVE THE QUEEN!

*Dandenong Valley Authority Act 1963.*

FLOOD-PRONE AREA NUMBER 10.

PROCLAMATION

By His Excellency the Lieutenant-Governor of the State of Victoria and its Dependencies in the Commonwealth of Australia, &c., &c., &c.

WHEREAS section 27 of the *Dandenong Valley Authority Act 1963* provides that the Governor in Council may, at the request of the Dandenong Valley Authority, declare by proclamation any specified area or areas of land within the district of the Authority to be within the flood plain of any river or group of rivers within that district;

AND WHEREAS the said Authority has complied with the provisions of section 27 of the aforementioned Act relative to the publication and service of notices in relation thereto;

NOW THEREFORE I, the Lieutenant-Governor of the State of Victoria by and with the advice of the Executive Council thereof, do by this Proclamation declare that the areas shown coloured pink on the plans numbered F19 and F20, approved by the Governor in Council and deposited in the office of the State Rivers and Water Supply Commission, Melbourne, are within the flood plain of the Corhanwarrabul Creek for the purposes of the said Act and shall be known as Flood-Prone Area Number 10.

Given under my Hand and the Seal of the State of Victoria aforesaid, at Melbourne, this twenty-second day of October, in the year of our Lord, One thousand nine hundred and sixty-eight, and in the seventeenth year of the reign of Her Majesty Queen Elizabeth II.

(L.S.) E. F. HERRING.

By His Excellency's Command,  
W. BORTHWICK,  
Minister of Water Supply.

GOD SAVE THE QUEEN!

*Dandenong Valley Authority Act 1963.*

FLOOD-PRONE AREA NUMBER 11.

PROCLAMATION

By His Excellency the Lieutenant-Governor of the State of Victoria and its Dependencies in the Commonwealth of Australia, &c., &c., &c.

WHEREAS section 27 of the *Dandenong Valley Authority Act 1963* provides that the Governor in Council may, at the request of the Dandenong Valley Authority, declare by proclamation any specified area or areas of land within the district of the Authority to be within the flood plain of any river or group of rivers within that district:

AND WHEREAS the said Authority has complied with the provisions of section 27 of the aforementioned Act relative to the publication and service of notices in relation thereto:

NOW THEREFORE I, the Lieutenant-Governor of the State of Victoria by and with the advice of the Executive Council thereof, do by this Proclamation declare that the areas shown coloured pink on the plans numbered F21 and F22, approved by the Governor in Council and deposited in the office of the State Rivers and Water Supply Commission, Melbourne, are within the flood plain of the Mordialloc Main Drain for the purposes of the said Act and shall be known as Flood-Prone Area Number 11.

Given under my Hand and the Seal of the State of Victoria aforesaid, at Melbourne, this twenty-second day of October, in the year of our Lord, One thousand nine hundred and sixty-eight, and in the seventeenth year of the reign of Her Majesty Queen Elizabeth II.

(L.S.) E. F. HERRING.

By His Excellency's Command,  
W. BORTHWICK,  
Minister of Water Supply.

GOD SAVE THE QUEEN!

**GOVERNMENT NOTICES***Foreign Judgments Act 1962.***PART II. EXTENDED TO MALAYSIA.****ORDER**

By His Excellency the Lieutenant-Governor of the State of Victoria and its Dependencies in the Commonwealth of Australia, &c., &c., &c.

**I.** THE Lieutenant-Governor of the State of Victoria, in the Commonwealth of Australia, by and with the advice of the Executive Council of the said State, being satisfied that in the event of the benefits conferred by Part II. of the *Foreign Judgments Act 1962* being extended to judgments given in the superior Courts of Malaysia, substantial reciprocity of treatment will be assured as respects the enforcement within that country of judgments given in the superior Courts of Victoria, do by this Order direct—

- (a) that Part II. of the *Foreign Judgments Act 1962* shall extend to Malaysia; and
- (b) that the Federal Court of Malaysia, the High Court of Malaya and the High Court of Borneo should, for the purposes of the said Part II. be deemed superior Courts of Malaysia.

Given under my Hand and the Seal of the State of Victoria aforesaid, at Melbourne, this twenty-second day of October, in the year of our Lord, One thousand nine hundred and sixty-eight, and in the seventeenth year of the reign of Her Majesty Queen Elizabeth II.

(L.S.) E. F. HERRING.

By His Excellency's Command,  
G. O. REID,  
Attorney-General.

GOD SAVE THE QUEEN!

**HOLIDAY.—MELBOURNE CUP DAY.**

NOTICE is hereby given that on—

TUESDAY, THE 5TH NOVEMBER, 1968,

the Public Offices in the municipalities mentioned hereunder will be closed, that day being appointed by the *Public Service Act 1958* to be observed as a holiday in the Public Offices:—

The Cities of Box Hill, Brighton, Broadmeadows, Brunswick, Camberwell, Caulfield, Chelsea, Coburg, Collingwood, Dandenong, Doncaster and Templestowe, Essendon, Fitzroy, Footscray, Frankston, Hawthorn, Heidelberg, Keilor, Kew, Malvern, Melbourne, Moorabbin, Mordialloc, Northcote, Nunawading, Oakleigh, Port Melbourne, Prahran, Preston, Richmond, Ringwood, St. Kilda, Sandringham, South Melbourne, Springvale, Sunshine, Waverley and Williamstown; the Shires of Altona, Bacchus Marsh, Berwick, Bulla, Cranbourne, Croydon, Diamond Valley, Eltham, Gisborne, Hastings, Knox, Lillydale, Melton, Mornington, Romsey, Sherbrooke, Werribee and Whittlesea.

This notice relates only to the closing of the State Public Offices. All inquiries regarding holidays in other offices and in shops and industry should be directed to the Department of Labour and Industry, 110 Exhibition-street, Melbourne. (Telephone 63 0321, Extensions 6158, 6721 or 6859.)

A. G. RYLAH,  
Chief Secretary.

Chief Secretary's Office,  
Melbourne, 7th October, 1968.

**Drainage Areas Act.****SPECIAL MAINTENANCE CHARGE MADE BY THE COUNCIL OF THE SHIRE OF SOUTH GIPPSLAND IN RESPECT OF THE BLACK SWAMP DRAINAGE AREA.**

NOTICE is hereby given that, on the fifteenth day of October, 1968, in accordance with the provisions of section 36 of the *Drainage Areas Act 1958*, the Governor in Council approved of the estimate of the cost of proposed maintenance works in the Black Swamp Drainage Area submitted by the Council of the Shire of South Gippsland, and of the making by the Council of a Special Maintenance Charge on properties within the said Drainage Area, for the year ending 30th June, 1969.

J. ROSSITER,  
Clerk of the Executive Council.

**LOCAL GOVERNMENT DEPARTMENT.****PETITION FOR PROCLAMATION OF THE SHIRE OF KNOX AS A CITY.**

**I**N pursuance of the provisions of the *Local Government Act 1958*, as amended, the substance and prayer of a petition presented to His Excellency the Governor in Council in accordance with section 20 of the said Act, are published, viz.:—

The petition of the President, Councillors and Ratepayers of the Shire of Knox showeth that the said municipality:

- (a) is substantially urban in character;
- (b) has a population of at least ten thousand inhabitants; and
- (c) in the year ended on the thirtieth day of September last passed yielded a revenue from general and extra rates of not less than One hundred and sixty thousand dollars (\$160,000.00).

The petitioners therefore pray that His Excellency the Governor in Council, in exercise of the powers and authorities contained in section 18 (1) (k) of the *Local Government Act 1958*, as amended, will proclaim the municipality of the Shire of Knox to be a City to be known as the CITY OF KNOX.

R. J. HAMER,  
Minister for Local Government.

Local Government Department,  
Melbourne.

**LOCAL GOVERNMENT DEPARTMENT.****ORDER CONFIRMED.—SHIRE OF BERWICK.**

**T**HE Minister of the Crown administering the *Local Government Act 1958*, on the 15th day of October, 1968, confirmed the Order hereinafter referred to in pursuance of section 514 of the said Act namely:

An Order of the Council of the Shire of Berwick made on the 20th November, 1967, directing the compulsory taking of certain land being lot 193D on plan of subdivision No. 5068, lodged in the Office of Titles for the purpose of opening a road.

R. J. HAMER,  
Minister for Local Government.

Local Government Department,  
Melbourne.

**Cemeteries Act 1958.****SCALE OF FEES.**

**I**N pursuance of the powers conferred upon them by the *Cemeteries Act*, the trustees of the Cassilis and Glen Wills Public Cemeteries hereby make the following scale of fees, which shall come into operation upon publication in the *Government Gazette*, and from and after such publication every scale of fees heretofore made by the said trustees shall be and is hereby rescinded to the extent to which it conflicts with this scale.

Charge for single interment in open ground if site is selected by the trustees .. .. .	\$30.00
Charge for single interment in open ground if site is selected by applicant .. .. .	\$34.00
Charge for interment in open ground of child under twelve years or of stillborn child .. .. .	\$14.00
Charge for reopening grave for further interment .. .. .	\$20.00
Charge for reopening grave for insertion of urn containing ashes of cremated body .. .. .	\$10.00
Extra charges for all interments carried out on a Sunday .. .. .	\$15.00
Extra charges for all interments carried out on a Saturday .. .. .	\$10.00
Extra charges for all interments not carried out in the usual hours .. .. .	\$10.00
Charge for permission to erect an upright pedestal or monument .. .. .	\$10.00
Charge for permission to erect any other form of headstone .. .. .	\$6.00
Land (single grave) .. .. .	\$6.00

J. E. CONNLEY, Trustee.  
J. L. CRISP, Trustee.  
E. W. A. FITZGERALD, Trustee.

Approved by the Governor in Council, 15th October, 1968.—J. ROSSITER, Clerk of the Executive Council.

Transport Regulation Act.  
TRANSPORT REGULATION BOARD.

## HEARING OF APPLICATIONS.

**NOTICE** is hereby given that the following applications will be considered by the Transport Regulation Board at its offices at the corner of Lygon and Princes streets, Carlton, at 10.15 a.m. on Wednesday, 13th November, 1968.

**GIBB, J. R.**, Betka-road, Mallacoota. One commercial passenger vehicle (S/C. 5) to operate as a country taxi-cab from Mallacoota.

**PICT LTD.**, Forster-road, Notting Hill. Two commercial passenger vehicles with small seating capacities to operate for the carriage of own employees only, free of charge, to and from various towns throughout Victoria from and to farms in the same areas, for the purpose of crop harvesting.

**NOTE.**—This application does not include any ability to operate on an intertown basis.

**REED, R. V.**, Box 165 P.O., Bairnsdale. One commercial passenger vehicle with large seating capacity to operate in substitution for but not in addition to vehicle licensed T.S.810.

**APPLICATION** for renewal of licences as shown, by persons listed hereunder to operate under the same terms and conditions.

**BALSARINI, G. W.**, P.O. Box 69, Ultima; T.S.692.

**BRAMMALL, C.**, Gibbo Park, via Benambra; T.S.908.

**DAY, R. W. & H. E.**, Main-street, Beeac; C.O.398.

**FISHER, L. J.**, Fisher-terrace, Lang Lang; T.P.119.

**FRINDT, J. A. S.**, 6 Jolly-street, Dandenong; C.T.287.

**GEELONG CHURCH OF ENGLAND GRAMMAR SCHOOL**, Biddlecombe-avenue, Corio, Geelong; T.P.35.

**HALL, M. J. & N.**, Buckland Lower, via Porepunkah; T.S.907.

**KAY, M. J.**, William-street, Lismore; C.T.316.

**MCCASKIE, K. R.**, Post Office, Lockington; T.S.9.

**POVEY, M. J. & M. B.**, Merino; T.P.110.

**RUSSELL, W. A.**, Post Office, Harrow; T.P.5.

**SUTTON, J. N. & N. M.** (trading as Premier Taxi Service), 17 MacArthur-street, Bairnsdale; T.P.85.

Notice of any objection should be forwarded to reach the Secretary of the Board not later than Wednesday, 6th November, 1968.

Applicants are advised that it will not be necessary to appear on the hearing date specified above, unless advised in writing by the Board.

**B. P. KAY,**  
Secretary.

Corner Lygon and Princes streets, Carlton, Wednesday, 23rd October, 1968.

Commercial Goods Vehicles Act.  
TRANSPORT REGULATION BOARD.

## HEARING OF APPLICATIONS.

**NOTICE** is hereby given that the following applications will be considered by the Transport Regulation Board at its offices at the corner Lygon and Princes streets, Carlton, at 10.15 a.m. on Wednesday, 13th November, 1968.

**ALCOCK, K. A.**, 7 Symonds-street, Golden Square, 3555. One commercial goods vehicle (L/C. 200 cwt.) to operate within a 50-mile radius of the plant of F. & N. Bruhn at Bendigo solely on behalf of the said company—premixed concrete in a specially constructed agitator vehicle.

**ANSETT MOTORS PTY. LTD.**, 210 Gray-street, Hamilton, 3300. One commercial goods vehicle (L/C. 11 cwt.) to operate within a 100-mile radius of the post office at Hamilton in the course of business as "Machinery Distributor" for the purpose of operating the vehicle as a service unit—tools of trade, spare parts and equipment incidental to repairing, servicing and installing farm machinery.

**ARNOLD, G. H. C.**, Lot 13, Molan-street, Ringwood, 3134. One commercial goods vehicle (L/C. 10 cwt.) to operate throughout the State of Victoria in the course of business as "Salvage Operators and Mechanical Engineers" for the purpose of servicing and repairing own vehicles and own clients' vehicles—tools of trade, equipment and spare parts incidental to such servicing and repair in the field only.

**ASCOM PTY. LTD.**, 63 Queen's Bridge-street, South Melbourne, 3205. Application to vary conditions of licences numbered D.A.34589, D.A.34589/1, D.A.34589/9 and D.A.34589/40 (L/C. 124, 305, 237 and 125 cwt.) by deleting paragraph (a) of the existing conditions and adding in lieu:—"(a) Within a 25-mile radius of the post office at the corner of Bourke and Elizabeth streets in the City of Melbourne—own goods."

**AUTO REPLACEMENT CO. PTY. LTD.**, 25 Deakin-avenue, Mildura, 3500. One commercial goods vehicle (L/C. 12 cwt.) to operate within a 100-mile radius of the post office at Mildura and from and to the City of Mildura to and from the Township of Hopetoun in the course of business as "Automobile Engineers"—tools of trade, spare parts, motor car accessories, wet and dry batteries and engine blocks for repair or having been repaired.

**HALL, B.** (trading as Barry Transport), 206 Broadway, Reservoir, 3073. One commercial goods vehicle (L/C. 243 cwt.) to operate within a 35-mile radius of the G.P.O., Melbourne, solely on behalf of Consolidated Quarries Ltd.—sand, soil, screenings and premix.

**BLACKNEY'S INVESTMENTS PTY. LTD.**, 34-36 Smythe-street, Geelong, 3220. One commercial goods vehicle (L/C. 153 cwt.) to operate for the carriage of frozen meat, frozen poultry, frozen fish, frozen seafoods, frozen vegetables, frozen pastries, frozen fruit juices, frozen pies, frozen chicken rolls, frozen prepared meals, frozen egg whites and ice-cream in a specially constructed refrigerated van at a temperature not exceeding 10° F. in the course of business as "Frozen Food Suppliers" in the following areas only:—(a) Within a 50-mile radius of the chief post office in the City of Geelong. (b) From and to own premises in the City of Geelong to and from—(i) The City of Warrambrook and the Township of Portland via the Princes Highway; thence to the City of Hamilton and the Townships of Coleraine and Casterton and places *en route* via the Henty and Glenelg Highways. (ii) The Cities of Horsham and Warrambrook and places *en route* via the Western, Henty and Princes Highways. (iii) The City of Ballarat via Midland Highway; thence via Western Highway and places *en route* to the Townships of Nhill and Warracknabeal; thence via the North Eastern Highway to the Townships of Avoca and Maryborough and the Cities of Ballarat and Geelong and serving places *en route*. (iv) The Township of Apollo Bay and places *en route* via the Great Ocean-road. (v) The City of Bendigo and places *en route* via the Townships of Bacchus Marsh and Ballan.

**BUBB, L. J.**, Panmure, 3276. One commercial goods vehicle (L/C. 258 cwt.) to operate: (a) Within a 25-mile radius of the post office at Panmure—general goods provided that no goods shall be carried whether by one stage or by more than one stage between places within the above radius which are more than thirty road miles apart by the nearest practicable route. (b) From and to places within the radius as defined in paragraph (a) above to and from places within a 50-mile radius of the post office at Panmure—livestock.

**CERAMIC TRANSPORT PTY. LTD.**, corner Princes Highway and Smith-road, Springvale North, 3171. One commercial goods vehicle (L/C. 220 cwt.) to operate: (a) Within a 20-mile radius of the post office at Springvale—general goods. (b) Within a 70-mile radius of the premises of Brick Industries Ltd., at East Burwood—bricks on behalf of the said company.

**COLLINS, A. J.**, 356 Springvale-road, Springvale, 3171. One commercial goods vehicle (L/C. 259 cwt.) to operate within a 35-mile radius of the G.P.O., Melbourne, solely on behalf of Consolidated Quarries Ltd.—screenings, stone dust and quarry products.

**CROSBY, WILLIAM (MERCHANDISE) PTY. LTD.**, 266 King-street, Melbourne, 3000. One commercial goods vehicle (L/C. 10 cwt.) to operate throughout the State of Victoria in course of business as "Wholesale Merchants and Contractors"—tools of trade and small quantities of materials incidental to the servicing and laying of bituminous and Thermotile roofing, fibre boards, wall and floor tiles.

**DUNCAN, R. M.**, 12 Duncan-avenue, Greensborough, 3088. One commercial goods vehicle (L/C. 10 cwt.) to operate throughout the State of Victoria in course of business as "Service Engineer" on behalf of Frederick Pearson Pty. Ltd. for the purpose of servicing packaging machinery—tools of trade, spare parts, machines for repair, or having been repaired, and materials incidental to servicing only.

**DUNLOP TYRE SERVICE (VIC.) PTY. LTD.**, 191 Lyttleton-terrace, Bendigo, 3550. Application to vary conditions of licence No. D.A.60416/60 (L/C. 11 cwt.) by

- deleting the existing conditions and adding in lieu:—  
"Within a 50-mile radius of own branch premises at Charlton in the course of business as 'Tire Retreaders and Distributors'—new tires and tubes, tires and tubes for repair or having been repaired also batteries, petrol, oil, greases and polythene piping."
- GEBBIE, J. A.**, corner Police and Dandenong roads, Springvale North, 3170. One commercial goods vehicle (L/C. 132 cwt.) to operate from own sawmill at Bunyip to consignees within a 50-mile radius thereof in course of business as "Sawmiller and Timber Merchant"—own sawn timber.
- GENERAL ENGINEERING SALES PTY. LTD.**, 340 Dudley-street, West Melbourne, 3003. Two commercial goods vehicles (L/C. 13 cwt. each) to operate throughout the State of Victoria in the course of business as "Fork Lift Truck Distributor"—tools of trade, spare parts and materials incidental to the servicing and maintenance of fork lift trucks in the field only.
- GRANT, J. T., & F. W. CROCKER**, Box 44, Beaufort, 3373. Three commercial goods vehicles (L/C. 155, 100 and 164 cwt.) to operate: (a) From forest sites within a 50-mile radius from the post office at Beaufort and also from Harcourt to own treatment works at Beaufort—pine logs. (b) To consignees within a 50-mile radius from the post office at Beaufort and to Mortlake and Colac—treated pine posts, strainers and stays.
- JAGOE & JOHNSTONE**, 81 Clifton-street, Euroa, 3666. Application to vary conditions of licence No. D.A.1362/4 (L/C. 60 cwt.) by deleting "Within a 100-mile radius from the post office at Euroa" from paragraph (a) of the existing conditions and adding in lieu:—"Within a 50-mile radius from the post office at Euroa."
- JULIEN, D. R.**, 37 Candover-street, Geelong West, 3218. One commercial goods vehicle (L/C. 32 cwt.) to operate: (a) Within a 50-mile radius of own premises at Geelong West in course of business as "Marine Dealer and Drum Merchant"—own goods. (b) Throughout the State of Victoria in the course of business as "Marine Collector"—special wares, marine stores and old metals as designated in the *Marine Stores and Old Metals Act 1958* (No. 6303), Part 1, Section 3, but excluding the carriage of any such marine stores or old metals to wharves, docks or ships at Melbourne for shipment or export purposes with the proviso that the combined load capacity of both prime mover and any trailer attached thereto shall not exceed 120 cwt.
- KIMPTON, W. S., & SONS PTY. LTD.**, 143 Queen-street, Melbourne, 3000. Application to vary conditions of licence No. T.D.A.6317/7 (L/C. 223 cwt.) by adding to paragraph (b) of the existing conditions after "within 80-mile radius of the G.P.O., Melbourne" the words "and to Morwell".
- KOPEX ENGINEERING LTD.**, 255 Barkly-street, Brunswick, 3056. One commercial goods vehicle (L/C. 30 cwt.) to operate within a 50-mile radius of the post office at Moe on behalf of Spotless Ltd.—shoes for repair or having been repaired and articles for laundering or dry cleaning or having been laundered or dry cleaned.
- LATINOPOULOS, C.**, 1 Kelvinside-road, Noble Park, 3174. One commercial goods vehicle (L/C. 215 cwt.) to operate within a 50-mile radius of the premises of Albion Reid Pty. Ltd.—at North Melbourne—road-making plant, materials premix and hot asphalt on behalf of the said company—but excluding the carriage of cement and lime from Geelong.
- LEE, B. W.**, 179 Military-road, Avondale Heights, 3034. One commercial goods vehicle (L/C. 10 cwt.) to operate within a 50-mile radius of the G.P.O., Melbourne, in course of business as "Contract Installer" solely on behalf of Dural Leeds Pty. Ltd.—blinds, awnings, insect screens, cornice boxes, screen doors and small quantities of materials incidental to the completion of own contracts.
- LEIGHTON, E. G. & A. J.**, 20 Howard-street, Sale, 3850. One commercial goods vehicle (L/C. 288 cwt.) to operate: (a) Within a 25-mile radius of the post office at Sale—general goods, provided that no goods shall be carried whether by one stage or by more than one stage between places within the above radius which are more than 30 road miles apart by the nearest practicable route. (b) Within a 50-mile radius of own lime pit at Darriman—bulk lime.
- LEMKE, K. H.**, 21 Bank-street, Port Fairy, 3284. One commercial goods vehicle (L/C. 10 cwt.) to operate within a 50-mile radius from the post office at Port Fairy in the course of business as "Electrical Retailer" for the purpose of installing, repairing and maintaining electrical appliances—television sets and antennae for installation, for repair or having been repaired and materials incidental thereto.
- LESTER, P. J.** (trading as P. & J. Lester), Newby-street, Numurkah, 3636. One commercial goods vehicle (L/C. 243 cwt.) to operate throughout the State of Victoria in the course of business as "Earth-moving Contractor"—own earth-moving equipment.
- LOOGMAN, G. C.**, 89 Bogong-avenue, Glen Waverley, 3150. One commercial goods vehicle (L/C. 191 cwt.) to operate within a 50-mile radius of the premises of Pioneer Concrete (Vic.) Pty. Ltd., at Notting Hill, solely on behalf of the said company—premixed concrete in a specially constructed agitator vehicle.
- MATTHEWS, T. C. L.**, P.O. Box 326, Bendigo, 3550. Application to vary conditions of licence No. D.A.52629/12 (L/C. 184 cwt.) by adding to the existing conditions as an additional paragraph—"In the course of business as 'Carriers' on behalf of McNiece Bros. Pty. Ltd. (an approved decentralized secondary industry carried on by such company at Midland Highway, Bendigo)—goods and materials to, and manufactured articles from the said decentralized secondary industry premises".
- MERRY, K. J.**, 211 Henty-street, Casterton, 3311. One commercial goods vehicle (L/C. 6 cwt.) to operate from Casterton to the Township of Penola (S.A.) serving towns en route—parcels and mail under contract to the Postmaster General's Department.
- MIDLAND FUELS & FERTILIZERS PTY. LTD.**, Loan-street, Maryborough, 3465. One commercial goods vehicle (L/C. 143 cwt.) to operate: (a) Within a 25-mile radius from own premises at Maryborough—general goods, provided that no goods shall be carried whether by one stage or by more than one stage between places within the above radius which are more than thirty (30) miles apart by the nearest practicable route. (b) From the Shell Co. of Australia Ltd. depot at Ballarat for delivery within a 25-mile radius of Maryborough—petroleum products in prescribed types of containers.
- MILLER, E.**, 7 Hawthorn-avenue, Caulfield, 3162. One commercial goods vehicle (L/C. 39 cwt.) to operate throughout the State of Victoria in course of business as "Refrigerated Transports"—frozen poultry, frozen fish, frozen meat, frozen pies, frozen vegetables, frozen snack rolls, frozen dim sims and ice-cream in a specially constructed insulated and refrigerated van.
- MILLSOM, W. J.**, 4 Primula-avenue, North Altona, 3025. One commercial goods vehicle (L/C. 149 cwt.) to operate within a 35-mile radius from the G.P.O., Melbourne, solely on behalf of Consolidated Quarries Ltd.—screenings, stone dust and quarry products.
- MITCHELL & CO. PTY. LTD.**, 12 Cross-street, West Footscray, 3012. One commercial goods vehicle (L/C. 13 cwt.) to operate throughout the State of Victoria in course of business as "Agricultural Machinery Manufacturers"—tools of trade and spare parts necessary for the servicing and repair of agricultural machinery.
- MORRISON, W. A.**, 60 Bowmore-road, Noble Park, 3174. One commercial goods vehicle (L/C. 74 cwt.) to operate throughout the State of Victoria in the course of business as "Marine Dealer"—special wares, marine stores and old metals as designated in the *Marine Stores and Old Metals Act 1958* Part 1, Section 3, with the proviso that the combined load capacity of both prime mover and any trailer attached thereto shall not exceed 120 cwt.
- MCCCLUSKEY, M. J.**, 195 Westblade-avenue, Kerang, 3579. One commercial goods vehicle (L/C. 140 cwt. approximately) to operate: (a) Within a 50-mile radius of the post office at Kerang as a "Road Contractor"—road-making plant and materials. (b) Within a 25-mile radius from the post office at Kerang—general goods, provided that no goods shall be carried whether by one stage or by more than one stage between places within the above radius which are more than thirty (30) miles apart by the nearest practicable route.
- MCDONNELL, N. F.** (trading as N. F. McDonnell & Sons), P.O. Box 434, Mount Gambier, 5290. Two commercial goods vehicles (L/C. 316 and 308 cwt.) to operate: (a) Within a 25-mile radius of the post office at Rennick—general goods provided that no goods shall be carried whether by one stage or by more than one stage between places within the above radius which are more than 30 miles apart by the nearest practicable route. (b) Within a 50-mile radius of own premises at Mumbanner in course of business as "Primary Producers"—own goods.
- MCGURK, A. M.**, 54 Booth-street, Golden Square, 3555. One commercial goods vehicle (L/C. 14 cwt.) to operate within a 70-mile radius of the chief post office at Bendigo and to the City of Kerang in the course of business as "Painter and Tile Roof Cleaner"—tools of trade and equipment incidental to the completion of own contracts.

- McNULTY, D. N., 8 Jeans-crescent, Benalla, 3672. Application to vary conditions of licence No. D.T.4141 (L/C. 279 cwt.) by adding as additional paragraphs (e) and (f)—“(e) From private properties within a 50-mile radius from the post office at Benalla to Ryan and McNulty's sawmill at Benalla—logs. (f) From Ryan and McNulty's sawmill at Benalla to consignees within a 50-mile radius of the post office at Benalla—sawn timber.”.
- OAKLEIGH BRICK CO. PTY. LTD., 68 Dawson-street, Brunswick, 3056. One commercial goods vehicle (L/C. 127 cwt.) to operate within a 70-mile radius of own premises at Oakleigh in course of business as Brick Manufacturers—own bricks.
- O'HARA BROS. PLANT HIRE PTY. LTD., 19 Clarke-street, Wangaratta, 3677. Four commercial goods vehicles (L/C. 32, 64, 14, 8 cwt.) to operate: (a) Within a 50-mile radius of the post office at Wangaratta in the course of business as “Plant Hirers and Civil Engineers”—own goods. (b) Throughout the State of Victoria—own earth-moving equipment, tools of trade and spare parts and up to two drums of fuel for use in own machinery but excluding the carriage of any spare parts from the Melbourne Metropolitan Area. (c) Within a 25-mile radius from the site of any current contract site or from the railway station nearest thereto—materials for use on such contract.
- ORCHARD SPRAYERS PTY. LTD., Moller-street, Shepparton, 3630. One commercial goods vehicle (L/C. 9 cwt.) to operate throughout the State of Victoria in the course of business as “Manufacturing Engineers”—(an approved Decentralized Secondary Industry) for the purpose of servicing own manufactured products—tools of trade, spare parts and materials incidental thereto.
- PAGE, C. W., 19 St. Leonards-avenue, Spotswood, 3015. One commercial goods vehicle (L/C. 177 cwt.) to operate within a 50-mile radius of the G.P.O., Melbourne solely on behalf of Consolidated Quarries Ltd.—premixed concrete in a specially constructed agitator vehicle.
- PAGE, J. A., 398 Williamstown-road, Yarraville, 3013. One commercial goods vehicle (L/C. 183 cwt.) to operate within a 50-mile radius of the G.P.O., Melbourne solely on behalf of Consolidated Quarries Ltd.—premixed concrete in a specially constructed agitator vehicle.
- PCTT LTD., Forster-road, Notting Hill, 3168. One commercial goods vehicle (L/C. 130 cwt.) to operate throughout the State of Victoria in the course of business as “Frozen Food Distributors” in a specially constructed refrigerated vehicle—frozen processed vegetables, frozen fish and frozen poultry at a temperature not exceeding ten (10) degrees Fahrenheit.
- POWERS, P. M., 40 Grammar-street, Wendouree, 3355. One commercial goods vehicle (L/C. 15 cwt.) to operate throughout the State of Victoria in the course of business as “Refrigeration Engineer” for the purpose of installing and repairing refrigeration equipment—tools of trade and materials incidental thereto.
- RAGGATT, P. M., Marnoo, 3387. One commercial goods vehicle (L/C. 245 cwt.) to operate: (a) Within a 50-mile radius of the post office at Marnoo in the course of business as “Primary Producer”—own goods. (b) From and to places within a 50-mile radius of the post office at Marnoo to and from the “A” class depot of H. C. Sleigh Ltd., at Horsham solely on behalf of the said company—petroleum products in prescribed types of containers and empty return containers.
- REID, G. F., Colbinabbin, 3559. One commercial goods vehicle (L/C. 236 cwt.) to operate: (a) Within a 50-mile radius of the post office at Colbinabbin as a “Road Contractor”—road-making plant and materials. (b) Within a 25-mile radius of the post office at Colbinabbin—general goods provided that no goods shall be carried whether by one stage or by more than one stage between places within the above radius which are more than 30 road miles apart by the nearest practicable route.
- RIDEWOOD, B. E., 11 Ridge-avenue, Moorabbin, 3189. One commercial goods vehicle (L/C. 241 cwt.) to operate within a 35-mile radius of the G.P.O., Melbourne, solely on behalf of Consolidated Quarries Limited—screenings, sand, premix and quarry products.
- SMALL, G. P., 18 Soderlund-drive, Doncaster, 3108. One commercial goods vehicle (L/C. 200 cwt.) to operate within a 50-mile radius of the G.P.O., Melbourne, on behalf of Consolidated Quarries Ltd.—premixed concrete in a specially constructed agitator vehicle.
- SMITH, B. E., 11 Tooronga-crescent, Croydon, 3136. One commercial goods vehicle (L/C. 153 cwt.) to operate within a 50-mile radius of the premises of Albion Reid Pty. Ltd., at North Melbourne—road-making plant, materials, premix and hot asphalt on behalf of the said company, excluding the carriage of cement or lime from the Geelong Urban district.
- SMITH, L. F. (trading as Smiths Caravans), 40 Benalla-road, Shepparton, 3630. One commercial goods vehicle (L/C. 10 cwt. approx.) to operate in the course of business as “Caravan Manufacturers, Distributors and Hirers” for—(i) The purpose of towing own caravans or partly completed caravans from places of manufacture at Melbourne and Ballarat, and places within a 50-mile radius of Shepparton. (ii) The carriage of own goods within a 50-mile radius of Shepparton.
- STACEY, B. M., Blampied, 3364. One commercial goods vehicle (L/C. 308 cwt.) to operate: (a) From forest landings in the Daylesford and Blakeville areas to the Colonial Sugar Refining Co. factory at Bacchus Marsh—pulpwood. (b) From the Ballarat Water Commission plantations at Gong Gong and White Swan areas to the railway station at East Ballarat—pine pulp. (c) From Ballarat Water Commission Plantation in the Wallace area to the Wallace railway station—pine logs.
- THORPE, J. A., 21 Dunlop-avenue, Ormond, 3204. One commercial goods vehicle (L/C. 208 cwt.) to operate within a 50-mile radius of the G.P.O., Melbourne, solely on behalf of Consolidated Quarries Ltd.—premixed concrete in a specially constructed agitator vehicle.
- WATER SUPPLY EQUIPMENT PTY. LTD., Lot 13, Dickason-road, Heathmont, 3135. One commercial goods vehicle (L/C. 67 cwt.) to operate: (a) Within a 50-mile radius of the G.P.O., Melbourne in course of business as “Pump Suppliers”—own goods. (b) Throughout the State of Victoria for the purpose of test boring—tools of trade and boring equipment incidental thereto.
- WATHEN, B. J., 298 Canterbury-road, Forest Hill, 3131. One commercial goods vehicle (L/C. 140 cwt.) to operate: (a) Within a 25-mile radius of own premises at Forest Hill in the course of business as “Garden and Building Supplier”—own goods. (b) From pits at Bacchus Marsh to own premises at Forest Hill—own river pebbles and own honeycomb rock. (c) From Beveridge to own premises at Forest Hill—own scoria gravel and own rock.
- WATTS, K. I., 105 Princes Highway, Port Fairy, 3284. One commercial goods vehicle (L/C. 120 cwt.) to operate: (a) Within a 25-mile radius of the post office at Port Fairy—general goods, provided that no goods shall be carried whether by one stage or by more than one stage between places within the above radius which are more than 30 miles apart by the nearest practicable route. (b) From and to the depot of B.P. Australia Ltd., at Portland, to and from places situated within the radius as defined in paragraph (a) above—petroleum products in prescribed types of containers and empty return containers.
- WEBSTER, R. B., Alfred-drive, Yinnar, 3869. One commercial goods vehicle (L/C. 132 cwt.) to operate: (a) Within a 50-mile radius of the post office at Yinnar in the course of own business as an “Agricultural Fertilizer Spreading Contractor”—Agricultural fertilizers for spreading purposes, with the proviso that all such fertilizers have been previously railed to stations situated within the above radius or obtained from lime pits situated within the above radius. (b) Within a 50-mile radius of the post office at Yinnar—plant the property of a contractor and required by him for use in connexion with the construction or maintenance of some specific; existing or proposed street, footpath, bridge, pier, wharf, weir or channel and also the following materials viz.: metal, stones, screenings, ashes, gravel, sand and earth. (c) Within a 20-mile radius of the site of any construction or maintenance work performed pursuant to paragraph (a) above, or from the railway station nearest thereto—any other materials required for such work.
- BLACKNEY, A. (trading as Western District Frozen Foods), Marshall, 3221. One commercial goods vehicle (L/C. 40 cwt.) to operate: For the carriage of frozen meat, frozen poultry, frozen fish, frozen seafoods, frozen vegetables, frozen pastries, frozen fruit juices, frozen pies, frozen chicken rolls, frozen prepared meals, frozen egg whites and ice-cream in a specially constructed refrigerated vehicle at a temperature not exceeding 10 deg. Fahrenheit in the course of business as “Frozen Food Suppliers” in the following areas only, namely—(a) Within a 50-mile radius of the chief post office in the City of Geelong. (b) From and to own premises in the City of Geelong to and from—(i) The City of Warrambool and the Township of Portland via Princes Highway; thence to the City of Hamilton and the Townships of Coleraine and Casterton and places en route via the Henty and

Glennel Highways. (ii) The Cities of Horsham and Warrambool and places *en route* via Western, Henty and Princes Highways. (iii) The City of Ballarat via Midland Highway; thence via Western Highway to Nhill and Warracknabeal and places *en route*; thence via North Western Highway to Avoca, Maryborough, Ballarat and Geelong and serving places *en route*. (iv) The Township of Apollo Bay and places *en route* via the Great Ocean-road.

WITHAM, D. C., Duke-street, Boolarra, 3870. Two commercial goods vehicles (L/C. 199 and 207 cwt.) to operate within a 50-mile radius of the premises of Valcrete Pty. Ltd., at Morwell, solely on behalf of the said company—premixed concrete in a specially constructed agitator vehicle.

WITHAM, D. C., Duke-street, Boolarra, 3870. Application to vary conditions of licence No. D.A.7700/2 (L/C. 187 cwt.) by deleting "Yallourn" from the existing conditions and adding in lieu "Morwell".

#### TOW TRUCKS.

BAMFORD, A. J. & M. A. (trading as Andy's Service Station), Tarcombe-street, Euroa, 3666. One commercial goods vehicle (L/C. 40 cwt.) to operate throughout the State of Victoria as a "Tow Truck"—(a) Solely for the purpose of lifting and carrying or towing motor cars and the carriage of tools and equipment necessary for such purpose only. (b) The carriage of tools and equipment necessary for the repair of a disabled motor to and from the place at which such disablement has occurred.

NOTE.—This application subject to the cancellation of licence No. D.A.41363 in the name of A. L. Willcox Euroa.

MELBOURNE TOWING SERVICE PTY. LTD., 169 City-road, South Melbourne, 3205. One commercial goods vehicle to operate as a specially constructed heavy duty six wheel drive salvage unit of 200 cwt. carrying capacity throughout the State of Victoria for the purpose of—(a) Lifting and carrying or towing motor cars and the carriage of tools and equipment necessary for such purpose only. (b) The carriage of spare parts necessary for the repair of a disabled motor to and from the place at which such disablement has occurred.

POLLAK, F. E. & J. (trading as Richmond Motor Service), 57-59 Bridge-road, Richmond, 3121. One commercial goods vehicle (to be purchased) to operate throughout the State of Victoria as a "Tow Truck" solely—(a) For the purpose of lifting and carrying or towing motor cars and the carriage of tools and equipment necessary for such purpose only. (b) The carriage of spare parts necessary for the repair of a disabled motor to and from the place at which such disablement has occurred.

#### RENEWALS.

APPLICATIONS for renewal of licences as shown by persons listed hereunder to operate under the same terms and conditions from the expiry shown in each case.

ARTHUR BROS. DAIRIES PTY. LTD., 146 Beach-street, Frankston, 3199; D.A.53996/2; 21st December, 1968; 100 cwt.

ARTHURS MILK TRANSPORT PTY. LTD., 146 Beach-street, Frankston, 3199; D.A.53996; 1st December, 1968; 112 cwt.

BALLARAT DEEP FREEZE FOOD CO. PTY. LTD., 21 Grenville-street north, Ballarat, 3350; T.D.A.39041/5; 21st December, 1968; 76 cwt.

BROWN'S OFFICE CLEANING SERVICES PTY. LTD., 367 High-street, Kew, 3101; D.A.750/21; 12th December, 1968; 5 cwt.

CAKEBREAD CONSTRUCTION CO. PTY. LTD., Nepean Highway, Mornington, 3931; D.A.31653/3; 1st December, 1968; 134 cwt.

CHRISTEY'S MOTOR AUCTIONS PTY. LTD., 334 William-street, Melbourne, 3000; D.A.40914; 20th December, 1968; 77 cwt.

COLLINS, R. & L., PTY. LTD., 46 Maude-street, Shepparton, 3630; D.A.53755; 9th November, 1968; 75 cwt.

CURL, G., 185 Station-street, Aspendale, 3195; D.A.929; 1st December, 1968; 10 cwt.

EDWARDS, S. J., 4 Coomleigh-avenue, Glen Waverley, 3150; D.A.53966; 3rd December, 1968; 19 cwt.

FAGONE, L., 43 Fisher-street, Maidstone, 3012; D.A.53231; 31st August, 1968; 147 cwt.

FOX, ALBERT H., PTY. LTD., 493 Mt. Alexander-road, Moonee Ponds, 3039; D.A.35038/5; 1st February, 1968; 10 cwt.

GOLLER, J. J. & CO. PTY. LTD., 114 Lydiard-street north, Ballarat, 3350; D.A.33540/2; 5th December, 1968; 11 cwt.

GORDON BROTHERS PTY. LTD., 110-120 Union-street, Brunswick, 3056; D.A.1172/8; 14th December, 1968; 10 cwt.

INNIS, L. J., 442 Buckley-street, Essendon West, 3040; D.A.54152; 21st December, 1968; 262 cwt.

JOSEPH, C. A., 395 Union-road, North Albury, 2640; D.A.36162/1; 1st December, 1968; 165 cwt.

JOSEPH K. M., Co. PTY. LTD., P.O. Box 36, Prahran, 3181; D.A.38452/12; 9th November, 1968; 65 cwt.

MELCOCCO BROS. PTY. LTD., P.O. Box 113, Springvale, 3171; D.A.1280/3; 21st December, 1968; 78 cwt.

MYER SOUTHERN STORES LTD., 295 Lonsdale-street, Melbourne, 3000; D.A.61148; 14th November, 1968; 18 cwt.

MCKENZIES TRANSPORT & AGENCY PTY. LTD., 53 Barkers-road, Kew, 3101; D.A.1689/1; 23rd December, 1968; 196 cwt.

NILSEN, OLIVER J., & CO. PTY. LTD., 45 Bourke-street, Melbourne, 3000; D.A.53992; 1st December, 1968; 10 cwt.

O'LOUGHLAN, A. & K., 7 Francis-street, Clayton, 3168; D.A.41192; 5th December, 1968; 140 cwt.

PHELAN, W., & SONS PTY. LTD., 157 High-street, Maryborough, 3465; D.A.3633/25; 14th December, 1968; 50 cwt.

PROUT, L. R. & S., 7 Taylor's-lane, Rowville, 3178; D.A.53539; 1st December, 1968; 155 cwt.

ROUGHAN HAULAGE PTY. LTD., Varman-court, Nunawading, 3131; T.D.A.54237; 21st December, 1968; 285 cwt.

SANDHURST TIMBER & JOINERY WORKS PTY. LTD., 18-20 St. Andrew's-avenue, Bendigo, 3550; D.A.53846; 21st December, 1968; 69 cwt.

SEAL, T. W., 31 Dover-street, Williamstown, 3016; D.A.2005/1; 1st December, 1968; 199 cwt.

SNATH, R. J., 27-29 Flinders-lane, Melbourne, 3000; D.A.41217; 5th December, 1968; 8 cwt.

TALBOT, P. A., 46 Melbourne-street, Mulwala, 2647; T.D.A.61355; 18th December, 1968; 12 cwt.

#### TOW TRUCK RENEWAL.

VINES, R. J., Stanley-street, Toora, 3962; T.D.A.42382; 20th March, 1968; 20 cwt.

#### RENEWALS WITH VARIATION.

APPLICATIONS by the persons listed hereunder for renewal of the licences listed with variation of conditions in the manner set out opposite the names.

BRIGHT, L. R., Arthurs Seat-road, Main Ridge, 3928; D.A.35401; 1st December, 1968; application to renew and vary conditions of licence No. D.A.35401 (L/C. 146 cwt.) by adding to the existing conditions as an additional paragraph (c)—“(c) From and to Dandenong to and from places situated within a 5-mile radius of the post office at Red Hill—general goods.

Route Proposed.—Via Frankston, then the Nepean Highway or Three Chain-road.

DALGETY & NEW ZEALAND LOAN LTD., 1 Malop-street, Geelong, 3220; D.A.46170/36; 8th December, 1968; Application to renew and vary conditions of licence No. D.A.46170/36 (L/C. 10 cwt.) by deleting the existing conditions and adding in lieu—“Within a 50-mile radius of the post office at Goroke in the course of business as 'Stock and Station Agents'—own goods subject to the condition that all goods so carried shall have been initially consigned by rail to Goroke”.

JOHNSTON, J. W., PTY. LTD., 22 Rutland-road, Box Hill, 3128; D.A.40170/1; 1st December, 1968; Application to renew and vary conditions of licence No. D.A.40170/1 (L/C. 130 cwt.) by adding as an additional paragraph (d)—“(d) From places within a 50-mile radius of own approved decentralized secondary industry at Faraday to the said premises—raw materials for use in such industry”.

PASSIONA BOTTLING Co. (MELB.) LTD., 215 Chesterville-road, Moorabbin, 3189; D.A.7560/6; 17th December, 1968; Application to renew and vary conditions of licence No. D.A.7560/6 (L/C. 161 cwt.) by adding to the existing conditions after "Melbourne" the words "and to Anglesea and Malmesbury".



PITTS, K. McK., 30 Clifton-road, Hawthorn East, 3123; D.A.40541; 7th November, 1968; Application to renew and vary conditions of licence No. D.A.40541 (L/C. 235 cwt.) by deleting "Albion Quarrying Co. Pty. Ltd., at North Melbourne" and adding in lieu—"Conmac Asphalt Pty. Ltd. at Moorabbin or Brooklyn".

Notice of any objection should be forwarded to reach the Secretary of the Board not later than Wednesday, 6th November, 1968.

Applicants are advised that it will not be necessary to appear on the hearing date specified above, unless advised in writing by the Board.

B. P. KAY,  
Secretary.

Corner Lygon and Princes streets, Carlton, 3053, Friday, 18th October, 1968.

Transport Regulation Act.  
TRANSPORT REGULATION BOARD.

NOTICE No. 81.

Hiring Rates and Fares Specified for Metropolitan Taxi-cabs and Private Hire Cars.

TAKE notice that, pursuant to powers conferred on the Board by the provisions of Regulation 45 of Part III. of the Transport Consolidated Regulations 1960, the Board hereby specifies, in accordance with the provisions of Regulation 5 of Part I. of the said Regulations, hiring rates and fares to be charged for the carriage of passengers in vehicles the licences issued in respect of which are classified as Metropolitan Taxi-cabs or Private Hire Cars as the case may be.

Hiring rates and fares specified herein shall apply to journeys commencing at or after midnight on Saturday, 26th October, 1968, from which date and time hiring rates and fares previously specified by the Board as related to vehicles of such licence classifications are hereby repealed.

Hiring rates specified herein relate to journeys wholly within a 25-mile radius from the General Post Office situated at the corner of Bourke and Elizabeth streets in the City of Melbourne. The hiring rate applicable in respect of any journey to or from (where permitted by the conditions of licence) a destination outside the said radius shall be the rate agreed by the hirer prior to the commencement of such journey.

PART A.—HIRING RATES.

1. By distance from the place of picking up of the hirer to the place of setting down—

(a) On a journey which commences and finishes within the area defined in Part D hereof, including any journey which is not wholly within the said area, the hiring rate shall be computed—

	\$ c.
For the first one-ninth of a mile or any part thereof .. .. .	0.20
For each additional one-ninth of a mile or any part thereof .. .. .	0.02

(b) On journeys partly within and partly outside or wholly outside the area defined in Part D hereof, where permitted by the conditions of licence, the hiring rate shall be computed at the rates specified in (a) above plus an additional 10 cents for each complete mile over which the hirer is carried outside the said area..

2. By time for detention on all journeys at the rate per hour of .. .. . 2.00

3. If the vehicle is bespoken by the intending hirer through a depot to which the vehicle hired is attached an additional charge shall be made of .. .. . 0.15

4. Luggage: For each package carried outside of the passenger compartment of such vehicle .. .. . 0.05

(No charge shall be made for luggage carried inside the passenger compartment.)

PART B.—WEDDINGS AND FUNERALS.

1. By time-on journeys which commence and finish within the area defined in Part D hereof, irrespective of distance travelled, the charge shall be computed from the ordered time of first picking up of the passengers to the final setting down thereof—

	\$ c.
(a) In respect of vehicles approved by the Board as large cars—	
For the first hour or any part thereof .. .. .	9.50
For each additional half-hour or part thereof .. .. .	2.00

(b) In respect of vehicles other than large cars—

	\$ c.
For the first hour or part thereof .. .. .	7.00
For each additional half-hour or part thereof .. .. .	1.50

2. By time-on journeys which commence within the area defined in Part D hereof but finish outside of such area or which commence outside such area, where permitted by the conditions of the licence, the charge shall be computed as specified in clause 1 of this Part plus an additional charge as under for each complete mile by the most direct route between the point where the journey commences or finishes, as the case may be, outside of such area and the limits of the boundary of the said area—

	\$ c.
(a) In respect of vehicles approved by the Board as large cars .. .. .	0.20
(b) In respect of vehicles other than large cars .. .. .	0.15

3. For the purposes of this Part—

- (a) a wedding hiring shall relate solely to hirings for the conveyance of the bridal party provided that the hiring has been pre-booked in advance and a deposit has been paid in respect thereof at the time of such pre-booking; and
- (b) a funeral hiring shall relate solely to hirings pre-booked by funeral directors as supplementary mourning coaches.

PART C.—REQUEST FOR LARGE CAR.

Where the hirer requests a special service with a large car and a vehicle approved as a large car is supplied, the hiring rate shall be computed on the basis of the charges specified in Part A hereof excluding those specified in clause 3 of that Part plus an additional charge of One dollar for each half-hour or part thereof for the duration of the hiring.

PART D.—THE METROPOLITAN TAXI PICK-UP AND METER FARE AREA.

The pick-up and meter fare area for vehicles the licences issued in respect of which are classified as Metropolitan Taxi-cabs or Private Hire Cars shall be—

The area bounded by the coastline from Mordialloc Creek to Point Cook, a straight line to the intersection of Skeleton Creek and the Princes Highway, a straight line to Diggers Rest Railway Station, a straight line to the corner of Plenty-road and McDonald-lane, Plenty-road, the boundary of eight (8) miles radius from the corporate limits of the City of Melbourne, the Yarra River, Mullum Mullum Creek, Tindals, Stintons and Falconer roads, Warrandyte-Ringwood road, Hall-road, the northern and eastern boundaries of the City of Ringwood, Dandenong Creek, Wellington-road, the eastern boundary of the City of Oakleigh, Westall, Heatherton and Boundary roads, and the Mordialloc Creek to the coast.

PART E.—APPROVAL OF LARGE CARS.

The Board hereby approves as a large car:

- (i) Any vehicle licensed with the Board under the classification of a Metropolitan Taxi-cab or Private Hire Car which, as at 30th June, 1968, was approved as a large car; and
- (ii) Any vehicle of the following makes and models:—  
Chevrolet—Belair and Impala.  
Dodge—Phoenix.  
Ford—Fairlane 500 and Galaxie.  
Pontiac—Laurentian and Parisienne.  
Rambler—Rebel.

The approval contained in this Part in respect of Metropolitan Taxi-cabs and Private Hire Cars is hereby extended to those Country Taxi-cabs which are required by permit to operate at hiring rates and fares specified for such Metropolitan vehicles.

PART F.—SPECIAL PROVISIONS.

Notwithstanding the provisions of Part A hereof, while carrying more than one hirer within the provisions of Regulation 21 of Part III. of the Transport Consolidated Regulations 1960, the driver of any vehicle to which this notice relates may not charge each hirer an amount for hire exceeding 75 per centum of the meter fare for a journey by the most direct route between the point of pick-up and destination of the respective hirer.

PART G.—FARES.

1. Notwithstanding the provisions of Regulation 21 of Part III. of the Transport Consolidated Regulations 1960, passengers may be carried at separate and distinct fares for each passenger in vehicles the licences issued in

respect of which are classified as Metropolitan Taxi-cabs solely between loading stands and destinations specified in this part under the following conditions:—

(a) Every journey shall—

- (i) commence at a loading stand within a municipality as specified and finish at a destination related thereto or commence at a loading stand at a destination as specified and finish in the vicinity of the loading stand within a municipality related thereto;
- (ii) subject to the direction of traffic control authorities, follow the most direct route between such loading stand and the destination related thereto or between such destination and the vicinity of the loading stand related thereto; and
- (iii) with the exception of journeys to the Flemington Racecourse on Melbourne Cup Day, be made from such loading stands to destinations related thereto under a system known as "Odds and Evens" whereby vehicles where the last numeral appearing on the registration plate is an odd numeral, and vehicles where the last numeral is an even numeral, operate to such destinations in alternate weeks, the week related to such "Odd" vehicles being the week commencing on 28th October, 1968;

- (b) The fare to be charged for each passenger on each journey shall be the fare specified in this Part related to such journey.
- (c) Subject to the provisions of Regulation 36 (ix) of Part III. of the said Regulations, the driver of such a vehicle who has placed his vehicle on a loading stand specified in this Part shall carry any passenger desiring transport to a destination related to such loading stand at the fare specified in this Part; and
- (d) With the exception of Melbourne Cup Day, such vehicles shall not occupy loading stands specified in this Part before 9 a.m. on days on which sporting events are being held at the destinations related thereto.

2. Loading stands to be used, destinations related thereto, and fares related to journeys between such points shall be as specified hereunder:—

	\$ c.
Between Loading Stands in the City of Melbourne (excluding Newmarket) and Flemington Racecourse .. .. .	0.40
Flemington Racecourse (Melbourne Cup Day) .. .. .	0.50
Moonee Valley Racecourse .. .. .	0.40
Caulfield Racecourse .. .. .	0.50
West Melbourne Stadium (Festival Hall) .. .. .	0.25
R.A.S. Showgrounds (Trotting Meetings only) .. .. .	0.40
Melbourne Cricket Ground .. .. .	0.20
Sandown Park Racecourse (Horse Race-meetings only) .. .. .	1.20
Between Loading Stand in Racecourse-road, Newmarket, City of Melbourne, and Flemington Racecourse .. .. .	0.15
Flemington Racecourse (Melbourne Cup Day) .. .. .	0.25
R.A.S. Showgrounds (Trotting Meetings only) .. .. .	0.15
Moonee Valley Racecourse .. .. .	0.25
Between Loading Stands in the City of Brunswick and Flemington Racecourse .. .. .	0.40
Flemington Racecourse (Melbourne Cup Day) .. .. .	0.50
Moonee Valley Racecourse .. .. .	0.25
R.A.S. Showgrounds (Trotting Meetings only) .. .. .	0.40
Between Loading Stands in the City of Camberwell and Caulfield Racecourse .. .. .	0.40
Sandown Park Racecourse (Horse Race-meetings only) .. .. .	0.90
Between Loading Stand in Gordon-street, Elsternwick, City of Caulfield and Caulfield Racecourse .. .. .	0.25
Sandown Park Racecourse (Horse Race-meetings only) .. .. .	0.80
Between Loading Stand in Railway-avenue, City of Caulfield and Flemington Racecourse .. .. .	0.60
Flemington Racecourse (Melbourne Cup Day) .. .. .	0.70
Moonee Valley Racecourse .. .. .	0.60
Between Loading Stands in the City of Essendon and Flemington Racecourse .. .. .	0.25
Flemington Racecourse (Melbourne Cup Day) .. .. .	0.40
Caulfield Racecourse .. .. .	0.60
R.A.S. Showgrounds (Trotting Meetings only) .. .. .	0.25
West Melbourne Stadium (Festival Hall) .. .. .	0.40

	\$ c.
Between Loading Stands in the City of Footscray and Flemington Racecourse .. .. .	0.20
Flemington Racecourse (Melbourne Cup Day) .. .. .	0.30
Moonee Valley Racecourse .. .. .	0.30
Caulfield Racecourse .. .. .	0.60
R.A.S. Showgrounds (Trotting Meetings only) .. .. .	0.25
West Melbourne Stadium (Festival Hall) .. .. .	0.25
Between Loading Stands in the City of Northcote and Flemington Racecourse .. .. .	0.40
Flemington Racecourse (Melbourne Cup Day) .. .. .	0.50
Caulfield Racecourse .. .. .	0.50
Moonee Valley Racecourse .. .. .	0.40
R.A.S. Showgrounds (Trotting Meetings only) .. .. .	0.40
Between Loading Stands in the City of Preston and Flemington Racecourse .. .. .	0.40
Flemington Racecourse (Melbourne Cup Day) .. .. .	0.50
Moonee Valley Racecourse .. .. .	0.40
Caulfield Racecourse .. .. .	0.60
Between Loading Stands in the City of St. Kilda and Flemington Racecourse .. .. .	0.50
Flemington Racecourse (Melbourne Cup Day) .. .. .	0.60
Moonee Valley Racecourse .. .. .	0.50
Caulfield Racecourse .. .. .	0.40
R.A.S. Showgrounds (Trotting Meetings only) .. .. .	0.50
Sandown Park Racecourse (Horse Race-meetings only) .. .. .	0.90

By order of the Transport Regulation Board,  
B. P. KAY,  
Secretary.

Pipelines Act 1967, No. 7541.

APPLICATION FOR A PERMIT TO OWN AND USE A PIPELINE.

MINISTRY OF FUEL AND POWER.

NOTICE.

1. In accordance with the provisions of section 11 (1) of the Pipelines Act 1967, notice is given that an application has been received by me from Hematite Petroleum Proprietary Limited and Esso Exploration and Production Australia Inc. for a permit to own and use a pipeline from Pearceedale to the Long Island Point Fractionation Plant at Hastings.

2. The proposed route of the pipeline is as follows:—  
A 10-in. internal diameter pipeline, 7.2 miles in length, commencing at the boundary of the Shires of Cranbourne and Hastings at a point one tenth of a mile east of the junction of Boundary-road and Tooradin to Tyabb road, Pearceedale, and continuing in a southerly direction of 1.2 miles; thence turning in a west-south-westerly direction to continue for three tenths of a mile to Rolfe-road; thence crossing Rolfe-road to continue in a south-westerly direction for one mile to Pike-road; thence crossing Pike-road to continue in a southerly direction for half a mile; thence turning at a right angle to proceed in a westerly direction for four tenths of a mile to McKirdy-road; thence turning at a right angle to continue in a southerly direction parallel to McKirdy-road for half a mile; thence turning at a right angle to cross McKirdy-road and proceed in a westerly direction for three tenths of a mile parallel to Thornell-road; thence turning at a right angle to proceed in a southerly direction for a quarter of a mile to Denham-road; thence crossing Denham-road and turning at a right angle to continue in a westerly direction for three tenths of a mile; thence turning in a southerly direction to continue parallel to the Hastings-road for three tenths of a mile; thence turning in a south-easterly direction to continue for seven tenths of a mile to Bay View-road; thence crossing Bay View-road and turning in an east-south-easterly direction to proceed parallel to Bay View-road for six tenths of a mile; thence turning about 100 degrees right to proceed in a southerly direction for six tenths of a mile; thence turning at a right angle to proceed in an easterly direction for a quarter of a mile to terminate at the perimeter of the Long Island Point Fractionation Plant at Hastings.

3. Plans of the proposed route of the foregoing pipeline may be inspected, commencing Wednesday, 16th October, 1968, between the hours of 10 a.m. and 4 p.m. on Mondays to Fridays (excluding public holidays) at—

Ministry of Fuel and Power, 15th Floor, Princes Gate West, 171 Flinders-street, Melbourne, 3000.  
Municipal Offices, Hastings, 3915.

Additional copies of plans are not available.

4. Any objections to the proposed route of the pipeline must be addressed to me and reach the office of the Ministry no later than Friday, 15th November, 1968.

16th October, 1968.

J. C. M. BALFOUR,  
Minister for Fuel and Power.

COMMONWEALTH OF AUSTRALIA.

*Petroleum (Submerged Lands) Act 1967-1968.*

STATE OF VICTORIA.

*Petroleum (Submerged Lands) Act 1967.*

## PROHIBITION OF ENTRY INTO SAFETY ZONE.

I, JAMES CHARLES MURRAY BALFOUR, Minister of Mines for the State of Victoria, the Designated Authority in respect of the area specified as being adjacent to the State of Victoria, hereby prohibit from entering into or remaining in, except with my consent in writing, the area of the safety zone described hereunder, all vessels other than vessels engaged in or in connexion with petroleum exploration operations or operations for the recovery of petroleum authorized by me in the area concerned.

## DESCRIPTION OF AREA OF SAFETY ZONE.

The area which extends to a distance of 500 metres measured from each point of the structure known as the Barracoutta platform, situated at or near the point of latitude 38 deg. 17 min. 54.2 sec. south, longitude 147 deg. 40 min. 35.4 sec. east.

Dated this 16th day of October, 1968.

Made under the *Petroleum (Submerged Lands) Act*  
1967-1968 of the Commonwealth of Australia.

Made under the *Petroleum (Submerged Lands) Act*  
1967 of the State of Victoria.

JIM BALFOUR,

Designated Authority.

COMMONWEALTH OF AUSTRALIA.

*Petroleum (Submerged Lands) Act 1967-1968.*

STATE OF VICTORIA.

*Petroleum (Submerged Lands) Act 1967.*

## PROHIBITION OF ENTRY INTO SAFETY ZONE.

I, JAMES CHARLES MURRAY BALFOUR, Minister of Mines for the State of Victoria, the Designated Authority in respect of the area specified as being adjacent to the State of Victoria, hereby prohibit from entering into or remaining in, except with my consent in writing, the area of the safety zone described hereunder, all vessels other than vessels engaged in or in connexion with petroleum exploration operations or operations for the recovery of petroleum authorized by me in the area concerned.

## DESCRIPTION OF AREA OF SAFETY ZONE.

The area which extends to a distance of 500 metres measured from each point of the structure known as the Halibut platform, situated at or near the point of latitude 38 deg. 24 min. 22 sec. south, longitude 148 deg. 19 min. 11 sec. east.

Dated this 16th day of October, 1968.

Made under the *Petroleum (Submerged Lands) Act*  
1967-1968 of the Commonwealth of Australia.

Made under the *Petroleum (Submerged Lands) Act*  
1967 of the State of Victoria.

JIM BALFOUR,

Designated Authority.

COMMONWEALTH OF AUSTRALIA.

*Petroleum (Submerged Lands) Act 1967-1968.*

STATE OF VICTORIA.

*Petroleum (Submerged Lands) Act 1967.*

## PROHIBITION OF ENTRY INTO SAFETY ZONE.

I, JAMES CHARLES MURRAY BALFOUR, Minister of Mines for the State of Victoria, the Designated Authority in respect of the area specified as being adjacent to the State of Victoria, hereby prohibit from entering into or remaining in, except with my consent in writing, the area of the safety zone described hereunder, all vessels other than vessels engaged in or in connexion with petroleum exploration operations or operations for the recovery of petroleum authorized by me in the area concerned.

## DESCRIPTION OF AREA OF SAFETY ZONE.

The area which extends to a distance of 500 metres measured from each point of the structure known as the Marlin platform, situated at or near the point of latitude 38 deg. 13 min. 56.0 sec. south, longitude 148 deg. 13 min. 16.3 sec. east.

Dated this 16th day of October, 1968.

Made under the *Petroleum (Submerged Lands) Act*  
1967-1968 of the Commonwealth of Australia.

Made under the *Petroleum (Submerged Lands) Act*  
1967 of the State of Victoria.

JIM BALFOUR,

Designated Authority.

## STATE RIVERS AND WATER SUPPLY COMMISSION.

LICENCES TO DIVERT WATER AND CUT RACES PURSUANT TO THE PROVISIONS OF SECTION 204 OF THE WATER ACT 1958 (AS AMENDED).

THE Governor in Council has approved of the granting by the State Rivers and Water Supply Commission of licences as detailed hereunder for the term of years from the date specified in each case to the persons named in the following Schedule:—

## SCHEDULE.

Licence No.	Term of Licence and Commencing Date.	Name and Address of Person to whom Licence is to be Granted.	Source of Supply.	Area Authorized to be Irrigated Per Annum.	Volume of Water Authorized to be Diverted Per Annum.
				acres.	ac. ft.
2509	Five years from 1.7.68	Robert Bertie Adams, Merriang South ..	Buffalo River ..	90	135
2510	Five years from 1.7.68	Jean Isobel Hodgkinson, Buffalo River South	Buffalo River ..	75	112½
2511	Five years from 1.7.68	Francis George Johnson, Buffalo River ..	Buffalo River ..	130	195
2512	Five years from 1.7.68	Francis George Johnson, Buffalo River ..	Buffalo River ..	88	132
2513	Five years from 1.7.68	W. A. Moore Pastoral Co. Pty. Ltd., Buffalo River	Buffalo River ..	120	180
2514	Five years from 1.7.68	Janet Frances McGuffie, Buffalo River ..	Buffalo River ..	14	21
2515	Five years from 1.7.68	William James McGuffie, Buffalo River ..	Buffalo River ..	38	52
2516	Five years from 1.7.68	John Herbert McKibbin, Buffalo River South	Buffalo River ..	50	75
2517	Five years from 1.7.68	G. S. and R. E. McLees, Buffalo River ..	Buffalo River ..	50	75
2518	Five years from 1.7.68	Mario Rinaldi and Elsa Rinaldi, Myrtleford	Buffalo River ..	100	150
2519	Five years from 1.7.68	Mario Roso, Luigi Roso and Guiseppe Palezza, Buffalo River	Buffalo River ..	130	195
2520	Five years from 1.7.68	Geoffrey James Smith and Merle Smith, Buffalo River	Buffalo River ..	90	135
2521	Five years from 1.7.68	James Smith, Myrtleford .. ..	Buffalo River ..	90	135
2522	Five years from 1.7.68	James Smith, Myrtleford .. ..	Buffalo River ..	40	60
2523	Five years from 1.7.68	K. and M. Smith Agricultural Co. Pty. Ltd., Myrtleford	Buffalo River ..	80	120
2524	Five years from 1.7.68	Vittorio Baroni, Eurobin .. ..	Ovens River ..	10	15
2525	Five years from 1.7.68	William Gore Brett and Elizabeth Enid Bett, Yarrowonga Roadside	Ovens River ..	240	300
2526	Five years from 1.7.68	Champagnat College, Wangaratta ..	Ovens River ..	33	66
2527	Five years from 1.7.68	Nicholas William Clemens, Myrtleford ..	Ovens River ..	25	37½
2528	Five years from 1.7.68	Carmine De Grazia, Myrtleford ..	Ovens River ..	14	21
2529	Five years from 1.7.68	Gordon Robert Heywood, Everton ..	Ovens River ..	18	27
2530	Five years from 1.7.68	Estate Late P. C. Hirschfield, Tarrawingee	Ovens River ..	20	30
2531	Five years from 1.7.68	M. Ivone and Sons, Markwood ..	Ovens River ..	32	48
2532	Five years from 1.7.68	Raymond Tilston Lack, Wangaratta ..	Ovens River ..	20	30
2533	Five years from 1.7.68	A. and T. Mancuso and S. and S. Diliberto, Whorouly	Ovens River ..	30	45
2534	Five years from 1.7.68	Rex Ralph Mapley, Wangaratta ..	Ovens River ..	15	22½
2535	Five years from 1.7.68	Luigi Fortunato Marasco, Myrtleford ..	Ovens River ..	6	9
2536	Five years from 1.7.68	Rosario Marotta and Giovanni Paola, Markwood	Ovens River ..	40	60
2537	Five years from 1.7.68	Antonio Panozzo, Giovanni Panozzo and Gioacchino Panozzo, Oxley Flats	Ovens River ..	40	60
2538	Five years from 1.7.68	Alfred William Richardson, Ovens ..	Ovens River ..	96	144
2539	Five years from 1.7.68	Santo Rossato and Cristiano Rigoni, Myrtleford	Ovens River ..	15	22½
2540	Five years from 1.7.68	Fredrick George Wood and Clarence Albert Wood, Markwood	Ovens River ..	40	60
2541	Five years from 1.7.68	Alberto Zanotto and Giuseppina Zanotto, Myrtleford	Ovens River ..	20	30

In each case, the annual fee payable in respect of each acre-foot of water authorized to be diverted is the equivalent of one-half of the irrigation charge per acre-foot fixed in the Goulburn-Murray Irrigation District for the preceding financial year.

Office of the State Rivers and Water Supply Commission,  
Melbourne, 22nd October, 1968.

G. W. LEWIS, Secretary,  
State Rivers and Water Supply Commission.

## STATE RIVERS AND WATER SUPPLY COMMISSION.

LICENCE TO DIVERT WATER AND CUT RACE PURSUANT TO THE PROVISIONS OF SECTION 204 OF THE WATER ACT 1958 (AS AMENDED).

THE Governor in Council has approved of the granting by the State Rivers and Water Supply Commission of a licence as detailed hereunder for the term of years from the date specified in the person named in the following Schedule:—

## SCHEDULE.

Licence No.	Term of Licence and Commencing Date.	Name and address of Person to whom Licence is to be granted.	Source of Supply.	Area Authorized to be Irrigated Per Annum.	Volume of Water Authorized to be Diverted Per Annum.	Annual Fee.
				acres.	ac. ft.	\$
2548/391	Five years from 1.7.68	Geoffrey Howard Peace, Cohuna ..	Box Creek ..	25	50	25.00

Office of the State Rivers and Water Supply Commission,  
Melbourne, 22nd October, 1968.

G. W. LEWIS, Secretary,  
State Rivers and Water Supply Commission.

## STATE RIVERS AND WATER SUPPLY COMMISSION.

LICENCES TO DIVERT WATER PURSUANT TO THE PROVISIONS OF SECTION 204 OF THE WATER ACT 1958. (AS AMENDED).

THE Governor in Council has approved of the granting by the State Rivers and Water Supply Commission of licences as detailed hereunder for the term of years from the date specified in each case to the persons named in the following Schedule :—

## SCHEDULE.

Licence No.	Term of Licence and Commencing Date.	Name and Address of Person to whom Licence is to be Granted.	Source of Supply.	Area Authorized to be Irrigated Per Annum.	Volume of Water Authorized to be Diverted Per Annum.
				acres.	ac. ft.
2009	Four years from 1.7.68	Bernard Clement Keenan, Yarrowonga ..	River Murray (Lake Mulwala)	100	200
2542	Five years from 1.7.68	Keith Joseph Howell, Merriang ..	Buffalo River ..	42	63
2543	Five years from 1.7.68	Marcello Antonello and Maria Antonello, Myrtleford	Ovens River ..	11	16½
2544	Five years from 1.7.68	Carmelo Notarianni, Vittorio Notarianni, and Angelo Torcaso, Myrtleford	Ovens River ..	11	16½
2545	Five years from 1.7.68	Ian Douglas Flett Rendell and Mary Laurel Rendell, Yarrowonga Roadside	Ovens River ..	28	28

In each case, the annual fee payable in respect of each acre-foot of water authorized to be diverted is the equivalent of one-half of the irrigation charge per acre-foot fixed in the Goulburn-Murray Irrigation District for the preceding financial year.

Office of the State Rivers and Water Supply Commission,  
Melbourne, 22nd October, 1968

G. W. LEWIS, Secretary,  
State Rivers and Water Supply Commission.

## STATE RIVERS AND WATER SUPPLY COMMISSION.

LICENCES TO DIVERT WATER AND CUT RACES PURSUANT TO THE PROVISIONS OF SECTION 204 OF THE WATER ACT 1958 (AS AMENDED).

THE Governor in Council has approved of the granting by the State Rivers and Water Supply Commission of licences as detailed hereunder for the term of years from the date specified in each case to the persons named in the following Schedule :—

## SCHEDULE.

Licence No.	Term of Licence and Commencing Date.	Name and Address of Person to whom Licence is to be Granted.	Source of Supply.	Area Authorized to be Irrigated Per Annum.	Volume of Water Authorized to be Diverted Per Annum.
				acres.	ac. ft.
1941	Four years from 1.7.68	George Gregory Myers, Boundary Bend	River Murray ..	5	15
1956	Four years from 1.7.68	Ernest Joseph Smith, Robinvale ..	River Murray ..	3	9

In each case, the annual fee payable is calculated by applying to the quantity of 18 acre feet the equivalent of one-half of the irrigation charge per acre-foot fixed in the Goulburn-Murray Irrigation District for the preceding financial year.

Office of the State Rivers and Water Supply Commission,  
Melbourne, 22nd October, 1968.

G. W. LEWIS, Secretary,  
State Rivers and Water Supply Commission.

## STATE RIVERS AND WATER SUPPLY COMMISSION.

LICENCES TO DIVERT WATER AND CUT RACES PURSUANT TO THE PROVISIONS OF SECTION 204 OF THE WATER ACT 1958 (AS AMENDED).

THE Governor in Council has approved of the granting by the State Rivers and Water Supply Commission of licences as detailed hereunder for the term of years from the date specified in each case to the persons named in the following Schedule :—

## SCHEDULE.

Licence No.	Term of Licence and Commencing Date.	Name and Address of Person to whom Licence is to be Granted.	Source of Supply.	Area Authorized to be Irrigated Per Annum.	Volume of Water Authorized to be Diverted Per Annum.
				acres.	ac. ft.
2546	Five years from 1.7.68	Donald Ian Hodgkinson, Buffalo River South	Buffalo River ..	4	6
2547	Five years from 1.7.68	Eric Adrian Weston, Eurobin ..	Ovens River ..	5	7½

The annual fee payable is calculated by applying to the quantity of 9 acre-feet the equivalent of one-half of the irrigation charge per acre-foot fixed in the Goulburn-Murray Irrigation District for the preceding financial year.

Office of the State Rivers and Water Supply Commission,  
Melbourne, 22nd October, 1968.

G. W. LEWIS, Secretary,  
State Rivers and Water Supply Commission.

STATE RIVERS AND WATER SUPPLY COMMISSION.

LICENCES TO DIVERT WATER AND CUT RACES PURSUANT TO THE PROVISIONS OF SECTION 204 OF THE WATER ACT 1958 (AS AMENDED).

THE Governor in Council has approved of the granting by the State Rivers and Water Supply Commission of licences as detailed hereunder for the term of years from the date specified in each case to the persons named in the following Schedule :—

SCHEDULE.

Licence No.	Term of Licence and Commencing Date.	Name and Address of Person to whom Licence is to be Granted.	Source of Supply.	Area Authorized to be Irrigated Per Annum.	Volume of Water Authorized to be Diverted Per Annum.
				acres.	ac. ft.
1447	Four years from 1.7.68	Valentino Audino, Robinvale .. ..	River Murray ..	50	150
1942	Four years from 1.7.68	Reginald Robert Etherington, Mildura ..	River Murray ..	12½	37½
1958	Four years from 1.7.68	Florence Annie McQueen and the Executors of the Estate of the late Leslie John McQueen, Boundary Bend	River Murray ..	50	150
1972	Four years from 1.7.68	Walter John Cleave and Robert Brentnall, Yarroweyah North	River Murray ..	30	60
1985	Four years from 1.7.68	Stephen Collett and Rex Mervyn Collett, Nangiloc	River Murray ..	70	210
1986	Four years from 1.7.68	Aubrey William Irwin, Colignan ..	River Murray ..	100	300
1993	Four years from 1.7.68	Per Olaf Engstrom and Dulcie May Engstrom, Piangil	River Murray .. (Narcooyia Creek)	40	120
2031/1661	Four years from 1.7.68	Frank Henry Thomson, Wemen ..	River Murray ..	20	60

In each case, the annual fee payable in respect of each acre-foot of water authorized to be diverted is the equivalent of one-half of the irrigation charge per acre-foot fixed in the Goulburn-Murray Irrigation District for the preceding financial year.

Office of the State Rivers and Water Supply Commission,  
Melbourne, 22nd October, 1968.

G. W. LEWIS, Secretary,  
State Rivers and Water Supply Commission.

LAW DEPARTMENT.

COURTS OF PETTY SESSIONS.—ADDITIONAL DAYS APPOINTED.

HIS Excellency the Lieutenant-Governor of the State of Victoria, by and with the advice of the Executive Council thereof, doth by Order made on the 15th day of October, 1968, and pursuant to the provisions of section 64 of the Justices Act 1958, appoint the days and hours contained in the Schedule below for the holding of Courts of Petty Sessions at the places named in such Schedule, to take effect from the dates shown.

SCHEDULE.

Place.	Days and Hours.
Heyfield ..	Fridays at 10 a.m., in lieu of the days and hours heretofore appointed, to take effect from the 3rd January, 1969.
Kerang ..	Tuesdays at 10 a.m., in addition to the days and hours heretofore appointed, to take effect from the 29th October, 1968.
Lorne ..	Fridays at 10 a.m., in lieu of the days and hours heretofore appointed, to take effect from the 3rd January, 1969.

J. ROSSITER,  
Clerk of the Executive Council.  
At the Executive Council Chamber,  
Melbourne, 15th October, 1968.

LAW DEPARTMENT.

CURATOR OF CONVICTS PROPERTY.

HIS Excellency the Lieutenant-Governor of the State of Victoria, by and with the advice of the Executive Council thereof, doth by Order made on the twenty-second day of October, 1968, and pursuant to the provisions of section 550 of the Crimes Act 1958, commit the custody and management of the property of the convict, John Michael Colrain, to James Thomas Ryan, of 626 Bourke-street, Melbourne, as a Curator hereby appointed in that behalf.

J. ROSSITER,  
Clerk of the Executive Council.  
At the Executive Council Chamber,  
Melbourne, 22nd October, 1968.

Co-operation Act 1958.

LEONGATHA-DUMBULK A.B. CO-OPERATIVE LIMITED.

NOTICE OF DISSOLUTION OF SOCIETY.

NOTICE is hereby given that I have this day registered the dissolution of the above-named society and cancelled its registration under the above-named Act.

Dated at Melbourne, this 30th day of September, 1968.

M. V. HAMMOND,  
Deputy Registrar of Co-operative Societies.

Co-operation Act 1958.

LOCH ARTIFICIAL BREEDERS CO-OPERATIVE LIMITED.

NOTICE OF DISSOLUTION OF SOCIETY.

NOTICE is hereby given that I have this day registered the dissolution of the above-named society and cancelled its registration under the above-named Act.

Dated at Melbourne, this 30th day of September, 1968.

M. V. HAMMOND,  
Deputy Registrar of Co-operative Societies.

Co-operation Act 1958.

ST. CECILIA'S CO-OPERATIVE COMMUNITY ADVANCEMENT SOCIETY LIMITED.

ASHWOOD PRIMARY SCHOOL CO-OPERATIVE DEVELOPMENT SOCIETY LIMITED.

WATTLE PARK STATE SCHOOL CO-OPERATIVE SOCIETY LIMITED.

NOTICE is hereby given, in pursuance of section 78 (7) of the Co-operation Act 1958 and section 308 (2) of the Companies Act 1961, that, at the expiration of three months from the date hereof, the names of the aforementioned societies will, unless cause is shown to the contrary, be struck off the register and the societies will be dissolved.

Dated this 30th day of September, 1968.

M. V. HAMMOND, Deputy Registrar.

## Private Agents Act 1966.

## NOTICE OF RECEIPT OF APPLICATIONS FOR LICENCES UNDER THE PROVISIONS OF THE PRIVATE AGENTS ACT 1966.

THE Clerk(s) of the Court(s) of Petty Sessions as listed hereunder hereby give notice that applications, as under, have been lodged for hearing by the said Court(s) on the date(s) specified.

Any person desiring to object to any of such applications must—

- (a) lodge with the respective Clerk of Petty Sessions a notice in the prescribed form of his objection and of the grounds thereof;
- (b) cause a copy of such notice to be served personally or by post upon the applicant at least three days before the hearing of the application; and
- (c) send or deliver—
  - (i) where the objection is not made by the officer in charge of the police district in which the Court is situated—a copy of the notice to such officer; and
  - (ii) where the objection is not made by the Registrar or Deputy Registrar—a copy to the Registrar.

Full Name of Applicant or in the case of a Firm or Corporation, of the Nominee.	Place of Abode of Applicant or Nominee.	Name of Firm or Corporation.	Address for Registration.	Type of Licence.	Date of Hearing of Application.
---	---	------------------------------	---------------------------	------------------	---------------------------------

## COURT OF PETTY SESSIONS, PRAHRAN.

Stevens, Russell Raymond ..	Flat 7, 19 Kireep-road, Balwyn	Arie Kraus ..	576 Chapel-street, South Yarra	Commercial Sub-Agent	7.11.68
-----------------------------	--------------------------------	---------------	--------------------------------	----------------------	---------

Dated at Prahran this 16th day of October, 1968.

G. T. WHEELHOUSE, Clerk of Petty Sessions.

## COURT OF PETTY SESSIONS, FOOTSCRAY.

Staines, Jeffrey Colvin ..	83 Maidstone-street, Altona	.. .. .	Advance Patrol Service, Richards-street, Yarraville	Guard Agent ..	6.11.68
----------------------------	-----------------------------	---------	---	----------------	---------

Dated at Footscray this 14th day of October, 1968.

G. S. HOARE, Clerk of Petty Sessions.

## COURT OF PETTY SESSIONS, SALE.

Fahy, Patrick .. .. .	Paradise Beach via Sale	Australian Watching Co. Pty. Ltd.	340 Abbotsford-street, North Melbourne	Watchman ..	5.11.68
-----------------------	-------------------------	-----------------------------------	--	-------------	---------

Dated at Sale this 15th day of October, 1968.

D. R. WALKER, Clerk of Petty Sessions.

## COURT OF PETTY SESSIONS, COBURG.

Tizzoni, Gianfranco ..	29 Springhall-parade, Pascoe Vale South	.. .. .	29 Springhall-parade, Pascoe Vale South	Process Server ..	19.12.68
------------------------	---	---------	---	-------------------	----------

Dated at Coburg this 15th day of October, 1968.

F. J. TENNI, Clerk of Petty Sessions.

## COURT OF PETTY SESSIONS, SOUTH MELBOURNE.

Black, Constantine Nicklos ..	36 Yerrawa-drive, Watsonia	.. .. .	101-105 Clarke-street, South Melbourne	Watchman ..	11.11.68
-------------------------------	----------------------------	---------	--	-------------	----------

Dated at South Melbourne this 14th day of October, 1968.

G. MILLER, Clerk of Petty Sessions.

## COURT OF PETTY SESSIONS, HASTINGS.

Williams, George William ..	15 Fleet-street, Mornington	Australian Watching Co. Pty. Ltd.	340 Abbotsford-street, North Melbourne	Watchman ..	13.11.68
-----------------------------	-----------------------------	-----------------------------------	--	-------------	----------

Dated at Mornington this 10th day of October, 1968.

F. R. HODGENS, Clerk of Petty Sessions.

## COURT OF PETTY SESSIONS, SOUTH MELBOURNE.

Burton, James Allan Frank ..	13 Lernes-street, Forest Hill	.. .. .	101-105 Clarke-street, South Melbourne	Watchman ..	11.11.68
------------------------------	-------------------------------	---------	--	-------------	----------

Dated at South Melbourne this 15th day of October, 1968.

G. MILLER, Clerk of Petty Sessions.

## COURT OF PETTY SESSIONS, TOORA.

Duffus, Bryan James ..	Fish Creek ..	Australian Watching Co. Pty. Ltd.	340 Abbotsford-street, North Melbourne	Watchman ..	17.12.68
------------------------	---------------	-----------------------------------	--	-------------	----------

Dated at Toora this 16th day of October, 1968.

R. A. ISON, Clerk of Petty Sessions.

## COURT OF PETTY SESSIONS, COLLINGWOOD.

Korac, Ilija .. .. .	22 Hoddle-street, Abbotsford	.. .. .	22 Hoddle-street, Abbotsford	Inquiry Agent ..	25.11.68
----------------------	------------------------------	---------	------------------------------	------------------	----------

Dated at Collingwood this 17th day of October, 1968.

H. P. B. KING, Clerk of Petty Sessions.

## COURT OF PETTY SESSIONS, PRAHRAN.

Weber, Laurence Ian ..	29 Rosedale-crescent, Broadmeadows	Factory Guard Service	Suite 17, 562 St. Kilda-road, Melbourne	Watchman ..	8.11.68
------------------------	------------------------------------	-----------------------	---	-------------	---------

Dated at Prahran this 18th day of October, 1968.

L. D. PILGRIM, Clerk of Petty Sessions.

## PRIVATE AGENTS—continued.

Full Name of Applicant or in the case of a Firm or Corporation, of the Nominee.	Place of Abode of Applicant or Nominee.	Name of Firm or Corporation.	Address for Registration.	Type of Licence.	Date of Hearing of Application.
COURT OF PETTY SESSIONS, MELBOURNE.					
Clark, Basil Alfred ..	5 Brentwood-crescent, Frankston	Australian Watching Co. Pty. Ltd.	340 Abbotsford-street, North Melbourne	Inquiry Agent (Individual)	6.11.68
Coffey, Edward John ..	89 "Kelvinside"-road, Noble Park	" "	" "	Watchman ..	" "
Dingle, William Peter ..	Flat 1, 310 Beaconsfield-parade, Middle Park	" "	" "	" "	" "
Swansson, Eric Wallace ..	52 Charles-street, St. Kilda	" "	" "	" "	" "
Tobin, Desmond Maurice ..	36 Freeman-street, Yarraville	" "	" "	" "	" "
Zielonkowsky, Herbert ..	14 Duke-street, Avondale Heights	" "	" "	" "	" "

Dated at Melbourne this 16th day of October, 1968.

G. L. WEBSTER, Clerk of Petty Sessions.

## AUCTION SALES ACT 1958.

**BAIRNSDALE.**—Notice is hereby given that the Annual Meeting of Justices for the Licensing of Auctioneers will be held at the Court House, Bairnsdale, on Tuesday, the 26th day of November, 1968, at the hour of Ten o'clock in the forenoon. Dated this 11th day of October, 1968.—D. H. WARD, Clerk of Petty Sessions.

**CAMPERDOWN.**—Notice is hereby given that the Annual Meeting of Justices for the Licensing of Auctioneers will be held at the Court House, Camperdown, on Tuesday, the 26th day of November, 1968, at the hour of Ten o'clock in the forenoon. Dated this 14th day of October, 1968.—M. W. GERKENS, Clerk of Petty Sessions.

**CASTLEMAINE.**—Notice is hereby given that the Annual Meeting of Justices for the licensing of auctioneers will be held at the Court House, Castlemaine, on Tuesday, the 26th day of November, 1968, at the hour of Ten o'clock in the forenoon. Dated this 17th day of October, 1968.—I. L. GALAGHER, Clerk of Petty Sessions.

**ECHUCA.**—Notice is hereby given that the Annual Meeting of Justices for the Licensing of Auctioneers will be held at the Court House, Echuca, on Tuesday, the 26th day of November, 1968, at the hour of Ten o'clock in the forenoon. Dated at Echuca this 14th day of October, 1968.—M. M. SAUNDER, Clerk of Petty Sessions.

**KERANG.**—Notice is hereby given that the Annual Meeting of Justices for the Licensing of Auctioneers will be held at the Court House, Kerang, on Tuesday, the 26th day of November, 1968, at the hour of Ten o'clock in the forenoon. Dated this 14th day of October, 1968.—P. W. WESTMORE, Clerk of Petty Sessions.

**MOE.**—Notice is hereby given that the Annual Meeting of Justices for the Licensing of Auctioneers will be held at the Court House, Moe, on Tuesday, the 26th day of November, 1968, at the hour of Ten o'clock in the forenoon. Dated this 11th day of October, 1968.—K. T. RYAN, Clerk of Petty Sessions.

**MYRTLEFORD.**—Notice is hereby given that the Annual Meeting of Justices for the Licensing of Auctioneers will be held at the Court House, Myrtleford, on Tuesday, the 26th day of November, 1968, at the hour of Ten o'clock in the forenoon. Dated this 14th day of October, 1968.—A. F. SPENCER, Clerk of Petty Sessions.

**NUMURKAH.**—Notice is hereby given that the Annual Meeting of Justices for the licensing of auctioneers will be held at the Court House, Numurkah, on Tuesday, the 26th day of November, 1968, at the hour of Ten o'clock in the forenoon. Dated this 9th day of October, 1968.—J. L. COLLINS, Clerk of Petty Sessions.

**STAWELL.**—Notice is hereby given that the Annual Meeting of Justices for the Licensing of Auctioneers will be held at the Court House, Stawell, on Tuesday, the 26th day of November, 1968, at the hour of Ten o'clock in the forenoon. Dated at Stawell the 15th day of October, 1968.—G. B. DALTON, Clerk of Petty Sessions.

**TERANG.**—Notice is hereby given that the Annual Meeting of Justices for the Licensing of Auctioneers will be held at the Court House, Terang, on Tuesday, the 26th day of November, 1968, at the hour of Ten o'clock in the forenoon. Dated this 14th day of October, 1968.—M. W. GERKENS, Clerk of Petty Sessions.

**WARRNAMBOOL.**—Notice is hereby given that the Annual Meeting of Justices for the Licensing of Auctioneers will be held at the Law Courts, Warrnambool, on Tuesday, the 26th day of November, 1968, at Ten o'clock in the forenoon.—V. G. STAFFORD, Clerk of Petty Sessions.

**WODONGA.**—Notice is hereby given that the Annual Meeting of Justices for the Licensing of Auctioneers will be held at the Court House, Wodonga, on Tuesday, the 26th day of November, 1968, at the hour of Ten o'clock in the forenoon. Dated at Wodonga this 16th day of October, 1968.—J. T. KNIGHT, Clerk of Petty Sessions.

**WONTHAGGI.**—Notice is hereby given that the Annual Meeting of Justices for the licensing of auctioneers will be held at the Court House, Wonthaggi, on Tuesday, 26th November, 1968, at Ten o'clock in the forenoon. Dated at Wonthaggi this 11th day of October, 1968.—M. J. SHELTON, Clerk of Petty Sessions.

Health Act 1958 (No. 6270).

## NOTIFICATION OF CONVICTION OF OFFENCE AGAINST PART XIV.

**PURSUANT** to the provisions of section 294 (2) of the Health Act 1958, notification is hereby given that at the Court of Petty Sessions, Carlton, on the 2nd September, 1968, the following company was convicted and fined on the charge set out below:—

Continental Kosher Butchers Pty. Ltd., 343 High-street, St. Kilda.

Charge:—Selling adulterated manufactured meat.

Fine:—\$100.

A. T. GARDNER, Secretary.

Commission of Public Health.



**ORDERS IN COUNCIL.**—(Series 1968-69.)**STATE ELECTRICITY COMMISSION.**

1031. For the supply of 22 kV, 750 MVA, outdoor switchgear and accessories for metropolitan substations and country power stations, to Specification No. 68/131, \$265,607.—Email Ltd.

1032. For the supply and installation of local and remote supervisory control and telemetering equipment for Hazelwood Terminal Station, to Specification No. 68/77, \$95,296.—The Nissho Co. (Australia) Pty. Ltd.

Approved by the Governor in Council, 10th September, 1968.—J. ROSSITER, Clerk of the Executive Council.

1033. For the supply of galvanized structural steelwork for switchyards at Hazelwood Terminal Station, to Specification No. 68/265, \$130,390.—Ascom Pty. Ltd.

1034. For the construction of civil engineering works and building for substation EW, Elwood, to Specification No. 68/255, \$115,924.—W. J. Cody & Quinn Pty. Ltd.

1035. For the supply of power line carrier terminal equipment for protection signalling of 500 kV transmission lines, to Specification No. 68/93, \$61,376.—The Nissho Co. (Aust.) Pty. Ltd.

Approved by the Governor in Council, 24th September, 1968.—J. ROSSITER, Clerk of the Executive Council.

1170. For the construction of civil engineering works and buildings for Horsham Terminal Station, to Specification No. 68/237, \$221,975.—P. & A. Coutts Pty. Ltd.

1171. For the supply of voice frequency signalling equipment for provision of protection signalling and supervisory and telephone channels for 66 kV subtransmission system, to Specification No. 68/21, \$127,917.—Hawker de Havilland (Aust.) Pty. Ltd.

1172. For the supply of 60 kV, 20 kV and 9 kV surge diverters for metropolitan and regional terminal and substations, to Specification No. 68/111, \$116,430.—Bowthorpe Australia Pty. Ltd.

1173. For earthworks, concrete structures and rising mains for the Melbourne Swamp drain diversion at Yallourn, to Specification No. 68/198, at Schedule rates.—J. Jeffrey and Sons Pty. Ltd.

Approved by the Governor in Council, 17th September, 1968.—J. ROSSITER, Clerk of the Executive Council.

1174. For the supply of polythene insulated and sheathed supervisory control cable for a period of two years with optional extension of three months, to Specification No. 68/230, at Schedule rates.—Cablemakers (A.C.T.) Pty. Ltd.

Approved by the Governor in Council, 1st October, 1968.—J. ROSSITER, Clerk of the Executive Council.

**PUBLIC WORKS.**

1036. Shannon Park, State School No. 4748, supply of urgently required tables and chairs, \$1,303.60.—D. F. Cowan Sales Pty. Ltd.—(V.89514.)

1037. Green's Building, Cancer Institute, Melbourne, provision of a fire alarm system, \$1,494.00.—Wormald Bros. (Aust.) Pty. Ltd.—(C.68533 "F".)

1038. Emily McPherson College of Domestic Economy, Melbourne, renovations to various rooms, \$1,045.00.—C. E. Nicholls.—(C.116457.)

1039. Olinda State School, No. 3494, clearing of land recently provided for school purposes, \$1,400.00.—(N.E.132222.)

1040. "Turana" Youth Training Centre, Parkville, conversion of cooking equipment to oil firing, &c., \$3,415.00.—(E.M.137223.)

1041. Various Schools situated in Northern Victoria as directed by the Education Department, urgent installation of air circulators, \$1,076.00.—Keystone General Electric Pty. Ltd.—(V.105662.)

Approved by the Governor in Council, 15th October, 1968.—J. ROSSITER, Clerk of the Executive Council.

**CONTRACTS ACCEPTED.**—(Series 1968-69.)**STATE RIVERS AND WATER SUPPLY COMMISSION.**

1042. Erection of brick pumphouse, Tresco, \$7,442.—A. R. P. Crow and Sons Pty. Ltd.

Sealed by Commission, 2nd July, 1968.

1043. Erection of house (transportable type), garage and woodshed, Rochester, \$8,921.—M. Diedrich.

Sealed by Commission, 25th July, 1968.

No. 88.—9613/68.—2

1044. Supply and installation of switchboard and wiring, Tresco Pumping Station, \$7,657.—Asea Electric (Aust.) Pty. Ltd.

Sealed by Commission, 12th August, 1968.

1045. Welding of Westernport industrial pipe-line, \$6,381.—William McCormack.

Sealed by Commission, 27th August, 1968.

1046. Fencing of Wonthaggi and Cape Paterson storage sites, \$2,922.—J. Otter Fencing Pty. Ltd.

Sealed by Commission, 24th September, 1968.

1047. Construction of excavated storage at Shoreham, \$42,760.—Jack Legge Contractors Pty. Ltd.

Approved by Governor in Council, 21st May, 1968.—J. ROSSITER, Clerk of the Executive Council.

1048. Installation of reticulation mains at Cape Paterson, \$11,015.—Doherty and McCabe.

Approved by the Governor in Council, 9th July, 1968.—J. ROSSITER, Clerk of the Executive Council.

1049. Erection of residence with office, garage, woodshed, at Bridgewater, \$13,321.—M. Diedrich.

Approved by the Governor in Council, 8th January, 1968.—J. ROSSITER, Clerk of the Executive Council.

**PUBLIC WORKS.**

1050. Moe, High School, repairs to roof, &c., \$1,681.00.—W. G. Campbell Constructions Pty. Ltd.

1051. Kiewa Valley, Consolidated School Residence, 2 Huon-road, renovations, \$1,484.00.—H. A. Morley.

1052. Ballarat, Mental Hospital, extension of heating system, \$1,824.42.—Mentay Engineering Pty. Ltd.

1053. Orbost, Lands and Survey Department Residence, internal and external painting, \$1,770.00.—Edward G. Knight.

1054. Benalla East, State School No. 2256, Residence, 35 Nunn-street, renovations, \$1,450.00.—B. Holland.

1055. Dromana, Technical School, electrical installation, \$29,941.00.—Jordan's Pty. Ltd.

1056. Batesford, State School No. 1845, renovations and painting, \$2,132.00.—G. Cooke & Son.

1057. Shepparton, High School, mechanical services, \$14,285.00.—A. J. Norton Pty. Ltd.

1058. Malmsbury, State School No. 1408, new chalkboards to school, external renovations to school and residence, \$2,420.00.—J. E. Acott & G. A. McFarlane.

1059. Birchip, High school, asphalt and drainage works, &c., \$5,870.00.—S. T. Hamilton.

1060. Mittyack, State School No. 4000, external repairs and painting, \$2,111.00.—R. B. McDonald.

1061. Mont Park, Larundel, Mental Hospital, construction of blow down pits at boiler house, \$2,050.00.—Geo. H. Curtis & Sons Pty. Ltd.

1062. Wheelers Hill, "Hillside" Boys' Home, Social Welfare Department, asphalt, concrete and drainage works, \$1,250.50.—Richards Road Construction Company Pty. Ltd.

1063. Heidelberg, High school, electrical installation, \$3,250.—Namford Pty. Ltd.

1064. Altona North, State School No. 4931, electrical installation, \$1,289.00.—J. F. & E. E. Veall.

1065. Buckley Park, High School, erection of three class-rooms, &c., \$30,929.00.—A. V. Jennings Industries (Australia) Ltd.

1066. Fawkner, High School, fire reinstatement, \$12,158.00.—A. V. Jennings Industries (Australia) Ltd.

1067. Brunswick South West, State School No. 4304, concrete and drainage works, &c., \$6,344.40.—Richards Road Construction Co. Pty. Ltd.

1068. Heidelberg, Girls' Secondary School, asphalt and concrete works, &c., \$7,143.00.—W. N. Kirkpatrick.

1069. Blackburn, Middlefield State School No. 4878, external repairs and painting, \$1,140.00.—Stanley R. Sheers.

1070. Burwood, State School No. 461, external painting, \$5,448.00.—Super Painting & Decorating Co. Pty. Ltd.

1071. Whittlesea, State School No. 2090, Asphalt, concrete and drainage works, &c., \$5,679.00.—Rainbow Construction Co. Pty. Ltd.

1072. Altona West, State School No. 4862, electrical installation, \$2,649.00.—J. F. & E. E. Veall.

1073. South Yarra, Melbourne Boy's High School, asphalt, drainage and gravel works, &c., \$5,491.87.—Richards Road Construction Co. Pty. Ltd.

1074. Frankston, Keith Turnbull Research Station, cooling and heating system in glasshouse No. 2, \$17,846.00.—Thos. J. Tait Pty. Ltd.

1075. Various, erection of Stage 1 C.800, High Schools Seaford—Carrum, Syndal and Laverton, \$1,270,135.00.—A. V. Jennings Industries (Australia) Ltd.

1076. Box Hill, Girls' Technical School, extensions and remodelling, \$1,505,780.00.—A. R. P. Crow & Sons Pty. Ltd.

1077. Hawthorn, erection and completion of new teachers' training college, \$1,454,862.00.—A. V. Jennings Industries (Australia) Ltd.

1078. Parkville, Secondary Teachers' College, new science centre, \$1,790,716.00.—A. V. Jennings Industries (Australia) Ltd.

1079. Portland, Police Station Residence, external renovation, \$1,175.00.—S. Robson.

1080. Bacchus Marsh, High School, mechanical services, \$1,883.00.—David M. Beaumont.

1081. Nhill, erection of brick veneer police station and residence, \$26,356.00.—C. R. Ballinger & Sons.

1082. Colac South West, State School No. 4775, internal painting, \$1,796.00.—N. Hager.

1083. Williamstown, Dredging Depot, Ports and Harbours Branch, supply and erection of mesh fencing and gates, &c., \$2,468.60.—R. W. Lee.

1084. Kangaroo Flat, Technical School Residence, 12 Pantom-street, repairs and painting, \$1,986.00.—G. W. Hardy.

1085. Maryborough, Technical School, connexion of toilet block to sewerage and demolition of septic tank, \$1,160.00.—B. C. Daniel.

1086. East Loddon, Consolidated School, internal and external painting and renovations, \$11,178.00.—G. W. Hardy.

1087. Preston East, State School No. 4316, Residence, renovations, \$1,750.00.—Phillip Heppleston.

1088. Bentleigh, High School, asphalt, concrete and drainage works, &c., \$4,064.80.—H. Mueller.

1089. Melbourne, Royal Melbourne Institute of Technology, Photographic School, air-conditioning and exhaust hoods, \$15,001.00.—Gray & Wood.

1090. Sunshine North, Technical School, external painting, \$4,890.00.—N. Dalla Vecchia.

1091. Melbourne, Lands and Survey, Treasury-place, lay with adhesive, seal and polish lino and floor treatment, \$1,410.00.—A. Easton.

1092. Barkly, State School, repairs and painting; original, \$922.00; additional, \$704.57; \$1,626.57.—W. C. Barker.

1093. Box Hill, High School, lay with adhesive lino, \$1,470.00.—J. Ellis.

1094. Royal Melbourne Institute of Technology, ducting, &c., for telephone cabling, \$2,473.92.—J. Newell Pty. Ltd.

1095. White Hills, Technical School, Residence, renovations; original, \$960.00; additional, \$271.00; \$1,231.00.—Bull & Guy.

1096. Ballarat, High School, renovations to caretaker's residence, \$1,068.00.—M. G. Flynn.

1097. Port Fairy, Consolidated School Residence, internal and external repairs and painting, \$1,514.60.—L. P. Thistethwaite.

1098. French Island, Prison Farm, supply of parts for engine, \$1,139.90.—Deutz Australia Pty. Ltd.

1099. Portarlington, State School 2455, replacement of boundary fencing, \$1,275.00.—Geelong Fencing Suppliers Pty. Ltd.

1100. Irymple, Insectary, mechanical services, \$1,444.61.—McNiece Bros. Refrigeration.

1101. Stawell, High School Residence, external repairs and renovations; original, \$568.00; additional, \$515.00; \$1,083.00.—A. Fiscalini.

1102. Lemnos, State School, renovations; original, \$4,819.00; additional, \$242.96; \$5,061.96.—Maxwell J. Lear.

1103. Koorangie, Fisheries and Wildlife Reserve, supply and erection of tank and stand; original, \$296.00; additional, \$716.00; \$1,012.00.—J. Bakker & W. A. Hayman.

1104. Numurkah, State School, supply and installation of room heaters, \$1,600.00.—D. M. & R. Graham.

#### EXTRAS ON CONTRACTS.

##### Original Gazette Reference.

- 1105. Serial No. 67/68-3257.—\$2,400.00.
- 1106. Serial No. 67/68-1943.—\$204.00.
- 1107. Serial No. 67/68-752.—\$91.75.
- 1108. Serial No. 67/68-786.—\$1,279.00.
- 1109. Serial No. 66/67-1332.—\$9,517.27.
- 1110. Serial No. 67/68-3124.—\$471.91.
- 1111. Serial No. 66/67-1382.—\$1,239.92.
- 1112. Serial No. 67/68-3053.—\$196.00.
- 1113. Serial No. 66/67-4115.—\$2,091.25.
- 1114. Serial No. 67/68-3124.—\$404.75.
- 1115. Serial No. 66/67-4124.—\$2,301.50.
- 1116. Serial No. 66/67-1323.—\$1,174.21.

- 1117. Serial No. 67/68-3124.—\$472.01.
- 1118. Serial No. 67/68-3555.—\$1,276.54.
- 1119. Serial No. 67/68-1592.—\$311.46.
- 1120. Serial No. 67/68-3124.—\$445.07.
- 1121. Serial No. 67/68-3781.—\$863.00.
- 1122. Serial No. 67/68-3451.—\$1,150.00.
- 1123. Serial No. 66/67-3221.—\$215.00.
- 1124. Serial No. 67/68-3062.—\$623.00.
- 1125. Serial No. 67/68-962.—\$508.00.
- 1126. Serial No. 67/68-3124.—\$713.81.
- 1127. Serial No. 67/68-3983.—\$282.00.
- 1128. Serial No. 67/68-1431.—\$2,377.76.
- 1129. Serial No. 67/68-1421.—\$531.14.
- 1130. Serial No. 65/66-2504.—\$32,070.62.
- 1131. Serial No. 67/68-1419.—\$2,016.11.
- 1132. Serial No. 67/68-3094.—\$709.00.
- 1133. Serial No. 67/68-2821.—\$643.60.
- 1134. Serial No. 67/68-772.—\$954.90.
- 1135. Serial No. 67/68-3095.—\$1,199.60.
- 1136. Serial No. 67/68-2270.—\$247.47.
- 1137. Serial No. 67/68-2302.—\$5,029.46.
- 1138. Serial No. 67/68-1908.—\$1,073.00.
- 1139. Serial No. 67/68-3267.—\$170.69.
- 1140. Serial No. 67/68-3474.—\$187.00.
- 1141. Serial No. 67/68-3524.—\$285.00.
- 1142. Serial No. 67/68-1984.—\$265.00.
- 1143. Serial No. 67/68-2301.—\$2,337.01.
- 1144. Serial No. 67/68-1909.—\$650.00.
- 1145. Serial No. 67/68-1687.—\$894.10.
- 1146. Serial No. 67/68-1899.—\$213.20.
- 1147. Serial No. 65/66-4166.—\$829.00.
- 1148. Serial No. 67/68-3519.—\$295.18.
- 1149. Serial No. 67/68-2595.—\$4,627.60.
- 1150. Serial No. 67/68-3472.—\$5,342.95.
- 1151. Serial No. 67/68-4007.—\$391.40.
- 1152. Serial No. 67/68-882.—\$185.08.
- 1153. Serial No. 67/68-3482.—\$464.42.
- 1154. Serial No. 65/66-4375.—\$1,083.70.
- 1155. Serial No. 66/67-4211.—\$17,585.72.
- 1156. Serial No. 66/67-1177.—\$5,527.13.
- 1157. Serial No. 67/68-1908.—\$98.00.
- 1158. Serial No. 67/68-4068.—\$9,991.91.
- 1159. Serial No. 65/66-4287.—\$6,317.50.
- 1160. Serial No. 66/67-2634.—\$685.05.
- 1161. Serial No. 67/68-1435.—\$1,858.38.
- 1162. Serial No. 67/68-1422.—\$844.21.
- 1163. Serial No. 66/67-4252.—\$458.95.
- 1164. Serial No. 67/68-1466.—\$539.73.
- 1165. Serial No. 66/67-4076.—\$317.15.
- 1166. Serial No. 66/67-1964.—\$895.00.
- 1167. Serial No. 67/68-1955.—\$56.10.
- 1168. Serial No. 67/68-1430.—\$15,523.48.
- 1169. Serial No. 67/68-1478.—\$1,292.82.

G. SERPELL, Secretary for Public Works. 18.10.68.

#### CEREALS.

Requirements under Sub-Schedule No. 10 of Schedule No. 1 for the period 1st November, 1968, to 31st January, 1969, are to be purchased from the under-mentioned firm at the rates per cwt. respectively indicated, viz., Robert Harper & Co. Ltd.—Barley—pearl, \$5.20; Oatmeal—plain, \$6.75; Oatmeal—flaked, \$7.25; Peas—split, yellow, \$10.75; Rice—dressed, \$10.60; Tapioca—seed, \$7.70.

#### PRISONERS' MEALS IN LOCK-UPS.

##### CONTRACT CANCELLED.

Gazette No. 59, 3rd July, 1968, Prisoners' Meals, Ararat. Contract No. 247, is hereby cancelled.

##### CONTRACTS ACCEPTED.

1175. For the supply of Prisoners' Meals at Ararat, from 1st October, 1968, Breakfast and Tea, 50 cents; Hot Dinner, 70 cents.—J. A. and P. M. Davies.

1176. For the supply of Prisoners' Meals at North Melbourne, from 1st July, 1968, Breakfast and Tea, 40 cents; Hot Dinner, 50 cents.—I. Small.

#### TOOLS.

Gazette No. 30, 5th April, 1968, Schedule No. 52, Tools (General).—For rates shown opposite Item No. 190, substitute the rates as set out hereunder:—Flat or Spindle, plastic handled, 4-in., 16 cents; 6-in., 17 cents; 8-in., 32 cents; 10-in., 43 cents; 12-in., 67 cents each; Phillips Head, 3-in., 39 cents; 4-in., 49 cents; 6-in., 67 cents; 8-in., 80 cents each, as from 16th October, 1968.

E. P. WATSON, Secretary to the Tender Board. 21.10.68.

## Melbourne and Metropolitan

## BOARD OF WORKS.

## GENERAL NOTICE.

THE Melbourne and Metropolitan Board of Works having made provision for carrying off the sewage of each and every property which or any part of which is situate in the Sewerage Areas hereinafter described doth hereby declare that on and after the 16th day of November, 1968, each and every property so situate shall be deemed to be a sewered property within the meaning of the *Melbourne and Metropolitan Board of Works Act 1958*.

The Sewerage Areas hereinbefore referred to are:—

*Sewerage Area No. 2221.*

*City of Heidelberg.*—Commencing at the junction of Maleela-grove and McCrae-road; thence southerly and south-easterly along McCrae-road, westerly along Banyule-road, north-westerly along Haughton-parade, easterly and southerly along the northern and portion of the eastern boundaries of lot 91 Haughton-parade, generally easterly along the northern boundaries of lots 1 to 5 Banyule-road, northerly along the western boundary of lot 15 Mercedes-court, further northerly by a line to the north-western angle of lot 13 Mercedes-court, easterly along portion of the northern boundary of the said lot 13, northerly along the western boundaries of lots 9 and 10 McCrae-road, easterly along Mercedes-court, northerly along McCrae-road, westerly along the southern boundary of lot 23 McCrae-road, northerly along the western boundaries of the said lot 23 and lot 24 McCrae-road, north-westerly by a line to the boundary of Sewerage Area No. 2045 at the south-eastern angle of lot 13 Rowell-street, northerly and easterly following the said area boundary to the commencing point.

*Sewerage Area No. 2222.*

*Cities of Oakleigh and Waverley.*—Commencing at the junction of Nantilla-road and Wellington-road; thence westerly along Wellington-road, northerly along the western boundary of lot 1 Wellington-road, easterly along the northern boundary of the said lot 1 and a line in continuation to the south-western boundary of lot 6 Nantilla-road, north-westerly along the south-western boundaries of the said lot 6 and lots 8 and 9 Nantilla-road to the production of the southern boundary of lot 1 Blackburn-road, westerly by a line to and along the said southern boundary, northerly along Blackburn-road, easterly along Duerdin-street to the south-western angle of lot 10 Duerdin-street, generally northerly and easterly along the south-western, north-western and northern boundaries of the said lot 10, southerly along Nantilla-road to a point 654 feet north of the northern boundary of Wellington-road, easterly by a line to and along the northern boundary of lot 2 Wellington-road, northerly along portion of the western boundary of an adjoining lot 2 Wellington-road to its north-western angle, easterly along the northern boundary of the last-mentioned lot 2 and a line in continuation to the north-western angle of lot 1 Springvale-road, southerly by a line parallel to Springvale-road to the south-western angle of lot 1 Wellington-road, westerly along Wellington-road to the commencing point.

*Sewerage Area No. 2223.*

*City of Heidelberg.*—Commencing at the junction of Grandview-grove and Davies-street; thence westerly along Davies-street, northerly along Waiora-road to the boundary of Sewerage Area No. 1819 in Ruthven-street, easterly, southerly and easterly following the said area boundary to Ellesmere-parade, southerly along Ellesmere-parade to the boundary of Sewerage Area No. 1225, westerly, northerly, westerly and southerly following the said area boundary and the boundary of Sewerage Area No. 1697 to the commencing point.

*Sewerage Area No. 2224.*

*Shire of Eltham.*—Commencing at the junction of Eltham-road and Panorama-avenue; thence southerly along Panorama-avenue, westerly along the southern boundaries of lots 4 Panorama-avenue and lots 8 and 9 Beleura-grove, northerly along portion of the western boundary of the said lot 9, westerly along the southern boundary of lot 5 Edwards-street, northerly along Edwards-street, westerly along the southern boundaries of lots 21 Edwards-street and lots 9 and 8 Devon-court, northerly along the western boundaries of the said lot 8 and lot 7 Devon-court, further northerly along portion of the western boundary of lot 6 Devon-court, westerly and northerly along the southern and western boundaries of lot 2 Eltham-road, easterly along Eltham-road to the commencing point.

*Sewerage Area No. 2225.*

*Shire of Altona.*—Commencing at the junction of Freemans-road and Blackshaws-road; thence westerly along Blackshaws-road, southerly, westerly and northerly along the boundaries of lot 97 Blackshaws-road, westerly along Blackshaws-road, northerly along the western boundaries of lots 1 Blackshaws-road and 137 to 127, 219 to 223 and 290 to 297 Knapp-street, further northerly by a line in continuation to Buchanan-road, westerly along Buchanan-road, northerly along Blackshaws-road, north-easterly along Princes Highway, easterly along Paw Paw-road, southerly along Smith-street, easterly along Clelland-road, southerly along Freemans-road, westerly along Buchanan-road to a point 170 feet east of the eastern boundary of Burgess-street, southerly by a line to and along the eastern boundary of lot 297 Knapp-street, further southerly along Knapp-street, easterly along the northern boundary of lot 51 Knapp-street, northerly along portion of the western boundary of lot 53 Binns-street, easterly along Binns-street, northerly along Freemans-road, easterly along the northern boundary of lot 326 Freemans-road, northerly and easterly along the western and northern boundaries of lot 268 Misten-avenue, north-easterly by a line to the north-western angle of lot 243 Misten-avenue, easterly along the northern boundary of the said lot 243, northerly and easterly along the western and northern boundaries of lot 181 Rosala-avenue, further easterly by a line to and along the northern boundary of lot 159 Rosala-avenue, northerly and easterly along the western and northern boundaries of lot 95 Irwin-avenue, north-easterly by a line to the north-western angle of lot 76 Irwin-avenue, easterly along the northern boundary of the said lot 76, northerly and easterly along the western and northern boundaries of lot 8 Chambers-road, southerly along Chambers-road, westerly along Blackshaws-road to the commencing point.

*Sewerage Area No. 2226.*

*Cities of Oakleigh and Waverley.*—Commencing at the junction of Blackburn-road and Connan-avenue; thence easterly along Connan-avenue, northerly along Murdo-road, westerly along the southern boundaries of lots 245 and 246 Wellington-road, northerly along the western boundary of the said lot 246, easterly along Wellington-road, southerly along the eastern boundary of lot 10 Wellington-road, easterly along portion of the northern boundary of lot 12 Garden-road, southerly along the eastern boundaries of lots 12 to 15 Garden-road to the boundary of Sewerage Area No. 2176, generally westerly and southerly following the said area boundary to Princes Highway, north-westerly along Princes Highway to the boundary of Sewerage Area No. 1738, northerly, north-westerly and northerly following the last-mentioned area boundary to the commencing point.

By order of the Board,

H. J. SNADDEN,

Secretary.

110 Spencer-street, Melbourne, 3001, 15th October, 1968.

## Melbourne and Metropolitan

## BOARD OF WORKS.

NOTICE TO THE OWNERS OF TENEMENTS IN THE UNDER-MENTIONED STREETS AND THE PRIVATE STREETS, LANES, COURTS AND ALLEYS OPENING THERETO.

THE main pipe in the said streets being laid down, the owners of all tenements situated as under are hereby required on or before the 25th November, 1968, to cause a proper pipe and stop cocks to be laid so as to supply water within such tenements from the main pipe.

H. J. SNADDEN,

Secretary.

15th October, 1968.

## STREET AND POSITION.

*Altona.*

Kororoit Creek-road, from Grieve Highway eastwards 720 feet.  
Marsh-street, from 150 feet south of Hill-street southwards 350 feet.  
Rymill-street, from 90 feet south of Hill-street southwards 200 feet.

*Doncaster.*

Hertford-road, from Bareena-grove north-eastwards 620 feet.  
Bareena-grove, from Hertford-road northwards 620 feet.  
Honni-mews, from Bareena-grove westwards 200 feet.  
Randell-court, from Bareena-grove north-eastwards 340 feet.  
Le Roy-place, from Bareena-grove westwards 340 feet.  
Glendora-lane, from Hertford-road northwards 650 feet.  
Orlon-court, from Hertford-road southwards 380 feet.

*Keilor.*

San Remo-drive, from 120 feet south of Riviera-road south-eastwards 630 feet.  
 Cannes-avenue, from 100 feet south of Riviera-road southwards 550 feet.  
 Menton-court, from San Remo-drive north-eastwards 360 feet.  
 Barbara-crescent, from Duke-street, south-westwards and north-westwards 1,310 feet.  
 Christina-court, from Barbara-crescent north-westwards and northwards 630 feet.  
 Jennifer-court, from Barbara-crescent north-westwards 278 feet.

*Moorabbin.*

Walter-street, from Ebdon-street northwards 550 feet.  
 Summit-avenue, from Howitt-avenue westwards 130 feet.

*Nunawading.*

Alwyn-court, from Alwyn-street northwards 297 feet.  
 Eliza-court, from Whitehorse-road southwards 260 feet.  
 Moore-road, from Boronia-road southwards 880 feet.  
 Carlinga-drive, from Moore-road westwards and north-westwards 670 feet.  
 Belleura-avenue, from Carlinga-drive southwards 720 feet.  
 Olinda-crescent, from Belleura-avenue westwards 270 feet.  
 Cowra-street, from Belleura-avenue westwards 260 feet.

*Oakleigh.*

Rayhur-street, from 480 feet south-east of Liam-street south-eastwards 100 feet.

*Springvale.*

Westall-road, from Heritage-drive northwards 440 feet.  
 Bertha-street, from Heritage-drive northwards 480 feet.  
 Ellen-street, from Heritage-drive northwards 460 feet.  
 Heritage-drive, from Bertha-street to Ellen-street.

*Sunshine.*

Mawson-avenue, from Station-street westwards 1,320 feet.  
 Station-street, from 100 feet north of Soame-street northwards 290 feet.  
 Little-street, from Mawson-street southwards 160 feet.  
 Throsby-crescent, from Tasman-avenue northwards and westwards 740 feet.  
 Tasman-avenue, from Little-street westwards 630 feet.

*Waverley.*

Lum-road, from Wellington-road to Lansborough-avenue.  
 Wellington-road, from Lum-road eastwards 640 feet.  
 Lanoma-court, from Wellington-road northwards 420 feet.

*Werribee.*

Stanley-road, from Pipe-road north-westwards 600 feet.

*Whittlesea.*

Settlement-road, from Norris-crescent westwards 820 feet.  
 Kathleen-court, from Nickson-street northwards 320 feet.  
 Neilsen-crescent, from unnamed road southwards and eastwards 1,460 feet.  
 Unnamed road, from Settlement-road to Neilsen-crescent.  
 Norris-crescent, from unnamed road south-eastwards 130 feet.  
 Nara-court, from Neilsen-crescent eastwards 410 feet.

Melbourne and Metropolitan  
 BOARD OF WORKS.

NOTICE is hereby given that after the publication of this advertisement in the *Government Gazette*, and once in not less than two daily newspapers published in the metropolis, the Melbourne and Metropolitan Board of Works will proceed to compulsorily take (unless the same is in the meantime acquired by the Board from the owner or owners or other persons interested by mutual agreement) the land mentioned and described in the Schedule hereto.

The nature of the works in respect of which the land is proposed to be taken is the construction of the South-Eastern Sewerage Purification Works.

A plan of the proposed works will be open for inspection at the Offices of the Board, 110 Spencer-street, Melbourne, from the date hereof, until the 31st October, 1968, during office hours.

The quantity of land which the Board requires for the purpose of such works and other particulars are set forth below.

The consent of the Governor in Council was duly obtained in terms of the Board's Principal Act (No. 6310) on the 17th September, 1968.

## SCHEDULE.

All that piece of land containing 6 acres and 1 3/10th perches or thereabouts and being part of lot 5, lodged plan 4489, Parish of Lyndhurst and being the whole of the land described in certificate of title, volume 8416, folio 758.

Dated the 10th day of October, 1968.

H. J. SNADDEN,  
 Secretary.

## DEPARTMENT OF MINES.

SUBJECT to any necessary excisions, &c., it is proposed to grant the following leases:—

- 8622, Mineral; John Gordon Antliff; 61a. 3r. 23p., Parish of Walwa.  
 8657, Mineral; Martin Hogan; 11a. 2r. 11p., Parish of Everton.

## APPLICATIONS FOR EXTRACTIVE INDUSTRY LEASES REFUSED.

- 18, Extractive Industry Lease; Sandhurst Clay Supplies Pty. Ltd., 13 acres, Parish of Knowsley.  
 19, Extractive Industry Lease; Sandhurst Clay Supplies Pty. Ltd., 241 acres, Parish of Huntly.  
 21, Extractive Industry Lease; Brick & Pipe Industries Ltd., 31a. 1r. 3p., Parish of Sandhurst.

## APPLICATION FOR EXPLORATION LICENCE DECLARED ABANDONED.

- 106, Exploration Licence; Portland Properties Pty. Limited; 995 square miles, Counties of Dundas, Follett and Lowan.

## MINING LEASE TRANSFERRED.

- 5625, Gippsland; from Gordon Christopher McMillan to the Estate of Gordon Christopher McMillan.

## MINING LEASES EXPIRED.

- 7325, Mineral; Bendigo Pottery Proprietary Limited; 3a. 1r. 12p., Parish of Sandhurst.  
 8151, Mineral; Colonial Sugar Refining Company Limited; 9a. 1r. 13p., Parish of Goonegul.

## TAILINGS LICENCES EXPIRED.

- 3592, Tailings Licence; The President, Councillors and Ratepayers of the Shire of Yackandandah; "Rowdy Flat" mine dump situated at Yackandandah.  
 3603, Tailings Licence; Allan Chan; "North Johnson's" shaft situated at Eaglehawk.

## MINERAL SEARCH LICENCES EXPIRED.

- 790, Mineral Search Licence; Peter Ludlow Mahan, Noel Geoffrey Lamb; 90 acres, Parish of Bungal.  
 795, Mineral Search Licence; Geoffrey Tremlett White; 300 acres, Parish of Whanregarwen.

J. C. M. BALFOUR,  
 Minister of Mines.

## MINING LEASE DECLARED VOID.

- 5631, Gippsland; New Dawn Consolidated No Liability; 19a. 1r. 10p., Parish of Butgulla.

E. CONDON,  
 Secretary for Mines.

## COMPANIES ACT 1961.

NOTICE is hereby given in pursuance of section 308 (2) and 308 (3) of the Companies Act 1961, that at the expiration of three months from the date hereof the names of the following Companies will, unless cause be shown to the contrary, be struck off the Register and the said Companies will be dissolved.

Dated this 18th day of October, 1968.

E. B. MITCHAM,  
Assistant Registrar of Companies.

Companies Registration Office,  
Melbourne.

## COMPANIES ABOVE REFERRED TO.

Name of Company.	Number of Registration.
The Golden Rose Supply Co. Pty. Ltd.	7359
M. Wardle Pty. Ltd.	9653
Hotham Court Pty. Ltd.	12930
Melbourne Property Exchange Pty. Ltd.	13470
Tivoli Celebrity Vaudeville Pty. Ltd.	16243
Marquis Mouldings Pty. Ltd.	19778
Sylvel Investments Pty. Ltd.	23307
Adroit Manufacturing Pty. Ltd.	27937
Stellite (Australasia) Pty. Ltd.	28741
World Investments Pty. Ltd.	30714
Cochrane Shoe Co. Pty. Ltd.	31144
Muralla Investments Pty. Ltd.	31789
Hilstan Pty. Ltd.	31813
P. H. Mielch Pty. Ltd.	33412
J.N.H. Builders Pty. Ltd.	34745
J.N.H. Holding Pty. Ltd.	34746
Crescent Shoes Pty. Ltd.	35026
T. Pascoe & Son Pty. Ltd.	35059
J. M. Patience Pty. Ltd.	36284
W. F. Hewitt & Coy. Pty. Ltd.	36514
Alfred Court Pty. Ltd.	38007
General & Industrial Catering Pty. Ltd.	38451
C. W. Rowe Pty. Ltd.	38529
A. J. Parsons Constructions Pty. Ltd.	39015
Watman Investments Pty. Ltd.	39303
Purmas & Co. Pty. Ltd.	40155
St. Leonard's Store Pty. Ltd.	40431
Brendon Estates Pty. Ltd.	42106
Tomada Concrete Paving & Construction Pty. Ltd.	42764
S.R.M. Nominees Pty. Ltd.	43375
First Acceptance Corporation Ltd.	44926
Chevron-Hilton Hotels Ltd.	45114
Magdelyn Estates Pty. Ltd.	45817
Nilumbik Investments Pty. Ltd.	45833
Noeldale Constructions Pty. Ltd.	45834
Bourne Manufacturing Co. Pty. Ltd.	46066
Chevron-Hilton Newcastle Ltd.	46267
Croydon Development Pty. Ltd.	46380
Chevron Inns Pty. Ltd.	46665
Record Paving & Construction Co. Pty. Ltd.	46666
Greater Melbourne Investments Pty. Ltd.	47630
Stanhill Constructions Pty. Ltd.	48495
Descoatings (Vic.) Pty. Ltd.	51147
McCarty's Pty. Ltd.	51202
Service Station Association of Australia Ltd.	52670
Service Station Holdings Pty. Ltd.	52755
Baldissera Investments Pty. Ltd.	52960
Service Station Association Tyre Service Pty. Ltd.	53343
Record Equipment Coy. Pty. Ltd.	53550
Gammafield Pty. Ltd.	55023
A. Fracanzani Pty. Ltd.	55518
J. & G. Meakin (Australia) Pty. Ltd.	55668
Parkway Motors Pty. Ltd.	55759
J.H.S. Cars Pty. Ltd.	56432
Dome Refrigeration Pty. Ltd.	56660
Tom The Cheap Grocer Melbourne Pty. Ltd.	57623
Baldissera Construction Co. Pty. Ltd.	57902
Harrop & McLeod Pty. Ltd.	58766
Luno & Co. Pty. Ltd.	59378
Coburg Trading Post Pty. Ltd.	60394
Gweneter Homes Pty. Ltd.	61179
Venture Capital Ltd.	62501
Kelrob Pty. Ltd.	64631
Australian Institute of Business Practice Pty. Ltd.	64892
M.Y.B. Constructions Pty. Ltd.	65203
Minden International (Aust.) Pty. Ltd.	65255
Motorville Pty. Ltd.	65289
Nash's Plant Hire Co. Pty. Ltd.	67196
Station Street Transport Pty. Ltd.	67197
Caravan Cafe Pty. Ltd.	71860

## PUBLIC TRUSTEE ACT 1958 (No. 6350), SECTION 17.

I HEREBY give notice that on the 9th October, 1968, the Public Trustee filed elections to administer the following deceased persons' estates, in accordance with section 17 of the Public Trustee Act 1958:—

CALHOUN, VERA EMILY, late of 366 Inkerman-street, East St. Kilda, spinster, died 25th August, 1968.

HENRY, WALTER GEORGE, late of Bentleigh House Private Hospital, 193 Jasper-road, Bentleigh, T.P.I. pensioner, died 16th July, 1968.

MCKEE, AGNES ELIZA, formerly of 221 Elgin-street, Carlton, but late of 24 Bateman-court, East Coburg, spinster, died 14th August, 1968.

ZUBKO, TROFIM, late of 19 Belair-street, Glenroy, pensioner, died 27th August, 1968.

J. K. COOK,  
Acting Public Trustee.

256 Flinders-street, Melbourne, 16th October, 1968.

## NOTICE.

CREDITORS, next of kin and others having claims against the estate of any of the under-mentioned deceased persons, are required to send particulars of their claims to the Public Trustee, 256 Flinders-street, Melbourne, 3000, the personal representative, on or before the 31st December, 1968, after which date the Public Trustee may convey or distribute the assets, having regard only to the claims of which the Public Trustee then has notice:—

BLANDFORD, DORIS, late of 35 Newton-street, East Preston, married woman, died 30th June, 1968.

CALHOUN, VERA EMILY, late of 366 Inkerman-street, East St. Kilda, spinster, died 25th August, 1968.

CLYNE, JANE WESTHEAD, late of 30 Glen Ebor-avenue, Blackburn, widow, died 11th June, 1968.

DODDS, CARR BURRELL, late of 12 Balmoral-avenue, Strathmore, retired electrical fitter, died 23rd July, 1968.

DUFF, ALBERT HUGH, late of 74 Spensley-street, Clifton Hill, retired foreman, died 22nd July, 1967.

GRAY, MARGARET, late of Flat 5, 8 Ridgeway-avenue, Kew, widow, died 21st May, 1968.

HABAHIAN, ARMENAK, formerly of 24 Esplanade-road, Clifton Hill, but late of 29 Victoria-avenue, Macleod West, wood machinist, died 26th June, 1968.

HENRY, WALTER GEORGE, late of Bentleigh House Private Hospital, 193 Jasper-road, Bentleigh, T.P.I. pensioner, died 16th July, 1968.

HICKS, RUBY HILDA, late of 52 Herbert-street, Dandenong, spinster, died 13th August, 1968.

HINKS, LOUIS WILLIAM, also known as Hinks Lewis William, late of 24 Goodwin-street, West Preston, retired bricklayer, died 8th August, 1968.

INGLIS, HERBERT JOHN, late of 68 Campbell-road, East Hawthorn, retired P.M.G. employee, died 5th June, 1968.

LANGE, ANNIE QUEENIE VICTORIA, also known as Queenie Lange, late of 42 Dalgety-road, Beaumaris, spinster, died 5th April, 1967.

MATHESON, ELIZABETH MARY, late of 187 Elizabeth-street, North Richmond, married woman, died 11th August, 1937.

MCKEE, AGNES ELIZA, formerly of 221 Elgin-street, Carlton, but late of 24 Bateman-court, East Coburg, spinster, died 14th August, 1968.

PLUNKET, JOHN LESLIE, late of 28 Walter-street, Ascot Vale, military pensioner, died 10th July, 1968.

THOMAS, GEORGE HAROLD, formerly known as Michael Henry Stigwood, late of 17 Clifton-street, Clifton Hill, labourer, died 6th April, 1968.

UPFILL, JAMES ANDERSON, late of 1 Pleasant-road, Hawthorn East, retired railway employee, died 28th April, 1947.

WILSON, MOLLIE MARY JANE, late of 29 McPhail-street, Essendon, widow, died 26th June, 1968.

ZUBKO, TROFIM, late of 19 Belair-street, Glenroy, pensioner, died 27th August, 1968.

J. K. COOK,  
Acting Public Trustee.

Melbourne, 16th October, 1968.

## Stamps Act 1958, Section 97.

## ANNUAL LICENCE.

I HEREBY notify that the necessary stamp duty has been paid by the under-mentioned company for a licence to carry on assurance and insurance business in Victoria, from 30th April, 1968 to 31st December, 1968, and that the relevant Annual Licence has been issued accordingly:

ACCIDENT INSURANCE MUTUAL LIMITED.

R. M. PHIBBS,  
Comptroller of Stamps.

Chief Office for Stamp Duties,  
Melbourne, 16th October, 1968.

## DIMBOOLA SEWERAGE AUTHORITY.

## FIXING THE LIMIT OF BANK OVERDRAFT.

HIS Excellency the Lieutenant-Governor of the State of Victoria, by and with the advice of the Executive Council thereof, doth by Order made on the twenty-second day of October, 1968, fix the limit of the overdraft to be obtained by the Dimboola Sewerage Authority, pursuant to the provisions of section 78 of the Sewerage Districts Act at Four thousand dollars (\$4,000).

J. ROSSITER,

Clerk of the Executive Council.

At the Executive Council Chamber,  
Melbourne, 22nd October, 1968.

## BIRCHIP SEWERAGE AUTHORITY.

## FIXING THE LIMIT OF BANK OVERDRAFT.

HIS Excellency the Lieutenant-Governor of the State of Victoria, by and with the advice of the Executive Council thereof, doth by Order made on the twenty-second day of October, 1968, fix the limit of the overdraft to be obtained by the Birchip Sewerage Authority, pursuant to the provisions of section 79 of the Sewerage Districts Act, at Seventy-five thousand dollars (\$75,000).

J. ROSSITER,

Clerk of the Executive Council.

At the Executive Council Chamber,  
Melbourne, 22nd October, 1968.

## MIRBOO NORTH WATERWORKS TRUST.

## AUTHORITY TO OBTAIN BANK OVERDRAFT.

HIS Excellency the Lieutenant-Governor of the State of Victoria, by and with the advice of the Executive Council thereof, doth by Order made on the twenty-second day of October, 1968, authorize the Mirboo North Waterworks Trust to obtain, in pursuance of the provisions of section 286 of the Water Act 1958 (No. 6413), an advance or advances during the year 1969, by overdraft of the Trust's current account, such overdraft not to exceed at any one time the sum of One thousand four hundred dollars (\$1,400).

J. ROSSITER,

Clerk of the Executive Council.

At the Executive Council Chamber,  
Melbourne, 22nd October, 1968.

## YARRAM WATERWORKS TRUST.

## BY-LAW No. 5.

THE Yarram Waterworks Trust in pursuance of and in exercise of the powers conferred by the Water Act 1958 and of any and every other power it thereunto enabling doth hereby make a By-Law as follows:—

1. The meter or meters measuring the supply of water to any lands or tenements shall be read as near as practicable to twelve months from the date that it was read previously and the quantity of water so measured as having been supplied during the period between any two successive such readings (hereinafter called "the meter year") shall be the basis of the calculating of charges payable under this By-Law provided always that where a meter has been installed on any land or tenement during the course of a meter year the quantity of water measured as having been supplied during the period between the date of such installation and the date of the reading shall be the basis of calculating such charges.

2. Subject as is hereinafter provided in respect of any land or tenement rated by the Trust:—

- (a) The maximum quantity of water to be supplied in any meter year without charge is hereby fixed as a quantity which if charged at FIFTEEN cents per thousand gallons for any meter year would give an amount equal to the amount of the rate payable in respect of the land or tenement for the financial year in which the said meter year ended.
- (b) For all water supplied in any meter year in excess of the maximum quantity referred to in paragraph (a) of this clause the charge is hereby fixed at THIRTEEN cents per thousand gallons for any meter year.
- (c) For all water supplied to farm properties within the Urban District of the Trust in any meter year in excess of the maximum quantity referred to in paragraph (a) of this clause the charge is hereby fixed at TWENTY-FIVE cents per thousand gallons for any meter year.

3. Subject as is hereinafter provided for water supplied by measure to any property not rated by the Trust is hereby fixed at TWENTY-FIVE cents per thousand gallons.

4. The minimum charge for water supplied by measure to any property not rated by the Trust is hereby fixed at TWENTY DOLLARS for any meter year.

5. The aforesaid charges shall be payable within seven days of demand upon the owner or occupier at the office of the Trust during normal business hours.

6. The provisions of clauses 2, 3, & 4 of this By-Law shall not apply to any land tenement or property supplied with water by the Trust under a special agreement pursuant to Section 215 of the Water Act 1958.

Passed this 10th day of October, 1968.

(SEAL)

J. F. KING-CHURCH, Chairman.  
S. PONSFORD, Secretary.

Approved, 17th October, 1968.—W. BORTHWICK, Minister of Water Supply.

## YARRAM WATERWORKS TRUST.

## RATING BY-LAW FOR THE YEAR 1969.

THE Yarram Waterworks Trust in pursuance of and in exercise of the powers conferred by the Water Act 1958 and of any and every other power it thereunto enabling doth hereby make a By-Law as follows:—

1. The Trust hereby makes and levies a rate in respect of all the lands and tenements within the Yarram Urban District of FIVE cents in the Dollar on the net annual value set out in the valuation at present in force of such lands and tenements for the purposes of the municipal rate of the Shire of Alberton which is hereby adopted as the valuation of such lands and tenements respectively.

2. Such rate shall be made and levied upon the occupier and owners of such lands and tenements for the year commencing on the 1st day of January, 1969 and shall be payable on the 6th day of March, 1969 at the office of the said Trust.

3. In no case shall the rate payable in respect of any land on which there is a building be less than FIFTEEN DOLLARS and in respect of land on which there is no building be less than SIX DOLLARS.

4. Water supplied by the Trust is in all cases subject to the right of the Trust by notice to prohibit or restrict the use of same for all purposes (other than domestic purposes) during such period or at such time or from time to time as may be fixed by the Trust and stated in such notice, and such notice shall cease to have effect at such time the Trust from time to time directs by a notice so published.

Such notice may be given by printed posters placed in a prominent position within the Trust District or by advertisement in some newspaper circulating in such district.

No person shall use or permit or suffer water supplied by the Trust to be used contrary to any such prohibitions or restrictions.

No person shall use or permit or suffer the use of a hose or any such other appliance to be attached to a tap or service pipe for the purpose of supplying water during such restricted periods.

Dated this 10th day of October, 1968.

(SEAL)

J. F. KING-CHURCH, Chairman.  
S. PONSFORD, Secretary.

Approved, 17th October, 1968.—W. BORTHWICK, Minister of Water Supply.

## TONGALA WATERWORKS TRUST.

## RATING BY-LAW 1969.

## By-law No. 1.

THE Tongala Waterworks Trust in pursuance of and in exercise of the powers conferred by the Water Act 1958 and of any and every other power it thereunto enabling doth hereby make a By-law as follows:—

1. The Trust hereby makes and levies a rate in respect of all the lands and tenements within the Tongala (Waterworks District) of 9.5 cents in the dollar on the net annual value set out in the valuation at present in force of such lands and tenements for the purposes of the municipal rate of the (Shire of Deakin) which is hereby adopted as the valuation of such lands and tenements respectively.

2. Such rate shall be made and levied upon the occupiers and owners of such lands and tenements for the year commencing on the 1st day of January 1969 and shall be payable on the 31st day of December 1969 at the office of the said Trust.

3. In no case shall the rate payable hereunder in respect of any land on which there is a building be less than \$12 dollars and in respect of land on which there is no building be less than \$4 dollars.

The foregoing By-law was made by the Tongala Waterworks Trust and passed the 8th day of October 1968.

(SEAL) L. E. HARVEY, Chairman.  
B. PEARL, Secretary.

Approved, 11th October, 1968.—W. BORTHWICK, Minister of Water Supply.

ALBERTON—PORT ALBERT WATERWORKS TRUST.  
RATING BY-LAW FOR THE YEAR 1968.

THE Alberton—Port Albert Waterworks Trust in pursuance of and in exercise of the powers conferred by the Water Act 1958 and of any and every other power it thereunto enabling doth hereby make a By-Law as follows:—

1. The Trust hereby makes and levies a rate in respect of all the lands and tenements within the Alberton and the Port Albert Urban Districts of 17.5 Cents in the Dollar on the net annual value set out in the valuation at present in force of such lands and tenements for the purposes of the municipal rate of the Shire of Alberton which is hereby adopted as the valuation of such lands and tenements respectively.

2. Such rate shall be made and levied upon the occupiers and owners of such lands and tenements for the year commencing on the 1st day of January 1968 and shall be payable on the 20th day of December 1968 at the office of the said Trust.

3. In no case shall the rate payable hereunder in respect of any land on which there is a building be less than Seventeen Dollars and in respect of land on which there is no building be less than Five Dollars.

Passed this eighth day of October, 1968.

(SEAL) J. N. CHRISTENSEN, Chairman.  
N. E. LIPSCOMBE, Commissioner.  
C. J. PATERSON, Secretary.

Approved, 17th October, 1968.—W. BORTHWICK, Minister of Water Supply.

TONGALA WATERWORKS TRUST.  
EXCESS WATER BY-LAW 2.

THE Tongala Waterworks Trust in pursuance of and in exercise of the powers conferred by the Water Act 1958 and of any and every other power it thereunto enabling doth hereby make a By-law as follows:—

1. The meter or meters measuring the supply of water to any land or tenement shall be read as near as practicable to twelve months from the date that it was read previously and the quantity of water so measured as having been supplied during the period between any two successive such readings (hereinafter called "the meter year") shall be the basis of the calculating of charges payable under this By-law provided always that where a meter has been installed on any land or tenement during the course of a meter year the quantity of water measured as having been supplied during the period between the date of such installation and the date of the reading shall be the basis of calculating such charges.

2. Subject as is hereinafter provided in respect of any land or tenement rated by the Trust—

(a) The maximum quantity of water to be supplied in any meter year without charge is hereby fixed at a quantity which if charged at 25 cents per thousand gallons for any meter year would give an amount equal to the amount of the rate payable in respect of the land or tenement for the financial year in which the said meter year ended.

(b) For all water supplied in any meter year in excess of the maximum quantity referred to in paragraph (a) of this clause the charge is hereby fixed at 20 cents per thousand gallons for the first 20,000,000 gallons supplied, 16 cents per thousand gallons for the second 20,000,000 gallons supplied and 12 cents per thousand gallons for any subsequent water supplied for any meter year.

3. Subject as is hereinafter provided the charge for water supplied by measure to any property not rated by the Trust is hereby fixed at the same charges as provided under Clause 2.

4. The minimum charge for water supplied by measure to any property not rated by the Trust is hereby fixed at \$12.

5. The aforesaid charges shall be payable within seven days of demand upon the owner or occupier at the offices of the Trust during normal business hours.

6. The provisions of Clauses 2, 3, and 4 of this By-law shall not apply to any land tenement or property supplied with water by the Trust under a special agreement pursuant to Section 215 of the Water Act 1958.

This foregoing By-law was made by the Tongala Waterworks Trust and passed this 8th day of October, 1968.

(SEAL) L. E. HARVEY, Chairman.  
B. PEARL, Secretary.

Approved, 11th October, 1968.—W. BORTHWICK, Minister of Water Supply.

AVOCA TOWNSHIP WATERWORKS TRUST.  
BY-LAW No. 30.

THE Avoca Township Waterworks Trust in pursuance of and in exercise of the powers conferred by the Water Act 1958 and of any and every other power it thereunto enabling doth hereby make a By-law as follows:

1. The meter or meters measuring the supply of water to any land or tenement shall be read as near as practicable to twelve months from the date that it was read previously and the quantity of water so measured as having been supplied during the period between any two successive such readings (hereinafter called "the meter year") shall be the basis of the calculating of charges payable under this By-law provided always that where a meter has been installed on any land or tenement during the course of a meter year the quantity of water measured as having been supplied during the period between the date of such installation and the date of the reading shall be the basis of calculating such charges.

2. Subject as is hereinafter provided in respect of any land or tenement rated by the Trust—

(a) The maximum quantity of water to be supplied in any meter year without charge is hereby fixed at a quantity which if charged at twenty cents per thousand gallons for any meter year would give an amount equal to the amount of the rate payable in respect of the land or tenement for the financial year in which the said meter year ended.

(b) For all water supplied in any meter year in excess of the maximum quantity referred to in paragraph (a) of this clause the charge is hereby fixed at twenty cents per thousand gallons for any meter year.

3. Subject as is hereinafter provided the charge for water supplied by measure to any property not rated by the Trust is hereby fixed at twenty cents per thousand gallons.

4. The minimum charge for water supplied by measure to any property not rated by the Trust is hereby fixed at six dollars.

5. The aforesaid charges shall be payable within seven days of demand upon the owner or occupier at the office of the Trust during normal business hours.

6. The provisions of Clauses 2, 3 and 4 of this By-law shall not apply to any land tenement or property supplied with water by the Trust under a special agreement pursuant to Section 215 of the Water Act 1958.

Passed this seventh day of October, 1968.

The corporate seal of the Avoca Township Waterworks Trust was hereunto affixed this seventh day of October, 1968, in the presence of—

(SEAL) W. R. J. GLEDHILL, Chairman.  
R. D. PECK, Commissioner.  
F. C. S. EDWARDS, Secretary.

Approved, 16th October, 1968.—W. BORTHWICK, Minister of Water Supply.

## AVOCA TOWNSHIP WATERWORKS TRUST.

## RATING BY-LAW FOR THE YEAR 1969.

THE Avoca Township Waterworks Trust in pursuance of and in exercise of the powers conferred by the Water Act 1958 and of any and every other power it thereunto enabling doth hereby make a By-law as follows:

1. The Trust hereby makes and levies a rate in respect of all the lands and tenements within the Avoca Township Waterworks Trust Urban District of ten cents in the dollar on the net annual value set out in the valuation at present in force of such lands and tenements for the purposes of the municipal rate of the Shire of Avoca which is hereby adopted as the valuation of such lands and tenements respectively.

2. Such rate shall be made and levied upon the occupiers and owners of such lands and tenements for the year commencing on the 1st day of January 1969 and shall be payable on the 3rd day of January 1969 at the office of the said Trust.

3. In no case shall the rate payable hereunder in respect of any land on which there is a building be less than six dollars and in respect of land on which there is no building be less than four dollars.

Passed this seventh day of October, 1968.

The corporate seal of the Avoca Township Waterworks Trust was hereunto affixed this seventh day of October, 1968, in the presence of—

(SEAL) W. R. J. GLEDHILL, Chairman.  
R. D. PECK, Commissioner.  
F. C. S. EDWARDS, Secretary.

Approved, 16th October, 1968.—W. BORTHWICK, Minister of Water Supply.

## GOORAMBAT WATERWORKS TRUST.

## RATING BY-LAW FOR THE YEAR 1968.

THE Goorambat Waterworks Trust, in pursuance and exercise of the powers conferred by the Water Act, doth hereby make a rate for the supply of water for domestic purposes, on lands and tenements liable to be rated within the Goorambat Urban District, of 22.5 cents in the dollar of the annual municipal valuation of lands and tenements not exceeding \$250, fifty-five dollars on each tenement having a Net Annual Value exceeding \$250 but not exceeding \$400, eighty dollars on each tenements having a Net Annual Value exceeding \$400 but not exceeding \$750, and one hundred dollars on each tenement having a Net Annual Value of more than \$750.

Provided that in no case shall the amount of rate payable per annum in respect of any tenement (other than land on which there is no building) be less than 22 dollars, and in respect of any land on which there is no building less than 5 dollars.

Such rates are made and shall be levied upon the occupiers or owners of the said lands and tenements for the year commencing on the 1st day of January, 1968, and shall be payable on the 30th day of November, 1968, at the offices of the said Trust.

The maximum quantity of water to be supplied in any one year without further charge to any property rated by the Trust is hereby fixed at the quantity which, at a charge of 40 cents per 1,000 gallons, would produce an amount equal to the amount of the rate levied on such property for the said year.

The charge for the water supplied by measure to any property rated by the Trust in excess of such maximum quantity, computed as in the last preceding clause, is hereby fixed at 40 cents per 1,000 gallons.

The charge for the water supplied by measure to any property not rated by the Trust is hereby fixed at 40 cents per 1,000 gallons, and the minimum quantity of water to be charged for in cases where water is so supplied is fixed at 50,000 gallons.

The charge for water supplied by measure shall be payable, on demand, at the office of the Trust.

Passed this 11th day of October, 1968.

(SEAL) C. W. COOPER, Chairman.  
J. K. ASHTON, Secretary.

Approved, 17th October, 1968.—W. BORTHWICK, Minister of Water Supply.

## HORSHAM WATERWORKS TRUST.

## RATING BY-LAW FOR THE PERIOD 1ST OCTOBER, 1968, TO 30TH SEPTEMBER, 1969.

THE Commissioners of the Horsham Waterworks Trust, in pursuance of the provisions of the Water Acts, do hereby make the following By-law:—

1. The water rate for the year ending 30th September, 1969, on all lands and tenements liable to be rated within the Horsham Waterworks Trust District shall be 4 cents in the Dollar on the municipal valuation of the City of Horsham for the year 1968-69.

Provided in no case shall the amount of rate payable in respect of any property on which there is a building be less than Twelve Dollars (\$12) and in respect of any property on which there is no building less than Ten Dollars Fifty Cents (\$10.50).

2. (a) The maximum quantity of water to be supplied during the year ending 30th September, 1969, without further charge to any property rated by the Trust, is hereby fixed at the quantity which, at a charge of Ten Cents (10c) per 1,000 gallons, would produce an amount equal to the amount of the rate levied on such property for the said period.

(b) The charge for water supplied by measure to any property rated by the Trust in excess of such maximum quantity, computed as in the preceding sub-clause, is hereby fixed at Eight Cents (8c) per 1,000 gallons.

(c) The charge for water supplied within the Waterworks Trust District by measure to any property not rated by the Trust, is hereby fixed at Eight Cents (8c) per 1,000 gallons, and the minimum quantity of water to be charged for in cases where water is so supplied is hereby fixed at 27,000 gallons.

(d) The charge for water supplied outside the Waterworks Trust District by measure to any property is hereby fixed at Twenty Cents (20c) per 1,000 gallons, and the minimum quantity of water to be charged for in cases where water is so supplied is hereby fixed at 47,000 gallons.

(e) The charge for water supplied by measure shall be payable, on demand, at the office of the Trust.

3. All water rates shall be payable on the 6th day of December, 1968, at the office of the Trust, Wilson Street, Horsham, where payments will be received during office hours.

4. Such officers as the Trust from time to time may appoint for the purpose are hereby authorized to demand, receive, and recover the said rates and charges.

The foregoing By-law was passed by the Commissioners of the Horsham Waterworks Trust on the 7th day of October, 1968, and the common seal affixed hereunder, in the presence of—

(SEAL) IAN PALLOT, Chairman.  
E. GERLACH, Commissioner.  
A. R. CONN, Secretary.

Approved, 11th October, 1968.—W. BORTHWICK, Minister of Water Supply.

## DROUIN WATERWORKS TRUST.

## RATING BY-LAW 1969.

THE Drouin Waterworks Trust in pursuance of and in exercise of the powers conferred by the Water Act 1958 and of any and every other power it thereunto enabling doth hereby make a By-law as follows:—

1. The Trust hereby makes and levies a rate in respect of all the lands and tenements within the Drouin Urban District of five cents in the dollar on the net annual value set out in the valuation at present in force of such lands and tenements for the purpose of the municipal rate of the Shire of Buln Buln which is hereby adopted as the valuation of such lands and tenements respectively.

2. Such rate shall be made and levied upon the occupiers and owners of such lands and tenements for the year commencing on the 1st day of January 1969 and shall be payable on the 2nd day of March 1959 at the office of the said Trust.

3. In no case shall the rate payable hereunder in respect of any land on which there is a building be less than ten dollars and in respect of land on which there is no building be less than four dollars.

Passed this 10th day of October, 1968.

(SEAL) K. L. NICKELL, Chairman.  
K. R. GRANT, Commissioner.  
E. J. AUSTIN, Secretary.

Approved, 16th October, 1968.—W. BORTHWICK, Minister of Water Supply.



## DROUIN WATERWORKS TRUST.

## By-LAW No. 4.

THE Drouin Waterworks Trust in pursuance of and in exercise of the powers conferred by the *Water Act 1958* and of any and every other power it thereunto enabling doth hereby make a By-law as follows:—

1. The meter or meters measuring the supply of water to any land or tenement shall be read as near as practicable to twelve months from the date that it was read previously and the quantity of water so measured as having been supplied during the period between any two successive such readings (hereinafter called "the meter year") shall be the basis of the calculating of charges payable under this By-law provided always that where a meter has been installed on any land or tenement during the course of a meter year the quantity of water measured as having been supplied during the period between the date of such installation and the date of the reading shall be the basis of calculating such charges.

2. Subject as is hereinafter provided in respect of any land or tenement rated by the Trust—

(a) The maximum quantity of water to be supplied in any meter year without charge is hereby fixed as a quantity which if charged at twenty-five cents per thousand gallons for any meter year would give an amount equal to the amount of the rate payable in respect of the land or tenement for the financial year in which the said meter year ended.

(b) For all water supplied in any meter year in excess of the maximum quantity referred to in paragraph (a) of this clause the charge is hereby fixed at twenty-five cents per thousand gallons for any meter year.

3. Subject as is hereinafter provided the charge for water supplied by measure to any property not rated by the Trust is hereby fixed at twenty-five cents per thousand gallons.

4. The minimum charge for water supplied by measure to any property not rated by the Trust is hereby fixed at four dollars.

5. The aforesaid charges shall be payable within seven days of demand upon the owner or occupier at the office of the Trust during normal business hours.

6. The provisions of Clauses 3, 4 and 5 of this By-law shall not apply to any land tenement or property supplied with water by the Trust under a special agreement pursuant to Section 215 of the *Water Act 1958*.

Passed this 10th day of October, 1968.

(SEAL) K. L. NICKELL, Chairman.  
K. R. GRANT, Commissioner.  
E. J. AUSTIN, Secretary.

Approved, 16th October, 1968.—W. BORTHWICK, Minister of Water Supply.

## LINTON WATERWORKS TRUST.

## By-LAW No. 15.

THE Linton Waterworks Trust in pursuance of and in exercise of the powers conferred by the *Water Act 1958* and of any and every other power it thereunto enabling doth hereby make a By-law as follows:—

1. The meter or meters measuring the supply of water to any land or tenement shall be read as near as practicable to twelve months from the date that it was read previously and the quantity of water so measured as having been supplied during the period between any two successive such readings (hereinafter called "the meter year") shall be the basis of the calculating of charges payable under this By-law provided always that where a meter has been installed on any land or tenement during the course of a meter year the quantity of water measured as having been supplied during the period between the date of such installation and the date of the reading shall be the basis of calculating such charges.

2. Subject as is hereinafter provided in respect of any land or tenement rated by the Trust—

(a) The maximum quantity of water to be supplied in any meter year without charge is hereby fixed as a quantity which if charged at twenty-five cents per thousand gallons for any meter year would give an amount equal to the amount of the rate payable in respect of the land or tenement for the financial year in which the said meter year ended.

(b) For all water supplied in any meter year in excess of the maximum quantity referred to in paragraph (a) of this clause the charge is hereby fixed at twenty-five cents per thousand gallons for any meter year.

3. Subject as is hereinafter provided the charge for water supplied by measure to any property not rated by the Trust is hereby fixed at twenty-five cents per thousand gallons.

4. The minimum charge for water supplied by measure to any property not rated by the Trust is hereby fixed at TWO Dollars.

5. The aforesaid charges shall be payable within seven days of demand upon the owner or occupier at the office of the Trust during normal business hours.

6. The provision of Clauses 2, 3 and 4 of this By-Law shall not apply to any land tenement or property supplied with water by the Trust under a special agreement pursuant to Section 215 of the *Water Act 1958*.

Passed this 10th day of October, 1968.

(SEAL) I. S. GRIGG, Chairman.  
S. E. MORGAN, Commissioner.  
T. J. CAREY, Commissioner.  
L. OLDHAM, Secretary.

Approved, 16th October, 1968.—W. BORTHWICK, Minister of Water Supply.

## LINTON WATERWORKS TRUST.

## By-LAW No. 14.

THE Linton Waterworks Trust in pursuance of and in exercise of the powers conferred by the *Water Act 1958* and of any and every other power it thereunto enabling doth hereby make a By-law as follows:—

1. The Trust hereby makes and levies a rate in respect of all lands and tenements within the Linton Urban District of EIGHT cents in the Dollar on the Nett Annual Value up to \$500 and then a rate of FOUR cents in the Dollar on the nett annual value thereafter, set out in the valuation at present in force of such lands and tenements for the purposes of the municipal rate of the Shire of Grenville which is hereby adopted as the valuation of such lands and tenements respectively.

2. Such rate shall be made and levied upon the occupiers and owners of such lands and tenements for the year commencing on the 1st day of January 1969 and shall be payable on the 3rd day of February 1969 at the office of the said Trust.

3. In no case shall the rate payable hereunder in respect of any land on which there is a building be less than FOURTEEN dollars and in respect of land on which there is no building be less than TWO Dollars.

Passed this 10th day of October, 1968.

(SEAL) I. S. GRIGG, Chairman.  
W. S. GRIGG, Commissioner.  
S. E. MORGAN, Commissioner.  
L. OLDHAM, Secretary.

Approved, 16th October, 1968.—W. BORTHWICK, Minister of Water Supply.

## APPOINTMENTS AND RESIGNATIONS

## APPOINTMENTS.

HIS Excellency the Lieutenant-Governor of the State of Victoria, by and with the advice of the Executive Council thereof, has, by Orders made on the 15th day of October, 1968, been pleased to make the under-mentioned appointments, viz.:—

CHIEF SECRETARY'S DEPARTMENT.  
*Electoral Registrars (Acting).*

WILLIAM WOOLMORE  
to be Electoral Registrar (Acting) for the Camberwell, Camberwell South and Highfield Park Subdivisions of the Electoral District of Camberwell; the Glen Iris Subdivision of the Electoral District of Glen Iris; and the Auburn Subdivision of the Electoral District of Hawthorn, to take effect on and from the 1st October, 1968, during the absence on leave of William Niel Robertson;

JAMES THOMAS MCALLEN  
to be Electoral Registrar (Acting) for the Koo-Wee-Rup, Korumburra, Loch, Pakenham and Wonthaggi Subdivisions of the Electoral District of Gippsland West; the Morwell and Yallourn Subdivisions of the Electoral District of

Morwell; and for the Drouin, Neerim South, Newborough, Trafalgar, Warragul and Warragul North Subdivisions of the Electoral District of Narracan, to take effect on and from the 23rd September, 1968, during the absence on leave of John Ronald Geoffrey Hayes;

GEORGE LEO CHAMBERLAIN  
to be Electoral Registrar (Acting) for the Surrey Hills Subdivision of the Electoral District of Balwyn; the Box Hill and Doncaster Subdivisions of the Electoral District of Box Hill; the Healesville, Hurstbridge, Lilydale and Warburton Subdivisions of the Electoral District of Evelyn; the Diamond Creek, Eltham and Rosanna Subdivisions of the Electoral District of Greensborough; the Heidelberg Subdivision of the Electoral District of Ivanhoe; and the Donvale and Warrandyte Subdivisions of the Electoral District of Ringwood, to take effect on and from the 30th September, 1968, during the absence on leave of Herbert William Hodgson.

*Governor of Fairlea Female Prison (Acting).*

LUCY KATHLEEN TILLYER,  
pursuant to the provisions of the *Gaols Act 1958*, to be Governor (Acting) of Fairlea Female Prison, from the 29th September, 1968, to the 18th October, 1968, during the absence on leave of Governor Elsie Mabel Irvine.

*Member of the Liquor Control Commission.*

WILLIAM FRANCIS HAYES,  
pursuant to the provisions of the *Liquor Control Act 1968*, to be a member of the Liquor Control Commission, for the period from the 16th October, 1968, to the 30th June, 1975, both dates inclusive.

MINISTRY OF HEALTH.

*Members of Committees of Management of Hospitals.*

RUGBY WINTER LARMOUR  
to be a Member of the Committee of Management of the Wycheproof Hospital, pursuant to proviso (a) to section 48 (1) of the *Hospitals and Charities Act 1958*, for a further period of three years ending 26th October, 1971; and

JOHN MAXWELL BAKER  
to be a Member of the Committee of Management of Morwell and District Community Hospital, pursuant to proviso (a) to section 48 (1) of the *Hospitals and Charities Act 1958*, for a period of three years, vice N. C. Bell, resigned.

*Members of the Dietitians Registration Board of Victoria.*

ROSEMARY BARTON HEPBURN,  
WILMA MARY CAMPBELL, and  
CAROLINE NANCY TURNER,  
to be Members of the Dietitians Registration Board of Victoria, pursuant to the provisions of section 4 (2) (d) of the *Dietitians Registration Act 1958*, for the period ending 28th September, 1971.

*Member of the Food Standards Committee.*

RAYMOND CHARLES STANHOPE, M.Sc.  
to be a Member of the Food Standards Committee, pursuant to section 288 (2) (f) of the *Health Act 1958*, vice W. R. Jewell, resigned.

*Deputy Superintendent of the Larundel Mental Hospital.*

DANIEL KAHANS, M.B., B.S., D.P.M.,  
to be Deputy Superintendent of the Larundel Mental Hospital, pursuant to section 26 (1) of the *Mental Health Act 1959*, for the period from 27th October, 1968, to 11th November, 1968, vice Dr. S. H. Lorbeer on leave.

*Trustees of Public Cemeteries.*

NEIL HARRISON  
to be a Trustee of the Burwood General Cemetery, additional trustee;

FREDERICK ELSTON, and  
LINDSAY LUMMAS,  
to be Trustees of the Euroa Public Cemetery, vice A. Rollason, deceased, and A. Jacka, deceased;

FRANCIS JAMES MAHER, and  
JAMES CANFIELD,  
to be Trustees of the Yarrayne Public Cemetery, vice S. Foley, resigned, and H. O'Brien, resigned;

GEORGE JOHN BENTLEY  
to be a Trustee of the Footscray General Cemetery, vice T. Bentley, deceased;

ALAN WALLACE UEBERGANG  
to be a Trustee of the Horsham Public Cemetery, vice C. Dougall, resigned;

ALAN STEVENS  
to be a Trustee of the Malmsbury Public Cemetery, vice E. Cordy, resigned;

MAX MOOR  
LEIGH MCCANN, and  
DENIS GALLAWAY  
to be Trustees of the Barmah Public Cemetery, vice G. Henney, resigned, J. Lawford, resigned, and H. Moor, resigned;

D'ARCY MALONEY, and  
BERNARD MALONEY  
to be Trustees of the Barmah Public Cemetery, additional trustees;

ALBERT JOSEPH CARDELL  
to be a Trustee of the Clarendon Public Cemetery, vice A. McKee, deceased;

ADRIAN O'BRIEN  
to be a Trustee of the Woodend Public Cemetery, additional trustee; and  
MURRAY JOHN DAVIS

ALAN HAMILTON ASTBURY  
ALISTER DANUEAL ROPER, and  
JOHN WILFRED PAINE  
to be Trustees of the Dergholm Public Cemetery, additional trustees.

*Public Vaccinators.*

ELAINE MARY TWIST, M.B., B.S.,  
to be a Public Vaccinator of the Municipality of Diamond Valley;

NORMA KELSO, M.B., B.S.,  
to be a Public Vaccinator of the Municipality of Kew; and

LINDSAY DAVID SWALWELL, M.B., B.S.,  
to be a Public Vaccinator of the Municipality of Winchelsea.

LAW DEPARTMENT.

*Commissioners for Taking Declarations, &c.*

LOLA MARIA FITZCLARENCE, care of Save the Children Fund, Welfare Centre, Nowa Nowa, and  
REX TREVOR MCLEOD, care of McKenzie & Holland (Australia) Pty. Ltd., Stephenson-street, Spotswood,

to be Commissioners for taking Declarations and Affidavits, pursuant to the provisions of the *Evidence Act 1958*, to resign upon ceasing to occupy their present positions; and

MAURICE SMITH, 5 Glenfern-avenue, Doncaster,  
CYRIL TOMKIN FRITH, 11 Avondale-road, Morwell,  
ROBERT DE PLEDGE CRABTREE, 3 Caroline-street, Dandenong,  
REGINALD ERNEST CARBERY, 18 Springvale-road, Springvale, and  
CONSTANTINE MITCHELL, Flat 6, 18 Darling-street, South Yarra,

to be Commissioners for taking Declarations and Affidavits, pursuant to the provisions of the *Evidence Act 1958*, to resign upon removing from the neighbourhood of the addresses stated.

*Justices of the Peace.*

ALFRED REGINALD BRUCE McDONNELL, Parliament House, Melbourne,  
to Keep the Peace in all Bailiwicks of the State of Victoria;

GEORGE EDWARD DRAPER, Summerhill-road, Wollert,  
to Keep the Peace in the Central Bailiwick of the State of Victoria;

LESLIE THOMAS LEO MOGG, Station-street, Cobram, and  
JOHN BRIAN CATOR, Strathmerton,  
to Keep the Peace in the Northern Bailiwick of the State of Victoria;

ROBERT HAMILTON KNOX, Weeapoinah  
to Keep the Peace in the Southern Bailiwick of the State of Victoria; and

ELLIOT GEORGE GERRY, 2 Sailors Gully-road, Eaglehawk, and  
THOMAS ALLAN DRECHSLER, Sedgwick,  
to Keep the Peace in the Midland Bailiwick of the State of Victoria,

## DEPARTMENT OF WATER SUPPLY.

*Waterworks Trust Commissioners.*

FREDERICK ROBERT JONES, and  
GEORGE DOUGLAS TELFER

to be Commissioners of the Lindenow Waterworks Trust, to hold such position for a period of four years from the date hereof, subject to the provisions of the *Water Act 1958*;

HORACE EDWARD CROSSLEY

to be a Commissioner of the Mortlake Waterworks Trust, to hold such position for a period of four years from the date hereof, subject to the provisions of the *Water Act*;

ANGUS LOCHIEL PARRIS

to be a Commissioner of the Nagambie Waterworks Trust, to hold such position during the present term of office of Harry Hollaway, as a Councillor for the Central Riding of the Shire of Goulburn, subject to the provisions of the *Water Act*; and

PETER KEITH BENNIE  
GEOFFREY DAVID GOODING  
ARTHUR LINDSAY MAGUIRE  
RICHARD MACKLEY NOBLE, and  
WILLIAM JOHN STEPHENSON

to be Commissioners of the Seaspray Waterworks Trust, to hold such position for the period from the date hereof until the day of the ordinary election of Commissioners to be held in October, 1970, subject to the provisions of the *Water Act*.

J. ROSSITER,  
Clerk of the Executive Council.

At the Executive Council Chamber,  
Melbourne, 15th October, 1968.

*Liquor Control Act 1968.*

## APPOINTMENT OF LICENSING INSPECTORS.

IN accordance with the authority conferred upon me by sub-section (1) of Section 22 of the *Liquor Control Act 1968*, I, Rupert Henry Arnold, Chief Commissioner of Police, hereby appoint the following Officers of Police as Licensing Inspectors for the Divisions of the Police Districts as shown:

Division Number.	Police District.	Rank and Name.
2	Henty ..	Chief Inspector John Harrison
3	Loddon ..	Inspector Walter Raymond George
1	Melbourne ..	Inspector James Patrick Ryan
1	Upper Murray ..	Inspector Hiram O'Sullivan
2	Yarra ..	Chief Inspector Harry Parker

R. H. ARNOLD,  
Chief Commissioner of Police.

## FORESTS DEPARTMENT.

## APPOINTMENT OF COMMITTEE OF MANAGEMENT OF "GRAMPIANS WONDERLAND FOREST PARK".

WHEREAS by section 50 of the *Forests Act 1958* (No. 6254), it is provided that the Minister of Forests may, on the recommendation of the Forests Commission, appoint any number of persons, not less than three, to be a Committee of Management of any land forming part of any reserved forest, such land being set aside as a forest park, and may remove any of those persons: Now therefore, I, Edward Raymond Meagher, Her Majesty's Minister of Forests for the State of Victoria, on the recommendation of the Forests Commission, do hereby appoint—

CR. ARTHUR WILLIAM McCracken,  
vice Cr. W. J. McNamara, as a member of the Committee of Management until the 30th day of November, 1970, of the land forming part of the reserved forest in the Parishes of Boroka and Willam, County of Borung, described in the accompanying Schedule, and known as the "Grampians Wonderland Forest Park".

## SCHEDULE ABOVE REFERRED TO.

Parishes of Boroka and Willam, County of Borung, comprising 2,200 acres, more or less, shown by pink colour on plan marked 61/750 over 30.11.61, on file of correspondence No. 67/1763 in the Forests Department.

Dated at Melbourne the eighteenth day of October, 1968.

E. R. MEAGHER,  
Minister of Forests.

## RESIGNATIONS.

HIS Excellency the Lieutenant-Governor of the State of Victoria, by and with the advice of the Executive Council thereof, has, by Orders made on the 15th day of October, 1968, accepted the resignations of the persons named hereunder of the offices mentioned, viz.:—

## LAW DEPARTMENT.

*Commissioners for Taking Declarations, &c.*

REGINALD CHARLES HUMPHRIES, as a Commissioner for taking Declarations and Affidavits, pursuant to the provisions of the *Evidence Act 1958*.

*Justices of the Peace.*

The resignations of the persons named in the first column of the Schedule hereto, from the Commission of the Peace for the respective Bailiwicks of the State of Victoria set opposite their names in the second column of the said Schedule.

Name.	SCHEDULE.	Bailiwick.
WILLIAM MARK CAMPBELL .. .. .	.. .. .	Northern
STEWART JOHN BAIN .. .. .	.. .. .	Central

J. ROSSITER,  
Clerk of the Executive Council.

At the Executive Council Chamber,  
Melbourne, 15th October, 1968.

## ORDERS IN COUNCIL

## GAS AND FUEL CORPORATION ACT 1958.

At the Executive Council Chamber, Melbourne, the  
fifteenth day of October, 1968.

## PRESENT:

His Excellency the Lieutenant-Governor of Victoria.  
Mr. Porter | Mr. Meagher.  
Mr. Balfour

## APPOINTMENT OF STATE DIRECTOR OF THE GAS AND FUEL CORPORATION OF VICTORIA.

IN pursuance of the powers conferred by the *Gas and Fuel Corporation Act 1958* (No. 6260), His Excellency the Lieutenant-Governor of the State of Victoria, by and with the advice of the Executive Council thereof, doth by this Order appoint:—

## FRANCIS JOSEPH SWEENEY,

to be a State Director of the Gas and Fuel Corporation of Victoria, for a period of three years as from and including the nineteenth day of October, 1968.

And the Honorable James Charles Murray Balfour, Her Majesty's Minister for Fuel and Power for the State of Victoria, shall give the necessary directions herein accordingly.

J. ROSSITER,  
Clerk of the Executive Council.

LOCAL GOVERNMENT DEPARTMENT.

At the Executive Council Chamber, Melbourne, the fifteenth day of October, 1968.

PRESENT:

His Excellency the Lieutenant-Governor of Victoria. Mr. Porter | Mr. Meagher. Mr. Balfour

CONFIRMATION OF SEPARATE RATE—CITY OF BALLAARAT.

IN pursuance of the provisions of Section 287 of the Local Government Act 1958, His Excellency the Lieutenant-Governor of the State of Victoria, by and with the advice of the Executive Council thereof, hereby confirms a separate rate of 4.356 cents in the dollar on the net annual value of certain properties described hereunder, which rate was made by the Council of the City of Ballaarat on the 16th September, 1968, for the purpose of providing off-street parking facilities for use in connexion with the Bridge Street Shopping Area.

Properties to be Rated:

- (a) Within the area bounded by Curtis-street on the north, Peel-street on the east, Little Bridge-street on the south and Grenville-street on the west. (b) Abutting the north side of Bridge-street between Peel-street and Victoria-street and known as Nos. 83 (including upstairs rooms numbered 1-6) and Nos. 85-99 Bridge-street (both inclusive). (c) Abutting the south side of Bridge-street between Peel-street and Main-street and known as Nos. 92-104 Bridge-street (both inclusive).

And the Honorable Rupert James Hamer, Her Majesty's Minister for Local Government for the State of Victoria, shall give the necessary directions herein accordingly.

J. ROSSITER, Clerk of the Executive Council.

LOCAL GOVERNMENT DEPARTMENT.

At the Executive Council Chamber, Melbourne, the fifteenth day of October, 1968.

PRESENT:

His Excellency the Lieutenant-Governor of Victoria. Mr. Porter | Mr. Meagher. Mr. Balfour

ALTERATION OF TIME FOR CLOSING POLL AT MUNICIPAL ELECTIONS—SHIRE OF HUNTLY.

HIS Excellency the Lieutenant-Governor of the State of Victoria, by and with the advice of the Executive Council thereof, in pursuance of the powers conferred by Section 134 of the Local Government Act 1958, and in compliance with the prayer of a petition presented by the Council of the Shire of Huntly hereby declares that the hour for closing the poll at municipal elections for the said Shire shall be eight o'clock in the afternoon.

And the Honorable Rupert James Hamer, Her Majesty's Minister for Local Government for the State of Victoria, shall give the necessary directions herein accordingly.

J. ROSSITER, Clerk of the Executive Council.

LOCAL GOVERNMENT ACT 1958.

At the Executive Council Chamber, Melbourne, the fifteenth day of October, 1968.

PRESENT:

His Excellency the Lieutenant-Governor of Victoria. Mr. Porter | Mr. Meagher. Mr. Balfour

LAND IN DISCONTINUED ROAD TO BE RETAINED BY CITY OF CAMBERWELL.

PURSUANT to the provisions of paragraph (baa) of subsection (2) of Section 528 of the Local Government Act 1958, I, the Lieutenant-Governor of the State of

Victoria, by and with the advice of the Executive Council thereof, hereby direct that the land in portion of a right-of-way between Gordon and King streets, Balwyn, in the municipal district of the City of Camberwell and being the land shown hatched and cross-hatched on the plan hereunder—which portion of the said road was discontinued by an Order made under the said Section 528 (2) and published in the Government Gazette of the 23rd August, 1967, at Pages 2609 and 2610—shall be retained by the municipality for municipal purposes.

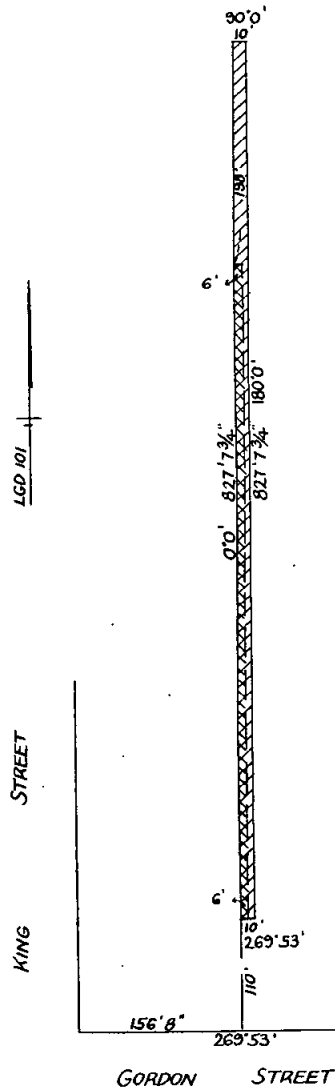

The fee of the land shown hatched and cross hatched was contained in certificate of title V. 2456 F-158 on 6-9-68.

The measurements are in feet and inches.

And the Honorable Rupert James Hamer, Her Majesty's Minister for Local Government for the State of Victoria, shall give the necessary directions herein accordingly.

J. ROSSITER, Clerk of the Executive Council.

COUNTRY ROADS BOARD.

At the Executive Council Chamber, Melbourne, the  
fifteenth day of October, 1968.

PRESENT:

His Excellency the Lieutenant-Governor of Victoria.

Mr. Porter | Mr. Meagher.  
Mr. Balfour

ORDER CONFIRMING RESOLUTIONS OF THE COUNTRY  
ROADS BOARD.

HIS Excellency the Lieutenant-Governor of the State of  
Victoria, by and with the advice of the Executive  
Council thereof, doth hereby, in pursuance of the provisions  
of the Country Roads Act 1958, confirm the resolutions  
of the Country Roads Board, the dates whereof and  
the terms of which are scheduled hereunder:—

SCHEDULE.

State highways.

Resolution dated the Seventh day of October One  
Thousand Nine Hundred and Sixty-eight, made pursuant to  
Sections 21, 58 and 74 of the Country Roads Act 1958,  
declaring the deviation from the Calder Highway in the  
City of Keilor as indicated by diagonal hatching on Plan  
numbered G.P.4647 hereunder to be part of a State  
highway within the meaning and for the purposes of the  
said Act, and also declaring that such deviation shall be  
in lieu of the existing road or part thereof indicated by  
cross hatching on the said plan.

STATE HIGHWAY  
CALDER HIGHWAY  
CITY OF KEILOR

Measurements in links.

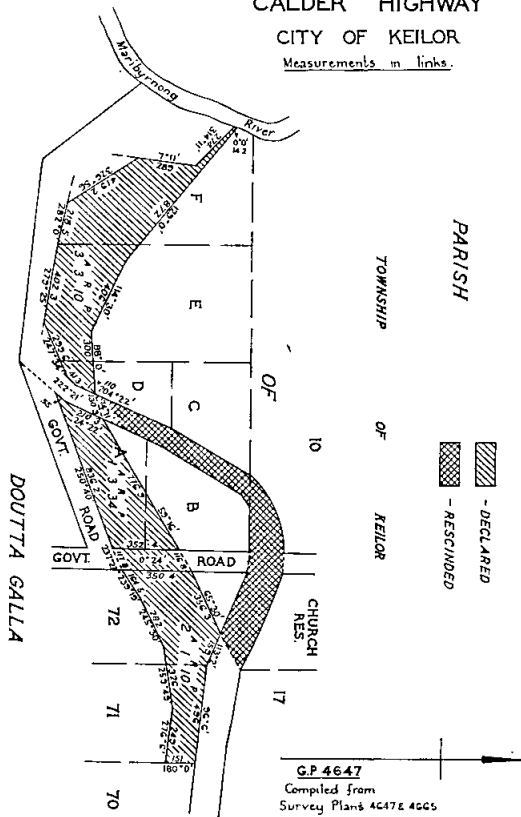

Resolution dated the Seventh day of October One  
Thousand Nine Hundred and Sixty-eight, made pursuant to  
Sections 21 and 74 of the Country Roads Act 1958 declar-  
ing the widening of the Calder Highway in the City of

Keilor as shown hatched on Plan numbered G.P.9366  
hereunder to be part of a State highway within the  
meaning and for the purposes of the said Act.

STATE HIGHWAY  
CALDER HIGHWAY

CITY OF KEILOR

Meas. in feet & inches

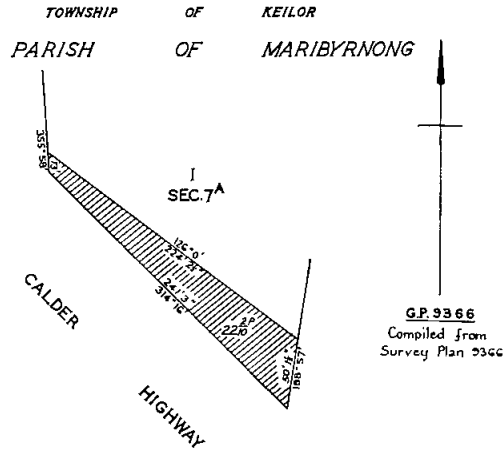

Resolution dated the Seventh day of October One  
Thousand Nine Hundred and Sixty-eight, made pursuant to  
Sections 21, 58 and 74 of the Country Roads Act 1958,  
declaring the deviation from the Princes Highway in the  
Shire of Tambo as indicated by diagonal hatching on Plan  
numbered G.P.11196A hereunder to be part of a State  
highway within the meaning and for the purposes of the  
said Act, and also declaring that such deviation shall be  
in lieu of the existing road or part thereof indicated by  
cross hatching on the said plan.

STATE HIGHWAY  
PRINCES HIGHWAY

SHIRE OF TAMBO

Measurements in links

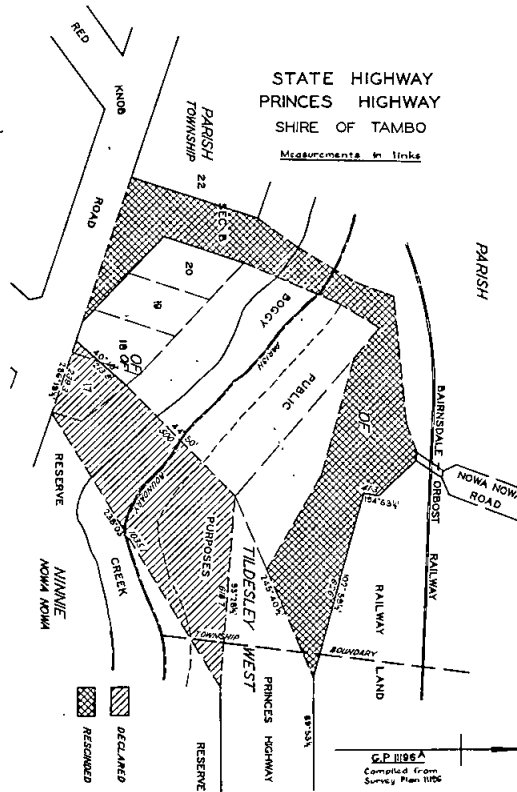

Resolution dated the Seventh day of October One Thousand Nine Hundred and Sixty-eight, made pursuant to Sections 21 and 74 of the *Country Roads Act 1958* declaring the widening of the Bass Highway in the Shire of Woorayl as shown hatched on Plan numbered G.P.9812 hereunder to be part of a State highway within the meaning and for the purposes of the said Act.

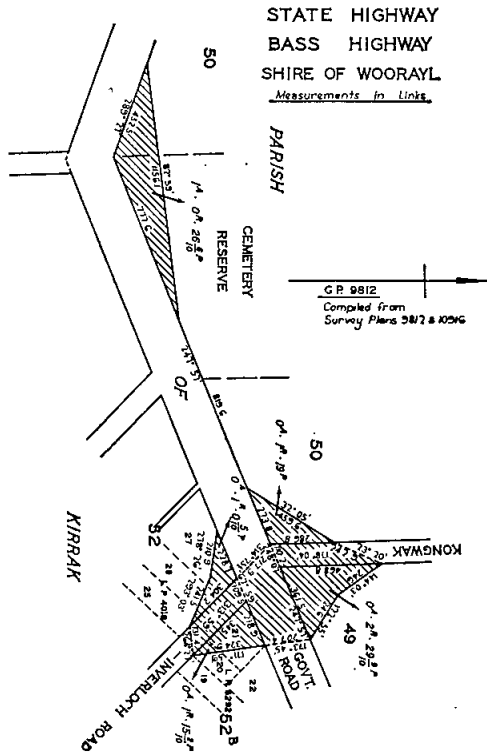

Main roads.

Resolution dated the Seventh day of October One Thousand Nine Hundred and Sixty-eight, made pursuant to Section 18 of the *Country Roads Act 1958* declaring the highway in the Shire of Tambo as shown hatched on Plan numbered G.P.11196B hereunder to be a main road (Nowa Nowa Road) within the meaning and for the purposes of the said Act.

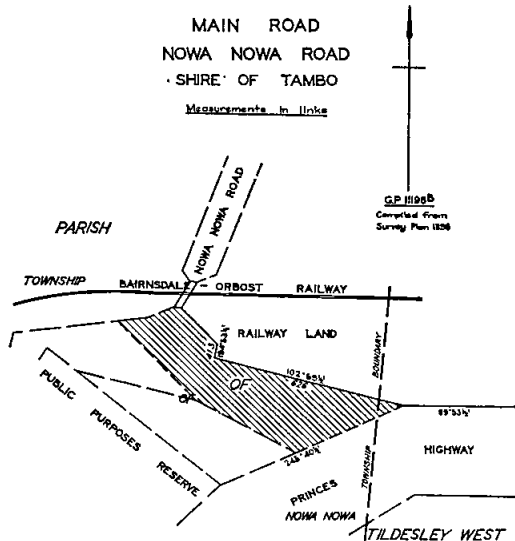

Resolution dated the Seventh day of October One Thousand Nine Hundred and Sixty-eight, made pursuant to Sections 21 and 58 of the *Country Roads Act 1958* declaring the deviation from The Grand Ridge Road in the Shire of Morwell as indicated by diagonal hatching on Plan numbered G.P.11053 hereunder to be part of a main road within the meaning and for the purposes of the said Act, and also declaring that such deviation shall be in lieu of the existing road or part thereof indicated by cross hatching on the said plan and that such part of the said existing road shall be discontinued.

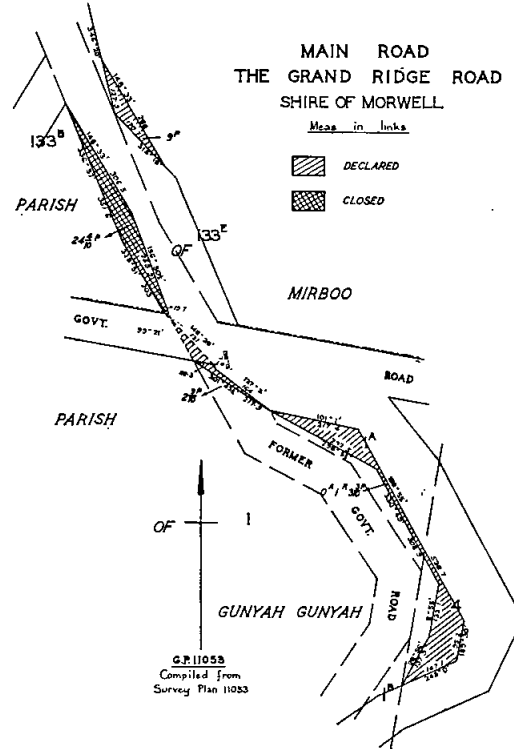

And the Honorable Murray Victor Porter, Her Majesty's Minister of Public Works for the State of Victoria, shall give the necessary directions herein accordingly.

J. ROSSITER,  
Clerk of the Executive Council.

COUNTRY ROADS BOARD.

At the Executive Council Chamber, Melbourne, the fifteenth day of October, 1968.

PRESENT:  
His Excellency the Lieutenant-Governor of Victoria.  
Mr. Porter | Mr. Meagher.  
Mr. Balfour

ORDER APPROVING OF LAND BEING ACQUIRED AND ROADS, DEVIATIONS OR WIDENINGS BEING MADE.

HIS Excellency the Lieutenant-Governor of the State of Victoria, by and with the advice of the Executive Council thereof, being satisfied that there are funds legally available for acquiring the land, doth hereby approve the acquiring of the land described in the Schedule hereunder and the making of new roads and deviations from and widenings of existing roads referred to in the said Schedule.

SCHEDULE.

State highways.

The land shown hatched on Plan numbered G.P.11508 hereunder required for the widening of the Midland Highway in the Shire of Buninyong and making of the widening thereon.

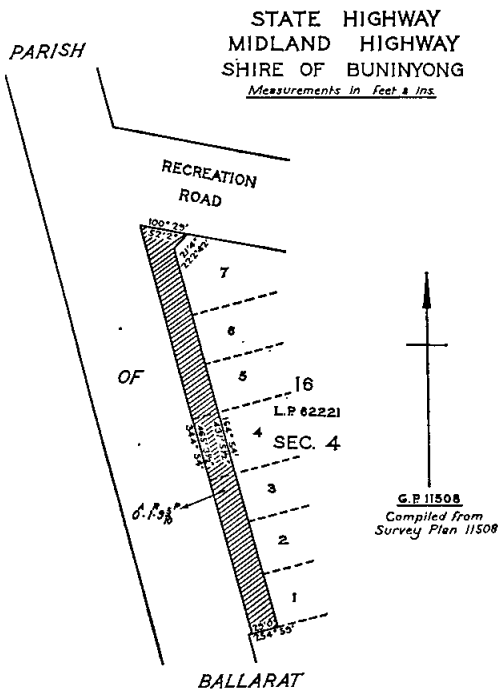

The land shown hatched on Plans numbered G.P.11150, G.P.11151 and G.P.11152 hereunder required for the widening of the Murray Valley Highway in the Shire of Wodonga and making of the widening thereon.

STATE HIGHWAY  
MURRAY VALLEY HIGHWAY  
SHIRE OF WODONGA

MEASUREMENTS IN FEET & INCHES

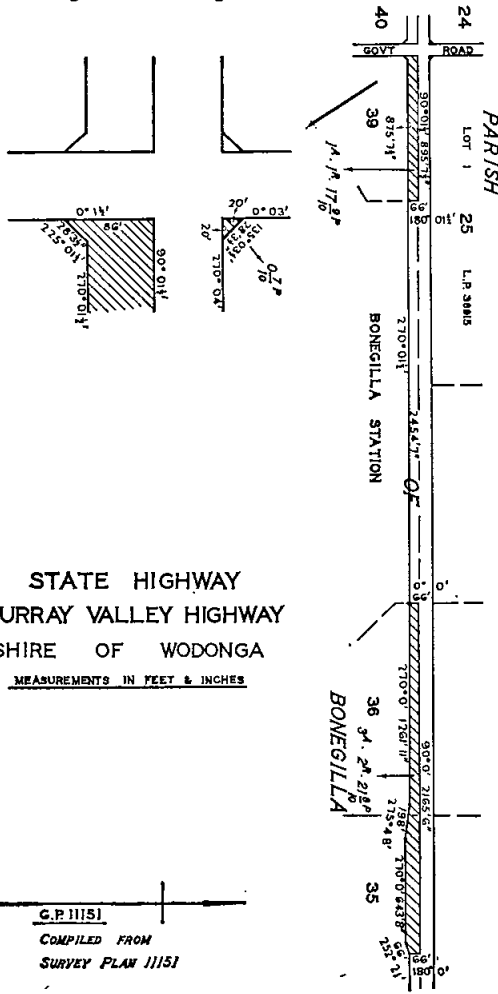
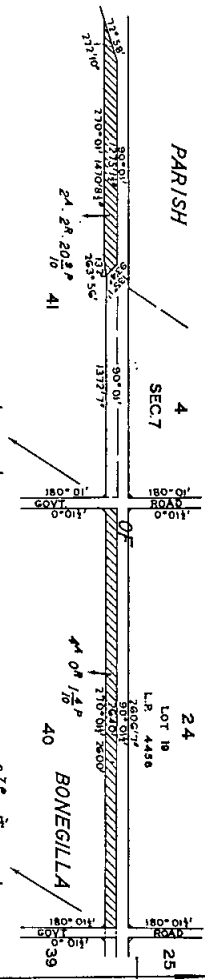
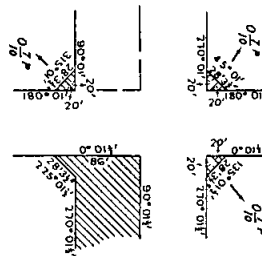

STATE HIGHWAY  
MURRAY VALLEY HIGHWAY  
SHIRE OF WODONGA

MEASUREMENTS IN FEET & INCHES

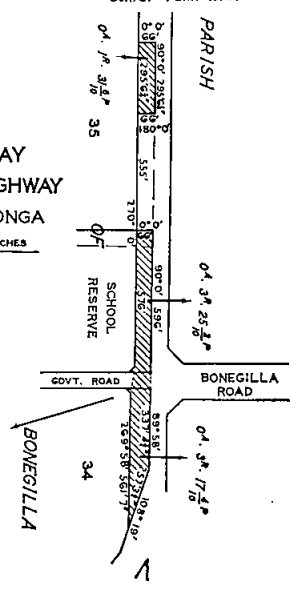
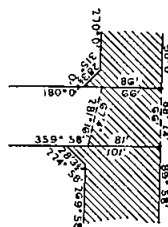

**Main roads.**

The land shown hatched on Plans numbered G.P.11366, G.P.11367 and G.P.11368A hereunder required for the deviation from the Mirboo North-Thorpdale Road in the Shire of Mirboo and making of the deviation thereon.

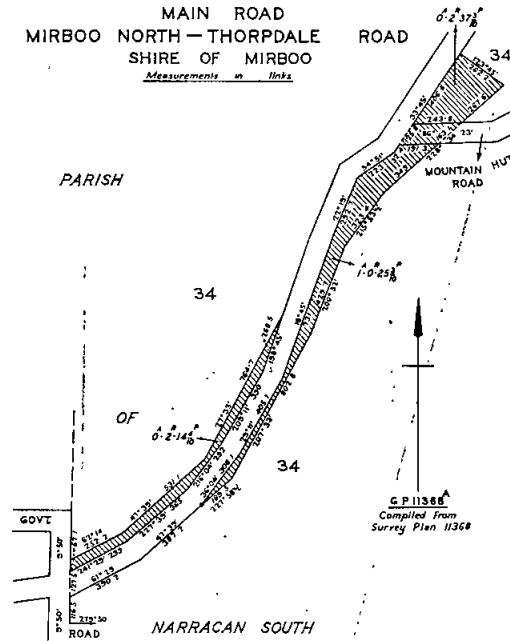
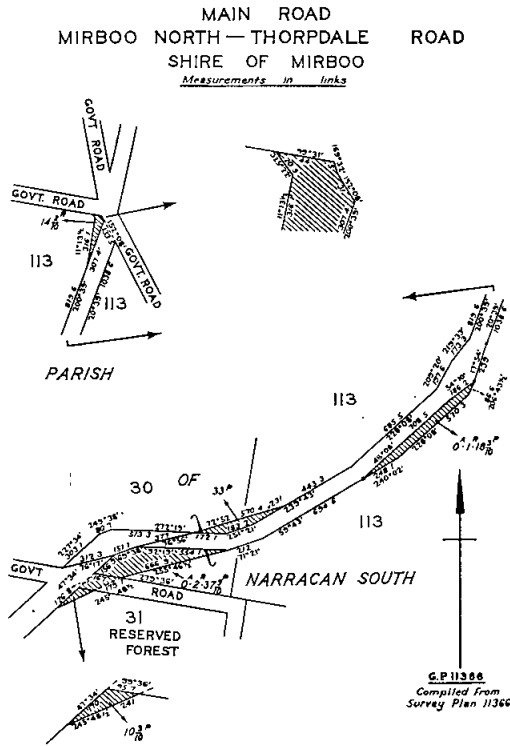

The land shown hatched on Plan numbered G.P.11400 hereunder required for the deviation from Buffalo River Road in the Shires of Myrtleford and Oxley and making of the deviation thereon.

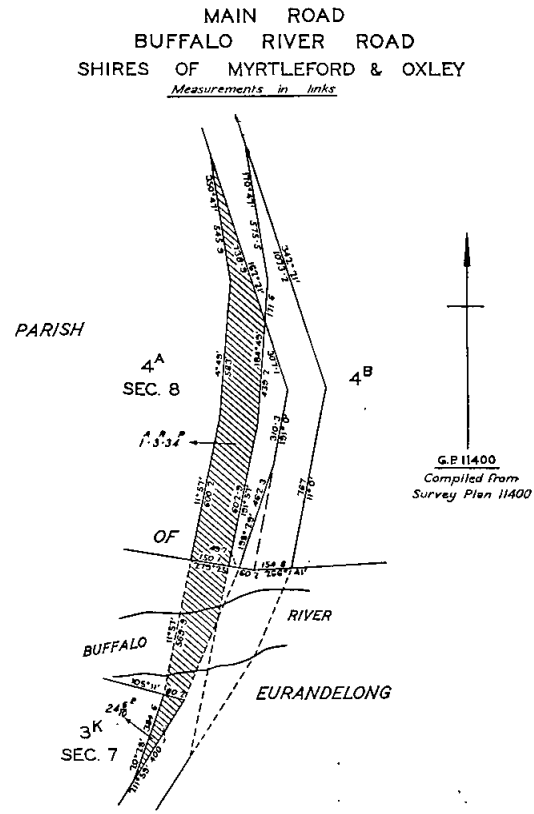
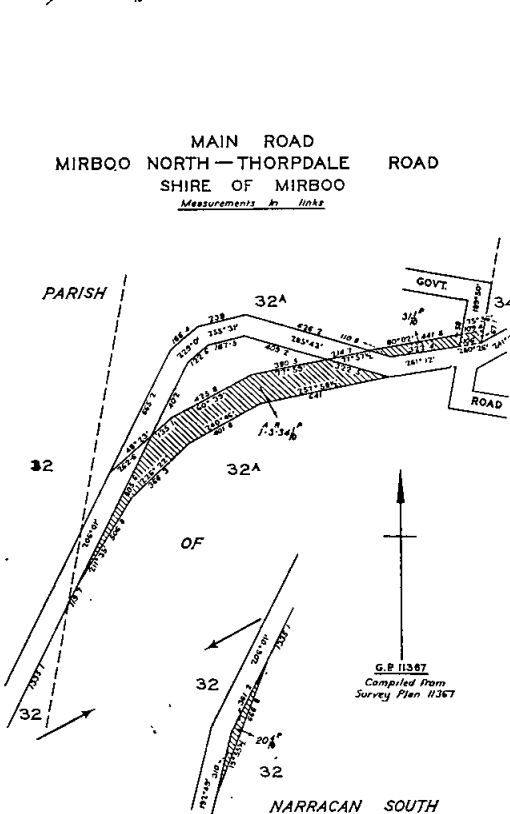



The land shown hatched on Plan numbered G.P.11405 hereunder required for the widening of Happy Valley Road in the Shire of Myrtleford and making of the widening thereon.

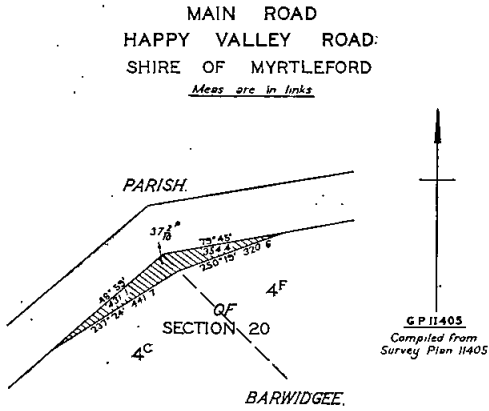

Unclassified road.  
The land shown hatched on Plan numbered G.P.11368B hereunder required for the widening of Mountain Hut Road in the Shire of Mirboo and making of the widening thereon.

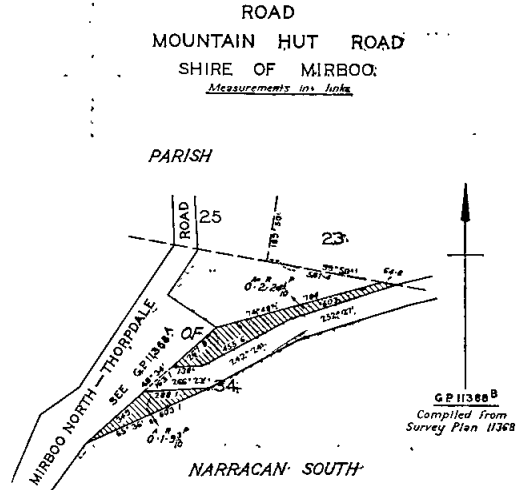

And the Honorable Murray Victor Porter, Her Majesty's Minister of Public Works for the State of Victoria, shall give the necessary directions herein accordingly.

J. ROSSITER,  
Clerk of the Executive Council.

The land shown hatched on Plan numbered G.P.11447 hereunder required for the widening of Navarre Road in the Town of Stawell and making of the widening thereon.

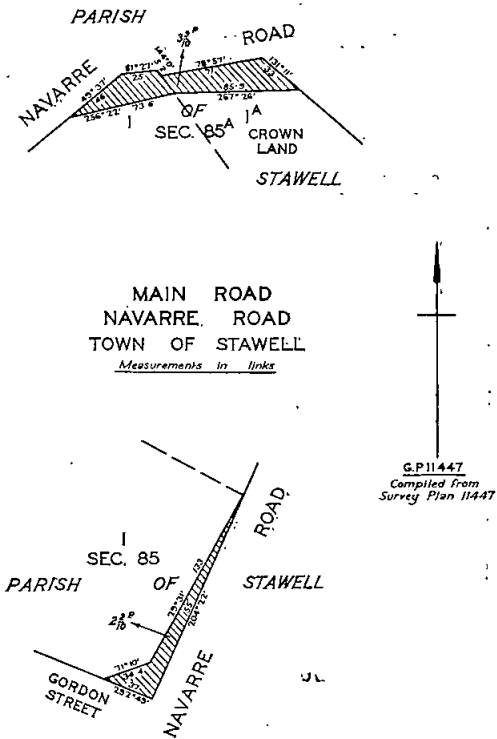

DEPARTMENT OF CROWN LANDS AND SURVEY.

At the Executive Council Chamber, Melbourne, the fifteenth day of October, 1968.

PRESENT:

His Excellency the Lieutenant-Governor of Victoria.

Mr. Porter  
Mr. Balfour

Mr. Meagher.

LANDS TEMPORARILY RESERVED AS SITES.

HIS Excellency the Lieutenant-Governor of the State of Victoria, by and with the advice of the Executive Council thereof, doth hereby, in pursuance of section 14 of the Land Act 1958, reserve temporarily from sale, from being leased and from having a licence granted in respect thereof, and also except from occupation for mining purposes, under any miner's right, the land hereinafter described:—

RAINBOW.—Site for State School purposes; 12 perches., Township of Rainbow, Parish of Werrap, County of Weeah, as indicated by hatching on plan hereunder.—(R.89<sup>(s)</sup>) (Rs.3485).

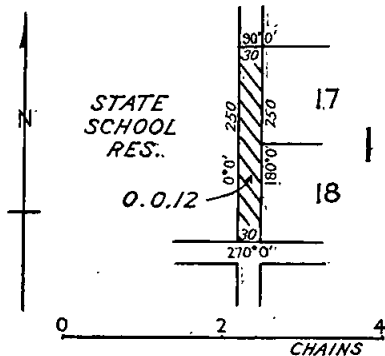

POMPONDEROO.—Site for Public Recreation and Camping purposes, 44 acres, more or less, Parish of Pomponderoo, County of Lowan, as indicated by hatching on plan hereunder.—(P.186<sup>(1)</sup>) (Rs.9078).

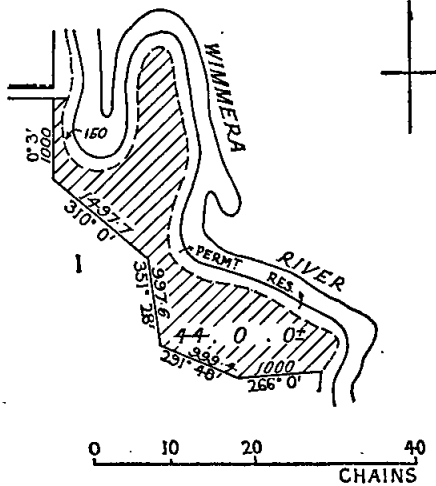

BARWIDGEE.—Site for Public purposes (Forests Department purposes), 1 acre 1 rood 15 perches, Parish of Barwidgee, County of Bogong, as indicated by hatching on plan hereunder.—(B.637<sup>(8)</sup>) (Rs.9027).

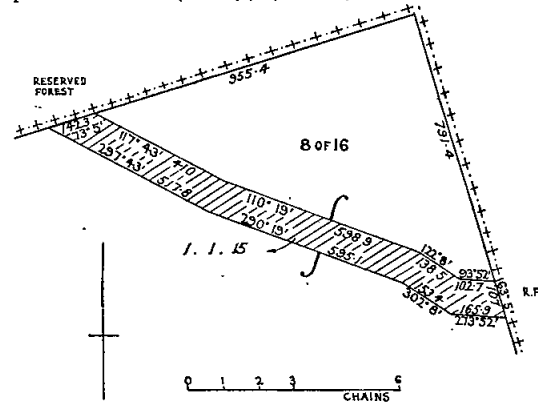

MILDURA.—Site for Railway purposes, 3 roods 33 perches, Parish of Mildura, County of Karkaroc, as indicated by hatching on plan hereunder.—(M.533<sup>(2)</sup>) (Rs.9064).

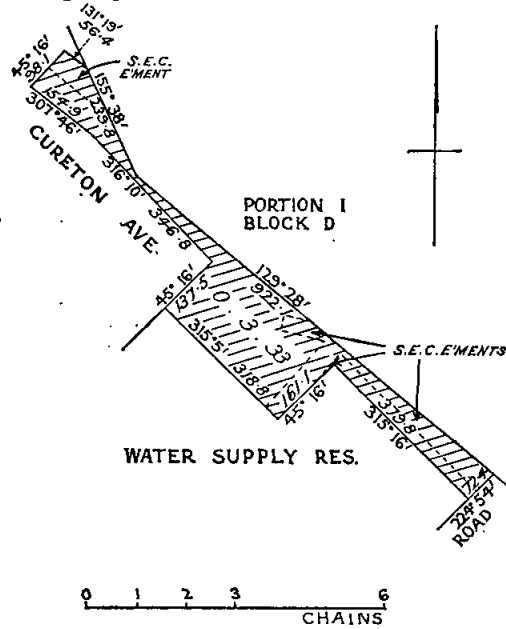

CURRAJUNG.—Site for Public purposes (Supply of Gravel), 6 acres, more or less, Parish of Currajung, County of Buln Buln, as indicated by hatching on plan hereunder.—(C.432<sup>(8)</sup>) (Rs.9080).

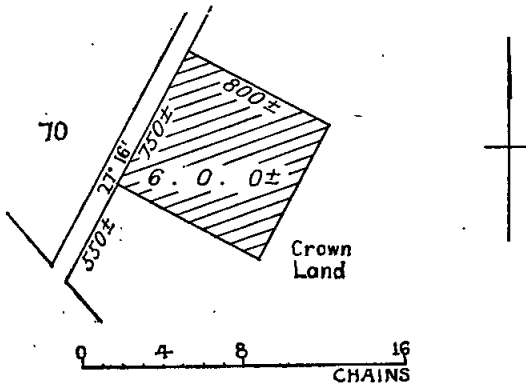

BRIGHT.—Site for Public purposes (Municipal purposes), 3 acres 3 roods 20 perches, more or less, Parish of Bright, County of Delatite, as indicated by hatching on plan hereunder.—(B.574<sup>(11)</sup>) (Rs.9072).

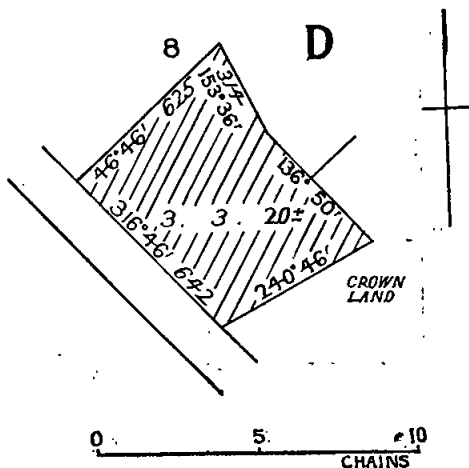

TINAMBA (HEYFIELD).—Site for Public purposes (Police purposes), 36 perches, Parish of Tinamba, County of Tanjil, as indicated by hatching on plan hereunder.—(T.147<sup>(4)</sup>) (Rs.9061).

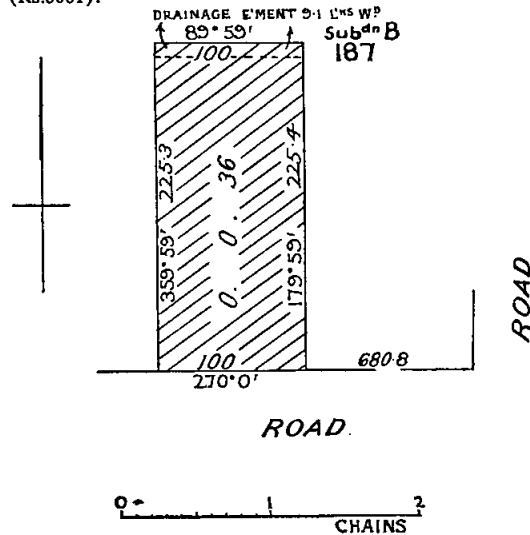

And the Honorable Sir William John Farquhar McDonald, Her Majesty's Minister of Lands for the State of Victoria, shall give the necessary directions herein accordingly.

J. ROSSITER,  
Clerk of the Executive Council.

DEPARTMENT OF CROWN LANDS AND SURVEY.

At the Executive Council Chamber, Melbourne, the fifteenth day of October, 1968.

PRESENT:

His Excellency the Lieutenant-Governor of Victoria.  
Mr. Porter | Mr. Meagher.  
Mr. Balfour

REVOCATION OF TEMPORARY RESERVATIONS OF LANDS BY ORDERS IN COUNCIL.

HIS Excellency the Lieutenant-Governor of the State of Victoria, by and with the advice of the Executive Council thereof, doth hereby in pursuance of the provisions of the Land Act 1958, revoke the temporary reservations of lands by Orders in Council hereinafter referred to, viz:—

GREENSBOROUGH.—Order in Council of 14th May, 1866, of 5 acres of land in the Parish of Greensborough, as a site for a Cricket Ground.—(Rs.1460.)

BAYNTON.—Order in Council of 26th March, 1877, of 1 acre 0 roods 16 perches of land in the Parish of Baynton, as a site for Public purposes (State School).—(76E608.)

LORNE.—Order in Council of 31st May, 1880, of 6 acres 1 rood 12 perches of land in the Township of Lorne as a site for Cricket and Other purposes of Public Recreation so far only as regards the portion thereof comprised within the boundaries published in the Government Gazette of 11th September, 1968, and containing 8 perches more or less.—(Rs.90.)

BOROKA.—Order in Council of the 29th June, 1953, of 3 acres 1 rood 20 perches, more or less, of land in the Parish of Boroka as a site for State School purposes, so far only as regards the portion thereof comprised within the boundaries published in the Government Gazette of the 11th September, 1968, and containing 1 rood.—(Rs.3550.)

TIMBEROO.—Order in Council of the 30th October, 1933, of 995 acres 2 roods 10 perches of land in the Parish of Timberoo as a site for Water Supply, The Growth and Preservation of Timber and Public purposes, revoked as to part by Order of the 12th May, 1964, is about to be revoked, so far only as the portion containing 60 acres 3 roods 11 perches, indicated by hatching on plan hereunder, is concerned.—(T.225<sup>(2)</sup>) (Rs.4339).

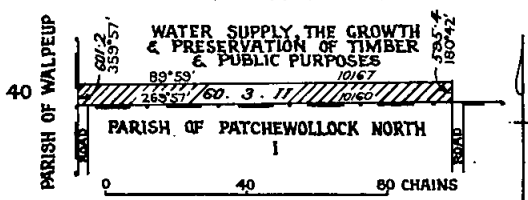

And the Honorable Sir William John Farquhar McDonald, Her Majesty's Minister of Lands for the State of Victoria, shall give the necessary directions herein accordingly.

J. ROSSITER,  
Clerk of the Executive Council.

DEPARTMENT OF CROWN LANDS AND SURVEY.

At the Executive Council Chamber, Melbourne, the fifteenth day of October, 1968.

PRESENT:

His Excellency the Lieutenant-Governor of Victoria.  
Mr. Porter | Mr. Meagher.  
Mr. Balfour

UNUSED ROADS CLOSED.

HIS Excellency the Lieutenant-Governor of the State of Victoria, by and with the advice of the Executive Council thereof, doth hereby direct that, in pursuance of

the provisions of section 349 of the Land Act 1958, the unused roads referred to hereunder be closed, viz:—

Parish of Wychitella, County of Gladstone, being the road indicated by hatching on plan hereunder.—(W.311<sup>(1)</sup>) (C.96699).

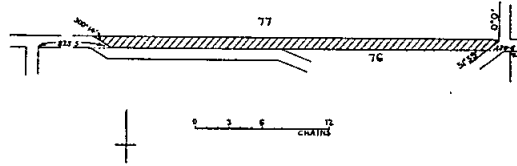

Parish of Illawarra, County of Borung, being the roads indicated by hatching on plan hereunder.—(I.13<sup>(6)</sup>) (M.53569.)

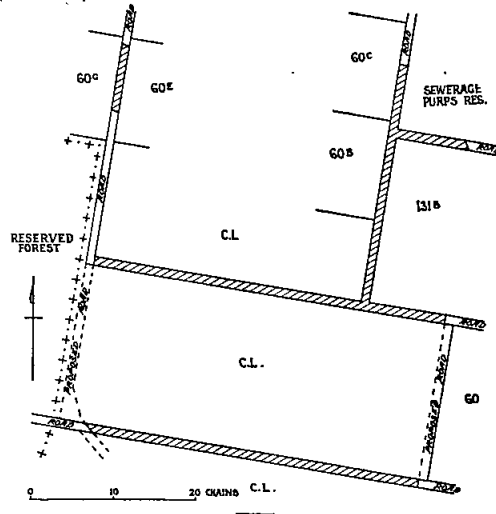

And the Honorable Sir William John Farquhar McDonald, Her Majesty's Minister of Lands for the State of Victoria, shall give the necessary directions herein accordingly.

J. ROSSITER,  
Clerk of the Executive Council.

DANDENONG VALLEY AUTHORITY ACT 1963.

At the Executive Council Chamber, Melbourne, the twenty-second day of October, 1968.

PRESENT:

His Excellency the Lieutenant-Governor of Victoria.  
Mr. Rossiter | Mr. Dickie.  
Mr. Manson

DANDENONG VALLEY AUTHORITY.—REVISION OF DISTRICT BOUNDARIES.

WHEREAS the Dandenong Valley Authority desires to revise the map defining the boundaries of the Dandenong Valley Authority District by excising from the same certain lands within the Shire of Berwick: And whereas in pursuance of the provisions of Section 15 (4) of the Dandenong Valley Authority Act 1963 the Authority may, with the approval of the Governor in Council, revise the map defining the district of the Authority:

Now, therefore, His Excellency the Lieutenant-Governor of Victoria, acting by and with the advice of the Executive Council, and in pursuance of the said Act and all other powers thereunto him enabling, doth hereby declare, order and direct as follows:—

That the map defining the boundaries of the district of the Dandenong Valley Authority within the Shire of Berwick shall be revised by excising from the same the lands shown by red colour on a plan numbered A56, approved by the Governor in Council and deposited in the office of the State Rivers and Water Supply Commission, Melbourne.

And the Honorable William Archibald Borthwick, Her Majesty's Minister of Water Supply for the State of Victoria, shall give the necessary directions herein accordingly.

J. ROSSITER,  
Clerk of the Executive Council.

**DANDENONG VALLEY AUTHORITY.**

*At the Executive Council Chamber, Melbourne, the  
twenty-second day of October, 1968.*

**PRESENT:**

His Excellency the Lieutenant-Governor of Victoria:  
Mr. Rossiter | Mr. Dickie.  
Mr. Manson

**CONSENT TO BORROWING \$50,000.**

**U**NDER the powers conferred by the Dandenong Valley Authority Act and all other powers enabling him in that behalf, His Excellency the Lieutenant-Governor of the State of Victoria, by and with the advice of the Executive Council of the said State, doth hereby consent to the Dandenong Valley Authority borrowing at interest by mortgage of the General Fund the sum of Fifty thousand dollars (\$50,000) to meet the cost of river improvement and drainage works.

And the Honorable William Archibald Borthwick, Her Majesty's Minister of Water Supply for the State of Victoria, shall give the necessary directions herein accordingly.

J. ROSSITER,  
Clerk of the Executive Council.

**DROUIN WATERWORKS TRUST.**

*At the Executive Council Chamber, Melbourne, the  
twenty-second day of October, 1968.*

**PRESENT:**

His Excellency the Lieutenant-Governor of Victoria:  
Mr. Rossiter | Mr. Dickie.  
Mr. Manson

**CONSENT TO BORROWING \$26,925.**

**U**NDER the powers conferred by the Water Act and all other powers enabling him in that behalf, His Excellency the Lieutenant-Governor of the State of Victoria, by and with the advice of the Executive Council of the said State, doth hereby consent to the Drouin Waterworks Trust borrowing at interest by mortgage of the General Fund the sum of Twenty-six thousand nine hundred and twenty-five dollars (\$26,925) for the conversion of Loan No. 2.

And the Honorable William Archibald Borthwick, Her Majesty's Minister of Water Supply for the State of Victoria, shall give the necessary directions herein accordingly.

J. ROSSITER,  
Clerk of the Executive Council.

**WARRAGUL WATERWORKS TRUST.**

*At the Executive Council Chamber, Melbourne, the  
twenty-second day of October, 1968.*

**PRESENT:**

His Excellency the Lieutenant-Governor of Victoria:  
Mr. Rossiter | Mr. Dickie.  
Mr. Manson

**EXTENT OF WATERWORKS AND URBAN DISTRICTS INCREASED.**

**U**NDER the powers conferred by the Water Act and all other powers enabling him in that behalf, His Excellency the Lieutenant-Governor of the State of Victoria, by and with the advice of the Executive Council of the said State, doth hereby declare, order and direct that the extent of the Waterworks and Urban Districts of the Warragul Waterworks Trust be increased by adding to the same the lands comprised within the boundaries shown on a plan approved by the Governor in Council by and with this Order and deposited in the office of the State Rivers and Water Supply Commission, Melbourne (Corres. No. 68/4281/16) and as on and from the date hereof the extent of such Districts shall be and be deemed to be increased accordingly.

And the Honorable William Archibald Borthwick, Her Majesty's Minister of Water Supply for the State of Victoria, shall give the necessary directions herein accordingly.

J. ROSSITER,  
Clerk of the Executive Council.

**CHELSEA SEWERAGE AUTHORITY.**

*At the Executive Council Chamber, Melbourne, the  
twenty-second day of October, 1968.*

**PRESENT:**

His Excellency the Lieutenant-Governor of Victoria:  
Mr. Rossiter | Mr. Dickie.  
Mr. Manson

**CONSENT TO BORROWING \$150,000.**

**U**NDER the powers conferred by the Sewerage Districts Act and all other powers enabling him in that behalf, His Excellency the Lieutenant-Governor of the State of Victoria, by and with the advice of the Executive Council of the said State, doth hereby consent to the Chelsea Sewerage Authority borrowing at interest by mortgage of the General Fund the sum of One hundred and fifty thousand dollars (\$150,000) in two amounts of One hundred thousand dollars (\$100,000) and Fifty thousand dollars (\$50,000) respectively to meet the cost of sewerage works; as set forth in the detailed statement bearing date 17th October, 1968.

And the Honorable William Archibald Borthwick, Her Majesty's Minister of Water Supply for the State of Victoria, shall give the necessary directions herein accordingly.

J. ROSSITER,  
Clerk of the Executive Council.

**HORSHAM SEWERAGE AUTHORITY.**

*At the Executive Council Chamber, Melbourne, the  
twenty-second day of October, 1968.*

**PRESENT:**

His Excellency the Lieutenant-Governor of Victoria:  
Mr. Rossiter | Mr. Dickie.  
Mr. Manson

**CONSENT TO BORROWING \$19,000.**

**U**NDER the powers conferred by the Sewerage Districts Act and all other powers enabling him in that behalf, His Excellency the Lieutenant-Governor of the State of Victoria, by and with the advice of the Executive Council of the said State, doth hereby consent to the Horsham Sewerage Authority borrowing at interest by mortgage of the General Fund the sum of Nineteen thousand dollars (\$19,000) for the conversion of Loan No. 8.

And the Honorable William Archibald Borthwick, Her Majesty's Minister of Water Supply for the State of Victoria, shall give the necessary directions herein accordingly.

J. ROSSITER,  
Clerk of the Executive Council.

**LEONGATHA SEWERAGE AUTHORITY.**

*At the Executive Council Chamber, Melbourne, the  
twenty-second day of October, 1968.*

**PRESENT:**

His Excellency the Lieutenant-Governor of Victoria:  
Mr. Rossiter | Mr. Dickie.  
Mr. Manson

**CONSENT TO BORROWING \$40,000.**

**U**NDER the powers conferred by the Sewerage Districts Act and all other powers enabling him in that behalf, His Excellency the Lieutenant-Governor of the State of Victoria, by and with the advice of the Executive Council of the said State, doth hereby consent to the Leongatha Sewerage Authority borrowing at interest by mortgage of

the General Fund the sum of Forty thousand dollars (\$40,000) to meet the cost of sewerage works as set forth in the detailed statement bearing date 17th October, 1968.

And the Honorable William Archibald Borthwick, Her Majesty's Minister of Water Supply for the State of Victoria, shall give the necessary directions herein accordingly.

J. ROSSITER,  
Clerk of the Executive Council.

MORWELL SEWERAGE AUTHORITY.

At the Executive Council Chamber, Melbourne, the twenty-second day of October, 1968.

PRESENT:

His Excellency the Lieutenant-Governor of Victoria.  
Mr. Rossiter | Mr. Dickie.  
Mr. Manson

CONSENT TO BORROWING \$19,000.

UNDER the powers conferred by the Sewerage Districts Act and all other powers enabling him in that behalf, His Excellency the Lieutenant-Governor of the State of Victoria, by and with the advice of the Executive Council of the said State, doth hereby consent to the Morwell Sewerage Authority borrowing at interest by mortgage of the General Fund the sum of Nineteen thousand dollars (\$19,000) for the conversion of Loan No. 16.

And the Honorable William Archibald Borthwick, Her Majesty's Minister of Water Supply for the State of Victoria, shall give the necessary directions herein accordingly.

J. ROSSITER,  
Clerk of the Executive Council.

SALE SEWERAGE AUTHORITY.

At the Executive Council Chamber, Melbourne, the twenty-second day of October, 1968.

PRESENT:

His Excellency the Lieutenant-Governor of Victoria.  
Mr. Rossiter | Mr. Dickie.  
Mr. Manson

CONSENT TO BORROWING \$19,000.

UNDER the powers conferred by the Sewerage Districts Act and all other powers enabling him in that behalf, His Excellency the Lieutenant-Governor of the State of Victoria, by and with the advice of the Executive Council of the said State, doth hereby consent to the Sale Sewerage Authority borrowing at interest by mortgage of the General Fund, the sum of Nineteen thousand dollars (\$19,000) for the conversion of Loan No. 1.

And the Honorable William Archibald Borthwick, Her Majesty's Minister of Water Supply for the State of Victoria, shall give the necessary directions herein accordingly.

J. ROSSITER,  
Clerk of the Executive Council.

COUNTRY ROADS BOARD.

At the Executive Council Chamber, Melbourne, the twenty-second day of October, 1968.

PRESENT:

His Excellency the Lieutenant-Governor of Victoria.  
Mr. Rossiter | Mr. Dickie.  
Mr. Manson

ORDER APPROVING OF LAND BEING ACQUIRED AND ROADS, DEVIATIONS OR WIDENINGS BEING MADE.

HIS Excellency the Lieutenant-Governor of the State of Victoria, by and with the advice of the Executive Council thereof, being satisfied that there are funds legally available for acquiring the land, doth hereby approve the acquiring of the land described in the Schedule hereunder and the making of new roads and deviations from and widenings of existing roads referred to in the said Schedule.

SCHEDULE.

State highway.

The land shown hatched on Plans numbered G.P.11483, G.P.11484, G.P.11485 and G.P.11486 hereunder required for the widening of the Princes Highway in the Shire of Buln Buln and making of the widening thereon.

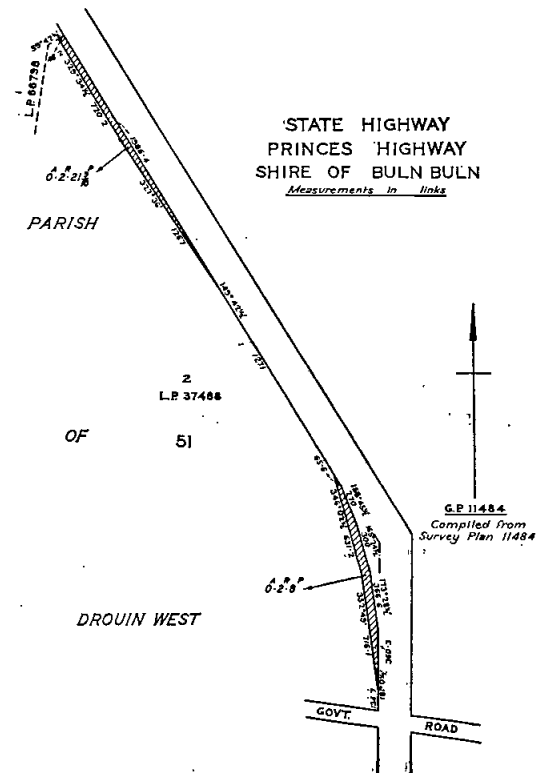
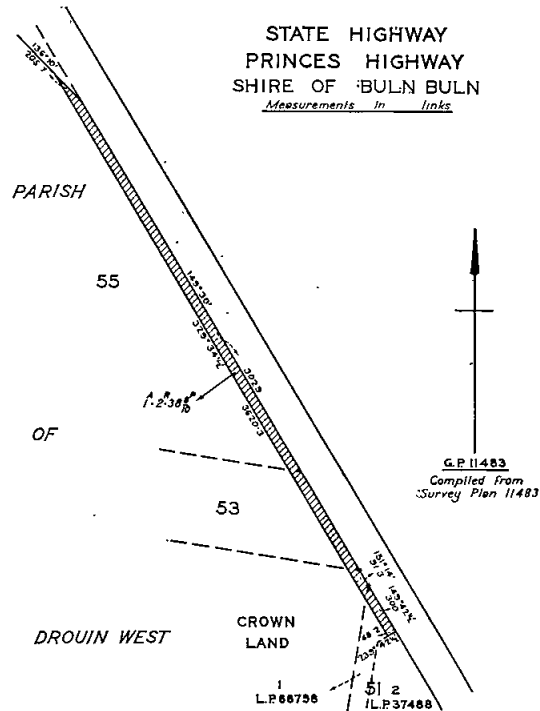

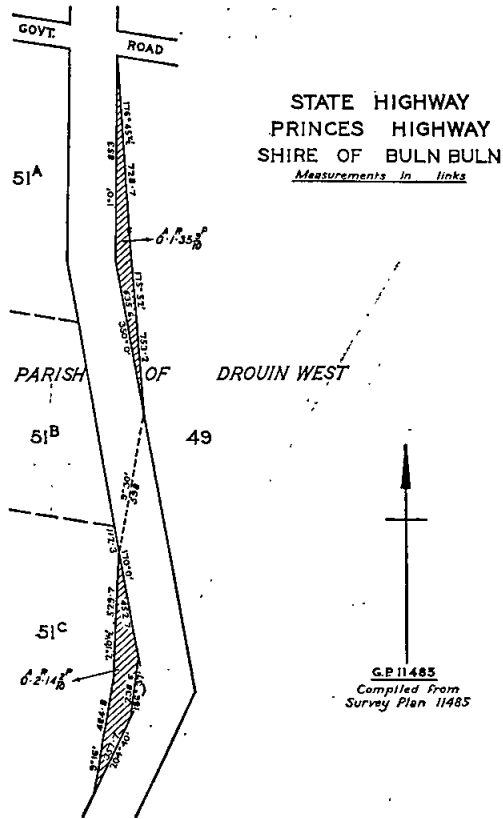

Main roads.  
The land shown hatched on Plans numbered G.P.11453, G.P.11454 and G.P.11455 hereunder required for the deviation from the Stawell-Pomonal Road in the Shire of Ararat and making of the deviation thereon.

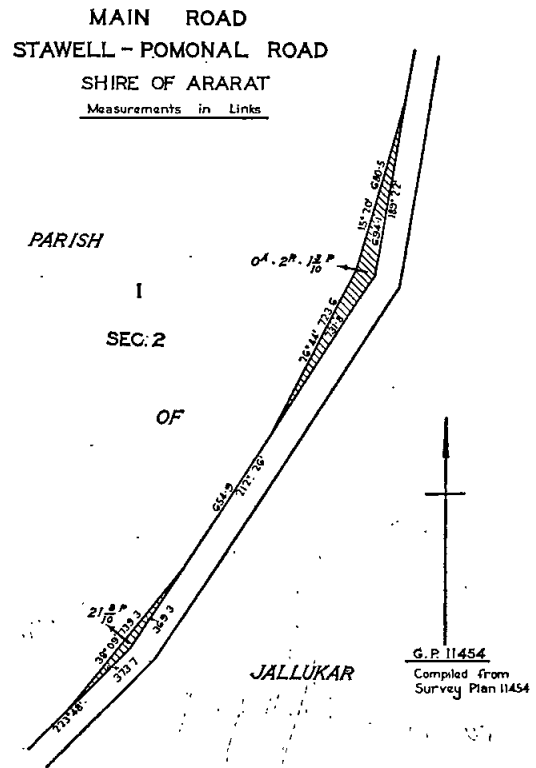
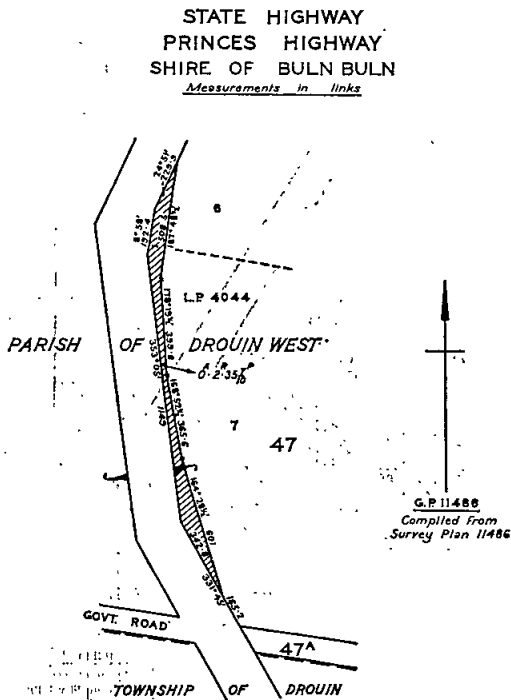
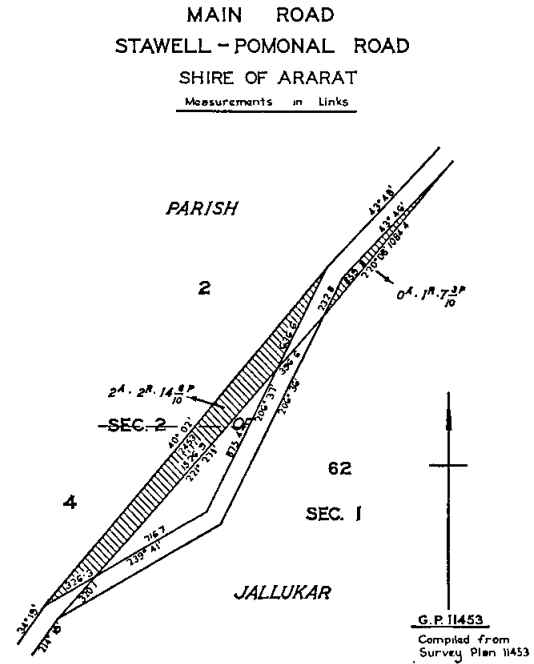

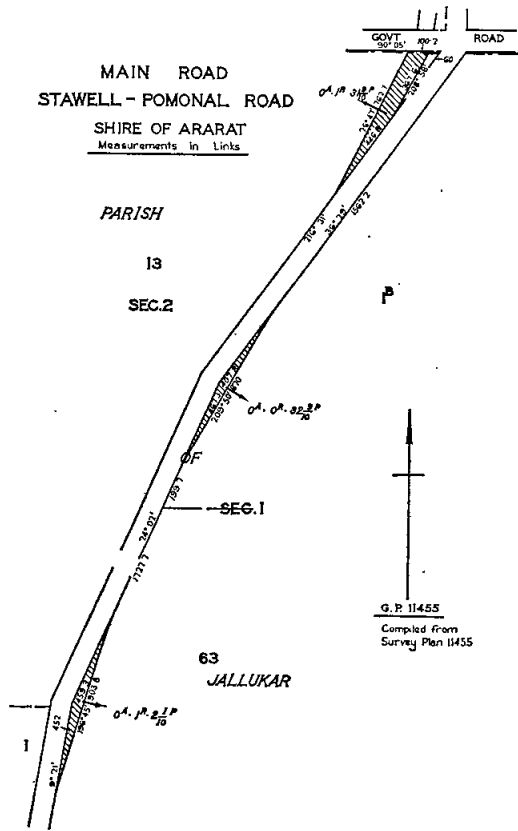

The land shown hatched on Plan numbered G.P.11480 hereunder required for the widening of the Heidelberg-Doncaster Road in the City of Doncaster and Templestowe and making of the widening thereon.

MAIN ROAD  
HEIDELBERG — DONCASTER ROAD  
CITY OF DONCASTER & TEMPLESTOWE  
Measurements in feet & inches

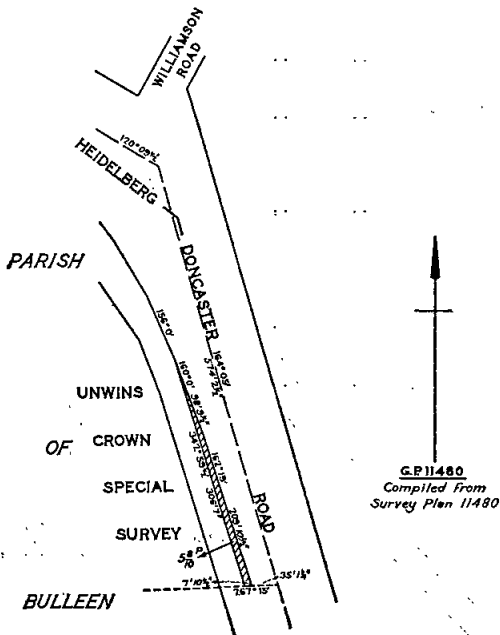

By-pass road.

The land shown hatched on Plan numbered G.P.11495A hereunder required for the making of a new by-pass road in the City of Port Melbourne.

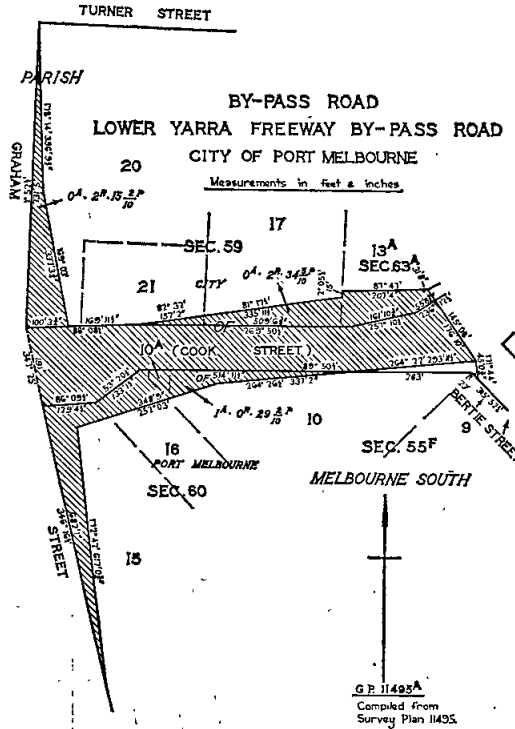

Unclassified road.

The land shown hatched on Plans numbered G.P.11495B, G.P.11496 and G.P.11497 hereunder required for the widening of Roger and Brady Streets in the Cities of Port Melbourne and South Melbourne and making of the widening thereon.

ROAD  
ROGER STREET  
CITY OF PORT MELBOURNE  
Measurements in feet & inches

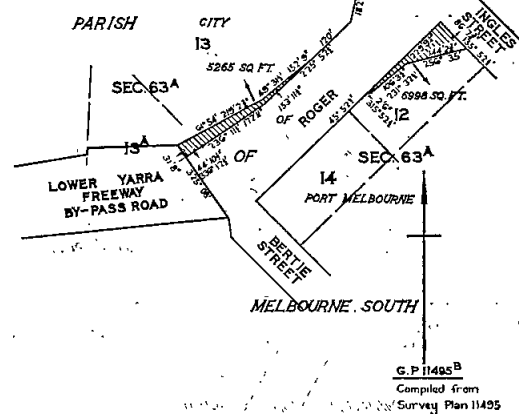

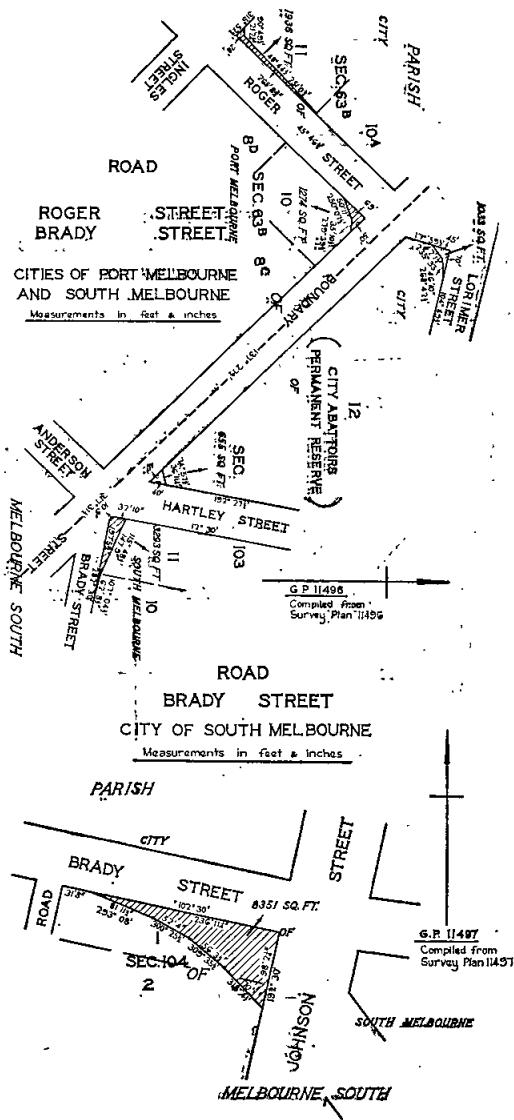

And the Honorable Murray Victor Porter, Her Majesty's Minister of Public Works for the State of Victoria, shall give the necessary directions herein accordingly.

J. ROSSITER,  
Clerk of the Executive Council.

**COUNTRY FIRE AUTHORITY ACT 1958.**

At the Executive Council Chamber, Melbourne, the twenty-second day of October, 1968.

PRESENT:  
His Excellency the Lieutenant-Governor of Victoria,  
Mr. Rossiter Mr. Dickie.  
Mr. Manson

**CONSENT TO BORROWING ONE HUNDRED THOUSAND DOLLARS BY THE COUNTRY FIRE AUTHORITY.**

WHEREAS by Section 82 of the Country Fire Authority Act 1958, it is enacted that the Country Fire Authority, with the consent of the Governor in Council may from time to time, borrow such moneys as it deems necessary in order to enable it to carry out and perform the powers, authorities and duties vested in or conferred or imposed upon it by the said Act:

And whereas the Country Fire Authority deems it necessary to borrow the sum of One Hundred Thousand Dollars for the purposes aforesaid:

Now therefore, His Excellency the Lieutenant-Governor of the State of Victoria, in the Commonwealth of Australia, by and with the advice of the Executive Council of the said State and in pursuance of the powers conferred by the said Section 82 of the Country Fire Authority Act 1958 and all other powers him thereunto enabling, doth by this order consent to the borrowing by the Country Fire Authority of the sum of One Hundred Thousand Dollars (\$100,000) for a period of Fifteen (15) years, to be liquidated by half-yearly repayments on the principal sum, with interest at the rate of Five and Seven-Eighths (\$5.875) per centum per annum.

And the Honorable Sir Arthur Gordon Rylah, Her Majesty's Chief Secretary for the State of Victoria, shall give the necessary directions herein accordingly.

J. ROSSITER,  
Clerk of the Executive Council.

**COURTS OF GENERAL SESSIONS OF THE PEACE FOR THE YEAR 1969.**

At the Executive Council Chamber, Melbourne, the twenty-second day of October, 1968.

PRESENT:  
His Excellency the Lieutenant-Governor of Victoria,  
Mr. Rossiter Mr. Dickie.  
Mr. Manson

IN pursuance of the provisions of the Justices Act 1958, His Excellency the Lieutenant-Governor of the State of Victoria, by and with the advice of the Executive Council thereof, doth by this present Order direct that the dates for holding Courts of General Sessions of the Peace during the year 1969, be appointed as specified in the subjoined Schedule, viz.:

SCHEDULE.	
Ararat	Tuesday, 4th March. Tuesday, 16th September.
Bairnsdale	Tuesday, 22nd April. Tuesday, 1st July. Tuesday, 14th October.
Ballarat	Tuesday, 4th February. Monday, 5th May. Monday, 28th July. Monday, 3rd November.
Bendigo	Tuesday, 4th February. Tuesday, 6th May. Tuesday, 29th July. Tuesday, 2nd December.
Colac	Tuesday, 15th April. Tuesday, 1st July. Wednesday, 5th November.
Geelong	Monday, 3rd March. Monday, 2nd June. Monday, 1st September. Wednesday, 1st October. Monday, 1st December.
Hamilton	Tuesday, 18th March. Tuesday, 1st July. Tuesday, 21st October.
Horsham	Tuesday, 4th February. Tuesday, 3rd June. Wednesday, 5th November.
Kerang	Tuesday, 4th March. Tuesday, 1st July. Tuesday, 7th October.
Korumburra	Thursday, 10th April. Monday, 2nd June. Monday, 20th October.
Melbourne	Monday, 20th January. Monday, 3rd February. Monday, 3rd March. Tuesday, 1st April. Thursday, 1st May. Monday, 2nd June. Tuesday, 1st July. Friday, 1st August. Monday, 1st September. Wednesday, 1st October. Monday, 3rd November. Monday, 1st December.



Mildura .. .. .	Monday, 14th April. Tuesday, 17th June. Monday, 1st September. Monday, 17th November.
Morwell .. .. .	Tuesday, 18th March. Tuesday, 13th May. Tuesday, 29th July. Tuesday, 11th November.
Sale ... .. .	Tuesday, 4th February. Tuesday, 3rd June. Tuesday, 16th September.
Shepparton ... ..	Tuesday, 18th February. Tuesday, 20th May. Tuesday, 19th August. Tuesday, 18th November.
Wangaratta .. .. .	Tuesday, 4th March. Tuesday, 6th May. Tuesday, 2nd September. Tuesday, 2nd December.
Warragul .. .. .	Monday, 17th February. Tuesday, 17th June. Wednesday, 1st October.
Warmambool .. .. .	Tuesday, 15th April. Tuesday, 17th June. Tuesday, 2nd September. Tuesday, 2nd December.

And the Honorable George Oswald Reid, Her Majesty's Attorney-General for the State of Victoria, shall give the necessary directions herein accordingly.

J. ROSSITER,  
Clerk of the Executive Council.

**LANDS DEPARTMENT NOTICES**

**APPROACHING LAND SALES.**

SALES of Crown Lands, in fee-simple, will be held at the under-mentioned places and dates, viz.:-

	No. of Gazette.
Ballarat.—Tuesday, 12th November, 1968 ..	80
Castlemaine.—Tuesday, 29th October, 1968 ..	78
Kyneton.—Tuesday, 29th October, 1968 ..	78
Murrayville.—Wednesday, 20th November, 1968	84
Ouyen.—Monday, 18th November, 1968 ..	84
Red Cliffs.—Thursday, 21st November, 1968 ..	84
Wonthaggi.—Friday, 1st November, 1968 ..	80

**SALE BY AUCTION OF THE RIGHT TO LEASE CROWN LAND.**

Wonthaggi.—Friday, 1st November, 1968 ..	80
--	----

**ADDENDUM.**

IN Victoria Government Gazette No. 80, of 25th September, 1968, page 3305, under the heading Lot 26 after "Area 2a. 1r. 28p." the following shall be inserted, "Allotment 1b of section 6", and at page 3307 under the heading Lot 1 and after "Area 4a. 2r." the following shall be inserted, "Allotment 4c of section 117."

**PROPOSED REVOCATIONS OF TEMPORARY RESERVATIONS OF LANDS BY ORDERS IN COUNCIL.**

IN pursuance of the provisions of the Land Act 1958, notice is hereby given that it is the intention of the Governor in Council to revoke the temporary reservations of lands by Orders in Council hereunder referred to, viz.:-

The following Notices were published 1° on the 16th October, 1968, pursuant to Orders of the 8th October, 1968.

**BREAMLEA.**—The temporary reservation, by Order in Council of the 31st May, 1955, of 3 acres 2 roods 32 perches of land in the Township of Breamlea as a site for State School purposes is about to be revoked.—(B.795(4)) (Rs. 7344).

**ARARAT.**—The temporary reservation as a site for a Public Park and the withholding from sale, leasing and licensing by Order in Council of the 12th September, 1879 of 26 acres 2 roods 19 perches of land in the Township of Ararat are about to be revoked so far only as the portion containing 13 acres 1 rood 9 perches, indicated by hatching on plan hereunder, is concerned.—(A.148(1)) (Rs.5307).

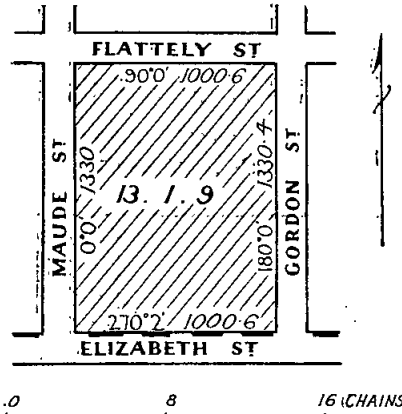

**CORRYONG.**—The temporary reservation, by Order in Council of the 20th August, 1888, of 137 acres 1 rood of land in the Township of Corryong as a site for a Race-course and other purposes of Public Recreation, revoked as to part by Order of the 24th August, 1909, and the temporary reservation for the additional purpose of Show Yards of the balance by Order of the 12th October, 1909, both reservations being revoked as to part by Order of the 19th December, 1967, are about to be revoked so far only as the portion containing 4 acres 3 roods 39 perches, indicated by hatching on plan hereunder, is concerned.—(C.427(3)) (Rs.1930).

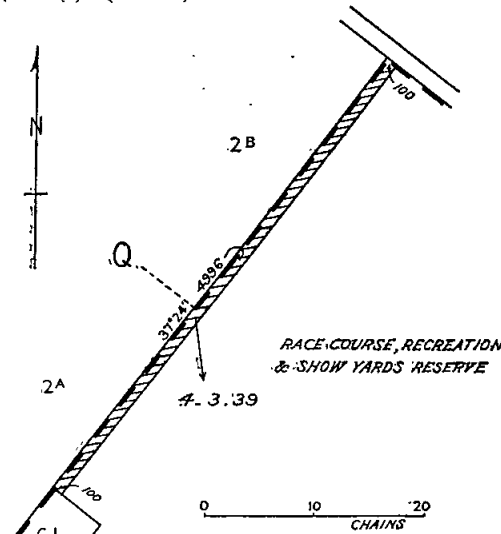

**KOOEM.**—The temporary reservation, by Order in Council of the 9th July, 1940, of 29 acres 1 rood 4 perches of land in the Parish of Kooem as a site for the use of the State Rivers and Water Supply Commission is about to be revoked so far only as the portion containing 2 acres 2 roods 36 perches, indicated by hatching on plan hereunder, is concerned.—(K.193(3)) (Rs.5053).

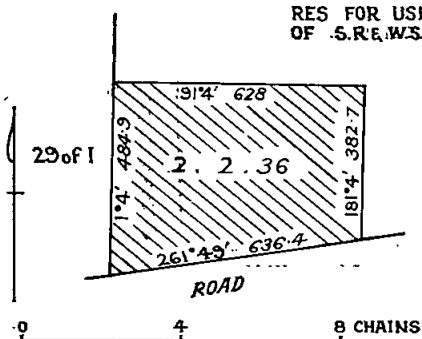

**KATUNGA.**—The temporary reservation, by Order in Council of the 12th December, 1887, of 2 roods 4 perches of land in the Parish of Katunga as a site for Railway purposes is about to be revoked so far only as the portion containing 24 perches, indicated by hatching on plan hereunder, is concerned.—(K.166<sup>(\*)</sup>) (C.99953).

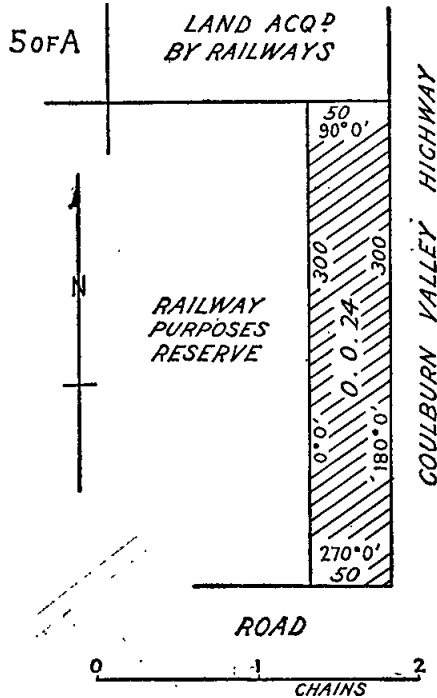

**PROPOSED PERMANENT RESERVATION OF LAND AS A SITE.**

IN pursuance of sections 14 and 21 of the Land Act 1958, notice is hereby given that it is the intention of the Governor in Council to reserve permanently from sale, from being leased and from having a licence granted in respect thereof the land hereinafter described:—

The following Notice was published 1<sup>o</sup> on the 16th October, 1968, pursuant to Order of the 8th October, 1968.

**BALNARRING BEACH.**—Land proposed to be permanently reserved as a site for Public purposes, 2 roods 37 perches, Township of Balnarring Beach, Parish of Balnarring, County of Mornington, as indicated by hatching on plan hereunder.—(T.260<sup>(1)</sup>) (Rs.2091).

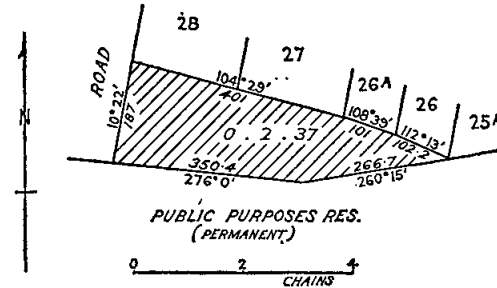

W. J. F. McDONALD,  
Minister of Lands.

**PROPOSED REVOCATIONS OF TEMPORARY RESERVATIONS OF LANDS BY ORDERS IN COUNCIL.**

IN pursuance of the provisions of the Land Act 1958, notice is hereby given that it is the intention of the Governor in Council to revoke the temporary reservations of lands by Orders in Council hereunder referred to, viz:—

The following Notices were published 1<sup>o</sup> on the 9th October, 1968, pursuant to Orders of the 1st October, 1968.

**BOROKA (HALL'S GAP).**—The temporary reservation, by Order in Council of the 9th December, 1935, of 49 acres 2 roods 19 perches of land in the Parish of Boroka as a site for Public purposes (Hall's Gap Picnic Reserve), revoked as to part by various Orders, is about to be revoked so far only as the portion containing 6 perches, more or less, indicated by hatching on plan hereunder, is concerned.—(B.678<sup>(\*)</sup>) (Rs.477).

**MARONG.**—The temporary reservation, by Order in Council of the 13th August, 1946, of 102 acres 2 roods 24 perches of land in the Parish of Marong as a site for the growth of timber for the purpose of the manufacture or production of eucalyptus oil is about to be revoked.—(M.32<sup>(\*)</sup>) (Rs.5843).

**MOCAMBORO.**—The temporary reservation, by Order in Council of the 10th November, 1874, of 5 acres of land in the Parish of Mocamboro as a site for State School purposes is about to be revoked.—(M.214<sup>(\*)</sup>) (74 N 2532).

**PRAHRAN (EAST MALVERN).**—The temporary reservation, by Order in Council of the 7th July, 1941, of 3 acres 1 rood 23 perches of land in the Parish of Prahran, at Gardiner, as a site for Railway purposes is about to be revoked so far only as the portion containing 22 perches, indicated by hatching on plan hereunder, is concerned.—(P.81<sup>(10)</sup>) (Rs.5172).

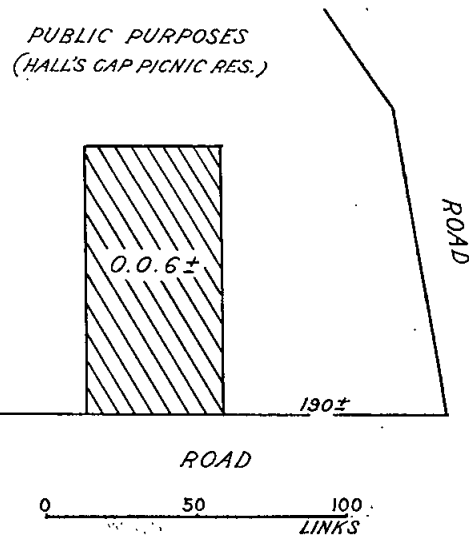
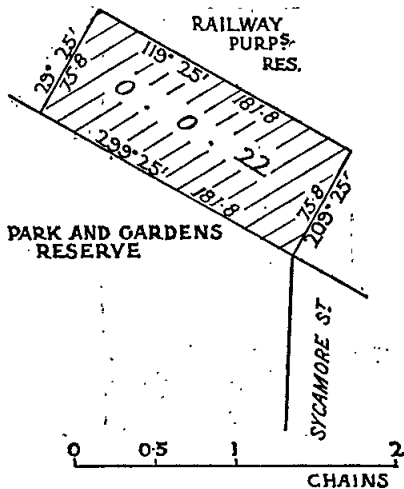

W. J. F. McDONALD,  
Minister of Lands.

**KEELBUNDORA.**—The temporary reservation, by Order in Council of the 11th January, 1943, of 456 acres 1 rood 32 perches of land in the Parish of Keelbundora as a site for Mental Hospital purposes, revoked as to part by various Orders, is about to be revoked so far only as the portion containing 228 acres, more or less, indicated by hatching on plan hereunder, is concerned.—(K.25<sup>(\*)</sup> (Rs.5380).

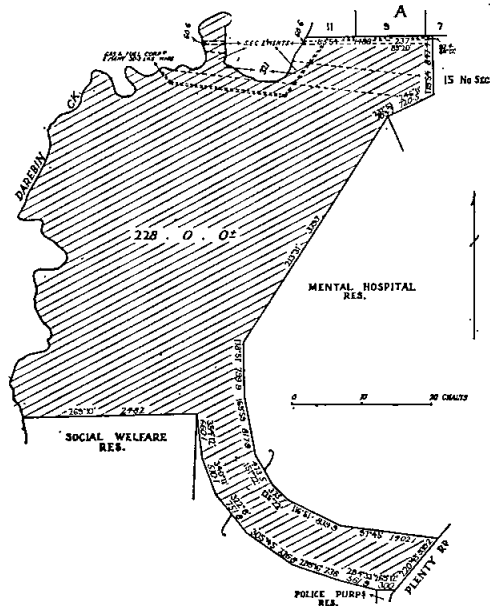

**MANSFIELD.**—The temporary reservation, by Order in Council of the 6th February, 1865, of 2 acres of land in the Township of Mansfield as a site for Court House and Police Buildings, revoked as to part by various Orders, is about to be revoked so far only as the portion containing 1 rood 5 perches, indicated by hatching on plan hereunder, is concerned.—(M.35<sup>(\*)</sup> (Rs.8549).

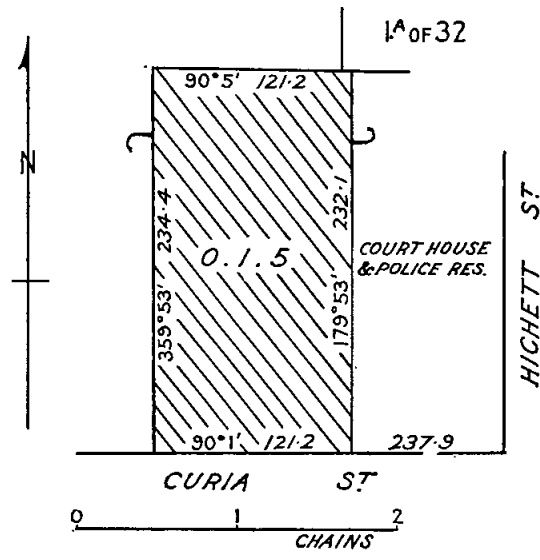

**BULLA.**—The temporary reservation, by Order in Council of the 28th October, 1861, of 1 acre 0 roods 33 perches of land in the Township of Bulla as a site for Church of England School purposes is about to be revoked so far only as the portion containing 2 roods 18 perches, indicated by hatching on plan hereunder, is concerned.—(B.522<sup>(\*)</sup> (C.98539).

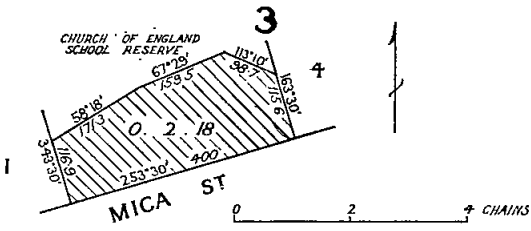

**TERANG.**—The temporary reservation, by Order in Council of the 18th July, 1924, of 1 rood 24 1/10 perches of land in the Township of Terang as a site for Police purposes is about to be revoked so far only as the portion containing 30 perches, indicated by hatching on plan hereunder, is concerned.—(T.85<sup>(\*)</sup> (Rs.2971).

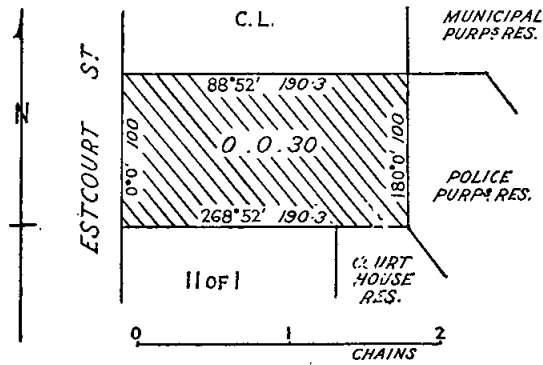

**CASTERTON.**—The temporary reservation as a site for a Cemetery and the withholding from sale, leasing and licensing by Order in Council of the 3rd June, 1879 (see *Government Gazette*, 6th June, 1879, page 1246) of 10 acres of land in the Parish of Casterton are about to be revoked so far only as the portion containing 2 acres 0 roods 17 perches, indicated by hatching on plan hereunder, is concerned.—(C.178<sup>(\*)</sup> (Rs.9055).

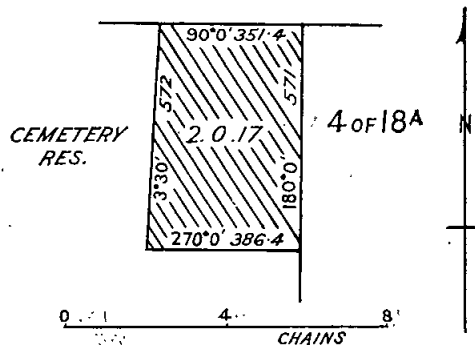

W. J. F. McDONALD,  
Minister of Lands.

**PROPOSED REVOCATIONS OF TEMPORARY RESERVATIONS OF LANDS BY ORDERS IN COUNCIL.**

IN pursuance of the provisions of the *Land Act 1958*, notice is hereby given that it is the intention of the Governor in Council to revoke the temporary reservations of lands by Orders in Council hereunder referred to, viz.:

The following Notices were published 1° on the 2nd October, 1968, pursuant to Orders of the 24th September, 1968.

**CANN RIVER.**—The temporary reservation, by Order in Council of the 30th July, 1968, of 3 roods of land in the Township of Cann River as a site for the Use and Benefits of the Aboriginal Inhabitants is about to be revoked, so

far only as the portion containing 1 rood, indicated by hatching on plan hereunder, is concerned.—(N.156J) (Rs.9031).

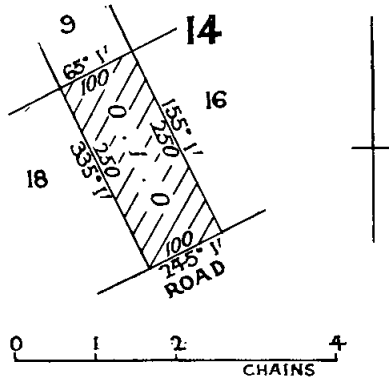

COHUNA.—The temporary reservation, by Order in Council of the 18th January, 1909, of 1 acre of land in the Township of Cohuna as a site for Police purposes is about to be revoked, so far only as the portion containing 2 roods, indicated by hatching on plan hereunder, is concerned.—(C.424<sup>(\*)</sup>) (C.41704).

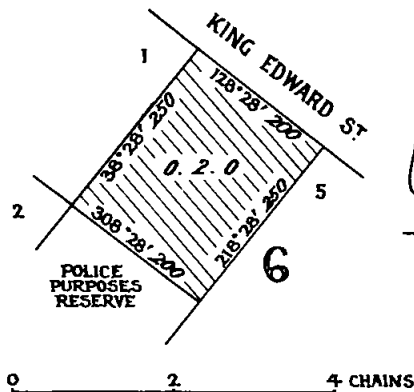

W. J. F. McDONALD,  
Minister of Lands.

PROPOSED PERMANENT RESERVATION OF LAND AS A SITE.

IN pursuance of sections 14 and 21 of the *Land Act* 1958, notice is hereby given that it is the intention of the Governor in Council to reserve permanently from sale, from being leased and from having a licence granted in respect thereof the land hereinafter described:—

The following Notice was published 1° on the 23rd October, 1968, pursuant to Order of the 15th October, 1968.

MILDURA.—Land proposed to be permanently reserved as a site for Water Supply purposes, 1 acre 2 roods 5 perches, Parish of Mildura, County of Karkaroc, as indicated by hatching on plan hereunder.—(M.533<sup>(2)</sup>) (Rs.9054).

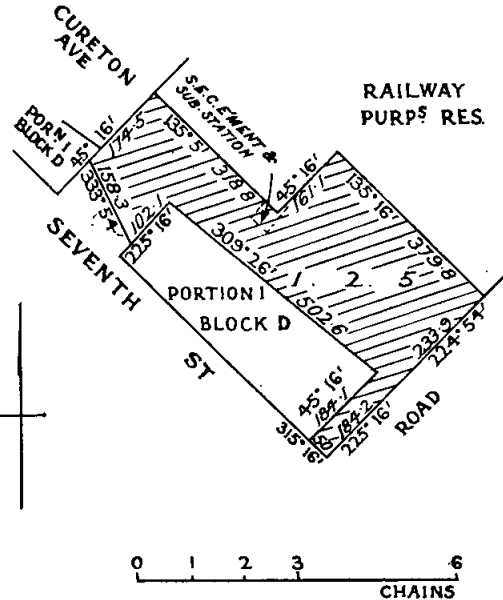

W. J. F. McDONALD,  
Minister of Lands.

COMMON ABOUT TO BE DIMINISHED.

IN pursuance of the provisions contained in the *Land Act* 1958, notice is hereby given that it is the intention of the Governor in Council to diminish the common hereinafter mentioned, viz.:—

The following Notice was published 1° on the 9th October, 1968, pursuant to Order of the 1st October, 1968.

The Boort Common proclaimed as such on the 15th August, 1892, extended by proclamation of the 13th February, 1894, and diminished by various proclamations, is about to be further diminished by the excision therefrom of the portion containing 20 acres, more or less, indicated by hatching on plan hereunder.—(Rs.46.)

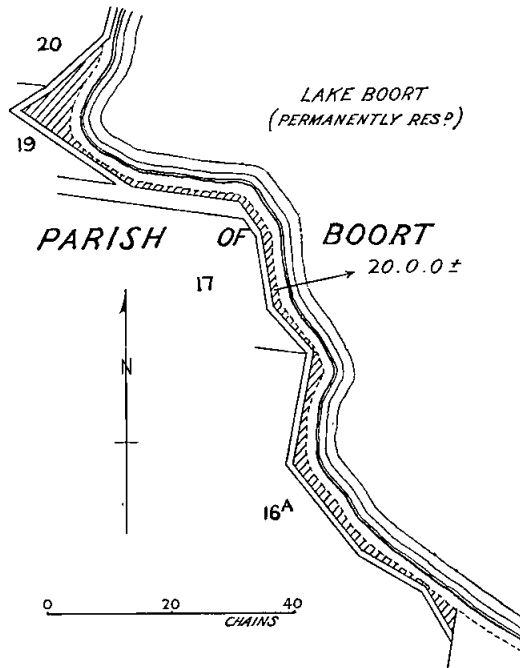

W. J. F. McDONALD,  
Minister of Lands.

*Land Settlement Act 1959.*

## LAND AVAILABLE FOR APPLICATION.

NOTIFICATION is hereby given in accordance with section 7 of the *Land Settlement Act 1959*, that the undermentioned holdings are available for settlement.

Any male person who is not less than 21 years of age and who is a British subject may apply on the prescribed form for settlement on any holding or holdings. Where he applies for more than one holding he should indicate his order of preference.

Prescribed application forms, plans and further details may be obtained from the Secretary, Rural Finance and Settlement Commission, Embank House, 325 Collins-street, Melbourne, 3000.

Closing date for receipt of completed application forms for settlement on these holdings is the 18th November, 1968, such applications to be in the hands of the Secretary, Rural Finance and Settlement Commission, on or before that date.

M. J. CRONIN,  
Secretary.

Rural Finance and Settlement Commission,  
Melbourne, 3000. 16th October, 1968.

## SCHEDULE OF ALLOTMENTS.

## SUBDIVISION OF FIRST PORTION OF ROCHESTER IRRIGATION AREA.

PARISH OF DIGGORRA—COUNTY OF BENDIGO.

*Suitable for the Establishment of Dairying under Irrigation.*

Lot Number on Plan of Subdivision.	Approximate Area in Acres
10	116
11	106
18	97
19	103

## SCHEDULE OF ALLOTMENTS.

## SUBDIVISION OF TWELFTH PORTION OF THE EAST GOULBURN IRRIGATION AREA.

PARISH OF DUNBULBALANE—COUNTY OF MOIRA.

*Suitable for the Establishment of Dairying under Irrigation.*

Lot Number on Plan of Subdivision.	Area in Acres.
118	103 acres 2 roods 10 perches
119	110 acres 2 roods 10 perches

## COMMITTEES OF MANAGEMENT OF RESERVES.

## APPOINTMENTS.

NOTICE is hereby given that, in pursuance of section 221 of the *Land Act 1958*, the following appointments of Committees of Management of reserved Crown Lands have been made by the Minister of Lands:—

## "BUTSON PARK", YACKANDANDAH.

Cedric Ian Permezel, George Alexander Beatty, Gary James Britton, Ernest Christman Britton and Bernard Alfred Britton as a Committee of Management for a period of three (3) years of the land temporarily reserved by Order in Council dated 4th April, 1950, as a site for Public Park and Public Recreation in the Township and Parish of Yackandandah, and known as the "Butson Park".—(Corres. No. Rs.6523.)

## "CARAMUT RECREATION RESERVE."

Albert Kosch, Austin Howley, Keith Russell, Jack Raymond Edwards, Reginald Graeme Surkitt, Percival John Bryce and Terence Leslie McDonald as a Committee of Management for a period of three (3) years of the land in the Township of Caramut, temporarily reserved as a site for Public Recreation by Orders in Council dated 18th August, 1952, and 24th August, 1954, and known as the "Caramut Recreation Reserve".—(Corres. No. Rs.7005.)

## "KIATA RECREATION RESERVE."

Kenneth Winston Schultz, Lawrence Desmond Argall, William Donald Bridgewater, Frederick Samuel Argall, Lloyd Frederick Henseleit, Daniel Edwin Cole and Allan Percival Hann as a Committee of Management for a period of three (3) years of the land temporarily reserved by Orders in Council dated the 21st November, 1927, and 12th June, 1962, as a site for Public Recreation in the Township and Parish of Kiata, and known as the "Kiata Recreation Reserve".—(Corres. No. Rs.3571.)

## "KINGLAKE WEST RECREATION RESERVE" AND THE "KINGLAKE WEST PUBLIC HALL RESERVE".

Joseph Burton Crick, Don Newton, Edna May Crick, Barbara Carboon, Eunice Hilda Robertson, Stanley William Owen and Mary Margaret Johnston as a Committee of Management for a period of three (3) years of the remaining portion of land in the Parish of Kinglake, temporarily reserved by Order in Council dated the 16th December, 1904, as a site for Public Recreation and the land temporarily reserved by Order in Council dated 16th December, 1907, as a site for a Mechanics' Institute in the Parish of Kinglake, and known as the "Kinglake West Recreation Reserve" and the "Kinglake West Public Hall Reserve" respectively.—(Corres. Nos. Rs.4696 and Rs.4697.)

## "LETHBRIDGE RECREATION RESERVE."

Keith Henry Ackland, Stephen Arthur Jarick, Eric Angus McGillivray, Arthur Geoffrey Clarke, William Albert Miller, Raymond James Kelly, Neil Leslie McConachy, George Reid Simpson and Bernard Dooley as a Committee of Management for a period of three (3) years of the land temporarily reserved by Order in Council dated 29th July, 1930, as a site for Public Recreation in the Township of Lethbridge, Parish of Wabdallah, and known as the "Lethbridge Recreation Reserve".—(Corres. No. Rs.3268.)

## "MINYIP RECREATION RESERVE."

Fancis Joseph Maher, Peter Luckie Westerland, Robert Francis Baker, Thomas Walter Wright, John Joseph Drum, John James Lloyd, Leslie John Midgley, Alexander Ralston Mackenzie, Carlotta Schultz, William Samuel Oliver Coates, Charles A. Wood, Walter John Cowan, Jack McKay and Jack E. Boshen as a Committee of Management for a period of three (3) years of the land in the Township of Minyip temporarily reserved by Orders in Council dated the 1st May, 1928, 21st September, 1937, and 15th August, 1950, as sites for Public Recreation, and known as the "Minyip Recreation Reserve".—(Corres. No. Rs.3658.)

## "STREATHAM RECREATION RESERVE."

Peter Anthony Seedsman, James Patrick Hogan, David Reid, Geoffrey James Flanner, William James Black, Wallace Eldon Perry and Thomas Edward Seedsman as a Committee of Management for a period of three (3) years of the land temporarily reserved by Order in Council dated the 29th May, 1923, as a site for Recreation purposes in the Township of Streatham, and known as the "Streatham Recreation Reserve".—(Corres. No. Rs.2738.)

## "TURRIFF RECREATION RESERVE."

Clarence Trevor Casey, Stanley Emonson, Edward Ralph Roberts, Everett M. Torpey and Keith J. Torpey as a Committee of Management for a period of three (3) years of the land temporarily reserved by Order in Council dated 1st October, 1918, as a site for Recreation purposes in the Parish of Gorya at Turriff, and known as the "Turriff Recreation Reserve".—(Corres. No. Rs.1845.)

## "SAILORS FALLS RECREATION RESERVE."

Keith Cole, John Shanahan, Albert Burrows, John Muir, Andrew Rodoni, Peter Giacometti, Walter Pilmore and Robert Cooper as a Committee of Management for a period ending the 19th November, 1969, of the land in the Parish of Wombat temporarily reserved by Orders in Council dated the 23rd November, 1891, and 20th August, 1968, as site for Public Recreation, and known as "Sailors Falls Recreation Reserve".—(Corres. No. Rs.457.)

**"GEELONG AND DISTRICT MEMORIAL SWIMMING POOL."**

Barry Julius Solomon (for so long only as he continues to be the nominee of the Council of the City of Newtown), in the place of George Reginald Lunn (deceased), as a member of the Committee of Management of the land at Geelong in the Parish of Corio as indicated by hachure on plan hereunder, and known as the "Geelong and District Swimming Pool".—(Corres. No. C.99773.)

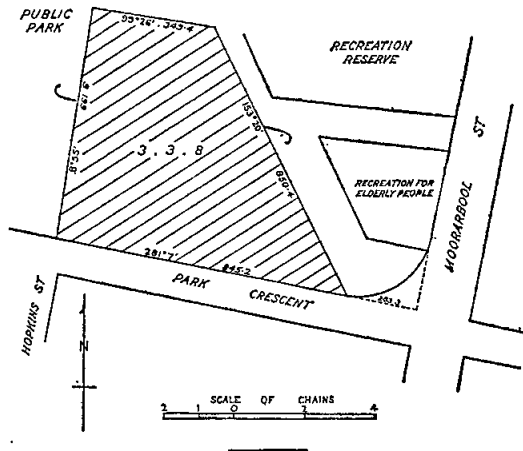
**PUBLIC PURPOSES (PRE-SCHOOL CENTRE) RESERVE, DUNKELD.**

The Corporation of the Shire of Mount Rouse as the Committee of Management of the land in the Township and Parish of Dunkeld temporarily reserved by Order in Council dated the 27th August, 1968, for Public purposes (Pre-School Centre).—(Corres. No. Rs.9047.)

W. J. F. McDONALD,  
Minister of Lands.

Department of Crown Lands and Survey,  
Melbourne, 15th October, 1968.

**TENDERS****PUBLIC WORKS DEPARTMENT**

**TENDERS** will be received at Public Works Department, Treasury-place, Melbourne, until **TWO** p.m. on dates shown and for purposes mentioned hereunder.

Particulars and tender forms available at Contracts Office, Room 7, Building Division, Parliament-place and at places indicated in brackets hereunder.

Abbreviations in brackets mean:—W.O.—Inspector of Works Office; P.S.—Police Station; C.S.—Consolidated School; H.E.S.—Higher Elementary School; H.S.—High School; S.S.—State School; T.S.—Technical School.

Tenders to be submitted on the Department's printed Tender Form and will not be received by telephone. All tenders must be on a "Firm Tender" basis. The lowest or any tender will not necessarily be accepted.

Address tenders to the Minister of Public Works, and endorse the envelope containing the tender "Tender for \_\_\_\_\_", closing Tuesday,

Hand delivered tenders to be placed in the Tender Box of the Public Works Department, located on the wall of the centre entrance foyer, Ground Floor, New Treasury Building, Treasury-place, Melbourne.

No preliminary deposit is required with any tender, but a successful tenderer will be required to pay a deposit for any accepted tender of \$4,000 or over.

**Tuesday, 29th October, 1968.****Building, Electrical and Mechanical Works.**

Carlton.—P.A.B.X. & P.B.X. installation, Collins Motors Building. (Amended Specification.)  
Essendon North.—Provision of aluminium roofing and ceiling to Bristol Pre-fab., S.S. 4015.  
Mont Park.—Remodelling, Ward F.3, Mental Hospital.  
Mont Park.—Electrical services, Ward F.3, Mental Hospital.

Mont Park.—Mechanical services, Ward F.3; Mental Hospital.

Moomba Park.—Alternate water supply, S.S. 4876.

Myrtleford.—Renovations, Residence, Consolidated School. (W.O., Wangaratta; C.S., Myrtleford.)

Various.—Erection of 30 proprietary type residences, Schools.

Werribee.—Pressurized water system, State Research Farm. (W.O., Geelong.)

**Furniture and Furnishings.**

Ballarat.—Supply and fix curtains, Mental Hospital.

Carlton.—Supply of steel filing cabinets, Motor Registration Branch.

Dromana.—Supply of furniture, Court House.

Heatherhill.—Supply of tables and trolleys, High School. (Re-advertised.)

Kew.—Supply of furniture, Soil Conservation Authority, 378 Cotham-road.

Mont Park.—Provision of vinyl floor and wall covering, Mental Hospital.

**Site Works.**

Doveton West.—Asphalt, concrete, drainage and gravel works, &c., S.S. 4820.

Prahran.—Repairs and maintenance to asphalt paving and construction of drainage works, Girls' Technical School.

**Miscellaneous.**

Melbourne.—Maintenance cleaning for the period, 1st December, 1968, to 31st May, 1971, Agriculture Department, Treasury-place.

Ringwood.—Maintenance cleaning for the period 1st November, 1968, to 31st May, 1971, Social Welfare Department, corner Ringwood-street and Civic-place.

**Wednesday, 6th November, 1968.****Building, Electrical and Mechanical Works.**

Aspendale.—Erection of type "800" Assembly Hall, Technical School.

Aspendale.—Electrical services, Technical School.

Aspendale.—Mechanical services, Technical School.

Broadmeadows East.—Renovations, &c., S.S. 4732.

Broadmeadows West.—Erection of First Section, Technical School.

Broadmeadows West.—Electrical installation, Technical School.

Broadmeadows West.—Mechanical services, Technical School.

Chelsea Heights.—Erection of shelter pavilion, S.S. 3341.

Myrtleford.—New storeroom, Tobacco Research Station.

(W.O., Benalla and Wangaratta.)

Nunawading.—Mechanical services, "Winlaton", Girls' Home.

Nunawading.—Electrical alterations in Staff Quarters, "Winlaton" Training Centre.

South Yarra.—Attention to floor of Assembly Hall, Melbourne Boys' High School.

Sunbury.—Renovations, Mental Hospital.

**Furniture and Furnishings.**

Murrumbidgee.—Supply and fix Auditorium curtains, High School.

**Site Works.**

Boronia Heights.—Asphalt, concrete, drainage and gravel works, &c., S.S. 4967.

Koonung.—Asphalt, concrete and drainage works, &c., High School.

Malvern East.—Asphalt, concrete and drainage works, &c., S.S. 4139.

**Miscellaneous.**

Box Hill.—Supply and fix Gymnasium equipment, High School.

**Tuesday, 12th November, 1968.****Building, Electrical and Mechanical Works.**

Ballarat.—Mechanical services, Mental Hospital. (W.O., Ballarat.)

Box Hill.—Supply and installation of exhaust system, Technical School.

Greysthorne.—Renovations, High School.

Mont Park.—Replacement of Staff paging system, Larundel Psychiatric Hospital.

Murtoa.—Erection of Science and Class-room Wing, High School. (W.O., Warracknabeal.)

Murtoa.—Electrical services, High School. (W.O., Horsham.)  
 Murtoa.—Mechanical services, High School. (W.O., Horsham and Bendigo.)  
 Pascoe Vale.—Repairs to passage floor, Melbourne School of Textiles.  
 Port Melbourne.—Erection of fencing, &c., S.S. 2932.  
 Solway.—Renovations, S.S. 4641.  
 Sunshine.—Renewal of sewerage fittings, S.S. 3113.  
 Sunshine East.—Renovations, S.S. 4645.  
 Thornbury.—Erection of mesh fencing, High School.  
 Tongala.—Supply and installation of heaters, Consolidated School. (W.O., Shepparton.)  
 Wandin East.—Erection of fencing, S.S. 3934.

**Site Works.**

Boolarra.—Asphalt and drainage works, &c., S.S. 2617. (W.O., Warragul and Traralgon.)  
 Heatherhill.—Construction of heavy duty road, concrete and drainage works, &c., High School.  
 Mount Waverley.—Asphalt, drainage and gravel works, &c., S.S. 3432.

**Miscellaneous.**

Mont Park.—Supply and delivery of laundry cloth, Larundel Psychiatric Hospital.  
 Mont Park.—Supply and delivery of timber, Mental Hospital.

**Tuesday, 19th November, 1968.**

**Building, Electrical and Mechanical Works.**

Heidelberg.—Erection of additions, High School. (Bills of Quantities Available.)  
 Heidelberg.—Electrical services, High School.  
 Heidelberg.—Mechanical services, High School.

**Miscellaneous.**

Williamstown.—Construction of two all welded mild steel work barges, Dredging Depot, Ports & Harbours Branch. (Re-advertised.)

**Tuesday, 3rd December, 1968.**

**Miscellaneous.**

Williamstown.—Construction of one all welded mild steel 8-in. cutter suction dredge, Dredging Depot, Ports & Harbours Branch.

M. V. PORTER,  
 Minister of Public Works.

Public Works Department,  
 Melbourne, 3002, 21st October, 1968.

**PUBLIC SERVICE NOTICES**

No. 93.

**PUBLIC SERVICE ACT 1958.**

THE Public Service Board, in pursuance of the powers conferred by the *Public Service Act 1958*, hereby amends the Public Service (Public Service Board) Regulations as shown below:—

**PART II.—APPOINTMENTS TO THE PUBLIC SERVICE.**

**DIVISION III.—PROFESSIONAL DIVISION.**

In Regulation 23 the words "Draughtsman, Class 'D-1'" are deleted.

Regulation 24 is revoked and the following Regulation is substituted therefor:—

"24. No person shall be eligible for appointment to the office of Draughtsman unless he possesses a draughting certificate or equivalent approved by the Board."

**PART IV.—SALARIES AND INCREMENTS.**

**DIVISION III.—PROFESSIONAL DIVISION.**

In sub-regulation (1) of Regulation 95 the words "Draughtsman, Class 'D-1'" and Class "D-1" are deleted and the words "Trainee Draughtsman" and "Class 'DT-1'", respectively, are substituted therefor.

In sub-regulation (2) of Regulation 95 the words "Draughtsman, Class 'D-2'" are deleted.

In Regulation 96 the words "Draughtsman, Class 'D-1' or Class 'D-2'", "Draughtsman, Class 'D-1'" and "Draughtsman, Class 'D-2'" are deleted.

**DIVISION IV.—TECHNICAL AND GENERAL DIVISION.**

In sub-regulation (3) of Regulation 97 after paragraph (b) the following paragraph is inserted:—

"(c) adults occupying offices of Draughting Assistant, Grade I. and Grade II. shall be granted the following annual increments:—

Grade I.—one of \$133, one of \$114, one of \$133, one of \$111 and one of \$131;

Grade II.—one of \$126, one of \$108 and two of \$127".

Sub-clause (a) (ii) of Regulation 98 is revoked.

**PART V.—ALLOWANCES.**

**DIVISION I.—ALLOWANCES FOR QUALIFICATIONS OR EFFICIENCY.**

*Professional Division.*

Regulation 109 is revoked.

*Technical and General Division.*

The heading "General—Draughtsmen (or Draughtswomen)" is deleted and the following heading is substituted therefor:—

"General—Draughting Assistants and Draughtswomen."

In Regulation 111 the words "Draughting Assistant, Grade I." are substituted for the words "Draughtsman, Grade IA." wherever appearing.

*This Regulation shall have effect as on and from the 6th October, 1968.*

F. E. CAHILL, Chairman.

R. H. DURRANT, Acting Secretary.

Office of the Public Service Board,  
 Melbourne, 7th October, 1968.

No. 95.

*Public Service Act 1958, Section 50.*

**REGULATIONS.—PART IV.—SALARIES AND INCREMENTS.**

THE Public Service Board, in pursuance of the powers conferred by the *Public Service Act 1958*, hereby amends its Regulations as shown below:—

**SIXTH SCHEDULE.**

**TEMPORARY EMPLOYEES.**

*Designations of Positions and Rates of Salaries.*

Department and Designation of Position.	Yearly Rate of Salary.		Increments (Annual).
	Minimum.	Maximum.	
DEPARTMENT OF AGRICULTURE.	\$	\$	
<i>Delete the existing yearly rates of salary for the following positions and substitute the rates shown hereunder in lieu thereof—</i>			
Caretaker—Caterer (Female), Horticultural Research Station, Tatura †	2,032	2,217	Σ
Caretaker and Overseer, Glenormiston †	2,458	2,705	Σ
Σ See Regulation 97 (2). † With quarters when required to reside on premises. ‡ With quarters.			

*This Regulation shall have effect as on and from the 13th October, 1968.*

F. E. CAHILL, Chairman.

R. H. DURRANT, Acting Secretary..

Office of the Public Service Board,  
 Melbourne, 11th October, 1968.

No. 92.

Public Service Act 1958.

REGULATIONS.—PART IV.—SALARIES AND INCREMENTS.

THE Public Service Board, in pursuance of the powers conferred by the Public Service Act 1958, hereby amends its Regulations as follows:—

SECOND SCHEDULE.

TECHNICAL AND GENERAL DIVISION.

Grades and Salary Scales.

MALES:

The following Grades are added:—

Grade Number.	Yearly Rate of Salary.	
	\$	
49A .. .. .	4,750	
51A .. .. .	5,000	
52A .. .. .	5,125	
53A .. .. .	5,250	
54A .. .. .	5,375	
55A .. .. .	5,500	
56A .. .. .	5,626	
57A .. .. .	5,756	
58A .. .. .	5,891	
59A .. .. .	6,031	
60A .. .. .	6,177	
61A .. .. .	6,323	
62A .. .. .	6,470	
63A .. .. .	6,618	

THIRD SCHEDULE:

PART B.

PROFESSIONAL DIVISION.

Scale of Rates of Annual Salaries.

Immediately following, and as an addition to, the table for "Draughtsmen (or Draughtswomen)" insert—

Class.	Annual Salary of Each Subdivision of Each Class.								
	1.	2.	3.	4.	5.	6.	7.	8.	9.
DR-1 ..	\$ 3,432	\$ 3,540	\$ 3,667	\$ 3,794	\$ 3,921	\$ 4,067	\$ 4,190	\$ 4,313	\$ 4,438
DR-2 ..	4,563	4,688	4,875	..	..	..	..	..	..
DR-3 ..	5,000	5,188	5,375	..	..	..	..	..	..
DR-4 ..	5,500	5,689	5,891	..	..	..	..	..	..
DR-5 ..	6,031	6,177	6,323	..	..	..	..	..	..
DR-6 ..	6,470	6,692	..	..	..	..	..	..	..
DR-7 ..	6,820	7,206	..	..	..	..	..	..	..
DR-8 ..	7,778	..	..	..	..	..	..	..	..

TRAINEE DRAUGHTSMAN.

Class	Annual Salary of Each Subdivision.					
	1.	2.	3.	4.	5.	6.
DT-1 ..	\$ 1,634	\$ 1,959	\$ 2,294	\$ 2,654	\$ 2,983	\$ 3,270

SIXTH SCHEDULE.

TEMPORARY EMPLOYEES.

Designations of Positions and Rates of Salaries.

Department and Designation of Position.	Yearly Rate of Salary:		Increments (Annual)..
	Minimum.	Maximum.	
GENERAL.	\$	\$	
Delete— Draughtsman, Senior, Grade II.	5,063	5,313	Σ
Draughtsman, Senior, Grade I.	4,438	4,688	Σ

SIXTH SCHEDULE—continued.

Department and Designation of Position.	Yearly Rate of Salary.		Increments (Annual).
	Minimum.	Maximum.	
GENERAL—continued.	\$	\$	
Draughtsman, Grade IV...	3,958	4,190	Σ
Draughtsman, Grade III.	3,199	3,740	Σ
Draughtsman, Grade II. ..	2,648	2,911	Σ
Draughtsman, Grade I.— Junior—			
Under 16 years of age	..	996	..
At 16 years of age ..	..	1,063	..
At 17 years of age ..	..	1,252	..
At 18 years of age ..	..	1,479	..
At 19 years of age ..	..	1,702	..
At 20 years of age ..	..	1,971	..
Adult.. .. .	2,334	2,572	Σ
Draughtsman, Grade IA. //— Junior—			
Under 16 years of age	..	1,039	..
At 16 years of age ..	..	1,106	..
At 17 years of age ..	..	1,346	..
At 18 years of age ..	..	1,576	..
At 19 years of age ..	..	1,832	..
At 20 years of age ..	..	2,087	..
Adult.. .. .	2,334	2,572	Σ
Add—			
Draughting Assistant, Grade II.	3,306	3,794	††
Draughting Assistant, Grade I. //— Junior—			
Under 16 years of age	..	1,039	..
At 16 years of age ..	..	1,106	..
At 17 years of age ..	..	1,346	..
At 18 years of age ..	..	1,576	..
At 19 years of age ..	..	1,832	..
At 20 years of age ..	..	2,087	..
Adult.. .. .	2,401	3,023	††
Draughtsman, Supervising	5,500	5,891	a (i)
Draughtsman, Senior ..	5,000	5,375	a (ii)
Draughtsman, Grade II. ..	4,563	4,875	a (iii)
Draughtsman, Grade I. ..	3,432	4,438	a (iv)
Draughtsman, Trainee— Junior—			
At 16 years of age ..	..	1,634	..
At 17 years of age ..	..	1,959	..
At 18 years of age ..	..	2,294	..
At 19 years of age ..	..	2,654	..
At 20 years of age ..	..	2,983	..
Adult.. .. .	..	3,270	..
Σ			See Regulation 97 (2)
//			Appointees shall be eligible, within the limits of this range, to receive allowances for qualifications in terms of the scales prescribed in Regulation 111.
††			See Regulation 97 (3) (c)
a (i)			Increments in accordance with the scale of rates of salaries as set out for Draughtsman, Class DR-4 in Part B of the Third Schedule
a (ii)			Increments in accordance with the scale of rates of salaries as set out for Draughtsman, Class DR-3 in Part B of the Third Schedule.
a (iii)			Increments in accordance with the scale of rates of salaries as set out for Draughtsman, Class DR-2 in Part B of the Third Schedule
a (iv)			Increments in accordance with the scale of rates of salaries as set out for Draughtsman, Class DR-1 in Part B of the Third Schedule

This Regulation shall have effect as on and from the 6th October, 1968..

F. E. CAHILL, Chairman:

R. H. DURRANT, Acting Secretary.

Office of the Public Service Board,  
Melbourne, 7th October, 1968.



No. 94.

Public Service Act 1958, Section 50.

REGULATIONS.—PART IV.—SALARIES AND INCREMENTS.

THE Public Service Board in pursuance of the powers conferred by the Public Service Act 1958, hereby amends its Regulations as shown below:—

SIXTH SCHEDULE.

TEMPORARY EMPLOYEES.

Designations of Positions and Rates of Salaries.

Department and Designation of Position.	Yearly Rate of Salary.		Increments (Annual).
	Minimum.	Maximum.	
TREASURY.	\$	\$	
GOVERNMENT PRINTING OFFICE.			
<i>Delete—</i> Tradesman (Engineer) ..	..	†	..
<i>Add—</i> Tradesman (Metal Trades)	..	†	..

† Rates in accordance with the Metal Trades award.

|| In addition, an allowance at the rate of an amount equal to the difference between the appropriate award rate expressed as an annual figure and the actual salary rate appropriate to the yearly rate of salary prescribed above for the corresponding adult tradesman designation.

F. E. CAHILL, Chairman.

R. H. DURRANT, Acting Secretary.

Office of the Public Service Board,  
Melbourne, 7th October, 1968.

No. 96.

PUBLIC SERVICE ACT 1958.

THE Public Service Board, in pursuance of the powers conferred by the Public Service Act 1958, hereby amends the Public Service (Public Service Board) Regulations as follows:—

PART V.—ALLOWANCES.

DIVISION I.—ALLOWANCES FOR QUALIFICATIONS OR EFFICIENCY.  
Regulation 105.

Paragraph (c) of sub-regulation (1) is deleted and the following paragraph is substituted therefor:—

"(c) Membership, other than student membership, of one of the following bodies:—

- (i) The Australian Society of Accountants;
- (ii) The Chartered Institute of Secretaries;
- (iii) The Incorporated Australian Insurance Institute;"

F. E. CAHILL, Chairman.

R. H. DURRANT, Acting Secretary.

Office of the Public Service Board,  
Melbourne, 8th October, 1968.

No. 97.

PUBLIC SERVICE ACT 1958.

THE Public Service Board, in pursuance of the powers conferred by the Public Service Act 1958, hereby amends the Public Service (Public Service Board) Regulations as follows:—

PART IV.—SALARIES AND INCREMENTS.

DIVISION I.—GENERAL.

Regulation 87 is revoked and the following Regulation is substituted therefor:—

"87. Notwithstanding anything in this Part, the salaries and wages of officers and employees as prescribed in the First, Second, Third, Fourth, Fifth, Sixth and Seventh Schedules to these Regulations (other than the salaries or wages of officers and employees whose rates are prescribed by reference in any such Schedule to a Commonwealth Award or State Wages Board Determination) shall be increased by the addition of amounts determined in accordance with the following scale:—

Amount.  
(a) Adult Males and Married Male Minors \$123  
(b) Adult Females .. .. \$123  
(c) Minors other than Married Male Minors—

	Amount.	
	Male.	Female.
At 16 years and under ..	61	61
At 17 years .. ..	74	61
At 18 years .. ..	86	64
At 19 years .. ..	99	74
At 20 years .. ..	111	83 "

This Regulation shall have effect as on and from the 3rd November, 1968.

F. E. CAHILL, Chairman.

R. H. DURRANT, Acting Secretary.

Office of the Public Service Board,  
Melbourne, 11th October, 1968.

PRIVATE ADVERTISEMENTS

NOTICE is hereby given that the Mirboo North Golf Club has applied for a lease under section 134 of the Land Act 1958, for a term of 21 years, in respect of an area of approximately 64 acres, being allotment 10A, section 8, in the Township of Mirboo North, as a site for amusement and recreation (golf club). 4920

NOTICE is hereby given that the Hamilton City Council has applied for a lease under section 134 Land Act 1958, for a term of 21 years over an area of approximately 6/10 acre in the south-west corner of the Recreation Reserve, at the corner of High and Gordon streets, Township of Hamilton, for the purpose of amusement and recreation (site for basketball stadium). 5040

I, ROBERT WILLIAM GUTHRIE MACDONALD, do hereby declare that as of today, the 23rd October, 1968, I will accept no responsibility for debts incurred in my name without my written consent. 5181

NOTICE OF INTENTION TO APPLY FOR A LICENCE TO DIVERT WATER AND CUT RACE FROM THE RIVER MURRAY, AT WOOD WOOD.

I HEREBY give notice that I intend to apply for a licence empowering me to divert water for a term of 3 years to the extent of 150 acre-feet per annum at a maximum rate of 3 acre-feet per day of 24 hours for the irrigation of citrus, vines and lucerne (nursery purposes), being part of allotment 159, Parish of Piangil, and to occupy certain Crown lands for works of diversion, and to cut a race thereon.

Any objection to such application must be forwarded in writing to reach the State Rivers and Water Supply Commission, Melbourne before 18th November, 1968, being 30 days from the first publication of this notice.

E. J. FLEMING & SONS PTY. LTD.

Box 34, Nyah. 5183

Sewerage Districts Act.

PROPOSED SEWERAGE AUTHORITY.

NOTICE is hereby given that the Dimboola Shire Council has made application to the Honorable the Minister of Water Supply for the constitution of a Sewerage Authority and for the proclamation of a Sewerage District at Rainbow, and for the construction, maintenance and continuance of sewerage works within that District under the provisions of the Sewerage Districts Act.

A general plan and description of the proposed works have been submitted with the application and copies of same may be seen at Mr. K. Wishart's shop, Federal-street, Rainbow.

Dated at Jeparit, the 15th day of October, 1968.

R. T. LIVINGSTON,  
Secretary.

The Act requires that this notice be published weekly for three weeks in a newspaper circulating locally and the Government Gazette, and provides that within one month of the third notice in the Government Gazette any person having an interest therein who is likely to be injuriously affected by the proposed sewerage works may forward to the Minister of Water Supply a petition seeking refusal or amendment to the application. In this case the period for objections will expire on 4th December, 1968. 5168

## ORBOST WATERWORKS TRUST.

## BY-LAW No. 12.

*Water Restrictions.—Stage One.*

**T**HE Orbst Waterworks Trust (hereinafter referred to as "the Trust") in pursuance and exercise of the powers conferred by the *Water Act 1958*, doth hereby make the By-Law following, restricting the use for other than domestic purposes of water supplied by the said Trust.

1. This By-Law shall come into operation at such time as the Trust from time to time directs by a notice published in a newspaper circulating generally within the District (hereinafter referred to as the "specified area") and shall cease to have operation at such time as the Trust from time to time directs by a notice so published.

2. Subject to the provisions of Clause 3 of this By-Law no person shall with water supplied by the Trust:—

(a) Water any garden, lawn or other land (other than commercial market gardens, commercial nurseries or land used for the growing of green feed for commercial poultry farms) within the specified area except by means of a hose held in the hand or by means of a can or other vessel held in the hand.

(b) Fill, add to or cleanse any private swimming pool within the specified area.

3. No person shall, with water supplied by the Trust, water any lands comprising sports grounds, golf courses, race courses, public and club bowling and croquet greens and public and club tennis courts within the specified area by means of fixed sprinklers except between the hours of 6.00 p.m. and 10.00 p.m. of each day.

4. Every person who uses or permits or suffers water supplied by the Trust to be used contrary to the provisions of this By-Law shall be guilty of an offence, and shall be liable to a penalty not exceeding One Hundred Dollars.

5. If any person supplied with water by the Trust wrongfully does or causes or permits to be done anything in contravention of this By-Law the Trust may (without prejudice to any remedy in respect thereof) close or cut off any of the pipes by or through which water is supplied to him or for his use and may cease to supply him with water as provided by the *Water Act 1958*.

The foregoing By-Law was made and passed by the Commissioners of the Orbst Waterworks Trust on the third day of September, 1968, and the seal of the Trust affixed hereto, in the presence of—

(SEAL) K. E. G. MOORE, Chairman.  
J. D. TORLEY, Commissioner.  
L. SPINK, Secretary.

Certified and approved by the Governor in Council at the Executive Council Meeting held on 1st October, 1968. 5200

## ORBOST WATERWORKS TRUST.

## BY-LAW No. 13.

*Water Restrictions.—Stage Two.*

**T**HE Orbst Waterworks Trust (hereinafter referred to as "the Trust") in pursuance and exercise of the powers conferred by the *Water Act 1958*, doth hereby make the By-Law following, restricting the use for other than domestic purposes of water supplied by the said Trust.

1. This By-Law shall come into operation at such time as the Trust from time to time directs by a notice published in a newspaper circulating generally within the District (hereinafter referred to as the "specified area") and shall cease to have operation at such time as the Trust from time to time directs by a notice so published.

2. Subject to the provisions of Clauses 3 and 4 of this By-Law no person shall, with water supplied by the Trust:—

(a) Water any garden, lawn or other land (other than commercial market gardens, commercial nurseries or land used for the growing of green feed for commercial poultry farms) within the specified area except by means of a hose held in the hand or by means of a can or other vessel held in the hand, between the hours of 5.30 p.m. and 8.00 p.m., on each day.

(b) Fill, add to or cleanse any private swimming pool within the specified area.

(c) Wash or cleanse any motor vehicle with a hose.

(d) Wash down footpaths or pavements.

3. No person shall, with water supplied by the Trust, water any commercial market gardens, commercial nurseries or land used for the growing of green feed for commercial poultry farms within the specified area by means of fixed sprinklers between the hours of 5.30 p.m. and 8.00 p.m. of each day.

4. No person shall with water supplied by the Trust, water any lands comprising sports grounds, golf courses, race courses, public and club bowling and croquet greens and public and club tennis courts within the specified area by means of fixed sprinklers except between the hours of 6.00 p.m. and 8.00 p.m. of each day.

5. Every person who uses or permits or suffers water supplied by the Trust to be used contrary to the provisions of this By-Law shall be guilty of an offence, and shall be liable to a penalty not exceeding One Hundred Dollars.

6. If any person supplied with water by the Trust wrongfully does or causes or permits to be done anything in contravention of this By-Law, the Trust may (without prejudice to any remedy in respect thereof) close or cut off any of the pipes by or through which water is supplied to him or for his use and may cease to supply him with water as provided by the *Water Act 1958*.

The foregoing By-Law was made and passed by the Commissioners of the Orbst Waterworks Trust on the third day of September, 1968, and the seal of the Trust affixed hereto, in the presence of—

(SEAL) K. E. G. MOORE, Chairman.  
J. D. TORLEY, Commissioner.  
L. SPINK, Secretary.

Certified and approved by the Governor in Council at the Executive Council Meeting held on 1st October, 1968. 5201

## ORBOST WATERWORKS TRUST.

## BY-LAW No. 14.

*Water Restrictions.—Stage Three.*

**T**HE Orbst Waterworks Trust (hereinafter referred to as "the Trust") in pursuance and exercise of the powers conferred by the *Water Act 1958*, doth hereby make the By-Law following, restricting the use for other than domestic purposes of water supplied by the said Trust.

1. This By-Law shall come into operation at such time as the Trust from time to time directs by a notice published in a newspaper circulating generally within the District (hereinafter referred to as the "specified area") and shall cease to have operation at such time as the Trust from time to time directs by a notice so published.

2. Subject to the provisions of Clauses 3 and 4 of this By-Law no person shall, with water supplied by the Trust:—

(a) Water any garden, lawn or other land (other than commercial market gardens, commercial nurseries or land used for the growing of green feed for commercial poultry farms) within the specified area except by means of a can or other vessel held in the hand, between the hours of 5.30 p.m. and 8.00 p.m. of each day.

(b) Fill, add to or cleanse any private swimming pool within the specified area.

(c) Wash or cleanse any motor vehicle with a hose.

(d) Wash down footpaths or pavements.

3. No person shall with water supplied by the Trust, water any commercial market gardens, commercial nurseries or land used for the growing of green feed for commercial poultry farms within the specified area by means of fixed sprinklers except between the hours of 6.00 a.m. and 10.00 a.m. of each day or by means of a hose held in the hand or by means of a can or other vessel held in the hand.

4. No person shall with water supplied by the Trust, water any land comprising sports grounds, golf courses, race courses, public and club bowling and croquet greens and public and club tennis courts within the specified area except by means of a hose held in the hand or by means of a can or other vessel held in the hand, between the hours of 6.00 p.m. and 8.00 p.m. of each day.

5. Every person who uses or permits or suffers water supplied by the Trust to be used contrary to the provisions of this By-Law shall be guilty of an offence, and shall be liable to a penalty not exceeding One Hundred Dollars.

6. If any person supplied with water by the Trust wrongfully does or causes or permits to be done anything in contravention of this By-Law, the Trust may (without prejudice to any remedy in respect thereof) close or cut

off any of the pipes by or through which water is supplied to him or for his use, and may cease to supply him with water as provided by the *Water Act 1958*.

The foregoing By-Law was made and passed by the Commissioners of the Orbost Waterworks Trust on the third day of September, 1968, and the seal of the Trust affixed hereto, in the presence of—

(SEAL) K. E. G. MOORE, Chairman.  
J. D. TORLEY, Commissioner.  
L. SPINK, Secretary.

Certified and approved by the Governor in Council at the Executive Council Meeting held on 1st October, 1968. 5202

## ORBOST WATERWORKS TRUST.

## BY-LAW No. 15.

*Water Restrictions.—Stage Four.*

**T**HE Orbost Waterworks Trust (hereinafter referred to as "the Trust") in pursuance and exercise of the powers conferred by the *Water Act 1958*, doth hereby make the By-Law following, restricting the use for other than domestic purposes of water supplied by the said Trust.

1. This By-Law shall come into operation at such time as the Trust from time to time directs by a notice published in a newspaper circulating generally within the District (hereinafter referred to as the "specified area") and shall cease to have operation at such time as the Trust from time to time directs by a notice so published.

2. Subject to the provisions of Clause 3 of this By-Law, no person shall, with water supplied by the Trust:—

(a) Water any garden, lawn or other land (other than commercial market gardens, commercial nurseries or land used for the growing of green feed for commercial poultry farms) within the specified area.

(b) Fill, add to or cleanse any private swimming pool within the specified area.

(c) Wash or cleanse any motor vehicle with a hose.

(d) Wash down footpaths or pavements.

3. No person shall with water supplied by the Trust water any commercial market gardens, commercial nurseries or land used for the growing of green feed for commercial poultry farms within the specified area except by means of a can or other vessel held in the hand or between the hours of 6.00 a.m. and 8.00 a.m. of each day by means of a hose held in the hand.

4. No person shall, with water supplied by the Trust, water any lands comprising sports grounds, golf courses, race courses, public and club bowling and croquet greens and public and club tennis courts within the specified area.

5. Every person who uses or permits or suffers water supplied by the Trust to be used contrary to the provisions of this By-Law shall be guilty of an offence, and shall be liable to a penalty not exceeding One Hundred Dollars.

6. If any person supplied with water by the Trust wrongfully does or causes or permits to be done anything in contravention of this By-Law, the Trust may (without prejudice to any remedy in respect thereof) close or cut off any of the pipes by or through which water is supplied to him or for his use, and may cease to supply him with water as provided by the *Water Act 1958*.

The foregoing By-Law was made and passed by the Commissioners of the Orbost Waterworks Trust on the third day of September, 1968, and the seal of the Trust affixed hereto, in the presence of—

(SEAL) K. E. G. MOORE, Chairman.  
J. D. TORLEY, Commissioner.  
L. SPINK, Secretary.

Certified and approved by the Governor in Council at the Executive Council Meeting held on 1st October, 1968. 5203

GEELONG WATERWORKS AND SEWERAGE TRUST.  
GAZETAL OF WATER MAINS.

**N**OTICE to owners of tenements in the under-mentioned streets and private streets, lanes, courts and alleys opening thereto:—

*Shire of Corio.*

Holmes-street, 185 feet north from lot 27 to lot 31.  
Oswald-avenue, 1,508 feet west from Bacchus Marsh-road to lot 9.  
Right-of-way rear of Rose-avenue, 331 feet between Plume-street and Camellia-crescent.

Downie-crescent, 276 feet east from Teak-street to lot 84.  
Epsom-road, 262 feet north from Cox-road.  
Right-of-way off The Centreway, 360 feet north from The Centreway.

Stapleton-road, 298 feet north from Cox-road to lot 111.  
Newton-avenue, 1,034 feet west from lot 130 to lot 148.  
Melbourne-road, 1,577 feet north from Cuthbertson-avenue to Harpur-road.  
Kosciusko-avenue, 1,083 feet between Melbourne-road to Torbreck-street.  
Gambier-grove, 753 feet between Bogong-street and Kosciusko-avenue.  
Bogong-street, 730 feet between Buffalo-avenue and Kosciusko-avenue.  
Buffalo-avenue, 1,370 feet between Purnell-road and Melbourne-road.  
Leura-court, 508 feet east from Buffalo-avenue.  
Torbreck-street, 131 feet west from Kosciusko-avenue.

*Shire of South Barwon.*

James-street, 86 feet east from lot 26 to right-of-way west from Glyn-street.

Right-of-way off James-street, 80 feet south from James-street.

Voce-court, 759 feet east from Fairfield-avenue.

Fairfield-avenue, 397 feet between Kidman-avenue and Voce-court.

Aringa-avenue, 196 feet west from lot 3 to lot 5.

Sherwood-court, 406 feet south from Aringa-avenue.

Montpellier-drive, 71 feet north from lot 33 to lot 107.

Byambee-crescent, 705 feet south from Karana-avenue.

Patonga-drive, 1,066 feet between Byambee-crescent and Burdoo-drive.

Burdoo-drive, 612 feet south from Karana-avenue to lot 206.

Marma-court, 823 feet south from Patonga-drive.

Meda-court, 583 feet south from Patonga-drive.

Hagan-court, 140 feet north from Mt. Pleasant-road to lot 6.

Thornbury-lane, 130 feet east from lot 72 to lot 78.

Brassey-avenue, 375 feet west from Dunsmore-road to lot 14.

Grove-road, 1,266 feet east from Torquay-road.

Northam-avenue, 180 feet south from lot 122 to lot 119.

Amoore-avenue, 626 feet from Roycroft-avenue to lot 92.

Cheryl-crescent, 1,256 feet from Fairfield-avenue to Torquay-road.

Fairfield-avenue, 625 feet between Voce-court and Cheryl-crescent.

*Shire of Bellarine.*

Buckington-street, 110 feet between Collins-street and Durran-street.

Durran-street, 350 feet west from Buckington-street to lot 32.

High-street, 119 feet between Wattle Park-avenue and Twitts-road.

Twitts-road, 954 feet south from High-street to lot 1.

Richard-street, 1,152 feet east from Wilsons-road to lot 145.

Diosma-court, 298 feet south from Richard-street.

Jacaranda-court, 368 feet south from Richard-street.

Hibiscus-crescent, 2,069 feet between Richard-street and Wilsons-road.

Cassia-court, 261 feet east from Hibiscus-crescent.

Lavender-court, 274 feet west from Hibiscus-crescent.

Fuschia-court, 286 feet east from Hibiscus-crescent.

Veronica-avenue, 1,016 feet between Hibiscus-crescent and Wilsons-road.

Protea-court, 323 feet south from Veronica-avenue.

Alnus-court, 295 feet south from Veronica-avenue.

Hillford-street, 18 feet south from lot 19 to lot 18.

*City of Geelong.*

Little Fyans-street, 218 feet from existing dead end to Swanston-street.

The main pipe in the said streets being laid down the owners of all tenements situated as above are hereby required on or before the 31st December, 1968, to cause a proper pipe and stop cocks to be laid so as to supply water within such tenements from the main pipe.

The common seal of the Geelong Waterworks and Sewerage Trust was hereunto affixed this 16th day of October, 1968, in the presence of—

(SEAL) J. W. CARR, Chairman.  
R. W. WHITESIDE, Commissioner.  
B. C. HENSHAW, Secretary.

## CITY OF BRIGHTON.

## LOAN No. 80.

*Notice of intention to borrow the sum of \$75,000 for Permanent Works and Undertakings.*

NOTICE is hereby given that the Council of the City of Brighton proposes to borrow the sum of \$75,000 secured by a charge over the general rates of the Municipality, such sum to be raised by the grant of a mortgage in accordance with the provisions of the *Local Government Act 1958*.

1. The maximum rate of interest that may be paid is 5.875 per cent. per annum.

2. The purpose for which the loan is to be applied shall be:—

Construction of Works Depot Municipal Golf Links	22,000
Erection of Scout Hall	10,000
Erection of Caretaker's Residence, Dendy Park	11,000
Development and Improvement of sporting facilities, Dendy Park	32,000
	\$75,000

3. The loan shall have a currency of 40 years and interest thereon shall be payable half-yearly on the first days of January and July in each year, the first payment to be made on the 1st July, 1969 and the final payment on the 1st day of July, 2008. All payments to be made to the State Superannuation Board, Treasury-place, Melbourne.

4. The loan is to be liquidated by a Sinking Fund which shall be created in accordance with the provisions of the *Local Government Acts* by the yearly investment of such amount as the Auditor General certifies will be sufficient to repay the principal moneys secured by the mortgage within the currency of the loan in such manner as the Treasurer of Victoria shall direct.

Plans and specifications, and the estimate of costs of the proposed works and the statement showing the proposed expenditure of the money to be borrowed are open for inspection at the office of the City of Brighton, Boxshall-street, Brighton.

15th October, 1968.

5188

A. C. G. DE GARIS, Town Clerk.

## CITY OF CAMBERWELL.

## LOAN No. 78.

*Notice of intention to borrow the sum of \$50,000 for permanent works and undertakings.*

NOTICE is hereby given that the Council of the City of Camberwell proposes to borrow the principal sum of fifty thousand Dollars (\$50,000) secured by a charge over the general rates of the municipality, such sum to be raised by the grant of a mortgage in accordance with the provisions of the *Local Government Act 1958*.

1. The maximum rate of interest that may be paid is 5.875 per cent. per annum.

2. The purpose for which the loan is to be applied is part cost of erection of new Civic Centre.

3. The period of the loan shall be fifteen years.

4. The moneys borrowed shall be repayable by providing out of the Municipal Fund half-yearly instalments of approximately \$2,530.40 each including principal and interest on the first day of July and the first day of January during the currency of the loan. The first instalment shall be payable on the 1st day of July, 1969.

5. Such moneys shall be payable to the Commissioners of the State Savings Bank of Victoria at the office of the said Commissioners, corner Elizabeth and Bourke streets, Melbourne.

The plans and specifications and the estimate of the cost of the proposed works and a statement showing the proposed expenditure of the moneys to be borrowed are open for inspection at the office of the Council of the City of Camberwell, at the Civic Centre, Camberwell.

18th October, 1968.

5185

L. F. CHEFFERS,  
Town Clerk and Chief Administrator.

## CITY OF FOOTSCRAY.

## LOAN No. 88.

*Notice of Intention to Borrow the Sum of \$25,000 for Permanent Works and Undertakings.*

NOTICE is hereby given that the Council of the City of Footscray proposes to borrow the sum of Twenty-five thousand dollars (\$25,000) secured by a charge over

the general rates of the municipality, such sum to be raised by the grant of a mortgage in accordance with the provisions of the *Local Government Act 1958*.

1. The maximum rate of interest that may be paid is 5.75 per centum per annum.

2. The purpose for which the loan is to be applied is as follows:—

Portion of Council's contribution (estimated at \$70,000) towards the cost of reconstruction, by the Country Roads Board, of Whitehall-street.

3. The period of the loan shall be ten (10) years.

4. The moneys borrowed shall be repayable by providing out of the municipal fund half-yearly instalments of approximately \$1,661.04 each including principal and interest on the 1st day of January and the 1st day of July in each year during the currency of the loan.

5. Such moneys shall be repayable to the Australia and New Zealand Savings Bank Limited, 186 Barkly-street, Footscray.

The plans and specifications and the estimate of the cost of the proposed works and the statement showing the proposed expenditure of the moneys to be borrowed are open for inspection at the Municipal Offices, Napier-street, Footscray.

Dated this 21st day of October, 1968.

5196

W. H. SWABY, Town Clerk.

*Local Government Act 1958.*

## CITY OF GEELONG WEST.

## NOTICE OF THE FIXING OF NEW ALIGNMENT OF AUTUMN STREET.

NOTICE is hereby given that—

1. The Council of the City of Geelong West in exercise of the powers conferred by section 621 of the above-mentioned Act did by Resolution dated the 26th day of June, 1968, widen that section of Autumn-street lying between Western-street and Latrobe-terrace by fixing a new northern alignment varying between 6 ft. 3 in. and 6 ft. 5 in. north of the old northern alignment thereof.

2. In accordance with the requirements of section 622 of the said Act a plan of the new alignment prepared and certified by a licensed surveyor and showing the position of the new alignment with reference to permanent marks and the old alignment and the position of walls fences buildings and other permanent structures and features is now available for inspection by any person without fee at the municipal offices, Town Hall, Geelong West, at any time at which such offices are open for business; and

3. Copies of the said plan also certified by the said surveyor have been lodged by the Council in the office of the Registrar of Titles and in the office of the Registrar-General respectively and are there available for inspection by any person without fee at any time such offices are open for business.

Dated the 17th day of October, 1968.

By order of the Council,

5184

R. J. HAMMETT, Town Clerk.

## CITY OF PRESTON.

## - LOAN No. 81.

*Notice of Intention to Borrow.*

NOTICE is hereby given that the Council of the City of Preston intends to borrow the sum of \$100,000 (One hundred thousand dollars) by the grant of a mortgage secured by a charge over the general rates of the municipality in accordance with the provisions of the *Local Government Acts*.

In connexion therewith, the following information is stated—

(a) The amount of the principal moneys which it is proposed to borrow is \$100,000.

(b) The maximum rate of interest that may be paid is 5.875 per centum per annum.

(c) The times which the moneys borrowed are to be repayable are the 1st days of June and December during the years 1969 to 1983 (inclusive) and that the place such moneys shall be repayable is at the Bank of New South Wales, Preston.

(d) The purpose for which the loan is to be applied is for the construction of—

Capital Works in the Electricity Department.

(e) The manner in which the loan is to be liquidated is by provision out of the municipal fund in each half-year during the currency of the loan of the sum of \$5,060.80 which includes principal and interest.

The plans and specifications and estimate of the cost of the works and a statement showing the proposed expenditure of the moneys to be borrowed are open for inspection at the Town Hall, Preston, during office hours.

Dated this 23rd day of October, 1968.

5231 J. C. DONATH, F.I.M.A., Town Clerk.

	\$
Construction of Pavilion, "J. C. Donath" Reserve (part cost) . . . . .	1,100
Road Widening and Construction of Footpaths, Oakhill Avenue . . . . .	39,500
Purchase of Office Machinery . . . . .	2,930
Road Widening and Reconstruction, Edwardes Street . . . . .	18,501
	\$100,000

CITY OF PRESTON.

LOAN NO. 82.

Notice of Intention to Borrow.

NOTICE is hereby given that the Council of the City of Preston intends to borrow the sum of \$100,000 (One hundred thousand dollars) secured by a charge over the general rates of the municipality, such sum to be raised by the grant of a mortgage in accordance with the provisions of the Local Government Act 1958.

In connexion therewith, the following information is stated—

1. The amount of the principal moneys which it is proposed to borrow is \$100,000.

2. The maximum rate of interest that may be paid is 5.875 per centum per annum.

3. The purposes for which the loan is to be applied are—

Acquisition of land, "W. H. Robinson Reserve" . . . . .	\$5,450
Acquisition of land, Glasgow-avenue . . . . .	5,830
Acquisition of land, Dumbarton-street . . . . .	6,190
Acquisition of land, Radford-road . . . . .	2,650
Council contribution to Country Roads Board Works . . . . .	57,660
Reconstruction of roadway and footpaths, Byfield-street . . . . .	12,500
Reconstruction of roads, Burbank Estate . . . . .	8,000
Construction of conveniences at rear of Town Hall . . . . .	1,720
	\$100,000

4. The period of the loan shall be Forty (40) years.

5. The loan shall be repaid by the establishment and accumulation of a sinking fund pursuant to the provisions of section 428A of the Local Government Act 1958 by provision out of the municipal fund of an appropriate amount in each half-year during the period of the loan.

6. The loan shall be repaid in one amount at maturity at the office of the State Superannuation Board, Treasury-place, Melbourne, or at such other place as the Board may require.

7. Interest shall be payable at the office of the Board on such other place as the Board may require in half-yearly payments of \$2,937.50 each on the 1st day of February and the 1st day of August in each year during the currency of the loan, the first of such payments being made on the 1st day of August, 1969.

Plans and specifications and estimate of the cost of the works and a statement showing the proposed expenditure of the moneys to be borrowed are open for inspection at the Town Hall, Preston, during office hours.

21st October, 1968.

5232 J. C. DONATH, F.I.M.A., Town Clerk.

CITY OF PRESTON.

LOAN NO. 79.

Notice of Intention to Borrow the sum of \$100,000 for Permanent Works and Undertakings.

NOTICE is hereby given that the Council of the City of Preston proposes to borrow the principal sum of One hundred thousand dollars (\$100,000) secured by a charge over the General Rates of the municipality, such sum to be raised by the grant of a mortgage in accordance with the provisions of the Local Government Act 1958.

1. The maximum rate of interest that may be paid is 5.875 per centum per annum.

2. The purposes for which the loan is to be applied are—

Establishment of Elderly Citizens' Club, Reservoir . . . . .	\$ 16,700
Establishment of Elderly Citizens' Club, East Preston . . . . .	17,100
Construction of Pavilion, "H. L. T. Oulton" Park (part cost) . . . . .	4,169

3. The period of the Loan shall be fifteen years.

4. The moneys borrowed shall be repayable by providing out of the Municipal Fund half-yearly instalments of approximately \$5,060 each including principal and interest on the 1st day of June and the 1st day of December during the currency of the loan, the first instalment shall be repayable on the 1st day of June, 1969.

5. Such moneys shall be repayable to the Commissioners of the State Savings Bank of Victoria at the office of the said Commissioners, corner Elizabeth and Bourke-streets, Melbourne.

The plans and specifications, and the estimate of the cost of the proposed works, and a statement showing the proposed expenditure of the moneys to be borrowed, are open for inspection at the office of the Council of the City of Preston, Town Hall, High Street, Preston.

Dated this 21st day of October, 1968.

5233 J. C. DONATH, F.I.M.A., Town Clerk.

CITY OF PRESTON.

LOAN NO. 80.

NOTICE OF INTENTION TO BORROW.

NOTICE is hereby given that the Council of the City of Preston intends to borrow the sum of One hundred and seventy-five thousand dollars (\$175,000) by the grant of a mortgage secured by a charge over the general rates of the municipality in accordance with the provisions of the Local Government Acts.

In connection therewith, the following information is stated—

(a) The amount of the principal moneys which it is proposed to borrow is \$175,000.

(b) The maximum rate of interest that may be paid is 5.875 per centum per annum.

(c) The times which the moneys borrowed are to be repayable are the first days of June and December during the years 1969 to 1983 (inclusive) and that the place such moneys shall be repayable is at the Bank of New South Wales, Preston.

(d) The purposes for which the loan is to be applied are:—

	\$
Extension of Manager's Residence, Preston Baths (part cost) . . . . .	1,500
Installation of Traffic Signals intersection of Murray-road and Plenty-road . . . . .	6,300
Installation of Traffic Signals intersection of Murray-road and St. Georges-road . . . . .	9,340
Construction of Bridge—Broadhurst-avenue . . . . .	24,000
Construction of Bridge—Henty-street . . . . .	31,000
Construction of Bridge—Chenies-street . . . . .	33,000
Purchase of Compressor and Generator . . . . .	4,100
Erection of Bus Shelters (3) . . . . .	1,170
Purchase of Band Instruments . . . . .	6,000
Development of Dumbarton-street Parkland . . . . .	750
Erection of Amenities Building, Edwardes Park . . . . .	28,300
Erection of Pavilion, "C. T. Barling" Park . . . . .	13,000
Water Reticulation at Hockey Reserve, Plenty-road . . . . .	2,100
Completion of "K. P. Hardiman" Pavilion, Hockey Reserve, Plenty-road . . . . .	6,000
Alterations to Infant Welfare Centre Building, Reservoir . . . . .	1,900
Extension of Garage at Nursery . . . . .	6,540
	\$175,000

(e) The manner in which the loan is to be liquidated is by provision out of the municipal fund in each half-year during the currency of the loan of the sum of \$8,856.39 which includes Principal and interest.

The plans and specifications, and estimate of the cost of the works and a statement showing the proposed expenditure of the moneys to be borrowed are open for inspection at the Town Hall, Preston, during office hours.

Dated this 23rd day of October, 1968.

5234 J. C. DONATH, F.I.M.A., Town Clerk.

CITY OF RINGWOOD.

LOAN No. 87.

Notice of Intention to Borrow the Sum of \$50,000 for Permanent Works and Undertakings.

NOTICE is hereby given that the Council of the City of Ringwood proposes to borrow the principal sum of Fifty thousand dollars (\$50,000) secured by a charge over the general rates of the municipality, such sum to be raised by the grant of a mortgage, in accordance with the provisions of the Local Government Act 1958.

1. The maximum rate of interest that may be paid is 5.75 per centum per annum.

2. The purposes for which the loan is to be applied are—

Sports Pavilion—Mullum Reserve	..	\$40,000
Toilet Block—Ringwood Lake Park	..	10,000
Total	..	\$50,000

3. The period of the loan shall be fourteen years.

4. The moneys borrowed shall be repayable by providing out of the municipal fund half-yearly instalments of approximately \$2,624.11 each, including principal and interest, on the 1st days of August and February in each year during the currency of the loan. The first instalment shall be payable on the 1st day of August, 1969.

5. Such moneys shall be repayable to the Commissioners of the State Savings Bank of Victoria at the office of the said Commissioners, corner Elizabeth and Bourke streets, Melbourne.

The plans and specifications and the estimate of the cost of the proposed works, and a statement showing the proposed expenditure of the moneys to be borrowed, are open for inspection at the office of the Council of the City of Ringwood, Maroondah Highway, Ringwood.

5166 F. P. DWERRYHOUSE, Town Clerk.

CITY OF RINGWOOD.

LOAN No. 88.

Notice of Intention to Borrow the Sum of \$50,000 for Permanent Works and Undertakings.

NOTICE is hereby given that the Council of the City of Ringwood proposes to borrow the principal sum of Fifty thousand dollars (\$50,000) secured by a charge over the general rates of the municipality, such sum to be raised by the grant of a mortgage, in accordance with the provisions of the Local Government Act 1958.

1. The maximum rate of interest that may be paid is 5.75 per centum per annum.

2. The purposes for which the loan is to be applied are—

Road Works.

Council Contribution to—

Wantirna-road Bridge at Dandenong Creek; Approaches to Wantirna-road at Dandenong Creek; Station-street Reconstruction \$20,500

Drainage—

Sewer Extension Bedford Park; Wantirna-road Approaches to Bridge; Drainage Station-street; Drainage Wonga-road .. 10,800

Kerb and Channel—

Phillip-street; Lorient-street; Wantirna-road, east side, Dandenong Creek North; Wantirna-road, west side, Dandenong Creek North; Station-street, both sides; Wilson-street, both sides; Car Park—Civic Centre, The Boulevard Group .. 15,400

Parks and Gardens—

B. J. Hubbard Reserve—Soccer Oval—Proportion of Cost .. 3,300

Total .. \$50,000

3. The period of the loan shall be ten years.

4. The moneys borrowed shall be repayable by providing out of the municipal fund half-yearly instalments of approximately \$3,322.05 each, including principal and interest, on the 1st days of July and January in each year during the currency of the loan. The first instalment shall be payable on the 1st day of July, 1969.

5. Such moneys shall be repayable to the Commissioners of the State Savings Bank of Victoria at the office of the said Commissioners, corner Elizabeth and Bourke streets, Melbourne.

The plans and specifications and the estimate of the cost of the proposed works, and a statement showing the proposed expenditure of the moneys to be borrowed, are open for inspection at the office of the Council of the City of Ringwood, Maroondah Highway, Ringwood.

5167 F. P. DWERRYHOUSE, Town Clerk.

CITY OF SANDRINGHAM.

ORDER CHANGING NAME OF STREET.

NOTICE is hereby given that at a meeting of the Council of the City of Sandringham, held on the 25th June, 1968, the said Council, in pursuance of the powers conferred by the Local Government Act 1958, did make an Order changing the name of the following street:—

Old Name.—Alfred-street.

New Name.—McKay-avenue.

Location.—Off Bluff-road, Black Rock, easterly.

5172 J. L. ANDERSON, Town Clerk.

CITY OF WARRNAMBOOL.

LOAN No. 79.

Notice of Intention to Borrow the Sum of \$70,000 for Permanent Works and Undertakings.

NOTICE is hereby given that the Council of the City of Warrnambool proposes to borrow the principal sum of Seventy thousand dollars (\$70,000) secured by a charge over the general rates of the municipality, such sum to be raised by the grant of a mortgage in accordance with the provisions of the Local Government Act 1958.

1. The maximum rate of interest that may be paid is 5.875 per cent. per annum.

2. The purposes for which the loan is to be applied are:—

(a) Council Contribution C.A.R. Grant 1968-69.	\$	21,820
(b) Kerb and Channel, Drainage, Widen Pavement—		
(i) Banyan-street—Darling-street to Highway ..	\$1,920	
(ii) Henna-street—Lava to Merri-streets ..	11,860	
(iii) Lindsay-street ..	1,400	
(iv) Merrivale Main-road ..	2,200	
(v) Raglan-parade — Liebigs to Craig streets ..	18,120	
		35,500
(c) Simpson-street Tunnel (Subsidised) ..		12,680
		<u>\$70,000</u>

3. The period of the loan shall be fifteen years.

4. The loan is to be liquidated by the creation of a sinking fund, pursuant to the provisions of Section 428A of the Local Government Act 1958.

5. Such moneys shall be repayable at the expiration of the loan to the Hospital Benefits Association, 390 Little Collins-street, Melbourne.

The plans, specifications and estimate of the cost of the proposed works and a statement showing the proposed expenditure of the moneys to be borrowed, are open for inspection at the Office of the Council of the City of Warrnambool, at the Municipal Chambers, Warrnambool.

Dated this 16th day of October, 1968.

5192 K. L. ARNEL, Town Clerk.

TOWN OF BAIRNSDALE.

BY-LAW No. 3.

A By-Law of the Town of Bairnsdale made under the provisions of the Dog Act 1958 as amended, and numbered 3 for the purpose of prescribing the fees to be charged for the registration of dogs and other fees payable.

IN pursuance of the powers conferred by the Dog Act 1958, as amended and by every power thereunto enabling the Mayor, Councillors and Burgesses of the Town of Bairnsdale order as follows:—

1. All By-Laws of the Shire of Bairnsdale made under the provisions of the Dog Act are hereby repealed insofar as their application to the Town of Bairnsdale.

2. This By-Law shall apply to and have effect throughout the whole of the municipal district of the Town of Bairnsdale.

3. The following fees and sums are fixed pursuant to the Dog Act 1958, as amended.

- (a) For registration pursuant to Section 6 of the Dog Act 1958 as amended by any Act . . . . . \$1.00
- (b) For particulars of any dog or for the name of the registered owner thereof or for a certified copy of the receipt mentioned in Section 12 of the Dog Act 1958 as amended by any Act . . . . . \$0.25
- (c) Sum payable to the Registration Officer pursuant to Section 15 of the Dog Act 1958 as amended by any Act . . . . . \$2.00
- (d) Sum payable to the Registration Officer pursuant to Section 16 of the Dog Act 1958 as amended by any Act . . . . . \$5.00

Resolution for passing this By-Law agreed to by the Council of the Town of Bairnsdale on the 9th day of September, 1968, and confirmed on the 14th day of October, 1968.

The common seal of the Mayor, Councillors and Burgesses of the Town of Bairnsdale was hereto affixed in the presence of—

(SEAL) K. C. MASON, Mayor.  
R. BREWER, Councillor.  
T. N. MUNTZ, Town Clerk.

5170

SHIRE OF CRANBOURNE.

LOAN NO. 30.

Notice of Intention to Borrow the Sum of \$30,000 for Permanent Works and Undertakings.

NOTICE is hereby given that the Council of the Shire of Cranbourne proposes to borrow the principal sum of \$30,000 secured by a charge over the general rates of the municipality, such to be raised by the grant of a mortgage in accordance with the provisions of the Local Government Act 1958.

1. The maximum rate of interest that may be paid is 5.5625 per cent. per annum.

2. The purpose for which the loan is to be applied is—

Construction of a Pre-School Centre at Pearcedale—(part cost) . . . . .	9,500
Drainage Construction—Rossiter-road Koo-wee-rup (part cost) . . . . .	2,000
Construction of Kitchen Building Pearcedale Recreation Reserve . . . . .	2,000
Construction of Tennis Courts—Lang Lang . . . . .	2,500
Construction of Clarendon-street, Cranbourne (part cost) . . . . .	14,000
	\$30,000

3. The period of the loan shall be nine years.

4. The moneys borrowed shall be repayable by providing out of the municipal fund half-yearly instalments of approximately \$2,141 each including principal and interest on the first day of January and the first day of July during the currency of the loan. The first instalment shall be payable on the first day of July, 1969.

5. Such moneys shall be repayable to the Commissioners of the State Savings Bank of Victoria at the office of the said Commissioners, corner Elizabeth and Bourke-streets, Melbourne.

The plans and specifications, and the estimate of the cost of the proposed works, and a statement showing the proposed expenditure of the moneys to be borrowed, are open for inspection at the office of the Council of the Shire of Cranbourne at Cranbourne.

Dated this 23rd day of October, 1968.

5189 T. W. GRANT, Shire Secretary.

SHIRE OF DIMBOOLA.

LOAN NO. 31.

Notice of Intention to Borrow the Sum of \$30,000 for Permanent Works and Undertakings.

NOTICE is hereby given that the Council of the Shire of Dimboola intends to borrow the principal sum hereinafter mentioned on the credit of the municipal revenues of the President, Councillors and Ratepayers of the Shire of Dimboola by the grant of a mortgage in accordance with the provisions of the Local Government Acts, and Notice is hereby further given:—

(a) That the amount of the principal sum which it is proposed to borrow is \$30,000.

(b) The maximum rate of interest that may be paid is 5½ per centum per annum.

(c) The moneys borrowed and interest thereon are to be repayable by twenty half-yearly instalments each of approximately \$2,004.83 on the 1st day of January and the 1st day of July in each year, and the place at which such moneys are to be repayable is the State Savings Bank of Victoria, Melbourne. The first instalment shall be payable on the 1st day of July, 1969.

(d) The purposes for which the loan is to be applied are Purchase of Road Making Plant.

(e) The loan is to be liquidated by appropriation out of the municipal fund.

(f) The plans, specifications and estimate for the cost of such works, and the statement showing the proposed expenditure of the money to be borrowed, are open for inspection at the office of the Council, Jeparit, during office hours.

Dated the 18th October, 1968.

5193 R. T. LIVINGSTON, Shire Secretary.

SHIRE OF ELTHAM.

IN pursuance of the powers conferred on it by section 522 of the Local Government Act 1958, the Council of the Shire of Eltham hereby directs that the following pieces of land which have been taken, purchased or acquired by it shall be Public Highways from and after the date of publication of this order in the Government Gazette:—

- (1) All that piece of land described in Certificate of Title Volume 8622 Folio 460 lodged in the Office of Titles, known as (portion of) Silver-street, Eltham.
- (2) All those pieces of land described in Certificates of Title Volume 6865 Folio 830, Volume 6865 Folio 829, and Volume 6639 Folio 785 lodged in the Office of Titles, known as (portion of) Grove-street, Eltham.
- (3) All that piece of land being part of Lot 2 on Plan of Subdivision No. 61042 lodged in the Office of Titles, known as (portion of) Brisbane-street, as shown in the diagram herewith.

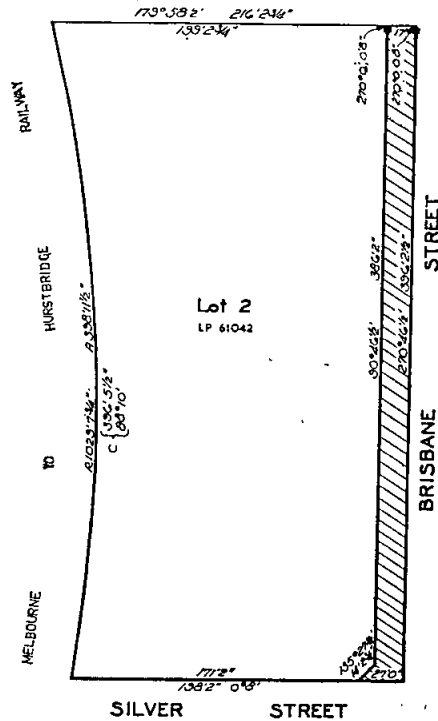

Land shown hatched to be acquired for road making purposes

The common seal of the President, Councillors and Ratepayers of the Shire of Eltham was hereto affixed this 21st day of October, 1968, in the presence of—

(SEAL) D. C. O'BEIRNE, Acting Shire President.  
J. A. LEWIS, Councillor.  
M. B. WATSON, Shire Secretary.

5180

## Twelfth Schedule.

## Town and Country Planning Act 1961.

## SHIRE OF KNOX PLANNING SCHEME 1965.

NOTICE THAT A PLANNING SCHEME HAS BEEN PREPARED AND IS AVAILABLE FOR INSPECTION.

Amendment Number 47, 1968.

NOTICE is hereby given that the Council of the Shire of Knox in pursuance of its powers under the Town and Country Planning Act 1961 has prepared a planning scheme for portions of the Shire of Knox for the purpose of amending the principal scheme by rezoning the following areas:—

- (a) All the land on the east side of Wedmore-road, Bayswater, to a depth of approximately 280 feet, north of Mountain Highway and the Dandenong Creek, plus any area north of Dorcas-street between Dorset-road and Wedmore-road through to the southern boundary of the Dandenong Creek.
- (b) All the land on the east side of Scoresby-road, Bayswater, between the railway line and Mountain Highway to a depth of approximately 350 feet.
- (c) Land on the west side of Dorset-road, Boronia, 2,640 feet south of Mountain Highway. The total frontage of the area is 500 feet and the depth 400 feet.
- (d) Land on the south side of Burwood Highway, Fern Tree Gully between Dobson-street and High-street. The major part of the area extends to a distance half-way between Hayward-road and Renwick-road.
- (e) Land on the south side of Burwood Highway, Fern Tree Gully, east of Lysterfield-road extending to a distance of 300 feet along the frontage and to a depth of 260 feet, and; An area west of Dorset-road, Bayswater, between Longstaff-road and the Dandenong Creek to a depth of 400 feet.

A copy of the scheme has been deposited at the Office of the Shire of Knox, Spring-street, Fern Tree Gully, and at the Office of the Town and Country Planning Board, 179 Queen-street, Melbourne, and will be open for inspection during office hours by any person free of charge.

Any persons affected by the Planning Scheme are required to set forth in writing all objections they may have, addressed to the Shire Secretary, Shire of Knox, Spring-street, Fern Tree Gully, on or before the 23rd day of January, 1969, and to state whether they wish to be heard in respect of their objections.

5173

N. G. HAYNES, Shire Secretary.

## SHIRE OF KNOX.

## LOAN No. 43.

## Special Order.

NOTICE is hereby given that the Council of the Shire of Knox, at a meeting held on the 16th day of October, 1968, did pass the following Special Order:—

"That the Council of the Shire of Knox, in pursuance of powers conferred by the Local Government Act 1958, proceed to borrow the sum of \$50,000 secured on the general rates of the municipality, such sum to be raised by the grant of a mortgage, in accordance with the said Act and under the following conditions:—

- (a) The amount of principal moneys it is proposed to borrow is \$50,000.
- (b) The maximum rate of interest that may be paid is 5½ per cent. per annum.
- (c) The period of the loan will be ten years and the time or times at which the moneys borrowed is to be repayable is on the 1st day of June and the 1st day of December in each year during the currency of the loan, commencing on the 1st day of June, 1969, until the final payment on 1st December, 1978.
- (d) The purpose for which the loan is to be applied is for permanent works and undertakings, viz.:—

## Private Streets Construction.

- (e) The loan is to be liquidated by half-yearly payments of approximately \$3,322, including principal and interest, payable out of the Private Streets Fund.

(f) The place of repayment will be—

E.S. & A. Bank Ltd., 206 Dorset-road, Boronia.

and further:

That the Resolution of the Council making the Special Order to borrow \$50,000, Loan No. 43, be brought forward as Extraordinary Business for confirmation at the meeting of the Council, to be held in the Council Chambers, Shire Offices, Fern Tree Gully, on the 20th day of November, 1968, at 7.30 p.m."

5171

N. G. HAYNES, Shire Secretary.

## SHIRE OF MANSFIELD.

NOTICE is hereby given that on 28th August, Senior Constable Lindsay Lyons No. 11645 was appointed Prosecuting Officer and Inspector of Nuisances for the Shire of Mansfield.

5159

R. WOMERSLEY, Shire Secretary.

## SHIRE OF MELTON.

## LOAN No. 34.

Notice of Intention to Borrow the Sum of \$43,000 for Permanent Works and Undertakings.

NOTICE is hereby given that the Council of the Shire of Melton proposes to borrow the principal sum of \$43,000 secured by a charge over the general rates of the municipality, such sum to be raised by the grant of a mortgage, in accordance with the provisions of the Local Government Act 1958, as amended.

1. The maximum rate of interest that may be paid is 5.75 per centum per annum.
2. The purpose for which the loan is to be applied is Part Construction of Township Drainage Scheme No. 7 (Kendale and Overs Estates).
3. The period of the loan shall be ten years.
4. The moneys borrowed shall be repayable by providing out of the municipal fund half-yearly instalments of approximately \$2,856 each including principal and interest on the 1st day of June and the 1st day of December during the currency of the loan. The first instalment shall be payable on the 1st day of June, 1969.
5. Such moneys shall be repayable to the Head Office of the National Bank Savings Bank Limited, Melbourne.

The plans and specifications and the estimate of the cost of the proposed works and a statement showing the proposed expenditure of the moneys to be borrowed are open for inspection at the office of the Council of the Shire of Melton, at Melton.

5161

D. J. R. DUNTON, Shire Secretary.

## SHIRE OF MORNINGTON.

## DECLARATION OF PUBLIC HIGHWAY.

NOTICE is hereby given that the Council of the Shire of Mornington passed the following resolution at its meeting on 15th October, 1968, viz.:—

"That pursuant to section 522 of the Local Government Act 1958 the Council of the Shire of Mornington hereby orders and directs that all those pieces of land being part of Crown allotments 9 and 11, section 22, Parish of Moorooduc, the boundaries of which are as follows and of which the president, councillors and ratepayers of the Shire of Mornington is the registered proprietor—

- (a) Commencing at a point distant 328 deg. 6½ min. 264 ft. and 62 deg. 1½ min. 132 ft. 3½ in. from the north-east corner of the intersection of Main-street and Barkly-street; thence by lines bearing respectively 328 deg. 6½ min. 124 ft. 2½ in., 284 deg. 10½ min. 13 ft. 2½ in., 61 deg. 19½ min. 40 ft. 2¼ in., 148 deg. 6½ min. 132 ft. 6 in., 240 deg. 3 min. 31 ft. 0¼ in. home to the commencing point.
- (b) Commencing at a point distant 74 deg. 53½ min. 167 ft. 9 in. from the southernmost corner of the intersection of Blake-street and Main-street; thence by lines bearing respectively 74 deg. 53½ min. 2 ft. 8½ in., 153 deg. 45 min. 174 ft. 4½ in., 148 deg. 6½ min. 225 ft. 3½ in., 240 deg. 45½ min. 31 ft. 0½ in., 328 deg. 6½ min. 183 ft. 9½ in., 333 deg. 39½ min. 81 ft. 11 in., 75 deg. 33 min. 23 ft. 9 in., 334 deg. 12½ min. 140 ft. 8½ in. home to the commencing point.



(c) Commencing at the easternmost corner of McLaren-place and Barkly-street; thence by lines bearing respectively 328 deg. 6½ min. 100 ft., 62 deg. 2 min. 4 ft. 3in., 148 deg. 6½ min. 42 ft. 9½ in., 151 deg. 43 min. 57 ft. 1½ in., 242 deg. 2 min. 0 ft. 9 in. home to the commencing point

shall be a public highway."

5187 D. G. COLLINGS, Shire Secretary.

Town and Country Planning Act 1961 (Twelfth Schedule).

SHIRE OF MORNINGTON.—SHIRE OF MORNINGTON PLANNING SCHEME 1959.

NOTICE THAT A PLANNING SCHEME HAS BEEN PREPARED AND IS AVAILABLE FOR INSPECTION.

Amendment No. 40, 1968.

NOTICE is hereby given that the Council of the Shire of Mornington, in pursuance of its powers under the Town and Country Planning Act 1961, has prepared a Planning Scheme for—

Land in the Residential Zone, being the land situate at the corner of Conway-street and Nepean Highway—ordinance amendment to include Art Gallery and Sale of Works of art as a permitted use.

All Road Reserves—ordinance amendment to provide for control of removal of trees, shrubs and other vegetation therefrom.

A copy of the scheme has been deposited at the Shire Office, Queen-street, Mornington, and at the office of the Town and Country Planning Board, 179 Queen-street, Melbourne, and will be open for inspection during office hours by any person, free of charge.

Any persons affected by the Planning Scheme are required to set forth in writing all objections they may have, addressed to the Shire Secretary, Shire of Mornington, Shire Office, Mornington, on or before 23rd November, 1968, and to state whether they wish to be heard in respect of their objections.

23rd October, 1968.

5206 D. G. COLLINGS, Shire Secretary.

SHIRE OF RODNEY.

LOAN No. 63.

Notice of Intention to Borrow the Sum of \$16,500 for Permanent Works and Undertakings.

NOTICE is hereby given that the Council of the Shire Rodney proposes to borrow the principal sum of Sixteen thousand five hundred dollars, secured by a charge over the general rates of the municipality, such sum to be raised by the grant of a mortgage in accordance with the provisions of the Local Government Act 1958.

1. The maximum rate of interest that may be paid is 5.75 per centum per annum.

2. The purpose for which the loan is to be applied is:—

Purchase of land for Drainage Reserve.

Description of Land.—All that Piece of Land having an area of 40 acres, 1 rood, 13 perches or thereabouts, being Lots 198, 204 and 205 on Plan of Subdivision 13302, lodged in the Office of Titles, and being the whole of the Land in Certificate of Title, volume 5874, folio 694.

3. The period of the loan shall be ten (10) years.

4. The moneys borrowed shall be repayable by providing out of the municipal fund half-yearly instalments of approximately \$1,096.29 each including principal and interest on the 1st day of January and the 1st day of July, during the currency of the loan. The first instalment shall be payable on the 1st day of July, 1969.

5. Such moneys shall be repayable to the Commissioners of the State Savings Bank of Victoria at the office of the said Commissioners, corner Elizabeth and Bourke streets, Melbourne.

The plans and specifications and the estimate of the cost of the proposed works and a statement showing the proposed expenditure of the moneys to be borrowed are open for inspection at the office of the Council of the Shire of Rodney at Tatura.

5158 R. PERRY, Shire Secretary.

SHIRE OF TAMBO.

NOTICE OF CHANGING ROAD NAMES.

NOTICE is hereby given that the Council of the Shire of Tambo has made an Order changing the names of certain roads in the Parish of Colquhoun as follows:—

Old Name; New Name; Location.

Merrangbaur-street; Merrangbaur-road; between Golf Links-road and the Princes Highway.

Merrangbaur-street; Lower Merrangbaur-road; between Eastern Beach-road and Golf Links-road.

5197 G. W. RIDSDALE, F.I.M.A., J.P., Shire Secretary.

SHIRE OF WHITTLESEA.

LOAN No. G.14.

Notice of Intention to Borrow the Sum of \$30,000, for Permanent Works and Undertakings.

NOTICE is hereby given that the Council of the Shire of Whittlesea proposes to borrow the principal sum of \$30,000 secured by a charge over the general rates of the municipality, such sum to be raised by the grant of a mortgage in accordance with the provisions of the Local Government Act, 1958.

1. The maximum rate of interest that may be paid is 5½ per cent. per annum.

2. The purposes for which the loan is to be applied are:—

(a) Main Drainage—

(i) Stage 6 Epping Township Drainage	\$6,000	
(ii) Plenty-road, South Morang, west side Gorge-road to the school	2,000	
(iii) Schotters-road, Mernda	9,500	
(iv) Childs-road, railway to open drain	1,700	
(v) Fir-street extension	2,000	
(vi) Beech-street extension	1,500	\$22,700

(b) Footpath Construction—Council Contribution—

(i) Whittlesea Township	2,000	
(ii) High-street, Thomastown, west side Spring-street to Settlement-road	1,300	
(iii) Plenty-road, east side south of Gorge-road	1,750	5,050

(c) Kerb and Channel—Council Contribution—

(i) Whittlesea Township	1,250	
(ii) Epping Township	1,000	2,250
		\$30,000

3. The period of the loan shall be fifteen years.

4. The moneys borrowed shall be repayable by providing out of the municipal fund half-yearly instalments of approximately \$1,518 each including principal and interest on the 1st day of June and the 1st day of December, during the currency of the loan. The first instalment shall be payable on the 1st day of June, 1969.

5. Such moneys shall be repayable to the Commissioners of the State Savings Bank of Victoria, at the office of the said Commissioners, corner Elizabeth and Bourke streets, Melbourne.

The plans and specifications and the estimate of the cost of the proposed works, and a statement showing the proposed expenditure of the moneys to be borrowed, are open for inspection at the office of the Council of the Shire of Whittlesea at High-street, Epping.

5165 R. G. C. COOK, Shire Secretary.

NOTICE OF DISSOLUTION OF PARTNERSHIP.

NOTICE is hereby given that the partnership heretofore subsisting between the undersigned Ernest Victor Attridge, and Victor Kevin Attridge, carrying on business as graziers at Harrierville, under the name of E. V. Attridge & Son has been dissolved by mutual consent, as from the 30th day of June, 1968. All debts due to and owing by the said late firm will be received and paid by the said Ernest Victor Attridge, who will continue to carry on the business at the same place.

Dated at Myrtleford this 14th day of October, 1968.

E. V. ATTRIDGE.  
V. K. ATTRIDGE.

5169

## NOTICE OF DISSOLUTION OF PARTNERSHIP.

NOTICE is hereby given that the partnership heretofore subsisting between the undersigned Giuseppe Mammone and Carmelo Lando, carrying on business as Retail Shoe Store, at 61 High-street, Shepparton, under the name of Giuseppe Mammone and Carmelo Lando, has been dissolved by mutual consent as from the 1st day of October, 1968. All debts due to and owing by the said late firm will be received and paid by Giuseppe Mammone who will continue to carry on the business at the same place.

Dated this 10th day of October, 1968.

Signed G. MAMMONE.  
Signed C. LANDO.  
Witness A. SOFRA.

5157

TAKE notice that the partnership existing between Ian James Dudley and John Kearns carrying on business under the name of Defiant International was dissolved by agreement between the above-named partners on the 26th day of January, 1967, and as from that date the said business is being carried on under the name of Defiant International by the said John Kearns alone.

MACKENZIE & ROSS, solicitors and agents for Ian James Dudley and John Kearns. 5164

The Companies Act 1961.—In the matter of EDEN INDUSTRIES (VICTORIA) PTY. LTD.—Notice Re Meeting of Creditors, Pursuant to Section 260.

NOTICE is hereby given that a meeting of creditors of the above-named company will be held at Victorian Employers' Federation Meeting Rooms, Room 314, 3rd Floor, East Tower, Princes Gate, 151 Flinders-street, Melbourne, on Thursday, 31st October, 1968, at 11 a.m., the company having convened a meeting of its members for the same day for the purpose of considering a Resolution that the company be wound up voluntarily.

Dated this 11th day of October, 1968.

J. PRICE, Director.

Bent & Cogle, public accountants, Suite 18, 545 St. Kilda-road, Melbourne, 3004. 5162

In the Supreme Court 1968—C.O. 7604.—In the matter of the Companies Act 1961, and in the matter of L. E. HICKEY & COMPANY PROPRIETARY LIMITED.

NOTICE is hereby given that a petition for the winding-up of the above-named company by the Supreme Court was, on the 15th day of October, 1968, presented by Jack Dawson Proprietary Limited, and that the said petition is directed to be heard before the Court sitting in the Fourteenth Court, Law Courts, William-street, Melbourne, at the hour of 10.30 o'clock in the forenoon on the 14th day of November, 1968, and any creditor or contributory of L. E. Hickey & Company Proprietary Limited, desiring to support or oppose the making of an Order on the said petition may appear at the time of the hearing by himself or his counsel, for that purpose, and a copy of the petition will be furnished to any creditor or contributory of the said L. E. Hickey & Company Proprietary Limited, requiring the same by the undersigned on payment of the regulated charge for the same.

The petitioner's address is 825 Glenferrie-road, Hawthorn.

The petitioner's solicitors are Messrs. Evans, Masters & Gilbert, of 34 Queen-street, Melbourne.

EVANS, MASTERS & GILBERT.

NOTE.—Any person who intends to appear on the hearing of the said petition must serve on or send by post to the above-named Messrs. Evans, Masters & Gilbert notice in writing of his intention so to do. This notice must state the name and address of the person, or, if a firm, the name and address of the firm, and must be signed by the person or firm or his or their solicitor (if any) and must be served, or, if posted, must be sent by post in sufficient time to reach the above named not later than 4 o'clock in the afternoon of the 13th day of November, 1968. 5178

In the Supreme Court 1968.—C.O.7605.—In the matter of the Companies Act 1961, and in the matter of R. S. CAYZER (CONTRACTING) PROPRIETARY LIMITED.

NOTICE is hereby given that a petition for the winding-up of the above-named company by the Supreme Court was, on the 16th day of October, 1968, presented by Steel Protection & Painting Co. Pty. Ltd., and that the said petition is directed to be heard before the Court sitting in the Fourteenth Court, Law Courts, William-street, Melbourne, at the hour of 10.30 o'clock in the forenoon on the 14th day of November, 1968, and any creditor or contributory of R. S. Cayzer (Contracting) Proprietary

Limited, desiring to support or oppose the making of an Order on the said petition may appear at the time of the hearing by himself or his counsel, for that purpose, and a copy of the petition will be furnished to any creditor or contributory of the said R. S. Cayzer (Contracting) Proprietary Limited requiring the same by the undersigned on payment of the regulated charge for the same.

The petitioner's address is 61 Little Malop-street, Geelong.

The petitioner's solicitors are Messrs. Evans, Masters & Gilbert, of 34 Queen-street, Melbourne.

EVANS, MASTERS & GILBERT.

NOTE.—Any person who intends to appear on the hearing of the said petition must serve on or send by post to the above-named Messrs. Evans, Masters & Gilbert notice in writing of his intention so to do. This notice must state the name and address of the person, or, if a firm, the name and address of the firm, and must be signed by the person or firm or his or their solicitor (if any) and must be served, or, if posted, must be sent by post in sufficient time to reach the above named not later than 4 o'clock in the afternoon of the 13th day of November, 1968. 5179

Companies Act, 1961, Section 272 (2).

AUSTRALIAN CO-OPERATIVE MOTORISTS ASSOCIATED LTD. (IN LIQUIDATION).

NOTICE OF FINAL MEETING OF MEMBERS.

NOTICE is hereby given that the above meeting will be held at 50 Lydiard-street south, Ballarat, on Monday, 18th November, 1968, at 10 a.m.

The object of this meeting is to submit the liquidator's final accounts showing how the winding up has been conducted and the property of the company has been disposed and to give any explanation thereof.

14th October, 1968.

5195

C. R. PROWSE, Liquidator.

OAKLEIGH (No. 3) CO-OPERATIVE HOUSING SOCIETY LIMITED (IN LIQUIDATION).

SPECIAL RESOLUTION.

Passed 18th October, 1968.

AT a Special General Meeting of the above-named society duly convened and held at the Registered Office, 63 Atherton-road, Oakleigh, at 7.30 p.m. on Friday, 18th October, 1968, the subjoined Special Resolution was duly passed:—

That the society, having successfully completed its objectives five months ahead of the notional period, be wound up voluntarily and that Ernest Alfred Best Graham, of 63 Atherton-road, Oakleigh, be appointed liquidator for the purposes of the winding-up.

5207

E. A. B. GRAHAM, Liquidator.

Form 7.

Companies Act 1961, Section 254 (2) (b).

STEWART & McMAHON TYRE AND ENGINEERING SERVICE PROPRIETARY LIMITED.

NOTICE OF RESOLUTION.

AT a General Meeting of the members of Stewart & McMahon Tyre and Engineering Service Pty. Ltd. duly convened and held at 36 Berry-street, East Melbourne, on the 1st day of October, 1968, the Special Resolution set out below was duly passed.

It was resolved that the company be wound up voluntarily and that Charles Gary Condon, chartered accountant, of 36 Berry-street, East Melbourne, be hereby appointed liquidator of the company.

Dated this 7th day of October, 1968.

5220

C. G. CONDON, Liquidator.

The Companies Act 1961.—In the matter of FIORELLO PTY. LIMITED (IN LIQUIDATION).

NOTICE is hereby given that a Second and Final Dividend is intended to be declared in this matter. Creditors who have not proved their debts by the 12th day of November, 1968, will be excluded from the Dividend.

Dated this 18th day of October, 1968.

A. M. HORSBURGH, Liquidator.

Kennedy, Smail & Middlemiss, 296-304 Little Lonsdale-street, Melbourne, Victoria, 3000. 5222

The Companies Act 1961.—In the matter of GLENFORD SALES & SERVICE PTY. LTD. (RECEIVER AND MANAGER APPOINTED).—Notice of Meeting of Creditors, Pursuant to Section 260.

NOTICE is hereby given that a meeting of creditors of the above-named company will be held at the office of Kennedy, Smail & Middlemiss, 296 Little Lonsdale-street, Melbourne, at 3 p.m., on the 28th day of October, 1968, the company having convened a meeting of its members for the same day for the purpose of considering a Resolution that the company be wound up voluntarily.

Dated this 16th day of October, 1968.

F. G. CLEARY, Director.

Kennedy, Smail & Middlemiss, 296 Little Lonsdale-street, Melbourne, 3000. 5221

The Companies Act 1961.—SPACE CONFECTIONERY PROPRIETARY LIMITED (in Liquidation).—Notice Convening Final Meeting of Members and Creditors, pursuant to Section 272.

NOTICE is hereby given, pursuant to section 272 of the Companies Act 1961, that a General Meeting of the members and creditors of the above-named company will be held in the offices of Kennedy, Smail & Middlemiss, 296-304 Little Lonsdale-street, Melbourne, on Wednesday, the 20th day of November, 1968, at 10.30 a.m., for the purpose of having an account laid before them showing the manner in which the winding up has been conducted and the property of the company disposed of and of hearing any explanations that may be given by the liquidator.

Dated this 18th day of October, 1968.

A. M. HORSBURGH, Liquidator.

Kennedy, Smail & Middlemiss, 296-304 Little Lonsdale-street, Melbourne, 3000. 5223

The Companies Act 1961.—EGAN TRANSPORT PROPRIETARY LIMITED (in Liquidation).—Notice convening Final Meeting of Members and Creditors, Pursuant to Section 272.

NOTICE is hereby given, pursuant to section 272 of the Companies Act 1961, that a General Meeting of the members and creditors of the above-named company will be held in the offices of Kennedy, Smail & Middlemiss, 296-304 Little Lonsdale-street, Melbourne, on Wednesday, the 20th day of November, 1968, at 11 a.m., for the purpose of having an account laid before them showing the manner in which the winding up has been conducted and the property of the company disposed of and of hearing any explanations that may be given by the liquidator.

Dated this 18th day of October, 1968.

A. M. HORSBURGH, Liquidator.

Kennedy, Smail & Middlemiss, 296-304 Little Lonsdale-street, Melbourne, 3000. 5224

#### PATRICKS DAY PROPRIETARY LIMITED.

AT a Special Meeting held at 68 Greenhill-road, Wayville, South Australia, on 14th October, 1968, it was resolved that the company be wound up voluntarily, and that I. E. Lohrey, of 164 Koroit-street, Warrnambool, be appointed liquidator at a fee to be arranged.

R. K. BAKER, Director, 19 Bellevue-drive, Beaumont, S.A. 5176

Companies Act 1961, Section 272.

ATMAN PTY. LTD. (IN LIQUIDATION).

NOTICE OF FINAL MEETING.

THE Final Meeting of the company and its creditors will be held at the office of Tempny & Penfold, chartered accountants, 441 Bay-street, Brighton, on 26th November, 1968, at 10 a.m., for the purpose of receiving the liquidator's account and report.

5237

C. A. J. TEMPANY, F.C.A., Liquidator.

In the Supreme Court of Victoria—1968, C.O.7607.—In the matter of the Companies Act 1961 and in the matter of ROCO INDUSTRIES PROPRIETARY LIMITED.

NOTICE is hereby given that a petition for the winding up of the above-named company by the Supreme Court was, on the 17th day of October, 1968, presented by Leo Thomas Fitzgerald, Deputy Commissioner of Taxation of the Commonwealth of Australia: And that the said petition is directed to be heard before the Court sitting at the Fourteenth Court, Law Courts, William-street, Melbourne, at the hour of 10.30 o'clock in the forenoon on the 8th day of November, 1968, and any creditor or contributory of the said company desiring to support or oppose the making of an order on the said petition may

appear at the time of hearing by himself or his Counsel for that purpose; and a copy of the said petition will be furnished to any creditor or contributory of the said company requiring the same by the undersigned on payment of the regulated charge for the same.

The petitioner's official address is 152 Elizabeth-street, Melbourne.

The petitioner's solicitor is Harold Edward Renfree, Crown Solicitor for the Commonwealth, of 99 Queen-street, Melbourne.

H. E. RENFREE.

NOTE.—Any person who intends to appear on the hearing of the said petition must serve on or send by post to the above-named H. E. Renfree notice in writing of his intention so to do. The notice must state the name and address of the person, or, if a firm, the name and address of the firm, and must be signed by the person or firm, or his or their solicitor (if any), and must be served or, if posted, must be sent by post in sufficient time to reach the above named not later than Four o'clock in the afternoon of the 7th day of November, 1968. 5238

Companies Act 1961.

COMPANIES REGULATIONS, SECTION 262, REGULATIONS 28 (2) (b) AND 46 (2).

WAVERTON EXCAVATIONS (VIC.) PROPRIETARY LIMITED.

Notice of Meeting of Creditors.

NOTICE is hereby given that a meeting of the creditors of Waverton Excavations (Vic.) Proprietary Limited will be held at The Victorian Employers Federation, Princes Gate Building, Eastern Tower, 191 Flinders-street, Melbourne, on the 1st day of August, 1968, at 9.30 in the forenoon.

AGENDA.

1. To consider a report from the directors of the company on the financial position of the company, and to receive notice that the shareholders have passed a Resolution for the voluntary winding up of the company and the appointment of a liquidator.

2. Pursuant to section 261 of the Companies Act, to consider whether to confirm the appointment of the liquidator appointed by the company or, alternatively, appoint a person to be liquidator for the purpose of winding up the affairs and distributing the assets of the company.

3. To advise the remuneration of the liquidator appointed.

4. To consider the appointment of a committee of inspection, pursuant to the provisions of section 262 of the Companies Act.

Dated this 21st day of October, 1968.

On behalf of the Board,

5240

NORMAN J. BOWERS.

MADGE BARKLEY, late of 8 Oakwood-avenue, Brighton, married woman, DECEASED.

CREDITORS, next of kin and others having claims in respect of the estate of the deceased (who died on the 15th July, 1968), are required by the applicant for grant of probate of the will of the deceased, Alan Sherwin Barkley, of 8 Oakwood-avenue, Brighton, bank manager, to send particulars to him, care of the undersigned solicitors, by the 2nd January, 1969, after which date he may convey or distribute the assets, having regard only to the claims of which he then has notice.

Dated 18th October, 1968.

LEWIS ORR & GIBSON, 825 Burke-road, Camberwell.

5214

CREDITORS, next of kin and others having claims in respect of the estate of Ida Jean Weidemann, late of Flat 6, 260 Williams-road, Toorak, widow, deceased (who died on the 13th day of May, 1968), are requested to send particulars of their claims to The Trustees Executors and Agency Company of Australasia Limited, of 401 Collins-street, Melbourne, the duly appointed syndic of the executor, The West Australian Trustee, Executor and Agency Company Limited, of 135 St. Georges-terrace, Perth, Western Australia, by the 28th day of December, 1968, after which date the company will distribute the assets, having regard only to the claims of which it then has notice.

MAHONY, O'BRIEN & DUGGAN, solicitors, 37 Queen-street, Melbourne. 5215

**CREDITORS**, next of kin and others having claims in respect of the estate of Cecil William Alexander Petty, late of The Railway Hotel, Nicholson-street, Footscray, in the State of Victoria, clerk, deceased (who died on the 14th day of May, 1968), are requested by the executor Valentine Clifford Petty, of 22 Alexandra-street, Greensborough, in the State of Victoria, manufacturer's representative, to send particulars of their claims to him, care of the undersigned solicitors, by the 26th day of December, 1968, after which date he will distribute the estate, having regard only to the claims of which he then has notice.

FREDERICK OWEN & ASSOCIATES, solicitors, 84 William-street, Melbourne. 5217

**CREDITORS**, next of kin and others having claims in respect of the estate of Alice Mildred Owen, formerly of Flat 2, 2 Tivoli-place, South Yarra, but late of Ernest Poolman House, 255 Domain-road, South Yarra, spinster, deceased (who died on the 14th day of July, 1968), are to send particulars of their claims to The Union-Fidelity Trustee Company of Australia Limited, of 100 Exhibition-street, Melbourne, by the 31st day of December, 1968, after which date it will distribute the assets, having regard only to the claims of which it then has notice.

Dated the 17th day of October, 1968.

MADDEN BUTLER ELDER & GRAHAM, solicitors, 31 Queen-street, Melbourne. 5218

**CREDITORS**, next of kin and others having claims in respect of the estate of Annie May Cummings, late of 57 Westbury-street, East St. Kilda, spinster, deceased (who died on the 30th day of July, 1968), are to send particulars of their claims to the executors, Charlotte Lillian Muriel Drake and William Charles Anderson, care of the under-mentioned solicitors, on or before the 24th day of December, 1968, after which date the executors will distribute the assets, having regard only to the claims of which they then have notice.

MARTIN & MARTIN, solicitors, 37 Queen-street, Melbourne. 5219

**CREDITORS**, next of kin and others having claims in respect of the estate of Bertram McLeod, deceased, intestate, late of 2 Herald-street, Cheltenham, wire basket maker (who died on the 24th June, 1968), are to send particulars of their claims to Harry McLeod, care of the under-mentioned solicitor, by the 26th December, 1968, after which he will distribute the assets, having regard only to the claims of which he then has notice.

IVAN L. McDONALD, solicitor, 114 Balcombe-road, Mentone. 5225

SELENA MARY HOUGH (in the will called and also known as Selina Mary Hough, and also known as Lena Mary Hough) late of 10 Kembla-street, Hawthorn, widow, DECEASED.

**CREDITORS**, next of kin and others having claims in respect of the estate of the deceased (who died on 3rd September, 1968), are required by the trustee Roy Clive Hopetoun Beattie, of 61 Union-street, Armadale, solicitor, to send particulars to him by 18th December, 1968, after which date he may convey or distribute the assets, having regard only to the claims of which he then has notice.

R. C. H. BEATTIE, solicitor, 509 Collins-street, Melbourne. 5226

**CREDITORS**, next of kin and others having claims in respect of the estate of Jack Tinkler, deceased, intestate, late of Reddens-road, Balliang, poultry farmer (who died on the 11th day of March, 1968), are to send particulars of their claims to Hazel Beatrice Tinkler, care of the under-mentioned solicitor, by 26th December, 1968, after which she will distribute the assets, having regard only to the claims of which she then has notice.

IVAN L. McDONALD, solicitor, 114 Balcombe-road, Mentone. 5227

**CREDITORS**, next of kin and others having claims in respect of the estate of Lillian Coultham, formerly of "Kent", 23 Jacobs-street, Belmont, but late of Kardinia House, Bellarine-street, Geelong, widow, deceased (who died on the 25th day of July, 1968), are to send particulars of their claims to The Union-Fidelity Trustee Company of Australia Limited, at 100 Exhibition-street, Melbourne, by the 9th day of January, 1969, after which date it will distribute the assets, having regard only to the claims of which it then has notice.

LEACH & THOMSON, solicitors, 472 Bourke-street, Melbourne. 5228

CHARLES ARTHUR CLARKE, late of Malcolm-street; Mansfield, forest commission employee, DECEASED.

**CREDITORS**, next of kin and others having claims in respect of the deceased (who died on the 17th day of June, 1968), are required by his trustee, William Henderson Glen, of Mansfield, solicitor, to send particulars to him care of the under-mentioned firm of solicitors, by the 27th day of December, 1968, after which date the trustee may convey and distribute the assets, having regard only to the claims to which he then has notice.

MAL. RYAN & GLEN, High-street, Mansfield, solicitors for the trustee. 5190

PERCIVAL WILLIAM CURNOW, late of Swan Hill, in the State of Victoria, refrigeration engineer, DECEASED.

**CREDITORS**, next of kin and other persons having claims against the estate of the said deceased (who died on the 15th day of April, 1968), are required to send particulars of same to the executors, William David Hughes and Athol Andrew Stephen, in care of the undersigned on or before the 23rd day of December, 1968, after which date they will distribute the assets, having regard only to the claims of which they then have notice.

DELANEY & DWYER, barristers and solicitors, 201 Campbell-street, Swan Hill. 5209

**CREDITORS**, next of kin and other persons having claims against the estate of David Stanley Mills, late of 12 Earl-street, North Carlton, in the State of Victoria, gentleman, deceased (who died on the 24th day of July, 1968), are required to send particulars of their claims to the executor, National Trustees, Executors and Agency Company of Australasia Limited, whose registered office is situated at 95 Queen-street, Melbourne, by the 30th December, 1968, after which date the executor will distribute the assets, having regard only for the claims of which it then has had notice.

JAMES P. OGGE & CO., solicitors, of 165 Greville-street, Prahran. 5212

JOHN EDWARD RYAN, late of 20 New-street, Mansfield, timber worker, DECEASED.

**CREDITORS**, next of kin and others having claims in respect of the deceased (who died on the 2nd day of August, 1968), are required by his trustees, Kathleen Ryan, of 20 New-street, Mansfield, widow and Michael Thomas Ryan, of 10 Bangerang-avenue, Sunshine, textile worker, to send particulars to them care of the under-mentioned firm of solicitors by the 2nd day of January, 1969, after which date the trustees may convey and distribute the assets, having regard only to the claims to which they then have notice.

MAL. RYAN & GLEN, High-street, Mansfield, solicitors for the trustees. 5230

HAZEL EDITH MILLER, formerly of 140 Shaftesbury-parade, Thornbury, but late of Unit 21, "Strathdon", Jolimont-road, Forest Hill, in the State of Victoria, widow, DECEASED.

**CREDITORS**, next of kin and others having claims in respect of the estate of the deceased (who died on the 9th day of February, 1968), are required to send particulars of their claims to The Equity Trustees, Executors and Agency Company Limited, of 472 Bourke-street, Melbourne, before the 1st day of January, 1969, after which date it will distribute the assets, having regard only to the claims of which it then has notice.

F. P. & M. J. WALSH, solicitors, 452 High-street, Northcote. 5235

HERBERT PROVVIS WILTON, late of 38 The Avenue, Windsor, retired leather merchant, DECEASED.

**CREDITORS**, next of kin and others having claims in respect of the estate of the above-named deceased, (who died on the 21st May, 1968), are required by the executors Geoffrey Ronald Wilton, of "Coolawarra", Cobram, grazier, and Marjorie Ellen Wilton, of 38 The Avenue, Windsor, spinster, to send particulars to them, in care of their under-mentioned solicitors, by 30th December, 1968, after which date the executors may convey or distribute the assets, having regard only to the claims of which they then have notice.

W. H. FLOOD & PERMEZEL, 388 Bourke-street, Melbourne, solicitors for the executors. 5216

JAMES STIRLING HUME COX, late of 78 Moubray-street, Albert Park, in the State of Victoria, gentleman, DECEASED.

CREDITORS, next of kin and others having claims in respect of the estate of the said deceased (who died on the 1st day of July, 1968), are to send particulars of their claims to National Trustees Executors and Agency Company of Australasia Limited, of 95 Queen-street, Melbourne, in the said State, by the 1st day of January, 1969, after which date the said company will distribute the assets in the said estate, having regard only to the claims of which it then has notice.

PAVEY WILSON COHEN & CARTER, solicitors, 390 Lonsdale-street, Melbourne. 5211

JEAN KATHLEEN ASTON, late of 7 Royal-crescent, Camberwell, spinster, DECEASED.

CREDITORS, next of kin and others having claims in respect of the estate of the deceased (who died on the 9th August, 1968, are required by the applicant for grant of probate of the will of the deceased, Beryl Rita Aston, of 7 Royal-crescent, Camberwell, spinster), to send particulars to her, care of the undersigned solicitors, by the 2nd January, 1969, after which date she may convey or distribute the assets, having regard only to the claims of which she then has notice.

Dated 18th October, 1968.

LEWIS ORR & GIBSON, 825 Burke-road, Camberwell. 5213

CREDITORS, next of kin and others having claims in respect of the estate of Roy Allan Watts, late of 628 Bridge-road, Richmond, retired cartage contractor, deceased (who died on the 15th day of June, 1968), are to send particulars of their claims to The Equity Trustees, Executors and Agency Company Limited, at 472 Bourke-street, Melbourne, by the 9th day of January, 1969, after which date it will distribute the assets, having regard only to the claims of which it then has notice.

LEACH & THOMSON, solicitors, 472 Bourke-street, Melbourne. 5229

JANE EMILY GREGORY, late of Princess-street, Kew, widow, DECEASED.

CREDITORS, next of kin and others having claims against the estate of the aforementioned deceased are required by the executor thereof, National Trustees, Executors and Agency Company of Australasia Limited, of 46 Queen-street, Bendigo, to forward particulars thereof to it, on or before the 30th day of December, 1968, after which date it will distribute the assets of the estate, having regard only to the claims of which it then has notice.

Dated the 23rd day of October, 1968.

HYETT & HYETT, solicitors, 51 Bull-street, Bendigo. 5163

JOHN ROBERT NASH, late of Lara-road, Corio, farmer, DECEASED.

CREDITORS, next of kin and others having claims in respect of the estate of the deceased (who died on the 7th December, 1964), are required by the surviving personal representative, Francis Gerald Gargan, of National Bank Buildings, 51 Malop-street, Geelong, solicitor, to send particulars to him by the 31st day of December, 1968, after which date he may convey or distribute the assets, having regard only to the claims of which he then has notice.

Dated the 15th day of October, 1968.

F. G. GARGAN, solicitor, National Bank Buildings, 51 Malop-street, Geelong. 5160

CREDITORS, and others having claims in respect of the estate of Donald Robert McDonald, late of Lake Bolac, retired farmer, deceased (who died on the 20th April, 1968), are required by The Union-Fidelity Trustee Company of Australia Limited, of 101 Lydiard-street north, Ballarat, Mavis Gwendoline Hamilton, of Lake Bolac, married woman and Flora Jean Porter, of Streatham, married woman, the executors of the will of the said deceased, to send particulars, in writing, of their claims to the said company at its above address on or before the 24th day of December, 1968, after which date they will distribute the assets, having regard only to the claims of which they then have notice.

BRUCE R. TIVEY, solicitor, Ararat. 5182

ADA MARY ARABELLA KIPPING, late of Merton, widow, DECEASED.

CREDITORS, next of kin and others having claims in respect of the deceased (who died on the 10th day of August, 1968), are required by her trustee David Henry Kipping, of Merton, grazier, to send particulars to him care of the under-mentioned firm of solicitors, by the 3rd day of January, 1969, after which date the trustee may convey and distribute the assets, having regard only to the claims of which he then has notice.

MAL. RYAN & GLEN, High-street, Mansfield, solicitors for the trustee. 5155

DORA OSLER, late of 59 Austin-street, Newtown, Geelong, spinster, DECEASED.

CREDITORS, next of kin and others having claims in respect of the estate of the said deceased (who died on the 24th August, 1968), are required by the applicant for grant of probate of the will of Richard Lloyd Kefford, of 9 Dudley-avenue, Newtown, Geelong, accountant, to send particulars to him care of the undersigned solicitors, by the 1st January, 1969, after which date the said applicant may convey or distribute the assets, having regard only to the claims of which he then has notice.

WIGHTON & McDONALD, solicitors, 89 Myers-street, Geelong. 5175

ERNEST WEITNAUER, late of Batesford, retired orchardist, DECEASED.

CREDITORS, next of kin and others having claims in respect of the estate of the deceased (who died on the 4th day of July, 1968), are required by the personal representatives, The Union-Fidelity Trustee Company of Australia Limited, of 200 Exhibition-street, Melbourne and Allan Lindsay Morrison, of 21 Logan-street, Geelong West, director, to send particulars to the Geelong Branch of the said company, 8 Malop-street, Geelong, by the 31st day of December, 1968, after which date the personal representatives may convey or distribute the assets, having regard only to the claims of which they then have notice.

WHYTE, JUST & MOORE, solicitors, 27 Malop-street, Geelong. 5186

CREDITORS, next of kin and others having claims in respect of the estate of Herbert Henry Silk (also known as Harry Silk), late of 15 Cambridge-street, Collingwood, in the State of Victoria, cleaner, deceased, intestate (who died on the 13th day of December, 1960), are hereby required to send particulars of their claims to the Equity Trustees, Executors and Agency Company Limited, of 472 Bourke-street, Melbourne, the administrator of his estate, by the 31st day of December, 1968, after which date it will distribute the assets, having regard only to the claims of which it then has had notice.

L'ESTRANGE & KENNEDY, solicitors, of 291 Bridge-road, Richmond. 5199

JOHN WILLIAM ANDREWS, late of 18 Bernborough-avenue, Balwyn, manager, DECEASED (who died on the 17th day of April, 1968).

CREDITORS, next of kin and all other persons having claims against the estate of the deceased, are required by the administratrix of his estate, Hilda Elizabeth Andrews, of 18 Bernborough-avenue, Balwyn, widow, to send particulars thereof to her, care of the under-mentioned solicitors before the 23rd day of December, 1968, after which date she may distribute the assets of the deceased, having regard only to the claims of which she then has notice.

COLTMAN, WYATT & ANDERSON, solicitors, of 578 Bourke-street, Melbourne. 5208

THE TRUSTEES, EXECUTORS AND AGENCY COMPANY LIMITED, of 401 Collins-street, Melbourne, the executor of the will of Edith Muriel Johnson, late of 7 Jennings-street, Sandringham, spinster, deceased (who died on the 17th day of August, 1968), requires all creditors, next of kin and others having claims against the property or estate of the said deceased, to send to it the said executor at the address afore-mentioned on or before the 26th day of December, 1968, particulars, in writing, of such claims, after which date the said executor intends to convey or distribute such property or estate to or among the persons entitled thereto, having regard only to the claims of which it shall have had notice.

DARVALL & HAMBLETON, solicitors, 7th Floor, T. & G. Building, 147 Collins-street, Melbourne. 5239

**CREDITORS**, next of kin and others having claims in respect of the estate of Percy Alexander Gartside, late of 376 Mountain Highway, Bayswater, retired, deceased, intestate (who died on the 9th July, 1968), are required to send particulars of such claims to the administrator, James Gartside, care of the under-mentioned solicitors, before the 25th December, 1968, after which date he will distribute the assets, having regard only to the claims of which he then has notice.

DOYLE & KERR, solicitors, 108 Queen-street, Melbourne. 5210

JAMES CLIFFORD MURPHY, late of Kooloonong, in the State of Victoria, farmer, deceased (who died on the 27th day of June, 1968).

**CREDITORS**, next of kin and all other persons having claims against the estate of the deceased, are required by the executors of the will, John Andrew Murphy and George Murphy, to send particulars to them, care of the undersigned on or before the 14th day of January, 1969, after which date they will distribute the assets, having regard only to the claims of which they then have notice.

GARDEN & GREEN, solicitors, 4 McCallum-street, Swan Hill. 5156

**CREDITORS**, next of kin and others having claims against the estate of Ethel May Czynski, late of 406 Drummond-street south, Ballarat, in the State of Victoria, married woman, deceased (who died on the 28th day of June, 1968), are required to send particulars of their claim to The Union-Fidelity Trustee Company of Australia Limited, of 101 Lydiard-street north, Ballarat, in the said State, the executor of the will of the said deceased by the 19th day of December, 1968, after which date the said executor will distribute the assets, having regard only to the claims of which it then has notice.

BYRNE, JONES & TORNEY, solicitors, Ballarat. 5194

**PURSUANT** to the *Trustee Act 1958*, notice is hereby given that all persons having claims against the estate of Vincent Aloisius Moloney, late of 1246 Dandenong-road, Murrumbena, in the State of Victoria, transport driver, deceased (who died on the 17th day of October, 1967, and probate of whose will was granted by the Supreme Court of the said State in its probate jurisdiction on the 19th day of August, 1968, to Leila Mary Moloney, of 1246 Dandenong-road, Murrumbena, in the said State, widow), are hereby required to send particulars, in writing, of such claims to the undersigned at his office hereunder mentioned, on or before the 18th day of December, 1968, after which date the said Leila Mary Moloney, will proceed to distribute the assets of the said Vincent Aloisius Moloney, deceased, which shall have come to her hands amongst the persons entitled thereto, having regard only to the claims of which she shall have had notice. And notice is hereby further given that the said Leila Mary Moloney will not be liable for the assets so distributed or any part thereof to any person of whose claim he shall not have had notice as aforesaid.

Dated this 18th day of October, 1968.

MCGREGOR, SPARKS & CO., Professional Suite 72, 1341 Dandenong-road, Chadstone Centre, solicitors for the said Leila Mary Moloney. 5204

**CREDITORS**, next of kin and others having claims against the estate of Kevin Aloisius O'Toole, late of Yarragon, farmer, deceased (who died on the 13th day of June, 1968), are requested to send particulars of their claims to William Thomas O'Toole and Kevin Gerard O'Toole, both of Yarragon, farmers, the executors appointed by the deceased's will, in care of the undersigned, by the 31st day of December, 1968, after which date they will distribute the assets, having regard only to the claims of which they then shall have had notice.

M. DAVINE & CO., solicitors, Warragul. 5177

**CREDITORS**, next of kin and others having claims in respect of the estate of Thomas Williams Lloyd, late of Flat 2, 41 Adams-street, South Yarra, invalid pensioner, deceased (who died on the 10th day of April, 1968), are requested to send particulars of their claims to the executor, Keith Ronald Ross, care of the under-mentioned solicitors, by the 28th day of December, 1968, after which date he will distribute the assets, having regard only to the claims of which he then has notice.

MAHONY, O'BRIEN & DUGGAN, solicitors, 37 Queen-street, Melbourne. 5236

**IMPOUNDINGS**

**ALEXANDRA**.—Impounded in Alexandra Pound.

- 1 red heifer, no visible brand
- 1 Shorthorn heifer, no visible brand

If not claimed and expenses paid, to be sold on 1st November, 1968.

G. MAUDOUIT,  
Poundkeeper.  
5241—\$1.75

**KERANG**.—Impounded in Kerang Pound, on the 18th October, 1968.

- 1 saddle back store pig, no visible brand

If not claimed and expenses paid, to be sold on 7th November, 1968.

F. HASTIE,  
Poundkeeper.  
5205—\$1.75

**PAKENHAM**.—Impounded in Pakenham Pound, from Princes Highway, Doveton.

- 2 bay geldings, 15 hands, no visible brand

If not claimed and expenses paid, to be sold on 1st November, 1968.

Impounded from Heather-ton-road, Doveton.  
1 Black Poll crossbred bull, no visible brand  
If not claimed and expenses paid, to be sold on 4th November, 1968.  
H. SMITH,  
Poundkeeper.  
5191—\$2.75

**TERANG**.—Impounded in Terang Pound, from Ecklin-Terang road, at Dixie.

- 1 Dorset Horn ram, no visible brand

If not claimed and expenses paid, to be sold on 11th November, 1968.

D. M. KIDD,  
Poundkeeper.  
5174—\$1.75

*Subordinate Legislation Act 1962.*

**NOTICE OF MAKING OF STATUTORY RULES.**

**IN** pursuance of the provisions of the *Subordinate Legislation Act 1962* and the Regulations made thereunder, notice is given of the making of the following statutory rules:—

No.	Goods Act 1958.	Price.
256/1968.	Goods (Trade Descriptions) (Amendment No. 2) Regulations 1968	10c
<i>Police Regulation Act 1958.</i>		
257/1968.	Police (Authorized Strength No. 3) Regulations 1968	10c
<i>Melbourne Harbor Trust Act 1958.</i>		
258/1968.	Melbourne Harbor Trust Superannuation Regulations 1957 (Amendment No. 3/68)	10c

Copies of these statutory rules may be purchased at the Sale of Publications Section of the Government Printing Office, located at Macarthur-street, Melbourne, 3002. If ordered by mail, remittance should be addressed to "The Government Printer, Box 203, P.O., North Melbourne, 3051", and should include 5c extra for postage. If a credit account is held at this office, no remittance is required with the mail order.

The annual subscription rate for Statutory Rules (including a Bound Volume) is \$15, payable in advance. The subscription year commences on 1st January.

A. C. BROOKS,  
Government Printer.

**ACTS REPRINTED IN ACCORDANCE WITH THE AMENDMENTS INCORPORATION ACT 1958 (No. 6422), AND FOR SALE AT THE SALE OF PUBLICATIONS BRANCH OF THE GOVERNMENT PRINTING OFFICE, MACARTHUR-STREET, MELBOURNE, 3002.**

No.	(These prices do not include postage.)	Price.
6189.	Acts Interpretation (Incorporating amendments up to No. 7146)	\$0.15
6191.	Administration and Probate (Third Reprint—Incorporating amendments up to No. 7332)	\$0.38
6194.	Agricultural Colleges (First Reprint—Incorporating amendments up to No. 7302)	\$0.15

ACTS REPRINTED IN ACCORDANCE WITH THE AMENDMENTS  
INCORPORATION ACT 1958 (No. 6422)—*continued*.

No.	Price.
7117. Appeal Costs Fund Act 1964 ( <i>First Reprint</i> —Incorporating amendments up to No. 7488)	\$0.25
6199. Apprenticeship ( <i>First Reprint</i> —Incorporating amendments up to No. 7312)	\$0.25
6203. Audit ( <i>First Reprint</i> —incorporating amendments up to No. 7377)	\$0.35
6209. Boiler Inspection (Incorporating amendments up to No. 7072)	\$0.18
6210. Building Societies (Incorporating amendments up to No. 7125)	\$0.25
6218. Children's Court (Incorporating amendments up to No. 7084)	\$0.20
6219. Children's Welfare ( <i>Second Reprint</i> —Incorporating amendments up to No. 7084)	\$0.35
6220. Clean Air (Incorporating amendments up to No. 6886)	\$0.10
6221. Coal Mines ( <i>First Reprint</i> —Incorporating amendments up to No. 7628)	\$1.05
6222. Commercial Goods Vehicles ( <i>Second Reprint</i> —Incorporating amendments up to No. 7358)	\$0.22
6839. Companies Act 1961 ( <i>Second Reprint</i> —Incorporating amendments up to No. 7332)	\$2.32
6225. Co-operation ( <i>Second Reprint</i> —Incorporating amendments up to No. 7083)	\$0.42
6226. Co-operative Housing Societies (Incorporating amendments up to No. 7097)	\$0.40
6228. Country Fire Authority ( <i>Second Reprint</i> —Incorporating Amendments up to No. 7476)	\$0.50
6229. Country Roads ( <i>Second Reprint</i> —Incorporating Amendments up to No. 7506)	\$0.60
6230. County Court Act ( <i>First Reprint</i> —Incorporating amendments up to No. 7420)	\$0.35
6231. Crimes ( <i>Second Reprint</i> —Incorporating amendments up to No. 7407)	\$1.33
7060. Dandenong Valley Authority Act 1963 ( <i>First Reprint</i> —Incorporating amendments up to No. 7523)	\$0.35
6236. Dog ( <i>Second Reprint</i> —Incorporating amendments up to No. 7065)	\$0.15
6239. Dried Fruits Act 1968 ( <i>First Reprint</i> —Incorporating amendments up to No. 7337)	\$0.25
6240. Education ( <i>First Reprint</i> —Incorporating amendments up to No. 7533)	\$0.45
6241. Electric Light and Power ( <i>First Reprint</i> —Incorporating amendments up to No. 7315)	\$0.30
6242. Employers and Employés (Incorporating amendments up to No. 6740)	\$0.18
6243. Entertainments Tax ( <i>First Reprint</i> —Incorporating amendments up to No. 7315)	\$0.25
6245. Estate Agents Act ( <i>Third Reprint</i> —Incorporating amendments up to No. 7425)	\$0.50
6246. Evidence ( <i>Second Reprint</i> —Incorporating amendments up to No. 7366)	\$0.42
7499. Extractive Industries Act 1966 ( <i>First Reprint</i> —Incorporating amendments up to No. 7632)	\$0.35
6249. Fences (Incorporating amendments up to No. 6550)	\$0.12
6250. Fertilizers (Incorporating amendments up to No. 7142)	\$0.25
6251. Firearms ( <i>Second Reprint</i> —Incorporating amendments up to No. 7484)	\$0.40
6252. Fisheries Act ( <i>First Reprint</i> —Incorporating amendments up to No. 7389)	\$0.35
6916. Foreign Judgments Act 1963 ( <i>First Reprint</i> —including amendments made by No. 7332)	\$0.15
6585. Forests (Pulpwood Agreement) (Incorporating amendments up to No. 6886)	\$0.15
6254. Forests ( <i>First Reprint</i> —Incorporating amendments up to No. 7356)	\$0.60
6255. Friendly Societies ( <i>First Reprint</i> —Incorporating amendments up to No. 7554)	\$0.60
6256. Fruit and Vegetables ( <i>First Reprint</i> —incorporating amendments up to No. 6944)	\$0.30
6258. Game—( <i>First Reprint</i> —Incorporating amendments up to No. 7389)	\$0.30
6259. Gaols (Incorporating amendments up to No. 6651)	\$0.15
6260. Gas and Fuel Corporation ( <i>First Reprint</i> —Incorporating amendments up to No. 7422)	\$0.70
6261. Gas Regulation ( <i>First Reprint</i> —Incorporating amendments up to No. 7580)	\$0.30
6262. Geelong Harbor Trust ( <i>First Reprint</i> —Incorporating amendments up to No. 7547)	\$0.45
6263. Geelong Waterworks and Sewerage ( <i>First Reprint</i> —Incorporating amendments up to No. 7547)	\$0.75
6265. Goods ( <i>Third Reprint</i> —Incorporating amendments up to No. 7131)	\$0.35

ACTS REPRINTED IN ACCORDANCE WITH THE AMENDMENTS  
INCORPORATION ACT 1958 (No. 6422)—*continued*.

No.	Price.
6266. Grain Elevators ( <i>First Reprint</i> —Incorporating amendments up to No. 7486)	\$0.35
6270. Health ( <i>Second Reprint</i> —Incorporating amendments up to No. 7490)	\$1.65
6933. Home Finance Act 1962 ( <i>First Reprint</i> —Incorporating amendments up to No. 7363)	\$0.25
6274. Hospitals and Charities ( <i>Second Reprint</i> —Incorporating amendments up to No. 7455)	\$0.50
6275. Housing ( <i>First Reprint</i> —Incorporating amendments up to No. 7507)	\$0.85
6279. Instruments ( <i>Third Reprint</i> —Incorporating amendments up to No. 7315)	\$0.38
6282. Justices ( <i>Second Reprint</i> —Incorporating amendments up to No. 7369)	\$1.23
6283. Labour and Industry ( <i>Third Reprint</i> —Incorporating amendments up to No. 7410)	\$1.00
6284. Land (Incorporating amendments up to No. 7360)	\$1.53
6534. Land Settlement Act 1959 ( <i>First Reprint</i> —Incorporating amendments up to No. 7328)	\$0.30
6289. Land Tax ( <i>Second Reprint</i> —Incorporating amendments up to No. 7466)	\$0.40
6285. Landlord and Tenant ( <i>Second Reprint</i> —Incorporating amendments up to No. 6996)	\$0.50
6286. Lands Compensation—( <i>First Reprint</i> —incorporating amendments up to No. 7332)	\$0.25
6290. Latrobe Valley ( <i>First Reprint</i> —Incorporating amendments up to No. 7332)	\$0.35
6291. Legal Profession Practice ( <i>Second Reprint</i> —Incorporating amendments up to No. 7539)	\$0.70
6295. Limitation of Actions ( <i>Second Reprint</i> —Incorporating amendments up to No. 7457)	\$0.25
6298. Local Authorities Superannuation (Incorporating amendments up to No. 6894)	\$0.25
6299. Local Government ( <i>Second Reprint</i> —Incorporating amendments up to No. 7689)	\$4.00
6302. Marine (Incorporating amendments up to No. 7350)	\$0.72
6304. Marketing of Primary Products ( <i>First Reprint</i> —Incorporating amendments up to No. 7491)	\$0.45
6306. Marriage ( <i>First Reprint</i> —Incorporating amendments up to No. 6959)	\$0.25
6309. Medical ( <i>Second Reprint</i> —Incorporating amendments up to No. 7408)	\$0.40
6310. Melbourne and Metropolitan Board of Works ( <i>Second Reprint</i> —Incorporating amendments up to No. 7547)	\$1.10
6312. Melbourne Harbor Trust ( <i>First Reprint</i> —Incorporating amendments up to No. 7356)	\$0.48
6605. Mental Health (Incorporating amendments up to No. 7135)	\$0.45
6315. Metropolitan Fire Brigades (Incorporating amendments up to No. 6886)	\$0.28
6316. Mildura Irrigation and Water Trusts ( <i>First Reprint</i> —Incorporating amendments up to No. 7448)	\$0.75
6317. Milk and Dairy Supervision (Incorporating amendments up to No. 6964)	\$0.40
6318. Milk Board (Incorporating amendments up to No. 7093)	\$0.22
6320. Mines ( <i>First Reprint</i> —Incorporating amendments up to No. 7499)	\$1.90
6184. Monash University ( <i>First Reprint</i> —Incorporating amendments up to No. 7533)	\$0.30
6324. Money Lenders (Incorporating amendments up to No. 6886)	\$0.25
6832. Motor Boating (Incorporating amendments up to No. 6961)	\$0.15
6325. Motor Car ( <i>Second Reprint</i> —Incorporating amendments up to No. 7361)	\$0.82
6326. National Parks (Incorporating amendments up to No. 7275)	\$0.25
6328. Nurses (Incorporating amendments up to No. 6716)	\$0.20
6330. Partnership ( <i>Second Reprint</i> —Incorporating amendments up to No. 7315)	\$0.25
6331. Patriotic Funds ( <i>First Reprint</i> —Incorporating amendments up to No. 7338)	\$0.25
6257. Pesticides Act 1968 ( <i>First Reprint</i> —Incorporating amendments up to No. 7595)	\$0.15
6889. Poisons Act 1962 ( <i>Second Reprint</i> —Incorporating amendments up to No. 7588)	\$0.50
6337. Police Offences (Incorporating amendments up to No. 7145)	\$0.82
6338. Police Regulation (Incorporating amendments up to No. 7081)	\$0.45
6340. Portland Harbor Trust ( <i>First Reprint</i> —Incorporating amendments up to No. 7475)	\$0.35
6341. Pounds ( <i>First Reprint</i> —Incorporating amendments up to No. 7315)	\$0.25

ACTS REPRINTED IN ACCORDANCE WITH THE AMENDMENTS  
INCORPORATION ACT 1958 (No. 6422)—*continued*.

No.	Price.
6890. Probate Duty (Incorporating amendments up to No. 6970) ..	\$0.38
6344. Property Law (Incorporating amendments up to No. 6867) ..	\$0.90
6349. Public Service ( <i>Second Reprint</i> —Incorporating amendments up to No. 7356) ..	\$0.40
6350. Public Trustee (Incorporating amendments up to No. 6961) ..	\$0.35
6353. Racing ( <i>Second Reprint</i> —Incorporating amendments up to No. 7691) ..	\$0.85
6355. Railways ( <i>First Reprint</i> —Incorporating amendments up to No. 7475) ..	\$0.75
6564. Registration of Births Deaths and Marriages Act 1959 ( <i>First Reprint</i> —Incorporating amendments up to No. 7332) ..	\$0.25
6359. Road Traffic ( <i>Second Reprint</i> —Incorporating amendments up to No. 7332) ..	\$0.18
6360. Rural Finance ( <i>First Reprint</i> —Incorporating amendments up to No. 7328) ..	\$0.12
6846. Rural Finance and Settlement Commission Act 1961 ( <i>First Reprint</i> —Incorporating amendments up to No. 7332) ..	\$0.20
6975. Sale of Land Act 1962 ( <i>First Reprint</i> —Incorporating amendments up to No. 7332) ..	\$0.18
6363. Second-hand Dealers ( <i>First Reprint</i> —Incorporating amendments up to No. 7529) ..	\$0.25
6367. Settled Land ( <i>Second Reprint</i> —Incorporating amendments up to No. 7065) ..	\$0.50
6368. Sewerage Districts ( <i>Second Reprint</i> —Incorporating amendments up to No. 7547) ..	\$0.75
6651. Social Welfare Act 1960 ( <i>Third Reprint</i> —Incorporating amendments up to No. 7332) ..	\$0.20
6372. Soil Conservation and Land Utilization (Incorporating amendments up to No. 6961) ..	\$0.20
6373. Soldier Settlement ( <i>First Reprint</i> —Incorporating amendments up to No. 7328) ..	\$0.42
6375. Stamps ( <i>Third Reprint</i> —Incorporating amendments up to No. 7359) ..	\$0.82
6377. State Electricity Commission ( <i>Second Reprint</i> —Incorporating Amendments up to No. 7421) ..	\$0.65
6379. State Savings Bank (Incorporating amendments up to No. 6886) ..	\$0.42
6381. Stock and Share Brokers ( <i>First Reprint</i> —Incorporating amendments up to No. 7444) ..	\$0.15
6886. Subordinate Legislation (Incorporating amendments up to No. 6961) ..	\$0.15
6386. Superannuation ( <i>First Reprint</i> —Incorporating amendments up to No. 7417) ..	\$0.60
6387. Supreme Court ( <i>First Reprint</i> —Incorporating amendments up to No. 7522) ..	\$0.75
6391. Teaching Service ( <i>First Reprint</i> —Incorporating amendments up to No. 7536) ..	\$0.35
7223. Tomato Processing Industry (Uniform Agreement) Act 1964 ( <i>First Reprint</i> —Incorporating amendments up to No. 7342) ..	\$0.15
6395. Tourist ( <i>First Reprint</i> —Incorporating amendments up to No. 7335) ..	\$0.15
6849. Town and Country Planning ( <i>First Reprint</i> —Incorporating amendments up to No. 7276) ..	\$0.45
6399. Transfer of Land Act ( <i>Third Reprint</i> —Incorporating amendments up to No. 7551) ..	\$0.65
6400. Transport Regulation ( <i>First Reprint</i> —Incorporating amendments up to No. 7358) ..	\$0.22
6401. Trustee ( <i>Second Reprint</i> —Incorporating amendments up to No. 6963) ..	\$0.42
6879. Unclaimed Moneys (Incorporating amendments up to No. 6961) ..	\$0.12
6653. Valuation of Land Act 1960 ( <i>Second Reprint</i> —Incorporating amendments up to No. 7333) ..	\$0.22

ACTS REPRINTED IN ACCORDANCE WITH THE AMENDMENTS  
INCORPORATION ACT 1958 (No. 6422)—*continued*.

No.	Price.
6407. Vegetation and Vine Diseases ( <i>First Reprint</i> —Incorporating amendments up to No. 7423) ..	\$0.30
6409. Vermin and Noxious Weeds ( <i>First Reprint</i> —Incorporating amendments up to No. 7463) ..	\$0.35
6410. Veterinary Surgeons ( <i>First Reprint</i> —Incorporating amendments up to No. 7343) ..	\$0.15
7291. Victoria Institute of Colleges Act 1965 ( <i>First Reprint</i> —Incorporating amendments up to No. 7644) ..	\$0.25
6413. Water ( <i>Second Reprint</i> —Incorporating amendments up to No. 7590) ..	\$1.95
6414. Weights and Measures ( <i>Second Reprint</i> —Incorporating amendments up to No. 7332) ..	\$0.32
6416. Wills ( <i>First Reprint</i> —Incorporating amendments up to No. 7238) ..	\$0.25
6419. Workers Compensation ( <i>Second Reprint</i> —Incorporating amendments up to No. 7332) ..	\$0.52

FIRST NOTIFICATION OF REPRINT.

6383. Stock Foods ( <i>First Reprint</i> —Incorporating amendments up to No. 7607) ..	\$0.28
---	--------

CONTENTS

	PAGE
Acts of Parliament .. .. .	3538
Acts of Parliament on sale at the Government Printing Office .. .. .	3598
Appointments .. .. .	3561
Auction Sales Act .. .. .	3552
Cemetery—Scale of Fees .. .. .	3540
Companies Act 1961—Notice .. .. .	3557
Contracts .. .. .	3553
Courts .. .. .	3550
Estates of Deceased Persons .. .. .	3557
Government Notices .. .. .	3540
Holiday—Melbourne Cup Day .. .. .	3540
Impoundings .. .. .	3598
Lands .. .. .	3577
Melbourne and Metropolitan Board of Works—Notices .. .. .	3555
Mining .. .. .	3556
Notice of Making of Statutory Rules .. .. .	3598
Orders in Council—	
Acts—Gas and Fuel Corporation; Local Government; Country Roads; Land; Dandenong Valley Authority; Water; Sewerage Districts; Country Roads; Country Fire Authority; Justices. .. .. .	3563 et seq
Private Advertisements .. .. .	3585
Proclamations .. .. .	3537
Public Service Notices .. .. .	3583
Resignations .. .. .	3563
State Rivers and Water Supply Commission .. .. .	3548
Tenders .. .. .	3582
Transport Regulation Board—Public Hearings .. .. .	3541
Waterworks Trusts .. .. .	3558