

[3701]



VICTORIA
GOVERNMENT GAZETTE

Published by Authority

[Registered at the General Post Office, Melbourne, for transmission by post as a newspaper.]

No. 93]

TUESDAY, NOVEMBER 12

[1968

CONTRACTS ACCEPTED

(Series 1968-69)

REQUISITES FOR EDUCATION
DEPARTMENT

CONTRACTS ACCEPTED.—(Series 1968-69.)
REQUISITES FOR EDUCATION DEPARTMENT.
 SCHEDULE No. 1.

REQUISITES (JUNIOR SCHOOL) EDUCATION DEPARTMENT.

Contract from 1st September, 1968, to 31st August, 1969.

1968/1209.— <i>Art and Craft Supply Co. Pty. Ltd.</i>	Security, \$150.
1968/1210.— <i>Belco Pty. Ltd.</i>	Security, \$500.
1968/1211.— <i>Colour Products (Aust.) Pty. Ltd.</i>	Security, \$500.
1968/1212.— <i>Michael A. Dortheimer Pty. Ltd.</i>	Security, \$100.
1968/1213.— <i>Clifford J. Hose</i>	Security, \$6.
1968/1214.— <i>Sands and McDougall Pty. Ltd.</i>	Security, \$200.
1968/1215.— <i>Charles Tims Pty. Ltd.</i>	Security, \$200.
1968/1216.— <i>Scientific and Laboratory Supply Co.</i>	Security, \$50.

Where the name of the supplier opposite any item is shown in italics, with the sign (A), no contract has been executed nor security lodged, requirements of such items are to be purchased from the supplier named, under Tender Board Agreement.

Item No.	Description of Articles.	Education Dept. Code No.	Quantity.	Rate.	Name of Contractor.
				\$	
1	Poster, colours in, 1-pint containers "Vynol"				
	Red	29734	Per pint	0.36	} Colour Products (Aust.) Pty. Ltd.
	Blue	to	"	0.36	
	Yellow	29823	"	0.36	
	Black		"	0.36	
	White		"	0.36	
2	Brushes (hair), No. 8—				
	(a) ½" round "Rubens" 102 No. 14	29424	per doz.	1.33	} Michael A. Dortheimer Pty. Ltd.
	(b) ½" flat "Rubens" 105 No. 14	29416	"	1.28	
3	Newsprint, white, 20" x 15", in packets of (a) 50 sheets (b) 500 sheets	29645	per packet	..	} Obtain from Government Printer
4	Chalkboards (Temper Plate), green, size 16" x 12"	29483	each	0.17	Charles Tims Pty. Ltd.
5	Chalk, white, in boxes of 200 Dustless "A"	29505	per box	0.45	} Belco Pty. Ltd.
6	" coloured, in boxes of 200—Dustless "A"	29513	"	0.75	
	(a) Yellow	} 29491	"	} No. 80 1.00 No. 52 0.70	
	(b) Mixed—ratio per box as follows:—				
	24 sticks—Bright yellow				
	18 " Terracotta brown				
	24 " Orange				
	12 " Bright Red				
	12 " Blue				
	12 " Dark Green				
	18 " Leaf green				
	12 " Purple				
	12 " Black				
7	Surface Paper, Squares, mixed colours in packets of 360 squares—				
	(a) 5" squares (pkt. of 360)	29920	per packet	0.33	} Sands and McDougall Pty. Ltd.
	(b) 10" squares (pkt. of 360)	29939	"	1.20	
	Each packet of 360 squares to contain colours collated in the following ratio:— 60 squares each—Red, blue, yellow, sea green 20 " " Purple, turquoise, orange leaf green 10 " " White, black, grey, brown				
8	Plain White Card, 4-sheet pasteboard—				
	(a) 8" squares in pkts. of 50	29726	"	0.25	} Sands and McDougall Pty. Ltd.
	(b) sheets 20" x 12½" in pkts. of 50 sheets	29718	"	0.82	
9	Scissors, Metal, Kindergarten	29882	per doz.	0.88	Scientific and Laboratory Supply Co.
10	Beads, Plastic, ½" coloured in boxes of 100 beads. Each box to contain 20 beads of different medium sizes and shapes in the following colours: red, green, blue, yellow and white	29408	per box	0.24	Art and Craft Supply Co. Pty. Ltd.
11	Laces, Plastic, for threading 20 beads ½". To be in equal numbers or colours, red, green, blue, yellow, white	29580	per gross	0.67	Clifford J. Hose
12	Tablets, Plastic, reversible, blue, yellow, 1" squares by ½" deep; in packets of 100 in the following colours:—red, green, black and white.	30007	per dozen packets	5.00	Art and Craft Supply Co. Pty. Ltd.
13	Sticks, Plastic, Coloured, in packets of 100. Each packet to contain 20 sticks of the following colours:—red, green, blue yellow, white:—				
	(a) Size 2"	29890	"	2.40	} Art and Craft Supply Co. Pty. Ltd.
	(b) Size 4"	29904	"	3.60	
	(c) Size 6"	29912	"	4.80	

CONTRACTS ACCEPTED.—(Series 1968-69.)

REQUISITES FOR EDUCATION DEPARTMENT.

SCHEDULE No. 2.

EXERCISE BOOKS AND REQUISITES, EDUCATION DEPARTMENT.

Contract from 1st September, 1968, to 31st August, 1969.

1968/1217.—Art and Craft Supply Co. Pty. Ltd.	Security, \$10.
1968/1218.—Hercules Fibre Containers	Security, \$150.
1968/1219.—William Irving	Security, \$100.
1968/1220.—Rulex Pty. Ltd.	Security, \$60.
1968/1221.—S. C. Smith	Security, \$40.

All supplies under this Schedule will be ordered by the Stores Officer, Education Department, and must be delivered as directed by him.

Item No.	Description of Articles.	Education Dept. Code No.	Quantity.	Rate.	Name of Contractor.
				\$	
1	Compasses, 4" legs "Kent" No. 490	9202	per doz.	..	Purchase (Regulation 109) William Irving
2	" " wooden, 12" legs rubber tip	9199	each	1.04	
3	Erasers, Blackboard, Felt	9423	..	0.17	William Irving ..
4	} Pastels, 12 in a box "Reeves" STC 12's	10022	per box	..	} Purchase (Regulation 109)
4		10030	per box	..	
5	Rulers, box, flat, 12", marked in inches, eighths, and metric measures	6815	per gross	..	
6	Rulers, Blackboard, graduated	10154	each	0.40	Rulex Pty. Ltd.
7	Squares, set, 45°, 5" side, calibrated	10316	} Purchase (Regulation 109)
8	" " 60°, 6" side, calibrated	10324	
9	" " Blackboard } 45°	10294	..	0.45	} Rulex Pty. Ltd.
9	" " Blackboard } 60°	10308	..	0.45	
10	" " T. 18", oiled, wooden	10332	} Purchase (Regulation 109) S. C. Smith
11	" " T. 24", oiled, wooden	0.59	
12	" " T. 42", oiled	
13	Ink wells (plastic), covered, to fit 1½" hole	9628	per gross	..	} Purchase (Regulation 109)
14	Slate cloth, on rollers, 52" x 36"	10278	each	6.00	
15	Protractors, Blackboard	10049	..	0.49	Art and Craft Supply Co. Pty. Ltd. S. C. Smith
16	Forks, Tuning, "C", C.523/3, 125 c.m. length	9520	} Purchase (Regulation 109)
17	Books, Exercise, 4 sheet, foolscap quarto, 8" x 6½", plain sheet. Quality of the paper to be cream wove 18 lb. large post 16½" x 21", 500 sheets to the ream, hard engine sized. Cover to be of white chip-board, green marbled, .014-.015, printed "Exercise Book, Grades I. and II.", and may bear a trade symbol	9040	per gross	..	
18	Books, Exercise, 6 sheet, size 9" x 7", with faint ruling 18 m.m. from line to line. Quality of paper to be cream wove, 18 lb. large post 16½" x 21", 500 sheets to ream, hard engine size. Cover to be of white chip-board, .014-.015 printed in green to an approved typographical design "Exercise Book, Grade III. with 18 m.m. rulings", and may bear a trade symbol	9059	
19	Books, Exercise, 6 sheet, size 9" x 7", with faint ruling 14 m.m. from line to line. Quality of paper to be cream wove 18 lb. large post 16½" x 21", 500 sheets to ream, hard engine sized. Cover to be of white chip-board .014-.015 printed in green to an approved typographical design "Exercise Book, Grade IV. with 14 m.m. rulings" and may bear a trade symbol	9067	
20	Books, Exercise, 12 sheet, 1 section stapled, size 9" x 7", with faint ruling, 9 m.m. from line to line. Quality of paper to be cream wove, 18 lb. large post 16½" x 21", 500 sheets to ream, hard engine sized. Cover to be of white chip-board .014-.015 printed in bronze blue to an approved typographical design "Exercise Book", and may bear a trade symbol	9075	} Purchase (Regulation 109)
21	Books, Exercise, 24 sheet, size 9" x 7", section sewn, quarto bound, ruling, quality of paper and cover to be as prescribed for Item 20, cover to be printed "Exercise Book" and may bear a trade symbol	9083	
22	Books, Exercise, Mapping, 8 sheet, 9" x 7", Burnie cream wove paper, plain—cover to be of marble chip-board, printed "Exercise Book—Mapping", and may bear a trade symbol	9032	
23	Books, Exercise, Science, 8 sheet, 9" x 7", quality of paper and cover to be as prescribed for Item 20, cover to be red, printed "Science Book". The leaves to be lithographed faint ruled on one side, and in tenths on the reverse side, the tenths to appear on the right hand side when the book is opened, the inch ruling to be slightly thicker to show the inch lines distinctly. Each page to contain 48 1" squares, 8 down, 6 across and may bear a trade symbol	9091	

Item No.	Description of Articles.	Education Dept. Code No.	Quantity.	Rate.	Name of Contractor.
				\$	
24	Books, Drawing, line, 8 leaves, 10½" x 7½", stapled along longer side, white cartridge paper. Imperial, 56 lb., 480 sheets, smooth, wood free, opaque. Cover to be blue pressings, Quad Cap., 72 lb., 480 sheets, printed "Drawing Book", and may bear a trade symbol	9016	per gross	..	} Purchase (Regulation 109)
25	Containers, cardboard, corrugated fibre, 16" x 12" x 12"	..	each	..	
26	" " cardboard, corrugated fibre, 12" x 12" x 12"	..	"	..	} Hercules Fibre Containers
27	" " cardboard, corrugated fibre, 12" x 9" x 12"	..	"	..	
28	" " cardboard, corrugated fibre, 15" x 9½" x 12" No. 1 Board	..	per 1,000	138.00	
29	Containers, cardboard, corrugated fibre, 15" x 9½" x 4"	..	"	..	} Purchase (Regulation 109)
30	" " cardboard, corrugated fibre, 20" x 15" x 12" No. 1 Board	..	"	230.00	
31	Containers, cardboard, corrugated fibre, 24" x 15" x 12" No. 1 Board	..	"	275.00	} Hercules Fibre Containers
32	Containers, cardboard, corrugated fibre, 42" x 8" x 8" No. 1 Board	..	"	225.00	

Approved—H. E. BOLTE, Treasurer. 20.8.1968.

REQUISITES FOR EDUCATION DEPARTMENT.

- Schedule No. 3 Chemicals for Science Classes for District High Schools and Higher Elementary Schools, &c.
- Schedule No. 4 Requisites for Science Classes for District High Schools and Higher Elementary Schools, &c.
- Schedule No. 5 Utensils and Requisites for Girls' Schools Cookery and Needlework Centres.

Requirements under the above-mentioned Schedules for the period from 1st September, 1968, to 31st August, 1969, are to be obtained in accordance with the provisions of regulation 109, Part V., Public Accounts and Stores Regulations 1958.

J. M. PAWSON,
Acting Secretary to the Tender Board.
21.8.1968

GENERAL STORES.

SCHEDULE No. 69.

STATIONERY, GENERAL.

Contract from 1st September, 1968, to 31st August, 1969.

- 1968/1222.—Angus and Co. Pty. Ltd. Security, \$100.
- 1968/1223.—Arnold Ribbon Co. Security, \$40.
- 1968/1224.—Biro Bic and Gollin Pty. Ltd. Agreement.
- 1968/1225.—Bowater Paper Company Ltd. Security, \$20.
- 1968/1226.—Caribonum Aust. Pty. Ltd. Security, \$100.
- 1968/1227.—J. F. Clementson Security, \$6.
- 1968/1228.—Columbia Writing Products Pty. Ltd. Security, \$6.
- 1968/1229.—W. & G. Dean, Pty. Ltd. Security, \$50.
- 1968/1230.—Michael A. Dortheimer Pty. Ltd. Agreement.
- 1968/1231.—Dunlop Industrial Products Division Agreement.
- 1968/1232.—Dunlopillo Pty. Ltd. Agreement.
- 1968/1233.—Dymo Australia Pty. Ltd. Security, \$6.
- 1968/1234.—Ellams Duplicator Co. (Melb.) Pty. Ltd. Security, \$6.
- 1968/1235.—Edwards Dunlop and Co. Ltd. Security, \$40.
- 1968/1236.—A. W. Faber-Castell (Aust.) Pty. Ltd. Security, \$350.
- 1968/1237.—General Stationers Pty. Ltd. Security, \$6.
- 1968/1238.—Gibson, Kelite Chemicals Ltd. Security, \$20.
- 1968/1239.—Granville Trading Co. Security, \$50.
- 1968/1240.—Highness Trading Pty. Ltd. Security, \$10.
- 1968/1241.—Clive Hogbin (Interstate) Pty. Ltd. Security, \$300.
- 1968/1242.—Jasco Pty. Ltd. Security, \$100.
- 1968/1243.—M.O.E. Manufacturers Pty. Ltd. Security, \$150.
- 1968/1244.—Mason-Kolok Mfg. Co. Ltd. Security, \$400.
- 1968/1245.—Thos. Mitchell and Co. Pty. Ltd. Security, \$10.
- 1968/1246.—Morgan Inks Pty. Ltd. Security, \$100.
- 1968/1247.—R. E. Mustow Security, \$420.
- 1968/1248.—Norton Australia Pty. Ltd. Security, \$10.
- 1968/1249.—Norman Bros. Pty. Ltd. Security, \$10.
- 1968/1250.—Olympia (Aust.) Pty. Ltd. Security, \$400.
- 1968/1251.—P.S.R. Products Pty. Ltd. Security, \$30.
- 1968/1252.—Sydney Pincombe Pty. Ltd. Security, \$400.
- 1968/1253.—Ponsford, Newman and Benson Ltd. Agreement.
- 1968/1254.—Ramsay and Hall Pty. Ltd. Security, \$250.
- 1968/1255.—Rexall Products Security, \$6.
- 1968/1256.—Rulux Pty. Ltd. Security, \$20.
- 1968/1257.—Sands and McDougall Pty. Ltd. Security, \$200.
- 1968/1258.—Scientific and Laboratory Supply Co. Security, \$40.
- 1968/1259.—Sellotape (Australia) Ltd. Security, \$200.
- 1968/1260.—Spicers Paper Industries Ltd. Security, \$6.
- 1968/1261.—Maurice Tye Security, \$40.
- 1968/1262.—John Withers and Son Pty. Ltd. Security, \$200.
- 1968/1263.—Max Wurcker Pty. Ltd. Security, \$30.

All supplies under this Schedule will be ordered by the Stores Officer, Education Department, and must be delivered as directed by him.

Item No.	Description of Articles.	Education Dept. Code No.	Quantity.	Rate.	Name of Contractor.
SUB-SCHEDULE A.					\$
1	Balances, Letter, with weights, ½ oz. to 16 oz. . .	1635	each	5.45	R. E. Mustow
2	Bands, elastic, 0½, 2" x ¼" x ⅜", in boxes of 1 gross . .	1643	per doz. boxes	1.60*	
3	" elastic, 00½, 2½" x ¼" x ⅜", in boxes of 1 gross	1651	"	1.95*	Clive Hogbin (Interstate) Pty. Ltd.
4	" elastic, 000½, 3" x ¼" x ⅜", in boxes of 1 gross	1678	"	2.35*	
5	" elastic, 0000½, 3½" x ¼" x ⅜", in boxes of 1 gross	1686	"	2.60*	Purchase (Regulation 109) Dunlop Industrial Product Division Clive Hogbin (Interstate) Pty. Ltd.
6	" elastic, flat, 4½" x ¼" x ⅜", in boxes of 1 gross	1694	"	1.46	
7	" elastic, flat, 6" x ¼" x ⅜", in boxes of 1 gross	1708	per gross	0.45*	Purchase (Regulation 109)
8	" elastic, thread, grey, 1" x ⅛" x ⅜", in boxes of 1 gross	1716	per doz. boxes	0.68*	
9	" elastic, thread, grey, 1½" x ⅛" x ⅜", in boxes of 4 oz.	1724	"	0.90*	Clive Hogbin (Interstate) Pty. Ltd.
10	" elastic, thread, grey, 2" x ⅛" x ⅜", in boxes of 1 gross	1732	"	0.25	
11	" elastic, thread, grey, 3" x ⅛" x ⅜", in boxes of 1 gross	1740	"	0.825	Sands and McDougall Pty. Ltd.
12	Baskets, document, wire, foolscap	1759	each	0.45	
13	" waste paper, top 11½" in diameter, bottom 7½" diameter, height 10½", metal bucket type	1775	each	0.25	Purchase (Regulation 109)
14	" waste paper, plastic, round bucket type, top 11½" in diameter, bottom 7½" diameter, height 10½"	1767	"	0.40	
15	Bibles, Church of England, Ruby	1783	"	0.40	Purchase (Regulation 109)
16	Binders, metal fasteners, with washers, ⅜" No. 641, in boxes of 1 gross	1791	per box	0.43	
17	" metal fasteners, with washers, ½" No. 642, in boxes of 1 gross	1805	"	0.43	Purchase (Regulation 109)
18	" metal fasteners, with washers, ⅜" No. 643, in boxes of 1 gross	1813	"	0.43	
19	" metal fasteners, with washers, 1" No. 644, in boxes of 1 gross	1821	"	0.47	Purchase (Regulation 109)
20	" metal fasteners, with washers, 1½" No. 645, in boxes of 1 gross	1848	"	0.50	
21	" metal fasteners, with washers, 1½" No. 646, in boxes of 1 gross	1856	"	0.25†	Purchase (Regulation 109)
22	" screws, brass, 1" (Boxes of 12)	1864	"	0.80	
23	" screws, brass, 1½"	1872	"	0.10†	Purchase (Regulation 109)
24	" screw, brass, 2"	1880	"	0.50	
25	" screw, brass, 2½" (Boxes of 10)	1899	"	0.255†	Sands and McDougall Pty. Ltd. Edwards Dunlop and Co. Ltd.
26	Bodkins, with eye, riveted through handle, 4½" blade	1910	each	0.80	
27	" with eye, riveted through handle, 7" blade	1929	each	0.10†	Sands and McDougall Pty. Ltd. Edwards Dunlop and Co. Ltd.
28	Bowls, glass, pin or sponge approx. 3½" diameter at top, No. 2992	1988	each	0.84	
29	Boxes, cloth covered for ledger cards, 4" x 6" . .	1996	"	0.84	Purchase (Regulation 109)
30	" cloth covered, for ledger cards, 6" x 8" . .	2003	"	3.85	
31	" cash 8", with trays SWS series 57	2011	"	0.28	Purchase (Regulation 109)
32	" cash, 12", with trays	2038	"	0.34	
33	" cash, 14", with trays	2046	"	0.85	Purchase (Regulation 109)
34	Brushes, Artists—			5.03	
34	Sable (red), crow, finest, in quills, Winsor and Newton's	2054	each	0.28	Purchase (Regulation 109)
35	Sable (red), duck, finest, in quills, Winsor and Newton's	2062	"	0.34	
36	Sable (red), goose, finest, in quills, Winsor and Newton's	2070	"	0.85	Purchase (Regulation 109)
37	Sable (red), large swan, finest, in quills, Winsor and Newton's	2089	each	5.03	
38	Sable (red), medium swan, finest, in quills, Winsor and Newton's	2097	"	3.65	Purchase (Regulation 109)
39	Sable (red), small swan, finest, in quills, Winsor and Newton's	2100	"	1.91	
40	Brushes, litho., sable, Series 16, No. 0 " Habico " No. 351A	2127	per doz.	2.18	Purchase (Regulation 109)
41	Brushes, litho., sable, Series 16, No. 1 " Habico " No. 351A	2135	"	3.04	
42	Brushes, litho., sable, Series 16, No. 2 " Habico " No. 351A	2143	"	3.38	Purchase (Regulation 109)
43	Brushes, litho., sable, Series 16, No. 3 " Habico " No. 351A	2151	"	4.50	
44	Brushes, litho., sable, Series 16, No. 4 " Habico " No. 351A	2178	"	2.194	Purchase (Regulation 109)
45	Brushes, litho., sable, Series 16, No. 5 " Habico " No. 351A	2186	"	2.208	
46	Brushes, litho., sable, Series 16, No. 6 " Habico " No. 351A	2194	"	0.25	Purchase (Regulation 109)
47	Brushes, litho., sable, Series 16, No. 7 " Habico " No. 351A	2208	"	0.30	
48	Brushes, paste and gum, ½", flat	2224	each	0.2275	Purchase (Regulation 109)
49	" paste and gum, ¾", flat	2232	"	0.18	
50	" typewriter, tooth brush type, 6" overall	2240	"	0.18	Purchase (Regulation 109)
51	" typewriter, wire handle, bottle type	2259	"	2410	
52	Cards, playing	2410	per packet		

† Items less 3½ per cent.—7 days or 2½ per cent.—30 days.

* Items less 2½ per cent.

Item No.	Description of Articles.	Education Dept. Code No.	Quantity.	Rate.	Name of Contractor.	
SUB-SCHEDULE A—continued.					\$	
53	Cases, attache, solid leather, with one X tin plate enamelled frame clamped into body of case, two Australian locks; lined with leather cloth, round leather covered metal handle, best make and finish metal protected corners riveted on lid.	2437 to 2453	each 16" 18" 20"	Purchase (Regulation 109)	
54	Stationery head for previous item, to be of best leather cloth throughout, well sewn, best make and finish, pockets fastened with leather flap	..	each	..	Purchase (Regulation 109)	
55	Satchels, black leather, zip folio, zip 3 sides full, reinforced metal back	6998	Purchase (Regulation 109)	
56	Clag— In 10-oz. bottles, with brushes	2461	per bottle	0.138	Angus and Co. Pty. Ltd.	
57	In 20-oz. bottles, without brushes	2488	..	0.175		
58	In 1 gallon jars "School Paste"	2496	..	0.84	Rowall Products	
59	Clam paste or equivalent, 5-oz. bottles	2518	..	0.23	Angus and Co. Pty. Ltd.	
60	Clips, bulldog, 2½" "Gold Bell" No. 4	2534	per gross	4.60	Clive Hogbin (Interstate) Pty. Ltd.	
61	bulldog, small "Gold Bell" No. 1	2526	..	1.70		
62	" glider or equal thereto, large, in boxes of 100	2550	per 1000	0.38	John Withers and Son Pty. Ltd.	
63	" glider or equal thereto, small, in boxes of 100	2542	..	0.33	Clive Hogbin (Interstate) Pty. Ltd.	
64	" letter, side, foolscap size	2569	each	0.28	P.S.R. Products Pty. Ltd.	
65	" letter, end, foolscap size	2577	..	0.28		
66	Colours, water, moist, whole cakes in pans, Winsor and Newton's— Series No. 1—Burnt Sienna, Burnt Umber, Chinese White, Chrome, Yellow, Emerald Green, Indian Red, Mauve, Neutral Tint, Payn's Grey, Prussian Blue, Raw Sienna, Raw Umber, Vandyke Brown, Venetian Red, Yellow Ochre, Chrome Orange, Ivory Black, Olive Green	2585 to 2763	per pan	0.26	W. and G. Dean Pty. Ltd.	
67	Series No. 2.—Gamboge, Hooker's Green, No. 1, Hooker's Green, No. 2, Indigo, Purple Lake, Scarlet Lake, Sepia, Crimson Lake	2771 to 2860	..	0.26		
68	Series No. 3.—Cobalt Blue, French Blue, French Ultramarine, Cadmium Yellow, Vermillion	2879 to 2917	..	0.32	..	
69	(a) Series No. 4.—Aurora Yellow, Violet Carmine, Carmine,	2925 to 2941	..	0.39		
70	Colours, liquid, Chinese White, Winsor and Newton's in bottles, 1 oz.	2968	per bottle	..	Purchase (Regulation 109)	
71	" Texta colours " in boxes of 12 colours	7781	per box	..	Purchase (Regulation 109)	
72	" Texta colours " as ordered, boxes of 12	7803 to 7870	..	0.79	Highness Trading Pty. Ltd.	
73	Covers, typewriter, foolscap size, plastic	2976	each	0.62	Granville Trading Co.	
74	" typewriter, brief size, plastic	2984	..	0.75		
75	" typewriter, policy size, plastic	2992	..	0.85		
76	Crayons, solid marking, soft type, all colours	3018 to 3069	..	0.021	Ponsford, Newman and Benson Ltd.	
77	Cushions, chair rubber, uncovered, code No. 5	3077	each	0.67	Dunlopillo Pty. Ltd.	
78	Damper, label 5", roller bakelite	3204	..	0.80	Clive Hogbin (Interstate) Pty. Ltd.	
79	Diaries, Australian, various pocket series	3220	Invicta List Price Less 50%	
80	" Australian, various, cloth series					
81	" Australian, various, rough series	Purchase (Regulation 109)	
82	Directors, municipal, ¼-bound or library, latest edition	3239	Purchase (Regulation 109)	
83	Directories, Victorian, latest edition	3247	..	35.00	Sands and McDougall Pty. Ltd.	
84	Dispenser tape Cellulose to take 1296", small	3255	..	1.65	John Withers and Son Pty. Ltd.	
85	" " " " 2592", large	3263	..	1.80	Clive Hogbin (Interstate) Pty. Ltd.	
86	Erasers, circular, typewriter	3417	per doz	0.29	John Withers and Son Pty. Ltd.	
87	" combined, 2½", ink and pencil	3425	per gross	2.28	A. W. Faber-Castell (Aust.) Pty. Ltd.	
88	" draughtsmen, "Pelikan" Special 32	3433	per doz.	1.00	Michael A. Dortheimer Pty. Ltd.	
89	" pliable, pencil, "Lyceum"	3441	..	0.17	R. E. Mustow	
90	Eyelets, short—500 in box	3468	per box	..	Purchase (Regulation 109)	
91	" medium	3476		
92	" long	3484		
93	Fasteners, paper, ¼", S.O. and R.O., 1 gross in box	3638 and 3646	..	0.18*	Edward Dunlop and Company Ltd.	
94	" paper, ¾", S.1. and R.1., 1 gross in box	3654 and 3662	Purchase (Regulation 109)	
95	" paper, ¾", S.2. and R. 2., 1 gross in box	3670 and 3689		
96	" paper, ¾", S.3. and R.3, 1 gross in box	3697 and 3700	..	0.23*	Edwards Dunlop and Company Ltd.	
97	" paper, ¾", S.4 and R.4, 1 gross in box	3719 and 3727	..	0.30*		

* Items less 2½ per cent.—30 days.

Item No.	Description of Articles.	Education Dept. Code No.	Quantity.	Rate.	Name of Contractor.
SUB-SCHEDULE A—continued.					\$
98	Fasteners paper, 1", S.5 and R.5, 1 gross in box ..	3735 and 3743	per box each	0.32*	Edwards Dunlop and Company Ltd.
99	" paper, 1½", S.6 and R.6, 1 gross in box ..	3751 and 3778	"	0.37*	
100	" paper, 1½", S.7 and R.7, 1 gross in box ..	3786 and 3794	"	"	
101	" paper, 2", S.8 and R.8, 1 gross in box ..	3808 and 3816	"	"	Purchase (Regulation 109)
102	" paper, 2½", S.10 and R.10, 100 in box ..	3824 and 3832	per 1000	5.34	Clive Hogbin (Interstate) Pty. Ltd.
103	" paper, "Ty-tite", 1 gross in box ..	3840	per box	4.60	Maurice Tye
104	Files, box, indexed, foolscap with clip, 15" x 11¼" x 3"	3859	each	0.94	R. E. Mustow
105	" box, foolscap, not indexed, 14¼" x 9½" x 2" ..	3867	"	0.49	General Stationers Pty. Ltd.
106	" concertina, manila, foolscap ..	3883	"	1.00	Clive Hogbin (Interstate) Pty. Ltd.
107	" concertina, manila, quarto ..	3875	"	0.90	R. E. Mustow
108	" foolscap, with index L. A. Tempered Fibre Board	3891	"	0.62	
109	" springback, foolscap ..	3095	"	0.56	General Stationers Pty. Ltd.
110	" springback, music size ..	3913	"	0.75	
111	" springback, octavo ..	3921	"	0.57	
112	" springback, large quarto, 11¼" x 9"	3956	"	0.55	M.O.E. Manufactures Pty. Ltd.
113	" springback, small quarto ..	3948	"	0.55	
114	" Suspension, Frames ..	7331	"	0.54	Purchase (Regulation 109)
115	" " in packets of 50 ..	7323	per pkt.	3.13	
116	" " Metal tabs, in packets of 50 ..	7358	"	0.33	Purchase (Regulation 109)
117	" " Shields, clear and colours, in packets of 50	7366	"	"	
118	" " Label paper inserts, in packets of 50	7374	"	"	Purchase (Regulation 109)
119	Glue, "Seccotine", 3 oz. tubes ..	4103	per tube	"	
120	Grips, finger and thumb, large, small ..	4111 to 4111	per gross	3.38*	Edwards Dunlop and Company Ltd.
121	" finger, thimble style, large ..	4154	"	1.80	Clive Hogbin (Interstate) Pty. Ltd.
122	" finger, thimble style, medium ..	4146	"	1.80	
123	" finger, thimble style, small ..	4138	"	1.80	
124	Gum, art blocks, 2½" x 1½" x 1½" "Viscol" No. 278. "Art Gum"	3490	"	9.80	Jasco Pty. Ltd.
125	" liquid, 5-oz. bottles with cap and spatula ..	4162	per bottle	0.13	Gibson, Kelite Chemicals Ltd.
126	Ink, fountain pen blue or red, 4-oz. as ordered ..	4383 to 4413	per gross	9.60	Biro Bic and Gollin Pty. Ltd.
127	" fountain pen swan blue or black, 4-oz. as ordered	4421 to 4448	per bottle	"	Purchase (Regulation 109)
128	" India rubber stamp, 1-oz., black, blue, green, purple, red, as ordered ..	4456 to 4499	"	0.105	Clive Hogbin (Interstate) Pty. Ltd.
129	" India rubber stamp, 4-oz., black, blue, green, purple, red, as ordered	4502 to 4545	"	0.20	Angus and Co. Pty. Ltd.
130	" Marking, ½-oz. bottles ..	4553	"	0.0833	R. E. Mustow
131	" Metal stamp, 1-oz., black, green, red, blue, violet as ordered	4561 to 4636	"	0.12	Clive Hogbin (Interstate) Pty. Ltd.
132	" Powder, blue-black (1 packet makes 2 pints) ..	4634	per pkt.	"	Purchase (Regulation 109)
133	" Waterproof, tracing, 1-oz., black, orange, red, yellow, green, blue, as ordered, "Pelikan" 517	4650 to 4707	per doz.	5.00	Max Wurcker Pty. Ltd.
134	" obliterating, I.R., stamp ..	4707	per bot.	"	Purchase (Regulation 109)
135	" obliterating, metal stamp ..	4707	"	"	
136	Inkstands, glass, with tray, two holes and caps ..	4175	each	"	Purchase (Regulation 109)
137	" glass, round, 3½", metal top ..	4723	"	"	
138	Knives, desk erasers ..	4898	each	0.65	Norman Bros. Pty. Ltd.
139	Labels, gummed, 2" x 1½", with border, pads of 100	5010	per pad	0.12*	Edwards Dunlop and Company Ltd.
140	" gummed, 1" x ¾" with border, box of 100	5010	per box	"	Purchase (Regulation 109)
141	Machines, eyelet, hand punches "Velos 950" ..	3492	each	2.27	Clive Hogbin (Interstate) Pty. Ltd.
	" Labeling, plastic, "Dymo M-4" and 10 rolls ¼" tapes	5002	"	"	Purchase (Regulation 109)
143	" numbering, "Velos" 999, 6 figure ..	5282	"	4.60	Clive Hogbin (Interstate) Pty. Ltd.
144	" stapling, "Celco 80" ..	7145	"	1.89	Jasco Pty. Ltd.
145	" " Long arm type "Velos 347" ..	7153	"	3.10	Clive Hogbin (Interstate) Pty. Ltd.
146	Oil, for typewriters, small tins ..	5428	"	0.13	F. J. Clementson
147	Openers, letter, stainless steel ..	5436	"	0.15	Clive Hogbin (Interstate) Pty. Ltd.
148	Pads, self-inking, I.R. stamp, 2½" x 4½", red, blue, purple, black, green No. 1	5541 to 5592	"	0.20	Sands and McDougall Pty. Ltd.
149	" self-inking, I.R. stamp 3½" x 6", green, black, blue, red, purple, No. 2	5606 to 5622	"	0.32	Gibson Kelite Chemicals Ltd.

* Items less 2½ per cent—30 days.

Item No.	Description of Articles.	Education Dept. Code No.	Quantity.	Rate.	Name of Contractor.
SUB-SCHEDULE A—continued.				\$	
150	Paper, rolls, for adding machines, 3 ¹ / ₈ " x 3 ¹ / ₂ ", in 80-yd. rolls	5770	per roll	0.17	John Withers and Son Pty. Ltd.
151	" rolls for adding machines, 2 ¹ / ₂ " x 3 ¹ / ₂ ", in 80-yd. rolls	5789	per 100 rolls	12.96*	Edwards Dunlop and Company Ltd.
152	" rolls for adding machines, 2 ¹ / ₂ " x 2 ¹ / ₂ " in 40-yd. rolls	5762	"	8.91	Columbia Writing Products Pty. Ltd.
153	" rolls, for cash register, size " Y "	..	"	..	
154	Pencil, lengthener	5029	per doz.	..	Purchase (Regulation 109)
155	Pencils, coloured, hexagonal, blue	5819	"	..	
156	" coloured, blue, round	5800	"	..	
157	" coloured, hexagonal, green	5835	"	..	
158	" coloured, green, round " Tintorex "	5827	per doz.	0.28	R. E. Mustow
159	" coloured, hexagonal, red " Staedtler "	5851	"	..	Purchase (Regulation 109)
160	" coloured, red, round " Tintorex "	5843	per doz.	0.28	R. E. Mustow
161	" coloured, round, combined red and blue	5878	"	..	Purchase (Regulation 109)
162	" coloured, violet, round	5886	"	..	
163	" coloured, yellow, round	5894	"	..	
164	" crayon, coloured, in boxes of 12 " Columbia Colorsketch "	6033	per doz. boxes	..	
165	" drawing, " Faber Castel " in all grades as required	5916 to 6025	per doz.	0.80	A. W. Faber-Castell (Aust.) Pty. Ltd.
166	" office, H.B. " Pacific "	5908	per gross	1.89	R. E. Mustow
167	" indelible, " Eagle "	6041	"	..	Purchase (Regulation 109)
168	" refills, for propellers, black	6068	per doz. boxes	..	
169	" refills, for propellers, coloured	"	..	
170	" waterproof, " Black Prince "	per doz.	..	
171	Pens, Ball-point, " Throw away " type, standard, Black	6130	per doz.	0.38	A. W. Faber-Castell (Aust.) Pty. Ltd.
172	" Ball-point, " Throw away " type, standard, Blue	6092	"	0.38	
173	" Ball-point, " Throw away " type, standard, Red	6114	"	0.38	
174	" Ball-point, " Throw away " type, standard, Green	6157	"	0.38	
175	" Ball-point, " Throw away " type, fine point, Black	6149	"	0.38	
176	" Ball-point, " Throw away " type, fine point, Blue	6106	"	0.38	
177	" Ball-point, " Throw away " type, fine point, Red	6122	"	0.38	
178	" Ball-point, " Throw away " type, fine point, Green	6165	"	0.38	
179	" Ball-point, " Biro "—Retractable type	6173	"	..	
180	" refills for above, black	6432	"	..	
Pen Nibs, in boxes of 1 gross—					
181	Argyle	per box	..	Purchase (Regulation 109)
182	Australian, No. 9 " Brandauers "	6262	"	..	
183	Journal	"	..	
184	Iridinoid, M.R.3	6270	"	..	
185	" First class ", No. 9	"	..	
186	Gillots, No. 170	6181	"	..	
187	" No. 290		"	..	
188	" No. 292		"	..	
189	" No. 293		"	..	
190	" No. 303		"	..	
191	" Nos. 404M, 404F, " Brandauer "		"	..	
192	" mapping, " Hentswells "		"	..	
193	" J " Myers, black	6289	"	..	
194	" J ", Heaths, black		"	..	
195	" J ", elongated, Heaths, " Gilt "		"	..	
196	" J ", black, " Gilt "		"	..	
197	Magazine, Brandauer and Co.		"	..	
198	Mail, No. 2134		"	..	
199	Manifolding, No. 0505		"	..	
200	Probate, Esterbrook		"	..	
201	Relief		"	..	
202	Review, Brandauer and Co.		"	..	
203	Scribbler, No. 147, " Ariel "	"	..		
204	Times	"	..		
205	Waverley	"	..		
206	Lawson	"	..		
207	Leicester	"	..		
208	Dawson, No. 9	"	..		
209	Mitchell	"	..		
210	Kopinib	"	..		
211	Latem	"	..		
212	Pedigree	"	..		
213	Penholders, plastic, rubber grip, assorted colours	6297	per gross	..	John Withers and Son Pty. Ltd.
214	Pins, drawing, ¹ / ₂ " diameter, 100 in box	6300	per box	0.12	

* Items less 2 1/2 per cent.—30 days.

Item No.	Description of Articles.	Education Dept. Code No.	Quantity.	Rate.	Name of Contractor.
				\$	
215	Pounce		per lb.	..	} Purchase (Regulation 109)
216	Protractors, 6" celluloid		each	..	
217	Protractors, circular celluloid, 5", full circle, $\frac{1}{16}$ " thick, $\frac{1}{2}$ " top bevel, two-way reading	6335	each	0.90	R. E. Mustow
218	Punches, for files, two holes, c to c, small $3\frac{1}{2}$ " "General" 220	6343	"	0.27	Clive Hogbin (Interstate) Pty. Ltd.
219	Ring, reinforcements, boxes of 100	6440	per box	..	Purchase (Regulation 109)
220	Refills, for table calendars "Pioneer"	7498	each	0.22	} Sands and McDougall Pty. Ltd.
221	" " " " "Invicta"	7498	"	0.22	
222	Stands for table calendars, "Pioneer"	7501	"	0.30	} Spicers Paper Industries Ltd.
223	" " " " "Invicta"	7501	"	0.53	
224	Rulers, ebony, round, 15"	6831	"	..	Sands and McDougall Pty. Ltd.
225	" flat, 15", brass edge	6823	per gross	16.50	Purchase (Regulation 109)
226	" flexible, metal, 15"	6866	"	..	Rulex Pty. Ltd.
227	Scissors, office, 6"	7005	each	0.16	Purchase (Regulation 109)
228	" Surgical, 6"	7013	"	0.38	Scientific and Laboratory Supply Co.
229	Scales, draughtsmen's, boxwood, engine-divided-- $\frac{1}{8}$ " and $\frac{1}{4}$ " ; $\frac{1}{4}$ " and $\frac{1}{2}$ " ; $\frac{3}{8}$ " and $\frac{1}{2}$ " ; $\frac{1}{2}$ " and 1" ; Armstrong	6874	"	..	} Purchase (Regulation 109)
230	" survey, boxwood, engine-divided, 10/20, 20/40, 30/60, 40/80, 40/160, 50/100—double-sided	6890	"	..	
231	Seals, gummed, notarial, No. 3 (packet of 100)	7021	per box	0.16	} Clive Hogbin (Interstate) Pty. Ltd.
232	Sharpeners, pencil, rotary, adjustable "Apsco Giant"	7048	each	2.04	
233	Silencers, mats, for typewriters, 12" x 12" Navy blue, grey or green	5177	"	0.88	R. E. Mustow
234	Sponges, coloured to fit bowls, $3\frac{1}{4}$ " diameter	7056	"	0.06	Clive Hogbin (Interstate) Pty. Ltd.
235	Squares, set, 45°, celluloid, 6" 0.40 "Longo"	7064	each	0.06	Jasco Pty. Ltd.
236	" set, 45° celluloid, 8" 0.40	7072	"	..	Purchase (Regulation 109)
237	" set, 45° celluloid, 10" 0.060 "Longo"	7080	"	0.18	Jasco Pty. Ltd.
238	" set, 60°, celluloid, 6" 0.40	7099	per doz.	1.05	General Stationers Pty. Ltd.
239	" set, 60° celluloid, 8" 0.060 "Longo"	7102	each	..	Purchase (Regulation 109)
240	" set, 60°, celluloid, 10" 0.060 "Longo"	7110	"	0.10	Jasco Pty. Ltd.
241	Stamps, dating, medium, No. 2 "Dominion"	7137	"	0.225	} R. E. Mustow
242	" " small, No. 1 $\frac{1}{2}$	7129	"	0.1608	
243	Rests for stamps, metal, to take twelve stamps, circular 839	6459	each	0.70	Jasco Pty. Ltd.
244	Staples for stapling machines— Type as ordered 5.000 in box "Velos 350"	7161 and 7188	per box	0.34	Clive Hogbin (Interstate) Pty. Ltd.
245	Straps, cotton, 2 ft., 1-in. wide, with buckle	7293	each	0.057	} Arnold Ribbon Co.
246	" cotton, 3 ft., 1-in. wide, with buckle	7307	"	0.075	
247	" cotton, 4 ft., 1-in. wide, with buckle	7315	"	0.093	
248	Tape, Cellulose, $\frac{1}{4}$ in. x 72 yards	7579	per roll	0.19	} Sellotape (Aust.) Ltd.
249	" " $\frac{1}{2}$ in. x 72 yards	7587	"	0.28	
250	" " 1 in. x 72 yards	7595	"	0.36	
251	" " $\frac{1}{4}$ in. x 36 yards	7544	"	0.13	Norton Australia Pty. Ltd.
252	" " $\frac{1}{2}$ in. x 36 yards	7552	"	0.17	} Sellotape (Aust.) Ltd.
253	" " 1 in. x 36 yards	7560	"	0.22	
254	" " 1 in. x 36 yds., coloured, red, green, blue, yellow, as required	7609	"	0.56	
255	" " $\frac{1}{4}$ in. x 225 in. (and dispenser)	7633	each	0.07	Norton Australia Pty. Ltd.
256	" " $\frac{1}{2}$ in. x 300 in. (and dispenser)	7528 and 7536	"	..	Purchase (Regulation 109)
257	" Labeling, for machines, all colours, "Dymo"— No. 5254, $\frac{1}{4}$ in. x 6 ft. No. 5201, $\frac{1}{4}$ in. x 12 ft. No. 158, $\frac{1}{2}$ in. x 12 ft.	7722 to 7765	per roll	0.45	Dymo Australia Pty. Ltd.
258	" Linen, adhesive, $\frac{1}{2}$ in. x 50 yards	7641	"	0.75	Sellotape (Aust.) Ltd.
259	" Paper, brown, gummed, 1 in. No. 60 x 500 ft.	7706	"	0.265	} Spicers Paper Industries Ltd.
260	" " " " 2 in. No. 60 x 500 ft.	7714	"	0.515	
261	Teledex	7773	each	1.62	R. E. Mustow
262	Trays, pen, glass, $9\frac{1}{2}$ in. x 3 in.	8001	"	..	Purchase (Regulation 109)
263	Type cleaner 2 in. x 2 in.	8052	"	0.15	Clive Hogbin (Interstate) Pty. Ltd.
264	Typewriters, foolscap size 12"	31216	"	60.50	Sydney Pincombe Pty. Ltd.
265	" brief size SG3N 15"	31232	"	67.80	} Olympia (Aust.) Pty. Ltd.
266	" policy size SG3N 18"	31259	"	78.80	
267	Wax, sealing, red, packed in 1-lb. boxes	8249	per lb.	0.46	Norman Bros. Pty. Ltd.
268	Weights, paper, glass, 4 in. x 2 $\frac{1}{2}$ in. x 1 in.	8257	each	..	Purchase (Regulation 109)

Approved—H. E. BOLTE, Treasurer. 20.8.68.

All supplies of Carbon Papers, Typewriters Ribbons and Trypograph Material under this Schedule will be ordered by Stores Officer, Education Department, and must be delivered as directed by him.

All the items must be of the very best description. If, after delivery, any deficiency or deficit is discovered in the quality, the balance of the articles on hand may be returned to the Contractor.

Carbon Papers must be cut to size in the Commonwealth, and packed in boxes of Commonwealth manufacture.

Item No.	Description of Articles.	Education Dept. Code No.	Quantity.	Rate.	Name of Contractor.
SUB-SCHEDULE B.					
CARBON PAPERS.					
Carbon Papers, for Typewriters, in boxes of colours as ordered.					
To take up to—					
	Weight of paper for ream.				
269	5 copies, standard weight, foolscap size, 8 lb.	5681 to 5703	per box (200 sheets)	0.62	Caribonum Aust. Pty. Ltd.
270	5 copies, standard weight, sizes as ordered, 8 lb.	Purchase (Regulation 109)
271	12 copies, light weight, foolscap size, 5 lb.	5711 to 5738	..	0.62	Caribonum Aust. Pty. Ltd.
272	12 copies, light weight, sizes as ordered, 5 lb.	Purchase (Regulation 109)
273	20 copies, featherweight, foolscap size, 4 lb.	5746 to 5754	..	1.10	Ramsay and Hall Pty. Ltd.
274	20 copies, featherweight, sizes as ordered, 4 lb.	} Purchase (Regulation 109)
275	Brief size—to take up to— 9 copies, light weight 3 lb.	
276	Pencil—Foolscap, in boxes of sheets, No. 10S ..	5665 to 5673	..	0.60	Bowater Paper Co. Ltd.
277	.. sizes as ordered	Purchase (Regulation 109)
278	Pen—in boxes of sheets, foolscap	5649 to 5657	..	0.60	Ellams Duplicator Co. (Melb.) Pty. Ltd.
279	.. in sheets, 13" x 8½"	Purchase (Regulation 109)
SUB-SCHEDULE C.					
RIBBONS, FOR TYPEWRITERS, ACCOUNTING AND ADDING MACHINES.					
(To be of the best description and supplied on reels as ordered).					
Two colour—					
280	½-in. wide, on spools containing 12 yards, Record	6475 to 6807	per reel	0.21	Ramsay and Hall Pty. Ltd.
One-colour—					
281	½-in. wide, on spools containing 12 yards, Copying	Purchase (Regulation 109)
282	½-in. wide, on spools containing 12 yards, Record	0.21	Ramsay and Hall Pty. Ltd.
283	Ribbons for Remington Accounting Machines, ¼-in. red and black	6467	} Purchase (Regulation 109)
284	Ribbons for Adding Machines	
SUB-SCHEDULE D.					
TRYPOGRAPH MATERIAL, ETC.					
Stencil Paper—Dry Indestructible—					
285	For all Standard Rotary and Flat Duplicators in 2-quire boxes, "Duplicopy"	7196 to 7285	per quire	0.90	Mason Kolok Mfg. Co. Ltd.
Ink—					
286	For Standard Rotary Duplicators, { "Roneo"	4359	each	1.10*	Morgan Inks Pty. Ltd.
	{ "Ellams"	4367	Purchase (Regulation 109)
287	in 1-lb. tubes or bottles { "Gestetner"	4375	..	1.00*	Morgan Inks Pty. Ltd.
	Varnish, Stencil, in 1-oz. bottles, with brush	8141	per doz.	2.00	} Ramsay and Hall Pty. Ltd.
288	Developer, in 1-oz. bottles	3212	..	1.80	

* Items less 5 per cent.—14 days or 2½ per cent.—30 days.

SCHEDULE NO. 68.
GENERAL STORES—STAMPS, RUBBER.

Contract from 1st September, 1968, to 31st August, 1969.

1967/1264.—Allstamps and Services .. Security, \$20

Delivery to be made to the place of delivery designated on order within 7 days of receipt of order.

Item No.	Description of Articles.	Rate.	Name of Contractor.	
	Stamps, rubber, wooden handle and mount, any length up to 5", type up to $\frac{3}{8}$ " high—	\$		
1	One line each	0.33	} Allstamps and Services	
2	Two lines "	0.43		
3	Three lines "	0.49		
4	Four lines "	0.57		
5	Over four lines line extra	0.13		
	Stamps, rubber, wooden handle and mount, circular, oval or square, any wording not exceeding—			
6	2" x 1 $\frac{1}{4}$ " each	0.75		
7	3" x 2" "	0.95		
8	4" x 3" "	1.20		

Approved—H. E. BOLTE, Treasurer. 20.8.68.



VICTORIA GOVERNMENT GAZETTE

Published by Authority

[Registered at the General Post Office, Melbourne, for transmission by post as a newspaper.]

No. 94]

WEDNESDAY, NOVEMBER 13

[1968

PROCLAMATIONS

Land Act 1958.

AREA OF LAND COMPRISED IN CERTAIN CLASSES DIMINISHED OR INCREASED.

PROCLAMATION

By His Excellency the Governor of the State of Victoria and its Dependencies in the Commonwealth of Australia, &c., &c., &c.

WHEREAS by the *Land Act 1958* it is amongst other things enacted that the Governor in Council may, by Proclamation to be published in the *Government Gazette*, at any time diminish or increase the area of land comprised in any of the classes mentioned in Part I., Division 1, Section 5, of the said *Land Act 1958*, but that the area of lands which may be sold by auction (Class 6), shall not be increased except as in certain cases in the said Act provided: Now therefore I, the Governor of the State of Victoria, in the Commonwealth of Australia, by and with the advice of the Executive Council of the said State, and in accordance with the provisions of Sections 94 and 117 of the *Land Act 1958* aforesaid, do hereby diminish or increase (as the case may be) the areas of Crown lands comprised in Classes 6 and 7 of the classes mentioned in Section 5 of the *Land Act 1958* aforesaid, to the extent set forth in the subjoined Schedule (that is to say):—

Schedule referred to.

CLASSES DIMINISHED OR INCREASED.

County.	Parish.	Allotment.	Section.	Area.	Diminished.	Increased.	Description.
					Class.	Class.	
				A. R. P.			
Bogong	Tarrawingee	F4	A	22 1 32	7	6	In the north of Parish Fronting east side of main Colac-Warrion Road
Grenville	Warrion	7	..	2 1 34	..	6	

Given under my Hand and the Seal of the State of Victoria, aforesaid, at Melbourne, this sixth day of November, in the year of our Lord One thousand nine hundred and sixty-eight, and in the seventeenth year of the reign of Her Majesty Queen Elizabeth II.

ROHAN DELACOMBE.

(L.S.)

By His Excellency's Command,
W. J. F. McDONALD,
Minister of Lands.

GOD SAVE THE QUEEN!

Land Act 1958.

UNALIENATED CROWN LAND AVAILABLE FOR SETTLEMENT UNDER IMPROVEMENT PURCHASE LEASES.

PROCLAMATION

By His Excellency the Governor of the State of Victoria and its Dependencies in the Commonwealth of Australia, &c., &c., &c.

IN pursuance of the provisions of Section 153 of the Land Act 1958, I, the Governor of the State of Victoria, in the Commonwealth of Australia, by and with the advice of the Executive Council of the said State, do by this Proclamation declare the unalienated Crown lands mentioned in the subjoined schedule, to be available for settlement under improvement purchase leases.

SCHEDULE.

County.	Parish.	Allotment.	Section.	Area.			Land Valuation.
				A.	R.	P.	
Croajingolong	Tonghi	34	..	200	0	0	\$10.00 per acre
Dargo	Dargo	17	20	70	0	0	\$5.00 per acre
Dundas	Ganoo Ganoo	22A and 23	A1	210	0	0±	\$8.00 per acre

Given under my Hand and the Seal of the State of Victoria aforesaid, at Melbourne this sixth day of November, in the year of our Lord One thousand nine hundred and sixty-eight and in the seventeenth year of the reign of Her Majesty Queen Elizabeth II.

ROHAN DELACOMBE.

(L.S.)

By His Excellency's Command,
W. J. F. McDONALD,
Minister of Lands

GOD SAVE THE QUEEN !

Land Act 1958, Section 25.
TOWNSHIP OF DRY DIGGINGS DIMINISHED.

PROCLAMATION

By His Excellency the Governor of the State of Victoria and its dependencies in the Commonwealth of Australia, &c., &c., &c.

I, THE Governor of the State of Victoria, in the Commonwealth of Australia, by and with the advice of the Executive Council of the said State, and in pursuance of the provisions contained in Section 25 of the Land Act 1958, do by this Proclamation diminish the Township of Dry Diggings, proclaimed as such on the 2nd April, 1951, and extended by proclamation of the 30th May, 1967, by the excision therefrom of the portion indicated by hatching on plan hereunder.—(D.221⁽²⁾) (C.56693).

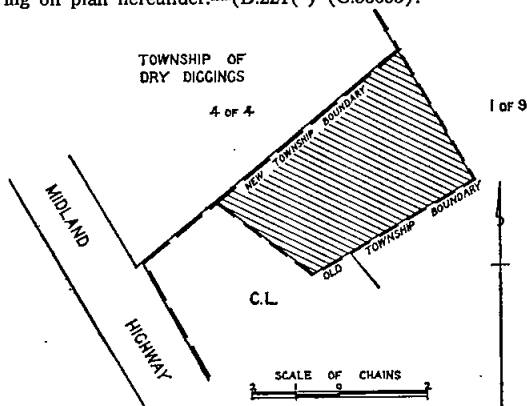

—(C.56693.)

Given under my Hand and the Seal of the State of Victoria aforesaid, at Melbourne, this sixth day of November, in the year of our Lord One thousand nine hundred and sixty-eight, and in the seventeenth year of the reign of Her Majesty Queen Elizabeth II.

(L.S.) ROHAN DELACOMBE.

By His Excellency's Command,
W. J. F. McDONALD,
Minister of Lands.

GOD SAVE THE QUEEN !

ROADS PROCLAIMED.

PROCLAMATION

By His Excellency the Governor of the State of Victoria and its Dependencies in the Commonwealth of Australia, &c., &c., &c.

IN pursuance of the provisions of Section 25 of the Land Act 1958, the Governor of the State of Victoria by and with the advice of the Executive Council of the said State, do hereby proclaim as roads the lands in the Township of Dimboola, Parish of Dimboola, County of Borung as indicated by hatching on plan hereunder.—(D.150⁽⁹⁾) (Rs.8552).

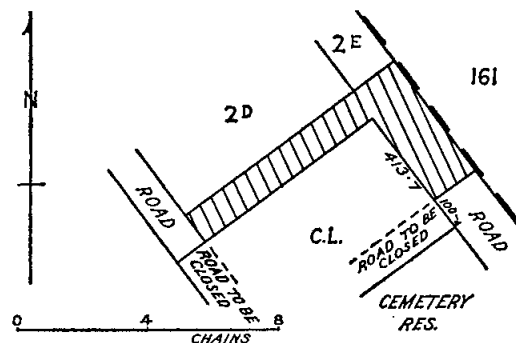

Given under my Hand and the Seal of the State of Victoria aforesaid, at Melbourne, this sixth day of November, in the year of our Lord One thousand nine hundred and sixty-eight, and in the seventeenth year of the reign of Her Majesty Queen Elizabeth II.

(L.S.) ROHAN DELACOMBE.

By His Excellency's Command,
W. J. F. McDONALD,
Minister of Lands.

GOD SAVE THE QUEEN !

ACTS OF PARLIAMENT.

PROCLAMATION

By His Excellency the Governor of the State of Victoria and its Dependencies in the Commonwealth of Australia, &c., &c., &c.

I, THE Governor of the State of Victoria, in the Commonwealth of Australia, do hereby declare that I have this day assented, in Her Majesty's name, to the Bills passed by the Parliament of the said State, the titles whereof are hereunder set forth, together with the short titles, that is to say:—

No. 7714. "An Act to increase Certain Penalties in the Margarine Act 1958." (*Margarine (Penalties) Act 1968.*)

Given under my Hand and the Seal of the State of Victoria aforesaid, at Melbourne, this sixth day of November, in the year of our Lord One thousand nine hundred and sixty-eight, and in the seventeenth year of the reign of Her Majesty Queen Elizabeth II.

(L.S.) ROHAN DELACOMBE.

By His Excellency's Command,
HENRY BOLTE,
Premier.

GOD SAVE THE QUEEN I

SWINE COMPENSATION ACT 1967.

DATE OF COMING INTO OPERATION OF PARTS I., II., III. AND IV.

PROCLAMATION

By His Excellency the Governor of the State of Victoria and its Dependencies in the Commonwealth of Australia, &c., &c., &c.

WHEREAS by an Act of Parliament of the State of Victoria passed in the sixteenth year of the reign of Her Majesty Queen Elizabeth II entitled the *Swine Compensation Act 1967* it is amongst other things enacted that Parts I, II, III and IV of the said Act shall come into operation on a day to be fixed by the Proclamation of the Governor in Council published in the *Government Gazette*.

Now therefore I, the Governor of the State of Victoria, in the Commonwealth of Australia, by and with the advice of the Executive Council of the said State, do by this my Proclamation fix Monday, the second day of December, One thousand nine hundred and sixty-eight as the day on which the said Parts I, II, III and IV of the said *Swine Compensation Act 1967* shall come into operation.

Given under my Hand and the Seal of the State of Victoria aforesaid, at Melbourne, this sixth day of November, in the year of our Lord One thousand nine hundred and sixty-eight, and in the seventeenth year of the reign of Her Majesty Queen Elizabeth II.

(L.S.) ROHAN DELACOMBE.

By His Excellency's Command,
G. L. CHANDLER,
Minister of Agriculture.

GOD SAVE THE QUEEN I

CATTLE COMPENSATION ACT 1967.

DATE OF COMING INTO OPERATION OF PARTS I., II., III. AND IV.

PROCLAMATION

By His Excellency the Governor of the State of Victoria and its Dependencies in the Commonwealth of Australia, &c., &c., &c.

WHEREAS by an Act of Parliament of the State of Victoria passed in the sixteenth year of the reign of Her Majesty Queen Elizabeth II entitled the *Cattle Compensation Act 1967* it is amongst other things enacted that Parts I, II, III and IV of the said Act shall come into operation on a day to be fixed by the Proclamation of the Governor in Council published in the *Government Gazette*.

Now therefore I, the Governor of the State of Victoria, in the Commonwealth of Australia, by and with the advice of the Executive Council of the said State, do by this my Proclamation fix Monday, the second day of December, One

thousand nine hundred and sixty-eight as the day on which the said Parts I, II, III and IV of the said *Cattle Compensation Act 1967* shall come into operation.

Given under my Hand and the Seal of the State of Victoria aforesaid, at Melbourne, this sixth day of November, in the year of our Lord One thousand nine hundred and sixty-eight, and in the seventeenth year of the reign of Her Majesty Queen Elizabeth II.

(L.S.) ROHAN DELACOMBE.

By His Excellency's Command,
G. L. CHANDLER,
Minister of Agriculture.
GOD SAVE THE QUEEN I

GOVERNMENT NOTICES

Survey Co-ordination (Place Names) Act, No. 7360.

NOTICE OF INTENTION.

PURSUANT to the powers conferred under Section 28 of the above Act, the Place Names Committee hereby gives notice of its intention to alter the names of the creeks mentioned hereunder:—

Municipality.—Shire or Lillydale.

Location.—Commencing near the south-eastern corner of Crown allotment 39, Parish of Mooroolbark, then flowing generally westerly and north-westerly to allotment 30E, Parish of Ringwood; thence generally south-westerly to its junction with the Bungalook Creek.

Present Name.—Little Dandenong Creek, North Branch.

Proposed Name.—Bungalook Creek.

Location.—Commencing on the north side of allotment 50, Parish of Mooroolbark; thence flowing in a westerly by north-westerly direction to the west boundary of allotment 44A of the said Parish; thence westerly and north-westerly to its junction with the Bungalook Creek.

Present Name.—Little Dandenong Creek, South Branch.

Proposed Name.—Little Bungalook Creek.

Any person who objects to the above may give such objections, in writing, stating the reasons therefor, to the Secretary of the Committee not more than two months following the publication of this notice.

By order of the Committee,
C. E. E. BARLOW,
Secretary.

CONSUL.

NOTICE is given that full recognition has been accorded Mr. D. Hakim as Consul of the United States of America at Melbourne, with jurisdiction throughout the States of Victoria and Tasmania, as from 26th October, 1968.

A. G. COULTHARD, Secretary.
Premier's Office,
Melbourne, Vic. 3002, 6th November, 1968.

MOTOR CAR ACT 1958.—SECTION 19.

NOTICE is hereby given that, for the purpose of section 19 of the *Motor Car Act 1958*, approval has been granted to the associations listed below to organize and conduct official rallies of veteran and vintage motor cars.

Western District Historic Vehicle Club.
North Central Vintage Car Club.
Wimmera-Mallee Historical Vehicle Society.

R. H. ARNOLD,
Chief Commissioner.

Police Regulation Act 1958, section 122.

SALE OF UNCLAIMED MOTOR VEHICLE.

AN owner is required for a 1952 model, black Dodge sedan motor vehicle, ex-registered No. YB-547, engine No. D.40214345C, with a wooden trailer attached.

The vehicle and trailer came into the possession of Police on the 13th June, 1968, and, if not claimed, will be sold by public auction at the Broadmeadows Police Station, cnr. Widford and Freda streets, Broadmeadows, at 2 p.m., on the 18th December, 1968.

R. H. ARNOLD,
Chief Commissioner of Police.

REGISTER OF DISTRIBUTORS OF PRINTED MATTER.

The following is a copy of the Register corrected to the end of October, 1968 and is published in accordance with the requirements of sub-section (3) of section 182 of *Police Offences Act 1958*.

Name.	Address.	Date of Registration.
Hyde Distributing Company Pty. Ltd.	247 Collins-street, Melbourne	18.8.54
Victorian Magazine Distributors Pty. Ltd.	247 Collins-street, Melbourne	18.8.54
Australian Musical Productions Pty. Ltd.	Princess Theatre, Spring-street, Melbourne	2.9.54
Consolidated Press Limited	247 Collins-street, Melbourne	2.9.54
Shakespeare Head Press Pty. Ltd.	247 Collins-street, Melbourne	2.9.54
Robertson and Mullens Limited	107-113 Elizabeth-street, Melbourne	7.9.54
J. Ewins and Sons Pty. Ltd.	111 Sturt-street, Ballarat	7.9.54
Moe Books and Stationery Pty. Ltd.	46A George-street, Moe	7.9.54
The Argus and Australasia Ltd.	26 Flinders-street, Melbourne	8.9.54
Gordon and Gotch (Australasia) Ltd.	511 Little Collins-street, Melbourne	13.9.54
The Book Depot	c/o The Methodist Conference of Victoria and Tasmania, 288 Little Collins-street, Melbourne	15.9.54
L. J. M. Hodder and Company	328 Flinders-street, Melbourne	21.9.54
B. H. Walshe and Son	34 Queen-street, Melbourne	23.9.54
Stanley Young Pty. Ltd.	244 Swanston-street, Melbourne	23.9.54
Associated Newspapers Limited	392-396 Little Collins-street, Melbourne	23.9.54
Hicks Smith and Sons Pty. Ltd.	23 McKillop-street, Melbourne	27.9.54
Lothian Publishing Co. Pty. Ltd.	1 Fleming-place, Melbourne	27.9.54
Whitcombe and Tombs Pty. Ltd.	20 Bond-street, Melbourne	4.10.54
W. Ramsay (Surgical) Limited	340 Swanston-street, Melbourne	7.10.54
Frederick Theodore Sambell	33 Lonsdale-street, Melbourne	12.10.54
Edwards Dunlop and Co. Ltd.	568 Collins-street, Melbourne	13.10.54
Alex. Cowan (Australia) Pty. Ltd.	500 Collins-street, Melbourne	14.10.54
F. W. Cheshire Pty. Ltd.	338 Little Collins-street, Melbourne	20.10.54
Longmans Green and Co. Ltd.	Railway-crescent, Croydon	22.10.54
Angus and Robertson Ltd.	66-68 Elizabeth-street, Melbourne	25.10.54
Geoffrey Francis Sheppard	1024 High-street, Armadale	29.10.54
Southdown Press Pty. Ltd.	51 Queen-street, Melbourne	29.10.54
G. J. Coles and Company Ltd.	282 Little Collins-street, Melbourne	1.11.54
Technical Book and Magazine Co.	297-299 Swanston-street, Melbourne	3.11.54
Cassell and Company Ltd.	210 Queen-street, Melbourne	4.11.54
The Herald and Weekly Times	44-74 Flinders-street, Melbourne	5.11.54
H. and S. Publications	Bringelly-road, Austral, New South Wales	10.11.54
Davies, Cyril Victor	66 McBride-avenue, Wonthaggi	10.11.54
Berry, Anderson and Company	207 Sturt-street, Ballarat	16.11.54
William Collins (Overseas) Ltd.	527-531 Little Collins-street, Melbourne	16.11.54
MacMillan and Company Limited	32 Flinders-street, Melbourne	25.11.54
Thompson, James Walter	137 Gloucester-street, Sydney, New South Wales	2.12.54
Oxford University Press Australian Branch	346 Little Collins-street, Melbourne	2.12.54
Jack Gordon	63 River-street, Richmond	21.2.55
N.S.W. Bookstall Co. Pty. Ltd.	112 Castlereagh-street, Sydney, New South Wales	22.2.55
Robert Burns Book Club	17 Railway-avenue, Caulfield	1.3.55
Georgian House Pty. Ltd.	296 Beaconsfield-parade, Middle Park	9.3.55
Cologravure Publications	44-74 Flinders-street, Melbourne	24.3.55
United Press Book Division	44-74 Flinders-street, Melbourne	24.3.55
Herald-Sun Readers Book Club	44-74 Flinders-street, Melbourne	24.3.55
"Truth" and "Sportsman" Limited	Hosking House, Hosking-place, 84A Pitt-street, Sydney, New South Wales	29.3.55
The Legend Press Pty. Ltd.	31 Macquarie-place, Sydney, New South Wales	27.4.55
Spicers (Australia) Pty. Ltd.	160 Fulham-road, Fairfield	17.7.57
Unification Pty. Ltd.	497 Collins-street, Melbourne	27.9.57
Horwitz Publications Inc. Pty. Ltd.	406 Lonsdale-street, Melbourne	9.5.58
Brian Vincent Casey—Distribution in Victoria on behalf of Adult Education Publications, Pelican-street, Surry Hills, New South Wales	572 Lonsdale-street, Melbourne	1.9.58
Goldray Publications	P.O. Box 2, Austral, New South Wales ; Lot 4A Bringelly- road, Austral, New South Wales	25.9.59
Herald Gravure Printers	26 Flinders-street, Melbourne	14.11.61
Alice Lesley Mather	335 Beaconsfield-parade, St. Kilda	8.6.64
R. G. & H. Hornblow	2 Hawthorn-avenue, Belmont, Geelong	14.1.66
Jack Milton De Lissa	372 Pitt-street, Sydney, New South Wales	8.11.66
Baker Publishing Pty. Ltd.	420 St. Kilda-road, Melbourne	5.12.66
S. John Bacon Publishing Company Pty. Ltd.	119 Burwood-road, Burwood	24.2.67
Hutchinson Publishing Group Limited	76 Flinders-lane, Melbourne	6.3.67
Morgan, Margery Mary	4A Hadyn-street, Blackburn	14.3.67
Monash University	Wellington-road, Clayton	16.3.67
Strautins, Austra	306 Little Collins-street, Melbourne	16.3.67
Sun Books Pty. Ltd.	459 Little Collins-street, Melbourne	21.3.67
Oliver, Stephen Andrew under the business name of Goulburn Murray Pictorial	Archer-street, Shepparton	3.4.67
International Bookshop Pty. Ltd.	17 Elizabeth-street, Melbourne	20.4.67
Time Life International (Australia) Pty. Ltd.	447 Collins-street, Melbourne	5.6.67
James Robinson	24 The Crest, Frankston	28.11.67
Terence William Blake	447A Rathdown-street, Carlton	9.1.67
Leslie Furze-Morrish and Lorraine Furze-Morrish	10 Orrong-grove, Nth. Caulfield	30.4.68
Leslie William Swallow	Tootal-road, Dingley	16.9.68
Leonard George Milroy Williams	29 Mabel-avenue, Mildura	15.10.68
George Atwell and Peter John Harris	15 Selwyn-avenue, Craigieburn	17.10.68

Private Agents Act 1966.

NOTICE OF RECEIPT OF APPLICATIONS FOR LICENCES UNDER THE PROVISIONS OF THE PRIVATE AGENTS ACT 1966.

THE Clerk(s) of the Court(s) of Petty Sessions as listed hereunder hereby give notice that applications, as under, have been lodged for hearing by the said Court(s) on the date(s) specified.

Any person desiring to object to any of such applications must—

- (a) lodge with the respective Clerk of Petty Sessions a notice in the prescribed form of his objection and of the grounds thereof ;
- (b) cause a copy of such notice to be served personally or by post upon the applicant at least three days before the hearing of the application ; and
- (c) send or deliver—
 - (i) where the objection is not made by the officer in charge of the police district in which the Court is situated—a copy of the notice to such officer ; and
 - (ii) where the objection is not made by the Registrar or Deputy Registrar—a copy to the Registrar.

Full Name of Applicant or in the case of a Firm or Corporation, of the Nominee.	Place of Abode of Applicant or Nominee.	Name of Firm or Corporation.	Address for Registration.	Type of Licence.	Date of Hearing of Application.
---	---	------------------------------	---------------------------	------------------	---------------------------------

COURT OF PETTY SESSIONS, FOOTSCRAY.

Kennedy, Byron Eric ..	5 Jepson-street, Yarraville	17 Richards-street, Yarraville	Watchman ..	18.11.68
------------------------	-----------------------------	---------	--------------------------------	-------------	----------

Dated at Footscray this 28th day of October, 1968.

G. S. HOARE, Clerk of Petty Sessions.

COURT OF PETTY SESSIONS, GEELONG.

Walters, Bruce Paul ..	121 Fyans-street, Geelong	Individual ..	121 Fyans-street, Geelong	Inquiry Agent ..	15.11.68
------------------------	---------------------------	---------------	---------------------------	------------------	----------

Dated at Geelong this 25th day of October, 1968.

J. R. AITKEN, Clerk of Petty Sessions.

COURT OF PETTY SESSIONS, PRAHRAN.

Davidson, Percival ..	12 Antwerp-street, Broadmeadows	Factory Guard Service Pty. Ltd.	562 St. Kilda-road, Melbourne	Watchman ..	19.11.68
Nelson, Gordon Robert ..	14 Louise-street, Bayswater	" "	" "	" ..	"

Dated at Prahran this 29th day of October, 1968.

G. T. WHEELHOUSE, Clerk of Petty Sessions.

COURT OF PETTY SESSIONS, SOUTH MELBOURNE.

Harris, Ronald Colin ..	3 Valerie-street, Pascoe Vale	101-105 Clarke-street, Melbourne South	Watchman ..	29.11.68
-------------------------	-------------------------------	---------	--	-------------	----------

Dated at South Melbourne this 31st day of October, 1968.

G. MILLER, Clerk of Petty Sessions.

COURT OF PETTY SESSIONS, PRAHRAN.

Hall, Robert Frederick Longden	Flat 8, Alma-road, St. Kilda	Melbourne Night Patrol Service	Suite 18, 614 St. Kilda-road, Melbourne	Watchman ..	29.11.68
--------------------------------	------------------------------	--------------------------------	---	-------------	----------

Dated at Prahran this 31st day of October, 1968.

G. T. WHEELHOUSE, Clerk of Petty Sessions.

COURT OF PETTY SESSIONS, PRAHRAN.

Seggie, David Ross ..	10 Irving-avenue, Murrumbeena	Melbourne Night Patrol Service	614 St. Kilda-road, Melbourne	Watchman ..	25.11.68
-----------------------	-------------------------------	--------------------------------	-------------------------------	-------------	----------

Dated at Prahran this 1st day of November, 1968.

G. T. WHEELHOUSE, Clerk of Petty Sessions.

COURT OF PETTY SESSIONS, MELBOURNE.

Bryant, Edward George ..	7 Meredith-street, Broadmeadows	Australian Watching Co. Pty. Ltd.	340 Abbotsford-street, North Melbourne	Watchman ..	20.11.68
Cahill, Edward James ..	58 Jensen-road, East Preston	" "	" "	" ..	"
Clark, Rowland James ..	18 Barry-street, Seaford	Mayne Nickless Limited	94 York-street, South Melbourne	" ..	"
Cranston, Ronald Albert William	29 Crimson-drive, Doveton	Australian Watching Co. Pty. Ltd.	340 Abbotsford-street, North Melbourne	" ..	"
Cremin, David Lawrence ..	30 Shaftsbury-street, Coburg	" "	" "	" ..	"
Long, Allan ..	7 Blenheim-avenue, Surrey Hills	" "	" "	" ..	"

Dated at Melbourne this 30th day of October, 1968.

G. L. WEBSTER, Clerk of Petty Sessions.

Transport Regulation Act.
TRANSPORT REGULATION BOARD.
HEARING OF APPLICATIONS.

NOTICE is hereby given that the following applications will be considered by the Transport Regulation Board, at its offices at the corner of Lygon and Princes streets, Carlton, at 10.15 a.m., on Wednesday, 27th November, 1968:—

ANSELL, G. E., 20 Wilby-street, Sorrento. One commercial passenger vehicle (S/C. 12) to operate as follows:—
(1) Shopping tours from Sorrento to (a) Southland, (b) Melbourne. (2) Tours from Sorrento to (a) Cultural Centre, (b) City and suburbs, (c) various Snow Resorts. (3) As a country special service omnibus from Sorrento.

LITTLES GIPPSLAND COACHES PTY. LTD., 9 Macalister-street, Sale. Application to operate a country stage service between Sale and the Esso/Hematite Headquarters at Dutton as and when required. Fares: 60c single.

SPRIGGS, A. J., Private Bag 72, Hamilton. One luxury commercial passenger vehicle (S/C. 5) to be purchased, to operate as a touring omnibus on specialized nature study tours from Melbourne to places throughout the State of Victoria as follows:—

Tour 1—

Melbourne — Benalla — Wodonga — Corryong — Mt. Beauty — Melbourne.

Tour 2—

Melbourne — Alexandra — Mt. Buller — Benalla — Echuca — Melbourne.

Tour 3—

Melbourne — Castlemaine — Kerang — Mildura — Rainbow — Melbourne.

Tour 4—

Melbourne — Ballarat — Hamilton — Edenhope — Horsham — Melbourne.

Tour 5—

Melbourne — Bendigo — Echuca — Shepparton — Melbourne.

Fares: To be determined.

Notice of any objection should be forwarded to reach the Secretary of the Board not later than Wednesday, 20th November, 1968.

Applicants are advised that it will not be necessary to appear on the hearing date specified above, unless advised in writing by the Board.

B. P. KAY,
Secretary.

Corner Lygon and Princes streets, Carlton, Wednesday, 6th November, 1968.

Commercial Goods Vehicles Act.
TRANSPORT REGULATION BOARD.
HEARING OF APPLICATIONS.

NOTICE is hereby given that the following applications will be considered by the Transport Regulation Board at its offices at the corner of Lygon and Princes streets, Carlton, at 10.15 a.m., on Wednesday, 27th November, 1968:—

ALLEN, A. W., SALES PTY. LTD., 51-63 Riverside-avenue, South Melbourne, 3205. Application to vary conditions of licence No. D.A. 2218 (L/C. 77 cwt.) by deleting the existing conditions and adding in lieu:—
In the course of business as "Wholesale Confectionery Distributors"—own goods as follows:—(a) Within a 50-mile radius of the post office at the corner of Bourke and Elizabeth streets in the City of Melbourne. (b) From the railway station at Sale to retailers within that part of the State of Victoria bounded by the Townships of Inverloch, Leongatha, Thorpdale, Callignee North, Glengarry, Glenmaggie, Briagolong, Stratford, Sale, Seaspray and the Victorian coastline from Seaspray to Inverloch. (c) From and to the railway stations at Orbost, and Bairnsdale to and from retailers at Orbost, Bairnsdale, Walpa and Lindenow South.

ALLEN, A. W., SALES PTY. LTD., 51-63 Riverside-avenue, South Melbourne, 3205. Application to vary conditions of licence No. D.A.2218/3 (L/C. 77 cwt.) by deleting the existing conditions and adding in lieu:—
"(a) Within a 50-mile radius from the chief post office in the City of Bendigo and north to places astride the main road on the following route—Bendigo to Kerang, Swan Hill, Ultima, Quambatook and return to Bendigo in the course of business as 'Wholesale Confectionery Distributors'—own goods,

provided that all such goods carried shall have been initially consigned by rail to Bendigo and Swan Hill. (b) From the City of Bendigo to the City of Melbourne once per month for the sole purpose of servicing the vehicle, and on return trips to Bendigo to carry snowballs and marshmallow products".

ALLEN, A. W., SALES PTY. LTD., 51-63 Riverside-avenue, South Melbourne, 3205. Application to vary conditions of licence No. D.A.2218/5 (L/C. 65 cwt.) by deleting "the Township of Nyah West" from paragraph (i) of the existing conditions and adding in lieu "the Town of Vinifera" and also deleting paragraph (ii) of the existing conditions and adding in lieu:—
"(ii) On the south by a line drawn from the Town of Vinifera through the Township of Turriff and thence to the Victorian/South Australian Border".

ALLEN, A. W., SALES PTY. LTD., 51-63 Riverside-avenue, South Melbourne, 3205. Application to vary conditions of licence No. D.A.2218/6 (L/C. 74 cwt.) by deleting parts (ii) and (iii) of paragraph (a) and adding in lieu:—
"(i) From the railway station at Traralgon to towns on or astride the Princes Highway as far west as the Township of Drouin, to towns north of Warragul as far as Neerim South, and to Hazelwood and Yinnar. (iii) From and to the railway stations at Orbost and Bairnsdale to and from retailers at Orbost, Bairnsdale, Walpa and Lindenow South."

ALLEN, A. W., SALES PTY. LTD., 51-63 Riverside-avenue, South Melbourne, 3205. Application to vary conditions of licence No. D.A.2218/7 (L/C. 60 cwt.) by adding to the existing conditions as an additional paragraph—
"(d) From the railway station at Wonthaggi to retailers within that part of the State of Victoria bounded by the Towns of Newhaven, Nyora, Poowong and Korumburra and Cape Patterson in course of business as 'Wholesale Confectionery Distributors'—own confectionery."

ANDERSON, B. F., 8 Cambria-street, Noble Park, 3174. One commercial goods vehicle (L/C. 11 cwt.) to operate throughout the State of Victoria in course of business as "Fencing Contractor" for the purpose of supervising own contracts—tools of trade, construction equipment, and small quantities of materials incidental to the completion of own contracts.

ANDERSON, B. F., 8 Cambria-street, Noble Park, 3174. One commercial goods vehicle (L/C. 153 cwt.) to operate: (a) Within a 50-mile radius of own premises at Noble Park in course of business as "Fencing Contractor"—own goods. (b) Throughout the State of Victoria for the purpose of completing own fencing contracts—tools of trade, erection equipment, palings, fencing rails and a small quantity only of chain wire, sand and screenings and red gum. (c) Within a 25-mile radius of any contract site or from the nearest railway station thereto—any other materials required for such contract.

BAR'S LEAKS (AUSTRALIA) PTY. LTD., 75A Bonanza-road, Beaumaris, 3193. One commercial goods vehicle (L/C. 9 cwt.) to operate throughout the State of Victoria in the course of business as "Manufacturers of Automotive Products" (car cooling systems) for the purpose of sales promotion and demonstration of own manufactured products with the ability to make an urgent incidental delivery.

BRENNAN, W. F. (trading as P. A. & W. F. Brennan), 10 Glancy-street, Horsham, 3400. One commercial goods vehicle (L/C. 341 cwt.) to operate: (a) Within a 25-mile radius of the post office at Horsham—general goods provided that no goods shall be carried whether by one stage or by more than one stage between places within the above radius which are more than thirty road miles apart by the nearest practicable route. (b) Within a 50-mile radius of the post office at Horsham in the course of business as "Primary Producer"—own goods. (c) Within a 50-mile radius of the post office at Horsham in the course of business as "Agricultural Contractor"—own goods.

C. & I. CLEANING PTY. LTD., 173 Grange-road, Fairfield, 3078. One commercial goods vehicle (L/C. 6 cwt.) to operate throughout the State of Victoria in the course of business as "Industrial Cleaning Service"—own specialized cleaning equipment and cleaning materials incidental only to own contracts.

CAIRNS, R. J., Bennie-court, Flinders, 3929. One commercial goods vehicle (L/C. 159 cwt.) to operate within a 30-mile radius from the premises of Hillview Quarries Pty. Ltd., at Dromana—solely on behalf of the said company—screenings, stone dust and quarry products.

COCA-COLA BOTTLERS (MELBOURNE) PTY. LTD., Levanswell-road, Moorabbin, 3189. One commercial goods vehicle (L/C. 143 cwt.) to operate within a 50-mile radius of the G.P.O., Melbourne, in course of business as

- "Aerated Water Manufacturers"—aerated waters and empty return containers, but excluding operations to or from the City of Geelong.
- COOTES & STAFF PTY. LTD., Racecourse-road, Casterton, 3311. One commercial goods vehicle (L/C. 116 cwt.) to operate within a 50-mile radius of the post office at Casterton in the course of business as "Agricultural Machinery Dealers"—farm machinery, motor bikes, boats and boat trailers and tools and equipment incidental to the servicing of such machinery.
- CRISPIN, A., 62 Birdwood-avenue, Sebastopol, 3356. One commercial goods vehicle (L/C. 18 cwt.) to operate within that part of the State of Victoria west of a north/south line drawn through Ballarat and south of the Western Highway in course of business as "Salesman" solely on behalf of Sunshine Biscuits Ltd.—samples of goods for display and advertising purposes, advertising materials, and also the ability to carry up to a maximum of four (4) cwt. at any one time of biscuits for delivery from the Ballarat Manufacturing Plant to the Hamilton Depot of the said company in an emergency.
- CURWOOD, C. A., 291 Station-street, Chelsea, 3196. One commercial goods vehicle (L/C. 22 cwt.) to operate within a 100-mile radius of the G.P.O., Melbourne in course of business as "House Removalist" as a service vehicle—tools of trade, equipment and spare parts incidental to the servicing of own equipment in the field only.
- DAVIS, J. L., PTY. LTD., 7 Curdie-street, Camperdown, 3260. Application to vary conditions of licence No. D.A.30402/2 (L/C. 147 cwt.) by adding to the existing conditions as an additional paragraph (d)—"(d) From Garden City Flour Mills at Ballarat to own premises situated at 7 Curdie-street, Camperdown—stock foods".
- DEPPELER, M. F., 217 Lexton-street, Ballarat, 3350. One commercial goods vehicle (L/C. 111 cwt.) to operate: (a) Within a 50-mile radius from the post office at Ballarat—plant the property of a contractor and required by him for use in connexion with the construction or maintenance of some specific, existing or proposed road, street, footpath, bridge, pier, wharf, weir channel and also the following materials, viz.: metal, stones, screenings, ashes, gravel, sand and earth. (b) Within a 20-mile radius from the site of any construction or maintenance work performed pursuant to paragraph (a) above or from the railway station nearest thereto—any other materials required for such work. (c) Within a 25-mile radius of the post office at Ballarat—general goods.
- DERIU, G., Box 17, Heyfield, 3858. One commercial goods vehicle (L/C. 200 cwt. approximately) to operate from landings in the Licola area to sawmills at Heyfield—logs.
- DE VOND, L., 16 Kiama-court, North Clayton, 3168. Application to vary conditions of licence No. D.A.61793 (L/C. 144 cwt.) by adding to the existing conditions as an additional paragraph (b)—"(b) within a 25-mile radius from the post office at North Clayton—general goods, provided that no goods shall be carried whether by one stage or by more than one stage between places within the above radius which are more than thirty (30) miles apart by the nearest practicable route.
- DUNLOP TYRE SERVICE (VIC.) PTY. LTD., Leongatha Branch, 6 Church-street, Leongatha, 3953. Three commercial goods vehicles (L/C. 13, 11 & 10 cwt.) to operate within a 50-mile radius of own branch premises at Leongatha in the course of business as "Tire Retailers and Retreaders"—own new tires for delivery, used tires and tubes for repair or for retreading and having been repaired or retreaded, also batteries subject to the condition that all new tires and new tubes and new batteries carried on the vehicle shall have been initially consigned by rail to Leongatha.
- DURAL LEEDS PTY. LTD., corner Calder Highway and Roberts-road, Niddrie, 3042. One commercial goods vehicle (L/C. 14 cwt.) to operate throughout the State of Victoria in the course of business as "Blind and Awning Manufacturers" for the purpose of sales promotion, repairing and measuring contracts—samples, display materials, tools of trade, blinds and awnings for repair, having been repaired and for specialized installation and materials incidental thereto.
- GENERAL MOTORS-HOLDEN'S PTY. LTD., Princes Highway, Dandenong, 3175. Two commercial goods vehicles (L/C. 13 cwt. each) to operate within a 50-mile radius of own premises at Dandenong in course of business as "Motor Vehicle Manufacturers"—own motor parts and chassis members.
- COLIN GRIMSBY AGENCIES PTY. LTD., 221 Whitehorse-road, Balwyn, 3103. One commercial goods vehicle (L/C. 16 cwt.) to operate: (a) Within a 50-mile radius of the G.P.O., Melbourne, in the course of business as "Automotive Parts Distributor"—own goods. (b) Throughout the State of Victoria—advertising materials and automotive parts and batteries for display purposes only.
- HAIR, H. K. & G. S., PTY. LTD., Bolinda-lane, Campbellfield, care of P.O. Campbellfield, 3061. Application to vary conditions of licences numbered D.A.46541/1, D.A.46541/2, D.A.46541/3, and T.D.22150, T.D.22151 (L/C. 251, 255, 250, 217 and 224 cwt.) by adding to the existing conditions as an additional paragraph—"From the pit of Peninsula Potteries at Sommerville to the premises of Brick Industries Ltd., at Burwood—clay solely on behalf of Brick Industries Ltd."
- MARIANI, G., 2 Frank-street, Lalor, 3075. One commercial goods vehicle (L/C. 203 cwt.) to operate within a 50-mile radius of the premises of Albion Reid Pty. Ltd., at North Melbourne, solely on behalf of the said company—premixed concrete in a specially constructed agitator vehicle.
- MORRIS, C. H. & SONS, PTY. LTD., Mia Mia Vineyard, Rutherglen, 3685. One commercial goods vehicle (L/C. 10 cwt.) to operate: (a) Within a 50-mile radius of own premises at Rutherglen in course of business as "Wine Manufacturers"—own goods. (b) Within the area bounded in the west by a north/south line drawn through Echuca in the south by an east/west line drawn through Broadford and in the east by a north/south line drawn through Mansfield and Corryong for the purpose of sales promotion and booking orders—samples, display and advertising materials, a small quantity of wine to replace damaged or unsaleable stock or to leave in an emergency, empty return containers and damaged or unsaleable stock.
- MCDONALD, C. H., Elizabeth-street, Nathalia, 3638. One commercial goods vehicle (L/C. 92 cwt.) to operate: (a) Within a 25-mile radius of the post office at Nathalia—general goods provided that no goods shall be carried whether by one stage or by more than one stage between places within the above radius which are more than thirty road miles apart by the nearest practicable route. (b) From and to places within the radius as defined in paragraph (a) above to and from places within a 50-mile radius of the post office at Nathalia—livestock.
- OAKLEIGH BRICK CO. PTY. LTD., 68 Dawson-street, Brunswick, 3056. One commercial goods vehicle (L/C. 128 cwt.) to operate within a 70-mile radius of own premises at Oakleigh in course of business as "Brick Manufacturers"—own bricks.
- PERRY, W. C. L., Buxton, 3711. Application to vary conditions of licence No. D.A.58537 (L/C. 88 cwt.) by adding to the existing conditions of paragraph (b) after "own depot at Buxton" the words "and to consignees within a 20-mile radius of such depot".
- PETERSVILLE AUSTRALIA LTD., Wellington-road, Clayton, 3168. One commercial goods vehicle (L/C. 76 cwt.) to operate throughout the State of Victoria as a specially constructed insulated and refrigerated van for the purpose of supplying own distributors with ice-cream, frozen vegetables, frozen fish and frozen poultry at a temperature not exceeding 10 degrees F.
- RODEN PRODUCTS PTY. LTD., 164 Murphy-street, Richmond, 3121. One commercial goods vehicle (L/C. 10 cwt.) to operate: (a) Within a 50-mile radius of own premises at Richmond in course of business as "Stove Manufacturers"—own goods. (b) Throughout the State of Victoria for the purpose of displaying and demonstrating own stoves and booking orders—stoves and display materials for sales promotion.
- ROWLANDS QUARRIES PTY. LTD., 19 Coora-road, Huntingdale, 3166. One commercial goods vehicle (L/C. 13 cwt.) to operate within a 100-mile radius of the premises of Rowlands Quarries (Clayton) Pty. Ltd., at South Clayton for the carriage of own drilling equipment and tools of trade together with samples of minerals or earth excavated.
- ROWLANDS TRANSPORT PTY. LTD., 19 Coora-road, Huntingdale, 3166. One commercial goods vehicle (L/C. 258 cwt.) to operate within a 35-mile radius from the premises of Rowlands Quarries (Narre Warren) Pty. Ltd., at Narre Warren North solely on behalf of the said company—quarry products, screenings, crushed rock and sealing aggregates.
- RUNDLE, G. H., 28 Frank-street, Campbellfield, 3061. One commercial goods vehicle (L/C. 7 cwt.) to operate within a 50-mile radius of G.P.O., Melbourne, in course of business as "Carpet Layer"—tools of trade, carpets and floor coverings for laying only and materials incidental thereto.
- RYAN'S REMOVALS PTY. LTD., 50 Eddington-street, Warrnambool, 3280. One commercial goods vehicle (L/C. 47 cwt.) to operate: (a) Within a 25-mile radius of the post office at Colac—general goods,

provided that no goods shall be carried whether by one stage or by more than one stage between places within the above radius which are more than thirty (30) road miles apart by the nearest practicable route. (b) Within a 50-mile radius of the post office at Colac—household furniture being personal effects of a householder or of a member of his family when being moved:—(i) From residence to residence. (ii) From residence to storage or sale. (iii) From storage to residence. (iv) From vendor to the residence of a purchaser.

- RYAN'S REMOVALS PTY. LTD.**, 50 Eddington-street, Warrnambool, 3280. One commercial goods vehicle (L/C. 50 cwt.) to operate: (a) Within a 25-mile radius of the post office at Hamilton—general goods, provided that no goods shall be carried whether by one stage or by more than one stage between places within the above radius which are more than thirty (30) road miles apart by the nearest practicable route. (b) Within a 50-mile radius of the post office at Hamilton—household furniture being personal effects of a householder or of a member of his family when being moved:—(i) From residence to residence. (ii) From residence to storage or sale. (iii) From storage to residence. (iv) From vendor to the residence of a purchaser.
- SCHROETER, A. A.**, 45 Anderson-street, Heyfield, 3858. One commercial goods vehicle (L/C. 265 cwt.) to operate from landings in the Licola area to sawmills at Heyfield—logs.
- BUTLER, J. J.** (trading as A. R. Scoones & Co.), 108 Allan-street, Kyabram, 3620. One commercial goods vehicle (L/C. 158 cwt.) to operate within a 50-mile radius of own branch premises at Shepparton in the course of business as "Fertilizer and Petroleum Agents"—fertilizers and petroleum products in prescribed types of containers and empty return containers.
- SOLOPITIAS, A.**, 24-26 Bowmore-road, Noble Park, 3174. One commercial goods vehicle (L/C. 190 cwt.) to operate within a 50-mile radius of the premises of Albion Reid Pty. Ltd. at North Melbourne—road-making plant, materials, premix and hot asphalt on behalf of the said company, but excluding the carriage of cement and lime from Geelong.
- STUART, L.**, 38 Lewton-road, Mount Waverley, 3149. One commercial goods vehicle (L/C. 8 cwt.) to operate within a 50-mile radius of own premises at Mount Waverley in course of business as "Blind and Awning Fitter"—tools of trade, blinds, awnings and curtains for fitting and materials incidental thereto.
- WALKER, H. B.**, 2 Rodney-drive, Knoxfield, 3180. One commercial goods vehicle (L/C. 138 cwt.) to operate within a 70-mile radius of the premises of Atlas Industries Australia Ltd., at Springvale solely on behalf of the said company—concrete roofing tiles, tile fixing materials and battens.
- WARREN, C. S.**, Briagolong, via Maffra, 3860. One commercial goods vehicle (L/C. 146 cwt.) to operate: (a) From forest areas in the Willung and Stradbroke areas to the Australian Paper Manufacturers mill at Maryvale—pulpwood. (b) Within a 30-mile radius of the post office at Maffra, in course of business as "Pulpwood Contractor"—tools of trade, equipment and fuel incidental to the completion of own contracts.
- WILKINSON, K. R.**, corner Lake-road and Fenaughty-street, Kyabram, 3620. One commercial goods vehicle (L/C. 75 cwt.) to operate throughout the State of Victoria in the course of business as "Marine Collector"—special wares, marine stores and old metals as designated in the *Marine Stores and Old Metals Act 1958* (No. 6303), Part 1, section 3, but excluding the carriage of any such marine stores or old metals to wharves, docks or ships for shipment or export purposes with the proviso that the combined load capacity of both prime mover and any trailer attached thereto shall not exceed 120 cwt.
- WILLCOX, L. H.**, 6 Davies-street, Bairnsdale, 3875. One commercial goods vehicle (L/C. 140 cwt. approximately) to operate within a 50-mile radius of the post office at Bairnsdale in course of business as "Stone Crushing Operator"—own tools of trade and equipment, screenings, gravel and sand.
- WILLIAMS, D. J. & E. A.**, P.O. Box 90, Heyfield, 3858. One commercial goods vehicle (L/C. 200 cwt. approximately) to operate from landings in the Tamboritha area to sawmills at Heyfield—logs.

TOW TRUCKS.

- CAMPBELL'S, D., MOTORS PTY. LTD.**, 41 Carrington-road, Box Hill, 3128. One commercial goods vehicle (to be purchased) to operate within a 50-mile radius of the post office at Box Hill as a "Tow Truck" solely—

(a) For the purpose of lifting and carrying or towing motor cars and the carriage of tools and equipment necessary for such purpose only. (b) The carriage of spare parts necessary for the repair of a disabled motor to and from the place at which such disablement has occurred.

- PHILLIPS, K. H.**, Running Creek, via Dederang, 3691. One commercial goods vehicle (L/C. 30 cwt.) to operate within a 25-mile radius of the post office at Running Creek as a "Tow Truck" solely—(a) For the purpose of lifting and carrying or towing motor cars and the carriage of tools and equipment necessary for such purpose only. (b) The carriage of spare parts necessary for the repair of a disabled motor to and from the place at which such disablement has occurred.

RENEWALS.

- A** PPLICATIONS for renewal of licences as shown by persons listed hereunder to operate under the same terms and conditions from the expiry shown in each case.
- ALLAN, C. S.**, P.O. Oxley, 3678; D.A.54034; 8th December, 1968; 123 cwt.
- ASHLAR STONE & PAVING SUPPLIES PTY. LTD.**, corner South and Warrigal roads, Moorabbin, 3189; D.A.41179; 5th December, 1968; 73 cwt.
- BEAUREPAIRE TYRE SERVICE PTY. LTD.**, 102 Victoria-street, Carlton, 3053; D.A.629/22; 29th January, 1969; 17 cwt.
- BELL, R.**, 39 Smith-street, Stawell, 3380; D.A.49536/2; 21st December, 1968; 240 cwt.
- BLACKNEY'S FROZEN FOODS PTY. LTD.** (trading as Blackney's Fish Supply), 34-36 Smyth-street, Geelong, 3220; T.D.A.36140/1; 21st December, 1968; 61 cwt.
- BLEWETT, W. J. & A. G.**, Bruarong, via Yackandandah, 3749; D.A.53953/1; 21st December, 1968; 144 cwt.
- BOWD, R. A.**, 43 Leonora-street, Robinvale, 3549; D.A.53993; 21st December, 1968; 36 cwt.
- CANT, F. W.**, 88 Waterloo-road, Trafalgar, 3824; D.A.53333; 14th December, 1968; 147 cwt.
- CHALK, A. B.**, 103-105 Mary-street, Morwell, 3840; D.A.32615/6; 21st December, 1968; 126 cwt.
- CONTRACT DRILLING (VIC.) PTY. LTD.**, 9 Salisbury-street, Sunshine, 3020; D.A.49565/1; 21st December, 1968; 15 cwt.
- DAY, G. C.**, 28 Cohen-street, East Keilor, 3042; D.A.53964; 1st December, 1968; 14 cwt.
- DUNLOP TYRE SERVICE (VIC.) PTY. LTD.**, GEELONG BRANCH, corner Gheringhap and Little Myers streets, Geelong, 3220; D.A.604416/7; 20th December, 1968; 15 cwt.
- FITZPATRICK, P. J.**, 1108 Ettiwanda-avenue, Mildura, 3500; D.A.54221; 21st December, 1968; 20 cwt.
- GLADMAN, G. G. & G. J.** (trading as G. Gladman & Son), Serpentine, 3517; D.A.1154; 16th December, 1968; 134 cwt.
- GREEN, F. L. & B. E.**, Standish-street, Myrtleford, 3737; D.A.48511/2; 1st December, 1968; 121 cwt.; D.A.48511/3; 1st December, 1968; 8 cwt.
- HESSE BROS. ELECTRICAL SALES PTY. LTD.**, 239-243 Lyttleton-terrace, Bendigo, 3550; D.A.41578/2; 5th December, 1968; 8 cwt.; D.A.41578/8; 8th December, 1968; 3 cwt.
- HESSE BROS. ELECTRICAL SERVICE PTY. LTD.**, 239-243 Lyttleton-terrace, Bendigo, 3550; D.A.37007/1; 5th December, 1968; 10 cwt.; D.A.37007/2; 5th December, 1968; 11 cwt.
- HILL, J., & SONS (FISH SALESMAN) PTY. LTD.**, Footscray-road, Footscray, 3011; T.D.A.35096/1; 21st December, 1968; 102 cwt.
- HILLGROVE, A. D.**, P.O. Box 176, Birchip, 3483; D.A.1302/20; 7th December, 1968; 19 cwt.
- HINE, L. J.**, Box 12, R.S.D., Bacchus Marsh, 3340; D.A.1303/2; 13th December, 1968; 80 cwt.
- INGPEN, T. A., PTY. LTD.**, 77 Little Malop-street, Geelong, 3220; D.A.41093; 5th December, 1968; 9 cwt.; D.A.41093/1; 5th December, 1968; 17 cwt.
- JONES, W. L.** (trading as W. T. Jones & Son), 11 Piper-street, Kyneton, 3444; D.A.1404; 1st December, 1968; 112 cwt.
- LARSON, A. A. P.**, Carlisle River, 3239; D.A.1472/2; 1st December, 1968; 68 cwt.
- LEWIS, W. J.**, Watson-street, Penshurst, 3289; D.A.43584/3; 8th December, 1968; 140 cwt.
- LITTLE, J. R.**, 20 Coghill-street, Yarrowonga, 3730; D.A.54198; 21st December, 1968; 138 cwt.
- MALADY, L. J.** (trading as Malady & Sons), 42 Waterloo-road, Trafalgar, 3824; D.A.5192/1; 20th December, 1968; 132 cwt.
- MASON, C. W.**, corner Williamson and Myers streets, Bendigo, 3550; D.A.53528; 1st December, 1968; 9 cwt.
- MILROY, T.**, 1 Newton-street, Chadstone, 3148; D.A.38038/1; 23rd January, 1969; 67 cwt.

MONUMENT, C. F., 13 Cooper-street, Stawell, 3380; D.A.54078; 14th December, 1968; 130 cwt.

MORTIMER, D. A. & N. J., High-street, Drysdale, 3222; D.A.41456/5; 1st December, 1968; 112 cwt.

MCCUSKY, B. A. (trading as McCusky's Farm Tyre Service), 117 Hargreaves-street, Bendigo, 3550; D.A.40284/1; 8th December, 1968; 11 cwt.

NATIONAL BANK OF AUSTRALASIA LTD., THE, 271-285 Collins-street, Melbourne, 3000; D.A.1706; 14th January, 1969; 70 cwt.; D.A.1706/1; 14th January, 1969; 10 cwt.; D.A.1706/2; 14th January, 1969; 47 cwt.

NATIONAL CASH REGISTER CO. PTY. LTD., THE, 124-130 Russell-street, Melbourne, 3000; D.A.1707/12; 14th January, 1969; 11 cwt.

NELSON, L. G., P.O. Box 67, Colac, 3250; D.A.1711; 1st December, 1968; 116 cwt.

NOLAN, D. F., 205 Errard-street, Ballarat, 3350; D.A.41074; 5th December, 1968; 146 cwt.

O'HARA BROS. PLANT HIRE PTY. LTD., 19 Clark-street, Wangaratta, 3677; D.A.53969; 1st December, 1968; 296 cwt.

PERMEWAN WRIGHT LTD., 147-179 Alexandra-parade, Abbotsford, 3067; D.A.1809/42; 31st August, 1968; 8 cwt.

PERMEWAN WRIGHT LTD., 147-179 Alexandra-parade, Abbotsford, 3067; D.A.1809/45; 1st December, 1968; 15 cwt.

PHOENIX BISCUIT CO. PTY. LTD., Grosvenor-street, Abbotsford, 3067; D.A.39491/8; 5th October, 1968; 58 cwt.

ROGERSON, R. D., Derrinallum, 3325; D.A.1946; 23rd December, 1968; 122 cwt.

SHEPPARTON NEWSPAPERS PTY. LTD., 159-165 High-street, Shepparton, 3630; D.A.53140; 8th December, 1968; 14 cwt.

SINGH, P. L., 49 Hume-street, Wangaratta, 3677; D.A.42685/2; 8th December, 1968; 228 cwt.

STEPHEN, J., Won Wron, 3844; D.A.41382; 12th December, 1968; 77 cwt.

SUPER AGENCIES PTY. LTD., Grassmere Junction, 3279; D.A.53264; 1st December, 1968; 249 cwt.

TARAX DRINKS (GEELONG) PTY. LTD., 3-9 Douro-street, North Geelong, 3215; D.A.2133/4; 1st December, 1968; 10 cwt.

TARAX DRINKS (GEELONG) PTY. LTD., 3-9 Douro-street, North Geelong, 3215; D.A.2133/12; 1st December, 1968; 10 cwt.

WARRNAMBOOL CHEESE & BUTTER FACTORY COMPANY LTD., THE, Allansford, 3277; D.A.52834; 1st December, 1968; 79 cwt.

WEAVER, R. E., corner Hyland and Fyans streets, Fyansford, 3221; D.A.36207/6; 20th December, 1968; 226 cwt.

WEBB, FRED, PTY. LTD., 197 Graham-street, Wonthaggi, 3995; D.A.5014/2; 20th December, 1968; 12 cwt.

DOCKING, I. R. (trading as Wodonga Joinery), South-street, Wodonga, 3690; D.A.53801; 1st December, 1968; 70 cwt.

TOW TRUCKS.

COOK, L. T. (trading as Broadford Junction Garage), High-street, Broadford, 3658; D.A.2349; 21st December, 1968; 75 cwt.

JENKINS, G. C. & C. I. (trading as Jenkins Garage), Bridge-water, 3516; T.D.A.37703; 7th December, 1968; 71 cwt.

NALDER, W. G. (trading as Nalder's Garage), 4 Patrick-street, Stawell, 3380; D.A.27941; 17th December, 1968; 55 cwt.

O'CONNELL MOTORS PTY. LTD., 2-12 Stradbroke-avenue, Swan Hill, 3585; T.D.A.46494; 10th December, 1968; 78 cwt.

RIX, J. O., 273 Nepean Highway, Parkdale, 3194; D.A.31028/1; 11th January, 1969; 50 cwt.

THOMPSON, B. E., (trading as Shepparton Auto Wreckers), Archer-street, Shepparton, 3630; D.A.41174; 5th December, 1968; 26 cwt.

WATERS, T. S., (trading as Stanbil Motors), Charing-cross, Bendigo, 3550; T.D.A.2092; 21st December, 1968; 26 cwt.

RENEWALS WITH VARIATION.

LEECH, A. G., PTY. LTD., 62 Nolan-street, Maryborough, 3465; D.A.1482/2; 17th December, 1968; Application to renew and vary conditions of licence No. D.A.1482/2 (L/C. 213 cwt.) by deleting the existing conditions and adding in lieu:—“(a) Within a 50-mile radius of the post office at Maryborough—plant the property of a contractor and required by him for use in connexion with the construction or maintenance of some specific, existing or proposed road, street, footpath, bridge, pier, wharf, weir, channel and also the following materials viz.: metal, stones, screenings, ashes, gravel, sand and earth. (b) Within a 20-mile radius from

the site of any construction or maintenance work performed pursuant to paragraph (a) above or from the railway station nearest thereto—any other materials required for such work. (c) Within a 25-mile radius of the post office at Maryborough—general goods provided that no goods shall be carried whether by one stage or by more than one stage between places within the above radius which are more than thirty (30) miles apart by the nearest practicable route.

OWEN, K. M., 30 Pine-road, Mooroolbark, 3138; D.A.1769; 1st December, 1968; application to renew and vary conditions of licence No. D.A.1769 (L/C. 119 cwt.) by deleting “the Co-op. Brick Co. Pty. Ltd., at Auburn” and adding in lieu “The City Brick Co. Pty. Ltd., at Scoresby”.

Notice of any objection should be forwarded to reach the Secretary of the Board not later than 20th November, 1968.

Applicants are advised that it will not be necessary to appear on the hearing date specified above, unless advised in writing by the Board.

B. P. KAY,

Secretary.

Corner Lygon and Princes streets, Carlton, 3053, Friday, 1st November, 1968.

Transport Regulation Act.
TRANSPORT REGULATION BOARD.

HEARING OF APPLICATIONS.

NOTICE is hereby given that the following applications will be considered by the Transport Regulation Board at its offices at the corner of Princes and Lygon streets, Carlton, at 10.15 a.m. on Wednesday, 4th December, 1968.

MELBOURNE-BRIGHTON BUS LINES PTY. LTD., 43 Head-street, Elwood. Application for variation of any two M.O. licensed vehicles on Route 1 (Melbourne-Gardenvale) and Route 2 (Melbourne-Middle Brighton) to operate two special trips, morning and afternoon for the carriage of school children from:—(i) Corner of New and Park streets, via New-street, Rusden-street, Nepean Highway, Hotham-street, Williams-road, Malvern-road, Orrong-road, Riddell-parade, Clarence-street and Kooyong-road to the corner of Kooyong and North roads and, (ii) From the corner of Kooyong and North roads to the corner of New and Park streets via the same route in reverse as part (i) of the application.

TIME-TABLE (WEEKDAYS ONLY).

	Morning.	Afternoon.
(i) Dep. Corner New & Park streets	7.40 a.m.	3.20 p.m.
(ii) Dep. Corner Kooyong & North roads	7.55 a.m.	3.55 p.m.

Fares.

To be the same sectional fares as Routes 1 & 2 plus one extra section for Malvern-road.

PARLORCARS (VIC.) PTY. LTD., Lower Plaza, Southern Cross Building, cnr. Bourke and Exhibition streets, Melbourne. Two commercial passenger vehicles each with large seating capacity to operate as Metropolitan Special Service Omnibuses.

POINT COOK WERRIBEE PASSENGER SERVICE PTY. LTD., Railway-avenue, Laverton. Application for variation of C.O. licence conditions Route (f) (Laverton-Laverton North) to extend service from the corner of Bladin-street and Henderson-street, North Laverton via Henderson-street, Robertson-crescent, Tarran-street and Old Geelong-road to Bladin-street and normal route.

SMITH, H. F., 447 The Esplanade, Mt. Martha. One commercial passenger vehicle (S/C. 5) to operate under the same terms and conditions as existing C.T. licences subject to cancellation of licence C.H. 91 in the name of the applicant.

SKEHAN, P., Promontory-road, Yanakie. Application to operate a feeder service for the carriage of school children only between Yanakie and Fish Creek under contract to the Education Department.

APPLICATION for renewal of licences as shown, by persons listed hereunder to operate under the same terms and conditions.

BATES, G. & E., 77 Main-street, Stawell. C.T.2, C.T.133, C.T.225.

DICKINSON, E. N. & T. A., & B. C. STONEHOUSE, 37 Tocumwal-road, Numurkah. T.S.600, T.S.630, T.S.727.

FLEETWAYS HAULWAY PTY. LTD., 61 Bertie-street, Port Melbourne. T.P.207.
 MONTEATH, I. G. & E. M., 14 Ingrid-street, Dandenong. C.T.295.
 YOUNG, F. & A. (trading as Young's Child minding Centre), 39 Isabella-street, Moorabbin. T.P.72.

APPLICATION by—

ALTVILLA, O., 6 Wheeler-street, Ormond.
 AMATO, P., 34 Ross-street, Westgarth.
 ANTHONY, R. H., Flat 11, 4 Parkside-street, Elsternwick.
 ANTONIOU, H., 132 Wilson-street, Cheltenham.
 BARBAGALLO, A., 94 May-street, North Fitzroy.
 BARNES, T. B., 11 Queens-parade, Ashwood.
 BEEVORS, R. J., 1 Bond-street, Clayton.
 BELL, W. H., 7 Granville-grove, Clayton South.
 BENDER, M., Flat 6, 122 Glenhuntly-road, Elwood.
 BERTA, B., 85 Eskdale-road, Caulfield.
 BOGHOSSIAN, J., 20 Molesworth-street, North Melbourne.
 BRDAR, L., 900 Lygon-street, Carlton.
 BROOKS, J. E., 9 Houston-street, Mentone.
 BROWN, S. E., 3 Malans-street, East Bentleigh.
 BURKE, J., 5 Lansdown-road, Hampton.
 BUTTRESS, W. W., 5 Towers-street, Beaumaris.
 CAIA, A., 9 Watsons-road, Glen Waverley.
 CAMERON, R. A., 230 East Boundary-road, East Bentleigh.
 CAULFIELD, E. M., 8 Riviera-street, Mentone.
 CERVI, W. G., 379 Highett-road, Highett.
 CLARK, J. V., 4 Bourke-street, Bulleen.
 COLEMAN, B. A., 17 Lincoln-drive, Cheltenham.
 CONDRON, M. R., 5 Princess-street, Merlynston.
 COURTIER, S. C. A., 44 Briggs-street, Caulfield.
 DALTON, K. W., 60 Goldsmith-street, Elwood.
 EASTMAN, J. D., 2 Tennyson-street, Sandringham.
 EDSALL, E. J., 61A Manning-road, East Malvern.
 FITZSIMONS, J. W., 28 Ardie-road, East Malvern.
 FREEDMAN, M., 15 The Crescent, Springvale.
 FERGUSON, D. S., 1585 Dandenong-road, Oakleigh.
 GAFFNEY, G. J., 4 Kenneth-street, Bulleen.
 GAMBLE, J. R., 70 Oakwood-avenue, Noble Park.
 GARDINER, P. R., 13 Derby-court, Carnegie.
 GARLICK, G. E. J., 60 Coorigil-road, Murrumbeena.
 GARTH, R. N., 7 Una-street, Mt. Waverley.
 GERMON, W. J., 3/8 Balaclava-road, East St. Kilda.
 GIOVANNOPOULOS, G., 22 Oakleigh-crescent, Ormond.
 GOSS, H. W. C., 183 Beach-road, Mordialloc.
 GRANT, R. G., 16 Barnett-street, Hampton.
 GRAY, H. A., 19 Truganini-road, Carnegie.
 GREANEY, P. F., 58 Thackeray-road, Reservoir.
 HAMILTON, A. C., 44 Corrigil-road, Carnegie.
 HERBERT, D. L., 43 Peter-street, Springvale.
 JURMAN, A., 79 Neville-street, Carnegie.
 KOUKOUNAS, G., 73 Albion-road, Glen Iris.
 KALLINICOS, J., 5 Tyrone-street, South Yarra.
 KAYNE, V. A., Villa 2, 23 Hartington-street, Elsternwick.
 KENT, R. B., 28 Glen Orme-avenue, McKinnon.
 KNEZEVIC, V., 386 Springfield-road, Nunawading.
 KONING, P., 5 Gillard-street, East Brighton.
 KOVACS, A., 54 Hobart-road, Murrumbeena.
 KRASEY, LOUIS, 48 Parkington-street, Kew.
 LECHMERE, R. S., 372 Barkly-street, Elwood.
 LEEK, J. C., 25 Phillip-avenue, Springvale North.
 LOWE, G. F., 58 Beaunavista-drive, Rye.
 LUXMOORE, L., 2 Munro-avenue, Cheltenham.
 MADDEN, F. W., 14 Leslie-street, Richmond.
 MARKBY, A. C., 12 Ash-grove, East Malvern.
 MAVRIDIS, G., 42 Chomley-street, East Prahran.
 MAY, G. B., 8/579 Dandenong-road, Armadale.
 MEADE, W. P., 9 Alpine-street, Frankston.
 MENDELOUTS M. I., 10 Dickens-street, Moorabbin.
 MENICH, J., 1 Rishon-avenue, South Blackburn.
 MINAHAN, A. J., 3 Pitt-street, Oakleigh.
 MOURIKIS, P., 39 Tooronga-road, Hawthorn.
 MURPHY, I. L., 13 Field-street, Hampton.
 MCCONNELL, R. W., 40 Lord-street, Richmond.
 MCGREGOR, J., 17 Fairbank-road, Moorabbin.
 MCINTYRE, S. R., 93 Couch-street, Sunshine.
 NEWMAN, F. D. J., 5 Griffin-street, East Brighton.
 O'REILLY, P. M., 35 Harrington-avenue, North Balwyn.
 PAHOFF, H., 37 King-street, Prahran.
 PARNELL, R. K., 115 Power-avenue, Chadstone.
 PARSONS, C. J., 23 Beech-street, South Caulfield.
 PLANNER, R. C., 70 Essex-road, Mt. Waverley.
 PRITCHARD, O. F., 38 Dromana-avenue, East Bentleigh.
 PUC, A., 30 Cedar-street, South Caulfield.
 RADCLIFFE, A. L., 9/31 Rosstown-road, Carnegie.
 REGAN, B., 36 Woodville-avenue, Glenhuntly.
 ROBINSON, H. E., 1 Albany-road, North Clayton.
 ROSEFIELD, H. K., 13 Frederick-street, South Caulfield.
 ROY, R. L., 20 Ashley-street, West Footscray.
 SANDOR, G., 9/91 Glenhuntly-road, Elwood.
 SAPOUNTZIS, K., 1 Hunter-street, Abbotsford.
 SAVVA, A., Lot 129, Denver-crescent, Rowville.

SEDDON, E. S., 10 Higinbotham-street, Brighton.
 SENIOR, C. I. H., 50 Oakleigh-road, Carnegie.
 SMITH, C. E., 62 Timms-avenue, Kilsyth.
 SMYTH, K., 9 Dixon-street, Malvern.
 TARABARAS, J., 1 Raglan-place, South Melbourne.
 TALBOT, W. H., 15 Avoca-avenue, Elwood.
 TAYLOR, A., 1 Dermot-street, South Oakleigh.
 TONKIN, R. T., 9 Ormond-street, Mordialloc.
 TSARDAKAS, G., Lot 25, Melosa-avenue, Clayton.
 TZOUVELIS, N., 113 Morell-street, Glenroy.
 WAIN, J., 13 Bayview-road, East Highton.
 WALTON, E. A., 13 Edith-court, East Bentleigh.
 WANZENBOECK, G., 2/54 Southey-street, Elwood.
 WARD, J. D., 8 John-street, Balwyn.
 WILSON, D. G., 13 Milloo-crescent, Mt. Waverley.
 WILSON, H. R., 13 Nicholis-street, Ormond.
 WYNN, H., 7 Maxwell-grove South Caulfield.
 ZIGAS, T., 3/45 Spring-street, Prahran.

Each for a commercial passenger vehicle with seating capacity for five (5) persons to operate as a Metropolitan Private Hire Car under composite conditions from an approved depot in Zone "B".

Notice of any objection should be forwarded to reach the Secretary of the Board not later than Wednesday, 27th November, 1968.

Applicants are advised that it will not be necessary to appear on the hearing date specified above, unless advised in writing by the Board.

B. P. KAY,
Secretary.

Corner Lygon and Princes streets, Carlton, Wednesday, 13th November, 1968.

Commercial Goods Vehicles Act.

TRANSPORT REGULATION BOARD.

HEARING OF APPLICATIONS.

NOTICE is hereby given that the following applications will be considered by the Transport Regulation Board at its offices at the corner of Lygon and Princes streets, Carlton, at 10.15 a.m., on Wednesday, 4th December, 1968.

AGSERV. DIVISION OF GEIGY AUST. PTY. LTD., 21 Ilex-avenue, Warrnambool, 3280. One commercial goods vehicle (L/C. 10 cwt.) to operate within that part of the State of Victoria south of an east/west line drawn through Lake Bolac, east of a north/south line drawn through Portland, and west of a north/south line drawn through Apollo Bay in the course of business as "Agricultural Suppliers"—own goods provided that all such goods are initially consigned by rail to either Warrnambool or Hamilton.

ALLEN BROS. PTY. LTD., corner Hovell and Huon streets, Wodonga, 3690. One commercial goods vehicle (L/C. 58 cwt.) to operate within a 50-mile radius of the post office at Wodonga in the course of business as "Road-Making and Paving Contractors"—own tools of trade, equipment and materials for use in the completion of a contract.

ANSETT MOTORS PTY. LTD., 210 Gray-street, Hamilton, 3300. One commercial goods vehicle (L/C. 10 cwt.) to operate within a 100-mile radius from the post office at Hamilton in the course of business as "Machinery Distributor" for the purpose of operating the vehicle as a service unit—tools of trade, spare parts and equipment incidental to repairing, servicing and installing farm machinery.

BARRY, N. U. & F. H., King-street, Yarra Glen, 3775. Application to vary conditions of licence No. D.A.60223 (L/C. 110 cwt.) by deleting the existing conditions and adding in lieu: "(a) In the course of business as 'Garden Suppliers'—within a 30-mile radius of own premises at Yarra Glen and to and from Frankston—own goods. (b) Within a 25-mile radius of own premises at Yarra Glen—road-making plant and materials. (c) From Garfield to own premises at Yarra Glen—own sand and soil".

BONIYONG PASTORAL CO. PTY. LTD., Browns-road, Rosebud, 3939. Application to vary conditions of licence No. D.A.55169 (L/C. 233 cwt.) by deleting "Within a 25-mile radius from the general post office in the City of Melbourne" and adding in lieu: "Within a 50-mile radius from the general post office in the City of Melbourne".

BORDER READY MIXED CONCRETE PTY. LTD., Wodonga-street, Wodonga, 3690. One commercial goods vehicle (L/C. 16 cwt.) to operate within a 90-mile radius of the post office of Wangaratta in the course of business as "Gravel, Sand and Concrete Suppliers and Earth-moving Contractors"—own tools of trade, machinery, testing equipment and samples of aggregate for testing.

- BOYES, A. S., 82 Murray-street, East Colac, 3250. One commercial goods vehicle (L/C. 10 cwt.) to operate within that part of the State of Victoria west of a north/south line drawn through Werribee in the course of business as "Turf Aerator and Green Renovator"—own tools of trade and up to 1 cwt. of grass seed and fertilizers.
- BRITISH PHOSPHATE COMMISSIONERS, THE, 515 Collins-street, Melbourne, 3000. Application to vary conditions of licence No. D.A.2346/1 (L/C. 132 cwt.) by adding to the existing conditions as paragraph (c): "(c) Between the City of Geelong and the Town of Portland—own stevedoring gear, tools, equipment and ship's stores".
- BROWN, B. F., CO. INCORPORATED, 100 Young-street, Frankston, 3199. One commercial goods vehicle (L/C. 10 cwt.) to operate within a 25-mile radius of the post office at Traralgon—in the course of business as "Caterers"—own goods.
- BURDEN, J. F., 25 Farleigh-avenue, Burwood, 3125. Application to vary conditions of licence No. T.T.D.1231 (L/C. 294 cwt.) by adding to the existing conditions as additional paragraphs (b) and (c): "(b) From The Islander Pty. Ltd. sawmill at Broadford to timber yards within a 25-mile radius of the G.P.O., Melbourne—pallets. (c) From the Dandenong Railway Station and the Graham-street siding to timber yards and building sites within a 25-mile radius of the G.P.O., Melbourne—sawn timber".
- CARLTON & UNITED BREWERIES LTD., 16 Bouverie-street, Carlton, 3053. Two commercial goods vehicles (L/C. 10 cwt. each) to operate throughout the State of Victoria in the course of business as "Brewers" for the purpose of advertising and sales promotion, advertising and display, materials, tools of trade and also for the purposes of collection and replacement of damaged or unsaleable products.
- CLARKE, J. W., Stonehaven, 3221. One commercial goods vehicle (L/C. 240 cwt.) to operate: (a) Within a 25-mile radius of the post office at Stonehaven—general goods provided that no goods shall be carried whether by one stage or by more than one stage between places within the above radius which are more than 30 road miles apart by the nearest practicable route. (b) From and to places within the radius as defined in paragraph (a) above to and from places within a 50-mile radius of the post office at Stonehaven—livestock.
- CLAVARINO, L. L. & G. N., Foster, 3960. One commercial goods vehicle (L/C. 140 cwt.) to operate: (a) Within a 25-mile radius of the post office at Foster—general goods, provided that no goods shall be carried whether by one stage or by more than one stage between places within the above radius which are more than 30 miles apart by the nearest practicable route. (b) From the State Electricity Commission at Morwell to consignees situated at Foster and Fish Creek—briquettes.
- DAVIS, J. L., PTY. LTD., 7 Curdie-street, Camperdown, 3260. Application to vary conditions of licence No. D.A.30402/2 (L/C. 147 cwt.) by adding to the existing conditions as an additional paragraph (d): "(d) Goods associated with own approved decentralized secondary industry (Stock Food Manufacturers) at Camperdown as follows:—To own factory from points within a 150-mile radius of such factory—goods required in connexion with own manufacturing activities".
- DOWLE, R. G., "Omaru", Derby-street, Warburton, 3799. One commercial goods vehicle (L/C. 9 cwt.) to operate throughout the State of Victoria in course of business as "Carpet Layer"—tools of trade and floor coverings in house lots only for laying purposes.
- GIBBS, J. & D., 190 Andrews-street, Albury, 2640. Two commercial goods vehicles (L/C. 152 cwt. each) to operate: (a) Within a 70-mile radius of the point where the Hume Highway crosses the Victorian/N.S.W. border in the course of business as "House Wreckers"—tools of trade and equipment. (b) Within a 20-mile radius from the site of any contract currently engaged upon—second-hand building materials from such contracts for disposal. (c) Within a 50-mile radius of the point where the Hume Highway crosses the Victorian/N.S.W. border in the course of business as "Road Making Material and Earth-moving Equipment Supplier"—road-making materials and earth-moving equipment.
- GLEN IRIS BRICK TILE & TERRA COTTA CO. PTY. LTD., Templestowe-road, Bulleen, 3105. One commercial goods vehicle (L/C. 138 cwt.) to operate from pits at Bacchus Marsh to own premises at Bulleen in course of business as "Brick Manufacturers"—own clay.
- GREALY, R., 365 Cheyenne-street, Lavington, 2641. One commercial goods vehicle (L/C. 127 cwt.) to operate: (a) Within a 50-mile radius of the point where the Hume Highway crosses the Victorian/New South Wales border—plant the property of a contractor and required by him for use in connexion with the construction or maintenance of some specific, existing or proposed road, street, footpath, bridge, pier, wharf, weir or channel and also the following materials, viz., metal, stones, screenings, ashes, gravel, sand and earth. (b) Within a 20-mile radius from the site of any construction or maintenance work performed pursuant to paragraph (a) above, or from the nearest railway station thereto—any other materials required for such work. (c) Within a 25-mile radius of the point where the Hume Highway crosses the Victorian/New South Wales border—general goods provided that no goods shall be carried whether by one stage or by more than one stage between places within the above radius which are more than 30 road miles apart by the nearest practicable route.
- HEALING (SALES) PTY. LTD., 127 A'Beckett-street, Melbourne, 3000. Three commercial goods vehicles (L/C. 14 cwt. each) to operate within a 50-mile radius of own branch premises at Ballarat in the course of business as "Automotive and Electrical Wholesalers"—own goods.
- HEALING (SALES) PTY. LTD., 127 A'Beckett-street, Melbourne, 3000. Four commercial goods vehicles (L/C. 14 cwt. each) to operate within a 50-mile radius of own branch premises at Bendigo in the course of business as "Automotive and Electrical Wholesalers"—own goods.
- HEALING (SALES) PTY. LTD., 127 A'Beckett-street, Melbourne, 3000. Two commercial goods vehicles (L/C. 14 cwt.) to operate within a 50-mile radius of own branch premises at Shepparton in the course of business as "Automotive and Electrical Wholesalers"—own goods.
- HEALING (SALES) PTY. LTD., 127 A'Beckett-street, Melbourne, 3000. Two commercial goods vehicles (L/C. 14 cwt. each) to operate within a 50-mile radius of own branch premises at Horsham in the course of business as "Automotive and Electrical Wholesalers"—own goods.
- HEALING (SALES) PTY. LTD., 127 A'Beckett-street, Melbourne, 3000. Two commercial goods vehicles (L/C. 14 cwt. each) to operate within a 50-mile radius of own branch premises at Hamilton in the course of business as "Automotive and Electrical Wholesalers"—own goods.
- HICKSON, R., Hannan-street, Sea Lake, 3533. Application to vary conditions of licence No. D.A.40405 (L/C. 10 cwt.) by deleting "the Township of Woomelang" and adding in lieu "the Township of Sea Lake".
- HULSTON, S. B., 10 Byng-street, Cheltenham, 3192. Two commercial goods vehicles (L/C. 203 and 198 cwt.) to operate within a 50-mile radius from the premises of Albion Reid Pty. Ltd., at North Melbourne solely on behalf of the said company—premixed concrete in a specially constructed agitator vehicle.
- HUTTON, J. C., PTY. LTD., 65 High-street, Preston, 3072. One commercial goods vehicle (L/C. 84 cwt.) to operate throughout the State of Victoria in the course of business as "Bacon and Smallgoods Manufacturers" in a specially constructed insulated and refrigerated vehicle—fresh meat, cooked meat, sausages and smallgoods with the ability to carry a small quantity not exceeding 3 cwt., at any one time of lard, dripping, cheese and canned ham.
- INGPEN, T. A., PTY. LTD., 77 Little Malop-street, Geelong, 3220. One commercial goods vehicle (L/C. 16 cwt.) to operate in the course of business as "Wholesale Distributors"—own confectionary, cigarettes, soap and foodstuffs—(i) Within a 50-mile radius from the chief post office in the City of Geelong. (ii) From own premises in the City of Geelong to the Township of Apollo Bay via the Great Ocean-road, serving places en route.
- DAVIDSON, J. B., (trading as Inter Sales & Service Echuca), 23 Ogilvie-avenue, Echuca, 3625. One commercial goods vehicle (L/C. 133 cwt.) to operate: (a) Within a 50-mile radius of own premises at Echuca in the course of business as "Truck and Farm Machinery Dealers"—own goods. (b) Within that part of a 75-mile radius of own premises at Echuca, north of an east/west line drawn through Bendigo—new and second-hand trucks, tractors and farm machinery for delivery or repair or having been repaired and tools of trade and spare parts incidental to servicing in the field only. (c) Within a 50-mile radius of own premises at Echuca—new and second-hand trucks, tractors and farm machinery for display at Agricultural Shows and Field Days.

NOTE.—All farm implements, tractors and parts so carried to be initially railed to Echuca.

- JEPARIT MOTORS PTY. LTD., Box 69, Jeparit, 3423. One commercial goods vehicle (L/C. 9 cwt.) to operate within a 30-mile radius of the post office at Jeparit in course of business as "Motor Garage Proprietor"—tools of trade, spare parts and equipment incidental to the maintenance, servicing and repair of motor cars and machinery.
- KENNEDY, J. H., 47 Ashwood-drive, Nunawading, 3131. One commercial goods vehicle (L/C. 197 cwt.) to operate within a 50-mile radius of the premises of Ready Mixed Concrete (Victoria) Pty. Ltd., at Nunawading solely on behalf of the said company—premixed concrete in a specially constructed agitator vehicle.
- LAMSON ENGINEERING AUSTRALIA PTY. LTD., 30 Lexton-road, Box Hill, 3129. One commercial goods vehicle (L/C. 15 cwt.) to operate throughout the State of Victoria in the course of business as "Suppliers and Installers of Air Tube Conveyor and Dictograph Intercommunicating Telephone Systems"—tools of trade and materials required for installation and maintenance of Lamson Air Tube Conveyor and Dictograph Intercommunicating Systems.
- LARSEN, R. E., Eskdale, via Tallangatta, 3700. Application to vary conditions of licence No. D.A.61762 (L/C. 52 cwt.) by deleting the existing conditions and adding in lieu:—(a) Within a 25-mile radius from the post office at Mitta Mitta—general goods, provided that no goods shall be carried whether by one stage or by more than one stage between places within the above radius which are more than 30 miles apart by the nearest practicable route. (b) From and to places situated within a 25-mile radius from the post office at Mitta Mitta to and from places outside that radius which are wholly within a 50-mile radius of the said post office—livestock. (c) From and to places situated within a 25-mile radius from the post office at Mitta Mitta to and from Wodonga via Lockharts Gap or Tallangatta—general goods.
- LITTLEJOHN, R. K., Toora, 3962. Application to vary conditions of licences numbered D.A.35513/2, and D.A.35513/3 (L/C. 246 and 242 cwt.) by adding to the existing conditions as an additional paragraph—"From the premises of the Toora Knackery at Toora to the premises of Lance Creek Meat Works at Lance Creek—offal".
- DUNDAS, G. M. (trading as Mansfield Bulk Spreading Service), 5 Reynolds-street, Mansfield, 3722. One commercial goods vehicle (L/C. 142 cwt.) to operate: (a) Within a 25-mile radius from the post office at Mansfield—general goods, provided that no goods shall be carried whether by one stage or by more than one stage between places within the above radius which are more than 30 miles apart by the nearest practicable route. (b) From and to the B.P. Australia Ltd. depot at Benalla to and from consignees within a 50-mile radius of the post office at Mansfield—petroleum products in prescribed types of containers and empty return containers. (c) From the railway stations at Mansfield, Mairdample, Bonnie Doon, Woodfield and Merton to spreading sites within a 50-mile radius thereof—fertilizer for spreading purposes only. (d) From and to places situated within a 25-mile radius of the post office at Mansfield to and from places outside that radius which are wholly within a 50-mile radius of the said post office and to and from Newmarket—livestock.
- MARTIN, C. E., A'Beckett-street, Yea, 3717. Application to vary conditions of licence No. D.T.1242 (L/C. 280 cwt.) by adding to the existing conditions as paragraph (b) within a 50-mile radius of the post office at Yea in course of business as "Agricultural Contractor"—own earth-moving machinery, tools of trade, fuels, oils and associated equipment incidental to the operation of such machinery.
- HOOPER, G. L. and J. L. (trading as Melbourne Scale & Repair Co.), 61 Arden-street, North Melbourne, 3051. One commercial goods vehicle (L/C. 14 cwt.) to operate throughout the State of Victoria in course of business as "Scale Distributors and Service Specialists"—tools of trade, spare parts, scales for repair, having been repaired and scales for specialized installation.
- MICK SIMMONS TOBACCO PTY. LTD., 113 Franklin-street, Traralgon, 3844. Application to vary conditions of licence No. D.A.59560 (L/C. 7 cwt.) by deleting the existing conditions and adding in lieu:—"Within that part of the State of Victoria east of a north/south line drawn through the Town of Pakenham and west of a north/south line drawn through the Town of Lakes Entrance in course of own business as "Cigarette Vending Machine Operators"—own packets of cigarettes with loose coins in required denominations as change to refill vending machines with the proviso that all cigarettes carried will have been previously consigned by rail to Traralgon.
- MURDOCH, A., 22 Hilltop-crescent, Burwood East, 3151. One commercial goods vehicle (L/C. 57 cwt.) to operate throughout the State of Victoria in the course of business as "Boring Contractor"—own tools of trade and boring equipment for use in the completion of own contracts.
- MCLAIVE, K. D., 8 Pollock-avenue, Traralgon, 3844. One commercial goods vehicle (L/C. 13 cwt.) to operate within a 50-mile radius of the post office at Bairnsdale and within that part of the State of Victoria east of a north/south line drawn through the Township of Bairnsdale, in course of business as "Painter and Interior Decorator"—tools of trade, paint and materials incidental to the completion of own contracts.
- NANKERVIS, G. A., 14 Raglan-parade West, Warrnambool, 3280. One commercial goods vehicle (L/C. 10 cwt. and 31 cwt. trailer) to operate: (a) Within a 50-mile radius of the post office at Warrnambool in the course of business as "Panel Beater and Motor Body Repairer"—spare parts and materials incidental to the completion of own vehicle repairing contracts. (b) Within a 150-mile radius of the post office at Warrnambool for the purpose of carrying damaged or wrecked motor vehicles on a specially constructed car-carrying trailer—tools of trade and damaged or wrecked vehicles provided that no such vehicle shall be carried from the scene of an accident.
- OAKLEIGH BRICK CO. PTY. LTD., 68 Dawson-street, Brunswick, 3056. One commercial goods vehicle (L/C. 127 cwt.) to operate: (a) Within a 70-mile radius of own premises at Oakleigh in the course of business as "Brick Manufacturers"—own bricks. (b) Within a 20-mile radius of own premises at Oakleigh in the course of business as "Brick Manufacturers"—own goods.
- OTIS ENGINEERING CORP. (nominee J. T. Cliburn), 64 Bell-street, Preston, 3072. One commercial goods vehicle (L/C. 16 cwt.) to operate between Melbourne and Barry Beach and Sale and return and along the pipeline between the said cities or towns for the purpose of servicing such pipe-lines or installations on behalf of Otis Engineering Corp.—tools of trade, and spare parts incidental to servicing in the field only.
- PADBURY, A. W., & Co. PTY. LTD., 277 William-street, Melbourne, 3000. Two commercial goods vehicles (L/C. 10 cwt. each) to operate throughout the State of Victoria in course of business as "Funeral Directors" as mortuary vehicles.
- PINDER, C. R., 24 Benson-street, Benalla, 3672. One commercial goods vehicle (L/C. 15 cwt. and 20 cwt. trailer) to operate: (a) Within a 100-mile radius of the post office at Benalla in the course of business as "Monumental Mason"—own goods. (b) From own premises at Benalla to cemeteries throughout the State of Victoria—monumental masonry for erection at such cemeteries and tools and equipment incidental thereto. (c) From the Cities of Melbourne or Bendigo to own premises at Benalla or to cemeteries throughout the State of Victoria—monumental masonry for erection at such cemeteries under contract to the Commonwealth War Graves Commission.
- PLUM, A. J., 125 McKellar-street, Benalla, 3672. One commercial goods vehicle (L/C. 12 cwt.) to operate within that part of a 100-mile radius of the post office at Benalla situated north of a line drawn due east and west through the Township of Euroa in the course of business as "Marine Collector"—special wares, marine stores and old metals as designated in the *Marine Stores and Old Metals Act 1958* (No. 6303), Part I., section 3.
- ROBB, T. J., 27 Hayman-avenue, Seaford, 3198. One commercial goods vehicle (L/C. 195 cwt.) to operate within a 50-mile radius of the plant of Pioneer Concrete (Vic.) Pty. Ltd., at Hastings, solely on behalf of the said company—premixed concrete in a specially constructed agitator vehicle.
- RUSSELL, E. J. & R. E. (COLAC) PTY. LTD., 395 Murray-street, Colac, 3250. One commercial goods vehicle (L/C. 148 cwt.) to operate: (a) Within a 50-mile radius of the post office at Colac—plant the property of a contractor and required by him for use in connexion with the construction or maintenance of some specific, existing or proposed road, street, footpath, bridge, pier, wharf, weir or channel; and also the following materials viz., metal, stones, screenings, ashes, gravel, sand and earth. (b) Within a 20-mile radius from the site of any construction or maintenance work performed pursuant to paragraph (a) above, or from the railway station nearest thereto—any other materials required for such work. (c)

- Within a 25-mile radius of the post office at Colac—general goods, provided that no goods shall be carried whether by one stage or by more than one stage between places within the above radius, which are more than 30 road miles apart by the nearest practicable route.
- SCHWEPPE (AUST.) LTD.**, 137 Chesterville-road, Highett, 3190. One commercial goods vehicle (L/C. 111 cwt.) to operate within a 50-mile radius of the post office situated at the corner of Bourke and Elizabeth streets in the City of Melbourne in the course of business as "Aerated Water Manufacturers" but excluding the carriage of any goods to the City of Geelong— aerated waters and empty containers for return.
- SCOTT, I. B.**, P.O. Princetown, 3269. One commercial goods vehicle (L/C. 157 cwt.) to operate: (a) Within a 25-mile radius of the post office at Princetown—general goods provided that no goods shall be carried whether by one stage or by more than one stage between places within the above radius which are more than 30 road miles apart by the nearest practicable route. (b) Within a 50-mile radius of the post office at Princetown in the course of business as "Primary Producer"—own goods and goods the property of W. B. & D. E. Scott and K. D. Scott.
- SELKIRK FREIGHT LINES PTY. LTD.**, Howitt-street, Ballarat, 3350. One commercial goods vehicle (L/C. 300 cwt.) to operate: (a) From the brick kilns of James Selkirk Pty. Ltd. in the Ballarat district to any place within the State of Victoria—products manufactured and/or processed by the said company of such brick kilns. (b) From any point within the State of Victoria to the brick kilns of James Selkirk Pty. Ltd., in the Ballarat district—general goods solely for the use of the said company for the manufacture and processing of their products. (c) From the metropolitan area as defined in the *Transport Regulation Act 1958*, to the Ballarat Urban District as also defined in the said Act—common bricks.
- SIDES, W. L., & SON PTY. LTD.**, Wellington-road, Clayton, 3168. Application to vary conditions of licence No. D.A.28601/15 (L/C. 112 cwt.) by deleting the words "and materials" from the existing conditions and adding in lieu as an additional paragraph (b): "(b) Within a 20-mile radius from the site of any contract currently engaged upon or from the railway station nearest thereto—materials for use on such contract".
- STEWART & BAYLEY HAULAGE PTY. LTD.**, 54 Steven-street, Portarlington, 3223. One commercial goods vehicle (L/C. 190 cwt.) to operate within a 50-mile radius of the chief post office in the City of Geelong—solely on behalf of Geelong Premixed Concrete Pty. Ltd.—pre-mixed concrete in a specially constructed agitator vehicle.
- VAN KEMPEN, J.**, 63 Laverock-road, Warrnambool, 3280. One commercial goods vehicle (L/C. 78 cwt.) to operate: (a) Throughout the State of Victoria in the course of business as "Bridge Builder"—tools of trade and equipment incidental to own contracts. (b) Within a 20-mile radius of any current contract site or from the nearest railway station thereto—materials for use on such contract.
- VAN VLODROP, J.**, 26 Gillies-street, Shepparton, 3630. One commercial goods vehicle (L/C. 22 cwt.) to operate within a 50-mile radius of the post office at Shepparton and/or within a 25-mile radius of the post office at Alexandra in the course of business as "Floor Covering Contractor"—tools of trade, floor coverings and laying materials with the proviso that all such floor coverings and laying materials have been consigned by rail to either Shepparton or Alexandra and that no goods shall be carried from the railway station in either of the above towns to points outside the respective radius of such town.
- WEST, W. K.**, 12 Victoria-street, Eaglehawk, 3556. One commercial goods vehicle (L/C. 164 cwt.) to operate: (a) Within a 95-mile radius of the post office at Cohuna and/or within a 100-mile radius of the post office at Merbein (Bendigo Division of the Country Roads Board)—plant the property of a contractor and required for use in connexion with the construction or maintenance of some specific, existing or proposed road, street, footpath, bridge, wharf, pier, weir or channel. (b) Within a 20-mile radius from site of construction or maintenance work performed pursuant to paragraph (a) above, or from the nearest railway station thereto—metals, stones, screenings, ashes, gravel, sand and any other materials required for such work. (c) Within a 25-mile radius of the post office at Bendigo—general goods.
- WILLIAMSON, L. M. & J. M.**, P.O. Alvie, 3253. Two commercial goods vehicles (L/C. 165 cwt.) to operate: (a) Within a 25-mile radius of the post office at Alvie—general goods, provided that no goods shall be carried whether by one stage or by more than one stage between places within the above radius which are more than 30 miles apart by the nearest practicable route. (b) From and to places situated within a 25-mile radius of the post office at Alvie to and from places outside that radius which are wholly within a 50-mile radius of the said post office—live-stock. (c) From and to the Garden City Flour Mill at Ballarat to and from consignees within that part of the State of Victoria bounded by the Townships of Leslie Manor, Beeac, Deans Marsh, Beech Forest, Lavers Hill, Chapple Vale, Simpson and Tandarook—bagged stock feed and empty bags on return journey.
- WORMALD BROTHERS (AUST.) PTY. LTD.**, 453 Williamstown-road, Port Melbourne, 3207. Two commercial goods vehicles (L/C. 11 and 14 cwt.) to operate throughout the State of Victoria in course of business as "Fire Protection Engineers" for the purpose of servicing and installing fire alarm systems—tools of trade, fire alarm equipment for repair having been repaired and for specialized installation.

TOW TRUCK.

- NANKERVIS, G. A.** (trading as Geoff. Nankervis Panel Works), 14 Raglan-parade West, Warrnambool, 3280. One commercial goods vehicle (to be purchased) to operate throughout the State of Victoria as a "Tow Truck" solely: (a) For the purpose of lifting and carrying or towing motor cars and the carriage of tools and equipment necessary for such purpose only. (b) The carriage of spare parts necessary for the repair of a disabled motor to and from the place at which such disablement has occurred.

RENEWALS.

- APPLICATIONS** for renewal of licences as shown, by persons listed hereunder, to operate under the same terms and conditions from the expiry shown in each case.
- BEAUREPAIRE TYRE SERVICE PTY. LTD.**, 102 Victoria-street, Carlton, 3053; D.A.629/4; 21st January, 1969; 42 cwt.
- BEAUREPAIRE TYRE SERVICE PTY. LTD.**, 102 Victoria-street, Carlton, 3053; D.A.629/5; 21st January, 1969; 16 cwt.
- BEAUREPAIRE TYRE SERVICE PTY. LTD.**, 102 Victoria-street, Carlton, 3053; D.A.629/55; 16th January, 1969; 11 cwt.
- BERRY, HENRY, & CO. (AUSTRALASIA) LTD.**, 1 Fennell-street, Port Melbourne, 3207; D.A.661/6; 12th January, 1969; 11 cwt.
- BLEWETT, W. J. & A. G.**, Bruarong, via Yackandandah; 3749; D.A.53953; 1st December, 1968; 97 cwt.
- BOWER, H. R.**, 15 Cumming-avenue, Birchip, 3483; D.A.41315; 12th December, 1968; 204 cwt.
- CERAMIC TRANSPORT PTY. LTD.**, corner Princes Highway and Smith-road, Springvale North, 3171; D.A.50824/25; 11th January, 1969; 117 cwt.; D.A.50824/27; 11th January, 1969; 144 cwt.
- CRAIGIE (CLAYS) PTY. LTD.**, 68 Dawson-street, Brunswick, 3056; D.A.52478/8; 26th January, 1969; 228 cwt.
- DALE, C. W.**, 3 View-street, Castlemaine, 3450; D.A.60156; 12th December, 1968; 13 cwt.
- DALGETY & NEW ZEALAND LOAN LTD.**, 538 Collins-street, Melbourne, 3000; D.A.46170/45; 11th January, 1969; 11 cwt.
- DALGETY & NEW ZEALAND LOAN LTD.**, 538 Collins-street, Melbourne, 3000; D.A.46170/49; 11th January, 1969; 11 cwt.
- DALGETY & NEW ZEALAND LOAN LTD.**, 538 Collins-street, Melbourne, 3000; D.A.46170/51; 11th January, 1969; 10 cwt.
- DALGETY & NEW ZEALAND LOAN LTD.**, 538 Collins-street, Melbourne, 3000; D.A.46170/53; 11th January, 1969; 11 cwt.
- DAVEY, F. W., AND CO. PTY. LTD.**, Hargreaves-street, Huntingdale, 3166; D.A.949/2; 29th January, 1969; 10 cwt.; D.A.949/3; 29th January, 1969; 10 cwt.
- DAVIS, D. F.**, 8 Palmer-street, Winchelsea, 3241; D.A.41134; 5th December, 1968; 203 cwt.
- DE SENSI, D.**, 14 Stanley-street, Brunswick, 3056; D.A.43738; 11th January, 1969; 203 cwt.
- DEW, R. M.**, 58 Marshall-street, Chilwell, Geelong, 3220; D.A.53723; 21st December, 1968; 318 cwt.
- ELSWORTH, G. G. & M. L.**, 21 Hawke-street, Mentone, 3194; D.A.54314; 11th January, 1969; 143 cwt.
- ENGLISH, SCOTTISH & AUSTRALIAN BANK LTD., THE**, 287 Collins-street, Melbourne, 3000; D.A.28093; 14th January, 1969; 60 cwt.; D.A.28093/1; 14th January, 1969; 30 cwt.
- GEELONG CHURCH OF ENGLAND GRAMMAR SCHOOL**, Corio, Geelong, 3220; D.A.30829/1; 20th December, 1968; 74 cwt.
- GENERAL PROVIDORS (AUST.) PTY. LTD.**, 51 Playne-street, Frankston, 3199; T.D.A.53767/6; 26th January, 1969; 40 cwt.

GILBARCO AUST. LTD., 11 Anderson-road, Thornbury, 3071; D.A.1144/50; 16th January, 1969; 24 cwt.; D.A.1144/51; 16th January, 1969; 23 cwt.; D.A.1144/52; 16th January, 1969; 23 cwt.; D.A.1144/53; 16th January, 1969; 24 cwt.

GORDON BROTHERS PTY. LTD., 110-120 Union-street, Brunswick, 3056; D.A.1172/5; 23rd January, 1969; 17 cwt.

HEAL, W. J., 23 Curtin-crescent, Dandenong, 3175; D.A.53974; 1st December, 1968; 213 cwt.

HICKMAN, R. F., 4 May-street, Kangaroo Flat, 3555; D.A.54039; 8th December, 1968; 139 cwt.

JAMES, G. C., 14 Kevin-street, Tootgarook, 3941; D.A.40943; 14th November, 1968; 124 cwt.

JENKINS, J. P. (trading as J. P. Jenkins & Son), Kiewa via Wodonga, 3690; D.A.39032/3; 1st December, 1968; 135 cwt.

ROBIN KEATH (S.A.) PTY. LTD., Box 128, Horsham, 3400; D.A.22517/21; 1st December, 1968; 220 cwt.

KNOCHES, A., 193 Camberwell-road, Camberwell, 3124; D.A.54459; 26th January, 1969; 218 cwt.

LAMBERT, T., 9 Buchanan-street, Bairnsdale, 3875; D.A.27944; 17th December, 1968; 7 cwt.

LITTLE, W., 20 Coghill-street, Yarrowonga, 3730; D.A.54025; 8th December, 1968; 142 cwt.

MOLLER, A. O. H., Church-street, Kangaroo Flat, 3555; D.A.28478; 17th December, 1968; 8 cwt.

MONIER BESSER PTY. LTD., 462 St. Kilda-road, Melbourne, 3004; D.A.54402; 26th January, 1969; 61 cwt.

MOTOR TYRE SERVICE PTY. LTD., 5 Scott-street, Colac, 3258; D.A.38161/3; 14th December, 1968; 11 cwt.

PETERSVILLE AUSTRALIA LTD., Wellington-road, Clayton, 3168; D.A.1813/21; 8th January, 1969; 72 cwt.; D.A.1813/22; 8th January, 1969; 73 cwt.; D.A.1813/24; 22nd January, 1969; 71 cwt.; D.A.1813/25; 23rd January, 1969; 72 cwt.; D.A.1813/84; 27th January, 1969; 75 cwt.; D.A.1813/85; 27th January, 1969; 77 cwt.; D.A.1813/110; 11th January, 1969; 77 cwt.; D.A.1813/111; 11th January, 1969; 80 cwt.; D.A.1813/112; 26th January, 1969; 36 cwt.

REES, E. T. & P. L., High-street, Cranbourne, 3977; D.A.34634/1; 8th December, 1968; 130 cwt.

TAHIR, Z., Jumbunna, 3951; D.A.53931; 1st December, 1968; 166 cwt.

TAYLOR, R. J. Gerang Gerang, 3417; D.A.53951; 1st December, 1968; 118 cwt.

VOSILAITIS, B., 28 Berkshire-road, North Sunshine, 3020; D.A.28102/3; 5th October, 1968; 213 cwt.

WORTHY, W. T., Gymbowen via Horsham, 3400; D.A.34333/1; 1st December, 1968; 122 cwt.

TOW TRUCKS.

BOON, C., 262-266 Bay-road, Cheltenham, 3192; D.A.52315/1; 11th January, 1969; 69 cwt.

BROWN, K. R. (trading as Brown's Central Motor Garage), 36 Bay-street, Golden Square, 3555; T.D.A.45856; 10th December, 1968; 25 cwt.

COMACK MOTORS PTY. LTD., 398 Neerim-road, Murrumbena, 3163; D.A.57938; 26th January, 1969; 44 cwt.

HALL, N. H., Dunolly, 3472; T.D.A.37929; 14th December, 1968; 25 cwt.

KELTY, D. W. & A. J., IRVINE (trading as Hamilton Motor Body Works), 52 Lonsdale-street, Hamilton, 3300; D.A.36544; 29th June, 1968; 27 cwt.

HOKIN, H. W. (trading as Hokin's Service Garage), Bell-street, Yarra Glen, 3775; T.D.A.46579; 18th February, 1969; 37 cwt.

PATTERSON, J. R., Calder Highway, Diggers Rest, 3427; D.A.61813; 26th January, 1969; 30 cwt.

Notice of any objection should be forwarded to reach the Secretary of the Board not later than 27th November, 1968.

Applicants are advised that it will not be necessary to appear on the hearing date specified above, unless advised in writing by the Board.

B. P. KAY,
Secretary.

Corner Lygon and Princes streets, Carlton, 3053, Friday, 8th November, 1968.

STATE RIVERS AND WATER SUPPLY COMMISSION.

LICENCES TO DIVERT WATER AND CUT RACES PURSUANT TO THE PROVISIONS OF SECTION 204 OF THE WATER ACT 1958. (AS AMENDED).

THE Governor in Council has approved of the granting by the State Rivers and Water Supply Commission of licences as detailed hereunder for the term of years from the date specified in each case to the persons named in the following Schedule:—

SCHEDULE.

Licence No.	Term of Licence and Commencing Date.	Name and Address of Person to Whom Licence is to be Granted.	Source of Supply.	Area Authorized to be Irrigated per Annum.	Volume of Water Authorized to be Diverted per Annum.
				acres.	ac. ft.
1998	Four years from 1.7.68 ..	Antonios Psaralagos, Robinvale ..	River Murray ..	32	96
2003	Four years from 1.7.68 ..	Cedric Horatio Richards, Robinvale ..	River Murray ..	13½	40
2136	Four years from 1.7.68 ..	Jack Alexander Isaacs, Red Cliffs ..	River Murray ..	46	138
2574	Four years from 1.7.67 ..	Leslie Neil Bombardieri, Kooloonong ..	River Murray ..	100	300
2575	Four years from 1.7.67 ..	M. and D. Briggs and Co., Colignan ..	River Murray ..	100	300
2576	Four years from 1.7.68 ..	Adrian Bruce Davy, Nichols Point ..	River Murray ..	20	60
2577	Four years from 1.7.68 ..	Wesley Samuel Davy, Nichols Point ..	River Murray ..	20	60
2578	Four years from 1.7.68 ..	Douglas Wolseley Haig, Kerang ..	River Murray ..	9½	19
2579	Four years from 1.7.68 ..	Keith Robert Munro, Nichols Point ..	River Murray ..	20	60
2580	Four years from 1.7.67 ..	Piambie Farms Pty. Ltd., Bendigo ..	River Murray ..	50	150
2581	Four years from 1.7.67 ..	Frank Newington Plant, Mt. Alfred ..	River Murray ..	25	50
2582	Four years from 1.7.68 ..	William Samuel Francis Stones, Rutherglen ..	River Murray ..	20	40
2583	Four years from 1.7.68 ..	Alex Wildes, Echuca	River Murray ..	23	46

In each case, the annual fee payable in respect of each acre-foot of water authorized to be diverted is the equivalent of one-half of the irrigation charge per acre-foot fixed in the Goulburn-Murray Irrigation District for the preceding financial year.

Office of the State Rivers and Water Supply Commission,
Melbourne, 6th November, 1968.

W. J. WILSON, Acting Secretary,
State Rivers and Water Supply Commission.

Motor Car Act 1958.—Section 41.

EFFECTIVE DATE OF WITHDRAWAL BY AUTHORIZED INSURER.

WHEREAS by notice in writing, dated the sixth day of November, 1968, the following authorized insurer under Part V. of the Motor Car Act 1958, namely:—

EDWARD LUMLEY & SONS (VIC.) PTY. LTD.,
has withdrawn from business in terms of the aforesaid part:

Now therefore I, Her Majesty's Chief Secretary for the State of Victoria, in pursuance of section 41 of the said Act, do hereby fix the thirty-first day of December, 1968, as the date upon which such withdrawal shall have effect.

A. G. RYLAH,
Chief Secretary.

Chief Secretary's Office,
Melbourne, 11th November, 1968.

Health Act 1958.

VICTORIA—DEPARTMENT OF HEALTH.

NOTICE TO ATTEND FOR RADIOLOGICAL EXAMINATION.

To all persons aged twenty-one years and over enrolled or resident in the Subdivisions specified hereunder in the State Electoral District of Mitcham.

TAKE notice that you are required to attend at a Department of Health X-ray unit sited in the public street at or as near as possible to the main entrance to the premises specified in this notice, at any time between the hours specified on one of the days specified and during the period specified in respect of those premises, and thereat to submit yourself to radiological examination of the chest for the purpose of ascertaining whether you may be suffering from pulmonary tuberculosis. If you have had a Chest X-ray within the last twelve months and for that reason do not wish to be examined now, you should attend the unit as directed and submit particulars of the previous examination.

SPECIFIED SUBDIVISIONS, PREMISES, PERIODS, DAYS AND HOURS.

Subdivision.	Premises.	Period.	Days.	Hours.
Mitcham ..	Australian and Continental Delicatessen, cnr. Caroline-crescent and Katrina-street, Blackburn North	Friday, 29th November, 1968, to Tuesday, 3rd December, 1968 (inclusive)	Each day during the period except Saturday, Sunday and Public Holidays	From 10 a.m. to 8.30 p.m.
	Shopping Centre, Salisbury-avenue, Laburnum	Friday, 29th November, 1968, to Tuesday, 3rd December, 1968 (inclusive)	Each day during the period except Saturday, Sunday and Public Holidays	From 10 a.m. to 8.30 p.m.
	Cnr. Charles-street and Junction-road, Nunawading	Monday, 2nd December, 1968, to Wednesday, 4th December, 1968 (inclusive)	Each day during the period except Public Holidays	From 10 a.m. to 8.30 p.m.
	Shopping Centre, South-parade, Blackburn, (2 units)	Wednesday, 4th December, 1968, to Monday, 9th December, 1968 (inclusive)	Each day during the period except Saturday, Sunday and Public Holidays	From 10 a.m. to 8.30 p.m.
	James' Pharmacy, 146A Springfield-road, Blackburn North	Thursday, 5th December, 1968, to Wednesday, 11th December, 1968 (inclusive)	Each day during the period except Saturday, Sunday and Public Holidays	From 10 a.m. to 8.30 p.m.
	Blackburn Lake State School, Florence-street, Nunawading	Tuesday, 10th December, 1968	Tuesday, 10th December, 1968	From 10 a.m. to 8.30 p.m.
	Total Service Station, cnr. Springvale-road and Laughlin-avenue, Nunawading	Tuesday, 10th December, 1968 to Tuesday, 17th December, 1968 (inclusive)	Each day during the period except Saturday, Sunday and Public Holidays	From 10 a.m. to 8.30 p.m.
	Shopping Centre, cnr. Mt. Pleasant road and Lorikeet-street, Nunawading	Wednesday, 11th December, 1968, to Monday, 16th December, 1968 (inclusive)	Each day during the period except Saturday, Sunday and Public Holidays	From 10 a.m. to 8.30 p.m.
	Sharwood's Pharmacy, 546 Whitehorse-road, Mitcham	Thursday, 12th December, 1968 to Monday, 23rd December, 1968 (inclusive)	Each day during the period except Saturday, Sunday and Public Holidays	From 10 a.m. to 8.30 p.m.
	Caltex Service Station, cnr. Carween-avenue and Mitcham-road, Mitcham (Rangeview)	Tuesday, 17th December, 1968, to Monday, 23rd December, 1968 (inclusive)	Each day during the period except Saturday, Sunday and Public Holidays	From 10 a.m. to 8.30 p.m.
	Dobyn's Pharmacy, 60 Mitcham-road, Mitcham North	Wednesday, 18th December, 1968, and Thursday, 19th December, 1968	Wednesday, 18th December, 1968 Thursday, 19th December, 1968	From 10 a.m. to 8.30 p.m. From 10 a.m. to 8.30 p.m.
	Heatherdale Self Service Grocery, 697 Whitehorse-road, Heatherdale	Friday, 20th December, 1968, and Monday, 23rd December, 1968	Friday, 20th December, 1968 Monday, 23rd December, 1968	From 10 a.m. to 8.30 p.m. From 10 a.m. to 8.30 p.m.

NOTE.—Any person to whom this notice applies and who without reasonable excuse fails to comply with the requirements of the notice shall be guilty of an offence, and shall be liable to a penalty of not more than Forty dollars.

Dated this 18th day of October, One thousand nine hundred and sixty-eight.

R. J. FARNBACH,
Chief Health Officer.

LOCAL GOVERNMENT DEPARTMENT.

ORDER CONFIRMED.—SHIRE OF KYNETON.

THE Minister of the Crown administering the *Local Government Act 1958*, on the 31st day of October, 1968, confirmed the Order hereinafter referred to in pursuance of section 514 of the said Act namely:—

An Order of the Council of the Shire of Kyneton made on the 11th September, 1968, directing the compulsory taking of certain land being Crown allotments 1, 2, 6, 7, 8 and 10, Section L, Township of Kyneton, Parish of Lauriston for the purpose of the provision of a garbage disposal area.

R. J. HAMER,
Minister for Local Government.

Local Government Department,
Melbourne.

LOCAL GOVERNMENT DEPARTMENT.

ORDER CONFIRMED.—CITY OF BRIGHTON.

THE Minister of the Crown administering the *Local Government Act 1958* on the 11th day of November, 1968, confirmed the Order hereinafter referred to in pursuance of section 514 of the said Act namely:

An Order of the Council of the City of Brighton made on the 21st October, 1968, directing the compulsory taking of the lands described in certificates of title, volume 3315, folio 982 and volume 3412, folio 220 for the purpose of altering and increasing the width of Francis-road or Snooks-lane and associated redevelopment of the surrounding area.

R. J. HAMER,
Minister for Local Government.

Local Government Department,
Melbourne.

COMPANIES ACT 1961.

NOTICE is hereby given that in pursuance of section 308 (4) of the Companies Act 1961, the names of the Companies referred to below have been struck off the Register, and on publication of this notice in the Government Gazette the said Companies will be dissolved.

Dated this 8th day of November, 1968.

E. B. MITCHAM,
Assistant Registrar of Companies.

Companies Office,
Melbourne.

NAME OF COMPANY.	NUMBER OF REGISTRATION.
Beefine Pty. Ltd.	7322
L. G. Strachan Pty. Ltd.	8813
T. E. R. Pty. Ltd.	13772
Dalleys Motors Pty. Ltd.	17688
H. S. Gerard & Coy. Pty. Ltd.	17919
R. D. Gault Pty. Ltd.	19358
T. J. Neighbour & Co. Pty. Ltd.	20789
Fuel & Chemical Industries Ltd.	20984
Simpson Agencies Pty. Ltd.	21489
Housewares Pty. Ltd.	23801
Consolidated Distributors Pty. Ltd.	23802
Harclay's (Geelong) Pty. Ltd.	25306
The Whare Furniture Co. Pty. Ltd.	26331
Lygon Investments Pty. Ltd.	27921
Australian Fuel & Chemicals Pty. Ltd.	28344
P. T. C. Pty. Ltd.	29407
Henry Bedford Pty. Ltd.	29519
L. G. Keat Pty. Ltd.	30244
C. P. Publications Pty. Ltd.	31510
The Brake Safety Club of Australia Pty. Ltd.	31600
Roach Bros. & Roach Pty. Ltd.	32669
A. E. Seidel Pty. Ltd.	32820
K. & C. Motors Pty. Ltd.	33621
The Borden Food Coy. (Australia) Pty. Ltd.	34501
Flynn Brothers Contractors Pty. Ltd.	36184
Stivic Meat Supply Pty. Ltd.	38226
Central Winding & Battery Co. Pty. Ltd.	38763
Flec Fabrics Pty. Ltd.	38877
Loans & Deposits Ltd.	40056
A. J. Pastoral Coy. Pty. Ltd.	40570
Cardigan Investment Co. Pty. Ltd.	40581
Windex Sportswear Pty. Ltd.	40587
Knoxdale Investments Pty. Ltd.	41862
T. & A. Mitchell Transport Pty. Ltd.	42156
Lindenlock Pty. Ltd.	42560
T. J. Woods & Co. Pty. Ltd.	43806
Kelstone Pty. Ltd.	43819
Sauber Holdings Pty. Ltd.	44520
C.Q. Audio (Australia) Pty. Ltd.	44572
Jonsales (Australia) Pty. Ltd.	44938
K.B.S. Distributors Pty. Ltd.	45005
Polish Migrants Association of Victoria Ltd.	45284
One Hundred and One Barkly Street Pty. Ltd.	46137
Weblane Freight Lines Pty. Ltd.	46688
Austman Pty. Ltd.	46790
Lorant Tyre & Rubber Co. Pty. Ltd.	47717
David E. Ballingall Pty. Ltd.	48143
Viking Mills (Sales) Pty. Ltd.	48459
Laroche Building Co. Pty. Ltd.	48639
John McKenzie Air Conditioning Pty. Ltd.	50119
Ray Hanson Industrial Building Pty. Ltd.	50607
Sunvale Homes Pty. Ltd.	52509
T. L. Phelan Pty. Ltd.	60463
Electrical Installation Materials Association (Victoria) Ltd.	61780
Cross Constructions Pty. Ltd.	61985

State Electricity Commission Acts.

STATE ELECTRICITY COMMISSION OF VICTORIA.

ELECTRICAL APPROVALS BOARD.

IN accordance with the requirements of the Electrical Approvals Regulations—Proceedings of Electrical Approvals Board, the State Electricity Commission of Victoria, hereby gives notice that the following appointment has been made pursuant to the provisions contained in section 51 of the State Electricity Commission Act 1958, and the said Regulations, viz.:—

REGINALD WILLIAM ROSE, as representing the interests of the electrical contractors, to be a Member of the said Board to hold office until the 30th day of June, 1970.

Dated the 13th day of November, 1968.

F. P. CHIPPERFIELD, Secretary.

Country Fire Authority Act 1958.

SUMMER PERIOD IN RESPECT OF SPECIFIED PARTS OF THE COUNTRY AREA OF VICTORIA.

WHEREAS by section 4 of the Country Fire Authority Act 1958, it is enacted that the Chief Secretary of Victoria, after consultation with the Minister of Forests, may from time to time by declaration published in the Government Gazette declare any period to be the summer period in respect of the country area of Victoria, or any specified part or parts thereof and, without affecting the generality of the foregoing, may declare different periods to be the summer period in respect of different parts of the said country area:

And whereas the Chief Secretary and the Minister of Forests have consulted accordingly:

Now therefore I, the Chief Secretary of Victoria, do hereby declare the period commencing at midnight on the 15th November, 1968, and ending at midnight on the 30th April, 1969, to be the summer period in respect of the parts of the country area of Victoria specified in the Schedule hereto and being portions of the Eighteenth and Twentieth Fire Control Regions:

SCHEDULE (No. 2).

Those portions of the Eighteenth Fire Control Region comprised by those portions of the municipal district of the Shire of Swan Hill which lie north of a road and a line joining the north-western angle of the Parish of Mittyack with the north-eastern angle of the Parish of Tyntynder North with the exception of the Soldier Settlement Subdivision of the Robinvale Irrigation District; and

those portions of the Twentieth Fire Control Region comprised by those portions of the municipal district of the Shire of Wycheproof which lie north of the Woomelang—Banyan—Berriwillock road, the western, southern and eastern boundaries of the Township of Berriwillock and the Berriwillock—Springfield—Ultima road.

A. G. RYLAH,
Chief Secretary.

Chief Secretary's Office,
Melbourne, 12th November, 1968.

Melbourne and Metropolitan
BOARD OF WORKS.

NOTICE is hereby given that after the publication of this advertisement in the Government Gazette and once in not less than two daily newspapers published in the metropolis, the Melbourne and Metropolitan Board of Works will proceed to compulsorily take (unless the same is in the meantime acquired by the Board from the owner or owners or other persons interested by mutual agreement) the land mentioned and described in the Schedule hereto.

The nature of the works in respect of which the land is proposed to be taken is the construction of a Pumping Station.

A plan of the proposed works will be open for inspection at the offices of the Board, 110 Spencer-street, Melbourne, from the date hereof until the 11th December, 1968, during office hours.

The quantity of land which the Board requires for the purpose of such works and other particulars are set forth below.

The consent of the Governor in Council was duly obtained in terms of the Board's principal Act (No. 6310) on the 8th October, 1968.

SCHEDULE.

All that land being part of Crown allotment 4, section 10, Parish of Nillumbik, in the County of Evelyn, commencing at the south-western corner of lot 2 on lodged plan No. 20394; thence by lines bearing 7 deg. 33 min. for 50 feet and 74 deg. 9 min. 30 sec. for 149 ft. 3½ in. to the western alignment of Reynolds-road; thence southerly by that alignment bearing 179 deg. 52 min. for 60 feet and generally westerly by lines bearing 273 deg. 41 min. for 40 feet, 179 deg. 52 min. for 40 feet, and 273 deg. 41 min. for 110 ft. 9 in. to the commencing point and containing 343/10 perches.

Dated the 7th day of November, 1968.

H. J. SNADDEN,
Secretary.

NOTICE TO MARINERS.
[No. 20 of 1968.]

AUSTRALIA.—VICTORIA.
PORT PHILLIP.

Light to be Withdrawn.

Date.—On or about 18th November, 1968.

Position of Light.—St. Kilda Outer North End Inner Breakwater. Lat. 37 deg. 51.8 min. south. Long. 144 deg. 57.9 min. east (approximately).

Remarks.—Approximately 600 feet of the Inner Breakwater is being demolished and the flashing white light in the position described above will be permanently withdrawn. No further notice will be issued.

Charts Effected.—Aus. 153. B.A.1171.

Publication Effected.—Victorian Sailing Directions, 1959, page 697.

A. J. WAGGLEN,
Port Officer.

Public Works Department,
Ports and Harbors Branch,
Treasury-place,
Melbourne, Vic. 3002.
5th November, 1968.

SHIRE OF YEA.
ROAD DEVIATION ORDER.

PURSUANT to the provisions of sections 522 and 526 of the Local Government Act 1958, the Council of the Shire of Yea hereby directs that land in the Parish of Yea indicated by hatching on the plan hereunder, which has been purchased, taken or acquired by it, shall be a public highway on and from the date of publication of this order in the Government Gazette and declares that such land shall be a public highway in lieu of the land indicated by cross-hatching on the said plan.

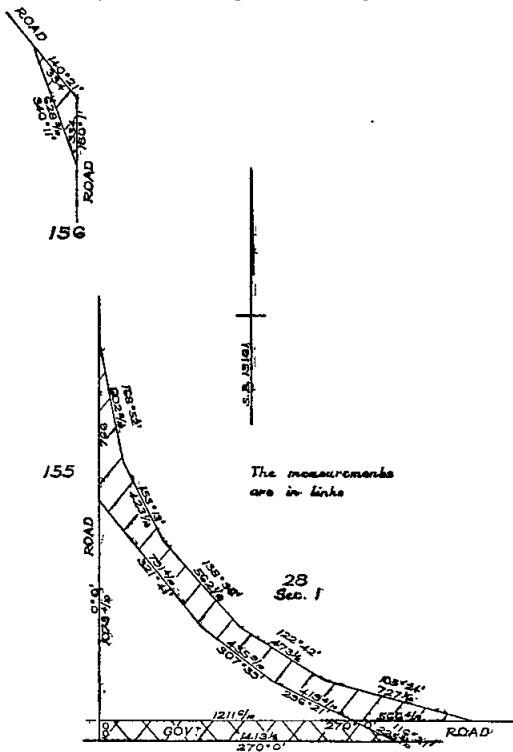

The common seal of the President, Councillors and Ratepayers of the Shire of Yea was hereunto affixed, this 6th day of October, 1968, in the presence of—

(SEAL) A. S. PURVIS, Shire President.
M. P. COONAN, Councillor.
F. F. BERKERY, Shire Secretary.

Confirmed by the Governor in Council, 6th November, 1968.—J. ROSSITER, Clerk of the Executive Council.

SHIRE OF YEA.

PURSUANT to the provisions of sections 522 and 526 of the Local Government Act 1958, the Council of the Shire of Yea hereby directs that the land in the Parish of Woodbourne indicated by hatching on the diagram hereunder, which has been purchased, taken or acquired by it, shall be a public highway on and from the date of publication of this order in the Government Gazette and declares that such lands shall be a public highway in lieu of the land indicated by cross hatching on the said diagram.

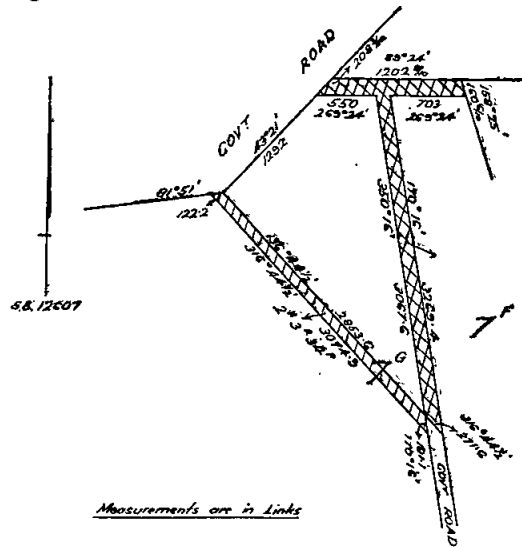

The common seal of the President, Councillors and Ratepayers of the Shire of Yea was hereunto affixed, this 3rd day of October, 1968, in the presence of—

(SEAL) A. J. BETT, Shire President.
A. S. PURVIS, Councillor.
F. F. BERKERY, Shire Secretary.

Confirmed by the Governor in Council, 6th November, 1968.—J. ROSSITER, Clerk of the Executive Council.

Fruit and Vegetation Act 1958 (No. 6256).

PERSONS AUTHORIZED TO TAKE PROCEEDINGS.

HIS Excellency the Lieutenant-Governor of the State of Victoria and with the advice of the Executive Council thereof, doth by Order made on the 24th day of September, 1968, in accordance with section 48 of the Fruit and Vegetation Act 1958 (No. 6286), authorize the persons named hereunder, who are Inspectors under the said Act, to take proceedings in respect of offences against Part II. of the said Act on the Regulations thereunder:—

WILLIAM JAMES HAMILTON.
KEITH CHARLES LEAMON.
ADRIAN WILLIAM ROLINS.

J. ROSSITER,
Clerk of the Executive Council

At the Executive Council Chamber,
Melbourne, 24th September, 1968.

CONTRACTS ACCEPTED.—(Series 1968-69.)

VICTORIAN RAILWAYS.

47. Design, manufacture, supply and delivery of 100 No. bulk wheat hopper wagons, for \$6,088.00 each (Contract 63198).—Industrial Engineering Ltd. (Steel Weld Div.).
48. Removing Departmental Residence No. 3403 from site adjacent to level crossing at 21M. 51C. 69L. and re-establishing in Underwood-road, Ferntree Gully, together with fencing, outbuilding and services for the amount of \$4,441.90 (Contract 63346).—C. D. Wilson & Sons.
49. Earthworks for the deviation of the main line track at Denilquin between mileages 198M. 55C. and 199M. 20C., at rates (Contract 63348).—Rod Drutt & Co.

By order of the Victorian Railways Commissioners,
W. WALKER, Secretary. 8.11.68.

PUBLIC WORKS.

1200. Frankston, Technical School, supply workshop equipment, \$25,490.65.—Demco Machinery Co. (Vic.) Pty. Ltd.

1201. Port Melbourne, P.W.D. Storeyard, supply air compressors, \$5,516.80.—Holman Bros. (Aust.) Pty. Ltd.

1202. Port Melbourne, P.W.D. Storeyard, supply fire extinguishers, \$1,314.00.—Wormald Bros. (Aust.) Pty. Ltd.

1203. Upper Ferntree Gully, Technical School, supply stacking chairs, \$6,361.60.—Aristoc Industries Pty. Ltd.

1204. Melbourne, Melbourne Teachers' College, supply lockers, \$2,849.00.—Fileguard (Aust.) Pty. Ltd.

1205. Ballarat, School of Mines, supply various furniture, \$1,911.30.—Westbury Timber Co. Pty. Ltd.

1206. Flemington, Travancore Developmental Centre, supply and fix curtains, \$3,219.89.—Fischer Furnishings Pty. Ltd.

1207. Port Melbourne, P.W.D. Storeyard, supply vibrat-ing rollers, \$26,287.00.—Davleco Equipment Pty. Ltd.

1208. Warrnambool, Law Courts, supply furniture, \$1,142.00.—Weeks & Hansen.

G. SERPELL, Secretary for Public Works. 4.11.68.

ORDERS IN COUNCIL.—(Series 1968-69.)

PUBLIC WORKS.

1197. Girls' Secondary School, Shepparton, electrical installation in old building, \$1,409.76.—K. J. Dupuy.—(N.E.82940 "A")

1198. Companies Registration Branch, 453 La Trobe-street, Melbourne, supply and installation of electrical equipment, \$2,415.00.—Bayley & Grimster Ltd.—(C.137220 "A")

1199. High School, Maryvale, completion of contract determined with Hannah Builders Pty. Ltd., \$100,000.00.—A. V. Jennings Industries (Aust.) Ltd.—(S.E.142323.)

Approved by the Governor in Council, 6th November, 1968.—J. ROSSITER, Clerk of the Executive Council.

STATE ELECTRICITY COMMISSION.

1194. For the supply of 66 kV, 22 kV, 11 kV and 6.6/11 kV capacitor banks for metropolitan and Latrobe Valley substations and regional terminal stations to Specification No. 68/130, \$292,941.—Ducon Condenser Pty. Ltd.

Approved by the Governor in Council, 15th October, 1968.—J. ROSSITER, Clerk of the Executive Council.

1195. For the supply of galvanized structural steelwork for 500 kV switchyards, Keilor Terminal Station to Specification No. 68/316, \$70,707.—Ascom Pty. Ltd.

1196. For the provision and operation of a helicopter for inspection of high voltage transmission lines for a period of two years with optional extension of three months to Specification No. 68/305, at Schedule rates.—Jayrow Helicopters.

Approved by the Governor in Council, 22nd October, 1968.—J. ROSSITER, Clerk of the Executive Council.

PUBLIC TRUSTEE ACT 1958 (No. 6350), SECTION 17.

I HEREBY give notice that on the 22nd October, 1968, the Public Trustee filed elections to administer the following deceased persons' estates, in accordance with section 17 of the Public Trustee Act 1958:—

CAMERON, HECTOR McDONALD, late of 20 Gordon-street, Newport, watchman, died between 20th and 22nd April, 1968.

GELDEREN, MARTINUS, late of 29 Donnithorne-street, Kyneton, died 20th June, 1968.

WEST, KEITH HAROLD, late of 11 Walter-street, Sunshine, process worker, died 27th June, 1968.

J. K. COOK,
Acting Public Trustee.

256 Flinders-street, Melbourne, 6th November, 1968.

NOTICE.

CREDITORS, next of kin and others having claims against the estate of any of the under-mentioned deceased persons are required to send particulars of their claims to the Public Trustee, 256 Flinders-street, Melbourne, 3000, the personal representative, on or before the 21st January, 1969, after which date the Public Trustee may convey or distribute the assets, having regard to the claims of which the Public Trustee then has notice:—

CAMERON, HECTOR McDONALD, late of 20 Gordon-street, Newport, watchman, died between 20th and 22nd April, 1968.

GELDEREN, MARTINUS, late of 29 Donnithorne-street, Kyneton, retired fireman, died 20th June, 1968.

JACOBSON, VIOLET VERA (formerly Vera Fagan), formerly of 35 Argyle-place, Carlton, and 103 Southern-road, West Heidelberg, but late of Mont Park, pensioner, died 27th July, 1964.

WEST, KEITH HAROLD, late of 11 Walter-street, Sunshine, process worker, died 27th June, 1968.

WILSON, WINIFRED, late of 110 Keon-street, Thornbury, spinster, died 22nd August, 1968.

WRIGHT, SYDNEY SPENCER, late of Edmond-crescent, Wandin North, press operator, died 31st May, 1968.

J. K. COOK,
Acting Public Trustee.

Melbourne, 6th November, 1968.

DEPARTMENT OF MINES.

SUBJECT to any necessary excisions, &c., it is proposed to grant the following leases:—

9264, Castlemaine; Gold Mines Consolidated Proprietary Limited; 16a. 3r. 28p., Parish of Elphinstone.

8402, Mineral; Roland Walton; 624a. 2r. 24p., Parish of Boorgunyah.

8416, Mineral; Roland Walton; 397a. 0r. 30p., Parish of Boorgunyah.

8417, Mineral; Roland Walton; 598a. 2r. 20p., Parish of Boorgunyah.

8821, Mineral; Murray Valley Gypsum Pty. Ltd., 5a. 3r. 31p., Parish of Carool.

8824, Mineral; Murray Valley Plaster Proprietary Limited; 10a. 2r. 15p., Parish of Bitterang.

8825, Mineral; Murray Valley Plaster Proprietary Limited; 65a. 1r. 28p., Parish of Bitterang.

MINING LEASE GRANTED.

8754, Mineral; Lake Cooper Quarries Pty. Limited; 7a. 3r. 10p., Parish of Burrarboot.

J. C. M. BALFOUR,
Minister of Mines.

MINING LEASE DECLARED VOID.

8362, Mineral; Clifford E. Wolfe; 4a. 0r. 5p., Parish of Loy Yang.

E. CONDON,
Secretary for Mines.

DEPARTMENT OF MINES.

SUBJECT to any necessary excisions, &c., it is proposed to grant the following lease:—

5637, Gippsland; Peter Bates, Ian Alan Jenkins; 19a. 1r. 10p., Parish of Butgulla.

APPLICATIONS FOR LEASES DECLARED ABANDONED.

11377, Bendigo; George Heywood; 45a. 0r. 37p., Parish of Nerring.

9256, Castlemaine; Peter John Wilson, Lillian Wilson.

APPLICATION FOR EXTRACTIVE INDUSTRY LEASE REFUSED.

20, Extractive Industry Lease; Brick and Pipe Industries Ltd.; 11 acres, Parish of Mandurang.

EXPLORATION LICENCES GRANTED.

100, Exploration Licence; C.R.A. Exploration Pty. Limited; 141 square miles; County of Croajingolong.

101, Exploration Licence; C.R.A. Exploration Pty. Limited; 208 square miles; County of Croajingolong.

102, Exploration Licence; C.R.A. Exploration Pty. Limited; 756 square miles; County of Croajingolong.

103, Exploration Licence; C.R.A. Exploration Pty. Limited; 370 square miles; County of Croajingolong.

104, Exploration Licence; C.R.A. Exploration Pty. Limited; 15 square miles; County of Croajingolong.

114, Exploration Licence; C.R.A. Exploration Pty. Limited; 450 square miles; Counties of Bogong, Benambra, Tambo.

EXPLORATION LICENCE DECLARED ABANDONED.

10, Exploration Licence; Donald Garnet Smith; 9 square miles, Counties of Berringa, Talgarno.

MINERAL SEARCH LICENCE GRANTED.

825, Mineral Search Licence; Victorian Refining and Smelting Company Proprietary Limited; 206 square miles; Counties of Croajingolong, Tambo.

MINERAL SEARCH LICENCE EXPIRED.

775, Mineral Search Licence; Patrick Anthony Mackay; 220 acres, Parish of Tarrawarra North.

J. C. M. BALFOUR,
Minister of Mines.

MINING LEASE DECLARED VOID.

8365, Mineral; Arthur John Dixon, Thelma Dixon; 16a. 1r. 25p., Parish of Gama.

E. CONDON,
Secretary for Mines.

Town and Country Planning Act 1961.

CITY OF CAMBERWELL PLANNING SCHEME 1954.

AMENDMENT No. 37, 1968.

Notice of Amendment.

IN pursuance of the powers conferred by sub-section 6 of section 32 of the *Town and Country Planning Act 1961*, the Governor in Council, by and with the advice of the Executive Council on the 6th November, 1968, amended the City of Camberwell Planning Scheme 1954 by deleting a road reserve linking Park, Iris and Sunhill roads, Camberwell.

A copy of the amendment may be inspected during office hours at the office of the Town and Country Planning Board, 179 Queen-street, Melbourne; at the office of the Council of the City of Camberwell, at Camberwell, and when available at the Office of Titles, Melbourne, and at the Central Plan Office of the Department of Crown Lands and Survey, Melbourne.

W. H. CRAIG, Secretary,
Town and Country Planning Board.

Town and Country Planning Act 1961.

CITY OF SHEPPARTON PLANNING SCHEME 1953.

AMENDMENT No. 18, 1968.

Notice of Amendment.

IN pursuance of the powers conferred by sub-section 6 of section 32 of the *Town and Country Planning Act 1961*, the Governor in Council, by and with the advice of the Executive Council on the 6th November, 1968, amended the City of Shepparton Planning Scheme 1953 in respect of the ordinance provisions relating to the Special Uses Zone. A copy of the amendment may be inspected during office hours at the Office of the Town and Country Planning Board, 179 Queen-street, Melbourne; at the office of the council of the City of Shepparton, at Shepparton, and when available at the Office of Titles, Melbourne; and at the Central Plan Office of the Department of Crown Lands and Survey, Melbourne.

W. H. CRAIG, Secretary,
Town and Country Planning Board.

HEYWOOD WATERWORKS TRUST.

AUTHORITY TO OBTAIN BANK OVERDRAFT.

HIS Excellency the Governor of the State of Victoria, by and with the advice of the Executive Council thereof, doth by Order made on the sixth day of November, 1968, authorize the Heywood Waterworks Trust to obtain, in pursuance of the provisions of section 286 of the *Water Act 1958* (No. 6413), an advance or advances during the year ending 30th September, 1969, by overdraft of the Trust's current account, such overdraft not to exceed at any one time the sum of Six thousand dollars (\$6,000).

J. ROSSITER,
Clerk of the Executive Council.

At the Executive Council Chamber,
Melbourne, 6th November, 1968.

LEONGATHA WATERWORKS TRUST.

AUTHORITY TO OBTAIN BANK OVERDRAFT.

HIS Excellency the Governor of the State of Victoria, by and with the advice of the Executive Council thereof, doth by Order made on the sixth day of November, 1968, authorize the Leongatha Waterworks Trust to obtain, in pursuance of the provisions of section 286 of the *Water Act 1958* (No. 6413), an advance or advances during the year 1969, by overdraft of the Trust's current account, such overdraft not to exceed at any one time the sum of Twenty thousand dollars (\$20,000).

J. ROSSITER,
Clerk of the Executive Council.

At the Executive Council Chamber,
Melbourne, 6th November, 1968.

LANDSBOROUGH WATERWORKS TRUST.

AUTHORITY TO OBTAIN BANK OVERDRAFT.

HIS Excellency the Governor of the State of Victoria, by and with the advice of the Executive Council thereof, doth by Order made on the sixth day of November, 1968, authorize the Landsborough Waterworks Trust to obtain, in pursuance of the provisions of section 286 of the *Water Act 1958* (No. 6413), an advance or advances during the year 1969, by overdraft of the Trust's current account, such overdraft not to exceed at any one time the sum of One thousand dollars (\$1,000).

J. ROSSITER,
Clerk of the Executive Council.

At the Executive Council Chamber,
Melbourne, 6th November, 1968.

WOODS POINT WATERWORKS TRUST.

AUTHORITY TO OBTAIN BANK OVERDRAFT.

HIS Excellency the Governor of the State of Victoria, by and with the advice of the Executive Council thereof, doth by Order made on the sixth day of November, 1968, authorize the Woods Point Waterworks Trust to obtain, in pursuance of the provisions of section 286 of the *Water Act 1958* (No. 6413), an advance or advances during the year 1969, by overdraft of the Trust's current account, such overdraft not to exceed at any one time the sum of Four hundred dollars (\$400).

J. ROSSITER,
Clerk of the Executive Council.

At the Executive Council Chamber,
Melbourne, 6th November, 1968.

MACALISTER RIVER IMPROVEMENT TRUST.

BY-LAW No. 13.

THE Macalister River Improvement Trust, in pursuance and exercise of the powers conferred by the *River Improvement Act 1958*, doth hereby make the following By-Law:—

1. The following rate, to be called the "Macalister River Improvement District River Improvement Rate" is hereby made and shall be levied upon the occupiers and owners of all properties within the Macalister River Improvement District which are rateable to any Municipality a Rate of one cent in the Dollar on the Annual Municipal Value of such properties provided that the sum of ten cents shall be the minimum amount of rate in respect of any property liable to be rated in the said district.

2. Such rate is made and shall be levied for the year beginning with the 1st day of January, 1969 and ending with the 31st day of December, 1969 and shall be payable on the 1st day of May, 1969 at the Office of the Macalister River Improvement Trust at Maffra.

3. Such person or persons as the Macalister River Improvement Trust may from time to time appoint for that purpose shall be and is or are, hereby authorized to demand, collect and recover the said rate.

The foregoing By-Law was made by the Macalister River Improvement Trust on the 17th day of October, 1968, and the Common Seal of the said Trust was hereunto affixed on the 17th day of October, 1968.

(SEAL) G. A. GRAY, Chairman.
JAMES P. CAFFREY, Commissioner.
M. H. McMAHON, Secretary.

Approved by the Governor in Council, 6th November, 1968.—J. ROSSITER, Clerk of the Executive Council.

BOORT WATERWORKS TRUST.

RATING BY-LAW FOR THE YEAR 1969.

THE Boort Waterworks Trust, in pursuance and exercise of the powers conferred by the Water Acts, doth hereby make a rate for the supply of water for domestic purposes of seven cents in the dollar on the amount of the annual municipal valuation of the land and tenements liable to be rated within the Boort Urban District.

Provided that in no case shall the amount of the rate payable per annum in respect of any tenement (other than land on which there is no building) be less than eighteen dollars, and in respect of any land on which there is no building less than five dollars.

Such rates are made and shall be levied upon occupier or owner of the said lands and tenements for the year commencing on the 1st day of January 1969, and shall be payable on the 1st day of February 1969, at the office of the Trust.

The maximum quantity of water to be supplied in any one year without further charge to any property rated by the Trust, is hereby fixed at the quantity which, at a charge of 20 cents per 1,000 gallons, would produce an amount equal to the amount of the rate levied on such property for the said year.

The charge for water supplied by measure to any property rated by the Trust in excess of such maximum quantity, computed as in the last preceding clause, is hereby fixed at 20 cents per 1,000 gallons.

The charge for water supplied by measure shall be payable, on demand, at the office of the Trust.

Passed this 25th day of October, 1968.

(SEAL) C. R. JAMES, Chairman.
H. M. JONES, Secretary.

Approved 31st October, 1968.—W. BORTHWICK, Minister of Water Supply.

CHARLTON WATERWORKS TRUST.

BY-LAW No. 91.

THE Charlton Waterworks Trust in pursuance of and in exercise of the powers conferred by the Water Act 1958 and of any and every other power it thereunto enabling doth hereby make a By-Law as follows:—

1. The meters or meter measuring the supply of water to any land or tenement shall be read as near as practicable to twelve months from the date that it was read previously and the quantity of water so measured as having been supplied during the period between any two successive readings (hereinafter called "the meter year") shall be the basis of the calculating of charges payable under this By-Law provided always that when a meter has been installed on any land or tenement during the course of a meter year the quantity of water measured as having been supplied during the period between the date of such installation and the date of the reading shall be the basis of calculating such charges. Without affecting the purpose of this clause the meter year 1969 shall be a nine month period from December 1968 to September 1969.

2. This By-Law shall have effect as from the commencement of the meter year, ending in the financial year, beginning, January 1st 1969.

3. Subject as is hereinafter provided in respect of any land or tenement rated by the Trust—

- (a) The maximum quantity of water to be supplied in any meter year without charge is hereby fixed as a quantity which if charged at 25 cents per 1,000 gallons for any meter year would give an amount equal to the amount of the rate payable in respect of the land or tenement for the financial year in which the said meter year ended.
- (b) For all water supplied in any meter year in excess of the maximum quantity referred to in paragraph (a) of this clause the charge is hereby fixed at 25 cents per thousand gallons for any meter year.

4. Subject as is hereinafter provided the charge for water supplied by measure to any property not rated by the Trust is hereby fixed at 25 cents per thousand gallons.

5. The minimum charge for water supplied by measure to any property not rated by the Trust is hereby fixed at \$15.00.

6. The charge for water supplied from any standpipe on the Trust's mains is hereby fixed at 50 cents per thousand gallons and shall be payable on demand at the offices of the said Trust.

7. The aforesaid charges shall be payable within seven days of demand upon the owner or occupier at the offices of the Trust during normal business hours.

8. The provisions of Clauses 3, 4 and 5 of this By-Law shall not apply to any land, tenement or property supplied with water by the Trust under a special agreement pursuant to Section 215 of the Water Act 1958.

The foregoing By-law No. 91 was made by the Charlton Waterworks Trust on the 22nd day of October, 1968, and the seal of the Trust was hereto affixed in the presence of—

(SEAL) V. J. RYAN, Chairman.
C. FANNING, Commissioner.
A. F. HELYAR, Secretary.

Approved, 4th November, 1968.—W. BORTHWICK, Minister of Water Supply.

CHARLTON WATERWORKS TRUST.

BY-LAW No. 90.

THE Charlton Waterworks Trust in pursuance of and in exercise of the powers conferred by the Water Act 1958 and of any and every other power it thereunto enabling doth hereby make a By-Law as follows:—

1. The Trust hereby makes and levies a rate in respect of all the lands and tenements within the Charlton Urban District of 4.5 cents in the dollar on the net annual value set out in the valuation at present in force of such lands and tenements for the purposes of the Municipal Rate of the Shire of Charlton which is hereby adopted as the valuation of such lands and tenements respectively.

2. Such rate shall be made and levied upon the occupiers and owners of such lands and tenements for the rating year commencing on the first day of January 1969 and ending on the 30th day of September 1969 and shall be payable on the 10th day of April 1969 at the offices of the said Trust.

3. In no case shall the rate payable hereunder in respect of any land on which there is a building be less than six dollars and in respect of land on which there is no building be less than three dollars.

The foregoing By-Law No. 90, was made by the Charlton Waterworks Trust on the 22nd day of October, 1968, and the seal of the Trust was hereto affixed in the presence of—

(SEAL) V. J. RYAN, Chairman.
C. FANNING, Commissioner.
A. F. HELYAR, Secretary.

Approved, 4th November, 1968.—W. BORTHWICK, Minister of Water Supply.

MURTOA WATERWORKS TRUST.

BY-LAW No. 17.

THE Murtoa Waterworks Trust, in pursuance of and in exercise of the powers conferred by the Water Act 1958 and of any and every other power it thereunto enabling doth hereby make By-law No. 17 as follows:—

1. The meter or meters measuring the supply of water to any land or tenement shall be read as near as practicable to twelve months from the date that it was read previously and the quantity of water so measured as having been supplied during the period between any two successive such readings (hereinafter called "the meter year") shall be the basis of the calculating of charges payable under this By-law, provided always that where a meter has been installed on any land or tenement during the course of a meter year the quantity of water measured as having been supplied during the period between the date of such installation and the date of the reading shall be the basis of calculating such charges.

2. Subject as is hereinafter provided in respect of any land or tenement rated by the Trust—

- (a) The maximum quantity of water to be supplied in any meter year without charge is hereby fixed as a quantity which if charged at Twelve cents per thousand gallons for any meter year would give an amount equal to the amount of the rate payable in respect of the land or tenement for the financial year in which the said meter year ended.

(b) For all water supplied in any meter year in excess of the maximum quantity referred to in paragraph (a) of this clause the charge is hereby fixed at Twelve cents per thousand gallons for any meter year.

3. Subject as is hereinafter provided the charge for water supplied by measure to any property not rated by the Trust is hereby fixed at Twelve cents per thousand gallons.

4. The minimum charge for water supplied by measure to any property not rated by the Trust is hereby fixed at Five Dollars (\$5.00).

5. The charge for water supplied by measure to any land, on which there is no building, but rated by the Trust, is hereby fixed at Twelve Cents per 1,000 gallons with a minimum charge per annum of Five Dollars (\$5.00).

6. The charge for water supplied from a Stand-pipe is hereby fixed at Twenty Five Cents per 1,000 gallons, provided that in no case shall a charge be less than Twenty Five Cents for any lesser quantity than 1,000 gallons, taken at one delivery.

7. The aforesaid charges shall be payable within seven days of demand upon the owner or occupier at the Office of the Trust during normal business hours.

8. The provisions of Clauses 2, 3, 4, and 5 of this By-law shall not apply to any land tenement or property supplied with water by the Trust under a special agreement pursuant to Section 215 of the *Water Act 1958*.

Passed this 28th day of October, 1968.

(SEAL) H. D. HATELEY, Chairman.
V. E. MADDERN, Commissioner.
H. L. PETSCHER, Commissioner.
N. E. REITHER, Secretary.

Approved, 4th November, 1968.—W. BORTHWICK,
Minister of Water Supply.

MURTOA WATERWORKS TRUST.
RATING BY-LAW FOR THE YEAR 1969.

THE Murtoa Waterworks Trust, in pursuance of and in exercise of the powers conferred by the *Water Act 1958* and of any and every other power it thereunto enabling doth hereby make and levy a rate in respect of all the lands and tenements within the Murtoa Urban District of Seven cents in the Dollar on the net annual value set out in the valuation at present in force of such lands and tenements for the purposes of the municipal rate of the Shire of Dunmunkle which is hereby adopted as the valuation of such lands and tenements respectively.

Such rate shall be made and levied upon the occupiers and owners of such lands and tenements for the year commencing on the 1st day of January 1969, and shall be payable on the 1st day of February 1969, at the Office of the said Trust.

In no case shall the rate payable hereunder in respect of any land on which there is a building be less than Five Dollars (\$5.00), and in respect of land on which there is no building be less than Two Dollars (\$2.00).

Passed this 28th day of October, 1968.

(SEAL) H. D. HATELEY, Chairman.
H. L. PETSCHER, Commissioner.
V. E. MADDERN, Commissioner.
N. E. REITHER, Secretary.

Approved, 4th November, 1968.—W. BORTHWICK,
Minister of Water Supply.

HEALESVILLE WATERWORKS TRUST.
WATER CHARGES BY-LAW.

THE Healesville Waterworks Trust in pursuance of and in exercise of the powers conferred by the *Water Act 1958* and of any and every other power it thereunto enabling doth hereby make a By-law as follows:—

1. The meter or meters measuring the supply of water to any land or tenement shall be read as near as practicable to twelve months from the date that it was read previously and the quantity of water so measured as having been supplied during the period between any two successive such readings (hereinafter called "the meter year") shall be the basis of the calculating of charges payable under this By-law provided always that where a meter has been installed on any land or tenement during the course of a meter year the quantity of water measured as having been supplied during the period between the date of such installation and the date of the reading shall be the basis of calculating such charges.

2. Subject as is hereinafter provided in respect of any land or tenement rated by the Trust—

(a) The maximum quantity of water to be supplied in any meter year without charge is hereby fixed as a quantity of which if charged at 15

cents per thousand gallons for any meter year would give an amount equal to the amount of the rate payable in respect of the land or tenement for the financial year in which the said meter year ended.

(b) For all water supplied in any meter year in excess of the maximum quantity referred to in paragraph (a) of this clause the charge is hereby fixed at 10 cents per thousand gallons for any meter year.

3. Subject as is hereinafter provided the charge for water supplied by measure to any property not rated by the Trust is hereby fixed at 10 cents per thousand gallons.

4. The minimum charge for water supplied by measure to any property not rated by the Trust is hereby fixed at \$10.

5. The aforesaid charges shall be payable within seven days of demand upon the owner or occupier at the office of the Trust during normal business hours.

6. The provisions of clauses 2, 3, and 4 of this By-law shall not apply to any land tenement or property supplied with water by the Trust under a special agreement pursuant to Section 215 of the *Water Act 1958*.

(SEAL) E. R. FROGLEY, Chairman.
W. M. OLIVER, Secretary.

Approved, 1st November, 1968.—W. BORTHWICK,
Minister of Water Supply.

HEALESVILLE WATERWORKS TRUST.
RATE BY-LAW 1969.

THE HEALESVILLE Waterworks Trust in pursuance of and in exercise of the powers conferred by the *Water Act 1958* and of any and every other power it thereunto enabling doth hereby make a By-law as follows:—

1. The Trust hereby makes and levies a rate in respect of all the lands and tenements within the HEALESVILLE Waterworks District of 4.5 cents in the dollar on the net annual value set out in the valuation at present in force of such lands and tenements for the purposes of the municipal rate of the SHIRE OF HEALESVILLE which is hereby adopted as the valuation of such lands and tenements respectively.

2. Such rate shall be made and levied upon the occupiers and owners of such lands and tenements for the year commencing on the 1st day of January 1969 and shall be payable on the 1st day of January 1969 at the office of the said Trust.

3. In no case shall the rate payable hereunder in respect of any land on which there is a building be less than ten dollars and in respect of land on which there is no building be less than ten dollars.

(SEAL) E. R. FROGLEY, Chairman.
W. M. OLIVER, Secretary.

Approved, 1st November, 1968.—W. BORTHWICK,
Minister of Water Supply.

YALLOURN NORTH SEWERAGE AUTHORITY.
GENERAL NOTICE.
Sixth Schedule.

THE above-mentioned Sewerage Authority, having made provision for carrying off the sewage from each and every property which or any part of which is within the sewerage area hereinafter described, doth hereby declare that on and after the 11th day of November, 1968, each and every property which or any part of which is within the said sewerage area shall be deemed to be a seweraged property within the meaning of the *Sewerage Districts Act 1958*.

The boundaries of the sewerage area hereinbefore referred to are as described hereunder.

TECHNICAL DESCRIPTION.

Yallourn North Sewerage District.

Commencing at a point on the western boundary of Crown allotment 18 of A, Parish of Tanjil East, County of Tanjil, being a point at the most north-eastern angle of lot 5 on lodged plan 29792, being part of Crown allotment 18c of A; thence generally south-easterly for a distance of 800 ft. 0 in. to a point within Crown allotment 18 of A; thence due south across part of Crown allotment 18 of A, Crown allotment 18d and a road known as Tyers road to a point on the southern boundary of the said road; thence generally westerly, south-westerly and westerly along the southern boundary of the said road

and the eastern and southern boundary of a road known as Third-street; thence generally northerly along the western boundary of a road known as Reserve-street to a point on the southern boundary of a road known as Latrobe River-road; thence generally westerly and north-westerly along the southern boundary of the said Latrobe River-road to a point on that boundary; thence due north to the most southerly angle of lot 7 on lodged plan 54609; thence generally north-westerly along the southern boundaries of lots 7, 8, 9, 10, 11, 12 and 13 on the said lodged plan 54609 and lots 14, 15, 16, 17, 18, 19, 20, 21, 22, 23, 24, 25, 26 and 27, on lodged plan 54608; thence generally north-westerly and westerly along the western and southern boundaries of lots 27, 28, 29, 30, 31, 34, 35, 36, 37 and 38, on the said lodged plan 54608; thence generally westerly to a point at the most southerly angle of a lot occupied by the Serbian Orthodox Church; thence westerly and north-easterly along the southern and western boundaries of the said lot, to a point on the southern boundary of a road known as North-road, all in Crown allotment 13b; thence generally westerly along the southern boundary of the said road to a point corresponding with the projection of the western boundary of lot 62 on lodged plan 12979, being part of Crown allotment 18e; thence generally northerly across the said road to a point at the most southern angle of the said lot 62; thence generally northerly along the western boundary of the said lot 62, across a road known as Government-road to a point on the northern boundary of the said road; thence generally north-easterly along the northern boundary of the said road; thence south-easterly across the said road to a point at the most northern angle of lot 78 on lodged plan 12979; thence generally south-westerly to a point at the most northern angle of lot 77; thence generally south-easterly along the northern boundaries of lots 77, 76, 75 and 74; thence generally easterly, across a road known as Baillie-street to a point at the most northerly angle of lot 84; thence generally south-easterly along the northern boundary of the said lot 84 to a point at the most southern angle of lot 83; thence generally north-easterly along the eastern boundary of the said lot 83 to a point at the most north-westerly angle of lot 85; thence generally easterly along the northern boundaries of the said lot 85 and lots 86, 87, 88, 89 and 90; thence generally south-easterly across lots 91 and 92, all on the said lodged plan 12979, to a point at the most northern angle of lot 1 on lodged plan 15282; thence along the northern boundaries of the said lot 1 and lots 2, 3 and 4 to the north-eastern angle of the said lot 4 on lodged plan 15282, all in Crown allotment 18e; thence generally northerly to a point at the most northern angle of lot 17 on lodged plan 12016, being part of Crown allotment 18c of A; thence generally easterly along the northern boundaries of the said lot 17 and lots 18, 19 and 20 on lodged plan 12016 and lots 1 and 2 to a point at the most westerly angle of lot 3 on lodged plan 20882; thence generally north-easterly to the most northerly angle of the said lot 3; thence generally easterly to the most north-western angle of lot 3 on lodged plan 29792; thence generally easterly along the northern boundaries of the said lot 3 and lots 4 and 5 on the said lodged plan 29792, all in Crown allotment 18c of A to the point of commencement, all in the Parish of Tanjil East, County of Tanjil.

By order of the said Sewerage Authority.

C. E. LUCAS, Chairman.
J. F. BOAG, Secretary.

PLENTY-YARRAMBAT WATERWORKS TRUST.

RATING BY-LAW FOR THE YEAR 1968-1969.

THE Plenty-Yarrambat Waterworks Trust in pursuance of and in exercise of the powers conferred by the Water Act 1958 and of any and every other power it thereunto enabling doth hereby make a By-law as follows:—

1. The Trust hereby makes and levies a rate in respect of all the lands and tenements within the Plenty-Yarrambat District of nine (9) cents in the dollar on the net annual value set out in the valuation at present in force of such lands and tenements for the purpose of the municipal rate of the Shire of Diamond Valley which is hereby adopted as the valuation of such lands and tenements respectively. Provided that in no case shall the amount of the rate payable per annum in respect of any tenement (other than the land on which there is no building) be less than thirteen dollars fifty cents and in respect of any land where there is no building less than four dollars.

2. Such rate shall be made and levied upon the occupiers and owners of such lands and tenements for the year commencing on the 1st day of October, 1968, and shall be due and payable on the 1st day of January, 1969, at the office of the said Trust, Shire Office, Greensborough.

3. When any charge is not paid within six months after it has become payable interest thereon at the rate of eight per centum per annum from the date when such charge became payable until such charge is paid shall be payable.

4. The meter or meters measuring the supply of water to any land or tenement shall be read as near as practicable to twelve months from the date that it was read previously and the quantity of water so measured as having been supplied during the period between any two successive such readings (hereinafter called "the meter year") shall be the basis of the calculating of charges payable under this By-Law provided always that where a meter has been installed on any land or tenement during the course of a meter year the quantity of water measured as having been supplied during the period between the date of such installation and the date of the reading shall be the basis of calculating such charges.

5. Subject as is hereinafter provided in respect of any land or tenement rated by the Trust—

(a) The maximum quantity of water to be supplied in any meter year without charge is hereby fixed as a quantity which if charged at forty cents per thousand gallons for any meter year would give an amount equal to the amount of the rate payable in respect of the land or tenement for the financial year in which the said meter year ended.

(b) For all water supplied in any meter year in excess of the maximum quantity referred to in paragraph (a) of this clause the charge is hereby fixed at forty cents per thousand gallons for any meter year.

6. The aforesaid charges shall be payable within fourteen days of demand upon the owner or occupier at the office of the Trust during normal business hours.

(SEAL) G. T. UPTON, Chairman.
W. K. ROBERTSON, Commissioner.
F. PHILLIPS, Secretary.

Approved, 1st November, 1968.—W. BORTHWICK, Minister of Water Supply.

WOODEND WATERWORKS TRUST.

RATING BY-LAW FOR THE PERIOD COMMENCED OCTOBER 1ST 1968 AND ENDING SEPTEMBER 30TH 1969.

THE Woodend Waterworks Trust in pursuance and exercise of the powers conferred by the Water Acts, doth hereby make a rate for the supply of water for domestic purposes of six point five cents in the dollar of the annual municipal valuation of lands and tenements liable to be rated within the Woodend Urban District.

Provided that in no case shall the amount of rate payable in respect of any tenements (other than land on which there is no building) be less than six dollars, and in respect of any land on which there is no building, less than three dollars.

Such rates are made and shall be levied upon the occupiers or owners of the said lands and tenements for the period commenced the first day of October 1968 and ending thirtieth day of September 1969 and shall be payable on the third day of January 1969 at the office of the Trust.

The maximum quantity of water to be supplied in the period without any further charge to any property rated by the Trust, is hereby fixed at the quantity, which at a charge of twenty cents per 1,000 gallons, would produce an amount equal to the amount of the rate levied on such property for the said period.

The charge for water supplied by measure to any property rated by the Trust in excess of such maximum quantity computed as in the last preceding clause, is hereby fixed at twenty cents per 1,000 gallons.

The charge for water supplied by measure to any property not rated by the Trust is hereby fixed at twenty cents per 1,000 gallons, and the minimum quantity of water to be charged for in cases where water is so supplied is hereby fixed at sixty thousand gallons.

The charge for water supplied by measure shall be payable on demand at the Office of the Trust.

Passed this tenth day of September, 1968.

(SEAL) F. J. M. WRIGHT, Commissioner.
GILBERT GORDON, Commissioner.
Wm. MCGARRY, Secretary.

Approved, 1st November, 1968.—W. BORTHWICK, Minister of Water Supply.

RUSHWORTH WATERWORKS TRUST.

RATING BY-LAW FOR THE YEAR 1969.

THE Rushworth Waterworks Trust, in pursuance and exercise of the powers conferred by the Water Acts, doth hereby make and levy a Rate for the supply of water for Domestic Purposes of thirteen and a half cents in the dollar on the Municipal Valuation of the lands and tenements to be rated within the Rushworth Urban District.

Provided that in no case shall the amount of Rate payable in respect of any tenement (other than land on which there is no building) be less than sixteen dollars twenty cents, and in respect of land on which there is no building less than four dollars.

Such rates are made and shall be levied on the occupiers and owners of the said lands and tenements for the year commencing on the 1st day of January 1969 and shall be payable on the 1st day of February 1969 at the Office of the Trust.

The maximum quantity of water to be supplied in any one year without further charge to any property rated by the Trust is hereby fixed at the quantity which at the charge of twenty cents per 1,000 gallons, would produce an amount equal to the amount of rate levied on such property for the said year.

The charge for water supplied by measure to any property rated by the Trust in excess of such maximum quantity, computed as in the last preceding clause, is hereby fixed at fifteen cents per 1,000 gallons.

The charge for water supplied by measure shall be payable on demand.

Passed this 28th day of October, 1968.

(SEAL) L. C. COYLE, Chairman.
T. McK. KING, Secretary.

Approved, 1st November, 1968.—W. BORTHWICK, Minister of Water Supply.

APPOINTMENTS AND RESIGNATIONS

APPOINTMENTS.

HIS Excellency the Governor of the State of Victoria, by and with the advice of the Executive Council thereof, has, by Orders made on the 6th day of November, 1968, been pleased to make the under-mentioned appointments, viz.:

DEPARTMENT OF CROWN LANDS AND SURVEY:

Bailiffs of Crown Lands.

BARRY JOHN LEE, 61 Niringa-avenue, Aspendale, and MAURICE LESLIE PORTINGALE, 422 Station-street, Carrum,

to be Bailiffs of Crown Lands without salary, pursuant to section 30 of the *Land Act 1958*, in the places of Jack Stewart Cuthbertson and Allan David Graham; and

WILLIAM DOUGLAS MAYWOOD, 35 Fairview-road, Mount Waverley,

to be a Bailiff of Crown Land without salary, pursuant to section 30 of the *Land Act 1958*, in the place of Frederick James Glenn.

Members of Committee of Management of Park.

DONALD BRUCE GRANTER and
ROBERT GRANVILLE WARD

to be Members of the Committee of Management of Elsternwick Park, in place of Alexander William McLiesh and Albert Richard Roberts who have ceased to be Councillors of the City of Brighton, provided nevertheless that the said Donald Bruce Granter and Robert Granville Ward shall hold office as members of such committee for so long only as they continue to be councillors and the elect of the Council of the City of Brighton.

MINISTRY OF HEALTH.

Member of Committee of Management of Hospital.

JAMES BARKER

to be a Member of the Committee of Management of Healesville and District Hospital, pursuant to proviso (a) to section 48 (1) of the *Hospitals and Charities Act 1958*, for a period of three years ending 6th November, 1971.

LAW DEPARTMENT.

Commissioners for Taking Declarations, &c.

JAN HORVATH, care of Stationmaster's Office, Victorian Railways, Spencer-street, Melbourne,
to be a Commissioner for taking Declarations and Affidavits,

pursuant to the provisions of the *Evidence Act 1958*, to refrain from charging fees and to resign upon ceasing to occupy his present position;

KENNETH RUSSELL CARR, care of Melbourne Greyhound Racing Association, Olympic Park, Swan-street, Melbourne,

to be a Commissioner for taking Declarations and Affidavits, pursuant to the provisions of the *Evidence Act 1958*, to resign upon ceasing to occupy his present position; and

EDWARD EDISON WATERS, Mallacoota,

LESLIE DOUGLAS RIORDAN, 33 Wells-road, Chelsea Heights,

BRUCE CLIFFORD HOOPER, 30 Seccull-drive, Chelsea Heights, and

ERIC DAVID QUITT, 35 Burden-street, Springvale,

to be Commissioners for taking Declarations and Affidavits, pursuant to the provisions of the *Evidence Act 1958*, to resign upon removing from the neighbourhood of the addresses stated.

Justices of the Peace.

LIONEL SINCLAIR DICKSON, 24 Eaton-street, Oakleigh, to Keep the Peace in the Central Bailiwick of the State of Victoria; and

MERVYN ALBERT MILLER, Nelson, and

JOHN GEOFFREY KAYE, Glenpatrick, via Elmhurst,

to Keep the Peace in the Western Bailiwick of the State of Victoria.

DEPARTMENT OF THE TREASURER.

Collector of Imposts.

BRIAN FRANCIS CARROLL

to be Collector of Imposts, Premier's Department, vice F. T. Cron, relieved.

Receiver of Revenue (Acting).

JOHN JOSEPH CAVEN

to act temporarily as Receiver of Revenue, Warrnambool, vice V. G. Stafford, on leave.

DEPARTMENT OF WATER SUPPLY.

Members of Sewerage Authorities.

ROBERT JAMES DEAN

to be a Member of the Red Cliffs Sewerage Authority, to hold such position for a period of four years from the date hereof, subject to the provisions of the *Sewerage Districts Act*; and

KENNETH WILLIAM DURIE,

EDWARD JOHN MOLLOY and

TREVOR WILLIAM TAYLOR

to be Members of the Wycheproof Sewerage Authority, to hold such position for a period of four years from the date hereof, subject to the provisions of the *Sewerage Districts Act*.

Waterworks Trust Commissioners.

JOHN EDWIN CLARENCE RADCLIFFE

to be a Commissioner of the Cobram Waterworks Trust, to hold such position for a period from the date hereof until 9th August, 1969, subject to the provisions of the *Water Act*; and

KEITH RANDALL GRANT

to be a Commissioner of the Drouin Waterworks Trust, to hold such position for a period of four years from the date hereof, subject to the provisions of the *Water Act*.

River Improvement Trust Commissioner.

ROY THORNTON HILL

to be a Commissioner of the Broken River Improvement Trust, to hold such position for a period of four years from the date hereof, subject to the provisions of the *River Improvement Act*.

J. ROSSITER,

Clerk of the Executive Council.

At the Executive Council Chamber,
Melbourne, 6th November, 1968.

Stock Medicines Act 1958.

APPOINTMENT OF A MEMBER OF THE STOCK MEDICINES BOARD.

IN pursuance of the powers conferred upon me by section 4 (2) (c) of the *Stock Medicines Act 1958*, I Gilbert Lawrence Chandler, Minister of Agriculture for the time being of the State of Victoria, hereby appoint LESLIE FRANCIS MCMANAMNY, a Veterinary Surgeon nominated by the Veterinary Board of Victoria, as a member of the Stock Medicines Board constituted under the provisions of the said Act, for the period from the 7th November, 1968, to the 6th May, 1969, both dates inclusive.

4th November, 1968.

G. L. CHANDLER,
Minister of Agriculture.

FORESTS DEPARTMENT.

APPOINTMENT OF COMMITTEE OF MANAGEMENT OF "STEAVENSON FALLS SCENIC RESERVE".

WHEREAS by section 50 of the Forests Act 1958 (No. 6254), it is provided that the Minister of Forests may, on the recommendation of the Forests Commission, appoint any number of persons, not less than three, to be a Committee of Management of any land forming part of any Reserved Forest, such land being set aside as a Scenic Reserve, and may remove any of those persons: Now therefore, I, Edward Raymond Meagher, Her Majesty's Minister of Forests for the State of Victoria, on the recommendation of the Forests Commission, do hereby appoint—

- CR. GEOFFREY GORDON CUZENS,
- CR. JACK HAYCRAFT,
- JOHN ALFRED GRIEVE,
- FREDERICK FISKE, and
- KENNETH RICHARD MORRISON,

as Members of the Committee of Management for a period of three years until the 15th October, 1971, of the land forming part of the Reserved Forest in the Parish of Steavenson, County of Anglesey, described in the accompanying Schedule, and known as "Steavenson Falls Scenic Reserve".

SCHEDULE ABOVE REFERRED TO.

Parish of Steavenson, County of Anglesey, 469 acres, more or less, being the area shown by pink colour on plan marked A.58/613 over 15.10.59, on file of correspondence No. 67/800 of the Forests Department.

Dated at Melbourne, the fourth day of November, 1968.

E. R. MEAGHER,
Minister of Forests.

Liquor Control Act 1968.

APPOINTMENT OF LICENSING INSPECTOR.

IN accordance with the authority conferred upon me by Sub-section (1) of Section 22 of the Liquor Control Act 1968, I, Rupert Henry Arnold, Chief Commissioner of Police, hereby appoint the following Officer of Police as a Licensing Inspector for the Division of the Police District as shown:

Division Number.	Police District.	Rank and Name.
2	East Gippsland..	Inspector William Edward Burns

R. H. ARNOLD,
Chief Commissioner of Police.

RESIGNATIONS.

HIS Excellency the Governor of the State of Victoria, by and with the advice of the Executive Council thereof, has, by Orders made on the 6th day of November, 1968, accepted the resignations of the persons named hereunder of the offices mentioned, viz.:—

LAW DEPARTMENT.

Associate.

BASIL SPENCER SIMS, as Associate to His Honour Judge Harris, to take effect as from midnight on the 2nd November, 1968.

Justices of the Peace.

The resignations of the persons named in the first column of the Schedule hereto, from the Commission of the Peace for the respective Bailiwicks of the State of Victoria set opposite their names in the second column of the said Schedule.

SCHEDULE.

MICHAEL CHRISTOPHER CHARLES JORDAN .. Central
WILLIAM RAMSAY WYRILL .. Midland

J. ROSSITER,
Clerk of the Executive Council.

At the Executive Council Chamber,
Melbourne, 6th November, 1968.

ORDERS IN COUNCIL

DEPARTMENT OF CROWN LANDS AND SURVEY

At the Executive Council Chamber, Melbourne, the sixth day of November, 1968.

PRESENT:

His Excellency the Governor of Victoria.
Mr. Thompson | Mr. Manson.

LANDS TEMPORARILY RESERVED AS SITES.

HIS Excellency the Governor of the State of Victoria, by and with the advice of the Executive Council thereof, doth hereby, in pursuance of section 14 of the Land Act 1958, reserve temporarily from sale, from being leased and from having a licence granted in respect thereof, and also except from occupation for mining purposes under any miner's right the lands hereinafter described:—

JIKA JIKA (NORTH MELBOURNE).—Site for Public purposes (Police purposes) 29 perches, at North Melbourne, Parish of Jika Jika, County of Bourke, as indicated by hatching on plan hereunder.—(M.314⁽¹⁸⁾) (Rs.9086).

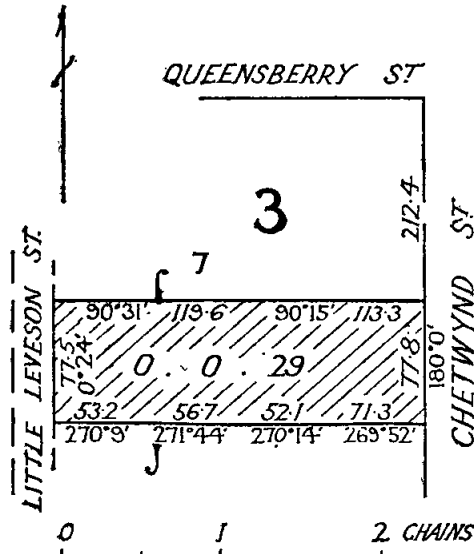

MELBOURNE.—Site for Public purposes (Police purposes) 1 rood 4 perches, City of Melbourne, Parish of Melbourne North, County of Bourke, as indicated by hatching on plan hereunder.—(M.314⁽⁹⁾) (Rs.6460).

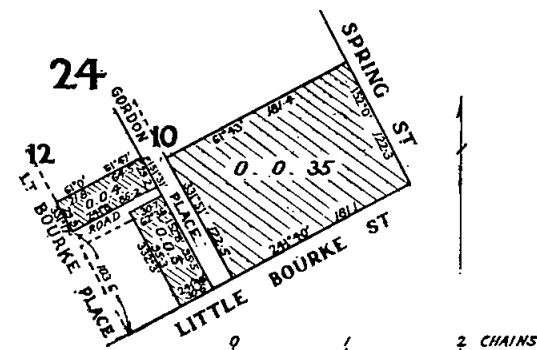

Total Area of Hatched Portions: 0.14

MURCHISON.—Site for Public Recreation, 15 acres, more or less, Township of Murchison and Parish of Murchison, County of Rodney, as indicated by hatching on plan hereunder.—(M.272⁽³⁾); (M.273^(*)) (Rs.9051).

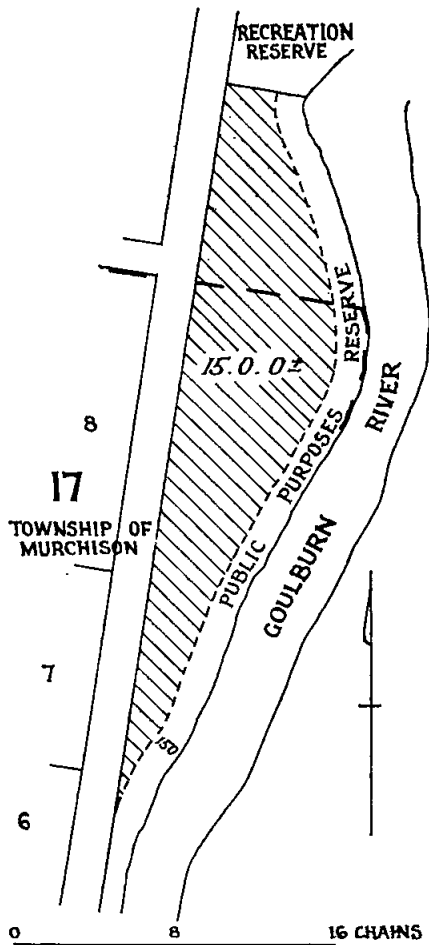

POREPUNKAH.—Site for Camping Purposes, 10 acres 3 roods 14 perches, more or less, Parish of Porepunkah, County of Delatite, as indicated by hatching on plan hereunder.—(P.70(A8) Rs.5158).

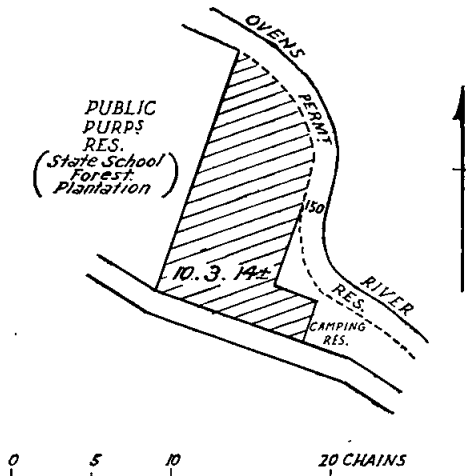

WARANGA.—Site for Water Supply purposes, 4 acres more or less, Parish of Waranga, County of Rodney, as indicated by hatching on plan hereunder.—(W.37(*) (Rs.9042)).

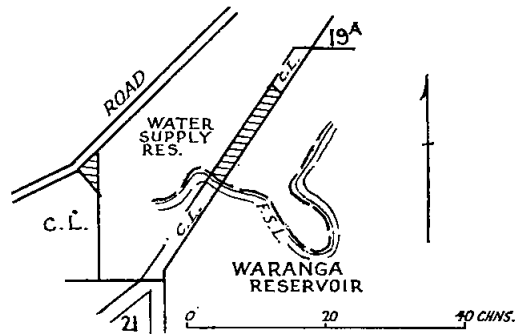

TOTAL AREA OF HATCHED PORTIONS:— 4. 0. 0±

And the Honorable Sir William John Farquhar McDonald, Her Majesty's Minister of Lands for the State of Victoria, shall give the necessary directions herein accordingly.

J. ROSSITER,
Clerk of the Executive Council.

DEPARTMENT OF CROWN LANDS AND SURVEY.

At the Executive Council Chamber, Melbourne, the sixth day of November, 1968.

PRESENT:

His Excellency the Governor of Victoria.
Mr. Thompson | Mr. Manson.

REVOCATION OF TEMPORARY RESERVATIONS OF LANDS BY ORDERS IN COUNCIL.

HIS Excellency the Governor of the State of Victoria, by and with the advice of the Executive Council thereof, doth hereby, in pursuance of the provisions of the Land Act 1958, revoke the temporary reservations of lands by Orders in Council hereinafter referred to, viz.:

CANN RIVER.—Order in Council of 30th July, 1968, of 3 roods of land in the Township of Cann River as a site for Use and Benefits of the Aboriginal Inhabitants so far only as regards the portion thereof comprised within the boundaries published in the Government Gazette of 2nd October, 1968, and containing 1 rood.—(Rs.9031.)

COHUNA.—Order in Council of 18th January, 1909, of 1 acre of land in the Township of Cohuna as a site for Police purposes so far only as regards the portion thereof comprised within the boundaries published in the Government Gazette of 2nd October, 1968, and containing 2 roods.—(C.41704.)

And the Honorable Sir William John Farquhar McDonald, Her Majesty's Minister of Lands for the State of Victoria, shall give the necessary directions herein accordingly.

J. ROSSITER,
Clerk of the Executive Council.

DEPARTMENT OF CROWN LANDS AND SURVEY.

At the Executive Council Chamber, Melbourne, the sixth day of November, 1968.

PRESENT:

His Excellency the Governor of Victoria.
Mr. Thompson | Mr. Manson.

UNUSED ROADS CLOSED.

HIS Excellency the Governor of the State of Victoria, by and with the advice of the Executive Council thereof, doth hereby direct that, in pursuance of the provisions of section 349 of the Land Act 1958, the unused roads referred to hereunder be closed, viz.:

Parish of Ellesmere, County of Bendigo, being the road between allotment 30 and allotments 30A, 30B.—(E.97(*) (W.86484)).

Parish of Grassdale, County of Normanby, being the road between allotments E, D and allotment 5, section 10.—(G.125(*) (J.30275)).

Parish of Wooronook, County of Kara Kara being the portion of the width of the road indicated by hatching on plan hereunder.—(W.298(*) (W.87511)).

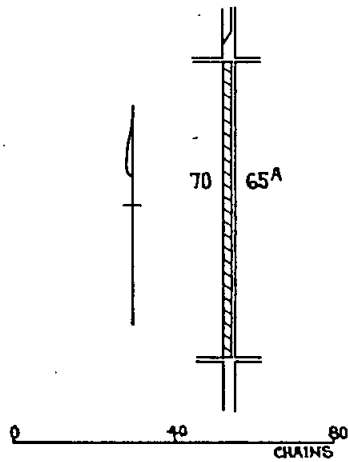

And the Honorable Sir William John Farquhar McDonald, Her Majesty's Minister of Lands for the State of Victoria, shall give the necessary directions herein accordingly.

J. ROSSITER,
Clerk of the Executive Council.

LANDLORD AND TENANT ACT 1958.

At the Executive Council Chamber, Melbourne, the sixth day of November, 1968.

PRESENT:

His Excellency the Governor of Victoria.
Mr. Thompson | Mr. Manson.

ORDER EXTENDING APPLICATION OF PART V. OF THE LANDLORD AND TENANT ACT 1958 TO CERTAIN PREMISES.

IN pursuance of the powers conferred by Section 44 of the *Landlord and Tenant Act 1958*, His Excellency the Governor of Victoria, by and with the advice of the Executive Council, doth hereby declare that the application of Part V. of the *Landlord and Tenant Act 1958* shall extend to the following premises:—

The premises known as Number 494 Abbotsford-street, North Melbourne, and to all premises forming part of such premises.

And the Honorable Arthur Gordon Rylah, Her Majesty's Acting Attorney-General in and for the State of Victoria, shall give the necessary directions herein accordingly.

J. ROSSITER,
Clerk of the Executive Council.

COUNTRY ROADS BOARD.

At the Executive Council Chamber, Melbourne, the sixth day of November, 1968.

PRESENT:

His Excellency the Governor of Victoria.
Mr. Thompson | Mr. Manson.

ORDER CONFIRMING RESOLUTIONS OF THE COUNTRY ROADS BOARD.

HIS Excellency the Governor of the State of Victoria, by and with the advice of the Executive Council thereof, doth hereby, in pursuance of the provisions of the *Country Roads Act 1958*, confirm the resolutions of the Country Roads Board, the dates whereof and the terms of which are scheduled hereunder:—

SCHEDULE.

State highways.

Resolution dated the Twenty-eighth day of October, One Thousand Nine Hundred and Sixty-eight, made pursuant to Sections 21, 58 and 74 of the *Country Roads Act 1958* declaring the deviation from the Hamilton Highway in the

Shire of Corio as indicated by diagonal hatching on Plan numbered G.P.10984 hereunder to be part of a State highway within the meaning and for the purposes of the said Act, and also declaring that such deviation shall be in lieu of the existing road or part thereof indicated by cross hatching on the said plan and that such part of the said existing road shall be discontinued.

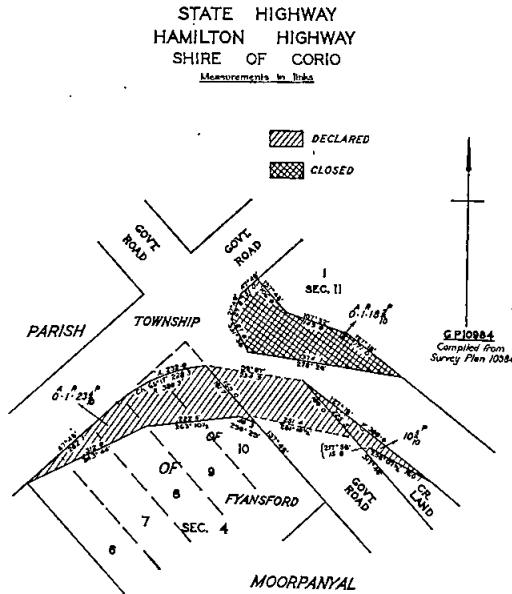

Resolution dated the Twenty-eighth day of October, One Thousand Nine Hundred and Sixty-eight, made pursuant to Sections 21, 58 and 74 of the *Country Roads Act 1958* declaring the deviation from the Midland Highway in the Shire of Daylesford and Glenlyon as indicated by diagonal hatching on Plans numbered G.P.8354 and G.P.8355A hereunder to be part of a State highway within the meaning and for the purposes of the said Act, and also declaring that such deviation shall be in lieu of the existing road or part thereof indicated by cross hatching on Plan numbered G.P.8354.

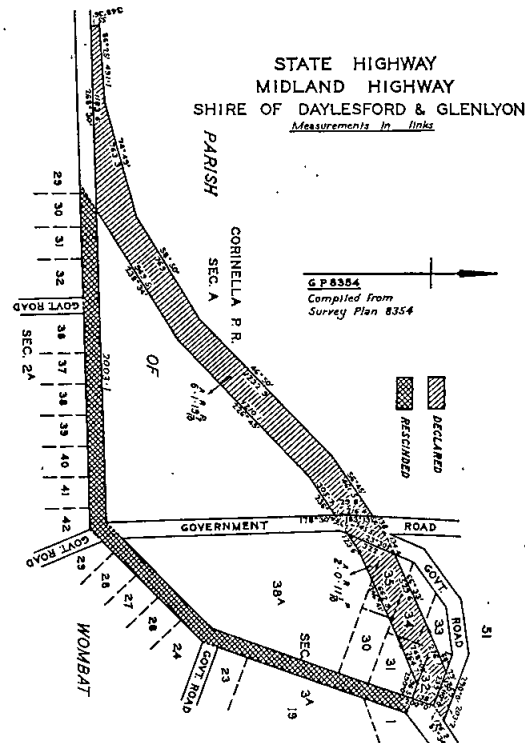

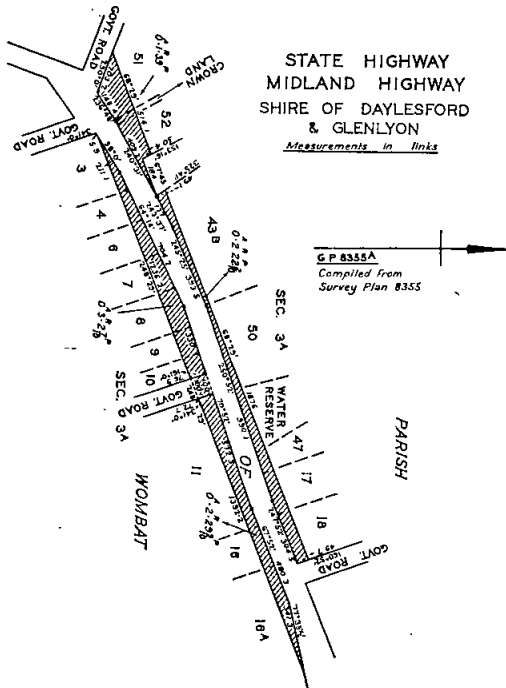

Main roads.

Resolution dated the Twenty-eighth day of October, One Thousand Nine Hundred and Sixty-eight, made pursuant to Sections 21 and 58 of the *Country Roads Act 1958* declaring the deviation from the Meredith-Mt. Mercer Road in the Shire of Bannockburn as indicated by diagonal hatching on Plan numbered G.P.10694 hereunder to be part of a main road within the meaning and for the purposes of the said Act, and also declaring that such deviation shall be in lieu of the existing road or part thereof indicated by cross hatching and horizontal hatching on the said plan which part indicated by cross hatching on the said plan shall be discontinued.

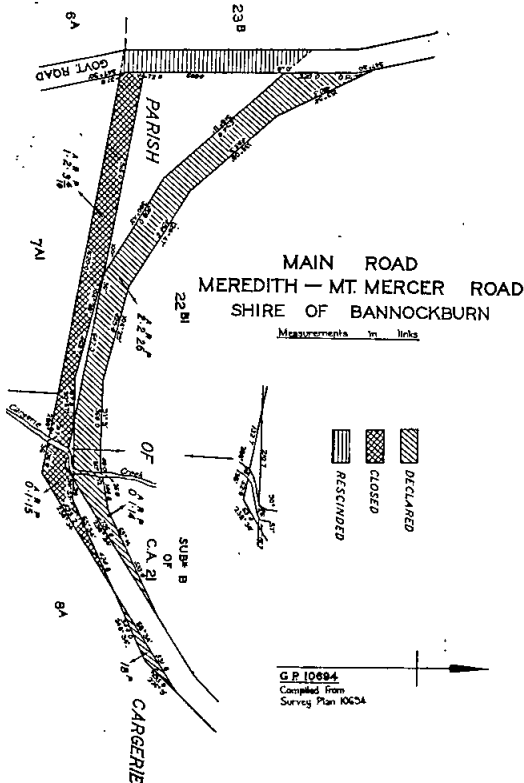

Resolution dated the Twenty-eighth day of October, One Thousand Nine Hundred and Sixty-eight, made pursuant to Sections 21 and 58 of the *Country Roads Act 1958* declaring the deviation from the Trafalgar-Thorpdale Road in the Shire of Narracan as indicated by diagonal hatching on Plans numbered G.P.11176 and G.P.11177 hereunder to be part of a main road within the meaning and for the purposes of the said Act, and also declaring that such deviation shall be in lieu of the existing road or part thereof indicated by cross hatching on the said plans and horizontal hatching on Plan numbered G.P.11176 which part indicated by cross hatching on the said plans shall be discontinued.

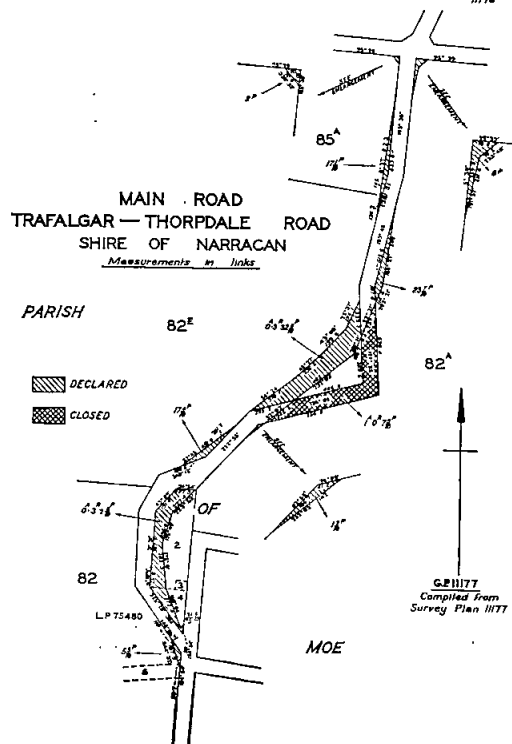
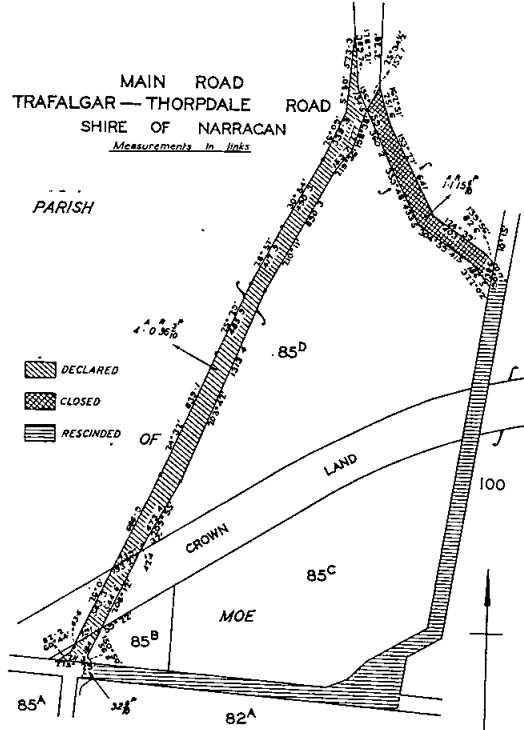

Resolution dated the Twenty-eighth day of October, One Thousand Nine Hundred and Sixty-eight, made pursuant to Section 21 of the *Country Roads Act 1958*, declaring the widening of the Woodend-Lancefield Road in the Shire of Romsey as shown hatched on Plan numbered G.P.8967 hereunder to be part of a main road within the meaning and for the purposes of the said Act.

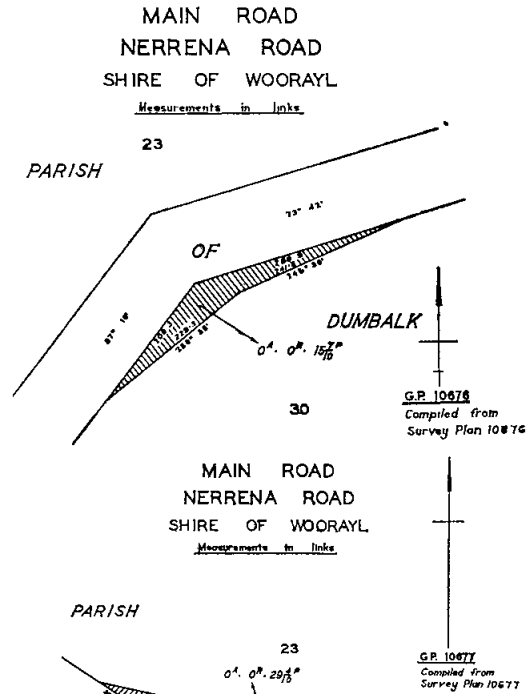
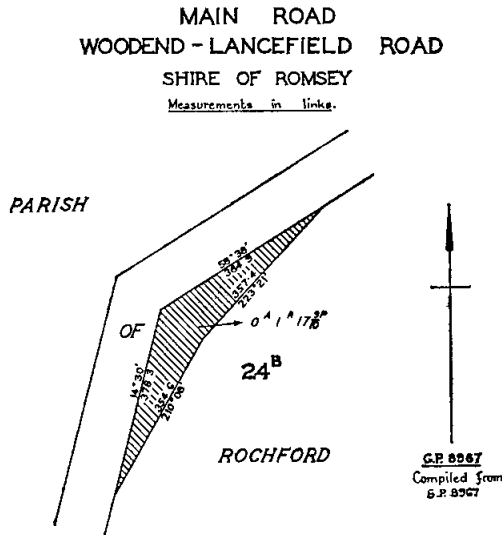

Resolution dated the Twenty-eighth day of October, One Thousand Nine Hundred and Sixty-eight, made pursuant to Section 21 of the *Country Roads Act 1958*, declaring the widening of the Nerrena Road in the Shire of Woorayl as shown hatched on Plans numbered G.P.10674, G.P.10675, G.P.10676, G.P.10677 and G.P.11112 hereunder to be part of a main road within the meaning and for the purposes of the said Act.

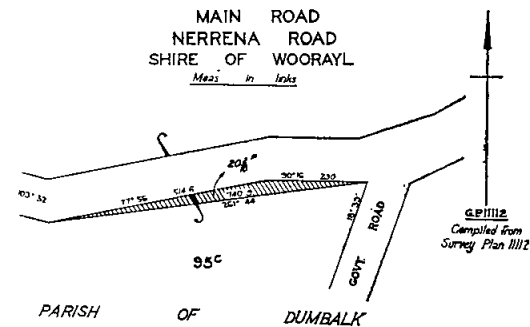
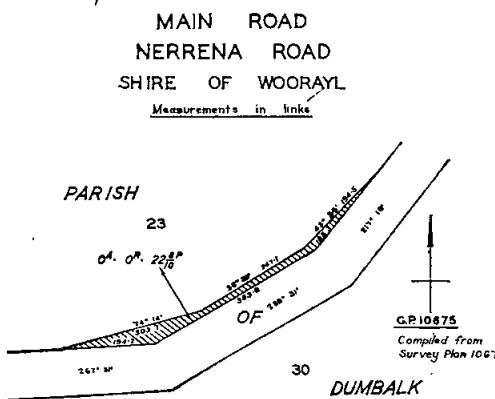
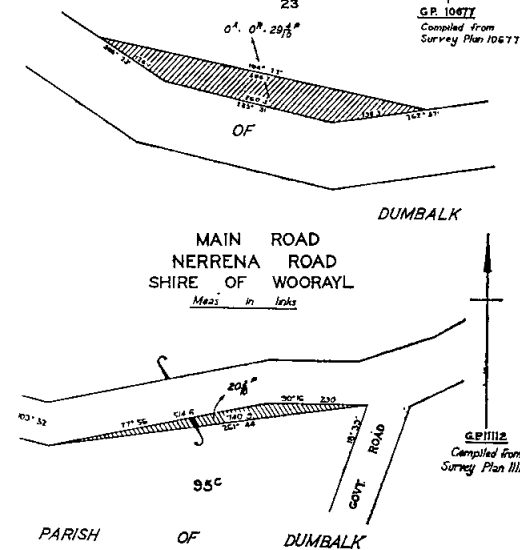
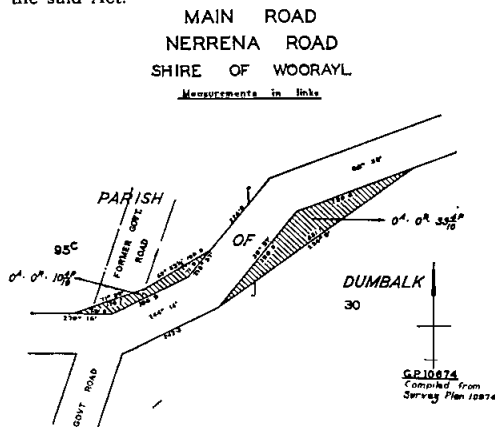

And the Honorable Murray Victor Porter, Her Majesty's Minister of Public Works for the State of Victoria, shall give the necessary directions herein accordingly.

J. ROSSITER,
Clerk of the Executive Council.

CROYDON SEWERAGE AUTHORITY.

At the Executive Council Chamber, Melbourne, the
sixth day of November, 1968.

PRESENT:

His Excellency the Governor of Victoria.
Mr. Thompson | Mr. Manson.

**EXTENT OF SEWERAGE DISTRICT INCREASED,
DIMINISHED AND DISTRICT BOUNDARY REDEFINED.**

UNDER the powers conferred by the Sewerage Districts Act and all other powers enabling him in that behalf His Excellency the Governor of the State of Victoria by and with the advice of the Executive Council of the said State doth hereby declare, order and direct that the

Croydon Sewerage District be extended and diminished as shown on a plan approved by and with this Order and the District boundary as extended and diminished be redefined as described in the Schedule hereto, and as on and from the date hereof the extent of such District shall be and be deemed to be increased and diminished accordingly.

SCHEDULE.

Commencing at a point on the northern boundary of the Municipality of the Shire of Croydon, being the north-western angle of Lodged Plan of Subdivision No. 31526, Parish of Warrandyte, County of Evelyn; thence easterly and generally southerly along the said municipal boundary to a point, being the intersection of the eastern boundary of Crown allotment E, Parish of Mooroolbark, County of Mornington, with the southern boundary of a drainage reserve; thence generally south-westerly, westerly and north-westerly along the said southern boundary of a drainage reserve, to a point on the eastern boundary of Dorset Road; thence southerly along the said eastern boundary of Dorset Road to a point on the centreline of a drain approximately 442 links south of the north-eastern angle of Crown allotment 30E, Parish of Ringwood, County of Mornington; thence generally south-westerly along the centreline of the said drain to a point on the south-western boundary of Lodged Plan of Subdivision No. 5504, Parish of Ringwood, County of Mornington; thence south-easterly along the said south-western boundary of the said Lodged Plan of Subdivision No. 5504 to the southern angle of the said Lodged Plan of Subdivision No. 5504; thence south-easterly across Canterbury Road to a point being the intersection of the south-eastern boundary of Canterbury Road with the north-eastern boundary of Hamilton Road; thence south-easterly and south-westerly along the north-eastern and south-eastern boundaries of Hamilton Road to a point on the southern boundary of the municipality of the Shire of Croydon; thence generally westerly and northerly, easterly, northerly, westerly and northerly along the said municipal boundary of the Shire of Croydon to a point on the north-western boundary of the Melbourne-Lilydale Railway reserve; thence generally north-easterly along the north-western boundary of the said Railway reserve to a point in line with the continuation of the southern boundary of Lodged Plan of Subdivision No. 11028, Parish of Ringwood, County of Mornington; thence westerly across a road and along the said southern boundary of the Lodged Plan of Subdivision No. 11028 to the westernmost angle; thence northerly along the western boundary of the said Lodged Plan of Subdivision No. 11028 to a point on the southern boundary of Mount Dandenong Road; thence north-westerly across the said Mount Dandenong Road to a point being the intersection of the northern boundary of the said Mount Dandenong Road with the south-western boundary of Murray Road; thence north-westerly along the south-western boundary of the said Murray Road to a point in line with the continuation of the north-western boundary of Crown allotment 37b, Parish of Warrandyte, County of Evelyn; thence north-easterly across the said Murray Road and continuing along the said north-western boundary of Crown allotment 37b to its northernmost angle; thence north-westerly along the north-eastern boundary of Crown allotment 37a to a point being the intersection of the said north-eastern boundary of Crown allotment 37a with the western boundary of Kenmare Avenue; thence northerly along the western boundary of the said Kenmare Avenue to its intersection with the south-western boundary of Alto Avenue; thence north-westerly along the said south-western boundary of Alto Avenue and by the continuation thereof across the Maroondah Highway to a point on the north-western boundary of the said Maroondah Highway; thence generally north-easterly along the said north-western boundary of the said Maroondah Highway to its intersection with the western boundary of Alice Street; thence generally northerly along the western boundary of the said Alice Street to a point on the southern boundary of Crown allotment 22e, Parish of Warrandyte, County of Evelyn; thence easterly, northerly and westerly along the southern, eastern and northern boundaries of the said Crown allotment 22e to a point being the intersection of the northern boundary of the said Crown allotment 22e with the western boundary of Fairview Avenue; thence generally northerly along the western boundary of the said Fairview Avenue to a point on the southern boundary of Exeter Road; thence north-easterly across the said Exeter Road to a point on its northern boundary, being the south-western angle of Lodged Plan of Subdivision No. 31526, Parish of Warrandyte, County of Evelyn; thence northerly along the western boundary of the said Lodged Plan of Subdivision No. 31526 to the point of commencement.

All of which boundary is shown on the said plan approved by the Governor in Council by and with this Order and deposited in the office of the State Rivers and Water Supply Commission, Melbourne.—(Corres. No. 60/1459/115.)

And the Honorable William Archibald Borthwick, Her Majesty's Minister of Water Supply for the State of Victoria, shall give the necessary directions herein accordingly.

J. ROSSITER,
Clerk of the Executive Council.

SHEPPARTON URBAN WATERWORKS TRUST.

At the Executive Council Chamber, Melbourne, the sixth day of November, 1968.

PRESENT:

His Excellency the Governor of Victoria.
Mr. Thompson | Mr. Manson.

EXTENT OF DISTRICT INCREASED.

UNDER the powers conferred by the Water Act 1958 and all other powers enabling him in that behalf, His Excellency the Governor of the State of Victoria, with the advice of the Executive Council of the said State, doth hereby declare order and direct as follows:—

That the extent of the Waterworks District of the Shepparton Urban Waterworks Trust be increased by adding to the same the land set out and described in the Schedule hereto, and as on and from the 1st day of December, 1968 the extent of such district shall be deemed to be increased accordingly.

SCHEDULE.

The whole of lots 1, 2, 3, 4, 5, 6, 7, 8 and 9 on lodged plan of subdivision No. 42232 being part of allotment 22A1, Parish of Shepparton, together with that portion of a road adjoining the southern boundary of said lot 3.

The land set out and described in the foregoing Schedule is shown on a plan approved by the Governor in Council, and deposited in the office of the State Rivers and Water Supply Commission, Melbourne.—(Corr. No. 68/3623).

And the Honorable William Archibald Borthwick, Her Majesty's Minister of Water Supply for the State of Victoria, shall give the necessary directions herein accordingly.

J. ROSSITER,
Clerk of the Executive Council.

BACCHUS MARSH WATER SUPPLY DISTRICT—LOCAL GOVERNING BODY, BACCHUS MARSH SHIRE COUNCIL.

At the Executive Council Chamber, Melbourne, the sixth day of November, 1968.

PRESENT:

His Excellency the Governor of Victoria.
Mr. Thompson | Mr. Manson.

AREA OF DISTRICT DIMINISHED.

UNDER the powers conferred by the Water Act 1958 and all other powers enabling him in that behalf, His Excellency the Governor of the State of Victoria, with the advice of the Executive Council of the said State, doth hereby declare, order and direct that the area of the Bacchus Marsh Water Supply District, under the control of the Bacchus Marsh Shire Council, as a local governing body, be diminished by excising therefrom the portion of the same shown on a plan approved by the Governor in Council and deposited in the Office of the State Rivers and Water Supply Commission, Melbourne (Corr. No. 65/4710) and as from the 30th day of November, 1968, such portion shall be deemed to be excised accordingly.

And the Honorable William Archibald Borthwick, Her Majesty's Minister of Water Supply for the State of Victoria, shall give the necessary directions herein accordingly.

J. ROSSITER,
Clerk of the Executive Council.

MANSFIELD SEWERAGE AUTHORITY.

At the Executive Council Chamber, Melbourne, the sixth day of November, 1968.

PRESENT:

His Excellency the Governor of Victoria.
Mr. Thompson | Mr. Manson.

CONSENT TO BORROWING \$50,000.

UNDER the powers conferred by the Sewerage Districts Act and all other powers enabling him in that behalf, His Excellency the Governor of the State of Victoria, by and with the advice of the Executive Council of the said State, doth hereby consent to the Mansfield Sewerage Authority borrowing at interest by mortgage of the General Fund the sum of Fifty thousand dollars (\$50,000) to meet the cost of sewerage works as set forth in the detailed statement bearing date 31st October, 1968.

And the Honorable William Archibald Borthwick, Her Majesty's Minister of Water Supply for the State of Victoria, shall give the necessary directions herein accordingly.

J. ROSSITER,
Clerk of the Executive Council.

SEYMOUR SEWERAGE AUTHORITY.

At the Executive Council Chamber, Melbourne, the sixth day of November, 1968.

PRESENT:

His Excellency the Governor of Victoria.
Mr. Thompson | Mr. Manson.

CONSENT TO BORROWING \$50,000.

UNDER the powers conferred by the Sewerage Districts Act and all other powers enabling him in that behalf, His Excellency the Governor of the State of Victoria, by and with the advice of the Executive Council of the said State, doth hereby consent to the Seymour Sewerage Authority borrowing at interest by mortgage of the General Fund the sum of Fifty thousand dollars (\$50,000) to meet the cost of sewerage works as set forth in the detailed statement bearing date 31st October, 1968.

And the Honorable William Archibald Borthwick, Her Majesty's Minister of Water Supply for the State of Victoria, shall give the necessary directions herein accordingly.

J. ROSSITER,
Clerk of the Executive Council.

SPRINGVALE AND NOBLE PARK SEWERAGE AUTHORITY.

At the Executive Council Chamber, Melbourne, the sixth day of November, 1968.

PRESENT:

His Excellency the Governor of Victoria.
Mr. Thompson | Mr. Manson.

CONSENT TO BORROWING \$130,000.

UNDER the powers conferred by the Sewerage Districts Act and all other powers enabling him in that behalf, His Excellency the Governor of the State of Victoria, by and with the advice of the Executive Council of the said State, doth hereby consent to the Springvale and Noble Park Sewerage Authority borrowing at interest by mortgage of the General Fund the sum of One hundred and thirty thousand dollars (\$130,000) in two amounts of Thirty thousand dollars (\$30,000) and One hundred thousand dollars (\$100,000) respectively to meet the cost of sewerage works as set forth in the detailed statement bearing date 31st October, 1968.

And the Honorable William Archibald Borthwick, Her Majesty's Minister of Water Supply for the State of Victoria, shall give the necessary directions herein accordingly.

J. ROSSITER,
Clerk of the Executive Council.

Water Act 1958.

STATE RIVERS AND WATER SUPPLY COMMISSION.

At the Executive Council Chamber, Melbourne, the sixth day of November, 1968.

PRESENT:

His Excellency the Governor of Victoria.
Mr. Thompson | Mr. Manson.

BACCHUS MARSH IRRIGATION DISTRICT—DISTRICT EXTENDED.

UNDER the powers conferred by the Water Act 1958 and all other powers enabling him in that behalf, His Excellency the Governor of the State of Victoria, with the advice of the Executive Council of the said State, on the recommendation of the State Rivers and Water Supply Commission, doth hereby declare, order and direct that the Bacchus Marsh Irrigation District be extended by adding to the same the land shown on a plan approved by the Governor in Council and deposited in the Office of the State Rivers and Water Supply Commission, Melbourne (Corres. Nos. 65/4710) and as on and from the 1st day of December, 1968, such District shall be deemed to be so extended.

And the Honorable William Archibald Borthwick, Her Majesty's Minister of Water Supply for the State of Victoria, shall give the necessary directions herein accordingly.

J. ROSSITER,
Clerk of the Executive Council.

STATE RIVERS AND WATER SUPPLY COMMISSION.

At the Executive Council Chamber, Melbourne, the sixth day of November, 1968.

PRESENT:

His Excellency the Governor of Victoria.
Mr. Thompson | Mr. Manson.

GOULBURN-MURRAY IRRIGATION DISTRICT—PORTION EXCISED.—SHEPPARTON IRRIGATION AREA—BOUNDARIES VARIED.

UNDER the powers conferred by the Water Act 1958 and all other powers enabling him in that behalf, His Excellency the Governor of the State of Victoria, with the advice of the Executive Council of the said State on the recommendation of the State Rivers and Water Supply Commission, doth hereby declare, order and direct as follows:—

That there shall be excised from the Goulburn-Murray Irrigation District that portion of the same set out and described in the Schedule hereto and that the boundaries of the Shepparton Irrigation Area be varied to excise from the said Area the aforesaid portion, which portion shall be deemed to be excised from the said Irrigation District and Irrigation Area as from the 30th day of November, 1968.

SCHEDULE.

The whole of lots 1, 2, 3, 4, 5, 6, 7, 8 and 9 on lodged plan of subdivision No. 42232 being part of allotment 22A1, parish of Shepparton, together with that portion of a road adjoining the southern boundary of said lot 3.

The land set out and described in the foregoing Schedule is shown on a plan approved by the Governor in Council, and deposited in the office of the State Rivers and Water Supply Commission, Melbourne.—(Corres. No. 68/3623.)

And the Honorable William Archibald Borthwick, Her Majesty's Minister of Water Supply for the State of Victoria, shall give the necessary directions herein accordingly.

J. ROSSITER,
Clerk of the Executive Council.

FORESTS DEPARTMENT.

At the Executive Council Chamber, Melbourne, the sixth day of November, 1968.

PRESENT:

His Excellency the Governor of Victoria.
Mr. Thompson | Mr. Manson.

ALIENATED LAND ACQUIRED BY EXCHANGE, ETC., AND DEDICATED AS RESERVED FOREST.

WHEREAS by section 42, sub-section 8, of the Forests Act 1958, it is prescribed that the Governor in Council may acquire by exchange of land dedicated as reserved forest—

- (a) any alienated land or Crown land licensed or leased with in inchoate right of purchase; or
(b) any land, public or private, and whether vested in trustees or otherwise,
and may by Order published in the *Government Gazette* dedicate the same as reserved forest:

Now, therefore, His Excellency the Governor of the State of Victoria, by and with the advice of the Executive Council of the said State, and in pursuance of the provisions of section 42, sub-section 8, of the Forests Act 1958, doth by this Order—

- (1) acquire the alienated land described in Schedule "A" hereto by exchange of land dedicated as reserved forest described in Schedule "B" hereto;
(2) excise from the reserved forest the area described in the aforesaid Schedule "B", such excision to take effect 30 days from date hereof;
(3) dedicate the land described in Schedule "A" aforementioned as reserved forest, such dedication to take effect 30 days from date hereof.

SCHEDULE ABOVE REFERRED TO.

Schedule "A"—Dedication Schedule No. 202.

Alienated land acquired from Harold Ian Beadel and Thelma Daphne Beadel, both of North Road, Langwarrin, being part of Crown Allotment 84A, Parish of Allambee East, County of Buln Buln, and comprising 22 acres 1 rood 15 perches.

Schedule "B"—Excision Schedule No. 163.

Land excised from reserved forest for Harold Ian Beadel and Thelma Daphne Beadel of North Road, Langwarrin, being Crown Allotment 84B, Parish of Allambee East, County of Buln Buln, and comprising 48 acres 2 roods 8 perches.

And the Honorable Edward Raymond Meagher, Her Majesty's Minister of Forests for the State of Victoria, shall give the necessary directions herein accordingly.

J. ROSSITER,
Clerk of the Executive Council.

HOUSING ACT 1958.

At the Executive Council Chamber, Melbourne, the sixth day of November, 1968.

PRESENT:

His Excellency the Governor of Victoria.
Mr. Thompson | Mr. Manson.

CLOSING OF ROADS AND EXTINGUISHMENT OF EASEMENTS AND RESTRICTIVE COVENANTS—CITY OF MELBOURNE.

WHEREAS by virtue and in exercise of the powers contained in the Housing Act 1958 (No. 6275) Housing Commission has recommended to the Governor-in-Council that the roads easements and restrictive covenants described in the Schedule hereto be closed and extinguished.

NOW THEREFORE His Excellency the Governor of the State of Victoria in the Commonwealth of Australia by and with the advice of the Executive Council of the said State, doth in pursuance of the powers conferred by the said Act

and upon such recommendation, consent and by this Order hereby close and extinguish such roads easements and restrictive covenants.

SCHEDULE.

First:—The roads subsisting over all those pieces of land within the Municipality of the City of Melbourne being parts of Crown Allotment 18 Section 2, Parish of Doutta Galla and being the land remaining untransferred in the following Certificates of Title:—

Volume.	Folio.
1907	395
4936	086
5836	032

Secondly:—Any easements and restrictive covenants affecting all those pieces of land within the Municipality of the City of Melbourne being parts of Crown Allotments 17 and 18 Section 2 Parish of Doutta Galla and being the land at present comprised in the following Certificates of Title:—

Volume.	Folio.
3755	883
3952	345
4842	242
4842	243
4936	086
6317	222
8144	255
8144	256
8187	272
8214	182
8348	766
8486	591

And the Honorable Edward Raymond Meagher, Her Majesty's Minister of Housing for the State of Victoria shall give the necessary directions herein accordingly.

J. ROSSITER,
Clerk of the Executive Council.

LANDS DEPARTMENT NOTICES

APPROACHING LAND SALES.

SALES of Crown Lands, in fee-simple, will be held at the under-mentioned places and dates, viz.:—

	No. of Gazette.
Daylesford.—Tuesday, 17th December, 1968 ..	89
Hamilton.—Friday, 20th December, 1968 ..	94
Meredith.—Thursday, 19th December, 1968 ..	94
Murrayville.—Wednesday, 20th November, 1968	84
Ouyen.—Monday, 18th November, 1968 ..	84
Red Cliffs.—Thursday, 21st November, 1968 ..	84
Sale.—Thursday, 12th December, 1968 ..	89

SALE OF FREEHOLD LAND BY AUCTION.

Paschendale.—Thursday, 5th December, 1968 89

SALE OF CROWN LAND BY AUCTION.

The land will be offered for sale in fee-simple, and subject to the provisions of the Land Act and Regulations thereunder.

The upset price is the sum at which bidding will start, and no bid below that sum can be accepted. The highest bidder at or above that sum shall be the purchaser, subject to signature of contract and any necessary payment.

TERMS:—

A deposit of at least 12½% of the purchase price must be paid at the sale, either in cash or by cheque.

The residue is payable in half-yearly instalments, in accordance with the following scale, or may be paid off at any earlier time.

\$40 and under, 6 instalments.
Over \$40, and not exceeding \$100, 8 instalments.
Over \$100, and not exceeding \$200, 10 instalments.
Over \$200, and not exceeding \$400, 12 instalments.
Over \$400, and not exceeding \$600, 14 instalments.
Over \$600, and not exceeding \$800, 16 instalments.
Over \$800, and not exceeding \$1,000, 18 instalments.
Over \$1,000, 20 instalments.

Interest at the rate of 5% per annum is payable with all payments of residue, and is computed for each instalment from the date of sale to the date of such payment. Additional interest is charged if any instalment is not paid on or before the due date.

If paid off within 30 days of sale, no interest is payable.

FEES, ETC.:

Also payable at the sale, in addition to the deposit, are the survey fee and, if applicable, the valuation of improvements (if purchaser be not the owner thereof).

Payable with balance of purchase money—

Crown Grant fee—

50 acres and under	\$3
Over 50 acres	\$4
Purchase money \$10 or under	\$2

Assurance Fund contribution.—One cent in every Five dollars or part thereof of purchase price. (This is a fund established to guarantee the validity of freehold titles.)

Transfer of interest prior to completion of payment may be allowed on payment of \$2 fee and subject to stamp duty.

If unable to attend personally, a prospective purchaser may arrange for another person to bid as his agent.

Attention is drawn to section 95, Land Act 1958, which provides that the purchaser shall be deemed to be the owner for the purposes of other Acts; also to an amendment to the Local Government Act providing for Government roads, in certain circumstances, to be declared "private streets", thus making the purchaser liable to contribute to the cost of street construction.

W. J. F. McDONALD,
Minister of Lands.

Office of Crown Lands and Survey,
Melbourne, 13th November, 1968.

MEREDITH.—Sale (No. 11975) of Crown land in fee-simple, by auction, will be held at the LAND INSPECTOR'S OFFICE, MEREDITH, on THURSDAY, 19th DECEMBER, 1968, at TEN o'clock a.m. To be conducted by D. M. O'CONNOR, Land Officer, Geelong.

Lot 1.

PARISH OF BORHONEYGHURK, COUNTY OF GRANT.

About 5 miles north-east of Elaine and about 1 mile east of the Elaine-Egerton road.

Upset price \$400 the lot. Survey fee \$53.25.

Area 85a. 1r. 13p., allotment 9J.—(G.61894.)

HAMILTON.—Sale (No. 11976) of Crown land is fee-simple by auction will be held at the LAND OFFICE, HAMILTON, on FRIDAY, the 20th DECEMBER, 1968, at half-past ELEVEN o'clock a.m. To be conducted by K. C. GITTINS, Land Officer, Hamilton.

Lot 1.

PARISH OF MOKANGER, COUNTY OF DUNDAS.

In the north of the parish abutting the reservation to the north-western side of Ti-Tree Creek.

Upset price \$150 the lot. Survey fee \$24.50.

Area 15a. 3r. 27p., allotment 4A.—(J.32585.)

LOCAL LAND BOARDS.

IN pursuance of the provisions of section 34 of the Land Act 1958, notice is hereby given that public hearings at the following places and times, will be conducted by the persons respectively mentioned, being duly appointed in that behalf.

W. J. F. McDONALD,
Minister of Lands.

Department of Crown Lands and Survey,
Melbourne.

SCHEDULE.

WARRAGUL COURT HOUSE, Monday, 25th November, 1968, to Friday, 29th November, 1968 (inclusive), at 9.30 a.m.—E. Kennedy and J. R. Wilding.

BAIRNSDALE STATE PUBLIC OFFICES, Monday, 9th December, 1968, at 12 noon.—J. Buck and E. Kennedy.

BAIRNSDALE STATE PUBLIC OFFICES, Tuesday, 10th December, 1968, at 9.30 a.m.—J. Buck and E. Kennedy.

BENDIGO STATE PUBLIC OFFICES, Monday, 2nd December, 1968, at 9 a.m.—T. A. Comte and E. Kennedy.

PAKENHAM EAST (LAND INSPECTOR'S OFFICE) Friday, 29th November, 1968, at 11 a.m.—E. Kennedy and J. R. Wilding.

SWAN HILL STATE PUBLIC OFFICES, Tuesday, 3rd December, 1968, at 9 a.m.—T. A. Comte and E. Kennedy.

PROPOSED REVOCATIONS OF TEMPORARY RESERVATIONS OF LANDS BY ORDERS IN COUNCIL.

IN pursuance of the provisions of the Land Act 1958, notice is hereby given that it is the intention of the Governor in Council to revoke the temporary reservations of lands by Orders in Council hereunder referred to, viz.:

The following Notices were published 1° on the 6th November, 1968, pursuant to Orders of the 30th October, 1968.

ALBACUTYA.—The temporary reservation, by Order in Council of the 14th June, 1910, of 2 acres of land in the Parish of Albacutya as a site for a State School is about to be revoked.—(A.175⁽³⁾) (C.45665).

GRACEDALE.—The temporary reservation, by Order in Council of the 25th February, 1930, of 19 acres 1 rood 9 perches of land in the Parish of Gracedale as a site for a Public Park is about to be revoked.—(G.166⁽²⁾) (Rs.3962).

KILLARA.—The temporary reservation, by Order in Council of the 5th April, 1892, of 2 acres of land in the Parish of Killara as a site for a State School is about to be revoked.—(K.151⁽³⁾) (E.14063).

KILLARA.—The temporary reservation, by Order in Council of the 4th November, 1901, of 1 acre of land in the Parish of Killara as a site for a State School is about to be revoked.—(K.151⁽³⁾) (C.14374).

LYNDHURST (ASPENDALE).—The temporary reservation by Order in Council of the 30th October, 1939, of 1 acre 2 roods 28 perches of land in the Parish of Lyndhurst as a site for Public purposes is about to be revoked so far only as the portion containing 1 rood 18 perches, indicated by hatching on plan hereunder, is concerned.—(L.101⁽²⁾) (Rs.1365).

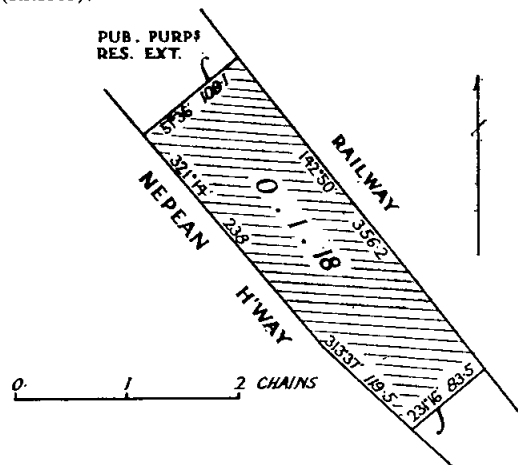

W. J. F. McDONALD,
Minister of Lands.

PROPOSED PERMANENT RESERVATION OF LAND AS A SITE.

IN pursuance of sections 14 and 21 of the Land Act 1958, notice is hereby given that it is the intention of the Governor in Council to reserve permanently from sale, from being leased and from having a licence granted in respect thereof the land hereinafter described:—

The following Notices were published 1° on the 30th October, 1968, pursuant to Orders of the 22nd October, 1968.

WANNAEUE (ROSEBUD).—Land proposed to be permanently reserved as a site for Public purposes, 66 acres, more or less, Parish of Wannaeue, County of Mornington, as indicated by hatching on plan hereunder:—(W.32⁽²⁾) (Rs.3351).

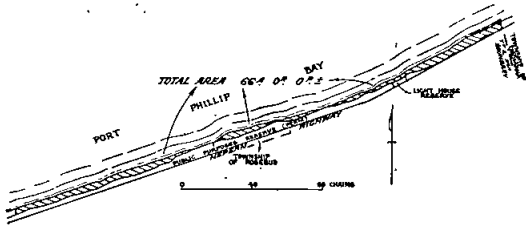

MOORABBIN (CHELTENHAM).—Land proposed to be permanently reserved as a site for a Cemetery, 2 roods 39 perches, Parish of Moorabbin, County of Bourke, as indicated by hatching on plan hereunder.—(M.164⁽³⁾) (Rs.4547).

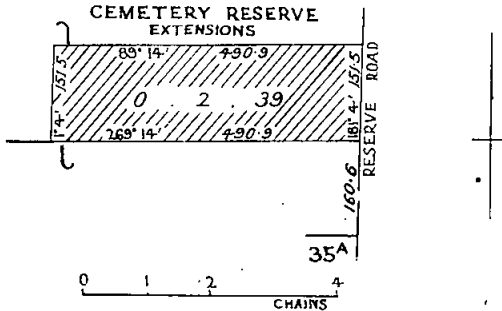

W. J. F. McDONALD,
Minister of Lands.

PROPOSED PERMANENT RESERVATION OF LAND AS A SITE.

IN pursuance of sections 14 and 21 of the Land Act 1958, notice is hereby given that it is the intention of the Governor in Council to reserve permanently from sale, from being leased and from having a licence granted in respect thereof the land hereinafter described:—

The following Notice was published 1^o on the 23rd October, 1968, pursuant to Order of the 15th October, 1968.

MILDURA.—Land proposed to be permanently reserved as a site for Water Supply purposes, 1 acre 2 roods 5 perches, Parish of Mildura, County of Karkaroc, as indicated by hatching on plan hereunder.—(M.533⁽²⁾) (Rs.9054).

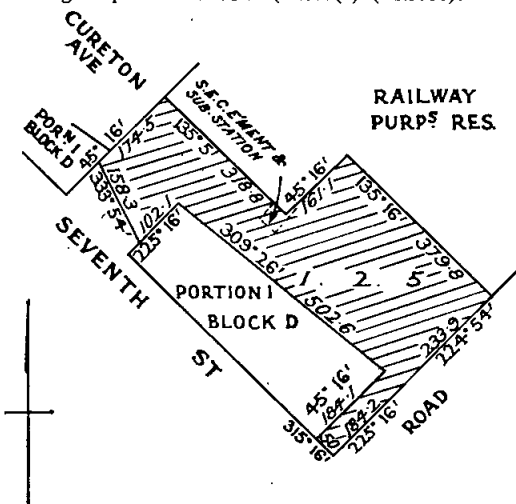

W. J. F. McDONALD,
Minister of Lands.

PROPOSED REVOCATION OF TEMPORARY RESERVATIONS OF LANDS BY ORDERS IN COUNCIL.

IN pursuance of the provisions of the Land Act 1958, notice is hereby given that it is the intention of the Governor in Council to revoke the temporary reservation of land by Order in Council hereunder referred to, viz.:

The following Notice was published 1^o on the 13th November, 1968, pursuant to Orders of the 6th November, 1968.

DOON.—The temporary reservation as a site for Watering and Camping purposes and the withholding from sale, leasing and licensing by Order in Council of the 14th December, 1874, of 193 acres 1 rood 8 perches of land in the Parish of Doon, revoked as to part by Order of the 18th September, 1876, are about to be revoked so far only as the portion containing 4 acres 18 perches, indicated by hatching on plan hereunder is concerned.—(D.167⁽⁴⁾) (Rs.6340).

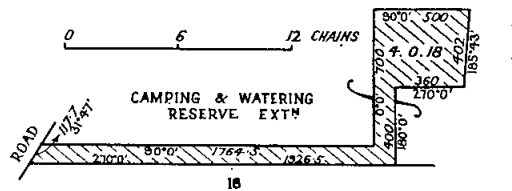

KERRIE.—The temporary reservation by Order in Council of the 15th May, 1888, of 66 acres, more or less, of land in the Parish of Kerrie as a site for Recreation and Road purposes, revoked as to part by Order of the 26th November, 1929, is about to be revoked so far only as the portion containing 36 acres, more or less, indicated by hatching on plan hereunder, is concerned.—(K.26⁽⁶⁾) (Rs.5818).

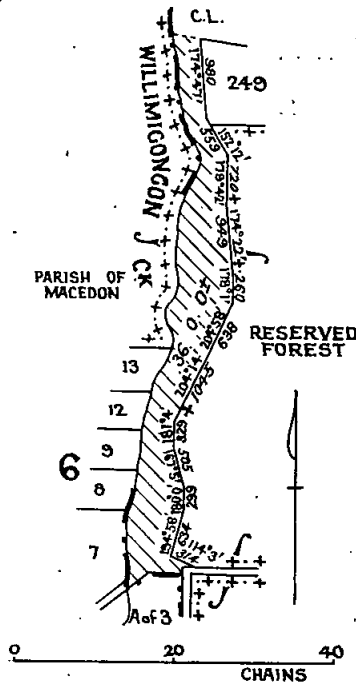

PIAMBIE.—The temporary reservation by Order in Council of the 24th August, 1920, of 3 acres of land in the Parish of Piambie (formerly Parish of Wakool) as a site for State School is about to be revoked.—(P.184⁽³⁾) (Rs.2188).

WERRAP.—The temporary reservation as a site for the purposes of the Soil Conservation Authority by Order in Council of the 27th April, 1954, of 255 acres 3 roods 12 perches of land in the Parish of Werrap, is about to be revoked so far only as the portion containing 1 rood 3 perches indicated by hatching on plan hereunder is concerned.—(W.386⁽⁴⁾) (Rs.7244).

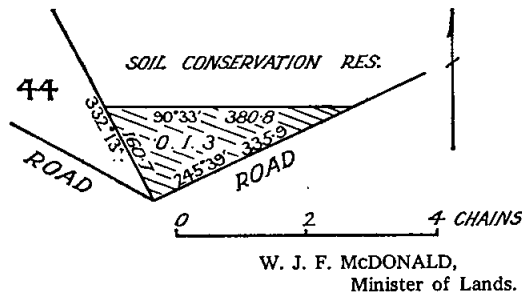

W. J. F. McDONALD,
Minister of Lands.

PROPOSED REVOCATIONS OF TEMPORARY RESERVATIONS OF LANDS BY ORDERS IN COUNCIL.

IN pursuance of the provisions of the *Land Act 1958*, notice is hereby given that it is the intention of the Governor in Council to revoke the temporary reservations of lands by Orders in Council hereunder referred to, viz.:—
The following Notices were published 1° on the 30th October, 1968, pursuant to Orders of the 22nd October, 1968.

BENALLA.—The temporary reservation, by Order in Council of the 30th August, 1966, of 4 acres 2 roods 27 perches, more or less, of land in the Parish of Benalla as a site for Public purposes (Municipal Depot) is about to be revoked so far only as the portion containing 1 acre 1 rood 30 perches, more or less, indicated by hatching on plan hereunder, is concerned.—(B.392^(*)) (Rs.8203).

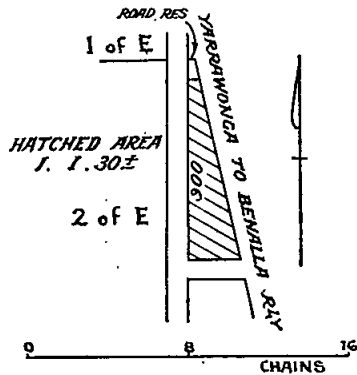

DARTMOOR.—The temporary reservation, by Order in Council of the 12th October, 1936, of 5 acres 3 roods 13 perches of land in the Parish of Dartmoor as a site for a Quarry and Road purposes, is about to be revoked.—(D.32^(*)) (Rs.4625).

DRYSDALE.—The temporary reservation, by Order in Council of the 4th March, 1867, of 1 acre of land in the Township of Drysdale as a site for Police purposes is about to be revoked, so far only as the portion containing 1 rood 23 perches, indicated by hatching on plan hereunder, is concerned.—(D.99^(*)) (Rs.8669).

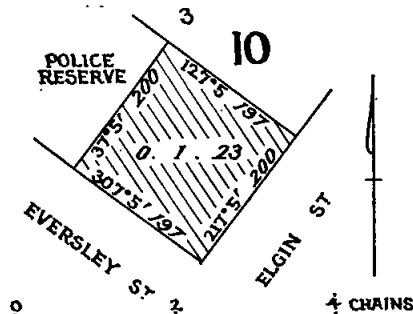

HEATHCOTE.—The temporary reservation, by Order in Council of the 9th July, 1894, of 117 acres 0 roods 248/10 perches of land in the Township of Heathcote as a site for a Racecourse is about to be revoked so far only as the portions containing 1 acre 0 roods 248/10 perches, indicated by hatching on plan hereunder, are concerned.—(H.74^(*)) (Rs.1165).

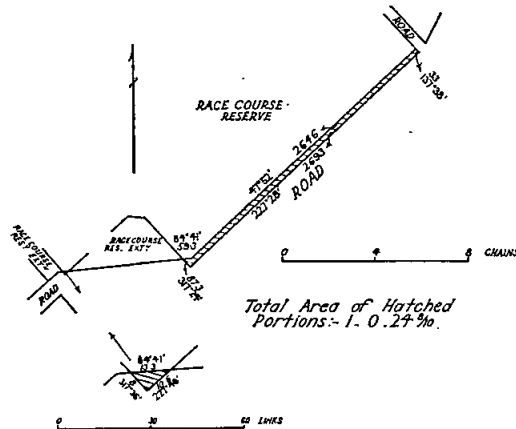

Total Area of Hatched Portions:- 1. 0. 27 ±.

HEATHCOTE.—The temporary reservation, by Order in Council of the 3rd August, 1954, of 6 acres 2 roods 20 perches, more or less, of land in the Township of Heathcote as a site for a Racecourse is about to be revoked, save and except the portions containing 6 acres 1 rood 38 perches, as indicated by hatching on plan hereunder.—(H.74^(*)) (Rs.1165).

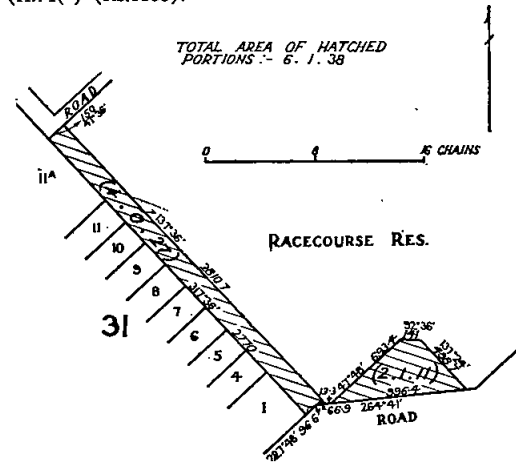

MONBULK.—The temporary reservation, by Order in Council of the 18th May, 1965, of 6 acres, more or less, of land in the Parish of Monbulk as a site for Public Recreation, is about to be revoked.—(M.555⁽¹²⁾) (Rs. 8129).

MONBULK.—The temporary reservation, by Order in Council of the 8th May, 1962, of 8 acres, more or less, of land in the Parish of Monbulk as a site for Public Recreation, is about to be revoked.—(M.555⁽¹²⁾) (Rs.8129).

WILLOWMAVIN (KILMORE).—The temporary reservation, by Order in Council of the 3rd February, 1953, of 5 acres 1 rood 18 perches of land in the Parish of Willowmavin as a site for Hospital purposes, is about to be revoked.—(M.139⁽²⁾) (Rs.7034).

YANGERY.—The temporary reservation, by Order in Council of the 12th September, 1967, of 3 acres 2 roods 15 perches of land in the Parish of Yangery as a site for the purposes of the Fisheries and Wildlife Department, is about to be revoked.—(Y.53^(*)) (Rs.2687).

YANGERY.—The temporary reservation, by Order in Council of the 26th June, 1962, of 2 acres 0 roods 31 perches, more or less, of land in the Parishes of Koroit and Yangery as a site for the purposes of the Fisheries and Wildlife Department, is about to be revoked.—(K.79⁽²⁾, Y.53^(*)) (Rs.2687).

YANGERY.—The temporary reservation, by Order in Council of the 7th March, 1961, of 1,475 acres, more or less, of land in the Parishes of Koroit and Yangery as a site for the purposes of the Fisheries and Wildlife Department, is about to be revoked.—(K.79⁽²⁾, Y.53^(*)) (Rs.2687).

W. J. F. McDONALD,
Minister of Lands.

LOCAL GOVERNMENT ACT 1958.

IN pursuance of the powers conferred by sub-section 3A of section 575 of the *Local Government Act 1958* I, William John Farquhar McDonald, Her Majesty's Minister of Lands in the State of Victoria hereby declare that the roads set out on Crown land in the Township of Cann River, Parish of Noorinbee, County of Croajingolong, as delineated and indicated by hachure on the plan hereunder be private streets within the meaning of and for the purposes of Division 10, Part XIX., of the said Act.—(Corres. No. H.032601.)

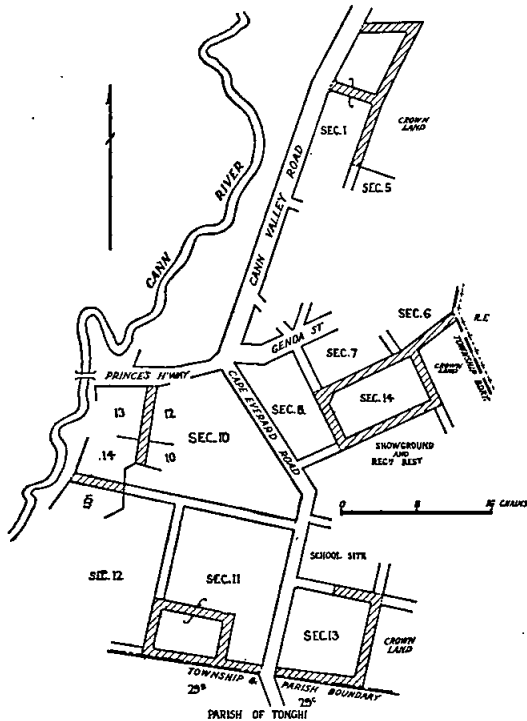

Dated at Melbourne this 4th day of November, 1968.

W. J. F. McDONALD,
Minister of Lands.

LOCAL GOVERNMENT ACT 1958.

IN pursuance of the powers conferred by sub-section 3A of section 575 of the *Local Government Act 1958* I, William John Farquhar McDonald, Her Majesty's Minister of Lands in the State of Victoria hereby declare that the roads set out on Crown land in the Township of Castlemaine, Parish of Castlemaine, County of Talbot, as delineated and indicated by hachure on the plan hereunder be private streets within the meaning of and for the purposes of Division 10, Part XIX., of the said Act.—(Corres. No. W.89198.)

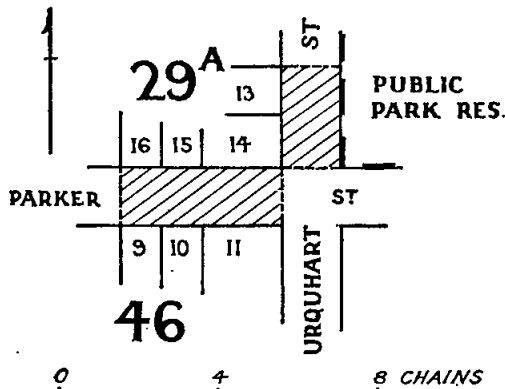

Dated at Melbourne this 4th day of November, 1968.

W. J. F. McDONALD,
Minister of Lands.

REGULATIONS FOR THE CARE, PROTECTION AND MANAGEMENT OF THE LAKE MARMA RESERVE.

WHEREAS by section 218 of the *Land Act 1958* the Minister of Lands is empowered to make regulations as to any land which under the provisions of that Act or of any other Act relating to Crown lands has been reserved for any public purpose whatsoever and which has not been conveyed to or vested in trustees: And whereas certain Crown lands in the Parish of Ashens were reserved as a site for Public Park and Gardens: And whereas such lands (hereinafter called "the Reserve") have not been conveyed to or vested in trustees: And whereas it is expedient that regulations for the care, protection and management of the Reserve and for other purposes connected therewith should be made: Now therefore I, William John Farquhar McDonald, Her Majesty's Minister of Lands in and for the State of Victoria, in pursuance of the powers aforesaid, do hereby make the following Regulations for or with respect to the Reserve:—

The Reserve has been placed under the control of a Committee of Management with power and authority to enforce the following regulations.

REGULATIONS.

1. The Reserve shall be open to the public (but not to any stand or building erected thereon) from sunrise to sunset, free of charge, except as hereinafter provided.
2. The Committee shall have the power to hold entertainments and performances in the Reserve and may appoint days upon which the Reserve or some well-defined part thereof may be set aside for the purpose of holding sports, fêtes, games or holiday amusements, and on any of the days so set apart the following charges may be made and taken, namely:—

For the admission of every adult person, motor vehicle, or other vehicle to the Reserve, such sum as the Committee may from time to time determine, not exceeding Two Dollars.

3. Upon application, in writing, not less than fourteen days prior to the required date, any club, association or person may be granted exclusive use of the Reserve or any well-defined part thereof for the holding of any sports, fêtes, games or holiday amusement and may charge for the admission thereto, subject to the provisions of these Regulations and shall, if required, pay to the Committee such charges as the Committee may from time to time deem to be reasonable and consistent with these Regulations, such charge to be paid upon application being granted. The Committee may, however, refuse any such application.
4. The Committee may set apart any portion of the Reserve for the purpose of any lawful games, recreation or sports, and from time to time grant to any person, club or association, upon such terms and conditions as it may deem to be consistent with these Regulations the use of the ground so set apart.

5. No person shall put or bring into the Reserve any cattle, horses, sheep, goats, pigs or other animal, including domestic dogs and cats, without the permission, in writing, of the Committee first obtained.
6. The Committee shall have power to impound any cattle found trespassing on the Reserve, and shall be deemed to be the occupier of the Reserve (with all power incidental to that status) within the meaning of any law for time being in force relating to the impounding of cattle. For the purpose of this clause "cattle" has the same meaning as in section 3 of the *Pounds Act 1958*.

7. No person shall park any motor vehicle or other vehicle in the Reserve, except at such place or places set apart for that purpose by the Committee.
8. No person shall—

- (a) mark, write on or deface, or in any way damage any building, post, fence, railing, pillar or any other structure or property within the Reserve;
- (b) affix any bill, sign or notice board to any tree or structure within the Reserve without permission in writing of the Committee first obtained.

9. No person shall play or perform in any band of music, or deliver or read any public speech, lecture, prayer, sermon or address of any kind, sing any sacred or secular song, enter into any public discussions, or hold or take part in any public assemblage at any entertainment, sports, ceremony or meeting on the Reserve, except with the consent of the Committee, in writing, first obtained.

10. No person shall wilfully obstruct or interrupt or in any way interfere with any Officer, Member, employee or appointee of the Committee in the proper execution of his or her work or duty within the Reserve.

11. No person shall enter or remain in the Reserve who may offend against decency as regards dress, language or conduct and for maintaining good order in the Reserve,

the Committee or any person authorized by the Committee may refuse any person admission to the Reserve or any structure therein.

12. No person shall light any fire in the Reserve without the permission, in writing, of the Committee first obtained, except in the fireplaces as provided by the Committee.

13. No person shall bring into the Reserve any dog unless controlled by a chain or leash.

14. No person shall without the permission, in writing, of the Committee, hawk, sell or offer for sale in the Reserve any goods or articles, or offer any goods or other article for hire.

15. No person shall spit or expectorate or commit any nuisance on the paths or in or on any building, structure, or erection in the Reserve.

16. No person whilst in the Reserve shall without the consent, in writing of the Committee first had and obtained carry, use or discharge any firearm, air gun or other lethal weapon or carry, use, explode or light any fireworks or explosives; Provided always that nothing in this Regulation contained shall be deemed to prohibit the bona fide use by officials or any sporting body lawfully using the Reserve or any part thereof of any starter's pistol or starting gun in the conduct of sporting events.

17. No person shall bring into or sell or distribute in the Reserve any intoxicating liquor, unless authorized, in writing, by the Committee and holding any licences or permit required pursuant to the *Licensing Act 1958* for the sale or drinking of intoxicating liquor therein, or employed by or acting on behalf of or delivering intoxicating liquor to any person so authorized and licensed or holding a permit, and then only in such portions of the Reserve as may be set apart for the purpose or in such booths, buildings and kiosks therein wherein the sale or drinking of intoxicating liquor is permitted by the Committee and licences or permits granted pursuant to the *Licensing Act 1958*.

18. No person shall have in his possession or control or consume or drink in the Reserve any intoxicating liquor unless authorized, in writing, by the Committee, save and except in such portions of the Reserve and in such booths, buildings and kiosks therein as may from time to time be licensed premises within the meaning of the *Licensing Act 1958* or in respect of which permits permitting the drinking of intoxicating liquor have been granted pursuant to the *Licensing Act 1958*.

19. No person shall, without the permission, in writing, of the Committee first obtained, erect in the Reserve any post, rail, fence, pole, tent, booth, stand, building or other structure.

20. Any person committing any of the following offences within the Reserve shall (in addition to any other penalty to which such person may be liable therefor) be liable to be ejected from the Reserve, namely:—

- (a) Being drunk or under the influence of intoxicating liquor.
- (b) Using profane, abusive, insulting, threatening, indecent or obscene language.
- (c) Assaulting any person or behaving in a riotous or disorderly manner.
- (d) Wilfully interfering with or disturbing any entertainment, performance, game, sports, amusement, match or tournament to the annoyance, detriment or discomfort to any person or persons engaged or taking part in such entertainment, performance, game, sports, match, amusement or tournament.
- (e) Obtaining admission to or being found in any part of the Reserve when not entitled to admission thereto under these Regulations.

21. No seasonal or monthly tickets shall be transferable and any holder of a seasonal or monthly ticket who allows any other person to use the same shall immediately forfeit such ticket and all moneys paid thereon and all the rights and privileges given by such ticket.

22. No male over the age of six years shall enter or use any place, room, convenience or building or any separate passage or approach thereto set apart for the use of females and no females shall enter or use any place, room, convenience or building or any separate passage or approach thereto set apart for the use of males.

23. The owner or driver of any vehicle shall park such vehicle within the Reserve in such place and manner as directed by the duly appointed officer of the Committee.

24. Persons renting or hiring any stand or building, erection or enclosure on the occasion of fêtes, sports or holiday amusements or otherwise, may be required to

deposit any sum which the Committee of Management may at any time determine, not exceeding \$200, by way of guarantee that due care shall be taken of such stand, building, erection or enclosure, and such Committee may in its absolute discretion make good any damage or other injuries sustained by such stand, building, erection or enclosure, or anything contained therein during such occupancy or hiring, and deduct the cost of making good such loss or damage from the sum of money deposited by way of guarantee, and all persons so renting or hiring shall abide by these Regulations and by any order given by the Committee of Management. If no money is deposited as aforesaid or if the money deposited is insufficient to recompense the damage, the Committee of Management may recover the amount of the damage or the deficiency, as the case may be, from the person committing any such damage as aforesaid.

25. No person except labourers and workmen employed in the Reserve, shall enter any plots therein which may be enclosed for plantations of any young trees or shrubs.

26. No person other than the participants and the officials connected with games, competitions or races or sports shall intrude upon any portion of the Reserve set apart, therefore during the course of such game, competition, race or sport.

27. Every person holding or purporting to hold any receipt or permission, in writing, issued by the Committee shall, on demand by any member of the Committee or any officer thereof or any member of the Police Force, produce such receipt or permission.

28. No person shall drive any motor car or other vehicle of any kind or ride any bicycle, motor cycle or horse except on a road or parking area made for the purpose in the Reserve and then only as near as practicable to the left hand side of such road.

29. No person shall drive any motor car or other vehicle of any kind or ride any bicycle, motor cycle or horse within the Reserve or in any parking area or along any road therein recklessly or at a speed or in a manner which is dangerous to the Public having regard to all the circumstances of the case including the nature and the amount of traffic which actually is at the time on which might reasonably be expected to be on such road, parking area, or in the Reserve. The maximum allowable speed, motor races excepted, at any time is 10 m.p.h.

30. No person, club, or other body shall, without the consent of the Committee first obtained, grade or scrape the ground off or cut or burn any grass growing on any part of the Reserve.

31. No person shall remove any earth, sand, stone, marl or gravel from the Reserve.

32. No person shall make any wager for money or play any unlawful game in the Reserve.

33. No person shall give out or distribute any hand bills, placards, notices, advertisements, books, pamphlets or papers in the Reserve without permission of the Committee first obtained, or litter same by scattering or throwing down any hand bills, placards, notices, advertisements, books, pamphlets or papers.

34. No person shall throw or deposit any glass, filth, rubbish, refuse, junk, building material or waste material of any kind, or cause any glass, filth, rubbish, refuse, junk, building material or waste material of any kind to fall or to be thrown or deposited upon or in the Reserve.

35. Persons using the Reserve for any purpose shall, prior to leaving the area, collect and remove or cause to be collected or removed, all waste material, scraps, bottles, glass or litter of any kind brought or made by them.

36. Nothing in these Regulations shall prevent the Committee closing the Reserve or portion thereof and excluding the public therefrom whenever it shall think it fit.

37. Every person to whom a ticket has been issued authorizing such person to enter upon the Reserve shall, upon demand, produce and, if required, surrender such ticket to any gatekeeper or other person duly authorized to demand such production or surrender of tickets.

38. No person shall in or upon the Reserve, kill, wound, trap or snare or attempt to kill, wound trap or snare any bird or other native game, or have any dead bird or other native game, or the skin or pelt thereof, in his possession.

39. No person shall without permission in writing of the Committee first obtained, operate or use any loudspeaker, amplifier or broadcasting equipment (mechanical or electrical) for broadcasting music, speech, or other noises or sound within the Reserve.

40. No person shall remove or displace any board, plate or fitting for the exhibition of any Regulations, neither shall any person remove or displace any notice fixed or set up in the Reserve by the Committee.

41. No person over the age of fourteen years shall use playground equipment erected within the Reserve.

42. No person shall at any time carelessly or negligently break or injure or improperly interfere with any lock, tap or fitting within the Reserve, nor carelessly, negligently or wilfully damage or injure any furniture or fitting or write upon or deface the walls or partitions or any part of the baths.

43. Any person finding any article in this part of the Reserve shall immediately thereafter deliver same to the attendant in charge or the nearest Police Station.

44. The Committee shall not be responsible for any article lost by or stolen from any person whilst in the Reserve.

45. The Committee shall have power from time to time, by Resolution, to give such directions as it may consider necessary for the proper care and management of the Reserve consistent with these Regulations.

46. No person or organization or person or persons acting on behalf of any organization shall without the consent, in writing, of the Committee first had and obtained and without first paying to the Committee such fees therefor as the Committee may demand, enter or remain in the grounds of the Reserves, with or in or from any part of the said grounds set up, conduct or operate, or take any part in the setting up conduct or operation of any side-show or any device, machine or equipment of, or in the nature of a merry-go-round, swinging boat, oceanwave, miniature-railway, shooting gallery, water-boat, or any other device, machine or equipment (whether of the same or similar nature or not) usually run by professional side-show proprietors for the amusement of the public for reward.

47. The person in charge of a vehicle and who desires to park the same in the Reserve shall park it on a camping site as directed by the Manager, or, in his absence, on a vacant camping site in the said Reserve and shall pay to the Manager the fees prescribed in accordance with these Regulations.

48. No occupier or other person shall park any vehicle and/or erect any tent or annex so that any part thereof shall extend beyond the limits of the camping site occupied by him.

49. No person other than a person desirous of holidaying in the Reserve shall bring a Caravan therein and then only for a period of not more than two months at any one time save that under exceptional circumstances the Committee may extend the period of time upon receipt of a request in writing from the person or persons concerned.

50. No person shall sub-let any vehicle within the Reserve without the permission in writing of the Committee first obtained.

51. Each occupier shall keep the camping site allocated to him clean and tidy.

52. Waste water shall be placed in or directed into receptacles provided by the Committee and under no circumstances shall waste water be deposited on or allowed to overflow on to the ground of the Reserve. Occupiers shall be responsible for the emptying of such receptacles as directed by the Manager and then only into gully traps provided for that purpose.

53. The digging of trenches around vehicles or tents is prohibited.

54. No person shall erect any building or structure in the Reserve other than annexes made of canvas or similar material which shall be deemed to be part of a vehicle and any tent or similar structure approved by the Manager.

55. Every occupier shall pay to the Manager the respective fees prescribed from time to time by the Committee.

Swimming Pool.

56. Every person within this part of the Reserve as defined by the Committee shall wear a suitable bathing costume and no person shall dress or undress or remove any part of his or her bathing costume in any part of this part of the Reserve open to public view.

57. No person shall climb upon or jump over any fence in this part of the Reserve.

58. No person shall enter this part of the Reserve whilst in an unclean condition, or suffering from any cutaneous, infectious or contagious disease, and any such person shall retire from this part of the Reserve immediately upon being requested to do so by the attendant in charge.

59. No person shall enter the swimming pool until he or she has first used the showers provided.

60. No person shall expectorate within this part of the Reserve or improperly foul or pollute the water in the baths, or shower baths, or wilfully or improperly soil or

defile any towel or bathing costume, or any dressing-room, closet, box or compartment, or any part of the baths, or any furniture or article therein, or use any soap or other preparation.

61. No person shall interfere with the use and enjoyment of this part of the Reserve by any other person, and any person so acting or otherwise behaving in an unseemly or improper manner, shall immediately leave this part of the Reserve when required to do so by the attendant in charge.

62. For the purpose of maintaining good order the attendant or person in charge of this part of the Reserve may refuse admission to any person.

63. No boy or girl under the age of six years will be admitted to this part of the Reserve unless such child is, in the opinion of the attendant in charge, in the care of a responsible person.

64. No person shall use or interfere with any rope, raft, or lifebuoy or other lifesaving appliance unless in the case of accident or danger of a bather rendering the use necessary for the saving of life.

65. The Committee shall have power from time to time to fix and regulate by resolution, the fees to be paid for admission to this part of the Reserve and the times during which this part of the Reserve shall be open to the public.

66. The Committee shall have power to let this part of the Reserve to any club, association, school or person for the purposes of holding entertainments, performances or sports, subject to the payment of such fees and on such conditions as it may deem to be reasonable and to authorize any club, association, school or person to make a charge for admission thereto.

67. Beach balls, motor tubes or other inflated rubber or plastic articles are not permitted in the Main Pool.

68. A dressing shed shall be used for dressing and undressing only. No person shall play games or, without reasonable excuse, loiter in or in the vicinity of such dressing shed.

69. If any person breaks any bottle or any article or glass or earthenware in or upon any part of the foreshore, dressing shed, or water used by the public for bathing purposes, he or she shall forthwith collect all portions of such bottle or article and deposit them in a receptacle provided by the Committee for that purpose.

Fishing.

70. No person shall clean fish in any part of the Reserve or fish at any point within the Reserve at, on or within 100 yards of any pier, jetty or swimming pool.

71. No person shall fish in the Lake during any organized entertainment.

Given under my hand at Melbourne, on the fourth day of November, 1968.

W. J. F. McDONALD,
Minister of Lands.

Every person who contravenes or fails to comply with these Regulations shall, in accordance with the provisions of section 218 of the *Land Act* 1958, for each offence be liable to a penalty of not more than Fifty dollars, and every person who contravenes or fails to comply with any such Regulations, and who, after he has been warned by any bailiff of Crown lands or by any member of the Police Force, does not desist therefrom may be forthwith apprehended by such bailiff or member of the Police Force and taken before some justice to be dealt with according to law and shall be liable to a penalty of not more than One hundred dollars.

REGULATIONS FOR THE CARE, PROTECTION AND MANAGEMENT OF THE SHELFORD RECREATION RESERVE.

WHEREAS by section 218 of the *Land Act* 1958 the Minister of Lands is empowered to make Regulations with respect to certain land and for extending or applying all or any of these Regulations to certain other land: Now therefore I, William John Farquhar McDonald, Her Majesty's Minister of Lands in and for the State of Victoria, do hereby make the following Regulation:—

All the Regulations made on the 11th March, 1964, with respect to the land in the Township of Shelford temporarily reserved by Order in Council dated 14th December, 1906, as a site for Public Recreation, together with the adjoining permanent reserve along the Leigh River, are

hereby applied to the land in the Township of Shelford temporarily reserved by Order in Council dated the 13th August, 1968, as a site for Public Recreation.—(Rs.4830.)

Given under my hand at Melbourne, on the fourth day of November, 1968.

W. J. F. McDONALD,
Minister of Lands.

Every person who contravenes or fails to comply with these Regulations shall, in accordance with the provisions of section 218 of the *Land Act 1958*, for each offence be liable to a penalty of not more than Fifty dollars, and every person who contravenes or fails to comply with any such Regulations, and who, after he has been warned by any bailiff of Crown lands or by any member of the Police Force, does not desist therefrom may be forthwith apprehended by such bailiff or member of the Police Force and taken before some justice to be dealt with according to law and shall be liable to a penalty of not more than One hundred dollars.

REGULATIONS FOR THE CARE, PROTECTION AND MANAGEMENT OF THE WHITE HILLS BOTANICAL GARDENS.

WHEREAS by section 218 of the *Land Act 1958* power is given to the Minister of Lands to make Regulations in respect of the care, protection and management of any Crown land which has been reserved under the *Land Act* for any public purpose whatsoever and which has not been conveyed to or vested in trustees, and for further purposes as enacted: Now therefore the Minister of Lands, in pursuance of the power conferred aforesaid, doth hereby make the following additional Regulations in respect of the land at Bendigo, in the Parish of Sandhurst, temporarily reserved by Order in Council of the 19th June, 1956, as a site for Public Gardens and Public Recreation, and known as the White Hills Botanical Gardens.

REGULATIONS.

30. The Pool will be open to the public daily during such times and periods of the year as the Committee shall from time to time determine.

31. (a) No person shall enter the Pool without paying such admission fee as is fixed from time to time by the Committee.

(b) No season ticket shall be transferable and any holder of such ticket who allows any other person to use the same shall immediately forfeit such ticket and all moneys paid thereon and all rights and privileges given by such ticket.

32. The maximum charges for admission to the Pool shall be as follows:—

Persons—

Under sixteen years of age	..	10 cents
Sixteen years of age and over	..	20 cents

Season Tickets—

Under sixteen years of age	..	\$4.00
Sixteen years of age and over	..	\$8.00
Family tickets	..	\$20.00
Patrons	..	\$2.00

33. No person shall use soap in any part of the Pool other than in the cleansing shower baths.

34. No person shall at any time whilst in the Pool use any substance or preparation whereby the water in the swimming pool may be discoloured, or rendered turbid or otherwise unfit or unpleasant for the proper use of bathers.

35. No person shall at any time carelessly or negligently injure or destroy or otherwise improperly interfere with any lock, tap, fittings, or appliances on or about the Pool, or carelessly or negligently damage or injure any furniture or fittings or appliances or any towel or bathing gown or other article supplied for use in the Pool premises, or write upon or deface the walls or partitions or any other part of the pool.

36. Any person hiring any towel or bathing gown or other article from any of the attendants or person in charge of the Pool shall return same before leaving the Pool.

37. Any person finding any article which may have been left in any dressing room or any other part of the Pool shall immediately after finding such article deliver the same to one of the attendants in charge of the Pool who shall thereupon register a description of same and all particulars relating thereto in the book kept for that purpose, and any person who shall have lost such article shall upon giving satisfactory proof thereof receive such

article from the attendant in charge upon writing his or her signature and address in the book referred to as a receipt for such article in the aforesaid book.

38. The Committee will not be responsible for any article lost by or stolen from any person whilst in the Pool or Pool premises.

39. No male person shall enter any portion of the Pool premises set apart for females, and no female shall enter any portion of the said premises set apart for males.

40. No person shall interfere with the use or enjoyment of the Pool by any other person and any person so acting or behaving in an unseemly or improper manner shall immediately leave the pool when requested to do so by any attendant in charge of the Pool.

41. No person shall at any time bring any intoxicating liquor into the pool enclosure.

42. In the event of the Committee holding, or permitting to be held, a swimming carnival or other entertainment in the Pool, the Committee shall have power to prohibit bathing in the Pool whilst such carnival is being held.

43. No person shall bring any dog into the Swimming Pool enclosure.—(Rs.4855.)

Given under my hand at Melbourne, on the fourth day of November, 1968.

W. J. F. McDONALD,
Minister of Lands.

Every person who contravenes or fails to comply with these Regulations shall, in accordance with the provisions of section 218 of the *Land Act 1958*, for each offence be liable to a penalty of not more than Fifty dollars, and every person who contravenes or fails to comply with any such Regulations, and who, after he has been warned by any bailiff of Crown lands or by any member of the Police Force, does not desist therefrom may be forthwith apprehended by such bailiff or member of the Police Force and taken before some justice to be dealt with according to law and shall be liable to a penalty of not more than One hundred dollars.

COMMITTEES OF MANAGEMENT OF RESERVES.

APPOINTMENTS.

NOTICE is hereby given that, in pursuance of section 221 of the *Land Act 1958*, the following appointments of Committees of Management of reserved Crown Lands have been made by the Minister of Lands:—

"BENNISON RECREATION RESERVE."

Ronald L. Lay, Fred E. Tyers, Edward F. Tyers, Donald Taylor, Michael L. O'Sullivan, John Thomas Doran and M. P. Hammet as a Committee of Management for a period of three (3) years of the land temporarily reserved by Order in Council date the 5th November, 1924, as a site for Public Recreation in the Township of Franklin, now named Bennison, and known as the "Bennison Recreation Reserve".—(Corres No. Rs.3026.)

"BIRCHIP RECREATION RESERVE."

James Ryan Sheridan, Arthur Duncan Hillgrove, Colin Foster Russell, Frank R. Bolden, James Joseph Ryan, Anthony John Ruyg, Robert John Reid, George Felix Cartwright, Norman Ernest Haslam, David Rees Davies, Herbert J. Bennett, John Gerrard Coffey, Edward Roy Lee and William John Rickard as a Committee of Management for a period of three (3) years of the remaining portion of the lands in the Township of Birchip reserved by Orders in Council of the 29th August, 1905 and the 25th September, 1909, as a site for a Public Park and other purposes of Public Recreation and of the lands in the Township of Birchip, reserved by Orders in Council of the 25th August, 1890, and 29th November, 1894, as a site for Show Yards, and known as the "Birchip Recreation and Showgrounds Reserve".—(Corres. Nos. Rs.1922 and Rs.1923.)

"BUANGOR WATER RESERVE."

Lloyd Arthur Frohlich, Ian Donald MacInnes, Allen David Pobjoy, Stewart Charles Carra, Desmond Joseph Brennan, Arthur White, Mervyn John White, John King Pickford and George Albert White as a Committee of Management for a period of three (3) years of that portion of the land in the Parish of Buangor temporarily reserved by Orders in Council dated the 8th May, 1876 and 9th September, 1947, as a site for Watering Purposes, as indicated by hachure over red color on plan marked "B/15-3-43" and known as the "Buangor Water Reserve".—(Corres. No. Rs.5807.)

"CLEMATIS PARK RESERVE," EMERALD.

Thomas William Dalziel, Alfred Goodwin Hart, Gustaf F. Ryberg, Geoffrey David Johns, Harry H. Neville, George S. C. Semmens, Gwen A. Semmens, Robert W. Stephenson and Ernest W. Jones as a Committee of Management for a period of three (3) years of the land in the Township of Emerald temporarily reserved by Order in Council dated the 5th September, 1950, as a site for Public Recreation, and known as "Clematis Park".—(Corres. No. Rs.6565.)

"CORIO (BELMONT COMMON) PUBLIC RECREATION RESERVE," PARISHES OF CONEWARRE AND CORIO.

George Alexander Cameron (for so long only as he continues to be the elect of the Council of the Shire of South Barwon) and Archibald Kingswell Lloyd (for so long only as he continues to be a councillor and the elect of the Council of the City of Newtown) in the place of G. R. S. Lunn (deceased) as members of the Committee of Management of the land in the Parishes of Conewarre and Corio temporarily reserved by Order in Council dated the 7th June, 1966, as a site for Public Recreation.—(Corres. No. Rs.8658.)

"HEATHCOTE SHOW GROUNDS RESERVE."

Edwin Alfred Kemp, Robert Hagan Perry, Keith Thomas Wilkie, James Louis Tranter and Rodney McRobert as a Committee of Management for a period of three (3) years of the remaining portion of land in the Parish of Heathcote temporarily reserved by Orders in Council dated the 4th January, 1883 and 28th January, 1905, as sites for Show Yards, and known as the "Heathcote Show Grounds Reserve".—(Corres. No. Rs.662.)

"KAMAROOKA RECREATION RESERVE."

Geoff Pedersen, Bruce Albert Cail, John Aylwin Ludeman, Arthur Clement Evans, Neville John McKenzie, John Frederick Cail, William George Cail, John Home Hay, George Geoffrey Cail, Barry Edward Ayres and Desmond O. Donoghue as a Committee of Management for a period of three (3) years of the land in the Parish of Kamarooka, temporarily reserved by Order in Council dated the 18th April, 1950, as a site for Public Recreation, and known as the "Kamarooka Recreation Reserve".—(Corres. No. Rs.6529.)

"LLANELLY RECREATION RESERVE."

Robert Alexander Gray, Eric Reginald Green, George Hamilton Alexander, Kenneth George Clark, Noel William Alexander, Harry William John Douglas, Albert Richard Hurford, Donald William Clark and Leslie Benjamin Dale as a Committee of Management for a period of three (3) years of the land in the Township of Llanelly temporarily reserved by Order in Council dated the 15th July, 1913, as a site for Public Recreation, and known as the "Llanelly Recreation Reserve".—(Corres. No. Rs.423.)

"MALLACOOTA RESERVES" AND THE "BETKA CAMPING RESERVE."

The Corporation of the Shire of Orbost as the Committee of Management of the reserved Crown lands in the Township of Mallacoota shown by red color on plan "M/25.1.1960" attached to Lands Department correspondence Rs.2419 together with the land in the Parish of Betka temporarily reserved by Order in Council dated the 13th October, 1964, as a site for Tourist Camping Purposes, and the land in the Parishes of Betka and Mallacoota temporarily reserved by Order in Council dated the 24th September, 1968, as a site for Recreation and Camping purposes, together with so much of the permanent reserve for Public purposes along the shore of Bass Strait and Mallacoota Inlet as abuts on such land.

This appointment is made in lieu of all previous appointments which are hereby revoked.—(Corres. Nos. Rs.2419 and Rs.8374.)

"MURCHISON PUBLIC GARDENS RESERVE."

David Cosby Campell, Arthur James Trevaskis, John Geoffrey Mitchell, Richard Alfred Matthey, George Sidney O'Mahony, David P. Jones, Sydney James Commons, Robert Frederick Williams and John Edward Hammond as a Committee of Management for a period of three (3) years of such portion of the Reserve for Public Purposes in the Town of Murchison as indicated by red tint on plan marked "M/1.2.49" attached to Lands Department correspondence Rs.785, and known as the "Murchison Public Gardens Reserve".—(Corres. No. Rs.785.)

"RUSSELL RESERVE", LAKE BURRUMBEET."

John Garvan Hurley, Andrew McLean, Albert Victor Watson, John Stanley Pascoe, Stephen Richard Greenbank, Ernest John Nunn, Henry John Fraser, Roy James Gough and John A. Strange as a Committee of Management for a period of three (3) years of the reserved lands in the Parishes of Brewster, Haddon and Burrumbeet shown in red colour on lithograph plan marked B/7.8.57 attached to Lands Department correspondence C.70834.

This appointment is in lieu of all previous appointments in respect of the said land which are hereby revoked.—(Corres. No. C.70834.)

"STRATH CREEK PUBLIC HALL RESERVE."

Kevin Michael Fitzgerald, Leslie Albert Hooper, Francis William Daws, Ernest Chancellor Lade, George Henry McDonald, Frank Arnold Lade and Gerald John Tehan as a Committee of Management for a period of three (3) years of the lands temporarily reserved by Orders in Council dated 8th November, 1905 and 30th June, 1913, as a site for a Mechanics' Institute in the Township of Strath Creek, and known as "Strath Creek Public Hall Reserve".—(Corres. No. Rs.2843.)

"SUNBURY RECREATION RESERVE."

Eric Lionel Boardman, Ralph George Watkins, Francis Millett, Frederick Christian Mommson, Jack Easton Taylor and John Alfred Forbes for a period of three (3) years and John James McMahon for so long only as he continues to be a Councillor and the elect of the Council of the Shire of Bulla as a Committee of Management of the land in the Township of Sunbury temporarily reserved by Orders in Council dated the 18th November, 1872, 19th July, 1926 and 13th April, 1954, as sites for Public Recreation, and together known as the "Sunbury Recreation Reserve".—(Corres. No. Rs.1115.)

"TARRAWINGEE RECREATION RESERVE."

Archibald Gordon Douglas, James Kenneth Stewart, Henry Pete Nolan, William James McCormack, William John Murray, Laurence Duncan Stewart, Robert Francis Iskov, Francis Vincent Keogh and Stanley James Diffey as a Committee of Management for a period of three (3) years of the remaining portion of land temporarily reserved by Order in Council dated the 29th June, 1868, as a site for Recreation Purposes in the Parish of Tarrawingee West, and known as the "Tarrawingee Recreation Reserve".—(Corres. No. Rs.1800.)

"THOM'S BRIDGE PICNIC AND CAMPING RESERVE."

Gordon Hall, Reginald Brinsmead, Patrick Turvey, Stanley Cook, John Derham, Clarrie Murray and Anthony Derham as a Committee of Management for a period of three (3) years of that portion of the land permanently reserved for Public Purposes along the Latrobe River, in the Parish of Tanjil East, as is indicated in red colour on the plan marked T/3.6.49 attached to Lands Department correspondence No. Rs.6376 and known as "Thom's Bridge Picnic and Camping Reserve".—(Corres. No. Rs.6376.)

"THOWGLA RECREATION RESERVE."

Jack Sheather, Athol Alexander Paton, Donald J. McVean, Maurice William Simpson, John Keith Barker, Ernest James Paton and Ivan Gordon Noel Paton as a Committee of Management for a period of three (3) years of the land in the Parish of Towong temporarily reserved by Order in Council dated the 17th March, 1953, as a site for Public Recreation and known as the "Thowgla Recreation Reserve".—(Corres. No. Rs.7084.)

"WOODEND SWIMMING POOL AND CHILDREN'S PLAYGROUND RESERVE."

Oswald Geoffrey Batchelor (for so long only as he continues to be a Councillor and the elect of the Council of the Shire of Newham and Woodend) in the place of Ruby Emily McKenzie (no longer a Councillor) as a member of the Committee of Management of the land in the Township of Woodend temporarily reserved by Orders in Council dated the 18th January, 1949 and the 16th August, 1966, as sites for a Swimming Pool and Children's Playground and known as the "Woodend Swimming Pool and Children's Playground Reserve".—(Corres. No. Rs.6309.)

"WOODVALE (SYDNEY FLAT) RECREATION RESERVE."

James Preston Evans, Godfrey Phillips Daly, John Leslie Bayliss, Roy Daly, Austin Phillips Daly, Thomas Alfred Rothacker, Ernest Janaway, Thomas Joseph Debnam, Thomas Joseph Hughes as a Committee of Management for a period of three (3) years of the land in the Parish of Nerring temporarily reserved by Order in Council dated the 26th May, 1902, as a site for Cricket and Public Recreation, and known as the "Woodvale (Sydney Flat) Recreation Reserve".—(Corres. No. Rs.4813.)

"WOOD WOOD RECREATION RESERVE."

Alexander Robert Algie, William Thomas Gillick, Oscar James Gillick, Leslie George Irvin, Neville Wallace Algie, Shirley May Gillick, Albert Benjamin Curran and Elaine Francis Gillick as a Committee of Management for a period of three (3) years of the land in the Township of Woort Woort temporarily reserved by Order in Council dated the 18th January, 1909, as a site for Public Recreation and known as the "Wood Wood Recreation Reserve".—(Corres. No. Rs.1716.)

W. J. F. McDONALD,
Minister of Lands.

Department of Crown Lands and Survey,
Melbourne, 4th November, 1968.

TENDERS will be received at Public Works Department, Treasury-place, Melbourne, until **TWO** p.m. on dates shown and for purposes mentioned hereunder.

Particulars and tender forms available at Contracts Office, Room 7, Building Division, Parliament-place and at places indicated in brackets hereunder.

Abbreviations in brackets mean:—W.O.—Inspector of Works Office; P.S.—Police Station; C.S.—Consolidated School; H.E.S.—Higher Elementary School; H.S.—High School; S.S.—State School; T.S.—Technical School.

Tenders to be submitted on the Department's printed Tender Form and will not be received by telephone. All tenders must be on a "Firm Tender" basis. The lowest or any tender will not necessarily be accepted.

Address tenders to the Minister of Public Works, and endorse the envelope containing the tender "Tender for , closing Tuesday,

Hand delivered tenders to be placed in the Tender Box of the Public Works Department, located on the wall of the centre entrance foyer, Ground Floor, New Treasury Building, Treasury-place, Melbourne.

No preliminary deposit is required with any tender, but a successful tenderer will be required to pay a deposit for any accepted tender of \$4,000 or over.

Tuesday, 19th November, 1968.

Building, Electrical and Mechanical Works.

- Bairnsdale.—Roof repairs, Technical School. (W.O., Bairnsdale.) (Amended Specification.)
- Beechworth.—Renovations, Fletcher's Flats, Mental Hospital. (W.O., Wangaratta.)
- Belgrave South.—Erection of chain mesh fencing, S.S. 3551. (S.S., Belgrave South.)
- Bobinawarra East.—Extensions, renovations, &c., S.S. 3325. (W.O., Benalla.)
- Brunswick.—Demolition and removal of three residences, Nos. 22, 24 and 28 Gardner-street, High School.
- Coburg.—Supply, delivery and fixing of plate glass, Young Offenders Building, Prison.
- Fawkner.—Erection of type "800C" Assembly Hall, High School.
- Fawkner.—Electrical services, High School.
- Fawkner.—Mechanical services, High School.
- Frankston.—Electrical installation, Technical School.
- Heidelberg.—Erection of additions, High School. (Bills of Quantities Available.)
- Heidelberg.—Electrical services, High School.
- Heidelberg.—Mechanical services, High School.
- Malvern.—New P.A.X. telephone installation, Clinic, 321 Glenferrie-road.
- Mont Park.—Evaporative coolers, Mental Hospital.
- Northcote.—Demolition and removal of residence at No. 15 Speight-street, S.S. 3139.
- St. Kilda Park.—Dismantling, transportation and re-erection of two class-room buildings from J. H. Boyd Domestic College to S.S. 2460.
- Tatura.—Septic system, Research Station. (W.O., Shepparton.)
- Werribee.—Erection of a glasshouse, State Research Farm. (W.O., Geelong.)
- Werribee.—Evaporative coolers, State Research Farm.
- Werribee.—Electrical services, State Research Farm. (W.O., Geelong.)

Furniture and Furnishings.

Royal Park.—Supply and fix curtains, Residences and Clinics, Psychiatric Hospital.

Miscellaneous.

- Frankston.—Supply and delivery of workshop equipment, Technical School.
- Williamstown.—Construction of two all welded mild steel work barges, Dredging Depot, Ports & Harbours Branch. (Re-advertised.)

Tuesday, 26th November, 1968.

Building, Electrical and Mechanical Works.

- Brighton.—Gas welding installation, Technical School.
- Berwick.—Renovations, Police Station. (P.S., Berwick.)
- Dooen.—Conversion of Laboratory to Lecture Theatre, Longerenong Agricultural College. (W.O., Horsham.)
- Melbourne.—Supply and installation of air-conditioning unit, Accounts Branch, Public Works Department.
- Newborough East.—Renovations, &c., S.S. 4670. (W.O., Traralgon.) (Re-advertised.)
- Preston.—Provision of pipe-framed chain mesh screens, Institute of Technology.
- Preston.—Renovations, Ernest Jones Clinic.

PUBLIC SERVICE NOTICES

No. 104.

Public Service Act 1958, Section 50.

REGULATIONS—PART IV.—SALARIES AND INCREMENTS.

THE Public Service Board, in pursuance of the powers conferred by the *Public Service Act 1958*, hereby amends its Regulations as shown below:—

SIXTH SCHEDULE.

TEMPORARY EMPLOYEES.

Designations of Positions and Rates of Salaries.

Department and Designation of Position.	Yearly Rate of Salary.		Increments (Annual).
	Minimum.	Maximum.	
GENERAL.	\$	\$	
Add— Machinist (Female), Senior	2,483	2,559	Σ
Σ See Regulation 97 (2).			

This Regulation shall have effect as on and from the 7th October, 1968.

F. E. CAHILL, Chairman.
R. H. DURRANT, Acting Secretary.

Office of the Public Service Board,
Melbourne, 1st November, 1968.

TENDERS

PUBLIC WORKS DEPARTMENT

REGISTRATION FOR SELECTIVE TENDERING.

APPLICATIONS are invited from members of the building industry for registration as pre-selected tenderers for works of the following nature:—

- Architectural works in excess of \$100,000.
- Mechanical Engineering Works related to buildings in excess of \$20,000.
- Electrical engineering works related to buildings in excess of \$10,000.
- Civil engineering works in excess of \$20,000.

Requests for application forms should be directed to—
The Registrar, Selective Tendering,
Public Works Department,
2 Treasury-place, Melbourne, Victoria, 3002.

Telephone inquiries should be directed to 651 7355.

Receipt of applications will be formally acknowledged, and all information submitted by contractors will be treated as strictly confidential.

Seymour.—Renovations, Police Station. (W.O., Alexandra; P.S., Seymour.)
 South Yarra.—Renovations, S.S. 583.
 Westgarth.—Renovations, S.S. 4177.

Furniture and Furnishings.

Bendigo.—Supply and lay asbestos vinyl tiles, Training Prison. (W.O., Bendigo.)
 Ferntree Gully.—Supply and fix stage and auditorium curtains, Technical School.

Site Works.

Blackburn Lake.—Concrete, drainage and gravel works, &c., S.S. 4860.
 Chelsea Heights.—Asphalt, drainage and gravel works, &c., S.S. 3341.
 Newport.—Asphalt, concrete, drainage and gravel works, &c., S.S. 113.

Miscellaneous.

Various.—Supply and installation of woodwork machine safety guards, Public Works Department. (Re-advertised.)

Tuesday, 3rd December, 1968.

Building, Electrical and Mechanical Works.

Coburg.—Erection of Northern Suburbs Motor Trades School. (Specified bill of quantities available.)
 Coburg.—Electrical services, Northern Suburbs Motor School.
 Coburg.—Mechanical services, Northern Suburbs Motor School.
 Croydon.—Domestic and fire service installation, S.S. 2900.
 Footscray.—Renovations, Institute of Technology.
 Geelong East.—Supply and installation of exhaust fans, Technical College. (W.O., Geelong.)
 Kallista.—Renovations, S.S. 3993. (S.S., Kallista.)
 Malvern.—Renovations, S.S. 1604.
 Oakleigh East.—Electrical services, S.S. 4327.
 Oak Park.—Internal and external painting, S.S. 4721.
 Parkville.—Joinery fittings and laboratory fittings, Secondary Teachers' College. (Bills of quantities available.)
 Parkville.—Supply and installation of windows and screens, Secondary Teachers' College. (Bills of quantities available.)
 Preston East.—Erection of chain mesh fencing, Technical School.
 St. Kilda.—Renovations, Police Station.
 Syndal.—New toilet block, connexion to sewer and conversion of staff room, S.S. 4714.
 Warragul.—Mechanical services, Assembly Hall, High and Technical Schools. (W.O., Warragul.)

Furniture and Furnishings.

Various.—Supply of tables and chairs, schools.

Site Works.

Beaumaris.—Asphalt, concrete and drainage works, &c., High School.

Miscellaneous.

Ballarat.—Supply of laundry equipment, Mental Hospital.
 Williamstown.—Construction of one all welded mild steel 8-in. cutter suction dredge, Dredging Depot, Ports & Harbours Branch.

M. V. PORTER,
 Minister of Public Works.

Public Works Department,
 Melbourne, 3002, 11th November, 1968.

TENDERS FOR THE SERVICE, 1968-69.

PROVISIONS—MEAT.

TENDERS will be received until Eleven o'clock a.m. on Friday, 29th November, 1968, from persons willing to furnish the under-mentioned supplies, in such quantities as may be ordered by the Victorian Government—delivery to be made at the under-mentioned places—during the three months commencing on 1st February, 1969.

In all cases the total cost of each item must be extended in the columns provided.

The places for which tenders will be received and the amount of the security required for the due fulfilment of each contract, are as follows:—

	Security.
Schedule No. 1.—Melbourne District—	\$
Meat—Kew Mental Hospital	40
.. .. Children's Cottages, Kew	30

Meat—Pentridge Penal Establishment, Coburg, and "Fairlea" Female Prison, Fairfield	70
" " "Turana" Youth Training Centre, Royal Park; and Travancore Developmental Centre, Flemington ..	16
" " "Winlaton" Girls' Training Centre, Nunawading, and "Allambie" Reception Centre, 70 Elgar-road, Burwood	10
" " Psychiatric Hospital, Royal Park ..	20
Schedule No. 2.—Mont Park, Bundoora, Larundel, Janefield, Gresswell, and Pleasant View, Wood-street, Preston—	
Meat—Mont Park	70
" Preston	10
" Gresswell	30
Schedule No. 3.—S.S. Rip and Dredges—	
Meat	10
Schedule No. 4.—Teachers' College and Hostels at Grattan-street, 93 Drummond-street, Carlton; 470, 481 and 572 St. Kilda-road, Melbourne; 19 Queen's-road, Melbourne; 152 Toorak-road west, South Yarra; Frank Tate House, 373 Dandenong-road, Armadale; "Redcourt", 6, "Larnook", 13 and No. 10A Orrong-road, Armadale; 11 Patterson-street, Hawthorn; 174 Punt-road, Prahran; 221 Burwood-road, Burwood; John Cannon House, 32 Belmont-avenue, Kew; 23 Moule-avenue, Brighton; and Hastings-road, Frankston; and Police Hospital, St. Kilda-road, Melbourne; Mental Hygiene Clinic, 321 Glenferrie-road, Malvern, St. Nicholas Hospital—	
Meat	30
Schedule No. 5.—Heatherston Sanatorium, Cheltenham—	
Meat	10
Schedule No. 6.—Ararat District—	
Meat	60
Schedule No. 7.—Ballarat District—	
Meat—Mental Hospital	70
" Teachers' Hostels	10
Schedule No. 8.—Beechworth District—	
Meat	60
Schedule No. 9.—Bendigo District—	
Meat—Gaoil	10
" Teachers' Hostels	10
" Sandhurst Boys' Centre, Mental Hygiene	10
Schedule No. 10.—Castlemaine District—	
Meat	10
Schedule No. 11.—School of Forestry, Creswick—	
Meat	6
Schedule No. 13.—McLeod Settlement, French Island—	
Meat	10
Schedule No. 14.—Geelong District—	
Meat—Gaoil	10
" Teachers' Hostels	10
Schedule No. 15.—Cooriemungle Prison Camp, Heytesbury Forest—	
Meat	8
Schedule No. 17.—Langi Kal Kal Training Centre—	
Meat	10
Schedule No. 20.—Sale Gaoil—	
Meat	6
Schedule No. 21.—Pleasant Creek Special School, Stawell—	
Meat	6
Schedule No. 22.—Sunbury District—	
Meat	80
Schedule No. 23.—Warrnambool District—	
Meat	30
Schedule No. 24.—Hobson Park Hospital, Traralgon—	
Meat	10

	Security
Schedule No. 25.—Morwell River Reforestation Prison—	\$
Meat	10
Schedule No. 26.—State Research Farm, Werribee—	
Meat	10
Schedule No. 27.—“ Hillside ” Boys' Home, Wheelers Hill—	
Meat	6
Schedule No. 28.—Malmsbury Youth Training Centre—	
Meat	6
Schedule No. 29.—Won Wron Reforestation Prison—	
Meat	10
Schedule No. 30.—Dhurrigile Rehabilitation Centre—	
Meat	10

Printed forms of tender and the conditions of contract may, in all cases, be obtained from the Secretary to the Tender Board, 2nd Floor, South Building, New State Public Offices, Treasury-place, Melbourne, 3002, by whom also any information or explanation will be afforded to persons tendering.

Security will be acquired either in Commonwealth Treasury Bonds, or approved bank guarantee, fixed deposit receipt, Savings Bank deposit book, or non-negotiable cheque in favour of the Secretary to the Tender Board, as the tenderer may elect.

The security must be completed and the contract signed within five days of acceptance of the tender, failing which the service may be again advertised, or another tender accepted.

The lowest or any tender will not necessarily be accepted.

In the event of tenderers withdrawing or attempting to withdraw their tenders before notification of acceptance of same, or failing to take up their accepted tenders within the prescribed period after notification of acceptance they may be disqualified from tendering or holding any future contracts for Government supplies for a period of twelve months, such disqualification to date from the notification of acceptance of tender. It is also stipulated that, if a tenderer be a member of a firm and such firm be interested in the contract, the tender shall be in the name of the firm and not in that of the individual and that, for a breach of this condition, the tender will be declared informal.

Tenders enclosed in a separate envelope, and having the words “ Tender for at ” (as the case may be) written thereon, must be deposited in the Tender Box at the Tender Board Offices, 2nd Floor, South Building, New State Public Offices, Treasury-place, Melbourne, 3002, or, if sent by post, postage must be prepaid, and the tenders addressed to the Chairman of the Tender Board, Tender Board Offices, 2nd Floor, South Building, New State Public Offices, Treasury-place, Melbourne, 3002, which office they must reach not later than by first post on the date of closing of tenders.

CONDITIONS OF CONTRACT.

The conditions of contract are those published in the *Victoria Government Gazette*, No. 23, dated 13th March, 1968, pages 755 to 757.

H. E. BOLTE,
Treasurer.

The Treasury,
Melbourne, 11th November, 1968.

PRIVATE ADVERTISEMENTS

NOTICE is hereby given that Elliot Engineering Co., of Bairnsdale, has applied for a lease, pursuant to section 134 of the *Land Act 1958*, for an area of Crown land on Bullock Island, Parish of Colquhoun, as a site for Marine and General Engineering Works, for a term of 21 years.—(H.032687.) 5258

NOTICE is hereby given that Gregory John Benstead has applied for a lease under section 134 of the *Land Act 1958*, for a term of 21 years in respect of an area of 12 acres 2 roods 0 perches more or less south of allotment 2, section 4, Parish of Freeburgh, as a site for provision of accommodation and facilities for tourists (Caravan Park).—(H.029175.) 5266

GREGORY JOHN BENSTEAD.

NOTICE is hereby given that Gunnerson Nosworthy Limited has applied for a lease, pursuant to section 134 of the *land Act 1958*, for a term of 75 years in respect of allotment 6d, section 59, City of Port Melbourne, containing 3 acres 2 roods 21 perches, as a site for wholesale merchandising and storage and for fabricating purposes. 5467

NOTICE is hereby given that the South-Western Victoria Ambulance Service has applied for a lease under section 134 *Land Act 1958* of allotment 19, section 19, Township of Mortlake for a term of 21 years as a site for an Ambulance Station. 5451

LATROBE VALLEY WATER AND SEWERAGE BOARD.

IN pursuance of Section 65 (6) of the *Latrobe Valley Act 1958*, notice is hereby given of the making, pursuant to sub-section (4) of that section of two agreements both dated the 26th day of April, 1968, and made between Latrobe Valley Water and Sewerage Board of 7-9 Seymour-street, Traralgon, of the one part and Australian Paper Manufacturers Limited of South Gate, South Melbourne, of the other part relating to the discharge of waste into the Latrobe River and both of which agreements were approved by the Governor in Council on the 16th day of July, 1968.

Dated this 31st day of October, 1968.

5442 J. W. GARDINER, Secretary,
Latrobe Valley Water and Sewerage Board.

NOTICE OF INTENTION TO APPLY FOR A LICENCE TO DIVERT WATER AND CUT RACE FROM THE BROKEN RIVER, AT NALINGA.

I HEREBY give notice that I intend to apply for a licence empowering me to divert water for a term of four years to the extent of 80 acre-feet per annum at a maximum rate of 8 acre-feet per day of 24 hours for the irrigation of pasture, being allotments 6A and 6c, Parish of Gowangardie, and to occupy certain Crown lands for works of diversion, and to cut a race thereon.

Any objection to such application must be forwarded, in writing, to reach the State Rivers and Water Supply Commission, Melbourne, before 6th December, 1968, being 30 days from the first publication of this notice.

LESLIE GEORGE WILLIAMS.

Nalinga, R.S.D., Dookie, Vic. 5438

GEE LONG WATERWORKS AND SEWERAGE TRUST.

PURSUANT to section 60 (2) of the *Geelong Waterworks and Sewerage Act 1958* (No. 6263) notice is hereby given of the intention of the Trust to construct sewers to provide for properties in and adjacent to:—

Montpellier-drive, North Highton, Shire of South Barwon.

Richard-street, Newcomb, Shire of Bellarine.

Stork-avenue, Belmont East, Shire of South Barwon.

Fellmongers-road, Breakwater, City of Geelong.

Ewrick-crescent, North Highton, Shire of South Barwon.

Hinton-street, Norlane, Shire of Corio.

Lower Anakie-road, South from Braund-avenue, Bell Post Hill, Shire of Corio,

and more particularly as shown on maps which are open for public inspection at the Trust's Offices, Rynie-street, Geelong, between the hours of 9 a.m. and 4 p.m., daily, from Monday to Friday.

5452 B. C. HENSHAW, Secretary.

I, MICHAEL LUCIANO STOKEL, of 38 Scotia-street, Moonee Ponds, computer operator, hereby give notice that by deed poll No. 45808, registered in the office of the Registrar-General, on the 6th day of November, 1968, I renounced and abandoned the name of Luciano Michael Stocchelli, by which I was formerly known, and adopted in lieu thereof the name of Michael Luciano Stokel.

5503

M. L. STOKEL.

CITY OF BRIGHTON.

LOAN No. 81.

Notice of Intention to Borrow the Sum of \$30,000 for Permanent Works and Undertakings.

NOTICE is hereby given that the Council of the City of Brighton proposes to borrow the principal sum of \$30,000 secured by a charge over the general rates of the municipality, such sum to be raised by the grant of a mortgage, in accordance with the provisions of the *Local Government Act 1958*.

1. The maximum rate of interest that may be paid is 5.875 per cent. per annum.

2. The purpose for which the loan is to be applied is—

Reconstruction Works in the following streets:—

North Ward—

May, Spink and Drake streets.

Central Ward—

Black and Burrowes streets.

East Ward—

Grant-street and Elizabeth-street group.

South Ward—

Lucas and Regent streets.

3. The period of the loan shall be fifteen years.

4. The moneys borrowed shall be repayable by providing out of the municipal fund 30 half-yearly instalments of approximately \$1,518.24 each, including principal and interest, on the 1st day of January and the 1st day of July during the currency of the loan. The first instalment shall be payable on the 1st day of July, 1969.

5. Such moneys shall be repayable to the Commissioners of the State Savings Bank of Victoria, at the office of the said Commissioners, corner of Elizabeth and Bourke streets, Melbourne.

The plans and specifications and the estimate of the cost of the proposed works, and a statement showing the proposed expenditure of the moneys to be borrowed, are open for inspection at the office of the Council of the City of Brighton, at Boxshall-street, Brighton.

5453

A. C. G. DE GARIS, Town Clerk.

CITY OF CAMBERWELL.

LOAN No. 79.

Notice of Intention to Borrow the Sum of \$50,000 for Permanent Works and Undertakings.

NOTICE is hereby given that the Council of the City of Camberwell proposes to borrow the principal sum of Fifty Thousand Dollars (\$50,000), secured by a charge over the general rates of the municipality, such sum to be raised by the grant of a mortgage in accordance with the provisions of the *Local Government Act 1958*.

1. The maximum rate of interest that may be paid is 5½ per cent. per annum.

2. The purpose for which the loan is to be applied is part cost of erection of the new Civic Centre.

3. The period of the loan shall be fifteen years.

4. The moneys borrowed shall be repayable by providing out of the Municipal Fund half-yearly instalments of approximately \$2,530.40 each, including principal and interest, on the 1st day of January and the 1st day of July, during the currency of the loan. The first instalment shall be payable on the 1st day of July, 1969.

5. Such moneys shall be payable at the Head Office of the Commercial Savings Bank of Australia Limited, Melbourne.

The plans and specifications and the estimate of the cost of the proposed works and a statement, showing the proposed expenditure of the moneys to be borrowed, are open for inspection at the office of the Council of the City of Camberwell, at the Civic Centre, Camberwell.

5460.

L. F. CHEFFERS,
Town Clerk and Chief Administrator.

CITY OF CAMBERWELL.

BY-LAW No. 173.

Building.

A By-Law of the City of Camberwell made under Section 926 of the *Local Government Act 1958* and the Uniform Building Regulations, Victoria, and numbered 173 for determining dispensing with or regulating certain matters left to be determined applied dispensed with or regulated by the Council of the said City or in respect of which powers are conferred or duties are imposed on the Council under the Uniform Building Regulations, Victoria.

IN pursuance of the powers conferred by the *Local Government Act 1958*, the Uniform Building Regulations, Victoria and any and every other power it thereunto enabling the Mayor, Councillors and Citizens of the City of Camberwell order as follows:—

1. This By-Law shall come into operation and have effect immediately upon its publication in the *Victoria Government Gazette*.

2. This By-Law shall from the time of its coming into operation be read and construed as one with By-Law No. 115.

3. Clause 2 of the By-Law No. 115 is hereby amended by including therein after the words "Schedule A" and "Schedule B" the words "and Schedule A" of By-Law No. 173.

4. Each of the areas of land in the said Municipal District set out and described in "Schedule A" hereto is hereby prescribed as an area of land on which a building or buildings of Class II Occupancy shall contain in the aggregate not more than the number of flats as set out against the particular area.

5. In this By-Law unless inconsistent with the context or subject matter:—

(a) "Building of Class II Occupancy" has the meaning assigned to that expression in Chapter 6 of the Uniform Building Regulations, Victoria.

(b) "Flat" has the meaning assigned thereto in Chapter 1 of the said Regulations.

(c) "Site" shall have the same meaning as in Clause 815 of the said Regulations.

SCHEDULE "A".

LAND—5 Holly Street—east side—commencing 192 ft. 0 in. north from Cookson Street, having a frontage of 107 ft. 10 in. and being 99 ft. 10 in. wide at the rear and having a depth along the northern boundary of 157 ft. 10½ in. and a depth along the southern boundary of 158 ft. 5 in. 10 flats.

Resolution for passing this By-Law agreed to by the Council the 8th day of July, 1968.

Confirmed the 5th day of August, 1968.

The common seal of the Mayor Councillors and Citizens of the City of Camberwell was hereto affixed by Order of the Council the 5th day of August, 1968, in the presence of:—

(SEAL) W. G. BOUNDY, Mayor.
W. A. FORDHAM, Councillor.
C. J. BOCK, Town Clerk.

Approved by the Governor in Council the 6th day of November, 1968. 5504

CITY OF CAMBERWELL.

BY-LAW No. 176.

Building.

A By-Law of the City of Camberwell made under Section 926 of the *Local Government Act 1958* and the Uniform Building Regulations, Victoria, and numbered 176 for determining dispensing with or regulating certain matters left to be determined applied dispensed with or regulated by the Council of the said City or in respect of which powers are conferred or duties are imposed on the Council under the Uniform Building Regulations, Victoria.

IN pursuance of the powers conferred by the *Local Government Act 1958*, the Uniform Building Regulations, Victoria and any and every other power it thereunto enabling the Mayor, Councillors and Citizens of the City of Camberwell order as follows:—

1. This By-Law shall come into operation and have effect immediately upon its publication in the *Victoria Government Gazette*.

2. This By-Law shall from the time of its coming into operation be read and construed as one with By-Law No. 115.

3. Clause 2 of the By-Law No. 115 is hereby amended by including therein after the words "Schedule A" and "Schedule B" the words "and Schedule A" of By-Law No. 176.

4. Each of the areas of land in the said Municipal District set out and described in "Schedule A" hereto is hereby prescribed as an area of land on which a building or buildings of Class II Occupancy shall contain in the aggregate not more than the number of flats as set out against the particular area.

5. In this By-Law unless inconsistent with the context or subject matter:—

- (a) "Building of Class II Occupancy" has the meaning assigned to that expression in Chapter 6 of the Uniform Building Regulations, Victoria.
- (b) "Flat" has the meaning assigned thereto in Chapter 1 of the said Regulations.
- (c) "Site" shall have the same meaning as in Clause 815 of the said Regulations.

SCHEDULE "A".

LAND—5 High Road—east side—commencing 332 feet from Toorak Road, having a frontage of 66 feet and being 66 feet wide at the rear and having a depth along the northern boundary of 198 ft. 4 in. and a depth along the southern boundary of 199 ft. 0½ in. 5 flats.

Resolution for passing this By-Law agreed to by the Council the 19th day of August, 1968.

Confirmed the 16th day of September, 1968.

The common seal of the Mayor Councillors and Citizens of the City of Camberwell was hereto affixed by Order of the Council the 16th day of September, 1968, in the presence of—

(SEAL) W. A. FORDHAM, Mayor.
R. EDWIN GILLIES, Councillor.
L. F. CHEFFERS, Town Clerk.

Approved by the Governor in Council the 6th day of November, 1968. 5505

CITY OF CAMBERWELL.

BY-LAW No. 177.

Building.

A By-Law of the City of Camberwell made under Section 926 of the *Local Government Act 1958* and the Uniform Building Regulations, Victoria, and numbered 177 for determining dispensing with or regulating certain matters left to be determined applied dispensed with or regulated by the Council of the said City or in respect of which powers are conferred or duties are imposed on the Council under the Uniform Building Regulations, Victoria.

IN pursuance of the powers conferred by the *Local Government Act 1958*, the Uniform Building Regulations, Victoria and any and every other power it thereunto enabling the Mayor, Councillors and Citizens of the City of Camberwell order as follows:—

1. This By-Law shall come into operation and have effect immediately upon its publication in the *Victoria Government Gazette*.

2. This By-Law shall from the time of its coming into operation be read and construed as one with By-Law No. 115.

3. Clause 2 of the By-Law No. 115 is hereby amended by including therein after the words "Schedule A" and "Schedule B" the words "and Schedule A" of By-Law No. 177.

4. Each of the areas of land in the said Municipal District set out and described in "Schedule A" hereto is hereby prescribed as an area of land on which a building or buildings of Class II Occupancy shall contain in the aggregate not more than the number of flats as set out against the particular area.

5. In this By-Law unless inconsistent with the context or subject matter:—

- (a) "Building of Class II Occupancy" has the meaning assigned to that expression in Chapter 6 of the Uniform Building Regulations, Victoria.
- (b) "Flat" has the meaning assigned thereto in Chapter 1 of the said Regulations.
- (c) "Site" shall have the same meaning as in Clause 815 of the said Regulations.

SCHEDULE "A".

LAND—Raynes Street—south side—commencing 330 ft. 4½ in. or thereabouts, west from Hilary Court, having a frontage of 65 feet, and being Lot 21A on P.S. 8902 in the

Office of Titles and being the land more particularly described in Certificate of Title Volume 7495 Folio 174. 6 flats.

Resolution for passing this By-Law agreed to by the Council the 19th day of August, 1968.

Confirmed the 16th day of September, 1968.

The common seal of the Mayor Councillors and Citizens of the City of Camberwell was hereto affixed by Order of the Council the 16th day of September, 1968, in the presence of:—

(SEAL) W. A. FORDHAM, Mayor.
R. EDWIN GILLIES, Councillor.
L. F. CHEFFERS, Town Clerk.

Approved by the Governor in Council the 6th day of November, 1968. 5506

CITY OF CAMBERWELL.

BY-LAW No. 178.

Building.

A By-Law of the City of Camberwell made under Section 926 of the *Local Government Act 1958* and the Uniform Building Regulations, Victoria, and numbered 178 for determining dispensing with or regulating certain matters left to be determined applied dispensed with or regulated by the Council of the said City or in respect of which powers are conferred or duties are imposed on the Council under the Uniform Building Regulations, Victoria.

IN pursuance of the powers conferred by the *Local Government Act 1958*, the Uniform Building Regulations, Victoria and any and every other power it thereunto enabling the Mayor, Councillors and Citizens of the City of Camberwell order as follows:—

1. This By-Law shall come into operation and have effect immediately upon its publication in the *Victoria Government Gazette*.

2. This By-Law shall from the time of its coming into operation be read and construed as one with By-Law No. 115.

3. Clause 2 of the By-Law No. 115 is hereby amended by including therein after the words "Schedule A" and "Schedule B" the words "and Schedule A" of By-Law No. 178.

4. Each of the areas of land in the said Municipal District set out and described in "Schedule A" hereto is hereby prescribed as an area of land on which a building or buildings of Class II Occupancy shall contain in the aggregate not more than the number of flats as set out against the particular area.

5. In this By-Law unless inconsistent with the context or subject matter:—

- (a) "Building of Class II Occupancy" has the meaning assigned to that expression in Chapter 6 of the Uniform Building Regulations, Victoria.
- (b) "Flat" has the meaning assigned thereto in Chapter 1 of the said Regulations.
- (c) "Site" shall have the same meaning as in Clause 815 of the said Regulations.

SCHEDULE "A".

LAND—184 Riversdale Road—being Lot 9, Block B on plan of subdivision No. 6509 lodged in the Office of Titles and being part of Crown portion 131 Parish of Boroondara County of Bourke and being the whole of the land more particularly described in Certificate of Title Volume 4025 Folio 8890. 6 flats.

Resolution for passing this By-Law agreed to by the Council the 16th day of September, 1968.

Confirmed the 14th day of October, 1968.

The common seal of the Mayor Councillors and Citizens of the City of Camberwell was hereto affixed by Order of the Council the 14th day of October, 1968, in the presence of—

(SEAL) W. A. FORDHAM, Mayor.
G. GAFFNEY, Councillor.
L. F. CHEFFERS, Town Clerk.

Approved by the Governor in Council the 6th day of November, 1968. 5507

CITY OF CAMBERWELL.

BY-LAW NO. 179.

Building.

A By-Law of the City of Camberwell made under Section 926 of the *Local Government Act 1958* and the Uniform Building Regulations, Victoria, and numbered 179 for determining dispensing with or regulating certain matters left to be determined applied dispensed with or regulated by the Council of the said City or in respect of which powers are conferred or duties are imposed on the Council under the Uniform Building Regulations, Victoria.

IN pursuance of the powers conferred by the *Local Government Act 1958*, the Uniform Building Regulations, Victoria and any and every other power it thereunto enabling the Mayor, Councillors and Citizens of the City of Camberwell order as follows:—

1. This By-Law shall come into operation and have effect immediately upon its publication in the "*Victoria Government Gazette*".

2. This By-Law shall from the time of its coming into operation be read and construed as one with By-Law No. 115.

3. Clause 2 of the By-Law No. 115 is hereby amended by including therein after the words "Schedule A" and "Schedule B" the words "and Schedule A" of By-Law No. 179.

4. Each of the areas of land in the said Municipal District set out and described in "Schedule A" hereto is hereby prescribed as an area of land on which a building or buildings of Class II Occupancy shall contain in the aggregate not more than the number of flats as set out against the particular area.

5. In this By-Law unless inconsistent with the context or subject matter:—

- (a) "Building of Class II Occupancy" has the meaning assigned to that expression in Chapter 6 of the Uniform Building Regulations, Victoria.
- (b) "Flat" has the meaning assigned thereto in Chapter 1 of the said Regulations.
- (c) "Site" shall have the same meaning as in Clause 815 of the said Regulations.

SCHEDULE "A".

LAND—128 Riversdale Road—being part of Crown portion 127 Parish of Boroondara County of Bourke and being the whole of the land more particularly described in Certificate of Title Volume 5901 Folio 133. 5 flats.

Resolution for passing this By-Law agreed to by the Council the 16th day of September, 1968.

Confirmed the 14th day of October, 1968.

The common seal of the Mayor Councillors and Citizens of the City of Camberwell was hereto affixed by Order of the Council the 14th day of October, 1968, in the presence of:—

(SEAL) W. A. FORDHAM, Mayor.
G. GAFFNEY, Councillor.
L. F. CHEFFERS, Town Clerk.

Approved by the Governor in Council the 6th day of November, 1968. 5508

CITY OF CAMBERWELL.

BY-LAW NO. 180.

Building.

A By-Law of the City of Camberwell made under Section 926 of the *Local Government Act 1958* and the Uniform Building Regulations, Victoria, and numbered 180 for determining dispensing with or regulating certain matters left to be determined applied dispensed with or regulated by the Council of the said City or in respect of which powers are conferred or duties are imposed on the Council under the Uniform Building Regulations, Victoria.

IN pursuance of the powers conferred by the *Local Government Act 1958*, the Uniform Building Regulations, Victoria and any and every other power it thereunto enabling the Mayor, Councillors and Citizens of the City of Camberwell order as follows:—

1. This By-Law shall come into operation and have effect immediately upon its publication in the "*Victoria Government Gazette*".

2. This By-Law shall from the time of its coming into operation be read and construed as one with By-Law No. 115.

3. Clause 2 of the By-Law No. 115 is hereby amended by including therein after the words "Schedule A" and "Schedule B" the words "and Schedule A" of By-Law No. 180.

4. Each of the areas of land in the said Municipal District set out and described in "Schedule A" hereto is hereby prescribed as an area of land on which a building or buildings of Class II Occupancy shall contain in the aggregate not more than the number of flats as set out against the particular area.

5. In this By-Law unless inconsistent with the context or subject matter:—

- (a) "Building of Class II Occupancy" has the meaning assigned to that expression in Chapter 6 of the Uniform Building Regulations, Victoria.
- (b) "Flat" has the meaning assigned thereto in Chapter 1 of the said Regulations.
- (c) "Site" shall have the same meaning as in Clause 815 of the said Regulations.

SCHEDULE "A".

LAND—55 Yarrbat Avenue—being Lot 19 on plan of subdivision No. 55526 in the Office of Titles and being the land remaining untransferred in Certificate of Title Volume 5786 Folio 092. 9 flats.

Resolution for passing this By-Law agreed to by the Council the 16th day of September, 1968.

Confirmed the 14th day of October, 1968.

The common seal of the Mayor Councillors and Citizens of the City of Camberwell was hereto affixed by Order of the Council the 14th day of October, 1968, in the presence of:—

(SEAL) W. A. FORDHAM, Mayor.
G. GAFFNEY, Councillor.
L. F. CHEFFERS, Town Clerk.

Approved by the Governor in Council the 6th day of November, 1968. 5509

CITY OF FRANKSTON.

NOTICE is hereby given that the Council of the City of Frankston has appointed:—

Sergeant Alexandra Costa, No. 9525, Police Station, Frankston,

in lieu of Sergeant Terence Stephen Bible, No. 8646, retired, to be Prosecuting Officer for the City of Frankston, as from 1st November, 1968.

G. C. PENTLAND, Town Clerk.
Civic Centre, Frankston. 5458

CITY OF FRANKSTON.

LOAN NO. 130.

Notice of Intention to Borrow the Sum of \$150,000 for Permanent Works and Undertakings.

NOTICE is hereby given that the Council of the City of Frankston proposes to borrow the principal sum of \$150,000 secured by a charge over the general rates of the municipality, such sum to be raised by the grant of a mortgage, in accordance with the provisions of the *Local Government Act 1958*.

1. The maximum rate of interest that may be paid is 5½ per cent. per annum.

2. The purpose for which the loan will be applied is—

- (a) Town planning—land purchase .. \$85,000
- (b) Towards the construction of Library—
Cultural Centre .. 40,000
- (c) Towards the construction of a pavilion—
Seaford Reserve .. 25,000

Total .. \$150,000

3. The period of the loan shall be fifteen years.

4. The moneys borrowed shall be repayable out of the municipal fund by 29 half-yearly instalments of approximately \$5,347.59 each, including principal and interest, on the 10th day of January and the 10th day of July during the currency of the loan, and a final payment of approximately \$111,013, including principal and interest, on the 10th day of January, 1984. The first instalment shall be payable on the 10th day of July, 1969.

5. Such moneys shall be repayable at the Commercial Savings Bank of Australia Limited, Melbourne.

The plans and specifications and estimates of the cost of the proposed works, and a statement showing the proposed expenditure of the moneys to be borrowed, are open for inspection at the Civic Centre, Frankston.

G. C. PENTLAND, Town Clerk.
Civic Centre, Frankston. 5457

CITY OF HORSHAM.

LOAN No. 69.

Notice of Intention to Borrow the Sum of \$16,000 for Permanent Works and Undertakings.

NOTICE is hereby given that the Council of the City of Horsham intends to borrow the principal sum hereinafter mentioned on the credit of the municipal revenues of the Mayor, Councillors and Citizens of the City of Horsham by the grant of a mortgage, in accordance with the provisions of the Local Government Acts.

1. The amount of the principal moneys which it is proposed to borrow is \$16,000.

2. The maximum rate of interest that may be paid is 5½ per centum per annum.

3. The period of the loan shall be ten years.

4. The moneys borrowed shall be repayable by providing out of the Municipal Fund twenty equal half-yearly instalments of approximately \$1,063.06 each, including principal and interest on the 10th day of July and the 10th day of January during the currency of the loan. The first instalment shall be payable on the 10th day of July, 1969.

5. Such moneys shall be repayable at the Commercial Savings Bank of Australia Ltd., 335 Collins-street, Melbourne, or at the Council's Bankers for the time being in the City of Melbourne.

6. The purpose for which the loan is to be applied is:—
Purchase of new Street Sweeper .. \$16,000.

7. The plans, specifications and estimate for the cost of such works, and the statement showing the proposed expenditure of the money to be borrowed, are open for inspection at the office of the Council, Town Hall, Horsham during office hours.

Dated the 7th day of November, 1968.

5477 A. R. CONN, Town Clerk.

CITY OF MALVERN.

LOAN No. 46.

Notice of Intention to Borrow the Sum of \$40,000 for Permanent Works and Undertakings.

NOTICE is hereby given that the Council of the Municipality of the City of Malvern intends to borrow the principal sum of forty thousand dollars on the security of the general rates of the said Municipality, such principal sum to be raised by the grant of a mortgage in accordance with the provisions of the Local Government Act 1958.

1. The maximum rate of interest that may be paid is 5.875 per centum per annum.

2. The moneys borrowed are to be repayable on 1st July and 1st January each year to the English Scottish and Australian Bank Ltd., at the office of the said bank, 266 Glenferrie-road, Malvern.

3. The purpose for which the loan is to be applied is—
Reconstruction of the Malvern Municipal Baths (Part) .. \$40,000

4. The loan is to be liquidated by providing out of the Municipal Fund 30 equal half-yearly instalments of \$2,024.32 (which instalments shall comprise principal and interest) each on the appropriate date.

The plans and specifications and the estimate of the cost of the proposed works and a statement showing the proposed expenditure of the moneys to be borrowed are open for inspection at the City Hall, Malvern, during office hours.

5465 D. W. LUCAS, Town Clerk.

TOWN OF PORTLAND.

LOAN No. 73.

Notice of Intention to Borrow the Sum of \$16,000 for Permanent Works and Undertakings.

NOTICE is hereby given that the Council of the Town of Portland proposes to borrow the sum of Sixteen thousand dollars (\$16,000) secured by a charge over the general rates of the municipality, such sum to be raised by the grant of a mortgage in accordance with the provisions of the Local Government Act 1958.

1. The maximum rate of interest that may be paid is 5.875 per cent. per annum.

2. The purpose for which the loan is to be applied is:—
Construction of Cavalier Park Recreation Area .. \$12,000
Part Cost Toilet Blocks—Alexandra and Hanlon Parks .. \$ 4,000

3. The period of the loan shall be twenty years.

4. The moneys borrowed shall be repayable by providing out of the Municipal Fund 40 half-yearly instalments of approximately \$685.22 each, including principal and interest on the 3rd day of July and the 3rd day of January during the currency of the loan. The first instalment shall be payable on the 3rd day of July, 1969.

5. Such moneys shall be repayable to the Portland Harbor Trust, Barton-place, Portland.

The plans and specifications and the estimate of the cost of the proposed works and a statement showing the proposed expenditure of the moneys to be borrowed are open for inspection at the Town Hall, Portland.

4th November, 1968.

5449 L. FELL, Town Clerk.

TOWN OF PORTLAND.

LOAN No. 74.

Notice of Intention to Borrow the Sum of \$30,000 for Permanent Works and Undertakings.

NOTICE is hereby given that the Council of the Town of Portland proposes to borrow the sum of Thirty thousand dollars (\$30,000) secured by a charge over the general rates of the municipality, such sum to be raised by the grant of a mortgage in accordance with the provisions of the Local Government Act 1958.

1. The maximum rate of interest that may be paid is 5.75 per cent. per annum.

2. The purpose for which the loan is to be applied is:—
Construction of Roads, Footpaths, Kerbs and Channels .. \$30,000

3. The period of the loan shall be ten years.

4. The moneys borrowed shall be repayable by providing out of the Municipal Fund 20 half-yearly instalments of \$1,993.24 each, including principal and interest on the 3rd day of July and the 3rd day of January during the currency of the loan. The first instalment shall be payable on the 3rd day of July, 1969.

5. Such moneys shall be repayable at the Australia and New Zealand Savings Bank Limited, Melbourne.

The plans and specifications and the estimate of the cost of the proposed works and a statement showing the proposed expenditure of the moneys to be borrowed are open for inspection at the Town Hall, Portland.

4th November, 1968.

5450 L. FELL, Town Clerk.

BOROUGH OF KYABRAM.

BY-LAW No. 21.

A By-Law of the Borough of Kyabram made under the provisions of Section 198 (1) (h) (i) & (ii) of the Local Government Act 1958, and numbered 21 for the purpose of:—

(a) Prohibiting on from and after a date specified herein the erection or placing against or in front of any house or building abutting upon any public footway in any street or part thereof specified herein, of any verandah over or across such footway unless such verandah is supported by cantilever brackets or projecting supports and not otherwise.

(b) Requiring the pulling down and removal before a date specified herein of all verandahs erected or placed against or in front of any house or building abutting upon such public footway when verandahs are upon over or across such footway and are supported otherwise than by cantilever brackets or projecting supports.

In pursuance of the powers conferred by the Local Government Act 1958, the Mayor, Councillors and Burgesses of the Borough of Kyabram order as follows:—

1. On from and after the first day of December, 1968 no persons shall erect or place in front of any house or building abutting upon any public footway in any street or part thereof within the Borough of Kyabram any verandah over or across such footway unless such verandah is supported by cantilever brackets or projecting supports.

2. Save as otherwise provided for in this By-Law, the owner of any verandah which is now or before the first day of December, 1968 shall have been erected or placed against or in front of any house or building abutting upon any public footway of any street or part thereof in the Borough of Kyabram which verandah is upon over or across such footway and is supported otherwise than by cantilever brackets or projecting supports, shall pull down and remove such verandah before the 1st day of December, 1978.

3. This By-Law shall apply and have operation throughout the whole of the municipal district of the Borough of Kyabram.

4. Any person who contravenes or fails to comply with any provisions of this By-Law shall be guilty of an offence against this By-Law and shall be liable to a penalty of not less than Thirty Dollars and not more than Forty Dollars and in the case of a continuing offence against this By-Law shall be liable to a further penalty of Ten Dollars for each day on which such offence is continued after a conviction or order by any Court in respect of such offence.

Resolution for passing this By-Law agreed to by the Council of the Borough of Kyabram the 13th day of August, 1968, and confirmed at the meeting of the said Council held on the 24th day of September, 1968.

The common seal of the Mayor, Councillors and Burgesses of the Borough of Kyabram was affixed hereto, by order of the Council, this 24th day of September, 1968.

(SEAL) W. A. ROBINSON, Mayor.
K. N. KING, Councillor.
E. T. CORNISH, Town Clerk.

Approved by the Governor in Council, 22nd October, 1968.—J. ROSSITER, Clerk of the Executive Council. 5456

SHIRE OF BALLARAT.

BY-LAW No. 45.

NOTICE is hereby given that in pursuance of the powers conferred by the Local Government Acts, the President, Councillors and Ratepayers of the Shire of Ballarat have made By-Law No. 45 for the fixing of camping fees and other charges at Lake Learmonth Camping Ground.

The resolution for making the By-Law was passed on the 9th September, 1968 and confirmed on the 14th October, 1968.

Approval of the Governor-in-Council was given on the 30th October, 1968.

A copy of the By-Law is open for inspection free of charge during office hours at the office of the Council, Gillies Street, Wendouree.

5468 JAMES H. MITCHELL, Shire Secretary.

SHIRE OF BULN BULN.

BY-LAW No. 80.

A By-law of the Shire of Buln Buln, made under the *Local Government Act 1958* and the *Uniform Building Regulations, Victoria* and numbered 80 for amending By-law No. 65 and for determining, applying, dispensing with, or regulating such matters or things as are left to be determined, applied, dispensed with, or regulated by the Council of the said Shire, under the *Uniform Building Regulations, Victoria*.

IN pursuance of the powers conferred by the *Local Government Act 1958* and the *Uniform Building Regulations, Victoria*, the operation of which was extended to the said Shire by proclamation dated 24th March, 1959, and of any and every power it thereunto enabling, the President, Councillors and Ratepayers of the Shire of Buln Buln order as follows:—

1. The Schedule in By-law No. 65 shall be and is hereby repealed and the following Schedule substituted therefor:—

" SCHEDULE.

All those pieces of land situated in the Town of Drouin, Parish of Drouin West being—

- (a) The whole of Section 18, but excluding thereout ALL THAT piece of land being the land more particularly described in Certificate of Title entered in the Register Book Volume 6155 Folio 952;

- (b) Such part of the Railway Station Reserve as is bounded by Princes Highway, Hope Street, the railway line, and a production of the eastern building line of Bank Place to the railway line;
- (c) Section 10;
- (d) Section 11;
- (e) So much and such parts of Crown Allotments 10, 13 and 14, Section 9 as lie parallel to the building line of Young Street for the depth of 150 feet from such building line; and
- (f) So much and such parts of Crown Allotments 8 and 9 Section 9 as lie parallel to the building line of Young Street for the depth of 66 feet from such building line."

Resolution for passing this By-law agreed to by the Council of the Shire of Buln Buln on the 19th day of August, 1968, and confirmed the 16th day of September, 1968.

The common seal of the President, Councillors and Ratepayers of the Shire of Buln Buln was hereto affixed, in the presence of—

(SEAL) WM. MARTIN, Shire President.
H. F. MCKAY, Councillor.
K. A. PRETTY, Shire Secretary.

Approved by the Governor in Council, 22nd October, 1968.—J. ROSSITER, Clerk of the Executive Council. 5461

SHIRE OF CHARLTON.

NOTICE is hereby given that on 24th September, 1968, Senior Constable Leslie Victor Cody, No. 10393, was appointed Prosecuting Officer and Inspector of Nuisances for the Shire of Charlton in lieu of Senior Constable Gilbert Douglas, No. 10908, transferred.

5448 A. F. HELYAR, Shire Secretary.

Town and Country Planning Act 1961 (Twelfth Schedule).

SHIRE OF CROYDON PLANNING SCHEME 1961.

NOTICE THAT A PLANNING SCHEME HAS BEEN PREPARED AND IS AVAILABLE FOR INSPECTION.

Amendment No. 14, 1968.

NOTICE is hereby given that the Council of the Shire of Croydon, in pursuance of its powers under the *Town and Country Planning Act 1961*, has prepared a Planning Scheme for the purpose of making Reception Rooms a use permitted subject to conditions in the Residential Zone of the Shire of Croydon.

A copy of the scheme has been deposited at the Shire Offices, Shire of Croydon, Railway-crescent, Croydon, and at the office of the Town and Country Planning Board, 179 Queen-street, Melbourne, and will be open for inspection during office hours by any person free of charge.

Any persons affected by the Planning Scheme are required to set forth, in writing, all objections they may have, addressed to the Shire Secretary, Shire of Croydon, Shire Offices, Railway-crescent, Croydon, on or before the 13th day of December, 1968, and to state whether they wish to be heard in respect of their objections.

Dated 1st November, 1968.

5441 K. A. MCKAY, Shire Secretary.

Town and Country Planning Act 1961 (Twelfth Schedule).

SHIRE OF CROYDON PLANNING SCHEME 1961.

NOTICE THAT A PLANNING SCHEME HAS BEEN PREPARED AND IS AVAILABLE FOR INSPECTION.

Amendment No. 17, 1968.

NOTICE is hereby given that the Council of the Shire of Croydon, in pursuance of its powers under the *Town and Country Planning Act 1961*, has prepared a Planning Scheme for part of Crown allotment 43, Parish of Mooroolbark, for the purpose of rezoning from General Industrial to Residential.

A copy of the scheme has been deposited at the Shire Offices, Shire of Croydon, Railway-crescent, Croydon, and at the office of the Town and Country Planning Board, 179 Queen-street, Melbourne, and will be open for inspection during office hours by any person free of charge.

Any persons affected by the Planning Scheme are required to set forth, in writing, all objections they may have, addressed to the Shire Secretary, Shire of Croydon, Shire Offices, Railway-crescent, Croydon, on or before the 20th day of December, 1968, and to state whether they wish to be heard in respect of their objections.

5481 K. A. MCKAY, Shire Secretary.

SHIRE OF FLINDERS.

LOAN No. 63.

Notice of Intention to Borrow the Sum of \$50,000 for Permanent Works and Undertakings.

NOTICE is hereby given that the Council of the Shire of Flinders proposes to borrow the principal sum of \$50,000 secured by a charge over the general rates of the municipality, such sum to be raised by the grant of a mortgage in accordance with the provisions of the *Local Government Act 1958*.

1. The maximum rate of interest that may be paid is 5½ per centum per annum.
2. The period of the loan shall be fifteen years.
3. The purpose for which the loan will be applied is purchases of lands for reserves.
4. The moneys borrowed shall be repayable out of the municipal fund by 30 half-yearly instalments of \$2,530.40 each including principal and interest on the 3rd day of September and the 3rd day of March during the currency of the loan. The first instalment shall be payable on the third day of September, 1969.

5. Such moneys shall be repayable to the Australian Mutual Provident Society, 425 Collins-street, Melbourne.

The plans, specifications and estimates of the cost of the proposed works and a statement showing the proposed expenditure of the moneys to be borrowed are open for inspection at the Shire office, Dromana.

5478

S. WILLIAMS, Shire Secretary.

SHIRE OF KNOX.

LOAN No. 45.—SPECIAL ORDER.

NOTICE is hereby given that the Council of the Shire of Knox, at a Meeting held on the 6th day of November, 1968, did pass the following Special Order:—

"That the Council of the Shire of Knox in pursuance of powers conferred by the *Local Government Act 1958*, proceed to borrow the sum of \$100,000 secured on the general rates of the municipality, such sum to be raised by the grant of a mortgage in accordance with the said Act and under the following conditions:—

- (a) The amount of principal moneys it is proposed to borrow is \$100,000.
- (b) The maximum rate of interest that may be paid is 5½ per cent. per annum.
- (c) The period of the loan will be fifteen years and the time or times at which the moneys borrowed is to be repayable is on the 3rd day of February and the 3rd day of August in each year during the currency of the loan commencing on the 3rd day of August, 1969, until the final payment on 3rd February, 1984.
- (d) The purpose for which the loan is to be applied is for permanent works and undertakings, viz.:—
Private street construction.
- (e) The loan is to be liquidated by half-yearly payments of approximately \$5,061, including principal and interest, payable out of the Private Streets Fund.
- (f) The place of repayment will be A.M.P. Society, 425 Collins-street, Melbourne, and further,

That the resolution of the Council making the Special Order to borrow \$100,000, Loan 45, be brought forward as Extraordinary Business for confirmation at the meeting of the Council to be held in the Council Chambers, Shire Offices, Fern Tree Gully, on the 4th day of December, 1968, at 7.30 p.m."

5474

N. G. HAYNES, Shire Secretary.

SHIRE OF MYRTLEFORD.

LOAN No. 16.

Notice of Intention to Borrow the Sum of \$10,000 for Permanent Works and Undertakings.

NOTICE is hereby given that the Council of the Shire of Myrtleford proposes to borrow the principal sum of Ten thousand dollars, secured by a charge over the general rates of the municipality, such sum to be raised by the grant of a mortgage, in accordance with the provisions of the *Local Government Act 1958*.

1. The maximum rate of interest that may be paid is 5.875 per cent. per annum.
2. The purpose for which the loan is to be applied is—
Establishment of Permanent Municipal Depot \$10,000
3. The period of the loan shall be fifteen years.

4. The moneys borrowed shall be repayable by providing out of the municipal fund half-yearly instalments of \$506.08 each, including principal and interest, on the 1st day of January and the 1st day of July, during the currency of the loan. The first instalment shall be payable on the 1st day of July, 1969.

5. Such moneys shall be repayable to the Australia and New Zealand Savings Bank Limited, 394-396 Collins-street, Melbourne.

The plans and specifications and the estimate of the cost of the proposed works and a statement showing the proposed expenditure of the moneys to be borrowed, are open for inspection at the office of the Council of the Shire of Myrtleford, at Myrtleford.

Dated 5th November, 1968.

5459

K. S. LANE, Shire Secretary.

SHIRE OF ROMSEY.

BY-LAW No. 26.

By-Law Prohibiting the Keeping of Swine in Certain Areas.

A By-Law of the Shire of Romsey made under Section 394 of the *Health Act 1958*, and every other power enabling it in that behalf and numbered 26 for the purpose of making it unlawful to keep any swine or any pig-sty within the limits fixed hereunder.

IN pursuance of the powers conferred by the *Health Act 1958* and by every other power enabling it in that behalf, the President, Councillors, and Ratepayers of the Shire of Romsey order as follows:—

1. No person shall keep any swine, or erect or maintain any pig-sty within the limits fixed by, and described in, the schedule and plan attached hereto.
2. Every person who by act or default be guilty of any breach of any of the provisions of this By-Law shall be liable to a penalty of not more than forty dollars (\$40) and in the case of a continuing offence to a further daily penalty of not more than ten dollars (\$10).
3. Notwithstanding the provisions of Clause 1 hereof this By-Law shall not prohibit the continuance of the keeping of swine on premises registered with the Council under Section 96 of the *Health Act 1958* before the coming into operation of this By-Law.

Resolution adopting this By-Law was agreed to by the Council on the 3rd day of July, 1968, and confirmed on the 7th day of August, 1968.

The common seal of the President, Councillors, and Ratepayers of the Shire of Romsey was hereunto affixed in the presence of—

(SEAL) IAN S. AMESS, President.
R. C. HEMPHILL, Councillor.
BRIAN F. CARNE, Secretary.

SCHEDULE.

Those portions of the Municipal District of the Shire of Romsey shown coloured red on the plan attached hereto.

Approved by the Governor in Council, 15th October, 1968.—J. ROSSITER, Clerk of the Executive Council.

The plan referred to is deposited at the Municipal Offices, Shire of Romsey and will be open to the inspection of any person at all reasonable times. 5513

SHIRE OF ROSEDALE.

BY-LAW No. 43.

NOTICE is hereby given that the Council of the Shire of Rosedale did make, pass and confirm By-law No. 43 under the provisions of the *Local Government Act 1958*, for the purpose of:

Prescribing areas within the municipal district within which the erection including the adaptation for use of any building is prohibited unless the building is connected to a septic tank system in accordance with the requirements of the Septic Tank Regulation 1932, as amended.

A copy of the said By-law is open for inspection, free of charge, during office hours, at the office of the Council of the Shire of Rosedale, Rosedale.

5439

G. W. THOMSON, Shire Secretary.

SHIRE OF WHITTLESEA.

LOAN No. P.S. 20.

Private Streets Account.

NOTICE is hereby given that at the meeting of the Council of the Shire of Whittlesea, held at the Shire Office, Epping, on Monday, 7th October, 1968, the said Council did agree to the following Resolution, that is to say:—

"That—

- (a) This Council borrow moneys by the grant of a mortgage, secured on the general rates of the municipality, pursuant to section 585 of the Local Government Acts.
- (b) The amount of the principal moneys to be borrowed be \$130,000.
- (c) The rate of interest to be paid be 5½ per cent. per annum.
- (d) The moneys borrowed be repayable by 30 instalments of \$6,579.03 each, payable respectively on the 1st day of June and on the 1st day of December of each year, the first such instalment being repayable on the 1st day of June, 1969.
- (e) The moneys borrowed be repayable to the Commercial Savings Bank of Australia Limited, Melbourne.
- (f) The loan be applied for the purpose of defraying part of the cost of the execution of schemes for the construction of private streets, pursuant to Division 10 of Part XIX. of the Local Government Acts.
- (g) The loan be liquidated by providing out of the receipts from owners made liable under the schemes, or, in case such receipts are insufficient, then by providing from the municipal fund, in each half year during the currency of the loan the sum of \$6,579.03, which sum includes principal and interest."

And notice is hereby further given that, at the meeting of the said Council, held at the Shire Office, Epping, on Monday, 4th November, 1968, the said Resolution was confirmed.

5480

R. G. C. COOK, Shire Secretary.

SHIRE OF WOORAYL.

LOAN No. 27.

Notice of Intention to Borrow the Sum of \$75,000 for Permanent Works and Undertakings.

NOTICE is hereby given that the Council of the Shire of Woorayl proposes to borrow the sum of \$75,000 on the credit of the President, Councillors and Ratepayers of the said Shire of Woorayl by the grant of a mortgage in accordance with the provisions of the *Local Government Act 1958*.

1. The maximum rate of interest that may be paid is 5.875 per cent.
2. The purposes for which the loan is to be applied is the purchase of land and erection of buildings for an approved decentralized industry.
3. The period of the loan shall be 25 years.
4. The money borrowed shall be repayable by the creation of a sinking fund in accordance with the provisions of the *Local Government Act 1958*. Interest of \$2,203.13 shall be payable on the 15th day of February and the 15th day of August, during the currency of the loan.
5. The principal money shall be repayable at the National Bank of Australasia, Western Branch, Melbourne, on 15th February, 1994.
6. Plans and specifications and estimates of the cost of the proposed works and a statement showing the proposed expenditure of the money to be borrowed are open for inspection at the office of the Council of the Shire of Woorayl, Leongatha.

Dated at Leongatha this 8th day of November, 1968.

5434

K. G. BRYDON, Shire Secretary.

NOTICE OF DISSOLUTION OF PARTNERSHIP.

NOTICE is hereby given that the partnership between Peter Humphrey Gilbert MacCallum and Gregory Thomas Prouse, carrying on a private hospital business at 88 Cunningham-street, Northcote, in the State of Victoria, under the name "Wyuna Hospital", has been dissolved by mutual consent from the 31st day of October, 1968. All debts due to and owing by the late firm will

No. 94.—10366/68.—4

be received and paid respectively by Gregory Thomas Prouse, who will continue to carry on the business at the same address.

Dated the 31st day of October, 1968.

5484 PETER HUMPHREY GILBERT MACCALLUM.
GILBERT THOMAS PROUSE.

NOTICE is hereby given that the partnership heretofore subsisting between Thomas Richard Pascoe and Hazel Pascoe, under the name of T. R. Pascoe and Co., Floor Sanders, trading at 12 St. James-avenue, Springvale, in the State of Victoria, has been dissolved as and from the 30th day of June, 1968.

All debts due and owing to the said late firm will be received and paid by the said Thomas Richard Pascoe.

Dated at Springvale, this 28th day of October, 1968.

Witness—K. H. MORGAN. T. R. PASCOE.
5510

NOTICE is hereby given that the partnership heretofore subsisting between Andrew Henry Bruse, Jane Bruse, Alexander Fyfe Bruse and Jean Bruse, carrying on the business of sales, service, maintenance and testing of milking machines, at Station-street, Koo-wee-rup, under the business name of "Milk Machine Technical Service" has been dissolved as from the 31st day of October, 1968, as far as concerns the said Andrew Henry Bruse and Jane Bruse, who retired from the said business.

Dated 1st day of November, 1968.

ROWLAND P. HASSALL, solicitor for retiring partners.
5443

The Companies Act 1961.

DURAH INVESTMENTS PROPRIETARY LIMITED (IN LIQUIDATION).

NOTICE CONVENING FINAL MEETING OF MEMBERS AND CREDITORS, PURSUANT TO SECTION 272.

NOTICE is hereby given, pursuant to section 272 of the *Companies Act 1961*, that a General Meeting of the members and creditors of the above-named company will be held in the offices of Kennedy, Smail & Middlemiss, 296-304 Little Lonsdale-street, Melbourne, on Wednesday, the 11th day of December, 1968, at 10.30 a.m., for the purpose of having an account laid before them showing the manner in which the winding up has been conducted and the property of the company disposed of, and of hearing any explanations that may be given by the liquidator.

Dated this 6th day of November, 1968.

E. R. SMAIL, Liquidator.
Kennedy, Smail & Middlemiss, 296-304 Little Lonsdale-street, Melbourne, 3000.
5489

The Companies Act 1961.

REDSON GREEN PROPRIETARY LIMITED (IN LIQUIDATION).

NOTICE CONVENING FINAL MEETING OF MEMBERS AND CREDITORS, PURSUANT TO SECTION 272.

NOTICE is hereby given, pursuant to section 272 of the *Companies Act 1961*, that a General Meeting of the members and creditors of the above-named company will be held in the offices of Kennedy, Smail & Middlemiss, 296-304 Little Lonsdale-street, Melbourne, on Wednesday, the 11th day of December, 1968, at 10 a.m., for the purpose of having an account laid before them showing the manner in which the winding up has been conducted and the property of the company disposed of, and of hearing any explanations that may be given by the liquidator.

Dated this 6th day of November, 1968.

E. R. SMAIL, Liquidator.
Kennedy, Smail & Middlemiss, 296-304 Little Lonsdale-street, Melbourne, 3000.
5490

GEELONG EX-SERVICEMEN'S CO-OPERATIVE HOUSING SOCIETY LIMITED (IN LIQUIDATION).

NOTICE OF FINAL MEETING IN VOLUNTARY WINDING UP.

TAKE notice that the affairs of the above-named society are now fully wound up and that, in pursuance of section 272 (1) of the *Companies Act 1961* and of the *Co-operative Housing Societies Act 1958*, a General Meeting

of the society will be held at Aberdeen House, 115 Aberdeen-street, Geelong, on the 16th day of December, 1968, at 8 p.m., for the purposes of—

- (i) laying before it an account showing how the winding up has been conducted and the property of the society disposed of, and giving any explanations thereof; and
- (ii) passing a Resolution that the books and papers of the said society and of the liquidator relevant to the affairs of the society be destroyed after a period of twelve months from the date of the meeting.

Dated the 7th day of November, 1968.

5462

B. G. THOM, Liquidator.

In the Supreme Court of Victoria.—1968 Co. No. 7620.—In the matter of the Companies Act 1961; and in the matter of FEIJAN FABRICS (KNITTING MILLS HOLDINGS) PTY. LTD.

NOTICE is hereby given that a petition for the winding up of the above-named company by the Supreme Court was, on the 1st day of November, 1968, presented by B. S. Stillwell & Co. Pty. Ltd.: And that the said petition is directed to be heard before the Court sitting at the Fourteenth Court, Law Courts, William-street, Melbourne, on the 2nd day of December, 1968, at the hour of 10.30 o'clock in the forenoon; and any creditor or contributory of the said company desiring to support or oppose the making of an order on the said petition may appear at the time of hearing by himself or his counsel for that purpose; and a copy of the petition will be furnished to any creditor or contributory of the said company requiring the same by the undersigned on payment of the regulated charge for the same.

The petitioner's address is 142 Cotham-road, Kew.

The petitioner's solicitors are Messrs. W. B. & O. McCutcheon, of 150 Queen-street, Melbourne.

W. B. & O. McCUTCHEON, solicitors for the petitioner.

NOTE.—Any person who intends to appear on the hearing of the said petition must serve or send by post to the above-named solicitors, notice, in writing, of his intention to do so. The notice must state the name and address of the person; or, if a firm, the name and address of the firm and must be signed by the person or firm or his or their solicitors (if any) and must be served, or if posted, must be sent by post in sufficient time to reach the above named not later than 4 o'clock in the afternoon on the 29th day of November, 1968.

5528

In the matter of the Companies Act 1961; and in the matter of DUNNING WHITE AND COMPANY PROPRIETARY LIMITED (in Liquidation).—Notice of Final Meeting.

NOTICE is hereby given that pursuant to section 272 of the Companies Act 1961 a Final Meeting of the members and creditors of the above-named company will be held at the offices of Messrs. Norman, Cartledge and Browne, 1 Palmerston-crescent, South Melbourne, on Monday, 16th December, 1968, at Two o'clock in the afternoon for the purpose of presenting the liquidator's account of the winding up.

Dated this 8th day of November, 1968.

H. K. CARTLEDGE, Liquidator.

Norman, Cartledge and Browne, chartered accountants, 1 Palmerston-crescent, South Melbourne, Victoria, 3205.

5522

In the matter of the Companies Act 1961; and in the matter of AUSTRALASIAN ASIATIC TRADING AND ENGINEERING CO. PROPRIETARY LIMITED (in Liquidation).—Notice of Final Meeting.

NOTICE is hereby given that pursuant to section 272 of the Companies Act 1961 a Final Meeting of the members and creditors of the above-named company will be held at the offices of Messrs. Norman, Cartledge and Browne, chartered accountants, 1 Palmerston-crescent, South Melbourne, on Monday, 16th day of December, 1968, at 11 o'clock in the forenoon for the purpose of presenting the liquidator's account of the winding up.

Dated this 8th day of November, 1968.

H. K. CARTLEDGE, Liquidator.

Norman, Cartledge and Browne, chartered accountants, 1 Palmerston-crescent, South Melbourne, Victoria, 3205.

5523

In the matter of CITY INDUSTRIAL PROPRIETARY LIMITED (Receiver and Manager Appointed).

NOTICE is hereby given that creditors of City Industrial Proprietary Limited (Receiver and Manager Appointed) who have not proved their debts or claims are required to do so by the 22nd day of November, 1968.

Dated this 12th day of November, 1968.

5521

L. P. SMART, Receiver and Manager.

Companies Act 1961.—In the matter of WHEELS & RIMS AUSTRALIA PROPRIETARY LIMITED.

AT an Extraordinary General Meeting of the above-named company duly convened and held at 145 Arthur-street, Flemington, Sydney, New South Wales, on the 11th day of November, 1968, the following Resolution was duly passed as a Special Resolution:—

“That the Company be wound up Voluntarily”.

And at such meeting, Kenneth Victor Harrison, chartered accountant, of 360 Collins-street, Melbourne, was appointed liquidator for the purposes of the winding up.

Dated this 12th day of November, 1968.

5530

H. F. WEST, Secretary.

The Companies Act 1961.—In the matter of ELECTROSONICS PTY. LIMITED (in Voluntary Liquidation).

NOTICE is hereby given that at an Extraordinary Meeting of the members of the above-named company held on Friday, the 8th day of November, 1968, it was resolved that the company be wound up voluntarily and at a meeting of creditors held on the same day it was resolved that for such purpose, Scott Maurice Nunan, of 260 Queen-street, Melbourne, chartered accountant, be appointed liquidator.

Notice is also given that after 21 days from this date I shall proceed to distribute the assets. All creditors having any claim against the company should furnish particulars of same by that date, otherwise I shall proceed to distribute the assets without regard to their claim.

Dated this 13th day of November, 1968.

S. M. NUNAN, Liquidator.

Hall & Rose, chartered accountants, 260 Queen-street, Melbourne, 3000.

5529

Companies Act 1961.—In the matter of JAYESS DISTRIBUTING CO. PTY. LTD.—Notice of Meeting of Creditors, Pursuant to Section 260.

NOTICE is hereby given that a meeting of creditors of the above-named company will be held at Victorian Employers' Federation Meeting Rooms, 3rd Floor, East Tower, Princes Gate, 151 Flinders-street, Melbourne, on Monday, 25th November, 1968, at 11 a.m., the company having convened a meeting of its members for the same day for the purpose of considering a Resolution that the company be wound up voluntarily.

Dated this 8th day of November, 1968.

C. N. WING, Director.

Bent & Cogle, public accountants, Suite 18, 545 St. Kilda-road, Melbourne, 3004.

5473

The Companies Act 1961.—In the matter of VICTORIAN HELICOPTERS PTY. LTD. (in Liquidation).

NOTICE is hereby given that pursuant to section 272 of the Companies Act a Final Meeting of the creditors of the above company will be held at the offices of Bent & Cogle, on Tuesday, 17th December, 1968, at 10 a.m.

Business—To receive the Liquidator's accounts.

Dated this 6th day of November, 1968.

D. J. COUGLE, Liquidator.

Bent & Cogle, public accountants, Suite 18, 545 St. Kilda-road, Melbourne, 3004.

5435

Companies Act 1961.

PARLORCARS PTY. LTD. (IN VOLUNTARY LIQUIDATION). NOTICE TO CREDITORS OF INTENTION TO DECLARE A DIVIDEND.

A PRELIMINARY distribution is intended to be declared in the above matter. Any creditor who does not prove his debt by the 25th day of November, 1968, will be excluded from the distribution.

The date of the liquidation was the 13th day of August, 1967.

5511

E. JOHN BROWN, Liquidator.

A. A. PINDER PROPRIETARY LIMITED.

SPECIAL RESOLUTION TO WIND UP.

Pursuant to Section 254 of the Companies Act 1961.

AT an Extraordinary General Meeting of the above-named company, duly convened and held at Yarra Junction on the 4th day of November, 1968, the following Resolution was duly passed as a Special Resolution:—
“That the company be wound up voluntarily.”

And at such last-mentioned meeting Arthur Albert Pinder was appointed liquidator for the purpose of the winding up.

Dated this 4th day of November, 1968.

5447 A. PINDER, Liquidator.

Companies Act 1961.—In the matter of G.K.N.—PECO PROPRIETARY LIMITED (in Voluntary Liquidation).

Notice of Final Meeting.—Members' Winding Up.

NOTICE is hereby given, pursuant to section 272 of the Companies Act 1961, that the Final General Meeting of Members of the above-named company will be held at 44 Queen-street, Melbourne (4th Floor) on 12th December, 1968, at 9 a.m., when I shall lay before the meeting an account of how the winding up has been conducted and the property of the company disposed of.

Dated this 6th day of November, 1968.

5437 C. J. WAUGH, Liquidator.

The Companies Act 1961.—In the matter of EDEN INDUSTRIES (VICTORIA) PTY. LTD.

NOTICE is hereby given that at an Extraordinary Meeting of the members of the above-named company held on the 31st day of October, 1968, it was resolved that the company be wound up voluntarily and at a meeting of creditors held on the same day pursuant to section 260, it was resolved that for such purpose Everett Thomson Bent, of Suite 18, 545 St. Kilda-road, Melbourne, accountant, be appointed liquidator.

Notice is also given that after 21 days from this date I shall proceed to distribute the assets. All creditors having any claims against the company should furnish particulars of same by that date, otherwise I shall proceed to distribute the assets, without regard to their claim.

Dated this 31st day of October, 1968.

E. T. BENT, Liquidator.

Bent & Cogle, public accountants, Suite 18, 545 St. Kilda-road, Melbourne, 3004. 5436

Companies Act 1961.

WITHERS TRANSPORT INDUSTRIES PTY. LTD.

(IN VOLUNTARY LIQUIDATION).

NOTICE TO CREDITORS OF INTENTION TO DECLARE A DIVIDEND.

A PRELIMINARY distribution is intended to be declared in the above matter. Any creditor who does not prove his debt by the 25th day of November, 1968, will be excluded from the distribution.

The date of the liquidation was the 13th day of August, 1967.

5512 E. JOHN BROWN, Liquidator.

BALLARAT TELECASTERS LIMITED.

NOTICE is hereby given that the following Special Resolution was passed at an Extraordinary General Meeting of members of Ballarat Telecasters Ltd., held at the registered office of the company, Walker-street, Ballarat, on 6th November, 1968:—

“That the company being a non-operating company and one which has ceased to carry on business be wound up voluntarily.”

5514 B. F. JACKSON, Secretary.

GHYLL INVESTMENTS PTY. LIMITED (IN VOLUNTARY LIQUIDATION).

NOTICE OF FINAL MEETING IN VOLUNTARY WINDING UP.

TAKE notice that the affairs of the above-named company are now fully wound up and that in pursuance of section 272 (1) of the Companies Act 1961, a General Meeting of the company will be held at 2.30 p.m., on Friday, the 20th day of December, 1968, at 54 Malop-street, Geelong, for the purpose of laying before it an account showing how the winding-up has been conducted and the property of the company disposed of and giving any explanation thereof.

Dated at Geelong, the 6th day of November, 1968.

G. T. PYLE, A.A.S.A., Liquidator, 54 Malop-street, Geelong. 5432

In the Supreme Court of Victoria.—1968, C.O.7614.—In the matter of the Companies Act 1961 and in the matter of BELLARINE CONSTRUCTIONS PROPRIETARY LIMITED.

NOTICE is hereby given that a petition for the winding up of the above-named company by the Supreme Court was, on the 29th day of October, 1968, presented by Apex Plumbing Service Proprietary Limited: And that the said petition is directed to be heard before the Court sitting at the Fourteenth Court, Law Courts, William-street, Melbourne, at the hour of 10.30 o'clock in the forenoon on the 3rd day of December, 1968, and any creditor or contributory of the said company desiring to support or oppose the making of an order on the said petition may appear at the time of hearing by himself or his counsel for that purpose; and a copy of the said petition will be furnished to any creditor or contributory of the said company requiring the same by the undersigned on payment of the regulated charge for the same.

The petitioner's address is 172 Williamson-street, Bendigo.

The petitioner's solicitor is T. W. Iser, of 182 Mitchell-street, Bendigo, whose Melbourne agents are Messrs. McCay & Thwaites, of 360 Collins-street, Melbourne.

T. W. ISER.

NOTE.—Any person who intends to appear on the hearing of the said petition must serve on or send by post to the above-named Messrs. McCay & Thwaites notice in writing of his intention so to do. The notice must state the name and address of the person, or, if a firm, the name and address of the firm, and must be signed by the person or firm, or his or their solicitor (if any), and must be served or, if posted, must be sent by post in sufficient time to reach the above named not later than Four o'clock in the afternoon of the 2nd day of December, 1968. 5470

Companies Act 1961.

W. T. WHITELAW & SON PTY. LTD. (IN VOLUNTARY LIQUIDATION).

MEMBERS WINDING UP.

NOTICE is hereby given that, pursuant to section 272 of the Companies Act 1961, a Final Meeting of members will be held at 109 Murrumbena-road, Murrumbena, on Monday, 16th December, 1968, at 11 a.m.

Business: To receive the liquidator's accounts.

Dated this 7th day of November, 1968.

R. H. ANDERSON, Liquidator.

Brentnall, Dale & Co., chartered accountants, 360 Collins-street, Melbourne, 3000. 5488

ROCROY PTY. LTD.

NOTICE OF VOLUNTARY LIQUIDATION.

AT an Extraordinary General Meeting of Rocroy Pty. Ltd., held at 104 Liebig-street, Warrnambool, on the 7th day of November, 1968, the following Resolutions were passed as Special Resolutions:—

1. That the company be wound up voluntarily, and that William George Sinclair, of 104 Liebig-street, Warrnambool, accountant, be and he is hereby appointed liquidator for the purpose of such winding up.

2. That the liquidator be and is hereby authorized when and so soon as the debts and liabilities of the company have been paid and satisfied or duly provided for, to distribute in specie or kind amongst the members of the company in accordance with their respective rights, and interest therein, the whole or any part of the assets of the company as he shall think fit.

5479 W. G. SINCLAIR, F.A.S.A., Liquidator.

CREDITORS, next of kin and others having claims against the estate of Mary Mulquiny, formerly of Clunes, but late of 102 Ascot-street south, Ballarat, spinster, deceased (who died on the 2nd day of August, 1968), are requested to send particulars of their claims to the executor, The National Trustees, Executors and Agency Company of Australasia Limited, by the 17th day of January, 1969, after which date the said executor will distribute the assets, having regard only to the claims of which it then has notice.

NEVETT, GLENN & COUTTS, 205 Dana-street, Ballarat. 5475

CREDITORS, next of kin and others having claims against the estate of Annie Feil, late of 36 Wattle-road, Hawthorn, widow, deceased (who died on the 25th day of August, 1968), are required to send particulars of their claims to Annie Raphaele Violet Feil, care of the under-mentioned solicitors, by the 20th January, 1969, after which date the said executrix will distribute the estate, having regard only to the claims of which she then has notice.

J. A. REDMOND & CO.; solicitors, 358 Collins-street, Melbourne. 5486

CREDITORS, next of kin and others having claims against the estate of John Emery Klein, late of Flat 9, 97 Punt-road, Windsor, in the State of Victoria, shopkeeper, deceased (who died on the 12th day of April, 1968), are required to send particulars of their claims to the administratrix of his estate, Rose Klein, care of the under-mentioned solicitors, before the 15th day of January, 1969, after which date the said administratrix will distribute the estate of the said deceased, having regard only to the claims of which she then has notice.

J. OKNO & CO., solicitors, of 390 Lonsdale-street, Melbourne. 5491

CREDITORS, next of kin and others having claims against the estate of Ladislav Herlinger, late of 6 Sheffield-street, Caulfield South, deceased (who died on the 18th day of April, 1968), are required to send particulars to Rosa Biller, the administratrix of his estate, care of the under-mentioned solicitors, by the 31st day of January, 1969, after which date she will distribute the assets, having regard only to the claims of which she then has notice.

LEO BROWNE, solicitor, of 180 Elgin-street, Carlton. 5497

CREDITORS, next of kin and others having claims against the estate of William Ariss, late of 155 Stewart-street, East Brunswick, deceased (who died on the 22nd day of August, 1968), are required to send particulars to Geoffrey Ariss and William Peter Ariss, executors of his estate, care of the under-mentioned solicitors, by the 31st day of January, 1969, after which date he will distribute the assets, having regard only to the claims of which he then has notice.

LEO BROWNE, solicitor, of 180 Elgin-street, Carlton. 5498

CREDITORS, next of kin and others having claims against the estate of Rhoda Ann Hart, late of Grace McKellar House, Ballarat-road, North Geelong, widow, deceased (who died on the 27th day of August, 1968), are required to send particulars to Frank Mitchell and Elizabeth Heid, the executors of her estate, care of the under-mentioned solicitors, by the 31st day of January, 1969, after which date they will distribute the assets, having regard only to the claims of which they then have notice.

PRICE, HIGGINS & FIDGE, solicitors, "Douglas House", 47 Yarra-street, Geelong. 5440

JOHN GURNER BURNELL, formerly of "Yarralla", 8 Parker-street, Castlemaine, in the State of Victoria, but late of 33A Thompson-road, Napier, New Zealand, retired engineer, DECEASED.

CREDITORS, next of kin and others having claims in respect of the estate of the deceased (who died on the 11th day of October, 1967), are required by the executors Reginald Dewez Burnell, of "Summerlea", Benalla, and Lynette Mary Harris, of "Murringong", Benalla, to send particulars to them, care of the under-mentioned solicitors, by the 15th day of January, 1969, after which date the executors may convey or distribute the assets, having regard only to the claims of which they then have notice.

Dated the 7th day of November, 1968.

MADDEN BUTLER ELDER & GRAHAM, solicitors, 31 Queen-street, Melbourne. 5518

CREDITORS, next of kin and others having claims in respect of the estate of Edward Thomas Egan, of St. Mary's Presbytery, 633 High-street, Golden Square, Catholic priest, deceased (who died on the 20th day of January, 1968), are to send particulars of their claims to National Trustees, Executors and Agency Company of Australasia Limited, of 46-48 Queen-street, Bendigo, by the 21st day of January, 1969, after which date it will distribute the assets, having regard only to the claims of which it then has notice.

HOGAN, HOGAN & PETERSEN, solicitors, of 68 Bull-street, Bendigo. 5472

CREDITORS, next of kin and others having claims against the estate of Walter Corin, late of 11 Fenton-street, Warragul, retired process worker (who died on the 22nd day of July, 1968), are requested to send particulars of their claims to Melva Alison Hawke, of 11 Fenton-street, Warragul, married woman, the executor, appointed by the deceased's will, in care of the undersigned by the 10th day of January, 1969, after which date they will distribute the assets, having regard only to the claims of which she then shall have had notice.

M. DAVINE & CO., solicitors, Warragul. 5446

CREDITORS, next of kin and others having claims against the estate of Daisy Ethel Jubber, late of 11 Hermitage-street, Lilydale, in the State of Victoria, widow, deceased (who died on 31st August, 1968), are required to send particulars of their claims to the executor The Equity Trustees Executors and Agency Company Limited, of 472 Bourke-street, Melbourne, on or before the 16th day of January, 1969, after which date the company will proceed to distribute the assets of the estate, having regard only to claims of which it shall then have had notice.

EALES & MILLER, solicitors, 443 Little Collins-street, Melbourne. 5517

WINIFRED SYBIL BUGDEN, late of 171 Orrong-road, Toorak, spinster, DECEASED, intestate (who died on the 19th/20th March, 1968).

CREDITORS, next of kin and others having claims against the estate of the deceased are required by the administrator, The Trustees Executors and Agency Company Limited, of 401 Collins-street, Melbourne, to send particulars of their claims to the said company, on or before the 16th January, 1969, after which date it will distribute the assets, having regard only to the claims of which it then has notice.

HOME, WILKINSON & LOWRY, solicitors, of 401 Collins-street, Melbourne. 5519

CHARLES JOHN RICHARDS, late of "Brownie", 102 Willsmere-road, North Kew, master printer, DECEASED.

CREDITORS, next of kin and all other persons having claims against the estate of the deceased, are required by the executors, the National Trustees Executors and Agency Company of Australasia Limited, to send particulars to its office, at 95 Queen-street, Melbourne, before the 24th day of January, 1969, after which date it will distribute the assets, having regard only to the claims of which it then has notice.

J. ALLAN ANDERSON & SON, solicitors, 472 Bourke-street, Melbourne, 3000. 5527

CYRIL HENRY BROWN, formerly of 42 Charman-road, Mentone, but late of 5 Maskell-street, North Brighton, retired wardman, DECEASED.

CREDITORS, next of kin and all other persons having claims against the estate of the deceased are required by the Executor, Mary Baguley, of 9 Maskell-street, North Brighton, married woman, to send particulars to her, care of the under-mentioned solicitors, on or before the 24th day of January, 1969, after which date she will distribute the assets, having regard only to the claims of which she then has notice.

J. ALLAN ANDERSON & SON, solicitors, 472 Bourke-street, Melbourne, 3000. 5524

JOHN MARSHALL GAHAN, late of 16 Harker-street, Alphington, in the State of Victoria, clerk, DECEASED.

CREDITORS, next of kin and all other persons having claims against the estate of the deceased, are required by the executor, Carmel Mary Gearing, of the Esplanade, Metung, married woman, to send particulars to her, care of the under-mentioned solicitors, on or before the 24th day of January, 1969, after which date she will distribute the assets, having regard only to the claims of which she then has notice.

J. ALLAN ANDERSON & SON, solicitors, 472 Bourke-street, Melbourne, 3000. 5525

WINIFRED MURIEL VICKERS CLARKSON, late of 18 Millicent-avenue, Toorak, in the State of Victoria, widow, DECEASED.

CREDITORS, next of kin and all other persons having claims against the estate of the deceased are required by the executors, Edna Rowena Hunt, of "Yamala", Olivers Hill, Frankston, married woman, and John Finlay Anderson, of 472 Bourke-street, Melbourne, solicitor, to send particulars to them, care of the under-mentioned solicitors, on or before the 24th day of January, 1969, after which date they will distribute the assets, having regard only to the claims of which they then have notice.

J. ALLAN ANDERSON & SON, solicitors, 472 Bourke-street, Melbourne, 3000. 5526

CREDITORS, next of kin and other persons having claims against the estate of Edith Mary Goynne, formerly of 70 Albert-road, South Melbourne, in the State of Victoria, but late of Mount Royal, Poplar-road, Parkville, in the said State, spinster, deceased (who died on the 8th June, 1968), are required to send particulars of their claims to National Trustees, Executors and Agency Company of

Australasia Limited, whose registered office is situated at 95 Queen-street, Melbourne, by the 14th January, 1969, after which date the executor will distribute the assets, having regard only for the claims of which it then has had notice.

LESTER, PEARN & FIELDEN, solicitors, 14 Haughton-road, Oakleigh. 5463

ESTHER WILSON, late of 47 Orrong-road, Elsternwick, widow, DECEASED.

CREDITORS, next of kin and others having claims in respect of the estate of the deceased (who died on the 12th day of August, 1968), are required by The Perpetual Executors and Trustees Association of Australia Limited, of 100-104 Queen-street, Melbourne, to send particulars of their claims to the said company, by the 17th day of January, 1969, after which date it will convey or distribute the assets, having had regard only to the claims of which the company then has notice.

DARVALL & HAMBLETON, solicitors, 7th Floor, T. & G. Building, 147 Collins-street, Melbourne. 5520

CREDITORS, next of kin and others having claims against the estate of Colin Thomas Boland, late of 100 Albert-street, Warragul, in the State of Victoria, but temporarily of Coronation-drive, Mount Morgan, in the State of Queensland (who died on the 7th day of January, 1968), are requested to send particulars of their claims to Lionel Francis Seear, registered bookmaker, of 100 Albert-street, Warragul, and Milo Charles Davine, solicitor, of Warragul, the executors, appointed by the deceased's will, in care of the undersigned, by the 10th day of January, 1969, after which date they will distribute the assets, having regard only to the claims of which they then shall have had notice.

M. DAVINE & CO., solicitors, Warragul. 5445

MARGARET ELLEN BROWN, late of 21 Leopold-street, Burwood, widow, DECEASED.

CREDITORS, next of kin and others having claims in respect of the estate of the deceased (who died on the 22nd June, 1968), are required by the executor Leslie Arthur Cheong, of 49 Vears-road, Burwood, insurance official, to whom probate of the will of the above-named deceased has been granted, to send particulars to him, care of the under-mentioned solicitor, by the 16th day of February, 1969, after which date the executor may convey or distribute the assets, having regard only to the claims of which he then has notice.

THOMAS BURKE, solicitor, of 152 Wattletree-road, Malvern. 5464

ALFRED JAMES DAY, late of Garden-street, Geelong, accountant, DECEASED.

CREDITORS, next of kin and others having claims in respect of the estate of the said deceased (who died 3rd July, 1968), are required by the applicants for grant of probate of the will, Howard Norman Day, of 24 Wimmera-avenue, Manifold Heights, Geelong, chartered accountant, and The Equity Trustees Executors & Agency Company Limited, of 472 Bourke-street, Melbourne, to send particulars to them, care of The Equity Trustees Executors & Agency Company Limited, 472 Bourke-street, Melbourne, by 15th January, 1969, after which date the said applicants may convey or distribute the assets, having regard only to the claims of which they then have notice.

WIGHTON & McDONALD, solicitors, 89 Myers-street, Geelong. 5433

CREDITORS, next of kin and others having claims in respect of the estate of William Alfred Denney, late of 18 Bokhara-road, Caulfield, railway employee, deceased (who died on the 25th day of June, 1968), are requested to send particulars of their claims to Kenneth John Clements, of 255 Glenhuntingly-road, Elsternwick, solicitor, the executor of the will of the said deceased, by the 1st day of February, 1969, after which date the executor will distribute the assets, having regard only to the claims of which he has notice.

KENNETH J. CLEMENTS & SON, solicitors, 255 Glenhuntingly-road, Elsternwick. 5455

CREDITOR, next of kin and all other persons having claims in respect of the estate of Gelsomine Joseph Pittorino (also known as Jesmin Joseph Pittorino), late of 14 Flowers-street, Caulfield, in the State of Victoria, company director, deceased, intestate (who died on the 17th day of January, 1967), are to send in particulars of their claims to Joseph Jesmen Felice Pittorino, care of Septimus

Jones & Lee, solicitors, 327 Collins-street, Melbourne, by the 24th day of January, 1969, after which date the said administrator will distribute the assets, having regard only to the claims of which they shall then have notice.

SEPTIMUS JONES & LEE, of 327 Collins-street, Melbourne, proctors for the administrator. 5454

JOHN RICHARD SAVILLE SEALY, late of Auckland, New Zealand, company manager, DECEASED.

CREDITORS, next of kin and others having claims in respect of the estate of the above-named deceased (who died on the 4th February, 1965), are required by the trustee Peter Balmford, of 166 Queen-street, Melbourne, solicitor, to send particulars to him care of the undersigned by the 15th day of January, 1969, after which date the trustee may convey or distribute the assets, having regard only to the claims of which he then has notice.

WHITING & BYRNE, 166 Queen-street, Melbourne. 5482

WILLIAM GEORGE BORROW, late of 49 Daley-street, Bentleigh, in the State of Victoria, retired salesman, DECEASED, intestate.

CREDITORS, next of kin and others having claims in respect of the estate of the deceased (who died on the 3rd day of September, 1968), are required by The National Trustees, Executors and Agency Company of Australasia Limited, of 95 Queen-street, Melbourne, to send particulars of their claims to the said company by the 14th day of January, 1969, after which date they will convey or distribute the assets, having regard only to claims of which the company then has notice.

WEIGALL & CROWTHER, 83 William-street, Melbourne. 5483

CREDITORS, next of kin and others having claims in respect of the estate of William Whatley Ingram, late of 22 Thames-street, Heidelberg, retired clergyman, deceased (who died on the 23rd August, 1968), are to send particulars of their claims to National Trustees, Executors and Agency Company of Australasia Limited, of 95 Queen-street, Melbourne, by the 17th January, 1969, after which date it will convey or distribute the assets, having regard only to the claims of which it then has notice.

Dated the 5th November, 1968.

MALLESONS, solicitors, 105 King-street, Melbourne. 5485

CREDITORS, next of kin and others having claims in respect of the estate of Sydney Charles Hainsworth, late of 241 Waterdale-road, Ivanhoe, in the State of Victoria, retired engineer, deceased (who died on the 30th August, 1968), are required to send particulars of their claims to the National Trustees, Executors and Agency Company of Australasia Limited, of 95 Queen-street, Melbourne, in the said State by the 15th January, 1969, after which date it will distribute the assets, having regard only to the claims of which it then has notice.

HERBERT TURNER & SON, solicitors, 411 Collins-street, Melbourne. 5487

RONALD EVAN THURLING, DECEASED.

CREDITORS, next of kin and others having claims in respect of the estate of Ronald Evan Thurling, late of 27 Waltham-street, Richmond, retired railway employee, deceased (who died on 18th May, 1968), are to send particulars of their claims to Ray Ernest Wait, of Flat No. 1, 35 Clyde-street, East Kew, company director (the executor of the will of the said deceased) care of the under-mentioned solicitors by the 23rd January, 1969, after which date he will distribute the assets, having regard only to the claims of which he then has notice.

COLE & O'HEARE, solicitors, 465 Collins-street, Melbourne. 5496

ESTHER SUITER, late of 42 Victoria-street, Williamstown, spinster, DECEASED.

CREDITORS, next of kin and others having claims in respect of the estate of the deceased (who died on 22nd day of August, 1968), are required by the trustee, John Wallace Ball, of 430 Little Collins-street, Melbourne, solicitor, to send particulars to him by the 22nd day of January, 1969, after which date the trustee may convey or distribute the assets, having regard only to claims of which he then has notice.

MESSRS. HENDERSON & BALL, 430 Little Collins-street, Melbourne. 5500

WALTER HERBERT NOSKE, late of 5 Smythe-avenue, Mont Albert, in the State of Victoria, clergyman, DECEASED.

CREDITORS, next of kin and others having claims in respect of the estate of the deceased (who died on the 10th day of April, 1968), are required by the trustees, The Equity Trustees, Executors and Agency Company Limited, of 472 Bourke-street, Melbourne, in the said State, and Dennis John Grieger, of 5 Smythe-avenue, Mont Albert, in the said State, to send particulars to them by the 15th January, 1969, after which date the trustees may convey or distribute the assets, having regard only to the claims of which they then have notice.

SLATER & GORDON, solicitors, 395 Collins-street, Melbourne. 5501

PURSUANT to the provisions of the *Trustee Act 1958*, creditors, next of kin and all other persons having claims in respect of the estate of Margaret Wilson, late of 23 Benjamin-street, Sunshine, home duties (who died on the 6th August, 1968), are required to send particulars of their claims to the executor, The Union-Fidelity Trustee Company of Australia Limited, the registered office of which is situate at 100 Exhibition-street, Melbourne, by the 15th January, 1969, after which date the company will distribute the assets, having regard only to the claims of which it shall then have had notice.

MADDOCK, LONIE & CHISHOLM, solicitors, 339 Collins-street, Melbourne. 5499

CREDITORS, next of kin and others having claims in respect of the estate of Mary Margaret Cumming, formerly of 64 Warrigal-road, Mentone, but late of 40 Savige-street, Morwell, widow, deceased (who died on the 4th day of July, 1968) and probate of whose will has been granted to Joy Marie Smith, of 40 Savige-street, Morwell, are required to send particulars of their claims to the said executrix, care of the under-mentioned solicitors, by the 13th day of January, 1969, after which date she will distribute the assets, having regard only to the claims of which she then has notice.

TRUCANO & MACMILLAN, solicitors of Buckley-street, Morwell. 5515

CREDITORS, next of kin and others having claims in respect of the estate of Robert James Hodgens, late of 25 Junier-street, Morwell, clerk, deceased (who died on the 21st June, 1968, and probate of whose will has been granted to Shirley Jean Hodgens, of 25 Junier-street, Morwell and Thomas Kevin Kennedy, of 9 Joy-street, Morwell), are required to send particulars of their claims to the said executors, care of the under-mentioned solicitors, by the 13th day of January, 1969, after which date they will distribute the assets, having regard only to the claims of which they then have notice.

TRUCANO & MACMILLAN, solicitors of Buckley-street, Morwell. 5516

PURSUANT to the provisions of the *Trustee Act 1958*, creditors, next of kin and all other persons having claims in respect of the estate of Annie Maria McCulloch, formerly of Wickham-road, Moorabbin, but late of Chelmer Hospital, Nepean Highway, Cheltenham, widow, deceased (who died on the 11th April, 1968), are required to send particulars of their claims to the executors, Lyston Arthur Chisholm and Donald Lyston Chisholm, both of 339 Collins-street, Melbourne, solicitors, by the 22nd January, 1969, after which date they will distribute the assets, having regard only to the claims of which they shall then have had notice.

MADDOCK, LONIE & CHISHOLM, solicitors, 339 Collins-street, Melbourne. 5492

CHARLES ALOYSIUS O'HALLORAN, late of 369 Alma-road, Caulfield, company director, DECEASED (who died on 1st June, 1968).

CREDITORS, next of kin and other persons having claims against the estate of the deceased are required by the executors of his will, Dorothy O'Halloran, of 369 Alma-road, Caulfield, widow and Patricia Mary Abrahams, of "Two Hills", Riddells Creek, married woman, to send particulars thereof to them care of the under-mentioned solicitors before 15th January, 1969, after which date they may distribute the assets of the deceased, having regard only to the claims of which they then have notice.

COLTMAN, WYATT & ANDERSON, solicitors, of 578 Bourke-street, Melbourne. 5502

BERTHA LOUISA MUNRO, late of "Bem Brae", Molesworth, widow, DECEASED (who died on the 28th day of June, 1968).

CREDITORS, next of kin and all other persons having claims against the estate of the deceased, are required by the executor of her will, Leslie Franzl, of 24 Scott-street, Bentleigh, chauffeur to send particulars thereof to him, care of the under-mentioned solicitors, before the 13th day of January, 1969, after which date he may distribute the assets of the deceased, having regard only to the claims of which he then has notice.

COLTMAN, WYATT & ANDERSON, solicitors, of 578 Bourke-street, Melbourne. 5495

VIOLET MARY ISABEL SQUIRE, late of 224 Balcombe-road, Mentone, widow, DECEASED (who died on the 30th day of June, 1968).

CREDITORS, next of kin and all other persons having claims against the estate of the deceased, are required by the executor of her will, Frederick Edwin Barlow Warden, of Woorigee, via Beechworth, farmer, to send particulars thereof to him, care of the under-mentioned solicitors, before the 13th day of January, 1969, after which date he may distribute the assets of the deceased, having regard only to the claims of which he then has notice.

COLTMAN, WYATT & ANDERSON, solicitors, 578 Bourke-street, Melbourne. 5494

LILIAN BEST, late of 3 Gawith-court, Toorak, widow DECEASED (who died on the 25th day of August, 1968).

CREDITORS, next of kin and all other persons having claims against the estate of the deceased, are required by the executrices of her will, Joan Blennerhasset Best, secretary and Judith Blennerhasset Best, radiographer, both of 3 Gawith-court, Toorak, to send particulars thereof to them, care of the under-mentioned solicitors before the 13th day of January, 1969, after which date they may distribute the assets of the deceased, having regard only to the claims of which they then have notice.

COLTMAN, WYATT & ANDERSON, solicitors, of 578 Bourke-street, Melbourne. 5493

CREDITORS, next of kin and others having claims against the estate of Thomas White, late of McIvor-road, Bendigo, in the State of Victoria, retired farmer, deceased, intestate (who died on the 18th day of May, 1968), are required to send particulars thereof to National Trustees, Executors and Agency Company of Australasia Limited, of 46 Queen-street, Bendigo, in the said State, by the 6th day of January, 1969, after which date the said company will distribute the assets of the said deceased, having regard only to the claims of which it then has notice.

WATSON, JAMES & ROGERS, solicitors, Bull-street, Bendigo. 5469

IMPOUNDINGS

COBRAM.—Impounded in Cobram Pound, from Murray Valley Highway, Cobram.

1 cream coloured gelding, 16½ hands, no visible brand
If not claimed and expenses paid, to be sold on 27th November, 1968.

5466—\$1.75 R. T. CUTTS,
Shire Secretary.

FLINDERS.—Impounded in Flinders Shire Pound.

1 colt, yearling, 12 hands, cream colour, black points, no visible brand

If not claimed and expenses paid, to be sold on 28th November, 1968.

5476—\$1.75 O. J. BISHOP,
Poundkeeper.

SWAN HILL.—Impounded in Swan Hill Pound on 6th November, 1968 and 8th November, 1968.

1 Guernsey heifer, brown and white, no visible brand
1 Merino ewe, green JH joined on back, blue tag left ear
2 off-shears wethers, brown AC joined on rump

If not claimed and expenses paid, to be sold on 2nd December, 1968.

5531—\$2.25 F. G. BLAIR,
Poundkeeper.

WHITTLESEA.—Impounded in Epping Pound, by Ranger.

1 Black Poll cow, M cut on bottom of left ear, V cut on top of right ear, branded W over JC on left rump
If not claimed and expenses paid, to be sold on 29th November, 1968.

5444—\$1.75
W. HERD,
Poundkeeper.

WODONGA.—Impounded in Wodonga Pound by W. Mullins, from his property at Bandiana, on 31st October, 1968.

1 black Hereford bull, about 12 months old, no ear mark, no visible brand
If not claimed and expenses paid, to be sold on 19th November, 1968.

Impounded by W. Mullins, from his property at Bandiana, on 31st October, 1968.

1 aged cross-bred ewe, W out of top of off ear, piece out of top of near ear, no visible brand

If not claimed and expenses paid, to be sold on 18th November, 1968.

5471—\$3.75
A. A. NUGENT,
Poundkeeper.

Subordinate Legislation Act 1962.

NOTICE OF MAKING OF STATUTORY RULES.

IN pursuance of the provisions of the *Subordinate Legislation Act 1962* and the Regulations made thereunder, notice is given of the making of the following statutory rules:—

No.	Police Regulation Act 1958.	Price.
274/1968.	Police (Summer Uniform) Regulations 1968	15c
	<i>Juries Act 1967.</i>	
276/1968.	Jury Service Appeals Rules 1968	10c
	<i>Cattle Compensation Act 1967.</i>	
277/1968.	Cattle Compensation Regulations 1968	15c
	<i>Swine Compensation Act 1967.</i>	
278/1968.	Swine Compensation Regulations 1968	15c
	<i>Education Act 1958.</i>	
279/1968.	Adult Education Regulations (Salaries) 1968, No. 2	10c
	<i>Discharged Servicemen's Preference Act 1943.</i>	
280/1968.	Discharged Servicemen's Preference Act 1943—Salaries Regulations	10c

Copies of these statutory rules may be purchased at the Sale of Publications Section of the Government Printing Office, located at Macarthur-street, Melbourne, 3002. If ordered by mail, remittance should be addressed to "The Government Printer, Box 203, P.O., North Melbourne, 3051", and should include 5c extra for postage. If a credit account is held at this office, no remittance is required with the mail order.

The annual subscription rate for Statutory Rules (including a Bound Volume) is \$15, payable in advance. The subscription year commences on 1st January.

A. C. BROOKS,
Government Printer.

STATE ACTS, 1967

COPIES of the following Acts of Parliament of Victoria may be obtained at the Government Printing Office, or from any accredited agents, at the price set opposite to each (these prices do not include postage).

The annual subscription for State Acts 1967 et seq. is \$8 payable in advance.

Bound Volumes of State Acts are also available on a subscription basis at \$15 per annum.

No.	Price.
7515. New Melbourne Cemetery Lands	\$0.10
7516. Country Fire Authority (Prosecutions)	\$0.10
7517. Social Welfare (Detention)	\$0.10
7518. Zoological Gardens	\$0.15

STATE ACTS, 1967—continued.

No.	Price.
7519. Richmond (South-Eastern Freeway) Lands	\$0.10
7520. The Geelong Gas Company's	\$0.10
7521. Co-operative Housing Societies (Indemnities)	\$0.10
7522. Supreme and County Courts (Sittings)	\$0.10
7523. Dandenong Valley Authority (Amendment)	\$0.15
7524. State Savings Bank (Amendment)	\$0.10
7525. Land (Surf Life Saving Association)	\$0.10
7526. Warragul (Public Park) Lands	\$0.10
7527. Tobacco Leaf Marketing Board (Appointment of Manager) (Amendment)	\$0.10
7528. Stock Artificial Breeding (Amendment)	\$0.10
7529. Second-hand Dealers (Amendment)	\$0.10
7530. Legal Aid (Amendment)	\$0.10
7531. Weights and Measures (Amendment)	\$0.25
7532. The Constitution Act Amendment (Electoral)	\$0.10
7533. Education and Teaching Service (Amendment)	\$0.15
7534. Public Officers Salaries and Allowances	\$0.10
7535. Railways (State Coal Mine Officers)	\$0.10
7536. Public Officers (Long Service Leave)	\$0.15
7537. Pipelines (Submerged Lands)	\$0.30
7538. Police Regulation (Pensions)	\$0.10
7539. Legal Profession Practice (Victoria Law Foundation)	\$0.10
7540. Petroleum (Barracouta and Marlin Fields Agreement)	\$0.25
7541. Pipelines	\$0.25
7542. Local Government (Amendment)	\$0.15
7543. Stamps (Amendment)	\$0.10
7544. Police Offences (Obscene Publications)	\$0.10
7545. Melbourne University (Amendment)	\$0.10
7546. Crimes	\$0.15
7547. Instruments (Corporate Bodies Contracts)	\$0.10
7548. Land (Amendment)	\$0.25
7549. Water (Amendment)	\$0.10
7550. Dowling Forest Racecourse Lands	\$0.15
7551. Strata Titles	\$0.40
7552. Revocation and Excision of Crown Reservations	\$0.15
7553. Tullamarine Freeway Lands	\$0.15
7554. Friendly Societies Investment	\$0.10
7555. Victorian Institute of Colleges (Board of Studies)	\$0.10
7556. Consolidated Revenue	\$0.10
7557. Consolidated Revenue	\$0.10
7558. Joint Select Committee (Drainage)	\$0.15
7559. Consolidated Revenue	\$0.10
7560. Consolidated Revenue	\$0.10
7561. Grain Elevators (Borrowing Powers)	\$0.10
7562. Building Societies (Unsecured Loans)	\$0.10
7563. Money Lenders (Corporation Licences)	\$0.10
7564. Barley Marketing (Amendment)	\$0.10
7565. Medical (Foreign Practitioners)	\$0.10
7566. Masseurs (Amendment)	\$0.10
7567. Firearms (Prohibited Persons)	\$0.10
7568. Joint Select Committee (Meat Industry)	\$0.10
7569. Council of Law Reporting in Victoria	\$0.15
7570. Marketable Securities	\$0.15
7571. Railway Lands	\$0.10
7572. Labour and Industry (Fees)	\$0.10
7573. Geelong Waterworks and Sewerage	\$0.10
7574. Aboriginal Affairs	\$0.25
7575. Co-operative Housing Societies (Amendment)	\$0.10
7576. Rural Finance (Amendment)	\$0.10
7577. Crimes (Amendment)	\$0.10
7578. Revocation and Excision of Crown Reservations (No. 2)	\$0.15
7579. Gaols (Amendment)	\$0.10
7580. Gas Regulation (Amendment)	\$0.10
7581. Judges and Public Officers Salaries	\$0.15
7582. Portland Harbor (Exchange of Land)	\$0.15
7583. Carlton (Recreation Ground) (Amendment) Land	\$0.10
7584. Superannuation (Amendment)	\$0.15
7585. Stamps	\$0.30
7586. Educational Grants	\$0.10
7587. Motor Car (Hours of Driving)	\$0.10
7588. Poisons (Amendment)	\$0.10
7589. Housing (Amendment)	\$0.10
7590. Water (Further Amendment)	\$0.15
7591. Petroleum (Submerged Lands)	\$0.90
7592. Supreme Court (Judges)	\$0.10
7593. Motor Car	\$0.15
7594. Labour and Industry (Bread)	\$0.15
7595. Pesticides (Amendment)	\$0.10
7596. Judicial Proceedings Report (Amendment)	\$0.10
7597. Administration and Probate (Amendment)	\$0.10
7598. Mental Health (Pathological Examinations)	\$0.10
7599. Veterinary Surgeons (Amendment)	\$0.10
7600. Licensing (Rutherglen Wine Festival)	\$0.10
7601. Estate Agents (Objections)	\$0.10
7602. Joint Select Committee (Road Safety)	\$0.10

STATE ACTS, 1967—continued.

No.	Price.
7603. Richmond High School Land ..	\$0.10
7604. Fertilizers (Amendment) ..	\$0.15
7605. Milk and Dairy Supervision (Amendment) ..	\$0.10
7606. Country Fire Authority (Notices) ..	\$0.10
7607. Stock Foods (Amendment) ..	\$0.15
7608. Litter ..	\$0.10
7609. Municipal Association (Amendment) ..	\$0.10
7610. Maintenance (Amendment) ..	\$0.10
7611. Yea Civic Centre and Court House ..	\$0.15
7612. Shepparton Abattoirs ..	\$0.15
7613. Yarraville (Recreation Ground) Lands ..	\$0.15
7614. Swine Compensation ..	\$0.25
7615. Cattle Compensation ..	\$0.25
7616. Ringwood and Warrandyte Lands ..	\$0.10
7617. Harbor Charges ..	\$0.15
7618. Melbourne Harbor Trust Land ..	\$0.10
7619. Justices (Amendment) ..	\$0.10
7620. Portland Harbor Trust (Amendment) ..	\$0.10
7621. Racing ..	\$0.15
7622. Melbourne and Metropolitan Tramways (Detours) ..	\$0.10
7623. Land (Committees of Management) ..	\$0.15
7624. Mildura Irrigation and Water Trusts (Amendment) ..	\$0.10
7625. Apprenticeship (Amendment) ..	\$0.10
7626. Local Government (Municipalities Assistance Fund) ..	\$0.10
7627. Fitzroy (Edinburgh Gardens) Lands ..	\$0.15
7628. Coal Mines (Pensions) ..	\$0.10
7629. Lifts and Cranes ..	\$0.15
7630. Licensing (Amendment) ..	\$0.10
7631. The Geelong Gas Company's (Amendment) ..	\$0.15
7632. Extractive Industries (Amendment) ..	\$0.10
7633. Land Tax (Rates) ..	\$0.10
7634. Sunday Entertainment ..	\$0.15
7635. Summary Offences ..	\$0.10
7636. Stamps (Exemptions) ..	\$0.10
7637. Rain-making Control ..	\$0.15
7638. Cemeteries (St. Kilda Public Cemetery) ..	\$0.10
7639. Weights and Measures (Pre-packed Articles) ..	\$0.30
7640. State Forests Loan Application ..	\$0.10
7641. Fisheries (Amendment) ..	\$0.15
7642. Barry Beach Railway Construction ..	\$0.10
7643. Marketing of Primary Products (Amendment) ..	\$0.10
7644. Victoria Institute of Colleges ..	\$0.15
7645. Crimes (Driving Offences) ..	\$0.15
7646. Private Agents ..	\$0.10
7647. Teaching Service (Teachers Tribunal) ..	\$0.15
7648. Motor Car (Compulsory Third Party Insurance) ..	\$0.10
7649. Public Works Loan Application ..	\$0.15
7650. Railway Loan Application ..	\$0.15
7651. Juries ..	\$0.35
7652. Westernport Development ..	\$0.15
7653. North Melbourne Lands (Amendment) ..	\$0.10
7654. Water Supply Loan Application ..	\$0.25
7655. Appropriation of Revenue ..	\$1.15

A. C. BROOKS,
Government Printer.

AGENTS FOR THE "VICTORIA GOVERNMENT GAZETTE".

THE following have been appointed agents to receive Advertisements and Subscriptions for the *Victoria Government Gazette*:—

- ARMSTRONG'S AGENCY, 205 Queen-street, Melbourne, Victoria 3000.
- ARNALL & JACKSON, 390 Barkly-street, Brunswick, Victoria 3056.
- BAIRNSDALE AUTHORIZED NEWSAGENCY, 132 Main-street, Bairnsdale, Victoria 3875.
- BICKNELL, M. J., Authorized Newsagent, 196 Timor-street, Warrambool, Victoria 3280.
- BLANE'S AUTHORIZED NEWSAGENTS, 162 Murray-street, Colac, Victoria 3250.
- R. G. CARTER ADVERTISING SERVICE PTY. LTD., Suite 24, 65 Queens-road, Melbourne, Victoria 3004.
- DAVIES, G. & M. V., 112 Gray-street, Hamilton, Victoria 3300.
- DAVIS, WM. (MILDURA) PTY. LTD., 126 Eighth-street, Mildura, Victoria 3500.

- DIXON'S NEWSAGENCY, 89 Firebrace-street, Horsham, Victoria 3400.
- EDGAR'S NEWSAGENCY PTY. LTD., 293 Hargreaves-street, Bendigo, Victoria 3550.
- EDGARS' AUTHORIZED NEWSAGENCY, 45 Bridge-street, Benalla, Victoria 3672.
- FRANKS, H., & CO., 184 Ryrie-street, Geelong, Victoria 3220.
- GORDON & GOTCH AUSTRALASIA LTD., 511 Little Collins-street, Melbourne, Victoria 3000.
- GULLAN'S NEWSAGENCY, 88 Bridge-street, Ballarat, Victoria 3350.
- HAMPTON, A. C., 243 Mitchell-street, Bendigo, Victoria 3550.
- HARSTON, PARTRIDGE & CO. PTY. LTD., 455 Little Collins-street, Melbourne, Victoria 3000.
- KYNETON GUARDIAN PTY. LTD., P.O. Box 18, Kyneton, Victoria 3444.
- LATIMER'S, Newsagents, 45 Station-street, Malvern, Victoria 3144.
- LIVINGSTON'S SHEPPARTON NEWSAGENCY, 246 Wyndham-street, Shepparton, Victoria 3630.
- THE MERCANTILE EXCHANGE, 67 Queen-street, Melbourne, Victoria, 3000.
- MCGILL'S AUTHORIZED NEWSAGENCY, 183-5 Elizabeth-street, Melbourne, Victoria 3000.
- PHILLIPS AUTHORIZED AGENCY, 83 Murphy-street, Wangaratta, Victoria 3677.
- PURDIE, J., & CO., 138 Moorabool-street, Geelong, Victoria 3220.
- SALE AUTHORIZED NEWSAGENCY, 142 Raymond-street, Sale, Victoria 3850.
- SKINNER'S AUTHORIZED NEWSAGENCY, 49-51 Franklin-street, Traralgon, Victoria 3844.
- STEVENSON, A. C. & M., NEWSAGENTS, 132 Henty-street, Casterton, Victoria 3311.
- VERNON, C. F. & H. J., 162 Bridge-road, Richmond, Victoria 3121.
- VIEW POINT AUTHORIZED NEWSAGENCY, 4 View-Point, Bendigo, Victoria 3550.

A copy of the *Gazette* filed at each place for public reference.

CONTENTS

	PAGE
Acts of Parliament	3715
Acts of Parliament on sale at the Government Printing Office	3767
Appointments	3735
Companies Act 1961—Notice	3728
Contracts	3729
Estates of Deceased Persons	3730
Government Notices	3715
Impoundings	3766
Lands	3743
Melbourne and Metropolitan Board of Works—Notice	3728
Mining	3730
Notice to attend for Radiological Examination	3727
Notice to Mariners	3729
Notice of Making of Statutory Rules	3767
Orders in Council—	
Acts—Land; Landlord and Tenant; Country Roads; Sewerage Districts; Water; et seq Forests; Housing.	3736
Police Sale	3715
Private Advertisements	3754
Proclamations	3713
Public Service Notices	3752
Resignations	3736
State Rivers and Water Supply Commission	3726
Tenders	3752
Transport Regulation Board—Public Hearings	3718
Waterworks Trusts	3731