



# VICTORIA GOVERNMENT GAZETTE

Published by Authority

[Registered at the General Post Office, Melbourne, for transmission by post as a newspaper.]

No. 781

WEDNESDAY, SEPTEMBER 3

[1969

## PROCLAMATIONS

*Land Act 1958.*

AREA OF LAND COMPRISED IN CERTAIN CLASSES DIMINISHED OR INCREASED.

### PROCLAMATION

By His Excellency the Governor of the State of Victoria and its Dependencies in the Commonwealth of Australia, &c., &c., &c.

WHEREAS by the *Land Act 1958* it is amongst other things enacted that the Governor in Council may, by Proclamation to be published in the *Government Gazette*, at any time diminish or increase the area of land comprised in any of the classes mentioned in Part I., Division 1, Section 5, of the said *Land Act 1958*, but that the area of lands which may be sold by auction (Class 6), shall not be increased except as in certain cases in the said Act provided: Now therefore I, the Governor of the State of Victoria, in the Commonwealth of Australia, by and with the advice of the Executive Council of the said State, and in accordance with the provisions of Sections 94 and 117 of the *Land Act 1958* aforesaid, do hereby diminish or increase (as the case may be) the areas of Crown lands comprised in Classes 6 and 7 of the classes mentioned in Section 5 of the *Land Act 1958* aforesaid, to the extent set forth in the subjoined Schedule (that is to say):—

Schedule referred to.  
CLASSES DIMINISHED OR INCREASED.

County.	Parish.	Allotment.	Section.	Area.	Diminished.	Increased.	Description.
					Class.	Class.	
				A. R. P.			
Bogong ..	Beechworth ..	1F	K	2 1 33	7	6	In the centre of the Parish
Bogong ..	Yackandandah ..	7F	A5	1 2 29	7	6	In the east of the Parish
Borong ..	Boroka ..	5H	..	7 0 18	..	6	In the north west of the Parish

Given under my Hand and the Seal of the State of Victoria, aforesaid, at Melbourne, this twenty-sixth day of August, in the year of our Lord One thousand nine hundred and sixty-nine, and in the eighteenth year of the reign of Her Majesty Queen Elizabeth II.

(L.S.)

ROHAN DELACOMBE.

By His Excellency's Command,  
W. J. F. McDONALD,  
Minister of Lands.

GOD SAVE THE QUEEN !

Land Act 1958.

UNALIENATED CROWN LAND AVAILABLE FOR SETTLEMENT UNDER IMPROVEMENT PURCHASE LEASES.

PROCLAMATION

By His Excellency the Governor of the State of Victoria and its Dependencies in the Commonwealth of Australia, &c., &c., &c.

IN pursuance of the provisions of Section 153 of the Land Act 1958, I, the Governor of the State of Victoria, in the Commonwealth of Australia, by and with the advice of the Executive Council of the said State, do by this Proclamation declare the unalienated Crown lands mentioned in the subjoined schedule, to be available for settlement under improvement purchase leases.

SCHEDULE.

County.	Parish.	Allotment.	Section.	Area.		Land Valuation.
				A.	R. P.	
Evelyn	Beenak	74D, 74E	..	187	0 7	\$30 per acre
		74, 74C	..	172	0 7	\$30 per acre
		75	..	184	2 35	\$30 per acre
		75A, 75B	..	144	2 21	\$30 per acre
Normanby	Mouzie	39	9	248	0 0	\$15 per acre
Normanby	Mouzie	32	9	212	0 0	\$15 per acre
Tambo	Buchan	7F and 7G	C	80	0 0	\$6 per acre

Given under my Hand and the Seal of the State of Victoria aforesaid, at Melbourne, this twenty-sixth day of August, in the year of our Lord One thousand nine hundred and sixty-nine and in the eighteenth year of the reign of Her Majesty Queen Elizabeth II.

(L.S.)

ROHAN DELACOMBE.

By His Excellency's Command,

W. J. F. McDONALD,  
Minister of Lands.

GOD SAVE THE QUEEN !

LAND ACT 1958, SECTION 153.

PROCLAMATION RESCINDED

By His Excellency the Governor of the State of Victoria and its Dependencies in the Commonwealth of Australia, &c., &c., &c.

IN pursuance of the provisions of Section 153 of the Land Act 1958, I, the Governor of the State of Victoria in the Commonwealth of Australia, by and with the advice of the Executive Council of the said State, do hereby rescind the Proclamation made on the 30th October, 1968, published in the Government Gazette of the 6th November, 1968, on page 3651 whereby 50 acres of Crown land in the Parish of Beechworth, County of Bogong was made available for settlement under improvement purchase leases at a land valuation of \$20.00 per acre.—(H.032339).

Given under my Hand and the Seal of the State of Victoria aforesaid, at Melbourne, this twenty-sixth day of August, in the year of our Lord One thousand nine hundred and sixty-nine, and in the eighteenth year of the reign of Her Majesty Queen Elizabeth II.

(L.S.)

ROHAN DELACOMBE.

By His Excellency's Command,

W. J. F. McDONALD,  
Minister of Lands.

GOD SAVE THE QUEEN !

the Parish of Gembrook, Counties of Evelyn and Mornington as indicated by hatching on plan hereunder.—(G.206(14) (G.69508).

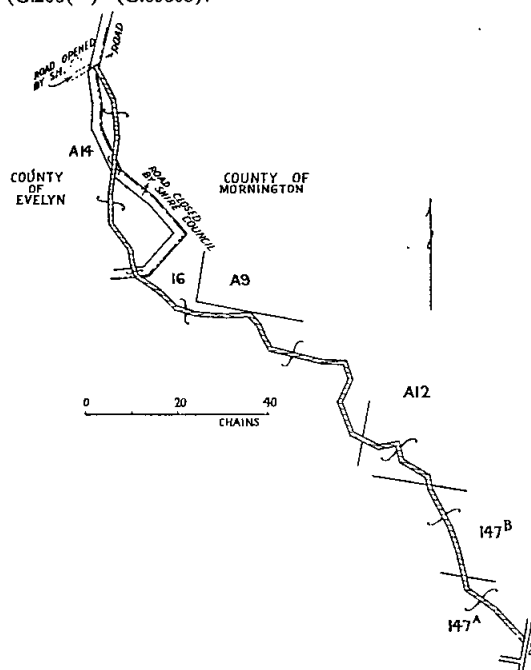

Given under my Hand and the Seal of the State of Victoria aforesaid, at Melbourne, this twenty-sixth day of August, in the year of our Lord One thousand nine hundred and sixty-nine, and in the eighteenth year of the reign of Her Majesty Queen Elizabeth II.

(L.S.)

ROHAN DELACOMBE.

By His Excellency's Command,

W. J. F. McDONALD,  
Minister of Lands.

GOD SAVE THE QUEEN !

Land Act 1958, Section 25.

ROAD PROCLAIMED.

PROCLAMATION

By His Excellency the Governor of the State of Victoria and its Dependencies in the Commonwealth of Australia, &c., &c., &c.

IN pursuance of the provisions of Section 25 of the Land Act 1958, I, the Governor of the State of Victoria, by and with the advice of the Executive Council of the said State, do hereby proclaim as a road the land in

LOCAL GOVERNMENT (RATING EXEMPTIONS)  
ACT 1969.—No. 7847.  
DAY OF COMING INTO OPERATION.

PROCLAMATION

By His Excellency the Governor of the State of Victoria and its Dependencies in the Commonwealth of Australia, &c., &c., &c.

IN pursuance of the provisions of Section 1 (3) of the *Local Government (Rating Exemptions) Act 1969, I*, the Governor of the State of Victoria, by and with the advice of the Executive Council thereof, do, by this my Proclamation fix the 1st October, 1969, as the day on which the provisions of the said Act shall come into operation.

Given under my Hand and the Seal of the State of Victoria aforesaid, at Melbourne, this twenty-sixth day of August, in the year of our Lord One thousand nine hundred and sixty-nine, and in the eighteenth year of the reign of Her Majesty Queen Elizabeth II.

(L.S.) ROHAN DELACOMBE.

By His Excellency's Command,  
R. J. HAMER,  
Minister for Local Government.

GOD SAVE THE QUEEN!

GOVERNMENT NOTICES

LOCAL GOVERNMENT DEPARTMENT.

ORDER CONFIRMED.—CITY OF BRIGHTON.

THE Minister of the Crown administering the *Local Government Act 1958*, on the 1st day of September, 1969, confirmed the Order hereinafter referred to, in pursuance of section 514 of the said Act namely:

An Order of the Council of the City of Brighton, made on the 21st July, 1969, directing the compulsory taking of the land described hereunder for the purpose of providing a car parking area in the vicinity of the Church-street Shopping Centre, Brighton.

All that piece of land being part of the land described in certificate of title, volume 4825, folio 928, commencing at a point 132 ft. 5 in. south-west of a point 269 ft. 10 in. along the south-west boundary of Black-street from its intersection with the south-east boundary of Carpenter-street; thence south-east for 62 ft. 7½ in.; south-west for 32 ft. 2 in.; north-west for 9 feet; north-east for 0 ft. 6 in.; north-west for 53 ft. 4 in.; and north-east for 31 ft. 8 in. to the point of commencement.

R. J. HAMER,  
Minister for Local Government.

Local Government Department,  
Melbourne.

Co-operation Act 1958.

CHANGE OF NAME OF A SOCIETY.

NOTICE is hereby given that St. Patrick's Wangaratta Co-operative Credit Society Limited, which was incorporated as a Credit Society under the above-named Act on the nineteenth day of October, 1964, has registered a change of its name and is now incorporated under the name of Wangaratta Co-operative Credit Society Limited under the said Act.

Dated at Melbourne this twenty-eighth day of August, 1969.

M. V. HAMMOND,  
Deputy Registrar of Co-operative Societies.

OCEAN GROVE SEWERAGE AUTHORITY.

ANNUAL BALANCE.

HIS Excellency the Governor of the State of Victoria, by and with the advice of the Executive Council thereof, doth by Order, made on the second day of September, 1969, and in pursuance of the provisions of the Sewerage Districts Act, fix the thirtieth day of September, in each year as the day to which the accounts of the Ocean Grove Sewerage Authority shall be balanced.

J. ROSSITER,  
Clerk of the Executive Council.

At the Executive Council Chamber,  
Melbourne, 2nd September, 1969.

AMENDMENT OF REGULATIONS FOR THE CARE,  
PROTECTION AND MANAGEMENT OF THE  
CAULFIELD RACECOURSE RESERVE.

WE,

SIR NORMAN DE WINTON ROBINSON,  
THOMAS SYMINGTON CARLYON,  
JOHN LESLIE DAVIS,  
SIR RUPERT CLARKE,  
ANDREW JOHN GEORGE SINCLAIR,  
ERNEST EDWIN GUNN,  
WILLIAM RICHARDSON THOMSON,  
SIR ARTHUR GORDON RYLAH,  
JAMES DAVID MACDONALD, and  
SIR HERBERT HYLAND,

being duly appointed Trustees of the land reserved for Racing, Recreation and Public Park purposes and premises, being allotment A, at Caulfield, in the Parish of Prahran, County of Bourke, the subject matter of a Crown Grant, volume 7275, folio 1454814, and known as the "Caulfield Racecourse Reserve", in the exercise of the powers conferred on us by the said Crown Grant, and by the *Land Act 1958* and of any and every other power enabling us so to do, and with the approval of the Governor in Council do hereby amend the Regulations made by the Trustees on the 7th July, 1931, and approved by the Governor in Council on the 13th October, 1931, and as were amended by the Trustees on the 22nd August, 1950, 21st February, 1953, 30th June, 1965, 27th May, 1966, 6th March, 1967, and 11th September, 1967, respectively and approved by the Governor in Council on the 31st October, 1950, 31st March, 1953, 24th August, 1965, 12th July, 1966, 27th April, 1967, and 17th October, 1967, respectively by amending the tolls entrance fees and charges for admission stated in Regulation XVII. to read:—

"For the admission of each person to the first division . . . . .	\$1.35
For the admission of each person to the sixth division from the first division . . . . .	.35
For the admission of each person to the first and sixth divisions . . . . .	\$1.70
For the admission of each person to the fourth division . . . . .	.73
For the admission of each person to the ninth division . . . . .	.20
For the admission to the eighth division of every horse, with or without a vehicle, and of every motor car, or motor bicycle, with or without side-car, or . . . . .	.50
the annual equivalent of 50 cents per race meeting."	

Dated this ninth day of July, 1969.

T. S. CARLYON.  
SIR RUPERT CLARKE.  
DR. J. L. DAVIS.  
SIR NORMAN ROBINSON.  
CR. A. J. G. SINCLAIR.  
CR. W. R. THOMSON.  
CR. E. E. GUNN.  
SIR ARTHUR RYLAH.  
SIR HERBERT HYLAND.  
J. D. MACDONALD.

Approved by the Governor in Council, 26th August, 1969.—J. ROSSITER, Clerk of the Executive Council.

THE LIQUOR CONTROL ACT 1968.

WHEREAS the Hotelkeeper's Licence for the licensed premises known as the Star Hotel, situate at Bruthen, has been surrendered as from 14th May, 1969, notice is hereby given that the amount of compensation payable to the owner of such premises pursuant to the provisions of the *Liquor Control Act 1968* is as under:—

Owner—\$21,800.

Dated at Melbourne, this 28th day of August, 1969.

J. CROWE, Secretary,  
Liquor Control Commission.

THE LIQUOR CONTROL ACT 1968.

WHEREAS the Hotelkeeper's Licence for the licensed premises known as the Railway Hotel, situate at Lindenow South, has been surrendered as from 30th September, 1968, notice is hereby given that the amount of compensation payable to the owner of such premises pursuant to the provisions of the *Liquor Control Act 1968* is as under:—

Owner—\$24,500.

Dated at Melbourne, this 25th day of August, 1969.

J. CROWE, Secretary,  
Liquor Control Commission.

## Transport Regulation Act.

## TRANSPORT REGULATION BOARD.

## HEARING OF APPLICATIONS.

**NOTICE** is hereby given that the following applications will be considered by the Transport Regulation Board at its offices at the corner of Lygon and Princes streets, Carlton, at 10.15 a.m., on Wednesday, 24th September, 1969.

**BELL STREET BUS CO. PTY. LTD.**, 326 Bell-street, Preston. Application for variation of M.O. licence conditions Route 6A, Part B (Westbreen—Olive-grove) to delete the existing route and instead to operate as follows:— From Westbreen via Rhodes-parade, Watt-avenue, Snell-grove, Nerissa-grove, Devon-road, Northumberland-road, Fawkner-road, Railway-parade, Gaffney-street, and Cumberland-road to the corner of Olive-grove and Cumberland-road. Return from Olive-grove to be via Cumberland-road, Prospect-street, Fawkner-road, Heath-street, Gaffney-street and Railway-parade to Fawkner-street and normal route. Turning procedure at Westbreen to be via Pascoe-street, Lake-avenue and Northumberland-road to Rhodes-parade. Sections, fares and time-table to be determined.

**BROADMEADOWS BUS SERVICE PTY. LTD.**, 145 Lynch-road, Fawkner. One commercial passenger vehicle with large seating capacity to be purchased to operate as an additional metropolitan special service omnibus.

**BUTTERWORTH, V. F.**, Buchan South. One commercial passenger vehicle (S/C. 3) to operate for the carriage only of guests of the applicant's caravan park at South Buchan, on tours within a 40-mile radius for the purpose of Lapidary and Field Naturalist Studies. *Fares*: 10c per mile, per car load.

**FLETCHER INDUSTRIES LTD.**, 469 Somerville-road, West Footscray. One commercial passenger vehicle with small seating capacity to be purchased to operate free of charge for the carriage of employees on a round route from the company's premises at Somerville-road, West Footscray via Somerville and Paramount roads, Dempster, Ashley, Barkly, Hopkins, Leeds, Irving, Nicholson, Buckley, Victoria, Charles and Gamon streets, Somerville, Geelong, McDonald and Somerville roads to the company's premises. *Time-table* (Monday–Friday): Depart Factory 8.30 a.m. Depart Factory 4.30 p.m.

**HOLLANDIA PTY. LTD.**, John-street, Lilydale. One commercial passenger vehicle (S/C. 3) to operate for the carriage of the applicant company's own staff and goods free of charge between the Lilydale and Healesville factories of the applicant company. *Time-table*: 7.30 a.m. depart Lilydale. Arrive 5.00 p.m. 8.00 a.m. arrive Healesville. Depart 4.30 p.m. Also night staff workers as required between 10.00 p.m. and 6.00 a.m. (Monday to Sunday inclusive).

**KASTORIA BUS LINES PTY. LTD.**, 3 Louis-street, Airport West. Application for variation of all M.O. licence conditions on Route 39 (Keilor—Essendon—Moonee Ponds) to extend service from the intersection of North and Milleara roads and Buckley-street via Milleara and Military roads, Riverside-avenue, Raglan and Canning streets, Military-road to a stand in Military-road south of Riverside-avenue. *Time-table* and fares to be determined.

**KASTORIA BUS LINES PTY. LTD.**, 3 Louis-street, Airport West. Application for permit authority to operate any one of the applicant company's licensed vehicles at separate and distinct fares for the carriage of students between the corner of Somerton and Old Sydney roads, Greenvale via Old Sydney and Mickleham roads, Rylands-drive, South Circular-road, Gladstone Park-drive, Mickleham, Broadmeadows, Sharps and Bulla roads, Harper-street, Matthews-avenue, Keilor-road, Ryder and George streets to Niddrie Technical School; thence via Teague-street, Hoffmans-road, Buckley-street to St. Columba's College; thence via Leslie-road, Stanley-street, Leslie-road to Lowther Hall Church of England Girls' Grammar School; thence via Leslie-road, Park-street to Penleigh Presbyterian Ladies' College; thence via Park-street, Mt. Alexander-road, Buckley, Nicholson and Raleigh streets to Essendon Grammar Junior School. *Time-table* (School Days only): Depart Greenvale 7.45 a.m. Depart Essendon Grammar Junior School 3.30 p.m. *Fares*: Route fares prescribed on Route 210A (Broadmeadows—Moonee Ponds) to apply between West Broadmeadows and Essendon, plus three additional sections.

**NIXON, W. E., D. J. & W. B.** (trading as Valley Bus Lines), 326 Bell-street, Preston. Application for a required number of commercial passenger vehicles with large seating capacity to operate Route 87A, Part B (Heidelberg—Eltham via Greensborough) as presently operated under M.O. licences with the ability to extend service from Greensborough to Diamond Creek via Para-road, Main-street, Diamond Creek and Hurstbridge roads, Wensley and Patyah streets. Journeys from Diamond Creek to operate via Patyah-street, Phipps-crescent, Hurstbridge-road to normal route. Turning procedure at Greensborough to operate via Grimshaw-street, Flintoff-street and Para-road. *Time-table* to be determined.

**SAN PEDRO (OFFSHORE) PTY. LTD.**, P.O. Box 4, Port Welshpool. One commercial passenger vehicle (S/C. 11) to operate as follows:—(a) For the carriage of the applicant company's own employees and goods between the company's base at Port Welshpool and the Esso Terminal at Barrys Beach and between Port Welshpool and the Esso Terminal at Longford (via Yarram) and to Paynesville and Marlo; depending upon where the company's helicopters are based for ships supply and crew change operations. (b) For the carriage of the company's own goods within a 20-mile radius of Port Welshpool.

**VENTURA MOTORS PTY. LTD.**, 1037 Centre-road, South Oakleigh. Four commercial passenger vehicles with large seating capacity to operate Route 207A, Part E (Mitcham—Alwyn-street) as presently operated under C.O. licences held by the applicant to extend service from the corner of Alwyn-street and Rooks-road via Rooks-road, Canterbury-road, Terrara-road, Jolimont-road and Stevens-road to Parkmore Shopping Centre—subject to the cancellation of existing C.O. licences on Route 207A. Sections, fares and time-table to be determined.

**VENTURA MOTORS PTY. LTD.**, 1037 Centre-road, South Oakleigh. Four commercial passenger vehicles with large seating capacity to operate Route 207A (Mitcham—Vermont—Heatherdale—Eastland Shopping Centre) as presently operated under C.O. licences held by the applicant with the ability to extend service from the corner of Centre-road and Blanche-drive, Vermont via Centre-road, Boronia-road, Lusk-drive and Cosgrove-street and Beddoe-road to Centre-road and normal route subject to the cancellation of existing C.O. licences on Route 207A.

**WILLIS BUS SERVICE PTY. LTD.**, 518 Canterbury-road, Vermont. Eleven commercial passenger vehicles with large seating capacity to operate Route 206A (Mitcham—Vermont—Forest Hill Shopping Centre—Nunawading) as presently operated under C.O. licences held by the applicant with the ability to extend service from the corner of Canterbury and Nurlindi roads, Vermont, via Nurlindi-road, Karwitha-street, Philip-street, Marina-street, Morack-road, Boronia-road, Lusk-drive, Beddoe-street, Centre-road, Boronia-road to the corner of Boronia-road and Mountain Highway, Warrirna, subject to the cancellation of existing C.O. licences on Route 206A. Sections, fares and time-table to be determined.

**APPLICATION** for renewal of licences as shown, by persons listed hereunder to operate under the same terms and conditions.

**GEELONG & DISTRICT ASSOCIATION FOR THE WELFARE OF DEAF CHILDREN**, care of 54 Malop-street, Geelong; T.P. 80, T.P. 19.

**MCGILL, J. L. & T.**, 25 Egmont-street, Benalla; T.S. 168, T.S. 749, T.S. 612.

**SOUTH, F. R.**, High-street, Woodend; T.P. 228.

**UNDERWOOD, L. G.**, 62 Clifton-street, Euroa; T.S. 138, T.S. 145, T.S. 834, T.S. 945.

Notice of any objection should be forwarded to reach the Secretary of the Board not later than Wednesday, 17th September, 1969.

Applicants are advised that it will not be necessary to appear on the hearing date specified above, unless advised in writing by the Board.

B. P. KAY,  
Secretary.

Corner Lygon and Princes streets, Carlton, Wednesday, 3rd September, 1969.

Commercial Goods Vehicles Act.  
TRANSPORT REGULATION BOARD.

## HEARING OF APPLICATIONS.

NOTICE is hereby given that the following applications will be considered by the Transport Regulation Board at its offices at the corner Lygon and Princes streets, Carlton, at 10.15 a.m., on Wednesday, 24th September, 1969.

- ALQUO, G. & A., 21 George-street, Brunswick, 3056. One commercial goods vehicle (L/C. 156 cwt.) to operate: (a) Within a 35-mile radius of the G.P.O. in the City of Melbourne on behalf of Consolidated Quarries Ltd.—quarry materials, sand and concrete. (b) From the City of Melbourne to own farm at Kinglake in course of business as "Primary Producer"—own goods.
- AMALGAMATED CHEMICALS (VIC.), 24-30 Prahran-grove, Elsternwick, 3185. One commercial goods vehicle (L/C. 10 cwt.) to operate within a 50-mile radius of own branch depot at Shepparton in the course of business as "Chemical Manufacturers"—samples, display materials and a small quantity of chemicals subject to the condition that all goods carried on the vehicle shall have been initially consigned by rail to Shepparton.
- AMALGAMATED CHEMICALS (VIC.), 24-30 Prahran-grove, Elsternwick, 3185. One commercial goods vehicle (L/C. 10 cwt.) to operate within a 75-mile radius of own branch depot at Warragul and to and from Lakes Entrance and Orbost in course of business as "Chemical Manufacturers"—samples, display materials and a small quantity of chemicals subject to the condition that all goods carried on the vehicle shall have been initially consigned by rail to Warragul.
- AMALGAMATED CHEMICALS (VIC.), 24-30 Prahran-grove, Elsternwick, 3185. One commercial goods vehicle (L/C. 10 cwt.) to operate within a 75-mile radius of own branch depot at Mildura in course of business as "Chemical Manufacturer"—samples, display materials and a small quantity of chemicals subject to the condition that all goods carried on the vehicle shall have been initially consigned by rail to Mildura.
- ARMISTEAD, E. P. & R. J., Station-street, Forrest, 3236. One commercial goods vehicle (L/C. 236 cwt.) to operate: (a) Within a 25-mile radius of the post office at Forrest—general goods provided that no goods shall be carried whether by one stage or by more than one stage between places within the above radius which are more than thirty (30) road miles apart by the nearest practicable route. (b) From and to places within the radius as defined in paragraph (a) above, to and from places outside that radius but wholly within a 50-mile radius of the post office at Forrest—livestock.
- BALMER & JONES PTY. LTD., Scott-street, Orbost, 3888. Four commercial goods vehicles (L/C. 11, 77, 130, 151 cwt.) to operate: (a) From and to own Mobil Oil (Aust.) Ltd. depot at Bairnsdale to and from own Mobil Oil (Aust.) Ltd. depot at Orbost in the course of business as "Agents" of the said company—petroleum products in prescribed types of containers and empty containers for return. (b) From and to own said Mobil Oil (Aust.) Ltd. depot at Bairnsdale to and from consignees situated within a 50-mile radius of the post office at Bairnsdale in the course of business as "Agents" of the said company—petroleum products in bulk or in prescribed types of containers and empty containers for return also tools of trade, spare parts and dispensing equipment. (c) From and to own Mobil Oil (Aust.) Ltd. depot at Orbost to and from consignees situated within a 50-mile radius of the post office at Orbost in the course of business as "Agents" of the said company—petroleum products in bulk or in prescribed types of containers and empty containers for return, also tools of trade, spare parts and dispensing equipment. (d) From own depot at Orbost to consignees situated within a 50-mile radius of the post office at Orbost in course of business as "Agent" for C.I.G. industrial gases—cylinders of industrial gases, welding equipment and empty cylinders for return.
- BALMER & JONES PTY. LTD., Scott-street, Orbost, 3888. Application to vary the conditions of licences numbered D.A.50680/1 and D.A.50680/2 (L/C. 70 and 14 cwt.) by deleting the existing conditions and adding in lieu:—(a) From and to own Mobil Oil (Aust.) Ltd. depot at Bairnsdale to and from own Mobil Oil (Aust.) Ltd. depot at Orbost in the course of business as "Agents" of the said company—petroleum products in prescribed types of containers and empty containers for return. (b) From and to own said Mobil Oil (Aust.) Ltd. depot at Bairnsdale to and from consignees situated within a 50-mile radius of the post office at Bairnsdale in the course of business as "Agents" of the said company—petroleum products in bulk or in prescribed types of containers and empty containers for return, also tools of trade, spare parts and dispensing equipment. (c) From and to own Mobil Oil (Aust.) Ltd. depot at Orbost to and from consignees situated within a 50-mile radius of the post office at Orbost in course of business as "Agents" of the said company—petroleum products in bulk or in prescribed types of containers and empty containers for return also tools of trade, spare parts and dispensing equipment. (d) From own depot at Orbost to consignees situated within a 50-mile radius of the post office at Orbost in course of business as "Agent" for C.I.G. industrial gases—cylinders of industrial gases, welding equipment and empty cylinders for return.
- BENNETT, W. H., & SONS PTY. LTD., 56 Hesse-street, Colac, 3250. Two commercial goods vehicles (L/C. 278, 261 cwt.) to operate from forest landings within a 20-mile radius of Beech Forest to own sawmills at Gellibrand and Deans Marsh—logs.
- BOWMAN, N. T., 199 Tramway-parade, Beaumaris, 3193. One commercial goods vehicle (L/C. 8 cwt.) to operate within a 50-mile radius of G.P.O., Melbourne, in course of business as "Electrical Mechanic" on behalf of N. T. Bowman Pty. Ltd., for the purpose of servicing fork lift trucks—tools of trade, spare parts and fork lift battery changing equipment for repair or having been repaired.
- BRAMBLES HOLDINGS LTD., care of P.O. Box 207, Shepparton, 3630. One commercial goods vehicle (L/C. 14 cwt.) to operate within a 50-mile radius of the post office at Shepparton and to Wodonga and Bendigo in the course of business as "Cartage Contractors"—own tools of trade and up to 4 cwt. of replacement parts for own company vehicle and forklift trucks provided that all such parts have been initially consigned by rail to Shepparton.
- C. & I. CLEANING PTY. LTD., 253 Wellington-street, Collingwood, 3066. Three commercial goods vehicles (L/C. 24 cwt. each) to operate throughout the State of Victoria in the course of business as "Industrial Cleaning Service"—own specialized cleaning equipment and cleaning materials incidental only to own contracts.
- CARTWRIGHT, R. W. & M. M., 19A Arndt-road, Pascoe Vale, 3044. One commercial goods vehicle (L/C. 234 cwt.) to operate within a 35-mile radius of the G.P.O. in the City of Melbourne on behalf of Consolidated Quarries Ltd.—sand, soil, screenings and premix.
- HUMPHREY, K. V. (trading as Cressy Spraying Service), Station-street, Cressy, 3322. One commercial goods vehicle (L/C. 30 cwt.) to operate within a 100-mile radius of the post office at Cressy in the course of business as "Agricultural Spray Contractor"—tools of trade and spraying equipment and small quantity not exceeding 4 cwt. at any one time of spraying materials subject to the condition that all such tools of trade, equipment and materials carried are incidental to and for own use in carrying out own spraying contracts and that all supplies of concentrated chemicals, pesticides, insecticides and weedicides carried for own use in such contracts have been initially conveyed by rail to Cressy.
- CROWN CONTROLS AUSTRALIA PTY. LTD., corner Balmain and Chestnut streets, Richmond, 3121. One commercial goods vehicle (L/C. 17 cwt.) to operate throughout the State of Victoria in the course of business as "Manufacturers of Mechanical Handling Equipment" for the purpose of servicing such equipment—tools of trade, spare parts and materials incidental to servicing.
- DAVIDSON, D. J., Clyde-street, Myrtleford, 3737. One commercial goods vehicle (L/C. 36 cwt.) to operate within a 100-mile radius of the post office at Myrtleford in the course of business as "Second-hand dealer"—second-hand furniture and antiques.
- DODGE, V. W. R., Powlett-street, Broadford, 3658. One commercial goods vehicle (L/C. 236 cwt.) to operate: (a) From forest landings situated within a 50-mile radius of the post office at Broadford to sawmills at Broadford—sawmill logs. (b) From the sawmill of The Islander Pty. Ltd. at Broadford to places within a 50-mile radius of the said sawmill—sawn timber and pallets.
- DOODY, NORMAN, & SONS PTY. LTD., Creswick-road, Ballarat, 3350. Application to vary the conditions of all "D" licences by adding to paragraph (b) part (i) the word "bricks".
- EUROA QUARRIES PTY. LTD., Brock-street, Euroa, 3666. One commercial goods vehicle (L/C. 244 cwt.) to operate within a 50-mile radius from own quarry at Balmatium in the course of business as "Quarry Master" own screenings, stone dust and sand.

- FELMINGHAM, F. J., 58 Stawell-street, Sale, 3850. One commercial goods vehicle (L/C. 161 cwt.) to operate: (a) Within a 95-mile radius of the post office at Orbost (Bairnsdale Division of the Country Roads Board) and/or within a 70-mile radius of the post office at Yarram (Traralgon Division of the Country Roads Board)—road contracting plant used in the construction or maintenance of road, street, footpath, bridge, wharf, pier, weir or channel. (b) Within a 20-mile radius from site of construction or maintenance work performed pursuant to paragraph (a) above or from the railway station nearest thereto—materials required for such work. (c) Within a 25-mile radius of the post office at Sale—general goods provided that no goods shall be carried whether by one stage or by more than one stage between places within the above radius, which are more than 30 miles apart by the nearest practicable route.
- FIRESTONE AUSTRALIA PTY. LTD., corner Benalla & Lockwood roads, Shepparton, 3630. One commercial goods vehicle (L/C. 12 cwt.) to operate within a 50-mile radius of own branch premises at Shepparton in the course of business as "New and Second-hand Tyre and Car Accessories Distributor"—tyres and tubes for sale and delivery, used tyres for repair or retreading or having been repaired or retreaded, also batteries, oil and motor car accessories and polythene piping.
- FOODLAND STORES PTY. LTD., 619 Springvale-road, Glen Waverley, 3150. One commercial goods vehicle (L/C. 200 cwt.) to operate from the bulk store of Foodland Holdings Ltd., at Glen Waverley to retail grocery stores associated with the Foodland group situated within a 25-mile radius of the said bulk store at Glen Waverley and/or to any retail store associated with the Foodland group situated on the Mornington Peninsula or at Koo-Wee-Rup, Warburton, Healesville, Wesburn and Bunyip—groceries solely on behalf of Foodland Holdings Ltd.
- FOX, K. W., 42 William-street, Port Fairy, 3284. One commercial goods vehicle (L/C. 8 cwt. and 38 cwt. trailer) to operate: (a) Within a 20-mile radius of the post office at Port Fairy—general goods. (b) From the residences and/or premises of professional fishermen at Port Fairy to the City of Melbourne—fresh fish and also fishermen's gear for repair. (c) From the City of Melbourne to the Township of Port Fairy—fishermen's gear, bait and equipment solely on behalf of and for use by professional fishermen.
- FOXBORO PTY. LTD., Maroondah Highway, Lilydale, 3140. One commercial goods vehicle (L/C. 14 cwt.) to operate throughout the State of Victoria in course of business as "Process Instrumentation Manufacturers" as a service vehicle—tools of trade, spare parts for servicing in the field with the ability to carry measuring instruments for repair or having been repaired.
- GAS & FUEL CORPORATION OF VICTORIA, 171 Flinders-street, Melbourne, 3000. One commercial goods vehicle (L/C. 19 cwt.) to operate in course of business as "Gas and Gas Appliance Retailers" as follows:—(a) Within a 100-mile radius of the post office at Sale and/or within that part of the State of Victoria east of a line drawn due north and south through the Township of Bairnsdale—tools of trade equipment and materials incidental to servicing of own clients gas and appliances. (b) Within a 20-mile radius of the post office at Sale—gas appliances and cylinders of gas for sale or demonstration purposes.
- GAS & FUEL CORPORATION OF VICTORIA, 171 Flinders-street, Melbourne, 3000. One commercial goods vehicle (L/C. 13 cwt.) to operate in course of business as "Petroleum Gas Supplier and Fitter of Petroleum Gas Domestic and Industrial Installations"—(a) Within a 50-mile radius of the post office at Sale. (b) Within that part of the State of Victoria east of a line drawn north and south through the City of Sale. (c) From own premises in McMillan-street, Sale to the Townships of Cowes, Koo-Wee-Rup, Mirboo North, Leongatha, Korumburra, Wonthaggi, Inverloch, Fish Creek, Foster and Boolarra—gas appliances for initial installation, supplies of petroleum in cylinders and empty cylinders for return, also tools of trade and spare parts incidental to the servicing of such appliances but subject to the condition that all new appliances gas cylinders and spare parts carried on the vehicle shall have been initially forwarded by rail to Sale.
- GERACE, C., 29 Tramoo-street, Lalor, 3075. One commercial goods vehicle (L/C. 134 cwt.) to operate within a 35-mile radius of the G.P.O., Melbourne solely on behalf of Consolidated Quarries Ltd.—sand, screenings, premix and quarry products.
- GREEN, H. G. & M. A., 23 Alice-street, Yarraville, 3013. One commercial goods vehicle (L/C. 174 cwt.) to operate within a 50-mile radius of the G.P.O. in the City of Melbourne on behalf of Supremix Concrete Pty. Ltd.—premixed concrete in a specially constructed agitator vehicle solely on behalf of the said company.
- GREGG, R. D., Tyson-road, Heyfield, 3858. Application to vary the conditions of licence No. D.A.1112/1 (L/C. 270 cwt.) by adding as additional paragraphs (b), (c), (d) as follows:—(b) Within a 30-mile radius of the post office situated at Benambra in the course of his own business as 'Logging Contractor'—own bulldozer. (c) To and from own premises at Heyfield and points situated within the area defined in paragraph (b) above—own bulldozer. (d) Within a 50-mile radius of the post office situated at Heyfield in the course of business as 'Agricultural Contractor'—own bulldozer.
- HANCOCK, A. W., & Co. PTY. LTD., 104 Armstrong-street, Ballarat, 3350. One commercial goods vehicle (L/C. 129 cwt.) to operate within a 50-mile radius of the chief post office in the City of Ballarat in the course of business as "Produce and General Merchants"—own goods.
- HARRINGTON, D. & L., 19 Clunies Ross-crescent, Mulgrave, 3170. One commercial goods vehicle (L/C. 270 cwt.) to operate from the pits of Tynon Coarse Sand Supplies at Bunyip solely on behalf of the said firm to the plants of Conmac Asphalt Pty. Ltd. at Oakleigh and Clarinda—coarse washed sand.
- HEDDITCH CONSTRUCTIONS PTY. LTD., 54 Otway-street, Portland, 3305. Two commercial goods vehicles (L/C. 13, 14 cwt.) to operate: (a) Within a 50-mile radius of the post office at Portland in the course of business as "Plant Hirer and Building Contractor"—own goods. (b) Within a 50-mile radius of the post office at Maryborough and to and from Portland in the course of business as "Plant Hirer"—own goods.
- HOLTEN, W. E., Murrayville, 3512. One commercial goods vehicle (L/C. 7 cwt.) to operate from own premises at Murrayville to and from Mildura in the course of business as "Frozen Food Distributors" frozen fish, frozen poultry, frozen processed fruit and vegetables, ice-cream and empty return containers.
- ILIAKOPOULOS, P., 20 Harts-parade, East Hawthorn, 3123. One commercial goods vehicle (L/C. 219 cwt.) to operate within a 50-mile radius of the G.P.O. in the City of Melbourne on behalf of Albion Reid Pty. Ltd.—sand, screenings, aggregate and premix, excluding the carriage of cement or lime from the Geelong Urban District (as defined in the *Transport Regulation Act 1958*).
- INTERS BENDIGO PTY. LTD., 144 Mitchell-street, Bendigo, 3550. One commercial goods vehicle (L/C. 121 cwt.) to operate in the course of business as "Garage Proprietors and Vehicle Machinery Dealers" as follows:—(a) Within a 50-mile radius of own premises at Bendigo—tools of trade, spare parts and farm equipment and machinery. (b) Within a 75-mile radius of own premises at Bendigo—tools of trade and spare parts incidental to servicing farm machinery in the field only and also farm machinery for repair or having been repaired but excluding any operations to or from the City of Melbourne and/or the Metropolitan area (as defined in the *Transport Regulation Act 1958*).
- JOHNSON, K. W., 15 Blair-crescent, Leongatha, 3953. One commercial goods vehicle (L/C. 149 cwt.) to operate: (a) Within a 50-mile radius of the post office at Leongatha—as a "Road Contractor"—road-making plant and materials. (b) Within a 25-mile radius of the post office at Leongatha—general goods provided that no goods shall be carried whether by one stage or by more than one stage between places within the above radius, which are more than thirty (30) road miles apart by the nearest practicable route. (c) Within a 50-mile radius of own premises at Leongatha in the course of business as "Quarry Master and Sand Pit Proprietor"—own sand, own crushed rock and own screenings.
- KENNEDY, P., PTY. LTD., P.O. Box 11, Wendouree, 3355. One commercial goods vehicle (L/C. 266 cwt.) to operate in the course of business as "Excavation Contractor"—(a) Throughout the State of Victoria—own excavation machinery and a quantity of fuel sufficient only for the operation of such machinery on site. (b) Within a 20-mile radius of the site of any contract currently engaged upon—materials for use in such contract.
- KERAMARIS, G. P., 14 Newport-road, Clayton South, 3169. One commercial goods vehicle (L/C. 224 cwt.) to operate within a 50-mile radius from the premises

- of Albion Reid Pty. Ltd., at North Melbourne—road-making plant, materials, premix and hot asphalt on behalf of the said company, excluding the carriage of cement or lime from the Geelong Urban District (as defined in the *Transport Regulation Act 1958*).
- LEIGHTON CONSTRUCTIONS LTD., Longford, via Sale, 3851. One commercial goods vehicle (L/C. 12 cwt.) to operate: (a) Within a 50-mile radius of Longford in course of business as "Civil Engineers"—own goods. (b) To and from the City of Melbourne from and to the Township of Longford—urgently required spare parts and equipment solely for use in connexion with own contract.
- LOCKLEY, C., Nilma, 3821. One commercial goods vehicle (L/C. 218 cwt.) to operate: (a) Within a 30-mile radius of the post office at Nilma and to the Township of Officer in the course of business as "Logging and Timber Contractor"—mill logs, poles, fence posts and firewood. (b) From forest landings situated within a 30-mile radius of the post office at Nilma to the premises of the Australian Paper Manufacturers Ltd., at Maryvale—pulpwood.
- MARSHALL, R. R., Ensay, 3895. One commercial goods vehicle (L/C. 50 cwt.) to operate: (a) Between Bairnsdale and places on or reached from the road between Bairnsdale and a point on the Omeo Highway one mile nearer to Omeo than the Township of Ensay South—general goods. (b) From the railway station at Bruthen direct to properties of primary producers situated in the Shire of Omeo—superphosphate in bulk in a specially constructed bulk fertilizer unit. (c) From and to places within a 20-mile radius of the post office at Bruthen and from places within a 50-mile radius of the post office at Bruthen—household furniture being the property or personal effects of a householder or of a member of his family when such goods are being moved—(i) From residence to residence. (ii) From residence for storage or sale. (iii) From storage to residence. (iv) From a vendor to the residence of the purchaser. (d) Within the Shire of Omeo and from and to the Townships of Bairnsdale, Buchan, Gelantipy, Corryong, Yarra, Rosedale, Heyfield and Maffra, the City of Sale and the Townships of Stratford, Orbost and Cann River to and from places situated within the Shire of Omeo—livestock.
- MATTECCI, L., 29 Auburn-grove, Hawthorn, 3122. Two commercial goods vehicles (L/C. 131 and 227 cwt.) to operate within a 50-mile radius of the G.P.O. in the City of Melbourne on behalf of Albion Reid Pty. Ltd.—road-making plant, hot asphalt, and road-making materials but excluding the carriage of cement and lime from the Geelong Urban District (as defined in the *Transport Regulation Act 1958*).
- MAWSON, E. B. & SONS PTY. LTD., 141 King George-street, Cohuna, 3568. One commercial goods vehicle (L/C. 8 cwt.) to operate throughout the State of Victoria in the course of business as "Contractors and Quarrymasters"—tools of trade, spare parts and materials incidental to the servicing and maintenance of own vehicles and earthmoving equipment but excluding the carriage of spare parts and materials from the Metropolitan Area (as defined in the *Transport Regulation Act 1958*).
- MILLSOM, J. M., Johnstone-street, Thorpdale, 3835. One commercial goods vehicle (L/C. 117 cwt.) to operate from forest landings within a 15-mile radius of the post office at Thorpdale to sawmills at Drouin and Longwarry—mill logs.
- MURNANE, S. J., Irrewarra P.O., via Colac, 3244. One commercial goods vehicle (L/C. 104 cwt.) to operate: (a) Within a 50-mile radius from the post office at Colac as a "Road Contractor"—road-making plant and materials. (b) Within a 25-mile radius of the post office at Irrewarra—general goods provided that no goods shall be carried whether by one stage or by more than one stage between places within the above radius which are more than 30 miles apart by the nearest practicable route.
- KELLY, H. E. (trading as Northern Pest Control), 201 Walnut-avenue, Mildura, 3500. One commercial goods vehicle (L/C. 10 cwt.) to operate from and to own premises at Mildura—tools of trade, equipment and materials incidental to the completion of own contracts in the course of business as "Pest Exterminators" but excluding any carriage of any materials whatsoever from the metropolitan area (as defined in the *Transport Regulation Act 1958*).
- NOYES RICHARDSON PTY. LTD., Kepler-street, Warrnambool, 3280. Two commercial goods vehicles (L/C. 12 and 10 cwt.) to operate within a 50-mile radius of own premises at Warrnambool and Camperdown in the course of business as "Garage Proprietors" (tractor, agricultural machinery and chain saw agents) for the purpose of demonstrating and servicing agricultural machinery—agricultural machinery for demonstration, or for repair or having been repaired, also tools of trade, spare parts and materials incidental thereto with the condition that all goods be initially consigned by rail to Warrnambool, Terang or Camperdown.
- O'CALLAGHAN, M. F., Fuller-street, Ouyen, 3490. One commercial goods vehicle (L/C. 10 cwt.) to operate throughout the State of Victoria in the course of business as "House Moving Contractor"—tools of trade, equipment and materials incidental to the completion of own contracts excluding the carriage of materials from places within a 25-mile radius of Melbourne.
- O'FLYNN, A. W., 62 Morris-road, Warrnambool, 3280. One commercial goods vehicle (L/C. 9 cwt.) to operate throughout the State of Victoria in the course of business as "Sign Writer"—own tools of trade and materials incidental to the completion of own contracts excluding the carriage of materials from places within a 25-mile radius of Melbourne.
- PARKER, W. & J. A., "Lanceville", Main-road, Kinglake West, 3757. One commercial goods vehicle (L/C. 74 cwt.) to operate from and to Melbourne to and from the Townships of Kinglake via Whittlesea serving places on or adjacent to the road between Whittlesea and Kinglake—general goods.
- PLANT, A. K., Box 26, Yarram, 3971. One commercial goods vehicle (L/C. 7 cwt.) to operate: (a) Within a 50-mile radius of the post office situated at Yarram in the course of business as "Plumber"—own goods. (b) Throughout the State of Victoria in course of business as a "Plumber"—own tools of trade and equipment. (c) Within a 20-mile radius of any contract site currently engaged upon or from the railway station nearest thereto—materials required for the completion of such contract.
- PRIMAL CHEMICALS, 26 Collins-street, Melbourne, 3000. One commercial goods vehicle (L/C. 13 cwt.) to operate within that part of the State of Victoria bounded on the south by the Western Highway from the South Australian border to Bacchus Marsh, on the east by a line drawn from Bacchus Marsh through Kilmore and Seymour to Echuca on the west by the South Australian/Victorian border and on the north by the N.S.W./Victoria border in the course of business as "Veterinary, Agricultural and Horticultural Chemical Manufacturers" as a travellers vehicle—own manufactured chemicals for display together with advertising and display materials with the ability to leave an urgent incidental order when required provided that all goods carried on the vehicle shall have been initially consigned by rail to Bendigo.
- RAMADIN, S., 9 Stewart-street, Thomastown, 3074. One commercial goods vehicle (L/C. 248 cwt.) to operate within a 35-mile radius of the G.P.O. in the City of Melbourne on behalf of Consolidated Quarries Ltd.—sand, soil, screenings and premix.
- HIRST, R., Swansea-road, Lilydale, 3140. One commercial goods vehicle (L/C. 146 cwt.) to operate within a 70-mile radius of the premises of Atlas Industries Australia Ltd. at Springvale, solely on behalf of the said company—roofing tiles.
- SHIELDS, R. H., 8 Cowra-street, Altona West, 3018. One commercial goods vehicle (L/C. 239 cwt.) to operate within a 50-mile radius from the premises of Albion Reid Pty. Ltd. at North Melbourne—road-making plant, materials premix and hot asphalt on behalf of the said company excluding the carriage of cement or lime from the Geelong Urban District (as defined in the *Transport Regulation Act 1958*).
- SMITH, D., 7 Kirk-street, Moe, 3825. One commercial goods vehicle (L/C. 11 cwt.) to operate within a 50-mile radius of the post office at Moe in the course of business as "Automotive Engineer and Spare Parts Retailer"—automotive parts and accessories for sale or for repair or having been repaired with the proviso that all goods carried for sale shall have been initially consigned by rail to Moe or delivered to the applicant's premises by other distributors.
- SMITH, F. G., 22 Oswald-street, Portland, 3305. One commercial goods vehicle (L/C. 164 cwt.) to operate: (a) Within a 50-mile radius of the post office at Portland as a "Road Contractor"—road-making plant and materials. (b) Within a 25-mile radius of the post office at Portland—general goods provided that no goods shall be carried whether by one stage or by more than one stage between places within the above radius, which are more than thirty (30) road miles apart by the nearest practicable route.

SMITH, R. C., 111 Moore-street, Moe, 3825. One commercial goods vehicle (L/C. 136 cwt.) to operate: (a) Within a 30-mile radius of the post office at Moe in the course of business as "Waste Collector"—waste cardboard and paper. (b) From Moe to the premises of Australian Paper Manufacturers Ltd. at Preston—waste cardboard and paper in bales.

Note.—It is a condition of this licence that no trailer shall be towed in conjunction with the vehicle for the carriage of goods pursuant to this licence.

STEPHENS, E. E., Powells-avenue, Bendigo East, 3550. Application to vary the conditions of licence No. D.A.62939 (L/C. 208 cwt.) by adding as an additional paragraph (b)—(b) From places situated within a 25-mile radius of the plant of Ready Mix Group (Vic.) at Bendigo—sand and screenings to such plant."

SUPERINA HAULAGE PTY. LTD., 67 Almond-street, North Balwyn, 3104. One commercial goods vehicle (L/C. 280 cwt.) to operate within a 50-mile radius of the premises of Albion Reid Pty. Ltd. at North Melbourne solely on behalf of the said company—road-making materials, premix and hot asphalt but excluding the carriage of cement or lime from the Geelong Urban District (as defined in the Transport Regulation Act 1958).

SUTTIE, A. J., 100 Rutherford-street, Swan Hill, 3585. One commercial goods vehicle (L/C. 206 cwt.) to operate: (a) Within a 50-mile radius from the post office at Swan Hill as a "Road Contractor"—road-making plant and materials. (b) Within a 25-mile radius of the post office at Swan Hill—general goods provided that no goods shall be carried whether by one stage or by more than one stage between places within the above radius which are more than thirty (30) road miles apart by the nearest practicable route.

YENSCH, R. E. & B., 1056 Sylvania-avenue, Albury, 2640. One commercial goods vehicle (L/C. 114 cwt.) to operate in the course of business as "Building and Renovating Contractor and House Remover"—(a) Within a 50-mile radius of own premises at Wodonga—own goods. (b) Within a 100-mile radius of own premises at Wodonga—houses and sheds when being moved from site to site for subsequent re-erection.

YOUNG'S FROZEN FOODS PTY. LTD., 20A Whitehorse-road, Ringwood, 3134. One commercial goods vehicle (L/C. 30 cwt.) to operate within a 100-mile radius of own premises at Oakleigh in course of business as "Frozen Food Distributors" as a specially constructed refrigerated vehicle—frozen fish, frozen meat, frozen poultry, frozen processed fruit, and vegetables, frozen pastries and ice-cream at a temperature of 0° degrees.

#### TOW TRUCKS.

BAMFORD, A. J. (trading as Andy's Service Station), Tarcombe-street, Euroa, 3666. One commercial goods vehicle (L/C. 40 cwt.) to operate throughout the State of Victoria as a "Tow Truck" solely—(a) For the purposes of lifting and carrying or towing of wrecked or disabled motor vehicles and the carriage of tools and equipment necessary for such purposes. (b) The carriage of spare parts necessary for the repair of a disabled motor vehicle to and from the place at which such disablement has occurred.

CONWAY, N. F. (trading as Eltham Panel Beating Service), corner Bridge and Susan streets, Eltham, 3095. One commercial goods vehicle (to be purchased) to operate within a 25-mile radius of own premises at Eltham as a "Tow Truck" solely—(a) For the purpose of lifting and carrying or towing motor vehicles and the carriage of tools and equipment necessary for such purpose only. (b) The carriage of spare parts necessary for the repair of a disabled motor vehicle to and from the place at which such disablement has occurred.

WILSON, W. D. & L. M., PTY. LTD., 3 Fairvie-street, Traralgon, 3844. One commercial goods vehicle (to be purchased) to operate within that part of the State of Victoria east of a north/south line drawn through the City of Dandenong and west of a north/south line drawn through the Town of Lakes Entrance as a "Tow Truck" solely—(a) For the purposes of lifting and carrying or towing of wrecked or disabled motor vehicles and the carriage of tools and equipment necessary for such purposes. (b) The carriage of spare parts necessary for the repair of a disabled motor vehicle to and from the place at which such disablement has occurred.

Note. That operations shall only occur from the scene of a motor car accident if the licensed owner or certificated driver of the said tow truck has been previously bespoken, but not at the scene of such accident by the owner of the damaged or disabled motor car, or his agent, or the person in charge of the said damaged motor car or disabled motor car.

#### RENEWALS.

APPLICATION for renewal of licences as shown by persons listed hereunder to operate under the same terms and conditions from the expiry shown in each case.

BUROW, J. W., Box 123, Peshurst, 3289. D.A. 769; 14th November, 1969; 100 cwt.

CARINYA PTY. LTD., Woolsthorpe, 3279. D.A. 15269; 27th November, 1969; 109 cwt.

CORIO TIMBER CO. PTY. LTD., Roseneath-street, North Geelong, 3215. D.A. 44823; 20th November, 1969; 252 cwt.

DODGE, V. W. R., Powlett-street, Broadford, 3658. D.A. 57525; 22nd November, 1969; 221 cwt.

FERRUM METAL EXPORTS PTY. LTD., 60 Clarendon-street, South Melbourne, 3205. D.A. 2818/1; 8th November, 1969; 243 cwt.

GEELONG CHURCH OF ENGLAND GRAMMAR SCHOOL, Corio, Geelong, 3214. D.A. 30829; 19th November, 1969; 66 cwt.

GEORGE, A. R., Yarra Glen-road, Healesville, 3777. D.T. 203; 29th November, 1969; 256 cwt.

GLENELG REGIONAL HOSPITALS' CENTRAL LINEN SERVICE, P.O. Box 283, Hamilton, 3300. D.A. 57511; 22nd November, 1969; 23 cwt.

GRADY, F. W., 35 Beauchamp-street, Kyneton, 3444. D.A. 44774; 20th November, 1969; 13 cwt.

ROBERT HUTCHINSON LTD., Hartington-street, Glenroy, 3046. D.A. 27836/32; 22nd November, 1969; 140 cwt.

ROBERTSON HUTCHINSON LTD., Hartington-street, Glenroy, 3046; D.A.27836; 5th November, 1969; 148 cwt.; D.A.27836/2; 5th November, 1969; 152 cwt.; D.A.27836/3; 5th November, 1969; 153 cwt.; D.A.27836/4; 5th November, 1969; 153 cwt.; D.A.27836/13; 7th November, 1969; 240 cwt.

ROBIN KEATH PTY. LTD., Box 128, Horsham, 3400; D.A.22517/5; 7th November, 1969; 11 cwt.

MOORE ROAD MACHINERY (VIC.) PTY. LTD., 501 Williams-town-road, Port Melbourne, 3207; D.A.10734/14; 7th November, 1969; 17 cwt.

MORTIMER, L. & COULSHED, T. (trading as Mortimer & Coulshed), Narre Warren North-road Narre Warren North, 3804; D.A.45048; 18th November, 1969; 145 cwt.

MOTOR TYRE SERVICE PTY. LTD., 169 Baillie-street, Horsham, 3400; D.A.30929/1; 5th November, 1969; 13 cwt.

NATIONAL CASH REGISTER CO. PTY. LTD., 124 Russell-street, Melbourne, 3000; D.A.1707/15; 27th November, 1969; 18 cwt.; D.A.1707/18; 27th November, 1969; 18 cwt.; D.A.1707/19; 27th November, 1969; 11 cwt.; D.A.1707/21; 27th November, 1969; 11 cwt.

NEW HOLLAND DIVISION SPERRY RAND AUSTRALIA LTD., 232 Princes Highway, Dandenong, 3175; D.A.40613/1; 8th November, 1969; 8 cwt.; D.A.40613/2; 8th November, 1969; 8 cwt.; D.A.40613/3; 8th November, 1969; 11 cwt.

PETERSVILLE AUST. LTD., Wellington-road, Clayton, 3168; T.D.A.1813/18; 11th November, 1969; 74 cwt.; T.D.A.1813/47; 11th November, 1969; 68 cwt.; T.D.A.1813/49; 11th November, 1969; 68 cwt.; T.D.A.1813/51; 11th November, 1969; 72 cwt.; T.D.A.1813/52; 11th November, 1969; 78 cwt.; T.D.A.1813/53; 11th November, 1969; 69 cwt.; T.D.A.1813/54; 11th November, 1969; 73 cwt.; T.D.A.1813/55; 11th November, 1969; 78 cwt.; T.D.A.1813/58; 11th November, 1969; 76 cwt.; T.D.A.1813/60; 11th November, 1969; 73 cwt.; T.D.A.1813/61; 11th November, 1969; 74 cwt.; T.D.A.1813/62; 11th November, 1969; 74 cwt.; T.D.A.1813/63; 11th November, 1969; 76 cwt.; T.D.A.1813/64; 11th November, 1969; 74 cwt.; T.D.A.1813/65; 11th November, 1969; 72 cwt.; T.D.A.1813/66; 11th November, 1969; 73 cwt.; T.D.A.1813/67; 11th November, 1969; 74 cwt.; T.D.A.1813/69; 11th November, 1969; 74 cwt.; T.D.A.1813/70; 11th November, 1969; 73 cwt.; T.D.A.1813/71; 11th November, 1969; 73 cwt.; T.D.A.1813/72; 11th November, 1969; 74 cwt.; T.D.A.1813/73; 11th November, 1969; 72 cwt.; T.D.A.1813/77; 11th November, 1969; 69 cwt.; T.D.A.1813/78; 11th November, 1969; 63 cwt.; T.D.A.1813/130; 8th November, 1969; 69 cwt.; T.D.A.1813/131; 22nd November, 1969; 69 cwt.

ROBERTS, J. V., & SON PTY. LTD., Murray-street, Piangil, 3597; D.A.38370/2; 22nd November, 1969; 119 cwt.

ROSS, J. W. & A. G. (trading as Ross & Saunders), 49 Moran-street, Bendigo, 3550; D.A.31202; 26th November, 1969; 9 cwt.

RUMBLE, K. L., 126 Park-street West, Ballarat, 3350; D.A.27320/7; 13th July, 1969; 78 cwt.

SOUTH-EASTERN MILK PRODUCTS LTD., 40 Commercial-road, Yarram, 3971; D.A.34664/4; 4th October, 1969; 10 cwt.



MOORE, S. L. (trading as Talbot Produce), Talbot, 3371; D.A.27895; 19th November, 1969; 125 cwt.  
 TAYLOR, N. R., 392 Chapel-street, South Yarra; D.A.57370; 8th November, 1969; 11 cwt.; D.A.57370/1; 8th November, 1969; 19 cwt.  
 TAYLOR, R. H., 5 Clyde-street, Lilydale, 3140; D.A.57542; 29th November, 1969; 214 cwt.  
 KENNY, P. A. (trading as Town & Country Towing Service), 378 Mt. Alexander-road, Ascot Vale, 3032; D.A.35191/4; 8th November, 1969; 8 cwt.  
 TOWNSEND, L. J., 11 Perth-street, Belmont, 3216; D.A.40748/1; 20th November, 1969; 11 cwt.  
 TROWER, E. D. & P. J., Archdale via Bealiba, 3613; D.A.31350; 19th November, 1969; 103 cwt.  
 VAN AKKEREN, A. J., 9 King-street, Dandenong, 3175; D.A.44864; 7th November, 1969; 72 cwt.  
 VICTORIAN INDUSTRIAL SALES & SERVICE PTY. LTD., Hume Highway, Somerton, 3047; D.A.2205/4; 19th November, 1969; 14 cwt.  
 WITTINGSLOW, TOM, PTY. LTD., 4 Austin-street, Fairfield, 3078; D.A.22859/3; 20th March, 1969; D.A.22859/4; 20th March, 1969; 118 cwt.; D.A.22859/5; 20th March, 1969; 242 cwt.

## TOW TRUCKS.

PETTIGREW, W. J. (trading as Garden Motors), Princes Highway, Hernes Oak, Yallourn, 3838; D.A.42621; 20th March, 1969; 26 cwt.  
 MARETT, A. V. E. (trading as Grant Motors), 66 Grant-street, Bacchus Marsh, 3340; T.D.A.31078; 5th November, 1969; 28 cwt.  
 ANDREW, J. E. (trading as Ivanhoe Panel Works), 1027 Heidelberg-road, Darebin, 3079; D.A.30499/1; 20th November, 1969; 30 cwt.

## RENEWALS WITH VARIATION.

**A**PPPLICATIONS by the persons listed hereunder for renewal of the licences listed with variation of conditions in the manner set out opposite the names.

EVERY, W. & T., (AUSTRALIA) PTY. LTD., 255 Williams-street, Melbourne, 3000. D.A.6333/4; 5th November, 1969. Application to renew and vary the conditions of licence No. D.A.6333/4 (L/C. 11 cwt.) by deleting the existing conditions and adding in lieu as follows:—  
 "Within that part of the State of Victoria east of a north/south line drawn through Dandenong for the purpose of testing and repairing weighing machines—tools of trade, spare parts and materials incidental to own contracts."

COLAC AERATED WATER CO. PTY. LTD., 284-288 Murray-street, Colac, 3250. D.A.864/3, 19th November, 1969; and D.A.864/6, 27th November, 1969. Application to renew and vary the conditions of licences numbered D.A.864/3 and D.A.864/6 (L/C. 7 and 67 cwt.) by adding as an additional paragraph (c) as follows:—  
 "(c) Within a 60-mile radius of the post office at Colac—plastics, confectionery and foodstuffs on behalf of Cadbury Fry Pascall Aust. Ltd., MacRobertson Pty. Ltd., Cerebos (Aust.) Ltd., Rosella Foods Pty. Ltd., Marrickville Margarine Pty. Ltd., Mountain Maid Foods Co-operative Ltd. and Lumacell Plastics Pty. Ltd."

HARVEST FOODS LTD., 865 Nepean Highway, Moorabbin, 3189. D.A.30851/2; 29th November, 1969. Application to renew and vary the conditions of licence No. D.A.30851/2 (L/C. 67 cwt.) by deleting the existing conditions and adding in lieu—  
 "(a) From the townships of Koo-Wee-Rup, Warragul and Pakenham to own premises at Moorabbin in the course of business as 'Food Canners and Processors'—fresh fruit and vegetables.  
 (b) Within a 50-mile radius of own premises at Moorabbin—own goods."

JOHNSON, R. A., Kinglake Central, via Whittlesea, 3757. T.D.A.61310; 27th November, 1969. Application to vary the conditions of licence No. T.D.A.61310 (L/C. 270 cwt.) by deleting from paragraph (b) "Within a 5-mile radius of the post office at Buxton" and adding in lieu "within a 10-mile radius of the post office at Molesworth."

Notice of any objection should be forwarded to reach the Secretary of the Board not later than 17th September, 1969.

Applicants are advised that it will not be necessary to appear on the hearing date specified above, unless advised in writing by the Board.

B. P. KAY,  
 Secretary.

Corner Lygon and Princes streets, Carlton, 3053, Friday, 29th August, 1969.

## NOTICE TO MARINERS.

[No. 12 of 1969.]

## AUSTRALIA.—VICTORIA.

## PORT PHILLIP.

## ALTERATION IN POSITION OF LIGHT BUOY.

Date.—On or about 15th September, 1969.

Position.—Prince George Light Beacon lat. 38 deg. 6 min. S. Long. 144 deg. 44 min. E. (approximately).

Details.—The "Werribee" light buoy (Gp. Fl. (2) G. 6 secs.) 340 degrees, 3.12 miles—from the above position will be moved southward 1.12 miles to a new position. The light characteristics will remain unchanged.

New Position of Buoy.—329 degrees distant 2.15 miles from the above position.

Charts effected.—Aus. 157; B.A. 1171.

Publication effected.—Sailing Directions, Victoria, 1959 pages 307 and 713.

A. J. WAGGLEN,  
 Port Officer.

Public Works Department,  
 Ports and Harbours Division,  
 Treasury-place,  
 Melbourne, Vic., 3002, 27th August, 1969.

## NOTICE TO MARINERS.

[No. 13 (T) of 1969.]

## AUSTRALIA.—VICTORIA.

## WESTERNPORT.

Former Notice No. 8 (T) of 1968 cancelled.

## (1) Harbour Works in Progress.

Position.—Hastings Jetty Light, Lat. 38 deg. 19 min. S. Long. 145 deg. 12 min. E. (approximately).

Dredging and other harbour works are in progress in an area within the following boundaries:—

From a position 069 degrees 4,000 feet from the above light in a 180 degrees direction for 4,400 feet; thence 090 degrees 5,600 feet; thence 180 degrees 11,000 feet; thence 090 degrees 1,600 feet; thence 000 degrees 19,000 feet; thence 270 degrees to the shore.

Mariners are warned to keep clear of the area described above as submerged piles and other underwater obstructions may be encountered.

## (2) Light Buoys to be Established.

Date.—On or about 1st September, 1969.

Position.—Tortoise Head Light Lat. 38 deg. 25 min. S. Long. 145 deg. 16 min. E. (approximately).

Details.—Buoys will be established in the following positions from the above light.

(a) 131 degrees distant 1.77 miles.

(b) 146 degrees distant 1.4 miles.

(c) 222 degrees distant 1.58 miles.

Remarks.—The buoys at positions (a) and (b) will mark the eastern and western extremities of a spoil ground and each will exhibit a Quick Flashing White light (Qk. Fl.). The buoy at position (c) will exhibit a quick flashing Red light (Qk. Fl. R).

The buoys will be withdrawn upon completion of dredging operations.

Charts effected.—Aus. 156, 788.

A. J. WAGGLEN,  
 Port Officer.

Public Works Department,  
 Ports and Harbours Division,  
 Treasury-place,  
 Melbourne, Vic., 3002, 27th August, 1969.

## CONTRACTS ACCEPTED.—(Series 1969-70.)

## GENERAL STORES.

Gazette No. 59, 10th July, 1969, Schedule No. 64, Polishes, Dusters, &c.—For rate shown opposite Item No. 38, substitute \$4.84, as from 1st July, 1969.

E. P. WATSON, Secretary to the Tender Board. 1.9.69.

## ORDERS IN COUNCIL.—(Series 1969-70.)

## PUBLIC WORKS.

624. Melbourne, for security services to Stage II, New State Offices, 1 Macarthur-street, from 15th August, 1969, to 31st May, 1970, \$5,200.—Australian Watching Co. Pty. Ltd.—(C.30771).

Approved by the Governor in Council, 26th August, 1969.—J. ROSSITER, Clerk of the Executive Council.

NOTICE PURSUANT TO WEIGHTS AND MEASURES ACT 1958.

PURSUANT to sub-section (1) of section 41 of the Weights and Measures Act as substituted by section 10 of the *Weights and Measures (Amendment) Act 1965* No. 7331 I hereby—

(A) Direct that every local authority shall provide for the use of its inspectors Tertiary State Standards and accessories of materials and forms in accordance with the following:—

(1) Tertiary State Standards of volume constructed of metal, of cylindrical form and with glass strike discs, of denominations and accuracies of certification in accordance with the following Table:—

Denomination.	Accuracy of Ascertained Values of Tertiary State Standards as Stated in Relevant Certificate to be at least as Good as Stated Hereunder.
1 gallon	± 12 minims
$\frac{1}{2}$ gallon	± 6 minims
1 quart	± 3 minims
1 pint	± 2 minims
$\frac{1}{2}$ gill	± 1 minim
$\frac{1}{4}$ gill	± $\frac{1}{2}$ minim

(2) two portable beam-scales of capacities of seven and fifty-six pounds respectively currently certified pursuant to sub-Regulation (1) of Regulation 9 of the *Weights and Measures Regulations 1968*;

(3) suitable cases for all inspectors' standards of weight provided by such local authorities;

(4) weights denominated in terms of the grain (to be used as tolerance weights) complying with the requirements of the *Weights and Measures Regulations* for weights to be used in trade and able to be used in combination to make up any integral number of grains up to 110 grains;

(5) at least one steel verification punch suitable for applying marks of verification to Tertiary State Standards, pursuant to Regulation 6 of the *Weights and Measures Regulations 1968*;

(6) at least one steel verification punch suitable for stamping inspectors' standards as prescribed in sub-Regulation (1) of Regulation 7 of the *Weights and Measures Regulations 1968*;

(7) set of at least three steel verification punches of suitable assorted sizes as prescribed in sub-Regulation (2) of Regulation 15 of the *Weights and Measures Regulations 1968*;

(8) at least two steel punches of suitable sizes incorporating a design in the form of an asterisk for the obliteration of marks of verification;

(9) dispensing measures verified and stamped pursuant to the *Weights and Measures Regulations 1968* or corresponding previous Regulations, of denominations—

- 20 or 10 fluid ounces;
- 4, 2 and 1 fluid ounces;
- 4 fluid drachms;
- 2 or 1 fluid drachms;

(10) sealing pliers for use with lead-and-wire seals, including the design prescribed in sub-Regulation (2) of Regulation 15 of the *Weights and Measures Regulations 1968*; and

(11) sets of letter and number punches suitable for applying date marks in accordance with sub-Regulation (1) of Regulation 15 of the *Weights and Measures Regulations 1968*.

(B) Direct that any local authority whose district includes any area in which firewood is required to be sold by weight shall provide for the use of its inspectors a conveniently portable weighing instrument (steelyard, platform weighing machine or spring balance) of a capacity of not less than 120 pounds, such instrument—

(1) complying with the relevant tolerances in excess or deficiency or in sensitiveness reciprocal from time to time prescribed in the *Weights and Measures Regulations*; and

(2) unless in use in the administration of the *Weights and Measures Act* before the twenty-fourth day of August, 1966, being of a pattern approved, for use in trade, by the National Standards Commission or pursuant to the *Weights and Measures Act 1958* or corresponding previous enactment.

(C) Approve of the provision, by any local authority (for the use of its inspectors) whose district does not include any area in which firewood is required to be sold by weight, of a weighing instrument as described in part (B) of this notice.

(D) Approve of the provision by any local authority, for the use of its inspectors, of a beam-scale or counter scale for weighing bread, such instrument—

(1) to be of a capacity of not less than 7 pounds;

(2) to comply with the relevant tolerance in excess or deficiency from time to time prescribed in the *Weights and Measures Regulations 1968*;

(3) to have a sensitiveness reciprocal not exceeding—

(a) the relevant tolerance in excess or deficiency from time to time prescribed in the *Weights and Measures Regulations 1968*; or

(b) 3 drams—  
whichever is the smaller;

(4) unless in use in the administration of the *Weights and Measures Act 1958* before the twenty-fourth day of August, 1966, to be of a pattern approved, for use in trade, by the National Standards Commission or under the *Weights and Measures Act 1958* or corresponding previous enactment.

(E) Approve of the provision by any local authority for the use of its inspectors of Tertiary State Standards constructed of metal, of cylindrical form and with glass strike discs of denominations and accuracies of certification in accordance with the following Table:—

Denomination.	Accuracy of Ascertained Values of Tertiary State Standards as Stated in Relevant Certificate to be at least as Good as Stated Hereunder.
2 gallons	25 minims
$\frac{1}{2}$ bushel	50 minims
1 bushel	100 minims

(F) Approve of the provision by any local authority, for the use of its inspectors, of inspectors' standards, being measures of volume (conical or cylindrical and conical) of denominations of 4 and 5 gallons (constructed of galvanized steel or stainless steel, not less than 0.064 inch thick).

(G) Approve of the provision by any local authority, for the use of its inspectors, of an inspectors' standard of volume, of a denomination of 44 gallons.

All previous directions or approvals, pursuant to section 41 of the *Weights and Measures Act 1958*, are hereby revoked.

R. J. HAMER,  
Minister for Local Government.

Dated 29th August, 1969.

WEIGHTS AND MEASURES ACT 1958.

IN relation to the direction given on 24th August, 1966, pursuant to section 40 of the *Weights and Measures Act 1958* as amended by section 9 of the *Weights and Measures (Amendment) Act 1965*. I hereby further direct pursuant to the aforesaid section that—

1. The avoirdupois weights referred to in the aforesaid direction shall be constructed of brass, bronze or other suitable non-ferrous material.

2. Every local authority shall provide inspectors' standards of weight, constructed of iron and of a total quantity of not less than five hundredweight, each such weight being of a denomination of 56, 28 or 14 pounds.

R. J. HAMER,  
Minister for Local Government.

Dated 29th August, 1969.

Private Agents Act 1966.

NOTICE OF RECEIPT OF APPLICATIONS FOR LICENCES UNDER THE PROVISIONS OF THE PRIVATE AGENTS ACT 1966.

THE Clerk(s) of the Court(s) of Petty Sessions as listed hereunder hereby give notice that applications, as under, have been lodged for hearing by the said Court(s) on the date(s) specified.

Any person desiring to object to any such applications must—

- (a) lodge with the respective Clerk of Petty Sessions a notice in the prescribed form of his objection and of the grounds thereof;
- (b) cause a copy of such notice to be served personally or by post upon the applicant at least three days before the hearing of the application; and
- (c) send or deliver—
  - (i) where the objection is not made by the officer in charge of the police district in which the Court is situated—a copy of the notice to such officer; and
  - (ii) where the objection is not made by the Registrar or Deputy Registrar—a copy to the Registrar.

Full Name of Applicant or in the Case of a Firm or Corporation, of the Nominee.	Place of Abode of Applicant or Nominee.	Name of Firm or Corporation.	Address for Registration.	Type of Licence.	Date of Hearing of Application.
---	---	------------------------------	---------------------------	------------------	---------------------------------

COURT OF PETTY SESSIONS, SOUTH MELBOURNE.

McInnes, Norman John ..	1 Swindon-road, Oakleigh		101-105 Clarke-street, South Melbourne	Watchman ..	22.9.69
-------------------------	--------------------------	--	--	-------------	---------

Dated at South Melbourne this 26th day of August, 1969.

G. MILLER, Clerk of Petty Sessions.

COURT OF PETTY SESSIONS, PRAHRAN.

McMahon, Patrick Joseph ..	185 Drummond-street, Carlton	Factory Guard Service Pty. Ltd.	Suite 17, 562 St. Kilda-road, Melbourne	Watchman ..	16.9.69
----------------------------	------------------------------	---------------------------------	---	-------------	---------

Dated at Prahran this 26th day of August, 1969.

G. T. WHEELHOUSE, Clerk of Petty Sessions.

COURT OF PETTY SESSIONS, MOE.

Lipski, Boleslaw ..	5 Rutherglen-road, Newborough		5 Rutherglen-road, Newborough	Guard Agent ..	18.9.69
Lipski, Boleslaw ..	5 Rutherglen-road, Newborough		5 Rutherglen-road, Newborough	Inquiry Agent ..	18.9.69

Dated at Moe this 27th day of August, 1969.

K. T. RYAN, Clerk of Petty Sessions.

COURT OF PETTY SESSIONS, FOOTSCRAY.

Jeffery, Mervyn Edwin ..	2 Eaton-parade, North Laverton		17 Richards-street, Yarraville	Watchman ..	22.9.69
--------------------------	--------------------------------	--	--------------------------------	-------------	---------

Dated at Footscray this 29th day of August, 1969.

G. S. HOARE, Clerk of Petty Sessions.

COURT OF PETTY SESSIONS, PRAHRAN.

Heylbut, Jack William ..	27 Lyons-street, Rye	C. Furzer	Suite 12, 614 St. Kilda-road, Melbourne	Commercial Sub-agent	19.9.69
Dixon, Peter Stewart ..	40 Clay-street, Moorabbin	" "	" "	" "	" "
Man "Dort", Gerald Henry ..	59 "Donald"-street, Prahran	" "	" "	Inquiry Agent .. Commercial Sub-agent	" "
Gregory, William James ..	4-7 Simmons-crescent, South Yarra	Factory Guard Service Pty. Ltd.	Suite "17, 562 St. Kilda-road, Melbourne	Inquiry Agent .. Watchman ..	" "

Dated at Prahran this 29th day of August, 1969.

G. T. WHEELHOUSE, Clerk of Petty Sessions.

COURT OF PETTY SESSIONS, SANDRINGHAM.

Darling, Barrie John ..	12 Central-avenue, Moorabbin		12 Central-avenue, Moorabbin	Process Server ..	15.9.69
-------------------------	------------------------------	--	------------------------------	-------------------	---------

Dated at Sandringham this 29th day of August, 1969.

J. A. BARNS, Clerk of Petty Sessions.

COURT OF PETTY SESSIONS, MELBOURNE.

Lawrance, Dudley Charles ..	Woodlands-avenue, Sassafras	Wormald Brothers (Aust.) Pty. Ltd.	447-459 Williams-town-road, Port Melbourne	Watchman ..	17.9.69
-----------------------------	-----------------------------	------------------------------------	--	-------------	---------

Dated at Melbourne this 26th day of August, 1969.

G. L. WEBSTER, Clerk of Petty Sessions.

COURT OF PETTY SESSIONS, SOUTH MELBOURNE.

O'Neill, William Roy ..	54 Ford-street, Ringwood		101-105 Clarke-street, South Melbourne	Watchman ..	23.9.69
Preston, Norman Thomas ..	7-22 Hunter-street, Malvern		" "	" "	" "

Dated at South Melbourne 28th day of August, 1969.

G. MILLER, Clerk of Petty Sessions.

## STATE RIVERS AND WATER SUPPLY COMMISSION.

LICENCES TO DIVERT WATER PURSUANT TO THE PROVISIONS OF SECTION 204 OF THE WATER ACT 1958 (AS AMENDED).

THE Governor in Council has approved of the granting by the State Rivers and Water Supply Commission of licences as detailed hereunder for the term of years from the date specified in each case to the persons named in the following Schedule :—

## SCHEDULE.

Licence No.	Term of Licence and Commencing Date.	Name and Address of Person to whom Licence is to be granted.	Source of Supply.	Area Authorized to be Irrigated per Annum.	Volume of Water Authorized to be Diverted per Annum.	Annual Fee.
				acres.	ac. ft.	\$
1238/1425	Five years from 1.7.69 ..	Roy Cain, Kelvin Percy Cain, Harold Roy Cain and Graeme Herbert Cain, Laanecoorie	Loddon River ..	40	80	40.00
2824	Four years from 1.7.68	Executors of the estate of the late Edward John Ginnivan, Melbourne	Broken Creek ..	20	40	50.00
2825	Four years from 1.7.69	Ian Francis Burton, Benalla ..	Broken River ..	40	80	100.00
2826	Four years from 1.7.69	Gareth Rush, Benalla ..	Broken River ..	40	80	100.00
2827	Four years from 1.7.68	Merron Pty. Ltd., Tallarook	Goulburn River ..	32	64	64.00 (1st year thence \$80.)
2828	One year from 1.7.69 ..	B. and C. Medved, Oxley Flats	Ovens River ..	20	30	30.00
2829	Five years from 1.7.69 ..	John Lawrence O'Brien, Cowwarr	Rainbow Creek ..	30	60	30.00
*2830	Four years from 1.7.69	Pasquale Vincenzo Costantino, Wangaratta	Ovens River ..	10	15	..

\*The annual fee payable in respect of each acre-foot of water authorized to be diverted is the equivalent of one-half of the irrigation charge per acre-foot fixed in the Goulburn-Murray Irrigation District for the preceding financial year.

Office of the State Rivers and Water Supply Commission,  
Melbourne, 26th August, 1969.

G. W. LEWIS, Secretary,  
State Rivers and Water Supply Commission.

## STATE RIVERS AND WATER SUPPLY COMMISSION.

LICENCES TO DIVERT WATER AND CUT RACES PURSUANT TO THE PROVISIONS OF SECTION 204 OF THE WATER ACT 1958 (AS AMENDED).

THE Governor in Council has refused the granting by the State Rivers and Water Supply Commission of licences as detailed hereunder for the term of years from the date specified in each case to the persons named in the following Schedule :—

## SCHEDULE.

Licence Application No.	Term of Licence Sought.	Name and Address of Applicant.	Source of Supply.	Area sought to be Authorized to be Irrigated.	Volume of Water sought to be Authorized to be Diverted per Annum.
				acres.	ac. ft.
3115	Four years from 1.7.69	Mildred Sanger Armstrong, "Goomalibee Park" Benalla	Broken River ..	40	80
3312	Four years from 1.7.67	J. B. Houston and Sons, Burrowye, P.B.8, Wodonga	River Murray ..	45	94
3364	Four years from October 1968	Stanislaw Haller, 17 Carrier-street, Benalla	Broken River ..	3	6

In each case, the annual fee payable in respect of each acre-foot of water authorized to be diverted is the equivalent of one-half of the irrigation charge per acre-foot fixed in the Goulburn-Murray Irrigation District for the preceding financial year.

Office of the State Rivers and Water Supply Commission,  
Melbourne, 2nd September, 1969.

G. W. LEWIS, Secretary,  
State Rivers and Water Supply Commission.

## STATE RIVERS AND WATER SUPPLY COMMISSION.

LICENCES TO DIVERT WATER AND CUT RACES PURSUANT TO THE PROVISIONS OF SECTION 204 OF THE WATER ACT (AS AMENDED).

THE Schedule of Licences as detailed hereunder to divert water and cut races have been revoked by the Governor in Council :—

## SCHEDULE.

Licence No.	Term of Licence and Commencing Date.	Name and Address of Person to whom Licence granted.	Source of Supply.
104	Fifteen years from 1.7.57 ..	Alan Southern, Leitchville ..	Gunbower Creek
1931	Six years from 1.7.64 ..	The Executors of the Estate of Ronald Cuttle (dec'd), Illialio N.S.W.	River Murray
2228/1577	Four years from 1.7.66 ..	Pasquale Sindoni, Werribee ..	Little River

## STATE RIVERS AND WATER SUPPLY COMMISSION.

LICENCE TO DIVERT WATER PURSUANT TO THE PROVISIONS OF SECTION 204 OF THE WATER ACT 1958 (AS AMENDED).

THE schedule of Licence as detailed hereunder to divert water has been revoked by the Governor in Council :—

## SCHEDULE.

Licence No.	Term of Licence and Commencing Date.	Name and Address of Person to Whom Licence Granted.	Source of Supply.
2665	Four years from 1.7.68 ..	Frank Gordon Baines, Benalla ..	Broken River

Office of the State Rivers and Water Supply Commission,  
Melbourne, 2nd September, 1969.G. W. LEWIS, Secretary,  
State Rivers and Water Supply Commission.

## STATE RIVERS AND WATER SUPPLY COMMISSION.

LICENCES TO DIVERT WATER AND CUT RACES PURSUANT TO THE PROVISIONS OF SECTION 204 OF THE WATER ACT 1958 (AS AMENDED).

THE Governor in Council has approved of the granting by the State Rivers and Water Supply Commission of licences as detailed hereunder for the term of years from the date specified in each case to the persons named in the following Schedule :—

## SCHEDULE.

Licence No.	Term of Licence and Commencing Date.	Name and Address of Person to whom Licence is to be granted.	Source of Supply.	Area Authorized to be Irrigated per Annum.	Volume of Water Authorized to be Diverted per Annum.	Annual Fee.
				acres.	ac. ft.	\$
1829	Fifteen years from 1.7.69	State Electricity Commission of Victoria, Melbourne	Kiewa River ..	25	50	50.00
2815	Four years from 1.7.68	Alan Rowlands Holdings Pty. Ltd., Shepparton	Broken River ..	40	80'	100.00
2816	Fifteen years from 1.7.69	Henry Brooke Lawrence Gipps, Iona	Bunyip Main Drain	10	20	25.00
2817	Fifteen years from 1.7.69	Noel Bickford Johnson, Koo-wee-rup	Bunyip Main Drain	50	100	125.00
2818	Four years from 1.7.69	Leon George Ash and Margery Elizabeth Ash, Echuca Village	Goulburn River ..	30	60	75.00
2819	Four years from 1.7.69	Henry Job Gerrard, Mangalore	Goulburn River ..	50	100	125.00
2820	Four years from 1.7.69	Garth Austin Bear, Seymour	Goulburn River ..	15	30	37.50
2821	Fifteen years from 1.7.69	Allan Francis Neely, Nathalia	Goulburn River ..	12	24	30.00
2822	Four years from 1.7.69	Donald Bruce Mathews, Colignan	River Murray ..	100	300	375.00
*2823	Five years from 1.7.69 ..	James Gerard Harrington, Whorouly	Ovens River and Dragline Hole	20	30	

\*The annual fee payable in respect of each acre-foot of water authorized to be diverted is the equivalent of one-half of the irrigation charge per acre-foot fixed in the Goulburn-Murray Irrigation District for the preceding financial year.

Office of the State Rivers and Water Supply Commission,  
Melbourne, 26th August, 1969.G. W. LEWIS, Secretary,  
State Rivers and Water Supply Commission.

**SITTINGS OF THE SUPREME COURT FOR THE HEARING OF CRIMINAL TRIALS IN MELBOURNE FOR THE YEAR 1970.**

THE Judges of the Supreme Court have appointed that the Sittings of the said Supreme Court for the hearing of Criminal Trials in Melbourne shall, during the year 1970, be held on the days and dates indicated in the Schedule following, that is to say :—

SCHEDULE.

February.	March.	April.	May.	June.	July.	August.	September.	October.	November.	December.
Mon. 2	Mon. 2	Thur. 2	Fri. 1	Mon. 1	Wed. 15	Mon. 3	Tues. 1	Thur. 1	Mon. 2	Tues. 1

P. S. MALBON,  
Prothonotary of the Supreme Court.

Dated the 28th day of August, 1969.

*Police Regulation Act 1958, Section 122.*

**SALE OF UNCLAIMED MOTOR VEHICLE.**

AN owner is required for a Volkswagen combi-van, ex-registered No. GHP-347, engine No. V591593.

The vehicle came into the possession of Police on the 15th November, 1967, and if not claimed will be sold by public auction, at the Brighton Police Station, Carpenter-street, Brighton, at 2 p.m., on 8th October, 1969.

N. WILBY,  
Chief Commissioner of Police.

*Police Regulation Act 1958, Section 122.*

**SALE OF UNCLAIMED MOTOR VEHICLE.**

AN owner is required for a 1961 model, light-green Pontiac sedan motor vehicle, ex-registered No. GAJ-888, engine No. 6S 50884.

The vehicle came into the possession of Police on the 27th April, 1968, and if not claimed, will be sold by public auction, at the Oakleigh Police Station, Atkinson-street, Oakleigh, at 2 p.m., on the 23rd September, 1969.

N. WILBY,  
Chief Commissioner of Police.

**MOTOR CAR ACT 1958.—SECTION 19.**

NOTICE is hereby given that, for the purposes of Section 19 of the Motor Car Act 1958, approval has been granted to the association listed below to organize and conduct official rallies for veteran and vintage motor cars.

GIPPSLAND HISTORICAL AUTOMOBILE CLUB.

N. WILBY,  
Chief Commissioner of Police.

**DEPARTMENT OF MINES.**

SUBJECT to any necessary excisions, &c., it is proposed to grant the following lease:—

9263, Castlemaine; William Baden Powell Henry; 62a. 1r. 1p.; Parish of Maldon.

**APPLICATION FOR LEASE DECLARED ABANDONED.**

8445, Beechworth; James Say; Eric Ronald Judd; 30 acres, Parish of Lauraville.

**MINING LEASE EXPIRED.**

8238, Mineral; Ivan John Harrington Walscott; 10a. 1r. 0p., Parish of Kinabulla.

J. C. M. BALFOUR,  
Minister of Mines.

**PUBLIC TRUSTEE ACT 1958 (No. 6350), SECTION 17.**

I HEREBY give notice that on the 13th August, 1969, the Public Trustee filed elections to administer the following deceased persons' estate in accordance with section 17 of the Public Trustee Act 1958:—

KEMPTON, GEORGE, late of Gippsland Base Hospital, Sale, pensioner, died 10th February, 1969.

N. P. BRODY,  
Public Trustee.

256 Flinders-street, Melbourne, 3000, 28th August, 1969.

**NOTICE.**

CREDITORS, next of kin and others having claims against the estate of any of the under-mentioned deceased persons are required to send particulars of their claims to the Public Trustee, 256 Flinders-street, Melbourne, Vic., 3000, the personal representative, on or before the 12th November, 1969, after which date the Public Trustee may convey or distribute the assets, having regard only to the claims of which the Public Trustee then has notice:—

GEORGE, EDITH ANNIE, formerly of 18 Fock-street, Box Hill, but late of 24 Fock-street, Box Hill, widow, died 19th June, 1969.

GIBSON, WINIFRED, late of 276 Beaconsfield-parade, Middle Park, pensioner, died 12th May, 1969.

GREEN, RAYMOND JOHN, late of 40 Andrews-avenue, Preston East, boiler attendant, died 26th February, 1968.

HILDER, OLIVER CARLYLE, formerly of 45 Coster-street, Alexandra, but late of 56 Nihil-street, Alexandra, school teacher, died 30th May, 1969.

HILLE, WILLIAM CHARLES, formerly of 414 Kooyong-road, South Caulfield, but late of Burnside Hospital, 7 Hartington-street, Elsternwick, retired insurance officer, died 5th April, 1969.

JAGGER, MARY, late of 273 Mont Albert-road, Surrey Hills, married woman, died 19th April, 1969.

KIRKPATRICK, MADELINE THERESA, late of "Bethany", 10 Orion-street, Vermont, retired domestic and spinster, died 15th March, 1969.

LONGMORE, FRANCIS ALFRED, late of 2 Marong-grove, Balwyn, journal editor, died 2nd June, 1969.

NORTON, MAUD VICTORIA, late of 20 Canterbury-street, Moonee Ponds, widow, died 25th March, 1969.

POTTENGER, WALTER LESLIE, formerly of 263 Hawthorn-road, Caulfield, but late of 6 Pine-street, Hawthorn, retired P.M.G. driver, died 3rd July, 1969.

KEMPTON, GEORGE, late of Gippsland Base Hospital, Sale, pensioner, died 10th February, 1969.

SANDERSON, FLORENCE ELIZABETH, late of 17 Clynden-avenue, East Malvern, widow, died 4th July, 1969.

TRAPANI, ADRIANA, late of 16 Blair-street, East Coburg, widow, died 29th April, 1968.

WATERS, OSWALD JOSEPH, also known as Waters, Joseph Oswald, late of 41 Station-street, Moreland, gentleman, died 11th May, 1969.

WRIGLEY, ALFRED, late of 131 Wood-street, Preston, pensioner, died 14th December, 1968.

N. P. BRODY,  
Public Trustee.

Melbourne, 28th August, 1969.

**APPOINTMENTS AND RESIGNATIONS**

**APPOINTMENTS.**

HIS Excellency the Governor of the State of Victoria, by and with the advice of the Executive Council thereof, has, by Orders made on the 26th day of August, 1969, been pleased to make the under-mentioned appointments, viz.:—

**CHIEF SECRETARY'S DEPARTMENT.**

*Electoral Returning Officers.*

Laurie Thomas Williams to be Returning Officer for the Electoral District of Balwyn, vice W. J. M. Bailey, resigned;

Laurie Thomas Williams to be Returning Officer for the East Yarra Province; vice H. Clennell, deceased; and

Richard Eric Kerr to be Returning Officer for the Electoral District of Kara Kara, vice D. J. Yurcina, resigned.

*Honorary Probation Officers.*

ROBERT MAXWELL ANDERSON, 152 The Boulevard, Thomastown,  
 BRUCE FLEMING BELCHER, 355 Danks-street, Middle Park,  
 LESLIE NORMAN BLACKLEY, 13 McKay-street, Sunshine  
 KEITH WILLIAM JOYCE COUNCILLOR, 22 Rodney-avenue Merlynston,  
 ERIC THOROLD DALTON, 15 Eton-street, Wendouree,  
 WILLIAM DARRYL DEARNALEY (the Reverend), St. Mary's Rectory, High-street, Kangaroo Flat,  
 WILLIAM JOHN EDWARDS (the Reverend), 14 Portland-street, Norlane,  
 EDWARD WILLIAM ALLEN FINCH, 48 Salisbury-street, Moonee Ponds,  
 ALBERT THOMAS GARDNER, 18 Altma-avenue, Airport West,  
 BRIAN PATRICK GOUGH, 2 Nyah-court, Dallas,  
 GEORGE WILLIAM GRANT (the Reverend), 12 Desailly-street, Sale,  
 MAXWELL JAMES HALL, 9 Lytton-street, Kew,  
 KEITH WILFRED HARBOUR, Flat 6, 1 Munro-street, Armadale,  
 RAYMOND KENT, Flat 2, 30 Ashley-street, Reservoir,  
 WILLIAM HENRY KNEEBONE, 24 Lind-street, Strathmore,  
 HERBERT MCGREGOR (the Reverend), Presbyterian Manse, Snake Valley,  
 CON PHOTOPoulos, 552 Dandenong-road, Caulfield,  
 THOMAS JAMES TREZISE, 10 Fyans-street, Chilwell, and  
 GREGORY NORMAN VAUGHAN (the Reverend), "Cronulla Flats", Daylesford,

pursuant to the provisions of section 10 (1) of the *Children's Court Act 1958*, to be Honorary Probation Officers for all Children's Courts in Victoria; and

ERIC THOROLD DALTON, 15 Eton-street, Wendouree,  
 GEORGE WILLIAM GRANT (the Reverend), 12 Desailly-street, Sale,  
 WILLIAM ALBERT MACRAE, 4 Callaghan-street, Noble Park, and  
 THOMAS JAMES TREZISE, 10 Fyans-street, Chilwell, pursuant to the provisions of section 507 (1) of the *Crimes Act 1958*, to be Honorary Probation Officers for all Adult Courts in Victoria.

*Member of the Totalizer Agency Board.*

DAVID JOSEPH BOURKE, pursuant to the provisions of the *Racing Act 1958*, to be a member of the Totalizer Agency Board, for the period ending 31st May, 1972, vice William Henry Bailey, resigned.

MAURICE MORGANTI, pursuant to the provisions of the *Street Trading Act 1958*, to be a Member and Chairman of the Street Traders Licences Board, for a period of two years, from the 26th September, 1969.

*Members of the Street Traders Licences Board.*

JOHN WILLIAM ROBINSON, pursuant to the provisions of the *Street Trading Act 1958*, to be a member of the Street Traders Licences Board, for a period of two years, from the 4th September, 1969; and

ALBERT NORMAN CRAIG, pursuant to the provisions of the *Street Trading Act 1958*, to be a member of the Street Traders Licences Board, for a period of two years, from the 13th September, 1969.

*Public Auditor.*

STANLEY ARTHUR HESTER, pursuant to the provisions of the *Friendly Societies Act 1958*, to be a Public Auditor.

## EDUCATION DEPARTMENT.

*Members of Council of Victoria Institute of Colleges.*

JOHN RICHARD GRENVILLE,  
 HAROLD TEBBUTT MCKERN, and  
 FRANCIS REGINALD DORRINGTON MORGAN,  
 pursuant to the powers conferred by sections 7 (1) (b) and 7 (1) (i) of the *Victoria Institute of Colleges Act 1965*, to be members of the Council of the Victoria Institute of Colleges for a period of four years.

## MINISTRY OF HEALTH.

*Member of the Medical Board.*

JOHN DOUGLAS WHITESIDE, M.B., B.S., to be a Member of the Medical Board, pursuant to section 7 of the *Police Regulation Act 1958* (No. 6338), vice Dr. H. K. B. Bailey, resigned.

*Municipal Nominees on Committees of Management of Hospitals.*

Councillor FRANK THOMAS DAVEY, J.P., to be Municipal Nominee on the Committee of Management of the West Gippsland Hospital, for a further period of three years from 27th September, 1969, pursuant to section 48 (1) (b) of the *Hospitals and Charities Act 1958*;

Councillor JOHN GREGORY DORE, to be Municipal Nominee on the Committee of Management of the Westernport Memorial Hospital, for a further period of three years from 27th September, 1969, pursuant to section 48 (1) (b) of the *Hospitals and Charities Act 1958*; and

Councillor MAURICE KELVIN ANDERSON, to be Municipal Nominee on the Committee of Management of the Shelly Memorial Hospital, for a further period of three years from 27th September, 1969, pursuant to section 48 (1) (b) of the *Hospitals and Charities Act 1958*.

*Government Members on Committees of Management of Hospitals.*

MAX JOHN CLARK, to be Government Member on the Committee of Management of the Frankston Community Hospital, for a further period of three years from 24th September, 1969, pursuant to section 48 (1) (a) (ii) of the *Hospitals and Charities Act 1958*;

CHARLES FREDERICK RUSSELL, to be Government Member on the Committee of Management of the Mildura Base Hospital, for a further period of three years from 29th September, 1969, pursuant to section 48 (1) (a) (ii) of the *Hospitals and Charities Act 1958*;

ALAN RAY DAVID, to be Government Member on the Committee of Management of Grace McKellar House, for a further period of three years from 4th October, 1969, pursuant to section 48 (1) (a) (ii) of the *Hospitals and Charities Act 1958*;

JAMES GEORGE GILLESPIE, M.B.E., to be Government Member on the Committee of Management of the Greenvale Village for the Aged, for a period of three years, pursuant to section 48 (1) (a) (ii) of the *Hospitals and Charities Act 1958*; and

IAN LAURIE FULTON, to be Government Member on the Committee of Management of the Rupyany and District Hospital, for a period of three years, pursuant to section 48 (1) (a) (ii) of the *Hospitals and Charities Act 1958*, vice Gordon Kennedy, resigned.

## LAW DEPARTMENT.

*Commissioners for Taking Declarations, &c.*

DANIEL JOHN KEARY, 5 Lesley-street, Burwood,  
 JOHN CARRUTHERS, 878 Canterbury-road, Box Hill South,  
 BRUCE SYDNEY DYKER, 32 Selworthy-avenue, Oakleigh South, and  
 RONALD PETER BATAGOL, 292 Waterloo-road, Oak Park, to be Commissioners for taking Declarations and Affidavits, pursuant to the provisions of the *Evidence Act 1958*, to resign upon removing from the neighbourhood of the addresses stated; and

CLIVE LITTLE, care of Wilson, Danby and Giddy, chartered accountants, 253 Wyndam-street, Shepparton,

ROBERT VERNON HUGHES, care of Hughes, Fincher & Rodda, chartered accountants, 343 Little Collins-street, Melbourne, and

GEORGE HAROLD JACKES, care of Carba Australia Limited, 679 Victoria-street, Abbotsford, to be Commissioners for taking Declarations and Affidavits, pursuant to the provisions of the *Evidence Act 1958*, to resign upon ceasing to occupy their present positions.

*Justices of the Peace.*

WILLIAM JAMES YOUNG, 6 Cumming-street, Burwood,  
 AUSTIN HOWLEY, Caramut, and  
 WILLIAM JAMES BLACK, Katandra West, to keep the Peace in the State of Victoria.

*Deputy Prothonotary.*

KEVIN GEORGE MCMAHON, to be Deputy Prothonotary and Registrar of the County Court at Warrnambool, during the absence of G. G. Moon, on recreation leave, to take effect from the date of commencement of duty.

## DEPARTMENT OF THE TREASURER.

Receiver of Revenue (Acting).

KEVIN GEORGE MCMAHON  
to act temporarily as Receiver of Revenue, Warrnambool,  
vice G. G. Moon, on leave.

## DEPARTMENT OF WATER SUPPLY.

Waterworks Trust Commissioners.

PHILLIP WILLOUGHBY MESSENGER  
to be a Commissioner of the Benalla Waterworks Trust, to  
hold such position for the period from the date hereof  
until 29th March, 1971, subject to the provisions of the  
Water Act;

LEO CLARENCE LLOYD  
to be a Commissioner of the Corryong Waterworks Trust,  
to hold such position for a period of four years from the  
date hereof, subject to the provisions of the Water Act;

WILLIAM JOHN WHITE  
to be a Commissioner of the Moe Waterworks Trust, to  
hold such position for a period of four years from the date  
hereof, subject to the provisions of the Water Act; and

WILLIAM JOHN CHARLES PEACOCK  
to be a Commissioner of the Yallourn North Waterworks  
Trust, to hold such position for a period of four years  
from the date hereof, subject to the provisions of the  
Water Act.

J. ROSSITER,  
Clerk of the Executive Council.

At the Executive Council Chamber,  
Melbourne, 26th August, 1969.

## WEST MOORABOOL WATER BOARD.

AUDIT OF ACCOUNTS.

Appointment of Auditor.

HIS Excellency the Governor of the State of Victoria,  
by and with the advice of the Executive Council  
thereof, doth by Order, made on the second day of  
September, 1969, and in pursuance of the provisions of the  
West Moorabool Water Board Act, appoint J. N. Morey,  
care of E. N. Morey & Sons, 141 High-street, Prahran,  
3181, an Auditor holding a certificate of competency from  
the Municipal Auditors' Board under the *Local Government*  
*Act 1958*, to audit and report upon the accounts of the  
West Moorabool Water Board for the year ending thirtieth  
June, 1970.

J. ROSSITER,  
Clerk of the Executive Council.

At the Executive Council Chamber,  
Melbourne, 2nd September, 1969.

## FORESTS DEPARTMENT.

## APPOINTMENT OF COMMITTEE OF MANAGEMENT OF CHAFFEY'S BEND FLORA AND FAUNA RESERVE.

WHEREAS by section 50 of the *Forests Act 1958* (No.  
6254), it is provided that the Minister of Forests  
may, on the recommendation of the Forests Commission,  
appoint any number of persons, not less than three, to be  
a Committee of Management of any land forming part of  
any reserved forest, such land being set aside as a flora  
and fauna reserve, and may remove any of those persons:  
Now therefore, I, Edward Raymond Meagher, Her Majesty's  
Minister of Forests for the State of Victoria, on the recom-  
mendation of the Forests Commission, do hereby appoint—

SYDNEY CAMERON MILLS,  
WILLIAM GEORGE KELLY,  
CLAUDE ERSKINE NEVILLE,  
GARY AMOS HUDAK,  
WILLIAM FREDERICK SMART, and  
MORAY GUILD DOUGLAS,

as members of the Committee of Management until the  
fourth day of March, 1972, of the land forming part of  
the reserved forest in the Parish of Mildura, County of  
Karkaroc, described in the accompanying Schedule, and  
known as "Chaffey's Bend Flora and Fauna Reserve".

## SCHEDULE ABOVE REFERRED TO.

Parish of Mildura, County of Karkaroc, comprising  
22 acres, more or less, being the area shown by pink  
colour on plan marked A60/1573 over 12.4.62, on the file  
of correspondence No. 67/1892 of the Forests Department.

Dated at Melbourne, the Twenty-second day of August,  
1969.

E. R. MEAGHER,  
Minister of Forests.

## FORESTS DEPARTMENT.

## APPOINTMENT OF MEMBERS OF COMMITTEE OF MANAGEMENT OF MT. ARAPILES CENTENARY PARK RESERVE.

WHEREAS by section 50 of the *Forests Act 1958* (No.  
6254), it is provided that the Minister of Forests  
may, on the recommendation of the Forests Commission,  
appoint any number of persons, not less than three, to be  
a Committee of Management of land forming part of any  
reserved forest, such land being set aside and declared to  
be a reserve for special purposes, and may remove any  
of those persons: Now therefore, I, Edward Raymond  
Meagher, Her Majesty's Minister of Forests for the State  
of Victoria, on the recommendation of the Forests Com-  
mission, do hereby appoint—

LOUIS HERMANN LANGE,  
IAN CARL SUDHOLZ,  
FREDERICK ANTON SUDHOLZ,  
PETER JAMES SUDHOLZ,  
ARTHUR EDWARD LEVITZKE,  
LANCLOT JOHN CROSS, and  
WILLIAM GEORGE DYER MIDDLETON,

as members of the Committee of Management until the  
fourth day of April, 1972, of the area of land forming  
part of the reserved forest in the Parish of Arapiles,  
County of Lowan, described in the accompanying Schedule,  
and known as Mt. Arapiles Centenary Park Reserve.

## SCHEDULE ABOVE REFERRED TO.

Parish of Arapiles, County of Lowan, 18 acres:—Com-  
mencing at a point on the west side of a 1 chain road bear-  
ing south 6 deg. 58 min. east 700 links from the south-east  
angle of allotment 41; bounded thence by the said road  
bearing south 6 deg. 58 min. east, 1,000 links; and thence  
by lines bearing respectively south 83 deg. 2 min. west  
1,800 links, north 6 deg. 58 min. west 1,000 links, and  
north 83 deg. 2 min. east 1,800 links to the commencing  
point—(67/90).

Dated at Melbourne, the 20th day of August, 1969.

E. R. MEAGHER,  
Minister of Forests.

## FORESTS DEPARTMENT.

## APPOINTMENT OF MEMBERS OF COMMITTEE OF MANAGEMENT OF MT. ARAPILES PICNIC GROUND RESERVE.

WHEREAS by section 50 of the *Forests Act 1958* (No.  
6254), it is provided that the Minister of Forests may,  
on the recommendation of the Forests Commission, appoint  
any number of persons, not less than three, to be a Com-  
mittee of Management of land forming part of any  
reserved forest, such land being set aside as a picnic  
ground reserve, and may remove any of those persons:  
Now therefore, I, Edward Raymond Meagher, Her Majesty's  
Minister of Forests for the State of Victoria, on the recom-  
mendation of the Forests Commission, do hereby appoint—

LOUIS HERMANN LANGE,  
IAN CARL SUDHOLZ,  
FREDERICK ANTON SUDHOLZ,  
PETER JAMES SUDHOLZ,  
ARTHUR EDWARD LEVITZKE,  
LANCLOT JOHN CROSS, and  
WILLIAM GEORGE DYER MIDDLETON,

as members of the Committee of Management until the  
fourth day of April, 1972, of the area of land forming part  
of the reserved forest in the Parish of Arapiles, County  
of Lowan, described in the accompanying Schedule, and  
known as Mt. Arapiles Picnic Ground Reserve.

## SCHEDULE ABOVE REFERRED TO.

Parish of Arapiles, County of Lowan, 5 acres, more  
or less, being the area shown by pink colour on the plan  
marked 8.2.62 over 59/1491, in file of correspondence No.  
67/90 of the Forests Department.

Dated at Melbourne, the 20th day of August, 1969.

E. R. MEAGHER,  
Minister of Forests.



RESIGNATIONS.

HIS Excellency the Governor of the State of Victoria, by and with the advice of the Executive Council thereof, has, by Orders made on the 26th day of August, 1969, accepted the resignations of the persons named hereunder of the offices mentioned, viz.:—

LAW DEPARTMENT.  
Justice of the Peace.

LEONARD MASON, from the Commission of the Peace for the State of Victoria.

Member of Discharged Servicemen's Employment Board.

NORMAN DAVID WILSON, as a member of the Discharged Servicemen's Employment Board.

J. ROSSITER,  
Clerk of the Executive Council.

At the Executive Council Chamber,  
Melbourne, 26th August, 1969.

ORDERS IN COUNCIL

DEPARTMENT OF CROWN LANDS AND SURVEY.

At the Executive Council Chamber, Melbourne, the twenty-sixth day of August, 1969.

PRESENT:

His Excellency the Governor of Victoria.  
Mr. Balfour | Mr. Rossiter.

UNUSED ROADS CLOSED.

HIS Excellency the Governor of the State of Victoria, by and with the advice of the Executive Council thereof, doth hereby direct that, in pursuance of the provisions of section 349 of the Land Act 1958, the unused roads referred to hereunder be closed, viz.:—

Township of Amphitheatre, Parish of Glenlogie, County of Kara Kara, being the road between allotment 13 of section 2 and allotment 24 of section 3.—(A.179(+)) (Rs.9204).

Parish of Campbelltown, County of Talbot, being the road indicated by hatching on plan hereunder.—(C.364(+)) (J.29277).

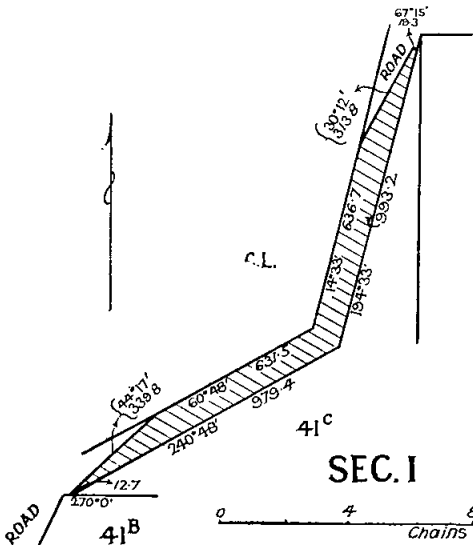

Parish of Clunes, County of Talbot, being the road between allotment 27 and allotment 33A of section E.—(C.395L<sup>6</sup>) (J.32297).

Parish of Gembrook, County of Evelyn, being the road indicated by hatching on plan hereunder.—(G.206(+)) (M.3849).

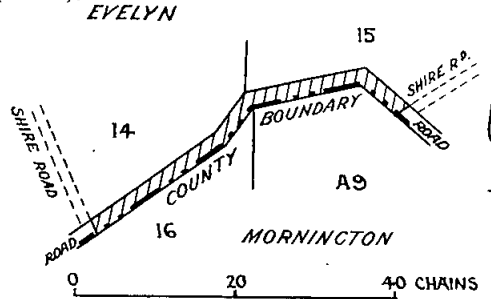

Township of Gerang Gerung, Parish of Gerang Gerung, County of Lowan, being the portion of the width of the road indicated by hatching on plan hereunder.—(G.212(+)) (Z.27567).

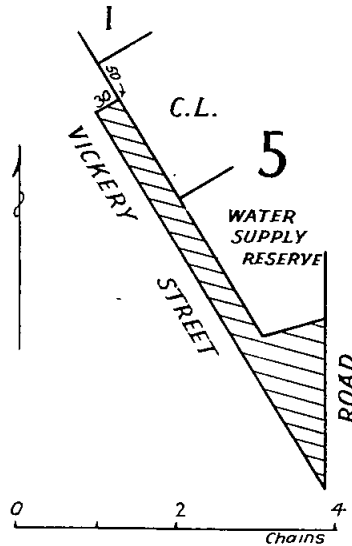

Parish of Kanawinka, County of Follett, being the portion of the width of the road indicated by hatching on plan hereunder.—(K.156(+)) (J.29941).

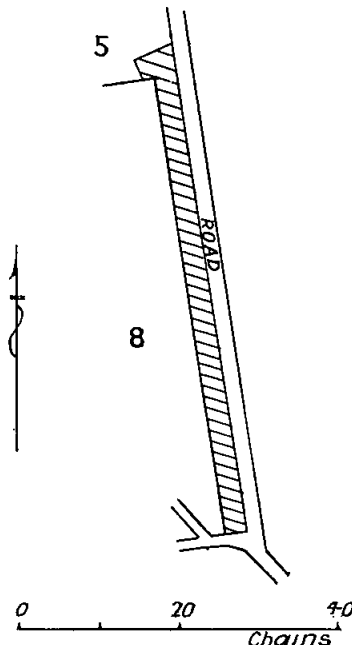

Parish of Knowsley, County of Rodney, being the road indicated by hatching on plan hereunder.—(K.59<sup>(2)</sup>) (W.87428).

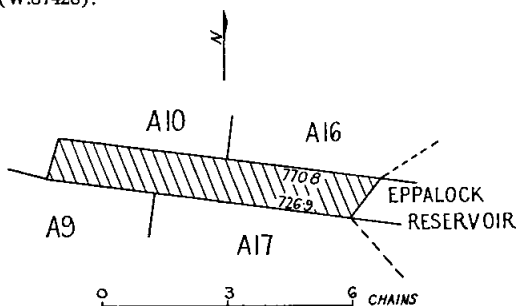

Parish of Tyntynder West, County of Tatchera, being the portion of the width of the road indicated by hatching on plan hereunder.—(T.302(U) (M.61493).

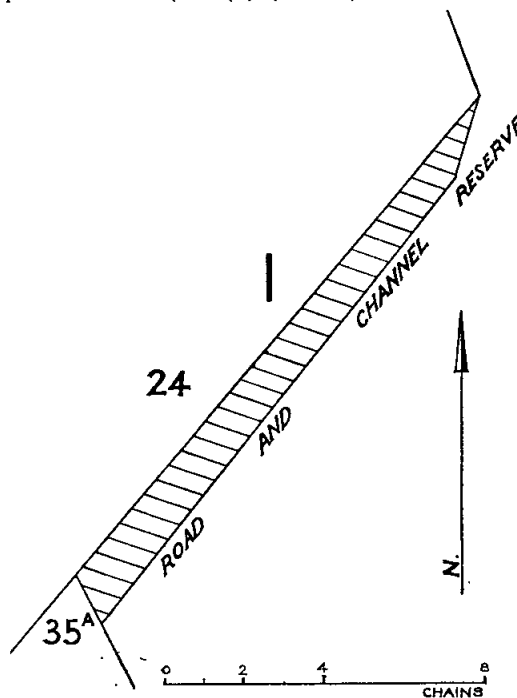

Township of Muckatah, Parish of Katamatite, County of Moira, being the road between allotments 1, 1A of section 21 and allotments 4, 5, 6 of section 19.—(M.487<sup>(3)</sup>) (H.031808).

Parish of Toora, County of Buln Buln, being the roads indicated by hatching on plan hereunder.—(T.257<sup>(7)</sup>) (M.3836).

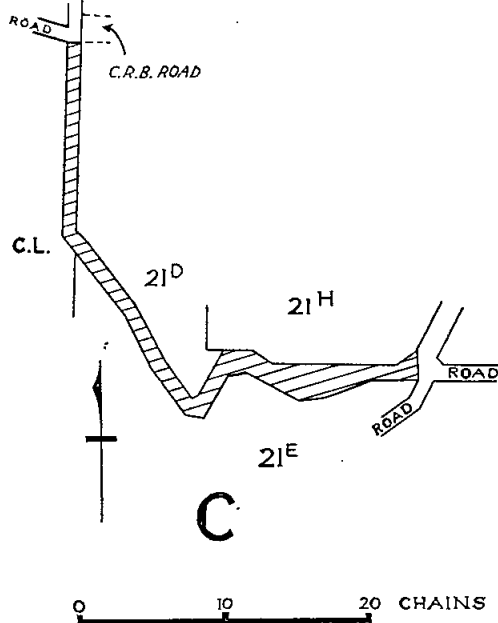

Township of Waygara, Parish of Tildesley East, County of Tambo, being the roads indicated by hatching on plan hereunder.—(W.395(C<sup>1</sup>) (266/138).

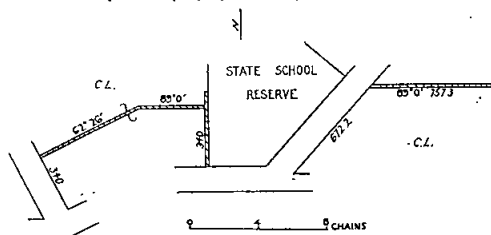

Parish of Yaughar, County of Polwarth, being the road indicated by hatching on plan hereunder.—(Y.115<sup>(8)</sup>) (565/155).

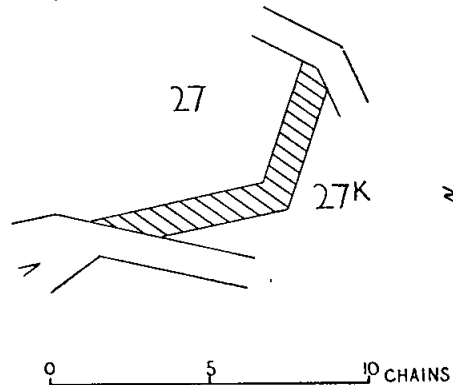

Parish of Tyntynder West, County of Tatchera, being the portion of the width of the road indicated by hatching on plan hereunder.—(T.302(U) (M.60723).

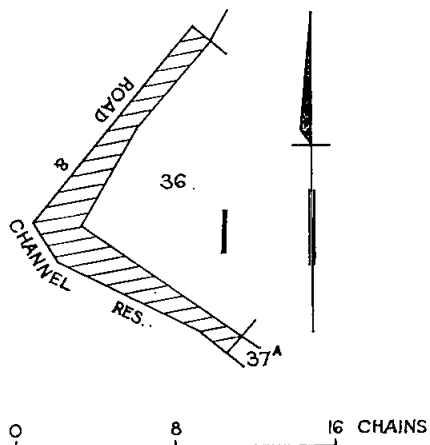

And the Honorable Sir William John Farquhar McDonald, Her Majesty's Minister of Lands for the State of Victoria, shall give the necessary directions herein accordingly.

J. ROSSITER,  
Clerk of the Executive Council.

DEPARTMENT OF CROWN LANDS AND SURVEY.

At the Executive Council Chamber, Melbourne, the twenty-sixth day of August, 1969.

PRESENT:

His Excellency the Governor of Victoria.  
Mr. Balfour | Mr. Rossiter.

REVOCATIONS OF TEMPORARY RESERVATIONS OF LANDS BY ORDERS IN COUNCIL.

**HIS** Excellency the Governor of the State of Victoria, by and with the advice of the Executive Council thereof, doth hereby, in pursuance of the provisions of the Land Act 1958, revoke the temporary reservations of lands by Orders in Council hereinafter referred to, viz.:—

**ARARAT.**—Order in Council of 24th November, 1873, of 19 8/10 perches of land in the Township of Ararat, as a site for Fire Brigade purposes.—(Rs.3919.)

**CALLIGNEE.**—Order in Council of 4th July, 1928, of 1 rood 15 perches of land in the Parish of Callignee, as a site for Public purposes.—(Rs.3703.)

**CALLIGNEE.**—Order in Council of 4th July, 1928, of 3 roods 22 perches of land in the Parish of Callignee, as a site for Public purposes.—(Rs.3703.)

**CALLIGNEE.**—Order in Council of 4th July, 1928, of 2 acres 1 rood 8 perches of land in the Parish of Callignee, as a site for Public purposes.—(Rs.3703.)

**CALLIGNEE.**—Order in Council of 4th July, 1928, of 1 acre 1 rood 34 perches of land in the Parish of Callignee, as a site for Public purposes.—(Rs.3707.)

**CRESWICK.**—Order in Council of 5th November, 1877, and the withholding from sale, leasing and licensing of 4 acres 3 roods of land in the Parish of Creswick, as a site for Public purposes (State School).—(Rs.9103.)

**KARADOC.**—Order in Council of 18th November, 1940, of 1 acre 0 roods 38 perches of land in the Parish of Karadoc, as a site for a State School.—(Rs.5130.)

**LARUNDEL.**—Order in Council of 2nd November, 1921, of 5 acres of land in the Parish of Larundel, as a site for State School.—(Rs.2418.)

**MARNOO.**—Order in Council of 19th February, 1889, of 2 acres of land in the Parish of Marnoo, as a site for State School purposes.—(C.100349.)

**THURRA.**—Order in Council of 16th August, 1886, of 1,370 acres, more or less, of land in the Parish of Thurra, as a site for Lighthouse purposes.—(C.69601.)

**NAPOLEONS.**—Order in Council of 8th June, 1927, of 1 acre 2 roods 37 perches of land in the Township of Napoleons, as a site for State School purposes.—(Rs.1488.)

**AVENEL.**—Order in Council of 30th May, 1939, of 13 acres 2 roods 10 perches, more or less, of land in the Township of Avenel, as a site for Public Park, so far only as regards the portion thereof comprised within the boundaries published in the *Government Gazette* of 23rd July, 1969, and containing 2 roods 33 perches.—(Rs.4949.)

**BRIGHT.**—Order in Council of 18th May, 1875, of 4 acres, more or less, of land in the Township of Bright, as a site for Public purposes and the withholding from sale, leasing and licensing, so far only as regards the portion thereof comprised within the boundaries published in the *Government Gazette* of 23rd July, 1969, and containing 1 rood 3 perches, more or less.—(Rs.5179.)

**CORINELLA.**—Order in Council of 27th September, 1921, of 247 acres 2 roods 25 perches of land in the Parish of Corinella, as a site for Gravel purposes, so far only as regards the portion thereof comprised within the boundaries published in the *Government Gazette* of 23rd July, 1969, and containing 4 acres 3 roods 25 perches.—(Rs.2391.)

**ESSENDON.**—Order in Council of 4th May, 1909, of 3 acres 2 roods 4 perches of land in the Town of Essendon, as a site for Public Park and other purposes of Public Recreation, so far only as regards the portion thereof comprised within the boundaries published in the *Government Gazette* of 23rd July, 1969, and containing 2 roods 13 perches.—(Rs.2793.)

**FRANKSTON.**—Order in Council of 15th October, 1957, of 25 acres of land in the Parish of Frankston, as a site for Preservation of Native Flora, so far only as regards the portion thereof comprised within the boundaries published in the *Government Gazette* of 23rd July, 1969, and containing 2 acres.—(Rs.1526.)

**GOWAR.**—Order in Council of 17th January, 1876, of 11 acres 2 roods 32 perches of land in the Parish of Gowar, as a site for Affording access to water and the withholding from sale, leasing and licensing, so far only as regards the portion thereof comprised within the boundaries published in the *Government Gazette* of 23rd July, 1969, and containing 1 acre 3 roods 20 perches, more or less.—(Rs.3045.)

**ST. ARNAUD.**—Order in Council of 29th January, 1866, of 1 acre 1 rood 12 perches of land in the Township of St. Arnaud, as a site for Police purposes, so far only as regards the portion thereof comprised within the boundaries published in the *Government Gazette* of 23rd July, 1969, and containing 1 rood 6 perches.—(Rs.6196.)

**WY YUNG.**—Order in Council of 9th February, 1892, of 20 acres of land in the Parish of Wy Yung, as a site for Supply of Gravel, so far only as regards the portion thereof comprised within the boundaries published in the *Government Gazette* of 23rd July, 1969, and containing 6 acres 0 roods 28 perches.—(C.79956.)

**THURRA.**—Order in Council of 11th August, 1879, of certain Crown land in the Parish of Thurra, as a site for Public purposes, so far only as regards the portion thereof comprised within the boundaries published in the *Government Gazette* of 23rd July, 1969, and containing 120 acres, more or less.—(Rs.2362.)

**RUNNYMEDE.**—Order in Council of 3rd May, 1869, of 35 acres of land in the Parish of Runnymede, as a site for Watering purposes, save and except the portion thereof comprised within the boundaries published in the *Government Gazette* of 23rd July, 1969, and containing 24 acres, more or less.—(Rs.9191.)

And the Honorable Sir William John Farquhar McDonald, Her Majesty's Minister of Lands for the State of Victoria, shall give the necessary directions herein accordingly.

J. ROSSITER,  
Clerk of the Executive Council.

DEPARTMENT OF CROWN LANDS AND SURVEY.

At the Executive Council Chamber, Melbourne, the twenty-sixth day of August, 1969.

PRESENT:

His Excellency the Governor of Victoria.  
Mr. Balfour | Mr. Rossiter.

LANDS TEMPORARILY RESERVED AS SITES.

**HIS** Excellency the Governor of the State of Victoria, by and with the advice of the Executive Council thereof, doth hereby, in pursuance of section 14 of the Land Act 1958, reserve temporarily from sale, from being leased and from having a licence granted in respect thereof, and also except from occupation for mining purposes under any miner's right, the land hereinafter described:—

**COONGULMERANG (LINDENOW SOUTH).**—Site for Public Recreation, 18 acres 3 roods, more or less, Parish of Coongulmerang, County of Tanjil, as indicated by hatching on plan hereunder.—(C.369<sup>(2)</sup>) (Rs.1).

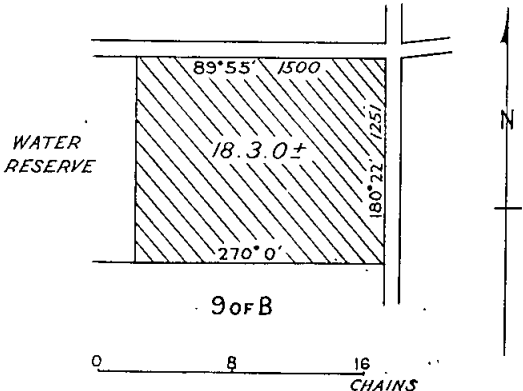

DUNOLLY.—Site for Public Recreation and Camping purposes, 5 acres 1 rood 24 perches, Township of Dunolly, Parish of Dunolly, County of Gladstone, as indicated by hatching on plan hereunder.—(D.124<sup>(8)</sup>) (Rs.6256).

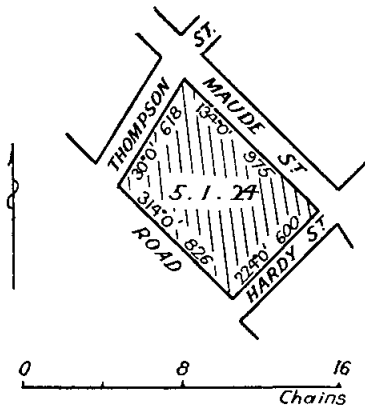

ESSENDON.—Site for Public purposes (Homes for Elderly People), 2 roods 9 perches, at Essendon, Parish of Doutra Galla, County of Bourke, as indicated by hatching on plan hereunder.—(E.68(c)) (Rs.2793).

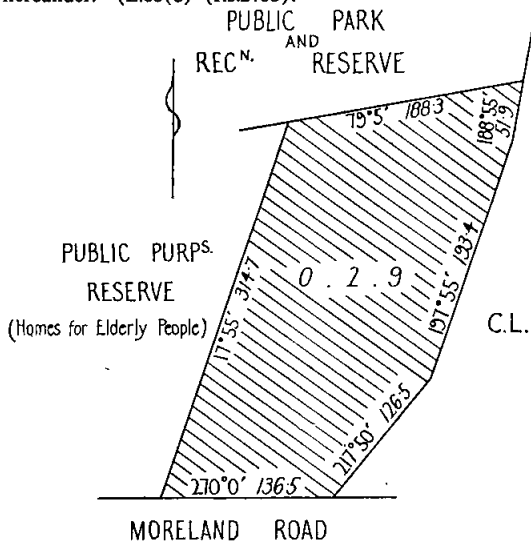

HARROW.—Site for Public purposes (Sanitary Depot), 13 acres 3 roods 2 perches, Parish of Harrow, County of Lowan, as indicated by hatching on plan hereunder.—(H.493) (Rs.9205).

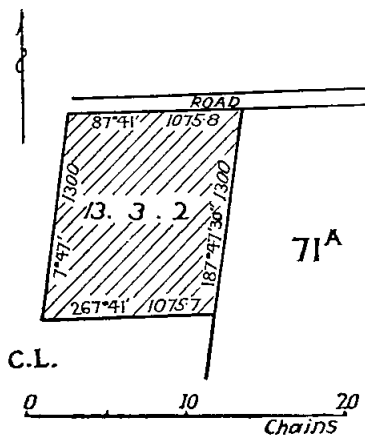

KEELBUNDORA (RESERVOIR).—Site for Public purposes (Elderly Citizen's Club Rooms), 1 rood 8 perches, Parish of Keelbundora, County of Bourke, as indicated by hatching on plan hereunder.—(K.25<sup>(5)</sup>) (Rs.9200).

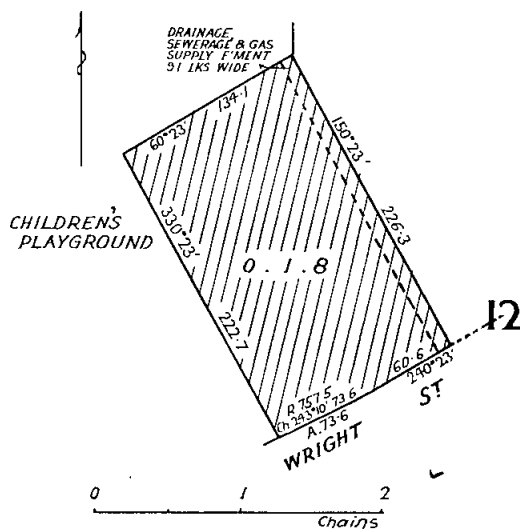

KIRKSTALL.—Site for Public Recreation, 1 acre, Township of Kirkstall, Parish of Warrong, County of Villiers, as indicated by hatching on plan hereunder.—(K.54<sup>(2)</sup>) (Rs.9192).

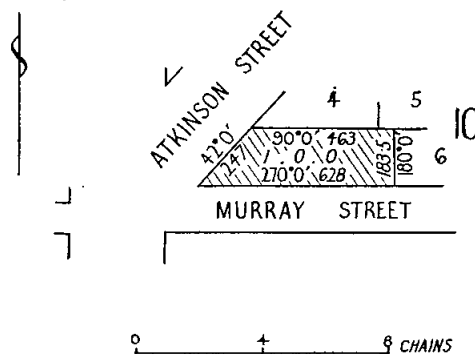

SKIPTON.—Site for Public Recreation, 17 acres 3 roods 25 perches, more or less, Township of Skipton, Parish of Skipton, County of Hampden, as indicated by hatching on plan hereunder.—(S.289<sup>(3)</sup>) (Rs.6462).

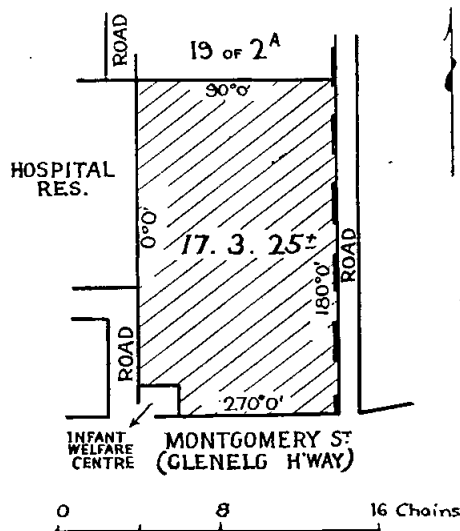

TOOAN.—Site for State School purposes, 3 roods 10 perches, Parish of Tooan, County of Lowan, as indicated by hatching on plan hereunder.—(T.185(\*) (Rs.9199).

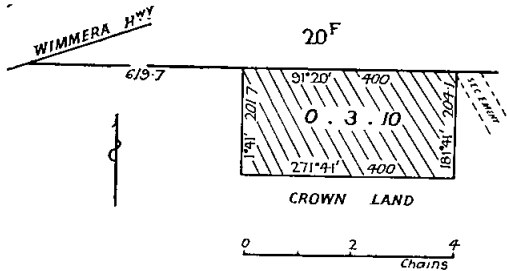

WOORRAGEE NORTH.—Site for Camping and Watering purposes, 1 acre 1 rood, more or less, Parish of Wooragee North, County of Bogong, as indicated by hatching on plan hereunder.—(W.210(\*) (Rs.9203).

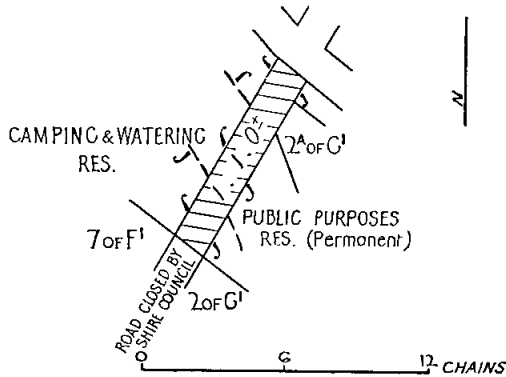

And the Honorable Sir William John Farquhar McDonald, Her Majesty's Minister of Lands for the State of Victoria, shall give the necessary directions herein accordingly.

J. ROSSITER,  
Clerk of the Executive Council.

ST. ARNAUD SEWERAGE AUTHORITY.

At the Executive Council Chamber, Melbourne, the twenty-sixth day of August, 1969.

PRESENT:  
His Excellency the Governor of Victoria.  
Mr. Balfour | Mr. Rossiter.

EXTENT OF SEWERAGE DISTRICT INCREASED.

UNDER the powers conferred by the Sewerage Districts Act and all other powers enabling him in that behalf, His Excellency the Governor of the State of Victoria, by and with the advice of the Executive Council of the said State, doth hereby declare, order and direct that the extent of the Sewerage District of the St. Arnaud Sewerage Authority be increased by adding thereto the lands as shown on a plan approved by the Governor in Council by and with this Order and deposited in the office of the State

Rivers and Water Supply Commission, Melbourne (Corr. No. 59/1245/104), and as on and from the date hereof the extent of such District shall be and be deemed to be increased accordingly.

And the Honorable William Archibald Borthwick, Her Majesty's Minister of Water Supply for the State of Victoria, shall give the necessary directions herein accordingly.

J. ROSSITER,  
Clerk of the Executive Council.

EDUCATION ACT 1958.

At the Executive Council Chamber, Melbourne, the twenty-sixth day of August, 1969.

PRESENT:  
His Excellency the Governor of Victoria.  
Mr. Balfour | Mr. Rossiter.

WHEREAS pursuant to sub-section (1) of section 29A of the Education Act 1958 the Governor in Council has by Orders dated 25th September, 1968, constituted the Councils of Caulfield Institute of Technology, Footscray Institute of Technology, Preston Institute of Technology, and Yallourn Technical College, as bodies corporate and whereas such Orders provide inter alia that the Councils shall have power to employ members of their administrative staffs on such terms and conditions as are for the time being fixed by the Governor in Council on the recommendation of the Council of the Victoria Institute of Colleges:

Now therefore His Excellency the Governor of the State of Victoria by and with the advice of the Executive Council thereof doth on the recommendation of the Council of the Victoria Institute of Colleges hereby fix the salary and classification structure for the administrative staffs of Caulfield Institute of Technology, Footscray Institute of Technology, Preston Institute of Technology and Yallourn Technical College in accordance with the following scale:—

Office.	Yearly Rate of Salary.				
	Subdivisions.				
	1	2	3	4	5
	\$	\$	\$	\$	\$
Admin. Asst. Grade I.	2,378	2,468	2,567	2,690	2,813
Admin. Asst. Grade II.	2,936	3,059	3,182	3,350	3,428
Admin. Officer, Grade I.	3,551	3,674	3,797	3,920	
Admin. Officer, Grade II.	4,043	4,166	4,289	4,412	4,535
Admin. Officer, Grade III.	4,658	4,781	4,904	5,027	5,150
Admin. Officer, Grade IV.	5,273	5,396	5,519	5,642	5,764
Senior Admin. Officer, Grade I.	5,071	5,321	5,571	5,821	6,071
Senior Admin. Officer, Grade II.	6,321	6,571	6,821	7,071	7,321
Senior Admin. Officer, Grade III.	7,571	7,821	8,071	8,321	8,571
Senior Admin. Officer, Grade IV.	8,821	9,071	9,321	9,571	

And the Honorable Lindsay Hamilton Simpson Thompson, Her Majesty's Minister of Education for the State of Victoria, shall give the necessary directions herein accordingly.

J. ROSSITER,  
Clerk of the Executive Council.

COUNTRY ROADS BOARD.

COUNTRY ROADS BOARD.

At the Executive Council Chamber, Melbourne, the twenty-sixth day of August, 1969.

At the Executive Council Chamber, Melbourne, the twenty-sixth day of August, 1969.

PRESENT:

His Excellency the Governor of Victoria.  
Mr. Balfour | Mr. Rossiter.

PRESENT:

His Excellency the Governor of Victoria.  
Mr. Balfour | Mr. Rossiter.

ORDER CONFIRMING RESOLUTIONS OF THE COUNTRY ROADS BOARD.

ORDER APPROVING OF LAND BEING ACQUIRED AND ROADS, DEVIATIONS OR WIDENINGS BEING MADE.

HIS Excellency the Governor of the State of Victoria, by and with the advice of the Executive Council thereof, doth hereby, in pursuance of the provisions of the Country Roads Act 1958, confirm the resolution of the Country Roads Board, the dates whereof and the terms of which are scheduled hereunder:—

HIS Excellency the Governor of the State of Victoria, by and with the advice of the Executive Council thereof, being satisfied that there are funds legally available for acquiring the land, doth hereby approve the acquiring of the land described in the schedule hereunder and the making of new roads and deviations from and widenings of existing roads referred to in the said schedule.

SCHEDULE.

SCHEDULE.

State Highway.

State Highways.

Resolution dated the eighteenth day of August, One thousand nine hundred and sixty-nine, made pursuant to section 70 of the Country Roads Act 1958 declaring the highway in the Cities of Malvern and Caulfield as shown hatched on Plan numbered G.P.11880 hereunder to be a State highway (Princes Highway) within the meaning and for the purposes of the said Act.

The land shown hatched on Plan numbered G.P.11858 hereunder required for the widening of the Ovens Highway in the Shire of Bright and making of the widening thereon.

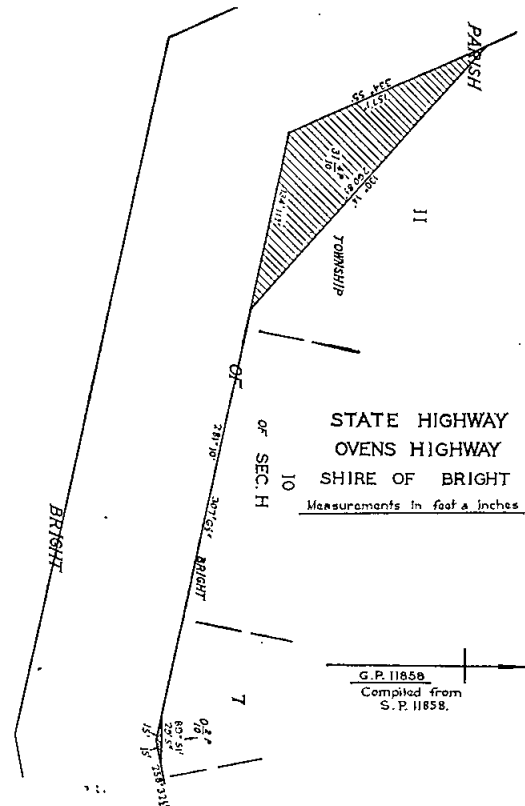
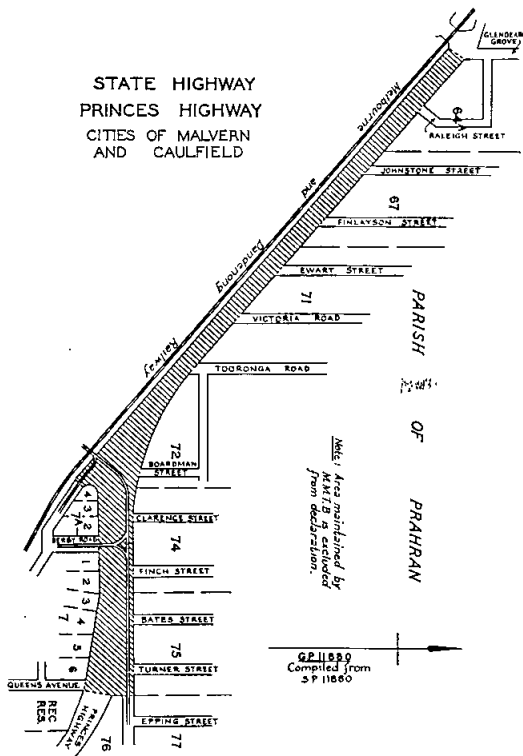

And the Honorable Murray Victor Porter, Her Majesty's Minister of Public Works for the State of Victoria, shall give the necessary directions herein accordingly.

The land shown hatched on Plan numbered G.P.11857 hereunder required for the widening of the Loddon Valley Highway in the Shire of Kerang and making of the widening thereon.

J. ROSSITER,  
Clerk of the Executive Council.

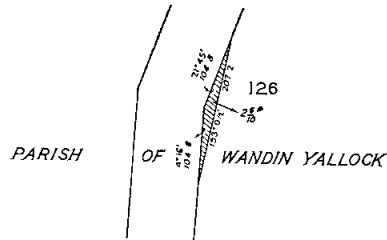
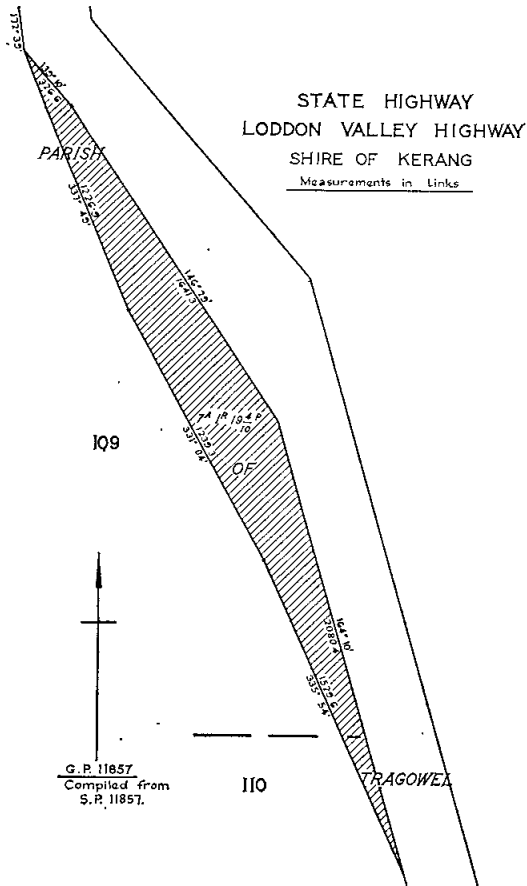

MAIN ROAD  
LILYDALE—MONBULK ROAD  
SHIRE OF LILLYDALE  
Measurements in links

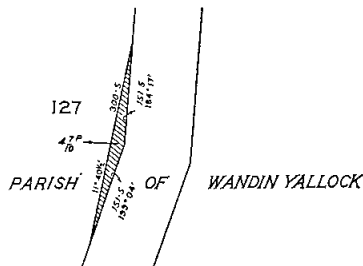

MAIN ROAD  
LILYDALE—MONBULK ROAD  
SHIRE OF LILLYDALE  
Measurements in links

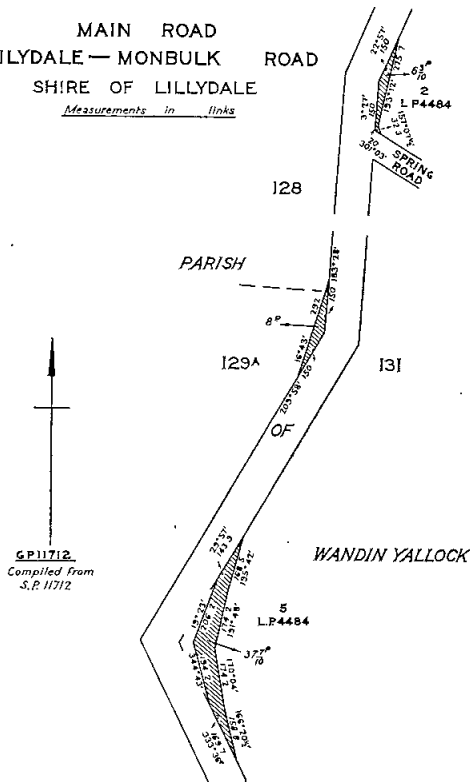

**Main Roads.**  
The land shown hatched on Plans numbered G.P.11710, G.P.11711 and G.P.11712 hereunder required for the widening of the Lilydale-Monbulk road in the Shire of Lillydale and making of the widening thereon.

MAIN ROAD  
LILYDALE—MONBULK ROAD  
SHIRE OF LILLYDALE  
Measurements in links

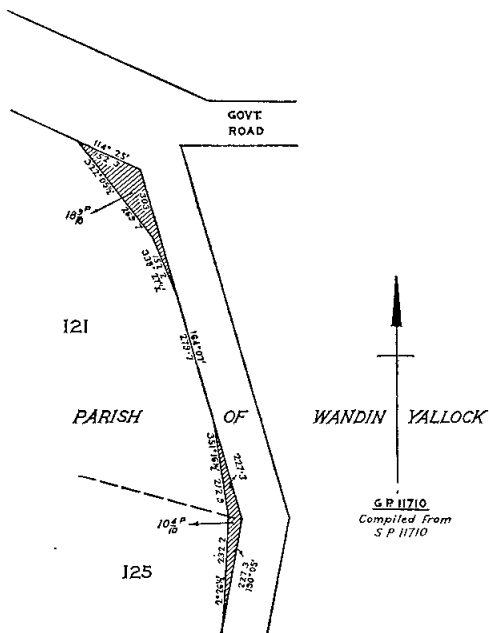

The land shown hatched on Plan numbered G.P.11830 hereunder required for the widening of Barwon Heads-road in the Shire of South Barwon and making of the widening thereon.

MAIN ROAD  
BARWON HEADS ROAD  
SHIRE OF SOUTH BARWON  
*Measurements in Links*

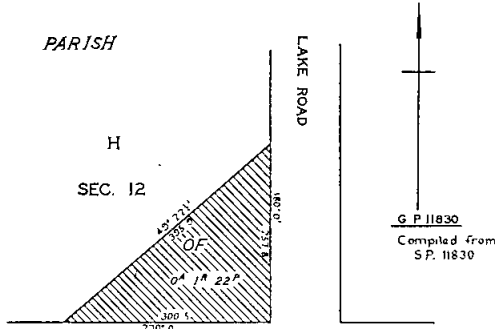

The land shown hatched on Plan numbered G.P.11819 hereunder required for the widening of Traralgon Creek-road in the City of Traralgon and making of the widening thereon.

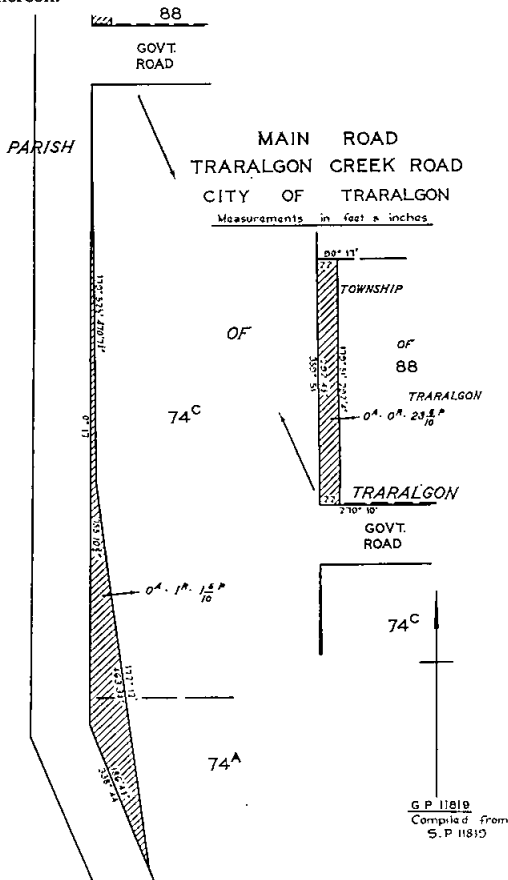

And the Honorable Murray Victor Porter, Her Majesty's Minister of Public Works for the State of Victoria, shall give the necessary directions herein accordingly.

J. ROSSITER,  
Clerk of the Executive Council.

DANDENONG VALLEY AUTHORITY.

At the Executive Council Chamber, Melbourne, the twenty-sixth day of August, 1969.

PRESENT:

His Excellency the Governor of Victoria.  
Mr. Balfour | Mr. Rossiter.

COMPULSORY TAKING OF LAND.

UNDER the powers conferred by the Dandenong Valley Authority Act and all other powers enabling him in that behalf, His Excellency the Governor of the State of Victoria, by and with the advice of the Executive Council of the said State, doth hereby consent to the compulsory taking by the Dandenong Valley Authority of all lands shown in red colour on the plan numbered A60 deposited in the office of the State Rivers and Water Supply Commission, Melbourne, being part of lot 9, lodged plan 4287, Parish of Mooroolbark.

And the Honorable William Archibald Borthwick, Her Majesty's Minister of Water Supply for the State of Victoria, shall give the necessary directions herein accordingly.

J. ROSSITER,  
Clerk of the Executive Council.

WARRANTYTE WATERWORKS TRUST.

At the Executive Council Chamber, Melbourne, the twenty-sixth day of August, 1969.

PRESENT:

His Excellency the Governor of Victoria.  
Mr. Balfour | Mr. Rossiter.

AMENDMENT OF ORDER.

UNDER the powers conferred by the Water Act and all other powers enabling him in that behalf, His Excellency the Governor of the State of Victoria, by and with the advice of the Executive Council of the said State, doth hereby amend as follows, the Order made by the Governor in Council on 19th July, 1960, as amended by Order made on 14th June, 1961 and published in the Victoria Government Gazette dated 20th July, 1960 and 21st June, 1961, respectively, fixing the limit of the overdraft to be obtained by the Warrandyte Waterworks Trust.

For the expression "at an amount not to exceed at any one time the sum of Seven thousand pounds (£7,000)" there shall be substituted the expression "at Fifty thousand dollars (\$50,000)".

And the Honorable William Archibald Borthwick, Her Majesty's Minister of Water Supply for the State of Victoria, shall give the necessary directions herein accordingly.

J. ROSSITER,  
Clerk of the Executive Council.

GEELONG WATERWORKS AND SEWERAGE TRUST.

At the Executive Council Chamber, Melbourne, the twenty-sixth day of August, 1969.

PRESENT:

His Excellency the Governor of Victoria.  
Mr. Balfour | Mr. Rossiter.

CONSENT TO BORROWING \$100,000.

UNDER the powers conferred by the Geelong Waterworks and Sewerage Act and all other powers enabling him in that behalf, His Excellency the Governor of the State of Victoria, by and with the advice of the Executive Council of the said State, doth hereby consent to the Geelong Waterworks and Sewerage Trust borrowing at interest, subject to the Geelong Waterworks and Sewerage Act, the sum of One hundred thousand dollars (\$100,000) to meet the cost of sewerage works.

And the Honorable William Archibald Borthwick, Her Majesty's Minister of Water Supply for the State of Victoria, shall give the necessary directions herein accordingly.

J. ROSSITER,  
Clerk of the Executive Council.



## GEELONG WATERWORKS AND SEWERAGE TRUST.

At the Executive Council Chamber, Melbourne, the twenty-sixth day of August, 1969.

PRESENT:

His Excellency the Governor of Victoria.  
Mr. Balfour | Mr. Rossiter.

## CONSENT TO BORROWING \$93,000.

UNDER the powers conferred by the Geelong Waterworks and Sewerage Act and all other powers enabling him in that behalf, His Excellency the Governor of the State of Victoria, by and with the advice of the Executive Council of the said State, doth hereby consent to the Geelong Waterworks and Sewerage Trust borrowing at interest, subject to the Geelong Waterworks and Sewerage Act, the sum of Ninety-three thousand dollars (\$93,000) for the conversion of Loan No. 77.

And the Honorable William Archibald Borthwick, Her Majesty's Minister of Water Supply for the State of Victoria, shall give the necessary directions herein accordingly.

J. ROSSITER,  
Clerk of the Executive Council.

## WEST MOORABOOL WATER BOARD.

At the Executive Council Chamber, Melbourne, the twenty-sixth day of August, 1969.

PRESENT:

His Excellency the Governor of Victoria.  
Mr. Balfour | Mr. Rossiter.

## CONSENT TO BORROWING \$50,000.

UNDER the powers conferred by the West Moorabool Water Board Act and all other powers enabling him in that behalf, His Excellency the Governor of the State of Victoria, by and with the advice of the Executive Council of the said State, doth hereby consent to the West Moorabool Water Board borrowing at interest the sum of Fifty thousand dollars (\$50,000) to meet the cost of water storage works as set forth in the detailed statement bearing date 21st August, 1969.

And the Honorable William Archibald Borthwick, Her Majesty's Minister of Water Supply for the State of Victoria, shall give the necessary directions herein accordingly.

J. ROSSITER,  
Clerk of the Executive Council.

## SWAN HILL SEWERAGE AUTHORITY.

At the Executive Council Chamber, Melbourne, the second day of September, 1969.

PRESENT:

His Excellency the Governor of Victoria.  
Mr. Reid | Mr. Porter.

## CONSENT TO BORROWING \$17,700.

UNDER the powers conferred by the Sewerage Districts Act and all other powers enabling him in that behalf, His Excellency the Governor of the State of Victoria, by and with the advice of the Executive Council of the said State, doth hereby consent to the Swan Hill Sewerage Authority borrowing at interest by mortgage of the General Fund the sum of Seventeen thousand seven hundred dollars (\$17,700) for the conversion of Loan No. 9.

And the Honorable William Archibald Borthwick, Her Majesty's Minister of Water Supply for the State of Victoria, shall give the necessary directions herein accordingly.

J. ROSSITER,  
Clerk of the Executive Council.

## WODONGA SEWERAGE AUTHORITY.

At the Executive Council Chamber, Melbourne, the second day of September, 1969.

PRESENT:

His Excellency the Governor of Victoria.  
Mr. Reid | Mr. Porter.

## AMENDMENT OF ORDER.

UNDER the powers conferred by the Sewerage Districts Act and all other powers enabling him in that behalf, His Excellency the Governor of the State of Victoria, by and with the advice of the Executive Council of the said State, doth hereby amend as follows, the Order made by the Governor in Council on 23rd November, 1965, as amended by Order made on 9th July, 1968, and published in the *Victoria Government Gazette*, dated 24th November, 1965, and 10th July, 1968, respectively, fixing the limit of the overdraft to be obtained by the Wodonga Sewerage Authority.

For the expression "at an amount not to exceed at any one time the sum of Twenty thousand pounds (£20,000)" there shall be substituted the expression "at an amount not to exceed at any one time the sum of Sixty thousand dollars (\$60,000)".

And the Honorable William Archibald Borthwick, Her Majesty's Minister of Water Supply for the State of Victoria, shall give the necessary directions herein accordingly.

J. ROSSITER,  
Clerk of the Executive Council.

## RIVER IMPROVEMENT ACT 1958.

At the Executive Council Chamber, Melbourne, the second day of September, 1969.

PRESENT:

His Excellency the Governor of Victoria.  
Mr. Reid | Mr. Porter.

## TARWIN RIVER IMPROVEMENT TRUST—RATING DIVISIONS 1969.

UNDER the powers conferred by the *River Improvement Act 1958*, and all other powers enabling him in that behalf, His Excellency the Governor of the State of Victoria, by and with the advice of the Executive Council of the said State, doth by this Order repeal the Order made on the 4th February, 1958, determining rating divisions in the Tarwin River Improvement District, and doth hereby determine that the properties within the Tarwin River Improvement District shall be arranged in two divisions in the manner hereinafter provided:—

- (1) That the said divisions shall be known as the First and Second Divisions.
- (2) That the First Division shall comprise those lands shown coloured green on the plan titled "Tarwin River Improvement District, Rating Divisions 1969", approved by the Governor in Council and deposited at the office of the State Rivers and Water Supply Commission, Melbourne.—(Corres. No. 59/2428/44.)
- (3) That the Second Division shall comprise all those lands shown uncoloured on the said plan.

And the Honorable William Archibald Borthwick, Her Majesty's Minister of Water Supply for the State of Victoria, shall give the necessary directions herein accordingly.

J. ROSSITER,  
Clerk of the Executive Council.

LANDLORD AND TENANT ACT 1958.

At the Executive Council Chamber, Melbourne, the second day of September, 1969.

PRESENT:

His Excellency the Governor of Victoria.  
Mr. Reid | Mr. Porter.

ORDER EXTENDING APPLICATION OF PART V. OF THE LANDLORD AND TENANT ACT 1958 TO CERTAIN PREMISES.

IN pursuance of the powers conferred by Section 44 of the *Landlord and Tenant Act 1958*, the Governor of the State of Victoria, by and with the advice of the Executive Council thereof, doth hereby declare that the application of Part V. of the *Landlord and Tenant Act 1958* shall extend to the premises being a bungalow at the rear of the main dwelling at 231 Nepean Highway, Seaford South, which was on the 25th August, 1969, leased to Mr. Kenneth Dalrymple and Mrs. Kathleen Dalrymple.

And the Honorable George Oswald Reid, Her Majesty's Attorney-General in and for the State of Victoria, shall give the necessary directions herein accordingly.

J. ROSSITER,  
Clerk of the Executive Council.

THE CONSTITUTION ACT AMENDMENT ACT 1958.

At the Executive Council Chamber, Melbourne, the second day of September, 1969.

PRESENT:

His Excellency the Governor of Victoria.  
Mr. Reid | Mr. Porter.

APPOINTMENT OF POLLING PLACES FOR THE ELECTORAL DISTRICT OF DANDENONG.

WHEREAS by a Proclamation, made on the 12th day of March, 1969, and published in the *Victoria Government Gazette* of the 17th day of March, 1969, the Electoral District of Dandenong among others, was divided into subdivisions and the boundaries and names of such subdivisions were specified in the said Proclamation:

And whereas the Chief Electoral Officer has certified, in writing, that it is necessary for polling places to be appointed for the afore-mentioned subdivisions of the Electoral District of Dandenong:

Now, therefore, His Excellency the Governor of the State of Victoria, by and with the advice of the Executive Council thereof, doth by this Order, hereby appoint the polling places set out in column 2 of the Schedule hereto to be polling places within and for the subdivisions of the Electoral District of Dandenong named in conjunction therewith in column 1 of the said Schedule:

SCHEDULE.	
COLUMN 1. Subdivision.	COLUMN 2. Polling Places.
Dandenong ..	Cleeland, Dandenong, Dandenong West.
Dandenong North ..	Dandenong North.
Doveton ..	Doveton, Doveton West.
Keysborough ..	Bangholme, Chelsea Heights, Keysborough, Kirkham.
Noble Park ..	Harrisfield, Noble Park, Yarraman Park.

And the Honorable William Archibald Borthwick, Her Majesty's Acting Chief Secretary for the State of Victoria, shall give the necessary directions herein accordingly.

J. ROSSITER,  
Clerk of the Executive Council.

THE CONSTITUTION ACT AMENDMENT ACT 1958.

At the Executive Council Chamber, Melbourne, the second day of September, 1969.

PRESENT:

His Excellency the Governor of Victoria.  
Mr. Reid | Mr. Porter.

APPOINTMENT OF POLLING PLACES FOR THE ELECTORAL DISTRICT OF RESERVOIR.

WHEREAS by a Proclamation made on the 12th day of March, 1969, and published in the *Victoria Government Gazette* of the 17th day of March, 1969, the Electoral District of Reservoir among others, was divided into subdivisions and the boundaries and names of such subdivisions were specified in the said Proclamation:

And whereas the Chief Electoral Officer has certified, in writing, that it is necessary for polling places to be appointed for the afore-mentioned subdivisions of the Electoral District of Reservoir:

Now, therefore, His Excellency the Governor of the State of Victoria, by and with the advice of the Executive Council thereof, doth by this Order, hereby appoint the polling places set out in column 2 of the Schedule hereto to be polling places within and for the subdivisions of the Electoral District of Reservoir named in conjunction therewith in column 1 of the said Schedule:

SCHEDULE.	
COLUMN 1. Subdivision.	COLUMN 2. Polling Places.
Reservoir ..	Boldrewood, Regent, Reservoir North-East.
Reservoir East ..	Regent East.
Reservoir North ..	Keon Park, Kingsbury, Reservoir North.
Reservoir West ..	Merrilands, Reservoir, Reservoir Central, Reservoir South, Reservoir West.

And the Honorable William Archibald Borthwick, Her Majesty's Acting Chief Secretary for the State of Victoria, shall give the necessary directions herein accordingly.

J. ROSSITER,  
Clerk of the Executive Council.

LANDS DEPARTMENT NOTICES

APPROACHING LAND SALES.

SALES of Crown Lands, in fee-simple, will be held at the under-mentioned places and dates, viz.:-

	No. of Gazette.
Ararat.—Thursday, 11th September, 1969 ..	63
Ballarat.—Tuesday, 9th September, 1969 ..	63
Beaufort.—Thursday, 11th September, 1969 ..	63
Cohuna.—Tuesday, 23rd September, 1969 ..	73
Geelong.—Monday, 15th September, 1969 ..	72
Nelson.—Monday, 13th October, 1969 ..	74
Stawell.—Friday, 26th September, 1969 ..	73

SALE OF FREEHOLD LAND BY AUCTION.

Pyramid Hill.—Tuesday, 23rd September, 1969 73

LOCAL LAND BOARDS.

IN pursuance of the provisions of section 34 of the *Land Act 1958*, notice is hereby given that public hearings at the following places and times, will be conducted by the persons respectively mentioned, being duly appointed in that behalf.

W. J. F. McDONALD,  
Minister of Lands.

Department of Crown Lands and Survey,  
Melbourne.

SCHEDULE.

BENDIGO, LAND OFFICE, Wednesday, 24th September, 1969, at 10 a.m.—R. F. Jones, and Thursday, 25th September, 1969, at 9 a.m.—T. A. Comte.

LOCAL LAND BOARDS.

IN pursuance of the provisions of section 34 of the Land Act 1958, notice is hereby given that public hearings at the following places and times, will be conducted by the persons respectively mentioned, being duly appointed in that behalf.

W. J. F. McDONALD,  
Minister of Lands.

Department of Crown Lands and Survey,  
Melbourne.

SCHEDULE.

BAIRNSDALE, STATE PUBLIC OFFICES, Tuesday, 16th September, 1969, at 9.30 a.m.—J. Buck and H. McDonald.

YEA LAND INSPECTOR'S OFFICE, Thursday, 18th September, 1969, at 10 a.m.—J. Cox and W. McIntosh.

MANSFIELD LAND INSPECTOR'S OFFICE.—Thursday, 18th September, 1969, at 2 p.m.—J. Cox and W. McIntosh.

Land Act 1958.

LEASE CANCELLED.

NOTICE is hereby given that the Governor in Council has cancelled the Lease mentioned in the Schedule hereunder for the reason specified.

District.	Corr. No.	Name.	Section of Land Act under which Leased.	Parish.	Allotment.	Section.	Area.	Annual Rental.	Reason.
Beechworth	28/155	Allen Keith Sandford	155	Woor-rangee North	3	B1	A. R. P. 378 0 37	\$ 113.47	Substitute Lease to issue

Department of Crown Lands and Survey,  
Melbourne, 25th August, 1969.

W. J. F. McDONALD,  
Minister of Lands.

Land Act 1958.

LEASE DECLARED VOID.

NOTICE is hereby given that the Governor in Council has declared void the Lease mentioned in the Schedule hereunder for the reason specified.

District.	Corr. No.	Name.	Section of Land Act under which Leased.	Parish.	Allotment.	Section.	Area.	Annual Rental.	Reason.
Melbourne	0502/134	Lane's Motors Proprietary Limited	134	Melbourne South (at South Melb.)	23	101A	A. R. P. 1 0 14 <sup>10</sup> / <sub>100</sub>	\$ 3852.00	Lease expired

Department of Crown Lands and Survey,  
Melbourne, 25th August, 1969.

W. J. F. McDONALD,  
Minister of Lands.

Land Act 1958.

LICENCE UNDER THE LAND ACTS CANCELLED.

NOTICE is hereby given that the Licence in the Schedule hereunder has been Cancelled for the reason specified.

District.	Corr. No.	Name of Licensee.	Section of Land Act under which Licensed.	Parish.	Allotment.	Section.	Area.	Annual Rental.	Reason for Voiding.
Bairnsdale	247/138	Douglas Ian Brownlie	138	Cann River	21	1	A. R. P. 0 0 36	\$ 10.00	Non-compliance with residence and improvement conditions

Department of Crown Lands and Survey,  
Melbourne, 28th August, 1969.

W. J. F. McDONALD,  
Minister of Lands.

**PROPOSED REVOCATIONS OF TEMPORARY RESERVATIONS OF LANDS BY ORDERS IN COUNCIL.**

IN pursuance of the provisions of the *Land Act 1958*, notice is hereby given that it is the intention of the Governor in Council to revoke the temporary reservations of lands by Orders in Council hereunder referred to, viz.:-

The following Notices were published 1° on the 20th August, 1969, pursuant to Orders of the 12th August, 1969.

**BALLARAT EAST.**—The temporary reservation by Order in Council of the 22nd February, 1949, of 1 acre 2 roods 16 5/10 perches of land in the Township of Ballarat East as a site for Public Gardens is about to be revoked.—(B.128(47) (Rs.6129.)

**GINQUAM.**—The temporary reservation by Order in Council of the 22nd November, 1921, of 5 acres of land in the Parish of Ginquam as a site for a State School is about to be revoked.—(G.244(2) (Rs.2429.)

**KIRKELLA.**—The temporary reservation by Order in Council of the 15th August, 1887 (see *Government Gazette*, 19th August, 1887, page 2487) of 7 acres 3 roods 1 perch of land in the Parish of Kirkella as a site for supply of gravel, is about to be revoked.—(K.106(5) (C.100346.)

W. J. F. McDONALD,  
Minister of Lands.

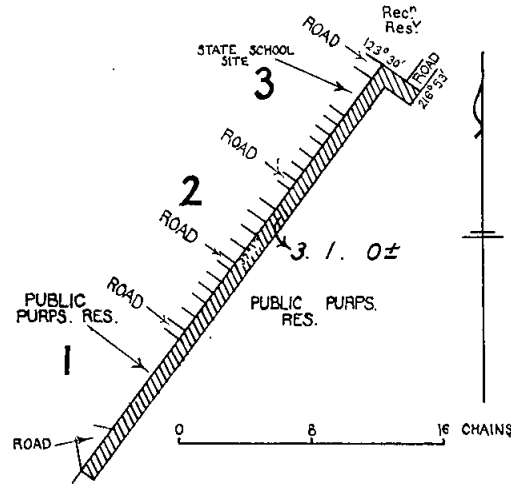

**PURGAGOO LAH.**—The temporary reservation, by Order in Council of the 12th November, 1918, of 5 acres of land in the Parish of Purgagoolah as a site for a State School, is about to be revoked.—(P.161(4) (Rs.1862).

**STAWELL.**—The temporary reservation, by Order in Council of the 6th June, 1967, of 1 rood of land in the Township of Stawell as a site for Hospital purposes, is about to be revoked.—(S.329(13) (Rs.6104).

**WARRACKNABEAL.**—The temporary reservation, by Order in Council of the 29th August, 1887, of 17 acres 3 roods 16 perches of land in the Township of Warracknabeal as a site for Racecourse and other purposes of Public Recreation is about to be revoked, so far only as the portion containing 1 acre 2 roods 16 perches, indicated by hatching on plan hereunder, is concerned.—(W.293(7) (Rs.916).

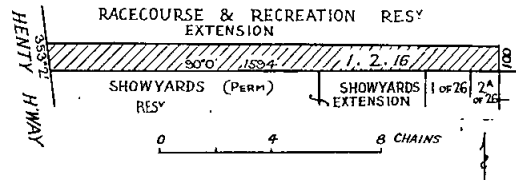

**KATAMATITE.**—The temporary reservation as a site for the use of the Police Department and the withholding from sale, leasing and licensing by Order in Council of the 7th August, 1882, of 3 acres of land in the Township of Katamatite are about to be revoked so far only as the portion containing 2 acres indicated by hatching on plan hereunder is concerned.—(K.137(4) (Rs.1238).

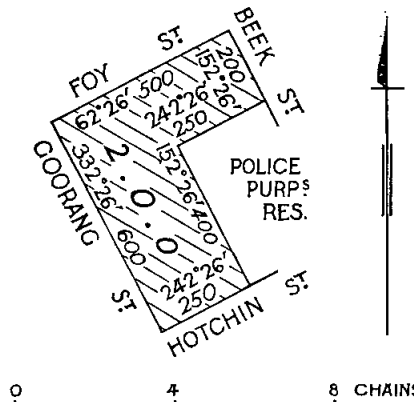

W. J. F. McDONALD,  
Minister of Lands.

**PROPOSED REVOCATIONS OF TEMPORARY RESERVATIONS OF LANDS BY ORDERS IN COUNCIL.**

IN pursuance of the provisions of the *Land Act 1958*, notice is hereby given that it is the intention of the Governor in Council to revoke the temporary reservations of lands by Orders in Council hereunder referred to, viz.:-

The following Notices were published 1° on the 7th August, 1969, pursuant to Orders of the 29th July, 1969.

**BRIGHT.**—The temporary reservation, by Order in Council of 6th December, 1955 (see *Government Gazette* 14th December, 1955, page 6672) of 3 roods 24 perches, more or less, of land in the Parish of Bright, as a site for a State Battery is about to be revoked so far only as the portion containing 20 perches, more or less, indicated by hatching on plan hereunder is concerned.—(B.574(11) (Rs.7410).

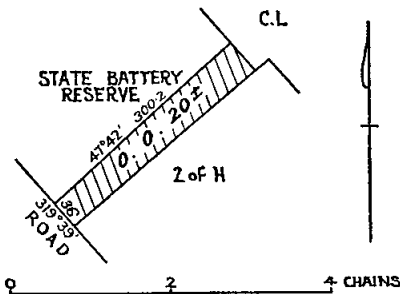

**SEASPRAY.**—The temporary reservation, by Order in Council of the 11th August, 1879, of certain Crown lands situated on the shore of Bass Strait and the Indian Ocean (named Southern Ocean in Order) as a site for Public purposes, revoked as to part by various Orders, is about to be revoked, so far only as the portion containing 3 acres 1 rood, more or less, indicated by hatching on plan hereunder, is concerned.—(S.461(6) (Rs.2362).

**PROPOSED REVOCATIONS OF TEMPORARY RESERVATIONS OF LANDS BY ORDERS IN COUNCIL.**

IN pursuance of the provisions of the *Land Act 1958*, notice is hereby given that it is the intention of the Governor in Council to revoke the temporary reservations of lands by Orders in Council hereunder referred to, viz.:—

The following Notices were published 1° on the 3rd September, 1969, pursuant to Orders of the 26th August, 1969.

**BALNARRING.**—The temporary reservation by Order in Council of the 3rd February, 1925, of 1 rood of land in the Parish of Balnarring, as a site for Mechanics' Institute is about to be revoked.—(B.74<sup>(6)</sup>) (Rs.3068.)

**CASTLEMAINE.**—The temporary reservation by Order in Council of the 15th November, 1966, of 2 roods 2 perches of land in the Township of Castlemaine as a site for Public purposes (Children's Playground) is about to be revoked so far only as the portion containing 1 rood indicated by hatching on plan hereunder is concerned.—(C.99<sup>(8)</sup>) (Rs.8692.)

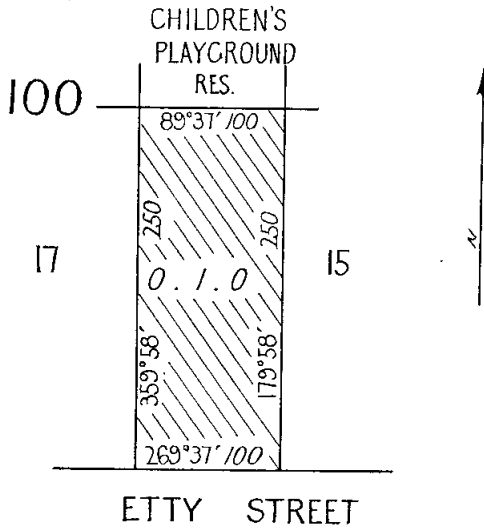

**DEREEL.**—The temporary reservation by Order in Council of the 30th September, 1913, of 12 acres 2 roods 16 perches of land in the Parish of Dereel as a site for Railway Purposes is about to be revoked.—(D.172<sup>(7)</sup>) (Rs.233.)

**DURDIDWARRAH.**—The temporary reservation by Order in Council of the 17th May, 1955, of 6 acres 1 perch of land in the Parish of Durdidwarrah, as a site for Supply of Gravel is about to be revoked.—(D.135<sup>(4)</sup>) (Rs.7355.)

**ELDORADO.**—The temporary reservation by Order in Council of the 19th April, 1869, of 2 acres of land in the Township of Eldorado as a site for Common School purposes, is about to be revoked so far only as the portion containing 1 rood 6 perches, more or less, indicated by hatching on plan hereunder, is concerned.—(E.89<sup>(4)</sup>) (Rs.9207.)

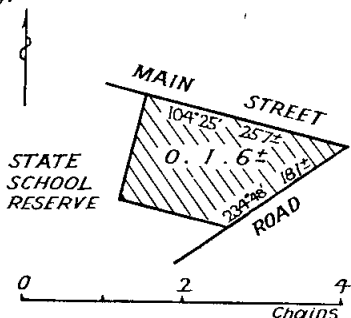

**HARROW.**—The temporary reservation, by Order in Council of the 19th October, 1915 (see *Government Gazette* 27th October, 1915, page 4195) of 9 acres 1 rood 27 perches of land in the Parish of Harrow as a site for a Sanitary Depot, is about to be revoked.—(H.49<sup>(3)</sup>) (C.63679).

**NORTHCOTE.**—The temporary reservation, by Order in Council of the 12th July, 1910, of 1 rood 26 perches of land in the Township of Northcote (now in the Parish of Jika Jika) as a site for a Public Park is about to be revoked.—(N.71<sup>(1A)</sup>) (Rs.677).

**SCARSDALE.**—The temporary reservation by Order in Council of the 4th October, 1966, of 1 rood 34 perches of land in the Parish of Scarsdale as a site for Public purposes (Forests Department purposes) is about to be revoked.—(S.249<sup>(12)</sup>) (Rs.8483).

**SMYTHESDALE.**—The temporary reservation by Order in Council of the 15th June, 1960, of 5 acres 2 roods, more or less, of land in the Township of Smythesdale, as a site for purposes of the Forest Act is about to be revoked.—(S.297<sup>(5)</sup>) (Rs.7630).

**WINNINDOO.**—The temporary reservation of a site for Public purposes (State School) and the withholding from sale, leasing and licensing by Order in Council of the 3rd May, 1880, of 3 acres of land in the Parish of Winnindoo is about to be revoked.—(W.169<sup>(4)</sup>) (C.73762).

W. J. F. McDONALD,  
Minister of Lands.

**PROPOSED PERMANENT RESERVATION OF LAND AS A SITE.**

IN pursuance of sections 14 and 21 of the *Land Act 1958*, notice is hereby given that it is the intention of the Governor in Council to reserve permanently from sale, from being leased and from having a licence granted in respect thereof the land hereinafter described:—

The following Notice was published 1° on the 13th August, 1969, pursuant to Order of the 5th August, 1969.

**MELBOURNE NORTH, AT EAST MELBOURNE.**—Land proposed to be permanently reserved as a site for a Public Park, 2 acres 3 roods 7 perches, at East Melbourne, City of Melbourne, Parish of Melbourne North, County of Bourke, as indicated by hatching on plan hereunder and being the balance of the land temporarily reserved therefor by Order in Council of the 18th July, 1950.—(M.366G) (Rs.4134).

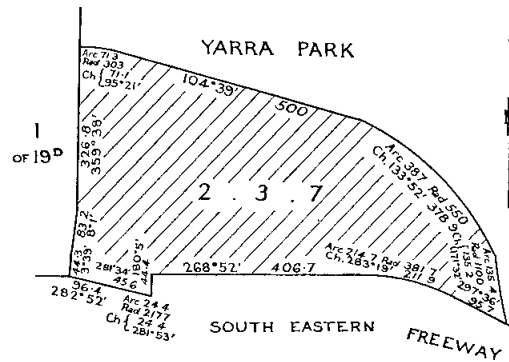

W. J. F. McDONALD,  
Minister of Lands.

**COMMITTEES OF MANAGEMENT OF RESERVES. APPOINTMENTS.**

NOTICE is hereby given that, in pursuance of section 221 of the *Land Act 1958*, the following appointments of Committees of Management of reserved Crown lands have been made by the Minister of Lands.

**" AMPHITHEATRE RECREATION RESERVE."**

Henry Herbert Cocking, John Henry Dridan, Leslie Charles Ward, Cecil Herbert Townsing, John Watson Lusby, Vernon Desmond Morvell, John Joseph Clancy, Ronald Anderson and Ian Charles Irvin as a Committee of Management for a period of three (3) years from the 18th March, 1969, of the remaining portion of the lands in the Township of Amphitheatre temporarily reserved by Orders in Council dated the 21st February, 1870, 4th June, 1940 and

1st April, 1941, as sites for Public Recreation together with the land in the same township, temporarily reserved by Order in Council dated the 12th August, 1969, as a site for Public Recreation the whole known as the "Amphitheatre Recreation Reserve".—(Corres. No. Rs.705.)

"BADDAGINNIE RECREATION RESERVE."

Frederick Albert Cook, Frank Sydney Dosser, Donal Carlisle Robinson, Ron Hilton Cook, Arthur James Cook, Allan Edwin Roy Croxford, Clive Linton Cook, Eugene Joseph Vallence and John Patrick Mack as a Committee of Management for a period of three (3) years of the land in the Town of Baddaginnie, temporarily reserved by Order in Council dated the 9th February, 1904, as a site for Public Recreation, and known as the "Baddaginnie Recreation Reserve".—(Corres. No. Rs.2252.)

"BAGSHOT RECREATION RESERVE."

Morris James Clay, Ronald Matthew Brown, Cyril Henry Peatling, Kieth M. Shay and W. A. S. Petherick as a Committee of Management for a period of three (3) years of the land in the Parish of Bagshot, temporarily reserved by Order in Council dated the 6th June, 1922, as a site for Public Recreation, and known as the "Bagshot Recreation Reserve".—(Corres. No. Rs.2364.)

"BEARII RECREATION RESERVE."

The Corporation of the Shire of Numurkah as the Committee of Management of the land temporarily reserved by Order in Council dated the 22nd June, 1914, as a site for Public Recreation in the Township of Bearii and known as the "Bearii Recreation Reserve".

This appointment is made in lieu of all previous appointments in respect of the said land which are hereby revoked.—(Corres. No. Rs.800.)

"BENDIGO AERODROME RESERVE."

Charles W. Baker (as Government representative), Rodney Warren Cambridge and Kevin Stanley Curran (for so long only as they continue to be Councillors and the elect of the Council of the City of Bendigo), Clarence Christian Rodda, Arthur Roy Collins, William Albert Sparks Petherick and Kenneth Alfred Burch (for so long only as they continue to be Councillors and elect, respectively, of the Councils of the Shires of Strathfieldsaye, Marong and Huntly and the Borough of Eaglehawk) as a Committee of Management of the land in the Parish of Sandhurst, County of Bendigo, temporarily reserved by Order in Council dated the 10th June, 1969, as a site for Aerodrome purposes, and known as the "Bendigo Aerodrome Reserve".—(Corres. No. Rs.1741.)

"CALEDONIAN PARK RESERVE," BALLAN.

Charles Albert Dehnert, Charles Edward Cattran, Colin Reginald Poole, Trevor Arthur Holmes, Albert Edward Allen, Norman John Aspre Hobbs, Petrus de Bruyn, Ronald Frederick Haddon, Desmond Francis Shortall and James Francis Wheelahan as a Committee of Management for a period of three (3) years of the lands in the Township of Ballan, temporarily reserved by Orders in Council dated the 15th August, 1870 and 12th December, 1950, as sites for Public Recreation, together with the abutting reservation along the Werribee River as is indicated by red color on plan marked "C/2.10.50" attached to Lands Department correspondence Rs.4832, and known as "Caledonian Park Reserve".—(Corres. No. Rs.4832.)

"CHESHUNT RECREATION RESERVE."

Algernon Cory Swinburne, Jeo Tiso, Ronald Lindsay Miller, Keith Petersen, Frank Ryan, Paul Hoskins, Jeffery Sheather, Guido Pizzini and William Gallacher as a Committee of Management for a period of three (3) years of the remaining portion of land in the Parish of Edi, temporarily reserved by Order in Council dated the 17th July, 1902, as a site for Public Recreation, and known as the "Cheshunt Recreation Reserve".—(Corres. No. Rs. 3369.)

"CHILTERN VALLEY RECREATION RESERVE."

Basil Fuge, Bernard Marengo, Gerald Regis Terrill, Vivian Mark Evans, Terrence Peter Reeves, Andrew William Allan and William Charles Meagher as a Committee of Management for a period of three (3) years of the land in the Parish of Chiltern West, temporarily reserved by Order in Council dated the 14th May, 1956, as a site for Public Recreation, and known as the "Chiltern Valley Recreation Reserve".—(Corres. No. Rs.7570.)

"CORINELLA RECREATION RESERVE."

Lloyd Davies, John Isbester, David Young, Clyde Hamilton, Edward John Hunt, Alan David Williamson, Michael Cahalane and Robert James McNabb as a Committee of Management for a period ending the 22nd May, 1972, of the land in the Parish of Corinella, temporarily reserved by Order in Council dated the 26th April, 1932, as a site for Public Recreation, and known as the "Corinella Recreation Reserve".—(Corres. No. Rs.312.)

"DOOEN PUBLIC HALL RESERVE."

William Longstaff Johns, Evan Ernest Woolman, Wilfrid Howard Hobbs, Hector Albert Mills, David Ernest Ladlow, Colin Alexander Hobbs, Robert Murray Kearn, Cecil John Hobbs, Frederick George Mills, Maxwell James Johns, Henry Neil Natrass and James Molyneaux as a Committee of Management for a period of three (3) years of the land in the Parish of Dooen, temporarily reserved by Order in Council dated the 11th January, 1949, as a site for a Public Hall, and known as the "Dooen Public Hall Reserve".—(Corres. No. Rs.6095.)

"EVERARD MEMORIAL PARK," PARISH OF GRACEDALE.

The Corporation of the Shire of Healesville as the Committee of Management of the land in the Parish of Gracedale, temporarily reserved by Order in Council dated the 3rd June, 1969, as a site for a Public Park.—(Corres. No. Rs.3962.)

"GORAE WEST RESERVE."

Alfred John Hedditch, Russell James Hann, Stanley George Murray, Robert John Beauglehole, Edwin Hugh Adams, and Ernest James Antony as a Committee of Management for a period of three (3) years of the land in the Parish of Mouzie, temporarily reserved by Order in Council dated the 30th January, 1940, as a site for Public Purposes, and known as the "Gorae West Reserve".—(Corres. No. Rs.5011.)

"GRENVILLE RECREATION RESERVE."

Edward Clifford Freeman, Michael Dean Colvin, Maurice Gordon Turner, and Ronald Claude Wylie as a Committee of Management for a period of three (3) years of the land in the Township of Grenville, temporarily reserved by Order in Council dated the 31st July, 1900, as a site for Public Recreation, and known as the "Grenville Recreation Reserve".—(Corres. No. Rs.270.)

"HARKAWAY PUBLIC HALL RESERVE."

Jack Smith, Edith Smith, Graeme Peterson, Duncan Sheard, Allan Barker and Malcolm Kirkham as a Committee of Management for a period of three (3) years of the land permanently reserved by Order in Council dated 24th April, 1923, as a site for Public Hall in the Parish of Berwick and known as the "Harkaway Public Hall Reserve".—(Corres. No. Rs.2734.)

"HORSHAM SHOWGROUNDS RESERVE."

Francis Bruce Langlands, John Allen Russell and Raymond Oscar Huf as a Committee of Management for a period of three (3) years of the land in the Township and Parish of Horsham, temporarily reserved by Order in Council dated the 8th March, 1932, as a site for Agricultural Showgrounds, and known as the "Horsham Showgrounds Reserve".—(Corres. No. Rs.2497.)

"PUBLIC RECREATION RESERVE," AT KALKALLO.

The Corporation of the Shire of Whittlesea as the Committee of Management of the land in the Township and Parish of Kalkallo temporarily reserved by Order in Council dated the 10th June, 1969, as a site for Public Recreation.—(Corres. No. Rs.9165.)

PUBLIC PARK AND RECREATION RESERVE, KERANG.

The Corporation of the Borough of Kerang as the Committee of Management of the land in the Township and Parish of Kerang, temporarily reserved by Order in Council dated the 3rd June, 1969, as a site for Public Park and Recreation.—(Corres. No. Rs.9174.)

## SITE FOR WATER SUPPLY PURPOSES, PARISH OF KOOEM.

The State Rivers and Water Supply Commission as the Committee of Management of the land in the Parish of Kooem, temporarily reserved by Order in Council dated the 24th June, 1969, as a site for Water Supply Purposes.—(Corres. No. Rs.9176.)

## "KOONDROOK RACECOURSE AND RECREATION RESERVE."

Maxwell Francis Hird, Edward Ernest Hollingworth, Herbert Henry Richard Chick, Horace Henry Simons, Reginald Nicholas Penglase, Beryl Annie Campbell and Arthur Molin as a Committee of Management for a period of three (3) years of the land in the Parish of Murrabit, temporarily reserved by Orders in Council dated the 5th March, 1889, and 16th July, 1934, as sites for a Racecourse and Public Recreation and known as the "Koon-drook Racecourse and Recreation Reserve".—(Corres. No. Rs.813.)

## "LAKE BOGA WATER SUPPLY, RECREATION AND PUBLIC PARK RESERVE."

The Corporation of the Shire of Swan Hill as the Committee of Management of the reserved Crown land in the Township of Lake Boga, Parish of Kunat Kunat, as shown colored red and black on plan marked KB/13.8.69 attached to Lands Department correspondence Rs.2824 and known as the "Lake Boga Water Supply, Recreation and Public Park Reserve".—(Corres. Nos. Rs.2824, Rs.6286.)

## "LAKE LORNE PUBLIC PURPOSES RESERVE," DRYSDALE.

The Corporation of the Shire of Bellarine as the Committee of Management of the land in the Township of Drysdale, temporarily reserved by Order in Council dated the 4th May, 1915, as a site for Public purposes, and known as the "Lake Lorne Public Purposes Reserve".—(Corres. No. Rs.711.)

## "LAKE MERAN FORESHORE RESERVE."

Herbert Keith Chamberlain, Edward Leslie Pay, Frank Levi Chamberlain, Thomas Henry Malone, Robert Noel Williams, James William English, Barrie George Baulch, Clement Lawrence English, John Douglas Chamberlain, Murray Cyril Moresi, Cyril James Condely and Maxwell Allan Shipp as a Committee of Management for a period of three (3) years of the reserved Crown land in the Parish of Meering as indicated by blue outline on plan marked "M/6.9.60" attached to Lands Department correspondence Rs.6030, and known as the "Lake Meran Fore-shore Reserve".—(Corres. No. Rs.6030.)

## "LAKE MERRIMU RESERVOIR."

The State Rivers and Water Supply Commission as the Committee of Management of the land in the Parish of Merrimu, temporarily reserved by Order in Council dated the 3rd June, 1969, as a site for a Reservoir, and known as the "Lake Merrimu Reservoir".—(Corres. No. Rs.9115.)

## "LEITCHVILLE (BOWLING GREEN) RECREATION RESERVE."

Reginald Charles Munzel, David Ernest Hipwell and Edward Gilmour Brown as a Committee of Management for a period of three (3) years of the land in the Parish of Gunbower West, deemed to be permanently reserved as a site for the recreation, convenience or amusement of the public (pursuant to section 22c (5) of the Land Act 1958) and known as the "Leitchville (Bowling Green) Recreation Reserve".—(Corres. No. C.99886.)

## SITE FOR WATER SUPPLY PURPOSES, AT LORNE.

The Lorne Waterworks Trust as the Committee of Management of the land in the Township and Parish of Lorne, temporarily reserved by Order in Council dated the 10th June, 1969, as a site for Water Supply Purposes.—(Corres. No. Rs.9159.)

## "EYE AND EAR HOSPITAL PURPOSES RESERVE," MELBOURNE.

The Committee of Management of the Royal Victorian Eye and Ear Hospital as the Committee of Management of the land in the Parish of Melbourne North, at East Melbourne, temporarily reserved by Order in Council dated the 24th June, 1969, as a site for Eye and Ear Hospital Purposes.—(Corres. No. Rs.5543.)

## "MT. RICHMOND RESERVE."

Norman Robert Kennett, Ernest James Posselt, Noel James Johnstone, Alan Norman Compton, Russell Compton, Russell John Greenham and Maxwell James Stevenson as a Committee of Management for a period of three (3) years of the land in the Parish of Mouzie, temporarily reserved by Order in Council dated the 28th November, 1938, as a site for Public Recreation, and known as the "Mt. Richmond Reserve".—(Corres. No. Rs.4889.)

## "MYRRHEE RECREATION RESERVE."

Kenneth Mildren, Victor H. Handcock, Earnest W. Forge, Earnest W. Handcock, Joseph J. Northey, Robert Hill, W. Edward Martin, Ronald V. Moshing, Clive O. Evans and J. Austin Evans as a Committee of Management for a period of three (3) years of the land in the Parish of Whitfield temporarily reserved by Order in Council dated the 2nd May, 1916, as a site for Public Recreation and known as the "Myrrhee Recreation Reserve".—(Corres. No. Rs.996.)

## "NARRACAN FALLS RESERVE," MOE.

Alan Francis Gunn and Edward James Crowe (for so long only as they continue to be Councillors and the elect of the Council of the Shire of Narracan) and Norman L. Savige, Frank Savige, James Auchterlonie, Roy Francis Savige, Norman E. Osler as a Committee of Management for a period of three (3) years of the land in the Parish of Moe, temporarily reserved by Order in Council dated the 21st January, 1941, as a site for Public purposes, together with portion of the permanent reservation along the Narracan Creek, as shown by blue and red colours respectively on plan marked "M/6.11.1941" attached to Lands Department correspondence Rs.5159, together known as the "Narracan Falls Reserve".—(Corres. No. Rs.5159.)

## "NORADJUHA PUBLIC HALL RESERVE."

Alan Cossar Hood, Donald James Leslie, George Ambrose Walter, James Henry Northfield, Alvin Charles Walker, Lionel Robert Mewett and Joseph Maurice Leslie as a Committee of Management for a period of three (3) years of land in the Township of Noradjuha, temporarily reserved by Order in Council dated the 1st July, 1947, as a site for a Public Hall, and known as the "Noradjuha Public Hall Reserve".—(Corres. No. Rs.5987.)

## INFANT WELFARE CENTRE, AT NORTHCOTE.

The Corporation of the City of Northcote as the Committee of Management of the land in the Parish of Jika Jika, at Northcote, temporarily reserved by Order in Council dated the 8th July, 1969, as a site for Public purposes (Infant Welfare Centre).—(Corres. No. Rs.9183.)

## "NYAH PUBLIC PARK AND RECREATION RESERVE."

Robert William Coburn, William George Ditchfield, Albert Graeme McCartney, Kenneth Ian McClean, Walter Kelly, Reginald David McMillan, Maxwell Archie Henson, Donald William Hayden, Kenneth William Phelan, Frederick Lawrence Boulton and Raymond Thomas Burrage as a Committee of Management for a period ending the 28th August, 1971, of the land in the Township of Nyah, temporarily reserved by Order in Council dated the 22nd July, 1969, as a site for Public Park and Recreation, being an extension to the existing reservation, and known as the "Nyah Public Park and Recreation Reserve".—(Corres. No. Rs.2051.)

## "PATHO WATER SUPPLY PURPOSES RESERVE."

The State Rivers and Water Supply Commission as the Committee of Management of the land in the Parish of Patho, Township of Gunbower, temporarily reserved by Order in Council dated the 3rd June, 1969, as a site for Water Supply Purposes.—(Corres. No. Rs.9172.)

## "SHELFORD PUBLIC HALL RESERVE."

Douglas Andrew Simpson, James Edward Barrie, Leslie Samual Parker, Frederick William Butcher, Dennis Elliot Smith, Roy Gillett, Brian Laurance Parker, Ian Graham Stone and Llewellyn Lloyd Palmer as a Committee of Management for a period of three (3) years of the land in the Township of Shelford, Parish of Doroq, temporarily reserved by Order in Council dated the 15th January, 1963, as a site for Public Hall and Recreation purposes, and known as the "Shelford Public Hall Reserve".—(Corres. No. Rs.2561.)

“STONY CREEK RECREATION AND RACECOURSE RESERVE.”

Frederick Henry Helms, Colin Rhodes Carmichael, William Frederick Helms, Ian Keppell Greig, Kevin Patrick Dempsey, Norman Roy Shanoley, Keith William McGrath, Edgar Andrew McCaughan and Joseph Harold Ross as a Committee of Management for a period of three (3) years of the land in the Township of Dumbalk, temporarily reserved by Order in Council dated the 14th September, 1910, as a site for a Racecourse and other purposes of Public Recreation, and known as the “Stony Creek Racecourse and Recreation Reserve”.—(Corres. No. Rs.1371.)

“STRATFORD GRAVEL RESERVE.”

The Corporation of the Shire of Avon as the Committee of Management of the land in the Parish of Stratford, temporarily reserved by Order in Council dated the 24th September, 1968, as a site for Public purposes (Supply of Gravel).—(Corres. No. Rs.9030.)

“TUBBUT PUBLIC HALL RESERVE.”

Robert William Stokes, Geoffrey George Clark, Alan James Neven, and Clement James Ingram as a Committee of Management for a period of three (3) years of the land in the Parish of Tubbut, temporarily reserved by Order in Council dated the 11th September, 1956, as a site for a Public Hall, and known as the “Tubbut Public Hall Reserve”.—(Corres. No. Rs.7496.)

SITE FOR CAMPING PURPOSES, TOWNSHIP OF WARNEET.

William Stephen Tamo, Valentine Wright, Robert Oliver Luxford, Leonard Kent Preston, Solly Friedman, Leslie William Crouch and John McDougal Stewart as a Committee of Management for a period ending the 25th April, 1970, of the land in the Township of Warneet, Parish of Sherwood, temporarily reserved by Order in Council, dated the 8th July, 1969, as a site for Camping purposes.—(Corres. No. Rs.9186.)

SITE FOR PUBLIC PURPOSES (SUPPLY OF STONE), PARISH OF WARRAQUIL.

The Corporation of the Shire of Lowan as the Committee of Management of the land in the Parish of Warraquil, temporarily reserved by Order in Council dated the 29th July, 1969, as a site for Public purposes (Supply of Stone).—(Corres. No. Rs.9197.)

“WONTHAGGI DISTRICT HOSPITAL.”

The Committee of the Wonthaggi and District Hospital as the Committee of Management of the land in the Township and Parish of Wonthaggi, temporarily reserved by Order in Council dated the 18th June, 1969, as a site for Hospital purposes.—(Corres. No. Rs.949.)

“WONTHAGGI HOMES FOR THE AGED RESERVE.”

The Corporation of the Wonthaggi and District Elderly Citizens' Homes as the Committee of Management of the lands in the Township of Wonthaggi temporarily reserved by Orders in Council dated the 9th July, 1963, and 18th June, 1969, as sites for Homes for the Aged and Public purposes (Homes for the Aged) respectively.

This appointment is made in lieu of all previous appointments, in respect of the said lands, which are hereby revoked.—(Corres. No. Rs.8216.)

SITE FOR WATERING AND RECREATION PURPOSES, PARISH OF WOORRAGEE.

The Corporation of the United Shire of Beechworth as the Committee of Management of the land in the Parish of Woorragee, temporarily reserved by Order in Council dated the 1st July, 1969, as a site for Watering and Recreation purposes.—(Corres. No. Rs.9019.)

W. J. F. McDONALD,  
Minister of Lands.

Department of Crown Lands and Survey,  
Melbourne, 28th August, 1969.

REGULATIONS FOR THE CARE, PROTECTION AND MANAGEMENT OF THE PICNIC POINT RECREATION RESERVE, PARISH OF DIMBOOLA.

WHEREAS by section 218 of the *Land Act 1958* the Minister of Lands is empowered to make regulations as to any land which under the provisions of that Act or of any other Act relating to Crown lands has been reserved for any public purpose whatsoever and which has not been conveyed to or vested in trustees: And whereas certain Crown lands in the Parish of Dimboola and described in a notice published in the *Gazette* of the 19th day of June, 1968, were reserved as a site for Public Recreation: And whereas such lands (hereinafter called “the Reserve”) have not been conveyed to or vested in trustees: And whereas it is expedient that regulations for the care, protection and management of the Reserve and for other purposes connected therewith should be made: Now therefore I, William John Farquhar McDonald, Her Majesty's Minister of Lands in and for the State of Victoria, in pursuance of the powers aforesaid, do hereby make the following Regulations for or with respect to the Reserve:—

The Reserve has been placed under the control of a Committee of Management, with power and authority to enforce the following regulations:—

*Regulations.*

1. The reserve shall be open to the public from sunrise to sunset free of charge, except as hereinafter provided and also except on such days (not exceeding twenty-six in any one year) as the Reserve may be set apart for sports, fetes, or holiday amusements, on any of which occasions a sum not exceeding fifty cents may be charged and taken for the admission of every adult to the Reserve.
2. No person shall enter or remain in the Reserve who may offend against decency as regards dress, language, or conduct.
3. No person shall damage in any way the trees, shrubs, or flowers in the Reserve, nor shall fires be lighted therein, except in fireplaces previously approved by the Committee.
4. No person shall climb or jump over the gates or fences in or around the Reserve, stick bills thereon, or in any way damage or injure any of the buildings, trees, gates, fences, seats, in the Reserve, nor leave or deposit any paper, glass, straw, manure, or any rubbish, nor throw stones or missiles of any kind to the danger of any person.
5. No person shall put into the Reserve any cattle, horses, sheep or any other animals without the permission, in writing of the Committee first obtained. Any such stock trespassing on the Reserve will be impounded.
6. Without the permission of the Committee previously obtained, no person shall bring into the Reserve any dog unless controlled by a cord or chain.
7. No person shall camp in the Reserve, except in an area set apart by the Committee for the purpose, nor shall any person erect therein any booth or other structure for any purpose whatsoever without the permission, in writing, of the Committee first obtained.
8. No person shall dig or remove any sand, soil or other material in or from the Reserve.
9. No person shall remove or displace any board, plate fitting, or written notice for the exhibition of Regulations or notice fixed or set up by the Committee in the Reserve.
10. The Committee may set apart portions of the Reserve for the purposes of a camping ground or a swimming pool, and make the same available for use by the public, subject to such conditions and the payment of such fees as it may consider reasonable and consistent with these Regulations.
11. No person shall bathe within the Reserve unless decently attired in a suitable bathing costume.
12. No person shall carry or discharge any firearms in the Reserve.
13. The Committee may set apart any portion of the Reserve for the purpose of any lawful game or sports, and from time to time grant any club, or association of clubs, upon such terms and conditions as the Committee may deem to be consistent with these Regulations, the use of grounds so set apart.
14. No person shall in the Reserve wilfully obstruct, disturb, or annoy any other person in the proper use of the Reserve, or any part thereof, or wilfully obstruct or disturb any servant of the Committee in the proper execution of his duty or work.



15. Persons renting or hiring the Reserve or part thereof for any purpose whatsoever, and who make any charge to the public for admission to the ground, shall pay to the Committee a fee for the use of the ground, such fee to be fixed by the Committee, but shall not exceed the sum of \$3.00 per day.

16. Boat trailers and other vehicles shall be parked in the area set aside for parking and shall not obstruct entry to the boat launching ramp.

17. No person shall spit or expectorate on the paths or on any structure or erection in the Reserve.

18. Persons renting or hiring any stand, building, erection or enclosure on the occasions of any fetes, sports, or holiday amusements, may be required to deposit any sum which the Committee may at any time determine, not exceeding Twenty dollars (\$20), by way of guarantee that due care shall be taken of such stand, building, erection, or enclosure, and such Committee, in its absolute discretion, may make good any damage, or injury sustained by such stand, building, erection or enclosure, or anything contained therein, during such occupancy or hiring, and deduct the cost of making good such loss or damage from the sum of money deposited by way of guarantee, and all persons so renting or hiring shall abide by these Regulations and by any order given by the Committee.

19. No male person other than boys under the age of seven (7) years, shall enter or use any playground, oval place, room, or building set aside for the use of females, and no female person shall enter or use any playground, place, room, or building set apart for the use of males.

20. No person shall affix, print, post, paint, cut, or mark any advertisements sign, picture, bill, placard, notice, words, letter or figures to or upon any wall or fence in or enclosing the Reserve, or to, or upon any tree, building, barrier, railing, seat, structure, erection, flagging or path in the Reserve without the consent of the Committee. RS. 8999.

Given under my hand at Melbourne, on the 28th day of August, 1969.

W. J. F. McDONALD.  
Minister of Lands.

Every person who contravenes or fails to comply with these Regulations shall, in accordance with the provisions of Section 218 of the *Land Act 1958*, for each offence be liable to a penalty of not more than Fifty dollars, and every person who contravenes or fails to comply with any such Regulations, and who, after he has been warned by any bailiff of Crown lands or by any member of the Police Force, does not desist therefrom may be forthwith apprehended by such Bailiff or member of the Police Force and taken before some justice to be dealt with according to law and shall be liable to a penalty of not more than One Hundred Dollars.

## TENDERS

### PUBLIC WORKS DEPARTMENT

TENDERS will be received at Public Works Department, 2 Treasury-place, Melbourne, until TWO p.m. on dates shown and for purposes mentioned hereunder.

Particulars and tender forms available at Contracts Office, Room 7, Building Division, Parliament-place and at places indicated in brackets hereunder.

Abbreviations in brackets mean:—W.O.—Inspector of Works Office; P.S.—Police Station; C.S.—Consolidated School; H.E.S.—Higher Elementary School; H.S.—High School; S.S.—State School; T.S.—Technical School.

Tenders to be submitted on the Department's printed Tender Form and will not be received by telephone. All tenders must be on a "Firm Tender" basis. The lowest or any tender will not necessarily be accepted.

Address tenders to the Minister of Public Works, and endorse the envelope containing the tender "Tender for , closing Tuesday,

Hand delivered tenders to be placed in the Tender Box of the Public Works Department, located on the wall of the centre entrance foyer, Ground Floor, 2 Treasury-place, Melbourne.

No preliminary deposit is required with any tender, but a successful tenderer will be required to pay a deposit for any accepted tender of \$4,000 or over.

No. 78.—7672/69.—3

### Tuesday, 9th September, 1969.

#### Building, Electrical and Mechanical Works.

Beechworth.—Erection of four (4) Proprietary Type Brick Veneer Residences, Mental Hospital. (W.O., Wangaratta.)

Beechworth.—Replacement of floors and floor coverings, Ward M7, Mental Hospital. (W.O., Wangaratta.)

Doncaster East.—Alterations and renovations, S.S. 2096.

Kew.—Erection of two (2) Proprietary Type Brick Veneer Residences, Mental Hospital.

Melbourne.—Supply and installation of goods lift, William Angliss Food Trades School.

Mont Park.—Erection of two (2) Proprietary Type Brick Veneer Residences, Larundel Mental Hospital.

Newcomb.—Mechanical services, High School.

Riddell.—Renovations, S.S. 528 and Residence. (W.O., Kyneton.)

Traralgon.—Erection of two (2) Proprietary Type Brick Veneer Residences, Hobson Park Hospital. (W.O., Traralgon.)

#### Furniture and Furnishings.

Melbourne.—Steel shelving, Police Headquarters, Russell-street.

#### Site Works.

Armata.—Asphalt and concrete works, &c., S.S. 4965.

Morwell.—Concrete paving and associated works, Technical School. (W.O., Traralgon and Warragul.)

### Tuesday, 16th September, 1969.

#### Building, Electrical and Mechanical Works.

Bundoora.—Erection of L.T.C. Classroom, store and corridor extension, "Janefield" Training Centre.

Janefield.—Extension of sewerage and water mains to Nurses' Hostels, Training Centre. (W.O., Mental Hospital, Mont Park.)

Won Wron.—Supply and installation of laundry equipment, Reforestation Prison.

#### Miscellaneous.

Colac.—Supply of tool and cutter grinder, Technical School.

### Tuesday, 23rd September, 1969.

#### Building, Electrical and Mechanical Works.

Bendigo.—Erection of a Brick Veneer Proprietary Type Residence, Sandhurst Boys' Centre. (W.O., Bendigo.)

Bendigo.—Erection of ten (10) Brick Veneer Proprietary Type Residences, Mental Hospital. (W.O., Bendigo.)

Bendigo.—Erection of three (3) Nurses' Homes, one (1) Recreation Building, two (2) Car-Ports and paving, Psychiatric Hospital. (W.O., Bendigo.)

Port Welshpool.—Electrical installation, Fishermens Pier, Ports and Harbours Branch. (W.O., Korumburra.)

Seymour.—Provision of sick-bay facilities, High School. (Re-Advertised.)

Traralgon.—Erection of one (1) brick veneer Nurses' Hostel, one (1) Recreation Building and a car-port, Hobson Park Hospital. (W.O., Traralgon.)

Various.—L.P. gas installations, portable class-rooms, Schools.

Wangaratta.—Erection of standard Hall Type "800C" Technical School. (W.O., Wangaratta.)

Wangaratta.—Electrical installation, Technical School. (W.O., Benalla, Shepparton and Wangaratta.)

Wangaratta.—Mechanical services, Technical School. (W.O., Wangaratta.)

### Tuesday, 30th September, 1969.

#### Miscellaneous.

Williamstown.—Construction of one (1) all welded mild steel 45 feet workboat, Ports and Harbours Dredging Depot, Ann-street. (Dredging Depot, Williamstown.)

M. V. PORTER,  
Minister of Public Works.

Public Works Department,  
Melbourne, 3002, 1st September, 1969.

*Teaching Service Act 1958.*

TEACHING SERVICE (CLASSIFICATION, SALARIES AND ALLOWANCES) REGULATIONS.

AMENDMENT No. 166 (C.S. & A.11).

THE Teachers Tribunal, in pursuance of the powers conferred by the *Teaching Service Act 1958*, hereby amends the Teaching Service (Classification, Salaries and Allowances) Regulations in the manner following, that is to say:—

PART III.—SECONDARY SCHOOLS DIVISION.

In clause 16A delete the words "subdivision 4 of".

PART IV.—TECHNICAL SCHOOLS DIVISION.

In clause 25 delete the words "subdivision 4 of".

(To take effect from and including the 1st September, 1969.)

W. E. SAMPSON, Chairman.

A. F. LE CLERCQ, Secretary.

Office of the Teachers Tribunal,  
Melbourne, 1st September, 1969.

**PUBLIC SERVICE NOTICES**

No. 300.

PUBLIC SERVICE ACT 1958.

THE Public Service Board, in pursuance of the powers conferred by the *Public Service Act 1958*, hereby amends the Public Service (Public Service Board) Regulations as shown below—

PART IV.—SALARIES AND INCREMENTS.

DIVISION IV.—TECHNICAL AND GENERAL DIVISION.

*Regulation 98.*

In sub-clause (a) (iii) the expression "Grade 41A" is substituted for the expression "Grade 37".

This Regulation shall have effect as on and from the 15th June, 1969.

F. E. CAHILL, Chairman.  
V. P. SCULLY, Secretary.

Office of the Public Service Board,  
Melbourne, 22nd August, 1969.

No. 298.

*Public Service Act 1958, Section 50.*

REGULATIONS.—PART IV.—SALARIES AND INCREMENTS.

THE Public Service Board, in pursuance of the powers conferred by the *Public Service Act 1958*, hereby amends its Regulations as shown below:—

SIXTH SCHEDULE.

TEMPORARY EMPLOYEES.

*Designations of Positions and Rates of Salaries.*

Department and Designation of Position.	Yearly Rate of Salary.		Increments (Annual).
	Minimum.	Maximum.	
MINISTRY OF ABORIGINAL AFFAIRS.	\$	\$	
Add— Hostel Supervisor (Female)	2,464	2,614	Σ

Σ See Regulation 97 (2).

F. E. CAHILL, Chairman.  
V. P. SCULLY, Secretary.

Office of the Public Service Board,  
Melbourne, 22nd August, 1969.

No. 299.

*Public Service Act 1958, Section 50.*

REGULATIONS.—PART IV.—SALARIES AND INCREMENTS.

THE Public Service Board, in pursuance of the powers conferred by the *Public Service Act 1958*, hereby amends its Regulations as shown below:—

SIXTH SCHEDULE.

TEMPORARY EMPLOYEES.

*Designations of Positions and Rates of Salaries.*

Department and Designation of Position.	Yearly Rate of Salary.		Increments (Annual).
	Minimum.	Maximum.	
CHIEF SECRETARY'S DEPARTMENT.	\$	\$	
SOCIAL WELFARE.			
<i>Family Welfare Division.</i>			
Delete— Child Care Officer (Male)	2,986	3,060	Σ
Add— Child Care Officer (Male)	2,986	3,092	Σ
<i>Youth Welfare Division.</i>			
Delete— Youth Officer (Male)	2,986	3,060	Σ
Add— Youth Officer (Male)	2,986	3,092	Σ
<i>Prisons Division.</i>			
Delete— Prison Officer (Male)	2,986	3,060	Σ
Add— Prison Officer (Male)	2,986	3,092	Σ

Σ See Regulation 97 (2).

F. E. CAHILL, Chairman.  
V. P. SCULLY, Secretary.

Office of the Public Service Board,  
Melbourne, 22nd August, 1969.

**PRIVATE ADVERTISEMENTS**

**NOTICE** is hereby given that the Victorian Field and Game Association has applied for a lease under Section 134 of the *Land Act 1958*, for a term of 21 years over an area of 57 acres 3 roods 39 perches being part of allotments 48A and 48B, Parish of Narree Worran, as a site for the purposes of amusement and recreation (Shooting School, Gun Club). 9580

**NOTICE** is hereby given that Esso Exploration and Production Australia Incorporated and Hematite Petroleum Proprietary Limited has made application for a lease pursuant to section 134 of the *Land Act 1958* over an area of approximately 5 acres and 35 4/10 perches in the Parish of Dulungalong for the purpose of pipe-line pumping station and ancillary operations. 9675

**NOTICE** is hereby given that John Buckley and Lorna Patricia Buckley, have applied for a lease under section 134 of the *Land Act 1958*, for a term of ten years in respect of an area of approximately 3 acres in section 79, Township of Euroa, as a site for a sawmill.

MAL, RYAN & GLEN, solicitors, 9 High-street, Mansfield, 3722, solicitors for the applicants. 9636

**NOTICE OF INTENTION TO APPLY FOR A LICENCE TO DIVERT WATER AND CUT RACE (RE-ISSUE) FROM THE RIVER MURRAY, AT LAKE POWELL.**

**WE** hereby give notice that we intend to apply for a licence empowering us to divert water for a term of four years to the extent of 117 acre-feet per annum at a maximum rate of 3 acre-feet per day of 24 hours for the irrigation of 39 acres of trees, vines, vegetables, pasture and cereal crops, being part of allotment 4A and being lot 1 on plan of subdivision No. 79531, Parish of Nenandie, and to occupy certain Crown lands for works of diversion, and to cut a race thereon.

Any objection to such application must be forwarded, in writing, to reach the State Rivers and Water Supply Commission, Melbourne, before the 6th day of October, 1969, being 30 days from the first publication of this notice.

EMANUEL CULLIAS.  
MARIA CULLIAS.

Robinvale. 9886

**NOTICE OF INTENTION TO APPLY FOR A LICENCE TO DIVERT WATER AND CUT RACE (RE-ISSUE) FROM THE RIVER MURRAY AT COLIGNAN.**

**WE** hereby give notice that we intend to apply for a licence empowering us to divert water for a term of fifteen years to the extent of 75 acre-feet per annum at a maximum rate of 3 acre-feet per day of 24 hours for the irrigation of pasture, being part of allotment 22, Parish of Colignan, and to occupy certain Crown lands for works of diversion, and to cut a race thereon.

Any objection to such application must be forwarded in writing to reach the State Rivers and Water Supply Commission, Melbourne, before 25th September, 1969, being 30 days from the first publication of this notice.

ERIC JACK & ELSIE MAY SANDFORD.

Colignan P.O. 9941

**NOTICE OF INTENTION TO APPLY FOR A LICENCE TO DIVERT WATER AND CUT RACE (RE-ISSUE) FROM THE RIVER MURRAY, AT YARRAWONGA WEIR BACKWATER.**

**I** HEREBY give notice that I intend to apply for a licence empowering me to divert water for a term of fifteen years to the extent of 8 acre-feet per annum at a maximum rate of 1 acre-foot per day of 24 hours for the irrigating of 4 acres of pasture, being part of allotment 9, Parish of Bundalong, and to occupy certain Crown lands for works of diversion, and to cut a race thereon.

Any objection to such application must be forwarded, in writing, to reach the State Rivers and Water Supply Commission, Melbourne, before 3rd October, 1969, being 30 days from the first publication of this notice.

COLIN RAYMOND WATSON.

Lake Rowan, 3727. 9876

**NOTICE OF INTENTION TO APPLY FOR A LICENCE TO DIVERT WATER AND CUT RACE (RE-ISSUE) FROM THE OVENS RIVER, AT OVENS.**

**WE** hereby give notice that we intend to apply for a licence empowering us to divert water for a term of two years to the extent of 4 1/2 acre-feet per annum at a maximum rate of 1 acre-foot per day of 24 hours for the irrigation of 3 acres of tobacco, being part of allotment 17, section 30, Parish of Barwidgee, and to occupy certain Crown lands for works of diversion, and to cut a race thereon.

Any objection to such application must be forwarded, in writing, to reach the State Rivers and Water Supply Commission, Melbourne, before 3rd October, 1969, being 30 days from the first publication of this notice.

PETER SCALZO.  
FRANK SCALZO.  
ANTONIO SCALZO.  
P.O. Ovens, 3738. 9870

**NOTICE OF INTENTION TO APPLY FOR A LICENCE TO DIVERT WATER AND CUT RACE FROM THE OVENS RIVER, AT TARRAWINGEE.**

**I** HEREBY give notice that I intend to apply for a licence empowering me to divert water for a term of four years to the extent of 54 acre-feet per annum, at a maximum rate of 6 acre-feet per day of 24 hours for the irrigation of 36 acres of pasture and lucerne, being part of allotment 25, section F, Parish of Tarrawingee, and to occupy certain Crown lands for works of diversion, and to cut a race thereon.

Any objection to such application must be forwarded, in writing, to reach the State Rivers and Water Supply Commission, Melbourne, before 1st October, 1969, being 30 days from the first publication of this notice.

DONALD WALTER LINTON SIMMONS.  
"Reidsdale", Tarrawingee, via Eldorado. 9924

**NOTICE OF INTENTION TO APPLY FOR A LICENCE TO DIVERT WATER AND CUT RACE (RE-ISSUE) FROM THE RIVER MURRAY, AT PATHO.**

**WE** hereby give notice that we intend to apply for a licence empowering us to divert water for a term of fifteen years to the extent of 156 acre-feet per annum at a maximum rate of 10 acre-feet per day of 24 hours for the irrigation of 78 acres of pastures, being part of allotment 50, section D, Parish of Patho, and to occupy certain Crown lands for works of diversion, and to cut a race thereon.

Any objection to such application must be forwarded, in writing, to reach the State Rivers and Water Supply Commission, Melbourne, before 4th October, 1969, being 30 days from the first publication of this notice.

PHILLIP ALBERT BROWN.  
MARJORIE BROWN.  
Tarcoola, Torrumbarry, Vic., 3627. 9923

**ROCHESTER SEWERAGE AUTHORITY.****GENERAL NOTICE.**

**T**HE above-mentioned Sewerage Authority having made provision for carrying off the sewage from each and every property which or any part of which is within the sewerage area hereinafter described doth hereby declare that on and after the first day of December, 1969, each and every property which or any part of which is within the said sewerage area shall be deemed to be a seweraged property within the meaning of the *Sewerage Districts Act 1958*.

The boundaries of the sewerage area hereinbefore referred to are:—

**SEWERAGE AREA No. 2.**

Boundaries as delineated in a plan which has been lodged in the office of the State Rivers and Water Supply Commission and of which a copy may be inspected at the office of the Rochester Sewerage Authority.

By order of the said Sewerage Authority,

A. G. FULLER, Chairman.  
H. R. WESTCOTT, Secretary.

## GEELONG WATERWORKS AND SEWERAGE TRUST.

THE above-mentioned Trust having made provision for carrying off the sewage from each and every property which or any part of which is within the sewerage area hereinafter described doth hereby declare that on and after the first day of September, 1969, each and every property which or any part of which is within the said sewerage area shall be deemed and taken to be seweraged property within the meaning of the *Geelong Waterworks and Sewerage Act 1958*.

## SEWERAGE AREA No. 419.

*Shire of South Barwon, Parish of Barrarbool,  
County of Grant.*

Commencing at a point being the north-east corner of the intersection of Torquay-road and Autumn-street, East Belmont, which is also on the boundary of Sewerage Area No. 305; thence southerly across Autumn-street and continuing southerly along the east side of Torquay-road to the prolongation of the south side of Kidman-avenue; thence westerly across Torquay-road and the Service road and continuing westerly and south-westerly along the south side of Kidman-avenue to the prolongation of the western boundary of shop site No. 38 Kidman-avenue; thence northerly across Kidman-avenue and continuing northerly along the western boundary of the said shop site No. 38 and the western boundaries of lots Nos. 33 to 29 inclusive in Charles-street and also crossing a service road to the north-west corner of the said lot No. 29, which is also on the boundary of Sewerage Area No. 305; thence easterly, southerly, easterly, northerly and easterly following the boundary of Sewerage Area No. 305 and crossing Charles-street, a Service road and Torquay-road to the point of commencement.

## SEWERAGE AREA No. 420.

*Shire of Corio, Parish of Moorpanyal,  
County of Grant.*

Commencing at a point being the north-west corner of the intersection of Braund-avenue and Lower Anakie-road, Bell Post Hill, which is also on the boundary of Sewerage Area No. 408; thence southerly across Braund-avenue and continuing southerly along the west side of Lower Anakie-road and crossing Jemma-street to the north-west corner of the intersection of Lower Anakie-road and Liston-street; thence westerly along the north side of Liston-street to the north-east corner of the intersection of Liston-street and Eagleview-crescent; thence northerly along the east side of Eagleview-crescent to the south-east corner of the intersection of Eagleview-crescent and Jemma-street; thence westerly across Eagleview-crescent and continuing westerly along the south side of Jemma-street and crossing Beauford-avenue and Ward-street to the south-west corner of the intersection of Jemma and Ward streets; thence northerly across Jemma street and continuing northerly along the west side of Ward-street and crossing Braund-avenue, Kinlock-street and Darriwill-street to the north-west corner of the intersection of Ward-street and Darriwill street; thence easterly across Ward-street and continuing easterly along the north side of Darriwill-street and crossing Beauford-avenue to the north-east corner of the intersection of Darriwill-street and Beauford-avenue, which is also on the boundary of Sewerage Area No. 408; thence southerly, easterly, southerly, north-easterly, easterly, south-easterly, easterly, southerly and easterly following the boundary of Sewerage Area No. 408 and crossing Darriwill-street, Kinlock-street and Eagleview-crescent to the point of commencement.

## SEWERAGE AREA No. 421.

*Shire of Bellarine, Parish of Moolap, County of Grant.*

Commencing at a point being on the west side of Wilsons-road, Newcomb, which is also on the boundaries of Sewerage Areas Nos. 238 and 331; thence easterly, north-easterly, north-westerly, northerly, north-easterly, north-westerly, northerly, easterly, northerly, easterly, southerly, easterly, southerly and easterly following the boundary of Sewerage Area No. 331 and crossing Wilsons-road, Richard-street, Lindsay-street and Newland-street to the prolongation of the eastern boundary of lot No. 145 Richard-street; thence southerly across Richard-street and continuing southerly along the eastern boundary of the said lot No. 145 and the eastern boundaries of lots Nos. 154 to 156 inclusive Cassia-court, lots Nos. 158 to 170 inclusive Hibiscus-crescent and lots Nos. 171 and 172 Fuchsia-court to the south-east corner of the said lot No. 172; thence westerly along the southern boundaries of lots Nos. 172 to 174 inclusive Fuchsia-court and lots Nos. 175 to 181 inclusive Hibiscus-court for a distance of 535 feet approximately; thence southerly by a line bearing 180 degrees for a distance of 240 feet approximately; thence westerly by a line bearing 270 degrees and crossing Wilsons-road to the west side of Wilsons-road which is

also on the boundary of Sewerage Area No. 226; thence northerly along the west side of Wilsons-road and crossing Francis-street and Charlotte-avenue to the prolongation of the north side of Hibiscus-crescent; thence easterly across Wilsons-road and continuing easterly along the north side of Hibiscus-crescent to the south-west corner of lot No. 186 Hibiscus-crescent; thence northerly along the western boundaries of lot No. 186 Hibiscus-crescent and lots Nos. 210 and 211 Alnus-court and crossing Veronica-avenue and continuing northerly along the western boundary of lot No. 212 Veronica-avenue to the north-west corner of the said lot No. 212; thence westerly by a line bearing 270 degrees and crossing Wilsons-road to the west side of Wilsons-road, which is also on the boundary of Sewerage Area No. 238; thence northerly along the west side of Wilsons-road to the point of commencement.

## SEWERAGE AREA No. 422.

*Shire of South Barwon, Parish of Barrarbool,  
County of Grant.*

Commencing at a point being the south-east corner of lot No. 138 Culzean-crescent, North Highton, the said point being also on the west side of Culzean-crescent and on the boundary of Sewerage Area No. 328; thence westerly along the southern boundary of the said lot No. 138 to the south-west corner of lot No. 138, which is also on the boundaries of Sewerage Areas Nos. 328 and 398; thence northerly and north-westerly along the western boundaries of lots Nos. 138 to 140 inclusive Culzean-crescent to the north-west corner of the said lot No. 140; thence north-easterly along the northern boundary of lot No. 140 to the west side of Culzean-crescent; thence south-easterly and southerly along the west side of Culzean-crescent to the point of commencement.

## SEWERAGE AREA No. 423.

*Shire of South Barwon, Parish of Barrarbool,  
County of Grant.*

Commencing at a point being the south-west corner of the intersection of Ewwick-crescent and Thornbury-lane, North Highton, which is also on the boundaries of Sewerage Areas Nos. 366 and 403; thence south-easterly across Thornbury-lane and continuing south-easterly along the south side of Thornbury-lane to the north-east corner of lot No. 74 Ewwick-crescent; thence southerly along the eastern boundaries of lots Nos. 74 to 72 inclusive Ewwick-crescent to the south-east corner of the said lot No. 72, which is also on the boundaries of Sewerage Areas Nos. 246 and 281; thence westerly, northerly and north-easterly following the boundaries of Sewerage Areas Nos. 281 and 366 and crossing Ewwick-crescent to the point of commencement.

## SEWERAGE AREA No. 424.

*Shire of Bellarine, Parish of Moolap, County of Grant.*

Commencing at a point being the south-east corner of the intersection of Townsend and Boundary roads, Whittington, which is also on the boundary of Sewerage Area No. 374; thence easterly and southerly following the boundary of Sewerage Area No. 374 and crossing Westmoreland-street to the south side of Westmoreland-street; thence westerly along the south side of Westmoreland-street to the south-east corner of the intersection of Westmoreland-street and Boundary-road; thence northerly across Westmoreland-street and continuing northerly along the east side of Boundary-road to the point of commencement.

Signed under Seal of the Geelong Waterworks and Sewerage Trust, this 28th day of August, 1969—

9867

(SEAL)

J. W. CARR, Chairman.

B. C. HENSHAS, Secretary.

## CITY OF BENDIGO.

## LOAN No. 53.

*Notice of Intention to Borrow the Sum of \$30,000 for  
Permanent Works and Undertakings.*

NOTICE is hereby given that the Council of the City of Bendigo proposes to borrow the principal sum of Thirty thousand dollars, secured by a charge over the general rates of the municipality, such sum to be raised by the grant of a mortgage in accordance with the provisions of the *Local Government Act 1958*.

1. The maximum rate of interest that may be paid is 6.15 per cent. per annum.

2. The purpose for which the loan is to be applied is:—

Purchase of diesel crawler tractor with attachments.

3. The period of the loan shall be seven years.

4. The moneys borrowed shall be repayable by providing out of the municipal fund fourteen half-yearly instalments of approximately \$2,669 each, including principal

and interest on the 1st day of June and the 1st day of December, during the currency of the loan. The first instalment shall be repayable on the 1st day of June, 1970.

5. Such moneys shall be repayable to the Commissioners of the State Savings Bank of Victoria at the office of the said Commissioners, corner Elizabeth and Bourke streets, Melbourne.

The plans and specifications and the estimate of the cost of the proposed works and a statement showing the proposed expenditure of the moneys to be borrowed, are open for inspection at the office of the Council of the City of Bendigo, at the City Hall, Bendigo.

Dated 25th August, 1969.

9871

A. J. WATTS, Town Clerk.

*Town and Country Planning Act 1961.*

**CITY OF BENDIGO PLANNING SCHEME.**

NOTICE THAT A PLANNING SCHEME HAS BEEN PREPARED AND IS AVAILABLE FOR INSPECTION.

*Amendment No. 7, 1969.*

NOTICE is hereby given that the Council of the City of Bendigo in pursuance of its powers under the *Town and Country Planning Act 1961* has prepared a Planning Scheme for the following purposes:

To rezone from Residential to Commercial "B".

- (i) Land being Crown allotments 3, 4, 15 and 16, section 12A, Parish of Sandhurst, between Beech and Fir streets, having frontages of 132 feet to High-street and 132 feet to Panton-street.
- (ii) Land being Crown allotment 11 and part of Crown allotment 10, section 12A, Parish of Sandhurst, at the corner of High and Beech streets having frontages of 132 feet to High-street and 85 feet to Beech-street.

A copy of the scheme has been deposited at the City Hall, Bendigo, and at the office of the Town and Country Planning Board, 179 Queen-street, Melbourne, and will be open for inspection during office hours by any person free of charge.

Any persons affected by the Planning Scheme are required to set forth, in writing, all objections they may have, addressed to the Town Clerk, City Hall, Bendigo, on or before 6th October, 1969, and to state whether they wish to be heard in respect of their objections.

Dated 29th August, 1969.

9891

A. J. WATTS, Town Clerk.

*Town and Country Planning Act 1961 (Twelfth Schedule).*

**CITY OF ECHUCA PLANNING SCHEME 1964.**

NOTICE THAT A PLANNING SCHEME HAS BEEN PREPARED AND IS AVAILABLE FOR INSPECTION.

*Amendment 7, 1969.*

NOTICE is hereby given that the City of Echuca in pursuance of its powers under the *Town and Country Planning Act 1961* has prepared a Planning Scheme for portions of the City of Echuca for the purpose of—

Amending Clause 12, Part 11 of the Planning Scheme Ordinance by the addition of the following permitted use within Commercial "A" Zone, viz.:—

Motel subject to the grant of a permit by the Responsible Authority provided—

- (i) not less than one-third of the area of the site is laid out and maintained and used only as a vehicle parking area; and
- (ii) not less than three hundred square feet of the vehicular parking area referred to in (i) hereof is provided adjacent to each accommodation unit.

A copy of the Scheme has been deposited at the City Offices, corner Hare and Heygarth streets, Echuca, and at the office of the Town and Country Planning Board, Fifth Floor, 235 Queen-street, Melbourne, and will be open for inspection during office hours by any person free of charge.

Any persons affected by the Planning Scheme are required to set forth, in writing, all objections they may have, addressed to the Town Clerk, City of Echuca, corner Hare and Heygarth streets, Echuca, on or before the 6th day of October, 1969, and to state whether they wish to be heard in respect of their objections.

Dated this 27th day of August, 1969.

9894

K. F. MCCARTNEY, Town Clerk.

**CITY OF NUNAWADING.**

No. 1374.

**LOAN No. 109.**

*Notice of Intention to Borrow the Sum of \$50,000 for Permanent Works and Undertakings.*

NOTICE is hereby given that the Council of the City of Nunawading proposes to borrow the principal sum of \$50,000, secured by a charge over the general rates of the municipality, such sum to be raised by the grant of a mortgage in accordance with the provisions of the *Local Government Act 1958*.

1. The maximum rate of interest that may be paid is 6.40 per cent. per annum.

2. The purposes for which the loan is to be applied are:—

- |  |          |
|--|----------|
| (a) Highbury-road, reconstruction between Middleborough-road and Blackburn-road      | \$30,000 |
| (b) White Horse-road, construction of Service-road from Cook-road to Deep Creek-road | 11,000   |
| (c) Mahoneys-road, construction (part cost)  | 9,000    |

\$50,000

3. The period of the loan shall be fifteen years.

4. The moneys borrowed shall be repayable by providing out of the municipal fund 30 half-yearly instalments of \$2,617.36 each, including principal and interest on the 1st day of May and the 1st day of November, during the currency of the loan. The first instalment shall be payable on the 1st day of May, 1970.

5. Such moneys shall be repayable at the Commonwealth Savings Bank of Australia, Melbourne.

The plans and specifications and the estimate of the cost of the proposed works and a statement showing the proposed expenditure of the moneys to be borrowed, are open for inspection at the office of the Council of the City of Nunawading, at Whitehorse-road, Nunawading.

9855

J. H. BROWN, Town Clerk.

**CITY OF NUNAWADING.**

No. 1375.

**LOAN No. 111.**

*Notice of Intention to Borrow the Sum of \$50,000 for Permanent Works and Undertakings.*

NOTICE is hereby given that the Council of the City of Nunawading proposes to borrow the sum of Fifty thousand dollars (\$50,000), secured by a charge over the general rates of the municipality, such sum to be raised by the grant of a mortgage in accordance with the provisions of the *Local Government Act 1958*.

1. The maximum rate of interest to be paid is 6.40 per centum per annum, payable half-yearly on the 1st day of June and the 1st day of December, during the currency of the loan. The first of such payments shall be made on the 1st day of June, 1970.

2. The purpose for which the loan is to be applied is development of places of public resort and recreation, Eley-road, Jolimont-road and Mahoneys-road.

3. The period of the loan shall be 40 years. The principal amount of the loan will be repayable on 1st December, 2009.

4. The loan is to be liquidated by the creation of a Sinking Fund pursuant to the provisions of section 428A of the *Local Government Act 1958*.

5. Such moneys shall be repayable at the office of the State Superannuation Board, Treasury Buildings, Melbourne, or at such other places as the lender may from time to time direct at the expiration of the borrowing period.

The plans and specifications and the estimate of the cost of the proposed works and a statement showing the proposed expenditure of the moneys to be borrowed, are open for inspection at the Municipal Offices, Nunawading.

9856

J. H. BROWN, Town Clerk.

**CITY OF NUNAWADING.**

No. 1376.

**LOAN No. 110.**

*Notice of Intention to Borrow.*

NOTICE is hereby given that the Council of the City of Nunawading intends to borrow Twenty thousand dollars (\$20,000), secured by a charge over the general rates of the municipality by the grant of a mortgage, in accordance with the provisions of the *Local Government Act*.

In connexion therewith the following information is stated:—

- (a) The amount of the principal moneys which it is proposed to borrow is Twenty thousand dollars.
- (b) The maximum rate of interest that may be paid is \$6.40 per centum per annum.
- (c) The times which the moneys borrowed are to be repayable are the 15th day of May, 1970 and the 15th days of May and November, during the years 1970-1984 inclusive, and that the place such moneys shall be repayable is at the Bank of New South Wales.
- (d) The purpose for which the loan is to be applied is:—  
Road construction, Mahoney's-road (part cost)—\$20,000.
- (e) The manner in which the loan is to be liquidated is by provision out of the municipal fund in each half-year during the currency of the loan of the sum of \$1,046.95, which includes principal and interest.

The plans and specifications and estimate of the cost of the works and a statement showing the proposed expenditure of the moneys to be borrowed, are open for inspection at the Municipal Offices, Nunawading.

Dated this 25th day of August, 1969.

9857

J. H. BROWN, Town Clerk.

CITY OF TRARALGON.

RE-NAMING OF STREET/ROAD.

NOTICE is hereby given that by order of the Council the following street/road within the municipality has been re-named as follows:—

Old Name.—Stockdale-lane.

New Name.—Cross's-road.

Location.—West from intersection of Stockdale-road to municipal boundary.

9938

K. J. SAUNDERS, Town Clerk.

CITY OF WAVERLEY.

NOTICE is hereby given that the Council of the City of Waverley at a meeting held on Tuesday, 19th August, 1969, ordered and specified the following areas to be shopping areas for the purpose of section 17 of the Dog Act 1958, viz.:—

Burwood.

Cnr. Highbury-road and Evans-street; lots 49 to 56 Highbury-road; L.P.26844.

Ashwood.

Cleveland-road, cnr. Mavron-street; lots 12 to 20 Cleveland-road; L.P.53862.

Cnr. High Street and Warrigal-roads; north of May Park-avenue, lots 1 and 2, High Street-road; L.P.2648.

Cnr. High Street-road and Raymond-street; lots 37 and 1 to 6 High Street-road; L.P.31288.

Mavron-street; lots 1 to 11 Mavron-street; L.P.53509.

Cnr. Ashwood and Vannam-drives; lots 56 to 61 Vannam-drive; L.P.33324.

Warrigal-road between High Street-road and Closter-avenue; lots 1 to 19 Warrigal-road; L.P.12951.

Warrigal-road between Douglas-street and Closter-avenue; lots 106 to 112 Warrigal-road; L.P.21013; lots 4, 5 and 6 Warrigal-road; L.P.42935; lots 1 to 6 Warrigal-road; L.P.50050.

Warrigal-road near Douglas-street; lots 55 to 58 Warrigal-road; L.P.21013.

Warrigal-road north of May Park-avenue; lots 3, 4 and 5 Warrigal-road; L.P.2648.

Yertchuk-avenue cnr. Arthur-street; lots 182 and 183 Yertchuk-avenue; L.P.51123; lots 1 to 9 Yertchuk-avenue; L.P.67770.

May Park-avenue; lots 276 and 277 May Park-avenue; L.P.3408; lot 11 May Park-avenue; L.P.2648.

Chadstone.

Batesford-road cnr. Power-avenue; lots 1 to 11 Batesford-road; L.P.55996.

Bolwarra-street; lots 4 and 5; L.P.55367.

Huntingdale-road cnr. Railway-parade south; lots 1 to 6 Huntingdale-road; L.P.53961.

Warrigal-road cnr. Batesford-road; lots 1 to 16 Warrigal-road; L.P.16980; lots 1, 2 and 3 Warrigal-road; L.P.68960.

Clayton North.

Ferntree Gully-road cnr. Blackburn-road; lots 1, 2 and 3 Ferntree Gully-road; L.P.80416; lots 3 to 7 Ferntree Gully-road; L.P.19050.

Westerfield-drive near cnr. Tamala-avenue; lots 414 to 419 Westerfield-drive; L.P.55753.

East Oakleigh.

Bellerive-avenue; lots 6 to 10 Bellerive-avenue; L.P.81645.  
Dickson-street cnr. Solomon-street; lots 53 to 57 Dickson-street; L.P.60994.

Stanley-avenue cnr. Ian-grove; lots 1, 2 and 3 Stanley-avenue; L.P.42840; lots 1, 2 and 3 Stanley-avenue; L.P.60643; lots 1, 2 and 3 Stanley-avenue; L.P.43215.

Mulgrave.

Albany-drive; lot 599; L.P.70818.

Clunies Ross-crescent cnr. Monash-drive; lots 1 and 2 Clunies Ross-crescent; L.P.77221.

Dandenong-road cnr. Springvale-road; lots 1 to 6 Dandenong-road; L.P.12519.

Dunoon-court; lots 57 to 65; L.P.43663.

Mackie-road cnr. Medoro-grove; lots 83 to 88 Mackie-road; L.P.65472.

Springvale-road cnr. Dandenong-road; lots 7 to 18 Springvale-road; L.P.12519.

Wanda-street near Valewood-drive; lots 2, 3, 4 and 5 Wanda-street; L.P.68279; lots 190, 191 and 192; L.P.60820.

Glen Waverley.

Blackburn-road; lots 4 to 12 Blackburn-road.

Between Syndal Station and High Street-road; lot 16 to 18, lots 1, 2 and 3, lots 19 to 30, lots 31 to 37; L.P.26019.

Coleman-parade; lots 1 and 2 Coleman-parade; L.P.25688/9. Opposite Syndal Station; lots 5 to 18 Coleman-parade.

Coleman-parade between Kingsway and Springvale-road; lots 1 to 14 Coleman-parade; L.P.13459.

Glenwood-avenue cnr. Waverley-road; lots 7, 1, 2, 3, 11 and 12 Glenwood-avenue; L.P.44914.

Hampshire-road near cnr. Blackburn-road; lots 29 to 40 Hampshire-road; L.P.43335.

High Street-road cnr. Blackburn-road; lots 38 to 43 High Street-road; L.P.26019.

High Street-road west cnr. Myers-avenue; lots 5 to 13 High Street-road; L.P.13623.

High Street-road east cnr. Myers-avenue; lots 14 to 20 High Street-road; L.P.13623.

Kerrie-road cnr. High Street-road; lots 4 to 15 Kerrie-road; L.P.54973.

Kingsway between O'Sullivan's-road and Railway-parade north; lots 23 to 41 Kingsway; L.P.13532.

Kingsway west side; lots 34 to 40; L.P.26006; lots 35, 38 to 41; L.P.13459; lots 1 and 2; L.P.82052; lots 42 to 52; L.P.13459; lots 1 to 6; L.P.19570.

Kingsway east side; lots 16 to 34; L.P.13459; lots 41 to 46; L.P.26006; lots 1 to 9; V.R. land.

Leicester-avenue near cnr. Waverley-road; lots 41 to 50 Leicester-avenue; L.P.51445.

Martin-place cnr. Walter-street; lots 62 to 69 Martin-place; L.P.42601.

Railway-parade north cnr. Euneva-avenue; lots 15 to 29 Railway-parade north; L.P.13583.

Railway-parade north cnr. Springvale-road; lots 6 to 19 Railway-parade north; L.P.13532.

Springvale-road north of Waverley-road; lots 1 to 6 Springvale-road; L.P.22333.

Springvale-road near cnr. Waverley-road; lots 8 to 12 Springvale-road; L.P.17911.

Springvale-road north-west cnr. Waverley-road; lots 1 and 2.

Springvale-road cnr. Frank-street; lots 1 and 2; Miscellaneous Plan H139.

Springvale-road cnr. O'Sullivan's-road; lot 1; L.P.84883; lots 1 to 7 Springvale-road; L.P.52414.

Thompson-street cnr. Grantley-drive; lot 37 Thompson-street; L.P.60308.

Viewpoint-avenue cnr. Waverley-road; lots 84 to 87 Viewpoint-avenue; L.P.51925; lots 1 and 2; L.P.60943.

Watsons-road cnr. Whites-lane; lot 1 Watsons-road; L.P.65758.

Winmalee-drive cnr. Elmwood-crescent; lot 275 Winmalee-drive; L.P.68180.

Willow-avenue cnr. Medina-road; lots 1 to 3 Willow-avenue; L.P.66142; lots 82 to 85 Willow-avenue; L.P.54319; lots 86, 87 and 88 Willow-avenue; L.P.55770.

Mount Waverley.

Alexander-street cnr. Stephenson's-road; lots 1 and 1 to 4 Alexander-street; L.P.64218.

Andrew-street cnr. Highbury-road; lots 50 to 59 Andrew-street; L.P.43359.

Anthony-drive cnr. Rhonda-drive; lots 36 to 41 Anthony-drive; L.P.51465.

Barlyn-road cnr. Huntingdale-road; lots 21 to 27 Barlyn-road; L.P.44851.

Blackburn-road cnr. Lucerne-street; lots 116 to 122 Blackburn-road; L.P.44997; lots 14 to 18 Blackburn-road; L.P.50456.

Blackburn-road cnr. High Street-road; lots 16 to 21 Blackburn-road; L.P.17847.

Blackburn-road near cnr. Doynton-parade; lots 7 to 19 Blackburn-road; L.P.12770.  
 Bruce-street cnr. Minilya-avenue; lots 22 to 27 Bruce-street; L.P.44542.  
 Bernard-street cnr. Pamela-street west side; lots 43 to 48 Bernard-street; L.P.51554.  
 Centreway south side; lots 7 to 18 Centreway; L.P.54801.  
 Centreway east side; lots 1 to 6 Centreway; L.P.54801.  
 Rear of south side; lots 27 and 28 Centreway; L.P.54801.  
 Rear of west side; lots 20 and 25 Centreway; L.P.54801.  
 Corner south-west; lots 1 and 2 Centreway; L.P.63571.  
 Corner north-west; lots 1 and 2 Centreway; L.P.64182.  
 Essex-road near cnr. Huntingdale-road; lots 24 to 29 Essex-road; L.P.40122.  
 Essex-road cnr. Surrey-road; lots 36 to 42 Essex-road; L.P.29621.  
 Hamilton-place south side; lots 1 to 14 Hamilton-place; L.P.41439; lots 15 to 22 Hamilton-place; L.P.43170.  
 Hamilton-walk; lots 17 to 22 Hamilton-walk; L.P.50047.  
 Hamilton-place west side; lots 5 to 11 Hamilton-place; L.P.42716.  
 Hamilton-place west side; lots 13 and 14 Hamilton-place; L.P.38785.  
 Hamilton-place near Mt. Waverley Station; lots 11 to 16 West Hamilton-place; L.P.26882; lots 4 to 10 East Hamilton-place; L.P.26882.  
 High Street-road cnr. Blackburn-road; lots 1 to 13 High Street-road; L.P.17847; lots 1 and 2 High Street-road; L.P.79877.  
 High Street-road cnr. Leeds-road; lots 1 to 9 High Street-road; lots 23, 24 and 25 High Street-road; L.P.23899.  
 High Street-road near cnr. Blackburn-road; lots 1 to 5 High Street-road; L.P.41442.  
 Huntingdale-road near cnr. Waverley-road; lots 1 and 2 Huntingdale-road; L.P.19659; lots 1 and 2 Huntingdale-road; L.P.36696; lots 1 and 2 Huntingdale-road; L.P.35476; lots 1, 2 and 3 Huntingdale-road; L.P.35345.  
 Lawrence-road cnr. Josephine-avenue; lots 25 and 26 Lawrence-road; L.P.72068.  
 Marianne-way cnr. Jacqueline-road; lots 72 to 85 Marianne way; L.P.43619.  
 Montgomery-avenue cnr. Lawrence-road; lot 1 Montgomery-avenue; L.P.57925.  
 McLochlan-street; lots 1 to 8; L.P.44854.  
 Park-lane near State School; lot 197 Park-lane; L.P.12275.  
 Stephensons-road south cnr. Virginia-street; lots 1 to 7 Stephensons-road; L.P.11953.  
 Stephensons-road north cnr. Virginia-street; lots 8 to 21 Stephensons-road; L.P.11953.  
 Stephensons-road cnr. The Highway; lots 13 to 23 Stephensons-road; L.P.13952; south side lots 1 to 6 Stephensons-road; L.P.34160.  
 Stephensons-road cnr. Waimarie-drive; lots 1 and 2 Stephensons-road; L.P.57083.  
 Stephensons-road near cnr. Waimarie-drive; lots 78 to 85 Stephensons-road; L.P.44649.  
 Sunhill-road cnr. Richard-road; lots 18 to 25 Sunhill-road; L.P.43625.  
 The Highway cnr. Stephensons-road north side; lots 1 to 6 The Highway; L.P.13952.  
 Wadham-parade cnr. Miller-crescent west side; lots 1 and 2 Wadham-parade; L.P.81103; lots 9 to 16 Wadham-parade; L.P.23915.  
 Waverley-road near cnr. Huntingdale-road; lots 1, 2 and 3 Waverley-road; L.P.54521.  
 Waverley-road near cnr. Stephensons-road; lots 1 to 14 Waverley-road; L.P.12275.  
 Windsor-avenue cnr. Hillview-avenue; lots 6 to 16 Windsor-avenue; L.P.20099.  
 Windsor-avenue cnr. Malcolm-court; lots 1 to 5 Windsor-avenue; L.P.52366.

Dated this 3rd day of September, 1969.

9893 F. S. BALES, Town Clerk.

#### BOROUGH OF KYABRAM.

DOG ACT 1958—ORDER No. 1.

#### Declaration of Shopping Areas.

IN pursuance of the powers conferred by section 17 of the Dog Act 1958, the Council of the Borough of Kyabram doth order that the portions of the streets described hereunder shall be shopping areas for the purpose of the aforementioned Act, viz.:—

- All that portion of Allen-street, Kyabram, between its intersection with the eastern alignment with Unwin-street, and its intersection with the eastern alignment of Bishop-street.
- All that portion of Albion-street, Kyabram, between Allan-street and the southern side of the Echuca-Toolamba Railway line.
- All that portion of Union-street between the northern boundary of Fenaughty-street and the southern boundary of Bradley-street.

In witness whereof the common seal of the Mayor, Councillors and Burgesses of the Borough of Kyabram was hereto affixed this 26th day of August, 1969.

(SEAL) W. A. ROBINSON, Mayor.  
 A. E. CROW, Councillor.  
 E. T. CORNISH, Town Clerk.

9939

#### SHIRE OF BACCHUS MARSH.

LOAN No. 15.

*Notice of Intention to Borrow the Sum of \$20,000 for Permanent Works and Undertakings.*

NOTICE is hereby given that the Council of the Shire of Bacchus Marsh proposes to borrow the principal sum of \$20,000, secured by a charge over the general rates of the municipality, such sum to be raised by the grant of a mortgage in accordance with the provisions of the *Local Government Act 1958*.

- The maximum rate of interest that may be paid is 6.40 per centum per annum.
- The purpose for which the loan is to be applied is the purchase of land and the erection of a dwelling for use by Council staff.
- The period of the loan shall be fifteen years.
- The moneys borrowed shall be repayable by providing out of the municipal fund half-yearly instalments of \$1,046.94 each, including principal and interest on the 10th of May and the 10th day of November, during the currency of the loan. The first instalment shall be payable on the 10th May, 1970.
- Such moneys shall be payable at the Commercial Savings Bank of Australia Ltd., 335 Collins-street, Melbourne.

The plans and specifications and the estimate of the cost of the proposed works and a statement showing the proposed expenditure of the moneys to be borrowed, are open for inspection at the office of the Council of the Shire of Bacchus Marsh, at Main-street, Bacchus Marsh.

Dated 1st September, 1969.

9937 B. E. LEACH, Shire Secretary.

#### SHIRE OF BELLARINE.

LOAN No. 45.

*Notice of Intention to Borrow the Sum of \$30,000 for Permanent Works and Undertakings.*

NOTICE is hereby given that the Council of the Shire of Bellarine proposes to borrow the principal sum of thirty thousand dollars, secured by a charge over the general rates of the municipality, such sum to be raised by the grant of a mortgage in accordance with the provisions of the *Local Government Act 1958*.

- The maximum rate of interest that may be paid is 6.3 per cent. per annum.
- The purposes for which the loan is to be applied are:—
 

Purchase of house and land, Collins-street, Drysdale, for extensions to Municipal Offices and store-yard	\$5,000
Purchase of building and land, Stewart-grove, Portarlinton, for purposes of public resort	2,000
Purchase of land, Ibbotson-street, St. Leonards, for extension to garbage depot	500
Purchase of land, Draper-street, Ocean Grove, for car parking	1,800
Construction of kerb and channel in Asbury-street west from Field-street, Ocean Grove	3,300
Construction of kerb and channel in Lelean-street east of Sweetman-parade, Ocean Grove	3,000
Construction of underground drain, kerb and channel at intersection High and De Burgh streets, Drysdale	800
Construction of kerb and channel, Bellarine Highway, north side, Wilsons-road to Twitts-road	5,500
Construction of underground drainage in Smythe-street west, east of Geelong-road and at intersection of Sproat and Langdon streets, Portarlinton	8,100
	\$30,000
- The period of the loan shall be ten years.
- The moneys borrowed shall be repayable by providing out of the municipal fund half-yearly instalments of approximately \$2,044 each, including principal and interest on the 1st day of May and the 1st day of November, during the currency of the loan. The first instalment shall be payable on the 1st day of May, 1969.

5. Such moneys shall be repayable to the Commissioners of the State Savings Bank of Victoria at the office of the said Commissioners, corner Elizabeth and Bourke streets, Melbourne.

The plans and specifications and the estimate of the cost of the proposed works and a statement showing the proposed expenditure of the moneys to be borrowed, are open for inspection at the office of the Council of the Shire of Bellarine, Drysdale.

Dated 26th August, 1969.

9853

H. A. WILLIAMS, Shire Secretary.

## SHIRE OF CORIO.

LOAN No. 82.

*Construction of Private Streets.*

NOTICE is hereby given that a meeting held at Osborne House, North Geelong, on the 27th day of August, 1969, the said Council did agree to the following Resolution:—

1. That the Council, by Special Order, resolves to borrow on the credit of the President, Councillors and Ratepayers of the Shire of Corio, the sum of One hundred thousand dollars (\$100,000), such sum to be secured by the grant of a mortgage, in accordance with the provisions of the Local Government Act.

2. The rate of interest to be paid is 6.3 per centum per annum.

3. The moneys borrowed to be repayable by twenty instalments of approximately \$6,815.13 (principal and interest combined), payable respectively on the 10th day of March and the 10th day of September in each year, the first instalment being repayable on the 10th day of March, 1970.

4. The moneys borrowed to be repayable to the Commercial Savings Bank of Australia Ltd.

5. The loan to be applied for the purposes of defraying part of the cost of the execution of schemes for the construction of private streets, pursuant to Division 10 of Part XIX. of the Local Government Act.

6. The loan to be liquidated by providing out of the receipts from owners made liable under the schemes, or in case such receipts are insufficient, then by providing from the municipal fund in each half-year, during the currency of the loan, the sum of approximately \$6,815.13, which sum includes principal and interest.

Notice is hereby further given that at a meeting of the said Council to be held at Osborne House, North Geelong, on the 24th September, 1969, the said Resolution will be confirmed.

9874

W. H. MYERS, Shire Secretary.

## SHIRE OF GISBORNE.

LOAN No. 17.

*Notice of Intention to Borrow the Sum of \$20,000 for Permanent Works and Undertakings.*

NOTICE is hereby given that the Council of the Shire of Gisborne proposes to borrow the sum of Twenty thousand dollars on the credit of the municipal revenue of the President, Councillors and Ratepayers of the Shire of Gisborne, such sum to be raised by the grant of a mortgage, in accordance with the provisions of the Local Government Act 1958.

1. The maximum rate of interest that may be paid is 6.10 per cent. per annum.

2. The purpose for which the loan is to be applied is part of the purchase price of a power grader—\$20,000.

3. The period of the loan shall be six years.

4. The moneys borrowed shall be repayable by providing out of the municipal fund twelve half-yearly instalments of approximately \$2,015 each, including principal and interest, on the 1st day of May and 1st day of November, during the currency of the loan. The first instalment shall be payable on the 1st day of May, 1970.

5. Such moneys shall be repayable to the Commissioners of the State Savings Bank of Victoria, at the office of the said Commissioners, 139-165 Elizabeth-street, Melbourne.

The plans and specifications and the estimates of the cost of the proposed works and a statement showing the proposed expenditure of the moneys to be borrowed, are open for inspection at the office of the Council of the Shire of Gisborne, at Gisborne.

9884

K. V. ROBINSON, Shire Secretary.

## SHIRE OF HEALESVILLE.

IN pursuance of the powers conferred on it by section 522 of the Local Government Act 1958 the Council of the Shire of Healesville hereby directs that the following lands which have been taken purchased or acquired by it shall be public highways from and after the date of publication of this Order in the Government Gazette.

All of the lands described in Certificates of Title:—

Volume 8721, Folio 272.

Volume 8740, Folio 658.

By Order made by the Council of the Shire of Healesville, this 26th day of August, 1969.

9858

E. R. FROGLEY, President.

G. G. CUZENS, Councillor.

W. M. OLIVER, Secretary.

## SHIRE OF MORNINGTON.

BY-LAW No. 122.

*Meeting Procedure Amendment (No. 4) By-law.*

NOTICE is hereby given that the Council of the Shire of Mornington has made a by-law, numbered 122, under the Local Government Act 1958, as amended, and all other powers it thereunto enabling, for the purposes of—

1. Amending the Shire of Mornington By-law number 79 (as amended by By-law number 117).

2. Changing the regular days and times of ordinary meetings of the Council as prescribed under clause 5 of the said By-law number 79 (as amended). By-law number 122 provides that after 1st January, 1970, ordinary meetings of the Council will commence at 5.30 p.m.

The first meeting in each year will be held on the fourth Monday in January and thereafter meetings will be held at three weekly intervals until the forty-ninth Monday in each year.

Notice is also hereby given that a copy of the above-mentioned by-law is open for inspection, free of charge, during office hours, at the Office of the said Council, Queen-street, Mornington.

9854

D. G. COLLINGS, Shire Secretary.

## SHIRE OF SOUTH BARWON.

LOAN No. 80.

*Notice of Intention to Borrow.*

NOTICE is hereby given that the Council of the Shire of South Barwon intends to borrow the sum of Fifty thousand dollars (\$50,000), secured by a charge over the general rates of the municipality by the grant of a mortgage in accordance with the provisions of the Local Government Act 1958.

In connexion therewith the following information is stated:—

(a) The amount of principal moneys which it is proposed to borrow is \$50,000.

(b) The maximum rate of interest that may be paid is 6.30 dollars per centum per annum.

(c) The times which the moneys borrowed are to be repayable are the 1st May and the 1st November, during the currency of the loan. The first instalment will be payable on the 1st May, 1970 and the final instalment shall be payable on 1st November, 1979.

(d) The place such money shall be repayable is at the Bank of New South Wales, Belmont.

(e) The period of the loan shall be ten years.

(f) The loan is to be applied for the purpose of financing purchase of land in North Valley-road, Highton, containing approximately 7 acres to achieve the proper development of such area in accordance with the Geelong Planning Scheme 1959.

(g) The manner in which the loan is to be liquidated is by the provision out of the municipal fund in each half-year during the currency of the loan of the sum of approximately \$3,407.58, which includes principal and interest.

The plans and specifications and estimate of the cost of the works and a statement showing the proposed expenditure of the moneys to be borrowed are open for inspection at the Shire Office, Belmont.

Dated 2nd September, 1969.

9873

A. A. N. DEED, Shire Secretary.



SHIRE OF STAWELL WATERWORKS TRUST.

HALLS GAP URBAN DISTRICT.

Notice to the Owners of Tenements in Silver Springs East-road and the Private Streets, Lanes, Courts and Alleys Opening Thereto.

THE main pipe in the said street being laid down the owners of all tenements situated as above are hereby required, on or before the 22nd day of September next, to cause a proper pipe and stop cocks to be laid so as to supply water within such tenements from the main pipe.

9895 V. C. NIELSEN, Secretary.

SHIRE OF TAMBO.

APPOINTMENT OF PROSECUTING OFFICER.

THE Council of the Shire of Tambo has appointed Senior Constable J. J. West, No. 9185, as Prosecuting Officer.

G. W. RIDSDALE, Shire Secretary.

Shire Office, Bruthen. 9869

SHIRE OF TOWONG.

IN pursuance of the powers conferred by sections 522 and 526 of the Local Government Act 1958 the Council of the Shire of Towong doth hereby direct that the land in the Parish of Wagra shown hatched on the Plan hereunder, which has been taken purchased or acquired by it, shall be a public highway from and after the date of publication of this Order in the Government Gazette.

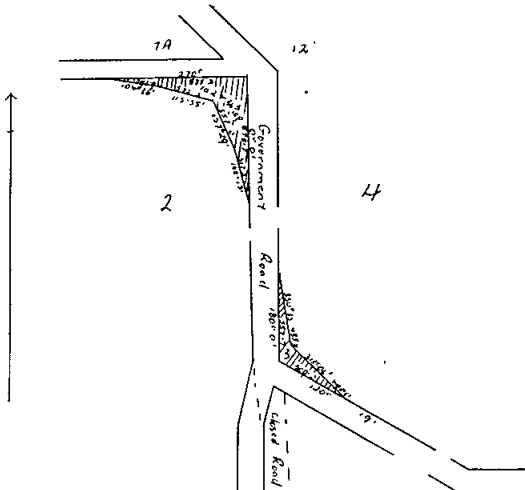

The common seal of the President, Councillors and Ratepayers of the Shire of Towong was hereunto affixed, in the presence of—

9875 (SEAL) J. RONAN, President.  
H. F. BOCK, Councillor.  
I. M. BOWMAN, Secretary.

SHIRE OF YEA.

BY-LAW No. 33.

Wheels of Vehicles.

NOTICE is hereby given that the Council has made By-law 33 for prohibiting or regulating the use on any road of any vehicle not having the nails on its wheels countersunk or having on its wheels any bars spikes or other projections forbidden by such by-law or of any vehicle which moves wholly or partly on crawler or revolving tracks without the previous written permission of an officer of the Council.

A copy of the By-law is open for inspection free of charge during office hours at the Council Office, Civic Centre, Yea.

9863 F. F. BERKERY, Shire Secretary.

SHIRE OF TOWONG.

IN pursuance of the powers conferred by sections 522 and 526 of the Local Government Act 1958 the Council of the Shire of Towong doth hereby direct that the land in the Parish of Berringa shown hatched on the Plan

hereunder, which has been taken purchased or acquired by it, shall be a public highway from and after the date of publication of this Order in the Government Gazette.

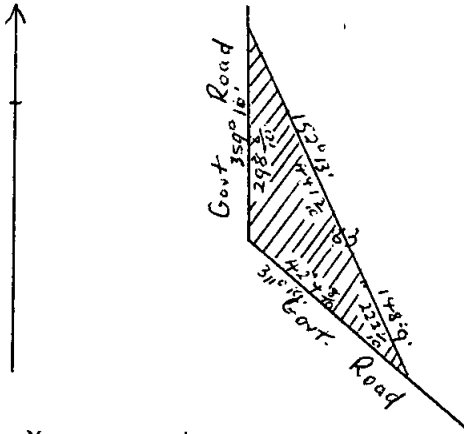

Measurements are in Links.

The common seal of the President, Councillors and Ratepayers of the Shire of Towong was hereunto affixed, this 17th day of June, 1969, in the presence of—

9888 (SEAL) J. RONAN, President.  
H. F. BOCK, Councillor.  
I. M. BOWMAN, Secretary.

NOTICE is hereby given that the partnership heretofore subsisting between James Walter McKeown and Yvonne McKeown, carrying on the business of motor garage proprietors and motor racing, at 435 Mt. Dandenong-road, Kilsyth, under the style or firm name of "Jim McKeown Motors", has been dissolved by mutual consent as from the 31st day of August, 1969, so far as concerns the said Yvonne McKeown, who retires from the said firm and that the said business shall from that date be carried on by the said James Walter McKeown, under the said style or firm name.

Dated this 1st day of September, 1969.

Y. MCKEOWN.  
J. MCKEOWN.  
Pavey, Wilson, Cohen & Carter, solicitors, 390 Lonsdale-street, Melbourne. 9934

In the Supreme Court of Victoria—1969 No. of Coy. 7791 —In the matter of the Companies Act 1961; and in the matter of DAVIS BROS. FURS PROPRIETARY LIMITED.

NOTICE is hereby given that a petition for the winding up of the above-named company by the Supreme Court was, on the 21st day of August, 1969, presented by Kosky Bros. Proprietary Limited; And that the said petition is directed to be heard before the Court sitting at the Thirteenth Court, Law Courts, William-street, Melbourne, at the hour of 10.30 a.m., on Tuesday the 23rd day of September, 1969; and any creditor or contributory of the said company desiring to support or oppose the making of an Order on the said petition may appear at the time of hearing by himself or his Counsel for that purpose; and a copy of the petition will be furnished to any creditor or contributory of the said company requiring the same by the undersigned on payment of the regulated charge for the same.

The petitioner's address is 69 City-road, South Melbourne.

The petitioner's solicitors are Messrs, Corr & Corr, of 290 Latrobe-street, Melbourne.

CORR AND CORR, solicitors for the petitioner.

NOTE.—Any person who intends to appear on the hearing of the said petition must serve on or send by post to the above-named solicitors, notice in writing of his intention so to do. The notice must state the name and address of the person, or, if a firm, the name and address of the firm, and must be signed by the person or firm, or his or their solicitor (if any), and must be served, or, if posted, must be sent by post in sufficient time to reach the above-named not later than 4 o'clock in the afternoon of the 22nd day of September, 1969.

In the Supreme Court of Victoria—1967 No. of Coy. 7795  
—in the matter of the *Companies Act 1961*—And in the  
matter of VALIANT CONSTRUCTION COMPANY PROPRIETARY  
LIMITED.

NOTICE is hereby given that a petition for the winding  
up of the above-named company by the Supreme  
Court was on the 29th day of August, 1969, presented by  
James Canny, Deputy Commissioner of Taxation of the  
Commonwealth of Australia and that the said petition is  
directed to be heard before the Court sitting at the  
Fourteenth Court, Law Courts, William-street, Melbourne,  
at the hour of 10.30 o'clock in the forenoon on the 29th  
day of September, 1969, and any creditor or contributory  
of the said company desiring to support or oppose the  
making of an order on the said petition may appear at  
the time of hearing by himself or his Counsel for that  
purpose; and a copy of the said petition will be furnished  
to any creditor or contributory of the said company  
requiring the same by the undersigned on payment of the  
regulated charge for the same.

The petitioner's official address is 350 Collins-street,  
Melbourne.

The petitioner's solicitor is Harold Edward Renfree,  
Crown Solicitor for the Commonwealth, of 99 Queen-  
street, Melbourne.

H. E. RENFREE.

NOTE.—Any person who intends to appear on the  
hearing of the said petition must serve on or send by  
post to the above-named H. E. Renfree, notice in writing  
of his intention so to do. The notice must state the name  
and address of the person, or if a firm, the name and  
address of the firm, and must be signed by the person or  
firm, or his or their solicitor (if any), and must be served  
or, if posted, must be sent by post in sufficient time to  
reach the above-named not later than 4 o'clock in the  
afternoon of the 26th day of September, 1969. 9947

In the Supreme Court of Victoria—In the matter of the  
*Companies Act 1961*—And in the matter of ROBERTSON  
& ASSOCIATES PTY. LTD., formerly known as STUDIO  
PRINT PUBLICITY PTY. LTD.

NOTICE is hereby given a petition for the winding up of  
the above-named company by the Supreme Court was  
on the 20th day of August, 1969, presented by Photo Art  
Reproductions Pty. Ltd. And that the said petition is  
directed to be heard before the Court sitting at the  
Fourteenth Court, Law Courts, William-street, Melbourne,  
on the 1st day of October, 1969, at the hour of 10.30  
o'clock in the forenoon; and any creditor or contributory  
of the said company desiring to support or oppose the  
making of an order on the said petition may appear at  
the time of hearing by himself or his counsel for that purpose;  
and a copy of the petition will be furnished to any creditor  
or contributory of the said company requiring the same  
by the undersigned on payment of the regulated charge  
for the same.

The petitioner's address is 68 York-street, South Mel-  
bourne.

The petitioner's solicitors are John J. Cantwell & Co.,  
of 253 Lonsdale-street, Melbourne.

JOHN J. CANTWELL & CO., solicitors for the petitioner.

NOTE.—Any person who intends to appear on the  
hearing of the said petition must serve or send by  
post to the above-named solicitors, notice in writing of his  
intention to do so. The notice must state the name and  
address of the person, or if a firm, the name and address  
of the firm and must be signed by the person or firm or his  
or their solicitors (if any) and must be served, or if posted,  
must be sent by post in sufficient time to reach the  
above-named not later than 4 o'clock in the afternoon on  
the 30th day of September, 1969. 9942

The *Companies Act 1961*.

SUN VALLEY FEED CO. PTY. LTD. (IN LIQUIDATION).

NOTICE OF MEETING OF MEMBERS AND CREDITORS.

NOTICE is hereby given that pursuant to section 272 (1)  
of the *Companies Act 1961*, a meeting of the  
Members and Creditors of the Sun Valley Feed Co. Pty.  
Ltd. (in Liquidation) will be held at the office of Cox  
Johnston & Co., chartered accountants, 446 Collins-street,  
Melbourne, on Friday the 3rd day of October, 1969, at  
10.30 a.m., for the purpose of laying before the meeting  
an account showing how the winding up has been con-  
ducted and the property of the company has been disposed  
of and providing any explanations thereof.

Dated this 2nd day of September, 1969.

A. I. SINCLAIR, Liquidator.

Cox Johnston & Co., 446 Collins-street, Melbourne, 3000.

9948

In the Supreme Court of Victoria—In the matter of the  
*Companies Act 1961*—And in the matter of STEELFORMED  
PROPRIETARY LIMITED.

NOTICE is hereby given that a petition for the winding  
up of the above-named company by the Supreme  
Court was on the 20th day of August, 1969, presented by  
Stansfield Steel Co. Pty. Ltd.: And that the said petition  
is directed to be heard before the Court sitting at the  
Fourteenth Court, Law Courts, William-street, Melbourne,  
on the 1st day of October, 1969, at the hour of 10.30  
o'clock in the forenoon; and any creditor or contributory  
of the said company desiring to support or oppose the  
making of an order on the said petition may appear at  
the time of hearing by himself or his counsel for that  
purpose; and a copy of the petition will be furnished to  
any creditor or contributory of the said company requiring  
the same by the undersigned on payment of the regulated  
charge for the same.

The petitioner's address is 171 William-street, Mel-  
bourne.

The petitioner's solicitors are John J. Cantwell & Co.,  
of 253 Lonsdale-street, Melbourne.

JOHN J. CANTWELL & CO., solicitors for the petitioner.

NOTE.—Any person who intends to appear on the  
hearing of the said petition must serve or send by  
post to the above-named solicitors, notice in writing of his  
intention to do so. The notice must state the name and  
address of the person, or if a firm, the name and address  
of the firm and must be signed by the person or firm or his  
or their solicitors (if any) and must be served, or if posted,  
must be sent by post in sufficient time to reach the  
above-named not later than 4 o'clock in the afternoon on  
the 30th day of September, 1969. 9943

The *Companies Act 1961*, Section 254 (2).

BYAMEE AGENCIES PROPRIETARY LIMITED.

SPECIAL RESOLUTION DULY PASSED AT GENERAL MEETING  
OF THE ABOVE COMPANY.

THAT it has been proved to the satisfaction of this  
Meeting that the company cannot by reason of its  
liabilities continue its business and that it is advisable to  
wind up the same, and accordingly, that the company be  
wound up voluntarily, and that Hudson Bernard Pitt,  
public accountant, be appointed liquidator of the company  
and that the liquidator's remuneration be within the scale  
laid down by the Australian Society of Accountants and  
that pursuant to the provisions of Article 54 of the  
Articles of Association of the company, in view of the  
fact that all members entitled to attend and vote are  
present either personally or by proxy this Resolution is  
passed as a Special Resolution.

Dated this 29th day of August, 1969.

9921

TODD TREVAKS, Director.

*Companies Act 1961*.—In the matter of HONG KONG  
ENTERPRISES PTY. LTD.

AT an Extraordinary General Meeting of the above-  
named company, duly convened and held at 351  
Collins-street, Melbourne, on the 1st day of September,  
1969, the following Resolution was duly passed as a  
Special Resolution:—

"That the company be wound up voluntarily."

And at such meeting, Ernest Harding Niemann, 44  
Market-street, Melbourne, was appointed liquidator for  
the purposes of the winding up.

Dated this 1st day of September, 1969.

9928

A. W. ADENA, Secretary.

The *Companies Act 1961*.—In the matter of LE ROY  
(ORBOST) PROPRIETARY LIMITED.

NOTICE is hereby given that at an Extraordinary General  
Meeting of the members of the above-named com-  
pany held on the 27th day of August, 1969, it was resolved  
that the company be wound up voluntarily, and at a  
meeting of creditors held on the 28th day of August,  
1969, pursuant to section 260, it was resolved that for  
such purpose Robert Eastaugh Ramsay, of 296 Little  
Lonsdale-street, Melbourne, accountant, be appointed  
liquidator.

Notice is also given that after 21 days from this  
date I shall proceed to distribute the assets. All creditors  
having any claims against the company should furnish  
particulars of same by that date, otherwise I shall proceed  
to distribute the assets without regard to their claim.

Dated this 2nd day of September, 1969.

R. E. RAMSAY, Liquidator.

Kennedy, Smail & Middlemiss, 296 Little Lonsdale-street,  
Melbourne, 3000. 9946

## Unclaimed Moneys Act 1962.

## REGISTER of Unclaimed Moneys held by the—

Name of Owner on Books and Last Known Address.	Total Amount Due to Owner.	Description of Unclaimed Moneys.	Date when Amount first became Payable.
<b>MURRAY GOULBURN CO-OPERATIVE CO. LIMITED.</b>			
\$			
Craddock, K., Kyabram .. .. .	58.43	Revolving Fund .. .. .	30.6.67
Moschetti, R. S., Wyuna East .. .. .	105.34	" " .. .. .	"
O'Neill, N. S., Narrogin, W.A. .. .. .	128.84	" " .. .. .	"
Pyke, J. D., Kyabram .. .. .	88.45	" " .. .. .	"
Fitzgerald, M., Cobram .. .. .	21.72	Wages .. .. .	"
Edmonstone, L., Cobram .. .. .	23.13	" " .. .. .	"
Osborne, H. and H., Unknown .. .. .	37.37	Debtors refund .. .. .	"
Gilbert, K. B., Unknown .. .. .	13.07	" " .. .. .	"
Payne, T. P., Unknown .. .. .	66.43	" " .. .. .	26.7.67

9920

## Companies Act 1961.—In the matter of WYOMING ENTERPRISES PTY. LTD.

AT an Extraordinary General Meeting of the above-named company, duly convened and held at 351 Collins-street, Melbourne, on the 1st day of September, 1969, the following Resolution was duly passed as a Special Resolution:—

"That the company be wound up voluntarily."

And at such meeting, Ernest Harding Niemann, 44 Market-street, Melbourne, was appointed liquidator for the purposes of the winding up.

Dated this 1st day of September, 1969.

9929 A. W. ADENA, Secretary.

## LAUGHTONS PROPRIETARY LIMITED (IN LIQUIDATION). MEMBERS VOLUNTARY LIQUIDATION.

NOTICE is hereby given that at an Extraordinary General Meeting of the above-named company duly convened and held on the 27th day of August, 1969, the following Special Resolution was duly passed:—

"That the company be wound up voluntarily and that for the purposes of such winding up Keith W. G. Watson, of 419 Lonsdale-street, Melbourne, be appointed liquidator."

Dated 29th August, 1969.

9949 KEITH W. G. WATSON, Liquidator.

## In the matter of the Companies Act 1961; and in the matter of ROCHESTER TYRE SERVICE PROPRIETARY LIMITED.

NOTICE is hereby given that at an Extraordinary General Meeting of the Members of Rochester Tyre Service Proprietary Limited, held at Rochester, on the 24th day of August, 1969, the following Special Resolution was duly passed.

"That the company be wound up voluntarily and that for such purpose Francis Brian Jennings, of 358 McCrae-street, Bendigo, be appointed liquidator."

Dated this 25th day of August, 1969.

9851 F. B. JENNINGS, Liquidator.

## The Companies Act 1961.—In the matter of F. W. HEATING &amp; SHEET METAL PTY. LTD. (in Voluntary Liquidation).

NOTICE is hereby given that at an Extraordinary Meeting of the members of the above-named company, held on Thursday, the 28th day of August, 1969, it was resolved that the company be wound up voluntarily and at a meeting of creditors, held on Thursday, the 28th day of August, 1969, it was resolved that for such purpose Scott Maurice Nunan, of Hall & Rose, 260 Queen-street, Melbourne, chartered accountant, be appointed liquidator.

Notice is also given that after 21 days from this date I shall proceed to distribute the assets. All creditors having any claim against the company should furnish particulars of same by that date, otherwise I shall proceed to distribute the assets without regard to their claim.

Dated this 29th day of August, 1969.

S. M. NUNAN, Liquidator.

Hall & Rose, chartered accountants, 260 Queen-street, Melbourne. 9906

## Companies Act 1961.—423 HIGH STREET PRESTON PTY. LTD. (IN VOLUNTARY LIQUIDATION).

NOTICE is hereby given that a Final Meeting of members and creditors of the above-named company will be held on the 17th day of October, 1969, at 3 p.m., at 372 High-street, Preston, pursuant to section 272 of the Companies Act 1961 for the purpose of laying before the meeting an account showing how the winding up has been conducted and how the assets have been disposed of.

R. M. PARKS, Liquidator.

Dated the 1st day of September, 1969. 9880

## Companies Act 1961.—Section 272 (1). TASMANIAN DEVELOPMENTS PTY. LTD. (IN LIQUIDATION).

NOTICE is hereby given that a Final Meeting of members and creditors of Tasmanian Developments Pty. Limited (in liquidation) will be held at the registered office of the company, 4th Floor, 403 Bourke-street, Melbourne, on the 6th day of October, 1969, at 11 o'clock in the forenoon, for the purpose of laying before the meeting an account showing how the winding up has been conducted and the property of the company has been disposed of, and of giving any explanation thereof.

Dated this 27th day of August, 1969.

E. H. NIEMANN, Liquidator.

Messrs. Hungerford, Spooner & Kirkhope, 44 Market-street, Melbourne, 3000. 9896

## The Companies Act 1961.—In the matter of ROLEC PLATING INDUSTRIES PTY. LTD. (in Liquidation).

NOTICE is hereby given that a Final Meeting of members and creditors of the above-named company will be held on Wednesday, the 8th day of October, 1969, at 11.30 a.m., at the office of Lewis Luckins & Co., 2nd Floor, 289 Flinders-lane, Melbourne, pursuant to section 272 of the Companies Act 1961 for the purpose of laying before the meeting an account showing how the winding up has been conducted and how the assets have been disposed of.

Dated this 1st day of September, 1969.

LEWIS LUCKINS, F.C.A., Liquidator.

Lewis Luckins & Co., chartered accountants, 289 Flinders-lane, Melbourne, 3000, telephone 63 8827. 9916

## The Companies Act 1961.—In the matter of VIC. CASSAR &amp; SONS PTY. LTD. (in Liquidation).

NOTICE is hereby given that a Final Meeting of members and creditors of the above-named company will be held on Thursday, the 2nd day of October, 1969, at 11.30 a.m., at the office of Lewis Luckins & Co., 2nd Floor, 289 Flinders-lane, Melbourne, pursuant to section 272 of the Companies Act 1961, for the purpose of laying before the meeting an account showing how the winding up has been conducted and how the assets have been disposed of.

Dated this 1st day of September, 1969.

LEWIS LUCKINS, F.C.A., Liquidator.

Lewis Luckins & Co., chartered accountants, 289 Flinders-lane, Melbourne, 3000, telephone 63 8827. 9917

The Companies Act 1961.—In the matter of P.D.M. PRY. Ltd.—Notice Re Meeting of Creditors, Pursuant to Section 260.

NOTICE is hereby given that a Meeting of Creditors of the above-named company will be held at the offices of Kennedy, Smail & Middlemiss, 296 Little Lonsdale-street, Melbourne, at 10.30 a.m., on the 4th day of September, 1969, the company having convened a meeting of its members for the same day for the purpose of considering a Resolution that the company be wound up voluntarily.

Dated this 28th day of August, 1969.

R. R. BLASHKI, Director.

Kennedy, Smail & Middlemiss, 296 Little Lonsdale-street,  
Melbourne, 3000. 9918

The Companies Act 1961.—In the matter of DOLLAR VIEW PRY. LTD. (in Liquidation).

A FIRST and Final Dividend is intended to be declared in the above-mentioned matter. Creditors who have not proved their debts by the 15th day of September, 1969, will be excluded from the dividend.

Dated this 25th day of August, 1969.

A. M. HORSBURGH, Liquidator.

Kennedy, Smail & Middlemiss, 296 Little Lonsdale-street,  
Melbourne, 3000. 9919

In the Supreme Court of Victoria.—In the matter of the Companies Act 1961; and in the matter of PENDAR CONSTRUCTIONS PROPRIETARY LIMITED.

NOTICE is hereby given that a petition for the winding up of the above-named company by the Supreme Court was on the 16th day of July, 1969, presented by Lamcal Trading Co. Proprietary Limited: And that the said petition is directed to be heard before the Court sitting at the Fourteenth Court, Law Courts, William-street, Melbourne, at the hour of 10.30 o'clock in the forenoon on the 18th day of September, 1969, and any creditor or contributory of the said company desiring to support or oppose the making of an order on the said petition, may appear at the time of hearing by himself or his counsel for that purpose and a copy of the petition will be furnished to any creditor or contributory of the said company requiring the same by the undersigned on payment of the regulated charge for the same.

The petitioner's address is 74-76 Northern-road, West Heidelberg.

The petitioner's solicitors are Graeme Steinfort & Co., of 580 High-street, Thornbury.

GRAEME STEINFORT & CO., solicitors for the petitioner.

NOTE.—Any person who intends to appear on the hearing of the said petition must serve on or send by post to the above-named Graeme Steinfort & Co., notice, in writing, of his intention so to do. The notice must state the name and address of the person, or, if a firm, the name and address of the firm and must be signed by the person or firm or his or their solicitor (if any) and must be served on, or if posted, must be sent by post in sufficient time to reach the above named not later than 4 o'clock in the afternoon of the 17th day of September, 1969. 9879

LEE & MCGLOIN PTY. LTD.

TAKE notice that the affairs of the above-named company are now fully wound up and that in pursuance of section 272 (1) of the Companies Act 1961 a general meeting of the company will be held at the office of E. C. Candy & Co., 118 Queen-street, Melbourne, on the 6th day of October, 1969, at 10.30 a.m. in the forenoon, for the purpose of laying before it an account showing how the winding up has been conducted and the property of the company disposed of and giving any explanation thereof.

Dated the 1st day of September, 1969.

9877

B. C. CANDY, Liquidator.

OWEN MILLS PROPRIETARY LIMITED.

TAKE notice that the affairs of the above-named company are now fully wound up and that in pursuance of section 272 (1) of the Companies Act 1961 a general meeting of the company will be held at the office of E. C. Candy & Co., 118 Queen-street, Melbourne, on the 6th day of October, 1969, at 10.00 a.m. in the forenoon, for the purpose of laying before it an account showing how the winding up has been conducted and the property of the company disposed of and giving any explanation thereof.

Dated the 1st day of September, 1969.

9878

B. C. CANDY, Liquidator.

HENRY GORDON McCOSKER, late of Dennington, farmer, DECEASED.

CREDITORS, next of kin and all others having claims in respect of the above-named deceased (who died on the 9th day of May, 1969), are requested to send particulars of their claims in writing to the executor The National Trustees Executors and Agency Company of Australasia Limited, of 95 Queen-street, Melbourne, at that address on or before the 5th day of November, 1969, after which date it will distribute the assets of the said estate, having regard only to the claims of which it then has notice as aforesaid.

DESMOND DUNNE & DWYER, solicitors, Warrambool. 9861

EVA TERESA POPE, late of 22 Lava-street, Warrambool, widow, DECEASED.

CREDITORS, next of kin and all others having claims in respect of the above-named deceased (who died on the 2nd day of July, 1969), are requested to send particulars of their claims in writing to the executor Oscar Vivian Henry, care of the undersigned on or before the 5th day of November, 1969, after which date the said Oscar Vivian Henry will distribute the assets of the said estate, having regard only to the claims of which he then has notice as aforesaid.

DESMOND DUNNE & DWYER, solicitors, Warrambool. 9862

JOHN WILSON, late of Kooloonong, in the State of Victoria, retired farmer, DECEASED (who died on the 8th July, 1969).

CREDITORS, next of kin and all other persons having claims against the estate of the deceased, are required by the executors of the will, John James Larkin and Lena Isabel Larkin, to send particulars to them care of the undersigned on or before the 27th day of November, 1969, after which date they will distribute the assets, having regard only to the claims of which they then have notice.

GARDEN & GREEN, solicitors, 4 McCallum-street, Swan Hill. 9868

IMMACOLATA MARSOLINO, late of Swan Hill, in the State of Victoria, married woman, DECEASED (who died on the 1st October, 1968).

CREDITORS, next of kin and all other persons having claims against the estate of the deceased are required by the executors of the will, Salvatore Marsolino and Paolo Marsolino, to send particulars to them, care of the undersigned on or before the 25th day of November, 1969, after which date they will distribute the assets, having regard only to the claims of which they then have notice.

GARDEN & GREEN, solicitors, 4 McCallum-street, Swan Hill. 9864

GEORGE WILLIAM YOUNG, formerly of 121 High-street, Glen Iris, but late of "Lumeah", 78 Bruce-street, Preston, gentleman, DECEASED.

CREDITORS, next of kin and others having claims against the estate of the deceased (who died on 18th June, 1969), are required by the executor, The Trustees Executors and Agency Company Limited, of 401 Collins-street, Melbourne, to send particulars of the claims to the company by the 5th day of December, 1969, after which date it may convey and distribute the assets, having regard only to the claims of which it then has notice.

S. W. MISSON & BARTLEY, solicitors, 59 Waverley-road, East Malvern. 9865

VALLORY GAIL PLOENGES of care of Darvall & Hambleton, solicitors, 7th Floor, T. & G. Building, 147 Collins-street, Melbourne, the administratrix of the estate of Keith Hatchett, late of 21 Loyola-avenue, East Brunswick, dental mechanic, deceased, intestate (who died on the 23rd day of December, 1968), requires all creditors, next of kin and others having claims against the property or estate of the said deceased to send to her, the said administratrix, at her address aforementioned, on or before the 30th day of October, 1969, particulars in writing of such claims, after which date the said administratrix intends to convey or distribute such property or estate to or among the persons entitled thereto, having regard only to the claims of which she shall have had notice.

DARVALL & HAMBLETON, solicitors, 7th Floor, T. & G. Building, 147 Collins-street, Melbourne. 9912

**CREDITORS**, next of kin and others having claims in respect of the estate of George Albert Dalgleish, late of 488 Middleborough-road, Blackburn, in the State of Victoria, retired jeweller, deceased (who died on the 18th day of June, 1969), are required to send particulars of their claims to the trustee, The Trustees Executors and Agency Company Limited, of 401 Collins-street, Melbourne, in the said State, by the 10th day of November, 1969, after which date the trustees may convey or distribute the assets, having regard only to the claims of which it then has notice.

B. J. T. STONE & LEIGHTON, solicitors, 221 High-street, Kew. 9890

**CREDITORS**, next of kin and others having claims in respect of the estate of James Thomas Beament, late of Speed, pensioner, deceased (who died on 9th September, 1968), are to send particulars of their claims to Robert Noel Edgar, care of Messrs. J. M. Smith & Emmerton at 170 Queen-street, Melbourne, by 5th November, 1969, after which date he will distribute the assets, having regard only to the claims of which he then has notice.

J. M. SMITH & EMMERTON, solicitors, 170 Queen-street, Melbourne. 9897

**CREDITORS**, next of kin and others having claims in respect of the estate of Geoffrey Ernest Floyd, late of 25 Grandview-road, Brighton, in the State of Victoria, gentleman, deceased (who died on the 26th April, 1969), are to send particulars of their claims to Mary Wilson Floyd, of 25 Grandview-road, Brighton, in the State of Victoria, the executrix appointed by the will of the said deceased, by the 5th November, 1969, after which date the executrix will distribute the assets, having regard only to the claims of which she shall then have notice.

H. L. YUNCKEN & YUNCKEN, solicitors, of 443 Little Collins-street, Melbourne. 9898

**CREDITORS**, next of kin and others having claims in respect of the estate of Horatio Vincent Ockley, late of "Wandana", Ogilvy-road, Emerald, in the State of Victoria, retired chemist, deceased (who died on the 23rd of May, 1969), are to send particulars of their claims to Ellen Mary Ockley, of "Wandana", Ogilvy-road, Emerald, in the State of Victoria, the executrix appointed by the will of the said deceased, by the 5th November, 1969, after which date the executrix will distribute the assets, having regard only to the claims to which she shall then have notice.

H. L. YUNCKEN & YUNCKEN, solicitors, of 443 Little Collins-street, Melbourne. 9899

**CREDITORS**, next of kin and others having claims in respect of the estate of Bertha May Hardie, late of 211 Melbourne-road, North Williamstown, in the State of Victoria, widow (who died on the 5th July, 1969), are required by the executor, NATIONAL TRUSTEES, EXECUTORS AND AGENCY COMPANY OF AUSTRALASIA LIMITED, of 95 Queen-street, Melbourne, to send particulars to it, on or before the 5th of November, 1969, after which date the executor will convey or distribute the assets, having regard only to the claims of which it shall then have had notice.

ARTHUR SECOMB & CO., of 128 William-street, Melbourne, solicitors for the executor. 9900

JEAN VICTORIA DRISCOLL, late of 19 Ascot-street, South Ballarat, nursing aide, DECEASED (who died on the 22nd June, 1969).

**CREDITORS**, next of kin and all persons having claims against the estate of the deceased are required to send particulars to the administrator, The Union-Fidelity Trustee Company of Australia Limited, of 101 Lydiard-street north, Ballarat, on or before the 4th November, 1969, after which date it will distribute the assets, having regard only to the claims of which it shall then have notice.

HEINZ & GORDON, solicitors, 209 Dana-street, Ballarat. 9881

**CREDITORS**, next of kin and others having claims against the estate of Brian Tarbolton, late of 229 Nell-street, Watsonia, senior packer and despatcher, deceased, intestate (who died on the 9th day of December, 1968), and letters of administration of whose estate have been granted to Valda Louisa Tarbolton, of 229 Nell-street, Watsonia, widow, are hereby required to send particulars of their claims to the said administratrix, care of the under-mentioned solicitors, by the 6th day of November,

1969, after which date she will distribute the assets, having regard only to the claims of which she then has notice.

PEARCE & WEBSTER, solicitors, 430 Little Collins-street, Melbourne. 9901

**CREDITORS**, next of kin and others having claims against the estate of Jane Hazel Williamson (also known as Jean Hazel Williamson), formerly of 17 Moule-street, Brighton, cook, but late of Flat 5, 10 Affleck-street, South Yarra, spinster, deceased (who died on the 25th day of February, 1969), and probate of whose will has been granted to Arthur Dean Pearce, of 430 Little Collins-street, Melbourne, solicitor, are hereby required to send particulars of their claims to the said executor, care of the under-mentioned solicitors, by the 6th day of November, 1969, after which date he will distribute the assets, having regard only to the claims of which he then has notice.

PEARCE & WEBSTER, solicitors, 430 Little Collins-street, Melbourne. 9902

**CREDITORS**, next of kin and others having claims against the estate of Thomas Gerald Alban Gill (usually known as and in the will called Gerald Alban Gill), late of 51 Broadway, Camberwell, accountant, deceased (who died on 8th June, 1969), are required by Patrick Francis Toohey, the executor of the will of deceased, to send to him, care of the undersigned solicitors, particulars thereof, on or before the 8th day of November, 1969, after which date he will distribute the assets, having regard only to the claims of which he shall then have notice.

GAVAN DUFFY & KING, solicitors, 95 Queen-street, Melbourne. 9903

JOSEPHINE MORGAN, late of 37 Bank-street, Yarrawonga, spinster, DECEASED (who died on the 10th January, 1969).

**CREDITORS**, next of kin and all other persons having claims against the estate of the deceased are required by the executrix of her will, Mary Margaret Lees, of 37 Bank-street, Yarrawonga, married woman, to send particulars thereof to her, care of the under-mentioned solicitors, before the 10th November, 1969, after which date she may distribute the assets of the deceased, having regard only to the claims of which she then has notice.

COLTMAN, WYATT & ANDERSON, solicitors, of 578 Bourke-street, Melbourne. 9904

FRANK ROBERT PERRING, late of 59 Hunt-crescent, Ascot Vale, gentleman, DECEASED (who died on the 19th June, 1969).

**CREDITORS**, next of kin and all other persons having claims against the estate of the deceased are required by the executor of his will, Douglas Dundas Aitken, of 81 Maribyrnong-road, Ascot Vale, merchant, to send particulars thereof to him, care of the under-mentioned solicitors, before the 10th November, 1969, after which date he may distribute the assets of the deceased, having regard only to the claims of which he then has notice.

COLTMAN, WYATT & ANDERSON, solicitors, of 578 Bourke-street, Melbourne. 9905

ELLEN MARY BURKE, late of 28 Botanic-road, Warrnambool, spinster, DECEASED.

**CREDITORS**, next of kin and all others having claims in respect of the above-named deceased (who died on the 7th day of June, 1969), are requested to send particulars of their claims in writing to the executor James Michael Dwyer, care of the under-signed on or before the 5th day of November, 1969, after which date the said James Michael Dwyer, will distribute the assets of the said estate, having regard only to the claims of which he then has notice as aforesaid.

DESMOND DUNNE & DWYER, solicitors, Warrnambool. 9860

**CREDITORS**, next of kin and others having claims against the estate of Stanley James Holford, late of "Pyrenees House" Girdlestone-street, Ararat, retired caretaker, deceased (who died on the 29th day of July, 1969), are requested to send particulars of their claims to the executor, Ord Howard Gienn, of 9 St. Aidan's-drive, Ballarat, solicitor, by the 29th day of October, 1969, after which date the said executor will distribute the assets, having regard only to the claims of which he then has notice.

NEVETT, GLENN & COUTTS, solicitors, 205 Dana-street, Ballarat. 9852

**CREDITORS**, next of kin and others having claims against the estate of Lyle Jackson, late of Crusoe-road, Kangaroo Flat (who died on the 8th day of January, 1969), are required by the executor to send particulars, in writing, of their claim to National Trustees, Executors and Agency Company of Australasia Limited, of 46 Queen-street, Bendigo, on or before, the 31st day of October, 1969, after which date the said executor will distribute the assets, having regard only to the claims of which the said company then has notice.

ERIC C. COHEN, solicitor, Victoria-place, Pall Mall, Bendigo. 9859

**AFTER** fourteen days application will be made to the Supreme Court of Victoria, that probate of the will, dated the 13th day of May, 1969, of Ryska Szenwic, late of Flat 2, 54 Kooyong-road, Caulfield, in the State of Victoria, married woman, deceased, be granted to Louis Perlen, of 688 Hawthorn-road, East Brighton, in the said State, pharmaceutical chemist, the executor named therein.

DAVID BRISTOL, LL.B., solicitors, of 549 Hampton-street, Hampton. 9889

GLADYS BEATRICE SMITH, late of 20 Charnwood-crescent, St. Kilda, machinist, DECEASED, intestate.

**CREDITORS**, next of kin and all others having claim against the estate of the above-named deceased (who died on the 25th October, 1968), are to send particulars of their claims to Victor Dudley Smith, the administrator, care of his solicitor, John I. Sullivan, corner of Kooyong and Glenhuntly roads, Caulfield, by the 5th day of November, 1969, after which date the trustee will convey or distribute the assets of the deceased, having regard only to the claims of which he then has notice.

JOHN I. SULLIVAN, solicitor, corner of Kooyong and Glenhuntly roads, Caulfield. 9922

TERESA FRY, also known as TERESA MARGARET FRY, late of 17 Bayliss-street, Preston, comptometrist, presumed dead, at Common Law not having been heard of for more than seven years, DECEASED intestate.

**CREDITORS**, next of kin and others having claims in respect of the estate of the above-named deceased are required to send the particulars of their claims to the executrix, Christine Maryon Fry, care of the under-named solicitors, by the 5th day of November, 1969, after which date she will distribute the assets, having regard only to those claims of which she then has notice.

NORRIS COATES & HEARLE, solicitors, of 422 Collins-street, Melbourne. 9907

**CREDITORS**, next of kin and others having claims in respect of the estate of James William Barker, late of 6 Hillside-avenue, Caulfield, in the State of Victoria, retired estate agent, deceased (who died on 23rd June, 1969), are required by the executor of his will, The Trustees Executors and Agency Company Limited, of 401 Collins-street, Melbourne, in the said State, to send particulars to it, by the 5th November, 1969, after which date the executor may convey or distribute the assets, having regard only to the claims of which it then has notice.

MOLOMBY & MOLOMBY, solicitors, 411 Collins-street, Melbourne. 9908

**CREDITORS**, next of kin and others having claims in respect of the estate of Doris May Harrison, late of 72 Keilor-road, North Essendon, home duties, deceased intestate (who died on the 30th day of May, 1968), are required by the administrator, Ernest Frederick Ross Harrison, of 72 Keilor-road, North Essendon, seaman, to send particulars of their claims to him, in care of Messrs. Rogers & Gaylard, solicitors, 281 Collins-street, Melbourne, prior to the 12th day of November, 1969, after which date the said administrator will distribute the assets of the deceased, having regard only to the claims of which he then shall have had notice.

ROGERS & GAYLARD, solicitors, 281 Collins-street, Melbourne. 9909

**CREDITORS**, next of kin and others having claims against the estate of Richard Clayton Wardle, late of 3 Davis-avenue, Camberwell, Victoria, gentleman, deceased (who died on the 11th June, 1969), are required by the executor, The Trustees Executors and Agency Company Limited, of 401 Collins-street, Melbourne, Victoria, to send particulars to it, by the 4th November, 1969, after which date it may distribute the assets, having regard only to the claims of which it then has notice. 9913

RUBY ROBINSON, late of 247 Abbotsford-street, North Melbourne, widow, DECEASED.

**CREDITORS**, next of kin and others having claims in respect of the estate of the above-named deceased (who died on the 9th day of April, 1969), are required to send particulars thereof to Irving S. Plotkin, Scott & Opat, of 379 Bourke-street, Melbourne, solicitors for the executors, on or before the 6th day of November, 1969, otherwise they may be excluded when the assets are being distributed.

IRVING S. PLOTKIN, SCOTT & OPAT, solicitors, 379 Bourke-street, Melbourne. 9911

**CREDITORS**, next of kin and others having claims in respect of the estate of John Herbert Winnen, late of 2A Parlington-street, Canterbury, retired clerk, deceased (who died on the 9th February, 1969), are to send particulars of their claims to the Equity Trustees Executors and Agency Company Limited, of 472 Bourke-street, Melbourne, by the 7th day of November, 1969, after which date it will distribute the assets, having regard only to the claims of which it then has notice.

WILLIAM M. SERONG, solicitor, 167 Queens-parade, Clifton Hill. 9872

**CREDITORS**, next of kin and others having claims against the estate of Phyllis Gertrude Berry, formerly of Flat 4, 66 Walsh-street, South Yarra, Victoria, but late of 99 Carrington-road, Wairoonga, New South Wales, widow, deceased (who died on the 23rd July, 1968), are required by the executor, The Equity Trustees Executors and Agency Company Limited, of 472 Bourke-street, Melbourne, Victoria, to send particulars to it, by the 4th November, 1969, after which date it may distribute the assets, having regard only to the claims of which it then has notice. 9914

**ALL** persons having claims against the estate of Alexander Stalker Lancaster, late of General Hospital, Parish of Saint Helier, Island of Jersey, Channel Islands, retired army officer, deceased (who died on the 2nd October, 1967, and probate of whose will was on the 17th October, 1967, granted by The Royal Court of Jersey, Probate Division, to Lloyds Bank, Executor and Trustee Company (Channel Islands) Limited and Denys Philip Richardson, one of the specially appointed attorneys of Alexander Thomas Lancaster, and of Joseph Raymond Lancaster, and application to the Supreme Court of Victoria (Probate Jurisdiction) by The Perpetual Executors and Trustees Association of Australia Limited, to seal such probate, having been granted on the 8th August, 1969), are hereby required to send particulars of such claims to The Perpetual Executors and Trustees Association of Australia Limited, at its registered office at 100-104 Queen-street, Melbourne, on or before 5th November, 1969, after which date the said Company will proceed to transfer, convey or distribute the said estate to or among the persons entitled thereto, having regard only to the claims of which it shall then have had notice, and will not be liable for the assets, so transferred, conveyed or distributed to any person of whose claim it shall not then have had notice. 9915

VICTOR JOHN BATSON, late of 42 Bayliss-street, Preston, retired, DECEASED.

**CREDITORS**, next of kin and others having claims in respect of the estate of the deceased (who died on the 26th day of June, 1969), are requested to send particulars of their claims to the executrix, Grace Broadfoot Amor Batson, care of the under-signed solicitor, by the 4th November, 1969, after which date the said executrix will proceed to distribute the estate, having regard only to the claims of which she then has notice.

MARJORY C. COATES, solicitor, 422 Collins-street, Melbourne. 9910

ELSIE MAY CAMERON, 45 Kendall-street, West Preston, widow, DECEASED.

**CREDITORS**, next of kin and others having claims in respect of the estate of deceased (who died on the 5th day of February, 1969), are required by the personal representative, Violet Olive Scouller, of 47 Kendall-street, West Preston, home duties, to send particulars to her by the 15th day of November, 1969, after which date the personal representative may convey or distribute the assets, having regard only to the claims of which she then has notice.

Dated this 1st day of September, 1969.

F. J. CORDER & CO., solicitors, 358 Lonsdale-street, Melbourne. 9931

**CREDITORS**, next of kin and others having claims in respect of the estate of Catherine Agnes Keane, late of 6 Coral-court, Cheltenham, widow, deceased (who died on the 18th day of May, 1969), are required to send particulars of their claims to the executrix, Mary Josephine Keane, care of the under-mentioned solicitors, by the 30th day of November, 1969, after which date the said executrix will distribute the assets of the deceased, having regard only to the claims of which she then has had notice.

HEFFEY & BUTLER, solicitors, 358 Lonsdale-street, Melbourne. 9932

DOUGLAS CECIL NEILL FORSYTH-GRANT, late of 18 The Avenue, Blackburn, company director, DECEASED.

**CREDITORS**, next of kin and others having claims in respect of the estate of the said deceased (who died on the 2nd day of February, 1966), are required by the executor, Andrew Kenneth Duncan, of 11 Bank-place, Melbourne, solicitor, to send particulars to them, care of the under-signed, on or before the 4th November, 1969, after which date they will distribute the assets, having regard only to the claims of which they then have notice.

WISEWOULD DUNCAN & HANGER, solicitors, 11 Bank-place, Melbourne. 9933

FRANCIS JOHN ROSE, late of Ida-grove, Olinda South, Victoria, retired, DECEASED.

**CREDITORS**, next of kin and others having claims in respect of the estate of the deceased (who died on 16th August, 1968), are required by the executor, The Trustees Executors and Agency Company Limited, of 401 Collins-street, Melbourne, to send particulars to the said Company by the 5th November, 1969, after which date it may convey or distribute the assets, having regard only to the claims of which it then has notice.

HEDDERWICK FOKES & ALSTON, 103 William-street, Melbourne. 9945

**CREDITORS**, next of kin and others having claims in respect of the estate of Elsie Jane Hughes, late of 28 Seaview-crescent, Seaholme (who died on the 5th April, 1969), are to send particulars of their claims to The Union-Fidelity Trustee Company of Australia Limited, of 100 Exhibition-street, Melbourne, by the 30th October, 1969, after which date it will distribute the assets, having regard only to the claims of which it then has notice. 9944

HARRIET VIOLET ROBERTS, formerly of 350 Toorak-road, South Yarra, but late of 2 Gascoyne-street, Canterbury, widow, DECEASED.

**CREDITORS**, next of kin and those having claims against the above-named deceased (who died on the 13th May, 1969), are to send particulars of their claims to the executors Leo Malcolm Roberts and John Keith Roberts, care of the under-mentioned solicitors, by the 4th November, 1969, after which date they will distribute the assets, having regard only to the claims of which they then have notice.

F. E. O'BRIEN & CO., solicitors, of 470 Bourke-street, Melbourne, 3000. 9930

Trustee Act 1958.

#### NOTICE TO CLAIMANTS.

**PURSUANT** to the Trustee Act 1958, creditors, next of kin and all other persons having claims in respect of the estate of any deceased person named below are required to send particulars to the legal personal representative or representatives, at the addresses stated, after which date the representative or representatives will distribute the assets, having regard only to the claims of which notice has been received:—

Charlotte Alma Baden Glen, late of 68 Agg-street, Newport, widow, deceased, died on the 16th day of May, 1969.—Claims to the executor, Albert Edward Glen, of 3 Begonia-avenue, North Altona, slaughterman, care of John F. Carroll, of 4 Paisley-street, Footscray, solicitor, by the 6th day of November, 1969. John F. Carroll, LL.B., solicitor, 4 Paisley-street, Footscray. 9926

Ettie Elsum, late of 30 Davies-street, Newport, widow, deceased, died on the 20th day of May, 1969.—Claims to the executrices, Thelma Loraine Elsum, clerical assistant, and Eunice Millicent Elsum, textile worker, both of 30 Davies-street, Newport, care of John F. Carroll, of 4 Paisley-street, Footscray, solicitor, by the 6th day of November, 1969. John F. Carroll, LL.B., solicitor, 4 Paisley-street, Footscray. 9927

James Septimus Darby, late of 9 Home-road, Newport, retired butcher, deceased, died on the 19th day of December, 1968.—Claims to the executor, Edward James Darby, of Victoria-parade, Fitzroy, medical practitioner, care of John F. Carroll, of 4 Paisley-street, Footscray, solicitor, by the 6th day of November, 1969. John F. Carroll, LL.B., solicitor, 4 Paisley-street, Footscray. 9925

In the Supreme Court of the State of Victoria.

#### SALE BY THE SHERIFF.

**ON** Friday, the 10th of October, 1969, at 10 a.m., at the Police Station, Fitzroy (unless process be stayed or satisfied):—

All the estate and interest (if any) of Panagiotis Mitsinikos and Ekaterini Mitsinikos, labourer and married woman, respectively, both of 454 Gore-street, Fitzroy, as joint proprietors of an estate in fee-simple in the land described in certificate of title, volume 7444, folio 655, upon which is erected a dwelling house known as No. 454 Gore-street, Fitzroy.

Caveat No. D.382285 affects the said estate and interest.

Terms: Cash only.

N. FROGLEY, Sheriff's Officer.

2nd September, 1969.

9936

#### IMPOUNDINGS

**DANDENONG**.—Impounded in Dandenong Pound by T. Longmuir for A. Smith, Hampton Park, from Hampton Park.

1 Friesian heifer, rubber and wire yoke on neck, no visible brand

If not claimed and expenses paid to be sold on 22nd September, 1969.

9885—\$2.25

D. D. NAPIER,

Poundkeeper.

**DIAMOND VALLEY**.—Impounded in Diamond Creek Pound on 22nd August, 1969.

1 Black Poll cow, no visible brand

If not claimed and expenses paid to be sold on 18th September, 1969.

9882—\$1.75

B. J. MORGAN,

Shire Secretary.

**DONALD**.—Impounded in Donald Pound, from the Jeffcott area.

1 ram lamb, no visible brand or ear marks

If not claimed and expenses paid to be sold on 29th September, 1969.

9950—\$1.75

W. A. CAMERON,

Poundkeeper.

**KERANG**.—Impounded in Kerang Pound on 29th August, 1969.

1 Friesian cow, notch back right ear, heifer calf at foot, no visible brand

If not claimed and expenses paid, to be sold on 18th September, 1969.

9883—\$2.00

F. HASTIE,

Poundkeeper.

**PENSHURST**.—Impounded at Penshurst by Shire Ranger.

1 white nanny goat

If not released and expenses paid to be sold at noon on 12th September, 1969.

9940—\$1.50

A. WALLER,

Poundkeeper.

**SWAN HILL**.—Impounded in Swan Hill Pound at 5 p.m. on Thursday, 28th August, 1969.

1 Yellow Poll Jersey cow, nick out of right ear, pink mark behind head, blue mark between hips

If not claimed and expenses paid, to be sold on 22nd September, 1969.

9892—\$2.00

F. G. BLAIR,

Poundkeeper.

## Subordinate Legislation Act 1962.

**NOTICE OF MAKING OF STATUTORY RULES.**

IN pursuance of the provisions of the *Subordinate Legislation Act 1962* and the Regulations made thereunder, notice is given of the making of the following statutory rules:—

<i>Local Government Act 1958.</i>	
177/1969. Unenrolled Voters (Elections of Municipal Councillors) Regulations 1969 ..	10c
<i>Water Act 1958.</i>	
178/1969. Water (Green's Lake Recreational Area) Regulations 1969 ..	15c
<i>Explosives Act 1960.</i>	
179/1969. Classification of Explosives Amendment No. 2, 1969 ..	10c
<i>Country Fire Authority Act 1958.</i>	
180/1969. Country Fire Authority (Loan No. 74) Regulations 1969 ..	10c
<i>Legal Profession Practice Act 1958.</i>	
181/1969. Rules Relating to the Qualification and Admission of Candidates ..	10c

Copies of these statutory rules may be purchased at the Sale of Publications Section of the Government Printing Office, located at Macarthur-street, Melbourne, 3002. If ordered by mail, remittance should be addressed to "The Government Printer, Box 203, P.O., North Melbourne, 3051", and should include 5c extra for postage. If a credit account is held at this office, no remittance is required with the mail order.

The annual subscription rate for Statutory Rules (including a Bound Volume) is \$15, payable in advance. The subscription year commences on 1st January.

A. C. BROOKS,  
Government Printer.

**CONTENTS**

	PAGE
Appointments .. .. .	3064
Contracts .. .. .	3059
Courts .. .. .	3064
Estates of Deceased Persons .. .. .	3064
Government Notices .. .. .	3053
Impoundings .. .. .	3097
Lands .. .. .	3076
Mining .. .. .	3064
Notice to Mariners .. .. .	3059
Notice of Making of Statutory Rules .. .. .	3098
Orders in Council—	
Acts—Land; Sewerage Districts; Education; Country Roads; Dandenong Valley Authority; Water; Geelong Waterworks and Sewerage; West Moorabool Water Board; River Improvement; Landlord and Tenant; The Constitution Act Amendment.	3067 et seq
Police Sales .. .. .	3064
Private Advertisements .. .. .	3085
Proclamations .. .. .	3051
Public Service Notices .. .. .	3084
Regulations—	
Acts—Teaching Service .. .. .	3084
Resignations .. .. .	3067
State Rivers and Water Supply Commission .. .. .	3062
Tenders .. .. .	3083
Transport Regulation Board—Public Hearings .. .. .	3054