



VICTORIA
GOVERNMENT GAZETTE

Published by Authority

[Registered at the General Post Office, Melbourne, for transmission by post as a newspaper.]

No. 3] WEDNESDAY, JANUARY 14 [1970

PROCLAMATIONS

Motor Boating Act 1961.

EXEMPTION OF CERTAIN MOTOR BOATS FROM THE PROVISIONS OF PART II. OF THE MOTOR BOATING ACT 1961.

PROCLAMATION

By His Excellency the Governor of the State of Victoria and its Dependencies in the Commonwealth of Australia, &c., &c., &c.

I, THE Governor of the State of Victoria, in the Commonwealth of Australia, by and with the advice of the Executive Council of the said State, and in pursuance of the powers conferred upon me by the provisions of section 6 of the *Motor Boating Act 1961* and all other powers thereunto enabling do hereby exempt from the provisions of Part II. of the *Motor Boating Act 1961* any motor boat used on the Victorian waters of the Hume Reservoir and Yarrowonga Weir which is controlled by a person ordinarily resident in the State of New South Wales who holds a locality permit for such motor boat issued in accordance with the provisions of the *Water Traffic Regulations—N.S.W.* made under the provisions of the *Maritime Services Act 1935*, as amended, of the State of New South Wales.

Given under my Hand and the Seal of the State of Victoria aforesaid, at Melbourne, this thirteenth day of January, in the year of our Lord One thousand nine hundred and seventy, and in the eighteenth year of the reign of Her Majesty Queen Elizabeth II.

(L.S.) ROHAN DELACOMBE.

By His Excellency's Command,

A. G. RYLAH,
Chief Secretary.

GOD SAVE THE QUEEN!

Milk Pasteurization Act 1958.

DECLARING AREAS TO BE PASTEURIZED MILK DISTRICTS.

PROCLAMATION

By His Excellency the Governor of the State of Victoria and its Dependencies in the Commonwealth of Australia, &c., &c., &c.

WHEREAS by section 4 of the *Milk Pasteurization Act 1958* it is amongst other things enacted that the Governor in Council may by proclamation declare any area specified in such proclamation to be a pasteurized milk district on and after a date specified in the proclamation: Now therefore I, the Governor of the State of Victoria by and with the advice of the Executive Council thereof, do by this my Proclamation hereby declare the areas specified in the Schedule hereto to be pasteurized milk districts on and after the first day of February, One thousand nine hundred and seventy.

SCHEDULE.

(1) All that portion of the municipal district of the Shire of Avon within the Parishes of Bundalaguah, Sale, Stratford, Nuntin, Yeerung, Meerlieu and Bengworden South.

(2) The Township of Seymour.

Given under my Hand and the Seal of the State of Victoria aforesaid, at Melbourne, this thirteenth day of January, in the year of our Lord One thousand nine hundred and seventy, and in the eighteenth year of the reign of Her Majesty Queen Elizabeth II.

(L.S.) ROHAN DELACOMBE.

By His Excellency's Command,

G. L. CHANDLER,
Minister of Agriculture.

GOD SAVE THE QUEEN!

GOVERNMENT NOTICES

Private Agents Act 1966.

NOTICE OF RECEIPT OF APPLICATIONS FOR LICENCES UNDER THE PROVISIONS OF THE PRIVATE AGENTS ACT 1966.

THE Clerk(s) of the Court(s) of Petty Sessions as listed hereunder hereby give notice that applications, as under, have been lodged for hearing by the said Court(s) on the date(s) specified.

Any person desiring to object to any of such applications must—

- (a) lodge with the respective Clerk of Petty Sessions a notice in the prescribed form of his objection and of the grounds thereof ;
- (b) cause a copy of such notice to be served personally or by post upon the applicant at least three days before the hearing of the application ; and
- (c) send or deliver—
 - (i) where the objection is not made by the officer in charge of the police district in which the Court is situated—a copy of the notice to such officer ; and
 - (ii) where the objection is not made by the Registrar or Deputy Registrar—a copy to the Registrar.

Full Name of Applicant or in the Case of a Firm or Corporation, of the Nominee.	Place of Abode of Applicant or Nominee.	Name of Firm or Corporation.	Address for Registration.	Type of Licence.	Date of Hearing of Application
---	---	------------------------------	---------------------------	------------------	--------------------------------

COURT OF PETTY SESSIONS, HASTINGS.

Garwood, Peter William	4 Pecolo-court, Frankston		340 Abbotsford-street, North Melbourne	Watchman	4.2.70
------------------------	---------------------------	--	--	----------	--------

Dated at Hastings this 6th day of January, 1970.

T. O'KEEFE, Clerk of Petty Sessions.

COURT OF PETTY SESSIONS, SOUTH MELBOURNE.

Braden, Leon	142 Noble-street, Noble Park		101-105 Clarke-street, South Melbourne	Watchman	3.2.70
Cook, Gordon Philip	35 Denman-street, Brunswick		" "	"	"
Hobeika, Shafik	Flat 14, 45 Robe-street, St. Kilda		" "	"	"
Wilson, Anthony Phillip	Flat 21, 74 Denbigh-road, Armadale		" "	"	"

Dated at South Melbourne this 8th day of January, 1970.

J. M. DUGAN, Clerk of Petty Sessions.

COURT OF PETTY SESSIONS, BRIGHTON.

Osmond, Kenneth Russell	24 Whyte-street, Brighton		24 Whyte-street, Brighton	Process Server	27.1.70
"	"		"	Inquiry Agent	"

Dated at Brighton this 7th day of January, 1970.

E. W. GOWAN, Clerk of Petty Sessions.

PUBLIC HOLIDAY.—AUSTRALIA DAY.

IT is hereby notified that on—

MONDAY, THE 26TH JANUARY, 1970.

the Public Offices will be closed, such day having been appointed by the *Public Service Act 1958*, to be observed as a holiday in the Public Offices throughout the State of Victoria.

This notice relates only to the closing of the State Public Offices. All inquiries regarding the holiday in other offices and in shops and industry should be directed to the Department of Labour and Industry, 110 Exhibition-street, Melbourne, 3000. (Telephone 63 0321, Extension 6158, 6721 or 6859.)

A. G. RYLAH,
Chief Secretary.

Chief Secretary's Office,
Melbourne, 5th January, 1970.

POLICE OFFENCES ACT 1958.

IN pursuance of the powers conferred upon the Chief Secretary by sub-section (3) of section 184 of the *Police Offences Act 1958*, I do by this notice grant exemption from compliance with sub-sections (1) and (2) of section 184 of the said Act with respect to the publication "The Melting Man" distributed by Colorgravure Publications, 61 Flinders-lane, Melbourne.

JAMES W. MANSON,
Acting Chief Secretary.

Chief Secretary's Office,
Melbourne, 9th January, 1970.

Police Regulation Act 1958, Section 122.

SALE OF UNCLAIMED MOTOR VEHICLE.

AN owner is required for a green FJ Holden sedan, ex-registered No. GJP-184, engine No. 9934.

The vehicle came into the possession of Police on the 25th August, 1969, and if not claimed, will be sold by public auction, at the Sunshine Police Station, Sun-crescent, Sunshine, at 2 p.m., on 9th February, 1970.

N. WILBY,
Chief Commissioner of Police.

PUBLIC NOTICE.

ALL persons who as producers of farm produce, have any claims against the business carried on under the name of McKeddie Orchards at Main Ridge, Victoria, arising from any failure on its part to pay or account for any moneys payable to them by the said McKeddie Orchards for farm produce, are invited to forward particulars and proof of such claims to The Director of Agriculture, Treasury-place, Melbourne, on or before 4th February, 1970. (Postal address:—Department of Agriculture, Box 4041, G.P.O., Melbourne, Vic. 3001.)

PUBLIC NOTICE.

ALL persons who as producers of farm produce, have any claims against Keith Clifton How, of 12 Folkestone-road, Glen Waverley, arising from any failure on his part to pay or account for any moneys payable to them by the said Keith Clifton How, for farm produce, are invited to forward particulars and proof of such claims to the Director of Agriculture, Treasury-place, Melbourne, on or before 4th February, 1970. (Postal address:—Department of Agriculture, Box 4041, G.P.O., Melbourne, Vic. 3001.)

Transport Regulation Act.
TRANSPORT REGULATION BOARD.

HEARING OF APPLICATIONS.

NOTICE is hereby given that the following applications will be considered by the Transport Regulation Board at its offices at the corner of Lygon and Princes streets, Carlton, at 10.15 a.m., on Wednesday, 4th February, 1970.

BENDERS BUSWAYS PTY. LTD., Edol-street, North Geelong. Application for variation of C.O. licence conditions to include the ability to operate between Geelong and the V.F.L. Park, at Waverley when Geelong is playing at the Park.

KASTORIA BUS LINES PTY. LTD., 3 Louis-street, Airport West. Application for variation of C.O. licence conditions Route 210A (Moonee Ponds—Broadmeadows) to deviate service from the corner of South Circular-road and Gladstone Park-drive, via South Circular-drive, Carrick drive, Sherbourne-road, Burnleigh-drive, and South Circular-drive to Gladstone Park-drive and normal route.

MEE, R. E. & B. E. (trading as Mee's Bus Line), 1 Percy-street, Heidelberg West. Application for permit authority to vary the conditions of licence T.P.146, which authorizes the carriage of students between Research/Diamond Creek and Warrandyte State School, to include the ability to operate the vehicle on various short charter trips to baths, cricket and other sporting activities from the school.

MCGILL, J. L. & T., Egmont-street, Benalla. Two commercial passenger vehicles with large S/C. to operate town and shopper services in the Township of Benalla, along the following routes:—

(a) *Town Service*: Benalla Technical School, via Goodwin, Crook, Shadforth, Arundel and Bridge streets, to terminus at corner of Bridge and Nunn streets.

Mondays—Fridays.

Depart Technical School—8.45 a.m.

Depart Terminus—5.30 p.m.

(b) *Town Service*: Corner of Arundel and Bridge streets, via Arundel, Cecil, Benson, Garden, Waller, Dunn, Crofton, Clarke, Wedge, Arundel and Bridge streets to terminus at corner of Bridge and Nunn streets.

Mondays—Fridays.

Depart Arundel-street—8.40 a.m.

Depart Terminus—5.30 p.m.

(c) *Shoppers Service*: Commencing at corner of Arundel and Bridge streets; thence via route (b) to Technical School; thence via route (a) to terminus at corner of Bridge and Nunn streets.

Depart—1.15 p.m. Mondays, Thursdays and Fridays.

Return—3.30 p.m.

(d) *Shoppers Service*: As per route (a).

Depart—9.30 a.m.

Return—11.50 a.m., Mondays, Thursdays and Fridays.

REA, A. E., 45 Anderson-street, Euroa. One commercial passenger vehicle with S/C. for 5 persons to operate as a country hire car from Euroa.

REICHEL, R. C. & M. R., 69 Nelson-street, Nhill. One commercial passenger vehicle with S/C. for 10 persons to operate day tours from Nhill to the Little Desert.

RENNIE, F. H., & SON PTY. LTD., 285 Station-road, Box Hill. Application for permit authority to operate a required number of the applicant company's licensed vehicles at separate and distinct fares for the carriage of passengers from Box Hill Railway Station to the V.F.L. Park, Waverley, on occasions when league football matches are being played via Station-street, Riversdale, Elgar and Burwood roads, Station-street, Highbury and Huntingdale roads to Waverley-road; thence via a route to be determined to the Park.

Fares and time-table to be determined.

SANDRINGHAM BUS CO. PTY. LTD., corner Abbott and Beaumont streets, Sandringham. Application for variation of M.O. licence conditions on Route 43A (Sandringham—Cheltenham—Southland) to extend service from the Southland Shopping Centre to the Victorian Football League Park, Waverley, only when matches are being played at the Park. Time-table, fares and route to be determined.

VENTURA MOTORS PTY. LTD., 1037 Centre-road, South Oakleigh. A required number of commercial passenger vehicles to operate as follows:—(a) under the same terms and conditions as C.O. licensed vehicles in the name of the applicant company. (b) As country special service omnibuses with a 3-mile pick-up radius of Bayswater.

APPLICATION for renewal of licences as shown, by persons listed hereunder to operate under the same terms and conditions:—

GERRARD WIRE TYING MACHINES CO. PTY. LTD., corner Geelong and Little Boundary roads, Brooklyn; T.P.206.

RUSSELL, W. A., Post Office, Harrow; T.P.5.

ALLEN, W. W., Creswell-street, Crib Point; T.S.756.

BEATTIE, D. R., Goroke, Victoria; T.S.769.

GEELONG MENTALLY HANDICAPPED CHILDREN'S WELFARE ASSOCIATION, Humble-street, East Geelong; T.P.189.

HAYSE, G. L. & W. E., 89 Cleeland-street, Dandenong; C.T.688.

KENDALL, C. G. & I. I., 40 Queen Elizabeth-drive, Tallangatta; T.S.766; T.S.896.

KRAFT FOODS LTD., Salmon-street, Port Melbourne; T.P.142.

MACKELLAR, K. M., 41 Bellevue-road, Golden Square; C.O.537.

O'CONNELL, P. D., Queen Elizabeth-drive, Tallangatta; T.S.581; T.S.835.

U.S. MOTORS (TAXIS) PTY. LTD., 68 Monbulk-road, Belgrave; C.T.680.

Notice of any objection should be forwarded to reach the Secretary of the Board not later than Wednesday, 28th January, 1970.

Applicants are advised that it will not be necessary to appear on the hearing date specified above, unless advised in writing by the Board.

B. P. KAY,

Secretary.

Corner Lygon and Princes streets, Carlton, 3053, Wednesday, 14th January, 1970.

Commercial Goods Vehicles Act.
TRANSPORT REGULATION BOARD.

HEARING OF APPLICATIONS.

NOTICE is hereby given that the following applications will be considered by the Transport Regulation Board at its offices at the corner Lygon and Princes streets, Carlton, at 10.15 a.m. on Wednesday, 4th February, 1970.

POLITES, A. (trading as Aleck Seafoods), 2 South Wharf, South Melbourne, 3205. One commercial goods vehicle (L/C. 75 cwt.) to operate: (a) Within a 50-mile radius of own premises at South Melbourne in the course of business as "Frozen Food and Fish Distributors"—own goods. (b) Throughout the State of Victoria in a specially constructed refrigerated vehicle—fresh and frozen fish, frozen poultry, frozen meat, frozen vegetables and a small quantity not exceeding a total of two dozen bottles at any one time of mussels and onions.

ARMOURD ESCORTS PTY. LTD., Cnr. Arden and Lothian streets, North Melbourne, 3051. One commercial goods vehicle (L/C. 11 cwt.) to operate throughout the State of Victoria as an Armoured Vehicle for the purposes of making special deliveries in the course of business as "Armoured Escorts".

ARNOTT-BROCKHOFF-GUEST PTY. LTD., 53 Huntingdale-road, Burwood, 3125. Application to vary conditions of licence No. D.A.60213/5 (L/C. 64 cwt.) by adding to the existing conditions after "own branch premises at Morwell" the words "and to and from the Township of Wonthaggi."

ASCOT PTY. LTD., 63 Queens Bridge-street, South Melbourne, 3205. Application to vary conditions of licence No. D.A.34589/14 (L/C. 14 cwt.) by deleting the existing conditions and adding in lieu—"Throughout the State of Victoria for the purpose of supervising own contracts in the course of business as 'Civil Engineers'—tools of trade, spare parts and materials incidental to the completion of own contracts."

BAGGETT, G., 111 Service-road, Moe, 3825. One commercial goods vehicle (L/C. 20 cwt.) to operate between the premises of Latrobe Cake Supply at Moe (an approved decentralized secondary industry) and consignees situated within a 30-mile radius of the post office at Moe on behalf of the said company—cakes, pastries and empty return containers.

BEAUREPAIRE TYRE SERVICE PTY. LTD., 102 Victoria-street, Carlton, 3053. One commercial goods vehicle (L/C. 20 cwt.) to operate within a 50-mile radius of own branch store in the Township of Corryong in the course of business as "Tyre Retreaders and Distributors"—tyres and tubes for sale and delivery, used tyres for retreading or repair or having been retreaded or repaired, batteries, oil and motor car accessories.

AINGER, R. C. (trading as Boundary Metals), Coleraine-road, North Hamilton, 3300. One commercial goods vehicle (L/C. 142 cwt.) to operate within a 100-mile radius of the post office at Hamilton to and from the Cities of Ballarat, Geelong and Melbourne in the course of business as "Marine Collector"—special wares,

- marine stores and old metals as designated in the *Marine Stores and Old Metals Act 1958* (No. 6303), Part I, section 3, but excluding the carriage of any such marine stores or old metals to wharves, docks or ships for shipment or export purposes with the proviso that no trailer shall be hauled in conjunction with this vehicle.
- CAREW, J. I., Weering, 3251. One commercial goods vehicle (L/C. 116 cwt.) to operate: (a) Within a 25-mile radius of the post office at Weering—general goods, provided that no goods shall be carried whether by one stage or by more than one stage between places within the above radius which are more than thirty (30) road miles apart by the nearest practicable route. (b) From and to places within a 25-mile radius of the post office at Weering to and from places outside that radius but wholly within a 50-mile radius of the said post office—livestock.
- CONDEMI, B., 10 Dalgety-street, Preston, 3072. One commercial goods vehicle (L/C. 200 cwt.) to operate within a 50-mile radius of the G.P.O. in the City of Melbourne on behalf of Albion Reid Pty. Ltd.—road-making plant, hot asphalt, premix and road-making materials but excluding the carriage of cement and lime from the Geelong Urban District (as defined in the *Transport Regulation Act 1958*).
- CONTRACT FENCING & FLOORING CO. PTY. LTD., Industrial-avenue, Thomastown, 3074. Two commercial goods vehicles (L/C. 16 and 17 cwt.) to operate: (a) Throughout the State of Victoria in the course of business as "Building and Fencing Contractors" for the purpose of supervising own contracts—tools of trade, builders plant, sheds and surplus building materials from contract site to contract site and for return to own premises at Melbourne, also with the ability to carry from Melbourne a maximum of 5 cwt. of replacement building materials and supplies on any one trip. (b) Within a 25-mile radius of the site of any building or fencing contract currently engaged upon or to such site from the nearest railway station thereto—materials required for use in such contract. Note.—Subject to cancellation of licence No. T.D.A.63054 previously held in the name of Viva Building Co. Pty. Ltd.
- DE MERLO, V. J. A., C/o. Post Office, Tarwin Lower, 3955. Application to vary conditions of licence No. D.A.62609 (L/C. 120 cwt.) by adding to paragraph (b) of the existing conditions "and materials".
- DERIU, G., Post Box 17, Heyfield, 3858. One commercial goods vehicle (L/C. 258 cwt.) to operate from forest landings in the Connor's Plains, Mt. McDonald and Tamboritha areas to sawmills at Heyfield—mill logs.
- GRIFFIN, P. E., "Tralee", Bastow-road, Lilydale, 3140. One commercial goods vehicle (L/C. 162 cwt.) to operate within 35-mile radius of the G.P.O., Melbourne on behalf of Consolidated Quarries Ltd.—sand, soil, screenings, premix and quarry products.
- HALL, W. N., Mallacoota, 3889. One commercial goods vehicle (L/C. 140 cwt.) to operate: (a) Within a 95-mile radius of the post office at Orbest (Bairnsdale Division of the Country Roads Board)—road contracting plant used in the construction or maintenance of a road, street, footpath, bridge, wharf, pier, weir or channel. (b) Within a 20-mile radius from site of construction or maintenance work performed pursuant to paragraph (a) above or from a railway station nearest thereto—materials required for such work. (c) Within a 25-mile radius of the post office at Mallacoota—general goods provided that no goods shall be carried whether by one stage or by more than one stage between places within the above radius which are more than thirty (30) road miles apart by the nearest practicable route.
- HAMILTON, J. A., 17 Albert-road, Lilydale, 3140. One commercial goods vehicle (L/C. 200 cwt.) to operate: (a) Within a 30-mile radius of the railway station at Lilydale in the course of business as "Super Spreaders"—own bulk superphosphate for spreading purposes provided that all superphosphate carried on the vehicle shall have been initially forwarded by rail to either Lilydale, Coldstream, Yarra Glen or Healesville. (b) Within a 40-mile radius of the railway station at Lilydale in the course of business as "Bulk Lime Distributor"—own bulk lime for spreading purposes only provided all lime carried on the vehicle shall have been initially forwarded by rail to either Lilydale, Coldstream, Yarra Glen or Healesville. (c) From the railway station at Alexandra to places within a 10-mile radius of such railway station—bulk lime which has been initially consigned by rail to the said railway station. (d) Within a 25-mile radius of the railway station at Lilydale—lime produced by David Mitchell Estate at Lilydale.
- HAYDEN, R. W., Mystic Park, 3582. One commercial goods vehicle (L/C. 243 cwt.) to operate: (a) Within a 50-mile radius of the post office at Kerang as a "Road Contractor"—road-making plant and materials. (b) Within a 25-mile radius of the post office at Kerang—general goods provided that no goods shall be carried whether by one stage or by more than one stage between places within the above radius which are more than thirty (30) road miles apart by the nearest practicable route.
- HEALTHWAY DAIRY PRODUCTS PTY. LTD., Holmes-street, North Geelong, 3215. Three commercial goods vehicles (L/C. 25, 24 and 19 cwt.) to operate: (a) Within a 50-mile radius of own premises at North Carlton in course of business as "Dairy Produce Manufacturers and Distributors"—own goods. (b) From own premises at North Carlton to Ballarat and places en route and to Sale and places en route via Princes Highway or South Gippsland Highway in refrigerated or insulated vehicle—cream, yoghurt and up to 2 cwt. of soft cheese at a temperature of 40 deg. F.
- HILL, L. J., 112 San Mateo-avenue, Mildura, 3500. One commercial goods vehicle (L/C. 7 cwt.) to operate within a 50-mile radius of the post office at Mildura—in the course of business as "General Wholesale Merchant", goods on behalf of Robur Tea Co. Pty. Ltd., Bushells Pty. Ltd., and Sunshine Biscuits Ltd.
- INTERNATIONAL HARVESTER CO. OF AUSTRALIA PTY. LTD., North Shore, Geelong, 3214. One commercial goods vehicle (L/C. 24 cwt.) to operate: (a) Throughout the State of Victoria in the course of business as "Truck, Tractor and Farm Implement Manufacturer"—farm implements and accessories for experimental and/or for demonstration purposes, also tools of trade incidental to the servicing and maintenance of own machinery and equipment, also spare parts for use solely at site of machinery being tested. (b) Within a 25-mile radius of the chief post office in the City of Geelong in the course of business as "Motor Vehicle and Farm Machinery Manufacturers"—own goods.
- JENKINS, K. C., 21 Male-street, Middle Brighton, 3186. One commercial goods vehicle (L/C. 296 cwt.) to operate within a 50-mile radius of the G.P.O. in the City of Melbourne on behalf of Consolidated Quarries Ltd.—premixed concrete in a specially constructed agitator vehicle.
- KERTON, W. K., Walpa, 3866. Two commercial goods vehicles (L/C. 12 and 13 cwt.) to operate within that part of the State of Victoria situated east of a line drawn due north and south through the Township of Warragul and south of a line drawn due east and west through the Township of Omeo in the course of business as "Concrete Tank Manufacturers"—tools of trade, equipment and materials incidental to the completion of own contracts provided that all materials carried on the vehicle shall have been initially consigned by rail to Lindenow or Bairnsdale or shall have been purchased within a 20-mile radius of the particular contract site.
- KLEEHAMMER CONTRACTING PTY. LTD., Seehusan-avenue, Bruthen, 3885. Three commercial goods vehicles (L/C. 122, 194 and 131 cwt.) to operate for the carriage of pre-mixed concrete in a specially constructed agitator vehicle, solely on behalf of Pioneer Concrete Pty. Ltd. from the plants of the above-mentioned company situated at Morwell, Sale, Bairnsdale and Orbest to consignees within a 50-mile radius of the said plants.
- KRUZINGA, W., 139 Liddiard-road, Traralgon, 3844. One commercial goods vehicle (L/C. 237 cwt.) to operate from forest and private landings situated within a 25-mile radius of the premises of Australian Paper Manufacturers Ltd. at Maryvale to the said premises at Maryvale—pulpwood.
- KUHNE, J. H., 19-21 Mill-street, Horsham, 3400. Two commercial goods vehicles (L/C. 10 and 13 cwt.) to operate: (a) Within a 25-mile radius of own depot at Horsham—general goods provided that no goods shall be carried whether by one stage or by more than one stage between places within the above radius which are more than thirty (30) road miles apart by the nearest practicable route. (b) Within a 50-mile radius of own depot at Horsham as an agent for Mobil Oil Aust. Pty. Ltd.—petroleum products in prescribed types of containers and empty return containers and farm storage tanks.
- KUHNE, J. H., 19-21 Mill-street, Horsham, 3400. One commercial goods vehicle (L/C. 137 cwt.) to operate: (a) Within a 25-mile radius of own depot at Horsham—general goods provided that no goods shall be carried whether by one stage or by more than one stage between places within the above radius which are more than thirty (30) road miles apart by the nearest practicable route. (b) Within a 50-mile radius of own

- depot at Horsham and to Minimay, Edenhope, Apsley and Langkoop as agents for Mobil Oil Aust. Pty. Ltd.—petroleum products in prescribed types of containers and empty return containers and farm storage tanks.
- KUHNE, J. H., 19-21 Mill-street, Horsham, 3400. One commercial goods vehicle (L/C. 136 cwt.) to operate within a 50-mile radius of own depot at Horsham and to Minimay, Edenhope, Apsley and Langkoop as agents for Mobil Oil Aust. Pty. Ltd.—petroleum products in prescribed types of containers and empty return containers and farm storage tanks.
- LLOYD-TAYLOR, E. M., 10 Wilson-street, Rosebud, 3939. One commercial goods vehicle (L/C. 160 cwt.) to operate within a 30-mile radius of the plant of Hillview Quarries Pty. Ltd. at Dromana solely on behalf of the said company—screenings, stone dust and quarry products.
- MAMOS, B., 4 Nichol-street, Hampton, 3188. One commercial goods vehicle (L/C. 140 cwt.) to operate within a 50-mile radius of the G.P.O. in the City of Melbourne on behalf of Albion Reid Pty. Ltd.—road-making plant, hot asphalt, premix and road-making materials but excluding the carriage of cement and lime from the Geelong Urban District (as defined in the *Transport Regulation Act 1958*).
- MARRICKVILLE HOLDINGS SALES PTY. LTD., 254 Ballarat-road, Braybrook, 3019. One commercial goods vehicle (L/C. 18 cwt.) to operate within a 50-mile radius of own branch premises at Bendigo and to and from St. Arnaud in course of business as "Food Manufacturers"—groceries, potato chips, confectionery and margarine.
- MARRICKVILLE HOLDINGS SALES PTY. LTD., 254 Ballarat-road, Braybrook, 3019. One commercial goods vehicle (L/C. 18 cwt.) to operate within a 50-mile radius of own branch premises at Geelong and to Apollo Bay and to Derrinallum in course of business as "Food Manufacturers"—groceries, confectionery, margarine and potato chips.
- MILLARD, C. M., Byaduk North, 3285. One commercial goods vehicle (L/C. 11 cwt.) to operate: (a) Within a 25-mile radius of the post office at Byaduk—general goods provided that no goods shall be carried whether by one stage or by more than one stage between places within the above radius which are more than thirty (30) road miles apart by the nearest practicable route. (b) From and to places situated within a 25-mile radius of the post office at Byaduk to and from places outside that radius which are wholly within a 50-mile radius of the said post office—livestock.
- MILLEGE BROS. PTY. LTD., corner City-road and Cecil-street, South Melbourne, 3205. One commercial goods vehicle (L/C. 10 cwt.) to operate: (a) Within a 50-mile radius of own premises at South Melbourne in course of business as "Motor Cycle and Motor Boat Distributors"—own goods. (b) Throughout the State of Victoria for the purpose of carrying motor cycles taking part in race-meetings.
- MOHAN, O. A., 55 Welsford-street, Shepparton, 3630. One commercial goods vehicle (L/C. 7 cwt.) to operate: (a) As a hearse throughout the State of Victoria in the course of business as Funeral Director. (b) Within a 25-mile radius of the post office at Shepparton—goods required in the course of business as a "Funeral Director".
- McMULLEN'S TRANSPORT PTY. LTD., Tyndall-street, Orbst, 3888. One commercial goods vehicle (L/C. 151 cwt.) to operate: (a) From points within a 10-mile radius of the post office at Dandenong to building sites and timber yards on the Mornington Peninsula on behalf of Club Terrace Sawmills Pty. Ltd. and Henry's Timber Co. Pty. Ltd.—sawn timber. (b) From the railway stations at either Dandenong or Clayton to building sites or timber yards within a 25-mile radius of the post office at Dandenong—sawn timber.
- NATIONAL CASH REGISTER CO. PTY. LTD., THE, 124 Russell-street, Melbourne, 3000. Application to vary conditions of licences numbered D.A.1707/15, D.A.1707/18, D.A.1707/19 and D.A.1707/21 (L/C. 18, 18, 11 and 11 cwt.) by adding to paragraph (a) of the existing conditions "accounting machines or adding machines".
- NEON ELECTRIC SIGNS LTD., corner Cecil and Whiteman streets, South Melbourne, 3206. One commercial goods vehicle (L/C. 48 cwt.) to operate throughout the State of Victoria in the course of business as "Fluorescent Electric Sign Manufacturers"—fluorescent signs for installation and repair, tools of trade, spare parts and materials incidental to the installation and servicing of such signs.
- O'CONNOR, A. H., Vaggs-road, Yinnar, 3869. One commercial goods vehicle (L/C. 491 cwt.) to operate: (a) From forest landings in the Silver Creek and Mirboo North areas to the premises of Australian Paper Manufacturers Ltd. at Maryvale—pulpwood logs. (b) From forest landings in the Jerralang, Longford and Trafalgar areas to sawmills at Drouin and Longwarry—logs.
- PEEK FREAN (AUST.) PTY. LTD., 282 Bay-road, Cheltenham, 3192. One commercial goods vehicle (L/C. 11 cwt.) to operate: (a) Within a 50-mile radius of own premises at Cheltenham in course of business as "Biscuit Manufacturers"—own goods. (b) Throughout the State of Victoria as a "Traveller's Vehicle" for the purpose of booking orders and sales promotion—samples, display and advertising materials with the ability to leave a sample and to return to Melbourne with damaged or unsaleable stock.
- PYE, R. J., 3 Farmer-crescent, Traralgon, 3844. Application to vary conditions of licence No. D.T.759 (L/C. 152 cwt.) by deleting the existing conditions and adding in lieu:—"From forest and private landings situated within a 25-mile radius of the premises of Australian Paper Manufacturers Ltd. at Maryvale to the said premises at Maryvale—pulpwood".
- RADFORD, N. F., 5 Bristol-street, Moe, 3825. One commercial goods vehicle (L/C. 281 cwt.) to operate: (a) From forest and private landings situated within a 25-mile radius of the premises of Australian Paper Manufacturers Ltd. at Maryvale to the said premises at Maryvale—pulpwood. (b) From forest and private landings situated within the area defined in paragraph (a) above to Dyer Bros. Sawmill at Boolarra—mill logs.
- REID, J. D., Lyndhurst-road, Lyndhurst, 3975. Application to vary conditions of licence No. D.A.62173 (L/C. 118 cwt.) by deleting "Mornington" where appearing in the existing conditions and adding in lieu "Lyndhurst".
- REYNOLDS, R. E., 96 Wilsons-road, Newcomb, 3219. One commercial goods vehicle (L/C. 192 cwt.) to operate: (a) Within a 50-mile radius of the chief post office in the City of Geelong solely on behalf of Sunkist Foods Pty. Ltd.—unprocessed market garden and orchard produce. (b) From and to the premises of Sunkist Foods Pty. Ltd. at Geelong and/or the depot of such company at Melbourne to and from points throughout the State of Victoria in a specially constructed refrigerated vehicle—frozen meat, frozen poultry, frozen fish, frozen vegetables, frozen pastries, frozen berries, frozen fruit juices, frozen pies, frozen chicken rolls, frozen prepared meals, frozen egg whites and ice-cream but excluding the carriage of any canned goods whatsoever.
- ROGERS, L. O., 11 Betleigh-street, Anglesea, 3230. One commercial goods vehicle (L/C. 10 cwt.) to operate: (a) Within a 50-mile radius of the post office at Anglesea in the course of business as "Installation Contractor" for the purpose of installing flywire screens and flywire doors—tools of trade, flywire screens, flywire doors and materials incidental to own installation contracts only. (b) Within that part of the State of Victoria west of a north/south line drawn through the City of Melbourne as a traveller's unit for display and sales promotion purposes in the course of business as "Gift and Haberdashery Agent" with the ability to carry samples for display purposes only.
- SINGH, P. L., 49 Hume-street, Yarrowonga, 3730. One commercial goods vehicle (L/C. 228 cwt.) to operate: (a) Within a 90-mile radius of the post office at Wangaratta (Benalla Division of the Country Roads Board) as a "Road Contractor"—road-making plant and materials. (b) Within a 20-mile radius from site of construction or maintenance work performed pursuant to paragraph (a) above, or from the railway station nearest thereto—metal, stones, screenings, ashes, gravel, sand, earth and any other materials required for such work.
- SUNSHINE BISCUITS LTD., 9 Dundas-lane, Albert Park, 3206. Application to vary conditions of licence No. D.A.30986/11 (L/C. 10 cwt.) by deleting "Melbourne" from paragraph (a) of the existing conditions and adding in lieu "Ballarat".
- WILSON, C. J. (trading as Superior Transport), 7 Standfield-street, Bacchus Marsh, 3340. Two commercial goods vehicles (L/C. 220 and 233 cwt.) to operate from pits at Bacchus Marsh to the premises of Supermix Concrete Pty. Ltd. at Northcote on behalf of the said company—sand.
- SUPER SPREAD AVIATION (AUST.) PTY. LTD., Hanger 7, Moorabbin Airport, Cheltenham, 3192. One commercial goods vehicle (Mobile Crane) to operate throughout the State of Victoria for the purpose of operating the vehicle as a "Mobile Crane" incidental to loading superphosphate into aircraft for dusting purposes with the ability also to carry excess aviation fuel from property to property upon completion of a contract in the course of business as "Aerial Crop Dusters".

THOMAS, E. A., 13 Bennett-street, Bendigo, 3550. One commercial goods vehicle (L/C. 17 cwt.) to operate throughout the State of Victoria in the course of business as "Marine Dealer"—special wares, marine stores and old metals as designated in the *Marine Stores and Old Metals Act 1958* (No. 6303), Part 1, section (3), but excluding the carriage of any such goods to wharves, docks or ships for shipment or export purposes.

NOTE.—The combined load capacity of both the prime mover and any trailer attached thereto shall not exceed one hundred and twenty hundredweight (120 cwt.).

WEATHER MASTER PTY. LTD., 2 Attenborough-street, Dandenong, 3175. One commercial goods vehicle (L/C. 10 cwt.) to operate within that part of the State of Victoria west of a north/south line drawn through Cobram and north of an east/west line drawn through Daylesford in the course of business as "Insulation Manufacturer and Installer" on behalf of Insulfluf (Central Victoria) Pty. Ltd.—own tools of trade, spare parts, equipment and materials incidental to the installation of insulation material and bagged insulation material for installation, providing all such materials shall have been initially consigned by rail to either Echuca, Kyabram, Shepparton, Bendigo, Stawell, Horsham, Swan Hill or Kerang.

WHITEHEAD, W. J., 15 King-street, Warrnambool, 3280. One commercial goods vehicle (L/C. 243 cwt.) to operate: (a) Within a 25-mile radius of the main post office at Warrnambool—general goods provided that no goods shall be carried whether by one stage or by more than one stage between places within the above radius which are more than thirty (30) miles apart by the nearest practicable route. (b) From and to places situated within the radius as defined in paragraph (a) above to and from places outside that radius which are wholly within a 50-mile radius of the post office at Warrnambool—livestock.

RENEWALS.

APPLICATIONS for renewal of licences as shown by persons listed hereunder to operate under the same terms and conditions from the expiry shown in each case.

ALBION REID PTY. LTD., 83 Riversdale-road, Hawthorn, 3122; D.A.520/173; 15th March, 1970; 143 cwt.

ARMoured ESCORTS PTY. LTD., corner Arden and Lothian streets, North Melbourne, 3051; D.A. 37566/11; 28th February, 1970; 11 cwt.; D.A.37566/12; 28th February, 1970; 11 cwt.

BANTICK BROS. PTY. LTD., Murchison-street, Marysville, 3779; D.T.116/1; 28th February, 1970; 254 cwt.

BANTICK BROS. PTY. LTD., Murchison-street, Marysville, 3779; D.T.116/3; 28th February, 1970; 256 cwt. (timber jinker); 220 cwt. (low-loader).

BEAUREPAIRE TYRE SERVICE PTY. LTD., 102 Victoria-street, Carlton, 3053; D.A.629/69; 19th March, 1970; 11 cwt.

BEAUREPAIRE TYRE SERVICE PTY. LTD., 102 Victoria-street, Carlton, 3053; D.A.629/71; 19th March, 1970; 13 cwt.

BEAUREPAIRE TYRE SERVICE PTY. LTD., 102 Victoria-street, Carlton, 3053; D.A.629/72; 19th March, 1970; 14 cwt.

DAVID BROWN TRACTORS PTY. LTD., 209 Princes Highway, Dandenong, 3175; D.A.58266; 7th March, 1970; 14 cwt.; D.A.58266/1; 7th March, 1970; 14 cwt.

CARLTON & UNITED BREWERIES LTD., 16 Bouverie-street, Carlton, 3053; D.A.808/1; 20th March, 1970; 11 cwt.; D.A.808/2; 22nd March, 1970; 11 cwt.

CLAUDE NEON LTD., 291 Mt. Alexander-road, Ascot Vale, 3032; D.A.1714/2; 24th March, 1970; 59 cwt.

COHEN, M., 47 Drummond-street, Chadstone, 3148; D.A.58336; 7th March, 1970; 193 cwt.

CROCKFORD & ROBERTSON PTY. LTD., 15 Abbott-street, Fairfield, 3078; D.A.4914/8; 5th March, 1970; 16 cwt.

DEIPENAU, H. E., PTY. LTD., 73 Victoria-street, East Brunswick, 3057; D.A.17846/23; 7th March, 1970; 194 cwt.

DICKINS, S. E., PTY. LTD., 16 Nicholson-street, East Brunswick, 3057; D.A.28229/10; 7th March, 1970; 11 cwt.

DOMANSKI, M. A., 25 Thornton-street, South Oakleigh, 3167; D.A.58206; 7th March, 1970; 140 cwt.

E.I.L. SERVICE PTY. LTD., 161-173 Sturt-street, South Melbourne, 3205; D.A.30374/7; 24th March, 1970; 14 cwt.

EMOLEUM (AUSTRALIA) LTD., Arden-street, North Melbourne, 3051; D.A.1042/4; 24th March, 1970; 136 cwt.

EMOLEUM (AUSTRALIA) LTD., Arden-street, North Melbourne, 3051; D.A.1042/8; 19th March, 1970; 227 cwt.

EVERON INDUSTRIAL DRY CLEANERS PTY. LTD., 12 Burnley-street, Richmond, 3121; D.A.31362; 24th March, 1970; 15 cwt.

FALLON, G. V., 27 Mahoneys-road, Reservoir, 3073; D.A.58309; 7th March, 1970; 223 cwt.

FEIGLIN, M., & SONS PTY. LTD., Station-street, Nunawading, 3131; D.T.193/5; 7th March, 1970; 129 cwt.

FEIGLIN, M., & SONS PTY. LTD., Station-street, Nunawading, 3131; D.A.1066/11; 19th March, 1970; 62 cwt.

FIAT OF AUSTRALIA PTY. LTD. (trading as Fiat Tractors (Victoria)), P.O. Box 132, Moorabbin, 3189; D.A.46942/5; 19th March, 1970; 30 cwt.

G.M.D. REFRIGERATION PTY. LTD., 14-16 Kolora-road, West Heidelberg, 3081; D.A.55573/1; 28th February, 1970; 10 cwt.

GENDORE PTY. LTD., Tooradin, 3980; D.A.37242/15; 28th March, 1970; 14 cwt.; D.A.37242/16; 28th March, 1970; 14 cwt.

GENERAL MOTORS—HOLDEN'S PTY. LTD., Princes Highway, Dandenong, 3175; D.A.27925/45; 19th March, 1970; 14 cwt.; D.A.27925/46; 19th March, 1970; 14 cwt.

HALLIWELL, C. L., 133 Mitchell-street, Maidstone, 3012; D.A.58479; 15th March, 1970; 184 cwt.

HEMINGWAY, LEO, & PICKETT PTY. LTD., 330 Sydney-road, Brunswick, 3056; D.A.39955/19; 15th March, 1970; 63 cwt.; D.A.39955/20; 15th March, 1970; 48 cwt.; D.A.39955/21; 15th March, 1970; 65 cwt.

HEMINGWAY, LEO, & PICKETT PTY. LTD., 330 Sydney-road, Brunswick, 3056; D.A.39955/22; 15th March, 1970; 39 cwt.

HEMINGWAY, LEO, & PICKETT PTY. LTD., 330 Sydney-road, Brunswick, 3056; D.A.39955/23; 15th March, 1970; 25 cwt.

HEMINGWAY, LEO, & PICKETT PTY. LTD., 330 Sydney-road, Brunswick, 3056; D.A.39955/25; 15th March, 1970; 18 cwt.; D.A.39955/26; 15th March, 1970; 22 cwt.

HEMINGWAY, LEO, & PICKETT PTY. LTD., 330 Sydney-road, Brunswick, 3056; D.A.39955/27; 15th March, 1970; 44 cwt.; D.A.39955/28; 15th March, 1970; 20 cwt.

HICKS, W. G., PTY. LTD., 562 City-road, South Melbourne, 3205; T.D.A.62469; 17th March, 1970; 14 cwt.; T.D.A.62469/1; 17th March, 1970; 67 cwt.

HILL, G. C. & A. S., 5 Maroondah Highway, Healesville, 3777; D.T.709/1; 28th March, 1970; 250 cwt.

HORNDRALIC (AUSTRALIA) PTY. LTD., Keys-road, Moorabbin, 3189; D.A.29515/1; 28th February, 1970; 13 cwt.

INTERNATIONAL HARVESTER Co. OF AUST. PTY. LTD., 171-205 City-road, South Melbourne, 3205; D.A.1351/66; 28th March, 1970; 18 cwt.

JONES, D. W., PTY. LTD., 126 Cecil-street, Williamstown, 3016; D.A.1392/12; 19th March, 1970; 245 cwt.

KELVINATOR AUSTRALIA LTD., 487 Williamstown-road, Port Melbourne, 3207; D.A.1420/23; 7th March, 1970; 14 cwt.; D.A.1420/24; 7th March, 1970; 14 cwt.

KRAFT FOODS LTD., Salmon-street, Port Melbourne, 3207; D.A.1456/20; 19th March, 1970; 78 cwt.

KRAFT FOODS LTD., Salmon-street, Port Melbourne, 3207; D.A.1456/25; 7th March, 1970; 9 cwt.; D.A.1456/26; 7th March, 1970; 9 cwt.; D.A.1456/27; 7th March, 1970; 9 cwt.; D.A.1456/28; 7th March, 1970; 9 cwt.; D.A.1456/29; 7th March, 1970; 9 cwt.

KREGLINGER (AUST.) PTY. LTD., 530 Collins-street, Melbourne, 3000; D.A.45519; 19th March, 1970; 23 cwt.

MALE, A. H. (trading as A. H. Male & Co., 21 Hilton-street, Beaumaris, 3193; T.D.A.60462; 6th March, 1970; 15 cwt.

MANN'S TRANSPORT PTY. LTD., P.O. Box 288, Footscray, 3011; D.A.37473/7; 28th March, 1970; 77 cwt.

MARZANO, V. A., 140 Mitchell-street, Maidstone, 3012; D.A.45371; 31st January, 1970; 215 cwt.

MEYERS, T. W., Lot 23, Glen Park-road, Eltham North, 3095; D.A.45505; 5th March, 1970; 142 cwt.

MITCHELL & Co. PTY. LTD., 12-36 Cross-street, West Footscray, 3012; D.A.63252; 15th March, 1970; 11 cwt.

MUNAF0, J., 1 Peverill-street, Glen Waverley, 3150; D.A.58527; 15th March, 1970; 143 cwt.

MCCOLL ELECTRIC WORKS PTY. LTD., 134-142 Springvale-road, Springvale, 3171; D.A.58481; 15th March, 1970; 19 cwt.

MCPHEE, G. C., Firtree Lodge, Gladysdale, 3797; D.T.798; 7th March, 1970; 276 cwt.

NATIONAL CASH REGISTER Co. PTY. LTD., THE, 124 Russell-street, Melbourne, 3000; D.A.1707/38; 15th March, 1970; 11 cwt.; D.A.1707/39; 15th March, 1970; 11 cwt.; D.A.1707/40; 15th March, 1970; 11 cwt.; D.A.1707/41; 15th March, 1970; 12 cwt.

OAKGROVE LOGGING Co. PTY. LTD., Cavanagh-road, Millgrove, 3139; T.T.D.769/3; 6th March, 1970; 277 cwt.

PATERSONS PTY. LTD., 152 Bourke-street, Melbourne, 3000; D.A.1782/55; 28th March, 1970; 14 cwt.

PENTREATH, M. G., PTY. LTD., 58 Omar-street, Maidstone, 3012; D.A.31643/13; 19th February, 1970; 211 cwt.

PENTREATH HAULAGE PTY. LTD., 58 Omar-street, Maidstone, 3012; D.A.31643/12; 19th February, 1970; 144 cwt.

PERRY, W. C. L., Buxton, 3711; D.A.58537; 15th March, 1970; 88 cwt.

DONALD, N. F. D. & V. L. C. (trading as Premier Plumbing Service), 39 Hertford-street, Sebastopol, 3356; D.A.43574/3; 19th February, 1970; 10 cwt.

- RAMSAY & TREGANOWAN LTD., 475 Latrobe-street, Melbourne, 3000; D.A.31536/12; 16th March, 1970; 80 cwt.
- RICE, N., 21 Clarke-street, Thomastown, 3074; D.A.58267; 7th March, 1970; 137 cwt.
- RICHARDSON, JAMES, PTY. LTD., 35-45 Lithgow-street, Abbotsford, 3067; D.A.45596; 19th March, 1970; 27 cwt.; D.A.45596/1; 19th March, 1970; 37 cwt.
- ROBUR TEA COMPANY LTD., 28 Clarendon-street, South Melbourne, 3205; D.A.1940/3; 25th March, 1970; 64 cwt.
- ROCHE BROS. PTY. LTD., 22 Dynon-road, South Kensington, 3031; D.A.1941/26; 20th March, 1970; 25 cwt.
- RULE, C. L. & R. A., PTY. LTD., 10 Williamson-road, Box Hill North, 3219; D.A.54909/1; 28th March, 1970; 197 cwt.
- SCHAPER, S. H., 27 Inkerman-street, Maidstone, 3012; D.A.58622; 28th March, 1970; 206 cwt.
- SHEARER, DAVID, LTD., P.O. Box 21, Mannum, South Australia, 5238; D.A.18514/18; 7th March, 1970; 10 cwt.; D.A.18514/17; 7th March, 1970; 10 cwt.
- SIDES, W. L., & SON PTY. LTD., P.O. Box 228, Clayton, 3168; D.A.28601/21; 19th March, 1970; 118 cwt.
- SIDES, W. L., & SON PTY. LTD., P.O. Box 228, Clayton, 3168; D.A.28601/22; 19th March, 1970; 63 cwt.; D.A.28601/24; 19th March, 1970; 11 cwt.
- SOUTER, R. J. W., 4 Lehem-avenue, Oakleigh South, 3167; T.D.A.48476; 28th March, 1970; 6 cwt.
- STEWART, M. J., Myers Creek-road, Healesville, 3777; D.T.1009; 7th March, 1970; 262 cwt.
- SUNBEAM CORPORATION LTD., Sloane-street, Maribyrnong, 3032; D.A.14579/26; 24th March, 1970; 8 cwt.; D.A.14579/27; 24th March, 1970; 8 cwt.
- SUNKIST FOODS PTY. LTD., 50 Nott-street, Port Melbourne, 3207; D.A.47865/28; 7th March, 1970; 56 cwt.
- SUNKIST FOODS PTY. LTD., 50 Nott-street, Port Melbourne, 3207; D.A.47865/30; 7th March, 1970; 57 cwt.
- SUPER SPREAD AVIATION (AUST.) PTY. LTD., Hangar 7, Moorabbin Airport, Cheltenham, 3192; D.A.32508/27; 28th March, 1970; Mobile Crane; D.T.32508/28; 28th March, 1970; Mobile Crane.
- TARAXALE BREWING CO. PTY. LTD., 315 North-road, Huntingdale, 3167; D.A.2133/11; 18th March, 1970; 109 cwt.
- TAYLOR INSTRUMENT COMPANIES OF AUSTRALIA PTY. LTD., 275 Middleborough-road, Box Hill, 3128; D.A.45429/3; 7th March, 1970; 11 cwt.
- TINCKNELL, D. B., PTY. LTD., 22 Overton-road, Frankston, 3199; D.A.2166; 27th March, 1970; 65 cwt.
- VRASPIR, J., 32 Kidgall-street, Lilydale, 3140; D.A.3429; 19th March, 1970; 98 cwt.
- BOWEN, L. D., Heskett, via Woodend, 3442; D.T.146; 28th February, 1970; Application to renew and vary the conditions of licence No. D.T.146 (L/C. 198 cwt.) by deleting the words "North Essendon" from paragraph (a) of the existing conditions and adding in lieu "Niddrie".
- BURRELL, F. S., 2 Walsh-avenue, Thornbury, 3071; D.A.58546; 15th March, 1970; Application to renew and vary the conditions of licence No. D.A.58546 (L/C. 140 cwt.) by deleting the words "East Burwood" from the existing conditions and adding in lieu "Northcote".
- MOCSAN, S. (trading as Dean's Disposals), 24 Hillview-avenue, Mt. Waverley, 3149; D.A.58637; 28th March, 1970; Application to renew and vary the conditions of licence No. D.A.58637 (L/C. 41 cwt.) by adding to the existing conditions "and empty second-hand drums" and also by deleting the existing special conditions and adding in lieu: "The combined load capacity of the vehicle and any trailer attached thereto shall not exceed 120 cwt".
- DOWD, MAURICE C., PTY. LTD., 4 Railway-walk, Brighton Beach, 3186; D.A.58425; 28th February, 1970; Application to renew and vary the conditions of licence No. D.A.58425 (L/C. 137 cwt.) by deleting "Collingwood" from paragraph (b), part (i) and adding in lieu "Ormond".
- EBBAGE, E. E., 14 Matlock-street, Geelong West, 3218; D.A.50877/1; 28th March, 1970; Application to renew and vary the conditions of licence No. D.A.50877/1 (L/C. 80 cwt.) by adding to the existing conditions "and own ponies".
- PETERSVILLE AUSTRALIA LTD., Wellington-road, Clayton, 3168; D.A.1813/142; 28th March, 1970; Application to renew and vary the conditions of licence No. D.A.1813/142 (L/C. 69 cwt.) by deleting the existing conditions and adding in lieu—"Throughout the State of Victoria as a specially constructed and refrigerated van for the purpose of supplying own distributors with ice-cream, frozen vegetables, frozen poultry and frozen fish at a temperature not exceeding 10 degrees fahrenheit".

Notice of any objection should be forwarded to reach the Secretary of the Board not later than 28th January, 1970.

Applicants are advised that it will not be necessary to appear on the hearing date specified above, unless advised in writing by the Board.

B. P. KAY,

Secretary.

Corner Lygon and Princes streets, Carlton, 3053, Wednesday, 4th February, 1970.

Country Fire Authority Act 1958.

FIRE DANGER PERIOD IN RESPECT OF SPECIFIED PARTS OF THE COUNTRY AREA OF VICTORIA.

WHEREAS by section 4 of the *Country Fire Authority Act 1958* it is enacted that the Chief Secretary of Victoria, after consultation with the Minister of Forests, may from time to time by declaration published in the *Government Gazette* declare any period to be the fire danger period in respect of the country area of Victoria, or any specified part or parts thereof and, without affecting the generality of the foregoing, may declare different periods to be the fire danger period in respect of different parts of the said country area:

And whereas the Chief Secretary and the Minister of Forests have consulted accordingly:

Now therefore I, the Chief Secretary of Victoria, do hereby declare the period commencing at midnight on the 16th January, 1970, and ending at midnight on the 30th April, 1970, to be the fire danger period in respect of the parts of the country area of Victoria situated within the municipal districts or parts of municipal districts, being the balance of the Thirteenth Fire Control Region specified in the Schedule hereunder:—

SCHEDULE NO. 20.

Shire of Lilydale.
Shire of Sherbrooke.

A. G. RYLAH,
Chief Secretary.

Chief Secretary's Office,
Melbourne, 13th January, 1970.

TOW TRUCKS.

- BRADREY PANELS PTY. LTD., 521-531 High-street, East Prahran, 3181; D.A.37923/7; 28th March, 1970; 33 cwt.
- GUETTI, S. & G. (trading as Globe Motor Body Works & Engineering), 23 Harrison-street, East Brunswick, 3057; D.A.61547; 28th March, 1970; 49 cwt.
- INKERMAN PANEL WORKS PTY. LTD., 83 Inkerman-street, St. Kilda, 3182; D.A.58275; 7th March, 1970; 25 cwt.
- MELBOURNE TOWING SERVICE PTY. LTD., 169 City-road, South Melbourne, 3205; D.A.28169/20; 7th March, 1970; 79 cwt.
- PERLOW MOTORS PTY. LTD., 108-118 Little Lonsdale-street, Melbourne, 3000; D.A.43039/4; 7th March, 1970; 30 cwt.; D.A.43039/5; 28th March, 1970; 45 cwt.
- PHILLIPS, E. J. C., 114 Mt. Eliza-way, Mt. Eliza, 3930; D.A.58633; 28th March, 1970; 54 cwt.
- ROGRAY PANELS PTY. LTD., 35 Weston-street, Brunswick, 3056; D.A.50367/2; 31st January, 1970; 36 cwt.
- DANIEL, J. E. (trading as Temple Service Station), 233 Warrigal-road, Oakleigh South, 3167; D.A.46306/2; 15th March, 1970; 25 cwt.

RENEWALS WITH VARIATION.

APPLICATIONS by the persons listed hereunder for renewal of the licences listed with variation of conditions in the manner set out opposite the names.

- BEAUREPAIRE TYRE SERVICE PTY. LTD., 102 Victoria-street, Carlton, 3053; D.A.629/28; 10th February, 1970; Application to renew and vary conditions of licence No. D.A.629/28 (L/C. 14 cwt.) by deleting the word "Warragul" from the existing conditions and adding in lieu "Leongatha".
- BEAUREPAIRE TYRE SERVICE PTY. LTD., 102 Victoria-street, Carlton, 3053; D.A.629/68; 19th March, 1970; Application to renew and vary the conditions of licence No. D.A.629/68 (L/C. 16 cwt.) by deleting "own premises at Horsham" from the existing conditions and adding in lieu "own branch premises at Barkly-street, West Footscray".

MONEY LENDERS ACT 1958.

IN accordance with the provisions of the above-mentioned Act the following is published for general information.

List of persons to whom Money Lenders' Licences have been issued for year ending 30th June, 1970.

Name.	Authorized Name.	Authorized Address.	Date of Issue.
BFC Finance Limited (J. P. O'Halloran, Appointee)	BFC Finance Limited	Shop 7, Boronia Village Shopping Centre, Boronia	29.10.69
Bendigo Investments Limited (L. H. Jackman, Appointee)	Bendigo Investments Limited ..	27 Queen-street, Bendigo ..	23.10.69
Commercial and General Acceptance Limited (J. F. Snelling, Appointee)	Commercial and General Acceptance Limited	2nd Floor, Westfield Tower, Doncaster Shoppingtown, Cnr. Doncaster and Williamsons roads, Doncaster	21.10.69
Commercial and General Acceptance Limited (J. F. Snelling, Appointee)	Commercial and General Acceptance Limited	Shop 91, Chadstone Shopping Centre, 1341 Dandenong-road, Chadstone	18.12.69
East Gippsland Finance Pty. Ltd. (W. H. Kellow, Appointee)	East Gippsland Finance Pty. Ltd. ..	Room 3, 1st Floor, National Mutual Buildings, Hotham-street, Traralgon	27.10.69
Esanda Limited (M. L. Broun, Appointee)	Esanda Limited	542 Footscray-road, West Melbourne	26.11.69
General Loans and Mortgages Finance Co. Pty. Ltd. (B. Lang, Appointee)	General Loans and Mortgages Finance Co. Pty. Ltd.	304-310 Lonsdale-street, Melbourne	30.10.69
Interprovincial Finance Pty. Ltd. (B. Lang, Appointee)	Interprovincial Finance Pty. Ltd. ..	304-310 Lonsdale-street, Melbourne	30.10.69
L. Jackman and Co. (Investors) Pty. Ltd. (L. H. Jackman, Appointee)	L. Jackman and Co. (Investors) Pty. Ltd.	27 Queen-street, Bendigo ..	23.10.69
Betty Lang	Betty Lang	304-310 Lonsdale-street, Melbourne	30.10.69
Robert Lansell Finance Pty. Ltd. (R. L. Cotterill, Appointee)	Robert Lansell Finance Pty. Ltd. ..	1143 Malvern-road, Malvern ..	20.11.69
Seaboard Finance Company Ltd. (D. Broad, Appointee)	Seaboard Finance Company Ltd. ..	73 Bridge-street, Ballarat ..	20.11.69
Seaboard Finance Company Ltd. (D. Broad, Appointee)	Seaboard Finance Company Ltd. ..	45 Riversdale-road, Camberwell ..	9.12.69
Seaboard Finance Company Ltd. (D. Broad, Appointee)	Seaboard Finance Company Ltd. ..	240 Commercial-road Morwell ..	26.11.69
Seaboard Finance Company Ltd. (D. Broad, Appointee)	Seaboard Finance Company Ltd. ..	100 Maroondah Highway, Ringwood	21.11.69
Waltons Credits Ltd. (E. T. Traynor, Appointee)	Waltons Credits Ltd.	Cnr. Morgan-court and Glenroy-road, Glenroy	3.12.69
Watson, Geoffrey McNeil	Watson, Geoffrey McNeil	36 Salisbury-avenue, Ivanhoe ..	13.10.69

* New Authorized Address. ** Transfer of Nominee.

State Treasury,
Melbourne, Victoria 3002.

W. WATTS, Registrar,
Money Lenders Act.

NOTICE.

CREDITORS, next of kin and others having claims against the estate of any of the under-mentioned deceased persons are required to send particulars of their claims to Public Trustee, 256 Flinders-street, Melbourne, Vic. 3000, personal representative, on or before the 22nd March, 1970, after which date the Public Trustee may convey or the assets, having regard only to the claims of the Public Trustee then has notice:—

FERRE, PAUL, late of 2 Mangana-drive, Springvale North, estate manager, died 14th February, 1969.

McCONNELL, ARTHUR WILLIAM, late of 16 Faye-street, Reservoir, retired railway employee, died 11th March, 1969.

NICHOLLS, MABEL MAY, late of 174 Beach-road, Mordialloc, died 5th May, 1969.

O'CONNOR, WILLIAM REGINALD, late of 58 Helen's-road, retired tram conductor, died 2nd August, 1969.

OLIVER, PHILIP AUBREY, late of 5 Stewart-street, Castlemead, retired engineer, died on or about 15th October, 1969.

REID, HARRY JOHN, late of 13 Chapmans-road, Trafalgar, P.M.G. employee, died 13th October, 1969.

SCOVELL, ADA ANNIE, late of 7 Fulmer Way, Ealing, London, England, widow, died 24th November, 1966.

SMITH, DAISY EVELINE, late of 46 Ferny Creek-avenue, Fern Tree Gully, widow, died 6th August, 1969.

STURROCK, ANDREW ROBERT, late of 53 Huntingdon-grove, Coburg, retired butcher, died 27th September, 1969.

TROUNSON, FRANCIS JOHN, also known as Frank John Trounson, late of "Avonlea", Nhill, pensioner, died 17th October, 1969.

WATSON, DAISY MAY, late of 11 Birdwood-street, Balwyn, died 19th September, 1969.

WEST, IVY BEATRICE, formerly of 10 Hutton-street, Thornbury, late of Condare-court, 8 Joffre-street, Burwood, died 19th August, 1969.

N. P. BRODY,
Public Trustee.

Melbourne, 8th January, 1970.

NOTICE.

Farm Produce Merchants and Commission Agents Act 1965.
NOTICE is hereby given that pursuant to section 11 of the Farm Produce Merchants and Commission Agents Act 1965, the Minister of Agriculture has cancelled, as from and inclusive of 21st November, 1969, the Farm Produce Merchant's Licence which was issued for the year ending 30th June, 1970, upon the application of John Wilmont Bradford on behalf of Kinglake Poultry Industries Pty. Ltd.

Water Act 1958.

STATE RIVERS AND WATER SUPPLY COMMISSION.
BERWICK AND NEWSTEAD URBAN DISTRICTS.

NOTICE to owners of tenements in the under-mentioned streets in the above-mentioned Urban Districts and the private streets, lanes, courts and alleys opening there to:—

BERWICK URBAN DISTRICT.

Berwick.

Buchanans-road, from end of existing main (opposite lot 1, about 11 chains northerly from Brisbane-street) to existing main opposite lot 4, about 24 chains northerly from Brisbane-street.

Inglis-road, from Lyall-road to Buchanans-road.

NEWSTEAD URBAN DISTRICT.

Newstead.

Canrobert-street, from end of existing main (opposite allotment 5, section 27) to Peel-street.

The main pipe in the said streets being laid down, the owners of all tenements situated as above are hereby required, on or before the 1st day of March, next, to cause proper pipes and stop cocks to be laid, so as to supply water within such tenements from the main pipe.

G. W. LEWIS, Secretary,
State Rivers and Water Supply Commission.

Melbourne, 9th January, 1970.

CONTRACTS ACCEPTED.—(Series 1969-70.)**VICTORIAN RAILWAYS.**

65. Supply and delivery of thirty colour light signal operating mechanisms, each for \$360.00 (Contract 63481).—McKenzie & Holland (Aust.) Pty. Ltd. 66. Rewinding of G.E. 237 traction motor armatures, at rates (Contract 63503).—Cheltenham Electric Pty. Ltd.

By order of the Victorian Railways Commissioners,
W. WALKER, Secretary. 9.1.70.

*Marketing of Primary Products Act 1958.***ELECTION NOTICE.—THE EGG AND EGG PULP MARKETING BOARD.**

PURSUANT to the provisions of section 38 of the *Marketing of Primary Products Act 1958*, I hereby give notice that I have appointed Saturday, the 17th January, 1970, as the date for the purpose of calculating eligibility of producers of eggs to vote at an election of one (1) representative of such producers to be an elected member of The Egg and Egg Pulp Marketing Board, to be held on Thursday, the 28th May, 1970.

G. L. CHANDLER,
Minister of Agriculture.

ECHUCA WATERWORKS TRUST.**AUTHORITY TO OBTAIN BANK OVERDRAFT.**

HIS Excellency the Governor of the State of Victoria, by and with the advice of the Executive Council thereof doth by Order made on the 13th day of January, 1970, authorize the Echuca Waterworks Trust to obtain in pursuance of the provisions of section 286 of the *Water Act 1958* (No. 6413) an advance or advances during the year ending 30th September, 1970, by overdraft of the Trust's current account, such overdraft not to exceed at any one time the sum of Four thousand dollars (\$4,000).

J. ROSSITER,
Clerk of the Executive Council.

At the Executive Council Chamber,
Melbourne, 13th January, 1970.

LEXTON WATERWORKS TRUST.**AUTHORITY TO OBTAIN BANK OVERDRAFT.**

HIS Excellency the Governor of the State of Victoria, by and with the advice of the Executive Council thereof doth by Order made on the 13th day of January, 1970, authorize the Lexton Waterworks Trust to obtain in pursuance of the provisions of section 286 of the *Water Act 1958* (No. 6413) an advance or advances during the year ending 30th September, 1970, by overdraft of the Trust's current account, such overdraft not to exceed at any one time the sum of One thousand six hundred dollars (\$1,600).

J. ROSSITER,
Clerk of the Executive Council.

At the Executive Council Chamber,
Melbourne, 13th January, 1970.

LATROBE RIVER IMPROVEMENT TRUST.**RATING BY-LAW No. 20.**

THE Latrobe River Improvement Trust, in pursuance and exercise of the powers conferred by the *River Improvement Act 1958*, doth hereby make the By-Law following:—

1. The following rates, to be called the "Latrobe River Improvement District River Improvement Rate", are hereby made, and shall be levied upon the occupiers or owners of all properties within the Latrobe River Improvement District which are rateable to any Municipality:—

A rate of Thirteen Cents (13c) in the dollar on the net annual value of all properties in the First Division, being those properties coloured purple on the plan of the Latrobe River Improvement District, titled the "Latrobe River Improvement District Rating Divisions, 1970", approved by the Governor in Council and lodged at the office of the State Rivers and Water Supply Commission at Melbourne.

A rate of Six Cents (6c) in the dollar on the net annual value of all properties in the Second Division, being those properties shown coloured blue on the said plan.

A rate of Four Cents (4c) in the dollar on the net annual value of all properties in the Third Division, being those properties shown coloured green on the said plan.

A rate of Three and One Half Cents (3.5c) in the dollar on the net annual value of all properties in the Fourth Division, being those properties shown coloured orange on the said plan.

A rate of Three and Two-tenths Cents (3.2c) in the dollar on the net annual value of all properties in the Fifth Division, being those properties shown coloured red on the said plan.

A rate of Two and One Half Cents (2.5c) in the dollar on the net annual value of all properties in the Sixth Division, being those properties shown coloured yellow on the said plan.

A rate of One Cent (1c) in the dollar on the net annual value of all properties in the Seventh Division, being those properties coloured brown on the said plan.

A rate of One Half Cent (0.5c) in the dollar on the net annual value of all properties in the Eighth Division, being those properties shown coloured pink on the said plan.

2. In respect of all those properties within the Ninth Division, being all those properties uncoloured on the said plan, no rate is made or levied for the period beginning with the 1st day of January, 1970, and ending with the 31st day of December, 1970.

3. In respect of any rateable property other than those included in the Ninth Division the minimum amount payable shall be Fifty Cents.

4. Such rates are made and shall be levied for the period beginning with the 1st day of January, 1970, and ending with the 31st day of December, 1970, and shall be payable on the 1st day of June, 1970, at the office of the Latrobe River Improvement Trust at Traralgon.

5. Such person or persons as the Latrobe River Improvement Trust may from time to time appoint for the purpose shall be and is or are hereby authorized to demand, receive, collect and recover the said rate.

The foregoing By-Law was made by the Latrobe River Improvement Trust on the 19th day of December, 1969, and the common seal of the said Trust was hereunto affixed, this 19th day of December, 1969, in the presence of—

(SEAL) A. G. BURNET, Chairman.
S. COOK, Commissioner.
W. TEASDALE, Secretary.

Approved by the Governor in Council, 13th January, 1970.
—J. ROSSITER, Clerk of the Executive Council.

THOMSON RIVER IMPROVEMENT TRUST.**RATING BY-LAW 1970.**

THE Thomson River Improvement Trust, in pursuance and exercise of the powers conferred by the *River Improvement Act 1958*, doth hereby make the following By-Law:

1. The following rate, to be called "Thomson River Improvement Rate," is hereby made and shall be levied upon the occupiers or owners of all properties within the Thomson River Improvement District which are rateable to any Municipality:—

A rate of One Cent in the Dollar on the Net Annual Municipal Value of such properties. Provided that the sum of Ten Cents shall be the minimum amount of rate in respect of any property liable to be rated in the said District.

2. Such rate is made and shall be levied for the year beginning with the 1st January, 1970, and ending with the 31st December, 1970, and shall be payable on the 1st day of July, 1970, at the Office of the Thomson River Improvement Trust, Room 9, 76-84 Hotham-street, Traralgon.

3. Such person or persons as the Thomson River Improvement Trust may, from time to time, appoint for that purpose, shall be and is, or are hereby authorized to demand, receive, collect and recover the said rate.

The foregoing By-Law was made by the Thomson River Improvement Trust on the 1st December, 1969, and the Common Seal of the Trust was hereunto affixed, this 1st day of December, 1969, in the presence of—

(SEAL) N. R. GOOCH, Chairman.
D. J. GRIGG, Secretary.

Approved by the Governor in Council, 13th January, 1970.
—J. ROSSITER, Clerk of the Executive Council.

ORDERS IN COUNCIL**THE BALLARAT WATER COMMISSIONERS.**

At the Executive Council Chamber, Melbourne, the thirteenth day of January, 1970.

PRESENT:

His Excellency the Governor of Victoria.
Mr. Manson | Mr. Borthwick.

SALE OF LAND.

UNDER the powers conferred by the Water Act and all other powers enabling him in that behalf, His Excellency the Governor of the State of Victoria, by and with the advice of the Executive Council of the said State, doth hereby consent to the sale of land for easement purposes being part of Crown allotments 3, section 2, 1 section 2, 11 section 3, Parish of Ballaarat, County of Grant, and allotments A², section 8, A²A section 8, Parish of Bungaree, County of Grenville by the Ballarat Water Commissioners to the State Electricity Commission. The said land is shown on a plan approved by the Governor in Council by and with this Order and deposited in the office of the State Rivers and Water Supply Commission, Melbourne.—(Corres. 67/3016/157.)

And the Honorable William Archibald Borthwick, Her Majesty's Minister of Water Supply for the State of Victoria, shall give the necessary directions herein accordingly.

J. ROSSITER,
Clerk of the Executive Council.

SEA LAKE SEWERAGE AUTHORITY.

At the Executive Council Chamber, Melbourne, the thirteenth day of January, 1970.

PRESENT:

His Excellency the Governor of Victoria.
Mr. Manson | Mr. Borthwick.

DECLARATION AS AN AUTHORITY.

UNDER the powers conferred by section 3 of the *Public Authorities Works Act 1958*, No. 6346, and all other powers enabling him in that behalf, His Excellency the Governor of the State of Victoria, by and with the advice of the Executive Council of the said State, doth hereby declare the Sea Lake Sewerage Authority to be an Authority for the purposes of the said Act.

And the Honorable William Archibald Borthwick, Her Majesty's Minister of Water Supply for the State of Victoria, shall give the necessary directions herein accordingly.

J. ROSSITER,
Clerk of the Executive Council.

WYCHEPROOF SEWERAGE AUTHORITY.

At the Executive Council Chamber, Melbourne, the thirteenth day of January, 1970.

PRESENT:

His Excellency the Governor of Victoria.
Mr. Manson | Mr. Borthwick.

DECLARATION AS AN AUTHORITY.

UNDER the powers conferred by section 3 of the *Public Authorities Works Act 1958*, No. 6346, and all other powers enabling him in that behalf, His Excellency the Governor of the State of Victoria, by and with the advice of the Executive Council of the said State, doth hereby declare the Wycheproof Sewerage Authority to be an Authority for the purposes of the said Act.

And the Honorable William Archibald Borthwick, Her Majesty's Minister of Water Supply for the State of Victoria, shall give the necessary directions herein accordingly.

J. ROSSITER,
Clerk of the Executive Council.

RIVER IMPROVEMENT ACT 1958.

At the Executive Council Chamber, Melbourne, the thirteenth day of January, 1970.

PRESENT:

His Excellency the Governor of Victoria.
Mr. Manson | Mr. Borthwick.

LATROBE RIVER IMPROVEMENT TRUST—RATING DIVISIONS 1970.

UNDER the powers conferred by the *River Improvement Act 1958*, and all other powers enabling him in that behalf, His Excellency the Governor of the State of Victoria, by and with the advice of the Executive Council of the said State, doth by this Order repeal the Order made on the 15th April, 1969, determining rating divisions in the Latrobe River Improvement District, and doth hereby determine that the properties within the Latrobe River Improvement District shall be arranged in nine divisions in the manner hereinafter provided—

- (1) That the said divisions shall be known as the First, Second, Third, Fourth, Fifth, Sixth, Seventh, Eighth and Ninth Divisions.
- (2) That the First Division shall comprise those lands shown coloured purple on the plan titled "Latrobe River Improvement District Rating Divisions 1970" approved by the Governor in Council and deposited at the office of the State Rivers and Water Supply Commission, Melbourne.—(Corres. No. 69/1585/82.)
- (3) That the Second Division shall comprise all those lands shown coloured blue on the said plan.
- (4) That the Third Division shall comprise all those lands shown coloured green on the said plan.
- (5) That the Fourth Division shall comprise all those lands shown coloured orange on the said plan.
- (6) That the Fifth Division shall comprise all those lands shown coloured red on the said plan.
- (7) That the Sixth Division shall comprise all those lands shown coloured yellow on the said plan.
- (8) That the Seventh Division shall comprise all those lands shown coloured brown on the said plan.
- (9) That the Eighth Division shall comprise all those lands shown coloured pink on the said plan.
- (10) That the Ninth Division shall comprise all those lands shown uncoloured on the said plan.

And the Honorable William Archibald Borthwick, Her Majesty's Minister of Water Supply for the State of Victoria, shall give the necessary directions herein accordingly.

J. ROSSITER,
Clerk of the Executive Council.

HORSHAM SEWERAGE AUTHORITY.

At the Executive Council Chamber, Melbourne, the thirteenth day of January, 1970.

PRESENT:

His Excellency the Governor of Victoria.
Mr. Manson | Mr. Borthwick.

CONSENT TO BORROWING \$20,500.

UNDER the powers conferred by the *Sewerage Districts Act* and all other powers enabling him in that behalf, His Excellency the Governor of the State of Victoria, by and with the advice of the Executive Council of the said State, doth hereby consent to the Horsham Sewerage Authority borrowing, at interest by mortgage of the General Fund the sum of Twenty thousand five hundred dollars (\$20,500) to meet the cost of sewerage works as set forth in the detailed statement bearing date 8th January, 1970.

And the Honorable William Archibald Borthwick, Her Majesty's Minister of Water Supply for the State of Victoria, shall give the necessary directions herein accordingly.

J. ROSSITER,
Clerk of the Executive Council.

THE BALLARAT WATER COMMISSIONERS.

At the Executive Council Chamber, Melbourne, the
thirteenth day of January, 1970.

PRESENT:

His Excellency the Governor of Victoria.
Mr. Manson | Mr. Borthwick.

EXCHANGE AND SALE OF LAND.

UNDER the powers conferred by the Water Act and all other powers enabling him in that behalf, His Excellency the Governor of the State of Victoria, by and with the advice of the Executive Council of the said State doth hereby:—

- (a) sanction the exchange of an area of land amounting to 0 acres 2 roods 11.3 perches between the Ballarat Water Commissioners and Bungaree Shire Council, and
- (b) consent to the sale of 0 acre 1 rood and 29.2 perches of land by The Ballarat Water Commissioners to the Bungaree Shire Council.

The area of lands to be exchanged and sold as said at present under the management of The Ballarat Water Commissioners being 1 acre 0 rood 0.5 perches, and shown in red colour on the plan accompanying this Order, and the area of land to be exchanged as said at present under the management of the Bungaree Shire Council being 0 acres 2 roods 11.3 perches, and shown in blue colour on the said plan; such lands being part of section 16, Parish of Dean, County of Grant; and the said plan is approved by the Governor in Council by and with this order and deposited in the office of the State Rivers and Water Supply Commission, Melbourne.—(Corres. No. 67/3016/155.)

And the Honorable William Archibald Borthwick, Her Majesty's Minister of Water Supply for the State of Victoria, shall give the necessary directions herein accordingly.

J. ROSSITER,
Clerk of the Executive Council.

WATER ACT.

At the Executive Council Chamber, Melbourne, the
thirteenth day of January, 1970.

PRESENT:

His Excellency the Governor of Victoria.
Mr. Manson | Mr. Borthwick.

RE-APPOINTMENT OF A COMMISSIONER AND CHAIRMAN OF THE COMMISSIONERS OF THE STATE RIVERS AND WATER SUPPLY COMMISSION.

PURSUANT to the provisions of the Water Act, His Excellency the Governor of the State of Victoria by and with the advice of the Executive Council thereof doth by this Order re-appoint

ALFRED LEYSTER TISDALL

a Commissioner and Chairman of Commissioners of the State Rivers and Water Supply Commission for a further term commencing on the 1st day of February, 1970, and ending on the 31st day of January, 1975, both dates inclusive and doth hereby fix the salary to be paid to the said Alfred Leyster Tisdall during the said term at the amount of Fourteen thousand, six hundred and fifty dollars (\$14,650) per annum.

And the Honorable William Archibald Borthwick, Her Majesty's Minister of Water Supply for the State of Victoria, shall give the necessary directions herein accordingly.

J. ROSSITER,
Clerk of the Executive Council.

WATER ACT.

At the Executive Council Chamber, Melbourne, the
thirteenth day of January, 1970.

PRESENT:

His Excellency the Governor of Victoria.
Mr. Manson | Mr. Borthwick.

RE-APPOINTMENT OF A COMMISSIONER AND DEPUTY CHAIRMAN OF THE STATE RIVERS AND WATER SUPPLY COMMISSION.

PURSUANT to the provisions of the Water Act, His Excellency the Governor of the State of Victoria by and with the advice of the Executive Council thereof doth by this Order re-appoint

ROBERT ALLAN HORSFALL

a Commissioner and Deputy Chairman of the State Rivers and Water Supply Commission for a further term commencing on the 1st day of February, 1970, and ending on the 31st day of January, 1975, both dates inclusive and doth hereby fix the salary to be paid to the said Robert Allan Horsfall during the said term at the amount of Twelve thousand and fifty dollars (\$12,050) per annum.

And the Honorable William Archibald Borthwick, Her Majesty's Minister of Water Supply for the State of Victoria, shall give the necessary directions herein accordingly.

J. ROSSITER,
Clerk of the Executive Council.

WATER ACT.

At the Executive Council Chamber, Melbourne, the
thirteenth day of January, 1970.

PRESENT:

His Excellency the Governor of Victoria.
Mr. Manson | Mr. Borthwick.

RE-APPOINTMENT OF A COMMISSIONER OF THE STATE RIVERS AND WATER SUPPLY COMMISSION.

PURSUANT to the provisions of the Water Act, His Excellency the Governor of the State of Victoria by and with the advice of the Executive Council thereof doth by this Order re-appoint

KENNETH DAVID GREEN

a Commissioner of the State Rivers and Water Supply Commission for a term commencing on the 1st day of February, 1970, and ending on the 31st day of January, 1975, both dates inclusive and doth hereby fix the salary to be paid to the said Kenneth David Green during the said term at the amount of Eleven thousand five hundred and fifty dollars (\$11,550) per annum.

And the Honorable William Archibald Borthwick, Her Majesty's Minister of Water Supply for the State of Victoria, shall give the necessary directions herein accordingly.

J. ROSSITER,
Clerk of the Executive Council.

LANDLORD AND TENANT ACT 1958.

At the Executive Council Chamber, Melbourne, the
thirteenth day of January, 1970.

PRESENT:

His Excellency the Governor of Victoria.
Mr. Manson | Mr. Borthwick.

ORDER EXCLUDING CERTAIN PREMISES FROM THE OPERATION OF CERTAIN OF THE PROVISIONS CONTAINED IN PART V. OF THE LANDLORD AND TENANT ACT 1958.

IN pursuance of the powers conferred upon him by the Landlord and Tenant Act 1958, His Excellency the Governor of the State of Victoria, by and with the advice of the Executive Council thereof, doth hereby declare that the premises known as Number 14 Derby-street, Colling-

shall be excluded from the operation of the whole of provisions contained in Divisions 2 and 3 of Part V. of *Landlord and Tenant Act 1958*.

And the Honorable George Oswald Reid, Her Majesty's Attorney-General in and for the State of Victoria, shall give necessary directions herein accordingly.

J. ROSSITER,
Clerk of the Executive Council.

LANDLORD AND TENANT ACT 1958.

At the Executive Council Chamber, Melbourne, the thirteenth day of January, 1970.

PRESENT:

His Excellency the Governor of Victoria.
Mr. Manson | Mr. Borthwick.

ORDER EXTENDING APPLICATION OF PART V. OF THE LANDLORD AND TENANT ACT 1958 TO CERTAIN PREMISES.

IN pursuance of the powers conferred by section 44 of the *Landlord and Tenant Act 1958*, the Governor of the State of Victoria, by and with the advice of the Executive Council thereof, doth hereby declare that the application of Part V. of the *Landlord and Tenant Act 1958* shall extend to the following—

1. The premises known as Number 26 Prospect-street, Box Hill.

And the Honorable George Oswald Reid, Her Majesty's Attorney-General in and for the State of Victoria, shall give the necessary directions herein accordingly.

J. ROSSITER,
Clerk of the Executive Council.

MARKETING OF PRIMARY PRODUCTS ACT 1958.

At the Executive Council Chamber, Melbourne, the thirteenth day of January, 1970.

PRESENT:

His Excellency the Governor of Victoria.
Mr. Manson | Mr. Borthwick.

APPOINTMENT OF A DAY FOR A POLL TO BE TAKEN OF THE PRODUCERS OF EGGS FOR THE ELECTION OF A REPRESENTATIVE OF SUCH PRODUCERS TO BE AN ELECTED MEMBER OF THE EGG AND EGG PULP MARKETING BOARD.

IN pursuance of the powers conferred by section 38 of the *Marketing of Primary Products Act 1958*, His Excellency the Governor of the State of Victoria, by and with the advice of the Executive Council thereof, doth by this Order hereby appoint Thursday, the twenty-eighth day of May, 1970, as the day for a poll to be taken of the producers of eggs for the election of one (1) representative of such producers to be an elected member of The Egg and Egg Pulp Marketing Board and doth further appoint one (1) electoral area, defined as follows, for such election, that is to say:—

ELECTORAL AREA NO. 1.

The Ballarat East, Ballarat West, Ballan, Sebastopol and Warrenheip Subdivisions of the State Electoral District of Ballarat South; the Alexandra, Kilmore and Yea Subdivisions of the State Electoral District of Evelyn; the Kyneton and Woodend Subdivisions of the State Electoral District of Gisborne; the Ararat, Beaufort, Camperdown, Lexton, Linton, Mortlake and Willaura Subdivisions of the State Electoral District of Hampden; the Beac, Beech Forest, Birregurra, Colac, Jancourt and Port Campbell Subdivisions of the State Electoral District of Polwarth; and the State Electoral Districts of Ballarat North, Benalla, Benambra, Bendigo, Dundas, Kara Kara, Lowan, Midlands, Mildura, Murray Valley, Portland, Rodney, Shepparton, Swan Hill, and Warrnambool.

And the Honorable Gilbert Lawrence Chandler, Her Majesty's Minister of Agriculture for the State of Victoria, shall give the necessary directions herein accordingly.

J. ROSSITER,
Clerk of the Executive Council.

LANDS DEPARTMENT NOTICES

APPROACHING LAND SALES.

SALES of Crown Lands, in fee-simple, will be held at the under-mentioned places and dates, viz.:—

	No. of Gazette.
Bairnsdale.—Tuesday, 20th January, 1970	109
Cann River.—Monday, 26th January, 1970	112
Dartmoor.—Tuesday, 10th March, 1970	3
Geelong.—Wednesday, 21st January, 1970	112
Inglewood.—Thursday, 15th January, 1969	104
Mallacoota.—Tuesday, 27th January, 1970	112
Robinvale.—Tuesday, 24th February, 1970	3
Sea Lake.—Thursday, 15th January, 1969	104
Stawell.—Friday, 27th February, 1970	3

SALE OF CLOSER SETTLEMENT LAND.

Colac.—Thursday, 22nd January, 1970 .. 112

SALE OF FREEHOLD LAND BY AUCTION.

Coleraine.—Tuesday, 10th March, 1970 .. 3

SALE OF CROWN LAND BY AUCTION.

The land will be offered for sale in fee-simple, and subject to the provisions of the Land Act and Regulations thereunder.

The upset price is the sum at which bidding will start, and no bid below that sum can be accepted. The highest bidder at or above that sum shall be the purchaser, subject to signature of contract and any necessary payment.

TERMS:—

A deposit of at least 12½% of the purchase price must be paid at the sale, either in cash or by cheque.

The residue is payable in half-yearly instalments, in accordance with the following scale, or may be paid off at any earlier time.

\$40 and under, 6 instalments.
Over \$40, and not exceeding \$100, 8 instalments.
Over \$100, and not exceeding \$200, 10 instalments.
Over \$200, and not exceeding \$400, 12 instalments.
Over \$400, and not exceeding \$600, 14 instalments.
Over \$600, and not exceeding \$800, 16 instalments.
Over \$800, and not exceeding \$1,000, 18 instalments.
Over \$1,000, 20 instalments.

Interest at the rate of 5% per annum is payable with all payments of residue, and is computed for each instalment from the date of sale to the date of such payment. Additional interest is charged if any instalment is not paid on or before the due date.

If paid off within 30 days of sale, no interest is payable.

FEES, ETC.:

Also payable at the sale, in addition to the deposit, are the survey fee and, if applicable, the valuation of improvements (if purchaser be not the owner thereof).

Payable with balance of purchase money—

Crown Grant fee—	
50 acres and under	\$3
Over 50 acres	\$4
Purchase money \$10 or under	\$2

Assurance Fund contribution.—One cent in every Five dollars or part thereof of purchase price. (This is a fund established to guarantee the validity of freehold titles.)

Transfer of interest prior to completion of payment may be allowed on payment of \$2 fee and subject to stamp duty.

If unable to attend personally, a prospective purchaser may arrange for another person to bid as his agent.

Attention is drawn to section 95, *Land Act 1958*, which provides that the purchaser shall be deemed to be the owner for the purposes of other Acts; also to an amendment to the Local Government Act providing for Government roads, in certain circumstances, to be declared "private streets", thus making the purchaser liable to contribute to the cost of street construction.

W. J. F. McDONALD,
Minister of Lands.

Office of Crown Lands and Survey,
Melbourne, 14th January, 1970.

ROBINVALE.—Sale (No. 12036) of Crown land in fee-simple, by auction, will be held at the LAND INSPECTOR'S OFFICE, ROBINVALE on TUESDAY, the 24th day of FEBRUARY, 1970, at TEN o'clock a.m. To be conducted by T. A. Comte, Land Officer, Bendigo.

PARISH OF BUMBANG, COUNTY OF KARKAROOC.

Three lots fronting Government roads about $\frac{1}{4}$ mile east of the main Manangatang-Robinvale road, about 4 miles south of Robinvale.

Lot 1.

Upset price \$240 the lot. Survey fee \$24.50.

Area 16 acres 1 rood 20 perches, allotment 80 of section B. Subject to State Rivers and Water Supply Commission easement 50 links wide. One month allowed for the removal of improvements.

Lot 2.

Upset price \$110 the lot. Survey fee \$19.25.

Area 7 acres 2 roods 6 perches, allotment 80A of section B. Subject to State Rivers and Water Supply Commission easement 50 links wide. One month allowed for the removal of improvements.

Lot 3.

Upset price \$350 the lot. Survey fee \$27.25.

Area 23 acres 2 roods 4 perches, allotment 80B of section B. One month allowed for the removal of improvements.—(M.61603.)

STAWELL.—Sale (No. 12037) of Crown land in fee-simple, by auction, will be held at the COURT HOUSE, PATRICK-STREET, STAWELL, on FRIDAY, the 27th day of FEBRUARY, 1970, at HALF PAST TEN o'clock a.m. To be conducted by E. M. Floyd, Land Officer, Horsham.

AT STAWELL, PARISH OF ILLAWARRA, COUNTY OF BORUNG.

Lot 1.

Fronting the north side of Lake-road about 8 chains west of Hines-road.

Upset price \$3,000 the lot. Survey fee \$19.25.

Area 6 acres 0 roods 8 perches, allotment 136B.

Lot 2.

Fronting the north side of the Western Highway about 16 chains west of Hines-road.

Upset price \$1,000 the lot. Survey fee \$16.

Area 3 roods 31 perches, allotment 136C.

Lot 3.

Fronting the north side of the Western Highway about 20 chains west of Hines-road.

Upset price \$1,500 the lot. Survey fee \$16.

Area 1 acre 2 roods, allotment 136E.

NOTE.—No road abuttal on the west of the above allotment has been provided.

SPECIAL CONDITION.—Sale of the above lots (3) is subject to a condition requiring that the purchaser shall erect improvements thereon to the value of \$5,000 within two years from the date of sale or such further period as may be determined by the Minister of Lands; a Crown grant will not be issued until this condition has been complied with. Building construction shall comply with all requirements of responsible authorities.—(M.61507.)

DARTMOOR.—Sale (No. 12038) of Crown land in fee-simple, by auction, will be held at the LAND INSPECTOR'S OFFICE, DARTMOOR, on TUESDAY, the 10th day of MARCH, 1970, at ONE o'clock p.m. To be conducted by K. C. Gittens, Land Officer, Hamilton.

TOWNSHIP OF LYONS, PARISH OF GLENAULIN, COUNTY OF NORMANBY.

In the south-east of the Township fronting a Government road which adjoins the Railway.

Lot 1.

Upset price \$40 the lot. Survey fee \$16.

Area 1 acre 3 roods 39 perches, allotment 11 of section 2. One month allowed for the removal of improvements.—(J.33360.)

Lot 2.

Upset price \$60 the lot. Survey fee \$16.

Area 1 acre 3 roods 20 perches, allotment 12 of section 2.

Lot 3.

Upset price \$60 the lot. Survey fee \$16.

Area 1 acre 3 roods 9 perches, allotment 13 of section 2.

Lot 4.

Upset price \$50 the lot. Survey fee \$16.

Area 1 acre 1 rood 31 perches, allotment 14 of section 2.—(J.33581.)

Lot 5.

PARISH OF DRUMBORG, COUNTY OF NORMANBY.

Fronting the northern side of the Henty Highway about $3\frac{1}{2}$ miles north of Heywood, being the former Mt. Eckersley State School Reserve.

Upset price \$150 the lot. Survey fee \$19.25.

Area 6 acres 2 roods, subject to survey. Allotment 8 of section 11.—(J.33260.)

Lot 6.

PARISH OF MOCAMBORO, COUNTY OF NORMANBY.

In the north-west of the Parish, being former State School Reserve.

Upset price \$72 the lot. Survey fee \$16.

Area 7 acres 2 roods, subject to survey. Allotment 1E of section 22. Valuation of Improvements \$70 (pine trees and fencing) (Education Department).—(J.32448.)

COLERAINE.—A sale of freehold land, by auction, for and on behalf of the Minister of Education will be held at the LAND INSPECTOR'S OFFICE, COLERAINE, on TUESDAY, the 10th day of MARCH, 1970, at TEN o'clock a.m. To be conducted by K. C. Gittens, Land Officer, Hamilton.

CONDITIONS:—Deposit of at least 12 $\frac{1}{2}$ per cent. of purchase price payable at the sale and balance within 60 days. Purchaser to arrange for and bear costs of registration of transfer of titles (2).

Lot 1.

PARISH OF HILGAY, COUNTY OF DUNDAS.

Being the former Tarranlea State School site.

Upset price \$250 the lot.

Area 4 acres, being part allotment 7 of section 13 and being the whole of the land more particularly described in freehold certificates of title, volume 3445, folio 869, and volume 4813, folio 537. Improvements consist of old school building, shelter shed and toilet (all in poor condition).—(J.33254.)

PROPOSED REVOCATIONS OF TEMPORARY RESERVATIONS OF LANDS BY ORDERS IN COUNCIL.

IN pursuance of the provisions of the Land Act 1958, notice is hereby given that it is the intention of the Governor in Council to revoke the temporary reservations of lands by Orders in Council hereunder referred to, viz.:—

The following Notices were published 1° on the 9th January, 1970, pursuant to Orders of the 16th December, 1969.

BOOMAHNOOMOONAH, BUNDALONG, PELLUEBLA, YARRAWONGA.—The temporary reservation, by Order in Council of the 12th April, 1882, of 713 acres 1 rood 24 perches in the Parishes of Boomahnoomoonah, Bundalong, Pelluebla and Yarrawonga, as a site for Conservation of Water, revoked as to part by various Orders, is about to be revoked, so far as the balance containing 690 acres 2 roods 12 perches, is concerned.—(B.701^(*), B.559^(*), P.145^(*), Y.86^(*)) (Rs.1422).

BUNINYONG.—The temporary reservation by Order in Council of the 29th October, 1946, of 24 acres, more or less, of land in the Parish of Buninyong as a site for Rubbish Depot, is about to be revoked.—(B.489⁽¹⁰⁾) (Rs.5889).

HOTHAM AND YERTO.—The temporary reservation by Order in Council of the 14th March, 1962, of 38,000 acres, more or less, of land in the Counties of Bogong, Dargo, Delatite and Wonnangatta, as a site for an Alpine Resort, revoked as to part by various Orders is about to be revoked so far only as the portion containing 17 acres 4 perches indicated by hatching on plan hereunder is concerned.—(County Plan 4) (Rs.8115).

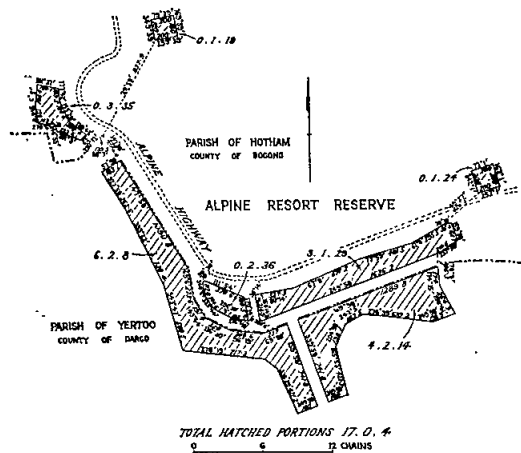

HOTHAM AND YERTOOS.—The temporary reservation by Order in Council of the 14th March, 1962, of 38,000 acres, more or less, of land in the Counties of Bogong, Dargo, Delatite and Wonnangatta, as a site for an Alpine Resort, revoked as to part by various Orders, is about to be revoked so far only as the portion containing 11 acres 3 roods 23 perches indicated by hatching on plan hereunder is concerned.—(County Plan 4) (Rs.8115).

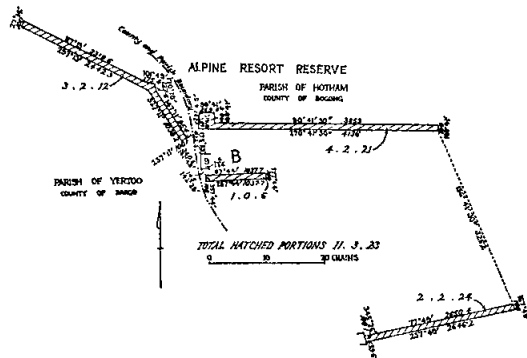

MARYBOROUGH.—The temporary reservation by Order in Council of the 7th October, 1958, of 1 rood 13 perches of land in the Parish of Maryborough, as a site for the purposes of the Forests Act, is about to be revoked.—M.66(18) (Rs.7619).

W. J. F. McDONALD,
Minister of Lands.

PROPOSED REVOCATIONS OF TEMPORARY RESERVATIONS OF LANDS BY ORDERS IN COUNCIL.

IN pursuance of the provisions of the *Land Act 1958*, notice is hereby given that it is the intention of the Governor in Council to revoke the temporary reservations of lands by Orders in Council hereunder referred to, viz.:

The following Notices were published 1° on the 9th January, 1970, pursuant to Orders of the 23rd December, 1969.

LANDSBOROUGH.—The temporary reservation by Order in Council of the 19th November, 1866, of 89 acres 1 rood 6 perches of land in the Parish of Landsborough as a site for a Racecourse and the temporary reservation by Order in Council of the 10th March, 1903, of 2 roods 5 perches of land in the Parish of Landsborough as an extension thereto are about to be revoked.—(L.119(7)) (Rs.646).

WATCHEM.—The temporary reservation by Order in Council of the 11th March, 1890, of 2 acres of land in the Parish of Watchem as a site for a State School is about to be revoked.—(W.304(9)) (E.13635).

BOLWARRA.—The temporary reservation by Order in Council of the 19th January, 1917, of 364 acres 2 roods 32 perches of land in the Parish of Bolwarra (formerly Parishes of Bolwarra and Gorae) as a site for a Quarry for the use of the Department of Public Works, revoked

as to part by order of the 12th October, 1954, is about to be revoked so far only as the portion containing 60 acres indicated by hatching on plan hereunder is concerned.—(B.428(8)) (Rs.1429).

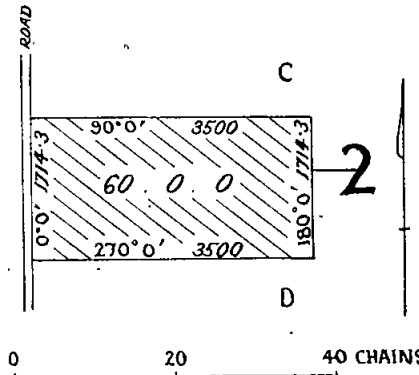

GEELONG.—The temporary reservation by Order in Council of the 4th April, 1911, of 1 rood 17½ perches of land in the City of Geelong, Parish of Corio as a site for Railway purposes is about to be revoked so far only as the portion containing 17 perches indicated by hatching on plan hereunder is concerned.—(C.272(6)) (Rs.1172).

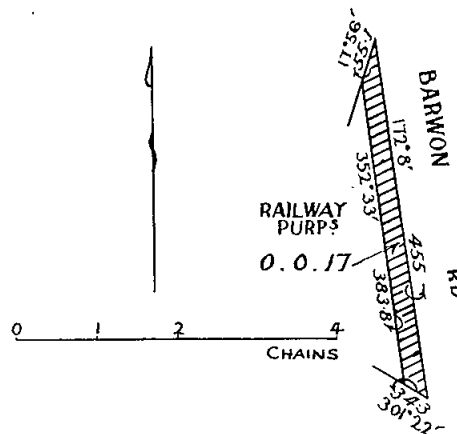

BAIRNSDALE.—The temporary reservation by Order in Council of the 14th April, 1862 (see *Government Gazette* 27th May, 1862, page 917), of 2 roods 39 perches of land in the Township of Bairnsdale as a site for Police purposes is about to be revoked.—(B.66(11)) (Rs.2300).

GERANG GERUNG.—The temporary reservation by Order in Council of the 31st May, 1910, of 1 rood 7 perches of land in the Township of Gerang Gerung as a site for Water Supply purposes is about to be revoked.—(G.212(4)) (C.41924).

GLENORCHY.—The temporary reservation, by Order in Council of the 29th December, 1868 (see *Government Gazette* 8th January, 1869, page 40) of 3 roods 20 perches of land in the Township of Glenorchy as a site for Police purposes, is about to be revoked.—(C.79(6)) (68.Q.772).

W. J. F. McDONALD,
Minister of Lands.

PROPOSED REVOCATION OF TEMPORARY RESERVATION OF LAND BY ORDER IN COUNCIL.

IN pursuance of the provisions of the *Land Act 1958*, notice is hereby given that it is the intention of the Governor in Council to revoke the temporary reservation of land by Order in Council hereunder referred to, viz.:

The following Notice was published 1° on the 10th December, 1969, pursuant to Order of the 2nd December, 1969.

CARPENDEIT.—The temporary reservation by Order in Council of the 30th September, 1940, of 15 acres 2 roods 10 perches of land in the Parish of Carpendeit as a site for the supply of gravel, is about to be revoked.—(C.386(2)) (Rs.5092.)

W. J. F. McDONALD,
Minister of Lands.

PROPOSED REVOCATIONS OF TEMPORARY RESERVATIONS OF LANDS BY ORDERS IN COUNCIL.

IN pursuance of the provisions of the *Land Act 1958*, notice is hereby given that it is the intention of the Governor in Council to revoke the temporary reservations of lands by Orders in Council hereunder referred to, viz.:—

The following Notices were published 1° on the 19th December, 1969, pursuant to Orders of the 9th December, 1969.

TANJIL.—The temporary reservation, by Order in Council of the 21st February, 1870 (see *Government Gazette*, 25th February, 1870, page 381) of 4 acres 2 roods of land in the Parish of Tanjil as a site for Recreation purposes and the temporary reservation by Order in Council of the 12th July, 1966, of 3 acres of land in the Parish of Tanjil, as an extension thereto, are about to be revoked.—(T.189⁽¹⁵⁾) (Rs.8214).

EDI.—The temporary reservation, by Order in Council of the 31st May, 1886 (see *Government Gazette*, 4th June, 1886, page 1399) of 8 acres 2 roods 4 perches of land in the Parish of Edi as a site for a Cemetery is about to be revoked.—(E.108⁽⁹⁾) (H.032372).

RICHMOND.—The temporary reservation, by Order in Council of the 16th July, 1918, of 18 acres 2 roods 20 perches, more or less, of land in the City of Richmond, Parish of Jika Jika, as a site for Recreation purposes, revoked as to part by various Orders, is about to be revoked so far only as the portion containing 1 acre 3 roods 15 perches, indicated by hatching on plan hereunder, is concerned.—(R.19⁽⁴⁾) (Rs.1802).

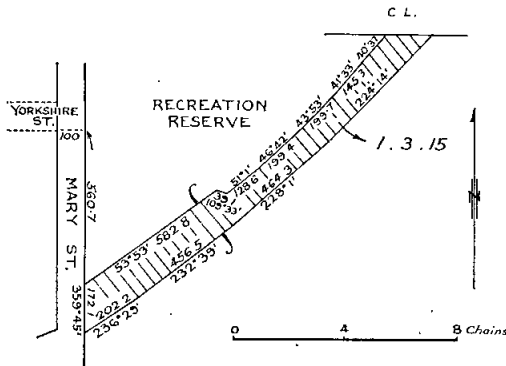

MURRAMURRANGBONG.—The temporary reservation as a site for affording access to Water and the withholding from sale, leasing and licensing by Order in Council of the 18th October, 1880, of 16 acres 1 rood 22 perches of land in the Parish of Murrumbidgee revoked as to part by Order of the 14th May, 1946, are about to be revoked so far only as the portion containing 1 acre 1 rood, more or less, indicated by hatching on plan hereunder is concerned.—(M.286⁽³⁾) (Rs.5297).

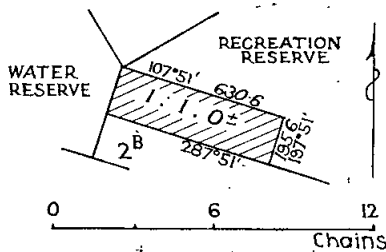

W. J. F. McDONALD,
Minister of Lands.

Land Settlement Act 1959.

LAND AVAILABLE FOR APPLICATION.

NOTIFICATION is hereby given in accordance with Section 7 of the *Land Settlement Act 1959*, that the under-mentioned holdings are available for settlement.

Any male person who is not less than 21 years of age, who is a British subject may apply on the prescribed form for settlement on any holding, indicating where he applies in respect of more than one holding his order of preference therefor.

Prescribed application forms, plans and further details may be obtained from the Secretary, Rural Finance and Settlement Commission, Embank House, 325 Collins-street, Melbourne, Victoria, 3000. (Tel. 61 3771, Ext. 60.)

Closing date for receipt of completed application forms for settlement on these holdings is the 9th February, 1970, such applications to be in the hands of the Secretary, Rural Finance and Settlement Commission, on or before that date.

SCHEDULE OF ALLOTMENTS.

SUBDIVISION OF THE 24TH PORTION OF HEYTESBURY PROJECT.

PARISH OF CORADJIL—COUNTY OF HEYTESBURY.

Suitable for Dairying with Supplementary Production of Fat Stock.

Lot Number of Plan of Subdivision.	Approximate Area in Acres (Subject to Survey).
355	190
361	195
366	194
369	205
370	195
371	190
372	190
373	200
374	200
450	195
454	200
455	200
456	200

M. J. CRONIN,
Secretary.

Rural Finance and Settlement Commission,
Melbourne, 3000, 8th January, 1970.

PUBLIC SERVICE NOTICE

No. 399.

Public Service Act 1958, Section 39.

REGULATIONS.—PART IV.—SALARIES AND INCREMENTS.

THE Public Service Board, in pursuance of the powers conferred by the *Public Service Act 1958*, hereby amends its Regulations as shown below:—

FIRST SCHEDULE.

PROFESSIONAL DIVISION.

Amount of Salary Assigned to Offices in Class "A1".

Office.	Yearly Rate of Salary.
CHIEF SECRETARY'S DEPARTMENT.	\$
Delete— Director of Fisheries and Wildlife ..	12,060
Add— Director of Fisheries and Wildlife. ..	13,450

This Regulation shall have effect as on and from the 4th January, 1970.

F. E. CAHILL, Chairman.
V. P. SCULLY, Secretary.

Office of the Public Service Board,
Melbourne, 24th December, 1969.

TENDERS**PUBLIC WORKS DEPARTMENT**

TENDERS will be received at Public Works Department, 2 Treasury-place, Melbourne, until **TWO p.m.** on dates shown and for purposes mentioned hereunder.

Particulars and tender forms available at Contracts Office, Room 7, Building Division, Parliament-place and at places indicated in brackets hereunder.

Abbreviations in brackets mean:—W.O.—Inspector of Works Office; P.S.—Police Station; C.S.—Consolidated School; H.E.S.—Higher Elementary School; H.S.—High School; Pr.S.—Primary School; T.S.—Technical School.

Tenders to be submitted on the Department's printed Tender Form and will not be received by telephone. All tenders must be on a "Firm Tender" basis. The lowest or any tender will not necessarily be accepted.

Address tenders to the Minister of Public Works, and endorse the envelope containing the tender "Tender for , closing Tuesday,

Hand delivered tenders to be placed in the Tender Box of the Public Works Department, located on the wall of the centre entrance foyer, Ground Floor, 2 Treasury-place, Melbourne.

No preliminary deposit is required with any tender, but a successful tenderer will be required to pay a deposit for any accepted tender of \$4,000 or over.

Tuesday, 20th January, 1970.**Building, Electrical and Mechanical Works.**

Ballarat.—Additions to heating system, Ward 18, Lakeside Hospital. (W.O., Ballarat.)

Briar Hill.—Provision of toilet block and loop water service, Pr.S.

Maffra.—Extension of heating system, High School. (W.O., Traralgon.)

Mont Park.—External repairs and painting to Wards F1, F4, F6, M3 to M6A and airing court shelters, Mental Hospital. (Re-Advertised.)

Myrtleford.—Erection of a Brick Court House. (W.O., Wangaratta and Benalla.)

Site Works.

Tatura.—Concrete, drainage and gravel works, &c., Pr.S. (W.O., Shepparton.)

Wednesday, 28th January, 1970.**Building, Electrical and Mechanical Works.**

Ascot Vale.—Repairs and external painting, Pr.S.

Ballarat North.—Replacement of roof on Bristol Building, Pr.S. (W.O., Ballarat.)

Heatherton.—Supply and installation of oil fired incinerator, Sanatorium.

Sunshine.—Installation of fire service, High School.

Site Works.

Rutherglen.—Asphalt, drainage, earthworks and gravel works, &c., Pr.S. (W.O., Wangaratta.)

Tuesday, 3rd February, 1970.**Building, Electrical and Mechanical Works.**

Coburg.—Replacement of roofing to various buildings, Pentridge Prison.

Glenormiston.—Electrical installation for existing Mansion, Glenormiston Estate. (W.O., Warrnambool.)

Melbourne.—Erection of additional brick veneer wing, Victorian School for Deaf Children. (Re-Advertised.)

Miscellaneous.

Port Melbourne.—Supply and delivery of six (6) only 5 cubic yards Tipping Trucks, Plant Depot, Public Works Department.

Williamstown.—Supply and delivery of Mild Flanged Pipes, Ports & Harbours Branch, Dredging Depot.

Tuesday, 10th February, 1970.**Building, Electrical and Mechanical Works.**

Foster.—Internal and external renovations, new toilet facilities and entrance lobby, Court House. (W.O., Korumburra.)

Miscellaneous.

Kew.—Steam heating for Wards F.3 and F.4, Mental Hospital.

M. V. PORTER,
Minister of Public Works.

Public Works Department,
Melbourne, 3002, 12th January, 1970.

PRIVATE ADVERTISEMENTS

NOTICE is hereby given that Aurora Ski Club has applied for a lease under Section 134 of the Land Act 1958, for a term of 21 years in respect of an area of 0 acres 2 roods 7 perches, being allotment 7, Section 1, Parish of Yertoo, as a site for a Ski Club Lodge.

P. CROCKER,
Secretary, Aurora Ski Club.

1719

NOTICE OF INTENTION TO APPLY FOR A LICENCE TO DIVERT WATER AND CUT RACE (RE-ISSUE) FROM THE RIVER MURRAY, AT NANGILOC.

I HEREBY give notice that I intend to apply for a licence empowering me to divert water for a term of fifteen years to the extent of 150 acre-feet per annum, for the irrigation of 50 acres of pastures and citrus being part of allotment 19, Parish of Carwarp, and to occupy certain Crown lands for works of diversion, and to cut a race thereon.

Any objection to such application must be forwarded in writing to reach the State Rivers and Water Supply Commission, Melbourne, before 14th February, 1970, being 30 days from the first publication of this notice.

ROYAL GEORGE KAUFFMAN.

Care of Box 405, Mildura, 3500. 2144

NOTICE OF INTENTION TO APPLY FOR A LICENCE TO DIVERT WATER AND CUT RACE FROM THE RIVER MURRAY AT PIANGIL.

I HEREBY give notice that I intend to apply for a licence empowering me to divert water for a term of four years to the extent of 150 acre-feet per annum at a maximum rate of 15 acre-feet per day of 24 hours for the irrigation of grazing pasture, being part of allotment 124A, Parish of Piangil, and to occupy certain Crown lands for works of diversion, and to cut a race thereon.

Any objection to such application must be forwarded in writing to reach the State Rivers and Water Supply Commission, Melbourne, before 14th February, 1970, being 30 days from the first publication of this notice.

FRANK REGINALD GRANT.

Chinkapook. 2144

NOTICE OF INTENTION TO APPLY FOR A LICENCE TO DIVERT WATER AND CUT RACE (RE-ISSUE) FROM THE GOULBURN RIVER, AT LAKE NAGAMBIE.

I HEREBY give notice that I intend to apply for a licence empowering me to divert water for a term of fifteen years to the extent of 200 acre-feet per annum at a maximum rate of 10 acre-feet per day of 24 hours, for the irrigation of pasture and lucerne, being part of Bailleston Pre-Emptive, Parish of Bailleston, and to occupy certain Crown lands for works of diversion, and to cut a race thereon.

Any objection to such application must be forwarded in writing to reach the State Rivers and Water Supply Commission, Melbourne, before 14th February, 1970, being 30 days from the first publication of this notice.

K. R. MENZIES ESTATE.

Polloch, Nagambie, 3608. 2110

NOTICE OF INTENTION TO APPLY FOR A LICENCE TO DIVERT WATER AND CUT RACE (RE-ISSUE) FROM THE RIVER MURRAY, AT YELTA.

I HEREBY give notice that I intend to apply for a licence empowering me to divert water for a term of fifteen years to the extent of 9 acre-feet per annum, for the irrigation of 3 acres of market garden, orchard and pastures being part of allotment 38, Parish of Yelta, and to occupy certain Crown lands for works of diversion, and to cut a race thereon.

Any objection to such application must be forwarded in writing to reach the State Rivers and Water Supply Commission, Melbourne, before 14th February, 1970, being 30 days from the first publication of this notice.

MICHAEL PATRICK KAIRNS.

Care of Box 405, Mildura, 3500. 2145

NOTICE OF INTENTION TO APPLY FOR A LICENCE TO DIVERT WATER AND CUT RACE (RE-ISSUE) FROM THE RIVER MURRAY AT YELTA.

I HEREBY give notice that I intend to apply for a licence empowering me to divert water for a term of fifteen years to the extent of 21 acre-feet per annum at a maximum rate of 1 acre-feet per day of 24 hours for the stock water and grass covering in saleyards so as to

obviate dust being part of allotment 1, section 4, Township of Cowanna, Parish of Yelta, and to occupy certain Crown lands for works of diversion, and to cut a race thereon.

Any objection to such application must be forwarded in writing to reach the State Rivers and Water Supply Commission, Melbourne, before 14th February, 1970, being 30 days from the first publication of this notice.

For ELDER SMITH GOLDSBROUGH
MORT LIMITED.

Wentworth, N.S.W., 2648.

2148

NOTICE OF INTENTION TO APPLY FOR A LICENCE TO DIVERT WATER AND CUT RACE (RE-ISSUE) FROM THE RIVER MURRAY, AT NICHOL'S POINT.

I HEREBY give notice that I intend to apply for a licence empowering me to divert water for a term of fifteen years to the extent of 93 acre-feet per annum at a maximum rate of 2 acre-feet per day of 24 hours for the irrigation of 31 acres of vines being part of allotment A (lot 3 and part of lot 2, L.P.14431), Parish of Mildura, and to occupy certain Crown lands for works of diversion, and to cut a race thereon.

Any objection to such application must be forwarded in writing to reach the State Rivers and Water Supply Commission, Melbourne, before 14th February, 1970, being 30 days from the first publication of this notice.

MATTHEW VICTOR MATOTEK
& HELEN MATOTEK.

Nichol's Point, Post Office, 3501.

2151

NOTICE OF INTENTION TO APPLY FOR A LICENCE TO DIVERT WATER AND CUT RACE (RE-ISSUE) FROM THE RIVER MURRAY, AT ECHUCA, VICTORIA.

WE hereby give notice that we intend to apply for a licence empowering us to divert water for a term of fifteen years to the extent of 200 acre-feet per annum at a maximum rate of 20 acre-feet per day of 24 hours for the irrigation of lucerne and pastures, being part of allotments 115, 116, 116A, 117, 118, 119, 120 and 121, and lot 1 on L.P. 68862, Parish of Wharparilla, and to occupy certain Crown lands for works of diversion, and to cut a race thereon.

Any objection to such application must be forwarded, in writing, to reach the State Rivers and Water Supply Commission, Melbourne, before 14th February, 1970, being 30 days from the first publication of this notice.

ELLERSTON (N.S.W.) PROPRIETARY LIMITED.

Merrylands, P.O. Box 46, Sorrento, Vic., 3943.

2102

NOTICE OF INTENTION TO APPLY FOR A LICENCE TO DIVERT WATER AND CUT RACE FROM THE GOULBURN RIVER, AT ALEXANDRA.

I HEREBY given notice that I intend to apply for a licence to divert water for a term of fifteen years to the extent of 140 acre-feet per annum at a maximum rate of 2 acre-feet per day of 24 hours, for the purpose of irrigating 70 acres of pasture on parts of allotment 38 and the whole of allotment 39, Parish of Alexandra, and to occupy certain Crown lands for the purpose of diversion, and to cut a race thereon.

Any objection to such application must be forwarded, in writing, to reach the State Rivers and Water Supply Commission, Melbourne, before the 14th February, 1970, being 30 days from the first publication of this notice.

OSWALD DUNN.

Box 34, Alexandra.

2104

TRARALGON SEWERAGE AUTHORITY.

THE Traralgon Sewerage Authority, having made provision for the carrying off of sewage from each and every property which or any part of which is within the sewerage area hereinafter described, doth hereby declare that on and after the 1st day of December, 1969, each and every property which or any part of which is within the said sewerage area, shall be deemed to be a seweraged property within the meaning of the *Sewerage Districts Act 1958*.

The boundaries of the sewerage area hereinbefore referred to are as follows:—

Sewerage Area No. 55.—Commencing at the intersection of the boundaries of Sewerage Area No. 53 and Sewerage Area No. 49, being a point on the north-east corner of lot No. 81, lodged plan No. 23924; thence southerly along the boundary of Sewerage Area No. 53 and Sewerage Area No. 15; thence easterly along the boundary of Sewerage Area No. 15, across West-court and Canfield-crescent to a point on the east building line of Canfield-crescent; thence generally north-easterly along the east

building line of Canfield-crescent to the northern corner of lot No. 116, lodged plan No. 23924; thence westerly along the boundary of Sewerage Area No. 49 to the point of commencement—all of which boundaries are shown on a plan which is open for inspection at the office of the Traralgon Sewerage Authority.

By order of the said Sewerage Authority.

DONALD DUNBAR, Chairman.

2121 KENNETH JAMES SAUNDERS, Secretary.

SHEPPARTON SEWERAGE SOCIETY.

BY LAW No. 12.

NOTICE is hereby given that the Shepparton Sewerage Authority, in pursuance and exercise of powers conferred by the Sewerage Districts Acts, has made By-Law No. 12.—

- (i) Providing for the repeal of By-Laws Nos. 1 and 5;
- (ii) Prescribing general regulations relating to applications for consent to connect with the sewerage system or to do plumbing and drainage work connected therewith;
- (iii) Fixing fees for the supply of plans and for examining, testing and inspecting work relating to the connecting of premises to the Authority's sewers;
- (iv) Providing for the licensing and control of plumbers and drainers performing work within the sewerage district;
- (v) Prescribing conditions of discharge of trade waste refuse into the Authority's sewers;
- (vi) Controlling the use of materials and detailing methods of plumbing installation;
- (vii) Providing for the By-Law to be read in conjunction with the appropriate clauses in the Uniform Building Regulations 1969 relating to house connection work.

A copy of the said By-Law is open for inspection, free of charge, during office hours at the office of the Sewerage Authority, Civic Centre, Welsford-street, Shepparton.

6th January, 1970.

2129

R. O'BRIEN, Secretary.

CITY OF DONCASTER AND TEMPLESTOWE.

LOAN No. 132.

Notice of Intention to Borrow the Sum of \$120,000 for Permanent Works and Undertakings.

NOTICE is hereby given that the Council of the City of Doncaster and Templestowe proposes to borrow the principal sum of One hundred and twenty thousand dollars secured by a charge over the general rates of the municipality, such sum to be raised by the grant of a mortgage, in accordance with the provisions of the *Local Government Act 1958*.

1. The maximum rate of interest that may be paid is 6.4 per cent. per annum.

2. The purpose for which the loan is to be applied is—

- (a) Part cost of construction of Stage 1 of the Swimming Pool Project . . . \$70,000
- (b) Cost of purchase of the following property:—

Part lot 2A on P/S 46654 being No. 895 Doncaster-road, Doncaster (balance) . . .	22,100
Land remaining in C/T vol. 3495, fol. 888, being No. 293 Manningham-road, Lower Templestowe Lot 50 Balsam-street, Lower Templestowe . . .	21,250
Lot 9 High-street, Doncaster (part compensation) . . .	4,400
	2,250
	<hr/>
	\$120,000

3. The period of the loan shall be fifteen years.

4. The moneys borrowed shall be repayable by providing out of the municipal fund 30 half-yearly instalments of approximately \$6,281 each, including principal and interest, on the 1st day of April and the 1st day of October, during the currency of the loan. The first instalment shall be payable on the 1st day of October, 1970.

5. Such moneys shall be repayable to the Commissioners of the State Savings Bank of Victoria at the office of the said Commissioners, corner Elizabeth and Bourke streets, Melbourne.

The plans and specifications and the estimate of the cost of the proposed works, and a statement showing the expenditure of the moneys to be borrowed, are open for inspection at the office of the Council of the City of Doncaster and Templestowe at Municipal Offices, Doncaster-road, Doncaster.

J. W. THOMSON, Town Clerk.

CITY OF FOOTSCRAY.

LOAN No. 96.

Notice of Intention to Borrow the Sum of \$85,000 for Permanent Works and Undertakings.

NOTICE is hereby given that the Council of the City of Footscray proposes to borrow the sum of Eighty-five thousand dollars secured by a charge over the general rates of the Municipality, such sum to be raised by the grant of a mortgage in accordance with the provisions of the Local Government Act 1958.

That the maximum rate of interest that may be paid shall be 6.4 per centum per annum.

The purpose for which the loan is to be applied is for the purchase of land situated on the north side of Kinnear-street, Footscray, to provide a rubbish tip for the inoffensive disposal and/or destruction of refuse and rubbish within the municipality.

The period of the loan shall be forty (40) years.

The moneys borrowed shall be repayable by providing out of the municipal fund eighty equal half-yearly instalments of \$2,958.03 which shall cover principal and interest, on the 1st day of March and the 1st day of September in each year, during the currency of the loan. The first instalment shall be payable on the 1st day of September, 1970.

Such moneys shall be repayable at the office of the Australian Mutual Provident Society, 535 Bourke-street, Melbourne.

The plans, specifications and estimate of the cost of the works and a statement showing the proposed expenditure of the moneys to be borrowed are open for inspection at the Town Hall, Napier-street, Footscray.

Dated this 5th day of January, 1970.

W. H. SWABY, Town Clerk.

Town and Country Planning Act 1961.

CITY OF GEELONG—GEELONG PLANNING SCHEME 1959.

NOTICE THAT A PLANNING SCHEME HAS BEEN PREPARED AND IS AVAILABLE FOR INSPECTION.

Amendment No. 13.

NOTICE is hereby given that the City of Geelong, in pursuance of its powers under the Town and Country Planning Act 1961, has prepared a planning scheme for—

Land within the City of Geelong and situate at the south-west corner of Garden and Richmond streets, being part of section 81, Parish of Corio.

A copy of the scheme has been deposited at the City of Geelong, Gheringhap-street, Geelong, and at the office of the Town and Country Planning Board, 235 Queen-street, Melbourne, and will be open for inspection during office hours by any person, free of charge.

Any persons affected by the planning scheme are invited to set forth in writing, all objections they may have, addressed to the Town Clerk, City of Geelong, City of Geelong, Gheringhap-street, Geelong, on or before the 14th day of January, 1970, and to state whether they wish to be heard in respect of their objection.

Dated the 14th January, 1970.

L. L. WALTER, Town Clerk.

CITY OF HEIDELBERG.

LOAN No. 150.

Notice of Intention to Borrow the Sum of \$100,000 for Permanent Works and Undertakings.

NOTICE is hereby given that the Council of the City of Heidelberg intends to borrow the sum of \$100,000 (one hundred thousand dollars) secured by a charge over the general rates of the municipality, such sum to be raised by the grant of a mortgage, in accordance with the provisions of the Local Government Act 1958.

1. The maximum rate of interest that may be paid is 6.4 per centum per annum.

2. The purposes for which the loan is to be applied are—

The carrying out of capital works for the extension of the electric energy undertaking	\$52,000
Country Roads Board Works	\$48,000
	\$100,000

3. The period of the loan shall be 40 years.

4. The money borrowed shall be repayable by providing out of the municipal fund half-yearly instalments of \$3,480.03, including principal and interest, on the 6th day of April and the 6th day of October in each year during the currency of the loan. The first instalment shall be payable on the 6th day of October, 1970.

5. Such moneys shall be repayable to the Australian Mutual Provident Society, Victoria Branch.

The plans and specifications and the estimate of the cost of the proposed works, and a statement showing the proposed expenditure of the money to be borrowed, are open for inspection at the office of the Council, Town Hall, Ivanhoe.

2128

E. C. W. JACK, Town Clerk.

CITY OF KEW.

LOAN No. 59.

Notice of Intention to Resolve to Borrow Principal Moneys Amounting to \$30,000 for Permanent Works and Undertakings.

NOTICE is hereby given that the Council of the City of Kew proposes to resolve to borrow principal moneys amounting to \$30,000, secured by a charge over the general rates of the municipality, such moneys to be raised by the grant of a mortgage, in accordance with the provisions of the Local Government Acts.

1. The maximum rate of interest that may be paid is 6.4 per centum per annum.

2. The period of the loan shall be fifteen years.

3. The moneys borrowed shall be repayable by providing out of municipal fund 30 half-yearly instalments of approximately \$1,570.00 each, including principal and interest, on the 1st day of March and 1st day of September during the currency of the loan. The first instalment shall be payable on the 1st day of September, 1970.

4. Such moneys shall be repayable to the Commissioners of the State Savings Bank of Victoria at the office of the said Commissioners, corner Elizabeth and Bourke streets, Melbourne.

5. The purposes for which the loan is to be applied are—

Construction of Roads (C.R.B. Main)	
Studley Park-road	\$20,000
Underground Drains	
Disraeli-street/Park-crescent (part cost).	\$10,000
	\$30,000

The plans and specifications and the estimate of the cost of the proposed works, and a statement showing the proposed expenditure of the moneys to be borrowed, are open for inspection at the Town Hall, Walpole-street, Kew.

Dated this 9th day of January, 1970.

2127

J. L. JOHNSON, Town Clerk.

TOWN OF ST. ARNAUD.

LOAN No. 35.

Notice of Intention to Borrow the Sum of \$7,900 for Permanent Works and Undertakings.

NOTICE is hereby given that the Council of the Town of St. Arnaud proposes to borrow the principal sum of \$7,900 secured by a charge over the general rates of the municipality, such sum to be raised by the grant of a mortgage in accordance with the provisions of the Local Government Act 1958.

1. The maximum rate of interest that may be paid is 6.4 per cent. per annum.

2. The purpose for which the loan is to be applied is:—

Concrete Footpaths:	
Canterbury and Bewley streets and Queens-avenue	\$1,310
Kerb and Channel:	
Silvermines-road, Butcher-street, Mill-street, Bowen-street, Market and Canterbury streets, Navarre-road, Bewley and Millett streets	4,990
Purchase of a utility	1,600
	\$7,900

3. The period of the loan shall be fifteen years.

4. The moneys borrowed shall be repayable by providing out of the municipal fund half-yearly instalments of \$413.54 each, including principal and interest, on the 2nd day of March and the 2nd day of September during the currency of the loan. The first instalment shall be payable on the 2nd day of September, 1970.

5. Such moneys shall be repayable to the National Bank Savings Bank Limited, at 271-285 Collins-street, Melbourne.

The plans and specifications and the estimate of the cost of the proposed works, and a statement showing the proposed expenditure of the moneys to be borrowed, are open for inspection at the office of the Council of the Town of St. Arnaud at the Town Hall, St. Arnaud.

2109

J. B. NEAL, Town Clerk.

TOWN OF BAIRNSDALE.

BY-LAW No. 5.

A By-Law of the Town of Bairnsdale made under the provisions of the *Dog Act 1958* as amended, and numbered 5 for the purpose of prescribing the fees to be charged for the registration of dogs and other fees payable.

IN pursuance of the powers conferred by the *Dog Act 1958*, as amended and by every power thereunto enabling the Mayor, Councillors and Burgesses of the Town of Bairnsdale order as follows:—

1. By-Law No. 3 is hereby repealed.

2. This By-law shall apply to and have effect throughout the whole of the municipal district of the Town of Bairnsdale.

3. The following fees and sums are fixed pursuant to the *Dog Act 1958*, as amended.

(a) For registration pursuant to Section 6 of the <i>Dog Act 1958</i> as amended by any Act	\$2.00
(b) For particulars of any dog or for the name of the registered owner thereof or for a certified copy of the receipt mentioned in Section 12 of the <i>Dog Act 1958</i> as amended by any Act	\$0.25
(c) Sum payable to the Registration Officer pursuant to Section 15 of the <i>Dog Act 1958</i> as amended by any Act	\$2.00
(d) Sum payable to the Registration Officer pursuant to Section 16 of the <i>Dog Act 1958</i> as amended by any Act	\$5.00

Resolution for passing this By-law agreed to by the Council of the Town of Bairnsdale on the 24th day of November, 1969 and confirmed on the 22nd day of December, 1969.

The common seal of the Mayor, Councillors and Burgesses of the Town of Bairnsdale was hereunto affixed in the presence of—

(SEAL) J. G. GIBBONS, Mayor,
H. R. HAYLOCK, Councillor.
T. N. MUNTZ, Town Clerk.

2108

SHIRE OF BRIGHT.

LOAN No. 42.

Notice of Intention to Borrow the Sum of \$9,000 for Permanent Works and Undertakings.

NOTICE is hereby given that the Council of the Shire of Bright proposes to borrow the principal sum of \$9,000 secured by a charge over the general rates of the municipality such sum to be raised by the grant of a mortgage in accordance with the provisions of the *Local Government Act 1958*.

1. The maximum rate of interest that may be paid is 5 per cent. per annum.

2. The purpose for which the loan is to be applied is the construction of a caretaker's residence at the Porepunkah Camping Park.

3. The period of the loan shall be fifteen years.

4. The moneys borrowed shall be repayable by providing out of the municipal fund 30 half-yearly instalments of \$430.00 each, including principal and interest, on the 1st day of September and the 1st day of March during the currency of the loan. The first instalment shall be payable on the 1st day of September, 1970.

5. Such moneys shall be repayable at the Australian and New Zealand Bank, Melbourne.

6. The plans and specifications and the estimates of the cost of the proposed works, and a statement showing the proposed expenditure of the moneys to be borrowed, are open for inspection at the office of the Council of the Shire of Bright at Ireland-street, Bright.

Dated the 8th January, 1970.

2119

H. G. HAYMES, Shire Secretary.

SHIRE OF CRESWICK—SMEATON WATER SUPPLY DISTRICT.

BY-LAW No. 6.

NOTICE is hereby given that the Shire of Creswick has made By-Law No. 6 in pursuance and exercise of the powers and authorities conferred by the *Water Act 1958*, which shall apply to and have force throughout the whole of the Smeaton Water Supply District for the purpose of:—

(a) Repealing By-Law No. 1 of the Shire of Creswick—Smeaton Water Supply District,

(b) Licensing of plumbers.

(c) Construction and arrangement of works.

(d) Specifications for piping and materials.

(e) Connections to mains.

(f) Repairs to private services.

(g) Installation of meters.

(h) Misuse and waste of water.

(i) Private fire services.

(j) Inspections.

(k) Penalties.

The Resolution for passing this By-Law was agreed to by the Council of the Shire of Creswick on 11th day of August 1969 and confirmed on 8th day of September, 1969.

Approved by the Governor in Council at the Executive Council Meeting held on 23rd December, 1969.

A copy of the By-Law is available for inspection, free of charge, during office hours at the Municipal Office, Albert-street, Creswick.

2117

B. C. REES, Shire Secretary.

SHIRE OF DIAMOND VALLEY.

BY-LAW No. 244.

Metropolitan Hawkers.

A By-Law of the Shire of Diamond Valley made under the provisions of Section 36 of the *Hawkers and Pedlars Act 1958*, and numbered 244 for prescribing the limits whether as to time or place within which a person holding a Metropolitan Hawkers Licence may sell or offer or expose for sale any articles specified in their licences in any street, road or public place.

IN pursuance of the powers conferred by the *Hawkers and Pedlars Act 1958*, and by every other Act or power enabling it in that behalf, the Council of the Shire of Diamond Valley with the approval of the Governor-in-Council order as follows:—

1. This By-Law shall be known as the Metropolitan Hawkers By-Law.

2. In this By-Law the words "Metropolitan Hawkers" mean the holder of a Metropolitan Hawkers Licence under the *Hawkers and Pedlars Act 1958*.

3. The limits as to time within which the selling or offering or exposing for sale by a Metropolitan Hawker of any article specified in his licence issued under the *Hawkers and Pedlars Act 1958*, is permitted within such street road or public place within the Municipal District of the Shire of Diamond Valley as are situated in the Metropolitan being the Metropolitan within the meaning of the *Melbourne and Metropolitan Board of Works Act 1958*, are hereby prescribed as between the hours of 10 o'clock in the forenoon and 3 o'clock in the afternoon on any day other than Saturday, Sunday or a public holiday and between the hours of 10 o'clock in the forenoon and 1 o'clock in the afternoon on any Saturday.

4. No Metropolitan Hawker shall so sell or offer or expose for sale any articles specified in his licence issued under the *Hawkers and Pedlars Act 1958*, at any time other than a time permitted by the last preceding clause.

5. Any person guilty of any wilful act or default contrary to this By-Law shall be liable to a penalty of not less than Ten Dollars nor more than Forty Dollars and any person guilty of a continuing offence against this By-Law shall be liable to a penalty of not more than Ten Dollars for each day on which an offence against this By-Law is continued after a conviction or order by any Court.

The resolution for passing this By-Law was agreed to by the Council on the 12th May, 1969, and confirmed on the 9th June, 1969.

(SEAL) R. W. FELL, President
H. G. BARNARD, Councillor.
B. J. MORGAN, Shire Secretary.

Approved by the Governor in Council on the 18th November, 1969.—J. ROSSITER, Clerk of the Executive Council. 2116

SHIRE OF LILLYDALE.

LOAN No. 92.

Notice of Intention to Borrow the Sum of \$55,000 for Permanent Works and Undertakings.

NOTICE is hereby given that the Council of the Shire of Lillydale proposes to borrow the sum of \$55,000 (Fifty-five thousand dollars) secured by a charge over the general rates of the municipality, such sum to be raised by the grant of a mortgage, in accordance with the provisions of the Local Government Act, for permanent works and undertakings within the municipality.

1. The maximum rate of interest that may be paid is 6.4 per centum per annum.

2. The purpose for which the loan is to be applied is—
Extensions to Shire Offices (part cost)—\$55,000.

3. The period of the loan shall be 40 years.

4. The moneys borrowed shall be repayable by providing out of the municipal fund eighty (80) half-yearly instalments, including principal and interest, of approximately \$1,914.02 each on the 2nd days of March and September in each year with a final payment on the 2nd day of March, 2010. The first instalment shall be payable on the 2nd day of September, 1970.

5. Such moneys shall be repayable at the Australian Mutual Provident Society, 425 Collins-street, Melbourne.

The plans, specifications, and an estimate of the cost of the proposed works, are open for inspection at the Shire Office, Anderson-street, Lillydale, during office hours. 2122 G. L. FREEMAN, Acting Shire Secretary.

SHIRE OF MORTLAKE.

LOAN No. 18.

Notice of Intention to Borrow the Sum of \$8,500 for Permanent Works and Undertakings.

NOTICE is hereby given that the Council of the Shire of Mortlake proposes to borrow the sum of \$8,500 secured by a charge over the general rates of the municipality, such sum to be raised by the grant of a mortgage in accordance with the provisions of the Local Government Act 1958.

1. The maximum rate of interest that may be paid is 6.15 per centum per annum.

2. The loan is to be applied for the following purpose:—
Council contribution to improvement works at the Mortlake Recreation Reserve.

3. The period of the loan shall be nine years.

4. The moneys borrowed shall be repayable by providing out of the municipal fund, eighteen half-yearly instalments of \$621.95 each, including principal and interest, on the 1st day of September and the 1st day of March during the currency of the loan. The first instalment shall be payable on the 1st day of September, 1970.

5. Such moneys shall be repayable at the C.B.C. Savings Bank Limited, Melbourne.

The plans and specifications and estimates of the cost of the proposed works, and a statement showing the proposed expenditure of the moneys to be borrowed, are open for inspection at the Shire Offices, Mortlake.

Dated 14th January, 1970.

2124 W. J. GRAY, Shire Secretary.

SHIRE OF NEWHAM AND WOODEND.

LOAN No. 20.

Notice of Intention to Borrow the Sum of \$17,500 for Permanent Works and Undertakings.

NOTICE is hereby given that the Council of the Shire of Newham and Woodend proposes to borrow the principal sum of \$17,500 secured by a charge over the general rates of the municipality such sum to be raised by a grant of a mortgage in accordance with the provisions of the Local Government Act 1958.

1. The maximum rate of interest that may be paid is 6.3 per cent. per annum.

2. The purpose for which the loan is to be applied is:—
Purchase of residence for Council staff .. \$16,000
Purchase of furnishings and renovation of residence 1,500
\$17,500

3. The period of the loan shall be ten years.

4. The moneys borrowed shall be repayable by providing out of the municipal fund twenty half-yearly instalments of approximately \$1,192.65 each, including principal and interest, on the 1st day of October and the 1st day of April during the currency of the loan. The first instalment shall be payable on the 1st day of October, 1970.

5. Such moneys shall be repayable to the Commissioners of the State Savings Bank of Victoria at the office of the said Commissioners, corner Elizabeth and Bourke streets, Melbourne.

The plans and specifications and the estimate of the cost of the proposed works, and a statement showing the proposed expenditure of the moneys to be borrowed, are open for inspection at the office of the Council, Shire Office, Woodend.

2120 N. M. SMITH, Shire Secretary.

SHIRE OF PHILLIP ISLAND.

LOAN No. 50.

Notice of Intention to Borrow the Sum of \$1,000 for Permanent Works and Undertakings.

NOTICE is hereby given that the Council of the Shire of Phillip Island proposes to borrow the principal sum of \$1,000 secured by a charge over the general rates of the municipality, such sums to be raised by the grant of a mortgage, in accordance with the provisions of the Local Government Act 1958.

1. The maximum rate of interest that may be paid is 6.30 per cent. per annum.

2. The purpose for which the loan is to be applied is—
Construction of tennis court—Newhaven.

3. The period of the loan shall be ten years.

4. The moneys borrowed shall be repayable by providing out of the municipal fund twenty half-yearly instalments of approximately \$68.15 each, including principal and interest, on the 1st day of September and the 1st day of March during the currency of the loan. The first instalment shall be payable on the 1st day of September, 1970.

5. Such moneys shall be repayable to the National Bank of Australasia Limited, 271-285 Collins-street, Melbourne.

The plans and specifications and the estimate of the cost of the proposed works and a statement showing the proposed expenditure of the moneys to be borrowed are open for inspection at the office of the Council of the Shire of Phillip Island.

2130 STAN A. HARRIS, Municipal Clerk.

SHIRE OF TULLAROOP

BY-LAW No. 28.

A By-law of the Shire of Tullaroop made under the provisions of Section 197 (1) (xliia) of the Local Government Act 1958 and numbered 28 prescribing areas within the municipal district within which the erection including the adaption for use of any building is prohibited unless the building is connected to a septic tank system.

IN pursuance of the powers contained in the Local Government Act 1958 and of every other power enabling them in that behalf, the President, Councillors and Ratepayers of the Shire of Tullaroop do hereby order as follows:

1. In this By-law unless inconsistent with the context or subject matter—

“ Dwelling ” means any building or portion of a building which is intended, adapted or designed for use for living purposes.

“ Shop ” means a shop as defined by Section 3 (1) of the Labour and Industry Act 1958.

“ Other Building ” means any building or portion of a building which is intended, adapted or designed for use for the purposes of any class of trade industry manufacture business public amusement or public utility.

2. No person shall erect or adapt for use any dwelling, shop or other building unless such dwelling, shop or other building is connected to a septic tank system in accordance with the requirements of the Septic Tank Regulations 1932 as amended.

3. This By-law shall apply to and have operation throughout those parts of the Municipal District as specified and set out in the Schedule hereto.

4. This By-law shall come into operation on its approval by the Governor-in-Council, and immediately after publication in the *Government Gazette*.

5. Any person guilty of any contravention of the provision of this By-law shall be liable on conviction to a penalty not less than \$10 or more than \$40 and in the case of a continuing offence to a further penalty of not more than \$10.

Schedule.

- (a) The whole of the land within the boundaries of the following Waterworks Trust Districts:
Carisbrook Waterworks Trust.
Bowenvale—Timor Waterworks District.
- (b) These portions of land within the boundaries of the Municipal District of the Shire of Tullaroop and zoned residential under the Lake Cairn Curran Planning Scheme or any interim development order relating to such Planning Scheme.

Resolution for making and passing this By-law was agreed to by the Council of the Shire of Tullaroop on the 12th day of August, 1969, and confirmed on the 9th day of September, 1969.

The common seal of the President, Councillors and Ratepayers of the Shire of Tullaroop was hereunto affixed this 14th day of October, 1969 in the presence of—

(SEAL) COLIN J. FORBES, President.
W. H. FREEMANTLE, Councillor.
BRIAN F. O'CONNOR, Shire Secretary.

Approved by the Governor in Council, 25th November, 1969.—J. ROSSITER, Clerk of the Executive Council. 2106

SHIRE OF WOORAYL.

LOAN No. 32.

Notice of Intention to Borrow the Sum of \$85,000 for Permanent Works and Undertakings.

NOTICE is hereby given that the Council of the Shire of Woorayl proposes to borrow the principal sum of \$85,000 to be secured by a mortgage in accordance with the provisions of the *Local Government Act 1958*.

1. The maximum rate of interest that may be paid is 6.4 per cent. per annum.

2. The purposes for which the loan is to be applied is:—

(1) Land compensation: Widening of A'Beckett-street, Inverloch ..	\$20,500.00
(2) Land compensation for Car Parking, Township of Inverloch ..	4,500.00
(3) Land compensation: Community purposes, Smith-street, Leongatha ..	35,000.00
(4) Land compensation: Airfield purchase, Parish of Leongatha ..	25,000.00
Total ..	\$85,000.00

3. The period of the loan shall be 40 years.

4. The moneys borrowed shall be repayable by providing out of the municipal fund half-yearly instalments of approximately \$2,958.03 each, including principal and interest, on the 6th day of April and the 6th day of October, during the currency of the loan. The first instalment shall be payable on the 6th day of October, 1970.

Such moneys shall be repayable to the Australian Mutual Provident Society at the office of the said Society, situate 535 Bourke-street, Melbourne, 3000.

The plans and specifications and the estimate of the cost of the proposed works, and a statement showing the proposed expenditure of the moneys to be borrowed, are open for inspection at the office of the Council of the Shire of Woorayl at Leongatha.

2115 K. G. BRYDON, Shire Secretary.

GEM TAXIS PTY. LTD. (IN VOLUNTARY LIQUIDATION).

PURSUANT to section 272 (1) of the *Companies Act 1961*, I hereby give notice that a General Meeting of the company will take place at 2 p.m., on Tuesday, 17th February, 1970, at the office of R. W. Fox, C. A. Gregory & Associates, 112 Patterson-road, Moorabbin, for the purpose of considering my account of the winding up and how the company's property has been disposed of.

2112 R. W. FOX, Liquidator.

In the Supreme Court of Victoria.—No. of CO. 39766, CO. 7851.—In the matter of the *Companies Act 1961*, and in the matter of POINT COOK—WERRIBEE PASSENGER SERVICE PTY. LTD.

TAKE notice that a Special Resolution of the members of Point Cook—Werribee Passenger Service Pty. Ltd., duly passed on the 27th day of November, 1969, reducing the nominal and paid up capital of the company subject to the approval of the Supreme Court of Victoria, was confirmed and approved by Order of the said Supreme Court, on the 16th day of December, 1969.

Notice is hereby given that an office copy of such said Order of the Supreme Court of Victoria and notice of Special Resolution reducing capital has been filed with and registered by the Registrar of Companies of the State of Victoria.

R. W. HOLT & CLEMINSON, 1 Ringwood-street, Ringwood, solicitors for Point Cook—Werribee Passenger Service Pty. Ltd. 2147

The *Companies Act 1961*.

CHAMCO PROPRIETARY LIMITED (IN LIQUIDATION).

NOTICE CONVENING FINAL MEETING OF MEMBERS AND CREDITORS, PURSUANT TO SECTION 272.

NOTICE is hereby given, pursuant to section 272 of the *Companies Act 1961*, that a General Meeting of the members and creditors of the above-named company, will be held at 95 Dow-street, Port Melbourne, 3207, at 12 noon, on Thursday, the 19th day of February, 1970, for the purpose of having an account laid before them showing the manner in which the winding up has been conducted and the property of the company disposed of and of hearing any explanations that may be given by the liquidator.

Dated this 6th day of January, 1970.

2150 H. G. RASMUSSEN, Liquidator.

THE SERGEANT MAJOR PTY. LTD.

NOTICE is hereby given that a meeting of the creditors of the above-named company will be held at the Board Room of the Institute of Chartered Accountants, 23 McKillop-street, Melbourne, at 9.30 a.m., on Thursday, 22nd January, 1970, the company having convened a meeting of its members for the 21st January, 1970, for the purpose of considering the following Special Resolution:—

"That the company be wound up voluntarily, and that William Arthur Browne, chartered accountant, of 24 Jeffcott-street, Melbourne, be appointed liquidator for the purpose of the winding up." 2152

The *Companies Act 1961*.—In the matter of OAK MOTOR PANEL PROPRIETARY LIMITED.

NOTICE is hereby given that at an Extraordinary Meeting of the members of the above-named company held on the 30th day of December, 1969, it was resolved that the company be wound up voluntarily and at a meeting of creditors held on the same day, pursuant to section 260, it was resolved that for such purpose Thomas Dunn Maclean, of Suite 3, 545 St. Kilda-road, Melbourne, accountant, be appointed liquidator.

Notice is also given that after 21 days from this date I shall proceed to distribute the assets. All creditors having any claims against the company should furnish particulars of same by that date otherwise I shall proceed to distribute the assets without regard to their claim.

Dated the 6th day of January, 1970.

T. D. MACLEAN, Liquidator.

T. D. Maclean & Company, consulting accountants, Suite 3, 545 St. Kilda-road, Melbourne, 3004, telephone 51 1207.

2157

Companies Act 1961.

JAGS HOLDINGS PROPRIETARY LIMITED (IN VOLUNTARY LIQUIDATION).

NOTICE CONVENING FINAL MEETING OF MEMBERS.

NOTICE is hereby given, pursuant to section 272 of the *Companies Act 1961*, that a General Meeting of the company will be held at the offices of Cox Johnston & Co., 446 Collins-street, Melbourne, on 9th February, 1970 at 10 o'clock in the forenoon.

Dated this 5th day of January, 1970.

ANDREW IAN SINCLAIR, Liquidator.

Cox Johnston & Co., 446 Collins-street, Melbourne. 2136

Unclaimed Moneys Act 1962.

REGISTER of Unclaimed Moneys held by the—

Name of Owner on Books and Last Known Address.	Total Amount Due to Owner.	Description of Unclaimed Moneys.	Date when Amount First Became Payable.
\$ c			
MATURED PINE TREES LIMITED.			
Abraham, Norah, 37 Aileen-avenue, South Caulfield	10.00	200 shares	1.7.66
Aitkin, G. M. and E. J., 500 Chapple-lane, Broken Hill, N.S.W. ..	10.00	200 shares	"
Allen, Alfred J., 10 Champion-street, Brighton	10.00	200 shares	"
Althaus, John J., Mt. Whitestone, via Grantham, Qld.	10.00	200 shares	"
Anders, Neville, 431 Macaulay-road, Kensington,	10.00	200 shares	"
Andrews, William A. B. (estate of), c/o G. M. Andrews, Ky Valley	20.00	400 shares	"
Angus, Catherine M., 6 Fuller-street, Essendon	30.00	600 shares	"
Archer, Elizabeth J., 8 Suffolk-avenue, Coburg	10.00	200 shares	"
Arndell, Alice M., 34 Green-street, Richmond	10.00	200 shares	"
Austin, Augusta V. C., 4 James-street, Northcote	10.00	200 shares	"
Barber, Winifred R., c/o R. N. Barber, 377 Little Collins-street, Melbourne	20.00	400 shares	"
Barlow, Alan W., 328 Flinders-street, Melbourne	10.00	200 shares	"
Barrand, Leslie, 25 Sunshine-avenue, Wagga, N.S.W.	15.00	300 shares	"
Barton, Edith W. (estate of), c/o Public Trustee, Melbourne ..	10.00	200 shares	"
Bateson, George E., Pymble-avenue, Inverloch	10.40	208 shares	"
Bell, James, 36 Flora-street, Arncliffe, N.S.W.	10.00	200 shares	"
Bennett, Agnes E., 5 Miller-avenue, Ashfield, N.S.W.	10.00	200 shares	"
Bernal, Wilkin and B. B. and E. S., 2 Barnet-street, Yarraville ..	10.40	208 shares	"
Berriman, Arthur E. (estate of), c/o 45 Boundary-street, Roseville, N.S.W.	10.00	200 shares	"
Bidwell, Jane L., 147 Station-street, Fairfield	40.80	816 shares	"
Blackney, Mercy E., 18 McLeod-street, Bairnsdale	10.00	200 shares	"
Blainey, Charles G., 414 George-street, Sydney, N.S.W.	15.00	300 shares	"
Body, Louisa, 14 Fewster-road, Hampton	10.00	200 shares	"
Bolding, Cyril G., 619 Burwood-road, Auburn	10.40	208 shares	"
Bowen, John W., 457 Townsend-street, Albury, N.S.W.	10.00	200 shares	"
Bramhill, Lucy E., Mark-street, Rosebud	10.20	204 shares	"
Bray, Harold E., 40b Birriga-road, Bellevue Hill, N.S.W.	10.00	200 shares	"
Bretherton, Kenneth W., Warrane-road, East Roseville, N.S.W. ..	10.00	200 shares	"
Broster, Gilbert C., Le Roy, via Traralgon	10.40	208 shares	"
Bruce, Herbert B., Lac, New Guinea	15.00	300 shares	"
Bruce, Herbert G. B., Lac, New Guinea	41.00	820 shares	"
Brumpton, Charles N., 38 Jasper-terrace, Frankston	10.00	200 shares	"
Bullen, George V., 103 Essex-road, Epping, N.S.W.	10.00	200 shares	"
Burdett, Tom, Vernon-street, Blackburn	10.40	208 shares	"
Butler, Mabel, 8 Bent-street, South Caulfield	10.00	200 shares	"
Cameron, John A., Shire Office, Hopetoun	15.00	300 shares	"
Cannon, Thomas (estate of), c/o I.M.P. Cannon and E. J. Davies, 13 Valley-road, Yallourn	25.00	500 shares	"
Carey, Isa I., 14 Erin-street, Preston	21.20	424 shares	"
Carroll, William J. (estate of), 231 Russell-street, Melbourne ..	12.40	248 shares	"
Carter, Iris M., 161 Geelong-road, Footscray	20.00	400 shares	"
Carter, Valda H., 33 Albert-street, Woody Point, Q'ld.	10.00	200 shares	"
Charles, James L., 21 Carlton-street, Harbord, N.S.W.	10.00	200 shares	"
Charlesworth, John S., 75 Lord-street, Richmond	10.00	200 shares	"
Charlton, Frank E. R., 8 Willis-street, Frankston	11.00	220 shares	"
Churches, Annie E., c/o 2 Grey-street, Brighton	10.00	200 shares	"
Cogle, Alice E. and Lancelot G., Grand Ridge-road, Trida, via Leongatha	10.00	200 shares	"
Collins, Leah, 110 Wilson-street, Horsham	10.00	200 shares	"
Collins, Robert, 110 Wilson-street, Horsham	10.00	200 shares	"
Cornish, Frederick C., 13 Bolingbroke-grove, Toorak Gardens, S.A. ..	10.60	212 shares	"
Cornish, Rene, 13 Bolingbroke-grove, Toorak Gardens, S.A.	10.60	212 shares	"
Coupe, Henry M., Brandon road, Runcorn, Q'ld	15.00	300 shares	"
Cousins, Evan R., Gapsted	15.00	300 shares	"
Cowan, Francis M., 628 Hampton-street, Brighton	10.80	216 shares	"
Crooke, Kathleen, 28 Grove-road, Hawthorn	10.00	200 shares	"
Crossley, Frederick F., 30 Raymond-road, Springwood, N.S.W. ..	10.80	216 shares	"
Crowe, Alfred W., 18 Payne-street, Caulfield	10.00	200 shares	"
Crutchfield, Florence (estate of), c/o I.C. Bulldon, Keogh-street, Burwood	15.00	300 shares	"
Day, Annie, Tumberumba, N.S.W.	10.00	200 shares	"
Dippel, Charles H. (estate of), c/o S. McConnel, Margaret-street, Toowoomba, Q'ld	15.00	300 shares	"
Donald, Harry, 55 Villamanta-street, West Geelong	20.00	400 shares	"
Downie, George, 48 Hart's-parade, Hawthorn East	10.00	200 shares	"
Driscoll, Hugh, Joadga-road, Mittagong, N.S.W.	21.20	424 shares	"
Duffy, Margaret M., 47 Cross-street, Guildford, N.S.W.	10.00	200 shares	"
Duncan, Lawler, Box 509, Shepparton	20.00	400 shares	"
Dunn, Verna E., 79 Carlisle-crescent, Oakleigh	15.00	300 shares	"
Dunne, Henry F. S., 110 Little Collins-street, Melbourne	10.00	200 shares	"
Dyer, David T., 57 Calidonian-street, Bexley, N.S.W.	15.00	300 shares	"
Edge, John S., 4 Allee-street, Brighton	10.00	200 shares	"
Egan, Sydney L., 2 Vears-road, Ashburton	15.00	300 shares	"
Evans, Ruth D., 26 Hartington-street, Kew	20.00	400 shares	"
Farmer, Ronald J., Gellibrand-road, Elliminyh	10.80	216 shares	"
Fils, Richard, Ipswich-road, Rocklea, Q'ld.	10.00	200 shares	"

Unclaimed Moneys Act 1962.

REGISTER of Unclaimed Moneys held by the—

Name of Owner on Books and Last Known Address.	Total Amount Due to Owner.	Description of Unclaimed Moneys.	Date when Amount First Became Payable.
\$ c			
MATURED PINE TREES LIMITED.— <i>continued.</i>			
Fisher, Claude, 17 Glenard-drive, Heidelberg	10.00	200 shares	1-7-66
Fitchew, Mabel O., c/o Mrs. Dartnell, Victoria Point-road, Victoria Point, Q'ld	11.00	220 shares	"
Flannery, John V. (estate of), c/o Maurice E. Piper, 17 Montana Flats, Cremorne Point, N.S.W.	10.80	216 shares	"
Fink, Max A., (estate of), c/o Hayes and Wilson, 114 Castlereagh-street, Sydney, N.S.W.	15.60	312 shares	"
Fletcher, Charles E., Box 57, Cohuna	15.00	300 shares	"
Flight, James P., Burraboi via Batham, N.S.W.	10.00	200 shares	"
Fox Mary A. F., 6 Nyira-street, East Malvern	10.00	200 shares	"
Fraser, Alice M., 56 Southernhay-street, Preston	10.00	200 shares	"
Fraser, May E., 56 Southernhay-street, Regent	10.00	200 shares	"
Fry, Charles E., Melbourne-road, Norlane	56.00	1,120 shares	"
Gale, Basil G., Lachlan Park Hospital, New Norfolk, Tas.	10.00	200 shares	"
Gibson, Robert A., Murray-street, Sandgate, Q'ld	10.00	200 shares	"
Giddons, Andrew H., 61 Southernhay-street, Regent	15.00	300 shares	"
Gill, Robert B., Coogee Bay Hotel, Coogee, N.S.W.	10.40	208 shares	"
Gillett, Emily A., 25 Heydon-street, Mosman, N.S.W.	10.00	200 shares	"
Gillett, Harry N., 5 Hartwell-road, Camberwell	10.00	200 shares	"
Gloag, David (estate of), c/o R. M. and A. Gloag, 22 Karrabah-road, Auburn, N.S.W.	15.00	300 shares	"
Godfrey, Robert L., 123 The Boulevard, Ivanhoe	10.00	200 shares	"
Good, William G., 100 Avenel-road, Seymour	10.00	200 shares	"
Gooding, Harold E., Flat 2, 103 Grosvenor-street, St. Kilda	10.00	200 shares	"
Gratton, Clifford, Mirboo North	20.80	416 shares	"
Gray, Troilus (estate of), c/o 10 Sloane-street, Stawell	16.60	332 shares	"
Gregory, Horace B., Prince-street, Myrtleford	20.00	400 shares	"
Gruchy, A. M. and E. C., Pirie and Nagle-streets, Liverpool, N.S.W.	10.00	200 shares	"
Hall, Kenneth, 25 Ronald-street, North Essendon	30.00	600 shares	"
Halley, Louise, Post Office, Blackwood	10.80	216 shares	"
Halsall, George S., 7 Chandos-street, Coburg	10.00	200 shares	"
Hamilton, Mary E., 4 Foote-street, Dromana	10.00	200 shares	"
Hands, Arthur W., 38 Railway-parade, Murrumbeena	10.00	200 shares	"
Hanger, Julia M., 5 Hodgkinson-street, Clifton Hill	11.00	220 shares	"
Harcourt, Percy W., Braeside Post Office, via Mordialloc	72.00	1,440 shares	"
Harlem, Louis H., 21 Dunstan-avenue, East Brunswick	10.00	200 shares	"
Harrop, James G., 17 Powlett-street, East Melbourne	10.40	208 shares	"
Harvey, Richard W. T., "Casa Loma", Chamberlain-road, Padstow, N.S.W.	10.00	200 shares	"
Hayes, George E., 305 Bat-street, Brighton	20.00	400 shares	"
Hayes, Lee A., 34 Hill-street, Fairlight, N.S.W.	10.40	208 shares	"
Hayward, George A., 59 Powell-street, Regent	10.20	204 shares	"
Heal, Frank A. J., P.O., Lindelow, East Gippsland	10.00	200 shares	"
Higham, Sydney, "Seville", Spring-street, Middle Ridge, Toowoomba, Q'ld	10.00	200 shares	"
Hines, George W. (estate of), c/o L. M. Coonan, 96 Fletcher-street, Essendon	16.20	324 shares	"
Hogg, Lawrence O., 6 Raven-grove, East St. Kilda	10.00	200 shares	"
Hore, Florence L., High-street, Mt. Waverley	10.00	200 shares	"
Hore, Maisie C. (estate of), 11 McNeilly's-road, Drouin	10.00	200 shares	"
Hosking, John W. L., Lot 32, Windmill-street, Newhaven	10.00	200 shares	"
Hoswell, Gordon T., Victoria-street, Eugowra, N.S.W.	10.00	200 shares	"
Howard, Ada M. (estate of), c/o Upton Helson, 100 Queen-street, Melbourne	15.00	300 shares	"
Howdey, Joan, Flat 1, Rutland Court, 183 Gregory-terrace, Brisbane, Q'ld	10.00	200 shares	"
Howman, Daisy E., c/o L. J. Roche, 18 Yarra Ford-avenue, Alphington	10.00	200 shares	"
Hughes, Mabel M., Henry-street, Greensborough	20.00	400 shares	"
Hull, Edith L., 241 Gilbert-road, Preston	35.00	700 shares	"
Hunt, William A. M., 33 Meriel-street, Sans Souci, N.S.W.	10.00	200 shares	"
Hunter, Elsie A., 92 Nimmo-street, Middle Park	10.00	200 shares	"
Hyslop, Lillian L., 2 Pretoria-street, Deepdene	10.00	200 shares	"
Hyslop, Olive L., 584 Princes Highway, Sylvania, N.S.W.	10.00	200 shares	"
Inglis, Henry R., Dangore-street, Tingoorra, Q'ld	10.40	208 shares	"
Innes, Sydney E. K., c/o K. B. Roseby, 107 Elizabeth-street, Sydney, N.S.W.	10.40	208 shares	"
Jarvis, Joseph, 55 Flinders-street, Thornbury	10.00	200 shares	"
Jennings, Herbert V., 211 Bouverie-street, Carlton	10.00	200 shares	"
Jennings, John R., 5 Reid-street, Murrumbeena	10.00	200 shares	"
Johns, Albert G., 462 Thomas-street, Broken Hill	10.00	200 shares	"
Jones, James J., 46 Buckingham-street, Footscray	10.00	200 shares	"
Jones, William G., 301 Castlereagh-street, Sydney, N.S.W.	10.00	200 shares	"
Julliff, Lester L., 81 Devonshire-street, West Footscray	10.00	200 shares	"
Keating, Elsie E. (estate of), c/o 12 Tennyson-street, Dulwich Hill, N.S.W.	10.20	204 shares	"
Kennett, Daisy E., 50 Grant-street, East Malvern	15.60	312 shares	"
King, Leslie D., 9 Riversdale-avenue, North Balwyn	10.50	210 shares	"
King, Neville B., 29 Murrabin-avenue, Matraville, N.S.W.	20.00	400 shares	"
King, Thomas M., G.P.O. Box 4044, Sydney, N.S.W.	10.00	200 shares	"
Knibbs, Layton, A. H., "Wybalina," Main Western-road, Blaxland, N.S.W.	10.00	200 shares	"
Laidlaw, Walter T., c/o W. A. Laidlaw, Coombs-road, Kinglake West	50.00	1,000 shares	"
Lambert, Leslie R., 196 Victoria-street, East Brunswick	10.00	200 shares	"
Lamberton, Algernon E., Girgarre	10.00	200 shares	"

Unclaimed Moneys Act 1962.

REGISTER of Unclaimed Moneys held by the—

Name of Owner on Books and Last Known Address.	Total Amount Due to Owner.	Description of Unclaimed Money.	Date when Amount First Became Payable.
\$ c			
MATURED PINE TREES LIMITED.—continued.			
Langsford, Leaf M. (estate of), c/o 59 Paisley-street, Footscray ..	10-80	216 shares	1-7-66
Law, Anna M. A., Goombungee, Q'ld.	10-40	208 shares	"
Lawrence, Abraham C. J., 10 Hillside, Yallourn	10-40	208 shares	"
Lee, Edith D., 16 Kingsley-parade, Glenhuntly	10-00	200 shares	"
Leslie, Frances, 789 Warrigal-road, Oakleigh	15-00	300 shares	"
Lewis, Ethel L., 22 Park-avenue, Burwood, N.S.W.	10-00	200 shares	"
Lewis, Ethel L., 10 Logie-street, Oakleigh	10-00	200 shares	"
Lithgo, John H., 67 Minimbah-road, Northbridge, N.S.W. ..	15-00	300 shares	"
Locke, Walter C., 107 The Parade, Ascot Vale	10-00	200 shares	"
Luth, Rex R., 5 Sussex-street, Middle Brighton	25-00	500 shares	"
Maden, Henry (estate of), c/o A. C. Bulcher, 422 Collins-street, Melbourne	15-60	312 shares	"
Mallaby, Alice M. E., 2 Jamieson-street, North Curl Curl, N.S.W.	25-00	500 shares	"
Mangan, Catherine, 36 Mary-street, Sydney	21-60	432 shares	"
Maunder, Frances J., 30 Mitchell-street, Brunswick	15-00	300 shares	"
May, Ernest B., 139 High-street, Glen Iris	30-00	600 shares	"
Mewing, William H. T., 69 Lambton-street, Annerley, Q'ld. ..	10-00	200 shares	"
Miller, Ivan D., 16 Everton-grove, Surrey Hills	10-00	200 shares	"
Miller, Robert G., 9 Victoria-road, Lilydale	10-00	200 shares	"
Millett, Rose A., 12 Villiers-street, Elsternwick	20-00	400 shares	"
Mills, Annie E., 25 Netherlee-street, Glen Iris	10-00	200 shares	"
Minster, Dorothy D., 17 Rathmines-street, Auburn	10-00	200 shares	"
Minster, Trevor E., 17 Rathmines-street, Auburn	10-00	200 shares	"
Mitchelson, James M. (estate of), c/o A. J. Mitchelson, 19 Innes-street, Mordialloc	20-00	400 shares	"
Moore, Alice B., 12 Parslow-street, Malvern	10-00	200 shares	"
Morgan, Susan A., c/o F. W. Turton, 34 Hunter-street, Sydney ..	20-00	400 shares	"
Mountjoy, Gordon A., Waddell-street, Watchem	10-80	216 shares	"
Moxon, James K., "Kurrawong" East Douglas-street, St. Ives, N.S.W.	10-60	212 shares	"
Muldoon, Arabella B., Kinkora-road, Hawthorn	10-00	200 shares	"
McAlpin, Henry J., Chatsfield-avenue and Highton-grove, Balwyn	15-00	300 shares	"
McDonald, Alexander W., 63 Boldrewood-street, Turner, Canberra, A.C.T.	10-00	200 shares	"
McDonald, Annie R., 18 Valley-street, Annerley, Q'ld.	10-00	200 shares	"
McDowell, Robert J., 130 Canterbury-road, Middle Park	10-00	200 shares	"
McGee, John D., 55 Amherst-street, Cammeray, N.S.W.	15-00	300 shares	"
McGrath, Charles F. R., 140A Miller-street, North Fitzroy	10-00	200 shares	"
McKinnon, Archibald and James, 27 Chubb-street, One Mile Estate, Ipswich, Q'ld.	10-00	200 shares	"
McLean, Shirley, P.O. Box 761, Cairns, N. Q'ld	10-00	200 shares	"
Keeble, Winnie (estate of), c/o F. McNab, 422 Collins-street, Melbourne	10-00	200 shares	"
Nairn, Thomas A., 90 Amy-street, Regent's Park, N.S.W.	10-40	208 shares	"
Nash, Frederick, Red Hill	20-00	400 shares	"
Newman, Wyndham T., c/o Ronald J. Sicree	12-00	240 shares	"
Newton, Herbert G., 140 Elizabeth-street, Sydney	30-00	600 shares	"
Newton, Joseph J., Flat 2, 5A The Avenue, East St. Kilda	10-00	200 shares	"
Nichol, Ruby Blanch, 105 Bent-street, Northcote	10-00	200 shares	"
Nicholls, Mona I., Dromana Hotel, Dromana	10-00	200 shares	"
Nightingale, Frederick W., 19 Regent-street, Mayfield, N.S.W. ..	10-00	200 shares	"
O'Brien, Ada L., 294 Heatherton-road, Noble Park	10-00	200 shares	"
O'Donnell, Ellen E. C., 11 Webb-street, Middle Brighton	10-00	200 shares	"
Palmer, Maaida E., 7 Corsewall Close, Hawthorn	22-00	440 shares	"
Panzenhagen, Otto G. E. (estate of), c/o Borehead and Holland, 371 Queen-street, Brisbane, Q'ld	10-00	200 shares	"
Pappas, George, 30 Anglesea-street, Bondi, N.S.W.	10-00	200 shares	"
Partington, Charlotte, 13 Frederick-street, Fairfield, N.S.W. ..	10-00	200 shares	"
Partington, Helen K., 13 Frederick-street, Fairfield, N.S.W. ..	10-00	200 shares	"
Paton, Nancy T., 25 Albert-avenue, Chatswood, N.S.W.	10-00	200 shares	"
Paton, Sylvia M., 330 Nicholson-street, Fitzroy	16-20	324 shares	"
Peake, Frederick J., 69 Wornack-road, Murrumbena	15-00	300 shares	"
Percy, Cecil, 15 Younger-street, Coburg East	10-00	200 shares	"
Perks, Wallace W., P.O., Nathalia	10-00	200 shares	"
Peters, Ida E. M., c/o Mrs. Anderson, 14 Raleigh-street, Windsor	10-00	200 shares	"
Phillips, Arthur F., 504 Bay-street, Port Melbourne	10-00	200 shares	"
Phillips, Edwin G., 3A Whitehorse-road, Ringwood	10-00	200 shares	"
Phillips, Gwyneth V., 182 Blackburn-road, Blackburn	10-00	200 shares	"
Phillips, Richard P., 182 Blackburn-road, Blackburn	10-00	200 shares	"
Pressley, Elizabeth W., 191 Glenferrie-road, Malvern	10-00	200 shares	"
Punch, Nicholas A., 283 Old South Head-road, Bondi, N.S.W. ..	10-00	200 shares	"
Pursell, George E., Blackburn-road, Blackburn	11-60	232 shares	"
Pyne, Annie L., c/o Middleton and McEacharn, 60 Market-street, Melbourne	40-00	800 shares	"
Quast, C. G. and C. R., P.O. Box 25, Albury, N.S.W.	15-00	300 shares	"
Rabinov, Meta, 75 Crockford-street, Port Melbourne	10-00	200 shares	"
Radford, Olive (estate of), c/o Pavey and Waterhouse, 24 Weymouth-street, Adelaide, S.A.	50-00	1,000 shares	"
Raven, Ethel A., 126 Bourke-street, Dubbo, N.S.W.	26-80	536 shares	"
Redwood, Eustace W., Western Camp	10-00	200 shares	"
Reed, Colin G., 55 Worth-street, Leichardt, N.S.W.	10-00	200 shares	"
Reid, Gordon E., 34 Pyke-street, Bairnsdale	20-00	400 shares	"

Unclaimed Moneys Act 1962.

REGISTER of Unclaimed Moneys held by the—

Name of Owner on Books and Last Known Address.	Total Amount Due to Owner.	Description of Unclaimed Moneys.	Date when Amount first became Payable.
\$ c			
MATURED PINE TREES LIMITED.— <i>continued.</i>			
Rhodes, Maurice A., 6 Mutimer-street, East Preston	50-80	1,016 shares	1.7.66
Richards, Annie, 84 Hudson-street, Spotswood	15-00	300 shares	"
Ritzman, Dora J. (estate of), Drayton-street, Dalby, Q'ld.	10-00	200 shares	"
Robertson, D. C. and M.A.C., Finley, N.S.W.	35-00	700 shares	"
Robinson, William J., 44 Murray-street, Wagga, N.S.W.	15-00	300 shares	"
Rose Mark N., 7 The Crossway, Strathmore	10-00	200 shares	"
Rourke, John K. (estate of), 12 Allawah-avenue, Cars Park, N.S.W.	10-00	200 shares	"
Sawtell, Kathleen L. H., 184 Lutwyche-road, Windsor, Q'ld.	10-00	300 shares	"
Sawyer, Doris L., 5 Florence-avenue, Frankston	15-00	200 shares	"
Scott, John Henry, 7 Wilson's-road, Mornington	15-00	300 shares	"
Seller's, George Cecil (estate of), c/o E. V. Merchant, Barrington, via Gloucester, N.S.W.	10-00	200 shares	"
Sheahan, Thomas E., Flat 1, 7 Glenwood-avenue, Coogee, N.S.W.	17-00	340 shares	"
Sheridan, William J., 463 Parramatta-road, Leichardt, N.S.W.	10-00	200 shares	"
Siddle, Annie F., Darling-avenue, Upwey	10-00	200 shares	"
Sly, Ormond V., 22 Nicholson-street, Abbotsford	10-20	204 shares	"
Smart, Doris E., 18 Greville-street, Coogee, N.S.W.	35-00	700 shares	"
Smartt, Ada, 7 Fraser-avenue, Edithvale	10-00	200 shares	"
Smith, Ethel M. A., 181 Deakin-avenue, Mildura	20-00	400 shares	"
Smith, Willfred W., "Oakleslea," Heatherton-road, Clayton	25-00	500 shares	"
Smith, William, 21 Burrage-street, Toowoomba, Q'ld.	15-60	312 shares	"
Spence, Joyce Ethel, John-street, Templestowe	10-00	200 shares	"
Starling, Frederick G. (estate of), c/o Jane E. Starling, 11 Hampton-street, Hampton	10-00	200 shares	"
Story, Thomas D., 33 Lyton-road, East Brisbane, Q'ld	18-10	362 shares	"
Switzer, Annie J., Box 10, Wynnum, Q'ld.	10-00	200 shares	"
Taylor, Charles F., 5 Park-road, Marryatville, S.A.	10-00	200 shares	"
Templeton, Grace L., 4 Rogers-street, Richmond	10-00	200 shares	"
Thomas, William H., Marlborough, via Rockhampton, Q'ld.	10-00	200 shares	"
Thomson, Florence O., 6 Jolimont-terrace, Jolimont	10-00	200 shares	"
Thompson, Yorke H., Phillip House, Phillip-street, Sydney, N.S.W.	10-00	200 shares	"
Thomson, Christian M. E., Grantham, Q'ld.	20-00	400 shares	"
Todhunter, Albert A., 8 Bobbin Head-road, Pymble, N.S.W.	10-00	200 shares	"
Treziise, Stanley J. (estate of), c/o C. M. Treziise, 22A Gladstone-street, Ballarat	10-00	200 shares	"
Tucker, Ilene B., Avoca Vale, Mt. Martha	10-00	200 shares	"
Tully, Joseph H., 15 Turnbull-street, Clifton Hill	21-20	424 shares	"
Turner, Henry N., Hurstville, N.S.W.	30-00	600 shares	"
Turner, James S. (estate of), c/o M. M. Turner, Surrey-street, Coraki, N.S.W.	10-00	200 shares	"
Umpfelby, Ellen M., 35 Victoria-street, Camberwell	15-00	300 shares	"
Walker, Cecil I. (estate of), c/o Brook Bromman, 39 Martin Place, Sydney	15-00	300 shares	"
Walter, George C., 248 Nepean Highway, Seaford	15-00	300 shares	"
Walton, Ralph A. L., 159 St. Lucia-street, St. Lucia, Q'ld.	10-00	200 shares	"
Watts-Browne, Violet F., c/o 376 Barkley-street, Elwood	15-00	300 shares	"
Wearin, Isabel S., Granville, Maryborough, Q'ld	10-00	200 shares	"
West, Cissy B., MacLean, Clarence River, N.S.W.	10-00	200 shares	"
Whelpton, Marion A., 143 Barkly-street, Mornington	15-00	300 shares	"
Whitelock, Lucy A. (estate of), c/o 14 Balfour-road, Kensington, N.S.W.	10-00	200 shares	"
Whiteway, Ethel A., 6 Laurel-street, Toowoomba, Q'ld.	10-00	200 shares	"
Wicke, Frank H., Grose Vale, via Richmond, N.S.W.	15-30	306 shares	"
Wiles, William F., Post Office, Paddington, Q'ld.	11-00	220 shares	"
Williams, Mary I., 121 Royal-parade, Pascoe Vale	10-00	200 shares	"
Williams, Sarah J., 27 Chauvel-street, South Oakleigh	10-00	200 shares	"
Wilson, Alice S. (estate of), c/o Whatmore McGee and Co., 14 Spring-street, Sydney, N.S.W.	25-00	500 shares	"
Wilson, Frederick E., 39 Dunstan-avenue, East Brunswick	10-00	200 shares	"
Wilson, Stuart, 19 Charles-street, East Brighton	10-00	200 shares	"
Wilson, Violet I., 371 Sydney-road, Baigowlah, N.S.W.	15-00	300 shares	"
Woodtli, Adolph E., 17 Mt. Pleasant-road, Belmont, Geelong	11-00	220 shares	"
Wuttke, Oscar B., c/o Grenfell Hotel, Grenfell-street, Adelaide S.A.	14-00	280 shares	"
Zander, Leslie H., Springfield-road, Blackburn	10-00	200 shares	"
Farrell, Thomas, 25 Driffield-road, Morwell	10-40	208 shares	"
Hartley, Lillian A., "Hillend," Rutherford-road, Upwey	25-00	500 shares	"
Holmes, Henrietta, 4 Hollywood-crescent, Willoughby, N.S.W.	10-00	200 shares	"
Peiris, Doris C., 14 Shaa-road, Acton, London, W. 3., England	42-50	1,000 shares	"
Ewen, Gertrude, 123 Cobham-road, Seven Kings, Ilford, Essex, England	21-25	500 shares	"
Kingston, Mabel F., "Hybla," Arundel-road, Seaford, Sussex, U.K.	17-00	400 shares	"
Lodge, Ivy I., c/o Mrs. Elstab, 808 Crammond-avenue, Tokoroa, N.Z.	17-00	400 shares	"

1718

BARNET ROCKMAN AND CO.

Giering, H. (Mrs.), 32 Williams-road, Windsor	971-95	Share of sale of Lot 67 Clunies Ross-crescent, Glen Waverley	2-12-66
---	--------	--	---------

1998

Unclaimed Moneys Act 1962.

REGISTER of Unclaimed Moneys held by the—

Name of Owner on Books and Last Known Address.	Total Amount Due to Owner.	Description of Unclaimed Moneys.	Date when Amount first became Payable.
§			
THE VICTORIA INSURANCE COMPANY LIMITED.			
Adair, Ellen (estate of), 70 Moira-avenue, Carnegie	10.00	Interim Dividend	— 3.64
Hamilton, P. A. R., 11 Waimea-avenue, Sandy Bay, Hobart	24.30		
Coombes, Elizabeth A., c/o W. MacLean and Sons, 3 Spring-street, Sydney	15.00	Final Dividend	— 10.65
McKinnon, Ewan D., "Langi Willi", Linton	45.00	" "	
Wheeler, Mary (Mrs.), 49 Russell-street, Vaucluse	153.23	" "	— 10.66
2114			

Companies Act 1961.

R.M.H. CONSTRUCTIONS PROPRIETARY LIMITED (IN LIQUIDATION).

NOTICE CONVENING FINAL MEETING OF MEMBERS AND CREDITORS, PURSUANT TO SECTION 272.

NOTICE is hereby given, pursuant to section 272 of the *Companies Act 1961*, that a General Meeting of the members and creditors of the above-named company will be held in the offices of Kennedy, Smail & Middlemiss, 296-304 Little Lonsdale-street, Melbourne, on Wednesday, the 11th day of February, 1970, at 11.30 a.m., for the purpose of having an account laid before them, showing the manner in which the winding up has been conducted and the property of the company disposed of and of hearing any explanations that may be given by the liquidator.

Dated this 9th day of January, 1970.

N. E. STRETTON, Liquidator.

Kennedy, Smail & Middlemiss, 296-304 Little Lonsdale-street, Melbourne, 3000. 2137

Companies Act 1961.

AMBASSADOR TRANSPORT PROPRIETARY LIMITED (IN LIQUIDATION).

NOTICE CONVENING FINAL MEETING OF MEMBERS AND CREDITORS, PURSUANT TO SECTION 272.

NOTICE is hereby given, pursuant to section 272 of the *Companies Act 1961*, that a General Meeting of the members and creditors of the above-named company will be held in the offices of Kennedy, Smail & Middlemiss, 296-304 Little Lonsdale-street, Melbourne, on Wednesday, the 11th day of February, 1970, at 10.30 a.m., for the purpose of having an account laid before them showing the manner in which the winding up has been conducted and the property of the company disposed of and of hearing any explanations that may be given by the liquidator.

Dated this 15th day of December, 1969.

A. M. HORSBURGH, Liquidator.

Kennedy, Smail & Middlemiss, 296-304 Little Lonsdale-street, Melbourne, 3000. 2138

Companies Act 1961.

DOLLAR VIEW PROPRIETARY LIMITED (IN LIQUIDATION).

NOTICE CONVENING FINAL MEETING OF MEMBERS AND CREDITORS, PURSUANT TO SECTION 272.

NOTICE is hereby given, pursuant to section 272 of the *Companies Act 1961*, that a General Meeting of the members and creditors of the above-named company will be held in the offices of Kennedy, Smail & Middlemiss, 296-304 Little Lonsdale-street, Melbourne, on Wednesday, the 11th day of February, 1970, at 11 a.m., for the purpose of having an account laid before them showing the manner in which the winding up has been conducted and the property of the company disposed of and of hearing any explanations that may be given by the liquidator.

Dated this 15th day of December, 1969.

A. M. HORSBURGH, Liquidator.

Kennedy, Smail & Middlemiss, 296-304 Little Lonsdale-street, Melbourne, 3000. 2139

Companies Act 1961.

L. N. PARK PROPRIETARY LIMITED (IN LIQUIDATION).

NOTICE CONVENING FINAL MEETING OF MEMBERS AND CREDITORS, PURSUANT TO SECTION 272.

NOTICE is hereby given, pursuant to section 272 of the *Companies Act 1961*, that a General Meeting of the members and creditors of the above-named company will be held in the offices of Kennedy, Smail & Middlemiss, 296-304 Little Lonsdale-street, Melbourne, on Wednesday, the 11th day of February, 1970, at 10 a.m., for the purpose of having an account laid before them showing the manner in which the winding up has been conducted and the property of the company disposed of and of hearing any explanations that may be given by the liquidator.

Dated this 15th day of December, 1969.

N. E. STRETTON, Liquidator.

Kennedy, Smail & Middlemiss, 296-304 Little Lonsdale-street, Melbourne, 3000. 2140

VICTOR WILFRED BUTLER, late of 1608 Malvern-road, Glen Iris, brick manufacturer, DECEASED.

CREDITORS, next of kin and others having claims in respect of the estate of the deceased (who died on the 7th day of June, 1969), are required by the executors, National Trustees, Executors and Agency Company of Australasia Limited, of 95 Queen-street, Melbourne, and Charles Gamble Doria Butler, of 10 Haverbrack-avenue, Malvern, manager, to send particulars to the above-named company, by the 16th day of March, 1970, after which date the executors may convey or distribute the assets, having regard only to the claims of which the said company then has notice.

Dated the 12th day of January, 1970.

OSWALD BURT & CO., solicitors, 178 William-street, Melbourne. 2158

CREDITORS, next of kin and others having claims in respect to the estate of William Charles McDiarmid, of 13 Galeka-street, Merlynston, gentleman (who died on the 19th September, 1969), are to send particulars of their claims to The Union-Fidelity Trustee Company of Australia Limited, of 100 Exhibition-street, Melbourne, by the 16th March, 1970, after which date it will distribute the assets, having regard only to the claims of which it then has notice. 2159

NORA MARJORIE WILKINSON, late of 395 Toorak-road, South Yarra, married woman, DECEASED.

CREDITORS, next of kin and others having claims in respect of the estate of the deceased (who died on the 15th day of July, 1969), are required by The Union-Fidelity Trustee Company of Australia Limited, of 100 Exhibition-street, Melbourne, Cyril Quintin (usually known as Quinton), Wilkinson, gentleman, and Elizabeth Ann Wilkinson, secretary, both of 395 Toorak-road, South Yarra, and Athol James Kennedy, of 401 Collins-street, Melbourne, solicitor, the applicants for a grant of administration, to send particulars of their claims to the said applicants in the care of the said company, by the 20th day of March, 1970, after which date they will convey or distribute the assets, having regard only to the claims of which they then have notice.

RUSSELL, KENNEDY & COOK, solicitors, 401 Collins-street, Melbourne. 2162

CREDITORS, next of kin and others having claims in respect of the estate of John Peristerides, late of 5 Argyle-place, Carlton, tailor, deceased, are to send their claims to the executrix, care of Allan Moore, LL.B., 140 Queen-street, Melbourne, by the 14th March, 1970, after which date the executrix may convey or distribute the assets, having regard only to the claims of which she then has notice.

ALLAN MOORE, LL.B., 140 Queen-street, Melbourne. 2105

CREDITORS, next of kin and others having claims in respect of the will of Stanley Spencer, late of 8 Railway-place, Newmarket, in the State of Victoria, formerly billiard room keeper, but late retired (who died on the 28th day of November, 1969), are requested to send particulars of their claims to the executor, John Eudes Stewart, care of the undermentioned address, by the 31st day of March, 1970, after which date he will distribute the assets, having regard only as to the claims of which he then has notice.

JOHN STEWART, solicitor, of 290 Racecourse-road, Newmarket. 2118

CHARLES ALFRED DAW, late of 51 First-avenue, Rosebud, retired, DECEASED.

CREDITORS, next of kin and others having claims in respect of the estate of the deceased (who died on the 28th day of March, 1969), are required by the trustee, Reginald Clarence Daw, of Unit 2, 3 Wellesley-street, Mont Albert, retailer, to send particulars to him, at Unit 2, 3 Wellesley-street, Mont Albert, by the 31st day of March, 1970, after which date the trustee may convey or distribute the assets, having regard only to the claims of which they then have notice.

Dated the 8th day of January, 1970.

JOHN P. RHODEN, solicitors, 376 Collins-street, Melbourne. 2133

CREDITORS, next of kin and others having claims in respect of the estate of Giovanni Pasa, late of 618 Drummond-street, North Carlton, gentleman (who died on the 15th day of March, 1969), are to send particulars of their claims to the executor, The Equity Trustees, Executors and Agency Company Limited, of 472 Bourke-street, Melbourne, by the 15th day of March, 1970, after which date it will distribute the assets, having regard only to the claims of which it then has notice.

HALL & WILCOX, solicitors, 20 Queen-street, Melbourne. 2134

ADA NEWNHAM, late of 38 Uplands-road, Strathmore, retired nursing sister, DECEASED.

CREDITORS, claimants and others having claims against the estate of the above deceased are required to send particulars of same, in writing, to the executor, Ormond Andrew Dickinson, of 11 Irilbarra-road, Canterbury, on or before the 21st day of March, 1970, after which date the executor intends to distribute the assets in this estate, having regard only to those claims of which he then has notice.

KIDDLE, BRIGGS & WILLOX, 400 Collins-street, Melbourne, solicitors for the executor. 2131

GEORGE GILBERT WALLER, late of 274 Albert-street, Sebastopol, contractor, DECEASED (who died on the 7th August, 1968).

CREDITORS, next of kin and all persons having claims against the estate of the deceased are required to send particulars to the executor, Stanley Spencer Waller, of 85 Norman-street, Ballarat, clerk, care of 209 Dana-street, Ballarat, on or before the 15th March, 1970, after which date he will distribute the assets, having regard only to the claims of which he shall then have notice.

HEINZ & GORDON, solicitors, 209 Dana-street, Ballarat. 2111

CREDITORS, next of kin and others having claims in respect of the estate of Ina Beatrice Maroney (also known as Beatrice Maroney), late of 47 Pender-street, Preston, spinster, deceased, intestate (who died on the 4th day of May, 1969), are to send particulars of their claims to Rovston T. Cahir & Martin, solicitors, of 17 Queen-street, Melbourne, by the 16th day of March, 1970, after which date the administratrix will distribute the assets of the estate, having regard only to claims of which she has notice.

ROYSTON T. CAHIR & MARTIN, solicitors, 17 Queen-street, Melbourne. 2155

JOHN MARTIN O'NEILL, late of 71 Bayswater-road, Kensington, retired drover, DECEASED.

CREDITORS, next of kin and others having claims in respect of the estate of the deceased (who died on the 26th day of October, 1969), are required by National Trustees, Executors and Agency Company of Australasia Limited, of 95 Queen-street, Melbourne, and Barry Keogh, of 48 Robinson-grove, Bulleen, public servant, the applicant for a grant of probate, to send particulars of their claims to the said applicants, in the care of the said company, by the 31st day of March, 1970, after which date they will convey or distribute the assets, having regard only to the claims of which they then have notice.

Dated the 9th day of January, 1970.

MADDEN BUTLER ELDER & GRAHAM, solicitors, 31 Queen-street, Melbourne. 2135

NORMAN FRANCIS HAMMOND, late of Flat 9, 11 Ardene-court, Hawthorn, retired insurance company manager, DECEASED.

CREDITORS, next of kin and others having claims in respect of the estate of the deceased (who died on the 24th day of May, 1969), are required by National Trustees, Executors and Agency Company of Australasia Limited, of 95 Queen-street, Melbourne, to send particulars of their claims to the said company by the 25th day of March, 1970, after which date it will convey or distribute the assets, having regard only to the claims of which the company then has notice.

STEDMAN, CAMERON, MEARES & HALL, 339 Collins-street, Melbourne. 2141

CREDITORS, next of kin and other persons having claims against the estate of Alice Mabel Malcolm, late of 6 Euston-street, Malvern, widow, deceased (who died on the 9th day of November, 1969), are required to send particulars of their claims to the executor, National Trustees, Executors and Agency Company of Australasia Limited, whose registered office is situated at 95 Queen-street, Melbourne, by the 14th March, 1970, after which date the executor will distribute the assets, having regard only for the claims of which it then has had notice.

JAMES P. OGG & CO., solicitors, of 165 Greville-street, Prahran. 2143

NOTICE TO CREDITORS.—NEVILLE FREDERICK DUNN.

CREDITORS of Neville Frederick Dunn, of 113 Canterbury-road, Camberwell, in the State of Victoria, are hereby advised that the debtor has executed a deed of assignment, as required by the provisions of the Resolution passed at the meeting of creditors held on the 19th day of December, 1969, at the office of the Institute of Chartered Accountants, McKillop-street, Melbourne. Creditors desirous of examining the deed are advised that it may be examined at the office of the trustee, Downie and Taylor, 49 Victoria-street, Warragul, 3820.

2103

E. P. TAYLOR, Trustee.

DORIS MADGE DAW, late of 51 First-avenue, Rosebud, widow, DECEASED.

CREDITORS, next of kin and others having claims in respect of the estate of the deceased (who died on the 22nd day of July, 1969), are required by the trustee, Philip Edington Rhoden, of 376 Collins-street, Melbourne, solicitor, to send particulars to him at 376 Collins-street, Melbourne, by the 31st day of March, 1970, after which date the trustee may convey or distribute the assets having regard only to the claims of which he then has notice.

Dated the 8th day of January, 1970.

JOHN P. RHODEN, solicitors, 376 Collins-street, Melbourne. 2132

IAN BALDOCK MACDOUGALL, late of 1 Toorak-avenue, Toorak, managing director, DECEASED.

CREDITORS, next of kin and others having claims in respect of the estate of the above-named deceased (who died on the 7th day of November, 1969), are required by the trustees, Stanley William Byrne, of 166 Queen-street, Melbourne, solicitor, and Peter Kenneth MacDougall, of 3 Hopetoun-road, Toorak, general manager, to send particulars to them, care of the undersigned by the 16th day of March, 1970, after which date the trustees may convey or distribute the assets, having regard only to the claims of which they then have notice.

WHITING & BYRNE, solicitors, 166 Queen-street, Melbourne. 2154

MARGARET BATEMAN, late of 139A North-road, Garden-vale, in the State of Victoria, widow, DECEASED.

CREDITORS, next of kin and all others having claims in respect of the estate of the deceased (who died on the 10th day of September, 1969) are required by the executor, The Trustees, Executors and Agency Company Limited, of 401 Collins-street, Melbourne, in the State of Victoria, to send particulars of such claims to the said company, by the 14th day of March, 1970, after which date the said company will distribute the assets, having regard only to the claims of which it then has notice.

DAVIES, CAMPBELL & PIESSE, solicitors, 401 Collins-street, Melbourne. 2161

CREDITORS, next of kin and others having claims in respect of the estate of Lindsay Dorice French, late of 463 Bell-street, Pascoe Vale, married woman, deceased (who died on the 15th day of October, 1969), are required by the executors, Ronald Hamilton French, of 82 The Eyrie, Eaglemont, dentist, and Edward Keith Doery, of 4 Birdwood-avenue, Elwood, accountant, to send particulars of their claims to them in care of Messrs. Rogers & Gaylard, solicitors, of 281 Collins-street, Melbourne, prior to the 25th day of March, 1970, after which date the said executors will distribute the assets of the deceased, having regard only to the claims of which they then shall have had notice.

ROGERS & GAYLARD, solicitors, 281 Collins-street, Melbourne. 2160

In the Supreme Court of the State of Victoria.

SALE BY THE SHERIFF.

ON Friday, the 27th of February, 1970, at Ten a.m., at the Police Station, Carpenter-street, Brighton (unless process be stayed or satisfied):—

All the estate and interest (if any) of Edwin Carlton Ellis, of 16 Tennyson-street, Brighton, shipping officer, as proprietor of an estate in fee-simple in the land described in certificate of title, volume 4727, folio 279, upon which is erected a six-roomed brick dwelling-house known as No. 16 Tennyson-street, Brighton.

Registered mortgage No. C.741669 affects the said estate and interest.

Terms: Cash only.

DAVID J. JOHNSTON, Sheriff's Officer.

12th January, 1970.

2142

INSOLVENCY NOTICE

Commonwealth of Australia.

The Bankruptcy Act 1966-68.

ASSIGNED ESTATE OF STUART WALTER ROBSON (TRADING AS "RIVERLAND SERVICE STATION").

NOTICE is hereby given that at a meeting of creditors of the above-named held at 260 Queen-street, Melbourne, on the 12th day of January, 1970, the following Special Resolution was passed:—

"That a composition be accepted on the basis that priority creditors, pursuant to section 109 of the Bankruptcy Act 1966-68, be paid in full and that the unsecured creditors be paid ten cents in the dollar forthwith in full settlement of their debts and that Mr. G. O. Harrison be trustee of the composition."

Dated this 12th day of January, 1970.

G. O. HARRISON, Trustee.

Hall & Rose, chartered accountants, 260 Queen-street, Melbourne, 3000. 2153

IMPOUNDINGS

BENALLA.—Impounded in Benalla Pound, by Mr. J. S. Stickland (Ranger), on 1st January, 1970.

- 1 Border Leicester full mouth crossbred ewe, green brand on back
- 1 crossbred lamb, no visible marks or brand
- 2 Dorset Horn crossbred wethers, one with nick out of top of left ear and green raddle marks, both have horns
- 1 crossbred ewe (6 tooth) and lamb, green ear tag on left ear, blue "E" mark on back, lamb not branded

If not claimed and expenses paid to be sold on 29th January, 1970.

C. H. WALLACE,

2156—\$3.50

Poundkeeper.

DONALD.—Impounded in Donald Pound, from private property, at Swanwater, at 2 p.m., on 9th January, 1970.

- 1 black and white steer (very poor condition), M or double notch lower left ear

If not claimed and expenses paid, to be sold on 30th January, 1970.

W. A. CAMERON,

2163—\$2.25

Poundkeeper.

NHILL.—Impounded in Nhill Pound.

- 1 crossbred ewe with lamb at foot, no visible brand
- 1 Merino wether lamb, no visible brand

If not claimed and expenses paid to be sold on 29th January, 1970.

H. RHODES,

2123—\$1.75

Poundkeeper.

ROSEDALE.—Impounded in Rosedale Pound, on the 31st December, 1969.

- 1 Border Leicester cross ram, full mouth, notch end both ears
- 1 Dorset Horn ram, 6 tooth, metal tag off ear 67-124

If not claimed and expenses paid, to be sold at the Cattle Sale Yards, Traralgon.

E. W. HAMMOND,

2113—\$2.25

Poundkeeper.

SHEPPARTON.—Impounded in Shire of Shepparton Pound.

- 1 2-tooth shorn wether, no visible brand

If not claimed and expenses paid, will be sold on Thursday, 29th January, 1970.

C. L. MANSELL,

2149—\$1.75

Poundkeeper.

Subordinate Legislation Act 1962.

NOTICE OF MAKING OF STATUTORY RULES.

IN pursuance of the provisions of the Subordinate Legislation Act 1962 and the Regulations made thereunder, notice is given of the making of the following statutory rules:—

- | | | |
|---------|---|--------|
| No. | Melbourne Harbor Trust Act 1958. | Price. |
| 1/1970. | Melbourne Harbor Trust Superannuation Regulations 1957 (Amendment No. 1/70) | 10c |

Copies of these statutory rules may be purchased at the Sale of Publications Section of the Government Printing Office, located at Macarthur-street, Melbourne, 3002. If ordered by mail, remittance should be addressed to "The Government Printer, Box 203, P.O., North Melbourne, 3051", and should include 5c extra for postage. If a credit account is held at this office, no remittance is required with the mail order.

The annual subscription rate for Statutory Rules (including a Bound Volume) is \$15, payable in advance. The subscription year commences on 1st January.

A. C. BROOKS,

Government Printer.

STATE ACTS, 1967

COPIES of the following Acts of Parliament of Victoria may be obtained at the Government Printing Office, Sale of Publications Branch, off Parliament-place, Melbourne, phone 63 0321, extension 6181, or from any accredited agent, at the price set opposite to each (these prices do not include postage).

The annual subscription for State Acts 1967 et seq. is \$8 payable in advance.

Bound Volumes of State Acts are also available on a subscription basis of \$15 per annum.

No.		Price.
7515.	New Melbourne Cemetery Lands ..	\$0.10
7516.	Country Fire Authority (Prosecutions) ..	\$0.10
7517.	Social Welfare (Detention) ..	\$0.10
7518.	Zoological Gardens ..	\$0.15
7519.	Richmond (South-Eastern Freeway) Lands	\$0.10
7520.	The Geelong Gas Company's ..	\$0.10

STATE ACTS, 1967—continued.

No.	Price.
7521. Co-operative Housing Societies (Indemnities)	\$0.10
7522. Supreme and County Courts (Sittings)	\$0.10
7523. Dandenong Valley Authority (Amendment)	\$0.15
7524. State Savings Bank (Amendment)	\$0.10
7525. Land (Surf Life Saving Association)	\$0.10
7526. Warragul (Public Park) Lands	\$0.10
7527. Tobacco Leaf Marketing Board (Appointment of Manager) (Amendment)	\$0.10
7528. Stock Artificial Breeding (Amendment)	\$0.10
7529. Second-hand Dealers (Amendment)	\$0.10
7530. Legal Aid (Amendment)	\$0.10
7531. Weights and Measures (Amendment)	\$0.25
7532. The Constitution Act Amendment (Electoral)	\$0.10
7533. Education and Teaching Service (Amendment)	\$0.15
7534. Public Officers Salaries and Allowances	\$0.10
7535. Railways (State Coal Mine Officers)	\$0.10
7536. Public Officers (Long Service Leave)	\$0.15
7537. Pipelines (Submerged Lands)	\$0.30
7538. Police Regulation (Pensions)	\$0.10
7539. Legal Profession Practice (Victoria Law Foundation)	\$0.10
7540. Petroleum (Barracouta and Marlin Fields Agreement)	\$0.25
7541. Pipelines	\$0.25
7542. Local Government (Amendment)	\$0.15
7543. Stamps (Amendment)	\$0.10
7544. Police Offences (Obscene Publications)	\$0.10
7545. Melbourne University (Amendment)	\$0.10
7546. Crimes	\$0.15
7547. Instruments (Corporate Bodies Contracts)	\$0.10
7548. Land (Amendment)	\$0.25
7549. Water (Amendment)	\$0.10
7550. Dowling Forest Racecourse Lands	\$0.15
7551. Strata Titles	\$0.40
7552. Revocation and Excision of Crown Reservations	\$0.15
7553. Tullamarine Freeway Lands	\$0.15
7554. Friendly Societies Investment	\$0.10
7555. Victorian Institute of Colleges (Board of Studies)	\$0.10
7556. Consolidated Revenue	\$0.10
7557. Consolidated Revenue	\$0.10
7558. Joint Select Committee (Drainage)	\$0.15
7559. Consolidated Revenue	\$0.10
7560. Consolidated Revenue	\$0.10
7561. Grain Elevators (Borrowing Powers)	\$0.10
7562. Building Societies (Unsecured Loans)	\$0.10
7563. Money Lenders (Corporation Licences)	\$0.10
7564. Barley Marketing (Amendment)	\$0.10
7565. Medical (Foreign Practitioners)	\$0.10
7566. Masseurs (Amendment)	\$0.10
7567. Firearms (Prohibited Persons)	\$0.10
7568. Joint Select Committee (Meat Industry)	\$0.10
7569. Council of Law Reporting in Victoria	\$0.15
7570. Marketable Securities	\$0.15
7571. Railway Lands	\$0.10
7572. Labour and Industry (Fees)	\$0.10
7573. Geelong Waterworks and Sewerage	\$0.10
7574. Aboriginal Affairs	\$0.25
7575. Co-operative Housing Societies (Amendment)	\$0.10
7576. Rural Finance (Amendment)	\$0.10
7577. Crimes (Amendment)	\$0.10
7578. Revocation and Excision of Crown Reservations (No. 2)	\$0.15
7579. Gaols (Amendment)	\$0.10
7580. Gas Regulation (Amendment)	\$0.10
7581. Judges and Public Officers Salaries	\$0.15
7582. Portland Harbor (Exchange of Land)	\$0.15
7583. Carlton (Recreation Ground) (Amendment) Land	\$0.10
7584. Superannuation (Amendment)	\$0.15
7585. Stamps	\$0.30
7586. Educational Grants	\$0.10
7587. Motor Car (Hours of Driving)	\$0.10
7588. Poisons (Amendment)	\$0.10
7589. Housing (Amendment)	\$0.10
7590. Water (Further Amendment)	\$0.15
7591. Petroleum (Submerged Lands)	\$0.90
7592. Supreme Court (Judges)	\$0.10
7593. Motor Car	\$0.15
7594. Labour and Industry (Bread)	\$0.15
7595. Pesticides (Amendment)	\$0.10
7596. Judicial Proceedings Report (Amendment)	\$0.10
7597. Administration and Probate (Amendment)	\$0.10
7598. Mental Health (Pathological Examinations)	\$0.10
7599. Veterinary Surgeons (Amendment)	\$0.10
7600. Licensing (Rutherglen Wine Festival)	\$0.10
7601. Estate Agents (Objections)	\$0.10
7602. Joint Select Committee (Road Safety)	\$0.10
7603. Richmond High School Land	\$0.10
7604. Fertilizers (Amendment)	\$0.15

STATE ACTS, 1967—continued.

No.	Price.
7605. Milk and Dairy Supervision (Amendment)	\$0.10
7606. Country Fire Authority (Notices)	\$0.10
7607. Stock Foods (Amendment)	\$0.15
7608. Litter	\$0.10
7609. Municipal Association (Amendment)	\$0.10
7610. Maintenance (Amendment)	\$0.10
7611. Yea Civic Centre and Court House	\$0.15
7612. Shepparton Abattoirs	\$0.15
7613. Yarraville (Recreation Ground) Lands	\$0.15
7614. Swine Compensation	\$0.25
7615. Cattle Compensation	\$0.25
7616. Ringwood and Warrandyte Lands	\$0.10
7617. Harbor Charges	\$0.15
7618. Melbourne Harbor Trust Land	\$0.10
7619. Justices (Amendment)	\$0.10
7620. Portland Harbor Trust (Amendment)	\$0.10
7621. Racing	\$0.15
7622. Melbourne and Metropolitan Tramways (Detours)	\$0.10
7623. Land (Committees of Management)	\$0.15
7624. Mildura Irrigation and Water Trusts (Amendment)	\$0.10
7625. Apprenticeship (Amendment)	\$0.10
7626. Local Government (Municipalities Assistance Fund)	\$0.10
7627. Fitzroy (Edinburgh Gardens) Lands	\$0.15
7628. Coal Mines (Pensions)	\$0.10
7629. Lifts and Cranes	\$0.15
7630. Licensing (Amendment)	\$0.10
7631. The Geelong Gas Company's (Amendment)	\$0.15
7632. Extractive Industries (Amendment)	\$0.10
7633. Land Tax (Rates)	\$0.10
7634. Sunday Entertainment	\$0.15
7635. Summary Offences	\$0.10
7636. Stamps (Exemptions)	\$0.10
7637. Rain-making Control	\$0.15
7638. Cemeteries (St. Kilda Public Cemetery)	\$0.10
7639. Weights and Measures (Pre-packed Articles)	\$0.30
7640. State Forests Loan Application	\$0.10
7641. Fisheries (Amendment)	\$0.15
7642. Barry Beach Railway Construction	\$0.10
7643. Marketing of Primary Products (Amendment)	\$0.10
7644. Victoria Institute of Colleges	\$0.15
7645. Crimes (Driving Offences)	\$0.15
7646. Private Agents	\$0.10
7647. Teaching Service (Teachers Tribunal)	\$0.15
7648. Motor Car (Compulsory Third Party Insurance)	\$0.10
7649. Public Works Loan Application	\$0.15
7650. Railway Loan Application	\$0.15
7651. Juries	\$0.35
7652. Westernport Development	\$0.15
7653. North Melbourne Lands (Amendment)	\$0.10
7654. Water Supply Loan Application	\$0.25
7655. Appropriation of Revenue	\$1.15

A. C. BROOKS,
Government Printer.

STATE ACTS, 1968

COPIES of the following Acts of Parliament of Victoria may be obtained at the Government Printing Office, Sale of Publications Branch, off Parliament-place, Melbourne, phone 63 0321, extension 6181, or from any accredited agent, at the price set opposite to each (these prices do not include postage).

The annual subscription for State Acts 1968 et seq. is \$8 payable in advance.

Bound Volumes of State Acts are also available on a subscription basis of \$15 per annum.

No.	Price.
7656. The Constitution Act Amendment (Governor's Salary)	\$0.10
7657. Victorian Limbless Soldiers' Provident Fund (Closing)	\$0.15
7658. Country Roads (Borrowing Powers)	\$0.10
7659. Hairdressers Registration (Amendment)	\$0.10
7660. Evidence (Attestations)	\$0.10
7661. Melbourne Harbor Trust (Borrowing Powers)	\$0.10
7662. Cheltenham Cemetery Lands Exchange	\$0.10
7663. Administration and Probate (Amendment)	\$0.10
7664. Road Traffic (Infringements)	\$0.10
7665. Transport Regulation (Amendment)	\$0.10
7666. Commercial Goods Vehicles (Amendment)	\$0.10
7667. Tyabb to Long Island Railway Construction	\$0.10
7668. Marriage (Liability in Tort)	\$0.10
7669. La Trobe University (Amendment)	\$0.10
7670. Children's Court (Procedure)	\$0.10
7671. Labour and Industry (Amendment)	\$0.15

STATE ACTS, 1968—continued.

No.	Price.
7672. Cemeteries (Exhumation Licences) ..	\$0.10
7673. Consolidated Revenue ..	\$0.10
7674. Forests (Amendment) ..	\$0.10
7675. Drought Relief ..	\$0.15
7676. Town and Country Planning (Amendment) ..	\$0.35
7677. Sunday Entertainment (Amendment) ..	\$0.10
7678. Police Offences (Publications) ..	\$0.10
7679. The Constitution Act Amendment ..	\$0.10
7680. Portland Harbor Trust (Borrowing Powers) ..	\$0.10
7681. Acts Interpretation (Prior Convictions) ..	\$0.10
7682. Aerial Spraying Control (Amendment) ..	\$0.10
7683. Shearers Accommodation (Amendment) ..	\$0.15
7684. Racing (Amendment) ..	\$0.15
7685. Health (Amendment) ..	\$0.10
7686. State Electricity Commission (Amendment) ..	\$0.15
7687. Kyneton Cattle Market Lands Exchange ..	\$0.15
7688. Swine (Application of Fund) ..	\$0.10
7689. Local Government (Amendment) ..	\$0.40
7690. Royal Society for the Prevention of Cruelty to Animals ..	\$0.15
7691. Racing (Trotting Meetings) ..	\$0.10
7692. Labour and Industry (Shop Trading Hours) ..	\$0.10
7693. Justices (General Sessions Jurisdiction) ..	\$0.10
7694. Latrobe Valley (Amendment) ..	\$0.10
7695. Liquor Control ..	\$0.75
7696. Crimes (Amendment) ..	\$0.10
7697. Country Roads (Amendment) ..	\$0.10
7698. West Moorabool Water Board ..	\$0.35
7699. Melbourne and Metropolitan Board of Works (Borrowing Powers) ..	\$0.10
7700. Teaching Service (Amendment) ..	\$0.10
7701. Children's Welfare (Amendment) ..	\$0.10
7702. Consolidated Revenue ..	\$0.10
7703. Abolition of Bailiwicks ..	\$0.15
7704. Footscray (Recreation Ground) Lands ..	\$0.15
7705. County Court (Jurisdiction) ..	\$0.25
7706. Shrine of Remembrance Trustees (Powers) ..	\$0.10
7707. Margarine (Amendment) ..	\$0.10
7708. National Parks (Amendment) ..	\$0.10
7709. Revocation and Excision of Crown Reservations ..	\$0.15
7710. West Melbourne Lands ..	\$0.15
7711. Kew Lands (Grant Amendment) ..	\$0.10
7712. Agricultural Education (Amendment) ..	\$0.10
7713. Melbourne Sailors' Home (Powers of Trustees) ..	\$0.10
7714. Margarine (Penalties) ..	\$0.10
7715. State Coal Mines (Winding Up) ..	\$0.10
7716. Property Law (Amendment) ..	\$0.10
7717. Auction Sales (Night Auctions) ..	\$0.10
7718. Coal Mines (Pensions) ..	\$0.10
7719. Teaching Service (Amendment) ..	\$0.10
7720. State Forests Loan Application ..	\$0.10
7721. Aboriginal Affairs (Amendment) ..	\$0.10
7722. Police Assistance Compensation ..	\$0.10
7723. Parliamentary Salaries and Superannuation ..	\$0.25
7724. Stock Diseases ..	\$0.30
7725. Juries (Amendment) ..	\$0.10
7726. Stock Medicines (Amendment) ..	\$0.10
7727. Parliamentary Committees ..	\$0.25
7728. Bread Industry (Legal Proceedings) ..	\$0.10
7729. Sewerage Districts ..	\$0.15
7730. Municipalities (Commutation of Licensing Payments) ..	\$0.10
7731. Housing (Amendment) ..	\$0.10
7732. Second-hand Dealers (Amendment) ..	\$0.10
7733. Fences ..	\$0.25
7734. Melbourne Harbor Trust (Exchange of Yarraville Lands) ..	\$0.10
7735. Inflammable Liquids (Petrol Service Stations) ..	\$0.10
7736. Tomato Processing Industry (Amendment) ..	\$0.10
7737. Marketing of Primary Products (Egg and Egg Pulp Marketing Board) ..	\$0.10
7738. Children's Welfare (Prosecutions) ..	\$0.10
7739. Consumers Protection (Amendment) ..	\$0.10
7740. Forests (Amendment) ..	\$0.10
7741. State Electricity Commission ..	\$0.10
7742. Settlement Grants and Mortgages ..	\$0.10
7743. Water Supply Loan Application ..	\$0.25
7744. Door to Door (Sales) (Amendment) ..	\$0.10
7745. Medical (Organ Transplants) ..	\$0.15
7746. Public Works Loan Application ..	\$0.15
7747. Pesticides (Proclamations) ..	\$0.10
7748. Stock (Artificial Breeding) (Amendment) ..	\$0.10
7749. National Parks (Little Desert and Mount Richmond) ..	\$0.10
7750. Perpetuities and Accumulations ..	\$0.15
7751. Road Traffic (Crown Land) ..	\$0.10
7752. Lotteries Gaming and Betting (Penalties) ..	\$0.10
7753. Liquor Control (Amendment) ..	\$0.15
7754. Liquefied Gases ..	\$0.15
7755. Labour and Industry (Miscellaneous Provisions) ..	\$0.10

STATE ACTS, 1968—continued.

No.	Price.
7756. Pounds (Amendment) ..	\$0.15
7757. Aerial Spraying Control (Security) ..	\$0.10
7758. Melbourne University (Council) ..	\$0.10
7759. Weights and Measures (Amendment) ..	\$0.15
7762. Valuation of Land (Amendment) ..	\$0.15
7763. Dandenong Valley Authority (Amendment) ..	\$0.10
7764. Melbourne Harbor Trust Land ..	\$0.10
7765. Chiropodists ..	\$0.15
7766. Wheat Industry Stabilization ..	\$0.15
7767. Railway Loan Application ..	\$0.15
7768. Poultry Processing ..	\$0.15
7769. Country Roads (Declarations) ..	\$0.10
7770. Building Societies (Amendment) ..	\$0.10
7771. Goods (Textile Products) ..	\$0.10
7772. Alcoholics and Drug-dependent Persons ..	\$0.25
7773. Land Tax ..	\$0.15
7774. Public Lands and Works (Amendment) ..	\$0.10
7775. Milk Board (Amendment) ..	\$0.10
7776. Married Women's Superannuation Fund ..	\$0.15
7760. Melbourne Wholesale Fruit and Vegetable Market ..	\$0.15
7761. Mines (Amendment) ..	\$0.10
7777. Motor Car (Further Amendment) ..	\$0.15
7778. Melbourne and Metropolitan Board of Works (Amendment) ..	\$0.25
7779. Superannuation (Amendment) ..	\$0.15
7780. Fisheries ..	\$0.40
7781. Water ..	\$0.15
7782. Crimes (Evidence) ..	\$0.10
7783. Land (Special Land) ..	\$0.10
7784. Consolidated Revenue ..	\$0.10
7785. Appropriation of Revenue ..	\$1.00

A. C. BROOKS,
Government Printer.

STATE ACTS, 1969

COPIES of the following Acts of Parliament of Victoria may be obtained at the Government Printing Office, Sale of Publications Branch, off Parliament-place, Melbourne, phone 63 0321, extension 6181, or from any accredited agent, at the price set opposite to each (these prices do not include postage).

The annual subscription for State Acts 1969 et seq. is \$8 payable in advance.

Bound Volumes of State Acts are also available on a subscription basis of \$15 per annum.

No.	Price.
7786. Summary Offences (Sunday Newspapers) ..	\$0.10
7787. Town and Country Planning (Transitional Appeals) ..	\$0.10
7788. Discharged Servicemen's Preference (Amendment) ..	\$0.10
7789. Water (Amendment) ..	\$0.10
7790. Agricultural Education Cadetships ..	\$0.10
7791. Trustee (Amendment) ..	\$0.10
7792. Appeal Costs Fund (Amendment) ..	\$0.10
7793. Footscray (Lower Yarra Crossing Access Road) Land ..	\$0.10
7794. River Improvement (Amendment) ..	\$0.15
7795. Geelong Waterworks and Sewerage (Amendment) ..	\$0.15
7796. West Moorabool Water Board (Amendment) ..	\$0.10
7797. Sewerage Districts (Amendment) ..	\$0.15
7798. Drought Relief (Amendment) ..	\$0.10
7799. Legal Profession Practice (Amendment) ..	\$0.10
7800. Parliamentary Salaries and Superannuation (Administration) ..	\$0.10
7801. Protection of Animals (Penalties) ..	\$0.10
7802. Lotteries Gaming and Betting (Calcutta Sweepstakes) ..	\$0.10
7803. Belmont Common Recreation Ground Lands ..	\$0.10
7804. Listening Devices ..	\$0.10
7805. Coal Mines (Pensions) ..	\$0.10
7806. Marine (Amendment) ..	\$0.10
7807. Theatres (Amendment) ..	\$0.15
7808. Victorian Inland Meat Authority (Amendment) ..	\$0.10
7809. The Constitution Act Amendment (Electoral) ..	\$0.15
7810. Consolidated Revenue ..	\$0.10
7811. Gas and Fuel Corporation (Borrowing) ..	\$0.10
7812. Weights and Measures (Amendment) ..	\$0.10
7813. Health (Municipal Charges) ..	\$0.10
7814. Transfer of Land (Subdivision of Allotments) ..	\$0.15
7815. St. Vincent's Private Hospital (Guarantees) ..	\$0.10
7816. Strata Titles (Amendment) ..	\$0.15
7817. Sunday Entertainment (Evidence) ..	\$0.10

STATE ACTS 1969—continued.

No.		Price.
7818.	Dried Fruits (Packing Houses) ..	\$0.10
7819.	Town and Country Planning (Further Amendment) ..	\$0.10
7820.	Milk Board (Amendment) ..	\$0.10
7821.	Medical (Pharmaceutical Chemists) ..	\$0.10
7822.	Melbourne Wholesale Fruit and Vegetable Market (Amendment) ..	\$0.10
7823.	Education (Director-General) ..	\$0.10
7824.	Wombat Bonuses ..	\$0.10
7825.	Revocation and Excision of Crown Reservations ..	\$0.15
7826.	Mildura Irrigation and Water Trusts ..	\$0.25
7827.	South Melbourne (Roman Catholic Orphanage) Lands ..	\$0.15
7828.	Racing (Amendment) ..	\$0.10
7829.	Commercial Goods Vehicles (Tow Trucks) ..	\$0.10
7830.	Stamps (Amendment) ..	\$0.15
7831.	Gas and Fuel Corporation (Sale Undertaking) ..	\$0.15
7832.	Melbourne (St. Kilda-road Underpass) ..	\$0.15
7833.	Trustee (Authorized Investments) ..	\$0.10
7834.	Consolidated Revenue ..	\$0.10
7835.	Local Government ..	\$0.60
7836.	Melbourne Wholesale Fruit and Vegetable Market (Advisory Committee) ..	\$0.10
7837.	Teaching Service (Amendment) ..	\$0.10
7838.	State Electricity Commission (Borrowing and Investing Powers) ..	\$0.10
7839.	Motor Car (Amendment) ..	\$0.10
7840.	Mines (Abolition of Courts) ..	\$0.30
7841.	Manango (O'Shanessy River Watershed) Lands ..	\$0.10
7842.	State Savings Bank (Amendment) ..	\$0.10
7843.	Apprenticeship (Commission) ..	\$0.10
7844.	Swan Hill Race-course and Golf-course Lands ..	\$0.15
7845.	Imitation Milk ..	\$0.15
7846.	Finance Brokers ..	\$0.25
7847.	Local Government (Rating Exemptions) ..	\$0.15
7848.	Labour and Industry (Amendment) ..	\$0.10
7849.	Groundwater ..	\$0.30
7850.	Consolidated Revenue ..	\$0.10
7851.	Mental Health (Chairmanship) ..	\$0.10
7852.	Instruments (Bills of Exchange Amendment) ..	\$0.10
7853.	Supreme Court (Correction of Sentences) ..	\$0.10
7854.	Summary Offences ..	\$0.10
7855.	Church of England in Australia (Mount Shadwell Land) ..	\$0.10
7856.	State Rivers and Water Supply Commission (Special Projects) ..	\$0.10
7857.	Coal Mines (Pensions Increase) ..	\$0.10
7858.	Trustee Companies (Burns Philp Trustee Company Limited) ..	\$0.10
7859.	Latrobe Valley (Amendment) ..	\$0.10
7860.	Maintenance (Amendment) ..	\$0.10
7861.	Aboriginal Affairs (Amendment) ..	\$0.10
7862.	Goods (Trade Descriptions) ..	\$0.10
7863.	Marine Stores and Old Metals (Amendment) ..	\$0.15
7864.	Fire Authorities (Borrowing Powers) ..	\$0.10
7865.	Acts Interpretation (Time) ..	\$0.10
7866.	Narre Worrnan Lands ..	\$0.10
7867.	Moorpanyal Lands ..	\$0.10
7868.	Juries (Amendment) ..	\$0.10
7869.	Apprenticeship (Regulations) ..	\$0.10
7870.	Portland Lands Exchange ..	\$0.10
7871.	Melbourne University (Property) ..	\$0.10
7872.	Latrobe Valley (Lands for Ambulance Services) ..	\$0.10
7873.	Ministry of Transport (Director of Transport) ..	\$0.10
7874.	Administration and Probate (Foreign Grants) ..	\$0.10
7875.	Road Traffic (Amendment) ..	\$0.10
7876.	Justices (Amendment) ..	\$0.35
7877.	Country Fire Authority (Amendment) ..	\$0.15
7878.	Coal Mines (Accidents Relief) ..	\$0.10
7879.	Preston School of Design and Free Library Land ..	\$0.10
7880.	Lands Compensation (Costs and Expenses) ..	\$0.10
7881.	Evidence (Bankers' Books) ..	\$0.10
7882.	Transport Regulation (Financial) ..	\$0.10
7883.	Railways (Surplus Lands) ..	\$0.10
7884.	Abolition of Obsolete Offences ..	\$0.10
7885.	Fire Brigades (Contributions) ..	\$0.15

A. C. BROOKS,
Government Printer.

PUBLICATION OF OFFICIAL MATTER.

ATTENTION is invited to the following procedure in relation to the publication of official matter in the *Government Gazette*:—

Publication will be facilitated by the submission of carbon copies for the use of the *Gazette Officer*.

1. *Matter submitted to the Executive Council.*

Matter submitted to the Executive Council which requires gazettal will normally be published in the issue of the following week.

Where urgent gazettal is required, special arrangements should be made with the *Gazette Officer*, Room 9, first floor, Old Treasury Building.

2. *Other matter.*

(a) All other matter duly certified by a responsible officer for publication should be lodged with the *Gazette Officer* not later than half-past Nine a.m. on Tuesday...

(b) Lengthy or involved notices should be forwarded several days before publication.

(c) Proofs, which will be supplied only when specifically requested or at the direction of the *Gazette Officer*, should be returned promptly to avoid delay in publication.

(d) No additions or amendments to matter for publication will be accepted by telephone.

THE "VICTORIA GOVERNMENT GAZETTE".

SUBSCRIPTIONS.—The subscription, including postage, is \$10 per annum, or \$5 per half year, payable in advance.

Subscriptions are required for whole months, and must cover at least a half year.

Single copies are 20 cents, posted 25 cents. Subscribers do not receive the Acts of Parliament with the GAZETTE.

GAZETTES are held in stock for five years only.

PRIVATE ADVERTISEMENTS.—The charge for insertion is 25 cents per line single column, and 50 cents per line double column. The title forms one or more lines as a heading. On an average ten words make a line of single column. Every signature must likewise be counted as a line. The final words of a paragraph, though only portion of a line, must be counted as one line. Signatures (in particular) and proper names must be written very plainly in the text; ONE SIDE ONLY of each sheet of paper, should be WRITTEN UPON.

All documents illegibly written will be returned unpublished, and where brands occur unprovided for by the ordinary letters of the alphabet, a worded explanatory description must be furnished.

THE VICTORIA GOVERNMENT GAZETTE is published on WEDNESDAY EVENING in each week, and Notices for insertion will be received by the Government Printer at or before ONE p.m. at ordinary rates, and late advertisements between ONE p.m. and FOUR p.m. at double rates on the day preceding the day of publication.

PAYMENTS.—Unless the advertiser has a credit account, all payments are required in advance. Remittances should be made by cheque, postal order, or money order payable to "GOVERNMENT PRINTER".

ADDRESS.—All communications should be addressed to "The Government Printer, Box 203, P.O., North Melbourne". 3051.

AGENTS FOR THE "VICTORIA GOVERNMENT GAZETTE".

THE following have been appointed agents to receive Advertisements and Subscriptions for the *Victoria Government Gazette*:—

ARMSTRONG'S AGENCY, 205 Queen-street, Melbourne, Victoria 3000.

ARNALL & JACKSON, 390 Barkly-street, Brunswick, Victoria 3056.

BAIRNSDALE AUTHORIZED NEWSAGENCY, 132 Main-street, Bairnsdale, Victoria 3875.

BICKNELL, M. J., Authorized Newsagent, 196 Timor-street, Warrambool, Victoria 3280.

BLANE'S AUTHORIZED NEWSAGENTS, 162 Murray-street, Colac, Victoria 3250.

CARTER, R. G., ADVERTISING SERVICE PTY. LTD., Suite 24, 65 Queens-road, Melbourne, Victoria 3004.

DAVIES, G. & M. V., 112 Gray-street, Hamilton, Victoria 3300.

DAVIS, WM. (MILDURA) PTY. LTD., 126 Eighth-street, Mildura, Victoria 3500.

DIXON'S NEWSAGENCY, 89 Firebrace-street, Horsham, Victoria 3400.
 EDGAR'S NEWSAGENCY PTY. LTD., 293 Hargreaves-street, Bendigo, Victoria 3550.
 EDGARS' AUTHORIZED NEWSAGENCY, 45 Bridge-street, Benalla, Victoria 3672.
 FRANKS, H., & CO., 184 Ryrie-street, Geelong, Victoria 3220.
 GATLEY, A. & J., 250 Lonsdale-street, Dandenong, Victoria 3175.
 GORDON & GOTCH AUSTRALASIA LTD., 467 Collins-street, Melbourne, Victoria 3000.
 GULLAN'S NEWSAGENCY, 88 Bridge-street, Ballarat, Victoria 3350.
 HAMPTON, A. C., 243 Mitchell-street, Bendigo, Victoria 3550.
 HARSTON, PARTRIDGE & CO. PTY. LTD., 455 Little Collins-street, Melbourne, Victoria 3000.
 KYNETON GUARDIAN PTY. LTD., P.O. Box 18, Kyneton, Victoria 3444.
 LATIMER'S, Newsagents, 45 Station-street, Malvern, Victoria 3144.
 LIVINGSTON'S SHEPPARTON NEWSAGENCY, 246 Wyndham-street, Shepparton, Victoria 3630.
 THE MERCANTILE EXCHANGE, 67 Queen-street, Melbourne, Victoria, 3000.
 MCGILL'S AUTHORIZED NEWSAGENCY, 183-5 Elizabeth-street, Melbourne, Victoria 3000.
 PHILLIPS AUTHORIZED AGENCY, 83 Murphy-street, Wangaratta, Victoria 3677.
 PURDIE, J., & CO., 138 Moorabool-street, Geelong, Victoria 3220.
 SALE AUTHORIZED NEWSAGENCY, 142 Raymond-street, Sale, Victoria 3850.
 SKINNER'S AUTHORIZED NEWSAGENCY, 49-51 Franklin-street, Traralgon, Victoria 3844.
 STEVENSON, A. C. & M., NEWSAGENTS, 132 Henty-street, Casterton, Victoria 3311.
 VERNON, C. F. & H. J., 162 Bridge-road, Richmond, Victoria 3121.

VIEW POINT AUTHORIZED NEWSAGENCY, 4 View-Point, Bendigo, Victoria 3550.

A copy of the Gazette filed at each place for public reference.

CONTENTS		PAGE
Acts of Parliament on Sale at the Government Printing Office		118
Contracts		99
Estates of Deceased Persons		98
Government Notices		92
Impoundings		118
Insolvency Notice		118
Lands		102
Money Lenders Act 1958—Supplementary List ..		98
Notice of Making of Statutory Rule		118
Orders in Council—		
Acts—Water; Public Authorities Works; River Improvement; Sewerage Districts; Landlord and Tenant; Marketing of Primary Products.		100 et seq
Police Sale		92
Private Advertisements		106
Proclamations		91
Public Holiday—Australia Day		92
Public Service Notice		105
State Rivers and Water Supply Commission ..		98
Tenders		106
Transport Regulation Board—Public Hearings ..		93
Waterworks Trusts		99