



VICTORIA
GOVERNMENT GAZETTE

Published by Authority

[Registered at the General Post Office, Melbourne, for transmission by post as a newspaper.]

No. 43]

WEDNESDAY, APRIL 29

[1970

PROCLAMATIONS

Land Act 1958.

AREA OF LAND COMPRISED IN CERTAIN CLASSES DIMINISHED OR INCREASED.

PROCLAMATION

By the Lieutenant-Governor as Deputy for His Excellency the Governor of the State of Victoria and its Dependencies in the Commonwealth of Australia, &c., &c., &c.

WHEREAS by the *Land Act 1958* it is amongst other things enacted that the Governor in Council may, by Proclamation to be published in the *Government Gazette*, at any time diminish or increase the area of land comprised in any of the classes mentioned in Part I., Division 1, Section 5, of the said *Land Act 1958*, but that the area of lands which may be sold by auction (Class 6), shall not be increased except as in certain cases in the said Act provided: Now therefore I, the Lieutenant-Governor as Deputy for the Governor of the State of Victoria, in the Commonwealth of Australia, by and with the advice of the Executive Council of the said State, and in accordance with the provisions of Sections 94 and 117 of the *Land Act 1958* aforesaid, do hereby diminish or increase (as the case may be) the areas of Crown lands comprised in Classes 3 and 6 of the classes mentioned in Section 5 of the *Land Act 1958* aforesaid, to the extent set forth in the subjoined Schedule (that is to say):—

Schedule referred to
CLASSES DIMINISHED OR INCREASED.

County.	Parish.	Allotment.	Section.	Area.	Diminished.	Increased.	Description.
					Class.	Class.	
Follett	Dartmoor ..	5B	—	A. R. P. 51 2 0	3	6	In the north-east of the Parish.—(J32692)

Given under my Hand and the Seal of the State of Victoria, aforesaid, at Melbourne, this twenty-second day of April, in the year of our Lord One thousand nine hundred and seventy, and in the nineteenth year of the reign of Her Majesty Queen Elizabeth II.

(L.S.)

E. F. HERRING.
By His Excellency's Command,
W. J. F. McDONALD,
Minister of Lands

GOD SAVE THE QUEEN!

Land Act 1958.

UNALIENATED CROWN LAND AVAILABLE FOR SETTLEMENT UNDER IMPROVEMENT PURCHASE LEASES.

PROCLAMATION

By the Lieutenant-Governor as Deputy for His Excellency the Governor of the State of Victoria and its Dependencies in the Commonwealth of Australia, &c., &c., &c.

IN pursuance of the provisions of Section 153 of the Land Act 1958, I, the Lieutenant-Governor as Deputy for the Governor of the State of Victoria, in the Commonwealth of Australia, by and with the advice of the Executive Council of the said State, do by this Proclamation declare the unalienated Crown lands mentioned in the subjoined schedule, to be available for settlement under improvement purchase leases.

SCHEDULE.

County.	Parish.	Allotment.	Section.	Area.	Land Valuation.
Bogong	Mudgeegonga	12	16	27.5 ac.±	\$10.00 per acre

Given under my Hand and the Seal of the State of Victoria aforesaid, at Melbourne this twenty-second day of April in the year of our Lord One thousand nine hundred and seventy, and in the nineteenth year of the reign of Her Majesty Queen Elizabeth II.

(L.S.) E. F. HERRING.
By His Excellency's Command,
W. J. F. McDONALD,
Minister of Lands.

GOD SAVE THE QUEEN !

Land Act 1958, Section 25.

TOWNSHIP OF KYNETON EXTENDED.

PROCLAMATION

By the Lieutenant-Governor as Deputy for His Excellency the Governor of the State of Victoria and its Dependencies in the Commonwealth of Australia, &c., &c., &c.

IN pursuance of the provisions of Section 25 of the Land Act 1958, I, the Lieutenant-Governor as Deputy for the Governor of the State of Victoria, by and with the advice of the Executive Council of the said State, do hereby extend the Township of Kyneton (in the Parish of Lauriston, County of Dalhousie) proclaimed as such on the 1st April, 1941, by the addition thereto of the portion indicated by hatching on plan hereunder.—(K.96⁽²⁾) (C.84429).

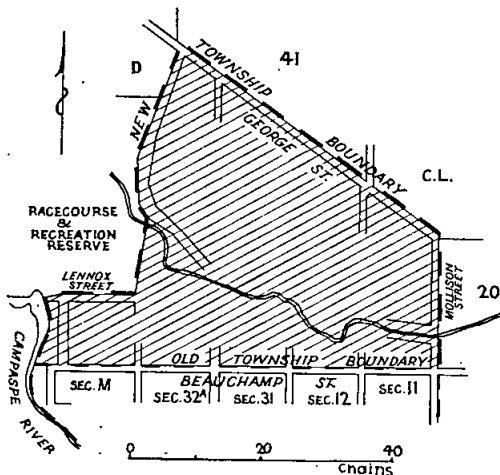

Given under my Hand and the Seal of the State of Victoria aforesaid, at Melbourne, this twenty-second day of April, in the year of our Lord One thousand nine hundred and seventy, and in the nineteenth year of the reign of Her Majesty Queen Elizabeth II.

(L.S.) E. F. HERRING.
By His Excellency's Command,
W. J. F. McDONALD,
Minister of Lands.

GOD SAVE THE QUEEN !

Land Act 1958, Section 25.

ROAD PROCLAIMED.

PROCLAMATION

By the Lieutenant-Governor as Deputy for His Excellency the Governor of the State of Victoria and its Dependencies in the Commonwealth of Australia, &c., &c., &c.

IN pursuance of the provisions of Section 25 of the Land Act 1958, I, the Lieutenant-Governor as Deputy for the Governor of the State of Victoria, by and with the advice of the Executive Council of the said State, do hereby proclaim as a road the land in the City of Melbourne, Parish of Melbourne North, County of Bourke, as indicated by hatching on plan hereunder.—(M.314⁽⁹⁾) (Rs.1124).

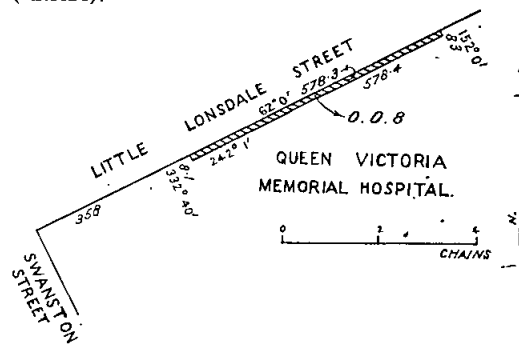

Given under my Hand and the Seal of the State of Victoria aforesaid, at Melbourne, this twenty-second day of April, in the year of our Lord One thousand nine hundred and seventy, and in the nineteenth year of the reign of Her Majesty Queen Elizabeth II.

(L.S.) E. F. HERRING.
By His Excellency's Command,
W. J. F. McDONALD,
Minister of Lands.

GOD SAVE THE QUEEN !

PUBLIC HIGHWAY.—CITY OF HEIDELBERG.

PROCLAMATION

By the Lieutenant-Governor as Deputy for His Excellency the Governor of the State of Victoria and its Dependencies in the Commonwealth of Australia, &c., &c., &c.

WHEREAS by the *Local Government Act 1958*, section 519 it is amongst other things enacted that it shall be lawful for the Governor in Council at any time and from time to time upon the request of the Council of any municipality by notice in the *Government Gazette* to proclaim any land reserved used or by purchase or exchange acquired for a street, road, highway, thoroughfare, bridge, square, court, alley, or right-of-way or any street, road, lane or passage made or laid out or proposed to be made or laid out on any land of which a plan of subdivision delineating that street, road, lane or passage has been sealed with the seal of the municipality under subdivision (3) of Division 9 of Part XIX of the *Local Government Act 1958*, or a corresponding previous enactment to be a public highway and that such land shall thereupon and thenceforth from the date of such proclamation become and be absolutely dedicated to the public as a public highway within the meaning of any law then or thereafter in force.

And whereas the Council of the City of Heidelberg has requested that the land hereinafter mentioned, being a street, road, lane or passage made or laid out or proposed to be made or laid out on land of which a plan of subdivision delineating the street, road, lane or passage has been sealed with the seal of the municipality under subdivision (3) of Division 9 of Part XIX of the *Local Government Act 1958*, or a corresponding previous enactment, be so declared to be a public highway.

Now therefore, I, the Lieutenant-Governor as Deputy for the Governor of the State of Victoria in the Commonwealth of Australia, by and with the advice of the Executive Council of the said State, do by this Proclamation declare that Castleton Road, shown hatched on the plan hereunder, shall be a public highway within the meaning of the said Act.

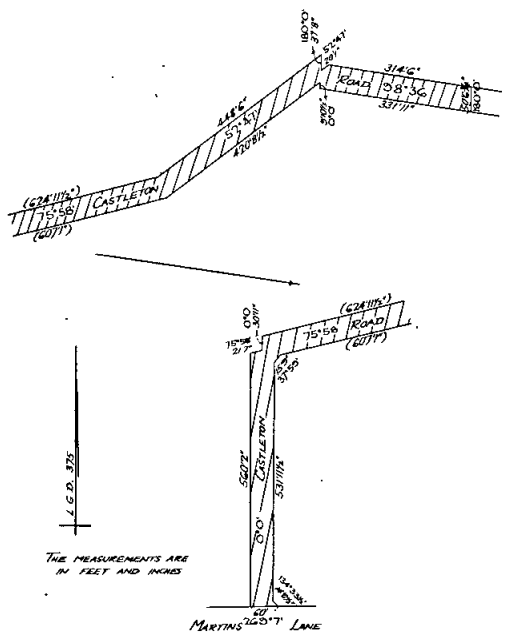

Given under my Hand and the Seal of the State of Victoria aforesaid, at Melbourne, this twenty-second day of April, in the year of our Lord One thousand nine hundred and seventy and in the nineteenth year of the reign of Her Majesty Queen Elizabeth II.

(L.S.) E. F. HERRING.

By His Excellency's Command,
R. J. HAMER,
Minister for Local Government.
GOD SAVE THE QUEEN!

POISONS ACT 1962 (No. 6889).

PROCLAMATION

By the Lieutenant-Governor as Deputy for His Excellency the Governor of the State of Victoria and its Dependencies in the Commonwealth of Australia, &c., &c., &c.

WHEREAS by Section 4 of the *Poisons Act 1962*, it is amongst other things enacted that the Governor in Council may by proclamation published in the *Government Gazette*, amend any of Schedules One, Two, Three, Four, Five, Six, Seven or Eight to such Act by adding to any such Schedules or removing therefrom any item:

Now, therefore, I, the Lieutenant-Governor as Deputy for the Governor of the State of Victoria in the Commonwealth of Australia, by and with the advice of the Executive Council of the said State, by virtue of the provisions of the said Section and all other enabling powers, do by this Proclamation—

1. Amend Schedule Four to the said Act by removing therefrom the following items:—

- AMPHETAMINE
- CODEINE in compounded preparations—
 - (a) In tablet or capsule form containing 100 milligrams or less of codeine in each such tablet or capsule; or
 - (b) In any other form containing 2.5 per centum or less of codeine, except in substances containing 1 per centum or less of codeine.

1-HYDROXY-PYRIDO (3, 2,)-5-PHENOXAZONE-3-CARBOXYLIC ACID CATAPRES for therapeutic use.

and by adding thereto the following items:—

- BETAHISTINE HYDROCHLORIDE
- BENZPHETAMINE and other substances structurally derived from beta-aminopropylbenzene or beta-aminoisopropylbenzene by substitution in the side chain or by ring closure therein (or by both such substitution and such closure) except when specifically provided for in this or any other Schedule.

BROMHEXINE

BUPHENINE HYDROCHLORIDE for oral therapeutic use.

- CLOMIDINE HYDROCHLORIDE
- CODEINE—
 - (a) In compounded preparations in tablet or capsule form containing 100 milligrams or less of codeine in each such tablet or capsule, except in substances containing 1 per centum or less of codeine; or
 - (b) In any other substance containing 2.5 per centum or less of codeine, except in substances containing 1 per centum or less of codeine.

DIISOPROPYLAMINE DICHLOROACETATE for therapeutic use.

1-(3, 4-DIMETHOXYPHENYL)-1-DIMETHYLAMINO-4-PHENYLBUTANE-HYDROCHLORIDE

ETHCHLORVYNOL

1-HYDROXY-PYRIDO (3, 2, a)-5-PHENOXAZONE-3-CARBOXYLIC ACID

THIABENDAZOLE for human therapeutic use.

TRIAMTERENE.

2. Amend Schedule Five to the said Act by removing therefrom the following item:—

- 1, 1, 1-TRICHLOROETHANE packed in containers having a capacity of 4 gallons or less, unless such containers comply with the provisions of the Act and the Regulations made thereunder and are labelled with a warning label.

and by adding thereto the following item:—

- 1, 1, 1-TRICHLOROETHANE, as such, packed in containers having a capacity of 4 gallons or less, unless such containers comply with the provisions of the Act and Regulations made thereunder and are labelled with a warning label.

3. Amend Schedule Six to the said Act by adding thereto the following items:—

- FENAZAFLOR
- NITROXYNIL

4. Amend Schedule Eight to the said Act by adding thereto the following items:—

AMPHETAMINE
BEZITRAMIDE
DEXAMPHETAMINE
METHYLAMPHETAMINE

Given under my Hand and the Seal of the State of Victoria aforesaid, at Melbourne, this twenty-second day of April, in the year of our Lord One thousand nine hundred and seventy, and in the nineteenth year of the reign of Her Majesty Queen Elizabeth II.

(L.s.) E. F. HERRING.

By His Excellency's Command,
VANCE DICKIE,
Minister of Health.

GOD SAVE THE QUEEN !

PESTICIDES ACT 1958.

PROCLAMATION

By the Lieutenant-Governor as Deputy for His Excellency the Governor of the State of Victoria and its Dependencies in the Commonwealth of Australia, &c., &c., &c.

IN pursuance of the powers in that behalf conferred by section 6A of the *Pesticides Act 1958*, I, the Lieutenant-Governor as Deputy for His Excellency the Governor of the State of Victoria in the Commonwealth of Australia, by and with the advice of the Executive Council thereof do by this my proclamation hereby amend the proclamation made on the third day of March, 1970, and published in the *Government Gazette* on the eleventh day of March, 1970 as follows:—

In the Schedule to the Proclamation—

(a) in paragraph (b) of Column 2 of Type of Pesticide Numbered 11 for the expression "25 per cent." there shall be substituted the expression "2.5 per cent."; and

(b) in paragraph (f) of Column 2 of Type of Pesticide Numbered 13 for the word "returned" there shall be substituted the word "retained".

Given under my Hand and the Seal of the State of Victoria aforesaid, at Melbourne, this twenty-second day of April, in the year of our Lord One thousand nine hundred and seventy, and in the nineteenth year of the reign of Her Majesty Queen Elizabeth II.

(L.s.) E. F. HERRING.

By His Excellency's Command,
G. L. CHANDLER,
Minister of Agriculture.

GOD SAVE THE QUEEN !

WESTERN PORT (STEEL WORKS) ACT 1970.

DATE OF COMING INTO OPERATION.

PROCLAMATION

By the Lieutenant-Governor as Deputy for His Excellency the Governor of the State of Victoria and its Dependencies in the Commonwealth of Australia, &c., &c., &c.

WHEREAS by an Act of Parliament of the State of Victoria passed in the nineteenth year of the reign of Her Majesty Queen Elizabeth II entitled the *Western Port (Steel Works) Act 1970* (No. 7950) it is amongst other things enacted that the provisions of the said Act shall come into operation on a day to be fixed by proclamation of the Governor in Council published in the *Government Gazette*:

Now therefore I, the Lieutenant-Governor as Deputy for the Governor of the State of Victoria, in the Commonwealth of Australia, by and with the advice of the Executive Council of the said State do by this my proclamation fix the thirtieth day of April, 1970, as the day upon which the said Act shall come into operation.

Given under my Hand and the Seal of the State of Victoria aforesaid, at Melbourne, this twenty-eighth day of April, in the year of our Lord One thousand nine hundred and seventy, and in the nineteenth year of the reign of Her Majesty Queen Elizabeth II.

(L.s.) E. F. HERRING.

By His Excellency's Command,
R. J. HAMER,
Minister of Public Works.

GOD SAVE THE QUEEN !

MOTOR CAR (TRAFFIC OFFENDERS) ACT 1969, No. 7915.

DATE OF COMING INTO OPERATION.

PROCLAMATION

By The Lieutenant-Governor as Deputy for His Excellency the Governor of the State of Victoria and its Dependencies in the Commonwealth of Australia, &c., &c., &c.

WHEREAS by an Act of Parliament of the State of Victoria passed in the eighteenth year of the reign of Her Majesty Queen Elizabeth II. entitled the *Motor Car (Traffic Offenders) Act 1969* (No. 7915) it is amongst other things enacted that the said Act shall come into operation on a day to be fixed by proclamation of the Governor in Council published in the *Government Gazette*;

Now therefore, I, The Lieutenant-Governor as Deputy for His Excellency the Governor of the State of Victoria, in the Commonwealth of Australia, by and with the advice of the Executive Council of the said State do by this my Proclamation fix Friday, the first day of May, One thousand nine hundred and seventy as the day of which the said *Motor Car (Traffic Offenders) Act 1969*, No. 7915, shall come into operation.

Given under my Hand and the Seal of the State of Victoria aforesaid, at Melbourne, this twenty-eighth day of April, in the year of our Lord One thousand nine hundred and seventy, and in the nineteenth year of the reign of Her Majesty Queen Elizabeth II.

(L.s.) E. F. HERRING.

By His Excellency's Command,
A. G. RYLAH,
Chief Secretary.

GOD SAVE THE QUEEN !

DAIRY PRODUCTS (BOARD MEMBERSHIP) ACT 1970.

DATE OF COMING INTO OPERATION.

PROCLAMATION

By The Lieutenant-Governor as Deputy for His Excellency the Governor of the State of Victoria and its Dependencies in the Commonwealth of Australia, &c., &c., &c.

WHEREAS by an Act of Parliament of the State of Victoria passed in the nineteenth year of the reign of Her Majesty Queen Elizabeth II. entitled the *Dairy Products (Board Membership) Act 1970*, it is amongst other things enacted that the said Act shall come into operation on a day to be fixed by proclamation of the Governor in Council published in the *Government Gazette*;

Now therefore, I, The Lieutenant-Governor as Deputy for His Excellency the Governor of the State of Victoria, in the Commonwealth of Australia, by and with the advice of the Executive Council of the said State, do by this my Proclamation fix Wednesday, the twenty-ninth day of April, One thousand nine hundred and seventy as the day on which the said *Dairy Products (Board Membership) Act 1970* shall come into operation.

Given under my Hand and the Seal of the State of Victoria aforesaid, at Melbourne, this twenty-eighth day of April, in the year of our Lord One thousand nine hundred and seventy, and in the nineteenth year of the reign of Her Majesty Queen Elizabeth II.

(L.s.) E. F. HERRING.

By His Excellency's Command,
G. L. CHANDLER,
Minister of Agriculture.

GOD SAVE THE QUEEN !

BANK HALF-HOLIDAY.

PROCLAMATION

By The Lieutenant-Governor as Deputy for His Excellency the Governor of the State of Victoria and its Dependencies in the Commonwealth of Australia, &c., &c., &c.

IN pursuance of the provisions of the *Bank Holidays Act 1958*, I, The Lieutenant-Governor as Deputy for the Governor of the State of Victoria, in the Commonwealth of Australia, do by this my Proclamation appoint the day

and date named hereunder a special day to be observed as a Bank Half-Holiday at the place respectively mentioned, that is to say:—

Bank Half-Holiday from Eleven a.m.

FRIDAY, THE 29TH MAY, 1970, at Coleraine.

Given under my Hand and the Seal of the State of Victoria aforesaid, at Melbourne, this twenty-eighth day of April, in the year of our Lord One thousand nine hundred and seventy, and in the nineteenth year of the reign of Her Majesty Queen Elizabeth II.

(L.S.) E. F. HERRING.

By His Excellency's Command,

A. G. RYLAH,
Chief Secretary.

GOD SAVE THE QUEEN!

PUBLIC HOLIDAY.

PROCLAMATION

By The Lieutenant-Governor as Deputy for His Excellency the Governor of the State of Victoria and its Dependencies in the Commonwealth of Australia, &c., &c., &c.

IN pursuance of the provisions contained in Part III. of the *Public Service Act 1958*, I, The Lieutenant-Governor as Deputy for the Governor of the State of Victoria, in the Commonwealth of Australia, by and with the advice of the Executive Council of the said State, do by this my Proclamation appoint the day and date hereunder mentioned to be observed as a Public Half-Holiday at the place respectively specified, viz.:—

Public Half-Holiday from the Hour of Twelve o'clock noon:—

FRIDAY, THE 29TH MAY, 1970, throughout the Coleraine Riding of the Shire of Wannoo.

Given under my Hand and the Seal of the State of Victoria aforesaid, at Melbourne, this twenty-eighth day of April, in the year of our Lord One thousand nine hundred and seventy, and in the nineteenth year of the reign of Her Majesty Queen Elizabeth II.

(L.S.) E. F. HERRING.

By His Excellency's Command,

A. G. RYLAH,
Chief Secretary.

GOD SAVE THE QUEEN!

BANK-HOLIDAY.

PROCLAMATION

By the Lieutenant-Governor as Deputy for His Excellency the Governor of the State of Victoria and its Dependencies in the Commonwealth of Australia, &c., &c., &c.

IN pursuance of the provisions of the *Bank Holidays Act 1958*, I, the Lieutenant-Governor as Deputy for the Governor of the State of Victoria, in the Commonwealth of Australia, do by this my Proclamation appoint the day and date named hereunder a special day to be observed as a Bank Holiday at the place respectively mentioned, that is to say:—

Bank Holiday:—

MONDAY, THE 15TH JUNE, 1970, throughout the State of Victoria.

Given under my Hand and the Seal of the State of Victoria aforesaid, at Melbourne, this twenty-second day of April, in the year of our Lord One thousand nine hundred and seventy, and in the nineteenth year of the reign of Her Majesty Queen Elizabeth II.

(L.S.) E. F. HERRING.

By His Excellency's Command,

A. G. RYLAH,
Chief Secretary.

GOD SAVE THE QUEEN!

GOVERNMENT NOTICES

ERRATUM.

Pesticides Act 1958.

IN *Government Gazette*, No. 19, of 11th March, 1970, page 576, Schedule to the Proclamation—

- (a) in paragraph (a) of column 2 of the Type of Pesticide Numbered 6 for the expression "(As₂O₃)" there shall be substituted the expression "(As₂O₅)"; and
- (b) in paragraph (b) of column 2 of the Type of Pesticide Numbered 8 for the expression "(NaClO₂)" there shall be substituted the expression "(NaClO₃)".

D. S. WISHART,
Director of Agriculture.

PUBLIC SERVICE ACT 1958.

IT is hereby notified that a certain charge has been preferred against DOUGLAS LESLIE JONES, Assistant (Male), Grade I, Technical and General Division, Education Department, under section 55 of the *Public Service Act 1958*, and that a registered letter asking him whether he admits or denies the truth of the charge has been posted to his last-known address, viz.:—"The Shrubbery", Old Government-road, Selby.

Unless a reply to such communication be received by Monday, the 11th May, 1970, he shall be deemed to deny the truth of the charge, and the investigation thereof will be proceeded with on Friday, the 15th May, 1970, at 9.30 a.m., at the Office of the Public Service Board, Public Offices, Treasury-place, Melbourne.

By order,

V. P. SCULLY,
Secretary.

Office of the Public Service Board (Victoria),
Melbourne, 24th April, 1970.

PUBLIC TRUSTEE ACT 1958 (No. 6350).—SECTION 17.

I HEREBY give notice that on the 8th April, 1970, the Public Trustee filed elections to administer the following deceased persons' estates in accordance with section 17 of the *Public Trustee Act 1958*:—

FLETCHER, RICHARD GEORGE HENRY, late of Flat 75, 140 Neill-street, Carlton, process worker, died 26th August, 1969.

HOUSTON, ANNIE MARY, late of Beechworth, spinster, died 29th June, 1969.

HYDE, EMILY ANNIE, late of Queen Elizabeth Home, 102 Ascot-street south, Ballarat, pensioner, died 28th November, 1969.

MALKIN, GEORGE ERNEST WILLIAM, formerly of 77 Moubray-street, Albert Park, but late of Bundoora, storeman, died 8th February, 1969.

MCDONALD, DONALD ARTHUR, late of 48 Prendergast-street, Pascoe Vale South, accountant, died 28th October, 1969.

ROBERTSON, CECIL RHODES, late of Prince of Wales Hotel, 109 Church-street, Richmond, retired welder, died 26th September, 1969.

SYMONS, HANNAH LOUISA, late of 36 Rose-street, Altona, married woman, died 9th February, 1970.

N. P. BRODY,
Public Trustee.

256 Flinders-street, Melbourne 3000, 22nd April, 1970.

NOTICE.

CREDITORS, next of kin, and others having claims against the estate of any of the under-mentioned deceased persons are required to send particulars of their claims to the Public Trustee, 256 Flinders-street, Melbourne, Vic. 3000, the personal representative, on or before the 6th July, 1970, after which date the Public Trustee may convey or distribute the assets, having regard only to the claims of which the Public Trustee then has notice:—

ALLEN, WILLIAM HENRY FREDERICK, late of Repatriation Hospital, Macleod, nursing aide, died 15th December, 1969.

CHERRY, ALBERT WILLIAM, late of 32 Ashley-street, Reservoir, retired railway employee, died 26th December, 1969.

DANDO, MARY ELLEN, also known as Mary Dando, late of 47 Richardson-street, Essendon, married woman, died 24th November, 1969.

DEAN, PERCY, late of 36 St. Leonard-road, Ascot Vale, retired labourer, died 1st January, 1969.

DOUGLAS, LILLIAN MAUD, formerly of 68 Brunning-street, Balaclava, but late of 208 Middleborough-road, South Blackburn, spinster, died 25th December, 1969.

FLETCHER, RICHARD GEORGE HENRY, late of Flat 75, 140 Neill-street, Carlton, process worker, died 26th August, 1969.

GILES, DOROTHY OLIVE, late of Flat 6, 67 Denham-street, Hawthorn, spinster, died 2nd January, 1970.

GREEN, LYNETTE RAE, late of 8 Collins-street, Essendon, housewife, died 28th September, 1969.

GREENWOOD, IRENE MARY, formerly of 4 Talbot-street, Hampton, but late of 69 David-street, Hampton, home duties, died 2nd December, 1969.

HOUSTON, ANNIE MARY, late of Beechworth, spinster, died 29th June, 1969.

HYDE, EMILY ANNIE, late of Queen Elizabeth Home, 102 Ascot-street south, Ballarat, pensioner, died 28th November, 1969.

LENNEY, PEARL, formerly of 102 Peel-street, Windsor, but late of 87 Chapel-street, St. Kilda, spinster, died 18th December, 1969.

LEWIS, ADA ELIZABETH, formerly of 45 Macpherson-street, Footscray, but late of Flat 13, 42 Rickett-street, Dandenong, widow, died 30th December, 1969.

MALKIN, GEORGE ERNEST WILLIAM, formerly of 77 Moubay-street, Albert Park, but late of Bundoora, storeman, died 8th February, 1969.

MULLER, DOROTHY CHRISTINA, late of 48 Russell-place, North Williamstown, married woman, died 27th January, 1970.

MCDONALD, DONALD ARTHUR, late of 48 Prendergast-street, Pascoe Vale South, accountant, died 28th October, 1969.

POMFRET-DODD, EVELYN ANNIE LAURIE, late of Christchurch, New Zealand, spinster, died on or about 17th August, 1969.

ROBERTSON, CECIL RHODES, late of Prince of Wales Hotel, 109 Church-street, Richmond, retired welder, died 26th September, 1969.

SMITH, ALBERT EDWARD, formerly of Iris-avenue, Boronia, but late of Kew, gentleman, died 20th November, 1969.

SYMONS, HANNAH LOUISA, late of 36 Rose-street, Altona, married woman, died 9th February, 1970.

TABERNER, HORACE STANFORD THOMAS, late of 30 Fenwick-street, North Carlton, retired hotelkeeper, died 17th November, 1969.

THOMSON, FRANCIS COMFORT, late of 22 Denman-avenue, Glen Iris, clerk, died 11th October, 1969.

TYRRELL, JOSEPH THOMAS, late of 48 Chandler-street, North Williamstown, engineer, died 14th November, 1969.

WILLIAMS, BRUCE, late of 29 Fox-court, Jacana, Commonwealth car driver, died 6th January, 1970.

N. P. BRODY,
Public Trustee.

Melbourne, 22nd April, 1970.

WORKERS COMPENSATION ACT 1958.

THE Lieutenant-Governor as Deputy for His Excellency the Governor of the State of Victoria by and with the advice of the Executive Council thereof doth on this 22nd day of April, 1970, and pursuant to the provisions of section 72 of the Workers Compensation Act, approve of the Sydney Mutual Insurance Limited as an insurer for the period ending 30th June, 1970.

J. ROSSITER,
Clerk of the Executive Council.

At the Executive Council Chamber,
Melbourne, 22nd April, 1970.

GAS AND FUEL CORPORATION OF VICTORIA.

THE following notice was published 1^o on the 29th April, 1970, re: Gas Odorization Plant, Parish of Coolungoolun.

"Notice is hereby given that the Gas and Fuel Corporation of Victoria has applied for a lease under section 134 of the Land Act 1958 for a term of 21 years in respect of an area of 0 acres 0 roods 27 5/10 perches more or less, being portion of the Black Swamp, Parish of Coolungoolun, as a site for Gas Odorization plant and ancillary purposes.—(H.033469.)"

DEPARTMENT OF MINES.

SUBJECT to any necessary excisions, &c., it is proposed to grant the following mining lease:—

8608, Mineral; Abraham David Hargreaves; 43a. 3r. 12p., Parish of Kerit Bareet.

MINING LEASE GRANTED.

9250, Ballarat; Australian Gold and Tungsten N.L.; 21a. 3r. 11p., Parish of Argyle.

APPLICATIONS FOR MINING LEASES DECLARED ABANDONED.

8289, Mineral; George Milton; 640 acres; Parish of Buchan.
8312, Mineral; George Milton; 249 acres; Parish of Buchan.

MINERAL SEARCH LICENCE GRANTED.

865, Mineral Search Licence; Victorian Refining and Smelting Company Proprietary Limited; 10 square miles; Parish of Bogong North.

TAILINGS LICENCE GRANTED.

3662, Tailings Licence; Alan Heywood Sutherland to remove tailings from the Government Road between Allotments 19d and 19c in the Parish of Toora.

EXPLORATION LICENCES GRANTED.

125, Exploration Licence; VAM Limited; 139 square miles; Counties of Grenville, Hampden, Ripon.
138, Exploration Licence; George D. Malouf; 488 square miles; County of Benambra.
155, Exploration Licence; Gippsland Minerals No Liability; 28 square miles; Parishes of Gungarian, Indi.
156, Exploration Licence; Gippsland Minerals No Liability; 470 square miles; Counties of Benambra, Bogong, Dargo, Tambo.

APPLICATION FOR EXPLORATION LICENCE REFUSED.

248, Exploration Licence; Development Equity Corporation Limited; 494 square miles; Counties of Tanjil, Wonnangatta.

TAILINGS LICENCES EXPIRED.

3471, Tailings Licence; The President, Councillors and Ratepayers of the Shire of Avoca; Gravel reserve adjoining Allotments 17, 18 of Section K, Parish of Glenmona.
3479, Tailings Licence; The President, Councillors and Ratepayers of the Shire of Ballarat; "Argyle" tailings dump situated at Smythesdale.
3580, Tailings Licence; Allan Chan; "Johnson's No. 3 Shaft" situated at California Gully, Eaglehawk.
3604, Tailings Licence; Allan Chan; "North Hercules" and Energetic Shaft (New Chum Line Reef), situated at Bendigo.

MINING LEASE TRANSFERRED.

8243, Mineral; From Frederick Britton to William Jay.

TERM OF EXPLORATION LICENCE EXTENDED.

34, Exploration Licence; Western Mining Corporation Limited; 92 square miles; County of Talbot.

J. C. M. BALFOUR,
Minister of Mines.

Stamps Act 1958.

ANNUAL LICENCE.

NOTIFICATION PURSUANT TO SECTION 97.

I HEREBY notify that stamp duty has been paid for a licence under section 110 of the Stamps Act 1958, in respect of the year ending 31st December, 1970, by the following:—

The Broken Hill Proprietary Company Limited.

R. M. PHIBBS,
Comptroller of Stamps.

Chief Office for Stamp Duties,
Melbourne, 29th April, 1970.

Transport Regulation Act.
TRANSPORT REGULATION BOARD.

HEARING OF APPLICATIONS.

NOTICE is hereby given that the following applications will be considered by the Transport Regulation Board at its offices at the corner of Lygon and Princes streets, Carlton, at 10.15 a.m. on Monday, 18th May, 1970.

ALCAN AUSTRALIA LTD., Barry-road, Campbellfield. Application for one commercial passenger vehicle (S/C. 7) to operate for the carriage of employees free of charge on the following route:—Commencing at the corner of Barry-road and Mason-street, Campbellfield, via Barry-road, Hume Highway to Craigieburn; thence via Hume Highway, Somerset-road, Clarke-street, Palm-court, Clarke-street, Somerset-road, Hume Highway, Barry-road, Blair-street, Waranga and Gosford crescents, Kitchener-street, Railway-crescent, Cuthbert, Seymour, Kitchener and Cohuna streets, Waranga-crescent, Blair, Ismore and Hepburn streets, Colac-crescent, Torquay, Berger and King streets and Barry-road to the factory.

Time-table (Monday-Friday).

Depart Factory 7.45 a.m.

Depart Factory 4.00 p.m.

VENTURA MOTORS PTY. LTD., 1037 Centre-road, South Oakleigh. Application for variation of C.O. licence conditions on Route 225A (Box Hill-Wantirna South) to delete that part of the route between the corner of Holland and Eley roads and the corner of Blackburn-road and Burwood Highway and instead operate via Eley-road, Royton-street and Burwood Highway to K.Mart and thence normal route.

APPLICATION for renewal of licences as shown, by persons listed hereunder to operate under the same terms and conditions.

ABBOTT, W. J., 20 Henham-street, East Hawthorn; M.T.852.
AINALIS, E., 25 Donald-street, Footscray; M.T.1886.
ALBA, S., Flat 6, 7A Coleridge-street, Elwood; M.T.1470.
ALEXANDROPOULOS, I., 7 Medely-street, South Yarra; M.T.1859.
ALLARDYCE, J. W., 26 Shepherd-street, Surrey Hills; M.T.1161.
ALLARDYCE, L. C., 23 Madelaine-street, Burwood; M.T.4128.
ANDERSON, C. C., 26 Stevenson-street, Deer Park; M.H.2058.
BABB, W. J., 31 Waverly-parade, Pascoe Vale South; M.T.1115.
BAJARI, A., Flat 1, 2 Avoca-street, Elwood; M.T.4362.
BAKER, G. T., 92 Ramu-parade, West Heidelberg; M.T.4266.
BECIC, S., 34 Lockhart-street, Camberwell; M.H.4018.
BLANK, A., Flat 6, 19 Milton-street, Elwood; M.T.1627.
BOUZOS, G., 15 Ward-street, South Melbourne; M.T.4099.
BUCHANAN, G. T., 38 Clarke-road, Cranbourne; M.H.2055.
BURGIN, R. C., 22 Middle-street, Ascot Vale; M.T.527.
CARDAMONE, D., 481 Murray-road, West Preston; M.T.1855.
CAULFIELD, G. B., 11 Neville-street, Mentone; M.H.1786.
CHANDLER, R. R., 387 Rae-street, North Fitzroy; M.T.665.
CHARALAMBOUS, N., 88 Huntingdale-road, Burwood; M.T.1453.
CLARKE, S. M., 28 Walnut-street, Ormond; M.H.1489.
CLOUTANG, D. E., Unit 5, 207 Grange-road, Glenhuntly; M.H.1554.
COLES, J. M., 39 Kennedy-street, Glen Waverley; M.H.1627.
COLSON, A. F., 31 Ryan-street, Northcote; M.T.1005.
CZUBA, F., 8 Myrtle-grove, Airport West; M.T.1477.
DALE, N. C., 197 Poath-road, Hughesdale; M.T.1357.
DAVIS, A., 94 Disraeli-street, Kew; M.T.1849.
DE ANGELIS, C., 44 Howard-street, Glen Iris; M.T.4227.
DE VALLE, G., 80 Esplanade, Clifton Hill; M.T.1579.
DICKINS, G. F., 36 Humble-street, East Geelong; U.T.675.
DOLPHIN, W. A., 34 York-street, Bonbeach; M.H.1885.
ESKDALE, G. D., Unit 4, 18 Downshire-road, Elsternwick; M.T.1358.
EVANS, J. K., 11 Highland-avenue, Croydon; M.H.2061.
FABRIZIO, A., 27 Best-street, North Fitzroy; M.T.1356.
FAIRWEATHER, A., 173 Eureka-street, Ballarat; U.T.3.
FAIRWEATHER, N. A., 301A Drummond-street north, Ballarat; U.T.167.
FALVEY, L. L., 17 Coates-street, Moonee Ponds; M.T.1060.
FATOUROS, A., 33 Charles-street, St. Kilda; M.T.4334.
FELDHEIM, I., Flat 6, 18 Kinkora-road, Hawthorn; M.T.1987.
FELGATE, W. C., 28 Holyrood-avenue, Strathmore; M.T.562.
FERZIS, P., 1 Beaconsfield-parade, Port Melbourne; M.T.4297.
FIRER, J. L., Flat 2, 1 Truscott-street, East Brunswick; M.T.1645.
FOSTER, G. A., 51 Mackie-road, East Bentleigh; M.T.1152.
FRANKENBERG, H. E., 10 Hoban-avenue, Montmorency; M.T.1116.
FREEMAN, A. L., 36 Purches-avenue, Pascoe Vale; M.T.1625.

ENSABELLA, A., 20 Wild-street, Regent; M.H.1993.
GAIN, N., 30 Charteris-drive, Ivanhoe; M.T.1551.
GENTLE, A. J., 64 Blackburn-road, Blackburn; C.T.545.
GEORGE, C., 301 South-road, Brighton; M.H.1944.
GOLDWASSER, I., 311 Carlisle-street, Balaclava; M.T.1714.
GRAHAM, L. C., 13 Irving-avenue, Box Hill; M.H.2082.
GRANGER, N. F., 3 Gatis-street, Burwood; M.T.4208.
GROSFELD, J., 10 Agnes-street, East Bentleigh; M.T.1370.
HAMMETT, L. F., 7 Moffatt-crescent, Werribee; M.H.1847.
HARDEMAN, L. J., 14 Royena-road, Moorabbin; M.H.1777.
HAVIN, S. M., 285 Glen Eira-road, Caulfield; M.T.1348.
HEALEY, I. K., 124 Swanston-street, Lower Templestowe; M.T.2120.
HORNER, G. B., 47 Monash-street, Ascot Vale; M.T.676.
HUDSON, J. K., 121 Melville-road, Pascoe Vale; M.T.1563.
KOETSVELD, A. R., 7 View Hill-road, North Balwyn; M.T.1628.
JOFFE, A. (Estate of the Late), 34 Redan-street, Caulfield; M.T.4184, M.T.1507.
JACKSON, N. C., Flat 7, 70 Gould-street, Frankston; M.T.1718.
KALLINICOS, J., 5 Tyrone-street, South Yarra; M.T.4218.
KAPLANDJIAN, A., 184 Tucker-road, Bentleigh; M.T.1957.
KASSIS, A., 37 Chaucer-street, Moonee Ponds; M.T.1850.
KATSIS, C., 22 Barbara-street, Glenroy; M.T.1624.
KENDALL, K. J., 103 Grandview-avenue, Pascoe Vale South; M.T.717, M.T.1147.
KENNEDY, B. B., Flat 12, 313 Beaconsfield-parade, St. Kilda; M.T.4140.
KENNEDY, V. E., 9 Katrina-street, Blackburn; M.T.1352.
KLISSMAN, M., 23 Fosberry-avenue, North Caulfield; M.T.4130.
KLOOGER, K. B., 51 Bellevue-road, East Bentleigh; M.H.1890.
KLOSS, J., Flat 13, 289 Barkly-street, East St. Kilda; M.T.1593.
KRYCER, S., 33 Tranmere-avenue, Carnegie; M.T.1514.
KYRIAKOU, L. S., 44 Cleary-court, Clayton; M.T.4309.
KYRKILIS, E., 3 Ryan-street, Northcote; M.T.4139.
LAMERTON, N. W., 72 Cummins-road, Moorabbin; M.T.926.
LIBRANDI, G., 16 Bouchier-street, Glenroy; M.T.1845.
LICHTER, B., 45 Seymour-road, Elsternwick; M.T.1697.
LOCK, W. J. (TAXI SERVICE) PTY. LTD., 427 Lygon-street, East Brunswick; M.T.818.
LUPONE, G., 103 Rennie-street, East Coburg; M.T.1899.
MARGELLIS, S., 11 Mulga-street, Thomastown; M.T.1876.
MARSHALL, R. G., 60 Sherbourne-road, Montmorency; M.H.2424.
MEIGHAN, E. R., 9 Newmarket-street, Northcote; M.T.774.
MICKAELIAN, K., 2 Otford-close, Moorabbin; M.T.4337.
MILLER, W. J. E., 6 Holberg-street, Moonee Ponds; M.T.1575, M.T.4116.
MITCHELL, A. P., 18 Crimea-street, St. Kilda; M.T.1075.
MITCHELL, C. C. S., 3 Royal-crescent, Armadale; M.T.827.
MOLLOY, J. W., 30 Worrill-street, Nunawading; M.H.1975.
MORFUNI, G., 77 Davies-street, Brunswick; M.T.1956.
MORLEY, P., 13 Gladwyn-avenue, East Bentleigh; M.T.1367.
MUNRO TAXI SERVICE PTY. LTD., THE MANAGER, 49 Harding-street, Coburg; M.T.472, M.T.474, M.T.475, M.T.953.
McCoy, J. P., Flat 7, 638 Centre-road, East Bentleigh; M.H.1933.
MCGEARY, G. A., 179 Tucker-road, Bentleigh; M.H.1498.
MCKENNA, B. D., 8 Chester-street, Burwood; M.T.642.
MCINERNEY, J. C., 338 North-road, East Brighton; M.H.1267, M.H.2068.
NEESON, N. D., 160 George-street, East Melbourne; M.T.976.
NEWMAN, F. D. J., 5 Griffin-street, East Brighton; M.T.1661.
NICHOLLS, H. L., Flat 3, 3 Walsh-street, Ormond; M.T.801.
NIKOLICH, V., 23 Ormond-road, Elwood; M.T.1472.
NOLAN, V. J., 52 Mountainview-road, Montmorency; M.T.1133.
NORTON, S. F., 4 North-court, Surrey Hills; M.T.762.
OTT, H., Flat 1, 399 Toorak-road, South Yarra; M.T.4078.
OUCIN, I., 28 Lawson-street, North Carlton; M.T.1881.
PALMIERI, A. D., 7 Miller-street, Alphington; M.T.1836.
PANDELIU, E., 213 Danks-street, Albert Park; M.T.4024.
PARKES, E. S., 440 Bell-street, Pascoe Vale South; M.T.1340.
PASSIDIS, D., 104 Peel-street, Windsor; M.T.4237.
PAYTON, A. F., 25 Grosvenor-street, Moonee Ponds; M.T.4121.
PETER-BUDGE, W. J., 14 Montgomery-street, East Doncaster; M.H.2071.
PIGGOTT, A., 21 Bransgrove-street, East Preston; M.T.1610.
PINKNEY, V. T., 40 Griffiths-street, Heidelberg; M.H.2072.
PRATT, D. F., 17 Seaton-road, Highett; M.H.2046.
PRESTON, J. T., 2 Neylon-street, Yarraville; M.H.2056.
PRESTON, O., Flat 13, 19 Milton-street, Elwood; M.H.1824.
PRICE, A. J., 110 McPherson-street, Essendon; M.T.1439.
PRINZ, H., 68 Sunderland-road, Armadale; M.T.1708.
PUGLIESE, R., 92 Gardenvale-road, Gardenvale; M.T.4056.
QUAN, F. R., 19A Fisher-parade, Ascot Vale; M.T.844, M.T.4124.
RANK, R. A. W., 9 Rushworth-street, Watsonia; M.H.2078.

REVIS, T., Flat 4, 2 Avoca-avenue, Elwood; M.T.1703, M.T.4205.
 RIGNEY, J. V., 31 McKittrick-road, Moorabbin; M.T.1554.
 ROTH, J., Flat 8, 3 Halstead-street, Caulfield; M.T.4306.
 RUSSEL, K. S., 20 Royal-avenue, Heathmont; M.H.4026.
 SHAW, J., 19 Morgan-street, Glenhuntly; M.T.1334.
 SHAW, L. V., 5 Bartlett-street, Moorabbin; C.T.155.
 SHEPHERDSON, H. R., 170 Eglinton-street, Kew; M.T.911.
 SINCLAIR, J., 281 Victoria-road, Thornbury; M.T.694.
 STANKOVIC, R., 28 De Chene-parade, Coburg; M.T.1713.
 STEINKALK, I., 4 Shirley-court, East Brighton; M.T.1480.
 STEVENSON, J. C., 301 Station-street, Fairfield; M.T.1337.
 STEWART, N. A., 59 Iona-avenue, Belmont, Geelong; U.T.691.
 STEWART, S., 2 Noel-court, Moorabbin; M.H.2069.
 THEODORAKOPOULOS, I., 5 Stewart-street, Murrumbena; M.T.1863.
 THOMAS, T. J., 18 Campbell-parade, Box Hill; M.T.4170.
 THORNE, W. F., 12 Loxton-street, Kew; M.T.4350.
 UTTING, T. E., 16 Outlook-drive, Eaglemont; M.T.437, M.T.439, M.T.440, M.T.441, M.T.442, M.T.443, M.T.941, M.T.1132.
 VALLAS, E., 11 York-street, Prahran; M.T.1935.
 VOGAN, N., 3 Central-avenue, Altona; M.H.1963.
 WALKER, A. W., Flat 10, 11 Milton-street, Elwood; M.T.696.
 WALLACE, G. J., 17 Foley-place, East Bentleigh; M.T.1015.
 WALSH, J. E. J., 34 St. Elmo-road, Ivanhoe; M.H.2049.
 WEINER, L., 27 Clifton-street, Hawthorn; M.T.4300.
 WRIGHT, W. N., 3 Elgin-street, Newport; M.H.1996.
 YOUNG, T. T., 104 Park-street, Brunswick; M.T.1346.
 ZMOOD, R., 148 Thomas-street, East Brighton; M.H.2045.
 BERRY, J. W. S., 33 Charles-street, Ascot Vale; M.T.1580.
 CALDER HIGHWAY COACH SERVICE PTY. LTD., 44 Chapel-street, Bendigo; C.O.238, C.O.360, C.O.834.
 ELDER SMITH GOLDSBOROUGH MORT LTD., Portland; T.P.9.
 HOLMES, T. A. & D. B., Edols-street, Ballan; T.S.793, T.S.811.
 MACKELLAR, K. M., (MRS.), 41 Bellevue-road, Golden Square, Bendigo; C.O.182, C.O.297, C.O.629, C.O.910.

Notice of any objection should be forwarded to reach the Secretary of the Board not later than Wednesday, 13th May, 1970.

Applicants are advised that it will not be necessary to appear on the hearing date specified above, unless advised in writing by the Board.

B. P. KAY,
Secretary.

Corner Lygon and Princes streets, Carlton, Wednesday, 29th April, 1970.

Commercial Goods Vehicles Act.
 TRANSPORT REGULATION BOARD.
 HEARING OF APPLICATIONS.

NOTICE is hereby given that the following applications will be considered by the Transport Regulation Board at its offices at the corner of Lygon and Princes streets, Carlton, at 10.15 a.m. on Monday, 18th May, 1970.

AITKEN, L. J., Murchison East, 3611. One commercial goods vehicle (L/C. 10 cwt.) to operate: (a) Within a 50-mile radius of own premises at Murchison East in the course of business as a "Garage Proprietor"—own goods. (b) Throughout the State of Victoria—disabled motor vehicles on a specially constructed car-carrying trailer, excluding the ability to attend the scene of an accident.

BRUNT, A. J., 9 Grayling-street, Belmont, 3216. One commercial goods vehicle (L/C. 10 cwt.) to operate within a 50-mile radius of the chief post office in the City of Geelong in the course of business as "Electrical Serviceman"—television sets, radio sets and electrical appliances for installation, repair or having been repaired, and also tools of trade and materials incidental to the installation, servicing and maintenance of such appliances.

BRUNT, R., TRANSPORT PTY. LTD., 61 Beverin-street, Sebastopol, 3356. One commercial goods vehicle (L/C. 240 cwt.) to operate: Goods as follows solely on behalf of Concrete Industries (Monier) Ltd., an approved decentralized secondary industry (manufacturers of concrete roofing tiles) carried on by such company at its factory premises at Ballarat: (1) To the premises of the said company at Ballarat from points within the area defined hereunder—goods and materials required by such company for its own use in the manufacturing of concrete roofing tiles in the said decentralized industry (but excluding the carriage of cement). (2) From the premises of the said company at Ballarat to points within the area defined hereunder—products manufactured by the said company in the said decentralized industry. Note.—Within that part of the State of Victoria bounded on the east by a line drawn from the City of Shepparton in a southerly direction through the

City of Springvale to the sea coast; on the north by a line drawn in an east/west direction through Shepparton and Echuca and Wycheproof and Dimboola and on the west by a line drawn north and south from Dimboola to Portland.

BYRNE, W. A., 30 Hamilton-street, Gisborne, 3437. One commercial goods vehicle (L/C. 129 cwt.) to operate: (a) Within a 15-mile radius of own premises at Gisborne in course of business as "Fuel Supply, Produce Merchant and Soil and Screening Supplier"—own goods. (b) From Melbourne to own premises at Gisborne—petroleum products, own briquettes, own stockfeed and own fencing materials.

COWLAND, R. B., Box 67, Macarthur, 3286. One commercial goods vehicle (L/C. 233 cwt.) to operate: (a) Within a 50-mile radius of the post office at Macarthur as a "Road Contractor"—road-making plant and materials. (b) Within a 25-mile radius of the post office at Macarthur—general goods, provided that no goods shall be carried whether by one stage or by more than one stage between places within the above radius which are more than thirty (30) road miles apart by the nearest practicable route.

DAVIES, G. A. (trading as Davies Motor Wreckers), 18 Elsworth-street, Ballarat, 3350. Application to vary the conditions of licence No. D.A.34746/3 (L/C. 11 cwt.) by deleting from the existing conditions "load capacity shall not at any time exceed ten hundred-weights (10 cwt.)" and adding in lieu "that no more than 10 cwt. of goods be carried on the vehicle at any one time".

DELAINE, G., 7 Gerbert-street, Broadmeadows, 3047. One commercial goods vehicle (L/C. 142 cwt.) to operate: (a) From the premises of motor vehicle distributors and dealers direct to consignees throughout the State of Victoria—complete motor vehicles on behalf of Fleetways Transport Services Pty. Ltd. (b) Between the Cities of Melbourne, Geelong and Dandenong—motor car bodies on behalf of Fleetways Transport Services Pty. Ltd., provided that no delivery of such goods shall be made to any wharf at which rail facilities are available subject to the cancellation of licence No. D.A.48588/31 in the name of Fleetways Haulaway Pty. Ltd.

ELLIS, P. (trading as P. & L. J. Ellis), 4 Pearce-street, Shepparton, 3630. One commercial goods vehicle (L/C. 30 cwt.) to operate: (a) Within a 25-mile radius of the post office at Shepparton—general goods but subject to the condition that no goods shall be carried whether in one or more stages from any one point within the said radius to any other point within the said radius situated more than thirty (30) miles apart by the nearest practicable route. (b) From the City of Shepparton to the Townships of Numurkah, Katunga, Strathmerton, Yarroweyah, Cobram, Tocumwal (N.S.W.), Katamatite and Invergordon—daily newspapers.

EMERY, C. (trading as Emery Motors), 6 Orana-crescent, Rosebud West, 3940. One commercial goods vehicle (L/C. 147 cwt.) to operate within a 35-mile radius of the premises of Hillview Quarries Pty. Ltd. at Dromana on behalf of the said company—sand, soil, screenings, premix and quarry products.

FOODLAND STORES PTY. LTD., 619 Springvale-road, Glen Waverley, 3150. One commercial goods vehicle (L/C. 99 cwt.) to operate: (a) From bulk store of Foodland Holdings Ltd., at Glen Waverley to retail grocery stores associated with the Foodland Group situated within a 25-mile radius of the said bulk store in Springvale-road, Glen Waverley and/or at Warburton, Healesville, Wesburn and Bunyip—groceries solely on behalf of the said Foodland Holdings Ltd. (b) From Wallan to own premises at Glen Waverley—fresh eggs.

FRANCIS, T. N., 106-120 French-street, Hamilton, 3300. One commercial goods vehicle (L/C. 71 cwt.) to operate: (a) From the premises of Australian Motor Industries Ltd. in Melbourne to own premises at Hamilton and Portland—own new motor vehicles and motor vehicles for demonstration purpose. (b) From own premises at Portland or Hamilton to dealers in Melbourne—used or wrecked vehicles. (c) From and to the premises of earth-moving equipment distributors in Melbourne to and from places within an 80-mile radius of own premises at Hamilton in the course of business as "Agricultural Machinery and Equipment Sales and Service" on behalf of Allis Chalmers, Fiat and A.M.I.—new or used tractors and agricultural machinery for demonstration purposes only, and for subsequent return to Melbourne Distributors.

GIBSON, K., 127 Lorne-street, Fawkner, 3060. One commercial goods vehicle (L/C. 73 cwt.) to operate: (a) From the premises of motor vehicle distributors, and dealers direct to consignees throughout the State

- of Victoria—complete motor vehicles on behalf of Fleetways Transport Services Pty. Ltd. (b) Between the Cities of Melbourne, Geelong and Dandenong—motor car bodies on behalf of Fleetways Transport Services Pty. Ltd.; provided that no delivery of such goods shall be made to any wharf at which rail facilities are available, subject to the cancellation of licence No. D.A.48588/29 in the name of Fleetways Haulway Pty. Ltd.
- HARDING, P. E.**, 81 Turana-street, Doncaster, 3108. One commercial goods vehicle (L/C. 193 cwt.) to operate within a 50-mile radius of the premises of Ready Mixed Concrete (Vic.) Pty. Ltd. at North Melbourne solely on behalf of the said company—premixed concrete in a specially constructed agitator vehicle.
- INVERLOCH TRADING CO. PTY. LTD.**, A'Beckett-street, Inverloch, 3996. One commercial goods vehicle (L/C. 139 cwt.) to operate: (a) From the premises of the State Electricity Commission at Morwell and Yallourn to own premises at Inverloch for distribution to consignees situated within a 20-mile radius of the post office at Inverloch—briquettes. (b) From pits situated at Leongatha North, The Gurdies, Leongatha South and Cranbourne to consignees situated within a 20-mile radius of the post office at Inverloch—sand and screenings. (c) Within a 25-mile radius of the post office at Leongatha—general goods provided that no goods shall be carried whether by one stage or by more than one stage between places within the above radius which are more than thirty (30) road miles apart by the nearest practicable route.
- KATSAMBANIS, C.**, 3 Ford-street, Clifton Hill, 3068. One commercial goods vehicle (L/C. 231 cwt.) to operate within a 50-mile radius of the premises of Albion Reid Pty. Ltd. at North Melbourne on behalf of the said company—road-making plant, hot asphalt, premix and road-making materials but excluding the carriage of cement and lime from the Geelong urban district (as defined in the *Transport Regulation Act 1958*).
- KENT INSTRUMENTS (AUSTRALIA) PTY. LTD.**, 563 Victoria-street, Abbotsford, 3067. One commercial goods vehicle (L/C. 11 cwt.) to operate throughout the State of Victoria in the course of business as "Instrument Manufacturers" for the purpose of servicing instruments in industry—tools of trade, and spare parts incidental to on site servicing.
- KNOX, K. S.**, 17 Third-avenue, North Altona, 3025. One commercial goods vehicle (L/C. 196 cwt.) to operate within a 50-mile radius of the G.P.O., Melbourne solely on behalf of Consolidated Quarries Ltd.—premixed concrete in a specially constructed agitator vehicle.
- LAING, N.**, 5 Stewart-grove, Campbellfield, 3061. One commercial goods vehicle (L/C. 136 cwt.) to operate: (a) From the premises of motor vehicle distributors and dealers direct to consignees throughout the State of Victoria—complete motor vehicles on behalf of Fleetways Transport Services Pty. Ltd. (b) Between the Cities of Melbourne, Geelong and Dandenong—motor car bodies on behalf of Fleetways Transport Services Pty. Ltd. provided that no delivery of such goods shall be made to any wharf at which rail facilities are available, subject to the cancellation of licence No. D.A.48588/7 in the name of Fleetways Haulway Pty. Ltd.
- LEECH, A. H.**, Main-road, Campbells Creek, 3451. One commercial goods vehicle (L/C. 122 cwt.) to operate throughout the State of Victoria in the course of business as "Marine Collector"—special wares, marine stores and old metals as designated in the *Marine Stores and Old Metals Act 1958* (No. 6303), Part 1, Section (3), but excluding the carriage of any such special wares, marine stores or old metals to wharves, docks or ships for shipment or export purposes.
- NOTE.**—No trailer is to be hauled in conjunction with this vehicle.
- LEECH, I. M.**, 4 Maclise-street, Castlemaine, 3450. Application to vary the conditions of licence No. D.A.63639 (L/C. 245 cwt.) by deleting from the existing conditions paragraph (a) and adding in lieu: "Within a 50-mile radius from the chief post office in the City of Melbourne—plant the property of a contractor and required by him for use in connexion with the construction or maintenance of some specific, existing or proposed road, street, footpath, bridge, pier, wharf, weir or channel and also the following materials, viz.: metal, stones, screenings, ashes, gravel, sand and earth.
- LEMPRIERE METALS PTY. LTD.**, 45 Moreland-street, Footscray, 3011. One commercial goods vehicle (L/C. 71 cwt.) to operate throughout the State of Victoria in the course of business as "Marine Collector"—special wares as designated in the *Marine Stores and Old Metals Act 1958* (No. 6303), part 1, section 3.
- NOTE.**—That the total combined load capacity of the vehicle as prime mover and of any trailer attached thereto shall not exceed 120 cwt.
- LEWIS, J.**, Lot 4, Main-road, Hurstbridge, 3099. One commercial goods vehicle (L/C. 138 cwt.) to operate: (a) From the premises of motor vehicle distributors and dealers direct to consignees throughout the State of Victoria—complete motor vehicles on behalf of Fleetways Transport Services Pty. Ltd. (b) Between the Cities of Melbourne, Geelong and Dandenong—motor car bodies on behalf of Fleetways Transport Services Pty. Ltd., provided that no delivery of such goods shall be made to any wharf at which rail facilities are available, subject to the cancellation of licence No. D.A.48588/4 in the name of Fleetways Haulway Pty. Ltd.
- MANN, W. L. J.**, 819 Howitt-street, Ballarat, 3350. One commercial goods vehicle (L/C. 109 cwt.) to operate within a 50-mile radius of own premises at Ballarat in the course of business as "Distributor"—own aerated waters.
- O'BRIEN, R. E.** (trading as Milltown Sawmillers), Heathmere, 3292. Application to vary the conditions of licence No. D.T.1193 (L/C. 102 cwt.) by deleting from the existing conditions paragraph (b) and adding in lieu:—"(b) From own sawmill at Heathmere to consignees within a 50-mile radius of the said sawmill—sawn timber and mill waste."
- O'CONNOR, J. P.**, Willung South, 3844. One commercial goods vehicle (L/C. 340 cwt.) to operate: (a) From any one of own pits at Merryman's Creek, Longford, Yanakie and Bairsdale to consignees within a 50-mile radius respectively of such pit—own bulk lime. (b) Throughout the total area of the combined radii of fifty (50) miles of each of the pits specified in part (a) of this document in the course of business as "Lime Contractor"—own equipment. (c) From the premises of the State Electricity Commission of Victoria at Morwell to the premises of South Eastern Milk Products Ltd., which are located in the Towns of Foster, Traralgon and Yarram—briquettes in bulk.
- PAKENHAM FRUITGROWERS & PRODUCERS CO-OP. LTD.**, 38 James-street, Pakenham East, 3810. Application to vary the conditions of licences numbered D.A.43041/1, D.A.43041/2 and D.A.43041/3 (L/C. 117, 135, 151 cwt.) by deleting from the existing conditions paragraph (c) and adding in lieu:—"Between own store at Pakenham and the City of Melbourne—own goods."
- PETERSVILLE MILK PRODUCTS PTY. LTD.**, 95 Cecil-street, South Melbourne, 3205. One commercial goods vehicle (L/C. 74 cwt.) to operate within a 55-mile radius of own branch premises at Shepparton in the course of business as "Food Manufacturers, Distributors and Merchandisers" in a refrigerated van—own butter, yoghurt, cheese products, sour cream.
- POWELL, G.**, 19 Nott-street, Port Melbourne, 3207. One commercial goods vehicle (L/C. 140 cwt.) to operate: (a) From the premises of motor vehicle distributors and dealers direct to consignees throughout the State complete motor vehicles on behalf of Fleetways Transport Services Pty. Ltd. (b) Between the Cities of Melbourne, Geelong and Dandenong—motor car bodies on behalf of Fleetways Transport Services Pty. Ltd., provided that no delivery of such goods shall be made to any wharf at which rail facilities are available, subject to the cancellation of licence No. D.A.48588/26 in the name of Fleetways Haulway Pty. Ltd.
- READY MIXED CONCRETE (VIC.) PTY. LTD.**, 68 Burwood-road, Burwood, 3125. One commercial goods vehicle (L/C. 254 cwt.) to operate: (a) Within a 25-mile radius of the post office situated at the corner of Bourke and Elizabeth streets, Melbourne, and also from and to points within such radius to and from own premises at Bittern—raw materials for use in the manufacture of concrete. (b) From suppliers situated within a 20-mile radius of the post office at Bittern to and from own premises at Bittern—sand and screenings. (c) To own plant at Geelong either from quarries situated within a 10-mile radius of the said plant or from pits in the You Yangs area—sand and screenings. (d) From pits at Bacchus Marsh to own plants situated either within a 25-mile radius of the post office at the corner of Bourke and Elizabeth streets, Melbourne, or to own plant at Geelong—own sand. (e) From pits at Bunyip, Tynong and Nar-Nar-Goon to own plant at Vermont—own sand. (f) From quarries at Anakie to own plants situated within a 25-mile radius of the post office situated at the corner of Bourke and Elizabeth streets Melbourne—own rock.
- READY MIXED CONCRETE (VIC.) PTY. LTD.**, 68 Burwood-road, Burwood, 3125. One commercial goods vehicle (L/C. 343 cwt.) to operate: (a) Within a 25-mile radius of the post office at the corner of Bourke and Elizabeth

streets in the City of Melbourne, and also from and to the Township of Crib Point, in the course of business as "Concrete Manufacturers"—own bulk cement in a specially constructed bulk vehicle. (b) From green pasture lime plant situated in Geelong—own asphalt plant situated in Rooks-road, Vermont—bulk lime.

- RENNEY, J. E., Boundary Bend, 3599. Two commercial goods vehicles (L/C. 250 and 129 cwt.) to operate: (a) Within a 35-mile radius of the post office at Boundary Bend under contract to the Victorian Railways—wood, superphosphate and heavy hardware. (b) Within a 50-mile radius of the post office at Swan Hill—petroleum products in prescribed types of containers and empty return containers. (c) Throughout the State of Victoria—livestock to and from agricultural shows or exhibitions, or between farm and farm or market or agistment or stud livestock or race-horses.
- ROYCROFT, R. E., Roadside Delivery, Broadford, 3658. One commercial goods vehicle (L/C. 300 cwt. approx.) to operate: (a) From forest landings and private properties at Yea and within a 20-mile radius of the post office at Kinglake to sawmills at Reservoir—sawmill logs. (b) From forest landings within a 10-mile radius of Kinglake to the S.E.C. depot at Brooklyn—poles.
- SHAW, E., 55 Elgin-street, Sale, 3850. One commercial goods vehicle (L/C. 131 cwt.) to operate: (a) From the premises of motor vehicle distributors and dealers direct to consignees throughout the State of Victoria—complete motor vehicles on behalf of Fleetways Transport Services Pty. Ltd. (b) Between the Cities of Melbourne, Geelong and Dandenong—motor car bodies on behalf of Fleetways Transport Services Pty. Ltd., provided that no delivery of such goods shall be made to any wharf at which rail facilities are available, subject to the cancellation of licence No. D.A.48588/30 in the name of Fleetways Haulaway Pty. Ltd.
- SPERRY RAND AUSTRALIA LTD., REMINGTON RAND DIVISION, 334 City-road, South Melbourne, 3205. Two commercial goods vehicles (L/C. 14 and 13 cwt.) to operate throughout the State of Victoria for the purpose of servicing and maintaining office machines—tools of trade and spare parts incidental to on site servicing also office machines for replacement purposes only.
- STAMM, W., 17 Barundah-street, Glenroy, 3046. One commercial goods vehicle (L/C. 125 cwt.) to operate: (a) From the premises of motor vehicle distributors and dealers direct to consignees throughout the State of Victoria—complete motor vehicles on behalf of Fleetways Transport Services Pty. Ltd. (b) Between the Cities of Melbourne, Geelong and Dandenong—motor car bodies on behalf of Fleetways Transport Services Pty. Ltd., provided that no delivery of such goods shall be made to any wharf at which rail facilities are available, subject to the cancellation of licence No. D.A.48588/16 in the name of Fleetways Transport Services.
- TRVILLIAN, J., Lot 83, Buna-avenue, Boronia, 3155. One commercial goods vehicle (L/C. 115 cwt.) to operate: (a) From the premises of motor vehicle distributors and dealers direct to consignees throughout the State of Victoria—complete motor vehicles on behalf of Fleetways Transport Services Pty. Ltd. (b) Between the Cities of Melbourne, Geelong and Dandenong—motor car bodies on behalf of Fleetways Transport Services Pty. Ltd. provided that no delivery of such goods shall be made to any wharf at which rail facilities are available, subject to the cancellation of licence No. D.A.48588/2 in the name of Fleetways Haulaway Pty. Ltd.
- WOOSTER, N. M., 50 Wunalla-road, Seaford, 3198. One commercial goods vehicle (L/C. 150 cwt. approximately) to operate: (a) Within a 70-mile radius of the post office at Healesville (Dandenong Division of the Country Roads Board)—road-contracting plant used in the construction or maintenance of a road, street, footpath, bridge, wharf, pier, weir or channel. (b) Within a 20-mile radius from the site of construction or maintenance work performed pursuant to paragraph (a) above or from the railway station nearest thereto—any other materials required for such work.
- XENOS, J., & E. MASSISTAS, 172 Vere-street, Abbotsford, 3067. One commercial goods vehicle (L/C. 225 cwt.) to operate within a 50-mile radius of the G.P.O., Melbourne solely on behalf of Albion Reid Pty. Ltd.—road-making plant, hot asphalt, premix and road-making materials excluding the carriage of cement and lime from the Geelong Urban District (as defined in the Transport Regulation Act 1958).

TOW TRUCKS.

- BAMFORD, A. J. & M. A. (trading as Andy's Service Station), Hume Highway, Euroa, 3666. One commercial goods vehicle (L/C. 140 cwt.) to operate within a 50-mile radius from the post office at Euroa as "Heavy Salvage Tow Truck" solely—(a) For the purposes of lifting and carrying or towing of wrecked or disabled motor cars and the carriage of tools and equipment necessary for such purposes only. (b) For the carriage of spare parts necessary for the repair of a disabled motor car to and from the place within the said radius at which such disablement has occurred.
- VAN GOOL, J. W. (trading as J. & J. Van Gool Panels), Hersford-road, Mt. Evelyn, 3796. One commercial goods vehicle (L/C. 25 cwt.) to operate throughout the State of Victoria as a "Tow Truck" solely—(a) For the purposes of lifting and carrying or towing of wrecked or disabled motor vehicles and the carriage of tools and equipment necessary for such purposes. (b) The carriage of spare parts necessary for the repair of a disabled motor vehicle to and from the place at which such disablement has occurred, with the proviso:—(i) That operations shall only occur from the scene of a motor car accident if the licensed owner or certificated driver of the said tow truck has been previously bespoken, but not at the scene of such accident, by the owner of the damaged or disabled motor car, or his agent, or the person in charge of the said damaged motor car or disabled motor car. (ii) The licensed vehicle shall at all times exhibit a black plate 9 in. x 2½ in. on which appears in white letters 1½ in. high the word "RESTRICTED" to be affixed immediately above the front and rear registration plates.

RENEWALS.

APPLICATIONS for renewal of licences as shown by persons listed hereunder to operate under the same terms and conditions from the expiry shown in each case.

- ALLEN, J. R. & M. W., Lower Gellibrand, 3237; D.A.46764; 16th July, 1970; 145 cwt.
- ANDERSON, D. N., PTY. LTD., 69 Arnold-street, Orbost, 3888; D.T.1056/1; 26th July, 1970; 296 cwt.
- BAGGS, H. W., & SON, 120 Day-street, Bairnsdale, 3875; D.A.60009; 26th July, 1970; 10 cwt.; D.A.60009/1; 26th July, 1970; 10 cwt.
- BALLARAT GLASS CO., 54 Humffray-street, Ballarat, 3350; D.A.46715; 9th July, 1970; 80 cwt.
- BAULCH, D. K., 7 Hancock-street, Ouyen, 3490; D.A.57972; 18th April, 1970; 236 cwt.
- BROWN, T. K. (trading as T. K. Brown Motors), Whyte-street, Coleraine, 3315; D.T.1017; 16th May, 1970; 236 cwt.
- BROWN, T. K. (trading as T. K. Brown Motors), Whyte-street, Coleraine, 3315; D.A.54920/1; 14th June, 1970; 39 cwt.
- CANAVAN, P. J., P.O. Myamyn, 3292; D.A.32732; 1st July, 1970; 166 cwt.
- CLOTHIER, H. W., 9 Newton-court, Noble Park, 3174; D.A.59042; 10th May, 1970; 10 cwt.
- COWLAND, R. B., Box 67, Macarthur, 3286; D.A.43704/3; 11th July, 1970; 226 cwt.
- DIDELAS, K., 3 Donald-avenue, Essendon, 3040; D.A.62923; 4th July, 1969; 235 cwt.
- DUNLOP TYRE SERVICE (MILDURA) PTY. LTD., 124 Langtree-avenue, Mildura, 3500; D.A.60416/32; 11th July, 1970; 19 cwt.
- ELIOTT'S M.F. SERVICES PTY. LTD., 47 Lonsdale-street, Dandenong, 3175; D.A.44951/1; 16th July, 1970; 17 cwt.
- FRENCH, J. C. D. (trading as J. C. French & Co.), 28 Mickle-street, Warrnambool, 3280; T.D.A.1105/2; 21st July, 1970; 12 cwt.
- FRY, A. T., Leitchville, 3567; D.A.58512/1; 18th July, 1970; 155 cwt.
- GREYMANS, J. & F., 3 Daniel-street, Lakes Entrance, 3909; D.T.1234; 11th July, 1970; 277 cwt.
- HARRISON, E. H. & L. G., 33 Wellman-street, Box Hill, 3128; D.A.42027/2; 28th June, 1970; 11 cwt.
- INTRAC PTY. LTD., 256-264 Princes Highway, Dandenong, 3175; D.A.60004; 26th July, 1970; 17 cwt.; D.A.60004/1; 26th July, 1970; 13 cwt.; D.A.60004/2; 26th July, 1970; 14 cwt.; D.A.60004/3; 26th July, 1970; 6 cwt.
- IOVIERO, M., 9 Voltri-street, Mentone, 3194; D.A.62573; 16th July, 1970; 150 cwt.
- JOHNSON'S TRANSPORT SERVICE PTY. LTD., corner Henna and Kerr streets, Warrnambool, 3280; D.A.32762/16; 11th July, 1970; 25 cwt.
- JOINER, L. D., 60 Wolseley-street, Orbost, 3888; D.T.738; 18th July, 1970; 257 cwt.
- KINGDOM, J. F., 9 Sullivan-street, Springvale, 3171; D.A.58315; 7th March, 1970; 8 cwt.

LOGAN, E. R. & C. G., 8 Service-street, Bairnsdale, 3875; D.A.46811; 30th July, 1970; 10 cwt.
 LOWE, W. M., & SONS PTY. LTD., 31 Pye-street, Swan Hill, 3585; D.A.46901; 30th July, 1970; 76 cwt.
 MALONE, P. R., TRANSPORTS PTY. LTD., Grasmere Junction, 3279; D.A.35478/18; 18th April, 1970; 9 cwt.
 MATTHEWS, R. A. & E. T., Government-road, Buchan, 3892; D.T.803/1; 14th June, 1970; 337 cwt.; D.T.803/2; 14th June, 1970; 292 cwt.
 MAY'S V.C. TRANSPORT PTY. LTD., 277-281 Wickham-road, Moorabbin, 3189; D.A.34611/3; 2nd July, 1970; 265 cwt.
 MURRAY VALLEY SAND & GRAVEL CO. PTY. LTD., P.O. Box 312, Albury, N.S.W., 2640; D.A.46405/2; 18th July, 1970; 267 cwt.
 MCCULLAGH BROS., P.O. Box 229, 34 Kuck-street, Merrivale via Warrnambool, 3280; D.A.51995/1; 27th June, 1970; 8 cwt.
 MCPHERSON, J. J., Davis-street, Warrnambool, 3280; D.A.58047; 18th July, 1970; 113 cwt.
 NELSON, L. G., 276 Roslyn-road, Highton, 3216; D.A.33410; 14th July, 1970; 349 cwt.
 OAKLEY & WALDRON, Main-road, The Patch, 3792; D.A.59916; 11th July, 1970; 377 cwt.
 PENNANT, C. W., PTY. LTD., 89 Bridge-street, Ballarat, 3350; D.A.8151/1; 9th July, 1970; 11 cwt.
 PHOENIX BISCUIT CO. PTY. LTD., Grosvenor-street, Abbotsford, 3067; D.A.39491/12; 11th July, 1970; 67 cwt.
 RAVELL, J. R., 240 Barker-street, Castlemaine, 3450; T.D.A.60772; 17th July, 1970; 12 cwt.
 REED, R. W., 248 Nicholson-street, Orbost, 3888; D.T.1392; 14th June, 1970; 258 cwt.
 SAWYER, S. W., 12 Richardson-street, Portland, 3305; D.T.339/3; 16th May, 1970; 224 cwt.
 SINCLAIR, R. T., 6 Vickery-street, East Malvern, 3145; D.A.36098/1; 7th May, 1970; 104 cwt.
 SMEATH BROS. PTY. LTD., 173 Spring-street, Regent, 3073; D.A.2055/17; 26th July, 1970; 143 cwt.
 STEEL, R. & J., High-street, Wedderburn Junction, 3551; D.A.46874; 30th July, 1970; 122 cwt.
 FRANCO DELIVERY PTY. LTD., Lennon-street, South Kensington, 3031; D.A.35236/9; 30th July, 1970; 143 cwt.
 WIGGS, W. T., PTY. LTD., 60 Little Rynie-street, Geelong, 3220; D.A.40407/5; 30th July, 1970; 17 cwt.
 ZOVKO, S., 35 Fulton-crescent, Burwood, 3125; D.A.58443/1; 28th March, 1970; 232 cwt.

TOW TRUCKS.

BARTON, R., & TOTH, J. (trading as S. & T. Motors), 525 Kooyong-road, Elsternwick, 3185; D.A.63177/2; 26th July, 1970; 30 cwt.
 GROSE, V. R., 2 Mountjoy-parade, Lorne, 3232; D.A.39585/1; 27th June, 1970; 12 cwt.

RENEWALS WITH VARIATION.

APPLICATIONS by the persons listed hereunder for renewal of the licences listed with variation of conditions in the manner set out opposite the names.

BENNETT, W. H., & SONS PTY. LTD., 56 Hesse-street, Colac, 3250; D.T.127/2; 11th July, 1970; D.T.127/3; 11th July, 1970; Application to renew and vary the conditions of licences numbered D.T.127/2 and D.T.127/3 (L/C. 264 and 265 cwt.) by deleting from the existing conditions paragraph (b) and adding in lieu—“(b) From forest landings within a 20-mile radius of Beech Forest to own sawmills at Deans Marsh and Gellibrand—logs.”
 COUTTS, B. J. (trading as B. J. & R. D. Coutts), Berrybank, 3223; D.A.45967; 21st May, 1970; Application to renew and vary the conditions of licence No. D.A.45967 (L/C. 143 cwt.) by adding as an additional paragraph (d)—“From own premises at Berrybank to the premises of Meggitt Ltd. at Brooklyn in the course of business as ‘Primary Producer’—own rape seed and own linseed.”
 COX, F. K., 95 Wood-street, Templestowe, 3106; D.A.59973; 11th July, 1970; Application to renew and vary the conditions of licence No. D.A.59973 (L/C. 135 cwt.) by deleting the existing conditions and adding in lieu:—“(a) Within a 50-mile radius of the plant of Pioneer Asphalts (Melbourne) Pty. Ltd. at Notting Hill—hot asphalt. (b) Within a 25-mile radius of the plant of Pioneer Asphalt (Melbourne) Pty. Ltd. at Notting Hill—sand, screenings and quarry products.”
 GOYDEN, K., PTY. LTD., 15 Eddington-street, Warrnambool, 3280; D.A.42286/1; 18th April, 1970; Application to renew and vary the conditions of licence No. D.A.42286/1 (L/C. 72 cwt.) by deleting from the existing conditions “Within a 100-mile radius of the post office at Warrnambool” and adding in lieu “Throughout the State of Victoria”.

KAKOSCHKE, K. K., 20 Primula-avenue, North Altona, 3025; D.A.46837; 30th July, 1970; Application to renew and vary the conditions of licence No. D.A.46837 (L/C. 202 cwt.) by deleting from the existing conditions “Specified Concrete (Vic.) Pty. Ltd. at Newport” and adding in lieu “Albion Reid Concrete (Vic.) Pty. Ltd. at Sunshine”.

PELLNY, R., 2273 Dandenong-road, Springvale North, 3232; D.A.46710; 9th July, 1970; Application to renew and vary the conditions of licence No. D.A.46710 (L/C. 140 cwt.) by deleting from the existing conditions “Monier Reid Asphalt Pty. Ltd.” and adding in lieu “Allen Bros. (Asphalting Contractors) Pty. Ltd.”.

Notice of any objections should be forwarded to reach the Secretary of the Board not later than 11th May, 1970.

Applicants are advised that it will not be necessary to appear on the hearing date specified above, unless advised in writing by the Board.

B. P. KAY,
Secretary.

Corner Lygon and Princes streets, Carlton, 3053,
Wednesday, 29th April, 1970.

Commercial Goods Vehicles Act.

TRANSPORT REGULATION BOARD.

HEARING OF APPLICATIONS.

NOTICE is hereby given that the following applications will be considered by the Transport Regulation Board at the Court House, Alexandra, at 9.15 a.m. on Wednesday, 20th May, 1970.

EILDON BOAT HARBOUR PTY. LTD., Boat Harbour, Eildon, 3713. One commercial goods vehicle (L/C. 20 cwt.) to operate in the course of business as “Boat Builder, Boat Harbour Operator and Storekeeper”: (a) Between the Township of Alexandra and own premises at Eildon—own goods. (b) From the City of Melbourne to own premises at Eildon—(i) Own goods in course of business as “General Storekeeper”.—(ii) Raw materials required in the course of business as “Boat Builder”, being an approved decentralized industry. (iii) Engines and other marine equipment having been repaired. (c) From own premises at Eildon to the City of Melbourne—empty return containers—engines and other marine equipment for repair.

HARRIS, R. I. & C. J. (trading as Eildon Brick and Hardware Company), Eildon, 3713. One commercial goods vehicle (L/C. 28 cwt.) to operate: (a) From the City of Melbourne to own approved decentralized secondary industry premises at Eildon in the course of business as “Brick Manufacturers”—cement limil brick colouring, mesh, &c. (b) Within a 60-mile radius of own premises at Eildon—own goods for delivery having been manufactured at such premises. (c) From the City of Melbourne to own premises at Eildon in the course of business as “General Hardware and Building Suppliers”—general hardware, builders' supplies drainage pipes, &c. (d) From Melbourne to Eildon—general foodstuffs, perishable goods and liquor for use in own licensed motel and restaurant. (e) From Melbourne to Eildon—ladies' clothing for retailing in own boutique.

KELSALL, R. R., 28 Binney-street, Euroa, 3666. One commercial goods vehicle (L/C. 10 cwt.) to operate in the course of business as “Electrical Retailer and Repairer”—(a) Within a 50-mile radius of applicants premises at Euroa and Alexandra—new and used electrical appliances and associated spare parts, new and used motor mowers and liquid fuel heaters and associated spare parts, own electrical testing equipment and tools of trade. (b) Between the City of Melbourne and own premises at Euroa and Alexandra used electrical appliances and liquid fuel heaters for repair or having been repaired. (c) From the City of Melbourne to own premises at Euroa and Alexandra—small lots of urgently required spare parts for electrical appliances, liquid fuel heaters and motor mowers.

Notice of any objections should be forwarded to reach the Secretary of the Board not later than 13th May, 1970.

B. P. KAY,
Secretary.

Corner Lygon and Princes streets, Carlton, 3053.

Private Agents Act 1966.

NOTICE OF RECEIPT OF APPLICATIONS FOR LICENCES UNDER THE PROVISIONS OF THE PRIVATE AGENTS ACT 1966.

THE Clerk(s) of the Magistrates' Court(s) as listed hereunder hereby give notice that applications, as under, have been lodged for hearing by the said Court(s) on the date(s) specified.

Any person desiring to object to any of such applications must—

- (a) lodge with the respective Clerk of the Magistrates' Court a notice in the prescribed form of his objection and of the grounds thereof;
- (b) cause a copy of such notice to be served personally or by post upon the applicant at least three days before the hearing of the application; and
- (c) send or deliver—
 - (i) where the objection is not made by the officer in charge of the police district in which the Court is situated—a copy of the notice to such officer; and
 - (ii) where the objection is not made by the Registrar or Deputy Registrar—a copy to the Registrar.

Full Name of Applicant or in the Case of a Firm or Corporation, of the Nominee.	Place of Abode of Applicant or Nominee.	Name of Firm or Corporation.	Address for Registration.	Type of Licence.	Date of Hearing of Application.
---	---	------------------------------	---------------------------	------------------	---------------------------------

MAGISTRATE'S COURT OAKLEIGH.

Herrick, Clifford Gordon .. | 22 Donald-street, Mt. Waverley | .. | Commercial Agent | 8.5.70

Dated at Oakleigh this 17th day of April, 1970.

G. T. WHEELHOUSE, Clerk of the Magistrates' Court.

MAGISTRATES' COURT, CHELSEA.

Hyland, William Charles .. | 72 Sherwood-avenue, Chelsea | .. | 72 Sherwood-avenue, Chelsea | Process Server .. | 12.5.70

Dated at Chelsea this 17th day of April, 1970.

D. E. BYRNE, Clerk of the Magistrates' Court.

MAGISTRATE'S COURT, HEIDELBERG.

Loveridge, Kenneth James .. | 7 Malahang-parade, West Heidelberg | .. | 7 Malahang-parade, West Heidelberg | Inquiry Agent .. | 13.5.70

Dated at Heidelberg this 15th day of April, 1970.

R. J. CUTHILL, Clerk of the Magistrates' Court.

State Electricity Commission Acts.
ELECTRICAL APPROVALS BOARD.

PURSUANT to Regulation 16 of the Electrical Approvals Regulations—Approval of Equipment, 1953, the State Electricity Commission of Victoria hereby gives notice that it has withdrawn approval of the undermentioned articles:—

Name of Applicant.	Article and Reference No.	Date of Certificate of Approval.	Date of Withdrawal of Approval.	Approvals Marking.
Tomlinson Electric & Engineering Co. Pty. Ltd.	Soldering Iron, Trade Name "Superior", Cat. No. C1, Ref. No. AQ/A2L/02	4.8.64	20.3.70	S/15/C1
" " "	Soldering Iron, Trade Name "Superior", Cat. No. A1D, Ref. No. AQ/A2L/03	4.9.64	18.3.70	S/15/A1D
" " "	Soldering Iron, Trade Name "Superior", Cat. No. A4D, Ref. No. AQ/A2L/04	4.8.64	18.3.70	S/15/A4D
" " "	Soldering Iron, Trade Name "Superior", Cat. No. A0D, Ref. No. AQ/A2L/05	4.8.64	18.3.70	S/15/A0D
" " "	Soldering Iron, Trade Name "Superior", Cat. No. S4, Ref. No. AQ/A2L/06	4.8.64	18.3.70	S/15/S4
" " "	Soldering Iron, Trade Name "Superior", Cat. No. C2, Ref. No. AQ/A2L/07	4.8.64	20.3.70	S/15/C2
A. E. Ackland Pty. Ltd.	Earth Leakage Circuit Breakers, Trade Name "Standard A", Cat. No. 3002, Ref. No. AS/A1/01	13.1.38	18.3.70	..
" " "	Earth Leakage Circuit Breakers, Trade Name "Standard A", Cat. No. 3003, Ref. No. AS/A1/03	6.8.38	18.3.70	..
Electric Control & Engineering Pty. Ltd.	Electric Iron, Trade Name "Kead Kordless", Ref. No. AV/CZ/01	20.8.47	18.3.70	..
George A. Fox & Co. Pty. Ltd.	Electric Iron, Trade Name "Walmac", Ref. No. AV/A1/01	20.11.47	17.3.70	..
Homecrafts Pty. Ltd.	Electric Iron, Trade Name "Capitol", Ref. No. AV/FI/02	24.2.50	18.3.70	..
Moffat-Virtue Ltd.	Electric Iron, Trade Name "Hawkins-Universal", Cat. No. LGH120, Ref. No. AV/KB/03	24.2.50	18.3.70	..
A. E. Ackland Pty. Ltd.	Lampholders, Trade Name, "Ashley", Cat. No. AL101, Ref. No. BA/A1/02	26.7.48	18.3.70	..
" " "	B.C. Lampholder, Trade Name "Treva", Ref. No. BA/A1/04	17.3.49	18.3.70	..
" " "	Lampholder, Trade Name "Fixalite", Ref. No. BA/A1/05	29.3.49	18.3.70	..
" " "	Lampholder, Trade Name "Ashley", Cat. No. AL215, Ref. No. BA/A1/06	16.5.49	18.3.70	..
Moffat-Virtue Ltd.	Portable Range, Trade Name "Frymatic", Cat. No. MDF200, Ref. No. BB/KB/01	4.6.54	18.3.70	V/KB/ MDF200
" " "	Griller, Trade Name "Hawkins Sideboard Chef.", Cat. No. LGH1100, Ref. No. BC/KB/03	7.5.53	18.3.70	..
" " "	Griller, Trade Name "Dinermatic", Cat. No. MDM300, Ref. No. BC/KB/05	13.4.56	18.3.70	V/KB/ MDM300

Dated the 27th day of April, 1970.

F. P. CHIPPERFIELD, Secretary.

STATE RIVERS AND WATER SUPPLY COMMISSION.

LICENCES TO DIVERT WATER AND CUT RACES PURSUANT TO THE PROVISIONS OF SECTION 204 OF THE WATER ACT 1958 (AS AMENDED).

THE Governor in Council has approved of the granting by the State Rivers and Water Supply Commission of licences as detailed hereunder for the term of years from the date specified in each case to the persons named in the following Schedule :—

SCHEDULE.

Licence No.	Term of Licence and Commencing Date.	Name and Address of Person to whom Licence is to be Granted.	Source of Supply.	Area Authorized to be Irrigated Per Annum.	Volume of Water Authorized to be Diverted Per Annum.	Annual Fee.
3047	Four years from 1.7.69	Kathleen Cahill, Tongala ..	Goulburn River ..	4	8	\$ 15.00
3048	Three years from 1.7.69	Bevan Mervan Nicholls and Lettie Christina Nicholls, Swan Hill	River Murray ..	33½	101½	126.56

Office of the State Rivers and Water Supply Commission, Melbourne, 23rd April, 1970.

G. W. LEWIS, Secretary,
State Rivers and Water Supply Commission.

STATE RIVERS AND WATER SUPPLY COMMISSION.

LICENCE TO DIVERT WATER PURSUANT TO THE PROVISIONS OF SECTION 204 OF THE WATER ACT (AS AMENDED).

THE Schedule of Licences as detailed hereunder to divert water has been revoked by the Governor in Council.

SCHEDULE.

Licence No.	Term of Licence and Commencing Date.	Name and Address of Person to whom Licence Granted.	Source of Supply.
2873	Four years from 1.7.68 ..	Richard Lloyd Trewin, Benalla	Broken River

Office of the State Rivers and Water Supply Commission, Melbourne, 23rd April, 1970.

G. W. LEWIS, Secretary,
State Rivers and Water Supply Commission.

Soil Conservation and Land Utilization Act 1958 (No. 6372).
SHELBOURNE HILLS No. 3 GROUP CONSERVATION AREA.

NOTICE is hereby given that I, William John Farquhar McDonald, Her Majesty's Minister for Conservation for the State of Victoria, under powers conferred by Division 1A, Section 24A of the *Soil Conservation and Land Utilization Act 1958* (No. 6372) hereby declare to be a Group Conservation Area the land embraced by the Crown Allotments listed below, together with the Road Reserves in the Parishes of Shelbourne, Woodstock and Tarnagulla, as particularly designated in Drawing Nos. 1443, 1444 and 1681, marked GA/30 and lodged at the office of the Soil Conservation Authority, 378 Cotham-road, Kew, and do further declare that it shall be known as the Shelbourne Hills No. 3 Group Conservation Area.

Parish.	Section.	Crown Allotments.
Shelbourne ..	IV	3A, 3B, 3C, 3D, 3E, 3F, 4, 5
	V	1, 1A, 1C, 1D, 1F, 1G, 2, 2A, 2A1, 3, 2A2, 3A2, 3A1, 3A3, 3B, 4A1, 4B, 5B2, 4B1, 5, 5A1, 5B1, 5B, 6A, 6B1, 7, 8, 9, 9A, 10, 11, 12, 13, 14, 15, 15A, 15B, 18, 18A, 18B (Water reserve), 19, 19A.
Woodstock ..	VI	1A, 1AB1, 2A1, 2A2, 2A3, 2A4, 2A5, 2BB, 2BC, 3AB1, 3B1
	XXI	1, 2, 3, 4
	XXVI	1, 1A, 1B, 1C
	I	1, 2, 3, 4, 5A, 5B, 6, 6A, 7, Pt. 8, 9, 10, 11, 12A, 12B
Tarnagulla ..	IV	1, 1A, 2, 3, 3A, 4
	V	1, 1A, 2, 2A
	VIII	Pt. 1, 1A, Pt. 2, 2B
	XXX	1A, 2A, 2B, 3, 4, 5A, 6B, 11, 12
	XXXI	1B, 1C, 2, 3A, 6
	XII	1, 2

And such Crown Land and Road Reserves in the above-named Parishes as are located within the area designated in Drawing Nos. 1443, 1444 and 1681.

W. J. F. McDONALD,
Minister for Conservation.

21st April, 1970.

Police Regulation Act 1958, Section 122.
SALE OF UNCLAIMED MOTOR VEHICLES.

AN owner is required for a 1958 F.C. model Holden sedan, ex-registered No. GOP-195, engine No. L311528. The vehicle came into the possession of Police on the 16th July, 1969, and if not claimed, will be sold by public auction at the Northcote Police Station, 43 James-street, Northcote, at 2 p.m., on 20th May, 1970.

N. WILBY,
Chief Commissioner of Police.

THE LIQUOR CONTROL ACT 1968.

WHEREAS the Hotelkeeper's Licence for the licenced premises known as the Telegraph Hotel, situate at Charlton, has been surrendered as from 31st March, 1970, notice is hereby given that the amount of compensation payable to the owner of such premises, pursuant to the provisions of the *Liquor Control Act 1968*, is as under—
Owner, \$22,750.

Dated at Melbourne this 23rd day of April, 1970.

J. P. CROWE, Secretary,
Liquor Control Commission.

POLICE OFFENCES ACT 1958.

IN pursuance of the powers conferred upon the Chief Secretary by sub-section (3) of section 184 of the *Police Offences Act 1958*, I do by this notice grant exemption from compliance with sub-sections (1) and (2) of section 184 of the said Act with respect to the publication "Football 1970—The Queens Year", distributed by Color-gravure Publications, 61 Flinders-lane, Melbourne.

A. G. RYLAH,
Chief Secretary.

Chief Secretary's Office,
Melbourne, 21st April, 1970.

Stock Diseases Act 1958.

DEPARTMENT OF AGRICULTURE.

THE Public Service Board has, by certificate dated the 2nd April, 1970, appointed DAVID WALTER BROADBENT, to be an Inspector of Stock under the provisions of Part I, of the *Stock Diseases Act 1958*, without additional salary.

D. S. WISHART,
Director of Agriculture.

SHIRE OF WOORAYL.
ROAD DEVIATION ORDER.

PURSUANT to the provisions of sections 522 and 526 of the *Local Government Act 1958*, the Council of the Shire of Woorayl hereby directs that the land in the Parish of Tarwin South, indicated by hatching on the diagram hereunder, which has been purchased, taken or acquired by it, shall be a Public Highway on and from the date of publication of this Order in the *Government Gazette*, and declares that such land shall be a Public Highway in lieu of the land indicated by cross-hatching in the said diagram.

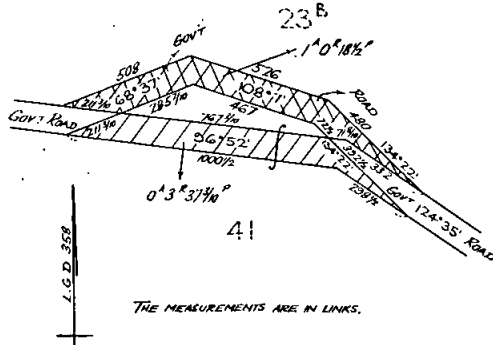

The common seal of the President, Councillors and Ratepayers of the Shire of Woorayl was hereunto affixed this tenth day of April, 1970, in the presence of—

W. R. TILSON, Shire President.
(SEAL) I. L. HUGHES, Councillor.
K. G. BRYDON, Shire Secretary.

Confirmed by the Governor in Council, 22nd April, 1970.
—J. ROSSITER, Clerk of the Executive Council.

Town and Country Planning Act 1961.
CITY OF COLAC PLANNING SCHEME 1963.
AMENDMENT No. 4, 1970.
Notice of Amendment.

IN pursuance of the powers conferred by sub-section 6 of section 32 of the *Town and Country Planning Act 1961*, the Governor in Council, by and with the advice of the Executive Council on the 22nd April, 1970 amended the City of Colac Planning Scheme in so far as it relates to strata subdivisions in the Residential Zone.

A copy of the amendment may be inspected during office hours at the office of the Town and Country Planning Board, 235 Queen-street, Melbourne; at the office of the Council of the City of Colac at Colac; and when available at the Office of Titles, Melbourne; and at the Central Plan Office of the Department of Crown Lands and Survey, Melbourne.

W. H. CRAIG, Secretary,
Town and Country Planning Board.

Town and Country Planning Act 1961.
SHIRE OF FLINDERS PLANNING SCHEME, 1962.—
INTERIM DEVELOPMENT ORDER.
AMENDMENT No. 21, 1970.
(Multi-dwelling Units.)

BY virtue of the powers conferred by the *Town and Country Planning Act 1961*, and of every other power enabling it in that behalf the Council of the Shire of Flinders (hereinafter referred to as the Responsible Authority) having commenced the preparation of a Planning Scheme on the 4th day of February, 1970, in accordance with the *Town and Country Planning Act 1961*, hereby makes the following Interim Development Order for the purpose of regulating restricting restraining or prohibiting the use or development of any land for the erection or construction of multi-dwelling units within the area described in the Schedule hereto.

For the purpose of this Interim Development Order, the following definitions apply:

“Multi-dwelling unit” means a building or buildings used for human habitation whether self-contained or not and includes apartment house, flat, residential building, stratum title units, aged persons units, group house or other similar types of housing groups located in composite form on a single site.

“Apartment house” means a building (not being a residential building as hereinafter defined) used for human habitation not providing self-contained living accommodation for individual families or facilities for persons other than residents or their guests, but does not include such accommodation where it forms part of an educational establishment, a hospital, an hotel, an institutional home, a mental institution, a reformatory institution, a tourist establishment or a motel.

“Flat” means that portion of a building which is used or intended adapted or designed to be used as a dwelling and it is a self-contained unit; but does not include a caretaker's house or industrial dwelling.

“Residential building” means a boarding house or a common lodging house (as such terms are defined in the *Health Act 1958*) or a residential club, but does not include a restaurant, dining room or café available to persons other than residents or their guests or a motel.

“Group house” means one of two or more self-contained dwellings situate on a single site which has appurtenant thereto land or garden area set aside exclusively for the use of the dwelling's occupants (semi-detached or duplex houses are included in this definition) and each having at least one wall in common with another such dwelling or being connected by carport, garage or utility room.

1. After the coming into operation of this Interim Development Order, no person shall use or develop any land for the purpose of the erection or construction of multi-dwelling units, within the area included in the Schedule except in accordance with the provisions of a permit issued by the Responsible Authority.

2. Every application for a permit under the provisions of this Order shall be made on the prescribed form, copies of which may be obtained from the office of the Responsible Authority at the Municipal Offices.

3. Nothing in this Interim Development Order shall prevent—

(a) The continuance of the use of any land for the purposes for which it was being lawfully used immediately before the coming into operation of this Order or the use of any building or works for any purpose for which it was being lawfully erected or carried out immediately before that time;

(b) Any dealing or the registration of any dealing with any land in a subdivision of which a plan has been sealed by the Council of the Shire of Flinders or confirmed by the arbitrator pursuant to sections 569b and 570 respectively of the *Local Government Act 1958*, before the coming into operation of this Order.

4. *Schedule.*—Those areas of land within the Municipal District of the Shire of Flinders being the Residential “A” and “B” zones under the Shire of Flinders Planning Scheme, 1962, including any approved amendments thereof.

The common seal of the Council of the Shire of Flinders was hereunto affixed on the 20th day of February, 1970, in the presence of—

K. EVANS, Councillor.
(SEAL) R. J. ROWLEY, Councillor.
G. W. WHITE, Shire Secretary.

Approved by the Governor in Council, 22nd April, 1970.—
J. ROSSITER, Clerk of the Executive Council.

Town and Country Planning Act 1961.
SHIRE OF MORNINGTON PLANNING SCHEME, 1959.—
INTERIM DEVELOPMENT ORDER.
AMENDMENT No. 45, 1969.
(Multi-dwelling Units.)

BY virtue of the powers conferred by the *Town and Country Planning Act 1961*, and of every other power enabling it in that behalf the Council of the Shire of Mornington (hereinafter referred to as the Responsible Authority) having commenced the preparation of a Planning Scheme on the 20th day of May, 1969, in accordance with the *Town and Country Planning Act 1961*, hereby makes the following Interim Development Order for the purpose of regulating restricting restraining or

prohibiting the use or development of any land for the erection or construction of multi-dwelling units within the area described in the Schedule hereto.

For the purpose of this Interim Development Order, the following definitions apply:

"Multi-dwelling unit" means a building or buildings used for human habitation whether self-contained or not and includes apartment house, flat, residential building, stratum title units, aged persons units, group house or other similar types of housing groups located in composite form on a single site.

"Apartment house" means a building (not being a residential building as hereinafter defined) used for human habitation not providing self-contained living accommodation for individual families or facilities for persons other than residents or their guests, but does not include such accommodation where it forms part of an educational establishment, a hospital, an hotel, an institutional home, a mental institution, a reformatory institution, a tourist establishment or a motel.

"Flat" means that portion of a building which is used or intended adapted or designed to be used as a dwelling and it is a self-contained unit, but does not include a caretaker's house or industrial dwelling.

"Residential building" means a boarding house or a common lodging house (as such terms are defined in the Health Act 1958) or a residential club, but does not include a restaurant, dining room or café available to persons other than residents or their guests or a motel.

"Group house" means one of two or more self-contained dwellings situate on a site which has appurtenant thereto land or garden area set aside exclusively for the use of the dwelling's occupants (semi-detached or duplex houses are included in this definition) and each having at least one wall in common with another such dwelling or being connected by carport, garage or utility room.

1. After the coming into operation of this Interim Development Order, no person shall use or develop any land for the purpose of the erection or construction of multi-dwelling units, within the area included in the Schedule except in accordance with the provisions of a permit issued by the Responsible Authority.

2. Every application for a permit under the provisions of this Order shall be made on the prescribed form, copies of which may be obtained from the office of the Responsible Authority at the Municipal Offices.

3. Nothing in this Interim Development Order shall prevent—

(a) The continuance of the use of any land for the purposes for which it was being lawfully used immediately before the coming into operation of this Order or the use of any building or works for any purpose for which it was being lawfully erected or carried out immediately before that time;

(b) Any dealing or the registration of any dealing with any land in a subdivision of which a plan has been sealed by the Council of the Shire of Mornington or confirmed by the arbitrator pursuant to sections 569b and 570 respectively of the Local Government Act 1958, before the coming into operation of this Order.

4. Schedule.—Those areas of land within the Municipal District of the Shire of Mornington being the Residential "A", "B", "C", "D", "E" and "F" Zones under the Shire of Mornington Planning Scheme, 1959, including any approved amendments thereof.

The common seal of the Council of the Shire of Mornington was hereunto affixed on the 13th day of January, 1970, in the presence of—

E. G. SHEEHAN, Councillor.

(SEAL) A. B. CAMERON, Councillor.

D. G. COLLINGS, Shire Secretary.

Approved by the Governor in Council, 22nd April, 1970.—
J. ROSSITER, Clerk of the Executive Council.

Melbourne and Metropolitan

BOARD OF WORKS.

NOTICE TO THE OWNERS OF TENEMENTS IN THE UNDER-MENTIONED STREETS AND THE PRIVATE STREETS, LANES, COURTS AND ALLEYS OPENING THERETO.

THE main pipe in the said streets being laid down, the owners of all tenements situated as under are hereby required on or before the 1st June, 1970, to cause a proper pipe and stopcocks to be laid so as to supply water within such tenements from the main pipe.

H. J. SNADDEN,
Acting Secretary.

21st April, 1970.

STREET AND POSITION.

Berwick.

Power-road, from 220 feet north of Spruce-street, northwards 2,427 feet.

Box Hill.

Daisy-court, from Peter-street southwards 230 feet.

Broadmeadows.

Ripplebrook-drive, from Rosebud-crescent to Dimboola-road.

Dimboola-road, from Ripplebrook-drive to Sorrento-street.
Timboon-crescent, from Ripplebrook-drive to Dimboola-road.

Benambra-street, from Timboon-crescent to Sorrento-street.
Merrickes-street, from Rosebud-crescent to Benambra-street.

Hastings-crescent, from Rosebud-crescent to Merrickes-street.

Bittern-street, from Ripplebrook-drive to Hastings-crescent.

Olinda-court, from Hastings-crescent southwards 240 feet.

Boneo-court, from Rosebud-crescent northwards 190 feet.

Samara-grove, from Elmhurst-road to O'Bega-court.

Jessop-court, from Samara-grove north-westwards 320 feet.

O'Bega-court, from Samara-grove north-westwards 290 feet.

Altair-drive, from Elmhurst-road south-westwards 410 feet.

Winslow-court, from Elmhurst-road south-westwards 350 feet.

Dandenong.

Darwin-street, from 20 feet south of Waratah-drive south-westwards 720 feet.

Kandra-street, from Darwin-street south-eastwards 170 feet.

Laemmle-street, from Darwin-street south-eastwards 350 feet.

Orchid-avenue, from Laemmle-street south-westwards 140 feet.

Laemmle-street, from 50 feet east of Orchid-avenue south-eastwards 780 feet.

Boronia-avenue, from 100 feet north of Pinewood-avenue to Kandra-street.

Waranga-street, from 30 feet north of Tanjil-court northwards and eastwards 870 feet.

Glenelg-street, from Waranga-street north-westwards 620 feet.

Kiewa-court, from Glenelg-street eastwards 300 feet.

Avoca-court, from Glenelg-street south-westwards 220 feet.

Tarwin-court, from Waranga-street westwards 460 feet.

Buldah-street, from Waranga-street south-eastwards 540 feet.

Utah-court, from Buldah-street south-westwards 220 feet.

Diamond Valley.

Chaucer-crescent, from Luton-way north-westwards 750 feet.

Bowen-court, from Chaucer-crescent northwards 290 feet.

Kipling-court, from Chaucer-crescent north-eastwards 720 feet.

Tucker-street, from Kipling-court to Shelley-avenue.

Lamb-court, from Tucker-street south-westwards 200 feet.

Sandhurst-crescent, from Luton-way to Cameron-parade.

Chester-place, from Sandhurst-crescent northwards 270 feet.

Milford-place, from Sandhurst-crescent northwards 240 feet.

Trafalgar-crescent, from Sandhurst-crescent north-eastwards 480 feet.

Regent-place, from Trafalgar-crescent northwards 160 feet.

York-place, from Trafalgar-crescent south-eastwards 170 feet.

Doncaster and Templestowe.

Sharon-street, from Victoria-street to Lauer-street.

Libere-court, from Sharon-street southwards 380 feet.

Nathan-street, from Sharon-street southwards 360 feet.

Dawson-street, from Sharon-street northwards 100 feet.

Persimmon-street, from Sharon-street southwards 380 feet.

Heidelberg.

Phillips-crescent, from Finlayson-street westwards, southwards and eastwards 1,300 feet.
 Finlayson-street, from Pyalong-avenue north-eastwards 870 feet.
 Pickworth-court, from Finlayson-street westwards 500 feet.
 Korong-road, from Orthla-avenue southwards 150 feet.
 Kolora-road, from Orthla-avenue to Dougharty-road.
 Orthla-avenue, from Kolora-road to Korong-road.
 Mologa-road, from Lillimur-avenue to Northern-road.

Keilor.

William-street, from Fosters-road westwards 640 feet.
 William-street, from 270 feet east of Market-street eastwards 340 feet.
 Flinders-street, from 480 feet west of Fosters-road westwards 160 feet.
 Flinders-street, from 680 feet east of Fosters-road eastwards 520 feet.
 Eliza-street, from 280 feet west of Fosters-road westwards 360 feet.
 Eliza-street, from 820 feet east of Fosters-road to Collinson-street.
 Batman-avenue, from 470 feet north of Calder Highway northwards 210 feet.
 Market-street, from 70 feet north of William-street, northwards 210 feet.
 Victory-street, from 180 feet east of Fosters-road eastwards 640 feet.
 Collinson-street, from Flinders-street to Queensberry-street.
 Collinson-street, from William-street to Kingston-street.
 Spence-street, from Collinson-street to Latrose-street.
 Kingston-street, from Collinson-street to Erebus-street.
 Queensberry-street, from Collinson-street to Erebus-street.
 Eliza-street, from Collinson-street to Sprint-street.
 Swan-street, from 450 feet east of Collinson-street eastwards 280 feet.
 Victory-street, from 210 feet east of Collinson-street eastwards 520 feet.
 Erebus-street, from 80 feet north of Victory-street to Spence-street.
 Russelton-street, from Erebus-street to Latrose-street.
 Snow-street, from Erebus-street to Latrose-street.
 Latrose-street, from Snow-street to Spence-street.
 Beck-street, from Eliza-street to Snow-street.
 Sprint-street, from Eliza-street to Snow-street.

Nunawading.

Cochrane-street, from Hodgson-street southwards 190 feet.
 Munro-street, from Orient-avenue northwards 340 feet.
 Fuller-street, from 390 feet south-east of Munro-street eastwards 250 feet.

Ringwood.

Berkley-drive, from 80 feet east of Avis-court to Kenwood-crescent.
 Berkley-drive, from Kenwood-crescent eastwards 170 feet.

Waverley.

Torwood-avenue, from 100 feet south of Creswick-drive southwards 410 feet.
 Appletree-drive, from 60 feet east of Torwood-avenue to Links-avenue.
 Lisa-court, from Appletree-drive southwards 310 feet.
 Appletree-drive, from Torwood-avenue eastwards and northwards to Links-avenue.

MITTA MITTA RIVER IMPROVEMENT TRUST.

RATING BY-LAW No. 16.

THE Mitta Mitta River Improvement Trust, in pursuance and exercise of the powers conferred by the *River Improvement Act 1958*, doth hereby make the By-law following:—

1. The following rate, to be called the "Mitta Mitta River Improvement District River Improvement Rate" is hereby made and shall be levied upon the occupiers or owners of all properties within the Mitta Mitta River Improvement District which are rateable to any municipality:—

A rate of twenty two hundredths of a cent in the dollar on the unimproved capital value of all those properties within the First Division, as determined by the Order in Council made on the 1st day of February, 1961, and published in the *Government Gazette* on the 8th day of February, 1961.

A rate of eleven hundredths of a cent in the dollar on the unimproved capital value of all those properties within the Second Division, as determined by the said Order in Council.

No rate on all those properties within the Third Division, as determined by the said Order in Council.

2. Such rates are made and shall be levied for the period beginning with the 1st day of January, 1970, and ending with the 31st day of December, 1970, and shall be payable on the 1st day of July, 1970, at the office of the Mitta Mitta River Improvement Trust, Tallangatta.

3. Such person or persons as the Mitta Mitta River Improvement Trust may from time to time appoint for that purpose shall be and is or are hereby authorised to demand, receive, collect and recover the said rate.

The foregoing By-law was made by the Mitta Mitta River Improvement Trust on the 9th day of April, 1970, and the common seal of the Trust was hereunto affixed on the 9th day of April, 1970, in the presence of—

(SEAL) H. F. BOCK, Chairman.
 C. P. TOBIN, Commissioner.
 H. R. CRAIG, Secretary.

Approved by the Governor in Council, 22nd April, 1970.—
 J. ROSSITER, Clerk of the Executive Council.

OMEOWATERWORKS TRUST.

INCREASING THE LIMIT OF BANK OVERDRAFT.

THE Lieutenant-Governor as Deputy for His Excellency the Governor of the State of Victoria by and with the advice of the Executive Council thereof doth by Order made on the 22nd day of April, 1970, increase the total amount of the sums which the Omeo Waterworks Trust may owe at any one time in respect of moneys borrowed by overdraft of current account, pursuant to the provisions of section 288 of the *Water Act 1958*, and fixed by the Governor in Council on 17th March, 1965, at Five thousand pounds (£5,000) to Twenty-five thousand dollars (\$25,000).

J. ROSSITER,
 Clerk of the Executive Council.

At the Executive Council Chamber,
 Melbourne, 22nd April, 1970.

COHUNA WATERWORKS TRUST.

AUTHORITY TO OBTAIN BANK OVERDRAFT.

THE Lieutenant-Governor as Deputy for His Excellency the Governor of the State of Victoria by and with the advice of the Executive Council thereof doth by Order made on the 22nd day of April, 1970, authorize the Cohuna Waterworks Trust to obtain in pursuance of the provisions of section 286 of the *Water Act 1958* (No. 6413) an advance or advances during the year ending 30th September, 1970, by overdraft of the Trust's current account, such overdraft not to exceed at any one time the sum of Four thousand dollars (\$4,000).

J. ROSSITER,
 Clerk of the Executive Council.

At the Executive Council Chamber,
 Melbourne, 22nd April, 1970.

Farm Produce Merchants and Commission Agents Act 1965 (No. 7274).

LIST OF NAMES AND ADDRESSES OF PERSONS TO WHOM LICENCES HAVE BEEN GRANTED DURING MARCH, 1970.

IN accordance with the above Act, those issued with a Merchant's or Commission Agent's licence have lodged a fidelity bond. All licences, unless earlier cancelled, shall continue in force until 30th June, 1970.

D. S. WISHART,
 Director of Agriculture.

MERCHANTS.

Name, Principal Place of Business.

Baum, Milton, 6 Raglan-street, Daylesford, 3460.
 Bulk Citrus Distributors (Mildura), 3 Floral-avenue, Mildura, 3500.
 Davis Lancaster and Co., 601 Little Lonsdale-street, Melbourne, 3000.
 Greenfield, Edward D., & Co., Maroondah Highway, Lilydale, 3140.
 Whaley, Geo., & Sons Pty. Ltd., 9 Fitzgibbon-avenue, West Brunswick, 3055.

COMMISSION AGENT.

Musico, Rocco, Main-road, Silvan, 3795.

SECONDARY WHOLESALERS.

Alter and Saks Pty. Ltd., 320 Carlisle-street, Balaclava, 3183.
 Associated Foods (Vic.) Pty. Ltd., 2 Ashburn-place, Blackburn, 3130.
 Central Fruit Palace, 142 Liebig-street, Warrnambool, 3280.
 Dugan Bros., Mickleham-road, Westmeadows, 3047.
 Fiorelli Distributing Co. Pty. Ltd., 11 Ricketts-road, Notting Hill, 3168.
 Fiorelli Produce Co. Pty. Ltd., 11 Ricketts-road, Notting Hill, 3168.
 Mario's Poultry, 39 Coppards-road, Newcomb, 3219.

MILK BOARD ACT 1958.

IN accordance with the provisions of section 4A of the Milk Board Act 1958, the Milk Board hereby exempts from the provisions of the said Act all milk intended for use in the manufacture of the product known as "Tom Piper Creamed Rice", from 1st July, 1969, to 30th June, 1971; and such exemption shall be subject to the following conditions:—

1. Such milk shall be purchased from an authorized depot agent of the Milk Board and shall be transported in bulk in tankers direct from the premises of the depot agent to the premises of Tom Piper Ltd., in Williamstown-road, Port Melbourne, by a milk carrier licensed under the Milk Board Act.

2. Tom Piper Ltd. shall lodge with the Board, by the 10th day of each month, a return setting out the following information in respect of milk so purchased during the preceding calendar month:—

- (i) Depot agent or agents from whom supply was obtained.
- (ii) Quantity.
- (iii) Price or prices paid.
- (iv) Name of carrier or carriers.
- (v) Cartage rate or rates charged.

Tom Piper Ltd. shall certify on such return that all of the milk so purchased was used in the process of manufacturing "Tom Piper Creamed Rice".

W. DOBINSON,
 Secretary.

MILK BOARD ACT 1958.

IN accordance with the provisions of section 4A of the Milk Board Act 1958, the Milk Board hereby exempts from the provisions of the said Act all milk intended for use by Regal Cream Products, of 43 Connor-street, Colac, in the manufacture of the product known as "Regal Ice Cream Mix", from 1st July, 1969, to 30th June, 1971; and such exemption shall be subject to the following conditions:—

1. Such milk shall be purchased from the factory of the Colac Dairying Co. Ltd., at Cororooke, and transported in vehicles owned by Regal Cream Products direct from the Cororooke factory to the premises of Regal Cream Products, at 43 Connor-street, Colac.

2. Regal Cream Products shall lodge with the Board, by the 10th day of each month, a return setting out the following information in respect of milk so purchased during the preceding calendar month:—

- (i) Quantity.
- (ii) Price or prices paid.

3. Regal Cream Products shall certify on such return that all of the milk so purchased was used in the process of manufacturing "Regal Ice Cream Mix".

W. DOBINSON,
 Secretary.

LOCAL GOVERNMENT DEPARTMENT.

ORDER CONFIRMED.—CITY OF NUNAWADING.

THE Minister of the Crown administering the Local Government Act 1958, on the twentieth day of April, 1970, confirmed the Order hereinafter referred to, in pursuance of section 514 of the said Act, namely:—

An Order of the Council of the City of Nunawading made on the 10th March, 1970, directing the compulsory taking of the land described hereunder for the purpose of providing a place of public resort and recreation and access thereto—

All that piece of land being part of Crown portion 66, Parish of Nunawading, and being that part of allotment 17 on plan of subdivision No. 21077 contained within a boundary line commencing at a point located on the west

alignment of Springvale-road distant 746 ft. 9 in. north of Spencer-street and being the south-east corner of the said allotment 17; thence on a bearing of 269 deg. 22½ min. for a distance of 330 feet; thence on a bearing of 356 deg. 45 min. for a distance of 25 feet; thence on a bearing of 89 deg. 22½ min. for a distance of 150 feet; thence on a bearing of 97 deg. 19½ min. for a distance of 180 ft. 7 in. to the point of commencement.

R. J. HAMER,
 Minister for Local Government.
 Local Government Department,
 Melbourne.

CONTRACTS ACCEPTED.—(Series 1969-70.)
 GENERAL STORES.

Gazette No. 59, 10th July, 1969, Schedule No. 39, Furniture, Blinds, &c.—For rates shown opposite Item Nos. 39 and 45 to 50 inclusive, add 3 per cent., as from 1st March, 1970.

CEREALS.

Requirements under sub-schedule No. 10 of Schedule No. 1 for the period 1st May, 1970, to 31st July, 1970, are to be purchased from the under-mentioned firms at the rates indicated, viz.:—Ward, McKenzie Pty. Ltd., Barley—pearl, \$4.00 per cwt.; Oatmeal—plain, \$7.50 per cwt.; Oatmeal—flaked, \$6.00 per cwt.; Peas—split, yellow, \$6.00 per cwt.; Producers Co-operative Distributing Society Ltd., Rice—dressed, \$214.20 per ton less 2½ per cent., 30 days. Supplies of Tapioca-seed, should be purchased under Regulation 109.

PRISONERS' MEALS IN LOCK-UPS.

CONTRACT CANCELLED.

Gazette No. 50, 25th June, 1969, Prisoners' Meals, Prahran. Contract No. 172, is hereby cancelled.

CONTRACT ACCEPTED.

1345. For the supply of Prisoners' Meals at Prahran, as from 30th March, 1970, Breakfast and Tea, 50 cents; Hot Dinner, 60 cents.—K. Seretis.

E. P. WATSON, Secretary to the Tender Board. 274.70.

PUBLIC WORKS.

1312. Carlton, Public Offices, Queensberry-street, maintenance cleaning for the period 9th March, 1970, to 8th March, 1973, \$31,866.12 per annum.—D.P.C. Cleaning Service.

1313. Boroondara, Primary School 4724, extension to L.T.C. Building, \$6,825.00.—P. T. Dawes.

1314. Norlane, High School, mechanical services, \$11,416.00.—Ford-Swinton Industries Pty. Ltd.

1315. Bendigo, Sandhurst Boys' Centre, extension to sewerage and water service to new residence, \$7,072.00.—John W. Henderson Bendigo Pty. Ltd.

1316. Ararat, H.M. Prison, supply and installations of additional steam generator, \$8,365.90.—Mentay Engineering Pty. Ltd.

1317. Bayswater South, Primary School 4973, site works, \$62,203.50.—G. Mueller.

1318. Noble Park, High School, mechanical services, \$11,575.00.—R. G. Thomson.

1319. Oakleigh, Police Station, erection of new office accommodation, stage 2, \$55,505.00.—W. J. Cody & Quinn Pty. Ltd.

1320. Mildura, High School, concrete drainage, etc., \$4,906.00.—K. P. Collins.

1321. Glenormiston, Agricultural College, alterations and repairs to existing mansion, \$110,184.80.—Fotheringham Constructions Pty. Ltd.

1322. Burwood, Technical School, mechanical services, \$8,741.00.—A. T. Heating & Plumbing Pty. Ltd.

1323. Heatherton, Sanatorium, electrical installation, \$9,400.00.—J. E. Hudson.

1324. Noble Park, High School, electrical installation, \$7,990.00.—Jarrett & Crikis.

1325. Ballarat North, Technical School, mechanical services, \$5,300.00.—McLean & Boakes.

1326. Maryborough, Court House, external repairs and painting and internal painting, \$5,884.00.—W. Phelan & Sons Pty. Ltd.

1327. Echuca, Technical School, erection of wool classing room and toilet block, \$39,885.00.—W. J. Pryde.

1328. Verdale, Primary School 4987, site works, \$43,596.60.—Derek Saathoff.

1329. Noble Park, High School, erection of a standard school hall type "800C", \$89,637.00.—Vanvliet & Gardner.

1330. Armadale, "Minimbah" Secondary Teachers College Hostel, internal renovations, \$5,985.00.—Don Renovations.

1331. Myrtleford, erection of a brick Court House, \$27,901.60.—P. N. Barton & R. T. Blake.

1332. Mortlake, Police Station, erection of brick veneer office and residence, \$24,950.00.—J. Golsworthy & Sons.

1333. Melbourne, Victorian School for Deaf Children 3774, erection of additional brick veneer wing, \$65,585.00.—Hosie Constructions Pty. Ltd.

1334. Burwood, Technical School, erection of L.T.C. Science extensions, \$27,350.00.—Hosie Constructions Pty. Ltd.

1335. Malmsbury, Youth Training Centre, electrical installation, \$7,614.00.—R. Lonsdale & Co.

1336. Lilydale, High School, supply and placing 12-in. and 15-in. diameter pipes, etc., \$6,066.70.—Mulsite Company.

1337. Burwood, Teachers' College, erection of Lecture Wing, Gymnasium and Assembly Hall, \$951,527.00.—H. T. McKern & Sons Pty. Ltd.

1338. Myrtleford, High School, internal and external renovations, \$6,250.00.—Pascoe Vale Painters Construction Co.

1339. Springvale North, Primary School 1658, external and internal renovations, \$5,588.00.—N. Peshut.

1340. Broadmeadows, "Attwood" Veterinary Laboratory, electrical installation—incinerator block, \$7,550.00.—Ken R. Phelan Pty. Ltd.

1341. Broadmeadows, "Attwood" Veterinary Laboratory, supply and installation of refrigeration system for cool room, \$4,785.00.—Ray Johnson Refrigeration Engineering Pty. Ltd.

1342. Sebastopol, Technical School, renovations, \$10,750.00.—J. C. & B. J. Thomas.

1343. Tongala, Consolidated School, electrical installation, \$6,010.44.—R. W. & B. M. Belcher.

SOIL CONSERVATION AUTHORITY.

CONTRACT No. 7003.

1344. Construction of seven (7) reinforced concrete structures, Eppalock Project, \$3,780.—A. R. & E. I. Mansfield, Mia Mia.

P. J. McCALLUM,
Secretary.

ORDERS IN COUNCIL.—(Series 1969-70.)

PUBLIC WORKS.

1307. Melbourne, Dredge "Matthew Flinders", supply of four (4) rubber dredging sleeves, \$8,127.00.—Firestone Australia Pty. Ltd.—(P. and H. 157703.)

Approved by the Governor in Council, 22nd April, 1970.—J. ROSSITER, Clerk of the Executive Council.

STATE ELECTRICITY COMMISSION.

1308. For the supply and erection of Stage 3, West Field coal conveyor system, Morwell Open Cut, to Specification No. 69/266, \$1,181,609.—Mechanical Handling Ltd.

Approved by the Governor in Council, 3rd February, 1970.—J. ROSSITER, Clerk of the Executive Council.

1309. For the supply of insulated annealed copper cable for a period of two years, with optional extension of three months, to Specification No. 69/365, at Schedule rates.—Gilbert Lodge & Co. Ltd.

Approved by the Governor in Council, 3rd March, 1970.—J. ROSSITER, Clerk of the Executive Council.

1310. For the supply of high strength disc insulators for 220 kV transmission lines for a period of two years, with optional extension of three months, to Specification No. 69/337, at Schedule rates.—Doulton Insulators Australia Pty. Ltd.

Approved by the Governor in Council, 11th March, 1970.—J. ROSSITER, Clerk of the Executive Council.

1311. For the construction of unit control room, Yallourn "W" Power Station, to Specification No. 70/69, \$51,423.—Sola Construction Pty. Ltd.

Approved by the Governor in Council, 17th March, 1970.—J. ROSSITER, Clerk of the Executive Council.

APPOINTMENTS AND RESIGNATIONS

APPOINTMENTS.

THE Lieutenant-Governor as Deputy for His Excellency the Governor of the State of Victoria, by and with the advice of the Executive Council thereof, has, by Orders made on the 22nd day of April, 1970, been pleased to make the under-mentioned appointments, viz.:—

CHIEF SECRETARY'S DEPARTMENT.

President and Members of the Council of Trustees of the National Gallery of Victoria.

NORMAN RICHARD SEDDON, C.B.E., pursuant to the provisions of the *National Gallery of Victoria Act 1966*, to be a Member and President of the Council of Trustees of the National Gallery of Victoria, for the period of three years ending 16th May, 1973; and

WILLIAM RITCHIE,
ANDREW SHEPPARD GRIMWADE,
DOCTOR LEONARD BELL COX, C.M.G.,
Colonel AUBREY HICKS LAWSON GIBSON, E.D.,
Sir ARTHUR TENNYSON SMITHERS, C.B.E.,
ROBIN GERARD PENLEIGH BOYD,
Dame ELISABETH MURDOCH, D.B.E., and
Professor RICHARD IVAN DOWNING,

pursuant to the provisions of the *National Gallery of Victoria Act 1966*, to be Members of the Council of Trustees of the National Gallery of Victoria, for the period of three years ending 16th May, 1973.

Postal Voting Officers.

SIMON BANAMBA KAUMI (Port Moresby),
GORDON ROY FINDLAY (Norfolk Island),
CECIL WILLIAM SUTHERN (Cocos (Keeling) Islands),
and

JAMES STEPHEN CLEAVER (Hong Kong),
to be Postal Voting Officers for the conjoint Parliamentary election to be held on the 30th May, 1970, pursuant to section 147A of *The Constitution Act Amendment Act 1958*.

Assistants to the Inspector of Fisheries.

SIDNEY JAMES COWLING,
PETER WILLIAM HOLBEACH,
GAVIN EDWIN CERINI,
SALVINE RAIS,
DONALD MURDOCH WHITE,
COLIN EDWARD CHALMERS, and
DAVID RONALD VENN,
pursuant to the provisions of the *Fisheries Act 1958*, to be Assistants to the Inspector of Fisheries.

MINISTRY OF HEALTH.

Government Appointees on Committees of Management of Hospitals.

KEVIN FRANCIS RIORDAN
to be Government appointee on the Committee of Management of the Mooroopna and District Base Hospital, for a further period of three years from 14th May, 1970, pursuant to section 48 (1) (a) (ii) of the *Hospitals and Charities Act 1958*; and

BRIAN EDWARD MADDEN
to be Government appointee on the Committee of Management of the Numurkah and District War-Memorial Hospital, pursuant to section 48 (1) (a) (ii) of the *Hospitals and Charities Act 1958*, for a period of three years, vice John Henry Knight, resigned.

LAW DEPARTMENT.

Commissioners for Taking Declarations, &c.

FREDERICK ROBERT TAIT, and
JACK FITZGERALD,
care of Department of Crown Lands and Survey,
2 Treasury-place, Melbourne, and
ROBIN JAMES CONDRON, care of Department of
Agriculture, Victoria, 3 Treasury-place, Melbourne,
to be Commissioners for taking Declarations and Affidavits, pursuant to the provisions of the *Evidence Act 1958*, to refrain from charging fees and to resign upon ceasing to occupy their present positions;

LEO BERNARD HOGAN, 83 Panton-street, Golden Square,
ALEC WILLIAM SEYMOUR WILSON, 8 Greenwood-street,
Abbotsford, and

PETER MURDOCH ALLAN, 18 Northam-road, East Bentleigh,
to be Commissioners for taking Declarations and Affidavits, pursuant to the provisions of the *Evidence Act 1958*, to resign upon removing from the neighbourhood of the addresses stated; and

JOHN MICHAEL CURRIE, care of City Treasurer's Office, Town Hall, Melbourne,
 DOROTHY ETHEL DURHAM, care of Fidelity Insurance Brokers Pty. Ltd., 20 Whitehorse-road, Ringwood,
 BARRY JOHN SMITH, care of M. C. Herd Pty. Ltd., Bacchus Marsh-road, Corio,
 ROBERT WILLIAM COOK, care of The Chamber of Manufactures Insurance Limited, 368-374 St. Kilda-road, Melbourne,
 CHARLES HENRY SPAULL, care of Yallourn Briquette Factory, Yallourn,
 ARTHUR MATZNER, care of The Royal Melbourne Hospital, Grattan-street, Parkville,
 NORMAN WILLIAM CAIRNES, and
 THOMAS MATTHEW MCCAW,
 care of Town Clerk's Office, Town Hall, Melbourne,
 RICHARD CHARLES EVANS, care of Herbert Osborne Pty. Ltd., 30 Thistlethwaite-street, South Melbourne, and
 NORMAN ARTHUR CHARLES WATKINSON, care of Australian Char Pty. Ltd., Porters-road, Morwell,
 to be Commissioners for taking Declarations and Affidavits, pursuant to the provisions of the Evidence Act 1958, to resign upon ceasing to occupy their present positions.

Justices of the Peace.

DAVID JAMES JACKSON, "The Pines", Waaiia,
 JAMES ROBERT FITZWILLIAM, 80 Bank-street, Port Fairy, and
 LEONARD CHARLES BAUD, 112 Bluff-road, Black Rock, to keep the Peace in the State of Victoria.

PUBLIC WORKS DEPARTMENT.

Member of the Marine Board of Victoria.

LESLIE PERCIVAL VICTORIA BENTLEY, representing the Marine Underwriters and Salvage Association of Victoria Limited,
 to be a member of the Marine Board of Victoria for the period ending 20th December, 1971.

Wharf Manager.

Sergeant HAROLD DAY, No. 10446,
 to be a Wharf Manager at Altona, to carry out that portion of Part II. of the Marine Act 1958, which relates to the management of Public Wharves and to be an officer under section 19 of such Act, to levy and collect wharfage rates thereat, vice Sergeant Alan Lindsay Bodey, No. 10105, transferred.

DEPARTMENT OF WATER SUPPLY.

Improvement Trust Commissioner.

JOHN LESLIE MULLIGAN
 to be a Commissioner of the Cann River Improvement Trust, to hold such position for a period of four years from the date hereof, subject to the provisions of the River Improvement Act.

J. ROSSITER,
 Clerk of the Executive Council.

At the Executive Council Chamber,
 Melbourne, 22nd April, 1970.

FORESTS DEPARTMENT.

APPOINTMENT OF COMMITTEE OF MANAGEMENT OF TANJIL BREN VILLAGE.

WHEREAS by section 50 of the Forests Act 1958 (No. 6254), it is provided that the Minister of Forests may, on the recommendation of the Forests Commission, appoint any number of persons, not less than three, to be a Committee of Management of any land forming part of any reserved forest, such land being set aside and declared to be a site for a village, and may remove any of those persons: Now therefore, I, Edward Raymond Meagher, Her Majesty's Minister of Forests for the State of Victoria, on the recommendation of the Forests Commission, do hereby appoint—

THOMAS IGNATIUS VAUGHAN,
 vice J. A. McCormack resigned, as a member of the Committee of Management until the 22nd day of April, 1972, of the land forming part of the reserved forest in the Parish of Fumina North, County of Buln Buln, described in the accompanying Schedule, and known as the "Tanjil Bren Village".

SCHEDULE ABOVE REFERRED TO.

Parish of Fumina North, County of Buln Buln, comprising 47 acres, more or less, as shown within red border on plan marked A60/1246, over 18/7/63 file of correspondence No. 64/37 in the Forests Department.

Dated at Melbourne, the 21st day of April, 1970.

E. R. MEAGHER,
 Minister of Forests.

FORESTS DEPARTMENT.

APPOINTMENT OF COMMITTEE OF MANAGEMENT OF THE MCKENZIE RIVER RESERVE.

WHEREAS by section 50 of the Forests Act 1958 (No. 6254), it is provided that the Minister of Forests may, on the recommendation of the Forests Commission, appoint any number of persons, not less than three, to be a Committee of Management of any land forming part of any reserved forest, such land being set aside as a Special Purpose Reserve, and may remove any of those persons: Now therefore, I, Edward Raymond Meagher, Her Majesty's Minister of Forests for the State of Victoria, on the recommendation of the Forests Commission do hereby appoint—

JOSEPH WILLIAM MCDOWELL,
 IAN ROYCE PALLOT,
 GEOFFREY LANCELOT MCTAVISH,
 ROBERT HENRY CARINE,
 ERNEST FREDERICK PAUL GERLACH,
 SIDNEY REX CARR,
 EGIN MELVILLE FLOYD,
 LAWRENCE MURRAY JONES,
 FRANCIS DONALD ANDERSON, and
 JOHN DAVID GILLESPIE,

as members of the Committee of Management until the twelfth day of December, 1972, of the land forming part of the reserved forest in the Parishes of Burrong North and Burrong South, County of Borung, described in the accompanying Schedule and known as "McKenzie River Reserve".

SCHEDULE ABOVE REFERRED TO.

Parishes of Burrong North and Burrong South, County of Borung, 889 acres, more or less, being the area shown by pink colour on plan marked A.52/1382 over 13.12.54, on file of correspondence No. 65/1943 of the Forests Department.

Dated at Melbourne, the 17th day of April, 1970.

E. R. MEAGHER,
 Minister of Forests.

FORESTS DEPARTMENT.

APPOINTMENT OF COMMITTEE OF MANAGEMENT OF THE YOU YANGS FOREST PARK.

WHEREAS by section 50 of the Forests Act 1958 (No. 6254), it is provided that the Minister of Forests may, on the recommendation of the Forests Commission, appoint any number of persons, not less than three, to be a Committee of Management of any land forming part of any reserved forest, such land being set aside as a Forest Park, and may remove any of those persons: Now, therefore, I, Edward Raymond Meagher, Her Majesty's Minister of Forests for the State of Victoria, on the recommendation of the Forests Commission, do hereby appoint—

TREVOR PESCOTT, and
 JOHN KEMSHALL DONOAN,
 vice E. J. Hanks and J. G. Hallett resigned, as members of the Committee of Management until the 8th day of September, 1970, of the land forming part of the reserved forest in the Parish of Wurd Youang, County of Grant, described in the accompanying Schedule, and known as "The You Yangs Forest Park".

SCHEDULE ABOVE REFERRED TO.

Parish of Wurd Youang, County of Grant, 1,100 acres, more or less, being the area shown by blue border on plan marked A63.107 over 17/12/64 in file of correspondence 67/1238 of the Forests Department.

Dated at Melbourne, the 21st day of April, 1970.

E. R. MEAGHER,
 Minister of Forests.

RESIGNATIONS.

THE Lieutenant-Governor as Deputy for His Excellency the Governor of the State of Victoria, by and with the advice of the Executive Council thereof, has, by Orders made on the 22nd day of April, 1970, accepted the resignations of the persons named hereunder of the offices mentioned, viz.:-

LAW DEPARTMENT.

Commissioners for Taking Declarations, &c.

RAYMOND FREDERICK PARKER, and
 THOMAS KEVIN KELLY,
 as Commissioners for Taking Declarations and Affidavits, pursuant to the provisions of the Evidence Act 1958.

Justices of the Peace.

PATRICK JOHN KENNELLY,
MARK HENRY FORSYTH,
EDGAR THOMAS VIVIAN ELLIS, and
FRANK EDWARD STRAUSS,
from the Commission of the Peace for the State
of Victoria.

J. ROSSITER,
Clerk of the Executive Council.

At the Executive Council Chamber,
Melbourne, 22nd April, 1970.

ORDERS IN COUNCIL

THE CONSTITUTION ACT AMENDMENT ACT 1958.

At the Executive Council Chamber, Melbourne, the
twenty-second day of April, 1970.

PRESENT:

The Lieutenant-Governor as Deputy for His Excellency
the Governor of Victoria.

Mr. Reid | Mr. Manson.

ALTERATION OF APPOINTMENT OF POLLING PLACE.

WHEREAS by Orders in Council made on the twenty-fourth day of March, 1970, and published in the *Victoria Government Gazette* on the twenty-fifth day of March, 1970, polling places were appointed for the Subdivisions of Electoral Provinces and for the Subdivisions of Electoral Districts:

And whereas the Chief Electoral Officer has certified in writing that it is necessary to alter the appointment of the Bentleigh South East polling place:

Now therefore, the Lieutenant-Governor as Deputy for His Excellency the Governor of the State of Victoria, by and with the advice of the Executive Council thereof, doth by this Order revoke the appointment of Bentleigh South East as a polling place within and for the Bentleigh Sub-division of the Higinbotham Province and of the Electoral District of Bentleigh, and doth appoint Bentleigh South East as a polling place within and for the Bentleigh East Sub-division of the Higinbotham Province and of the Electoral District of Bentleigh.

And the Honorable Sir Arthur Gordon Rylah, Her Majesty's Chief Secretary for the State of Victoria, shall give the necessary directions herein accordingly.

J. ROSSITER,
Clerk of the Executive Council.

LANDLORD AND TENANT ACT 1958.

At the Executive Council Chamber, Melbourne, the
twenty-second day of April, 1970.

PRESENT:

The Lieutenant-Governor as Deputy for His Excellency
the Governor of Victoria.

Mr. Reid | Mr. Manson.

ORDER EXCLUDING CERTAIN PREMISES FROM THE OPERATION OF CERTAIN OF THE PROVISIONS CONTAINED IN PART V. OF THE LANDLORD AND TENANT ACT 1958.

IN pursuance of the powers conferred upon him by the *Landlord and Tenant Act 1958*, the Lieutenant-Governor as Deputy for His Excellency the Governor of the State of Victoria, by and with the advice of the Executive Council thereof, doth hereby declare that the premises known as Number 38 Brooke-street, South Melbourne, and Number 40 Perry-street, Alphington, shall be excluded from the operation of the whole of the provisions contained in Divisions 2 and 3 of Part V. of the *Landlord and Tenant Act 1958*.

And the Honorable George Oswald Reid, Her Majesty's Attorney-General in and for the State of Victoria, shall give the necessary directions herein accordingly.

J. ROSSITER,
Clerk of the Executive Council.

LANDLORD AND TENANT ACT 1958.

At the Executive Council Chamber, Melbourne, the
twenty-second day of April, 1970.

PRESENT:

The Lieutenant-Governor as Deputy for His Excellency
the Governor of Victoria.

Mr. Reid | Mr. Manson.

ORDER EXTENDING APPLICATION OF PART V. OF THE LANDLORD AND TENANT ACT 1958 TO CERTAIN PREMISES.

IN pursuance of the powers conferred by section 44 of the *Landlord and Tenant Act 1958*, the Lieutenant-Governor as Deputy for the Governor of the State of Victoria, by and with the advice of the Executive Council thereof, doth hereby declare that the application of Part V. of the *Landlord and Tenant Act 1958* shall extend to the following:—

The premises known as Number 9 Albert-street, Moonee Ponds.

And the Honorable George Oswald Reid, Her Majesty's Attorney-General in and for the State of Victoria, shall give the necessary directions herein accordingly.

J. ROSSITER,
Clerk of the Executive Council.

Railways Act 1958 (No. 6355).
VICTORIAN RAILWAYS.

At the Executive Council Chamber, Melbourne, the
twenty-second day of April, 1970.

PRESENT:

The Lieutenant-Governor as Deputy for His Excellency
the Governor of Victoria.

Mr. Reid | Mr. Manson.

APPOINTMENT OF VICTORIAN RAILWAYS COMMISSIONER.

IN pursuance of the powers in that behalf, conferred by the *Railways Act 1958*, the Lieutenant-Governor as Deputy for His Excellency the Governor of the State of Victoria, by and with the advice of the Executive Council thereof, doth by this order hereby appoint Leslie Arthur Reynolds, as a Victorian Railways Commissioner, as from and including the twenty-fourth day of April, 1970, until the twenty-third day of October, 1970.

And the Honorable Vernon Francis Wilcox, Her Majesty's Minister of Transport for the State of Victoria, shall give the necessary directions herein accordingly.

J. ROSSITER,
Clerk of the Executive Council.

STATE ELECTRICITY COMMISSION ACT 1958, No. 6377.

At the Executive Council Chamber, Melbourne, the
twenty-second day of April, 1970.

PRESENT:

The Lieutenant-Governor as Deputy for His Excellency
the Governor of Victoria.

Mr. Reid | Mr. Manson.

WHEREAS the Lieutenant-Governor as Deputy for His Excellency the Governor of the State of Victoria by and with the advice of the Executive Council thereof has this day consented pursuant to the provisions of the *State Electricity Commission Act 1958* to the State Electricity Commission of Victoria raising by way of a loan the sum of Four hundred and five thousand one hundred dollars (\$405,100); And whereas the Lieutenant-Governor as Deputy for His Excellency the Governor is satisfied that a sufficient proportion of the loan to be raised will fall due and be repaid in each year during the currency of the proposed loan; Now therefore it is directed pursuant to the provisions of section 91 (3) of the said Act, that it shall not be necessary to provide a sinking fund in connexion with such loan.

And the Honorable Sir Henry Edward Bolte, Her Majesty's Treasurer for the State of Victoria, shall give the necessary directions herein accordingly.

J. ROSSITER,
Clerk of the Executive Council.

COUNTRY ROADS BOARD.

At the Executive Council Chamber, Melbourne, the twenty-second day of April, 1970.

PRESENT:

The Lieutenant-Governor as Deputy for His Excellency the Governor of Victoria.

Mr. Reid | Mr. Manson.

ORDER APPROVING OF LAND BEING ACQUIRED AND ROADS, DEVIATIONS OR WIDENINGS BEING MADE.

THE Lieutenant-Governor as Deputy for His Excellency the Governor of the State of Victoria, by and with the advice of the Executive Council thereof, being satisfied that there are funds legally available for acquiring the land, doth hereby approve the acquiring of the land described in the Schedule hereunder and the making of new roads and deviations from and widenings of existing roads referred to in the said Schedule.

SCHEDULE. State Highways.

The land shown hatched on Plans numbered G.P.12067, G.P.12068 and G.P.12069 hereunder required for the deviation from the Midland Highway in the Shire of Daylesford and Glenlyon and making of the deviation thereon.

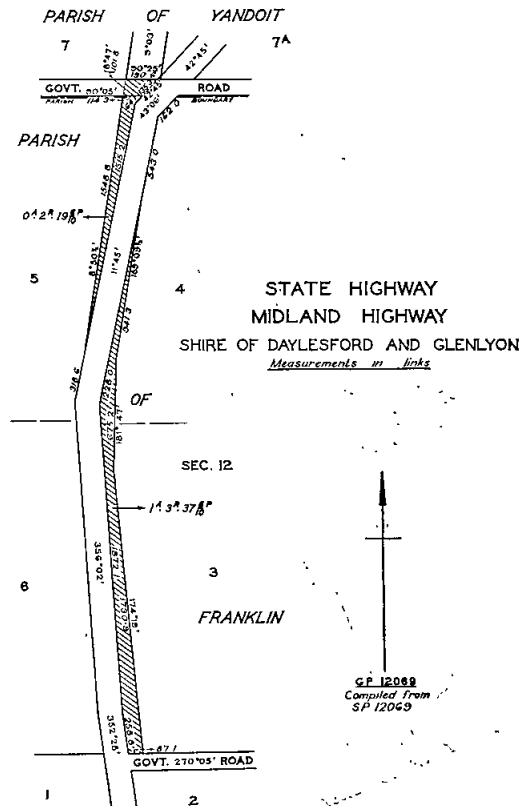
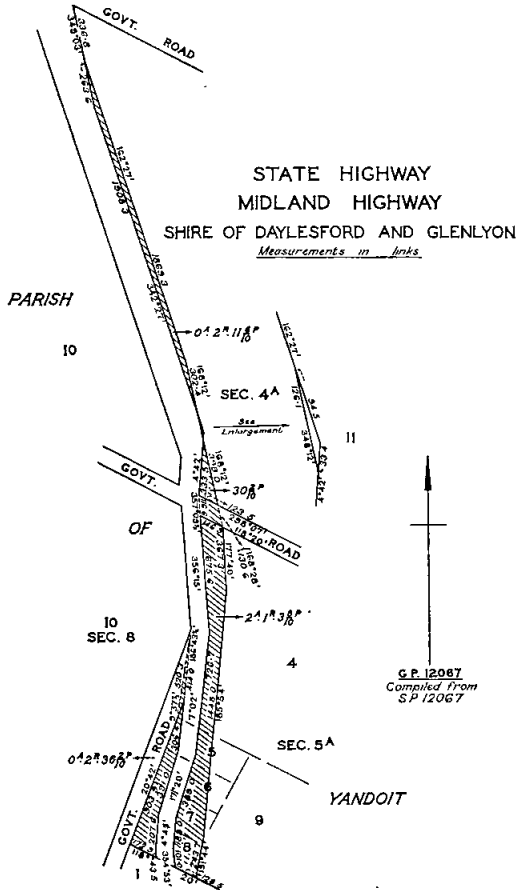
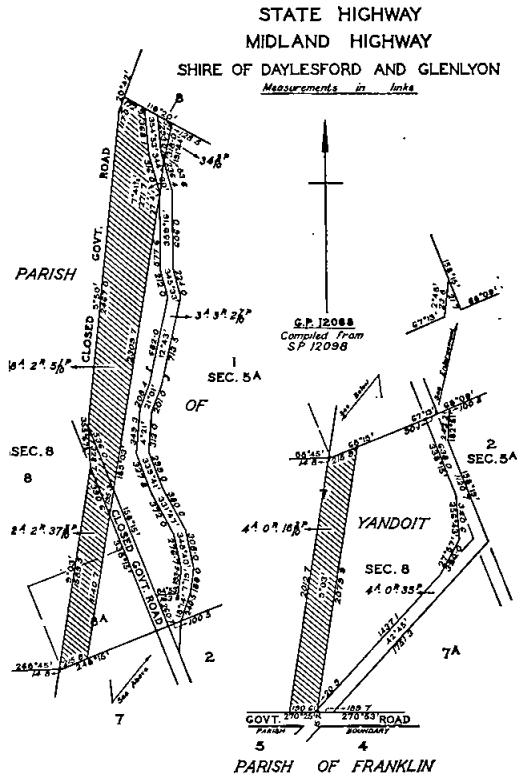

The land shown hatched on Plan numbered G.P.11941 hereunder required for the widening of the Murray Valley Highway in the City of Echuca and making of the widening thereon.

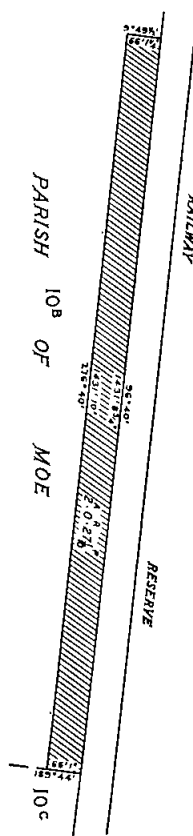
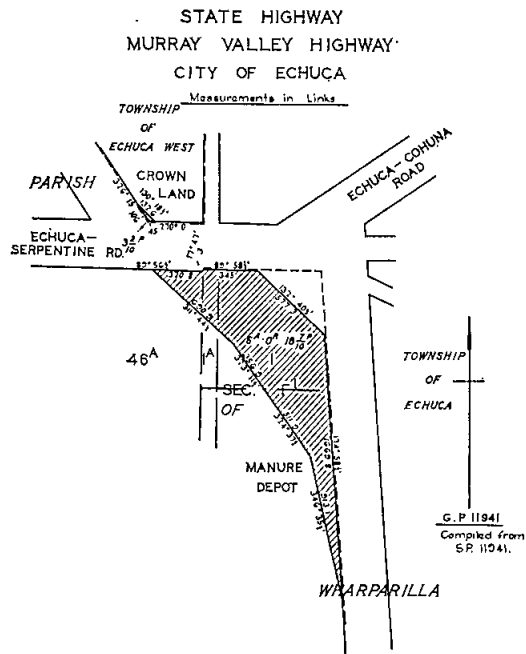

G.P. 6444
Compiled From
S.P. 6444

The land shown hatched on Plans numbered G.P.6442, G.P.6444, G.P.6445A and G.P.6445B hereunder required for the widening of the Princes Highway in the Shires of Warragul and Narracan and making of the widening thereon.

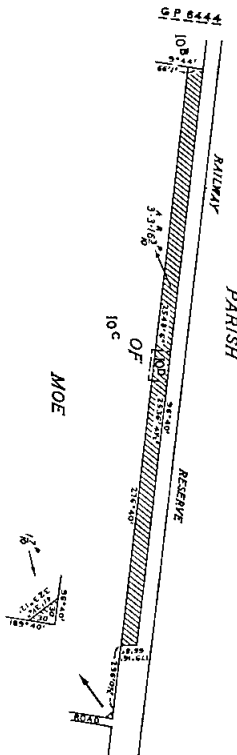
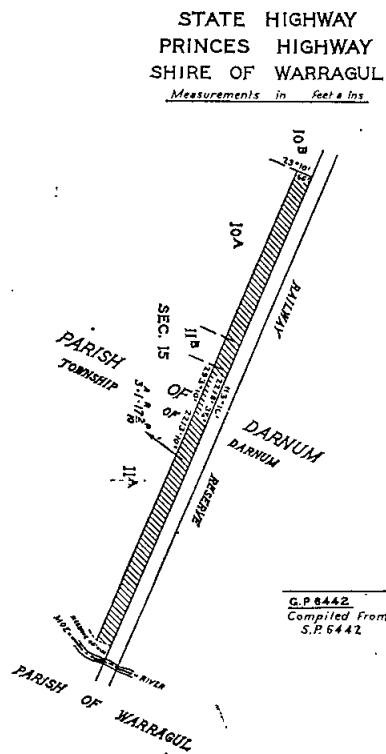

G.P. 6444A
Compiled From
S.P. 6445 & 6444

STATE HIGHWAY
 PRINCES HIGHWAY
 SHIRE OF NARRACAN
Measurements in feet & ins.

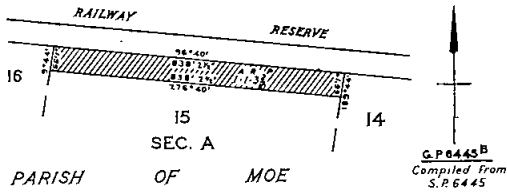

Main Roads.

The land shown hatched on Plan numbered G.P.12152 hereunder required for the widening of Dorset-road in the City of Knox and making of the widening thereon.

MAIN ROAD
 DORSET ROAD
 CITY OF KNOX
Measurements in feet & ins.

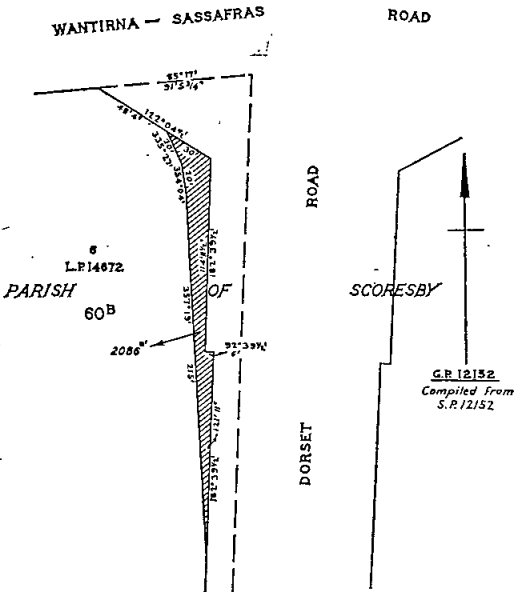

The land shown hatched on Plans numbered G.P.12051, G.P.12052 and G.P.12053 hereunder required for the widening of Birregurra-road in the Shire of Winchelsea and making of the widening thereon.

MAIN ROAD
 BIRREGURRA ROAD
 SHIRE OF WINCHELSEA
Measurements in Links

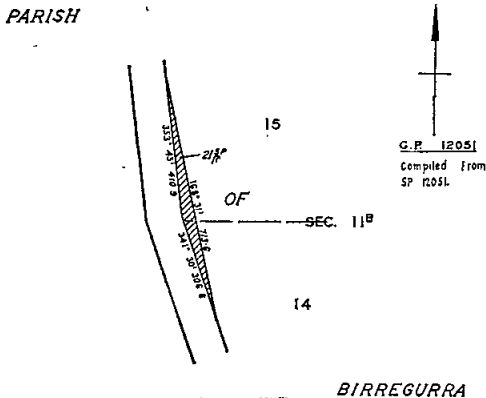

MAIN ROAD
 BIRREGURRA ROAD
 SHIRE OF WINCHELSEA
Measurements in Links

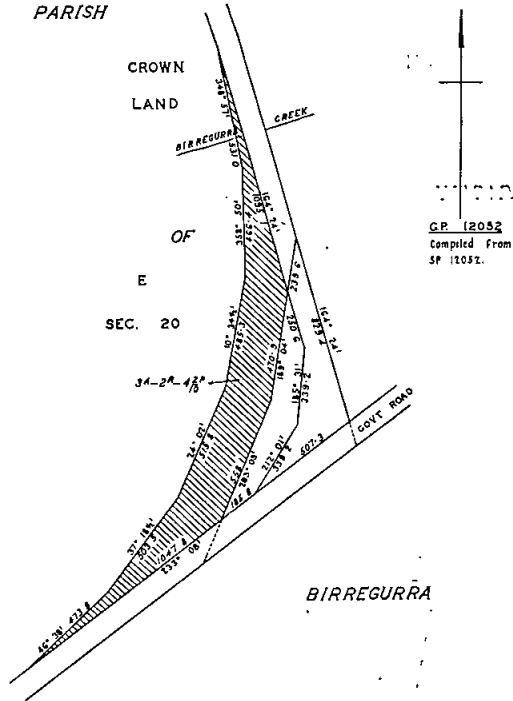

MAIN ROAD
 BIRREGURRA ROAD
 SHIRE OF WINCHELSEA
Measurements in Links

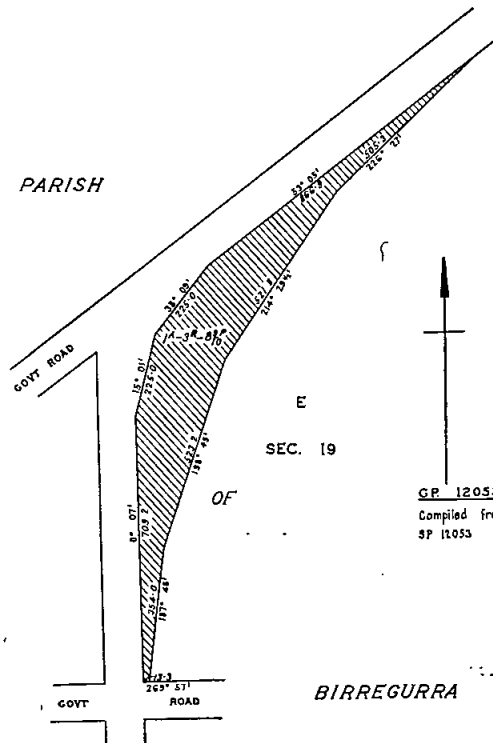

The land shown hatched on Plan numbered G.P.12041 hereunder required for the deviation from Falls-road in the Shire of South Gippsland and making of the deviation thereon.

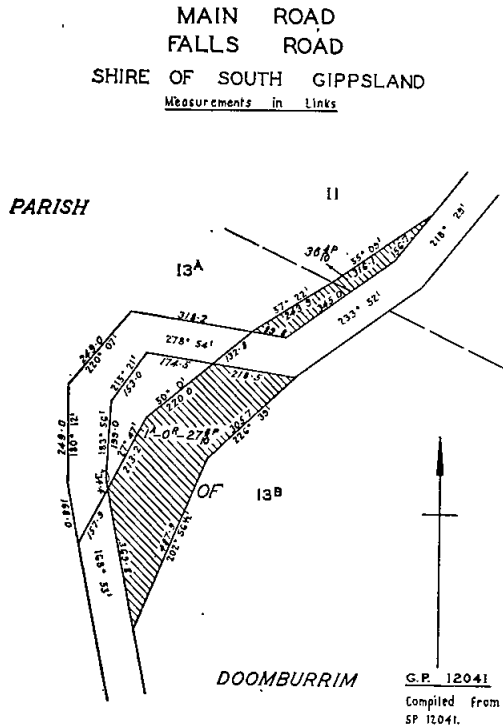

And the Honorable Rupert James Hamer, Her Majesty's Minister of Public Works for the State of Victoria, shall give the necessary directions herein accordingly.

J. ROSSITER,
Clerk of the Executive Council.

COUNTRY ROADS BOARD.

At the Executive Council Chamber, Melbourne, the twenty-second day of April, 1970.

PRESENT:

The Lieutenant-Governor as Deputy for His Excellency the Governor of Victoria.

Mr. Reid | Mr. Manson.

ORDER APPROVING OF LAND BEING ACQUIRED AND A ROAD, DEVIATION OR WIDENING BEING MADE.

THE Lieutenant-Governor as Deputy for His Excellency the Governor of the State of Victoria, by and with the advice of the Executive Council thereof, being satisfied that there are funds legally available for acquiring the land, doth hereby approve the acquiring of the land described in the Schedule hereunder and the making of a new road and deviation from and widening of existing road referred to in the said Schedule.

SCHEDULE.

State Highway.

The land shown hatched on Plan numbered G.P.12105 hereunder required for the widening of the Princes Highway in the Shire of Bairnsdale and making of the widening thereon.

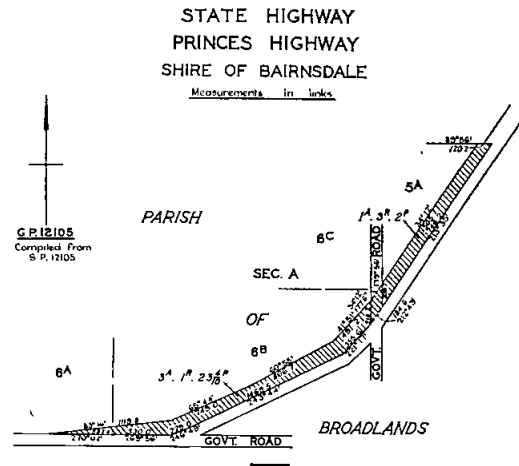

And the Honorable Rupert James Hamer, Her Majesty's Minister of Public Works for the State of Victoria, shall give the necessary directions herein accordingly.

J. ROSSITER,
Clerk of the Executive Council.

DEPARTMENT OF CROWN LANDS AND SURVEY.

At the Executive Council Chamber, Melbourne, the twenty-second day of April, 1970.

PRESENT:

The Lieutenant-Governor as Deputy for His Excellency the Governor of Victoria.

Mr. Reid | Mr. Manson.

LANDS TEMPORARILY RESERVED AS SITES.

THE Lieutenant-Governor as Deputy for His Excellency the Governor of the State of Victoria, by and with the advice of the Executive Council thereof, doth hereby, in pursuance of section 14 of the Land Act 1958, reserve temporarily from sale, from being leased and from having a licence granted in respect thereof, and also except from occupation for mining purposes under any miner's right, the land hereinafter described:—

NILLAHCOOTE.—Site for Water Supply purposes, 9 acres 1 rood 11 perches, Parish of Nillahcoote, County of Delatite, as indicated by hatching on plan hereunder.—(N.83⁽³⁾) (Rs.9283).

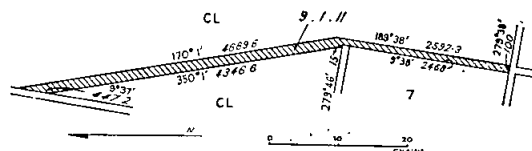

WARRANTYTE (CROYDON).—Site for Public Park, 3 acres, Parish of Warrandyte, County of Evelyn, as indicated by hatching on plan hereunder.—(W.26⁽³⁾) (Rs.9250).

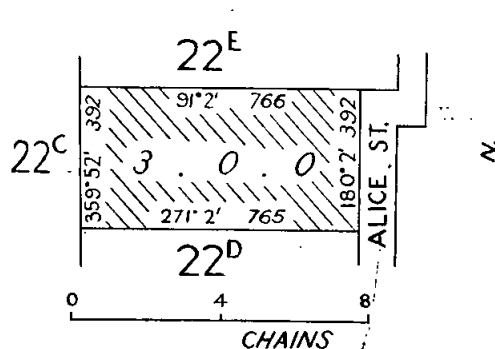

TALLYGAROPNA.—Site for Water Supply purposes, 10 acres 3 roods 35 perches, Parish of Tallygaropna, County of Moira, as indicated by hatching on plan hereunder.—(T.234⁽³⁾) (Rs.9279).

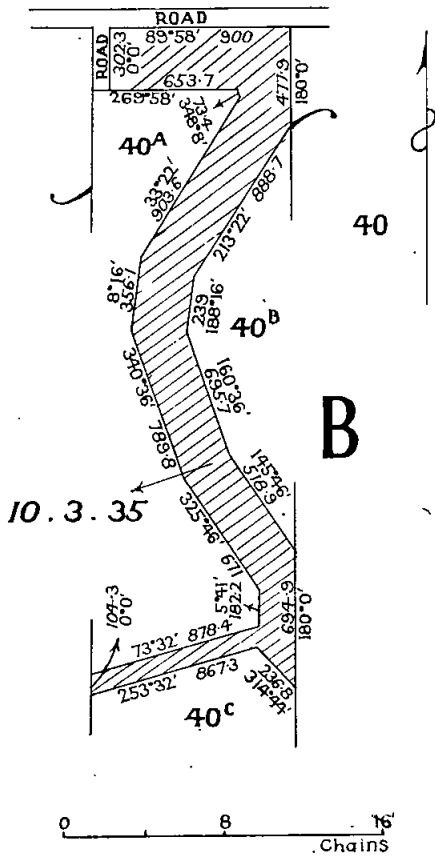

SANDHURST (AT EAGLEHAWK).—Site for Public Purposes (Homes for the Aged), 7 acres 3 roods 14 perches, at Eaglehawk, Parish of Sandhurst, County of Bendigo, as indicated by hatching on plan hereunder.—(S.371⁽²⁷⁾) (Rs.8874).

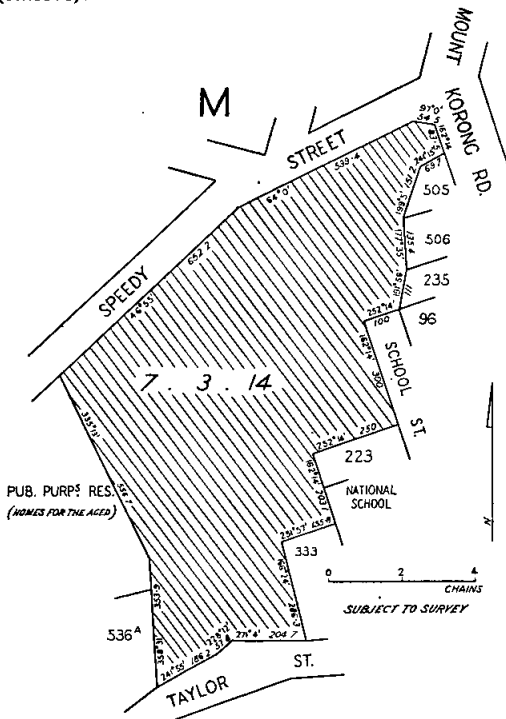

At Eaglehawk
Parish of Sandhurst
County of Bendigo

MERBEIN.—Site for Public Recreation, 48 acres 3 roods 3 perches, Parish of Merbein, County of Karkaroc, as indicated by hatching on plan hereunder.—(M.572⁽⁹⁾) (Rs.9285).

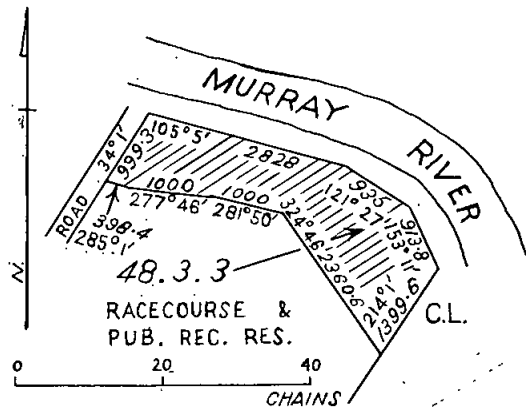

MOOROODUC (MOUNT MARTHA).—Site for Water Supply purposes, 1 rood 33 perches, Parish of Moorooduc, County of Mornington, as indicated by hatching on plan hereunder.—(M.161⁽⁹⁾) (Rs.9304).

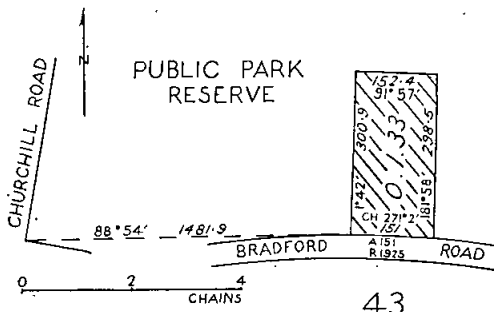

MELBOURNE (CITY).—Site for Public purposes (Public and Government Buildings and Car Park), 2 acres 1 rood 21 perches, City of Melbourne, Parish of Melbourne North, County of Bourke, as indicated by hatching on plan hereunder.—(M.314⁽¹⁰⁾) (Rs.1019).

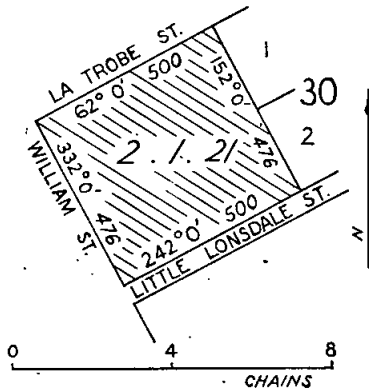

And the Honorable Sir William John Farquhar McDonald, Her Majesty's Minister of Lands for the State of Victoria, shall give the necessary directions herein accordingly.

J. ROSSITER,
Clerk of the Executive Council.

DEPARTMENT OF CROWN LANDS AND SURVEY.

At the Executive Council Chamber, Melbourne, the twenty-second day of April, 1970.

PRESENT:

The Lieutenant-Governor as Deputy for His Excellency the Governor of Victoria.

Mr. Reid | Mr. Manson.

UNUSED ROADS CLOSED.

THE Lieutenant-Governor as Deputy for His Excellency the Governor of the State of Victoria, by and with the advice of the Executive Council thereof, doth hereby direct that, in pursuance of the provisions of section 349 of the Land Act 1958, the unused roads referred to hereunder be closed, viz.:—

Parish of Carina, County of Weeah, being the road indicated by hatching on plan hereunder.—(C.477⁽⁶⁾) (M.61050).

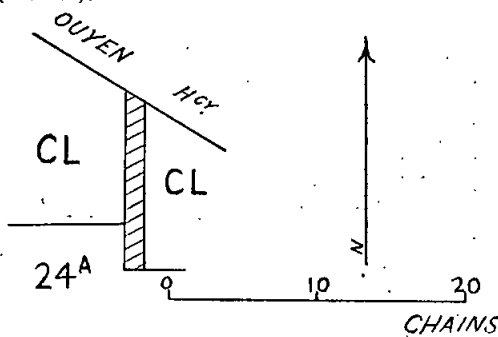

Township of Bullarto South, Parish of Bullarto, County of Talbot, being the road between the land temporarily reserved as a site for a State School, by Order in Council of the 27th July, 1885, and allotment 11, section 12.—(B.645^(D2)) (W.89508).

Parish of Killingworth, County of Anglesey, being the portion of the width of the road indicated by hatching on plan hereunder.—(K.55⁽²⁾) (Rs.428).

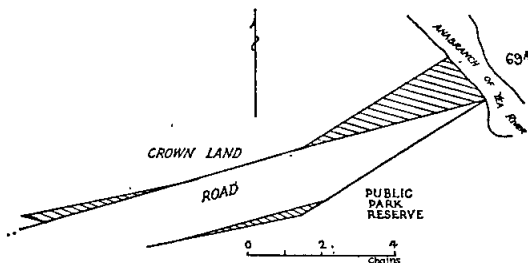

Township of Spring Hill, Parish of Coliban, County of Talbot, being the road indicated by hatching on plan hereunder.—(C.252⁽³⁾) (W.87687).

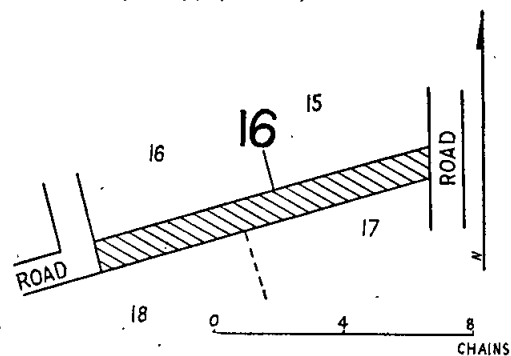

And the Honorable Sir William John Farquhar McDonald, Her Majesty's Minister of Lands for the State of Victoria, shall give the necessary directions herein accordingly.

J. ROSSITER,
Clerk of the Executive Council.

DEPARTMENT OF CROWN LANDS AND SURVEY.

At the Executive Council Chamber, Melbourne, the twenty-second day of April, 1970.

PRESENT:

The Lieutenant-Governor as Deputy for His Excellency the Governor of Victoria.

Mr. Reid | Mr. Manson.

LAND TEMPORARILY RESERVED FOR AN ADDITIONAL PURPOSE.

THE Lieutenant-Governor as Deputy for His Excellency the Governor of the State of Victoria, by and with the advice of the Executive Council thereof, doth hereby, in pursuance of the provisions of the Land Act 1958, reserve, temporarily, the land hereinafter described for an additional purpose:—

MOUZIE.—1 acre 4 perches, Parish of Mouzie, County of Normanby, being the site temporarily reserved for a public Hall, by Order in Council, 22nd June, 1954, is hereby temporarily reserved for the additional purpose of Public Recreation.—(M.513⁽⁶⁾) (Rs.7273).

And the Honorable Sir William John Farquhar McDonald, Her Majesty's Minister of Lands for the State of Victoria, shall give the necessary directions herein accordingly.

J. ROSSITER,
Clerk of the Executive Council.

DEPARTMENT OF CROWN LANDS AND SURVEY.

At the Executive Council Chamber, Melbourne, the twenty-second day of April, 1970.

PRESENT:

The Lieutenant-Governor as Deputy for His Excellency the Governor of Victoria.

Mr. Reid | Mr. Manson.

REVOCATION OF TEMPORARY RESERVATION OF LAND BY ORDER IN COUNCIL.

THE Lieutenant-Governor as Deputy for His Excellency the Governor of the State of Victoria, by and with the advice of the Executive Council thereof, doth hereby, in pursuance of the provisions of the Land Act 1958, revoke the temporary reservation of land by Order in Council hereinafter referred to, viz.:—

BARKLY.—Order in Council of 11th February, 1941, of 3 acres of land in the Parish of Barkly, as a site for Public Recreation and Plantation purposes.—(Rs.3629.)

OUYEN.—Order in Council of 26th October, 1926, of 4 acres 1 rood 26 perches of land in the Township of Ouyen, as a site for a Children's Playground.—(Rs.3238.)

PANYYABYR.—Order in Council of 23rd July, 1957, of 40 acres of land in the Parish of Panyabyr, as a site for Public Recreation.—(Rs.7654.)

SALE.—Order in Council of 14th June, 1967, of 30 acres more or less of land in the Township of Sale, as a site for Public Recreation.—(Rs.4096.)

STAWELL.—Order in Council of the 30th August, 1869, of 2 roods of land in the Township of Stawell, as a site for Police purposes.—(Rs.2884.)

STAWELL.—Order in Council of the 15th July, 1947, of 1 rood 16/10 perches of land in the Township of Stawell, as a site for Police purposes (revoked as to part by Order of the 9th December, 1947) so far only as the balance thereof containing 20 8/10 perches, more or less, is concerned.—(Rs.2884.)

WAHRING.—Order in Council of 1st December, 1873, of 2 acres 0 roods 5 perches of land in the Parish of Warring, as a site for State School purposes.—(C.95779.)

WEDDERBURN.—Order in Council of the 20th January, 1919, of 2 acres 2 roods 16 perches of land in the Township of Wedderburn, as a site for the Supply of Gravel (revoked as to part by Order of the 11th March, 1947) so far as the balance thereof containing 3 roods 12 8/10 perches is concerned.—(Rs.1884.)

WEDDERBURN.—Order in Council of 28th January, 1947, of 1 rood 12 4/10 perches of land in the Township of Wedderburn as a site for Supply of Gravel.—(Rs.1884.)

WEDDERBURN.—Order in Council of 20th August, 1894, of 1 acre 3 roods 14 4/10 perches of land in the Township of Wedderburn, as a site for Water Supply purposes.—(Rs.6018.)

WERRIKOO.—Order in Council of the 24th March, 1903, of 351 acres 2 roods 29 perches of land in the Parishes of Werrikoo and Wilkin (now the Parish of Werrikoo) as a site for Water Supply, Camping and Road purposes (revoked as to part by Order of 26th August, 1941), so far as the balance thereof, containing 351 acres 30 perches.—(Rs.622.)

KANGAROO FLAT.—Order in Council of 16th October, 1956, of 1 acre 1 rood 17 perches of land in the Township of Kangaroo Flat, as a site for Public Recreation, so far only as regards the portion thereof comprised within the boundaries published in the *Government Gazette* of 11th March, 1970, and containing 3 roods.—(Rs.3893.)

NEWMERELLA.—Order in Council of 18th July, 1927, of 103 acres 1 rood 25 perches of land in the Parish of Newmerella as a site for a Racecourse and Public Recreation so far only as regards the portion thereof comprised within the boundaries published in the *Government Gazette* of 11th March, 1970, and containing 3 acres 1 rood 15 perches.—(Rs.3519.)

SANDHURST (AT BENDIGO).—Order in Council of the 10th July, 1917, of 77 acres 3 roods of land in the Parish of Sandhurst (at Bendigo), as a site for Supply of Gravel so far only as regards the portion thereof comprised within the boundaries published in the *Government Gazette* of the 25th March, 1970, and containing 15 perches.—(Rs.3837.)

And the Honorable Sir William John Farquhar McDonald, Her Majesty's Minister of Lands for the State of Victoria, shall give the necessary directions herein accordingly.

J. ROSSITER,
Clerk of the Executive Council.

ROAD TRAFFIC ACT 1958.

At the Executive Council Chamber, Melbourne, the twenty-second day of April, 1970.

PRESENT:

The Lieutenant-Governor as Deputy for His Excellency the Governor of Victoria.

Mr. Reid | Mr. Manson.

IN pursuance of the powers conferred by the Road Traffic Act 1958, the Lieutenant-Governor as Deputy for His Excellency the Governor of the State of Victoria, in the Commonwealth of Australia, by and with the advice of the Executive Council of the said State, and at the request in writing of the Council of the City of Warrnambool, doth by this Order extend the provisions of the said Act to the following land under the control of the City of Warrnambool.

"Warrnambool Municipal Saleyards", being that area of land bounded by Caramut-road, Coghlan's-road and Rooney's-road in the Parish of Wangoom, County of Villiers, being Crown allotment 33.

And the Honorable Sir Arthur Gordon Rylah, Her Majesty's Chief Secretary for the State of Victoria, shall give the necessary directions herein accordingly.

J. ROSSITER,
Clerk of the Executive Council.

ROAD TRAFFIC ACT 1958.

At the Executive Council Chamber, Melbourne, the twenty-second day of April, 1970.

PRESENT:

The Lieutenant-Governor as Deputy for His Excellency the Governor of Victoria.

Mr. Reid | Mr. Manson.

IN pursuance of the powers conferred by the Road Traffic Act 1958, the Lieutenant-Governor as Deputy for His Excellency the Governor of the State of Victoria, in the Commonwealth of Australia, by and with the advice of the Executive Council of the said State, and at the request in

writing of the Council of the City of Caulfield, doth by this Order extend the provisions of the said Act to the following land under the control of the City of Caulfield.

All the land shown hachured on the Plan hereunder, adjoining the Town Hall, Caulfield, at the corner of Glen Eira and Hawthorn roads and the corner of Glen Eira-road and Hartley-avenue, Caulfield.

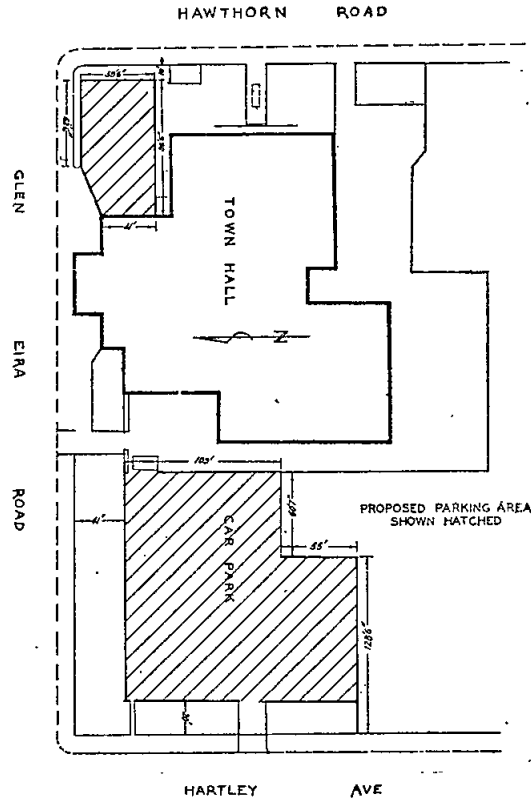

And the Honorable Sir Arthur Gordon Rylah, Her Majesty's Chief Secretary for the State of Victoria, shall give the necessary directions herein accordingly.

J. ROSSITER,
Clerk of the Executive Council.

ROAD TRAFFIC ACT 1958.

At the Executive Council Chamber, Melbourne, the twenty-second day of April, 1970.

PRESENT:

The Lieutenant-Governor as Deputy for His Excellency the Governor of Victoria.

Mr. Reid | Mr. Manson.

IN pursuance of the powers conferred by the Road Traffic Act 1958, the Lieutenant-Governor as Deputy for His Excellency the Governor of the State of Victoria, in the Commonwealth of Australia, by and with the advice of the Executive Council of the said State, and at the request in writing of the Council of the City of Springvale, doth by this Order extend the provisions of the said Act to the following land under the control of the City of Springvale.

All that land shown hachured on the Plan hereunder, being part lot 1 and part lot 2, L.P.17182; lot 2, L.P.55864; part lot 2, L.P.4817; Lot 2, L.P.24120; and part lot 1, L.P.4817.

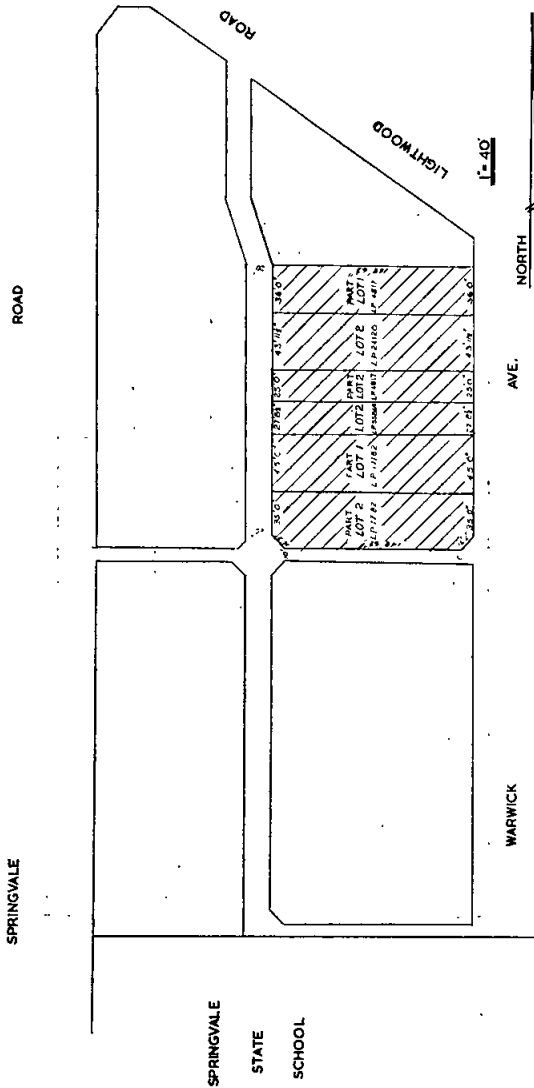

And the Honorable Sir Arthur Gordon Rylah, Her Majesty's Chief Secretary for the State of Victoria, shall give the necessary directions herein accordingly.

J. ROSSITER,
Clerk of the Executive Council.

ROAD TRAFFIC ACT 1958.

At the Executive Council Chamber, Melbourne, the twenty-second day of April, 1970.

PRESENT:

The Lieutenant-Governor as Deputy for His Excellency the Governor of Victoria.

Mr. Reid | Mr. Manson.

IN pursuance of the powers conferred by the Road Traffic Act 1958, the Lieutenant-Governor as Deputy for His Excellency the Governor of the State of Victoria, in the Commonwealth of Australia, by and with the advice of the Executive Council of the said State, and at the request in writing of the Council of the City of Melbourne, doth by this Order extend the provisions of the said Act to the following land under the control of the City of Melbourne.

All that land shown hachured on the Plan hereunder. (Plan 6D.9956.)

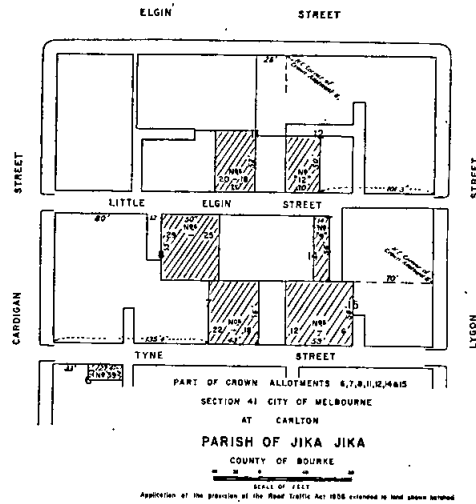

And the Honorable Sir Arthur Gordon Rylah, Her Majesty's Chief Secretary for the State of Victoria, shall give the necessary directions herein accordingly.

J. ROSSITER,
Clerk of the Executive Council.

LABOUR AND INDUSTRY ACT 1958.

At the Executive Council Chamber, Melbourne, the twenty-second day of April, 1970.

PRESENT:

The Lieutenant-Governor as Deputy for His Excellency the Governor of Victoria.

Mr. Reid | Mr. Manson.

VARIATION OF POWERS OF THE WOODWORKERS BOARD.

IN pursuance of the powers conferred by the Labour and Industry Act 1958, the Lieutenant-Governor as Deputy for His Excellency the Governor of the State of Victoria, by and with the advice of the Executive Council thereof, doth hereby vary the powers of the Woodworkers Board so that in substitution for the powers heretofore conferred on the said Woodworkers Board it shall have the power to determine any industrial matter in relation to the following trades, viz.:-

- (a) box-making;
- (b) stacking, sorting, loading or unloading sawn, hewn or split timber or logs;
- (c) the work of a sawmill, timber-yard, timber seasoning plant, box factory or joiners' workshop (other than the work of carpenters or joiners);
- (d) building tramways for the conveyance of logs or timber;
- (e) felling, hewing or splitting timber;
- (f) conveying timber to a sawmill when done by forest workers;
- (g) conveying timber from a sawmill by tramway;
- (h) making articles of wood not under the jurisdiction of any Wages Board heretofore appointed—

but excluding any occupation subject to the Agricultural Implements Board, the Carpenters Board, the Fuel and Fodder Board or the Furniture Board, or any occupation in connexion with ship or boat building, or the erection of bridges, wharfs or similar structures.

And the Honorable John Frederick Rossiter, Her Majesty's Minister of Labour and Industry for the State of Victoria, shall give the necessary directions herein accordingly.

J. ROSSITER,
Clerk of the Executive Council.

LABOUR AND INDUSTRY ACT 1958.

At the Executive Council Chamber, Melbourne, the twenty-second day of April, 1970.

PRESENT:

The Lieutenant-Governor as Deputy for His Excellency the Governor of Victoria.

Mr. Reid | Mr. Manson.

APPOINTMENT OF A HOSPITAL DENTAL OFFICERS BOARD.

IN pursuance of the powers conferred by the Labour and Industry Act 1958, the Lieutenant-Governor as Deputy for His Excellency the Governor of the State of Victoria, by and with the advice of the Executive Council thereof, doth hereby—

- (a) declare that it is expedient to appoint and doth hereby appoint a Wages Board for the occupation of a dentist employed by a public hospital;
(b) order that such Wages Board shall consist of four members and a Chairman;
(c) direct that such Wages Board may be described for all purposes as the "Hospitals Dental Officers Board"; and
(d) define the area within which the determination of such Wages Board shall be operative as the whole of the State of Victoria.

And the Honorable John Frederick Rossiter, Her Majesty's Minister of Labour and Industry for the State of Victoria, shall give the necessary directions herein accordingly.

J. ROSSITER, Clerk of the Executive Council.

VICTORIAN INLAND MEAT AUTHORITY ACT 1958.

At the Executive Council Chamber, Melbourne, the twenty-second day of April, 1970.

PRESENT:

The Lieutenant-Governor as Deputy for His Excellency the Governor of Victoria.

Mr. Reid | Mr. Manson.

APPOINTMENT OF MEMBERS AND CHAIRMAN OF THE VICTORIAN INLAND MEAT AUTHORITY.

IN pursuance of the powers in that behalf conferred by the Victorian Inland Meat Authority Act 1958 and all other powers him thereunto enabling, the Lieutenant-Governor as Deputy for His Excellency the Governor of the State of Victoria, by and with the advice of the Executive Council thereof, doth by this Order hereby appoint—

The Honorable SIR NORMAN MARTIN, to be a member and Chairman of the Victorian Inland Meat Authority; and

GEORGE PRITCHARD HARVEY WILSON, and CYRIL JOHN WATSON, to be members of the said Authority for a period of three (3) years from and inclusive of the 24th April, 1970.

And the Honorable Gilbert Lawrence Chandler, Her Majesty's Minister of Agriculture for the State of Victoria, shall give the necessary directions herein accordingly.

J. ROSSITER, Clerk of the Executive Council.

LOCAL GOVERNMENT DEPARTMENT.

At the Executive Council Chamber, Melbourne, the twenty-second day of April, 1970.

PRESENT:

The Lieutenant-Governor as Deputy for His Excellency the Governor of Victoria.

Mr. Reid | Mr. Manson.

ROADS DISCONTINUED—CITY OF SUNSHINE.

WHEREAS it is provided in section 528 (2) of the Local Government Act 1958, that where a road (whether or not a public highway but not being a road set out on land of the Crown) or any part thereof is not required for public use, the Governor in Council, on the request of the Council of the municipality in which such road is situated made not less than one month after publishing in a newspaper generally circulating in the district and posting to the registered proprietor (if any) of the land and the owners and occupiers (if any) of lands abutting or immediately adjacent to the road notice of intention to make such a request may by Order published in the Government Gazette direct that such road or part shall be discontinued and thereupon such road or part shall be discontinued accordingly.

And whereas the Council of the City of Sunshine has requested that the Governor in Council direct that portions of Ayton-street, Rothray, Auburn and Elwood avenues Sunshine, be discontinued and not less than one month previously, has published in a newspaper generally circulating in the district and posted to the registered proprietor of the land in the said roads and to the owners and occupiers of lands abutting or immediately adjacent to the roads notice of intention to make such request.

Now therefore, the Lieutenant-Governor as Deputy for His Excellency the Governor of the State of Victoria, by and with the advice of the Executive Council thereof, hereby directs that the said roads which are shown hatched on the plan hereunder shall be discontinued and that the lands may be sold by the Council of the City of Sunshine by agreement.

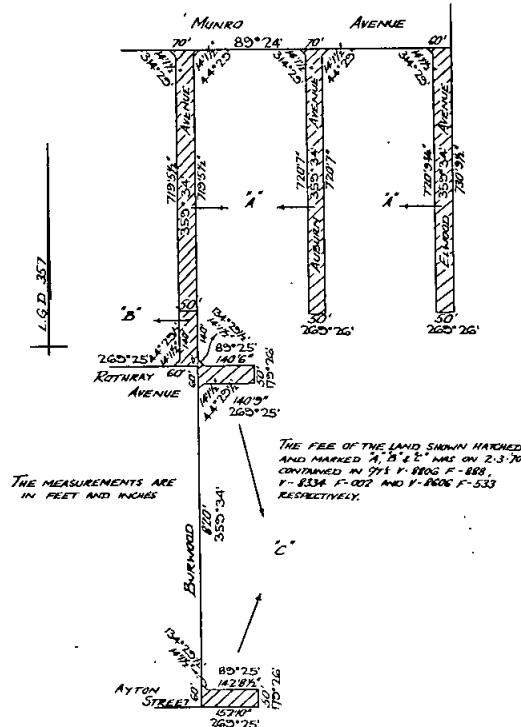

And the Honorable Rupert James Hamer, Her Majesty's Minister for Local Government for the State of Victoria, shall give the necessary directions herein accordingly.

J. ROSSITER, Clerk of the Executive Council.

LOCAL GOVERNMENT DEPARTMENT.

LOCAL GOVERNMENT DEPARTMENT.

At the Executive Council Chamber, Melbourne, the twenty-second day of April, 1970.

At the Executive Council Chamber, Melbourne, the twenty-second day of April, 1970.

PRESENT:

PRESENT:

The Lieutenant-Governor as Deputy for His Excellency the Governor of Victoria.

The Lieutenant-Governor as Deputy for His Excellency the Governor of Victoria.

Mr. Reid | Mr. Manson.

Mr. Reid | Mr. Manson.

ROAD DISCONTINUED—SHIRE OF CORIO.

ROAD DISCONTINUED.—CITY OF PRAHRAN.

WHEREAS it is provided in section 528 (2) of the Local Government Act, that where a road (whether or not a public highway but not being a road set out on land of the Crown) or any part thereof is not required for public use the Governor in Council on the request of the Council of the municipality in which such road is situated made not less than one month after publishing in a newspaper generally circulating in the district and posting to the registered proprietor (if any) of the land and the owners and occupiers (if any) of the lands abutting or immediately adjacent to the road notice of intention to make such request may by Order published in the Government Gazette direct that such road or part shall be discontinued and thereupon such road or part shall be discontinued accordingly.

WHEREAS it is provided in section 528 (2) of the Local Government Act, that where a road (whether or not a public highway but not being a road set out on land of the Crown) or any part thereof is not required for public use the Governor in Council on the request of the Council of the municipality in which such road is situated made not less than one month after publishing in a newspaper generally circulating in the district and posting to the registered proprietor (if any) of the land and the owners and occupiers (if any) of the lands abutting or immediately adjacent to the road notice of intention to make such request may by Order published in the Government Gazette direct that such road or part shall be discontinued and thereupon such road or part shall be discontinued accordingly.

And whereas the Council of the Shire of Corio, has requested that the Governor in Council direct that portion of a right-of-way, between Hastie and Braund avenues, North Geelong be discontinued and not less than one month previously has published in a newspaper generally circulating in the district and posted to the registered proprietor of the land in the road and to the owners and occupiers of lands abutting or immediately adjacent to the road notice of intention to make such request.

And whereas the Council of the City of Prahran, has requested that the Governor in Council direct that portion of a right-of-way, off Anchor place, Prahran, be discontinued and not less than one month previously has published in a newspaper generally circulating in the district and posted to the registered proprietor of the land in the road and to the owners and occupiers of lands abutting or immediately adjacent to the road notice of intention to make such request.

Now therefore, the Lieutenant-Governor as Deputy for His Excellency the Governor of the State of Victoria, by and with the advice of the Executive Council, thereof, hereby directs that the said road, which is shown hatched on the plan hereunder shall be discontinued and that the land may be sold by the Council of the Shire of Corio by agreement.

Now therefore, the Lieutenant-Governor as Deputy for His Excellency the Governor of the State of Victoria, by and with the advice of the Executive Council, thereof, hereby directs that the said road, which is shown hatched on the plan hereunder shall be discontinued and that the land may be sold by the Council of the City of Prahran by agreement.

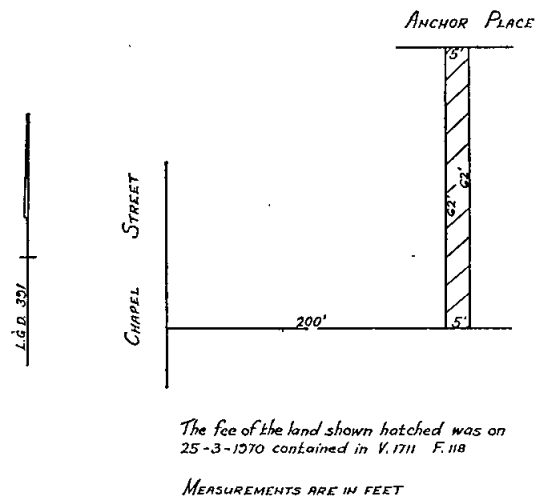
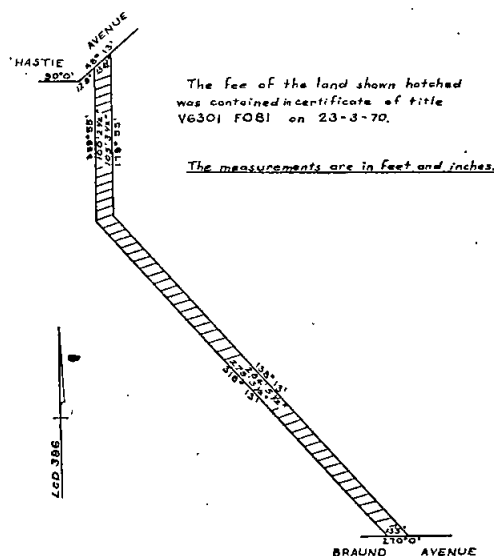

And the Honorable Rupert James Hamer, Her Majesty's Minister for Local Government for the State of Victoria, shall give the necessary directions herein accordingly.

And the Honorable Rupert James Hamer, Her Majesty's Minister for Local Government for the State of Victoria, shall give the necessary directions herein accordingly.

J. ROSSITER, Clerk of the Executive Council.

J. ROSSITER, Clerk of the Executive Council.

LOCAL GOVERNMENT DEPARTMENT.

At the Executive Council Chamber, Melbourne, the twenty-second day of April, 1970.

PRESENT:

The Lieutenant-Governor as Deputy for His Excellency the Governor of Victoria.

Mr. Reid | Mr. Manson.

ROAD DISCONTINUED—SHIRE OF CORIO.

WHEREAS it is provided in section 528 (2) of the Local Government Act 1958, that where a road (whether or not a public highway but not being a road set out on land of the Crown) or any part thereof is not required for public use the Governor in Council on request of the Council of the municipality in which such road is situated made not less than one month after publishing in a newspaper generally circulating in the district and posting to the registered proprietor (if any) of the land and to the owners and occupiers (if any) of the lands abutting or immediately adjacent to the road notice of intention to make such a request may by Order published in the Government Gazette direct that such road or part shall be discontinued and thereupon such road or part shall be discontinued accordingly.

And whereas the Council of the Shire of Corio has requested that the Governor in Council direct that Nicholson-crescent North Geelong, be discontinued and not less than one month previously has published in a newspaper generally circulating in the district and posted to the registered proprietor of the land in the road and to the owners and occupiers of lands abutting or immediately adjacent to the road notice of intention to make such request.

Now therefore, the Lieutenant-Governor as Deputy for His Excellency the Governor of the State of Victoria, by and with the advice of the Executive Council thereof, hereby directs:

- (a) that the said road which is shown by hachure and cross-hachure on the diagram hereunder shall be discontinued.
- (b) that notwithstanding such discontinuance the Geelong Waterworks and Sewerage Trust shall continue to have and possess the same right title power authority or interest in or in relation to the land shown cross-hatched on the said diagram as it had or possessed prior to such discontinuance with respect to or in connexion with any drains or pipes laid or erected in on or over such land for the purposes of drainage or sewerage; and
- (c) that subject to any such right title power authority or interest, the land in the said road may be sold by the Council of the Shire of Corio, by agreement.

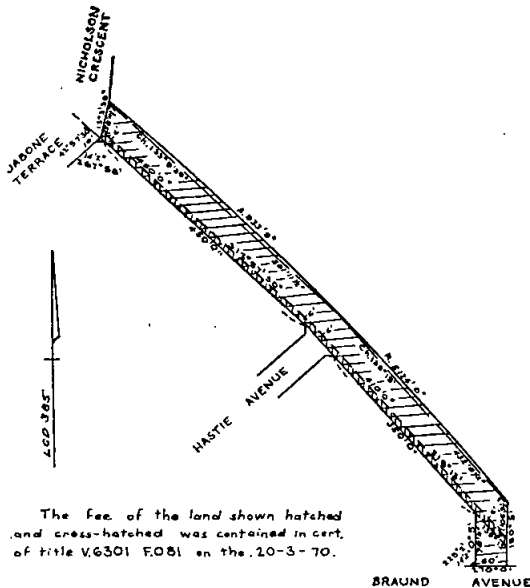

The fee of the land shown hatched and cross-hatched was contained in cert. of title V.6301 F.O.B.I. on the 20-3-70.

The measurements are in feet and inches.

And the Honorable Rupert James Hamer, Her Majesty's Minister for Local Government for the State of Victoria, shall give the necessary directions herein accordingly.

J. ROSSITER,
Clerk of the Executive Council.

BENEFIT ASSOCIATIONS ACT 1958.

At the Executive Council Chamber, Melbourne, the twenty-second day of April, 1970.

PRESENT:

The Lieutenant-Governor as Deputy for His Excellency the Governor of Victoria.

Mr. Reid | Mr. Manson.

ASSOCIATION DECLARED TO BE EXEMPT FROM THE PROVISIONS OF THE ACT.

IN pursuance of the provisions of the Benefit Associations Act 1958, the Lieutenant-Governor as Deputy for His Excellency the Governor of the State of Victoria in the Commonwealth of Australia, by and with the advice of the Executive Council of the said State, after consideration by the Minister of reports in writing made by the Registrar of Sickness, Hospital, Medical and Funeral Benefit Associations, and the Government Statist relative to the proposed exemption of the Post Office Mutual Benefit Society of New South Wales and to the terms and conditions to be imposed, doth by this Order declare the said Association to be exempt from the provisions of the said Act, subject to the following terms and conditions:—

1. That no benefit covered by the definitions of Sickness, or Funeral Benefit business in the Benefit Associations Act 1958 or any amendment thereto, shall be contracted by the Society in respect of persons resident in Victoria.
2. That copies of all published accounts shall be forwarded to the Registrar as soon as they are available.
3. Any information or statistics required by the Government Actuary from time to time shall be made available by the Society.
4. That the Society shall furnish the Registrar with the name and address of the Public Officer of the Society.

And the Honorable Sir Arthur Gordon Rylah, Her Majesty's Chief Secretary for the State of Victoria, shall give the necessary directions herein accordingly.

J. ROSSITER,
Clerk of the Executive Council.

STAMPS ACT 1958, No. 6375.

At the Executive Council Chamber, Melbourne, the twenty-second day of April, 1970.

PRESENT:

The Lieutenant-Governor as Deputy for His Excellency the Governor of Victoria.

Mr. Reid | Mr. Manson.

THE Lieutenant-Governor as Deputy for His Excellency the Governor of the State of Victoria, by and with the advice of the Executive Council thereof, doth by this Order made pursuant to section 131C of the Stamps Act 1958 (No. 6375) revoke the declaration made on 30th August, 1966, and published in the Government Gazette on the 31st August, 1966, declaring certain persons to be "approved vendors" for the purposes of sub-division (14) of Division 3 of Part II. of the Stamps Act 1958 in so far as the said declaration refers to the under-mentioned person—

225. Gross Finance Pty. Ltd.

And the Honorable Sir Henry Edward Bolte, Her Majesty's Treasurer for the State of Victoria, shall give the necessary directions herein accordingly.

J. ROSSITER,
Clerk of the Executive Council.

ANGLESEA SEWERAGE AUTHORITY.

*At the Executive Council Chamber, Melbourne, the
twenty-second day of April, 1970.*

PRESENT:

The Lieutenant-Governor as Deputy for His Excellency
the Governor of Victoria.

Mr. Reid | Mr. Manson.

CONSENT TO BORROWING \$70,000.

UNDER the powers conferred by the Sewerage Districts Act and all other powers enabling him in that behalf, the Lieutenant-Governor as Deputy for His Excellency the Governor of the State of Victoria, by and with the advice of the Executive Council of the said State, doth hereby consent to the Angelsea Sewerage Authority borrowing at interest, by mortgage of the general fund, the sum of Seventy thousand dollars (\$70,000) to meet the cost of sewerage works as set forth in the detailed statement bearing date 16th April, 1970.

And the Honorable William Archibald Borthwick, Her Majesty's Minister of Water Supply for the State of Victoria, shall give the necessary directions herein accordingly.

J. ROSSITER,
Clerk of the Executive Council.

BARWON HEADS SEWERAGE AUTHORITY.

*At the Executive Council Chamber, Melbourne, the
twenty-second day of April, 1970.*

PRESENT:

The Lieutenant-Governor as Deputy for His Excellency
the Governor of Victoria.

Mr. Reid | Mr. Manson.

CONSENT TO BORROWING \$50,000.

UNDER the powers conferred by the Sewerage Districts Act and all other powers enabling him in that behalf, the Lieutenant-Governor as Deputy for His Excellency the Governor of the State of Victoria, by and with the advice of the Executive Council of the said State, doth hereby consent to the Barwon Heads Sewerage Authority borrowing at interest, by mortgage of the general fund the sum of Fifty thousand dollars (\$50,000) to meet the cost of sewerage works as set forth in the detailed statement bearing date 16th April, 1970.

And the Honorable William Archibald Borthwick, Her Majesty's Minister of Water Supply for the State of Victoria, shall give the necessary directions herein accordingly.

J. ROSSITER,
Clerk of the Executive Council.

MORWELL SEWERAGE AUTHORITY.

*At the Executive Council Chamber, Melbourne, the
twenty-second day of April, 1970.*

PRESENT:

The Lieutenant-Governor as Deputy for His Excellency
the Governor of Victoria.

Mr. Reid | Mr. Manson.

CONSENT TO BORROWING \$17,000.

UNDER the powers conferred by the Sewerage Districts Act and all other powers enabling him in that behalf, the Lieutenant-Governor as Deputy for His Excellency the

Governor of the State of Victoria, by and with the advice of the Executive Council of the said State, doth hereby consent to the Morwell Sewerage Authority borrowing at interest, by mortgage of the general fund, the sum of Seventeen thousand dollars (\$17,000) to meet the cost of sewerage works as set forth in the detailed statement bearing date 16th April, 1970.

And the Honorable William Archibald Borthwick, Her Majesty's Minister of Water Supply for the State of Victoria, shall give the necessary directions herein accordingly.

J. ROSSITER,
Clerk of the Executive Council.

PORT FAIRY SEWERAGE AUTHORITY.

*At the Executive Council Chamber, Melbourne, the
twenty-second day of April, 1970.*

PRESENT:

The Lieutenant-Governor as Deputy for His Excellency
the Governor of Victoria.

Mr. Reid | Mr. Manson.

CONSENT TO BORROWING \$50,000.

UNDER the powers conferred by the Sewerage Districts Act and all other powers enabling him in that behalf, the Lieutenant-Governor as Deputy for His Excellency the Governor of the State of Victoria, by and with the advice of the Executive Council of the said State, doth hereby consent to the Port Fairy Sewerage Authority borrowing at interest by mortgage of the general fund the sum of Fifty thousand dollars (\$50,000) to meet the cost of sewerage works as set forth in the detailed statement bearing date 16th April, 1970.

And the Honorable William Archibald Borthwick, Her Majesty's Minister of Water Supply for the State of Victoria, shall give the necessary directions herein accordingly.

J. ROSSITER,
Clerk of the Executive Council.

WILLAURA SEWERAGE AUTHORITY.

*At the Executive Council Chamber, Melbourne, the
twenty-second day of April, 1970.*

PRESENT:

The Lieutenant-Governor as Deputy for His Excellency
the Governor of Victoria.

Mr. Reid | Mr. Manson.

CONSENT TO BORROWING \$900.

UNDER the powers conferred by the Sewerage Districts Act and all other powers enabling him in that behalf, the Lieutenant-Governor as Deputy for His Excellency the Governor of the State of Victoria, by and with the advice of the Executive Council of the said State, doth hereby consent to the Willaura Sewerage Authority borrowing at interest by mortgage of the general fund the sum of Nine hundred dollars (\$900) to meet the cost of sewerage works as set forth in the detailed statement bearing date 16th April, 1970.

And the Honorable William Archibald Borthwick, Her Majesty's Minister of Water Supply for the State of Victoria, shall give the necessary directions herein accordingly.

J. ROSSITER,
Clerk of the Executive Council.

DAIRY PRODUCTS ACT 1958.
DAIRY PRODUCTS (BOARD MEMBERSHIP) ACT 1970.

At the Executive Council Chamber, Melbourne, the
twenty-eighth day of April, 1970.

PRESENT:

The Lieutenant-Governor as Deputy for His Excellency
the Governor of Victoria.

Mr. Thompson | Mr. Wilcox.

APPOINTMENT OF MEMBER OF THE VICTORIAN
DAIRY PRODUCTS BOARD.

IN pursuance of the powers conferred by section 4 of
the Dairy Products Act 1958, section 4 of the Dairy
Products (Board Membership) Act 1970 and all other
powers him thereunto enabling, the Lieutenant-Governor
as Deputy for His Excellency the Governor of the State
of Victoria, by and with the advice of the Executive
Council thereof, doth by this Order hereby appoint IAN
GRAHAM PATIENCE nominated by the Victorian Division
of the Australian Institute of Dairy Factory Managers and
Secretaries as a member of the Victorian Dairy Products
Board for the period from the 29th April, 1970 to the
14th February, 1973, both dates inclusive.

And the Honorable Gilbert Lawrence Chandler, Her
Majesty's Minister of Agriculture for the State of Victoria,
shall give the necessary directions herein accordingly.

J. ROSSITER,
Clerk of the Executive Council.

HOUSING ACT 1958.

At the Executive Council Chamber, Melbourne, the
twenty-eighth day of April, 1970.

PRESENT:

The Lieutenant-Governor as Deputy for His Excellency
the Governor of Victoria.

Mr. Thompson | Mr. Wilcox.

DECLARATION OF PRIVATE STREETS AS PUBLIC
HIGHWAYS WITHIN THE CITY OF SANDRINGHAM.

WHEREAS pursuant to section 107 of the Housing Act
1958 it is among other things enacted that where
works have been carried out in accordance with an agree-
ment for the full construction of any roads, pavements,
culverts or drains made pursuant to the provisions of the
said section 107 such roads, pavements, culverts or drains
shall be under the care and management of the Municipality
which shall be liable for the cost of any maintenance,
repair, alteration or reconstruction thereof and the
Governor in Council may by order published in the
Government Gazette declare any road so constructed to
be a public highway.

And whereas by Order dated the seventeenth day of
December, 1968, the Governor in Council consented to an
agreement between the Housing Commission and the City
of Sandringham regarding the repair and/or reconstruc-
tion of all the roads set out on lodged plan 72836 in the
Sandringham Estate situate in the Municipality of the City
of Sandringham and the carrying out of the works enu-
merated in the said agreement.

And whereas the works of road pavements, culvert and
drainage construction have now been carried out in accor-
dance with the said agreement between the Housing
Commission and the City of Sandringham.

Now therefore the Lieutenant-Governor as Deputy for
His Excellency the Governor of the State of Victoria by
and with the advice of the Executive Council of the said
State and in pursuance of the powers conferred by section
107 of the Housing Act and upon recommendation of the
Housing Commission doth by this Order declare the internal
roads more particularly delineated and shown hatched on
the plan hereunder to be absolutely dedicated to the public
as public highways within the meaning of any law now
or hereafter in force: And that the Council of the
Municipality in which the internal roads are situate shall
hereafter be liable for all cost of any maintenance, repair,
alteration or reconstruction thereof.

No. 43.—3459/70.—3

PART OF CROWN PORTION 16

PARISH OF MOORABBIN

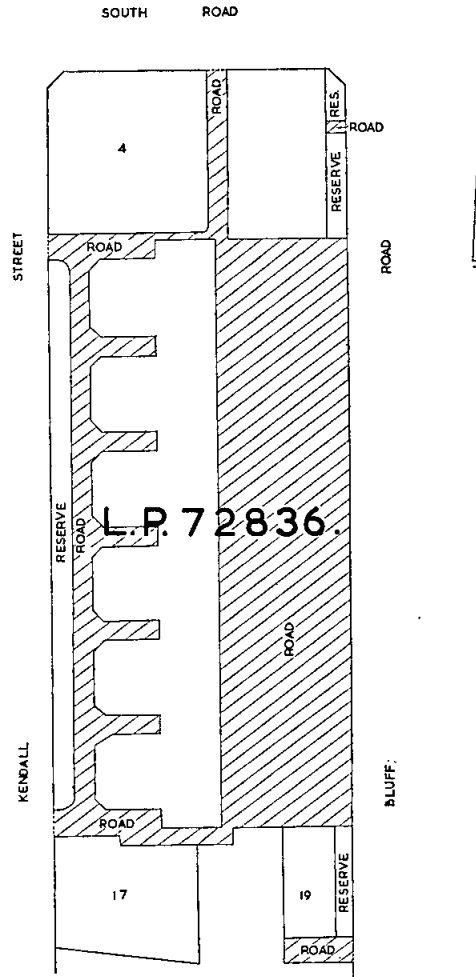

And the Honorable Edward Raymond Meagher, Her
Majesty's Minister of Housing for the State of Victoria,
shall give the necessary directions herein accordingly.

J. ROSSITER,
Clerk of the Executive Council.

LANDS DEPARTMENT NOTICES

APPROACHING LAND SALES.

SALES of Crown Lands, in fee-simple, will be held at the
under-mentioned places and dates, viz.:-

	No. of Gazettes.
Bendigo.—Thursday, 14th May, 1970	32
Charlton.—Tuesday, 2nd June, 1970	43
Chiltern.—Monday, 1st June, 1970	43
Dartmoor.—Wednesday, 13th May, 1970	32
Donald.—Monday, 1st June, 1970	43
Dunolly.—Monday, 11th May, 1970	32
Geelong.—Monday, 1st June, 1970	39
Healesville.—Friday, 12th June, 1970	43
Heathcote.—Thursday, 14th May, 1970	32

APPROACHING LAND SALES—continued.

	No. of Gazette.
Melbourne.—Thursday, 30th April, 1970 ..	20
Meredith.—Thursday, 11th June, 1970 ..	43
Rushworth.—Thursday, 14th May, 1970 ..	32
Wonthaggi.—Friday, 29th May, 1970 ..	39
Yarra Junction.—Friday, 12th June, 1970 ..	43

AUCTION OF RIGHT TO LEASE CROWN LAND.

Melbourne.—Thursday, 30th April, 1970 ..	20
Queenscliff.—Monday, 1st June, 1970 ..	39

SALE OF CROWN LAND BY AUCTION.

The land will be offered for sale in fee-simple, and subject to the provisions of the Land Act and Regulations thereunder.

The upset price is the sum at which bidding will start, and no bid below that sum can be accepted. The highest bidder at or above that sum shall be the purchaser, subject to signature of contract and any necessary payment.

TERMS:—

A deposit of at least 12½% of the purchase price must be paid at the sale, either in cash or by cheque.

The residue is payable in half-yearly instalments, in accordance with the following scale, or may be paid off at any earlier time.

\$40 and under, 6 instalments.	
Over \$40, and not exceeding \$100, 8 instalments.	
Over \$100, and not exceeding \$200, 10 instalments.	
Over \$200, and not exceeding \$400, 12 instalments.	
Over \$400, and not exceeding \$600, 14 instalments.	
Over \$600, and not exceeding \$800, 16 instalments.	
Over \$800, and not exceeding \$1,000, 18 instalments.	
Over \$1,000, 20 instalments.	

Interest at the rate of 5% per annum is payable with all payments of residue, and is computed for each instalment from the date of sale to the date of such payment. Additional interest is charged if any instalment is not paid on or before the due date.

If paid off within 30 days of sale, no interest is payable.

FEES, ETC.:

Also payable at the sale, in addition to the deposit, are the survey fee and, if applicable, the valuation of improvements (if purchaser be not the owner thereof).

Payable with balance of purchase money—

Crown Grant fee—	
50 acres and under	\$3
Over 50 acres	\$4
Purchase money \$10 or under ..	\$2

Assurance Fund contribution.—One cent in every Five dollars or part thereof of purchase price. (This is a fund established to guarantee the validity of freehold titles.)

Transfer of interest prior to completion of payment may be allowed on payment of \$2 fee and subject to stamp duty.

If unable to attend personally, a prospective purchaser may arrange for another person to bid as his agent.

Attention is drawn to section 95, Land Act 1958, which provides that the purchaser shall be deemed to be the owner for the purposes of other Acts; also to an amendment to the Local Government Act providing for Government roads, in certain circumstances, to be declared "private streets", thus making the purchaser liable to contribute to the cost of street construction.

W. J. F. McDONALD,
Minister of Lands.

Office of Crown Lands and Survey,
Melbourne, 29th April, 1970.

CHILTERN.—Sale (No. 12060) of Crown land in fee-simple, by auction, will be held at the LAND INSPECTOR'S OFFICE, CHILTERN, on MONDAY, the 1st day of JUNE, 1970, at TEN o'clock a.m. To be conducted by F. F. HOLT, Land Officer, Wangaratta.

Lot 1. PARISH OF CARLYLE, COUNTY OF BOGONG.

Fronting the north-east side of Hopetoun-road, about 1 mile north of the Rutherglen water tower.

Upset price \$250 the lot. Survey fee \$13.

Area 1a. 0r. 33p., allotment 36 of section 41. One month allowed for the removal of improvements.—(H.033591.)

Lot 2. PARISH OF CHILTERN, COUNTY OF BOGONG.

Fronting the south side of the Mount Pleasant-road, about 4 miles north of Chiltern.

Upset price \$375 the lot. Survey fee \$24.50.

Area 20a. 0r. 2p., allotment 19A of section C. Valuation of improvements (fencing) \$140.—H. A. Gillman.—(H.032186.)

Also the following freehold land will be offered:—

NOTE.—This lot is not subject to the provisions as set out above, but comprises of freehold land offered on behalf of the Education Department on the following conditions:—

(a) Deposit of at least 12½ per cent. payable at the sale and balance within 60 days.

(b) Purchaser to arrange for, and bear costs of, registration of transfer of title.

Lot 3. PARISH OF LILLIPUT, COUNTY OF BOGONG.

Being the former Lake Moodemere State School site.

Upset price \$70 the lot.

Area 2 acres. Allotment 10A of section 1, being the land described in C.G., volume 744, folio 698.—(H.033233.)

MEREDITH.—Sale (No. 12061) of Crown land in fee-simple, by auction, will be held at the LAND INSPECTOR'S OFFICE, MEREDITH, on THURSDAY, the 11th day of JUNE, 1970, at half-past TEN o'clock a.m. To be conducted by D. M. O'CONNOR, Land Officer, Geelong.

PARISH OF DURIDWARAH, COUNTY OF GRANT.

At New Chum, north of the Township of Steiglitz.

Lot 1. Upset price \$200 the lot. Survey fee \$18.

Area 1r. 18p., allotment 7A, of section B.

Lot 2. Upset price \$200 the lot. Survey fee \$18.

Area 1r. 18 p., allotment 7B, of section B.

Lot 3. Upset price \$200 the lot. Survey fee \$18.

Area 1r. 18p., allotment 7C, of section B.

Lot 4. Upset price \$150 the lot. Survey fee \$18.

Area 1r. 12p., allotment 8A, of section B.

Lot 5. Upset price \$150 the lot. Survey fee \$18.

Area 1r. 12p., allotment 8B, of section B.—(G.66176.)

CHARLTON.—Sale (No. 12062) of Crown land in fee-simple, by auction, will be held at the COURT HOUSE, CHARLTON, on TUESDAY the 2nd day of JUNE, 1970, at ELEVEN o'clock a.m. To be conducted by R. F. JONES, Land Officer, St. Arnaud.

Lot 1. TOWNSHIP OF CHARLTON, PARISH OF CHARLTON, COUNTY OF GLADSTONE.

Fronting the south-western side of Watson-street, about 7 chains south-east of Kaye-street (No. 50 Watson-street).

Upset price \$3,200 the lot. Survey fee \$13.

Area 1r. 38p., allotment 5 of section 15. Improvements.—(Weatherboard dwelling, outbuildings, &c.—(W.89542.)

HEALESVILLE.—Sale (No. 12063) of Crown land in fee-simple, by auction, will be held at the LAND INSPECTOR'S OFFICE, HEALESVILLE, on FRIDAY, the 12th day of JUNE, 1970, at half-past NINE o'clock a.m. To be conducted by W. J. MACKINTOSH, Land Officer, Melbourne.

Lot 1. PARISH OF TARRAWARRA, COUNTY OF EVELYN.

On the east side of Healesville-Tolangi road, approximately 3½ miles from Healesville.

Upset price \$100 the lot. Survey fee \$80.

Area 1r. 34p., allotment 114A.—(G.73802.)

YARRA JUNCTION.—Sale (No. 12064) of Crown land in fee-simple, by auction, will be held at the LAND INSPECTOR'S OFFICE, YARRA JUNCTION, on FRIDAY, the 12th day of JUNE, 1970, at half-past ELEVEN o'clock a.m. To be conducted by W. J. MACKINTOSH, Land Officer, Melbourne.

Lot 1.

TOWNSHIP OF POWELLTOWN, PARISH OF BEENAK,
COUNTY OF EVELYN.

In Surrey-road, Powelltown.

Upset price \$200 the lot. Survey fee \$13.

Area 1r. 6p., subject to survey. Allotment 11, of section G. Valuation of improvements \$160 (House and shed).
—Mrs. E. Bell.—(G.72579.)

DONALD.—Sale (No. 12057) of Crown land in fee-simple, by auction, will be held at the LAND INSPECTOR'S OFFICE, DONALD, on MONDAY, the 1st day of JUNE, 1970, at FOUR o'clock p.m. To be conducted by R. F. JONES, Land Officer, St. Arnaud.

Lot 1.

PARISH OF CORACK, COUNTY OF BORUNG.

Four miles east of Massey Railway Station and adjoining the western side of Lake Buloke.

Upset price \$6,000 the lot. Survey fee \$56.75.

Area 118a. 3r. 15p., subject to survey. Allotment 87A. Improvements, dam and drain, the valuation of which is included in the upset.—(W.90026.)

PROPOSED REVOCATIONS OF TEMPORARY RESERVATIONS OF LANDS BY ORDERS IN COUNCIL.

IN pursuance of the provisions of the Land Act 1958, notice is hereby given that it is the intention of the Governor in Council to revoke the temporary reservations of lands by Orders in Council hereunder referred to, viz.:

The following Notices were published 1° on the 15th April, 1970, pursuant to Orders of the 7th April, 1970.

CASTERTON.—The temporary reservation by Order in Council of the 13th December, 1886, of 3 acres 0 roods 34 perches of land in the Township of Casterton, as a site for Water Supply purposes, revoked as to part by order of the 27th June, 1898, is about to be revoked, so far as the balance containing 2 acres 2 roods 9 8/10 perches is concerned.—(C.177(2) (Rs.5258).

CRAIGIE, EGLINTON AND MAJORCA.—The temporary reservation, by Order in Council of the 5th August, 1872, of certain land in the Parishes of Craigie and Eglinton (now in the Parishes of Craigie and Eglinton and the Township of Majorca), as a site for Reservoirs and Catchment Area purposes, revoked as to part by various orders, is about to be revoked, so far as the balance is concerned.—(C.330(1), E.18(4), M.425(6) (C.77910).

ILLAWARRA.—The temporary reservation, by Order in Council of the 28th August, 1939, of 1 acre 3 roods 24 perches of land in the Parish of Illawarra, as a site for Water Supply purposes, is about to be revoked.—(I.13(2) (Rs.4961).

MINDAI AND CAPE CLEAR.—The temporary reservation as a site for Water Supply purposes and the withholding from sale, leasing and licensing by Order in Council of the 20th October, 1879, of 473 acres 0 roods 32 perches of land in the Parishes of Mindai and Clarkesdale, revoked as to part by various Orders, are about to be revoked, so far only as the portions containing 8 acres 2 roods 10 perches, more or less, indicated by hatching on plan hereunder, are concerned.—(C.480(1), M.122(2) (Rs.5263).

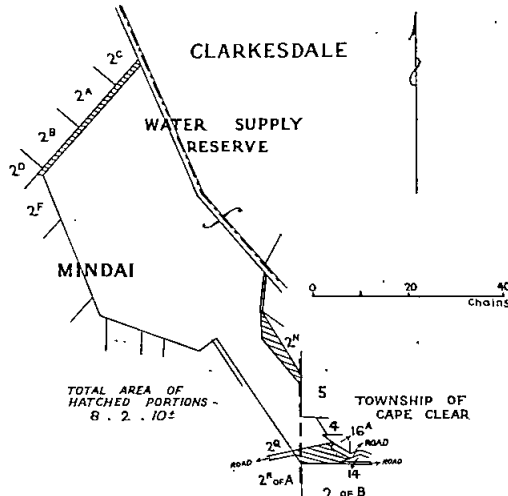

TATONGA.—The temporary reservation, by Order in Council of the 30th September, 1958, of 56 acres 2 roods, more or less, of land in the Parish of Tatonga, as a site for Public Recreation, revoked as to part by Order of the 30th March, 1965, is about to be revoked, so far only as the portion containing 6 perches, indicated by hatching on plan hereunder, is concerned.—(T.256(2) (Rs.4176).

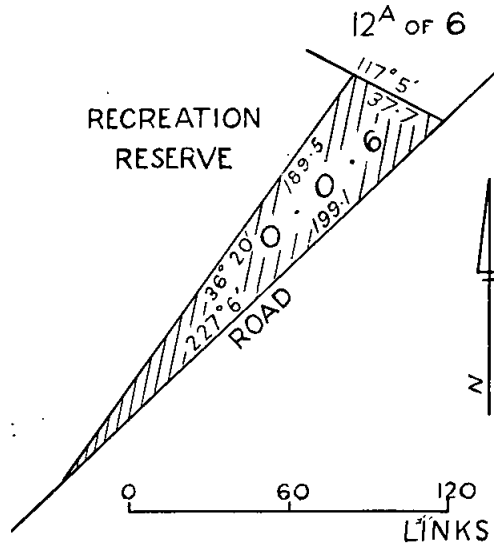

W. J. F. McDONALD,
Minister of Lands.

PROPOSED PERMANENT RESERVATION OF LANDS AS SITES.

IN pursuance of sections 14 and 21 of the Land Act 1958, notice is hereby given that it is the intention of the Governor in Council to reserve permanently from sale, from being leased and from having a licence granted in respect thereof the land hereinafter described:—

The following Notices were published 1° on the 15th April, 1970, pursuant to Orders of the 7th April, 1970.

TRUGANINA (ALTONA).—Land proposed to be permanently reserved as a site for Public Recreation, 25 acres 3 roods, more or less, Parish of Truganina, County of Bourke, as indicated by hatching on plan hereunder.—(T.109(2) (Rs.7827).

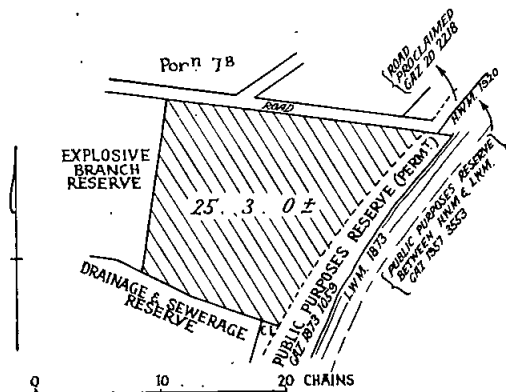

W. J. F. McDONALD,
Minister of Lands.

PROPOSED REVOCATIONS OF TEMPORARY RESERVATIONS OF LANDS BY ORDERS IN COUNCIL.

IN pursuance of the provisions of the Land Act 1958, notice is hereby given that it is the intention of the Governor in Council to revoke the temporary reservations of lands by Orders in Council hereunder referred to, viz.:

The following Notices were published 1° on the 29th April, 1970, pursuant to Orders of the 22nd April, 1970.

TALBOT.—The temporary reservation, by Order in Council of the 28th June, 1928, of 3 roods 7 perches of land in the Township of Talbot, as a site for Public Baths, is about to be revoked.—(T.136(?) (Rs.3695).

BARWO.—The temporary reservation as a site for Water Supply purposes and the withholding from sale, leasing and licensing by Order in Council of the 16th December, 1884 (see Government Gazette 19th December, 1884, page 3564) of 110 acres, more or less, in two separate portions in the Township of Nathalia and the Parish of Barwo, are about to be revoked, so far only as the portion in the Parish of Barwo, containing 4 perches, indicated by hatching on plan hereunder, is concerned.—(B.690(A³) (Rs.2360).

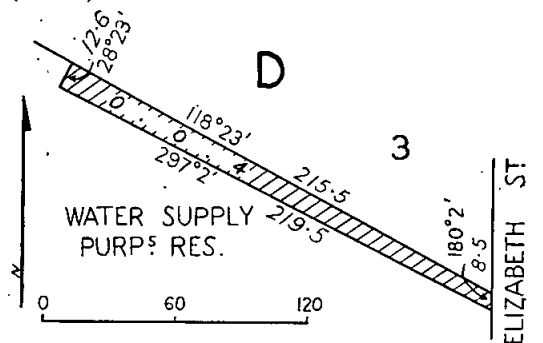

CRANBOURNE.—The temporary reservation, as a site for Public purposes (State School) and the withholding from sale, leasing and licensing, by Order in Council of the 5th February, 1877, of 1 acre of land in the Township of Cranbourne, is about to be revoked.—(C.329(?) (Rs.5820).

SANDHURST (KENNINGTON).—The temporary reservation, by Order in Council of the 24th September, 1912, of 5 acres 1 rood 9 perches of land in the Parish of Sandhurst, as a site for Public Gardens, revoked as to part by various Orders, is about to be revoked, so far only as the portion containing 2 acres, more or less, indicated by hatching on plan hereunder, is concerned.—(S.371⁽²⁰⁾) (Rs.782).

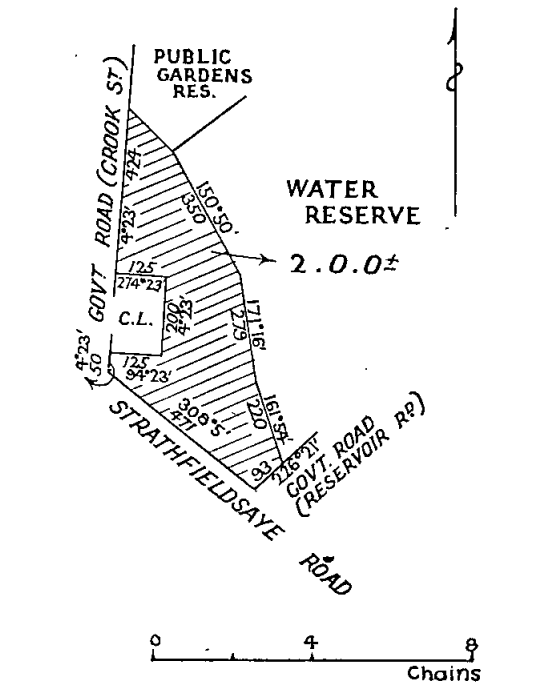

BEECHWORTH.—The temporary reservation, by Order in Council of the 26th September, 1864, of 201 acres 2 roods 26 perches of land in the Parish of Beechworth (now in the Township), as a site for a Mental Hospital, is about to be revoked, so far only as the portion containing 10 perches, indicated by hatching on plan hereunder, is concerned.—(B.348(?) (Rs.1221).

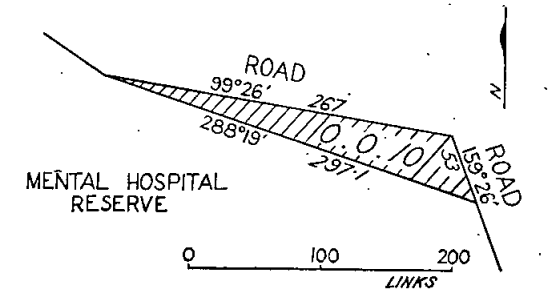

CARLYLE.—The temporary reservation, by Order in Council of the 25th September, 1894, of 10 acres of land in the Parish of Carlyle, as a site for a Night-soil Depot, for the municipal district of the Shire of Rutherglen, is about to be revoked, so far only as the portion containing 5 acres 19 perches, indicated by hatching on plan hereunder is concerned.—(C.187(?) (Rs.9309).

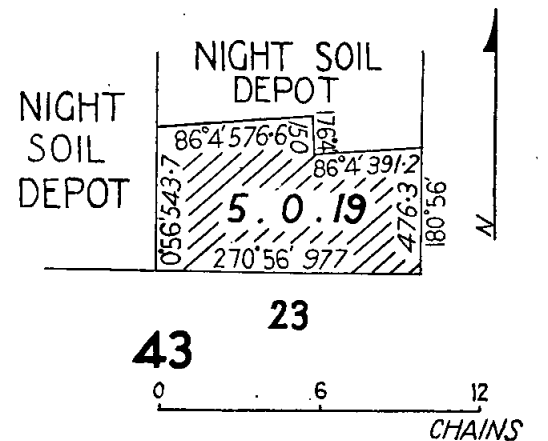

CARLYLE.—The temporary reservation, by Order in Council of the 14th November, 1893, of 10 acres of land in the Parish of Carlyle, as a site for a Night-soil Depot, is about to be revoked, so far only as the portion containing 5 acres 2 perches, indicated by hatching on plan hereunder is concerned.—(C.187(?) (Rs.9309).

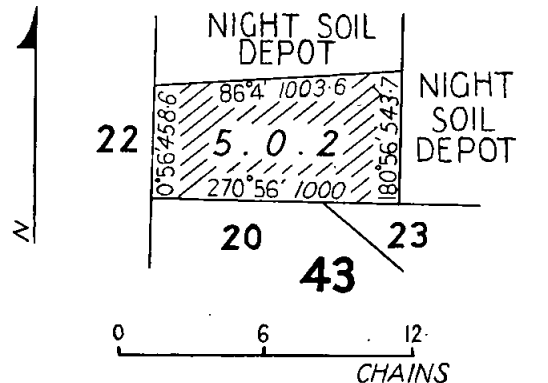

KILLINGWORTH.—The temporary reservation, by Order in Council of the 10th March, 1903, of 64 acres of land in the Parish of Killingworth, as a site for a Public Park, is about to be revoked, so far only as the portions containing 1 acre 1 rood 30 perches, more or less, indicated by hatching on plan hereunder are concerned.—(K.55(?) (Rs.428).

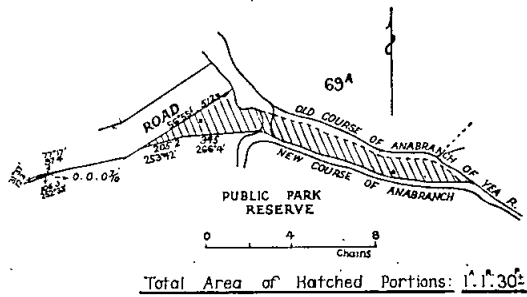

MOOLERR.—The temporary reservation, as a site for Conservation of Water, and the withholding from sale, leasing and licensing by Order in Council, of the 5th June, 1882, of 17 acres 3 roods 5 perches of land in the Parish of Moolerr, are about to be revoked, so far only as the portion containing 15 acres 3 roods 9 perches, indicated by hatching on plan hereunder, is concerned.—(M.427⁽³⁾) (Rs.9298).

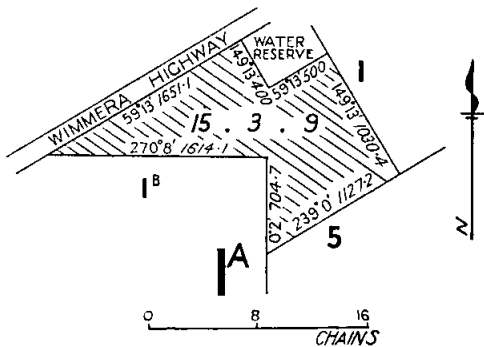

SPRINGHURST.—The temporary reservation, by Order in Council of the 9th December, 1885, of 71 acres 3 roods 20 perches of land in the Township of Springhurst, (formerly Town of Naringa), as a site for Public Recreation, is about to be revoked, so far only as the portion containing 3 acres 38 perches, indicated by hatching on plan hereunder is concerned.—(N.135⁽²⁾) (Rs.610).

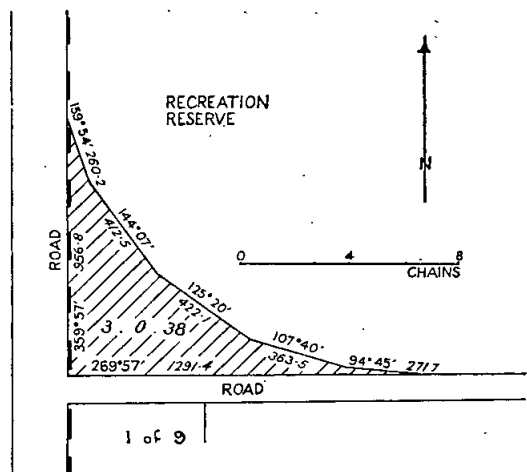

WEDDERBURNE.—The temporary reservation, by Order in Council of the 15th July, 1912, of 95 acres 31 perches of land in the Parish of Wedderburne, as a site for Supply of Material for Road-making, is about to be revoked, so far only as the portion containing 2 roods 32 perches, indicated by hatching on plan hereunder is concerned.—(W.116⁽¹⁴⁾) (Rs.6880).

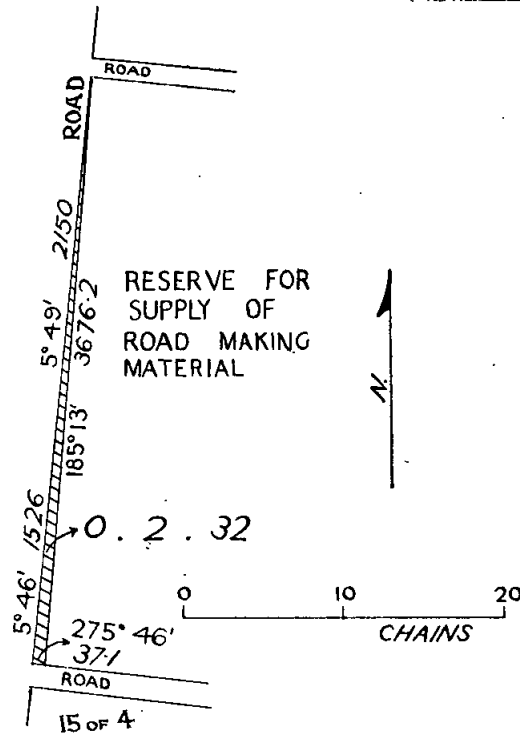

BALLAN.—The temporary reservation, by Order in Council of the 9th December, 1872 (see *Government Gazette* 13th December, 1872, page 2262), of 1 acre of land in the Township of Ballan, as a site for a Court House, is about to be revoked, so far only as the portion containing 2 roods, indicated by hatching on plan hereunder is concerned.—(B.23⁽⁴⁾) (C.75794).

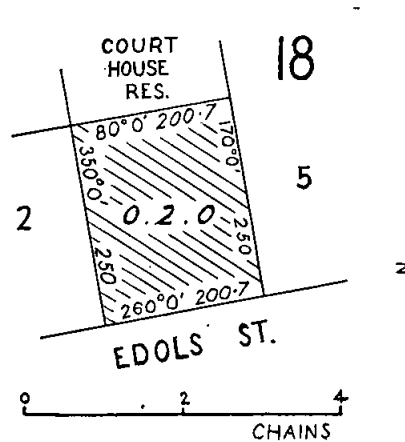

W. J. F. McDONALD,
Minister of Lands.

PROPOSED REVOCATIONS OF TEMPORARY RESERVATIONS OF LANDS BY ORDERS IN COUNCIL.

IN pursuance of the provisions of the Land Act 1958, notice is hereby given that it is the intention of the Governor in Council to revoke the temporary reservations of lands by Orders in Council hereunder referred to, viz.:—
The following Notices were published 1° on the 8th April, 1970, pursuant to Orders of the 2nd April, 1970.

MOE.—The temporary reservation, by Order in Council of the 10th April, 1940, of 2 roods more or less, of land in the Parish of Moe as a site for Public Purposes, is about to be revoked so far only as the portion containing 15 perches, more or less, indicated by hatching on plan hereunder, is concerned.—(M.498⁽¹¹⁾) (Rs.5029).

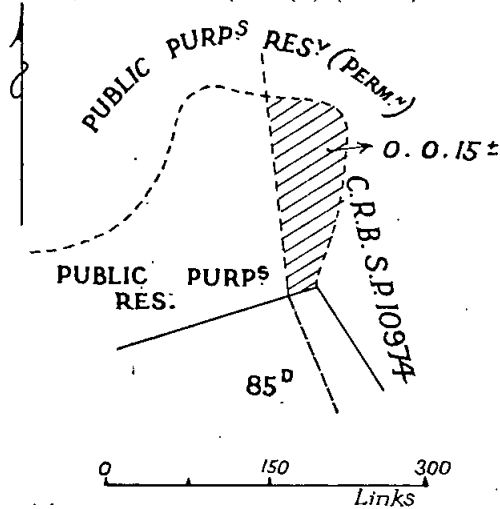

WODONGA.—The temporary reservation, by Order in Council of the 26th January, 1874, of 75 acres, more or less, of land in the Parish of Belvoir (now in the Township of Wodonga) as a site for Camping Purposes, revoked as to part by various Orders, is about to be revoked, save and except the area of 3 acres 2 roods 30 perches, more or less, indicated by hatching on plan hereunder, is concerned.—(W.308(s³)) (Rs.2122).

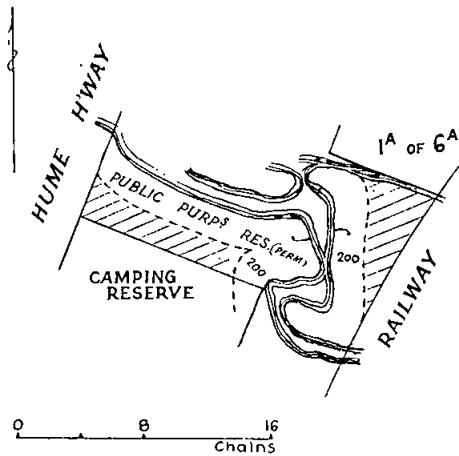

TOTAL AREA OF HATCHED PORTIONS: 3. 2. 30±

W. J. F. McDONALD,
Minister of Lands.

Land Act 1958.

LEASES DECLARED VOID.

NOTICE is hereby given that the Governor in Council has declared void the Leases mentioned in the Schedule hereunder for the reason specified in each case.

District.	Corr. No.	Name.	Section of Land Act under which Leased.	Parish.	Allotment.	Section.	Area.	Annual Rental.	Reason.
Sale	159/50	A. G. Laurie.	50— Land Act 1958	Dulungalong	7	A	A. R. P. 319 2 34	\$ 32.00	Non-payment of rent and non-compliance with conditions
Bairnsdale	69/155	R. C. M. Friend	155— Land Act 1958	Colquhoun East	13	D	368 0 20	110.44	Substitute lease to to issue pursuant to Section 4 of the Land (Amendment) Act 1967

Department of Crown Lands and Survey,
Melbourne, 20th April, 1970.

W. J. F. McDONALD,
Minister of Lands.

TENDERS

PUBLIC WORKS DEPARTMENT

TENDERS will be received at Public Works Department, 2 Treasury-place, Melbourne, until TWO p.m. on dates shown and for purposes mentioned hereunder.

Particulars and tender forms available at Contracts Office, Room 8, Building Division, Parliament-place and at places indicated in brackets hereunder.

Abbreviations in brackets mean:—W.O.—Inspector of Works Office; P.S.—Police Station; C.S.—Consolidated School; H.E.S.—Higher Elementary School; H.S.—High School; Pr.S.—Primary School; T.S.—Technical School.

Tenders to be submitted on the Department's printed Tender Form and will not be received by telephone. All tenders must be on a "Firm Tender" basis. The lowest or any tender will not necessarily be accepted.

Address tenders to the Minister of Public Works, and endorse the envelope containing the tender "Tender for , closing Tuesday,

Hand delivered tenders to be placed in the Tender Box of the Public Works Department, located on the wall of the centre entrance foyer, Ground Floor, 2 Treasury-place, Melbourne.

No preliminary deposit is required with any tender, but a successful tenderer will be required to pay a deposit for any accepted tender of \$4,000 or over.

Tuesday, 5th May, 1970.

Building, Electrical and Mechanical Works.

Beechworth.—Extension of fire and general water service, Mental Hospital. (W.O., Wangaratta.)
Benalla.—Erection of a standard school hall type "572c", Technical School. (W.O., Benalla.)

Benalla.—Electrical services, Technical School. (W.O., Benalla, Shepparton and Wangaratta.)

Benalla.—Mechanical services, Technical School. (W.O., Wangaratta.)

Carlton.—Repairs and renovations to school and residence, Pr.S. 2605.

Dooen.—Erection of timber residence (Proprietary Type), and garage, Longerenong Agricultural College. (W.O., Horsham.)

Dunolly.—Erection of brick veneer residence (Proprietary Type), and garage, Police Station. (W.O., Maryborough.)

Ellimbank.—Erection of brick veneer residence (Proprietary Type), and garage, Dairy Research Station. (W.O., Warragul.)

Kerang.—Erection of brick veneer residence (Proprietary Type), and garage, Police Station. (W.O., Swan Hill.)

Lara.—Erection of brick veneer residence (Proprietary Type), and garage, "Serendip" Research Station. (W.O., Geelong.)

Melbourne.—External re-painting, Alan Ramsay House, 19 Queens-road.

Myrtleford.—Erection of timber residence (Proprietary Type), and garage, Tobacco Research Station. (W.O., Wangaratta.)

Oberon South.—Erection of brick veneer 7 (seven) class-room Primary School, Pr.S. 4983. (W.O., Geelong.) (Amended specification.)

Oberon South.—Mechanical services, Pr.S. 4983. (W.O., Geelong.) (Amended specification.)

Rochester.—Erection of brick veneer residence (Proprietary Type), and garage, Police Station. (W.O., Bendigo.)

Rutherglen.—Erection of brick veneer residence (Proprietary Type), and garage, Research Station. (W.O., Wangaratta.)

Tungamah.—Erection of brick veneer residence (Proprietary Type), and garage, Police Station. (W.O., Benalla and Shepparton.)

Walpeup.—Erection of timber residence (Proprietary Type), and garage, Mallee Research Station. (W.O., Mildura.)

Wedderburn.—Erection of brick veneer residence (Proprietary Type), and garage, Police Station. (W.O., Bendigo.)

Wonthaggi.—Re-blocking, repairs and renovations to residence, 21 Broome-crescent, Pr.S. 3650. (Primary School, Wonthaggi and W.O., Korumburra.)

Miscellaneous.

Williamstown.—Fabrication of two only mild steel gas buoys, Ports and Harbours Dredging Depot, Ann-street. (W.O., Geelong.)

Williamstown.—Supply and delivery of two (2) diesel engined double drum friction winches, 3 ton capacity, Ports and Harbours Dredging Depot, Ann-street.

Tuesday, 12th May, 1970.

Building, Electrical and Mechanical Works.

Ballarat.—Additional fire alarm installation, Lakeside Hospital. (W.O., Ballarat.)

Melbourne.—Repairs to ceilings and walls, Crown Law Offices, 459 Lonsdale-street. (Re-advertised.)

Mont Park.—Supply and installation of steam heating to sewing room, Mental Hospital.

Springvale.—Alterations and additions, Court House.

Werribee.—Alterations and additions to milking shed and dairy, Research Farm. (Re-advertised.)

Miscellaneous.

Brighton.—Maintenance cleaning for the period 1st June, 1970, to 31st May, 1973, Court House.

Dandenong.—Maintenance cleaning for the period 1st June, 1970, to 31st May, 1973, Court House.

Dandenong.—Maintenance cleaning for the period 1st June, 1970, to 31st May, 1973, Labour and Industry Department.

Elsternwick.—Maintenance cleaning for the period 1st June, 1970, to 31st May, 1973, Court House.

Fitzroy North.—Maintenance cleaning for the period 1st June, 1970, to 31st May, 1973, Health Department, School Dental Centre.

Hawthorn.—Maintenance cleaning for the period 1st June, 1970, to 31st May, 1973, Social Welfare Department.

Kew.—Maintenance cleaning for the period 1st June, 1970, to 31st May, 1973, Court House.

Melbourne.—Maintenance cleaning for the period 1st June, 1970, to 31st May, 1973, Labour and Industry Department.

Tuesday, 19th May, 1970.

Building, Electrical and Mechanical Works.

Altona.—Connexion to M.M.B.W. sewer, Altona High School, Altona West Primary School 4862. (Re-advertised.)

Ballarat.—Interior and exterior renovations, High School. (W.O., Ballarat.)

Echuca.—Internal and external repairs and painting, High School. (W.O., Shepparton.)

Fairfield.—Demolish brick building, re-modelling, &c., Fairlea Female Prison.

Irymple.—Electrical installation, Glasshouse, Mildura Horticultural Research Station. (W.O., Mildura.)

Macleod.—Erection of L.T.C. Science extension, Technical School.

Macleod.—Mechanical services, science extensions, Technical School.

Wendouree.—Erection of two class-rooms and library, in brick veneer, Primary School 1813.

Wendouree.—Mechanical services, new class-room wing, Primary School 1813. (W.O., Ballarat.)

Yarram.—Renovations and re-blocking, High School Residence. (W.O., Traralgon and High School, Yarram.) (Amended Specification.)

Site Works.

Eaglehawk.—Construction of oval and playing fields, High School. (W.O., Bendigo.)

Sale.—Asphalt, concrete and drainage work, &c., Technical School. (W.O., Traralgon.)

Miscellaneous.

Fitzroy.—Maintenance cleaning for the period 1st June, 1970, to 31st May, 1973, Store, Education Department.

Westernport.—Dredging at Hastings, Ports and Harbours Branch. (Buoy Depot, Stony Point.) (Amended Specification.)

R. J. HAMER,

Minister of Public Works.

Public Works Department,

Melbourne, 3002, 27th April, 1970.

TENDERS FOR THE SERVICE, 1970-71.

CARTAGE OF GOODS AND PARCELS (METROPOLITAN).

TENDERS will be received until Eleven o'clock a.m. on Friday, 15th May, 1970, for the cartage and delivery in the Metropolitan Area of such goods and parcels, with the exceptions set out in clause 1 of the Conditions of Contract, as may be forwarded to and from the various Government Offices and Institutions, Railways, &c., by the Stores and Transport Office, for and on behalf of the Government of Victoria, from 1st July, 1970, to 30th June, 1971, as per Schedule No. 1.

In the event of the contractor carrying out the service to the satisfaction of the Tender Board the contract may, at the option of the Board and with the consent of the contractor, be extended for a further period of twelve months from the 1st July, 1971.

Security will be required either in Commonwealth Treasury Bonds, or approved bank guarantee, fixed deposit receipt, Savings Bank deposit book, or non negotiable cheque in favor of the Secretary to the Tender Board, as the tenderer may elect.

The security must be completed and the contract signed within five days of acceptance of the tender, failing which the service may be again advertised, or another tender accepted.

Tenderers failing to take up their accepted tenders may be disqualified from tendering or holding any future contract or contracts for a period of twelve months from the date of such disqualification.

Full particulars, forms of tender, &c., may be obtained at the office of the Secretary to the Tender Board, 2nd Floor, South Building, New State Public Offices, Treasury Place, Melbourne, 3002

The lowest or any tender will not necessarily be accepted.

Tenders enclosed in an envelope, and having the words "Tender for Cartage" written thereon, must be deposited in the Tender-box at the Tender Board Offices, 2nd Floor, South Building, New State Public Offices, Treasury Place, Melbourne, 3002, or, if sent by post, postage must be prepaid, and tenders addressed to the Chairman of the Tender Board, Tender Board Offices, 2nd Floor, South Building, New State Public Offices, Treasury Place, Melbourne, 3002, which office they must reach not later than by first post on the date of closing of tenders.

CONDITIONS OF CONTRACT.

1. The rates tendered shall be deemed to cover all descriptions of goods and parcels, with the exception of office and school furniture, officers' furniture and effects, exhibits for show purposes and such goods as are carried by Government owned vehicles.

2. No subletting shall be allowed; all work must be carried out by the contractor, and every person engaged in the cartage tendered for in this schedule shall be paid such wages and employed subject to such labor conditions as are or may be determined by any Federal Arbitration Court award or any State Wages Board determination, and a copy of such labor conditions shall be kept conspicuously and continually posted on the premises of the contractor. Any infringement of this condition, in the opinion of the Treasurer, will subject the contractor, upon report from the Tender Board, to such mulct, not exceeding one hundred dollars (\$100), as the Treasurer may direct, and the amount will be deducted from the contractor's account or from the security money; and the Treasurer's decision shall be binding, final, and conclusive as to the fact of infringement and in all other respects.

3. Accounts shall be rendered fortnightly, and shall be subject to any deductions for goods or parcels lost or damaged whilst in the custody of the contractor or for storage or demurrage charges which may accrue through delay or default by the contractor in taking delivery of the goods.

4. The contractor will be held liable for any damage to Government property occasioned by the contractor or any person engaged by the contractor during the performance of any service required under the contract.

5. No claims for detention shall be entertained, but should the contractor be subjected to unreasonable delay the cause of delay, if reported, shall be investigated.

6. The contractor must have an office connected by telephone, and within a radius of 20 miles of the Melbourne (Elizabeth-street) Post Office. Thirty minutes will be deemed sufficient notice, and in the event of the contractor failing to supply the vehicles when ordered, and to the satisfaction of the officer requiring his services, such services will be performed at his risk and expense, and the extra expense incurred will be deducted as provided in clause 2.

7. No services performed under these contracts shall be deemed to be of a special nature, provided that the contractor be given reasonable notice that his services shall be required, and no increase in the contract rates shall be permitted.

8. All vehicles in which the goods or parcels are carried must be fitted with good waterproof covers, be in thorough working order and, in general, suitable for requirements.

9. Vehicles as required must call at the Railway Goods Sheds not later than 8.30 a.m., and at the State Tender Board not later than 11 a.m. and 3.30 p.m. daily, for the necessary instructions, and on such other occasions, when notified without extra payment.

10. In the event of failure to provide vehicles as and when required, the service will be performed at the contractor's risk and expense of the amount deducted as provided in clause 2.

11. The contract shall not be considered broken, infringed, or vitiated by the Government performing the service or arranging for the carrying out of the same otherwise than by the contractor in the event of urgency or emergency.

12. The contractor is not at liberty to transfer his contract under cover of power of attorney, coupled with an interest or otherwise, and no such transfer will be recognized by the Government.

13. Under no circumstances will the contractor be permitted to abandon his contract. In the event of the contractor failing to carry on the contract, the security money will in that case be absolutely forfeited and, in addition, the contractor may be held liable for any loss which the Government may sustain in consequence of such failure.

14. A refusal to execute orders, irregularity, or delay in delivering the goods or parcels as required, or failure to comply with the requirements of clause 3 or any breach of Railway or Harbor Trust Regulations, will subject the contractor upon report from the Tender Board to such mulct, as the Treasurer may direct, and the amount may be deducted as provided in clause 2. It will also be in the power of the said Treasurer upon such refusal, irregularity, or delay, to terminate the contract forthwith,

and declare forfeit the whole or any portion of the security money, and, in addition, the contractor will be disqualified from tendering or holding any future contract or contracts for a period of twelve months from the date of such disqualification.

15. In the event of any dispute arising as to matters or things contained in the contract or schedule the same shall be settled by the Tender Board, and the Board's decision shall be binding, final and conclusive.

HENRY BOLTE,
Treasurer.

The Treasury,
Melbourne, 27th April, 1970.

TENDERS FOR THE SERVICE, 1970-72.

REMOVAL OF DEAD BODIES TO MELBOURNE CITY MORTUARY (METROPOLITAN).

TENDERS will be received until Eleven o'clock a.m. on Friday, 15th May, 1970, from persons willing to undertake Removals of Dead Bodies to the Melbourne Morgue, as required by the several Departments of the Government of Victoria, from 1st July, 1970 to 30th June, 1972 in various police sub-districts, as per Schedule No. 2.

Printed forms of tender giving full particulars and lists of places for which the service is required are obtainable from the Secretary to the Tender Board, 2nd Floor, South Building, New State Public Offices, Treasury-place, Melbourne, 3002.

Separate prices for removals must be stated for adults and for children as specified in the tender form.

Tenderers are required to state on the tender form— (a) the number and description of the vehicles that they have available to carry out the service. (b) their business branches and the telephone numbers thereof, as these factors will be taken into consideration when dealing with tenders.

Security will be required in the sum of \$40 for each sub-schedule accepted, either in Commonwealth Treasury Bonds, or approved bank guarantee, fixed deposit receipt, Savings Bank deposit book, or non-negotiable cheque in favour of the Secretary to the Tender Board, as the tenderer may elect.

The security must be completed and the contract signed within five days of acceptance of the tender, failing which the service may be again advertised, or another tender accepted.

The lowest or any tender will not necessarily be accepted.

In the event of tenderers withdrawing or attempting to withdraw their tenders before notification of acceptance of same, or failing to take up their accepted tenders within the prescribed period after notification of acceptance, they may be disqualified from tendering or holding any future contracts for Government supplies for a period of two years, such disqualification to date from the notification of acceptance of tender. It is also stipulated that, if a tenderer be a member of a firm and such firm be interested in the contract, the tender shall be in the name of the firm and not in that of the individual and that, for a breach of this condition, the tender will be declared informal.

Tenders enclosed in a separate envelope, and having the words "Tender for Removals only" written thereon, must be deposited in the Tender-box at the Tender Board Offices, 2nd Floor, South Building, New State Public Offices, Treasury-place, Melbourne, 3002, or, if sent by post, postage must be prepaid and the tenders addressed to the Chairman of the Tender Board, Tender Board Offices, 2nd Floor, South Building, New State Public Offices, Treasury Place, Melbourne, 3002, which office they must reach not later than by the first post on the date of closing of tenders.

CONDITIONS OF CONTRACT.

1. The services are to be performed upon an order issued by a member of the Police Force.

2. The vehicles and such other plant employed in carrying out the contract must be suitable and ample to the necessities of a prompt and efficient service, and such vehicles and other plant must be maintained throughout the period of the contract in satisfactory condition of

repair. Should complaint be made that the vehicles or plant employed in the service are unsuitable, inefficient, or otherwise unsatisfactory, the Tender Board upon investigation of the complaint may recommend that the contract be cancelled and the security forfeited.

3. The contractor must be prepared to undertake any removals from the police sub-district or area contracted for at any hour and on any day when called upon by the police. In the event of the contractor failing to attend punctually to any order, the work will be otherwise performed, and the extra expense incurred, if any, will be charged to the contractor. Should any circumstances, however, make it necessary in any particular case that an immediate removal to the Melbourne City Mortuary be effected, the hiring of another vehicle for the purpose will not be an infringement of the contract.

4. When it becomes necessary to remove a dead body to the Melbourne City Mortuary, and the next of kin present or the legal personal representative of the deceased makes request in person to the police to be allowed to employ the family undertaker to conduct such removal, the police may at their discretion accede to such request, provided such removal is effected at no cost to the Government, and, also, under the supervision of the police as in the case of a removal by the Government contractor. The contract is not to be considered as having been broken, infringed, or vitiated by such removal having been effected by other than the contractor.

5. Bodies to be removed to the Melbourne City Mortuary shall be placed by the contractor before removal in shell coffins, zinc-lined and water-tight, securely closed, and shall be conveyed in suitable covered four-wheeled vehicles. The contractor shall send two men for the purpose of removing the body to the vehicle, and from the vehicle to the Melbourne City Mortuary.

6. Every practicable precaution must be taken in order to prevent offensiveness from decomposition, but in no case of removal must any disinfectant be used without the authority of the medical officer performing the *post-mortem* examination.

7. *Under no circumstances will the contractor be permitted to use any undue or improper influence with the friends or relatives of, or any other person connected or associated with, the deceased person for the purpose of obtaining any concession or privilege whatsoever in regard to the funeral of such person. Any infringement of this condition will, on report of the Tender Board, subject the contractor to the immediate cancellation of his contract, the forfeiture of the security money, and such other penalties as the Treasurer may direct; the decision of the Board as to whether any breach of this condition has taken place to be final and conclusive.*

8. The account is to be rendered monthly to the officer ordering the service for payment by the Treasury, Melbourne.

9. A refusal to execute orders, impropriety, neglect, or delay in conducting the removals will subject the contractor, upon report from the Tender Board, to such mulct, not exceeding \$100, as the said Treasurer may direct, and the amount may be deducted from the contractor's account or from the security money. It will also be in the power of the said Treasurer, upon such refusal, impropriety, neglect, or delay to terminate the contract forthwith, and forfeit the whole or any part of the security money.

10. Under no circumstances will a contractor be permitted to abandon his contract. In the event of the contractor failing to carry on the contract, the security money will in that case be absolutely forfeited, and, in addition, the contractor will be held liable for any loss which the Government may sustain in consequence of such failure, and may be disqualified from tendering or holding any future contract or contracts for a period of two years from the date of such disqualification.

11. Contractors are not at liberty to transfer their contracts under cover of power of attorney, coupled with an interest or otherwise, and no such transfer will be recognized by the Government.

12. The contract shall not be considered broken, infringed or vitiated by the Government performing the service or arranging for the carrying out of the same otherwise than by the contractor in the event of urgency or emergency.

HENRY BOLTE,
Treasurer.

The Treasury,
Melbourne, 27th April, 1970.

TENDERS FOR THE SERVICE, 1970-72.

FUNERALS OF DESTITUTE PERSONS (METROPOLITAN).

TENDERS will be received until Eleven o'clock a.m. on Friday, 15th May, 1970, from persons willing to undertake funerals of destitute persons to the Necropolis, Springvale, the New Melbourne Cemetery, Fawkner, and the cemeteries at Footscray or Williamstown, required by the several Departments of the Government of Victoria, from 1st July, 1970, to 30th June, 1972, in the Melbourne and metropolitan areas, as per Schedule No. 1.

Subject to the proviso in clause 7 of the Conditions of Contract, burials of deceased persons from police sub-districts south of the Yarra River, including burials from the Melbourne City Mortuary, will take place at the Necropolis, Springvale, those from sub-districts north of the Yarra River, at the New Melbourne Cemetery, Fawkner, and those from the Williamstown-Footscray sub-districts, at the Williamstown or Footscray cemeteries. Burials of deceased persons whose bodies have been removed to the Melbourne City Mortuary from places north of the Yarra River, and from places from within the Williamstown-Footscray area, respectively, shall take place at the Necropolis, Springvale, and are included in sub-schedule A accordingly.

Printed forms of tender giving full particulars and lists of places for which the funerals are required are obtainable from the Secretary to the Tender Board, 2nd Floor, South Building, New State Public Offices, Treasury Place, Melbourne, 3002.

Separate prices for ordinary funerals and for funerals under clause 6 of the conditions of contract must be stated (a) for adults, (b) for children above five years and under fourteen-years of age, and (c) for children five years and under, including stillborn—one sum is to be stated for each, including interment, conveyance, and all other charges.

Tenderers are required to state on the tender form—(a) the number and description of the vehicles that they have available to carry out the service. (b) their business branches and the telephone numbers thereof, as these factors will be taken into consideration when dealing with tenders.

Security will be required in the sum of \$40 for each sub-schedule accepted, either in Commonwealth Treasury Bonds, or approved bank guarantee, fixed deposit receipt, Savings Bank deposit book, or non-negotiable cheque in favour of the Secretary to the Tender Board as the tenderer may elect.

The security must be completed and the contract signed within five days of acceptance of the tender, failing which the service may be again advertised, or another tender accepted.

The lowest or any tender will not necessarily be accepted.

In the event of tenderers withdrawing or attempting to withdraw their tenders before notification of acceptance of same, or failing to take up their accepted tenders within the prescribed period after notification of acceptance, they may be disqualified from tendering or holding any future contracts for Government supplies for a period of two years, such disqualification to date from the notification of acceptance of tender. It is also stipulated that, if a tenderer be a member of a firm and such firm be interested in the contract, the tender shall be in the name of the firm and not in that of individual and that, for a breach of this condition, the tender will be declared informal.

Tenders enclosed in a separate envelope, and having the words "Tender for Funerals" written thereon, must be deposited in the Tender-box at the Tender Board Offices, 2nd Floor, South Building, New State Public Offices, Treasury Place, Melbourne, 3002, or, if sent by post, postage must be prepaid and the tenders addressed to the Chairman of the Tender Board, Tender Board Offices, 2nd Floor, South Building, New State Public Offices, Treasury Place, Melbourne, 3002, which office they must reach not later than by first post on the date of closing of tenders.

CONDITIONS OF CONTRACT.

1. The services are to be performed upon an order signed by a member of the Police Force. Under the *Cemeteries Act 1958* (No. 6217), cemetery fees are not payable in the cases of poor persons buried upon an order signed by a Justice, and in such cases the contractor's account for the burial will be correspondingly reduced.

2. No claim will be allowed under this contract for any burial respecting which the Contractor receives or arranges for any payment whatever from the relatives or friends of the deceased; but in the event of friends or relatives desiring to have the deceased buried in private ground, while availing themselves of the Government funeral, they must, in such case, pay all the cemetery charges.

3. The funerals are to be of the most economical description consistent with propriety. A plain hearse for an adult, and a covered, plain, suitable four-wheeled vehicle for a child under five years of age, to be provided.

4. The body shall be taken direct to the Necropolis, or to the New Melbourne Cemetery, as the case may be. Not more than one body shall be carried in the hearse or vehicle at a time. No body shall be retained on the premises of the Contractor. Any infringement of this condition will subject the Contractor, upon report from the Tender Board, to such mulct, not exceeding \$20, as the Treasurer may direct, and the amount shall be deducted as in clause 15.

5. Coffins for funerals must be waterproof and sufficiently long, deep, wide, and substantial to bear the corpse and permit it to lie extended at full length, and must be made of 1-in., white pine timber covered with black cloth, and fastened down with screws, and pitched in the seams to prevent leakage. The Contractor shall provide 2 inches of sawdust for the bottom of the coffin; a small block of wood to keep the head of the deceased in position, and sufficient white calico to cover the body. Coffins to be properly lowered into the graves, and the graves filled up again.

6. In cases of burials of bodies which are, in the opinion of the Department ordering the burial, of a distinctly offensive character, such as of persons drowned and long in the water or such as are in a state of putrefaction from any other cause, or persons who have died from an infectious disease, such bodies shall, on certification of the officer ordering the burial that such precaution is necessary, be placed for burial in zinc-lined coffins, of timber 1 inch in thickness, hermetically sealed by soldering the lids of same, such coffins to be provided by the Contractor.

7. Bodies of deceased persons, with the exception of those provided for under clause 2, must be conveyed to the Necropolis, Springvale, for the burial should the death of such person take place in any sub-district south of the Yarra River, including burials of bodies from the Melbourne City Mortuary, and to the New Melbourne Cemetery, Fawkner, should the death take place in any sub-district north of the Yarra River, excepting bodies buried from the Melbourne City Mortuary. Burials in the Williamstown-Footscray sub-districts shall be made in the Williamstown or Footscray Cemeteries, as the police may direct, excepting bodies buried from the Melbourne City Mortuary.

Provided, however, that the Tender Board may on application by the Contractor and subject to such conditions as it may determine, authorize the burial of bodies in a cemetery other than those specified.

8. The graves to be dug of the proper depth, and in conformity with the Necropolis and respective Cemeteries Regulations.

9. In the event of the Contractor failing to attend punctually to any order, the work will be otherwise performed, and the extra expense incurred, if any, will be charged to the Contractor or deducted from the contract security money.

10. When burials are required to take place on Sunday, or, in the case of any Mental Hospital, burials on the same day as the inquest, no delay must take place in complying therewith, and any additional fees charged by the Necropolis or cemetery authorities will be repaid to the Contractor.

11. The attendance of a minister of the denomination named in the order for the burial must, if practicable, be provided. If for any burial such minister is not available the burial service is to be conducted by the resident chaplain deputed by the denomination and in cases where no such deputy is appointed by the denomination, or where the religious denomination of the deceased is unknown, the services are to be performed by the resident chaplains alternatively, and the Contractor must inform the police of the hour when the funeral service will take place, so that the friends of the deceased may attend at the cemetery if they wish. The order for burial shall be produced at the cemetery when the Contractor gives instruction for interment. The Contractor must pay the Minister's fee for reading the burial service should it be claimed.

12. Should the religious belief, however, of the deceased preclude the burial being carried out in conformity with the above clause as regards the attendance of the officiating clergyman, the friends of the deceased shall, if practicable, be notified by the police with respect to the service. In the case of foreigners, the Consul of the country to which he is reputed to belong shall also be notified by the Police Department of his decease, in which case, when practicable, the Consul may provide for such service as he may consider necessary.

13. Under no circumstances will the Contractor be permitted to use any undue or improper influence with the friends or relatives of, or any other person connected or associated with, the deceased person for the purpose of obtaining any concession or privilege whatsoever in regard to the funeral of such person. Any infringement of this condition will, on report of the Tender Board, subject the Contractor to the immediate cancellation of his contract, the forfeiture of the security money, and such other penalties as the Treasurer may direct; the decision of the Board as to whether any breach of this condition has taken place to be final and conclusive.

14. The amount is to be rendered monthly to the officer ordering the service for payment by the Treasury, Melbourne.

15. A refusal to execute orders, impropriety, neglect, or delay in conducting the funerals or any infringement of clause 11, will subject the Contractor, upon report from the Tender Board, to such mulct, not exceeding \$100, as the said Treasurer may direct, and the amount may be deducted from the Contractor's account or from the security money. It will also be in the power of the said Treasurer, upon such refusal, impropriety, neglect, or delay, to terminate the contract forthwith, and forfeit the whole or any of the security money.

16. Under no circumstances will a Contractor be permitted to abandon his contract. In the event of the Contractor failing to carry on the contract, the security money will in that case be absolutely forfeited, and in addition, the Contractor will be held liable for any loss which the Government may sustain in consequence of such failure, and may be disqualified from tendering or holding any future contract or contracts for a period of two years from the date of such disqualification.

17. Contractors are not at liberty to transfer their contracts under cover of power of attorney, coupled with an interest or otherwise, and no such transfer will be recognized by the Government.

18. The contract shall not be considered broken, infringed, or vitiated by the Government performing the service or arranging for the carrying out of the same otherwise than by the contractor in the event of urgency or emergency.

HENRY BOLTE,
Treasurer.

The Treasury,
Melbourne, 27th April, 1970.

TENDERS FOR THE SERVICE, 1970-71.

GENERAL STORES.

TENDERS will be received until Eleven o'clock a.m., on Friday, the 29th May, 1970, from persons willing to supply the under-mentioned articles in such quantities as may be ordered by the Victorian Government during the period commencing 1st July, 1970—

Schedule No. 39. Furniture, Blinds, and Carpets.

The prices tendered must not include sales tax.

Security—Five per cent. of total amount of tender accepted, but in no case will security of less than \$6 be received.

Schedules as above, with full particulars, may be obtained from the Secretary to the Tender Board, 2nd Floor, South Building, New State Public Offices, Treasury-place, Melbourne, 3002, by whom also the samples will be shown and any information afforded to persons tendering.

In all cases the total cost of each item must be extended in the columns provided.

Security will be required either in Commonwealth Treasury Bonds, or approved bank guarantee, fixed deposit receipt, Savings Bank deposit book, or non-negotiable cheque in favour of the Secretary to the Tender Board, as the tenderer may elect.

The security must be completed and the contract signed within five days of acceptance of the tender, failing which the service may be again advertised, or another tender accepted.

The lowest or any tender will not necessarily be accepted.

In the event of tenderers withdrawing or attempting to withdraw their tenders before notification of acceptance of same, or failing to take up their accepted tenders within the prescribed period after notification of acceptance, they may be disqualified from tendering or holding any future contracts for Government supplies for a period of twelve months, such disqualification to date from the notification of acceptance of tender. It is also stipulated that, if a tenderer be a member of a firm and such firm be interested in the contract, the tender shall be in the name of the firm and not in that of the individual and that, for a breach of this condition, the tender will be declared informal.

Tenders enclosed in a separate envelope, and having the words "Tender for—" (as the case may be) written thereon, must be deposited in the Tender-box at the Tender Board Offices, 2nd Floor, South Building, New State Public Offices, Treasury-place, Melbourne, 3002, or if sent by post, postage must be prepaid and the tenders addressed to the Chairman of the Tender Board, Tender Board Offices, 2nd Floor, South Building, New State Public Offices, Treasury-place, Melbourne, 3002, which office they must reach not later than by first post on the date of closing of tenders.

Read—

Nurse Student (Male)—
Junior†
At 20 years of age and under \$2,321

For—

Nurse Student (Female)—
Junior†
At 20 years of age \$1,900

Read—

Nurse Student (Female)—
Junior†
At 20 years of age and under \$1,900

By order,
V. P. SCULLY,
Secretary.

Office of the Public Service Board,
Melbourne, 21st April, 1970.

PRIVATE ADVERTISEMENTS

CITY OF DONCASTER AND TEMPLESTOWE.

LOAN No. 135.

NOTICE is hereby given that the Council of the City of Doncaster and Templestowe did at its meeting held on Monday, 16th March, 1970, for which notice of the making of a Special Order for borrowing money had been given, agree to the following resolution, that is to say:—

That the Council does by Special Order hereby resolve to borrow the principal sum of One hundred thousand dollars (\$100,000), secured by a charge over the general rates of the municipality, such sum to be raised by the grant of a mortgage in accordance with the provisions of the *Local Government Act 1958*.

The rate of interest that will be paid is 6.30 per centum per annum.

The moneys borrowed shall be repayable at the E.S. & A. Savings Bank Limited at Doncaster, Melbourne, by twenty half-yearly instalments of \$6,815.13, including principal and interest, on the 1st day of January and the 1st day of July during the currency of the loan. The first instalment shall be payable on the 1st day of January, 1971.

The purpose for which the loan is to be applied is the liquidation of part of the amount due to the English Scottish and Australian Bank Limited from which the Council has obtained an advance under section 583 of the *Local Government Act* by overdraft of current account.

The loan shall be liquidated from the receipts of money payable under the schemes constructed under the provisions of division 10 of part XIX. of the *Local Government Act 1958*.

Notice is hereby further given that the said resolution was confirmed at a meeting of the said Council held on Monday, 20th April, 1970.

3906 J. W. THOMSON, Town Clerk.

CITY OF DONCASTER AND TEMPLESTOWE.

LOAN No. 137.

Notice of Intention to Borrow the Sum of \$50,000 for Permanent Works and Undertakings.

NOTICE is hereby given that the Council of the City of Doncaster and Templestowe proposes to borrow the principal sum of Fifty thousand dollars (\$50,000), secured by a charge over the general rates of the municipality, such sum to be raised by the grant of a mortgage in accordance with the provisions of the *Local Government Act 1958*.

1. The maximum rate of interest that may be paid is 6.4 per centum per annum.

2. The purpose for which the loan is to be applied is part cost of construction of Stage 2 of the Swimming Pool Project.

3. The period of the loan shall be 30 years.

4. The moneys borrowed shall be repayable in one amount on the 1st day of May, 2000, by the creation of a sinking fund pursuant to the provisions of section 428A of the *Local Government Act 1958*, and an amount of \$752.57 will be set aside annually out of the municipal fund for such purposes.

5. Interest at the rate of 6.4 per centum per annum will be payable on the 1st day of May and the 1st day of November in each year during the currency of the loan. The first payment to be made on the 1st day of November, 1970.

PUBLIC SERVICE NOTICES

No. 452.

Public Service Act 1958, Section 50.

REGULATIONS—PART IV.—SALARIES AND INCREMENTS.

THE Public Service Board, in pursuance of the powers conferred by the *Public Service Act 1958*, hereby amends its Regulations as shown below:—

EIGHTH SCHEDULE.

PROFESSIONAL DIVISION.

Temporary Positions.

Department and Position.	Scale of Rates of Annual Salary with Incremental Stages.
CHIEF SECRETARY'S DEPARTMENT.	
SOCIAL WELFARE.	
Probation and Parole Division.	
Add—	
Probation and Parole Officer †	\$3,460—\$3,838—\$4,083—\$4,340— \$4,589—\$4,862—\$5,103—\$5,372

† Employees must possess a Diploma of Social Studies or be eligible for membership of the Australian Association of Social Workers.

This Regulation shall have effect as on and from the 27th January, 1970.

F. E. CAHILL, Chairman.
V. P. SCULLY, Secretary.

Office of the Public Service Board,
Melbourne, 17th April, 1970.

CORRIGENDUM.

PUBLIC SERVICE BOARD OF VICTORIA.
Public Service Act 1958.

REGULATIONS.—PART IV.—SALARIES AND INCREMENTS.

IN serial No. 395 published in *Government Gazette* No. 115, dated 23rd December, 1969—

FIFTH SCHEDULE.

TEMPORARY EMPLOYEES.

DEPARTMENT OF HEALTH.

MENTAL HYGIENE.

Designations of Positions and Rates of Salaries.

For—

Nurse Student (Male)—
Junior†
At 20 years of age \$2,321

6. Such moneys shall be repayable at the office of the Metropolitan Fire Brigades Board, Gisborne-street, East Melbourne.

The plans and specifications and the estimate of the cost of the proposed works and a statement showing the proposed expenditure of the moneys to be borrowed are open for inspection at the office of the Council of the City of Doncaster and Templestowe, at the Municipal Offices, Doncaster-road, Doncaster.

3902 J. W. THOMSON, Town Clerk.

CITY OF ESSENDON.

LOAN NO. 67.

Notice of Intention to Borrow the Sum of \$100,000 for Permanent Works and Undertakings.

NOTICE is hereby given that the Council of the City of Essendon intends to borrow the principal sum of \$100,000, secured by a charge over the general rates of the municipality, such sum to be raised by the grant of a mortgage in accordance with the provisions of the *Local Government Act 1958*.

(i) The maximum rate of interest that may be paid is 6.3 per centum per annum.

(ii) The purposes for which the loan is to be applied are:—

Footpath construction	\$70,000
Road works	30,000
	<u>\$100,000</u>

(iii) The period of the loan shall be ten (10) years.

(iv) The moneys borrowed shall be repayable out of the municipal fund by twenty (20) half-yearly instalments of approximately \$6,815.13 each, including principal and interest, on the 1st day of December and the 1st day of June, during the currency of the loan. The first instalment shall be payable on the 1st day of December, 1970.

(v) Such moneys shall be repayable at the Commonwealth Savings Bank of Australia, Melbourne.

The plans and specifications and the estimates of the cost of the proposed works and a statement showing the proposed expenditure of the moneys to be borrowed, are open for inspection at the Town Hall, Moonee Ponds.

Dated 20th April, 1970.

J. P. SCOTT, Town Clerk.

Town Hall, Moonee Ponds. 3989

CITY OF FOOTSCRAY.

LOAN NO. 98.

Notice of Intention to Borrow the Sum of \$115,000 for Permanent Works and Undertakings.

NOTICE is hereby given that the Council of the City of Footscray proposes to borrow the sum of One hundred and fifteen thousand dollars (\$115,000), secured by a charge over the general rates of the municipality, such sum to be raised by the grant of a mortgage in accordance with the provisions of the *Local Government Act 1958*.

That the maximum rate of interest that may be paid shall be 6.4 per centum per annum.

The purposes for which the loan is to be applied are:—

Council's contribution towards the cost of works carried out in the municipality by the Country Roads Board \$100,000

Part payment of the cost of purchasing an area of land off Kinnear-street, Footscray, for use as a rubbish tip for the inoffensive disposal and/or destruction of refuse and rubbish 15,000

\$115,000

The period of the loan shall be fifteen (15) years.

The moneys borrowed shall be repayable by providing out of the municipal fund 30 equal half-yearly instalments of \$6,019.91, which shall cover principal and interest, on the 1st day of January and the 1st day of July in each year, during the currency of the loan. The first instalment shall be payable on the 1st day of January, 1971.

Such moneys shall be repayable to the Commonwealth Savings Bank of Australia, Footscray.

The plans, specifications and estimate of the cost of the works and a statement showing the proposed expenditure of the moneys to be borrowed, are open for inspection at the Town Hall, Napier-street, Footscray.

Dated this 27th day of April, 1970.

3981 W. H. SWABY, Town Clerk.

Town and Country Planning Act 1961.—(Twelfth Schedule.)

CITY OF KNOX PLANNING SCHEME 1965.

NOTICE THAT A PLANNING SCHEME HAS BEEN PREPARED AND IS AVAILABLE FOR INSPECTION.

Amendment No. 75, 1970.

NOTICE is hereby given that the Council of the City of Knox, in pursuance of its powers under the *Town and Country Planning Act 1961*, has prepared a Planning Scheme for portions of the City of Knox for the purpose of amending the Principal Scheme by rezoning two lots in St. Elmo-avenue, Fern Tree Gully, from Special Uses (F) to Residential B, and lots 2 and 3, Underwood-road and lots 39, 40 and 41, Lording-street, Fern Tree Gully, from Residential B to Special Uses (F).

A copy of the scheme has been deposited at the office of the City of Knox, Spring-street, Fern Tree Gully, and at the office of the Town and Country Planning Board, 5th Floor, 235 Queen-street, Melbourne, and will be open for inspection during office hours by any person, free of charge.

Any persons affected by the Planning Scheme are required to set forth, in writing, all objections they may have, addressed to the Town Clerk, City of Knox, Spring-street, Fern Tree Gully, on or before the 20th day of May, 1970, and to state whether they wish to be heard in respect of their objections.

3905 N. G. HAYNES, Town Clerk.

SHIRE OF BERWICK.

LOAN NO. 44.

Notice of Intention to Borrow the Sum of \$50,000 for Permanent Works and Undertakings.

NOTICE is hereby given that the Council of the Shire of Berwick proposes to borrow the principal sum of Fifty thousand dollars (\$50,000) secured by a charge over the general rates of the Municipality, such sum to be raised by the grant of a mortgage, in accordance with the provisions of the *Local Government Act 1958*.

1. The maximum rate of interest that may be paid is 6.3 per centum per annum.

2. The purpose for which the loan is to be applied is:—
Land Acquisition :

Cockatoo—Garden City.
Part lot 193, L.P.5068 \$400.00
Part C.A. "B" 100.00

Beaconsfield.
Beaconsfield-avenue—widening part lots 1 and 33, L.P.2804 600.00
Community centre land 6,000.00

Doveton.
Lot 32, Hawthorn-road L.P.54282 .. 10,000.00
23 Betula-street, lot 693, L.P.57861 .. 1,387.00
158 Kidd-road, lot 213, L.P.58889 .. 1,515.00
2 Rowen-drive, lot 214, L.P.58889 .. 1,205.00
126A Kidd-road, lot 1, L.P.54130 .. 1,202.00
Kidd-road, lot 42, L.P.57761 .. 2,300.00

Hallam.
Charles-avenue, lots 53 and 54, L.P.43985 8,000.00

Pakenham East.
John-street, part C.A.43 3,291.00
Earl Park to Main-street, part lot 2, L.P.16990 300.00

Narre Warren.
Railway land, part C.P.22 4,500.00

Narre Warren North.
Pre-school site, part lot 1, subdivision reference 2239 5,000.00

Bunyip.
Mary-street, lot 3, L.P.63235 2,200.00

Tynong.
Depot site, lot 7, L.P.9150 2,000.00

\$50,000.00

3. The period of the loan shall be ten years.

4. The moneys borrowed shall be repayable by providing out of the municipal fund twenty half-yearly instalments of approximately \$3,407.60 each, including principal and interest, on the first day of January and the first day of

July during the currency of the loan. The first instalment shall be payable on the first day of January, 1971.

5. Such moneys shall be repayable to the Commissioners of the State Savings Bank of Victoria at the office of the said Commissioners, corner Elizabeth and Bourke streets, Melbourne.

The plans and specifications and the estimate of the cost of the proposed works and a statement showing the proposed expenditure of the moneys to be borrowed are open for inspection at the office of the Council of the Shire of Berwick, at Main-street, Pakenham East, during normal office hours.

Dated this 3rd day of April, 1970.

3966

B. J. WALLIS, Shire Secretary.

SHIRE OF BERWICK.

LOAN NO. 45.

Notice of Intention to Borrow the Sum of \$40,000 for Permanent Works and Undertakings.

NOTICE is hereby given that the Council of the Shire of Berwick proposes to borrow the principal sum of Forty thousand dollars (\$40,000), secured by a charge over the general rates of the municipality, such sum to be raised by the grant of a mortgage, in accordance with the provisions of the Local Government Act 1958.

1. The maximum rate of interest that may be paid is 6.30 per centum per annum.
2. The purposes for which the loan is to be applied are:—

Berwick Outfall Drain Contribution to D.V.A.	\$10,097
Nash-road, Bunyip: Street Construction ..	4,600
Pakenham Main-street Widening ..	2,500
Pakenham Main Drainage ..	2,203
Webb-street, Narre Warren, Street Construction ..	16,600
Nar-Nar-Goon Public Conveniences ..	4,000
Total	\$40,000

3. The period of the loan shall be ten years.
4. The moneys borrowed shall be repayable by providing out of the municipal fund twenty half-yearly instalments of \$2,726.07 each, including principal and interest, on the 10th day of June and the 10th day of December during the currency of the loan. The first instalment shall be payable on the 10th day of December, 1970.
5. Such moneys shall be repayable to the Commercial Savings Bank of Australia Limited, Pakenham East.

The plans and specifications and the estimate of the cost of the proposed works and a statement showing the proposed expenditure of the moneys to be borrowed are open for inspection at the office of the Council of the Shire of Berwick, at Main-street, Pakenham East, during normal office hours.

3895

B. J. WALLIS, Shire Secretary.

Town and Country Planning Act 1961.—(Twelfth Schedule.)

SHIRE OF CROYDON PLANNING SCHEME 1961.

NOTICE THAT A PLANNING SCHEME HAS BEEN PREPARED AND IS AVAILABLE FOR INSPECTION.

Amendment No. 21, 1969.

NOTICE is hereby given that the Croydon Shire Council, in pursuance of its powers under the Town and Country Planning Act 1961, has prepared a Planning Scheme for part of lot 52, P/S.8854, Dorset-road, Croydon, for the purpose of rezoning from Light Industrial to Commercial (Shopping).

A copy of the scheme has been deposited at the Croydon Shire Offices, Foch-avenue, Croydon, and at the office of the Town and Country Planning Board, 235 Queen-street, Melbourne, and will be open for inspection during office hours by any person, free of charge.

Any persons affected by the Planning Scheme are required to set forth, in writing, all objections they may have, addressed to the Shire Secretary, Croydon Shire Office, Foch-avenue, Croydon, on or before 29th May, 1970, and to state whether they wish to be heard in respect of their objections.

3886

K. A. MCKAY, Shire Secretary.

SHIRE OF EAST LODDON.

IN pursuance of the powers conferred by section 522 of the Local Government Act 1958, the Council of the Shire of East Loddon doth hereby direct that the land in the Parish of Janiember West, shown hatched on the plan hereunder which has been purchased or acquired by it, shall be a public highway from and after the date of publication of this Order in the Government Gazette.

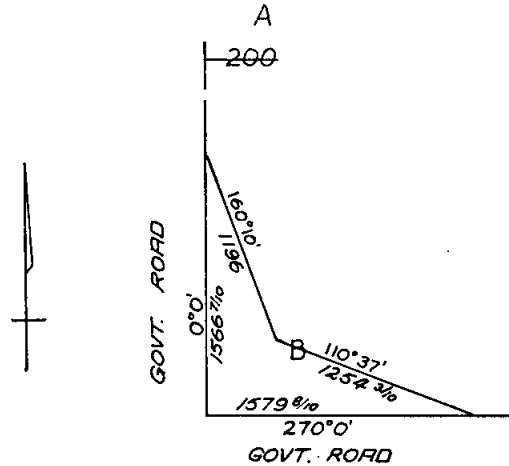

Measurements are in links

The common seal of the President, Councillors and Ratepayers of the Shire of East Loddon was hereunto affixed this 23rd day of April, 1970, in the presence of—

(SEAL) H. J. VINNICOMBE, President.
H. W. TWIGG, Councillor.
T. J. RUDKINS, Secretary.

3979

SHIRE OF EAST LODDON.

IN pursuance of the powers conferred by section 522 of the Local Government Act 1958, the Council of the Shire of East Loddon doth hereby direct that the land in the Parish of Jarclin shown hatched on the plan hereunder which has been purchased or acquired by it, shall be a public highway from and after the date of publication of this Order in the Government Gazette.

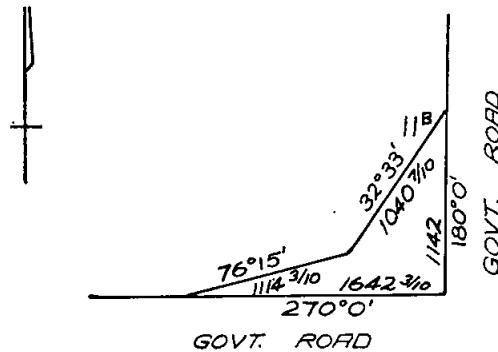

Measurements are in links

The common seal of the President, Councillors and Ratepayers of the Shire of East Loddon was hereunto affixed this 23rd day of April, 1970, in the presence of—

(SEAL) H. J. VINNICOMBE, President.
H. W. TWIGG, Councillor.
T. J. RUDKINS, Secretary.

3980

SHIRE OF HASTINGS.
ORDER—NAMING STREETS.

IN accordance with the provisions of the *Local Government Act 1958*, the Council of the Shire of Hastings has made an Order naming the following streets within the municipal district:—

1. *Reid-parade*.
Location.—Runs in an easterly direction between Salmon-street and Frankston-Flinders road, Hastings, commencing immediately north of the Warringine Creek bridge on the Frankston-Flinders road.
2. *Ross-street*.
Location.—Runs north/south between Reid-parade and Martin-street, Hastings, commencing approximately 1,050 feet west of Salmon-street.
3. *Gaskin-avenue*.
Location.—Runs off the south side of Martin-street, Hastings, commencing approximately 250 feet west of Salmon-street, and turns in a westerly direction to join Ross-street.
4. *Perrott-court*.
Location.—Runs off the south/east side of Gaskin-avenue, commencing approximately 400 feet south of Martin-street.
5. *Knox-court*.
Location.—Runs off the south side of Martin-street, Hastings, commencing approximately 500 feet west of Salmon-street.
6. *Floyd-court*.
Location.—Runs off the south side of Martin-street, Hastings, commencing approximately 800 feet west of Salmon-street.

L. A. WALKER, Shire Secretary.

Municipal Offices, Hastings, 24th April, 1970. 4010

Town and Country Planning Act 1961.

SHIRE OF MAFFRA.—MAFFRA PLANNING SCHEME 1965.

NOTICE THAT A PLANNING SCHEME HAS BEEN PREPARED AND IS AVAILABLE FOR INSPECTION.

Amendment No. 2, 1970.

NOTICE is hereby given that the Shire of Maffra, in pursuance of its powers under the *Town and Country Planning Act 1961*, has prepared a Planning Scheme for Public Purposes Reserve and Pound Reserve, bounded by John, George and Kent streets, Maffra, for the purpose of altering the zoning to Residential.

A copy of the scheme has been deposited at the office of the Shire of Maffra, Johnson-street, Maffra, and at the office of the Town and Country Planning Board, 235 Queen-street, Melbourne, and will be open for inspection during office hours by any person, free of charge.

Any persons affected by the Planning Scheme are required to set forth, in writing, all objections they may have, addressed to the Shire Secretary, Shire Office, Maffra, on or before the 31st July, 1970, and to state whether they wish to be heard in respect of their objections.

20th April, 1970.

3903 J. RENNICK, Municipal Clerk.

Town and Country Planning Act 1961.

SHIRE OF MAFFRA.—MAFFRA PLANNING SCHEME 1965.

NOTICE THAT A PLANNING SCHEME HAS BEEN PREPARED AND IS AVAILABLE FOR INSPECTION.

Amendment No. 3, 1970.

NOTICE is hereby given that the Shire of Maffra, in pursuance of its powers under the *Town and Country Planning Act 1961*, has resolved to amend the Maffra Planning Scheme 1965 in relation to the erection of flats in the Residential Zone.

A copy of the scheme has been deposited at the office of the Shire of Maffra, Johnson-street, Maffra, and at the office of the Town and Country Planning Board, 235 Queen-street, Melbourne, and will be open for inspection during office hours by any person, free of charge.

Any persons affected by the Planning Scheme are required to set forth, in writing, all objections they have, addressed to the Shire Secretary, Shire Office, Maffra, on or before the 29th May, 1970, and to state whether they wish to be heard in respect of their objections.

20th April, 1970.

3904 J. RENNICK, Municipal Clerk.

SHIRE OF MORNINGTON.

LOAN No. 70.

Notice of Intention to Borrow the Sum of \$30,000 for Permanent Works and Undertakings.

NOTICE is hereby given that the Council of the Shire of Mornington proposes to borrow the principal sum of \$30,000, secured by a charge over the general rates of the municipality, such sum to be raised by the grant of a mortgage in accordance with the provisions of the *Local Government Act 1958*.

1. The maximum rate of interest that may be paid is 6.4 per cent. per annum.

2. The moneys borrowed are to be repaid to the National Bank Savings Bank Limited, at the head office of the said Bank in Melbourne or at such other place as the Bank may require.

3. The purpose for which the loan is to be applied is—

Purchase of land, described hereunder, for Places of Public Resort and Recreation and Car Parks (* refer footnote):—

(a) Land fronting Tyabb-road, Moorooduc, being an area of approximately 25 acres (part cost), and

(b) Land at the rear of land fronting Tyabb-road, Moorooduc, being an area of approximately ten acres (adjoining area (a)).

4. The moneys borrowed shall be repayable by providing out of the municipal fund 40 half-yearly instalments of approximately \$1,340.16 each, including principal and interest, on the first days of December and June during the period of the loan. The first instalment shall be payable on the 1st day of December, 1970.

5. The period of the loan shall be twenty years, from 1st June, 1970.

The plans and specifications and the estimate of the cost of such works and undertakings, and a statement of the proposed expenditure of the money to be borrowed, are open for inspection at the office of the Council of the Shire of Mornington, Queen-street, Mornington.

D. G. COLLINGS, Shire Secretary.

* Council contemplates that at some appropriate future time portion of this land may be used for regional developments, pursuant to any future amendments to the relevant planning scheme, subject to these being approved by the Governor in Council. 3892

SHIRE OF TULLAROOP.

BY-LAW No. 29.

A By-law of the Shire of Tullaroop made under Section 197 of the *Local Government Act 1958* and Sections 92 and 93 of the *Health Act 1958* and numbered 29 for the purpose of amending the Schedule described in By-law number 22 which regulates the keeping of animals and birds.

IN pursuance of the powers contained in the *Health Act 1958* and the *Local Government Act 1958* and any other power enabling it in that behalf, the Council of the Shire of Tullaroop in the name of the President, Councillors and Ratepayers of the said Shire for the purpose of carrying the said Act into execution within their jurisdiction, make the following By-law:—

1. This By-law shall be read and construed as one with By-law No. 22, By-law No. 24 and any By-law amending the same.

2. The schedule referred to and described in By-law No. 22 shall be amended by adding to the area previously described the following land in Carisbrook:

(a) The area with the boundary commencing at the south end of Church Street; thence by lines leading respectively southerly along a line parallel to the Talbot-Eddington Road to a point ten chains south of Victoria Street, westerly along a line parallel to and ten chains south of Victoria Street to a point in line with Pleasant Street, northerly along Pleasant Street to the Maryborough—Castlemaine Railway, north-westerly along the Maryborough—Castlemaine Railway to Church Street and southerly along Church Street to the point of commencement.

(b) The area with the boundary commencing at the intersection of the Maryborough—Castlemaine Railway and Cameron Street; thence by lines leading north-easterly along the Maryborough—Castlemaine Railway to Moolort Street, easterly along Moolort Street to Heape Street, south-westerly along Heape Street to Hunter Street, south-easterly along Hunter Street to Simson Street and continuing in a line parallel to

Hunter Street to the Deep Creek, westerly and southerly along the Deep Creek to a point in line with Cameron Street and north-westerly along Cameron Street to the point of commencement.

3. Application for registration of any poultry farm, situated within the additional areas included in the schedule and described in Clause 2 of the By-law, as a "Commercial Poultry Farm" shall be lodged in writing at the Tullaroop Shire Office not later than June 30th, 1970 if it is desired that the exemptions applicable to "Commercial Poultry Farms" as listed in Part 2, Paragraphs 1 and 2 of By-law No. 22 are to apply to such premises.

4. Application for registration of any stable, situated within the additional areas included in the schedule and described in Clause 2 of this By-law, as a "Registered Stable" shall be lodged in writing at the Tullaroop Shire Office not later than 30th June, 1970, if it is desired that

the exemptions applicable to "Registered Stables" as listed in Part 5, Paragraph 1 of By-law No. 22 are to apply to such premises.

Resolution for passing this By-law agreed to by the Council of the Shire of Tullaroop on the 14th day of October, 1969, and confirmed on the 11th day of November, 1969.

The corporate seal of the Shire of Tullaroop was hereunto affixed in the presence of—

(SEAL) COLIN J. FORBES, President.
JOHN C. HARKIN, Councillor.
BRIAN F. O'CONNOR, Secretary.

Approved by the Governor in Council, 24th March, 1970.—J. ROSSITER, Clerk of the Executive Council.

Submitted to the Commission of Public Health at its meeting on 24th February, 1970.—A. T. GARDNER, Secretary, Commission of Public Health. 3877

SHIRE OF TOWONG.

IN pursuance of the powers conferred by sections 522 and 526 of the Local Government Act 1958, the Council of the Shire of Towong doth hereby direct that the land in the Parish of Tallandoon shown hatched on the plan hereunder, which has been taken, purchased or acquired by it, shall be a public highway from and after the date of publication of this order in the Government Gazette.

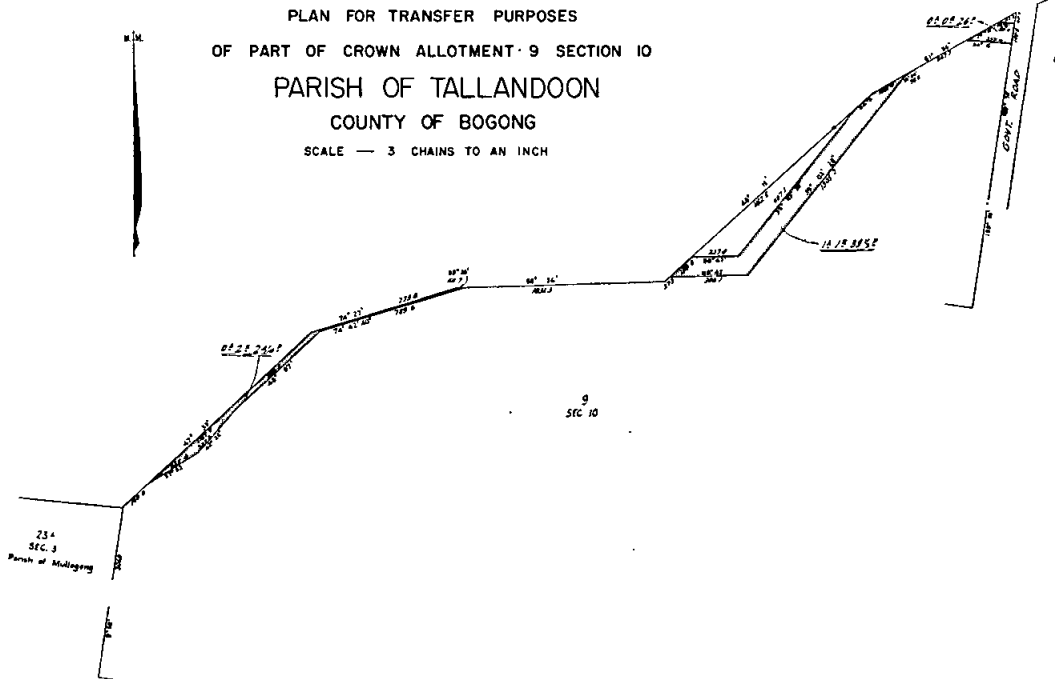

The common seal of the President, Councillors and Ratepayers of the Shire of Towong was hereunto affixed this 16th day of February, 1970, in the presence of—

(SEAL) JAS. H. HARVEY, President.
D. F. KELLY, Councillor.
I. MCK. BOWMAN, Secretary.

3874

SHIRE OF YEA.

LOAN NO. 41.

Notice of Intention to Borrow the Sum of \$8,000 for Permanent Works and Undertakings.

NOTICE is hereby given that the Council of the Shire of Yea proposes to borrow the principal sum of eight thousand dollars on the credit of the municipal revenues of the President, Councillors and Ratepayers of the said Shire, such sum to be raised by the grant of a mortgage in accordance with the provisions of the Local Government Act 1958, as amended.

1. The maximum rate of interest that may be paid is 6.10 per cent. per annum.

2. Such moneys shall be repayable to the Commercial Savings Bank of Australia, at the office of the said Bank, 337 Collins-street, Melbourne, by half-yearly instalments due on 10th January, and 10th July, during the currency of the loan.

3. The purposes for which the loan is to be applied is—

Purchase of Roadmaking Plant and Machinery	\$6,500
Preparation of a Planning Scheme and for works and undertakings pursuant to such scheme and for the acquisition of land in Snodgrass-street, Yea	1,500
	<u>\$8,000</u>

4. The moneys borrowed shall be repayable by providing out of the municipal fund ten half-yearly instalments of \$940.25 each, including principal and interest and the first instalment shall be payable on the 10th day of January, 1971.

The plans and specifications and the estimate of the cost of the proposed works and a statement showing the proposed expenditure of the moneys to be borrowed are open for inspection at the office of the Council of the Shire of Yea.

Dated 27th April, 1970.

3964 F. F. BERKERY, Shire Secretary.

FRANKSTON SEWERAGE AUTHORITY.

DECLARATION OF SEWERED AREA No. 17.

THE Frankston Sewerage Authority, having made provision for carrying off sewage from each and every property which or any part of which is within the sewerage area hereinafter described, doth hereby declare that on and after the 1st day of May, 1970, each and every property which or any part of which is within the said sewerage area shall be deemed to be a seweraged property within the meaning of the *Sewerage Districts Act 1958*.

The boundaries of the sewerage area hereinbefore referred to are:—

Area No. 17.

Commencing at the western corner of No. 237 Frankston-Dandenong road, then north-easterly along Frankston-Dandenong road to northern corner of No. 253, then along the north-eastern boundary of No. 253 Frankston-Dandenong road to the eastern corner, then north-easterly and south-easterly along the rear and side boundaries of No. 1 Plantation-avenue to Plantation-avenue, then southerly along Plantation-avenue to Pine-street, then easterly and north-easterly along Pine-street to Tallowood-street, easterly along Tallowood-street to Blackbutt-court, southerly along Blackbutt-court to the north-western corner of No. 3 Blackbutt-court, easterly along the northern boundaries of No. 3 Blackbutt-court and No. 19 Messmate-street to Messmate-street and continuing on the same line across Reserve to Silvertop-street, then northerly along Silvertop-street to Forest-drive, easterly along Forest-drive to Hickory-crescent, southerly and easterly along Hickory-crescent to Stone-street, southerly along Stone-street to Coolgardie-street, easterly along Coolgardie-street to Longleaf-street, then to the north-western corner of No. 39 Longleaf-street and along its northern boundary, then southerly along rear of Nos. 39 and 41 Longleaf-street, then north-westerly along the southern boundary of No. 41 Longleaf-street, across Longleaf-street and along side boundary of No. 26 Longleaf-street, along the rear boundaries of No. 48 to No. 4 Coolgardie-street, and the southern boundary of No. 19 Silvertop-street, across Silvertop-street, along the southern boundary of the Reserve, across Messmate-street, along the southern boundary of No. 23 Messmate-street, and the rear boundaries of No. 5 and No. 7 Blackbutt-court, along the rear boundaries of Nos. 44 to 2 Pine-street and along the southern boundary of No. 237 Frankston-Dandenong road to the point of commencement.

By Order of the said Sewerage Authority,

H. V. JOHNSTON, Chairman.
G. C. PENTLAND, Secretary.

Civic Centre, Frankston, 27th April, 1970. 3983

NOTICE is hereby given that C. Monteath & Sons (Successors) Proprietary Limited, has applied for a lease, pursuant to section 134 of the *Land Act 1958*, for a term of ten years in respect of allotment 9, section 101A, City of South Melbourne, containing 1 rood 18 2/10 perches, as a site for a factory and general engineering works. 3793

GEMBROOK, COCKATOO AND EMERALD WATERWORKS TRUST.

NOTICE TO OWNERS OF TENEMENTS IN THE STREETS LISTED HEREUNDER.

THE main pipes in the said streets being laid down, the owners of all tenements situated in these streets are hereby required on or before the 22nd April, 1971, to cause a proper pipe and stop cocks to be laid so as to supply water within such tenements from the main pipe:—

EMERALD.

List of Streets.

Anne-street, from 440 feet east of Church-street approximately 65 feet easterly.
Curtis-road, from Upton-road 190 feet westerly.
D'Urban-road, from 560 feet southerly and easterly of Old Gembrook-road, 540 feet easterly.
Queen's-road (Emerald Lake-road), from Princess-avenue 1,000 feet easterly.
Sherriff-road, from Queen's-road to Old Gembrook-road.

COCKATOO.

Woodrow-court, from View Hill-road, 80 feet easterly.

BEATRICE THOMAS, Secretary,
Gembrook, Cockatoo and Emerald Waterworks Trust.

3901

Water Acts.

PROPOSED DERRINALLUM URBAN DISTRICT AND PROPOSED EXTENSION OF THE WATERWORKS DISTRICT OF THE LISMORE WATERWORKS TRUST.

NOTICE is hereby given that the Lismore Waterworks Trust has made application to the Honorable the Minister of Water Supply for the extension of the Lismore Waterworks District, and for the proclamation of an Urban District at Derrinallum, and the construction, maintenance, and continuance of Water Supply Works within that District under the provisions of the Water Acts.

A general plan and description of the proposed works have been submitted with the application, and copies of same may be seen at the (Trust's) office at Lismore.

Dated at Lismore the 16th day of April, 1970.

3840

JOSEPH S. SMITH, Secretary.

NOTICE OF INTENTION TO APPLY FOR A LICENCE TO DIVERT WATER AND CUT RACE FROM THE RIVER MURRAY, AT YUNGERA.

I HEREBY give notice that I intend to apply for a licence empowering me to divert water for a term of fifteen years to the extent of 150 acre-feet per annum at a maximum rate of 5 acre-feet per day of 24 hours for the irrigation of pastures and market garden, being allotment 3, Parish of Yungera, and to occupy certain Crown lands for works of diversion, and to cut a race thereon.

Any objection to such application must be forwarded, in writing, to reach the State Rivers and Water Supply Commission, Melbourne, before 29th May, 1970, being 30 days from the first publication of this notice.

ARTHUR COLIN CAMERON.

Box 5, Boundary Bend.

3907

NOTICE OF INTENTION TO APPLY FOR A LICENCE TO DIVERT WATER AND CUT RACE (RE-ISSUE) FROM THE RIVER MURRAY, AT BARNAWARTHA NORTH, 3688.

I HEREBY give notice that I intend to apply for a licence empowering me to divert water for a term of 10 years to the extent of 50 acre-feet per annum at a maximum rate of 2 acre-feet per day of 24 hours for the 25 acres of crops and pasture, being part of allotments 1-17, Township of Boorgunyah, allotments 12, 13 and 14, section F, Parish of Barnawartha North, and to occupy certain Crown lands for works of diversion, and to cut a race thereon.

Any objection to such application must be forwarded, in writing, to reach the State Rivers and Water Supply Commission, Melbourne, before 29th May, 1970, being 30 days from the first publication of this notice.

PHILLIP JAMES SYMONS.

"Red Bank", Barnawartha North, 3688.

3908

NOTICE OF INTENTION TO APPLY FOR A LICENCE TO DIVERT WATER AND CUT RACE (RE-ISSUE) FROM THE RIVER MURRAY, AT ROBINVALE.

I HEREBY give notice that I intend to apply for a licence empowering me to divert water for a term of fifteen years to the extent of 63 acre-feet per annum at a maximum rate of 5 acre-feet per day of 24 hours for the irrigation of vines, orchard and market garden, being part of allotment 2A, lot 4 on lodged plan 29193, Parish of Bumbang, and to occupy certain Crown lands for works of diversion, and to cut a race thereon.

Any objection to such application must be forwarded, in writing, to reach the State Rivers and Water Supply Commission, Melbourne, before 29th May, 1970, being 30 days from the first publication of this notice.

PAUL LANZA.

Box 192, Robinvale.

3909

NOTICE OF INTENTION TO APPLY FOR A LICENCE TO DIVERT WATER AND CUT RACE (RE-ISSUE) FROM THE RIVER MURRAY, AT SWAN HILL AND LITTLE MURRAY RIVER, AT PENTAL ISLAND.

WE hereby give notice that we intend to apply for licences empowering us to divert water for a term of five years to the extent of 968 acre-feet per annum at a maximum rate of 50 acre-feet per day of 24 hours for the irrigation of 484 acres of pasture, being part of allotments 1, 2, 10B and 13, Parish of Pental Island, and to occupy certain Crown lands for works of diversion, and to cut a race thereon.

Any objection to such application must be forwarded, in writing, to reach the State Rivers and Water Supply Commission, Melbourne, before 29th May, 1970, being 30 days from the first publication of this notice.

C. T. JAMES.
K. L. JAMES.
3910

Box 122, Swan Hill.

NOTICE OF INTENTION TO APPLY FOR A LICENCE TO DIVERT WATER AND CUT RACE FROM THE RIVER MURRAY AT IRAAK.

I HEREBY give notice that I intend to apply for a licence empowering me to divert water for a term of fifteen years to the extent of 9 acre-feet per annum at a maximum rate of 15 acre-feet per day of 24 hours for the irrigation of vines, citrus and vegetables, being part of allotment 29, Parish of Carwarp, and to occupy certain Crown lands and portion of a school reserve at Iraak, for works of diversion and to cut a race thereon.

Any objection to such application must be forwarded, in writing, to reach the State Rivers and Water Supply Commission, Melbourne, before the 29th May, 1970, being 30 days from the first publication of this notice.

MURRAY R. WILCOX.

Care of Messrs. Hillards, solicitors, 71 Deakin-avenue, Mildura, 3500. 3912

NOTICE OF INTENTION TO APPLY FOR A LICENCE TO DIVERT WATER AND CUT RACE FROM THE RIVER MURRAY AT IRAAK.

WE hereby give notice that we intend to apply for a licence empowering us to divert water for a term of fifteen years to the extent of 42 acre-feet per annum at a maximum rate of 15 acre-feet per day of 24 hours for the irrigation of vines, citrus and vegetables, being part of allotment 29, Parish of Carwarp, and to occupy certain Crown lands and portion of a school reserve at Iraak, for works of diversion and to cut a race thereon.

Any objection to such application must be forwarded, in writing, to reach the State Rivers and Water Supply Commission, Melbourne, before the 29th May, 1970, being 30 days from the first publication of this notice.

JOHN CHARLES GRATTON.
GREGORY PHILIPS MOORE.
BRUCE GORDON JACKSON.

Care of Hillards, solicitors, 71 Deakin-avenue, Mildura. 3913

NOTICE OF INTENTION TO APPLY FOR A LICENCE TO DIVERT WATER AND CUT RACE (RE-ISSUE) FROM THE RIVER MURRAY, AT BENJEROOP.

I HEREBY give notice that I intend to apply for a licence empowering me to divert water for a term of fifteen years to the extent of 40 acre-feet per annum at a maximum rate of 5 acre-feet per day of 24 hours for the purpose of irrigating pasture, being part of allotment 5A, section 2, Parish of Benjeroop, and to occupy certain Crown lands for works of diversion, and to cut a race thereon.

Any objection to such application must be forwarded, in writing, to reach the State Rivers and Water Supply Commission, Melbourne, before 29th May, 1970, being 30 days from the first publication of this notice.

DONALD GRANT CALDWELL.

R.M.S. 452, Kerang, Victoria. 3961

NOTICE OF INTENTION TO APPLY FOR A LICENCE TO DIVERT WATER AND CUT RACE (RE-ISSUE) FROM THE RIVER MURRAY, AT WHARPARILLA.

I HEREBY give notice that I intend to apply for a licence empowering me to divert water for a term of fifteen years to the extent of 1,000 acre-feet per annum at a maximum rate of 20 acre-feet per day of 24 hours for the irrigation of 2,112 acres, being lots 1, 2, 3, 4, 5, 6, 17, 19A, 19E, 19F, 19G, Parish of Turrumberry, and to occupy certain Crown lands for works of diversion, and to cut a race thereon.

Any objection to such application must be forwarded, in writing, to reach the State Rivers and Water Supply Commission, Melbourne, before 29th May, 1970, being 30 days from the first publication of this notice.

HUGH C. OLIVER.

445 St. Kilda-road, Melbourne. 3962
No. 43.—3459/70.—4

NOTICE OF INTENTION TO APPLY FOR A LICENCE TO DIVERT WATER AND CUT RACE (RE-ISSUE) FROM THE GOULBURN RIVER, AT EILDON.

WE hereby give notice that we intend to apply for a licence empowering us to divert water for a term of fifteen years to the extent of 50 acre-feet per annum at a maximum rate of one acre-foot per day of 24 hours for the irrigation of 25 acres of pasture, being part of allotment Crown pre-emptive, section A, Parish of Eildon, and to occupy certain Crown lands for works of diversion, and to cut a race thereon.

Any objection to such application must be forwarded, in writing, to reach the State Rivers and Water Supply Commission, Melbourne, before 29th May, 1970, being 30 days from the first publication of this notice.

Mrs. M. E. A. NICHOLAS.
R. L. NICHOLAS.

Thornton, Victoria 3712.

3960

NOTICE OF INTENTION TO APPLY FOR A LICENCE TO DIVERT WATER AND CUT RACE (RE-ISSUE) FROM THE RIVER MURRAY, ANA BRANCH, AT MILDURA.

WE hereby give notice that we intend to apply for a licence empowering us to divert water for a term of fifteen years to the extent of 24 acre-feet per annum at a maximum rate of 1 acre-foot per day of 24 hours for the irrigation of 6 acres of pasture, being part of allotments 10 and 11, section 5A, Parish of Mildura, and to occupy certain Crown lands for works of diversion, and to cut a race thereon.

Any objection to such application must be forwarded, in writing, to reach the State Rivers and Water Supply Commission, Melbourne, before 29th May, 1970, being 30 days from the first publication of this notice.

KENNETH ARTHUR ELLERY.
MARGARET ELLERY.

Care of Post Office, Nichols Point, Victoria 3501. 3958

NOTICE OF INTENTION TO APPLY FOR A LICENCE TO DIVERT WATER AND CUT RACE (RE-ISSUE) FROM THE GOULBURN RIVER, AT MANGALORE.

WE hereby give notice that we intend to apply for a licence empowering us to divert water for a term of fifteen years to the extent of 200 acre-feet per annum at a maximum rate of 20 acre-feet per day of 24 hours for the irrigation of 200 acres of lucerne and pastures, being part of lot 2, Parish of Mangalore, and to occupy certain Crown lands for works of diversion, and to cut a race thereon.

Any objection to such application must be forwarded, in writing, to reach the State Rivers and Water Supply Commission, Melbourne, before 29th May, 1970, being 30 days from the first publication of this notice.

C. G. GRIFFITHS.
D. E. GRIFFITHS.

"Yamarla", Mangalore 3663, Victoria. 3959

NOTICE is hereby given that "Tor Fibrous Plaster", a firm registered under the *Business Names Act 1962*, of the State of Victoria and carrying on the business of Fibrous Plasterers, at 257 Princes Highway, Dandenong (previously 29 Booloora-road, Springvale), will not accept liability for any debts incurred in its name as from 16th April, 1970, without the consent, in writing, of both partners.

FRANCIS THOMAS SKINNER, Partner.
BRUCE PETER LAWSON, Partner.
3931

NOTICE is hereby given that the partnership heretofore subsisting between Linda Nellie Olsen, of 26 Blair-street, Broadmeadows, and Dorothy May Reardon, of Flat 5, 27 Harold-street, Ascot Vale, carrying on business at 26 Blair-street, Broadmeadows, as Parcel Delivery and Messenger Service, under the name of "All-Brite Messenger Service", has been dissolved by mutual consent as from the 28th day of February, 1970, by the retirement of the said Dorothy May Reardon from the said firm on that date. All debts due to and owing by the said firm shall be received and paid by the said Linda Nellie Olsen, who will continue to carry on the business under the same firm name, at 26 Blair-street, Broadmeadows.

Dated this 28th day of February, 1970.

Signed by the said Linda Nellie Olsen—

L. OLSEN.

Signed by the said Dorothy May Reardon—

3956

D. M. REARDON.

NOTICE is hereby given that the partnership heretofore subsisting between Patrick Ryan, of 12 Winter-street, Geelong, and Patrick Clarence McCormack, of Healy's Point Hotel, Dynon-road, South Kensington, carrying on business at Healy's Point Hotel, Dynon-road, South Kensington, under the name of "P. Ryan & P. C. McCormack", has been dissolved by mutual consent as from the 22nd day of April, 1970, by the retirement of the said Patrick Ryan, from the said firm on that date. All debts due to and owing by the said firm shall be received and paid by the said Patrick Clarence McCormack, who will continue to carry on the business at Healy's Point Hotel, Dynon-road, South Kensington.

Dated this 22nd day of April, 1970.

Signed by the said Patrick Ryan, in the presence of—
M. J. CORRIGAN.

P. RYAN.

Signed by the said Patrick Clarence McCormack, in the presence of—G. A. CONLAN.

3944

P. C. McCORMACK.

NOTICE is hereby given that the partnership heretofore subsisting between Lola Smibert, of Skye-road, Frankston, and Mavis Elsie Cutts, of 187 Heidelberg-road, Fairfield, and under which partnership they carried on the business of Caterers at Malo House, Skye-road, Frankston, under the firm name of Malo Catering, has been dissolved as from the 28th February, 1970, the said Lola Smibert having retired from the said firm. The business will hereafter be carried on in partnership at Malo House, Skye-road, Frankston, by the said Mavis Elsie Cutts and Ronald George Cutts, and all moneys due to the said firm and all debts owing by the said firm will be received and paid by them respectively.

Dated this 3rd day of April, 1970.

LOLA SMIBERT.

Witness—BARNET ROCKMAN.

MAVIS E. CUTTS.
RONALD G. CUTTS.

Witness—W. H. PEAKE.

4007

NOTICE is hereby given that, as from the 1st of May, 1970, Dr. L. H. Larsen has elected to retire from general practice and has therefore ceased to be a partner in the medical practice of Doctors T. Farrell, J. James and L. Larsen, at 213 Church-street, Middle Brighton (Surgery—3 Collington-avenue, Middle Brighton).

The practice will continue as before with the remaining partners.

L. LARSEN.
T. FARRELL.
J. JAMES.

4009

CHANGE OF OWNERSHIP OF REAL ESTATE FIRM.

WE, Duncan Joseph McColl, of 28 Lansell-avenue, Hightett, and Hector Edward Ragg of 9 Lansdown-road, Hampton, formally trading as partners in the (Real Estate) firm known as Mentone Estate Agency and Beaumaris Estate Agency do hereby give notice to the public generally and to our clients of the dissolution of the said partnership of the said Real Estate firm as from the 31st August, 1969, as per our dissolution of the same date.

And we the said Duncan Joseph McColl and the said Hector Edward Ragg do further give notice that the above-mentioned firm, agency and business is now being continued by a private company known as D. J. McColl and Co. Pty. Ltd. (which company incorporates Mentone and Beaumaris Real Estate Agency).

3878

The Companies Act 1961.—In the matter of GARTH CONSTRUCTIONS PTY. LTD. (in Liquidation).

NOTICE is hereby given that, pursuant to section 272 of the Companies Act, a Final Meeting of the creditors of the above company will be held at the offices of Bent & Cogle, on Tuesday, 2nd June, 1970; at 10.30 a.m.

Business: To receive the liquidator's accounts.

Dated this 21st day of April, 1970.

D. J. COUGLE, Liquidator.

Bent & Cogle, public accountants, Suite 18, 545 St. Kilda-road, Melbourne.

3888

In the matter of the Companies Act 1961 and LAND AND EQUITIES LIMITED—45938.

NOTICE is hereby given that a general meeting of the company will be held at Room 1, 10th Floor, 422 Collins-street, Melbourne, on the 4th day of June, 1970, at 4 p.m., to receive the final account of the liquidator.

3957

R. C. BACKHOLER, Liquidator.

The Companies Act 1961.—In the matter of the following companies (in Voluntary Liquidation).—Members Winding Up.

BENSAMAR PTY. LTD.
BALWYN COURT PTY. LTD.
BURKE ROAD HEIGHTS PTY. LTD.
YARN DYERS PTY. LTD.
TWO FAWKNER STREET PTY. LTD.
BRANDSAM PTY. LTD.
BRANDJOHN PTY. LTD.
BRANDPAUL PTY. LTD.
JOANN HOLDINGS PTY. LTD.
ANSAM HOLDINGS PTY. LTD.
SAJAN HOLDINGS PTY. LTD.
JOHNPAUL HOLDINGS PTY. LTD.
BRANDANN PROPRIETARY LIMITED.

NOTICE is hereby given that at the Extraordinary General Meeting of the above-named companies duly convened and held at 2 Vida-street, Essendon, in the State of Victoria, on the 24th day of April, 1970, the following Resolution was proposed and passed as a Special Resolution:—

"That the company be wound up voluntarily."

Dated this 25th day of April, 1970.

R. W. BETTS, Liquidator.

Messrs. Cooper Brothers & Co., chartered accountants,
461 Bourke-street, Melbourne.

3890

H. E. STONE (DISTRIBUTORS) PROPRIETARY LIMITED.
SPECIAL RESOLUTION TO WIND UP, PURSUANT TO SECTION 254 OF THE COMPANIES ACT 1961.

AT an Extraordinary General Meeting of the above-named company, duly convened and held at 200 Little Lonsdale-street, Melbourne, on the 22nd day of April, 1970, the following Resolution was duly passed as a Special Resolution:—

"That the company be wound up voluntarily."

And at such last-mentioned meeting Edward Manning Fyson was appointed liquidator for the purpose of the winding up.

Dated this 22nd day of April, 1970.

3900

E. M. FYSON, Liquidator.

The Companies Act 1961.—In the matter of SUNRAYSA FISH & GAME DISTRIBUTORS PTY. LTD.—Notice of Final Meeting.

NOTICE is hereby given that, pursuant to section 272 of the Companies Act 1961, a General Meeting of the members of the above-named company will be held at 114 Ontario-avenue, Mildura, on Saturday, 30th May, 1970, at 10 o'clock in the forenoon, for the purpose of having an account laid before them showing the manner in which the winding up has been conducted and the property of the company disposed of, and of hearing any explanation that may be given by the liquidator.

Dated the 17th day of April, 1970.

3881

ARTHUR KINERL MILLS, Liquidator.

SOUTHERN PLANNING (VICTORIA) PROPRIETARY LIMITED (IN VOLUNTARY LIQUIDATION).

Members' Final Meeting.

NOTICE is hereby given that, in terms of section 272 of the Companies Act 1961, as amended, the final meeting of the company will be held at the office of Treweeke, Loder & Co., 275 George-street, Sydney, New South Wales, on Wednesday, the 3rd day of June, 1970, at 10 o'clock a.m., for the purposes of having laid before it by the liquidator an account showing how the winding up has been conducted and the property of the company disposed of.

Sydney, 27th April, 1970.

4008

H. G. TREWEEKE, Liquidator.

The Companies Act 1961.—In the matter of AUTO PRINT PTY. LTD. (in Liquidation)—Regulation 28 (b).

NOTICE is hereby given that a meeting of the creditors of Auto Print Proprietary Limited will be held in the National Mutual Life Association Theatre, 447 Collins-street, Melbourne, on Friday, the 8th day of May, 1970, at 10.30 a.m.

Dated this 28th day of April, 1970.

DAVID A. CRAWFORD, Official Liquidator.

John C. Couzens & Associates, 527 Collins-street, Melbourne, 3000.

4011

Unclaimed Moneys Act 1962.

REGISTER of Unclaimed Moneys held by the—

Name of Owner on Books and Last Known Address.	Total Amount Due to Owner.	Description of Unclaimed Moneys.	Date when Amount first became Payable.
§			
THE BROKEN HILL PROPRIETARY COMPANY LIMITED.			
Albright, Valerie B. (Mrs.), 8/13 Drummond-street, Belmore, N.S.W.	43.42	Dividend and/or Interest ..	1.4.68
Alexander, Tana M., 21 Hays Mews, London, W.1, U.K. . . .	21.67	" " " " ..	" "
Alford, Robert G., 34 Wolseley-road, Mosman, N.S.W. 2088 ..	43.52	" " " " ..	" "
Allen, Colin R., 76 Woonama-avenue, Wahroonga, N.S.W. 2076 ..	19.00	" " " " ..	" "
Allen, Loudon G., Post Office, Westmere, Wanganui, N.Z. . . .	13.82	" " " " ..	" "
Allen, Mary E. (Mrs.), Mission-road, Westmere, via Wanganui ..	42.80	" " " " ..	" "
Ambrose, Eric S., Maccab, The Ridgeway, London, N.W.7, U.K. . .	13.14	" " " " ..	" "
Arnold Bloch Nominees Pty. Ltd., 167 Queen-street, Melbourne, Vic. 3000	332.50	" " " " ..	" "
Assael, Stanley I., 1225 Broadway, New York, 10001, U.S.A. . . .	32.30	" " " " ..	" "
Bamford, Nina C. (Miss), 6 Goldington-avenue, Bedford, U.K. . . .	13.17	" " " " ..	" "
Bank of New South Wales (London) Nominees Ltd., "E" Account, 29 Threadneedle-street, London, E.C.2, U.K. . . .	54.52	" " " " ..	" "
Banom Corporation, 36 Wall-street, New York, U.S.A. . . .	32.71	" " " " ..	" "
Barclays Nominees Branches Limited, 4 George Yard, Lombard-street, London, E.C.3, U.K. . . .	127.60	" " " " ..	" "
Barker, Sydney M., 26 Arnold-street, Killara, N.S.W. 2071 ..	10.83	" " " " ..	" "
Barrow, Patricia F. (Mrs.), c/o Mrs. R. F. Guymey, 1 Wilton House, 87 Knightsbridge, London, S.W.1, U.K. . . .	19.00	" " " " ..	" "
Barton, Owen, c/o T. E. Barton, 110 Pendarves-street, New Plymouth, N.Z. . . .	55.08	" " " " ..	" "
Batkin, Arthur W., 21 Tomlinson-road, Singapore	33.25	" " " " ..	" "
Baverstock, William T. and Victoria (Mrs.), 19 Milton Close, Rustington, Littlehampton, Sussex	21.78	" " " " ..	" "
Bayne-Powell, Philip W. F., The Mount, Borough Green, Seven Oaks, Kent, U.K.	13.97	" " " " ..	" "
Begg, John McQ., 4 R.D. Balclutha, Otago, N.Z.	71.10	" " " " ..	" "
Begg, Margaret A. (Miss) and John M., 4 R.D., Balclutha, N.Z. . .	45.06	" " " " ..	" "
Bell Nominees Ltd., 33 Old Broad-street, London, E.C.2, U.K. . . .	70.11	" " " " ..	" "
Bellam Investments Ltd., P.O. Box 12062, Penrose, Auckland, N.Z. .	32.31	" " " " ..	" "
Bennett, Alan G., c/o Box 421, G.P.O., Sydney, N.S.W. 2001	33.25	" " " " ..	" "
Bennett, Isobel I. (Mrs.), 69 Carabella-street, Kirribilli, N.S.W. . .	11.10	" " " " ..	" "
Bentley, Clare E. (Mrs.), c/o Brisbane Special Hospital, Goonda, Qld. 4860	19.00	" " " " ..	" "
Berger, Jean (Mrs.), 1615 Avenue 1, Brooklyn 30, New York, U.S.A.	40.38	" " " " ..	" "
Berrick, Major Robert H. A., 450 Yarranabee Gardens, Yarranabee-road, Darling Point, N.S.W. 2027	15.20	" " " " ..	" "
Bilger, Edward, Gilmore-road, Woodridge, Qld. 4114	10.45	" " " " ..	" "
Birch, Jean P. (Mrs.), 2709E Victor Hugo, Phoenix, Arizona, 85032, U.S.A.	16.16	" " " " ..	" "
Birchwood, Frank O., 35 McIntosh-street, Gordon, N.S.W. 2072 ..	19.00	" " " " ..	" "
Blackburn, Guy, 4 Holly Lodge Gardens, London, N.6, U.K.	11.17	" " " " ..	" "
Bladen, Patricia Mary (Mrs.), 11 Lipton-street, West Geelong, Vic. 3218	16.25	" " " " ..	" "
Blake, Simon T., Lyndhurst, Westland Green, Little Hadham, Herts., U.K.	12.58	" " " " ..	" "
Blaxland, Elizabeth D. (Miss), c/o Bank of N.S.W., Cnr. George and Bridge Streets, Sydney, N.S.W. 2000	62.42	" " " " ..	" "
Bluck, Duncan R. Y., Commercial Director, Cathay Pacific Airlines, Union House, Hong Kong	19.95	" " " " ..	" "
Boot, Florence M. (Mrs.), 1 Fred Ben-avenue, Cammeray, N.S.W. 2062	70.00	" " " " ..	" "
Bowie-Wilson, John D. A. (Mrs.), 40 Woolwich-road, Hunters Hill, N.S.W. 2110	32.87	" " " " ..	" "
Bownas, Mabel S. (Mrs.), Unit 621 Moruben-road, Mosman, N.S.W. 2088	25.27	" " " " ..	" "
Bradford, Anthony J., Rua Das Amoreiras 70/0, Lisbon, Portugal . . .	11.66	" " " " ..	" "
Bradley, Audrey P. (Mrs.), 37 Wade-street, Wadestown, N.Z. . . .	33.04	" " " " ..	" "
Bradley, Stuart Loxley, Parawere, No. 2 R.D., Te Awamutu, N.Z. . .	18.42	" " " " ..	" "
Branch Nominees Ltd., "A" Account, 15 Bishopsgate, London, E.C.2, U.K.	81.78	" " " " ..	" "
Brock, Dr. Lawrence G., c/o National Bank of New Zealand, 14 Charles II-street, London, U.K.	38.76	" " " " ..	" "
Browning, Ronald M., Riverslea, Yarrowonga, Vic. 3730	41.80	" " " " ..	" "
Bushby, Charles W. and Thomas M. and Neilsen, Mary F. (Mrs.), c/o T. M. Bushby, P.O. Box 84, Wynyard, Tas. 7325	59.57	" " " " ..	" "
Bywater, Hilda E. (Mrs.) and Bailey, Hilda M. (Mrs.), Summerhill, Highton Hill, Ringwood, Hants, U.K.	11.17	" " " " ..	" "
Caracciola, Donna M. D. (Mrs.), The Park, Grange-road, Rathfarnham, Dublin 14, Eire	29.94	" " " " ..	" "
Cargill, James D., c/o A.N.Z. Bank Ltd., 68 St. George's-terrace, Perth, W.A.	38.00	" " " " ..	" "
Carrington, William S. and Cooke, Valerie A. (Mrs.) and Holloway, Frederick J., 67 Chiswell-street, London, E.C.1, U.K.	27.93	" " " " ..	" "
Caves, Toni L. (Mrs.), 19 Rini-street, Edgcombe, Bay of Plenty, N.Z.	16.16	" " " " ..	" "
Charlesby, Arthur, 13 Park-avenue, Shrivenham, near Swindon, Wiltshire, England	16.15	" " " " ..	" "
Cheng, Lee S., Maritime Building, Singapore 1.	32.79	" " " " ..	" "
Choy, Dr. Chong K. and Choo, Dr. Ong M. S., 196 Rasah-road, Seremban, Malaysia	13.30	" " " " ..	" "
Clay, Charles J. J. and Davey, James A. and Armstrong, David G., 12 Old Square, Lincolns Inn, London, W.C.2, U.K.	15.25	" " " " ..	" "
Close, Alan, 50 Tie-street, London, S.W.3, U.K.	66.99	" " " " ..	" "
Coates, Michael O., Summerhill, Beacon Field, Sevenoaks, Kent, U.K.	11.17	" " " " ..	" "
Cohen, Jack, 2347 Tiebout-avenue, Bronx 58, New York, U.S.A. . . .	16.15	" " " " ..	" "
Cole, John and Meynell, David, c/o 66 Lincolns Inn Fields, London, W.C.2., U.K.	64.18	" " " " ..	" "

Unclaimed Moneys Act 1962.

REGISTER of Unclaimed Moneys held by the—

Name of Owner on Books and Last Known Address.	Total Amount Due to Owner.	Description of Unclaimed Moneys.	Date when Amount first became Payable.
§			
THE BROKEN HILL PROPRIETARY COMPANY—continued.			
Cole, Philip J. L., 32 Queen-street, Petoni, near Wellington, N.Z. . .	38.76	Dividend and/or Interest . .	1.4.68
Coleman, David N., 6/242 Buffalo-road, Ryde, N.S.W. 2112 . . .	28.79	" " " " . .	"
Conville, David H. and Kenyon, George V., c/o Isle of Man Bank, Douglas, Isle of Man . . .	23.28	" " " " . .	"
Cooke, David C., 133 The Boulevard, Strathfield, N.S.W. . . .	47.22	" " " " . .	"
Crawford, Dorothea (Mrs.), 42 Carlotta-road, Double Bay, N.S.W. 2028 . . .	14.00	" " " " . .	"
Crawford, Elwyn M. (Mrs.), c/o G. T. Young, 4 Woodland-street, Ashgrove, Qld. 4060 . . .	83.60	" " " " . .	"
Curtis, Lorna B. A. (Mrs.), Wimlak, Glen-street, Glenbrook, N.S.W. 2773 . . .	12.16	" " " " . .	"
Davies, David B., Plas Dinam, Llandinam, Mont., U.K. . . .	27.93	" " " " . .	"
Davies, Margaret E. (Mrs.), Ellendoone, Finley, N.S.W. 2713 . . .	10.83	" " " " . .	"
Davis, Enid C. (Mrs.), 38 Grosvenor-road, Wahroonga, N.S.W. 2076 . .	28.50	" " " " . .	"
Davis, Jessie M. F. (Mrs.), 32 Kardella-avenue, Killara, N.S.W. 2071 . .	10.74	" " " " . .	"
Davis, Lyle M., 2nd Floor, 81 York-street, Sydney, N.S.W. 2000 . .	10.17	" " " " . .	"
Dawson, Adela M. (Mrs.), and Richard B., 75 Macquarie-street, Chatswood, N.S.W. 2067 . . .	22.80	" " " " . .	"
De La Guerrande, Vicompte Gaston, Chateau de Kerrozeu, Marque Pre Lambaile, France . . .	13.17	" " " " . .	"
De Marchi, Leone J. (Mrs.), 29 St. Leonard-street, Mosman Park, W.A. 6012 . . .	15.49	" " " " . .	"
Dempster, Noel W., c/o A.N.Z. Bank, Martin-place and George-street, Sydney, N.S.W. 2000 . . .	32.30	" " " " . .	"
De Vincens De Causans, Marie M., 9 Place de la Republique, 57 Thinville, Moselle, France . . .	16.30	" " " " . .	"
Dickinson, Robert J. and Taylor, Dorothy J. (Mrs.), "A" Account, Cross House, Westgate-road, Newcastle-upon-Tyne, 1, U.K. . . .	22.33	" " " " . .	"
Dickson, Duncan G., Casa Bandanga, Carrestesia de Ojen, Marbella, Malaga, Spain . . .	254.13	" " " " . .	"
District Bank W.A. Account, 17 Spring Gardens, Manchester, U.K. . .	85.66	" " " " . .	"
Dixon, Richard R., G.P.O. Box 738, Sydney, N.S.W. 2001 . . .	28.50	" " " " . .	"
Dollond, Jack J., 260A Shirland-road, Paddington, London, W.9 . . .	78.17	" " " " . .	"
Dormer, Francis V., 12 Ada-street, Concord, N.S.W. . . .	10.83	" " " " . .	"
Dowlen, Hereward, 39 Park-crescent, Fairfield, Vic. 3078 . . .	49.88	" " " " . .	"
Downey, David C. L., 31/9 Struan-street, Toorak, Vic. 3142 . . .	80.75	" " " " . .	"
Dreyfus, Suzanne (Mme.), 2 Rue Moncey, Paris 90, France . . .	95.97	" " " " . .	"
Druce, Madeline L. (Mrs.), 209 Old Prospect-road, Wentworthville, N.S.W. 2145 . . .	55.67	" " " " . .	"
Evans, Jasper O. and Mrs. Elizabeth J., P.O. Kampi-Ya-Moto, Kenya, East Africa . . .	11.17	" " " " . .	"
Felgatt, Bridget E. (Mrs.), A/c C.S., c/o The Chartered Bank, London, E.C.2, U.K. . . .	77.54	" " " " . .	"
Fenton, Mary (Mrs.), Flat 1, 147 Alma-road, East St. Kilda, Vic. 3183 . .	46.56	" " " " . .	"
Fitzgerald, Kathleen (Mrs.), P.O. Box 351, Potts Point, N.S.W. 2011 . .	20.33	" " " " . .	"
Fitzpatrick, Noel J., 12/10 Challis-avenue, Potts Point, N.S.W. 2010 . .	311.98	" " " " . .	"
Fletcher, Antony T. R. and Andrews, Ian M. D., South House, Holland Park-road, London, W.14, U.K. . . .	20.55	" " " " . .	"
Forkas, Alice (Mrs.), 73 Lumeah-road, North Caulfield, Vic. 3161 . . .	19.00	" " " " . .	"
Forster, Dr. John F. A., 11 Blackfriars Close, Toorak, Vic. 3142 . . .	119.42	" " " " . .	"
Forshall, Samuel, 148 High-street, Burton on Trent, Staffs., U.K. . .	27.91	" " " " . .	"
Forshall, Samuel and Scrimgeour, Alexander, 148 High-street, Burton- on-Trent, Staffs., U.K. . . .	27.93	" " " " . .	"
Foster, Linley R., c/o Dept. of Treasury, Konedobu, T.P.N.G. . . .	91.66	" " " " . .	"
Fougeres, Jeanne E. J. (Mrs.), 3 Boulevard Carnot, Dijon, France . . .	10.19	" " " " . .	"
Fraser, Judith A. (Miss), La Maison Maret, Trinity, Jersey, Channel Islands . . .	22.15	" " " " . .	"
Gedclin Pty. Ltd., c/o Cooper Bros., Hong Kong. . . .	66.50	" " " " . .	"
Goldberg, Alwin I., 4254 West Lyons, Skokie, Illinois, U.S.A. . . .	16.16	" " " " . .	"
Goldhammer, Helen (Mrs.), 41 Pine-street, Cammeray, N.S.W. . . .	15.58	" " " " . .	"
Goldsmith, Oliver L., P.O. Box 115, Wellington, C.1., N.Z. . . .	16.15	" " " " . .	"
Green, William C., c/o T. Fitzgerald, 166 Beaumont-street, Hamilton, N.S.W. . . .	19.01	" " " " . .	"
Gundry, John H. B., c/o Bank of N.S.W. H.O., 341 George-street, Sydney, N.S.W. 2000 . . .	76.00	" " " " . .	"
Halloran, Audrey (Mrs.), c/o H. F. Halloran and Co., 153 Elizabeth- street, Sydney, N.S.W. 2000 . . .	95.58	" " " " . .	"
Hamilton, MacDonald R., Calingunee, Goondiwindi, Qld. 4390 . . .	40.85	" " " " . .	"
Harco Nominees Ltd., c/o Morton Bros., 97 Gresham-street, London, E.C.2, U.K. . . .	20.19	" " " " . .	"
Harding, Egerton S. S. and Hornyold-Strickland, Henry and Ogilvie, Jasper J., The Gables, Prospect-road, Market Drayton, Salop, U.K. . .	13.97	" " " " . .	"
Harray, Alistair S., 706 Auson-street, Mayfair, Hastings, N.Z. . . .	85.12	" " " " . .	"
Harris, Valma J. (Mrs.), 7 Kings-road, Vaucluse, N.S.W. 2030 . . .	43.52	" " " " . .	"
Harrison, Janet L. (Mrs.), 34 Winnall-street, Clapham, S.A. . . .	70.00	" " " " . .	"
Hart, Patrick L., 7 Mount-street, Hunters Hill, N.S.W. . . .	12.73	" " " " . .	"
Harvey, John F. C., 22 Couch-road, Newton Abbot, Devon, U.K. . . .	59.74	" " " " . .	"
Hauger, Eugene, 79 Rue de Bale, Mulhouse, Haut Rhin, France . . .	12.73	" " " " . .	"
Helier, Dorothy H. S. (Mrs.), Wallington Chase, Baldock, Herts., U.K. . .	30.71	" " " " . .	"
Hiller, Ernest, 14 Cotswold-road, Strathfield, N.S.W. 2135 . . .	95.00	" " " " . .	"
Hindlip, Lord, Vern Leaze, Calne, Wilts., U.K. . . .	37.34	" " " " . .	"
Hoffman, Leonard H., 15 Merton-street, Oxford, U.K. . . .	12.29	" " " " . .	"
Hofmann, Thomas R. and Mary G. (Mrs.), c/o Trust Dept., Crocker-	72.68	" " " " . .	"

Unclaimed Moneys Act 1962.

REGISTER of Unclaimed Moneys held by the—

Name of Owner on Books and Last Known Address.	Total Amount Due to Owner.	Description of Unclaimed Moneys.	Date when Amount First Became Payable.
§			
THE BROKEN HILL PROPRIETARY COMPANY—continued.			
Citizens Nat. Bank, P.O. Box 3514, Rincon Annex, San Francisco, Calif., U.S.A.		Dividend and/or Interest ..	1.4.68
Holt, Betty (Mrs.), 3216 East 65th-street, Tulsa, Oklahoma, U.S.A.	16.16	" " " "	" "
Hood, Bruce C., 19 Temple-street, Meadowbank, Auckland, N.Z.	69.21	" " " "	" "
Hopkins, Margaret E. (Mrs.), 15 Milner-crescent, Wollstoncraft, N.S.W. 2065	33.25	" " " "	" "
Houlahan, Francis P., 252 Ilan-road, Fendalton, Christchurch, N.Z.	18.90	" " " "	" "
Huppert, G., 94 Hotham-street, East St. Kilda, Vic. 3183	1626.97	" " " "	" "
Hutton, Margaret A. (Miss), Geelong Grammar School, Corio, Vic. 3214	76.01	" " " "	" "
Iverson, Peter C., 3102 East 67th-street, Tulsa, Oklahoma, 74105, U.S.A.	24.23	" " " "	" "
Jamison, Effie G. (estate of) and Hurdie, James M., c/o Cooper Bros. and Co., G.P.O. Box 2650, Sydney, N.S.W. 2001	125.02	" " " "	" "
Jellinek, Lionel, 3 Temple Gardens, Temple, London, E.C.4, U.K.	30.43	" " " "	" "
Johnstone, Kathleen (Mrs.), Commercial-road, Yarram, Vic. 3971	10.83	" " " "	" "
Johnstone, Michelle (Miss), 57A Sydney-street, Willoughby, N.S.W. 2068	28.03	" " " "	" "
Jones, David L. and Stafford, Widdrington R., 5 London Wall Buildings, Finsbury Circus, London, E.C.2, U.K.	13.97	" " " "	" "
Jones, Maureen M. (Mrs.), Maydon G. A. Pastoral Co., Ravensthorpe, W.A. 6346	19.00	" " " "	" "
Jopp, Florence E. (Mrs.), Moutere Station, No. 3 R.D., Alexandra, Central Otago, N.Z.	32.30	" " " "	" "
Kalb, Bernard, c/o C.B.S. News, 2 Kennedy-street, Hong Kong	13.30	" " " "	" "
Kaplan, Phillip and Clara (Mrs.), 11 Cleveland-road, Marblehead, Mass., U.S.A.	16.15	" " " "	" "
Karpovitch, Leo N., c/o Police Headquarters, Arsenal-street, Hong Kong	17.39	" " " "	" "
K.B. (C.I.) Nominees Ltd., P.O. Box 76, 15 New-street, St. Helier, Jersey, C.1	159.61	" " " "	" "
Kelly, Carmen M. (Mrs.), 121 Mugga Way, Red Hill, A.C.T. 2603	65.18	" " " "	" "
Kendall, Peggy E. (Mrs.) and Raymond J., Box 233, P.O., Auckland, N.Z.	10.34	" " " "	" "
King, Jean E. (Mrs.), 3 Olga-street, Coburg, Vic. 3058	10.83	" " " "	" "
Knight, Horatio T. D., 72 Selwyn-road, Epsom, Auckland, N.Z.	12.12	" " " "	" "
Kraus, Ethel (Mrs.), 216 Orrong-road, East St. Kilda Vic. 3183	10.83	" " " "	" "
Kutak, Gerald and Mrs. Mary Kutak, 1305 Sycamore-avenue, Bohemia, New York, U.S.A.	16.15	" " " "	" "
Laan, Priscilla T. S. (Miss), c/o Hong Kong and Shanghai Banking Co., P.O. Box 64, Hong Kong	11.97	" " " "	" "
Lai, So Chun (Mrs.), P.O. Box 406, Tawau, Sabah, East Malaysia	26.60	" " " "	" "
Lancester, Beatrice M. (Mrs.), 1 Fredben-avenue, Cammeray, N.S.W. 2062	234.55	" " " "	" "
Latrobe Bond and Free Stores Pty. Ltd., G.P.O. Box 2195T, Melbourne, Vic. 3000	19.00	" " " "	" "
Lee, Barbara J. (Mrs.), Te Marua, Humphries-road, Frankston, Vic. 3199	45.32	" " " "	" "
Lafcort, Margaret (Mrs.), 443 West 50th Street, New York, U.S.A.	32.30	" " " "	" "
Livingstone, Elizabeth V. (Mrs.), 690 River-road, Beaver, Penn., U.S.A.	16.16	" " " "	" "
Lloyds Bank Ltd., Executor and Trustee Dept., A/c 97073, 39 Threadneedle-street, London, E.C.2, U.K.	12.87	" " " "	" "
Lloyds Bank 39 Threadneedle Street Nominees Ltd., "L" Account, 39 Threadneedle-street, London, E.C.2, U.K.	27.93	" " " "	" "
Logan, Isabel S. (Mrs.), c/o 41 Barrack-street, Perth, W.A. 6000	29.83	" " " "	" "
Lommel Nominees Pty. Ltd., c/o Cazenove and Co., 12 Tokenhouse Yard,	19.00	" " " "	" "
Loveday, Richard, 28 Ducks Hill-road, Northwood, Middlesex, U.K.	11.17	" " " "	" "
Lowrison, Elizabeth (Mrs.), Low Friarside Farm, Rowlands Gill, Co. Durham, U.K.	22.33	" " " "	" "
Lutyens, Martin C., 7 Queensborough Studios, Porchester-terrace, London, W.2, U.K.	11.17	" " " "	" "
Macalpine, George W., 10 Golden Square, London, W.1, U.K.	16.75	" " " "	" "
MacDonald, Frances A. (Mrs.), Tuki Tuki-road, R.D. 2, Hastings, N.Z.	16.15	" " " "	" "
MacDougall, Helen S. (Miss), 32 Wentworth-road, Strathfield, N.S.W. 2135	77.00	" " " "	" "
MacKenzie, Hector C. B., 24 Downshire Hill, London, N.W.3, U.K.	13.68	" " " "	" "
MacKinnon, Ian M., Glen Esk, Conara, Tas. 7211	33.92	" " " "	" "
MacQueen, David B., 15 Gilmour-street, Paisley, U.K.	23.33	" " " "	" "
MacQueen, Jane (Mrs.), Westwick Cottage, Leverstock Green, Herts., U.K.	22.35	" " " "	" "
Maddern, Peter J., 6 Arawata-drive, Doncaster East, Vic. 3109	10.83	" " " "	" "
Mann, Joan H. (Mrs.), 29 Broadway, Glenelg, S.A. 5045	43.42	" " " "	" "
Marcel, Joseph, St. Brieuc, Cotes du Nord, France	21.88	" " " "	" "
Martin, Frederick B. (estate of), c/o Mrs. Joan Martin, 19A Ednah-street, Como, W.A. 6152	12.26	" " " "	" "
Maurice, Norman B., c/o Macclesfield Oiled Silks Ltd., Park Green Works, Macclesfield, U.K.	15.36	" " " "	" "
McAra, Johnston, 27 Belgrave-crescent, Roslyn, Dunedin, N.Z.	60.57	" " " "	" "
McAuliffe, Peter C., 183 Macquarie-street, Sydney, N.S.W. 2000	58.43	" " " "	" "
McCormick, Kathleen (estate of), c/o Maurice M. Flynn, Vulcan Buildings, Cnr. Queen-street and Vulcan-lane, Auckland, C.1, N.Z.	21.32	" " " "	" "
McDonnell and Co. Inc., 120 Broadway, New York, 10005, U.S.A.	142.12	" " " "	" "

Unclaimed Moneys Act 1962.

REGISTER of Unclaimed Moneys held by the—

Name of Owner on Books and Last Known Address.	Total Amount Due to Owner.	Description of Unclaimed Moneys.	Date when Amount first became Payable
5			
THE BROKEN HILL PROPRIETARY COMPANY— <i>continued.</i>			
McKinnon, Mairi C. W. (Miss), Taobh Na Mara, Balemartin Tirel, Argyleshire, Scotland	47.60	Dividend and/or Interest ..	1.4.68
McLachlan, Julia M. (Mrs.), Strathrowan, Omihi R.D. 3, Amberley, North Canterbury, N.Z.	10.75	" " " "	"
McKoe, Ralph H., 635 Riverside-drive, New York 10031, U.S.A.	80.75	" " " "	"
McMahon, Edward D. (estate of), c/- Magney and Magney, 79 Elizabeth-street, Sydney, N.S.W. 2000	27.84	" " " "	"
McMicking, David J., 328089 A/c, c/o Lloyds Bank Ltd., 6 Pall Mall, London, S.W.1, U.K.	16.75	" " " "	"
McNicoll, Jean M. (Mrs.), 75 Kambala-road, Bellevue Hill, N.S.W. 2023	23.37	" " " "	"
Melkie, Edmund, 298 Cleveland-road, Surrey Hills, N.S.W. 2010	28.50	" " " "	"
Mere, Robin M., The Mill House, Chiddingfold, Surrey, U.K.	63.76	" " " "	"
Methven, Donald J. and Harrison, Lily M. (Mrs.) and Wingfield, Ernest H., Exors of George E. Harrison, Saddlers Hall, Cheapside, London, E.C.2, U.K.	33.49	" " " "	"
Midover Limited, 48 Egerton-crescent, London, S.W.3, U.K.	42.99	" " " "	"
Millco Nominees Ltd., Pinners Hall, Austin Friars, London, U.K.	16.15	" " " "	"
Mills, Elayne M. (Mrs.), 38c Mona-road, Darling Point, N.S.W. 2027	21.38	" " " "	"
Mills, Wing Cmdr. Garth T., 17 Hope-street, Blaxland, N.S.W. 2774	13.30	" " " "	"
Milton, Emma (Mrs.) and Toovey, Geoffrey W., 102 Everton-street, Hamilton, N.S.W.	22.80	" " " "	"
Mitchell, Helen M. (Mrs.), 533 Saunders-avenue, Albury, N.S.W. 2640	10.13	" " " "	"
Modesti, Dorothy V. (Mrs.), 27 Rue Caulaincourt, Paris 18, France	76.21	" " " "	"
Morris, Mary (Miss), The Retreat, No. 8 Kalang-road, Elanora Heights, Narrabeen, N.S.W. 2101	32.30	" " " "	"
Murray, Harriet M. (Mrs.), 7 Sutton-street, North Balwyn, Vic. 3104	19.00	" " " "	"
Nagano, Shigeo, 34-44 Chome, Matsubara Setagayw-ku, Tokyo, Japan	15.18	" " " "	"
Nam, Heo Tat, 25 Thomson-road, Singapore	13.30	" " " "	"
Nelson, Olive M. (Miss), c/o Mrs. K. P. Fraser, Bank of New Zealand, 339 George-street, Sydney, N.S.W. 2000	21.76	" " " "	"
Netcher, Elizabeth J. (Mrs.), 516 South Harrison-street, Arlington, Virginia, U.S.A.	16.16	" " " "	"
Newcombe, Charles B., Little Bay-road, Newington, New Hampshire, U.S.A.	10.91	" " " "	"
Ng, Madam Sau Y., c/o Dr. W. K. Gin, 26 Ridout-road, Singapore 10	66.50	" " " "	"
Nosworthy, Richard G., 2/84 Bay-road, Mt. Gambier, S.A. 5290	70.00	" " " "	"
N. P. Trusts Limited, MCR A/c, 15 Bishopsgate, London, E.C.2, U.K.	28.52	" " " "	"
O'Brien, Justin, c/o R. A. Noss, Patrick and Co., 16 O'Connell-street, Sydney, N.S.W. 2000	14.25	" " " "	"
Old Broad Street Securities Nominees Ltd., 39 King-street, London, E.C.2, U.K.	22.33	" " " "	"
O'Leary, Emily F. (Mrs.), Flat 32, 25 Billyard-avenue, Elizabeth Bay, N.S.W.	33.92	" " " "	"
O'Leary, Emily F. (Mrs.), c/o J. B. McGrath, 3rd Floor, 53 Martin-place, Sydney, N.S.W. 2000	13.59	" " " "	"
Olsen, Hazel M. (Mrs.), 199 Canley Vale-road, Canley Vale, N.S.W. 2166	13.68	" " " "	"
Osmond, Ronald T., P.O. Box 3, Cambridge, N.Z.	32.30	" " " "	"
Pattenden, Donald G. L., Flat 6, 10 Hams-crescent, London, S.W.1, U.K.	16.75	" " " "	"
Payten, John N. and Imelda M. (Mrs.) and Margaret M. (Mrs.), Kite-street, Orange, N.S.W. 2800	35.00	" " " "	"
Pennefather, Kathleen M. A. (Mrs.), Byron House, Harrow-on-the-Hill, Middlesex, U.K.	16.75	" " " "	"
Penrose, Edgar R. (estate of), c/o W. B. T. Leete, P.O. Box 400, Christchurch, N.Z.	62.35	" " " "	"
Perry, Alfred S., 400 Sandy Bay-road, Hobart, Tas. 7000	28.60	" " " "	"
Peterson, Marian A. (Miss), 42 Amritsar-street, Khandallah, Wellington, N.Z.	11.63	" " " "	"
Pevny, Charles, 15 Cowdroy-avenue, Cammeray, Sydney, N.S.W. 2000	19.00	" " " "	"
Philidrew Nominees Ltd., Lee House, London Wall, London, E.C.2, U.K.	32.30	" " " "	"
Pini, Bertram J. and Eunice M. (Mrs.), 60 Juliet-street, Mackay, Qld.	13.66	" " " "	"
Powell, Patrick B. and Bulmer, Howard and Soole, Brian A. S. and Burnett-Stuart, Angus M., c/o National Commercial Bank of Scotland, 37 Nicholas-lane, London, E.C.4, U.K.	16.75	" " " "	"
Pegre, Jacques (estate of), 67 Rue Croulbarbe, Paris 13, France	32.86	" " " "	"
Pritchard, Harold M. and Helen (Mrs.), 5314 Lynn Hill-street, Kalamazoo, Michigan, 49001, U.S.A.	16.15	" " " "	"
Ramsbotham, Maria (Mrs.), c/o Hong Kong and Shanghai Banking Corp., Collyer Quay, Singapore	31.92	" " " "	"
Reeve, John Kenneth, Two Bays Private Hotel, The Esplanade, Torquay, Vic. 3228	10.83	" " " "	"
Rich, David U. G., c/o L. J. Stephens Woods and Co., Queens-arcade, Customs-street, Auckland, N.Z.	12.14	" " " "	"
Richardson, Arthur J., Currawidgee, Trangie, N.S.W. 2823	65.17	" " " "	"
Romand, Marie L. (Mrs.), Admin. of Emile Romand (estate of), Chateau de Villeneuve St. Aaron, Pres. Lamballe, Cotes du Nord, France	48.66	" " " "	"
Ross, Ian R., 212 Burnbank-street, Ballarat, Vic. 3350	14.25	" " " "	"
Ross, William G., 55 Melville Beach-road, Applecross, W.A. 6153	10.83	" " " "	"
Rouxel, Rosa B. (Mrs.) and O'Connell, Keith E., 182 Homebush-road, Strathfield, N.S.W.	23.18	" " " "	"
Rundle, Valmae L. (Mrs.), 193 Macquarie-street, Sydney, N.S.W. 2000	88.16	" " " "	"

Unclaimed Moneys Act 1962.

REGISTER of Unclaimed Moneys held by the—

Name of Owner on Books and Last Known Address.	Total Amount Due to Owner.	Description of Unclaimed Moneys.	Date when Amount First Became Payable.
S			
THE BROKEN HILL PROPRIETARY COMPANY—continued.			
Ryan, Kathleen (Mrs.), 9 Menzies-street, Sumner, Christchurch, N.Z.	16.16	Dividend and/or Interest ..	1.4.68
Salomon, Julian M., c/o Credit Suisse, A/c No. 576233, Geneva, Switzerland	41.10	" " " " ..	" "
Saphir, Adolph D., 39 Fairacres-lane, Rochampton, London, S.W.15, U.K.	16.15	" " " " ..	" "
Saunt, Tessa R. E. (Mrs.), 20 Bute-street, London, S.W.7, U.K.	17.88	" " " " ..	" "
Saunt, Wilfred H. G., 7 St. Peter-street, Winchester, Hants., U.K.	11.17	" " " " ..	" "
Schaffer, Alwine, c/o Boese (Mrs.), Manor House Boarding Estab., Bewdley, Worcs., U.K.	18.55	" " " " ..	" "
Scott, Barry R., 582 Lt. Collins-street, Melbourne, Vic., 3000	57.00	" " " " ..	" "
Sedgley, Harry G. R., 12 Takahe-drive, Christchurch, N.Z.	27.38	" " " " ..	" "
Sharp, Dr. Frank L. R., 21 Mary-street, Longueville, N.S.W. 2066	190.00	" " " " ..	" "
Shepherd, Richard J., Stratton End., Cirencester, Glos., U.K.	27.91	" " " " ..	" "
Shuttleworth, Annie (Miss), 39 South Mead-road, Westbury-on-Tryon, Bristol, U.K.	10.34	" " " " ..	" "
Skillington, Helen J. (Mrs.), 7 Garth-avenue, Sandy Bay, Tas. 7005	13.30	" " " " ..	" "
Smith, Raymond F. K., P.O. Box No. 121, Manuka, A.C.T. 2603	10.83	" " " " ..	" "
Smith, Robert F., Hume Highway, Mittagong, N.S.W.	120.56	" " " " ..	" "
Smith, Zelma A. (Miss), All Saints Rectory, Willaura, Vic. 3291	19.01	" " " " ..	" "
Solomon, Frank D., 134 Headland-road, Dee Why, N.S.W. 2099	37.06	" " " " ..	" "
Speleological Research Council Ltd., 36 Euroka-street, Northbridge, N.S.W. 2063	84.00	" " " " ..	" "
St. Leger, Hugh (estate of), c/o Beechcroft and Co., 29 Bedford Square, London, C.1, U.K.	187.20	" " " " ..	" "
Strange, Ronald Glen, c/o Trade Commissioner Directorate, Dept. of Trade, Canberra, A.C.T. 2601	10.83	" " " " ..	" "
Sturton, Hubert J. P. and Armstrong, Harold J., 16 Castle Park, Lancaster, U.K.	27.91	" " " " ..	" "
Syred, Dr. Roy H., 135 Macquarie-street, Sydney, N.S.W.	21.76	" " " " ..	" "
Talbot, Major Raeburn R., 27 Princes-street, Auckland, N.Z.	76.23	" " " " ..	" "
Tanner, Frances M. (Mrs.), 17 Rawson-street, Deakin, A.C.T.	17.39	" " " " ..	" "
Taylor, Dr. John H., 8 Elmstone-avenue, Auckland, N.Z.	85.05	" " " " ..	" "
Taylor, Katharine (Mrs.), Brookfield Center, Connecticut, U.S.A.	16.15	" " " " ..	" "
Throsby, Peter Wentworth, G.P.O. Box 290, Sydney, N.S.W. 2001	21.66	" " " " ..	" "
Tighe, Florence M. (Mrs.), 39 Gregory-street, North Ward, Townsville, Qld. 4810	16.25	" " " " ..	" "
Tinker, Rosetta (Mrs.), c/o Barclays Bank Ltd., Town Hall Branch, Church-road, Hore, Sussex, U.K.	11.17	" " " " ..	" "
Togget, Frank H., Flat 5, 575 Inkerman-road, Caulfield, Vic. 3162	42.75	" " " " ..	" "
Toone, Agnes B. D. (Mrs.), The Old Hall, Rearsby, Leicester, U.K.	12.84	" " " " ..	" "
Torr, Bernice M. (Mrs.), Flat 3, 120 Old South Head-road, Bellevue Hill, N.S.W. 2023	12.54	" " " " ..	" "
Trickett, Paul D., G.P.O. Box 276, Wellington, N.Z.	50.73	" " " " ..	" "
Vautier, Ray (estate of), c/o V. Benson, 160 Castlereagh-street, Sydney, N.S.W. 2000	27.18	" " " " ..	" "
Ventura, Dorothy E. (Mrs.), 14332 Martha-street, Van Nuys, California, U.S.A.	14.72	" " " " ..	" "
Vetch, Grahame F. H., c/o Standard Bank Ltd., 117 Park-lane, London, W.1, U.K.	19.95	" " " " ..	" "
Victory Holdings Pty. Ltd., c/o Lister Closter and Barnett, 109 Pitt-street, Sydney, N.S.W. 2000	248.33	" " " " ..	" "
Villiers, Ellen M. (Mrs.), Flat 10, 35 Kensington-court, London, W.8, U.K.	11.17	" " " " ..	" "
Waddington, John P., c/o Girard Trust Bank, P.O. Box 7334, Trust Dept., Philadelphia, Penn., 19101, U.S.A.	181.69	" " " " ..	" "
Walford, Geoffrey H. and Wilbraham, Richard B., 27 Bolton-street, Piccadilly, London, W.1, U.K.	11.17	" " " " ..	" "
Walker, Marshall, 72 Friern Barnet-lane, London, N.11, U.K.	11.17	" " " " ..	" "
Walker, Rosemary (Mrs.), c/o Mrs. Rosemary Yencken, 56 Domain-street, South Yarra, Vic. 3141	19.00	" " " " ..	" "
Walker, William T., Box 70, P.O., Wellington, N.S.W. 2820	22.80	" " " " ..	" "
Wallis, Neville and Newton, Ivor, The Lodge, Fenny Compton, Warwickshire, U.K.	34.62	" " " " ..	" "
Ward, William H., 113 Frederick-street, Merewether, N.S.W. 2291	123.50	" " " " ..	" "
Waterman, Harry, Cherry Vale, Acrefield-road, Liverpool, 25, U.K.	13.96	" " " " ..	" "
Watson, John M., c/o Bank of N.S.W., Suva, Fiji	15.96	" " " " ..	" "
Webb, David E., Shandon, St. Georges Hill, Weybridge, U.K.	24.23	" " " " ..	" "
Webro Pty. Ltd., 26 Bambara-road, Caulfield, Vic. 3162	19.00	" " " " ..	" "
Weil, James L. and Gaze, Natalie D. (Mrs.) and Collis, Frank, c/o 18 Bentinck-street, London, W.1, U.K.	12.58	" " " " ..	" "
Weinman, Georges E., 16 Rue de la Fauvette, Epernay, France	10.84	" " " " ..	" "
Weir, Viscount James K. and Weir, Hon. William K. J., "A" A.C., Holm Foundry, Cathcart, Glasgow, S.4, Scotland	32.31	" " " " ..	" "
Westmacott, Guy R. and Wethered, Roger H., St. Alphege House, 2 Fore-street, London, E.C.2, U.K.	23.45	" " " " ..	" "
Westmacott, Richard K. and Guy, Harold C., c/o Hoare and Co., 1 King-street, London, E.C.2, U.K.	55.83	" " " " ..	" "
Wicarr Nominees Ltd., Garrard House, 31 Gresham-street, London, E.C.2, U.K.	117.10	" " " " ..	" "
Williams, Christine I. (Mrs.), Slade Point, Via Mackay, Qld. 4740	38.00	" " " " ..	" "
Williams, Kenneth J., Leomar, 252 Boundary-road, Bardon, Brisbane, Qld. 4065	10.83	" " " " ..	" "
Wills, Allan M., 72 Spencer-street, Killara, N.S.W. 2071	10.83	" " " " ..	" "
Wilson, Ian F. E., P.O. Box 17015, Green-lane, Auckland, N.Z.	14.54	" " " " ..	" "

Unclaimed Moneys Act 1962.

REGISTER of Unclaimed Moneys held by the—

Name of Owner on Books and Last Known Address.	Total Amount Due to Owner.	Description of Unclaimed Moneys.	Date when Amount first became Payable.
5			
THE BROKEN HILL PROPRIETARY COMPANY— <i>continued.</i>			
Wilson, Penelope G. (Mrs.), c/o Dr. L. G. Wilson, 175 Macquarie-street, Sydney, N.S.W. 2000	10.83	Dividend and/or Interest ..	1.4.68
Wilson, Stanley, Sandside Farm, Bolton-le-Sands, Carnforth, Lancashire, U.K.	15.96	" " " "	"
Winchcombe Carson Trustee Co. Ltd., "O" Account, 48-52 Bridge-street, Sydney, N.S.W. 2000	21.00	" " " "	"
Wolstenholme, Enid (Mrs.), The Vines, Wahgunyah, Vic. 3687	20.33	" " " "	"
Wong, Boon T., Flat 12, 15 Yarra-street, Hawthorn, Vic. 3122	43.52	" " " "	"
Wongs Investments Ltd., c/o Mrs. J. Ballas and Co., 5 Prince-street, P.O. Box 108, Singapore	133.00	" " " "	"
Wood, Geoffrey A., Box 408, Swan Hill, Vic. 3585	11.12	" " " "	"
Young, Agnes M. (Mrs.), Parkhill, Moss Vale, N.S.W. 2577 3752	37.63	" " " "	"
DAVIES COOP & CO. LTD.			
Aldom, Dorothy M. (Miss), 18 Kent-road, Surrey Hills ..	24.00	Dividend ..	30.3.68
Auriac, George, P.O. Box 136, Tennant Creek, N.T. ..	32.00	" ..	"
Baalman, Monica I. (Mrs.), 10, The Circle, Avalon, N.S.W. ..	20.00	" ..	"
Barker, Ruth S. (Miss), 348 Toorak-road, Burwood ..	20.00	" ..	"
Begg, Rosemary A. (Mrs.), 5 Cochran-avenue, Camberwell ..	12.00	" ..	30.9.67
Bell Investments Pty. Ltd., G.P.O. Box 78, Newcastle, N.S.W. ..	60.00	" ..	30.3.68
Best, Jean D. (Mrs.), 61 Elizabeth-street, Malvern ..	16.00	" ..	30.9.67
Blackburn, Bryony H. C., "Akaroa", Ayers Hill, Mount Lofty, S.A. ..	40.00	" ..	30.3.68
Cameron, Gladys E. (Mrs.), Presbyterian Ladies College, Pymble, N.S.W. ..	12.00	" ..	"
Campbell-Walker, Theodora J. (Miss), Mittagong, Winbourne-road, Mount Eliza ..	15.00	" ..	30.9.68
Chapman, Mary (Mrs.), P.O. Box 287, Townsville, Qld. ..	52.80	" ..	30.3.68
Christopher, John K., 389 St. Kilda-street, Elwood ..	80.00	" ..	"
Clark, Edmond J. (estate of), c/o Mr. W. J. Clark, 4 Rowe-street, South Hurstville, N.S.W. ..	16.00	" ..	30.9.67
Clark, Leila M. (Mrs.), c/o Mr. T. L. Clark, 66 David-street, Launceston, Tas. ..	70.00	" ..	30.3.68
Cobb, H. B. (Mrs.), Hordern, J. L. (Mrs.), and Douglas, C. L. (Mrs.), c/o Frensham Cottage, 15 Riverview-parade, Qld. ..	24.00	" ..	30.9.68
Cottee, Warwick F., 36 The Bulwark, Castelcrag, N.S.W. ..	16.00	" ..	30.9.67
Cribb, Geoffrey, G., 4 Landsborough-street, Kingston, A.C.T. ..	12.00	" ..	30.9.68
Crowl, Patricia J. (Mrs.), c/o Post Office, Ferny Creek ..	32.00	" ..	30.3.68
Davenport, George T. (estate of), 20 Virginia-street, Mount Waverley ..	14.78	" ..	"
Dixon, Elizabeth (Mrs.), 8 Milton-street, Canterbury ..	13.20	" ..	"
Doran, Mary (Miss), "Lachlan", St. Neotts-avenue, Potts Point, N.S.W. ..	20.00	" ..	"
Faragher, Robert N., G.P.O. Box 2299, Sydney, N.S.W. ..	12.00	" ..	"
Foley, Wendy (Mrs.), 6 Vista-avenue, Bayview, N.S.W. ..	16.00	" ..	30.9.68
Gardner, May C., (Mrs.), Unit 9, 12 Muston-street, Mosman, N.S.W. ..	20.96	" ..	30.3.68
Gillam, Florence M. (Miss), 166 Blackburn-road, East Doncaster ..	13.20	" ..	"
Green, Leslie S., 2 Green-court, Mentone ..	10.00	" ..	"
Griffiths, Mervyn L., 67 Botany-road, Waterloo, N.S.W. ..	20.00	" ..	"
Grosvenor, Vida A. (Mrs.), c/o Bank of N.S.W., Jannali, N.S.W. ..	40.00	" ..	"
Gruzman, Desmond S. and Glasser, Daniel, 27 Hunter-street, Sydney, N.S.W. ..	12.00	" ..	30.9.66
Harris, Ena G. (Mrs.), c/o Public School, South Gundagai, N.S.W. ..	16.00	" ..	30.3.68
Hayes, Laurence R., 4 Narramore-street, Kingsgrove, N.S.W. ..	16.00	" ..	30.9.67
Hazell, Harold B., Flat 2, 1435 High-street, Glen Iris ..	40.00	" ..	30.9.68
Hodgetts, Dawn (Mrs.), 19 Bay-street, Parklands, Burnie, Tas. ..	12.00	" ..	30.3.68
Hosking, Horace E., c/o Aldgate Village, (Mrs.), Payneham, S.A. ..	20.00	" ..	"
Howat, Roy W., 75 Bywong-street, Towong ..	20.00	" ..	30.9.68
Hulme, Mabel U. (Mrs.), 90 Normanby-road, Kew ..	40.00	" ..	"
Iceton, Edward A. (Dr.) P.O. Box 923, Darwin, N.T. ..	16.00	" ..	20.9.67
Jackson, Bruce L., 56 Wunnulla-road, Point Piper, N.S.W. ..	16.00	" ..	30.9.67
Kangas, Sotirios M., c/o Mr. N. J. Sophios, Golden Key Cafe, Gularrambone, N.S.W. ..	16.00	" ..	"
Kellett, Doris, A. (Mrs.), 73 The Boulevard, Dulwich Hill, N.S.W. ..	16.00	" ..	"
Larson, Ada M. (Mrs.), 6 Albion-street, Balaclava ..	12.00	" ..	30.3.68
Lynch, Andrea F. (Mrs.), 269 Oxford-street, Bondi Junction, N.S.W. ..	19.20	" ..	30.9.67
May, Reginald F. (Dr.), 7 Heyington Gardens, 2 Theodore-court, Toorak ..	52.80	" ..	30.3.68
Miles, Allan G., 1A Edward-street, Bondi, N.S.W. ..	10.00	" ..	"
Moore, Arthur C., 409 Woollooware-road, Burraneer Bay, N.S.W. ..	47.00	" ..	"
Moore, Jocelyn (Mrs.), Flat 2, 14 Macartney-avenue, Kew ..	12.00	" ..	30.9.68
McDonald, Diane L. (Miss), Flat 3, 7 Bradham-avenue, Mosman, N.S.W. ..	12.00	" ..	30.9.68
McDonald, Sybil G. (Mrs.), Flat 3, 7 Bradham-avenue, Mosman, N.S.W. ..	14.00	" ..	"
McGinnes, Avice A. (Mrs.), 109 Beatty-street, Ivanhoe ..	16.00	" ..	30.3.68
McGregor, Alfred G., 65 York-street, St. Kilda ..	12.00	" ..	"
Newman, Robert F., Box 20 P.O., Nanango, Qld. ..	40.00	" ..	"
Norman, Eldred D., Hope Valley, S.A. ..	10.54	" ..	30.9.68
Parry, Diana (Mrs.), c/o Mr. W. G. Parry, 381 Pitt-street, Sydney ..	81.20	" ..	30.3.68
Pearson, Doreen M. (Mrs.), Hayball-crescent, Noble Park ..	24.00	" ..	"
Pearson, Frank E., Rural Bank of N.S.W., Spit Junction Branch, Spit Junction, N.S.W. ..	30.00	" ..	"
Peak, Rear Admiral Richard I., Navy Office, Canberra, A.C.T. ..	20.00	" ..	30.9.68
Pennant, Charles W., 24 Victoria-avenue, Ballarat ..	10.00	" ..	30.3.68

Unclaimed Moneys Act 1962.

REGISTER of Unclaimed Moneys held by the—

Name of Owner on Books and Last Known Address.	Total Amount Due to Owner.	Description of Unclaimed Moneys.	Date when Amount first became Payable.
S			
DAVIES COOP & CO. LTD.—continued.			
Pritchard, Robert V., 16 Reid-street, Ashwood	20.00	Dividend	30.3.68
Pullman, Ronald W., c/o McMahon Construction Pty. Ltd., 309 Angus-street, Adelaide, S.A.	10.00	"	"
Rose, Clare R. (Mrs.), 46 Albany-road, Toorak	19.84	"	30.9.67
Schmidt-Elner, Hans A., Lot 117, Buraley-street, Doveton ..	12.00	"	"
Sheridan-Lea, Phyllis E. (Mrs.), 10 Binjat Hill, Binjat Park, Dunearn-road, Singapore	28.00	"	30.9.68
Snow, Moses, 3 Bremerton-avenue, Caulfield	40.00	"	30.3.68
Spedding, Richard, 80 Hannan-street, North Williamstown ..	44.88	"	"
Stirk, Geoffrey B., 62 Miskmi-street, Toowong, Brisbane, Qld. ..	120.00	"	"
Stone, Bevis, 15 Barnsbury-road, Balwyn	16.00	"	30.9.67
Thomas, Jack, c/o Daylesford Centenary Woollen Mills, Cnr. Nepean Highway and Thomas-street, Bentleigh	14.00	"	30.3.68
Thompson, Ronald S., 22 Ordnance-avenue, Lithgow, N.S.W. ..	36.00	"	30.9.67
Thonard, Constance G. (Mrs.), Flat 2, 22 Trentwood-avenue, North Balwyn	19.36	"	"
Webster, Gertie E. (Mrs.), 1031 Glenhuntly-road, Caulfield. . .	59.40	"	30.9.68
Williams, Kathleen M. (Mrs.), 30 Tring-terrace, Toombul, Brisbane, Qld.	16.00	"	30.9.67
Williamson, Peter J., Northbourne-avenue, Turner, A.C.T. ..	28.00	"	30.3.68
Williamson, Peter J., 416 Condamine-court, Turner, A.C.T. ..	12.00	"	"
Worthington, Leslie W., Flat 5, 17 Tennyson-avenue, Brighton Beach	16.00	"	"
Zahn, John F., 7 Pearl-street, Tweed Heads, N.S.W.	10.00	"	"
3471			
LEGGETT RUBBER INDUSTRIES PTY. LTD.			
Dimitracopoulos, A., 262 Church-street, Richmond	26.01	Unclaimed Wages	3.6.68
Kostopoulos, P., 9 Elm-grove, Richmond	26.74	"	29.11.68
Watkins, S., 289 Highett-street, Richmond	28.18	"	28.1.69
3647			
BRYSON INDUSTRIES LIMITED.			
Barlen Holdings Pty. Ltd., 470 Bourke-street, Melbourne	15.00	Ordinary dividend	26.11.68
Fincham, Muriel J. (Mrs.), 15 Alexander-avenue, South Yarra ..	30.00	Preference dividend	31.12.68
3714			
CAPEL COURT INVESTMENT COMPANY (AUSTRALIA) LTD.			
McArthur, E. H., P.O. Box 179, Ashburton, N.Z.	66.10	Dividend	25.3.68
3742			
HALIBURTON INVESTMENTS (AUSTRALIA) LIMITED.			
Dettman, A. D. G. (estate of), 43 Glencara-street, Avondale Heights	14.00	Dividend	24.2.69
3743			
AUSTRALIAN FOUNDATION INVESTMENT COMPANY LIMITED.			
Barnicoat, J. W. (estate of), c/o Trustees Executors & Agency Co. Ltd., 401 Collins-street	45.43	Dividend	23.9.68
Cave, A. M. (estate of), c/o Executor Trustees & Agency Co. of S.A. Ltd., 22 Grenfell-street, Adelaide, S.A.	109.50	"	"
Dawson, K. P. S., 9 Ollivier-street, St. Anne, Alderney, Guernsey, Channel Islands	18.70	"	"
Jago, L. G., 4A Musgrave-street, Mosman, N.S.W.	33.45	"	"
Liddiard, M. A. (estate of), Holmwood, 37A Lovelace-road, Surbiton, Surrey, U.K.	42.50	"	"
Lyster, B. I. (Miss), c/o Westminster Bank Ltd., Folkstone, Kent, U.K.	76.50	"	"
Miles, A. M. (estate of), c/o Gallaway Son & Chettleburgh, 17 Dowling-street, Dunedin, N.Z.	19.08	"	"
McArthur, A. H. (estate of), and E. H. McArthur, P.O. Box 179, Ashburton, N.Z.	57.37	"	"
McArthur, E. H., P.O. Box 179, Ashburton, N.Z.	479.10	"	"
Roberts, M. (Mrs.), Brooklands, Follifott, Harrogate, Yorkshire, U.K.	110.50	"	"
Warrington, P. A. (Mrs.), c/o Public Trustee, 256 Flinders-street, Melbourne	45.00	"	"
Henn-Collins, P. (Mrs.), 8 Lincoln-avenue, Wimbledon, S.W.19, U.K.	65.36	"	"
3744			
JASON INVESTMENT COMPANY (AUSTRALIA) LIMITED.			
Janet Investments Pty. Ltd., c/o Hardy Steel & Co., 34 Pirie-street, Adelaide, S.A.	28.00	Dividend	16.12.68
Lewis, M. E. (Mrs.), 59 McLean-street, Waitara, N.Z.	27.20	"	"
Strachan, E. S. (Miss), Wayside, 6 Rove-road, Mollington, near Chester, U.K.	31.76	"	"
3745			
NATIONAL RELIANCE INVESTMENT COMPANY LIMITED.			
Brady, E. F. (Mrs.), c/o Post Office, Mt. Hagan, N.G.	33.40	Dividend	24.6.68
Shute, F. J. A., 72 Luton-road, Harpenden, Herts, England ..	38.25	"	"
3746			
SHERBOURNE INVESTMENTS LIMITED.			
Coldham, C. W., 271 Mead-street, Glen Innes, N.S.W.	11.76	Dividend	26.8.68
3747			

Unclaimed Moneys Act 1962.

REGISTER of Unclaimed Moneys held by the—

Name of Owner on Books and Last Known Address.	Total Amount Due to Owner.	Description of Unclaimed Moneys.	Date when Amount first became Payable.
5			
THE AUSTRALIAN ESTATES CO. LTD.			
Bates, J. P., Stuart-street, Delegate	122.75	Unknown	26.5.67
McClure & Griffith, (address unknown)	26.20	Produce Proceeds	12.10.67
Unknown	18.91	"	16.11.67
Unknown, Narrandera	15.29	"	21.3.68
Unknown	14.04	"	—5.68
Farrant, C. H., "Calimo", Deniliquin	60.02	Proceeds Wool	—6.68
Grifford & Son, (address unknown)	46.96	"	—6.68
Unknown	98.29	"	12.7.68
Popiltah Properties, Popiltah via Wentworth	43.23	Proceeds Produce	25.7.68
Unknown	14.58	"	18.7.68
Unknown	10.78	"	1.8.68
Bowditch, L. & Co., Farm 1390, Hanwood	16.25	"	22.8.68
Hackney, B. C., "Wonalbee" Bathurst	27.10	Freight on Seed	23.8.68
Woodward, H. R., 679 Nepean Highway, Carrum	437.10	Produce Proceeds	19.9.68
Unknown	47.19	Cancelled Cheques	27.9.68
Messrs. Goesch Bros. Narraburra via Temora	48.39	Wool Proceeds	11.11.68
Dickins, Wahgunyah	12.38	"	28.11.68
National Trustees and Executors, 95 Queen-street, Melbourne	160.66	"	29.11.68
Unknown	150.29	"	31.12.68
Patterson, J. S., Box 82, Bairnsdale	16.07	Produce Proceeds	16.1.69
Unknown	64.44	"	—1.69
Redman, A. E., Springmount	69.58	Wool Proceeds	28.2.69
Scott, A., Private Bag, Swan Hill	300.39	Agistment	1.5.68
Smith, J., Pine Lodge	45.60	Stock Proceeds	20.5.68
Laggazino, J., Tatura	42.98	"	3.7.68
Lawlor, P. (address unknown)	45.30	"	18.7.68
Crow, J. T. & Sons, Orford	100.90	"	8.8.68
Cole, J., Katamatite	82.57	"	10.12.68
Woodward, H. R. & Sons, 679 Nepean Highway, Carrum	84.16	Sundry Creditor	17.12.68
3748			
BENDIGO AND CENTRAL VICTORIA TELECASTERS LIMITED.			
Almond, Robert L., 5 Monomeath-avenue, Toorak	40.00	Dividend due on 1000 shares	7.10.68
Bell, Robert L., 24 Charters-drive, Ivanhoe	20.00	" 500	7.10.68
Clayton, Desmond and Brennan, Lucy Joy, Dundas-street, St. Arnaud	13.00	" 400	21.9.67
Brennan, Lucy Joy, Dundas-street, St. Arnaud	13.00	" 400	21.9.67
Egan, William Thomas, 633 High-street, Golden Square	32.00	" 800	7.10.68
Ham, Francis Robert, Axedale	14.00	" 200	21.3.68
Hawkins, John, Axedale	26.00	" 800	21.9.67
Houlahan, William Francis, Eppalock	13.00	" 400	3.10.66
Hull, Sydney L. and Evelyn E. J., R.M.B. 53, Kyabram	15.00	" 600	31.3.67
Johnston, Leslie S., Swallow-street, Numurkah	30.00	" 500	7.10.68
Kelso, William, c/o National Bank of Aust. Ltd., Skipton	40.00	" 1000	7.10.68
Koch, Julia V., 117 Queen-street, Bendigo	12.00	" 300	"
McMath, Edward, 151 Neale-street, Bendigo	40.00	" 1000	"
Southern Factors Pty. Ltd., c/o Lavis, R. S., 110 Crown-street, Wollongong, N.S.W.	130.00	" 4000	21.9.67
Strickland, Veronica Ellen, "Allodale", Neale-street, Bendigo	12.00	" 400	21.3.68
Taylor, Norman H., 265 King-street, Bendigo	15.75	" 100	7.10.66
Worner, Frederick J., 35 Wackett-street, Macquarie, N.S.W.	13.00	" 400	21.9.67
Wright, Clifford J., 95 Locksby-road, Ivanhoe	12.00	" 300	7.10.68
3749			

CROP & ORCHARD CHEMICAL PTY. LTD.

NOTICE is hereby given that, pursuant to section 272 of the Companies Act 1961, a meeting of the members and creditors of the above-named company will be held at 440 Collins-street, Melbourne, on the 18th day of June, 1970, at 9.15 o'clock in the morning, for the purpose of having an account laid before them, showing how the winding up of the company has been conducted and the property of the company disposed of.

Dated this 21st day of April, 1970.

P. W. HARVEY, Liquidator.

A. L. Royce and Warne-Smith, chartered accountants,
440 Collins-street, Melbourne. 3955

Companies Act 1961, Section 272 (2).

A. P. VINCENT (PLUMBERS) PROPRIETARY LIMITED
(IN LIQUIDATION).

THE Final Meeting of the company and its creditors will be held at the office of the liquidator on 29th May, 1970, at 10 a.m., for the purpose of receiving the liquidator's account, showing how the winding up has been conducted and the property of the company disposed of.

Dated the 21st April, 1970.

F. Y. RATTRAY, Liquidator, 24 Jeffcott-street, Melbourne. 3929

The Companies Act 1961.—In the matter of A. E. SPECK & ASSOCIATES PROPRIETARY LIMITED (in Liquidation), A. E. SPECK CORRESPONDENCE COLLEGE PROPRIETARY LIMITED (in Liquidation), A. E. SPECK COMMERCIAL COLLEGE (DAY CLASS) PROPRIETARY LIMITED (in Liquidation), A. E. SPECK COMMERCIAL COLLEGE (EVENING CLASS) PROPRIETARY LIMITED (in Liquidation), SALES INSTITUTE OF AUSTRALIA PROPRIETARY LIMITED (in Liquidation), A. E. SPECK MANAGEMENT INSTITUTE PROPRIETARY LIMITED (in Liquidation), and FLINDERS BOOK COMPANY PROPRIETARY LIMITED (in Liquidation).

NOTICE is hereby given, in pursuance of section 272 of the Companies Act 1961, that a General Meeting of members of the above-named companies will be held at Moe South-road, Trafalgar, on Friday, the 29th day of May, 1970, commencing at 9 o'clock in the morning, for the purpose of having the liquidator's account laid before them, showing the manner in which the winding up of the above-named companies has been conducted, and the property of the above-named companies disposed of, and of hearing any explanation that may be given by the liquidator; and also of determining the manner in which the books, accounts and documents of the above-named companies and of the liquidator thereof shall be disposed of.

Dated the 28th day of April, 1970.

3968

A. E. MOORE, Liquidator.

*Companies Act 1961.***TWEEDSIDE MANUFACTURING CO. LTD.**
(IN LIQUIDATION).NOTICE Re MEETING OF CREDITORS AND CONTRIBUTORIES,
PURSUANT TO SECTION 272.

NOTICE is hereby given that a meeting of creditors and contributories of the above-named company will be held at the offices of Fell & Starkey, 19 Floor, 351 Collins-street, Melbourne, on Thursday, 4th June, 1970, at 10 a.m., to receive an account of the liquidation and any explanations thereof.

Dated this 22nd day of April, 1970.

3930

R. W. ELLIS, Liquidator.

*Companies Act 1961.***MEADOWLANDS PROPRIETARY LIMITED**
(IN VOLUNTARY LIQUIDATION).

NOTICE is hereby given, pursuant to section 272 (2) of the Companies Act 1961, that a General Meeting of members of the above-named company will be held at 346 Little Collins-street, Melbourne, on the 5th day of June, 1970, at 10 a.m., for the purpose of having an account laid before them, showing the manner in which the winding up has been conducted and the property of the company disposed of, and of hearing any explanation that may be given by the liquidator.

Dated this 27th day of April, 1970.

3948

W. B. McMAHON, Liquidator.

The Companies Act 1961.—In the matter of BRIDGE TIMBER COMPANY PROPRIETARY LIMITED.

AT a General Meeting of the members of Bridge Timber Company Proprietary Limited, duly convened and held at the offices of Kennedy, Smail & Middlemiss, 296 Little Lonsdale-street, Melbourne, on the 23rd day of April, 1970, the following Special Resolution was duly passed:—

"That the company be and is hereby wound up voluntarily, pursuant to the provisions of sub-division (2) of Division 3 of Part X. of the Companies Act 1961, and that for the purpose of such winding up, Norman Eric Stretton, of 296 Little Lonsdale-street, Melbourne, be appointed liquidator."

Dated this 24th day of April, 1970.

N. E. STRETTON, Liquidator.

Kennedy, Smail & Middlemiss, 296 Little Lonsdale-street,
Melbourne, 3000. 3949

In the matter of the Companies Act 1961, and in the matter of RAYNEON SIGNS LTD.

NOTICE is hereby given that at a meeting of the members of Rayneon Signs Ltd., held at Melbourne on the 22nd April, 1970, the following Resolution was passed as a Special Resolution:—

That the company be wound up voluntarily and that Mr. L. P. Smart, of 51 Queen-street, Melbourne, be appointed liquidator for the purposes of such winding up.

3950

L. P. SMART, Liquidator.

*Companies Act 1961.***DUPLICATIONS PTY. LTD. (IN VOLUNTARY LIQUIDATION).**

NOTICE is hereby given that at an Extraordinary Meeting of the members of the above-named company, held on Thursday, the 16th day of April, 1970, it was resolved that the company be wound up voluntarily, and at a Meeting of Creditors held on the same day it was resolved that for such purpose Lewis Luckins, chartered accountant, of 289 Flinders-lane, Melbourne, be appointed liquidator.

Notice is also given that, after 21 days from this date, I shall proceed to distribute the assets. All creditors having any claim against the company should furnish particulars of same by that date, otherwise I shall proceed to distribute the assets without regard to their claim.

Dated this 23rd day of April, 1970.

LEWIS LUCKINS, Liquidator.

Lewis Luckins & Co., chartered accountants, of 289
Flinders-lane, Melbourne, 3000. Telephone No. 63 8827.
3951*The Companies Act 1961.***W.L.I. PLATES PTY. LTD. (IN VOLUNTARY LIQUIDATION).**

NOTICE is hereby given that at an Extraordinary Meeting of the members of the above-named company, held on Thursday, the 16th day of April, 1970, it was resolved that the company be wound up voluntarily, and at a

Meeting of Creditors held on the same day it was resolved that for such purpose Lewis Luckins, chartered accountant, of 289 Flinders-lane, Melbourne, be appointed liquidator.

Notice is also given that, after 21 days from this date, I shall proceed to distribute the assets. All creditors having any claim against the company should furnish particulars of same by that date, otherwise I shall proceed to distribute the assets without regard to their claim.

Dated this 23rd day of April, 1970.

LEWIS LUCKINS, Liquidator.

Lewis Luckins & Co., chartered accountants, of 289
Flinders-lane, Melbourne, 3000. Telephone No. 63 8827.
3952

The Companies Act 1961.—In the matter of DAVID KLEIN PROPRIETARY LIMITED (in Voluntary Liquidation).

NOTICE is hereby given that at an Extraordinary Meeting of the members of the above-named company, held on Thursday, the 23rd day of April, 1970, it was resolved that the company be wound up voluntarily, and at a Meeting of creditors held on Thursday, the 23rd day of April, 1970, it was resolved that for such purpose, Harold Keith Cartledge, of 1 Palmerston-crescent, South Melbourne, be appointed liquidator.

Notice is also given that, after 21 days from this date I shall proceed to distribute the assets. All creditors having any claims against the company should furnish particulars of same by that date, otherwise I shall proceed to distribute the assets without regard to their claim.

Dated this 23rd day of April, 1970.

H. K. CARTLEDGE, Liquidator.

Norman, Cartledge and Browne, chartered accountants,
1 Palmerston-crescent, South Melbourne, Vic., 3205. 3953

The Companies Act 1961.—In the matter of TARNARD DEVELOPMENTS PTY. LTD.

NOTICE is hereby given that at an Extraordinary General Meeting of the above-named company, duly convened and held at 33 Ormond-esplanade, Elwood, on the 13th day of April, 1970, the following Special Resolution was duly passed:—

"That the company be wound up voluntarily, and that John Patrick Chaundy, of "Wellesley House", 126-130 Wellington-parade, East Melbourne, be appointed liquidator for the purposes of the winding up."

Dated this 14th day of April, 1970.

J. P. CHAUNDY, Liquidator.

(Issued in lieu of Notice appearing in Victoria Govern-
ment Gazette, No. 39, of 22nd April, 1970, page 1105.)
3967**SELF SIGNS PTY. LTD.**

NOTICE OF MEETING OF CREDITORS.

NOTICE is hereby given that a meeting of creditors of Self Signs Pty. Ltd. will be held at Suite 18, 545 St. Kilda-road, Melbourne, on Tuesday, the 12th day of May, 1970, at 10.30 o'clock in the forenoon.

Agenda.

To receive the company's statement of affairs and a report by the liquidator.

To consider and, if thought fit, pass a resolution appointing a committee of inspection.

BENT & COUGLE, public accountants, Suite 18, 545
St. Kilda-road, Melbourne, 3004. 3982

The Companies Act 1961.—In the matter of JOALEN PTY. LTD. (in Liquidation).

NOTICE is hereby given that, pursuant to section 272 of the Companies Act, a Final Meeting of creditors of the above company will be held at the offices of Bent & Cogle, on Tuesday, 2nd June, 1970, at 11 a.m.

Business.

To receive the liquidator's accounts.

Dated this 24th day of April, 1970.

D. J. COUGLE, Liquidator.

Bent & Cogle, public accountants, Suite 18, 545
St. Kilda-road, Melbourne. 3987

NOTICE is hereby given that a meeting of the members of Padua Hospital Pty. Limited, will be held at the office of William R. Gluyas, public accountant, 526 Malvern-road, East Prahran on Thursday, the 14th day of May, 1970, at the hour of 2.15 o'clock in the afternoon, for the purpose of laying before it the accounts of the company, and giving any explanation thereof.

3954

W. R. GLUYAS, Liquidator.

The Companies Act 1961.—In the matter of H. F. & J. M. WHITE PTY. LTD.—Notice of Final Meeting.

NOTICE is hereby given that, pursuant to section 272 of the Companies Act 1961, a General Meeting of the members of the above-named company will be held at Main-road, Hurstbridge, on Tuesday, the 23rd June, 1970, at 10 o'clock in the forenoon, for the purpose of having an account laid before them, showing the manner in which the winding up has been conducted and the property of the company disposed of, and of hearing any explanation that may be given by the liquidator.

Dated the 23rd day of April, 1970.

3914 HAROLD F. WHITE, Liquidator.

Form 92.

The Companies Act 1961, Section 272 (1).

CASHMORE & RUSSELL PTY. LTD. (in Liquidation).

NOTICE OF MEETING OF CREDITORS AND CONTRIBUTORIES.

Companies Regulations.

NOTICE is hereby given that a Final Meeting of the creditors and contributories of Cashmore & Russell Pty. Ltd. (in liquidation), will be held at the 4th Floor, 170 Queen-street, Melbourne, on Friday, 29th May, 1970, at 11.30 o'clock in the forenoon.

Agenda.

To receive the liquidator's account of his acts and dealings and of the conduct of the winding up and of hearing any explanations thereof.

Dated this 24th day of April, 1970.

3915 R. A. WATERS, Liquidator.

Companies Act 1961, Section 272 (2).

MOUNT INVESTMENT PROPRIETARY LIMITED (IN VOLUNTARY LIQUIDATION).

NOTICE OF FINAL MEETING.

NOTICE is hereby given that a General Meeting of the members of the above-named company will be held at the office of Arthur Andersen & Co., 9th Floor, 330 Collins-street, Melbourne, on Friday, 29th May, 1970, at 10 a.m., for the purpose of having an account laid before them, showing the manner in which the winding up has been conducted and the property of the company disposed of, and of hearing any explanation that may be given by the liquidator.

Dated this 24th day of April, 1970.

3916 R. S. PRIME, Liquidator.

Companies Act 1961, Section 272.

CRAFTMASTER ENGINEERING PTY. LTD. (IN LIQUIDATION).

NOTICE OF FINAL MEETING OF CREDITORS AND CONTRIBUTORIES.

NOTICE is hereby given that a meeting of the creditors and contributories of Craftmaster Engineering Pty. Limited (in Liquidation) will be held at the offices of Messrs. Fell & Starkey, chartered accountants, 19th Floor, 351 Collins-street, Melbourne, on the 1st day of June, 1970, at 9.15 o'clock in the forenoon.

AGENDA.

To lay before the meeting the liquidator's account showing how the winding up has been conducted and the property of the company has been disposed of and to give any explanation of the account which may be required.

Dated this 24th day of April, 1970.

3991 REG. W. ELLIS, Liquidator.

Companies Act 1961, Section 272.

D. & W. ELECTRICAL PRODUCTS PTY. LTD. (IN LIQUIDATION).

NOTICE OF FINAL MEETING OF CREDITORS AND CONTRIBUTORIES.

NOTICE is hereby given that a meeting of the creditors and contributories of D. & W. Electrical Products Pty. Limited (in Liquidation) will be held at the offices of Messrs. Fell & Starkey, chartered accountants, 19th Floor, 351 Collins-street, Melbourne, on the 1st day of June, 1970, at 9.45 o'clock in the forenoon.

AGENDA.

To lay before the meeting the liquidator's account showing how the winding up has been conducted and the property of the company has been disposed of and to give any explanation of the account which may be required.

Dated this 24th day of April, 1970.

3992 REG. W. ELLIS, Liquidator.

Companies Act 1961, Section 272.

DOMUS FLUORESCENT LIGHTING PTY. LTD. (IN LIQUIDATION).

NOTICE OF FINAL MEETING OF CREDITORS AND CONTRIBUTORIES.

NOTICE is hereby given that a meeting of the creditors and contributories of Domus Fluorescent Lighting Pty. Limited (in Liquidation) will be held at the offices of Messrs. Fell & Starkey, chartered accountants, 19th Floor, 351 Collins-street, Melbourne, on the 1st day of June, 1970, at 10.15 o'clock in the forenoon.

AGENDA.

To lay before the meeting the liquidator's account showing how the winding up has been conducted and the property of the company has been disposed of and to give any explanation of the account which may be required.

Dated this 24th day of April, 1970.

3993 REG. W. ELLIS, Liquidator.

Companies Act 1961, Section 272.

E. V. JOHNSON & CO. PTY. LTD. (IN LIQUIDATION).

NOTICE OF FINAL MEETING OF CREDITORS AND CONTRIBUTORIES.

NOTICE is hereby given that a meeting of the creditors and contributories of E. V. Johnson & Co. Pty. Ltd. (in Liquidation) will be held at the offices of Messrs. Fell & Starkey, chartered accountants, 19th Floor, 351 Collins-street, Melbourne, on the 1st day of June, 1970, at 10.45 o'clock in the forenoon.

AGENDA.

To lay before the meeting the liquidator's account showing how the winding up has been conducted and the property of the company has been disposed of and to give any explanation of the account which may be required.

Dated this 24th day of April, 1970.

3994 REG. W. ELLIS, Liquidator.

Companies Act 1961, Section 272.

LIGHTING ENGINEERS PTY. LTD. (IN LIQUIDATION).

NOTICE OF FINAL MEETING OF CREDITORS AND CONTRIBUTORIES.

NOTICE is hereby given that a meeting of the creditors and contributories of Lighting Engineers Pty. Limited (in Liquidation) will be held at the offices of Messrs. Fell & Starkey, chartered accountants, 19th Floor, 351 Collins-street, Melbourne, on the 1st day of June, 1970, at 11.15 o'clock in the forenoon.

AGENDA.

To lay before the meeting the liquidator's account showing how the winding up has been conducted and the property of the company has been disposed of and to give any explanation of the account which may be required.

Dated this 24th day of April, 1970.

3995 REG. W. ELLIS, Liquidator.

Companies Act 1961, Section 272.

NEONASIA CABLES PTY. LTD. (IN LIQUIDATION).

NOTICE OF FINAL MEETING OF CREDITORS AND CONTRIBUTORIES.

NOTICE is hereby given that a meeting of the creditors and contributories of Neonasia Cables Pty. Limited (in Liquidation) will be held at the offices of Messrs. Fell & Starkey, chartered accountants, 19th Floor, 351 Collins-street, Melbourne, on the 1st day of June, 1970, at 11.45 o'clock in the forenoon.

AGENDA.

To lay before the meeting the liquidator's account showing how the winding up has been conducted and the property of the company has been disposed of and to give any explanation of the account which may be required.

Dated this 24th day of April, 1970.

3996 REG. W. ELLIS, Liquidator.

Companies Act 1961, Section 272.

P. & D. DISTRIBUTORS PTY. LTD. (IN LIQUIDATION).

NOTICE OF FINAL MEETING OF CREDITORS AND CONTRIBUTORIES.

NOTICE is hereby given that a meeting of the creditors and contributories of P. & D. Distributors Pty. Limited (in Liquidation) will be held at the offices of Messrs. Fell

& Starkey, chartered accountants, 19th Floor, 351 Collins-street, Melbourne, on the 1st day of June, 1970, at 12.15 o'clock in the afternoon.

AGENDA.

To lay before the meeting the liquidator's account showing how the winding up has been conducted and the property of the company has been disposed of and to give any explanation of the account which may be required.

Dated this 24th day of April, 1970.

3997 REG. W. ELLIS, Liquidator.

Companies Act 1961, Section 272.

POWER & DISTRIBUTION TRANSFORMERS PTY. LTD.
(IN LIQUIDATION).

NOTICE OF FINAL MEETING OF CREDITORS AND
CONTRIBUTORIES.

NOTICE is hereby given that a meeting of the creditors and contributories of Power & Distribution Transformers Pty. Limited (in Liquidation) will be held at the offices of Messrs. Fell & Starkey, chartered accountants, 19th Floor, 351 Collins-street, Melbourne, on the 1st day of June, 1970, at 12.45 o'clock in the afternoon.

AGENDA.

To lay before the meeting the liquidator's account showing how the winding up has been conducted and the property of the company has been disposed of and to give any explanation of the account which may be required.

Dated this 24th day of April, 1970.

3998 REG. W. ELLIS, Liquidator.

Companies Act 1961, Section 272.

STROMETAL PTY. LTD. (IN LIQUIDATION).

NOTICE OF FINAL MEETING OF CREDITORS AND
CONTRIBUTORIES.

NOTICE is hereby given that a meeting of the creditors and contributories of Strometal Pty. Limited (in Liquidation) will be held at the offices of Messrs. Fell & Starkey, chartered accountants, 19th Floor, 351 Collins-street, Melbourne, on the 1st day of June, 1970, at 2 o'clock in the afternoon.

AGENDA.

To lay before the meeting the liquidator's account showing how the winding up has been conducted and the property of the company has been disposed of and to give any explanation of the account which may be required.

Dated this 24th day of April, 1970.

3999 REG. W. ELLIS, Liquidator.

Companies Act 1961, Section 272.

TRAVELLERS ADVERTISING PTY. LTD. (IN
LIQUIDATION).

NOTICE OF FINAL MEETING OF CREDITORS AND
CONTRIBUTORIES.

NOTICE is hereby given that a meeting of the creditors and contributories of Travellers Advertising Pty. Limited (in Liquidation) will be held at the offices of Messrs. Fell & Starkey, chartered accountants, 19th Floor, 351 Collins-street, Melbourne, on the 1st day of June, 1970, at 2.30 o'clock in the afternoon.

AGENDA.

To lay before the meeting the liquidator's account showing how the winding up has been conducted and the property of the company has been disposed of and to give any explanation of the account which may be required.

Dated this 24th day of April, 1970.

4000 REG. W. ELLIS, Liquidator.

Companies Act 1961, Section 272.

UVADALE PTY. LTD. (IN LIQUIDATION).

NOTICE OF FINAL MEETING OF CREDITORS AND
CONTRIBUTORIES.

NOTICE is hereby given that a meeting of the creditors and contributories of Uvadale Pty. Limited (in Liquidation) will be held at the offices of Messrs. Fell & Starkey, chartered accountants, 19th Floor, 351 Collins-street, Melbourne, on the 1st day of June, 1970, at 3 o'clock in the afternoon.

AGENDA.

To lay before the meeting the liquidator's account showing how the winding up has been conducted and the property of the company has been disposed of and to give any explanation of the account which may be required.

Dated this 24th day of April, 1970.

4001 REG. W. ELLIS, Liquidator.

CREDITORS, next of kin and other persons having claims against the estate of Maxwellina Curlett Jenner, late of 568 High-street, East Prahran, in the State of Victoria, spinster, deceased (who died on the 7th day of January, 1970), are required to send particulars of their claims to the administratrix, May Isabella Ackland, care of the under-mentioned solicitors, by the 29th June, 1970, after which date the administratrix will distribute the assets, having regard only for the claims of which she then has had notice.

JAMES P. OGGE & CO., solicitors, of 165 Greville-street, Prahran. 3971

CREDITORS, next of kin and other persons having claims against the estate of Thomas Cyril Doig, late of 10 Tivoli-road, South Yarra, in the State of Victoria, retired, deceased (who died on the 21st day of October, 1969), are required to send particulars of their claims to the executor, Reginald Charles Salter, care of the under-mentioned solicitors, by the 22nd day of June, 1970, after which date the executor will distribute the assets, having regard only for the claims of which he then has had notice.

JAMES P. OGGE & CO., solicitors, of 165 Greville-street, Prahran. 3972

CREDITORS, next of kin and all others having claims in respect of the estate of Elizabeth Jarvie, formerly of No. 74 but late of No. 331 Brunswick-road, West Brunswick, in the State of Victoria, gentlewoman, deceased (who died on the 3rd day of June, 1969), are required to send particulars of their claims to The Equity Trustees Executors and Agency Company Limited, at its registered office at 472 Bourke-street, Melbourne, by the 8th July, 1970, after which date the said company will distribute the estate, having regard only to the claims of which it then has notice.

J. M. SHANNON & SON, solicitors, 100 Queen-street, Melbourne. 3976

HAMILTON CLARKE, solicitor, and Eric Tuson Payne-Croston, Minister of Religion, both of Benalla, the executors of the will of Margaret Greta Irvine, late of 7 Market-street, Benalla, in the State of Victoria, widow, deceased (who died on the 9th day of January, 1970), require all creditors, next of kin and others having claims against the property or estate of the said deceased to send particulars in writing of such claims to them, care of the under-mentioned solicitors, on or before the 30th day of June, 1970, after which date the said executors intend to convey or distribute such property or estate to or among the persons entitled thereto, having regard only to the claims of which they shall then have had notice.

HAMILTON CLARKE & CLARKE, 55 Nunn-street, Benalla. 3984

CREDITORS, next of kin and others having claims in respect of the estate of Winifred Ruth Head, late of 8 Pembroke-street, Surrey Hills, spinster (who died on the 12th day of January, 1970), are required by the executors, Walter Gordon Allpress and Malcolm Noel Winn, to send particulars of their claims to them, care of the under-signed solicitors, by the 30th day of June, 1970, after which date the said executors will distribute the assets, having regard only to the claims of which they then have notice.

SALISBURY WARDLAW & CO., solicitors, of 882 Whitehorse-road, Box Hill. 4002

CREDITORS, next of kin and others having claims in respect of the estate of Violet Gibb, formerly of 18 Park-street, South Melbourne, but late of 19 Finlay-street, Albert Park, spinster, deceased (who died on the 8th day of December, 1969), are to send particulars of their claims to The Union-Fidelity Trustee Company of Australia Limited, at its registered office, 100 Exhibition-street, Melbourne, by the 1st day of July, 1970, after which date it will distribute the assets, having regard only to the claims of which it then has notice.

F. J. ORAMES & DOWNING, solicitors, 84 William-street, Melbourne. 4003

CREDITORS, next of kin and others having claims in respect of the estate of Alice Eliza Godfrey, late of 77 Gordon-street, Footscray, widow, deceased (who died on the 14th day of January, 1970), are to send particulars of their claims to the executors, Ronald Harry Weeks and Alma Muriel Widdicombe, care of the under-mentioned solicitors, on or before the 1st day of July, 1970, after which date the executors will distribute the estate, having regard only to the claims of which they then have notice.

MARTIN & MARTIN, solicitors, 37 Queen-street, Melbourne. 4004

NOTICE TO CREDITORS.

THE Trustees, Executors and Agency company Limited, of 401 Collins-street, Melbourne, the executor of the will of John Stanley, late of 52 Patterson-road, Moorabbin, public servant, deceased (who died on the 4th day of January, 1970), requires all creditors, next of kin and others having claims against the property or estate of the said deceased to send to it, the said executor at the address afore-mentioned, on or before the 30th day of June, 1970; particulars in writing of such claims after which date the said executor intends to convey or distribute such property or estate to or among the persons entitled thereto, having regard only to the claims of which it shall have had notice.

DARVALL & HAMBLETON, solicitors, 7th Floor, T. & G. Building, 147 Collins-street, Melbourne. 4005

CREDITORS, next of kin and others having claims in respect of the estate of Grace Brennan, late of 32 Washington-street, Toorak, Victoria, married woman, deceased (who died on the 18th day of June, 1969), are required to send particulars of their claims to National Trustees Executors and Agency Company of Australasia Limited, Farmers and Citizens Division, of 46-48 Queen-street, Bendigo, Victoria, by the 30th day of June, 1970, after which date the said company will distribute the assets, having regard only to the claims of which it then has notice.

GILLOTT, MOIR & WINNEKE, solicitors, 95 Queen-street, Melbourne. 4006

CREDITORS, next of kin and others having claims in respect of the estate of Geoffrey James Bourke, late of "Hilton Park", Bacchus Marsh, farmer, deceased (who died on the 25th day of July, 1969, and probate of whose will has been granted to Clarence Geoffrey Dudley Bourke, of 264 Dundas-street, Thornbury, firewood contractor, Charles Alfred Peter Bourke, of 71 Pender-street, Thornbury, assistant textile engineer, and James Forest Cornelius Bourke, of "Hilton Park", Bacchus Marsh, farmer), are required to send particulars of their claims to the said executors, care of the under-mentioned solicitors, by the 6th day of July, 1970, after which date they will distribute the assets, having regard only to the claims of which they then have notice.

PEARCE & WEBSTER, solicitors, 430 Little Collins-street, Melbourne. 3924

CREDITORS, next of kin and others having claims in respect of the estate of Myrtle Laura Lilian Davies, late of 23 Orient-grove, West Preston, married woman, deceased (who died on the 23rd day of December, 1969, and probate of whose will has been granted to Harry Davies, of 23 Orient-grove, West Preston, retired), are required to send particulars of their claims to the said executor, care of the under-mentioned solicitors, by the 6th day of July, 1970, after which date he will distribute the assets, having regard only to the claims of which he then has notice.

PEARCE & WEBSTER, solicitors, 430 Little Collins-street, Melbourne. 3925

ERNEST JOSEPH MONK, late of 23 Clyde-street, East Kew, storeman, DECEASED, intestate.

CREDITORS, next of kin and others having claims in respect of the estate of the deceased (who died on the 21st day of July, 1969), are required by the administratrix, Dorothy Mary Scott, of 23 Ormond-street, Mordialloc, married woman, to send particulars to her, care of the undersigned, by the 1st day of July, 1970, after which date the administratrix, may convey or distribute the assets, having regard only to the claims of which she then has notice.

T. D. ARMSTRONG, solicitor, 422 Collins-street, Melbourne. 3926

CREDITORS, next of kin and others having claims in respect of the estate of Nellie Victoria Lee, late of 198 Kooyong-road, Toorak, in the State of Victoria, widow, deceased (who died on the 22nd day of February, 1970), are required by the executor, Maxwell Harry Joseph, of 118 Queen-street, Melbourne, in the State of Victoria, solicitor, to send particulars of their claims to him in care of Strongman & Crouch, solicitors, of 118 Queen-street, Melbourne, by the 15th July, 1970, after which date the said executor will distribute the assets of the deceased, having regard only to the claims of which he then shall have had notice.

STRONGMAN & CROUCH, solicitors, of 118 Queen-street, Melbourne. 3928

SYDNEY ALLAN ARNOLD, deceased, late of 12 Goldsmith-street, Elwood, in the State of Victoria, gentleman, DECEASED.

CREDITORS, next of kin and others having claims in respect of the estate of the deceased (who died on the 27th day of May, 1969), are required by the personal representatives, Judith Delores Gibson, of 16 Randwick-street, Randwick, in the State of New South Wales, married woman, and David Valentine Fogarty, of 84 Chapel-street, St. Kilda, solicitor to send particulars to them, care of David Bullard, solicitor, of 443 Law Courts-place, Melbourne, by the 24th day of June, 1970, after which date the personal representatives may convey or distribute the assets, having regard only to the claims of which he then has notice.

DAVID BULLARD, solicitor, 443 Law Courts-place, Melbourne. 3927

THOMAS EDWARD BARTLETT, of 168 Gilbert-road, West Preston, in the State of Victoria, retired, DECEASED.

CREDITORS, next of kin and others having claims in respect of the estate of the deceased (who died on the 10th March, 1969), are requested to send particulars of their claims to the executrix, Rita Victoria Walker, care of the undersigned solicitor, by the 30th June, 1970, after which date the said executrix will proceed to distribute the estate, having regard only to the claims of which she then has notice.

MARJORY C. COATES, solicitor, 422 Collins-street, Melbourne, 3000. 3932

CREDITORS, next of kin and others having claims in respect of the estate of Mabel Victoria Powys, late of 20 Lisson-grove, Hawthorn, widow, deceased (who died on the 19th January, 1970), are required by the executor, John Charles Cawsey, of 10 Virginia-street, Mt. Waverley, industrial chemist, to send particulars of their claims to him in care of the under-mentioned solicitors, prior to the 8th July, 1970, after which date the said executor will distribute the assets of the deceased, having regard only to the claims of which he then shall have had notice.

ROGERS & GAYLARD, solicitors, 51 Queen-street, Melbourne. 3933

ELIZABETH BARLEY TANNER, late of 10 Wimba-avenue, Kew, Victoria, widow, DECEASED.

CREDITORS, next of kin and others having claims in respect of the estate of the deceased (who died on 2nd December, 1969), are required by the personal representative, Annie Jean Hodges, of 129 Mugga Way, Red Hill, Australian Capital Territory, married woman, to send particulars of their claims to her, by 30th June, 1970, after which date she may convey or distribute the assets, having regard only to the claims of which she then has notice.

HEDDERWICK FOOKES & ALSTON, solicitors, 121 William-street, Melbourne. 3934

CREDITORS, next of kin and all other persons having claims against the estate of Elsie Jane Joy, late of 3 Kelvin-grove, Thornbury, widow, deceased are required by the executor, Victor William Joy, of 20 Carrington-road, Reservoir, electrical engineer, to send particulars of their claims care of the undersigned, by the 30th day of June, 1970, after which date he will distribute the assets, having regard only to the claims of which he then has notice.

JOHN D. MUSTOW & CO., solicitors, of 131 Queen-street, Melbourne. 3935

CREDITORS, next of kin and others having claims in respect of the estate of Edna May Wood, late of 50 Wheatland-road, Malvern, widow, deceased, are to send particulars of their claims to the executrix, Florence Dorothy Carmichael, care of the undersigned, by the 2nd July, 1970, after which date she will commence to distribute the assets, having regard only to the claims of which she then has notice.

RENNICK & GAYNOR, solicitors, 481 Riversdale-road, Hawthorn East. 3943

CREDITORS, next of kin and others having claims in respect of the estate of Lillian Florence Edmunds, late of 385 Auburn-road, Hawthorn, married woman, deceased, are to send particulars of their claims to the executor, Barry Stevens, care of the undersigned by the 2nd July, 1970, after which date he will commence to distribute the assets, having regard only to the claims of which he then has notice.

RENNICK & GAYNOR, solicitors, 481 Riversdale-road, Hawthorn East. 3939

ARCHIBALD LILLINGTON SNEDDON, late of 23 Driffield-road, Yallourn, civil engineer, DECEASED (who died on the 3rd January, 1970).

CREDITORS, next of kin and all persons having claims against the estate of the deceased are required to send particulars to the executors, The Union-Fidelity Trustee Company of Australia Limited, of 101 Lydiard-street north, Ballarat, on or before the 30th June, 1970, after which date it will distribute the assets, having regard only to the claims of which it shall then have notice.

HEINZ & GORDON, solicitors, 209 Dana-street, Ballarat.
3899

ARTHUR ERNEST HORNBY, late of 761 Glenferrie-road, Hawthorn, café proprietor, DECEASED, intestate.

CREDITORS, next of kin and others having claims in respect of the estate of the above-named deceased (who died on the 16th day of February, 1970), are required by the administrator of the estate, Arthur James Gibson Hornby, of Clarkmont-road, Sassafras, physiotherapist, to send particulars to him by the 2nd day of July, 1970, after which date the administrator may convey or distribute the assets, having regard only to the claims of which he then has notice.

MACPHERSON & KELLEY, solicitors, 264 Lonsdale-street, Dandenong.
3875

GRAHAM ALLAN PINCHES, late of 37 Scotland-avenue, Greensborough, in the State of Victoria, plumber, DECEASED.

CREDITORS, next of kin and others having claims in respect of the estate of the deceased (who died on 27th January, 1970), are required by the executrix, Margery Edna Pinches, of 37 Scotland-avenue, Greensborough, aforesaid, widow, to send particulars to the under-mentioned firm by 23rd July, 1970, after which date the said executrix may convey or distribute the assets, having regard only to the claims of which she then has notice.

SETON WILLIAMS & HEATHFIELD, solicitors, 230 Collins-street, Melbourne.
3880

ETHEL MARY DONOHOE, late of Barkly-street, East Brunswick, spinster, DECEASED, intestate.

CREDITORS, next of kin and others having claims in respect of the estate of the deceased (who died on the 13th day of March, 1969), are required by the personal representative, James Donohoe, of 11 Barkly-street, East Brunswick, storeman, to send particulars to him by the 30th day of June, 1970, after which date he may convey or distribute the assets, having regard only to the claims of which he then has notice.

J. P. HENNESSY, solicitor, 186 Elgin-street, Carlton.
3882

WILLIAM CURRAN, late of 47 Arnold-street, Bendigo, retired farmer, DECEASED.

CREDITORS, next of kin and others having claims in respect of the estate of the above-named deceased are required by the administrator, National Trustees, Executors and Agency Company of Australasia Limited, of 95 Queen-street, Melbourne, and at 46 Queen-street, Bendigo, to send particulars to it by the 15th day of July, 1970, after which date the administrator will distribute the assets, having regard only to the claims of which it then has notice.

Dated the 29th day of April, 1970.

HYETT & HYETT, 51 Bull-street, Bendigo, solicitors for the applicant.
3889

CREDITORS, next of kin and others having claims in respect of the estate of Dorothea Josephine Crouch, late of 2 Horsley-street, Bentleigh, in the State of Victoria, married woman, deceased (who died on the 1st day of October, 1969), are to send particulars of their claims to Neville D. Kelly & Associates, solicitors, of 437 Centre-road, Bentleigh, by the 1st day of July, 1970, after which date the executors will distribute the assets of the said estate, having regard only to the claims of which they then have notice.

NEVILLE D. KELLY & ASSOCIATES, 437 Centre-road, Bentleigh.
3891

DAVID MILLAR, late of 5 Shamrock-street, Bendigo, retired miner, DECEASED.

CREDITORS, next of kin and others having claims in respect of the estate of the deceased (who died on the 27th day of November, 1969), are required by National Trustees, executors and Agency Company of Australasia

Limited, of 46 Queen-street, Bendigo, to send particulars to it by the 30th day of June, 1970, after which date it may convey or distribute the assets, having regard only to the claims of which it then has notice.

ERNEST S. CAHILL & SON, solicitors, 16 View-street, Bendigo.
3893

CREDITORS, next of kin and others having claims in respect of the estate of Norman John Tuck, late of 22 Keilor-avenue, East Reservoir, pensioner, deceased (who died on the 4th day of August, 1969), are required to send particulars of their claims to the executor of the estate, Edwin James Steward, care of Havyatt & Steward, solicitors, of 472 Bourke-street, Melbourne, by the 30th day of June, 1970, after which date the executor will distribute the assets of the deceased, having regard only to the claims of which he then has notice.
3897

CREDITORS, next of kin and others having claims against the estate of Herbert Stanley Seymour, late of Wattle-street, Bendigo, in the State of Victoria, carpenter, deceased (who died on the 18th day of October, 1969), are required to send particulars thereof to National Trustees, Executors and Agency Company of Australasia Limited, of 46 Queen-street, Bendigo, aforesaid, by the 30th day of June, 1970, after which date the said company will distribute the assets of the said deceased, having regard only to the claims of which it then has notice.

WATSON, JAMES & ROGERS, solicitors, Bull-street, Bendigo.
3884

HERBERT MCGINNESS, formerly of Framlingham and 30 Leonard-street, Wodonga, in the State of Victoria, and late of 3 Aberfeldy-street, Kenmore, in the State of Queensland, retired grazier, DECEASED.

CREDITORS, next of kin and all others having claims in respect of the estate of the above-named deceased (who died on the 19th day of January, 1970), are requested to send particulars of their claims, in writing, to the executors, John Beynon Dwyer, solicitor, Margaret Mary McGinness, spinster, and National Trustees, Executors & Agency Company of Australasia Limited, of 95 Queen-street, Melbourne, at that address, on or before the 2nd day of July, 1970, after which date they will distribute the assets of the said estate, having regard only to the claims of which they then have notice as aforesaid.

DESMOND DUNNE & DWYER, solicitors, Warrnambool.
3887

JOSEPH HENRY WILLIAMS, late of Swan Hill, in the State of Victoria, retired farmer, DECEASED (who died on the 19th January, 1970).

CREDITORS, next of kin and all other persons having claims against the estate of the deceased are required by the executors of the will, Joan Evelyn Dunstan and Ian Campbell Williams, to send particulars to them, care of the undersigned, on or before the 22nd day of July, 1970, after which date they will distribute the assets, having regard only to the claims of which they then have notice.

GARDEN & GREEN, solicitors, 4 McCallum-street, Swan Hill.
3898

CREDITORS, next of kin and all other persons having claims against the estate of William Alfred Farey, late of 41 Outlook dr., Eaglemont, gentleman, deceased, are required by the executors, Beatrice Farey, of 41 Outlook-drive, Eaglemont, gentlewoman, and John Duncan Mustow, of 131 Queen-street, Melbourne, solicitor, to send particulars of their claims, care of the undersigned, by the 30th day of June, 1970, after which date they will distribute the assets, having regard only to the claims of which they then have notice.

JOHN D. MUSTOW & CO., solicitors, of 131 Queen-street, Melbourne.
3936

EDITH CECILIA MANN (also known as Cecile Mann and Edith Cecile Mann), late of 58-62 Carr-street, Barwon Heads, Victoria, spinster, DECEASED.

CREDITORS, next of kin and others having claims in respect of the estate of the deceased (who died on 18th March, 1969), are required by the personal representative, Ian Rutherford Mann, of "Brie Brie", Glen-thompson, Victoria, grazier, to send particulars of their claims to him by 30th June, 1970, after which date he may convey or distribute the assets, having regard only to the claims of which he then has notice.

HEDDERWICK FOOKES & ALSTON, solicitors, 121 William-street, Melbourne.
3937

MABEL TAPP, late of 24 Chaucer-crescent, Canterbury, in the State of Victoria, widow, DECEASED.

CREDITORS, next of kin and others having claims in respect of the estate of the deceased (who died on 9th September, 1969), are required by The Union-Fidelity Trustee Company of Australia Limited, of 100 Exhibition-street, Melbourne, and Norman Aberfoyle Matthews Tapp, of "Koort Koort Nong", Camperdown, Victoria, grazier, the applicants for a grant of administration to send particulars of their claims to the said applicants in the care of the said company by 30th June, 1970, after which date they will convey or distribute the assets, having regard only to the claims of which they then have notice.

HEDDERWICK FOOKES & ALSTON, solicitors, 121 William-street, Melbourne. 3938

CREDITORS, next of kin and others having claims in respect of the estate of Nancy Allen Small (generally known as Nance Allen Small), late of 6 Dion-street, Burwood, in the State of Victoria, married woman, deceased (who died on the 17th day of October, 1969), are required by the proving executor, Robert James Lambert, of 4 Snowden-place, Canterbury, in the State of Victoria, company director, to send particulars of their claims to the executor, care of the undersigned solicitors, by the 29th day of June, 1970, after which date he will distribute the assets, having regard only to the claims of which he then has notice.

FREDERICK OWEN & ASSOCIATES, solicitors, 84 William-street, Melbourne. 3940

CREDITORS, next of kin and others having claims in respect of the estate of Charles Rupert Curnow, late of Unit 7, Gloucester-court, 423 Glenferrie-road, Malvern, in the State of Victoria, company director, deceased (who died on the 13th day of November, 1969), are required by the executor, Ronald Charles Curnow, of 43 Hopetoun-road, Toorak, in the State of Victoria, company director, to send particulars of their claims to the executor, care of the undersigned solicitors, by the 29th day of June, 1970, after which date he will distribute the assets, having regard only to the claims of which he then has notice.

FREDERICK OWEN & ASSOCIATES, solicitors, 84 William-street, Melbourne. 3941

CREDITORS, next of kin and others having claims in respect of the estate of Emilio Marta, late of 66 Arthurton-road, Northcote, in the State of Victoria, retired, deceased (who died on the 20th day of December, 1969), are required by the executrices, Guisepina Burnett, of Lot 9, High-street, Cranbourne, in the State of Victoria, and Margaret Forner, of 29 Hayes-street, Northcote in the said State, married women, to send particulars of their claims to the executrices, care of the undersigned solicitors, by the 29th day of June, 1970, after which date they will distribute the assets, having regard only to the claims of which they then have notice.

FREDERICK OWEN & ASSOCIATES, solicitors, 84 William-street, Melbourne. 3942

CREDITORS, next of kin and others having claims in respect of the estate of John Patrick Fitzgerald, late of 91 Cape Nelson-road, Portland, in the State of Victoria, boilermaker welder, deceased (who died on the 28th September, 1969), are to send particulars of their claims to the executor of the deceased's will, dated the 14th February, 1967, namely, The Union-Fidelity Trustee Company of Australia Limited, at 101 Lydiard-street north, Ballarat, in the said State, by the 15th July, 1970, after which date it will distribute the assets, having regard only to the claims of which it then has notice.

Dated this 23rd day of April, 1970.

GREY & HARRIS, 18 Henty-street, Portland, solicitors for the said executor. 3911

CREDITORS, next of kin and others having claims in respect of the estate of Gertrude Mary Robinson, late of Flat 7, 8 Trawalla-avenue, Toorak, widow, deceased (who died on the 29th day of October, 1969), are to send particulars of their claims to the executors, Eugene Gorman, of 13 Otrira-road, Caulfield, Queen's Counsel, and Robert Lendrum Atkins, of 447 Collins-street, Melbourne, chartered accountant, care of the under-mentioned solicitors, by the 1st day of July, 1970, after which date the said executors will distribute the assets in the said estate, having regard only to the claims of which they then have notice.

ARTHUR ROBINSON & CO., solicitors, 447 Collins-street, Melbourne. 3946

CREDITORS, next of kin and others having claims in respect of the estate of Donald Charles Roundtree, late of 25 Addison-street, Moonee Ponds, investor, deceased (who died on the 20th day of December, 1969), are to send particulars of their claims to The Trustees Executors and Agency Company Limited, at its registered office, 401 Collins-street, Melbourne, by the 30th day of July, 1970, after which date it will distribute the assets, having regard only to the claims of which it then has notice.

McKENNA & CO., solicitors, 358 Lonsdale-street, Melbourne. 3917

MAY EUGENIE McAVOY, late of 12 Seymour-road, Elsternwick, widow, DECEASED.

CREDITORS, next of kin and others having claims in respect of the estate of the deceased (who died on the 5th day of February, 1970), are required by James William Fitzwalter Thomson, of 422-8 Collins-street, Melbourne, to send particulars of their claims to him by the 1st day of July, 1970, after which date he will convey or distribute the assets, having regard only to the claims of which he then has notice.

READ & READ, solicitors, 422 Collins-street, Melbourne. 3918

ALEXANDER INGRAM, formerly of "Bon Accord", 164 Kooyong-road, Caulfield, but late of "Mayflower Hospital", 7 Centre-road, East Brighton, retired, manufacturer, DECEASED.

CREDITORS, next of kin and others having claims in respect of the estate of the deceased (who died on the 26th day of December, 1969), are required by James William Fitzwalter Thomson, of 422 Collins-street, Melbourne, and Alexander Smith McLean, of 53 Gardenvale-road, Gardenvale, to send particulars of their claims to them, by the 1st day of July, 1970, after which date they will then convey or distribute the assets, having regard only to the claims of which they then have notice.

READ & READ, solicitors, 422 Collins-street, Melbourne. 3919

ARTHUR HENRY GYNGELL, late of Flat 1, 69 St. Andrew's-street, Brighton, retired master builder, DECEASED.

CREDITORS, next of kin and others having claims in respect of the estate of the deceased (who died on the 31st-day of May, 1969), are required by James William Fitzwalter Thomson, and Dennis John Millikan, both of 422-8 Collins-street, Melbourne, solicitors, to send particulars of their claims to them, by the 1st day of July, 1970, after which date they will then convey or distribute the assets, having regard only to the claims of which they then have notice.

READ & READ, solicitors, 422 Collins-street, Melbourne. 3920

CREDITORS, next of kin and others having claims in respect of the estate of Knowles Alfred Bennett, formerly of 204 Belmore-road, Balwyn, late of 3 Gordon-grove, South Yarra, retired shipbroker, deceased (who died on 18th day of January, 1970), are required to send particulars to the administrator, National Trustees Executors and Agency Company of Australasia Limited, at its registered address, 95 Queen-street, Melbourne, by the 5th day of July, 1970, after which date it will distribute the assets, having regard only to the claims of which it then has notice.

BERNARD NOLAN & CO., solicitors, 595 Bourke-street, Melbourne. 3921

CREDITORS, next of kin and others having claims in respect of the estate of Agnes Priscilla Radcliffe, late of 76 Dickson-street, Bacchus Marsh, widow, deceased (who died on the 17th day of January, 1970, and probate of whose will has been granted to Lesley Doris Lorensini, of 11 Donald-street, Bacchus Marsh, married woman, and Margaret Agnes Johnson, of 74 Dickson-street, Bacchus Marsh, married woman), are required to send particulars of their claims to the said executrices, care of the under-mentioned solicitors, by the 6th day of July, 1970, after which date they will distribute the assets, having regard only to the claims of which they then have notice.

PEARCE & WEBSTER, solicitors, 430 Little Collins-street, Melbourne. 3922

CREDITORS, next of kin and others having claims in respect of the estate of Ada Mary Tudgey, late of 15 Belgrave-road, East Malvern, widow, deceased (who died on the 1st day of January, 1970, and probate of whose will has been granted to Hazel Edna Pearl Davis, married woman, and Alan Victor Davis, garage proprietor,

both of 15 Belgrave-road, East Malvern), are required to send particulars of their claims to the said executors, care of the under-mentioned solicitors, by the 6th day of July, 1970, after which date they will distribute the assets, having regard only to the claims of which they then have notice.

PEARCE & WEBSTER, solicitors, 430 Little Collins-street, Melbourne. 3923

LESLIE HAROLD FAIRNIE, late of "Artherton", 44 Osborne-drive, Mount Martha, in the State of Victoria, gentleman, DECEASED.

CREDITORS, next of kin and others having claims in respect of the estate of the deceased (who died on the 1st day of February, 1970), are required by the Perpetual Executors and Trustees Association of Australia Ltd., of 100-104 Queen-street, Melbourne, to send particulars of their claims to the said company by the 8th day of July, 1970, after which date it will convey or distribute the assets, having had regard only to the claims of which the company then has notice. 3945

TRIANAFILA PAPADOFRANGAKIS, late of 20 Emu-street, Maidstone, widow, DECEASED.

CREDITORS, next of kin and others having claims in respect of the estate of the above-named deceased (who died on 2nd July, 1969), are required by the trustee, John Thomas Bloom, of 343 Little Collins-street, Melbourne, solicitor, to send particulars to his solicitors, Paul C. Nunan & Bloom, at their address below by 10th July, 1970, after which date the trustee may convey or distribute the assets, having regard only to the claims of which he then has notice.

PAUL C. NUNAN & BLOOM, solicitors, 343 Little Collins-street, Melbourne. 3969

IVY HELENE BLYTH-WILLIMOTT, late of 12A Lytton-street, Elwood, widow, DECEASED.

CREDITORS, next of kin and others having claims in respect of the estate of the deceased (who died on the 30th day of October, 1969), are required by The Perpetual Executors and Trustees Association of Australia Limited, of 100-104 Queen-street, Melbourne, to send particulars of their claims to the said company by the 30th day of June, 1970, after which date it will convey or distribute the assets, having had regard only to the claims of which the company then has notice.

WEIGALL & CROWTHER, solicitors, 459 Little Collins-street, Melbourne. 3970

ANNA EVA FALCONER, late of 4 Cleeve-court, Toorak, in the State of Victoria, spinster, DECEASED.

CREDITORS, next of kin and others having claims in respect of the estate of the deceased (who died on the 24th January, 1970), are required to send particulars of their claims to The Equity Trustees, Executors and Agency Company Limited, of 472 Bourke-street, Melbourne, in the State of Victoria, by the 30th day of June, 1970, after which date it may convey or distribute the assets, having regard only to the claims of which it then has notice.

AITKEN, WALKER & STRACHAN, solicitors, 414 Collins-street, Melbourne. 3973

CREDITORS, next of kin and others having claims in respect of the estate of Ruth Langley, late of Flat 7, 23 South-road, Brighton Beach, married woman, deceased (who died on 7th November, 1969), are to send particulars of their claims to The Equity Trustees, Executors and Agency Company Limited, of 472 Bourke-street, Melbourne, by 27th July, 1970, after which date it will distribute the assets, having regard only to the claims of which it then has notice.

R. C. H. BEATTIE, solicitor, 509 Collins-street, Melbourne. 3977

CREDITORS, next of kin and others having claims in respect of the estate of Arthur Colin Smith, formerly of Moorra-street, Rushworth, fruiterer, late of Stanhope-road, Rushworth, retired, deceased (who died on the 7th day of November, 1969), are required by The Union-Fidelity Trustee Company of Australia Limited, to send particulars of their claims to it at its address, 100 Exhibition-street, Melbourne, by the 1st day of July, 1970, after which date the said company will distribute the assets, having regard only to the claims of which it then has notice.

O'TOOLE & McPHERSON, solicitors, Rushworth, 3612. 3985

CREDITORS, next of kin and others having claims in respect of the estate of Eric John Kingston, late of 34 Pickett-street, Dandenong, cattle dealer, deceased (who died 20th day of April, 1969), are hereby required to send particulars in writing of such claims to National Trustees, Executors and Agency Company of Australasia Limited, of 95 Queen-street, Melbourne, and Nancy Sheila Kingston, the executors of the said deceased, care of Gray and Gray, solicitors, of 128 Koornang-road, Carnegie, on or before the 15th day of July, 1970, after which date the said executors will proceed to distribute the assets of the said deceased, which shall have come to their hands amongst persons entitled thereto, having regard only to the claims of which they then shall have notice.

GRAY & GRAY, solicitors, of 128 Koornang-road, Carnegie, solicitors for the said executors. 3986

WILLIAM GEORGE PACKHAM, late of Myers Flat, retired farmer, DECEASED.

CREDITORS, next of kin and others having claims in respect of the estate of the above-named deceased are required by the executors, National Trustees, Executors and Agency Company of Australasia Limited, of 95 Queen-street, Melbourne, and at 46 Queen-street, Bendigo, and William Packham, of 15 Stonemark-street, Sunshine, caretaker, to send particulars thereof to the said company by the 15th day of July, 1970, after which date the executors will distribute the assets, having regard only to the claims of which they then have notice.

Dated this 28th day of April, 1970.

HYETT & HYETT, solicitors, of 51 Bull-street, Bendigo. 3988

PHILIP JAMES LEYDEN, formerly of Rhinds-road, Wallington, near Geelong, in the State of Victoria, farmer, DECEASED.

CREDITORS, next of kin and others having claims in respect of the estate of the deceased (who died on the 25th September, 1969), are required by the applicants for grant of probate of the will of the deceased, Alice Kathleen Leyden, of Rhinds-road, Wallington, widow, and Brendan Joseph McGuinness, of 118 Queen-street, Melbourne, solicitor, to send particulars to them care of the undersigned solicitors by the 29th of June, 1970, after which date they may convey or distribute the assets, having regard only to the claims of which they then have notice.

Dated 27th April, 1970.

BRENDAN MCGUINNESS & CO., 118 Queen-street, Melbourne, solicitors. 3990

In the Supreme Court of the State of Victoria.

SALE BY THE SHERIFF.

ON Friday, the 12th day of June, 1970, at Ten a.m., at the Police Station, Fairfield (unless process be stayed or satisfied).

All the estate and interest (if any) of Danilo Cuzzi, of 26 Bennett-street, Alphington, builder, as proprietor of an estate in fee-simple in the land described in certificate of title, volume 4782, folio 329, upon which is erected a dwelling-house known as No. 26 Bennett-street, Alphington.

Terms: Cash only.

N. FROGLEY, Sheriff's Officer.

27th April, 1970. 3974

In the Supreme Court of the State of Victoria.

SALE BY THE SHERIFF.

ON Friday, the 12th day of June, 1970, at Ten a.m., at the Police Station, Reservoir (unless process be stayed or satisfied).

All the estate and interest (if any) of Francesco Paonessa, of 12 Gordon-street, Clifton Hill, plasterer, as joint proprietor with Cornelius Calis, landscape gardener, of an estate in fee-simple in the land described in certificate of title, volume 8273, folios 507 and 508. The land is vacant, being lots 7 and 6 on the west side of Ayr-street, Reservoir, commencing approximately 372 feet from the intersection of Don-street.

Terms: Cash only.

DAVID J. JOHNSTON, Sheriff's Officer.

27th April, 1970. 3975

INSOLVENCY NOTICES

Bankruptcy District of the State of Victoria.—No. 93 of 1969, Part X., Re: Francis John Schmutter.
Bankruptcy Act 1966.

NOTICE is hereby given of my intention to declare an interim dividend in the estate of the above-named debtor to be paid on Friday, 12th June, 1970. I hereby set Friday, 8th May, 1970, as the latest date on which creditors may lodge proofs of debt. Any creditor who has not lodged a proof of debt by that date shall be excluded from the dividend, and I shall proceed to distribute the dividend without regard to any debt that has not been proved.

Dated this 29th day of April, 1970.

M. G. GEE, Trustee.

Max Gee & Co., 325 Warrigal-road, Burwood, 3125.
Telephone No. 288 5911. 3885

Bankruptcy District of the State of Victoria.—No. 29 of 1969, Part X., Re: Vincent Walter Weston.
Bankruptcy Act 1966.

NOTICE is hereby given of my intention to declare an interim dividend in the estate of the above-named debtor to be paid on Friday, 12th June, 1970. I hereby set Friday, 8th May, 1970, as the latest date on which creditors may lodge proofs of debt. Any creditor who has not lodged a proof of debt by that date shall be excluded from the dividend, and I shall proceed to distribute the dividend without regard to any debt that has not been proved.

Dated this 29th day of April, 1970.

M. G. GEE, Trustee.

Max Gee & Co., 325 Warrigal-road, Burwood, 3125.
Telephone No. 288 5911. 3883

K. N. JENKINS.—CIRCULAR TO CREDITORS.

NOTICE is hereby given as required by section 218, sub-section 1 of the Bankruptcy Act 1966, that on the 16th day of March, 1970, the said K. N. Jenkins did execute a deed of assignment under the provisions of Part X. of the Bankruptcy Act, to Edward Peter Taylor, Registered Trustee in Bankruptcy, 49 Victoria-street, Warragul (P.O. Box 19, Warragul, 3820).

E. P. TAYLOR, Trustee.

Bankruptcy Act 1966, Part X.

NOTICE OF MEETING OF CREDITORS OF ESTATE OF MR. JAMES ALBERT CRUMP.

TAKE notice that Mr. James Albert Crump, of 208 Burke-road, Glen Iris, has on the 1st day of April, 1970, signed an authority under sub-section (1) of section 188 of the Bankruptcy Act 1966, authorizing Lewis Luckins, chartered accountant, 289 Flinders-lane, Melbourne, to call a meeting of his creditors and to take over control of his property and that, in pursuance of section 194 of the Bankruptcy Act 1966 a meeting of the creditors of the above-mentioned debtor will be held at Princes Gate, East Tower, 3rd Floor, Rooms 328 and 329, 151 Flinders-street, Melbourne, on 29th April, 1970, at 2.30 o'clock in the afternoon.

Dated this 20th day of April, 1970.

LEWIS LUCKINS, F.C.A., Controlling Trustee.

Lewis Luckins & Co., chartered accountants, 289 Flinders-street, Melbourne, 3000. Telephone 63 8827. 3947

IMPOUNDINGS

ALEXANDRA.—Impounded in Alexandra Pound, at approximately 1.45 p.m., on 20th April, 1970, by Mr. R. Hunter, from Goulburn Valley Highway, near Eildon.
1 ewe with horns, no earmark, blue raddle on back, diamond brand on back

If not claimed and expenses paid, to be sold on 8th May, 1970.

G. MAUDOUT,

3879—\$2.25 Poundkeeper.

APOLLO BAY.—Impounded in Apollo Bay Pound.

1 ram, (lamb), no visible brand

If not claimed and expenses paid, to be sold on 14th May, 1970.

C. A. VARCOE,

3963—\$1.50 Poundkeeper.

HEYWOOD.—Impounded in Heywood Pound.

1 aged Corriedale ewe, no earmark or brand
1 Corriedale lamb notch out of tip of both ears, no visible brand

If not claimed and expenses paid to be sold on 13th May, 1970.

C. SKIPWORTH,

3978—\$2 Poundkeeper.

OXLEY.—Impounded in Oxley Pound on Wednesday, 22nd April, from Whitfield.

1 black Jersey cross bull, approximately 8 to 10 months old, no ear marks, no visible brand

If not claimed and expenses paid, to be sold on 13th May, 1970.

M. PERKINS,

3896—\$2. Poundkeeper.

WHITTLESEA.—Impounded in Epping Pound by Ranger.

11 Merino cross ewes, no visible brand
2 Merino cross lambs, no visible brand
1 Merino cross ram, no visible brand

If not claimed and expenses paid, to be sold on 15th May, 1970.

W. HERD,

3965—\$2.00 Poundkeeper.

Subordinate Legislation Act 1962.

NOTICE OF MAKING OF STATUTORY RULES.

IN pursuance of the provisions of the Subordinate Legislation Act 1962 and the Regulations made thereunder, notice is given of the making of the following statutory rules:—

No.	Local Government Act 1958.	Price.
82/1970.	Postal Voting (Elections of Municipal Councillors) Regulations 1970	25c
	Poisons Act 1962 (No. 6889)	
83/1970.	Drugs of Addiction and Restricted Substances Regulations 1970	10c
	Workers Compensation Act 1958.	
84/1970.	Workers Compensation Board (Amendment) Regulations 1970	10c
	Racing Act 1958.	
85/1970.	Trotting Control Board (Fees) Regulations 1970	10c
	Educational Grants Act 1967.	
86/1970.	Educational Grants Regulations 1970	10c

Copies of these statutory rules may be purchased at the Sale of Publications Section of the Government Printing Office, located at Macarthur-street, Melbourne, 3002. If ordered by mail, remittance should be addressed to "The Government Printer, Box 203, P.O., North Melbourne, 3051", and should include 5c extra for postage. If a credit account is held at this office, no remittance is required with the mail order.

The annual subscription rate for Statutory Rules (including a Bound Volume) is \$15, payable in advance. The subscription year commences on 1st January.

C. H. RIXON,

Government Printer.

STATE ACTS, 1969

COPIES of the following Acts of Parliament of Victoria may be obtained at the Government Printing Office; Sale of Publications Branch, off Parliament-place, Melbourne, phone 63 0321, extension 6181, or from any accredited agent, at the price set opposite to each (these prices do not include postage).

The annual subscription for State Acts 1969 et seq. is \$8 payable in advance.

Bound Volumes of State Acts are also available on a subscription basis of \$15 per annum.

7786.	Summary Offences (Sunday Newspapers)	\$0.10
7787.	Town and Country Planning (Transitional Appeals)	\$0.10
7788.	Discharged Servicemen's Preference (Amendment)	\$0.10

STATE ACTS 1969—continued.		STATE ACTS 1969—continued.	
No.	Price.	No.	Price.
7789. Water (Amendment)	\$0.10	7866. Narre Worrان Lands	\$0.10
7790. Agricultural Education Cadetships	\$0.10	7867. Moorpanyal Lands	\$0.10
7791. Trustee (Amendment)	\$0.10	7868. Juries (Amendment)	\$0.10
7792. Appeal Costs Fund (Amendment)	\$0.10	7869. Apprenticeship (Regulations)	\$0.10
7793. Footscray (Lower Yarra Crossing Access Road) Land	\$0.10	7870. Portland Lands Exchange	\$0.10
7794. River Improvement (Amendment)	\$0.15	7871. Melbourne University (Property)	\$0.10
7795. Geelong Waterworks and Sewerage (Amendment)	\$0.15	7872. Latrobe Valley (Lands for Ambulance Services)	\$0.10
7796. West Moorabool Water Board (Amendment)	\$0.10	7873. Ministry of Transport (Director of Transport)	\$0.10
7797. Sewerage Districts (Amendment)	\$0.15	7874. Administration and Probate (Foreign Grants)	\$0.10
7798. Drought Relief (Amendment)	\$0.10	7875. Road Traffic (Amendment)	\$0.10
7799. Legal Profession Practice (Amendment)	\$0.10	7876. Justices (Amendment)	\$0.35
7800. Parliamentary Salaries and Superannuation (Administration)	\$0.10	7877. Country Fire Authority (Amendment)	\$0.15
7801. Protection of Animals (Penalties)	\$0.10	7878. Coal Mines (Accidents Relief)	\$0.10
7802. Lotteries Gaming and Betting (Calcutta Sweepstakes)	\$0.10	7879. Preston School of Design and Free Library Land	\$0.10
7803. Belmont Common Recreation Ground Lands	\$0.10	7880. Lands Compensation (Costs and Expenses)	\$0.10
7804. Listening Devices	\$0.10	7881. Evidence (Bankers' Books)	\$0.10
7805. Coal Mines (Pensions)	\$0.10	7882. Transport Regulation (Financial)	\$0.10
7806. Marine (Amendment)	\$0.10	7883. Railways (Surplus Lands)	\$0.10
7807. Theatres (Amendment)	\$0.15	7884. Abolition of Obsolete Offences	\$0.10
7808. Victorian Inland Meat Authority (Amendment)	\$0.10	7885. Fire Brigades (Contributions)	\$0.15
7809. The Constitution Act Amendment (Electoral)	\$0.15	7886. Gas	\$0.30
7810. Consolidated Revenue	\$0.10	7887. Tobacco Leaf Industry Stabilization (Tobacco Quotas)	\$0.10
7811. Gas and Fuel Corporation (Borrowing)	\$0.10	7888. The Constitution Act Amendment (Standing Appropriations)	\$0.10
7812. Weights and Measures (Amendment)	\$0.10	7889. Legal Profession Practice	\$0.10
7813. Health (Municipal Charges)	\$0.10	7890. Navigable Waters (Oil Pollution) (Amendment)	\$0.15
7814. Transfer of Land (Subdivision of Allotments)	\$0.15	7891. Stamps (Mortgages)	\$0.10
7815. St. Vincent's Private Hospital (Guarantees)	\$0.10	7892. State Forests Loan Application	\$0.10
7816. Strata Titles (Amendment)	\$0.15	7893. Melbourne and Metropolitan Board of Works (Amendment)	\$0.15
7817. Sunday Entertainment (Evidence)	\$0.10	7894. Wheat Marketing	\$0.25
7818. Dried Fruits (Packing Houses)	\$0.10	7895. Revenue Deficits Funding	\$0.15
7819. Town and Country Planning (Further Amendment)	\$0.10	7896. Land Tax (Rates)	\$0.10
7820. Milk Board (Amendment)	\$0.10	7897. Probate Duty	\$0.10
7821. Medical (Pharmaceutical Chemists)	\$0.10	7898. Sale of Land (Amendment)	\$0.10
7822. Melbourne Wholesale Fruit and Vegetable Market (Amendment)	\$0.10	7899. Racing (Trotting Racing)	\$0.10
7823. Education (Director-General)	\$0.10	7900. Crown Proceedings (Forfeited Recognisances)	\$0.15
7824. Wombat Bonuses	\$0.10	7901. Weights and Measures (Fees)	\$0.10
7825. Revocation and Excision of Crown Reservations	\$0.15	7902. Town and Country Planning (Compensation)	\$0.10
7826. Mildura Irrigation and Water Trusts	\$0.25	7903. Wheat Industry Stabilization (Amendment)	\$0.10
7827. South Melbourne (Roman Catholic Orphanage) Lands	\$0.15	7904. Railway Loan Application	\$0.15
7828. Racing (Amendment)	\$0.10	7905. North Melbourne Lands (Loans to Lessees)	\$0.10
7829. Commercial Goods Vehicles (Tow Trucks)	\$0.10	7906. Theatres (Performance of Sacred Works)	\$0.10
7830. Stamps (Amendment)	\$0.15	7907. Marketing of Primary Products (Amendment)	\$0.15
7831. Gas and Fuel Corporation (Sale Undertaking)	\$0.15	7908. Water Supply Loan Application	\$0.25
7832. Melbourne (St. Kilda-road Underpass)	\$0.15	7909. Health (Amendment)	\$0.15
7833. Trustee (Authorized Investments)	\$0.10	7910. Superannuation (Amendment)	\$0.25
7834. Consolidated Revenue	\$0.10	7911. Friendly Societies (Amendment)	\$0.15
7835. Local Government	\$0.60	7912. The Constitution Act Amendment (Conjoint Elections)	\$0.10
7836. Melbourne Wholesale Fruit and Vegetable Market (Advisory Committee)	\$0.10	7913. Labour and Industry (Long Service Leave)	\$0.10
7837. Teaching Service (Amendment)	\$0.10	7914. Public Service (Amendment)	\$0.15
7838. State Electricity Commission (Borrowing and Investing Powers)	\$0.10	7915. Motor Car (Traffic Offenders)	\$0.10
7839. Motor Car (Amendment)	\$0.10	7916. Motor Car	\$0.15
7840. Mines (Abolition of Courts)	\$0.30	7917. Farm Produce Merchants and Commission Agents (Amendment)	\$0.25
7841. Manango (O'Shanessy River Watershed) Lands	\$0.10	7918. Education (Army Apprentices School)	\$0.10
7842. State Savings Bank (Amendment)	\$0.10	7919. Legal Aid	\$0.15
7843. Apprenticeship (Commission)	\$0.10	7920. Educational Grants (Amendment)	\$0.10
7844. Swan Hill Race-course and Golf-course Lands	\$0.15	7921. Crown Reservations (Revocation and Excision)	\$0.15
7845. Imitation Milk	\$0.15	7922. Firearms (Amendment)	\$0.10
7846. Finance Brokers	\$0.25	7923. Labour and Industry (Further Amendment)	\$0.10
7847. Local Government (Rating Exemptions)	\$0.15	7924. Forests (Softwood Timber Agreement)	\$0.15
7848. Labour and Industry (Amendment)	\$0.10	7925. Public Works Loan Application	\$0.15
7849. Groundwater	\$0.30	7926. Metropolitan Fire Brigades (Amendment)	\$0.15
7850. Consolidated Revenue	\$0.10	7927. Consolidated Revenue	\$0.10
7851. Mental Health (Chairmanship)	\$0.10	7928. National Parks (Amendment)	\$0.25
7852. Instruments (Bills of Exchange Amendment)	\$0.10	7929. Railways (Offences)	\$0.10
7853. Supreme Court (Correction of Sentences)	\$0.10	7930. Tourist	\$0.15
7854. Summary Offences	\$0.10	7931. Country Roads (Amendment)	\$0.15
7855. Church of England in Australia (Mount Shadwell Land)	\$0.10	7932. Appropriation of Revenue	\$1.15
7856. State Rivers and Water Supply Commission (Special Projects)	\$0.10		
7857. Coal Mines (Pensions Increase)	\$0.10		
7858. Trustee Companies (Burns Philp Trustee Company Limited)	\$0.10		
7859. Latrobe Valley (Amendment)	\$0.10		
7860. Maintenance (Amendment)	\$0.10		
7861. Aboriginal Affairs (Amendment)	\$0.10		
7862. Goods (Trade Descriptions)	\$0.10		
7863. Marine Stores and Old Metals (Amendment)	\$0.15		
7864. Fire Authorities (Borrowing Powers)	\$0.10		
7865. Acts Interpretation (Time)	\$0.10		

C. H. RIXON,
Government Printer.

THE "VICTORIA GOVERNMENT GAZETTE".

SUBSCRIPTIONS.—The subscription, including postage, is \$10 per annum, or \$5 per half year, payable in advance.

Subscriptions are required for whole months, and must cover at least a half year.

Single copies are 20 cents, posted 25 cents. Subscribers do not receive the Acts of Parliament with the GAZETTE.

GAZETTES are held in stock for five years only.

PRIVATE ADVERTISEMENTS.—The charge for insertion is 25 cents per line single column, and 50 cents per line double column. The title forms one or more lines as a heading. On an average ten words make a line of single column. Every signature must likewise be counted as a line. The final words of a paragraph, though only portion of a line, must be counted as one line. Signatures (in particular) and proper names must be written very plainly in the text; ONE SIDE ONLY of each sheet of paper should be WRITTEN UPON.

All documents illegibly written will be returned unpublished, and where brands occur unprovided for by the ordinary letters of the alphabet, a worded explanatory description must be furnished.

THE VICTORIA GOVERNMENT GAZETTE is published on WEDNESDAY EVENING in each week, and Notices for insertion will be received by the Government Printer at or before ONE p.m. at ordinary rates, and late advertisements between ONE p.m. and FOUR p.m. at double rates on the day preceding the day of publication.

PAYMENTS.—Unless the advertiser has a credit account, all payments are required in advance. Remittances should be made by cheque, postal order, or money order payable to "GOVERNMENT PRINTER".

ADDRESS.—All communications should be addressed to "The Government Printer, Box 203, P.O., North Melbourne", 3051.

AGENTS FOR THE "VICTORIA GOVERNMENT GAZETTE".

THE following have been appointed agents to receive Advertisements and Subscriptions for the Victoria Government Gazette:—

- ARMSTRONG'S AGENCY, 205 Queen-street, Melbourne, Victoria 3000.
- ARNALL & JACKSON, 390 Barkly-street, Brunswick, Victoria 3056.
- BAIRNSDALE AUTHORIZED NEWSAGENCY, 132 Main-street, Bairnsdale, Victoria 3875.
- BICKNELL, M. J., Authorized Newsagent, 196 Timor street, Warrnambool, Victoria 3280.
- BLANE'S AUTHORIZED NEWSAGENTS, 162 Murray-street, Colac, Victoria 3250.
- CARTER, R. G., ADVERTISING SERVICE PTY. LTD., Suite 24, 65 Queens-road, Melbourne, Victoria 3004.
- DAVIES, G. & M. V., 112 Gray-street, Hamilton, Victoria 3300.
- DAVIS, WM. (MILDURA) PTY. LTD., 126 Eighth-street, Mildura, Victoria 3500.
- DIXON'S NEWSAGENCY, 89 Firebrace-street, Horsham, Victoria 3400.
- EDGAR'S NEWSAGENCY PTY. LTD., 293 Hargreaves-street, Bendigo, Victoria 3550.
- EDGARS' AUTHORIZED NEWSAGENCY, 45 Bridge-street, Benalla, Victoria 3672.
- FRANKS, H., & CO., 184 Ryrie-street, Geelong, Victoria 3220.
- GATLEY, A. & J., 250 Lonsdale-street, Dandenong, Victoria 3175.
- GORDON & GOTCH AUSTRALASIA LTD., 467 Collins-street, Melbourne, Victoria 3000.
- GULLAN'S NEWSAGENCY, 88 Bridge-street, Ballarat, Victoria 3350.
- HAMPTON, A. C., 243 Mitchell-street, Bendigo, Victoria 3550.
- HARSTON, PARTRIDGE & CO. PTY LTD., 455 Little Collins-street, Melbourne, Victoria 3000.
- KYI DIARIAN PTY. LTD., P.O. Box 18, Kyneton, Victoria 3444.
- LATIMER'S, Newsagents, 45 Station-street, Malvern, Victoria 3144.
- LIVINGSTON'S SHEPPARTON NEWSAGENCY, 246 Wyndham-street, Shepparton, Victoria 3630.
- THE MERCANTILE EXCHANGE, 67 Queen-street, Melbourne, Victoria, 3000.
- MCGILL'S AUTHORIZED NEWSAGENCY, 183-5 Elizabeth-street, Melbourne, Victoria 3000.
- PHILLIPS AUTHORIZED AGENCY, 83 Murphy-street, Wangaratta, Victoria 3677.

- PURDIE, J., & CO., 138 Moorabool-street, Geelong, Victoria 3220.
 - SALE AUTHORIZED NEWSAGENCY, 142 Raymond-street, Sale, Victoria 3850.
 - SKINNER'S AUTHORIZED NEWSAGENCY, 49-51 Franklin-street, Traralgon, Victoria 3844.
 - STEVENSON, A. C. & M., NEWSAGENTS, 132 Henty-street, Casterton, Victoria 3311.
 - VERNON, C. F. & H. J., 162 Bridge-road, Richmond Victoria 3121.
 - VIEW POINT AUTHORIZED NEWSAGENCY, 4 View-Point, Bendigo, Victoria 3550.
- A copy of the Gazette filed at each place for public reference.

PUBLICATION OF OFFICIAL MATTER.

ATTENTION is invited to the following procedure in relation to the publication of official matter in the Government Gazette:—

Publication will be facilitated by the submission of carbon copies for the use of the Gazette Officer.

1. Matter submitted to the Executive Council.

Matter submitted to the Executive Council which requires gazettal will normally be published in the issue of the following week.

Where urgent gazettal is required, special arrangements should be made with the Gazette Officer, Room 9, first floor, Old Treasury Building.

2. Other matter.

(a) All other matter duly certified by a responsible officer for publication should be lodged with the Gazette Officer not later than half-past Nine a.m. on Tuesday.

(b) Lengthy or involved notices should be forwarded several days before publication.

(c) Proofs, which will be supplied only when specifically requested or at the direction of the Gazette Officer, should be returned promptly to avoid delay in publication.

(d) No additions or amendments to matter for publication will be accepted by telephone.

CONTENTS

	PAGE
Acts of Parliament on Sale at the Government Printing Office	1204
Appointments	1156
Bank Half-Holiday	1142
Bank Holiday	1143
Contracts	1155
Estates of Deceased Persons	1143
Government Notices	1143
Impoundings	1204
Insolvency Notices	1204
Lands	1171
Melbourne and Metropolitan Board of Works—	
Notice	1153
Mining	1144
Notice of Making of Statutory Rules	1204
Orders in Council—	
Acts—The Constitution Act Amendment; Landlord and Tenant; Railways; State Electricity Commission; Country Roads; Land; Road Traffic; Labour and Industry; Victorian Inland Meat Authority; Local Government; Benefit Associations; Stamps; Sewerage Districts; Dairy Products; Housing.	1158 et seq
Police Sale	1151
Private Advertisements	1181
Proclamations	1139
Public Holiday	1143
Public Service Notices	1181
Resignations	1157
State Rivers and Water Supply Commission	1151
Tenders	1176
Transport Regulation Board—Public Hearings	1145
Waterworks Trusts	1154

Pages 1207 and 1208 are not available online

**Please note that Victorian Government Gazette 1970,
Gazette number 44, is not part of the Gazette information
held by the State Library of Victoria**

**This information may be available from the Public Records Office
of Victoria or the Supreme Court of Victoria**

Pages 1207 and 1208 are not available online

**Please note that Victorian Government Gazette 1970,
Gazette number 44, is not part of the Gazette information
held by the State Library of Victoria**

**This information may be available from the Public Records Office
of Victoria or the Supreme Court of Victoria**