



VICTORIA GOVERNMENT GAZETTE

Published by Authority

[Registered at the General Post Office, Melbourne, for transmission by post as a newspaper.]

No. 45]

WEDNESDAY, MAY 6

[1970

PROCLAMATIONS

Land Act 1958.

UNALIENATED CROWN LAND AVAILABLE FOR SETTLEMENT UNDER IMPROVEMENT PURCHASE LEASES.

PROCLAMATION

By the Lieutenant-Governor as Deputy for His Excellency the Governor of the State of Victoria and its Dependencies in the Commonwealth of Australia &c., &c., &c.

IN pursuance of the provisions of Section 153 of the *Land Act 1958*, I, the Lieutenant-Governor as Deputy for the Governor of the State of Victoria, in the Commonwealth of Australia, by and with the advice of the Executive Council of the said State, do by this Proclamation declare the unalienated Crown lands mentioned in the subjoined schedule, to be available for settlement under improvement purchase leases.

SCHEDULE.

County.	Parish.	Allotment.	Section.	Area.	Land Valuation.
				A. R. P.	
Lowan	Durong	26	A	175 0 0±	\$6.00 per acre
Delatite	Moyhu	8B	1	250 0 0	\$6.00 per acre

Given under my Hand and the Seal of the State of Victoria aforesaid, at Melbourne this twenty-eighth day of April in the year of our Lord One thousand nine hundred and seventy and in the nineteenth year of the reign of Her Majesty Queen Elizabeth II.

(L.S.)

E. F. HERRING.
By His Excellency's Command,
W. J. F. McDONALD,
Minister of Lands.

GOD SAVE THE QUEEN!

Land Act 1958.

AREA OF LAND COMPRISED IN CERTAIN CLASSES DIMINISHED OR INCREASED.

PROCLAMATION

By the Lieutenant-Governor as Deputy for His Excellency the Governor of the State of Victoria and its Dependencies in the Commonwealth of Australia, &c., &c., &c.

WHEREAS by the Land Act 1958 it is amongst other things enacted that the Governor in Council may, by Proclamation to be published in the Government Gazette, at any time diminish or increase the area of land comprised in any of the classes mentioned in Part I, Division 1, Section 5, of the said Land Act 1958, but that the area of lands which may be sold by auction (Class 6), shall not be increased except as in certain cases in the said Act provided: Now therefore I, the Lieutenant-Governor as Deputy for the Governor of the State of Victoria, in the Commonwealth of Australia, by and with the advice of the Executive Council of the said State, and in accordance with the provisions of Sections 94 and 117 of the Land Act 1958 aforesaid, do hereby diminish or increase (as the case may be) the areas of Crown lands comprised in Class 6 of the classes mentioned in Section 5 of the Land Act 1958 aforesaid, to the extent set forth in the subjoined Schedule (that is to say):—

Schedule referred to.

CLASSES DIMINISHED OR INCREASED.

County.	Parish.	Allotment.	Section.	Area.	Diminished.	Increased.	Description.
					Class.	Class.	
				A. R. P.			
Moira	Wangaratta North	14A	5	0 0 31	..	6	Fronting Medowra Avenue
Tambo	Tildesley West ..	6	..	1 2 39	..	6	Being former Township Allotments
Tambo	Tildesley West ..	13	..	1 3 20	..	6	Being former Township Allotments
Bogong	Beechworth ..	6B	Q2	6 3 34	..	6	East of the Township of Beechworth

Given under my Hand and the Seal of the State of Victoria, aforesaid, at Melbourne, this 28th day of April, in the year of our Lord One thousand nine hundred and seventy, and in the nineteenth year of the reign of Her Majesty Queen Elizabeth II.

E. F. HERRING.

(L.S.)

By His Excellency's Command,
W. J. F. McDONALD,
Minister of Lands.

GOD SAVE THE QUEEN !

LEGAL AID ACT 1969, No. 7919.

DATE OF COMING INTO OPERATION.

PROCLAMATION

By the Lieutenant-Governor as Deputy for His Excellency the Governor of the State of Victoria and its Dependencies in the Commonwealth of Australia, &c., &c., &c.

WHEREAS by an Act of the Parliament of the State of Victoria, passed in the eighteenth year of the reign of Her Majesty Queen Elizabeth II, intitled the Legal Aid Act 1969, No. 7919, it is amongst other things enacted that the several provisions of the said Act shall come into operation on a day or the respective days to be fixed by proclamation or successive proclamations of the Governor in Council published in the Government Gazette.

Now therefore I, the Lieutenant-Governor as Deputy for the Governor of the State of Victoria, acting by and with the advice of the Executive Council thereof, do by this my proclamation fix Monday the first day of June One thousand nine hundred and seventy as the day upon which all the provisions of the Legal Aid Act 1969 No. 7919 other than the provisions contained in Part I. of the said Act, shall come into operation.

Given under my Hand and the Seal of the State of Victoria aforesaid, at Melbourne, this twenty-eighth day of April, in the year of our Lord One thousand nine hundred and seventy, and in the nineteenth year of the reign of Her Majesty Queen Elizabeth II.

(L.S.)

E. F. HERRING.

By His Excellency's Command,

G. O. REID,
Attorney-General.

GOD SAVE THE QUEEN !

COUNTRY ROADS (AMENDMENT) ACT 1969, No. 7931.

DATE OF COMING INTO OPERATION.

PROCLAMATION

By the Lieutenant-Governor as Deputy for His Excellency the Governor of the State of Victoria and its Dependencies in the Commonwealth of Australia, &c., &c., &c.

WHEREAS by an Act of Parliament of the State of Victoria passed in the nineteenth year of the reign of Her Majesty Queen Elizabeth II, entitled the Country Roads (Amendment) Act 1969, No. 7931, it is amongst other things enacted that Section 2 of the said Act shall come into operation on a day to be fixed by the proclamation of the Governor in Council published in the Government Gazette:

Now therefore I, the Lieutenant-Governor as Deputy for the Governor of the State of Victoria, in the Commonwealth of Australia, by and with the advice of the Executive Council of the said State, do by this my Proclamation fix Wednesday the Sixth day of May One Thousand Nine Hundred and Seventy as the day on which Section 2 of the said Country Roads (Amendment) Act 1969 shall come into operation.

Given under my Hand and the Seal of the State of Victoria aforesaid, at Melbourne, this twenty-eighth day of April, in the year of our Lord One thousand nine hundred and seventy, and in the nineteenth year of the reign of Her Majesty Queen Elizabeth II.

(L.S.)

E. F. HERRING.

By His Excellency's Command,

R. J. HAMER,
Minister of Public Works.

GOD SAVE THE QUEEN !

FIRST MILDURA IRRIGATION TRUST.

PROCLAMATION OF DAY ON WHICH THE RE-SUBDIVISION OF THE MID AREA SHALL BE OF FULL FORCE AND EFFECT.

By the Lieutenant-Governor as Deputy for His Excellency the Governor of the State of Victoria, and its Dependencies in the Commonwealth of Australia, &c., &c., &c.

UNDER the powers conferred by the Mildura Irrigation and Water Trusts 1969, and all other powers enabling me in that behalf, I, the Lieutenant-Governor as deputy for His Excellency the Governor of the State of Victoria, in the Commonwealth of Australia, by and with the advice of the Executive Council of the said State, do hereby proclaim that on and from the date hereof the re-subdivision of that portion of the First Mildura Irrigation District defined as the Mid Area in the *Mildura Irrigation and Water Trusts Act 1969* as proposed by the sealed plan and sealed schedule deposited with the Minister of Water Supply shall be of full force and effect.

Given under my Hand and the Seal of the State of Victoria aforesaid, at Melbourne, this fifth day of May, in the year of our Lord One thousand nine hundred and seventy, and in the nineteenth year of the reign of Her Majesty Queen Elizabeth II.

(L.S.)

E. F. HERRING.

By His Excellency's Command,

W. BORTHWICK,
Minister of Water Supply.

GOD SAVE THE QUEEN!

WESTERNPORT WATERWORKS TRUST.

PROCLAMATION OF KILCUNDA URBAN DISTRICT.

By the Lieutenant-Governor as Deputy for His Excellency the Governor of the State of Victoria, and its Dependencies in the Commonwealth of Australia, &c., &c., &c.

UNDER the powers conferred by the Water Act and all other powers enabling me in that behalf, I, the Lieutenant-Governor as Deputy for His Excellency the Governor of the State of Victoria, in the Commonwealth of Australia, by and with the advice of the Executive Council of the said State, do hereby proclaim that on and from the date hereof that portion of the Waterworks District of the Westernport Waterworks Trust, comprised within the boundaries of the Kilcunda Reticulation Area as shown red on a plan deposited in the office of the State Rivers and Water Supply Commission, Melbourne (Corr. No. 69/456/43) shall be and become an Urban District for the purposes of and within the meaning of the said Act and shall be known as the Kilcunda Urban District.

Given under my Hand and the Seal of the State of Victoria aforesaid, at Melbourne, this twenty-eighth day of April, in the year of our Lord One thousand nine hundred and seventy, and in the nineteenth year of the reign of Her Majesty Queen Elizabeth II.

(L.S.)

E. F. HERRING.

By His Excellency's Command,

W. BORTHWICK,
Minister of Water Supply.

GOD SAVE THE QUEEN!

Health Act 1958, Section 94.

BUSINESS OF STORAGE OF RAGS TO BE AN OFFENSIVE TRADE.

PROCLAMATION

By the Lieutenant-Governor as Deputy for His Excellency the Governor of the State of Victoria and its Dependencies in the Commonwealth of Australia, &c., &c., &c.

BY virtue of the powers conferred by Sections 94 and 389 of the *Health Act 1958*, and all other powers enabling me in that behalf, I, the Lieutenant-Governor as Deputy for the Governor of the State of Victoria, in the Commonwealth of Australia, on the recommendation of the Commission of Public Health and by and with the advice of the Executive Council of the said State, do by this my Proclamation declare the storage of rags carried on in connection with the business or occupation of rag collection to be an offensive trade within the meaning of the *Health Act 1958*.

Given under my Hand and the Seal of the State of Victoria aforesaid, at Melbourne, this twenty-eighth day of April, in the year of our Lord One thousand nine hundred and seventy, and in the nineteenth year of the reign of Her Majesty Queen Elizabeth II.

(L.S.)

E. F. HERRING.

By His Excellency's Command,

VANCE DICKIE,
Minister of Health.

GOD SAVE THE QUEEN!

Marketing of Primary Products Act 1958.

DECLARING THAT TOBACCO LEAF SHALL BECOME THE PROPERTY OF THE TOBACCO LEAF MARKETING BOARD FOR A FURTHER PERIOD OF TWO (2) YEARS.

PROCLAMATION

By the Lieutenant-Governor as Deputy for His Excellency the Governor of the State of Victoria and its Dependencies in the Commonwealth of Australia, &c., &c., &c.

WHEREAS by sub-section (1) of section 17 of the *Marketing of Primary Products Act 1958*, it is enacted that where a product has been declared a commodity and a board has been appointed in relation thereto, the Governor in Council may by proclamation—

- (a) provide and declare that the commodity shall forthwith upon the date of publication of the proclamation or on, from and after a later date specified in the proclamation, be divested from the producers of the commodity and become vested in and be the absolute property of the board as the owner thereof, and that upon any of the commodity coming into existence within a time specified in the same or a subsequent proclamation it shall by virtue of the said Act become vested in and be the absolute property of the board as the owner thereof; and
- (b) make such further provision as will enable the board effectively to obtain possession of the commodity as such owner, and to deal with the same:

And whereas by a proclamation made on the twentieth day of December, 1963, under the provisions of section 7 of the said Act the Governor in Council declared tobacco leaf to be a commodity under and for the purposes of the said Act:

And whereas by an Order made on the twenty-second day of April, 1964, the Governor in Council appointed a marketing board in relation to tobacco leaf and assigned to such board the name of "The Tobacco Leaf Marketing Board": Now therefore, I, the Lieutenant-Governor as Deputy for His Excellency the Governor of the State of Victoria in the Commonwealth of Australia, by and with the advice of the Executive Council of the said State, do by this my proclamation hereby provide and declare that on, from and after the thirteenth day of May, 1970, all tobacco leaf shall subject to and in accordance with the *Marketing of Primary Products Act 1958* be divested from the producers of tobacco leaf and become vested in and be the absolute property of The Tobacco Leaf Marketing Board as the owner thereof and that upon any tobacco leaf coming into existence within two (2) years from the thirteenth day of May, 1970, it shall by virtue of and subject to and in accordance with the said Act become vested in and be the absolute property of The Tobacco Leaf Marketing Board as the owner thereof: And to enable The Tobacco Leaf Marketing Board as owner of the abovementioned commodity effectively to obtain possession thereof and to deal with the same I do further provide that all such tobacco leaf shall subject to and in accordance with the provisions of the said Act be delivered by the producers thereof to The Tobacco Leaf Marketing Board or its authorized agent within such times at such places and in such manner as The Tobacco Leaf Marketing Board by public notice, or in a particular case in writing, directs or as are prescribed by Regulations made under the said Act.

Given under my Hand and the Seal of the State of Victoria aforesaid, at Melbourne, this twenty-eighth day of April, in the year of our Lord One thousand nine hundred and seventy, and in the nineteenth year of the reign of Her Majesty Queen Elizabeth II.

(L.S.)

E. F. HERRING.

By His Excellency's Command,

G. L. CHANDLER,
Minister of Agriculture.

GOD SAVE THE QUEEN!

GOVERNMENT NOTICES

GAS AND FUEL CORPORATION OF VICTORIA.

THE following notice was published 1° on the 29th April, 1970, re: Gas Odorization Plant, Parish of Coolungoolun.

"Notice is hereby given that the Gas and Fuel Corporation of Victoria has applied for a lease under section 134 of the Land Act 1958 for a term of 21 years in respect of an area of 0 acres 0 roods 27 5/10 perches more or less, being portion of the Black Swamp, Parish of Coolungoolun, as a site for Gas Odorization plant and ancillary purposes.—(H.033469.)"

**SHIRE OF NARRACAN.
ROAD DEVIATION ORDER.**

PURSUANT to the provisions of sections 522 and 526 of the Local Government Act 1958, the Council of the Shire of Narracan hereby directs that the land in the Parish of Moe indicated by hatching on the diagram hereunder, which has been purchased, taken or acquired by it, shall be a public highway on and from the date of publication of this Order in the Government Gazette, and declares that such land shall be a public highway in lieu of the land indicated by cross-hatching on the said diagram.

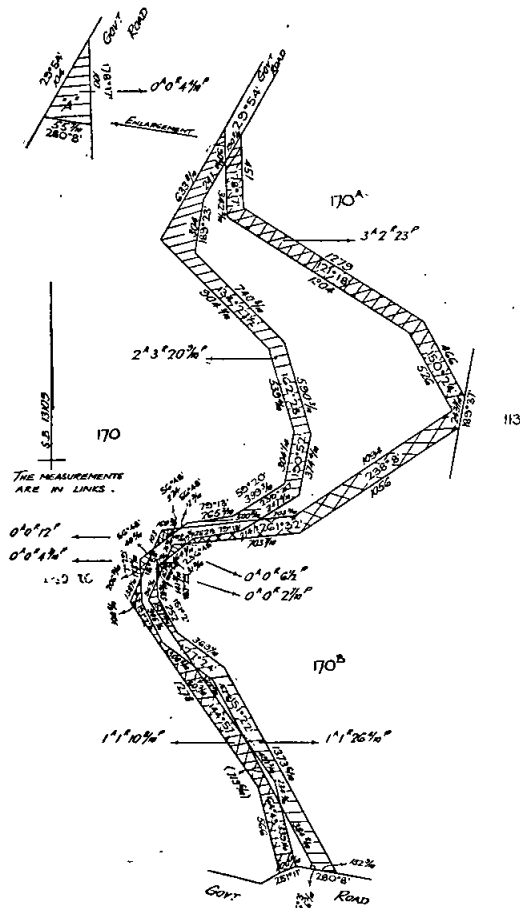

The common seal of the President, Councillors and Ratepayers of the Shire of Narracan was hereunto affixed, this 13th day of April, 1970, in the presence of—

(SEAL) D. S. CLARKE, Shire President.
W. J. HAY, Councillor.
W. F. NELSON, Shire Secretary.

Confirmed by the Governor in Council, 28th April, 1970.
—J. ROSSITER, Clerk of the Executive Council.

I HEREBY give notice that on the 15th April, 1970, the Public Trustee filed elections to administer the following deceased persons' estates in accordance with section 17 of the Public Trustee Act 1958:—

- BREUER, ALFRED, formerly of 249 Auburn-road, Hawthorn, but late of 342 Beaconsfield-parade, St. Kilda, mechanic, died 23rd January, 1970.
- FARREN, FRANK, late of Ararat, retired labourer, died 9th November, 1968.
- LEDDY, MARGARET, late of 13 Brougham-street, North Melbourne, pensioner, died 11th December, 1969.
- HARRISON, HENRY FREDERICK, late of 115 North-road, Reservoir, retired boiler attendant, died 20th February, 1970.
- MAHONEY, NORA, late of 11 Tollington-avenue, East Malvern, pensioner, died 23rd January, 1970.
- WILCOX, RONALD GORDON, late of 17 North-road, East Reservoir, psychiatric nurse, died 21st December, 1969.

I HEREBY give notice that on the 22nd April, 1970, the Public Trustee filed elections to administer the following deceased persons' estates in accordance with section 17 of the Public Trustee Act 1958:—

- BUSH, PHILLIP, late of State Research Farm, Werribee, public servant, died 29th March, 1969.
- CLARKE, ARTHUR JESSE, late of Brumfield-road, Healesville, pensioner, died 17th January, 1970.
- RENKIN, WILLIAM HAROLD, formerly of 70 Mitchell-drive, St. Laurence Park, Lara, but late of Adair-street, Maldon, retired linesman, died 15th February, 1970.
- ROBERTSON, LILLIAN ADA, late of 7A Kelley-grove, West Preston, married woman, died 13th March, 1970.
- TETENBURG, JOHANNA MARTHA, late of Flat 5, 63 Elizabeth-street, Richmond, nurse, died 21st August, 1969.

N. P. BRODY,
Public Trustee.

256 Flinders-street, Melbourne, 3000, 29th April, 1970.

CREDITORS, next of kin and others having claims against the estate of any of the under-mentioned deceased persons are required to send particulars of their claims to the Public Trustee, 256 Flinders-street, Melbourne, Vic., 3000, the personal representative, on or before the 12th July, 1970, after which date the Public Trustee may convey or distribute the assets, having regard only to the claims of which the Public Trustee then has notice:—

- BREUER, ALFRED, formerly of 249 Auburn-road, Hawthorn, but late of 342 Beaconsfield-parade, St. Kilda, mechanic, died 23rd January, 1970.
- BUSH, PHILLIP, late of State Research Farm, Werribee, public servant, died 29th March, 1969.
- CLARKE, ARTHUR JESSE, late of Brumfield-road, Healesville, pensioner, died 17th January, 1970.
- FARREN, FRANK, late of Ararat, retired labourer, died 9th November, 1968.
- FENNER, CHARLES ARTHUR LOGUE, late of 40 Burniewang-street, Sunshine, laboratory assistant, died 13th November, 1969.
- GROVER, JAMS CROWTHER, late of 20 Vincent-street, Edithvale, storeman, died 16th February, 1970.
- HARRISON, HENRY FREDERICK, late of 115 North-road, Reservoir, retired boiler attendant, died 20th February, 1970.
- KENNEDY, HELEN RUSSELL, late of 1 Salter-street, Essendon, widow, died 24th December, 1969.
- KIELY, ROSE ANN MARY, late of 13 Hill-street, Sunshine, widow, died 18th November, 1969.
- LEDDY, MARGARET, late of 13 Brougham-street, North Melbourne, pensioner, died 11th December, 1969.
- MAHONEY, NORA, late of 11 Tollington-avenue, East Malvern, pensioner, died 23rd January, 1970.
- MURPHY, RAYMOND ALBERT, late of "Rockingham", 1 Barkers-road, Kew, turner, died 7th July, 1969.
- MCMILLAN, ROSE ELLEN, late of 304 Albion-street, Brunswick, widow, died 18th January, 1970.
- POTTS, PHYLLIS MAY, also known as Phyllis Potts, late of 178 Daley-street, Glenroy, mess attendant, died 25th November, 1969.
- RENKIN, WILLIAM HAROLD, formerly of 70 Mitchell-drive, St. Laurence Park, Lara, but late of Adair-street, Maldon, retired linesman, died 15th February, 1970.
- ROBERTSON, LILLIAN ADA, late of 7A Kelley-grove, West Preston, married woman, died 13th March, 1970.
- SHIRLEY, IDA MAY, late of 23 Young-street, Albert Park, widow, died 26th January, 1970.
- TETENBURG, JOHANNA MARTHA, late of Flat 5, 63 Elizabeth-street, Richmond, nurse, died 21st August, 1969.
- WILCOX, RONALD GORDON, late of 17 North-road, East Reservoir, psychiatric nurse, died 21st December, 1969.

N. P. BRODY,
Public Trustee.

256 Flinders-street, Melbourne, 3000, 29th April, 1970.

VICTORIAN STATE PARLIAMENTARY ELECTIONS
to be held on Saturday, 30th May, 1970.

ABSENT AND POSTAL VOTING ARRANGEMENTS

Dates fixed for the election are :—

Issue of Writs	17th April, 1970.
Nominations close	8th May, 1970. (Noon).
Polling Day	30th May, 1970.

VOTING IS COMPULSORY.

ELECTORS ABSENT FROM THEIR ELECTORATE BUT WITHIN VICTORIA.

Electors who will be absent from their electorate but WITHIN the State of Victoria at the time of the election may vote in one of three ways :—

1. They may go to any booth open in the State *on polling day* and vote as an ABSENT VOTER ; or
 2. They may apply for a postal vote BEFORE polling day to the Returning Officer for the ASSEMBLY District in which they are enrolled ; or
 3. They may call in person on such Returning Officer BEFORE the polling day and vote before leaving the electorate.
- Postal vote application forms are available at all post offices in Victoria.

WHERE TO APPLY FOR POSTAL VOTES IN VICTORIA.

Electoral District.	Address.	Electoral District.	Address.
Albert Park ..	350 Clarendon-street, South Melbourne 3205	Hawthorn ..	Shop 12, Glenferrie-arcade, 675A Glenferrie-road, Hawthorn 3122
Ballaarat North ..	Commonwealth Offices, Curtis-street, Ballarat 3350	Heatherton ..	22 Ann-street, Springvale 3171
Ballaarat South ..	c/o P.O. Box 571, Ballarat 3350 (Curtis-street)	Ivanhoe ..	149 Cape-street, Heidelberg 3084
Balwyn ..	339 Whitehorse-road, Balwyn 3103	Kara Kara ..	107 High-street, Maryborough 3465
Bellarine ..	237A High-street, Belmont 3216	Kew ..	241 Cotham-road, Kew 3101
Benalla ..	Shire Office, Benalla 3672	Lowan ..	239 Scott-street, Warracknabeal 3393
Benambra ..	Shire Hall, Beechworth 3747	Malvern ..	55A Glenferrie-road, Malvern 3144
Bendigo ..	238 Hargreaves-street, Bendigo 3550	Melbourne ..	Room 156, Commonwealth Centre, cnr. Spring and La Trobe streets, Melbourne 3000
Bennettswood ..	20 Windsor-avenue, Mt. Waverley 3149	Mentone ..	110 Balcombe-road, Mentone 3194
Bentleigh ..	135 McKinnon-road, McKinnon 3204	Midlands ..	Methodist Hall, Laurel-street, Golden Square 3555
Box Hill ..	960 Whitehorse-road, Box Hill 3128	Mildura ..	Commonwealth Offices, Ninth-street, Mildura 3500
Brighton ..	409 Bay-street, Brighton 3186	Mitcham ..	Old Orchard Shopping Centre, Springfield-road, North Blackburn 3130
Broadmeadows ..	143 Wheatsheaf-road, Glenroy 3046	Monbulk ..	28 Ruskin-avenue, Croydon 3136
Brunswick East ..	534 Sydney-road, Brunswick 3056	Moonee Ponds ..	114 Puckle-street, Moonee Ponds 3039
Brunswick West ..	534 Sydney-road, Brunswick 3056	Moorabbin ..	423 South-road, Moorabbin 3189
Camberwell ..	202 Toorak-road, Hartwell 3124	Morwell ..	Broadway, Yallourn 3838
Caulfield ..	15 Palm-avenue, Caulfield North 3161	Murray Valley ..	Shire Offices, Yarrowonga 3730
Coburg ..	Town Hall, Coburg 3058	Narracan ..	44 Queen-street, Warragul 3820
Dandenong ..	294 Thomas-street, Dandenong 3175	Northcote ..	641 High-street, Thornbury 3071
Deer Park ..	c/o Municipal Offices, Alexandra-avenue, Sunshine 3020	Oakleigh ..	96A Poath-road, Hughesdale 3166
Dromana ..	20 Carrigg-street, Dromana 3936	Polwarth ..	57 Corangamite-street, Colac 3250
Dundas ..	79 French-street, Hamilton 3300	Portland ..	22 Glenelg-street, Portland 3305
Essendon ..	430 Gaffney-street, Pascoe Vale 3044	Prahran ..	c/o Town Hall, Prahran 3181
Evelyn ..	c/o Lands Office, Healesville 3777	Preston ..	159 High-street, Preston 3072
Footscray ..	80 Napier-street, Footscray 3011	Reservoir ..	36 Edwardes-street, Reservoir 3073
Frankston ..	Totfield House, Thompson-street, Frankston 3199	Richmond ..	217 Victoria-parade, Collingwood 3066
Geelong ..	Commonwealth Offices, Brougham-street, Geelong 3220	Ringwood ..	145-147 Whitehorse-road, Ringwood 3134
Geelong North ..	149A Pakington-street, Geelong West 3218	Rodney ..	R.A.O.B. Hall, Darling-street, Echuca 3625
Gippsland East ..	34 Service-street, Bairnsdale 3875	St. Kilda ..	101 Carlisle-street, St. Kilda 3182
Gippsland South ..	Commonwealth Offices, Raymond-street, Sale 3850	Sandringham ..	31 Abbott-street, Sandringham 3191
Gippsland West ..	Box 54, Korumburra 3950	Scoresby ..	Shop 11, Railway-arcade, Dorset-road, Boronia 3155
Gisborne ..	Shire Office, Gisborne 3437	Shepparton ..	212 Maude-street, Shepparton 3630
Glenhuntly ..	Methodist Church Hall, cnr. Grange-road and Wattle-avenue, Glenhuntly 3163	Sunshine ..	221 Hampshire-road, Sunshine 3020
Glen Iris ..	Church of Christ Hall, St. George's-crescent, Alamein 3147	Swan Hill ..	47 McCallum-street, Swan Hill 3585
Greensborough ..	24 Derreck-avenue, Bulleen 3105	Syndal ..	City Offices, Glen Waverley 3150
Hampden ..	P.O. Box 168, Camperdown 3260	Werrnambool ..	R.S.L. Hall, Liebig-street, Werrnambool 3280
		Williamstown ..	c/o Town Hall, Ferguson-street, North Williamstown 3016

ELECTORS ABSENT FROM VICTORIA.**INTERSTATE.**

Electors travelling in Australian States OTHER than Victoria may obtain postal votes BEFORE polling day by calling in person upon or applying to any Commonwealth Divisional Returning Officer in those States.

All Commonwealth Divisional Returning Officers in OTHER States have been appointed as Victorian Postal Voting Officers.

UNITED KINGDOM.

Electors travelling in the United Kingdom should call upon or apply to the Postal Voting Officer c/o Agent General for Victoria, Victoria House, Melbourne Place, Strand, W.C.2, London.

OTHER COUNTRIES.

Victorian Postal Voting Officers have also been appointed in 24 other countries—usually being located at the Australian Embassy, Consulate or Trade Commissioner's Office.

SOME POINTS TO REMEMBER.

1. No postal ballot-paper can be issued until after nominations close at noon on 8th May, 1970.
2. Every application and completed declaration envelope must be signed by an authorized witness (see list on application form).
3. Completed postal ballot-papers must be in the hands of the Returning Officer or Postal Voting Officer before close of the poll. Postal ballot-papers, of course, may be handed in at any polling booth on polling day.

C. W. PHILLIPS,

Chief Electoral Officer for the State of Victoria.

Old Treasury Building, Spring-street, Melbourne 3000. Telephone 651 6447.

Commercial Goods Vehicles Act.
TRANSPORT REGULATION BOARD.

HEARING OF APPLICATIONS.

NOTICE is hereby given that the following applications will be considered by the Transport Regulation Board at its offices at the corner of Lygon and Princes streets, Carlton, at 10.15 a.m., on Wednesday, 27th May, 1970.

ADDISON, D. W., 44 Yarrowee-street, Sebastopol, 3356. One commercial goods vehicle (L/C. 292 cwt.) to operate within a 50-mile radius of the plant of Pioneer Concrete Pty. Ltd., at Ballarat solely on behalf of the said company—premixed concrete in a specially constructed agitator vehicle.

ANTONIOU, L. & N., Huon Park-road, Cranbourne, 3977. One commercial goods vehicle (L/C. 222 cwt.) to operate within a 50-mile radius of the premises of Albion Reid Pty. Ltd., at North Melbourne solely on behalf of the said company—road-making plant, hot asphalt premix and road-making materials excluding the carriage of cement and lime from the Geelong Urban District (as defined in the *Transport Regulation Act 1958*).

APOSTOLOPOULOS, P., 157 Wood-street, East Preston, 3072. One commercial goods vehicle (L/C. 159 cwt.) to operate within a 35-mile radius of the G.P.O. in the City of Melbourne solely on behalf of Consolidated Quarries, Ltd.—sand, soil, screenings and premix.

AUSTRALIAN ESTATES CO. LTD., Edgar-street, Heywood, 3304. One commercial goods vehicle (L/C. 10 cwt.) to operate within a 50-mile radius of the post office at Heywood in the course of business as "Stock and Station Agents and General Merchants"—own goods.

AXIAK, L., 57 Lawn-road, Noble Park, 3174. One commercial goods vehicle (L/C. 140 cwt.) to operate within a 35-mile radius of the G.P.O. in the City of Melbourne solely on behalf of Pioneer Quarries (Vic.) Pty. Ltd.—sand, soil, screenings and premix.

BUCKINGHAM, T. P., 51 Gordon-grove, East Preston, 3072. One commercial goods vehicle (L/C. 61 cwt.) to operate: (a) Within a 25-mile radius of the applicant's own premises at East Preston—general goods subject to the condition that no goods shall be carried whether in one or more stages from any one point within the said radius situated more than thirty (30) miles apart by the nearest and most practicable route. (b) From or to places situated within a 25-mile radius of the post office at East Preston or from places outside that radius situated wholly within a 50-mile radius of the said post office—livestock.

BUNGE (AUST.) PTY. LTD., 447 Collins-street, Melbourne, 3000. Two commercial goods vehicles (L/C's. 83, and 84 cwt.) to operate on behalf of Bunge "Australia" Pty. Ltd. trading as Garden City Flour Mill an approved decentralized secondary at Ballarat: (a) From the railway sidings at Fitzroy or Cowper-street, to own store at Fitzroy—bag flour. (b) From own store at Fitzroy or Cowper-street, and Fitzroy railway sidings to consignee within a 25-mile radius of G.P.O. Melbourne—bag flour. (c) From Bunge "Australia" Pty. Ltd., trading as Garden City Flour Mill at Ballarat, to own store at Fitzroy or to consignee within a 25-mile radius of G.P.O. Melbourne—bag flour. (d) From places within a 25-mile radius of G.P.O. Melbourne to Bunge "Australia" Pty. Ltd., trading as Garden City Flour Mill at Ballarat—reject flour.

BUNGE (AUST.) PTY. LTD., 447 Collins-street, Melbourne, 3000. One commercial goods vehicle (L/C. 132 cwt.) to operate on behalf of Bunge "Australia" Pty. Ltd., trading as Garden City Flour Mill an approved decentralized secondary industry at Ballarat: (a) From the railway siding at Cowper-street, to own store at Fitzroy—bulk flour. (b) From own store at Fitzroy or Cowper-street siding to consignee within a 25-mile radius of G.P.O. Melbourne—bulk flour. (c) From Bunge "Australia" Pty. Ltd., trading as Garden City Flour Mill to own store at Fitzroy or to consignee within a 25-mile radius of G.P.O. Melbourne—bulk flour. (d) From places within a 25-mile radius of G.P.O. Melbourne to Bunge "Australia" Pty. Ltd., trading as Garden City Flour Mill at Ballarat—reject flour.

BURÓW, J. W., Racecourse-road, Peshurst, 3289. One commercial goods vehicle (L/C. 229 cwt.) to operate: (a) Within a 25-mile radius of the post office at Peshurst—general goods, provided that no goods shall be carried whether by one stage or by more than one stage between places within the above radius which are more than thirty (30) road miles apart by the nearest practicable route. (b) Within a 50-mile radius from the post office at Peshurst—posts and firewood. (c) Within a 50-mile radius from

the post office at Peshurst in the course of business as "Rural Contractor"—tools of trade, equipment, maintenance materials and fuel. (d) Throughout the State of Victoria—building and equipment incidental to the raising, removal and re-blocking of buildings.

CERAMIC TRANSPORT PTY. LTD., corner Princes Highway and Smith-road, Springvale, 3171. One commercial goods vehicle (L/C. 375 cwt.) to operate within a 70-mile radius from the Brickworks of Northcote Brick Co. at Northcote and Brick and Pipe Industries Ltd. at Burwood—bricks, returning with empty pallets.

CERAMIC TRANSPORT PTY. LTD., corner Princes Highway and Smith-road, Springvale, 3171. One commercial goods vehicle (L/C. 20 cwt.) to operate within a 100-mile radius of own premises at Springvale as a "Mobile Workshop" for the purpose of servicing own vehicles and equipment—tools of trade and spare parts for on-site servicing.

COMPOSITE BUYERS PTY. LTD., P.O. Box 169, Clayton, 3168. One commercial goods vehicle (L/C. 13 cwt.) to operate: (a) Within a 50-mile radius of own premises at Clayton in the course of business as "Wholesale Grocers"—own goods. (b) Throughout the State of Victoria for the purposes of sales promotion of own goods and agency lines—samples and advertising and display materials.

CROWN CONTROLS AUSTRALIA PTY. LTD., cnr. Balmain and Chestnut streets, Richmond, 3121. One commercial goods vehicle (L/C. 13 cwt.) to operate throughout the State of Victoria in the course of business as "Manufacturers of Mechanical Handling Equipment" for the purpose of servicing such equipment in the field only—tools of trade, spare parts and materials incidental to on site servicing.

DESMA ENGINEERING CO. PTY. LTD., 291-299 Wellington-street, Collingwood, 3066. One commercial goods vehicle (L/C. 55 cwt.) to operate: (a) Within a 50-mile radius of own premises at Collingwood in course of business as "General Engineers"—own goods. (b) throughout the State of Victoria for the purpose of erecting steelwork—tools of trade, erection equipment and a small quantity of fittings and parts incidental to the repair or completion of a contract or being surplus fittings from a contract. (c) Within a 25-mile radius of any contract site or from the nearest railway station thereto—materials for such contract.

DONOHUE, W. & H., BROS. PTY. LTD., 123 Graham-street, Wonthaggi, 3995. One commercial goods vehicle (L/C. 210 cwt.) to operate throughout the State of Victoria in the course of business as "House Removers"—houses and sheds for removal, tools of trade and small quantities of materials incidental to the re-erection of such buildings.

EXELL, R. R., P.O. Box 11, Minyip, 3392. One commercial goods vehicle (L/C. 114 cwt.) to operate: (a) Within a 50-mile radius of the post office at Minyip in the course of business as "Share Farmer"—own goods. (b) Within a 50-mile radius of the post office at Minyip as a "Road Contractor"—road-making plant and materials. (c) Within a 20-mile radius from the site of construction or maintenance work performed pursuant to paragraph (a) above or from the railway station nearest thereto—any other materials required for such work.

FRANCOMBE, W. R., 65 Mt. Dandenong-road, Ringwood East, 3135. One commercial goods vehicle (L/C. 199 cwt.) to operate within a 50-mile radius of the premises of Albion Reid Pty. Ltd. at North Melbourne on behalf of the said company—road-making plant, hot asphalt, premix and road-making materials, but excluding the carriage of cement and lime from the Geelong Urban District (as defined in the *Transport Regulation Act 1958*).

FRANCOMBE, W. R., 65 Mt. Dandenong-road, Ringwood East, 3135. One commercial goods vehicle (L/C. 199 cwt.) to operate within a 50-mile radius of the plant of Albion Reid Pty. Ltd. at Montrose on behalf of the said company—premixed concrete in a specially constructed agitator vehicle.

GARFIELD SANDS PTY. LTD., 4 Clive-street, Springvale, 3171. One commercial goods vehicle (L/C. 149 cwt.) to operate: (a) Within a 25-mile radius of own premises at Springvale in course of business as "Garden Supplier"—own goods. (b) From pits at Tynong North to own yard at Springvale—own sand.

GASPAR, S., 4 Talbot-avenue, East St. Kilda, 3182. One commercial goods vehicle (L/C. 138 cwt.) to operate within a 50-mile radius of the premises of Albion Reid Pty. Ltd. at North Melbourne on behalf of the said company—road-making plant, hot asphalt, premix and road-making materials but excluding the carriage of cement and lime from the Geelong Urban District (as defined in the *Transport Regulation Act 1958*).

- GEORGOPOULOS, I., 45 Richmond-terrace, Richmond, 3121. One commercial goods vehicle (L/C. 225 cwt.) to operate within a 25-mile radius of the G.P.O., Melbourne, on behalf of Consolidated Quarries Ltd.—sand, soil, screenings and premix.
- GIBSON BATTLE & COMPANY LTD., 120 Whitehall-street, Footscray, 3011. One commercial goods vehicle (L/C. 14 cwt.) to operate throughout the State of Victoria in the course of business as "Distributors of Diesel Engines"—tools of trade also small quantities of spare parts incidental to servicing and maintenance of diesel engines in the field only.
- GOODALL, H., & SON PTY. LTD., Ballarat-road, Lake Bolac, 3351. One commercial goods vehicle (L/C. 11 cwt.) to operate: (a) Within a 50-mile radius of own premises at Lake Bolac in course of business as "Garage Proprietors and Machinery Sales and Service"—own goods and machinery and parts for repair or having been repaired. (b) Within a 50-mile radius of own premises at Lake Bolac for the purpose of servicing disabled motor vehicles—tools of trade, spare parts and disabled motor vehicles on specially constructed car-carrying trailer, but excluding the ability to attend the scene of an accident.
- HADDEN, J. E., PTY. LTD., 384 McCrae-street, Bendigo, 3550. One commercial goods vehicle (L/C. 17 cwt.) to operate within a 50-mile radius of the chief post office in the City of Bendigo and to the town of Gisborne in the course of business as "Cigarette Distributors"—cigarettes, tobacco and tobacconists' supplies, provided that all goods are initially consigned by rail to Bendigo.
- HARDING, R. F., 24 Hallett-crescent, Wangaratta, 3697. One commercial goods vehicle (L/C. 272 cwt.) to operate: (a) From forest landings at Mount Cobbler to South Wangaratta sawmills—logs. (b) From South Wangaratta sawmill to consignees within a 50-mile radius of the premises of the South Wangaratta sawmill—sawn timber.
- HARDMAN INDUSTRIES PTY. LTD., 1432 Dandenong-road, Oakleigh, 3166. One commercial goods vehicle (L/C. 11 cwt.) to operate: (a) Throughout the State of Victoria in the course of business as "Lawn Mower Distributors"—own lawn mowers for display purposes and also display and advertising materials. (b) Throughout the State of Victoria in the course of business as "Lawn Mower Distributors and Repairers"—lawn mowers for repair or having been repaired, lawn mowers traded-in as deposit on new models and also tools of trade and equipment necessary for the repair of a lawn mower on site.
- HARRIS, P., 11 Victoria-street, Drouin, 3818. One commercial goods vehicle (L/C. 141 cwt.) to operate within a 25-mile radius of the post office at Healesville (Dandenong Division of the Country Roads Board) as a water tanker for the purpose of spraying road construction projects.
- HEATING CONTROLS PTY. LTD., 1 River-street, Richmond, 3121. Two commercial goods vehicles (L/C. 24 and 10 cwt.) to operate in the course of business as "Importers and Distributors of Heating, Cooling and Ventilating Equipment": (a) Within a 50-mile radius of own premises at Richmond—own goods. (b) Throughout the State of Victoria for the purposes of servicing and demonstrating heating, cooling and ventilating equipment—heating, cooling and ventilating equipment for demonstration or repair or having been repaired, also tools of trade, spare parts and materials incidental to servicing such equipment on site.
- HERBERTSON, A. E., Lexton, 3352. One commercial goods vehicle (L/C. 232 cwt.) to operate: (a) Within a 25-mile radius of the post office at Lexton—general goods, provided that no goods shall be carried whether by one stage or by more than one stage between places within the above radius which are more than thirty (30) road miles apart by the nearest practicable route. (b) From and to places situated within the radius as defined in paragraph (a) above to and from places outside that radius but wholly within a 50-mile radius of the said post office—livestock.
- HOVEY, R. C. (trading as Hovey's Transport Service), Thompsons-road, North Geelong, 3215. Three commercial goods vehicles (L/C. 225, 238, 290 cwt.) to operate: (a) Within a 25-mile radius of the chief post office in the City of Geelong—general goods. (b) From and to places situated within the radius defined in paragraph (a) above to and from places outside that radius but situated wholly within a 50-mile radius of the chief post office in the City of Geelong—livestock.
- INDUSTRIAL ENGINEERING LTD. (CONTRACTING PLANT DIVISION) Corner Dudley and Cowper streets, West Melbourne, 3003. One commercial goods vehicle (L/C. 14 cwt.) to operate throughout the State of Victoria in the course of business as "Distributors of Earth Moving Equipment" for the purpose of servicing such equipment—tools of trade and spare parts necessary for the repair of such vehicles or machinery on site.
- INNESS, J. J., 44 Boronia-grove, East Doncaster, 3109. One commercial goods vehicle (L/C. 350 cwt.) to operate: (a) Within a 25-mile radius of own yard at Doncaster in course of business as "Garden Supplier"—own goods. (b) From Bacchus Marsh to places in paragraph (a)—own river pebbles and own sand. (c) From Diggers Rest to places in paragraph (a)—own scoria.
- JACKSON, P.O. Sunnyclyffs, 3496. One commercial goods vehicle (L/C. 131 cwt.) to operate within a 95-mile radius from the post office at Cohuna and/or within a 100-mile radius from the post office at Merbein (Bendigo Division of the Country Roads Board) as a "Road Contractor"—tools of trade, spare parts and a small quantity of fuel grease incidental only to the operation of own vehicles.
- KEEP, K. C., 678 Canterbury-road, Vermont, 3133. One commercial goods vehicle (L/C. 10 cwt.) to operate throughout the State of Victoria in the course of business as "Contract Carpet Layer" on behalf of Patersons Pty. Ltd.—tools of trade floor coverings for laying purposes only.
- KENT INSTRUMENTS (AUSTRALIA) PTY. LTD., 563 Victoria-street, Abbotsford, 3067. One commercial goods vehicle (L/C. 14 cwt.) to operate throughout the State of Victoria in the course of business as "Instrument Manufacturers" for the purpose of servicing instruments in industry—tools of trade and spare parts incidental to on-site servicing.
- KEOGH, B. P., 102 Retreat-road, Bendigo, 3550. One commercial goods vehicle (L/C. 259 cwt.) to operate: (a) Within a 25-mile radius of the post office at Bendigo—general goods. (b) Within a 50-mile radius of the premises of Eppalock Quarries—screenings, crushed rock and screening dust.
- KOUVARIS, C., 253 O'Heas-road, Pascoe Vale, 3044. One commercial goods vehicle (L/C. 225 cwt.) to operate within a 50-mile radius of the premises of Albion Reid Pty. Ltd. at North Melbourne solely on behalf of the said company—road-making plant, hot asphalt, premix and road making materials, but excluding the carriage of cement and lime from the Geelong Urban District (as defined in the Transport Regulation Act 1958).
- ATKINS, T. M., (trading as Kyabram Motor Wreckers, 20 Julia-street, Kyabram, 3620. One commercial goods vehicle (L/C. 31 cwt.) in the course of business as "Motor Wrecker"—(a) Within a 50-mile radius of the post office at Kyabram and to Yea, Benalla and Bendigo—own goods. (b) Throughout the State of Victoria for the purpose of carrying damaged or disabled motor vehicles on a specially constructed car carrying trailer, but excluding the ability to attend the scene of an accident.
- JACK LEGGE PTY. LTD., 43 Thomson-street, Sale, 3850. One commercial goods vehicle (L/C. 22 cwt.) to operate: (a) Throughout the State of Victoria in the course of business as "Earth-moving and Road-making Contractor"—own tools and own equipment but excluding the carriage of new machinery, equipment or spare parts from the Metropolitan Area (as defined in the Transport Regulation Act 1958). (b) Within a 20-mile radius of the site of any construction or maintenance contract upon which the licence holder is currently engaged—metal, stones, screenings, ashes, gravel, sand, earth and any other materials required for such work.
- LUCAS, A. N., 42 Moonya-road, Carnegie, 3163. One commercial goods vehicle (L/C. 30 cwt.) to operate throughout the State of Victoria in the course of business as "Second-hand Tyre Dealer" for the purpose of collecting second hand tyres from garages and service stations for return to Melbourne—second-hand and scrap tyres with the proviso that the combined load capacities of the prime mover and any trailer attached thereto shall not exceed 120 cwt.
- MARRICKVILLE HOLDINGS (SALES) PTY. LTD., 254 Ballarat-road, Braybrook, 3019. One commercial goods vehicle (L/C. 18 cwt.) to operate within that part of the State of Victoria bounded by a straight line joining the Townships of San Remo and Drouin an east-west line drawn through the Township of Maffra and a north-south line drawn through the City of Sale in the course of business as "Foodstuffs Manufacturer and Wholesaler"—own goods with the proviso that all goods so carried shall have been initially consigned on rail to Morwell.
- MOORE ROAD MACHINERY (VIC.) PTY. LTD., 501 Williams-town-road, Port Melbourne, 3207. One commercial goods vehicle (L/C. 13 cwt.) to operate throughout the State of Victoria in the course of business as

- "Distributors of Road Machinery"—tools of trade, spare parts and materials incidental to servicing and repairing industrial road and farm machinery.
- MORTIMORE, J. R., Myers Creek-road, Toolangi, 3777. One commercial goods vehicle (L/C. 202 cwt.) to operate: (a) Within a 50-mile radius of own premises at Toolangi in the course of business as "Pulpwood Contractor"—own cutting and felling gear and equipment. (b) Within a 10-mile radius from the site of any contract currently engaged upon within the above radius—pulpwood and logs.
- McKAY MACLEOD PTY. LTD., 63-73 Mair-street, Ballarat, 3350. One commercial goods vehicle (L/C. 248 cwt.) to operate: (a) Within a 50-mile radius of the chief post office in the City of Ballarat in the course of business as "Wholesale Grocers Manufacturers and Wine and Spirit Merchants"—own goods. (b) Throughout the State of Victoria in the course of business as "Food Manufacturers" (being an approved secondary industry carried on at Main-street, East Ballarat)—raw materials for own use in the manufacture of food products for delivery only to the aforesaid place of business at Mair-street East, Ballarat, and manufactured articles and completed products from said place of business.
- McPHERSON, J. J., Davis-street, Warrnambool, 3280. One commercial goods vehicle (L/C. 65 cwt.) to operate: (a) Within a 25-mile radius of the post office at Warrnambool—general goods, provided that no goods shall be carried whether by one stage or by more than one stage between places within the above radius which are more than thirty (30) road miles apart by the nearest practicable route. (b) From and to the depot of Golden Fleece Petroleum Co. Pty. Ltd. at Portland and from places within a 20-mile radius of the chief post office in the City of Warrnambool in the course of business as "Petroleum Agent" on behalf of the said company—petroleum products in prescribed types of containers and empty containers for return.
- NOTT & DREW PTY. LTD., 31-33 Ryrie-street, Geelong, 3220. One commercial goods vehicle (L/C. 20 cwt.) to operate: (a) Within a 50-mile radius of the chief post office in the City of Geelong—own goods and plumbing equipment for repair or having been repaired. (b) Throughout the State of Victoria for the purpose of installing petrol pumps and tanks solely on behalf of Ampol Petroleum (Victoria) Pty. Ltd.—tools of trade and materials incidental to own contracts.
- OZANNE, J. M., 101 Mitchell-street, Echuca, 3625. One commercial goods vehicle (L/C. 23 cwt.) to operate throughout the State of Victoria in the course of business as "Marine Collector"—special wares, marine stores and old metals as designated in the *Marine Stores and Old Metals Act 1958* (No. 6303), Part 1, section (3) but excluding the carriage of any such goods to wharves, docks or ships for shipment or export purposes.
- NOTE.—The total combined load capacity of the prime mover and any trailer attached thereto shall not exceed 120 cwt.
- PENINSULA PAVING & CONTRACTING CO. PTY. LTD., Melbourne-road, Rye, 3941. One commercial goods vehicle (L/C. 130 cwt.) to operate: (a) Within a 25-mile radius of own premises at Rye in course of business as "Paving Contractors"—own goods. (b) From pits at Cranbourne to own premises at Rye—own sand. (c) From Moorabbin to own premises at Rye—own reinforcing mesh.
- S. & C. PLANT HIRE PTY. LTD., 637 Jones-street, Albany (P.O. Box 772), 2640. One commercial goods vehicle (L/C. 143 cwt.) to operate: (a) Throughout the State of Victoria in the course of business as "Sewerage Construction Contractors"—own plant and own equipment. (b) Within a 20-mile radius of the site of any contract currently engaged upon—materials for use on such contract and soil for disposal.
- READY MIXED CONCRETE (VICTORIA) PTY. LTD., 68 Burwood-road, Burwood, 3125. One commercial goods vehicle (L/C. 129 cwt.) to operate within a 50-mile radius of applicant's own premises at Huntingdale in the course of business as "Pre-Mixed Concrete Manufacturers"—own premixed concrete in a specially constructed agitator vehicle.
- RENTSCH, H., Mailors Flat, via Warrnambool, 3280. Application to vary the conditions of licence D.A.62038 (L/C. 79 cwt.) by adding to the existing conditions "and motor vehicles for wrecking purposes provided that no such vehicle shall be lifted or carried by the towing vehicle".
- ROCHE BROS. PTY. LTD., 22 Dynon-road, South Kensington, 3031. One commercial goods vehicle (L/C. 252 cwt.) to operate: (a) Throughout the State of Victoria in the course of business as "Earth-moving and Excavation Contractors"—own tools of trade, own plant and own earth-moving and excavation equipment incidental to own contracts. (b) Within a 25-mile radius of the G.P.O., Melbourne—general goods.
- SAVILLE, D., Riversdale-road, Yarra Junction, 3797. One commercial goods vehicle (L/C. 242 cwt.) to operate: (a) From forest landings in the Niagaroon and Upper Yarra Forestry Districts or North Big River area to sawmills at Warburton and Yarra Junction—logs. (b) From Bell and Say's sawmill at Yarra Junction to any timber yard or building contract site situated within a 25-mile radius of the post office at the corner of Bourke and Elizabeth streets in the City of Melbourne—sawn timber.
- SCHWENK, G., 34 Frank-avenue, Clayton, 3168. One commercial goods vehicle (L/C. 144 cwt.) to operate within a 35-mile radius of the G.P.O. in the City of Melbourne on behalf of Consolidated Quarries Ltd.—sand, soil, screenings, premix and quarry products.
- SCOONES, A. R. & Co. PTY. LTD., 94 Quinn-street, Numurkah, 3636. One commercial goods vehicle (L/C. 157 cwt.) to operate within a 50-mile radius of own premises at Numurkah in the course of business as "Fertilizer Distributor"—bagged and bulk fertilizer for distribution, provided that all such fertilizer is initially consigned by rail to Numurkah.
- LANCE SMITH EXCAVATIONS PTY. LTD., 30 Clarice-road, Box Hill South, 3128. One commercial goods vehicle (L/C. 281 cwt.) to operate throughout the State of Victoria in course of business as "Earth-moving Contractors"—own tools of trade, and own earth-moving plant incidental to own contracts.
- STRATTON, D. N., 4 Erica-court, Traralgon, 3844. One commercial goods vehicle (L/C. 140 cwt.) to operate: (a) Within a 50-mile radius of the post office at Traralgon as a "Road Contractor"—road-making plant and materials. (b) Within a 20-mile radius from the site of any construction or maintenance work performed pursuant to paragraph (a) above, or from the railway station nearest thereto—any other materials required for such work.
- SWINKELS, G., Raymond-street, Cockatoo, 3781. One commercial goods vehicle (L/C. 160 cwt.) to operate within a 35-mile radius of the premises of Pioneer Quarries (Vic.) Pty. Ltd. at Narre Warren North on behalf of the said company—sand, soil, screenings, premix and quarry products.
- THOMAS, R. W., Macarthur, 3286. One commercial goods vehicle (L/C. 123 cwt.) to operate: (a) From the premises of Macarthur Lime Co. at Macarthur to the properties of farmers situated within a 50-mile radius of the post office at Macarthur—lime for spreading. (b) Within a 50-mile radius of the post office at Macarthur in the course of business as "Primary Producer"—own goods.
- THOMSON, W., & SONS PTY. LTD., 10 Margaret-street, Huntingdale, 3166. One commercial goods vehicle (L/C. 120 cwt.) to operate throughout the State of Victoria as "Installation Contractor" on behalf of Australian Gypsum Ltd.—tools of trade, scaffolding, plaster sheets, cornice battens, and small quantities of sisal and stopping plaster.
- TURNER, C. J., 4 McMillans-street, Bairnsdale, 3875. One commercial goods vehicle (L/C. 8 cwt.) to operate throughout that part of the State of Victoria situated east of a north/south line drawn through Township of Stratford in course of business as "Motor Accessories and Spare Parts Distributor"—motor accessories and spare parts.
- VAN ROSMALEN, J. F., 3 Poplar-street, Campbellfield, 3061. One commercial goods vehicle (L/C. 130 cwt.) to operate: (a) From the premises of motor vehicle distributors and dealers direct to consignees throughout the State of Victoria—complete motor vehicles on behalf of Fleetways Transport Services Pty. Ltd. (b) Between the Cities of Melbourne, Geelong and Dandenong—motor car bodies on behalf of Fleetways Transport Services Pty. Ltd., provided that no delivery of such goods shall be made to any wharf at which rail facilities are available, subject to cancellation of licence No. D.A.48588/79 in the name of Fleetways Haulway Pty. Ltd.
- WALLACE, D. F., Teesdale, 3328. One commercial goods vehicle (L/C. 245 cwt.) to operate: (a) Within a 25-mile radius of the post office at Teesdale—general goods provided that no goods shall be carried whether by one stage or by more than one stage between places within the above radius which are more than 30 road miles apart by the nearest practicable route. (b) From and to places within the radius specified in part (a) above and from places outside that radius but wholly within a 50-mile radius of the post office at Teesdale—livestock. (c) From and to the depot of

- Ampol Petroleum (Vic.) Pty. Ltd. at Newport to and from own premises at Teesdale—petroleum products in prescribed types of containers and empty containers for return solely on behalf of the said company.
- WEIR, S. J., PTY. LTD., 43 Tenth-street, Mildura, 3500. One commercial goods vehicle (L/C. 20 cwt.) to operate: (a) Within a 50-mile radius of the post office at Mildura in the course of business as "Builder"—own goods. (b) Within a 150-mile radius of the post office at Mildura—own tools of trade and equipment incidental to own contracts only. (c) Within a 20-mile radius of the current contract site or from the railway station nearest thereto—materials required for use in such contract.
- WHOLESALE LTD., 18 Breed-street, P.O. Box 200, Traralgon, 3844. One commercial goods vehicle (to be purchased, approximately 40-60 cwt.) to operate from own premises at Traralgon to consignees situated in the Townships of Paynesville, Eagle Point, Bairnsdale, Swan Reach, Johnsonville, Metung and Lakes Entrance in the course of business as "Wholesale Grocers"—own goods for sale to retail outlets with the proviso that all goods so carried shall have been initially received on rail at Traralgon.
- YENKEN-GALE PTY. LTD., 7-11 Benalla-road, Shepparton, 3630. Two commercial goods vehicles (L/C. 14 and 25 cwt.) to operate in the course of business as "Hardware and Glass Merchants"—as follows:—(a) Within a 50-mile radius of the post office at Shepparton—own goods. (b) Within a 50-mile radius of the post office at Shepparton and Wangaratta, Wodonga, Mansfield, Yea, Kerang, Cohuna and Swan Hill—own glass and glazing materials.
- ZANKER, M. C. (trading as E. G. & M. C. Zanker), 24 Kellsall-street, Warracknabeal, 3393. One commercial goods vehicle (L/C. 8 cwt.) to operate: (a) Within a 50-mile radius of the post office at Warracknabeal as an "Agent" on behalf of the Caltex Oil Co.—petroleum products in prescribed types of containers and empty return containers. (b) Within a 50-mile radius of the post office at Warracknabeal in the course of business as "Marine Collector"—special wares, marine stores and old metals as designated in the *Marine Stores and Old Metals Act 1958*, No. 6303, Part 1, Section 3. Note.—The combined load capacity of the prime mover and of any trailer hauled in conjunction thereto shall not exceed 120 cwt.
- ZANKER, M. C. (trading as E. G. & M. C. ZANKER), 24 Kellsall-street, Warracknabeal, 3393. One commercial goods vehicle (L/C. 147 cwt.) to operate within a 50-mile radius of the post office at Warracknabeal and to Ouyen, Sea Lake, Yaapeet, Woomelang and Patchewollock as an "Agent" on behalf of Caltex Oil Co.—petroleum products in prescribed types of containers and empty return containers.
- FENN, A. T. G., Barkly-street, Wahgunyah, 3687; D.T.486/1; 18th July, 1970; 245 cwt.
- FRANCIS, K. & B. J., 59 Lonsdale-avenue, Moorabbin, 3189; D.A.59911; 11th July, 1970; 14 cwt.; D.A.59911/1; 11th July, 1970; 19 cwt.
- GOETZ, O., Princes Highway, Cann River, 3889; D.A.59937; 11th July, 1970; 11 cwt.
- HAGER & RAWLINGS, 17 Creswick-road, Ballarat, 3350; D.A.38420/1; 2nd July, 1970; 11 cwt.
- HAUSER, N., 31 Tallangatta-road, Wodonga, 3690; D.T.1061; 11th July, 1970; 281 cwt.
- HILLGROVE, A. D., P.O. Box 176, Birchip, 3483; D.A.1302/16; 30th May, 1970; 11 cwt.
- HUGHES, D., Station-street, Porepunkah, 3740; D.A.1336; 3rd July, 1970; 114 cwt.
- HUTCHINSON, J., Maindample, via Mansfield, 3721; D.A.59974; 11th July, 1970; 141 cwt.
- INGLETON, R. C., Lake-road, Stawell, 3380; D.T.487/2; 11th July, 1970; 271 cwt.
- LANES MOTORS (SALES) PTY. LTD., 367 Plummer-street, Port Melbourne, 3207; D.A.32487/4; 16th May, 1970; 34 cwt.; D.A.32487/3; 16th May, 1970; 27 cwt.
- LOVELL, J., 112 Livingstone-street, Orbost, 3888; D.T.740; 11th July, 1970; 400 cwt.
- MAWSON, E. B., & SONS PTY. LTD., 141 King George-street, Cohuna, 3568; D.A.30119/13; 1st July, 1970; 187 cwt.
- MELVILLE, R. J., 24 Silverwood-grove, Wangaratta, 3677; D.A.59917; 11th July, 1970; 54 cwt.
- MOORE, D. H., 5 Scott-crescent, Mildura, 3500; T.D.A.50951/2; 1st July, 1970; 138 cwt.
- MORRIS, G. H., Britannia Creek-road, Wesburn, 3139; D.T.279; 26th July, 1970; 230 cwt.
- OSBORNE, W. C., Anakie, via Geelong, 3221; D.A.59162/3; 26th July, 1970; 72 cwt.
- PECK, C. A., 16 Crowley-road, Healesville, 3777; D.T.313; 18th July, 1970; 120 cwt.
- POULTRYMEN & FARMERS TRADING CO. PTY. LTD., 793 Glenhurlty-road, South Caulfield, 3162; D.A.1847/8; 30th July, 1970; 114 cwt.; D.A.1847/9; 30th July, 1970; 113 cwt.; D.A.1847/10; 30th July, 1970; 113 cwt.
- FRESHA ENGINEERING PTY. LTD., Ferntree Gully-road, Notting Hill, 3168; D.A.1858/2; 26th July, 1970; 11 cwt.; D.A.1858/3; 26th July, 1970; 11 cwt.
- READY MIXED CONCRETE (VIC.) PTY. LTD., 68 Burwood-road, Burwood, 3125; D.A.48531/38; 27th June, 1970; 37 cwt.
- REYNOLDS, E. A., 96 Wilsons-road, Newcomb, Geelong, 3219; D.A.35694/3; 18th July, 1970; 262 cwt.
- SALTER, H., Lot 14, Birmingham-road, Mt. Evelyn, 3796; D.A.1978/1; 1st July, 1970; 80 cwt.
- SCHULZ, E. H. C., 33 Commercial-road, Benalla, 3672; D.T.342; 26th July, 1970; 259 cwt.
- SHARPE, L. O., 110 Salisbury-street, Orbost, 3888; D.T.421; 16th May, 1970; 265 cwt.

TOW TRUCK.

- HALL, G. H., Western Highway, Great Western, 3378. One commercial goods vehicle (to be purchased) to operate throughout the State of Victoria as a "Tow Truck" solely—(a) For the purpose of lifting and carrying or towing motor cars and the carriage of tools and equipment necessary for such purpose only. (b) For carriage of spare parts necessary for the repair of a disabled motor to and from the place at which such disablement has occurred.
- RALPH, R. W., Lot 1, Burwood Highway, Ferntree Gully, 3156. One commercial goods vehicle (to be purchased) to operate within a 10-mile radius of the post office at Ferntree Gully as a "Tow Truck" solely—(a) For the purpose of lifting and carrying or towing motor cars and the carriage of tools and equipment necessary for such purpose only. (b) The carriage of spare parts necessary for the repair of a disabled motor to and from the place at which such disablement has occurred.
- ALBION REID PTY. LTD., 83 Riversdale-road, Hawthorn, 3122; D.A.520/120; 14th July, 1970; 15 cwt.
- BELL, R., 39 Smith-street, Stawell, 3380; D.A.49536/3; 11th July, 1970; 107 cwt.
- BETIOL, A. & N., 43 Warrandyte-road, Ringwood, 3134; D.A.56450/1; 18th July, 1970; 197 cwt.
- THE COMMONWEALTH INDUSTRIAL GASES LTD., 90 Bell-street, Preston, 3072; D.A.838/27; 30th July, 1970; 17 cwt.
- DAVEY, G., Jarklin, via Inglewood, 3517; D.A.59037; 18th July, 1970; 140 cwt.
- DEIPENAU, H. E. PTY. LTD., 73 Victoria-street, East Brunswick, 3057; D.A.17846/24; 11th July, 1970; 140 cwt.
- DEW, A. M., 5 Sargent-avenue, Mildura, 3500; D.A.58597; 9th May, 1970; 7 cwt.
- EGAN, J. P., 30 McLean-street, Maffra, 3860; D.A.33098; 1st July, 1970; 146 cwt.
- PULLIN, R. J., MOTORS PTY. LTD., 102 High-street, Mansfield, 3722; T.D.A.46467; 13th May, 1970; 15 cwt.

RENEWALS WITH VARIATION.

- APPLICATIONS by the persons listed hereunder for renewal of the licences listed with variation of conditions in the manner set out opposite the names.
- CALCO SAWMILLING CO. PTY. LTD., 56 Hesse-street, Colac, 3250; D.T.699; 11th July, 1970; application to renew and vary the conditions of licence D.T.699 (L/C. 273 cwt.) by deleting from the existing conditions paragraph (a) and adding in lieu—(a) From forest landings within a 20-mile radius of Forrest to licence holders own sawmills at Gellibrand, Barongarook and Colac—logs".
- FRIZON, A., & SONS, Forrest, 3236; D.T.199; 26th July, 1970; Application to renew and vary the conditions of licence No. D.T.199 (L/C. 276 cwt.) by deleting the present conditions and adding in lieu—(a) From forest landings within a 20-mile radius of the Forrest Post Office to own sawmill at Forrest—logs. (b) From own sawmill at Forrest to consignees at Geelong, Anglesea, Torquay, Barwon Heads, Ocean Grove, Point Lonsdale, Queenscliff, St. Leonards, Portarlington and Drysdale—sawn timber.
- FRIZON, A., & SONS, Forrest, 3236; D.T.199/1; 16th May, 1970; Application to renew and vary the conditions of licence No. D.T.199/1 (L/C. 264 cwt.) by deleting from the existing conditions paragraph (b) and adding in lieu—(b) From own sawmill at Forrest to consignees at Geelong, Anglesea, Torquay, Barwon Heads, Ocean Grove, Point Lonsdale, Queenscliff, St. Leonards, Portarlington and Drysdale—sawn timber.
- HALL, G. W., 15 Calleen-street, Seymour, 3660; D.A.24141/1; 7th May, 1970; Application to renew and vary the conditions of licence No. D.A.24141/1 (L/C.

131 cwt.) by deleting from the existing conditions paragraphs (b), (c), (d) and adding in lieu—(b) From the properties of primary producers situated within a 10-mile radius of Seymour to the factory of Campbells Soups Pty. Ltd. at Shepparton—fresh vegetables for processing. (c) Within a 60-mile radius of the post office at Seymour—river gravel.

Notice of any objection should be forwarded to reach the Secretary of the Board not later than 20th May, 1970.

Applicants are advised that it will not be necessary to appear on the hearing date specified above unless advised in writing by the Board.

B. P. KAY,
Secretary.

Corner of Lygon and Princes streets, Carlton, 3053,
6th May, 1970.

Transport Regulation Act.
TRANSPORT REGULATION BOARD.

HEARING OF APPLICATIONS.

NOTICE is hereby given that the following applications will be considered by the Transport Regulation Board at its offices at the corner of Lygon and Princes streets, Carlton, at 10.15 a.m., on Wednesday, 27th May, 1970.

ATKINSON INTERNATIONAL (AUST.) LTD., Upper Thomson via Warburton. Two commercial passenger vehicles (S/C. 21) to operate under the same terms and conditions as existing T.P. licences in the name of the applicant company.

BARNES, J. D., 39-43 Fraser-street, Sunshine. Application for permit authority to operate any M.C. licensed vehicle for the carriage of workers between the West Footscray Railway Station and Containers Ltd., Cherry-lane, Derrimut via Geelong-road, Princes Highway, Doherty-road and Cherry-lane under contract to the company.

TIME-TABLE (Monday-Friday).

Depart West Footscray—6.30 a.m., 2.30 p.m.
Depart Containers Ltd.—3.15 p.m., 11.15 p.m.

Saturday.

Depart West Footscray—7 a.m.
Depart Containers Ltd.—3.55 p.m.

Sunday.

Depart West Footscray—6.30 a.m.
Depart Containers Ltd.—3.15 p.m.

BRYANT MOTORS PTY. LTD., 1011 Main-road, Eltham. Application for three commercial passenger vehicles with large seating capacity to operate as metropolitan special service omnibuses.

HAYWARD, J. I., Suite 13, 139 Alma-road, East St. Kilda. Application for one commercial passenger vehicle to be purchased to operate as a Touring Omnibus for the carriage of passengers throughout Victoria.

MCPHERSON, K. N., 52 Margaret-street, Werribee. One commercial passenger vehicle (S/C. 5) to operate under the same terms and conditions as existing taxi cabs licensed at Werribee.

NEWTON, J. & I. W., Fuller-avenue, Rochester. One commercial passenger vehicle (S/C. 33) to operate: (a) As a stage omnibus along the following route. Commencing at Mackay-street, Rochester; thence via Bridge-road to High street returning via Elizabeth-street, Echuca-road, McKenzie-street, King-street, Dudley-street, Edward street to State School; thence via Elizabeth, Victoria and Campaspe streets to Convent.

Fares.

10c return daily children.
40c return weekly children.
10c single 20c return adults.

TIME-TABLE.

Depart Mackay-street—8.30 a.m.
Arrive Convent—9.05 a.m.
Depart Convent—3.30 p.m.
Arrive Mackay-street—4 p.m.

(b) In substitution for but not in addition to school buses on school services only operated by the applicant.

PLUMMER, K. D. & W. S., 11 Whyte-grove, Mont Albert. Application for permit authority to operate any M.C. licensed vehicle for the carriage of students between the corner of Belmore and Balwyn roads and Camberwell Church of England Girls' Grammar Schools at Mont Albert (Junior School) and Camberwell (Senior School) via Balwyn-road, Echo-avenue, Hill-view and Bulleen roads, Dorado-avenue, Ursa and Aquila streets, Bulleen-road, The Nook, Fortuna-avenue, Doncaster, Greythorn, Belmore, Union and

Mont Albert roads to the Junior School Mont Albert; thence via Mont Albert-road, Parlington and Woodstock streets to the Senior School Camberwell and return to the Junior School under contract to the Schools. Return journey to terminate at the corner of Doncaster-road and Fortuna-avenue.

TIME-TABLE (School Days Only).

Depart corner Belmore and Balwyn roads—7.57 a.m.
Arrive Junior School—8.25 a.m.
Depart Senior School—3.55 p.m.

SWEETS TRANSPORT PTY. LTD., 11 Grant-street, Bacchus Marsh. One commercial passenger vehicle (S/C. 45) to operate for the carriage of school children only between Melton and Bacchus Marsh High School under contract to the Education Department.

UNDERWOOD, L. G., Clifton-street, Euroa. One commercial passenger vehicle (S/C. 15 to 18) to operate as follows:—(a) In substitution for but not in addition to T.S. licensed vehicles in the name of the applicant. (b) As a country special service omnibus within a 2-mile pick-up radius of Euroa.

WILKINS, R. D., 830 Barkley-street, Ballarat. One commercial passenger vehicle (S/C. 41) to operate as follows:—(a) For the carriage of school children only between Ballan and Ballarat under contract to the Education Department. (b) As a country special service omnibus from Ballan. (c) To undertake charter hirings from schools in Ballarat.

APPLICATION for renewal of licences as shown, by persons listed hereunder to operate under the same terms and conditions.

ADAM, A., 107 Allison-street, Elsternwick; M.T.1732.
ANDRIANOPOULOS, A., 8 Kalimna-street, Balwyn; M.T.1984.
ANGELUCCI, A., 21 Chappell-street, Thomastown; M.T.4186.
ASSOCIATED STEAMSHIP CO. PTY. LTD., 94 William-street, Melbourne; T.P.214.
AYTON, C. J., 200 Waiora-road, Rosanna; M.T.855.
BARKER, J., 2A McEvoy-street, Kew; M.T.1051, M.T.715, M.T.714.
BERMAN, L., 7 Keeverell-road, Caulfield; M.T.4067.
BIRCH, R. D., Flat 5, 15 Rockley-road, South Yarra; M.T.1170, M.T.982, M.T.977, M.T.523, M.T.520.
CRANBOURNE, V. M., 75 Burrindi-road, South Caulfield; M.T.1574.
COWLING, J. A., 10 Lulworth-street, Blackburn; M.T.1038.
DE MELIS, F., Flat 11, 176 Princes-street, Carlton; M.T.1642.
DOWLING, B., 17 Groves-street, East Keilor; M.H.1602.
DUNSTAN, N. O., 12 McNamara-avenue, Niddrie; M.H.2064.
GERRARD STRAPPING SYSTEMS, corner Geelong and Little Boundary roads, Brooklyn; T.P.246.
LA GRECA, A., 875 Centre-road, East Bentleigh; M.T.4259.
HAY, R. J., 37 Fairfield-avenue, Camberwell; M.T.1676.
HEYS, S. J., 133 Huntingdale-road, Ashwood; M.T.1347.
JACOBS, S., 85 Finch-street, East Malvern; M.T.1066.
KOUTOS, P., 16 Brougham-street, Richmond; M.T.1830.
MAISEL, F., 50 Barkly-street, St. Kilda; M.T.1777.
MALOUF, T. C., Flat 4, 1235 Hoddle-street, East Melbourne; M.T.1112.
MARSHALL, R. T. B., Flat 1, 60 Glen Iris-road, Glen Iris; M.T.4104.
MARTIN, H. J., 12 Wolai-avenue, South Oakleigh; M.T.935.
MARTIN, W. L., 20 Valkstone-street, McKinnon; M.T.1123.
MATHEWS, R. W., 52 George-street, West Preston; M.T.1725.
MCKENNA, G. (Executor for Estate of Late A. McKenna), 48 Baker-parade, Ashburton; M.T.1092.
NEWMAN, H. F., 713 North-road, Carnegie; M.T.1536, M.T.1674.
PARASKEVAS, G., 155 Glengala-road, Sunshine; M.T.4138.
PAUWELS, D. L., 655 Gilbert-road, Reservoir; M.T.1665.
PROVINCIAL TRADERS PTY. LTD., Forsyth-road, Laverton; T.P.114.
ROGERS, J., 81 Beverly-street, East Doncaster; M.H.1804.
SHAW, W. R., 6 Ludwell-crescent, East Bentleigh; M.H.2060.
SHOLLY, R. C., 5 Wyuna-road, Caulfield; M.T.1723.
STRANER, G., 56 Brady-road, East Bentleigh; M.T.1364.
SWAENEY, A. R., 84 Tennyson-street, Kensington; M.T.1052.
TUSZYNSKI, R., 368 Barkly-street, Elwood; M.T.1933.
WAINRIB, H., 3 Carween-avenue, East Brighton; M.T.1518.
WALTON, R. H., 5 Salem-avenue, East Oakleigh; M.T.1396.
WELLS, P. C., 119 The Righi, Heidelberg; M.T.4318.
WILSON, T. L., 17 Kendall-street, Coburg; M.T.1328.

APPLICATIONS by—

ANDERSON, T. A., 13 Beddoe-road, Vermont.
AUNINS, M. J., Flat 12, 203 Gold-street, Clifton Hill.
ASHTON, C. J., 4 Thomas-street, Ringwood.
AXARIS, H., 3 St. Phillips-street, Abbotsford.
BATCH, A. A., Flat 2, 184 Wattletree-road, Malvern.
BEATTIE, R. J., 16 Arlington-street, Ringwood.

- BOLJANAC, S., Flat 6, 104 Rowena-street, Richmond.
 BROMAGE, K. H., 43 Warburton-road, Canterbury.
 CIPRIANI, F., 25A Lindenow-street, Reservoir.
 CLARK, K. M. D., Flat 12, 18A Bloomfield-road, Ascot Vale.
 COX, R. E., 78 Fromer-street, Moorabbin.
 DAVIES, R. W., 18 Phillip-street, East Keilor.
 DONATO, N., 11 Rose-street, Box Hill.
 DUNBAR, J., 16 Joffre-street, Croydon.
 FRAZER, B. F., 99 Marianne-way, Mt. Waverley.
 GAHAN, J. P., 112 Heatherdale-road, Mitcham.
 GEORGE, P., 9 Roberts-street, East Keilor.
 GILES, J. A. S., Flat 4, 25 Dickens-street, Elwood.
 GODDARD, R., 7 Allen-street, Ringwood.
 GOW, J., 19 Campbell-parade, Box Hill South.
 HEMMING, L. T., 53 Vanbrook-street, Forest Hill.
 HAMILTON, A. C., 44 Corrigill-road, Carnegie.
 HERD, J. R., 26 Arnold-drive, Scoresby.
 HINCH, J. A., 24 Manuka-drive, Ferntree Gully.
 HOAD, R. C., Kardinia-crescent, Warranwood.
 HUNTER, R., 13 Garden-street, Box Hill North.
 HUTCHINSON, J. G., 14 Tennis-grove, North Caulfield.
 INNES, G. H., 2 McKeon-road, Mitcham.
 KELLERMANN, C. G., 5 Deborah-street, Boronia.
 KENNY, W. P., 14 Norfolk-avenue, Wantirna South.
 KWASNY, H. E., 29 Fricker-avenue, Greensborough.
 LANGELAAN, G. F. A., 121 Mt. Dandenong-road, East Ringwood.
 LILLYCRAPP, R. W., 4 Pinewood-avenue, East Ringwood.
 MARSH, K. A., 37 Illour-avenue, Ringwood East.
 MCLANE, R. J., 266 Mary-street, Richmond.
 MCINNES, J. F., 229 Hoddle-street, Abbotsford.
 MCINTYRE, G. N., 207 Nell-street, Watsonia.
 MCKENZIE, E. S., 4 Browns-avenue, Ringwood.
 NICHOLSON, B. B., 4 Bond-street, Ringwood.
 OGILVIE, J. R., 234 Springfield-road, Blackburn.
 O'RILEY, K. W., 24 Ashton-road, Ferntree Gully.
 PANAGOPOULOS, D., 20 Willis-street, East Prahran.
 PARSONS, F. W., Lot 9, Olanda Creek-road, Kalorama.
 PHILLIPS, W. C. A., 17 Venice-avenue, Mitcham.
 REICHEL, P. F. R., 21 Piperita-road, Ferntree Gully.
 RODDEN, F. W., 12 Sussex-street, Ringwood.
 ROSEFIELD, I., Flat 2, 57 Talbot-crescent, Kooyong.
 SANGSTON, N. G., 3 Victoria-avenue, Canterbury.
 SKEWS, W. H., 8 Cassia-court, Wantirna.
 SMITH, C. E., 62 Timms-avenue, Kilsyth.
 SMITH, R. H., 51 Great Valley-road, Glen Iris.
 STEVENS, P. J., 31 Rosedale-court, Broadmeadows.
 TAYLOR, C., 160 Austin-road, Seaford.
 TAYLOR, J. S., 16 Sturdee-road, Mitcham.
 TOIVONEN, P., 13 Newbury-street, Mitcham.
 TUBMAN, J., 4 Beleura-avenue, Vermont.
 VOULGARIS, S., 31 Council-street, Clifton Hill.
 VULETIC, A., 15 Sherwood-road, Ivanhoe.
 WARD, J. D., 8 John-street, Balwyn.
 WATSON, C. R., 41 Saunders-street, Coburg.
 WATSON, E. H., Flat 6, 468 Glenferrie-road, Hawthorn.
 WATSON, J. C., 22 Ranfurly-road, Forest Hill.
 WILLIAMS, J. A. R., 5 Deep Creek-road, Mitcham.
 WOODMAN, C. E., 1 Maxwell-court, Blackburn South.
 YOUNG, O. W., Castle-road, Warrandyte.
 ZATOVIC, R., 11 Pickles-street, Port Melbourne.

Each for a commercial passenger vehicle with seating capacity for five (5) persons to operate as a Metropolitan Private Hire Car under composite conditions from an approved depot in Zone "R".

APPLICATIONS by—

- ABELA, M., 31 Clyde-street, Newport.
 AMATO, P., 107 Sackville-street, Collingwood.
 ANGELINI, M. M., 21 Langham-street, Avondale Heights.
 APOSTOLOUDAS, G., 24 Temple-street, West Brunswick.
 AUNINS, M. J., Flat 12, 203 Gold-street, Clifton Hill.
 AXARIS, H., 3 St. Phillips-street, Abbotsford.
 BARBER, R. L., 30 Darebin-road, Northcote.
 BARBUTO, E. B., 33 Graham-street, Broadmeadows.
 BARNES, T. B., Flat 4, 88A Orrong-road, Elsternwick.
 BATTY, B. V., 17 Spurling-street, Maidstone.
 BEALE, D. C., 2 Kellett-street, Northcote.
 BELJAN, I., 13 Tasman-avenue, Strathmore.
 BLAKE, T. M., 39 Kingsville-street, Footscray.
 BOLJANAC, S., Flat 6, 104 Rowena-street, Richmond.
 BROOK, C., 3 Neville-street, East Keilor.
 BROWN, P. G., 17 McRae-avenue, St. Albans.
 BROWN, A. R., Flat 2, 36 Maribyrnong-road, Moonee Ponds.
 BRUCE, W. A., 57 Belmar-avenue, Altona West.
 BURGIN, M., 3 Fanny-street, Moonee Ponds.
 CAMBOURNE, J. T., 356 Somerville-road, Footscray.
 CARUSO, G., 10 Craigrossie-avenue, Moreland.
 CHRISTOFIS, A., 126 Millera-road, East Keilor.
 CIPRIANI, F., 25A Lindenow-street, Reservoir.
 CLEMMENS, R. T., 131 Express-avenue, Kingsville.
 CONDRON, M. R., 5 Princess-street, North Coburg.
 COOK, J. N., 12 Scott-street, West Footscray.
 CLARK, K. M. D., Flat 12, 18A Bloomfield-road, Ascot Vale.
 CONDYLLIS, E., 7 Lennox-street, Moonee Ponds.
 COOPER, N. W., 6 Nyah-street, East Keilor.
 CUNNINGHAM, W. R., 12 Halsbury-street, Hadfield.
 DALTON, K. W., 60 Goldsmith-street, Elwood.
 DAVIES, R. W., 18 Phillip-road, East Keilor.
 DEBATTISTA, C., 43 French-street, Lalor.
 DENNIS, N., 17 Gallipoli-parade, Pascoe Vale South.
 DEUTSCHER, E. C., 63 Hoffmans-road, Niddrie.
 DOHERTY, P., 26 Victoria-street, Footscray.
 DOUGHTY, C. W., 407 Park-street, Princes Hill.
 DUMMETT, T. R. K., 25 Buckley-street, Essendon.
 DUNN, W. T., 44 Fulham-road, Alphington.
 EDWARDS, J. L., 4 Goble-street, Laverton.
 EDWARDS, J. P., 16 Railway-crescent, Moonee Ponds.
 EVANS, J. G., 12 Thompson-avenue, Laverton North.
 FESTERDIS, S., 12 Wimble-street, Northcote.
 FORD, B. W., 6 Mattea-court, Reservoir.
 FREEMAN, K. A., 2 Myers-street, Pascoe Vale South.
 FRYLINK, J., 21 Prospect-street, Glenroy.
 GAZELAKIS, A., 181 Stephen-street, Yarraville.
 GIANNIAS, P., 173 Power-street, Hawthorn.
 GILES, J. A. S., Flat 4, 25 Dickens-street, Elwood.
 GREANEY, P. F., 58 Thackeray-road, Reservoir.
 GRIGORPOULOS, P., 13 Barkly-street, East Brunswick.
 GEORGE, P., 9 Roberts-street, East Keilor.
 HAMMETT, L., 106 Blyth-street, Altona.
 HIGHGATE, D. G., 6 Temby-street, Watsonia.
 HODAK, P., 2 Gipps-street, North Richmond.
 HOLZ, J., 1 Shaw-street, Fawkner.
 HUTCHINSON, J. G., 14 Tennis-grove, North Caulfield.
 HUTCHINSON, R. C., Pickles-street, South Melbourne.
 INGRAM, R. C., 18 Richmond-street, Glenroy.
 JACKSON, R. J., Flat 6, 28 Churchill-avenue, Ascot Vale.
 KALLINICOS, J., 5 Tyrone-street, South Yarra.
 KAVOURAS, A., 134 Glenhuntly-road, Elwood.
 KELLY, K. F., 31 Nepean-street, Watsonia.
 KING, W. J. A., Lot 70, Walter-street, Glen Waverley.
 KLEIN, M. A., 74 Lorne-street, Fawkner.
 KNIGHT, A. J. H., 49 Harding-street, Coburg.
 KOUGIAS, C., 21 Meager-street, Deer Park.
 KRASEY, L., 48 Pakington-street, Kew.
 LANGLEY, E. J., 5 King-street, Bulleen.
 LARTER, J. A., 37 Edward-avenue, North Altona.
 LAURIEN, H. R. U., 9 Emu-parade, Jacana.
 LECKEY, W., 68 Hanleth-avenue, Springvale.
 LELAS, W., 10 Amaranth-avenue, North Altona.
 LEONARD, G., 64 McNamara-avenue, Airport West.
 LEWIS, B. F., 11 Middlesex-street, Sunshine.
 LEWIS, C. M., 1 Alden-street, West Sunshine.
 LUXFORD, W. P., 6 Elgin-street, Newport.
 LYNCH, K. L., 198 Forrest-street, Ardeer.
 MAGHAMEZ, R., 201 Canning-street, Carlton.
 MEHMET, N., 54 Macey-avenue, Avondale Heights.
 MELMOTH, E. J., 45 Myrtle-grove, Altona.
 MILORADOVIC, S., 170 Cecil-street, Williamstown.
 MONTGOMERY, J. F., 23 Balmoral-street, Braybrook.
 MOYNIHAN, N. V., 96 Maidstone-street, Altona West.
 MUELLER, W., 39 Edward-avenue, North Altona.
 MURPHY, B. J., 27 Hudson-street, Fawkner.
 MURPHY, T. L., Point Cook-road, Laverton.
 MCLANE, R. J., 266 Mary-street, Richmond.
 MCDERMOTT, R. L., 8 Byron-court, West Heidelberg.
 McDONALD, E. A., 186 West-street, Glenroy.
 McDONALD, B. E., 87 Elizabeth-street, East Keilor.
 McDONNELL, A. L., 42 Donald-street, Footscray.
 MCGORLICK, G. W., 35 Vernon-street, South Kingsville.
 MCINNES, J. F., 229 Hoddle-street, Abbotsford.
 MCINTYRE, J. R., 23 Waratah-street, West Footscray.
 NIKAS, S., 40 East-street, Glenroy.
 O'KEEFE, T. E., 9 Ogilvie-street, West Essendon.
 OLIVER, R. J., 10 Hillman-street, Laverton.
 PANAGOPOULOS, D., 20 Willis-street, West Prahran.
 PAPADOPOULOS, J., 31 St. James-street, Moonee Ponds.
 PARTON, B., Flat 11, 28 Dunlop-avenue, Ascot Vale.
 POPINSKI, S., 10 Holt-street, Deer Park.
 POULTON, A. V., 67 Beauford-street, Huntingdale.
 RICHARDS, W., 27 Lincoln-avenue, Merlynston.
 ROBERTS, C. L., Flat 2, 19 Palmer-street, Collingwood.
 ROBINSON, H. M., 13 Baker-street, Sunshine.
 ROKAS, V., 76 Station-street, Port Melbourne.
 ROWE, H. R., 99 Marion-street, North Altona.
 ROY, R. L., 20 Ashley-street, West Footscray.
 SALTER, H., 22 Rose Hill-road, Niddrie.
 SAPOUNTZIS, K., 1 Hunter-street, Abbotsford.
 SCHMIDT, J. R., 39 Ross-road, North Altona.
 SEFFER, S., 103 Kitchener-street, Broadmeadows.
 SHORT, L. E., 32 Cunningham-street, Northcote.
 SIGANAKIS, J., 11 Olive-street, East Malvern.
 SIMMONDS, M. E., 14 Carlton-court, Braybrook.
 SKEWS, W. H., 8 Cassia-court, Wantirna.
 SMITH, F. C., 51 Ryder-street, Niddrie.
 SOTIROPOULOS, C., 358 Victoria-parade, East Melbourne.
 SPITTERI, R., 24 Hook-street, St. Albans.
 STANKOVIC, Z., 3 Merribell-avenue, East Coburg.

STEVENS, P. J., 31 Rosedale-court, Broadmeadows.
 SMITH, A. R., 169 Arthurton-road, Northcote.
 SPADA, F., 132 Lee-street, North Carlton.
 STAVROS, N., 107 Allison-road, Elsternwick.
 SWEENEY, B. T., 5 Agg-street, Newport.
 SZILAGYI, J., Flat 79, 510 Lygon-street, Carlton.
 TATE, J. W., Flat 10, 44 Dunlop-avenue, Ascot Vale.
 TEEUWSEN, P. J., Flat 3, 3 Ruskin-street, Elwood.
 TERPSINIS, N., 3 Monash-street, Footscray.
 TILLEY, K. G., 474 Blackshaws-road, North Altona.
 TILLEY, V. M., 474 Blackshaws-road, North Altona.
 TRAS, H., 143 Union-street, West Brunswick.
 TOLDI, I., 10 Caringa-street, Pascoe Vale.
 TZOUVELIS, N., 113 Morell-street, Glenroy.
 VANSTON, J. D., 10 Hinkler-street, Braybrook.
 VANSTON, J. M., 10 Hinkler-street, Braybrook.
 VESCOVI, G. G., Flat 4, 52 The Grove, Coburg.
 VIOLARIS, J., 102A Hoffmans-road, Niddrie.
 VOULGARIS, S., 31 Council-street, Clifton Hill.
 WAHAB, S., 22 Ferguson-street, Macleod.
 WARD, J. D., 8 John-street, Balwyn.
 WATSON, C. R., 41 Saunders-street, Coburg.
 WATSON, E. H., Flat 6, 468 Glenferrie-road, Hawthorn.
 WILLIAMS, B. J., 49 Esplanade, Altona.
 WILLIE, D. A., 50 George-street, St. Albans.
 WRIGHT, W. N., 3 Elgin-street, Newport.

YOUNG, H. J., 4 Hughes-street, Yarraville.
 ZAIRIS, A., 340 Somerville-road, West Footscray.
 ZAKKAS, I., 72 Walter-street, Ascot Vale.
 ZATOVIC, R., 11 Pickles-street, Port Melbourne.
 ZERNI, B., 13 Langley-street, Ardeer.
 ZIENTEK, E., Flat 6, 5 Gourlay-street, Balaclava.
 ZONDERVAN, A., 99 Sixth-avenue, North Altona.
 GEORGE, J. E., 5 Karingal-street, Altona.
 GAHAN, J. P., 112 Heatherdale-road, Mitcham.
 NOBILE, R., 60 Dover-street, Flemington.

Each for a commercial passenger vehicle with seating capacity for five (5) persons to operate as a Metropolitan Private Hire Car under composite conditions from an approved depot in Zone "K".

Notice of any objection should be forwarded to reach the Secretary of the Board not later than Wednesday, 20th May, 1970.

Applicants are advised that it will not be necessary to appear on the hearing date specified above, unless advised in writing by the Board.

B. P. KAY,
 Secretary.

Corner of Lygon and Princes streets, Carlton, Wednesday, 6th May, 1970.

Health Act 1958.

VICTORIA—DEPARTMENT OF HEALTH.

NOTICE TO ATTEND FOR RADIOLOGICAL EXAMINATION.

To all persons aged twenty-one years and over enrolled or resident in the subdivisions specified hereunder in the State Electoral District of Preston.

TAKE notice that you are required to attend at a Department of Health X-ray unit sited in the public street at or as near as possible to the main entrance to the premises specified in this notice, at any time between the hours specified on one of the days specified and during the period specified in respect of those premises, and thereat to submit yourself to radiological examination of the chest for the purpose of ascertaining whether you may be suffering from pulmonary tuberculosis. If you have had a Chest X-ray within the last twelve months and for that reason do not wish to be examined now, you should attend the unit as directed and submit particulars of the previous examination.

SPECIFIED SUBDIVISIONS, PREMISES, PERIODS, DAYS AND HOURS.

Subdivision.	Premises.	Period.	Days.	Hours.
Preston East	Entwistle's Foodland Store, 35A Victoria-street, Preston	Wednesday, 20th May, 1970, to Monday, 25th May, 1970 (inclusive)	Each day during the period except Saturday, Sunday and Public Holidays	From 10 a.m. to 8.30 p.m.
	Ganderton's Pharmacy, 29 Enfield-avenue, Preston East	Thursday, 21st May, 1970, to Tuesday, 26th May, 1970 (inclusive)	Each day during the period except Saturday, Sunday and Public Holidays	From 10 a.m. to 8.30 p.m.
	Berg's Milk Bar, cnr. Wood and Donald streets, Preston East	Friday, 22nd May, 1970, to Wednesday, 27th May, 1970 (inclusive)	Each day during the period except Saturday, Sunday and Public Holidays	From 10 a.m. to 8.30 p.m.
	Preston Motors Pty. Ltd., cnr. Dundas-street and Plenty-road, Preston	Friday, 22nd May, 1970, and Monday, 25th May, 1970	Friday, 22nd May, 1970, Monday, 25th May, 1970	From 10 a.m. to 8.30 p.m. From 10 a.m. to 8.30 p.m.
Thornbury	St. Mary's School, cnr. Mansfield and High streets, Thornbury	Monday, 25th May, 1970, to Monday, 1st June, 1970 (inclusive)	Each day during the period except Saturday, Sunday and Public Holidays	From 10 a.m. to 8.30 p.m.
	Cnr. Harold-street and St. George's-road, Thornbury	Tuesday, 26th May, 1970, to Friday, 29th May, 1970 (inclusive)	Each day during the period except Public Holidays	From 10 a.m. to 8.30 p.m.
	Church of Christ, cnr. Smith-street and St. George's-road, Thornbury	Tuesday, 26th May, 1970, to Friday, 29th May, 1970 (inclusive)	Each day during the period except Public Holidays	From 10 a.m. to 8.30 p.m.
Preston West	Amoco Service Station, 40 Gilbert-road, Preston West	Wednesday, 27th May, 1970, to Friday, 29th May, 1970 (inclusive)	Each day during the period except Public Holidays	From 10 a.m. to 8.30 p.m.
	Golden Fleece Service Station, 188 Gilbert-road, Preston West	Thursday, 28th May, 1970, to Wednesday, 3rd June, 1970 (inclusive)	Each day during the period except Saturday, Sunday and Public Holidays	From 10 a.m. to 8.30 p.m.
	Town Hall, Gower-street, Preston	Monday, 1st June, 1970, to Friday, 12th June, 1970 (inclusive)	Each day during the period except Saturday, Sunday and Public Holidays	From 10 a.m. to 8.30 p.m.
	Amoco Service Station, cnr. Plenty-road and Garnet-street, Preston	Monday, 1st June, 1970, to Wednesday, 3rd June, 1970 (inclusive)	Each day during the period except Public Holidays	From 10 a.m. to 8.30 p.m.
Preston North	Potts Delicatessen, 552A Murray-road, Preston West	Monday, 1st June, 1970, to Wednesday, 3rd June, 1970 (inclusive)	Each day during the period except Public Holidays	From 10 a.m. to 8.30 p.m.
	Driveway Shell Service Station, cnr. High-street and Wurrick-avenue, Regent	Tuesday, 2nd June, 1970, to Monday, 8th June, 1970 (inclusive)	Each day during the period except Saturday, Sunday and Public Holidays	From 10 a.m. to 8.30 p.m.

NOTE.—Any person to whom this notice applies and who without reasonable excuse fails to comply with the requirements of the notice shall be guilty of an offence, and shall be liable to a penalty of not more than Forty dollars.

Dated this Twenty-eighth day of April, One thousand nine hundred and seventy.

R. J. FARNBACH,
 Chief Health Officer.

Private Agents Act 1966.

NOTICE OF RECEIPT OF APPLICATIONS FOR LICENCES UNDER THE PROVISIONS OF THE PRIVATE AGENTS ACT 1966.

THE Clerk(s) of the Magistrates' Court(s) as listed hereunder hereby give notice that applications, as under, have been lodged for hearing by the said Court(s) on the date(s) specified.

Any person desiring to object to any of such applications must—

(a) lodge with the respective Clerk of the Magistrates' Court a notice in the prescribed form of his objection and of the grounds thereof;

(b) cause a copy of such notice to be served personally or by post upon the applicant at least three days before the hearing of the application; and

(c) send or deliver—

(i) where the objection is not made by the officer in charge of the police district in which the Court is situated—a copy of the notice to such officer; and

(ii) where the objection is not made by the Registrar or Deputy Registrar—a copy to the Registrar.

Full Name of Applicant or in the Case of a Firm or Corporation, of the Nominee.	Place of Abode of Applicant or Nominee.	Name of Firm or Corporation.	Address for Registration.	Type of Licence.	Date of Hearing of Application.
---	---	------------------------------	---------------------------	------------------	---------------------------------

MAGISTRATES' COURT, HAWTHORN.

Tyzack, Francis Helm ..	226 George - street, Fitzroy	Cnr. Kinkora-avenue and Glenferrie-road, Hawthorn	Watchman ..	13.5.70
-------------------------	------------------------------	---------	---	-------------	---------

Dated at Hawthorn this 22nd day of April, 1970.

D. M. CRANE, Clerk of the Magistrates' Court.

MAGISTRATES' COURT, OAKLEIGH.

Sanders, John William ..	61 Waverley-road, Chadstone	Watchman ..	22.5.70
--------------------------	-----------------------------	---------	---------	-------------	---------

Dated at Oakleigh this 27th day of April, 1970.

G. MEEHAN, Clerk of the Magistrates' Court.

MAGISTRATES' COURT, BENDIGO.

Macumber, Darryl Wayne ..	29 Chapell-street, Bendigo	186 Mitchell-street, Bendigo	Process Server ..	18.5.70
" ..	" ..	George Laurens Pty. Ltd.	" ..	Commercial Sub-agent	"

Dated at Bendigo this 24th day of April, 1970.

J. E. REILLY, Clerk of the Magistrates' Court.

MAGISTRATES' COURT, SOUTH MELBOURNE.

Ball, Robert Alan ..	144 Murray-road, Preston	101-105 street, Melbourne South	Watchman ..	8.5.70
Connell, Thomas Francis ..	25 Silver Ash-avenue, Ashwood	" ..	" ..	"
Coombes, Ronald ..	Wiltona Hostel, Williamstown	" ..	" ..	"
Dawes, Ian Russell ..	7 Tranmere-avenue, Carnegie	" ..	" ..	"
Hobbs, John William ..	9 Eldorado-court, Werribee	" ..	" ..	"
Leggo, Robert Fyfe ..	59 Bundoora-parade, Mentone	" ..	" ..	"
McAllister, Peter Keer Brown	"Alfona", Commonwealth Hostel, Williamstown	" ..	" ..	"
Phillips-Veirke, Richard Norman	5/7 Woonsocket-court, St. Kilda	" ..	" ..	"
Clifton Hugh	1/7 Farnham-court, Farnham-street, Flemington	" ..	" ..	"
Ray, Dennis Raymond ..	19 Oakland-street, Maribyrnong	" ..	" ..	"
Styman, Brian Anthony ..	113 Hoddle-street, Richmond	" ..	" ..	"
Turner, Alan ..	c/- 271 Elizabeth-street, East Coburg	" ..	" ..	"
Vicary, Ronald John ..					

Dated at South Melbourne this 20th day of April, 1970.

J. A. BARNES, Clerk of the Magistrates' Court.

MAGISTRATES' COURT, CAMBERWELL.

Wilson, Alan Phillip ..	33 Fisher-street, East Malvern	33 Fisher-street, East Malvern	Process Server ..	11.5.70
" ..	"	" ..	Inquiry Agent ..	"

Dated at Camberwell this 20th day of April, 1970.

J. C. TOBIN, Clerk of the Magistrates' Court.

MAGISTRATES' COURT, PRESTON.

Ginkel, Karl August Justus ..	55 Kooyong-road, Armadale	Victorian Night Patrol Service	55 Kooyong-road, Armadale	Watchman ..	7.5.70
-------------------------------	---------------------------	--------------------------------	---------------------------	-------------	--------

Dated at Preston this 16th day of April, 1970.

RON MUNRO, Clerk of the Magistrates' Court.

PRIVATE AGENTS—continued.

Full Name of Applicant or in the Case of a Firm or Corporation, of the Nominee.	Place of Abode of Applicant or Nominee.	Name of Firm or Corporation.	Address for Registration.	Type of Licence.	Date of Hearing of Application.
MAGISTRATES' COURT, MELBOURNE.					
Hawke, Graeme Arthur	Flat 2, 49 Norman-street, Ivanhoe	Armoured Escorts Pty. Ltd.	Cnr. Arden- and Lothian - streets, North Melbourne	Watchman	13.5.70
McEwan, Peter John	77A Como-parade, East Parkdale	" "	" "	"	"
Carney, Douglas Richard	5 Adelaide - street, Pascoe Vale	Australian Watching Co. Pty. Ltd.	340 Abbotsford-street, North Melbourne	"	"
Chenhall, Kevin John	Research-road, Warrandyte	" "	" "	"	"
Fletcher, Geoffrey Arthur Frank	13 Adrian - avenue, Blackburn South	" "	" "	"	"
Hilder, Patrick Joseph	7 Centenary-crescent, Werribee	" "	" "	"	"
Lucas, John Henry	Flat 10, 36 Philipson-street, Albert Park	" "	" "	"	"
Neil, Terrence Arthur William	48 Kennedy - street, Glenroy	" "	" "	"	"
Oliver, John Leonard	Flat 6, 7 Viewbank-road, Glen Iris	" "	" "	"	"
Smith, Albert Elder	600 High Street-road, Glen Waverley	" "	" "	"	"
Wilkinson, Robert Brian	6 Lloyds-avenue, Glen-huntly	" "	" "	"	"
Wilson, Edward James William	Flat 34, 235 Nelson-place, Williamstown	" "	" "	"	"

Dated at Melbourne this 21st day of April, 1970.

G. L. WEBSTER, Clerk of the Magistrates' Court.

MAGISTRATES' COURT, MORWELL.					
Perry, Raymond George	127 Comans - street, Morwell	" "	529-533 Little Lonsdale - street, Melbourne	Watchman	12.5.70

Dated at Morwell this 22nd day of April, 1970.

D. L. CROFT, Clerk of the Magistrates' Court.

MAGISTRATES' COURT, PRAHRAN.					
Helsloot, G. A.	42 Marina - road, Mentone	Factory Guard Service Pty. Ltd.	17/562 St. Kilda-road, Melbourne	Provisional Watchman	23.4.70
Smith, C. E.	2/24 Margaret-street, Murrumbeena	Melbourne Night Patrol Service Pty. Ltd.	18/614 St. Kilda-road, Melbourne	Watchman	18.4.70
Przibilla, D. K.	9 Eaton - parade, Laverton	" "	" "	"	"
Ham, R. S. F.	c/- J. Quilty, Shell Service Station, Werribee	" "	" "	"	"
Blackburn, P. J.	32 Heffernan-street, Laverton	" "	" "	"	"
Bramble, J. A.	176 Maidstone-street, Altona	" "	" "	"	"
Usher-Clarke, D. J. W.	154 Dallas-drive, Broadmeadows	" "	" "	"	"

Dated at Prahran this 23rd day of April, 1970.

G. MURPHY, Clerk of the Magistrates' Court.

MAGISTRATES' COURT, TRARALGON.					
Tyrie, Peter John	13 McEntee - court, Traralgon	Globe Security Service	7 Chilwill-avenue, Traralgon	Watchman	18.5.70

Dated at Traralgon this 23rd day of April, 1970.

I. J. BENNETT, Clerk of the Magistrates' Court.

MAGISTRATES' COURT, FOOTSCRAY.					
Halemba, Walter Jan	14 Rovo-street, West Newport	Mayne Nickless Armoured Div.	4 Cross-street, West Footscray	Watchman	18.5.70

Dated at Footscray this 24th day of April, 1970.

D. A. THOMPSON, Clerk of the Magistrates' Court.

MAGISTRATES' COURT, COBURG.					
Robinson, Henry William	158 Lorne-street, Fawkner	Mayne Nickless	88 Bakers-road, North Coburg	Watchman	19.5.70
Findlow, Derrick	12 Wampole-crescent, West Heidelberg	" "	" "	"	"

Dated at Coburg this 28th day of April, 1970.

F. J. TENNI, Clerk of the Magistrates' Court.

MAGISTRATES' COURT, MORWELL.					
McLochlan-Clark, Gilbert	Geoffrey Coast-road, North Mirboo	" "	529-533 Little Lonsdale-street, Melbourne	Watchman	19.5.70

Dated at Morwell this 27th day of April, 1970.

D. L. CROFT, Clerk of the Magistrates' Court.

PRIVATE AGENTS—continued.

Full Name of Applicant or in the Case of a Firm or Corporation, of the Nominee.	Place of Abode of Applicant or Nominee.	Name of Firm or Corporation.	Address for Registration.	Type of Licence.	Date of Hearing of Application.
---	---	------------------------------	---------------------------	------------------	---------------------------------

MAGISTRATES' COURT, PRAHRAN.

Cassell, Russell Robert ..	3 Burnett-street, St. Kilda	Factory Guard Service Pty. Ltd.	Flat 17, 562 St. Kilda-road, Melbourne	Watchman ..	18.5.70
----------------------------	-----------------------------	---------------------------------	--	-------------	---------

Dated at Prahran this 27th day of April, 1970.

G. MURPHY, Clerk of the Magistrates' Court.

MAGISTRATES' COURT, MELBOURNE.

Brock, Anthony Thomas ..	63 Masons-lane, Bacchus Marsh	Mayne Nickless Ltd.	94 York-street, South Melbourne	Watchman ..	20.5.70
Haworth, James Edward ..	Flat 2, 2 Sycamore-grove, Balaclava	Wormald Bros. (Aust.) Pty. Ltd.	447-459 Williams-town-road, Port Melbourne	" ..	"
Arnott, Gervais Colquhoun ..	16 Charles-street, Williamstown	Australian Watching Company Pty. Ltd.	340 Abbotsford-street, North Melbourne	" ..	"
Bottomley, Christopher John	75 Outer-crescent, Brighton	" "	" "	" ..	"
Carlin, Thomas ..	469 St. Kilda-street, Elwood	" "	" "	" ..	"
Hall, Gordon William ..	13 Dallas Colac-street,	" "	" "	" ..	"
Hartney, Michael Morgan ..	19 Waratah-street, Seaholme	" "	" "	" ..	"
Hyland, William Charles ..	72 Sherwood-avenue, Chelsea	" "	" "	" ..	"
Lynch, Kevin Patrick ..	13 Mountain-street, Essendon	" "	" "	" ..	"
Malcolm, Desmond James ..	Flat 4, 694 Inkerman-road, North Caulfield	" "	" "	" ..	"
McCurry, David Francis John	23 Falcon-drive, Melton	" "	" "	" ..	"
Travers, James Peter ..	"A" Goulburn, Commonwealth Hostels, Kororoit Creek-road, Williamstown	" "	" "	" ..	"
Wells, Ross ..	10 Gavan-court, Werribee	" "	" "	" ..	"
Wiggins, Barry James ..	Flat 1 "Candy Spot" Milk Bar, Fitzroy-street, St. Kilda	" "	" "	" ..	"

Dated at Melbourne this 29th day of April, 1970.

G. L. WEBSTER, Clerk of the Magistrates' Court.

MAGISTRATES' COURT, MORWELL.

Tutin, Michael Edward ..	32 Heesom-crescent, Churchill	" ..	94 York-street, South Melbourne	Watchman ..	19.5.70
--------------------------	-------------------------------	------	---------------------------------	-------------	---------

Dated at Morwell this 30th day of April, 1970.

D. L. CROFT, Clerk of the Magistrates' Court.

MAGISTRATES' COURT, FOOTSCRAY.

O'Neill, Marie Veronica ..	22 Williamstown-road, West Footscray	" ..	22 Williamstown-road, West Footscray	Process Server ..	25.5.70
----------------------------	--------------------------------------	------	--------------------------------------	-------------------	---------

Dated at Footscray this 1st day of May, 1970.

D. A. THOMPSON, Clerk of the Magistrates' Court.

MAGISTRATES' COURT DROMANA.

Van Lieshout, Johannes Antonius	15 Orchid-avenue, West Rosebud	" ..	1169 Nepean Highway, Rosebud	Guard Agent ..	18.5.70
---------------------------------	--------------------------------	------	------------------------------	----------------	---------

Dated at Dromana this 27th day of April, 1970.

W. R. JOHNSTON, Clerk of the Magistrates' Court.

STATE RIVERS AND WATER SUPPLY COMMISSION.

LICENCE TO DIVERT WATER AND CUT RACE PURSUANT TO THE PROVISIONS OF SECTION 204 OF THE WATER ACT 1958 (AS AMENDED).
 THE Licence as detailed hereunder to divert water and cut race has been revoked by the Governor in Council :—

SCHEDULE.

Licence No.	Term of Licence and Commencing Date.	Name and Address of Person to Whom Licence Granted.	Source of Supply.
1713	Seven years from 1.7.63 ..	Gothard John Huf and Gwendoline Annie Huf, Mildura	River Murray

Office of the State Rivers and Water Supply Commission,
 Melbourne, 28th April, 1970.

G. W. LEWIS, Secretary,
 State Rivers and Water Supply Commission.

STATE RIVERS AND WATER SUPPLY COMMISSION.

LICENCES TO DIVERT WATER PURSUANT TO THE PROVISIONS OF SECTION 204 OF THE WATER ACT 1958 (AS AMENDED).

THE Governor in Council has approved of the granting by the State Rivers and Water Supply Commission of licences as detailed hereunder for the term of years from the date specified in each case to the persons named in the following Schedule :—

SCHEDULE.

Licence No.	Term of Licence and Commencing Date.	Name and Address of Person to Whom Licence is to be Granted.	Source of Supply.	Area Authorized to be Irrigated Per Annum.	Volume of Water Authorized to be Diverted Per Annum.	Annual Fee.
				acres.	ac. ft.	\$
3049	Fifteen years from 1.7.69	Lempriere Holdings Pty. Ltd., Melbourne	Tarago River ..	20	40	50.00
3050	Four years from 1.7.69	Barry Gordon McKenzie and Elaine June McKenzie, Long- warry North	Tarago River ..	20	40	50.00

Office of the State Rivers and Water Supply Commission,
Melbourne, 28th April, 1970.

G. W. LEWIS, Secretary,
State Rivers and Water Supply Commission.

DEPARTMENT OF MINES.

MINERAL SEARCH LICENCES GRANTED.

- 885, Mineral Search Licence; Sedimentary Uranium N.L.; 710 square miles; Counties of Gladstone, Kara Kara, Tatchera.
886, Mineral Search Licence; Sedimentary Uranium N.L.; 802 square miles, Counties of Bendigo, Gladstone, Gunbower, Tatchera.
887, Mineral Search Licence; Sedimentary Uranium N.L.; 913 square miles, Counties of Borung, Gladstone, Kara Kara, Karkaroc, Tatchera.

TAILINGS LICENCES GRANTED.

- 3684, Tailings Licence; Stawell Brick Company Pty. Ltd.; "Cahill's Reward" tailings dump situated in the Parish of Illawarra.
3685, Tailings Licence; Stawell Brick Company Pty. Ltd.; "Wonga Mine" tailings dump situated in the Parish of Stawell.
3686, Tailings Licence; Stawell Brick Company Pty. Ltd.; Kempston Mine site situated in the Parish of Illawarra.
3688, Tailings Licence; the President, Councillors and Ratepayers of the Shire of Ripon; to remove tailings from the "Hobart Pasha" and "Victoria" dumps at Waterloo, "North Hope" dump at Beaufort, "South Sons of Freedom" dump at Raglan.

EXTRACTIVE INDUSTRY LICENCES GRANTED.

- 74, Extractive Industry Licence; Commonwealth Pottery Proprietary Limited; 42a. 3r. 36p., Parish of Scoresby.
90, Extractive Industry Licence; Springvale Washed Sand Proprietary Limited; 44 acres, more or less, Parish of Mordialloc.
103, Extractive Industry Licence; Castal Moulding Sand Proprietary Limited; 15a. 1r. 20p., Parish of Mordialloc.
178, Extractive Industry Licence; Praznovszky Carriers Proprietary Limited; 20 acres, Parish of Mordialloc.
301, Extractive Industry Licence; Rowlands Quarries (Springvale) Proprietary Limited, 28 acres, more or less, Parish of Mordialloc.

APPLICATION FOR MINING LEASE REFUSED.

- 8951, Mineral; Leslie George Milton; 7 acres, Parish of Morang.

APPLICATIONS FOR EXPLORATION LICENCES REFUSED.

- 129, Exploration Licence; William Harold Jay, Franklin Owen Howard, Edwin Thomas Meagher, William Peter Body; 760 square miles, Counties of Tanjil, Dargo.
180, Exploration Licence; Thompsons Prospecting Syndicate; 6 square miles, Parishes of Clonbinane, Glenburnie.
196, Exploration Licence; Maurice Allan Bourne, Judith Anne Bourne; 12 square miles, Parishes of Bet Bet, Eddington.

- 206, Exploration Licence; Gippsland Minerals No Liability; 25 square miles, Parish of Moliagul.
210, Exploration Licence; Barry Ernest Pillinger; 10 square miles, Parish of Maldon.
270, Exploration Licence; Donald Lewis Treasure; 225 acres, Parish of Quag-Munjie.

APPLICATIONS FOR EXPLORATION LICENCES DECLARED ABANDONED.

- 179, Exploration Licence; Robert John Gard, Anthony Wills, Baden Swan; 3 square miles, Parish of Broadford.
288, Exploration Licence; Development and Mining Exploration Proprietary Limited; 350 square miles, Counties of Borung, Kara Kara, Ripon.

APPLICATION FOR MINERAL SEARCH LICENCE REFUSED.

- 895, Mineral Search Licence; Alfred Cecil Stead, Reginald Nibbs, Sydney George Porch; 1,280 acres, Parishes of Fumina, Neerim East.

TERM OF EXPLORATION LICENCE EXTENDED.

- 61, Exploration Licence; Alliance Oil Development Australia N.L.; 47 square miles, Parishes of Waratah, Waratah North, Wonga Wonga South.

J. C. M. BALFOUR,
Minister of Mines.

LAW DEPARTMENT.
QUEEN'S COUNSEL.

THE Lieutenant-Governor as Deputy for His Excellency the Governor of the State of Victoria by and with the advice of the Executive Council thereof doth by Order made on the 28th day of April, 1970, issue Letters Patent to JOHN WILLIAM SMYTH, Q.C. (N.S.W.), to be one of Her Majesty's Counsel under the Regulations of the 11th October, 1955, to have precedence next after Antony Larkins, Esquire.

J. ROSSITER,
Clerk of the Executive Council.

At the Executive Council Chamber,
Melbourne, 28th April, 1970.

THE LIQUOR CONTROL ACT 1968.

WHEREAS the Hotelkeeper's Licence for the licensed premises known as the Railway Hotel, situate at Merino, has been surrendered as from 31st December, 1969, notice is hereby given that the amount of compensation payable to the owner of such premises pursuant to the provisions of the Liquor Control Act 1968 is as under:—

Owner \$18,000

Dated at Melbourne this 28th day of April, 1970.

J. CROWE, Secretary,
Liquor Control Commission.

LOCAL GOVERNMENT ACT 1958.

IN pursuance of the powers conferred by sub-section 3A of section 575 of the *Local Government Act 1958*, I, William John Farquhar McDonald, Her Majesty's Minister of Lands in the State of Victoria hereby declare that the road set out on Crown land in the Township of Wonthaggi, Parish of Wonthaggi, County of Mornington, as delineated and indicated by hachure on the plan hereunder be a private street within the meaning of and for the purposes of Division 10, Part XIX. of the said Act.—(Corres. No. G.72940.)

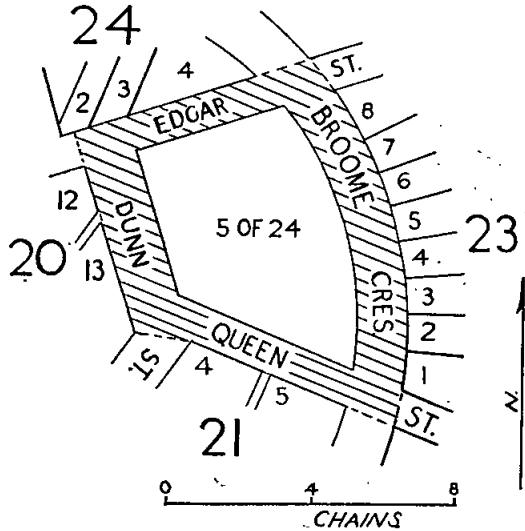

Dated at Melbourne, this 28th day of April, 1970.
W. J. F. McDONALD,
Minister of Lands.

LOCAL GOVERNMENT ACT 1958.

IN pursuance of the powers conferred by sub-section 3A of section 575 of the *Local Government Act 1958*, I, William John Farquhar McDonald, Her Majesty's Minister of Lands in the State of Victoria hereby declare that the road set out on Crown land in the Township of Wonthaggi, Parish of Wonthaggi, County of Mornington, as delineated and indicated by hachure on the plan hereunder be a private street within the meaning of and for the purposes of Division 10, Part XIX. of the said Act.—(Corres. No. G.66177.)

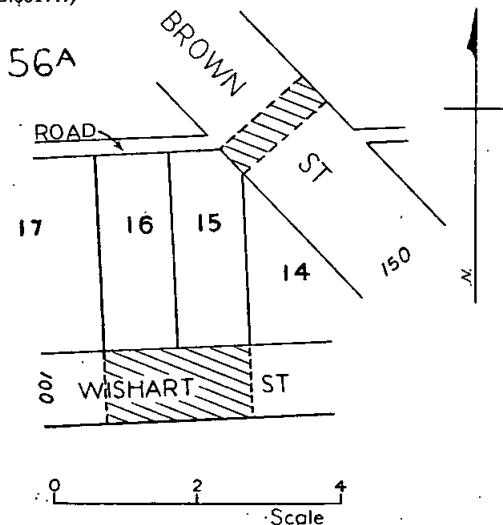

Dated at Melbourne, this 28th day of April, 1970.
W. J. F. McDONALD,
Minister of Lands.

LOCAL GOVERNMENT ACT 1958.

IN pursuance of the powers conferred by sub-section 3A of section 575 of the *Local Government Act 1958*, I, William John Farquhar McDonald, Her Majesty's Minister of Lands in the State of Victoria hereby declare that the road set out on Crown land in the Township of Creswick, Parish of Creswick, County of Talbot, as delineated and indicated by hachure on the plan hereunder be a private street within the meaning of and for the purposes of Division 10, Part XIX. of the said Act.—(Corres. No. J.33082.)

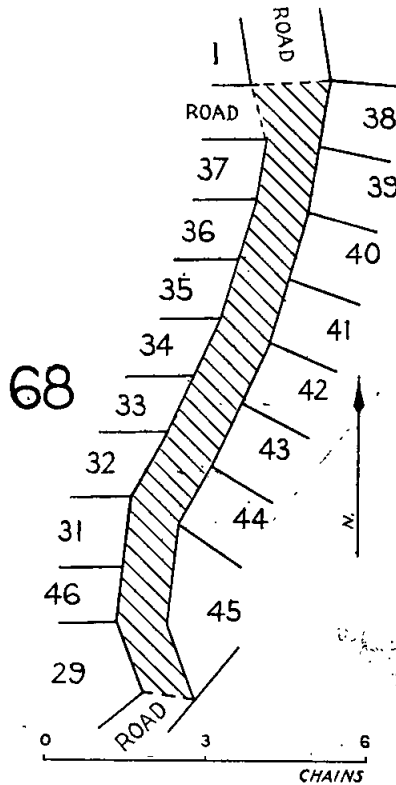

Dated at Melbourne, this 28th day of April, 1970.
W. J. F. McDONALD,
Minister of Lands.

ESTATE AGENTS ACT 1958.

WHEREAS by sub-section (2) of Section 11A of the *Estate Agents Act 1958* it is provided that if the Estate Agents Committee is satisfied that estate agency work is a minor part of the work of any Corporation it may recommend to the Minister that a declaration be made to that effect and the Minister may by notice published in the *Government Gazette* make a declaration accordingly: And whereas the Estate Agents Committee is satisfied that the estate agency work of the undermentioned Corporation is a minor part of the work of the said Corporation and has recommended that a declaration be made to that effect.

Now therefore I, Henry Edward Bolte, the Treasurer for the State of Victoria, do hereby declare the following Corporation—

WM. McNAMARA & Co. PTY. LTD.,
422 Collins-street,
Melbourne, Vic., 3002.

Dated at Melbourne, this twenty-seventh day of April, 1970.

H. BOLTE,
Treasurer.

THE BUILDING SOCIETIES ACT 1958.

NOTICE is hereby given that a Building Society called Gas Corporation Permanent Building Society is duly registered under the provisions of the above Act.

Dated this 27th day of April, 1970.

J. W. JUNGWIRTH,
Registrar of Building Societies.

COUNTRY ROADS BOARD.

RESOLUTIONS OF THE COUNTRY ROADS BOARD.

THE Country Roads Board, in pursuance of the provisions of the Country Roads Act 1958, has passed Resolutions the dates whereof and the terms of which are scheduled hereunder:—

SCHEDULE.

State Highway.

Resolution dated Twenty-seventh day of April, One Thousand Nine Hundred and Seventy, made pursuant to Sections 21 and 74 of the Country Roads Act 1958 declaring the widening of the North Western Highway in the Shire of Ballarat as shown hatched on Plan numbered G.P.6772 hereunder to be part of a State highway within the meaning and for the purposes of the said Act.

STATE HIGHWAY
NORTH WESTERN HIGHWAY
SHIRE OF BALLARAT

Measurements in links

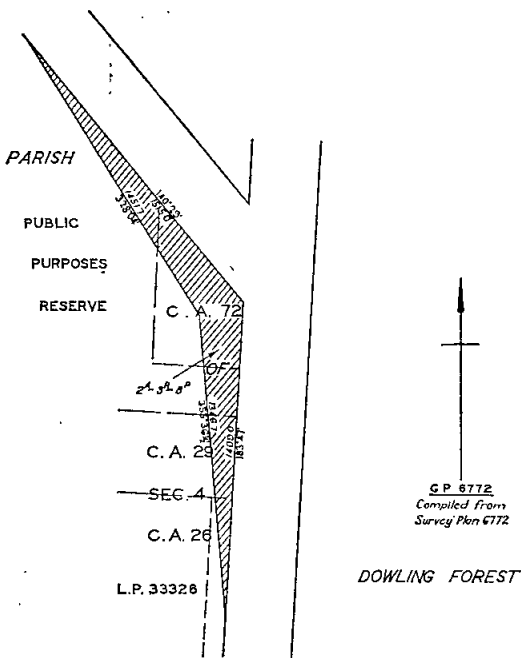

Main Roads.

Resolution dated Twenty-seventh day of April, One Thousand Nine Hundred and Seventy, made pursuant to Sections 21 and 58 of the Country Roads Act 1958, declaring the deviation from the Heidelberg-Kinglake Road in the Shire of Eltham as indicated by diagonal hatching on Plans numbered G.P.11233 and G.P.11234 hereunder to be part of a main road within the meaning and for the purposes of the said Act, and also declaring that such deviation shall be in lieu of the existing road or part thereof indicated by cross hatching on Plan numbered G.P.11234 and that such part of the said existing road shall be discontinued:

MAIN ROAD
HEIDELBERG—KINGLAKE ROAD
SHIRE OF ELTHAM

Measurements in links

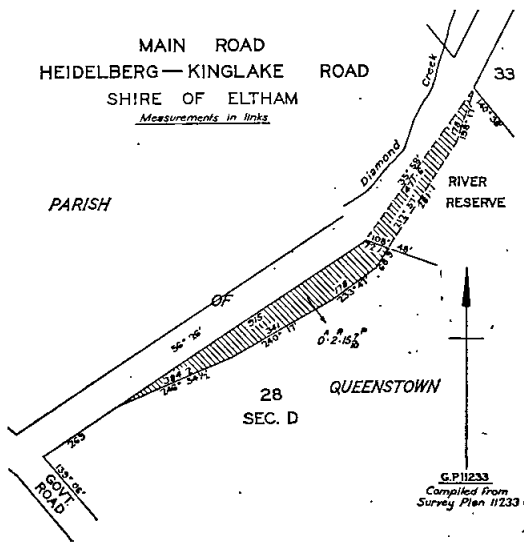

MAIN ROAD
HEIDELBERG—KINGLAKE ROAD
SHIRE OF ELTHAM

Measurements in links

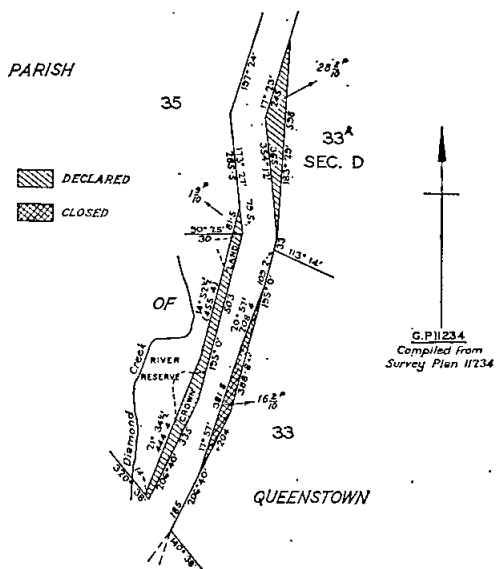

Resolution dated Twenty-seventh day of April, One Thousand Nine Hundred and Seventy, made pursuant to Sections 21 and 58 of the Country Roads Act 1958, declaring the deviation from the Colac-Forrest Road in the Shire of Otway as indicated by diagonal hatching on Plan numbered G.P.11607 hereunder to be part of a main road within the meaning and for the purpose of the said Act, and also declaring that such deviation shall be in lieu of the existing road or part thereof indicated by cross hatching on the said plan and that such part of the said existing road shall be discontinued.

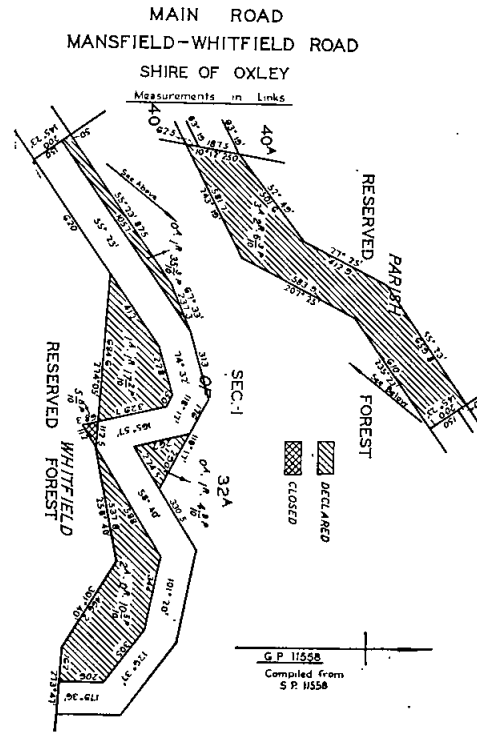
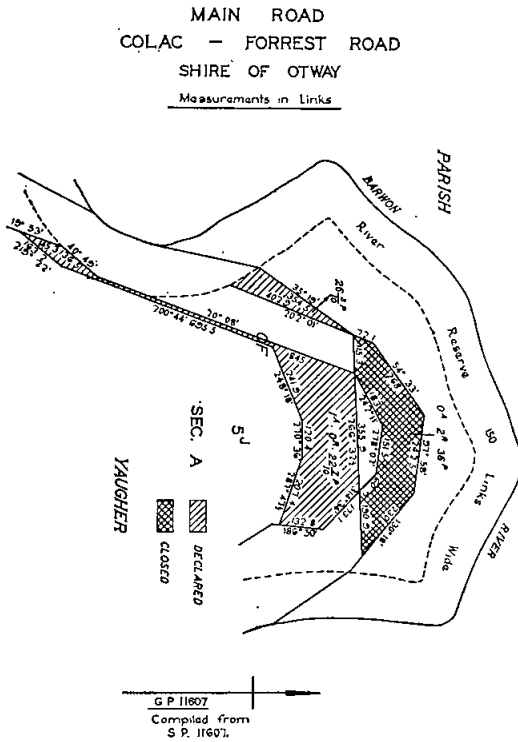

Resolution dated Twenty-seventh day of April, One Thousand Nine Hundred and Seventy, made pursuant to Sections 21 and 58 of the Country Roads Act 1958, declaring the deviation from the Mansfield-Whitfield Road in the Shire of Oxley as indicated by diagonal hatching on Plans numbered G.P.11557 and G.P.11558 hereunder to be part of a main road within the meaning and for the purposes of the said Act, and also declaring that such deviation shall be in lieu of the existing road or part thereof indicated by cross hatching on the said plans and that such part of the said existing road shall be discontinued.

Resolution dated Twenty-seventh day of April, One Thousand Nine Hundred and Seventy, made pursuant to Sections 21 and 58 of the Country Roads Act 1958, declaring the deviation from the Yackandandah-Wodonga Road in the Shire of Yackandandah as indicated by diagonal hatching on Plan numbered G.P.8398 hereunder to be part of a main road within the meaning and for the purposes of the said Act, and also declaring that such deviation shall be in lieu of the existing road or part thereof indicated by cross hatching on the said plan and that such part of the said existing road shall be discontinued.

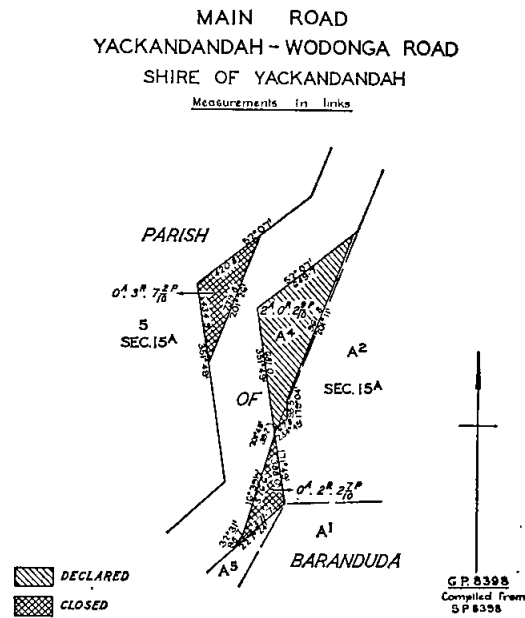
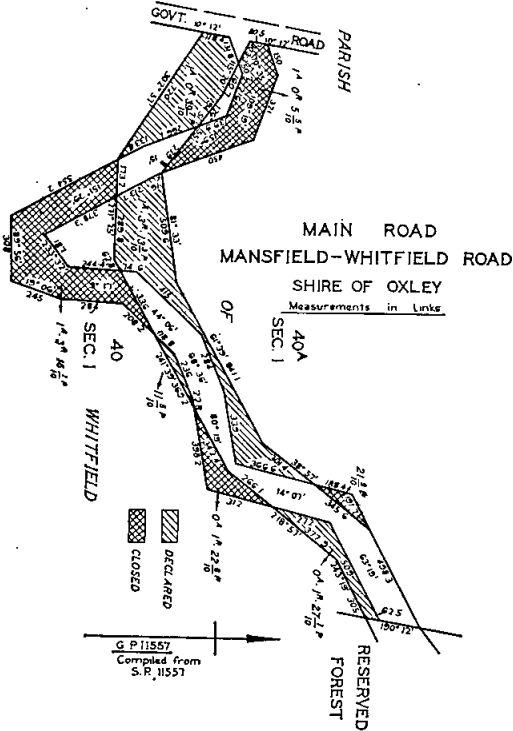

Unclassified Road.

Resolution dated Twenty-seventh day of April, One Thousand Nine Hundred and Seventy, made pursuant to Sections 21 and 110 of the *Country Roads Act 1958*, declaring the widening of Templeton-street in the City of Knox as shown hatched on Plan numbered G.P.10378A hereunder to be part of a road within the meaning and for the purposes of the said Act.

ROAD
 TEMPLETON STREET
 CITY OF KNOX
Measurements in Feet & inches.

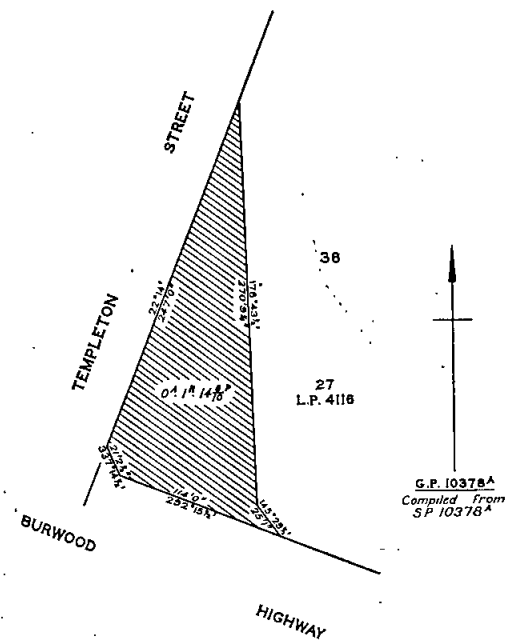

28th April, 1970.

N. L. ALLANSON,
 Secretary.

DRAINAGE AREAS ACT.

SPECIAL MAINTENANCE CHARGE MADE BY THE MINHAMITE SHIRE COUNCIL IN RESPECT OF THE MOYNE DRAINAGE AREA.

NOTICE is hereby given that, on the twenty-eighth day of April, 1970, in pursuance of the provisions of section 36 of the *Drainage Areas Act 1958*, the Governor in Council approved of the estimate of the cost of proposed maintenance works in the Moyne Drainage Area submitted by the Minhamite Shire Council, and of the making by the Council of a Special Maintenance Charge on properties within the said drainage area for the year ending 30th September, 1970.

J. ROSSITER,
 Clerk of the Executive Council.

At the Executive Council Chamber,
 Melbourne, 28th April, 1970.

Police Regulation Act 1958, Section 122.

SALE OF UNCLAIMED MOTOR VEHICLE.

AN owner is required for a 1954 FJ Holden sedan, ex-registered No. GLA-117, engine No. 249404.

The vehicle came into the possession of Police on the 10th January, 1970, and if not claimed, will be sold by public auction, at the Violet Town Police Station, Violet Town, at 2 p.m., on 8th June, 1970.

WYCHEPROOF SEWERAGE AUTHORITY.

Public Authorities Marks Act 1958.

By-Law No. 2.

WYCHEPROOF Sewerage Authority (declared by Order of the Governor in Council published in the *Government Gazette* on the third day of July One Thousand Nine Hundred and Sixty Eight, page two thousand four hundred and eighty eight, to be an authority for the purpose of the *Public Authorities Marks Act 1958*) pursuant to and in exercise of the powers and authorities conferred upon it by the said *Public Authorities Marks Act 1958* and by the *Sewerage Districts Act 1958* and pursuant to and in exercise and execution of any other powers and authorities in any wise enabling it in that behalf DOETH **HEREBY MAKE AND PRESCRIBE** the following By-Law that is to say:—

1. In this By-Law, unless the context and subject matter otherwise indicates:

“the said Act” means the *Public Authorities Marks Act 1958* and all amendments thereof;

“the Authority” means the Wycheproof Sewerage Authority;

“Stamp” or “Mark” includes a stamp or mark on any article, materials or thing in question or on a seal, tag or label affixed or otherwise attached to or connected with the same or any container thereof;

“Works” means any works or operations for or in connection with the carrying into effect of the purposes or objects of any provisions of the *Sewerage Districts Act 1958* or any amendments thereof or of any other Act relating to the Wycheproof Sewerage Authority whether the same are constructed, maintained or carried out by the Authority or by any other person on behalf of or under agreement with the Authority or by permission or authority of or under the supervision, direction or control of the Authority.

2. The stamp or mark hereby prescribed and adopted by the Authority under the authority of the said Act shall be the letters “WF SA” (meaning the Wycheproof Sewerage Authority) for indicating that any articles, materials or things referred to in the said Act and in this By-Law are duly tested, stamped, marked or authorised by the Authority.

3. The said stamp or mark shall be sealed, stamped marked or impressed or be affixed by tag or label by the Authority alone by its Officers duly authorised or by other persons duly authorised for the purpose upon the articles, materials or things to which the said Act applies.

4. The use of the said stamp or mark by any person other than by a person duly authorised by the Authority is prohibited.

5. The sale or supply by any person to any other person of any of the above-mentioned articles, materials or things which—

- (a) are stamped or marked otherwise than as hereby prescribed, or
- (b) are not duly tested stamped marked or authorised as hereby prescribed, or
- (c) comprises a component part not comprised in any such article, material or thing when stamped or marked is hereby prohibited.

6. Any person guilty of any contravention of this By-Law shall for every such offence be liable to a penalty not exceeding \$100 in respect of any one such contravention provided however that nothing in this clause contained shall affect the liability of any such person to be prosecuted and punished under any other Act or at Common Law but he shall not be liable to be punished twice for the same offence.

The Common Seal of the Wycheproof Sewerage Authority was hereto affixed, this 21st day of April, 1970—

(SEAL) D. P. SHEAHAN, Chairman.
 T. W. TAYLOR, Member.
 G. R. DRYDEN, Secretary.

Approved by the Governor in Council, 5th May, 1970.—
 J. ROSSITER, Clerk of the Executive Council.

QUEENSCLIFFE SEWERAGE AUTHORITY.

By-Law No. 1.

Public Authorities Marks Act 1958.

QUEENSCLIFFE Sewerage Authority (declared by Order of the Governor in Council published in the *Government Gazette* on the second day of October One Thousand Nine Hundred and sixty-nine, page 3328, to be an authority for the purpose of the *Public Authorities Marks Act 1958*) pursuant to and in exercise of the powers and authorities conferred upon it by the said *Public Authorities Marks Act 1958* and by the *Sewerage Districts Act 1958* and pursuant to and in exercise and execution of any other powers and authorities in any wise enabling it in that behalf DOTH HEREBY MAKE AND PRESCRIBE the following By-Law that is to say:—

1. In this By-Law, unless the context and subject matter otherwise indicates:

"the said Act" means the *Public Authorities Marks Act 1958* and all amendments thereof;

"the Authority" means the Queenscliffe Sewerage Authority;

"Stamp" or "Mark" includes a stamp or mark on any article, materials or thing in question or on a seal, tag or label affixed or otherwise attached to or connected with the same or any container thereof;

"Works" means any works or operations for or in connection with the carrying into effect of the purposes or objects of any provisions of the *Sewerage Districts Act 1958* or any amendments thereof or of any other Act relating to the Queenscliffe Sewerage Authority whether the same are constructed, maintained or carried out by the Authority or by any other person on behalf of or under agreement with the Authority or by permission or authority of or under the supervision, direction or control of the Authority.

2. The stamp or mark hereby prescribed and adopted by the Authority under the authority of the said Act shall be the letters "QUSA" (meaning the Queenscliffe Sewerage Authority) for indicating that any articles, materials or things referred to in the said Act and in this By-Law are duly tested, stamped, marked or authorised by the Authority.

3. The said stamp or mark shall be sealed, stamped, marked or impressed or be affixed by tag or label by the Authority alone by its Officers duly authorised or by other persons duly authorised for the purpose upon the articles, materials or things to which the said Act applies.

4. The use of the said stamp or mark by any person other than by a person duly authorised by the Authority is prohibited.

5. The sale or supply by any person to any other person of any of the above-mentioned articles, materials or things which—

(a) are stamped or marked otherwise than as hereby prescribed, or

(b) are not duly tested stamped marked or authorised as hereby prescribed, or

(c) comprises a component part not comprised in any such article, material or thing when stamped or marked

is hereby prohibited.

6. Any person guilty of any contravention of this By-Law shall for every such offence be liable to a penalty not exceeding \$100 in respect of any one such contravention provided however that nothing in this clause contained shall affect the liability of any such person to be prosecuted and punished under any other Act or at Common Law but he shall not be liable to be punished twice for the same offence.

Resolution for adopting this By-Law was passed by the Queenscliffe Sewerage Authority at a meeting on 18th December, 1969, and confirmed at a subsequent meeting held on the 10th March, 1970.

(SEAL) RAY L. FAIRBAIRN, Chairman.
H. D. FELDTMAN, Member.
R. T. FORBES, Secretary.
J. R. GOLIGHTLY, Member.

Approved by the Governor in Council, 5th May, 1970.—
J. ROSSITER, Clerk of the Executive Council.

SEA LAKE SEWERAGE AUTHORITY.

By-Law No. 2.

Public Authorities Marks Act 1958.

SEA LAKE Sewerage Authority (declared by Order of the Governor in Council published in the *Government Gazette* on the third day of July One Thousand Nine Hundred and Sixty Eight page two thousand four hundred and ninety three to be an authority for the purpose of the *Public Authorities Marks Act 1958*) pursuant to and in exercise of the powers and authorities conferred upon it by the said *Public Authorities Marks Act 1958* and by the *Sewerage Districts Act 1958* and pursuant to and in exercise and execution of any other powers and authorities in any wise enabling it in that behalf DOTH HEREBY MAKE AND PRESCRIBE the following By-Law that is to say:—

1. In this By-Law, unless the context and subject matter otherwise indicates:

"the said Act" means the *Public Authorities Marks Act 1958* and all amendments thereof;

"the Authority" means the Sea Lake Sewerage Authority;

"Stamp" or "Mark" includes a stamp or mark on any article, materials or thing in question or on a seal, tag or label affixed or otherwise attached to or connected with the same or any container thereof;

"Works" means any works or operations for or in connection with the carrying into effect of the purposes or objects of any provisions of the *Sewerage Districts Act 1958* or any amendments thereof or of any other Act relating to the Sea Lake Sewerage Authority whether the same are constructed, maintained or carried out by the Authority or by any other person on behalf of or under agreement with the Authority or by permission or authority of or under the supervision, direction or control of the Authority.

2. The stamp or mark hereby prescribed and adopted by the Authority under the authority of the said Act shall be the letters "SLSA" (meaning the Sea Lake Sewerage Authority) for indicating that any articles, materials or things referred to in the said Act and in this By-Law are duly tested, stamped, marked or authorised by the Authority.

3. The said stamp or mark shall be sealed, stamped, marked or impressed or be affixed by tag or label by the Authority alone by its Officers duly authorised or by other persons duly authorised for the purpose upon the articles, materials or things to which the said Act applies.

4. The use of the said stamp or mark by any person other than by a person duly authorised by the Authority is prohibited.

5. The sale or supply by any person to any other person of any of the above-mentioned articles, materials or things which—

(a) are stamped or marked otherwise than as hereby prescribed, or

(b) are not duly tested stamped marked or authorised as hereby prescribed, or

(c) comprises a component part not comprised in any such article, material or thing when stamped or marked is hereby prohibited.

6. Any person guilty of any contravention of this By-Law shall for every such offence be liable to a penalty not exceeding \$100 in respect of any one such contravention provided however that nothing in this clause contained shall affect the liability of any such person to be prosecuted and punished under any other Act or at Common Law but he shall not be liable to be punished twice for the same offence.

The Common Seal of the Sea Lake Sewerage Authority was hereto affixed, this 22nd day of April, 1970—

(SEAL) J. S. BAILEY, Chairman.
G. L. DRIEBERG, Member.
G. R. DRYDEN, Secretary.

Approved by the Governor in Council, 5th May, 1970.—
J. ROSSITER, Clerk of the Executive Council.

DONALD SEWERAGE AUTHORITY.
INCREASING LIMIT OF BANK OVERDRAFT.

THE Lieutenant-Governor as Deputy for His Excellency the Governor of the State of Victoria by and with the advice of the Executive Council thereof doth by Order made on the 28th day of April, 1970, increase the total amount of the sums which the Donald Sewerage Authority may owe at any one time, in respect of moneys borrowed by overdraft of current account, pursuant to the provisions of section 79 of the *Sewerage Districts Act 1958*, fixed by the Governor in Council on 3rd December, 1968, at Fifty thousand dollars (\$50,000) to Eighty thousand dollars (\$80,000).

J. ROSSITER,
Clerk of the Executive Council.

At the Executive Council Chamber,
Melbourne, 28th April, 1970.

TOWN OF STAWELL.

AUTHORITY TO OBTAIN BANK OVERDRAFT.

THE Lieutenant-Governor as Deputy for His Excellency the Governor of the State of Victoria by and with the advice of the Executive Council thereof doth by Order made on the 28th day of April, 1970, authorize the Council of the Town of Stawell to obtain during the year ending 30th September, 1970, in pursuance of the provisions of section 286 of the *Water Act 1958* (No. 6413), an advance or advances by overdraft of the Council's current account, the amount owing in respect of such overdraft not to exceed at any one time the sum of Forty thousand dollars (\$40,000).

J. ROSSITER,
Clerk of the Executive Council.

At the Executive Council Chamber,
Melbourne, 28th April, 1970.

COHUNA SEWERAGE AUTHORITY.

AUDIT OF ACCOUNTS.

Fees Payable to Auditor.

THE Lieutenant-Governor as Deputy for His Excellency the Governor of the State of Victoria by and with the advice of the Executive Council thereof doth by Order made on the 28th day of April, 1970, and in pursuance of the provisions of the *Sewerage Districts Act 1958*, No. 6368, authorize an increase in the amount payable to G. F. Cumming, Esq., as remuneration for making an audit of the accounts of the Cohuna Sewerage Authority for the year ending 30th September, 1969, from Sixty dollars (\$60), approved by the Governor in Council, on 2nd September, 1969, to One hundred and forty dollars (\$140).

J. ROSSITER,
Clerk of the Executive Council.

At the Executive Council Chamber,
Melbourne, 28th April, 1970.

LOCAL GOVERNMENT DEPARTMENT.

ORDER CONFIRMED.—CITY OF CAULFIELD.

THE Minister of the Crown administering the *Local Government Act 1958*, on the 30th day of April, 1970, confirmed the Order hereinafter referred to in pursuance of section 514 of the said Act namely:

An Order of the Council of the City of Caulfield made on the 3rd March, 1970, directing the compulsory taking of the land described hereunder for the purpose of constructing and providing a roadway:

All that piece of land being part of Crown allotment 32, Parish of Prahran, East of Elsternwick, and being part of the land now comprised in certificate of title, volume 4037, folio 388, commencing at a point 159 feet east of the intersection of Nepean Highway and North-road and proceeding in a northerly direction for 138 ft. 4 in.; thence south-easterly for a distance of 71 ft. 4 in.; thence southerly for a distance of 99 ft. 11 in. and returning in a westerly direction for a distance of 60 feet to the point of commencement.

R. J. HAMER,
Minister for Local Government.

Local Government Department,
Melbourne.

LOCAL GOVERNMENT DEPARTMENT.

ORDER CONFIRMED.—CITY OF ST. KILDA.

THE Minister of the Crown administering the *Local Government Act 1958*, on the 30th day of April, 1970, confirmed the Order hereinafter referred to in pursuance of section 514 of the said Act namely:

An Order of the Council of the City of St. Kilda made on 2nd March, 1970, directing the compulsory taking of the land described in certificate of title, volume 6274, folio 720, for the purpose of an extension to the existing car park situated near the corner of Nelson and Alfred streets, Balaclava.

R. J. HAMER,
Minister for Local Government.

Local Government Department,
Melbourne.

CONTRACTS ACCEPTED.—(Series 1969-70.)

VICTORIAN RAILWAYS.

86. Supply and delivery of semi-conductor rectifier sets and protective gear, at rates (Contract 63436).—Mitsubishi (Aust.) Pty. Ltd. 87. The removal of departmental residence No. 3997, from Burrumbeet and re-assembling at St. Arnaud, together with outbuilding, for the amount of \$1,591.00 (Contract 63524).—W. Phelan and Sons.

By order of the Victorian Railways Commissioners,
W. WALKER, Secretary for Railways. 1.5.1970.

PUBLIC WORKS.

1348. Leopold, Primary School 1146, renovations, \$5,448.00.—H. De Vries.
1349. Broadmeadows, High School, mechanical services, \$10,317.00.—Ford-Swinton Industries Pty. Ltd.
1350. Preston, Alcoholics Assessment Centre, erection of two (2) wards, \$382,359.47.—A. J. Galvin Pty. Ltd.
1351. Ringwood, High School, internal and external renovations, \$11,807.00.—Industrial Alterations & Building Decorating Co.
1352. Maryvale, High School, erection of stage 2, type C.800, \$421,474.00.—McDougall-Ireland Pty. Ltd.
1353. Swan Hill, Primary School 1142, renovations, \$9,999.00.—Pascoe Vale Painters Construction Co.
1354. Balwyn, Primary School 1026, internal and external renovations, \$11,900.00.—N. Peshut.
1355. Blackburn South, High School and Caretaker's Residence, renovations and painting, \$5,430.00.—N. Peshut.
1356. Norwood, High School, erection of new concrete veneer Science Wing, \$46,260.00.—G. & A. Power Pty. Ltd.
1357. Waverley North, Primary School 4884, asphalt, concrete and drainage works, &c., \$12,360.30.—Sheffield Paving and Construction Co. Pty. Ltd.
1358. Benalla, Technical School, erection of L.T.C. Science extension, \$29,000.00.—Alf. Richardson Constructions.

G. SERPELL, Director-General of Public Works. 30.4.70.

ORDERS IN COUNCIL.—(Series 1969-70.)

PUBLIC WORKS.

1346. Mont Park, Mental Hospital, general renovations to ablution area, \$4,568.—S. Laird.—(C.141500.)

Approved by the Governor in Council, 28th April, 1970.
—J. ROSSITER, Clerk of the Executive Council.

1347. Collingwood, High School, supply and erection of a Terrapin pre-fabricated building, \$14,971.00.—Willcroft-Terrapin Pty. Ltd.—(C.21246.)

Approved by the Governor in Council, 28th April, 1970.—
J. ROSSITER, Clerk of the Executive Council.

APPOINTMENTS AND RESIGNATIONS

APPOINTMENTS.

THE Lieutenant-Governor as Deputy for His Excellency the Governor of the State of Victoria, by and with the advice of the Executive Council thereof, has by Orders made on the 28th day of April, 1970, been pleased to make the under-mentioned appointments, viz.:

CHIEF SECRETARY'S DEPARTMENT.

Honorary Probation Officers.

THOMAS NESBITT McMULLAN, 37 Salisbury-street,
East Coburg.

IAN CHRISTIE LAIDLER (The Reverend), 66 Highett-street, Mansfield,
 GREGORY JOSEPH PERRY, 5 Sidwell-avenue, East St. Kilda,
 BERNARD FRANCIS SHAW, 62 Eastern-avenue, East Newborough,
 THOMAS JOSEPH TAYLOR, 19 Mardan-street, East Newborough,
 FREDERICK, THOMAS WEBB, 197 Graham-street, Wonthaggi,
 DAVID MONTAGU ROWLAND WERE, 171 Park-drive, Parkville,
 THOMAS GEORGE WILLIAMSON, 26 Carrington-street, Pascoe Vale,
 FRANCIS JOSEPH BARBER, 39 Randall-avenue, Edithvale,
 WILLIAM JOHN BINDLOSS, 29 Airlie-grove, Seaford,
 DESMOND WILLIAM BRYCELAND, 8 Lee-street, Noble Park,
 FRANK ANGLIN, 76 Devon-road, Pascoe Vale,
 WILLIAM ROBERT DIX (The Reverend), The Manse, Apollo Bay,
 ANTHONY KOSTAS, 12 Ferncroft-street, Vermont, and
 LINDSAY OWEN McMILLAN, 24 Middleborough-road, Burwood,

pursuant to the provisions of section 10 (1) of the *Children's Court Act 1958*, to be Honorary Probation Officers for all Children's Courts in Victoria.

Postal Voting Officers.

ELIZABETH ANNE DRAKE, Australian Embassy, Dublin,
 COLIN FORBUTT, Australian Embassy, Athens,
 HUGH BYASS PATTON, Australian Embassy, Djakarta,
 TERRY DAVID MICHAEL CRANAGE, Australian Consulate-General, San Francisco,
 RICHARD DMITRY ANTHONY DOWN, Australian High Commission, Colombo,
 ANTHONY FREDERICK ORDISH, Australian Embassy, Saigon,
 JAMES CONNELL BOWEN JACKSON, Australian Consulate, Nauru,
 GEOFFREY DOUGLAS WARREN-SMITH, Australian Consulate-General, New York,
 GEOFFREY LEONARD BAKER, Australian Commission, Suva,
 EMANUEL CANBERRA GRALLELIS, Australian High Commission, Wellington,
 RAY MOONEY, Australian Embassy, Washington, and
 ERIC RAYMOND FARMER, Australian Consulate, Cape-town,

to be Postal Voting Officers for the conjoint Parliamentary election to be held on the 30th May, 1970, pursuant to section 147A of *The Constitution Act Amendment Act 1958*.

MINISTRY OF HEALTH.

Deputy Superintendent of Mental Hospital.

WARREN MURRAY WHITE, M.B., B.S., D.P.M., M.A.N.Z.C.P.
 to be Deputy Superintendent, Mental Hospital and Psychiatric Hospital, Larundel, pursuant to section 26 (1) of the *Mental Health Act 1959*, as from 26th April, 1970.

LAW DEPARTMENT.

Chairman of Judges of the County Court.

His Honor JUDGE GEORGE LEO DETHRIDGE, a Judge of the County Court
 to be Chairman of Judges of the County Court of the State of Victoria, to take effect as from and inclusive of 28th April, 1970.

Commissioners for Taking Declarations, &c.

ALAN SAKER, 45 Osborne-street, Williamstown,
 DARYL ROBERT FRANCIS MARSH, "Nioka", Stinton-road, Park Orchards,
 FRANCIS O'HAGEN, 3 Brunswick-street, Footscray, and
 WILLIAM GEORGE GARDINER, 16 Tarrengower-street, Yarraville,
 to be Commissioners for Taking Declarations and Affidavits pursuant to the provisions of the *Evidence Act 1958*, to resign upon removing from the neighbourhood of the addresses stated.

ALBERT GEORGE BERSEY, care of Victorian Railways, 67 Spencer-street, Melbourne,
 to be a Commissioner for Taking Declarations and Affidavits pursuant to the provisions of the *Evidence Act 1958*, to refrain from charging fees and to resign upon ceasing to occupy his present position.

JOHN DOUGLAS BROWNLEE, care of Douglas, Ross & Wayne Pty. Ltd., 67 Queens-road, Melbourne,
 ROBERT EDWARD ELLARD, care of Australia and New Zealand Bank Limited, 351 Collins-street, Melbourne,

ADRIAN BERNARD COUNSEL, care of Regional Taxation Office, A.M.P. Building, 17 Lydiard-street north, Ballarat, and

ROY WILLIAM JACKSON, care of The Mission of St. James and St. John, 468 St. Kilda-road, Melbourne,
 to be Commissioners for Taking Declarations and Affidavits pursuant to the provisions of the *Evidence Act 1958*, to resign upon ceasing to occupy their present positions.

Justices of the Peace.

MICHAEL JOSEPH BUTLER, Kilmore East,
 SIDNEY FRANCIS JENKINS, 163 Glen Iris-road, Glen Iris,
 EUGENE CAIRNS, Shire Office, Highett-street, Mansfield,
 MALCOLM MURRAY BROWN, 48 Williamson-avenue, Strathmore,
 BRUCE D'ARCY HARVIE, 7 Linum-street, Blackburn, and
 BRUCE GEORGE ROBSON, 38 Timber Ridge, Doncaster,
 to Keep the Peace in the State of Victoria.

Deputy Coroner.

THOMAS GEORGE SULLIVAN, J.P., 19 Anderson-street, Euroa
 to be a Deputy Coroner, pursuant to the provisions of the *Coroner's Act 1958*, to act and have jurisdiction for and during the absence of the Coroner at and in the vicinity of Euroa.

MINES DEPARTMENT.

Mining Registrar.

JOHN E. RIELLY
 to act as Mining Registrar at Bendigo for the Sandhurst Division of the Bendigo Mining District, vice Alfred Thomas Ryall, resigned.

DEPARTMENT OF THE TREASURER.

Collector of Imposts (Acting).

JOHN FRANCIS JONES
 to act temporarily as Collector of Imposts, Government Printing Office, vice R. D. Peters on leave.

DEPARTMENT OF WATER SUPPLY.

Waterworks Trust Commissioner.

GEORGE HOGG SYDENHAM GRAHAM
 a Commissioner of the Wahgunyah Waterworks Trust to hold such position for the period from the date hereof until 27th May, 1972, subject to the provisions of the *Water Act*.

J. ROSSITER,

Clerk of the Executive Council.

At the Executive Council Chamber,
 Melbourne, 28th April, 1970.

ERRATUM.

IN *Government Gazette* No. 43 of 29th April, 1970, page 1157, "Forests Department"—

Appointment of Committee of Management of the You Yangs Forest Park.

For the name "JOHN KEMSHALL DONOAN" substitute the name—

"JOHN KEMSHALL DONOVAN".

RESIGNATIONS.

THE Lieutenant-Governor as Deputy for His Excellency the Governor of the State of Victoria, by and with the advice of the Executive Council thereof, has by Order made on the 28th day of April, 1970, accepted the resignation of the person named hereunder of the office mentioned, viz.:—

LAW DEPARTMENT.

Commissioner for Taking Declarations, &c.

BRUCE D'ARCY HARVIE
 as a Commissioner for Taking Declarations and Affidavits pursuant to the provisions of the *Evidence Act 1958*.

J. ROSSITER,

Clerk of the Executive Council.

At the Executive Council Chamber,
 Melbourne, 28th April, 1970.

ORDERS IN COUNCIL

COUNTRY ROADS BOARD.

At the Executive Council Chamber, Melbourne, the
twenty-eighth day of April, 1970.

PRESENT:

The Lieutenant-Governor as Deputy for His Excellency
the Governor of Victoria.

Mr. Thompson | Mr. Wilcox.

**ORDER APPROVING OF LAND BEING ACQUIRED AND
ROADS, DEVIATIONS OR WIDENINGS BEING MADE.**

THE Lieutenant-Governor as Deputy for His Excellency
the Governor of the State of Victoria, by and with
the advice of the Executive Council thereof, being satisfied
that there are funds legally available for acquiring the
land, doth hereby approve the acquiring of the land
described in the Schedule hereunder and the making of
new roads and deviations from and widenings of existing
roads referred to in the said Schedule.

SCHEDULE.

State Highways.

The land shown hatched on Plans numbered G.P.11659,
G.P.11660, G.P.11661, G.P.11662, G.P.11663, G.P.11664,
G.P.11665, G.P.11666 and G.P.11667 hereunder required for
the widening of the Princes Highway in the Shire of Colac
and making of the widening thereon.

STATE HIGHWAY
PRINCES HIGHWAY
SHIRE OF COLAC
Measurements in Links

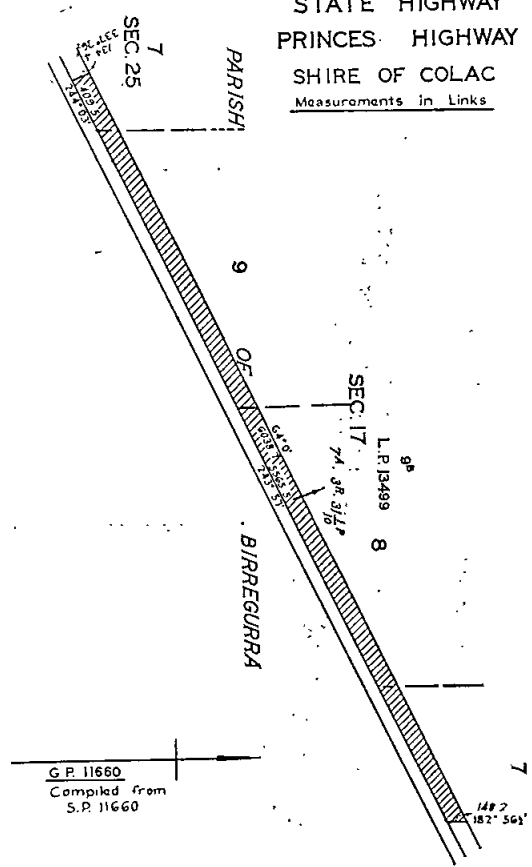

STATE HIGHWAY
PRINCES HIGHWAY
SHIRE OF COLAC
Measurements in Links

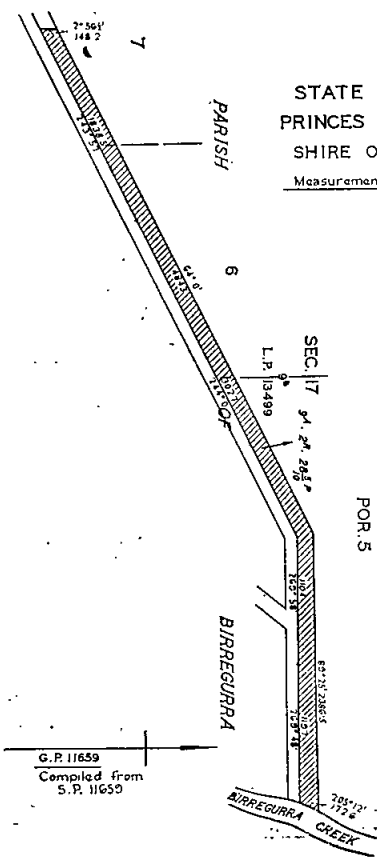

STATE HIGHWAY
PRINCES HIGHWAY
SHIRE OF COLAC
Measurements in Links

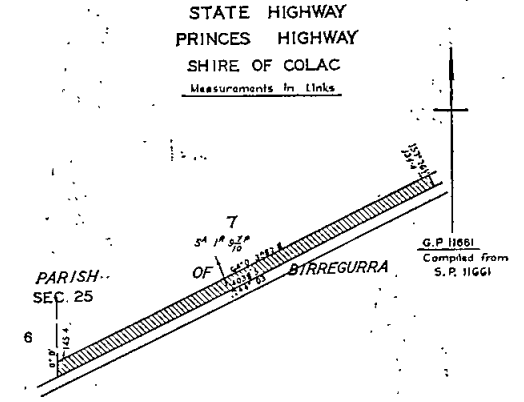

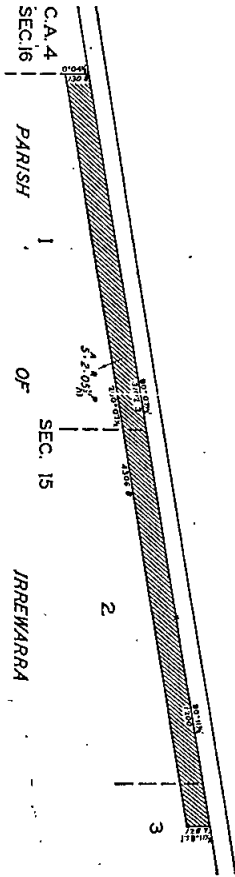

STATE HIGHWAY
PRINCES HIGHWAY
SHIRE OF COLAC
Measurements in links

G.P. 11662
Compiled from
S.P. 11662

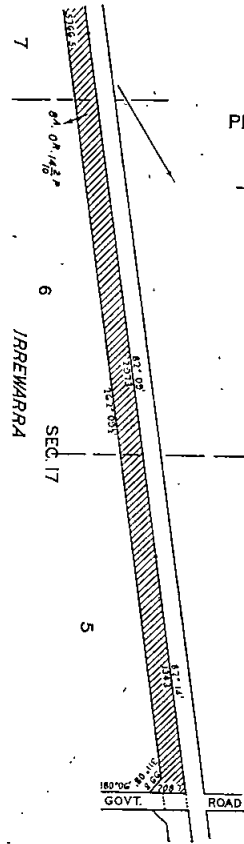

STATE HIGHWAY
PRINCES HIGHWAY
SHIRE OF COLAC
Measurements in Links

G.P. 11664
Compiled from
S.P. 11664

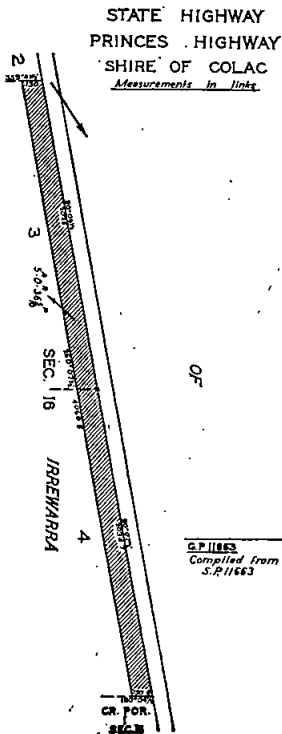

STATE HIGHWAY
PRINCES HIGHWAY
SHIRE OF COLAC
Measurements in links

G.P. 11665
Compiled from
S.P. 11665

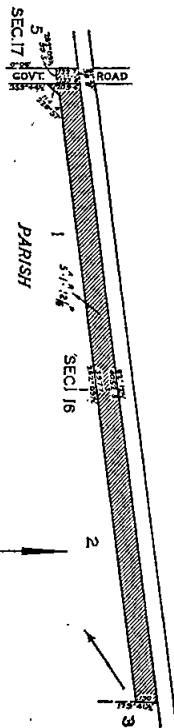

STATE HIGHWAY
PRINCES HIGHWAY
SHIRE OF COLAC
Measurements in links

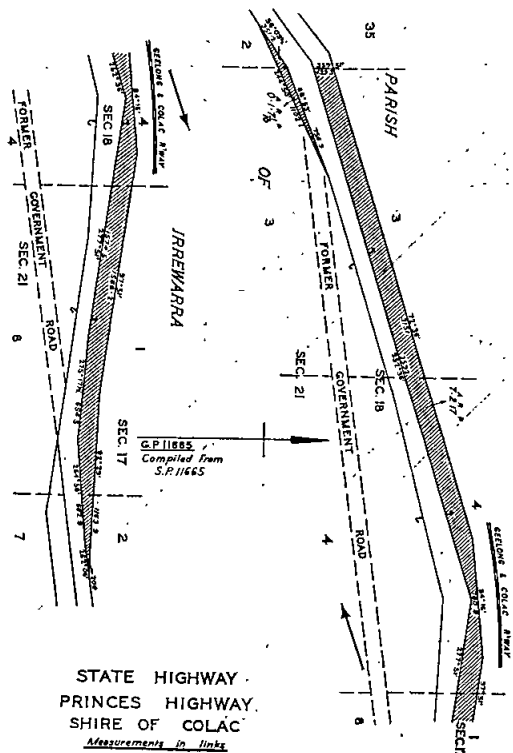

G.P. 11665
Compiled from
S.P. 11665

The land shown hatched on Plans numbered G.P.11632, G.P.11633, G.P.11634, G.P.11635, G.P.11636 and G.P.11637 hereunder required for the widening of the Princes Highway in the Shire of Winchelsea and making of the widening thereon.

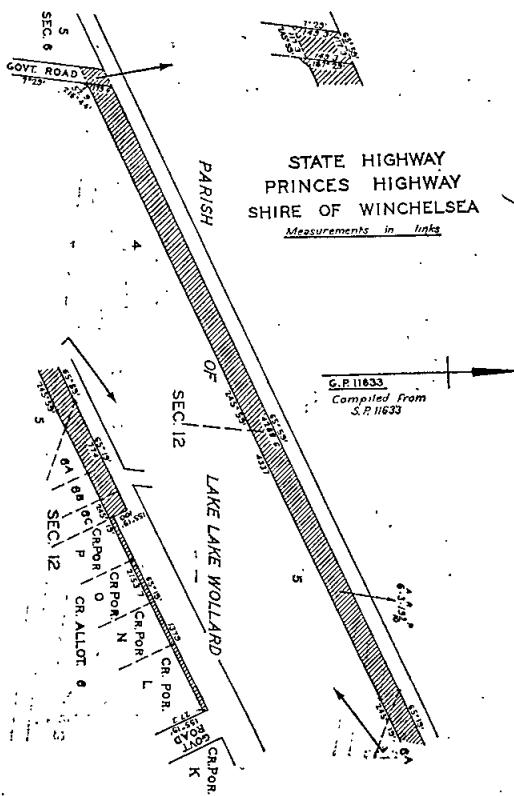
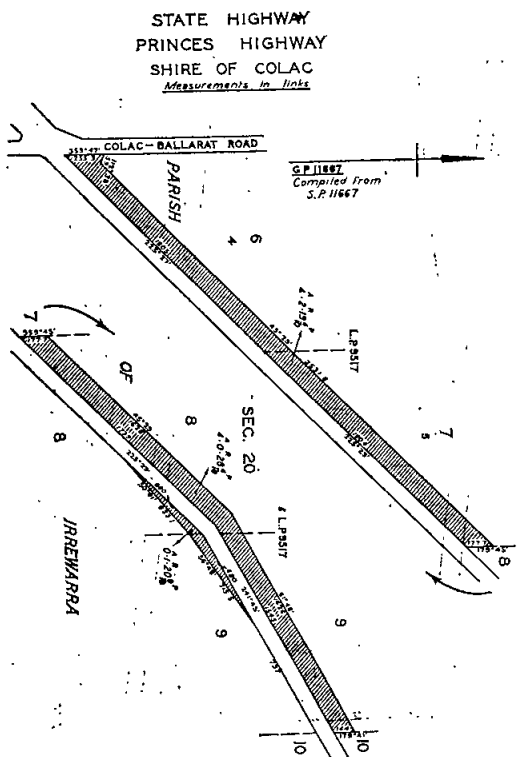
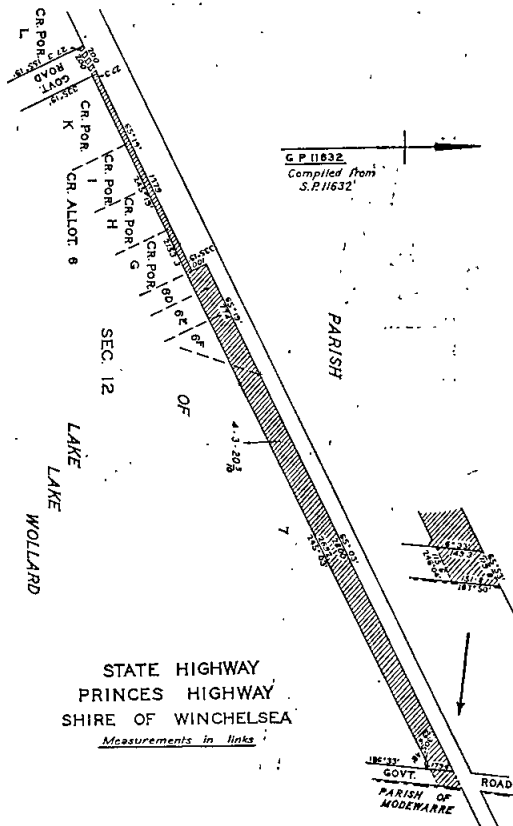
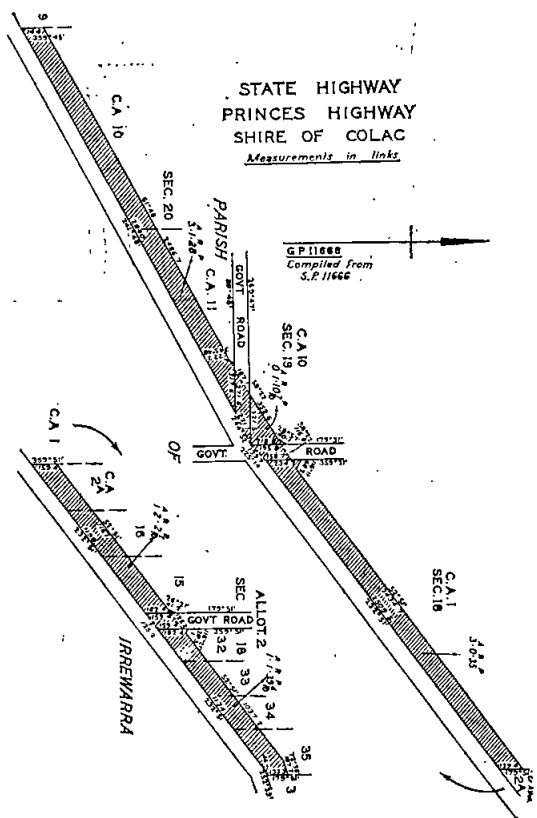

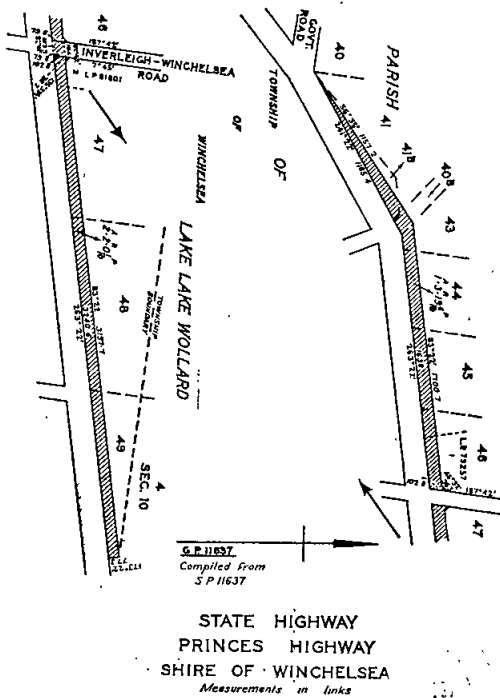
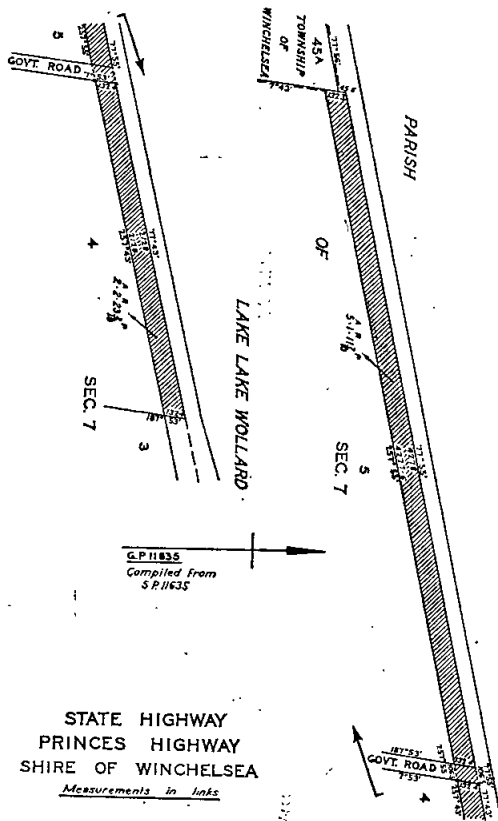
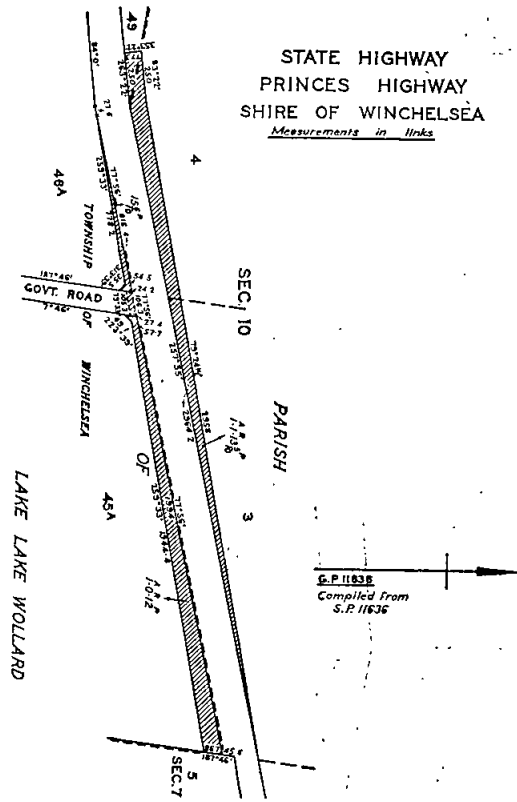
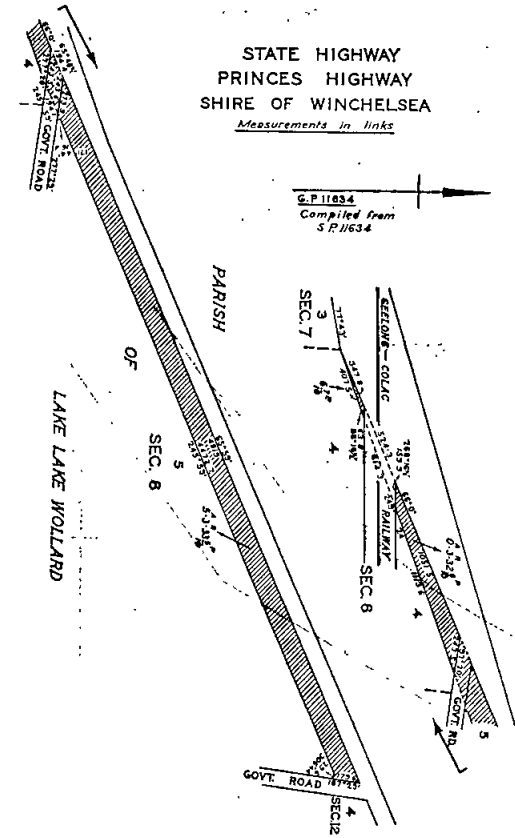

The land shown hatched on Plans numbered G.P.12075 and G.P.12076 hereunder required for the deviation from the Goulburn Valley Highway in the Shire of Yea and making of the deviation thereon.

STATE HIGHWAY
GOULBURN VALLEY HIGHWAY
SHIRE OF YEA
Measurements in links

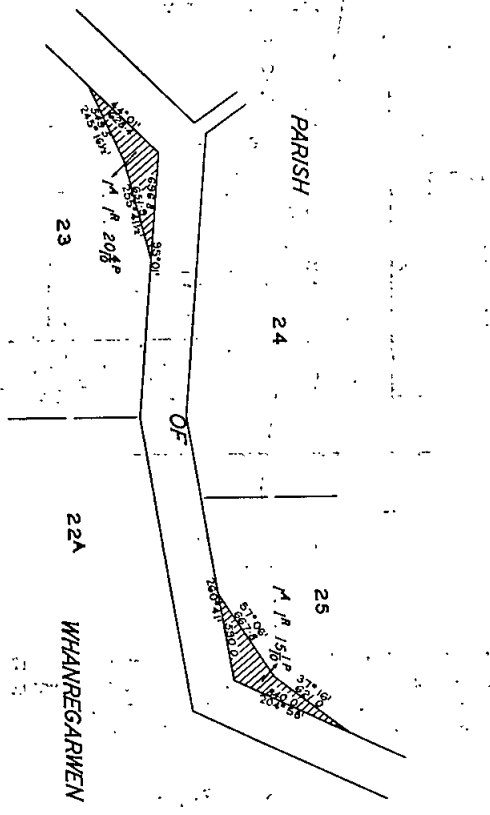

G.P.12075
Compiled from
S.P.12075

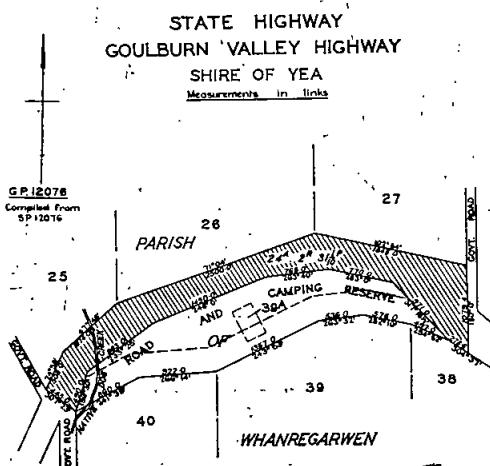

G.P.12076
Compiled from
S.P.12076

The land shown hatched on Plan numbered G.P.12094 hereunder required for the widening of the Heathcote-Rochester Road in the Shire of McIvor and making of the widening thereon.

MAIN ROAD
HEATHCOTE-ROCHESTER ROAD
SHIRE OF MCVIVOR
Measurements in Links

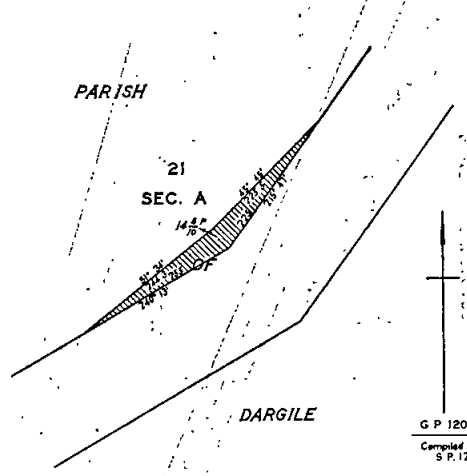

G.P.12094
Compiled from
S.P.12094

The land shown hatched on Plan numbered G.P.12096a hereunder required for the widening of Monbulk-road in the Shire of Sherbrooke, and making of the widening thereon.

MAIN ROAD
MONBULK ROAD
SHIRE OF SHERBROOKE
Measurements in Feet & Inches

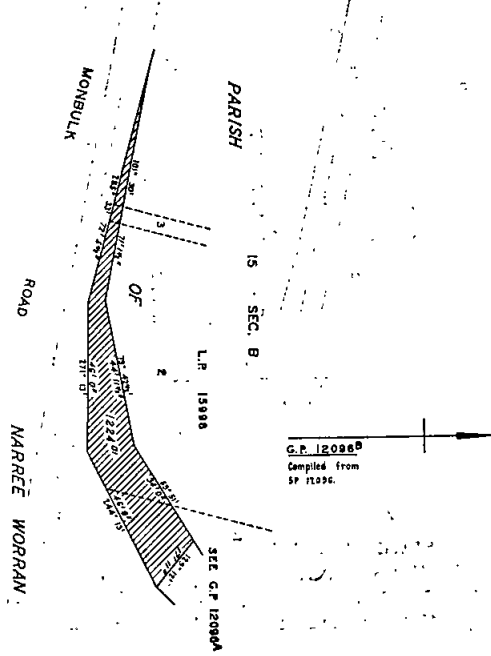

G.P.12096a
Compiled from
S.P.12096a

The land shown hatched on Plan numbered G.P.11976 hereunder required for the widening of Canavan-road in the Shire of Woorayl and making of the widening thereon.

MAIN ROAD
CANAVAN ROAD
SHIRE OF WOORAYL
Measurements in links

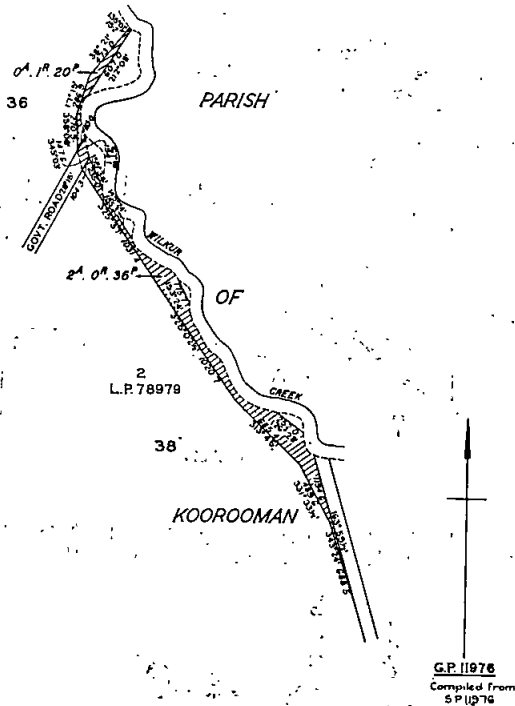

G.P. 11976
Compiled from
S.P. 11976

Unclassified Roads.

The land shown hatched on Plan numbered G.P.12110 hereunder required for the widening of Kalkee-road in the City of Horsham and making of the widening thereon.

ROAD
KALKEE ROAD
CITY OF HORSHAM
Measurements in feet & inches

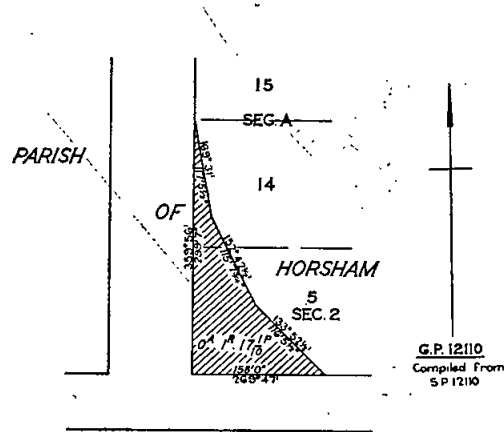

G.P. 12110
Compiled from
S.P. 12110

The land shown hatched on Plan numbered G.P.11938 hereunder required for the deviation from Ocean-road in the Shire of Barrabool and making of the deviation thereon.

TOURISTS' ROAD
OCEAN ROAD
SHIRE OF BARRABOOL
Measurements in ft & ins.

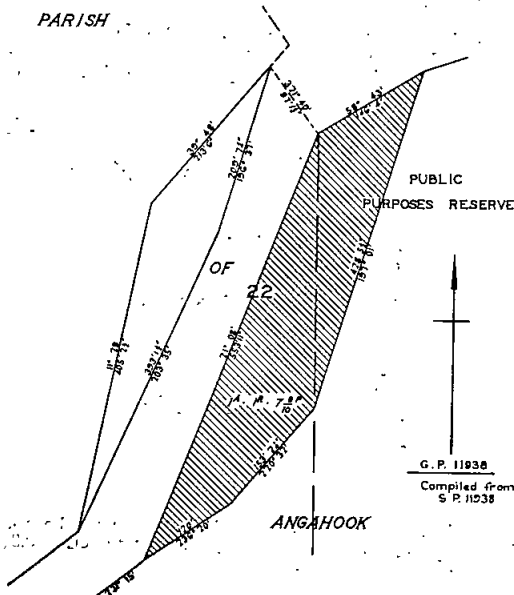

G.P. 11938
Compiled from
S.P. 11938

The land shown hatched on Plans numbered G.P.12095 and G.P.12096A hereunder required for the widening of Darling-avenue and Marchant-avenue in the Shire of Sherbrooke and making of the widening thereon.

ROAD
DARLING AVENUE
SHIRE OF SHERBROOKE
Measurements in feet & inches

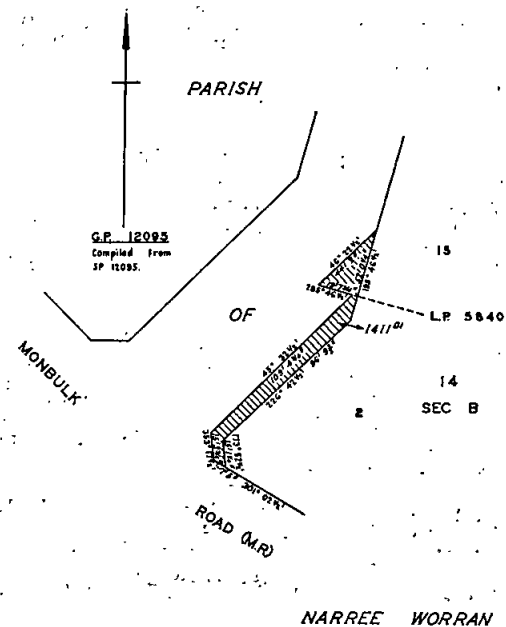

G.P. 12095
Compiled from
S.P. 12095

ROAD
MARCHANT AVENUE
SHIRE OF SHERBROOKE
Measurements in Feet & Inches

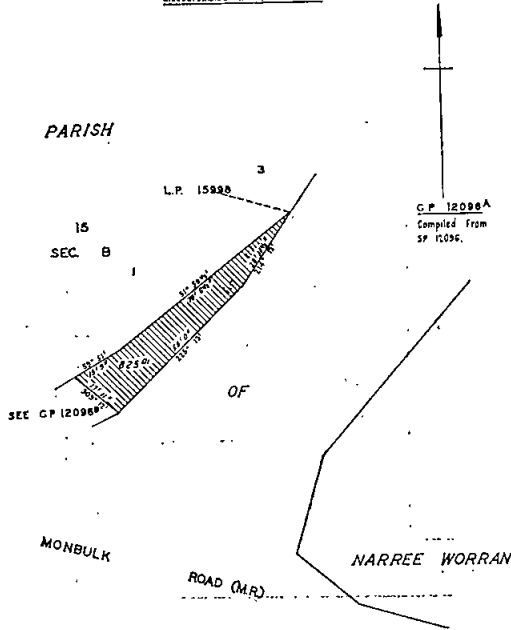

And the Honorable Rupert James Hamer, Her Majesty's Minister of Public Works for the State of Victoria, shall give the necessary directions herein accordingly.

J. ROSSITER,
Clerk of the Executive Council.

COUNTRY FIRE AUTHORITY ACT 1958.

At the Executive Council Chamber, Melbourne, the twenty-eighth day of April, 1970.

PRESENT:
The Lieutenant-Governor as Deputy for His Excellency the Governor of Victoria.
Mr. Thompson | Mr. Wilcox.

CONSENT TO BORROWING FIFTY THOUSAND DOLLARS BY THE COUNTRY FIRE AUTHORITY.
WHEREAS by section 82 of the Country Fire Authority Act 1958, it is enacted that the Country Fire Authority, with the consent of the Governor in Council may from time to time, borrow such moneys as it deems necessary in order to enable it to carry out and perform the powers, authorities and duties vested in or conferred or imposed upon it by the said Act:

And whereas the Country Fire Authority deems it necessary to borrow the sum of Fifty thousand dollars for the purposes aforesaid:

Now therefore, the Lieutenant-Governor as Deputy for His Excellency the Governor of the State of Victoria, in the Commonwealth of Australia, by and with the advice of the Executive Council of the said State and in pursuance of the powers conferred by the said Section 82 of the Country Fire Authority Act 1958 and all other powers him thereunto enabling, doth by this order consent to the borrowing by the Country Fire Authority of the sum of \$50,000 (Fifty thousand dollars) for a period of Twenty (20) years, to be liquidated by half-yearly repayments on the principal sum, with interest at the rate of \$6.40 per centum per annum.

And the Honorable Sir Arthur Gordon Rylah, Her Majesty's Chief Secretary for the State of Victoria, shall give the necessary directions herein accordingly.

J. ROSSITER,
Clerk of the Executive Council.

DEPARTMENT OF CROWN LANDS AND SURVEY.

At the Executive Council Chamber, Melbourne, the twenty-eighth day of April, 1970.

PRESENT:
The Lieutenant-Governor as Deputy for His Excellency the Governor of Victoria.
Mr. Thompson | Mr. Wilcox.

UNUSED ROADS CLOSED.

THE Lieutenant-Governor as Deputy for His Excellency the Governor of the State of Victoria, by and with the advice of the Executive Council thereof, doth hereby direct that, in pursuance of the provisions of section 349 of the Land Act 1958, the unused roads referred to hereunder be closed, viz.:-

Parish of Babatchio, County of Lowan, being the road indicated by hatching on plan hereunder.—(B.682⁽³⁾) (M.62292).

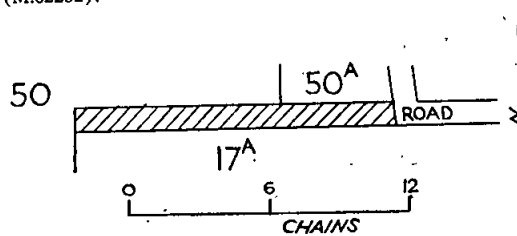

Parish of Cut-paw-paw, County of Bourke, being the road indicated by hatching on plan hereunder.—(C.345⁽¹⁸⁾) (M.3886).

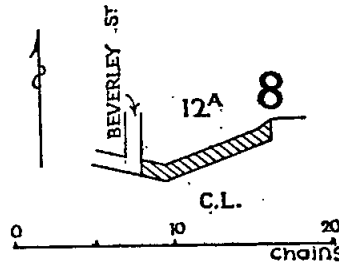

Parish of Kiata, County of Lowan, being the road between the land acquired by the North Western Railway Construction Act and allotment 52A.—(K.131⁽⁸⁾) (M.62250).

Parish of Neerim, County of Buln Buln, being the roads indicated by hatching on plan hereunder.—(P.8⁽⁴⁾) (G.62263).

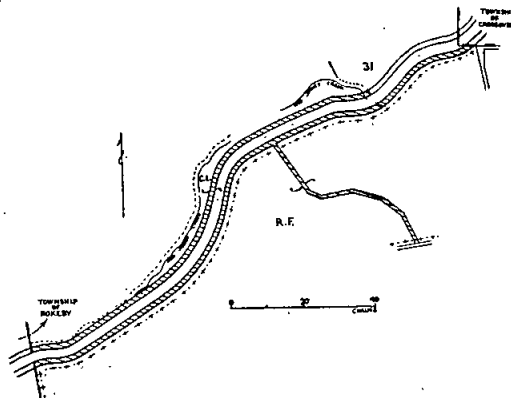

Parish of Parwan, County of Grant, being the roads indicated by hatching on plan hereunder.—(P.8⁽⁴⁾) (C.88875).

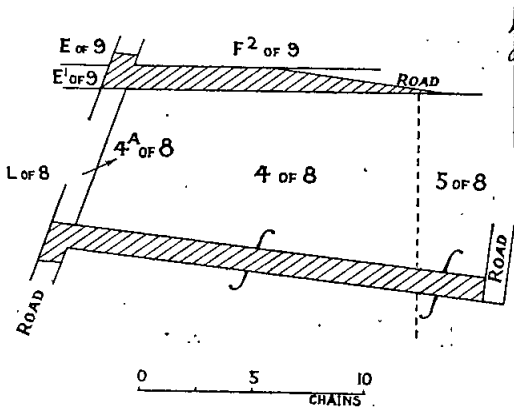

Township of Rainbow, Parish of Werrap, County of Weeah, being the road indicated by hatching on plan hereunder.—(R.89(4) (M.62426).

TIMBER & WATER
SUPPLY RESERVE

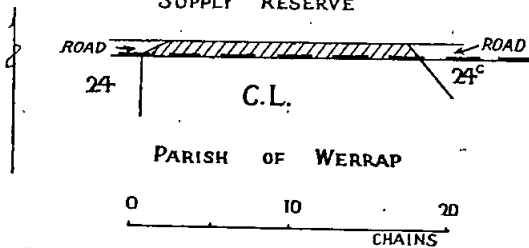

Parish of Wombat, County of Talbot, being the road indicated by hatching on plan hereunder.—(W.179(28) (W.82111).

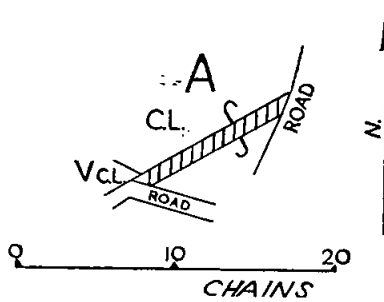

And the Honorable Sir William John Farquhar McDonald, Her Majesty's Minister of Lands for the State of Victoria, shall give the necessary directions herein accordingly.

J. ROSSITER,
Clerk of the Executive Council.

DEPARTMENT OF CROWN LANDS AND SURVEY.

At the Executive Council Chamber, Melbourne, the twenty-eighth day of April, 1970.

PRESENT:

The Lieutenant-Governor as Deputy for His Excellency the Governor of Victoria.

Mr. Thompson | Mr. Wilcox.

LANDS TEMPORARILY RESERVED AS SITES.

THE Lieutenant-Governor as Deputy for His Excellency the Governor of the State of Victoria, by and with the advice of the Executive Council thereof, doth hereby, in pursuance of section 14 of the Land Act 1958, reserve temporarily from sale, from being leased and from having a licence granted in respect thereof, and also except from occupation for mining purposes under any miner's right, the lands hereinafter described:—

BAIRNSDALE.—Site for State School purposes, 1 acre 1 rood 35 perches, more or less, Township of Bairnsdale, Parish of Bairnsdale, County of Tanjil, as indicated by hatching on plan hereunder.—(B.66(11) (Rs.2300).

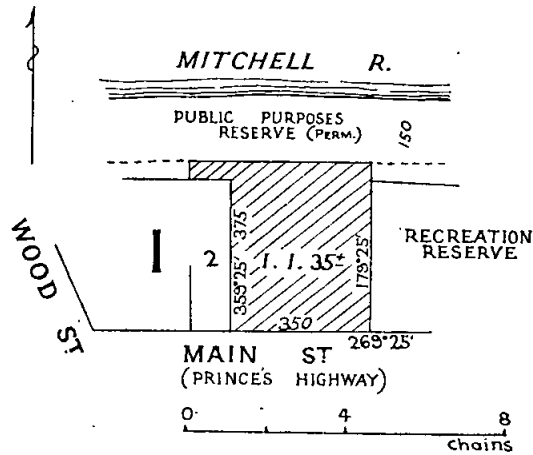

SUBJECT TO SURVEY

BALLARAT EAST.—Site for Public Park and Recreation, 1 rood, more or less, Township of Ballarat East, Parish of Ballarat, County of Grenville, as indicated by hatching on plan hereunder.—(B.128(41) (Rs.4739).

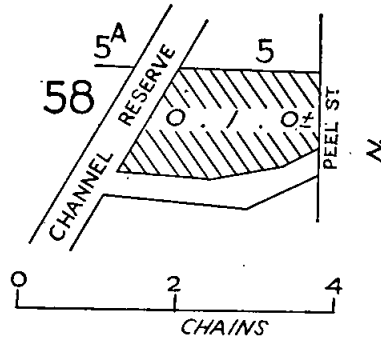

Subject to Survey

CRESWICK.—Site for Reservoir and Plantation purposes, 176 acres, more or less, Parish of Creswick, County of Talbot, as indicated by hatching on plan hereunder.—(C.400(A10) (Rs.9303).

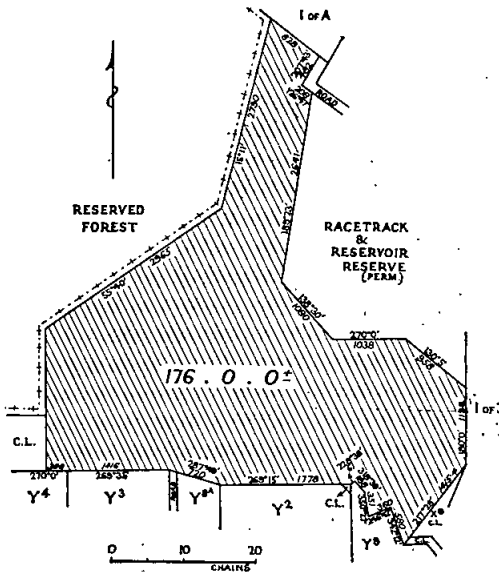

Subject to Survey

BARRABOOL.—Site for Water Supply, 1 acre 1 rood 20 perches, more or less, Parish of Barrabool, County of Grant, as indicated by hatching on plan hereunder.—(B.34⁽²⁾) (Rs.7643).

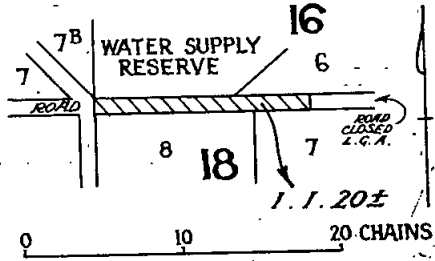

KARRAMOMUS.—Site for Water Supply purposes, 1 acre 3 roods 18 perches, Parish of Karramomus, County of Moira, as indicated by hatching on plan hereunder.—(K.145⁽²⁾) (Rs.9307).

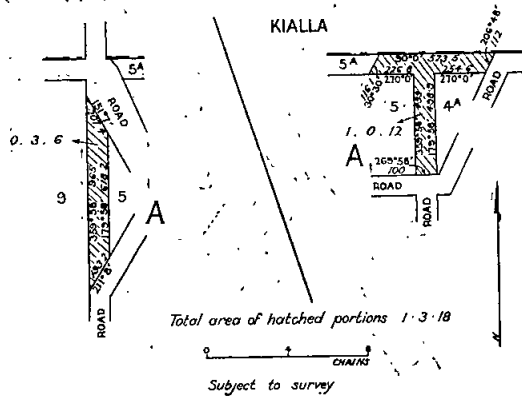

NEKEEYA.—Site for Water Supply purposes, 64 acres 3 roods, more or less, Parish of Nekeeya, County of Ripon, as indicated by hatching on plan hereunder.—(N.134⁽²⁾) (Rs.9003).

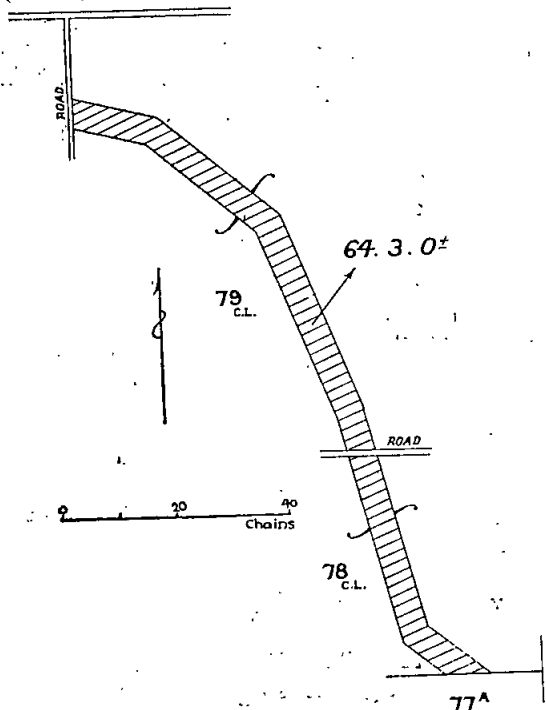

MARYBOROUGH.—Site for Public purposes (purposes of the Forests Act), 1 rood 27 perches, Parish of Maryborough, County of Talbot, as indicated by hatching on plan hereunder.—(M.66⁽¹⁸⁾) (Rs.7619).

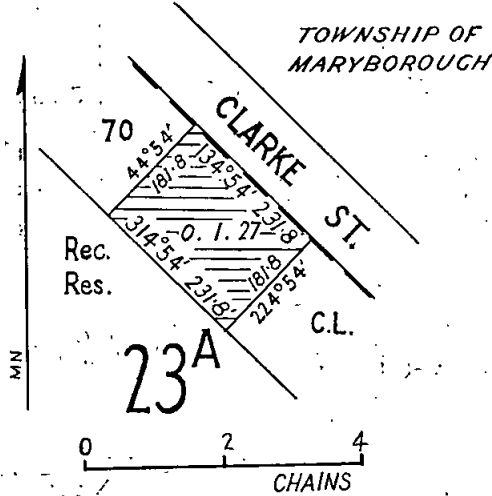

MODEWARRE.—Site for Water Supply purposes, 21 perches, Township of Modewarre, Parish of Gherang Gherang, County of Grant, as indicated by hatching on plan hereunder.—(G.34(B)) (Rs.9306).

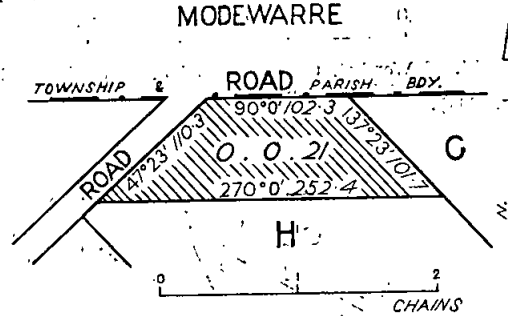

TANJIL.—Site for Public Park and Recreation, 368 acres, more or less, Parish of Tanjil, County of Buin Buln, as indicated by hatching on plan hereunder.—(T.189⁽¹⁵⁾) (Rs.9295).

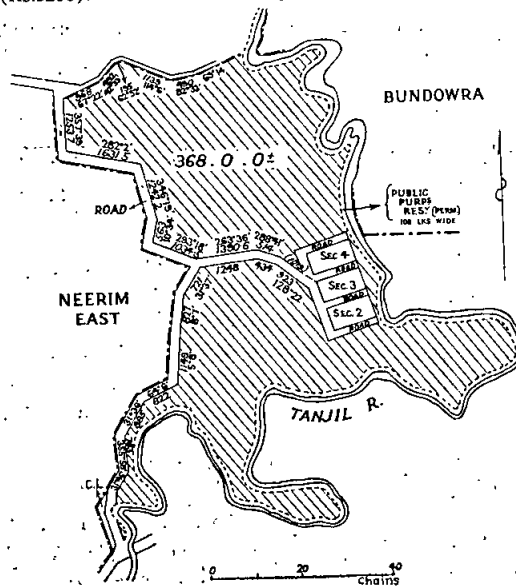

YANGERY.—Site for Water Supply purposes, 17 acres 0 roods 6 perches, Parish of Yangery, County of Villiers, as indicated by hatching on plan hereunder.—(Y.53 (D) (Rs.9276).

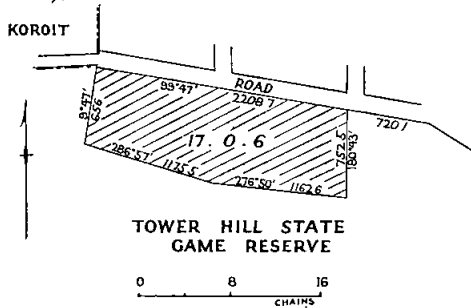

YANGERY.—Site for Public purposes (Conservation of Wildlife), 1,498 acres 2 roods, more or less, Parish of Yangery, County of Villiers, as indicated by hatching on plan hereunder.—(Y.53 (+) & (D) (Rs.2687).

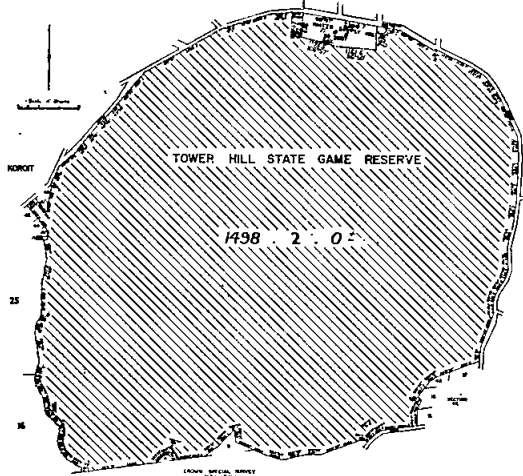

And the Honorable Sir William John Farquhar McDonald, Her Majesty's Minister of Lands for the State of Victoria, shall give the necessary directions herein accordingly.

J. ROSSITER,
Clerk of the Executive Council.

DEPARTMENT OF CROWN LANDS AND SURVEY.

At the Executive Council Chamber, Melbourne, the twenty-eighth day of April, 1970.

PRESENT:

The Lieutenant-Governor as Deputy for His Excellency the Governor of Victoria.

Mr. Thompson | Mr. Wilcox.

REVOCATIONS OF TEMPORARY RESERVATIONS OF LANDS BY ORDERS IN COUNCIL.

THE Lieutenant-Governor as Deputy for His Excellency the Governor of the State of Victoria, by and with the advice of the Executive Council thereof, doth hereby, in pursuance of the provisions of the Land Act 1958, revoke the temporary reservations of lands by Orders in Council hereinafter referred to, viz.:

KEELBUNDORA.—Order in Council of the 27th April, 1920, of 8 4/10 perches of land in the Parish of Keelbundora, as a site for Drainage purposes.—(Rs.8818.)

SANDHURST.—Order in Council of the 20th February, 1962, of 3 roods 33 perches in the Parish of Sandhurst, as a site for a Municipal Depot, and the temporary reservation by Order of the 4th September, 1962, of 1 rood 1 perch as an extension thereto.—(Rs.7801.)

DIMBOOLA.—Order in Council of 18th September, 1882, of 6 acres 1 rood 1 perch of land in the Township of Dimboola, as a site for Police Department, so far only as

regards the portion thereof comprised within the boundaries published in the *Government Gazette* of 25th March, 1970, and containing 1 acre 3 roods 27 perches.—(Rs.5081.)

KERANG.—Order in Council of 13th December, 1880, of 20 acres of land in the Parish of Kerang, as a site for Water Supply purposes and the withholding from sale, leasing and licensing, so far only as regards the portion thereof comprised within the boundaries published in the *Government Gazette* of 3rd April, 1970, and containing 1 acre 1 rood 5 perches.—(Rs.9299.)

WERRAP.—Order in Council of 28th April, 1897, of 905 acres 2 roods 39 perches of land in the Parish of Werrap, as a site for Timber and Water Supply purposes, so far only as regards the portion thereof comprised within the boundaries published in the *Government Gazette* of 3rd April, 1970, and containing 27 acres 2 roods 30 perches.—(Rs.191.)

PARUPA, NERRIN NERRIN AND WOORNDOO.—The temporary reservation as a site for Public purposes and the withholding from sale, leasing, and licensing by Order in Council of the 24th August, 1880, of certain land in the Parishes of Parupa, Nerrin Nerrin and Woorndoo, so far only as regards the portion thereof comprised within the boundaries as defined by technical description and hachure on plan published in the *Government Gazette* of 3rd April, 1970, containing 1 acre 2 roods, more or less.—(P.119 (+) (Rs.272).

And the Honorable Sir William John Farquhar McDonald, Her Majesty's Minister of Lands for the State of Victoria, shall give the necessary directions herein accordingly.

J. ROSSITER,
Clerk of the Executive Council.

LOCAL GOVERNMENT DEPARTMENT.

At the Executive Council Chamber, Melbourne, the twenty-eighth day of April, 1970.

PRESENT:

The Lieutenant-Governor as Deputy for His Excellency the Governor of Victoria.

Mr. Thompson | Mr. Wilcox.

APPROVAL OF RATING AGREEMENT BETWEEN THE TOWN OF PORTLAND AND HAUTE COUTOURE PTY. LTD.

WHEREAS:

(a) Haute Coutoure Proprietary Limited is the registered proprietor of certain land being part of lot 2 on plan of subdivision No. 79921 lodged in the Office of Titles and is desirous of establishing a clothing factory on the said land which land is not within a 25-mile radius of the General Post Office at Melbourne.

(b) the Council of the Town of Portland is of the opinion that the establishment and maintenance of the said factory within the municipality will make a substantial contribution towards the industrial development of the municipality and will encourage the decentralization of industry in Victoria; and

(c) the Mayor, Councillors and Burgesses of the Town of Portland and Haute Coutoure Proprietary Limited on the 24th day of March, 1970, entered into an agreement in respect of the above-described land as to the amount of rates that will be payable thereon by the said Company under the *Local Government Act 1958*, and copies of such agreement have been submitted to the Minister for Local Government.

Now therefore, the Lieutenant-Governor as Deputy for His Excellency the Governor of the State of Victoria, by and with the advice of the Executive Council thereof, and in pursuance of the provisions of the said section 390A of the *Local Government Act 1958*, hereby approves the said agreement.

And the Honorable Rupert James Hamer, Her Majesty's Minister for Local Government for the State of Victoria, shall give the necessary directions herein accordingly.

J. ROSSITER,
Clerk of the Executive Council.

LOCAL GOVERNMENT DEPARTMENT.

At the Executive Council Chamber, Melbourne, the
twenty-eighth day of April, 1970.

PRESENT:

The Lieutenant-Governor as Deputy for His Excellency
the Governor of Victoria.

Mr. Thompson | Mr. Wilcox.

ROAD DISCONTINUED.—SHIRE OF CORIO.

WHEREAS it is provided in section 528 (2) of the
Local Government Act 1958, that where a road
(whether or not a public highway but not being a road
set out on land of the Crown) or any part thereof is not
required for public use, the Governor in Council on the
request of the Council of the municipality in which such
road is situated made not less than one month after
publishing in a newspaper generally circulating in the
district and posted to the registered proprietor (if any)
of the land and the owners and occupiers (if any) of
lands abutting or immediately adjacent to the road notice
of intention to make such request may by Order published
in the *Government Gazette* direct that such road or part
shall be discontinued and thereupon such road or part
shall be discontinued accordingly.

And whereas the Council of the Shire of Corio has
requested that the Governor in Council direct that a
right-of-way between Hastie-avenue and Jabone-terrace,
North Geelong be discontinued and not less than one
month previously has published in a newspaper generally
circulating in the district and posted to the registered
proprietor of the land in the road and to the owners and
occupiers of lands abutting or immediately adjacent to the
road notice of intention to make such request.

Now therefore the Lieutenant-Governor as Deputy for
His Excellency the Governor of the State of Victoria, by
and with the advice of the Executive Council thereof,
hereby directs that the said road, which is shown hatched
on the plan hereunder, shall be discontinued and that the
land may be sold by the Council of the Shire of Corio by
agreement.

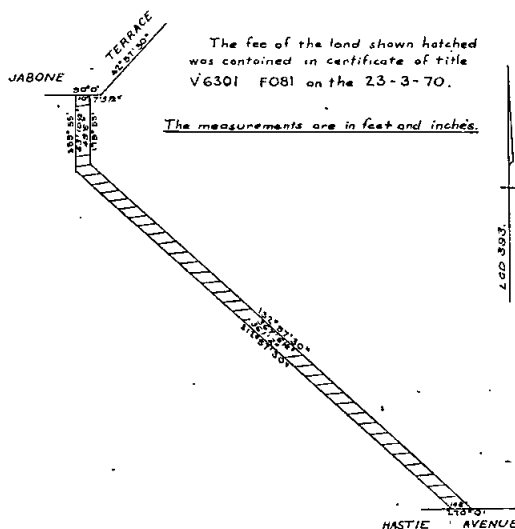

And the Honorable Rupert James Hamer, Her Majesty's
Minister for Local Government for the State of Victoria,
shall give the necessary directions herein accordingly.

J. ROSSITER,
Clerk of the Executive Council.

ARCHITECTS ACT 1958.

At the Executive Council Chamber, Melbourne, the
twenty-eighth day of April, 1970.

PRESENT:

The Lieutenant-Governor as Deputy for His Excellency
the Governor of Victoria.

Mr. Thompson | Mr. Wilcox.

APPOINTMENT OF A MEMBER OF THE ARCHITECTS
REGISTRATION BOARD OF VICTORIA.

PURSUANT to the provisions of the *Architects Act 1958*,
the Lieutenant-Governor as Deputy for His Excellency
the Governor of the State of Victoria, by and with the
advice of the Executive Council thereof, by this Order
appoint—

BRIAN BANNATYNE LEWIS, the nominee of the
University of Melbourne,
to be a member of the Architects Registration Board of
Victoria for the period of two years.

And the Honorable Rupert James Hamer, Her Majesty's
Minister of Public Works for the State of Victoria, shall
give the necessary directions herein accordingly.

J. ROSSITER,
Clerk of the Executive Council.

LABOUR AND INDUSTRY ACT 1958.

At the Executive Council Chamber, Melbourne, the
twenty-eighth day of April, 1970.

PRESENT:

The Lieutenant-Governor as Deputy for His Excellency
the Governor of Victoria.

Mr. Thompson | Mr. Wilcox.

ABOLITION OF POSTERHANGERS WAGES BOARD.

IN pursuance of the powers conferred by the *Labour and
Industry Act 1958*, the Lieutenant-Governor as
Deputy for His Excellency the Governor of the State of
Victoria, by and with the advice of the Executive Council
thereof, doth hereby abolish the Posterhangers Wages
Board.

And the Honorable John Frederick Rossiter, Her
Majesty's Minister of Labour and Industry for the State
of Victoria, shall give the necessary directions herein
accordingly.

J. ROSSITER,
Clerk of the Executive Council.

TERANG SEWERAGE AUTHORITY.

At the Executive Council Chamber, Melbourne, the
twenty-eighth day of April, 1970.

PRESENT:

The Lieutenant-Governor as Deputy for His Excellency
the Governor of Victoria.

Mr. Thompson | Mr. Wilcox.

CONSENT TO BORROWING \$30,000.

UNDER the powers conferred by the *Sewerage Districts
Act* and all other powers enabling him in that behalf,
the Lieutenant-Governor as Deputy for His Excellency
the Governor of the State of Victoria, by and with the
advice of the Executive Council of the said State, doth
hereby consent to the Terang Sewerage Authority borrow-
ing at interest, by mortgage of the General Fund the
sum of Thirty thousand dollars (\$30,000) to meet the
cost of sewerage works as set forth in the detailed state-
ment bearing date 23rd April, 1970.

And the Honorable William Archibald Borthwick, Her
Majesty's Minister of Water Supply for the State of
Victoria, shall give the necessary directions herein
accordingly.

J. ROSSITER,
Clerk of the Executive Council.

HORSHAM SEWERAGE AUTHORITY.

At the Executive Council Chamber, Melbourne, the
twenty-eighth day of April, 1970.

PRESENT:

The Lieutenant-Governor as Deputy for His Excellency
the Governor of Victoria.

Mr. Thompson | Mr. Wilcox.

CONSENT TO BORROWING \$22,000.

UNDER the powers conferred by the Sewerage Districts
Act and all other powers enabling him in that behalf,
the Lieutenant-Governor as Deputy for His Excellency
the Governor of the State of Victoria, by and with the
advice of the Executive Council of the said State, doth
hereby consent to the Horsham Sewerage Authority bor-
rowing at interest by mortgage of the General Fund the
sum of Twenty-two thousand dollars (\$22,000) for the
conversion of Loans Nos. 4 and 11.

And the Honorable William Archibald Borthwick, Her
Majesty's Minister of Water Supply for the State of
Victoria, shall give the necessary directions herein
accordingly.

J. ROSSITER,
Clerk of the Executive Council.

COLAC WATERWORKS TRUST.

At the Executive Council Chamber, Melbourne, the
twenty-eighth day of April, 1970.

PRESENT:

The Lieutenant-Governor as Deputy for His Excellency
the Governor of Victoria.

Mr. Thompson | Mr. Wilcox.

CONSENT TO BORROWING \$50,000.

UNDER the powers conferred by the Water Act and all
other powers enabling him in that behalf, the Lieuten-
ant-Governor as Deputy for His Excellency the Governor
of the State of Victoria, by and with the advice of the
Executive Council of the said State, doth hereby consent to
the Colac Waterworks Trust borrowing at interest by
mortgage of its revenue the sum of Fifty thousand dollars
(\$50,000) to meet the cost of water supply works.

And the Honorable William Archibald Borthwick, Her
Majesty's Minister of Water Supply for the State of
Victoria, shall give the necessary directions herein
accordingly.

J. ROSSITER,
Clerk of the Executive Council.

WEST MOORABOOL WATER BOARD.

At the Executive Council Chamber, Melbourne, the
twenty-eighth day of April, 1970.

PRESENT:

The Lieutenant-Governor as Deputy for His Excellency
the Governor of Victoria.

Mr. Thompson | Mr. Wilcox.

CONSENT TO BORROWING \$50,000.

UNDER the powers conferred by the West Moorabool
Water Board Act and all other powers enabling him
in that behalf, the Lieutenant-Governor as Deputy for
His Excellency the Governor of the State of Victoria,
by and with the advice of the Executive Council of the
said State, doth hereby consent to the West Moorabool
Water Board borrowing at interest the sum of Fifty
thousand dollars (\$50,000) to meet the cost of water
storage works as set forth in the detailed statement bearing
date 23rd April, 1970.

And the Honorable William Archibald Borthwick, Her
Majesty's Minister of Water Supply for the State of
Victoria, shall give the necessary directions herein
accordingly.

J. ROSSITER,
Clerk of the Executive Council.

Water Act 1958.

STATE RIVERS AND WATER SUPPLY COMMISSION.

At the Executive Council Chamber, Melbourne, the
twenty-eighth day of April, 1970.

PRESENT:

The Lieutenant-Governor as Deputy for His Excellency
the Governor of Victoria.

Mr. Thompson | Mr. Wilcox.

BERWICK URBAN DISTRICT—AREA OF DISTRICT
INCREASED.

UNDER the power conferred by the Water Act 1958 and
all other powers enabling him in that behalf, the
Lieutenant-Governor as Deputy for His Excellency the
Governor of the State of Victoria, with the advice of the
Executive Council of the said State on the recommenda-
tion of the State Rivers and Water Supply Commission,
doth hereby declare, order and direct that the area of the
Berwick Urban District be increased by adding to the
same the lands shown by blue colour on a plan approved
by the Governor in Council and deposited in the Office of
the State Rivers and Water Supply Commission, Mel-
bourne (Corr. No. 65/5355) and as on and from the 1st
day of May, 1970, the area of such district shall be deemed
to be so increased.

And the Honorable William Archibald Borthwick, Her
Majesty's Minister of Water Supply for the State of
Victoria, shall give the necessary directions herein
accordingly.

J. ROSSITER,
Clerk of the Executive Council.

MOUNT MACEDON WATERWORKS TRUST.

At the Executive Council Chamber, Melbourne, the
fifth day of May, 1970.

PRESENT:

The Lieutenant-Governor as Deputy for His Excellency
the Governor of Victoria.

Mr. Thompson | Mr. Reid.
Mr. Meagher

CONSENT TO BORROWING \$5,200.

UNDER the powers conferred by the Water Act and all
other powers enabling him in that behalf, the Lieuten-
ant-Governor as Deputy for His Excellency the
Governor of the State of Victoria, by and with the advice
of the Executive Council of the said State, doth hereby
consent to the Mount Macedon Waterworks Trust borrow-
ing at interest by mortgage of its revenue the sum of Five
thousand two hundred dollars (\$5,200) for the conversion
of Loan No. 1.

And the Honorable William Archibald Borthwick, Her
Majesty's Minister of Water Supply for the State of Vic-
toria, shall give the necessary directions herein accordingly.

J. ROSSITER,
Clerk of the Executive Council.

ORBOST WATERWORKS TRUST.

At the Executive Council Chamber, Melbourne, the
fifth day of May, 1970.

PRESENT:

The Lieutenant-Governor as Deputy for His Excellency
the Governor of Victoria.

Mr. Thompson | Mr. Reid.
Mr. Meagher

CONSENT TO BORROWING \$50,000.

UNDER the powers conferred by the Water Act and all
other powers enabling him in that behalf, the Lieuten-
ant-Governor as Deputy for His Excellency the
Governor of the State of Victoria, by and with the advice
of the Executive Council of the said State, doth hereby

consent to the Orbost Waterworks Trust borrowing at interest by mortgage of its revenue the sum of Fifty thousand dollars (\$50,000) to meet the cost of water supply works.

And the Honorable William Archibald Borthwick, Her Majesty's Minister of Water Supply for the State of Victoria, shall give the necessary directions herein accordingly.

J. ROSSITER,
Clerk of the Executive Council.

WARRAGUL WATERWORKS TRUST.

At the Executive Council Chamber, Melbourne, the fifth day of May, 1970.

PRESENT:

The Lieutenant-Governor as Deputy for His Excellency the Governor of Victoria.

Mr. Thompson		Mr. Reid.
Mr. Meagher		

CONSENT TO BORROWING \$6,058.

UNDER the powers conferred by the Water Act and all other powers enabling him in that behalf, the Lieutenant-Governor as Deputy for His Excellency the Governor of the State of Victoria, by and with the advice of the Executive Council of the said State, doth hereby consent to the Warragul Waterworks Trust borrowing at interest by mortgage of its revenue the sum of Six thousand and fifty-eight dollar (\$6,058) for the conversion of Loan No. 2.

And the Honorable William Archibald Borthwick, Her Majesty's Minister of Water Supply for the State of Victoria, shall give the necessary directions herein accordingly.

J. ROSSITER,
Clerk of the Executive Council.

EUROA SEWERAGE AUTHORITY.

At the Executive Council Chamber, Melbourne, the fifth day of May, 1970.

PRESENT:

The Lieutenant-Governor as Deputy for His Excellency the Governor of Victoria.

Mr. Thompson		Mr. Reid.
Mr. Meagher		

CONSENT TO BORROWING \$20,000.

UNDER the powers conferred by the Sewerage Districts Act and all other powers enabling him in that behalf, the Lieutenant-Governor as Deputy for His Excellency the Governor of the State of Victoria, by and with the advice of the Executive Council of the said State, doth hereby consent to the Euroa Sewerage Authority borrowing at interest, by mortgage of the General Fund the sum of Twenty thousand dollars (\$20,000) to meet the cost of sewerage works as set forth in the detailed statement bearing date 30th April, 1970.

And the Honorable William Archibald Borthwick, Her Majesty's Minister of Water Supply for the State of Victoria, shall give the necessary directions herein accordingly.

J. ROSSITER,
Clerk of the Executive Council.

THE BALLARAT SEWERAGE AUTHORITY.

At the Executive Council Chamber, Melbourne, the fifth day of May, 1970.

PRESENT:

The Lieutenant-Governor as Deputy for His Excellency the Governor of Victoria.

Mr. Thompson		Mr. Reid.
Mr. Meagher		

CONSENT TO BORROWING \$10,400.

UNDER the powers conferred by the Sewerage Districts Act and all other powers enabling him in that behalf, the Lieutenant-Governor as Deputy for His Excellency the

Governor of the State of Victoria, by and with the advice of the Executive Council of the said State, doth hereby consent to The Ballarat Sewerage Authority borrowing at interest by mortgage of the General Fund the sum of Ten thousand four hundred dollars (\$10,400) for the conversion of Loan I.

And the Honorable William Archibald Borthwick, Her Majesty's Minister of Water Supply for the State of Victoria, shall give the necessary directions herein accordingly.

J. ROSSITER,
Clerk of the Executive Council.

DANDENONG SEWERAGE AUTHORITY:

At the Executive Council Chamber, Melbourne, the fifth day of May, 1970.

PRESENT:

The Lieutenant-Governor as Deputy for His Excellency the Governor of Victoria.

Mr. Thompson		Mr. Reid.
Mr. Meagher		

CONSENT TO BORROWING \$100,000.

UNDER the powers conferred by the Sewerage Districts Act and all other powers enabling him in that behalf, the Lieutenant-Governor as Deputy for His Excellency the Governor of the State of Victoria, by and with the advice of the Executive Council of the said State, doth hereby consent to the Dandenong Sewerage Authority borrowing at interest by mortgage of the General Fund the sum of One hundred thousand dollars (\$100,000) to meet the cost of sewerage works as set forth in the detailed statement bearing date 30th April, 1970.

And the Honorable William Archibald Borthwick, Her Majesty's Minister of Water Supply for the State of Victoria, shall give the necessary directions herein accordingly.

J. ROSSITER,
Clerk of the Executive Council.

River Improvement Act 1958.

LOUGH CALVERT DRAINAGE TRUST.

At the Executive Council Chamber, Melbourne, the fifth day of May, 1970.

PRESENT:

The Lieutenant-Governor as Deputy for His Excellency the Governor of Victoria.

Mr. Thompson		Mr. Reid.
Mr. Meagher		

ACQUISITION OF AN EASEMENT.

UNDER the provisions of the River Improvement Act 1958 and all other powers thereunto him enabling, the Lieutenant-Governor as Deputy for His Excellency the Governor of the State of Victoria, by and with the advice of the Executive Council of the said State, doth hereby consent to the compulsory acquisition of an easement for drainage purposes by the Lough Calvert Drainage Trust over land being part of Crown allotment 6A2, Parish of Irrewarra, and being part of the land more particularly described in certificate of title, volume 1271, folio 023.

And the Honorable William Archibald Borthwick, Her Majesty's Minister of Water Supply for the State of Victoria, shall give the necessary directions herein accordingly.

J. ROSSITER,
Clerk of the Executive Council.

MILK BOARD ACT 1958.

At the Executive Council Chamber, Melbourne, the fifth day of May, 1970.

PRESENT:

The Lieutenant-Governor as Deputy for His Excellency the Governor of Victoria.

Mr. Thompson | Mr. Reid.
Mr. Meagher

APPOINTMENT OF MEMBER OF THE MILK BOARD.

IN pursuance of the powers in that behalf conferred by sections 6 and 7 of the Milk Board Act 1958 and all other powers him thereunto enabling, the Lieutenant-Governor as Deputy for His Excellency the Governor of the State of Victoria, by and with the advice of the Executive Council thereof, doth by this Order hereby appoint Richard Kenneth Harvey, as a member of the Milk Board for a period of three (3) years from and inclusive of the 10th May, 1970.

And the Honorable Gilbert Lawrence Chandler, Her Majesty's Minister of Agriculture for the State of Victoria, shall give the necessary directions herein accordingly.

J. ROSSITER,
Clerk of the Executive Council.

SUPERANNUATION ACT 1958.

At the Executive Council Chamber, Melbourne, the fifth day of May, 1970.

PRESENT:

The Lieutenant-Governor as Deputy for His Excellency the Governor of Victoria.

Mr. Thompson | Mr. Reid.
Mr. Meagher

PURSUANT to the powers conferred by the provisions of sub-section (1) of section 3 of the Superannuation Act 1958, as amended by paragraph (a) of sub-section 2 of section 18 of the Pensions Supplementation Act 1966 No. 7417, the Lieutenant-Governor as Deputy for His Excellency the Governor of the State of Victoria by and with the advice of the Executive Council thereof doth by this Order declare that the provisions of the Superannuation Act shall apply to James Carruthers, an officer of the Victoria Institute of Colleges constituted pursuant to the provisions of the Victoria Institute of Colleges Act 1965, No. 7291.

And the Honorable Sir Henry Edward Bolte, Her Majesty's Treasurer for the State of Victoria, shall give the necessary directions herein accordingly.

J. ROSSITER,
Clerk of the Executive Council.

LANDS DEPARTMENT NOTICES

APPROACHING LAND SALES.

SALES of Crown Lands, in fee-simple, will be held at the under-mentioned places and dates, viz.:

	No. of Gazette.
Bendigo.—Thursday, 14th May, 1970	32
Charlton.—Tuesday, 2nd June, 1970	43
Chiltern.—Monday, 1st June, 1970	43
Dartmoor.—Wednesday, 13th May, 1970	32
Donald.—Monday, 1st June, 1970	43
Geelong.—Monday, 1st June, 1970	39
Healesville.—Friday, 12th June, 1970	43
Heathcote.—Thursday, 14th May, 1970	32
Meredith.—Thursday, 11th June, 1970	43
Rushworth.—Thursday, 14th May, 1970	32
Wonthaggi.—Friday, 29th May, 1970	39
Yarra Junction.—Friday, 12th June, 1970	43

NOTE.—Sales previously gazetted for Dunolly and Donald for 11th May, 1970, have been cancelled.

AUCTION OF RIGHT TO LEASE CROWN LAND.

Queenscliff.—Monday, 1st June, 1970

SALE OF CROWN LAND BY AUCTION.

The land will be offered for sale in fee-simple, and subject to the provisions of the Land Act and Regulations thereunder.

The upset price is the sum at which bidding will start, and no bid below that sum can be accepted. The highest bidder at or above that sum shall be the purchaser, subject to signature of contract and any necessary payment.

TERMS:

A deposit of at least 12½% of the purchase price must be paid at the sale, either in cash or by cheque.

The residue is payable in half-yearly instalments, in accordance with the following scale, or may be paid off at any earlier time.

- \$40 and under, 6 instalments.
- Over \$40, and not exceeding \$100, 8 instalments.
- Over \$100, and not exceeding \$200, 10 instalments.
- Over \$200, and not exceeding \$400, 12 instalments.
- Over \$400, and not exceeding \$600, 14 instalments.
- Over \$600, and not exceeding \$800, 16 instalments.
- Over \$800, and not exceeding \$1,000, 18 instalments.
- Over \$1,000, 20 instalments.

Interest at the rate of 5% per annum is payable with all payments of residue, and is computed for each instalment from the date of sale to the date of such payment. Additional interest is charged if any instalment is not paid on or before the due date.

If paid off within 30 days of sale, no interest is payable.

FEES, ETC.:

Also payable at the sale, in addition to the deposit, are the survey fee and, if applicable, the valuation of improvements (if purchaser be not the owner thereof).

Payable with balance of purchase money—

Crown Grant fee—	
50 acres and under	\$3
Over 50 acres	\$4
Purchase money \$10 or under	\$2

Assurance Fund contribution.—One cent in every Five dollars or part thereof of purchase price. (This is a fund established to guarantee the validity of freehold titles.)

Transfer of interest prior to completion of payment may be allowed on payment of \$2 fee and subject to stamp duty.

If unable to attend personally, a prospective purchaser may arrange for another person to bid as his agent.

Attention is drawn to section 95, Land Act 1958, which provides that the purchaser shall be deemed to be the owner for the purposes of other Acts; also to an amendment to the Local Government Act providing for Government roads, in certain circumstances, to be declared "private streets", thus making the purchaser liable to contribute to the cost of street construction.

W. J. F. McDONALD,
Minister of Lands.

Office of Crown Lands and Survey,
Melbourne, 6th May, 1970.

CASTLEMAINE.—Sale (No. 12065) of Crown land in fee-simple, by auction, will be held at the LAND INSPECTOR'S OFFICE, CASTLEMAINE, on TUESDAY, the 30th day of JUNE, 1970, at half-past ONE o'clock p.m. To be conducted by T. A. COMTE, Land Officer, Bendigo. TOWNSHIP OF CAMPBELL'S CREEK, PARISH OF CASTLEMAINE, COUNTY OF TALBOT.

Lot 1.

About 2 chains east of the Daylesford—Castlemaine road in the south-west of the Township.

Upset price \$40. Survey fee \$12.

Area 18 perches, allotment 28A of section 1B. Subject to drainage easement 15 links wide. One month allowed for the removal of improvements.

NOTE.—This allotment is offered without legal access, and on the understanding that no such access will be provided in the future by the Crown.—(W.69368.)

Lot 2.

Fronting the south-western corner of two Government roads about ¼ mile north of the Railway Station.

Upset price \$100. Survey fee \$15.

Area 2r. 38p., allotment 93 of section 4A. One month allowed for the removal of improvements.—(W.88382.)

Lot 3.

PARISH OF MALDON, COUNTY OF TALBOT.
Fronting the north-east side of a Government road about ½ mile north-west of Maldon Railway Station.

Upset price \$30 the lot. Survey fee \$16.

Area 1a. 1r. 38p., allotment 16B of section 7. One month allowed for the removal of improvements (fencing).—(W.58969.)

Lot 4.

PARISH OF FRYERS, COUNTY OF TALBOT.
Fronting the north side of a Government road about 2 chains south of the Loddon river and south of the "Vaughan Springs" Reserve.

Upset price \$100 the lot. Survey fee \$13.

Area 1r. 13p., allotment 12 of section 3A.—(W.88293.)

Lot 5.

TOWNSHIP OF NEWSTEAD, PARISH OF STRANGWAYS, COUNTY OF TALBOT.
Fronting the north side of Palmerston-street and adjoining the south side of a gravel reserve in the east of the Township.

Upset price \$110 the lot. Survey fee \$17.

Area 3 acres, allotment 1 of section 19B. One month allowed for the removal of improvements.—(W.88319.)

TOWNSHIP OF CASTLEMAINE, PARISH OF CASTLEMAINE, COUNTY OF TALBOT.

Lot 6.

Fronting the north-west corner of Parkes and Urquhart streets.

Upset price \$150 the lot. Survey fee \$13.

Area 2 roods, allotment 13 of section 29A.

Lot 7.

Fronting the north side of Parkes-street about 2 chains west of Urquhart-street.

Upset price \$150 the lot. Survey fee \$13.

Area 2 roods 4 perches, allotment 15 of section 29A.

SPECIAL CONDITIONS FOR LOTS 6 AND 7:—

1. Subject to drainage and sewerage easement 10 links wide.

NOTE.—Parkes and Urquhart streets adjoining allotments 13 and 15 have been declared private streets and purchasers of lots 6 and 7 will therefore be liable to contribute to the cost of street construction.—(W.89198.)

Lot 8.

PARISH OF MALDON, COUNTY OF TALBOT.
Adjoining the western side of the Shelbourne railway about ¼ mile north-east of Maldon.

Upset price \$130 the lot. Survey fee \$24.50.

Area 9a. 3r. 32p., allotment 7A of section F and allotment 12D of section 10.

SPECIAL CONDITION:—

1. Subject to State Electricity Commission easement 54 links wide.—(W.87504.)

LOCAL LAND BOARDS.

IN pursuance of the provisions of section 34 of the Land Act 1958, notice is hereby given that public hearings at the following places and times, will be conducted by the persons respectively mentioned, being duly appointed in that behalf.

WILLIAM JOHN FARQUHAR McDONALD,
Minister of Lands.

Department of Crown Lands and Survey,
Melbourne.

SCHEDULE.

WANGARATTA LAND OFFICE, Thursday, 21st May, 1970, at 10 a.m.—F. F. Holt.

RED CLIFFS LAND OFFICE, Monday, 25th May to Friday, 29th May, 1970 (inclusive), 9 a.m. each.—N. J. Fitzgerald and R. F. Jones.

PROPOSED REVOCATIONS OF TEMPORARY RESERVATIONS OF LANDS BY ORDERS IN COUNCIL.

IN pursuance of the provisions of the Land Act 1958, notice is hereby given that it is the intention of the Governor in Council to revoke the temporary reservations of lands by Orders in Council hereunder referred to, viz.:—
The following Notices were published 1° on the 29th April, 1970, pursuant to Orders of the 22nd April, 1970.

TALBOT.—The temporary reservation, by Order in Council of the 28th June, 1928, of 3 roods 7 perches of land in the Township of Talbot, as a site for Public Baths, is about to be revoked.—(T.136(?) (Rs.3695).

BARWO.—The temporary reservation as a site for Water Supply purposes and the withholding from sale, leasing and licensing by Order in Council of the 16th December, 1884 (see Government Gazette 19th December, 1884, page 3564) of 110 acres, more or less, in two separate portions in the Township of Nathalia and the Parish of Barwo, are about to be revoked, so far only as the portion in the Parish of Barwo, containing 4 perches, indicated by hatching on plan hereunder, is concerned.—(B.690(A³) (Rs.2360).

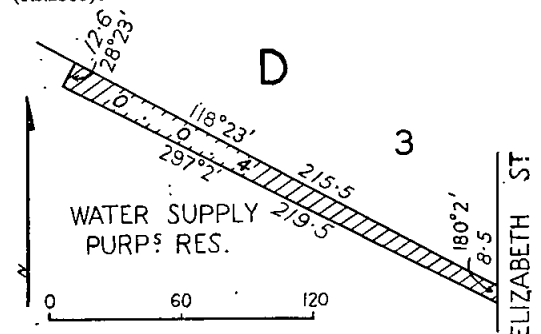

CRANBOURNE.—The temporary reservation, as a site for Public purposes (State School) and the withholding from sale, leasing and licensing, by Order in Council of the 5th February, 1877, of 1 acre of land in the Township of Cranbourne, is about to be revoked.—(C.329(4) (Rs.5820).

SANDHURST (KENNINGTON).—The temporary reservation, by Order in Council of the 24th September, 1912, of 5 acres 1 rood 9 perches of land in the Parish of Sandhurst, as a site for Public Gardens, revoked as to part by various Orders, is about to be revoked, so far only as the portion containing 2 acres, more or less, indicated by hatching on plan hereunder, is concerned.—(S.371(20) (Rs.782).

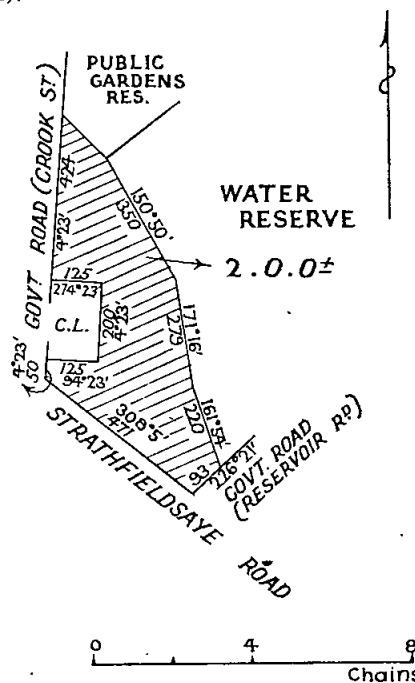

BEECHWORTH.—The temporary reservation, by Order in Council of the 26th September, 1864, of 201 acres 2 roods 26 perches of land in the Parish of Beechworth (now in the Township), as a site for a Mental Hospital, is about to be revoked, so far only as the portion containing 10 perches, indicated by hatching on plan hereunder, is concerned.—(B.348⁽⁹⁾) (Rs.1221).

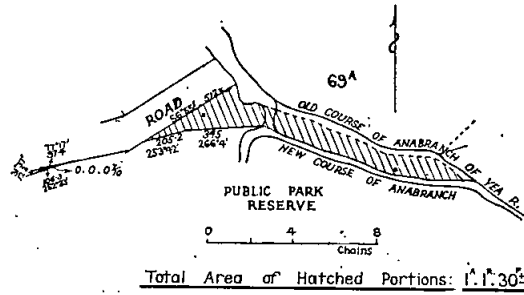
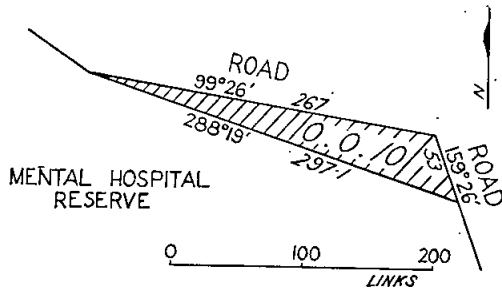

CARLYLE.—The temporary reservation, by Order in Council of the 25th September, 1894, of 10 acres of land in the Parish of Carlyle, as a site for a Night-soil Depot, for the municipal district of the Shire of Rutherglen, is about to be revoked, so far only as the portion containing 5 acres 19 perches, indicated by hatching on plan hereunder is concerned.—(C.187⁽⁷⁾) (Rs.9309).

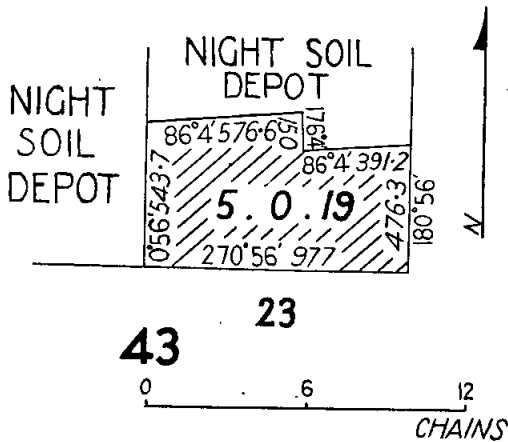

MOOLERR.—The temporary reservation, as a site for Conservation of Water, and the withholding from sale, leasing and licensing by Order in Council, of the 5th June, 1882, of 17 acres 3 roods 5 perches of land in the Parish of Moolerr, are about to be revoked, so far only as the portion containing 15 acres 3 roods 9 perches, indicated by hatching on plan hereunder, is concerned.—(M.427⁽³⁾) (Rs.9298).

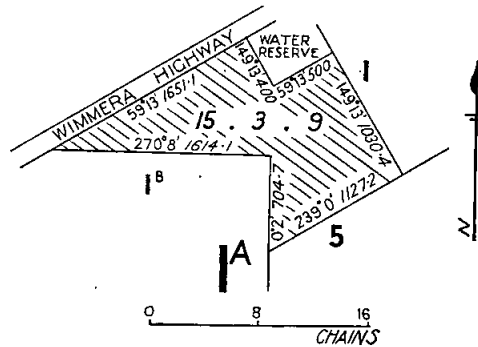

CARLYLE.—The temporary reservation, by Order in Council of the 14th November, 1893, of 10 acres of land in the Parish of Carlyle, as a site for a Night-soil Depot, is about to be revoked, so far only as the portion containing 5 acres 2 perches, indicated by hatching on plan hereunder is concerned.—(C.187⁽⁷⁾) (Rs.9309).

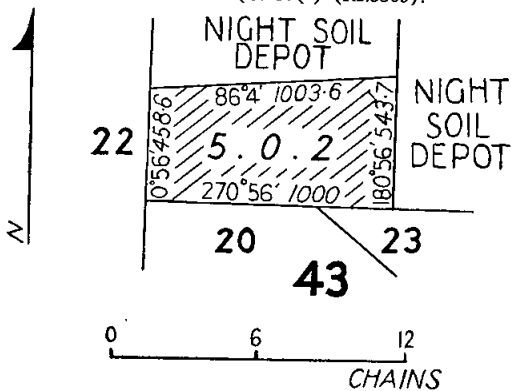

SPRINGHURST.—The temporary reservation, by Order in Council of the 9th December, 1885, of 71 acres 3 roods 20 perches of land in the Township of Springhurst, (formerly Town of Narimga), as a site for Public Recreation, is about to be revoked, so far only as the portion containing 3 acres 38 perches, indicated by hatching on plan hereunder is concerned.—(N.135⁽²⁾) (Rs.610).

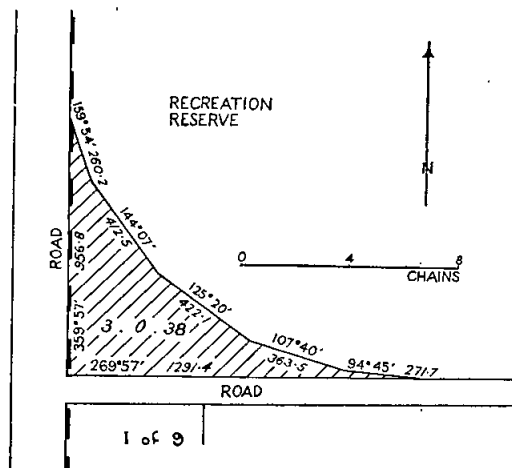

KILLINGWORTH.—The temporary reservation, by Order in Council of the 10th March, 1903, of 64 acres of land in the Parish of Killingworth, as a site for a Public Park, is about to be revoked, so far only as the portions containing 1 acre 1 rood 30 perches, more or less, indicated by hatching on plan hereunder are concerned.—(K.55⁽²⁾) (Rs.428).

WEDDERBURNE.—The temporary reservation, by Order in Council of the 15th July, 1912, of 95 acres 31 perches of land in the Parish of Wedderburne, as a site for Supply of Material for Road-making, is about to be revoked, so far only as the portion containing 2 roods 32 perches, indicated by hatching on plan hereunder is concerned.—(W.116(14)) (Rs.6880).

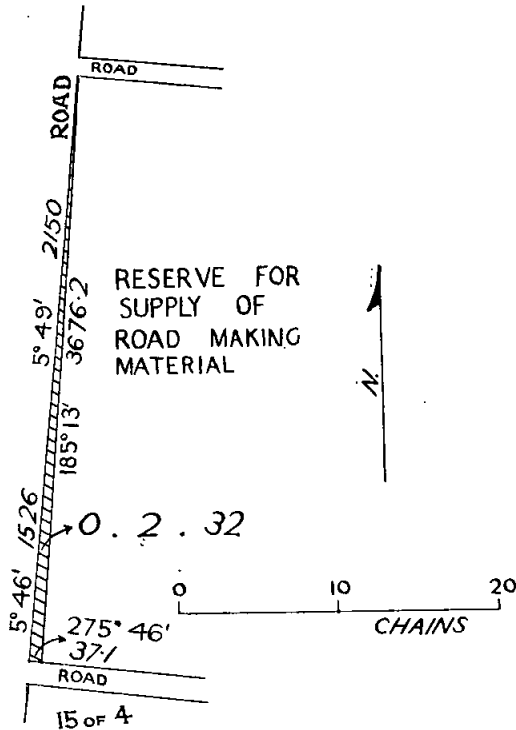

PROPOSED PERMANENT RESERVATION OF LANDS AS SITES.

IN pursuance of sections 14 and 21 of the Land Act 1958, notice is hereby given that it is the intention of the Governor in Council to reserve permanently from sale, from being leased and from having a licence granted in respect thereof the land hereinafter described:—

The following Notices were published 1° on the 15th April, 1970, pursuant to Orders of the 7th April, 1970.

TRUGANINA (ALTONA).—Land proposed to be permanently reserved as a site for Public Recreation, 25 acres 3 roods, more or less, Parish of Truganina, County of Bourke, as indicated by hatching on plan hereunder.—(T.109(6)) (Rs.7827).

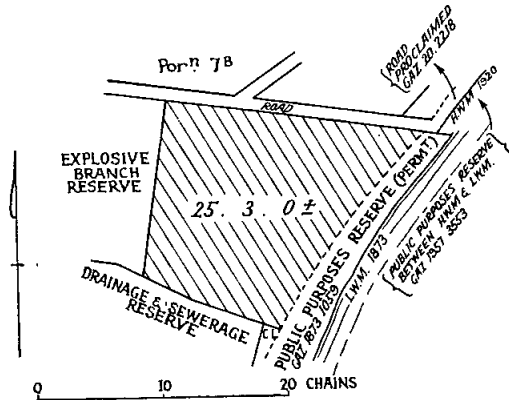

W. J. F. McDONALD,
Minister of Lands.

PROPOSED REVOCATIONS OF TEMPORARY RESERVATIONS OF LANDS BY ORDERS IN COUNCIL.

IN pursuance of the provisions of the Land Act 1958, notice is hereby given that it is the intention of the Governor in Council to revoke the temporary reservations of lands by Orders in Council hereunder referred to, viz.:—

The following Notices were published 1° on the 15th April, 1970, pursuant to Orders of the 7th April, 1970.

CASTERTON.—The temporary reservation by Order in Council of the 13th December, 1886, of 3 acres 0 roods 34 perches of land in the Township of Casterton, as a site for Water Supply purposes, revoked as to part by order of the 27th June, 1898, is about to be revoked, so far as the balance containing 2 acres 2 roods 9/10 perches is concerned.—(C.177(2)) (Rs.5258).

CRAIGIE, EGLINTON AND MAJORCA.—The temporary reservation, by Order in Council of the 5th August, 1872, of certain land in the Parishes of Craigie and Eglinton (now in the Parishes of Craigie and Eglinton and the Township of Majorca), as a site for Reservoirs and Catchment Area purposes, revoked as to part by various orders, is about to be revoked, so far as the balance is concerned.—(C.330(1)), E.18(4), M.425(6) (C.77910).

ILLAWARRA.—The temporary reservation, by Order in Council of the 28th August, 1939, of 1 acre 3 roods 24 perches of land in the Parish of Illawarra, as a site for Water Supply purposes, is about to be revoked.—(I.13(5)) (Rs.4961).

MINDAI AND CAPE CLEAR.—The temporary reservation as a site for Water Supply purposes and the withholding from sale, leasing and licensing by Order in Council of the 20th October, 1879, of 473 acres 0 roods 32 perches of land in the Parishes of Mindai and Clarkesdale, revoked as to part by various Orders, are about to be revoked, so far only as the portions containing 8 acres 2 roods 10 perches, more or less, indicated by hatching on plan hereunder, are concerned.—(C.480(1)), M.122(2) (Rs.5263).

BALLAN.—The temporary reservation, by Order in Council of the 9th December, 1872 (see Government Gazette 13th December, 1872, page 2262), of 1 acre of land in the Township of Ballan, as a site for a Court House, is about to be revoked, so far only as the portion containing 2 roods, indicated by hatching on plan hereunder is concerned.—(B.23(4)) (C.75794).

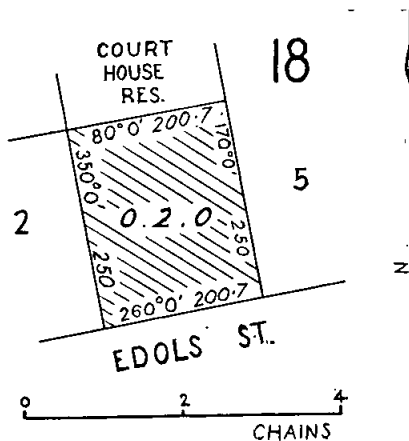

W. J. F. McDONALD,
Minister of Lands.

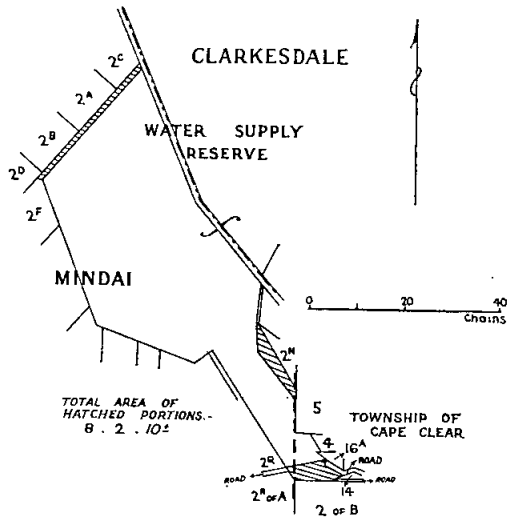

TATONGA.—The temporary reservation, by Order in Council of the 30th September, 1958, of 56 acres 2 roods, more or less, of land in the Parish of Tatonga, as a site for Public Recreation, revoked as to part by Order of the 30th March, 1965, is about to be revoked, so far only as the portion containing 6 perches, indicated by hatching on plan hereunder, is concerned.—(T.256⁽³⁾) (Rs.4176).

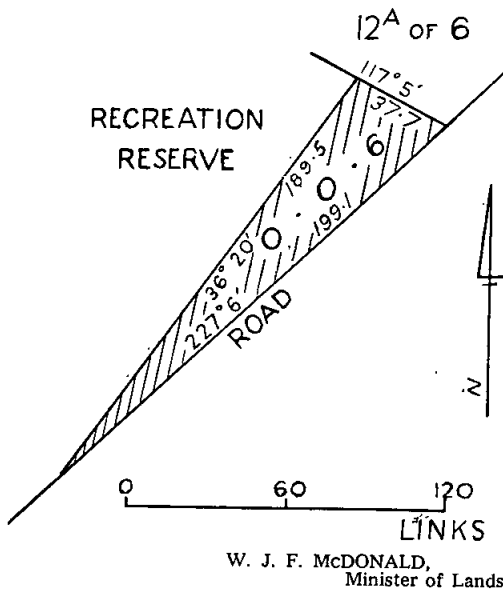

W. J. F. McDONALD,
Minister of Lands.

PROPOSED REVOCATIONS OF TEMPORARY RESERVATIONS OF LANDS BY ORDERS IN COUNCIL.

IN pursuance of the provisions of the Land Act 1958, notice is hereby given that it is the intention of the Governor in Council to revoke the temporary reservations of lands by Orders in Council hereunder referred to, viz.:

The following Notices were published 1^o on the 6th May, 1970, pursuant to Orders of the 28th April, 1970.

BEECHWORTH.—The temporary reservation by Order in Council of the 21st January, 1931, of 6 acres 3 roods 34 perches of land in the Parish of Beechworth, as a site for Public Recreation is about to be revoked.—(B.349⁽²⁴⁾) (Rs.4089).

ST. KILDA AND ELWOOD.—The temporary reservation by Order in Council of the 5th May, 1964, of certain lands at St. Kilda and at Elwood in the Parish of Melbourne South as a site for Public Recreation, revoked as to part by Order of the 24th October, 1967, is about to be revoked so far as the balance is concerned.—(M.333⁽²⁵⁾) (Rs.8333).

TYNTYNDER NORTH.—The temporary reservation by Order in Council of the 30th May, 1916, of 10 acres of land in the Parish of Tyntynder North as a site for a Sanitary Depot is about to be revoked.—(T.244⁽¹³⁾) (Rs.1042).

LAWLOIT.—The temporary reservation, by Order in Council of the 30th September, 1889, of 100 acres 4 perches of land in the Parish of Lawloit as a site for Water Supply purposes, revoked as to part by various Orders, is about to be revoked so far as the portion containing 19 acres 2 roods 24 perches, indicated by hatching on plan hereunder, is concerned.—(L.137⁽²⁾) (Rs.6447).

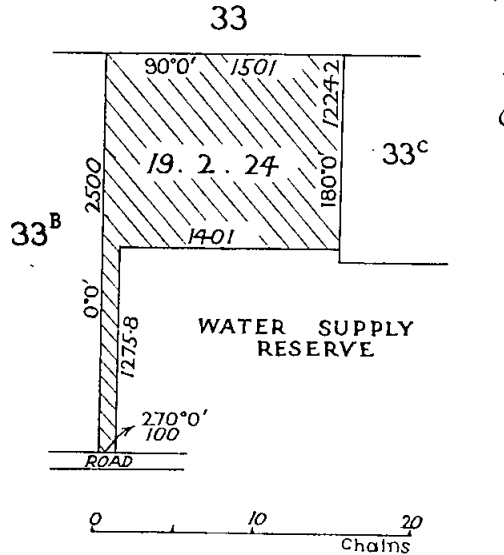

Subject to Survey

MELBOURNE SOUTH (POINT ORMOND).—The temporary reservation by Order in Council of the 30th November, 1915 (see Government Gazette, 8th December, 1915, page 4902) of 3 acres 3 roods, more or less, of land in the Parish of Melbourne South (named City of St. Kilda, at Elwood in order) as a site for Public Recreation, revoked as to part by order of the 24th October, 1967, is about to be revoked so far only as the portion containing 2 roods more or less indicated by hatching on plan hereunder is concerned.—(M.333⁽²⁵⁾) (Rs.444).

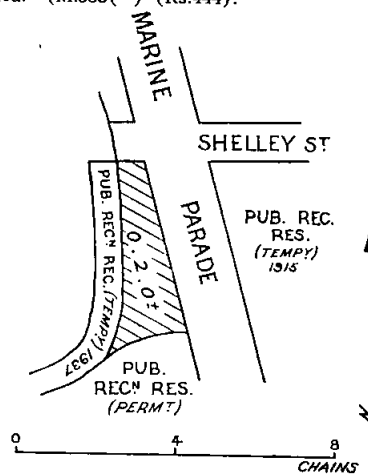

MELBOURNE SOUTH (POINT ORMOND).—The temporary reservation by Order in Council of the 7th April, 1937 (see Government Gazette, 14th April, 1937, page 1091), of 5 acres, more or less, of land in the Parish of Melbourne South (named City of St. Kilda at Elwood in Order) as a site for Public Recreation is about to be revoked so far only as the portion containing 2 roods, more or less, indicated by hatching on plan hereunder, is concerned.—(M.333⁽²⁵⁾) (Rs.444).

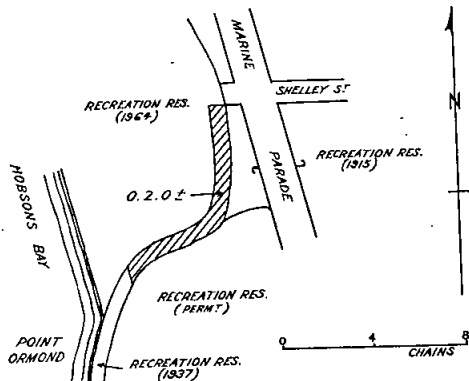

W. J. F. McDONALD,
Minister of Lands.

REGULATIONS FOR THE CARE, PROTECTION AND MANAGEMENT OF THE "LAKES ENTRANCE (CUNNINGHAM) RECREATION RESERVE".

WHEREAS by section 218 of the *Land Act 1958* the Minister of Lands is empowered to make Regulations with respect to certain land and for extending or applying all or any of those Regulations to certain other land: Now therefore I, William John Farquhar McDonald, Her Majesty's Minister of Lands in and for the State of Victoria, do hereby make the following Regulation:—

All the Regulations made on the 15th April, 1953 with respect to the land reserved by Orders in Council, dated 18th November, 1889, and 3rd November, 1893, as sites for Public Recreation in the Township of Lakes Entrance are hereby applied to the land reserved for Public purposes by Order in Council dated 29th July, 1969 and published on page 2473 in the *Government Gazette* of the 7th August, 1969.—(Rs.2251.)

Given under my hand at Melbourne, on the 28th day of April, 1970.

W. J. F. McDONALD,
Minister of Lands.

Every person who contravenes or fails to comply with these Regulations shall, in accordance with the provisions of section 218 of the *Land Act 1958*, for each offence be liable to a penalty of not more than Fifty dollars, and every person who contravenes or fails to comply with any such Regulations, and who, after he has been warned by any bailiff of Crown lands or by any member of the Police Force, does not desist therefrom may be forthwith apprehended by such bailiff or member of the Police Force and taken before some justice to be dealt with according to law and shall be liable to a penalty of not more than One hundred dollars.

REGULATIONS FOR THE CARE, PROTECTION AND MANAGEMENT OF THE "ELMORE SWIMMING POOL RESERVE".

WHEREAS by section 218 of the *Land Act 1958* the Minister of Lands is empowered to make Regulations with respect to certain land and for extending or applying all or any of those Regulations to certain other land:

Now therefore I, William John Farquhar McDonald, Her Majesty's Minister of Lands in and for the State of Victoria do hereby make the following Regulation:—

All the Regulations made on the 24th February, 1960, with respect to the land in the Parish of Elmore reserved as a site for Swimming Pool by Order in Council dated the 9th December, 1958 are hereby applied to the land in the Parish of Elmore reserved for Public purposes (Swimming Pool) by Order in Council dated the 17th December, 1968.—(Rs.921.)

Given under my hand at Melbourne, on the 28th day of April, 1970.

W. J. F. McDONALD,
Minister of Lands.

Every person who contravenes or fails to comply with these Regulations shall, in accordance with the provisions of section 218 of the *Land Act 1958*, for each offence be liable to a penalty of not more than Fifty dollars, and every person who contravenes or fails to comply with any such Regulations, and who, after he has been warned by

any bailiff of Crown lands or by any member of the Police Force, does not desist therefrom may be forthwith apprehended by such bailiff or member of the Police Force and taken before some justice to be dealt with according to law and shall be liable to a penalty of not more than One hundred dollars.

REGULATIONS FOR THE CARE, PROTECTION AND MANAGEMENT OF THE "LAKE COLAC WATER RESERVE".

WHEREAS by section 218 of the *Land Act 1958* the Minister of Lands is empowered to make Regulations as to any land which under the provisions of that Act or of any other Act relating to Crown lands has been reserved for any public purpose whatsoever and which has not been conveyed to or vested in trustees: Now therefore I, William John Farquhar McDonald, Her Majesty's Minister of Lands in and for the State of Victoria, in pursuance with the powers aforesaid, do hereby make the following additional Regulations with respect to the reserved Crown lands coloured red on plan marked C.6.7.61 attached to Lands Department correspondence Rs.1374:—

REGULATIONS.

30. No person shall—

- (a) enter or remain in the Reserve who may offend against decency as regards dress, language, or conduct or who may behave in a disorderly, unseemly, or offensive manner, or create or take part in any disturbance;
- (b) enter or remain in the Reserve whilst in a state of intoxication;
- (c) use indecent or offensive language in the Reserve;
- (d) bring any intoxicating liquor onto the Reserve without the consent of the Committee of Management first obtained.

31. No person shall drive, push, pull or place on the Reserve or park or leave thereon any motor-car, motorcycle, beach buggy, bicycle, horse-drawn vehicle, watercraft, trailer or other vehicle except in such places as are set aside for such purposes by the Committee, unless such person obtain the permission, in writing, of the Committee.

32. No person shall park any vehicle within the Reserve except—

- (a) in an area set apart for the purpose and clearly defined by signs; or
- (b) upon payment of such fees (if any) as may be prescribed.

33. No person shall, without the consent of the Committee of Management in writing first obtained, carry or discharge any firearm whilst on the Reserve.—(Rs.1374.)

Given under my hand at Melbourne, on the 28th day of April, 1970.

W. J. F. McDONALD,
Minister of Lands.

Every person who contravenes or fails to comply with these Regulations shall, in accordance with the provisions of section 218 of the *Land Act 1958*, for each offence be liable to a penalty of not more than Fifty dollars, and every person who contravenes or fails to comply with any such Regulations, and who, after he has been warned by any bailiff of Crown lands or by any member of the Police Force, does not desist therefrom may be forthwith apprehended by such bailiff or member of the Police Force and taken before some justice to be dealt with according to law and shall be liable to a penalty of not more than One hundred dollars.

REGULATIONS FOR THE CARE, PROTECTION AND MANAGEMENT OF THE DROUIN PUBLIC PURPOSES (CHILDREN'S PLAYGROUND) RESERVE AND THE DROUIN PUBLIC RECREATION RESERVE.

WHEREAS by section 218 of the *Land Act 1958* the Minister of Lands is empowered to make regulations as to any land which, under the provisions of that Act or of any other Act relating to Crown lands has been reserved for any public purpose whatsoever and which has not been conveyed to or vested in trustees: And whereas certain Crown lands in the Township of Drouin were temporarily reserved by Order in Council dated the 19th July, 1966, as a site for Public purposes (Children's Playground) (corres. No. 8604) together with certain other land in the aforesaid township were temporarily reserved by Order in Council dated the 15th March, 1967, as a site for Public Recreation (corrs. No. 8603): And whereas such lands (hereinafter called the "Reserve") have not been conveyed to or vested

in trustees. And whereas it is expedient that regulations for the care, protection and management of the Reserve and for other purposes connected therewith should be made.

Now therefore I, William John Farquhar McDonald, Her Majesty's Minister of Lands in and for the State of Victoria, in pursuance with the powers aforesaid, do hereby make the following Regulations for or with respect to the Reserves:—

REGULATIONS.

1. The Reserve shall be open to the public from sunrise to sunset free of charge.
2. No person shall enter or remain in the Reserve who may offend against decency as regards dress, language or conduct.
3. No person shall damage in any way trees, shrubs or flowers in the Reserve, nor shall fires be lighted therein, except in specially constructed fireplaces without permission, in writing, of the Committee of Management first obtained.
4. No person shall climb or jump over the gates or fences in or around the Reserve, nor post bills thereon or cut names on or in any way damage or injure any of the buildings, erections, gates, fences, seats or trees, nor leave or deposit any glass, paper or rubbish, nor roll or throw stones or any missiles of any kind therein.
5. No person shall put or bring into the Reserve, any dog unless secured by a chain or cord, or any cattle, horses, sheep, goats, pigs or other animals without the permission, in writing, of the Committee of Management first obtained.
6. No person shall camp in the Reserve.
7. No person shall erect therein, any structure without the permission, in writing, of the Committee of Management first obtained.
8. No person shall take part in any public entertainment of any sort in the Reserve without the permission, in writing, of the Committee of Management first obtained.
9. No person shall remove or displace any board, plate or tablet or any support, fastening or fitting used or constructed or adapted to be used for the exhibition of any regulation or notice and fixed or set up by the Committee of Management in the Reserve.
10. No person shall affix, print, post, paint, cut or mark any advertisement, sign, picture, bill, placard, notice, word, letter or figure to or upon any wall or fence in or enclosing the Reserve or to or upon any tree, building, barrier, railing, seat, structure, erection, flagging or path in the Reserve, without the consent of the Committee of Management.
11. No person except labourers or workmen employed in the Reserve shall enter any plots therein, which may be enclosed for the plantation of young trees or shrubs.
12. No person above the age of twelve years shall use any of the swings, or other appliances erected thereon.
13. No child shall use any of the swings or other appliances in the Reserve, except for the purposes for which they are respectively provided.
14. All papers, fruit peel, and other litter shall be placed in the receptacles provided by the Committee of Management for that purpose.
15. Every person in the Reserve shall obey the lawful directions of any officer of the Committee of Management in respect of his or her conduct therein.
16. Any bailiff of Crown lands, member of the Police Force or duly appointed officer or servant of the Committee of Management, shall have the right (in addition to any other penalty provided under these Regulations) to remove or exclude from the Reserve any person who commits a breach of these regulations or who wilfully damages any of the swings or other appliances or property in the Reserve.—(Rs.8603, Rs.8604.)

Given under my hand at Melbourne, on the 28th day of April, 1970.

W. J. F. McDONALD,
Minister of Lands.

Every person who contravenes or fails to comply with these Regulations shall, in accordance with the provisions of section 218 of the *Land Act 1958*, for each offence be liable to a penalty of not more than Fifty dollars and every person who contravenes or fails to comply with any such Regulations, and who, after he has been warned by any bailiff of Crown lands or by any member of the Police Force, does not desist therefrom may be forthwith apprehended by such bailiff or member of the Police Force and taken before some justice to be dealt with according to law and shall be liable to a penalty of not more than One hundred dollars.

REGULATIONS FOR THE CARE, PROTECTION AND MANAGEMENT OF THE GLENELG AND WESTERN BAY PUBLIC PURPOSES RECREATION RESERVE.

WHEREAS by section 218 of the *Land Act 1958* the Minister of Lands is empowered to make Regulations with respect to certain land and extending or otherwise all or any of those Regulations to certain other Land: therefore I, William John Farquhar McDonald, Her Majesty's Minister of Lands in and for the State of Victoria do hereby make the following Regulation:—

All the Regulations made on the 22nd April, 1949, in respect to certain lands in the Parish of Glenelg reserved as a site for Public Purposes and Recreation are hereby applied to the lands in the said Parish reserved for Public Purposes, and shown hatched red on plan marked "G/11.9.69" attached to Departmental Correspondence Rs.4859.

Given under my hand at Melbourne, on the 22nd day of April, 1970.

W. J. F. McDONALD,
Minister of Lands.

Every person who contravenes or fails to comply with these Regulations shall, in accordance with the provisions of section 218 of the *Land Act 1958*, for each offence be liable to a penalty of not more than Fifty dollars, and every person who contravenes or fails to comply with any such Regulations, and who, after he has been warned by any bailiff of Crown lands or by any member of the Police Force, does not desist therefrom may be forthwith apprehended by such Bailiff or member of the Police Force and taken before some justice to be dealt with according to law and shall be liable to a penalty of not more than One Hundred Dollars.

AMENDMENT TO REGULATIONS FOR THE CARE, PROTECTION AND MANAGEMENT OF THE "WESTERN BAY RESERVE" AT COLAC.

WHEREAS by section 218 of the *Land Act 1958* the Minister of Lands is empowered to make Regulations as to any land which under the provisions of that Act or of any other Act relating to Crown lands has been reserved for any public purpose whatsoever and which has not been conveyed to or vested in trustees: And whereas certain Crown lands in the Township of Colac temporarily reserved as sites for Public Park and Public Recreation by Orders in Council dated the 13th November, 1947 and 10th April, 1951 and together known as the "Western Bay Reserve" (hereinafter referred to as the "reserve"): Now therefore I, William John Farquhar McDonald, Her Majesty's Minister of Lands in and for the State of Victoria, in pursuance of the powers aforesaid, do hereby amend the said Regulations as follows:—

1. Regulation No. 1 shall be amended to read:—

The Reserve shall be open to the public, free of charge, at all times, except on such occasions not exceeding twenty-six (26) days in any one year, as the Reserve may be set apart for cricket, football or other matches, shows, sports, fêtes, musical performances, outdoor gatherings or holiday amusements, on any of which occasions fees may be charged and taken for admission of persons and vehicles to the Reserve, as hereinafter provided.—(Rs.6073.)

Given under my hand at Melbourne, on the 28th day of April, 1970.

W. J. F. McDONALD,
Minister of Lands.

Every person who contravenes or fails to comply with these Regulations shall, in accordance with the provisions of section 218 of the *Land Act 1958*, for each offence be liable to a penalty of not more than Fifty dollars, and every person who contravenes or fails to comply with any such Regulations, and who, after he has been warned by any bailiff of Crown lands or by any member of the Police Force, does not desist therefrom may be forthwith apprehended by such bailiff or member of the Police Force and taken before some justice to be dealt with according to law and shall be liable to a penalty of not more than One hundred dollars.

REGULATIONS FOR THE CARE, PROTECTION AND MANAGEMENT OF THE WYEEBOO RECREATION RESERVE.

WHEREAS by section 218 of the *Land Act 1958* the Minister of Lands is empowered to make regulations as to any land which under the provisions of that Act or of any other Act relating to Crown lands has been reserved for any public purpose whatsoever and which has not been conveyed to or vested in trustees: And whereas certain Crown lands in the Township of Wyeboon and described in a notice published in the *Gazette* of the

first day of August, 1900 were reserved as a site for Recreation: And whereas such lands (hereinafter "the Reserve") have not been conveyed to or in trustees: And whereas it is expedient that regard for the care, protection and management of the and for other purposes connected therewith should be observed: Now therefore I, William John Farquhar Her Majesty's Minister of Lands in and for the of Victoria, in pursuance of the powers aforesaid, do make the following Regulations for or with respect Reserve:—

REGULATIONS.

1. Reserve shall be open to the public from sunrise free of charge except on such days as the Reserve may be set apart by the Committee for recreation, matches, shows, fêtes, sports, or amusements on which occasions a sum not exceeding One dollar may be charged and collected for the admission of every person to the Reserve.

2. Committee may set apart any portion of the Reserve for the purpose of any lawful game of sports, and may from time to time grant any club, or association of persons, upon such terms and conditions as the Committee may think fit to be consistent with these Regulations the use of the Reserve shall be set apart.

3. No person shall—

a) enter or remain in the Reserve who may offend against decency as regards dress, language, or conduct or who behaves in a disorderly, unseemly, or offensive manner or creates or takes part in any disturbance.

b) cut, damage or disfigure any building, gate, fence, seat, sign or vegetation in the Reserve, or deposit and leave any glass, tins, bottles, paper or other refuse or litter in the Reserve except in receptacles provided for such purposes.

c) roll, throw or project any stone or missile in the Reserve.

d) spit or expectorate on the paths or in or on any structure in the Reserve.

e) except officers or employees of the Committee enter any plots which may be enclosed for plantations of trees, shrubs or other vegetation.

f) remove any earth, sand, stone, marl, gravel or timber from the Reserve without the permission in writing of the Committee first obtained.

g) obstruct, disturb, interrupt or annoy any officer or employee of the Committee in the proper execution of his duty.

h) except participants or authorized officials, intrude upon any arena or playing field during the course of any game of sport.

i) bring into the Reserve or carry or use therein any firearm or offensive weapon.

j) light fires in the Reserve except in fire-places as may be provided for such purpose.

No person shall without the consent in writing of the Committee first obtained:—

(a) bring into the Reserve any cattle, sheep, goats or pigs or any dog not controlled by a chain or leash.

(b) bet publicly on the Reserve.

(c) camp or erect any building or booth in the Reserve.

(d) conduct, play, practise or engage in any organized show, fête, game, sport or amusement and then only on such portions of the Reserve as may be set apart for the purpose and subject to payment of such fees and on such terms and conditions including authority to make and collect charges for admission, as may be determined by the Committee.

(e) grade or scrape the ground or burn any vegetation in the Reserve.

(f) affix, print, post, paint, cut or mark any advertisement, sign, bill, placard or notice to or upon any wall, fence or gate in or around the Reserve, or upon any tree, path, land or structure, within the Reserve.

No person shall park any motor car or vehicle in the Reserve except at such places as may be set apart for the purpose by the Committee which may charge and collect a parking fee not exceeding Twenty-five cents for motor car or vehicle.

6. No person shall pass over any playing area or oval with any vehicle, or on horse-back, without the permission of the Committee first obtained nor drive or ride to the danger or annoyance of persons assembled on any part of the Reserve.

7. No assemblies for concerts or for the purpose of public worship, preaching or public speaking of any kind shall take place in the Reserve without the permission in writing of the Committee first obtained.

8. Any person renting or hiring any stand, building, erection or enclosure on the occasion of any sports, fêtes, shows or amusements may be required to deposit such sum as the Committee may at any time determine, by way of guarantee that due care shall be taken of such stand, building, erection or enclosure and the Committee in its absolute discretion may make good any damage injury or loss sustained to such stand, building, erection or enclosure, or anything contained therein, during such renting or hiring and deduct the cost of making good such damage injury or loss from the money deposited by way of guarantee and all persons so renting or hiring shall abide by these Regulations and by any order given by the Committee or its authorized officers.

9. Persons obtaining from the Committee or its representative the key to any gate, door, stand, building or enclosure who go in or upon the Reserve on any occasion whatsoever may be required to deposit with the Committee the sum of Two dollars for each key so obtained. Such deposit will be refunded on return of the key undamaged within the time specified.—(Rs.4173).

Given under my Hand, at Melbourne, on the 28th day of April, 1970.

W. J. F. McDONALD,
Minister of Lands.

Every person who contravenes or fails to comply with these Regulations shall, in accordance with the provisions of section 218 of the Land Act 1958, for each offence be liable to a penalty of not more than Fifty dollars, and every person who contravenes or fails to comply with any such Regulations, and who, after he has been warned by any bailiff of Crown lands or by any member of the Police Force, does not desist therefrom may be forthwith apprehended by such Bailiff or member of the Police Force and taken before some justice to be dealt with according to law and shall be liable to a penalty of not more than One hundred dollars.

COMMITTEES OF MANAGEMENT OF RESERVES.

APPOINTMENTS.

NOTICE is hereby given that, in pursuance of section 221 of the Land Act 1958, the following appointments of Committees of Management of reserved Crown lands have been made by the Minister of Lands:—

"BRIDGEWATER SWIMMING POOL RESERVE."

Walter Vernon Gibbon, Lawrence James Street, John Charles Harrison, Charles George Lumber, Wilfred Ernest Mills, Edwin Joseph Fishlock, Geoffrey John Turpie, Jeffrey Wilson Redwood and Donald Keith McInnes as a Committee of Management for a period of three (3) years of the Crown land in the Township and the Parish of Bridgewater as shown by red colour on plan marked "B/27.6.60" attached to Lands Department correspondence C.79246, and known as the "Bridgewater Swimming Pool Reserve".—(Corres. No. C.79246.)

"CROWLANDS PUBLIC HALL RESERVE."

Vernon Henry Bates, Allen James Williams, Arthur Noel Boatman, Kevin William Lewis, George Ronald Matthews, Robert Shields, James Russell Price, Bernard Alexander Boatman and Alexander Tucker as a Committee of Management for a period of three (3) years of the land in the Township of Crowlands temporarily reserved by Order in Council dated the 17th September, 1957, as a site for a Public Hall, and known as the "Crowlands Public Hall Reserve".—(Corres. No. Rs.7659.)

"DEWHURST PUBLIC HALL RESERVE."

Linda Jean Cameron, John Henry Grove, William J. Cameron, Gweneth J. Cameron, Bruce D. Black, Terrence R. Worrell and Joseph A. Peart as a Committee of Management for a period of three (3) years of the land in the Parish of Gembrook, temporarily reserved by Order in Council dated the 7th August, 1945, as a site for a Public Hall, and known as the "Dewhurst Public Hall Reserve".

This appointment is made in lieu of the appointment made on the 21st March, 1969, in respect of the said land, which is hereby revoked.—(Corres. No. Rs.5674.)

"DUMBALK RECREATION RESERVE."

Donald George Pearson, Arthur Russell Ashenden, Reginald John Moore, Jack Lynton Trease, Charles Vincent Cook, Roy Graham Bright and Arthur Edward Cook as a Committee of Management for a period of three (3) years of the balance of the land in the Parish of Dumbalk, permanently reserved by Order in Council dated the 16th September, 1929, as a site for Public Recreation, and known as the "Dumbalk Recreation Reserve".—(Corres. No. Rs.3892.)

"DUMBALK (STONY CREEK) MECHANICS' INSTITUTE RESERVE."

Margaret Jane Helms, Margaret May Cummins, Eileen Veronica Hanrahan, Alan S. Sinclair, Marjory June Gilligan, John Kemp Braithwaite, Percy Le Page, Muriel Arup and Donald R. McKnight as a Committee of Management for a period of three (3) years from the 26th April, 1970, of the land in the Township of Dumbalk temporarily reserved by Order in Council dated the 28th September, 1893, as a site for a Mechanics' Institute, and known as the "Dumbalk (Stony Creek) Mechanics' Institute Reserve".—(Corres. No. Rs.4549.)

"FLINSTED MECHANICS' INSTITUTE RESERVE."

Percy Johann Detlef Rathjen, Arthur Henry Stuckey, Arthur Samuel Peck, Henry Roy Stuckey and Robert Stewart Stuckey as a Committee of Management for a period of three (3) years of the land in the Township of Flinthead temporarily reserved by Order in Council dated the 8th August, 1892, as a site for a Mechanics' Institute, and known as the "Flinthead Mechanics' Institute Reserve".—(Corres. No. Rs.2151.)

"GEMBROOK MEMORIAL HALL RESERVE."

Norman Smith, Raymond Ramage, William Bishop, Sydney Bates, Dorothy Bates, Julian Dyer, Leila Hooper and Ian Kenneth Dela Rue as a Committee of Management for a period of one (1) year of the land in the Parish of Gembrook, temporarily reserved by Order in Council dated the 17th February, 1942, as a site for a Public Hall, and known as the "Gembrook Memorial Hall Reserve".—(Corres. No. Rs.5339.)

"KILCUNDA MECHANICS' INSTITUTE AND FREE LIBRARY RESERVE."

Laurence Robert Cochrane, Mervyn Lindsay Churchill, Thora May Weatherall, Albert Alfred Weatherall, Wilfred Churchill, Ronald Henry Churchill and Ralf Piasente as a Committee of Management for a period of three (3) years of the land in the Township of Kilcunda, temporarily reserved by Order in Council dated the 8th October, 1901, as a site for a Mechanics' Institute and Free Library, and known as the "Kilcunda Mechanics' Institute and Free Library Reserve".—(Corres. No. Rs.3158.)

"LAANECOORIE RECREATION RESERVE."

Charles Cornwall, Brendon M. Lyon, Harold John Cole, William T. Trimble, Gavin J. Trimble, Nicholas T. Saunders, Keith Bayliss, Jack Galloway and Graham A. Brownbill, as a Committee of Management for a period of three (3) years of the land in the Township and Parish of Laanecoorie temporarily reserved by Order in Council dated the 4th May, 1948, as a site for Public Recreation, and known as the "Laanecoorie Recreation Reserve".—(Corres. No. Rs.6165.)

"SWIMMING POOL SITE FRONTING THE GOULBURN RIVER, MURCHISON."

Thomas Keith Gregory, Bryan Devis Brady, Vincent Edward Hare, Vincent Charles Grant, Trevor Stuart Shepard, Allan Thomas Brown, Bruce Alfred Brisbane, Arthur James Trevaskis and Arthur Leslie Syrett, as a Committee of Management for a period of three (3) years of such portion of the Reserve for Public purposes, in the Township of Murchison, as shown by yellow colour border on plan marked "M/29.10.68" attached to Lands Department correspondence Rs.785.—(Corres. No. Rs.785.)

This appointment is made in lieu of all previous appointments, in respect of the said portion, which are hereby revoked.

"SASSAFRAS MECHANICS' INSTITUTE AND LIBRARY RESERVE."

John Ernest King, Roy Hampton and Gordon H. Poole as a Committee of Management for a period of three (3) years of the remaining portion of the areas in the Parish

of Monbulk, temporarily reserved by Orders in Council dated the 6th August, 1894, and 24th August, 1948, as sites for Mechanics' Institute purposes, such areas together known as the "Sassafras Mechanics' Institute and Library Reserve".—(Corres. No. Rs.2710.)

"STAWELL RACECOURSE RESERVE."

George Mornane, Cyril Charles Nicholson, Colin Hector Allison, Alexander John Hewetson Gray, John Joseph Jones, Reginald Stephen Fisher and John William Monaghan as a Committee of Management for a period of three (3) years from the 25th January, 1970, of the lands in the Township of Stawell, temporarily reserved by Orders in Council dated the 20th November, 1876, and 13th November, 1944, as sites for Racing and General Recreation, and known as the "Stawell Racecourse Reserve".—(Corres. No. Rs.3938.)

"WILLATOOK PUBLIC HALL RESERVE."

Douglas Richmond Ralph Malseed, John James Farley, Allan Gordon Gow, Henry William Poynton, Clarence Otto Habel, Howard Vincent Glare and William Sidney Malseed as a Committee of Management for a period of three (3) years of the land in the Parish of Willatook, temporarily reserved by Order in Council dated the 4th September, 1963, as a site for a Public Hall and known as the "Willatook Public Hall Reserve".—(Corres. No. Rs.8260.)

"YANDOIT PUBLIC PARK AND RECREATION RESERVE."

Allan Henry Lee, William Brian Priest, Stanley Francis Sartori, Vincent Michael Gervasoni, Donald Edgar Morrison, Bryan Johns, Alick William Glass, Lindsay John Booker and Edgar Morrison as a Committee of Management for a period of three (3) years from the 26th April, 1970, of the land in the Township of Yandoit, temporarily reserved by Orders in Council dated the 16th November, 1908, and 1st December, 1924, as sites for Public Park and for the additional purpose of Public Recreation, and known as the "Yandoit Public Park and Recreation Reserve".—(Corres. No. Rs.3012.)

"YARCK MECHANICS' INSTITUTE AND FREE LIBRARY RESERVE."

William James Free, Alan Worrall Jones, Douglas Hayward, Roy Mervyn Fox, Linda Adelee Wright, Arnold Victor Blakeney, Joyce Stuart Butler, Joan Rialland and John Thomas Halligan as a Committee of Management for a period of three (3) years of the land in the Parish of Yarck, deemed to be permanently reserved as a site for a Mechanics' Institute and Library.—(Corres. No. Rs.8778.)

W. J. F. McDONALD,

Minister of Lands.

Department of Crown Lands and Survey,
Melbourne, 28th April, 1970.

COMMITTEE OF MANAGEMENT OF RESERVES.

APPOINTMENTS.

NOTICE is hereby given that, in pursuance of section 221 of the Land Act 1958, the following appointments of Committees of Management of reserved Crown Lands have been made by the Minister of Lands:—

PORTION OF THE PERMANENT RESERVE FOR PUBLIC PURPOSES ABUTTING THE DIAMOND CREEK IN THE TOWNSHIP OF DIAMOND CREEK.

The Corporation of the Shire of Diamond Valley as the Committee of Management of the portion of the land abutting the Diamond Creek permanently reserved for Public purposes, in the Township of Diamond Creek, and as shown by blue colour on plan marked "D/19.9.69" attached to Lands Department correspondence Rs.9311.—(Corres. No. Rs.9211.)

"ELTHAM PARK RESERVE."

The Corporation of the Shire of Eltham as the Committee of Management from the 1st May, 1970, of the land in the Township of Eltham permanently reserved by Order in Council dated the 29th June, 1965, as a site for Public Recreation, and known as the "Eltham Park Reserve".

This appointment is made in lieu of all previous appointments in respect of the said land.—(Corres. No. Rs.932.)

"MERINO MECHANICS' INSTITUTE RESERVE."

Murray Burgess Povey, Eric William Owens, Edgar Hardy Enscoe, Peter Joseph Leake, Vincent Rowland Davies, Douglas Nathaniel P. Wombwell, Anthony Arthur

Deutscher, John Charles Edwards and Emanuel Kenneth Wilde as a Committee of Management for a period ending the 31st May, 1970, of the lands in the Township of Merino, Parish of Merino, permanently reserved by Orders in Council dated the 11th June, 1878, and 10th April, 1888, as sites for Mechanics Institute purposes and together known as the "Merino Mechanics Institute Reserve".—(Corres. No. Rs.2245.)

"PHILLIP ISLAND KOALA RESERVES."

Alexander Bruce Wilkie in the place of Alexander Ernest Wilkie (deceased) as a member of the Committee of Management of the lands in the Parish of Phillip Island temporarily reserved by Orders in Council dated the 21st March, 1940, 1st April, 1958, and 16th April, 1962, as sites for the preservation of Koalas, and of so much of the land remaining in the area temporarily reserved by Order in Council dated the 24th December, 1937, as a site for a Sanctuary for Native Bears, and together known as the "Phillip Island Koala Reserves".—(Corres. No. Rs.79.)

"TOWONG MEMORIAL HALL."

Clive Noel Daly, Archibald Waugh Whitehead, William George Fortnum, Marion Ruth Reiners, Catherine Martha Hewatt, Gordon Edward Hewatt, Hazel May Hewatt and Leah Mary Fortnum as a Committee of Management of the land in the Township of Towong temporarily reserved by Order in Council dated the 17th April, 1924, as a site for a Public Hall, and known as "Towong Memorial Hall".—(Corres. No. Rs.2918.)

"WARNEET PUBLIC (FORESHORE) RESERVES."

Leslie William Crouch, Francis John Tuohy, Frank Holden Spiller, Leonard R. Preston, Valentine Clover Wright, William Stephen Tamo and Robert Oliver Luxford as a Committee of Management for a period of three (3) years from the 26th April, 1970, of the following lands:—

- (a) Land in the Township of Warneet, Parish of Sherwood, temporarily reserved by Orders in Council dated the 6th November, 1944, 28th June, 1960, and 21st February, 1961, as sites for Public purposes, and known as the "Warneet Foreshore Reserve".—(Rs.5524.)
- (b) land in the Parish of Sherwood temporarily reserved by Order in Council dated the 24th February, 1959, as a site for Public Recreation, and known as the "Warneet Recreation Reserve".—(Rs.7791.)
- (c) Land in the Township of Warneet, Parish of Sherwood, temporarily reserved by Order in Council dated the 7th September, 1948, as a site for a Public Hall, and known as the "Warneet Public Hall Reserve".—(Rs.6229.)
- (d) Land in the Township of Warneet, Parish of Sherwood, temporarily reserved by Order in Council dated the 8th July, 1969, as a site for Camping purposes.—(Rs.9186.) (Corres. Nos. Rs.5524, Rs.7791, Rs.6229 and Rs.9186.)

"WOODSIDE BEACH RESERVE."

The Corporation of the Shire of Alberton as the Committee of Management of such portion of the reservation for Public purposes along Bass Strait as abuts the remaining portion of the land in the Parish of Balloong temporarily reserved by Order in Council dated the 28th December, 1916, as a site for Public Recreation, as shown by yellow colour border on plan marked "B/18.2.70" attached to Lands Department correspondence Rs.1352.—(Corres. No. Rs.1352.)

"CURDIES INLET AND RIVER RESERVE."

Robert Henry Askew, John Stuart Irvine, Ronald George Cairns, Kenneth Neil Jepson, William Andrew Ward, Alan John Togni and Albert James Tanner as a Committee of Management for a period of three (3) years of the land permanently reserved for Public purposes abutting the Curdies River in the Township of Nirranda and Parish of Nirranda as shown by hatching on plan hereunder, such portions known as the "Curdies Inlet and River Reserve".—(Corres. No. Rs.8600.)

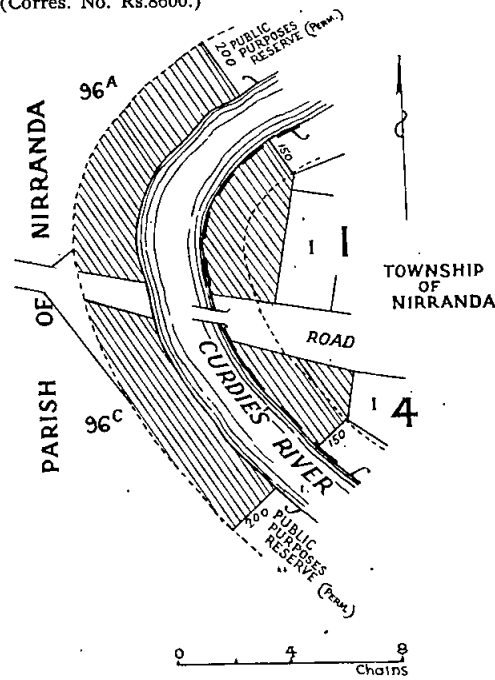

W. J. F. McDONALD,
Minister of Lands.
Department of Crown Lands and Survey,
Melbourne, 22nd April, 1970.

Land Act 1958.

LICENCE UNDER THE LAND ACTS DECLARED VOID.

NOTICE is hereby given that the Licence in the Schedule hereunder has been Declared Void for the reason specified.

District.	Corr. No.	Name of Licensee.	Section of Land Act under which Licensed.	Parish.	Allotment.	Section.	Area.	Annual Rental.	Reasons for Voiding.
St. Arnaud	0195/138	S. J. Tranter ..	138	Maryborough	5	53D	A. R. P. 0 2 0	\$ 2.00	Licence surrendered

Department of Crown Lands and Survey,
Melbourne, 22nd April, 1970.

W. J. F. McDONALD,
Minister of Lands.

Land Act 1958.

PERMIT CANCELLED.

NOTICE is hereby given that the permit in the schedule hereunder has been cancelled.

District.	Corr. No.	Name of Permit Holder.	Parishes.	Allotment.	Section.	Area.	Reason for Cancellation.
Mallee	C13/8 (212/264B)	A. W. B. and L. G. Astbury	Mildura Yatpool	Lot 13	Carwarp Settlement Area	A. R. P. 3,635 0 0	Purchase lease to issue

Department of Crown Lands and Survey,
Melbourne, 28th April, 1970.

W. J. F. McDONALD,
Minister of Lands.

TENDERS

PUBLIC WORKS DEPARTMENT

TENDERS will be received at Public Works Department, 2 Treasury-place, Melbourne, until **TWO** p.m. on dates shown and for purposes mentioned hereunder.

Particulars and tender forms available at Contracts Office, Room 8, Building Division, Parliament-place and at places indicated in brackets hereunder.

Abbreviations in brackets mean:—W.O.—Inspector of Works Office; P.S.—Police Station; C.S.—Consolidated School; H.E.S.—Higher Elementary School; H.S.—High School; Pr.S.—Primary School; T.S.—Technical School.

Tenders to be submitted on the Department's printed Tender Form and will not be received by telephone. All tenders must be on a "Firm Tender" basis. The lowest or any tender will not necessarily be accepted.

Address tenders to the Minister of Public Works, and endorse the envelope containing the tender "Tender for closing Tuesday,

Hand delivered tenders to be placed in the Tender Box of the Public Works Department, located on the wall of the centre entrance foyer, Ground Floor, 2 Treasury-place, Melbourne.

No preliminary deposit is required with any tender, but a successful tenderer will be required to pay a deposit for any accepted tender of \$4,000 or over.

Tuesday, 12th May, 1970.

Building, Electrical and Mechanical Works.

Ballarat.—Additional fire alarm installation, Lakeside Hospital. (W.O., Ballarat.)

Melbourne.—Repairs to ceilings and walls, Crown Law Offices, 459 Lonsdale-street. (Re-advertised.)

Mont Park.—Supply and installation of steam heating to sewing room, Mental Hospital.

Springvale.—Alterations and additions, Court House.

Werribee.—Alterations and additions to milking shed and dairy, Research Farm. (Re-advertised.)

Miscellaneous.

Brighton.—Maintenance cleaning for the period 1st June, 1970, to 31st May, 1973, Court House.

Dandenong.—Maintenance cleaning for the period 1st June, 1970, to 31st May, 1973, Court House.

Dandenong.—Maintenance cleaning for the period 1st June, 1970, to 31st May, 1973, Labour and Industry Department.

Elsternwick.—Maintenance cleaning for the period 1st June, 1970, to 31st May, 1973, Court House.

Fitzroy North.—Maintenance cleaning for the period 1st June, 1970, to 31st May, 1973, Health Department, School Dental Centre.

Hawthorn.—Maintenance cleaning for the period 1st June, 1970, to 31st May, 1973, Social Welfare Department.

Kew.—Maintenance cleaning for the period 1st June, 1970, to 31st May, 1973, Court House.

Melbourne.—Maintenance cleaning for the period 1st June, 1970, to 31st May, 1973, Labour and Industry Department.

Tuesday, 19th May, 1970.

Building, Electrical and Mechanical Works.

Altona.—Connexion to M.M.B.W. sewer, Altona High School, Altona West Primary School 4862. (Re-advertised.)

Ballarat.—Interior and exterior renovations, High School. (W.O., Ballarat.)

Carrum Downs.—Internal and external repairs and painting, Pr.S. 3613 and Residence.

Echuca.—Internal and external repairs and painting, High School. (W.O., Shepparton.)

Fairfield.—Demolish brick building, re-modelling, &c., Fairlea Female Prison.

Irymple.—Electrical installation, Glasshouse, Mildura Horticultural Research Station. (W.O., Mildura.)

Macleod.—Erection of L.T.C. Science extension, Technical School.

Macleod.—Mechanical services, science extensions, Technical School.

Wendouree.—Erection of two class-rooms and library, in brick veneer, Primary School 1813. (W.O., Ballarat.)

Wendouree.—Mechanical services, new class-room wing, Primary School 1813. (W.O., Ballarat.)

Yarram.—Renovations and re-blocking, High School Residence. (W.O., Traralgon and High School, Yarram.) (Amended Specification.)

Site Works.

Eaglehawk.—Construction of oval and playing fields, High School. (W.O., Bendigo.)

Sale.—Asphalt, concrete and drainage work, &c., Technical School. (W.O., Traralgon.)

Miscellaneous.

Fitzroy.—Maintenance cleaning for the period 1st June, 1970, to 31st May, 1973, Store, Education Department.

Westernport.—Dredging at Hastings, Ports and Harbours Branch. (Buoy Depot, Stony Point.) (Amended Specification.)

Tuesday, 26th May, 1970.

Building, Electrical and Mechanical Works.

Glenormiston.—Refrigeration system for three cool rooms, Agricultural College. (W.O., Warrnambool.)

Moonee Ponds.—Re-building of toilet block and erection of new shelter sheds, Central School 3987.

St. Arnaud.—External and internal renovations and painting, H.S. (W.O., Maryborough.)

Williamstown.—Erection of standard school hall type "800C", H.S.

Williamstown.—Electrical services, H.S.

Williamstown.—Mechanical services, H.S.

Wodonga.—Erection of a standard school hall type "800C", H.S. (W.O., Wangaratta.) (Re-advertised.)

R. J. HAMER,
Minister of Public Works.

Public Works Department,
Melbourne, 3002, 4th May, 1970.

PUBLIC SERVICE NOTICE

No. 457

Public Service Act 1958, Section 50.

REGULATIONS.—PART IV.—SALARIES AND INCREMENTS.

THE Public Service Board, in pursuance of the powers conferred by the *Public Service Act 1958*, hereby amends its Regulations as shown below :—

SIXTH SCHEDULE.

TEMPORARY EMPLOYEES.

Designations of Positions and Rates of Salaries.

Department and Designation of Position.	Yearly Rate of Salary.		Increments (Annual).
	Minimum.	Maximum.	
DEPARTMENT OF AGRICULTURE.	\$	\$	
<i>Add—</i> Animal Attendant (Female) Σ See Regulation 97(2)	2,002	2,314	Σ

This Regulation shall have effect as on and from the 1st April, 1970.

F. E. CAHILL, Chairman.
V. P. SCULLY, Secretary.

Office of the Public Service Board,
Melbourne, 20th April, 1970.

No. 455.

Public Service Act 1958, Section 50.

REGULATIONS.—PART IV.—SALARIES AND INCREMENTS.

THE Public Service Board, in pursuance of the powers conferred by the *Public Service Act 1958*, hereby amends its Regulations as shown below :—

SIXTH SCHEDULE.

TEMPORARY EMPLOYEES.

Designations of Positions and Rates of Salaries.

Department and Designation of Position.	Yearly Rate of Salary.		Increments (Annual).
	Minimum.	Maximum.	
CHIEF SECRETARY'S DEPARTMENT. SOCIAL WELFARE. <i>Family Welfare Division.</i>	\$	\$	
<i>Add—</i> Superintendent. (Female), "Illoura" Σ See Regulation 97(2)	3,466	3,694	Σ

This Regulation shall have effect as on and from the 27th January, 1970.

F. E. CAHILL, Chairman.
V. P. SCULLY, Secretary.

Office of the Public Service Board,
Melbourne, 20th April, 1970.

No. 453.

Public Service Act 1958, Section 50.

REGULATIONS.—PART IV.—SALARIES AND INCREMENTS.

THE Public Service Board, in pursuance of the powers conferred by the *Public Service Act 1958*, hereby amends its Regulations as shown below :—

FIRST SCHEDULE.

PROFESSIONAL DIVISION.

Amount of Salary Assigned to Offices in "Special" Class.

Office.	Yearly Rate of Salary.
MINES DEPARTMENT.	\$
<i>Delete—</i> Director of Geological Survey	12,060
<i>Add—</i> Director of Geological Survey	12,730

THIRD SCHEDULE.

PART B.

PROFESSIONAL DIVISION.

Scale of Rates of Annual Salaries.

GEOLOGISTS.

THE salary scale shown is deleted and the following salary scale is inserted in lieu thereof :—

Class.	Annual Salary of Each Subdivision of Each Class.						
	1.	2.	3.	4.	5.	6.	7.
	\$	\$	\$	\$	\$	\$	\$
G-1 ..	3,570	3,726	4,092	4,478	4,779	5,184	5,673
G-2 ..	5,811	6,002	6,410	6,552	6,751
G-3 ..	7,350
G-4 ..	8,138
G-5 ..	8,725
G-6 ..	9,345

This Regulation shall have effect as on and from the 19th April, 1970.

F. E. CAHILL, Chairman.
V. P. SCULLY, Secretary.

Office of the Public Service Board,
Melbourne, 17th April, 1970.

No. 454.

Public Service Act 1958, Section 39.

REGULATIONS.—PART IV.—SALARIES AND INCREMENTS.

THE Public Service Board, in pursuance of the powers conferred by the *Public Service Act 1958*, hereby amends its Regulations as shown below :—

FIRST SCHEDULE.

PROFESSIONAL DIVISION.

Amount of Salary Assigned to Offices in "Special" Class.

Office.	Yearly Rate of Salary.
DEPARTMENT OF HEALTH. <i>General Health Branch.</i>	\$
<i>Delete—</i> Epidemiologist	12,730

This Regulation shall have effect as on and from the 10th March, 1970.

F. E. CAHILL, Chairman.
V. P. SCULLY, Secretary.

Office of the Public Service Board,
Melbourne, 22nd April, 1970.

No. 456.

Public Service Act 1958, Section 50.

REGULATIONS.—PART IV.—SALARIES AND INCREMENTS.

THE Public Service Board, in pursuance of the powers conferred by the Public Service Act 1958, hereby amends its Regulations as shown below :—

SIXTH SCHEDULE.

TEMPORARY EMPLOYEES.

Designations of Positions and Rates of Salaries.

Department and Designation of Position.	Yearly Rate of Salary.		Increments (Annual).
	Minimum.	Maximum.	
	\$	\$	
PUBLIC WORKS DEPARTMENT.			
PORTS AND HARBOURS † ‡ §			
<i>Add—</i> Dredge Engine Driver ..	3,123	3,495	£

† See Regulation 156
‡ See Regulation 155
§ See Regulation 153
|| See Regulation 97 (2)

F. E. CAHILL, Chairman.
V. P. SCULLY, Secretary.

Office of the Public Service Board,
Melbourne, 20th April, 1970.

No. 458.

Public Service Act 1958, Section 50.

REGULATIONS.—PART IV.—SALARIES AND INCREMENTS.

THE Public Service Board, in pursuance of the powers conferred by the Public Service Act 1958, hereby amends its Regulations as shown below :—

SIXTH SCHEDULE.

TEMPORARY EMPLOYEES.

Designations of Positions and Rates of Salaries.

Department and Designation of Position.	Yearly Rate of Salary.		Increments (Annual).
	Minimum.	Maximum.	
	\$	\$	
GENERAL.			
<i>Add—</i> Draughtswoman, Trainee π π— Junior— Under 17 years of age	1,573	
At 17 years of age	1,573	
At 18 years of age	1,781	
At 19 years of age	2,011	
At 20 years of age	2,153	
Adult	Δ	

π π Appointees shall be eligible to receive allowances for qualifications in terms of the scales prescribed in Regulations 108 (1) (b) or 108 (1) (d).

Δ Rate prescribed in Eighth Schedule.

This Regulation shall have effect as on and from the 22nd January, 1970.

F. E. CAHILL, Chairman
V. P. SCULLY, Secretary.

Office of the Public Service Board,
Melbourne, 20th April, 1970.

No. 45.—3782/70.—4

PRIVATE ADVERTISEMENTS

CITY OF MELBOURNE.

BY-LAW No. 478.

A By-law of the City of Melbourne made under section 12 of the Melbourne Wholesale Fruit and Vegetable Market Act 1968 and numbered 478 to amend By-law No. 477

IN pursuance of the powers conferred by the above-mentioned enactment and of every other Act or power enabling it in that behalf, the Council of the City of Melbourne ORDERS as follows:

1. (1) This By-law may be cited as the "City of Melbourne Wholesale Fruit and Vegetable Market (Amendment) By-law 1970".

(2) In this By-law, the City of Melbourne Wholesale Fruit and Vegetable Market By-law 1969 (By-law No. 477) is referred to as the Principal By-law.

2. Clause 2 of the Principal By-law shall be amended as follows:

(a) In sub-clause (1)—

(i) the definition of "goods" shall be repealed and the following definition shall be substituted for it:
"goods" includes fruit and vegetables;

(ii) the definition of "Market concourse" shall be repealed and the following definition shall be substituted for it:
"Market concourse" means the building in the Market that occupies the area delineated and hatched on the plan in the Fifth Schedule and in which all stands and stores are situated;

(iii) in the definition of "stand" for the words "an agent" there shall be substituted the words "a grower";

(iv) in the definition of "store (type B)" for the word "or" (where fifthly occurring) there shall be substituted the word "and"; and

(v) the definition of "transport standing place" shall be repealed and the following definition shall be substituted for it:

"transport stand" means any space in the Market set apart for the loading of transports (being a space in or adjacent to the area delineated and cross-hatched on the plan in the Fifth Schedule), the boundaries of which are marked on the surface of the Market by painted white lines;

(b) In sub-clause (2) for the words "cut flowers" there shall be substituted the expression "bulbs, cut flowers, and plants".

3. Paragraph (e) of clause 6 of the Principal By-law shall be amended by substituting for the word "to" (where fourthly occurring) the word "for".

4. Paragraph (b) of clause 13 of the Principal By-law shall be amended by substituting for the word "the" the word "a".

5. Clause 14 of the Principal By-law shall be amended by inserting after the word "in" the expression "on".

6. Sub-clauses (4) and (5) of clause 18 of the Principal By-law shall be repealed and the following sub-clauses shall be substituted for them:

"(4) Any chattels, goods, merchandise or vehicle found by a market inspector—

(a) in or on any stand (other than a stand allotted and let to the owner or an agent of the owner of those chattels or goods or that merchandise or vehicle and for which the rent has been paid in advance, and then only during the time when that owner or agent or an employee of his is present on the stand); or

(b) in or on any footpath, road or other place in the Market, except when there with the prior consent of the Superintendent or a market inspector, or, in the case of a vehicle, when lawfully parked or left standing—

may be removed from the Market by any market inspector or other officer of the Corporation or by any member of the police force.

(5) Any expense incurred by the Corporation in removing any chattels, goods, merchandise or vehicle from the Market in accordance with sub-clause (4) of this clause shall be a debt payable by the owner of those

chattels or goods or that merchandise or vehicle to the Corporation and may be recovered by the Corporation in any court of competent jurisdiction."

7. Clause 19 of the Principal By-law shall be amended by inserting after the word "Market" the expression " , without the consent in writing of the Superintendent. "

8. Clause 31 of the Principal By-law shall be repealed and the following clause shall be substituted for it:

"31. (1) No person shall in the Market, without the consent in writing of the Superintendent—

- (a) carry about, display, exhibit, give out or distribute any handbill, placard, notice, advertisement, picture, postcard, book or pamphlet;
 - (b) solicit donations or sell raffle tickets or the like;
 - (c) drink or have in his possession any spirituous or intoxicating liquor; or
 - (d) wash fruit, vegetables or other articles or goods by permitting water to run continuously from any tap over them.
- (2) No person shall in the Market—
- (a) harangue or make any loud outcry or other loud noise;
 - (b) sing, whistle or play or operate any musical instrument, radio or television set to the annoyance or the discomfort of any other person;
 - (c) incite any riot or disturbance;
 - (d) curse or swear;
 - (e) use any gross, indecent or abusive language;
 - (f) be guilty of any gross or indecent conduct;
 - (g) expectorate, urinate or defecate, except in one of the public conveniences provided;
 - (h) loiter or trespass, when the Market is closed;
 - (i) cause or permit any dog to be in the Market, except when the dog is—
 - (i) on a leash held by the person; or
 - (ii) securely fastened to a vehicle;
 - (j) bring or take into the Market concourse or any other building any dog;
 - (k) play at cards or any game of skill or chance;
 - (l) play at cricket, football or any other game;
 - (m) drive any vehicle on or over any footpath;
 - (n) light any fire;
 - (o) fail, refuse or neglect to comply with any lawful direction of the Superintendent or a market inspector; or
 - (p) obstruct, hinder or resist any market inspector or any other officer or servant of the Corporation in the discharge of his duties."

9. Clause 32 of the Principal By-law shall be amended as follows:

- (a) In paragraph (a) of sub-clause (1) there shall be inserted after the word "liquor" the expression " , unless he has the consent in writing of the Superintendent to do so ".
- (b) In sub-clause (2) the word "such" shall be deleted, and there shall be inserted after the word "Market" (where first occurring) the expression "contrary to the provisions of sub-clause (1) of this clause ".

10. Paragraph (b) of clause 39 of the Principal By-law shall be amended by substituting for the expression "a white light ahead, and clearly visible from in front, of the vehicle" the expression "a white light ahead of, and clearly visible from in front of, the vehicle ".

11. At the end of clause 41 of the Principal By-law there shall be inserted the following expression " , unless that vehicle is a vehicle used exclusively for moving goods within the Market and regularly left standing in the Market in accordance with consent given by the Superintendent pursuant to clause 41 ".

12. The First Schedule to the Principal By-law shall be repealed and the following schedule shall be substituted for it:

"FIRST SCHEDULE.
(Clause 9.)

Hours of admission to and departure from, and hours of trading at, the Market

The hours of admission to and departure from, and the hours of trading in fruit and vegetables at, the Market and various parts of the Market are, subject to the provisions of this By-law, as follows:

A. *Hours of admission to, and departure from, the Market*

(1) *All parts of the Market, except the Market concourse—*

(a) Admission on each day Sunday to Friday inclusive—

7 p.m. to 9 p.m. Growers from outside the area within a radius of 100 miles from the General Post Office at the corner of Bourke Street and Elizabeth Street, Melbourne, and country-transport operators (being persons to whom transport stands have been allotted and let) may enter.

(b) Admission on each day Monday to Saturday inclusive—

(i) Midnight Growers, country-transport operators (being persons to whom transport stands have been allotted, and let), staff of tenants on duty to receive inwards deliveries, and vehicles delivering fruit and vegetables to the Market (in this schedule called "produce-delivery vehicles") may enter.

(ii) 3 a.m. Buyers and other staff of tenants of stores may enter.

(c) Departure—

(i) On each day Monday to Friday inclusive—

(I) 2 p.m. All buyers and produce-delivery vehicles shall leave by 2 p.m.

(II) 5 p.m. All persons and vehicles shall leave by 5 p.m., when the Market shall close.

(ii) On Saturday—

Noon All persons and vehicles shall leave by noon, when the Market shall close.

(2) *Market concourse—*

(a) Admission on each day Monday to Saturday inclusive—

(i) Midnight Growers, staff of tenants of stores on duty to receive inwards deliveries, and produce-delivery vehicles may enter.

(ii) 3 a.m. Other staff of tenants of stores may enter.

(iii) 4 a.m. Produce-delivery vehicles may enter up to, but not after, 4 a.m.

(iv) 5 a.m. Market concourse opens and buyers may enter.

(v) 9 a.m. Produce-delivery vehicles may re-enter.

(b) Departure—

(i) On each day Monday to Friday inclusive—

(I) 4.30 a.m. All produce-delivery vehicles shall leave, and be clear of, the Market concourse by 4.30 a.m.

(II) 10 a.m. All buyers shall leave by 10 a.m.

(III) 2 p.m. Produce-delivery vehicles shall leave by 2 p.m., when all deliveries of fruit and vegetables shall cease.

(IV) 5 p.m. All persons and vehicles shall leave by 5 p.m., when the Market shall close.

(ii) On Saturday—

(I) 4.30 a.m. All produce-delivery vehicles shall leave, and be clear of, the Market concourse by 4.30 a.m.

(II) 8.30 a.m. All buyers shall leave by 8.30 a.m.

(III) Noon All persons and vehicles shall leave by noon, when the Market shall close.

B. Hours of trading in fruit and vegetables

- (1) On each day Monday to Friday inclusive—
- (a) 5 a.m. Buying and selling may begin at, but not before, 5 a.m.
- (b) 10 a.m. Buying and selling shall cease.
- (2) Saturday—
- (a) 5 a.m. Buying and selling may begin at, but not before, 5 a.m.
- (b) 8.30 a.m. Buying and selling shall cease."

13. The Second Schedule to the Principal By-law shall be amended as follows:

(a) In Part I—Stands—

- (i) in paragraph (d) of sub-clause (1) of clause 2 for the words "to occupy and use the stand" there shall be substituted the words "to occupy and use that stand";
- (ii) in paragraph (e) of sub-clause (1) of clause 2 for the expression "48 hours before the beginning at the Market of buying and selling of fruit and vegetables on" there shall be substituted the words "two Market trading days before";
- (iii) for sub-clause (2) of clause 2 there shall be substituted the following sub-clause—
- "(2) (a) Every grower to whom a stand is allotted or let shall, if required by the Superintendent, produce to the Superintendent evidence to the satisfaction of the Superintendent that he is actively engaged in the commercial growing or production of fruit or vegetables for marketing.
- (b) Any evidence produced pursuant to paragraph (a) of this sub-clause shall be in the form of a certificate from the municipal clerk, the officer in charge of a police station or an inspector of the Department of Agriculture in the district in which the grower grows or produces his fruit or vegetables showing the name of the grower, his address, whether he is an owner or an occupier, the area (in acres) he has under cultivation, and the type or types of fruit or vegetables he grows.";
- (iv) in sub-clauses (1) and (2) of clause 8 there shall be inserted after the word "sell" the expression "in, on or";
- (v) in clause 9 there shall be inserted after the word "vegetables" (where first occurring) the expression "in," and after the words "satisfactory to the Superintendent or the" there shall be inserted the word "market"; and
- (vi) in clause 11 for the words "his employer's goods" there shall be substituted the expression "his employer's goods)".

(b) In Part II—Stores—

- (i) after clause 15 there shall be inserted the following clause—
- "15A. A commission agent to whom any store (type B) designated by a number in the range of numbers from 201 to 280 inclusive is leased shall not sell in, on or from that store any fruit or vegetables other than fruit or vegetables grown in the State of Victoria or in an area of the State of New South Wales or the State of South Australia that, together with a contiguous area in the State of Victoria, forms a reasonably continuous region in which is grown the fruit or vegetables sold by the commission agent.";
- (ii) in the form of leasehold agreement set out in clause 16—
- (I) in clause 1—
- (1) in the definition of "Market" the words "for the time being" shall be deleted;
- (2) for the definition of "Market concourse" there shall be substituted the following definition—
- "Market concourse" has the meaning ascribed to it by the By-law;"; and

(3) in the definition of "term" for the word "seven" there shall be substituted the word "four";

(II) in clause 2 for the expression beginning with the words "for the term of SEVEN YEARS" and ending with the words "fixed in that behalf by the By-law" there shall be substituted the expression "for the term of FOUR YEARS commencing on the day of _____, 19____, at the rent of \$ _____ a year".

(III) in clause 7—

- (1) in sub-paragraphs (i) and (v) of paragraph (a) for the words "fourteen" and "seven" respectively there shall be substituted the word "twenty-eight";
- (2) in paragraph (c) for the word "fourteen" there shall be substituted the word "twenty-eight";
- (3) in sub-paragraph (1) of paragraph (d) for the word "sub-paragraph" there shall be substituted the expression "paragraph (d)";
- (4) in sub-paragraph (2) of paragraph (d) for the expression "sub-sub-paragraph (1)" there shall be substituted the expression "sub-paragraph (1)", and after the words "of this paragraph" there shall be inserted the expression "(d)";
- (5) in paragraph (e) the words "or by inability of the Tenant or his representatives to gain entry to the demised premises due to absence of a Corporation representative" shall be repealed;
- (6) in sub-paragraph (ii) of paragraph (f) after the expression "paragraph (a) of this clause" there shall be inserted the expression "7.";
- (7) for sub-sub-paragraph (II) of sub-paragraph (ii) of paragraph (f) there shall be substituted the following sub-sub-paragraph—
- "(II) If the company commits a breach of the provisions of sub-sub-paragraph (II) or (III) of sub-paragraph (i) of this paragraph (f)";
- (8) in paragraphs (i) and (j) for the expressions "(i)" and "(j)" there shall be substituted the expressions "(j)" and "(k)" respectively; and
- (9) after paragraph (h) there shall be inserted the following paragraph—
- "(i) The Corporation agrees that it will, on the written request of the Tenant made not later than three calendar months before the expiration of the term and if there is not at that time any existing breach or non-observance of the Tenant's covenants contained in this Agreement, grant to the Tenant at his expense in all things a lease of the demised premises for the

further term of three years from the expiration of the term at the same rent and containing the like covenants and provisos as are contained in this Agreement, except this paragraph for renewal."

(c) In sub-clause (2) of clause 18 of Part III—Transport Stands for the expression "clause 1" there shall be substituted the expression "clause 17".

14. The Third Schedule to the Principal By-law shall be repealed and the following schedule shall be substituted for it:

"THIRD SCHEDULE.
(Clause 11.)

The rents for stands, stores and transport stands are as follows:

Rents for stands, stores and transport stands

(1) Stands—

- (a) For each stand used or required for use on Monday, Wednesday and Friday or on Tuesday, Thursday and Saturday each week by—
 - (i) a grower holding either a 1st right or a 2nd right .. \$42.00 a quarter
 - (ii) a carrier agent or a carrier merchant holding either a 1st right or a 2nd right .. \$42.00 a quarter, plus \$5.00 a day for each day on which the stand is used.
- (b) For each stand used or required for use on any day Monday to Saturday inclusive by—
 - (i) a grower other than a grower holding either a 1st right or a 2nd right .. \$2.10 a day
 - (ii) a carrier agent or a carrier merchant other than a carrier agent or a carrier merchant holding either a 1st right or a 2nd right .. \$2.10 a day, plus \$5.00 a day for each day on which the stand is used.

In this section (1) of this Schedule, "quarter" means a period of three months beginning on the first day of the month of January, April, July or October in any year. Each quarterly rent shall be paid in advance before or on the first day of the quarter for which it is payable.

(2) Stores—

- For each—
 - (a) store (type A) .. \$1,404.00 a year
 - (b) store (type B) .. \$1,032.00 a year

Each yearly rent specified in this section (2) of this Schedule shall be paid monthly in advance on the first day of each calendar month.

(3) Transport stands—

- (a) For each transport stand or part of a transport stand under cover occupied or to be occupied by—
 - (i) an articulated vehicle .. \$5.00 a day
 - (ii) any other type of vehicle .. \$2.50 a day
- (b) For each transport stand or part of a transport stand not under cover occupied or to be occupied by—
 - (i) an articulated vehicle .. \$3.00 a day
 - (ii) any other type of vehicle .. \$1.50 a day

Regular users of transport stands may arrange with the Superintendent of Markets or a market inspector to pay quarterly in advance before or on the first days of January, April, July and October each year the rents for the transport stands to be used by them, those rents to be calculated at the appropriate daily rates set out above in this section (3) of this Schedule for quarters of thirteen weeks each."

- 15. In the Fourth Schedule to the Principal By-law—
 - (a) after the words "FOURTH SCHEDULE" there shall be inserted the expression "(Clause 43 (3))"; and
 - (b) for the expression "\$10.00" there shall be substituted the expression "\$8.00".

16. For the Fifth Schedule to the Principal By-law there shall be substituted the following schedule:

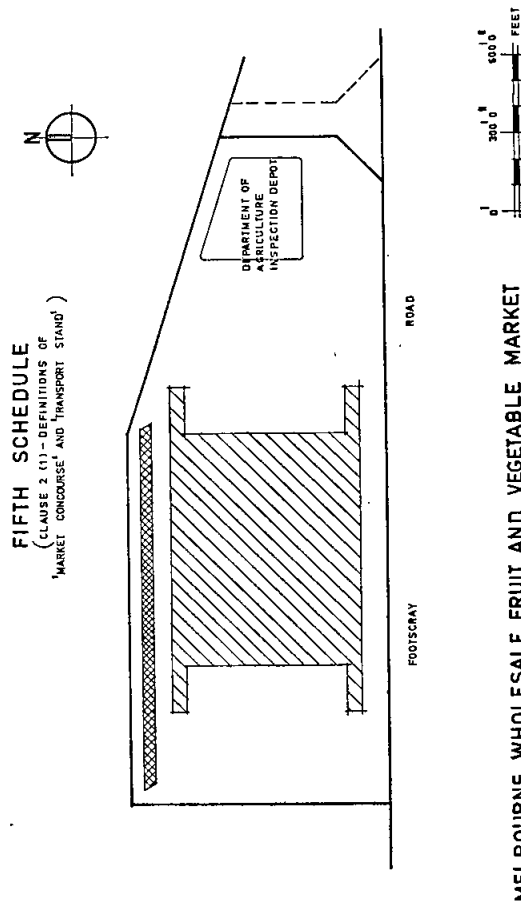

Resolution for passing this By-law agreed to by the Council of the City of Melbourne the 22nd day of December, 1969, and confirmed the 2nd day of February, 1970.

(SEAL) EDWARD W. BEST, Lord Mayor.
F. H. HOGAN, Town Clerk.

Approved by the Governor in Council, the 5th day of May, 1970, so far as the provisions for which approval is required pursuant to the Melbourne Wholesale Fruit and Vegetable Market Act 1958.

J. ROSSITER,
Clerk of the Executive Council.

CITY OF MORDIALLOC.

NOTICE is hereby given that, in pursuance of the powers conferred by the Local Government Act, the Council of the City of Mordialloc did at a meeting held on the 27th April, 1970, order that the following alteration be made in the name of the under-mentioned street and that such order take effect from the date of this publication.

Old Name.—Blossom-street.

New Name.—Ivy-street.

Situation.—The part of Blossom-street which is between the existing Ivy-street and the extension of Ivy-street through to Lower Dandenong-road.

4041

J. GRUT, Town Clerk.

CITY OF NUNAWADING.

No. 1439.

WHEREAS the Council of the City of Nunawading deems it expedient to exercise its powers of taking compulsorily the land described in the Schedule at the foot hereof for the work or undertaking of widening Dalmore-avenue: And whereas the Council has caused to be prepared a map and other papers setting out the general description of the work or undertaking, for which the land proposed to be taken is to be used, the description of the land proposed to be taken and the names of the owners or reputed owners lessees or reputed lessees mortgagees and occupiers of that land so far as those names are known to or can be ascertained by the Council: And whereas the said map and other papers are deposited at the office of the said Council at Nunawading and are and shall be open for inspection by all persons interested at all reasonable hours for the space of forty clear days after the publication of this notice in the *Government Gazette*: Now notice is hereby given to all persons affected by the proposed taking of the said land to set forth, in writing, addressed to the Council or the Town Clerk within forty clear days of the publication of this notice in the *Government Gazette*, all objections which they may have to the taking of the said land.

SCHEDULE HEREINBEFORE REFERRED TO.

All that piece of land being part of Crown portion 127, Parish of Nunawading, County of Bourke, and being that part of allotment 3 on plan of subdivision 23785 lodged in the Office of Titles, Melbourne, contained within a boundary line commencing at the most northerly corner of the said allotment 3; thence on a bearing of 173 deg. 1 min. for a distance of 50 ft. 1½ in.; thence on a bearing of 238 deg. 53 min. for a distance of 14 ft. 3¾ in.; thence on a bearing of 346 deg. 24½ min. for a distance of 53 ft. 8¾ in.; thence on a bearing of 75 deg. 18 min. for a distance of 19 ft. 5 in. to the point of commencement.

Dated the 29th day of April, 1970.

By Order of the Council,

4044

J. H. BROWN, Town Clerk.

CITY OF SOUTH MELBOURNE.

LOAN No. 71.

Notice of Intention to Borrow the Sum of \$100,000 for Permanent Works and Undertakings.

NOTICE is hereby given that the Council of the City of South Melbourne proposes to borrow the principal sum of One hundred thousand dollars (\$100,000), secured by a charge over the general rates of the municipality, such sum to be raised by the grant of a mortgage in accordance with the provisions of the *Local Government Act 1958*.

(1) The maximum rate of interest that may be paid is 6.4 per centum per annum.

(2) The purpose for which the loan is to be applied is:—Market Improvements, including Elevated Car Park—\$100,000.

(3) The period of the loan shall be twenty years.

(4) The moneys borrowed shall be repayable by providing out of the municipal fund forty half-yearly instalments of approximately \$4,467.21 each, including principal and interest, on the 1st day of January and the 1st day of July during the currency of the loan. The first instalment shall be payable on the 1st day of January, 1971.

(5) Such moneys shall be repayable to the English, Scottish and Australian Bank Limited, South Melbourne, or such other place or places as the Bank from time to time may require.

The plans and specifications and the estimate of the cost of the proposed works and a statement showing the proposed expenditure of the moneys to be borrowed are open

for inspection at the office of the Council of the City of South Melbourne, at the Town Hall, Bank-street, South Melbourne, during office hours.

22nd April, 1970.

J. J. COX, Town Clerk.

4033

Town and Country Planning Act 1961 (Twelfth Schedule).
TOWN OF PORTLAND.—PORTLAND PLANNING SCHEME 1957.

NOTICE THAT A PLANNING SCHEME HAS BEEN PREPARED AND IS AVAILABLE FOR INSPECTION.

Amendment No. 12, 1970.

NOTICE is hereby given that the Council of the Town of Portland in pursuance of its powers under the *Town and Country Planning Act 1961*, has prepared a Planning Scheme for amending the original scheme as it applies to the Town of Portland.

A copy of the Scheme has been deposited at the Town Hall, Portland, and at the office of the Town and Country Planning Board, 179 Queen-street, Melbourne, and will be open for inspection during office hours by any person, free of charge.

Any persons affected by the Planning Scheme are required to set forth in writing all objections they may have, addressed to the Town Clerk at the Town Hall, Portland, on or before the 6th day of August, 1970, and to state whether they wish to be heard in respect of their objections.

Dated the 29th April, 1970.

4069

L. FELL, Town Clerk.

BOROUGH OF KERANG.

LOAN No. 7.

Notice of Intention to Borrow the Sum of \$5,000 for Permanent Works and Undertakings.

NOTICE is hereby given that the Council of the Borough of Kerang proposes to borrow the principal sum of Five thousand dollars (\$5,000), secured by a charge over the general rates of the municipality, such sum to be raised by the grant of a mortgage in accordance with the provisions of the *Local Government Act 1958*.

1. The maximum rate of interest that may be paid is 6.10 per centum per annum.

2. The purpose for which the loan is to be applied is the purchase of plant.

3. The period of the loan shall be five years.

4. The moneys borrowed shall be repayable by providing out of the municipal fund ten half-yearly instalments of \$587.65 each including principal and interest on the 1st day of July and the 1st day of January, during the currency of the loan. The first instalment shall be payable on the 1st day of January, 1971.

5. Such moneys shall be repayable at the E.S. & A. Savings Bank Limited, Kerang.

The plans and specifications and the estimate of cost of the proposed works, and a statement showing the proposed expenditure of the moneys to be borrowed, are open for inspection at the offices of the Council, Wellington-street, Kerang, during office hours.

Dated this 1st day of May, 1970.

4074

G. H. TATE, Town Clerk.

SHIRE OF BENALLA.

APPOINTMENT OF PROSECUTING OFFICER.

NOTICE is hereby given of the appointment of Sergeant Kenneth Robert Vale, No. 10684, as Prosecuting Officer to the Council, in lieu of Sergeant A. F. Irwin.

4028

E. C. BATES, Shire Secretary.

SHIRE OF COLAC.

ORDER OF COUNCIL.

IN pursuance of the powers conferred by section 522 of the *Local Government Act 1958*, the Council of the Shire of Colac doth hereby direct that part of Crown portion B, section 12, in the Parish of Warrion, shown hatched on the plan hereunder, which has been taken purchased or acquired by it, shall be a public highway from and after the date of publication of this Order in the *Government Gazette*.

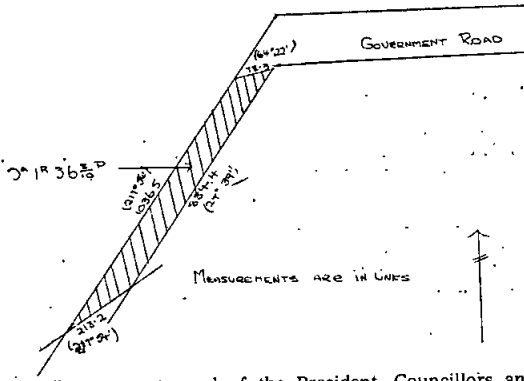

The corporate seal of the President, Councillors and Ratepayers of the Shire of Colac was hereto affixed, this 13th day of April, 1970, in the presence of—

(SEAL) PETER BOYD MERCER, President.
4018 KENNEDY DOUGLAS PATON, Councillor.
WILLIAM JOHN MAUNSELL, Secretary.

SHIRE OF FLINDERS.
CHANGE OF STREET NAME.

NOTICE is hereby given that, pursuant to the provisions of the Local Government Act, the Council of the Shire of Flinders has caused the following alteration of street name to be made:—

Old Name.—Beach-road.

New Name.—Ellerina-road.

Location.—Between Forrest-drive and Esplanade (Marine-drive).

Lodged Plans Concerned.—70745, 20687, 20671, 50133, 25446, 10599, 5066, 71910.

4043 S. WILLIAMS, Shire Secretary.

Town and Country Planning Act 1961 (Twelfth Schedule).

SHIRE OF HASTINGS.—SHIRE OF HASTINGS PLANNING SCHEME, 1962.

NOTICE THAT A PLANNING SCHEME HAS BEEN PREPARED AND IS AVAILABLE FOR INSPECTION.

Amendment No. 32, 1970.

NOTICE is hereby given that the Council of the Shire of Hastings in pursuance of its powers under the Town and Country Planning Act 1961, has prepared a Planning Scheme for the following area:—

“Land delineated on map numbered 1110 in the office of the Council, being lot 27, Pine-grove, Tyabb, for the purpose of rezoning from Public Purposes (Community Centre) Reserve to Residential “A” Zone.”

A copy of the scheme has been deposited at the Shire Office, Marine-parade, Hastings, and at the office of the Town and Country Planning Board, 235 Queen-street, Melbourne, and will be open for inspection during office hours, by any person free of charge.

Any persons affected by the Planning Scheme are required to set forth, in writing, all objections they may have addressed to the Shire Secretary, Shire of Hastings, Box 55, Post Office, Hastings, on or before the 6th August, 1970, and to state whether they wish to be heard in respect of their objections.

L. A. WALKER, Shire Secretary.
Municipal Offices, Hastings, 27th April, 1970. 4045

Town and Country Planning Act 1961 (Twelfth Schedule).

SHIRE OF KILMORE.—SHIRE OF KILMORE PLANNING SCHEME 1970.

NOTICE THAT A PLANNING SCHEME HAS BEEN PREPARED AND IS AVAILABLE FOR INSPECTION.

NOTICE is hereby given that the Council of the Shire of Kilmore in pursuance of its powers under the Town and Country Planning Act 1961, has prepared a Planning Scheme for the whole of the area within the Shire of Kilmore.

The purpose of the scheme is to provide for the planned development of the Shire.

A copy of the scheme has been deposited at the Shire Offices, Sydney-street, Kilmore, and at the office of the Town and Country Planning Board at 235 Queen-street, Melbourne, and will be open for inspection during office hours by any person free of charge.

Any persons affected by the planning scheme are required to set forth in writing all objections they may have, addressed to the Shire Secretary, Shire of Kilmore, Shire Offices, Kilmore, on or before the 6th day of August, 1970, and to state whether they wish to be heard in respect of their objection.

Dated this 28th day of April, 1970.

4068 B. J. HOBAN, Shire Secretary.

SHIRE OF ORBOST.

LOAN NO. 47.

Notice of Intention to Borrow the Sum of \$25,000 for Permanent Works and Undertakings.

NOTICE is hereby given that the Council of the Shire of Orbost proposes to borrow the principal sum of \$25,000, secured by a charge over the general rates of the municipality, such sum to be raised by the grant of a mortgage in accordance with the provisions of the Local Government Act 1958.

1. The maximum rate of interest that may be paid is 6.15 per cent. per annum.

2. The purposes for which the loan is to be applied are:—

Road Construction—Sealing edges of Roadways—			
Marlo	..	\$4,000	
Orbost	..	4,000	
			\$8,000
Construction Concrete Footpaths, Kerb and Channels—			
Marlo	..	\$2,000	
Mallacoota	..	5,000	
			\$7,000
Underground Drainage—			
Mallacoota	..	\$3,000	
Orbost (completion Ten-nyson-street)	..	4,000	
Cann River	..	3,000	
			\$10,000
			\$25,000

3. The period of the loan shall be nine years.

4. The moneys borrowed shall be repayable by providing out of the municipal fund half-yearly instalments of approximately \$1,829 each, including principal and interest on the 10th day of January and the 10th day of July, during the currency of the loan. The first instalment shall be payable on the 10th day of January, 1971.

5. Such moneys shall be repayable to the Commercial Bank of Australia, Savings Bank, Melbourne.

The plans and specifications and the estimate of the cost of the proposed works, and a statement of expenditure of the moneys to be borrowed are open for inspection at the office of the Council of the Shire of Orbost, Ruskin-street, Orbost.

4024 R. G. HEWSON, Shire Secretary.

Town and Country Planning Act 1961 (Twelfth Schedule).

SHIRE OF OTWAY.—APOLLO BAY PLANNING SCHEME.

NOTICE THAT A PLANNING SCHEME HAS BEEN PREPARED AND IS AVAILABLE FOR INSPECTION.

NOTICE is hereby given that the Council of the Shire of Otway in pursuance of its powers under the Town and Country Planning Act 1961 has prepared a Planning Scheme for the township of Apollo Bay for the purpose of regulating, restricting, restraining or prohibiting the use or development of any land or the erection, construction, or carrying out of any building or works.

A copy of the scheme has been deposited at the Shire Offices, Main-street, Beech Forest, at the Shire Offices, Seymour-crescent, Apollo Bay, and at the Office of the Town and Country Planning Board, 235 Queen-street, Melbourne, and will be open for inspection during office hours by any person free of charge.

Any persons affected by the Planning Scheme are required to set forth, in writing, all objections they may have, addressed to the Shire Secretary, Shire of Otway, Beech Forest, on or before the 6th day of August, 1970, and to state whether they wish to be heard in respect of their objections.

T. J. FRY, Shire Secretary.
15th April, 1970. 4035

SHIRE OF RUTHERGLEN.

LOAN No. 20.

Notice of Intention to Borrow the Sum of \$7,000.

NOTICE is hereby given that the Council of the Shire of Rutherglen proposes to borrow the sum of Seven thousand dollars (\$7,000), secured by a charge over the general rates of the municipality, by the grant of a mortgage in accordance with the provisions of the *Local Government Act 1958*.

(a) The amount of the principal moneys which it is proposed to borrow is Seven thousand dollars.

(b) The maximum rate of interest that may be paid is 6.4 per centum per annum.

(c) The moneys borrowed and interest thereon shall be repayable by 40 half-yearly instalments, each of approximately \$312.71, on the 1st day of January and the 1st day of July during the currency of the loan, and the place at which such moneys are to be repayable is the Commercial Banking Company Savings Bank Limited, Rutherglen. The first instalment shall be payable on the 1st day of January, 1971.

(d) The purpose for which the loan is to be applied is:—

Purchase of land for the supply of materials for road construction.

(e) The loan is to be liquidated by appropriation out of the municipal fund.

(f) The plans and specifications and the estimate of the cost of the proposed works, and the statements showing the proposed expenditure of the money to be borrowed, are open for inspection at the office of the Council, Shire Offices, High-street, Rutherglen, during office hours.

Dated this 4th day of May, 1970.

4067 WALTER J. MCQUILLEN, Shire Secretary.

Water Act.

SHIRE OF SHEPPARTON WATERWORKS TRUST.

EXTENSION OF WATERWORKS DISTRICT AND CONSTRUCTION OF WORKS FOR THE SUPPLY OF WATER TO DOOKIE.

NOTICE is hereby given that the Shire of Shepparton Waterworks Trust has made application to the Minister of Water Supply for the extension of its Waterworks District and the construction, maintenance, and continuance of Water Supply Works within that extended District to supply the town of Dookie under the provisions of the Water Act.

A general plan and description of the proposed works have been submitted with the application, and copies of same may be seen at the Shepparton Shire Office at Nixon-street, Shepparton, during office hours.

Dated at Shepparton, the 1st day of May, 1970.

4012 J. W. REED, Secretary.

SHIRE OF SHERBROOKE.

NOTICE OF INTENTION TO ACQUIRE LAND COMPULSORILY.

WHEREAS the Council of the Shire of Sherbrooke deems it expedient to exercise its powers of taking land compulsorily for the purpose of road widening, and whereas in the opinion of Council such compulsory taking of land is necessary and desirable.

Notice is hereby given as follows:—

1. The Council intends to acquire all that piece of land being part of lot 35, lodged plan 8321, Parish of Scoresby (corner of Mount View-road and Willow-road, Upper Fern Tree Gully) for roadwidening purposes.

2. The Council has caused to be prepared maps and other papers describing the proposed work or undertakings and the land proposed to be taken, together with the name of the owner, or reputed owner insofar as this can be ascertained by Council.

3. Such maps and other papers are deposited at the Shire Offices, Glenfern-road, Upwey, and shall be kept open for inspection by all persons interested at all reasonable hours for the space of forty clear days after publication of this notice in the *Government Gazette*.

4. All persons affected by the proposed taking of the land are hereby called to set forth in writing addressed to the Council or the Shire Secretary of the Shire of Sherbrooke, within forty clear days from the publication of this notice in the *Government Gazette*, all objections which they may have to the taking of the said land.

Dated the 1st day of May, 1970.

By order of the Council.

4066 A. JONES, Shire Secretary.

SHIRE OF SOUTH BARWON.

LOAN No. 87.

Private Streets Construction.

NOTICE is hereby given that at the meeting of the Council of the Shire of South Barwon held at the South Barwon Council Chamber, Thompson-street, Belmont, on Tuesday, 17th March, 1970, the said Council did agree to the following Resolution:—

"That this Council by special order resolve to borrow Fourteen thousand dollars (\$14,000), to be secured by a charge over the general rates of the municipality, by the grant of a mortgage in accordance with the provisions of the *Local Government Act*.

In connection therewith the following information is stated:—

(a) The amount of the principal moneys which it is proposed to borrow is \$14,000.

(b) The rate of interest to be paid is \$6.30 per centum per annum.

(c) The times which the moneys borrowed are to be repayable are the 30th day of October, 1970 and the 30th day of April and November during 1971 to 1979 inclusive and a final payment on the 30th April, 1980. The place the moneys shall be repayable is at the Bank of New South Wales, Belmont.

(d) The purpose for which the said loan shall be applied is for the construction of private streets under the provision of Division 10 of Part XIX. of the *Local Government Act 1958* as amended.

(e) The loan shall be liquidated from the receipts of money payable under schemes under Division 10 of Part XIX. of the *Local Government Act 1958* by twenty half-yearly repayments of approximately \$954.12 which includes principal and interest."

Notice is further given that at the meeting of the said Council held at the South Barwon Council Chamber, Thompson-street, Belmont, on Tuesday, 28th April, 1970, the said Resolution was confirmed.

4082 A. A. N. DEED, Shire Secretary.

SHIRE OF STRATHFIELDSAYE.

THE Council of the Shire of Strathfieldsaye has declared:—

1. Boronia-crescent from boundary of Subdivision No. 87473 to Desmond-street,

2. McKay-street that portion within boundaries of Subdivision No. 87473

to be dedicated to the public as Public Highways.

4019 M. BRENNAN, Shire Secretary.

SHIRE OF TAMBO.

BY-LAW No. 59.

A By-law of the Shire of Tambo made under Section 197 of the *Local Government Act 1958* and every other power it thereunto enabling and numbered 59 for:—

(a) providing for the health of the residents in the municipal district, and

(b) prohibiting or regulating the placing of caravans on private property.

IN pursuance of the powers conferred by the *Local Government Act 1958* and every other power in that behalf enabling it, the President, Councillors, and Rate-payers of the Shire of Tambo order as follows:—

1. In this By-law unless inconsistent with the context—
"Council" means the Council of the Shire of Tambo.
"Frontage" means the boundary line between private property and the street upon which such private property abuts and where such property abuts on more than one street then the boundary line between the said property and the street to which any building that may be erected thereon fronts. "Private Property" includes vacant land and a private street.

"Caravan" includes a covered van, a house on wheels, and any vehicle used or adapted for living quarters whether on wheels or not.

2. No person shall place or permit to be placed—

(a) More than one caravan on any private property in the one ownership or occupation.

(b) Any caravan on any private property in such a position that any part of the caravan is within a distance of twenty five (25) feet from the frontage to such property or is within a distance of five (5) feet from any other boundary of the said property.

Provided however the Council may permit more than one caravan to be placed on any private property and within lesser distances from the frontage or other boundary of the said property upon application in writing by the owner or occupier of such property.

3. No person shall occupy any caravan placed on any private property without the consent of the Council in writing.

4. (a) Every person applying to the Council for the placing of or for consent to occupy any caravan under this By-law shall make application in writing and supply all reasonable information required by the Council including the reasons for seeking such consent, the number, age, and sex of the persons proposing to occupy the caravan, the size and location of the caravan and the sanitation facilities to be provided in respect thereof.

(b) The Council may grant or refuse its consent to any such application as it thinks fit.

(c) Should the Council give its consent then the permit issued thereon shall be for a period not exceeding six months and be conditional upon the number of persons to occupy a caravan not exceeding the number set out in the permit and upon proper sanitation facilities being provided to the satisfaction of the Health Inspector of the Council and being available at all times to the occupants of the caravan.

(d) Should such sanitation facilities cease to be available during the period of the permit and not be restored within twenty four (24) hours after notice in writing has been given by the Health Inspector to the owner or occupier of the caravan or of the premises on which the caravan is placed then any permit granted hereunder shall at the expiration of the period of notice be immediately cancelled.

5. Any person guilty of a wilful act or default contrary to this By-law shall be guilty of an offence and shall be liable to a penalty of not less than ten dollars (\$10) or more than twenty dollars (\$20) and to a further penalty of not more than ten dollars (\$10) for each day upon which such offence is continued after a conviction or order is made by any Court.

6. This By-law shall apply to and have force throughout the whole of the Municipal District of the Shire of Tambo except such areas as are registered with the Council as camping areas under the provisions of the Health Acts.

Resolution for making this By-law passed by the Council on the 18th day of November, 1969, and confirmed on the 20th day of March, 1970.

The common seal of the President, Councillors and Ratepayers of the Shire of Tambo was hereunto affixed in our presence, on the 20th day of March, 1970—

(SEAL) CLEM JONES, President.
 CLYDE J. SYKES, Councillor.
 G. W. RIDSDALE, Shire Secretary.

Approved by the Governor in Council, 24th March, 1970.
 —J. ROSSITER, Clerk of the Executive Council. 4020

SHIRE OF WODONGA.

NOTICE OF INTENTION TO BORROW.

Mortgage Loan No. 50 and Mortgage Loan No. 51.

NOTICE is hereby given that the Council of the Shire of Wodonga intends to borrow \$100,000 (One hundred thousand dollars) under Loan No. 50, and \$200,000 (Two hundred thousand dollars) under Loan No. 51, secured by a charge over the General Rates of the Municipality by the grant of a mortgage in accordance with the provisions of the Local Government Acts.

In connexion therewith the following information is stated—

- (a) The amount of the principal moneys which it is proposed to borrow is \$300,000 (Three hundred thousand dollars).
- (b) The maximum rate of interest that may be paid is 6.40 per cent. per annum.
- (c) The times which the moneys borrowed to be repayable are the 17th day of June and the 17th day of December in each year during the currency of the loan, the first of such repayments will be made on the 17th day of December, 1970, and on the 5th day of August and the 5th day of February in each year during the currency of the loan, the first of such repayments will be made on the 5th day of February, 1971, respectively, and the place of such moneys shall be repayable at the Bank of New South Wales, Wodonga.

(d) The purpose for which the loan is to be applied is—
 Erection of Civic Centre.

(e) The manner in which the loans are to be liquidated is by provision out of municipal fund in each half year during the currency of the loans, of the sums of \$3,480.04 and \$6,960.07 respectively, which includes principal and interest.

The plan and specifications and estimate of the cost of the work, and a statement, showing the proposed expenditure of the moneys to be borrowed are open for inspection at the Shire Office.

Dated the 6th day of May, 1970.

4126 G. J. MORTON, Shire Secretary.

Town and Country Planning Act 1961 (Twelfth Schedule).
 SHIRE OF WOORAYL.—SHIRE OF WOORAYL
 PLANNING SCHEME.

NOTICE THAT A PLANNING SCHEME HAS BEEN PREPARED AND IS AVAILABLE FOR INSPECTION.

Amendment No. 6, 1970.

NOTICE is hereby given that the Shire of Woorayl, in pursuance of its powers under the Town and Country Planning Act 1961, has prepared an Amending Planning Scheme for the following areas and purposes:

1. Rezoning of Crown allotments 4, 5, 6, 9 to 13 and 22 to 26, section 4 and Government road, section 4 in the Township of Koonwarra, situate west of the South Gippsland Highway from Agricultural B and Residential to a Reserve for the preservation of flora and fauna.

2. Fifteen feet road widenings at Williams-street, Inverloch, over lot 1 on lodged plan No. 32729 situate corner of Kenneth and Williams street, Inverloch, lot 6, lodged plan No. 21092, situate corner of Bayview-avenue and Williams-street, Inverloch, and lot 3 on lodged plan No. 34723, situate corner of Bayview-avenue and Williams-street, Inverloch.

3. Amendment of Ordinance controlling the erection of flats which shall be subject to the grant of a permit by the Responsible Authority and to the following conditions:

- (1) The site shall have a minimum area of 9,500 square feet and a minimum frontage of 70 feet and a minimum depth of 100 feet.
- (2) No building shall be more than three storeys in height.
- (3) Flats of one or two storeys shall be set back from boundaries other than the frontage a minimum distance of ten feet.
- (4) Flats of three storeys shall be set back from boundaries other than the frontage a minimum distance of 10 feet provided that the third storey shall also comply with the 70 degrees angle of light required by the Uniform Building Regulations for three storey buildings.
- (5) Open space within the site shall be at the rate of 500 square feet per flat exclusive of car parking space.
- (6) Before granting a permit for the erection of flats the Responsible Authority shall give notice of any application to all owners of land within two chains of the site and shall consider all objections received within 14 days of giving such notice.
- (7) Notwithstanding the provisions of sub-paragraph (1) the Responsible Authority may permit the erection of flats on a site within the boundaries of the Township of Inverloch as defined at 31st December, 1969, having a minimum frontage of 65 feet provided that all buildings are not more than one storey in height and not closer than 5 feet from side boundaries.

4. Amending Clause 27 of Ordinance to provide Building Lines as follows:—

Zone.	Distance.
Agricultural "A" Zone	60 feet.
Agricultural "B" Zone	60 feet.
Residential Zone	20 feet.
Commercial "B" Zone	20 feet.
Industrial "A" Zone	15 feet.
Industrial "B" Zone	25 feet.
Industrial "C" Zone	25 feet.

After which paragraph there shall be added the following new paragraphs:

Notwithstanding the provisions of paragraphs (a) and (b) of this clause the Responsible Authority after consideration of the circumstances of a particular case may permit the construction of cattle ramps

or other outbuildings within the Agricultural Zones and abutting a main or secondary road at a distance less than 60 feet but not less than 25 feet from a road alignment.

Notwithstanding the provisions of paragraphs (a) and (b) of this clause the building line for roads shown as minor roads on the Planning Scheme maps within the Agricultural Zone shall be 25 feet with no provision for buildings to be erected at a lesser distance.

No loading ramp within the Agricultural Zone shall be closer than 25 feet to the road alignment and all loading ramps shall be located so that a vehicle 40 feet in length standing in a normal loading position on a prolongation of the centre line of the loading platform and ramp shall not encroach on the road reserve.

A copy of the Scheme has been deposited at the Shire Office, Leongatha, and at the Office of the Town and Country Planning Board, 235 Queen-street, Melbourne, and will be open for inspection during office hours by any person free of charge.

Any person affected by the Amending Planning Scheme is required to set forth, in writing, all objections they may have, and addressed to the Shire Secretary, Shire of Woorayl, P.O. Box 21, Leongatha, 3953, on or before the 7th day of August, 1970, and state whether they wish to be heard in respect of their objections.

Dated at Leongatha, the 16th day of April, 1970.

4014 K. G. BRYDON, Shire Secretary.

Water Acts.

PROPOSED DERRINALLUM URBAN DISTRICT AND PROPOSED EXTENSION OF THE WATERWORKS DISTRICT OF THE LISMORE WATERWORKS TRUST.

NOTICE is hereby given that the Lismore Waterworks Trust has made application to the Honorable the Minister of Water Supply for the extension of the Lismore Waterworks District, and for the proclamation of an Urban District at Derrinallum, and the construction, maintenance, and continuance of Water Supply Works within that District under the provisions of the Water Acts.

A general plan and description of the proposed works have been submitted with the application, and copies of same may be seen at the (Trust's) office at Lismore.

Dated at Lismore the 16th day of April, 1970.

3840 JOSEPH S. SMITH, Secretary.

Town and Country Planning Act 1961 (Twelfth Schedule). COBRAM PLANNING SCHEME 1949.

NOTICE THAT A PLANNING SCHEME HAS BEEN PREPARED AND IS AVAILABLE FOR INSPECTION.

Amendment No. 10, 1970.

NOTICE is hereby given that the Cobram Shire Council in pursuance of its powers under the *Town and Country Planning Act 1961* has prepared a Planning Scheme for the Township of Cobram for the purpose of amending the Cobram Planning Scheme 1949.

This Scheme proposes to rezone a small triangular piece of land bounded by Station-street, Main-street and Punt-road, Cobram, from Commercial Use to Public Open Spaces and secondly to rezone an area of land in Punt-road from Private Open Spaces to Residential Use.

A copy of the Scheme has been deposited at the Office of the Cobram Shire Council, Station-street, Cobram, and at the Office of the Town and Country Planning Board, 235 Queen-street, Melbourne, and will be open for inspection during office hours by any person free of charge.

Any person affected by the Planning Scheme are required to set forth, in writing, all the objections they may have, addressed to the Shire Secretary, Shire Office, Cobram, on or before the 6th August, 1970, and to state whether they wish to be heard in respect of their objections.

4039 RONALD T. CUTTS, Shire Secretary.

GEELONG WATERWORKS AND SEWERAGE TRUST.

PURSUANT to section 60 of the *Geelong Waterworks and Sewerage Act 1958* (No. 6263) the Trust has prepared plans to indicate the particulars of sewers and underground works in or adjacent to the following localities within the drainage area.

Walsgott, Giddings and Kerr streets, North Geelong; Shire of Corio.

Fellmongers-road, Breakwater; City of Geelong.

Notice is hereby given that the plans indicated above are open for public inspection at the Trust's Offices, Ryrie-street, Geelong, between the hours of 9 a.m. and 5 p.m., from Monday to Friday, public holidays excepted, by the owners and occupiers of land or premises within the drainage area.

4025

B. C. HENSHAW, Secretary.

NOTICE is hereby given that C. Monteath & Sons (Successors) Proprietary Limited, has applied for a lease, pursuant to section 134 of the *Land Act 1958*, for a term of ten years in respect of allotment 9, section 101A, City of South Melbourne, containing 1 rood 18 2/10 perches, as a site for a factory and general engineering works.

3793

NOTICE is hereby given that Chorki Ski Club has applied for a lease under section 134 of the *Land Act 1958*, for a term of 21 years in respect of an area of 1 rood 10 perches, more or less, being allotment 4, section A, Parish of Hotham, as a site for a ski lodge.—(H.O.33691.)

4130

T. C. TATTON, Secretary,
Chorki Ski Club.

NOTICE OF INTENTION TO APPLY FOR A LICENCE TO DIVERT WATER AND CUT RACE (RE-ISSUE) FROM THE LITTLE MURRAY RIVER, AT PENTAL ISLAND.

WE hereby give notice that we intend to apply for a licence empowering us to divert water for a term of five years to the extent of 100 acre-feet per annum at a maximum rate of 12 acre-feet per day of 24 hours for the irrigation of 50 acres of pastures, being part of allotments 40A and 41, Parish of Pental Island, and to occupy certain Crown lands for works of diversion, and to cut a race thereon.

Any objection to such application must be forwarded, in writing, to reach the State Rivers and Water Supply Commission, Melbourne, before 5th June, 1970, being 30 days from the first publication of this notice.

JOHN PATRICK BAKER.
PATRICK CORNELIUS BAKER.

Private Bag 130, Swan Hill 3585. 4062

NOTICE OF INTENTION TO APPLY FOR A LICENCE TO DIVERT WATER AND CUT RACE (RE-ISSUE) FROM THE RIVER MURRAY, AT COLIGNAN.

WE hereby give notice that we intend to apply for a licence empowering us to divert water for a term of fifteen years to the extent of 81 acre-feet per annum at a maximum rate of one acre-foot per day of 24 hours for the irrigation of fruit trees and vegetables, being part of allotments 1 and 2, section B, Parish of Colignan, and to occupy certain Crown lands for works of diversion, and to cut a race thereon.

Any objection to such application must be forwarded, in writing, to reach the State Rivers and Water Supply Commission, Melbourne, before 5th June, 1970, being 30 days from the first publication of this notice.

DONALD JAMES WILLIAMS.
DOROTHY PATRICIA WILLIAMS.

Colignan 3494. 4064

NOTICE OF INTENTION TO APPLY FOR A LICENCE TO DIVERT WATER AND CUT RACE (RE-ISSUE) FROM THE GOULBURN RIVER, AT MURCHISON EAST.

I HEREBY give notice that I intend to apply for a licence empowering me to divert water for a term of fifteen years to the extent of 120 acre-feet per annum at a maximum rate of 3 acre-feet per day of 24 hours for the irrigation of 60 acres of lucerne and pasture, being allotments 107, 108, 110 and 111, Parish of Dargalong, and to occupy certain Crown lands for works of diversion, and to cut a race thereon.

Any objection to such application must be forwarded, in writing, to reach the State Rivers and Water Supply Commission, Melbourne, before 5th June, 1970, being 30 days from the first publication of this notice.

ALAN JAMES TWEDDLE.

Murchison East. 4061

NOTICE OF INTENTION TO APPLY FOR A LICENCE TO DIVERT WATER AND CUT RACE (RE-ISSUE) FROM THE RIVER MURRAY, AT ROBINVALE.

I HEREBY give notice that I intend to apply for a licence empowering me to divert water for a term of fifteen years to the extent of 15 acre-feet per annum at a maximum rate of 2 acre-feet per day of 24 hours for the irrigation of pastures and market garden, being part of Allotment 11, L.P.29193, Parish of Bumbang, and to occupy certain Crown lands for works of diversion, and to cut a race thereon.

Any objection to such application must be forwarded, in writing, to reach the State Rivers and Water Supply Commission, Melbourne, before 5th June, 1970, being 30 days from the first publication of this notice.

KEVIN WILLIAM SMITH.

Box 109, Robinvale. 4065

NOTICE OF INTENTION TO APPLY FOR A LICENCE TO DIVERT WATER AND CUT RACE (RE-ISSUE) FROM THE MURPHYS CREEK, RIVER MURRAY, AT GOORAMADDA.

I HEREBY give notice that I intend to apply for a licence empowering me to divert water for a term of fifteen years to the extent of 50 acre-feet per annum at a maximum rate of 2 acre-feet per day of 24 hours for the irrigation of 25 acres of lucerne and permanent pasture, being part of allotments 7 and 8 and part of 1, section N1, Parish of Gooramadda, and to occupy certain Crown lands for works of diversion, and to cut a race thereon.

Any objection to such application must be forwarded, in writing, to reach the State Rivers and Water Supply Commission, Melbourne, before 5th June, 1970, being 30 days from the first publication of this notice.

ALLEN HENRY NOTT.

Box 35, Rutherglen. 4063

NOTICE OF INTENTION TO APPLY FOR A LICENCE TO DIVERT WATER AND CUT RACE (RE-ISSUE) FROM THE RIVER MURRAY, AT ROBINVALE.

I HEREBY give notice that I intend to apply for a licence empowering me to divert water for a term of fifteen years to the extent of 12 acre-feet per annum at a maximum rate of 2 acre-feet per day of 24 hours for the irrigation of ovals, being Recreation Reserve, Township and Parish of Bumbang, and to occupy certain Crown lands for works of diversion, and to cut a race thereon.

Any objection to such application must be forwarded, in writing, to reach the State Rivers and Water Supply Commission, Melbourne, before 5th June, 1970, being 30 days from the first publication of this notice.

M. HAEUSLER, Secretary.

Robinvale Recreation Reserve, Box 401, Robinvale. 4059

NOTICE OF INTENTION TO APPLY FOR A LICENCE TO DIVERT WATER AND CUT RACE (RE-ISSUE) FROM THE RIVER MURRAY, AT YELTA.

I HEREBY give notice that I intend to apply for a licence empowering me to divert water for a term of fifteen years to the extent of 52 acre-feet per annum at a maximum rate of 2½ acre-feet per day of 24 hours for the irrigation of 24 acres, being part of allotment 2, section H, Parish of Merbein, and to occupy certain Crown lands for works of diversion, and to cut a race thereon.

Any objection to such application must be forwarded, in writing, to reach the State Rivers and Water Supply Commission, Melbourne, before 5th June, 1970, being 30 days from the first publication of this notice.

ALFRED LYAL SMITH.

"Redgrove", Box 263, Merbein. 4124

NOTICE OF INTENTION TO APPLY FOR A LICENCE TO DIVERT WATER AND CUT RACE (RE-ISSUE) FROM THE RIVER MURRAY LAGOON, AT BARNAWARTHA NORTH.

I HEREBY give notice that I intend to apply for a licence empowering me to divert water for a term of fifteen years to the extent of two acre-feet per annum at a maximum rate of 3 acre-feet per day of 24 hours for the irrigation of 30 acres, being part of allotments 1, 1A, 1B, 2, 3, 4, 5, and 6, section 28, Parish of Barnawartha North, and to occupy certain Crown lands for works of diversion, and to cut a race thereon.

Any objection to such application must be forwarded, in writing, to reach the State Rivers and Water Supply Commission, Melbourne, before 5th June, 1970, being 30 days from the first publication of this notice.

MR. G. COYLE.

P.O. Box 115, Wodonga, Victoria. 4125

NOTICE OF INTENTION TO APPLY FOR A LICENCE TO DIVERT WATER AND CUT RACE (RE-ISSUE) FROM THE RIVER MURRAY, AT YARRAWONGA.

I HEREBY give notice that I intend to apply for a licence empowering me to divert water for a term of fifteen (15) years to the extent of 450 acre-feet per annum at a maximum rate of 12 acre-feet per day of 24 hours for the irrigation of 225 acres, being part of allotments 6B, 7C and 41, Parish of Yarrawonga, and to occupy certain Crown lands for works of diversion, and to cut a race thereon.

Any objection to such application must be forwarded, in writing, to reach the State Rivers and Water Supply Commission, Melbourne, before 5th June, 1970, being 30 days from the first publication of this notice.

RONALD DAVID BROWNING.

"Riverslea", P.O. Box 43, Yarrawonga, Victoria. 4120

NOTICE OF INTENTION TO APPLY FOR A LICENCE TO DIVERT WATER AND CUT RACE (RE-ISSUE) FROM THE TRAVELLERS CREEK, RIVER MURRAY, AT WODONGA.

WE hereby give notice that we intend to apply for a licence empowering us to divert water for a term of fifteen years to the extent of sixty acre-feet per annum at a maximum rate of 1 acre-foot per day of 24 hours for the irrigation of 30 acres, being part of Crown allotment 2, section 4, Parish of Belvoir West, and to occupy certain Crown lands for works of diversion, and to cut a race thereon.

Any objection to such application must be forwarded, in writing, to reach the State Rivers and Water Supply Commission, Melbourne, before 5th June, 1970, being 30 days from the first publication of this notice.

AENEAS TENNYSON RICHARDS.

WALLACE AENEAS RICHARDS.

"Yaralla", Wodonga West. 4121

NOTICE OF INTENTION TO APPLY FOR A LICENCE TO DIVERT WATER AND CUT RACE (RE-ISSUE) FROM THE RIVER MURRAY (SANDY CREEK), AT WAHGUNYAH.

WE hereby give notice that we intend to apply for a licence empowering us to divert water for a term of fifteen years to the extent of 40 acre-feet per annum at a maximum rate of 2 acre-feet per day of 24 hours for the irrigation of 20 acres of tobacco, being part of allotments 2, 4 and 6, section A, Parish of Carlyle, and to occupy certain Crown lands for works of diversion, and to cut a race thereon.

Any objection to such application must be forwarded, in writing, to reach the State Rivers and Water Supply Commission, Melbourne, before 5th June, 1970, being 30 days from the first publication of this notice.

WALLACE ROBERT NUGENT.

LILIAN ANNE NUGENT.

Care of Neil Stewart & Constable, P.O. Box 41, Wangaratta, 3677. 4122

NOTICE OF INTENTION TO APPLY FOR A LICENCE TO DIVERT WATER AND CUT RACE (RE-ISSUE) FROM THE RIVER MURRAY, AT WAHGUNYAH.

WE hereby give notice that we intend to apply for a licence empowering us to divert water for a term of fifteen years to the extent of 40 acre-feet per annum at a maximum rate of 2 acre feet per day of 24 hours for the irrigation of 20 acres of tobacco, being part of allotments 6D and 6F, section 8, Parish of Carlyle, and to occupy certain Crown lands for works of diversion, and to cut a race thereon.

Any objection to such application must be forwarded, in writing, to reach the State Rivers and Water Supply Commission, Melbourne, before 5th June, 1970, being 30 days from the first publication of this notice.

WALLACE ROBERT NUGENT.

LILIAN ANNE NUGENT.

Care of Neil Stewart & Constable, P.O. Box 41, Wangaratta. 4123

NOTICE is hereby given that the partnership heretofore subsisting between Noel Treyvaud Pullen and Norman Makepeace Barry, carrying on business as real estate agents, insurance and travel agents under the firm name of "Wilson & Pullen", of Moorabbin, has been dissolved as from 30th April, 1970.

Dated the 30th day, of April, 1970.

N. T. PULLEN.
N. M. BARRY.

TAKE notice that the partnership made on the 1st day of September, 1969, between Thomas David Linane and Clare Colleen Linane and Guy Swanson and Lynette Beverley Swanson and the business name of Ultra Acrylic-Glass Products was dissolved by deed of dissolution on the 25th day of September, 1969, and the business of Ultra Acrylic-Glass Products was to be used after that date by the said Guy Swanson and Lynette Beverley Swanson and all debts incurred after that date in the name of Ultra Acrylic-Glass Products is the responsibility of Guy Swanson and Lynette Beverley Swanson.

Dated this 23rd day of April, 1970.

Signed by the said Clare Colleen Linane, in Victoria, in the presence of—F. X. LYNCH.

C. LINANE.

Signed by the said Thomas David Linane, in Victoria, in the presence of—F. X. LYNCH.

4013

T. D. LINANE.

NOTICE is hereby given that the partnership heretofore subsisting between Bernard James Raikes, Eileen Margaret Raikes and Lucy Beatrice Raikes, carrying on business as Microfilmmers and Offset Printers, at 315 Canterbury-road, Canterbury, under the style or firm of Archive Recording Service, has been dissolved by mutual consent as from the 14th day of August, 1969, so far as concerns the said Lucy Beatrice Raikes, who retired from the said firm.

Dated the 28th day of April, 1970.

SALISBURY, WARDLAW & CO., 882 Whitehorse-road,
Box Hill. 4047

NOTICE OF DISSOLUTION OF PARTNERSHIP.

NOTICE is hereby given that the partnership heretofore subsisting between Russell John Williams and Irene Lorraine Williams, both of 94 Grey-street, Traralgon, in the State of Victoria, and Elmar Franz Effenberg and Maureen Jeanette Effenberg, both of 175 Liddiard-road, Traralgon, in the State of Victoria, carrying on business as Pastrycooks, Bakers, Retail Confectioners and Take-Away Food Retailers, at 81 Franklin-street, Traralgon, under the style or firm of "Almond Food Centre", has been dissolved as from the 30th day of April, 1970, so far as concerns the said Russell John Williams and Irene Lorraine Williams, who retire from the said firm, and that the said Elmar Franz Effenberg and Maureen Jeanette Effenberg will, as from the 1st-day of May, 1970, continue the said business at the same address and under the same firm name.

Dated the 30th day of April, 1970.

RUSSELL JOHN WILLIAMS.
IRENE LORRAINE WILLIAMS.
ELMAR FRANZ EFFENBERG.
MAUREEN JEANETTE EFFENBERG.

Peter W. Riches, solicitor, 96 Hotham-street, Traralgon.
4080

NOTICE is hereby given that the partnership heretofore subsisting between Gladys Edith Martin, Jack Richard Foster and Nancy Jean Foster, carrying on business as restaurant proprietors, at 150 Maroondah Highway, Croydon, under the firm name of "American Roadhouse Restaurant" has been dissolved by mutual consent as from the 20th day of April, 1970. All debts due to and owing by the said late firm will be received and paid by the said Gladys Edith Martin who will continue to carry on the business at the same address.

R. P. BARRETT & SON, solicitors, 472 Bourke-street,
Melbourne. 4115

The Companies Act 1961.—In the matter of H. ROBINS & SONS PTY. LTD., Registered Office, at 951 Nepean Highway, Moorabbin, formerly carrying on business as Car Dealers, at 65 Brighton-road, Elwood.—Notice Re Meeting of Creditors, pursuant to section 260.

NOTICE is hereby given that a Meeting of Creditors of the above-named company will be held at Victorian Chamber of Manufacturers, Room 2, 370 St. Kilda-road, Melbourne, on Thursday, the 21st day of May, 1970, at 11.15 a.m., the company having convened a meeting of its members for the 20th May, 1970, prior to this meeting for the purpose of considering a Resolution that the company be wound up voluntarily.

Dated this 28th day of April, 1970.

S. ROBINS, Director.

Bent & Cogle, public accountants, Suite 18, 545 St. Kilda-road, Melbourne, 3004. 4026

The Companies Act 1961.—In the matter of GLASS APPARATUS PTY. LTD., formerly B. & D. GLASS INSTRUMENTS PTY. LTD.—Notice Re Meeting of Creditors, pursuant to section 260.

NOTICE is hereby given that a Meeting of Creditors of the above-named company will be held at Victorian Chamber of Manufacturers, Room 2, 370 St. Kilda-road, Melbourne, on Thursday, the 21st May, 1970, at 10 a.m., the company having convened a meeting of its members on the same day for the purpose of considering a Resolution that the company be wound up voluntarily.

Dated this 27th day of April, 1970.

H. BARTELT, Director.

Bent & Cogle, public accountants, Suite 18, 545 St. Kilda-road, Melbourne. 4030

In the matter of CHAN PROPERTIES (TULLAMARINE) PTY. LTD.—Notice of Winding-up Order.

WINDING-UP Order made 27th day of April, 1970.

Name and address of Liquidator, Ernest Harding Niemann, 44 Market-street, Melbourne.

J. M. SMITH & EMMERTON.

Dated this 28th day of April, 1970. 4032

CAMBRIDGE AGENCIES PROPRIETARY LIMITED.

SPECIAL RESOLUTION TO WIND UP, PURSUANT TO SECTION 254 OF THE COMPANIES ACT 1961.

AT an Extraordinary General Meeting of the above-named company, duly convened and held at the offices of A. H. G. Clarke & Co., 460 Bourke-street, Melbourne, on the 30th day of April, 1970, the following Resolution was duly passed as a Special Resolution—

"That in accordance with the provisions of section 254 of the Companies Act 1961, the company be wound up voluntarily."

And at such last-mentioned meeting, Anthony Macavoy Locke, of 460 Bourke-street, Melbourne, was appointed liquidator for the purposes of the winding up.

Dated this 30th day of April, 1970.

4037 A. M. LOCKE, Liquidator.

In the matter of A. & R. MOTOR SALES PTY. LTD.; and in the matter of the Companies Act 1961.—Notice of Meeting of Creditors pursuant to section 260.

NOTICE is hereby given, pursuant to section 260 of the Companies Act 1961, that a meeting of the creditors of the above-named company will be held at Norman, Cartledge and Browne, chartered accountants of 1 Palmerston-crescent, South Melbourne, on Thursday, 14th day of May, 1970, at 9.45 o'clock in the forenoon for the following purposes:

1. To consider a Special Resolution for winding up passed by the above-named company.
2. To consider a statement of the position of the company's affairs together with a list of creditors and the estimated amount of their claims.
3. To nominate a person to be liquidator for the purpose of winding up the affairs and distributing the assets of the company.
4. If thought fit to appoint a committee of inspection.
5. To consider the persons and number thereof to be appointed as a committee of inspection.
6. To fix the remuneration of the liquidator.

Dated this 4th day of May, 1970.

By Order of the Board,

4150

V. ROTH, Secretary.

The Companies Act 1961.—In the matter of SHEPPARTON FERTILISERS PROPRIETARY LIMITED (in Voluntary Liquidation).

NOTICE is hereby given that, pursuant to section 272 of the Companies Act 1961, a Final Meeting of Members of the company will be held at 296A Canterbury-road, Surrey Hills, at 5.30 p.m., on Monday, 15th June, 1970, for the purpose of considering the liquidator's final accounts and in accordance with section 284 (3) (b) determine the period after which the books and papers of the company and of the liquidator may be destroyed.

Dated this 4th day of May, 1970.

4148

B. W. L. DOIG, Liquidator.

Unclaimed Moneys Act 1962.

REGISTER of Unclaimed Moneys held by the—

Name of Owner on Books and Last Known Address.	Total Amount Due to Owner.	Description of Unclaimed Moneys.	Date when Amount First Became Payable.
\$			
A.C.T. NOMINEES LIMITED.			
Anderson, M. (Mrs.), 39 Bay-street, Mordialloc	30.42	Dividend Natural Resources of Australia Trust	29.11.68
Jennings, G. W., 52 Victoria-street, Warragul	14.40	" " " "	"
Warwick, J. E. (Mrs.), 4/533 Rathdown-street, Carlton	21.60	" " " "	31.5.68
ALCOA OF AUSTRALIA LTD.			
Battley, N., 375 Shannon-avenue, Newtown, Geelong	119.11	Wages	31.5.68
Babb, P. J., Lot 25, Double-street, Ocean Grove	31.05	"	5.7.68
H. J. HEINZ CO. AUSTRALIA LTD.			
McClure, D., 18 Bel-Air-drive, Frankston	14.60	Pension Fund Payment	—7.68
Mills, J. C., Flat 10, Close-avenue, Dandenong, 3175	17.40	" " "	—12.68
Poulter, A. L., 37 Scott-street, Dandenong, 3175	48.00	" " "	—7.68
Watson, J. L., 3 Abrehart-street, Doveton, 3177	38.90	" " "	—11.68
Edwards, J. E., 42 Edwards-street, Dandenong, 3175	15.70	Wages	—1.69
Dempster, D., 87 Foster-street, Dandenong	32.80	"	—11.68
DUNLOP AUSTRALIA LIMITED.			
Aywazi, Halit, 77 Brunswick-street, Brunswick	16.26	Wages	7.9.68
Belle, Patrick, 2 McArthur-street, East Malvern	23.10	"	30.3.68
Brady, Gordon, Fishermen's Bend Hostel, Lorimer-street, Port Melbourne	18.90	"	20.7.68
Dalamitras, Evangelos, 30 Dover-street, Richmond	28.93	"	"
Delinaoum, Ilias, 45 Fulham-road, Alphington	29.72	"	7.12.68
Garbour, Youssuf, 69 Neill-street, Carlton	15.99	"	15.2.69
Georgopoulou, Viki, 83 Roseneath-street, Clifton Hill	36.06	"	23.3.68
Horner, Joseph Antoine, 49 St. John-street, Windsor	43.00	"	9.3.68
Jenkins, Graham, 162 Blyth-street, East Brunswick	30.07	"	"
Kacar, Andrea, 30 Hyde-street, Footscray	26.44	"	23.11.68
Kalioglou, Michael, 20 Cromwell-street, Collingwood	10.42	"	27.7.68
Kelly, Leon Francis, 194 Blyth-street, Brunswick	18.39	"	9.3.68
Klinovsky, Josef, 50 Greeves-street, St. Kilda	43.14	"	21.12.68
Lagas, Georgia, 130 Graham-street, Port Melbourne	19.97	"	1.3.69
Lettiere, Carolina (deceased), 494 Bay-street, Port Melbourne	31.47	"	3.8.68
Maranis, Ronald, 231 Ross-street, Port Melbourne	43.24	"	1.3.69
McFarlane, Bernard John, 2 Parker-street, Pascoe Vale	26.20	"	14.9.68
Mondell, Delvenita Lorrieni, 7 Charles-street, West Preston	27.28	"	14.12.68
Pendenza, Graziano, Maribyrnong Hostel, Williamson-road, Maribyrnong	20.50	"	10.8.68
Petras, Johanna (deceased), 142 Millers-road, Paisley	46.64	"	7.12.68
Rocca, Guiseppe, 200 Clarendon-street, Thornbury	14.68	"	6.4.68
Sarandoglou, Hrisostomos, 17 Bunbury-street, Footscray	18.65	"	20.7.68
Stark, John Robert, 97 Fitzroy-street, St. Kilda	36.22	"	4.5.68
Stronglyaki, Soula, 101 Union-street, Northcote	13.31	"	30.11.68
Davey, Edward Royce, 37 Nicholson-street, Fitzroy	10.08	Retirement Fund	25.5.68
Delinaoum, Ilias, 45 Fulham-road, Alphington	21.86	"	14.12.68
NATIONAL CONSOLIDATED LIMITED.			
Allen, Michael Donald, c/o The Bank of New Zealand, Box 507, G.P.O., Sydney, N.S.W.	12.00	Dividend	11.11.68
Clough, John Crossby, 84 Fordham-avenue, Hartwell, 3124	12.00	"	25.3.68 and 11.11.68
Burley, Jocelyn Anne, P.O. Box 7, Otahunu, N.Z.	42.84	Unclaimed Dividend No. 40	"
Merewether, Olive Lisle (Mrs.), Unit 4, 5 Marian-street, Killara, N.S.W.	14.40	"	"
Tetley, Henry Hamilton, 51A Mencks Spur, Christchurch, N.Z.	10.20	"	"
CUSTOM CREDIT CORPORATION LIMITED.			
O'Reilly, J. L., 29 Egremont-street, North Fitzroy	34.88	Interest Payment	31.3.68
Wills, F. M. (Mrs.), 10 Queen-street, Blackburn	18.12	"	"
Otto, J. R., H. J. and J. H., 14 Hill-street, Bellerive, Tas.	24.00	Interest Payments	"
Tyson, M. A., P.O. Box 626, Launceston, Tas.	33.75	Interest Payment	"
Wapling, G., c/o Mrs. Thornton, Curdie-street, Cobden	2.25	"	"
Collins, A. M., 21 Sandhurst-road, Eaglehawk	3.50	"	30.6.68
Tyson, M. A., P.O. Box 626, Launceston, Tas.	33.75	"	"
Lethlean, W. M. (estate of), 12 Capon-street, Chadstone	2.25	"	30.9.68
Tyson, M. A., P.O. Box 626, Launceston, Tas.	33.75	"	"
COCA-COLA BOTTLERS (MELBOURNE) PTY. LTD.			
Richey, Judy, 39 Wordsworth-street, Moonee Ponds	19.64	Unclaimed Wages	—3.68
Woods, Joyce, 5 Coral-street, Brunswick	22.86	"	"
Hickey, Fay, 30 Gray-street, Brunswick	11.07	"	"
Wilson, Graham, 5 Meller-street, Alphington	13.01	"	"
Murphy, Neil F., 329 Barkly-street, Brunswick	26.37	"	"
Fuccio, Francis, 29 Ormond-street, Mordialloc	25.48	"	"
Lanarus, George, 10 Portland-place, South Yarra	23.99	"	"
Haslett, Louis, Gamble-road, Skye	57.65	"	"
Howell, J., Flat 3, 63 Ramu-road, West Heidelberg	23.70	"	"
Naylor, P., 141 Barkley-street, East Brunswick	19.41	"	"
G. J. COLES AND COY. LIMITED STAFF RETIREMENT FUND.			
Moloney, Dennis C., 65 Somerville-road, Yarraville	14.10	Superannuation Entitlement	13.11.68

Unclaimed Moneys Act 1962.

REGISTER of Unclaimed Moneys held by the—

Name of Owner on Books and Last Known Address.	Total Amount Due to Owner.	Description of Unclaimed Moneys.	Date when Amount first became Payable.
§			
G. J. COLES AND CO. LIMITED.			
Dale, Betty K. (Mrs.), Danesby, Fourth-avenue, Frinton on Sea, Essex, U.K.	22.61	Dividend	7.9.68
Dawson, Kenneth P. S., Hazel Hill Cottage, Sandway, Lenham, Kent, U.K.	17.76	"	"
Sills, Kathleen R. (estate of), c/o Evans, Rendal and Oakeshott, Rolls Chambers, Star Yard, London, U.K.	66.86	"	"
Finlay, Jessie M. (Miss), 17 Giles-street, Kingston, Canberra, A.C.T.	37.62	"	"
Ashby, Frederick J. (estate of), c/o A. H. Cavell, Leitch and Pringle, cnr. Hereford and Manchester streets, Christchurch, N.Z.	30.68	"	"
Chandler, Ian M., c/o The National Bank of New Zealand, Jean Batten Place, Auckland, N.Z.	21.31	"	"
Coulter, Leonard J., 176 Ilam-road, Christchurch, N.Z.	106.59	"	"
Crofts, Stephanie E. (Mrs.), 255 Lyttleton-street, Spreydon, Christchurch, N.Z.	17.11	"	"
Fraher, James M. and Lola D. (Mrs.), P.O. Box 2574, Christchurch, N.Z.	11.62	"	"
Fraser, Catherine (Mrs.) and William A. R., Tamaki House, Kohimarama-road, Kohi, Auckland, N.Z.	21.31	"	"
Grundy, Charlotte (Mrs.), c/o M. Nobbs and M. A. G. Hornsby, 10 Avonside-drive, Christchurch, N.Z.	21.96	"	"
Kwok, Frank W., 16 Kelburn-parade, Wellington, N.Z.	11.62	"	"
Patrick, Laughton W., P.O. Box 83, Wellington, N.Z.	18.41	"	"
Roydhouse, Garth S., P.O. Box 1367, Wellington, N.Z.	16.79	"	"
Thomas, Fred W., Thomas-road, East Tamaki, Auckland, N.Z.	18.73	"	"
Flynn, Patrick, 29 Payne-street, Milton, Queensland	11.40	"	"
Hogan, Geoffrey S., 56 Bellevue-terrace, Clayfield, Brisbane, Queensland	13.30	"	"
Porter, Vivien I. (Mrs.), "Runaroo", M/S 101, Monto, Queensland	18.24	"	"
Bainton, John V., Flat 601, Araluen, 274 New South Head-road, Edgecliff, New South Wales	11.02	"	"
Carter, Ernest F., 6 Finlay-avenue, Beecroft, N.S.W.	58.52	"	"
Hackney, Ben C., "Wonalabee", Bathurst, N.S.W.	27.36	"	"
Thai, Chee K., 254 Darebin-road, Thornbury	11.40	"	"
Thomson, Alister C., c/o The Bank of N.S.W., 91 William-street, Melbourne	22.80	"	"
Watkins, Mary (estate of), c/o H. P. R. Morganti, 191 McKean-street, North Fitzroy	13.30	"	"
Manning, Lucy (Miss), McLaren Vale, S.A.	10.26	"	"
Beresford, Winifred S. (estate of), c/o W. A. Predergast and Robinson, 406 Lonsdale-street, Melbourne	84.36	"	"
Oates, Phyllis E. (Miss), c/o G.P.O. Box 1514 N, Melbourne	76.38	"	"
Quick, Florrie E. A. M. (Mrs.), 811 Centre-road, East Bentleigh	55.86	"	"
Renard, Clement J., 65 Manning-road, East Malvern	30.78	"	"
Finlay, Jessie M. (Miss), 17 Giles-street, Kingston, A.C.T.	19.80	"	8.3.69
Arnold, Elizabeth M. (Miss), 93 Maioro-street, Avondale, Auckland, N.Z.	27.20	"	"
Brook, Bertha (Miss), 84 Aorangi-road, Christchurch, N.Z.	42.16	"	"
Burley, Heather W. (Mrs.), P.O. Box 22007, Otahuhu, Auckland, N.Z.	17.00	"	"
Cowper, William D. (estate of), c/o Lloyd and Smith, P.O. Box 46, Dannevirke, N.Z.	66.98	"	"
Dixon, Leo G., 21 Shiphers-avenue, Epsom, Auckland, N.Z.	15.98	"	"
Gordon, Clive D., "Glenrossie", Waerenga-road, Otaki, N.Z.	23.80	"	"
Stapleton, Margaret (estate of), c/o Cassidy, Amodeo and Jacobson, P.O. Box 866, Christchurch, N.Z.	61.54	"	"
Bone, H. Russell, 82 Widmore-road, Bromley, Kent, U.K.	17.85	"	"
Dickeson, Helen F. (Mrs.), Water End, 9 Moor-lane, Rickmansworth, Herts, U.K.	15.30	"	"
Drew, Phyllis M. (Mrs.), c/o Colegrove and Co., 14-18 Gresham-street, London, U.K.	26.69	"	"
Goulstone, Henry W., 13 Bradenham-place, Penarth, Glamorgan, U.K.	71.91	"	"
Mackay, George R. and Drummond, David, c/o Rawlinson and Hunter, 51 Green-street, London, U.K.	33.32	"	"
Nelson, Sarah A. (Mrs.), and Nelson, Amos C., and Stanbie, Edward H., East Stone, Edge Cottage, Blacke, Nelson, Lancs., U.K.	151.30	"	"
Sills, Kathleen R. (estate of), c/o Evans, Rendal and Oakeshott, Rolls Chambers, Star Yard, London, U.K.	35.19	"	"
Cameron, Zeerust K., (Mrs.), "Lowstoft", Berridale, Tasmania	63.00	"	"
Armstrong, John W., (estate of), c/o J. W. Armstrong, G.P.O. Box N1012, Perth, W.A.	11.60	"	"
Nicholson, Peter John "Burenda Stud", Augathella, Qld.	10.00	"	"
Williams, Herbert (estate of), c/o Heiser, Bayley and Behan, G.P.O. Box 235D, Brisbane	21.20	"	"
Bate, Maureen J. (Mrs.), 20 Chamberlain-avenue, Rose Bay, N.S.W.	12.20	"	"
Browning, Robert H. (estate of), c/o McIntosh, McPhillamy and Co., P.O. Box 33, Bathurst, N.S.W.	10.00	"	"
McAuliffe, Peter, 195 MacQuarie-street, Sydney, N.S.W.	28.80	"	"
Nettlefold, Ernest A., c/o Permanent Trustee Co. of N.S.W. Ltd., 23-25 O'Connell-street, Sydney	107.40	"	"
Haughton, Vera S. (Miss), 72A Oakleigh-road, Carnegie	49.60	"	"
Lennon, Paul A., Flat 1, 23 Charming-street, Moorabbin	12.00	"	"
Mears, Russell A. (Dr.), 45 Spring-street, Melbourne	20.20	"	"
Nelson, Leslie G., P.O. Box 56, Colac	16.00	"	"
Oates, Phyllis E. (Miss), c/o G.P.O. Box 1514N, Melbourne	40.20	"	"
Quick, Florrie E. A. M. (Mrs.), 811 Centre-road, East Bentleigh	29.40	"	"
Renard, Clement J., 65 Manning-road, East Malvern	16.20	"	"

Unclaimed Moneys Act 1962.

REGISTER of Unclaimed Moneys held by the—

Name of Owner on Books and Last Known Address.	Total Amount Due to Owner.	Description of Unclaimed Moneys.	Date when Amount first became Payable
S			
G. J. COLES AND CO. LIMITED—continued.			
Walton, Kathleen G. (Miss), 18 Henry-street, Hawthorn	10.00	Dividend	8.3.69
Grose, Betty (Mrs.), 5 Pardy-street, Pascoe Vale	16.72	Balance of Wages and Holiday Pay	6.1.69
Quayle, Julie (Miss), Flat 1, 7 Fausett-street, Albert Park	21.04	" " " "	4.11.68
Godson, Joan (Mrs.), 531 Abercorn-street, Albury	12.26	" " " "	28.11.68
Ganly, Deidre (Miss), 11 Robert-street, Parkdale	15.03	" " " "	20.12.68
Samara, Ifigenia (Miss), 6/550 Toorak-road, Toorak	21.01	" " " "	9.10.68
Lamplugh, Helen Ettie (Miss), 14 Charles-street, Northcote	17.77	" " " "	17.10.68
Breen, Robert, 74 Hotham-street, East Melbourne	65.16	" " " "	3.2.69
Murphy, H. (Mrs.), Flat 2, 294/8 Ferrars-street, South Melbourne	14.98	Wages	30.5.68
Kucerans, Imants, 11 Keon-crescent, Sunshine	36.53	Holiday Pay	24.4.68

4015

AUSTRALIAN CONSOLIDATED INDUSTRIES LTD.

Albright, Valerie B. (Mrs.), 89 The Boulevard, Lakemba, N.S.W.	33.20	Dividends	1968
Blum, Peter W., 81 Birriga-road, Bellevue Hill, N.S.W.	16.00	" " " "	"
Bonnington, Cecil, (estate of), c/o R. A. Young, Hunter and Co., P.O. Box 929, Christchurch, N.Z.	1,343.34	" " " "	"
Browning, Robert H. (estate of), c/o McIntosh, McPhillamy and Co., P.O. Box 33, Bathurst, N.S.W.	52.32	" " " "	"
Clifford, James-N., P.O. Box 101, Tumut, N.S.W.	10.72	" " " "	"
Corey, Margaret B. (Mrs.), 57A Hoon Hay-road, Christchurch, N.Z.	17.00	" " " "	"
Dixon, Phillip V. (Dr.), 110 Homebush-road, Strathfield, N.S.W.	16.64	" " " "	"
Doherty, Lillian P. (estate of), c/o Maguire and McInerney, Crown-street, Wollongong, N.S.W.	37.68	" " " "	"
Doolan, Moya A. (Mrs.), c/o Hanley, Reddy and Doolan, P.O. Box 2, Crookwell, N.S.W.	18.00	" " " "	"
Eden, Ruby, (Miss), Flat 2, 58 Perouse-road, Randwick, N.S.W.	82.56	" " " "	"
Edward, David W., c/o A.N.Z. Bank, Martin Place, Sydney, N.S.W.	20.00	" " " "	"
Edwards, Christopher J., Colne Cottage, Colnbrook, Buckinghamshire, England	13.60	" " " "	"
Fry, William H., Lower Wonga, via Woollooga, Qld.	54.40	" " " "	"
Geddes, Margaret (estate of), c/o Mr. Fred Beehag, 37 Seven Ways, Rockdale, N.S.W.	16.56	" " " "	"
Hair, James R., 29 Iranui-road, Gisborne, N.Z.	47.60	" " " "	"
Hamilton, McDonald R., Goondiwindi, Qld.	45.60	" " " "	"
Heighway, William D., 37 Oswell-street, Rockdale, N.S.W.	10.00	" " " "	"
Hill, Stanley B., Murray-street, Finley, N.S.W.	12.00	" " " "	"
Long, Wilfred S., Cambridge-street, Levin, N.Z.	40.80	" " " "	"
Love, Gregor G. C., 64 Ocean-street, Woolmhara, N.S.W.	14.50	" " " "	"
Loveday, Ruth W. (Mrs.), 18A Fisher-street, Fullarton, S.A.	13.96	" " " "	"
Manoy, May M. (Miss), 215 Main-road, Karori, Wellington, N.Z.	20.40	" " " "	"
Mansfield, Jack, 195 Eastern-road, Wahroonga, N.S.W.	39.00	" " " "	"
Marsden, Edward A., c/o Lloyds Bank Limited, Water-street, Liverpool, 2 England	10.20	" " " "	"
Mitchell, Anthony S. (Dr.), 48 Onslow-street, Rose Bay, N.S.W.	10.80	" " " "	"
Moloney, Margaret E. (estate of), c/o W. J. Mullane, 4 Bridge-street, Sydney, N.S.W.	56.80	" " " "	"
Morrow, Millic A. (Mrs.), Box 297, P.O. Haymarket, George-street, Sydney, N.S.W.	156.80	" " " "	"
Mulligan, Helen B. (Mrs.), Kinarla, Enniskillen, County Fermanagh, Northern Ireland	10.20	" " " "	"
Nelson, Michael, 416 Alicia Way, Los Altos, California, U.S.A.	37.64	" " " "	"
Reid, Flora H. (Mrs.), 37 Telegraph-road, Pymble, N.S.W.	35.00	" " " "	"
Stephen, Kathleen R. (Mrs.) Frances E. C. Bennett (Mrs.) and Thomas A. Langley, c/o Fisher and Macansh, G.P.O. Box 508, Sydney, N.S.W.	41.44	" " " "	"
Taylor, John H., 8 Elmstone-avenue, Remuera, Auckland, SE2, N.Z.	82.97	" " " "	"
Thomas, Iva V. (Mrs.), 17 Parsley-road, Vacluse, N.S.W.	14.40	" " " "	"
Tyrrell, John, c/o Australian Pastoral Co., Bumble Bend, Cubbie, Dirrinbandi, Qld.	20.00	" " " "	"
Walker, Caroline M. (Miss), Flat 1, 25 Kareela-road, Cremorne Point, N.S.W.	120.00	" " " "	"
Williams, Christine I. (Mrs.), 7 Swallow-street, Slade Point, via Mackay, Qld.	30.00	" " " "	"
Young, Walter J., c/o Singapore Glass Manufacturing Co., P.O. Box 1, Alexandria, Singapore	21.00	" " " "	"

4016

THE PERPETUAL EXECUTORS AND TRUSTEES ASSOCIATION OF AUSTRALIA LIMITED.

Black, E. J. (Mrs.), 58 Strong-street, East Geelong	21.00	Dividend A.F.T. Property Trust No. 2	30.4.68
Drayton, A. D. (Miss), 222 Gordon-street, Footscray	53.29	" " " "	"
Hall, P. D., 53 Wonganella-drive, East Keilor	10.50	" " " "	31.10.68
Lee, M. A. (Mrs.), 2 Bruce-street, Box Hill	17.50	" " " "	30.4.68
Longhurst, W. E., Main-street, Warburton	42.00	" " " "	"
McDonald, E. L. (Mrs.), 27 Munro-street, Coburg	10.57	" " " "	31.10.68
Shepherd, H. (Miss), 13 Anne-crescent, Brighton	10.50	" " " "	30.4.68
Trounson, J. M., 13 Drumcondra-avenue, Geelong North	14.00	" " " "	31.10.68
Wilson, D. Z. (Mrs.), 123 Hulton-street, Thornbury	28.00	" " " "	"

Unclaimed Moneys Act 1962.

REGISTER of Unclaimed Moneys held by the—

Name of Owner on Books and Last Known Address.	Total Amount Due to Owner.	Description of Unclaimed Moneys.	Date when Amount first became Payable.
\$			
THE PERPETUAL EXECUTORS & TRUSTEES ASSOCIATION OF AUSTRALIA LIMITED—continued.			
Martin, A. B. S. (Mrs.), c/o F. W. Robson and Co., 175 William-street, Melbourne	19.32	Dividend Australian Industries Flexible Trust No. 1	29.3.68
Pyman, W. J., c/o Coles and Garrard, 376 Bourke-street, Melbourne	12.88	" " " " " "	" " " "
Bedford, D. O. (Miss), 39 Davies-street, Brunswick	76.19	Final Distribution " Australian Industries Flexible Trust No. 2	28.2.69
Bell, C. C. (estate of), c/o W. M. Bourke and J. Keating, 191 Grenville-street, Prahran	507.88	" " " " " "	" " " "
Bickford, E. D. (estate of), c/o Watson, James and Rogers, Bull-street, Bendigo	50.79	" " " " " "	" " " "
Brook, J., 54 Herbert-street, Parkdale	10.76	Dividend Australian Industries Flexible Trust No. 2	31.5.68
Charlton, L. H. (Mrs.), 1 Donald-street, Murrumbidgee	101.58	Final Distribution Australian Industries Flexible Trust No. 2	28.2.69
Dorn, E. B., 28 Langdon-road, Caulfield	50.79	" " " " " "	" " " "
Desmit, A. J., 61 Osborne-street, Williamstown	50.79	" " " " " "	" " " "
Dykstra, E. (Miss), 29 Melby-avenue, East St. Kilda	939.58	" " " " " "	" " " "
Edington, G. G., 37 Woyna-avenue, Rosebud West	50.79	" " " " " "	" " " "
Edwards, V. J., 3 Ross-street, Aspendale	126.97	" " " " " "	" " " "
Jennings, H. (Miss), Halls-road, Cranbourne	50.79	" " " " " "	" " " "
Lyon, J. (Mrs.), 2A Cooper-street, Essendon	10.76	" " " " " "	" " " "
Marshall, J. A., 75 Centre-road, East Brighton	101.58	Dividend Australian Industries Flexible Trust No. 2	31.5.68
Martin, A. J. (Miss), Box 26, Deniliquin, N.S.W.	24.05	Final Distribution Australian Industries Flexible Trust No. 2	28.2.69
McKenna, M. (estate of), c/o D. J. O'Connell and McKenna, P.O. Box 27, Wangaratta	380.91	Dividend Australian Industries Flexible Trust No. 2	31.5.68
Peck, G. E. (Mrs.), "Sunnyside", Boundry-road, Mt. Eliza	253.94	Final Distribution Australian Industries Flexible Trust No. 2	28.2.69
Proudfoot, L., 14 Sylvan-grove, Pascoe Vale	76.19	" " " " " "	" " " "
Savagin, G., P.O. Cabaretta, via Mildura	50.79	" " " " " "	" " " "
Saunders, D. (Miss), 58 Outer-crescent, Brighton	50.79	" " " " " "	" " " "
Turner, E. E. (estate of), c/o Anderson, Rice and Marshall, 43 Queen-street, Melbourne	50.79	" " " " " "	" " " "
Wallis, P. M. (Mrs.), 481 Hawthorn-road South Caulfield	126.97	" " " " " "	" " " "
Weilandt, J. H., P.O. Box 10, Talbot	507.88	" " " " " "	" " " "
Williamson, E. V. (estate of), c/o Doolan, Kemp and Townsend 340 Collins-street, Melbourne	2,581.80	" " " " " "	" " " "
Rosenwarne, G. L. G. (estate of), c/o J. McNeill and Simpson, P.O. Box 99, Hay, N.S.W.	319.20	Dividend Victorian Property and Buildings Trust	7.2.69
Waters, D., 14 Yuille-street, Brighton	19.50	" " " " " "	" " " "
Bruce, A. E. (Mrs.), Flat 5, Trawalla-avenue, Toorak	38.40	Dividend "A.F.T." Industrial Development Fund	31.7.68
Stone, L. B. (Miss), c/o Public Trustee, 601 Little Collins-street, Melbourne	12.50	Dividend First Victorian Balanced Fund	28.2.69
Thompson, E. C. and Q. I., 142 Niemann-street, Bendigo 4021	12.50	" " " " " "	" " " "
P. T. LIMITED.			
Martin, L. (Miss), 4 Wonga-road, Ringwood	19.53	Dividend A.F.T. Flexible Trust No. 2 (Vic.)	22.5.68
Peek, S. P. (Mrs.), c/o McAlpin, Wonga-road, Ringwood	13.04	" " " " " "	" " " "
Street, S. B. (Mrs.), 16 Hill-street, Bellerive, Tas.	24.80	Dividend "Australian Leaders Trust (Vic.)	7.11.68
Williams, L. A. and L. U. C., Burlah West	142.00	" " " " " "	" " " "
Boulton, H. M. (Miss), c/o Presbyterian Ladies College, Burwood-road, Burwood	46.85	" " " " " "	" " " "
Eddison, E. H., 4 Wolerna-road, Glen Iris	32.94	Dividend A.F.T. Commerce and Industry Trust (Vic.)	5.7.68
Edson, C. C. (estate of), c/o J. C. Arnold and Co., 67 Deakin-avenue, Mildura	14.85	" " " " " "	" " " "
Fox, H. V., 2 Dalgety-street, Preston	16.61	" " " " " "	" " " "
Yarker, J., Hunter-road, Wandin	45.94	" " " " " "	" " " "
Burke, G. and E. I. L., 25 Rusden-street, Elsternwick	37.20	" " " " " "	" " " "
Campbell, G. A., 188 Main-street, Ballarat	130.90	Dividend A.F.T. Balanced Fund (Vic.)	7.10.68
Law, F. A., 114A Nicholson-street, East Brunswick	37.60	" " " " " "	" " " "
Pain, D. W., 2 Odessa-street, St. Kilda	37.60	" " " " " "	" " " "
Pink, C., Wycheproof	39.48	" " " " " "	" " " "
Proppe, F. M. (Mrs.), 3 Mathews-court, Ferntree Gully	29.92	" " " " " "	" " " "
Swan, D. G., 105 Victoria-drive, Eastbourne, Sussex, Kent, U.K.	43.01	" " " " " "	" " " "
Johnson, G. R., 7 Illawarra-road, Hawthorn	28.74	" " " " " "	" " " "
McKenzie, D. H. (Mrs.), (address unknown)	13.05	Dividend A.F.T. Balanced Fund (Vic.) No. 4	21.6.68
Peek, S. P. (Mrs.), c/o McAlpin, Wonga-road, Ringwood	24.10	" " " " " "	" " " "
Barberis, M. A. (Mrs.), 7 Nelson-street, Nhill	16.80	" " " " " "	" " " "
Wilkinson, L., 23 Glenbrook-avenue, East Malvern	17.40	Dividend "A.F.T." Selected Securities Trust (Vic.)	15.1.69
		" " " " " "	15.7.68

Unclaimed Moneys Act 1962.

REGISTER of Unclaimed Moneys held by the—

Name of Owner on Books and Last Known Address.	Total Amount Due to Owner.	Description of Unclaimed Moneys.	Date when Amount first became Payable.
\$			
P. T. LIMITED—continued.			
Sinclair, R. H. and J. P., Olivers-road, Templestowe	10.56	Dividend A.F.T. Flexible Trust (Vic.)	22.5.68
Thornton, R., 84 Warrigal-road, Oakleigh	33.60	" " " " "	"
Kessick, D. and F. M., 11 Heron-avenue, Mildura	27.50	Dividend A.F.T. Unit Trust (Vic.)	22.3.68
Pitts, N. R., 17 Johnston-street, Castlemaine	11.50	" " " " "	20.9.68
Skinner, R. W., (Mrs.), 260 Toorak-road, Burwood	11.60	" " " " "	"
Yarker, J., Hunter-road, Wandin	17.25	" " " " "	"
Anderson, A. L. (Mrs.), Queen Elizabeth-drive, Tallangatta	18.43	Dividend Selected Equities Unit Trust (Vic.)	15.6.67
Glover, G. L. (Mrs.), 265 Clarke-street, Northcote	23.38	" " " " "	14.6.68
Watt, A., 7 Bent-street, Bentleigh	45.40	" " " " "	"
Thornton, R., 84 Warrigal-road, Oakleigh	140.03	Dividend "A.F.T." Industrial Development Fund (Vic.)	22.8.68
Whitta, W. T., Plenty-road, Mernda	41.80	" " " " "	"
Williamson, E. V. (estate of), c/o Doolan, Kemp and Townsend, 340 Collins-street, Melbourne	11.40	" " " " "	"
Holmes, D. A. (Miss), 77 Raglan-street, South Melbourne	178.48	Dividend A.F.T. Industrial Development Fund (Vic.) No. 2	"

4022

The Companies Act 1961.—In the matter of LINLEY INVESTMENTS PTY. LTD.

NOTICE is hereby given that a meeting of Linley Investments Pty. Ltd. (trading as "N. Linley") on the 27th day of April, 1970, resolved that the company be wound up voluntarily, and a meeting of creditors held on the same day pursuant to section 260 resolved that for such purpose, Edward Ronald Smail, of 296 Little Lonsdale-street, Melbourne, chartered accountant, be appointed liquidator.

Notice is also given that, after 21 days from this date, I shall proceed to distribute the assets. All creditors having any claims against the company should furnish particulars of same by that date, otherwise I shall proceed to distribute the assets without regard to their claim.

Dated this 29th day of April, 1970.

E. R. SMAIL, Liquidator.

Kennedy, Smail & Middlemiss, 296 Little Lonsdale-street, Melbourne. 4103

The Companies Act 1961.

HALLCRAFT PRINTERS PTY. LIMITED (UNDER OFFICIAL MANAGEMENT).

Pursuant to Section 206 of the Companies Act 1961.

NOTICE is hereby given that, at a meeting of the members of Hallcraft Printers Pty. Limited (Under Official Management), duly convened and held at the offices of Fell & Starkey, 351 Collins-street, Melbourne, on the 27th day of April, 1970, the Special Resolution set out below was duly passed.

"That the company be wound up voluntarily and that it be recommended to the creditors of the company at the meeting called for 27th April, 1970, at 10 a.m., that Mr. Noel Wilfred Buckley, of 461 Bourke-street, Melbourne, be appointed liquidator of the company for the purposes of such winding up."

Dated this 1st day of May, 1970.

R. W. ELLIS, Official Manager.

4116

Companies Act 1961.

A. ROYLE (ST. KILDA) PTY. LTD. (IN VOLUNTARY LIQUIDATION).

Notice of Final Meeting of Members.

NOTICE is hereby given, in pursuance of section 272 (1) of the Companies Act 1961, that the Final General Meeting of the members of A. Royle (St. Kilda) Pty. Ltd. (in Voluntary Liquidation) will be held at 10.30 a.m. on Monday, the 8th day of June, 1970, at the office of K. L. Paroissien, 280 Church-street, Richmond, for the purpose of the liquidator laying before it an account showing how the winding up has been conducted and the property disposed of, and to give any explanation thereof.

Dated this 27th day of April, 1970.

K. L. PAROISSIEN, Liquidator.

4117

In the matter of the Companies Act 1961; and in the matter of LEAD REFINERIES PROPRIETARY LIMITED.

NOTICE is hereby given that at an Extraordinary General Meeting of the above-named company, duly convened and held at the offices of Consolidated Metal Products Limited, 8 Bridge-street, Sydney, N.S.W., at 2.15 o'clock in the afternoon on the 24th day of April, 1970, the following Special Resolution was duly passed, viz.:-

"It was resolved that the company be wound up voluntarily and that David Carl Christensen, of 75 Fortuna-avenue, North Balwyn, be appointed liquidator for the purposes of such winding up and that the remuneration of the liquidator be determined according to the rates prescribed by The Institute of Chartered Accountants in Australia."

Dated the 27th day of April, 1970.

4100

J. H. BROINOWSKI, Chairman.

The Companies Act 1961.—In the matter of MAX DAW'S MENS WEAR PTY. LTD.

NOTICE is hereby given that at an Extraordinary General Meeting of the members of the above-named company held on the 29th day of April, 1970, it was resolved that the company be wound up voluntarily, and at a meeting of creditors held on the same day, pursuant to section 260, it was resolved that for such purpose, Alan Murray Horsburgh, of 296 Little Lonsdale-street, Melbourne, accountant, be appointed liquidator.

Notice is also given that after 21 days from this date I shall proceed to distribute the assets. All creditors having any claims against the company should furnish particulars of same by that date, otherwise I shall proceed to distribute the assets without regard to their claim.

Dated this 1st day of May, 1970.

A. M. HORSBURGH, Liquidator.

Kennedy, Smail & Middlemiss, 296 Little Lonsdale-street, Melbourne, 3000. 4101

The Companies Act 1961.—In the matter of EXTOL PROPRIETARY LIMITED.—Notice Re Meeting of Creditors, pursuant to Section 260.

NOTICE is hereby given that a Meeting of Creditors of the above-named company will be held at Princes Gate, East Tower, 3rd Floor, Rooms 326 and 7, 151 Flinders-street, Melbourne, on Wednesday, 13th day of May, 1970, at 2.30 p.m., the company having convened an Extraordinary Meeting of its members for the same day for the purpose of considering a Special Resolution that the company be wound up voluntarily.

Dated this 1st day of May, 1970.

KENNETH GRISKA, Director.

Lewis Luckins & Co., chartered accountants, of 289 Flinders-lane, Melbourne, 3000, telephone: 63 8827. 4102

In the matter of the *Companies Act 1961*; and in the matter of **NAMFORD PROPRIETARY LIMITED**.—Notice of Meeting of Creditors (Section 260 (1)).

NOTICE is hereby given that a meeting of creditors of Namford Proprietary Limited will be held at Honorary Justices Association, 528 Collins-street (3rd Floor), Melbourne, on Wednesday, the 13th day of May, 1970, at 10 o'clock in the morning.

Agenda.

1. To consider a Special Resolution for winding up, passed by the above-mentioned company and a statement of the position of the company's affairs together with a list of creditors of the Company and the estimated amount of their claims.
 2. To nominate a person to be liquidator for the purpose of winding up the affairs and distributing the assets of the above-named company.
 3. To fix the remuneration of the proposed liquidator.
- If thought fit, to appoint members of a Committee of Inspection.
4. To consider the appointment of members of a Committee of Inspection.

Dated this 4th day of May, 1970.

By order of the Board,

R. FORD,
L. FORD,
Directors.

4118

In the matter of the *Companies Act 1961*; and in the matter of the following companies (in Voluntary Liquidation).—Notice of Final Meetings of Members, Pursuant to Section 272.

DUNLOP TYRE SERVICE (BOX HILL) PTY. LTD.
DUNLOP TYRE SERVICE (HORSHAM) PTY. LTD.
DUNLOP TYRE SERVICE (MILDURA) PTY. LTD.
DUNLOP TYRE SERVICE (HAMILL) PTY. LTD.
DUNLOP TYRE SERVICE (SHEPPARTON) PTY. LTD.
DUNLOP TYRE SERVICE (GEELONG) PTY. LTD.
DUNLOP TYRE SERVICE (WARRAGUL) PTY. LTD.
DUNLOP TYRE SERVICE (TRARALGON) PTY. LTD.
DUNLOP TYRE SERVICE (FOOTSCRAY) PTY. LTD.
DUNLOP TYRE SERVICE (BAIRNSDALE) PTY. LTD.
DUNLOP TYRE SERVICE (SWAN HILL) PTY. LTD.
DUNLOP TYRE SERVICE (BENDIGO) PTY. LTD.
DUNLOP TYRE SERVICE (PRESTON) PTY. LTD.
DUNLOP TYRE SERVICE (HAMILTON) PTY. LTD.
DUNLOP TYRE SERVICE (WARRNAMBOOL) PTY. LTD.
DUNLOP TYRE SERVICE (BRUNSWICK) PTY. LTD.
DUNLOP TYRE SERVICE (TYRESOLES SOUTH MELB.) PTY. LTD.
DUNLOP TYRE SERVICE (WANGARATTA) PTY. LTD.
DUNLOP TYRE SERVICE (NORTH GEELONG) PTY. LTD.
DUNLOP TYRE SERVICE (ARARAT) PTY. LTD.
DUNLOP TYRE SERVICE (DANDENONG) PTY. LTD.
DUNLOP TYRE SERVICE (COLAC) PTY. LTD.
DUNLOP TYRE SERVICE (KERANG) PTY. LTD.
DUNLOP TYRE SERVICE (BALLARAT) PTY. LTD.
DUNLOP TYRE SERVICE (FRANKSTON) PTY. LTD.
DUNLOP TYRE SERVICE (LEONGATHA) PTY. LTD.
DUNLOP TYRE SERVICE (ESSENDON) PTY. LTD.
DUNLOP TYRE SERVICE (OAKLEIGH) PTY. LTD.
DUNLOP TYRE SERVICE (LILYDALE) PTY. LTD.
DUNLOP TYRE SERVICE (FAWKNER) PTY. LTD.
NATIONAL TYRE SERVICE (CASTLEMAINE) PTY. LTD.
DUNLOP TYRE SERVICE (RINGWOOD) PTY. LTD.
DUNLOP TYRE SERVICE (TERANG) PTY. LTD.
DUNLOP TYRE SERVICE (MOORABBIN) PTY. LTD.
DUNLOP TYRE SERVICE (ECHUCA) PTY. LTD.
DUNLOP TYRE SERVICE (BENALLA) PTY. LTD.

NOTICE is hereby given, in pursuance of section 272 of the *Companies Act 1961*, that a General Meeting of the members of each of the above companies will be held at the office of Messrs. Cooper Brothers & Co., 461 Bourke-street, Melbourne, on the 19th day of June, 1970, at 10 o'clock in the forenoon, for the purpose of having an account laid before it, showing the manner in which the winding up has been conducted, and the property of the company disposed of, and hearing any explanation that may be given by the liquidator.

Dated this 6th day of May, 1970.

R. F. HUGHES, Liquidator.

Messrs. Cooper Brothers & Co., chartered accountants,
461 Bourke-street, Melbourne.
No. 45.—3782/70.—5

4073

In the matter of the *Companies Act 1961*; and in the matter of **BATTERY EQUIPMENT SUPPLY CO. (VIC.) PTY. LIMITED**.

NOTICE is hereby given that at an Extraordinary General Meeting of the above-named company, duly convened and held at the offices of Consolidated Metal Products Limited, 8 Bridge-street, Sydney, N.S.W., at 2 o'clock in the afternoon on the 24th day of April, 1970, the following Special Resolution was duly passed, viz:—

"It was resolved that the company be wound up voluntarily and that David Carl Christensen, of 75 Fortuna-avenue, North Balwyn, be appointed liquidator for the purposes of such winding up and that the remuneration of the liquidator be determined according to the rates prescribed by The Institute of Chartered Accountants in Australia."

Dated the 27th day of April, 1970.

4099

J. H. BROINOWSKI, Chairman.

RE J. KING PROPRIETARY LIMITED.

NOTICE is hereby given that by an Order of the Supreme Court of the State of Victoria made on 28th April, 1970, the reduction of the capital of the company to \$324,419.54 divided into 177,354 ordinary shares of 1 cent each and 322,646 ordinary shares of \$1 each was confirmed.

ARTHUR ROBINSON & CO., 447 Collins-street, Melbourne, solicitors for the company. 4147

Companies Act 1961, Section 254.

YAMIL PROPRIETARY LIMITED.

NOTICE is hereby given that at an Extraordinary General Meeting of the members of the above-named company held on the 29th day of April, 1970, the following Resolution was passed as a Special Resolution:—

"That this company be wound up voluntarily and that Arthur Grahame Taylor, care of Messrs. Irish, Young & Outhwaite, A.M.P. Tower, 535 Bourke-street, Melbourne, be appointed liquidator for the purposes of such winding up."

4158

A. G. TAYLOR, Liquidator.

The Companies Act 1961.

M. & A. LEATHER MANUFACTURING & TRADING COMPANY PROPRIETARY LIMITED (IN LIQUIDATION).

NOTICE CONVENING FINAL MEETING OF MEMBERS AND CREDITORS, PURSUANT TO SECTION 272.

NOTICE is hereby given pursuant to section 272 of the *Companies Act 1961*, that a general meeting of the members and creditors of the above-named company will be held in the offices of Kennedy, Smail & Middlemiss, 296-304 Little Lonsdale-street, Melbourne, on Wednesday, the 3rd day of June, 1970, at 10.30 a.m., for the purpose of having an account laid before them showing the manner in which the winding up has been conducted and the property of the company disposed of, and of hearing any explanations that may be given by the liquidator.

Dated this 1st day of May, 1970.

A. M. HORSBURGH, Liquidator.

Kennedy, Smail & Middlemiss, 296-304 Little Lonsdale-street, Melbourne, 3000. 4155

The Companies Act 1961.

HACKELIS PRODUCTS PROPRIETARY LIMITED (IN LIQUIDATION).

NOTICE CONVENING FINAL MEETING OF MEMBERS AND CREDITORS, PURSUANT TO SECTION 272.

NOTICE is hereby given pursuant to section 272 of the *Companies Act 1961*, that a general meeting of the members and creditors of the above-named company will be held in the offices of Kennedy, Smail & Middlemiss, 296-304 Little Lonsdale-street, Melbourne, on Wednesday, the 3rd day of June, 1970, at 11.00 a.m., for the purpose of having an account laid before them showing the manner in which the winding up has been conducted and the property of the company disposed of, and of hearing any explanations that may be given by the liquidator.

Dated this 1st day of May, 1970.

R. E. RAMSAY, Liquidator.

Kennedy, Smail & Middlemiss, 296-304 Little Lonsdale-street, Melbourne, 3000. 4156

J. A. MCGILTON PTY. LTD. (IN VOLUNTARY LIQUIDATION).
 NOTICE CONVENING FINAL MEETING, PURSUANT TO
 SECTION 272 OF THE COMPANIES ACT 1961.

NOTICE is hereby given, in pursuance of section 272 of the Companies Act 1961, that a general meeting of the members of the above-named company will be held in the offices of Messrs. Peat, Marwick, Mitchell & Co., 447 Collins-street, Melbourne, on 3rd June, 1970, at 11.00 a.m., for the purpose of having an account laid before them, showing the manner in which the winding up has been conducted and the property of the company disposed of, and of hearing any explanation that may be given by the liquidator.

Dated the 5th day of May, 1970.

J. M. POULTON, liquidator, 447 Collins-street,
 Melbourne. 4151

FREIGHTER-HINO PTY. LTD. (IN VOLUNTARY LIQUIDATION).

NOTICE CONVENING FINAL MEETING, PURSUANT TO
 SECTION 272 OF THE COMPANIES ACT 1961.

NOTICE is hereby given, in pursuance of section 272 of the Companies Act 1961, that a general meeting of the members of the above-named company will be held in the offices of Messrs. Peat, Marwick, Mitchell & Co., 447 Collins-street, Melbourne, on 3rd June, 1970, at 11.15 a.m., for the purpose of having an account laid before them, showing the manner in which the winding up has been conducted and the property of the company disposed of, and of hearing any explanation that may be given by the liquidator.

Dated the 5th day of May, 1970.

J. M. POULTON, liquidator, 447 Collins-street,
 Melbourne. 4152

CAMERON & SUTHERLAND PTY. LTD. (IN VOLUNTARY LIQUIDATION).

NOTICE CONVENING FINAL MEETING, PURSUANT TO
 SECTION 272 OF THE COMPANIES ACT 1961.

NOTICE is hereby given, in pursuance of section 272 of the Companies Act 1961, that a general meeting of the members of the above-named company will be held in the offices of Messrs. Peat, Marwick, Mitchell & Co., 447 Collins-street, Melbourne, on 5th June, 1970, at 11.00 a.m., for the purpose of having an account laid before them, showing the manner in which the winding up has been conducted and the property of the company disposed of, and of hearing any explanation that may be given by the liquidator.

Dated the 5th day of May, 1970.

J. M. POULTON, liquidator, 447 Collins-street,
 Melbourne. 4153

FREIGHTER INDUSTRIES (VIC.) PTY. LTD. (IN VOLUNTARY LIQUIDATION).

NOTICE CONVENING FINAL MEETING, PURSUANT TO
 SECTION 272 OF THE COMPANIES ACT 1961.

NOTICE is hereby given, in pursuance of section 272 of the Companies Act 1961, that a general meeting of the members of the above-named company will be held in the offices of Messrs. Peat, Marwick, Mitchell & Co., 447 Collins-street, Melbourne, on 5th June, 1970, at 11.15 a.m., for the purpose of having an account laid before them, showing the manner in which the winding up has been conducted and the property of the company disposed of, and of hearing any explanation that may be given by the liquidator.

Dated the 5th day of May, 1970.

J. M. POULTON, liquidator, 447 Collins-street,
 Melbourne. 4154

The Companies Act 1961.

KOHANE INVESTMENT CO. PTY. LTD. (IN VOLUNTARY LIQUIDATION).
 PURSUANT TO SECTION 272.

NOTICE is hereby given that a Final Meeting of Members will be held at the offices of the Liquidator on Friday, 12th June, 1970 at 9 a.m. for the purpose of laying before the meeting the Liquidator's Accounts and to give any explanations thereof.

Dated this 5th day of May, 1970.

P. C. SIMMONS, Liquidator, 8th Floor, 150 Queen-street,
 Melbourne. 4098

The Companies Act 1961.—In the matter of STYLE TUBE & WIRE LIMITED (in Liquidation).—Creditors Winding Up.

NOTICE is hereby given that at the Extraordinary General Meeting of Style Tube & Wire Limited, duly convened and held at 372 South-road, Moorabbin, in the State of Victoria, on the 24th day of April, 1970, the following Resolution was proposed and passed as a Special Resolution.

“That the company be wound up voluntarily”.

At a subsequent meeting of creditors, duly convened and held at 318 Flinders-street, Melbourne, on 27th day of April, 1970, Messrs. R. W. Betts and J. L. F. Maffey of 461 Bourke-street, Melbourne, were appointed joint and several liquidators.

Dated this 30th day of April, 1970.

4072 R. W. BETTS, Liquidator.

Companies Act 1961, Section 254.

GABRIEL CHEMICAL COMPANY PROPRIETARY LIMITED.

NOTICE is hereby given that at an Extraordinary General Meeting of the members of the above-named company, held on 29th April, 1970, the following resolution was passed as a Special Resolution:—

“That this company be wound up voluntarily and that Mr. R. A. Waters, of 170 Queen-street, Melbourne, be appointed Liquidator for the purpose of such winding up.”

4086

R. A. WATERS, Liquidator.

Companies Act 1961.

COLERAINE & WESTERN DISTRICT BUTTER FACTORY CO. LIMITED.

MEMBERS VOLUNTARY WINDING UP.

NOTICE is hereby given that on the 29th day of April, 1970, the members of the company passed a Special Resolution to wind up the company by way of members voluntary winding up, and that Rockley Rex Crozier, of 37 Queen-street, Melbourne, be appointed liquidator for the purpose of winding up the affairs and distributing the assets of the company.

R. R. CROZIER, Liquidator.

Leane & Crozier, public accountants, of 37 Queen-street,
 Melbourne. 4095

Companies Act 1961.

PORTLAND DAIRY ASSOCIATE CO. LIMITED.

MEMBERS VOLUNTARY WINDING UP.

NOTICE is hereby given that on the 29th day of April, 1970, the members of the company passed a Special Resolution to wind up the company by way of members voluntary winding up, and that Rockley Rex Crozier, of 37 Queen-street, Melbourne, be appointed liquidator for the purpose of winding up the affairs and distributing the assets of the company.

R. R. CROZIER, Liquidator.

Leane & Crozier, public accountants, of 37 Queen-street,
 Melbourne. 4096

Companies Act 1961.

TANDAROOK DAIRY CO. LIMITED.

MEMBERS VOLUNTARY WINDING UP.

NOTICE is hereby given that on the 29th day of April, 1970, the members of the company passed a Special Resolution to wind up the company by way of members voluntary winding up, and that Rockley Rex Crozier, of 37 Queen-street, Melbourne, be appointed liquidator for the purpose of winding up the affairs and distributing the assets of the company.

R. R. CROZIER, Liquidator.

Leane & Crozier, public accountants, of 37 Queen-street,
 Melbourne. 4097

CREDITORS, next of kin and others having claims in respect of the estate of Daisy Ethel Wyatt, late of 15 Jessie-street, Moreland, widow, deceased (who died on the 5th day of January, 1970), are required to send particulars of their claims to her executor, Richard James Wyatt, care of the under-mentioned solicitors by the 14th day of July, 1970, after which date he will distribute the assets, having regard only to the claims of which he then has notice.

STRUGNELL & STRUGNELL, solicitors, 106 Bell-street
 (P.O. Box 62), Coburg, 3058. 4144

HENRY DOTHEL, late of 18 Briggs-street, Caulfield, gentleman, DECEASED.

CREDITORS, next of kin and others having claims in respect of the estate of the said deceased (who died on 5th November, 1968), are required by Emma Swift Bell Gault, of 5 Park-avenue, Glenhuntly, widow, the executrix to whom probate of the Will of the said deceased was granted by the Supreme Court on 6th November, 1969, to send particulars to her by the 7th day of July, 1970, after which date the said executrix may convey or distribute the assets, having regard only to the claims of which she then has notice.

Dated this 29th day of April, 1970.

MILLER & MILLER, solicitors, 331 Collins-street, Melbourne. 4093

CREDITORS, next of kin and others having claims in respect of the estate of Kurt Helmer Helstrup, formerly of 245 McKean-street, Clifton Hill, but late of 27 Dobson-avenue, Rosanna, in the State of Victoria, building contractor, deceased (who died on the 29th May, 1968), are required to send particulars of their claims to the executrix, Antonina Helstrup, care of the under-signed solicitors by the 30th June, 1970, after which date the said executrix will proceed to distribute the estate having regard only to the claims of which she may then have notice.

J. A. WILMOTH & SON, 4 Bank-place, Melbourne, solicitors for the applicant. 4094

ELIZA FULLARD, late of 15 Wilkes-street, Ferntree Gully, widow, DECEASED.

CREDITORS, next of kin and others having claims in respect of the estate of the deceased (who died on the 29th day of August, 1969), are required by the Perpetual Executors and Trustees Association of Australia Limited, of 100-104 Queen-street, Melbourne, to send particulars of their claims to the said company by the 7th day of July, 1970, after which date it will convey or distribute the assets, having had regard only to the claims of which the company then has notice.

BEST, HOOPER, RINTOUL & SHALLARD, solicitors, 100 Queen-street, Melbourne. 4092

MARIE ALLEN, late of 356 North-road, East Brighton, in the State of Victoria, widow, DECEASED.

CREDITORS, next of kin and others having claims in respect of the estate of the deceased (who died on the 3rd day of February, 1970), are required by The Perpetual Executors and Trustees Association of Australia Limited, of 100-104 Queen-street, Melbourne, to send particulars of their claims to the said company by the 31st day of July, 1970, after which date it will convey or distribute the assets, having had regard only to the claims of which the company then has notice.

SACKVILLE, WILKS & CO., solicitors, 100 Collins-street, Melbourne. 4104

ROSE MYRTLE ORROCK, late of 307 Dandenong-road, Windsor, widow, DECEASED.

CREDITORS, next of kin and others having claims in respect of the estate of the deceased (who died on the 24th day of February, 1970), are required by The Perpetual Executors and Trustees Association of Australia Limited, of 100-104 Queen-street, Melbourne, to send particulars of their claims to the said company by the 8th day of July, 1970, after which date it will convey or distribute the assets, having had regard only to the claims of which the company then has notice.

W. H. FLOOD & PERMEZEL, solicitors, 388 Bourke-street, Melbourne. 4088

ISOBEL ALICE MAPLESTONE, late of 25 Serpells-road, Templestowe, married woman, DECEASED.

CREDITORS, next of kin and others having claims in respect of the estate of the deceased (who died on the 12th day of July, 1969), are required by The Perpetual Executors and Trustees Association of Australia Limited, of 100-104 Queen-street, Melbourne, to send particulars of their claims to the said company by the 8th day of July, 1970, after which date it will convey or distribute the assets, having had regard only to the claims of which the company then has notice.

W. H. FLOOD & PERMEZEL, solicitors, 388 Bourke-street, Melbourne. 4089

PHILIP ALAN MAPLESTONE, late of 25 Serpells-road, Templestowe, retired physician, DECEASED.

CREDITORS, next of kin and others having claims in respect of the estate of the deceased (who died on the 13th day of July, 1969), are required by The Perpetual Executors and Trustees Association of Australia Limited, of 100-104 Queen-street, Melbourne, to send particulars of their claims to the said company by the 8th day of July, 1970 after which date it will convey or distribute the assets, having had regard only to the claims of which the company then has notice.

W. H. FLOOD & PERMEZEL, solicitors, 388 Bourke-street, Melbourne. 4090

WHITTENBURY WALTER JONES (also known as Walter Whittenbury Jones), late of 26 Lawson-street, Bentleigh, investment counsellor, DECEASED.

CREDITORS, next of kin and others having claims in respect of the estate of the above-named deceased (who died on the 6th November, 1969), are required by the executors Frederick Maurice Van Cuylenburg and David Kenneth Davies, both of 388 Bourke-street, Melbourne, solicitors to send particulars to them in care of the under-mentioned solicitors by 8th July, 1970, after which date the executors may convey or distribute the assets, having regard only to the claims of which they then have notice.

W. H. FLOOD & PERMEZEL, solicitors, 388 Bourke-street, Melbourne. 4091

HILDA TOMS, late of 56 Rennie-street, Thornbury, widow, DECEASED.

CREDITORS, next of kin and others having claims in respect of the estate of the deceased (who died on the 25th day of January, 1970), are required to send particulars of their claims to National Trustees, Executors and Agency company of Australasia Limited, of 95 Queen-street, Melbourne, before the 1st day of July, 1970, after which date it will distribute the assets, having regard only to the claims of which it then has notice.

F. P. & M. J. WALSH, solicitors, 452 High-street, Northcote. 4017

Re estate of ALICE GERTRUDE SUTHERLAND, late of 10 John-street, Corowa, in the State of New South Wales, widow, DECEASED.

CREDITORS, next of kin and others having claims in respect of the estate of the deceased (who died on the 27th day of September, 1969), are required by The Perpetual Executors and Trustees Association of Australia Limited, of 100-104 Queen-street, Melbourne, and Alison Clare McKechnie, of 72 Claremont-avenue, Malvern, the executors named in the deceased's will and the applicants for a grant of probate thereof, to send particulars of their claims to the said applicants, in care of the said company, by the 28th day of April, 1970, after which date they will distribute the assets, having regard only to the claims of which they then have notice.

FRANK B. LETHBRIDGE, solicitor, Main-street, Rutherglen. 4106

REUBEN PONTON, late of 25 Drew-street, West Yarraville, retired, DECEASED.

CREDITORS, next of kin and others having claims in respect of the estate of the deceased (who died on the 11th day of October, 1969), are required by The Perpetual Executors and Trustees Association of Australia Limited, of 100-104 Queen-street, Melbourne, to send particulars of their claims to the said company by the 15th day of July, 1970, after which date it will convey or distribute the assets, having had regard only to the claims of which the company then has notice.

E. A. ATKYNS & TOOP, solicitors, 414 Collins-street, Melbourne. 4109

CATHERINE FLYNN, late of Andra House Private Hospital, 350 New-street, Brighton, in the State of Victoria, widow, DECEASED.

CREDITORS, next of kin and others having claims in respect of the estate of the deceased (who died on the 2nd day of January, 1970), are required by the trustee National Trustees Executors and Agency Company of Australasia Limited, of 95 Queen-street, Melbourne, to send particulars to the said company at the above address by the 10th day of July, 1970, after which date it will convey or distribute the assets, having regard only to the claims of which it then has notice.

F. J. CORDER & CO., solicitors, 358 Lonsdale-street, Melbourne, 3000. 4143

Trustee Act 1958.

NOTICE TO CLAIMANTS.

PURSUANT to the Trustee Act 1958, creditors, next of kin and all other persons having claims in respect of the estate of any deceased person named below are required to send particulars to the legal personal representative or representatives at the addresses stated, after which date the representative or representatives will distribute the assets, having regard only to the claims of which notice

Costas Vassiliou, late of 35 Speight-street, Newport, driver, deceased, died on the 21st February, 1970.—Claims to the executrix, Antriana Vassiliou, of 35 Speight-street, Newport, widow, care of John F. Carroll, of 4 Paisley-street, Footscray, solicitor, by the 8th day of July, 1970.—John F. Carroll, LL.B., solicitor, 4 Paisley-street, Footscray. 4131

Frederick Leader, late of 160 Woods-street, Newport, retired storekeeper, deceased, died on the 7th day of October, 1969.—Claims to the executor, John Leader, of 160 Woods-street, Newport, retired storekeeper, care of John F. Carroll, of 4 Paisley-street, Footscray, solicitor, by the 15th day of July, 1970.—John F. Carroll, LL.B., solicitor, 4 Paisley-street, Footscray. 4133

Francis James Sheales, late of 83 Gamon-street, Yarraville, retired clerk, deceased, died on the 1st day of December, 1968.—Claims to the executors, Frances Sheales, of 83 Gamon-street, Yarraville, widow, and Michael William Sheales, of 30 Diamond-avenue, Glen Waverley, auditor, care of John F. Carroll, of 4 Paisley-street, Footscray, solicitor, by the 15th day of July, 1970.—John F. Carroll, LL.B., solicitor, 4 Paisley-street, Footscray. 4234

CREDITORS, next of kin and others having claims in respect of the estate of Beryl Inez Jones, late of 19 Hastings-street, North Bentleigh, in the State of Victoria, married woman, deceased (who died on the 23rd October, 1969), are to send particulars of their claims to the executor, The Equity Trustees, Executors and Agency Company Limited, care of the under-signed solicitors, by the 30th June, 1970, after which date it will distribute the assets, having regard only to the claims of which it then has notice.

HALL & WILCOX, solicitors, 20 Queen-street, Melbourne. 4159

JESSIE CRAIG, late of Majestic Hotel, Fitzroy-street, St. Kilda, Victoria, widow, DECEASED.

CREDITORS, next of kin and others having claims in respect of the estate of the deceased (who died on the 25th day of March, 1969), are required by the personal representative, Howard Edmund Parker, of 90 Collins-street, Melbourne, to send particulars of their claims to him by the 10th day of July, 1970, after which date he may convey or distribute the assets, having regard only to the claims of which he then has notice.

HEDDERWICK FOOKES & ALSTON, 121 William-street, Melbourne. 4145

CREDITORS, next of kin and others having claims in respect of the estate of Eileen Rose McMahon, formerly of 2 Black-street, Essendon, but late of St. Mark's Private Hospital, 829 Mt. Alexander-road, Moonee Ponds, spinster (who died on the 7th February, 1970), are to send the particulars of their claims to National Trustees, Executors and Agency Company of Australasia Limited, of 95 Queen-street, Melbourne, by the 7th July, 1970, after which date it will distribute the assets, having regard only to the claims of which it then has notice.

RYLAH & RYLAH, solicitors, 349 Collins-street, Melbourne. 4146

ELIZABETH VODDEN, late of Bendigo Home and Hospital for the Aged, Barnard-street, Bendigo, widow, DECEASED.

CREDITORS, next of kin and others having claims against the estate of the above-named deceased, are required by the Executor, John Rupert Hyett, of 120 Casey-street, Bendigo, solicitor, to forward particulars thereof to him care of the under-mentioned solicitors on or before the 9th day of July, 1970, after which date he will distribute the assets of the said estate, having regard only to the claims of which he then has notice.

Dated the 4th day of May, 1970.

HYETT & HYETT, solicitors, of 51 Bull-street, Bendigo. 4036

CREDITORS, next of kin, and others having claims in respect of the estate of Martha Wailes, formerly of 7 Edwin-street, Preston, but late of Prestonia Private Hospital, Hotham-street, Preston, in the State of Victoria, widow, deceased (who died on the 2nd day of March, 1970), are to send particulars of their claims to the NATIONAL TRUSTEES EXECUTORS AND AGENCY COMPANY OF AUSTRALASIA LIMITED, OF 95 QUEEN-STREET, MELBOURNE, the executor appointed by the will of the said deceased, by the 20th day of July, 1970.

J. & S. SHATIN, solicitors, of 224 Queen-street, Melbourne. 4127

JEAN LOVE McNAUGHTON, late of Traralgon in Victoria, school teacher, DECEASED.

CREDITORS, next of kin, and others having claims in respect of the estate of the deceased (who died on 17th June, 1969), are required by the trustee Mollie Amelia Kennedy, of Rosedale, to send particulars to her, care of the undersigned, by 15th July, 1970, after which date the trustee may convey or distribute the assets, having regard only to the claims of which she then has notice.

C. H. FORD, LL.M., solicitor, Princes-street, Traralgon. 4128

CREDITORS, next of kin, and others having claims in respect of the estate of John William Cummins, late of 27 Thompson-street, Clayton, retired railway employee, deceased (who died on the 16th July, 1969), are to send the particulars of their claims to The Union-Fidelity Trustee Company of Australia Limited, at 100 Exhibition-street, Melbourne, by the 20th day of July, 1970, after which date it will distribute the assets, having regard only to the claims of which it then has notice.

W. G. COLE & CO., solicitors, Oakleigh. 4132

CREDITORS, next of kin and others having claims in respect of the estate of Robert Charles Morgan Davidson, late of 245 Whitehorse-road, Blackburn, in the State of Victoria, orchardist, deceased, intestate (who died on the 22nd October, 1968), are to send particulars of their claims to Violet Mary Frances Hall, of 245 Whitehorse-road, Blackburn, in the said State, widow, the administratrix *de bonis non*, by the 7th July, 1970, after which date the said administratrix will distribute the assets, having regard only to the claims of which she shall then have notice.

H. L. YUNCKEN & YUNCKEN, 443 Little Collins-street, Melbourne. 4111

RONALD JOHN PARIOSIEN, late of 86 Wimble-street, Seymour, in the State of Victoria, railway employee, DECEASED.

CREDITORS, next of kin and others having claims in respect of the deceased (who died on the 12th day of July, 1969), are to send particulars of their claims to R. G. Hoban, solicitor, Sydney-street, Kilmore, by the 3rd day of July, 1970, after which the administratrix will distribute the assets of the said estate, having regard only to the claims of which she then has notice.

R. G. HOBAN, solicitor, Sydney-street, Kilmore. 4046

CREDITORS, next of kin and others having claims in respect of the will of Antonio Putrino (also known as Antonino Putrino), late of 4 Young-street, Footscray, in the State of Victoria, formerly fishmonger, but late shopkeeper, deceased (who died on the 21st day of December, 1969), are requested to send particulars of their claims to the executrix, Rosina Putrino, care of the under-mentioned solicitor, by the 15th day of July, 1970, after which date she will distribute the assets, having regard only as to the claims of which she then has notice.

EDWARD CURMI, solicitor, of 440 Victoria-street, North Melbourne. 4038

ALAN FRANKLAND JOLLEY, late of Flat 4, Trawalla Court, Lascelles-avenue, Toorak, Victoria, medical practitioner, DECEASED.

CREDITORS, next of kin and others having claims in respect of the estate of the deceased (who died on 19th June, 1969), are required by the personal representatives, David Alan Jolley, of 5 Luck-street, Eltham, Victoria, medical practitioner, and Carey Middleton McClellan, of 40 Boomerang-street, Turrumurra, New South Wales, bank officer, to send particulars of their claims to them, in the care of the said David Alan Jolley, by 10th July, 1970, after which date they will convey or distribute the assets, having regard only to the claims of which they then have notice.

HEDDERWICK FOOKES & ALSTON, 121 William-street, Melbourne, Vic., 3000. 4087

ALFRED CASPER, late of 3 Kerferd-street, Hampton, retired commercial traveller.

CREDITORS, next of kin and others having claims in respect of the estate of the deceased (who died on the 20th day of February, 1970), are required by The Perpetual Executors and Trustees Association of Australia Limited of 100-104 Queen-street, Melbourne, to send particulars of their claims to the said company by the 7th day of July, 1970, after which date it will convey or distribute the assets, having had regard only to the claims of which the company then has notice.

GRAY & GRAY, solicitors, Northcote. 4140

GEOGIA DERNIKOU, late of 109 Brighton-street, Richmond, in the State of Victoria, married woman, DECEASED (who died on the 6th day of February, 1970).

CREDITORS, next of kin and others having claims in respect of the estate of the above-named deceased are to send particulars of their claims to Susan Hamilton Santoro, care of Messrs. Price & Chamberlin, solicitors, 443 Little Collins-street, Melbourne, by the 30th July, 1970, after which date she will distribute the assets, having regard only to the claims of which she then has notice.

PRICE & CHAMBERLIN, solicitors, 433 Little Collins-street, Melbourne. 4139

EMILY ELIZABETH HUEGE de SERVILLE (usually known as Emily Elizabeth de Serville), late of 10 Downes-avenue, Brighton, widow, DECEASED.

CREDITORS, next of kin and others having claims in respect of the estate of the deceased (who died on the 15th day of March, 1969), are required by the trustees, The Equity Trustees Executors and Agency Company Limited, of 472 Bourke-street, Melbourne, and Frank Norman Falkiner, of 232B Kooyong-road, Toorak, sharebroker, to send particulars of their claims to the said trustees by the 7th day of July, 1970, after which date the trustees may convey or distribute the assets, having regard only to the claims of which they then have notice.

WEIGALL & CROWTHER, solicitors, 459 Little Collins-street, Melbourne. 4141

ELLEN FRANCES XAVIER PETERSON, late of 17 Wilson-street, Cheltenham, in the State of Victoria, widow, DECEASED.

CREDITORS, next of kin and others having claims in respect of the estate of the deceased (who died on the 14th day of September, 1969), are required by the applicant for a grant of probate of the Will of the deceased the National Trustees Executors & Agency Company of Australasia Limited, of 95 Queen-street, Melbourne, to send particulars to it care of the under-signed solicitors, by the 6th day of July, 1970, after which date it may convey or distribute the assets, having regard only to the claims of which it then has notice.

Dated the 4th May, 1970.

BRENDAN McGUINNESS & CO., 118 Queen-street, Melbourne, solicitors. 4142

GERTRUDE MARY CHAMPION, late of 10 Miller Cottages, Latrobe-terrace, Chilwell, Geelong, spinster, DECEASED.

CREDITORS, next of kin and others having claims in respect of the estate of the said deceased (who died 4th February, 1970), are required by the applicants for grant of probate of the will, William Ronald Champion, of 26 Spring-street, Belmont, Geelong, motor trimmer, and Norman William Deller, of Powell-street, East Geelong, retired textile clerk, to send particulars to them care of the undersigned solicitors by 17th July, 1970, after which date the said applicants may convey or distribute the assets, having regard only to the claims of which they then have notice.

WIGHTON & McDONALD, solicitors, 89 Myers-street, Geelong. 4031

KENNETH KERR McLEISH, late of Whittlesea-road, Yea, farmer, DECEASED.

CREDITORS, next of kin and others having claims in respect of the estate of the deceased (who died on the 1st December, 1969), are required by the personal representative, Peter Kenneth McLeish and Elsie Gladys McLeish, to send particulars to them in care of the under-signed by the 17th July, 1970, after which date the personal representatives may convey or distribute the assets, having regard only to the claims of which they then have notice.

WILFRID J. OSBORNE & OSBORNE, solicitors, Seymour. 4040

CREDITORS, next of kin and all others having claims against the estate of Beatrice Jane Orr, late of River-road, Murchison, in the State of Victoria, widow, deceased, are required to send particulars thereof to Stewart & Stewart, solicitors, Tatura, on or before the 29th day of July, 1970, otherwise they may be excluded when the assets are being distributed.

Messrs. STEWART & STEWART, solicitors, P.O. Box 199, Tatura 3616. 4029

CREDITORS, next of kin and others having claims against the estate of Ellen Beatrice Branson, late of 119 Neale-street, Bendigo, in the State of Victoria, widow, deceased (who died on the 26th day of December, 1969), are required to send particulars thereof to National Trustees, Executors and Agency Company of Australasia Limited, of 46 Queen-street, Bendigo, aforesaid, by the 15th day of July, 1970, after which date the said company will distribute the assets of the said deceased, having regard only to the claims of which it then has notice. 4027

LILLIAN MAUD YULE, formerly of 17 Pyne Court, Pyne-street, South Caulfield, late of 27 Sylverly-grove, Caulfield, gentlewoman, DECEASED.

CREDITORS, next of kin and others having claims in respect of the estate of the deceased (who died on the 24th November, 1969), are required by the trustees Keith Kelvin Clarke, of 27 Sylverly-grove, Caulfield, costume supervisor and William Frank McLaren Dimmick, of 37 Queen-street, Melbourne, solicitor, to send particulars of their claims to Messrs. Dugdale, Dimmick & Stevens, by the 7th day of July, 1970, after which date the trustees may convey or distribute the assets, having regard only to the claims of which they shall then have had notice.

DUGDALE, DIMMICK & STEVENS, solicitors, 37 Queen-street, Melbourne. 4110

CREDITORS, next of kin and others having claims in respect of the estate of George Henry James, late of 17 Cheviot-road, Mount Waverley, gentleman, deceased (who died on the 19th day of January, 1970, and probate of whose Will has been granted to Norman Kenneth James, of 15 Cheviot-road, Mount Waverley, manager), are required to send particulars of their claims to the said executor care of the under-mentioned solicitors by the 17th day of July, 1970, after which date he will distribute the assets, having regard only to the claims of which he then has notice.

PEARCE & WEBSTER, solicitors, 430 Little Collins-street, Melbourne. 4112

CREDITORS, next of kin and others having claims against the estate of Walter Marcus Bailey, late of 68 Fitzwilliam-street, Kew, in the State of Victoria, engineer, deceased (who died on the 4th day of September, 1969), are required to send particulars of their claims to the executor William Fletcher Renshaw, care of the under-signed solicitor before the 17th day of July, 1970, after which date the said executor will distribute the assets, having regard only to the claims of which he then has notice.

JOHN F. CARROLL, solicitor, 118 Queen-street, Melbourne. 4107

CREDITORS, next of kin and others having claims against the estate of Grace Rowe Harris, late of 8 Charlotte-street, Richmond, in the State of Victoria, widow, deceased (who died on the 20th day of March, 1970), are required to send particulars of their claims to the executors Alan Carlyle Harris and Henry George Harris, care of the under-signed solicitor before the 17th day of July, 1970, after which date the said executors will distribute the assets, having regard only to the claims of which they then have notice.

JOHN F. CARROLL, solicitor, 118 Queen-street, Melbourne. 4108

CREDITORS, next of kin and others having claims against the estate of Eileen O'Connor, late of "Lindisfarn" Noble-street, Newtown, Geelong, spinster, deceased (who died 27th January, 1970), are required to send particulars to the executors National Trustees Executors and Agency Company of Australasia Limited, Patricia Franklin, housewife, and Mary Katrine Franklin, spinster, both of 6 Bryce-avenue, Newtown, Geelong, care of the said company at its address aforesaid by the 15th day of July, 1970, after which date the said executors will distribute the assets, having regard only to the claims of which they then have notice.

BERNARD NOLAN & CO., solicitors, 595 Bourke-street, Melbourne. 4113

PATRICK MATHIESON, late of Tyntynder, in the State of Victoria, invalid pensioner, DECEASED.

CREDITORS, next of kin and other persons having claims against the estate of the said deceased (who died on the 2nd day of December, 1969), are required to send particulars of same to the executrix Kathleen Enid, in care of the under-signed on or before the day of July, 1970, after which date they will distribute the assets, having regard only to the claims of which they then have notice.

HANY & DWYER, barristers and solicitors, 201 William-street, Swan Hill. 4105

CREDITORS, next of kin and others having claims in respect of the estate of William Charles Roberts, late of Shakespeare-grove, Hawthorn, widower, deceased on the 29th day of November, 1969), are to send particulars of their claims to Royston T. Cahir, solicitors, of 17 Queen-street, Melbourne, by the day of July, 1970, after which date the administrator will distribute the assets of the estate, having regard only to the claims of which he has notice.

ROYSTON T. CAHIR & MARTIN, solicitors, 17 Queen-street, Melbourne. 4075

IRGE SHAKESPEARE COOMBS, late of 18 Rotherwood-road, Ivanhoe, in the State of Victoria, retired insurance broker, DECEASED.

CREDITORS, next of kin and others having claims in respect of the estate of the above deceased (who died the 18th day of January, 1970), are required by the executors, Margaret Ellen Coombs, of 18 Rotherwood-road, widow, and Aubrey Gaiway Schrader, of 166 Queen-street, Melbourne, in the said State, solicitor, to send particulars to them, care of the undersigned, by the 8th day of July, 1970, after which date the trustees may convey or distribute the assets, having regard only to the claims of which they then have notice.

HEATING & BYRNE, solicitors, 166 Queen-street, Melbourne. 4076

EA ELIZABETH VOGELE, late of 488 Burke-road, Camberwell, married woman, DECEASED.

CREDITORS, next of kin and others having claims in respect of the estate of the deceased (who died on the 1st day of March, 1970), are required by the applicant for grant of probate of the will of the deceased, Leslie John Wilton, of 4 Cumberland-court, Forest Hill, clerk, to send particulars to him, care of the under-signed solicitors, by the 8th July, 1970, after which date he may convey or distribute the assets, having regard only to the claims of which he then has notice.

GIBSON MCINTOSH & ASSOCIATES, 825 Burke-road, Camberwell. 4077

MYRTLE HISCOCK, formerly of 21 Marshall-avenue, Kew, but late of 48 Corhampton-road, North Balwyn, spinster, DECEASED.

CREDITORS, next of kin and others having claims in respect of the estate of the deceased (who died on the 4th November, 1969), are required by the applicant for grant of probate of the will of the deceased, Leslie John Wilton, of 28 Walpole-street, Kew, retired, to send particulars to him, care of the under-signed solicitors, by the 8th July, 1970, after which date he may convey or distribute the assets, having regard only to the claims of which he then has notice.

GIBSON MCINTOSH & ASSOCIATES, 825 Burke-road, Camberwell. 4078

GEORGE EWENSON, formerly of 41 Camberwell-road, Camberwell, but late of 403 Warrigal-road, Burwood, in the State of Victoria, baker, DECEASED.

CREDITORS, next of kin and others having claims in respect of the estate of the deceased (who died on the 22nd day of October, 1969), are required by the applicant for grant of probate of the will of the deceased, George Edward Cavanagh, of 5 Richardson's-road, North Rydon, master baker, Kenneth Hugh Thomas, of 23 Foster-avenue, Ashwood, bank accountant, and Geoffrey Dupuy, of 86 Marianne-way, Mount Waverley, solicitor, to send particulars to them, care of the under-signed solicitors, by the 8th July, 1970, after which date they may convey or distribute the assets, having regard only to the claims of which they then have notice.

Dated 24th April, 1970.

GIBSON MCINTOSH & ASSOCIATES, 825 Burke-road, Camberwell. 4079

MARY ISABELLA WALLACE, late of 6 Tivoli-place, South Yarra, Victoria, widow, DECEASED.

CREDITORS, next of kin and others having claims in respect of the estate of the deceased (who died on the 20th August, 1969), are required by the personal representative, Mary Wallace James, of 43 Marne-street, South Yarra, Victoria, married woman, to send particulars to her, by 10th July, 1970, after which date she may convey or distribute the assets, having regard only to the claims of which she then has notice.

HEDDERWICK FOOKES & ALSTON, solicitors, 121 William-street, Melbourne. 4085

CLEMENTINA VICTORIA SWANSON, formerly of Kyneton, but late of "Lumeah", 78 Bruce-street, West Preston, in the State of Victoria, widow, DECEASED.

CREDITORS, next of kin and others having claims in respect of the estate of the said deceased (who died on the 13th day of December, 1969), are to send particulars of their claims to The Union-Fidelity Trustee Company of Australia Limited, of 101 Lydiard-street north, Ballarat, Victoria 3350, by the 15th day of July, 1970, after which date it will distribute the assets, having regard only to the claims of which it then has notice.

H. HURRY & SON, solicitors, Kyneton and at Woodend. 4034

CREDITORS, next of kin and others having claims in respect of the estate of William Henry McKenzie, late of Flat 3, 10 Irvine-crescent, West Brunswick, service pensioner, deceased (who died on the 24th day of November, 1969), are to send the particulars of their claims to The Equity Trustees, Executors and Agency Company Limited, of 472 Bourke-street, Melbourne, by the 7th day of July, 1970, after which date it will distribute the assets, having regard only to the claims of which it then has notice.

ANDREW T. FRASER, solicitor, 541 Middleborough-road, Box Hill North. 4048

ROBERT WILLIAM REID, formerly of Huxtable-road, Pakenham Upper, but late of Upper Beaconsfield-road, Pakenham Upper, retired railway employee, DECEASED.

CREDITORS, next of kin and others having claims in respect of the estate of the deceased (who died on the 1st day of January, 1970), are required by the executors of his will, Eric William Humphreys, of 28 El Nida-grove, Glenhuntly, traveller, and Walter Colin Carne Black, of "Coniston", Pakenham Upper, farmer, to send particulars to them, in the care of the undersigned, by the 15th day of July, 1970, after which date the executors may convey or distribute the assets, having regard only to the claims of which they then have notice.

MACPHERSON & KELLEY, solicitors, 264 Lonsdale-street, Dandenong. 4070

In the Supreme Court of the State of Victoria.

SALE BY THE SHERIFF.

ON Friday, the 19th of June, 1970, at 10 a.m., at the Police Station, Altona (unless process be served or satisfied):—

All the estate and interest (if any) of Norman Woodcock, of 87 Millers-road, Altona, as joint proprietor with Bessie Woodcock, married woman, of an estate in fee-simple in the land described in certificate of title, volume 8474, folio 662, upon which is erected a dwelling house known as No. 87 Millers-road, Altona.

Registered mortgage No. B.871505 affects the said estate and interest.

Terms: Cash only.

N. FROGLEY, Sheriff's Officer.

5th May, 1970.

4138

In the Supreme Court of the State of Victoria.

SALE BY THE SHERIFF.

ON Friday, the 19th of June, 1970, at 11 a.m., at the Police Station, Lilydale (unless process be stayed or satisfied):—

All the estate and interest (if any) of Phillip George Moffatt, of 32 Market-street, Boronia, transport contractor, as proprietor of an estate in fee-simple in the land described in certificate of title, volume 8526, folio 788.

The land is vacant being Lot 446 and is situated on the south side of Chirnside-drive, Lilydale, commencing 183 ft. 1½ in. approximately, east of Drovers Walk.

Terms: Cash only.

DAVID J. JOHNSTON, Sheriff's Officer.

6th May, 1970.

4137

INSOLVENCY NOTICES*Bankruptcy Act 1966-1969.*

NOTICE OF MEETING OF WILLIAM JAMES MCLELLAND, TRADING AS "LOCKINGTON FARM SUPPLIES".

NOTICE is hereby given that the above-named debtor signed an authority under section 188 (1) of the Act authorizing Alex Neville Bird to take over control of his property and further take notice that a meeting of creditors will be held at the Board Room, Institute of Chartered Accountants, 23 McKillop-street, Melbourne, at 2.30 p.m., on Wednesday, the 20th day of May, 1970.

Dated this 5th day of May, 1970.

A. NEVILLE BIRD, Controlling Trustee.

A. Neville Bird & Co., chartered accountants, 289 Flinders-lane, Melbourne, 3000. Telephone 63 2874. 4149

Commonwealth of Australia.

The *Bankruptcy Act 1966.*

In the matter of a composition of RICHARD GROSS.—
No. 6 of 1964.

TAKE notice that it is intended to declare a second and final dividend in this matter. Creditors who have not proved their debts by 20th day of May, 1970, will be excluded from the dividend.

4083

J. B. TOLHURST, Trustee.

IMPOUNDINGS

DANDENONG.—Impounded at Dandenong, by the Town Clerk, from the Dandenong Stock Market.

- 1 black cow, notch off-side ear
- 1 black cow, notch near-side ear
- 1 black cow, two notches off-side ear
- 1 black baldy cow, no visible brand
- 1 Jersey calf, no visible brand

If not claimed and expenses paid, will be sold at Dandenong Market, on Wednesday, 27th May, 1970.

4084—\$2.75

D. D. NAPIER,
Poundkeeper.

KYNETON.—Impounded in Kyneton Pound.

- 1 Southdown ram, branded Rob Vale, on ear tag, red D on shoulder

If not claimed and expenses paid, to be sold on Thursday, 21st May, 1970.

4071—\$1.75

H. COOK,
Poundkeeper.

MORWELL.—Impounded at Morwell Pound.

- 1 Jersey cow, tan coloured tag in left ear, No. 322, and 20 painted in red on right side

If not claimed and expenses paid, to be sold on 19th May, 1970, at approximately 1.30 p.m.

4081—\$1.75

S. HUGUENIN,
Poundkeeper.

STRATFORD.—Impounded from Leebrook Lotton-road, Munro.

- 1 crossbred ewe, two notches front of off ear, green dob on back and side
- 1 crossbred ewe, two notches front of near ear, green dob on back and side
- 2 crossbred, two-tooth, green dob on back and side

If not claimed and expenses paid, to be offered for sale.

4129—\$2.25

(Mrs.) J. HARDY, Poundkeeper.

TONGALA.—Impounded in Tongala Pound, from Koyuga.

- 2 Friesian yearling calves, 0 ear mark from each ear, no visible brand

If not claimed and expenses paid, to be sold on 19th May, 1970.

4042—\$1.75

B. PEARL,
Shire Secretary.

UPWEY.—Impounded in Upwey Pound, on 17th April, 1970, from Emerald.

- 1 black pony, no visible brand

If not claimed and expenses paid, to be sold on 19th May, 1970, at the Dandenong Saleyards.

4160—\$1.75

H. P. MEANEY,
Poundkeeper.

Subordinate Legislation Act 1962.

NOTICE OF MAKING OF STATUTORY RULES.

IN pursuance of the provisions of the *Subordinate Legislation Act 1962* and the Regulations made thereunder, notice is given of the making of the following statutory rules:—

Country Fire Authority Act 1958.

87/1970. Country Fire Authority (Loan No. 78) Regulations 1970 10c

Supreme Court Act 1958.

88/1970. Supreme Court (Charge of Solicitor) Rules 1970 10c

Copies of these statutory rules may be purchased at the Sale of Publications Section of the Government Printing Office, located at Macarthur-street, Melbourne, 3002. If ordered by mail, remittance should be addressed to "The Government Printer, Box 203, P.O., North Melbourne, 3051", and should include 5c extra for postage. If a credit account is held at this office, no remittance is required with the mail order.

The annual subscription rate for Statutory Rules (including a Bound Volume) is \$15, payable in advance. The subscription year commences on 1st January.

C. H. RIXON,
Government Printer.

AGENTS FOR THE "VICTORIA GOVERNMENT GAZETTE".

THE following have been appointed agents to receive Advertisements and Subscriptions for the *Victoria Government Gazette*:—

ARMSTRONG'S AGENCY, 205 Queen-street, Melbourne, Victoria 3000.

ARNALL & JACKSON, 390 Barkly-street, Brunswick, Victoria 3056.

BAIRNSDALE AUTHORIZED NEWSAGENCY, 132 Main-street, Bairnsdale, Victoria 3875.

BICKNELL, M. J., Authorized Newsagent, 196 Timor street, Warrambool, Victoria 3280.

BLANE'S AUTHORIZED NEWSAGENTS, 162 Murray-street, Colac, Victoria 3250.

CARTER, R. G., ADVERTISING SERVICE PTY. LTD., Suite 24, 65 Queens-road, Melbourne, Victoria 3004.

DAVIES, G. & M. V., 112 Gray-street, Hamilton, Victoria 3300.

DAVIS, WM. (MILDURA) PTY. LTD., 126 Eighth-street, Mildura, Victoria 3500.

DIXON'S NEWSAGENCY, 89 Firebrace-street, Horsham, Victoria 3400.

EDGAR'S NEWSAGENCY PTY. LTD., 293 Hargreaves-street, Bendigo, Victoria 3550.

EDGARS' AUTHORIZED NEWSAGENCY, 45 Bridge-street, Benalla, Victoria 3672.

FRANKS, H., & CO., 184 Ryrie-street, Geelong, Victoria 3220.

GATLEY, A. & J., 250 Lonsdale-street, Dandenong, Victoria 3175.

GORDON & GOTCH AUSTRALASIA LTD., 467 Collins-street, Melbourne, Victoria 3000.

GULLAN'S NEWSAGENCY, 88 Bridge-street, Ballarat, Victoria 3350.

HAMPTON, A. C., 243 Mitchell-street, Bendigo, Victoria 3550.

HARSTON, PARTRIDGE & CO. PTY LTD., 455 Little Collins-street, Melbourne, Victoria 3000.

KYNETON GUARDIAN PTY. LTD., P.O. Box 18, Kyneton, Victoria 3444.

LATIMER'S, Newsagents, 45 Station-street, Malvern, Victoria 3144.

LIVINGSTON'S SHEPPARTON NEWSAGENCY, 246 Wyndham-street, Shepparton, Victoria 3630.

THE MERCANTILE EXCHANGE, 67 Queen-street, Melbourne, Victoria, 3000.
 MCGILL'S AUTHORIZED NEWSAGENCY, 183-5 Elizabeth-street, Melbourne, Victoria 3000.
 PHILLIPS AUTHORIZED AGENCY, 83 Murphy-street, Wangaratta, Victoria 3677.
 PURDIE, J., & CO., 138 Moorabool-street, Geelong, Victoria 3220.
 SALE AUTHORIZED NEWSAGENCY, 142 Raymond-street, Sale, Victoria 3850.
 SKINNER'S AUTHORIZED NEWSAGENCY, 49-51 Franklin-street, Traralgon, Victoria 3844.
 STEVENSON, A. C. & M., NEWSAGENTS, 132 Henty-street, Casterton, Victoria 3311.
 VERNON, C. F. & H. J., 162 Bridge-road, Richmond Victoria 3121.
 VIEW POINT AUTHORIZED NEWSAGENCY, 4 View-Point, Bendigo, Victoria 3550.

A copy of the Gazette filed at each place for public reference.

PUBLICATION OF OFFICIAL MATTER.

ATTENTION is invited to the following procedure in relation to the publication of official matter in the *Government Gazette*:—

Publication will be facilitated by the submission of carbon copies for the use of the *Gazette Officer*.

1. Matter submitted to the Executive Council.

Matter submitted to the Executive Council which requires gazettal will normally be published in the issue of the following week.

Where urgent gazettal is required, special arrangements should be made with the *Gazette Officer*, Room 9, first floor, Old Treasury Building.

2. Other matter.

(a) All other matter duly certified by a responsible officer for publication should be lodged with the *Gazette Officer* not later than half-past Nine a.m. on Tuesday.

(b) Lengthy or involved notices should be forwarded several days before publication.

(c) Proofs, which will be supplied only when specifically requested or at the direction of the *Gazette Officer*, should be returned promptly to avoid delay in publication.

(d) No additions or amendments to matter for publication will be accepted by telephone.

THE "VICTORIA GOVERNMENT GAZETTE".

SUBSCRIPTIONS.—The subscription, including postage, is \$10 per annum, or \$5 per half year, payable in advance.

Subscriptions are required for whole months, and must cover at least a half year.

Single copies are 20 cents, posted 25 cents. Subscribers do not receive the Acts of Parliament with the GAZETTE.

GAZETTES are held in stock for five years only.

PRIVATE ADVERTISEMENTS.—The charge for insertion is 25 cents per line single column, and 50 cents per line double column. The title forms one or more lines as a heading. On an average ten words make a line of single column. Every signature must likewise be counted as a line. The final words of a paragraph, though only portion of a line, must be counted as one line. Signatures (in particular) and proper names must be written very plainly in the text; ONE SIDE ONLY of each sheet of paper should be WRITTEN UPON.

All documents illegibly written will be returned unpublished, and where brands occur unprovided for by the ordinary letters of the alphabet, a worded explanatory description must be furnished.

THE VICTORIA GOVERNMENT GAZETTE is published on WEDNESDAY EVENING in each week, and Notices for insertion will be received by the Government Printer at or before ONE p.m. at ordinary rates, and late advertisements between ONE p.m. and FOUR p.m. at double rates on the day preceding the day of publication.

PAYMENTS.—Unless the advertiser has a credit account, all payments are required in advance. Remittances should be made by cheque, postal order, or money order payable to "GOVERNMENT PRINTER".

ADDRESS.—All communications should be addressed to "The Government Printer, Box 203, P.O., North Melbourne". 3051.

CONTENTS

	PAGE
Appointments	1230
Contracts	1230
Country Roads Board	1226
Estates of Deceased Persons	1212
Government Notices	1212
Impoundings	1279
Insolvency Notices	1279
Lands	1245
Mining	1224
Notice to Attend for Radiological Examination	1220
Notice of Making of Statutory Rules	1279
Orders in Council—	
Acts—Country Roads; Country Fire Authority;	1232
Crown Lands; Local Government;	et seq
Architects; Labour and Industry;	
Water; Milk Board; Superannuation.	
Police Sale	1228
Private Advertisements	1257
Proclamations	1209
Public Service Notices	1256
Resignations	1231
State Rivers and Water Supply Commission	1223
Tenders	1255
Transport Regulation Board—Public Hearings	1214
Waterworks Trusts	1228