



# VICTORIA GOVERNMENT GAZETTE

Published by Authority

[Registered at the General Post Office, Melbourne, for transmission by post as a newspaper.]

No. 46]

WEDNESDAY, MAY 13

[1970

## PROCLAMATIONS

*Land Act 1958.*

AREA OF LAND COMPRISED IN CERTAIN CLASSES DIMINISHED OR INCREASED.

### PROCLAMATION

By the Lieutenant-Governor as Deputy for his Excellency the Governor of the State of Victoria and its Dependencies in the Commonwealth of Australia, &c., &c., &c.

WHEREAS by the *Land Act 1958* it is amongst other things enacted that the Governor in Council may, by Proclamation to be published in the *Government Gazette*, at any time diminish or increase the area of land comprised in any of the classes mentioned in Part I, Division 1, Section 5, of the said *Land Act 1958*, but that the area of lands which may be sold by auction (Class 6), shall not be increased except as in certain cases in the said Act provided: Now therefore I, the Lieutenant-Governor as Deputy for the Governor of the State of Victoria, in the Commonwealth of Australia, by and with the advice of the Executive Council of the said State, and in accordance with the provisions of Sections 94 and 117 of the *Land Act 1958* aforesaid, do hereby diminish or increase (as the case may be) the areas of Crown lands comprised in Classes 6 and 7, of the classes mentioned in Section 5 of the *Land Act 1958* aforesaid, to the extent set forth in the subjoined Schedule (that is to say):—

Schedule referred to.

CLASSES DIMINISHED OR INCREASED.

County.	Parish.	Allotment.	Section.	Area.	Diminished.	Increased.	Description.
					Class.	Class.	
				A. R. P.			
Bogong ..	Byawatha ..	4	A2	4 0 2	..	6	In south of Parish (H030044)
Delatite ..	Bright ..	3	M	2 0 0	7	6	
Buln Buln ..	Mirboo ..	148C	..	20 0 29	..	6	Near township of Mirboo North. (G60921)
" ..	" ..	148D	..	21 2 23	..	6	
" ..	" ..	148E	..	20 0 5	..	6	
Evelyn ..	Beenak ..	70e	..	1 1 10	..	6	
							About 6 miles south-east of Launching Place. (G66917)

Given under my Hand and the Seal of the State of Victoria, aforesaid, at Melbourne, this fifth day of May, in the year of our Lord One thousand nine hundred and seventy, and in the nineteenth year of the reign of Her Majesty Queen Elizabeth II.

(L.S.)

By His Excellency's Command,

E. F. HERRING.

W. J. F. McDONALD,  
Minister of Lands.

GOD SAVE THE QUEEN!

Land Act 1958.

AREA OF LAND COMPRISED IN CERTAIN CLASSES DIMINISHED OR INCREASED.

PROCLAMATION

By the Lieutenant-Governor as Deputy for His Excellency the Governor of the State of Victoria and its Dependencies in the Commonwealth of Australia, &c., &c., &c.

WHEREAS by the Land Act 1958 it is amongst other things enacted that the Governor in Council may, by Proclamation to be published in the Government Gazette, at any time diminish or increase the area of land comprised in any of the classes mentioned in Part I, Division 1, Section 5, of the said Land Act 1958, but that the area of lands which may be sold by auction (Class 6), shall not be increased except as in certain cases in the said Act provided: Now therefore I, the Lieutenant-Governor as Deputy for the Governor of the State of Victoria, in the Commonwealth of Australia, by and with the advice of the Executive Council of the said State, and in accordance with the provisions of Sections 94 and 117 of the Land Act 1958 aforesaid, do hereby diminish or increase (as the case may be) the areas of Crown lands comprised in Classes 3 and 4 of the classes mentioned in Section 5 of the Land Act 1958 aforesaid, to the extent set forth in the subjoined Schedule (that is to say):—

Schedule referred to.

CLASSES DIMINISHED OR INCREASED.

County.	Parish.	Allotment.	Section.	Area.	Diminished.	Increased.	Description.
					Class.	Class.	
				A. R. P.			
Lowan .. ..	Yat Nat .. ..	7 and 8	1	146 3 35	4	3	As show on O.P.76002 (M.37694)

Given under my Hand and the Seal of the State of Victoria, aforesaid, at Melbourne, this fifth day of May, in the year of Our Lord One thousand nine hundred and seventy, and in the nineteenth year of the reign of Her Majesty Queen Elizabeth II.

(L.S.)

By His Excellency's Command,

E. F. HERRING.

W. J. F. McDONALD,  
Minister of Lands.

GOD SAVE THE QUEEN !

ROADS PROCLAIMED.

PROCLAMATION

By the Lieutenant-Governor as Deputy for His Excellency the Governor of the State of Victoria and its Dependencies in the Commonwealth of Australia, &c., &c., &c.

IN pursuance of the provisions of Section 25 of the Land Act 1958, the Lieutenant-Governor as Deputy for the Governor of the State of Victoria, by and with the advice of the Executive Council of the said State, do hereby proclaim as roads the under-mentioned lands:

Parish of Timbreeo, County of Karkaroo, being the land indicated by hatching on plan hereunder.—(T.225(2) (75/155).

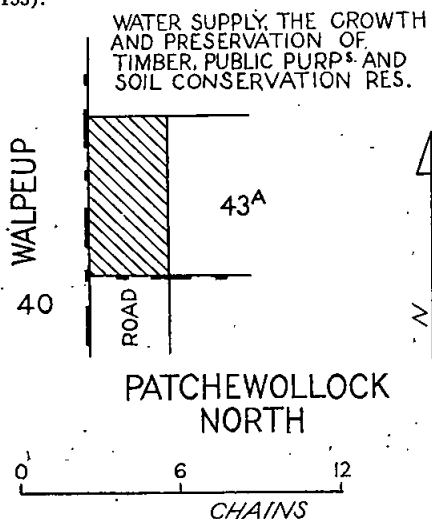

Township of Kaniva, Parish of Kaniva, County of Lowan, being the land indicated by hatching on plan hereunder.—(K.147(1) (M.61209).

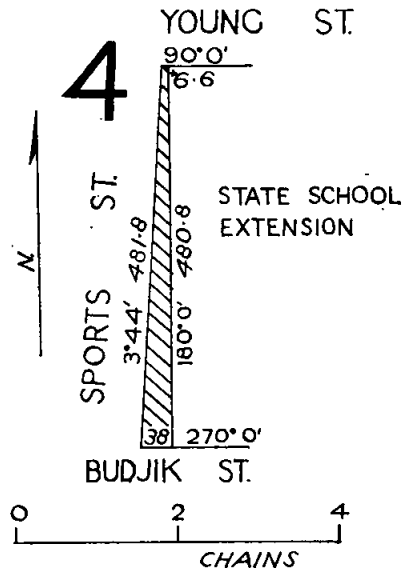

Given under my Hand and the Seal of the State of Victoria aforesaid, at Melbourne, this fifth day of May, in the year of our Lord One thousand nine hundred and seventy, and in the nineteenth year of the reign of Her Majesty Queen Elizabeth II.

(L.S.)

E. F. HERRING.

By His Excellency's Command,

W. J. F. McDONALD,  
Minister of Lands.

GOD SAVE THE QUEEN !

Health Act 1958 (No. 6270).  
EXTENSION OF THE ARARAT MEAT AREA.

PROCLAMATION

By the Lieutenant-Governor as Deputy for His Excellency the Governor of the State of Victoria and its Dependencies in the Commonwealth of Australia, &c., &c., &c.

BY virtue of the powers conferred by the Health Act 1958 (No. 6270), I, the Lieutenant-Governor as Deputy for the Governor of the State of Victoria in the Commonwealth of Australia, on the recommendation of the Commission of Public Health and by and with the advice of the Executive Council of the said State, do by this my Proclamation extend the Ararat Meat Area so as to include the whole of the municipal districts of the City of Ararat and the Shire of Ararat.

Given under my Hand and the Seal of the State of Victoria aforesaid, at Melbourne, this fifth day of May, in the year of our Lord One thousand nine hundred and seventy, and in the nineteenth year of the reign of Her Majesty Queen Elizabeth II.

(L.S.) E. F. HERRING.

By His Excellency's Command,  
VANCE DICKIE,  
Minister of Health.

GOD SAVE THE QUEEN!

GOVERNMENT NOTICES

GAS AND FUEL CORPORATION OF VICTORIA.

THE following notice was published 1° on the 29th April, 1970, re: Gas Odorization Plant, Parish of Coolungoolun.

"Notice is hereby given that the Gas and Fuel Corporation of Victoria has applied for a lease under section 134 of the Land Act 1958 for a term of 21 years in respect of an area of 0 acres 0 roods 27 5/10 perches more or less, being portion of the Black Swamp, Parish of Coolungoolun, as a site for Gas Odorization plant and ancillary purposes.—(H.033469.)"

LOCAL GOVERNMENT ACT 1958.

IN pursuance of the powers conferred by sub-section 3A of section 575 of the Local Government Act 1958, I, William John Farquhar McDonald, Her Majesty's Minister of Lands in the State of Victoria hereby declare that the road set out on Crown land in the Township of Ballarat North, Parish of Ballarat, County of Grenville, as delineated and indicated by hachure on the plan hereunder be a private street within the meaning of and for the purposes of Division 10, Part XIX. of the said Act.—(Corres. No. J.32740).

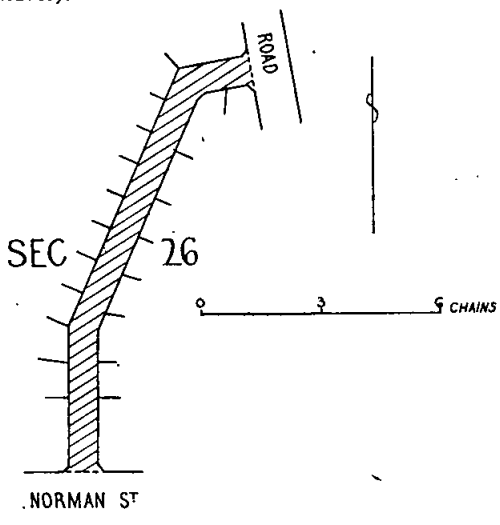

Dated at Melbourne, this fourth day of May, 1970.

W. J. F. McDONALD,  
Minister of Lands.

SHIRE OF OXLEY.

ROAD DEVIATION ORDER.

IN pursuance of the powers conferred by sections 522 and 526 of the Local Government Act 1958, the Council of the Shire of Oxley hereby orders that as from the date of publication hereof in the Government Gazette, the land shown hatched on the plan hereunder being land taken, purchased or acquired by it and being part of Crown allotment 108, Parish of Glenrowan, shall be a public highway in lieu of the land in the said Parish shown cross-hatched on the said plan.

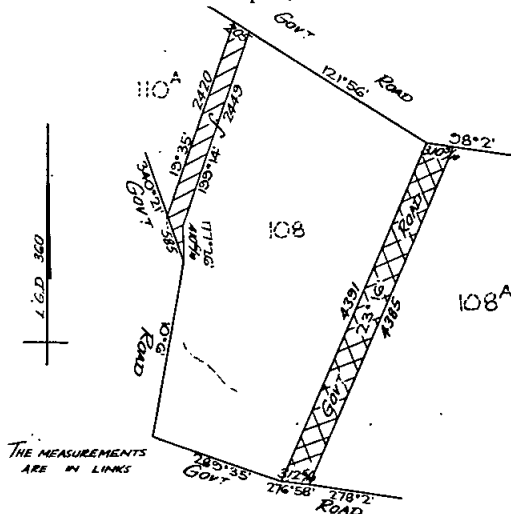

The common seal of the President, Councillors and Ratepayers of the Shire of Oxley was hereunto affixed, on the 1st day of April, 1970, in the presence of—

A. R. NICOLL, President.  
D. H. WALPOLE, Councillor.  
E. F. VAN LEEUWEN, Shire Secretary.

Confirmed by the Governor in Council, 5th May, 1970.—  
J. ROSSITER, Clerk of the Executive Council.

LAW DEPARTMENT.

SITTINGS OF THE SUPREME COURT AT HAMILTON.—  
ADDITIONAL DAYS APPOINTED.

THE Lieutenant-Governor as Deputy for His Excellency the Governor of the State of Victoria, by and with the advice of the Executive Council thereof, doth by Order made on the 5th day of May, 1970, appoint Monday, 15th June, 1970, to Tuesday, 30th June, 1970, inclusive, for the Sittings of the Supreme Court at Hamilton, in addition to the days heretofore appointed.

J. ROSSITER,  
Clerk of the Executive Council.  
At the Executive Council Chamber,  
Melbourne, 5th May, 1970.

Stock Diseases Act 1958.

DEPARTMENT OF AGRICULTURE.

THE Public Service Board has, by certificate dated the 10th April, 1970, appointed RICHARD JAMES CROSSING, to be an Inspector of Stock under the provisions of Part I. of the Stock Diseases Act 1958, without additional salary.

D. S. WISHART,  
Director of Agriculture.

Co-operation Act 1958.

NOTICE OF AMALGAMATION OF SOCIETIES.

NOTICE is hereby given that, pursuant to the provisions of the Co-operation Act 1958, Statax Co-operative Credit Society Limited and T.O.B.C.O. Credit Co-operative Limited were amalgamated into one society under the name of Statax Co-operative Credit Society Limited on the thirtieth day of April, 1970.

Dated at Melbourne, this thirtieth day of April, 1970.

M. V. HAMMOND,  
Deputy Registrar of Co-operative Societies.

Private Agents Act 1966.

NOTICE OF RECEIPT OF APPLICATIONS FOR LICENCES UNDER THE PROVISIONS OF THE PRIVATE AGENTS ACT 1966.

THE Clerk(s) of the Magistrates' Court(s) as listed hereunder hereby give notice that applications, as under, have been lodged for hearing by the said Court(s) on the date(s) specified.

Any person desiring to object to any of such applications must—

- (a) lodge with the respective Clerk of the Magistrates' Court a notice in the prescribed form of his objection and of the grounds thereof;
- (b) cause a copy of such notice to be served personally or by post upon the applicant at least three days before the hearing of the application; and
- (c) send or deliver—
  - (i) where the objection is not made by the officer in charge of the police district in which the Court is situated—a copy of the notice to such officer; and
  - (ii) where the objection is not made by the Registrar or Deputy Registrar—a copy to the Registrar.

Full Name of Applicant or in the Case of a Firm or Corporation, of the Nominee.	Place of Abode of Applicant or Nominee.	Name of Firm or Corporation.	Address for Registration.	Type of Licence.	Date of Hearing of Application.
---	---	------------------------------	---------------------------	------------------	---------------------------------

MAGISTRATES' COURT, GEELONG.

Haydn Lansdowne ..	1 Orr-street, Manifold Heights	A. A. Lucas Western and District Investigations	1 Orr-street, Manifold Heights	Commercial Sub-agent	28.5.70
--------------------	--------------------------------	---	--------------------------------	----------------------	---------

Dated at Geelong this 5th day of May, 1970.

J. R. AITKEN, Clerk of the Magistrates' Court.

MAGISTRATES' COURT, CAMBERWELL.

Louis .. .. .	13 Maria-avenue, Nunawading	.. .. .	647 Burwood-road, Hawthorn	Commercial Sub-agent	21.5.70
---------------	-----------------------------	---------	----------------------------	----------------------	---------

Dated at Camberwell this 4th day of May, 1970.

J. C. TOBIN, Clerk of the Magistrates' Court.

MAGISTRATES' COURT, SPRINGVALE.

Arena, Teresa Maria ..	38 Buckingham-avenue, Springvale	.. .. .	38 Buckingham-avenue, Springvale	Process Server ..	26.5.70
------------------------	----------------------------------	---------	----------------------------------	-------------------	---------

Dated at Springvale this 5th day of May, 1970.

J. B. DENNIS, Clerk of the Magistrates' Court.

MAGISTRATES' COURT, MELBOURNE.

Moore, Ian Alister ..	89 Beach-road, Mentone	.. .. .	140 Queen-street, Melbourne	Process Server ..	27.5.70
-----------------------	------------------------	---------	-----------------------------	-------------------	---------

Dated at Melbourne this 5th day of May, 1970.

G. L. WEBSTER, Clerk of the Magistrates' Court.

MAGISTRATES' COURT, OAKLEIGH.

Cryer, Charles .. .. .	Flat 8, 113 Burwood-road, East Burwood	.. .. .	Mulgrave Group Security, 310 Stephenson-road, Mt. Waverley	Watchman ..	29.5.70
Brown, Howard Geo. ..	9 Pleasant-drive, Heathmont	.. .. .	" " " "	" ..	"
Hayes, Gerald R. .. ..	Flat 4, 13 Jarra-road, Heathmont	.. .. .	" " " "	" ..	"

Dated at Oakleigh this 4th day of May, 1970.

G. McLAREN, Clerk of the Magistrates' Court.

MAGISTRATES' COURT, MELBOURNE.

Burns, James .. .. .	33 Morden-court, Nunawading, 3131	Armoured Escorts Pty. Ltd.	Cnr. Arden and Lothian streets, North Melbourne	Watchman ..	27.5.70
Cates, Anthony John ..	Flat 1, 17 Belmont-avenue, Glen Iris, 3146	" "	" " " "	" ..	"

Dated at Melbourne this 6th day of May, 1970.

G. L. WEBSTER, Clerk of the Magistrates' Court.

MAGISTRATES' COURT, MELBOURNE.

Taylor, Barry Ernest ..	Rear of 103 Bible-street, Eltham, 3095	Australian Watching Co., Pty. Ltd.	130 Abbotsford-street, North Melbourne	Inquiry Agent (Ind.)	27.5.70
-------------------------	--	------------------------------------	--	----------------------	---------

Dated at Melbourne this 6th day of May, 1970.

G. L. WEBSTER, Clerk of the Magistrates' Court.

MAGISTRATES' COURT, HAMILTON.

Butcher, Norman Stanley ..	50 French-street, Hamilton	.. .. .	47 Thompson-street, Hamilton	Commercial Sub-agent	4.6.70
" " " .. .. .	" " " .. .. .	.. .. .	" " " .. .. .	Process Server ..	"

Dated at Hamilton this 8th day of May, 1970.

J. E. WALLACE, Clerk of the Magistrates' Court.

PRIVATE AGENTS—continued.

Full Name of Applicant or in the Case of a Firm or Corporation, of the Nominee.	Place of Abode of Applicant or Nominee.	Name of Firm or Corporation.	Address for Registration.	Type of Licence.	Date of Hearing of Application.
MAGISTRATES' COURT, MORDIALLOC.					
Pierce, Kenley Ronald Wallace	10 Helm-street, Aspendale	.. .. .	10 Helm-street, Aspendale	Process Server Individual	4.6.70
" " "	" " "	.. .. .	" " "	Inquiry agent Individual	"
Dated at Mordialloc this 7th day of May, 1970.					
J. FERGUSON, Clerk of the Magistrates' Court.					
MAGISTRATES' COURT, FOOTSCRAY.					
Nido, Michael Peter	26 Somerville-road, Yarraville	.. .. .	.. .. .	Inquiry Agent	1.6.70
Ross, Derek James	2 Henry-street, Footscray	.. .. .	.. .. .	Process Server	"
McKenzie-McHarg, Gary John	" " "	.. .. .	.. .. .	" " "	"
Dated at Footscray this 8th day of May, 1970.					
D. A. THOMPSON, Clerk of the Magistrates' Court.					
MAGISTRATES' COURT, MOONEE PONDS.					
Fishenden, Ronald Douglas	35 Ridge-drive, Avondale Heights	.. .. .	35 Ridge-drive, Avondale Heights	Process Server	28.5.70
Dated at Moonee Ponds this 7th day of May, 1970.					
J. A. BARNES, Clerk of the Magistrates' Court.					
MAGISTRATES' COURT, WARRACKNABEAL.					
Duncan, Lawrence William	77 Lyle-street, Warracknabeal	.. .. .	77 Lyle-street, Warracknabeal	Guard Agent	28.5.70
Dated at Warracknabeal this 6th day of May, 1970.					
C. J. RYAN, Clerk of the Magistrates' Court.					
MAGISTRATES' COURT, PRESTON.					
Sinclair, Robert Graeme	33 Nicholson-street, Research	Rosanna Night Watch Service	33 Nicholson-street, Research	Guard Agent	4.6.70
" " "	" " "	" " "	" " "	Watchman	"
Dated at Preston this 8th day of May, 1970.					
P. C. CLOTHIER, Clerk of the Magistrates' Court.					
MAGISTRATES' COURT, PRAHRAN.					
Trood, Geoffrey Rupert	Flat 5, 61 Brickwood-street, Elsternwick	.. .. .	Suite 17, 562 St. Kilda-road, Melbourne	Watchman	5.6.70
Dated at Prahran this 8th day of May, 1970.					
H. V. BOARDER, Clerk of the Magistrates' Court.					
MAGISTRATES' COURT, SOUTH MELBOURNE.					
Holsken, Robert Theodor	.. .. .	.. .. .	101-105 Clarke-street, South Melbourne	Watchman	29.5.70
Smith, Kenneth Sydney	.. .. .	.. .. .	" " "	"	"
Dated at South Melbourne this 8th day of May, 1970.					
J. M. DUGAN, Clerk of the Magistrates' Court.					

MILK BOARD ACT 1958.

IN accordance with the provisions of section 4A of the Milk Board Act 1958, the Milk Board hereby exempts from the provisions of the said Act, all milk intended for use in the manufacture of the product known as "Parsons Riccream", from 1st July, 1969, to 30th June, 1971; and such exemption shall be subject to the following conditions:—

1. Such milk shall be purchased from an authorized depot agent of the Milk Board and shall be transported in bulk in tankers direct from the premises of the depot agent to the premises of Harvest Foods Ltd., at 865 Nepean Highway, Moorabbin, by a milk carrier licensed under the Milk Board Act.

2. Cottee's General Foods Ltd. shall lodge with the Board, by the tenth day of each month, a return setting out the following information in respect of milk so purchased during the preceding calendar month:—

- (i) Depot agent or agents from whom supply was obtained.
- (ii) Quantity.
- (iii) Price or prices paid.
- (iv) Name of carrier or carriers.
- (v) Cartage rate or rates charged.

Cottee's General Foods Ltd. shall certify on such return that all of the milk so purchased was used in the process of manufacturing "Parsons Riccream".

W. DOBINSON,  
Secretary.

EDUCATION DEPARTMENT.

SUMMONING OFFICER.

UNDER section 5 of the Education Act 1958, I hereby appoint—

Senior Constable KEVIN THOMAS KELLETT,  
Senior Constable RUSSELL LOUIS BERTRAM, and  
Sergeant ALFRED GEORGE PITTAWAY,  
to summon parents within the State of Victoria.

L. H. S. THOMPSON,  
Minister of Education.

23rd April, 1970.

EDUCATION DEPARTMENT.

SUMMONING OFFICER.

UNDER section 5 of the Education Act 1958, I hereby appoint—

Senior Constable NORMAN ROBERT DEHNE,  
First Constable MERVYN MABEY GOODSON, and  
Senior Constable JAMES EDWARD WHITE,  
to summon parents within the State of Victoria.

L. H. S. THOMPSON,  
Minister of Education.

1st May, 1970.

Transport Regulation Act.  
 TRANSPORT REGULATION BOARD.  
 HEARING OF APPLICATIONS.

NOTICE is hereby given that the following applications will be considered by the Transport Regulation Board at its offices at the corner of Lygon and Princes streets, Carlton, at 10.15 a.m., on Wednesday, 3rd June, 1970.

**BENDERS BUSWAYS PTY. LTD.**, Edol-street, North Geelong. One commercial passenger vehicle (S/C. 45) to operate under the same terms and conditions as existing U.O. licences in the name of the applicant company.

**CLARINDA TRANSPORT PTY. LTD.**, 1037 Centre-road, South Oakleigh. Application for a required number of commercial passenger vehicles with large seating capacity to operate as metropolitan stage omnibuses on the following route:—Glen Waverley—corner Lum and Waverley roads. Commencing at the Glen Waverley Railway Station; thence via Kingsway, Springvale, Wilson, Gallagher, Waverley and Lum roads to the corner Lum and Ferntree Gully roads. Sections, fares and time-table to be determined.

**GRENIDAS BUS SERVICES**, 9 Foster-street, Dandenong. Application for a required number of commercial passenger vehicles with large seating capacity to operate as country stage omnibuses on a route as follows:—Dandenong—Glen Waverley. Commencing at the Dandenong Railway Station; thence via Foster, Thomas, Clow, Cleeland, Herbert and James streets, Menzies-avenue, Gladstone, Police, Jackson's and Wellington roads, Brandon Park-drive, Ferntree Gully-road and Springvale-road to Glen Waverley Railway Station. Sections, fares and time-table to be determined.

**MORWELL BUS LINES LTD.**, TRARALGON BUS LINES LTD., 2-10 Ryan-street, Morwell. One commercial passenger vehicle (S/C. 39) to operate under the same terms and conditions as existing C.O. licences in the name of the applicant companies.

**RESERVOIR BUS CO. PTY. LTD.**, 907A High-street, Reservoir. Application for variation of M.O. licence conditions on route 138A (Keon Park—Reservoir—Northland Shopping Centre) to delete express operations between the corner of Yarra-avenue and Boldrewood-parade and Northland and instead to:—(a) Set down passengers beyond the corner of Yarra-avenue and Boldrewood-parade on journeys to Northland. (b) Pick up passengers on journeys from Northland. (c) Charge a minimum fare of 12c on journeys from Northland.

**SOUTHLAND BUS SERVICE PTY. LTD.**, corner Keys and Kilpa roads, Moorabbin. Application for five commercial passenger vehicles with large seating capacity to operate as country stage omnibuses as presently prescribed on Route 215A (Beaumaris East—Bentleigh via Cheltenham and Southland) with extension from the corner of Chesterville and Bellevue roads, Bentleigh to the corner of Tambat and North roads, East Bentleigh via Chesterville, Highview, Brady, Normanby, Bignell and Centre roads, Dover, Warwick, Sheffield and Tambat streets with turning procedure via North-road, Anarth and Blenheim streets to Tambat-street.

Sections.

1. Southland Shopping Centre—Corner Chesterville and Keys roads.
2. Corner Chesterville and Keys roads—Corner Chesterville and Highview roads.
3. Corner Chesterville and Highview roads—Corner Bignell-road and Florence-avenue.
4. Corner Bignell-road and Florence-avenue—Corner Sheffield-street and Stockdale-avenue.
5. Corner Sheffield-street and Stockdale-avenue—Corner Tambat-street and North-road.

Fares.	Adult.	Child.
1. Section	7c	4c
2. Sections	12c	7c
3. Sections	14c	8c
4. Sections	16c	9c
5. Sections	18c	10c

Time-table to be determined.

APPLICATION by—

- AMATO**, P., 107 Sackville-street, Collingwood.  
**AUNINS**, M. J., Flat 12, 203 Gold-street, Clifton Hill.  
**ANDREW**, N. D., 1 Warwick-street, Pascoe Vale.  
**ANDREW**, A. J., 207 Sussex-street, North Coburg.  
**ANGELINI**, M. M., 21 Langham-street, Avondale Heights.  
**APOSTOLOUDAS**, G., 24 Temple-street, West Brunswick.  
**ATKINSON**, J. K., 4 Lae-street, West Heidelberg.  
**AXARIS**, H., 3 St. Phillips-street, Abbotsford.  
**BACCI**, V., 10 Oulton-street, Moomba Park.

- BARBER**, R. L., 30 Darebin-road, Northcote.  
**BEALE**, D. C., 2 Kellett-street, Northcote.  
**BEER**, B. L., 2 Keats-street, Elwood.  
**BELJAN**, I., 13 Tasman-avenue, Strathmore.  
**BIANCHI**, T., 204 Canning-street, Carlton.  
**BOGHOSSIAN**, J., 4 Haines-street, North Melbourne.  
**BOLJANAC**, S., Flat 6, 104 Rowena-street, Richmond.  
**BRAIN**, C. A., 138 Rosanna-road, Rosanna.  
**BRDAR**, L., 147 Drummond-street, Carlton.  
**BROOK**, C., 3 Neville-street, East Keilor.  
**BROWN**, A. R., Flat 2, 36 Maribymong-road, Moonee Ponds.  
**BROWN**, P. G., 17 McRae-avenue, St. Albans.  
**BURGIN**, M., 3 Fanny-street, Moonee Ponds.  
**BURNS**, D. D. M., 270 Pascoe Vale-road, Essendon.  
**CARUSO**, G., 10 Craigrossie-avenue, Moreland.  
**CASSAR**, L. J., 88 Haldane-road, Niddrie.  
**CERINI**, J. L., 19 Esmale-street, Strathmore.  
**CHRISTENSEN**, L. G., 32 Ellen Vale-avenue, Pascoe Vale South.  
**CHRISTOFFS**, A., 126 Milleara-road, East Keilor.  
**CIPRIANI**, F., 25A Lindenow-street, Reservoir.  
**CLOUGH**, R., 55 Bradshaw-street, Essendon.  
**CONDON**, M. R., 5 Princess-street, North Coburg.  
**CLARK**, K. M. D., Flat 12, 18 Bloomfield-road, Ascot Vale.  
**CONDYLIS**, E., 7 Lennox-street, Moonee Ponds.  
**COOKE**, J. C., 33 Connelly-avenue, East Coburg.  
**COOPER**, N. W., 6 Nyah-street, East Keilor.  
**CORO**, M., 37 Shamrock-street, West Brunswick.  
**CRAKER**, J. F., 41 Keats-avenue, Kingsbury.  
**CROWE**, G. W., 18 Kathleen-grove, Bulleen.  
**CUNNINGHAM**, W. R., 12 Halsbury-street, Hadfield.  
**DAVIES**, R. W., 18 Phillip-road, East Keilor.  
**DAVIES**, T. W., 47 Scotland-avenue, Greensborough.  
**DAVIS**, H. C., 44 Devon-road, Pascoe Vale.  
**DE BATTISTA**, C., 43 French-street, Lalor.  
**DELANEY**, F. P., 8 Prunus-court, West Heidelberg.  
**DENNIS**, N., 17 Gallipoli-parade, Pascoe Vale South.  
**DEUTSCHER**, C. J., Flat 12, 322 Pascoe Vale-road, Essendon.  
**DEUTSCHER**, E. C., 63 Hoffmans-road, Niddrie.  
**DONALDSON**, F. C., 51 Mark-street, Coburg.  
**DOHERTY**, P., 129 Coronation-street, Yarraville.  
**DOUGHTY**, C. W., 407 Park-street, Princes Hill.  
**DUMMETT**, T. R. K., 25 Buckley-street, Essendon.  
**DUNN**, W. T., 44 Fulham-road, Alphington.  
**EDWARDS**, J. L., 4 Goble-street, Laverton.  
**EDWARDS**, J. P., 16 Railway-crescent, Moonee Ponds.  
**ELLIS**, G., 49 Epsom-road, Ascot Vale.  
**ELLSON**, E. F., 67 Lloyd-street, West Heidelberg.  
**ENGLAND**, F. J., 79 Northumberland-road, Pascoe Vale.  
**FESTERIDIS**, S., 12 Wimble-street, Northcote.  
**FINN**, F. J., 68 Fraser-street, Airport West.  
**FOLEY**, V. P., 35 Bloomfield-road, Ascot Vale.  
**FORGIONE**, P., 90 Cardinal-road, Glenroy.  
**FORD**, B. W., 6 Mattea-court, Reservoir.  
**FREEMAN**, K. A., 25 Wadham-street, Pascoe Vale South.  
**FRYLINK**, J., 21 Prospect-street, Glenroy.  
**FULLARD**, E. J., 3 McIvor-street, Reservoir.  
**GAHAN**, J. P., 112 Heatherdale-road, Mitcham.  
**GAFFNEY**, G. J., 4 Kenneth-street, Bulleen.  
**GARDNER**, R. G., 34 Beccles-street, North Fawkner.  
**GEE**, R. E., 3 Tilba-street, Essendon.  
**GEORGE**, J. E., 5 Karingal-street, Altona.  
**GEORGE**, P., 9 Roberts-street, East Keilor.  
**GERACE**, M., 83 Wood-street, Preston.  
**GIANFRIDDO**, G., 111 Derby-street, Pascoe Vale.  
**GIANNIAS**, P., 173 Power-street, Hawthorn.  
**GRANGER**, E. D., 8 Patterson-street, East Coburg.  
**GREANEY**, P. F., 58 Thackeray-road, Reservoir.  
**GRIGORPOULOS**, P., 13 Barkly-street, East Brunswick.  
**HARPER**, N. J., 8 Arbor-avenue, Reservoir.  
**HENNIGAN**, W. T., 17 Canterbury-street, Flemington.  
**HEANEY**, R. S., 47 Paxton-street, South Kingsville.  
**HERNAN**, F. M., 7 Ernest-street, Broadmeadows.  
**HIGHGATE**, D. G., 6 Temby-street, Watsonia.  
**HOLZ**, J., 1 Shaw-street, Fawkner.  
**HUTCHINSON**, J. G., 14 Tennis-grove, North Caulfield.  
**HUTCHINSON**, R. C., 6 Pickles-street, South Melbourne.  
**JACKSON**, R. J., Flat 6, 28 Churchill-avenue, Ascot Vale.  
**INGRAM**, R. C., 18 Richmond-street, Glenroy.  
**JENNINGS**, P. E., 122 Vincent-street, Oak Park.  
**KENDY**, J., Flat 16, 11 Balaclava-road, Balaclava.  
**KAVOURAS**, A., 134 Glenhuntly-road, Elwood.  
**KEATING**, J. T., 62 Hartington-street, Glenroy.  
**KELLY**, K. F., 31 Nepean-street, Watsonia.  
**KERY**, K., 61 Lorne-street, Fawkner.  
**KHODER**, J., 2 King-street, Lalor.  
**KLEIN**, M. A., 74 Lorne-street, Fawkner.  
**KNIGHT**, A. J. H., 49 Harding-street, Coburg.  
**KOSTA**, K. E., 8 Charlton-street, Broadmeadows.  
**KOUGIAS**, C., 21 Meager-street, Deer Park.  
**KRASEY**, L., 48 Pakington-street, Kew.  
**KWASNY**, H. E., Flat 2, 17 Mitford-street, St. Kilda.  
**LANGLEY**, E. J., 5 King-street, Bulleen.  
**LAURIEN**, H. R. U., 9 Emu-parade, Jacana.  
**LEONARD**, G., 64 McNamara-avenue, Airport West.

- LEWIS, C. M., 1 Alden-street, West Sunshine.  
 MARCHANT, R. J., Flat 2, 15 Bayswater-road, Kensington.  
 MILORADOVIC, S., 170 Cecil-street, Williamstown.  
 MORABITO, G., 11 Lawson-street, Moonee Ponds.  
 MACGILL, A. H., 115 Lynch-road, Fawkner.  
 MACKENZIE, R. J., 59 Dallas-drive, Dallas.  
 MAGHAMEZ, R., 201 Canning-street, Carlton.  
 MARTIN, J., 5 Timor-court, Broadmeadows.  
 MEHMET, N., 54 Macey-avenue, Avondale Heights.  
 MEYER, U., 28 Nisbett-street, East Reservoir.  
 MICHAELIDES, C., 5 Cuthbert-street, Broadmeadows.  
 MILAT, T., 34 Marks-street, Coburg.  
 MORTON, R. G., 17 Schofield-street, Essendon.  
 MOORE, R. J., 134 Arvon-road, Strathmore.  
 MOURIKIS, P., 504 Tooronga-road, East Hawthorn.  
 MOULIN, F. G., 3 Kiama-street, Glenroy.  
 MUELLER, W., 39 Edward-avenue, North Altona.  
 MURPHY, B. J., 27 Hudson-street, Fawkner.  
 McBLANE, R. J., 266 Mary-street, Richmond.  
 McDONALD, E. A., 186 West-street, Glenroy.  
 McDONALD, B. E., 87 Elizabeth-street, East Keilor.  
 MCINNES, J. F., 229 Hoddle-street, Abbotsford.  
 MCINTYRE, G. N., 207 Nell-street, Watsonia.  
 NEWMAN, E. W., 12 Elstone-avenue, Niddrie.  
 NEWMAN, H. J. W., 186 Curtain-street, North Carlton.  
 NIKAS, S., 40 East-street, Glenroy.  
 NINKOVICH, G., 50 Pascoe Vale-road, Moonee Ponds.  
 NOBLE, R., 60 Dover-street, Flemington.  
 O'KEEFE, T. E., 9 Ogilvie-street, West Essendon.  
 O'REILLY, P. M., 35 Harrington-street, North Balwyn.  
 PALADINO, V., 123 Outlook-drive, Glenroy.  
 PANAGOPOULOS, D., 20 Willis-street, East Prahran.  
 PAPANOPOULOS, J., 31 St. James-street, Moonee Ponds.  
 PHILLIPS, G. V., 23 Housden-street, Broadmeadows.  
 POESEL, C., Flat 4, 657 Brunswick-street, North Fitzroy.  
 POULTON, A. V., 67 Beauford-street, Huntingdale.  
 RACHELE, D., 33A Xavier-street, Oak Park.  
 REICH, F. J., 77 Nicholson-street, McKinnon.  
 RICHARDS, W., 27 Lincoln-avenue, Coburg.  
 ROBERTS, C. L., Flat 2, 19 Palmer-street, Collingwood.  
 ROKAS, V., 76 Station-street, Port Melbourne.  
 SADILEK, J., 61 Brougham-street, North Melbourne.  
 SALTER, H., 22 Rosehill-road, Niddrie.  
 SANOS, E., 42 Warncliffe-road, East Ivanhoe.  
 SAPOUNTZIS, K., 1 Hunter-street, Abbotsford.  
 SEFFER, S., 103 Kitchener-street, Broadmeadows.  
 SHERIDAN, V., 1 Brooker-court, Sunshine North.  
 SIGANAKIS, J., 11 Olive-street, East Malvern.  
 SKEWS, W. H., 8 Cassia-court, Wantirna.  
 SMART, J. E., Flat 5, 11A Murray-street, West Brunswick.  
 SMITH, F. C., 51 Ryder-street, Niddrie.  
 SOTIROPOULOS, C., 358 Victoria-parade, East Melbourne.  
 SPADE, F., 132 Lee-street, North Carlton.  
 SPITERI, R., 24 Hook-street, St. Albans.  
 STAPLETON, P. J., 30 Rangeview-grove, North Balwyn.  
 STAVROS, N., 107 Allison-road, Elsternwick.  
 STREIFF, C. F., 1 Hutchinson-street, East Coburg.  
 STEVENS, P. J., 31 Rosedale-court, Broadmeadows.  
 SZILAGYI, J., Flat 79, 510 Lygon-street, Carlton.  
 TATE, J. W., Flat 10, 44 Dunlop-avenue, Ascot Vale.  
 TERSPINIS, N., 3 Monash-street, Footscray.  
 TRAS, H., 143 Union-street, West Brunswick.  
 TOLDI, I., 10 Caringa-street, Pascoe Vale.  
 TUCKERMAN, B. T., 151 Bell-street, Coburg.  
 TZANEFF, N., 7 Ellesmere-road, Windsor.  
 TZOUVELIS, N., 113 Morell-street, Glenroy.  
 VESCOVI, G. G., Unit 4, 52 The Grove, Coburg.  
 VIOLA, A. V., 121 Gower-street, Preston.  
 VOULGARIS, S., 31 Council-street, Clifton Hill.  
 VULETICH, A., 15 Sherwood-road, Ivanhoe.  
 WAHAB, S., 22 Ferguson-street, Macleod.  
 WARD, J. D., 8 John-street, Balwyn.  
 WATSON, C. R., 41 Saunders-street, Coburg.  
 WATSON, E. H., Flat 6, 468 Glenferrie-road, Hawthorn.  
 WHITE, R. A., 14 Devon-road, Pascoe Vale.  
 WILLIAMS, L. A., 2 Lawson-parade, West Heidelberg.  
 WOODALL, J. F., 122 Cardinal-road, Glenroy.  
 YOUNG, H. J., 4 Hughes-street, Yarraville.  
 ZAIRIS, A., 340 Somerville-road, West Footscray.  
 ZAKKAS, I., 72 Walter-street, Ascot Vale.  
 ZATOVIC, R., 11 Pickles-street, Port Melbourne.  
 ZIENTEK, E., Flat 6, 5 Gourlay-street, Balaclava.  
 ZONDERVAN, A., 99 Sixth-avenue, North Altona.
- Each for a commercial passenger vehicle with seating capacity for five (5) persons to operate as a Metropolitan Private Hire Car under composite conditions from an approved depot in Zone "J".
- A**PPPLICATION by—
- AMATO, P., 247 Raleigh-street, Thornbury.  
 AMATO, F., 34 Ross-street, Westgarth.  
 ANTAL, F., 74 Anderson-street, Templestowe.  
 AUNINS, M. J., Flat 12, 203 Gold-street, Clifton Hill.
- APOSTOLOUDAS, G., 24 Temple-street, West Brunswick.  
 ASLANIDIS, E., 322 Riversdale-road, Hawthorn East.  
 ASTON, A. H., 70 Burwood Highway, East Burwood.  
 ATKINSON, J. K., 4 Lae-street, West Heidelberg.  
 AXARIS, H., 3 St. Phillips-street, Abbotsford.  
 BARBER, R. L., 30 Darebin-road, Northcote.  
 BARKER, D. E., 34 Avocet-street, East Doncaster.  
 BARNES, T. B., Flat 4, 88A Orrong-road, Elsternwick.  
 BATCH, A. A., Flat 2, 184 Wattletree-road, Malvern.  
 BEATTIE, R. J., 16 Arlington-street, Ringwood.  
 BEEVORS, R. J., 1 Bond-street, Clayton.  
 BELJAN, I., 13 Tasman-avenue, Strathmore.  
 BENDER, M., Flat 6, 122 Glenhuntly-road, Elwood.  
 BOLJANAC, S., Flat 6, 104 Rowena-street, Richmond.  
 BROOKS, J. E., 9 Houston-street, Mentone.  
 CARSON, W. C., 179 Eley-road, South Blackburn.  
 CIPRIANI, F., 25A Lindenow-street, Reservoir.  
 CHRISTIANA, F. A., 26 Joyhill-avenue, Box Hill South.  
 CLARK, K. M. D., Flat 12, 18 Bloomfield-road, Ascot Vale.  
 COOPER, A. E., 11 Stanhope-street, Mont Albert.  
 COUROUZOS, S. G., 17 Elsa-street, Fawkner.  
 COUSINS, L. A. E., 31 Blackburn-moor, Blackburn.  
 COX, R. E., 78 Fromer-street, Moorabbin.  
 CRAINE, E. P., 29 Bettina-street, East Burwood.  
 CRAKER, J. E., 41 Keats-avenue, Kingsbury.  
 CROWE, G. W., 18 Kathleen-grove, Bulleen.  
 DALTON, K. W., 60 Goldsmith-street, Elwood.  
 DANIELSON, J. M., 26 Marianne-way, Doncaster.  
 DAVIES, R. W., 18 Phillip-avenue, East Keilor.  
 DAVIES, T. W., 47 Scotland-avenue, Greensborough.  
 DEBATTISTA, C., 43 French-street, Lalor.  
 DELANEY, F. P., 8 Prunus-court, West Heidelberg.  
 DICKIE, R. L., 9 Marilyn-court, Blackburn North.  
 DONALDSON, F. C., Cnr. Innisfallen-avenue and Warrandyte-road, Templestowe.  
 DONATO, N., 11 Rose-street, Box Hill.  
 DRAKE, J. F., 4 Hodgson-street, Lower Templestowe.  
 ELLSON, E. F., 67 Lloyd-street, West Heidelberg.  
 FARLEY, J. D., 19 Rose-avenue, Bulleen.  
 FLYNN, V., 7 Tarakan-street, West Heidelberg.  
 FORD, B. W., 6 Mattea-court, Reservoir.  
 FRAZER, B. F., 99 Marianne-way, Mt. Waverley.  
 FROSTER, J. M., 6 Winston-drive, Doncaster.  
 GAHAN, G. P., 112 Heatherdale-road, Mitcham.  
 GARTH, R. N., 7 Una-street, Mount Waverley.  
 GEORGE, P., 9 Roberts-street, Keilor East.  
 GILES, J. A. S., Flat 4, 25 Dickens-street, Elwood.  
 GOW, J., 19 Campbell-parade, Box Hill South.  
 GREANEY, P. F., 58 Thackeray-road, Reservoir.  
 HAMILL, M. J., 1 Ian-grove, East Oakleigh.  
 HAMILTON, A. C., 44 Coorigil-road, Carnegie.  
 HARTLE, R. E., 14 Ness-street, Diamond Creek.  
 HERD, J. R., 26 Arnold-drive, Scoresby.  
 HIGHGATE, D. G., 6 Temby-street, Watsonia.  
 HINCH, J. A., 24 Manuka-drive, Ferntree Gully.  
 HOAD, R. C., Kardinia-crescent, Warranwood.  
 HOFER, G. G., 16 Plymouth-street, Glen Waverley.  
 HOUSTON, G. W., 2 Marshall-avenue, Doncaster.  
 HUGHES, H. T., 16 Eclipse-crescent, Watsonia.  
 HUNTER, R., 13 Garden-street, Box Hill.  
 HUTCHINSON, J. G., 14 Tennis-grove, North Caulfield.  
 KARANTZOUKIS, D., 26 Witchwood-crescent, East Burwood.  
 KAYNE, V. A., Flat 2, 23 Hartington-street, Elsternwick.  
 KELLERMANN, C. C., 5 Deborah-street, Boronia.  
 KELLY, K. F., 31 Nepean-street, Watsonia.  
 KENDY, J., Flat 16, 11 Balaclava-road, Balaclava.  
 KENNY, W. P., 14 Norfolk-avenue, Wantirna South.  
 KOUTLEMANIS, D., 59 Thea-grove, East Doncaster.  
 KRASEY, L., 48 Pakington-street, Kew.  
 KWASNY, H. E., Flat 2, 17 Mitford-street, St. Kilda.  
 LANGELAAN, G. F. A., 121 Mount Dandenong-road, East Ringwood.  
 LANGLEY, E. J., 5 King-street, Bulleen.  
 LEACH, A. F., Lot 8, Leber-street, Warrandyte.  
 LILLYCRAPP, R. W., 4 Pinewood-avenue, East Ringwood.  
 LOMBARDI, A., 58 Maple-street, Blackburn.  
 MANCHEE, K. D., 20 Woonah-street, Chadstone.  
 MENICH, J., 1 Rishon-avenue, South Blackburn.  
 MEYER, U., 28 Nisbett-street, East Reservoir.  
 MINAHAN, A. J., 3 Pitt-street, Oakleigh.  
 MOODY, O. D., 1 Yea-court, South Nunawading.  
 MOERLAND, W., 128 Blackburn-road, Syndal.  
 MOURIKIS, P., 504 Tooronga-road, East Hawthorn.  
 McBLANE, R. J., 266 Mary-street, Richmond.  
 McDERMOTT, R. E. S., Lot 1, De Fredericks-road, Yarrambat.  
 MCINNES, J. F., 229 Hoddle-street, Abbotsford.  
 MCINTYRE, G. N., 207 Nell-street, Watsonia.  
 O'NEILL, F. S., 6 Inez-avenue, Ringwood.  
 O'REILLY, P. M., 35 Harrington-avenue, North Balwyn.  
 ORMENYI, F., 183 Springvale-road, Nunawading.  
 PANAGOPOULOS, D., 20 Willis-street East, Prahran.  
 PARKER, W. V., 120 O'Connor-road, Knoxfield.  
 PARKINSON, D. F., 12 Pearce-street, Burwood.  
 PARRY, L. C., 42 Boyana-crescent, Croydon.  
 PARSONS, F. W., Lot 9, Olinda Creek-road, Kalorama.

PHILLIPS, W. C. A., 17 Venice-avenue, Mitcham.  
 PLEVCO, J., 30 Percy-street, Balwyn.  
 POLIS, J. A., 1 Pickford-street, East Burwood.  
 RACHELE, D., 4 Aberdeen-street, Brunswick.  
 REICHEL, P. F. R., 21 Piperita-road, Ferntree Gully.  
 ROBERTS, G. C., 43 Linda-avenue, Box Hill North.  
 RODDEN, F. W., 12 Sussex-street, Ringwood.  
 ROSEFIELD, H. K., 13 Frederick-street, South Caulfield.  
 ROSENFELD, I., Flat 2, 57 Talbot-crescent, Kooyong.  
 ROKAS, V., 76 Station-street, Port Melbourne.  
 SALTER, H., 22 Rosehill-road, Niddrie.  
 SANGSTON, N. G., 3 Victoria-avenue, Canterbury.  
 SAPOUNTZIS, K., 1 Hunter-street, Abbotsford.  
 SAVVA, A., Lot 129, Denver-crescent, Rowville.  
 SCHIULAZ, R., 38 Auburn-parade, Hawthorn.  
 SEFFER, S., 103 Kitchener-street, Broadmeadows.  
 SHEPPARD, R. L., 48 Headingley-road, Mt. Waverley.  
 SIGANAKIS, J., 11 Olive-street, East Malvern.  
 SKEWS, W. H., 8 Cassia-court, Wantirna.  
 SMITH, C. E., 62 Timms-avenue, Kilsyth.  
 SMITH, R. H., 51 Great Valley-road, Glen Iris.  
 SPADA, F., 132 Lee-street, North Carlton.  
 SOTIROPOULOS, C., 358 Victoria-parade, East Melbourne.  
 STACK, J. W., 70 Bindy-street, Forest Hill.  
 STEVENS, P. J., 31 Rosedale-court, Broadmeadows.  
 TAYLOR, C., 160 Austin-road, Seaford.  
 TAYLOR, J. S., 16 Sturdee-road, Mitcham.  
 TOIVONEN, P. C., 13 Newbury-street, Mitcham.  
 TOLDI, I., 10 Caringa-street, Pascoe Vale.  
 TSARDAKAS, G., Lot 25, Melosa-avenue, Clayton.  
 TSELIOS, T., 30 Woodlands-avenue, East Kew.  
 VAUGHAN, J. E. H., 3 Bordeaux-avenue, Blackburn North.  
 VOULGARIS, S., 31 Council-street, Clifton Hill.  
 VULETIC, A., 15 Sherwood-road, Ivanhoe.  
 WAHAB, S., 22 Ferguson-street, Macleod.  
 WARD, J. D., 8 John-street, Balwyn.  
 WATSON, C. R., 41 Saunders-street, Coburg.  
 WATSON, E. H., Flat 6, 468 Glenferrie-road, Hawthorn.  
 WATSON, J. C., 22 Ranfurly-road, Forest Hill.  
 WATSON, R. A., 230 Warrigal-road, Cheltenham.  
 WILLIAMS, A. J., 6 Coventry-street, East Burwood.  
 WILLIAMS, A. J., 48 Cleveland-road, Jordanville.  
 WILLIAMS, J. A. R., 5 Deep Creek-road, Mitcham.  
 WILSON, D. G., 13 Milloo-crescent, Mt. Waverley.  
 WISHART, T., 17 Claronga-street, South Oakleigh.  
 WOODMAN, C. E., 1 Maxwell-court, Blackburn South.  
 WRIGHT, A. H., 3 Sunhill-avenue, Burwood.  
 YOUNG, O. W., 347 Moreland-road, West Coburg.  
 YOUNG, R. D., "Lindsfarne", Springvale-road, Donvale.  
 ZANCO, G., 16 Jacania-avenue, Templestowe.  
 ZATOVIC, R., 11 Pickles-street, Port Melbourne.

Each for a commercial passenger vehicle with seating capacity for five (5) persons to operate as a Metropolitan Private Hire Car under composite conditions from an approved depot in Zone "T".

**A**PPPLICATION for renewal of licences as shown, by persons listed hereunder to operate under the same terms and conditions.

BARNES, J. D. (trading as W. T. Butler), 39-43 Fraser-street, Sunshine; M.C.17, M.C.505.  
 BRIEN, J. H. & Co. PTY. LTD., 2 Whitehall-street, Footscray; M.C.6, M.C.7, M.C.8, M.C.9, M.C.10, M.C.11, M.C.150, M.C.151, M.C.165, M.C.601, M.C.610, M.C.611.  
 MCKENZIES TOURIST SERVICES PTY. LTD., 53 Barkers-road, Kew; M.C.402.  
 NORTHERN BUS LINES PTY. LTD., 1 Walter-street, Glenroy; M.C.3.  
 COUGHLAN, J. D., 17 Kent-street, Sebastopol, Ballarat; C.O.598.  
 GEELONG ASSOCIATED BUSLINES PTY. LTD., 23 Catherine-street, Geelong; C.O.386, C.O.445, C.O.568, C.O.606, C.O.797, C.O.949, C.O.952, C.O.955, C.O.957, C.O.958, C.O.959, C.O.960, C.O.961, C.O.982, C.O.1022, C.O.948.  
 HOLLAND, J. L., 169 Skene-street, Bendigo; C.O.108.  
 MCHARRY, A.M. & N. J., 23 Catherine-street, West Geelong; C.O.132, T.S.888.  
 NEIL, I. A., 101 Brewster-road, Ararat; C.O.285.  
 WALKER'S, B. M., BUS SERVICE PTY. LTD., 112 Spring Gully-road, Bendigo; C.O.309, C.O.335, U.O.11, U.O.17.  
 TRANS OTWAY LTD., Corner Ryrie & Fenwick streets, Geelong; C.O.45, C.O.47, C.O.83, C.O.200, C.O.220, C.O.249, C.O.413, C.O.461, C.O.488, C.O.489, C.O.490, C.O.491, C.O.614, C.O.722, C.O.742, C.O.891, C.O.892, C.O.1000, C.O.1001, C.O.1007, C.O.1010, C.O.1063, C.O.919.  
 PINCINI, E. J. & L. PTY. LTD., Baths-road, Mirboo North; T.S.35, T.S.185, T.S.462, T.S.660, T.S.790, T.S.798, T.S.818, T.S.837, T.O.13.  
 DEE, J. M., 27 Gordon-crescent, Seymour; C.T.28.  
 BENDER'S BUSWAYS PTY. LTD., Edol-street, Geelong; T.P.75.

COMMONWEALTH AIRCRAFT CORPORATION PTY. LTD., 304 Lorimer-street, Port Melbourne; T.P.137.  
 EAST GIPPSLAND TIMBER CO. PTY. LTD., Cabbage Tree Creek via Orbost; T.P.109.  
 ILIC, MILAN, 10 Edgcombe-street, Geelong North; T.P.229.  
 RUSSELL, V. E. (trading as Tinyland Childminding Centre), 656 Bell-street, Pascoe Vale; T.P.31.  
 Richardson, G. W., 1 Flowers-street, South Caulfield; M.H.1903.  
 SCHMIDT, T. F., 9 Cantala-street, Pascoe Vale; M.H.4053.  
 STANFIELD, K. S., 27 White-road, Wantirna South; M.H.2074.  
 VARSAMARKIS, A., 271 Blackshaws-road, West Newport; M.H.1960.  
 CARROLL, L. J., 5 Lloyd-street, Northcote; M.T.592.  
 CHRISTOFORIDIS, C., 129 Tinning-street, Brunswick; M.T.4168.  
 DE SANTIS, G., 217 Ascot Vale-road, Ascot Vale; M.T.1868.  
 DWYER, L. S., 2 Bruce-street, Strathmore; M.T.4347.  
 EVANS MOTOR SERVICE PTY. LTD., THE MANAGER, 375 New-street, Brighton; M.T.1041.  
 FABRIZIO, E., 28 Plimsoll-avenue, Fairfield; M.T.1538.  
 GEYER, M. C. E., Villa 1, 76 Wattle Valley-road, Canterbury; M.T.636, M.T.637.  
 GILBERT, J., Flat 3, 63 Brighton-road, Elwood; M.T.1783.  
 HICKEY, J., 38 Vincent-street, Glen Iris; M.T.881.  
 KAIROUZ, J., 90 Carlton-street, Carlton; M.T.4050.  
 KEMP, R. J., 13 Powlett-street, Heidelberg; M.T.1384.  
 KONTOSSIS, L., 52 Hatfield-street, North Balwyn; M.T.4094.  
 KOUROIS, E., 990 Lygon-street, North Carlton; M.T.1800.  
 LEW, R., 8 Penleigh-court, East St. Kilda; M.T.1736.  
 LIMA, S., 307 Lennox-street, Richmond; M.T.1943.  
 MALLIARAS, C., 23 Darling-street, Oakleigh; M.T.4048.  
 MARINELLI, R., 2 Truganini-road, Carnegie; M.T.1848.  
 OVED, D., 3 Elswill-street, East Bentleigh; M.T.1230.  
 PAPAVALASSILOU, E., 28 Ramsden-street, Clifton Hill; M.H.1994.  
 PAVANO, S., 43 Charles-street, Ascot Vale; M.T.4240.  
 RIGOPOULOS, E., 162 Station-street, Carlton; M.T.1612.  
 ROINIOTIS, D., 32 Kingsway-drive, Lalor; M.T.1900.  
 ROSENZWIEG, M., 2 Keeron-street, South Caulfield; M.T.4165.  
 SHEAHAN, D. M., 43 Buninyong-street, Yarraville; M.T.1142.  
 STEIGLITZ (Mrs.) S., 22 Neerim-road, Caulfield; M.T.1873.  
 TAOUK, B., 24 Harold-street, Thornbury; M.T.4357.  
 YENDALL, O. L., Old Emerald-road, The Patch; M.T.1652.

Notice of any objection should be forwarded to reach the Secretary of the Board not later than Wednesday, 27th May, 1970.

Applicants are advised that it will not be necessary to appear on the hearing date specified above, unless advised in writing by the Board.

B. P. KAY,  
Secretary.

Corner Lygon and Princes streets, Carlton, Wednesday, 13th May, 1970.

Commercial Goods Vehicles Act.  
TRANSPORT REGULATION BOARD.

HEARING OF APPLICATIONS.

**N**OTICE is hereby given that the following applications will be considered by the Transport Regulation Board at its offices at the corner Lygon and Princes streets, Carlton, at 10.15 a.m. on Wednesday, 3rd June, 1970.

ALIQUO, G. & A., 21 George-street, Brunswick, 3056. One commercial goods vehicle (L/C. 133 cwt.) to operate: (a) Within a 35-mile radius of the G.P.O., Melbourne, solely on behalf of Consolidated Quarries Ltd.—sand, stone, screenings and premix; (b) From and to the City of Melbourne to and from own farm at Kinglake in the course of business as "Primary Producers"—own goods.

BALLARAT METAL PTY. LTD., 105 Creswick-road; Ballarat, 3350. One commercial goods vehicle (L/C. 15 cwt.) to operate throughout the State of Victoria in the course of business as "Marine Collector"—marine stores as designated in the *Marine Stores and Old Metals Act 1958* (No. 6303), Part 1, Section (3) but excluding the carriage of any such goods to wharves, docks or ships for shipment or export purposes.

**N**OTE.—The combined load capacity, of the prime mover and any trailer hauled in conjunction thereto shall not exceed 120 cwt.

BERTOLINI, C., 10 Tallarook-street, Seymour, 3660. One commercial goods vehicle (L/C. 151 cwt.) to operate: (a) Within a 50-mile radius from the post office at Seymour—as a "Road Contractor"—road-making plant and materials. (b) Within a 25-mile radius of the post office at Seymour—general goods provided that no goods shall be carried, whether by, one stage or by more than one stage between places within



- the above radius which are more than thirty (30) road miles apart by the nearest practicable route.
- BROWN'S, T. K., MOTORS,** Whyte-street, Coleraine, 3315. Application to vary the conditions of licence No. D.A.54920/1 (L/C. 39 cwt.) by adding to paragraph (a) of the existing conditions after Coleraine "and Casterton".
- BURR, A. W., & SONS PTY. LTD.,** 61 Madden-avenue, Mildura, 3500. One commercial goods vehicle (L/C. 11 cwt.) to operate within a 100-mile radius from the post office in the City of Mildura and to and from the Townships of Hopetoun, Donald and Birchip in the course of business as "Automobile Engineers"—tools of trade, spare parts, accessories, wet and dry batteries and engine blocks for repair or having been repaired.
- CLARK, M. L.,** Clarcoll-crescent, Kangaroo Flat, 3555. One commercial goods vehicle (L/C. 8 cwt.) to operate within a 100-mile radius of the G.P.O. in the City of Bendigo in the course of business as "Electrical Contractor"—tools of trade, electrical fittings and materials incidental to own contracts.
- COLLINS, F. B.,** 54 Tawonga Roadside, via Wodonga, 3697. One commercial goods vehicle (L/C. 109 cwt.) to operate: (a) Within a 90-mile radius of the post office at Wangaratta as a "Road Contractor"—road-making plant and materials. (b) Within a 20-mile radius from site of construction or maintenance work performed pursuant to paragraph (a) above, or from the railway station nearest thereto—metal, stones, screenings, ashes, gravel, sand, earth and any other materials required for such work.
- DALGETY & NEW ZEALAND LOAN LTD.,** 1 Malop-street, Geelong, 3220. One commercial goods vehicle (L/C. 14 cwt.) to operate within a 50-mile radius of the post office at Heywood in the course of business as "Stock and Station Agents"—own goods subject to the condition that all goods so carried shall be initially consigned by rail to Heywood.
- DICKIE, R. J.,** 15 Guild-street, Seymour, 3660. Two commercial goods vehicles (L/C. 79 and 164 cwt.) to operate: (a) Within a 25-mile radius of the post office at Seymour—general goods provided that no goods shall be carried whether by one stage or by more than one stage between places within the above radius which are more than thirty (30) miles apart by the nearest practicable route. (b) Within a 50-mile radius of own depot at Seymour—petroleum products in bulk or in prescribed types of containers and empty return containers, storage tanks and petroleum dispensing equipment solely on behalf of Ampol Petroleum (Vic.) Pty. Ltd.
- DOODT, NORM, & SONS PTY. LTD.,** Creswick-road, Ballarat, 3350. One commercial goods vehicle (L/C. 200 cwt.) to operate: (a) Within a 25-mile radius of the chief post office in the City of Ballarat—general goods. (b) Within a 70-mile radius of the chief post office in the City of Ballarat as follows: (i) Tiles, roof battens and tile fixing materials and bricks on behalf of Eureka Terra Cotta and Tile Co. of Aust. Ltd. (ii) Bricks, glazed bricks and glazed earthenware pipes and fittings on behalf of Martins Stoneware Pty. Ltd.
- DUMBRELL, N. L. & N. (trading as Latrobe Valley Auto Spares),** 41 Truscott-road, Moe, 3825. Application to vary the conditions of licence No. D.A.60937 (L/C. 19 cwt.) by deleting Morwell from existing conditions and adding in lieu "Moe" and by adding after Bairnsdale "and to Genoa and Mallacoota and places en route.
- EMERY, R.,** Douglas-parade, Yarra Junction, 3797. One commercial goods vehicle (L/C. 77 cwt.) to operate throughout the State of Victoria in the course of business as "Travelling Showman"—own sideshow equipment and novelty prizes.
- EVERY, F. J., PTY. LTD.,** 14 King-street, Bendigo, 3550. One commercial goods vehicle (L/C. 17 cwt.) to operate: (a) Within a 20-mile radius of the chief post office in the City of Bendigo in the course of business as "Booksellers and Stationers"—own goods. (b) Throughout the State of Victoria—samples of own goods for display purposes only.
- FIELD & TAYLOR PTY. LTD.,** care of Webster and Taylor, Suite 8, 545 St. Kilda-road, Melbourne, 3004. One commercial goods vehicle (L/C. 13 cwt.) to operate throughout the State of Victoria in the course of business as "Sewerage Construction Contractors" for the purpose of supervising own contracts—tools of trade, spare parts for servicing own equipment on site and a small quantity of materials to repair, service or complete a contract.
- READ, M. E. & J. (trading as A. Z. Gardenland),** 399 Maroondah Highway, Ringwood, 3134. One commercial goods vehicle (L/C. 134 cwt.) to operate: (a) Within a 25-mile radius of own premises at Ringwood in course of business as "Garden Supplier"—own goods. (b) From Bacchus Marsh to own premises at Ringwood—own river pebbles.
- BASSETT, H. (trading as Geelong Metals),** 117 Elizabeth-street, Geelong West, 3218. One commercial goods vehicle (L/C. 72 cwt.) to operate throughout the State of Victoria in the course of business as "Marine Collector"—special wares, marine stores and old metals as designated in the *Marine Stores and Old Metals Act 1958* (No. 6303), Part 1, Section (3) but excluding the carriage of any such goods to wharves, docks or ships for shipment or export purposes.
- NOTE.—The combined load capacity of the vehicle as prime mover and any trailer hauled in conjunction thereto shall not exceed 120 cwt.
- GEORGOPOULOS, I. & T.,** 45 Richmond-terrace, Richmond, 3121. One commercial goods vehicle (L/C. 225 cwt.) to operate within a 35-mile radius of the G.P.O., Melbourne on behalf of Consolidated Quarries Ltd.—sand, soil, screenings, premix and quarry products.
- GIBSON KELITE CHEMICALS LTD.,** 350 Reserve-road, Cheltenham, 3192. One commercial goods vehicle (L/C. 10 cwt.) to operate in the course of business as "Manufacturing Chemists": (a) Within a 50-mile radius of own premises at Cheltenham—own goods. (b) Throughout the State of Victoria for the purpose of operating as a traveller's unit—samples, display and advertising materials with the ability also to collect and carry empty return containers having been used initially for the forward consignment of own goods by rail.
- GOLDEN POULTRY FARM PTY. LTD.,** Grants-road, Somerville, 3912. One commercial goods vehicle (L/C. 79 cwt.) to operate throughout the State of Victoria in the course of business as "Frozen Food Distributors" in a specially constructed refrigerated van—frozen poultry and frozen vegetables.
- GORDON BROTHERS PTY. LTD.,** 110-120 Union-street, Brunswick, 3056. One commercial goods vehicle (L/C. 14 cwt.) to operate throughout the State of Victoria in the course of business as "Refrigeration and Air Conditioning Servicemen and Installers"—spare parts and tools of trade for on-site servicing only.
- HAMILTON, J.,** 6 Narracan-drive, Newborough, 3828. One commercial goods vehicle (L/C. 35 cwt.) to operate: (a) Within a 25-mile radius of the post office at Morwell in the course of business as "Marine Collector"—special wares, marine stores and old metals as designated in the *Marine Stores and Old Metals Act 1958* (No. 6303), part 1, section (3), but excluding the carriage of any such goods to wharves, docks or ships for shipment or export purposes. (b) From own premises at Morwell to consignees situated within a 20-mile radius of the City of Melbourne in the course of own business as "Marine Collector"—goods as defined in paragraph (a) above, subject to the same restrictions as those in the said paragraph.
- NOTE.—The combined load capacity of the prime mover and of any trailer hauled in conjunction therewith shall not exceed 120 cwt.
- HEATH'S MOTORS PTY. LTD.,** 160 Little Malop-street, Geelong, 3220. One commercial goods vehicle (L/C. 13 cwt.) to operate throughout the State of Victoria in the course of business as "Automotive Wreckers"—wrecked motor vehicles on a specially constructed car-carrying trailer and used secondhand spare parts dismantled from wrecked vehicles in country areas.
- HOUGHTON & BYRNE (VIC.) PTY. LTD.,** 80 Autumn-street, Geelong West, 3218. One commercial goods vehicle (L/C. 13 cwt.) to operate throughout the State of Victoria in the course of business as "Pest Exterminators"—tools of trade, equipment and materials incidental to the completion of own contracts.
- JOHNSTON, N. E.,** 22 King-street, Hastings, 3915. One commercial goods vehicle (L/C. 259 cwt.) to operate within a 30-mile radius of the premises of Pioneer Quarries (Vic.) Pty. Ltd. at Dromana—sand, soil, premix, stone-dust and quarry products.
- KATOS FISH SUPPLY PTY. LTD.,** 32 Smythe-street, Geelong, 3220. One commercial goods vehicle (L/C. 39 cwt.) to operate: (a) Within a 50-mile radius of own premises in Geelong in the course of business as "Fish and Frozen Food Distributors"—own goods. (b) Within that part of the State of Victoria west of a north/south line drawn through the City of Melbourne, in a specially constructed refrigerated vehicle—fresh and frozen fish, frozen meat, frozen poultry, frozen seafoods, frozen vegetables, frozen pastries, frozen fruit juices, frozen pies, frozen chicken rolls, frozen prepared meals, egg whites and ice-cream.
- KENNEDY, PATRICK, EXCAVATIONS PTY. LTD.,** Box 11, Wendouree, 3355. One commercial goods vehicle (L/C. 213 cwt.) to operate: (a) Throughout the State of Victoria in the course of business as "Earth-moving and Excavation Contractors"—tools of trade, spare

- parts and sufficient fuel for the operation of machinery on site but excluding the carriage of any spare parts from the Metropolitan Area (as defined in the *Transport Regulation Act 1958*) to the Ballarat Urban District (as similarly defined in the said Act). (b) Within a 20-mile radius of the site of any earth-moving or excavation contract currently engaged upon—materials for use on such contract.
- LEGE, JACK, PTY. LTD.**, 43 Thomson-street, Sale, 3850. One commercial goods vehicle (L/C. 15 cwt.) to operate: (a) Throughout the State of Victoria in the course of business as "Earth-moving and Road-making Contractor"—own tools and own equipment but excluding the carriage of new machinery, equipment or spare parts from the Metropolitan Area (as defined in the *Transport Regulation Act 1958*). (b) Within a 20-mile radius of the site of any construction or maintenance contract upon which the applicant is currently engaged—metal, stones, screenings, ashes, gravel, sand, earth and any other materials required for such work.
- LEPLASTRIER, P.**, 36 Norfolk-avenue, Wantirna South, 3152. One commercial goods vehicle (L/C. 139 cwt.) to operate within a 70-mile radius of the premises of Brick and Pipe Industries Ltd. at Burwood solely on behalf of the said company—bricks.
- LINFIX TANKERS PROPRIETARY LTD.**, 286 Chesterville-road, Moorabbin, 3189. Three commercial goods vehicles (L/C. 270, 385, 376 cwt.) to operate: (a) Within a 25-mile radius of the G.P.O., Melbourne—general goods. (b) Throughout the State of Victoria on behalf of B.P. Australia Ltd. as a specially constructed bulk tanker vehicle—petroleum products in bulk.
- MORGAN, G.**, Sayle-street, Sebastopol, 3356. One commercial goods vehicle (L/C. 120 cwt.) to operate: (a) Throughout the State of Victoria in the course of business as "Marine Collector"—special wares, marine stores and old metals as designated in the *Marine Stores and Old Metals Act 1958* (No. 6303), Part I, section 3, but excluding the carriage of any such marine stores or old metals to wharves, docks or ships for shipment or export purposes.
- NOTE.—(i) No trailer is to be hauled in conjunction with the vehicle; (ii) The load capacity of any replacement vehicle shall not exceed the load capacity of the original vehicle. (b) Within a 25-mile radius of the chief post office in the City of Ballarat—general goods.
- MCLEAN, J. G.**, Flat 5, 17 Moama-road, Malvern, 3144. One commercial goods vehicle (L/C. 5 cwt.) to operate throughout the State of Victoria in the course of business as "Air Conditioning Engineers" for the emergency repair and servicing of air conditioning equipment originally installed by applicant—tools of trade and equipment together with a quantity of spare parts not exceeding 1 cwt. in weight at any one time and sufficient only for on-site servicing and repair only.
- O'CALLIGAN, K. J.**, Longford-road, Rosedale, 3847. One commercial goods vehicle (L/C. 161 cwt.) to operate from forest and private landings situated within a 25-mile radius of the premises of Australian Paper Manufacturers Ltd. at Maryvale to the said premises at Maryvale—pulpwood.
- PHOENIX BISCUIT COMPANY PTY. LTD.**, Grosvenor-street, Abbotshurst, 3067. One commercial goods vehicle (L/C. 30 cwt.) to operate within a 50-mile radius of own branch depot at Shepparton in course of business as "Biscuit and Cake Manufacturers"—own goods subject to the condition that any goods so carried shall only be those initially consigned to Shepparton by rail.
- READY MIXED CONCRETE (VIC.) PTY. LTD.**, 68 Burwood-road, Burwood, 3125. One commercial goods vehicle (L/C. 332 cwt.) to operate in the course of business as "Ready Mixed Concrete Manufacturers" as follows:— (a) Within a 25-mile radius of the post office situated at the corner of Bourke and Elizabeth streets in the City of Melbourne and to the Township of Bittern—raw materials for use in the manufacture of concrete. (b) From suppliers situated within a 20-mile radius of the post office at Bittern to own premises at Bittern—sand and screenings. (c) To own plant at Geelong from quarries situated within a 10-mile radius of the said plant and from pits in the You Yangs area—sand and screenings. (d) From pits at Bacchus Marsh to own plants within a 25-mile radius of the post office situated at the corner of Bourke and Elizabeth streets, Melbourne, or to own plant at Geelong—own sand. (e) From pits at Bunyip, Tynong and Nar-Nar-Goon to own plant at Vermont—own sand. (f) From quarries at Anakie to own plants within a 25-mile radius of the post office at the corner of Bourke and Elizabeth streets, Melbourne—own rock.
- RUSSELL-KING MOBILE CRANES PTY. LTD.**, 7 Duffy-street, Burwood, 3125. One commercial goods vehicle (L/C. 240 cwt.) to operate: (a) Within a 25-mile radius of G.P.O., Melbourne—general goods. (b) Throughout the State of Victoria in the course of business as "Crane Hirers and Erection Engineers"—tools of trade, erection equipment and up to 2 x 44 gallon drums of fuel for erection of crane on site.
- STEPHENS, M. T.**, Gordon-street, Alexandria, 3714. One commercial goods vehicle (L/C. 273 cwt.) to operate: (a) From forest landings situated within a 25-mile radius of the post office at Alexandria to the sawmill operated by Ruokak Timber Pty. Ltd., at Alexandria—sawmill logs. (b) From forest landings situated within a 10-mile radius of the post office at Barjag and 10-mile radius of the post office at Terip Terip to sawmill at Healesville—sawmill logs.
- WALLACE, D. F.**, Teesdale, 3328. One commercial goods vehicle (L/C. 245 cwt.) to operate: (a) Within a 20-mile radius of the post office at Teesdale—general goods. (b) From and to places within the radius specified in part (a) above to and from places outside that radius but wholly within a 50-mile radius of the post office at Teesdale—livestock. (c) From and to the depot of Ampol Petroleum (Vic.) Pty. Ltd. at Newport to and from own premises at Teesdale—petroleum products in prescribed types of containers and empty containers for return solely on behalf of the said company.
- WHITE, A.**, 46 Springfield-road, Box Hill, 3128. One commercial goods vehicle (L/C. 196 cwt.) to operate within a 50-mile radius of the G.P.O., Melbourne on behalf of Consolidated Quarries Ltd.—premixed concrete in a specially constructed agitator vehicle.
- WILLIAMS, B. G.**, Victoria-street, Mansfield, 3722. One commercial goods vehicle (L/C. 271 cwt.) to operate from forest landings situated within a 50-mile radius of the post office at Mansfield to sawmills situated at Mansfield or Benalla—sawmill logs.
- YELLINEK, K.**, 10 Parliament-avenue, East Melbourne, 3002. One commercial goods vehicle (L/C. 17 cwt.) to operate throughout the State of Victoria as a "Marine Dealer"—special wares, marine stores and old metals as designated in the *Marine Stores and Old Metals Act 1958* (No. 6303) Part I, section 3.
- NOTE.—The combined load capacity of the prime mover and any trailer attached thereto shall not exceed 120 cwt.

## RENEWALS.

APPLICATIONS for renewal of licences as shown by persons listed hereunder to operate under the same terms and conditions from the expiry shown in each case.

- ADAMS, HERBERT, PTY. LTD.**, corner Wellington and Springvale roads, North Springvale, 3171; D.A.13322/1; 15th April, 1970; 61 cwt.
- ALBION REID PTY. LTD.**, 83 Riversdale-road, Hawthorn, 3122; D.A.520/73; 6th August, 1970; 87 cwt.
- ALBION REID PTY. LTD.**, 83 Riversdale-road, Hawthorn, 3122; D.A.520/101; 15th August, 1970; 150 cwt.
- ALBION REID PTY. LTD.**, 83 Riversdale-road, Hawthorn, 3122; D.A.520/103; 15th August, 1970; 77 cwt.
- ALLEN, A. W., SALES PTY. LTD.**, 2-14 Byrne-street, South Melbourne, 3205; D.A.2218; 9th August, 1970; 75 cwt.
- ASCOM, PTY. LTD.**, 63 Queensbridge-street, South Melbourne, 3205; D.A.34589/26; 8th August, 1970; 12 cwt.
- ASCOM, PTY. LTD.**, 63 Queensbridge-street, South Melbourne, 3205; D.A.34589/50; 1st August, 1970; 25 cwt.
- BELL, C.**, 29 Pope-road, Blackburn, 3130; D.A.47173; 27th August, 1970; 10 cwt.
- BENNETT, W. J.**, 18 Bardia-avenue, Seaford, 3198; D.A.60059; 15th August, 1970; 232 cwt.
- CLARK KING & CO. PTY. LTD.**, 324 William-street, Melbourne, 3000; D.A.57019/1; 15th August, 1970; 132 cwt.
- CONNOR SHEA & CO. PTY. LTD.**, Fourth-avenue, Sunshine, 3020; D.A.40050/1; 27th August, 1970; 8 cwt; D.A.40050/2; 27th August, 1970; 6 cwt.
- CORKHILLS RADIO & T.V. SERVICE**, 55 Beetham-parade, Rosanna, 3084; D.A.47041; 27th August, 1970; 6 cwt.
- CROCKFORD & ROBERTSON PTY. LTD.**, 15 Abbott-street, Fairfield, 3078; D.A.914/5; 11th August, 1970; 25 cwt.
- DALDY, R. J.**, 314 North-road, Huntingdale, 3166; D.A.59676; 15th August, 1970; 146 cwt.
- DAY, E. E., & SONS PTY. LTD.**, 822 Howitt-street, Wendouree, 3355; D.A.44530/1; 7th November, 1969; 8 cwt.
- FLETCHER INDUSTRIES LTD.**, 469 Somerville-road, West Footscray, 3012; D.A.1079; 11th August, 1970; 14 cwt.
- FORREST, R. G.**, 15 Heath-street, Moorabbin, 3189; D.A.32824; 11th August, 1970; 35 cwt.
- GODFREY PHILLIPS (AUSTRALIA) PTY. LTD.**, 111-193 Wellington-street, Collingwood, 3066; D.A.63821; 14th June, 1970; 8 cwt; D.A.63821/1; 14th June, 1970; 8 cwt; D.A.63821/2; 14th June, 1970; 6 cwt; D.A.63821/3; 14th June, 1970; 6 cwt; D.A.63821/4; 14th June, 1970; 6 cwt; D.A.63821/5; 14th June, 1970; 8 cwt;

D.A.63821/6; 14th June, 1970; 10 cwt; D.A.63821/7; 14th June, 1970; 8 cwt; D.A.63821/8; 14th June, 1970; 10 cwt; D.A.63821/9; 14th June, 1970; 8 cwt; D.A.63821/10; 14th June, 1970; 8 cwt; D.A.63821/11; 14th June, 1970; 8 cwt; D.A.63821/12; 14th June, 1970; 8 cwt; D.A.63821/13; 14th June, 1970; 8 cwt.

GOLLER, J. J., & Co. PTY. LTD., 114 Lydiard-street north, Ballarat, 3350; D.A.33540; 11th August, 1970; 19 cwt; D.A.33540/1; 11th August, 1970; 80 cwt.

GRANDIN, H. J. (trading as Grandin's Parcel Service), 6 Orr-street, Wangaratta, 3677; D.A.1183/1; 30th May, 1970; 9 cwt.

GRAY & WOOD PTY. LTD., 19 Park-road, Cheltenham, 3192; D.A.60058; 15th August, 1970; 32 cwt.

INGRAM, G. H., Lyppards-road, Cranbourne, 3977; D.A.46947; 6th August, 1970; 138 cwt.

JOHNSON, K. T. & M. E., 40 McLean-street, Maffra, 3860; D.A.46785; 30th July, 1970; 350 cwt.

JONES, D. W., PTY. LTD., 126 Cecil-street, Williamstown, 3016; D.A.1392/13; 6th August, 1970; 111 cwt.

KINGSLEY INDUSTRIES PTY. LTD., 877 Princes Highway, Springvale, 3171; D.A.15317; 23rd August, 1970; 73 cwt.

MATTHEWS, F. C., 60 Emu-road, Maidstone 3012; D.A.1576/2; 3rd July, 1970; 68 cwt.

MONKIVITCH, D. T. & V. J., 1 Delmont-avenue, Altona, 3018; D.A.46957; 6th August, 1970; 198 cwt.

NATIONAL CASH REGISTER CO. PTY. LTD., THE, 124 Russell-street, Melbourne, 3000; D.A.1707/23; 6th August, 1970; 14 cwt.

O'BERNE, J. & F., Skipton-road, Linton, 3360; D.A.33319; 18th August, 1970; 67 cwt.

PENINSULA HAULAGE PTY. LTD., P.O. Box 7, Frankston, 3199; D.A.1801/14; 11th August, 1970; 163 cwt.

PERMEWAN WRIGHT LTD., 147 Alexander-parade, Abbotsford, 3067; D.A.1809/63; 29th August, 1970; 139 cwt.

PETERSVILLE AUSTRALIA LTD., Wellington-road, Clayton, 3168; D.A.1813/149; 1st August, 1970; 77 cwt; D.A.1813/150; 8th August, 1970; 55 cwt.

QUEEN'S BRIDGE MOTOR & ENGINEERING COMPANY PTY. LTD., Cnr. Salmon and Plummer streets, Port Melbourne, 3207; D.A.1783/54; 29th August, 1970; 10 cwt.

REDMAN CONSTRUCTIONS, P.O. Box 18, Stawell, 3380; D.A.46560; 16th July, 1970; 14 cwt.

S.P.D., C/o UNILEVER AUSTRALIA PTY. LTD., 164-220 Ingles-street, Port Melbourne, 3207; D.A.46545; 18th June, 1970; 290 cwt.

W. A. & K. HARDWARE PTY. LTD. (trading as Sales & Installations Co.), Box 277, P.O., Clayton, 3168; D.A.49578/9; 1st August, 1970; 71 cwt.

SIDES, W. L. & SON PTY. LTD., P.O. Box 223, Clayton, 3168; D.A.28601/7; 18th August, 1970; 74 cwt.

SOUTHERN STATES DRILLING CO. PTY. LTD., 58 Plateau-road, Reservoir, 3073; D.A.33737; 18th August, 1970; 71 cwt.

STEVENSON, H. F., PTY. LTD., 10 Duffy-street, Burwood, 3125; T.D.A.2111/2; 7th August, 1970; 79 cwt.

SUNBEAM CORPORATION LTD., Sloane-street, Maribyrnong, 3032; D.A.14579/15; 23rd August, 1970; 8 cwt.

TIMMINS, J. D., Haven via Horsham, 3401; D.A.46789; 30th July, 1970; 70 cwt.

WABCO DISTRIBUTION AUSTRALIA PTY. LTD., 1608-1618 Sydney-road, Campbellfield, 3061; D.A.45971/4; 27th August, 1970; 36 cwt.

WILLIAMSON, H. H., Corinella, Westernport, 3984; D.A.17280; 30th August, 1970; 145 cwt.

## TOW TRUCK RENEWALS.

ASSOCIATED REPAIR SERVICE PTY. LTD., 320 Little Lonsdale-street, Melbourne, 3000; D.A.62960/1; 16th May, 1970; 42 cwt.

MARTIN'S PANEL SERVICE PTY. LTD., Main-road, Ferntree Gully, 3156; D.A.45802/3; 1st August, 1970; 40 cwt.

Notice of any objection should be forwarded to reach the Secretary of the Board not later than the 27th May, 1970.

Applicants are advised that it will not be necessary to appear on the hearing date specified above, unless advised in writing by the Board.

B. P. KAY,  
Secretary.

Corner Lygon and Princes streets, Carlton, 3053, Wednesday, 13th May, 1970.

Commercial Goods Vehicles Act.  
TRANSPORT REGULATION BOARD.

## HEARING OF APPLICATIONS.

NOTICE is hereby given that the following applications will be considered by the Transport Regulation Board at the Court House, Alexandra, at 9.15 a.m. on Wednesday, 20th May, 1970.

WILLIAMSON, R. T. & W. BIRCHALL (trading as Alexandra Freighters), 124 Grant-street, Alexandra, 3714. Three commercial goods vehicles (L/C. 108, 225 and 230

cwt.) to operate: (a) From and to the City of Melbourne, to and from places-situate on or most conveniently reached from the road between the Townships of Fernshaw and Alexandra via St. Fillans and Buxton—general goods, provided that no goods whatsoever shall be carried to or from the City of Melbourne from or to any place within a 3-mile radius from the Township of Alexandra. (b) From and to the Township of Healesville to and from places situate on or most conveniently reached from the road between the aforesaid Townships of Fernshaw and Alexandra via St. Fillans and Buxton—general goods provided that no goods whatsoever are carried to or from any place within a 3-mile radius from the Township of Alexandra. (c) From and to the City of Melbourne to and from places situate on or adjacent to the road between and including the Townships of Thornton and Eildon with the ability also to operate via the Township of Alexandra—general goods.

## Special Conditions.

Except in respect of goods consigned to and from the Township of Eildon—(i) It is a further condition of this licence that goods shall not be carried on the vehicle to any place or to any area authorized in this licence for the purpose of being transferred to any other licensed vehicle for the carriage to a further destination outside or beyond the places or areas to which or within which the vehicle is authorized in this licence to operate. (ii) It is a further condition of this licence that the off-loading or transfer of goods from or to the vehicle hereby licensed to or from any other licensed vehicle for the carriage of goods to or from any place or area other than that authorized in this licence is absolutely prohibited and any such off-loading or transfer of goods as aforesaid to or from any other vehicle shall be an infringement of this licence.

Notice of any objection should be forwarded to reach the Secretary of the Board not later than the 20th May, 1970.

B. P. KAY,  
Secretary.

Corner Lygon and Princes streets, Carlton, 3053.

## COMPANIES ACT 1961.

## WHEREAS:

I. Tjuringa Management Limited (hereinafter called "the company") is the management company within the meaning of section 76 of the Companies Act 1961 (hereinafter referred to as "the Act") in relation to a Deed dated the 14th April, 1970, constituting the Australian Mutual Mortgage Fund (hereinafter called "the Trust Deed").

II. Permanent Trustee Nominees (Canberra) Limited is the trustee for the purposes of the Trust Deed.

III. Application has been made by the company for exemption from compliance with the provisions of sub-section (1) of section 84 of the Act in respect of the holders of interests under the Trust Deed who are resident outside the State of Victoria.

Now therefore I, the undersigned, the Minister administering the Act, subject to the terms and conditions set out in the Schedule hereunder, do hereby exempt the company from compliance with the provisions of sub-section (1) of section 84 of the Act in respect of the holders of interests under the Trust Deed who are resident outside the State of Victoria.

## SCHEDULE.

1. The company shall keep in the State of New South Wales at a place and in the form and manner in which it is required to be kept pursuant to the Companies Act 1961 of that State a complete register of all holders of interests under the Trust Deed wherever resident.

2. The company shall keep in the State of Victoria a register of the holders of interests under the Trust Deed who are resident in Victoria and the requirements of sub-section (1) of section 84 of the Act shall be complied with in relation to such register.

3. The company shall within fourteen days after receiving a request from any person entitled to inspect the register by virtue of the provisions of section 153 of the Act make available to such person for inspection a copy of the register of all holders of interests under the Trust Deed, wherever resident.

Dated at Melbourne, this seventh day of May, 1970.

G. O. REID,  
Attorney-General.

**TRAFALGAR WATERWORKS TRUST.**

**RATING BY-LAW FOR 1970.**

**T**HE Trafalgar Waterworks Trust, in pursuance and exercise of the powers conferred by the Water Acts, doth hereby make a rate for the supply of water for domestic purposes of four cents in the Dollar of the annual municipal valuation of lands and tenements to be rated within the Trafalgar Urban District.

Provided that in no case shall the amount of the rate payable in respect of any tenement (other than land on which there is no building) be less than Ten Dollars and in respect of any land on which there is no building less than Five Dollars.

Such rates are made and shall be levied upon the occupiers or owners of the said lands and tenements for the year commencing on the 1st day of January, 1970, and ending on the 31st December, 1970, and shall be payable on the 1st day of June, 1970, at the office of the said Trust.

The maximum quantity of water to be supplied in any one year without further charge to any property rated by the Trust is hereby fixed at the quantity which, at a charge of Fifteen Cents per 1,000 gallons would produce an amount equal to the amount of rate levied on such property for the said year.

The charge for water supplied by measure to any property rated by the Trust in excess of such maximum quantity computed as in the last preceding clause, is hereby fixed at Twenty Cents per 1,000 gallons.

The Charge for water supplied by measure shall be payable, on demand at the office of the Trust.

Passed this 15th day of April, 1970.

(SEAL) K. A. NEILSON, Chairman.  
R. A. HOLMES, Commissioner.  
W. F. NELSON, Secretary.

Approved, 29th April, 1970.—W. BORTHWICK, Minister of Water Supply.

**UNDERBOOL WATERWORKS TRUST.**

**RATING BY-LAW FOR 1970.**

**T**HE Underbool Waterworks Trust, in pursuance of and in exercise of the powers conferred by the Water Act 1958 and of any and every other power it thereunto enabling doth hereby make a By-Law as follows:—

1. The Trust hereby makes and levies a rate in respect of all lands and tenements within the Underbool Urban District of Eighteen Cents (18c) in the Dollar on the Net annual value set out in the valuation at present in force of such lands and tenements for the purposes of the municipal rate of the Shire of Walpeup which is hereby adopted as the valuation of such lands and tenements respectively.

2. Such rate shall be made and levied upon the occupiers and owners of such lands and tenements for the year commencing on the 1st day of January, 1970, and shall be payable on the 30th day of June, 1970, at the Office of the said Trust, Ouyen.

3. In no case shall the rate payable hereunder in respect of any land on which there is a building be less than Fifteen Dollars (\$15.00) and in respect of land on which there is no building be less than Four Dollars (\$4.00).

4. The maximum quantity of water supplied in any one year without further charge to any property rated by the Trust, is hereby fixed at the quantity which, at a charge of Twenty-five cents per 1,000 gallons, would produce an amount equal to the amount levied upon such property for the said year.

5. The charge for water supplied by measure to any property rated by the Trust in excess of such maximum quantity computed as in the last preceding clause, is hereby fixed at Twenty-five cents per 1,000 gallons.

6. The charge for water supplied by measure shall be payable on demand, at the Office of the Trust, Ouyen.

The foregoing By-Law was made on the 16th day of April, 1970, and the common seal of the Underbool Waterworks Trust was affixed that day, in the presence of—

(SEAL) A. B. ELLIOT, Chairman.  
E. W. CROTHERS, Commissioner.  
BARRY CROSS, Secretary.

Approved, 28th April, 1970.—W. BORTHWICK, Minister of Water Supply.

**LILYDALE SEWERAGE AUTHORITY.**

**BY-LAW No. 2.**

**Minimum Sewerage Rate.**

**T**HE Lilydale Sewerage Authority, pursuant to and in exercise of the powers and authorities conferred on it by the Sewerage Districts Acts and of any and every other power or authority in any wise enabling it in that behalf, doth hereby make and prescribe the following By-law that is to say:—

In no case shall the amount of sewerage rate payable annually by the owner or occupier in respect of any rateable sewerer property on which there is a building be less than Twenty Dollars (\$20) or by the owner or occupier in respect of any rateable sewerer property on which there is no building be less than Twenty Dollars (\$20).

The above By-law was made and passed by the Lilydale Sewerage Authority on the 16th February, 1970, and confirmed on the 27th April, 1970.

In witness thereof the common seal of the Authority was hereto affixed, in the presence of—

(SEAL) A. LILLIE, Chairman.  
E. C. HILL, Member.  
F. O. KENT, Secretary.

Approved, 6th May, 1970.—W. BORTHWICK, Minister of Water Supply.

**TOORA WATERWORKS TRUST.**

**RATING BY-LAW FOR THE YEAR 1970.**

**T**HE Toora Waterworks Trust, in pursuance of and in exercise of the powers conferred by the Water Act 1958 and of any and every other power it thereunto enabling doth hereby make a By-Law as follows:—

1. The Trust hereby makes and levies rates in respect of all the lands and tenements within the respective Urban Districts of such amount in the dollar on the net annual value set out in the valuation at present in force of such lands and tenements for the purposes of the municipal rate of the Shire of South Gippsland which is hereby adopted as the valuation of such lands and tenements respectively as is set out in Column 2 opposite the name of the respective Urban Districts in Column 1 of the Schedule hereto.

2. Such rate shall be made and levied upon the occupiers and owners of such lands and tenements for the year commencing on the 1st day of January, 1970, and shall be payable on the 30th day of June, 1970, at the office of the said Trust.

3. In no case shall the rate payable hereunder in respect of any land on which there is a building be less than the sum set down in Column 3 opposite the name of the respective Urban Districts in Column 1 of the Schedule hereto and in respect of land on which there is no building be less than the sum set down in Column 4 opposite the name of the respective Urban Districts in Column 1 of the said Schedule.

**SCHEDULE.**

Name of Respective Urban Districts.	Amount of Rate in \$1 of the Municipal Valuation of Tenements (Subject to the Minimum Amount of Rates as set out in Columns 3 and 4).	Minimum Amount of Rate per Year in respect of Tenements (Other than Lands on which there is no building).	Minimum Amount of Rate per year in respect of Lands on which there is no Building.
Column 1.	Column 2.	Column 3.	Column 4.
	cents	\$	\$
Toora	4.5	10.00	2.00
Welshpool	7	10.00	2.00
Port Welshpool	7	10.00	2.00

Passed this 17th day of April, 1970—

W. E. COOK, Chairman.  
V. W. B. WOOD, Commissioner.  
C. J. PATERSON, Secretary.

Approved, 29th April, 1970.—W. BORTHWICK, Minister of Water Supply.

## TALLANGATTA WATERWORKS TRUST.

## RATING BY-LAW FOR THE YEAR 1970.

THE Tallangatta Waterworks Trust, in pursuance and exercise of the powers conferred by the Water Act, doth hereby make a rate for the supply of water for domestic purposes of five (5) cents in the dollar of the Net Annual Value of the lands and tenements liable to be rated within the Tallangatta Urban District.

Provided that in no case shall the amount of the rate payable per annum in respect to any tenements (other than land on which there is no building) be less than seventeen dollars and in respect to any land on which there is no building less than ten dollars.

Such rates are made and shall be levied upon the occupiers or owners of the said lands and tenements for the year commencing on the 1st day of January, 1970 and shall be payable on the 1st day of May, 1970 at the office of the Trust.

The maximum quantity of water to be supplied in any year without further charge to any property rated by the Trust is hereby fixed at the quantity which at a charge of eighteen cents per 1,000 gallons, would produce an amount equal to the amount of the rate levied on such property for the said year.

The charge for water supplied by measure to any property rated by the Trust in excess of such maximum quantity computed as in the last preceding clause is hereby fixed at eighteen cents per 1,000 gallons.

The charge for water supplied by measure shall be payable, on demand, at the office of the Trust.

Passed this 14th day of April, 1970.

(SEAL) J. J. LLOYD, Chairman.  
R. J. PINK, Commissioner.  
I. M. BOWMAN, Secretary.

Approved, 30th April, 1970.—W. BORTHWICK, Minister of Water Supply.

## MURRAYVILLE WATERWORKS TRUST.

## RATING BY-LAW FOR YEAR 1970.

THE Murrayville Waterworks Trust in pursuance of and in exercise of the powers conferred by the Water Act 1958 doth hereby make a By-Law as follows:—

1. The Trust hereby makes and levies a rate in respect of all lands and tenements within the Murrayville Urban District of Fifteen Cents in the Dollar on the net annual value set out in the valuation at present in force of such lands and tenements for the purposes of the municipal rate of the Shire of Walpeup which is hereby adopted as the valuation of such lands and tenements respectively.

2. Such rate shall be made and levied upon the occupiers and owners of such lands and tenements for the year commencing on the 1st day of January, 1970, and shall be payable on the 8th day of June, 1970, at the Office of the said Trust, Ouyen.

3. In no case shall the rate payable hereunder in respect of any land on which there is a building be less than Thirteen Dollars and Fifty Cents (\$13.50) and in respect of land on which there is no building be less than Four Dollars (\$4.00).

4. The maximum quantity of water to be supplied in any one year without further charge to any property rated by the Trust is hereby fixed at the quantity which, at a charge of Twenty Cents per 1,000 gallons, would produce an amount equal to the amount of rates levied on such property for the said year.

5. The charge for water supplied by measure to any property rated by the Trust in excess of such maximum quantity, computed as in the last preceding clause, is hereby fixed at Twenty Cents per 1,000 gallons.

The charge for water supplied by measure to any property not rated by the Trust and where no agreement exists, is hereby fixed at Twenty Cents per 1,000 gallons.

6. The charge for water supplied by measure shall be payable on demand at the Office of the Trust, Ouyen.

The foregoing By-Law was made on the 16th day of April, 1970, and the common seal of the Murrayville Waterworks Trust was affixed that day in the presence of—

(SEAL) M. WILLERSDORF, Chairman.  
C. C. THURLOW, Commissioner.  
BARRY CROSS, Secretary.

Approved, 27th April, 1970.—W. BORTHWICK, Minister of Water Supply.

## OMEO WATERWORKS TRUST.

## RATING BY-LAW FOR THE TWELVE MONTHS ENDING 31ST DECEMBER 1970.

THE Omeo Waterworks Trust, in pursuance and exercise of the powers conferred by the Water Acts, doth hereby make a rate for the supply of water for domestic purposes of seventeen and one half cents in the dollar on the annual municipal valuation of lands and tenements liable to be rated within the Omeo Urban District.

Provided that in no case shall the amount of rate payable for the period in respect of any tenement (other than land on which there is not a building), be less than eighteen dollars (\$18.00) and in respect of land on which there is no building less than five dollars (\$5.00).

Such rates are made and shall be levied upon the occupiers or owners of the said lands and tenements for the period commencing 1st January, 1970, and ending 31st December, 1970, and shall be payable in one amount on the 1st May, 1970, at the office of the said Trust, at Omeo.

The maximum quantity of water to be supplied for the twelve months period without further charge to any property rated by the Trust is hereby fixed at the quantity which, at a charge of thirty seven cents per 1,000 gallons, would provide an amount equal to the amount of the rate levied on such property for the said Twelve months period.

The charge for water supplied by measure to any property rated by the Trust in excess of such maximum quantity, computed as in the last preceding clause, is hereby fixed at thirty seven cents per 1,000 gallons.

The charge for water supplied by measure shall be payable, on demand, at the office of the Trust in Omeo.

Passed this 20th day of March, 1970.

The common seal of the Omeo Waterworks Trust was hereto affixed, this 20th day of March, 1970, in the presence of—

(SEAL) J. E. CONNLEY, Chairman.  
J. M. McGRATH, Commissioner.  
V. W. WEBSTER, Secretary.

Approved, 30th April, 1970.—W. BORTHWICK, Minister of Water Supply.

## PYALONG WATERWORKS TRUST.

## RATING BY-LAW FOR YEAR 1970.

THE Pyalong Waterworks Trust, in pursuance and exercise of the powers conferred by the Water Acts, doth hereby make a rate for the supply of water for domestic purposes of seventeen and one half cents (17½ cents) in the dollar on the Municipal valuation of all lands and tenements liable to be rated within the Pyalong Waterworks District.

Provided that in no case shall the amount of rate payable per annum in respect of any tenement (other than land on which there is no building) be less than eighteen dollars (\$18.00) and in respect of any land on which there is no building be less than Five dollars (\$5.00).

Such rate is made for the year commencing on the first day of January, and shall be payable in one sum on the first day of June, at the Office of the Trust.

The maximum quantity of water to be supplied in any one year without further charge to any property rated by the Trust is hereby fixed at the quantity which, at a charge of thirty-seven cents (37c) per 1,000 gallons, would produce an amount equal to the amount of the rate levied on such property for the said year.

The charges for water supplied by measure to any property rated by the Trust in excess of such maximum quantity, computed as in the last preceding clause, is hereby fixed at thirty-seven cents (37c) per 1,000 gallons, except in cases of special agreement with the Trust.

The charge for water supplied by measure shall be payable on demand at the office of the Trust.

Dated this 8th day of April, 1970.

(SEAL) JAMES WHALAN, Chairman.  
FRED S. GRIMWADE, Commissioner.  
H. BUTTERWORTH, Secretary.

Approved, 30th April, 1970.—W. BORTHWICK, Minister of Water Supply.

*Cemeteries Act 1958.*

**SCALE OF FEES OF CRESWICK PUBLIC CEMETERY.**

IN pursuance of the powers conferred upon them by the Cemeteries Act the trustees of the Creswick Public Cemetery hereby make the following scale of fees, which shall come into operation upon publication in the *Government Gazette*, and from and after such publication every scale of fees heretofore made by the said trustees shall be and is hereby rescinded to the extent to which it conflicts with this scale.

*Lawn Cemetery.*

Grave site (including sinking charge, concrete edging and plinth, establishment of lawn and perpetual maintenance, standard type granite headstone) .. .. .	\$150.00
Reopening grave .. .. .	\$40.00
Reservation (balance payable, when site is used, made at rate when reservation was originally made) .. .. .	\$75.00

H. R. RYALL, Chairman.  
G. SPITTLE, Trustee.  
S. GEDDES, Trustee.

Approved by the Governor in Council, 5th May, 1970.—  
J. ROSSITER, Clerk of the Executive Council.

*Cemeteries Act 1958.*

**SCALE OF FEES OF HAZELWOOD PUBLIC CEMETERY.**

IN pursuance of the powers conferred upon them by the Cemeteries Act the trustees of the Hazelwood Public Cemetery hereby make the following scale of fees, which shall come into operation upon publication in the *Government Gazette*, and from and after such publication every scale of fees heretofore made by the said trustees shall be and is hereby rescinded to the extent to which it conflicts with this scale.

*Public Graves.*

Interment in grave without exclusive right— stillborn child .. .. .	\$6.00
Interment in grave without exclusive right— others .. .. .	\$12.00
Number peg or label .. .. .	\$1.00

*Private Graves.*

Land, 8 ft. x 4 ft. .. .. .	\$20.00
Own selection of land (extra) .. .. .	\$5.00

*Sinking Charges for Private Graves.*

Sinking grave 6 feet deep .. .. .	\$30.00
Each additional foot .. .. .	\$3.00
Sinking oversize grave (extra) .. .. .	\$10.00
Sinking child's grave 4 ft. 6 in. deep .. .. .	\$20.00
Cancellation of order to sink (if commenced) .. .. .	\$5.00

*Reopening Charges.*

Reopening grave (no cover) .. .. .	\$25.00
Reopening grave (with cover) .. .. .	\$30.00

*Extra Charges.*

Interment outside prescribed hours, or on Saturdays, Sundays or Public Holidays .. .. .	\$10.00
Interment in a private grave without due notice .. .. .	\$10.00

*Miscellaneous Charges.*

Interment fee .. .. .	\$10.00
Certificate of right of burial .. .. .	\$1.00
Number plate or brick .. .. .	\$1.00
Permission to erect a headstone or monument— 5 per cent. of cost, with a minimum of \$6.00.	
Permission to construct a brick grave or to erect any stone kerb, brick tilework or concrete	\$4.00
Exhuming the remains of a body (when authorized) .. .. .	\$25.00
Interment of ashes in a private grave .. .. .	\$10.00

A. L. HARE, Trustee.  
W. MORRISON, Trustee.  
F. D. KELLY, Trustee.  
T. M. HOOD, Trustee.

Approved by the Governor in Council, 5th May, 1970.—  
J. ROSSITER, Clerk of the Executive Council.

*Cemeteries Act 1958.*

**SCALE OF FEES OF WILLIAMSTOWN PUBLIC CEMETERY.**

IN pursuance of the powers conferred upon them by the Cemeteries Act the trustees of the Williamstown Public Cemetery hereby make the following scale of fees, which shall come into operation upon publication in the *Government Gazette*, and from and after such publication every scale of fees heretofore made by the said trustees shall be and is hereby rescinded to the extent to which it conflicts with this scale.

*Public Grave.*

Land for new grave .. .. .	\$38.00
Sinking to 7 feet .. .. .	\$28.00
Reopening with stone kerb or other enclosure .. .. .	\$40.00
Reopening without stone kerb or other enclosure .. .. .	\$35.00
Reopening of stone or concrete covered grave .. .. .	\$41.00

J. E. PATTERSON, Trustee.  
S. H. ROBINSON, Trustee.  
E. S. LOFT, Trustee.  
C. W. SIDWAY, Secretary.

Approved by the Governor in Council, 5th May, 1970.—  
J. ROSSITER, Clerk of the Executive Council.

**NOTICE.**

**CREDITORS**, next of kin, and others having claims against the estate of any of the under-mentioned deceased persons are required to send particulars of their claims to the Public Trustee, 256 Flinders-street, Melbourne, Vic., 3000, the personal representative, on or before the 20th July, 1970, after which date the Public Trustee may convey or distribute the assets, having regard only to the claims of which the Public Trustee then has notice:—

- ADAMSON, DORA, otherwise known as Dora Henrietta Adamson, late of 5 Merton-place, Albert Park, home duties, died 10th February, 1970.
- BARTLETT, ROBERT CHARLES, late of 921 Canterbury-road, Box Hill, retired boilermaker, died 22nd December, 1969.
- BLIZZARD, FLORRIE, late of 84 Watson-avenue, Dromana, widow, died 21st January, 1970.
- BOWMAN, HYPATIA, late of 24 Hyde-street, Deer Park, married woman, died 7th August, 1969.
- CRAWLEY, HORACE POWELL, late of 54 Ebden-street, Elsternwick, retired labourer, died 5th December, 1969.
- GALLAGHER, JAMES, late of 12 Cooper-street, Springvale, clerk, died 18th October, 1969.
- HUGHES, CLARENCE W., also known as Clarence Walter, late of 28 Glanfield-street, Northcote, retired laboratory assistant, died 27th December, 1969.
- JOSHUA, PERCY FRANCIS, late of Ridge-road, Mount Dandenong, pensioner, died 3rd January, 1970.
- KAMENSKY, BORIS, late of 15 Victoria-street, Springvale, cleaner, died 19th June, 1969.
- KEEGAN, THOMAS, late of Eastern Hotel, Yallourn, trades assistant, died 4th January, 1970.
- LEE, ALBERT JAMES, late of 56 Packington-street, Windsor, retired construction foreman, died 1st February, 1970.
- LUND, BERT ERNEST, late of 9 Plimsoll-grove, Fairfield, retired electrician, died 13th October, 1969.
- MILLARD, HAROLD JOHN, late of Flat 10, 28 Barnsbury-road, Balwyn, retired municipal officer, died 21st February, 1970.
- MOORES, ELFRIEDA FLORENCE, formerly of 31 Passchendale-street, Hampton, but late of Judge Book Village, Eltham, widow, died 6th February, 1970.
- MORLEY, MAUDE LOVEDAY, late of 139 Gladstone-avenue, Northcote, widow, died 31st December, 1969.
- MORRISROE, EMMA ETHEL, formerly of 779 Frauenfelder-street, Albany, New South Wales, but late of Larundel, widow, died 22nd October, 1969.
- MURRISON, WILLIAM, also known as William John Murrison, late of 49 Coleman-parade, Syndal, retired accountant, died 19th November, 1969.
- MCCARTHY, MILLICENT CHRISTINA, formerly of 182 Nicholson-street, Coburg, but late of 9 Warwick-street, Pascoe Vale, widow, died 31st December, 1969.
- NELSON, WILLIAM CHARLES ERIC, late of 115 Orrong-crescent, North Caulfield, retired electrical engineer, died 21st November, 1969.
- OKES, FREDA, late of Ballarat, retired milliner, died 14th July, 1969.
- POLJAK, TOMISLAV, late of 4 Station-street, Seddon, typewriter mechanic, died 19th June, 1966.
- SINNOTT, MARGARET PHILOMENA, late of 95 Stanhope-street, Malvern, spinster, died 28th December, 1969.

N. P. BRODY,  
Public Trustee.

Melbourne, 6th May, 1970.

*Town and Country Planning Act 1961.*  
CITY OF KNOX PLANNING SCHEME 1965.  
AMENDMENT No. 67, 1969.

*Notice of Approval.*

IN pursuance of the powers conferred by the *Town and Country Planning Act 1961*, the Governor in Council on the 5th May, 1970, approved a Planning Scheme entitled the City of Knox Planning Scheme 1965, in respect of part of the municipal district of the City of Knox and such Planning Scheme comes into operation on the date this notice of approval is published in the *Government Gazette*.

A copy of the Planning Scheme as approved may be inspected free of charge during office hours, at the office of the Town and Country Planning Board, 235 Queen-street, Melbourne; at the office of the City of Knox, Fern Tree Gully, and when available, at the Office of Titles, Melbourne, and at the Central Plan Office of the Department of Crown Lands and Survey, Melbourne.

W. H. CRAIG, Secretary,  
Town and Country Planning Board.

*Town and Country Planning Act 1961.*  
CITY OF KNOX PLANNING SCHEME 1965.  
AMENDMENT No. 65, 1969.

*Notice of Approval.*

IN pursuance of the powers conferred by the *Town and Country Planning Act 1961*, the Governor in Council on the 5th May, 1970, approved a Planning Scheme entitled the City of Knox Planning Scheme 1965, Amendment No. 65, 1969, in respect of part of the municipal district of the City of Knox and such Planning Scheme comes into operation on the date this notice of approval is published in the *Government Gazette*.

A copy of the Planning Scheme as approved may be inspected free of charge during office hours, at the office of the Town and Country Planning Board, 235 Queen-street, Melbourne; at the office of the City of Knox, Fern Tree Gully, and when available, at the Office of Titles, Melbourne, and at the Central Plan Office of the Department of Crown Lands and Survey, Melbourne.

W. H. CRAIG, Secretary,  
Town and Country Planning Board.

*Town and Country Planning Act 1961.*  
SHIRE OF SHERBROOKE PLANNING SCHEME 1965.  
AMENDMENT No. 27, 1969.

*Notice of Approval.*

IN pursuance of the powers conferred by the *Town and Country Planning Act 1961*, the Governor in Council on the 5th May, 1970, approved a Planning Scheme entitled the Shire of Sherbrooke Planning Scheme 1965, Amendment No. 27, 1969, in respect of part of the municipal district of the Shire of Sherbrooke and such Planning Scheme comes into operation on the date this notice of approval is published in the *Government Gazette*.

A copy of the Planning Scheme as approved may be inspected free of charge during office hours at the office of the Town and Country Planning Board, 235 Queen-street, Melbourne; at the office of the Shire of Sherbrooke, Upwey, and when available, at the Office of Titles, Melbourne, and at the Central Plan Office of the Department of Crown Lands and Survey, Melbourne.

W. H. CRAIG, Secretary,  
Town and Country Planning Board.

*Town and Country Planning Act 1961.*  
CITY OF MOORABBIN PLANNING SCHEME 1952.  
REVOCATION No. 8, 1970.

*Notice of Revocation.*

IN pursuance of the powers conferred by sub-section 4 of section 32 of the *Town and Country Planning Act 1961*, the Governor in Council, by and with the advice of the Executive Council on the 5th May, 1970, revoked the City of Moorabbin Planning Scheme 1952 in so far as it affected lot 12, lodged plan 44526 at the corner of Cavanagh-street and Friendship-square, Cheltenham.

A copy of the revocation may be inspected during office hours, at the office of the Town and Country Planning Board, 235 Queen-street, Melbourne, and at the office of the Council of the City of Moorabbin, at Moorabbin.

W. H. CRAIG, Secretary,  
Town and Country Planning Board.

TEACHING SERVICE ACT 1958.—SECTION 73.

ALEXANDRA ELIZABETH MIKLOS, Record No. 85365, Assistant Teacher, Primary Schools Division, Thornbury High School, Education Department, having been charged under the provisions of section 55 of the *Public Service Act 1958*, as extended and made applicable to members of the teaching service by section 73 of the *Teaching Service Act 1958*, with being absent without leave from the 24th August, 1969, to the 6th November, 1969, and such charge having been referred, by direction of the Honorable the Minister of Education, to the Teachers Tribunal, the Tribunal after enquiry finds such charge proved and under the provisions of the section of the Act above cited, hereby dismisses the said Alexandra Elizabeth Miklos from the Teaching Service as from and including the 1st May, 1970.

W. E. SAMPSON, Chairman.  
A. F. LE CLERCQ, Secretary.

Office of the Teachers Tribunal,  
Melbourne, 1st May, 1970.

CONSULATE-GENERAL.

NOTICE is given that the Royal Norwegian Consulate in Melbourne has been raised to the status of a Consulate-General.

Mr. Edvard Aastad Alstergren, formerly Honorary Consul of Norway, and Mr. Edvard Hagbart Alstergren, formerly Honorary Vice-Consul of Norway, have been appointed Honorary Consul-General and Honorary Consul respectively.

L. W. CARVER,  
Acting Secretary.

Premier's Office,  
Melbourne, Vic. 3002, 4th May, 1970.

ORDERS IN COUNCIL.—(Series 1969-70.)

PUBLIC WORKS.

1359. Carlton, Education Department, supply of refrigeration equipment for cafeteria, \$6,023.04.—Ahearn, Main & Stott Pty. Ltd.—(C.49593 "H".)

1360. Melbourne, New State Public Offices, supply of additional furniture, \$31,816.00.—Brownbuilt Ltd., and \$22,561.94.—Peter F. Danby Pty. Ltd.—(C.60381 IV.)

1361. Melbourne, 467-469 Spencer-street, reimbursement for partitioning costs in leased premises for the Department of Mines, \$20,475.00.—Samuel Lees.—(C.144202.)

1362. Melbourne, New State Public Offices, supply of furniture, \$13,300.00.—V. Jomantos, \$15,515.80.—Better Built Office Equipment Pty. Ltd., and \$5,697.00.—Cematile Industries Pty. Ltd.—(C.60381 IV.)

1363. North Melbourne, Government Printing Office, repairs to air washer units, \$4,170.00.—Crockford and Robertson Pty. Ltd.—(C.163196.)

1364. Stawell, Primary School No. 502, gas heating to school, \$7,151.70.—Thermal Traders (Vic.) Pty. Ltd.—(W.159243.)

Approved by the Governor in Council, 5th May, 1970.—  
J. ROSSITER, Clerk of the Executive Council.

STATE ELECTRICITY COMMISSION OF VICTORIA.

1365. For the supply of 22,000-volt surge diverters for protection of the distribution system for a period of two years with optional extension of three months, to Specification No. 69/306, at Schedule rates.—A.S.E.A. Electric (Aust.) Pty. Ltd.

1366. For the supply of neutral screened cable for a period of one year with optional extension of three months, to Specification No. 69/309, at Schedule rates.—Cable-makers (A.C.T.) Pty. Ltd.

1367. For the supply of neutral screened cable for a period of one year with optional extension of three months, to Specification No. 69/309, at Schedule Rates.—Lawrence and Hanson Pty. Ltd.

Approved by the Governor in Council, 2nd April, 1970.—  
J. ROSSITER, Clerk of the Executive Council.

1368. For the provision of cleaning services in office premises at Lyle House, 22 William-street, Melbourne, for a period of three years, to Specification No. 70/42, \$101,340.—Utility Cleaning Co. (Vic.) Pty. Ltd.

1369. For the provision of cleaning services in office premises at Monash House, 15 William-street, Melbourne, for a period of three years, to Specification No. 70/43, \$325,800.—Utility Cleaning Co. (Vic.) Pty. Ltd.

Approved by the Governor in Council, 14th April, 1970.—  
J. ROSSITER, Clerk of the Executive Council.

1370. For the supply of paper towel and toilet rolls for a period of two years with optional extension of three months, to Specification No. 70/33, at Schedule rates.—Bowater-Scott Australia Limited.

1371. For the supply and installation of electric overhead travelling cranes and hoist at Yallourn "W" Power Station, to Specification No. 69/196, \$126,384.—Stoother and Pitt (Aust.) Pty. Ltd.

Approved by the Governor in Council, 22nd April, 1970.—J. ROSSITER, Clerk of the Executive Council.

1372. For the supply and delivery of insulating oil for a period of five years with optional extension of three months, to Specification No. 70/10, at Schedule rates.—The Shell Company of Australia Ltd.

Approved by the Governor in Council, 28th April, 1970.—J. ROSSITER, Clerk of the Executive Council.

## DEPARTMENT OF MINES.

## APPLICATION FOR EXPLORATION LICENCE REFUSED.

119, Exploration Licence; Gippsland Minerals No Liability; 800 square miles, Counties of Benambra, Bogong, Dargo, Tambo.

## APPLICATION FOR EXPLORATION LICENCE DECLARED ABANDONED.

224, Exploration Licence; Trevaskis/Rudov Syndicate; 500 square miles, Counties of Borung, Dundas, Ripon.

## EXTRACTIVE INDUSTRY LICENCES GRANTED.

- 182, Extractive Industry Licence; Peninsula Pottery Industries Proprietary Limited; 60a. 1r. 30 4/10p., Parish of Moorooduc.  
 300, Extractive Industry Licence; Rowlands Quarries (Clayton) Proprietary Limited; 81a. 1r. 18p., Parish of Mordialloc.  
 336, Extractive Industry Licence; Malcolm John Erskine, Dorothy Erskine, Malcolm John Thomas Erskine, Alice Erskine; 23 acres, Parish of Currawa.  
 391, Extractive Industry Licence; Rowlands Quarries Proprietary Limited; 11a. 3r. 15p., Parish of Mordialloc.

## TERM OF EXPLORATION LICENCE EXTENDED.

83, Exploration Licence; George Milton; 194 square miles, County of Tambo.

## MINING LEASES GRANTED.

- 8440, Beechworth; Walter Lewis Griffiths; 97a. 3r., Parish of Chiltern.  
 9263, Castlemaine; William Baden Powell Henry; 62a. 1r. 1p., Parish of Maldon.  
 8878, Mineral; Theodor Gerhard Bothe, Wilhelm Clements Bothe; 15 acres, Parish of Katyl.

## APPLICATIONS FOR MINING LEASES DECLARED ABANDONED.

- 8551, Mineral; Roland Walton; 540 acres, Parish of Tongaro.  
 8553, Mineral; Roland Walton; 560 acres, Parish of Wollonaby.  
 8865, Mineral; Arthur Holman Tilley, Leslie Cochrane; 110 acres, Parish of Carngham.

## APPLICATIONS FOR MINERAL SEARCH LICENCES REFUSED.

- 901, Mineral Search Licence; Noranda Australia Limited; 10 square miles, Parish of Harrierville.  
 902, Mineral Search Licence; Noranda Australia Limited; 10 square miles, Parish of Harrierville.  
 907, Mineral Search Licence; Noranda Australia Limited; 10 square miles, Parish of Harrierville.  
 908, Mineral Search Licence; Noranda Australia Limited; 10 square miles, Parish of Harrierville.

## APPLICATIONS FOR MINERAL SEARCH LICENCES DECLARED ABANDONED.

- 903-906, 909-959 (inclusive); Noranda Australia Limited; 540 square miles, Counties of Bogong, Delatite.

J. C. M. BALFOUR,  
Minister of Mines.

## Melbourne and Metropolitan

## BOARD OF WORKS.

## GENERAL NOTICE.

THE Melbourne and Metropolitan Board of Works having made provision for carrying off the sewage of each and every property which or any part of which is situate in the Sewerage Areas hereinafter described doth hereby declare that on and after the 13th day of June, 1970, each and every property so situate shall be deemed to be a seweraged property within the meaning of the Melbourne and Metropolitan Board of Works Act 1958.

The Sewerage Areas hereinbefore referred to are:—

## Sewerage Area No. 2333.

*Shire of Diamond Valley.*—Commencing at the junction of Watsonia-road and Morwell-avenue; thence north-westerly along Morwell-avenue, westerly along Greenwood-drive, northerly along Kenmare-street, north-westerly and westerly along Morwell-avenue, northerly along the western boundaries of lots 315 to 322 Ladd-street, easterly along Bungay-street, northerly along the western boundaries of lots 1 Bungay-street, 3 to 8 Loyola-court and 28 and 29 McKellar-street, easterly along the northern boundary of the said lot 29, northerly along McKellar-street, easterly along Grimshaw-street, northerly along Macorna-street, easterly along the northern boundaries of lots 25 Macorna-street and 68 Middleton-street, north-easterly and northerly along Middleton-street, easterly along the northern boundary of lot 1 Middleton-street, northerly along portion of the western boundary of lot 13 Kurrajong-crescent, north-easterly along the north-western boundary of the said lot 13, easterly along Kurrajong-crescent, northerly along Sellars-street, easterly and north-easterly along the centre line of Boyd-street, further north-easterly by a line to a point on the north-eastern boundary of lot 15 Kempston-street 340 feet north-west of its eastern angle, south-easterly along the said north-eastern boundary to the boundary of lot 2 William-street, generally northerly and generally south-easterly along the boundaries of the said lot 2, northerly along William-street, easterly along Yando-street to the boundary of Sewerage Area No. 2141, southerly, westerly, generally southerly and south-westerly following the said area boundary and the boundary of Sewerage Area No. 2171, to the south-eastern angle of lot 113 Nell-street, westerly along Nell-street, southerly along Longmuir-road, westerly along Thompson-street, north-easterly along Greensborough-road, westerly along the production of the centre line of Knight-street, north-easterly along the Eltham Railway Line, north-westerly along portion of the south-western boundary of lot 9 Kempston-street, south-westerly along the south-eastern boundaries of lots 5, 1, 2 and an adjoining lot 2 Kempston-street, westerly along the southern boundary of the said adjoining lot 2, northerly along Sellars-street, westerly along Trist-street, southerly and westerly along the eastern and southern boundaries of lot 18 Frye-street, south-westerly along Frye-street, westerly along Grimshaw-street, south-easterly along the north-eastern boundary of lot 196 Peters-street, southerly by a line to the north-western angle of lot 254 Knight-street, easterly along the northern boundaries of lots 254 to 258 Knight-street, southerly along the eastern boundary of the said lot 258, easterly along Knight-street, south-westerly along Greenaway-street, easterly along Nell-street to the Eltham Railway Line, south-westerly along the said railway line to Watsonia-road, northerly along Watsonia-road to the commencing point.

## Sewerage Area No. 2334.

*City of Nunawading.*—Commencing at the junction of Eley-road and the western part of Bonview-crescent; thence southerly and south-easterly along Bonview-crescent, south-westerly and north-westerly along the south-eastern and south-western boundaries of lot 8 Bonview-crescent, southerly along portion of the eastern boundary of lot 13 Sartori-street, westerly along Sartori-street, northerly and easterly along the western and portion of the northern boundaries of lot 11 Sartori-street, north-westerly along the south-western boundaries of lots 13 to 11 Streeton-court and 6 Eley-road, northerly by a line to the south-western angle of lot 17 Sylvia-street, easterly along the southern boundary of the said lot 17, northerly along Sylvia-street, easterly along the northern boundaries of lots 19 Sylvia-street and 16 and 41 Samuel-road, southerly along the eastern boundary of the said lot 41, easterly along the northern boundary of lot 32 Holroyd-street, further easterly along Holroyd-street, southerly along Bermuda-drive, easterly along Grange-road and the northern boundaries of lots 13 Holland-road and 26 Rishon-avenue, northerly along Rishon-avenue, easterly along the northern boundaries of lots 60 Rishon-avenue and 75 Shaun-avenue, southerly along Shaun-avenue, easterly along the northern boundary of lot 87 Shaun-avenue, northerly along portion of the western boundary of lot 122 Blackburn-road, easterly along the northern boundary of the said lot 122, southerly



along Blackburn-road to the boundary of Sewerage Area No. 1746, generally westerly and northerly following the said area boundary to Eley-road, westerly along Eley-road to the commencing point.

*Sewerage Area No. 2335.*

*City of Nunawading.*—Commencing at the junction of Burwood Highway and Tainton-road; thence northerly along Tainton-road, easterly along portion of the northern boundary of lot 24 Burwood Highway, northerly along the western boundary of lot 39 Ruby-street, easterly along Ruby-street, northerly along the western boundaries of lots 40 to 50 Hutchinson-street to the boundary of Sewerage Area No. 1746, generally easterly and northerly following the said area boundary to the north-western angle of lot 15 Pickford-street, easterly, south-easterly and easterly along Pickford-street, southerly along Mahoneys-road, westerly along the southern boundaries of lots 1 and 25 to 16 Pickford-street, southerly along the western boundaries of lots 2 Mahoneys-road and 1 Burwood Highway, westerly along Burwood Highway to the commencing point.

*Sewerage Area No. 2336.*

*City of Doncaster and Templestowe.*—Commencing at the junction of Hazel-drive and Manningham-road; thence westerly along Manningham-road northerly along the western boundary of lot 1 Manningham-road to the south-western boundary of lot 85 Feathertop-avenue, north-westerly along the south-western boundaries of lots 85 to 80 Feathertop-avenue and 3 Thompsons-road, north-easterly along Thompsons-road, south-easterly and easterly along Feathertop-avenue, southerly along the eastern boundary of lot 150 Feathertop-avenue, easterly along the northern boundaries of lots 148 to 140 Rooney-street, southerly along the eastern boundary of the said lot 140, easterly along Rooney-street, southerly along Macedon-road, easterly along the northern boundaries of lots 46 Macedon-road and 1 John-street, south-easterly along the north-eastern boundary of the said lot 1, southerly along Rosa-street, easterly along McGahy-street, south-westerly along High-street, westerly along Manningham-road to the commencing point.

*Sewerage Area No. 2337.*

*City of Nunawading.*—Commencing at the junction of Brunswick-road and Talbot-street on the boundary of Sewerage Area No. 2145; thence northerly, easterly and generally south-westerly following the boundaries of Sewerage Areas Nos. 2145 and 2229 to the south-eastern angle of lot 3 Purches-street westerly along the southern boundaries of the said lot 3 and lot 283 Fuller-street, north-westerly along the south-western boundary of the said lot 283, south-westerly along Fuller-street, north-westerly along the south-western boundary of lot 5 Fuller-street and a line to the south-eastern angle of lot 257 Somers-street, further north-westerly along the south-western boundaries of lots 257 to 260 Somers-street, northerly along the western boundary of the said lot 260, westerly and north-westerly along Somers-street, northerly along the western boundary of lot 46 Dudley-street, westerly and northerly along the southern and western boundaries of lot 14 Avon-avenue to the boundary of Sewerage Area No. 2188, generally northerly, generally easterly and generally northerly following the boundaries of Sewerage Areas Nos. 2118 and 2145 to the commencing point.

*Sewerage Area No. 2338.*

*City of Nunawading.*—Commencing at the junction of Fuller-street and Cochrane-street on the boundary of Sewerage Area No. 2069; thence northerly, generally easterly and south-easterly following the said area boundary to the eastern angle of lot 280 Fuller-street, westerly along the southern boundaries of the said lot 280 and lot 279 Fuller-street, north-westerly along the south-western boundaries of lots 278 and 277 Fuller-street, westerly along the southern boundary of lot 2 Munro-street, southerly along Munro-street, westerly along Orient-avenue, northerly along Cochrane-street to the commencing point.

By order of the Board,

H. J. SNADDEN,  
Acting Secretary.

425 Collins-street, Melbourne, 3001, 12th May, 1970.

**HOSPITALS AND CHARITIES ACT No. 6274 (1958).**

IT is hereby notified for general information that the Hospitals and Charities Commission has, under the provisions of section 50. of the above-mentioned Act, approved of the corporate name of Melbourne City Mission Incorporated, being changed to—

“COMMUNITY WELFARE FOUNDATION”.

Dated at Melbourne, this 4th day of May, 1970.

JOHN LINDELL,  
Chairman.

*Stamps Act 1958.*

**ANNUAL LICENCE.**

NOTIFICATION PURSUANT TO SECTION 97.

I HEREBY notify that stamp duty has been paid for a licence under section 96 of the Stamps Act to carry on assurance insurance business in Victoria, from 1st May, 1970, to 31st December, 1970, by the following:—

THE OXFORD INSURANCE COMPANY PTY. LTD.

R. M. PHIBBS,  
Comptroller of Stamps.

Chief Office for Stamp Duties,  
Melbourne, 6th May, 1970.

Survey Co-ordination (Place Names) Act No. 7360.

**NOTICE OF APPROVAL.**

PURSUANT to the powers conferred under section 32 of the above Act, the Place Names Committee hereby gives notice of its approval of the name of the under-mentioned automatic telephone exchange—

Municipality—Shire of Yackandandah.

Name Approved.—Bruarong.

By order of the Committee,

C. E. E. BARLOW,  
Secretary.

**APPOINTMENTS**

**APPOINTMENTS.**

THE Licutenant-Governor as Deputy for His Excellency the Governor of the State of Victoria, by and with the advice of the Executive Council thereof, has, by Orders made on the 5th day of May, 1970, been pleased to make the under-mentioned appointments, viz.:—

CHIEF SECRETARY'S DEPARTMENT.

Member of the Country Fire Authority.

PATRICK EDWARD SHELLY, J.P., pursuant to the provisions of section 7 (e) of the Country Fire Authority Act 1958, to be a member of the Country Fire Authority, for the period ending 30th June, 1971, vice J. S. Hore, M.B.E., J.P., deceased.

*Postal Voting Officers.*

WILLIAM FRANCIS GINNIVAN, Australian Embassy, Manila,  
HOWARD CRAIG BROWN, Australian Embassy, Tokyo,  
JENNIFER LINDEN KEYS, Australian Embassy, The Hague,  
WILLIAM MONAGHAN, Australian Embassy, Rome, and  
Dr. JAN WILLEM FLORIS ARRIENS, Australian High Commission, Kuala Lumpur,  
to be Postal Voting Officers for the conjoint Parliamentary Election, to be held on the 30th May, 1970, pursuant to section 147A of *The Constitution Act Amendment Act 1958.*

*Governors of Prisons (Acting).*

WILLIAM GEORGE SMITHERAM, pursuant to the provisions of the *Gaols Act 1958*, to be Governor (Acting) of Her Majesty's Training Prison, Beechworth, from the 28th April, 1970, to the 18th May, 1970, vice James Henry Fellows, on leave; and  
JOHN EDDY DIHM, pursuant to the provisions of the *Gaols Act 1958*, to be Governor (Acting) of McLeod Prison Farm, from the 10th April, 1970, vice Governor Roy Seamer Vodden, transferred.

*Honorary Probation Officers.*

WESLEY JOHN BLYGH (the Reverend), 17 Tyers-street, Portland,  
KENNETH DOUGLAS GARLAND, 15 Ewart-street, Malvern;  
BRIAN THOMAS GEARY, Kennewell-street, White Hills,  
ROSINA HAMILTON (Mrs.), Lockwood-road, Marong,  
ROY KENNETH LAWN, Presbyterian Boys' Hostel, 50 Power-street, Hawthorn,  
GRAHAM PHILLIP MORRIS, care of Signs Publishing Co., Warburton,

GERALD LEO MOYLAN (the Reverend), Presbytery, Box 144, Wodonga;  
 ALFRED KEITH RAWLINGS (Brigadier), The Salvation Army, 870 Drummond-street, North Carlton,  
 KEITH ERNEST REYNOLDS (Captain), 6 Hampton-street, Moe,  
 GEORGE F. DOUGLAS SMITH (the Reverend), St. Augustines, Maude-street, Shepparton,  
 RAYMOND WALTER STARLING (the Reverend), 13 Church-street, Wodonga,  
 JOHN FRANKLIN WATSON (the Reverend), 40 Pickering-street, Ouyen, and  
 THOMAS ARTHUR WATKIN, 40 Cumming-street, Burwood,

pursuant to the provisions of section 507 (2) of the *Crimes Act 1958*, to be Honorary Probation Officers for all Adult Courts in Victoria.

CROWN LANDS AND SURVEY DEPARTMENT.  
*Bailiff of Crown Lands.*

JAMES PATRICK BURKE-KENNEDY (Camp Park Attendant),  
 to be a Bailiff of Crown lands, in respect to the Reserve known as the "Livingstone Creek Reserve" in the Township of Omeo, in pursuance of the provisions of section 30 of the *Land Act 1958*.

MINISTRY OF HEALTH.

*Government Appointee on Committee of Management of Hospital.*

THOMAS MICHIE  
 to be the Government appointee on the Committee of Management of the Dimboola District Hospital for a further term of three years from 30th May, 1970, pursuant to section 48 (1) (a) (ii) of the *Hospitals and Charities Act 1958*; and  
 HUBERT JOHN PRISTON ELMS  
 to be the Government appointee on the Committee of Management of the Waranga Memorial Hospital for a further term of three years from 30th May, 1970, pursuant to section 48 (1) (a) (ii) of the *Hospitals and Charities Act 1958*.

*Public Vaccinators.*

BRIAN HOUSTAN OLIVER, M.B., B.S.,  
 to be Public Vaccinator for the Municipality of Essendon;  
 ARNOLD REVEL SILCOCK, M.R.C.S.,  
 to be Public Vaccinator for the Municipality of Footscray;  
 HERBERT J. REDMOND, M.B., B. Ch.  
 to be Public Vaccinator for the Municipality of Moorabbin;  
 CARSON ASHWORTH MOORE, M.B., B.S.,  
 to be Public Vaccinator for the Municipality of Moorabbin;  
 and  
 DAVID JAMES MURRAY BARTRAM, M.B., B.S.,  
 to be Public Vaccinator for the Municipality of Moorabbin, pursuant to section 151 of the *Health Act 1958*.

*Trustees of Public Cemeteries.*

HENRY JOHN OXLEY  
 to be a Trustee of the Donald Public Cemetery, vice F. Oakley, deceased;  
 RONALD RINGIN  
 to be a Trustee of the Carngham Public Cemetery, vice J. McKay, resigned; and  
 PETER JOHN LIDGETT,  
 PATRICK FRANCIS SHANAHAN, and  
 BRIAN JAMES SHANAHAN,  
 to be Trustees of the Greendale Public Cemetery, vice K. Andrew and H. Lidgett, resigned and F. D'Arcy, deceased.

LAW DEPARTMENT.

*Commissioners for Taking Declarations, &c.*

SIDNEY JOHN GRAF, Eramosa-road, Somerville,  
 KERRY PHILLIP GRILLS, 28 Ballantyne-crescent, Mooroolbark,  
 NORMAN FELIX KNUPPEL, 16 Palermo-street, Mentone,  
 MAURICE EUGENE WALLACE, 61 Belmont-avenue, Upwey,  
 WILLIAM EDWARD BROWNLEE, 13 Rodier-street, Ballarat,  
 JOSEPH JOHN BRIFFA, 68 Bernard-street, Cheltenham, and  
 GORDON HUGH ORTMANN, Flat 2, 12 Riversdale-road, Hawthorn,  
 to be Commissioners for taking Declarations and Affidavits, pursuant to the provisions of the *Evidence Act 1958*, to resign upon removing from the neighbourhood of the addresses stated;

DAVID LANCELOT MANUEL, care of Sunday Observer, 822 Lorimer-street, Fisherman's Bend,  
 THOMAS CHARLES MARTIN, care of the State Savings Bank of Victoria, 30 Burwood-road, Burwood East,  
 GORDON FARRER, care of S.E.C. Social League Credit Co-operative Limited, 238 Flinders-street, Melbourne, and  
 KERST HAAGSMA, care of International Insurance Brokers Pty. Limited, 48 High-street, St. Kilda,  
 to be Commissioners for taking Declarations and Affidavits, pursuant to the provisions of the *Evidence Act 1958*, to resign upon ceasing to occupy their present positions.

*Justices of the Peace.*

WALLACE ROBERT BRYANT, care of the Salvation Army, 69 Bourke-street, Melbourne, and  
 COLIN JAMES BOCK, Civic Centre, Camberwell,  
 to keep the Peace in the State of Victoria.

*Clerk of the Magistrates' Court.*

BARRY JOHN MAHER  
 to be Clerk of the Magistrates' Court and Clerk of the Children's Court at Ouyen, Woomelang, Murrayville and Sea Lake and Assistant Registrar at Ouyen for the County Court at Mildura, in the place of A. R. Dunlop, transferred, to take effect from the date of commencement of duty.

DEPARTMENT OF WATER SUPPLY.

*Waterworks Trust Commissioner.*

HORACE VICTOR DAVIS  
 to be a Commissioner of the Buninyong Waterworks Trust to hold such position for a period of four years from the date hereof, subject to the provisions of the *Water Act*.

J. ROSSITER,  
 Clerk of the Executive Council.

At the Executive Council Chamber,  
 Melbourne, 5th May, 1970.

**ORDERS IN COUNCIL**

LABOUR AND INDUSTRY ACT 1958.

At the Executive Council Chamber, Melbourne, the fifth day of May, 1970.

PRESENT:

The Lieutenant-Governor as Deputy for His Excellency the Governor of Victoria.

Mr. Thompson | Mr. Reid.  
 Mr. Meagher |

GENERAL BOARD—ORDER SPECIFYING AN ADDITIONAL TRADE.

WHEREAS, in accordance with the provisions of the *Labour and Industry Act 1958*, the Minister has recommended that the trade named hereunder in respect of which no Determination of any Wages Board is operative, be specified as a trade for the purposes of the said Act:

Now, therefore, the Lieutenant-Governor as Deputy for His Excellency the Governor of the State of Victoria, by and with the advice of the Executive Council thereof, doth hereby specify the trade of poster-hanging to be a trade for the purposes of section 21 of the *Labour and Industry Act 1958*.

And the Honorable John Frederick Rossiter, Her Majesty's Minister of Labour and Industry for the State of Victoria, shall give the necessary directions herein accordingly.

J. ROSSITER,  
 Clerk of the Executive Council.

COUNTRY ROADS BOARD.

At the Executive Council Chamber, Melbourne, the fifth day of May, 1970.

PRESENT:

The Lieutenant-Governor as Deputy for the Governor of Victoria.

Mr. Thompson | Mr. Reid.  
Mr. Meagher |

ORDER APPROVING OF LAND BEING ACQUIRED AND ROADS, DEVIATIONS OR WIDENINGS BEING MADE.

THE Lieutenant-Governor as Deputy for the Governor of the State of Victoria, by and with the advice of the Executive Council thereof, being satisfied that there are funds legally available for acquiring the land, do hereby approve the acquiring of the land described in the schedule hereunder and the making of new roads and deviations from and widenings of existing roads referred to in the said schedule.

SCHEDULE.  
State Highway.

The land shown hatched on Plan numbered G.P.12181 hereunder required for the widening of the Calder Highway in the Shire of Mildura and making of the widening thereon.

STATE HIGHWAY  
CALDER HIGHWAY  
SHIRE OF MILDURA  
*Measurements in links*

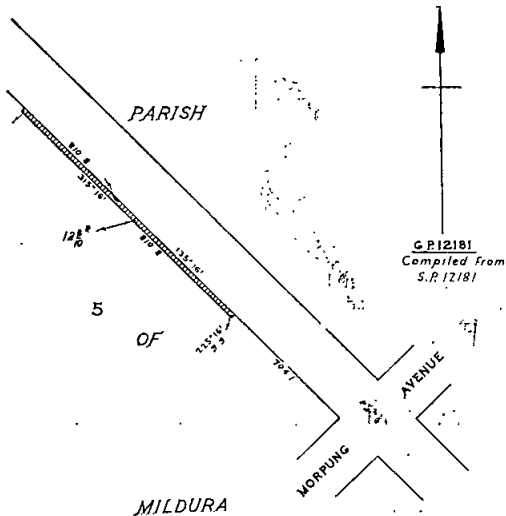

Main Roads.

The land shown hatched on Plan numbered G.P.12042 hereunder required for the widening of the Warncoort-Birregurra road in the Shire of Colac and making of the widening thereon.

MAIN ROAD  
WARNCOORT - BIRREGURRA ROAD  
SHIRE OF COLAC  
*Measurements in links*

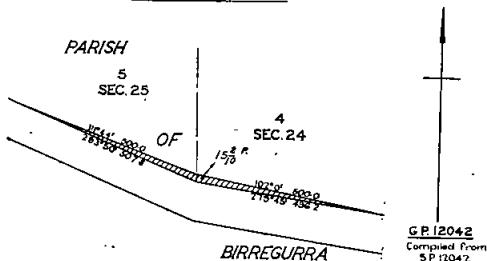

The land shown hatched on Plan numbered G.P.12098 hereunder required for the deviation from the Yarram-Traralgon road in the Shire of Alberton and making of the deviation thereon.

MAIN ROAD  
YARRAM - TRARALGON ROAD  
SHIRE OF ALBERTON  
*Measurements in links.*

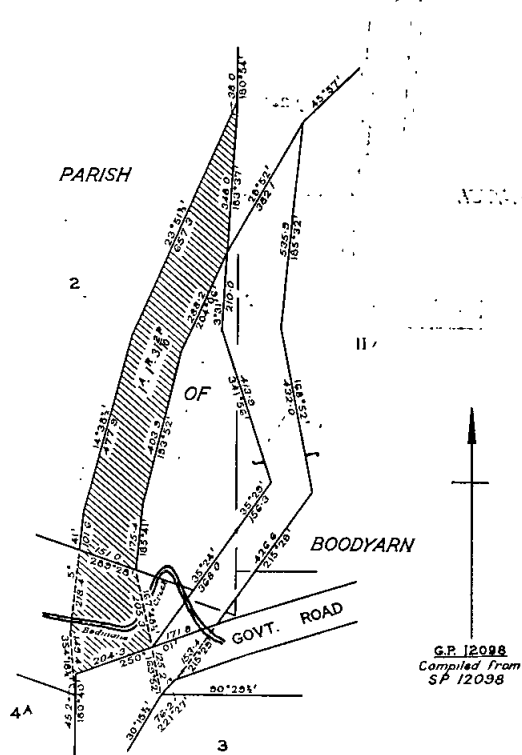

The land shown hatched on Plan numbered G.P.12097 hereunder required for the widening of the Yarram-Port Albert road in the Shire of Alberton and making of the widening thereon.

MAIN ROAD  
YARRAM - PORT ALBERT ROAD  
SHIRE OF ALBERTON  
*Measurements in links*

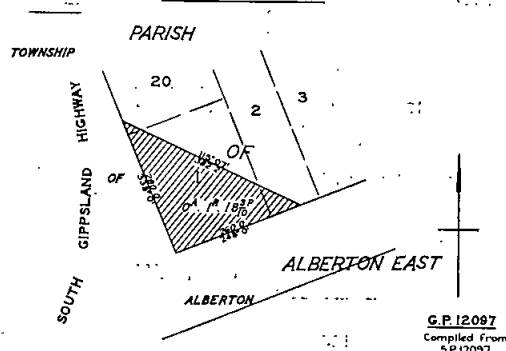

The land shown hatched on Plans numbered G.P.12111 and G.P.12112 hereunder required for the widening of the Colac-Ballarart road in the Shire of Leigh and making of the widening thereon.

The land shown hatched on Plan numbered G.P.12089 hereunder required for the deviation from the Wangaratta-Kilfeera road in the City of Wangaratta and making of the deviation thereon.

MAIN ROAD  
COLAC-BALLARAT ROAD

SHIRE OF LEIGH  
Measurements in links

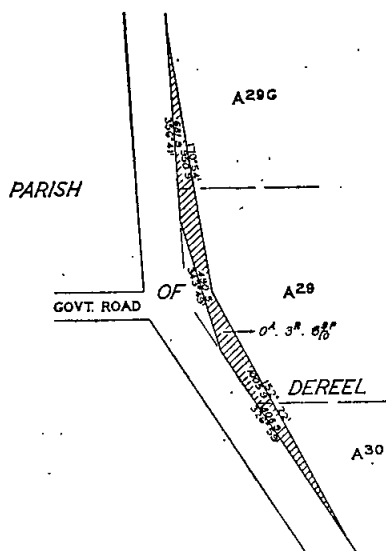

G.P.12111  
Compiled from  
S.P.12111

MAIN ROAD  
WANGARATTA-KILFEERA ROAD

CITY OF WANGARATTA  
Measurements in feet & inches

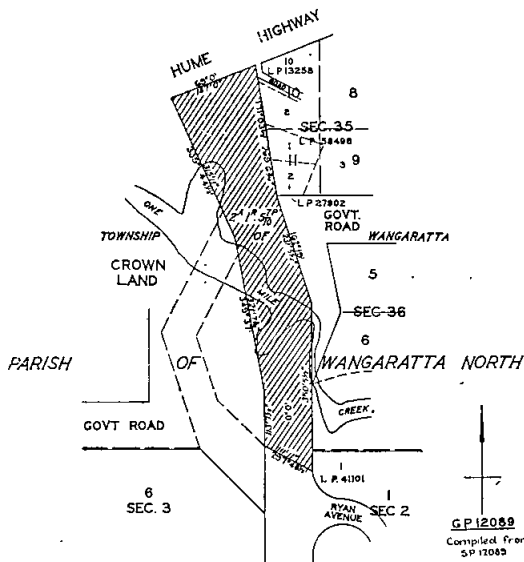

G.P.12089  
Compiled from  
S.P.12089

The land shown hatched on Plan numbered G.P.12122 hereunder required for the widening of the Yackandandah-Wodonga road in the Shire of Yackandandah and making of the widening thereon.

MAIN ROAD  
COLAC-BALLARAT ROAD

SHIRE OF LEIGH  
Measurements in links

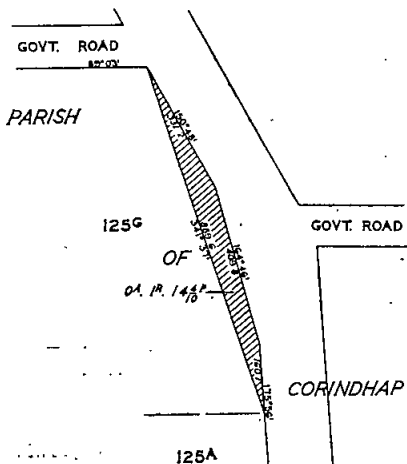

G.P.12112  
Compiled from  
S.P.12112

MAIN ROAD  
YACKANDANDAH - WODONGA ROAD

SHIRE OF YACKANDANDAH  
Measurements in links

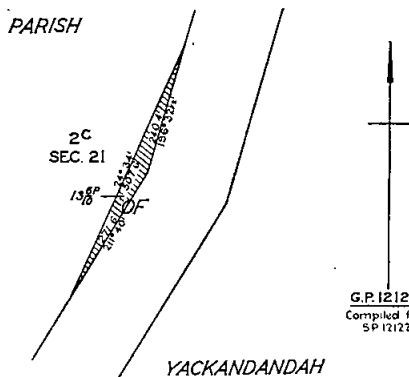

G.P.12122  
Compiled from  
S.P.12122

And the Honorable Rupert James Hamer, Her Majesty's Minister of Public Works for the State of Victoria, shall give the necessary directions herein accordingly.

J. ROSSITER,  
Clerk of the Executive Council.

## COUNTRY ROADS BOARD.

At the Executive Council Chamber, Melbourne, the  
fifth day of May, 1970.

PRESENT:

The Lieutenant-Governor as Deputy for the Governor  
of Victoria.

Mr. Thompson | Mr. Reid.  
Mr. Meagher

ORDER CONFIRMING RESOLUTIONS OF THE COUNTRY  
ROADS BOARD.

THE Lieutenant-Governor as Deputy for the Governor  
of the State of Victoria, by and with the advice of  
the Executive Council thereof, doth hereby, in pursuance  
of the provisions of the *Country Roads Act 1958*, confirm  
the Resolutions of the Country Roads Board, the dates  
whereof and the terms of which are scheduled here-  
under:—

## SCHEDULE.

## Main Road.

Resolution dated the Twenty-seventh day of April, One  
thousand nine hundred and seventy, made pursuant to  
section 18 of the *Country Roads Act 1958*, changing the  
names of various roads declared as main roads, and  
widening thereof and deviations therefrom, in the City  
of Swan Hill and Shires of Swan Hill and Wycheproof as  
described in the Schedule hereunder.

## SCHEDULE.

A.	B.	C.	D.
Municipality.	Present Name.	Declared in <i>Government Gazette</i> dated—	New Name.
Swan Hill City ..	Ultima ..	24. 3. 15 Page 1101	Sea Lake- Swan Hill
Swan Hill Shire	Ultima-Sea Lake	24. 3. 15 Page 1101	Sea Lake- Swan Hill
Wycheproof Shire	Sea Lake-Ultima	23. 12. 14 Page 5855 29. 6. 21 Page 2527	Sea Lake- Swan Hill

And the Honorable Rupert James Hamer, Her Majesty's  
Minister of Public Works for the State of Victoria, shall  
give the necessary directions herein accordingly.

J. ROSSITER,  
Clerk of the Executive Council.

## STATE ELECTRICITY COMMISSION ACT 1958, No. 6377.

At the Executive Council Chamber, Melbourne, the  
fifth day of May, 1970.

PRESENT:

The Lieutenant-Governor as Deputy for His Excellency  
the Governor of Victoria.

Mr. Thompson | Mr. Reid.  
Mr. Meagher

REAPPOINTMENT OF COMMISSIONER OF THE STATE  
ELECTRICITY COMMISSION OF VICTORIA.

PURSUANT to the provisions of the *State Electricity  
Commission Act 1958* (No. 6377), the Lieutenant-  
Governor as Deputy for His Excellency the Governor of  
the State of Victoria, acting by and with the advice of  
the Executive Council thereof, doth by this Order  
reappoint—

THOMAS PEAT SCOTT, F.A.I.I.  
to be a Commissioner of the State Electricity Commission  
of Victoria for a period of five (5) years from and inclusive  
of the 12th day of May, 1970.

And the Honorable James Charles Murray Balfour, Her  
Majesty's Minister for Fuel and Power for the State of  
Victoria, shall give the necessary directions herein  
accordingly.

J. ROSSITER,  
Clerk of the Executive Council.

BOARD OF INQUIRY INTO THE CONDUCT OF  
MR. J. MEDENIEKS, AT JANEFIELD TRAINING  
CENTRE.

At the Executive Council Chamber, Melbourne, the  
fifth day of May, 1970.

PRESENT:

The Lieutenant-Governor as Deputy for His Excellency  
the Governor of Victoria.

Mr. Thompson | Mr. Reid.  
Mr. Meagher

THE Lieutenant-Governor as Deputy for His Excellency  
the Governor of the State of Victoria, in the Com-  
monwealth of Australia, by and with the advice of the  
Executive Council of the said State, and in pursuance of  
the powers conferred by the Public Accounts and Stores  
Regulations made under the provisions of the *Audit Act  
1958* and all other powers him thereunto enabling, doth,  
by this Order sanction a maximum expenditure of the  
sum of Five thousand nine hundred and fifty dollars  
(\$5,950) by the Board appointed to inquire into and  
report upon the conduct of Mr. J. Medenieks, at Janefield  
Training Centre.

And the Honorable Sir Arthur Gordon Rylah, Her  
Majesty's Chief Secretary for the State of Victoria, shall  
give the necessary directions herein accordingly.

J. ROSSITER,  
Clerk of the Executive Council.

## DEPARTMENT OF CROWN LANDS AND SURVEY.

At the Executive Council Chamber, Melbourne, the  
fifth day of May, 1970.

PRESENT:

The Lieutenant-Governor as Deputy for His Excellency  
the Governor of Victoria.

Mr. Thompson | Mr. Reid.  
Mr. Meagher

REVOCATION OF TEMPORARY RESERVATION OF  
LAND BY ORDER IN COUNCIL.

THE Lieutenant-Governor as Deputy for His Excellency  
the Governor of the State of Victoria, by and with  
the advice of the Executive Council thereof, doth hereby,  
in pursuance of the provisions of the *Land Act 1958*, revoke  
the temporary reservation of land by Order in Council  
hereinafter referred to, viz.:—

MOE.—Order in Council of 10th April, 1940, of 2 roods,  
more or less, of land in the Parish of Moe, as a site for  
Public purposes, so far only as regards the portion thereof  
comprised within the boundaries published in the *Govern-  
ment Gazette* of 8th April, 1970, and containing 15 perches,  
more or less.—(Rs.5029.)

WODONGA.—Order in Council of 26th January, 1874, of  
75 acres, more or less, of land in the Township of Wo-  
donga, as a site for Camping purposes, save and except  
the portion thereof comprised within the boundaries  
published in the *Government Gazette* of 8th April, 1970,  
and containing 3 acres 2 roods 30 perches.—(Rs.2122.)

YEA.—Order in Council of 24th April, 1899, of 1 acre  
3 roods 9 perches of land in the Township of Yea as a  
site for Watering purposes.—(Y.56<sup>(a)</sup>) (C.9159.)

And the Honorable Sir William John Farquhar McDonald,  
Her Majesty's Minister of Lands for the State of Victoria,  
shall give the necessary directions herein accordingly.

J. ROSSITER,  
Clerk of the Executive Council.

DEPARTMENT OF CROWN LANDS AND SURVEY.

At the Executive Council Chamber, Melbourne, the fifth day of May, 1970.

PRESENT:

The Lieutenant-Governor as Deputy for His Excellency the Governor of Victoria.

Mr. Thompson | Mr. Reid.  
Mr. Meagher

UNUSED ROADS CLOSED.

THE Lieutenant-Governor as Deputy for His Excellency the Governor of the State of Victoria, by and with the advice of the Executive Council thereof, doth hereby direct that, in pursuance of the provisions of section 349 of the Land Act 1958, the unused roads referred to hereunder be closed, viz.:

Parish of Campbelltown, County of Talbot, being the road indicated by hatching on plan hereunder.—(C.364<sup>(4)</sup>) (J.32324).

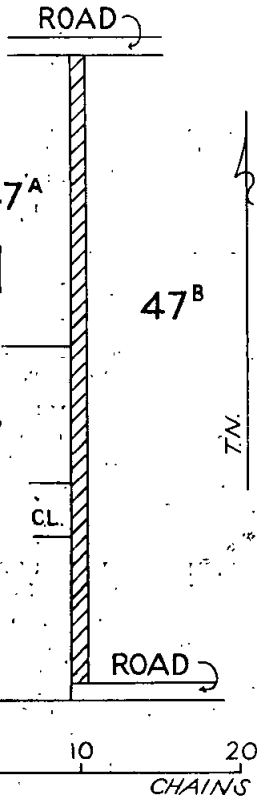

Parish of Elingamite, County of Heytesbury, being the portion of the width of the road indicated by hatching on plan hereunder.—(E.93<sup>(6)</sup>) (Misc.3831):

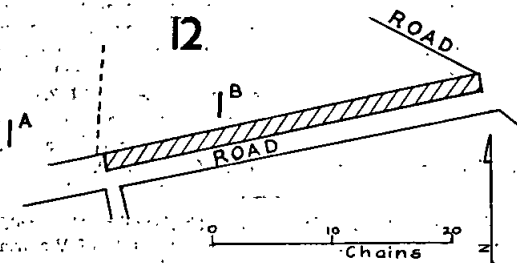

Township of Frankston, Parish of Frankston, County of Mornington, being the roads indicated by hatching on plan hereunder.—(F.86<sup>(4)</sup>) (Rs.6536).

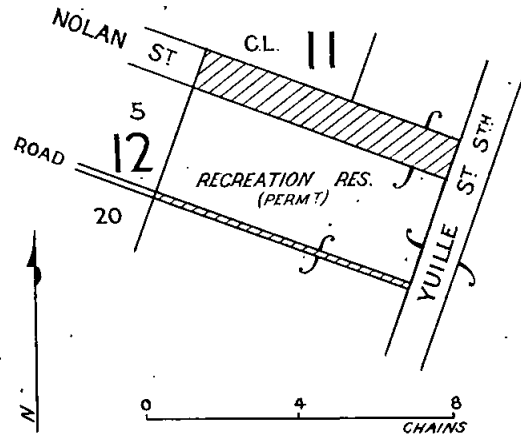

Parishes of Glenalbyn and Inglewood, County of Gladstone, being the roads indicated by hatching on plan hereunder.—(G.161<sup>(3)</sup>), (L.5<sup>(3)</sup>) (W.87988).

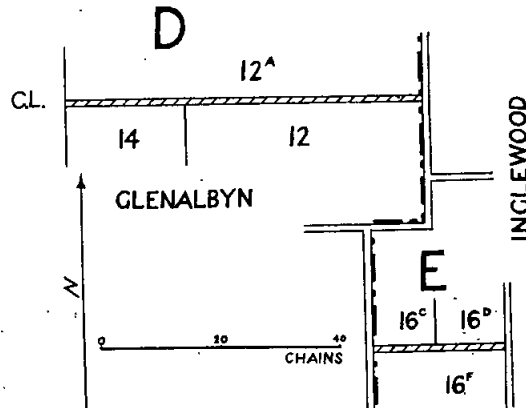

Township and Parish of Gobur, County of Anglesey, being the road indicated by hatching on plan hereunder.—(G.188<sup>(6)</sup>), G.188<sup>(7)</sup>) (H.031903).

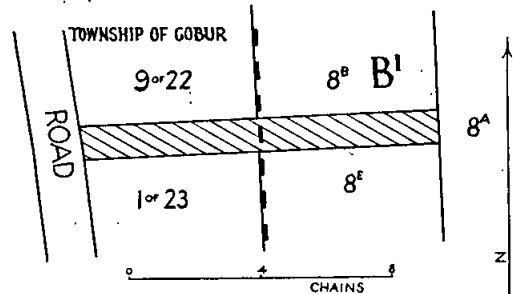

Township of Landsborough, Parish of Landsborough, County of Kara Kara, being the road indicated by hatching on plan hereunder.—(L.118<sup>(2)</sup>) (Rs.1230).

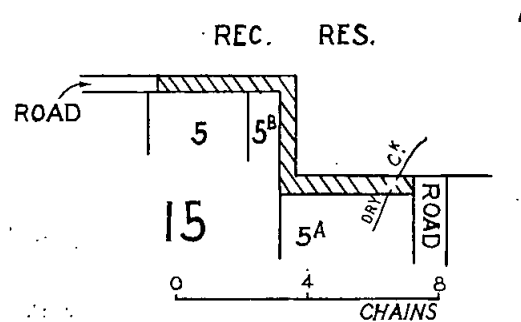

Township of Kaniva, Parish of Kaniva, County of Lowan, being the portion of the width of the road indicated by hatching on plan hereunder.—(K.147(\*) (M.61209).

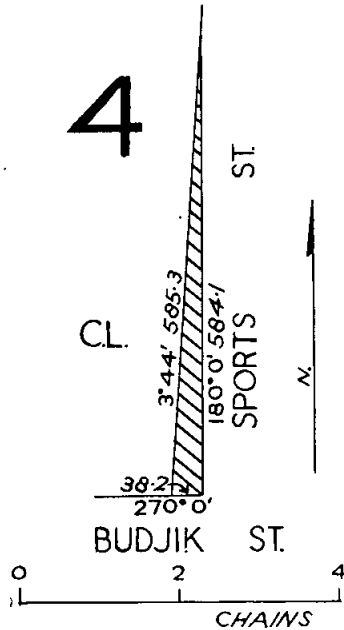

ECHUCA.—Site for Public purposes (Homes for the Aged), 1 rood 23 perches, Township of Echuca, Parish of Echuca North, County of Rodney, as indicated by hatching on plan hereunder.—(E.3(\*) (Rs.6175).

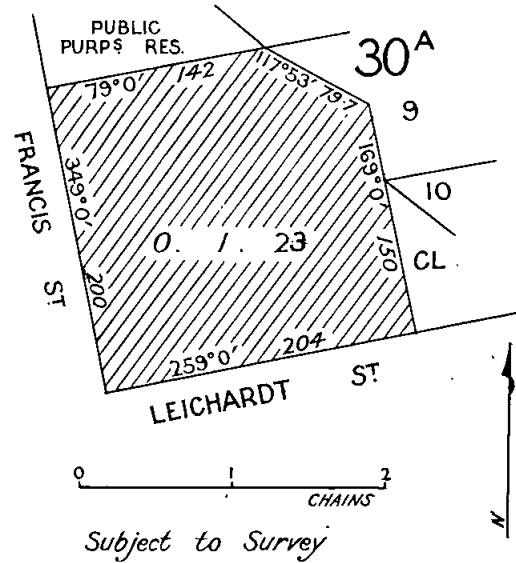

And the Honorable Sir William John Farquhar McDonald, Her Majesty's Minister of Lands for the State of Victoria, shall give the necessary directions herein accordingly.

J. ROSSITER,  
Clerk of the Executive Council.

DEPARTMENT OF CROWN LANDS AND SURVEY.

At the Executive Council Chamber, Melbourne, the fifth day of May, 1970.

PRESENT:

The Lieutenant-Governor as Deputy for His Excellency the Governor of Victoria.

Mr. Thompson | Mr. Reid.  
Mr. Meagher

LANDS TEMPORARILY RESERVED AS SITES.

THE Lieutenant-Governor as Deputy for His Excellency the Governor of the State of Victoria, by and with the advice of the Executive Council thereof, doth hereby, in pursuance of section 14 of the Land Act 1958, reserve temporarily from sale, from being leased and from having a licence granted in respect thereof, and also except from occupation for mining purposes under any miner's right, the land hereinafter described:—

JAN JUC.—Site for the Growth and Preservation of Timber, 176 acres 1 rood 14 perches, Parish of Jan Juc, County of Grant, as indicated by hatching on plan hereunder.—(J.7(\*) (Rs.9313).

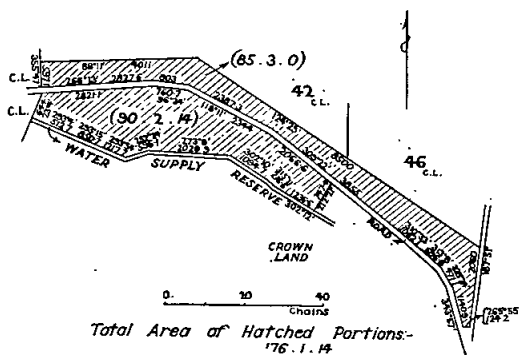

FRANKSTON.—Site for Public Recreation, 3 acres 1 rood 32 perches, Township of Frankston, Parish of Frankston, County of Mornington, as indicated by hatching on plan hereunder.—(F.86(\*) (Rs.6536).

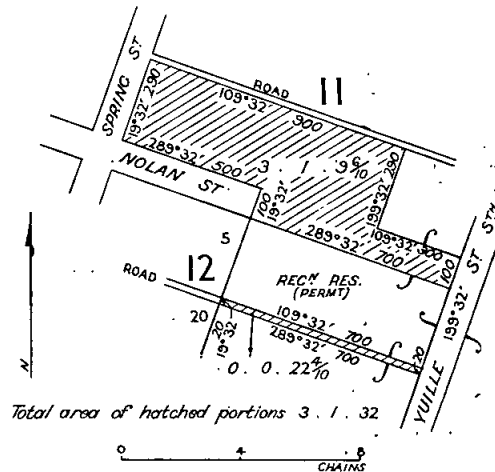

MOONDARRA.—Site for Public purposes (Forests Department purposes), 19 perches, Parish of Moondarra, County of Tanjil, as indicated by hatching on plan hereunder.—(M.508(\*) (Rs.8864).

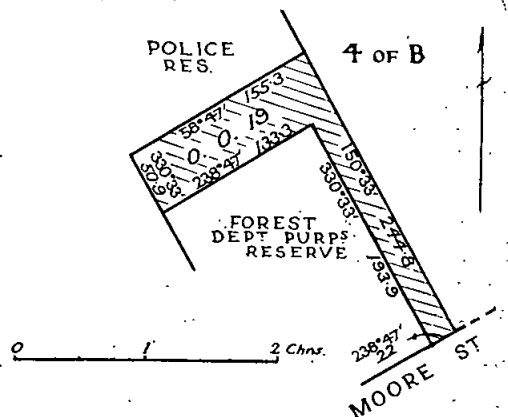

SUNBURY.—Site for a Public Park, 3 acres 3 roods, Township of Sunbury, Parish of Buttlejork, County of Bourke, as indicated by hatching on plan hereunder.—(S.351(\*) (Rs.9310).

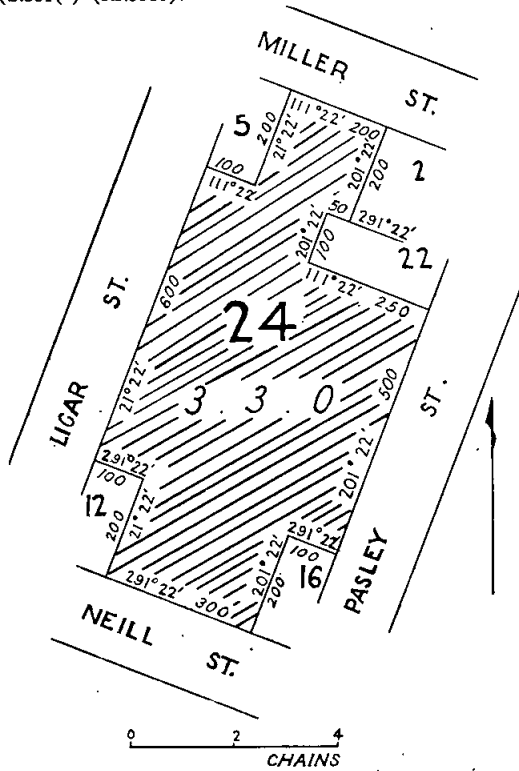

And the Honorable Sir William John Farquhar McDonald, Her Majesty's Minister of Lands for the State of Victoria, shall give the necessary directions herein accordingly.

J. ROSSITER,  
Clerk of the Executive Council.

LOCAL GOVERNMENT DEPARTMENT.

At the Executive Council Chamber, Melbourne, the fifth day of May, 1970.

PRESENT:

The Lieutenant-Governor as Deputy for His Excellency the Governor of Victoria.

Mr. Thompson | Mr. Reid.  
Mr. Meagher.

CONSENT TO THE INCLUSION OF A PROPERTY DURING THE CURRENCY OF A SEPARATE RATE, CITY OF SUNSHINE.

WHEREAS—

(a) By Order published in the *Government Gazette* on the 11th August, 1965, the Governor in Council, pursuant to the provisions of section 287 of the *Local Government Act 1958*, confirmed a separate rate made by the Council of the City of Sunshine on the 24th May, 1965, for the purposes of providing off-street parking facilities;

(b) The Council of the City of Sunshine is now of the opinion that certain property, being lot 40, Devonshire-road, Sunshine, not being property with respect to which the rate is levied would benefit from the works or undertakings carried out or to be carried out with the proceeds of the rate or with any moneys borrowed on the security of the rate; and

(c) The Council has not sooner than one month after serving written notice on the owner and occupier of the said property made and levied a rate of 10 cents in the dollar on the net annual value of that property.

Now therefore the Lieutenant-Governor as Deputy for His Excellency the Governor of the State of Victoria, by and with the advice of the Executive Council thereof and

in pursuance of the provisions of section 290 of the said Act, hereby consents to the rate so made and levied forming part of the separate rate confirmed by notice published in the *Government Gazette* as aforesaid.

And the Honorable Rupert James Hamer, Her Majesty's Minister for Local Government for the State of Victoria, shall give the necessary directions herein accordingly.

J. ROSSITER,  
Clerk of the Executive Council.

LOCAL GOVERNMENT DEPARTMENT.

At the Executive Council Chamber, Melbourne, the fifth day of May, 1970.

PRESENT:

The Lieutenant-Governor as Deputy for His Excellency the Governor of Victoria.

Mr. Thompson | Mr. Reid.  
Mr. Meagher.

CONSENT TO THE INCLUSION OF A PROPERTY DURING THE CURRENCY OF A SEPARATE RATE, CITY OF HEIDELBERG.

WHEREAS—

(a) By Order published in the *Government Gazette* on the 27th March, 1968, the Governor in Council, pursuant to the provisions of section 287 of the *Local Government Act 1958*, confirmed a separate rate made by the Council of the City of Heidelberg on the 29th May, 1967, for the purpose of providing off-street parking facilities;

(b) the Council of the City of Heidelberg is now of the opinion that certain property, being Number 191 Burgundy-street, Heidelberg, not being property with respect to which the rate is levied would benefit from the works or undertakings carried out or to be carried out with the proceeds of the rate or with any moneys borrowed on the security of the rate; and

(c) the Council has not sooner than one month after serving written notice on the owner and occupier of the said property made and levied a rate of 1.6 cents in the dollar on the unimproved capital value of that property.

Now therefore the Lieutenant-Governor as Deputy for His Excellency the Governor of the State of Victoria, by and with the advice of the Executive Council thereof and in pursuance of the provisions of section 290 of the said Act, hereby consents to the rate so made and levied forming part of the separate rate confirmed by notice published in the *Government Gazette* as aforesaid.

And the Honorable Rupert James Hamer, Her Majesty's Minister for Local Government for the State of Victoria, shall give the necessary directions herein accordingly.

J. ROSSITER,  
Clerk of the Executive Council.

LOCAL GOVERNMENT DEPARTMENT.

At the Executive Council Chamber, Melbourne, the fifth day of May, 1970.

PRESENT:

The Lieutenant-Governor as Deputy for His Excellency the Governor of Victoria.

Mr. Thompson | Mr. Reid.  
Mr. Meagher.

DETERMINATION OF A MATTER AFFECTING THE MUNICIPALITIES OF THE SHIRE OF KERANG AND THE BOROUGH OF KERANG.

WHEREAS it is provided by section 27 of the *Local Government Act 1958*, that where pursuant to section 18 of the said Act, part of a municipal district is severed therefrom, the Governor in Council, may from time to time by Order apportion settle adjust or determine any property income assets rights liabilities expenses or matters which have not been apportioned settled adjusted or determined by agreement duly made and approved by the Councils of the municipalities affected;

And whereas by an Order made on the twenty-fifth day of January, 1966, a part of the municipal district of the Shire of Kerang was severed and constituted the municipal district of the Borough of Kerang and in consequence thereof an unresolved matter requires determination.



Now therefore, the Lieutenant-Governor as Deputy for His Excellency the Governor of the State of Victoria, by and with the advice of the Executive Council thereof hereby makes the following determination—

That the amount of \$49,184 shown in the audited Statement of Accounts of the Shire of Kerang for the year ended 30th September, 1966, as owing by the Koondrook Electric Supply to the Kerang Electric Supply shall be settled and adjusted between the Shire of Kerang and the Borough of Kerang on the basis that the sum of \$41,239 became payable by the Shire of Kerang to the Borough of Kerang on the 30th September, 1969.

And the Honorable Rupert James Hamer, Her Majesty's Minister for Local Government for the State of Victoria, shall give the necessary directions herein accordingly.

J. ROSSITER,  
Clerk of the Executive Council.

Assurance Fund contribution—One cent in every five dollars or part thereof of purchase price. (This is a fund established to guarantee the validity of freehold titles.)

Transfer of interest prior to completion of payment may be allowed on payment of \$2 fee and subject to stamp duty.

If unable to attend personally, a prospective purchaser may arrange for another person to bid as his agent.

Attention is drawn to section 95, *Land Act 1958*, which provides that the purchaser shall be deemed to be the owner for the purposes of other Acts; also to an amendment to the Local Government Act providing for Government roads, in certain circumstances, to be declared "private streets", thus making the purchaser liable to contribute to the cost of street construction.

W. J. F. McDONALD,  
Minister of Lands.

Office of Crown Lands and Survey,  
Melbourne, 13th May, 1970.

**LANDS DEPARTMENT NOTICES**

**APPROACHING LAND SALES.**

SALES of Crown Lands, in fee-simple, will be held at the under-mentioned places and dates, viz.:-

	No. of Gazette
Bendigo.—Thursday, 14th May, 1970 ..	32
Charlton.—Tuesday, 2nd June, 1970 ..	43
Chiltern.—Monday, 1st June, 1970 ..	43
Dartmoor.—Wednesday, 13th May, 1970 ..	32
Donald.—Monday, 1st June, 1970 ..	43
Geelong.—Monday, 1st June, 1970 ..	39
Healesville.—Friday, 12th June, 1970 ..	43
Heathcote.—Thursday, 14th May, 1970 ..	32
Meredith.—Thursday, 11th June, 1970 ..	43
Rushworth.—Thursday, 14th May, 1970 ..	32
Wonthaggi.—Friday, 29th May, 1970 ..	39
Yarra Junction.—Friday, 12th June, 1970 ..	43

**AUCTION OF RIGHT TO LEASE CROWN LAND.**  
Queenscliff.—Monday, 1st June, 1970 .. 39

**SALE OF CROWN LAND BY AUCTION.**

The land will be offered for sale in fee-simple, and subject to the provisions of the Land Act and Regulations thereunder.

The upset price is the sum at which bidding will start, and no bid below that sum can be accepted. The highest bidder at or above that sum shall be the purchaser, subject to signature of contract and any necessary payment.

**TERMS:**

A deposit of at least 12½% of the purchase price must be paid at the sale, either in cash or by cheque.

The residue is payable in half-yearly instalments, in accordance with the following scale, or may be paid off at any earlier time.

Over \$40, and not exceeding \$100, 8 instalments.
Over \$100, and not exceeding \$200, 10 instalments.
Over \$200, and not exceeding \$400, 12 instalments.
Over \$400, and not exceeding \$600, 14 instalments.
Over \$600, and not exceeding \$800, 16 instalments.
Over \$800, and not exceeding \$1,000, 18 instalments.
Over \$1,000, 20 instalments.

Interest at the rate of 5% per annum is payable with all payments of residue, and is computed for each instalment from the date of sale to the date of such payment. Additional interest is charged if any instalment is not paid on or before the due date.

If paid off within 30 days of sale, no interest is payable.

**FEES, ETC.:**

Also payable at the sale, in addition to the deposit, are the survey fee and, if applicable, the valuation of improvements (if purchaser be not the owner thereof).

**Payable with balance of purchase money—**

Crown Grant fee—	
50 acres and under .. .. .	\$3
Over 50 acres .. .. .	\$4
Purchase money \$10 or under .. .. .	\$2

**ORBOST.**—Sale (No. 12066) of Crown land in fee-simple, by auction, will be held at the COURT HOUSE, ORBOST, on THURSDAY, the 2nd day of JULY, 1970, at half-past ELEVEN o'clock a.m. To be conducted by J. R. BUCK, Land Officer, Bairnsdale.

**Lot 1.**

PARISH OF ORBOST EAST, COUNTY OF CROAJINGOLONG.

Fronting the north side of the Princes Highway, 8½ miles east of Orbost.

Upset price \$100 the lot. Survey fee \$15.75.

Area 2a. 1r. 38p., allotment 36g of section C. Subject to State Electricity Commission easement 50 links wide. Three months allowed for the removal of improvements.—(H.031708.)

**CANN RIVER.**—Sale (No. 12067) of Crown land in fee-simple, by auction, will be held at the PUBLIC HALL, CANN RIVER, on THURSDAY, the 2nd day of JULY, 1970, at TWO o'clock p.m. To be conducted by J. R. BUCK, Land Officer, Bairnsdale.

**Lot 1.**

PARISH OF WINYAR, COUNTY OF CROAJINGOLONG.

Fronting the eastern side of the Combenbar-road near Club Terrace.

Upset price \$200 the lot. Survey fee \$19.25.

Area 5a. 3r. 15p., allotment 23. Valuation of improvements, \$30,800 (buildings, &c.) (Club Terrace Sawmills Pty. Ltd.)—(H.032340.)

**Lot 2.**

TOWNSHIP OF BEMM, PARISH OF BEMM, COUNTY OF CROAJINGOLONG.

Fronting the east side of Banksia-street.

Upset price \$600 the lot. Survey fee \$13.00.

Area 1r. 36p., allotment 9 of section H. Subject to drainage easement 10 links wide. Two months allowed for the removal of improvements.

NOTE.—Banksia-street has been declared a private street pursuant to section 575 (3A) of the Local Government Act, and the purchaser of this allotment will be liable to contribute to the cost of street construction.—(H.033152.)

**LOCAL LAND BOARDS.**

IN pursuance of the provisions of section 34 of the Land Act 1958, notice is hereby given that a public hearing at the following place and time, will be conducted by the person respectively mentioned, being duly appointed in that behalf.

W. J. F. McDONALD,  
Minister of Lands.

Department of Crown Lands and Survey,  
Melbourne.

**SCHEDULE.**

BROADFORD, LAND INSPECTOR'S OFFICE, on Thursday, 28th May, 1970, at 10 a.m.—J. Cox.

**PROPOSED REVOCATIONS OF TEMPORARY RESERVATIONS OF LANDS BY ORDERS IN COUNCIL.**

IN pursuance of the provisions of the Land Act 1958, notice is hereby given that it is the intention of the Governor in Council to revoke the temporary reservations of lands by Orders in Council hereunder referred to, viz.:—  
The following Notices were published 1° on the 29th April, 1970, pursuant to Orders of the 22nd April, 1970.

**TALBOT.**—The temporary reservation, by Order in Council of the 28th June, 1928, of 3 roods 7 perches of land in the Township of Talbot, as a site for Public Baths, is about to be revoked.—(T.136(?) (Rs.3695).

**BARWO.**—The temporary reservation as a site for Water Supply purposes and the withholding from sale, leasing and licensing by Order in Council of the 16th December, 1884 (see Government Gazette 19th December, 1884, page 3564) of 110 acres, more or less, in two separate portions in the Township of Nathalia and the Parish of Barwo, are about to be revoked, so far only as the portion in the Parish of Barwo, containing 4 perches, indicated by hatching on plan hereunder, is concerned.—(B.690(A<sup>3</sup>) (Rs.2360).

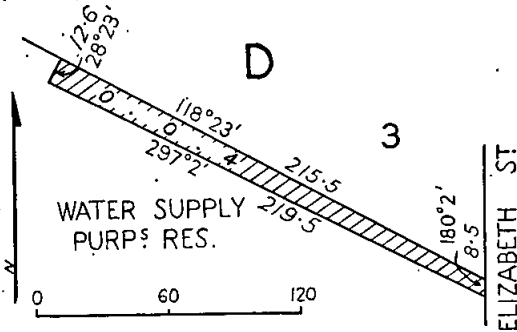

**CRANBOURNE.**—The temporary reservation, as a site for Public purposes (State School) and the withholding from sale, leasing and licensing, by Order in Council of the 5th February, 1877, of 1 acre of land in the Township of Cranbourne, is about to be revoked.—(C.329(?) (Rs.5820).

**SANDHURST (KENNINGTON).**—The temporary reservation, by Order in Council of the 24th September, 1912, of 5 acres 1 rood 9 perches of land in the Parish of Sandhurst, as a site for Public Gardens, revoked as to part by various Orders, is about to be revoked, so far only as the portion containing 2 acres, more or less, indicated by hatching on plan hereunder, is concerned.—(S.371(?) (Rs.782).

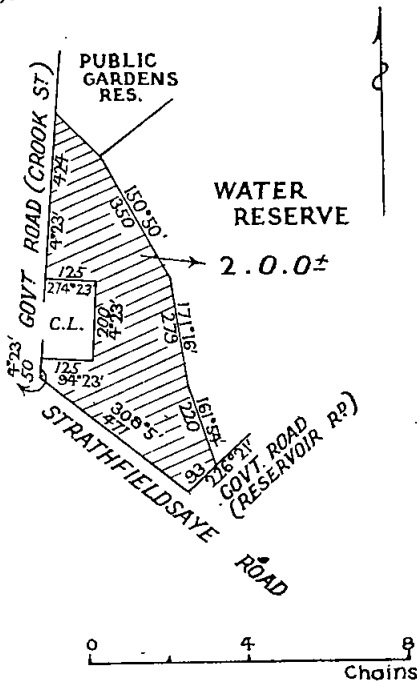

**BEECHWORTH.**—The temporary reservation, by Order in Council of the 26th September, 1864, of 201 acres 2 roods 26 perches of land in the Parish of Beechworth (now in the Township), as a site for a Mental Hospital, is about to be revoked, so far only as the portion containing 10 perches, indicated by hatching on plan hereunder, is concerned.—(B.348(?) (Rs.1221).

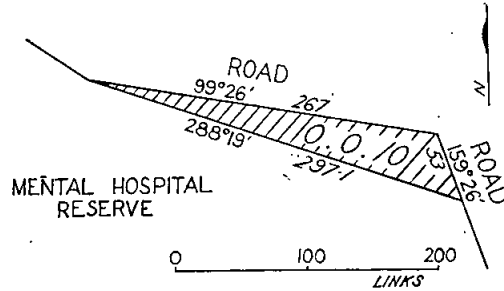

**CARLYLE.**—The temporary reservation, by Order in Council of the 25th September, 1894, of 10 acres of land in the Parish of Carlyle, as a site for a Night-soil Depot, for the municipal district of the Shire of Rutherglen, is about to be revoked, so far only as the portion containing 5 acres 19 perches, indicated by hatching on plan hereunder is concerned.—(C.187(?) (Rs.9309).

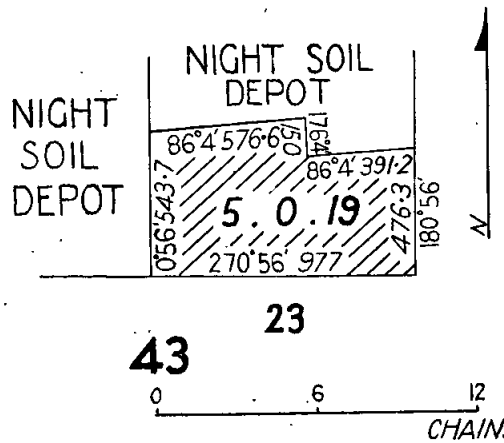

**CARLYLE.**—The temporary reservation, by Order in Council of the 14th November, 1893, of 10 acres of land in the Parish of Carlyle, as a site for a Night-soil Depot, is about to be revoked, so far only as the portion containing 5 acres 2 perches, indicated by hatching on plan hereunder is concerned.—(C.187(?) (Rs.9309).

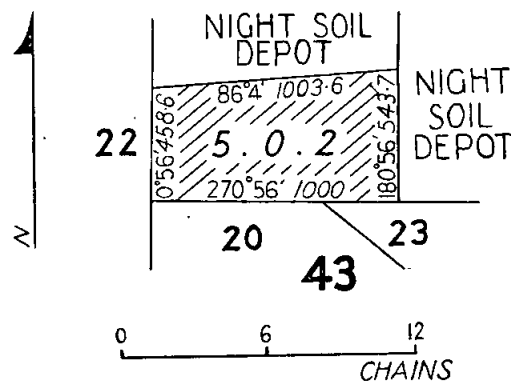

**KILLINGWORTH.**—The temporary reservation, by Order in Council of the 10th March, 1903, of 64 acres of land in the Parish of Killingworth, as a site for a Public Park, is about to be revoked, so far only as the portions containing 1 acre 1 rood 30 perches, more or less, indicated by hatching on plan hereunder are concerned.—(K.55(?) (Rs.428).

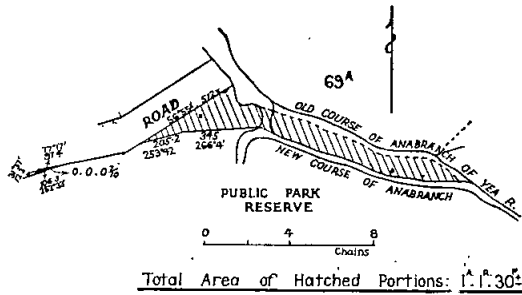

WEDDERBURNE.—The temporary reservation, by Order in Council of the 15th July, 1912, of 95 acres 31 perches of land in the Parish of Wedderburne, as a site for Supply of Material for Road-making, is about to be revoked, so far only as the portion containing 2 roods 32 perches, indicated by hatching on plan hereunder is concerned.—(W.116(14)) (Rs.6880).

MOOLLERR.—The temporary reservation, as a site for Conservation of Water, and the withholding from sale, leasing and licensing by Order in Council, of the 5th June, 1882, of 17 acres 3 roods 5 perches of land in the Parish of Moolerr, are about to be revoked, so far only as the portion containing 15 acres 3 roods 9 perches, indicated by hatching on plan hereunder, is concerned.—(M.427(9)) (Rs.9298).

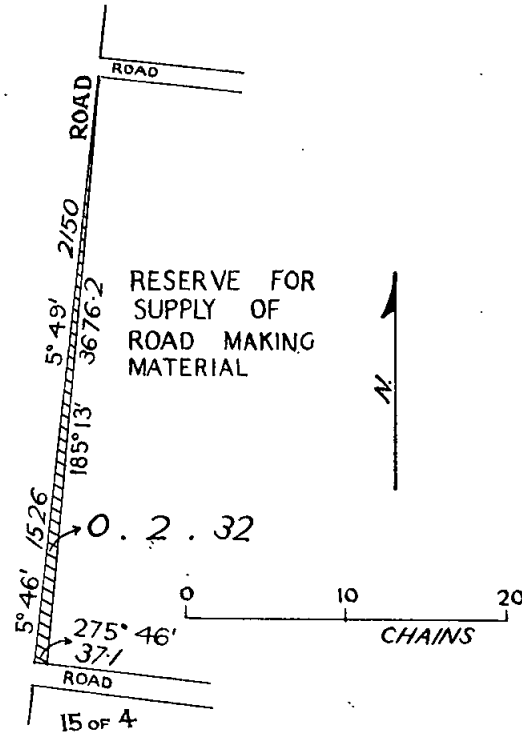
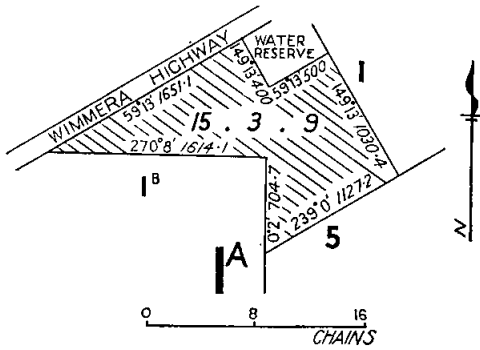

SPRINGHURST.—The temporary reservation, by Order in Council of the 9th December, 1885, of 71 acres 3 roods 20 perches of land in the Township of Springhurst, (formerly Town of Narimga), as a site for Public Recreation, is about to be revoked, so far only as the portion containing 3 acres 38 perches, indicated by hatching on plan hereunder is concerned.—(N.135(2)) (Rs.610).

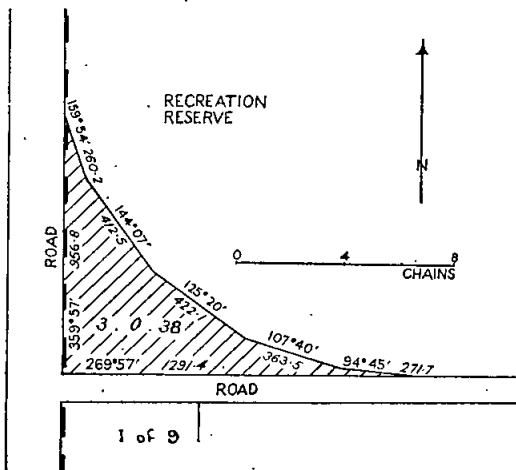

BALLAN.—The temporary reservation, by Order in Council of the 9th December, 1872 (see *Government Gazette* 13th December, 1872, page 2262), of 1 acre of land in the Township of Ballan, as a site for a Court House, is about to be revoked, so far only as the portion containing 2 roods, indicated by hatching on plan hereunder is concerned.—(B.23(4)) (C.75794).

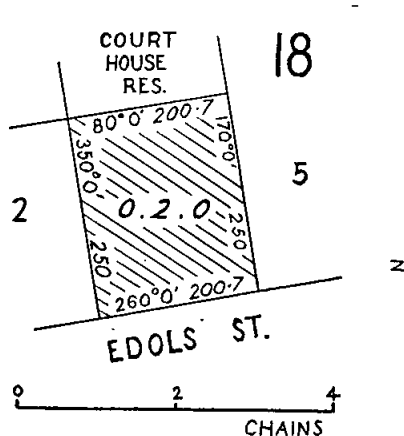

W. J. F. McDONALD,  
Minister of Lands.

**PROPOSED REVOCATIONS OF TEMPORARY RESERVATIONS OF LANDS BY ORDERS IN COUNCIL.**

IN pursuance of the provisions of the *Land Act 1958*, notice is hereby given that it is the intention of the Governor in Council to revoke the temporary reservations of lands by Orders in Council hereunder referred to, viz.:-

The following Notices were published 1° on the 6th May, 1970, pursuant to Orders of the 28th April, 1970.

**BEECHWORTH.**—The temporary reservation by Order in Council of the 21st January, 1931, of 6 acres 3 roods 34 perches of land in the Parish of Beechworth, as a site for Public Recreation is about to be revoked.—(B.349<sup>(24)</sup>) (Rs.4089).

**ST. KILDA AND ELWOOD.**—The temporary reservation by Order in Council of the 5th May, 1964, of certain lands at St. Kilda and at Elwood in the Parish of Melbourne South as a site for Public Recreation, revoked as to part by Order of the 24th October, 1967, is about to be revoked so far as the balance is concerned.—(M.333<sup>(25)</sup>) (Rs.8333).

**TYNTYNDER NORTH.**—The temporary reservation by Order in Council of the 30th May, 1916, of 10 acres of land in the Parish of Tyntynder North as a site for a Sanitary Depot is about to be revoked.—(T.244<sup>(18)</sup>) (Rs.1042).

**LAWLOIT.**—The temporary reservation, by Order in Council of the 30th September, 1889, of 100 acres 4 perches of land in the Parish of Lawloit as a site for Water Supply purposes, revoked as to part by various Orders, is about to be revoked so far as the portion containing 19 acres 2 roods 24 perches, indicated by hatching on plan hereunder, is concerned.—(L.137<sup>(2)</sup>) (Rs.6447).

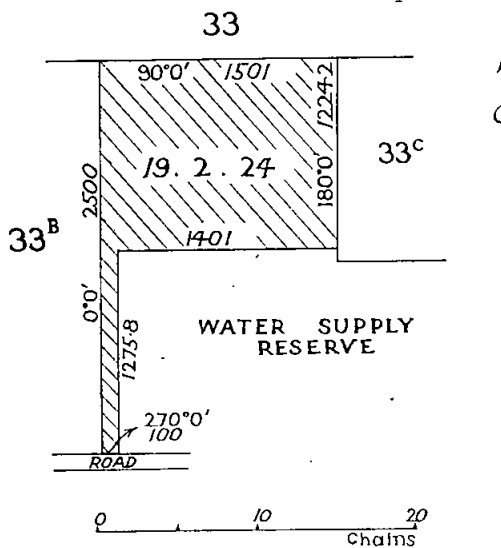

Subject to Survey

**MELBOURNE SOUTH (POINT ORMOND).**—The temporary reservation by Order in Council of the 30th November, 1915 (see *Government Gazette*, 8th December, 1915, page 4902) of 3 acres 3 roods, more or less, of land in the Parish of Melbourne South (named City of St. Kilda, at Elwood in order) as a site for Public Recreation, revoked as to part by order of the 24th October, 1967, is about to be revoked so far only as the portion containing 2 roods more or less indicated by hatching on plan hereunder is concerned.—(M.333<sup>(25)</sup>) (Rs.444).

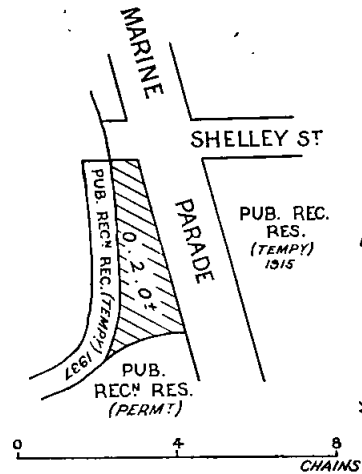

**MELBOURNE SOUTH (POINT ORMOND).**—The temporary reservation by Order in Council of the 7th April, 1937 (see *Government Gazette*, 14th April, 1937, page 1091), of 5 acres, more or less, of land in the Parish of Melbourne South (named City of St. Kilda at Elwood in Order) as a site for Public Recreation is about to be revoked so far only as the portion containing 2 roods, more or less, indicated by hatching on plan hereunder, is concerned.—(M.333<sup>(25)</sup>) (Rs.444).

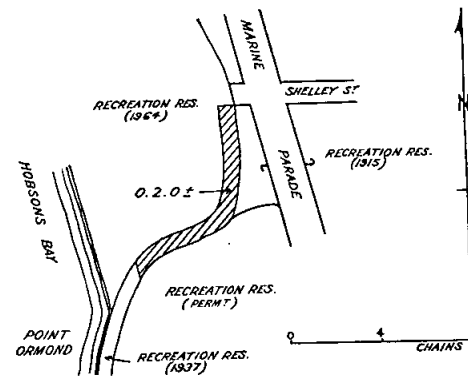

W. J. F. McDONALD,  
Minister of Lands.

**PROPOSED REVOCATIONS OF TEMPORARY RESERVATIONS OF LANDS BY ORDERS IN COUNCIL.**

IN pursuance of the provisions of the *Land Act 1958*, notice is hereby given that it is the intention of the Governor in Council to revoke the temporary reservations of lands by Orders in Council hereunder referred to, viz.:-

The following Notices were published 1° on the 13th May, 1970, pursuant to Orders of the 5th May, 1970.

**SANDHURST (AT BENDIGO).**—The temporary reservation, by Order in Council of the 14th February, 1939, of 1 acre 2 roods 21 perches of land, at Bendigo, Parish of Sandhurst, as a site for Public purposes (Children's Playground) is about to be revoked.—(S.372<sup>(112)</sup>) (Rs.4919).

**MOE.**—The temporary reservation, by Order in Council of the 21st November, 1887, of 82 acres 36 perches of land in the Parish of Moe, as a site for Railway purposes, revoked as to part by Order of the 26th March, 1935, is about to be revoked so far as the balance thereof containing 80 acres 3 roods 11 5/10 perches is concerned.—(M.498<sup>(12)</sup>) (C.81835).

**MOE.**—The temporary reservation, by Order in Council of the 12th February, 1935, of 1 acre 20 1/10 perches of land in the Parish of Moe, as a site for Railway purposes, is about to be revoked.—(M.498<sup>(12)</sup>) (C.81835).

**WARRNAMBOOL.**—The temporary reservation, by Order in Council of the 13th February, 1893, of 1 acre 8 perches of land in the Township of Warrnambool, as a site for Cattle Yards and General Market purposes, is about to be revoked.—(W.99<sup>(7)</sup>) (Rs.110).

**MURCHISON.**—The temporary reservation, by Order in Council of the 6th November, 1968, of 15 acres, more or less, of land in the Township and Parish of Murchison, as a site for Public Recreation, is about to be revoked, so far only as the portion containing 29 perches, more or less, indicated by hatching on plan hereunder, is concerned.—(M.272<sup>(2)</sup>) (Rs.9051).

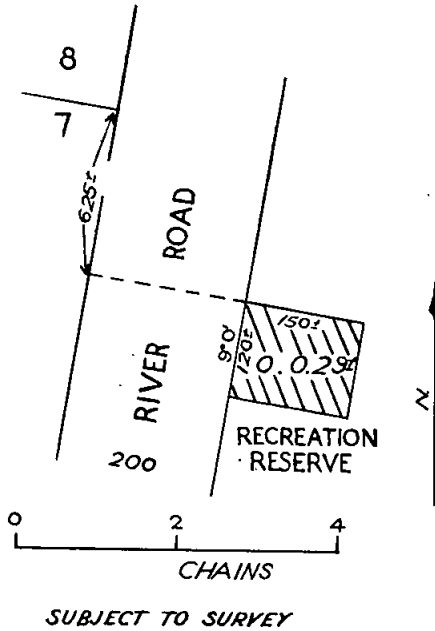

**WOMBAT.**—The temporary reservation, by Order in Council of the 29th June, 1914, of 7 acres of land in the Parish of Wombat, as a site for Watering purposes and for a Quarry, is about to be revoked, so far only as the portion containing 6 perches, indicated by hatching on plan hereunder is concerned.—(W.179<sup>(88)</sup>) (Rs.9238).

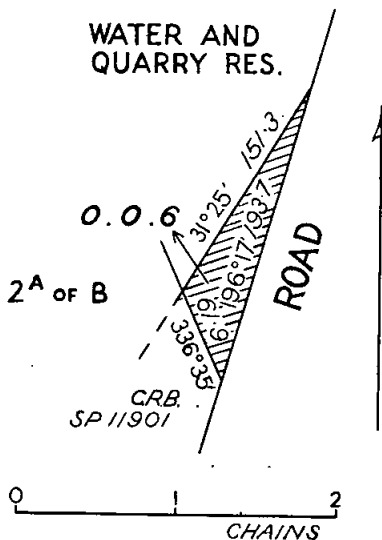

W. J. F. McDONALD,  
Minster of Lands.

**REGULATIONS FOR THE CARE, PROTECTION AND MANAGEMENT OF THE UNDERA RECREATION RESERVE.**

**WHEREAS** by section 218 of the *Land Act* 1958 the Minister of Lands is empowered to make regulations as to any land which under the provisions of that Act or of any other Act relating to Crown lands has been reserved for any public purpose whatsoever and which has not been conveyed to or vested in trustees: And whereas certain Crown lands in the Parish of Undera were deemed to be permanently reserved as a site for the Recreation, Convenience or Amusement of the People: And whereas such land (hereinafter called "the Reserve") have not been conveyed to or vested in trustees: And whereas it is expedient that regulations for the care, protection and management of the Reserve and for other purposes connected therewith should be made: Now therefore I, William John Farquhar McDonald, Her Majesty's Minister of Lands in and for the State of Victoria, in pursuance of the powers aforesaid, do hereby make the following Regulations for or with respect to the Reserve, which has been placed under the control of a Committee of Management with power and authority to enforce the said Regulations:—

**REGULATIONS.**

1. The Reserve shall be open to the public free of charge from sun-rise to sun-set except on such days as the Reserve may be set aside for any sporting organization or entertainment approved by the Committee of Management when a fee may be charged.
2. No person shall enter or remain in the Reserve who may offend against decency as regards dress, language or conduct.
3. No person shall damage in any way the trees, shrubs or flowers in the Reserve.
4. No person shall climb or jump over the gates or fences in or around the Reserve, stick bills thereon or cut names on or in any way damage or injure any of the buildings, gates, fences, seats or trees in the Reserve or leave or deposit any glass, paper or rubbish or roll or throw stones or missiles of any kind therein.
5. No person shall put in the Reserve any cattle, horses, sheep, goats, pigs or other animals without the permission in writing of the Committee of Management first obtained.
6. No person shall camp in the Reserve nor erect therein any building or any booth for the purpose of offering for sale any article without the permission in writing of the Committee of Management first obtained.
7. No person shall take part in any public entertainment of any sort in the Reserve without the permission in writing of the Committee of Management first obtained.
8. No person shall bet publicly in any part of the Reserve without permission in writing of the Committee of Management first obtained.
9. No person shall practise, play or engage in any organized game or sport within the Reserve at any time without permission in writing of the Committee of Management first obtained.
10. Persons renting or hiring any stand, building, erection or enclosure on the occasion of any sports, fêtes or holiday amusements may be required to deposit any sum which the Committee of Management may at any time determine by way of guarantee that due care shall be taken of such stand, building, erection or enclosure and such Committee in its absolute discretion may make good any damage or injury sustained by such building, erection, stand or enclosure or anything contained therein during the occupancy of hiring and deduct the cost of making good such damage injury or loss from the sum of money deposited by way of guarantee, and all persons so renting or hiring shall abide by these Regulations and by any order given by the Committee of Management.
11. No person shall remove any earth, trees, structures or materials on the Reserve without the permission in writing of the Committee of Management first obtained.
12. No person shall play, practise or engage in any sport including tennis, cricket, hockey, quoits or any game or foot running except in the portions set apart for that purpose and then only with the permission of the Committee of Management first obtained and such permission may be granted subject to such terms and conditions as the said Committee may determine.
13. No person shall enter the Reserve or pass over the playing area or oval with any vehicle or on horseback without the permission of the Committee of Management first obtained nor drive or ride amongst or to the danger or annoyance of persons assembled on any part of the Reserve.

14. No person shall obstruct, disturb, interrupt, or annoy any officer or employee of the Committee of Management in the proper execution of his work or duty.

15. No assemblies for social entertainment or for the purpose of public worship, preaching or public speaking of any kind shall take place in the Reserve without the permission in writing of the Committee of Management.

16. No person other than the players and officials connected with any game (football, cricket, tennis, hockey, croquet, bowls or golf) and other than any competitor and officials at any sports gathering shall intrude upon any playground or oval during the course of such games or sports.

17. No club, association or person shall hold entertainments, performances or sports without the consent in writing of the Committee of Management first had and obtained. Such consent may be granted subject to the payment of such fees and on such terms as the Committee deems to be reasonable and consistent with these Regulations. The Committee of Management may authorize any club, association or person to make a charge for the admission thereto.

18. No person shall park a motor car, vehicle or motor-cycle in the Reserve except at such places as are set apart for the purpose by the Committee who reserve the right to make a parking charge.—(Rs.8848).

Given under my hand, at Melbourne, on the 4th day of May, 1970.

W. J. F. McDONALD,  
Minister of Lands.

Every person who contravenes or fails to comply with these Regulations shall, in accordance with the provisions of section 218 of the *Land Act 1958*, for each offence be liable to a penalty of not more than Fifty dollars, and every person who contravenes or fails to comply with any such Regulations, and who, after he has been warned by any bailiff of Crown lands or by any member of the Police Force, does not desist therefrom may be forthwith apprehended by such bailiff or member of the Police Force and taken before some justice to be dealt with according to law and shall be liable to a penalty of not more than One hundred dollars.

#### AMENDMENT TO THE REGULATIONS FOR THE CARE, PROTECTION AND MANAGEMENT OF "DAVIS PARK", NHILL.

WHEREAS in pursuance of section 218 of the *Land Act 1958* as then enacted the Board of Land and Works on the 11th June, 1952, made regulations for the care, protection and management of certain land in the Township of Nhill and described in a notice published in the *Government Gazette* of the 28th March, 1890, which reserved the said land as a site for Public Recreation: And whereas the said Board was dissolved by the *Public Lands and Works Act 1964* which provided, *inter alia*, that all regulations made by the Board shall remain in force subject to the *Land Act 1958*: And whereas the Minister of Lands is now empowered to make regulations for or with respect to the said land (hereinafter called "the Reserve") in pursuance of section 218 of the *Land Act 1958*: And whereas it is expedient that the Regulations made by the Board as aforesaid should be amended: Now therefore, I, William John Farquhar McDonald, Her Majesty's Minister of Lands in and for the State of Victoria do hereby rescind Regulations numbered 1, 2, 4, 7 and 9 and substitute under numbers 1, 2 (g), 4 (a), 4 (b), 7, 9, 12 (a), 12 (b) and 12 (c) the following Regulations.

#### REGULATIONS.

1. The Reserve shall be open to the public, free of charge, from sunrise to sunset, except on such days, not exceeding sixty-five (65) in any one year, as the Reserve may be set apart for cricket, football, or other matches, shows, sports, fêtes, musical performances, outdoor gatherings, or holiday amusements, on any of which occasions a sum not exceeding seventy-five cents (75c) may be charged and taken for the admission of each adult person to the Reserve, but no person shall be permitted to enter any of the buildings on the Reserve on days on which fees for admission are not being charged without the permission, in writing, of the Committee of Management first obtained.

2. (g) No person shall practise or play the sport of golf on any part of the Reserve without the consent in writing of the Committee of Management first had and obtained.

4. (a) No club, association or person shall hold entertainments, performances or sports without the consent in writing of the Committee of Management first had and obtained. Such consent may be granted subject to the payment of such fees and on such terms as the Committee

deems to be reasonable and consistent with these Regulations. The Committee of Management may authorize any club, association or person to make a charge for the admission thereto.

4. (b) Any club, association, person, society or other body holding entertainments, performances, shows, sports or other functions for which any admission is charged whether by way of a direct admission or by way of programme, button or any other method whatsoever, which, in the opinion of the Committee of Management is a charge for admission to the Reserve, shall pay to the said Committee such a charge as the Committee shall determine not being less than the sum of \$500 or an amount of ten per centum of the total admission charges as aforesaid, whichever is the greater.

7. No person shall park a motor car, vehicle, or motor cycle in the Reserve, except at such places as are set apart for the purpose by the Committee of Management, who reserve the right to make a parking charge not exceeding 20 cents for each vehicle.

9. No person shall play, practise or engage in any organized game, sport or entertainment of any nature within the Reserve on Sundays or Good Fridays without the consent of the Committee of Management first had and obtained.

12. (a) The Committee of Management shall have the right to determine from time to time the fee payable for camping in the Reserve as aforesaid, such fee to be not less than 50 cents per day.

(b) The camping fee referred to in the last preceding sub-section shall be the fee payable for one caravan, tent or other vehicle or erection for living and/or sleeping purposes together with one motor vehicle for the conveyance of such caravan, tent or other vehicle or erection.

(c) The Committee shall have the right to control the parking of motor cars, motor cycles, or any other vehicles within the Reserve and, except as regards vehicles mentioned in the last preceding sub-section, to levy a parking fee of not less than 25 cents per day therefor to be determined by the Committee from time to time.—(Rs.6005).

Given under my hand, at Melbourne, on the 4th day of May, 1970.

W. J. F. McDONALD,  
Minister of Lands.

Every person who contravenes or fails to comply with these Regulations shall, in accordance with the provisions of section 218 of the *Land Act 1958*, for each offence be liable to a penalty of not more than Fifty dollars, and every person who contravenes or fails to comply with any such Regulations, and who, after he has been warned by any bailiff of Crown lands or by any member of the Police Force, does not desist therefrom may be forthwith apprehended by such bailiff or member of the Police Force and taken before some justice to be dealt with according to law and shall be liable to a penalty of not more than One hundred dollars.

#### REGULATIONS FOR THE CARE, PROTECTION AND MANAGEMENT OF THE "NEERIM SOUTH SWIMMING POOL RESERVE".

WHEREAS by section 218 of the *Land Act 1958* the Minister of Lands is empowered to make regulations as to any land which under the provisions of that Act or of any other Act relating to Crown lands has been reserved for any public purpose whatsoever and which has not been conveyed to or vested in trustees: And whereas certain Crown lands in the Parish of Neerim and described in a notice published in the *Gazette* of the Seventh day of August, 1969 were reserved as a site for Public purposes (Swimming Pool): And whereas such lands (hereinafter called "the Reserve") have not been conveyed to or vested in trustees: And whereas it is expedient that regulations for the care, protection and management of the Reserve and for other purposes connected therewith should be made: Now therefore I, William John Farquhar McDonald Her Majesty's Minister of Lands in and for the State of Victoria, in pursuance of the powers aforesaid, do hereby make the following Regulations for or with respect to the Reserve:—

#### REGULATIONS.

1. Every person within the Reserve shall wear suitable bathing costume and no person shall dress or undress or remove any part of his or her costume, in any part of the reserve other than in a place or places provided by the Committee for such purpose.

2. No person shall bring into or cause or allow any dog or other animal to enter or to remain within the Reserve.

3. No person shall loiter, misconduct himself or herself or commit a nuisance in the Reserve.
4. No person shall bring any rubbish or offensive matter into the Reserve, and no person shall deposit any rubbish therein unless it is deposited in a receptacle provided for the purpose.
5. No person shall climb or jump over the fences or walls of the reserve or roll or throw stones in the Reserve.
6. No person shall without the permission in writing of the Committee, hawk, sell or offer for sale, in the Reserve, any goods or articles.
7. No person shall damage or remove any placard or noticeboard within the Reserve.
8. No person shall bring any intoxicating liquor into the Reserve, and no person shall enter or remain in the Reserve whilst in the state of intoxication.
9. No person shall enter the Reserve whilst in an unclean condition, or suffering from any cutaneous, infectious or contagious disease, and any such person shall retire from the Reserve immediately upon being requested to do so by any attendant on duty in the Reserve.
10. No person shall expectorate within the Reserve or improperly foul or pollute the water in the baths, or wilfully or improperly soil or defile any towel or bathing costume, or any bathroom, dressing room closet, box or compartment or any part of the baths, within the Reserve.
11. No person shall at any time carelessly or negligently break or injure or improperly interfere with any lock, tap or fitting within the Reserve, nor carelessly, negligently or wilfully damage or injure any furniture or fitting, towel or other article supplied for use in the baths or write upon, or deface the walls or partitions or any part of the baths within the Reserve.
12. No person shall at any time within the Reserve use indecent or offensive language nor behave in an indecent manner nor offensive manner.
13. Any person finding any article in the Reserve, shall immediately thereafter deliver same to a responsible person, who shall thereupon register a description of same, and all particulars relating thereto, in the book kept for the purpose and any owner losing such article shall upon, giving satisfactory proof thereof, receive such article from the committee in charge upon entering his or her signature and address, and signing a receipt for the article in such book referred to.
14. The Committee shall not be responsible for any article lost or stolen from any person whilst in the Reserve.
15. No person shall interfere with the use and enjoyment of the Reserve by any other person, and any person so acting or otherwise behaving in an unseemly or improper manner shall immediately leave the reserve when required to do so by any attendant in charge of the Reserve.
16. No man or boy above the age of six years shall either use any dressing-rooms, shower or convenience which shall be appointed or appropriated for the use of any woman or girl, or any separate passage or approach thereto so appointed or appropriated.
17. No woman or girl shall enter or use any dressing room, shower or convenience which shall be appointed or appropriated for the use of any man or boy, or any separate passage or approach thereto so appointed or appropriated.
18. For the purpose of maintaining good order, the attendant or any person in charge of the Reserve may refuse admission to any person.
19. No person shall obstruct, hinder or interfere with the attendant, or any person employed within the Reserve or any officer of the Committee in the performance of his or her duty.
20. No person shall throw or cause to be thrown any ball or substance of any kind within the Reserve.
21. No person shall run or take part in any game or activity to the danger, inconvenience or annoyance of any other person.
22. No person shall bring into the reserve any diving stand apparatus, spear fishing gun, boat, tin, drum or structure without the consent of the Committee.
23. No person shall light any fire or burn any material other than in the fireplace provided, and then only in accordance with fire regulations, or discharge any firearm, airgun, explosive cracker or firework in the reserve.
24. The Committee shall have the power from time to time to fix and regulate the fees to be paid for admission to the Reserve, and the times which the Reserve shall be open to the public.

25. No club, association or person shall, without written authority of the Committee hold any entertainment, performance, sports or ceremony in any part of the Reserve.

26. No club, association or person shall hold entertainments, performances or sports without the consent in writing of the Committee of Management first had and obtained. Such consent may be granted subject to the payment of such fees and on such terms as the Committee deems to be reasonable and consistent with these Regulations. The Committee of Management may authorize any club, association or person to make a charge for the admission thereto.—(Rs.9177).

Given under my hand, at Melbourne, on the 4th day of May, 1970.

W. J. F. McDONALD,  
Minister of Lands.

Every person who contravenes or fails to comply with these Regulations shall, in accordance with the provisions of section 218 of the *Land Act 1958*, for each offence be liable to a penalty of not more than Fifty dollars, and every person who contravenes or fails to comply with any such Regulations, and who, after he has been warned by any bailiff of Crown lands or by any member of the Police Force, does not desist therefrom may be forthwith apprehended by such Bailiff or member of the Police Force and taken before some justice to be dealt with according to law and shall be liable to a penalty of not more than One hundred dollars.

#### REGULATIONS FOR THE CARE, PROTECTION AND MANAGEMENT OF THE QUAMBATOOK RECREATION RESERVE.

WHEREAS by section 218 of the *Land Act 1958* the Minister of Lands is empowered to make regulations as to any land which under the provisions of that Act or of any other Act relating to Crown lands has been reserved for any public purpose whatsoever and which has not been conveyed to or vested in trustees: And whereas certain Crown lands in the Parish of Quambatook, temporarily reserved by Orders in Council dated the 31st July, 1899, and 14th September, 1854, as sites for Public Recreation, together with the portion of the permanent reservation to the Avoca River bordered red on plan marked "Q/5.8.65" attached to Lands Department correspondence Rs.729: And whereas such lands (hereinafter called "the Reserve") have not been conveyed to or vested in trustees: And whereas it is expedient that regulations for the care, protection and management of the Reserve and for other purposes connected therewith should be made: Now therefore I, William John Farquhar McDonald, Her Majesty's Minister of Lands in and for the State of Victoria, in pursuance of the powers aforesaid, do hereby make the following Regulations for or with respect to the Reserve:—

The area has been placed under the control of a Committee of Management (hereinafter referred to as the Committee) with power and authority to enforce the following Regulations.

#### REGULATIONS.

1. No person shall—
  - (a) enter or remain in the Reserve who may offend against decency as regards dress, language or conduct or who may behave in a disorderly, unseemly or offensive manner or create or take part in any disturbance;
  - (b) enter or remain in the Reserve whilst in a state of intoxication;
  - (c) use indecent or offensive language in the Reserve;
  - (d) offer any article for sale without the consent of the Committee;
  - (e) bring any intoxicating liquor into the Reserve without the consent of the Committee;
  - (f) enter the Reserve while suffering from any infectious or contagious disease;
  - (g) obstruct, hinder or interfere with any person employed in the Reserve;
  - (h) enter the swimming pool without first using the showers provided.
2. For the purpose of maintaining good order, any person authorized by the Committee may refuse admission to any person to the Reserve.
3. No person shall use the swimming pool except on payment of the fee which may be fixed from time to time by the Committee.
4. No person shall enter or use any bathing box, dressing shed or other dressing places authorized by the Committee under any regulation until and unless the above-mentioned fee has been paid by him or her.

5. The Committee shall have power to hold entertainments or performances in the Reserve and to make a charge for admission thereto.

6. No club, association or person shall hold entertainments, performances or sports without the consent, in writing, of the Committee of Management first had and obtained. Such consent may be granted subject to the payment of such fee and on such terms as the Committee deems to be reasonable and consistent with these Regulations. The Committee of Management may authorize any club, association or person to make a charge for the admission thereto.

7. No club, association or person shall hold any entertainment, performance or ceremony in any part of the Reserve without the written authority of the Committee first being obtained.

8. No person shall play, practise or engage in any organized game or sport within the Reserve without the permission, in writing, of the Committee first obtained.

9. No person, except the Committee or its officers and employees on duty, shall enter any part of the Reserve when a charge is made for admission without first paying the fees chargeable for admission.

10. No person shall damage any building in the Reserve or the furniture or fittings thereof.

11. No person shall interfere with, or break, or damage any of the trees, plants or shrubs, or pluck any flowers, or walk on the beds or borders, or climb, jump, get upon or over any of the fences, gates, seats or other structures, nor roll or throw stones or other missiles, or leave any bottles, broken glass, paper, orange peel, or banana skins or any refuse or rubbish whatsoever or post bills or advertisements on any of the fences, gates, seats or other structures in the Reserve.

12. No person shall light a fire in the Reserve, except at such place or places as is or are set apart for that purpose by the Committee.

13. No person shall, without the permission of the Committee first being obtained, sell or offer for sale within the Reserve any articles of food or drink, or any other commodity or operate any money-making concern.

14. Children under the age of seven years not being under the control of some competent person may be removed from the Reserve.

15. No person shall carry or use firearms in the Reserve.

16. No person shall bring into the Reserve any dog unless controlled by a chain or cord without the permission, in writing, of the Committee.

17. No person shall permit, allow or suffer any horse, cow, goat, or other animal to wander or to be put or placed in the Reserve without the authority of the Committee first being obtained and no person shall bathe any horse, or cause, suffer or permit any dog or other animal to swim or enter the swimming pool in the Reserve.

18. No person shall remain in the Reserve at any time when lawfully directed by any officer or employee of the Committee to leave the same.

19. Any person found in a state of intoxication or behaving in a disorderly manner, or creating or taking part in any disturbance, or committing any act of indecency in the Reserve, or refusing to obey those authorized by the Committee, or by the club, association or persons renting or having been granted the use of the Reserve for the time being, to keep order shall be liable to be removed therefrom, notwithstanding that such person may have purchased a ticket for admission thereto, and shall also be liable to prosecution for an offence against these Regulations.

20. Persons hiring or renting any stand, building, erection or enclosure on the occasions of any sports, swimming, or holiday amusements may be required to deposit any sum which the Committee may at any time determine, not exceeding Thirty dollars, by way of guarantee that due care shall be taken of such stand, building, erection or enclosure, and such Committee, in its absolute discretion may make good any damage or injury sustained by such stand, building, erection or enclosure, or anything contained therein, during such occupancy or hiring, and deduct the cost of making good such loss or damage from the sum of money deposited by way of guarantee, and all persons so renting or hiring shall abide by these Regulations and by any order given by the Committee.

21. No person shall use soap or any other preparation or cause the water within the swimming pool to be polluted in any way.

22. No seasonal or monthly tickets shall be transferable and any holder of a seasonal or monthly ticket who allows any other person to use the same shall immediately forfeit such ticket and all moneys paid thereon and all the rights and privileges given by such ticket.

23. Beach balls, motor tubes or other inflated rubber or plastic articles are not permitted in the main swimming pool.

24. The Committee, manager, or lessee will not be responsible for any article lost by or stolen from any person whilst in the swimming pool.

25. The Committee may, by Resolution, close the swimming pool or any part thereof, on any days or day, or at any times, should it be considered necessary to do so, and may also vary the periods or hours during which the swimming pool shall be open to the public for bathing purposes.

26. The Committee shall have power from time to time, by Resolution, to give such directions as it may consider necessary for the proper care and management of the Reserve consistent with these Regulations.—Rs.729.

Given under my hand, at Melbourne, on the 4th May, 1970.

W. J. F. McDONALD,  
Minister of Lands.

Every person who contravenes or fails to comply with these Regulations shall, in accordance with the provisions of section 218 of the *Land Act 1958*, for each offence be liable to a penalty of not more than Fifty dollars, and every person who contravenes or fails to comply with any such Regulations, and who, after he has been warned by any bailiff of Crown lands or by any member of the Police Force, does not desist therefrom may be forthwith apprehended by such bailiff or member of the Police Force and taken before some justice to be dealt with according to law and shall be liable to a penalty of not more than One hundred dollars.

#### REGULATIONS FOR THE CARE, PROTECTION AND MANAGEMENT OF THE "BAYNES PARK" PUBLIC RECREATION RESERVE.

WHEREAS by section 218 of the *Land Act 1958* the Minister of Lands is empowered to make regulations as to any land which under the provisions of that Act or of any other Act relating to Crown lands has been reserved for any public purpose whatsoever and which has not been conveyed to or vested in trustees: And whereas certain Crown lands in the Parish of Monbulk and described in a notice published in the *Government Gazette* of the Twelfth day of November, 1969, were reserved as a site for Public Recreation purposes: And whereas such lands (hereinafter called "the Reserve") have not been conveyed or vested in trustees: And whereas it is expedient that regulations for the care, protection and management of the Reserve and for other purposes connected therewith should be made: Now therefore I, William John Farquhar McDonald, Her Majesty's Minister of Lands in and for the State of Victoria, in pursuance of the powers aforesaid, do hereby make the following Regulations for or with respect to the Reserve:—

#### REGULATIONS.

1. The Reserve shall be open to the public from sunrise to sunset, free of charge, except on such days, not exceeding 52 in any one year, as the Reserve may be set apart for cricket or football matches, fetes, sports, or holiday amusements, on any of which occasions a sum not exceeding Fifty cents may be charged and taken for admission of every adult to the Reserve.

2. No person shall—

- (a) enter or remain in the Reserve who may offend against decency as regards dress, language or conduct, or who may behave in a disorderly, unseemly, or offensive manner, or create or take part in any disturbance;
- (b) enter or remain in the Reserve whilst in a state of intoxication;
- (c) bring any intoxicating liquor on the Reserve without the consent of the Committee first obtained;
- (d) exercise or train any horse or pony on the Reserve, or any part thereof without the consent of the Committee first obtained.

3. The Committee shall have the power to hold entertainments, shows or performances on the Reserve, and to make a charge for admission thereto as hereinbefore provided.

4. No club, association or person shall hold entertainments, performances or sports without the consent, in writing, of the Committee of Management first had and obtained. Such consent may be granted subject to the payment of such fees and on such terms as the Committee deems to be reasonable and consistent with these



Regulations. The Committee of Management may authorize any club, association or person to make a charge for the admission thereto.

5. No person, except the Committee or its officers or employees on duty shall enter any part of the Reserve on an occasion when a charge is made for admission thereto without first paying the fees chargeable for such admission.

6. No person shall park a motor car, vehicle or motor cycle in the Reserve, except at such places as are set apart for the purpose by the Committee, who reserve the right to make a parking charge not exceeding Twenty cents for each vehicle.

7. No person shall play or engage in any organized sport, game or competition within the Reserve on Sundays, Good Friday or Anzac Day without the permission, in writing, of the Committee first obtained.

8. No person shall take part in any public entertainment of any sort in the Reserve without the permission, in writing, of the Committee first obtained.

9. No person shall play, practise or engage in any organized game or sport within the Reserve at any time without permission, in writing, of the Committee first obtained.

10. Persons renting or hiring any stand, building, erection or enclosure on the occasion of any sport, fetes or holiday amusements may be required to deposit any sum which the Committee may at any time determine by way of guarantee that due care shall be taken of any stand, building, erection or enclosure, and such Committee, in its absolute discretion, may make good any damage or injury sustained by such stand, building, erection or enclosure or anything contained therein, during such occupancy or hiring, and deduct the cost of making good such damage, injury or loss from the sum of money deposited by way of guarantee, and all persons so renting or hiring shall abide by these Regulations and by any order given by the Committee.

11. No person shall, in the Reserve, interfere with or break or damage any of the trees, plants or shrubs, or pluck any flowers, or climb, jump, or get over or under any of the fences, gates, seats, or any other structures therein, or roll or throw stones or other missiles, or leave any bottles, broken glass, paper, orange peel, banana skins, or any refuse or rubbish whatever therein, or post bills or advertisements on any of the fences, gates, seats or other structures therein.

12. No person shall light a fire in the Reserve, except in fireplaces provided for that purpose.

13. No person shall put in the Reserve any cattle, horses, sheep, goats, pigs or other animals without the permission, in writing, of the Committee first obtained.

14. No person shall bring into the Reserve any dog, unless controlled by a chain or cord, without permission, in writing, of the Committee first obtained.

15. No person shall camp in the Reserve, nor erect therein any building or any booth for the purpose of offering for sale any article without permission, in writing, of the Committee first obtained.

16. No person shall play, practise, or engage in any sport, including tennis, cricket, quoits, hockey or any other games or foot-racing, except in the portions of the Reserve set apart for that purpose, and then only with the permission of the Committee first obtained, and such permission may be granted subject to such terms and conditions as the Committee may determine.

17. No person shall enter the Reserve, or pass over the playing area or oval, with any vehicle, or on horseback without the permission of the Committee first obtained, nor ride or drive amongst or to the danger or annoyance of persons assembled on any part of the Reserve.

18. No person shall bet publicly in any part of the Reserve without permission, in writing, of the Committee first obtained.

19. No person, club or other body shall, without the consent of the Committee first obtained, grade or scrape the ground off or cut or burn any grass growing on any part of the Reserve.

20. No person shall remove any earth, sand, stone, marl or gravel from the Reserve.—(Rs.8129).

Given under my hand, at Melbourne, on 4th May, 1970.

W. J. F. McDONALD,  
Minister of Lands.

Every person who contravenes or fails to comply with these Regulations shall, in accordance with the provisions of section 218 of the *Land Act 1958*, for each offence be liable to a penalty of not more than Ten dollars, and

No. 46.—4051/70.—3

every person who contravenes or fails to comply with any such Regulations, and who, after he has been warned by any bailiff of Crown lands or by any member of the Police Force, does not desist therefrom may be forthwith apprehended by such Bailiff or member of the Police Force and taken before some justice to be dealt with according to law and shall be liable to a penalty of not more than Twenty dollars.

#### COMMITTEES OF MANAGEMENT OF RESERVES.

##### APPOINTMENTS.

NOTICE is hereby given that, in pursuance of section 221 of the *Land Act 1958*, the following appointments of Committees of Management of reserved Crown lands have been made by the Minister of Lands.

##### "ALBERTON WEST RECREATION RESERVE."

John Henry Speed, William P. Ryan, Albert William Greenaway, Christopher William Tudor, Ralph A. Brown, Robert E. Grimshaw, Nicholas Brennan, Arthur Peter Moore and Francis Edward Lawe as a Committee of Management for a period of three (3) years of the land in the Parish of Alberton West temporarily reserved by Order in Council dated the 26th February, 1889, as a site for Public Recreation, and known as the "Alberton West Recreation Reserve".—(Corres. No. Rs.1113.)

##### "APOLLO BAY CRICKET AND RECREATION RESERVE."

Alan Hamilton Coutts, for so long only as he continues to be a councillor and the elect of the Council of the Shire of Otway, and Colin Robert Coleman, Thomas H. Condon, Stanley Bruce Harrison, William John Biddle and Brian A. Costin (for a period of three (3) years from the 12th May, 1970) as a Committee of Management of the land in the Township of Apollo Bay, Parish of Krambruk, temporarily reserved by Order in Council dated the 11th April, 1933, as a site for Cricket and other purposes of Public Recreation, and known as the "Apollo Bay Cricket and Recreation Reserve".—(Corres. No. Rs.72.)

##### "PUBLIC PURPOSES (PICNIC GROUND) RESERVE", BARINGHUP.

The Corporation of the Shire of Maldon as the Committee of Management of the land in the Township and the Parish of Baringhup, temporarily reserved by Order in Council dated the 2nd April, 1970, as a site for Public Purposes (Picnic Ground) and of that portion of the permanent reservation for Public purposes along the Loddon River abutting on such land.—(Corres. No. Rs.9028.)

##### SITE FOR PUBLIC RECREATION, BENDIGO.

The Corporation of the City of Bendigo as the Committee of Management of the land in the Parish of Sandhurst, at Bendigo, temporarily reserved by Order in Council dated the 11th March, 1970, as a site for Public Recreation.—(Corres. No. Rs.6386.)

##### "CARDROSS LAKES WATER RESERVE."

Ian Thomas Anders (for as long only as he continues to be the representative of the State Rivers and Water Supply Commission) and Victor Richard Hewett, Ian William Duncan, Jack Samuel Harris, Leonard Setford, Thomas William Gooch, Robert John Crump and Heather Margaret Harris as a Committee of Management for a period of three (3) years of that portion of land in the Parish of Mildura temporarily reserved by Order in Council dated 22nd April, 1938, as a site for Water Supply purposes and indicated in red colour on plan marked M/14.3.45, attached to Lands Department correspondence Rs.4801, and known as the "Cardross Lakes Water Reserve".—(Corres. No. Rs.4801.)

##### "COCKATOO PUBLIC HALL RESERVE."

Arthur George Ford, Natalie Lowell Abbott, William Bishop, Herman Cripps, Graham Anthony Den Hartogh, J. F. Dost, John Leonard O'Leary, Adrian Edward Potts and Isabel Lillian Evans as a Committee of Management for a period of three (3) years of the land in the Parish of Gembrook, temporarily reserved by Order in Council, dated 30th September, 1912, as a site for Public Hall, and known as the "Cockatoo Public Hall Reserve".—(Corres. No. Rs.145.)

##### "GALLIPOLI PARK", MARYSVILLE.

Jack Haycraft, Sabotino Gianforte, John Lloyd Gould, Francis Sylvester Keppel, Kenneth Carl McKenzie, Kenneth Anthony Edward West, Percy Phillip Barton, Ronald Grotori, Geoffrey G. Cuzens, Kenneth Richard Morrison and Albert William Halliday as a Committee

of Management for a period of three (3) years of the land in the Township of Marysville, temporarily reserved by Order in Council dated the 28th July, 1953, as a site for Public Recreation, and known as "Gallipoli Park".—(Corres. No. Rs.7134.)

"KIEWA MEMORIAL PARK."

Robert Joseph Brown, Arnold Thomas Coulston, Leonard Roy Schliebs, Robert McDonald, Robert Stanley Speers, Walter Alan Quonoey, Samuel James Crothers, William John Crothers and Daniel McCarthy Ley as a Committee of Management for a period ending the 17th April, 1972, of the lands in the Parish of Murrumbidgee, temporarily reserved by Orders in Council dated the 4th July, 1899, 11th June, 1946, and 11th March, 1970, as sites for Public Recreation, and known as "Kiewa Memorial Park".—(Corres. No. Rs.815.)

PUBLIC PURPOSES (SUPPLY OF GRAVEL) RESERVE, KILLARA.

The Corporation of the Shire of Glenelg as the Committee of Management of the land in the Parish of Killara, temporarily reserved by Order in Council dated the 17th March, 1970, as a site for Public purposes (Supply of Gravel).—(Corres. No. Rs.8933.)

"LAKE FYANS RESERVE", IN THE PARISH OF BELLELLEN.

Kenneth Reginald Barlow (as representative of the State Rivers and Water Supply Commission) in the place of Richard Fellows Lewis Nicholson (transferred) as a member of the Committee of Management of the land in the Parish of Bellellen, temporarily reserved by Order in Council dated the 20th February, 1968, as a site for Water Supply and Public Recreation, and known as the "Lake Fyans Reserve".—(Corres. No. Rs.8410.)

"MARENGO" PUBLIC RECREATION PURPOSES RESERVE, AT APOLLO BAY, PARISH OF KRAMBRUK.

Alan Hamilton Coutts (for so long only as he continues to be a Councillor and the elect of the Shire of Otway) and John William Turner, Stanley Bruce Harrison (for a period of three (3) years) as a Committee of Management of the land in the Parish of Krambruk temporarily reserved by Order in Council dated the 25th October, 1966, as a site for Public Recreation purposes.—(Corres. No. Rs.8685.)

SITE FOR PUBLIC RECREATION, PARISH OF PINE LODGE.

The Corporation of the Shire of Shepparton as the Committee of Management of the land in the Parish of Pine Lodge temporarily reserved by Order in Council, dated the 17th March, 1970, as a site for Public Recreation.—(Corres. No. Rs.9237.)

"PYRAMID HILL RECREATION RESERVE."

The Corporation of the Shire of Gordon as the Committee of Management of the land in the Township of Pyramid Hill temporarily reserved by Order in Council dated 10th February, 1970, as a site for Public Recreation, and known as the "Pyramid Hill Recreation Reserve".—(Corres. No. Rs.1348.)

"STREATHAM RECREATION RESERVE", (ADDITIONAL AREA).

Robert Stewart, Derek Henry Doery, Robert Waring, Peter Anthony Seedsman, David Reid, Geoffrey James Flanner, William James Black, Wallace Eldon Perry and Thomas Edward Seedsman as a Committee of Management for a period ending the 14th October, 1971, of the land in the Township of Streatham, temporarily reserved by Order in Council dated the 17th March, 1970, as a site for Public Recreation, being an extension to the Reserve known as the "Streatham Recreation Reserve".—(Corres. No. Rs.2738.)

PUBLIC RECREATION PURPOSES RESERVE, IN THE PARISH OF WHARPARILLA.

The Corporation of the City of Echuca as the Committee of Management of that portion of the land temporarily reserved by Order in Council dated 24th February, 1970, as a site for Public Recreation, as shown by green colour on plan marked W/8.5.69, together with that portion of land indicated by orange colour on the same plan attached to Lands Department correspondence Rs.9268.—(Corres. No. Rs.9268.)

W. J. F. McDONALD,  
Minister of Lands.

Department of Crown Lands and Survey,  
Melbourne, 4th May, 1970.

Land Act 1958

LICENCE UNDER THE LAND ACTS DECLARED VOID.

NOTICE is hereby given that the Licence in the Schedule hereunder has been Declared Void for the reason specified.

District.	Corr. No.	Name of Licensee.	Section of Land Act under which Licensed.	Parish.	Allotments.	Section.	Area.	Annual Rental.	Reasons for Voiding
Ballarat	1050/138	Ballarat Mentally Retarded Children's Welfare Association	138	Ballarat	12A 1	76 82	A. R. P. 0.2.26	\$ 6.00	New licence to issue

Department of Crown Lands and Survey,  
Melbourne, 4th May, 1970.

W. J. F. McDONALD,  
Minister of Lands.

Teaching Service Act 1958.

TEACHING SERVICE (CLASSIFICATION, SALARIES AND ALLOWANCES) REGULATIONS.

AMENDMENT No. 180 (C.S. & A. 23.)

THE Teachers Tribunal, in pursuance of the powers conferred by the Teaching Service Act 1958, hereby amends the Teaching Service (Classification, Salaries and Allowances) Regulations in the manner following, that is to say:—

PART I.—PROFESSIONAL OFFICERS.

In Clause 5 under the sub-heading "(d) Other Positions—" before the expression "Publications Officer" insert the expressions "Assistant Supervisor of Education of Backward Children; Assistant Supervisor of Education of Physically Handicapped Children;"

W. E. SAMPSON, Chairman.  
A. F. LE CLERCQ, Secretary.

Office of the Teachers Tribunal,  
Melbourne, 7th May, 1970.

**PUBLIC SERVICE NOTICES**

No. 459.

*Public Service Act 1958.*

THE Public Service Board, in pursuance of the powers conferred by the *Public Service Act 1958*, hereby amends the Public Service (Public Service Board) Regulations as shown below:—

**THIRD SCHEDULE.**

**PART B.**

**PROFESSIONAL DIVISION.**

*Scale of Rates of Annual Salaries.*

**ACTUARIAL OFFICERS, CHIEF SECRETARY'S DEPARTMENT.**

The salary scale shown is deleted and the following salary scale is inserted in lieu thereof:—

Class.	Annual Salary of Each Subdivision of Each Class.					
	1.	2.	3.	4.	5.	6.
	\$	\$	\$	\$	\$	\$
AC-1 ..	5,145	5,301	5,422	..	..	..
AC-2 ..	5,766	5,948	6,161	6,552	6,700	6,901
AC-3 ..	7,449	7,693	..	..	..	..
AC-4 ..	9,809	..	..	..	..	..
AC-5 ..	10,839	..	..	..	..	..

F. E. CAHILL, Chairman.  
V. P. SCULLY, Secretary.

Office of the Public Service Board,  
Melbourne, 1st May, 1970.

No. 460.

*Public Service Act 1958.*

THE Public Service Board, in pursuance of the powers conferred by the *Public Service Act 1958*, hereby amends the Public Service (Public Service Board) Regulations as follows:—

**PART V.—ALLOWANCES.**

**DIVISION II.—OVERTIME AND STAND-BY ALLOWANCES.**

After Regulation 129 the following heading and Regulation are inserted:—

“CHIEF SECRETARY'S DEPARTMENT—

*Fisheries and Wildlife Branch.*

129A. Officers and employees indicated who by reason of the nature of their duties may be required to undertake duty outside the normal hours of duty shall be paid commuted allowances at the annual rates (calculated to the nearest dollar) by applying the percentages set out hereunder to the annual standard salary as varied in accordance with the provisions of Regulation 87—

Office or Position.	Percentage of Total Emolument.
	%
Technical Assistant (Male), Grade II. ..	8
Technical Assistant (Male), Grade I. ..	8
Assistant (Game Management), Senior ..	8
Technical Officers employed on the Port Phillip Bay Environmental Study .. ..	8

Provided that this Regulation shall not apply to Technical Assistants employed on the Port Phillip Bay Environmental Study.”

*This Regulation shall have effect as on and from the 1st January, 1970.*

F. E. CAHILL, Chairman.  
V. P. SCULLY, Secretary.

Office of the Public Service Board,  
Melbourne, 24th April, 1970.

No. 461.

*Public Service Act 1958, Section 50.*

**REGULATIONS.—PART IV.—SALARIES AND INCREMENTS.**

THE Public Service Board, in pursuance of the powers conferred by the *Public Service Act 1958*, hereby amends its Regulations as shown below:—

**EIGHTH SCHEDULE.**

**TECHNICAL AND GENERAL DIVISION.**

Department and Office.	Scale of Rates of Annual Salary with Incremental Stages.
DEPARTMENT OF AGRICULTURE.	
Add—	
Technical Officer, Veterinary Laboratory	\$3,294–\$3,393–\$3,492–\$3,591– \$3,690–\$3,789–\$3,888– \$4,005–\$4,122–\$4,229

**TEMPORARY POSITIONS**

Department and Position.	Scale of Rates of Annual Salary with Incremental Stages.
DEPARTMENT OF AGRICULTURE.	
Add—	
Technical Officer, Veterinary Laboratory	\$3,294–\$3,393–\$3,492–\$3,591– \$3,690–\$3,789–\$3,888– \$4,005–\$4,122–\$4,229

*This Regulation shall have effect as on and from the 10th March, 1970.*

F. E. CAHILL, Chairman.  
V. P. SCULLY, Secretary.

Office of the Public Service Board,  
Melbourne, 24th April, 1970.

No. 463.

*Public Service Act 1958, Section 50.*

**REGULATIONS.—PART IV.—SALARIES AND INCREMENTS.**

THE Public Service Board, in pursuance of the powers conferred by the *Public Service Act 1958*, hereby amends its Regulations as shown below:—

**SIXTH SCHEDULE.**

**TEMPORARY EMPLOYEES.**

*Designations of Positions and Rates of Salaries.*

Department and Designation of Position.	Yearly Rate of Salary.		Increments (Annual).
	Minimum.	Maximum.	
GENERAL.	\$	\$	
Add—			
Programmer (Female) .. Assistant ..	4,706	4,983	1 of \$156 and 1 of \$121

*This Regulation shall have effect as on and from the 24th March, 1970.*

F. E. CAHILL, Chairman.  
V. P. SCULLY, Secretary.

Office of the Public Service Board,  
Melbourne, 27th April, 1970.

No. 462.

*Public Service Act 1958, Section 50.*

**REGULATIONS.—PART IV.—SALARIES AND INCREMENTS.**

THE Public Service Board, in pursuance of the powers conferred by the *Public Service Act 1958*, hereby amends its Regulations as shown below :—

**SIXTH SCHEDULE.**

**TEMPORARY EMPLOYEES.**

*Designations of Positions and Rates of Salaries.*

Department and Designation of Position.	Yearly Rate of Salary.		Increments (Annual).
	Minimum.	Maximum.	
	\$	\$	
DEPARTMENT OF AGRICULTURE.			
<i>Add—</i>			
MILK BOARD.			
Inspector, Grade II. ..	3,887	4,440	Σ
Inspector, Grade I. ..	3,660	3,887	Σ
Σ See Regulation 97 (2).			

F. E. CAHILL, Chairman.  
V. P. SCULLY, Secretary.

Office of the Public Service Board,  
Melbourne, 24th April, 1970.

No. 464.

*Public Service Act 1958, Section 50.*

**REGULATIONS.—PART IV.—SALARIES AND INCREMENTS.**

THE Public Service Board, in pursuance of the powers conferred by the *Public Service Act 1958*, hereby amends its Regulations as shown below :—

**THIRD SCHEDULE.**

**PART B.**

**PROFESSIONAL DIVISION.**

*Scale of Rates of Annual Salaries.*

**TECHNICAL OFFICER, PREMIER'S DEPARTMENT.**

The salary scale shown is deleted and the following salary scale is inserted in lieu thereof—

Class.	Annual Salary of Each Subdivision.		
	1.	2.	3.
	\$	\$	\$
TE-1 .. .. .	5,948	6,109	6,269

F. E. CAHILL, Chairman.  
V. P. SCULLY, Secretary.

Office of the Public Service Board,  
Melbourne, 1st May, 1970.

No. 466.

*Public Service Act 1958, Section 50.*

**REGULATIONS.—PART IV.—SALARIES AND INCREMENTS.**

THE Public Service Board, in pursuance of the powers conferred by the *Public Service Act 1958*, hereby amends its Regulations as shown below :—

**THIRD SCHEDULE.**

**PART B.**

**PROFESSIONAL DIVISION.**

*Scale of Rates of Annual Salaries.*

**WATER DISTRIBUTION OFFICERS, WATER SUPPLY DEPARTMENT.**

The salary scale shown is deleted and the following salary scale is inserted in lieu thereof—

Class.	Annual Salary of Each Subdivision of Each Class.			
	1.	2.	3.	4.
	\$	\$	\$	\$
WD-1 ..	5,673	5,811	6,002	6,410
WD-2 ..	7,000	..	..	..
WD-3 ..	8,192	..	..	..

*This Regulation shall have effect as on and from the 26th April, 1970.*

F. E. CAHILL, Chairman.  
V. P. SCULLY, Secretary.

Office of the Public Service Board,  
Melbourne, 1st May, 1970.

No. 465.

*Public Service Act 1958, Section 39.*

**REGULATIONS.—PART IV.—SALARIES AND INCREMENTS.**

THE Public Service Board, in pursuance of the powers conferred by the *Public Service Act 1958*, hereby amends its Regulations as shown below :—

**FOURTH SCHEDULE.**

**ADMINISTRATIVE DIVISION.**

*Amount of Salary Assigned to Offices in Class "A1".*

Office.	Yearly Rate of Salary.
	\$
<b>PREMIER'S DEPARTMENT.</b>	
<i>Add—</i>	
Senior Public Service Inspector (Organisation and Methods) Office of the Public Service Board	9,438

F. E. CAHILL, Chairman.  
V. P. SCULLY, Secretary.

Office of the Public Service Board,  
Melbourne, 1st May, 1970.

**EXAMINATION OF APPLICANTS FOR LICENCE AS SHORTHAND WRITER.**

IT is hereby notified that an examination of applicants for licence as Shorthand Writer will be held at the Royal Melbourne Institute of Technology, Building No. 1, Room 1.C.14, 124-126 Latrobe-street, Melbourne (enter through car park next door), on Saturday, the 27th June, 1970, at ten o'clock a.m.

Applications for permission to attend the examination together with an entry fee of two dollars ten cents (\$2.10) must be forwarded to reach the Secretary, Public Service Board, Treasury-place, Melbourne, 3002 (where a copy of the Regulations may be obtained), not later than Saturday, the 13th June, 1970.

Satisfactory evidence of—

- (1) Name in full ..
- (2) Having attained the age of twenty-one (21) years, and
- (3) Good moral character

should be submitted with application.

By order,

V. P. SCULLY,  
Secretary.

Office of the Public Service Board,  
Melbourne, 8th May, 1970.

**TENDERS****PUBLIC WORKS DEPARTMENT**

**TENDERS** will be received at Public Works Department, 2 Treasury-place, Melbourne, until **TWO** p.m. on dates shown and for purposes mentioned hereunder.

Particulars and tender forms available at Contracts Office, Room 8, Building Division, Parliament-place and at places indicated in brackets hereunder.

Abbreviations in brackets mean:—W.O.—Inspector of Works Office; P.S.—Police Station; C.S.—Consolidated School; H.E.S.—Higher Elementary School; H.S.—High School; Pr.S.—Primary School; T.S.—Technical School.

Tenders to be submitted on the Department's printed Tender Form and will not be received by telephone. All tenders must be on a "Firm Tender" basis. The lowest or any tender will not necessarily be accepted.

Address tenders to the Minister of Public Works, and endorse the envelope containing the tender "Tender for , closing Tuesday,

Hand delivered tenders to be placed in the Tender Box of the Public Works Department, located on the wall of the centre entrance foyer, Ground Floor, 2 Treasury-place, Melbourne.

No preliminary deposit is required with any tender, but a successful tenderer will be required to pay a deposit for any accepted tender of \$4,000 or over.

**Tuesday, 19th May, 1970.****Building, Electrical and Mechanical Works.**

Altona.—Connexion to M.M.B.W. sewer, Altona High School, Altona West Primary School 4862. (Re-advertised.) Ballarat.—Interior and exterior renovations, High School. (W.O., Ballarat.)

Carrum Downs.—Internal and external repairs and painting, Pr.S. 3613 and Residence.

Echuca.—Internal and external repairs and painting, High School. (W.O., Shepparton.)

Fairfield.—Demolish brick building, re-modelling, &c., Fairlea Female Prison.

Irymple.—Electrical installation, Glasshouse, Mildura Horticultural Research Station. (W.O., Mildura.)

Macleod.—Erection of L.T.C. Science extension, Technical School.

Macleod.—Mechanical services, science extensions, Technical School.

Wendouree.—Erection of two class-rooms and library, in brick veneer, Primary School 1813. (W.O., Ballarat.)

Wendouree.—Mechanical services, new class-room wing, Primary School 1813. (W.O., Ballarat.)

Yarram.—Renovations and re-blocking, High School Residence. (W.O., Traralgon and High School, Yarram.) (Amended Specification.)

**Site Works.**

Eaglehawk.—Construction of oval and playing fields, High School. (W.O., Bendigo.)

Sale.—Asphalt, concrete and drainage work, &c., Technical School. (W.O., Traralgon.)

**Miscellaneous.**

Fitzroy.—Maintenance cleaning for the period 1st June, 1970, to 31st May, 1973, Store, Education Department.

Westernport.—Dredging at Hastings, Ports and Harbours Branch. (Buoy Depot, Stony Point.) (Amended Specification.)

**Tuesday, 26th May, 1970.****Building, Electrical and Mechanical Works.**

Glenormiston.—Refrigeration system for three cool rooms, Agricultural College. (W.O., Warrnambool.)

Moonee Ponds.—Re-building of toilet block and erection of new shelter sheds, Central School 3987.

St. Arnaud.—External and internal renovations and painting, H.S. (W.O., Maryborough.)

Williamstown.—Erection of standard school hall type "800C", H.S.

Williamstown.—Electrical services, H.S.

Williamstown.—Mechanical services, H.S.

Wodonga.—Erection of a standard school hall type "800C", H.S. (W.O., Wangaratta.) (Re-advertised.)

**Tuesday, 2nd June, 1970.****Building, Electrical and Mechanical Works.**

Burwood.—Erection of new science wing in concrete veneer and provision of additional staff accommodation, High School.

Burwood.—Electrical installation, High School.

Burwood.—Mechanical services, High School.

Cheltenham.—External and internal renovations, High School.

Hawksburn.—Internal repairs and painting, Pr.S. 1467. (Amended Specification.)

Merrilands.—Internal renovations, High School.

Mornington.—Installation of fire service, High School. (W.O., Mornington.)

Sale.—Erection of new primary school in brick veneer, Pr.S. 5021. (W.O., Bairnsdale, Warragul and Traralgon.)

Sale.—Electrical installation, Pr.S. 5021. (W.O., Bairnsdale, Traralgon and Warragul.)

Sale.—Mechanical services, Pr.S. 5021. (W.O., Traralgon, Warragul and Bairnsdale.)

**Miscellaneous.**

Coburg.—Supply and placing in position of kitchen equipment in cafeteria, Teachers' College.

R. J. HAMER,  
Minister of Public Works.

Public Works Department,  
Melbourne, 3002, 11th May, 1970.

**TENDERS FOR THE SERVICE, 1970-71.****GENERAL STORES.**

**TENDERS** will be received until Eleven o'clock a.m., on Friday, the 29th May, 1970, from persons willing to supply the under-mentioned articles in such quantities as may be ordered by the Victorian Government during the period commencing 1st September, 1970, to 30th June, 1971.

Schedule No. 69A. Typewriters.

The prices tendered must not include sales tax.

Security—Five per cent. of total amount of tender accepted, but in no case will security of less than \$6 be required.

Schedules as above, with full particulars, may be obtained from the Secretary to the Tender Board, 2nd Floor, South Building, New State Public Offices, Treasury-place, Melbourne, 3002, by whom also the samples will be shown and any information afforded to persons tendering.

In all cases the total cost of each item must be extended in the columns provided.

Security will be required either in Commonwealth Treasury Bonds, or approved bank guarantee, fixed deposit receipt, Savings Bank deposit book, or non-negotiable cheque in favour of the Secretary to the Tender Board, as the tenderer may elect.

The security must be completed and the contract signed within five days of acceptance of the tender, failing which the service may be again advertised, or another tender accepted.

The lowest or any tender will not necessarily be accepted.

In the event of tenderers withdrawing or attempting to withdraw their tenders before notification of acceptance of same, or failing to take up their accepted tenders within the prescribed period after notification of acceptance, they may be disqualified from tendering or holding any future contracts for Government supplies for a period of twelve months, such disqualification to date from the notification of acceptance of tender. It is also stipulated that, if a tenderer be a member of a firm and such firm be interested in the contract, the tender shall be in the name of the firm and not in that of the individual and that, for a breach of this condition, the tender will be declared informal.

Tenders enclosed in a separate envelope, and having the words "Tender for——" (as the case may be) written thereon, must be deposited in the Tender-box at the Tender Board Offices, 2nd Floor, South Building, New State Public Offices, Treasury-place, Melbourne, 3002, or if sent by post, postage must be prepaid and the tenders addressed to the Chairman of the Tender Board, Tender Board Offices, 2nd Floor, South Building, New State Public Offices, Treasury-place, Melbourne, 3002, which office they must reach not later than by first post on the date of closing of tenders.

The conditions of contract are those published in the *Victoria Government Gazette*, No. 20, dated 18th March, 1970.

The Treasury,  
Melbourne, 11th May, 1970.

HENRY BOLTE,  
Treasurer.

## TENDERS FOR THE SERVICE, 1970-71.

## REQUISITES FOR EDUCATION DEPARTMENT.

TENDERS will be received until Eleven o'clock a.m. on Friday, 29th May, 1970, from persons willing to supply the under-mentioned articles, in such quantities as may be ordered by the Victorian Government, from the 1st September, 1970, to the 30th June, 1971:—

## Schedule No.

## 1. Requisites (Junior School).

The prices tendered must not include sales tax.

Security.—Five per cent. of total amount of tender accepted, but in no case will security of less than \$5 be received.

Schedules as above, with full particulars, may be obtained from the Secretary to the Tender Board, by whom also the samples will be shown and any information afforded to persons tendering.

*Should the tenderer be in a position to supply a suitable substitute of Commonwealth production or manufacture in place of any sample exhibited that may be of imported origin, he may tender for such substitute, but must submit with his tender a sample of the article offered.*

In all cases the country of origin of the articles tendered must be stated, and the total cost of each item extended in the columns provided.

Security will be required either in Commonwealth Treasury Bonds, or approved bank guarantee, fixed deposit receipt, Savings Bank deposit book, or non-negotiable cheque in favour of the Secretary to the Tender Board, as the tenderer may elect.

The security must be completed and the contract signed within five days of acceptance of the tender, failing which the contract may be again advertised, or another tender accepted.

The lowest or any tender will not necessarily be accepted.

In the event of tenderers withdrawing or attempting to withdraw their tenders before notification of acceptance of same, or failing to take up their accepted tenders within the prescribed period after notification of acceptance, they may be disqualified from tendering or holding any future contracts for Government supplies for a period of one year, such disqualification to date from the notification of acceptance of tender. It is also stipulated that, if a tenderer be a member of a firm and such firm be interested in the contract, the tender shall be in the name of the firm and not in that of the individual and that, for a breach of this condition the tender will be declared informal.

Tenders enclosed in a separate envelope, and having the words "Tender for———" (as the case may be) written thereon, must be deposited in the Tender-box at the Tender Board Offices, 2nd Floor, South Building, New State Public Offices, Treasury-place, Melbourne, 3002, or if sent by post, postage must be prepaid, and the tenders addressed to the Chairman of the Tender Board, Tender Board Offices, 2nd Floor, South Building, New State Public Offices, Treasury-place, Melbourne, 3002, which office they must reach not later than by first post on the date of closing of tenders.

## CONDITIONS OF CONTRACT.

1. Except where definite quantities are specified the Government will not be bound to order from the contractor all the articles enumerated in the schedule, but only those articles, and such quantities of those articles, as it may be found necessary to order. Should the Government, however, require a larger supply of any article than the estimated quantity stated in the schedules, the contractor will nevertheless be bound to supply the same at contract rates.

The Government reserves the right to purchase otherwise than from the contractor articles of any of the several kinds enumerated in the schedules the purchase of which is, in the opinion of the Tender Board, necessary in order to meet special circumstances or special requirements.

2. The supplies are to be the same as sample where so stated, and of the particular manufacture indicated in the schedule of tenders. In the case of different makers' goods, the contractor will be required to supply the kind ordered. *The supplies are to be the best quality of their several kinds or manufacture.* In the event of the tender having been accepted for goods manufactured within the Commonwealth or manufactured within any other part of the British Empire (as the case may be), all such goods supplied shall, if required by the Government, bear evidence

that they are of the particular manufacture tendered for, and, in addition, the contractor may at any time during the currency of the contract be called on to furnish a statutory declaration as to the country of origin of the goods supplied.

3. Except where otherwise stated in the schedule, the value of all packages, cases, casks, &c., whether bulk be broken or not, must be included in the prices stated in the contractor's tender; all such packages, &c., to be considered the property of the Government, and no charges or expenses whatsoever beyond the price tendered and set out in the schedule will be allowed to the contractor for any articles or packages, cases, casks, &c. The net weight or quantity only will be paid for. Contractors must provide, without extra charge, whatever labour may be required in the packing of stores, and the stores shall be packed in such a manner as shall secure them from injury during transit, and until delivery such stores shall be at the risk of the contractor.

4. All orders for supplies will emanate from the Education Department. The goods shall be delivered as may be directed by the officer ordering the supply.

5. Supplies ordered for delivery in the Melbourne District are to be delivered free of all charges (whether cartage, freight, &c.), and, for the purposes of these contracts, Melbourne District will include a radius of 12 miles from the Elizabeth-street Post Office. For supplies outside that radius the goods must be delivered free on rails at Flinders-street or Spencer-street Railway Stations as required.

6. Arrangements as to time of delivery and inspection of goods will be made by the Secretary, Education Department, or such other officer whom he may appoint.

7. Orders must receive prompt execution; and in the event of the goods not being delivered within forty-eight hours after the contractor shall have received the order, or within such other time as the order may specify for delivery, it will be competent for the officer named in clause 6, or the head of the department to whom the goods are to be supplied, on giving the contractor twenty-four hours' notice to purchase the supplies, or any like supplies that are suitable for the service, at the contractor's risk, and the extra expense incurred over and above the contract price (if any) will be deducted from the contractor's account or from the security money.

8. Delivery will not be deemed to have been made until the goods have been approved. In case of the rejection or return of any supplies, the contractor shall bear the whole cost of replacing the supplies rejected or returned, otherwise purchases will be effected at the contractor's risk and the extra expense deducted as in clause 7.

9. The official order issued by the Education Department shall be forwarded by the contractor to the officer authorized to accept delivery, who shall acknowledge thereon the receipt of the goods accepted and return the order to the contractor, who will attach same to his claim for payment.

10. All orders, duly receipted, shall be returned to the Education Department at the end of each month, accompanied by an account in the prescribed form for the articles supplied during the month, and, on receipt of same, the contractor shall be entitled to payment, due time to be allowed for the examination and verification of the claim.

11. The acceptance of the supplies shall be subject to the approval of the officer authorized to take delivery of the stores, or such other officer as shall be named in the schedules. Delivery of the articles will not be deemed to have been made until they have been handed in good order and condition to the head teacher of the school or such other person as may be authorized to accept delivery, &c. The contractor may, however, claim a survey on any goods objected to; but in that case he must, within twenty-four hours after objection is made give notice thereof, in writing, to the officer rejecting the goods. If, after the delivery of the supplies has been taken, any deficiency or defect is discovered therein, such deficient or defective stores may be returned to the contractor.

12. The members of Boards of survey will be appointed by the Treasurer of the State for the time being, and the decision of the Board is to be considered as final. If the Board shall decide that the article is not of proper quality it must be immediately replaced by the contractor, failing which it, or any like supply that is suitable for the service, will be procured elsewhere, and the survey fees and extra expense (if any) will be deducted as in clause 7.

13. All goods forwarded under these contracts shall, where practicable, be forwarded by rail, and all consignments shall bear the number of the consignment notes under which they are forwarded, and also the name of the contractor by whom consigned, on a legibly-written business label.

14. When the contractor is required to make delivery of goods at a railway station for transmission by rail, he shall obtain a receipt for the goods in duplicate on the Stores and Transport consignment note, at the same time handing in a triplicate and quadruplicate of the form as an authority for the Railways to act as agent for, and charge the freight to, the Stores and Transport Office or such other Department as shall be named therein. He shall as soon as possible, and not later than twenty-four hours thereafter, deliver the original at the Tender Board Offices, the duplicate to be forwarded to consignee in accordance with clause 15, and the quintuplicate to be retained by himself. Should the goods thus forwarded be rejected, the contractor must bear the cost of replacing such goods, for which service the departmental consignment note is not to be used. Any infringement of this condition will subject the contractor to such mulct as the Tender Board may recommend under clause 17 of these conditions. Such mulct may be deducted as in clause 7.

15. Immediately after the consignment of the goods, the officer to whom they are forwarded shall be notified by the contractor, on the duplicate consignment note provided for the purpose, that the goods have been sent. On receipt of this document, the officer to whom it has been forwarded shall acknowledge thereon the receipt of the goods without delay to the Stores and Transport Office. In the event of loss through failure on the part of the contractor to comply with this condition he will be held responsible, and the amount of the loss incurred for same will be deducted as in clause 7.

16. Should the order on the contractor specially provide that goods of a fragile character, or such as are liable to suffer loss by leakage, shall be consigned at the risk of the Railways Commissioners under special freight conditions, the contractor shall in such instance provide in writing, on the consignment note an intimation to that effect, failing which, in the event of loss, he shall bear the whole cost of replacing the goods, the amount being deducted from the contractor's account or the security money.

17. A refusal to execute orders, irregularity in the quantity or quality of the supplies, delay in delivering or replacing them when required, or non-compliance with the terms of clauses 14 and 15 of these conditions respecting the forwarding of consignment notes, &c., will subject the contractor, upon report from the Tender Board, to such mulct not exceeding one hundred dollars as the said Treasurer may direct and the amount may be deducted as in clause 7. It will also be in the power of the said Treasurer upon such refusal, irregularity, or delay, to terminate the contract forthwith, and declare forfeit the whole or any portion of the security money; and, in addition, the contractor will be disqualified from tendering or holding any future contract or contracts for a period of one year from the date of such disqualification.

18. Contractors are not at liberty to transfer their contracts under cover of power of attorney, coupled with an interest or otherwise; and no such transfer will be recognized by the Government. If it is found during the currency of the contract that the contractor has not conformed to the condition of advertisement—which stipulates that if a tenderer be a member of a firm, and such firm be interested in the contract, the tender shall be in the name of the firm, and not in that of the individual—then the said Treasurer may, on the recommendation of the Tender Board, determine the contract, and forfeit the security money.

19. The contracts entered into under these conditions are not to be considered as being broken, infringed, or vitiated by the importation of stores for the Government service, or by any contracts or purchases made by the Agent-General for Victoria, or by any contracts or agreements made for supplies to Technical Schools, or by any article being made at any Government establishment and supplied for the use of the Education Department, or by the consumption of the surplus stock of any Government establishment.

20. Notwithstanding anything contained to the contrary in section 152 of the Customs Act 1901-36, it is hereby expressly provided that upon any alteration of the duty collected affecting the goods included in this contract, the contract price shall not be altered, and the contract may be terminated at the opinion of either party by two months' notice in writing from the first day of the calendar month next ensuing, and within the period for which the contract is made. The contract for the unaffected items shall remain in full force and effect. Any notice to be served under this condition shall be deemed to have been duly served if sent to the contractor in a registered letter to his last known place of business or abode.

21. Under no circumstances, other than those mentioned in clause 20, will a contractor be permitted to abandon his contract. In the event of the contractor failing to carry

on the contract, the contract security money will in that case be absolutely forfeited; and, in addition, the contractor will be held liable for any loss which the Government may sustain in consequence of such failure.

22. Should the Minister of Education for the time being decide to discontinue the use of any book, map, or any other article in the schedule, or to direct that any book, map, or any other article other than those enumerated therein be taken into use he shall at any time give six months' notice of such intention or decision to the contractor, and after the expiration of the period of such notice the Education Department shall not be bound to take any further supply of such book, map, or any other article, nor shall the contractor be bound to supply the same, and all books or maps not in the schedule, but which it may be decided to introduce, shall be supplied by the contractor after expiration of such notice at a price to be agreed on between the Minister of Education for the time being and the contractor.

HENRY BOLTE,  
Treasurer.

The Treasury,  
Melbourne, 11th May, 1970.

## PRIVATE ADVERTISEMENTS

The Sewerage Districts Act.

FOSTER SEWERAGE AUTHORITY.—GENERAL NOTICE.  
SIXTH SCHEDULE.

THE Foster Sewerage Authority, having made provision for carrying off the sewage from each and every property which or part of which is within the Sewerage Area hereinafter described, doth hereby declare that on and after the 7th day of May, 1970, each and every property which or any part of which is within the said Sewerage Area shall be deemed to be a seweraged property within the meaning of the Sewerage Districts Act 1958.

The properties within the boundary of the Sewerage Area hereinbefore referred to are:—

Area No. 1.

Allan-court: Street Nos. 1 to 3.  
Berry-street: Street Nos. 1 to 5; 2 to 10.  
Boundary-road: Street Nos. 1 to 5; 2 to 4.  
Bridge-street: Street Nos. 3 to 5; 2 to 6.  
Bruce-court: Street Nos. 1 to 11; 2 to 10.  
Byrnes-street: Street Nos. 1 to 3 and 2.  
Charles-street: Street Nos. 1 to 9 and 4.  
Church Hill-road: Street Nos. 1 to 15; 2 to 20.  
Collis-street: Street Nos. 1 to 41; 14 to 18.  
Cooper-road: Street Nos. 1 to 9; 2 to 6.  
Court-street: Street Nos. 9 and 24 to 28.  
Davis-road: Street Nos. 1 to 9; 4 to 14.  
Devlin-road: Street Nos. 19 to 47; 2 to 38.  
Fleet-street: Street Nos. 7 to 15.  
Fuller-road: Crown allotments 4 and 4A, section B, Parish of Wonga Wonga South.  
Gibbs-street: Street Nos. 1 to 21; 2 to 16.  
Hall-road: Street Nos. 1 to 13; 4 to 34.  
Hoddle-road: Street Nos. 5 to 37; 4 to 28.  
Hyland-street: Street Nos. 3 to 13.  
Jones-street: Street Nos. 2 to 16.  
Kaffir Hill-road: Street Nos. 5 to 21.  
Landy-road: Street Nos. 1 to 13.  
Lower Franklin-road: Street Nos. 2 to 54.  
McDonald-street: Street Nos. 1 to 15; and south side opposite.  
Main-street: McDonald-street to No. 87; McDonald-street to No. 92.  
Mine-road: Street Nos. 1 to 13; 4 to 8.  
Nelson-street: East side, Main-street to Jones-street; west side, Nos. 8 to 38.  
Pioneer-street: Street Nos. 1 to 93; 2 to 32.  
Reserve-street: Street Nos. 1 to 3; 4 to 8; and Foster Recreation Reserve.  
Richards-court: Street Nos. 1 to 3 and 2.  
Sherry-street: Street Nos. 1 to 3; 2 to 6.  
South Gippsland Highway: Crown allotment 26, section 2, Township of Foster.  
Station-road: Street Nos. 31 to 131; 2 to 130.  
Toora-road: Street Nos. 1 to 35; 2 to 26.  
Victory-avenue: Street Nos. 3 to 39; 4 to 32.  
Wilson-road: Street Nos. 4 to 8.  
Winchester-street: Street Nos. 1 to 15; 2 to 24.  
Wood-street: Street Nos. 2 to 6 (to Devlin-road).

By Order of the Foster Sewerage Authority.

J. H. McDONALD, Chairman.  
W. J. HOBSON, Secretary.

SPRINGVALE AND NOBLE PARK SEWERAGE  
AUTHORITY.

GENERAL NOTICE.

THE above-mentioned Sewerage Authority having made provision for carrying off the sewage from each and every property which, or any part of which, is within the Sewerage Areas hereinafter described, doth hereby declare that on and after the 1st day of May, 1970, each and every property which, or any part of which, is within the said Sewerage Areas shall be deemed to be a seweraged property within the meaning of the Sewerage Districts Act.

The boundaries of the Sewerage Areas hereinbefore referred to are:—

*Sewerage Area No. 286.—Springvale.*

Commencing at a point on the northern side of Athol-road, such point being the south-western angle of lot 1 on lodged plan of subdivision No. 71421; thence westerly along the northern side of Athol-road to the south-eastern angle of lot 6, on lodged plan of subdivision No. 67014; thence northerly along the eastern boundaries of the said lot 6 and lot 7, on lodged plan of subdivision No. 72466 to the north-eastern angle of the said lot 7; thence easterly along the southern boundaries of lots 12 and 13, on lodged plan of subdivision No. 80122 to the south-eastern angle of the said lot 13; thence northerly along the eastern boundary of the said lot 13 to its north-eastern angle; thence generally northerly along the eastern side of Dianne-court to the eastern angle of lot 28, on lodged plan of subdivision No. 88404; thence easterly along the northern boundary of the said lot 28 to the western boundary of lot 32, on the said lodged plan; thence northerly along the western boundary of the said lot 32 to its north-western angle; thence easterly along the northerly boundary of the said lot 32 and the easterly prolongation thereof to the eastern side of Olympic-avenue; thence southerly along the eastern side of Olympic-avenue to its intersection with the northern side of Bellavista-court; thence easterly along the northern side of Bellavista-court to the western angle of lot 18, on the said lodged plan; thence north-easterly along the north-western boundary of the said lot 18 to its northern angle; thence southerly along the eastern boundaries of the said lot 18 and lots 19 and 20, on the said lodged plan, and the southerly prolongation thereof to the point of commencement.

*Sewerage Area No. 287.—Springvale.*

Commencing at a point being the intersection of the eastern side of Olympic-avenue and the northern side of Wardale-road; thence easterly along the northern side of Wardale-road to the south-western angle of lot 12, on lodged plan of subdivision No. 79052; thence northerly along the western boundary of the said lot 12 to its north-western angle; thence westerly along the southern boundary of lot 60, on lodged plan of subdivision No. 63592 to its south-western angle; thence northerly along the western boundary of the said lot 60 to the southern side of Ludwig-street; thence easterly along the southern side of Ludwig-street to its intersection with the western side of Levin-street; thence southerly along the western side of Levin-street to its intersection with the southern side of Wardale-road; thence westerly along the southern side of Wardale-road to its intersection with the eastern side of Van Wyk-court; thence generally southerly along the eastern side of Van Wyk-court to the north-western angle of lot 48, on lodged plan of subdivision No. 79052; thence southerly along the western boundary of the said lot 48 to its south-western angle; thence westerly along the northern boundaries of lots 11 and 10, on lodged plan of subdivision No. 71421 to the north-western angle of the said lot 10; thence southerly along the eastern boundaries of lots 5, 6 and 7, on lodged plan of subdivision No. 88404 to the southern angle of the said lot 7; thence north-westerly along the south-western boundary of the said lot 7 and the north-westerly prolongation thereof to the northern side of Bellbird-court; thence westerly along the northern side of Bellbird-court to the south-western angle of lot 3, on the said lodged plan; thence northerly along the western boundary of the said lot 3 to its north-western angle; thence westerly along the northern boundary of lot 1, on the said lodged plan to the eastern side of Olympic-avenue; thence northerly along the eastern side of Olympic-avenue to the point of commencement.

*Sewerage Area No. 288.—Noble Park.*

All those pieces of land being lots 1 to 19 inclusive, on plan of subdivision No. 2453 lodged at the Offices of the City of Springvale.

Streets or parts of streets concerned in this area are Harold-road, Simon-avenue, Jeffery-avenue and Halinka-court.

For the purposes of these descriptions the lodged plans of subdivision unless otherwise specified shall be those lodged at the Office of Titles, Melbourne.

By order of the Springvale and Noble Park Sewerage Authority.

I. R. HETHERINGTON, Chairman.  
H. L. WILLIAMS, Secretary.

4167

GEELONG WATERWORKS AND SEWERAGE TRUST.  
GAZETAL OF WATER MAINS.

NOTICE to owners of tenements in the under-mentioned streets and private streets, lanes, courts and alleys opening thereto—

*Shire of South Barwon.*

Princes Highway, 132 feet east from existing dead end to lot 1.  
Konrads-crescent, 680 feet west from lot 192 to Valley-road south.  
Hendricks-court, 349 feet west from lot 210.  
Fryers-road, 347 feet west from Belle Vue-avenue to lot 217.  
Bundoora-crescent, 317 feet north from Gwyther-road to lot 43.  
Burdoo-drive, 1,105 feet between Gloucester-street and Pioneer-road.  
Pioneer-road, 528 feet west from existing dead end to Burdoo-drive.  
Davertry-avenue, 465 feet west from existing dead end to Burdoo-drive.  
Coventry-court, 581 feet south from Pioneer-road.  
Cotswold-court, 612 feet south from Daventry-avenue.  
Cannes-court, 627 feet south from Maidie-street.  
St. Cloud-court, 120 feet between Maidie-street and Montpellier-drive.  
Montpellier-drive, 484 feet south from St. Cloud-court to lot 52.  
Ryong-street, 649 feet north from existing dead end to Heyers-road.  
Merinda-court, 440 feet west from Ryong-street.

*Shire of Corio.*

Alcona-court, 269 feet north from Bruce-street.  
Guin-drive, 176 feet south from McClelland-avenue to lot 52.  
Martain-avenue, 158 feet north from Beverley-crescent to lot 10.  
Walsgott-street, 220 feet north from lot 58 to Kerr-street.

The main pipe in the said streets being laid down, the owners of all tenements situated above are hereby required on or before the 1st day of July, 1970, to cause a proper pipe and stop cocks to be laid so as to supply water within such tenements from the main pipe.

The common seal of the Geelong Waterworks and Sewerage Trust was hereunto affixed this 29th day of April, 1970, in the presence of—

(SEAL) J. CARR, Chairman.  
B. HENSHAW, Secretary.

4204

GEELONG WATERWORKS AND SEWERAGE TRUST:

PURSUANT to section 60 of the *Geelong Waterworks and Sewerage Act 1958* (No. 6263), the Trust has prepared plans to indicate the particulars of sewers and underground works in or adjacent to the following localities within the Drainage Area.

Torbreck and Benambra streets, Corio, Shire of Corio.

Notice is hereby given that the plans indicated above are open for public inspection at the Trust's Offices, Ryrie-street, Geelong, between the hours of 9 a.m. and 5 p.m., from Monday to Friday, public holidays excepted, by the owners and occupiers of land or premises within the Drainage Area.

4205

B. C. HENSHAW, Secretary.

*Water Act.*

SHIRE OF SHEPPARTON WATERWORKS TRUST.

EXTENSION OF WATERWORKS DISTRICT AND CONSTRUCTION OF WORKS FOR THE SUPPLY OF WATER TO DOOKIE.

NOTICE is hereby given that the Shire of Shepparton Waterworks Trust has made application to the Minister of Water Supply for the extension of its Waterworks District and the construction, maintenance, and continuance of Water Supply Works within that extended District to supply the town of Dookie under the provisions of the Water Act.

A general plan and description of the proposed works have been submitted with the application, and copies of same may be seen at the Shepparton Shire Office at Nixon-street, Shepparton, during office hours.

Dated at Shepparton, the 1st day of May, 1970.

4012

J. W. REED, Secretary.

NOTICE is hereby given that C. Monteath & Sons (Successors) Proprietary Limited, has applied for a lease, pursuant to section 134 of the *Land Act 1958*, for a term of ten years in respect of allotment 9, section 101A, City of South Melbourne, containing 1 rood 18 2/10 perches, as a site for a factory and general engineering works.

3793



**NOTICE** is hereby given that Chorki Ski Club has applied for a lease under section 134 of the *Land Act 1958*, for a term of 21 years in respect of an area of 1 rood 10 perches, more or less, being allotment 4, section A, Parish of Hotham, as a site for a ski lodge.—(H.O.33691.)

4130

T. C. TATTON, Secretary,  
Chorki Ski Club.

**NOTICE OF INTENTION TO APPLY FOR A LICENCE TO DIVERT WATER AND CUT RACE (RE-ISSUE) FROM THE RIVER MURRAY, AT LIPAROO.**

**I** HEREBY give notice that I intend to apply for a licence empowering me to divert water for a term of fifteen years to the extent of 150 acre-feet per annum at a maximum rate of 3 acre-feet per day of 24 hours for the irrigation of 50 acres of vines, being part of allotment 17, Parish of Liparoo, and to occupy certain Crown lands for works of diversion, and to cut a race thereon.

Any objection to such application must be forwarded, in writing, to reach the State Rivers and Water Supply Commission, Melbourne, before 12th June, 1970, being 30 days from the first publication of this notice.

LEO. EDWARD ENGLEFIELD.

Box 124, Robinvale, 3549.

4264

**NOTICE OF INTENTION TO APPLY FOR A LICENCE TO DIVERT WATER AND CUT RACE (RE-ISSUE) FROM THE RIVER MURRAY, AT TINTALDRA.**

**I** HEREBY give notice that I intend to apply for a licence empowering me to divert water for a term of fifteen years to the extent of 40 acre-feet per annum at a maximum rate of 4 acre-feet per day of 24 hours for the irrigation of 20 acres of summer crops, being part of allotment 10, section 1A, Parish of Tintaldra, and to occupy certain Crown lands for works of diversion, and to cut a race thereon.

Any objection to such application must be forwarded, in writing, to reach the State Rivers and Water Supply Commission, Melbourne, before 12th June, 1970, being 30 days from the first publication of this notice.

KEVIN JAMES CLARKE.

"Bonna Vista", Tintaldra, 3708.

4265

**NOTICE OF INTENTION TO APPLY FOR A LICENCE TO DIVERT WATER AND CUT RACE (RE-ISSUE) FROM THE RIVER MURRAY, AT PIANGIL.**

**I** HEREBY give notice that I intend to apply for a licence empowering me to divert water for a term of fifteen years to the extent of 42 acre-feet per annum at a maximum rate of 6 acre-feet per day of 24 hours for the irrigation of 14 acres of vines and market gardens, being part of allotment 147B and closed road, Parish of Piangil, and to occupy certain Crown lands for works of diversion, and to cut a race thereon.

Any objection to such application must be forwarded, in writing, to reach the State Rivers and Water Supply Commission, Melbourne, before 12th June, 1970, being 30 days from the first publication of this notice.

GIUSEPPE GALLICO.

Piangil.

4266

**NOTICE OF INTENTION TO APPLY FOR A LICENCE TO DIVERT WATER AND CUT RACE (RE-ISSUE) FROM THE RIVER MURRAY, AT NANGILOC.**

**I** HEREBY give notice that I intend to apply for a licence empowering me to divert water for a term of fifteen years to the extent of 54 acre-feet per annum at a maximum rate of 3 acre-feet per day of 24 hours for the irrigation of 18½ acres of citrus, being part of allotment 19, part of lot 4, lodged plan 26036, Parish of Carwarp, and to occupy certain Crown lands for works of diversion, and to cut a race thereon.

Any objection to such application must be forwarded, in writing, to reach the State Rivers and Water Supply Commission, Melbourne, before 12th June, 1970, being 30 days from the first publication of this notice.

ERIC ANDREW WRIGHT.

Nangiloc P.O.

4285

**NOTICE OF INTENTION TO APPLY FOR A LICENCE TO DIVERT WATER AND CUT RACE FROM THE RIVER MURRAY, AT NANGILOC.**

**WE** hereby give notice that we intend to apply for a licence empowering us to divert water for a term of fifteen years to the extent of 126 acre-feet per annum at a maximum rate of 3 acre-feet per day of 24 hours for the irrigation of citrus and vegetables, being part of

allotments 21 and 22, section B, Parish of Carwarp, and to occupy certain Crown lands for works of diversion, and to cut a race thereon.

Any objection to such application must be forwarded, in writing, to reach the State Rivers and Water Supply Commission, Melbourne, before 12th June, 1970, being 30 days from the first publication of this notice.

LAWRENCE GEORGE MCEWAN.  
BETTY MCEWAN.

Nangiloc.

4165

**NOTICE OF INTENTION TO APPLY FOR A LICENCE TO DIVERT WATER AND CUT RACE (RE-ISSUE) FROM THE RIVER MURRAY, AT NARRUNG.**

**WE** hereby give notice that we intend to apply for a licence empowering us to divert water for a term of fifteen years to the extent of 165 acre-feet per annum at a maximum rate of 4 acre-feet per day of 24 hours for the irrigation of citrus and vegetables, being part of allotment part A, section PR, Parish of Narrung, and to occupy certain Crown lands for works of diversion, and to cut a race thereon.

Any objection to such application must be forwarded, in writing, to reach the State Rivers and Water Supply Commission, Melbourne, before 12th June, 1970, being 30 days from the first publication of this notice.

ALEXANDER FISHER.  
NORA FISHER.

Piangil, Vic., 3597.

4173

**NOTICE OF INTENTION TO APPLY FOR A LICENCE TO DIVERT WATER AND CUT RACE (RE-ISSUE) FROM THE GOULBURN RIVER, AT TRAWOOL.**

**I** HEREBY give notice that I intend to apply for a licence empowering me to divert water for a term of five years to the extent of 12 acre-feet per annum at a maximum rate of 2 acre-feet per day of 24 hours for the irrigation of lucerne and vegetable growing, being part of allotments 120 and 121, Parish of Wyndham, and to occupy certain Crown lands for works of diversion, and to cut a race thereon.

Any objection to such application must be forwarded, in writing, to reach the State Rivers and Water Supply Commission, Melbourne, before 12th June, 1970, being 30 days from the first publication of this notice.

LESLIE STEPHENS.

Box 24, P.O., Seymour, 3660.

4176

**NOTICE OF INTENTION TO APPLY FOR A LICENCE TO DIVERT WATER AND CUT RACE (RE-ISSUE) FROM THE RIVER MURRAY (BILLABONG), AT IRAAK.**

**I** HEREBY give notice that I intend to apply for a licence empowering me to divert water for a term of fifteen years to the extent of 42 acre-feet per annum at a maximum rate of 3 acre-feet per day of 24 hours for the irrigation of vegetables, trees and vines, being part of allotment A, part lot 8, L.P.9767, Parish of Carwarp, and to occupy certain Crown lands for works of diversion, and to cut a race thereon.

Any objection to such application must be forwarded, in writing, to reach the State Rivers and Water Supply Commission, Melbourne, before 12th June, 1970, being 30 days from the first publication of this notice.

JAMES ROBERT MASON.

Box 480, Red Cliffs, Victoria.

4179

**NOTICE OF INTENTION TO APPLY FOR A LICENCE TO DIVERT WATER AND CUT RACE (RE-ISSUE) FROM THE RIVER MURRAY (BILLABONG), AT IRAAK.**

**I** HEREBY give notice that I intend to apply for a licence empowering me to divert water for a term of fifteen years to the extent of 1½ acre-feet per annum at a maximum rate of ½ acre-foot per day of 24 hours for the irrigation of vegetables, being part of Crown land in the Parish of Carwarp, and to occupy certain Crown lands for works of diversion, and to cut a race thereon.

Any objection to such application must be forwarded, in writing, to reach the State Rivers and Water Supply Commission, Melbourne, before 12th June, 1970, being 30 days from the first publication of this notice.

JAMES ROBERT MASON.

Box 480, Red Cliffs, Victoria.

4180

**NOTICE OF INTENTION TO APPLY FOR A LICENCE TO DIVERT WATER AND CUT RACE (RE-ISSUE) FROM THE RIVER MURRAY (CARWARP CREEK), AT IRAAK.**

I HEREBY give notice that I intend to apply for a licence empowering me to divert water for a term of fifteen years to the extent of 75 acre-feet per annum at a maximum rate of 3 acre-feet per day of 24 hours for the irrigation of 25 acres of vegetables, being part of allotment 3, L.P.9767, Parish of Carwarp, and to occupy certain Crown lands for works of diversion, and to cut a race thereon.

Any objection to such application must be forwarded, in writing, to reach the State Rivers and Water Supply Commission, Melbourne, before 12th June, 1970, being 30 days from the first publication of this notice.

GUIDO DALAFIOR.

16 Willis-street, Morwell, Victoria. 4181

**NOTICE OF INTENTION TO APPLY FOR A LICENCE TO DIVERT WATER AND CUT RACE (RE-ISSUE) FROM THE RIVER MURRAY, AT WEMEN.**

I HEREBY give notice that I intend to apply for a licence empowering me to divert water for a term of fifteen years to the extent of 147 acre-feet per annum at a maximum rate of 7 acre-feet per day of 24 hours for the irrigation of vines and pasture, being part of allotment 7, part lot 2, lodged plan 38500, Parish of Wemen, and to occupy certain Crown lands for works of diversion, and to cut a race thereon.

Any objection to such application must be forwarded, in writing, to reach the State Rivers and Water Supply Commission, Melbourne, before 12th June, 1970, being 30 days from the first publication of this notice.

ALMA JOYCE WILLIAMS.

Wemen P.O., 3549. 4189

**NOTICE OF INTENTION TO APPLY FOR A LICENCE TO DIVERT WATER AND CUT RACE (RE-ISSUE) FROM THE RIVER MURRAY, AT PIANGIL.**

I HEREBY give notice that I intend to apply for a licence empowering me to divert water for a term of fifteen years to the extent of 50 acre-feet per annum at a maximum rate of 2 acre-feet per day of 24 hours for the irrigation of citrus, stone fruit and pasture, being part of allotment 153a, Parish of Piangil, and to occupy certain Crown lands for works of diversion, and to cut a race thereon.

Any objection to such application must be forwarded, in writing, to reach the State Rivers and Water Supply Commission, Melbourne, before 12th June, 1970, being 30 days from the first publication of this notice.

FRASER EDWARD JOHN NICHOLS.

Box 63, Piangil, Victoria, 3597. 4190

**NOTICE OF INTENTION TO APPLY FOR A LICENCE TO DIVERT WATER AND CUT RACE (RE-ISSUE) FROM THE RIVER MURRAY, AT TORRUMBARRY.**

TORRUMBARRY Estate Company Pty. Ltd., hereby gives notice that it intends to apply for a licence empowering it to divert water for a term of fifteen years to the extent of 200 acre-feet per annum at a maximum rate of 10 acre-feet per day of 24 hours for the purpose of irrigating 100 acres of pasture, being part of allotments 9, 9a, 15, 15a and 20, section A, allotments 5, 7 and 19, section 2 (excluding lots 2 and 3 on plan of subdivision 69483), and allotments 25 and 26, section 3, allotment 20, section 8 and Turrumberry P.R., Parish of Turrumberry North, and to occupy certain Crown lands for works of diversion, and to cut a race thereon.

Any objection to such application must be forwarded, in writing, to reach the State Rivers and Water Supply Commission, Melbourne, before 12th June, 1970, being 30 days from the first publication of this notice.

TORRUMBARRY ESTATE CO. PTY. LTD.

Torrumbarry Estate, Torrumbarry. 4281

**NOTICE OF INTENTION TO APPLY FOR A LICENCE TO DIVERT WATER AND CUT RACE (RE-ISSUE) FROM THE RIVER MURRAY, AT ROBINVALE.**

I HEREBY give notice that I intend to apply for a licence empowering me to divert water for a term of fifteen years to the extent of 64 acre-feet per annum at a maximum rate of 10 acre-feet per day of 24 hours for the development and maintenance of Robinvale Riverside Park, being part of allotment A, Parish of Bumbang, and to occupy certain Crown lands for works of diversion, and to cut a race thereon.

Any objection to such application must be forwarded, in writing, to reach the State Rivers and Water Supply Commission, Melbourne, before 12th June, 1970, being 30 days from the first publication of this notice.

4203

J. D. LAURITZ, Shire Secretary.

**NOTICE OF INTENTION TO APPLY FOR A LICENCE TO DIVERT WATER AND CUT RACE (RE-ISSUE) FROM THE LITTLE RIVER, AT LITTLE RIVER.**

WE hereby give notice that we intend to apply for a licence empowering us to divert water for a term of fifteen years to the extent of 12 acre-feet per annum at a maximum rate of 6 acre-feet per day of 24 hours for lot 2 on lodged plan 74028, Parish of Murtcaim, being part of allotments B and C, section 26, Parish of Murtcaim, and to occupy certain Crown lands for works of diversion, and to cut a race thereon.

Any objection to such application must be forwarded, in writing, to reach the State Rivers and Water Supply Commission, Melbourne, before 12th June, 1970, being 30 days from the first publication of this notice.

CIRINO MAGLITTO.  
MARIA MAGLITTO.  
ANGELO MAGLITTO.

Wilson-road, Little River, 3211. 4191

**CITY OF FRANKSTON.**

**SPECIAL ORDER.**

Loan No. 136, \$100,000.

NOTICE is hereby given that the Council of the City of Frankston did at a meeting held on Monday, 13th April, 1970, agree to the following Resolution:—

- (i) That this Council borrow the sum of \$100,000, secured on the general rates of the municipality, such sum to be raised by the grant of a mortgage in accordance with section 585 of the *Local Government Act 1958*, as amended.
- (ii) That the rate of interest to be paid is 6.15 per centum per annum.
- (iii) That the period of the loan be nine (9) years and that the moneys borrowed be repayable by half-yearly instalments of \$7,317.06, including principal and interest on the 1st day of June and the 1st day of December, during the currency of the loan, the first instalment being payable on the 1st day of December, 1970.
- (iv) That such moneys be repayable at the State Savings Bank of Victoria, Melbourne.
- (v) That the loan be applied for the purpose of constructing private streets within the City of Frankston, in pursuance of and in accordance with the provisions of Division 10 of Part XIX. of the *Local Government Act 1958*.

And notice is hereby further given that the said Council did at a meeting held on Monday, 11th May, 1970, confirm such Resolution.

G. C. PENTLAND, Town Clerk, Civic Centre, Frankston.

4216

**CITY OF HEIDELBERG.**

WHEREAS the Council of the City of Heidelberg deems it expedient to exercise its powers of taking compulsorily the land described in the Schedule hereto for municipal purposes, viz.:—

The provision of an area for public resort and recreation at Heidelberg and acquiring the land for that purpose.

And whereas the Council has caused to be prepared such maps and other papers as may be necessary setting out the general description of the work or undertaking for which the land proposed to be taken is to be used, the description of the land proposed to be taken and the names of the owners or reputed owners, lessees or reputed lessees, mortgagees and occupiers of that land so far as those names are known to or can be ascertained by the Council: And whereas the said plans and other papers as are necessary are deposited at the office of the said Council at Ivanhoe and are and shall be open for inspection of all persons interested at all reasonable hours, for the space of 40 clear days after publication of this notice in the *Government Gazette*:

Now notice is hereby given to all persons affected by the proposed taking of the said land to set forth, in writing, addressed to the Council or the Town Clerk, within 40 clear days of the publication of this notice in the *Government Gazette*, all objections which they may have to the taking of the said land.

THE SCHEDULE HEREINBEFORE REFERRED TO.

All that piece of land being lot 73 on plan of subdivision No. 85458, being part of the land described in certificate of title, volume 8676, folio 649 and being land in Banyule-road, Heidelberg.

Dated the 7th day of May, 1970.

4195 E. C. W. JACK, Town Clerk.

Town and Country Planning Act 1961. CITY OF KNOX PLANNING SCHEME 1965. AMENDMENT No. 75, 1970.

NOTICE is hereby given that period of time of exhibition of this scheme has been extended to 29th May, 1970.

Any persons affected by the Planning Scheme are required to set forth, in writing, all objections they may have, addressed to the Town Clerk, City of Knox, Spring-street, Fern Tree Gully, 3156, on or before the 29th May, 1970, and state whether they wish to be heard in respect of their objection.

4174 N. G. HAYNES, Town Clerk.

CORRIGENDA. CITY OF MELBOURNE. BY-LAW No. 478.

AS published in Victoria Government Gazette, No. 45, of 6th May, 1970, at pages 1257-60.

Page 1260, second column—

- (a) 8th line from bottom—for "HOGAN" substitute "ROGAN".
(b) 4th line from bottom—for "1958" substitute "1968".

BOROUGH OF PORT FAIRY. LOAN No. 31.

Notice of Intention to Borrow.

NOTICE is hereby given that the Council of the Borough of Port Fairy proposes to borrow the sum of \$14,000 on the credit of the said Borough.

Such sum to be raised by grant of a mortgage in accordance with the Local Government Act 1958.

1. The maximum rate of interest that may be paid is 6.3 per centum per annum.

2. The purpose for which the loan is to be applied:—

Road Construction.—Church-street West, Earle-street, Gipps-street nature strips, road off William-street to Bowling Green, Regent-street off Gipps-street, Barclay-street (Cox to Bank), and channels west side bore and soakage pit, Polding-street channels and drain, footpath construction.

3. The period of the loan shall be ten years.

4. The moneys borrowed shall be repayable by providing out of the municipal fund twenty half-yearly instalments of approximately \$954.12 each including principal and interest, on 1st day of February and 1st day of August, during the currency of the loan. The first instalment shall be payable on the 1st day of February, 1971.

5. Such moneys shall be repayable at the Australia and New Zealand Savings Bank Limited, Melbourne, or at the Council's Bankers for the time being.

Plans and specifications and estimates of cost, and statement showing the proposed expenditure of moneys to be borrowed are open for inspection at the Borough Chambers.

4270 JOHN W. PHILLIPS, Town Clerk.

SHIRE OF CORIO.

NOTICE OF INTENTION TO ACQUIRE LAND COMPULSORILY. To Whom It May Concern.

WHEREAS the Council of the Shire of Corio deem it expedient to exercise its powers of taking land compulsorily for the work or undertaking mentioned hereunder.

Notice is hereby given as follows:—

1. The Council intends to acquire all that piece of land delineated and coloured white on the map hereto being part of Crown portions 97 and 101 situate in the Parish of Moorpanyal being parts of lot 228, and lots 230 to 278 (both inclusive) on plan of subdivision No. 13120 to be used for the purpose of executing works and undertakings which it is authorized to do pursuant to section 511 of the Local Government Act 1958, as amended.

2. A copy of the plan of survey of such land and a Schedule of owners thereof are deposited at the offices of the Shire of Corio, situate at Osborne House, Swinburne-street, North Geelong, and are there available for inspection by all interested parties during office hours, free of charge for the period of 40 clear days from the date of publication of this notice in the Government Gazette.

tion by all interested parties during office hours, free of charge for the period of 40 clear days from the date of publication of this notice in the Government Gazette.

3. The Council hereby requires all persons affected by the said proposal to set forth, in writing, addressed to the Shire Secretary, at Osborne House, Swinburne-street, North Geelong, within 40 clear days from the date of publication aforesaid all objections which they may have to the taking of the said land.

4. At the ordinary meeting of the Council next, after the expiration of the said 40 clear days, the Council will consider any such objection, and any person so objecting as aforesaid may appear before the Council in support of such objection.

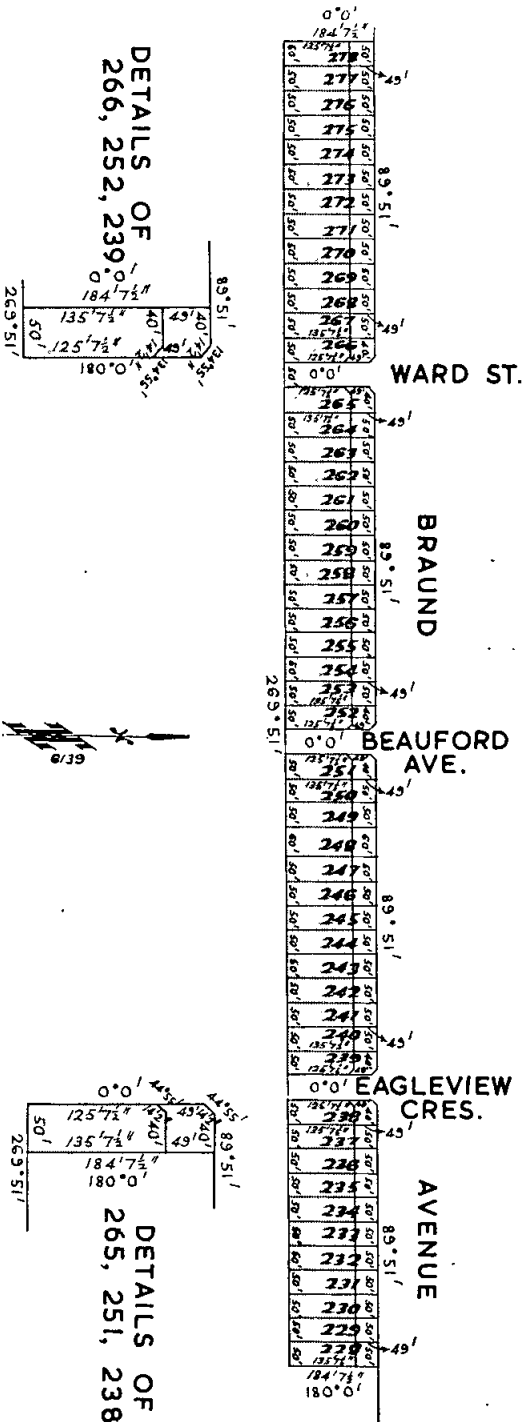

Dated the 5th day of May, 1970.

By order of the Council,

W. MYERS,  
Shire Secretary.

Price, Higgins & Fidge, solicitors, "Douglas House",  
47 Yarra-street, Geelong, solicitors for the said Council.  
4163

SHIRE OF FLINDERS.

CHANGE OF STREET NAME.

NOTICE is hereby given that, pursuant to the provisions of the Local Government Act, the Council of the Shire of Flinders has caused the following alteration of street name to be made:—

Old Name.—Beach-road.

New Name.—Ellerina-road.

Location between Forrest-drive and Esplanade (Marine-drive).

Lodged Plans Concerned.—70745, 20687, 20671, 50133, 25446, 10599, 5066 and 71910.

4210

S. WILLIAMS, Shire Secretary.

SHIRE OF FLINDERS.

LOAN No. 70.

Notice of Intention to Borrow the Sum of \$50,000 for Permanent Works and Undertakings.

NOTICE is hereby given that the Council of the Shire of Flinders proposes to borrow the principal sum of \$50,000, secured by a charge over the general rates of the municipality, such sum to be raised by the grant of a mortgage in accordance with the provisions of the Local Government Act 1958.

1. The maximum rate of interest that may be paid is 6.4 per centum.

2. The purposes for which the loan is to be applied are:—

Construction of Roads .. .. .	\$21,588
Places of Recreation and Resort .. .. .	8,900
Construction of Drains .. .. .	700
Purchases of Land .. .. .	13,500
Construction of Buildings .. .. .	1,312
Purchase of Equipment, Shire Office .. .. .	4,000
	<hr/>
	\$50,000

3. The period of the loan shall be fifteen years.

4. The moneys borrowed shall be repayable by providing, out of the municipal fund, half-yearly instalments of \$2,617.35 each, including principal and interest, on the 1st day of January and July during the currency of the loan.

5. The first instalment shall be payable on the 1st January, 1971, at the office of the National Bank of Australasia Ltd., Collins-street, Melbourne.

The plans and specifications and the estimate of the cost of the proposed works and a statement showing the proposed expenditure of the moneys to be borrowed are open for inspection at the office of the Council of the Shire of Flinders, Nepean Highway, Dromana.

4164

S. WILLIAMS, Shire Secretary.

SHIRE OF LILLYDALE.—SHIRE OF LILLYDALE  
PLANNING SCHEME 1958.

NOTICE THAT A PLANNING SCHEME HAS BEEN PREPARED  
AND IS AVAILABLE FOR INSPECTION.

Amendment No. 16, 1970.

NOTICE is hereby given that the Shire of Lillydale in pursuance of its powers under the Town and Country Planning Act 1961 has prepared a Planning Scheme for portions of the Shire of Lillydale for the purpose of amending the Principal Scheme (Shire of Lillydale Planning Scheme 1958).

A copy of the scheme has been deposited at the Shire Offices, Lillydale, and at the Office of the Town and Country Planning Board, 179 Queen-street, Melbourne, and will be open for inspection during office hours by any person free of charge.

Any persons affected by the Planning Scheme are required to set forth, in writing, all objections they may have, addressed to the Shire Secretary, Shire of Lillydale, Shire Offices, Lillydale—Monbulk-road, Lillydale, on or before the 13th day of August, 1970, and to state whether they wish to be heard in respect of their objections.

4267

F. O. KENT, Shire Secretary.

SHIRE OF LILLYDALE.—SHIRE OF LILLYDALE  
PLANNING SCHEME 1958.

NOTICE THAT A PLANNING SCHEME HAS BEEN PREPARED  
AND IS AVAILABLE FOR INSPECTION.

Amendment No. 17, 1970.

NOTICE is hereby given that the Shire of Lillydale in pursuance of its powers under the Town and Country Planning Act 1961 has prepared a Planning Scheme for the whole of the Shire of Lillydale for the purpose of amending the Principal Scheme (Shire of Lillydale Planning Scheme 1958).

A copy of the scheme has been deposited at the Shire Offices, Lillydale, and at the Office of the Town and Country Planning Board, 179 Queen-street, Melbourne, and will be open for inspection during office hours by any person free of charge.

Any persons affected by the Planning Scheme are required to set forth, in writing, all objections they may have, addressed to the Shire Secretary, Shire of Lillydale, Shire Offices, Lillydale—Monbulk-road, Lillydale, on or before the 13th day of August, 1970, and to state whether they wish to be heard in respect of their objections.

4268

F. O. KENT, Shire Secretary.

SHIRE OF LOWAN.

APPOINTMENT OF PROSECUTING OFFICER.

NOTICE is hereby given that Senior Constable Russell Louis Bertram, No. 12215, has been appointed Prosecuting Officer for the Shire of Lowan, in place of Senior Constable B. L. Dalton, transferred.

4172

F. W. FRITSCH, Shire Secretary.

SHIRE OF MIRBOO.

NOTICE OF MAKING OF BY-LAW.

NOTICE is hereby given that the Council of the Shire of Mirboo has, pursuant to the provisions of the Local Government Act 1958, made a By-Law numbered 25, for the purpose of adoption of Section (1) of Part IV of the Fifteenth Schedule to the Local Government Act 1958 relating to Public Libraries and Museums.

A copy of the By-Law is open for inspection free of charge during office hours at the Municipal Offices, Mirboo North.

4213

D. A. CARTLEDGE, Shire Secretary.

SHIRE OF MORNINGTON.

CHANGE OF STREET NAME.

NOTICE is hereby given that the Council of the Shire of Mornington has changed the name of a street within the municipality as follows:—

That portion of Beach-road, Mount Martha, as is within the Shire of Mornington—Beach-road being the continuation of Ellerina-road, Mount Martha, between Forest-drive and Esplanade (the Mornington—Dromana road).

Old Name.—Beach-road.

New Name.—Ellerina-road.

The change is to be effective as from 15th May, 1970.

4166

D. G. COLLINGS, Shire Secretary.

SHIRE OF TAMBO.

RE-SUBDIVISION AND RE-DEVELOPMENT SCHEME.

Stamford-road—Macrae-street Area—Lakes Entrance.

TAKE notice that the Council of the Shire of Tambo has caused to be prepared a scheme for re-development and re-subdivision of certain lands in the Stamford-road, Macrae-street area at Lakes Entrance.

A copy of the scheme is available for inspection at the Shire Office, Bruthen, during office hours.

Any person affected by the scheme may lodge an objection, in writing, addressed to the undersigned no later than the close of business on 24th June, 1970.

The Council will consider all objections to the scheme at its next ordinary meeting, to be held after 24th June, 1970.

G. W. RIDSDALE, F.I.M.A., J.P., Shire Secretary, Shire Office, Bruthen. 4186

NOTICE is hereby given that as from the 24th day of April, 1970, the partnership between Paul Detering and Dorothy Frances Detering, both of 26 Stuart-street, Armadale, and Barry John Wills and Joyce Merle Wills, both of 118 Harley-street, Knoxfield, has by mutual consent

been dissolved in respect of the fish and chip and take-away food business, carried on at 504 Kooyong-road, South Caulfield.

PAUL DETERING.  
DOROTHY FRANCES DETERING.  
BARRY JOHN WILLS.  
JOYCE MERLE WILLS.

4280

NOTICE is hereby given that the partnership heretofore subsisting between Jay Rainey Proprietary Limited and Joyce Gwendoline Doolin, carrying on a restaurant business, at 267 Ryrice-street, Geelong, under the name of "The Jay Rainey Bistro", has been dissolved by mutual consent on and from the 16th day of April, 1970.

All debts due to and owing by the said late firm will be received and paid by Jay Rainey Proprietary Limited, who will continue to carry on the business at the same place.

Dated this 21st day of April, 1970.

JAY RAINEY PROPRIETARY LIMITED.  
V. M. RAINEY, Director.  
J. G. DOOLIN.

4237

*Companies Act 1961.*—Section 260 (2).

F. MAXEY AND SON PROPRIETARY LIMITED.

NOTICE OF MEETING OF CREDITORS.

NOTICE is hereby given that, pursuant to sub-section (2) of section 260 of the *Companies Act 1961*, a meeting of the creditors of F. Maxey and Son Proprietary Limited, will be held at The Institute of Chartered Accountants on the 20th day of May, 1970, at 10.30 o'clock in the forenoon.

A statement of the creditors showing the names of all creditors and the amounts of their claims is attached.

Dated this 11th day of May, 1970.

4192

R. A. MAXEY, Secretary.

The *Companies Act 1961.*—In the matter of PRESTIGE GIFT WARE PROPRIETARY LIMITED, of 230 Princes-street, Port Melbourne.—Notice *Re* Meeting of Creditors, Pursuant to Section 260.

NOTICE is hereby given that a meeting of creditors of the above-named company will be held at Suite 18, 545 St. Kilda-road, Melbourne, on Tuesday, the 2nd day of June, 1970, at 11.30 a.m., the company having convened a meeting of its members for the 1st day of June, 1970, prior to this meeting for the purpose of considering a Resolution that the company be wound up voluntarily.

Dated this 7th day of May, 1970.

M. PORTER, Director.

Bent & Cogle, public accountant, Suite 18, 545 St. Kilda-road, Melbourne. 4194

SHARPS PLASTER PTY. LTD. (IN VOLUNTARY LIQUIDATION).

NOTICE is hereby given, pursuant to section 272 of the *Companies Act 1961*, that a meeting of the company will be held at the office of the liquidator, 161 Fitzroy-street, St. Kilda, on Wednesday, 17th June, 1970, at 2.30 p.m., for the purpose of receiving the liquidator's account showing how the winding up has been conducted and the property of the company has been disposed of, and hearing any explanation thereof that may be given by the liquidator.

Dated this 8th day of May, 1970.

E. SUMNER THOMSON, Liquidator, 161 Fitzroy-street, St. Kilda. 4201

DRY KILN SEASONING CO. PTY. LTD. (IN VOLUNTARY LIQUIDATION).

NOTICE is hereby given, in pursuance of section 272 of the *Companies Act 1961*, that a General Meeting of the members of the above-mentioned company will be held at the registered office of the company, corner Steel and Langford streets, North Melbourne, on Wednesday, 10th June, 1970, at 2.30 p.m., for the purpose of receiving the liquidator's account, showing how the winding up has been conducted and the company's property disposed of.

Dated the 7th May, 1970.

4209

K. G. HORE, Liquidator.

In the matter of DAYLITE ELECTRICAL CO. PTY. LTD.—  
Notice of Winding-up Order.

WINDING-UP Order made 29th April, 1970.

Ronald Dennis Widdows of 6 Marilyn-court, East Bentleigh, liquidator.

H. L. YUNCKEN & YUNCKEN, 443 Little Collins-street, Melbourne, petitioner's solicitors. 4236

The *Companies Act 1961.*

WILLCO HONEY PROPRIETARY LIMITED.

NOTICE is hereby given that at an Extraordinary General Meeting of the members of the above-named company held on the 5th May, 1970, it was resolved that the company be wound up voluntarily, and at a meeting of creditors held on the same day, pursuant to section 260, it was resolved for such purpose, Francis Penry Warton, of 360 Collins-street, Melbourne, be appointed liquidator.

Dated this 6th day of May, 1970.

F. P. WARTON, Liquidator.

Anderson Shackell & Co., 360 Collins-street, Melbourne, 3000. 4217

MURRAY VALLEY CO-OPERATIVE HOUSING SOCIETY  
(IN LIQUIDATION).

TAKE notice that the affairs of the above-named society are now fully wound up and that, in pursuance of section 272 (1) of the *Companies Act 1961*, and of the *Co-operative Housing Societies Act 1958*, a General Meeting of the Society will be held at 21 Station-street, Cobram, on the 1st June, 1970, at 8 p.m., for the purposes of—

- (i) laying before it an account showing how the winding up has been conducted and the property of the society disposed of and giving any explanations thereof; and
- (ii) passing a Resolution that the books and papers of the said society and of the liquidator relevant to the affairs of the society be destroyed after a period of twelve months from the date of the meeting.

Dated the 24th day of April, 1970.

4284

L. T. MOGG, Liquidator.

E. P. TAYLOR AS TRUSTEE FOR N. F. DUNN.

NOTICE OF DIVIDEND.

A DIVIDEND is to be distributed in the estate of N. F. Dunn on the 8th June, 1970. Creditors having claims against the estate are requested to lodge their proof of debt with the trustee by Monday, 1st July, 1970, to participate in the dividend.

E. P. TAYLOR, Trustee.

Downie, Thomson & Robb, P.O. Box 19, Warragul, 3820. 4277

SCHEDULE.

WILKE AND COMPANY LIMITED.

REDUCTION OF CAPITAL.

In the Supreme Court of Victoria.—1970 Co. No. 7913.—In the matter of the *Companies Act 1961*; and in the matter of WILKE AND COMPANY LIMITED.

NOTICE is hereby given that a petition presented to the Supreme Court on the 29th day of April, 1970, for confirmation of the reduction of the capital of the above-mentioned Wilke and Company Limited from \$4,000,000 divided into 6,031,720 Ordinary Shares of 50 cents each, 50,000 "A" Cumulative Preference Shares of \$2 each, 225,000 "B" Cumulative Redeemable Preference Shares of \$2 each, and 217,070 unclassified shares of \$2 each to \$2,392,070 divided into 6,031,720 Ordinary Shares of 25 cents each, 225,000 "B" Cumulative Redeemable Preference Shares of \$2 each, and 217,070 unclassified shares of \$2 each, such reduction to be effected by returning in cash to the holders of the issued 4,144,606 Ordinary Shares of 50 cents each paid up capital to the extent of 25 cents per share and by reducing the nominal value of the said 6,031,720 Ordinary Shares from 50 cents to 25 cents and by returning in cash to the holders of the said 50,000 "A" Cumulative Preference Shares of \$2 each, the sum of \$2 each paid up thereon and by cancelling the said 50,000 "A" Cumulative Preference Shares of \$2 each is directed to be heard at Law Courts, William-street, Melbourne, at 10.30 a.m., on the 27th day of May, 1970.

A copy of the said petition may be inspected during usual business hours at the offices of Messrs. Mallesons, whose address is set forth hereunder, the solicitors for the said Wilke and Company Limited. Any creditor or shareholder of the company wishing to oppose the said petition may appear himself or by his counsel upon the said hearing.

Dated the 12th day of May, 1970.

MALLESONS, solicitors, St. James Building, 121 William-street, Melbourne, Victoria, solicitors for the said Wilke and Company Limited. 4292

*Companies Act 1961, Section 272 (2).*  
KLEAM PROPRIETARY LIMITED (IN VOLUNTARY LIQUIDATION).

## NOTICE OF FINAL MEETING.

NOTICE is hereby given that a General Meeting of the members of the above-named company will be held at the office of Arthur Andersen & Co., 9th Floor, 330 Collins-street, Melbourne, on Friday, 12th June, 1970, at 12 noon, for the purpose of having an account laid before them, showing the manner in which the winding up has been conducted and the property of the company disposed of, and of hearing any explanation that may be given by the liquidator.

Dated this 6th day of May, 1970.

4288 R. S. PRIME, Liquidator.

## TATCHELL SHONE PTY. LTD. (IN VOLUNTARY LIQUIDATION).

AT a Meeting of Shareholders held on 7th May, 1970, the following Special Resolution was passed—that the company be wound up voluntarily.

E. SUMNER THOMSON, liquidator, 161 Fitzroy-street, St. Kilda. 4218

*Companies Act 1961.*

## THE ALLIED SOCIETIES TRUST LIMITED (IN VOLUNTARY LIQUIDATION).

NOTICE is hereby given that at an Extraordinary General Meeting of the Members of The Allied Societies Trust Limited, held on 7th day of May, 1970, the following was passed as a Special Resolution.

"That the company be wound up voluntarily."

C. R. TAYLOR, Liquidator.

Messrs. Tovell &amp; Lucas, Charter House, 4 Bank-place, Melbourne. 4223

In the Supreme Court of Victoria.—Co. No. 7908.—In the matter of the *Companies Act 1961*; and in the matter of KEYSTONE GENERAL ELECTRIC PROPRIETARY LIMITED.

NOTICE is hereby given that a petition for the winding up of the above-named company by the Supreme Court was, on the 21st day of April, 1970, presented by Samuel James Rose Junior, and that the said petition is directed to be heard before the Court sitting at the Fourteenth Court, Law Courts, William-street, Melbourne, at the hour of 10.30 o'clock in the forenoon, on the 1st day of June, 1970, and any creditor or contributory of the said company desiring to support or oppose the making of an order on the said petition may appear at the time of hearing by himself or his counsel for that purpose, and a copy of the petition will be furnished to any creditor or contributory of the said company, requiring the same by the undersigned on payment of the regulated charge for the same.

The petitioner's address is 38 Lothair-street, Pascoe Vale.

The petitioner's solicitors are Messrs. A. L. C. Flint &amp; Marrie, of 171 William-street, Melbourne.

A. L. C. FLINT &amp; MARRIE, solicitors for the petitioner.

NOTE.—Any person who intends to appear on the hearing of the said petition must serve on or send by post to the above-named solicitors notice in writing of his intention so to do. The notice must state the name and address of the person, or if a firm, the name and address of the firm, or his or their solicitor (if any), and must be served, or, if posted, must be sent by post in sufficient time to reach the above-named solicitors not later than Four o'clock in the afternoon of the 29th day of May, 1970. 4224

*Companies Act 1961.*

## DIANDO &amp; CO. PROPRIETARY LIMITED (IN VOLUNTARY LIQUIDATION).

NOTICE is hereby given that at an Extraordinary Meeting of the members of the above-named company held on Wednesday, 29th April, 1970, it was resolved that the company be wound up voluntarily and at a meeting of creditors held on the same day it was resolved that for such purpose Lewis Luckins, chartered accountant, of 289 Flinders-lane, Melbourne, be appointed liquidator.

Notice is also given that after 21 days from this date I shall proceed to distribute the assets. All creditors having any claim against the company should furnish particulars of same by that date, otherwise I shall proceed to distribute the assets without regard to their claim.

Dated this 11th day of May, 1970.

LEWIS LUCKINS, Liquidator.

Lewis Luckins &amp; Co., chartered accountants, of 289 Flinders-lane, Melbourne, 3000. Telephone 63 8827. 4250

*Companies Act 1961.*

## CLAYTON HOME FURNISHINGS PTY. LTD. (IN LIQUIDATION).

NOTICE TO CREDITORS OF INTENTION TO DECLARE DIVIDEND.  
A THIRD dividend is intended to be declared in the above matter. Creditors who have not proved their debt by the 25th May, 1970, will be excluded from this dividend. The date of liquidation was the 5th day of March, 1969.

Dated this 11th day of May, 1970.

LEWIS LUCKINS, F.C.A., Liquidator.

Lewis Luckins &amp; Co., chartered accountants, 289 Flinders-lane, Melbourne, 3000. Telephone No. 63 8827. 4248

*Companies Act 1961.*

## JUNE INVESTMENTS PTY. LTD.

AT a General Meeting of the Members of the above-named company duly convened and held at 313-315 Little Collins-street, Melbourne, on the 7th day of May, 1970, the Special Resolution set out below was duly passed.

"That the company be wound up voluntarily and that Ronald Moore and Eric Maxwell Huggard of the firm of Spry Walker & Co., chartered accountants, be appointed joint and several liquidators at a fee to be determined in accordance with the normal professional scale rates for the time occupied by the said liquidators and/or their staff in carrying out their duties as liquidators."

Dated this 12th day of May, 1970.

4247 M. VISBORD, Secretary.

*Companies Act 1961.*

## W. R. HUGHES PROPRIETARY LIMITED (IN LIQUIDATION).

NOTICE TO CREDITORS OF INTENTION TO DECLARE DIVIDEND.  
A FIRST Dividend (to deferred creditors) is intended to be declared in the above matter. Creditors who have not proved their debt by the 21st May, 1970, will be excluded from this dividend. The date of liquidation was 3rd January, 1968.

Dated this 7th day of May, 1970.

LEWIS LUCKINS, F.C.A., Liquidator.

Lewis Luckins &amp; Co., chartered accountants, 289 Flinders-lane, Melbourne, 3000. Telephone 63 8827. 4259

## In the matter of TRADESMEN HIRING SERVICES PTY. LIMITED.—Notice of Winding-up Order.

WINDING-UP Order made the 29th day of April, 1970.

Name and address of official liquidator, Ernest Harding Niemann, of the firm of Hungerford, Spooner & Kirkhope, of 44 Market-street, Melbourne.

J. CANNY, Deputy Commissioner of Taxation of the Commonwealth of Australia. 4258

The *Companies Act 1961*.—In the matter of VICTOR TRANSPORT PTY. LTD., of 551 Keilor-road, Niddrie.—Notice Re Meeting of Creditors, Pursuant to Section 260.

NOTICE is hereby given that a meeting of creditors of the above-named company will be held at the Honorary Justices Association, 528 Collins-street, Melbourne, on Monday the 18th day of May, 1970, at Eleven o'clock in the forenoon, the company having convened a meeting of its members for the same day for the purpose of considering a resolution that the company be wound up voluntarily.

Dated this 8th day of May, 1970.

R. A. McDOUGALL, Director.

C. P. Stephens, 130 Albert-road, South Melbourne. 4263

In the matter of the *Companies Act 1961*; and in the matter of THOMSON & MCKENZIE PTY. LIMITED.

NOTICE is hereby given that, at an Extraordinary General Meeting of the above-named company, duly convened and held at 184 George-street, Concord West, in the State of New South Wales, at Nine o'clock in the forenoon on the 30th day of April, 1970, the following Special Resolution was duly passed:—

"That the Company be voluntarily wound up by a members' voluntary winding up, and that Mr. John Stuart Walker be appointed liquidator of the company."

Dated the 30th day of April, 1970.

K. C. HOSKING, Chairman.

All inquiries should be directed to Mr. J. S. Walker, 422 Collins-street, Melbourne. 4257

The Companies Act 1961.

MARINER POOLS PTY. LTD. (IN VOLUNTARY LIQUIDATION).  
NOTICE OF MEETING OF MEMBERS AND CREDITORS.

NOTICE is hereby given that pursuant to section 272 (1) of the Companies Act 1961, a meeting of the members and creditors of Mariner Pools Pty. Ltd. (in voluntary liquidation) will be held at the offices of Cox, Johnston & Co., 446 Collins-street, Melbourne, on Tuesday, the 9th June, 1970, at 11.00 a.m. for the purpose of laying before the meeting an account showing how the winding up has been conducted and the property of the company has been disposed of and providing any explanation thereof.

Dated this 8th day of May, 1970.

A. I. SINCLAIR, Liquidator.

Cox, Johnston & Co., 446 Collins-street, Melbourne,  
3000. 4254

The Companies Act 1961.

KEYHILL MOTORS PROPRIETARY LIMITED (IN LIQUIDATION).

NOTICE CONVENING FINAL MEETING OF MEMBERS PURSUANT SECTION 272.

NOTICE is hereby given, pursuant to section 272 of the Companies Act 1961, that a General Meeting of the members of the above-mentioned company, will be held at 8th Floor, 108 Queen-street, Melbourne, on 19th June, 1970, for the purpose of having an account laid before the meeting, showing the manner in which the winding up has been conducted and the property of the company disposed of, and of having any explanations that may be given by the liquidator.

Dated this 11th day of May, 1970.

D. A. CONABERE, Liquidator.

4251

Unclaimed Moneys Act 1962.

REGISTER of Unclaimed Moneys held by the—

Name of Owner on Books and Last Known Address.	Total Amount Due to Owner.	Description of Unclaimed Money.	Date when Amount first became Payable.
§			
AUSTRALIAN PAPER MANUFACTURERS LIMITED.			
Alford, Robert G., 34 Wolseley-road, Mosman, N.S.W. 2088	43.20	Dividend on Ordinary Shares	30.4.68
Buddle, Colin B., Flat 5, 66 Shirley-road, Wollstonecraft, N.S.W. 2065	12.25	" " "	"
Dimant, Marjorie (estate of), c/o Victor H. Benson, J. A. Clayton and Co., 160 Castlereagh-street, Sydney, N.S.W. 2000	22.50	" " "	"
Edgar, David H. H. and Charles A. J. Tempany, 6 St. Johns-avenue, Mont Albert, Vic. 3127	73.37	" " "	31.10.68
Erskine, Margaret E. B. (Mrs.), 189 Grange-road, Flinders Park, S.A. 5025	22.50	" " "	30.4.68
Fairfax, Marjorie L. (Mrs.), 33 Rangers-road, Cremorne, N.S.W. 2090	20.57	" " "	31.10.68
Fletcher, Frederick B. C., 29 Wetherill-street, Narrabeen, N.S.W. 2101	24.66	" " "	30.4.68
Gloster, Thomas (estate of), c/o W. J. Enright and Son, P.O. Box 14, Maitland, N.S.W. 2320	13.75	" " "	31.10.68
Hannan, Leslie W. T., 29 Werner-avenue, Ashburton, Vic. 3147	41.40	" " "	30.4.68
Harry, Percy J. C. (estate of), 50 Dresden-street, Heidelberg, Vic. 3084	20.13	" " "	31.10.68
Irby, Florence M. (Miss) and Winifred E., Crysallen-street, Flynn's Beach, Pt. Macquarie, 2444	22.50	" " "	30.4.68
Leslie, Alfred J., 35 Quiros-street, Red Hill, A.C.T. 2603	20.02	" " "	31.10.68
Lewis, John M., Flat 14, 11 Mount-street, Perth, W.A. 6000	35.00	" " "	30.4.68
Meek, Mary P. (Mrs.), c/o The Manager, Commonwealth Bank of Australia, Woodlark-street, Lismore, N.S.W. 2480	51.48	" " "	31.10.68
Odewahn, Doris E. (Mrs.), 410 Heath-street, Albury, N.S.W. 2640	21.56	" " "	"
Poole, Brian W., 47 Lloyd-street, Oatley, N.S.W. 2223	18.00	" " "	30.4.68
Murray-Prior, Estella A. (Mrs.), 17 Madeline-street, Hunters Hill, N.S.W. 2110	137.39	" " "	31.10.68
Renard, Clement J., 65 Manning-road, East Malvern, Vic. 3145	22.50	" " "	30.4.68
Robertson, George N. (estate of), c/o J. W. Glover, Temple Court, 422 Collins-street, Melbourne, Vic. 3000	27.72	" " "	"
Steinmetz, Wolfgang, 496 Punt-road, South Yarra, Vic. 3141	16.74	" " "	"
Stephens, Hazel R. (Mrs.), 20 Sunray-court, Croydon, Vic. 3136	17.16	" " "	31.10.68
Tyson, Anthony, 82 Lumeah-road, North Caulfield, Vic. 3161	14.40	" " "	30.4.68
White, Dr. Richard C., c/o Fitzgerald Halliday and Co., Box 266, P.O., Muswellbrook, N.S.W. 2333	262.98	" " "	"
Wichmann, Karl D. P., 28 Gibbs-street, Newton, N.S.W. 2414	22.00	" " "	31.10.68
Alexander, Patricia M. (Mrs.), 1 College-avenue, Christchurch, N.Z.	18.70	" " "	"
Bonnington, Cecil (estate of), c/o Young, Hunter and Co., P.O. Box 929, Christchurch, N.Z.	496.03	" " "	30.4.68
Burley, Jocelyn A. (Miss), P.O. Box 7, Otahuhu, Auckland, S.E.7, N.Z.	56.10	" " "	31.10.68
Lees, John R. and Brian R., P.O. Box 7424, Nairobi, Kenya, East Africa	38.50	" " "	"
Marie Investments Ltd., P.O. Box 7, Otahuhu, New Zealand	45.90	" " "	30.4.68
McClure, John D., P.O. Box 299, Rabaul, T.P.N.G.	14.00	" " "	"
Woolmer, Hugh R., c/o The Chase Manhattan Bank, 41 Robinson-road, Singapore, 1.	53.90	" " "	"
Holmes, Bertha M. (estate of), c/o David R. Dooley, 65 Banksia-street, Heidelberg, Vic. 3084	11.88	" " "	2.8.68
Wilson, Horace E., 19 Alphington-street, Alphington, Vic. 3078	23.25	Interest on Unsecured Notes	29.8.68
Fraser, Ronald I. and Sylvia E. Fraser (estate of), c/o Maclean and Wiseman, 107-109 Elizabeth-street, Sydney, N.S.W. 2000	55.66	Dividend on Ordinary Shares	15.11.68
Wynne, Kenneth C., 32 Surrey-street, Potts Point, N.S.W. 2011	15.40	" " "	13.12.68
Taylor, John M., c/o Mrs. J. Schofield, Coolingdon, Cooma, N.S.W. 2630	15.00	Interest on Unsecured Notes	28.2.69

4135

AUSTRALIAN PAPER MANUFACTURERS LIMITED.

Anderson, C. G., 8 Daphne-street, Pascoe Vale South	25.20	Wages	6.4.68
McQualter, P., 15 Webb-street, Traralgon	106.10	"	19.4.68
Cooper, R., 49 Green-street, Noble Park	31.80	"	14.9.68
Allen, K. W., 15 Danks-street, St. Kilda	15.60	"	"
Gorman, F., Flat 5, 167 Glenhuntly-road, Elwood	17.40	"	12.10.68
Aburrow, G. L., 6 Faye-street, Reservoir	10.60	Bonus	28.12.68
Hughes, R. G., Flat 3, 100. Hotham-street, St. Kilda	37.70	Wages	4.1.69

4136

## Unclaimed Moneys Act 1962.

## REGISTER of Unclaimed Moneys held by the—

Name of Owner on Books and Last Known Address.	Total Amount Due to Owner.	Description of Unclaimed Moneys.	Date when Amount first became Payable.
5			
CENTRAL NORSEMAN GOLD CORPORATION N.L.			
Allen, Estelle A. (estate of), c/o M. W. Bednall and Co., 44 Grenfell-street, Adelaide, S.A. 5000	10.00	Dividend No. 46 on 100 shares	9.12.68
Bott, Leonidas C. (estate of), c/o Richard S. Hayes and Co., 115 St. George's-terrace, Perth, W.A. 6000	10.00	" " "	"
Britten-Jones, Robert, 5 Edwin-terrace, Gilberton, S.A. 5081	100.00	Dividend No. 46 on 1,000 shares	"
Brock, Linda V. L. c/o Greenways, King William-road, North Adelaide, S.A. 5006	20.00	Dividend No. 45 and 46 on 200 shares	12.6.68
Chipper, John M. (estate of), c/o Perpetual Exors. Trustees and Agency Co. W.A. Ltd., G.P.O. Box A3, Perth, W.A. 6001	40.00	Dividend No. 45 and 46 on 400 shares	12.6.68
Claring-Bould, Marguerite N. (estate of), c/o Ward Mollison Litchfield and Ward, 33 Pirie-street, Adelaide, S.A. 5000	100.00	Dividend No. 45 and 46 on 1,000 shares	12.6.68
Clutterbuck, Stanley H., 233 East-terrace, Adelaide, S.A. 5000	30.30	Dividend No. 46 on 303 shares	9.12.68
Connolly, Betty, 25 Kalgoorlie-street, Mount Hawthorn, Perth, W.A. 6016	60.80	Dividend No. 45 on 608 shares	12.6.68
Cuddihy, Minnie, c/o Union Fidelity Trustee Co. of Aust. Ltd., 100 Hotham-street, Traralgon, Vic. 3844	24.20	Dividend No. 46 on 242 shares	9.12.68
Deane, Thomas, Central Hotel, Wellington-street, Perth, W.A. 6000	40.40	Dividend No. 45 and 46 on 404 shares	12.6.68
Fairbrass, John, c/o Elders Goldsborough Mort, 115 St. George's-terrace, Perth, W.A. 6000	10.00	Dividend No. 46 on 100 shares	9.12.68
Furler, Percy S. N., Box 145, G.P.O., Adelaide, S.A. 5001	10.00	Dividend No. 46 on 100 shares	"
Goode, Matthew E. (estate of), c/o Dorothy C. Somerville, Epworth Building, Pirie-street, Adelaide, S.A. 5000	100.00	Dividend No. 45 and 46 on 1,000 shares	12.6.68
Griggs, Clarence M. (estate of), c/o Mrs. Adelaide M. Griggs, 35 Hughes-street, Unley, S.A. 5061	48.40	Dividend No. 45 and 46 on 484 shares	"
Hume, Ronald A., 44 Delaware-street, Reservoir, Vic. 3073	10.00	Dividend No. 46 on 100 shares	9.12.68
Humphery, Hilda A. (estate of), c/o Reginald W. McKay, Burns, Philp Trustee Co. Ltd., Box R321, Royal Exchange, Sydney, N.S.W. 2000	23.00	Dividend No. 46 on 230 shares	9.12.68
Lamberth, Francis C., c/o Department Agriculture and Stock, Private Mail Bag M/S54, via Tyr., Qld. 4807	20.00	Dividend No. 46 on 200 shares	"
Lane, Eleanor K. (estate of), c/o Patrick V. Lane, 233 William-street, Devonport, Tas. 7310	169.00	Dividend No. 45 and 46 on 1,696 shares	12.6.68
Leahy, Patrick (estate of), c/o West Australian Trustee Exors. and Agency Co. Ltd., 135 St. George's-terrace, Perth, W.A. 6000	20.00	Dividend No. 46 on 200 shares	9.12.68
Lodge, Rosslyn C. (estate of), c/o Mr. Sydney Lodge, 9 Adina-road, City Beach, W.A. 6015	97.00	Dividend No. 45 and 46 on 970 shares	12.6.68
McBride, Cyril S. (estate of), c/o Darbyshire Gillet and Huelin, 42 St. George's-terrace, Perth, W.A. 6000	40.00	Dividend No. 45 and 46 on 400 shares	"
Palmer, Percy F. (estate of), c/o Mazza Torre Talbot and Olivier, 20 Queen-street, Fremantle, W.A. 6160	50.00	Dividend No. 46 on 500 shares	9.12.68
Slatyer, William R., 14 View-avenue, Surfers Paradise, Qld. 4217	20.00	Dividend No. 46 on 200 shares	"
Smith, Harry, c/o Elder's Trustee and Executor Co. Ltd., 172 North-terrace, Adelaide, S.A. 5000	100.00	Dividend No. 45 on 1,000 shares	12.6.68
White, Richard A., 44 Wolsley-road, Coogee, N.S.W. 2034	10.00	Dividend No. 46 on 100 shares	9.12.68
Williamson, Arthur M. (estate of), c/o The West Australian Trustee E. and A. Co. Ltd., 135 St. George's-terrace, Perth, W.A. 6000	100.00	Dividend No. 46 on 1,000 shares	"
Wimble, Mary M., Flat 20, Valensole, Greenoaks and Ocean avenues, Double Bay, N.S.W. 2028. Also at 989 Barrenjoey-road, Palm Beach, N.S.W. 2108	30.00	Dividend No. 45 on 300 shares	12.6.68
4161			
FORD MOTOR COMPANY OF AUSTRALIA LIMITED.			
Asani, C., 1 Annard-street, North Fitzroy, Vic. 3068	14.59	Wages	— 9.68
Kinnunen, T., c/o Broadmeadows Hostel, Broadmeadows, Vic. 3047	22.38	Wages Cheque 27045	— 12.67
De Bono, G., 73 Glenlyon-road, Brunswick, Vic. 3056	21.76	Wages	18.6.68
Tripoli, F., 20 Nicholson-street, Melbourne, Vic.	43.60	"	14.6.68
Djokic, T., 20 Bell-street, Coburg, Vic. 3058	33.79	"	18.6.68
Wood, R., 21 Grosvenor-street, Moonee Ponds, Vic. 3039	32.01	"	14.6.68
Messina, R., 5 William-street, Footscray, Vic. 3011	34.81	"	27.9.68
Ropoljub, S., 26 Arndt-street, Pascoe Vale, Vic. 3044	25.63	"	20.1.69
4162			
HILTON CORPORATION LIMITED (now Courtaulds Hilton Limited).			
Leese, W. G., Ardmona, Vic., 3629	15.00	Dividends	22.3.68
4058			
J. GADSDEN AUSTRALIA LIMITED.			
Grainger, John William, 23 Hyslop-parade, Chadstone	10.12	Dividend	7.11.68
Lewis, Philip Alfred C., Box 1666, G.P.O., Adelaide, S.A.	12.00	"	7.11.68
Rankin, Norma (Mrs.), "Utona", Jerilderie, N.S.W.	10.08	"	7.5.68
Smith, Frederick Cecil, 30 Upper Beach-street, Balgowlah, N.S.W.	10.08	"	"
Walker, Dorothy Enid (Mrs.), 10 Scotsburn-grove, Toorak, 3142	18.00	"	"
Barbour, Nancy L. (Miss), 3/414 Wattle-tree-road, East Malvern, 3145	18.75	Registered Unsecured Interest	31.10.68
Holmes, Jessie Mary (Mrs.), 5 Trafalgar-street, Mont Albert, 3127	77.50	"	31.10.68
4056			



## Unclaimed Moneys Act 1962.

## REGISTER of Unclaimed Moneys held by the—

Name of Owner on Books and Last Known Address.	Total Amount Due to Owner.	Description of Unclaimed Moneys.	Date when Amount first became Payable
§			
ANGLO-AUSTRALIAN NOMINEES PTY. LIMITED.			
Unknown .. .. .	50.00	Dividend on 2,000 Ansett Transport Industries Ltd.	—12.68
Unknown .. .. .	369.00	Dividend on 6,150 Australian Consolidated Industries Ltd.	—9.68
Unknown .. .. .	235.53	Dividend on 2,480 Broken Hill Proprietary Co. Ltd.	—6.68
Unknown .. .. .	184.49	Dividend on 2,974 Broken Hill Proprietary Co. Ltd.	—12.68
Unknown .. .. .	112.50	Dividend on 1,800 Colonial Sugar Refining Co. Ltd.	—7.68
Unknown .. .. .	35.00	Dividend on 700 Commercial Bank of Australia Ltd.	—2.69
Unknown .. .. .	75.00	Dividend on 1,500 Consolidated Goldfields of Australia	—4.68
Unknown .. .. .	60.00	Dividend on 1,000 Consolidated Goldfields of Australia	—10.68
Unknown .. .. .	52.50	Dividend on 1,050 Consolidated Press Holdings Ltd.	—12.68
Unknown .. .. .	1,089.00	Dividend on 19,800 Dunlop Aust. Ltd.	—10.68
Unknown .. .. .	20.00	Dividend on 400 Hanimex Ltd.	—5.68
Unknown .. .. .	793.00	Dividend on 15,860 Hanimex Ltd.	—12.68
Unknown .. .. .	340.00	Dividend on 3,400 Herald and Weekly Times Ltd.	—12.68
Unknown .. .. .	50.06	Dividend on 801 Humes Ltd. ..	—3.68
Unknown .. .. .	253.00	Dividend on 8,433 A. V. Jennings	—10.66
Unknown .. .. .	35.00	Dividend on 500 Lend Lease Corp.	—3.67
Unknown .. .. .	887.98	Dividend on 16,145 London Australia Investment Co. Ltd.	—3.68
Unknown .. .. .	140.63	Dividend on 2,250 London Australia Investment Co. Ltd.	—3.69
Unknown .. .. .	35.75	Dividend on 550 John Lysaght Australia Ltd.	—3.68
Unknown .. .. .	43.75	Dividend on 700 John Lysaght Australia Ltd.	—9.68
Unknown .. .. .	24.00	Dividend on 1,200 Oil Drilling and Exploration	—4.68
Unknown .. .. .	168.75	Dividend on 3,000 Peko-Wallsend Ltd.	—10.68
Unknown .. .. .	562.50	Dividend on 12,500 Peko-Wallsend Ltd. (Prefs.)	—8.68
Unknown .. .. .	68.00	Dividend on 1,813 Repco Ltd.	—9.66
Unknown .. .. .	25.00	Dividend on 800 Thiess Hldgs. Ltd.	—11.68
Unknown .. .. .	24.00	Dividend on 1,200 Victorian Quarries	—12.68
Unknown .. .. .	63.70	Dividend on 6,370 Western Mining Corporation Ltd.	—8.68
Unknown .. .. .	64.40	Dividend on 6,440 Western Mining Corporation Ltd.	—2.69
Unknown .. .. .	25.00	Dividend on 1,000 Woolworths Ltd.	—10.68
Unknown .. .. .	2,564.66	Dividend on 128,233 Wynyard Holdings Ltd.	—3.69

4157

## DAVID SYME &amp; CO. LIMITED.

Critchley, P. L., 97 Crookston-road, Reservoir .. .. .	59.50	Wages and Holiday Pay .. .. .	13.7.68
Read, J. J., Flat 14, 254 Dandenong-road, East St. Kilda .. .. .	22.16	Holiday Pay .. .. .	8.11.68

4169

## DENNY'S LASCELLES LIMITED.

Olsson, Christina S. (Miss), 470 Bridge-road, Richmond .. .. .	45.50	Dividends .. .. .	29.8.68
Jones, Helen K. (estate of), Bank-street, Traralgon .. .. .	10.92	Dividend .. .. .	28.2.69
Kelly, Fanny C. (estate of) .. .. .	36.00	.. .. .	28.2.69
Mulroney Bros., P.B., Minimay .. .. .	93.35	Proceeds of 1 bale of B/C wool..	26.4.68
Woods, W. H., Watchem .. .. .	24.14	Proceeds of 1 pig less debit ..	9.8.68
Coffee, G. and L., Birchip .. .. .	14.55	Rebate commission .. .. .	20.9.68
Flavel, H. T., Jeparit .. .. .	72.17	Proceeds of 3 pigs .. .. .	4.10.68
Inkster, R. J. and D. A., 28 McLean-street, Warracknabeal .. .. .	49.87	Cartage of livestock .. .. .	26.11.68
Lyness, D. and M., Colac .. .. .	40.97	Cartage .. .. .	25.7.68

4168

## TARAX DRINKS HOLDINGS LIMITED.

Jesmond Pty. Ltd., c/o E. and R. Stephen Hart, 115 St. George's-terrace, Perth .. .. .	60.00	Ordinary Dividend .. .. .	—5.68
Fraser, Dr. Robin, 49 Carrol-street, Hughes, A.C.T. .. .. .	12.50	.. .. .	.. .. .
Carrick, Jean (Mrs.), 14 Bridges-avenue, Croydon .. .. .	83.28	.. .. .	.. .. .
McCormack, Rev. Brian A., R.A.A.F. Base, Laverton .. .. .	10.50	.. .. .	.. .. .
McLaren, Yvonne M. (Mrs.), 13 Albenca-street, Mentone .. .. .	45.50	.. .. .	.. .. .

4060

Unclaimed Moneys Act 1962.

REGISTER of Unclaimed Moneys held by the—

Name of Owner on Books and Last Known Address.	Total Amount Due to Owner.	Description of Unclaimed Money.	Date when Amount first became Payable.
5			
CARLTON AND UNITED BREWERIES LIMITED.			
Lindorfer, J., 2 Fitzroy-street, St. Kilda	40.00	Wages	29.7.68
Richards, A., 562 Toorak-road, Toorak	20.41	"	20.8.68
Bodi, B., 78 Flemington-road, North Melbourne	11.89	"	17.10.68
Karalis, C., 4 Stawell-street, Richmond	25.23	"	11.11.68
Hellessey, R., 68 Alma-road, St. Kilda	72.41	"	13.12.68
Sande, H., 339 Victoria-street, North Melbourne	11.65	"	24.1.69
Radojhi, D., 165 Drummond-street, Richmond	10.13	"	11.3.69
Menyhert, I., 38 Caroline-street, Hawthorn	126.25	"	13.2.69
Humphries, R. L., Flat 6, 28 Hopetoun-street, Moonee Ponds	19.39	"	20.2.69
Garro, S., 254 Lygon-street, Carlton	24.54	"	22.3.68
Stewart, F., 6 Alexandra-street, St. Kilda	14.92	"	7.5.68
Starr, R. E., 19 Grattan-street, Carlton	12.72	"	15.5.68
Kalivas, E., 2 Francis-street, Richmond	14.25	"	6.6.68
Tonna, L., 18 The Grove, Coburg	17.73	"	27.8.68
The Artcraft Press, 46 Cameron-street, Richmond	34.31	Creditor	29.3.67
Morton, M. A. C., 87 Hobsons-street, Newport	23.85	"	23.3.68
Hopkins, A., 179 Alexander-parade, Abbotsford	66.86	"	23.2.68
Cooper, L., Eastern-road, Hostel, East Yallourn	73.08	Wages	11.11.60
Chau, T., 11 Gertrude-street, Fitzroy	20.42	"	4.1.63
Bennewith, J., 445 Elizabeth-street, Melbourne	23.29	"	12.2.64
Ayton, P., 24 Woolsley-street, Coburg	17.22	"	28.6.65
Muir, S. R., 12 High-street, Horsham	11.00	"	21.7.65
Evans, P. J., 272 Rosslyn-street, West Melbourne	16.05	"	9.11.65
Allan, R. J., 467 Nicholson-street, North Carlton	36.26	"	21.3.66
Mayors Charity Fund, c/o Town Hall, Melbourne	10.50	Donation	9.7.62
Longlands, E. V., c/o P. R. Rogers, "Blue Horizon", Alexandra Headland, Mooloolaba, Qld.	60.00	Debenture Interest	31.12.60
Alexander, E. M., Palm Island via Townsville, North Qld.	13.76	Dividend	4.10.68
Arnold, E. M., 93 Maioro-street, Auckland, New Zealand	56.85	"	4.10.68
Blackley, C. F., 122 Chaucer-street, Moorooka Qld.	42.40	"	4.10.68
Dorward, D. J., 1 Stafford-grove, Marryatville, S.A.	16.00	"	4.10.68
Lynch, D. (Exors.), c/o Louis A. Grealy, 134 Adelaide-street, Brisbane, Qld.	160.48	"	4.10.68
McCaul, A. C. (estate of), Flat 12, 47 Kars-street, Frankston	32.00	"	4.10.68
McIntosh, E. (Exors.), c/o Laurence and Laurence G.P.O. Box 1616, Sydney, N.S.W.	16.00	"	4.10.68
Martin, G. A., "Chiloe" Beaumaris	4.80	"	4.10.68
Osborne, B. M., 71 Lewin-street, Bardon, Qld.	8.00	"	4.10.68
Power, N. P., Flat 20, 2 Mansfield-road, Hong Kong	35.20	"	4.10.68
Rickman, L., 88 Crosby-road, Albion, Qld.	16.00	"	4.10.68
Stocker, L. M., 41 Anson-road, Tufnell Park, London, N.7	39.98	"	4.10.68
Sutherland, K. McK., 219 Ray-road, Epping, N.S.W.	7.84	"	4.10.68
Fogarty, M., 3/3 Northbourne Flats, Northbourne-avenue, Turner, A.C.T.	21.57	Interest	30.6.68
Nicholas, J. M., c/o C. M. Williams, 4 Olinda-avenue, Beaumaris	18.60	"	30.6.68

The Companies Act 1961.  
**HOADLEY'S HOLDINGS LIMITED (IN VOLUNTARY LIQUIDATION).**  
 NOTICE OF FINAL MEETING.  
 NOTICE is hereby given that, pursuant to section 272 of the Companies Act 1961, a General Meeting of the members of Hoadley's Holdings Limited will be held on the 12th Floor, 447 Collins-street, Melbourne, on Tuesday, 16th June, 1970, at 10.30 o'clock in the forenoon. The purpose of the meeting is to lay accounts before it showing the manner in which the winding up has been conducted and the property of the company disposed of, and of hearing any explanation that may be given by the liquidator.  
 4252 J. M. POULTON, Liquidator.

The Companies Act 1961.  
**FAWN PUBLICITY PTY. LTD. (IN VOLUNTARY LIQUIDATION).**  
 NOTICE OF MEETING OF MEMBERS AND CREDITORS.  
 NOTICE is hereby given that pursuant to section 272 (1) of the Companies Act 1961, a meeting of the members and creditors of Fawn Publicity Pty. Ltd. (in voluntary liquidation) will be held at the offices of Cox, Johnston & Co., 446 Collins-street, Melbourne, on Tuesday, 9th June, 1970, at 10.00 a.m. for the purpose of laying before the meeting an account showing how the winding up has been conducted and the property of the company has been disposed of, and providing any explanation thereof.  
 Dated this 8th day of May, 1970.  
 A. I. SINCLAIR, Liquidator.  
 Cox, Johnston & Co., 446 Collins-street, Melbourne, 4253  
 3000.

Companies Act 1961.  
**OVERSEAS ELECTRICAL PROPRIETARY LIMITED (IN LIQUIDATION).**  
 NOTICE TO CREDITORS OF INTENTION TO DECLARE DIVIDEND.  
 A FIRST dividend is intended to be declared in the above matter. Creditors who have not proved their debt by the 25th day of May, 1970, will be excluded from this dividend. The date of liquidation was the 5th December, 1969.  
 Dated this 11th day of May, 1970.  
 LEWIS LUCKINS, F.C.A., Liquidator.  
 Lewis Luckins & Co., chartered accountants, 289 Flinders-lane, Melbourne, 3000. Telephone No. 63 8827. 4249

The Companies Act 1961.—In the matter of **DONBILT KITCHEN CENTRE PTY. LTD., 7 Excelsior-road, Box Hill South.**—Notice Re Meeting of Creditors, Pursuant to Section 260.  
 NOTICE is hereby given that a meeting of creditors of the above-named company will be held at Room 311, Princes Gate, 3rd Floor, East Tower, 151 Flinders-street, Melbourne, on Wednesday, 27th May, 1970, at 10.30 a.m., the company having convened a meeting of its members for the previous day for the purpose of considering a Special Resolution that the company be wound up voluntarily.  
 Dated this 11th day of May, 1970.  
 B. MERRETT, Director.  
 Bent & Cogle, public accountants, Suite 18, 545 St. Kilda-road, Melbourne. 4271

## The Companies Act 1961.

AIRPORT PLASTER CO. PTY. LTD. (IN LIQUIDATION).

NOTICE is hereby given that a first and final dividend is intended to be declared in the above matter. Creditors who have not proved their debts by the 5th June, 1970, may be excluded from this dividend.

Dated this 8th day of May, 1970.

J. K. HALL, Official Liquidator.

Hall &amp; Rose, chartered accountants, 254 Queen-street, Melbourne, 3000. 4234

## The Companies Act 1961.

SUBURBAN REFRIGERATION PTY. LTD. (IN LIQUIDATION).

NOTICE is hereby given that a first dividend is intended to be declared in the above matter. Creditors who have not proved their debts by the 28th day of May, 1970, may be excluded from this dividend.

Dated this 7th day of May, 1970.

G. O. HARRISON, Liquidator.

Hall &amp; Rose, chartered accountants, 260 Queen-street, Melbourne, 3000. 4235

In the matter of VICTORIAN FLOORING SPECIALISTS PTY. LIMITED.—Notice of Winding-up Order.

WINDING-UP Order made the 29th day of April, 1970.

Name and address of official liquidator, Ian Kenneth Mackinnon, of the firm of John Mackinnon & Company, of 562 St. Kilda-road, Melbourne.

J. CANNY, Deputy Commissioner of Taxation of the Commonwealth of Australia. 4256

The Companies Act 1961.—In the matter of A. ROSS &amp; SONS PTY. LTD.—Notice Re Meeting of Creditors, Pursuant to Section 260.

NOTICE is hereby given that a meeting of creditors of the above-named company will be held at the R.S.L. Hall, Scallan-street, Stawell, Victoria, at 11.30 a.m. on Monday, 18th May, 1970, the company having convened a meeting of its members for the same day for the purpose of considering a resolution that the company be wound up voluntarily.

Dated this 6th day of May, 1970.

J. A. G. ROSS, Director.

Kennedy, Smail &amp; Middlemiss, 296 Little Lonsdale-street, Melbourne, 3000. 4260

The Companies Act 1961.—In the matter of STAWELL INTERSTATE TRANSPORT PTY. LTD.—Notice Re Meeting of Creditors, Pursuant to Section 260.

NOTICE is hereby given that a meeting of creditors of the above-named company will be held at the R.S.L. Hall, Scallan-street, Stawell, Victoria, at 11.50 a.m. on Monday, 18th May, 1970, the company having convened a meeting of its members for the same day for the purpose of considering a resolution that the company be wound up voluntarily.

Dated this 6th day of May, 1970.

J. A. G. ROSS, Director.

Kennedy, Smail &amp; Middlemiss, 296 Little Lonsdale-street, Melbourne, 3000. 4261

## Companies Act 1961.

MARY MAXIM PROPRIETARY LIMITED.

AT an Extraordinary General Meeting of the members of Mary Maxim Proprietary Limited, duly convened and held at 49 Coppin-street, Richmond, on Monday the 11th May, 1970, at 10 a.m., the following Resolution was duly passed as a Special Resolution:—

"That the company be wound up voluntarily and that Mr. L. W. E. Charlton, of 15 Ellsa-street, North Balwyn, be and is hereby appointed liquidator."

Dated this 12th day of May, 1970.

L. W. E. CHARLTON, Liquidator.

Mann Judd &amp; Co., 249 William-street, Melbourne. 4262

PURSUANT to the provisions of the Trustee Act 1958, creditors, next of kin and all other persons having claims in respect of the estate of Lou Soong Yu, late of 695 High-street, Northcote, restaurant proprietor (who died on the 1st September, 1968), are required to send particulars of their claims to the executor, Neil Willis Johnston, of 527 Grimshaw-street, Bundoora, solicitor, by the 14th

July, 1970, after which the executor will distribute the assets, having regard only to the claims of which they shall then have had notice.

HOME, WILKINSON &amp; LOWRY, solicitors, 203 High-street, Thomastown. 4278

JOHN LAWRENCE WISE, late of Rupert-street, Lang Lang, linesman, DECEASED, intestate.

CREDITORS, next of kin and others having claims against the estate of the deceased (who died on the 15th September, 1969), are required by the administratrix, Eugenie Frances Mynard, to send particulars to her, care of the under-mentioned solicitors, by the 24th day of July, 1970, after which date she may convey and distribute the assets, having regard only to the claims of which she then has notice.

S. W. MISSON &amp; BARTLEY, solicitors, 59 Waverley-road, East Malvern. 4272

GENEVIEVE OLIVE LOVELOCK, late of 158 Roseneath-street, Clifton Hill, widow, DECEASED.

CREDITORS, next of kin and others having claims against the estate of the above-named Genevieve Olive Lovelock, deceased (who died on the 4th day of May, 1969), are required to send particulars thereof to the executors, Philip Kenneth Lovelock and Bernard John Lovelock, care of the undersigned solicitors, before the 29th day of July, 1970, after which date they will distribute the assets, having regard only to the claims of which they then have notice.

HEFFEY &amp; BUTLER, solicitors, 358 Lonsdale-street, Melbourne. 4279

CREDITORS, next of kin and others having claims in respect of the estate of Thomas Melling, late of Condon-street, Bendigo, in the State of Victoria, retired dairyman (who died on the 20th day of December, 1969), are to send the particulars of their claims to the National Trustees, Executors and Agency Company of Australasia Limited, of 46 Queen-street, Bendigo, by the 23rd day of July, 1970, after which date it will distribute the assets of the estate of the said deceased, having regard only to the claims of which it has notice.

EVERY &amp; EVERY, solicitors, V.P.C. Building, Bull-street, Bendigo. 4202

CREDITORS, next of kin and others having claims in respect of the estate of Maria Ethelstein Heath, formerly of 1 Malakoff-street, East St. Kilda, but late of Kyneton, widow, deceased (who died on the 22nd January, 1970, and probate of whose will was granted by the Supreme Court of Victoria on the 18th March, 1970, to John Graham Bolton, of Kyneton, solicitor, the executor therein named), are required to send particulars of their claims to the said executor, in care of the undersigned solicitors, before the 14th day of July, 1970, after which date he will distribute the assets, having regard only to the claims of which he shall then have had notice.

PALMER, STEVENS &amp; RENNICK, solicitors, Kyneton. 4211

GEORGIA DERNIKOU, late of 109 Brighton-street, Richmond, in the State of Victoria, married woman, DECEASED (who died on the 6th day of February, 1970).

CREDITORS, next of kin and others having claims in respect of the estate of the above-named deceased are to send particulars of their claims to Susan Hamilton Santoro, care of Messrs. Price and Chamberlin, solicitors, 443 Little Collins-street, Melbourne, by the 30th July, 1970, after which date she will distribute the assets, having regard only to the claims of which she then has notice.

PRICE &amp; CHAMBERLIN, solicitors, 443 Little Collins-street, Melbourne. 4219

FRANCES SUSAN SOMERSET, formerly of 32 Cecil-street, Kew, and 16 Barnsbury-road, Balwyn, but late of 186 Lower Heidelberg-road, Ivanhoe, in the State of Victoria, widow, DECEASED.

CREDITORS, next of kin and others having claims in respect of the estate of the deceased (who died on the 2nd day of February, 1970), are required by The Perpetual Executors and Trustees Association of Australia Limited, of 100-104 Queen-street, Melbourne, to send particulars of their claims to the said company by the 15th day of July, 1970, after which date it will convey or distribute the assets, having had regard only to the claims of which the company then has notice.

Dated the 13th day of May, 1970.

H. E. SHEPHERD, LL.B., of 76 South-parade, Blackburn, solicitor for the said The Perpetual Executors and Trustees Association of Australia Limited. 4283

**CREDITORS**, next of kin and others having claims in respect of the estate of Samuel Percy Tucker, late of 51 Vickery-street, Bentleigh, in the State of Victoria, formerly traveller but then retired gentleman, deceased (who died on the 6th day of August, 1969), are to send particulars of their claims to Dorothy Hope Harvey, care of the under-mentioned solicitors, by the 13th day of July, 1970, after which date she will distribute the assets, having regard only to the claims to which she then has notice.

Dated this 8th day of May, 1970.

REGINALD C. BUTLER & Co., solicitors, 312 Centre-road, Bentleigh. 4196

MORIENTE ELSIE SIMPSON, late of Railway-crescent, Wurruk, via Sale, married woman, DECEASED.

**CREDITORS**, next of kin and others having claims in respect of the estate of the deceased (who died on the 30th day of November, 1969), are required by The Perpetual Executors and Trustees Association of Australia Limited, of 100-104 Queen-street, Melbourne, to send particulars of their claims to the said company by the 10th day of July, 1970, after which date it will convey or distribute the assets, having regard only to the claims of which the company then has notice.

ROLLAND, RICE & RATHJEN, solicitors, Maffra. 4197

MABEL MONTGOMERIE, formerly of 249 View-street, Bendigo, in the State of Victoria, but late of 346 St. Georges-road, Thornbury, in the said State, widow, DECEASED.

**CREDITORS**, next of kin and others having claims in respect of the estate of the deceased (who died on the 5th day of July, 1969), are required by the trustee, John Kensel Griffin, of 32 Wedge-street, Benalla, in the said State, to send particulars to him by the 21st day of July, 1970, after which date the trustee may convey or distribute the assets, having regard only to the claims of which he then has notice.

Dated the 8th day of May, 1970.

COHEN KIRBY & Co., solicitors, Cnr. Pall Mall and Bull-street, Bendigo. 4200

WILLIAM EDWARD MORRISSEY, of 49 Oswald-street, Gardenvale, accountant, the sole executor of the will of Samuel George Cooper, late of Devenish in the State of Victoria, farmer, deceased (who died on the 3rd day of November, 1969), requires all creditors, next of kin and others having claims against the property or estate of the said deceased to send particulars in writing of such claims to him, care of the under-mentioned solicitors, on or before the 31st day of July, 1970, after which date the said executor intends to convey or distribute such property or estate to or among the persons entitled thereto, having regard only to the claims of which he shall then have had notice.

HAMILTON, CLARKE & CLARKE, 55 Nunn-street, Benalla. 4199

EVELYN ORRY KAIGHIN, late of 24 Kent-road, Surrey Hills, retired, DECEASED (who died on the 25th of November, 1969).

**CREDITORS**, next of kin and all other persons having claims against the estate of the deceased are required by the executrix of his will, Dorothy Kaighin, of 29 The Boulevard, Heathmont, widow, to send particulars thereof to her, care of the under-mentioned solicitors, before the 20th day of July, 1970, after which date she may distribute the assets of the deceased, having regard only to the claims of which she then has notice.

COLTMAN, WYATT & ANDERSON, solicitors, of 578 Bourke-street, Melbourne. 4225

ALFRED JAMES OCCLESHAW, late of "Lauriston", 112 Warrandyte-road, Ringwood, in the State of Victoria, retired chemist, DECEASED.

**CREDITORS**, next of kin and others having claims in respect of the estate of the deceased (who died on the 13th day of December, 1969), are required by The Perpetual Executors and Trustees Association of Australia Limited, of 100-104 Queen-street, Melbourne, and Hallam Alfred Occleshaw, of 130 Cardigan-road, Mooroolbark, chemical engineer, the applicants for a grant of administration, to send particulars of their claims to the said applicants, in the care of the said company, by the 10th day of July, 1970, after which date they will convey or distribute the assets, having regard only to the claims of which they then have notice.

RIVERS DICKINSON STIRLING & MUNZ, of 17 Queen-street, Melbourne, solicitors for the trustees. 4222

Trustee Act 1958.

**CREDITORS**, next of kin and others having claims against the estate specified below are required to send particulars, in writing, of such claims to the personal representatives of such estate, in care of Messrs. Morrison & Teare, solicitors, Numurkah, on or before 8th August, 1970, after which date the assets of the estate will be conveyed or distributed among the persons entitled thereto, having regard only to the claims to which the representatives shall then have had notice:—

EDWARD JAMES COXON, late of Numurkah, in the State of Victoria, motor garage proprietor, deceased (died 30th November, 1969).

NORMAN GEORGE JOHNSON, late of Numurkah, in the State of Victoria, butter factory employee, deceased (died 30th November, 1969).

FREDERICK GEORGE MOSS, late of Numurkah, in the State of Victoria, retired farmer, deceased (died 7th March, 1970).

JAMES CAMPBELL, late of 78 Balaclava-road, Shepparton, in the State of Victoria, retired farmer, deceased (died 17th February, 1970).

BERTIE JONES, late of Cobram, in the State of Victoria, farmer, deceased (died 17th November, 1969).

GEORGE VINCENT MASKELL, late of Marungi, in the State of Victoria, farmer, deceased (died 7th April, 1970).

EDWIN LOCKHART MAGNUSON, late of Nathalia, in the State of Victoria, farmer, deceased (died 1st January, 1970).

AGNES LOUISA GRAY, late of Numurkah, in the State of Victoria, widow, deceased (died 13th July, 1969).

MORRISON & TEARE, solicitors, Numurkah. 4193

CHARLES ANDREW MILLS, late of Lake Boga, in the State of Victoria, labourer, DECEASED (who died on 17th March, 1970).

**CREDITORS**, next of kin and all other persons having claims against the estate of the deceased, are required by the executor of the will, John William Manley, to send particulars to him, care of the undersigned, on or before the 7th day of August, 1970, after which date he will distribute the assets, having regard only to the claims of which he then has notice.

GARDEN & GREEN, solicitors, 4 McCallum-street, Swan Hill. 4214

ALICE SLONIMSKI, late of 27 Burrindi-road, Caulfield, in the State of Victoria, knitting mill proprietor, DECEASED.

**CREDITORS**, next of kin and others having claims in respect of the estate of the deceased (who died on the 18th day of December, 1969), are required by the executor, Abraham Slonimski, of 27 Burrindi-road, Caulfield, in the said State, knitting mill proprietor, to send particulars to him, care of the solicitors for the estate, Rivers Dickinson Stirling & Munz, of 17 Queen-street, Melbourne, by the 17th day of July, 1970, after which date the said executor may convey or distribute the assets, having regard only to the claims of which he then has notice.

Dated the 13th day of May, 1970.

RIVERS DICKINSON STIRLING & MUNZ, solicitors, 17 Queen-street, Melbourne. 4287

MARY ISABELLA WALLACE, late of 6 Tivoli-place, South Yarra, Victoria, widow, DECEASED.

**CREDITORS**, next of kin and others having claims in respect of the estate of the deceased (who died on 20th August, 1969), are required by the personal representative, Mary Wallace James, of 43 Marnie-street, South Yarra, Victoria, married woman, to send particulars to her, by 17th July, 1970, after which date she may convey or distribute the assets, having regard only to the claims of which she then has notice.

HEDDERWICK FOKES & ALSTON, solicitors, 121 William-street, Melbourne. 4289

DOROTHY HOWARD IRVING, formerly of 64A Williams-road, Windsor, but late of 3 Rostrevor-parade, Mont Albert, in the State of Victoria, school teacher, DECEASED.

**CREDITORS**, next of kin and others having claims in respect of the estate of the deceased (who died on the 1st day of February, 1970), are to send particulars of their claims to the executrices, Grace Marion Wilson and Elizabeth Ellen Pownall, care of the undersigned solicitors, by the 17th day of July, 1970, after which date they will proceed to distribute the estate, having regard only to the claims of which they then have notice.

HADEN SMITH & FITCHETT, solicitors, 405 Collins-street, Melbourne. 4290

**CREDITORS**, next of kin and others having claims in respect of the estate of Ellen Monica Smith, late of 30 Yuille-street, Brighton, married woman, deceased (who died on the 9th day of October, 1969), are required to send particulars of their claims to the executrices, Janet Maud Davis and Ellen Loretta Iacono, care of the under-mentioned solicitors, by the 15th of July, 1970, after which date they will distribute the assets, having regard only to the claims of which they then have notice.

J. A. REDMOND & Co., solicitors, of 482 Bourke-street, Melbourne, Victoria. 4244

**CREDITORS**, next of kin and others having claims in respect of the estate of Agnes Hearnden, formerly of 94 Queens-avenue, Carnegie, in the State of Victoria, but late of Flat 17, Block 5, Midland Highway, Morwell, in the said State, widow, deceased (who died on the 22nd day of November, 1969), are required to send particulars of their claims to National Trustees, Executors and Agency Company of Australasia Limited, of 95 Queen-street, Melbourne, in the said State, by the 22nd of July, 1970, after which date it will distribute the assets, having regard only to the claims of which it then has notice.

HERBERT, GEER & RUNDLE, solicitors, 612-614 Balcombe-road, Black Rock. 4245

**CREDITORS**, next of kin and others having claims in respect of the estate of Alice Rose Margon, formerly of 28 Macfarlan-street, South Yarra, but late of 13 Caroline-street, South Yarra, widow, deceased (who died on the 7th day of December, 1969), are to send particulars of their claims to the executor, Jack Peter Brent, of Messrs. J. P. Brent and Stephens, solicitors, 17 Queen-street, Melbourne, by the 31st day of July, 1970, after which date he will distribute the assets, having regard only to the claims of which he then has notice.

J. P. BRENT & STEPHENS, solicitors, 17 Queen-street, Melbourne. 4246

**CREDITORS**, next of kin and others having claims against the estate of Edgar Francis Lyons, late of 208 Rubicon-street, Ballarat, in the State of Victoria, boiler attendant, deceased, testate (who died on the 19th day of November, 1969), are required to send particulars of their claims to The Union Fidelity Trustee Company of Australia Limited, of 101 Lydiard-street north, Ballarat, in the said State, the executor of the will of the said deceased, by the 11th day of June, 1970, after which date the said executor will distribute the assets, having regard only to the claims of which it then has notice.

BYRNE, JONES & TORNEY, solicitors, Ballarat. 4198

**CREDITORS**, next of kin and others having claims against the estate of Ella Grace Barlow, late of 9 Farrington-street, Colac, widow, deceased (who died on the 18th May, 1969), are to send particulars of their claims to the said Lyla Cecilia McMinn and the said Ivor Hughes Barlow, executrix and executor of the will of the said deceased, care of the undersigned solicitors, before the 29th July, 1970, after which date the said Lyla Cecilia McMinn and the said Ivor Hughes Barlow, executrix and executor, will distribute the estate of the said deceased, having regard only to the claims, whether formal or not, of which she or he then have notice.

CUNNINGHAM & LARKINS, solicitors, Murray-street, Colac. 4220

**CREDITORS**, next of kin and others having claims against the estate of Mary Isabel O'Keefe, late of Elliminyt, widow, deceased (who died on the 3rd July, 1969), are to send particulars of their claims to the said John Joseph O'Keefe, executor of the will of the said deceased, care of the undersigned solicitors, before the 29th July, 1970, after which date the said John Joseph O'Keefe, executor, will distribute the estate of the said deceased, having regard only to the claims, whether formal or not, of which he then has notice.

CUNNINGHAM & LARKINS, solicitors, Murray-street, Colac. 4221

HELEN RUTH TINDALE, late of 9 Manton-street, Richmond, in the State of Victoria, clerk, DECEASED.

**CREDITORS**, next of kin and others having claims in respect of the estate of the deceased (who died on the 29th day of September, 1969), are required by The Perpetual Executors and Trustees Association of Australia Limited, of 100-104 Queen-street, Melbourne, to send particulars of their claims to the said company by the 15th day of June, 1970, after which date it will convey or distribute the assets, having had regard only to the claims of which the company then has notice.

4282

**CREDITORS**, next of kin and others having claims against the estate of Joseph Francis O'Toole, late of Old Fernshaw-road, Healesville, gentleman, deceased (who died on 24th January, 1970), are required to send particulars thereof to National Trustees, Executors and Agency Company of Australasia Limited, the executor of the will of the deceased, to the care of the said company at its registered office, 95 Queen-street, Melbourne, by the 21st day of July, 1970, after which date the said company will distribute the assets of the deceased, having regard only to the claims of which the said company shall then have notice.

GAVAN DUFFY & KING, solicitors, 95 Queen-street, Melbourne. 4229

JOHN ROBERT LITHERLAND, late of 129 Thompson's-road, Templestowe, retired, DECEASED.

**CREDITORS**, next of kin and others having claims against the estate of the said deceased (who died on 23rd August, 1968), are to send particulars of their claims to Christina Elizabeth Litherland and Bernard Gore Brett, care of 120 William-street, Melbourne, by the 17th day of July, 1970, after which date they will distribute the assets, having regard only to the claims of which they then have notice.

BLAKE & RIGGALL, solicitors, 120 William-street, Melbourne. 4241

**CREDITORS**, next of kin or others having claims in respect of the estate of Edward Barry Fitzgerald-Moore, late of 32 Montalto-avenue, Toorak, gentleman, deceased (who died on the 3rd March, 1970), are to send particulars of their claims to The Union-Fidelity Trustee Company of Australia Limited, of 100 Exhibition-street, Melbourne, and Oswald Reginald Charlton, of 49 Bruce-street, Toorak, public accountant, and Michael William Burrows, of 205a Osborne-street, Williamstown, clerk, the executors appointed by the said will, care of the said company, by the 14th July, 1970, after which date they will distribute the assets, having regard only to the claims of which they then have notice.

CORR & CORR, solicitors, 290 La Trobe-street, Melbourne. 4226

**ALL** persons having claims against the estate of Philip Bellair Hayes, late of "Elliminook", Humphries-road, Frankston, in the State of Victoria, gentleman, deceased (who died on the 2nd January, 1970), and probate of whose will was granted by the Supreme Court of Victoria to Gabrielle Dorothea Hayes, and The Trustees, Executors and Agency Company Limited, on the 29th April, 1970, are hereby required to send particulars of such claims to The Trustees, Executors and Agency Company Limited, at its registered office, at 401 Collins-street, Melbourne, on or before 15th July, 1970, after which date the said company and Gabrielle Dorothea Hayes will proceed to transfer convey or distribute the said estate to or among the persons entitled thereto, having regard only to the claims of which they shall then have had notice and will not be liable for the assets so transferred conveyed or distributed to any persons of whose claim they shall not then have had notice.

ELLISON HEWISON & WHITEHEAD, solicitors, 379 Collins-street, Melbourne. 4291

**CREDITORS**, next of kin and others having claims in respect of the estate of Edith Ellen Smith, late of 17 Pendle-street, Box Hill, in the State of Victoria, widow, deceased (who died on the 18th day of February, 1970), are to send particulars of their claims to Herbert Horatio Smith, of 17 Duncan-street, Box Hill, the executor appointed by the will of the said deceased by the 22nd day of July, 1970.

J. & S. SHATIN, solicitors, of 224 Queen-street, Melbourne. 4269

**CREDITORS**, next of kin and others having claims in respect of the estate of Norman Henry Michael, late of Newbridge, farmer, deceased (who died on the 9th day of October, 1969), are to send the particulars of their claims to The National Trustees Executors and Agency Company of Australasia Limited, of 46 Queen-street, Bendigo, on or before the 20th day of July, 1970, after which date it will distribute the assets, having regard only to the claims of which it has notice.

HERRING & BATHURST, solicitors, Maryborough. 4273

ELSA MINNA PAGENSTECHER, formerly of Tarrington, but late of 45 George-street, Hamilton, widow, DECEASED.

**CREDITORS**, next of kin and others having claims in respect of the estate of the deceased (who died on the 20th January, 1970), are required by the executors of the estate, Elsa Rosalie Finch, of 10 Carmichael-street, Hamilton, married woman, Conrad Alexander Pagenstecher, of 11 Shipley-street, Box Hill, bank officer, and Brian Erich Pagenstecher, of 10 Learmonth-street, Hamilton, public servant, to send particulars to them, care of the undermentioned solicitors, by the 31st July, 1970, after which date the executors may convey or distribute the assets, having regard to claims only of which they then have notice.

CAMERON & LOWENSTERN, solicitors, 62 Thompson-street, Hamilton. 4274

LINTON ERNEST SPARROW, formerly of 110 French-street, Hamilton, but late of Park-street, Hamilton, retired turner and fitter, DECEASED.

**CREDITORS**, next of kin and others having claims in respect of the estate of the deceased (who died on the 22nd February, 1970), are required by the executor, The Union-Fidelity Trustee Company of Australia Limited, of 100 Exhibition-street, Melbourne, to send particulars to it, care of the under-mentioned solicitors, by the 31st July, 1970, after which date the executor may convey or distribute the assets, having regard only to the claims of which it then has notice.

CAMERON & LOWENSTERN, solicitors, 62 Thompson-street, Hamilton. 4275

PAUL RENTSCH, formerly of 10 Skene-street, Hamilton, but late of Queen Victoria Cottages, Tyers-street, Hamilton, retired farmer, DECEASED.

**CREDITORS**, next of kin and others having claims in respect of the estate of the deceased (who died on the 28th January, 1970), are required by the executors of the estate, Stanley Gordon Rentsch, of Lake Linnithgow, farmer, and Edmund Eric Rentsch, of Tabor, farmer, to send particulars to them, care of the under-mentioned solicitors, by the 31st July, 1970, after which date the executors may convey or distribute the assets, having regard to claims only of which they then have notice.

CAMERON & LOWENSTERN, solicitors, 62 Thompson-street, Hamilton. 4276

**CREDITORS**, next of kin and others having claims in respect of the estate of Crawford William Myers, late of 24 Ozone-street, Rye, retired, deceased (who died on the 15th day of August, 1969), are to send particulars of their claims to Ronald Moss, of Old Emerald-road, Monbulk, the executor of the will of the said deceased, by the 20th day of July, 1970, after which date the said executor will distribute the assets, having regard only to the claims of which he shall then have notice.

JOHN M. GALVIN & ASSOCIATES, solicitors, of 343 Little Collins-street, Melbourne. 4227

ANTONI KORDAS, late of 28 Taylor-street, Moonee Ponds, in the State of Victoria, carpenter, DECEASED.

**CREDITORS**, next of kin and others having claims in respect of the estate of the above-mentioned deceased (who died on the 5th day of February, 1970), are required by the executors, Jerzy Ross Stanislaw Mendrek and Wincenty Smigielski to send particulars of their claims to them, care of the under-mentioned solicitors, by the 15th day of July, 1970, after which date they will distribute the assets, having regard only to the claims of which they then have notice.

J. OKNO & Co., solicitors, of 390 Lonsdale-street, Melbourne. 4228

LINDA LILLIAN HANSEN, late of 22 Kanooka-avenue, Ashwood, widow, DECEASED.

**CREDITORS**, next of kin and others having claims in respect of the estate of the deceased (who died on 19th September, 1969), are required by the trustee, Betty Lillian Menzel, of 22 Kanooka-avenue, Ashwood, married woman, to send particulars to her by the 15th July, 1970, after which date the trustee may convey or distribute the assets, having regard only to the claims of which she then has notice.

MORRISON TEARE & PURNELL, solicitors, 164 Flinders-street, Melbourne. 4230

**CREDITORS**, next of kin and others having claims in respect of the estate of Henry George Eifermann, of 40 Goodwin-street, Glen Iris, in the State of Victoria (who died on the 25th day of October, 1969), are to send particulars of their claims to the executor, Robert Wayne Eifermann, of 40 Goodwin-street, Glen Iris, by the 17th day of July, 1970, after which date the executor will distribute the assets, having regard only to the claims of which he then has notice.

DAVID BULLARD, solicitor, 443 Law Courts-place, Melbourne. 4231

**CREDITORS**, next of kin and others having claims in respect of the estate of William Patrick Joseph Aloysius McCormack, late of 1 Benson-street, Surrey Hills, in the State of Victoria, depot master, deceased (who died on the 15th January, 1970), are to send particulars of their claims to the National Trustee, of 95 Queen-street, Melbourne, by the 16th June, 1970, after which date the executor will distribute the estate, having regard only to the claims of which he then has notice.

VIRGIL B. GILL, KANE & Co., solicitors, 422 Collins-street, Melbourne. 4232

JAN BUGAJ, late of 38 Graham-street, Newport, in the State of Victoria, labourer, DECEASED intestate.

**CREDITORS**, next of kin and others having claims in respect of the estate of the above-named deceased (who died on the 27th day of February, 1970), are required by the administratrix, Feliksa Bugaj, to send particulars of their claims to her, care of the under-mentioned solicitors, by the 15th day of July, 1970, after which date she will distribute the assets, having regard only to the claims of which she then has notice.

J. OKNO & Co., solicitor, of 390 Lonsdale-street, Melbourne. 4233

PERCY THOMAS ARNOTT, late of 11 Malvern-road, Mont Albert, in the State of Victoria, retired, DECEASED.

**CREDITORS**, next of kin and others having claims in respect of the estate of the deceased (who died on the 16th day of October, 1969), are to send particulars of their claims to the executors, John Derry Arnott and The Equity Trustees, Executors and Agency Company Limited, care of the undersigned solicitors, by the 17th day of July, 1970, after which date they will proceed to distribute the estate, having regard only to the claims of which they then have notice.

HADEN SMITH & FITCHETT, solicitors, 405 Collins-street, Melbourne. 4238

**CREDITORS**, next of kin and others having claims in respect of the estate of Frederick Charles Dix, formerly of Goulburn Weir, via Nagambie, but late of Warramunda Village, Kyabram, retired (who died on the 20th December, 1969), are to send particulars of their claims to the executors, Carl William Harris and Irene May Norman, care of the undersigned, by the 6th day of July, 1970, after which date they will commence to distribute the assets, having regard only to the claims of which they then have notice.

RENNICK & GAYNOR, solicitors, 491 Bourke-street, Melbourne. 4239

**CREDITORS**, next of kin and others having claims in respect of the estate of Peter Samuel Wilde, late of Bayindeen near Buangor, farmer, deceased (who died on the 24th day of November, 1969), are to send particulars of their claims to the executor, Kevin John Wilde, care of Messrs. Briggs & O'Driscoll, solicitors, 94 Barkly-street, Ararat, by the 22nd day of July, 1970, after which date he will distribute the assets, having regard only to the claims of which he then has notice.

BRIGGS & O'DRISCOLL, solicitors, 94 Barkly-street, Ararat. 4171

RUBY AILEEN SHEATHER, late of Longwarry-road, Drouin, married woman, DECEASED.

**CREDITORS**, next of kin and others having claims in respect of the estate of the deceased (who died on the 24th day of February, 1970), are required by the trustees, Albert Edward Sheather, retired farmer, and Kelvin Edward Sheather, clerk, both of Longwarry-road, Drouin, to send particulars to them care of the under-mentioned solicitors, by the 6th July, 1970, after which date the trustee may convey or distribute the assets, having regard only to the claims of which they then have notice.

GRAY, FRIEND & LONG, solicitors, Warragul. 4177

**CREDITORS**, next of kin and others having claims in respect of the estate of Prudence Olivia Henderson, late of Flat 7, 14 Woorigoleen-road, Toorak, in the State of Victoria, married woman, deceased (who died on the 29th day of June, 1968), are required to send particulars of their claims to the executrix, Virginia Graham Henderson, care of M. A. White, Cleland & Associates, solicitors, 94 Young-street, Frankston, by the 14th day of July, 1970, after which date she will distribute assets of the estate of the said deceased, having regard only to the claims of which she shall then have had notice.

Dated this 7th day of May, 1970.

M. A. WHITE, CLELAND & ASSOCIATES, solicitors, 94 Young-street, Frankston. 4240

ELMAR PAUL PLANKEN, late of 28 Haldane-road, Niddrie, in the State of Victoria, foreman, DECEASED.

**CREDITORS**, next of kin and others having claims in respect of the estate of the deceased (who died on the 12th day of December, 1969), are required by the executor, National Trustees, Executors and Agency Company of Australasia Limited, of 95 Queen-street, Melbourne, in the said State, to send particulars of their claims to the said executor by the 24th day of July, 1970, after which date they will convey or distribute the assets, having regard only to the claims of which they then have notice.

HERBERT, GEER & RUNDLE, solicitors, 409 Keilor-road, Niddrie. 4242

ELIZABETH ELLEN LEE, late of 119 Church-road, Doncaster, spinster, DECEASED.

**CREDITORS**, next of kin and others having claims in respect of the estate of the above-named deceased (who died on the 15th February, 1970), are required by the executors, Gordon Archie Crouch, of 203 Church-road, Doncaster, traveller, and John William Lee, of Main Creek-road, Main Ridge, farmer, to send particulars to them, in care of the under-mentioned solicitors, by 15th July, 1970, after which date the executors may convey or distribute the assets, having regard only to the claims of which they then have notice.

W. H. FLOOD & PERMEZEL, solicitors, 388 Bourke-street, Melbourne. 4243

ROBERT SLOSS, late of Fairview Homes for the Aged, Warragul, retired, DECEASED.

**CREDITORS**, next of kin and others having claims in respect of the estate of the deceased (who died on the 24th day of February, 1970), are required by the trustees, Margaret Evelyn Algie, of Neerim, married woman, and Ernest Clive Sloss, of 205 Deepwater-road, Castle Cove, New South Wales, importer to send particulars to them care of the undersigned solicitors by the 6th day of July, 1970, after which date the trustees may convey or distribute the assets, having regard only to the claims of which they then have notice.

GRAY, FRIEND & LONG, solicitors, Warragul. 4178

JOHN MCKENZIE, late of Mansfield, retired grazier.

**CREDITORS**, next of kin and others having claims in respect of the deceased (who died on the 16th January, 1970), are required by his trustees, Charlotte Ellen McKenzie, of Mansfield, widow, and Evaline Lottie Myers, of East Malvern, married woman, to send particulars to them, care of the under-mentioned firm of solicitors, by the 9th day of July, 1970, after which date the trustees may convey and distribute the assets, having regard only to the claims of which they then have notice.

MAL. RYAN & GLEN, 9 High-street, Mansfield, solicitors for the trustees. 4185

**CREDITORS**, next of kin and others having claims in respect of the estate of Rupert Leigh Rymer, late of Hazeldene, Gladysdale, in the State of Victoria (who died on the 13th day of February, 1970), are to send particulars of their claims to the executor, Ian Frank Hoadley Ross, of 346 Little Collins-street, Melbourne, in the said State, solicitor, by the 21st day of July, 1970, after which date the executor will distribute the assets, having regard only to the claims of which he then has notice.

RYMER, LANGFORD & RITCHIE, solicitors, of 346 Little Collins-street, Melbourne. 4187

**CREDITORS**, next of kin and others having claims in respect of the estate of David Michael Joseph Scott, late of Eleventh-street, Mildura, retired horticulturist, deceased (who died on 16th June, 1969), are to send particulars of their claim to The Union-Fidelity Trustee Company of Australia Limited, 101 Lydiard-street north,

Ballarat, by the 30th day of July, 1970, after which date it will distribute the assets, having regard only for the claims of which it then has notice.

HILLARDS, solicitors, 71 Deakin-avenue, Mildura, 3500. 4188

In the Supreme Court of the State of Victoria.

SALE BY THE SHERIFF.

ON Friday, the 26th June, 1970, at 10 a.m., at the Police Station, Blackburn (unless process be stayed or satisfied):—

All the estate and interest (if any) of Gerald Henry Van Dort, of 155 Surrey-road, Blackburn, as proprietor of an estate in fee-simple in the land described in certificate of title, volume 7859, folio 129, upon which is erected a dwelling-house known as No. 155 Surrey-road, Blackburn.

Registered mortgage No. C.925159 and caveats D.502771 and D.640055 affect the said estate and interest.

Terms: Cash only.

N. FROGLEY, Sheriff's Officer.

11th May, 1970.

4286

### INSOLVENCY NOTICES

The Bankruptcy Act 1966-1969, Part X.

NOTICE OF MEETING OF LENNARD THOMAS CROFT.

NOTICE is hereby given that the above-named debtor signed an Authority under section 188 (1) of the Act authorizing Alex Neville Bird to take over control of his property and further take notice that a meeting of creditors will be held at the Ringwood Civic Centre, Maroonah Highway, Ringwood, at 2.30 p.m., on Thursday, the 21st day of May, 1970.

Dated this 7th day of May, 1970.

A. NEVILLE BIRD, Controlling Trustee.

A. Neville Bird & Co., chartered accountants, 289 Flinders-lane, Melbourne, 3000, telephone 63 2874. 4255

Bankruptcy District of the State of Victoria.—No. 47 of 1970, Part X., Re: Darrell Crofton Canet.

Commonwealth of Australia.

Bankruptcy Act 1966, Part X.

DARRELL CROFTON CANET.

Hotel Proprietor—"Waltzing Matilda Hotel", Smythesdale.

AT a meeting of creditors of the above-named debtor, held on Friday, 1st May, 1970, the following Special Resolution was duly passed:—

"That the debtors proposal for a composition be and is hereby accepted and that Maxwell George Gee be appointed trustee of the said composition."

NOTE.—In the terms of the composition the ordinary unsecured creditors will receive 50 cents in the dollar.

M. G. GEE, Registered Trustee.

Max Gee & Co., 325 Warrigal-road, Burwood, 3125, telephone 288 5911. 4170

### IMPOUNDINGS

DANDENONG.—Impounded in Dandenong Pound, from Sylvia-street, by Dandenong Ranger.

1 black and white goat, male, leather collar, no visible brand

If not claimed and expenses paid, to be sold on 2nd June, 1970.

Impounded from Frankston-road, by Dandenong Ranger.

2 Friesian heifers, horned, no visible brand

If not claimed and expenses paid, to be sold on 3rd June, 1970.

4212—\$3.00 D. D. NAPIER, Poundkeeper.

KYNETON.—Impounded at Kyneton, on 6th May, 1970.

1 full mouth Dorset Horn ram, ear tag marked Derby Downs over 66-146, no visible brand

1 full mouth Border Leicester ram, ear tag marked Lyon Bank 65 over OK 91, no visible brand

If not claimed and expenses paid, to be sold on 27th May, 1970.

4182—\$2.25 H. COOK, Poundkeeper.

**OXLEY.**—Impounded in Oxley Pound, on Wednesday, 6th May, from Eldorado.  
 2 Black Poll heifers, approximately 7 months old, notch in bottom of right ear, no visible brand  
 If not claimed and expenses paid, to be sold on 28th May, 1970.  
 4215—\$2.00 M. PERKINS, Poundkeeper.

**SHEPPARTON.**—Impounded in Shepparton Pound.  
 2 back fatter sows (1 white and 1 black and white), no visible brands  
 If not claimed and expenses paid, to be sold on 28th March, 1970.  
 4293—\$1.75 C. L. MANSELL, Poundkeeper.

*Subordinate Legislation Act 1962.*

**NOTICE OF MAKING OF STATUTORY RULES.**

IN pursuance of the provisions of the *Subordinate Legislation Act 1962* and the Regulations made thereunder, notice is given of the making of the following statutory rules:—

No.	Racing Act 1958.	Price.
89/1970.	Racing (Doubles Totalizator Amendment) Regulations 1970	10c
	<i>Apprenticeship Act 1958.</i>	
90/1970.	Apprenticeship (Bread Trade) (Amendment) Regulations 1970	10c
	<i>Apprenticeship Act 1958.</i>	
91/1970.	Apprenticeship (Stonemasonry Trade) (Amendment) Regulations 1970	10c
	<i>Education Act 1958.</i>	
92/1970.	Adult Education (Salaries) Regulations 1970, No. 4	10c
	<i>Health Act 1958.</i>	
93/1970.	Food and Drug Standards (Potable Water) Regulations 1970 (Amendment Serial No. 5)	10c

Copies of these statutory rules may be purchased at the Sale of Publications Section of the Government Printing Office, located at Macarthur-street, Melbourne, 3002. If ordered by mail, remittance should be addressed to "The Government Printer, Box 203, P.O., North Melbourne, 3051", and should include 5c extra for postage. If a credit account is held at this office, no remittance is required with the mail order.

The annual subscription rate for Statutory Rules (including a Bound Volume) is \$15, payable in advance. The subscription year commences on 1st January.

C. H. RIXON,  
 Government Printer.

**AGENTS FOR THE "VICTORIA GOVERNMENT GAZETTE".**

THE following have been appointed agents to receive Advertisements and Subscriptions for the *Victoria Government Gazette*:—

- ARMSTRONG'S AGENCY, 205 Queen-street, Melbourne, Victoria 3000.
- ARNALL & JACKSON, 390 Barkly-street, Brunswick, Victoria 3056
- BAIRNSDALE AUTHORIZED NEWSAGENCY, 132 Main-street, Bairnsdale, Victoria 3875.
- BICKNELL, M. J., Authorized Newsagent, 196 Timor street, Warrnambool, Victoria 3280.
- BLANE'S AUTHORIZED NEWSAGENTS, 162 Murray-street, Colac, Victoria 3250.
- CARTER, R. G., ADVERTISING SERVICE PTY. LTD., Suite 24, 65 Queens-road, Melbourne, Victoria 3004
- DAVIES, G. & M. V., 112 Gray-street, Hamilton, Victoria 3300
- DAVIS, WM. (MILDURA) PTY. LTD., 126 Eighth-street, Mildura, Victoria 3500.
- DIXON'S NEWSAGENCY, 89 Firebrace-street, Horsham, Victoria 3400.

- EDGAR'S NEWSAGENCY PTY. LTD., 293 Hargreaves-street, Bendigo, Victoria 3550.
- EDGARS' AUTHORIZED NEWSAGENCY, 45 Bridge-street, Benalla, Victoria 3672.
- FRANKS, H. & CO., 184 Ryrie-street, Geelong, Victoria 3220.
- GATLEY, A. & J., 250 Lonsdale-street, Dandenong, Victoria 3175.
- GORDON & GOTCH AUSTRALASIA LTD., 467 Collins-street, Melbourne, Victoria 3000.
- GULLAN'S NEWSAGENCY, 88 Bridge-street, Ballarat, Victoria 3350.
- HAMPTON, A. C., 243 Mitchell-street, Bendigo, Victoria 3550.
- HARSTON, PARTRIDGE & CO. PTY. LTD., 455 Little Collins-street, Melbourne, Victoria 3000.
- KYNETON GUARDIAN PTY. LTD., P.O. Box 18, Kyneton, Victoria 3444.
- LATIMER'S, Newsagents, 45 Station-street, Malvern, Victoria 3144.
- LIVINGSTON'S SHEPPARTON NEWSAGENCY, 246 Wyndham-street, Shepparton, Victoria 3630.
- THE MERCANTILE EXCHANGE, 67 Queen-street, Melbourne, Victoria, 3000.
- MCGILL'S AUTHORIZED NEWSAGENCY, 183-5 Elizabeth-street, Melbourne, Victoria 3000.
- PHILLIPS AUTHORIZED AGENCY, 83 Murphy-street, Wangaratta, Victoria 3677.
- PURDIE, J., & CO., 138 Moorabool-street, Geelong, Victoria 3220.
- SALE AUTHORIZED NEWSAGENCY, 142 Raymond-street, Sale, Victoria 3850.
- SKINNER'S AUTHORIZED NEWSAGENCY, 49-51 Franklin-street, Traralgon, Victoria 3844.
- STEVENSON, A. C. & M., NEWSAGENTS, 132 Henty-street, Casterton, Victoria 3311.
- VERNON, C. F. & H. J., 162 Bridge-road, Richmond, Victoria 3121.
- VIEW POINT AUTHORIZED NEWSAGENCY, 4 View-Point, Bendigo, Victoria 3550.

A copy of the *Gazette* filed at each place for public reference.

**CONTENTS**

	PAGE
Appointments	1297
Cemeteries—Scale of Fees	1294
Companies Act 1961—Notice	1291
Contracts	1295
Courts	1283
Estates of Deceased Persons	1294
Government Notices	1283
Impoundings	1335
Insolvency Notices	1335
Lands	1305
Melbourne and Metropolitan Board of Works— Notice	1296
Mining	1296
Notice of Making of Statutory Rules	1336
Orders in Council— Acts—Labour and Industry; Country Roads; State Electricity Commission; Audit; et seq Land; Local Government.	1298
Private Advertisements	1319
Proclamations	1281
Public Service Notices	1315
Regulations— Acts—Teaching Service	1314
Tenders	1317
Transport Regulation Board—Public Hearings	1286
Waterworks Trusts	1292