



VICTORIA GOVERNMENT GAZETTE

Published by Authority

[Registered at the General Post Office, Melbourne, for transmission by post as a newspaper.]

No. 60]

WEDNESDAY, JUNE 17

[1970

Government House,
Melbourne, 3004,
14th June, 1970.

THE QUEEN has been graciously pleased to signify Her Majesty's intention of conferring the following Honours and Awards in the Birthday Honours, 1970:—

TO BE KNIGHTS BACHELOR.

The Honourable Murray Victor Porter.
Major-General Robert Joseph Henry Risson, C.B.,
C.B.E., D.S.O., O.St.J., E.D., B.E., F.I.C.E., F.I.E.
(Aust.), M.Inst.T., F.A.I.M.

**THE MOST DISTINGUISHED ORDER OF SAINT
MICHAEL AND ST. GEORGE.**

To be a Companion of the said Most Distinguished Order:
Robert John Southey, Esquire, M.A.

**THE MOST EXCELLENT ORDER OF THE BRITISH
EMPIRE.**

To be Officers of the Civil Division of the said Most Excellent Order:

Councillor Nola Isabel Constance Barber, Dip.Dom.Sc.
Mrs. Isabel Alice Green.
Theodore Cuyler Jarrett, Esquire.
Grevor Chilton Molyneux, Esquire, B.E., A.F.R.Ae.Sc.,
M.I.Ae.Sc., M.I.E. (Aust.)
Herbert Edward Towers, Esquire.
Cornelius Peter Whelan, Esquire, B.D.Sc., L.D.S.

To be Members of the Civil Division of the said Most Excellent Order:

Thomas Andrew Alston, Esquire.
Councillor Arthur John Bett.
Mrs. Beryl Mabel Bowler.
Councillor Robert Alexander Fraser.
Councillor Edward Colin Hill.
Councillor Walter Edwin Richard Hope.
Councillor Horace Hilton Donald Ingersole.
Councillor Reginald John Langdon.
Francis Hay Lonié, Esquire, LL.B.

Norman John Neylan, Esquire.
Vere Walter Page, Esquire.
Mrs. Amy Dora Simpson.
Councillor Dudley Clarence Stalker.
Councillor Alfred James Wignell.

THE IMPERIAL SERVICE ORDER.

To be a Companion of the said Order:
Thomas Francis Edington Mornane, Esquire, LL.B.

**AWARDS OF THE BRITISH EMPIRE MEDAL
(CIVIL DIVISION).**

Mrs. Gladys Bell.
Mrs. Coral Hope Borgas.
Charles Walter Donne, Esquire.
Roy Dore, Esquire.
Bertie Victor Eames, Esquire.
Charles James Hemming, Esquire (deceased).
John Lawson, Esquire.
Mrs. Jessie Irene Ludge.
Mrs. Nan Maie Lukey.
Captain Laurence John Maguire, J.P.
Alfred Edward Moxey, Esquire.
William Henry Fleming, Esquire.
Clifford Bertram Ward Radford, Esquire.
Charles Roberts, Esquire.
Alan Schramm, Esquire, M.M.
Dudley John Schubert, Esquire.
James Leo Simpson, Esquire.
Miss Kathleen Margaret Tyrrell.
William Annandale Whyte, Esquire.

AWARDS OF THE QUEEN'S POLICE MEDAL.

John George McLaren, Assistant Commissioner.
Lindsay George Bent, Superintendent, Grade I.
James Andrew Ottery, Chief Inspector.
Arthur John Slater, Chief Inspector.
Lindsey Neil Patterson, V.B., Inspector, Grade I.
Colin Pearce Griffiths, Inspector, Grade I.

J. ROSSITER.

Official Secretary to the Governor.

PROCLAMATIONS

Land Act 1958.

UNALIENATED CROWN LAND AVAILABLE FOR SETTLEMENT UNDER IMPROVEMENT PURCHASE LEASES.

PROCLAMATION

By His Excellency the Governor of the State of Victoria and its Dependencies in the Commonwealth of Australia &c., &c., &c.

IN pursuance of the provisions of Section 153 of the *Land Act 1958*, I, the Governor of the State of Victoria, in the Commonwealth of Australia, by and with the advice of the Executive Council of the said State, do by this Proclamation declare the unalienated Crown lands mentioned in the subjoined schedule, to be available for settlement under improvement purchase leases.

SCHEDULE.

County.	Parish.	Allotment.	Section.	Area.			Land Valuation.
				A.	R.	P.	
Delatite	Buckland	7	C	50	0	0	\$22.00 per acre (H033345)
Normanby	Bolwarra	E	2	60	0	0	\$20.00 per acre (J30913)

Given under my Hand and the Seal of the State of Victoria aforesaid, at Melbourne, this ninth day of June in the year of our Lord One thousand nine hundred and seventy, and in the nineteenth year of the reign of Her Majesty Queen Elizabeth II.

ROHAN DELACOMBE.

(L.S.)

By His Excellency's Command,
W. J. F. McDONALD,
Minister of Lands.

GOD SAVE THE QUEEN !

Land Act 1958.

AREA OF LAND COMPRISED IN CERTAIN CLASSES DIMINISHED OR INCREASED.

PROCLAMATION

By His Excellency the Governor of the State of Victoria and its Dependencies in the Commonwealth of Australia, &c., &c., &c.

WHEREAS by the *Land Act 1958* it is amongst other things enacted that the Governor in Council may, by Proclamation to be published in the *Government Gazette*, at any time diminish or increase the area of land comprised in any of the classes mentioned in Part I., Division 1, Section 5, of the said *Land Act 1958*, but that the area of lands which may be sold by auction (Class 6), shall not be increased except as in certain cases in the said Act provided : Now therefore I, the Governor of the State of Victoria, in the Commonwealth of Australia, by and with the advice of the Executive Council of the said State, and in accordance with the provisions of Sections 94 and 117 of the *Land Act 1958* aforesaid, do hereby diminish or increase (as the case may be) the areas of Crown lands comprised in Class 6 of the classes mentioned in Section 5 of the *Land Act 1958* aforesaid, to the extent set forth in the subjoined Schedule (that is to say) :—

Schedule referred to.

CLASSES DIMINISHED OR INCREASED.

County.	Parish.	Allotment.	Section.	Area.	Diminished.	Increased.	Description.
					Class.	Class.	
Borong	Watchem	49B	..	A. R. P. 2 0 0	..	6	Being the former Watchem West School Site (W88968)

Given under my Hand and the Seal of the State of Victoria, aforesaid, at Melbourne, this ninth day of June, in the year of our Lord One thousand nine hundred and seventy, and in the nineteenth year of the reign of Her Majesty Queen Elizabeth II.

ROHAN DELACOMBE.

By His Excellency's Command,
W. J. F. McDONALD,
Minister of Lands.

GOD SAVE THE QUEEN !

Section 25, *Land Act 1958*.
ROAD PROCLAIMED.

PROCLAMATION

By His Excellency the Governor of the State of Victoria and its Dependencies in the Commonwealth of Australia, &c., &c., &c.

IN pursuance of the provisions of Section 25 of the *Land Act 1958*, I, the Governor of the State of Victoria, by and with the advice of the Executive Council of the said State, do hereby proclaim as a road the land in the City of Geelong, Parish of Corio, County of Grant, as indicated by hatching on plan hereunder.—(C.272^(*)) (G.68532).

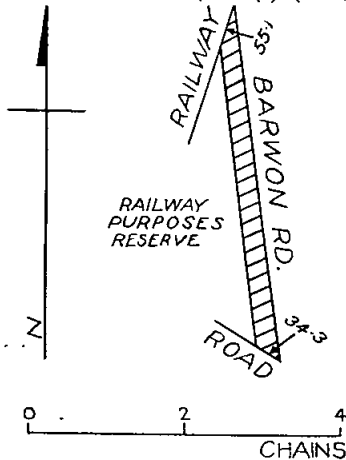

Given under my Hand and the Seal of the State of Victoria aforesaid, at Melbourne, this ninth day of June, in the year of our Lord One thousand nine hundred and seventy, and in the nineteenth year of the reign of Her Majesty Queen Elizabeth II.

(L.S.) ROHAN DELACOMBE.

By His Excellency's Command,
W. J. F. McDONALD,
Minister of Lands.

GOD SAVE THE QUEEN!

Section 25, *Land Act 1958*.
ROADS PROCLAIMED.

PROCLAMATION

By His Excellency the Governor of the State of Victoria and its Dependencies in the Commonwealth of Australia, &c., &c., &c.

IN pursuance of the provisions of Section 25 of the *Land Act 1958*, I, the Governor of the State of Victoria, by and with the advice of the Executive Council of the said State, do hereby proclaim as roads the land in the Township of Rainbow, Parish of Werrap, County of Weeah, as indicated by hatching on plan hereunder.—(R.89^(*)) (M.62427).

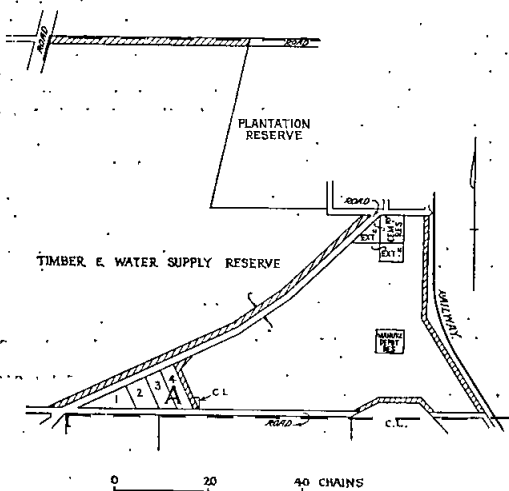

Given under my Hand and the Seal of the State of Victoria aforesaid, at Melbourne, this ninth day of June, in the year of our Lord One thousand nine hundred and seventy, and in the nineteenth year of the reign of Her Majesty Queen Elizabeth II.

(L.S.) ROHAN DELACOMBE.

By His Excellency's Command,
W. J. F. McDONALD,
Minister of Lands.

GOD SAVE THE QUEEN!

PUBLIC HIGHWAYS.—BOROUGH OF KYABRAM.

PROCLAMATION

By His Excellency the Governor of the State of Victoria and its Dependencies in the Commonwealth of Australia, &c., &c., &c.

WHEREAS by the *Local Government Act 1958*, Section 519 it is amongst other things enacted that it shall be lawful for the Governor in Council at any time and from time to time upon the request of the Council of any municipality by notice in the *Government Gazette* to proclaim any land reserved used or by purchase or exchange acquired for a street, road, highway, thoroughfare, bridge, square, court, alley, or right-of-way or any street, road, lane or passage made or laid out or proposed to be made or laid out on any land of which a plan of subdivision delineating that street, road, lane or passage has been sealed with the seal of the municipality under subdivision (3) of Division 9 of Part XIX of the *Local Government Act 1958*, or a corresponding previous enactment to be a public highway and that such land shall thereupon and thenceforth from the date of such proclamation become and be absolutely dedicated to the public as a public highway within the meaning of any law then or thereafter in force.

And whereas the Council of the Borough of Kyabram has requested that the lands hereinafter mentioned, being streets, roads, lanes or passages made or laid out or proposed to be made or laid out on land of which plans of subdivision delineating the streets, roads, lanes or passages have been sealed with the seal of the municipality under subdivision (3) of Division 9 of Part XIX of the *Local Government Act 1958*, or a corresponding previous enactment, be so declared to be public highways.

Now therefore, I, the Governor of the State of Victoria, in the Commonwealth of Australia, by and with the advice of the Executive Council of the said State, do by this Proclamation declare that Lewry Street coloured brown on Plan of Subdivision No. 26003 lodged in the Office of Titles and Underwood Grove coloured brown on Plans of Subdivision Nos. 26003 and 44244 lodged as aforesaid shall be public highways within the meaning of the said Act.

Given under my Hand and the Seal of the State of Victoria aforesaid, at Melbourne, this ninth day of June, in the year of our Lord One thousand nine hundred and seventy, and in the nineteenth year of the reign of Her Majesty Queen Elizabeth II.

(L.S.) ROHAN DELACOMBE.

By His Excellency's Command,
R. J. HAMER,
Minister for Local Government.

GOD SAVE THE QUEEN!

Water Act 1958.

STATE RIVERS AND WATER SUPPLY COMMISSION.

MORNINGTON PENINSULA WATERWORKS DISTRICT
—PORTION OF DISTRICT PROCLAIMED AN "URBAN DISTRICT".

PROCLAMATION

By His Excellency the Governor of the State of Victoria and its Dependencies in the Commonwealth of Australia, &c., &c., &c.

UNDER the powers conferred by the *Water Act 1958* and all other powers enabling me in that behalf, I, the Governor of the State of Victoria, with the advice of the Executive Council thereof do hereby proclaim that as on and from the first day of July, 1970 that portion of the Mornington Peninsula Waterworks District included within the boundaries set out and described in the Schedule

hereto, shall be and become an "Urban District" for the purpose of the said Act and shall be known as Devon Meadows-Tooradin Urban District.

SCHEDULE.

Boundaries of Devon Meadows-Tooradin Urban District

1. Commencing at the north-eastern angle of allotment 17, parish of Cranbourne; thence easterly by a line in continuation of the northern boundary of said allotment 17 to the north-eastern boundary of the South Gippsland highway; thence south-easterly by that highway to a point in line with the northern boundary of lot 1 on lodged plan of subdivision No. 51866, parish of Cranbourne; thence generally easterly by a line and the northern boundaries of lot 1 on lodged plan of subdivision No. 51866 and lots 9, 10, 17 and 26 on lodged plan of subdivision No. 53166 and by lines connecting those boundaries to the north-eastern angle of the last-mentioned lot; thence southerly by the eastern boundaries of lots 26 and 27 on lodged plan of subdivision No. 53166 and lot 29 on lodged plan of subdivision No. 51866, Parish of Cranbourne and lot 9 on lodged plan of subdivision No. 72818, Parish of Sherwood and by a line connecting those boundaries to the south-eastern angle of the last-mentioned lot; thence generally westerly by the southern boundaries of lots 9, 10, 11, 12, 13 and 14 on lodged plan of subdivision No. 72818, parish of Sherwood to the south-western angle of the last-mentioned lot; thence south-easterly and south-westerly by the north-eastern and south-eastern boundaries of lot 5 on lodged plan of subdivision No. 69098 to the south-eastern angle of that lot; thence generally south-easterly by the north-eastern boundary of the South Gippsland highway to the north-western angle of lot 4 on lodged plan of subdivision No. 34329; thence south-easterly by the north-eastern boundaries of the last-mentioned lot and of lot 2 on said lodged plan of subdivision No. 34329 to the north-eastern angle of the last-mentioned lot; thence southerly by the eastern boundary of the last-mentioned lot to its south-eastern angle; thence easterly by a line in continuation of the northern boundary of lot 6 on said lodged plan of subdivision No. 34329 to the eastern boundary of Clyde-Five Ways; thence southerly by the last-mentioned boundary to the north-western angle of lot 1 on lodged plan of subdivision No. 42892; thence easterly by the northern boundary of the last-mentioned lot to its north-eastern angle; thence southerly by the eastern boundaries of lots 1, 2, 2A, 3, 4 and 5 on lodged plan of subdivision No. 42892 and by a line in continuation thereof to a point in the northern boundary of lot 7 on lodged plan of subdivision No. 53369; thence westerly by the northern boundary of said lot 7 to its most north-western angle; thence generally south-easterly by the north-eastern boundary of the South Gippsland highway to the south-western angle of lot 208 on lodged plan of subdivision No. 3315; thence northerly by the western boundary of lot 208 to the south-western angle of lot 209; thence easterly by the southern boundary of lot 209 to its south-eastern angle; thence northerly and easterly by the western and northern boundaries of lot 210 to the north-eastern angle of that lot; thence generally easterly by a line and the northern boundaries of lots 24 and 25 on lodged plan of subdivision No. 11643 to the north-eastern angle of the last-mentioned lot; thence north-easterly by the south-eastern boundary of lot 18 to its north-eastern angle; thence easterly by the southern boundary of Hopetoun-road to the north-eastern angle of lot 90 on said lodged plan of subdivision No. 3315; thence generally south-westerly by the south-eastern boundaries of lots 90, 89, 88, 87, 86, 85, 84, 83, 82, 81, 80, 79, 78, 77, 76, 75, 74 and 73 on said lodged plan of subdivision No. 3315 to the south-eastern angle of the last-mentioned lot; thence easterly by the northern boundary of Bayview-road to the west-bank of Sawtells creek; thence generally southerly by that creek bank to a point in the north-eastern boundary of the South Gippsland highway in line with the southern boundary of lot 1 on lodged plan of subdivision No. 2588, parish of Koo-Wee-Rup; thence south-easterly by the north-eastern boundary of that highway to the south-western angle of the last-mentioned lot; thence north-easterly by the north-western boundary of lot 1 to its north-western angle; thence generally easterly by the northern boundaries of lots 1, 2, 3, 31, 30, 29, 28, 27, 26, 25, 24, 23, 22, 21, 20, 19 and 18 and by lines connecting those boundaries and by a line in continuation thereof to the south-eastern boundary of Ballarto-street; thence south-westerly by that street boundary and by a line in continuation thereof to the south-western boundary of the South Gippsland highway; thence north-westerly by that highway to the north-eastern angle of lot 8 on lodged plan of subdivision No. 41588; thence south-westerly by the eastern boundaries of the last-mentioned lot and of lot 78 on lodged plan of subdivision No. 1809 to its south-eastern angle; thence generally westerly by the

southern boundaries of said lot 78 and of lots 77, 48, 47, 16 and 15 and by lines connecting those boundaries and by a line in continuation thereof to the east-bank of Sawtells creek; thence generally northerly by that creek bank to a point in the south-western boundary of the South Gippsland highway in line with the northern boundary of lot 1 on lodged plan of subdivision No. 27922; thence north-westerly by that highway to the west-bank of Sawtells creek; thence generally north-westerly by that creek bank and by the east-bank of Evans Inlet to a point in the western boundary of allotment 1, section 1, parish of Sherwood; thence north-westerly by a line and the south-western boundary of the South Gippsland highway to its intersection with the eastern boundary of Fisheries-road; thence southerly by the last-mentioned road boundary to a point in line with the southern boundary of lot 149 on lodged plan of subdivision No. 6487; thence westerly by a line and the southern boundaries of said lot 149 and of lots 80, 81, 82, 83, 84, 85 and 86 to the north-eastern angle of lot 150 on lodged plan of subdivision No. 6596; thence southerly by the eastern boundaries of said lot 150 and of lots 172, 173 and 194 and by lines connecting those boundaries to the north-western angle of lot 10 on lodged plan of subdivision No. 6527; thence easterly by the northern boundaries of lots 10 and 1 and by a line connecting those boundaries and by a line in continuation thereof to the eastern boundary of Fisheries-road; thence southerly by that road boundary to the north-western angle of lot 1 on lodged plan of subdivision No. 18886; thence easterly by the northern boundary of the last-mentioned lot to a point distant 2 chains from the western boundary of that lot; thence southerly by a line parallel to the western boundary of said lot 1 to the northern boundary of North-road; thence westerly by that road boundary to the south-western angle of said lot 1; thence southerly and south-easterly by the eastern and north eastern boundaries of Fisheries-road to the north-western angle of lot 1 on lodged plan of subdivision No. 34360; thence generally easterly by the northern boundary of the last-mentioned lot to its north-eastern angle; thence south-easterly by the north-eastern boundaries of lots 1 to 13 (both inclusive) and by a line in continuation thereof to a point in the northern boundary of lot 86 on lodged plan of subdivision No. 13206; thence easterly by the northern boundaries of lots 86, 84, 83, 82, 81 and 80 and south-easterly by the north-eastern boundaries of lots 79, 78, 77, 76, 75, 74, 73, 72, 71, 70, 69, 68, 67, 66, 65, 64, 63, 62, 61, 60 and by a line in continuation thereof to the north-bank of Rutherford's Inlet; thence generally southerly and westerly by that Inlet bank to a point in line with the south-western boundary of allotment 93; thence north-westerly by a line and the last-mentioned boundary to a point in line with the south-western boundary of allotment 93; thence north-westerly by a line and the last-mentioned boundary to a point in line with the western boundary of lot 47 on lodged plan of subdivision No. 45584; thence northerly by a line, the western boundaries of lots 47 and 46 and by a line connecting those boundaries to the north-western angle of the last-mentioned lot; thence easterly by the northern boundary of said lot 46 to its north-eastern angle; thence northerly by the western boundary of Peters-road to its intersection with the northern boundary of Glenalva-parade; thence easterly by that parade to the south-western angle of lot 1 on lodged plan of subdivision No. 30515; thence northerly by the western boundary of the last-mentioned lot to its north-western angle; thence easterly by the northern boundaries of lots 1 to 21 (both inclusive) on lodged plan of subdivision No. 30515 and lots 22 to 29 (both inclusive) on lodged plan of subdivision No. 30700 and by lines connecting those boundaries to the north-eastern angle of the last-mentioned lot; thence north-westerly by the South-western boundaries of lots 32 to 45 (both inclusive) on lodged plan of subdivision No. 44578 and by a line connecting those boundaries to the north-western angle of the last-mentioned lot; thence north-easterly by the north-western boundary of the last-mentioned lot to the south-western boundary of Fisheries-road; thence north-westerly and northerly by the south-western and western boundaries of Fisheries-road to the north-eastern angle of Crown Portion 83; thence westerly by the southern boundary of North-road to the north-eastern angle of allotment 87; thence northerly by the western boundary of Hastings-road to the south-eastern angle of lot 217 on lodged plan of subdivision No. 51188; thence westerly by the southern boundaries of lots 217, 225, 224, 223, 222, 221, 220, 219, and 218 to the south-western angle of the last-mentioned lot; thence northerly by the western boundary of lot 218 and a line in continuation thereof to the south-western angle of lot 226; thence north-westerly and northerly by the south-western and western boundaries of lots 226 to 249 (both inclusive) and by a line connecting those boundaries to the north-western angle of the last-mentioned lot; thence north-westerly by the south-western boundaries

of lots 152, 151, 150, 149, 148, 147, 146, 145, 144, 143, 142, 141, 140, 139, 138, 137, 136, 135, 134, 133, 132, 131, 130, 129 and 128 on lodged plan of subdivision No. 51187 and by a line connecting those boundaries to the south-eastern angle of lot 5 on lodged plan of subdivision No. 54277; thence westerly and northerly by the southern and western boundaries of the last-mentioned lot and by a line in continuation thereof to the northern boundary of Bullarto-road; thence easterly by that road boundary to its intersection with the South Gippsland highway; thence north-westerly by the south-western boundary of that highway to the point of commencement.

2. Commencing at the most north-western angle of allotment 111, parish of Sherwood (at the intersection of Kallara and Warneet roads); thence north-easterly by the south-eastern boundary of Warneet-road to a point in line with the north-eastern boundary of Aruma-street; thence north-westerly by a line, the last-mentioned street boundary and by a line in continuation thereof to the south-bank of Rutherford's Inlet; thence generally westerly and southerly by that Inlet to a point in line with the southern boundary of Rutherford-parade; thence generally easterly and northerly by the southern and eastern boundaries of Rutherford-parade and generally northerly by the eastern boundary of Kallara-road to the point of commencement.

The lands set out and described in the foregoing Schedule are shown on a set of 6 plans approved by the Governor in Council and deposited in the office of the State Rivers and Water Supply Commission, Melbourne (Corr. No. 70/1193).

Given under my Hand and the Seal of the State of Victoria aforesaid, at Melbourne, this sixteenth day of June, in the year of our Lord One thousand nine hundred and seventy, and in the nineteenth year of the reign of Her Majesty Queen Elizabeth II.

(L.S.) ROHAN DELACOMBE.

By His Excellency's Command,
W. A. BORTHWICK,
For Minister of Water Supply.
GOD SAVE THE QUEEN!

GOVERNMENT NOTICES

DEPARTMENT OF MINES.

APPLICATIONS FOR MINING LEASES REFUSED.

- 8912, Mineral; Robert John Gard, Anthony Wills, Baden Swan; 200 acres, Parish of Broadford.
8916, Mineral; Michael B. Yoxon, Raymond Johnson; 50 acres, Parish of Broadford.
8919, Mineral; Michael B. Yoxon, Raymond Johnson; 200 acres, Parish of Broadford.

EXPLORATION LICENCES CANCELLED.

- 107, Exploration Licence; S. Baitz, C. M. Baitz, P. Baitz, H. F. Harden, B. L. Harden, J. Hanna, G. Hanna; 24 square miles, County of Benambra.
110, Exploration Licence; S. Baitz, C. M. Baitz, P. Baitz, H. F. Harden, B. L. Harden, J. Hanna, G. Hanna; 19 square miles, County of Benambra.
113, Exploration Licence; Oil and Mineral Quest N.L.; 800 square miles, County of Benambra.

EXPLORATION LICENCE EXPIRED.

- 74, Exploration Licence; Harold Neil Thomas and Renfrew Investments Proprietary Limited; 2 square miles, County of Bogong.

MINERAL SEARCH LICENCES GRANTED.

- 1016, Mineral Search Licence; R. D. Beattie Pty. Ltd., 2 square miles, Parish of Whroo.
1020, Mineral Search Licence; Gippsland Minerals No Liability; 930 acres, Parish of Sargood.

TAILINGS LICENCES GRANTED.

- 3690, Tailings Licence; Albert William Trotter; "Waterloo" mine dump situated at Steiglitz in the Parish of Durrdidwarrah (in lieu of 3648 Tailings Licence expired).
3697; Tailings Licence; The President, Councillors and Ratepayers of the Shire of Lexton; "Trengove's" mine dump situated in the Parish of Langi-kal-kal (in lieu of 3468 Tailings Licence expired).

3698, Tailings Licence; West Moorabool Water Board; "Mt. Egerton" and "Sister Rose" mine dumps situated in the Parish of Bungal (in lieu of 3636 Tailings Licence expired).

3701, Tailings Licence; The Mayor, Councillors and Citizens of the City of Bendigo; "Windmill Hill" mine dump situated at Bendigo in the Parish of Bendigo (in lieu of 3465 Tailings Licence expired).

3704, Tailings Licence; The Country Roads Board; "Sandy Creek Dredge" mine dump situated in the Parish of Scarsdale (in lieu of 3532 Tailings Licence expired).

PETROLEUM PROSPECTING LICENCES EXTENDED.

192, Petroleum Prospecting Licence; A.P.M. Development Proprietary Limited; 193 square miles, Parishes of Woundellah, Wurruk Wurruk, Denison, Winnindoo, Toongabbie North, Boola Boola and Tanjil East.

193, Petroleum Prospecting Licence; A.P.M. Development Proprietary Limited; 182 square miles, Parishes of Maryvale, Traralgon, Loy Yang, Rosedale and Tong Bong.

EXPLORATION LICENCE EXTENDED.

91, Exploration Licence; Alliance Oil Development Australia N.L., 11 square miles, County of Buln Buln.

J. C. M. BALFOUR,
Minister of Mines.

MINING LEASE DECLARED VOID.

8423, Mineral; Leslie Ernest Swift; 3a. 2r. 12p., Parish of Castlemaine.

E. CONDON,
Secretary for Mines.

Police Regulation Act 1958, Section 112.

SALE OF UNCLAIMED MOTOR VEHICLE.

AN owner is required for a 1957 model Holden sedan with a cream coloured body and reddish coloured top; ex-registered number N.S.W. BYR-816, engine No. L496956.

The vehicle came into the possession of Police on the 25th October, 1969, and if not claimed, will be sold by public auction, at the Mildura Police Station, Madden-avenue, Mildura, at 2 p.m., on 13th July, 1970.

N. WILBY,
Chief Commissioner of Police.

Farm Produce Merchants and Commission Agents Act 1965 (No. 7274).

LIST OF NAMES AND ADDRESSES OF PERSONS TO WHOM LICENCES HAVE BEEN GRANTED DURING MAY, 1970.

IN accordance with the above Act, those issued with a Merchant's or Commission Agent's licence have lodged a fidelity bond. All licences, unless earlier cancelled, shall continue in force until 30th June, 1970.

D. S. WISHART,
Director of Agriculture.

MERCHANTS.

Name; Principal Place of Business.

- Aloi, C. D. N. & P., 67 Bruce-street, Colac, Vic. 3250.
Anthony Brothers, 133 Wattletree-road, Malvern, Vic. 3144.
Cox, L. G., Pty. Ltd., "Florida", South Wangaratta, Vic. 3677.
Gangemi, G., Melbourne Wholesale Fruit and Vegetable Market, Footscray-road, Footscray, Vic. 3011.

COMMISSION AGENT.

McLeod, Ian, Aqueduct-avenue, McKillop, Victoria.

SECONDARY WHOLESALERS.

- McNaughton, Mary & Malcolm, 20 Russell-street, Bendigo, Vic. 3550.
Pastorella Myrtleford Fruit Paradise, Myrtle-street, Myrtleford, Vic. 3737.

Private Agents Act 1966.

NOTICE OF RECEIPT OF APPLICATIONS FOR LICENCES UNDER THE PROVISIONS OF THE PRIVATE AGENTS ACT 1966.

THE Clerk(s) of the Magistrates' Court(s) as listed hereunder hereby give notice that applications, as under, have been lodged for hearing by the said Court(s) on the date(s) specified.

Any person desiring to object to any of such applications must—

- (a) lodge with the respective Clerk of the Magistrates' Court a notice in the prescribed form of his objection and of the grounds thereof;
- (b) cause a copy of such notice to be served personally or by post upon the applicant at least three days before the hearing of the application; and
- (c) send or deliver—
 - (i) where the objection is not made by the officer in charge of the police district in which the Court is situated—a copy of the notice to such officer; and
 - (ii) where the objection is not made by the Registrar or Deputy Registrar—a copy to the Registrar.

Full Name of Applicant or in the Case of a Firm or Corporation, of the Nominee.	Place of Abode of Applicant or Nominee.	Name of Firm or Corporation.	Address for Registration.	Type of Licence.	Date of Hearing of Application.
MAGISTRATES' COURT, MELBOURNE.					
Barratt, Frederick George	14 Surrey-crescent, Clayton		Australian Watching Co. Pty. Ltd., 340 Abbotsford-street, North Melbourne	Watchman	24.6.70
Bartley, Frank	Flat 195/126 Racecourse-road, Flemington		" "	"	"
Barker, David	55 Gother-street, West Heidelberg		" "	"	"
Bogg, Lindsay Nevil	28 Reynard-street, Coburg		" "	"	"
Brooks, Lawrence Andrew	Flat 1, 20 Chancer-crescent, Canterbury		" "	"	"
Brown, Thomas Albert	49 Anderson-road, Fawkner		" "	"	"
Burke, Alan James	Flat 2, 4 Vasey-street, Ascot Vale		" "	"	"
Clow, Maxwell Stuart	4 Shield-court, Kilsyth		" "	"	"
Conway William	11 The Pass, Croydon		" "	"	"
Cumberledge, Richard Eric	25 Warleigh-grove, North Brighton		" "	"	"
Dean, Adrian Douglas	95 Tennyson-street, Elwood		" "	"	"
Stefanis, Antonio De	14 Derrick-street, Kew		" "	"	"
Farrelly, John Joseph	73 Morey-road, Beaumaris		" "	"	"
Ferrie, Robert John	11 Yungera-street, Fawkner		" "	"	"
Donaldson, Peter	33 Alma-avenue, Laverton		" "	"	"
Finlayson, Bruce McGregor	30 Loongawa-avenue, Glenroy		" "	"	"
Hanlon, Thomas	53 Bay-road, Sandringham		" "	"	"
Hutton, Kenneth Cyril	27 Clyde-street, West Newport		" "	"	"
Jones, Herbert Reginald	55A Euston-road, Oakleigh		" "	"	"
Jordan, Robert John Patrick	1 Queen-street, Kew		" "	"	"
Kennett, Reginald James	c/o Mr. D. Theobald, 34 Holyrood-avenue, Strathmore		" "	"	"
Kilbey, Brian Arthur	4 Quaintance-street, Mount Waverley		" "	"	"
Langridge, Carlyle William	30 Elliott-avenue, Broadmeadows		" "	"	"
Leggett, Ronald William	6 Newport-road, Clayton		" "	"	"
Massey, Robert Gordon	6 Fraser-street, Brunswick		" "	"	"
McAlpin, Hughbain	463 Station-street, Carrum		" "	"	"
McGifford, Mervyn Thomas	30 Glen-street, Glenroy		" "	"	"
McNally, Gerald	1/7 Jepson-street, Yarraville		" "	"	"
Muratovic, Salih	719B Malvern-road, Toorak		" "	"	"
Nelson, John	7 Grove-road Hawthorn		" "	"	"
Pastor, Mario Victor	1/18 Jackson-street, East St. Kilda		" "	"	"
Plail, Alfred James	18/10 Minnie-street, Brunswick		" "	"	"
Reid, John William	2 Correa-court, East Doncaster		" "	"	"
Rijavec, Vinko	72 Dunstan-avenue, Brunswick		" "	"	"

PRIVATE AGENTS—*continued.*

Full Name of Applicant or in the Case of a Firm or Corporation, of the Nominee.	Place of Abode of Applicant or Nominee.	Name of Firm or Corporation.	Address for Registration.	Type of Licence.	Date of Hearing of Application.
MAGISTRATES' COURT, MELBOURNE— <i>continued.</i>					
Robinson, James Richard ..	Flat 4, 196 Dorcas-street, South Melbourne	Australian Watching Co. Pty. Ltd., 340 Abbotsford-street, North Melbourne	Watchman ..	24.6.70
Safic, Hamid ..	46 Haladan-road, Niddrie	" "	" ..	"
Savage, Ronald Bernard ..	66 Kirby-street, East Reservoir	" "	" ..	"
Scott, David McQuat ..	22 Morton-street, Clayton North	" "	" ..	"
Smith, Joseph Christopher ..	6/9 Bluff-avenue, Elwood	" "	" ..	"
Spence, Frederick Alexander	151A Albert-street, East Preston	" "	" ..	"
Steffens, Hans George ..	Flat 2, 106 Westbury-street, East St Kilda	" "	" ..	"
Street, Mark ..	14 Macey-avenue, Avondale Heights	" "	" ..	"
Sutherland, Keith Douglas ..	177 Daley-street, Glenroy	" "	" ..	"
Sweeney, Garrett William ..	38 Loyola-grove, Burnley	" "	" ..	"
Thomas, Cornelius ..	172 Fortescue-avenue, Seaford	" "	" ..	"
Tombs, Robert George ..	21 Burrawong-avenue, Seaford	" "	" ..	"
Thompson, William Henry ..	14 Belmont-avenue, Upwey	" "	" ..	"
Tucker, William Frederick James	327 Barkly-street, Footscray	" "	" ..	"
Ward, James Stewart ..	6 Myrtle-street, Werribee	" "	" ..	"
Wilkinson, Brian Geoffrey ..	7 Tennyson-court, Mulgrave	" "	" ..	"
Williams, Peter Vincent ..	139 Royal-parade, Parkville	" "	" ..	"

Dated at Melbourne this 5th day of June, 1970.

G. L. WEBSTER, Clerk of the Magistrates' Court.

MAGISTRATES' COURT, WODONGA.					
Turton, Peter Hoyle ..	87 Gordon-street, Wodonga	87 Gordon-street, Wodonga	Process Server ..	30.6.70

Dated at Wodonga this 8th day of June, 1970.

G. MURPHY, Clerk of the Magistrates' Court.

MAGISTRATES' COURT, SOUTH MELBOURNE.					
Cooper, Edward James ..	1 Hawksburn-road, South Yarra	101-105 Clarke-street, Melbourne South	Watchman ..	30.6.70
Hardy, Alan John ..	66 Warrandyte-road, Ringwood	" "	" ..	"
Lis, Niki ..	H.M.A.S. Lonsdale, Rouse-street, Port Melbourne	" "	" ..	"
Maharaj, Vidya Dhar ..	41 Hambleton-street, Albert Park	" "	" ..	"
Males, Barry Victor ..	2/46 Epsom-road, Ascot Vale	" "	" ..	"
Murrell, John Raymond ..	7/9 Farnham-court, Flemington	" "	" ..	"
Pasinati, Peter ..	9/25 Williams-road, Windsor	" "	" ..	"

Dated at South Melbourne this 8th day of June, 1970.

J. M. DUGAN, Clerk of the Magistrates' Court.

MAGISTRATES' COURT, BRIGHTON.					
Hill, William Humphrey ..	25 Rose-street, Bentleigh	"Hilton" Private Detective Agency, 25 Rose-street, Bentleigh	Guard Agent ..	3.7.70

Dated at Brighton this 8th day of June, 1970.

E. McGOWAN, Clerk of the Magistrates' Court.

MAGISTRATES' COURT, WODONGA.					
Henderson, David Bruce ..	13 Mitchell-street, Wodonga	13 Mitchell-street, Wodonga	Process Server ..	30.6.70

Dated at Wodonga this 4th day of June, 1970.

J. T. KNIGHT, Clerk of the Magistrates' Court.

MAGISTRATES' COURT, HAWTHORN.					
Grundy, Gary Maurice ..	17 Vista-street, Bulleen	Mayne Nickless Ltd., Cnr. Kinkora and Glenferrie roads, Hawthorn	Watchman ..	1.7.70

Dated at Hawthorn this 10th day of June, 1970.

D. M. CRANE, Clerk of the Magistrates' Court.

Commercial Goods Vehicles Act.
TRANSPORT REGULATION BOARD.

HEARING OF APPLICATIONS.

NOTICE is hereby given that the following applications will be considered by the Transport Regulation Board at its offices at the corner Lygon and Princes streets, Carlton, at 10.15 a.m. on Wednesday, 8th July, 1970.

- ADAMS, H. M. & V. J., Powelltown, 3791. Application to vary the conditions of licence No. D.T.1160 (L/C. 223 cwt.) by deleting from the existing conditions "Noojee" and adding in lieu "Warburton".
- ALESCI, C., 28 Jersey-street, Coburg, 3058. One commercial goods vehicle (L/C. 227 cwt.) to operate within a 35-mile radius of the G.P.O., Melbourne, on behalf of Consolidated Quarries Ltd.—sand, soil, screenings, premix and quarry products.
- ANDERSON, N. E., 11 Scott-street, Orbost, 3888. Two commercial goods vehicles (L/C. 3 and 6 cwt.) to operate throughout the State of Victoria for the purpose of operating as a "Mortuary Vehicle" in the course of business as "Funeral Director".
- ANDERSON, R. W. (trading as R. W. & M. M. Anderson), Davis-street, Warrnambool, 3280. One commercial goods vehicle (L/C. 11 cwt.) to operate within a 50-mile radius of the post office at Warrnambool in the course of business as "Agent" on behalf of Mobil Oil (Aust.) Pty. Ltd.—petroleum products in prescribed types of containers, empty returns, bulk tanks and empty farm storage tanks.
- ATKINSON INTERNATIONAL (AUST.) PTY. LTD., Upper Thomson, via Warburton, 3799. One commercial goods vehicle (L/C. 19 cwt.) to operate: (a) Within a 50-mile radius of own construction site at Upper Thomson in the course of business as "Construction Engineers"—own goods. (b) From and to the Upper Thomson—Yarra Tunnel Project site to and from the Township of Warburton—mail under a portage contract with the Postmaster-General's Department.
- ATKINSON INTERNATIONAL (AUST.) PTY. LTD., Upper Thomson, via Warburton, 3799. One commercial goods vehicle (L/C. 116 cwt.) to operate within that part of a 50-mile radius of the post office at Warburton situated east of a line drawn due north and south through the Township of Warburton in the course of business as "Civil Engineers"—own goods.
- BALLARAT & WESTERN VICTORIA TELEVISION LTD., P.O. Box 464, Ballarat 3350. One commercial goods vehicle (L/C. 10 cwt.) to operate throughout the State of Victoria in the course of business as "Television and Radio Producers and Transmitters"—transmitting equipment, tools of trade, spare parts and materials incidental thereto.
- CALSIL BRICKS PTY. LTD., 223 Cranbourne-road, Frankston, 3199. Two commercial goods vehicles (L/C. 264 and 266 cwt.) to operate within a 70-mile radius of own premises at Frankston in course of business as "Brick Manufacturers"—own bricks and empty pallets.
- CHAMBERS, B. M., 79 Moroney-street, Bairnsdale, 3875. Application to vary the conditions of licence No. D.A.53372 (L/C. 67 cwt.) by deleting the existing "Special Condition" and adding in lieu: "(1) The load capacity of the present vehicle (96 cwt.) shall not be increased without Board approval, nor shall any trailer be used in conjunction with the licensed vehicle. (2) No more than (80 cwt.) of bagged superphosphate shall be carried on any one journey."
- CURZI, G., 181 Amess-street, North Carlton, 3054. One commercial goods vehicle (L/C. 225 cwt.) to operate within a 70-mile radius of the premises of Clifton Brick Holdings Ltd., at Brunswick solely on behalf of the said company—bricks.
- DALEY, H. J., 16 Caroline-court, Mooroolbark, 3138. One commercial goods vehicle (L/C. 7 cwt.) to operate: (a) Within a 50-mile radius of own premises at Mooroolbark in the course of business as "Distributor of Drapery, Toys and Hardware"—own goods. (b) Throughout the State of Victoria for the purpose of booking orders and sales promotion—samples only of own goods and display material.
- DALGETY & NEW ZEALAND LOAN LTD., 1 Malop-street, Geelong, 3220. One commercial goods vehicle (L/C. 14 cwt.) to operate within a 50-mile radius of own branch premises at Warrnambool in the course of business as "Stock and Station Agents"—own goods subject to the condition that all goods carried on the vehicle shall have been initially consigned by rail to Warrnambool.
- DALGETY & NEW ZEALAND LOAN LTD., 1 Malop-street, Geelong, 3220. One commercial goods vehicle (L/C. 14 cwt.) to operate within a 50-mile radius of own branch premises at Stawell in the course of business as "Stock and Station Agents"—own goods subject to the condition that all goods carried on the vehicle shall have been initially consigned by rail to Stawell.
- DRYSDALE, D. R., 32 Raglan-street, Sale, 3850. One commercial goods vehicle (L/C. 190 cwt.) to operate from the plants of Pioneer Concrete Pty. Ltd. at Morwell and Leongatha to consignees situated within a 50-mile radius of the particular plant—premixed concrete in a specially constructed agitator vehicle, solely on behalf of the said company.
- FOODLAND STORES PTY. LTD., P.O. Box 59, Glen Waverley, 3150. One commercial goods vehicle (L/C. 10 cwt.) to operate: (a) Within a 50-mile radius of own premises at Glen Waverley in the course of business as "Wholesale Grocers"—own goods. (b) Throughout the State of Victoria for the purpose of sales promotion of own goods and agency lines—samples and advertising and display materials.
- GRIGG, D. J., Flat 5, 1 Duncraig-avenue, Armadale, 3143. One commercial goods vehicle (L/C. 149 cwt.) to operate within a 50-mile radius of the premises of Ready Mixed Concrete (Vic.) Pty. Ltd., at North Melbourne solely on behalf of the said company—ready mixed concrete in a specially constructed agitator vehicle.
- HUTCHINSON, W. A., 97 Rattray-road, Montmorency, 3094. One commercial goods vehicle (L/C. 125 cwt.) to operate: (a) Within a 25-mile radius of own premises at Greensborough in the course of business as "Sand, Soil and Garden Suppliers"—own goods. (b) From pits at Bacchus Marsh to places within paragraph (a) above—river pebbles. (c) From pits at Cranbourne to places within paragraph (a) above—sand. (d) From pits at Toolangi to places within paragraph (a) above—mountain soil. (e) From pits at Melton to places within paragraph (a) above—rockery stone.
- JAKOBI, G. S., 11 Hope-street, Bunyip, 3815. One commercial goods vehicle (L/C. 118 cwt.) to operate: (a) Within a 25-mile radius of the post office at Bunyip—general goods subject to the condition that no goods shall be carried whether in one or more stages from any one point within the said radius to any other point within the said radius situated more than thirty (30) road miles apart by the nearest practicable route. (b) From the Depot of B.P. Australia Ltd. at Dandenong to applicant's own depot at Bunyip—petroleum products in prescribed types of containers and empty return containers. (c) From Yallourn to applicant's own premises at Bunyip in the course of business as "Fuel Merchants"—own briquettes. (d) From the mill of G. & J. Cole at Garfield to the timber yard of Hollensen Bros. at Bayswater and to Shelston Tile Works at Croydon—sawn timber and roofing battens.
- JONES, A. K., 29 Payne-street, Bairnsdale, 3875. One commercial goods vehicle (L/C. 321 cwt.) to operate from forest landings situated within a 30-mile radius of Stratford and within a 30-mile radius of Bairnsdale to the sawmills operated by S. M. Collins Pty. Ltd., at Stratford and Bairnsdale—mill logs.
- MARCHANTS AERATED WATERS AND CORDIALS PTY. LTD., 295 Raglan-parade, Warrnambool, 3280. Application to vary the conditions of licence No. D.A.46981/6 (L/C. 73 cwt.) by deleting the existing conditions and adding in lieu—"Within the area of the State of Victoria bounded by a north/south line drawn through the Township of Camperdown and south of an east/west line drawn through the Township of Casterton in the course of business as "Aerated Water Manufacturers"—own aerated waters and cordials, provided that all goods are initially consigned by rail to Warrnambool."
- MORGAN, D. McP., Private Bag, Glenorchy, 3385. One commercial goods vehicle (L/C. 143 cwt.) to operate: (a) Within a 25-mile radius of own premises at Dadswell's Bridge—general goods, provided that no goods shall be carried whether by one stage or by more than one stage between places within the above radius which are more than thirty (30) road miles apart by the nearest practicable route. (b) Within a 50-mile radius of own premises at Dadswell's Bridge in the course of business as "Share Farmer"—own goods.
- MCCARRON, K. E. & L. F., 20 Piper-street, Kyneton, 3444. One commercial goods vehicle (L/C. 133 cwt.) to operate: (a) Within a 12-mile radius of own premises at Kyneton and from and to the Township of Kyneton to and from the Townships of Mia Mia and Lancefield in the course of business as "Grain and Feed Merchants and Petroleum Agents"—own goods and petroleum products. (b) From Melbourne to own premises at Kyneton—stockfeed and petroleum products and empty containers for return.

NOTE.—Subject to the cancellation of licence No. D.A.58355 in the name of Willis Bros. Pty. Ltd.

MCDONELL, J. L., Shepparton-road, Echuca, 3625. One commercial goods vehicle (L/C. 198 cwt.) to operate within a 50-mile radius of the premises of Ready Mixed Concrete (Vic.) Pty. Ltd. situated at Echuca,

- Swan Hill and Bendigo—solely on behalf of the said company—premixed concrete in a specially constructed agitator vehicle.
- MCPHERSON, P. R., New Dookie-road, Shepparton, 3630. One commercial goods vehicle (L/C. 270 cwt.) to operate: (i) Within that part of the State of Victoria east of a north/south line drawn through St. Arnaud, north of an east/west line drawn through Wallan and west of a north/south line drawn through Wodonga in the course of business as "Earth-moving and Cable Laying Contractor" on behalf of the Postmaster-General's Department—tools of trade, earth-moving and cable laying equipment. (ii) (a) Within a 50-mile radius from the post office at Shepparton as a "Road Contractor"—road-making plant and materials. (b) Within a 25-mile radius of the post office at Shepparton—general goods provided that no goods shall be carried whether by one stage or by more than one stage between places within the above radius which are more than thirty (30) road miles apart by the nearest practicable route.
- NESTLE COMPANY (AUSTRALIA) LTD., THE, Bald Hill-road, Pakenham East, 3810. One commercial goods vehicle (L/C. 397 cwt.) to operate: (a) Within a 25-mile radius of the post office situated at the corner of Bourke and Elizabeth streets in the City of Melbourne, in the course of business as "Canners and Preservers of Foodstuffs"—own goods. (b) Within a 15-mile radius of the post office at Pakenham—fresh fruit and vegetables for use in own factory at Pakenham. (c) From the City of Melbourne to the Township of Pakenham—building materials and pre-fabricated building pieces for use in own factory. (d) From the City of Melbourne to own decentralized industry factories at Pakenham and Maffra—own products for processing and also raw materials and machinery requirements of such decentralized industries. (e) From own decentralized industry factories at Maffra and Pakenham to the City of Melbourne—own manufactured products of such decentralized industries.
- PRIDHAM, W. (AUST.) PTY. LTD., 11 Evans-street, Braybrook, 3019. One commercial goods vehicle (L/C. 114 cwt.) to operate: (a) Within a 25-mile radius of own premises at Braybrook in the course of business as "Animal By-Product Processors"—own goods. (b) Throughout the State of Victoria for the purpose of collecting from country abattoirs and killing centres—bones, offal, runners and animal waste materials in bulk.
- READY MIXED CONCRETE (VIC.) PTY. LTD., 68 Burwood-road, Burwood, 3215. One commercial goods vehicle (L/C. 127 cwt.) to operate within a 50-mile radius of the premises of Ready Mixed Concrete (Vic.) Pty. Ltd. Richmond—own ready mixed concrete in a specially constructed agitator vehicle.
- SOILMECH PTY. LTD., 31 Cremorne-street, Richmond, 3121. One commercial goods vehicle (L/C. 14 cwt.) to operate throughout the State of Victoria in the course of business as "Soil Testing Engineers"—own tools of trade and drilling rig with the ability to carry samples of soil for testing purposes.
- TARAXALE BREWING CO. PTY. LTD., 1317 North-road, Huntingdale, 3167. One commercial goods vehicle (L/C. 86 cwt.) to operate within a 50-mile radius of the G.P.O. in the City of Melbourne in the course of business as "Aerated Water manufacturers and Distributors"—own aerated waters and empty return containers but excluding the carriage of any such goods to the Geelong Urban District (as defined in the *Transport Regulation Act 1958*).
- TELSCO TRANSPORT PTY. LTD., 1317 North-road, Huntingdale, 3167. Two commercial goods vehicles (L/C. 95, 143 cwt.) to operate within a 50-mile radius of the G.P.O. in the City of Melbourne in the course of business as "Aerated Water Manufacturers and Distributors" as a subsidiary company of Taraxale Brewing Co. Pty. Ltd.—aerated waters and empty return containers, excluding the carriage of any such goods to the Geelong Urban District (as defined in the *Transport Regulation Act 1958*).
- TENACE, N., 113 Hutton-street, Thornbury, 3071. One commercial goods vehicle (L/C. 40 cwt.) to operate within a 25-mile radius of the G.P.O., Melbourne and to Pakenham and places en route as a "Salesman Agent" solely on behalf of Four'n Twenty Pies Pty. Ltd.—pies, pasties, sausage rolls and fruit drinks in waxed paper containers.
- THOMAS, H. E., Main Ridge, 3928. One commercial goods vehicle (L/C. 210 cwt.) to operate within a 30-mile radius of the premises of Pioneer Quarries (Vic.) Pty. Ltd. at Dromana on behalf of the said company—sand, soil, screenings, premix and quarry products.
- THOMPSONS (CASTLEMAINE) LTD., 5 Parker-street, Castlemaine, 3450. One commercial goods vehicle (L/C. 8 cwt.) to operate: (a) Throughout the State of Victoria in the course of business as "Engineers and Manufacturers" for the purpose of installing and servicing machinery—tools of trade, spare parts and equipment incidental only to own contracts. (b) Between own premises at Castlemaine and the City of Melbourne—a quantity not exceeding 8 cwt. at any one time of urgently required or fragile items.
- TULLOCK JENKIN PTY. LTD., 33 Desailly-street, Sale, 3850. Application to vary the conditions of licence No. D.A.2185/2 (L/C. 120 cwt.) by adding as an additional paragraph (b)—"Within a 25-mile radius of own premises at Sale in course of business as 'Seed and Grain Merchant'—own goods."
- TURNER, J. H., 54 Anderson-street, Leongatha, 3953. One commercial goods vehicle (L/C. 6 cwt.) to operate: (a) Within a 35-mile radius of the post office situated at Leongatha in the course of business as "General Engineer"—own goods. (b) From the premises of L. J. Russell at Bulleen to own premises at Leongatha in the course of business as "Trailer Dealer"—vehicle trailers for resale.
- WARDLE, R. A., 21 Rose-street, Doncaster, 3108. One commercial goods vehicle (L/C. 245 cwt.) to operate within a 35-mile radius of the G.P.O. in the City of Melbourne solely on behalf of Pioneer Quarries (Vic.) Pty. Ltd.—sand, soil, screenings, premix and quarry products.
- WILLIAMSON, L. M., Alvie via Colac, 3250. Application to vary the conditions of licence No. D.A.58742/6 (L/C. 164 cwt.) by deleting from paragraph (b) of the existing conditions "Meenyan" and adding in lieu "Lyndhurst" also add to paragraph (a) of the existing conditions "Cobden and Camperdown."

RENEWALS.

APPLICATIONS for renewal of licences as shown by persons listed hereunder to operate under the same terms and conditions from the expiry shown in each case.

ADAMS, W. D., 29 George-road, Ararat, 3377; D.A.60032; 1st August, 1970; 80 cwt.

AIR MIST PTY. LTD., care of Hanger 50.B, Aerodrome Parafield, 5106; D.A.60022; 1st August, 1970; 17 cwt.

ALBERT BATTY PTY. LTD., 45 Moreland-street, (P.O. Box 226), Footscray, 3011. D.A.622/13; 29th August, 1970; 7 cwt.

BILLS, L. J. & H. B., 101 Gladstone-street, Orbost, 3888; D.T.802; 12th September, 1970; 250 cwt.

BUILDERS EQUIPMENT PTY. LTD., 230 Church-street, Richmond, 3121; D.A.60251; 3rd October, 1970; 17 cwt.

COHNS (EASTERN) PTY. LTD., Tone-road, Wangaratta, 3677; D.A.47825; 6th August, 1970; 78 cwt; D.A.47825/1; 6th August, 1970; 139 cwt; D.A.47825/2; 6th August, 1970; 79 cwt; D.A.47825/3; 6th August, 1970; 138 cwt; D.A.47825/4; 6th August, 1970; 143 cwt.

DAVIES, R. M., Chenery-street, Mansfield, 3722; D.A.60150; 12th September, 1970; 79 cwt.

DEVONDALE CREAM (VIC.) PTY. LTD., 99 Bell-street, Preston, 3072; D.A.58730/3; 30th May, 1970; 78 cwt.

ELLIOTS, M. F., SERVICES PTY. LTD., 47 Lonsdale-street, Dandenong, 3175; D.A.44951/2; 17th September, 1970; 17 cwt.

J. & A. WRECKERS, Princes Highway, Warrnambool, 3280; D.A.60220; 26th September, 1970; 7 cwt.

KETTS, J. I., 26 Freeman-street, Echuca, 3625; D.A.60175; 12th September, 1970; 108 cwt.

KOCKUM AUSTRALIA PTY. LTD., 55 Derham-street, Port Melbourne, 3207; D.A.58474/2; 12th September, 1970; 14 cwt.

LEECH, C. E., 4 Maclise-street, Castlemaine, 3450; D.T.757; 12th September, 1970; 243 cwt.

LEGGE, J. W., 43 Thomson-street, Sale, 3850; D.A.22091/4; 22nd September, 1970; 297 cwt.

LUKE WRIGHT INDUSTRIES PTY. LTD., 120 Clarendon-street, South Melbourne, 3205; D.A.60238; 3rd October, 1970; 20 cwt.

MONK, B. W., P.O. Box 437, Orbost, 3888; D.T.1340; 12th September, 1970; 261 cwt.

NELSON, P., P.O. Box 1, Nowa Nowa, 3887; D.T.502; 12th September, 1970; 403 cwt.

OMED & TAMBO VALLEY DAILY SERVICE PTY. LTD., P.O. Box 10, Ormeo, 3898; D.A.30744/1; 12th September, 1970; 26 cwt.

READY MIXED CONCRETE (VIC.) PTY. LTD., 68 Burwood-road, Burwood, 3125; D.A.48531/43; 26th September, 1970; 40 cwt.

READY MIXED CONCRETE (VIC.) PTY. LTD., 68 Burwood-road, Burwood, 3125; D.A.48531/42; 29th August, 1970; 298 cwt.

READY MIXED CONCRETE (VIC.) PTY. LTD., 68 Burwood-road, Burwood, 3125; D.A.48531/39; 15th August, 1970; 192 cwt.; D.A.48531/40; 15th August, 1970; 211 cwt; D.A.48531/41; 29th August, 1970; 196 cwt.

REPLACEMENT PARTS PTY. LTD., 618 Elizabeth-street, Melbourne, 3000; D.A.1907/41; 3rd October, 1970; 14 cwt.
 ROWE, GAVIN, & Co., Coleraine-road, Hamilton, 3300; D.T.860; 26th September, 1970; 278 cwt.
 TAYLOR, W. D., High-street, Marong, 3515; D.A.47382; 24th September, 1970; 60 cwt.
 WITTE, W. (trading as V. & W. Transport), Flat 2, 18 Cranbourne-road, Frankston, 3199; D.A.60254; 3rd October, 1970; 178 cwt.
 WARANGA & HUME DISTRIBUTING CO. PTY. LTD., P.O. Box 124, Wangaratta, 3677; D.A.42124/23; 8th August, 1970; 17 cwt; D.A.42124/25; 8th August, 1970; 33 cwt; D.A.42124/26; 8th August, 1970; 15 cwt.
 WARANGA & HUME DISTRIBUTING CO. PTY. LTD., P.O. Box 124, Wangaratta, 3677; D.A.42124/20; 8th August, 1970; 18 cwt; D.A.42124/21; 8th August, 1970; 16 cwt.
 WARANGA & HUME DISTRIBUTING CO. PTY. LTD., P.O. Box 124, Wangaratta, 3677; D.A.42124/31; 8th August, 1970; 16 cwt; D.A.42124/33; 8th August, 1970; 10 cwt.

TOW TRUCK.

TEMPLE TOWING & BODYWORKS PTY. LTD., 1127A North-road, South Oakleigh, 3167; D.A.59769; 26th September, 1970; 28 cwt.

RENEWAL WITH VARIATION.

APPLICATION by the person listed hereunder for renewal of the licence listed with variation of conditions in the manner set out opposite the names.

BROND, R. D. & J. E., 19 Elvin-street, Mansfield, 3722; D.T.560; 9th May, 1970; Application to renew and vary the conditions of licence No. D.T.560 (L/C. 276 cwt.) by deleting the existing conditions and adding in lieu:—“(a) From forest landings situated within a 50-mile radius of the post office at Mansfield to sawmills situated at Mansfield and Benalla—sawmill logs. (b) Within a 50-mile radius of the post office at Mansfield—bulldozers, tractors and associated equipment for use in logging operations.”

Notice of any objection should be forwarded to reach the Secretary of the Board not later than 1st July, 1970.

Applicants are advised that it will not be necessary to appear on the hearing date specified above, unless advised in writing by the Board.

B. P. KAY,
 Secretary.

Corner Lygon and Princes streets, Carlton 3053, Wednesday, 17th June, 1970.

Transport Regulation Act.
 TRANSPORT REGULATION BOARD.
 HEARING OF APPLICATIONS.

NOTICE is hereby given that the following applications will be considered by the Transport Regulation Board at its offices at the corner of Lygon and Princes streets, Carlton, at 10.15 a.m. on Wednesday, 8th July, 1970.

COOK, I. J., & SON PTY. LTD., 321 Autumn-street, Geelong. One commercial passenger vehicle (S/C. 41) to operate under the same terms and conditions as existing U.O. licences in the name of the applicant company.

APPLICATION for renewal of licences as shown, by persons listed hereunder to operate under the same terms and conditions.

BAKER, R. W., 492 Pascoe Vale-road, North Essendon; T.P.79.

BALLINGER, M. R. (Mrs.), 53 Greensborough-road, Macleod; T.P.158.
 BULUMWAAL TIMBER & TRADING CO. PTY. LTD., Bulumwaal via Bairnsdale; T.P.234.
 CHRISTIE, R. J., G. J., A. T. & P. R., High-street, Yea; T.S.743.
 GIBSON, N. H., Woorinen; T.P.65.
 HUNTLEY, C. R., 9 Campbell-road, Briar Hill; T.P.219.
 NEGRAU, G., 52 Bruce-street, Bell Park, North Geelong; T.P.116.
 O'BRIEN, W. J. & P. N., Culgoa; T.S.747.
 PARKER, R. L., Monbulk-road, Silvan; T.P.89.
 SAN PEDRO (OFF SHORE) PTY. LTD., P.O. Box 4, Port Welshpool; T.P.90.
 SOUTH, F. R., High-street, Woodend; T.P.228.
 SOUTH WESTERN ROADWAYS PTY. LTD., 169 Koroit-street, Warrnambool; C.O.73, C.O.197, C.O.254, C.O.462, C.O.670, C.O.781, C.O.785, C.O.788, C.O.820, C.O.850, C.O.864, C.O.1025, C.O.1103, C.O.64, C.O.189, C.O.235, C.O.376, C.O.547, C.O.780, C.O.783, C.O.787, C.O.789, C.O.829, C.O.856, C.O.1024, C.O.1102, C.O.1104, C.O.1105, C.O.1106, C.O.1107, C.O.1109, C.O.1110, C.O.1111, C.O.1112, C.O.1113.

BENNETT, L. W., 3 Baker-street, Moorabbin; M.T.2692.
 BOLLING, M. B., 21 Gillard-street, East Brighton; M.T.4258, M.T.1948.
 BROMLEY, D. K., 1016 North-road, East Bentleigh; M.T.4272.
 BROWNE, W. J., 72 Alma-street, West Footscray; M.T.2636.
 COWEN, C. E., 20 Goulay-street, East St. Kilda; M.T.2698.
 COWELL, J. F., 14 James-street, Preston; M.T.2668.
 DAVIES, K. H., 2 Watsonia-street, Oakleigh; M.T.2656.
 DONDEY, J., 21 Beckley-street, East Coburg; M.T.990.
 DUNSTAN, I. H., 12 Johnson-street, Pascoe Vale; M.T.2677.
 EDWARDS, W. J. (Estate of the late), 44 Larissa-avenue, Ringwood; M.T.2580.
 FISHER, D. M., 18 Panorama-avenue, Highett; M.T.2644.
 GARNER, L. H., 25 Broadlea-crescent, East Rosanna; M.T.2612.
 GIANNOUKIS, G., 7 Ashley-grove, Malvern; M.T.1778.
 GRASSO, G., 122 Orrong-road, Armadale; M.T.4249.
 GRECO, F., 35 Dundas-street, Thornbury; M.T.4209.
 HILL, L. R. R., 27 Belleview-avenue, East Burwood; M.T.2674.
 JOHNSTON, T. F., 23 Victor-road, Glen Iris; M.T.2645.
 KENDALL, K. J., 103 Grandview-avenue, Pascoe Vale South; M.T.4087.
 KNOX, W. E., 15 First-avenue, Brunswick; M.T.2672.
 LUPONE, O., 103 Rennie-street, Coburg; M.T.4314.
 MATRANO, S., 48 Alec-crescent, Fawkner; M.T.1944.
 MITCHELL, J. A., 100 Gower-street, East Preston; M.T.2670.
 MOTYLSKI, W., 15 Convent-court, North Coburg; M.T.4054.
 O'ROURKE, J. P. (Executors for the estate of the late), 472 Bourke-street, Melbourne; M.T.2642.
 ROWE, K. J. (Estate of the late), Flat 3, 43 Havelock-road, East Hawthorn; M.T.2655.
 ROZENBERG, C., 63 Rowan-street, Burwood; M.T.4085.
 SAFLEKOS, N., 57 Dumbarton-street, Reservoir; M.T.4111.
 STEWART, K. J., 1 Gish-court, Hadfield; M.T.2650.
 STRINTZOS, A., 92 Bridge-street, Port Melbourne; M.T.4327.
 TAYLOR, W. T., 1 Gezireh-street, Pascoe Vale South; M.T.2646.
 TSAKALOFAS, J., 20 Barnett-street, Yarraville; M.T.4376.
 WOLRAT, M., Flat 2, 12 Pilley-street, East St. Kilda; M.T.4180.

Notice of any objection should be forwarded to reach the Secretary of the Board not later than Wednesday, 1st July, 1970.

Applicants are advised that it will not be necessary to appear on the hearing date specified above, unless advised in writing by the Board.

B. P. KAY,
 Secretary.

Corner Lygon and Princes streets, Carlton, Wednesday, 17th June, 1970.

STATE RIVERS AND WATER SUPPLY COMMISSION.

LICENCES TO DIVERT WATER AND CUT RACES PURSUANT TO THE PROVISIONS OF SECTION 204 OF THE WATER ACT (AS AMENDED).

THE Schedule of licences as detailed hereunder to divert water and cut races have been revoked by the Governor in Council.

SCHEDULE.

Licence No.	Term of Licence and Commencing Date.	Name and Address of Person to whom Licence granted.	Source of Supply.
111	Fifteen years from 1.7.57	Windsor Winston Tickell, Leitchville	Gunbower Creek
157	Fifteen years from 1.7.57	John Eric Keogh, Cohuna, (but now held by Trevor Roy Taylor and Alec William Roy Taylor, Cohuna)	Gunbower Creek
168	Fifteen years from 1.7.58	Alec William Roy Taylor, Cohuna	Gunbower Creek

Office of the State Rivers and Water Supply Commission, Melbourne, 16th June, 1970.

G. W. LEWIS, Secretary,
 State Rivers and Water Supply Commission.

Audit Act 1958.

DESIGNATION OF CERTIFYING OFFICERS.

PUBLIC ACCOUNTS AND STORES REGULATIONS—REGULATION 3.

HIS Excellency the Governor of the State of Victoria by and with the advice of the Executive Council thereof doth by Order made on the 16th day of June, 1970, revoke the Order made on the second day of July, 1958, pursuant to Regulation 3 of the Public Accounts and Stores Regulations 1958, as amended, designating certain offices as being offices, the occupiers of which shall certify accounts for payment in respect of the several services specified in the Order, as from and inclusive of the 1st July, 1970, insofar as it relates to the Division of the Honorable the Premier, and that in lieu thereof the under-named offices shall be designated as such offices under the said Division:—

Legislative Council	..	The Clerk of the Legislative Council or the Clerk-Assistant.
Legislative Assembly	..	The Clerk of the Legislative Assembly or the Clerk-Assistant.
House Committee of Parliament	}	Secretary, House Committee.
Parliamentary Refreshments Rooms		
Parliamentary Contributory Superannuation Fund	..	Secretary to the Trustees of the Fund.
Library—Parliament House	..	The Librarian.
Parliamentary Printing	..	The Clerk or the Clerk-Assistant of the Legislative Council or the Clerk or the Clerk-Assistant of the Legislative Assembly, or the Librarian, Parliamentary Library.
The Governor's Office	..	The Secretary or the Accountant, Premier's Department.
Premier's Office	..	
Agent-General's Office	..	
Emergency Flood Protection Works	..	
National Parks Fund	..	
Public Works Committee	..	
Soil Conservation Authority	..	The Auditor-General or the Assistant Auditor-General.
Victorian Parliamentary Debates	..	
Auditor-General	..	The Secretary or the Accountant, Premier's Department.
Audit Office	..	
The Public Service Board and Office	}	The Secretary or the Accountant, Premier's Department.
All other expenditure including that from Surplus Revenue Loan and Trust Fund, the responsibility of the Division of the Premier not set out above		

J. ROSSITER,
Clerk of the Executive Council.

At the Executive Council Chamber,
Melbourne, 16th June, 1970.

Stock Diseases Act 1958.

DEPARTMENT OF AGRICULTURE.

THE Public Service Board has, by certificate dated the 20th May, 1970, appointed THOMAS GLYNN and CHRISTOPHER JOHN OLIVER to be Inspectors of Stock under the provisions of Part 1 of the *Stock Diseases Act 1958*, without additional salary.

D. S. WISHART,
Director of Agriculture.

POLICE OFFENCES ACT 1958.

IN pursuance of the powers conferred upon the Chief Secretary by sub-section (3) of section 184 of the *Police Offences Act 1958*, I do by this notice grant exemption from compliance with sub-sections (1) and (2) of section 184 of the said Act with respect to the publication "Jean in the Morning" distributed by Colorgrave Publications, 61 Flinders-lane, Melbourne.

A. G. RYLAH,
Chief Secretary.

Chief Secretary's Office,
Melbourne, 9th June, 1970.

Cemeteries Act 1958.

SCALE OF FEES OF THE ELLERSLIE PUBLIC CEMETERY.

IN pursuance of the powers conferred upon them by the Cemeteries Act, the trustees of the Ellerslie Public Cemetery hereby make the following scale of fees, which shall come into operation upon publication in the *Government Gazette*, and from and after such publication every scale of fees heretofore made by the said trustees shall be and is hereby rescinded to the extent to which it conflicts with this scale.

Private Graves.

Land, 8 ft. x 4 ft.	\$8.00
Grave for an infant	\$10.00

Sinking Charges for Public Graves.

Sinking grave	\$25.00
---------------	----	----	----	----	---------

Re-opening Charges.

Re-opening grave	\$25.00
------------------	----	----	----	----	---------

Miscellaneous Charges.

Permission to erect a headstone of monument—	5 per cent. of cost, with a minimum of \$5.00.
--	----	----	----	----	--

M. N. MCKENZIE, Trustee.
ALAN JENNINGS, Trustee.
DOUG. ALFORD, Trustee.

Approved by the Governor in Council, 9th June, 1970.—
J. ROSSITER, Clerk of the Executive Council.

Cemeteries Act 1958.

SCALE OF FEES OF THE NHILL PUBLIC CEMETERY.

IN pursuance of the powers conferred upon them by the Cemeteries Act, the trustees of the Nhill Public Cemetery hereby make the following scale of fees, which shall come into operation upon publication in the *Government Gazette*, and from and after such publication every scale of fees heretofore made by the said trustees shall be and is hereby rescinded to the extent to which it conflicts with this scale.

Private Graves.

Land, 8 ft. x 4 ft.	\$10.00
Own selection of land (extra)	\$2.00

Public Graves.

Interment in grave without exclusive right—	\$6.00
stillborn child	
Interment in grave without exclusive right—	\$12.00
others	

Sinking Charges for Private Graves.

Sinking grave 6 feet deep	\$30.00
Each additional foot	\$3.00
Sinking oversize grave (extra)	\$5.00
Sinking oversize grave for American type casket (extra)	\$5.00
Cancellation of order to sink (if commenced)	\$5.00

Reopening Charges.

Reopening grave (no cover)	\$20.00
Reopening grave (with cover or kerb)	\$30.00

Extra Charges.

Interment not in the prescribed hours or on Saturdays, Sundays or Public Holidays	\$5.00
---	----	----	----	----	--------

Miscellaneous Charges.

Interment fee	\$7.00
Certificate of right of burial	\$1.00
Inspection of plan or register	\$1.00
Permission to erect a headstone or monument—	5 per cent. of cost, with a minimum of \$6.00.
Permission to construct a brick grave or to erect any stone kerb, brick, tilework or concrete	\$4.00
Exhuming the remains of a body (when authorized)	\$25.00
Interment of ashes in a private grave	\$10.00

G. A. GLATZ, Trustee.
L. H. G. MULHALLEN, Trustee.
A. G. BONE, Trustee.

Approved by the Governor in Council, 9th June, 1970.—
J. ROSSITER, Clerk of the Executive Council.

LOCAL GOVERNMENT DEPARTMENT.
SHIRE OF SOUTH BARWON—VARIATION OF
SEPARATE RATE.

On the 5th May, 1970, in compliance with the prayer of a petition of certain ratepayers in portion of the municipal district of the Shire of South Barwon, the Council of the Shire of South Barwon made a separate rate for the purpose of providing off-street parking facilities for the High-street, Belmont, Shopping Centre.

IN pursuance of the provisions of section 288 of the Local Government Act 1958, it is hereby notified that the Governor in Council has varied the rate by reducing the proposed amount of the rate in the dollar on the unimproved capital value of the properties specified below to the extent shown:—

Property.	Rate as Varied.	Rate as in Petition.
106A High-street, Belmont;	1.34 cents in lieu of 2.23 cents.	
110 High-street, Belmont;	1.61 cents in lieu of 2.68 cents.	
112 High-street, Belmont;	1.55 cents in lieu of 2.58 cents.	
118 High-street, Belmont;	0.804 cents in lieu of 1.34 cents.	
120-2 High-street, Belmont;	0.804 cents in lieu of 1.34 cents.	
124 High-street, Belmont;	0.804 cents in lieu of 1.34 cents.	
126 High-street, Belmont;	0.804 cents in lieu of 1.34 cents.	
128 High-street, Belmont;	0.804 cents in lieu of 1.34 cents.	
130 High-street, Belmont;	0.804 cents in lieu of 1.34 cents.	
9 Glenara-road, Belmont;	0.95 cents in lieu of 1.12 cents.	
10 Glenara-road, Belmont;	0.95 cents in lieu of 1.12 cents.	

Within one month from the date of the latest publication of this notice:

- (a) any person who signed the petition; or
(b) any person who became the owner or occupier of property in respect of which the petition was signed by the previous owner or occupier—

may, by writing under his hand delivered or sent by registered post to the Minister for Local Government, withdraw his signature or the signature of the previous owner or occupier (as the case may be) and any person qualified to sign the petition may in like manner accede to the petition.

R. J. HAMER,
Minister for Local Government.

Local Government Department,
61 Spring-street,
Melbourne, Vic., 3000.

CONTRACTS ACCEPTED.—(Series 1969-70.)

VICTORIAN RAILWAYS.

90. Design of circuits and manufacture, supply, delivery, construction, erection and installation of automatic power signalling between North Melbourne and Jewell and automatic boom barrier installations at Arden-street and Macaulay-road, Macaulay, and Poplar-road, Royal Park, for the amount of \$110,642.00 (Contract No. 63496).—McKenzie and Holland (Aust.) Pty. Ltd.

By order of the Victorian Railways Commissioners,
W. WALKER, Secretary for Railways. 12.6.70.

ORDERS IN COUNCIL.—(Series 1969-70.)

PUBLIC WORKS.

1418. Melbourne, Public Works Department, Treasury Reserve, supply of furniture—\$5,276.75.—Myer-Teale Pty. Ltd.—(S.P.162370 "E").

Approved by the Governor in Council, 9th June, 1970.—
J. ROSSITER, Clerk of the Executive Council.

Crimes Act 1958.

CURATOR OF CONVICT'S PROPERTY.

HIS Excellency the Governor of the State of Victoria, by and with the advice of the Executive Council thereof, doth by Order made on the 9th day of June, 1970, and pursuant to the provisions of section 550 of the Crimes Act 1958, commit the custody and management of the property of the convict, Dimitrios Papparonas, to John Lawrence O'Connell, of 470 Bourke-street, Melbourne, as a Curator hereby appointed in that behalf.

J. ROSSITER,
Clerk of the Executive Council.

At the Executive Council Chamber,
Melbourne, 9th June, 1970.

NOTICE TO MARINERS.

[No. 16 of 1970.]

AUSTRALIA.—VICTORIA.

THE following Notice to Mariners which has been received from the Harbor Master, Geelong, is published for general information.

A. J. WAGGLEN,
Port Officer.

Public Works Department,
Ports and Harbors Division,
Treasury-place,
Melbourne, Vic., 3002.
10th June, 1970.

GEELONG HARBOR TRUST COMMISSIONERS.

PORT OF GEELONG.

Channel Light Beacon Demolished.

Position.—No. 11 Light Beacon Hopetoun Channel, Lat. 38 deg. 7 min. 28 sec. S., Long. 144 deg. 24 min. 28 sec. E.
Details.—Light beacon in the above position has been demolished.

Remarks.—Construction of a new No. 11 beacon will commence immediately, 82 deg. 34 min.—327 feet from its former position.

Caution.—The new beacon will be unlighted during construction.

Stamps Act 1958.

ANNUAL LICENCE.

NOTIFICATION PURSUANT TO SECTION 97.

I HEREBY notify that stamp duty has been paid for a licence under section 96 of the Stamps Act to carry on assurance and insurance business in Victoria, from 16th June, 1970, to 31st December, 1970, by the following:—

FIRST MORTGAGE INSURANCE COMPANY OF AUSTRALIA
PTY. LTD.

R. M. PHIBBS,
Comptroller of Stamps.

Chief Officer for Stamp Duties,
Melbourne, 17th June, 1970.

APPOINTMENTS AND RESIGNATIONS

APPOINTMENTS.

HIS Excellency the Governor of the State of Victoria, by and with the advice of the Executive Council thereof, has, by Orders made on the 9th day of June, 1970, been pleased to make the under-mentioned appointments, viz.:—

CHIEF SECRETARY'S DEPARTMENT.

Member of the Liquor Control Commission.

The Honorable FRANCIS FIELD,
pursuant to the provisions of the Liquor Control Act 1968, to be a member of the Liquor Control Commission, for a period of two years from the 1st July, 1970.

President of the Metropolitan Fire Brigades Board.

ERNEST CHARLES MILTON SYMES,
to be President of the Metropolitan Fire Brigades Board, pursuant to the provisions of the Metropolitan Fire Brigades Act 1958, as from the 17th June, 1970.

Members of the Metropolitan Fire Brigades Board.

ALEXANDER FOXCROFT BOTTOMLEY, J.P. (Councillor),
JAMES PERCY BREBNER (Councillor),
ERNEST VICTOR JOHNSON (Councillor),
CLAUDE REGINALD AMIET,
LEWIS EDWARD GRIFFITHS,
JOHN CLIFFORD MOGG, and
FREDERICK EDWIN FARR,
pursuant to the provisions of the Metropolitan Fire Brigades Act 1958, to be members of the Metropolitan Fire Brigades Board, for a term of three years from the 17th June, 1970.

MINISTRY OF HEALTH.

Member of Committee of Management of Hospital.

HENRY JACKSON MCKEMMISH
to be Government appointee on the Committee of Management of the Sandringham and District Memorial Hospital, pursuant to section 48 (1) (a) (ii) of the Hospitals and Charities Act 1958.

Trustees of Public Cemeteries.

JOHN RONALD BUNN, and
ALEXANDER COLIN CHARLESON,
to be Trustees of the Creswick Public Cemetery vice A. C.
New and W. Zimmer, deceased;

ARTHUR SPEIGHT,
to be a Trustee of the Moonlight Head Public Cemetery
vice W. Wilson, resigned;

JAMES McCRAE,
JOHN COLLIDGE SYMONS, and
JAMES LINDSAY JOLLIFFE,
to be Trustees of the Ellerslie Public Cemetery, additional
Trustees,

THE COUNCIL OF THE MUNICIPALITY OF THE SHIRE OF
WARANGA,
to be Trustees of the Whroo Public Cemetery, vice Trustees,
resigned, pursuant to section 3 (2) of the *Cemeteries Act*
1958.

Public Vaccinator.

PETER MAURICE ARNDT, M.B., B.S.,
to be Public Vaccinator for the Municipality of Brunswick,
pursuant to section 151 of the *Health Act* 1958.

LAW DEPARTMENT.

Commissioners for Taking Declarations, &c.

HERBERT CHARLES BENNETT, care of Housing Commis-
sion, Victoria, 179 Queen-street, Melbourne,
AUDREY SCOTT MANN, care of Department of Labour
and Industry, 110 Exhibition-street, Melbourne,

PETER DANIEL O'RILEY,
LESLIE ALBERT COLEMAN,
JOHN RICHARD KERR-TAYLOR, and
WALTER ROBERT THOMAS TIPPING, care of H.M. Pent-
ridge Gaol, Coburg,
to be Commissioners for taking Declarations and Affidavits,
pursuant to the provisions of the *Evidence Act* 1958, to
refrain from charging fees and to resign upon ceasing to
occupy their present positions;

EDWARD ANDREW CALLOW, Private Bag 51, Koroit, and
JOHN GERHARD BAINBRIDGE, 95 Thames-promenade,
Chelsea,
to be Commissioners for taking Declarations and Affidavits,
pursuant to the provisions of the *Evidence Act* 1958, to
resign upon removing from the neighbourhood of the
addresses stated; and

HAROLD JOHN FRANCIS, care of Louis Dreyfus & Co.
Limited, 505 St. Kilda-road, Melbourne,

ALLAN FRANCIS MASON, care of John N. Robertson,
Thompson & Co., 379 Collins-street, Melbourne.
FRANCIS WALTER MARTIN, care of State Electricity Com-
mission of Victoria, Rosneath-street, North Gee-
long,

JOHN LEIGH WILLIAMS, care of Roach Williams & Co.,
379 Collins-street, Melbourne.

FREDERICK ANDREWS ERNEST KIMBERLEY, care of Kim-
berley Plastics Pty. Ltd., 58-60 Alex-avenue,
Moorabbin,

JOSEPH ANTHONY BONGIORNO, care of Bongiorno, Letho
and Associates Pty. Ltd., 21 Victoria-street, Mel-
bourne.

WILLIAM INCE THOMPSON, care of Bank of New South
Wales, 368 Collins-street, Melbourne,

JOHN CLIFFORD WALLACE GIBB, care of The English
Scottish and Australian Bank Limited, 287 Collins-
street, Melbourne,

HUBERT JOHN HERDMAN, care of Rocke Tompsitt & Co.,
Limited, 10 Griffiths-street, Richmond.

ALBERT BRUCE McCULLOCK, care of No. 2 Mill Section,
Dunlop Australia Limited, Normanby-road, Monta-
gue,

DENIS BOAK, care of Fidelity Insurance Brokers Pty.
Ltd., 800 Heidelberg-road, Alphington,

ROBERT ALEXANDER HEAL, care of The Oxford Insur-
ance Company Proprietary Limited, 138 Flinders-
street, Melbourne, and

LINDSAY GORDON WILLIAMS, care of Permewan Wright
Limited, 147-179 Alexandra-parade, Abbotsford,
to be Commissioners for taking Declarations and Affidavits,
pursuant to the provisions of the *Evidence Act* 1958,
to resign upon ceasing to occupy their present posi-
tions.

Justices of the Peace.

FREDERICK JAMES TERRILL, Audley-street, Rutherglen,
ALBERT KEITH TANNER, Lawler-street, Meredith, and
HUGH TANNAHILL LAMBIE, 76 Hesse-street, Queenscliff,
to keep the Peace in the State of Victoria.

PUBLIC WORKS DEPARTMENT.

Wharf Manager.

Sergeant ALAN LINDSAY BODEY, No. 10105,
to be Wharf Manager at Brighton, to carry out that portion
of Part II. of the *Marine Act* 1958, which relates to the
Management of Public Wharfs, and to be an officer under
section 19 of such Act to levy and collect wharfage rates
thereat, vice Sergeant Frederick Gordon Jones, V.B., No.
9955, transferred.

DEPARTMENT OF WATER SUPPLY.

Waterworks Trust Commissioners.

KEITH JAMES WARD,
to be a Commissioner of the Maffra Waterworks Trust, to
hold such position for the period from 11th June, 1970,
until 13th June, 1971, subject to the provisions of the
Water Act;

DONALD GODFREY WOODS,
to be a Commissioner of the Woods Point Waterworks
Trust, to hold such position for the period from the date
hereof until 1st July, 1972, subject to the provisions of the
Water Act; and

ALBERT CHARLES TRIGG,
to be a Commissioner of the Bungaree and Wallace Water-
works Trust, to hold such position for a period of one
year from the date hereof, subject to the provisions of the
Water Act.

J. ROSSITER,

Clerk of the Executive Council.

At the Executive Council Chamber,
Melbourne, 9th June, 1970.

Liquor Control Act 1968.

APPOINTMENT OF LICENSING INSPECTOR.

IN accordance with the authority conferred upon me by
sub-section (1) of section 22 of the *Liquor Control Act* 1968,
I, Noel Wilby, Chief Commissioner of Police, hereby appoint
the following Officer of Police as a Licensing Inspector for the
Division of the Police District as shown:—

Division Number.	Police District.	Rank and Name.
2	Bourke ..	Inspector John William Tobin vice Inspector L. N. Patterson
1st June, 1970.		N. WILBY, Chief Commissioner of Police.

RESIGNATIONS.

HIS Excellency the Governor of the State of Victoria,
by and with the advice of the Executive Council
thereof, has, by Orders made on the 9th day of June, 1970,
accepted the resignations of the persons named hereunder
of the offices mentioned, viz.:—

CHIEF SECRETARY'S DEPARTMENT.

Honorary Probation Officers.

ATHOL WILLIAM BARNARD (Captain),
RAY AUGUSTUS BARRY,
JOSEPH CURRAN,
GODFREY GILBERT (the Reverend),
JOHN FRANCIS HARDY (the Reverend Father),
KEITH CHARLES HOLLINGSWORTH,
ROBERT HUNT (Captain),
GRAEME T. KEARNS (Captain),
HECTOR JOHN MACK,
EDWARD MARTIN,
GORDON K. MOYES (the Reverend),
JAMES VERDUN NEWNHAM,
FRANCIS J. OWENS (the Reverend Father),
RONALD STEWART STEELE,
MICHAEL JOHN LOUIS SERRURIER,
JAMES VERNON PHILIP,
ATHANASIOS MARINAKIS (the Reverend Father),
WILLIAM JAMES FLEMING,
GRAHAM NATHAN (the Reverend),
JOHN ROLAND PARRIS (the Reverend),
CLIFFORD K. PAGE (the Reverend),
RONALD STANLEY HALLS (the Reverend Canon),
DAVID BLAKE IFE,
ALBERT RICHARD BURNS,
PATRICK JAMES MURPHY,
ALAN EDWARD NUNN (the Reverend),

SYDNEY SMALE (the Reverend),
NORMAN RAY THOMAS, and
DAVID IVOR ANTHONY (the Reverend),
Honorary Probation Officers for Children's Courts
in Victoria.

LAW DEPARTMENT.

Commissioners for Taking Declarations, &c.
ERIC NICHOLSON BARBOUR, and
REGINALD THOMAS THOROGOOD,
as Commissioners for taking Declarations and
Affidavits, pursuant to the provisions of the Evi-
dence Act 1958.

J. ROSSITER,
Clerk of the Executive Council.

At the Executive Council Chamber,
Melbourne, 9th June, 1970.

ORDERS IN COUNCIL

LOCAL GOVERNMENT DEPARTMENT.

At the Executive Council Chamber, Melbourne, the
second day of June, 1970.

PRESENT:

His Excellency the Governor of Victoria.
Mr. Chandler | Mr. Dickie

APPOINTMENT OF CHAIRMAN AND A MEMBER OF
THE MUNICIPAL CLERKS BOARD.

PURSUANT to the provisions of section 168 of the *Local Government Act 1958*, His Excellency the Governor of the State of Victoria, by and with the advice of the Executive Council thereof and with effect on and from the 1st day of July, 1970, hereby appoints:

- (1) DONALD MAXWELL PURDIE, a member of the Municipal Clerks Board, to be Chairman of that Board; and
- (2) IAN RONALD PAWSEY to be a member of the said Board, vice John Renfrew Alder.

And the Honorable Rupert James Hamer, Her Majesty's Minister for Local Government for the State of Victoria, shall give the necessary directions herein accordingly.

J. ROSSITER,
Clerk of the Executive Council.

THE CONSTITUTION ACT AMENDMENT ACT 1958.

At the Executive Council Chamber, Melbourne, the
ninth day of June, 1970.

PRESENT:

His Excellency the Governor of Victoria.
Mr. Rossiter | Mr. Borthwick.

WHEREAS in consequence of a Writ issued pursuant to the provisions of *The Constitution Act Amendment Act 1958* a poll for the election of a Member for the Monash Province will be held on the 20th June;

And whereas the Chief Electoral Officer has certified in writing that it is necessary that a polling place be appointed within the City of Melbourne to be a polling place for the Caulfield Subdivision of the aforementioned Province;

Now, therefore, His Excellency the Governor of the State of Victoria by and with the advice of the Executive Council thereof and in pursuance of the provisions of sub-section 4 of section 148 of *The Constitution Act Amendment Act 1958* and all other powers him thereunto enabling doth hereby appoint Spring-street within the City of Melbourne to be a polling place for the Caulfield Subdivision of the Monash Province at the election to be held on the 20th day of June, 1970.

And the Honorable Sir Arthur Gordon Rylah, Her Majesty's Chief Secretary for the State of Victoria, shall give the necessary directions herein accordingly.

J. ROSSITER,
Clerk of the Executive Council.

COUNTRY ROADS BOARD.

At the Executive Council Chamber, Melbourne, the
ninth day of June, 1970.

PRESENT:

His Excellency the Governor of Victoria.
Mr. Rossiter | Mr. Borthwick.

ORDER APPROVING OF LAND BEING ACQUIRED AND
ROADS, DEVIATIONS OR WIDENINGS BEING MADE.

HIS Excellency the Governor of the State of Victoria, by and with the advice of the Executive Council thereof, being satisfied that there are funds legally available for acquiring the land, doth hereby approve the acquiring of the land described in the Schedule hereunder and the making of new roads and deviations from and widenings of existing roads referred to in the said Schedule.

SCHEDULE.

State Highways.

The land shown hatched on Plans numbered G.P.12226 and G.P.12227 hereunder required for the deviation from the Murray Valley Highway in the Shire of Swan Hill and making of the deviation thereon.

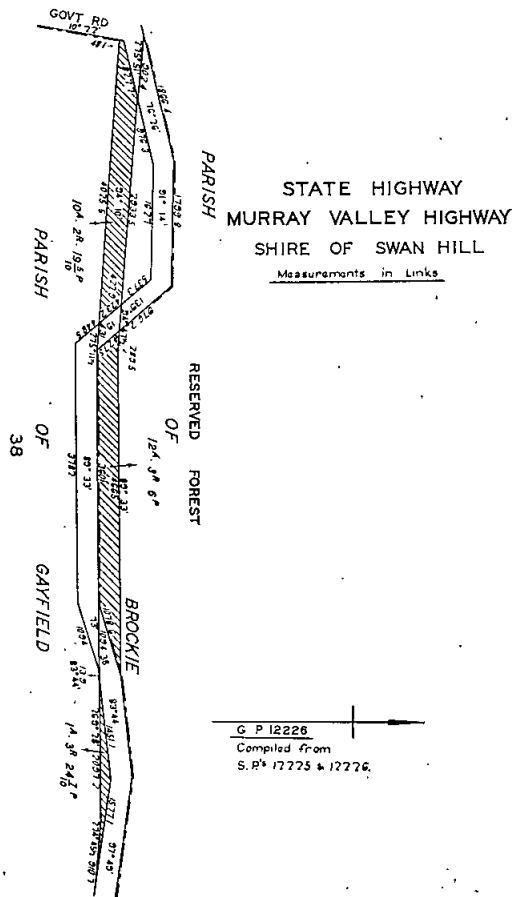

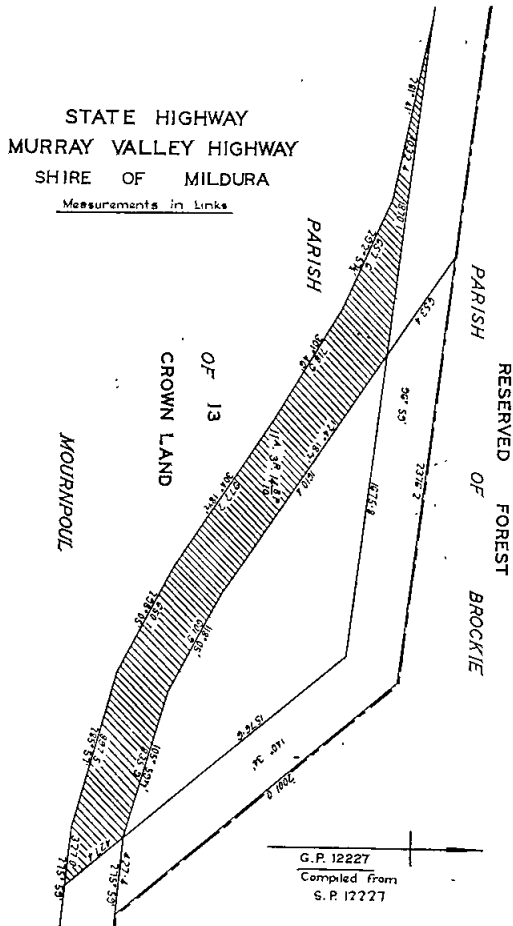

The land shown hatched on Plan numbered G.P.12251 hereunder required for the widening of the Hume Highway in the Shire of Seymour and making of the widening thereon.

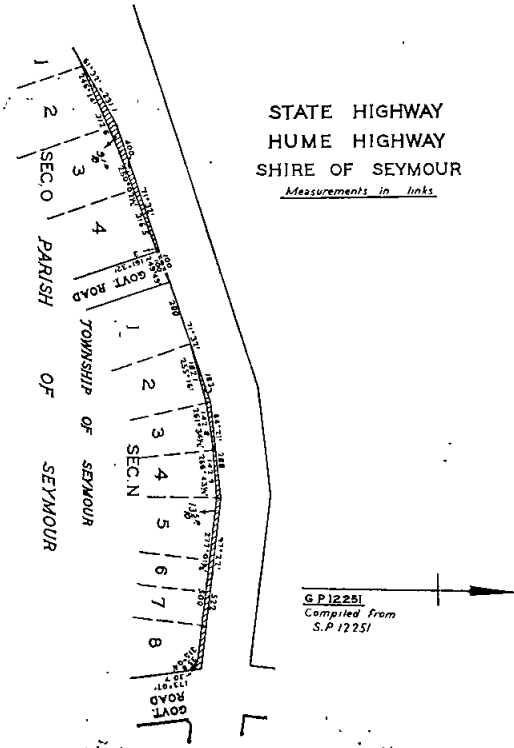

Main Road.
The land shown hatched on Plans numbered G.P.12200 and G.P.12201 hereunder required for the deviation from the Korumburra-Wonthaggi road in the Shire of Korumburra and making of the deviation thereon.

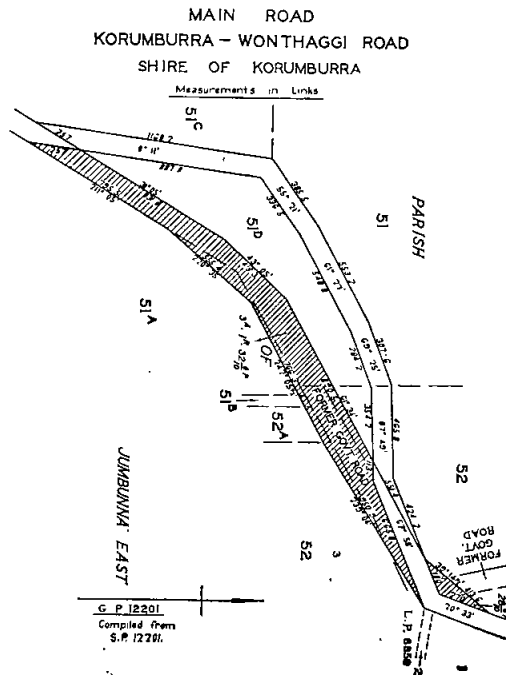
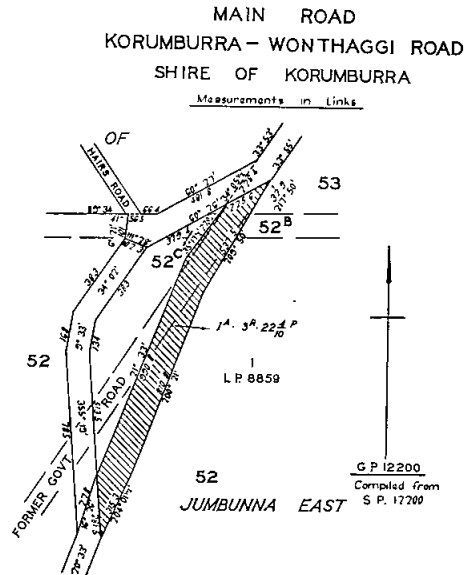
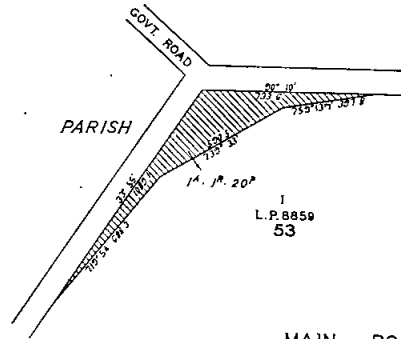

Freeway.

The land shown hatched on Plans numbered G.P.12156A, G.P.12157A, G.P.12158A, G.P.12159A and G.P.12160A hereunder required for the making of a new freeway (Mornington Peninsula Freeway) in the Shire of Flinders.

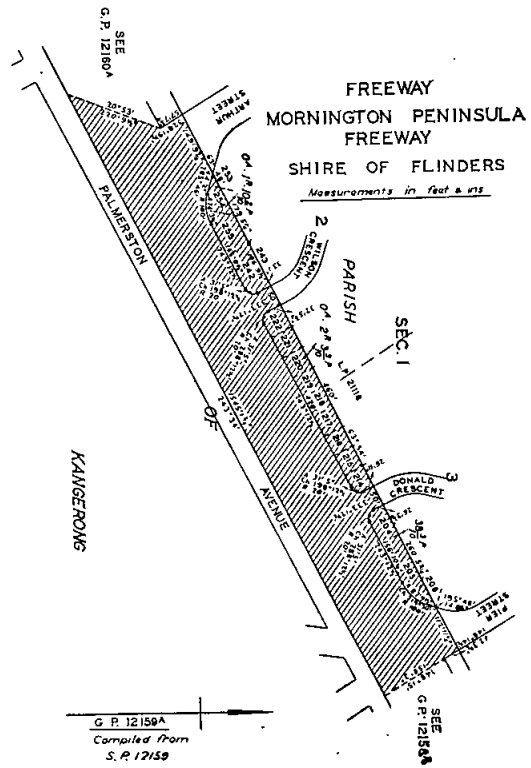
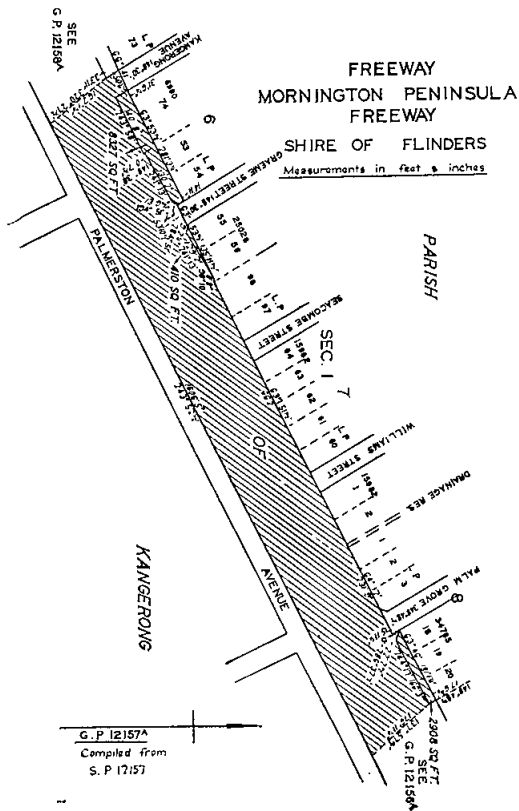
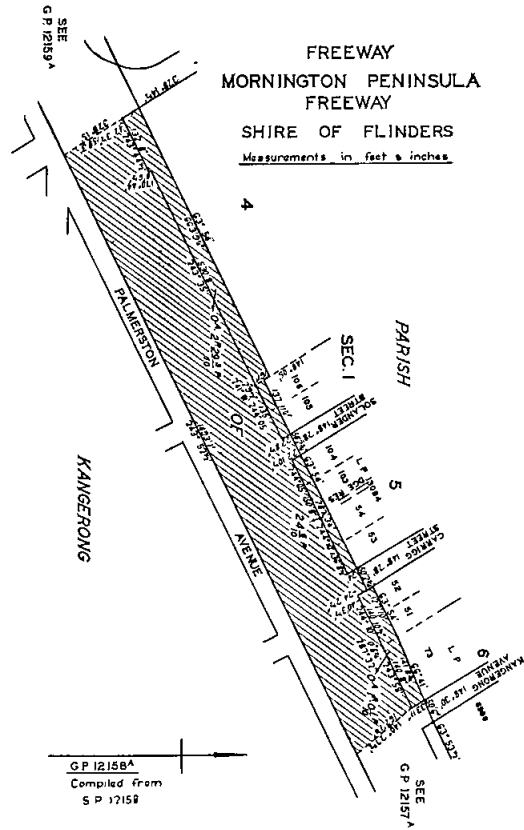
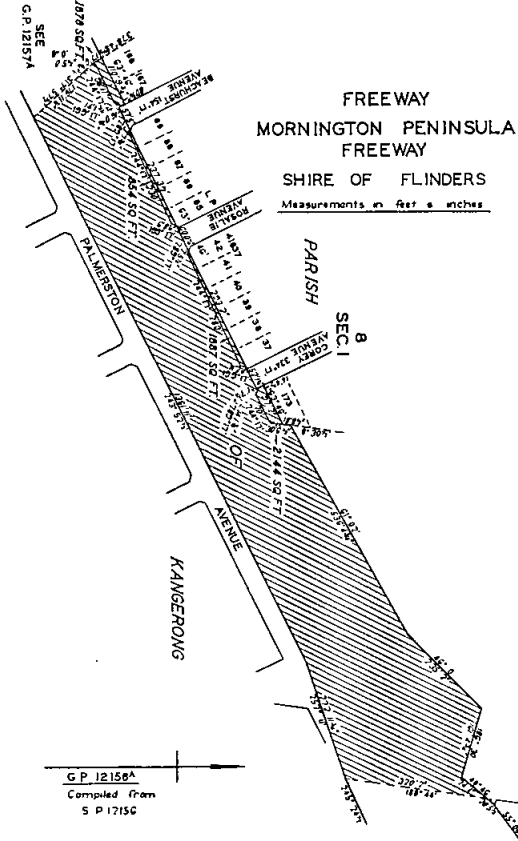

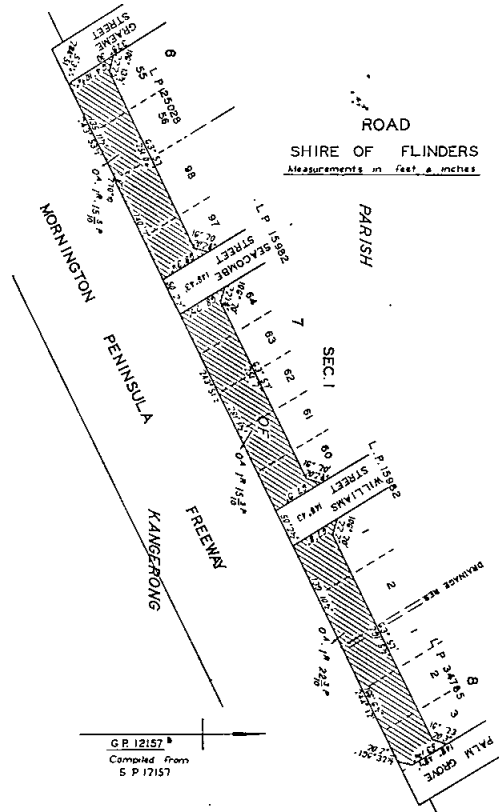
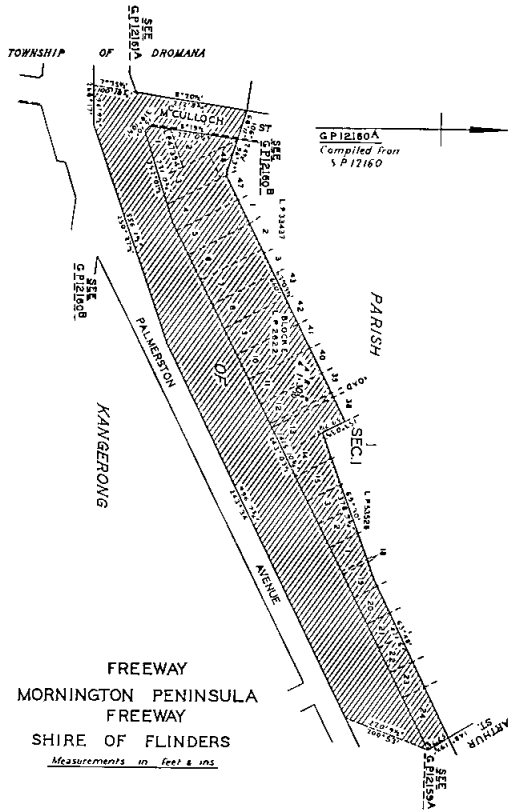

Unclassified Road.

The land shown hatched on Plans numbered G.P.12156B, G.P.12157B, G.P.12158B, G.P.12159B and G.P.12160B hereunder required for the making of a new road in the Shire of Flinders.

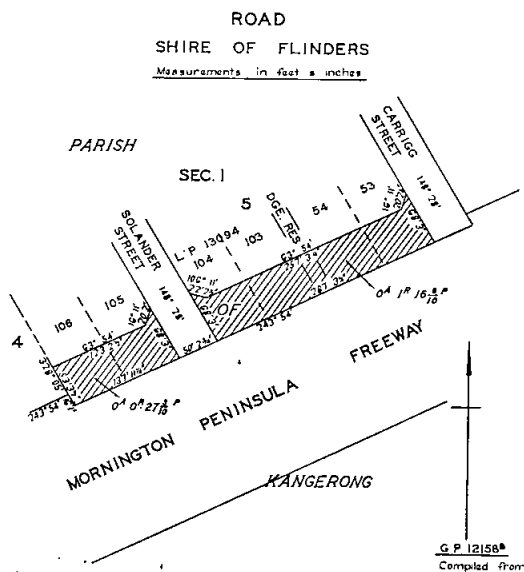
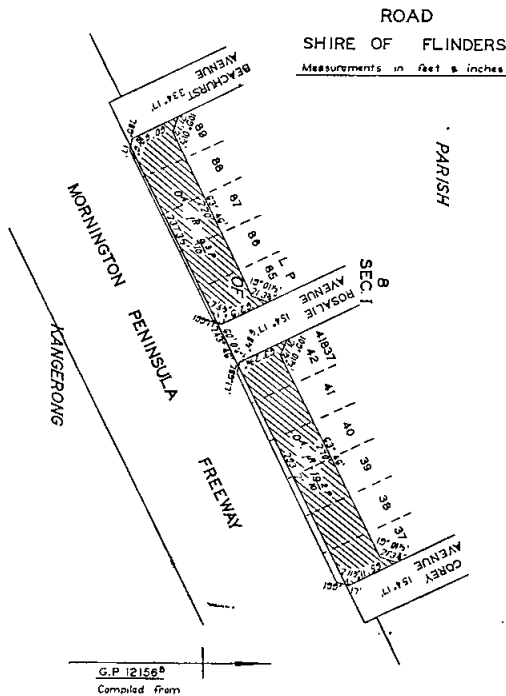

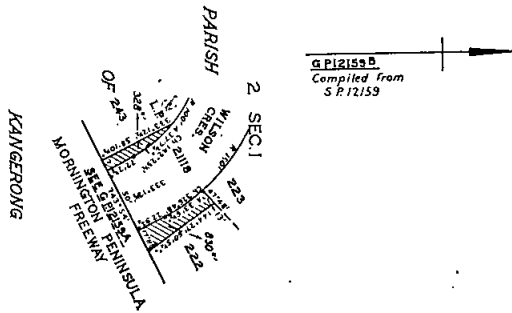

ROAD
SHIRE OF FLINDERS
Measurements in feet & ins.

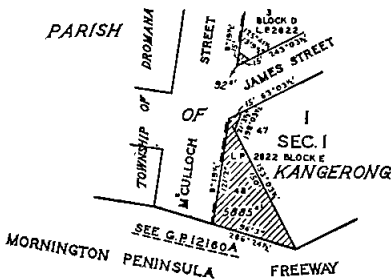
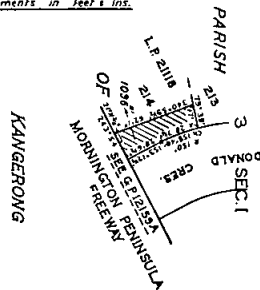

ROAD
SHIRE OF FLINDERS
Measurements in feet & ins.

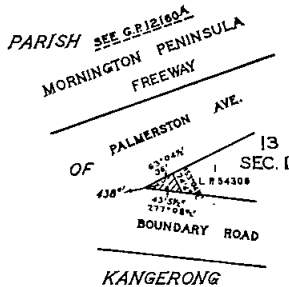

Forest Road.

The land shown hatched on Plan numbered G.P.12145 hereunder required for the widening of Warrowitue-road in the Shire of McIvor and making of the widening thereon.

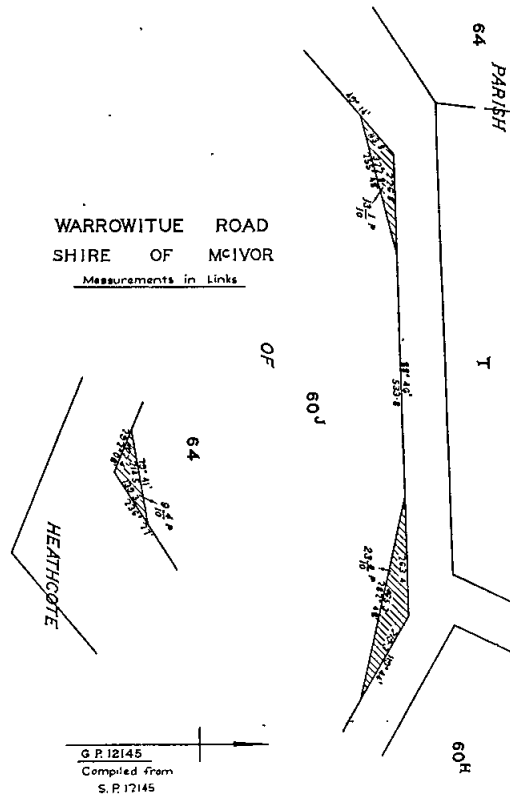

And the Honorable Rupert James Hamer, Her Majesty's Minister of Public Works for the State of Victoria, shall give the necessary directions herein accordingly.

J. ROSSITER,
Clerk of the Executive Council.

DEPARTMENT OF CROWN LANDS AND SURVEY.

At the Executive Council Chamber, Melbourne, the ninth day of June, 1970.

PRESENT:
His Excellency the Governor of Victoria.
Mr. Rossiter | Mr. Borthwick.

REVOCATION OF TEMPORARY RESERVATION OF LAND BY ORDER IN COUNCIL.

HIS Excellency the Governor of the State of Victoria, by and with the advice of the Executive Council thereof, doth hereby, in pursuance of the provisions of the Land Act 1958, revoke the temporary reservation of land by Order in Council hereinafter referred to, viz.:

SANDHURST (AT BENDIGO).—Order in Council of the 14th February, 1939, of 1 acre 2 roods 21 perches of land in the Parish of Sandhurst, at Bendigo, as a site for Public Purposes (Children's Playground).—(372⁽¹¹²⁾) (Rs.4919).

MOE.—Order in Council of the 12th February, 1935, of 1 acre 0 rood 20 1/10 perches of land in the Parish of Moe, as a site for Railway purposes.—(M.498⁽¹²⁾) (C.81835).

MOE.—Order in Council of the 21st November, 1887, of 82 acres 36 perches of land in the Parish of Moe, as a site for Railway purposes (revoked as to part by Order of the 26th March, 1935) so far as the balance thereof, containing 80 acres 3 roods 11 5/10 perches, as defined by the description published in the Government Gazette of the 13th May, 1970, is concerned.—(M.498⁽¹²⁾) (C.81835).

WARRNAMBOOL.—Order in Council of the 13th February, 1893, of 1 acre 0 rood 8 perches of land in the Township of Warrnambool, as a site for Cattle Yards and General Market purposes.—(W.99⁽⁷⁾) (Rs.110).

MURCHISON.—Order in Council of the 6th November, 1968, of 15 acres, more or less, of land in the Township and Parish of Murchison, as a site for Public Recreation,

so far only as regards the portion thereof comprised within the boundaries published in the *Government Gazette* of the 13th May, 1970, and containing 29 perches, more or less.—(M.272⁽²⁾) (Rs.9051).

WOMBAT.—Order in Council of the 29th June, 1914, of 7 acres of land in the Parish of Wombat, as a site for Watering purposes and for a Quarry, so far only as regards the portion thereof comprised within the boundaries published in the *Government Gazette* of the 13th May, 1970, and containing 6 perches.—(W.179⁽⁸⁸⁾) (Rs.9238).

And the Honorable Sir William John Farquhar McDonald, Her Majesty's Minister of Lands for the State of Victoria, shall give the necessary directions herein accordingly.

J. ROSSITER,
Clerk of the Executive Council.

DEPARTMENT OF CROWN LANDS AND SURVEY.

At the Executive Council Chamber, Melbourne, the ninth day of June, 1970.

PRESENT:

His Excellency the Governor of Victoria.
Mr. Rossiter | Mr. Borthwick.

LANDS TEMPORARILY RESERVED AS SITES.

HIS Excellency the Governor of the State of Victoria, by and with the advice of the Executive Council thereof, doth hereby, in pursuance of section 14 of the *Land Act 1958*, reserve temporarily from sale, from being leased and from having a licence granted in respect thereof, and also except from occupation for mining purposes under any miner's right, the land hereinafter described:—

BEENAK.—Site for Public purposes (State School Forest Plantation), 26 acres 2 roods, more or less, Parish of Beenak, County of Evelyn, as indicated by hatching on plan hereunder.—(B.680⁽⁹⁾) (Rs.9324).

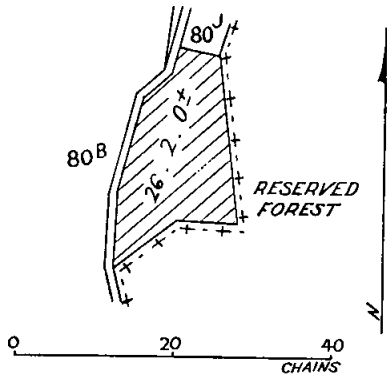

Subject to Survey

EGLINTON.—Site for Public purposes (State School Forest Plantation), 20 acres, more or less, Parish of Eglinton, County of Talbot, as indicated by hatching on plan hereunder.—(E.18⁽⁴⁾) (Rs.9329).

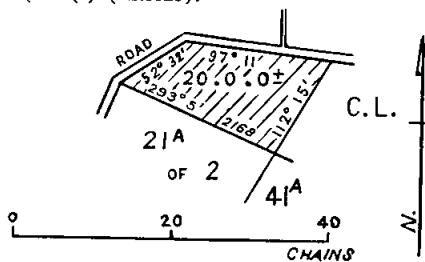

SUBJECT TO SURVEY

GEELONG.—Site for Public purposes (Departmental Residence), 32 perches, City of Geelong, Parish of Corio, County of Grant, as indicated by hatching on plan hereunder.—(C.272⁽⁶⁾) (Rs.9323).

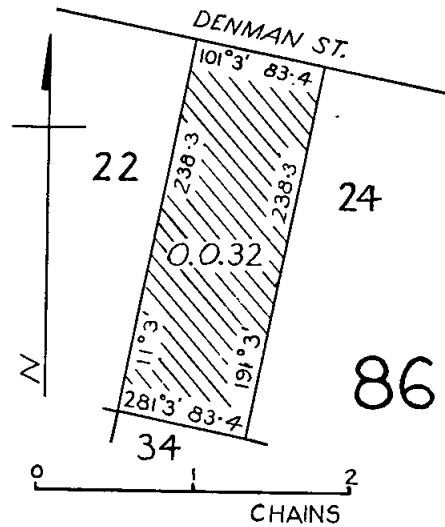

STAWELL.—Site for Public purposes (Education Department purposes), 2 roods, Township of Stawell, Parish of Stawell, County of Borung, as indicated by hatching on plan hereunder.—(S.329⁽¹³⁾) (Rs.9328).

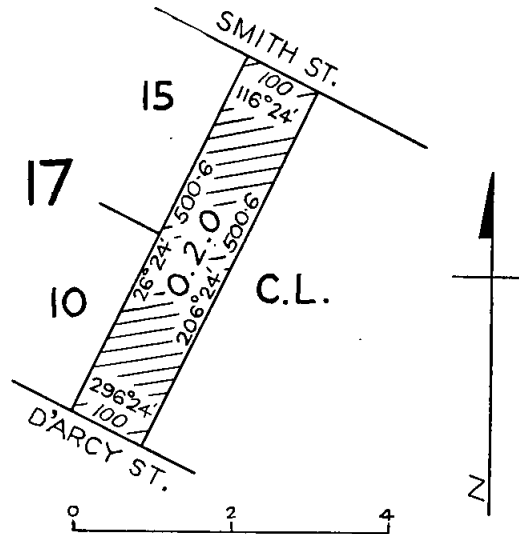

THURRA.—Site for Public purposes (Tourist Camping), 145 acres, more or less, Parish of Thurra, County of Croajingolong, as indicated by hatching on plan hereunder.—(T.312⁽¹⁾) (Rs.9331).

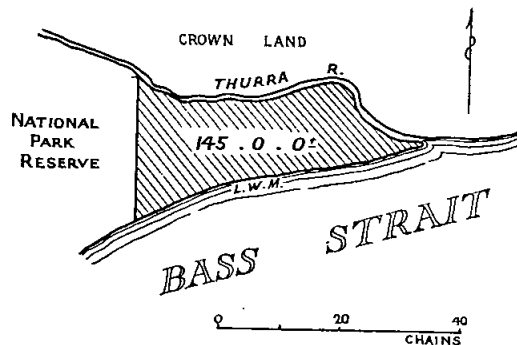

And the Honorable Sir William John Farquhar McDonald, Her Majesty's Minister of Lands for the State of Victoria, shall give the necessary directions herein accordingly.

J. ROSSITER,
Clerk of the Executive Council.

DEPARTMENT OF CROWN LANDS AND SURVEY.

At the Executive Council Chamber, Melbourne, the ninth day of June, 1970.

PRESENT:

His Excellency the Governor of Victoria.
Mr. Rossiter | Mr. Borthwick.

UNUSED ROAD CLOSED.

HIS Excellency the Governor of the State of Victoria, by and with the advice of the Executive Council thereof, doth hereby direct that, in pursuance of the provisions of section 349 of the Land Act 1958, the unused road referred to hereunder be closed, viz.:—

Parish of Stawell, County of Borung—being the road between sections 271 and 272.—(S.329(18) (M.61997).

And the Honorable Sir William John Farquhar McDonald, Her Majesty's Minister of Lands for the State of Victoria, shall give the necessary directions herein accordingly.

J. ROSSITER,
Clerk of the Executive Council.

LOCAL GOVERNMENT DEPARTMENT.

At the Executive Council Chamber, Melbourne, the ninth day of June, 1970.

PRESENT:

His Excellency the Governor of Victoria.
Mr. Rossiter | Mr. Borthwick.

ROAD DISCONTINUED—SHIRE OF WOORAYL.

WHEREAS it is provided in section 528 (2) of the Local Government Act 1958, that where a road (whether or not a public highway but not being a road set out on land of the Crown) or any part thereof is not required for public use, the Governor in Council on the request of the municipality in which such road is situated made not less than one month after publishing in a newspaper generally circulating in the district and posting to the registered proprietor (if any) of the land and the owners and occupiers (if any) of lands abutting or immediately adjacent to the road notice of intention to make such a request may by Order published in the Government Gazette direct that such road or part shall be discontinued and thereupon such road or part shall be discontinued accordingly.

And whereas the Council of the Shire of Woorayl has requested that a right-of-way off Pymble-avenue, Inverloch, be discontinued and not less than one month previously has published in a newspaper generally circulating in the district and posted to the registered proprietor of the land in the road and to the owners and occupiers of lands abutting or immediately adjacent to the said road notice of intention to make such request.

Now therefore, His Excellency the Governor of the State of Victoria, by and with the advice of the Executive Council thereof, hereby directs:

- (a) that the said road which is shown by hachure on the plan hereunder, shall be discontinued;
- (b) that notwithstanding such discontinuance the Council of the Shire of Woorayl shall continue to have and possess the same right title power authority or interest in or in relation to the whole of the land shown by hachure on the said plan as it had or possessed prior to such discontinuance with respect to or in connexion

with any pipes or drains laid or erected in or over such land for the purpose of drainage; and

- (c) that, subject to any such right title power authority or interest, the land in the said road may be sold by the Council of the Shire of Woorayl by agreement.

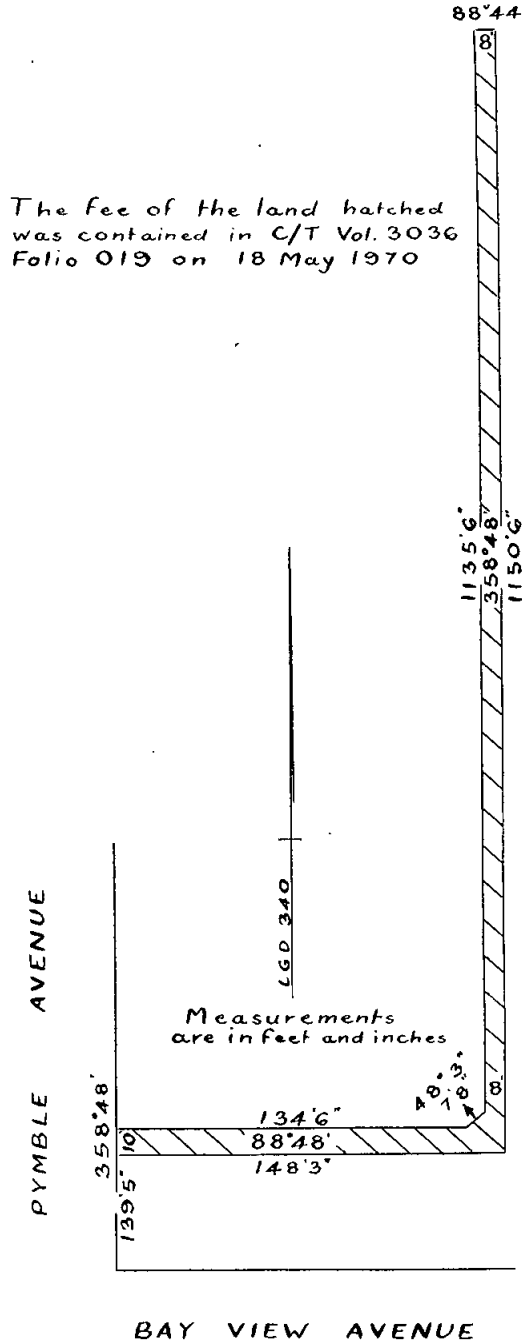

And the Honorable Rupert James Hamer, Her Majesty's Minister for Local Government for the State of Victoria, shall give the necessary directions herein accordingly.

J. ROSSITER,
Clerk of the Executive Council.

LOCAL GOVERNMENT DEPARTMENT.

At the Executive Council Chamber, Melbourne, the ninth day of June, 1970.

PRESENT:

His Excellency the Governor of Victoria.
Mr. Rossiter | Mr. Borthwick.

DECLARATION OF METROPOLITAN MAIN HIGHWAY CITIES OF MELBOURNE, ESSENDON, BRUNSWICK, COBURG AND BROADMEADOWS.

WHEREAS in pursuance of the provisions of section 206 of the Melbourne and Metropolitan Board of Works Act 1958 the Governor in Council on the fourth day of October 1966 approved a recommendation of the Melbourne and Metropolitan Board of Works for the construction of a new metropolitan main highway over certain land within the municipal districts of the Cities of Melbourne, Essendon, Brunswick, Coburg and Broadmeadows:

And whereas the Melbourne and Metropolitan Board of Works in pursuance of the said provisions, has certified that the highway known as the Tullamarine Freeway which has been made on the said land commencing from the north-eastern building alignments of Mount Alexander-road and Flemington-road, Melbourne and terminating at a point 300 feet north of the production of the southern alignment of Greenbank-crescent, Coburg, is fit to be used:

Now therefore, His Excellency the Governor of the State of Victoria, by and with the advice of the Executive Council thereof and in pursuance of the aforesaid provisions, hereby declares that the said land, which is indicated by hachure on the plan hereunder, shall be a metropolitan main highway under the name of the Tullamarine Freeway.

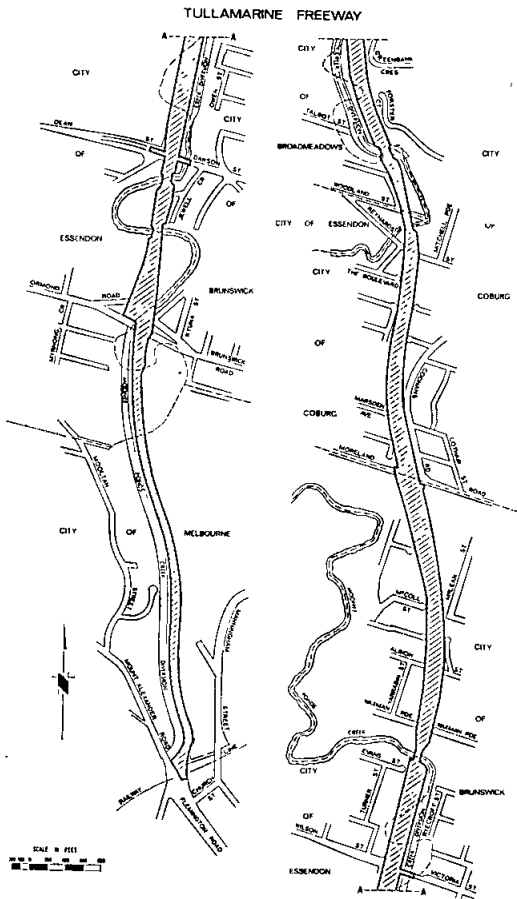

SCALE IN FEET

And the Honorable Rupert James Hamer, Her Majesty's Minister for Local Government for the State of Victoria, shall give the necessary directions herein accordingly.

J. ROSSITER,
Clerk of the Executive Council.

LOCAL GOVERNMENT DEPARTMENT.

At the Executive Council Chamber, Melbourne, the ninth day of June, 1970.

PRESENT:

His Excellency the Governor of Victoria.
Mr. Rossiter | Mr. Borthwick.

DECLARATION OF METROPOLITAN MAIN HIGHWAY—CITIES OF ST. KILDA AND PRAHRAN.

WHEREAS in pursuance of the provisions of section 206 of the Melbourne and Metropolitan Board of Works Act 1958 the Governor in Council on the 2nd day of November, 1966, approved a recommendation of the Melbourne and Metropolitan Board of Works for the construction of a new metropolitan main highway over certain land within the municipal districts of the Cities of St. Kilda and Prahran:

And whereas the Melbourne and Metropolitan Board of Works in pursuance of the said provisions, has certified that the highway known as Queens-way which has been made on the said land commencing from the south-western alignment of St. Kilda-road, St. Kilda, and terminating at the western building alignment of Chapel-street, Prahran, is fit to be used:

Now therefore, His Excellency the Governor of the State of Victoria, by and with the advice of the Executive Council thereof and in pursuance of the aforesaid provisions, hereby declares that the said land, which is indicated by hachure on the plan hereunder, shall be a metropolitan main highway under the name of Queens-way.

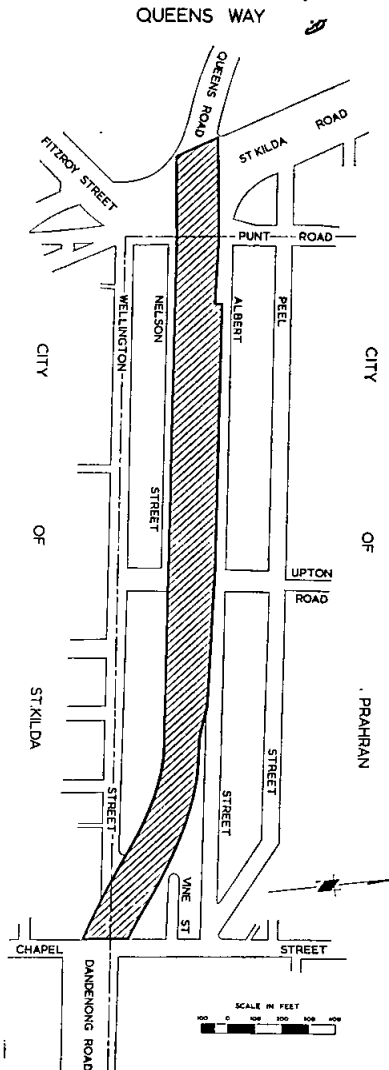

SCALE IN FEET

And the Honorable Rupert James Hamer, Her Majesty's Minister for Local Government for the State of Victoria, shall give the necessary directions herein accordingly.

J. ROSSITER,
Clerk of the Executive Council.

LOCAL GOVERNMENT DEPARTMENT.

At the Executive Council Chamber, Melbourne, the ninth day of June, 1970.

PRESENT:

His Excellency the Governor of Victoria.
Mr. Rossiter | Mr. Borthwick.

ROAD DISCONTINUED—CITY OF BRIGHTON.

WHEREAS it is provided in section 528 (2) of the Local Government Act 1958, that where a road (whether or not a public highway but not being a road set out on land of the Crown) or any part thereof is not required for public use the Governor in Council on the request of the Council of the municipality in which such road is situated made not less than one month after publishing in a newspaper generally circulating in the district and posting to the registered proprietor (if any) of the land and the owners and occupiers (if any) of the lands abutting or immediately adjacent to the road notice of intention to make such a request may by Order published in the Government Gazette direct that such road or part shall be discontinued and thereupon such road or part shall be discontinued accordingly.

And whereas the Council of the City of Brighton has requested that the Governor in Council direct that a right-of-way off Cluden-street, Brighton, be discontinued and not less than one month previously has published in a newspaper generally circulating in the district and posted to the registered proprietor of the land in the road and to the owners and occupiers of lands abutting or immediately adjacent to the road notice of intention to make such request.

Now therefore, His Excellency the Governor of the State of Victoria, by and with the advice of the Executive Council thereof, hereby directs that the said road, which is shown hatched on the plan hereunder, shall be discontinued and that the land may be sold by the Council of the City of Brighton by agreement.

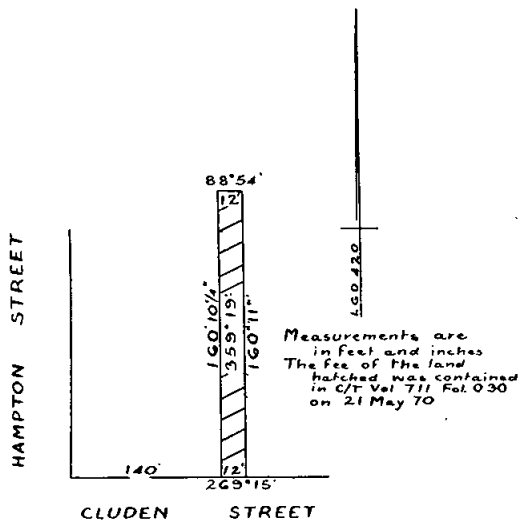

And the Honorable Rupert James Hamer, Her Majesty's Minister for Local Government for the State of Victoria, shall give the necessary directions herein accordingly.

J. ROSSITER,
Clerk of the Executive Council.

LOCAL GOVERNMENT DEPARTMENT.

At the Executive Council Chamber, Melbourne, the ninth day of June, 1970.

PRESENT:

His Excellency the Governor of Victoria.
Mr. Rossiter | Mr. Borthwick.

CONFIRMATION OF SEPARATE RATE—CITY OF CAMBERWELL.

IN pursuance of the provisions of section 287 of the Local Government Act 1958, His Excellency the Governor of the State of Victoria, by and with the advice of the Executive Council thereof, hereby confirms a separate rate of four point twenty (4.20) cents in the dollar on the unimproved capital value of the properties described in Schedule "A" hereunder, three point seven one (3.71) cents in the dollar on the unimproved capital value of the properties described in Schedule "B" hereunder, point three five (.35) cents in the dollar on the unimproved capital value of the properties described in Schedule "C" hereunder, point six five nine (.659) cents in the dollar on the unimproved capital value of the property described in Schedule "D" hereunder and point five six seven (.567) cents in the dollar on the unimproved capital value of the properties described in Schedule "E" hereunder, which rate was made by the Council of the City of Camberwell on the 2nd March, 1970, for the purpose of providing off-street parking facilities for use in connexion with the High-street, Glen Iris Shopping Centre.

SCHEDULE "A".

Properties to be rated at 4.20 cents in the Dollar.
(a) Numbers 15 to 57 (inclusive) High-street, Glen Iris.

SCHEDULE "B".

Properties to be rated at 3.71 cents in the Dollar.
(a) Numbers 14 to 42 (inclusive) High-street, Glen Iris.

SCHEDULE "C".

Properties to be rated at .35 cents in the Dollar.
(a) Numbers 58 to 74 (inclusive) High-street, Glen Iris.

SCHEDULE "D".

Property to be rated at .659 cents in the Dollar.
(a) Number 10 High-street, Glen Iris.

SCHEDULE "E".

Properties to be rated at .567 cents in the Dollar.
(a) Numbers 44 to 56 (inclusive) High-street, Glen Iris.

And the Honorable Rupert James Hamer, Her Majesty's Minister for Local Government for the State of Victoria, shall give the necessary directions herein accordingly.

J. ROSSITER,
Clerk of the Executive Council.

CEMETERIES ACT 1958 (No. 6217)—SECTION 36.

At the Executive Council Chamber, Melbourne, the ninth day of June, 1970.

PRESENT:

His Excellency the Governor of Victoria.
Mr. Rossiter | Mr. Borthwick.

PURSUANT to section 36 of the Cemeteries Act 1958, His Excellency the Governor of the State of Victoria by and with the advice of the Executive Council of the said State, hereby directs that the sum of Seven hundred and seventy dollars (\$770), being part of the balance of funds in the hands of the Trustees of the Daylesford Public Cemetery, be expended on the erection of a toilet block at the cemetery.

And the Honorable Vance Oakley Dickie, Her Majesty's Minister of Health for the State of Victoria, shall give the necessary directions herein accordingly.

J. ROSSITER,
Clerk of the Executive Council.

COUNTRY FIRE AUTHORITY ACT 1958.

At the Executive Council Chamber, Melbourne, the
ninth day of June, 1970.

PRESENT:

His Excellency the Governor of Victoria.
Mr. Rossiter | Mr. Borthwick.

CONSENT TO BORROWING FIFTY THOUSAND DOLLARS BY THE COUNTRY FIRE AUTHORITY.

WHEREAS by section 82 of the *Country Fire Authority Act 1958*, it is enacted that the Country Fire Authority, with the consent of the Governor in Council may, from time to time, borrow such moneys as it deems necessary in order to enable it to carry out and perform the powers, authorities and duties vested in or conferred or imposed upon it by the said Act.

And whereas the Country Fire Authority deems it necessary to borrow the sum of Fifty thousand dollars for the purposes aforesaid:

Now therefore, His Excellency the Governor of the State of Victoria, in the Commonwealth of Australia, by and with the advice of the Executive Council of the said State and in pursuance of the powers conferred by the said section 82 of the *Country Fire Authority Act 1958* and all other powers him thereunto enabling, doth by this Order consent to the borrowing by the Country Fire Authority of the sum of \$50,000 (Fifty thousand dollars) for a period of fifteen (15) years, to be repaid on the first day of June, 1985, with interest meantime at the rate of 7.4 per centum per annum payable half-yearly.

And the Honorable Sir Arthur Gordon Rylah, Her Majesty's Chief Secretary for the State of Victoria, shall give the necessary directions herein accordingly.

J. ROSSITER,
Clerk of the Executive Council.

MELBOURNE AND METROPOLITAN TRAMWAYS BOARD.

At the Executive Council Chamber, Melbourne, the
ninth day of June, 1970.

PRESENT:

His Excellency the Governor of Victoria.
Mr. Rossiter | Mr. Borthwick.

MELBOURNE AND METROPOLITAN TRAMWAYS ACT 1958 (No. 6311).

IN pursuance of the powers in that behalf, conferred by the *Melbourne and Metropolitan Tramways Act 1958*, His Excellency the Governor of the State of Victoria, by and with the advice of the Executive Council thereof, doth by this Order hereby appoint FRANCIS RICHARD KIRBY, as Chairman of the Melbourne and Metropolitan Tramways Board for a term of four years as from the first day of July, 1970.

And the Honorable Vernon Francis Wilcox, Her Majesty's Minister of Transport for the State of Victoria, shall give the necessary directions herein accordingly.

J. ROSSITER,
Clerk of the Executive Council.

Water Act 1958.

STATE RIVERS AND WATER SUPPLY COMMISSION.

At the Executive Council Chamber, Melbourne, the
sixteenth day of June, 1970.

PRESENT:

His Excellency the Governor of Victoria.
Mr. Reid | Mr. Hamer.

WESTERNPORT URBAN DISTRICT—AREA OF DISTRICT INCREASED.

UNDER the powers conferred by the *Water Act 1958*, and all other powers enabling him in that behalf, His Excellency the Governor of the State of Victoria, with the advice of the Executive Council of the said State, on

the recommendation of the State Rivers and Water Supply Commission, doth hereby declare, order and direct that the area of the Westernport Urban District be increased by adding to the same the land shown by blue colour on a plan approved by the Governor in Council and deposited in the Office of the State Rivers and Water Supply Commission, Melbourne (Corr. No. 65/2103) and as on and from the 1st day of July, 1970, the area of such District shall be deemed to be so increased.

And the Honorable Ian Winton Smith, Her Majesty's Minister of Water Supply for the State of Victoria, shall give the necessary directions herein accordingly.

J. ROSSITER,
Clerk of the Executive Council.

MORWELL WATERWORKS TRUST.

At the Executive Council Chamber, Melbourne, the
sixteenth day of June, 1970.

PRESENT:

His Excellency the Governor of Victoria.
Mr. Reid | Mr. Hamer.

APPROVAL OF PLAN SHOWING SITE OF A PIPELINE.

HIS Excellency the Governor of the State of Victoria, by and with the advice of the Executive Council thereof, doth hereby approve in accordance with the provisions of the *Water Act* and all other powers enabling him in that behalf, the work comprising a Pipeline to be constructed by the Morwell Waterworks Trust on the lands shown on a plan deposited in the office of the State Rivers and Water Supply Commission, Melbourne (Corr. 69/1324/40).

And the Honorable Ian Winton Smith, Her Majesty's Minister of Water Supply for the State of Victoria, shall give the necessary directions herein accordingly.

J. ROSSITER,
Clerk of the Executive Council.

DANDENONG SEWERAGE AUTHORITY.

At the Executive Council Chamber, Melbourne, the
sixteenth day of June, 1970.

PRESENT:

His Excellency the Governor of Victoria.
Mr. Reid | Mr. Hamer.

CONSENT TO BORROWING \$50,000.

UNDER the powers conferred by the *Sewerage Districts Act* and all other powers enabling him in that behalf, His Excellency the Governor of the State of Victoria, by and with the advice of the Executive Council of the said State, doth hereby consent to the Dandenong Sewerage Authority borrowing at interest, by mortgage of the General Fund, the sum of Fifty thousand dollars (\$50,000) to meet the cost of sewerage works as set forth in the detailed statement bearing date 10th June, 1970.

And the Honorable Ian Winton Smith, Her Majesty's Minister of Water Supply for the State of Victoria, shall give the necessary directions herein accordingly.

J. ROSSITER,
Clerk of the Executive Council.

WATER ACT 1958.

At the Executive Council Chamber, Melbourne, the
sixteenth day of June, 1970.

PRESENT:

His Excellency the Governor of Victoria.
Mr. Reid | Mr. Hamer.

TRANSFER OF CAPITAL LIABILITY FROM STATE RIVERS AND WATER SUPPLY COMMISSION TO CAMPERDOWN TOWN COUNCIL.

WHEREAS by Orders dated 10th June, 1969, the Governor in Council approved the excision of lands from the Otway and North Camperdown Waterworks Districts:

And whereas by Order dated 24th June, 1969, the Governor in Council approved of the constitution of the Camperdown Town Council as a Local Governing Body over the areas excised from the Otway and North Camperdown Waterworks Districts:

And whereas by the last-mentioned Order it was directed that the said Council shall as on and from the 1st July, 1969 take over from the State Rivers and Water Supply Commission and thereafter maintain and continue the water supply reticulation works supplying Camperdown:

And whereas by the last-mentioned Order that as on and from 1st July, 1969 there shall be transferred in the books of the Treasury Department from the said Commission to the said Council the actual net liability in respect of the assets and properties to be transferred, being the total existing liability less \$25,000 in respect of depreciation of works.

Now therefore His Excellency the Governor of the State of Victoria with the advice of the Executive Council of the said State on the recommendation of the Minister of Water Supply and in pursuance of the hereinbefore recited powers doth hereby direct that the total existing liability of \$56,779.07 shall be the liability so transferred in accordance with that Order.

And the Honorable Ian Winton Smith, Her Majesty's Minister of Water Supply for the State of Victoria, shall give the necessary directions herein accordingly.

J. ROSSITER,
Clerk of the Executive Council.

LANDS DEPARTMENT NOTICES

APPROACHING LAND SALES.

SALES of Crown Lands, in fee-simple, will be held at the under-mentioned places and dates, viz.:-

	No. of Gazette.
Castlemaine.—Tuesday, 30th June, 1970 ..	45
Dimboola.—Tuesday, 7th July, 1970 ..	51
Goroke.—Tuesday, 7th July, 1970 ..	51
Stawell.—Friday, 10th July, 1970 ..	54

PROPOSED REVOCATIONS OF TEMPORARY RESERVATIONS OF LANDS BY ORDERS IN COUNCIL.

IN pursuance of the provisions of the Land Act 1958, notice is hereby given that it is the intention of the Governor in Council to revoke the temporary reservations of lands by Orders in Council hereunder referred to, viz.:-

The following Notices were published 1° on the 3rd June, 1970, pursuant to Orders of the 26th May, 1970.

DONALD.—The temporary reservation as a site for Recreation purposes and the withholding from sale, leasing and licensing by Order in Council of the 23rd December, 1874, of 68 acres 3 roods 36 perches of land in the Township of Donald, revoked as to part by various orders, are about to be revoked, save and except the area of 6 acres 1 rood 20 perches, more or less, indicated by hatching on plan hereunder, is concerned.—(D.168(L⁴) (Rs.3088).

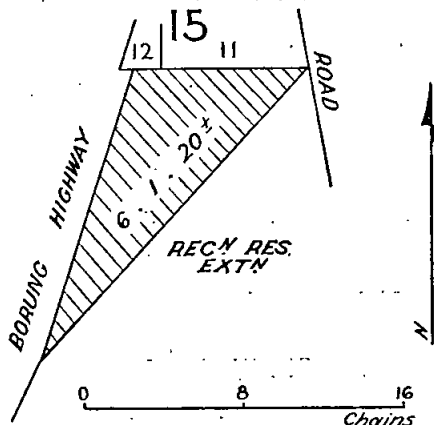

BALLAPUR.—The temporary reservation by Order in Council of the 17th August, 1891 (see Government Gazette, 21st August, 1891, page 3480), of 9 acres 3 roods 18

perches of land in the Parish of Ballapur, as a site for Watering purposes, is about to be revoked.—(B.754⁽³⁾) (M.36812).

SANDHURST, AT BENDIGO.—The temporary reservation by Order in Council of 28th November, 1950, of 4 acres 2 roods, more or less of land at Bendigo, Parish of Sandhurst, as a site for Public Recreation, is about to be revoked.—(S.372⁽¹¹²⁾) (Rs.6605).

JEFFCOTT.—The temporary reservation as a site for Public Purposes (State School) and the withholding from sale, leasing and licensing by Order in Council of the 18th July, 1878 (see Government Gazette, 26th July, 1878, page 1796), of 2 acres of land in the Parish of Jeffcott, is about to be revoked.—(J.36⁽²⁾) (W.88354).

W. J. F. McDONALD,
Minister of Lands.

PROPOSED REVOCATIONS OF TEMPORARY RESERVATIONS OF LANDS BY ORDERS IN COUNCIL.

IN pursuance of the provisions of the Land Act 1958, notice is hereby given that it is the intention of the Governor in Council to revoke the temporary reservations of lands by Orders in Council hereunder referred to, viz.:-

The following Notices were published 1° on the 17th June, 1970, pursuant to Orders of the 9th June, 1970.

BAYUP.—The temporary reservation, as a site for a Mechanics' Institute, and the withholding from sale, leasing and licensing, by Order in Council of the 25th November, 1879, of 37 8/10 perches of land in the village of Bayup (now the Township of Bayup), are about to be revoked.—(B.400(F²)) (Rs.4971).

GLENMAGGIE.—The temporary reservation, by Order in Council of the 10th September, 1900 (See Government Gazette, 14th September, 1900, page 3500) of 10 acres 38 perches of land in the Parish of Glenmaggie as a site for a Night-Soil Depot, is about to be revoked.—(G.178⁽¹⁰⁾) (99.C.8904).

ORBOST.—The temporary reservation, by Order in Council of the 21st May, 1929, of 4 acres 3 roods 3 perches of land in the Township of Orbost, as a site for Public purposes, is about to be revoked.—(O.23⁽⁸⁾) (Rs.2487).

PAYWIT (QUEENSLIFF).—The temporary reservation, as a site for Supply of Sand and Shell and the withholding from sale, leasing and licensing, by Order in Council of the 5th February, 1877 (See Government Gazette, 9th February, 1877, page 264), of land in the Parish of Paywit (named municipal district of Queenscliffe in Order), is about to be revoked.—(P.17⁽⁹⁾) (C.100415).

SALISBURY WEST.—The temporary reservation, as a site for Public purposes (State School) and the withholding from sale, leasing and licensing, by Order in Council of the 28th November, 1881, of 2 acres of land in the Parish of Salisbury West, is about to be revoked.—(S.441⁽⁷⁾) (C.77839).

KEELBUNDORA.—The temporary reservation, by Order in Council of the 11th January, 1943, of 456 acres 1 rood 32 perches of land in the Parish of Keelbundora as a site for Mental Hospital purposes, revoked as to part by various Orders, is about to be revoked so far only as the portion containing 22 acres 1 rood 33 perches, indicated by hatching on plan hereunder, is concerned.—(K.25⁽²⁾) (Rs.5380).

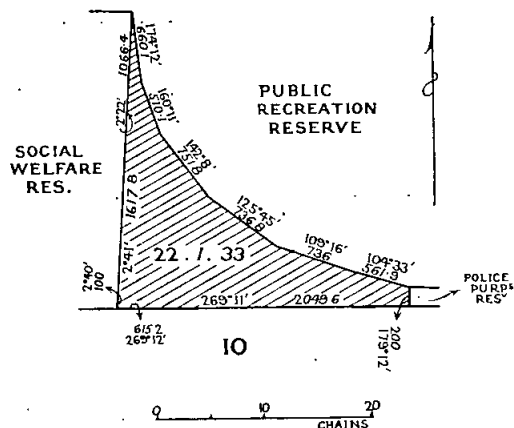

W. J. F. McDONALD,
Minister of Lands.

PROPOSED REVOCATIONS OF TEMPORARY RESERVATIONS OF LANDS BY ORDERS IN COUNCIL.

IN pursuance of the provisions of the *Land Act 1958*, notice is hereby given that it is the intention of the Governor in Council to revoke the temporary reservations of lands by Orders in Council hereunder referred to, viz.:—
The following Notices were published 1° on the 27th May, 1970, pursuant to Orders of the 19th May, 1970.

GLENMONA (LAMPLOUGH).—The temporary reservation, by Order in Council of the 5th October, 1915, of 3 acres 3 roods 21 6/10 perches of land in the Parish of Glenmona, as a site for a Supply of Gravel is about to be revoked.—(G.155⁽³⁾) (Rs.3724).

GEELONG.—The temporary reservation, by Order in Council of the 3rd August, 1954, of 15 acres 1 rood 10 perches, more or less, of land in the City of Geelong, as a site for Public Recreation, revoked as to part by Order of the 6th July, 1965, is about to be revoked, so far only as the portions containing 2 roods 8 perches, more or less, indicated by hatching on plan hereunder, are concerned.—(G.25(W¹)) (Rs.7240).

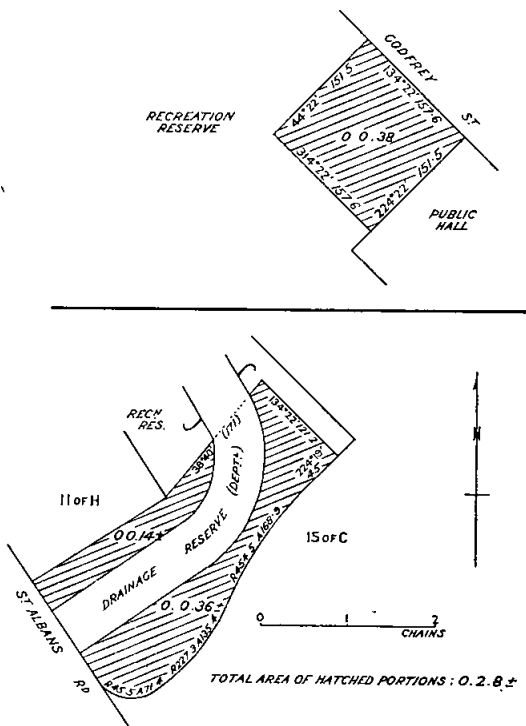

W. J. F. McDONALD,
Minister of Lands.

PROPOSED REVOCATIONS OF TEMPORARY RESERVATIONS OF LANDS BY ORDERS IN COUNCIL.

IN pursuance of the provisions of the *Land Act 1958*, notice is hereby given that it is the intention of the Governor in Council to revoke the temporary reservations of lands by Orders in Council hereunder referred to, viz.:—
The following Notices were published 1° on the 10th June, 1970, pursuant to Orders of the 2nd June, 1970.

BRUTHEN.—The temporary reservation by Order in Council of the 12th March, 1900, of 10 acres 2 roods 8 perches of land in the Township of Bruthen, as a site for Supply of Gravel, is about to be revoked.—(B.790⁽³⁾) (Rs.5327).

DUNOLLY.—The temporary reservation, by Order in Council of the 6th January, 1873, of 7 acres 2 roods, more or less, of land in the Borough of Dunolly (now the Township of Dunolly), as a site for Watering purposes, revoked as to part by Order of the 28th June, 1933, is about to be revoked, so far as the balance thereof containing 5 acres 2 roods, more or less, is concerned.—(D.124⁽³⁾) (Rs.6485).

SWANWATER.—The temporary reservation by Order in Council of the 19th March, 1918, of 3 acres 1 rood 17 perches of land in the Parish of Swanwater, as a site for a State School, is about to be revoked.—(S.367⁽⁷⁾) (Rs.228).

SWANWATER.—The temporary reservation as a site for Public purposes (State School), and the withholding from sale, leasing and licensing by Order in Council of the 26th June, 1882, of 2 acres 0 roods 2 perches of land in the Parish of Swanwater, are about to be revoked.—(S.367⁽⁷⁾) (Rs.228).

YOWANG.—The temporary reservation by Order in Council of the 25th August, 1873, of 5 acres of land in the Parish of Yowang, as a site for State School purposes, is about to be revoked.—(Y.69⁽²⁾) (G.65646).

PORTLAND AND TREWALLA.—The temporary reservation by Order in Council of the 11th August, 1879, of certain Crown lands situated on the shore of Bass Strait and the Indian Ocean (named Southern Ocean in Order), as a site for Public purposes, revoked as to part by various Orders, is about to be revoked, so far only as the portion containing 50 acres, more or less, indicated by hatching on plan hereunder, is concerned.—(P.69⁽³⁾) and T.114⁽²⁾) (Rs.2362).

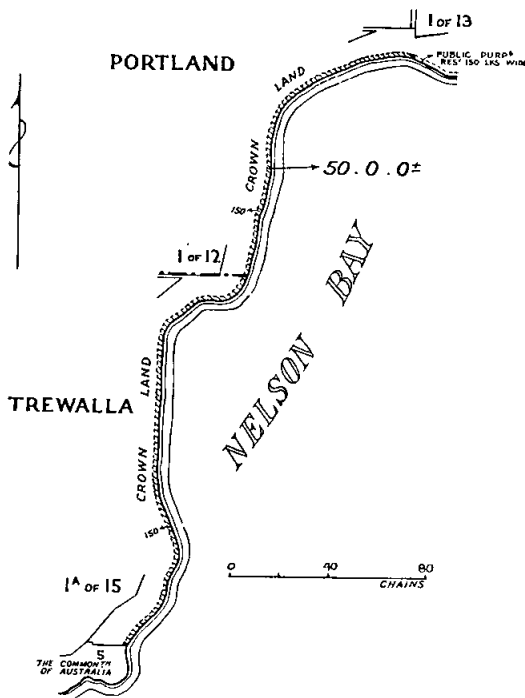

NERRING.—The temporary reservation by Order in Council of the 13th August, 1946 (see *Government Gazette*, 21st August, 1946, page 2606), of 340 acres, more or less, of land in the Parish of Nerring, as a site for the Growth of Timber for the purpose of the manufacture or production of eucalyptus oil, revoked as to part by Order of the 1st April, 1958 (see *Government Gazette*, 11th April, 1958, page 947), is about to be revoked, so far only as the portion containing 9 acres 2 roods 25 perches, indicated by hatching on plan hereunder is concerned.—(N.116⁽¹⁰⁾) (Rs.5847).

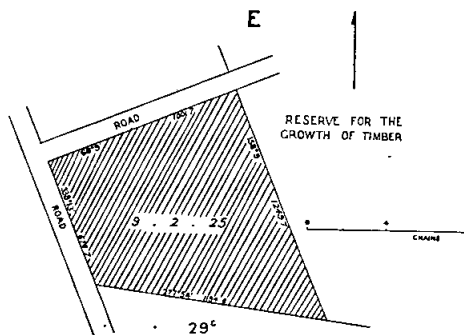

OXLEY.—The temporary reservation by Order in Council of the 12th May, 1885, of 6 acres 0 roods 16 perches of land in the Township of Oxley, as a site for the Supply of Gravel, is about to be revoked, so far only as the portion containing 2 acres indicated by hatching on plan hereunder, is concerned.—(O.16⁽²⁾) (Rs.3299).

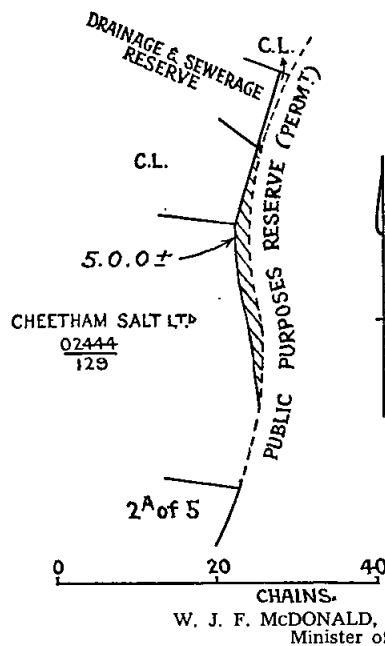
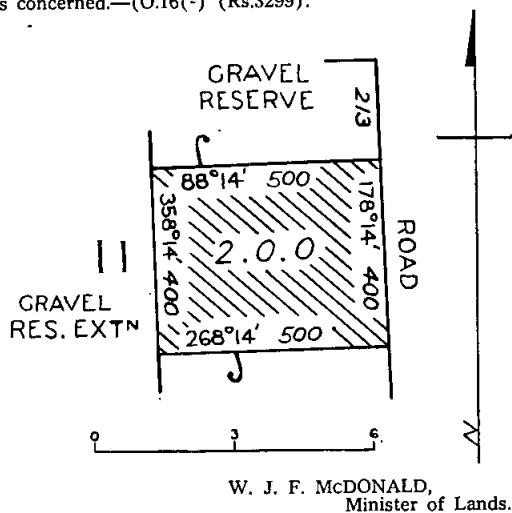

PROPOSED PERMANENT RESERVATION OF LAND AS A SITE.

IN pursuance of sections 14 and 21 of the Land Act 1958, notice is hereby given that it is the intention of the Governor in Council to reserve permanently from sale, from being leased and from having a licence granted in respect thereof the land hereinafter described:—

The following Notice was published 1^o on the 3rd June, 1970, pursuant to Order of the 26th May, 1970.

TRUGANINA (ALTONA).—Land proposed to be permanently reserved as a site for Public purposes, 5 acres, more or less, Parish of Truganina, County of Bourke, as indicated by hatching on plan hereunder.—(T.109⁽⁶⁾) (C.70845).

LOCAL LAND BOARDS.

IN pursuance of the provisions of section 34 of the Land Act 1958, notice is hereby given that the public hearing at the following place and time, will be conducted by the person mentioned, being duly appointed in that behalf.

W. BORTHWICK,
Minister of Lands.

Department of Crown Lands and Survey,
Melbourne.

SCHEDULE.

ARARAT LAND OFFICE, Thursday, 2nd July, 1970, at 9 a.m.—N. J. Fitzgerald.

Land Act 1958.

LEASE CANCELLED.

NOTICE is hereby given that the Governor in Council has cancelled the Lease mentioned in the Schedule hereunder for the reason specified.

District.	Corr. No.	Name.	Section of Land Act under which Leased.	Parish.	Allotment.	Section.	Area.	Annual Rental.	Reason.
Bairnsdale	8/134	Steel Boat Building Co. of Australia	134	Colquhoun	84E	—	A. R. P. — 2 16	\$ 462.00	Non-payment of rent ; non-compliance with building covenants

Department of Crown Lands and Survey,
Melbourne, 5th June, 1970.

W. J. F. McDONALD,
Minister of Lands.

TENDERS

PUBLIC WORKS DEPARTMENT

TENDERS will be received at Public Works Department, 2 Treasury-place, Melbourne, until **TWO** p.m. on dates shown and for purposes mentioned hereunder.

Particulars and tender forms available at Contracts Office, Room 8, Building Division, Parliament-place and at places indicated in brackets hereunder.

Abbreviations in brackets mean:—W.O.—Inspector of Works Office; P.S.—Police Station; C.S.—Consolidated School; H.E.S.—Higher Elementary School; H.S.—High School; Pr.S.—Primary School; T.S.—Technical School.

Tenders to be submitted on the Department's printed Tender Form and will not be received by telephone. All tenders must be on a "Firm Tender" basis. The lowest or any tender will not necessarily be accepted.

Address tenders to the Minister of Public Works, and endorse the envelope containing the tender "Tender for , closing Tuesday,

Hand delivered tenders to be placed in the Tender Box of the Public Works Department, located on the wall of the centre entrance foyer, Ground Floor, 2 Treasury-place, Melbourne.

No preliminary deposit is required with any tender, but a successful tenderer will be required to pay a deposit for any accepted tender of \$4,000 or over.

Tuesday, 23rd June, 1970.

Building, Electrical and Mechanical Works.

Alexandra.—Connexion to town sewerage, High School and Principal's Residence. (W.O., Alexandra.)

Miscellaneous.

Various.—Supply of Fire Extinguishers for the period 1st July, 1970, to 30th June, 1971, Schools and other Government Departments.

Tuesday, 30th June, 1970.

Building, Electrical and Mechanical Works.

Kyneton.—New shelter shed, external and internal repairs and renovations, Primary School 343. (W.O., Bendigo and Kyneton.)

Mont Park.—Extensions to roadway lighting, Janefield Training Centre.

Mont Park.—Supply and installation of steam heating system in the Occupational Therapy Project Unit, Mental Hospital.

Tuesday, 7th July, 1970.

Building, Electrical and Mechanical Works.

Benalla.—Electrical services for general purpose school hall type "572c", Technical School. (W.O., Benalla, Bendigo, Shepparton and Wangaratta.) (Re-advertised.)

Mont Park.—Remodelling and renovations, Ward F.5, Mental Hospital.

Mont Park.—Electrical installation, Mental Hospital.

Mont Park.—Mechanical services, Mental Hospital.

Mordialloc—Chelsea.—Modifications to heating system, High School, Station-street, Mordialloc.

Mount Egerton.—Alterations and renovations to School and Residence, Pr.S. 1918. (W.O., Ballarat.)

Miscellaneous.

Beechworth.—Supply and delivery of stainless steel tables, food containers, &c., Mental Hospital.

Kew.—Supply and delivery of stainless steel bread containers, baking dishes, &c., Mental Hospital.

M. BYRNE,
Minister of Public Works.

Public Works Department,
Melbourne, 3002, 12th June, 1970.

PUBLIC SERVICE NOTICES

No. 488.

Public Service Act 1958, Section 50.

REGULATIONS.—PART IV.—SALARIES AND INCREMENTS.

THE Public Service Board, in pursuance of the powers conferred by the Public Service Act 1958, hereby amends its Regulations as shown below:—

FIFTH SCHEDULE.

TEMPORARY EMPLOYEES.

DEPARTMENT OF HEALTH.

MENTAL HYGIENE.

Designations of Positions and Rates of Salaries.

Designation of Position.	Yearly Rate of Salary. £	
	Minimum.	Maximum.
<i>Delete the existing yearly rates of salary for the following positions and insert the rates shown hereunder in lieu thereof—</i>	\$	\$
Bricklayer	3,513	3,830
Butcher	2,696	2,952
Carpenter	3,332	3,642
Cleaner (Female)*	2,371	2,647
Cleaner and Labourer—Adult	2,602	2,874
Cook (Male)	2,677	2,933
Craft Supervisor (Male), Grade IV.	3,792	4,147
Craft Supervisor (Male), Grade III.	3,624	3,717
Craft Supervisor (Male), Grade II.	3,161	3,332
Craft Supervisor (Male), Grade I.—Adult	2,854	3,066
Craft Supervisor (Female), Grade IV.	2,933	3,023
Craft Supervisor (Female), Grade III.	2,781	2,857
Craft Supervisor (Female), Grade II.	2,547	2,607
Craft Supervisor (Female), Grade I.—Adult	2,390	2,487
Dental Attendant (Female), Grade II.	2,487	2,705
Dental Attendant (Female), Grade I.—Adult †	2,333	2,587
Dental Mechanic	3,660	3,977
Drainer and Joiner	3,066	3,332
Electrical Mechanic	3,296	3,624
Engineer Mechanic	3,296	3,624
Farm Assistant—Adult	2,715	2,971
Female Reliever	2,038	2,295
Fireman	2,834	3,104
Gardener—Adult	2,566	2,834
General Assistant—Adult	2,474	2,734
Hairdresser (Male)	3,047	3,350
Hairdresser (Female)	2,507	2,819
Kitchen Maid—Adult	2,038	2,295
Kitchenman—Adult	2,566	2,834
Kitchen and Wardsmaid—Adult	2,038	2,295
Labourer	2,436	2,696
Laundress, Grade II.	2,164	2,428
Laundress, Grade I.—Adult	2,020	2,257
Laundryman	2,566	2,834
Messroom Attendant (Female)—Adult	2,056	2,314
Mortuary Attendant	3,047	3,314
Motor Mechanic	3,296	3,624
Motor Truck Driver—Adult	2,894	3,142
Painter	3,476	3,792
Plasterer	3,531	3,849
Plumber	3,568	3,868
Seamstress, Grade II.	2,146	2,390
Seamstress, Grade I.—Adult	1,984	2,219
Shoemaker	3,085	3,404
Storeman, Grade II.	2,854	3,123
Storeman, Grade I.—Adult	2,774	3,028
Tailor	2,854	3,123
Tailoress	2,587	2,895
Upholsterer	2,584	2,854
Watchman	2,493	2,754

* See Regulation 148n.
† See Regulation 98 (b) (iii).

This Regulation shall have effect as on and from the 31st May, 1970.

A. H. RIGG, Member.
L. W. REGAN, Member.
V. P. SCULLY, Secretary.

Office of the Public Service Board,
Melbourne, 29th May, 1970.

No. 487.

Public Service Act 1958, Section 50.

REGULATIONS.—PART IV.—SALARIES AND INCREMENTS.

THE Public Service Board, in pursuance of the powers conferred by the Public Service Act 1958, hereby amends its Regulations as shown below:—

SIXTH SCHEDULE.

TEMPORARY EMPLOYEES.

Designations of Positions and Rates of Salaries.

Department and Designation of Position.	Yearly Rate of Salary.		Increments (Annual).
	Minimum.	Maximum.	
	\$	\$	
<i>Delete the existing yearly rates of salary for the following positions and insert the rates shown hereunder in lieu thereof—</i>			
GENERAL.			
Caretaker, Grade II.//	3,047	3,296	Σ
Caretaker, Grade I.//	2,814	3,066	Σ
Carpenter	3,332	3,642	Σ
Carpenter (Construction)	3,513	3,830	Σ
Cleaner (Female)θ	2,371	2,647	Σ
Cleaner (Male)θ	2,602	2,874	Σ
Electrician	3,296	3,624	Σ
Field Assistant (Survey), Grade II.	3,161	3,404	Σ
Field Assistant (Survey), Grade I.—Adult†	2,874	3,142	Σ
Fireman	2,834	3,104	Σ
Garage Attendant—Adult	2,436	2,696	Σ
Gardener, Grade II.	2,734	2,990	Σ
Gardener, Grade I.—Adult	2,566	2,834	Σ
General Assistant—Adult	2,436	2,715	Σ
Laboratory Attendant—Adult	2,658	2,933	Σ
Labourer, Senior	2,566	2,834	Σ
Labourer	2,436	2,696	Σ
Lift Attendant	2,602	2,854	Σ
Motor Mechanic	3,296	3,624	Σ
Motor Truck Driver—Adult	2,894	3,142	Σ
Painter	3,476	3,792	Σ
Plumber	3,568	3,868	Σ
Storeman, Grade II.	2,854	3,123	Σ
Storeman, Grade I.	2,774	3,028	Σ
Watchman	2,493	2,754	Σ
// With quarters when required to reside on premises. θ See Regulation 140. † See Regulation 141.			
DEPARTMENT OF AGRICULTURE.			
Caretaker-caterer (Female), Horticultural Research Station, Tatura//	2,409	2,607	Σ
Caretaker and Overseer, Glenormiston†	2,854	3,104	Σ
Farm Assistant—Adult	2,715	2,971	Σ
Fitter	3,296	3,624	Σ
Maintenance Officer, Cool Stores	3,458	3,755	Σ
Stockman and Assistant	2,715	2,971	Σ
<i>Dookie Agricultural College.</i>			
Blacksmith	3,314	3,642	Σ
Cook	2,971	3,239	Σ
Dairy Assistant	2,715	2,971	Σ
Farm Mechanic	3,296	3,624	Σ
Gardener, Head	3,047	3,296	Σ
Houseman, Senior	2,474	2,814	Σ
Houseman—Waiter	2,436	2,715	Σ
Piggery Assistant	2,854	3,104	Σ
Seamstress and Assistant	1,984	2,219	Σ
Waitress	1,930	2,182	Σ

SIXTH SCHEDULE.—continued.

Department and Designation of Position.	Yearly Rate of Salary.		Increments (Annual).
	Minimum.	Maximum.	
	\$	\$	
<i>Longerneong Agricultural College.</i>			
Blacksmith—Instructor	3,458	3,774	Σ
Cook	2,971	3,239	Σ
Steward	2,436	2,715	Σ
With quarters when required to reside on premises. † With quarters.			
CHIEF SECRETARY'S DEPARTMENT.			
SOCIAL WELFARE.			
<i>Family Welfare Division.</i>			
Domestic—Adult	1,930	2,182	Σ
General Reliever (Female)—Adult	2,038	2,295	Σ
Kitchenman	2,566	2,834	Σ
Laundress, Senior	2,164	2,428	Σ
Laundress	2,020	2,257	Σ
Seamstress	1,984	2,219	Σ
<i>Youth Welfare Division.</i>			
Cook (Male), "Winlaton"	2,971	3,239	Σ
Cook (Male), Assistant	2,620	2,894	Σ
Domestic—Adult	1,930	2,182	Σ
General Reliever (Female)—Adult	2,038	2,295	Σ
Kitchenman	2,566	2,834	Σ
Laundryman	2,566	2,834	Σ
Seamstress	1,984	2,219	Σ
FISHERIES AND WILDLIFE			
Hatchery Assistant, Snob's Creek—Adult	2,639	2,894	Σ
Liberation Officer—Adult	2,894	3,142	Σ
OFFICE OF THE CHIEF COMMISSIONER OF POLICE.			
Police Hospital—Housemaid	2,056	2,314	Σ
Wardsman	2,602	2,874	Σ
STATE LIBRARY, NATIONAL GALLERY, NATIONAL MUSEUM AND INSTITUTE OF APPLIED SCIENCE.			
General Assistant, Senior	2,566	2,834	Σ
General Assistant	2,436	2,696	Σ
Lavatory Attendant (Male)	2,474	2,734	Σ
Lavatory Attendant (Female)	2,110	2,371	Σ
DEPARTMENT OF CROWN LANDS AND SURVEY.			
Engineer Mechanic, Buchan Caves	3,458	3,755	Σ
Guide, Buchan Caves	2,734	2,874	Σ
<i>Royal Botanic Gardens.</i>			
Signwriter	3,476	3,792	Σ
DEPARTMENT OF HEALTH.			
GENERAL HEALTH.			
Attendant, Venereal Diseases Clinic	2,794	3,066	Σ
Exotic Diseases—Domestic	2,056	2,314	Σ
General Hand	2,474	2,734	Σ

SIXTH SCHEDULE.—continued.

SIXTH SCHEDULE.—continued.

Department and Designation of Position.	Yearly Rate of Salary.		Increments (Annual).	Department and Designation of Position.	Yearly Rate of Salary.		Increments (Annual).
	Minimum.	Maximum.			Minimum.	Maximum.	
<i>Maternal and Child Welfare.</i>	\$	\$		PORTS AND HARBOURS— <i>continued.</i>	\$	\$	
Articulated Vehicle Driver (Maker's capacity, 10 tons)	3,085	3,332	Σ	Dredge Operator, Grade I	3,350	3,660	Σ
Dental Attendant (Female), Senior	2,800	2,857	Σ	Engine Driver ("Fury")*	3,849	4,147	Σ
Dental Attendant (Female), Grade II.	2,487	2,705	Σ	Engine Driver ("Goudie")*	3,606	3,923	Σ
Dental Attendant (Female), Grade I.—Adult §	2,333	2,587	Σ	Fireman, Marine†θ	3,104	3,332	Σ
§ See Regulation 98 (a) (v).				Fitter and Turner=	3,296	3,624	Σ
<i>Tuberculosis</i>				Greaser and Storeman†θ	3,142	3,386	Σ
Dark Room Attendant (Male)—Adult	2,620	2,894	Σ	Master ("Fury")*	3,849	4,147	Σ
Dark Room Attendant (Female)—Adult	2,038	2,295	Σ	Master ("Goudie")*	3,606	3,923	Σ
<i>State Sanatoria.</i>				Navigation Lights Officer, Assistant	3,531	3,887	Σ
Boiler Attendant	2,834	3,104	Σ	Steward†θ	3,123	3,386	Σ
Chef	2,990	3,258	Σ	Tradesman's Assistant=	2,436	2,696	Σ
Cook (Male), Assistant	2,677	2,933	Σ	Wharf Carpenter and Boatman	3,513	3,830	Σ
Engineer Mechanic	3,458	3,755	Σ	‡‡ See Regulation 156.			
Gardener, Senior	3,047	3,296	Σ	φ See Regulation 155.			
General Hand	2,474	2,734	Σ	// See Regulation 153.			
Kitchenman	2,566	2,834	Σ	† With rations when required to live on the vessel.			
Laundryman	2,566	2,834	Σ	θ See Regulation 152.			
Laundress	2,020	2,257	Σ	* See Regulation 151.			
Laundress Assistant, and Housemaid	2,002	2,257	Σ	= See Regulation 154.			
Maid—Adult	2,038	2,295	Σ	‡ After the completion of two years' satisfactory service as such, will be eligible for progression to Able Seaman.			
Seamstress and Housemaid	1,984	2,219	Σ	STATE FORESTS DEPARTMENT.			
Wardmaid	2,056	2,314	Σ	Mechanic, Leading Hand, Fire Protection	3,458	3,755	Σ
Wardsman	2,602	2,874	Σ	Mechanic, Fire Protection	3,296	3,624	Σ
φ See Regulation 121.				Propagator, Forest Plants	2,814	3,066	Σ
LAW DEPARTMENT.				CENTRAL WORKSHOP.			
General Assistant, Coroner's Court	2,436	2,696	Σ	Electrical Fitter, Leading Hand¶	3,458	3,755	Σ
Mortuary Attendant, Assistant, Morgue	2,933	3,200	Σ	Fitter, Leading Hand¶	3,458	3,755	Σ
LOCAL GOVERNMENT DEPARTMENT.				Fitter and Turner, Leading Hand¶	3,458	3,755	Σ
WEIGHTS AND MEASURES.				Fitter¶	3,296	3,624	Σ
Truck Driver and Assistant	3,350	3,660	Σ	Machinery Float Driver (20 tons)	3,440	3,755	Σ
MINES DEPARTMENT.				Mobile Crane Driver	2,814	3,066	Σ
Bulldozer Operator (70–130 brake horsepower)	3,440	3,755	Σ	Welder, Special Class, Leading Hand¶	3,531	3,849	Σ
Fitter and Turner	3,296	3,624	Σ	Welder, Special Class¶	3,386	3,698	Σ
Mechanic, Senior	3,458	3,755	Σ	Welder, Leading Hand¶	3,458	3,755	Σ
Welder	3,296	3,624	Σ	Welder¶	3,296	3,624	Σ
PUBLIC WORKS DEPARTMENT.				¶ See Regulation 160.			
Electrical Fitter	3,296	3,624	Σ	MINISTRY OF TOURISM.			
Electrical Mechanic	3,296	3,624	Σ	General Assistant, Victorian Government Tourist Bureau	2,436	2,696	Σ
French Polisher	3,296	3,624	Σ	WATER SUPPLY DEPARTMENT.			
Mechanic	3,296	3,624	Σ	Mechanic, Senior	3,458	3,755	Σ
PORTS AND HARBOURS.‡‡φ//				Mechanical Assistant, Grade II	3,104	3,368	Σ
Able Seaman†θ*	3,009	3,277	Σ	Mechanical Assistant, Grade I	2,971	3,239	Σ
Blacksmith's Striker=	2,436	2,696	Σ	Σ See Regulation 97 (2).			
Carpenter and Shipwright=	3,422	3,717	Σ	<i>This Regulation shall have effect as on and from the 31st May, 1970.</i>			
Cook†θ	2,990	3,258	Σ	A. H. RIGG, Member.			
Deckhand‡†θ	2,894	3,161	Σ	K. J. TUTTY, Member.			
Dredge Engine Driver	3,606	3,923	Σ	V. P. SCULLY, Secretary.			
				Office of the Public Service Board, Melbourne, 29th May, 1970.			

No. 486.

Public Service Act 1958, Section 50.

REGULATIONS.—PART IV.—SALARIES AND INCREMENTS.

THE Public Service Board, in pursuance of the powers conferred by the Public Service Act 1958, hereby amends its Regulations as shown below:—

EIGHTH SCHEDULE.

TECHNICAL AND GENERAL DIVISION.

Department and Office.	Scale of Rates of Annual Salary with Incremental Stages.
<i>Delete the existing yearly rates of salary for the following positions and insert the rates shown hereunder in lieu thereof—</i>	
CHIEF SECRETARY'S DEPARTMENT.	
SOCIAL WELFARE.	
Family Welfare Division.	
Cook, Grade IV.	\$2,640—\$2,721—\$2,802—\$2,880
Cook, Grade III.	\$2,444—\$2,525—\$2,606—\$2,674
Cook, Grade II.	\$2,326—\$2,407—\$2,488—\$2,569
Cook, Grade I.	\$2,176—\$2,257—\$2,338—\$2,409
Youth Welfare Division.	
Cook, Grade IV.	\$2,640—\$2,721—\$2,802—\$2,880
Cook, Grade II.	\$2,326—\$2,407—\$2,488—\$2,569
Cook, Brunswick Hostel ^θ	\$2,444—\$2,525—\$2,606—\$2,674
^θ Rates of pay include payment for all incidents of employment including overtime, work at night and work on Saturdays, Sundays and Public Holidays.	

TEMPORARY POSITIONS.—continued.

Department and Position.	Scale of Rates of Annual Salary with Incremental Stages.
TUBERCULOSIS.	
State Sanatoria.	
Cook	\$2,691—\$2,772—\$2,853—\$2,932
Cook, Assistant	\$2,409—\$2,490—\$2,571—\$2,640
Cook, Second Assistant and Housemaid	\$2,409—\$2,490—\$2,571—\$2,640
^θ Rates of pay include payment for all incidents of employment including overtime, work at night and work on Saturdays, Sundays and Public Holidays.	

DEPARTMENT OF HEALTH.

MENTAL HYGIENE.

Office or Position.	Scale of Rates of Annual Salary with Incremental Stages.
TECHNICAL AND GENERAL DIVISION.	
GENERAL STAFF.	
Cook, Grade II.	\$2,691—\$2,772—\$2,853—\$2,932
Cook, Grade I.	\$2,409—\$2,490—\$2,571—\$2,640
TEMPORARY POSITIONS.	
Cook	\$2,409—\$2,490—\$2,571—\$2,640

This Regulation shall have effect as on and from the 31st May, 1970.

A. H. RIGG, Member.
K. J. TUTTY, Member.
V. P. SCULLY, Secretary.

Office of the Public Service Board,
Melbourne, 29th May, 1970.

TEMPORARY POSITIONS.

Department and Position.	Scale of Rates of Annual Salary with Incremental Stages.
CHIEF SECRETARY'S DEPARTMENT.	
SOCIAL WELFARE.	
Family Welfare Division.	
Cook, Grade III.	\$2,444—\$2,525—\$2,606—\$2,674
Cook, Grade II.	\$2,326—\$2,407—\$2,488—\$2,569
Cook, Grade I.	\$2,176—\$2,257—\$2,338—\$2,409
Youth Welfare Division.	
Cook, Grade IV.	\$2,640—\$2,721—\$2,802—\$2,880
Cook, Grade III.	\$2,444—\$2,525—\$2,606—\$2,674
Cook, Grade II.	\$2,326—\$2,407—\$2,488—\$2,569
Cook, Grade I.	\$2,176—\$2,257—\$2,338—\$2,409
Cook, "Sunshine" ^θ	\$2,444—\$2,525—\$2,606—\$2,674
Office of the Chief Commissioner of Police.	
Cook, Police Hospital	\$2,529—\$2,610—\$2,691—\$2,757
DEPARTMENT OF HEALTH.	
GENERAL HEALTH.	
Exotic Diseases— Cook	\$2,409—\$2,490—\$2,571—\$2,640

No. 485.

PUBLIC SERVICE ACT 1958.

THE Public Service Board, in pursuance of the powers conferred by the Public Service Act 1958, hereby amends the Public Service (Public Service Board) Regulations as follows—

PART IV.—SALARIES AND INCREMENTS.

Division IV.—Technical and General Division.

Regulation 98.

In sub-clause (a) (v) the expression "Grade F44" is substituted for the expression "Grade F20A".
In sub-clause (b) (iii) the expression "Grade F44" is substituted for the expression "Grade F20A".

This Regulation shall have effect as on and from the 31st May, 1970.

A. H. RIGG, Member.
K. J. TUTTY, Member.
V. P. SCULLY, Secretary.

Office of the Public Service Board,
Melbourne, 29th May, 1970.

PRIVATE ADVERTISEMENTS

CITY OF ARARAT.

LOAN No. 70.

NOTICE OF INTENTION TO BORROW.

NOTICE is hereby given that the Council of the City of Ararat intends to borrow Thirteen thousand dollars (\$13,000), secured by a charge over the general rates of the municipality by the grant of a mortgage in accordance with the provisions of the Local Government Acts.

(a) The amount of the principal moneys which it is proposed to borrow is Thirteen thousand dollars (\$13,000).

(b) The maximum rate of interest that may be paid is 7.3 per centum per annum.

(c) The times which the moneys borrowed are to be repayable are the 1st day of September during the years 1971-1980, and that the place such moneys shall be repayable is at the Ararat City Water Supply, Municipal Offices, Ararat.

(d) The purpose for which the loan is to be applied is:—
Part cost, construction and additions to Regional Municipal Library Building.

(e) The manner in which the loan is to be liquidated is by provision out of the municipal fund in each year, during the currency of the loan, the sum of \$1,300 principal, together with interest from time to time accruing, due on so much of the total amount of the said loan as is unpaid.

The plans and specifications and estimate of the cost of the works and a statement showing the proposed expenditure for the moneys to be borrowed are open for inspection at the Municipal Offices (Town Clerk's Department), Ararat.

Dated this 11th day of June, 1970.

4837

J. I. GRENFELL, Town Clerk.

CITY OF CASTLEMAINE.

By-Law No. 129.

NOTICE is hereby given that the Council of the City of Castlemaine has made a By-Law titled City of Castlemaine Meeting Procedure By-Law, for the purpose of regulating the proceedings of Council Meetings and Committee Meetings conducted by the City of Castlemaine and for other purposes.

The Resolution for passing this By-Law was agreed to by the Council of the City of Castlemaine on the 11th May, 1970, and confirmed on the 8th June, 1970.

A copy of the said By-Law is open for inspection free of charge during office hours at the office of the Council, Castlemaine.

4836

S. A. STEVENS, Town Clerk.

CITY OF COBURG.

LOAN No. 118.

Notice of Intention to Borrow the Sum of \$50,000 for Permanent Works and Undertakings.

NOTICE is hereby given that the Council of the City of Coburg proposes to borrow the principal sum of Fifty thousand dollars, secured by a charge over the general rates of the municipality, such sum to be raised by the grant of a mortgage in accordance with the provisions of the Local Government Act 1958.

1. The maximum rate of interest that may be paid is 6.4 per cent. per annum.

2. The purpose for which the loan is to applied is road and drainage construction:—

Moreland-road (C.R.B. Works).
Princes-terrace Drain.

3. The period of the loan shall be fifteen years.

4. The moneys borrowed shall be repayable by providing out of the municipal fund 30 half-yearly instalments of approximately \$2,618 each, including principal and interest on the 1st day of February and the 1st day of August, during the currency of the loan. The first instalment shall be payable on the 1st day of February, 1971.

5. Such moneys shall be repayable to the Commissioners of the State Savings Bank of Victoria at the office of the said Commissioners, corner Elizabeth and Bourke streets, Melbourne.

The plans and specifications and the estimate of the cost of the proposed works and statement showing the proposed expenditure of the moneys to be borrowed are open for inspection at the office of the Council of the City of Coburg, at Town Hall, Coburg.

Dated this 5th day of June, 1970.

4794

G. W. HARMAN, Acting Town Clerk.

CITY OF KEILOR.

LOAN No. 100.

Notice of Intention to Borrow the Sum of \$170,000 for Permanent Works and Undertakings.

NOTICE is hereby given that the Council of the City of Keilor intends to borrow the principal sum of One hundred and seventy thousand dollars (\$170,000) secured by a charge over the general rates of the municipality, such sum to be raised by the grant of a mortgage in accordance with the provisions of the Local Government Act 1958.

1. The maximum rate of interest that may be paid is 7.4 per cent. per annum.

2. Such moneys shall be repayable at the Bank of New South Wales, Niddrie.

3. The loan is to be liquidated by providing out of the municipal fund 30 half-yearly instalments of approximately \$9,476.18 each, including principal and interest on the 1st day of March and the 1st day of September during the currency of the loan. The first instalment shall be payable on the 1st day of March, 1971.

4. The purpose for which the loan is to be applied is the part liability for the construction of a swimming pool at St. Albans.

5. The period of the loan shall be fifteen years. The plans, specifications, estimate of the cost of the proposed works and a statement showing the proposed expenditure of the moneys to be borrowed are open for inspection at the Municipal Offices, Keilor.

Dated 8th June, 1970.

4846

R. F. B. KELLY, Town Clerk.

CITY OF RICHMOND.

By-Law No. 180.

Building By-law.

A By-law of the City of Richmond made under the provisions of Sections 197 and 198 of the Local Government Act 1958 and the Uniform Building Regulations Victoria (hereinafter called "the Regulations") for:

(a) Prescribing areas in which no person shall construct or cause to be constructed any building the exterior walls of which are of material other than masonry or concrete.

(b) Adopting the minimum depth and width of frontage specified in Column 1 of Table 804 as the minimum area depth and width of frontage of land on which a building of Class I or Class II occupancy shall be constructed throughout the whole of the Municipal District.

(c) Prescribing areas in which buildings of Classes II and III occupancy shall not be constructed to contain more than three storeys.

(d) Dispensing with the requirements of Clause 813 of the Regulations in certain cases.

(e) Repealing various By-laws.

IN pursuance of the powers conferred by the Local Government Act 1958 and the Regulations and of any and every other power it thereunto enabling the Mayor, Councillors and Citizens of the City of Richmond order as follows:—

1. This By-law may be known as the Building By-law.

2. By-laws Nos. 136 and 163 of the City of Richmond are hereby repealed.

3. The areas described in the First Schedule hereto are hereby prescribed as brick areas in which no person shall construct or cause to be constructed any building or any outbuildings named in the Second Schedule hereto the exterior walls of which are of material other than masonry or concrete.

4. The areas described in the Second Schedule hereto are hereby prescribed as areas in which buildings of Class II or Class III occupancy shall not be constructed to contain more than three storeys including the ground floor and the whole of the rest of the Municipal District is hereby prescribed as an area in which buildings of Class II or Class III occupancy shall not be constructed to contain more than two storeys including the ground storey. Provided always that where the ground storey is devoted exclusively to the parking of wheeled vehicles the building may contain one storey in excess of the maximum number prescribed under this Clause.

5. The minimum area depth and width of frontage specified in Column 1 of Table 804 of the Regulations are hereby adopted as the minimum area depth and width of frontage of land on which a building of Class I or Class II occupancy shall be constructed throughout the whole of the Municipal District.

6. In the case of a building on land forming part of a sub-division approved by the Council and lodged with the Office of Titles prior to the date of commencement of the Regulations and the requirement of Clause 813 of the Regulations may be dispensed with by resolution of the Council if it is satisfied that Section 452 of the Health Act 1958 can be otherwise complied with.

7. No person shall construct any fowl house, kennel, conservatory, green house or similar structure appurtenant to a building of Class I, II, III or IV occupancy except in accordance with the plans and specifications submitted to and approved by the Building Surveyor of the Council.

8. Any person guilty of any wilful act or default contrary to the provisions of this By-law shall be liable to a penalty of not less than \$10.00 nor more than \$40.00 and in the case of a continuing offence not more than \$10.00 for each day on which an offence against this By-law is continued after a conviction or order by any Court.

9. Save as is herein otherwise provided this By-law shall apply to and have operation throughout the whole of the Municipal District of the City of Richmond.

10. In this By-law "the Council" shall mean the Council of the City of Richmond.

Resolution for passing this By-law agreed to by the Council of the City of Richmond on the 17th day of March 1969 and confirmed on the 21st day of April 1969.

The corporate seal of the Mayor, Councillors and Citizens of the City of Richmond was hereunto affixed in the presence of—

(SEAL) A. J. BROWN, Mayor.
G. J. O'CONNELL, Councillor.
CHAS. C. EYRES, Town Clerk.

Approved by the Governor in Council on the 28th day of April, 1970.—J. ROSSITER, Clerk of the Executive Council.

FIRST SCHEDULE.

Brick Areas.

The streets set out hereunder and all land fronting to or abutting upon such streets and for a distance of 90 feet in depth from such street shall be prescribed as brick areas.

Street, Extent.

Bridge Road; both sides.
Brougham Street; both sides.
Bosisto Street; both sides.
Burnley Street; Victoria Street to Railway, both sides.
Charles Street; both sides.
Charlotte Street; both sides.
Church Street; both sides.
Clifton Street; both sides.
Coppin Street; Highett Street to Railway, both sides.
Darlington Parade; both sides.
Dockery Street; both sides.
Edinburgh Street; both sides.
Elm Grove; both sides.
Erin Street; both sides.
Gipps Street; both sides.
Goodwood Street; both sides.
Highett Street; both sides.
Hoddle Street; east side.
Lennox Street; both sides from Highett Street to Swan Street.
Lyndhurst Street; both sides.
Malleon Street; both sides.
Muir Street; both sides.
Punt Road; east side.
Richmond Terrace; Docker Street to the bend.
Rowena Parade; both sides.
Rowena Street; both sides.
Sherwood Street; both sides.
Stanley Street; both sides.
Swan Street; both sides.
Vauluse; both sides.
Victoria Street; south side.
Waltham Street; both sides.

SECOND SCHEDULE.

Outbuildings.

GARAGES
WORKSHOPS
SHEDS

Three Storey Areas.

The streets set out hereunder and all land fronting to or abutting upon such streets and for a distance of 90 feet in depth from such street shall be prescribed as areas in which buildings of Class II or Class III occupancy shall not be constructed to contain more than three storeys including the ground floor:—

Adam Street; both sides.
Burnley Street; both sides.

Barkly Avenue; from Mary Street to Twickenham Crescent.
Balmain Street; from Railway to Church Street.

Bosisto Street; both sides.
Bank Street; both sides.
Bridge Road; both sides.
Bendigo Street; both sides.
Bennett Street; both sides.
Baker Street; both sides.
Buckingham Street; both sides.
Coppin Street; both sides.
Church Street; both sides.
Cremorne Street; both sides.
Clifton Street; both sides.
Charles Street; both sides.
Charlotte Street; both sides.
Docker Street; both sides.
Darlington Pde.; both sides.
Davison Street; both sides.
Erin Street; both sides.
Elm Grove; both sides.
Elizabeth Street; both sides.
Gipps Street; both sides.
Gardner Street; both sides.
Gleadell Street; both sides.
Gibdon Street; both sides.
Highett Street; both sides.
Hoddle Street; East side.
Hull Street; both sides.
Kent Street; both sides.
Lennox Street; from Swan Street to Highett Street; both sides.
Loyola Grove; West side.
Leslie Street; both sides.
Lincoln Street; both sides.
McGrath Court; both sides.
Madden Grove (Burnley Street to Richmond Park, South side).
Mary Street (from Swan Street to River); East side.
Murphy Street (from Coppin Street to River); both sides.
Newry Street; both sides.
Punt Road; East side.
Palmer Street; both sides.
Richmond Tce.; (Docker Street to Bend, both sides).
River Street; both sides.
Rooney Street; both sides.
Somerset Street; both sides.
Shelley Street; both sides.
South Eastern Freeway; North side.
Stanley Street; both sides.
Stawell Street (South of Railway line to South Eastern Freeway, both sides).
Swan Street; both sides.
Thomas Street; both sides.
Tudor Street; both sides.
Victoria Street; South side.
Waltham Street; both sides.
Westbank Terrace; both sides.
Wall Street; both sides.

4770

CITY OF RINGWOOD.

LOAN No. 98.

Notice of Intention to Borrow the Sum of \$50,000 for Permanent Works and Undertakings.

NOTICE is hereby given that the Council of the City of Ringwood proposes to borrow the principal sum of \$50,000 (Fifty thousand dollars) secured by a charge over the general rates of the Municipality, such sum to be raised by the grant of a mortgage in accordance with the provisions of the Local Government Act 1958.

1. The maximum rate of interest that may be paid is 7.3 per cent. per annum.

2. The purposes for which the loan is to be applied are:—

- (a) Road Works—
 - (i) Council contribution to C.R.B. financed works
 - Wantima-road reconstruction—Canterbury-road to Mackay-court .. \$14,000
 - Wonga-road reconstruction—north of Oban-road (balance) 1,200
 - (ii) Council contribution
 - Heathwood-street Group 14,000
- (b) Kerb and Channel Works—
 - Council Contribution to Schemes in Canterbury-road, Mt. Dandenong-road, Federal-road, and Alexandra-road 7,200
- (c) Drainage Works—
 - Council Contribution to Scheme
 - Heathwood-street Group 4,600

(d) Parks, Gardens and Reserves—

(i) Reconstruction of North Ringwood Oval and construction of Toilet Block (Council contribution) ..	5,000
(ii) Construction of Pavilion—Mullum Reserve (part cost) ..	4,000
	\$50,000

3. The period of the loan shall be 10 (ten) years.

4. The moneys borrowed shall be repayable by providing out of the municipal fund half-yearly instalments of approximately \$3,565.98 each, including principal and interest on the 1st day of August and February in each year during the currency of the loan. The first instalment shall be payable on the 1st day of February, 1971.

5. Such moneys shall be repayable to the Commissioners of the State Savings Bank of Victoria, at the office of the said Commissioners, corner Elizabeth and Bourke streets, Melbourne.

The plans and specifications and the estimate of the cost of the proposed works and a statement showing the proposed expenditure of the moneys to be borrowed are open for inspection at the office of the Council of the City of Ringwood, Civic Centre, Maroondah Highway, Ringwood. 4780

J. N. WEBSTER, Town Clerk.

CITY OF SUNSHINE.

WHEREAS the Council of the City of Sunshine deems it expedient to provide the work or undertaking of constructing a drain on the land delineated and hatched on the map at the foot hereof and to exercise its power of taking compulsorily a drainage easement over the said land and whereas the Council has caused to be prepared a map and other papers setting out in general description of the work or undertaking for which the easement proposed to be taken is to be used the description of the land affected by the said easement and the names of the owners or reputed owners, lessees or reputed lessees, mortgagees and occupiers of that land so far as those names are known to or can be ascertained by the Council and whereas the said map and other papers are deposited at the office of the said Council at Sunshine and are and shall be open for inspection by all persons interested at all reasonable hours for the space of 40 clear days after the publication of this notice in the *Government Gazette* now notice is hereby given to all persons affected by the proposed taking of the said easement to set forth, in writing, addressed to the Council or the Town Clerk within 40 clear days of the publication of this notice in the *Government Gazette* all objections which they may have to the taking of the said easement.

P L A N
CERTIFICATE OF TITLE
VOL. 4024 FOLIO 612
MARIBYRNONG ROAD

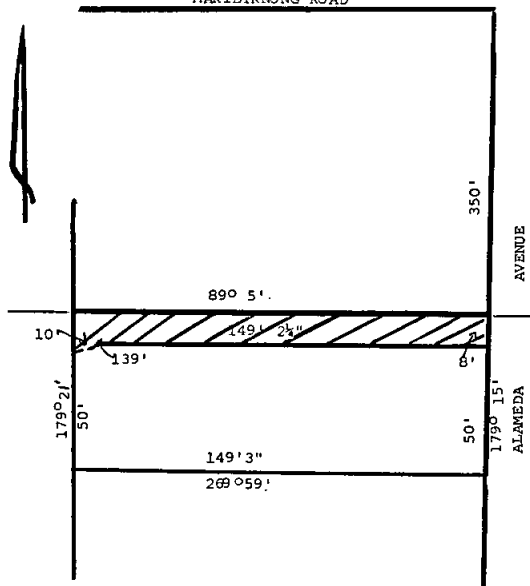

Dated the 8th day of June, 1970.

By order of the Council,

T. W. DEUTSCHMANN, Town Clerk.

4771

No. 60.—5321/70.—3

BOROUGH OF WONTHAGGI.

NOTICE is hereby given that the Council of the Borough of Wonthaggi has appointed Sergeant Reginald George Sparling, No. 10699, to the position of Prosecuting Officer for the Borough of Wonthaggi, in place of Sergeant John Roderick Hall, who has resigned.

4778

N. M. SIMMONS, Town Clerk.

SHIRE OF BROADFORD.

LOAN No. 38.

Notice of Intention to Borrow the Sum of \$5,000 for Permanent Works and Undertakings.

NOTICE is hereby given that the Council of the Shire of Broadford proposes to borrow the principal sum of Five thousand dollars secured by a charge over the general rates of the municipality, such sum to be raised by the grant of a mortgage in accordance with the provisions of the *Local Government Act 1958*.

1. The maximum rate of interest that may be paid is 7.10 per cent. per annum.

2. The purpose for which the loan is to be applied is:—

Office furniture and heating equipment ..	\$2,150
Extensions to Council depot and residence ..	2,300
Miscellaneous items of plant ..	550
	\$5,000

3. The period of the loan shall be six years.

4. The moneys borrowed shall be repayable by providing out of the municipal fund twelve equal half-yearly instalments of \$518.95 each, including principal and interest on the 15th day of February and the 15th day of August, during the currency of the loan. The first instalment shall be repayable on the 15th day of February, 1971.

5. Such moneys shall be repayable at the C.B.C. Savings Bank Limited, Melbourne.

The plans and specifications and the estimate of the cost of the proposed works and a statement showing the proposed expenditure of moneys to be borrowed are open for inspection at the Shire Office, Broadford.

4769

M. D. WADE, Shire Secretary.

SHIRE OF LILLYDALE.

LOAN No. 98.

NOTICE is hereby given that at a meeting of the Council of the Shire of Lillydale, held at the Shire Hall, Anderson-street, Lillydale, on 11th May, 1970, the said Council did agree to the following resolution, that is to say:—

1. That the Council do by Special Order and it does hereby resolve to borrow the sum of \$50,000 (Fifty thousand dollars) secured by a charge over the general rates of the municipality, such sum to be raised by the grant of a mortgage in accordance with the provisions of the *Local Government Act 1958* (as amended).

2. The rate of interest to be paid shall be 6.3 per cent. per annum.

3. The said loan shall be liquidated by the payment of 20 half-yearly instalments of \$3,407.57, comprising principal and interest on the 30th day of December, and the 30th day of June during the years 1970 to 1980 inclusive. The first instalment shall be payable on the 30th day of December, 1970, and the final instalment shall be payable on the 30th day of June, 1980.

4. The place at which the moneys shall be repayable is at the National Bank Savings Bank Ltd., Main-street, Lillydale.

5. The purposes for which the loan is to be applied are:—

Purchase of Reserves ..	\$10,000
Purchase of Mechanical Plant ..	15,000
Maintenance and improvement of public halls ..	4,000
Construction of private streets under the provisions of Division 10 of Part XIX. of the <i>Local Government Act 1958</i> ..	16,000
Drainage works and the Construction of a brick toilet block at Esther Park ..	5,000
	\$50,000

And notice is hereby further given that at a meeting of the said Council, held on the 8th day of June, 1970, the said resolution was confirmed.

4792

F. O. KENT, Shire Secretary.

SHIRE OF MAFFRA.

LOAN No. 42.

Notice of Intention to Borrow the Sum of \$16,000 for Permanent Works and Undertakings.

NOTICE is hereby given that the Council of the Shire of Maffra proposes to borrow the sum of Sixteen thousand dollars (\$16,000.00) secured by a charge over the general rates of the municipality, such sum to be raised by the grant of a mortgage in accordance with the provisions of the *Local Government Act 1958*.

1. The maximum rate of interest that may be paid is 7.3 per cent. per annum.

2. The purpose for which the loan is to be applied for is:—

Council contribution towards the cost of construction of Mills, McAdam and Glassford streets, Maffra \$16,000

3. The period of the loan shall be ten (10) years.

4. The moneys borrowed shall be repayable by providing out of the municipal fund, twenty half-yearly instalments of approximately \$1,141.00 each including principal and interest, on the 1st day of March and 1st day of September, during the currency of the loan. The first instalment shall be repayable on the 1st day of March, 1971.

5. Such moneys shall be repayable at the State Savings Bank of Victoria, corner Elizabeth and Bourke streets, Melbourne.

6. The plans, specifications and estimates of cost of the proposed works and a statement, showing the proposed expenditure of the money to be borrowed, are open for inspection at the Shire Office, Maffra.

Dated this 9th day of June, 1970.

4793

J. RENNICK, Shire Secretary.

SHIRE OF ROSEDALE.

NOTICE OF INTENTION TO TAKE LAND COMPULSORILY.

WHEREAS the Council of the Shire of Rosedale deems it expedient to exercise its power of taking compulsorily the land described in the Schedule at the foot hereof for road deviation works: And whereas the Council has caused to be prepared a map and other papers setting out the general description of the work or undertaking for which the land proposed to be taken is to be used, the description of the land proposed to be taken, and the names of the owners or reputed owners, lessees or reputed lessees, mortgagees and occupiers of that land so far as those names are known to or can be ascertained by the Council: And whereas the said map and other papers are deposited at the office of the said Council at Rosedale, and are and shall be open for inspection by all persons interested, at all reasonable hours for the space of forty (40) clear days after the publication in the *Government Gazette*: Now notice is hereby given to all persons affected by the proposed taking of the said land to set forth, in writing, addressed to the Council, or to the Shire Secretary, within forty (40) clear days of publication of this notice in the *Government Gazette*, all objections which they may have to the taking of the said land.

THE SCHEDULE HEREINBEFORE REFERRED TO:

Being all that piece of land being part of Crown allotment 9, section D, Parish of Wurruk Wurruk, County of Tanjil, required for road deviation purposes and being more particularly in Crown grant, volume 6644, folio 690.

Dated this 10th day of June, 1970.

4833

By order of the Council,

G. W. THOMSON, Shire Secretary.

SHIRE OF SEYMOUR.

CHANGE OF STREET NAME.

NOTICE is hereby given that, in pursuance of the powers conferred by the *Local Government Act* the Council of the Shire of Seymour did at a meeting held on 8th day of June, 1970, order that the following alteration be made in the name of Avenel-road between Whitehead's Creek and Tarcombe-road and that such order take effect from 1st July, 1970.

Old Name.—Avenel-road.

New Name.—Tarcombe-road.

4844

G. G. McWHINNEY, Shire Secretary.

SHIRE OF SHERBROOKE.

LOAN No. 124.

Special Order.

NOTICE is hereby given that at a meeting held on 16th June, 1970, the Council of the Shire of Sherbrooke did confirm the following Resolution:—

That the council do by Special Order and it does hereby resolve to borrow the sum of \$20,000 by the grant of a mortgage for such amount secured by a charge over the general rates of the municipality of the President, Councillors and Ratepayers of the Shire of Sherbrooke in accordance with the provisions of section 585 of the *Local Government Act* as amended.

That the rate of interest to be paid be 7.4 per centum per annum.

That the amount of the loan be fifteen (15) years and that the moneys borrowed be repayable by half-yearly instalments of approximately \$1,114.85, including principal and interest, on the 1st day of June and the 1st day of December during the currency of the loan. The first instalment being payable on the 1st day of December, 1970.

That such moneys be repayable at the State Savings Bank of Victoria, Melbourne.

That the loan be applied for the purpose of constructing private streets within the Shire of Sherbrooke in pursuance of and in accordance with the provisions of Division 10 of Part XIX of the *Local Government Act 1958*.

4845

A. JONES, Shire Secretary.

SHIRE OF STAWELL.

ORDER DECLARING PUBLIC HIGHWAY.

IN pursuance of the powers conferred by section 522 of the *Local Government Act 1958*, the Council of the Shire of Stawell doth hereby order:

That the lands hereinafter described, which have been purchased by it, shall be public highways, viz.:—

All those pieces of land being parts of Crown portions 1 and 2 and allotments B and 12, section 7 and 35A, 53, 54A, 54B, 55, 56 and 63, section 9, Parish of Crowlands as described in certificates of title volume 8812, folio 331; volume 8812, folio 335; volume 3803, folio 760440; volume 3877, folio 775276 and volume 3788, folio 757538.

All those pieces of land being parts of allotments 5, 8, 12, 24, 25 and 26, sections 3 and 10, section 4, Parish of Landsborough, as described in certificates of title, volume 8812, folio 332; volume 4115, folio 822919; volume 8195, folio 988; volume 3872, folio 774351; volume 3831, folio 766133; volume 3795, folio 758943 and volume 3797, folio 759291.

All those pieces of land being parts of allotments 4, 27, 28, 46, 47, 49, 50, 56, 85, 86, 88, 89, 92, 99, 100, 231A, 261A, 262 and former Government road, Parish of Navarre, as described in certificates of title, volume 8812, folio 334; volume 3820, folio 763978; volume 3806, folio 761041 and conveyance No. 840, book 716.

All that piece of land being part of suburban lot 221, Parish of Navarre, and being part of the land described in certificate of title, volume 8812, folio 333.

All those pieces of land being parts of allotments 21, Parish of Navarre, and 230, Township of Navarre, and being part of the lands described in certificate of title, volume 3873, folio 774460.

All that piece of land being that part of allotment 34, section 9, Parish of Crowlands, commencing at the south-eastern angle of the said allotment; thence northerly by its eastern boundary 400 links; thence south-westerly by a line to a point on its southern boundary 226.7 links west of the south-eastern angle; thence easterly by that boundary to the commencing point, and being part of the land described in certificate of title, volume 3795, folio 758899.

The common seal of the President, Councillors and Ratepayers of the Shire of Stawell was hereto affixed, this 2nd day of June, 1970, in the presence of—

M. D. RAHLEY, President.

(SEAL)

J. R. WILLIAMS, Councillor.

V. C. NIELSEN, Secretary.

4785

NOTICE is hereby given that the Australian Alpine Club has applied for a lease, pursuant to section 134 of the *Land Act 1958*, for a term of 21 years in respect of an area of $\frac{1}{2}$ acre in section B, Parish of Hotham, as a site for a ski lodge (subject to survey).—(H.033824.) 4421

SHIRE OF WODONGA.

NOTICE is hereby given that the President, Councillors and Ratepayers of the Shire of Wodonga have applied for a lease under section 134 of the Land Act 1958 for a term of 21 years in respect of an area of 17 acres, more or less, being former Tourist Camping Purposes Reserve, Township of Wodonga, as a site for the provisions of facilities for tourists (Caravan Park).

4665

G. J. MORTON, Shire Secretary.

DANDENONG VALLEY AUTHORITY.

NOTICE OF INTENTION TO DECLARE FLOOD-PRONE AREAS.

UNDER section 27 of the Dandenong Valley Authority Act No. 7060, the Dandenong Valley Authority proposes on or after the 3rd August, 1970, to have proclaimed specified areas along Hallam Valley Drain from the South Gippsland Railway Line to Wood-road, Narre Warren; being within the District of the Dandenong Valley Authority, to be within the flood plain of the Dandenong Creek and its tributaries.

Plans specifying the areas to be proclaimed may be inspected at—

The Offices of the Authority, 208 Princes Highway, Dandenong.

The State Rivers and Water Supply Commission, 90 Orrong-road, Armadale.

The Municipal Offices of the Shire of Cranbourne.
The Municipal Offices of the Shire of Berwick.

Any objections to the making of such proclamation made within six weeks of this notice, are to be considered by the Dandenong Valley Authority, before any such proclamation is made.

Dated the 19th June, 1970.

By direction of the Authority,

K. G. ABBERTON, Secretary,

4779

Dandenong Valley Authority.

NOTICE OF INTENTION TO APPLY FOR A LICENCE TO DIVERT WATER AND CUT RACE (RE-ISSUE) FROM THE RIVER MURRAY, AT BOUNDARY BEND.

I HEREBY give notice that I intend to apply for a licence empowering me to divert water for a term of fifteen years to the extent of 9 acre-feet per annum at a maximum rate of $\frac{1}{4}$ acre-foot per day of 24 hours for the irrigation of citrus, being part of allotment 1E, Parish of Narrung, and to occupy certain Crown lands for works of diversion, and to cut a race thereon.

Any objection to such application must be forwarded, in writing, to reach the State Rivers and Water Supply Commission, Melbourne, before 17th July, 1970, being 30 days from the first publication of this notice.

JOSEPH E. RENNEY.

P.O. Box 19, Boundary Bend.

4801

NOTICE OF INTENTION TO APPLY FOR A LICENCE TO DIVERT WATER AND CUT RACE (RE-ISSUE) FROM THE RIVER MURRAY, AT WHARPARILLA.

WE hereby give notice that we intend to apply for a licence empowering us to divert water for a term of fifteen years to the extent of 300 acre-feet per annum at a maximum rate of 12 acre-feet per day of 24 hours for the irrigation of 150 acres of pasture, being part of allotments 166, 167 and 168, Parish of Wharparilla, and to occupy certain Crown lands for works of diversion, and to cut a race thereon.

Any objection to such application must be forwarded, in writing, to reach the State Rivers and Water Supply Commission, Melbourne, before 17th July, 1970, being 30 days from the first publication of this notice.

J. KELLY.

M. D. KELLY.

P.O. Box 73, Echuca.

4795

NOTICE OF INTENTION TO APPLY FOR A LICENCE TO DIVERT WATER AND CUT RACE (RE-ISSUE) FROM THE LITTLE RIVER, AT LITTLE RIVER.

I HEREBY give notice that I intend to apply for a licence empowering me to divert water for a term of fifteen years to the extent of 24 acre-feet per annum at a maximum rate of 5 acre-feet per day of 24 hours for the irrigation of 12 acres of lucerne, being part of allotments 44-48, section 1, Township of Rothwell, Parish of Bulban, and to occupy certain Crown lands for works of diversion, and to cut a race thereon.

Any objection to such application must be forwarded, in writing, to reach the State Rivers and Water Supply Commission, Melbourne, before 17th July, 1970, being 30 days from the first publication of this notice.

WALTER AUBREY SCOTT.

129 Collins-street, Melbourne.

4784

NOTICE OF INTENTION TO APPLY FOR A LICENCE TO DIVERT WATER AND CUT RACE (RE-ISSUE) FROM THE RIVER MURRAY, AT PIANGIL.

I HEREBY give notice that I intend to apply for a licence empowering me to divert water for a term of fifteen years to the extent of 45 acre-feet per annum at a maximum rate of 5 acre-feet per day of 24 hours for the irrigation of 15 acres of vegetables and pasture, being part of allotment 147B, Parish of Piangil, and to occupy certain Crown lands for works of diversion, and to cut a race thereon.

Any objection to such application must be forwarded, in writing, to reach the State Rivers and Water Supply Commission, Melbourne, before 17th July, 1970, being 30 days from the first publication of this notice.

FRANCESCO POLIFRONI.

Piangil, 3597.

4799

NOTICE OF INTENTION TO APPLY FOR A LICENCE TO DIVERT WATER AND CUT RACE FROM THE RIVER MURRAY, AT MERBEIN.

I HEREBY give notice that I intend to apply for a licence empowering me to divert water for a term of fifteen years to the extent of 36 acre-feet per annum at a maximum rate of 1 acre-foot per day of 24 hours for the purpose of irrigation of 12 acres of vines, being part of allotment 20, section H, Parish of Merbein, and to occupy certain Crown lands for works of diversion, and to cut a race thereon.

Any objection to such application must be forwarded, in writing, to reach the State Rivers and Water Supply Commission, Melbourne, before 17th July, 1970, being 30 days from the first publication of this notice.

HAROLD FREDERICK ROSE.

P.O. Box 265, Merbein.

4797

NOTICE OF INTENTION TO APPLY FOR A LICENCE TO DIVERT WATER AND CUT RACE FROM THE RIVER MURRAY (LAKE MULWALA), AT YARRAWONGA.

I HEREBY give notice that I intend to apply for a licence empowering me to divert water for a term of four years to the extent of 100 acre-feet per annum at a maximum rate of 8 acre-feet per day of 24 hours for the purpose of irrigating 50 acres of pasture, being part of allotment 60, Parish of Bundalong, and to occupy certain Crown lands for works of diversion, and to cut a race thereon.

Any objection to such application must be forwarded, in writing, to reach the State Rivers and Water Supply Commission, Melbourne, before 17th July, 1970, being 30 days from the first publication of this notice.

IAN MALCOLM McPHERSON.

"Huntly", Bundalong Roadside, via Yarrowonga. 4861

NOTICE OF INTENTION TO APPLY FOR A LICENCE TO DIVERT WATER AND CUT RACE FROM THE RIVER MURRAY, AT KOONDROOK.

I HEREBY give notice that I intend to apply for a licence empowering me to divert water for a term of ten years to the extent of 6 acre-feet per annum at a maximum rate of 2 acre-feet per day of 24 hours for the purpose of irrigating 3 acres of pasture, being part of allotments 28A and 30A, section E, Parish of Murrabit, and to occupy certain Crown lands for works of diversion, and to cut a race thereon.

Any objection to such application must be forwarded, in writing, to reach the State Rivers and Water Supply Commission, Melbourne, before 17th July, 1970, being 30 days from the first publication of this notice.

MURRAY VICTOR TUCK.

Koondrook.

4862

NOTICE is hereby given that Alan Kennedy, Betty Kennedy, Wilvene Clifford and Arthur Clifford, trading as Mountain Drilling Company have by mutual consent agreed to dissolve partnership, as from 8th May, 1970, and the said business will be continued solely as from that date by Alan Kennedy and Betty Kennedy, of Main-road, Ferny Creek.

Dated 8th May, 1970.

4781

A. J. CLIFFORD, Director.

LET it be known that the partnership of "Delux Ladies Fashions" carrying on business at 1-3 McIlwrick-street, Windsor, was dissolved on 2nd May, 1970, and that the partners of that firm are no longer liable for any debts incurred in the name of "Delux Ladies Fashions".

4775

NOTICE is hereby given that the partnership heretofore subsisting between Ivan Aarons Cluse Loel, Alice Lucy Elizabeth Loel and Ivan Harris Loel, carrying on business as retailers of musical instruments and the like at the corner of Lonsdale and Russell streets, Melbourne, under the style or firm name of "Loel's Music Centre", has been dissolved by mutual consent, as from the 31st day of January, 1970. All debts due to and owing by the said firm will be respectively received and paid by Ivan Harris Loel, who will continue to carry on the said business under the same name at the above-mentioned address.

Dated the 2nd day of June, 1970.

IVAN A. C. LOEL.
A. L. E. LOEL.
I. H. LOEL.

4816

In the Supreme Court of Victoria.—1970. Co. No. 7930.—In the matter of the Companies Act 1961; and in the matter of THE MANAGEMENT COMPUTING CENTRE PTY. LTD.

NOTICE is hereby given that a petition for the winding up of the above-named company by the Supreme Court was on the 2nd day of June, 1970, presented by James Canny, Deputy Commissioner of Taxation of the Commonwealth of Australia. And that the said petition is directed to be heard before the Court sitting at the Fourteenth Court, Law Courts, William-street, Melbourne, at the hour of 10.30 o'clock in the forenoon on the 3rd day of August, 1970, and any creditor or contributory of the said company desiring to support or oppose the making of an order on the said petition may appear at the time of hearing by himself or his Counsel for that purpose; and a copy of the said petition will be furnished to any creditor or contributory of the said company requiring the same by the undersigned on payment of the regulated charge for the same.

The petitioner's official address is 350 Collins-street, Melbourne.

The petitioners' solicitor is Robert Burns Hutchison, Acting Crown Solicitor for the Commonwealth of 99 Queen-street, Melbourne.

R. B. HUTCHISON.

NOTE.—Any person who intends to appear on the hearing of the said petition must serve on or send by post to the above-named R. B. Hutchison, notice in writing of his intention so to do. The notice must state the name and address of the person, or, if a firm, the name and address of the firm, and must be signed by the person or firm, or his or their solicitor (if any), and must be served or, if posted, must be sent by post in sufficient time to reach the above-named not later than 4 o'clock in the afternoon of the 31st day of July, 1970.

4824

In the Supreme Court of Victoria.—1970. No. Co. 7906.—In the matter of the Companies Act 1961; and in the matter of SHEPPARTON TRADING AND ENGINEERING COMPANY PROPRIETARY LIMITED.

BEFORE HIS HONOUR MR. JUSTICE CROCKETT.

Friday, the 29th day of May, 1970.

UPON the petition of Shepparton Trading and Engineering Company Proprietary Limited (hereinafter called "the Company") dated the 14th day of April, 1970, preferred unto this Court coming on for hearing the 29th day of May, 1970, and upon hearing Mr. D. Graham of Counsel for the company: And upon reading the said petition and the two affidavits of Roy Lawrence Baglin, sworn the 8th day of April, and the 26th day of May, 1970, and filed herein and the exhibits thereto and the Order of Master Brett, made herein the 28th day of April, 1970, directing that the provisions of section 64 (2) of the Companies Act 1961, shall not apply to any class of creditors of the company this court doth order that the reduction of the capital of the company referred to in the Special Resolution set forth in paragraph 8 of the said petition be and the same is hereby confirmed and this court doth direct that an office copy of this Order be lodged with the Registrar within fourteen days of this day, and that notice of this Order be gazetted and advertised on or before the 26th day of June, 1970, by publishing a copy of this Order once in the Government Gazette and once in The Age newspaper, and this court doth declare pursuant to section 64 (5) of the said Act that the amount of the share capital of the company as altered by this

Order is \$37,500 divided into 25,000 shares of \$1.50 each of which 23,010 have been issued and are fully paid up and 1,990 are unissued.

By the Court,

G. S. BRETT, Master.

Entered the 9th day of June, 1970.

P. S. MALBON, Prothonotary.

John D. Mustow & Co., solicitors, of 131 Queen-street, Melbourne. 4827

The Companies Act 1961.—In the matter of PYRAMID SAWMILLS PROPRIETARY LIMITED.—Notice of Final Meeting.

NOTICE is hereby given that, pursuant to section 272 of the Companies Act 1961, a general meeting of the members of the above-named company will be held at 47 Robertson-street, Casterton, on Monday, the 20th day of July, 1970, at 10 o'clock in the forenoon, for the purpose of having an account laid before them showing the manner in which the winding up has been conducted and the property of the company disposed of, and of hearing any explanation that may be given by the liquidator.

Dated the 10th day of June, 1970.

4788

K. TAIT, Liquidator.

Companies Act 1961, section 254 (2) (b).

J. P. McMEEKIN PROPRIETARY LIMITED.

NOTICE is hereby given that at an extraordinary general meeting of the above-named company duly convened and held at 2 James-court, Mildura, on 8th June, 1970, the following Special Resolution was duly passed:—

"That the company be wound up as a members' voluntary winding up and that John Archibald McDonald, public accountant, of 75 Bridge-road, Richmond, be appointed liquidator of the company."

Dated this 10th day of June, 1970.

4772

J. A. McDONALD, Liquidator.

COMPACT CARS PTY. LTD.

THE shareholders of Compact Cars Pty. Ltd., on the 1st June, 1970, by Special Resolution authorized the voluntary liquidation of the company. Mr. A. L. Reid, of 137 Thomas-street, Hampton, was appointed liquidator.

4776

A. L. REID.

The Companies Act 1961.—In the matter of COLIN THOMSON PTY. LTD.—Notice of Final Meeting.

NOTICE is hereby given that, pursuant to section 272 of the Companies Act 1961, a general meeting of the members of the above-named company will be held at 5 The Crofts, Richmond, on Monday, the 27th day of July, 1970, at 10 o'clock in the forenoon, for the purpose of having an account laid before them showing the manner in which the winding up has been conducted and the property of the company disposed of, and of hearing any explanation that may be given by the liquidator.

Dated the 8th day of June, 1970.

4787

COLIN J. THOMSON, Liquidator.

Companies Act 1961.

EFFTEE INVESTMENTS PROPRIETARY LIMITED.

NOTICE OF FINAL MEETING OF MEMBERS' VOLUNTARY WINDING UP.

NOTICE is hereby given in pursuance of section 272 (1) that the Final General Meeting of the members of Efftee Investments Pty. Ltd., will be held at 10.30 a.m. on Friday, 17th day of July, 1970, at the office of Fell & Starkey, 351 Collins-street, Melbourne, for the purpose of the liquidator laying before it an account showing how the winding up has been conducted and the property disposed of and to give any explanation thereof.

4813

K. V. HARRISON, Liquidator.

The Companies Act 1961.

SUPERMATIC APPLIANCE CENTRE PTY. LTD.
(IN LIQUIDATION).

NOTICE is hereby given that a First Dividend is intended to be declared in the above matter. Creditors who have not proved their debts by the 30th day of June, 1970, may be excluded from this dividend.

Dated this 9th day of June, 1970.

G. O. HARRISON, Liquidator.

Hall & Rose, chartered accountants, 254 Queen-street, Melbourne. 4815

Companies Act 1958.

Re: FIESTA CONSTRUCTIONS (BENDIGO) PTY. LTD.
(IN LIQUIDATION).

NOTICE CONVENING FINAL MEETING OF MEMBERS AND
CREDITORS, PURSUANT TO SECTION 210.

NOTICE is hereby given, in pursuance of section 210 of the *Companies Act 1958*, that a General Meeting of the members of the above-named company will be held on the 24th day of July, 1970, at Honorary Justices Association, 528 Collins-street, Melbourne, at 9.00 a.m., in the forenoon, and that a meeting of creditors will be held at 9.15 a.m. in the forenoon at the same place and on the same day, for the purpose of having an account laid before them showing the manner in which the winding up has been conducted and the property of the company disposed of, and of hearing any explanations that may be given by the liquidator.

Dated this 8th day of June, 1970.

R. D. WIDDOWS, liquidator, 6 Marylin-court, East
Bentleigh. 4851

Companies Act 1958.

Re: FIESTA CONSTRUCTIONS (BALLARAT) PTY. LTD.
(IN LIQUIDATION).

NOTICE CONVENING FINAL MEETING OF MEMBERS AND
CREDITORS, PURSUANT TO SECTION 210.

NOTICE is hereby given, in pursuance of section 210 of the *Companies Act 1958*, that a General Meeting of the members of the above-named company will be held on the 24th day of July, 1970, at Honorary Justices Association, 528 Collins-street, Melbourne, at 10.00 a.m. in the forenoon, and that a meeting of creditors will be held at 10.15 a.m. in the forenoon at the same place and on the same day, for the purpose of having an account laid before them showing the manner in which the winding up has been conducted and the property of the company disposed of, and of hearing any explanations that may be given by the liquidator.

Dated this 8th day of June, 1970.

R. D. WIDDOWS, liquidator, 6 Marylin-court, East
Bentleigh. 4852

Companies Act 1958.

Re: FIESTA CONSTRUCTIONS (GEELONG) PTY. LTD.
(IN LIQUIDATION).

NOTICE CONVENING FINAL MEETING OF MEMBERS AND
CREDITORS, PURSUANT TO SECTION 210.

NOTICE is hereby given, in pursuance of section 210 of the *Companies Act 1958*, that a General Meeting of the members of the above-named company will be held on the 24th day of July, 1970, at Honorary Justices Association, 528 Collins-street, Melbourne, at 11.00 in the forenoon at the same place and on the same day for the purpose of having an account laid before them showing the manner in which the winding up has been conducted and the property of the company disposed of, and of hearing any explanations that may be given by the liquidator.

Dated this 8th day of June, 1970.

R. D. WIDDOWS, liquidator, 6 Marylin-court, East
Bentleigh. 4853

Companies Act 1958.

Re: STATLER BUILDING SUPPLIES PTY. LTD.
(IN LIQUIDATION).

NOTICE CONVENING FINAL MEETING OF MEMBERS AND
CREDITORS, PURSUANT TO SECTION 210.

NOTICE is hereby given, in pursuance of section 210 of the *Companies Act 1958*, that a General Meeting of the members of the above-named company will be held on the 24th day of July, 1970, at Honorary Justices Association, 528 Collins-street, Melbourne, at 12 noon, and that a meeting of creditors will be held at 12.15 in the afternoon at the same place and on the same day, for the purpose of having an account laid before them showing the manner in which the winding up has been conducted and the property of the company disposed of, and of hearing any explanations that may be given by the liquidator.

Dated this 8th day of June, 1970.

R. D. WIDDOWS, liquidator, 6 Marylin-court, East
Bentleigh. 4854

Companies Act 1958.

Re: H. H. STEPHENSON PRINTING & PUBLISHING
PTY. LTD. (IN LIQUIDATION).

NOTICE CONVENING FINAL MEETING OF MEMBERS AND
CREDITORS, PURSUANT TO SECTION 210.

NOTICE is hereby given, in pursuance of section 210 of the *Companies Act 1958*, that a General Meeting of the members of the above-named company will be held on the 24th day of July, 1970, at Honorary Justices Association, 528 Collins-street, Melbourne, at 1.00 p.m. in the afternoon and that a meeting of creditors will be held at 1.15 p.m. in the afternoon at the same place and on the same day, for the purpose of having an account laid before them showing the manner in which the winding up has been conducted and the property of the company disposed of, and of hearing any explanations that may be given by the liquidator.

Dated this 8th day of June, 1970.

R. D. WIDDOWS, liquidator, 6 Marylin-court, East
Bentleigh. 4855

Companies Act 1961.—Section 254 (2) (b).

FUN-SHU PROPRIETARY LIMITED.

NOTICE is hereby given that at an Extraordinary General Meeting of the above-named company duly convened and held at John-street, Lilydale, on 9th June, 1970, the following Special Resolution was duly passed:—

"That the company enter into a members voluntary winding up. Mr. Charles Austin Hungerford Ashton, of 281 Collins-street, Melbourne, be appointed liquidator for the purpose of such winding up and is sanctioned to distribute in specie any or all of the assets of the company."

Dated this 16th day of June, 1970.

4857 CHARLES A. H. ASHTON, Liquidator.

The Companies Act 1961.

EMEPA PTY. LTD. (IN VOLUNTARY LIQUIDATION).

Notice of Final Meeting.

NOTICE is hereby given that, pursuant to section 272 of the *Companies Act 1961*, a General Meeting of members of Emeпа Pty. Ltd., will be held at the offices of Spry Walker & Co., 339 Collins-street, Melbourne, on Friday, 17th July, 1970, at 9.30 a.m., for the purpose of laying before it accounts showing how the winding up has been conducted and the property of the company has been disposed of, and of hearing any explanations that may be given by the liquidators.

R. MOORE,

E. M. HUGGARD,

Joint and Several Liquidators.

4860

Companies Act 1961.

S. T. BOWLES PTY. LTD. (IN VOLUNTARY LIQUIDATION).

NOTICE OF GENERAL MEETING OF SHAREHOLDERS,
PURSUANT TO SECTION 272.

NOTICE is hereby given that the Final Meeting of shareholders of the company will be held at the office of F. E. & K. W. Dixon, 23 McKillop-street, Melbourne, on Wednesday, 22nd July, 1970, at 12.30 p.m., for the purpose of receiving the liquidator's account, showing how the winding up has been conducted and the property of the company has been disposed of and giving any explanation thereof.

Dated this 11th day of June, 1970.

4819 K. W. DIXON, Liquidator.

THRUBA PROPRIETARY LIMITED.

SPECIAL RESOLUTION TO WIND UP, PURSUANT TO SECTION 254
OF THE COMPANIES ACT 1961.

AT an Extraordinary General Meeting of the above-named company, duly convened and held at the offices of A. H. G. Clarke & Co., 460 Bourke-street, Melbourne, on the 11th day of June, 1970, the following Resolution was duly passed as a Special Resolution:—

"That in accordance with the provisions of section 254 of the *Companies Act 1961*, the company be wound up voluntarily."

And at such last-mentioned meeting, Anthony Macavoy Locke, of 460 Bourke-street, Melbourne, was appointed liquidator for the purposes of the winding up.

Dated this 11th day of June, 1970.

4796 A. M. LOCKE, Liquidator.

Unclaimed Moneys Act 1962.

REGISTER of Unclaimed Moneys held by the—

Name of Owner on Books and Last Known Address.	Total Amount Due to Owner.	Description of Unclaimed Moneys.	Date when Amount first became Payable.
§			
GRAZCOS CO-OPERATIVE LIMITED.			
Lingard, C., 8 Swan-street, Gore, N.Z.	10.00	Shearing wages	9.5.67
Collins, N. R., P.O. Fingal, Tasmania	11.31	Workers' Compensation payment	16.11.67
Freeman, C., Pine-street, Hay, N.S.W.	10.00	Shearing wages	5.3.69
4777			
TWENTIETH CENTURY BUILDING AND INVESTMENT SOCIETY.—PERMANENT BRANCH.			
Davidson, P. & I., Dryburgh-street, North Melbourne	10.00	Dividend and Interest on 50 Shares	—10.68 —2.69
4789			
MOOROODUC CO-OPERATIVE TRADING SOCIETY (In Liquidation).			
Bailey, Geoffrey Gordon, 44 Hume Highway, Lavington, via Albury, N.S.W.	196.87	Distributions	31.7.69
Brown, Osmond Samuel, Tocumwal, N.S.W.	56.25	"	"
Thompson, M. (Mrs.), Stanfields, Red Hill	56.25	"	"
Walker, C. A. (Mrs.), 1 Stockdale-road, Bittern Park, W.A.	56.25	"	"
Young, Ivan Sinclair, Ambleside, Beleura Hill-road, Mornington	56.25	"	"
Ramsay, I. M. (Mrs.), Baxter	56.25	"	"
Smith, Donald McGregor, 40 Grey-street, St. Kilda	393.75	"	"
4744			

J. C. BRADBURY & SONS PROPRIETARY LIMITED.
SPECIAL RESOLUTION TO WIND UP, PURSUANT TO SECTION 254 OF THE COMPANIES ACT 1961.

AT an Extraordinary General Meeting of the above-named company, duly convened and held at the offices of A. H. G. Clarke & Co., 460 Bourke-street, Melbourne, on the 10th day of June, 1970, the following Resolution was duly passed as a Special Resolution:—

"That in accordance with the provisions of section 254 of the Companies Act 1961, the company be wound up voluntarily."

And at such last-mentioned meeting, Anthony Macavoy Locke, of 460 Bourke-street, Melbourne, was appointed liquidator for the purposes of the winding up.

Dated this 10th day of June, 1970.

4798 A. M. LOCKE, Liquidator.

BRADSHAW & ALLAN PROPRIETARY LIMITED.
NOTICE PURSUANT TO SECTION 254 (2) (b) OF THE COMPANIES ACT 1961.

Notice of Resolution.

AT an Extraordinary General Meeting of the members of Bradshaw & Allan Proprietary Limited, held on the 3rd day of June, 1970, a Special Resolution was passed that the company be wound up voluntarily, and that Neil George Raven, of 84 Jolimont-street, Jolimont, be appointed liquidator of the company.

Dated this 8th day of June, 1970.

4812 N. G. RAVEN, Liquidator.

MCPHERSON'S ENGINEERING TRAINING CENTRE.
(A COMPANY LIMITED BY GUARANTEE.)
(In Voluntary Liquidation.)

NOTICE is hereby given that an Extraordinary General Meeting of members of the above association will be held at the office of the liquidator, 360 Collins-street, Melbourne, on Monday, 20th July, 1970, at 2.30 p.m., for the purpose of laying before the meeting an account, showing how the winding up has been conducted and the property of the association has been disposed of, and of giving any explanation of the account.

4826 F. P. WARTON, Liquidator.

The Companies Act 1961.
SUPERMATIC FURNITURE DIVISION PTY. LTD.
(IN LIQUIDATION).

NOTICE is hereby given that a First Dividend is intended to be declared in the above matter. Creditors who have not proved their debts by the 30th day of June, 1970, may be excluded from this dividend.

Dated this 9th day of June, 1970.

G. O. HARRISON, Liquidator.
Hall & Rose, chartered accountants, 254 Queen-street, Melbourne. 4814

The Companies Act 1961, Pursuant to Section 260, Form 92.
NOTICE OF MEETING OF CREDITORS OF DOMINANT ELECTRICAL INDUSTRIES PTY. LTD.

Registered Office, 18 Manton-street, Huntingdale, Vic.

Companies Regulations.

Regulation 28 (2) (b).

NOTICE is hereby given that a meeting of the creditors of Dominant Electrical Industries Pty. Ltd., will be held at the Board Room of the Institute of Chartered Accountants in Australia, 23 McKillop-street, Melbourne, on Friday, 26th June, 1970, at 3.30 p.m.

Agenda:

1. To consider a Special Resolution passed by the above-named company for winding up and the appointment of Maxwell George Gee, a registered liquidator, as the liquidator of the company.

2. To consider a statement of the position of the company's affairs together with a list of creditors and the estimated amount of their claims.

3. To confirm the appointment of the liquidator for the purpose of winding up the affairs and distributing the assets of the company.

4. If thought fit, to appoint a committee of inspection.

5. To consider the persons and number thereof to be appointed as a committee of inspection.

6. To fix the remuneration of the liquidator.

NOTE.—No person will be entitled to vote as a creditor at the meeting unless he has lodged with the chairman of the meeting a proof of debt which he claims due to him from the company.

Dated 17th June, 1970.

R. J. STARK, Director.

Max Gee & Co., public accountants, 325 Warrigal-road, Burwood, 3125. Telephone 288 5911. 4834

The Companies Act 1961.—In the matter of MAYCOL FURNITURE MANUFACTURERS PROPRIETARY LIMITED (in Liquidation).

NOTICE is hereby given that at an Extraordinary Meeting of the members of the above-named company held on Wednesday, the 10th day of June, 1970, it was resolved that for such purpose Harold Keith Cartledge, of 1 Palmerston-crescent, South Melbourne, be appointed liquidator.

Notice is also given that after 21 days from this date I shall proceed to distribute the assets. All creditors having any claims against the company should furnish particulars of same by that date, otherwise I shall proceed to distribute the assets without regard to their claim.

Dated this 10th day of June, 1970.

H. K. CARTLEDGE, Liquidator.

Norman, Cartledge and Browne, chartered accountants, 1 Palmerston-crescent, South Melbourne, Vic. 3205. 4825

Companies Act 1961.

FOWLER REX (VIC.) PTY. LTD.
(IN VOLUNTARY LIQUIDATION).

NOTICE OF FINAL MEETING, PURSUANT TO SECTION 272.

NOTICE is hereby given, pursuant to section 272 of the Companies Act, that the Final General Meeting of the members of the above-named company will be held at the offices of Fell & Starkey, chartered accountants, 351 Collins-street, Melbourne, on the 3rd August, 1970, at 10 a.m., for the purpose of having an account laid before it showing the manner in which the winding up has been conducted and the property of the company disposed of and hearing any explanation that may be given by the liquidator.

Dated this 9th day of June, 1970.

4817

K. V. HARRISON, Liquidator.

Victorian Companies Act 1961, Notice of Final Meeting.—
In the matter of SCOBLE STAFF SERVICES PTY. LIMITED (in
Liquidation).

NOTICE is hereby given that a Final Meeting of creditors and members of the above company will be held on Friday, 17th July, 1970, at 2 p.m., at the offices of Marquand & Co., 1st Floor, 51 Queen-street, Melbourne, to receive the liquidator's account of the winding up and his report thereon.

Dated the 17th June, 1970.

L. P. SMART.

Marquand & Co., 51 Queen-street, Melbourne. 4828

The Companies Act 1961.—In the matter of RELIANCE
SAFETY PTY. LTD. (in Liquidation).

A SECOND and Final Dividend is intended to be declared in the above-mentioned matter. Creditors who have not proved their debts by the 2nd July, 1970, will be excluded from the dividend.

Dated this 11th day of June, 1970.

N. E. STRETTON, Liquidator.

Kennedy, Smail & Middlemiss, 296 Little Lonsdale-street,
Melbourne, Vic. 3000. 4829

The Companies Act 1961, Section 272.

THE REGENT ESTATES PTY. LTD. (IN VOLUNTARY
LIQUIDATION).INVESTORS REALTY PTY. LTD. (IN VOLUNTARY
LIQUIDATION).

NOTICE is hereby given that a Final Meeting of members of the above-named companies will be held at the offices of J. V. M. Wood & Co., chartered accountants, 346 Little Collins-street, Melbourne, on Tuesday the 21st July, 1970. The meeting of the first-named company will be held at 11 a.m., the latter at 11.10 a.m., for the purpose of receiving accounts showing how the winding up of each company has been conducted and the property of the companies disposed of.

Dated this 10th day of June, 1970.

V. G. H. HARRISON.
P. M. WOOD.

Liquidators of the above-named companies.

Care of J. V. M. Wood & Co., chartered accountants,
346 Little Collins-street, Melbourne, Vic. 3000. 4830

CREDITORS, next of kin, and others having claims against the estate of Florence Margaret Kenny, formerly of 16 Pine-grove, Malvern, in the State of Victoria, late of Ardrossan Private Hospital, 18 Hull-road, Croydon, in the State of Victoria, spinster, deceased (who died on the 18th November, 1969), are required by Joseph Hall Kenny of 114 Hull-road, Croydon, and Ina Elizabeth Johnstone, of 13 Leith-road, Montrose, the executors of the will of the said deceased to send particulars of their claims to the said executors, care of the under-mentioned solicitors, by the 20th August, 1970, after which date the executors will convey or distribute the estate of the said deceased, having regard only to the claims of which it then has notice.

MELVILLE & MELVILLE, solicitors, 224 Glenferrie-road,
Malvern. 4802

CREDITORS, next of kin and others having claims in respect of the estate of Otto Karl Dorfler, late of 57 Carnarvon-road, Strathmore, in the State of Victoria, retired, deceased (who died on the 19th day of April, 1969), are required by the executrix of the estate, Georgina Margaret Dorfler, of 10 Edgecombe-street, Hamlyn Heights, Geelong, to send particulars to N. C. Gay & Co., solicitors,

of 136 Sydney-road, Brunswick, by the 1st day of September, 1970, after which date the said executrix may distribute the assets having regard only to claims of which she then has notice.

N. C. GAY & CO., solicitors, 136-138 Sydney-road,
Brunswick. 4835

CREDITORS, next of kin and others having claims in respect of the estate of Arthur Frederick Russell, late of 30 Clifton-grove, Coburg, engineer, deceased (who died on the 5th day of November, 1969), are required to send particulars of their claims to the executrix, Maria Rita Russell, care of the under-mentioned solicitor, on or before the 17th day of August, 1970, on which date the executrix will distribute the estate, having regard only to the claims of which she then has notice.

B. T. E. FLYNN, LL.B., solicitor, 125 Bell-street, Coburg,
4856WILLIAM GEORGE HARDESS, late of 10 Doulton-road,
Blackburn, gentleman, DECEASED.

CREDITORS, next of kin and others having claims in respect of the estate of William George Hardess, deceased (who died on the 12th day of March, 1970), are to send particulars of their claims to The Trustees, Executors & Agency Co. Ltd., of 401 Collins-street, Melbourne, the executor appointed by the will of the said deceased, by the 25th day of August, after which date it will distribute the assets, having regard only to the claims of which it shall then have notice.

H. L. YUNCKEN & YUNCKEN, 443 Little Collins-street,
Melbourne. 4858

CREDITORS, next of kin and others having claims against the estate of Elijah Wynn, late of 10 Victoria-street, Elsternwick, gentleman, deceased (who died on 25th April, 1969), are required by the executors, Jonas Pushett, of 2 Labassa-grove, Caulfield, paper manufacturer, and Sylvia Super, of 374 Bourke-street, Melbourne, solicitor, to send particulars of such claims to them at the office of the undersigned solicitor, on or before the 28th August, 1970, after which date they will distribute the assets, having regard only to the claims of which they shall then have had notice.

SYLVIA ROTHSTADT, M.A. LL.B., barrister and solicitor,
374 Bourke-street, Melbourne. 4832

CREDITORS, next of kin and others having claims against the estate of Rose Wynn, late of 9 Monomeath-avenue, Toorak, married woman, deceased (who died on 14th January, 1967), are required by the executrices, Bertha Bella Tweg, of 11A Milton-street, Elwood, married woman, and Sylvia Super, of 374 Bourke-street, Melbourne, solicitor, to send particulars of such claims to them at the office of the undersigned solicitor, on or before the 28th August, 1970, after which date they will distribute the assets, having regard only to the claims of which they shall then have had notice.

SYLVIA ROTHSTADT, M.A. LL.B., barrister and solicitor,
374 Bourke-street, Melbourne. 4831JOHN GOWAN BARNABY, late of Learmonth, in the State
of Victoria, medical practitioner, DECEASED.

CREDITORS, next of kin and all other persons having claims against the estate of the said deceased, are required by the executors, Helen Mary Reid, married woman, and Ernest John Reid, farmer and grazier, both of Waubra, in the said State to send detailed particulars of their claims in respect of the said estate to the under-mentioned firm on or before the 24th day of August, 1970, after which date the executors will proceed to distribute the said estate, having regard only to the claims of which they then have notice.

Dated the 16th day of June, 1970.

RAMSAY, GAUNT & FRASER, solicitors, 41 Lydiard-
street south, Ballarat, 3350. 4838

CREDITORS, next of kin and other persons having claims against the estate of Eva May Bailey, late of 49 Stewart-avenue, Parkdale, in the State of Victoria, widow, deceased (who died on the 20th day of March, 1970), are required to send particulars of their claims to the executor, Frederick Laurence Nolen Bailey, care of the under-mentioned solicitors, by the 25th August, 1970, after which date the executor will distribute the assets, having regard only for the claims of which he then has notice.

JAMES P. OGG & CO., solicitors, of 165 Greville-street,
Pahran. 4859

LEO ALEXANDER GOULD FINCH, of 288 Deakin-avenue, Mildura, in the State of Victoria, grazier, DECEASED.

CREDITORS, next of kin and others having claims in respect of the estate of the deceased (who died on the 20th day of May, 1970), are required by the executor, Leo Ronald Finch, of "Sunnyside", via Balranald in the State of New South Wales, to send particulars, in writing, to him by the 20th day of August, 1970, after which date the executor may convey or distribute the assets, having regard only to the claims of which he then has notice.

ALEC M. HAYES, solicitor, 148 Campbell-street, Swan Hill. 4768

CREDITORS, next of kin and others having claims in respect of the estate of Leslie Thackray, late of 184 Princes Highway, Traralgon, service station proprietor, deceased (who died on the 16th January, 1970), are to send particulars of their claims to The Union-Fidelity Trustee Company of Australia Limited, of 100 Exhibition-street, Melbourne, by the 31st August, 1970, after which date it will distribute the assets of the deceased, having regard only to the claims of which it then has notice.

Dated the 8th June, 1970.

BRUCE, LITTLETON & HACKFORD, solicitors, Traralgon. 4773

HAROLD BERTIE NATHAN, late of 1027 Glenhuntly-road, South Caulfield, in the State of Victoria, pensioner, DECEASED.

CREDITORS, next of kin and others having claims in respect of the estate of the deceased (who died on the 11th day of March, 1970), are required by the trustee, John Don, of 24-26 Riddell-parade, Elsternwick, to send particulars to him by the 21st day of August, 1970, after which date the trustee may convey or distribute the assets, having regard only to the claims of which he then has notice.

JOHN DON & EDNEY, solicitors, 24-26 Riddell-parade, Elsternwick. 4774

AFTER fourteen days application will be made to the Supreme Court of Victoria, that probate of the will dated the 18th day of December, 1969, of Alexander Cordery Lawrence, late of 5 Ascot-street, Preston, in the State of Victoria, retired farmer, deceased, be granted to The Equity Trustees, Executors and Agency Company Limited, of 472 Bourke-street, Melbourne, in the said State, the sole executor named therein.

DAVID BRISTOL, LEVINE & CO., solicitors, of 549 Hampton-street, Hampton, Vic., 3188. 4791

CREDITORS, next of kin and others having claims in respect of the estate of Ella Celia Mitchell, late of 96 Neale-street, Bendigo, in the State of Victoria, married woman, deceased, intestate, are to send the particulars of their claims to National Trustees, Executors and Agency Company of Australasia Limited, of 46 Queen-street, Bendigo, by the 15th August, 1970, after which date it will distribute the assets, having regard only to the claims of which it then has notice.

Dated 10th day of June, 1970.

MACOBOY, TAYLOR & TAYLOR, solicitors, 32 View-street, Bendigo. 4782

CREDITORS, next of kin and others having claims in respect of the estate of Gilbert Victor Vaughan, late of 331 Park-street, North Carlton, in the State of Victoria, retired gentleman (who died on the 5th day of January, 1970), are required to send particulars of their claims to the administratrix, Hilda May Twomey, of Flat 4, 13 Jolley-street, West Brunswick, in the said State, widow, care of the under-mentioned solicitors, by the 27th day of August, 1970, after which date the administratrix may convey or distribute the assets, having regard only to the claims of which she then has had notice.

GODFREY AND GODFREY, solicitors, 358 Lonsdale-street, Melbourne. 4806

CREDITORS, next of kin and others having claims in respect of the estate of Ernest Leslie Carlton, late of 84 Dresden-street, West Heidelberg, in the State of Victoria, retired wood machinist, deceased (who died on the 21st January, 1970), are to send particulars of their claims to Royston T. Cahir and Martin, solicitors, 17 Queen-street, Melbourne, in the said State by the 18th day of August, 1970, after which date the executor will distribute the assets of the estate, having regard only to claims of which he then has notice.

ROYSTON T. CAHIR & MARTIN, solicitors, 17 Queen-street, Melbourne. 4804

CREDITORS, next of kin and others having claims in respect of the estate of Ruth Greig, late of 273 Alma-road, North Caulfield, widow, deceased (who died on the 22nd day of March, 1970), are to send particulars of their claims to the National Trustees, Executors and Agency Company of Australasia Limited, the registered office of which is situate at 95 Queen-street, Melbourne, by the 19th day of August, 1970, after which date it will distribute the assets, having regard only to the claims of which it then has notice.

R. P. BARRETT & SON, solicitors, 472 Bourke-street, Melbourne. 4807

CREDITORS, next of kin and others having claims in respect of the estate of Christina Ada Lucy O'Connor, late of 26 St. James-street, Moonee Ponds, cleaner, deceased (who died 28th March, 1970), are to send particulars of their claims to the administratrix, Catherine May Lees, care of the under-mentioned solicitors by the 20th August, 1970, after which date she will distribute the assets, having regard only to the claims of which she has notice.

O'BRIEN & GALANTE, solicitors, 44 Pascoe Vale-road, Moonee Ponds. 4849

CREDITORS, next of kin and others having claims in respect of the estate of Mary Marks, late of Flat 2, 26 Beach-avenue, Elwood, widow, deceased (who died on 2nd March, 1970), are to send particulars of their claims to National Trustees, Executors and Agency Company of Australasia Limited, of 95 Queen-street, Melbourne, the executors appointed by deceased's will by the 20th day of August, 1970, after which date it will distribute the assets, having regard only to the claims of which it then has notice.

O'BRIEN & GALANTE, solicitors, 44 Pascoe Vale-road, Moonee Ponds. 4848

CREDITORS, next of kin and others having claims in respect of the estate of George Cordery Gent, late of 11 Kendall-street, Elwood, in the State of Victoria, gentleman, deceased (who died on the 23rd day of February, 1970), and probate of whose will was granted to The Equity Trustees, Executors and Agency Company Limited, of 472 Bourke-street, Melbourne, in the said State on the 8th day of June, 1970, are hereby requested to send particulars of such claims to the said company at its address as above, on or before the 14th day of September, 1970, after which date the said Equity Trustees, Executors and Agency Company Limited will proceed to distribute the assets of the said deceased amongst the persons entitled thereto, having regard only to claims of which the said company shall then have had notice.

Dated this 10th day of June, 1970.

TUNNOCK CLARKE & CASEY, 452 Lonsdale-street, Melbourne. 4810

CREDITORS, next of kin and others having claims in respect of the estate of Ida Gladys Allen, late of Flat 6, 1492 Malvern-road, Glen Iris, spinster, deceased (who died on 6th January, 1970), are to send particulars of their claims to Alice Doreen Ryan, the proving executrix of the will of the said deceased, care of the under-mentioned solicitors by 1st September, 1970, after which date the said executrix will distribute the assets in the said estate, having regard only to the claims of which she then has notice.

ARTHUR ROBINSON & CO., solicitors, 447 Collins-street, Melbourne. 4820

CREDITORS, next of kin and others having claims in respect of the estate of Bartolo Iacono, late of 7 Wight-street, Kensington, greengrocer, deceased, intestate (who died on the 22nd day of November, 1969), are requested to send particulars of their claims to the administrator, Francesco Iacono, care of the under-mentioned solicitors by the 19th day of August, 1970, after which date he will distribute the assets, having regard only to the claims of which he then has notice.

MAHONY O'BRIEN & DUGGAN, solicitors, 37 Queen-street, Melbourne. 4821

CREDITORS, next of kin, and others having claims against the estate of Edward Victor Mulhall, formerly of Repatriation Hospital, Heidelberg, in the State of Victoria, late of 48 Ballast Point-road, Birchgrove, in the State of New South Wales (who died on the 8th February, 1970), are required by William Patrick Melville, of 224 Glenferrie-road, Malvern, solicitor, the executor of the will of the said deceased, to send particulars of their

claims to the said executor, care of the under-mentioned solicitors, by the 20th August, 1970, after which date the executor will convey or distribute the estate of the deceased, having regard only to the claims of which it then has notice.

MELVILLE & MELVILLE, solicitors, 224 Glenferrie-road, Malvern. 4803

CREDITORS, next of kin, and others having claims against the estate of Charles William Boyle, late of 279 Warrigal-road, Burwood, in the State of Victoria, plumber, deceased (who died on the 20th day of December, 1969), are required to send particulars of their claims to the executors, Barbara Ann Cleary and National Trustees Executors and Agency Company of Australasia Limited, care of the said company at its registered office which is situated at 95 Queen-street, Melbourne, before the 28th day of August, 1970, after which date the said executors will distribute the assets, having regard only to the claims of which they then have notice.

JOHN F. CARROLL, solicitor, 118 Queen-street, Melbourne. 4808

CREDITORS, next of kin, and others having claims against the estate of Edith Rose Alves, late of 40 Dean-street, Kew, in the State of Victoria, spinster, deceased (who died on the 17th day of April, 1970), are required to send particulars of their claims to the executrix Patricia Claire Patton, care of the undersigned solicitor, before the 28th day of August, 1970, after which date she will distribute the assets, having regard only to the claims of which she then has notice.

JOHN F. CARROLL, solicitor, 118 Queen-street, Melbourne. 4809

JOAN MACKERSEY TRAVERS, late of 40 Domain-street, South Yarra, widow, DECEASED.

CREDITORS, next of kin, and others having claims against the estate of the said deceased (who died on 13th December, 1968), are to send particulars of their claims to Ian Dejaridin Mackinnon, and Peter Mackenzie Young, care of 120 William-street, Melbourne, by the 21st day of August, 1970, after which date they will distribute the assets, having regard only to the claims of which they then have notice.

BLAKE & RIGGALL, solicitors, 120 William-street, Melbourne. 4822

WILLIAM UNDERWOOD, late of 92 Thompson-street, Williamstown, retired, DECEASED.

CREDITORS, next of kin, and others having claims against the estate of the said deceased (who died on 13th May, 1969), are to send particulars of their claims to Ian Dejaridin Mackinnon and Christopher David Turnbull, care of 120 William-street, Melbourne, by the 19th day of August, 1970, after which date they will distribute the assets, having regard only to the claims of which they then have notice.

BLAKE & RIGGALL, solicitors, 120 William-street, Melbourne. 4823

CREDITORS, next of kin, and others having claims against the estate of Hugh Henry Norman McClements, late of 7 McKenzie-street, East Doncaster, in the State of Victoria, optical dispenser, deceased (who died on the 24th day of February, 1970) should send particulars of their claims to the executor National Trustees Executors and Agency Company of Australia Limited, 95 Queen-street, Melbourne, by the 24th day of August, 1970, after which date the estate will be distributed, having regard only to the claims of which the executor then has notice.

PRENDERGAST & ROBINSON, PARKINSON & HART, solicitors, 406 Lonsdale-street, Melbourne. 4786

JOHN CURTIS TEMPLETON, late of 22 Hector-street, Hamilton, retired school teacher, DECEASED.

CREDITORS, next of kin and others having claims in respect of the estate of the deceased (who died on the 31st day of October, 1969), are required by the executors of the estate, John Robert Templeton, of 12 Skene-street, Hamilton, clerk, and Colin Ayten Templeton, of 9 Melrose-street, Newport, bank clerk, to send particulars to them, care of the under-mentioned solicitors, by the 19th August, 1970, after which date the executors may convey or distribute the assets, having regard to claims only of which they then have notice.

CAMERON & LOWENSTERN, solicitors, 62 Thompson-street, Hamilton. 4840

Trustee Act 1958.

NOTICE TO CLAIMANTS.

PURSUANT to the Trustee Act 1958, creditors, next of kin and all other persons having claims in respect of the estate of any deceased person named below are required to send particulars to the legal personal representative or representatives at the addresses stated, after which date the representative or representatives will distribute the assets, having regard only to the claims of which notice has been received:—

William Evans, late of 27 Norfolk-street, Maidstone, retired municipal employee, deceased, died on the 6th day of March, 1970.—Claims to the executrix, Audrey Evans, of 27 Norfolk-street, Maidstone, machinist, care of John F. Carroll, of 4 Paisley-street, Footscray, solicitor, by the 20th day of August, 1970. John F. Carroll, LL.B., solicitor, 4 Paisley-street, Footscray. 4841

EVELYN DORA GLASSON, late of 49 Jupiter-street, South Caulfield, spinster, DECEASED.

CREDITORS, next of kin and others having claims in respect of the estate of the deceased (who died on the 3rd February, 1970), are to send particulars of their claims to The Union-Fidelity Trustee Company of Australia Limited, of 100 Exhibition-street, Melbourne, by the 24th August 1970, after which date it will distribute the assets, having regard only to the claims of which it then has notice.

CORR & CORR, solicitors, 290 Latrobe-street, Melbourne. 4811

HILDA TOMS, late of 56 Rennie-street, Thornbury, widow, DECEASED.

CREDITORS, next of kin and others having claims in respect of the estate of the deceased (who died on the 25th day of January, 1970), are required to send particulars of their claims to National Trustees, Executors and Agency Company of Australasia Limited, of 95 Queen-street, Melbourne, before the 29th day of August, 1970, after which date it will distribute the assets, having regard only to the claims of which it then has notice.

F. P. & M. J. WALSH, solicitors, 452 High-street, Northcote. 4790

CREDITORS, next of kin and others having claims in respect of the estate of George Smithwick, late of 26 Bowen-street, Warragul, Victoria, formerly farmer, but lately land and station agent, deceased (who died on the 18th day of March, 1969), are required by the executrix of the estate, Joan Smithwick, of 26 Bowen-street, Warragul, to send particulars to N. C. Gay and Co., solicitors, of 136 Sydney-road, Brunswick, by the 1st day of September, 1970, after which date the said executrix may distribute the assets, having regard only to claims of which she then has notice.

N. C. GAY & CO., solicitors, 136-138 Sydney-road, Brunswick. 4839

CREDITORS, next of kin and others having claims in respect of the estate of Charles Hubert Wynn Kenrick, late of Wynn Hall, Penycæ, near Wrexham, Denbighshire, England, landowner, deceased (who died on the 26th day of August, 1969), are required by The Equity Trustees, Executors and Agency Company Limited, of 472 Bourke-street, Melbourne, to send particulars to it by the 26th day of August, 1970, after which date the said company may convey or distribute the assets, having regard only to the claims of which it then has notice.

LEACH & THOMSON, solicitors, 472 Bourke-street, Melbourne. 4843

CREDITORS, next of kin and others having claims in respect of the estate of William Henry Charles Smith, late of 240 Orrong-road, Toorak, retired warehouseman, deceased (who died on the 3rd day of March, 1970), are required by The Trustees, Executors and Agency Company Limited, of 401 Collins-street, Melbourne, to send particulars to it by the 26th day of August, 1970, after which date the said company may convey or distribute the assets, having regard only to the claims of which it then has notice.

LEACH & THOMSON, solicitors, 472 Bourke-street, Melbourne. 4842

In the Supreme Court of the State of Victoria.

SALE BY THE SHERIFF.

ON Friday, the 24th of July, 1970, at 10 a.m., at the Police Station, Cranbourne (unless process be stayed or satisfied):—

All the estate and interest (if any) of Economy Used Cars Proprietary Limited, a company, the registered office of which is situated at 9 Debbie-street, Mt. Waverley, as proprietor of an estate in fee-simple in the land described in certificate of title, volume 8275, folio 634, the land which is vacant, is known as lot 14, Damian-court, Cranbourne, has a frontage of 50 ft. 7 in., and commences at a point 650 feet north of Camms-road.

Terms: Cash only.

N. FROGLEY, Sheriff's Officer.

12th June, 1970. 4805

INSOLVENCY NOTICE

In the matter of the *Bankruptcy Act 1966*, and in the matter of FRIEDRICH RUDOLF LEEB (trading as F. R. Leeb and Associates).

AT a meeting of creditors held at the offices of Messrs. Berg, Coleman, Morris & Associates, of which due notice was given, the creditors present in person and by proxy, resolved that Friedrich Rudolf Leeb, be required to execute a deed of assignment in the form provided in the Fourth Schedule of the *Bankruptcy Act 1966*, and that Kenneth Albert Coleman, be appointed trustee of the deed.

In accordance with the provisions of section 218 (i) (a) (i) of the Act, notice is given herein that the debtor and the trustee executed the deed of assignment on Tuesday, 26th May, 1970.

Dated this 8th day of June, 1970.

K. A. COLEMAN, Trustee.

Berg, Coleman, Morris & Associates, 9th Floor, 325 Collins-street, Melbourne. 4818

IMPOUNDINGS

DIAMOND VALLEY.—Impounded in Yan Yean-road, Plenty Pound, on 6th June, 1970.

1 black gelding, 13 hands, shod, green rug, no visible brand

Impounded on 8th June, 1970.

1 black mare, 13 hands, 2 white socks, unshod, no visible brand

1 grey mare, 13 hands, unshod, no visible brand

1 chestnut gelding, 15 hands, 3 white socks, white blaze, shod, no visible brand

If not claimed and expenses paid, to be sold on 2nd July, 1970.

B. J. MORGAN,

4850—\$3.50 Shire Secretary.

DONALD.—Impounded in Donald Pound, from the Watchem-Warmur district.

1 Cheviot ram, 3 years, 2 notches in front of left ear, no visible brand

If not claimed and expenses paid, to be sold on 26th June, 1970.

W. A. CAMERON,

4783—\$2 Poundkeeper.

DROUIN.—Impounded in Drouin Pound, from Drouin-road, Longwarry, by Shire Ranger.

1 brown and white Jersey heifer, 12 months old, V out of tip of right ear

If not claimed and expenses paid, to be sold on 3rd July, 1970.

FRED P. JONES,

4800—\$2 Poundkeeper.

UPWEY.—Impounded in Upwey Pound, on 25th May, 1970, from Tremont.

1 sheep-ewe, no visible brand

Impounded on 29th May, 1970, from Upper Fern Tree Gully.

1 sheep-ram, no visible brand

If not claimed and expenses paid, to be sold on 30th June, 1970.

H. P. MEANEY,

4847—\$2.50 Poundkeeper.

Subordinate Legislation Act 1962.

NOTICE OF MAKING OF STATUTORY RULES.

IN pursuance of the provisions of the *Subordinate Legislation Act 1962* and the Regulations made thereunder, notice is given of the making of the following statutory rules:—

No.	Water Act 1958.	Price.
109/1970.	Local Water Authorities (Long Service Leave) Regulations 1970	10c
	<i>Sewerage Districts Act 1958.</i>	
110/1970.	Sewerage Authorities (Long Service Leave) Regulations 1970	10c
	<i>River Improvement Act 1958.</i>	
111/1970.	River Improvement and Drainage Trusts (Long Service Leave) Regulations 1970	10c
	<i>Country Fire Authority Act 1958.</i>	
112/1970.	Country Fire Authority (Loan No. 80) Regulations 1970	10c
	<i>Melbourne and Metropolitan Board of Works Act 1958.</i>	
113/1970.	Melbourne and Metropolitan Board of Works By-law No. 103 Relating to Standing Orders	10c
	<i>Victoria Institute of Colleges Act 1965.</i>	
114/1970.	Statute 8.1.2—Degree of Master of Pharmacy (Revision)	10c

Copies of these statutory rules may be purchased at the Sale of Publications Section of the Government Printing Office, located at Macarthur-street, Melbourne, 3002. If ordered by mail, remittance should be addressed to "The Government Printer, Box 203, P.O., North Melbourne, 3051", and should include 5c extra for postage. If a credit account is held at this office, no remittance is required with the mail order.

The annual subscription rate for Statutory Rules (including a Bound Volume) is \$15, payable in advance. The subscription year commences on 1st January.

C. H. RIXON,
Government Printer.

STATE ACTS, 1969

COPIES of the following Acts of Parliament of Victoria may be obtained at the Government Printing Office, Sale of Publications Branch, off Parliament-place, Melbourne, phone 63 0321, extension 6181, or from any accredited agent, at the price set opposite to each (these prices do not include postage).

The annual subscription for State Acts 1969 et seq. is \$8 payable in advance.

Bound Volumes of State Acts are also available on a subscription basis of \$15 per annum.

7786.	Summary Offences (Sunday Newspapers) ..	\$0.10
7787.	Town and Country Planning (Transitional Appeals)	\$0.10
7788.	Discharged Servicemen's Preference (Amendment)	\$0.10
7789.	Water (Amendment)	\$0.10
7790.	Agricultural Education Cadetships	\$0.10
7791.	Trustee (Amendment)	\$0.10
7792.	Appeal Costs Fund (Amendment)	\$0.10
7793.	Footscray (Lower Yarra Crossing Access Road) Land	\$0.10
7794.	River Improvement (Amendment)	\$0.15
7795.	Geelong Waterworks and Sewerage (Amendment)	\$0.15
7796.	West Moorabool Water Board (Amendment)	\$0.10
7797.	Sewerage Districts (Amendment)	\$0.15
7798.	Drought Relief (Amendment)	\$0.10
7799.	Legal Profession Practice (Amendment)	\$0.10
7800.	Parliamentary Salaries and Superannuation (Administration)	\$0.10
7801.	Protection of Animals (Penalties)	\$0.10
7802.	Lotteries Gaming and Betting (Calcutta Sweepstakes)	\$0.10
7803.	Belmont Common Recreation Ground Lands	\$0.10
7804.	Listening Devices	\$0.10
7805.	Coal Mines (Pensions)	\$0.10
7806.	Marine (Amendment)	\$0.10
7807.	Theatres (Amendment)	\$0.15
7808.	Victorian Inland Meat Authority (Amendment)	\$0.10

STATE ACTS 1969—continued.		STATE ACTS 1969—continued.	
No.	Price.	No.	Price.
7809.	The Constitution Act Amendment (Electoral)	7887.	Tobacco Leaf Industry Stabilization (Tobacco Quotas)
7810.	Consolidated Revenue	7888.	The Constitution Act Amendment (Standing Appropriations)
7811.	Gas and Fuel Corporation (Borrowing)	7889.	Legal Profession Practice
7812.	Weights and Measures (Amendment)	7890.	Navigable Waters (Oil Pollution) (Amendment)
7813.	Health (Municipal Charges)	7891.	Stamps (Mortgages)
7814.	Transfer of Land (Subdivision of Allotments)	7892.	State Forests Loan Application
7815.	St. Vincent's Private Hospital (Guarantees)	7893.	Melbourne and Metropolitan Board of Works (Amendment)
7816.	Strata Titles (Amendment)	7894.	Wheat Marketing
7817.	Sunday Entertainment (Evidence)	7895.	Revenue Deficits Funding
7818.	Dried Fruits (Packing Houses)	7896.	Land Tax (Rates)
7819.	Town and Country Planning (Further Amendment)	7897.	Probate Duty
7820.	Milk Board (Amendment)	7898.	Sale of Land (Amendment)
7821.	Medical (Pharmaceutical Chemists)	7899.	Racing (Trotting Racing)
7822.	Melbourne Wholesale Fruit and Vegetable Market (Amendment)	7900.	Crown Proceedings (Forfeited Recognisances)
7823.	Education (Director-General)	7901.	Weights and Measures (Fees)
7824.	Wombat Bonuses	7902.	Town and Country Planning (Compensation)
7825.	Revocation and Excision of Crown Reservations	7903.	Wheat Industry Stabilization (Amendment)
7826.	Mildura Irrigation and Water Trusts	7904.	Railway Loan Application
7827.	South Melbourne (Roman Catholic Orphanage) Lands	7905.	North Melbourne Lands (Loans to Lessees)
7828.	Racing (Amendment)	7906.	Theatres (Performance of Sacred Works)
7829.	Commercial Goods Vehicles (Tow Trucks)	7907.	Marketing of Primary Products (Amendment)
7830.	Stamps (Amendment)	7908.	Water Supply Loan Application
7831.	Gas and Fuel Corporation (Sale Undertaking)	7909.	Health (Amendment)
7832.	Melbourne (St. Kilda-road Underpass)	7910.	Superannuation (Amendment)
7833.	Trustee (Authorized Investments)	7911.	Friendly Societies (Amendment)
7834.	Consolidated Revenue	7912.	The Constitution Act Amendment (Conjoint Elections)
7835.	Local Government	7913.	Labour and Industry (Long Service Leave)
7836.	Melbourne Wholesale Fruit and Vegetable Market (Advisory Committee)	7914.	Public Service (Amendment)
7837.	Teaching Service (Amendment)	7915.	Motor Car (Traffic Offenders)
7838.	State Electricity Commission (Borrowing and Investing Powers)	7916.	Motor Car
7839.	Motor Car (Amendment)	7917.	Farm Produce Merchants and Commission Agents (Amendment)
7840.	Mines (Abolition of Courts)	7918.	Education (Army Apprentices School)
7841.	Manango (O'Shanessy River Watershed) Lands	7919.	Legal Aid
7842.	State Savings Bank (Amendment)	7920.	Educational Grants (Amendment)
7843.	Apprenticeship (Commission)	7921.	Crown Reservations (Revocation and Excision)
7844.	Swan Hill Race-course and Golf-course Lands	7922.	Firearms (Amendment)
7845.	Imitation Milk	7923.	Labour and Industry (Further Amendment)
7846.	Finance Brokers	7924.	Forests (Softwood Timber Agreement)
7847.	Local Government (Rating Exemptions)	7925.	Public Works Loan Application
7848.	Labour and Industry (Amendment)	7926.	Metropolitan Fire Brigades (Amendment)
7849.	Groundwater	7927.	Consolidated Revenue
7850.	Consolidated Revenue	7928.	National Parks (Amendment)
7851.	Mental Health (Chairmanship)	7929.	Railways (Offences)
7852.	Instruments (Bills of Exchange Amendment)	7930.	Tourist
7853.	Supreme Court (Correction of Sentences)	7931.	Country Roads (Amendment)
7854.	Summary Offences	7932.	Appropriation of Revenue
7855.	Church of England in Australia (Mount Shadwell Land)	7933.	Evidence (Boards and Commissions)
7856.	State Rivers and Water Supply Commission (Special Projects)	7934.	The Constitution Act Amendment
7857.	Coal Mines (Pensions Increase)	7935.	Coroners (Amendment)
7858.	Trustee Companies (Burns Philp Trustee Company Limited)	7936.	Town and Country Planning (Appeals Tribunal)
7859.	Latrobe Valley (Amendment)	7937.	Melbourne (Veterinary Schools) Lands
7860.	Maintenance (Amendment)	7938.	Board of Inquiry (Corrupt Practices)
7861.	Aboriginal Affairs (Amendment)	7939.	Cabrini Private Hospital (Guarantees)
7862.	Goods (Trade Descriptions)	7940.	Judges' Salaries and Allowances
7863.	Marine Stores and Old Metals (Amendment)	7941.	Instruments (Amendment)
7864.	Fire Authorities (Borrowing Powers)	7942.	La Trobe University (Amendment)
7865.	Acts Interpretation (Time)	7943.	Business Names (Amendment)
7866.	Narre Worrnan Lands	7944.	Acts Interpretation (Nationality)
7867.	Moorpanyal Lands	7945.	Dairy Products (Board Membership)
7868.	Juries (Amendment)	7946.	Melbourne Harbor Trust (Amendment)
7869.	Apprenticeship (Regulations)	7947.	Aboriginal Affairs (Amendment)
7870.	Portland Lands Exchange	7948.	River Murray Waters
7871.	Melbourne University (Property)	7949.	River Murray Waters (Dartmouth Reservoir)
7872.	Latrobe Valley (Lands for Ambulance Services)	7950.	Western Port (Steel Works)
7873.	Ministry of Transport (Director of Transport)	7951.	Extractive Industries (Licences)
7874.	Administration and Probate (Foreign Grants)	7952.	Stamps (Salary or Wages)
7875.	Road Traffic (Amendment)	7953.	Melbourne Lands Exchange
7876.	Justices (Amendment)	7954.	Public Officers Salaries and Allowances
7877.	Country Fire Authority (Amendment)	7955.	Ballarat (Sovereign Hill) Land
7878.	Coal Mines (Accidents Relief)	7956.	Wombat Bonuses
7879.	Preston School of Design and Free Library Land	7957.	Richmond and Hawthorn Lands
7880.	Lands Compensation (Costs and Expenses)	7958.	Solicitor-General (Pensions)
7881.	Evidence (Bankers' Books)	7959.	Australia and New Zealand Banking Group
7882.	Transport Regulation (Financial)	7960.	Mildura Irrigation and Water Trusts (Amendment)
7883.	Railways (Surplus Lands)	7961.	Land Settlement (Financial)
7884.	Abolition of Obsolete Offences		
7885.	Fire Brigades (Contributions)		
7886.	Gas		

C. H. RIXON,
Government Printer.

AGENTS FOR THE "VICTORIA GOVERNMENT GAZETTE".

THE following have been appointed agents to receive Advertisements and Subscriptions for the Victoria Government Gazette:—

- ARMSTRONG'S AGENCY, 205 Queen-street, Melbourne, Victoria 3000.
- ARNALL & JACKSON, 390 Barkly-street, Brunswick, Victoria 3056.
- BAIRNSDALE AUTHORIZED NEWSAGENCY, 132 Main-street, Bairnsdale, Victoria 3875.
- BICKNELL, M. J., Authorized Newsagent, 196 Timor-street, Warmambool, Victoria 3280.
- BLANE'S AUTHORIZED NEWSAGENTS, 162 Murray-street, Colac, Victoria 3250.
- CARTER, R. G., ADVERTISING SERVICE PTY. LTD., Suite 24, 65 Queens-road, Melbourne, Victoria 3004.
- DAVIES, G. & M. V., 112 Gray-street, Hamilton, Victoria 3300.
- DAVIS, WM. (MILDURA) PTY. LTD., 126 Eighth-street, Mildura, Victoria 3500.
- DIXON'S NEWSAGENCY, 89 Firebrace-street, Horsham, Victoria 3400.
- EDGARS' AUTHORIZED NEWSAGENCY, 45 Bridge-street, Benalla, Victoria 3672.
- FRANKS, H., & CO., 184 Ryrie-street, Geelong, Victoria 3220.
- GATLEY, A. & J., 250 Lonsdale-street, Dandenong, Victoria 3175.
- GORDON & GOTCH AUSTRALASIA LTD., 467 Collins-street, Melbourne, Victoria 3000.
- GULLAN'S NEWSAGENCY, 88 Bridge-street, Ballarat, Victoria 3350.
- HAMPTON, A. C., 243 Mitchell-street, Bendigo, Victoria 3550.
- HARSTON, PARTRIDGE & CO. PTY. LTD., 455 Little Collins-street, Melbourne, Victoria 3000.
- KYNETON GUARDIAN PTY. LTD., P.O. Box 18, Kyneton, Victoria 3444.
- LATIMER'S, Newsagents, 45 Station-street, Malvern, Victoria 3144.
- LIVINGSTON'S SHEPPARTON NEWSAGENCY, 246 Wyndham-street, Shepparton, Victoria 3630.
- THE MERCANTILE EXCHANGE, 34 Queen-street, Melbourne, Victoria, 3000.
- MCGILL'S AUTHORIZED NEWSAGENCY, 183-5 Elizabeth-street, Melbourne, Victoria 3000.
- PHILLIPS AUTHORIZED AGENCY, 83 Murphy-street, Wangaratta, Victoria 3677.
- POWNEYS AUTHORIZED NEWSAGENCY, 293 Hargreaves-street, Bendigo, Victoria 3550.
- PURDIE, J., & CO., 138 Moorabool-street, Geelong, Victoria 3220.
- SALE AUTHORIZED NEWSAGENCY, 142 Raymond-street, Sale, Victoria 3850.
- SKINNER'S AUTHORIZED NEWSAGENCY, 49-51 Franklin-street, Traralgon, Victoria 3844.
- STEVENSON, A. C. & M., NEWSAGENTS, 132 Henty-street, Casterton, Victoria 3311.
- VERNONS OF RICHMOND, 162 Bridge-road, Richmond, Victoria 3121.
- VIEW POINT AUTHORIZED NEWSAGENCY, 4 View-Point, Bendigo, Victoria 3550.

A copy of the Gazette filed at each place for public reference.

THE "VICTORIA GOVERNMENT GAZETTE".

SUBSCRIPTIONS.—The subscription, including postage, is \$10 per annum, or \$5 per half year, payable in advance.

Subscriptions are required for whole months, and must cover at least a half year.

Single copies are 20 cents, posted 25 cents. Subscribers do not receive the Acts of Parliament with the GAZETTE.

GAZETTES are held in stock for five years only.

PRIVATE ADVERTISEMENTS.—The charge for insertion is 25 cents per line single column, and 50 cents per line double column. The title forms one or more lines as a heading. On an average ten words make a line of single column. Every signature must likewise be counted as a line. The final words of a paragraph, though only portion of a line, must be counted as one line. Signatures (in particular) and proper names must be written very plainly in the text; ONE SIDE ONLY of each sheet of paper should be WRITTEN UPON.

All documents illegibly written will be returned unpublished, and where brands occur unprovided for by the ordinary letters of the alphabet, a worded explanatory description must be furnished.

THE VICTORIA GOVERNMENT GAZETTE is published on WEDNESDAY EVENING in each week, and Notices for insertion will be received by the Government Printer at or before ONE p.m. at ordinary rates, and late advertisements between ONE p.m. and FOUR p.m. at double rates on the day preceding the day of publication.

PAYMENTS.—Unless the advertiser has a credit account, all payments are required in advance. Remittances should be made by cheque, postal order, or money order payable to "GOVERNMENT PRINTER".

ADDRESS.—All communications should be addressed to "The Government Printer, Box 203, P.O., North Melbourne". 3051.

PUBLICATION OF OFFICIAL MATTER.

ATTENTION is invited to the following procedure in relation to the publication of official matter in the Government Gazette:—

Publication will be facilitated by the submission of carbon copies for the use of the Gazette Officer.

1. Matter submitted to the Executive Council.

Matter submitted to the Executive Council which requires gazettal will normally be published in the issue of the following week.

Where urgent gazettal is required, special arrangements should be made with the Gazette Officer, Room 9, first floor, Old Treasury Building.

2. Other matter.

(a) All other matter duly certified by a responsible officer for publication should be lodged with the Gazette Officer not later than half-past Nine a.m. on Tuesday.

(b) Lengthy or involved notices should be forwarded several days before publication.

(c) Proofs, which will be supplied only when specifically requested or at the direction of the Gazette Officer, should be returned promptly to avoid delay in publication.

(d) No additions or amendments to matter for publication will be accepted by telephone.

CONTENTS

	PAGE
Acts of Parliament on Sale at the Government Printing Office	2098
Appointments	2068
Cemeteries—Scale of Fees	2067
Contracts	2068
Government Notices	2061
Impoundings	2098
Insolvency Notice	2098
Lands	2080
Mining	2061
Notice to Mariners	2068
Notice of Making of Statutory Rules	2098
Orders in Council—	
Acts—Local Government; The Constitution Act Amendment; Country Roads; Land; Local Government; Cemeteries; Country Fire Authority; Melbourne and Metropolitan Tramways; Water; Sewerage Districts.	2070 et seq
Police Sale	2061
Private Advertisements	2087
Proclamations	2058
Public Service Notices	2083
Queen's Birthday Honours	2057
Resignations	2069
State Rivers and Water Supply Commission	2066
Tenders	2083
Transport Regulation Board—Public Hearings	2064