

[3671]



VICTORIA

GOVERNMENT GAZETTE

Published by Authority

No. 104]

WEDNESDAY, NOVEMBER 24

[1971

**PUBLICATION OF THE "VICTORIA
GOVERNMENT GAZETTE".**

Christmas and New Year Holidays.

**Because of the Christmas and New Year
Holidays, the last issue of the Victoria Government
Gazette for 1971 will be published on
Wednesday, the 22nd December,
1971.**

**All official matter for publication therein
should be lodged with the Gazette Officer, Chief
Secretary's Department (Telephone Extension
6282), not later than 9.30 a.m. on
Tuesday, the 21st December, 1971.**

**The next Gazette, the first for 1972, will be
published on Friday, the 7th January, 1972,
and thereafter on each Wednesday, as usual.**

**C. H. RIXON,
Government Printer.**

PROCLAMATIONS

Land Act 1958, Section 25.
ROAD PROCLAIMED.

PROCLAMATION

By His Excellency the Governor of the State of Victoria and its Dependencies in the Commonwealth of Australia, &c., &c., &c.

In pursuance of the provisions of Section 25 (3) (c) of the Land Act 1958, I, the Governor of the State of Victoria, by and with the advice of the Executive Council of the said State, do hereby, proclaim as a road the land in the Parish of Wa-de-lock, County of Tanjil, as indicated by hatching on plan hereunder.—(W.89⁽¹⁴⁾) (H.034328).

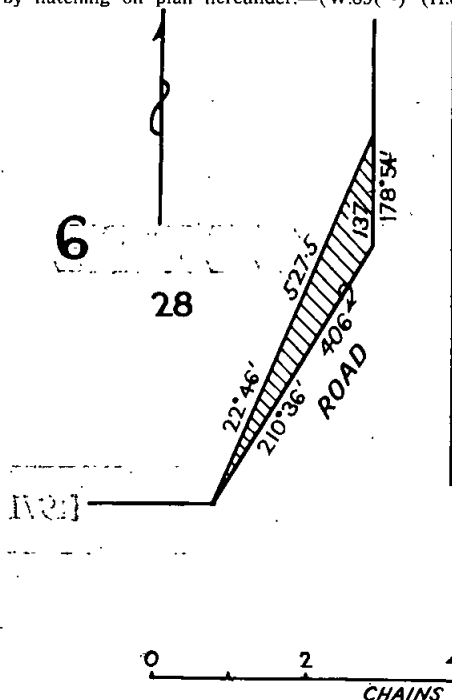

Given under my Hand and the Seal of the State of Victoria aforesaid, at Melbourne, this sixteenth day of November, in the year of our Lord One thousand nine hundred and seventy-one, and in the twentieth year of the reign of Her Majesty Queen Elizabeth II.

(L.S.) ROHAN DELACOMBE.

By His Excellency's Command,
W. BORTHWICK,
Minister of Lands.

GOD SAVE THE QUEEN!

ACTS OF PARLIAMENT.

PROCLAMATION

By His Excellency the Governor of the State of Victoria and its Dependencies in the Commonwealth of Australia, &c., &c., &c.

I, the Governor of the State of Victoria, in the Commonwealth of Australia, do hereby declare that I have this day assented, in Her Majesty's name, to the Bills passed by the Parliament of the said State, the titles whereof are hereunder set forth, together with the short titles, that is to say:—

- No. 8167. "An Act to declare the Rates of Land Tax for the Year ending on the 31st Day of December, 1972, and for other purposes." (*Land Tax Act 1971.*)
- No. 8168. "An Act relating to Policies of Accident Insurance in respect of Members of certain Authorities." (*Water Authorities Accident Insurance Act 1971.*)

- No. 8169. "An Act to increase the Maximum Amount relating to Special Advances under the *Building Societies Act 1958.*" (*Building Societies (Special Advances) Act 1971.*)
- No. 8170. "An Act to amend the Rate of Compensation of Jurors and the Fees for Civil Juries under the *Juries Act 1967.*" (*Juries (Compensation) Act 1971.*)
- No. 8171. "An Act to amend Part III. of the *Coal Mines Act 1958.*" (*Coal Mines (Pensions Increase) Act 1971.*)
- No. 8172. "An Act to amend Section Fourteen of the *Exhibition Act 1957.*" (*Exhibition (Borrowing Powers) Act 1971.*)
- No. 8173. "An Act to amend Section 5 of the *Sunday Entertainment Act 1967.*" (*Sunday Entertainment (Cinematograph Films) Act 1971.*)
- No. 8174. "An Act to amend the *Apprenticeship Act 1958* and to repeal certain Provisions of the *Employers and Employes Act 1958.*" (*Apprenticeship (Amendment) Act 1971.*)

Given under my Hand and the Seal of the State of Victoria aforesaid, at Melbourne, this sixteenth day of November, in the year of our Lord One thousand nine hundred and seventy-one, and in the twentieth year of the reign of Her Majesty Queen Elizabeth II.

(L.S.) ROHAN DELACOMBE.

By His Excellency's Command,
HENRY BOLTE,
Premier.

GOD SAVE THE QUEEN!

MENTAL HEALTH ACT 1959.

PROCLAMATION

By His Excellency the Governor of the State of Victoria and its Dependencies in the Commonwealth of Australia, &c., &c., &c.

Whereas by sub-section (1) of Section 24 of the *Mental Health Act 1959*, it is provided that the Governor in Council may by Proclamation published in the *Government Gazette* proclaim one or more buildings or places provided by the State for the treatment of the mentally ill or the intellectually defective or any part of such building or place to be—

- (a) a psychiatric hospital;
- (b) a mental hospital;
- (c) a training centre; or
- (d) a repatriation mental hospital;

And whereas by sub-section (2) of Section 24 it is provided that any proclamation made under Section 24 may at any time be varied or revoked by proclamation of the Governor in Council;

And whereas by a Proclamation of the Governor in Council made pursuant to sub-section (1) of Section 24 of the *Mental Health Act 1959*, and dated the seventeenth day of May, 1966, and published in the *Government Gazette* of the twenty-fifth day of May, 1966, the whole of the area in the Parish of Keelbundora, County of Bourke, indicated by hachure on the plan attached to the said Proclamation dated the seventeenth day of May 1966, was proclaimed as a mental hospital known as the Mental Hospital Mont Park;

And whereas the Mental Health Authority now desires that a certain building at present forming part of the Mental Hospital Mont Park and known as Ward F12 shall become a Psychiatric Hospital to be known as the Mont Park Psychiatric Hospital;

Now therefore, I, the Governor of the State of Victoria, in the Commonwealth of Australia, by and with the advice of the Executive Council of the said State, do by this my Proclamation—

- (a) revoke as from the first day of December, 1971 the proclamation constituting the Mental Hospital Mont Park so far as it relates to the building known as Ward F12; and
- (b) proclaim as from the first day of December, 1971, the afore-mentioned building known as Ward F12 to be a psychiatric hospital known as the Mont Park Psychiatric Hospital.

Given under my Hand and the Seal of the State of Victoria aforesaid, at Melbourne, this sixteenth day of November, in the year of our Lord One thousand nine hundred and seventy-one, and in the twentieth year of the reign of Her Majesty Queen Elizabeth II.

(L.S.) ROHAN DELACOMBE.

By His Excellency's Command,
J. F. ROSSITER,
Minister of Health.

GOD SAVE THE QUEEN!

MELBOURNE AND METROPOLITAN BOARD OF WORKS (AMENDMENT) ACT 1971, No. 8164.

DAY OF COMING INTO OPERATION.

PROCLAMATION

By His Excellency the Governor of the State of Victoria and its Dependencies in the Commonwealth of Australia, &c., &c., &c.

Pursuant to the provisions of the *Melbourne and Metropolitan Board of Works (Amendment) Act 1971, I*, the Governor of the State of Victoria, by and with the advice of the Executive Council thereof, do by this my Proclamation fix the 24th November, 1971 as the day on which the provisions of the said Act shall come into operation.

Given under my Hand and the Seal of the State of Victoria aforesaid, at Melbourne, this sixteenth day of November, in the year of our Lord One thousand nine hundred and seventy-one, and in the twentieth year of the reign of Her Majesty Queen Elizabeth II.

(L.S.) ROHAN DELACOMBE.

By His Excellency's Command,
A. J. HUNT,
Minister for Local Government.

GOD SAVE THE QUEEN!

GOVERNMENT NOTICES

BANNOCKBURN DISTRICT WATERWORKS TRUST.

AUTHORITY TO OBTAIN BANK OVERDRAFT.

His Excellency the Governor of the State of Victoria, by and with the advice of the Executive Council thereof, doth by Order made on the 23rd day of November, 1971, authorize the Bannockburn District Waterworks Trust to obtain during the year 1972, in pursuance of the provisions of section 286 of the *Water Act 1958 (No. 6413)*, an advance or advances by overdraft of the Trust's current account, the amount owing in respect of such overdraft not to exceed at any one time the sum of Four thousand dollars (\$4,000).

J. ROSSITER,
Clerk of the Executive Council.

At the Executive Council Chamber,
Melbourne, 23rd November, 1971.

PETERBOROUGH WATERWORKS TRUST.

AUTHORITY TO OBTAIN BANK OVERDRAFT.

His Excellency the Governor of the State of Victoria, by and with the advice of the Executive Council thereof, doth by Order made on the 23rd day of November, 1971, authorize the Peterborough Waterworks Trust to obtain during the year ending 30th September, 1972, in pursuance of the provisions of section 286 of the *Water Act 1958 (No. 6413)*, an advance or advances by overdraft of the Trust's current account, the amount owing in respect of such overdraft not to exceed at any one time the sum of One thousand dollars (\$1,000).

J. ROSSITER,
Clerk of the Executive Council.

At the Executive Council Chamber,
Melbourne, 23rd November, 1971.

KYABRAM BOROUGH COUNCIL.

AUTHORITY TO OBTAIN BANK OVERDRAFT.

His Excellency the Governor of the State of Victoria, by and with the advice of the Executive Council thereof, doth by Order made on the 23rd day of November, 1971, authorize the Kyabram Borough Council to obtain during the year ending 30th September, 1972, in pursuance of the

provisions of section 286 of the *Water Act 1958 (No. 6413)*, an advance or advances by overdraft of the Council's current account, the amount owing in respect of such overdraft not to exceed at any one time the sum of Twenty thousand dollars (\$20,000).

J. ROSSITER,
Clerk of the Executive Council.

At the Executive Council Chamber,
Melbourne, 23rd November, 1971.

Notice.

Pipelines Act 1967, No. 7541.

MINISTRY OF FUEL AND POWER.

APPLICATION FOR A PERMIT TO OWN AND USE A PIPELINE.

1. In accordance with the provisions of section 11 (1) of the *Pipelines Act 1967*, notice is given that an application has been received by me from the Gas and Fuel Corporation of Victoria for a permit to own and use a pipeline for the purpose of conveying natural gas from Croydon to Mooroolbark.

2. The proposed route of the pipeline is as follows:— a steel pipeline 2.3 miles long with an internal diameter of 10 inches and designed to operate at a maximum pressure of 400 p.s.i.g., commencing at the junction of Yarra-road and Plymouth-road, Croydon and proceeding in an east-south-easterly direction along the northern side of Yarra-road to the Maroondah Highway; thence turning to enter and continue in a generally north-easterly direction along the western side of such highway to a point approximately 25 feet east of the junction of Warrien-road and the Maroondah Highway; thence turning in a south-easterly direction to cross such highway to enter Lincoln-road and continue in a generally easterly direction along the northern side of such road to Dorset-road; thence crossing such road to enter Victorian Railways' property containing the Melbourne to Lilydale rail line and continue in a north-easterly direction along the northern side of such property for approximately 150 feet; thence turning in a south-south-easterly direction to cross the rail line and re-enter Lincoln-road; thence deviating to continue in an easterly direction along the northern side of such road to a point opposite Lionel-crescent; thence turning to cross Lincoln-road to the southern side of such road; thence turning to continue in an easterly direction along the southern side of Lincoln-road to terminate at a valve situated at the western corner of such road and Paul-street, Mooroolbark.

The proposed route of the pipeline is located along public highways and contained wholly within the City of Croydon.

3. Plans of the proposed route of the pipeline may be inspected, commencing Monday, 22nd November, 1971, between the hours of 10.00 a.m. and 4.00 p.m. on Mondays to Fridays (excluding public holidays) at—

- (a) Ministry of Fuel and Power, 15th Floor, 171 Flinders-street, Melbourne.
- (b) Plan Room, Gas and Fuel Corporation of Victoria, 8th Floor, 171 Flinders-street, Melbourne.
- (c) Municipal Offices at Croydon.

Additional copies of plans are not available and detailed route plans can be seen only at the Gas and Fuel Corporation's Plan Room, Melbourne.

4. Any objections to the proposed route of the pipeline must be addressed to me and reach the Office of the Ministry no later than Friday, 31st December, 1971.

22nd November, 1971.

J. C. M. BALFOUR,
Minister for Fuel and Power.

Social Welfare Act 1970.

SOCIAL WELFARE TRAINING COUNCIL.

In pursuance of the powers conferred by the *Social Welfare Act 1970*, I do hereby appoint—

STANLEY JOHNSTON

to be Chairman of the Social Welfare Training Council for the term of twelve months commencing on the twenty-first day of November, 1971.

IAN SMITH,
Minister for Social Welfare.

Office of the Minister for Social Welfare,
Melbourne, 15th November, 1971.

Transport Regulation Act.
TRANSPORT REGULATION BOARD.

HEARING OF APPLICATIONS.

Notice is hereby given that the following applications will be considered by the Transport Regulation Board at its offices at the corner of Lygon and Princes streets, Carlton, at 10.15 a.m. on Wednesday, 15th December, 1971.

FARTHING, V. T., Barry-street, Nathalia. One commercial passenger vehicle (S/C. 18) to operate between Nathalia and Shepparton via Waaia.

Fares.

\$1.00 return per day (weekly).
\$1.50 day return.
\$1.00 single.

TIME-TABLE.

Depart Nathalia 8.00 a.m.
Depart Shepparton 5.50 p.m.

VENTURA MOTORS PTY. LTD., 1037 Centre-road, South Oakleigh. Application for variation of licence conditions on Route 743 (Glen Waverley-Wheelers Hill via Lum-road) to delete that part of the route between the Glen Waverley Railway Station and the corner of Wilson and Gallaghers roads and from the corner of Waverley and Gallaghers roads to the corner of Jells and Ferntree Gully roads and instead operate from the Glen Waverley Railway Station via Glen-road, The Outlook, Townsend-street and Gallaghers-road to the corner of Gallaghers and Waverley roads.

WEDGE, D. E., 94 Victoria-street, Cobden. One commercial passenger vehicle with large seating capacity to operate as a country stage omnibus under the same terms and conditions as existing "C.O." licences held by the applicant company.

YOUNG, L. G., 11 York-street, Mont Albert. One commercial passenger vehicle with large seating capacity to operate as an additional metropolitan special service omnibus.

NORTH SUNSHINE BUS SERVICE PTY. LTD., 7 Hall-street, Yarraville. One commercial passenger vehicle with large seating capacity to operate as a metropolitan stage omnibus on Route 416 (Sunshine-Sunshine North).

CROYDON BUS SERVICE PTY. LTD., P.O. Box 95, Croydon. Application for variation of permit No. 2291 (i) part (b) 3 to operate from Warrandyte via Yarra-street, Warrandyte, Tindals, Old Warrandyte, Mitcham and Doncaster East roads, Maroondah Highway, Deep Creek, Loughnans, Wonga and Oban roads, Maroondah Highway and Kalinda-road. The route presently operates from the corner of Springvale and Mitcham roads via Mitcham, Old Warrandyte, Tindals and Warrandyte roads, Yarra-street, Warrandyte, Ringwood, Croydon, Wonga, Warranwood and Plymouth roads. (ii) part (b) 4 to operate from the corner of Blackburn and Doncaster roads via Blackburn-road, King-street, Tuckers and Serpells roads, Anderson and Porter streets, Newmans and Warrandyte roads, Yarra-street, Warrandyte, Ringwood, Falconer, Knees, Park, Beringa, Milne, Warrandyte, Ringwood, Warrandyte and Oban roads, Maroondah Highway and Kalinda-road. The route presently operates as above to the corner of Warrandyte, Ringwood and Croydon roads; thence via Croydon, Wonga, Warranwood and Plymouth roads. Both routes serve Yarra Valley Church of England Grammar School, Luther College and Tintern Church of England Girls' Grammar School.

Application for renewal of licences as shown, by persons listed hereunder to operate under the same terms and conditions.

ANSETT TRANSPORT INDUSTRIES (OPERATIONS) PTY. LTD. (trading as Ansett Motors), 21 Gray-street, Hamilton; C.O.71, C.O.261, C.O.385, C.O.412, C.O.924, C.O.1122, C.O.1123, C.O.1126, C.O.1133, C.O.1134, C.O.1136, C.O.1138, C.O.1140, C.O.1144, T.S.1107, T.S.1108, T.S.1109, T.S.1110, T.S.1111, T.S.1112, T.S.1113, T.S.1114, T.S.1115, T.S.1116, T.S.1117, T.S.1118.

BULUMWAAL TIMBER & TRADING CO. PTY. LTD., Bulumwaal via Bairnsdale; T.P.234.

MCFEAN, J. A., 44 Corinella-street, Bell Post Hill, Geelong; T.S.406.

QANTAS AIRWAYS LTD., Beach-road, Avalon; T.P.97, T.P.204.
MADAM, THELMA M., Gray-street, Maldon; T.P.161.

SCHEIDT, W. J. F. & M. M., Woodend-road, Lancefield; C.O.33, C.O.691, C.O.778, C.O.779.

WARRNAMBOOL BUS LINES PTY. LTD., 273 Raglan-parade, Warrnambool; C.O.26, C.O.84, C.O.178, C.O.495, C.O.496, C.O.498, C.O.501, C.O.504, C.O.507, C.O.771, C.O.946, C.O.1099, T.S.1121, T.S.1122, T.S.1123, T.S.1124, T.S.1125, T.S.1126, T.S.1127, T.S.1128, T.S.1129, T.S.1130, T.S.1131, T.S.1132, T.S.1133, T.S.1134, T.S.1135, T.S.1136, T.S.1137, T.S.1138, T.S.1139, T.S.1140, T.S.1141, T.S.1142, T.S.1143, T.S.1144, T.S.1145, T.S.1146, T.S.1244.

Notice of any objection should be forwarded to reach the Secretary of the Board not later than Wednesday, 8th December, 1971.

Applicants are advised that it will not be necessary to appear on the hearing date specified above, unless advised in writing by the Board.

B. P. KAY,
Secretary.

Corner Lygon and Princes streets, Carlton, Wednesday, 24th November, 1971.

Commercial Goods Vehicles Act.
TRANSPORT REGULATION BOARD.

HEARING OF APPLICATIONS.

Notice is hereby given that the following applications will be considered by the Transport Regulation Board at its offices at the corner of Lygon and Princes streets, Carlton, at 10.15 a.m., on Wednesday, 15th December, 1971.

AESLOP ELECTRICS PTY. LTD., Main-street, Stawell, 3380. One commercial goods vehicle (L/C. 13 cwt.) to operate within a 70-mile radius of the post office at Stawell in course of business as "Electrical Retailer"—tools of trade, equipment, new electrical goods and household appliances for delivery and installation, electrical goods for repair or having been repaired.

NOTE.—All electrical goods and household appliances to have been initially consigned by rail to Stawell.

ATKINS, A. C. (trading as A. C. & S. M. Atkins), Dingee, 3571. One commercial goods vehicle (L/C. 14 cwt.) to operate: (a) Within a 50-mile radius from own premises at Dingee in the course of business as "General Storekeeper"—own goods. (b) Within a 20-mile radius from own premises at Dingee—petroleum products in drums and empty return drums solely on behalf of B.P. Australia Ltd. (c) Within a 20-mile radius from the post office at Dingee—mail and parcels on behalf of the Postmaster-General's Department.

BAIRD, F. H. (trading as F. H. Baird & Co.), 75 Bruce-street, Colac, 3250. One commercial goods vehicle (L/C. 20 cwt.) to operate: (a) Within a 50-mile radius of own premises in the City of Colac in the course of business as "Wholesale Suppliers of Food Trade Equipment"—own goods. (b) From own premises in the City of Colac to places situated within a 25-mile radius of the G.P.O., Melbourne—own goods, viz.: paper and polythene wrapping and bags, knives, protective clothing, spices, seasoned sausage meals, sausage casings, saws, saw blades, twines, tubs, buckets, trays, benches, cutting boards and blocks and incidental machinery and equipment for the food trade for display to prospective purchasers with the ability to make a delivery of such goods, and unsold stock on the return journey subject to the condition all goods so carried shall only be those having been initially consigned by rail to the Colac Railway Station.

BALLE, J. L. & E. D., Loch Valley-road, Noojee, 3833. Application to vary the conditions of licence No. D.A.63633 (L/C. 223 cwt.) by deleting the existing conditions and adding in lieu—"Within a 50-mile radius of own premises at Noojee and to and from places within a 25-mile radius of Melbourne in the course of business as 'Earth-moving Contractor'—own earth-moving equipment".

BUSINESS EQUIPMENT HOLDINGS PTY. LTD., 408 Latrobe-street, Melbourne, 3000. One commercial goods vehicle (L/C. 13 cwt.) to operate throughout the State of Victoria as a Service Unit in the course of business as "Office Equipment Retailers"—tools of trade and spare parts incidental to servicing machines on site with the ability to carry up to six (6) second-hand machines for temporary replacement purposes and/or for repair or having been repaired.

CARLTON & UNITED BREWERIES LTD., 16 Bouverie-street, Carlton, 3053. One commercial goods vehicle (L/C. 155 cwt.) to operate: (a) Within a 25-mile radius of own premises at East Melbourne in the course of business as "Brewers"—own goods. (b) Within a 50-mile radius of own premises at East Melbourne—own beer and empty return containers.

NOTE.—Operations under paragraph (b) to be undertaken only on Saturdays or Public Holidays.

CARLTON & UNITED BREWERIES LTD., 16 Bouverie-street, Carlton, 3053. One commercial goods vehicle (L/C. 150 cwt.) to operate: (a) Within a 25-mile radius of own premises at Carlton in the course of business as "Brewers"—own goods. (b) Within a 50-mile radius of own premises at Carlton—own beer and empty return containers.

NOTE.—Operations under paragraph (b) to be undertaken only on Saturdays or Public Holidays.

CARLTON & UNITED BREWERIES LTD., 16 Bouverie-street, Carlton, 3053. One commercial goods vehicle (L/C. 152 cwt.) to operate: (a) Within a 25-mile radius of own premises at Abbotsford in the course of business as "Brewers"—own goods. (b) Within a 50-mile radius of own premises at Abbotsford—own beer and empty return containers.

NOTE.—Operations under paragraph (b) to be undertaken only on Saturdays or Public Holidays.

COCA COLA OPERATIONS PTY. LTD., Levanswell-road, Moorabbin, 3189. Eleven commercial goods vehicles (L/C. 144, 151, 152, 149, 143, 143, 143, 143, 143 and 143 cwt.) to operate within a 50-mile radius of the post office at the corner of Bourke and Elizabeth streets, Melbourne, in the course of business as "Aerated Water Manufacturers"—own aerated waters and empty return containers.

COLONIAL GAS ASSOCIATION LTD., THE, 107 Murphy-street, Wangaratta, 3677. One commercial goods vehicle (L/C. 12 cwt.) to operate within the area north of an east/west line drawn through the Township of Seymour and east of a north/south line drawn through Shepparton in the course of business as "Gas Manufacturers" for the purpose of servicing and installing gas appliances—tools of trade, spare parts and gas fittings.

NOTE.—All parts to be initially consigned by rail to Wangaratta.

DE IESI, F., Box 229, Block 67B, Robinvale, 3549. One commercial goods vehicle (L/C. 59 cwt.) to operate throughout that part of the State of Victoria west of a north/south line drawn through Melbourne in course of business as "Drapery Hawker"—own goods subject to the conditions that any goods so carried shall not be supplied to retail stores for resale.

GAMMALDI, V., 20 Normdale-road, East Bentleigh, 3165. One commercial goods vehicle (L/C. 182 cwt.) to operate within a 50-mile radius of the plant of Pronto Mixed Concrete Co. Pty. Ltd. at Footscray as a specially constructed agitator vehicle—premixed concrete.

HUTCHINSON, ROBERT, LTD., Hartington-street, Glenroy, 3046. Three commercial goods vehicles (L/C. 156 cwt. each) to operate within an 80-mile radius of own branch Stockfeed Mill at Pakenham East in the course of business as "Stockfeed Manufacturers" in a specially constructed bulk tanker unit for direct delivery to farms—own stockfeed in bulk.

KUZMICH, E., 332 Larter-street, Ballarat, 3350. One commercial goods vehicle (L/C. 204 cwt.) to operate: (a) Within a 50-mile radius of the post office at Beaufort, plant the property of a contractor and required for use in connexion with the construction or maintenance of some specific existing or proposed road, street, footpath, bridge, wharf, pier, weir or channel. (b) Within a 25-mile radius from site of construction or maintenance work performed pursuant to paragraph (a) above, or from the railway station nearest thereto—metal, stones, screenings, ashes, gravel, sand, earth and any other materials required for such work. (c) Within a 25-mile radius of the chief post office at Ballarat—general goods.

LAMSON ENGINEERING AUSTRALIA PTY. LTD., 22 Lexton-road, Box Hill, 3129. One commercial goods vehicle (L/C. 19 cwt.) to operate throughout the State of Victoria in the course of business as "Suppliers and Installers of Air Tube Conveyor and Dictograph Inter-Communicating Telephone Systems"—tools of trade and materials required for the installation and maintenance of Lamson Air Tube Conveyor and Dictograph Inter-Communicating Systems.

LAWRENCE & HANSON PTY. LTD., Dorcas-street, South Melbourne, 3205. One commercial goods vehicle (L/C. 13 cwt.) to operate within a 50-mile radius of own branch premises in the City of Geelong in the course of business as "Electrical Wholesalers"—own goods, but excluding all operations to and from places within a 25-mile radius of the G.P.O., Melbourne.

LONGMORE, A. M., 94 Patrick-street, Stawell, 3380. One commercial goods vehicle (L/C. 204 cwt.) to operate: (a) Within a 50-mile radius of the post office at Stawell as a "Road Contractor"—road-making plant and material. (b) Within a 25-mile radius of the post office at Stawell—general goods, provided that no goods shall be carried whether by one stage

or by more than one stage between places within the above radius, which are more than thirty (30) road miles apart by the nearest practicable route.

LYNDON, B. A., Flat 4, 35 Wilgan-street, East St. Kilda, 3182. One commercial goods vehicle (L/C. 10 cwt.) to operate: (a) Within a 25-mile radius of the G.P.O., Melbourne—general goods. (b) Within a 50-mile radius of the G.P.O., Melbourne—second-hand household furniture.

MURRAY, E. F., PTY. LTD., 67 Riverine-street, Bairnsdale, 3875. One commercial goods vehicle (L/C. 170 cwt.) to operate: (a) Within a 95-mile radius of the post office at Nowa Nowa (Bairnsdale Division of the Country Roads Board) as a "Road Contractor"—road-making plant and materials. (b) Within a 20-mile radius from site of construction or maintenance work performed pursuant to paragraph (a) above, or from the railway station nearest thereto—metal, stones, screenings, ashes, gravel, sand, earth and any other materials required for such work. (c) Within a 25-mile radius of the post office at Bairnsdale—general goods, provided that no goods shall be carried whether by one stage or by more than one stage between places within the above radius, which are more than thirty (30) road miles apart by the nearest practicable route.

MCCULLAGH, G. J. & A. E. (trading as McCullagh Bros.), 171 Fairy-street, Warrnambool, 3280. One commercial goods vehicle (L/C. 20 cwt.) to operate: (a) Within a 50-mile radius of own premises at Merrivale via Warrnambool in the course of business as "Sawmiller"—own goods. (b) Within a 70-mile radius of own premises at Warrnambool in the course of business as "Farm Machinery and Chain Saw Distributor and Servicing Specialist"—tools of trade and spare parts incidental thereto, farm machinery and chain saws for repair or having been repaired, second-hand traded-in machinery and chain saws and new machinery and chain saws for delivery or installation with the proviso that all new goods from Melbourne are consigned to Warrnambool by rail.

REED, R. D., 465 Princes Highway, Noble Park, 3174. One commercial goods vehicle (L/C. 150 cwt.) to operate within a 70-mile radius of the premises of Sun Cement Tiles Pty. Ltd. at Huntingdale on behalf of the said company—roofing tiles and battens.

RIVERINA VOLUNTARY BARLEY POOL PTY. LTD., 406 Lonsdale-street, Melbourne, 3000. One commercial goods vehicle (L/C. 10 cwt.) to operate throughout the State of Victoria for the purpose of servicing bulk oat handling equipment—tools of trade, grain samples for inspection and spare parts required for on site maintenance of handling equipment in the field only.

RUSSELL, D. M., 91 Read-street, Coleraine, 3315. One commercial goods vehicle (L/C. 144 cwt.) to operate: (a) Within a 25-mile radius of the post office at Coleraine—general goods subject to the condition that no goods shall be carried whether by one stage or more than one stage between places within the above radius which are more than thirty (30) road miles apart by the nearest practicable route. (b) From and to the depot of H. C. Sleigh Ltd. at Portland to and from own premises at Coleraine—petroleum products in prescribed types of containers and empty containers for return.

TAYLOR, F. B., Corner Warburton and Wallace roads, Seville, 3139. One commercial goods vehicle (L/C. 189 cwt.) to operate within a 50-mile radius of the premises of Albion Reid Pty. Ltd., at Montrose, on behalf of the said company—premixed concrete in a specially constructed agitator vehicle.

TELEHIN, M., 29 Stirling-street, Orbost, 3888. One commercial goods vehicle (L/C. 43 cwt.) to operate throughout the State of Victoria in the course of business as "Marine Collector"—special wares, marine stores and old metals as designated in the *Marine Stores and Old Metals Act 1958* (No. 6303), Part 1, section 3, but excluding the carriage of any such marine stores or old metals to wharves, docks or ships for shipment or export purposes with the proviso that the combined load capacity of both prime mover and any trailer attached thereto shall not exceed 120 cwt.

TROTTER, R. C., Carlisle River, 3239. One commercial goods vehicle (L/C. 267 cwt.) to operate: (a) From forest landings within a 10-mile radius of Lavers Hill to C. R. Hampshire's sawmill at Deans Marsh—logs. (b) Within a 20-mile radius of own premises at Carlisle River—logs and sawn timber.

WALLSPACE ADVERTISING (AUST.) PTY. LTD., 561 Dana-street, Ballarat, 3350. One commercial goods vehicle (L/C. 14 cwt.) to operate throughout the State of Victoria in the course of business as "Signwriter"—tools of trade, equipment and a small quantity of

- materials incidental to the completion of own contracts, but excluding the carriage of materials from places within a 25-mile radius of the G.P.O. Melbourne.
- WILLIAMS, W. J. (trading as Williams Plant Hire), 5 Stewart-street, Seymour, 3660. Application to vary the conditions of licence No. D.A.63812 (L/C. 140 cwt.) by deleting "ninety (90) miles" from paragraph (a) of the existing conditions and adding in lieu "ninety-five (95) miles".
- HOGAN, B. D. (trading as Craigieburn Motors), Lot 2, Old Hume Highway, Craigieburn, 3064. One commercial goods vehicle (to be purchased) to operate within a 10-mile radius of the post office at Craigieburn as a "Tow Truck" solely—(a) For the purpose of lifting and carrying or towing motor vehicles and the carriage of tools and equipment necessary for such purposes only. (b) The carriage of spare parts necessary for the repair of a disabled motor to and from the place at which such disablement has occurred.
- TROLLOPE, C., 118 Melville-road, West Brunswick, 3055. Application to vary the conditions of licence No. D.A.50165 (L/C. 25 cwt.) by deleting the existing conditions and adding in lieu—"Throughout the State of Victoria as a 'Tow Truck' solely—(a) For the purpose of lifting and carrying or towing motor vehicles and the carriage of tools and equipment necessary for such purposes only. (b) The carriage of spare parts necessary for the repair of a disabled motor to and from the place at which such disablement has occurred." NOTE.—(i) All such operations shall only occur from the scene of a motor car accident if the licensed owner or certificated driver of the said tow truck has been previously bespoken, but not at the scene of such accident by the owner of the damaged or disabled motor car, or his agent, or the person in charge of the said damaged motor car or disabled motor car. (ii) The licensed vehicle shall at all times exhibit a black plate 9 in. x 2½ in. on which appears in white letters 1½ in. high the word "Restricted" to be affixed immediately above the front and rear registration plates.

RENEWALS.

Applications for renewal of licences as shown by persons listed hereunder to operate under the same terms and conditions from the expiry shown in each case.

- ALLINSON, J. H., Box 17, Esplanade, Paynesville, 3880; T.D.A.63542; 27th April, 1972; 15 cwt.
- ANDREW, J. A., 56 Harold-street, Thornbury, 3071; D.A.24434; 27th April, 1972; 62 cwt.
- BEAMAN, R., Box 233, Irymple, 3498; D.A.61652; 1st April, 1972; 77 cwt.; D.A.61652/1; 1st April, 1972; 135 cwt.
- BELL, R., 39 Smith-street, Stawell, 3380; D.A.49536/1; 27th April, 1972; 18 cwt.
- CLIFFORD, N. W., 25 Aurisch-avenue, Glen Waverley, 3150; D.A.51807; 21st April, 1972; 229 cwt.
- CLOSTER, J. E., Fitzroy-street, Darley, 3340; D.A.51894; 21st April, 1972; 247 cwt.
- CONWAY, A., 162 Brunswick-road, Brunswick, 3056; D.A.25671; 23rd April, 1972; 12 cwt.
- COTTEE'S LTD., 160 Whitehorse-road, Blackburn, 3130; D.A.30358/8; 21st April, 1972; 69 cwt.
- CROZIER, N. J. & C. J., "Allambee"; W.S.D., Woodend, 3442; D.A.64821; 23rd April, 1972; 153 cwt.
- HANNAFORD, A., & Co. LTD., 932-942 Port-road, Woodville West, 5011; D.A.1232, D.A.1232/1, D.A.1232/3, D.A.1232/4, D.A.1232/5, D.A.1232/6, D.A.1232/7, D.A.1232/9, D.A.1232/10, D.A.1232/11, D.A.1232/12, D.A.1232/13, D.A.1232/14, D.A.1232/15, D.A.1232/16; 19th April, 1972; grader; D.A.1232/17; 19th April, 1972; 14 cwt.; D.A.1232/18, D.A.1232/19, D.A.1232/20; 19th April, 1972; grader; D.A.1232/21; 19th April, 1972; 78 cwt.; D.A.1232/23, D.A.1232/24, D.A.1232/25, D.A.1232/26, D.A.1232/27, D.A.1232/28, D.A.1232/29; 19th April, 1972; grader.
- HAMMOND, E. H., & SON, Warrandyte-road, Templestowe, 3106; D.A.51727; 21st April, 1972; 130 cwt.
- HEATHER, R. W. & G. F., 51 Lawson-street, Orbost, 3888; D.A.747/2; 28th March, 1972; 340 cwt.
- HEMPHILL, J. D., Stanley-street, Wallan, 3654; D.A.53463/2; 18th December, 1971; 145 cwt.
- HUTCHINSON, ROBERT, LTD., Hartington-street, Glenroy, 3046; D.A.27836/25; 21st April, 1972; 154 cwt.
- HUTCHINSON, ROBERT, LTD., Hartington-street, Glenroy, 3046; T.D.A.27836/49; 13th April, 1972; 203 cwt.; T.D.A.27836/52; 26th April, 1972; 138 cwt.
- JOHNSON, P. L., 4 Gunnedan-street, Sunshine, 3020; D.A.51788; 21st April, 1972; 260 cwt.
- KEEN, J., 22 Botanic-road, Warrnambool, 3280; D.A.61522; 22nd April, 1972; 70 cwt.
- KEEN, J., PTY. LTD., 22 Botanic-road, Warrnambool, 3280; D.A.61554; 22nd April, 1972; 58 cwt.
- KOBOZEV, W., 99 Northumberland-road, Pascoe Vale, 3044; D.A.61677; 22nd April, 1972; 147 cwt.

- LAGO, G., 5 West-street, Preston, 3072; D.A.61702; 22nd April, 1972; 209 cwt.
- LEITCH, J., 23 Sunrise-drive, Mulgrave, 3170; D.A.61690; 22nd April, 1972; 127 cwt.
- LEGGE, JACK, PTY. LTD., Lot 18, Frankston-road, Dandenong, 3175; D.A.22091/8; 27th April, 1972; 291 cwt.
- LUFF, N. C., 50A Darlot-street, Horsham, 3400; D.A.28477/1; 27th April, 1972; 16 cwt.
- MATTHEW, K. W. & R., 12 Simpson-street, East Kew, 3102; D.A.61688; 22nd April, 1972; 220 cwt.
- MILLER BROS. HIRING PTY. LTD., 2 Belgravia-street, Burnley, 3121; D.A.19927/4; 21st April, 1972; 57 cwt.
- MISZCZUCK, M., 15 Marong-road, Bendigo, 3550; D.A.28188; 23rd April, 1972; 145 cwt.
- MCBEATH, I. R., 8 Coronation-street, Kerang, 3579; D.A.60694; 17th April, 1972; 159 cwt.
- NESTLE CO. (AUST.) LTD., THE, 139-189 Racecourse-road; Flemington, 3031; D.A.31378/16; 29th April, 1972; 8 cwt.
- OLYMPIC GENERAL PRODUCTS PTY. LTD., Mephan-street, Footscray, 3011; D.A.47829/2; 27th April, 1972; 31 cwt.
- PEDERICK, I. H. (trading as H. J. Pederick & Sons), 70 Blake-street, Nathalia, 3638; D.A.1796; 19th April, 1972; 147 cwt.
- REPLACEMENT PARTS PTY. LTD., 618 Elizabeth-street, Melbourne, 3000; D.A.1907/20; 27th April, 1972; 13 cwt.
- REPLACEMENT PARTS PTY. LTD., 618 Elizabeth-street, Melbourne, 3000; D.A.1907/46; 22nd April, 1972; 13 cwt.; D.A.1907/47; 22nd April, 1972; 14 cwt.
- SCHULTZ, R. L., 97 Warracknabeal-road, Dimboola, 3414; D.A.61544; 4th March 1972; 16 cwt.
- STRATFORD & FRANK PTY. LTD., 3-5 Ashburn-place, Blackburn, 3130; D.A.51991; 27th April, 1972; 18 cwt.
- STRATFORD & FRANK PTY. LTD., 3-5 Ashburn-place, Blackburn, 3130; D.A.51991/1; 27th April, 1972; 18 cwt.
- STREETS ICE CREAM PTY. LTD., 615 Warrigal-road, Ashburton, 3147; D.A.2011/9; 27th April, 1972; 41 cwt.
- THOMAS, R. F., Wattle-street, Manangatang, 3546; D.A.61953; 22nd April, 1972; 11 cwt.
- TOLEDO BERKEL PTY. LTD., 525 Graham-street, Port Melbourne, 3207; D.A.2168/5; 22nd April, 1972; 19 cwt.
- TOORALAC MILK PRODUCTS PTY. LTD., P.O. Box 13, Dandenong, 3175; D.A.56830/7; 8th April, 1972; 115 cwt.; D.A.56830/8; 8th April, 1972; 114 cwt.; D.A.56830/10; 8th April, 1972; 196 cwt.
- WANDIN, C. J., Box 234, Kerang, 3579; D.A.51676; 6th April, 1972; 250 cwt.
- WILKIE, J. W. & P. M., Albert-street, Bacchus Marsh, 3340; D.A.61704; 22nd April, 1972; 196 cwt.
- YARRA VALLEY TYRE CO. PTY. LTD., 50 Maroondah Highway, Ringwood, 3134; D.A.43528/4; 27th April, 1972; 11 cwt.

TOW TRUCK RENEWALS.

- MCGRATH, P. F. (trading as J. F. Marshall Motors), 24 High-street, Hastings, 3915; D.A.60980; 27th November, 1971; 55 cwt.
- YARD, T. J., Murrayville, 3512; D.A.64333; 4th March, 1972; 40 cwt.

RENEWALS WITH VARIATION.

Applications made by the persons listed hereunder for renewal of the licences listed with variation of conditions in the manner set out opposite the names.

- BOOTS CO. (AUST.) PTY. LTD., THE, 24 Woorayl-street, Carnegie, 3163; D.A.36645/16; 8th April, 1972; Application to renew and vary the conditions of licence No. D.A.36645/16 (L/C. 8 cwt.) by deleting "Richmond" from the existing conditions and adding in lieu "Carnegie".
- GOLDRING, R. G., 12 Victoria-street, Doncaster, 3108; D.A.1168; 19th April, 1972; Application to renew and vary the conditions of licence No. D.A.1168 (L/C. 10 cwt.) by deleting "distilled water" from the existing conditions and adding in lieu "small packets of car globes".
- KUNAUS, A., 3 Barney-street, Bendigo, 3550; D.A.51787; 21st April, 1972; Application to renew and vary the conditions of licence No. D.A.51787 (L/C. 10 cwt.) by deleting the existing conditions and adding in lieu "Within a 75-mile radius from the chief post office in the City of Bendigo in the course of business as an 'Electrical Contractor' but excluding operations to or from places with a 25-mile radius from the post office at the corner of Bourke and Elizabeth streets,

Melbourne—tools of trade and equipment incidental to the installation and servicing of televisions and radio sets."

Notice of any objection should be forwarded to reach the Secretary of the Board not later than 8th December, 1971.

Applicants are advised that it will not be necessary to appear on the hearing date specified above, unless advised in writing by the Board.

B. P. KAY,
Secretary.

Corner Lygon and Princes streets, Carlton, 3053,
Wednesday, 24th November, 1971.

Co-operation Act 1958.

CHANGE OF NAME OF SOCIETY.

Notice is hereby given that Laverton Parish Co-operative Limited which was incorporated as a Credit Society under the above-named Act on the thirty-first day of March, 1966, has registered a change of its name and is now incorporated under the name of Laverton & District Credit Co-operative Limited under the said Act.

Dated at Melbourne, this sixteenth day of November, 1971.

R. F. SCOLLARD,
Deputy Registrar of Co-operative Societies.

Police Regulation Act 1958, Section 122.

SALE OF UNCLAIMED MOTOR VEHICLE.

An owner is required for a 1956 model Holden sedan, ex-registered No. (N.S.W.) CYN 514, engine No. L332037.

The vehicle came into the possession of Police on 25th February, 1971, and if not claimed, will be sold by public auction at the Stratford Police Station, Tyers-street, Stratford, at 2 p.m., on 3rd December, 1971.

R. JACKSON,
Chief Commissioner of Police.

DEPARTMENT OF AGRICULTURE.

PUBLIC NOTICE.

It is hereby notified that the Farm Produce Commission Agents licence issued to E. Seamer of McAllister-road, Monbulk, for the period 1st July, 1971, to 30th June, 1972, has been suspended in accordance with the provisions of section 15 (1) (c) of the *Farm Produce Merchants and Commission Agents Act 1965*.

A claim has been made against the Farm Produce Merchants and Commission Agents Guarantee Fund by a grower creditor of E. Seamer, and all persons who, as producers of farm produce, have any claim against E. Seamer arising from the failure on his part to pay or account for any moneys payable to them for farm produce supplied, are invited to forward particulars and proof of such claim to the Director of Agriculture, Treasury-place, Melbourne, on or before 22nd December, 1971. (Postal address, Department of Agriculture, Box 4041 G.P.O., Melbourne, Vic. 3001.)

D. S. WISHART,
Director of Agriculture.

Stamps Act 1958.

ANNUAL LICENCE.

NOTIFICATION PURSUANT TO SECTION 97.

I hereby notify that stamp duty has been paid for a licence under section 96 of the Stamps Act to carry on assurance and insurance business in Victoria, from 12th November, 1971, to 31st December, 1971, by the following:—

COMSURE INSURANCES PTY. LTD.
R. M. PHIBBS,
Comptroller of Stamps.

Chief Office for Stamp Duties,
Melbourne, 24th November, 1971.

Stamps Act 1958.

ANNUAL LICENCE.

NOTIFICATION PURSUANT TO SECTION 97.

I hereby notify that stamp duty has been paid for a licence under section 96 of the Stamps Act to carry on assurance and insurance business in Victoria, from 18th August, 1971, to 31st December, 1971, by the following:—

HARRIS & DIXON (INSURANCE) PTY. LTD.
R. M. PHIBBS,
Comptroller of Stamps.

Chief Office for Stamp Duties,
Melbourne, 24th November, 1971.

Town and Country Planning Act 1961.

EILDON RESERVOIR PLANNING SCHEME 1959—(SHIRE OF MANSFIELD).

AMENDMENT No. 7, 1969.

Notice of Approval.

In pursuance of the powers conferred by the *Town and Country Planning Act 1961*, the Governor in Council on the 16th November, 1971, approved a Planning Scheme entitled the Eildon Reservoir Planning Scheme 1959 (Shire of Mansfield) Amendment No. 7, 1969, in respect of part of the municipal district of the Shire of Mansfield and such Planning Scheme comes into operation on the date this notice of approval is published in the *Government Gazette*.

A copy of the Planning Scheme as approved may be inspected free of charge during office hours at the office of the Town and Country Planning Board, 235 Queen-street, Melbourne; at the office of the Shire of Mansfield, at Mansfield, and when available, at the Office of Titles, Melbourne, and at the Central Plan Office of the Department of Crown Lands and Survey, Melbourne.

W. H. CRAIG, Secretary,
Town and Country Planning Board.

Town and Country Planning Act 1961.

SHIRE OF BULLA PLANNING SCHEME 1959.

AMENDMENT No. 16, 1971.

Notice of Approval.

In pursuance of the powers conferred by the *Town and Country Planning Act 1961*, the Governor in Council on the 16th November, 1971, approved a Planning Scheme entitled the Shire of Bulla Planning Scheme 1959, Amendment No. 16, 1971, in respect of part of the municipal district of the Shire of Bulla and such Planning Scheme comes into operation on the date this notice of approval is published in the *Government Gazette*.

A copy of the Planning Scheme as approved may be inspected free of charge during office hours, at the office of the Town and Country Planning Board, 235 Queen-street, Melbourne; at the office of the Bulla Shire Council at Sunbury, and when available, at the Office of Titles, Melbourne, and at the Central Plan Office of the Department of Crown Lands and Survey, Melbourne.

W. H. CRAIG, Secretary,
Town and Country Planning Board.

Town and Country Planning Act 1961.

SHIRE OF SHERBROOKE PLANNING SCHEME 1965.

AMENDMENT No. 48, 1971.

Notice of Amendment.

In pursuance of the powers conferred by sub-section 6 of section 32 of the *Town and Country Planning Act 1961*, the Governor in Council, by and with the advice of the Executive Council on the 16th November, 1971, amended the Shire of Sherbrooke Planning Scheme by rezoning for residential purposes part of lots 7, 8 and 9, lodged plan 7343 at the corner of Kia Ora and Kumbada avenues, Upwey.

A copy of the amendment may be inspected during office hours at the office of the Town and Country Planning Board, 235 Queen-street, Melbourne; at the office of the Council of the Shire of Sherbrooke, at Upwey, and when available at the Office of Titles, Melbourne; and at the Central Plan Office of the Department of Crown Lands and Survey, Melbourne.

W. H. CRAIG, Secretary,
Town and Country Planning Board.

Town and Country Planning Act 1961.

SHIRE OF MORNINGTON PLANNING SCHEME 1959.

AMENDMENT No. 72, 1971.

Notice of Amendment.

In pursuance of the powers conferred by sub-section 6 of section 32 of the *Town and Country Planning Act 1961*, the Governor in Council, by and with the advice of the Executive Council on the 16th November, 1971, amended the Shire of Mornington Planning Scheme 1959, to rezone part of lot 12, lodged plan 80265, Mount Eliza Way, from Residential "C" to Commercial "A" Zone.

A copy of the amendment may be inspected during office hours at the office of the Town and Country Planning Board, 235 Queen-street, Melbourne; at the office of the Council of the Shire of Mornington, at Mornington; and when available at the Office of Titles, Melbourne; and at the Central Plan Office of the Department of Crown Lands and Survey, Melbourne.

W. H. CRAIG, Secretary,
Town and Country Planning Board.

STATE RIVERS AND WATER SUPPLY COMMISSION.

LICENCES TO DIVERT WATER AND CUT RACES PURSUANT TO THE PROVISIONS OF SECTION 204 OF THE WATER ACT 1958 (AS AMENDED).

The Governor in Council has approved of the granting by the State Rivers and Water Supply Commission of licences as detailed hereunder for the term of years from the date specified in each case to the persons named in the following Schedule:—

SCHEDULE.

Licence No.	Term of Licence and Commencing Date.	Name and Address of Person to whom Licence is to be Granted.	Source of Supply.	Area Authorized to be Irrigated Per Annum.	Volume of Water Authorized to be Diverted Per Annum.	Annual Fee.
				acres.	ac. ft.	\$
533	Fifteen years from 1.7.70	Peter Charles Orton, Eric Charles Orton, Veronica Maude Orton, John Robert Orton and Shirley Margaret Steel, Colignan	River Murray ..	30	90	112.50
619	Fifteen years from 1.7.71	Eric Edward Ruddick, Robinvale	River Murray ..	25	75	93.75
651	Fifteen years from 1.7.71	Arturo Pezzaniti and Teodora Pezzaniti, Red Cliffs	River Murray ..	34	102	127.50
660	Fifteen years from 1.7.71	Arthur Roger Montrose and Annie Morrie Montrose, Bundalong	River Murray (Lake Mulwala)	100	200	250.00
682	Fifteen years from 1.7.71	Richard Grenville Dawson Rogers, Nangiloc	River Murray ..	17	51	63.75
847	Fifteen years from 1.7.70	Norman Donnelly, Nichols Point	River Murray ..	2	6	15.00
933	Fifteen years from 1.7.70	Harry Charles Logie and Nancy Patricia Logie, Nathalia	Goulburn River ..	50	100	125.00
958	Fifteen years from 1.7.71	John Thomas Fawcett and Rupert Fawcett, Bendigo	Loddon River ..	40	80	100.00
960	Fifteen years from 1.7.71	Richard Raymond Benger, Eddington	Loddon River ..	92	186	233.00
984/1606	Fifteen years from 1.7.71	Thomas Benedict Hynes and Jean Mary Hynes, Kotupna	Goulburn River ..	100	200	250.00
990	Fifteen years from 1.7.71	Bernard Osmond Holland, Borung	Loddon River ..	75	150	187.50
992	Fifteen years from 1.7.71	Charles Albert Triplett, Salisbury West	Loddon River ..	50	100	125.00
1006	Fifteen years from 1.7.71	Edwin John Barty and John McCrae Barty, Maldon	Loddon River ..	50	100	125.00
1019	Fifteen years from 1.7.71	Harold Frederick Rose, Merbein	River Murray (Cowananna Billabong)	25	75	93.75
1036	Fifteen years from 1.7.71	Kevin James Martin and John Desmond Martin, Salisbury West	Loddon River ..	30	60	75.00
1063	Fifteen years from 1.7.71	Hugh Garnett Redwood, Bridge-water	Loddon River ..	40	80	100.00
1284	Fifteen years from 1.7.71	Collin Kenniwell Smith and Edna May Smith, Merbein	River Murray ..	49	147	183.75
1932/1017	One year from 1.7.71..	Constanzo Caccaviello, Piangil	River Murray ..	28½ rds.	87	109.25
1939	Fifteen years from 1.7.71	Thomas David Wilkinson, Mildura	River Murray ..	7	21	26.25
1960/541	Fifteen years from 1.7.70	Ernest Alfred Mattschoss, Robinvale	River Murray ..	30	90	112.50
2209	Fifteen years from 1.7.70	James Lyell Hogg, Merbein ..	River Murray ..	16½ rds.	50	62.50
2236	Fifteen years from 1.7.71	Mundatta Pty. Ltd., Barnawartha	River Murray Effluent	50	100	125.00
2285	Fifteen years from 1.7.71	Jeffrey Vernon Frost and Lorraine Frost, Echuca	River Murray ..	24	48	60.00
2310	Five years from 1.7.71	Jeffrey Frederick Cox, Bairnsdale	Mitchell River ..	35	70	70.00
2342	Fifteen years from 1.7.71	Brian Patrick McLinden and Mary Josephine McLinden, Salisbury West	Loddon River ..	50	100	125.00
2378	Fifteen years from 1.7.71	John Charles Moss and Agnes Lillian Moss, Piangil	River Murray ..	1	5	18.00
2617	Fifteen years from 1.7.71	Ian Terence Kneebone, Hansonville	Ovens River ..	15	22½	28.12
3156	Fifteen years from 1.7.71	Shire of Kerang, Kerang ..	Gunbower Creek (River Murray Backwater)	..	12	15.00
3163	Four years from 1.7.71	Modern Fruit and Vegetable Supermarket Pty. Ltd., Garema Fruit Retailers Pty. Ltd., and Bruno's Wholesale Fruiterers Pty. Ltd., Canberra	River Murray ..	225	675	843.75
3176	Fifteen years from 1.7.71	Kenneth Richard Graham, Serpentine	Loddon River ..	50	100	125.00
3184	Fifteen years from 1.7.71	City of Wangaratta, Wangaratta	Ovens River ..	50	100	125.00
3185	Four years from 1.7.71	Elsie Marion McDonald, Wangaratta	King River ..	20	30	37.50
3189	Four years from 1.7.71	James Albert Keat, Caniambo ..	Broken River ..	40	80	100.00
3192	Four years from 1.7.71	Salvatore Politini, Cheshunt ..	King River ..	40	60	75.00
3194	Four years from 1.7.71	Barber Bros., Whitfield ..	King River ..	40	60	75.00
3199	Four years from 1.7.71	Nankervis and Sons, Wangaratta	King River ..	100	150	187.50
3201	Four years from 1.7.71	Mona Isobel Paul, Mildura ..	River Murray ..	1½	4½	15.00
3203	Four years from 1.7.71	George Vincent White, Edi ..	King River ..	25	37½	46.88
3205	Four years from 1.7.71	Emmanuel Cullias and Maria Cullias, St. Peters	River Murray ..	39	117	146.25

STATE RIVERS AND WATER SUPPLY COMMISSION.

LICENCES TO DIVERT WATER PURSUANT TO THE PROVISIONS OF SECTION 204 OF THE WATER ACT 1958 (AS AMENDED).

The Governor in Council has approved of the granting by the State Rivers and Water Supply Commission of licences as detailed hereunder for the term of years from the date specified in each case to the persons named in the following Schedule :—

SCHEDULE.

Licence No.	Term of Licence and Commencing Date.	Name and Address of Person to whom Licence is to be Granted.	Source of Supply.	Area Authorized to be Irrigated Per Annum.	Volume of Water Authorized to be Diverted Per Annum.	Annual Fee.
				acres.	ac. ft.	\$
599	Fifteen years from 1.7.71	Arthur Roger Montrose and Annie Morrie Montrose, Bundalong	River Murray (Lake Mulwala)	25	50	62.50
944	Fifteen years from 1.7.71	June Lucille Longmore, Bannockburn	Moorarbool River..	6	12	15.00
946/947	Fifteen years from 1.7.71	Robert Lillie and Annis Marion Lillie, Baringhup	Loddon River ..	35	70	87.50
963	Fifteen years from 1.7.71	Peter Barkly Hyett and Marlene Dawn Hyett, Bridgewater	Loddon River ..	90	180	225.00
967/1335	Fifteen years from 1.7.71	Ernest William Graham, Arnold	Loddon River ..	40	80	100.00
969/1334	Fifteen years from 1.7.71	Samuel James Dudley, Baringhup	Loddon River ..	40	80	100.00
976	Two years from 1.7.71	William Clark Langham and Ethel Edna Jean Langham, Bridgewater	Loddon River ..	36	72	90.00
979	Fifteen years from 1.7.71	George Francis Pickering, Baringhup West	Loddon River ..	20	40	50.00
981	Fifteen years from 1.7.71	Albert Edwin Wylie, Bridgewater	Loddon River ..	10	20	25.00
1022	Fifteen years from 1.7.71	George Clifford Davies, Newbridge	Loddon River ..	5	10	15.00
1051	Fifteen years from 1.7.71	David John Hawker and Robert Keith Hawker, Serpentine	Loddon River ..	80	160	200.00
1138	Fifteen years from 1.7.71	David Alick Bissett and Doris Elizabeth Bissett, Serpentine	Loddon River ..	30	60	75.00
1400	Fifteen years from 1.7.71	Roy Francis Pickering, Baringhup West	Loddon River ..	20	40	50.00
2131	Fifteen years from 1.7.70	Cornelius Gilston Griffiths, Mangalore	Goulburn River (Ana-Branch and Lagoon)	100	200	250.00
2980	Fifteen years from 1.7.71	Pelubra (Victoria) Pty. Ltd., Yarrawonga	River Murray (Lake Mulwala)	30	60	75.00
3167	Four years from 1.7.71	Frank Gordon Baines, Benalla ..	Broken River ..	40	80	100.00
3186	Four years from 1.7.71	Lloyd George Solly and Fairley Hodgson Solly, Moyhu	King River ..	60	90	112.50

Office of the State Rivers and Water Supply Commission,
Melbourne, 16th November, 1971.

G. W. LEWIS, Secretary,
State Rivers and Water Supply Commission.

Water Act 1958.

STATE RIVERS AND WATER SUPPLY COMMISSION.
URBAN DISTRICT SUPPLIED WITH WATER FROM THE COLIBAN SYSTEM OF WATERWORKS

Notice to owners of tenements in the under-mentioned streets in the urban district supplied with water from the Coliban System of Waterworks, and the private streets, lanes, courts and alleys opening thereto:—

Barkers Creek.

Un-named north-south road (North of Barkers Creek State School), from end of existing main (opposite allotment 7A, in un-named east-west road) to a point opposite allotment 3, about 10 chains northerly.

Un-named east-west road (past Barkers Creek State School), from end of existing main (opposite allotment 7A) to a point opposite Barkers Creek State School, about 6½ chains westerly.

Bendigo.

Albert-avenue, from Cousins-street to a point opposite lot 45, about 5½ chains northerly.

Arblaster-street, from end of existing main (opposite allotment 209) to Bright-street.

Aspinal-street, from Alder-street to a point opposite allotment 67C, about 13½ chains south-westerly.

Bay-street, from end of existing main (opposite lot 19) to High-street.

Belinda-avenue, from McKenzie-street West to a point opposite lot 1, about 2½ chains easterly.

Bobs-street, from end of existing main (opposite allotment 15, about 8½ chains north-easterly from Grace-street) to existing main (opposite allotment 17, about 5 chains south-westerly from Cambridge-crescent).

Boronia-crescent, from end of existing main (opposite lot 53) to a point opposite lot 70, about 7½ chains generally northerly from Desmond-street.

Bright-street, from Oswald-street to—

- (i) a point opposite lot 1, about 6 chains north-westerly; and
- (ii) a point opposite lot 31, about 5 chains south-easterly.

Button-street, from end of existing main (opposite lot 18) to a point opposite lot 27, about 12 chains southerly from McIvor-road.

Comet-street, from Holmes-road to a point opposite allotment 23K, about 5 chains south-westerly.

Cousins-street, from end of existing main (opposite lot 27) to a point opposite lot 1, about 11½ chains south-easterly from Harley-street.

Day-street, from end of existing main (opposite allotment 296) to a point opposite lot 2, L.P. 90632, about 2½ chains northerly from Lloyd-street.

Elm-street, from end of existing main (opposite allotment 20) to McLachlan-street.

Faugh-A-Ballagh road, from end of existing main (opposite allotment 45) to a point opposite allotment 46, about 4½ chains westerly from Lawson-street.

Friswell-avenue (formerly Thompson's Gully-road), from end of existing main (opposite lot 9) to a point opposite lot 12, about 30 chains easterly from Osborne-street.

Gladstone-street, from end of existing main (opposite allotment 9) to Kilwinning-street.

Jacob-street, from end of existing main (opposite lot 44) to a point opposite lot 54, about 17 chains north-easterly from Holdsworth-road.

Kendall-street, from Shakespeare-street to a point opposite allotment 264A, about 5½ chains westerly.

Kilwinning-street, from Olinda-street to Gladstone-street.

Margaret-crescent, from end of existing main (opposite lot 1) to a point opposite lot 10 at end of crescent.

Miami-court, from end of existing main (opposite lot 91) to end of court.

McKenzie-street west, from end of existing main (opposite allotment 15) to a point opposite Bendigo Tooling Company Pty. Ltd., about 1 chain north-easterly from Collins-street.

McLachlan-street, from Elm-street to a point opposite lot 3, about 3½ chains north-easterly.

McPherson-street, from Midland Highway to a point opposite lot 4, about 5 chains westerly.

O'Keefe-street, from end of existing main (opposite lot 5) to O'Dwyer-street.

Oswald-street, from Bright-street to a point opposite lot 130, about one-half chain north-easterly from Truscott-avenue.

Osborn-avenue, from Wireless-road to McLachlan-street.

Palm-avenue, from Elizabeth-street to a point opposite lot 39, about one-half chain southerly.

Reservoir-road, from end of existing main (opposite lot 2) to a point opposite lot 5, about 11½ chains northerly.

Rosemary-avenue, from Cousins-street to a point opposite lot 62, about 7½ chains northerly.

Roy-court.

Short-street—(i) from end of existing main (opposite lot 10) to Wireless-road; and (ii) from Bowles-street to a point opposite lot 27, about 10 chains northerly.

Specimen Hill-road, from end of existing main (opposite allotment 51, about 8½ chains south-easterly from Pallett-street) to existing main (opposite Bendigo Elderly Citizens' Home, about 3½ chains north-westerly from Taylor-street).

Stanley-street, from Spring Gully-road to a point opposite lot 5, about 3½ chains easterly.

Strathdale-crescent, from end of existing main (opposite lot 7) to Desmond-street.

St. Aidens-road, from Strathdale-crescent to a point opposite lot 1, about 4 chains easterly.

Symonds-street, from end of existing main (opposite allotment 42E) to a point opposite lot 4, about 14 chains westerly from Aspinall-street.

Thomas-street (north-west side), from Upper-road to a point opposite allotment 20F, about 3½ chains north-easterly.

Union-street, from Dare-street to a point opposite allotment 482, about 7 chains generally northerly.

Willow-drive, from Strathfieldsaye-road to a point opposite lot 36, about 2 chains southerly from Banksia-court.

Woodbury-street, from end of existing main (opposite lot 99) to a point opposite lot 102, about 3 chains easterly; thence 5½ chains southerly from Putnam-avenue.

Yallambee-drive, from end of existing main (opposite lot 27) to a point opposite lot 38, about 12½ chains generally southerly from Steane-street.

Castlemaine.

Blakeley-road, from Sawmill-road to a point opposite allotment 39, about 7 chains southerly.

Lawson-parade, from Blakeley-road to Carol-street.

Parker-street, from end of existing main (opposite allotment 8) to a point opposite allotment 9, about 7 chains easterly from Hargraves-street.

Un-named street (off Pyrenees Highway), from end of existing main to a point opposite allotment 1A, section F1, about 3 chains easterly; thence one-half chain southerly.

Harcourt.

Bagshaw-street, from Buckley-street to a point opposite allotment 9, about 3 chains easterly.

Bridge-street, from High-street to Buckley-street.

Buckley-street, from Bridge-street to a point opposite allotment 5, about 6 chains southerly.

Kangaroo Flat.

Collins-street, from end of existing main (opposite lot 9) to a point opposite lot 6, about 10 chains south-westerly from Olympic-parade.

Raywood.

Bendigo-road, from Sandhurst-street to a point opposite Raywood State School, about 11 chains south-westerly.

Buckle-street, from Inglewood-street to a point opposite section 19, about 1 chain southerly.

Froude-street, from Speke-street to Grant-street.

Inglewood-street, from Buckle-street to a point opposite allotment 1, section 22, about 64 chains westerly.

Lincoln-street, from Sandhurst-street to a point opposite allotment 34, section 2, about 6½ chains easterly.

Sandhurst-street, from a point opposite the southern boundary of Raywood State School, to a point about 6½ chains north-easterly from Carlyle-street.

Speke-street, from Inglewood-street to a point opposite section 5, about 3½ chains northerly from Froude-street.

Un-named street (adjacent to Raywood Railway Station), from Inglewood-street to a point opposite allotment 1, Section 23, about 8 chains northerly.

Sebastian.

Bridgewater-road, from Pyramid Hill-road to a point opposite allotment 1F, section 19, about 72 chains westerly.

Pyramid Hill-road, from Bridgewater-road to a point opposite allotment 2A, section A, about 52½ chains northerly.

Un-named North-South Government Road (Adjacent to Eastern Boundary of Section 19), from Bridgewater-road to a point opposite section 19, about 30 chains south easterly.

Yarraberb.

Un-named East-West Government Road (Adjacent to Northern Boundary of Myer's Creek P.R.), from a point opposite the south-western corner of section 8, to a point opposite section 1, about 34½ chains easterly.

Un-named North-South Government Road (Between Sections 1, 2, 3 and 4), from un-named East-West Government Road (Adjacent to Northern Boundary of Myer's Creek P.R.), to a point about 22½ chains northerly.

The main pipe in the said streets being laid down, the owners of all tenements situated as above, are hereby required, on or before the 1st day of January next, to cause proper pipes and stop cocks to be laid, so as to supply water within such tenements from the main pipe.

G. W. LEWIS, Secretary,
State Rivers and Water Supply Commission.

19th November, 1971.

Water Act 1958.

STATE RIVERS AND WATER SUPPLY COMMISSION.
DEVON MEADOWS—TOORADIN, CENTREVILLE—SOUTH LYNDHURST, WESTERNPORT, FRANKSTON—MORNINGTON, DROMANA—PORTSEA, BERWICK, CRANBOURNE, DANDENONG—SPRINGVALE, PAKENHAM, OTWAY, AND NEWSTEAD URBAN DISTRICTS.

Notice to owners of tenements in the under-mentioned streets in the above-mentioned Urban Districts and the private streets, lanes, courts and alleys opening thereto:—

DEVON MEADOWS—TOORADIN URBAN DISTRICT.

Devon Meadows.

Houlder-avenue, from end of existing main (opposite lot 61) to May-road.

May-road, from Houlder-avenue to a point opposite lot 87, about 1½ chains south-westerly.

Spring-road, from Ballarto-road to a point opposite lot 130, about 6 chains south-easterly.

CENTREVILLE—SOUTH LYNDHURST URBAN DISTRICT.

Centreville.

Browns-road, from end of existing main (opposite lot 6), to a point opposite lot 7, about 15 chains easterly from Pearce-dale-road.

Carr-Boyd-road, from Woodlands-road to a point opposite lot 71, about 5 chains south-westerly.

Centre-road, from McKays-road to a point opposite lot 7, about 23 chains southerly.

McKays-road, from end of existing main (opposite lot 9), to Centre-road.

WESTERNPORT URBAN DISTRICT.

Crib Point.

Milne-street, from Martin-street to a point opposite lot 3, about 2 chains north-westerly.

The Esplanade, from Stony Point-road to a point opposite lot 31, about 12 chains north-westerly.

Hastings.

Frankston—Flinders road (East Side), from Wright-street to a point opposite lot 1, about ¼ chain northerly.

Mayne-avenue, from Wright-street to a point opposite lot 8, about 3 chains southerly.

Wright-street, from Frankston—Flinders road to a point opposite lot 1, about ¼ chain easterly.

Somerville.

Roslyn-street, from Eramosa-road to a point opposite lot 10, about 8 chains southerly.

Scott-grove, from end of existing main (opposite lot 21) to Grant-road.

FRANKSTON—MORNINGTON URBAN DISTRICT.

Carrum Downs.

McCormicks-road, from Brunnings-road to a point opposite lot 12, about 7 chains northerly.

Frankston.

Barclay-avenue, from end of existing main (opposite lot 207) to Frank-street.
 Bellvue-crescent, from end of existing main (opposite lot 195) to a point opposite lot 198, about 6 chains northerly from Seaford-road.
 Beverley-close.
 Blackheath-avenue.
 Bruce-street, from end of existing main (opposite lot 119) to Claude-street.
 Bunker-court.
 Chestfield-court.
 Chetwyn-court, from Humphries-road to a point opposite lot 2, about 13 chains north-easterly.
 Claude-street, from end of existing main (opposite lot 306) to Klauer-street.
 Connal-drive.
 Corio-avenue, from end of existing main (opposite lot 14, about 4½ chains south-westerly from Mincha-street) to existing main (opposite lot 6, about 3 chains north-easterly from Towerhill-road).
 Coventry-court.
 Derinya-drive, (i) from Overport-road to a point opposite lot 8, about 14 chains south-easterly; and (ii) from end of existing main (opposite lot 48) to a point opposite lot 16, about 17 chains generally southerly from Wandana-court.
 Drysdale-avenue, from end of existing main (opposite lot 481) to Barclay-avenue.
 Elliot-street, from end of existing main (opposite lot 95) to Claude-street.
 Frank-street, from end of existing main (opposite lot 103, about 3 chains north-easterly from Jacana-avenue) to existing main (opposite lot 10, about 18 chains south-westerly from Skye-road).
 Golf Links-road, from Frankston-Flinders-road to McMurtry Way.
 Greenbrier-court.
 Innerleven-court.
 Laleham-court.
 Lawn-court.
 Minton-drive, from end of existing main (opposite lot 113) to Barclay-avenue.
 Muirfield-court.
 Musselburgh-court.
 Prestwick-court.
 Roberts-street, from end of existing main (opposite lot 2) to Bloom-street.
 Tooyal-street, from end of existing main (opposite lot 28) to Bragge-street.
 Upminster-court.
 Wren-street, from end of existing main (opposite lot 20, about 2 chains southerly from Kookaburra-street) to existing main (opposite lot 31, about ½ chain northerly from Tooyal-street).
 Wright-street, from Claude-street to a point opposite lot 192, about ¼ chain easterly.

Langwarrin.

Gerald-avenue.
 Glazebury-court, from Moate-street to end of court.
 Horne-court.
 Long-street, from end of existing main (opposite lot 73) to a point opposite lot 50, about 3 chains north-easterly from Wootten-crescent.
 Malcolm-road, from Paterson-avenue to a point opposite lot 15, about 1 chain easterly.
 Paterson-avenue, from end of existing main (opposite lot 109) to Paul-place.
 Paul-place.
 Wootten-crescent, from Long-street to a point opposite lot 47, about 1½ chains north-westerly.

Mornington.

Schnapper Point-drive.

Mount Eliza.

Allison-road, from end of existing main (opposite lot 2) to a point opposite lot 94, about 6 chains south-easterly from Winona-road.
 Mather-road, from end of existing main (opposite lot 24) to a point opposite lot 1, about 2½ chains easterly from Lowe-street.

Mount Martha.

Coryule-road, from Orana-drive to a point opposite lot 126, about 5½ chains southerly.
 Orana-drive, from end of existing main (opposite lot 79, about one-half chain easterly from Walara-drive) to existing main (opposite lot 150, about 1½ chains westerly from Walara-drive).
 Roslyn-street, from Coryule-road to a point opposite lot 127, about 1 chain easterly.

Seaford.

Gray-street, from Kirkwood-avenue to a point opposite lot 20, about 5 chains easterly.
 Kirkwood-avenue, from—(i) Moresby-avenue to a point opposite lot 15, about 2 chains northerly from Gray-street; and (ii) end of existing main (opposite lot 2), to a point opposite lot 3, about 2½ chains southerly from Moresby-avenue.
 Northcote-street, from end of existing main (opposite lot 34) to a point opposite lot 16, about 9½ chains easterly from Halifax-street.

DROMANA—PORTSEA URBAN DISTRICT.

Blairgowrie.

Bath-street, from Godwin-street to a point opposite lot 846, about 4 chains south-westerly.
 Canterbury Jetty-road, from end of existing main (opposite lot 1) to a point opposite lot 112, about 1 chain northerly from Dolphin-avenue.
 David-street, from Whitehead-street to a point opposite lot 325, about 4½ chains generally south-easterly.
 Grant-street, from end of existing main (opposite lot 52) to a point opposite lot 54, about 4 chains easterly from Adelaide-street.
 Scott-street, from Lydgate-street to a point opposite lot 745, about 10½ chains generally south-easterly.
 Topaz-street, from end of existing main (opposite lot 837) to a point opposite lot 836, about 6 chains south-westerly from Godwin-street.

Dromana.

Shaw-street, from Watson-avenue to a point opposite lot 94, about 1½ chains southerly.
 Watson-avenue, from end of existing main (opposite lot 109) to Shaw-street.

McCrae.

Somers-avenue, from end of existing main (opposite lot 83) to a point opposite lot 82, about 9 chains westerly from Cairn-road.

Rosebud.

Foam-street, from end of existing main (opposite lot 33) to a point opposite lot 53, about 20 chains southerly from Seal-street.

Rye.

Dundas-street, from Mannana-street to Owarra-street.
 Flinders-street, from end of existing main (opposite lot 124) to a point opposite lot 126, about 2 chains southerly from Fairway-drive.
 Owarra-street, from Dundas-street to a point opposite lot 609, about 4 chains westerly.

Safety Beach.

Tassel-road, from Coutts-street to a point opposite lot 86, about 2 chains southerly.

Sorrento.

Legget-way, from Nepean Highway to a point opposite lot 7, about 3 chains easterly.
 Lincoln-avenue, from end of existing main (opposite lot 35) to a point opposite lot 32, about 12 chains westerly from Normanby-road.

BERWICK URBAN DISTRICT.

Beaconsfield.

George-street, from end of existing main (opposite lot 35) to a point opposite lot 36, about 3 chains westerly from Ann-street.

CRANBOURNE URBAN DISTRICT.

Cranbourne.

Alexander-street, from end of existing main (opposite lot 50) to a point opposite lot 54, about 14 chains westerly from High-street.
 Cochrane-street, from end of existing main (opposite lot 413, about ½ chain westerly from McLaren-street) to existing main (opposite lot 646 about 1½ chains easterly from Lorna-street).
 Hudson-street, from end of existing main (opposite lot 391) to Campbell-parade.
 Loch-street, from end of existing main (opposite lot 113) to a point opposite lot 115, about 4 chains westerly from Hotham-street.

DANDENONG—SPRINGVALE URBAN DISTRICT.

Dingley.

Imlach-court.

Noble Park.

Beatrice-street.
 Coomoorra-road, from end of existing main (opposite lot 15) to Darran-road.

Gertrude-court.
Goodman-drive, from end of existing main (opposite lot 18) to a point opposite lot 130, about 9 chains generally northerly from Thelma-street.

Mary-court.
Thelma-street.

Springvale South.

Cambridge-drive, from end of existing main (opposite lot 15) to Northgate-drive.

Northgate-drive, from end of existing main (opposite lot 8) to Coomooora-road.

Teddy-crescent, from Northgate-drive to a point opposite lot 17, about 1½ chains easterly.

PAKENHAM URBAN DISTRICT.

Pakenham.

Toomuc Valley-road, from Princes Highway to a point opposite lot 8, about 9 chains north-easterly.

Wadsley-avenue, from end of existing main (opposite lot 3) to a point opposite lot 12, about 6½ chains south-easterly from Roger-street.

Tynong.

Nar-Nar-Goon—Longwarry road, from Park-road to a point opposite lot 7, about 12 chains easterly.

OTWAY URBAN DISTRICT.

Terang.

Estcourt-street, from High-street to Baynes-street.

NEWSTEAD URBAN DISTRICT.

Newstead.

Codrington-street, from end of existing main (opposite allotment 2, section 27) to Palmerston-street.

Dundas-street, from Hilliers-street to Wyndham-street.

Palmerston-street, from Codrington-street to a point opposite allotment 3, section 28A, about 3½ chains north-easterly.

Wyndham-street, from Dundas-street to Monash-street.

The main pipe in the said streets being laid down, the owners of all tenements situated as above are hereby required, on or before the 1st day of January, next, to cause proper pipes and stop cocks to be laid, so as to supply water within such tenements from the main pipe.

G. W. LEWIS, Secretary,
State Rivers and Water Supply Commission.

Melbourne, 19th November, 1971.

FARM PRODUCE MERCHANTS AND COMMISSION AGENTS ACT 1965 (No. 7274).

List of names and addresses of persons to whom licences have been granted during October, 1971. In accordance with the above Act, those issued with a Merchant's or Commission Agent's licence have paid the prescribed fee to the Farm Produce Merchants and Commission Agents Guarantee Fund. All licences, unless earlier cancelled, shall continue in force until 30th June, 1972.

D. S. WISHART,
Director of Agriculture.

MERCHANTS.

Name; Principal Place of Business.

Calabro, S. and Sons, Bairnsdale. 3875.
De Luca and Son (Wangaratta); 50 Reid-street, Wangaratta. 3677.

Hoyle, P. and Son; Hoyles-road, Yelta.
Pays (Kerang) Pty. Ltd.; 657-677 Springvale-road, Mulgrave. 3170.

Permewans (Horsham) Pty. Ltd.; 657-677 Springvale-road, Mulgrave. 3170.

Permewans (Traralgon) Pty. Ltd.; 657-677 Springvale-road, Mulgrave. 3170.

Permewans (Wangaratta) Pty. Ltd.; 657-677 Springvale-road, Mulgrave. 3170.

Permewan Wright Limited, 657-677 Springvale-road, Mulgrave. 3170.

P.W. Proprietary Limited; 657-677 Springvale-road, Mulgrave. 3170.

Williams, G. R.; 49 Welfare-parade, Burwood. 3125.

SECONDARY WHOLESALER.

Woodford's Fruit Shop; 19 Violet-grove, Wendouree West. 3355.

Country Fire Authority Act 1958.

FIRE DANGER PERIOD IN RESPECT OF SPECIFIED PARTS OF THE COUNTRY AREA OF VICTORIA.

Whereas by section 4 of the *Country Fire Authority Act 1958* it is enacted that the Chief Secretary of Victoria, after consultation with the Minister of Forests, may from time to time by declaration published in the *Government Gazette* declare any period to be the fire danger period in respect of the country area of Victoria, or any specified part or parts thereof and, without affecting the generality of the foregoing, may declare different periods to be the fire danger period in respect of different parts of the said country area:

And, whereas the Chief Secretary and the Minister of Forests have consulted accordingly:

Now therefore I, the Chief Secretary of Victoria, do hereby declare the period commencing at midnight on the 26th day of November, 1971, and ending at midnight on the 30th day of April, 1972, to be the fire danger period in respect of the parts of the country area of Victoria situated within the municipal districts or parts of municipal districts, being portion of the eighteenth Fire Control Region, specified in the Schedule hereunder:—

SCHEDULE No. 4.

Part Shire of Karkaroc—West Riding; East Riding and South Riding.

R. J. HAMER,

Chief Secretary.

Chief Secretary's Office,
Melbourne, 22nd November, 1971.

AUCTION SALES ACT 1958.

CHARLTON.—Notice is hereby given that the Annual Meeting of Justices for the Licensing of Auctioneers will be held at the Magistrates' Court, Charlton, on Tuesday, the 29th day of November, 1971, at Ten o'clock in the forenoon. Dated the 16th day of November, 1971.—D. A. DRUMMOND, Clerk of the Magistrates' Court, Charlton.

DONALD.—Notice is hereby given that the Annual Meeting of Justices for the Licensing of Auctioneers will be held at the Magistrates' Court, Donald, on Tuesday, the 29th day of November, 1971, at Ten o'clock in the forenoon. Dated the 16th day of November, 1971.—D. A. DRUMMOND, Clerk of the Magistrates' Court, Donald.

ST. ARNAUD.—Notice is hereby given that the Annual Meeting of Justices for the Licensing of Auctioneers will be held at the Magistrates' Court, St. Arnaud, on Tuesday, the 29th day of November, 1971, at Ten o'clock in the forenoon. Dated the 16th day of November, 1971.—D. A. DRUMMOND, Clerk of the Magistrates' Court, St. Arnaud.

Survey Co-ordination Act 1958.

NOTICE OF INTENTION TO ASSIGN NAMES.

Pursuant to the powers conferred under section 28 of the above Act, the Place Names Committee hereby gives notice of its intention to assign the following names to the High Schools mentioned hereunder:—

Municipality.—City of Altona.

Location.—Situated north of the South Western Railway in the vicinity of the eastern boundary of the City.

Proposed name.—Altona East High School.

Municipality.—City of Keilor.

Location.—Avondale Heights.

Proposed name.—Avondale Heights High School.

Municipality.—City of Springvale.

Location.—Isaac-road, Noble Park.

Proposed name.—Chandler High School.

Municipality.—Shire of Rodney.

Location.—At Mooroopna.

Proposed name.—Mooroopna High School.

Any person who objects to any or all of the above proposals may give notice of objection, in writing, stating the reasons therefor, to the Secretary of the Committee not more than two (2) months following the publication of this notice.

By order of the Committee,

C. E. E. BARLOW, Secretary.

17th November, 1971.

Private Agents Act 1966.

NOTICE OF RECEIPT OF APPLICATION FOR LICENCES UNDER THE PROVISIONS OF THE PRIVATE AGENTS ACT 1966.

The Clerk(s) of the Magistrates' Court(s) as listed hereunder hereby give notice that applications, as under, have been lodged for hearing by the said Court(s) on the date(s) specified.

Any person desiring to object to any of such applications must—

- (a) lodge with the respective Clerk of the Magistrates' Court a notice in the prescribed form of his objection and of the grounds thereof;
- (b) cause a copy of such notice to be served personally or by post upon the applicant at least three days before the hearing of the application; and
- (c) send or deliver—
 - (i) where the objection is not made by the officer in charge of the police district in which the Court is situated—a copy of the notice to such officer; and
 - (ii) where the objection is not made by the Registrar or Deputy Registrar—a copy to the Registrar.

Full Name of Applicant or in the Case of a Firm or Corporation, of the Nominee.	Place of Abode of Applicant or Nominee.	Name of Firm or Corporation.	Address for Registration.	Type of Licence.	Date of Hearing of Application.
---	---	------------------------------	---------------------------	------------------	---------------------------------

MAGISTRATES' COURT, MANSFIELD.

Lucas, Vaughan Patrick John ..	Flat A102, 1st Floor, Twin Towers, Mt. Buller	Snowline Security Services	Flat A102, 1st Floor Twin Towers, Mt. Buller	Guard Agent ..	15.12.71
--------------------------------	---	----------------------------	--	----------------	----------

Dated at Mansfield this 15th day of November, 1971.

D. J. GEAR, Clerk of the Magistrates' Court.

MAGISTRATES' COURT, MOE.

Higgins, Alan ..	Flat 1, 62 Shanahan-parade, Newborough	Latrobe Security Services	71 Wirraway-street, Moe	Watchman ..	6.12.71
------------------	--	---------------------------	-------------------------	-------------	---------

Dated at Moe this 12th day of November, 1971.

I. M. GRIFFITHS, Clerk of the Magistrates' Court.

MAGISTRATES' COURT, SALE.

Lees, Thomas Lowther ..	38 Henry-street, Maffra	Sale Security Patrol	2 Topping-street, Sale	Watchman ..	7.12.71
-------------------------	-------------------------	----------------------	------------------------	-------------	---------

Dated at Sale this 11th day of November, 1971.

D. R. WALKER, Clerk of the Magistrates' Court.

MAGISTRATES' COURT, WANGARATTA.

Knox, John Edward ..	Milawa	Milawa (Postal Box 263, Wangaratta)	Process Server ..	21.12.71
----------------------	-----------	----	-------------------------------------	-------------------	----------

Dated at Wangaratta this 15th day of November, 1971.

F. J. MORTIMER, Clerk of the Magistrates' Court.

MAGISTRATES' COURT, WILLIAMSTOWN.

Harris, Kenneth John ..	211 Esplanade, Altona	..	211 Esplanade, Altona	Guard Agent ..	7.12.71
-------------------------	-----------------------	----	-----------------------	----------------	---------

Dated at Williamstown this 17th day of November, 1971.

R. WILSON, Clerk of the Magistrates' Court.

MAGISTRATES' COURT, ST. KILDA.

Peters, Gabrielle Pam ..	Flat 4, 45 Narong-road North Caulfield	Checkmate Pty. Ltd.	Flat 4, 45 Narong-road, North Caulfield	Watchman ..	23.12.71
Michell, Patricia Mary ..	Flat 3, 9 Albert-street, Caulfield	..	Flat 3, 9 Albert-street, Caulfield	Inquiry Agent ..	"
Hammill, Patricia Joyce ..	21 Somerlayson-crescent, Fawkner	..	21 Somerlayson-crescent, Fawkner	Process Server ..	"
White, Fay ..	75 Wilson-street, Middle Brighton	Checkmate Pty. Ltd.	75 Wilson-street, Middle Brighton	Inquiry Agent ..	"
" ..	" ..	Checkmate Pty. Ltd.	" ..	Watchman ..	"

Dated at St. Kilda this 19th day of November, 1971.

R. FREEMAN, Clerk of the Magistrates' Court.

MAGISTRATES' COURT, PRAHRAN.

Slaats, Josephine Lawrens ..	134 Eastfield-road, Croydon	Factory Guard Service Pty. Ltd.	Flat 17, 562 St. Kilda-road, Melbourne	Watchman ..	25.11.71
Tatham, Trevor Archibald ..	37 Drinkwater-crescent, Sunshine	" ..	" ..	" ..	29.11.71
Ford, Con Louis ..	13 Kerringal-street, Altona	" ..	" ..	" ..	13.1.72
Bennett, Michael Lovell ..	Flat 1, 12 Lennox-street, Richmond	" ..	" ..	" ..	4.1.72
Kousal, Jiri ..	74 Commercial-road, Prahran	..	80 Commercial-road, Prahran	Inquiry Agent ..	"

Dated at Prahran this 16th day of November, 1971.

J. PRESNELL, Clerk of the Magistrates' Court.

MAGISTRATES' COURT, OAKLEIGH.

Jacks, Philip Stanley ..	34 Centre Dandenong-road, Cheltenham	..	6 Hamilton-place, Mount Waverley	Watchman ..	10.12.71
--------------------------	--------------------------------------	----	----------------------------------	-------------	----------

Dated at Oakleigh this 16th day of November, 1971.

G. MEEHAN, Clerk of the Magistrates' Court.

PRIVATE AGENTS—continued.

Full Name of Applicant or in the Case of a Firm or Corporation, of the Nominee.	Place of Abode of Applicant or Nominee.	Name of Firm or Corporation.	Address for Registration.	Type of Licence.	Date of Hearing of Application.
MAGISTRATES' COURT, MORNINGTON.					
Morgan, Peter Claude	12 Nelson-street, Mornington		12 Nelson-street, Mornington	Process Server	6.12.71
Dated at Mornington this 15th day of November, 1971.					
R. J. McHUGH, Clerk of the Magistrates' Court.					
MAGISTRATES' COURT, MORDIALLOC.					
Reno, Karl..	205 Lower Dand-nong-road, Mentone	Hauser, Gifford C. T/as Standard Security Service	40 Melrose-street, Mordialloc	Watchman	23.12.71
Dated at Mordialloc this 17th day of November, 1971.					
M. O'CONNOR, Clerk of the Magistrates' Court.					
MAGISTRATES' COURT, MOE.					
Johnson, Ian	23 Peacc-avenue, Warragul	Latrobe Security Services	71 Wirraway-street, Moe	Watchman	16.12.71
Dated at Moe this 17th day of November, 1971.					
I. M. GRIFFITHS, Clerk of the Magistrates' Court.					
MAGISTRATES' COURT, GEELONG.					
Grant, Warren John	"Santa Fe" Torquay-road, Grovedale		55 The Esplanade, North Shore	Watchman	10.12.71
Dated at Geelong this 19th day of November, 1971.					
J. REILLY, Clerk of the Magistrates' Court.					
MAGISTRATES' COURT, CASTERTON.					
Lewis, Ian Colin	88 Jackson-street, Casterton		88 Jackson-street, Casterton	Process Server	9.12.71
Dated at Casterton this 15th day of November, 1971.					
T. J. WILSON, Clerk of the Magistrates' Court.					

Melbourne and Metropolitan
BOARD OF WORKS.

NOTICE TO THE OWNERS OF TENEMENTS IN THE UNDER-MENTIONED STREETS AND THE PRIVATE STREETS, LANES, COURTS AND ALLEYS OPENING THERETO.

The main pipe in the said streets being laid down, the owners of all tenements situated as under are hereby required on or before the 27th December, 1971, to cause a proper pipe and stopcocks to be laid so as to supply water within such tenements from the main pipe.

W. C. S. ELLIS,
Secretary.

16th November, 1971.

STREET AND POSITION.
Berwick.

Robert-crescent, from 270 feet north of Philip-road northwards 250 feet.

Doncaster and Templestowe.

Canopus-drive, from 130 feet east of Centaur-avenue to Polaris-drive.
Taurus-road, from Canopus-drive northwards 150 feet.
Saturn-terrace, from Polaris-drive westwards 700 feet.
Telopea-drive, from Polaris-drive southwards 380 feet.

Heidelberg.

Martins-lane, from 70 feet east of Kuranga-road eastwards 620 feet.
Rosemar-circuit, from 90 feet south of The Mews southwards 670 feet.
Norma-court, from Rosemar-circuit eastwards 390 feet.
Dawn-court, from Rosemar-circuit eastwards 355 feet.
Danson-street, from Winston-road to Rosemar-circuit.

Lilydale.

Daymar-drive, from Bimbadeen-drive northwards 1,500 feet.
Hayrick-lane, from 80 feet north of Parry-drive northwards 970 feet.
Bimbadeen-drive, from Hayrick-lane eastwards 440 feet.
Old Kent-road, from 400 feet east of Blueberry-road to Hayrick-lane.
Shadowplay-road, from Old Kent-road southwards and westwards 880 feet.

Meadowlark-lane, from Old Kent-road southwards 870 feet.
Bimbi-court, from Old Kent-road southwards 460 feet.
Turrella-court, from Meadowlark-lane eastwards 550 feet.
Western-way, from 510 feet east of Blueberry-road eastwards 260 feet.
High Point-avenue, from 610 feet east of Blueberry-road eastwards 160 feet.
Karabeal-court, from Stradbroke-road south-eastwards 500 feet.
Hull-road, from Greenslopes-drive northwards 270 feet.
Cherylnne-crescent, from 100 feet south of Butler-street southwards and eastwards 580 feet.
Landy-court, from Cherylnne-crescent south-westwards 480 feet.
Montrose-road, from 260 feet north of Foulds-court, northwards 400 feet.
Chestnut-court, from Montrose-road westwards 960 feet.
Gum-court, from Chestnut-court southwards 330 feet.
Everton-road, from Hereford-road to Bradman-avenue.

Melbourne.

Little Queen-street, from Little Bourke-street, south-eastwards 152 feet.

Moorabbin.

Warsaw-court, from Clayton-road westwards 180 feet.

Northcote.

Station-street, from Flinders-street northwards 90 feet.
Flinders-street, from Gladhall-avenue eastwards 570 feet.

Preston.

Hughes-parade, from Wilson Boulevard south-eastwards 420 feet.

Ringwood.

Mersey-street, from Farmar-street southwards 70 feet.
Suzanne-court, from 110 feet south of Gabriella-court southwards and eastwards.
Daniele-crescent, from 580 feet north of Bungalook-road northwards and westwards 620 feet.

Sunshine.

Central-avenue, from First-avenue to Second-avenue.

Cemeteries Act 1958.

SCALE OF FEES OF FERNTREE GULLY PUBLIC CEMETERY.

In pursuance of the powers conferred upon them by the Cemeteries Act the trustees of the Ferntree Gully Public Cemetery hereby make the following scale of fees, which shall come into operation upon publication in the Government Gazette, and from and after such publication every scale of fees heretofore made by the said trustees shall be and is hereby rescinded to the extent to which it conflicts with this scale.

Private Graves (Including Sinking).	
General denominational sections (8 ft. x 4 ft.)	\$80.00
Reopening Charges.	
General denominational monumental graves	\$35.00
Lawn Section graves	\$40.00
Oversize Graves.	
Oversize shaped graves (all sections) (extra)	\$10.00
Irregular shaped graves (7 ft. x 2 ft. 3 inches) (extra)	\$30.00
Exhumations.	
Exhumation of the remains of a body when authorized	\$80.00
Deeds.	
Execution of a duplicate deed	\$2.00
M. J. WHITE, Trustee. A. OWEN, Trustee. E. BOWTELL, Trustee.	

Approved by the Governor in Council, 16th November, 1971.—J. ROSSITER, Clerk of the Executive Council.

Cemeteries Act 1958.

SCALE OF FEES OF HARRIETVILLE PUBLIC CEMETERY.

In pursuance of the powers conferred upon them by the Cemeteries Act the trustees of the Harrietville Public Cemetery hereby make the following scale of fees, which shall come into operation upon publication in the Government Gazette, and from and after such publication every scale of fees heretofore made by the said trustees shall be and is hereby rescinded to the extent to which it conflicts with this scale.

Private Graves.	
Land 8 ft. x 4 ft.	\$20.00
Land 8 ft. x 8 ft.	\$40.00
Land 6 ft. x 3 ft. (for babies)	\$6.00
Selection of land (extra)	\$3.00
Sinking Charges for Private Graves.	
Sinking grave 6 feet deep	\$36.00
Each additional foot	\$4.00
Reopening Charges.	
Sinking grave (no cover)	\$30.00
Sinking grave (with cover)	\$35.00
Miscellaneous Charges.	
Commission to erect a headstone or monument	\$6.00
E. V. ATTRIDGE, Trustee. E. PIGGOT, Trustee. D. HOOKEY, Trustee.	

Approved by the Governor in Council, 16th November, 1971.—J. ROSSITER, Clerk of the Executive Council.

Cemeteries Act 1958.

SCALE OF FEES OF MEMORIAL PARK WILLIAMSTOWN PUBLIC CEMETERY.

In pursuance of the powers conferred upon them by the Cemeteries Act the trustees of the Memorial Park, Williamstown Public Cemetery hereby make the following scale of fees, which shall come into operation upon publication in the Government Gazette, and from and after such publication every scale of fees heretofore made by the said trustees shall be and is hereby rescinded to the extent to which it conflicts with this scale.

CREMATORIUM.	
Cremation Fees.	
Cremation fee	\$45.00
Additional Saturday fee	\$20.00

LAWN CEMETERY.

Burial Fees.

Lawn grave inclusive of sinking to 7 feet	\$120.00
Reopen	\$58.00
Exhumation fee	\$75.00
Interment of cremated remains	\$20.00
S. H. ROBINSON, Trustee. J. E. PATTERSON, Trustee. D. SMITH, Trustee. C. W. SIDWAY, Manager and Secretary.	

Approved by the Governor in Council, 16th November, 1971.—J. ROSSITER, Clerk of the Executive Council.

Cemeteries Act 1958.

SCALE OF FEES OF NEW MELBOURNE CEMETERY.

In pursuance of the powers conferred upon them by the Cemeteries Act the trustees of the New Melbourne Cemetery hereby make the following scale of fees, which shall come into operation upon publication in the Government Gazette, and from and after such publication every scale of fees heretofore made by the said trustees shall be and is hereby rescinded to the extent to which it conflicts with this scale.

Cremation: Interment of cremated remains	\$20
Full Cremation Fee:	\$45
Cremation: Flat rate Saturday morning	\$55
Exhumation Fee	\$100
Traditional Area Grave Sites:	
R. C. "T"	\$50
Protestant "E"	\$50
Presbyterian Ordinary	\$50
Greek "E"	\$50
Methodist "E"	\$50
Baptist "C"	\$50
Salvation Army	\$50
Church of Christ	\$50
Congregational "C"	\$50
Chinese "B"	\$50
Other Denominations	\$50
Mohamedan "B"	\$50
Macedonian "A"	\$50
Jews	\$65
Lawn Areas:	
Church of England "S"	\$70
Roman Catholic "R" Lawn	\$70
Presbyterian Lawn "E"	\$70

PINE RIDGE MEMORIAL PARK—COBURG.

Traditional Area—Lawn Area:	
All denominations (Traditional Area)	\$50
Lawn Areas	\$70
Exhumation:	\$100
J. MANSFELD, Trustee. H. G. CANTWELL, Trustee. K. W. JOYCE, Trustee. H. J. CROWHURST, Administrator and Secretary.	

Approved by the Governor in Council, 16th November, 1971.—J. ROSSITER, Clerk of the Executive Council.

Cemeteries Act 1958.

SCALE OF FEES OF WILLOW GROVE PUBLIC CEMETERY.

In pursuance of the powers conferred upon them by the Cemeteries Act the trustees of the Willow Grove Public Cemetery hereby make the following scale of fees, which shall come into operation upon publication in the Government Gazette, and from and after such publication every scale of fees heretofore made by the said trustees shall be and is hereby rescinded to the extent to which it conflicts with this scale.

Public Graves.	
Interment in grave without exclusive right—Still-born child	\$7.00
Interment in grave without exclusive right—Others	\$14.00
Number peg or label	\$3.00
Private Graves.	
Land 8 ft. x 4 ft.	\$24.00
Own selection of land (extra)	\$6.00
Sinking Charges for Private Graves.	
Sinking grave 6 ft. deep	\$36.00
Each additional foot	\$4.00
Sinking oversize grave (extra)	\$12.00
Cancellation of order to sink (if commenced)	\$6.00

Reopening Charges.

Reopening grave (no cover)	\$30.00
Reopening grave (with cover)	\$35.00

Extra Charges.

Interment outside prescribed hours, or on Saturdays, Sundays or Public Holidays	\$12.00
Interment in a private grave without due notice	\$12.00

Miscellaneous Charges.

Interment fee	\$12.00
Certificate of right of burial	\$1.00
Number plate or brick	\$3.00
Permission to erect a headstone or monument—5% of cost with a minimum of	\$6.00
Permission to construct a brick grave or to erect any stone kerb, brick tile-work or concrete	\$5.00
Exhuming the remains of a body (when authorized)	\$30.00
Interment of ashes in a private grave	\$12.00

N. L. ROBINSON, Trustee.
C. H. WILLIAMS, Trustee.
A. C. METHER, Trustee.

Approved by the Governor in Council, 16th November, 1971.—J. ROSSITER, Clerk of the Executive Council.

Cemeteries Act 1958.
SCALE OF FEES OF BALLARAT GENERAL CEMETERIES.

In pursuance of the powers conferred upon them by the Cemeteries Act the trustees of the Ballarat General Cemeteries hereby make the following scale of fees, which shall come into operation upon publication in the *Government Gazette*, and from and after such publication every scale of fees heretofore made by the said trustees shall be and is hereby rescinded to the extent to which it conflicts with this scale.

Miscellaneous Fees.

Consignment of cremated remains (within Australia)	\$5.00
Cremated remains taken from crematorium	\$2.00

E. G. LUDBROOK, Trustee.
B. HEDGECOCK, Trustee.
M. N. STONE, Trustee.
KENNETH A. CLAYTON, Secretary and Manager.

Approved by the Governor in Council, 16th November, 1971.—J. ROSSITER, Clerk of the Executive Council.

*Forests Act 1958 (No. 6254).***NOTICE DECLARING LAND TO BE SUBJECT TO SPECIAL CAMPING AND FIRE RESTRICTIONS.**

By virtue of the provisions of Regulation 1502 of the Forests (Part 1—Fire Protection) Regulations 1967 made under the Forests Act 1958, the Forests Commission by this notice declares so much of the Crown land as is described in the First Schedule to be subject to the restrictions and prohibitions set out in the Second Schedule for the period commencing on the fifteenth day of November in each year and ending on the thirtieth day of April in the year following.

FIRST SCHEDULE.

All Crown land which being part of a fire protected area is within 20 chains of the edge of the water on the southern shore of the big Eildon Reservoir extending from the Eildon Dam on the west to the Goulburn River on the east.

SECOND SCHEDULE.

- No person shall—
1. Erect, pitch or make use of a shelter, tent, hut, caravan or other means of encampment except—
 - (a) in a camping area established by the Forests Commission or by or under the control of a Committee of Management appointed pursuant to section 50 of the Forests Act 1958; or
 - (b) on land vested in the control of the State Rivers and Water Supply Commission or a Committee of Management appointed pursuant to section 206 (a) of the Water Act 1958, and set aside for the purpose of camping; or
 - (c) in accordance with a special authority issued by the District Forester, State Rivers and Water Supply Commission or a Committee of Management appointed pursuant to section 50 of the Forests Act or section 206 (a) of the Water Act 1958.

2. Light, kindle, maintain, permit to remain alight or knowingly or negligently cause to be kindled or maintained any fire in the open air for any purpose whatsoever, except—

- (a) in a fireplace constructed or caused to be constructed by the Forests Commission, State Rivers and Water Supply Commission or by or under the control of a Committee of Management appointed pursuant to section 50 of the Forests Act 1958, or section 206 (a) of the Water Act 1958, in any camping area as aforesaid; or
- (b) in accordance with a special authority issued by the District Forester, State Rivers and Water Supply Commission or a Committee of Management appointed pursuant to section 50 of the Forests Act 1958 or section 206 (a) of the Water Act 1958.

3. A fire lit in accordance with the provisions of clause 2 hereof—

- (a) shall not be left unattended at any time; and
- (b) shall immediately be extinguished upon the request of a forest officer or a member of the Police Force.

4. In the event of a fire spreading or being likely to spread, each person present or in attendance at the fire—

- (a) shall do everything that is reasonably within his power to prevent it from spreading; and
- (b) shall ensure that the existence of the fire and the fact of its spreading or being likely to spread is reported as soon as practicable to the nearest forest officer, member of the Police Force or member of a fire brigade.

5. Nothing in this notice shall be construed as an authority for lighting, kindling, maintaining or permitting to remain alight any fire contrary to—

- (a) the provisions of a notice under section 64 of the Forests Act 1958; or
- (b) a warning broadcast, pursuant to section 40 of the Country Fire Authority Act 1958.

D. J. LENNE,
Acting Secretary.

*Dairy Products Act.***QUOTAS FOR BUTTER AND CHEESE.****BUTTER QUOTA.**

I, GILBERT LAWRENCE CHANDLER, Minister of Agriculture in the State of Victoria, after consultation with the Victorian Dairy Products Board, and after ascertaining that the supply and distribution of butter at reasonable prices to consumers thereof in Victoria will be ensured, hereby determine a quota for butter as follows:—

The proportion shall be thirty eight point five eight per centum.

The period for which this quota is to operate shall be the month of December, 1971.

CHEESE QUOTA.

I, GILBERT LAWRENCE CHANDLER, Minister of Agriculture in the State of Victoria, after consultation with the Victorian Dairy Products Board, and after ascertaining that the supply and distribution of cheese at reasonable prices to consumers thereof in Victoria will be ensured, hereby determine a quota for cheese as follows:—

The proportion shall be thirty one point four four per centum.

The period for which this quota is to operate shall be the month of December, 1971.

G. L. CHANDLER,
Minister of Agriculture.

THE LIQUOR CONTROL ACT 1968.

Whereas the Hotelkeeper's licence for the licensed premises known as the Royal Hotel, situate at Rupanyup, has been surrendered as from 30th November, 1971; notice is hereby given that the amount of compensation payable to the owner of such premises pursuant to the provisions of the *Liquor Control Act 1968* is as under:—

Owner—\$24,000.

Dated at Melbourne, this 22nd day of November, 1971.

J. P. CROWE, Secretary.
Liquor Control Commission:

PUBLIC TRUSTEE ACT 1958 (No. 6350), SECTION 17.

I hereby give notice that on the 21st October, 1971, the Public Trustee filed elections to administer the following deceased persons' estates in accordance with section 17 of the Public Trustee Act 1958.

HURST, WILLIAM CHARLES, late of King-street, Myrtleford, labourer, died 28th August, 1971.

I hereby give notice that on the 5th November, 1971, the Public Trustee filed elections to administer the following deceased persons' estates in accordance with section 17 of the Public Trustee Act 1958.

COPLAND, HAROLD VICTOR, late of 6 Dane-street, Footscray, pastry cook, died 7th September, 1971.

COX, LOUISA, formerly of 5 Turner-avenue, Glenhuntly, late of 26 Burrows-street, Middle Brighton, widow, died 20th August, 1971.

HELDING, ALFRED, formerly of 22 Gordon-street, Deepdene, but late of Kew, pensioner, died 25th May, 1971.

MURRAY, CLARENCE MALVOLIO, formerly of 10 Arkle-street, East Prahran, but late of 7 Latrobe-street, Oakleigh, retired clerk, died 8th August, 1971.

SNOP, JAN, late of 99 Studley Park-road, Kew, cleaner, died 5th July, 1971.

WATSON, WILLIAM, late of 46 Kent-street, Richmond, died presumed—pursuant to Mr. Justice Crockett's Order of 27th August, 1971.

I hereby give notice that on the 11th November, 1971, the Public Trustee filed elections to administer the following deceased persons' estates in accordance with section 17 of the Public Trustee Act 1958.

LEARSCH, EDWARD FRANCIS, also known as Learsch Edward, late of 43 Fordham-road, East Reservoir and 30 Church-street, Fitzroy, driver, died between 11th and 14th July, 1971.

LEE, GEORGE ALBERT, formerly of 258 Maribyrnong-road, Moonee Ponds, but late of Flat 2, 15 Churchill-avenue, Maidstone, pensioner, died 21st December, 1967.

LEHANE, BRIDGET, also known as Lehane Delia, late of 290 The Kings Way, Caringbah, New South Wales, spinster, died 11th May, 1966.

MOLLISON, PHOEBE, formerly of 37 Shepparson-street, Carnegie, but late of Bentleigh House, 193 Jasper-road, Bentleigh, widow, died 8th September, 1971.

MORLEY, MARY ELLA, late of 47 Flinders-street, Mentone, spinster, died 21st September, 1971.

N. P. BRODY,
Public Trustee.

256 Flinders-street, Melbourne, 3000, 17th November, 1971.

NOTICE.

Creditors, next of kin, and others having claims against the estate of any of the under-mentioned deceased persons are required to send particulars of their claims to the Public Trustee, 256 Flinders-street, Melbourne, Vic. 3000, the personal representative on or before the 31st January, 1972, after which date the Public Trustee may convey or distribute the assets, having regard only to the claims of which the Public Trustee then has notice:—

BRIEN, MYRA ANN, late of 29 Kelsby-street, Reservoir, widow, died 30th July, 1971.

BROUGHTON, ETHEL MAY, formerly of 3 Albion-street, St. Kilda, but late of Queen Elizabeth Home, 102 Ascot-street, Ballarat, widow, died 30th June, 1971.

BROWNE, JAMES DANIEL, late of 7 Burrows-street, Golden Square, retired cyanider, died 25th July, 1971.

COPLAND, HAROLD VICTOR, late of 6 Dane-street, Footscray, pastry cook, died 7th September, 1971.

COX, LOUISA, formerly of 5 Turner-avenue, Glenhuntly, but late of 26 Burrows-street, Middle Brighton, widow, died 20th August, 1971.

DOWER, IDA, late of 1175 Dandenong-road, East Malvern, widow, died 9th September, 1971.

FISH, CYRIL, late of 3 Nepean Highway, East Brighton, retired electrical mechanic, died 19th August, 1971.

GODENZJ, LESLIE, late of 41 Repton-road, East Malvern, retired salesman, died 15th September, 1971.

HAMILTON, IVO ARCHIE HARRLIAM, also known as Hamilton, Ivo Archie, late of 16 Mount Pleasant-road, West Preston, retired tailor's cutter, died 28th July, 1971.

HELDING, ALFRED, formerly of 22 Gordon-street, Deepdene, but late of Kew, pensioner, died 25th May, 1971.

HURST, WILLIAM CHARLES, late of King-street, Myrtleford, labourer, died 28th August, 1971.

KEIGHERY, FRANCIS PATRICK, formerly of Bundoora, but late of Poowong, retired railway employee, died 10th February, 1970.

KEMP, JOHN VERNON, also known as John Gunter, formerly of 85 Kooyong-road, Armadale, but late of St.

Joseph's Home, St. Georges-road, Northcote, retired cook, died 20th July, 1971.

LEARSCH, EDWARD FRANCIS, also known as Learsch Edward, late of 43 Fordham-road, East Reservoir and 30 Church-street, Fitzroy, driver, died between 11th and 14th July, 1971.

LEE, GEORGE ALBERT, formerly of 258 Maribyrnong-road, Moonee Ponds, but late of Flat 2, 15 Churchill-avenue, Maidstone, pensioner, died 21st December, 1967.

LEHANE, BRIDGET, also known as Lehane Delia, late of 290 The Kings Way, Caringbah, New South Wales, spinster, died 11th May, 1966.

LIPMAN, FRANCES ADELAIDE, also known as Frances Rebecca Lipman, late of 2 Dalmore-avenue, Ormond, widow, died 23rd August, 1971.

MARSDEN, HARRIET ELLENOR, also known as Nellie Marsden, late of 13 Railway-crescent, Croydon, widow, died on or about 30th May, 1971.

MITCHELL, EDITH, formerly of 10 Talbot-avenue, Balwyn, and 106 Park-street, Abbotsford, but late of 14 Balwyn-road, Canterbury, widow, died 10th September, 1971.

MOLLISON, PHOEBE, formerly of 37 Shepparson-street, Carnegie, but late of Bentleigh House, 193 Jasper-road, Bentleigh, widow, died 8th September, 1971.

MORLEY, MARY ELLA, late of 47 Flinders-street, Mentone, spinster, died 21st September, 1971.

MUSEY, DORIS ROSA, late of 38 View-street, Alphington, widow, died 1st September, 1971.

MURRAY, CLARENCE MALVOLIO, formerly of 10 Arkle-street, East Prahran, but late of 7 Latrobe-street, Oakleigh, retired clerk, died 8th August, 1971.

NEWCOMBE, MARY KATHLEEN, commonly known as Kathleen Mary Newcombe, late of Unit 2, 15 Golden-avenue, Chelsea, spinster, died 2nd August, 1971.

PULLAR, NORMAN, formerly of 25 Moore-street, Elwood, but late of 35 Chandler-road, Boronia, retired engine driver, died 3rd May, 1971.

SNOP, JAN, late of 99 Studley Park-road, Kew, cleaner, died 5th July, 1971.

WARREN, HENRY DEERING, late of 6 O'Shannassy-street, Essendon North, retired farmer, died 18th July, 1971.

WATSON, WILLIAM, late of 46 Kent-street, Richmond, gripman, died presumed—pursuant to Mr. Justice Crockett's Order of 27th August, 1971.

WEBB, FRANK EVAN, late of 495 South-road, Black Forest, South Australia, retired manufacturers' representative, died 8th March, 1962.

WEEDON, IDA MAY, late of 53 Dunstan-parade, Garden City, widow, died 13th August, 1971.

WILKIE, CATHERINE, formerly of 5 Cordite-avenue, Maribyrnong and 170 Forrest-street, Ardeer, but late of Springfield Private Hospital, 162 Albert-avenue, Boronia, widow, died 16th September, 1971.

WOJDYNO, JAN, also known as Woydyno Jan, late of 28 Brighton-street, Flemington, retired S.E.C. employee, died 7th August, 1971.

N. P. BRODY,
Public Trustee.

Melbourne, 17th November, 1971.

CONTRACTS ACCEPTED.—(Series 1971-72.)

VICTORIAN RAILWAYS.

45. Re-roofing, re-cladding and partial concreting of floor of the locomotive depot on premises of the Corporation, in Alfred-street, Ararat, for the amount of \$7,240.00 (Contract 63726).—J. Pearce Builder Pty. Ltd.
46. Removing departmental residence No. 4218, from Port Fairy and re-assembling at Warrnambool, together with outbuilding for the amount of \$861.99 (Contract 63714).—J. W. Burow.

W. WALKER, Secretary for Railways. 19.11.71.

ORDERS IN COUNCIL.—(Series 1971-72.)

PUBLIC WORKS.

588. Burwood, Teachers College, supply and installation of Debron carpet, \$28,932.00.—Myer Teale Pty. Ltd.—(I. & D. 123377J).

589. Westernport, supply and installation of approach speed indicator on Long Island Jetty, \$26,650.00.—Amalgamated Wireless (Australasia) Ltd.—(P. & H. 166328).

Approved by the Governor in Council, 16th November, 1971.—J. ROSSITER, Clerk of the Executive Council.

DEPARTMENT OF MINES.

Subject to any necessary excisions, &c., it is proposed to grant the following mining leases:—

- 11399, Bendigo; North Deborah Mining Company No Liability; 21a. 1r. 8p., Parish of Sandhurst.
- 9277, Castlemaine; Herbert Claude Cann; 23a. 3r. 30p., Parish of Tylden.

APPLICATION FOR MINING LEASE DECLARED ABANDONED.

- 9125, Mineral; Vance O'Haire, Michael John Kent; 610 acres, Parish of Heathcote.

TERMS OF EXPLORATION LICENCES EXTENDED.

- 131, Exploration Licence; Western Mining Corporation Limited; 189 square miles, County of Moira.
- 132, Exploration Licence; Western Mining Corporation Limited; 144 square miles, County of Borung.

EXPLORATION LICENCES CANCELLED.

- 139, Exploration Licence; M.D.F. Pty. Ltd.; 360 square miles, County of Bogong.
- 195, Exploration Licence; Doogalook Mining Pty. Ltd.; 6 square miles, Parishes of Yea and Windham.

EXTRACTIVE INDUSTRY LICENCES GRANTED.

- 119, Extractive Industry Licence; Charles Samuel Franklin Trippit; 5a. 2r. 50p., Parish of Doutta Galla.
- 170, Extractive Industry Licence; Tyers Sand Pits Pty. Limited; 62a. 3r. 25p. more or less; Parish of Maryvale.
- 470, Extractive Industry Licence; Maskell & Gribben Pty. Ltd.; 9a. 0r. 17 7/10p., Parish of Kialla.

J. C. M. BALFOUR,
Minister of Mines.

MINING LEASE DECLARED VOID.

- 8922, Mineral; Doogalook Mining Pty. Ltd.; 6a. 0r. 13p., Parish of Yea.

E. CONDON,
Secretary of Mines.

COUNTRY ROADS BOARD.

RESOLUTIONS OF THE COUNTRY ROADS BOARD.

The Country Roads Board, in pursuance of the provisions of the Country Roads Act 1958, has passed Resolutions the dates whereof and the terms of which are Schedule hereunder:—

SCHEDULE.

State Highway.

Resolution dated the Eighth day of November, One thousand nine hundred and seventy-one, made pursuant to sections 21 and 74 of the Country Roads Act 1958, declaring the widening of the North Western Highway in the Shire of Donald as shown hatched on Plans numbered G.P.8077A and G.P.8078 hereunder to be part of a State highway within the meaning and for the purposes of the said Act.

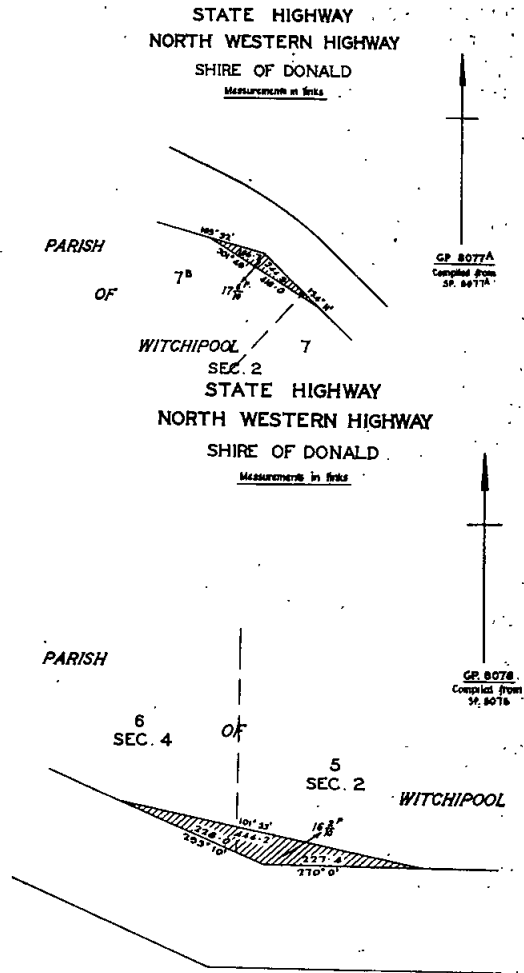
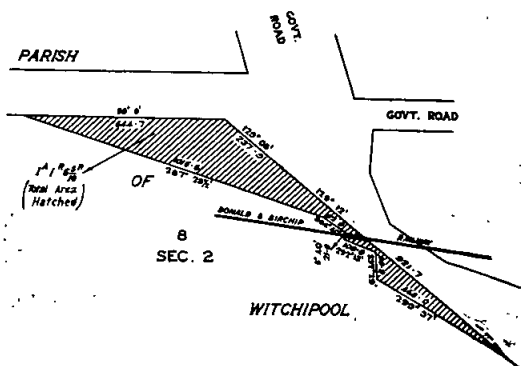

Main Roads.

Resolution dated the Eighth day of November, One thousand nine hundred and seventy-one, made pursuant to section 21 of the Country Roads Act 1958, declaring the widening of the Korumburra-Wonthaggi road in the Shire of Korumburra as shown hatched on Plan numbered G.P.10099 hereunder to be part of a main road within the meaning and for the purposes of the said Act.

MAIN ROAD
KORUMBURRA - WONTHAGGI ROAD

SHIRE OF KORUMBURRA

Measurements in feet & ins.

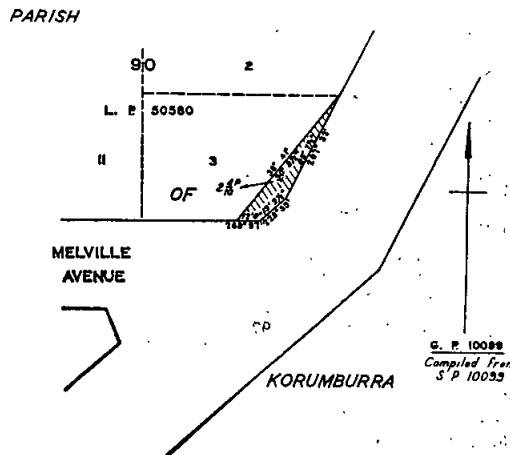

Resolution dated the Fifteenth day of November, One thousand nine hundred and seventy-one, made pursuant to section 21 of the Country Roads Act 1958, declaring the widening of the Barwon Heads-road in the Shire of South Barwon as shown hatched on Plans numbered G.P.9794, G.P.9795 and G.P.9796 hereunder to be part of a main road within the meaning and for the purposes of the said Act.

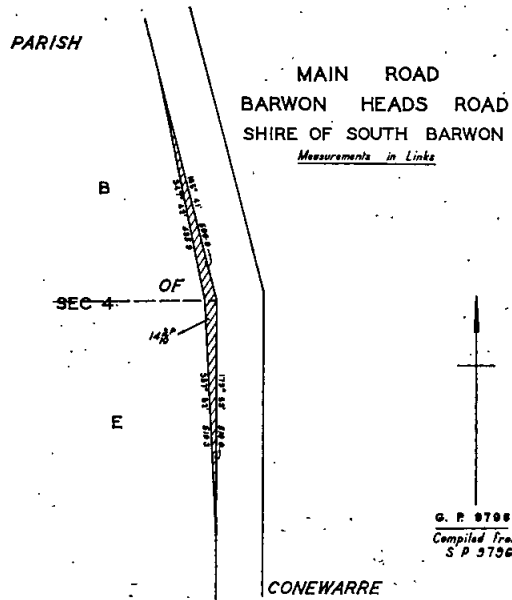
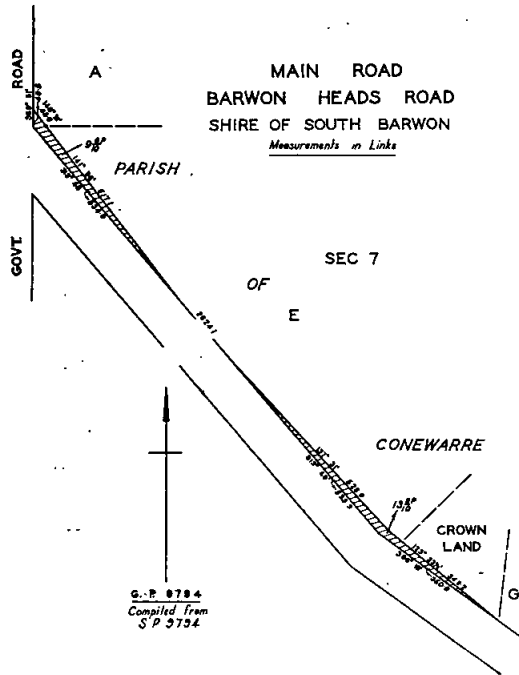

Resolution dated the Eighth day of November, One thousand nine hundred and seventy-one, made pursuant to section 21 of the Country Roads Act 1958, declaring the widening of the Allansford-Peterborough road in the Shire of Warrnambool as shown hatched on Plan numbered G.P.8180 hereunder to be part of a main road within the meaning and for the purposes of the said Act.

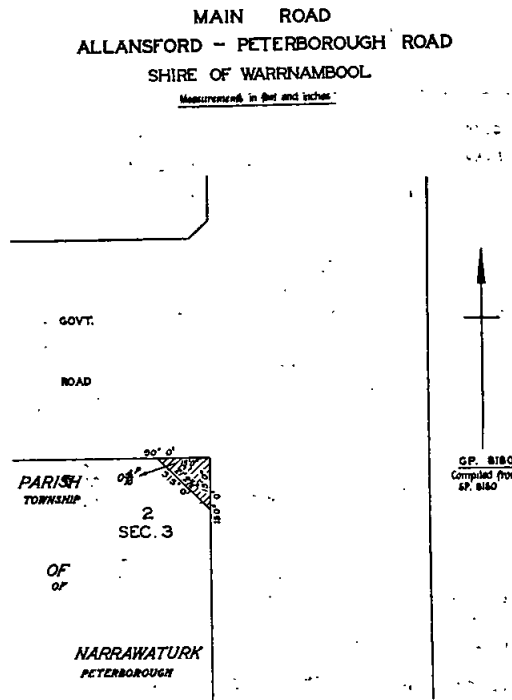
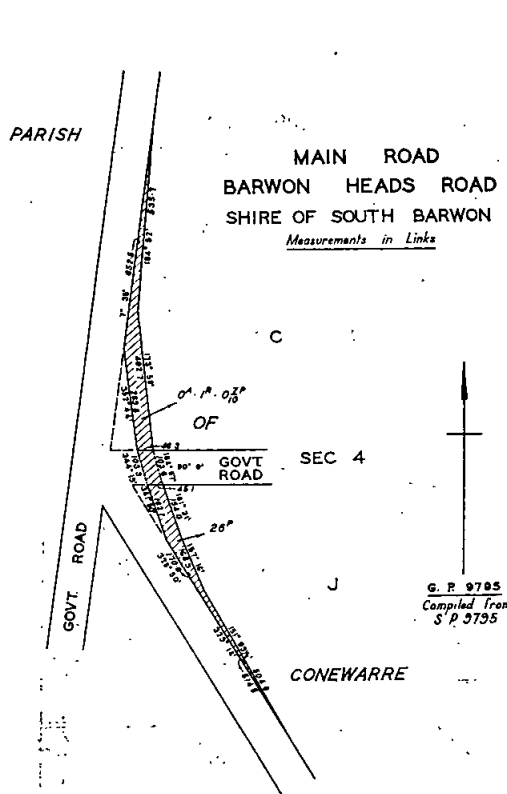

N. L. ALLANSON,
Secretary.

18th November, 1971.

COUNTRY ROADS BOARD.

RESOLUTIONS OF THE COUNTRY ROADS BOARD.

The Country Roads Board, in pursuance of the provisions of the *Country Roads Act 1958*, has passed Resolutions the dates whereof and the terms of which are Scheduled hereunder:—

SCHEDULE.

State Highways.

Resolution dated the First day of November, One thousand nine hundred and seventy-one, made pursuant to sections 21 and 74 of the *Country Roads Act 1958*, declaring the widening of the Glenelg Highway in the Shire of Grenville as shown hatched on Plan numbered G.P.6746 hereunder to be part of a State highway within the meaning and for the purposes of the said Act.

STATE HIGHWAY
GLENELG HIGHWAY
SHIRE OF GRENVILLE
Measurements in feet & inches

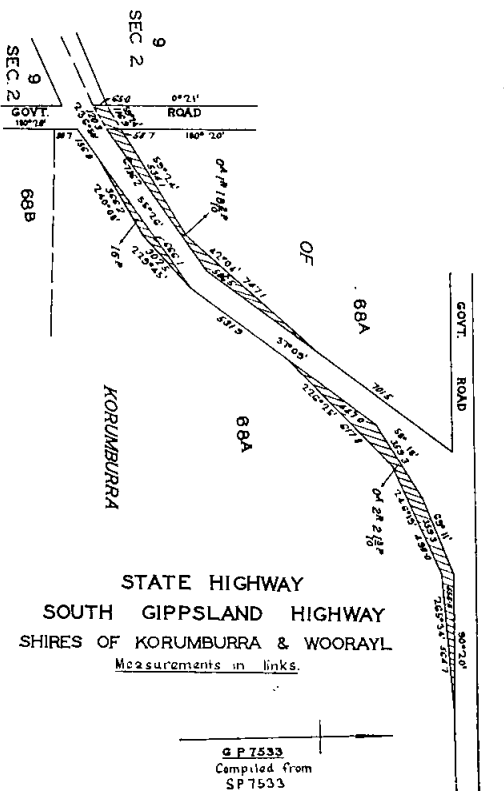
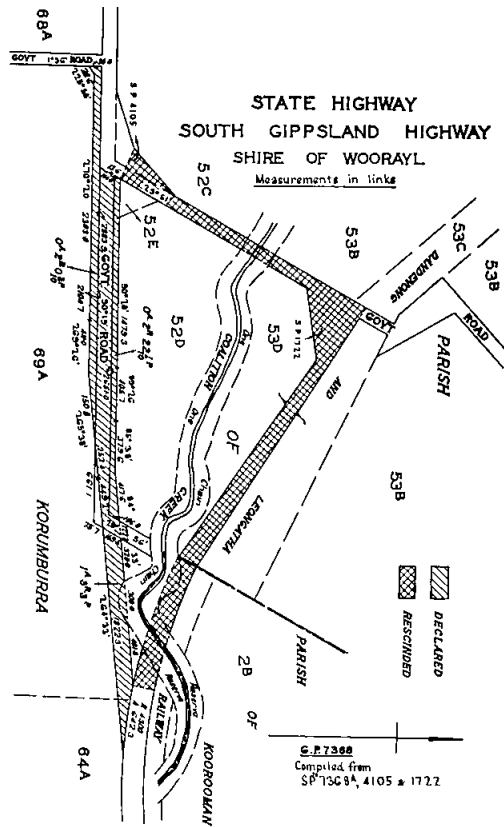
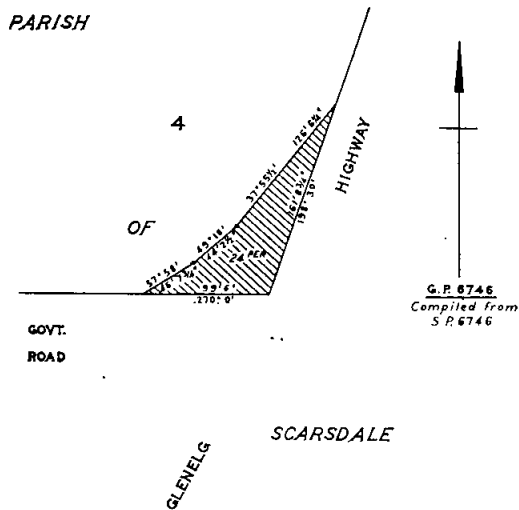

Resolution dated the First day of November, One thousand nine hundred and seventy-one, made pursuant to sections 21, 58 and 74 of the *Country Roads Act 1958*, declaring the deviation from the South Gippsland Highway in the Shire of Woorayl as indicated by diagonal hatching on Plans numbered G.P.7368 and G.P.7533 hereunder to be part of a State highway within the meaning and for the purposes of the said Act, and also declaring that such deviation shall be in lieu of the existing road or part thereof indicated by cross-hatching on Plan numbered G.P.7368.

Main Roads.

Resolution dated the First day of November, One thousand nine hundred and seventy-one, made pursuant to section 21 of the *Country Roads Act 1958*, declaring the widening of Caldermeade-road in the Shire of Cranbourne as shown hatched on Plan numbered G.P.8045 hereunder to be part of a main road within the meaning and for the purposes of the said Act.

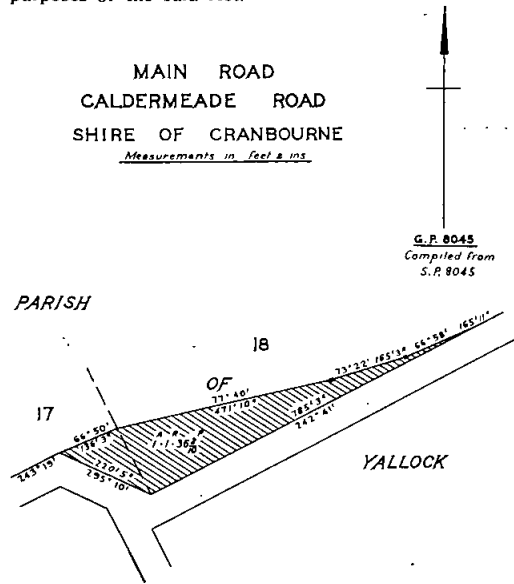

Templestowe as shown hatched on Plans numbered G.P.8089A and G.P.8165C hereunder to be part of a main road within the meaning and for the purposes of the said Act.

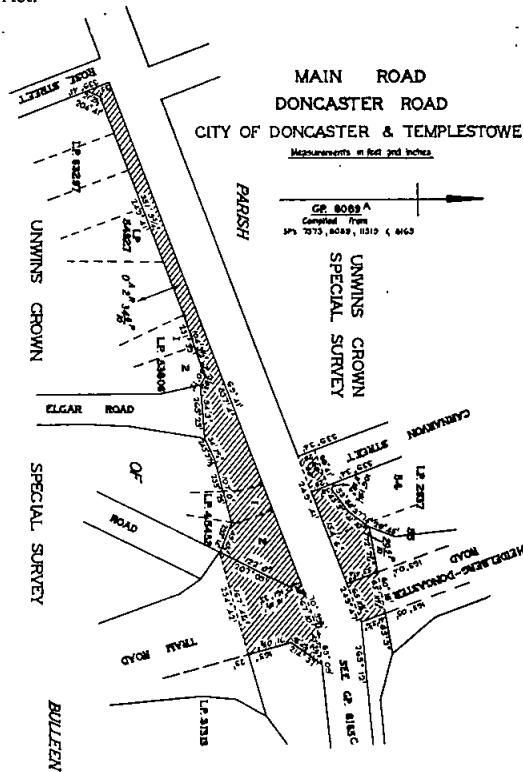

Resolution dated the First day of November, One thousand nine hundred and seventy-one, made pursuant to section 21 of the *Country Roads Act 1958*, declaring the widening of the Heidelberg-Doncaster road in the City of Doncaster and Templestowe as shown hatched on Plan numbered G.P.8165B hereunder to be part of a main road within the meaning and for the purposes of the said Act.

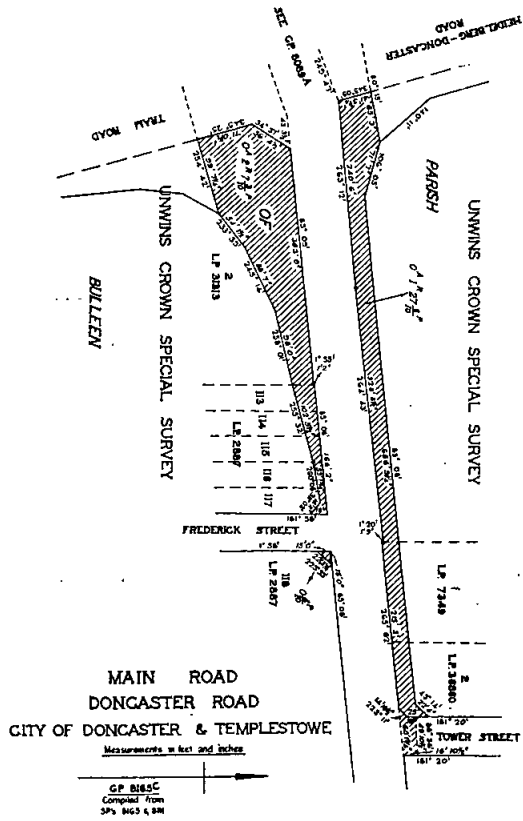
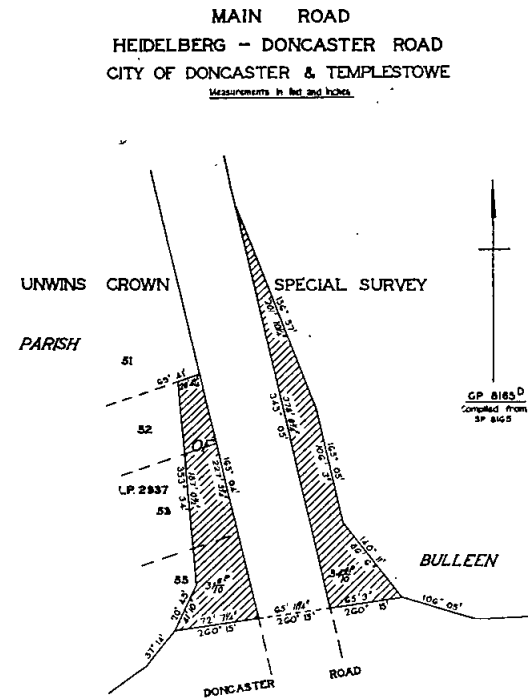

Resolution dated the First day of November, One thousand nine hundred and seventy-one, made pursuant to section 21 of the *Country Roads Act 1958*, declaring the widening of Doncaster-road in the City of Doncaster and

Resolution dated the First day of November, One thousand nine hundred and seventy-one, made pursuant to section 21 of the Country Roads Act 1958, declaring the widening of Wellington-road in the City of Knox as shown hatched on Plan numbered G.P.8234 hereunder to be part of a main road within the meaning and for the purposes of the said Act.

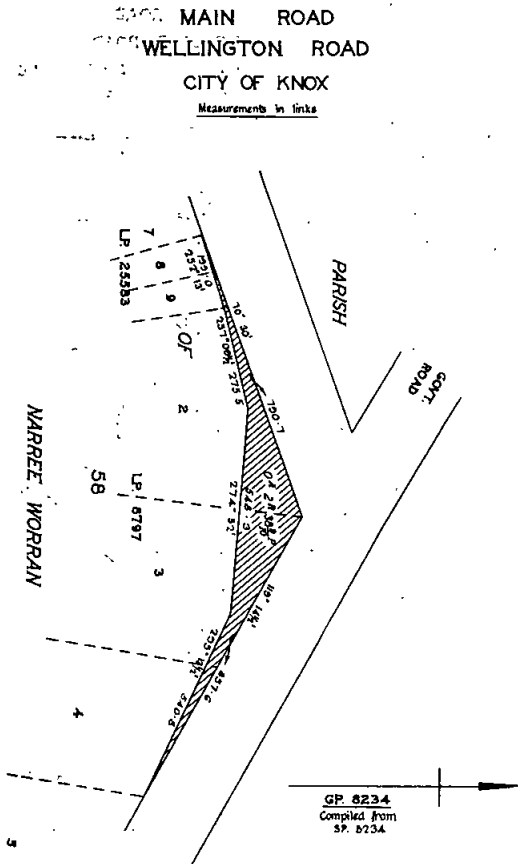

Resolution dated the First day of November, One thousand nine hundred and seventy-one, made pursuant to section 21 of the Country Roads Act 1958, declaring the widening of the Doncaster-Mordialloc road in the Cities of Nunawading and Box Hill as shown hatched on Plan numbered G.P.5677 hereunder to be part of a main road within the meaning and for the purposes of the said Act.

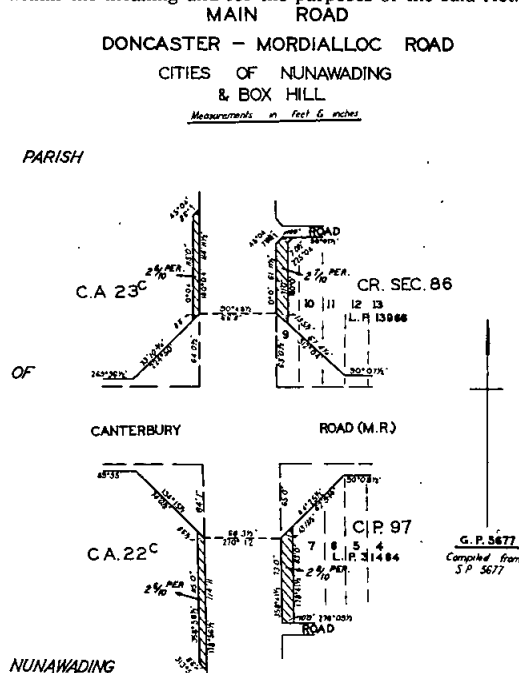

Resolution dated the First day of November, One thousand nine hundred and seventy-one, made pursuant to section 21 of the Country Roads Act 1958, declaring the widening of the Loch-Poowong road in the Shire of Korumburra as shown hatched on Plan numbered G.P.8186 hereunder to be part of a main road within the meaning and for the purposes of the said Act.

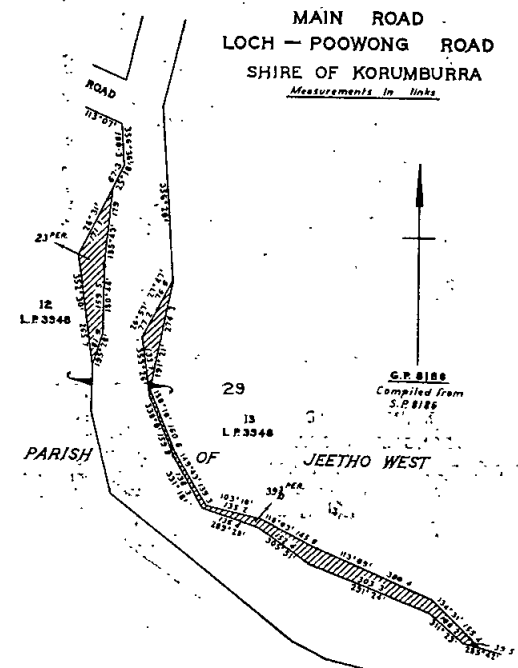

Resolution dated the First day of November, One thousand nine hundred and seventy-one, made pursuant to section 21 of the Country Roads Act 1958, declaring the widening of Canterbury-road in the Cities of Nunawading and Box Hill as shown hatched on Plans numbered G.P.5982A, G.P.5982B, G.P.5982C, G.P.5983A, G.P.5983B, G.P.5984A, G.P.5984B and G.P.5984C hereunder to be part of a main road within the meaning and for the purposes of the said Act.

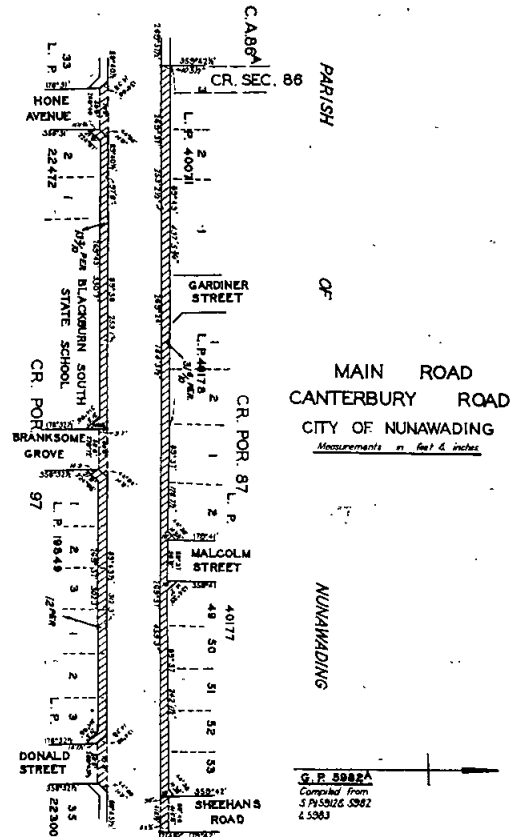

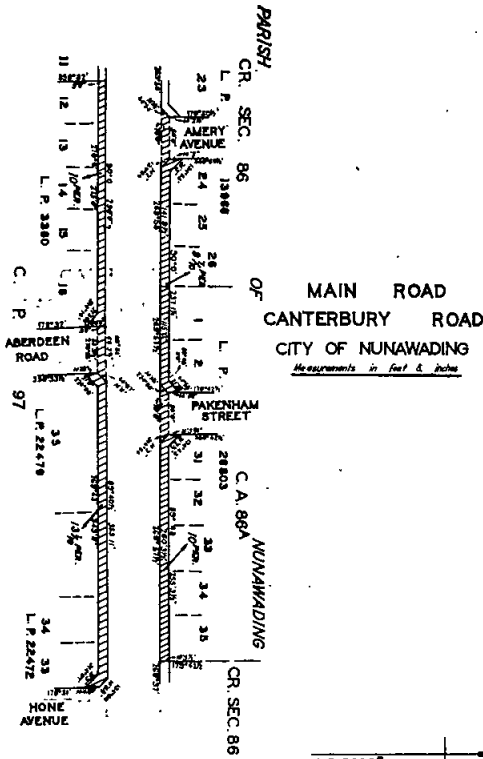

G.P. 5982B
Compiled from
S.P. 5582

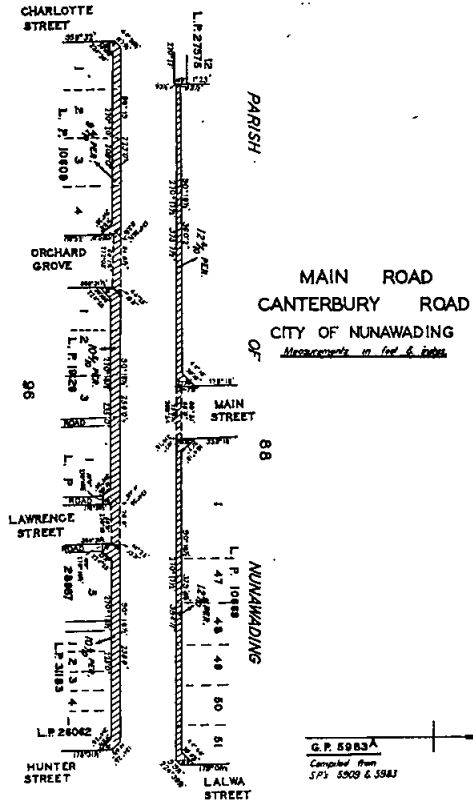

G.P. 5983A
Compiled from
S.P. 5589 & 5588

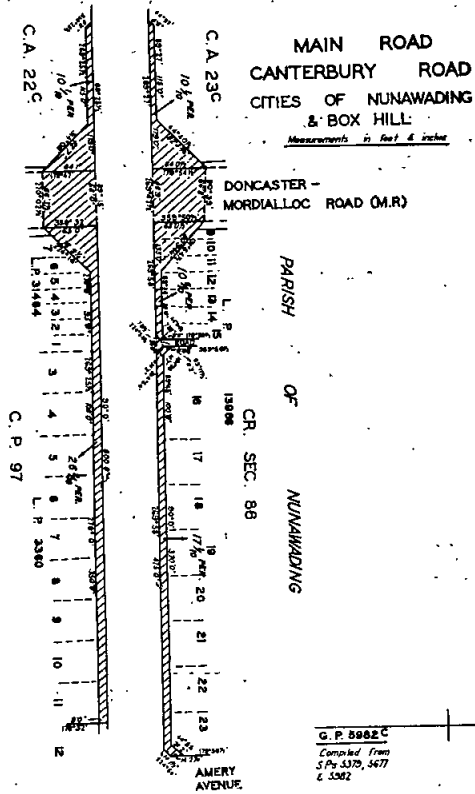

G.P. 5982C
Compiled from
S.P. 5379, 5477
& 5582

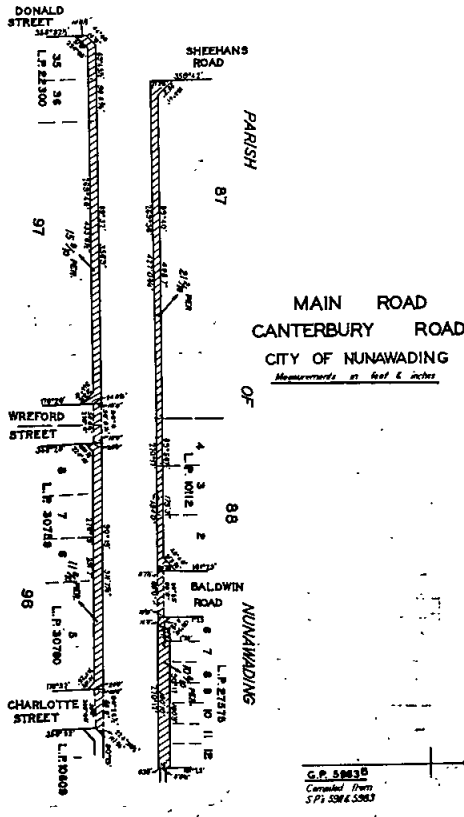

G.P. 5983B
Compiled from
S.P. 5586 & 5587

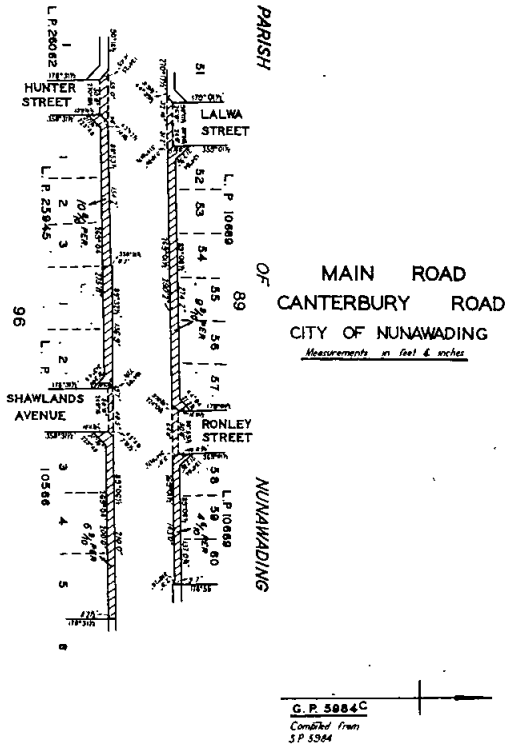
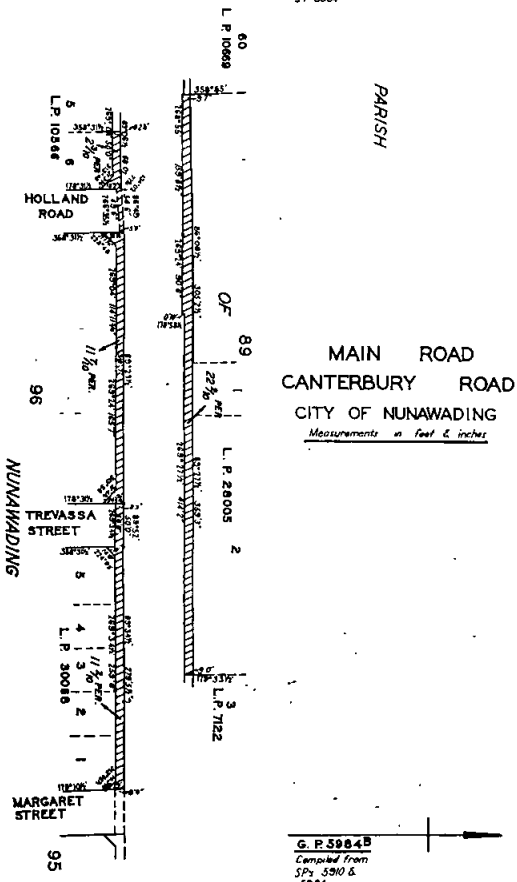
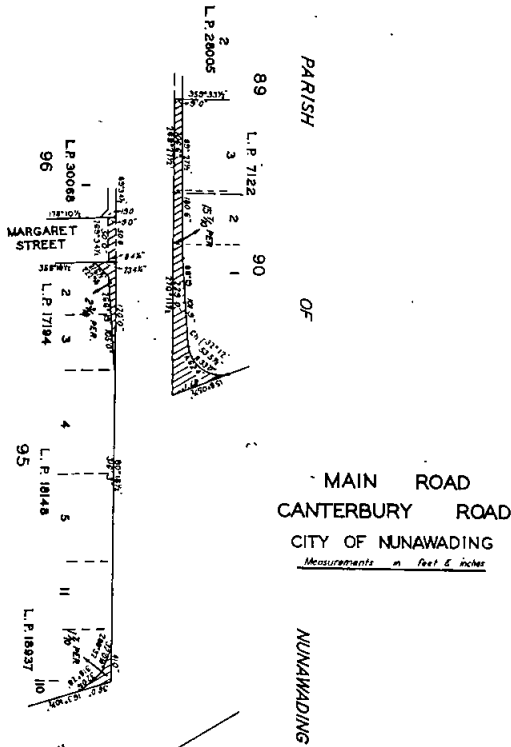

Resolution dated the First day of November, One thousand nine hundred and seventy-one, made pursuant to sections 21 and 58 of the *Country Roads Act 1958*, declaring the deviation from Gellibrand River-road in the Shire of Otway as indicated by diagonal hatching on Plans numbered G.P.12328 and G.P.12329 hereunder to be part of a main road within the meaning and for the purposes of the said Act, and also declaring that such deviation shall be in lieu of the existing road or part thereof indicated by cross-hatching on the said plans.

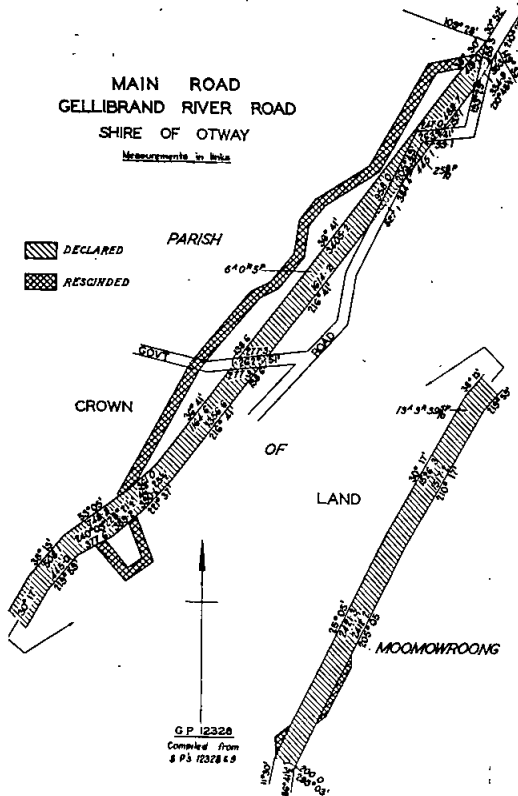

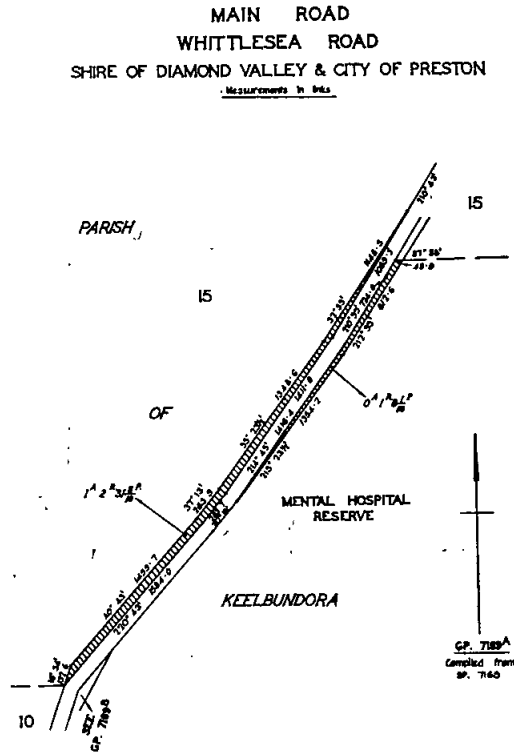
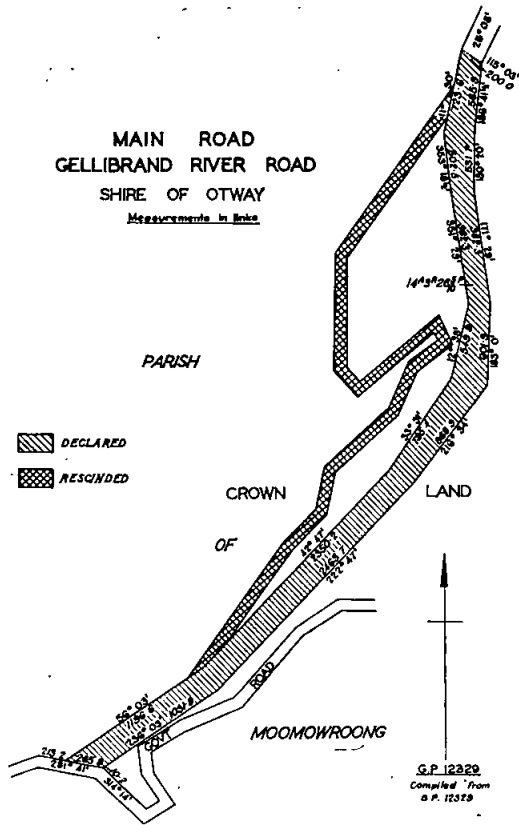

Resolution dated the First day of November, One thousand nine hundred and seventy-one, made pursuant to section 21 of the *Country Roads Act 1958*, declaring the widening of Whittlesea-road in the City of Preston and the Shires of Diamond Valley and Whittlesea as shown hatched on Plans numbered G.P.7087, G.P.7169A, G.P.7169B, G.P.7170A, G.P.7170B, G.P.7171A, G.P.7171B, G.P.7237A, G.P.7237B and G.P.7276 hereunder to be part of a main road within the meaning and for the purposes of the said Act.

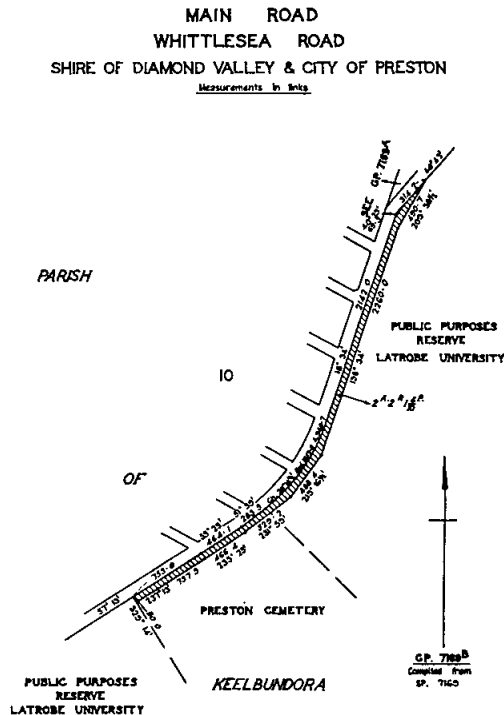
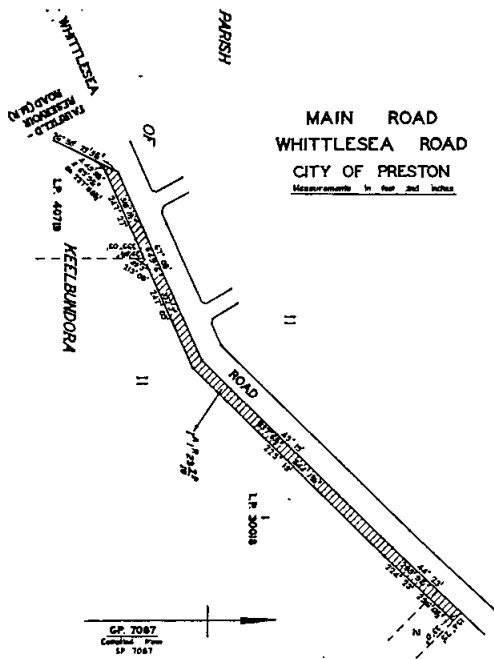

MAIN ROAD
WHITTLESEA ROAD
SHIRES OF WHITTLESEA AND DIAMOND VALLEY
AND CITY OF PRESTON

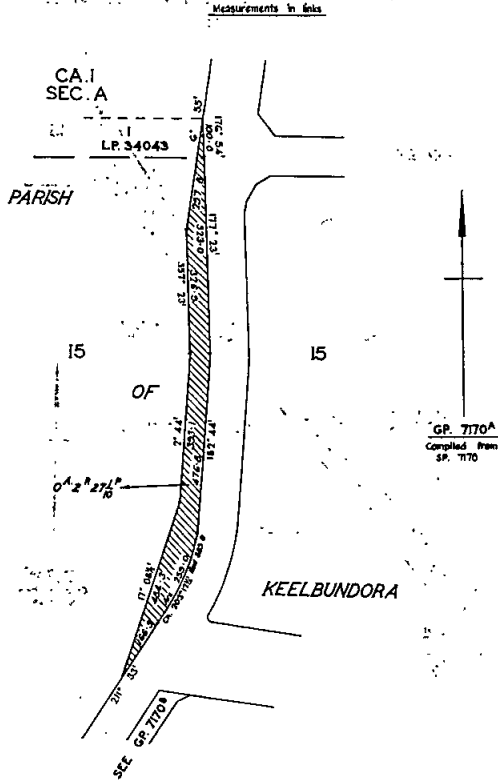

MAIN ROAD
WHITTLESEA ROAD
SHIRES OF WHITTLESEA AND DIAMOND VALLEY

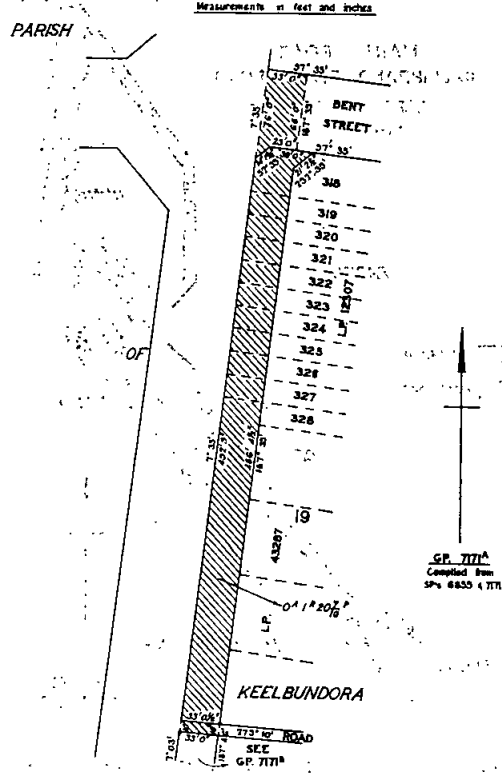

MAIN ROAD
WHITTLESEA ROAD
SHIRE OF DIAMOND VALLEY & CITY OF PRESTON

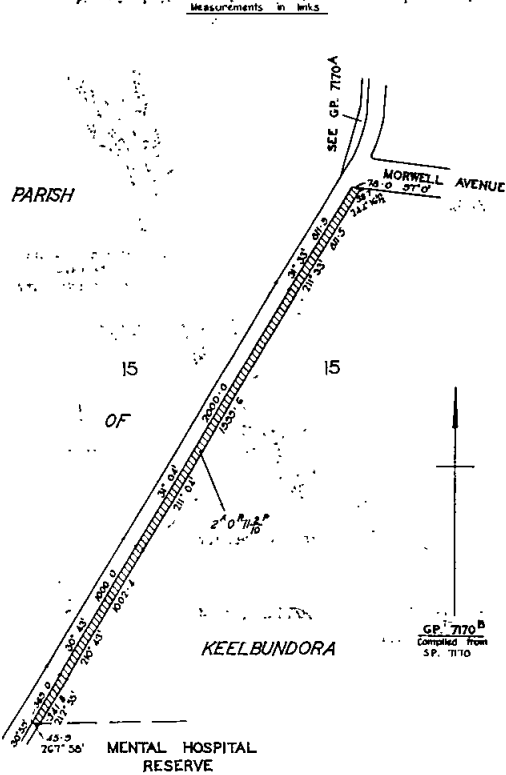

MAIN ROAD
WHITTLESEA ROAD
SHIRES OF WHITTLESEA AND DIAMOND VALLEY
AND CITY OF PRESTON

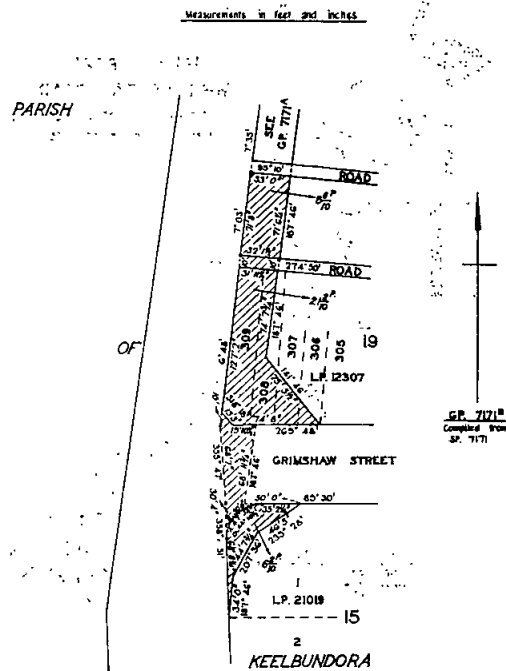

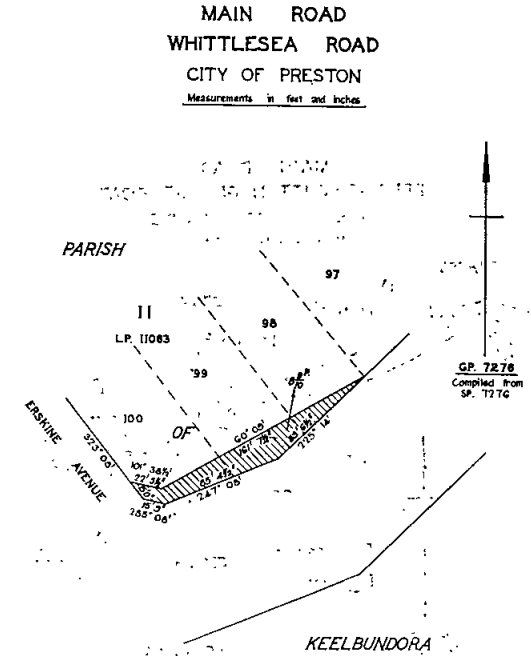
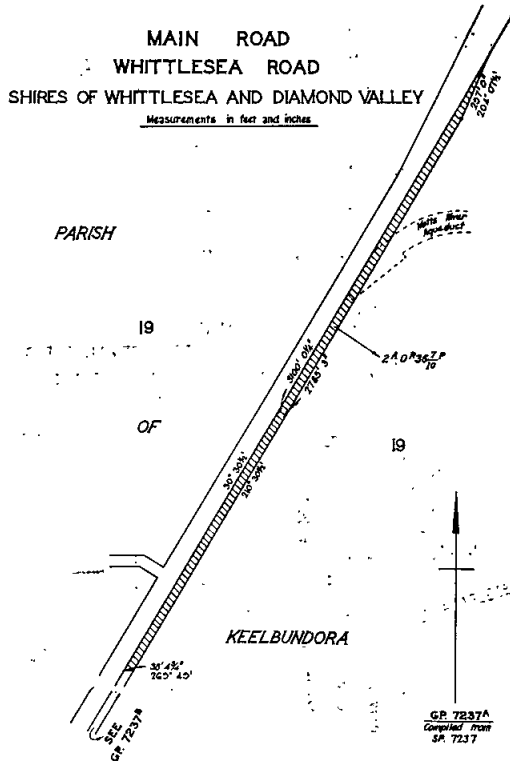

Resolution dated the First day of November, One thousand nine hundred and seventy-one, made pursuant to sections 21 and 58 of the Country Roads Act 1958, declaring the deviation from the Bendigo-Sutton Grange-road in the Shire of Strathfieldsaye as indicated by diagonal hatching on Plans numbered G.P.11120, G.P.11121, G.P.11122, G.P.11123 and G.P.12339 hereunder to be part of a main road within the meaning and for the purposes of the said Act, and also declaring that such deviation shall be in lieu of the existing road or part thereof indicated by cross-hatching on Plans numbered G.P.11120, G.P.11121, G.P.11122 and G.P.11123 and vertical hatching on Plans numbered G.P.11122, G.P.11123 and G.P.12339, which part indicated by cross-hatching on Plans numbered G.P.11120, G.P.11121, G.P.11122 and G.P.11123 shall be discontinued.

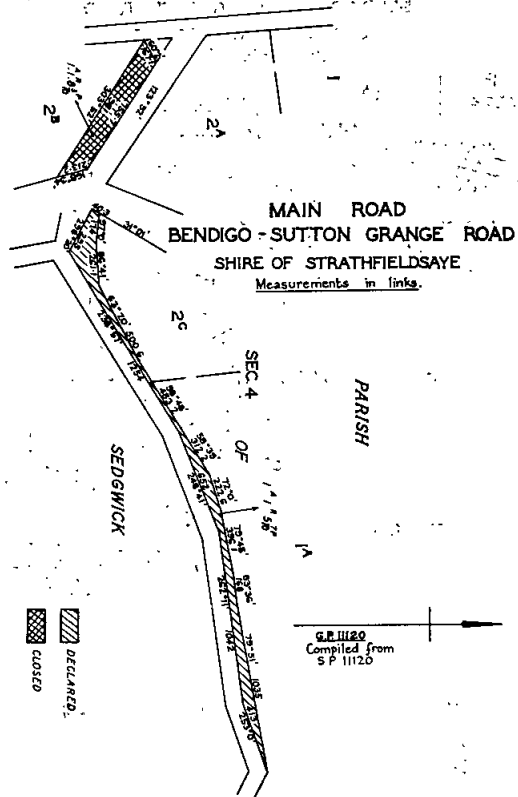
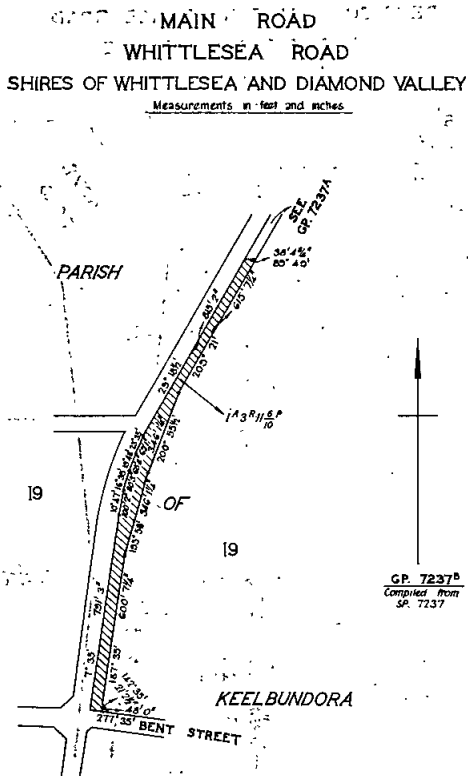

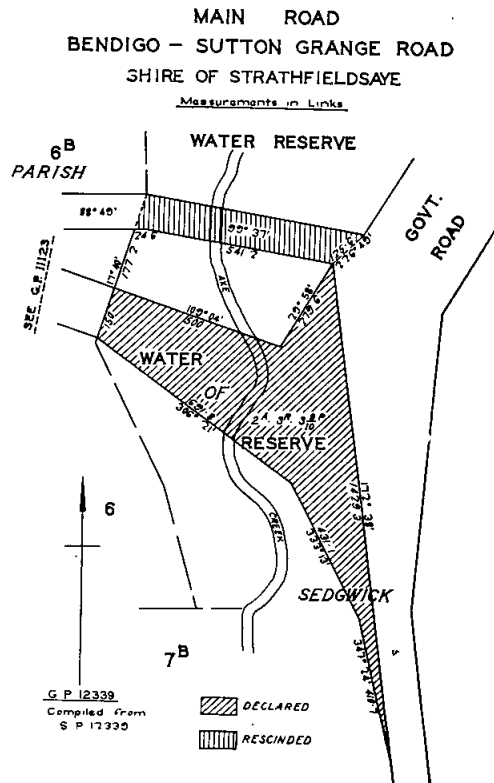
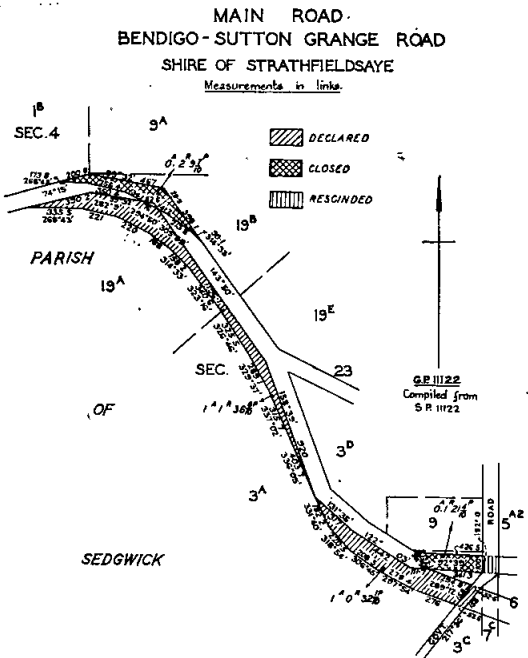
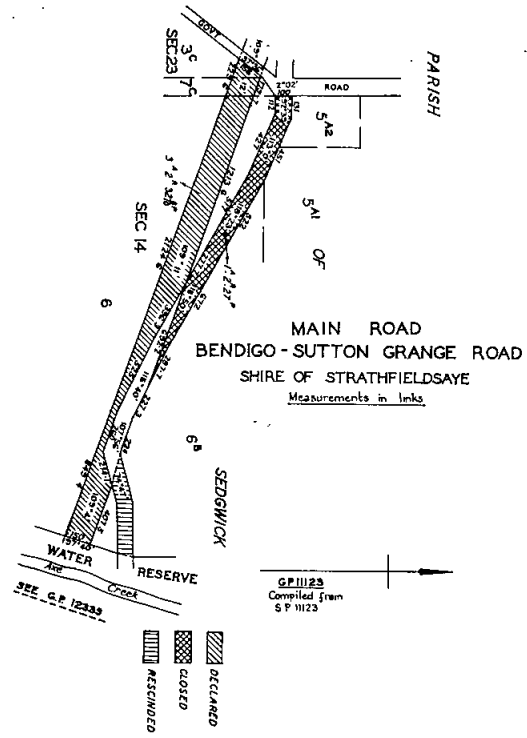
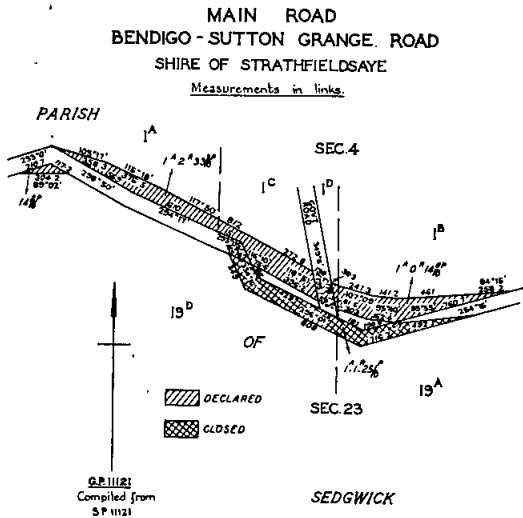

Resolution dated the First day of November, One thousand nine hundred and seventy-one, made pursuant to section 21 of the Country Roads Act 1958, declaring the widening of Dederang-road in the Shire of Yackandandah as shown hatched on Plan numbered G.P.9275 hereunder to be part of a main road within the meaning and for the purposes of the said Act.

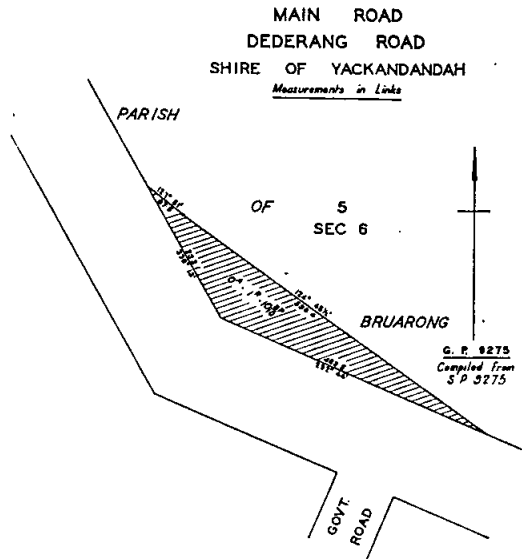

Resolution dated the First day of November, One thousand nine hundred and seventy-one, made pursuant to sections 21 and 110 of the Country Roads Act 1958, declaring the widening of Tram-road in the City of Doncaster and Templestowe as shown hatched on Plan numbered G.P.8827 hereunder to be part of a road within the meaning and for the purposes of the said Act.

ROAD
TRAM ROAD
CITY OF DONCASTER & TEMPLESTOWE
Measurements in feet & inches

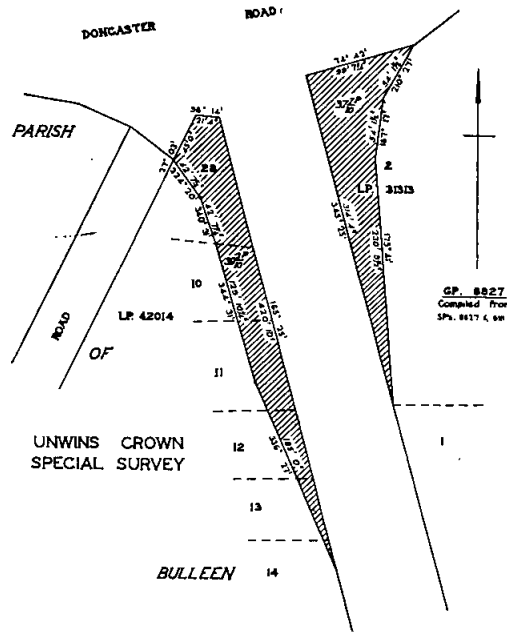

Unclassified Roads.

Resolution dated the First day of November, One thousand nine hundred and seventy-one, made pursuant to section 21 and 110 of the Country Roads Act 1958, declaring the road in the City of Doncaster and Templestowe as shown hatched on Plan numbered G.P.8089a hereunder to be a road (Elgar-road) within the meaning and for the purposes of the said Act.

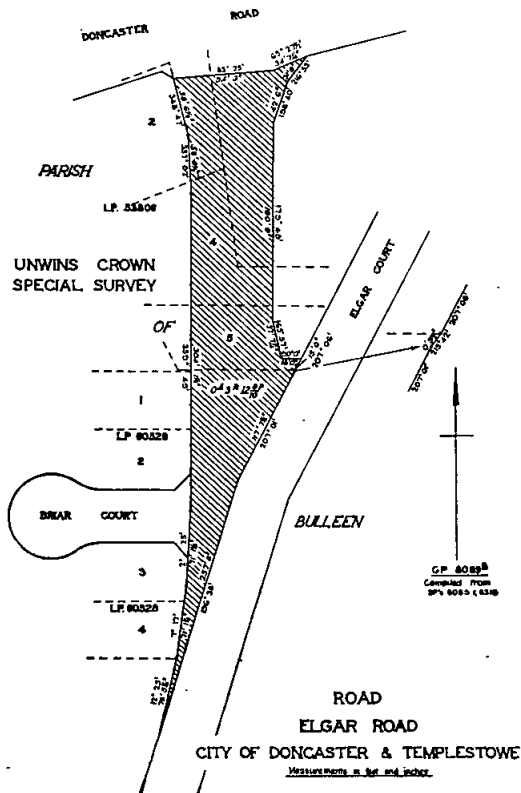

N. L. ALLANSON,
Secretary.

8th November, 1971.

SHIRE OF OMEO:

ROAD DEVIATION ORDER.

Pursuant to the provisions of sections 522 and 526 of the Local Government Act 1958, the Council of the Shire of Omeo hereby directs that the land in the Parish of Cobungra indicated by hatching on the diagram hereunder, which has been purchased taken or acquired by it shall be a public highway on and from the date of publication of this Order in the Government Gazette and declares that such land shall be a public highway in lieu of the land indicated by cross-hatching on the said diagram.

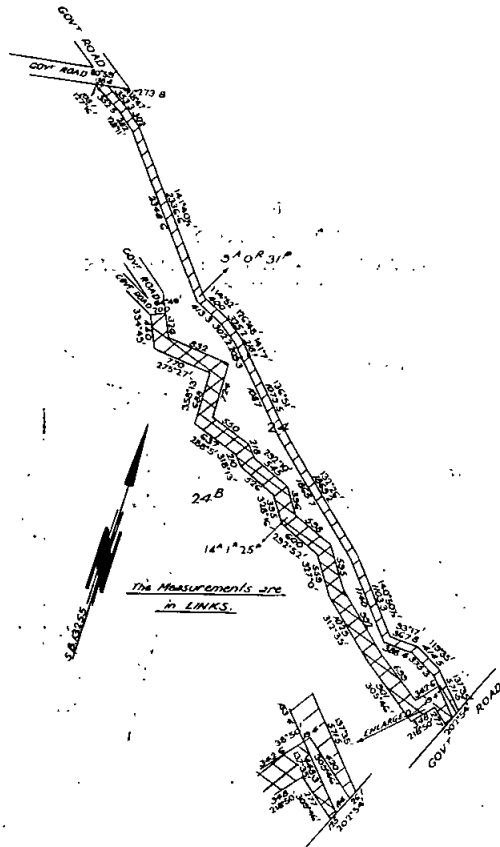

The common seal of the President, Councillors and Ratepayers of the Shire of Omeo was hereunto affixed this 15th day of April, 1971, in the presence of—

(SEAL) K. A. O'BRIEN, President.
E. D'A. FITZGERALD, Councillor.
K. OGBURN, Secretary.

Confirmed by the Governor in Council, 16th November, 1971.—J. ROSSITER, Clerk of the Executive Council.

APPOINTMENTS AND RESIGNATIONS

APPOINTMENTS.

His Excellency the Governor of the State of Victoria, by and with the advice of the Executive Council thereof, has, by Orders made on the 16th day of November, 1971, been pleased to make the under-mentioned appointments, viz.:

CHIEF SECRETARY'S DEPARTMENT.

Electoral Returning Officer.

GEORGE ALBERT MORTIMER
to be Returning Officer for the Electoral District of Gippsland West, vice L. E. Breen, resigned.

MINISTRY OF HEALTH.

Member of the Victorian Nursing Council.

ROBERT JAMES LEES
to be a Member of the Victorian Nursing Council, pursuant to section 4 (2) (e) (vi) of the Nurses Act 1958, for the period ending the 28th September, 1974.

Trustees of Public Cemeteries.

WILLIAM ARTHUR GOODREM,
KEITH CHARLES DENNIS,
ARTHUR HAROLD OXLADE, and
ARTHUR WILLIAM HENRY CHANT,
to be Trustees of the Rye Public Cemetery, vice E. Timmins and E. Stone, deceased, and W. Rattray and A. Sullivan, resigned;

WILLIAM GEORGE WOOLLEY and
THOMAS FREDRICK WHISTON,
to be Trustees of the Crib Point Public Cemetery, vice C. Ferguson, resigned, and C. Crow, deceased;

RAYMOND TWEDDLE
to be a Trustee of the Kilmore Public Cemetery, vice G. Hudson, deceased;

CHARLES EDWIN RIVETT,
JAMES MAY BURNS,
JOHN McDONALD,
ANGUS ERIC CAMERON,
MARK MATHEW CRANAGE, and
GRAHAM JOSEPH RYAN, to be Trustees of the Edenhope Public Cemetery, vice D. Caldow, deceased, and additional Trustees.

FREDRICK UBERGANG
to be a Trustee of the Green Lake Public Cemetery, vice K. McManus, resigned;

GEORGE EDWARD SHILL
to be a Trustee of the Castlemaine Public Cemetery, additional Trustee;

ARTHUR JAMES SHALLARD
to be a Trustee of the Epping Public Cemetery, vice R. Scott, resigned; and

PATRICK HOPKINS,
ERNEST JAMES MARRIOTT, and
WILLIAM BRUNT CAMPBELL,
to be Trustees of the Cranbourne Public Cemetery, vice J. Breen and H. Cockerill, deceased, and C. Dean, resigned, pursuant to section 3 (1) of the Cemeteries Act 1958.

Public Vaccinator.

JOAN PILKINGTON, M.B., B.S.,
to be a Public Vaccinator for the Municipality of the City of Knox, pursuant to section 151 of the Health Act 1958.

LAW DEPARTMENT.

Commissioners for Taking Declarations, &c.

HENRY BRUCE DONOHUE, 59 School-road, Trafalgar,
LINDSAY JAMES BRACK, Post Office, Childers,
RUPERT FREDERICK CUTHBERT, 65 Henry-street, Greensborough,

LEO JAMES CASEY, 27 Sherwood-street, Birchip, and
SAVVAS DAVID, 7 Daly-street, Sunshine,
to be Commissioners for Taking Declarations and Affidavits, pursuant to the provisions of the Evidence Act 1958, to resign upon removing from the neighbourhood of the addresses stated;

BERNADUS THEODORUS SLAGTMAN, care of Motor Registration Branch, Lygon-street, Carlton,
DONALD WILLIAM MCKEOWN, care of Titles Office, 283 Queen-street, Melbourne,

WILLIAM JEREMIAH CAMPION, care of Mines Department, West Tower, Princes Gate, 171 Flinders-street, Melbourne, and

RONALD HOWARD REYNOLDS, care of Commonwealth Taxation Office, 350 Collins-street, Melbourne,
to be Commissioners for Taking Declarations and Affidavits, pursuant to the provisions of the Evidence Act 1958, to refrain from charging fees and to resign upon ceasing to occupy their present positions; and

DOUGLAS WILLIAM MACKAY, care of Massey-Ferguson (Australia) Limited, 2 Devonshire-road, Sunshine, and,

ROSEMARY BARBARA, care of Malta Travel Service, 81B Bell-street, Coburg,

to be Commissioners for Taking Declarations and Affidavits, pursuant to the provisions of the Evidence Act 1958, to resign upon ceasing to occupy their present positions.

Justices of the Peace.

RUSSELL KEITH McDONALD, Cobram,
ARTHUR CARL WILLIAM JACOBSEN, Town Hall, Bell-street, Coburg, and

JOHN WALLACE DAVID KING, 102 Scott-street, Warracknabeal,
to keep the Peace in the State of Victoria.

SOCIAL WELFARE DEPARTMENT.

Honorary Probation Officers.

ALLAN MORICE ARNOT (Rev.), 6 Templeton-street, Sale,
 PETER BOAG, 30 Rattray-avenue, Wangaratta,
 EILEEN PAMALA BOOTH (Mrs.), "Rossleigh", Katunga,
 VICTOR ROY BURTON, Unit 2, 16 Mills-street, Hampton,
 KEITH FRANCIS CHRISTIE, Patchewollock,
 NEIL MACAULAY CLEMENT, 56 Moore-street, Moë,
 SHEILA O'RORKE CROOK (Mrs.), 87 Olinda-street,
 Bendigo,
 EDWARD HARRISON, 11 Hillside-parade, Box Hill North,
 MARGARET HINSON (Mrs.), Kay-street, Traralgon,
 JAMES ALEXANDER MCKENNA, 51 Church-street, Eagle-
 hawk,
 ELIZABETH ISOBEL MCKEOWN (Mrs.), 201 Melville-
 street, Numurkah,
 BRUCE McNICOL, 55 Domain-street, South Yarra,
 ALLAN HARVEY TASKER, P.O. Box 452, Morwell, and
 MARGARET WOOLFE (Mrs.), 43 Mabel-street, Traralgon,
 pursuant to the provisions of section 507 (2) of the
 Crimes Act 1958, and section 10 (1) of the Children's
 Court Act 1958, to be Honorary Probation Officers for all
 Adult and Children's Courts in Victoria.

J. ROSSITER,

Clerk of the Executive Council.

At the Executive Council Chamber,
 Melbourne, 16th November, 1971.

APPOINTMENTS.

His Excellency the Governor of the State of Victoria,
 by and with the advice of the Executive Council thereof,
 has, by Orders made on the 23rd day of November, 1971,
 been pleased to make the under-mentioned appointments,
 viz.:—

DEPARTMENT OF WATER SUPPLY.

Waterworks Trusts Commissioners.

KEITH JOHN RUSHTON WALKER,
 to be a commissioner of the Learmonth Waterworks Trust,
 to hold office as such for a period of one year from the
 date hereof, subject to the provisions of the Water Act;

FRANCIS IAN EZARD,
 DARYL CHARLES GALLAGHER, and
 LESLIE OWEN SKELTON,

to be Commissioners of the Swifts Creek Waterworks
 Trust, to hold such position for a period of four years
 from the date hereof, subject to the provisions of the
 Water Act; and

BERTIE OLIVER SHERIDAN
 to be a Commissioner of the Wahgunyah Waterworks
 Trust, to hold such position for a period of four years
 from the date hereof, subject to the provisions of the
 Water Act.

J. ROSSITER,

Clerk of the Executive Council.

At the Executive Council Chamber,
 Melbourne, 23rd November, 1971.

APPOINTMENTS.

His Excellency the Governor of the State of Victoria,
 by and with the advice of the Executive Council thereof,
 has, by Orders made on the 23rd day of November, 1971,
 been pleased to make the under-mentioned appointments,
 viz.:—

MINISTRY OF HEALTH.

Member of Advisory Committee.

SHEILAH AIMEE SHÉLDRAKE
 to be a member of the Advisory Committee to the Mental
 Health Authority, pursuant to section 19 (2) (d) of the
 Mental Health Act 1959, for the balance of the period
 ending 28th January, 1973.

Official Visitors.

JACK HAMILTON, and
 GERALD MARK LEON,
 to be Official Visitors to Bundoora Repatriation Mental
 Hospital, pursuant to section 66 of the Mental Health Act
 1959, for the period ending the 31st October, 1972.

J. ROSSITER,
 Clerk of the Executive Council.

At the Executive Council Chamber,
 Melbourne, 23rd November, 1971.

SUMMONING OFFICERS.

Under section 5 of the Education Act 1958, I hereby
 appoint—

Sergeant JAMES FREDERICK BURGOYNE.

Senior Constable EDMUND ROBERT CAPSTICK.

Senior Constable JAMES WILLIAM HUMPHREY.

Sergeant IVAN NOEL HANRAHAN.

Sergeant LESLIE CYRIL MILBORN.

Senior Constable IAN DAVID ROSS.

Sergeant ADRIAN KNOX BOOTH.

Sergeant ALAN JAMES WILLIAMS.

IAN SMITH,
 Minister for Social Welfare.

17th November, 1971.

Liquor Control Act 1968.

APPOINTMENT OF LICENSING INSPECTORS.

In accordance with the authority conferred upon me by
 Sub-section (1) of Section 22 of the *Liquor Control Act 1968*, I,
 Reginald Jackson, Chief Commissioner of Police, hereby appoint
 the following Officers of Police as Licensing Inspectors for the
 Divisions of the Police Districts as shown:—

Division Number.	Police District.	Rank and Name.
2	Barwon	Inspector George Bryan Hogg.
1	Flinders	Superintendent John McPartland <i>vice</i> Superintendent Bell
2	Melbourne	Inspector Norman Joseph Swan <i>vice</i> Inspector Standfield
2	Upper Goulburn	Inspector William Neale <i>vice</i> Inspector Howlett
1	Upper Murray	Superintendent Norman Harold Hume <i>vice</i> Superintendent Kennedy
2	Yarra	Superintendent Norman Sydney Sumpter <i>vice</i> Superintendent Robinson

11.11.71.

R. JACKSON,
 Chief Commissioner of Police.

RESIGNATIONS.

His Excellency the Governor of the State of Victoria,
 by and with the advice of the Executive Council thereof,
 has by Orders made on the 16th day of November, 1971,
 accepted the resignations of the persons named hereunder
 of the offices mentioned, viz.:—

LAW DEPARTMENT.

Commissioners for Taking Declarations and Affidavits, &c.

HARRY HAROLD ROWE,
 BRYAN MILLER RODD, and
 JOHN ROBERT BROWN,

as Commissioners for taking Declarations and
 Affidavits pursuant to the provisions of the
 Evidence Act 1958.

Honorary Probation Officers.

JOAN LEESON BARTLE (Mrs.), 25 Empire-street,
 Mornington,
 GERARD JOSEPH FENNING, 15 Hartwell Hill-road,
 Camberwell,
 WINIFRED HELEN GARNSEY (Miss), 163 Howard-street,
 North Melbourne, and
 ANDREW PETRAKIS, 48 Ludbrooke-avenue, Caulfield,
 as Honorary Probation Officers, pursuant to the
 provisions of section 507 (2) of the Crimes Act
 1958, and section 10 (1) of the Children's Court
 Act 1958 for all Adult and Children's Courts in
 Victoria.

J. ROSSITER,
 Clerk of the Executive Council.

At the Executive Council Chamber,
 Melbourne, 16th November, 1971.

ORDERS IN COUNCIL

COUNTRY ROADS BOARD.

At the Executive Council Chamber, Melbourne, the sixteenth day of November, 1971.

PRESENT:

His Excellency the Governor of Victoria.

Mr. Meagher | Mr. Smith.
Mr. Hunt |

ORDER APPROVING OF LAND BEING ACQUIRED AND ROADS, DEVIATIONS OR WIDENINGS BEING MADE.

His Excellency the Governor of the State of Victoria, by and with the advice of the Executive Council thereof, being satisfied that there are funds legally available for acquiring the land, doth hereby approve the acquiring of the land described in the Schedule hereunder and the making of new roads and deviations from and widenings of existing roads referred to in the said Schedule.

SCHEDULE.

Main Roads.

The land shown hatched on Plan numbered G.P.12779 hereunder required for the widening of Barkers-road in the City of Hawthorn and making of the widening thereon.

**MAIN ROAD
BARKERS ROAD
CITY OF HAWTHORN**
Measurements in Feet and inches

PARISH

G.P. 12779
Compiled from
S.P. 12719

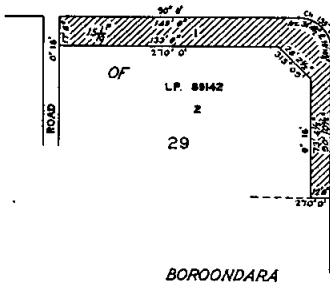

The land shown hatched on Plan numbered G.P.12746 hereunder required for the deviation from the Maffra-Rosedale road in the Shires of Maffra and Rosedale and making of the deviation thereon.

**MAIN ROAD
MAFFRA — ROSEDALE ROAD
SHIRES OF MAFFRA & ROSEDALE**
Measurements in Links

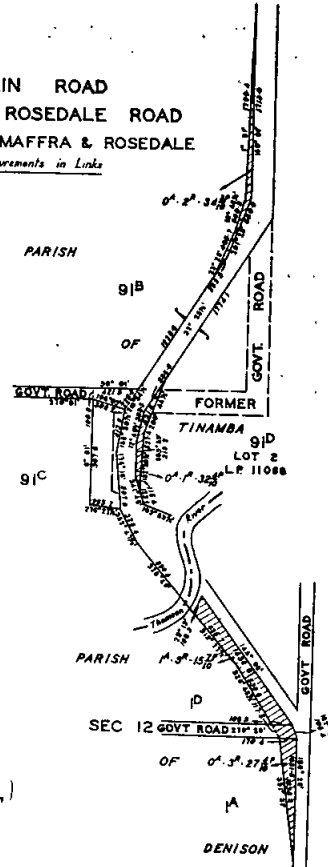

G.P. 12746
Compiled from
S.P. 12746

The land shown hatched on Plans numbered G.P.12488A, G.P.12488B, G.P.12489A, G.P.12489B, G.P.12490 and G.P.12491 hereunder required for the deviation from the Main Whittlesea-road in the Shire of Whittlesea and making of the deviation thereon.

**MAIN ROAD
MAIN WHITTLESEA ROAD
SHIRE OF WHITTLESEA**
Measurements in Feet & inches

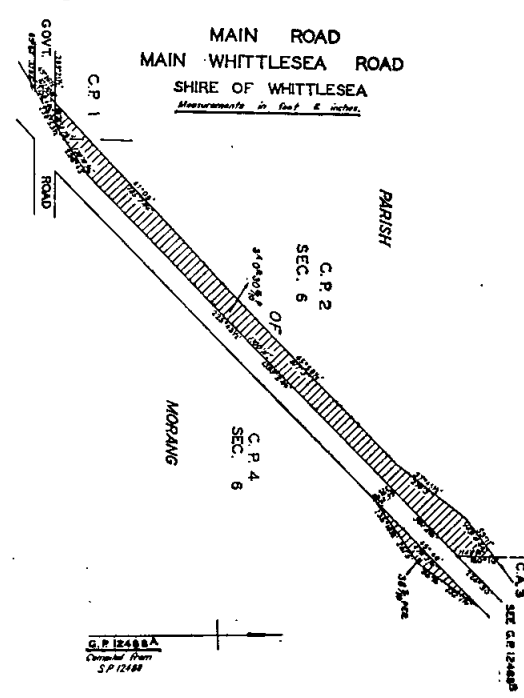

G.P. 12488A
Compiled from
S.P. 12488

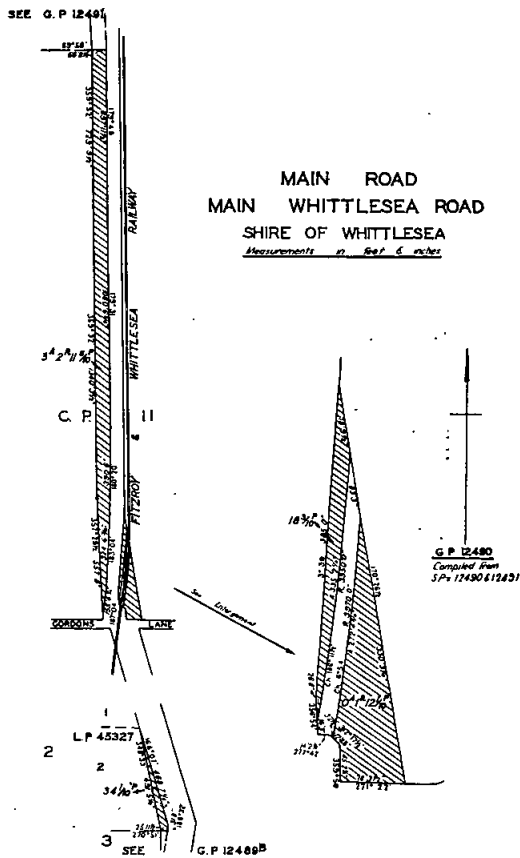
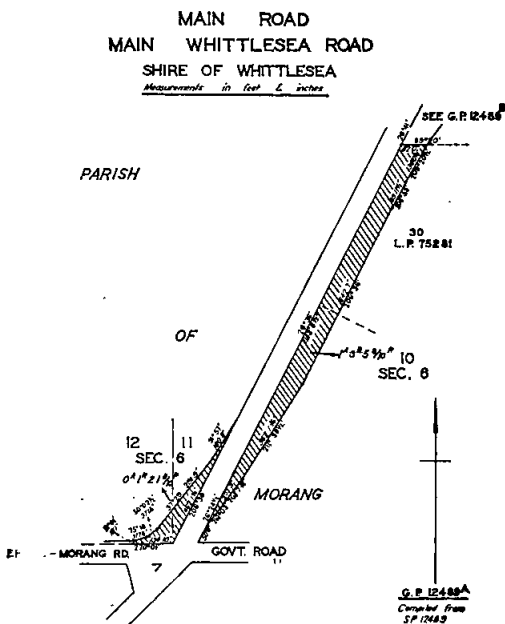
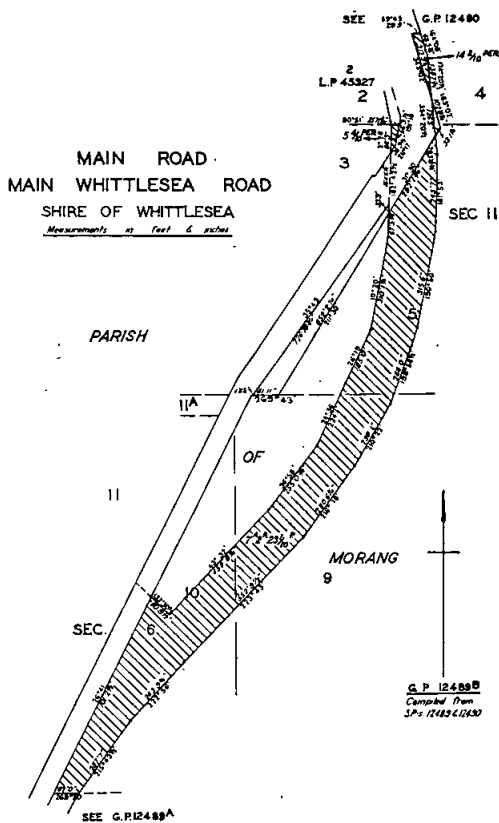
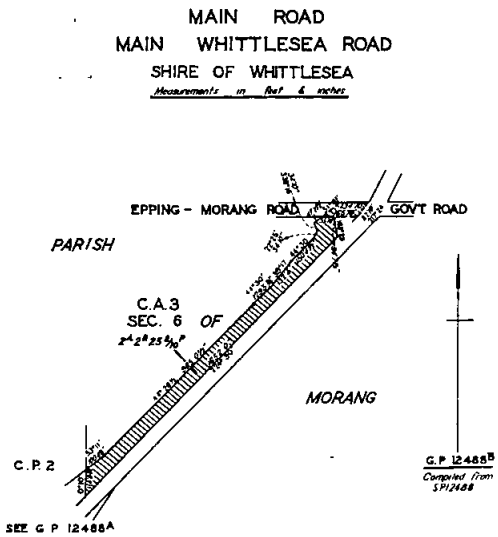

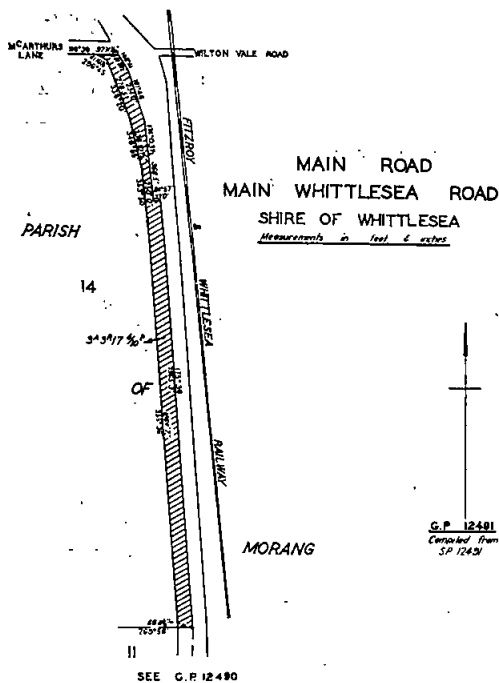

Unclassified Roads.

The land shown hatched on Plan numbered G.P.12686 hereunder required for the widening of a road in the City of Waverley and making of the widening thereon.

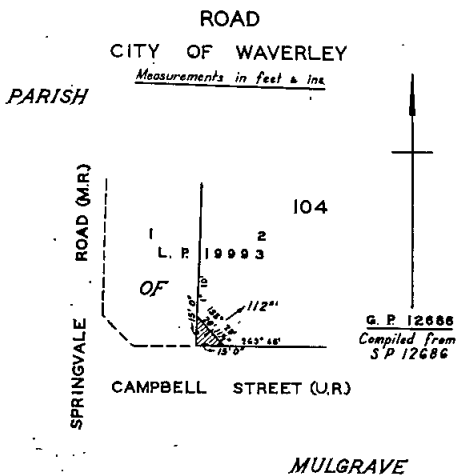

The land shown hatched on Plan numbered G.P.12488C hereunder required for the widening of the Epping-Morang road in the Shire of Whittlesea and making of the widening thereon.

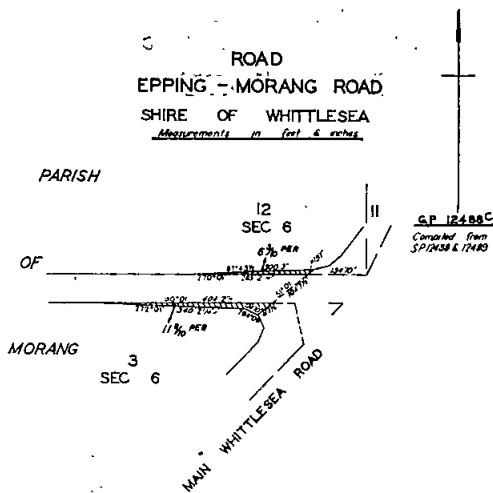

And the Honorable Alan John Hunt, Her Majesty's Minister for Local Government for the State of Victoria, shall give the necessary directions herein accordingly.

J. ROSSITER,
Clerk of the Executive Council.

Land Act 1958.

DEPARTMENT OF CROWN LANDS AND SURVEY.

At the Executive Council Chamber, Melbourne, the sixteenth day of November, 1971.

PRESENT:

His Excellency the Governor of Victoria.
Mr. Meagher | Mr. Smith.
Mr. Hunt

REVOCATION OF TEMPORARY RESERVATIONS OF LANDS BY ORDERS IN COUNCIL.

His Excellency the Governor of the State of Victoria, by and with the advice of the Executive Council thereof, doth hereby, in pursuance of the provisions of the Land Act 1958, revoke the temporary reservations of lands by Orders in Council hereinafter referred to, viz.:-

BEECHWORTH.—The temporary reservation, by Order in Council of the 27th November, 1962, of 278 acres 0 roods 13 perches of land in the Parish of Beechworth, as a site for Social Welfare purposes; so far only as the portion containing 1 acre 2 roods 12 perches, as defined by description and hachure published in the *Government Gazette* of 20th October, 1971.—(B.349⁽²²⁾) (Rs.8185).

MOOROOLBARK.—The temporary reservation, by Order in Council of the 5th March, 1906, of 9 acres 1 rood 34 perches of land in the Parish of Mooroolbark, as a site for Public Recreation, so far only as the portions containing 16 perches comprised within the boundaries published in the *Government Gazette* of 20th October, 1971.—(M.152⁽⁷⁾) (Rs.310).

WODONGA.—The temporary reservation as a site for Public Park and the withholding from sale, leasing and licensing by Order in Council of the 27th February, 1878, of 86 acres 1 rood 32 perches of land in the Township of Wodonga, revoked as to part by Order of the 22nd April, 1904, so far only as the portion containing 1 acre 1 rood 10 perches, more or less, as defined by description and hachure published in the *Government Gazette* of 20th October, 1971.—(W.308⁽⁵³⁾) (Rs.4548).

WOOMELANG.—The temporary reservation, by Order in Council of the 20th January, 1970, of 11 acres 2 roods, more or less, of land in the Township of Woomelang, as a site for Public purposes (Municipal purposes) (Storage of Water), so far only as the portion containing 26 perches, comprised within the boundaries published in the *Government Gazette* of 20th October, 1971.—(W.390⁽²⁾) (Rs.9248).

And the Honorable William Archibald Borthwick, Her Majesty's Minister of Lands for the State of Victoria, shall give the necessary directions herein accordingly.

J. ROSSITER,
Clerk of the Executive Council.

DEPARTMENT OF CROWN LANDS AND SURVEY.

At the Executive Council Chamber, Melbourne, the sixteenth day of November, 1971.

PRESENT:

His Excellency the Governor of Victoria.
Mr. Meagher Mr. Smith.
Mr. Hunt

LAND ADOPTED BY THE CROWN FOR ROAD PURPOSES IN LIEU OF FORMER ROAD IN THE TOWNSHIP OF NERRINA.

His Excellency the Governor of the State of Victoria, by and with the advice of the Executive Council thereof, in pursuance of the powers conferred by section 208 of the Land Act 1958, doth adopt for road purposes the land in the Township of Nerrina, Parish of Ballarat, County of Grenville, indicated by hatching, in lieu of those portions of the former road indicated by cross-hatching on plan hereunder.—(N.193(2) (J.29442).

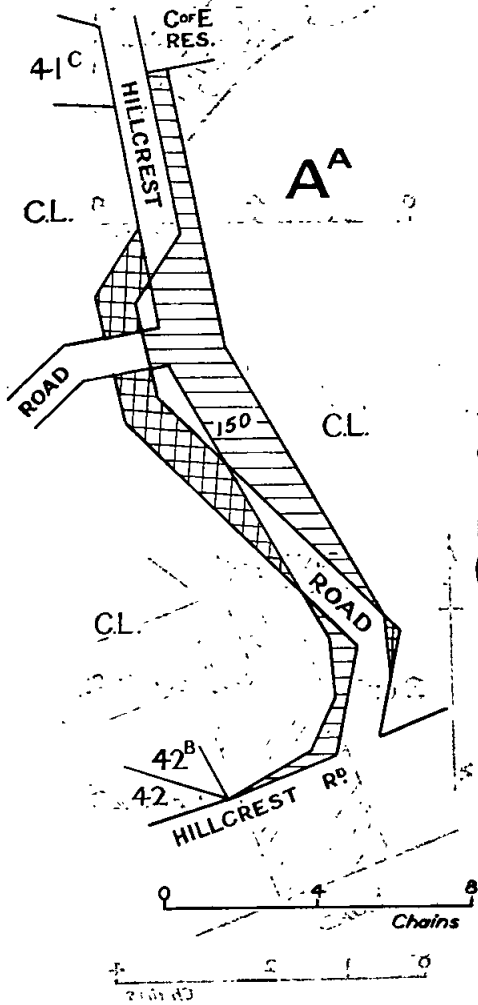

And the Honorable William Archibald Borthwick, Her Majesty's Minister of Lands for the State of Victoria, shall give the necessary directions herein accordingly.

J. ROSSITER,
Clerk of the Executive Council.

Land Act 1958, Section 15.
DEPARTMENT OF CROWN LANDS AND SURVEY.

At the Executive Council Chamber, Melbourne, the sixteenth day of November, 1971.

PRESENT:

His Excellency the Governor of Victoria.
Mr. Meagher Mr. Smith.
Mr. Hunt

PERMANENT RESERVATION OF LAND AND REVOCATION AS TO PART.

His Excellency the Governor of the State of Victoria, by and with the advice of the Executive Council thereof, doth hereby, in pursuance of the provisions of section 15 of the Land Act 1958, reserve permanently and revoke, as to part, certain land hereunder referred to, viz.:

SHEPPARTON.—Land to be permanently reserved for Public purposes, Parish of Mooroopna, County of Rodney, Crown land forming the new bed of the Goulburn River, where the course of the said river has become altered since the 23rd May, 1881, together with the Crown land on the banks thereof, as indicated by hatching on plan hereunder.

ORDER IN COUNCIL TO BE REVOKED AS TO PART.

The Order in Council of the 23rd May, 1881 (see Government Gazette of the 27th May, 1881, page 1389), by which the beds of certain lakes, rivers and creeks specified therein, and Crown lands on the margins and banks thereof respectively were permanently reserved for Public purposes, is about to be revoked so far only as it relates to that portion of the bed and banks of the Goulburn River in the Parish of Mooroopna, County of Rodney, and the Township of Shepparton, Parish of Shepparton, County of Moira, as indicated by cross-hatching on plan hereunder, to which it is no longer applicable in consequence of the course of the said river having become altered after the date of the said Orders.—(M.458(1B) (S.283(H2) (C.77846).

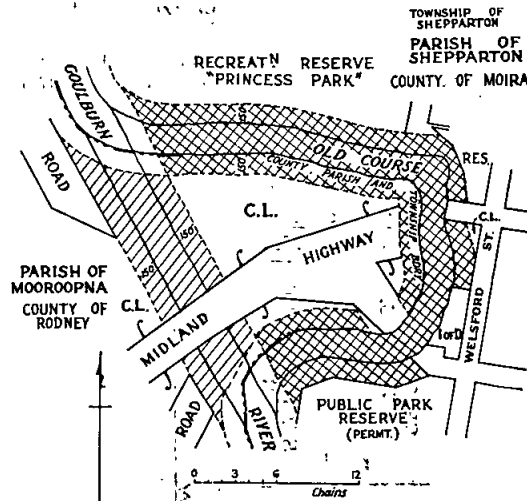

And the Honorable William Archibald Borthwick, Her Majesty's Minister of Lands for the State of Victoria, shall give the necessary directions herein accordingly.

J. ROSSITER,
Clerk of the Executive Council.

DEPARTMENT OF CROWN LANDS AND SURVEY.

At the Executive Council Chamber, Melbourne, the
sixteenth day of November, 1971.

PRESENT:

His Excellency the Governor of Victoria.
Mr. Meagher. | Mr. Smith.
Mr. Hunt. |

UNUSED ROADS CLOSED.

His Excellency the Governor of the State of Victoria,
by and with the advice of the Executive Council thereof,
doth hereby direct that, in pursuance of the provisions of
section 349 of the Land Act 1958, the unused roads
referred to hereunder be closed, viz.:

Parish of Blackwood, County of Bourke, being the road
indicated by hatching on plan hereunder.—(B.405⁽¹⁰⁾)
(J.33663).

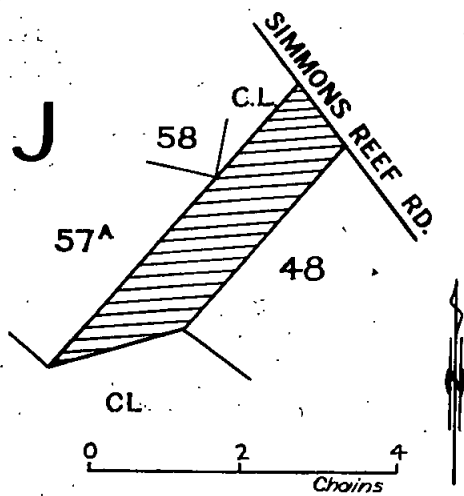

Parish of Flowerdale, County of Anglesey, being the
road indicated by hatching on plan hereunder.—(F.11⁽⁷⁾)
(C.84901).

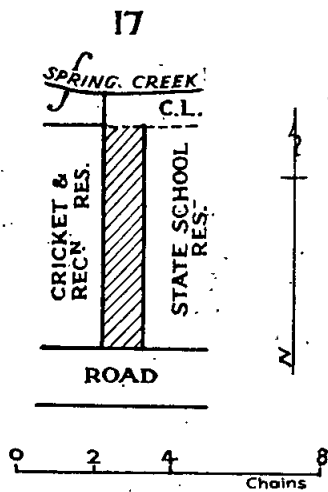

Parish of Framlingham East, County of Hampden, being
the road indicated by hatching on plan hereunder.—(F.92⁽²⁾)
(Rs.8849).

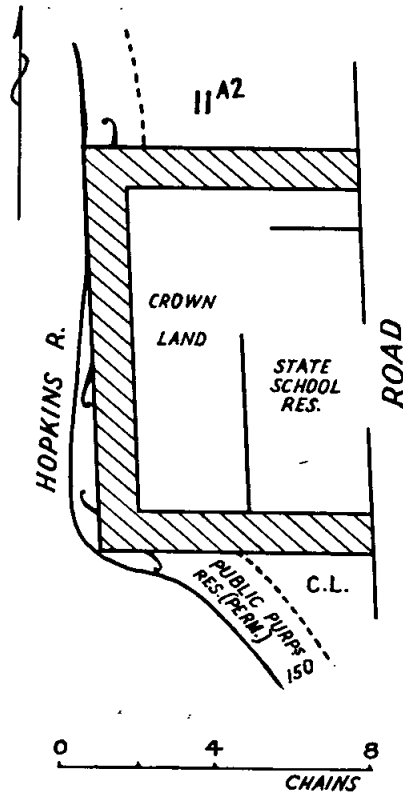

Township of Linton, Parish of Argyle, County of Grenville,
being the road indicated by hatching on plan hereunder.—(L.52⁽³⁾)
(J.32458).

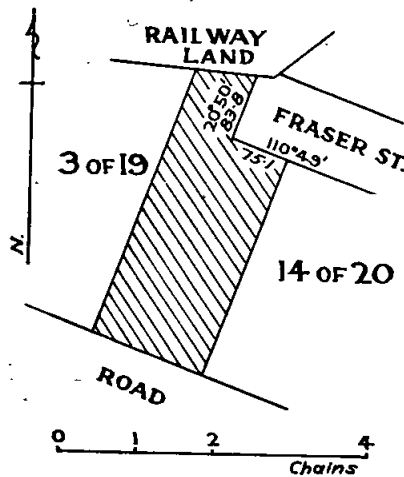

Parish of Stawell, County of Borung, being the road
indicated by hatching on plan hereunder.—(S.329⁽¹⁵⁾)
(M.62673).

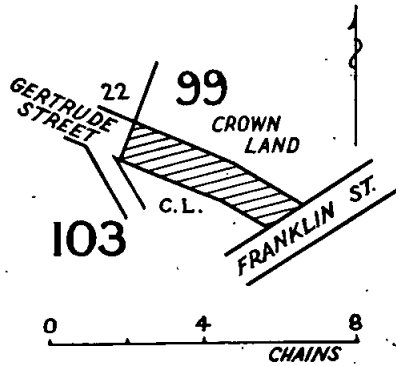

And the Honorable William Archibald Borthwick, Her Majesty's Minister of Lands for the State of Victoria, shall give the necessary directions herein accordingly.

J. ROSSITER,
Clerk of the Executive Council.

DEPARTMENT OF CROWN LANDS AND SURVEY.

At the Executive Council Chamber, Melbourne, the sixteenth day of November, 1971.

PRESENT:

His Excellency the Governor of Victoria.

Mr. Meagher | Mr. Smith.
Mr. Hunt

LANDS TEMPORARILY RESERVED AS SITES.

His Excellency the Governor of the State of Victoria, by and with the advice of the Executive Council thereof, doth hereby, in pursuance of section 14 of the Land Act 1958, reserve temporarily from sale, from being leased and from having a licence granted in respect thereof, and also except from occupation for mining purposes under any miner's right, the land hereinafter described:—

ANAKIE.—Site for Public purposes (Trigonometrical Survey Station), 1 rood 24 perches, Parish of Anakie, County of Grant, as indicated by hatching on plan hereunder.—(A.31⁽²⁾) (Rs.9547).

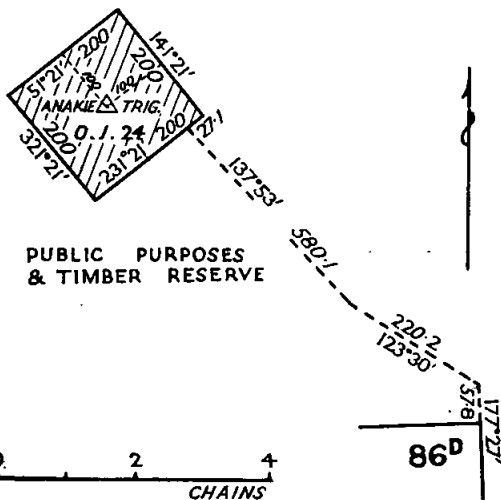

KIATA.—Site for Public purposes (purposes of the National Parks Service), 5 acres, Township of Kiata, Parish of Kiata, County of Lowan, as indicated by hatching on plan hereunder.—(P.131⁽¹⁾) (Rs.9562).

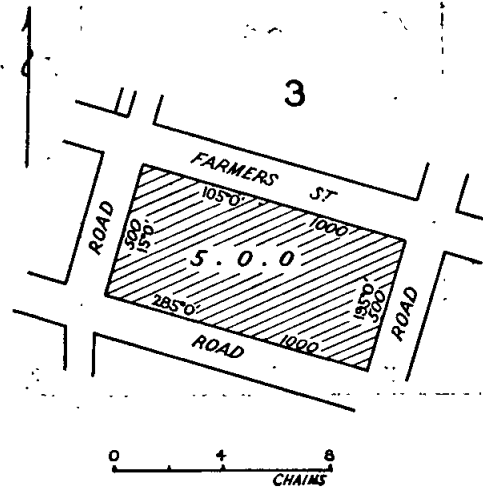

JEFFCOTT.—Site for Public purposes (Preservation of Native Flora and Fauna), 159 acres 3 roods 30 perches, Parish of Jeffcott, County of Kara Kara, as indicated by hatching on plan hereunder.—(J.36⁽⁴⁾) (Rs.4896).

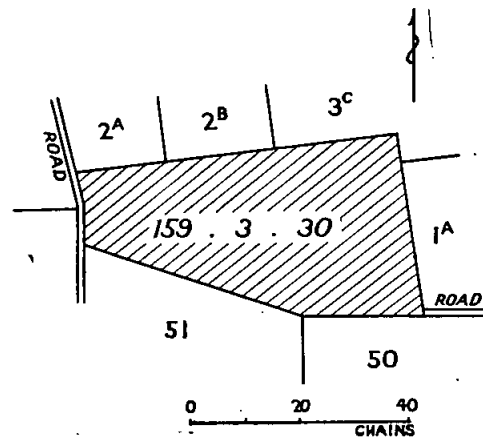

MILDURA (RED CLIFFS).—Site for Public purposes (Departmental Residence), 33 perches, at Red Cliffs, Parish of Mildura, County of Karkaroc, as indicated by hatching on plan hereunder.—(R.87⁽³⁾) (Rs.9504).

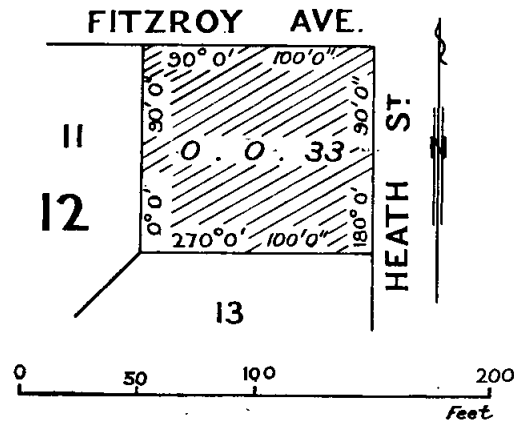

MILDURA (RED CLIFFS).—Site for Public purposes (Departmental Residence), 1 rood, at Red Cliffs, Parish of Mildura, County of Karkaroc, as indicated by hatching on plan hereunder.—(R.87⁽³⁾) (Rs.9506).

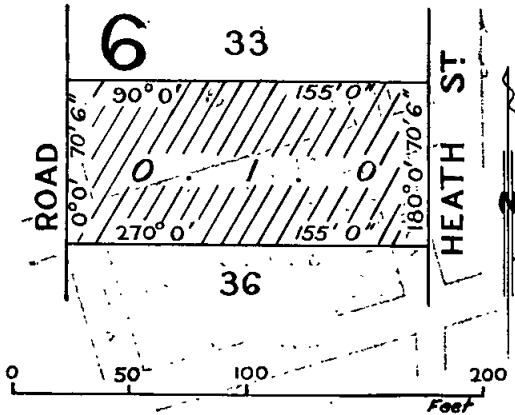

SPEED.—Site for Public purposes (Departmental Residence), 1 rood. 10 perches, Township of Speed, Parish of Gorya, County of Karkaroc, as indicated by hatching on plan hereunder.—(S.458⁽⁹⁾) (Rs.9561).

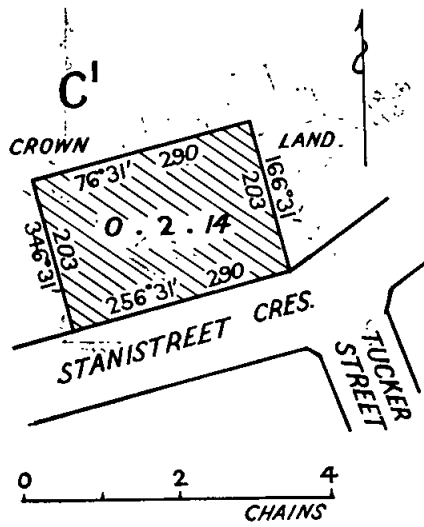

And the Honorable William Archibald Borthwick, Her Majesty's Minister of Lands for the State of Victoria, shall give the necessary directions herein accordingly.

J. ROSSITER,
Clerk of the Executive Council.

DEPARTMENT OF CROWN LANDS AND SURVEY.

At the Executive Council Chamber, Melbourne, the sixteenth day of November, 1971.

PRESENT:

His Excellency the Governor of Victoria.
Mr. Meagher
Mr. Hunt

Mr. Smith.

PERMANENT RESERVATION OF LAND AS A SITE.

His Excellency the Governor of the State of Victoria, by and with the advice of the Executive Council thereof, doth hereby, in pursuance of sections 14 and 21 of the Land Act 1958, reserve permanently from sale, from being leased and from having a licence granted in respect thereof, and also except from occupation for mining purposes under any miner's right the land hereinafter described, viz.:

NARREE WORRAN.—Site for Public purposes (Conservation of Wildlife), 4 acres, Parish of Narree Worrان, County of Mornington, as defined by the technical description published in the Government Gazette of the 6th October, 1971 (page 3277).—(N.19⁽¹⁰⁾) (Rs.9523).

And the Honorable William Archibald Borthwick, Her Majesty's Minister of Lands for the State of Victoria, shall give the necessary directions herein accordingly.

J. ROSSITER,
Clerk of the Executive Council.

DEPARTMENT OF CROWN LANDS AND SURVEY.

At the Executive Council Chamber, Melbourne, the sixteenth day of November, 1971.

PRESENT:

His Excellency the Governor of Victoria.
Mr. Meagher
Mr. Hunt

Mr. Smith.

REVOCATION OF TEMPORARY RESERVATION OF LAND BY ORDER IN COUNCIL.

His Excellency the Governor of the State of Victoria, by and with the advice of the Executive Council thereof, doth hereby, in pursuance of section 3 of the Portland

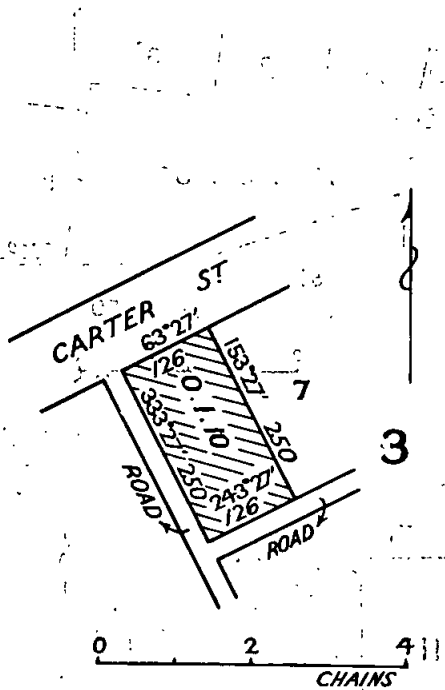

SANDHURST (BENDIGO).—Site for Public purposes (Trigonometrical Survey Station), 2 roods 14 perches, at Bendigo, Parish of Sandhurst, County of Bendigo, as indicated by hatching on plan hereunder.—(S.372⁽¹²⁾) (Rs.9556).

Lands Exchange Act 1969, revoke the temporary reservation of land by Order in Council hereinafter referred to, viz.:

PORTLAND.—The temporary reservation by Order in Council of the 13th November, 1865, of 20 perches of land in the Township of Portland as a site for Police purposes.—(P.69(1)) (Rs.5602).

And the Honorable William Archibald Borthwick, Her Majesty's Minister of Lands for the State of Victoria, shall give the necessary directions herein accordingly.

J. ROSSITER,
Clerk of the Executive Council.

LOCAL GOVERNMENT DEPARTMENT.

At the Executive Council Chamber, Melbourne, the sixteenth day of November, 1971.

PRESENT:

His Excellency the Governor of Victoria.

Mr. Meagher Mr. Smith.
Mr. Hunt

ROAD DISCONTINUED—CITY OF NUNAWADING.

Whereas it is provided in section 528 (2) of the Local Government Act 1958, that where a road (whether or not a public highway but not being a road set out on land of the Crown) or any part thereof is not required for public use, the Governor in Council on the request of the municipality in which such road is situated made not less than one month after publishing in a newspaper generally circulating in the district and posting to the registered proprietor (if any) of the land and the owners and occupiers (if any) of lands abutting or immediately adjacent to the road notice of intention to make such a request may by Order published in the Government Gazette direct that such road or part shall be discontinued and thereupon such road or part shall be discontinued accordingly:

And whereas the Council of the City of Nunawading has requested that portion of Masons-road, Blackburn, be discontinued and not less than one month previously has published in a newspaper generally circulating in the district and posted to the registered proprietor of the land in the road and to the owners and occupiers of lands abutting or immediately adjacent to the said road notice of intention to make such request.

Now therefore, His Excellency the Governor of the State of Victoria, by and with the advice of the Executive Council thereof, hereby directs—

- (a) that the portion of the said road which is shown by hachure on the plan hereunder, shall be discontinued;
- (b) that notwithstanding such discontinuance the Melbourne and Metropolitan Board of Works shall continue to have and possess the same right title power authority or interest in or in relation to the whole of the land shown by hachure on the said plan as it had or possessed prior to such discontinuance with respect to or in connexion with any pipes or drains laid or erected in on or over such lands for the purposes of drainage or sewerage; and
- (c) that, subject to any such right title power authority or interest the land in the said road may be retained by the Council of the City of Nunawading for municipal purposes.

MASONS ROAD

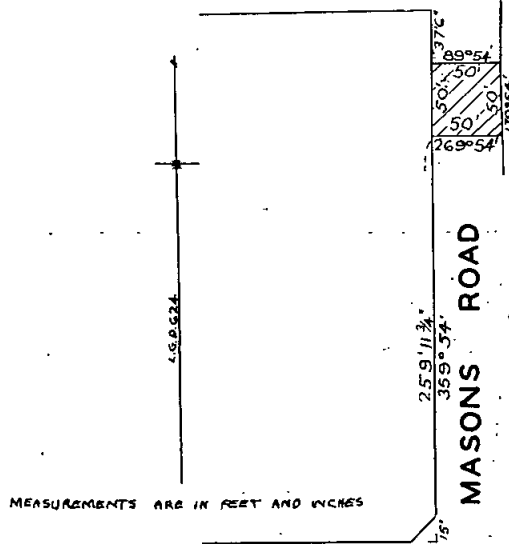

CANTERBURY ROAD

And the Honorable Alan John Hunt, Her Majesty's Minister for Local Government for the State of Victoria, shall give the necessary directions herein accordingly.

J. ROSSITER,
Clerk of the Executive Council.

Water Act 1958.

STATE RIVERS AND WATER SUPPLY COMMISSION.

At the Executive Council Chamber, Melbourne, the twenty-third day of November, 1971.

PRESENT:

His Excellency the Governor of Victoria.

Mr. Thompson Mr. Rossiter:
Mr. Dickie

STANHOPE URBAN DISTRICT—AREA OF DISTRICT INCREASED.

Under the powers conferred by the Water Act 1958 and all other powers enabling him in that behalf, His Excellency the Governor of the State of Victoria, with the advice of the Executive Council of the said State, on the recommendation of the State Rivers and Water Supply Commission, doth hereby declare, order and direct as follows:—

That the area of the Stanhope Urban District be increased by adding to the same the lands set out and described in the Schedule hereto, and as on and from the 1st day of December, 1971, the area of such district shall be deemed to be so increased.

SCHEDULE.

The whole of lot 12 on lodged plan of subdivision No. 15150, being part of allotment 76, Parish of Girgarre, together with that portion of Blamey-road adjoining the southern boundary of the said lot.

The lands set out and described in the foregoing Schedule are shown on a plan approved by the Governor in Council, and deposited in the office of the State Rivers and Water Supply Commission, Melbourne.—(Corr. No. 71/2818.)

And the Honorable Roberts Christian Dunstan, Her Majesty's Minister of Water Supply for the State of Victoria, shall give the necessary directions herein accordingly.

J. ROSSITER,
Clerk of the Executive Council.

Water Act 1958.

STATE RIVERS AND WATER SUPPLY COMMISSION.

At the Executive Council Chamber, Melbourne, the twenty-third day of November, 1971.

PRESENT:

His Excellency the Governor of Victoria.

Mr. Thompson		Mr. Rossiter.
Mr. Dickie		

WEST LODDON WATERWORKS DISTRICT—PORTION EXCISED.

Under the powers conferred by the *Water Act 1958* and all other powers enabling him in that behalf, His Excellency the Governor of the State of Victoria, with the advice of the Executive Council of the said State, on the recommendation of the State Rivers and Water Supply Commission, doth hereby declare, order and direct as follows:—

That there shall be excised from the West Loddon Waterworks District that portion of the same set out and described in the Schedule hereto, which portion, as from the 30th November, 1971, shall be deemed to be excised accordingly.

SCHEDULE.

The whole of the land comprised in certificate of title, volume 7984, folio 094, being part of allotment 147, Parish of Mysia, together with that portion of a road adjoining the southern boundary of the land in the said certificate of title.

The portion set out and described in the foregoing Schedule is shown on a plan approved by the Governor in Council, and deposited in the office of the State Rivers and Water Supply Commission, Melbourne.—(Corres. No. 70/1579.)

And the Honorable Roberts Christian Dunstan, Her Majesty's Minister of Water Supply for the State of Victoria, shall give the necessary directions herein accordingly.

J. ROSSITER,
Clerk of the Executive Council.

Water Act 1958.

STATE RIVERS AND WATER SUPPLY COMMISSION.

At the Executive Council Chamber, Melbourne, the twenty-third day of November, 1971.

PRESENT:

His Excellency the Governor of Victoria.

Mr. Thompson		Mr. Rossiter.
Mr. Dickie		

HEYFIELD URBAN DISTRICT.—AREA OF DISTRICT INCREASED.

Under the powers conferred by the *Water Act 1958* and all other powers enabling him in that behalf, His Excellency the Governor of the State of Victoria, with the advice of the Executive Council of the said State, on the recommendation of the State Rivers and Water Supply Commission, doth hereby declare, order and direct that the area of the Heyfield Urban District be increased by adding to the same the land shown by blue colour on a plan approved by the Governor in Council and deposited in the office of the State Rivers and Water Supply Commission, Melbourne (Corr. No. 71/2968) and as on and from the first day of December, 1971, the area of such District shall be deemed to be so increased.

And the Honorable Roberts Christian Dunstan, Her Majesty's Minister of Water Supply for the State of Victoria, shall give the necessary directions herein accordingly.

J. ROSSITER,
Clerk of the Executive Council.

Water Act 1958.

STATE RIVERS AND WATER SUPPLY COMMISSION.

At the Executive Council Chamber, Melbourne, the twenty-third day of November, 1971.

PRESENT:

His Excellency the Governor of Victoria.

Mr. Thompson		Mr. Rossiter.
Mr. Dickie		

GOULBURN—MURRAY IRRIGATION DISTRICT—DISTRICT EXTENDED.—BOORT IRRIGATION AREA—BOUNDARIES VARIED.

Under the powers conferred by the *Water Act 1958* and all other powers enabling him in that behalf, His Excellency the Governor of the State of Victoria, with the advice of the Executive Council of the said State, on the recommendation of the State Rivers and Water Supply Commission, doth hereby declare, order and direct as follows:—

That the Goulburn—Murray Irrigation District be extended and the boundaries of the Boort Irrigation Area be varied by adding to the said District and Area the lands set out and described in the Schedule hereto, and as on and from the first day of December, 1971, such District shall be deemed to be so extended and the boundaries of such Area shall be so varied.

SCHEDULE.

The whole of the land comprised in certificate of title, volume 7984, folio 094, being part of allotment 147, Parish of Mysia, together with that portion of a road adjoining the southern boundary of the land in the said certificate of title.

The lands set out and described in the foregoing Schedule are shown on a plan approved by the Governor in Council, and deposited in the office of the State Rivers and Water Supply Commission, Melbourne.—(Corres. No. 70/1579.)

And the Honorable Roberts Christian Dunstan, Her Majesty's Minister of Water Supply for the State of Victoria, shall give the necessary directions herein accordingly.

J. ROSSITER,
Clerk of the Executive Council.

METUNG WATERWORKS TRUST.

At the Executive Council Chamber, Melbourne, the twenty-third day of November, 1971.

PRESENT:

His Excellency the Governor of Victoria.

Mr. Thompson		Mr. Rossiter.
Mr. Dickie		

EXTENT OF URBAN DISTRICT INCREASED.

Under the powers conferred by the *Water Act* and all other powers enabling him in that behalf, His Excellency the Governor of the State of Victoria, by and with the advice of the Executive Council of the said State, doth hereby declare, order and direct that the extent of Metung Urban District of the Metung Waterworks Trust be increased by adding to the same the lands comprised within the boundaries shown on the plan approved by the Governor in Council by and with this Order and deposited in the office of the State Rivers and Water Supply Commission, Melbourne (Corr. 70/3831/6) and as on and from the date hereof, the extent of such District shall be and be deemed to be increased accordingly.

And the Honorable Roberts Christian Dunstan, Her Majesty's Minister of Water Supply for the State of Victoria, shall give the necessary directions herein accordingly.

J. ROSSITER,
Clerk of the Executive Council.

FOSTER SEWERAGE AUTHORITY.

At the Executive Council Chamber, Melbourne, the twenty-third day of November, 1971.

PRESENT:

His Excellency the Governor of Victoria.	
Mr. Thompson	Mr. Rossiter.
Mr. Dickie	

CONSENT TO BORROWING \$6,000.

Under the powers conferred by the Sewerage Districts Act and all other powers enabling him in that behalf, His Excellency the Governor of the State of Victoria, by and with the advice of the Executive Council of the said State, doth hereby consent to the Foster Sewerage Authority borrowing a sum of Six thousand dollars (\$6,000) to meet the cost of sewerage works as set forth in the detailed statement bearing date 18th November, 1971.

And the Honorable Roberts Christian Dunstan, Her Majesty's Minister of Water Supply for the State of Victoria, shall give the necessary directions herein accordingly.

J. ROSSITER,
Clerk of the Executive Council.

SWAN HILL SEWERAGE AUTHORITY.

At the Executive Council Chamber, Melbourne, the twenty-third day of November, 1971.

PRESENT:

His Excellency the Governor of Victoria.	
Mr. Thompson	Mr. Rossiter.
Mr. Dickie	

CONSENT TO BORROWING \$8,400.

Under the powers conferred by the Sewerage Districts Act and all other powers enabling him in that behalf, His Excellency the Governor of the State of Victoria, by and with the advice of the Executive Council of the said State, doth hereby consent to the Swan Hill Sewerage Authority borrowing the sum of Eight thousand four hundred dollars (\$8,400), for the conversion of Loan No. 11.

And the Honorable Roberts Christian Dunstan, Her Majesty's Minister of Water Supply for the State of Victoria, shall give the necessary directions herein accordingly.

J. ROSSITER,
Clerk of the Executive Council.

TATURA SEWERAGE AUTHORITY.

At the Executive Council Chamber, Melbourne, the twenty-third day of November, 1971.

PRESENT:

His Excellency the Governor of Victoria.	
Mr. Thompson	Mr. Rossiter.
Mr. Dickie	

CONSENT TO BORROWING \$50,000.

Under the powers conferred by the Sewerage Districts Act and all other powers enabling him in that behalf, His Excellency the Governor of the State of Victoria, by and with the advice of the Executive Council of the said State, doth hereby consent to the Tatura Sewerage Authority borrowing the sum of Fifty thousand dollars (\$50,000), to meet the cost of sewerage works as set forth in the detailed statement bearing date 18th November, 1971.

And the Honorable Roberts Christian Dunstan, Her Majesty's Minister of Water Supply for the State of Victoria, shall give the necessary directions herein accordingly.

J. ROSSITER,
Clerk of the Executive Council.

ROCHESTER SEWERAGE AUTHORITY.

At the Executive Council Chamber, Melbourne, the twenty-third day of November, 1971.

PRESENT:

His Excellency the Governor of Victoria.	
Mr. Thompson	Mr. Rossiter.
Mr. Dickie	

SALE OF LAND.

His Excellency the Governor of the State of Victoria, by and with the advice of the Executive Council thereof, doth hereby, under the provisions of the Sewerage Districts Act, approve of the sale by the Rochester Sewerage Authority, of the land shown on a plan approved by the Governor in Council by and with this Order and deposited in the office of the State Rivers and Water Supply Commission, Melbourne.—(Corr. No. 61/1601/100.)

And the Honorable Roberts Christian Dunstan, Her Majesty's Minister of Water Supply for the State of Victoria, shall give the necessary directions herein accordingly.

J. ROSSITER,
Clerk of the Executive Council.

LANDLORD AND TENANT ACT 1958.

At the Executive Council Chamber, Melbourne, the twenty-third day of November, 1971.

PRESENT:

His Excellency the Governor of Victoria.	
Mr. Thompson	Mr. Rossiter.
Mr. Dickie	

ORDER EXTENDING APPLICATION OF PART V. OF THE LANDLORD AND TENANT ACT 1958 TO CERTAIN PREMISES.

In pursuance of the powers conferred by section 44 of the Landlord and Tenant Act 1958, His Excellency the Governor of Victoria, by and with the advice of the Executive Council thereof, doth hereby declare that the application of Part V. of the Landlord and Tenant Act 1958 shall extend to the following premises.

1. The premises known as Flats 1, 2, 3 and 5, 40 Eildon-road, St. Kilda.
2. The premises known as Number 86 Argyle-avenue, Chelsea.

And the Honorable George Oswald Reid, Her Majesty's Attorney-General in and for the State of Victoria, shall give the necessary directions herein accordingly.

J. ROSSITER,
Clerk of the Executive Council.

MINES ACT 1958.

At the Executive Council Chamber, Melbourne, the twenty-third day of November, 1971.

PRESENT:

His Excellency the Governor of Victoria.	
Mr. Thompson	Mr. Rossiter.
Mr. Dickie	

WATER SUPPLY CATCHMENTS EXCEPTED FROM OCCUPATION UNDER MINER'S RIGHTS.

His Excellency the Governor of the State of Victoria, by and with the advice of the Executive Council thereof, doth hereby, in pursuance of the provisions of sections 7 and 347 of the Mines Act 1958, except from occupation for mining purposes under any miner's right, the following water supply catchments as shown on the plans specified and lodged in the Office of the Mines Department:

- Djerriwarrh Reservoir—Plan No. 1260.
- Lake Merrimu (Coimadai Creek)—Plan No. 1849A.
- Lake Merrimu (Goodmans Creek)—Plan No. 2246.
- Roslynne Reservoir (Jackson Creek)—Plan No. 2396.
- Roslynne Reservoir (Riddell Creek)—Plan No. 2526.

And the Honorable James Charles Murray Balfour, Her Majesty's Minister of Mines for the State of Victoria, shall give the necessary directions herein accordingly.

J. ROSSITER,
Clerk of the Executive Council.

LANDS DEPARTMENT NOTICES

APPROACHING LAND SALES.

Sales of Crown Lands, in fee-simple, will be held at the under-mentioned places and dates, viz.:-

	No. of Gazette.
Inglewood.—Thursday, 25th November, 1971	90

COMMON ABOUT TO BE DIMINISHED.

In pursuance of the provisions contained in the Land Act 1958, notice is hereby given that it is the intention of the Governor in Council to diminish the common hereinafter mentioned, viz.:-

The following Notice was published 1° on the 27th October, 1971, pursuant to Order of the 19th October, 1971.

The Ballarat West Town Common, proclaimed as such by the Governor in Council on the 28th January, 1861, (see Government Gazette of the 6th February, 1861, page 256) is about to be diminished by the excision therefrom of the portion in the Parish of Dowling Forest, containing 3 acres, indicated by hatching on plan hereunder.—(C.91998).

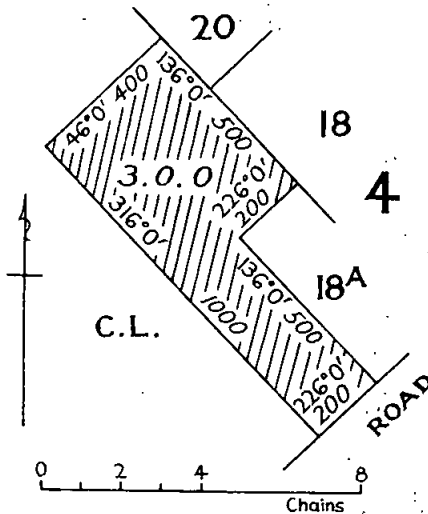

W. BORTHWICK,
Minister of Lands.

PROPOSED REVOCATIONS OF TEMPORARY RESERVATIONS OF LANDS BY ORDERS IN COUNCIL.

In pursuance of the provisions of the Land Act 1958, notice is hereby given that it is the intention of the Governor in Council to revoke the temporary reservations of lands by Orders in Council hereunder referred to, viz.:-

The following Notices were published 1° on the 10th November, 1971, pursuant to Orders of the 3rd November, 1971.

SANDHURST, AT BENDIGO.—The temporary reservation, by Order in Council of the 10th January, 1950, of 1 rood of land in the City of Bendigo (now at Bendigo) as a site for Police purposes, is about to be revoked.—(S.372⁽¹⁾) (Rs.6487).

FLOWERDALE.—The temporary reservation as a site for Cricket and other purposes of Public Recreation and the withholding from sale, leasing and licensing by Order in Council of the 4th January, 1883, of 3 acres 1 rood 37 perches of land in the Parish of Flowerdale, are about to be revoked.—(F.11^(?)) (Rs.400).

FLOWERDALE.—The temporary reservation as a site for Public purposes (State School) and the withholding from sale, leasing and licensing, by Order in Council of the 7th June, 1880, of 5 acres of land in the Parish of Flowerdale, are about to be revoked.—(F.11^(?)) (C.84901).

W. BORTHWICK,
Minister of Lands.

PROPOSED REVOCATIONS OF TEMPORARY RESERVATIONS OF LANDS BY ORDERS IN COUNCIL.

In pursuance of the provisions of the Land Act 1958, notice is hereby given that it is the intention of the Governor in Council to revoke the temporary reservations of lands by Orders in Council hereunder referred to, viz.:-

The following Notices were published 1° on the 3rd November, 1971, pursuant to Orders of the 26th October, 1971.

SUNBURY.—The temporary reservation by Order in Council of the 11th May, 1897, of 1 rood of land in the Township of Sunbury, as a site for Municipal purposes, is about to be revoked.—(S.351^(*)) (Rs.8618).

TORQUAY.—The temporary reservation by Order in Council of the 15th July, 1889, of 75 acres 3 roods 16 perches, more or less, of land in the Township of Torquay (formerly the Township of Puebla), as a site for Public Recreation, revoked as to part by various Orders, is about to be revoked so far only as the portion containing 2 acres 2 roods 9 perches, indicated by hatching on plan hereunder is concerned.—(T.316⁽¹⁾) (Rs.1644).

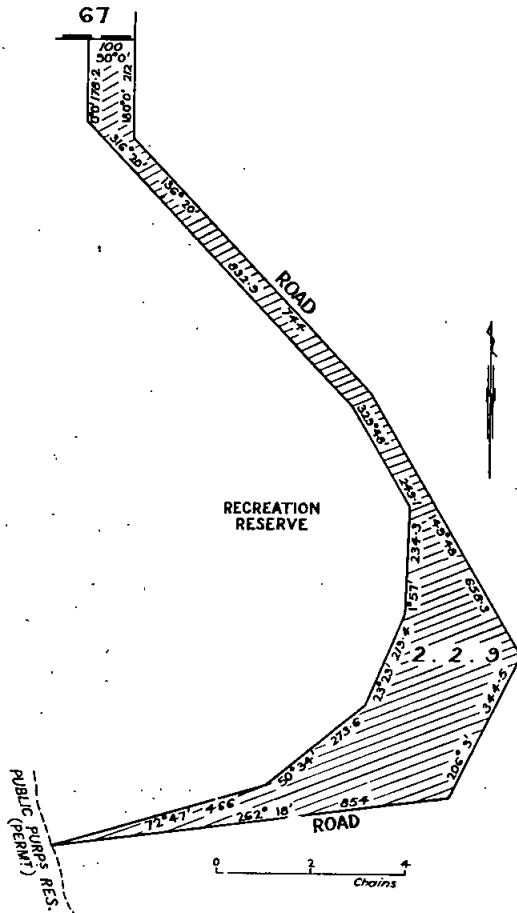

TORQUAY.—The temporary reservation by Order in Council of the 29th March, 1960, of 7 acres, more or less, of land in the Township of Torquay, as a site for Public Recreation, is about to be revoked so far only as the portion containing 23 perches, more or less, indicated by hatching on plan hereunder is concerned.—(T.316⁽¹⁾) (Rs.1644).

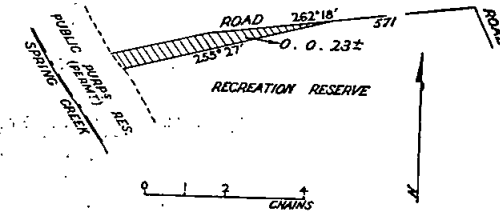

NELSON.—The temporary reservation by Order in Council of the 12th October, 1937, of 3 acres 3 roods 12 perches, more or less, of land in the Parish of Glenelg (now in the Township of Nelson), as a site for Public purposes, revoked as to part by Order of the 19th June, 1957, is about to be revoked so far only as the portion containing 1 rood 30 perches, more or less, indicated by hatching on the plan hereunder is concerned.—(N.51^(*)) (Rs.4731).

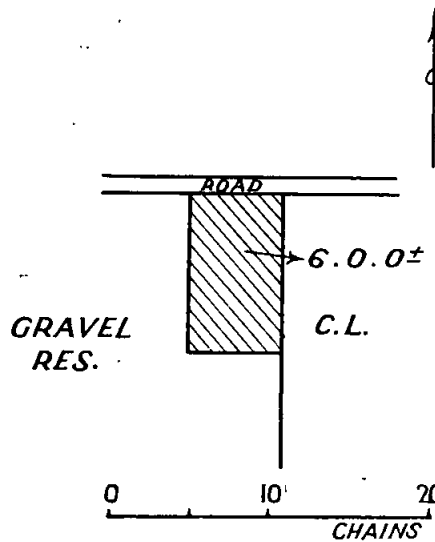
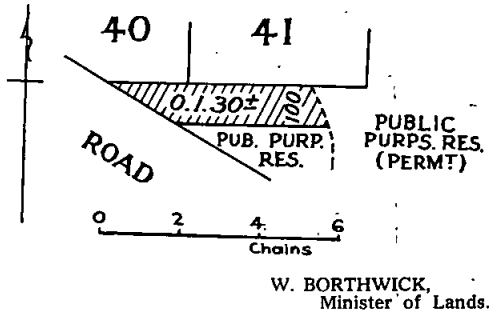

PROPOSED REVOCATIONS OF TEMPORARY RESERVATIONS OF LANDS BY ORDERS IN COUNCIL.

In pursuance of the provisions of the Land Act 1958, notice is hereby given that it is the intention of the Governor in Council to revoke the temporary reservations of lands by Orders in Council hereunder referred to, viz.:—
The following Notices were published 1° on the 17th November, 1971, pursuant to Orders of the 9th November, 1971.

KILMORE.—The temporary reservation by Order in Council of the 1st August, 1864, of 1 rood of land in the Township of Kilmore, as a site for a Common School, is about to be revoked.—(K.47^(*)) (C.84115).

HEYWOOD.—The temporary reservation by Order in Council of the 14th May, 1968, of 3 roods of land in the Township of Heywood, as a site for Public purposes (Municipal purposes), is about to be revoked, so far only as the portion containing 22 perches, indicated by hatching on plan hereunder, is concerned.—(H.86^(*)) (Rs.8966).

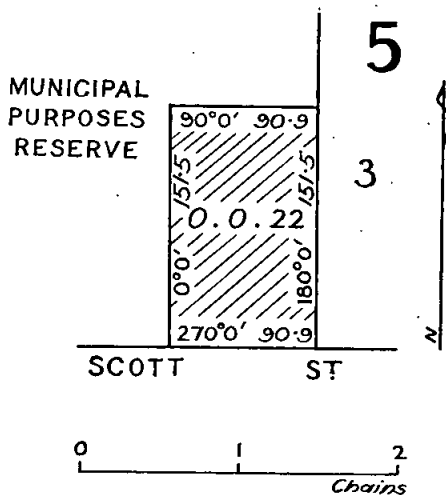

SANDHURST (AT BENDIGO).—The temporary reservation, by Order in Council of the 10th July, 1917, of 77 acres 3 roods, more or less, of land at Bendigo, in the Parish of Sandhurst, as a site for Supply of Gravel, revoked as to part by various Orders, is about to be revoked, so far only as the portion containing 1 acre 2 roods, more or less, indicated by hatching on plan hereunder, is concerned.—(S.372^(100, 114)) (Rs.3837).

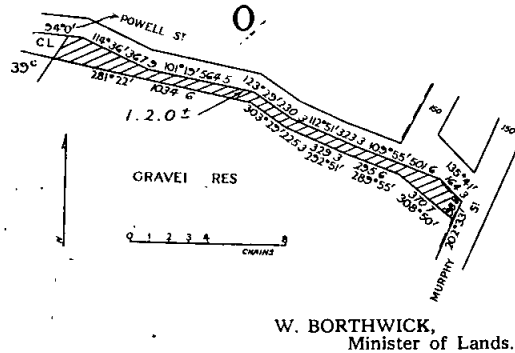

PROPOSED REVOCATIONS OF TEMPORARY RESERVATIONS OF LANDS BY ORDERS IN COUNCIL.

In pursuance of the provisions of the Land Act 1958, notice is hereby given that it is the intention of the Governor in Council to revoke the temporary reservations of lands by Orders in Council hereunder referred to, viz.:—

The following Notices were published 1° on the 24th November, 1971, pursuant to Orders of the 16th November, 1971.

PHILLIP ISLAND.—The temporary reservation as a site for Public purposes, and the withholding from sale, leasing and licensing by Order in Council of the 23rd July, 1877, (see Government Gazette of the 27th July, 1877, page 1423), revoked as to part by Orders of the 27th May, 1878 (see Government Gazette of the 31st May, 1878, page 1257), and the 2nd July, 1878 (see Government Gazette of the 5th July, 1878, page 1616), of 756 acres, more or less, of land in the Parish of Phillip Island, is about to be revoked, so far as the balance thereof, containing 427 acres, more or less, is concerned.—(P.136^(*)) (78.C.10355).

CUNDARE.—The temporary reservation, by Order in Council of the 19th January, 1874 of 5 acres of land in the Parish of Cundare, as a site for State School purposes is about to be revoked.—(C.350^(A1)) (C.84080).

PORTARLINGTON.—The temporary reservation, by Order in Council of the 4th August, 1970, of 96 acres, 2 roods, more or less, of land in the Township of Portarlington, as a site for Recreation and Public Purposes is about to be revoked.—(P.37^(*)) (Rs.2040).

CARISBROOK.—The temporary reservation by Order in Council of the 21st January, 1931 (see Government Gazette, 28th January, 1931, page 275), of 49 acres 1 rood 15 perches of land in the Parish of Carisbrook, as a site for the Supply of Gravel, is about to be revoked, so far only as the portion containing 6 acres, more or less, indicated by hatching on plan hereunder, is concerned.—(C.132^(*)) (Rs.4093).

MELBOURNE SOUTH (ST. KILDA).—The temporary reservation by Order in Council of the 6th July, 1965, of land at St. Kilda, in the Parish of Melbourne South, as a site for Public Recreation, is about to be revoked.—(M.333⁽²⁵⁾) (Rs.8333).

WILLIAMSTOWN.—The temporary reservation, by Order in Council of the 30th June, 1911, of 1 rood 24 perches of land in the Township of Williamstown, as a site for Lighthouse-keepers' Quarters, is about to be revoked.—(W.163⁽⁵⁾) (Rs.1382).

BAIRNSDALE.—The temporary reservation as a site for Public purposes and the withholding from sale, leasing and licensing, by Order in Council of the 21st January, 1879, of a portion of land in the Parish of Bairnsdale, are about to be revoked, so far only as the portion containing 11 perches, more or less, indicated by hatching on plan hereunder, is concerned.—(B.67⁽⁸⁾) (Rs.5532).

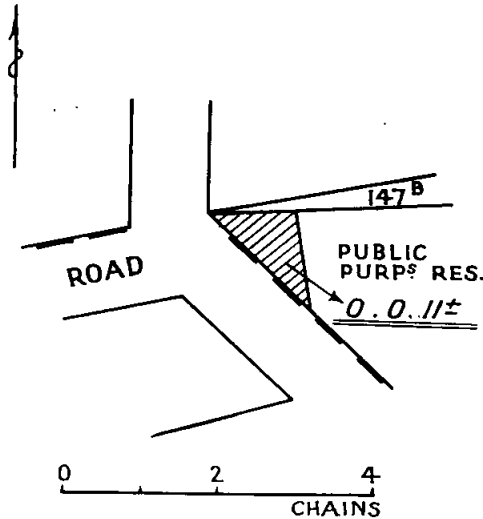

COBUNGRA.—The temporary reservation, by Order in Council of the 4th November, 1889, of certain unappropriated Crown land situate within a distance of three chains from the banks of the Livingstone Creek for the supply of Gravel and Sand, revoked as to part by various Orders, is about to be revoked, so far only as the portion in the Parish of Cobungra containing 1 acre 10 perches, more or less, indicated by hatching on plan hereunder is concerned.—(C.372⁽⁶⁾) (C.86890).

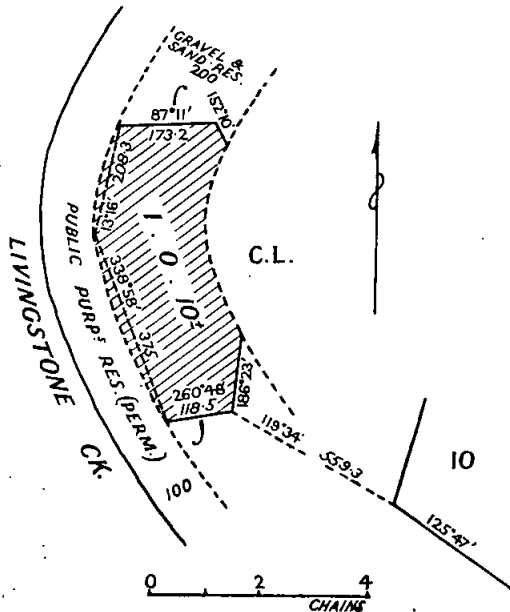

PENSHURST.—The temporary reservation, by Order in Council of the 10th November, 1863, of 1 acre 2 roods of land in the Township of Peshurst, as a site for Police purposes, revoked as to part by various authorized excisions, is about to be revoked, so far only as the portion containing 35 perches, indicated by hatching on plan hereunder is concerned.—(P.29⁽⁴⁾) (C.92424).

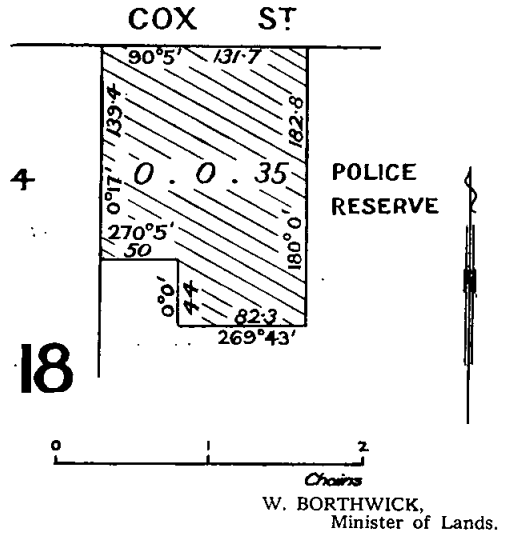

W. BORTHWICK,
Minister of Lands.

TENDERS

PUBLIC WORKS DEPARTMENT

Tenders will be received at Public Works Department, 2 Treasury-place, Melbourne, until **TWO** p.m. on dates shown and for purposes mentioned hereunder.

Particulars and tender forms available at Contracts Office, Room 8, Building Division, 7 Parliament-place and at places indicated in brackets hereunder.

Abbreviations in brackets mean:—W.O.—Inspector of Works Office; P.S.—Police Station; C.S.—Consolidated School; H.E.S.—Higher Elementary School; H.S.—High School; Pr.S.—Primary School; T.S.—Technical School.

Tenders to be submitted on the Department's printed Tender Form and will not be received by telephone. All tenders must be on a "Firm Tender" basis. The lowest or any tender will not necessarily be accepted.

Address tenders to the Minister of Public Works, and endorse the envelope containing the tender "Tender for , closing Tuesday,

Hand delivered tenders to be placed in the Tender Box of the Public Works Department, located on the wall of the centre entrance foyer, Ground Floor, 2 Treasury-place, Melbourne.

No preliminary deposit is required with any tender, but a successful tenderer will be required to pay a deposit for any accepted tender of \$4,000 or over.

Tuesday, 30th November, 1971.

Building, Electrical and Mechanical Works.

ARARAT.—Internal repairs and painting, Pr.S.800. (W.O., Ararat.)

ARMADALE.—Internal and external renovations, Secondary Teachers' Hostel, Frank Tate House.

ESSENDON NORTH.—External and internal renovations, Pr.S.4015.

GOWERVILLE.—Repairs and renovations, Pr.S.4674.

IVANHOE EAST.—External renovations, Pr.S.4386.

MELBOURNE.—External renovations, chalkboards, &c., Victorian School for Deaf Children.

MYRTLEFORD.—Extensions to laboratory, Tobacco Research Station. (W.O., Benalla, Wangaratta.)

MYRTLEFORD.—Mechanical services, Laboratory, Tobacco Research Station. (W.O., Wangaratta.)

NORTHCOTE.—Repairs and painting, Pr.S.1401.

PRESTON.—Erection of workshop, Stage I, Composite T.S.

TRARALGON.—External and internal renovations, H.S. (W.O., Traralgon.)

TRARALGON.—Improved electrical installation, H.S. (W.O., Traralgon.)

Site Works.

BELVEDERE PARK.—Site works, Pr.S.4902.

Miscellaneous.

WARRAGUL.—Supply of universal cylindrical grinder, T.S.

Tuesday, 7th December, 1971.

Building, Electrical and Mechanical Works.

ALBERT PARK.—Internal and external renovations, Pr.S.1181.

BURWOOD HEIGHTS.—Paving, drainage and associated works, Pr.S.4932.

CARLTON.—Internal and external repairs and painting, St. Nicholas Hospital.

COBURG.—External renovations, roofing, &c., H.S.

CORIO.—Internal and external renovations, Pr.S.124. (W.O., Geelong.)

CRESWICK.—Alterations to main building, Victorian School of Forestry. (W.O., Ballarat.)

CRESWICK.—Mechanical services, Victorian School of Forestry. (W.O., Ballarat.)

DINGWALL.—Repairs and painting, Pr.S.3183. (W.O., Swan Hill.)

DONCASTER PARK.—Exterior and interior renovations, Pr.S.4861.

HORSHAM.—Erection of a barn, Wheat Research Institute. (W.O., Horsham.)

PARKDALE.—Repairs and painting, Pr.S.4171.

RICHMOND NORTH.—Internal and external repairs and renovations, Pr.S.2798.

TOORAK.—Internal and external renovations, Teachers Centre.

STAWELL.—Erection of standard school hall type 572c, H.S. (W.O., Ararat and Horsham.)

STAWELL.—Electrical services, Hall, H.S. (W.O., Ballarat and Horsham.)

STAWELL.—Mechanical services, Hall, H.S. (W.O., Ballarat and Horsham.)

WATTLE PARK.—Internal and external repairs and painting, Pr.S.3841.

Site Works.

FRANKSTON.—Site works, H.S.

IRYMPLE.—Site works, T.S. (W.O., Mildura and Swan Hill.)

SALE.—Site works, Pr.S.5021. (W.O., Bairnsdale and Traralgon.)

Miscellaneous.

VARIOUS.—Supply of compressed oxygen, compressed nitrogen and dissolved acetylene for the period 1st January, 1972 to 31st December, 1972.

WILLIAMSTOWN.—Supply and delivery of one (1) only marine diesel engine and two (2) only marine propellers, Dredging Depot.

Tuesday, 14th December, 1971.

Building, Electrical and Mechanical Works.

DOVETON.—Erection of standard school hall type "800c", T.S.

DOVETON.—Electrical services, hall, T.S.

DOVETON.—Mechanical services, hall, T.S.

KEW.—Remodelling of Wards 26 and 27, Children's Cottages.

KEW.—Heating and hot water services, Children's Cottages.

MOONEE PONDS.—Erection of a new single storey brick Court House.

MOONEE PONDS.—Electrical installation, Court House.

MOONEE PONDS.—Mechanical services, Court House.

MIRBOO NORTH.—Resiting of package sewerage treatment plant, drainage, &c., Morwell River Reforestation Prison. (W.O., Traralgon.)

MURRUMBEENA.—Erection of sports Clubhouse, H.S. (Amended Specification.)

NORLANE.—External repairs and painting, Pr.S.4734. (W.O., Geelong.)

WERRIMULL.—Alterations and additions, C.S. (W.O., Mildura.)

WERRIMULL.—Electrical services, additions and alterations, C.S. (W.O., Mildura.)

WERRIMULL.—Mechanical services, additions and alterations, C.S. (W.O., Bendigo, Horsham, Mildura and Swan Hill.)

Site Works.

BELL PARK.—Site works, T.S. (W.O., Geelong.)

MURRUMBEENA.—Construction of porous Tennis Courts and associated works, &c., H.S. (Amended Specification.)

Miscellaneous.

PARKVILLE.—Supply and delivery of laundry equipment, "Turana" Youth Training Centre. (Amended Specification.)

Tuesday, 21st December, 1971.

Building, Electrical and Mechanical Works.

VARIOUS.—Mechanical services, Rates Contract 1971/72.

MURRAY BYRNE,

Minister of Public Works.

Public Works Department,
Melbourne, 3002, 22nd November, 1971.

PUBLIC SERVICE NOTICES

APPOINTMENT OF A DEPUTY TO A MEMBER OF THE PUBLIC SERVICE BOARD.

Whereas in the manner prescribed by the Regulations and at an election held in conjunction with the election of Leo Walker Regan, the mental hygiene representative on the Public Service Board, William Henry Templeton, was elected to be his deputy in the case of his suspension, illness or absence:

And whereas the said Leo Walker Regan will be absent from the meetings of the Board on the 29th November, 1971 and the 6th December, 1971:

Now therefore, at the request of the said Leo Walker Regan and in pursuance of the powers conferred by section 15 (2a) of the Public Service Act 1958, I do hereby appoint the said William Henry Templeton to be the deputy of Leo Walker Regan, on the above-mentioned days.

Given under my hand at Melbourne, this eighteenth day of November, 1971.

A. J. A. GARDNER, Chairman.

Office of the Public Service Board,
Melbourne, 18th November, 1971.

No. 108.

PUBLIC SERVICE ACT 1958.

The Public Service Board, in pursuance of the powers conferred by the Public Service Act 1958, hereby amends the Public Service (Public Service Board) Regulations as follows:—

PART V.—ALLOWANCES.

DIVISION II.—OVERTIME AND STANDBY ALLOWANCES.

STATE FORESTS DEPARTMENT.

Regulation 151.

In sub-regulation (3) the amount "85c" is substituted for the amount "65c".

This Regulation shall have effect as on and from the 7th November, 1971.

A. H. RIGG, Acting Chairman.
V. P. SCULLY, Secretary.

Office of the Public Service Board,
Melbourne, 9th November, 1971.

No. 109.

Public Service Act 1958, Section 50.
REGULATIONS.—PART IV.—SALARIES AND INCREMENTS.

The Public Service Board, in pursuance of the powers conferred by the *Public Service Act 1958*, hereby amends its Regulations as shown below :—

FIFTH SCHEDULE.
TEMPORARY EMPLOYEES.
DEPARTMENT OF HEALTH.
MENTAL HYGIENE.

Designations of Positions and Rates of Salaries.

Designation of Position.	Yearly Rate of Salary.Σ	
	Minimum.	Maximum.
	\$	\$
Delete— Fireman	3,046	3,392
Add— Fireman	3,392	3,743

ΣAnnual increments shall be in accordance with those prescribed by Sub-Regulations 113 (2) and 113 (3), provided that in the case of the position of Assistant (Male), Administrative, the annual increments shall be in accordance with those prescribed by Part A of the Third Schedule.

This Regulation shall have effect as on and from the 14th November, 1971.

A. H. RIGG, Acting Chairman.
V. P. SCULLY, Secretary.

Office of the Public Service Board,
Melbourne, 12th November, 1971.

No. 113.

Public Service Act 1958, Section 50.
REGULATIONS.—PART IV.—SALARIES AND INCREMENTS.

The Public Service Board, in pursuance of the powers conferred by the *Public Service Act 1958*, hereby amends its Regulations as shown below :—

SIXTH SCHEDULE.
TEMPORARY EMPLOYEES.

Designations of Positions and Rates of Salaries.

Department and Designation of Position.	Yearly Rate of Salary.		Increments (Annual).
	Minimum.	Maximum.	
	\$	\$	
Delete— Painter	3,782	4,139	Σ
Add— Painter	4,100	4,456	Σ

This Regulation shall have effect as on and from the 21st November, 1971.

A. J. A. GARDNER, Chairman.
V. P. SCULLY, Secretary.

Office of the Public Service Board,
Melbourne, 19th November, 1971.

No. 110.

Public Service Act 1958, Section 50.
REGULATIONS.—PART IV.—SALARIES AND INCREMENTS.

The Public Service Board, in pursuance of the powers conferred by the *Public Service Act 1958*, hereby amends its Regulations as shown below :—

SIXTH SCHEDULE.
TEMPORARY EMPLOYEES.

Designations of Positions and Rates of Salaries.

Department and Designation of Position.	Yearly Rate of Salary.		Increments (Annual).
	Minimum.	Maximum.	
	\$	\$	
<i>Delete the existing yearly rates of salary for the following positions and insert the rates shown hereunder in lieu thereof—</i>			
GENERAL.			
Fireman	3,392	3,743	Σ
DEPARTMENT OF HEALTH.			
<i>Tuberculosis.φ</i>			
<i>State Sanatoria.φ</i>			
Boiler Attendant	3,392	3,743	Σ
MINES DEPARTMENT.			
Bulldozer Operator (70–130 brake horsepower)	4,080	4,416	Σ
STATE FORESTS DEPARTMENT.			
<i>Central Workshop.</i>			
Mobile Crane Driver	3,270	3,627	Σ

This Regulation shall have effect as on and from the 14th November, 1971.

A. H. RIGG, Acting Chairman.
V. P. SCULLY, Secretary.

Office of the Public Service Board,
Melbourne, 12th November, 1971.

No. 111.

Public Service Act 1958, Section 50.
REGULATIONS.—PART IV.—SALARIES AND INCREMENTS.

The Public Service Board, in pursuance of the powers conferred by the *Public Service Act 1958*, hereby amends its Regulations as shown below :—

SIXTH SCHEDULE.
TEMPORARY EMPLOYEES.

Designations of Positions and Rates of Salaries.

Department and Designation of Position.	Yearly Rate of Salary.		Increments (Annual).
	Minimum.	Maximum.	
	\$	\$	
SOCIAL WELFARE DEPARTMENT.			
<i>Youth Welfare Division.</i>			
Add— Patrolman, "Winlaton"	2,940	3,290	Σ

This Regulation shall have effect as on and from the 11th November, 1971.

A. J. A. GARDNER, Chairman.
V. P. SCULLY, Secretary.

Office of the Public Service Board,
Melbourne, 16th November, 1971.

No. 112.

Public Service Act 1958, Section 50.
REGULATIONS—PART IV.—SALARIES AND INCREMENTS.

The Public Service Board, in pursuance of the powers conferred by the *Public Service Act 1958*, hereby amends its Regulations as shown below :—

FIFTH SCHEDULE.
TEMPORARY EMPLOYEES.
DEPARTMENT OF HEALTH.
MENTAL HYGIENE.

Designations of Positions and Rates of Salaries.

Designation and Position.	Yearly Rate of Salary. £.	
	Minimum.	Maximum.
	\$	\$
<i>Delete—</i> Painter	3,782	4,139
<i>Add—</i> Painter	4,100	4,456

Annual increments shall be in accordance with those prescribed by Sub-Regulations 113 (2) and 113 (3) provided that in the case of the position of Assistant (Male), Administrative, the annual increments shall be in accordance with those prescribed by Part A of the Third Schedule.

This Regulation shall have effect as on and from the 21st November, 1971.

A. J. A. GARDNER, Chairman.
 V. P. SCULLY, Secretary.

Office of the Public Service Board,
 Melbourne, 19th November, 1971.

PRIVATE ADVERTISEMENTS

CITY OF BALLAARAT.

LOAN No. 29.

Notice of Intention to Borrow the Sum of \$100,000 for Permanent Works and Undertakings.

Notice is hereby given that the Council of the City of Ballarat proposes to borrow the principal sum of One hundred thousand dollars (\$100,000) secured by a charge over the general rates of the municipality, such sum to be raised by the grant of a mortgage, in accordance with the provisions of the *Local Government Act 1958*.

1. The maximum rate of interest that may be paid is 7.4 per centum per annum.
2. The purposes for which the loan is to be applied are:—

City Oval Fencing	\$2,100
Town Hall Redevelopment	78,400
Path and Kerb Works	4,500
Town Planning—	
Acquisition of properties	15,000
	\$100,000

3. The period of the loan shall be 40 years.
4. The money borrowed shall be repayable by providing out of the municipal fund 80 half-yearly instalments of \$3,913.95 each, including principal and interest, on the 1st day of August and the 1st day of February during the currency of the loan. The first instalment shall be payable on the 1st day of August, 1972.

Such moneys are to be repayable at the office of the A.M.P. Society, Melbourne.

The plans and specifications and the estimate of the cost of the works, and a statement showing the proposed expenditure of the moneys to be borrowed are open for inspection at the Town Hall, Ballarat.

Dated 16th November, 1971.

3446 F. J. ROGERS, Town Clerk.

CITY OF CROYDON.

LOAN No. 101—PRIVATE STREET CONSTRUCTION.

Notice is hereby given that at the meeting of the Council of the City of Croydon, held at the Municipal Offices, Foch-avenue, Croydon, on the 6th day of September, 1971, the said Council did agree to the following Resolution, that is to say:

“That the Council do by Special Order and it does hereby resolve to borrow the sum of \$100,000 on the credit of the municipal revenues of the Mayor, Councillors and Citizens of the said City, such sum to be raised by the grant of mortgage, in accordance with the provisions of the *Local Government Act 1958*.

The rate of interest to be paid shall be 7.3 per centum per annum and the said loan shall be liquidated by twenty, half-yearly payments of principal and interest, at the National Bank Savings Bank, Limited, Melbourne, on the several days and in the several amounts specified in the schedule of payments.

The purposes for which the said loan shall be applied are for the construction of private streets under the provision of Division 10 of Part XIX. of the *Local Government Act 1958*, and the loan shall be liquidated from the receipts of money payable under scheme under the said Division.”

Notice is hereby further given that at a meeting of the said Council held at the Municipal Offices, Foch-avenue, Croydon, on the 15th day of November, 1971, the said Resolution was confirmed.

3428 K. A. McKAY, Town Clerk.

CITY OF DONCASTER AND TEMPLESTOWE.

Whereas the Council of the City of Doncaster and Templestowe deems it expedient to exercise its power of taking compulsorily the lands described in the Schedule hereto for the purpose of providing pleasure grounds and places of public resort and recreation on lands pursuant to section 799 of the *Local Government Act 1958*, by the provision of a hall to be used for public purposes and acquiring the said lands for that purpose and whereas the Council has caused to be prepared maps and other papers setting out the general description of the work or undertaking for which the lands proposed to be taken are to be used, the description of the lands proposed to be taken and the names of the owners or reputed owners, lessees or reputed lessees mortgagees and occupiers, of those lands so far as those names are known to or can be ascertained by the Council and whereas the said plans and other papers are deposited at the office of the said Council at Doncaster and are and shall be open for inspection by all persons interested at all reasonable hours for the space of forty clear days after the publication of this notice in the *Government Gazette* now notice is hereby given to all persons affected by the proposed taking of the said lands to set forth in writing addressed to the Council or Town Clerk within forty clear days of the publication of this notice in the *Government Gazette* all objections which they may have to the taking of the said lands.

The Schedule hereinbefore referred to—

Land described in Certificates of title, volume 5727, folio 331, and volume 6447, folio 295, and being land situate at the corner of Blackburn-road and Andersons-creek-road, Doncaster East.

By Order,
 3436 J. W. THOMSON, Town Clerk.

CITY OF HAMILTON.

LOAN No. 56.

Notice of Intention to Borrow the Sum of \$50,000 for Permanent Works and Undertakings.

Notice is hereby given that the Council of the City of Hamilton proposes to borrow the principal sum of \$50,000, secured by a charge over the general rates of the municipality, such sum to be raised by the grant of a mortgage, in accordance with the provisions of the *Local Government Act 1958*:

1. The maximum rate of interest that may be paid is 7.40 per centum per annum.
2. The purpose for which the loan is to be applied is—
 Extensions to the City of Hamilton Art Gallery—
 Council Contribution (Part).
3. The period of the loan shall be fifteen years.

4. The moneys borrowed shall be repayable by providing out of the municipal fund half-yearly instalments of approximately \$2,787.12 each, including principal and interest, on the 1st day of March and the 1st day of September, during the currency of the loan. The first instalment shall be payable on the 1st day of September, 1972.

5. Such moneys shall be repayable to the Commissioners of the State Savings Bank of Victoria, at the office of the said Commissioners, corner Elizabeth and Bourke streets, Melbourne.

The plans and specifications and the estimate of the cost of the proposed works, and a statement showing the proposed expenditure of the moneys to be borrowed, are open for inspection at the office of the Council of the City of Hamilton, at Brown-street, Hamilton.

Dated 25th November, 1971.

3431 H. F. DONALD, Town Clerk.

Town and Country Planning Act 1961 (Twelfth Schedule).
CITY OF KNOX PLANNING SCHEME 1965.

NOTICE THAT A PLANNING SCHEME HAS BEEN PREPARED AND IS AVAILABLE FOR INSPECTION.

Amendment No. 101, 1971.

Notice is hereby given that the Council of the City of Knox, in pursuance of its powers under the *Town and Country Planning Act 1961*, has prepared a Planning Scheme for portions of the City of Knox for the purpose of amending the Principal Scheme by rezoning land on the west side of Wantirna-road between Boronia-road and Clarence-road, Wantirna, from Rural "A" to Road Widening.

A copy of the Scheme has been deposited at the Office of the City of Knox, Spring-street, Fern Tree Gully and at the Office of the Town and Country Planning Board, 5th Floor, 235 Queen-street, Melbourne, and will be open for inspection during office hours by any person free of charge.

Any persons affected by the Planning Scheme are required to set forth in writing all objections they may have, addressed to the Town Clerk, City of Knox, Spring-street, Fern Tree Gully, on or before the 24th day of February, 1971 and to state whether they wish to be heard in respect of their objections.

3461 N. G. HAYNES, Town Clerk.

CITY OF MOE.

LOAN No. 50.

Notice of Intention to Borrow the Sum of \$100,000 for Permanent Works and Undertakings.

Notice is hereby given that the Council of the City of Moe proposes to borrow the sum of \$100,000, secured by a charge over the general rates of the municipality, such sum to be raised by the grant of a mortgage, in accordance with the Local Government Act.

1. The maximum rate of interest that may be paid is 7.4 per centum per annum.

2. The purpose for which the loan is to be applied is for the construction of roads and drains and the purchase and improvements to Council property.

3. The period of the loan shall be 40 years.

4. The moneys borrowed shall be repayable by providing out of the municipal fund 80 equal half-yearly instalments of \$3,913.95 each, including principal and interest, in each August and February, during the currency of the loan. The first instalment shall be payable on 1st August, 1972.

5. Such moneys shall be repayable to the head office of the Victorian Branch of the Australian Mutual Provident Society Ltd., presently 535 Bourke-street, Melbourne, 3000.

The plans and specifications and the estimate of the cost of the proposed works, and a statement showing the proposed expenditure of the moneys to be borrowed, are open for inspection at the City Offices, Albert-street, Moe, during office hours.

3440 R. J. PUGSLEY, Town Clerk.

SHIRE OF BAIRNSDALE.

PROSECUTING OFFICER.

Notice is hereby given that the Council of the Shire of Bairnsdale has appointed Sergeant Frank Irwin Morgan, No. 10610 as Prosecuting Officer for the Shire of Bairnsdale in place of Sergeant Walter William McKay, No. 10155, transferred.

3445 P. R. LEWIS, Shire Secretary.

Town and Country Planning Act 1961.

SHIRE OF BELLARINE.—GEE LONG PLANNING SCHEME.

NOTICE THAT A PLANNING SCHEME HAS BEEN PREPARED AND IS AVAILABLE FOR INSPECTION.

Amendment No. 11.

Notice is hereby given that the Shire of Bellarine in pursuance of its powers under the Town and Country Planning Act has prepared a planning scheme for the following areas:—

Parts of Sections 6 and 13, Parish of Moolap.

A copy of the Scheme has been deposited at the office of the Shire of Bellarine, Collins-street, Drysdale, and at the office of the Town and Country Planning Board, 5th Floor, 235 Queen-street, Melbourne, and may be inspected during office hours by any person, free of charge.

Any persons affected by the Planning Scheme are required to set forth in writing all objections that they may have, addressed to the Shire Secretary, Shire of Bellarine, Shire Office, Drysdale, on or before the 4th day of January, 1972.

16th November, 1971.

3432 H. A. WILLIAMS, Shire Secretary.

Town and Country Planning Act 1961 (Twelfth Schedule).

SHIRE OF BULLA PLANNING SCHEME 1959.

NOTICE THAT A PLANNING SCHEME HAS BEEN PREPARED AND IS AVAILABLE FOR INSPECTION.

Amendment No. 25, 1971.

Notice is hereby given that the Shire of Bulla in pursuance of its powers under the *Town and Country Planning Act 1961* has prepared a Planning Scheme for—

The whole of the municipal district of the Shire of Bulla outside the Melbourne Metropolitan Planning Scheme.

For the purpose of including the following clauses in the Town Planning Ordinance.

No lot shall be created in the residential zone unless it can be served by a water supply reticulation main, and a system of underground sewage collection pipes, which are to be provided at the cost of the owner of the land being subdivided.

Notwithstanding the provisions of the previous paragraph of this clause the Responsible Authority following a report from the Municipal Engineer, may permit the creation of an allotment which is not capable of being served by a water supply and/or a sewage collection system if the relevant Public Authority cannot make a water supply available or provide an outfall pipe for collection of the sewage from the subdivision or for any other reason that the Responsible Authority deems fit.

A copy of the scheme has been deposited at the Municipal Offices, Macedon Street, Sunbury, and at the office of the Town and Country Planning Board, 235 Queen-street, Melbourne, and will be open for inspection during office hours by any person free of charge.

Any persons affected by the Planning Scheme are required to set forth in writing all objections they may have, addressed to the Shire Secretary, Shire of Bulla, Municipal Offices, Macedon-street, Sunbury, on or before the 14th January, 1972, and to state whether they wish to be heard in respect of their objections.

15th November, 1971.

3469 JOHN M. KELLY, Shire Secretary.

SHIRE OF GOULBURN.

CHANGE OF ROAD NAME.

Notice is hereby given that the Council of the Shire of Goulburn did resolve at a meeting of the Council on the 18th day of November, 1971 to rename the following road:—

That the road heretofore known as:—

Slaughterhouse-lane or Slaughterhouse-road running east from the Goulburn Valley Highway between Kirwans Bridge—Longwood-road and Racecourse-road.

be now known as—

Coe-road.

3511 H. R. LOMAX, Shire Secretary.

SHIRE OF HASTINGS.

LOAN No. 42.

Special Order.

Notice is hereby given that the Council of the Shire of Hastings, at a meeting held on the 16th November, 1971, passed the following Resolution:—

"That the Council of the Shire of Hastings does by Special Order hereby resolve to borrow the sum of \$75,000 by the grant of a mortgage secured by a charge over the general rates of the municipality, in accordance with the provisions of the *Local Government Act 1958*, as amended, under the following terms and conditions:—

1. The maximum rate of interest to be paid shall be 7.3 per centum per annum.
2. The period of the loan shall be ten (10) years.
3. Repayment is to be made by half-yearly instalments of approximately \$5,348.96 each, including principal and interest, and payable on the 1st day of January and the 1st day of July, commencing in July, 1972.
4. The moneys shall be repayable at the National Bank of Australasia Ltd., Hastings.
5. The loan is to be applied for the purpose of defraying the cost of the execution of schemes for the construction of private streets pursuant to division 10, part XIX., of the *Local Government Act 1958*, as amended."

Notice is hereby further given that the said council will at an ordinary meeting to be held on the 21st day of December, 1971, proceed to confirm such special order.

19th November, 1971.

3470 L. A. WALKER, Shire Secretary.

SHIRE OF LILLYDALE.

LOAN No. 109.

Notice of Intention to Borrow the Sum of \$100,000 for Permanent Works and Undertakings.

Notice is hereby given that the Council of the Shire of Lillydale proposes to borrow the sum of \$100,000 (One hundred thousand dollars) secured by a charge over the general rates of the municipality, such sum to be raised by the grant of a mortgage in accordance with the provisions of the *Local Government Act*, for permanent works and undertakings within the municipality.

1. The maximum rate of interest that may be paid is 7.4 per centum per annum.
2. The purpose for which the loan is to be applied is as follows:—

Construction of buildings	\$41,000
Construction of Government roads ..	29,000
Main drainage works	5,000
Construction of Hawthory-road Swimming Pool (part cost)	25,000
	<u>\$100,000</u>

3. The period of the loan shall be forty years.
4. The moneys borrowed shall be repayable by providing out of the municipal fund eighty (80) half-yearly instalments, including principal and interest of approximately \$3,913.95 each on the 1st day of February and August during the years 1972 to 2012. The first instalment shall be payable on the 1st day of August, 1972, and the final instalment shall be payable on the 1st day of February, 2012.

5. Such moneys shall be repayable at the office of Australian Mutual Provident Society, 535 Bourke-street, Melbourne, 3000.

The plans, specifications and an estimate of the cost of the proposed works are open for inspection at the Shire Office, Anderson-street, Lillydale, during office hours.

3427 F. O. KENT, Shire Secretary.

SHIRE OF MELTON.

LOAN No. 47.

Notice of Intention to Borrow the Sum of \$100,000 for Permanent Works and Undertakings.

Notice is hereby given that the Council of the Shire of Melton proposes to borrow the principal sum of One hundred thousand dollars secured by a charge over the general rates of the municipality, such sum to be raised by the grant of a mortgage in accordance with the provisions of the *Local Government Act 1958*.

1. The maximum rate of interest that may be paid is 7.4 per cent. per annum.

No. 104.—10451/71.—4

2. The purposes for which the loan is to be applied are:

Melton Swimming Centre	\$55,000
Purchase of land	45,000
	<u>\$100,000</u>

3. The period of the loan shall be fifteen years.
4. The moneys borrowed shall be repayable by providing out of the municipal fund 29 half-yearly instalments of \$5,574.24 and a final instalment of \$5,573.52 including principal and interest on the 1st day of January and the 1st day of July during the currency of the loan. The first instalment shall be payable on the 1st day of July, 1972.

5. Such moneys shall be repayable to the Local Authorities Superannuation Board at the office of the said Board, 15 Queens-road, Melbourne.

The plans, specifications and an estimate of the cost of the proposed works and a statement showing the proposed expenditure of the moneys to be borrowed are open for inspection at the office of the Council of the Shire of Melton, at the Shire Offices, Melton.

3457

M. B. WATSON, Shire Secretary.

Dog Act 1970.

SHIRE OF NATHALIA.

The Council of the Shire of Nathalia hereby orders, pursuant to section 16 of the *Dog Act 1970* the under-mentioned shopping area to be a specified shopping area for the purposes of the said Act. The owner of any dog (not being a dog used in the droving of stock) which is found in such area and which is not under the effective control of some person by means of a chain, cord or leash shall be guilty of an offence.

Specified Shopping Area:

Elizabeth-street, Nathalia, from the railway crossing south to the Broken-creek, and Blake-street, south from the Broken-creek to Boaden-street.

Penalty—First offence, \$20; second or subsequent offence, \$50.

3460

J. K. DANCOCKS, Shire Secretary.

Town and Country Planning Act 1961 (Twelfth Schedule).

SHIRE OF SOUTH BARWON.—GEELONG PLANNING SCHEME 1959.

NOTICE THAT A PLANNING SCHEME HAS BEEN PREPARED AND IS AVAILABLE FOR INSPECTION.

Amendment No. 26, Shire of South Barwon, 1971.

Notice is hereby given that the Shire of South Barwon in pursuance of its powers under the *Town and Country Planning Act 1961* has prepared a planning scheme for:—

"Rezoning of parts Crown allotment A and 10, section 16, Parish of Barrabool, County of Grant, from Agricultural 'A' to Residential 'A'."

A copy of the scheme has been deposited at the Shire Office, 33 Mt. Pleasant-road, Belmont, and at the office of the Town and Country Planning Board, 235 Queen-street, Melbourne, and will be open for inspection during office hours by any person free of charge.

Any persons affected by the planning scheme are required to set forth in writing all objections they may have, addressed to the Shire Secretary, Shire of South Barwon, 33 Mt. Pleasant-road, Belmont, 3216, on or before the 24th day of December, 1971, and to state whether they wish to be heard in respect of their objections.

18th November, 1971.

3472

H. W. S. JACKSON, Shire Secretary.

SHIRE OF UPPER YARRA.

Notice is hereby given that the Council of the Shire of Upper Yarra has appointed Senior Constable Brian Frank Warton, No. 12400, as Prosecuting Officer for the said Shire in lieu of Senior Constable Kenneth Hubert Child, No. 11682, transferred.

9th November, 1971.

3452

J. N. EDDY, Shire Secretary.

SHIRE OF WHITTLESEA.

BY-LAW NO. 67.

A By-Law of the Shire of Whittlesea made under Section 756 of the *Local Government Act 1958* and numbered 67 for regulating the conduct of persons using public baths within the municipal district of the Shire of Whittlesea and prescribing charges for such use.

In pursuance of the powers conferred by the *Local Government Act* and of any and every other power enabling the President, Councillors and Ratepayers of the Shire of Whittlesea (hereinafter called "the Council") order as follows:—

1. This By-Law may be cited as the "Shire of Whittlesea (Public Baths) By-Law 1971".

2. The marginal notes shall not effect the interpretation of this By-Law.

3. In this By-Law unless inconsistent with the subject matter

"Adult" means any person who is sixteen (16) years of age or older than sixteen (16) years of age.

"Baths Premises" means any premises maintained by the Council as public baths or a public swimming pool including all buildings swimming pools and structures on such premises and all appurtenances and equipment and the site or curtilage thereof.

"Baths Manager" means the person by the authority of the Council for the time being in charge or control of the Baths Premises or of any Baths Attendant.

"Baths Attendant" means an employee of the Council performing any duties on or in connection with any Baths Premises.

"Bottle" means any article made wholly or partly of glass, china, porcelain, bakelite or like composition.

"Junior" means any person who is aged fifteen (15) years or under.

Words importing the masculine gender include the feminine and words importing the singular number only shall include the plural number and words importing the plural number shall include the singular number.

4. No person shall—

(a) bring into any Baths Premises any intoxicating liquor.

(b) consume intoxicating liquor on any Baths Premises.

(c) go into or appear in any Baths Premises in a drunken or disorderly state or be guilty of profane swearing or of foul or abusive language or of obscenity or indecency or conduct himself riotously or create a disturbance or obstruct hinder or resist in the execution of his duty any Baths Attendant or any officer or person appointed by the Council to conduct or aid in the good management of any Baths Premises or neglect or refuse to comply with any lawful request of any Baths Attendant or any such other officer or person made in accordance with the provisions of this By-Law.

(d) cause or permit any dog or other animal belonging to such person or under his control to enter or remain in or upon any Baths Premises.

(e) use any swimming pool unless he or she is properly attired in a bathing costume so as to preserve public decency.

(f) enter any Baths Premises or use any facility therein without having first paid to a Baths Attendant the proper fee or charge as fixed by the Council by resolution from time to time.

(g) bring into any Baths Premises or have in his possession or custody or under his control in any Baths Premises any bottle, can or any other article which in the opinion of the Baths Attendant may damage or injure Council property or injure or annoy any person.

(h) break any bottle or bottles on the Baths Premises.

(i) fail to report the breakage of any bottle or bottles.

(j) spit in any swimming pool nor on the floor or walls or any part of Baths Premises.

(k) smoke in any portion of the Baths Premises where a notice is displayed that smoking is not permitted.

5. No person suffering from any cutaneous infectious or contagious disease shall use any dressing room or Baths or enter any swimming pool.

6. No person shall—

(a) enter any swimming pool until he has thoroughly cleansed himself to the satisfaction of a Baths Attendant under a shower bath on the Baths Premises in which the use of soap is permitted.

(b) enter or remain in any swimming pool whilst he is in an unclean condition.

(c) use soap in any part of any Baths Premises other than in the shower baths in which the use of soap is permitted.

(d) use any substances or preparation whilst he is in a swimming pool whereby the water in that swimming pool may be discoloured or rendered turbid or rendered unfit in any way for the use of bathers.

(e) wilfully foul or pollute the water in any shower bath, separate bath or swimming pool.

(f) wilfully soil or defile any towel or any bathing dress, trunks or drawers the property of the Council.

(g) wilfully foul pollute or defile any Baths Premises.

(h) wilfully or negligently break, injure, damage, destroy or tamper with any Baths Premises or any key, or any towel or bathing dress, trunks or drawers the property of the Council.

(i) wilfully or negligently mark or deface any Baths Premises or any article of furniture therein or attached thereto.

(j) bring on to any Baths Premises or place in any Baths Premises or in any part thereof any chemical substance, liquid or powder.

Definitions.

Prohibition of Intoxicating Liquor.

Bad language or offensive behaviour.

Dogs.

Bathing Costumes.

Entry or Use without payment.

Bottles.

Spitting.

Smoking.

Prohibition of persons suffering from certain diseases.

Cleansing before entry.

Soap in swimming bath.

Use of Discolouring substances.

Pollution of Water.

Soiling of towels.

Pollution of premises.

Injury etc. to Premises or Council property.

Defacing Premises. Bringing Chemicals etc. on to Baths Premises.

- (k) enter the Baths Premises or any swimming pool unless the Baths Attendant is in attendance. Solo bathing is prohibited.
7. (a) Toys, balls, motor tubes, swimming aids of all kinds and inflatable rubber or plastic articles are prohibited on the Baths Premises except with the consent of the Baths Attendant. No person shall play or practice water polo save at such times and in such teams as shall be approved in writing by the Council. No other ball games of any kind whatsoever are permitted.
- (b) No person shall engage in boisterous or rough play within the Baths Premises.
- (c) No person shall bring into the Baths Premises any radio without the consent first being obtained from the Baths Attendant.
- (d) Betting or playing cards or any game of chance for money is strictly prohibited on the Baths Premises.
8. (a) No child under the age of seven (7) years will be admitted to the Baths Premises unless in the opinion of the Baths Attendant, such child is in the care of a responsible person.
- (b) No person under the age of ten (10) years who is unable to swim shall use the olympic pool without the permission of the Baths Attendant unless accompanied by an adult.
- (c) No person over the age of six (6) years shall use the wading pool except with the authority of the Baths Attendant.
- (d) No person shall use the diving pool unless, in the opinion of the Baths Attendant, such person is able to swim to sufficient standard to ensure personal safety.
- (e) Diving in the wading, learners and olympic pools is prohibited.
9. (a) For the purpose of maintaining good order the Baths Attendant may at any time refuse admission to the Baths Premises to any person without assigning any reason for such refusal.
- (b) The Council reserves the right by its officers and employees to refuse admission to any persons and to remove any person misconducting himself in any manner whatsoever.
10. (a) At every Baths Premises there shall be kept by the Baths Manager or by some Baths Attendant duly authorised by the Baths Manager a book (hereinafter referred to as the "lost property register").
- (b) Any person who finds any article which has been left in any Baths Premises shall forthwith deliver it to a Baths Attendant.
- (c) Upon receipt by a Baths Attendant of any article which has been left in any Baths Premises such Baths Attendant shall forthwith take charge of the article and enter or cause to be entered in the lost property register a description of the article, the time and date of its receipt and the name of the finder.
- (d) The Baths Attendant having the custody of the lost property registered may deliver to a person apparently the owner thereof any article particulars of which have been entered in the lost property register upon receiving satisfactory proof of ownership and on payment of the prescribed fee (if any) and upon such delivery such person shall by way of acknowledging receipt of the said article enter in the lost property register his name and address.
11. It shall be a condition of any person being admitted to enter any Baths Premises (whether on payment to the Council of a fee or otherwise howsoever) that if such person leaves upon such Baths Premises any article which is taken charge of by a Baths Attendant the Council or some person duly authorised in that behalf by the Council may, if such article be not claimed within three months of the date on which its receipt is recorded in the lost property register, sell or otherwise dispose of the same and shall be under no liability either to the owner or leaver thereof by reason of such sale or disposal.
12. Neither the Council nor any officer or employee of the Council shall be in any way responsible for any article lost by or stolen from any person whilst in Baths Premises or for any article damaged or destroyed whilst in or on Baths Premises.
13. A person shall not pay, nor shall any Baths Attendant or other officer or servant of the Council receive any fee for admission to or for the use of any facility in any Baths Premises, except in being permitted to pass through a turn-stile which automatically registers such admission or except in exchange for a printed ticket bearing the name of the Council or in exchange for a ticket issued from a cash register of the Council.
14. (a) No person shall enter any Baths Premises except through a prescribed entrance or leave any Baths Premises except by a prescribed exit.
- (b) No person shall enter or remain in any portion of any Baths Premises not set aside for public use.
- (c) Unless under the age of four (4) years and under the control of an adult, no male person shall enter or use any part of any Baths Premises for the time being set apart or appropriated for the use of females, nor shall any female person enter or use any part of Baths Premises for the time being set apart or appropriated for the use of males.
- (d) No person, unless authorised by an officer of the Council, shall climb or attempt to climb over or on to or upon or remain on or upon any fixtures, fountain, fence, roof, building or structure surrounding or appurtenant to the Baths Premises.
- (e) No unauthorised person shall enter the office, kiosk or filter house of the Baths Premises.
- (f) No person shall occupy a shower for an unreasonable time or enter any shower or water closet occupied by another person.
15. (a) Every person who hires a locker or other article the property of the Council shall pay a deposit in respect of each locker or article according to the scale which may from time to time be determined by the Council and shall return any article so hired by him to a Baths Attendant before leaving the Baths Premises.
- (b) If the locker key or any article so hired is returned in good order and condition the deposit paid in respect thereof shall be refunded to the person returning that key or article, but if any key or article is not returned or locker is damaged or article is returned in a damaged condition, then without prejudice to any other remedies of the Council a Baths Attendant may forfeit the whole or (in his discretion) any part of the deposit to the Council.

Non-attendance of Baths Attendant. Behaviour.

Care of Children.

Refusal of Admission.

Articles lost or found.

Disposal of lost property.

Non Responsibility.

Prohibition of payment except for ticket etc.

Use of prescribed entrances and exits. Prohibited areas.

Deposit on Lockers etc.

- Temporary closing. 16. The Baths Manager or in his absence, the Baths Attendant in charge may temporarily suspend admittance and/or clear the Baths Premises or any part thereof of any person or persons if in his opinion such action is considered necessary.
- Transfer of tickets etc. 17. No ticket, token, licence or receipt issued as provided by this By-Law shall be transferable and no person other than the person to whom same was originally issued shall enjoy any benefit therefrom or any privileges thereunder.
- Professional Coaching. 18. Without the permission of the Council in writing, no person shall for fee or reward instruct or coach any person or persons in any Baths Premises, but nothing in this clause shall prevent an authorised Instructor employed by the Education Department or a Teacher from any School (whether State School or otherwise) from giving instruction to pupils admitted to Baths Premises under school classes rates of admission.
- Suspension of charges during Galas. 19. During any period for which any Baths Premises or any part of a Baths Premises have been hired for Galas or other entertainments—
- The charges for admission to the Baths Premises or part thereof shall be suspended.
 - No tickets, licences or tokens issued by or on behalf of the Council shall have any force or effect or be available for entrance to or use at any such Galas or other entertainments.
 - Neither the Council nor any of its officers or employees shall be in any way responsible for the due carrying out or performance of such Gala or other entertainment.
 - Neither the Council nor any of its officers or employees shall be in any way responsible for any article deposited with any person in charge of or in any way connected with any such Gala or other entertainment or present thereat.
 - Neither the Council nor any of its officers or employees shall be in any way responsible for any injury to or any loss or damage sustained by any person during the time any such Gala or entertainment is being held.
- Power to eject offenders. 20. If any person offends against any of the provisions of this By-Law that person may (without prejudice to his liability to a penalty in respect of that offence) be requested by a Baths Attendant to leave the Baths Premises and if he does not forthwith do so any Baths Attendant may, using no more force than is reasonably necessary, eject that person from the Baths Premises.
- Penalties. 21. Any person committing a breach of or an offence against any of the provisions of this By-Law shall upon conviction for every such breach or offence, be liable to a penalty not exceeding One hundred Dollars (\$100).
- Hours of Admission. 22. Baths Premises will be open to the public on the days and between the hours as may be determined from time to time by resolution of the Council.
- Operation and Extent of Operation. 23. This By-Law shall apply to and have operation throughout the whole of the municipal district of the Shire of Whittlesea.
24. This By-Law shall come into operation and have effect immediately upon its publication in the *Victoria Government Gazette*.
- The Resolution adopting this By-Law No. 67 was agreed to at the meeting of the Council held on the 18th day of October, 1971, and confirmed on the 15th day of November, 1971.
- As witness the common seal of the President, Councillors and Ratepayers of the Shire of Whittlesea was hereunto affixed this 15th day of November, 1971, in the presence of—

3462

(SEAL)

V. R. MICHAEL, President.
J. W. TOWT, Councillor.
R. G. C. COOK, Shire Secretary.

Town and Country Planning Act 1961 (Twelfth Schedule).

SHIRE OF SOUTH BARWON.—GEE LONG PLANNING SCHEME 1959.

NOTICE THAT A PLANNING SCHEME HAS BEEN PREPARED AND IS AVAILABLE FOR INSPECTION.

Amendment No. 30, Shire of South Barwon, 1971.

Notice is hereby given that the Shire of South Barwon in pursuance of its powers under the *Town and Country Planning Act 1961* has prepared a planning scheme for:—

“Rezoning of those areas of land being part of Crown portions 8 and 9, Parish of Barrarbool, County of Grant, and part of Crown portions 14, 15 and 18, Parish of Duneed, County of Grant.”

A copy of the scheme has been deposited at the Shire of South Barwon, 33 Mt. Pleasant-road, Belmont, and at the office of the Town and Country Planning Board, 235 Queen-street, Melbourne, and will be open for inspection during office hours by any person, free of charge.

Any persons affected by the planning scheme are required to set forth in writing all objections they may have, addressed to the Shire Secretary, Shire of South Barwon, 33 Mt. Pleasant-road, Belmont, 3216, on or before the 24th day of February, 1972, and to state whether they wish to be heard in respect of their objections.

18th November, 1971.

3473

H. W. S. JACKSON, Shire Secretary.

SHIRE OF WARRAGUL.

By-Law No. 83.

A By-Law of the Shire of Warragul made under the provisions of Section 197 of the *Local Government Act 1958* and Section 93 of the *Health Act 1958* and numbered 83 for the purpose of regulating and keeping dogs and controlling and regulating the use of premises with a view to preventing objectionable noises within the Municipality of the Shire of Warragul.

In pursuance of the powers conferred by the *Local Government Act 1958* and the *Health Act 1958* the President, Councillors and Ratepayers of the Shire of Warragul, order as follows:—

1. No person shall be permitted to keep or keep on any property more than two dogs without the consent of the Council.

2. Any person applying for the consent under this By-Law shall

- Make application in writing.
- Specify the types, breeds and number of dogs desired to be kept.
- Set out the address and the area of the property for which it is desired consent to be granted.
- The reason for keeping such number of dogs.

3. Every Occupier of a premises where any dogs are kept shall cause the place of keeping of such dog to be thoroughly cleansed from time to time as often as is necessary for the purpose of keeping such place in a clean wholesome and sanitary state.

4. No person shall have, keep or allow or permit to be kept or allowed within or about any house building or premises any noisy dog which shall be or cause a nuisance or annoyance to any person residing in the neighbourhood of such house, building or premises.

5. This By-Law shall apply to and have operation throughout the whole of the Municipal district of the Shire of Warragul.

Resolution for the passing of this By-Law agreed to by the Council on the 9th day of June, 1970, and confirmed on the 14th day of July, 1970.

The common seal of the President, Councillors and Ratepayers of the Shire of Warragul was hereunto affixed this 14th day of July, 1970, in the presence of—

(SEAL) T. W. ADKINS, President.
M. A. McCARTHY, Councillor.
D. McADIE, Shire Secretary.

Submitted to the Commission of Public Health at the meeting on the 21st day of September, 1971.—A. T. GARDNER, Secretary.

Submitted to and approved by the Governor in Council, on the 28th day of September, 1971.—J. ROSSITER, Clerk of the Executive Council. 3433

Notice is hereby given that the McCrae Yacht Club has applied for a lease under section 134 of the *Land Act 1958*, for a term of 21 years in respect of an area of approximately $\frac{1}{2}$ acre, being portion of McCrae Lighthouse Reserve in the Parish of Wannaeue, as a site for Amusement and Recreation (Yacht Club and associated facilities). 3073

SHEPPARTON SEWERAGE AUTHORITY.
GENERAL NOTICE.

The above-mentioned Sewerage Authority, having made provision for carrying off the sewage from each and every property which or any part of which is within the Sewerage Areas hereinafter described, doth hereby declare that on and after the 1st day of October, 1971, each and every property which or any part of which is within the said Sewerage Areas shall be deemed to be a sewerer property within the meaning of the *Sewerage Districts Act 1958*.

The Sewerage Areas hereinbefore referred to are:—

Sewerage Areas Nos. 55, 56, 57, 58, 59, 60 and 61. Lands shown in red colour on a plan which has been lodged in the office of the State Rivers and Water Supply Commission and of which a copy may be inspected at the office of the Shepparton Sewerage Authority.

By the order of the said Sewerage Authority.

3463 R. L. TREVASKIS, Chairman.
R. D. O'BRIEN, Secretary.

NOTICE OF INTENTION TO APPLY FOR A LICENCE TO DIVERT WATER AND CUT RACE FROM THE KING RIVER AT EDI UPPER.

We hereby give notice that we intend to apply for a licence empowering us to divert water for a term of four years to the extent of 60 acre-feet per annum at a maximum rate of 4 acre-feet per day of 24 hours for the irrigation of pasture, being allotments 6, 7, 7B, 11, 11B, 11C and 11D, section A, Parish of Edi, and to occupy certain Crown lands for works of diversion, and to cut a race thereon.

Any objection to such application must be forwarded in writing to reach the State Rivers and Water Supply Commission, Melbourne, before 24th December, 1971, being 30 days from the first publication of this notice.

ALLAN JAMES NEWTON.
MARGARET MARY NEWTON.

Edi Upper. 3453

PLENTY-YARRAMBAT WATERWORKS TRUST.

Notice to the owners of tenements in the under-mentioned streets and private streets, lanes, courts and alleys opening thereto:—

Diamond Creek-road from Aqueduct-road to Larch-crescent.
Larch-crescent from Diamond Creek-road to Hillmartin-road.
Hillmartin-road from Larch-crescent to Cullen-crescent.

The main pipe in the said streets being laid down the owners of all tenements situated as above are hereby required on or before the 1st day of January, 1972, to cause a proper pipe and stop-cocks to be laid so as to supply water within such tenements from the main pipe.

F. PHILLIPS, Secretary.

301 Boulevard,
Ivanhoe, 24th November, 1971. 3509

Notice is hereby given that Tallangatta Valley Golf Club has applied for a lease pursuant to section 134 of the *Land Act 1958*, for a term of 21 years in respect of an area of Crown land adjoining the Tallangatta Valley Recreation Reserve. Area 0 acres 0 roods 18 perches, more or less (subject to survey).—(H.034434.)

HARRIS LIEBERMAN & CO., 90 High-street, Wodonga, solicitors for the applicants. 3528

NOTICE OF DISSOLUTION OF PARTNERSHIP.

Notice is hereby given that the partnership heretofore subsisting between Eric Margossis and Tadeusz Lukas carrying on the business of a fish and chip shop at 90 St. Georges-road, Shepparton, under the name of "E. Margossis & T. Lukas" has been dissolved by mutual consent as from the 15th day of November, 1971. Tadeusz Lukas will continue to carry on the business at the said address.

Dated at Shepparton this 15th day of November, 1971.

3434 E. MARGOSSIS.
T. LUKAS.

Notice is hereby given that the partnership heretofore subsisting between the undersigned Frank Armstrong Hargreaves and David Alfred Gaskin, formerly carrying on business at 84 Ormond-road, Ormond, but now carrying on business at 2 Docker-street, Elwood, under the business name of Antel T.V. Repairs has been dissolved by mutual consent, as from the 18th day of November, 1971.

Frank Armstrong Hargreaves will continue to carry on Antel T.V. Repairs.

Dated the 12th day of November, 1971.

Witness.—PATRICIA AFFLICK. F. A. HARGREAVES.
D. A. GASKIN.

Witness.—PATRICIA AFFLICK. 3529

Notice is hereby given by Peter Demay, insurance agent of Rattray-avenue, Wodonga, and Peter George Donald, of Wodonga, formerly cafe proprietor, that they have dissolved partnership as at the 1st November, 1971.

JOHN S. L. POTTER & CO., solicitors, 146 High-street, Wodonga. 3448

Notice is hereby given that the partnership heretofore subsisting between us the undersigned carrying on practice as surgeons and consultants at 376 Albert-street, East Melbourne, has been dissolved by mutual consent as from the 30th day of September, 1971.

Dated the 17th day of November, 1971.

3527 JOHN CLARKE McNEUR.
ROBIN CHARLES WINFIELD WILLIAMS.

The *Companies Act 1961*.—In the matter of BROOKLYN CABINET WORKS PTY. LTD.

Notice is hereby given that at an Extraordinary General Meeting of the above-named company, duly convened and held at 42A Albert-street, Footscray, on the 12th day of November, 1971, the following Resolution was proposed and passed as a Special Resolution:—

"That the company be wound up voluntarily and that Maxwell Bruce Wellington, of 482 Nepean Highway, Frankston, be appointed liquidator.

12th November, 1971.

3426 M. B. WELLINGTON, Secretary.

In the matter of the *Companies Act 1961* and in the matter of ATOMIC SPECTRAL LAMPS PTY. LIMITED (in voluntary liquidation).—Notice of Final Meeting of Members, Pursuant to Section 272.

Notice is hereby given, in pursuance of section 272 of the *Companies Act 1961* that a General Meeting of the members of the company will be held at the office of Messrs. Cooper Brothers & Co., 461 Bourke-street, Melbourne, on the 24th day of December, 1971, at 10 o'clock in the forenoon for the purpose of having an account laid

before it showing the manner in which the winding up has been conducted and the property of the company disposed of, and hearing any explanation that may be given by the liquidator.

Dated this 18th day of November, 1971.

3423 J. M. POULTON, Liquidator.

The Companies Act 1961.—In the matter of BEAM WELDER DISTRIBUTORS PTY. LTD. (in Liquidation).

A First and Final Dividend is intended to be declared in the above-mentioned matter. Creditors who have not proved their debts by the 13th day of December, 1971 will be excluded from the dividend.

Dated this 22nd day of November, 1971.

E. R. SMAIL, Liquidator.

Kennedy, Smail & Middlemiss, 296 Little Lonsdale-street, Melbourne, 3000. 3484

The Companies Act 1961.

GOLDIE MODES PROPRIETARY LIMITED (IN LIQUIDATION).

NOTICE CONVENING FINAL MEETING OF MEMBERS AND CREDITORS, PURSUANT TO SECTION 272.

Notice is hereby given pursuant to section 272 of the Companies Act 1961, that a General Meeting of the members and creditors of the above-named company will be held in the offices of Kennedy, Smail & Middlemiss, 296-304 Little Lonsdale-street, Melbourne, on Wednesday, the 22nd day of December, 1971, at 10.30 a.m., for the purpose of having an account laid before them showing the manner in which the winding up has been conducted and the property of the company disposed of and of hearing any explanations that may be given by the liquidator.

Dated this 16th day of November, 1971.

R. E. RAMSAY, Liquidator.

Kennedy, Smail & Middlemiss, 296-304 Little Lonsdale-street, Melbourne, 3000. 3485

The Companies Act 1961.

UNITED SEA FOODS PROPRIETARY LIMITED (IN LIQUIDATION).

NOTICE CONVENING FINAL MEETING OF MEMBERS AND CREDITORS, PURSUANT TO SECTION 272.

Notice is hereby given pursuant to section 272 of the Companies Act 1961, that a General Meeting of the members and creditors of the above-named company, will be held in the offices of Kennedy, Smail & Middlemiss, 296-304 Little Lonsdale-street, Melbourne, on Wednesday, the 22nd day of December, 1971, at 11 a.m., for the purpose of having an account laid before them showing the manner in which the winding up has been conducted and the property of the company disposed of and of hearing any explanations that may be given by the liquidator.

Dated this 16th day of November, 1971.

E. R. SMAIL, Liquidator.

Kennedy, Smail & Middlemiss, 296-304 Little Lonsdale-street, Melbourne, 3000. 3486

Companies Act 1961.—In the matter of SUNCRUSHED PTY. LTD. (in Liquidation).

Notice is hereby given that at an Extraordinary Meeting of the Members of the above-named company held on the 17th November, 1971, it was resolved that the company be wound up voluntarily, and at the meeting of creditors held on the same day, pursuant to section 260, it was resolved that for such purpose, Dennis John Cogle, of Suite 18, 545 St. Kilda-road, Melbourne, public accountant, be appointed liquidator.

Notice is also given that after 21 days from this date I shall proceed to distribute the assets. All creditors having any claim against the company should furnish particulars of same by that date, otherwise I shall proceed to distribute the assets, without regard to their claim.

Dated this 24th day of November, 1971.

D. J. COUGLE, Liquidator.

Bent & Cogle, public accountants, Suite 18, 545 St. Kilda-road, Melbourne, 3004. 3512

NOTICE OF SPECIAL RESOLUTION PASSED ON 18TH NOVEMBER, 1971.

That this company known as City Motor Panel & Engineering Proprietary Limited, be wound up under the provisions of the Companies Act 1961, as applicable to a members voluntary winding up. 3521

Companies Act 1961.—In the matter of NYCEL OFFICE SUPPLY Co. PTY. LTD.—Notice RE Meeting of Creditors, pursuant to section 260.

Notice is hereby given that a Meeting of Creditors of the above-named company will be held at Room 311, Victorian Employers Federation Officer, Princes Gate, East Tower, 151 Flinders-street, Melbourne, at 11 a.m., on the 2nd day of December, 1971, the company having convened a meeting of its members the same day for the purpose of considering a Resolution that the company be wound up voluntarily.

Dated this 17th day of November, 1971.

M. A. WEBB & CO., 1st Floor, 424 St. Kilda-road, Melbourne, Vic. 3004. 3508

Companies Act 1961.

GLENFERRIE TIMBER SUPPLY PROPRIETARY LIMITED.

NOTICE PURSUANT TO SECTION 254 (2).

Notice is hereby given that at an Extraordinary General Meeting of the members of the above-named company duly convened and held on the 15th day of November, 1971, the following Special Resolution was duly passed:—

That the company be wound up voluntarily and that Ivor Thomas McIvor, of 472 Bourke-street, Melbourne, public accountant, be appointed liquidator for the purposes of the winding up.

Dated this 15th day of November, 1971.

3520 I. T. MCIVOR, Liquidator.

In the matter of the Companies Act 1961; and in the matter of RUJO PRODUCTS PTY. LIMITED (in Voluntary Liquidation).—Notice of Final Meeting of Members Pursuant to Section 272.

Notice is hereby given in pursuance of section 272 of the Companies Act 1961 that a General Meeting of the members of the company will be held at the office of Messrs. Cooper Brothers & Co., 461 Bourke-street, Melbourne, on the 24th day of December, 1971, at 10 o'clock in the forenoon for the purpose of having an account laid before it showing the manner in which the winding up has been conducted and the property of the company disposed of, and hearing any explanation that may be given by the liquidator.

Dated this 18th day of November, 1971.

3424 R. W. BETTS, Liquidator.

Companies Act 1961.—In the matter of S.L.M. CONSTRUCTIONS PTY. LTD.—Notice Re Meeting of Creditors Pursuant to Section 260.

Notice is hereby given that a Meeting of Creditors of the above-named company will be held at Room 314, Third Floor, East Tower, Princes Gate, 151 Flinders-street, Melbourne, on Tuesday, 7th December, 1971, at 11.30 a.m., the company having convened a meeting of its members for the same day for the purpose of considering a Resolution that the company be wound up voluntarily.

Dated this 18th day of November, 1971.

W. H. MURPHY, Director.

Bent & Cogle, public accountants, suite 18, 545 St. Kilda-road, Melbourne, 3004. 3447

Companies Act 1961.—M. R. PETERS AND SONS PTY. LTD. (in Voluntary Liquidation).

Notice is hereby given that a General Meeting of the company will be held at 2A Wells-street, Frankston, on the 21st day of December, 1971, at 10 a.m., for the purpose of laying before the meeting the accounts of the liquidator showing how the winding up has been conducted and the property of the company has been disposed of, and giving any explanations thereof.

Dated the 18th day of November, 1971.

3455 G. A. O'NEILL, Liquidator.

The Companies Act 1961, Section 260.—In the matter of AUSTRALIA WIDE ASSESSING PTY. LTD.—Notice of Meeting of Creditors.

Notice is hereby given that a meeting of creditors of the above-named company will be held at the 6th Floor, 608 St. Kilda-road, Melbourne, in the State of Victoria, on Friday, 3rd December, at 9.30 a.m., the company having convened a meeting of its members for the same day for the purposes of considering a Resolution that the company be wound up voluntarily.

Dated this 22nd day of November, 1971.

COLIN WILLIAMS, Director.

O. W. Parkinson & Son, 343 Little Collins-street, Melbourne. 3464

In the Supreme Court of Victoria.—1971, No. C.O.8240.—In the matter of the *Companies Act* 1961; and in the matter of A.B.A. PTY. LIMITED.

Notice is hereby given that a petition for the winding-up of the above-named company by the Supreme Court of Victoria was on the 15th day of November, 1971, presented by Marjorie Jane Alder, of 18 Fairbairn-road, Toorak, married woman: And that the said petition is directed to be heard before the court sitting at the 14th Court, Law Courts, William-street, Melbourne, at the hour of 10.30 o'clock in the forenoon on the 16th day of December, 1971; and any creditor or contributory of the said company desiring to support or oppose the making of an order on the said petition may appear at the time of hearing by himself or his counsel for that purpose; and a copy of the said petition will be furnished to any creditor or contributory of the said company requiring the same by the undersigned on payment of the regulated charge for the same.

The petitioner's solicitors are Holding, Ryan & Redlich, of 140 Queen-street, Melbourne.

HOLDING, RYAN & REDLICH.

NOTE.—Any person who intends to appear on the hearing of the said petition must serve on or send by post to the above-named, Holding, Ryan & Redlich, notice in writing of his intention so to do. The notice must state the name and address of the person or, if a firm, the name and address of the firm, and must be signed by the person or firm, or his or their solicitor if any and must be served or, if posted, must be sent by post in sufficient time to reach the above-named not later than 4 o'clock in the afternoon of the 15th day of December, 1971. 3450

In the Supreme Court of Victoria.—1971 Co. No. 8225.—In the matter of the *Companies Act* 1961 and in the matter of R. L. & P. P. BALDWIN PROPRIETARY LIMITED.

Notice is hereby given a petition for the winding up of the above-named company by the Supreme Court was on the 1st day of November, 1971 presented by Dowell Australia Limited and that the said petition is directed to be heard before the Court sitting at the Fourteenth Court, Law Courts, William-street, Melbourne on the 8th day of February, 1972 at the hour of 10.30 o'clock in the forenoon; and any creditor or contributory of the said company desiring to support or oppose the making of an order on the said petition may appear at the time of hearing by himself or his Counsel for that purpose; and a copy of the petition will be furnished to any creditor or contributory of the said company requiring the same by the undersigned on payment of the regulated charge for the same.

The petitioner's address is 310 Queen-street, Melbourne.

The petitioner's solicitors are Wundele, Couzens & Co. of 253 Lonsdale-street, Melbourne.

WUNDELE, COUZENS & CO., solicitors for the petitioner.

NOTE.—Any person who intends to appear on the hearing of the said petition must serve or send by post to the above-named solicitors notice in writing of his intention to do so. The Notice must state the name and address of the person, or if a firm, the name and address of the firm and must be signed by the person or firm or his or their solicitors (if any) and must be served, or if posted, must be sent by post in sufficient time to reach the above-named not later than 4 o'clock in the afternoon on the 7th day of February, 1972. 3429

Companies Act 1961.—In the matter of FAWKNER STONEMASONS PTY. LTD., formerly KNOWLES MEMORIALS PTY. LTD.

Notice is hereby given that at an Extraordinary Meeting of the members of the above-named company held on the 16th November, 1971 it was resolved that the company be wound up voluntarily and at a meeting of creditors held on the same day pursuant to section 260, it was resolved that for such purpose Everett Thomson Bent, of Suite 18, 545 St. Kilda-road, Melbourne, public accountant, be appointed liquidator.

Notice is also given that after twenty-one days from this date I shall proceed to distribute the assets. All creditors having any claims against the company should furnish particulars of same by that date, otherwise I shall proceed to distribute the assets, without regard to their claim.

Dated this 16th day of November, 1971.

E. T. BENT, Liquidator.

Bent & Cogle, public accountants, Suite 18, 545 St. Kilda-road, Melbourne, 3004. 3444

In the Supreme Court of Victoria.—1971 Co. No. 8226.—In the matter of the *Companies Act* 1961 and in the matter of SCENIC ALUMINIUM DOORS & WINDOWS PTY. LTD.

Notice is hereby given a petition for the winding up of the above-named company by the Supreme Court was on the 1st day of November, 1971 presented by Overseas Corporation (Australia) Ltd. trading as Valectro Industries and that the said petition is directed to be heard before the Court sitting at the Fourteenth Court, Law Courts, William-street, Melbourne on the 8th day of February, 1972 at the hour of 10.30 o'clock in the forenoon; and any creditor or contributory of the said company desiring to support or oppose the making of an order on the said petition may appear at the time of hearing by himself or his Counsel for that purpose; and a copy of the petition will be furnished to any creditor or contributory of the said company requiring the same by the undersigned on payment of the regulated charge for the same.

The petitioner's address is 468-502 Princes Highway, Harrisfield.

The petitioner's solicitors are Wundele, Couzens & Co. of 253 Lonsdale-street, Melbourne.

WUNDELE, COUZENS & CO., solicitors for the petitioner.

NOTE.—Any person who intends to appear on the hearing of the said petition must serve or send by post to the above-named solicitors notice in writing of his intention to do so. The Notice must state the name and address of the person, or if a firm, the name and address of the firm and must be signed by the person or firm or his or their solicitors (if any) and must be served, or if posted, must be sent by post in sufficient time to reach the above-named not later than 4 o'clock in the afternoon on the 7th day of February, 1972. 3430

The *Companies Act* 1961.

R. BELL CAMERAS PTY. LTD. (IN LIQUIDATION).

PURSUANT TO SECTION 254 (2)

Notice is hereby given that at an Extraordinary General Meeting of members of the above-named company, held on Monday, 15th November, 1971, the following special resolution was duly passed, and at a meeting of creditors, held the same day, the said resolution was confirmed:

"That owing to the company being unable to meet its debts as and when they become due, that the company be and is hereby wound up voluntarily and that Michael Joseph O'Keeffe, a registered liquidator be and is hereby appointed liquidator to wind the company up and attend to matters relative thereto in accordance with the *Companies Act* 1961."

M. J. O'KEEFFE, Registered Liquidator.

M. J. O'Keeffe & Co., 162A High-street, Ashburton. 3441

The *Companies Act* 1961.—In the matter of TOMAX ELECTRICS PROPRIETARY LIMITED (in Liquidation).—Notice of Meeting of Members and Creditors, Pursuant to Section 272.

Notice is hereby given that the Final Meeting of members and creditors of Tomax Electrics Proprietary Limited (in liquidation), will be held at the offices of Messrs. Norman, Cartledge and Browne, 1 Palmerston-crescent, South Melbourne, on the 24th day of December, 1971, at 10.15 o'clock in the forenoon for the purpose of laying before the meeting the liquidator's final account and report.

Dated this 19th day of November, 1971.

G. K. SCAMBLER, Liquidator.

Norman, Cartledge and Browne, chartered accountants, 1 Palmerston-crescent, South Melbourne, Vic. 3205. 3539

The *Companies Act* 1961.—In the matter of JOHN BURGUYNE PROPRIETARY LIMITED (in Liquidation).—Notice of Meeting of Members and Creditors, Pursuant to Section 272.

Notice is hereby given that the Final Meeting of members and creditors of John Burgoyne Proprietary Limited (in liquidation), will be held at the offices of Messrs. Norman, Cartledge and Browne, 1 Palmerston-crescent, South Melbourne, on the 24th day of December, 1971, at 11.15 o'clock in the forenoon for the purpose of laying before the meeting the liquidator's final account and report.

Dated this 19th day of November, 1971.

G. K. SCAMBLER, Liquidator.

Norman, Cartledge and Browne, chartered accountants, 1 Palmerston-crescent, South Melbourne, Vic. 3205. 3540

*Companies Act 1961.***MACHINERY & FABRICATIONS (AUST.) PTY. LTD. (IN VOLUNTARY LIQUIDATION).**

Notice is hereby given that at an Extraordinary Meeting of the members of the above-named company, held on 14th October, 1971, it was resolved that the company be wound up voluntarily and at a meeting of creditors, held on the same day, it was resolved that for such purpose, Lewis Luckins, chartered accountant, of 130 Flinders-street, Melbourne, be appointed liquidator.

Notice is also given that after 21 days from this date I shall proceed to distribute the assets. All creditors having any claim against the company should furnish particulars of same by that date, otherwise I shall proceed to distribute the assets without regard to their claim.

Dated this 22nd day of November, 1971.

LEWIS LUCKINS, Liquidator.

Lewis Luckins & Co., chartered accountants, 130 Flinders-street, Melbourne, 3000. Telephone 63 8827.

3542

*Companies Act 1961.***SOLENOIDS RELAY PTY. LTD. (IN VOLUNTARY LIQUIDATION).**

Notice is hereby given that at an Extraordinary Meeting of the members of the above-named company, held on 11th November, 1971, it was resolved that the company be wound up voluntarily and at a meeting of creditors, held on the same day, it was resolved that Lewis Luckins, chartered accountant, of 130 Flinders-street, Melbourne, be appointed liquidator.

Notice is also given that after 21 days from this date I shall proceed to distribute the assets. All creditors having any claim against the company should furnish particulars of same by that date, otherwise I shall proceed to distribute the assets without regard to their claim.

Dated this 22nd day of November, 1971.

LEWIS LUCKINS, Liquidator.

Lewis Luckins & Co., chartered accountants, 130 Flinders-street, Melbourne, 3000. Telephone 63 8827.

3543

*Companies Act 1961.***JAY VEE FASHIONS PTY. LTD. (IN LIQUIDATION).****NOTICE TO CREDITORS OF INTENTION TO DECLARE DIVIDEND.**

A First Dividend is intended to be declared in the above matter. Creditors who have not proved their debt by the 6th December, 1971, will be excluded from this dividend. The date of liquidation was the 6th October, 1971.

Dated this 22nd day of November, 1971.

LEWIS LUCKINS, F.C.A., Liquidator.

Lewis Luckins & Co., chartered accountants, 130 Flinders-street, Melbourne, 3000. Telephone 63 8827.

3544

Companies Act 1961.—In the matter of HARRISON INVESTMENTS PTY. LTD.

At an Extraordinary General Meeting of the above-named company, duly convened and held at 23 King William-street, Adelaide, on 19th November, 1971, the following Resolution was duly passed as a Special Resolution:—

“That the company be wound up voluntarily.”

And at such meeting, Kenneth Victor Harrison, chartered accountant, 351 Collins-street, Melbourne, was appointed liquidator for the purposes of the winding up.

Dated this 19th November, 1971.

3545

A. V. ADAMSON, Director.

BEENHAM PROPRIETARY LIMITED.

Notice is hereby given that at an Extraordinary General Meeting of Beenham Proprietary Limited, held on the 22nd day of November, 1971, the following Special Resolution was passed:—

“That the company be wound up voluntarily.”

Dated the 22nd day of November, 1971.

3541

G. B. MACKAY, Secretary.

In the matter of A.Z. CONCRETE & TERRAZZO CO. PTY. LIMITED.—Notice of Winding-up Order.

Order made the 17th day of November, 1971.

Name and address of official liquidator, Robert Arthur Waters, of 170 Queen-street, Melbourne.

J. CANNY, Deputy Commissioner of Taxation of the Commonwealth of Australia.

3537

In the Supreme Court of Victoria.—No. Co. 8241 of 1971.

—In the matter of the Companies Act; and in the matter of MARK BARDLE (HOMES) PTY. LTD.

Notice is hereby given that a petition for the winding up of the above-named company by the Supreme Court was; on the 16th day of November, 1971, presented by Jindare Station Pty. Ltd.: And that the said petition is directed to be heard before the court sitting at Practice Court, Law Courts Building, William-street, Melbourne, at the hour of 10.30 o'clock in the forenoon, on the 10th day of December, 1971; and any creditor or contributory of the said company desiring to support or oppose the making of an order on the said petition may appear at the time of hearing by himself or his counsel for that purpose; and a copy of the petition will be furnished to any creditor or contributory of the said company requiring the same by the undersigned on payment of the regulated charge for the same.

The registered office of the petitioner is at 26 Bishop-street, Darwin, in the Northern Territory.

The petitioners solicitors are Messrs. Cridland & Bauer, of Mitchell Chambers, Mitchell-street, Darwin, aforesaid, acting through John McCormack, Esquire, of 59 Smith-street, Darwin, by his agents, Messrs. Davies, Campbell & Piesse, of 401 Collins-street, Melbourne, and the petitioners address for service is at the office of Messrs. Davies, Campbell & Piesse, of 401 Collins-street, Melbourne.

DAVIES, CAMPBELL & PIESSE.

NOTE.—Any person who intends to appear on the hearing of the said petition must serve on or send by post to the above-named Davies, Campbell & Piesse, notice, in writing, of his intention so to do. The notice must state the name and address of the person, or, if a firm, the name and address of the firm, and must be signed by the person or firm or his or their solicitor (if any), and must be served, or, if posted, must be sent by post in sufficient time to reach the above named not later than Four o'clock in the afternoon of the 9th day of December, 1971.

3534

The Companies Act 1961.—In the matter of ROSETTE KNITTING MILLS LIMITED (in Liquidation).—Notice of Meeting of Members and Creditors, Pursuant to Section 272.

Notice is hereby given that the Final Meeting of members and creditors of Rosette Knitting Mills Limited (in liquidation) will be held at the offices of Messrs. Norman, Cartledge and Browne, 1 Palmerston-crescent, South Melbourne, on the 24th day of December, 1971, at 9.15 o'clock in the forenoon for the purpose of laying before the meeting the liquidator's final account and report.

Dated this 19th day of November, 1971.

G. K. SCAMBLER, Liquidator.

Norman, Cartledge and Browne, chartered accountants, 1 Palmerston-crescent, South Melbourne, Vic. 3205.

3538

In the matter of the Companies Act 1961; and in the matter of I.S.I. PTY. LTD.

Notice is hereby given that a petition for the winding-up of the above-named company by the Supreme Court was on the 28th day of October, 1971, presented by John Maxwell Reid, and that the said petition is directed to be heard before a court sitting at the Fourteenth Court, Law Courts, William-street, Melbourne, on the 6th day of December, 1971, at the hour of 10.30 o'clock in the forenoon; and any creditor or contributory of the said company desiring to support or oppose the making of an order on the said petition may appear at the time of hearing by himself or his counsel for that purpose; and a copy of the petition will be furnished to any creditor or contributory of the said company requiring the same by the undersigned on payment of the regulated charge for the same.

The petitioner's address is 123 Dalgetty-road, Beaumaris. The petitioner's solicitors are Messrs. Ellison Hewison & Whitehead, 379 Collins-street, Melbourne.

NOTE.—Any person who intends to appear on the hearing of the said petition must serve on or send by post to the above-named solicitors, notice in writing of his intention so to do. The notice must state the name and address of the person, or if a firm, the name and address of the firm and must be signed by the person or firm, or his or their solicitor (if any) and must be served, or if posted must be sent by post in sufficient time to reach the above-named not later than 4 o'clock in the afternoon of the 3rd day of December, 1971.

3488

WENWOOD INVESTMENTS PTY. LIMITED (IN VOLUNTARY LIQUIDATION).

Notice is hereby given that a General Meeting of members of Wenwood Investments Pty. Limited (in Voluntary Liquidation) will be held at the offices of Weigall & Crowther, 12th Floor, 459 Little Collins-street, Melbourne, 3000, Victoria, on Monday, 10th January, 1972, at 2 p.m., for the purpose of laying before the meeting accounts pursuant to section 272 (1) of the Companies Act 1961 showing how the winding-up of the company has been conducted.

Dated at Melbourne, this 17th day of November, 1971.
3487 D. S. BAKER, Liquidator.

Companies Act 1961, Section 254.

D. L. HOLDINGS PROPRIETARY LIMITED.

Notice is hereby given that at an Extraordinary General Meeting of the members of the above-named company held on 9th November, 1971, the following Resolution was passed as a Special Resolution:—

“That this company be wound up as a members' voluntary liquidation and that Robert Arthur Waters, of 170 Queen-street, Melbourne, be appointed liquidator.”

3500 R. A. WATERS, Liquidator.

BERT PRESTON & COMPANY PTY. LTD. (IN VOLUNTARY LIQUIDATION).

NOTICE OF FINAL MEETING.

Notice is hereby given, in pursuance of section 272 of the Companies Act 1961, that a Final Meeting of members of Bert Preston & Company Pty. Ltd. (in Voluntary Liquidation) will be held at the office of John Morgan Hare, 206 Capel-street, North Melbourne, on the 23rd day of December, 1971, at 12 noon, for the purpose of having an account laid before it, showing the manner in which the winding up has been conducted and the property of the company disposed of, and hearing any explanation that may be given by the liquidator.

Dated this 17th day of November, 1971.
3501 J. M. HARE, Liquidator.

The Companies Act 1961.—In the matter of J. G. DENT MOTORS PTY. LTD. (in Voluntary Liquidation).

Notice is hereby given that at an Extraordinary Meeting of the members of the above-named company held on Tuesday, the 16th day of November, 1971, it was resolved that the company be wound up voluntarily and at a meeting of creditors held on the same day, it was resolved that for such purpose Scott Maurice Nunan, of Hall & Rose, chartered accountants, 254 Queen-street, Melbourne, be appointed liquidator.

Notice is also given that after 21 days from this date I shall proceed to distribute the assets. All creditors having any claim against the company should furnish particulars of same by that date, otherwise I shall proceed to distribute the assets without regard to their claim.

Dated this 16th day of November, 1971.
S. M. NUNAN, Liquidator.
Hall & Rose, chartered accountants, 254 Queen-street, Melbourne. 3502

The Companies Act 1961.—In the matter of G. J. F. PTY. LTD. (in Voluntary Liquidation).

Notice is hereby given that at an Extraordinary Meeting of the members of the above-named company, held on Friday, the 19th day of November, 1971, it was resolved that the company be wound up voluntarily and at a meeting of creditors held on the same day, it was resolved that for such purpose Scott Maurice Nunan, of Hall & Rose, chartered accountants, 254 Queen-street, Melbourne, be appointed liquidator.

Notice is also given that after 21 days from this date I shall proceed to distribute the assets. All creditors having any claim against the company should furnish particulars of same by that date, otherwise I shall proceed to distribute the assets without regard to their claim.

Dated this 19th day of November, 1971.
S. M. NUNAN, Liquidator.
Hall & Rose, chartered accountants, 254 Queen-street, Melbourne. 3503

FORECASTLE PTY. LTD. (IN VOLUNTARY LIQUIDATION).

Notice is hereby given that by a Resolution of the company, Eric Morris Cohen, of 26 Commercial-road, Prahran, was appointed liquidator of Forecastle Pty. Ltd. on the 19th November, 1971, and that the situation of the liquidator's office is care of Morris Cohen, Glen & Co., 26 Commercial-road, Prahran.

3506 ERIC M. COHEN, Liquidator.

ALAN G. WILSON & COMPANY PTY. LTD. (IN VOLUNTARY LIQUIDATION).

NOTICE OF FINAL MEETING.

Notice is hereby given, in pursuance of section 272 of the Companies Act 1961, that a Final Meeting of members of Alan G. Wilson & Company Pty. Ltd. (in Voluntary Liquidation) will be held at the office of John Morgan Hare, 206 Capel-street, North Melbourne, on the 23rd day of December, 1971, at 10 a.m., for the purpose of having an account laid before it, showing the manner in which the winding-up has been conducted and the property of the company disposed of, and hearing any explanation that may be given by the liquidator.

Dated this 17th day of November, 1971.
3504 J. M. HARE, Liquidator.

Companies Act 1961.

GHOST GUM INVESTMENTS PROPRIETARY LIMITED.

At an Extraordinary General Meeting of Ghost Gum Investments Proprietary Limited duly convened and held at 395 Collins-street, Melbourne, on Friday, 19th November, 1971, at 10.30 a.m., the following Resolution was duly passed as a Special Resolution:—

“That the company be wound up voluntarily and that Mr. C. G. Roberts, of 66 Airline-street, South Yarra, be and is hereby appointed liquidator.”

Dated this 19th day of November, 1971.
C. G. ROBERTS, Liquidator.

Mann, Judd & Co., 249 William-street, Melbourne. 3505

PERADENIYA PTY. LTD. (IN VOLUNTARY LIQUIDATION):

Notice is hereby given, in pursuance of section 272 of the Companies Act 1961, that a General Meeting of the members of the above-mentioned company will be held at the offices of Morris Cohen, Glen & Co., 26 Commercial-road, Prahran, on Wednesday, 22nd December, 1971, at 10 a.m., for the purpose of receiving the liquidator's account, showing how the winding up has been conducted and the company's property disposed of.

Dated 18th November, 1971.
3507 ERIC M. COHEN, Liquidator.

VICTORIA ADELIN TAYLOR, late of 4 George-street, Belmont, widow, DECEASED.

Creditors, next of kin and others having claims in respect of the estate of the deceased (who died on the 15th day of July, 1971), are required by the personal representatives John Welford Stubbs, solicitor and Niel Lindsay Davidson, solicitor, both of Malop-street, Geelong, to send particulars to them, care of the under-mentioned solicitors by the 31st day of January, 1972, after which date the personal representatives may convey or distribute the assets, having regard only to the claims of which they then have notice.

WHYTE, JUST & MOORE, solicitors, 27 Malop-street, Geelong. 3471

WALTER ORMOND LEONARD JOHNSTON, late of Mount Royal, Poplar-road, Parkville, retired, DECEASED.

Creditors, next of kin and others having claims in respect of the estate of the deceased (who died on the 19th October, 1971), are requested to send particulars of their claims to the executrix Gwynneth Maud Winnifred Thompson, care of the under-signed solicitor by the 25th January, 1972, after which date the said executrix will proceed to distribute the estate having regard only to the claims of which she then has notice.

MARJORY C. COATES, solicitor, of 422 Collins-street, Melbourne, 3000. 3476

Pursuant to the provisions of the Trustee Act 1958, creditors, next of kin and all other persons having claims in respect of the estate of Hector William Cooley, formerly of “Goronga” Pakenham Upper, but late of Highland Park Private Hospital, Upper Beaconsfield, retired public servant, (who died on the 4th July, 1971), are required to send particulars of their claims to the executors, The Union-Fidelity Trustee Company of Australia Limited, the registered office of which is situate at 100 Exhibition-street, Melbourne, Alan Sydenham Cooley, of 27 Garcia-street, Campbell, Australian Capital Territory, formerly Secretary of the Department of Supply, now Chairman of Public Service Board, and William Raleigh Mann, of “Goronga” Pakenham Upper, Orchardist, care of the said company by the 2nd February, 1972, after which date they will distribute the assets, having regard only to the claims of which they shall then have had notice.

MADDOCK LONIE & CHISHOLM, solicitors, 339 Collins-street, Melbourne. 3492

Trustee Act 1958.
NOTICE TO CLAIMANTS.

Pursuant to the *Trustee Act 1958*, creditors, next of kin and all other persons having claims in respect of the estate of any deceased person named below are required to send particulars to the legal personal representative or representatives at the addresses stated, after which date the representative or representatives will distribute the assets, having regard only to the claims of which notice has been received:—

Clarence William Cecil, late of 16 Heritage-street, Moonee Ponds, retired biograph operator, deceased, died on the 10th day of July, 1971.—Claims to the executrix, Ethel Victoria Cecil, of 16 Heritage-street, Moonee Ponds, widow, care of John F. Carroll, of 4 Paisley-street, Footscray, solicitor, by the 27th day of January, 1972. John F. Carroll, LL.B., solicitor, 4 Paisley-street, Footscray. 3517

Raymond James Davies, late of 56 Farm-street, Newport, driver-manager, deceased, died on the 22nd day of September, 1971.—Claims to the executrix, Jean Florence Davies, of 56 Farm-street, Newport, widow, care of John F. Carroll, of 4 Paisley-street, Footscray, solicitor, by the 27th day of January, 1972. John F. Carroll, LL.B., solicitor, 4 Paisley-street, Footscray. 3518

James Flannery, late of 1 Wilkins-street, Newport, fitter, deceased, died on the 25th day of September, 1971.—Claims to the executrices, Rose Ann Flannery, of 1 Wilkins-street, Newport, widow, and Valarie Rose Thomas, of 40A Maddox-road, Newport, married woman, care of John F. Carroll, of 4 Paisley-street, Footscray, solicitor, by the 26th day of January, 1972. John F. Carroll, LL.B., solicitor, 4 Paisley-street, Footscray. 3519

William Levi Chamberlain, late of Port Fairy East, labourer, deceased, died 29th day of July, 1971.—Claims to the executrix, Ruby Chamberlain, of Port Fairy East, widow, care of Conlan & Leishman, solicitors, 38 Bank-street, Port Fairy, by 3rd February, 1972. 3435

Creditors, next of kin and others having claims in respect of the estate of Catherine Jane Rogers, late of William-street, Bacchus Marsh, spinster, deceased (who died on the 10th November, 1971), are requested to send particulars of their claims to the executors Arthur Leslie Park and Eric Walter Rogers, care of the under-mentioned solicitors on or before the 26th January, 1972, after which date they will distribute the assets, having regard only to the claims of which they then have notice.

McKEAN & PARK, solicitors, 84 William-street, Melbourne. 3479

Creditors, next of kin and others having claims in respect of the estate of Roderick Alexander MacDonald, late of Christian Guest Home, 139 Atherton-road, Oakleigh, gentleman, deceased (who died on the 19th October, 1971), are requested to send particulars of their claims to the executors Roderick Ian MacDonald and Robert Stewart MacDonald, care of the under-mentioned solicitors on or before the 26th January, 1972, after which date they will distribute the assets, having regard only to the claims of which they then have notice.

McKEAN & PARK, solicitors, 84 William-street, Melbourne. 3480

Creditors, next of kin and others having claims in respect of the estate of Elma Gladys Fiegert, late of Wonthaggi, in the State of Victoria, widow, deceased, intestate (who died on the 29th day of September, 1968), are to send particulars of their claims to the administratrix Audrey Melva Fiegert, care of the under-mentioned solicitors, on or before the 15th day of January, 1972, after which date she will proceed to distribute the said estate, having regard only to the claims of which she then has notice.

F. J. ORAMES & DOWNING, solicitors of 121 William-street, Melbourne. 3481

Creditors, next of kin and others having claims in respect of the estate of Kathleen Margaret Woolnough, late of 146 Balaclava-road, Caulfield, widow, deceased (who died on the 20th September, 1971), are required by the executor George Frederick Dinan, of 24 Brown's-parade, Wendouree, Ballarat, butcher, to send particulars of their claims to him in care of the under-mentioned solicitors prior to the 2nd February, 1972, after which date the said executor will distribute the assets of the deceased, having regard only to the claims of which he then shall have had notice.

ROGERS & GAYLARD, solicitors, 51 Queen-street, Melbourne. 3482

EDITH MARY SARGEANT, late of 5 Brougham-street, Box Hill, in the State of Victoria, widow, DECEASED.

Creditors, next of kin and others having claims in respect of the estate of the deceased (who died on the 7th day of October, 1971), are required by the executors Douglas Keith Sargeant, of 32 Doncaster East-road, Mitcham, in the said State, sales representative, and Lawrence Raymond Sargeant, of 19 Burch-street, Blackburn, in the said State, army officer, to send particulars to them in care of the under-signed, by the 31st day of January, 1972, after which date the executors may convey or distribute the assets, having regard only to the claims of which they then have notice.

Dated the 19th day of November, 1971.

P. H. PIPEY, solicitor for the executors, 1 Watts-street, Box Hill. 3489

STELLA MARIA JANE GRIERSON, late of Currong-grove, Croydon, widow, DECEASED.

Creditors, next of kin and others having claims in respect of the estate of the deceased (who died on the 7th day of March, 1971), are required by the Perpetual Executors and Trustees Association of Australia Limited, of 100-104 Queen-street, Melbourne, and June Margaret Cutter, of 54 Bayswater-road, Croydon, married woman, the applicants for a grant of administration to send particulars of their claims to the said applicants in the care of the said company by the 18th day of February, 1972, after which date they will convey or distribute the assets having regard only to the claims of which they then have notice.

McLAUGHLIN, EAVES & JOHNSTON, of 358 Lonsdale-street, Melbourne, 3000. 3490

Creditors, next of kin and others having claims in respect of the estate of John Rogers Barnes, late of 4 Magazine-street, Eaglehawk, in the State of Victoria, carpenter (who died on the 31st day of May, 1971), are to send the particulars of their claims to Kenneth Fraser Johnston, of 17 Magazine-street, Eaglehawk, by the 27th day of January, 1972, after which date the executor will distribute the assets of the estate of the said deceased, having regard only to the claims of which he has notice.

EVERY & EVERY, solicitors, V.P.C. Building, Bull-street, Bendigo. 3449

ALICE LOUISA DAWSON, late of 22 Amiet-street, Greensborough, in the State of Victoria, widow, DECEASED.

Creditors, next of kin and others having claims in respect of the estate of the deceased (who died 12th July, 1971), are required by the personal representative Heather Adna Millar, of 527 Nicholson-street, North Carlton, home duties, to send particulars to her, care of the undersigned solicitors, by the 31st day of January, 1972, after which date she may convey or distribute the assets, having regard only to the claims of which she then has notice.

A. H. BOWMAN & SON, solicitors, 43 Yarra-street, Geelong. 3451

FRANCES MARY MORRIS, late of Orbost, widow, DECEASED.

Creditors, next of kin and others having claims in respect of the estate of the above deceased (who died on the 11th day of March, 1971), are required to send particulars of their claims to the executor, Harold Dutton Morris, care of the under-mentioned solicitors, by the 28th day of January, 1972, after which date he shall distribute the assets, having regard only to the claims of which he has notice.

MOSLEY & PALMER, solicitors, 139 Nicholson-street, Orbost. 3458

Creditors, next of kin and others having claims in respect of the estate of Reginald George Kennedy, formerly of 704 Neil-street, Ballarat, then care of Mrs. A. Drayton, 59 Scenic-drive, Merewether, Newcastle, New South Wales, but late care of The Anchorage Caravan Park, Urangan, Queensland, retired mining employee, deceased (who died on 25th June, 1971), are required to send particulars of their claims to the executor, The Union-Fidelity Trustee Company of Australia Limited, at its address, 101 Lydiard-street north, Ballarat, by 26th January, 1972, after which date the said company will distribute the assets, having regard only to the claims of which it then has notice.

BAIRD & MCGREGOR, solicitors, Ballarat. 3465

FLORENCE NITA YUILLE, late of Gillies-street, Ballarat, widow, DECEASED.

Creditors, next of kin and others having claims in respect of the estate of the deceased (who died on the 11th day of May, 1971), are required by the executor, Ronald Edgar Phillips, of 52 Edinburgh-street, Clayton, metal worker, to send particulars of their claims to him, care of the undersigned solicitors, by the 1st day of February, 1972, after which date the executor may convey or distribute the assets, having regard only to the claims of which he then has notice.

D. & A. ARONSON, solicitors, 104 Lydiard-street south, Ballarat. 3466

VERA KATHLEEN NEAL, late of 1 Austin-terrace, Newtown, Geelong, widow, DECEASED.

Creditors, next of kin and others having claims in respect of the estate of the above deceased (who died on 22nd February, 1969), are required by the executors, Harold John Cooper, estate agent and Albert Trevor Bruhn, solicitor, both care of 63 Gheringhap-street, Geelong, to send particulars to them by the 4th February, 1972, after which date the executors may convey or distribute the assets, having regard only to the claims of which they then have notice.

Dated the 19th day of November, 1971.

BRUHN & CO., solicitors, 63 Gheringhap-street, Geelong. 3467

Creditors, next of kin and others having claims in respect of the estate of Albert George Brooks, late of 593 South-road, Moorabbin, retired railway employee, deceased (who died on the 7th day of August, 1971), are requested to send particulars of their claims to Jean Gleed, of 593 South-road, Moorabbin, married woman, the executrix of the will of the said deceased, in care of the under-mentioned firm of solicitors, by the 30th day of January, 1972, after which date the executrix will distribute the assets, having regard only to the claims of which she has notice.

CLEMENTS, MOTT & BETT, solicitors, 253-255 Glen-huntly-road, Elsternwick, 3185. 3468

Creditors, next of kin and others having claims against the estate of Vera Ellen Craddock, formerly of "Innisfail", Strathmerton, but late of Flat 12, 163-165 Central-road, Nunawading, in the State of Victoria, widow, deceased (who died on the 25th day of July, 1971), are required to send particulars thereof to National Trustees, Executors and Agency Company of Australasia Limited, of 46 Queen-street, Bendigo, in the said State, by the 28th day of January, 1972, after which date the said company will distribute the assets of the said deceased, having regard only to claims of which it then has notice.

WATSON JAMES & ROGERS, solicitors, 61 Bull-street, Bendigo. 3459

FREDERICK HENRY GILPIN, late of 292 The Avenue, Parkville, plumber, DECEASED.

Creditors, next of kin and others having claims in respect of the estate of the deceased (who died on the 24th day of January, 1971), are required to send particulars of such claims to the executors, James O'Donoghue and James Collins, care of the under-mentioned solicitors, by the 28th day of January, 1972, after which date the executors may convey or distribute the assets, having regard only to the claims of which they then have notice.

HEFFEY & BUTLER, solicitors, 358 Lonsdale-street, Melbourne, 3000. 3491

CYRIL CHASE MIMS, formerly of Melbourne Mansions, Collins-street, Melbourne, club secretary, but late of 328 Wattle-tree-road, Malvern, in the State of Victoria, gentleman, DECEASED.

Creditors, next of kin and others having claims in respect of the estate of the above-named deceased (who died on the 22nd July, 1971), are required to send particulars of these claims to the executor, Richard Talbot Mims, of 328 Wattle-tree-road, Malvern, in the State of Victoria, care of the under-mentioned solicitors, by the 26th day of January, 1972, after which date he may convey or distribute the assets, having regard only to the claims of which he then has notice.

AITKEN, WALKER & STRACHAN, solicitors, 414 Collins-street, Melbourne, Vic. 3000. 3525

DORIS LILLIAN NATHAN, late of Flat 3, No. 5 Seaview-crescent, Black Rock, widow, DECEASED.

Creditors, next of kin and others having claims in respect of the estate of the deceased (who died on the 10th day of December, 1971), are required by The Equity Trustees, Executors and Agency Company Limited, of 472 Bourke-street, Melbourne, to send particulars of their claims to the said company, by the 14th day of February, 1972, after which date it will convey or distribute the assets, having regard only to the claims of which the company then has notice.

READ & READ, solicitors, of 422 Collins-street, Melbourne. 3493

Creditors, next of kin and others having claims in respect of the estate of Jacob Brodsky, late of 20 Victoria-street, South Melbourne, retired (who died on the 31st March, 1970), are requested to send particulars of their claims to the executor, Jewel Okno, care of the under-mentioned solicitors, by the 25th February, 1972, after which date the executor will distribute the assets, having regard only to the claims of which he then has notice.

J. OKNO & CO., solicitors, 390 Lonsdale-street, Melbourne, 3000. 3495

Creditors, next of kin and others having claims in respect of the estate of Percy James Turner, late of 1 Love-street, Hartwell, retired commercial traveller, deceased (who died on the 19th day of August, 1967), are required to send particulars of their claims to the executor, The Trustees, Executors and Agency Company Limited, of 401 Collins-street, Melbourne, by the 26th day of January, 1972, after which date the executor will distribute the assets, having regard only to the claims of which it then has notice.

PROUDFOOT HORTON & COOKE, solicitors, of 452 Lonsdale-street, Melbourne. 3496

KENNETH PATTERSON, late of 8 O'Connor-street, Reservoir, gentleman, DECEASED.

Creditors, next of kin and others having claims in respect of the estate of the deceased (who died on the 12th day of July, 1971), are required to send particulars of their claims to the executor, Melford Henry Russell Roberts, of 357 Little Collins-street, Melbourne, solicitor, by the 25th day of January, 1972, after which date he will convey or distribute the assets, having regard only to the claims of which he then has notice.

H. S. W. LAWSON HUGHES & CO., 357 Little Collins-street, Melbourne, solicitors. 3498

ETHEL LOUISA BEVAN, late of 1795 Malvern-road, Glen Iris, spinster, DECEASED (who died on the 11th day of June, 1971).

Creditors, next of kin and all other persons having claims against the estate of the deceased, are required by the executor of her will, Harold Frederick Day, of 118 Queen-street, Melbourne, accountant, to send particulars thereof to him, care of the under-mentioned solicitors, before the 26th day of January, 1972, after which date he may distribute the assets of the deceased, having regard only to the claims of which he then has notice.

COLTMAN WYATT & ANDERSON, solicitors, of 379 Collins-street, Melbourne. 3499

Creditors, next of kin and all other persons having claims against the estate of Stuart Adam Davis, late of 8 Fosbery-avenue, Caulfield, chartered accountant, deceased are required by the executor Stuart Bruce Davis, of 1 Brooklyn-avenue, Caulfield, oil company representative, to send particulars of their claims, care of the undersigned, by the 26th January, 1972, after which date they will distribute the estate, having regard to only those claims of which they have notice.

JOHN D. MUSTOW & CO., solicitors, of 131 Queen-street, Melbourne. 3483

LUCRETIA FANNY MILLSOM, late of 17 George-street, Lilydale, widow, DECEASED.

Creditors, next of kin and all other persons having claims in respect of the estate of Lucretia Fanny Millsom, late of 17 George-street, Lilydale, widow, deceased, (who died on the 17th day of July, 1971), are to send particulars of their claims to the trustees Dorothy Lucretia McIntyre, of 45 Myers-avenue, Glen Waverley, married woman, and Elsie Ada Hollingsworth, of 23 George-street, Lilydale, widow, care of the under-mentioned solicitors by the 1st day of February, 1972, after which date the Trustees may distribute the assets, having regard only to claims of which they have notice.

CLEVERDON, REID & FINLAY, 118 Queen-street, Melbourne. 3478

ROBERT HODDLE-WRIGLEY, late of 8 Ford-avenue, Oakleigh, civil engineer, DECEASED (who died on the 8th day of September, 1971).

Creditors, next of kin and all other persons having claims against the estate of the deceased are required by The Perpetual Executors and Trustees Association of Australia Limited, of 100-104 Queen-street, Melbourne, and Eileen Annie Hoddle-Wrigley, of 8 Ford-avenue, Oakleigh, widow, the applicants for a Grant of Administration to send particulars of their claims to the said applicants in the care of the said company before the 28th day of January, 1972, after which date they will convey or distribute the assets, having regard only to the claims of which they then have notice.

COLTMAN, WYATT & ANDERSON, solicitors, 379 Collins-street, Melbourne. 3494

MARGARET CONWAY, formerly of Watton-street, Penshurst, but late of Queen Elizabeth Home, Ballarat, spinster, DECEASED.

Creditors, next of kin and all others having claims in respect of the above-named deceased (who died on the 31st day of May, 1971), are requested to send particulars of their claims in writing to the executors Thomas Jeffries, of 12 Pevensey-street, Wendouree, and John Beynon Dwyer, of 95 Kepler-street, Warrnambool, care of the undersigned on or before the 18th day of January, 1972, after which date they will distribute the assets of the said estate, having regard only to the claims of which they then have notice as aforesaid.

DESMOND DUNNE & DWYER, solicitors, Warrnambool. 3443

Creditors, next of kin or others having claims in respect of the estate of Fred Sue Hen Chin, late of 72A Flemington-road, Parkville, watchman, deceased (who died on the 1st November, 1970), are to send particulars of their claims to the executor Clifton Law Sing, care of the under-mentioned solicitors by the 27th January, 1972, after which date he will distribute the assets, having regard only to the claims of which he then has notice.

F. E. O'BRIEN & CO., solicitors, 470 Bourke-street, Melbourne, 3000. 3497

CHARLOTTE ANNA EISNER, late of 135 Locksley-road, Ivanhoe, in the State of Victoria, widow, DECEASED.

Creditors, next of kin and others having any claim in respect of the estate of the deceased (who died on the 8th day of April, 1971), are required by Kurt Eisner, of 40 Hardy-terrace, East Ivanhoe, to send particulars to him at the office of Dudley Tregent & Co., of 422 Collins-street, Melbourne, solicitors, by the 26th day of January, 1972, after which date the executor will distribute the assets, having regard only to the claims to which he then has notice.

DUDLEY TREGENT & CO., solicitors, 422 Collins-street, Melbourne. 3474

SALVATORE FODERO, late of 81 Robeson-street, Preston, in the State of Victoria, pensioner, DECEASED.

Creditors, next of kin and others having any claim in respect of the estate of the deceased (who died on the 9th day of March, 1971), are required by Salvatore Fodero, of 78 Broadhurst-avenue, Reservoir, to send particulars to him at the office of Dudley Tregent & Co., of 422 Collins-street, Melbourne, solicitors, by the 26th day of January, 1972, after which date the executor will distribute the assets, having regard only to the claims to which he then has notice.

DUDLEY TREGENT & CO., solicitors, 422 Collins-street, Melbourne. 3475

Creditors, next of kin and others having claims in respect of the estate of Clarice Bourke, formerly of 52 Garden-street, South Yarra, in the State of Victoria, but late of 54 Garden-street, South Yarra, in the said State, widow, deceased (who died on the 12th June, 1971), are to send particulars of their claims to W. M. Bourke & John Keating, solicitors, of 191 Greville-street, Prahran, by the 26th February, 1972, after which date the executor will distribute the assets of the estate, having regard only to the claims of which he then has notice.

W. M. BOURKE & JOHN KEATING, solicitors, 191 Greville-street, Prahran. 3524

Creditors, next of kin and others having claims in respect of the estate of Alexander James McKinnon, late of Waratah-road, Fish Creek, livestock agent, deceased, intestate (who died on the 15th day of July, 1971), are to send particulars of their claims to Verna Mae McKinnon, care of the undersigned, by the 29th day of January, 1972, after which date she will distribute the assets, having regard only to the claims to which she then has notice.

BIRCH, ROSS, BARLOW & WOINARSKI, solicitors, 3 Lyon-street, Leongatha. 3515

GEORGE HAROLD FREDERICK LAWN, formerly of Hopetoun, but late of 4 Palm-avenue, Horsham, retired farmer, DECEASED.

Creditors, next of kin and others having claims in respect of the estate of the deceased (who died on 16th May, 1971), are required by the trustee The Union Fidelity Trustee Company of Australia Limited, of 101 Lydiard-street, Ballarat, to send particulars to it by the 20th day of February, 1972, after which date the trustee may convey or distribute the assets, having regard only to the claims of which it then has notice.

K. W. ENTWISLE, solicitor, Hopetoun, Vic. 3396. 3516

Creditors, next of kin and others having claims in respect of the estate of Donald Frederick Ridgers, late of Flat 1, 10 Abinger-place, Richmond, in the State of Victoria, fitter and turner, deceased (who died on the 22nd day of July, 1971), are required by the executrix to send particulars of their claims to Royston Cahir, Martin & Dillon, 17 Queen-street, Melbourne, by the 26th day of January, 1972, after which date the executrix will distribute the assets of the estate, having regard only to claims of which she then has notice.

ROYSTON CAHIR, MARTIN & DILLON, solicitors, 17 Queen-street, Melbourne. 3522

Creditors, next of kin and others having claims in respect of the estate of Geoffrey Herbert Fayle, late of 11 Izett-street, Prahran, in the State of Victoria, gentleman, deceased (who died on the 7th April, 1971), are to send particulars of their claims to W. M. Bourke & John Keating, solicitors, of 191 Greville-street, Prahran, by the 26th February, 1972, after which date the executor will distribute the assets of the estate, having regard only to the claims of which he then has notice.

W. M. BOURKE & JOHN KEATING, solicitors, 191 Greville-street, Prahran. 3523

Creditors, next of kin and others having claims in respect of the estate of Ivy Knott, late of Mont Park Mental Hospital, Mont Park, in the State of Victoria, widow, deceased (who died on the 30th day of October, 1970), are required by the executors, Philip Edginton Aitken and Harry Meares Hearn, both of 414 Collins-street, Melbourne, in the said State, solicitors, to send particulars of their claims to them, care of the under-mentioned solicitors, by the 26th day of January, 1972, after which date they may convey or distribute the assets, having regard only to the claims of which they then have notice.

AITKEN, WALKER & STRACHAN, solicitors, of 414 Collins-street, Melbourne. 3526

PERCY WALTER BURTON, late of 13 Craig-street, Warragul, director, DECEASED.

Creditors, next of kin and others having claims in respect of the estate of the deceased (who died on the 11th day of June, 1971), are required by the Trustees, Ernest Edward Burton, of 19 Bowen-street, Warragul, and Kenneth Walter Burton, of 9 Acacia-court, Warragul, merchants, to send particulars of their claims to them, care of the undersigned solicitors, by the 31st January, 1972, after which date the trustees may convey or distribute the assets, having regard only to the claims of which he then has notice.

GRAY, FRIEND & LONG, solicitors, Warragul. 3437

FREDERICK SAMUEL FRY, late of Howqua Hills, retired Forest Commission employee, DECEASED.

Creditors, next of kin and others having claims in respect of the deceased (who died on the 10th May, 1971), are required by his trustee, Robert Geoffrey Ritchie, of Delatie, Mansfield, grazier, to send particulars to him, care of the undermentioned firm of solicitors, by the 7th February, 1972, after which date the trustee may convey and distribute the assets, having regard only to the claims of which they then have notice.

MAL. RYAN & GLEN, 9 High-street, Mansfield, solicitors for the trustee. 3438

ROBERT JOHN FINDLAY, late of Glengarry, Thornton, grazier, DECEASED.

Creditors, next of kin and others having claims in respect of the deceased (who died on the 10th April, 1971), are required by his trustees, Janet Thelma Findlay, of Glengarry, Thornton, widow, Graeme John Findlay, of 10 Seventh-street, Eildon, grazier, and Janet Margaret Findlay, of Glengarry, Thornton, clerk, to send particulars to them, care of the under-mentioned firm of solicitors, by the 7th February, 1972, after which date the trustees may convey and distribute the assets, having regard only to the claims of which they then have notice.

MAL. RYAN & GLEN, 9 High-street, Mansfield, solicitors for the trustees. 3439

ESTELLA ELIZABETH GREEN, late of 14 Newmarket-street, Northcote, widow, DECEASED.

Creditors, next of kin and others having claims in respect of the estate of the deceased (who died on the 22nd day of June, 1971), are required to send particulars of their claims to Victor Gordon Green, care of F. P. & M. J. Walsh, solicitors, of 452 High-street, Northcote, before the 2nd day of February, 1972, after which date he will distribute the assets, having regard only to the claims of which he then has notice.

F. P. & M. J. WALSH, solicitors, 452 High-street, Northcote. 3510

ELIZABETH GILLIES, late of 15 Wales-street, West Footscray, widow, DECEASED.

Creditors, next of kin and others having claims in respect of the estate of the above-mentioned deceased (who died on the 29th day of August, 1971), are required by the executor, Roderick Merritt, care of his under-mentioned solicitor, to send particulars of their claims to him, by the 8th day of February, 1972, after which date he will convey or distribute the assets, having regard only to the claims of which he then has notice.

B. J. WILLIAMS, LL.B., solicitor, 129 Lower Plenty-road, Rosanna. 3513

Creditors, next of kin and others having claims in respect of the estate of Grace Annie Charlett, late of 7 Halford-street, Inverloch, widow, deceased (who died on the 25th day of August, 1971), are to send particulars of their claims to James William Watson, care of the undersigned, by the 29th day of January, 1972, after which date he will distribute the assets, having regard only to the claims of which he then has notice.

BIRCH, ROSS, BARLOW & WOINARSKI, solicitors, 3 Lyon-street, Leongatha. 3514

Creditors, next of kin and other persons having claims against the estate of Reginald Robert George Shields, late of 19 Wilson-avenue, Montmorency, in the State of Victoria, paper manufacturer, deceased (who died on the 5th of August, 1971), are required to send particulars of their claims to the executor, The Union-Fidelity Trustee Company of Australia Limited, of 100 Exhibition-street, Melbourne, by the 25th of January, 1972, after which date the executor will distribute the assets, having regard only for the claims of which it then has had notice. 3536

Creditors, next of kin and others having claims in respect of the estate of Richard Edward Clancy, late of 163 Beach-road, Mordialloc, in the State of Victoria, retired, deceased (who died on the 7th day of July, 1971), are required by the executor, Jack Arthur Reeves, of 12 Lancaster-street, East Bentleigh, in the said State, manager, to send particulars of their claims to him, in care of the under-mentioned solicitors, by the 30th day of January, 1972, after which date he will distribute the assets, having regard only to the claims of which he then has notice.

McCAY & THWAITES, solicitors, 374 Little Collins-street, Melbourne. 3535

JOHN KAUFMAN, late of 5 Haydens-road, Beaumaris, gentleman, DECEASED.

Creditors, next of kin and others having claims against the estate of the said deceased (who died on the 18th day of April, 1971), are to send particulars of their claims to Jeffrey Leslie Sher and Ian DeJardin Mackinnon, care of 120 William-street, Melbourne, by the 26th day of January, 1972, after which date they will distribute the assets, having regard only to the claims of which they then have notice.

BLAKE & RIGGALL, solicitors, 120 William-street, Melbourne. 3533

In the Supreme Court of the State of Victoria.

SALE BY THE SHERIFF.

On Friday, the 14th of January, 1972, at 11.00 a.m., at the Police Station, Mitcham (unless process be stayed or satisfied):—

All the estate and interest (if any) of Robert John Petersen (referred in the writ as R. Petersen), builder, of 7 Penlyne-avenue, Vermont, as joint proprietor with Iris Royce Petersen, of an estate in fee-simple, in the land described in certificate of title, volume 7983, folio 073, upon which is erected a brick dwelling, known as No. 7 Penlyne-avenue, Vermont.

Registered mortgage No. E.87577 affects the said estate and interest.

Terms: Cash only.

H. BUETTNER, Sheriff's Officer.

24th November, 1971. 3530

In the Supreme Court of the State of Victoria.

SALE BY THE SHERIFF.

On Thursday, the 13th day of January, 1972, at 2 p.m., at the Police Station, Geelong (unless process be stayed or satisfied):—

All the estate and interest (if any) of Edward Butwilowsky, television mechanic, and Beatrix Judith Butwilowsky, married woman, both of 446 Tatakan-avenue, Albury, as the last registered owners of the land described in Conveyance Book 679 No. 24, subject to a memorandum, having been filed in the Registrar-General's Office, No. 5876, pursuant to section 208 of the *Property Law Act 1958*, upon which is erected a brick veneer residence, known as No. 1 Fern-street, Newcomb.

Terms: Cash only.

R. M. BARTROP, Sheriff's Officer.

24th November, 1971. 3531

In the Supreme Court of the State of Victoria.

SALE BY THE SHERIFF.

On Thursday, the 6th day of January, 1972, at 2 p.m., at the Police Station, Mansfield (unless process be stayed or satisfied):—

All the estate and interest (if any) of "Hoot" Gibson (in the title referred to as Godfrey Angas Gibson), of 3 Reynolds-street, Mansfield, company director, firstly as proprietor of an estate in fee-simple in the land described in certificate of title, volume 7295, folio 831, upon which is erected a weatherboard dwelling-house, known as No. 3 Reynolds-street, Mansfield, and secondly, as proprietor of an estate in fee-simple in the land described in certificate of title, volume 4952, folio 285, upon which is erected a brick and iron garage, service station and cafe, known as "Ski Inn", Nos. 61-63 High-street, Mansfield.

Registered mortgages Nos. 1013818 and D.2200 affect the said estate and interest first-mentioned, and registered mortgages Nos. D.2200 and E.88607 affect the said estate and interest secondly mentioned.

Terms: Cash only.

R. L. BILLINGTON, Sheriff's Officer.

24th November, 1971. 3532

INSOLVENCY NOTICE

Bankruptcy Act 1966.

Bankruptcy District of the State of Victoria.—No. 144 of 1971, Part X, Re: Ronald John Baker, No. 145 of 1971, Part X, Re: John Barry Purcell.

NOTICE TO CREDITORS.

At separate meetings of creditors of the above-named debtors, held on Monday, 15th November, 1971, the following Special Resolution was passed at each meeting.

"That the debtor execute a deed of arrangement in accordance with the proposal as submitted to this meeting of creditors and that Maxwell George Gee be appointed Trustee under the deed."

The main provisions of the deeds being as follows:

That the debtors assign to the trustee all the assets of the business Satalite Electrical Industries for realization for the benefit of the creditors and that the trustee accept the offer to purchase the said assets, made by Ampco Distributors Pty. Ltd. and dated 8th November, 1971.

That the creditors accept the distributions made by the trustee from the administrations in full settlement of their claims.

MAXWELL GEORGE GEE, Registered Trustee.
Max Gee & Co., 325 Warrigal-road, Burwood, 3125.

3425

IMPOUNDINGS

COLERAINE.—Impounded in Coleraine Pound by F. Row, from Larrenled.

2 and 3 crossbred ewe and lamb, no visible brand
4 and 5 crossbred ewe and lamb, blue dot on rump

If not claimed and expenses paid, to be sold on 4th December, 1971

3456—\$2. 80

GEO. SPONG,
Poundkeeper.

EAGLEHAWK.—Impounded in Eaglehawk Pound from Nelson-street by the Borough Ranger.

1 dapple-grey shetland pony, no visible brand

If not claimed and expenses paid, to be sold on 6th December, 1971.

3454—\$2. 45

C. M. NANKERVIS,
Poundkeeper.

Subordinate Legislation Act 1962.

NOTICE OF MAKING OF STATUTORY RULES.

In pursuance of the provisions of the *Subordinate Legislation Act 1962* and the Regulations made thereunder, notice is given of the making of the following statutory rules:—

No.	Local Government Act 1958.	Price.
246/1971.	Local Government (Subdivision and Consolidation Fees) Regulations 1971	10c
<i>Health Act 1958.</i>		
247/1971.	Meat Transport Vehicles (Amendment) Regulations 1971	10c
<i>Local Authorities Superannuation Act 1958.</i>		
248/1971.	Local Authorities Superannuation Regulations 1971 (No. 11)	10c
<i>Police Regulation Act 1958.</i>		
249/1971.	Police (Authorized Strength No. 4) Regulations 1971	10c
<i>Forests Act 1958 (No. 6254).</i>		
250/1971.	Forests (Part I.—Fire Protection) (Amendment) Regulations 1971	10c
<i>Superannuation Act 1958.</i>		
251/1971.	Superannuation (Reserve Units) Regulations 1971	10c
<i>Health Act 1958 (No. 6270).</i>		
252/1971.	Animal Food (Amendment) Regulations 1971 (No. 2)	10c
<i>Films Act 1971.</i>		
253/1971.	Films Regulations 1971	30c
<i>Mental Health Act 1959 (No. 6605).</i>		
254/1971.	Mental Health (Medical Positions and Salaries) Regulations 1971 (No. 8)	10c
<i>Survey Co-ordination Act 1958.</i>		
255/1971.	Place Names Committee (Member's Traveling Expenses) Regulations 1971	10c
<i>Estate Agents Act 1958.</i>		
256/1971.	Estate Agents (Commission Amendment) Rules 1971	10c

Copies of these statutory rules may be purchased at the Sale of Publications Section of the Government Printing Office, located at 7A Parliament-place, Melbourne, 3002. If

ordered by mail, remittance should be addressed to "The Government Printer, Box 203, P.O., North Melbourne, 3051", and should include 7c extra for postage. If a credit account is held at this office, no remittance is required with the mail order.

The annual subscription rate for Statutory Rules (including Bound Volumes) is \$23, payable in advance. The subscription year commences on 1st January.

C. H. RIXON,
Government Printer.

STATE ACTS. 1970

Copies of the following Acts of Parliament of Victoria may be obtained at the Government Printing Office, Sale of Publications Branch, off Parliament-place, Melbourne, phone 63 0321, extension 6181, or from any accredited agent, at the price set opposite to each (these prices do not include postage).

No.	Price.
7933. Evidence (Boards and Commissions)	\$0. 10
7934. The Constitution Act Amendment	\$0. 10
7935. Coroners (Amendment)	\$0. 10
7936. Town and Country Planning (Appeals Tribunal)	\$0. 10
7937. Melbourne (Veterinary Schools) Lands	\$0. 10
7938. Board of Inquiry (Corrupt Practices)	\$0. 10
7939. Cabrini Private Hospital (Guarantees)	\$0. 10
7940. Judges' Salaries and Allowances	\$0. 10
7941. Instruments (Amendment)	\$0. 10
7942. La Trobe University (Amendment)	\$0. 10
7943. Business Names (Amendment)	\$0. 10
7944. Acts Interpretation (Nationality)	\$0. 10
7945. Dairy Products (Board Membership)	\$0. 10
7946. Melbourne Harbor Trust (Amendment)	\$0. 10
7947. Aboriginal Affairs (Amendment)	\$0. 10
7948. River Murray Waters	\$0. 15
7949. River Murray Waters (Dartmouth Reservoir)	\$0. 10
7950. Western Port (Steel Works)	\$0. 25
7951. Extractive Industries (Licences)	\$0. 10
7952. Stamps (Salary or Wages)	\$0. 10
7953. Melbourne Lands Exchange	\$0. 10
7954. Public Officers Salaries and Allowances	\$0. 15
7955. Ballarat (Sovereign Hill) Land	\$0. 15
7956. Wombat Bonuses	\$0. 10
7957. Richmond and Hawthorn Lands	\$0. 15
7958. Solicitor-General (Pensions)	\$0. 10
7959. Australia and New Zealand Banking Group	\$0. 25
7960. Mildura Irrigation and Water Trusts (Amendment)	\$0. 10
7961. Land Settlement (Financial)	\$0. 10
7962. Securities Industry	\$0. 35
7963. Mildura College Lands (Amendment)	\$0. 10
7964. Door to Door (Sales) (Amendment)	\$0. 15
7965. Consumer Protection	\$0. 10
7966. Justices (Alternative Procedure)	\$0. 15
7967. Summary Offences	\$0. 10
7968. Local Government (Amendment)	\$0. 30
7969. Motor Car (Falsification of Mileage)	\$0. 10
7970. Marketable Securities	\$0. 25
7971. Carriers and Innkeepers (Amendment)	\$0. 10
7972. Cemeteries (Coburg Public Cemetery)	\$0. 10
7973. Judges Pensions	\$0. 10
7974. Victoria Institute of Colleges (Affiliated Colleges)	\$0. 10
7975. Town and Country Planning (Responsible Authority)	\$0. 10
7976. Wheat Marketing (Special Quotas)	\$0. 10
7977. Joint Select Committee (Meat Industry)	\$0. 10
7978. Joint Select Committee (Road Safety)	\$0. 10
7979. Consolidated Revenue (Supply—July to September 1969-70)	\$0. 10
7980. Consolidated Revenue (Supplementary Estimates 1969-70)	\$0. 10
7981. Consolidated Revenue (Supply October to December, 1970)	\$0. 10
7982. Home Finance (Amendment)	\$0. 10
7983. Co-operative Housing Societies (Amendment)	\$0. 10
7984. Soldier Settlement	\$0. 10
7985. Judges' Pensions (Amendment)	\$0. 10
7986. Civil Aviation (Carriers' Liability)	\$0. 10
7987. Road Traffic (Amendment)	\$0. 15
7988. West Melbourne Market Land (Amendment)	\$0. 15
7989. West Gate Bridge Royal Commission	\$0. 10
7990. Motor Car (Amendment)	\$0. 10
7991. Discharged Servicemen's Preference (Amendment)	\$0. 10
7992. Labour and Industry (Shop Closing)	\$0. 10
7993. Country Fire Authority (Borrowing Powers)	\$0. 10
7994. Crimes (Amendment)	\$0. 10
7995. Lotteries Gaming and Betting (Amendment)	\$0. 10

STATE ACTS 1970—continued.

No.	Price.
7996. River Improvement (Amendment) ..	\$0.10
7997. Hospitals Superannuation (Amendment) ..	\$0.15
7998. Trustee Companies (Perpetual Trustees Australia Limited) ..	\$0.10
7999. Gas and Fuel Corporation (Borrowing) ..	\$0.10
8000. Victorian Inland Meat Authority (Amendment) ..	\$0.10
8001. Auditor (Auditor-General) ..	\$0.10
8002. Public Service (Amendment) ..	\$0.10
8003. Evidence (Scientific Tests) ..	\$0.10
8004. Boilers and Pressure Vessels ..	\$0.30
8005. Coal Mines (Pensions Increase) ..	\$0.10
8006. Stamps Act ..	\$0.15
8007. Methodist Church (Victoria) Property Trust ..	\$0.20
8008. Land Conservation ..	\$0.20
8009. River Entrance Docks Railway Construction ..	\$0.10
8010. Legal Profession Practice (Amendment) ..	\$0.15
8011. Juries Compensation ..	\$0.10
8012. Public Account ..	\$0.15
8013. Sewerage Districts (Amendment) ..	\$0.10
8014. Revocation and Exclusion of Crown Reservations ..	\$0.15
8015. State Forests Works and Services ..	\$0.10
8016. Money Lenders (Prescribed Interest) ..	\$0.10
8017. Gas and Fuel Corporation (The Gas Supply Company Limited) ..	\$0.30
8018. Labour and Industry (Amendment) ..	\$0.10
8019. Metropolitan Fire Brigades (Amendment) ..	\$0.15
8020. Stamps (Receipt Duty Abolition) ..	\$0.10
8021. Apprenticeship (Amendment) ..	\$0.10
8022. Water (Amendment) ..	\$0.10
8023. Melbourne Underground Rail Loop ..	\$0.40
8024. Westernport Development ..	\$0.15
8025. Vermin and Noxious Weeds (Amendment) ..	\$0.20
8026. Commonwealth Places (Administration of Laws) ..	\$0.15
8027. Hairdressers Registration (Amendment) ..	\$0.10
8028. Lifts and Cranes (Amendment) ..	\$0.15
8029. Wodonga Lands Exchange ..	\$0.10
8030. Second-hand Dealers (Charity Collectors) ..	\$0.15
8031. Water Supply Works and Services ..	\$0.25
8032. East Melbourne Land ..	\$0.10
8033. The Constitution Act Amendment (Responsible Ministers) ..	\$0.10
8034. Justices (Bail and Appeals) ..	\$0.10
8035. Forests (Amendment) ..	\$0.10
8036. Maintenance (Amendment) ..	\$0.10
8037. Hire Purchase (Insurance) ..	\$0.10
8038. Marketable Securities (Amendment) ..	\$0.15
8039. Mines (Compensation) ..	\$0.10
8040. Railways Land ..	\$0.15
8041. Probate Duty ..	\$0.10
8042. Teaching Service (Tribunal) ..	\$0.10
8043. Employers and Employés (Attachment of Wages) ..	\$0.10
8044. Aboriginal Lands ..	\$0.25
8045. Railway Works and Services ..	\$0.10
8046. Water (Further Amendment) ..	\$0.15
8047. Superannuation (Amendment) ..	\$0.20
8048. Motor Car (Fees) ..	\$0.10
8049. Public Works and Services ..	\$0.15
8050. Western Port Steel Works (Development Control) ..	\$0.10
8051. Housing (Amendment) ..	\$0.20
8052. Urban Renewal ..	\$0.40
8053. Wheat Marketing (Amendment) ..	\$0.10
8054. Local Authorities Superannuation (Disability Benefits) ..	\$0.20
8055. Land Tax ..	\$0.15
8056. Environment Protection ..	\$0.50
8057. Gas Franchises ..	\$0.15
8058. Road Traffic (Road Safety and Traffic Authority) ..	\$0.15
8059. Securities Industry (Amendment) ..	\$0.30
8060. Land (Amendment) ..	\$0.10
8061. Medical Practitioners ..	\$0.40
8062. Teacher Housing ..	\$0.20
8063. Criminal Appeals ..	\$0.10
8064. Groundwater (Amendment) ..	\$0.10
8065. Summary Offences (Trespass to Farms) ..	\$0.10
8066. Registration of Births Deaths and Marriages (Amendment) ..	\$0.10
8067. Tomato Processing Industry (Amendment) ..	\$0.15
8068. Weights and Measures (Amendment) ..	\$0.10
8069. Aerial Spraying Control (Amendment) ..	\$0.10
8070. Science Museum of Victoria ..	\$0.20
8071. Melbourne and Metropolitan Board of Works ..	\$0.15
8072. National Museum of Victoria Council ..	\$0.20
8073. Footwear Regulation ..	\$0.15
8074. Motor Car (Safety) ..	\$0.10
8075. Summary Offences ..	\$0.10
8076. Fertilizers and Stock Foods (Labelling) ..	\$0.10

STATE ACTS 1970—continued.

No.	Price.
8077. Architects (Amendment) ..	\$0.10
8078. Stock Diseases (Amendment) ..	\$0.10
8079. Dog Act ..	\$0.20
8080. Racing (Amendment) ..	\$0.15
8081. State Development ..	\$0.30
8082. Statutory Salaries ..	\$0.10
8083. National Parks ..	\$0.20
8084. Workers Compensation ..	\$0.15
8085. Summary Offences (Trespassers) ..	\$0.10
8086. Parliamentary Salaries ..	\$0.10
8087. Consolidated Revenue (Final Supplementary Estimates) ..	\$0.10
8088. Appropriation ..	\$2.10
8089. Social Welfare ..	\$1.10

C. H. RIXON,
Government Printer.

STATE ACTS, 1971

Copies of the following Acts of Parliament of Victoria may be obtained at the Government Printing Office, Sale of Publications Branch, off Parliament-place, Melbourne, phone 63 0321, extension 6181, or from any accredited agent, at the price set opposite to each (these prices do not include postage).

The annual subscription for State Acts 1971 et seq. is \$12.50 payable in advance.

Bound Volumes of State Acts are also available on a subscription basis of \$17.50 per annum.

No.	Price.
8090. Municipal Association (Amendment) ..	\$0.10
8091. Transfer of Land (Duplicate Certificates) ..	\$0.10
8092. Firearms ..	\$0.10
8093. Geelong Land (Special Grant) ..	\$0.10
8094. Churchill Water and Sewerage Works ..	\$0.10
8095. Superannuation (Railway Service) ..	\$0.10
8096. Vermin and Noxious Weeds (Amendment) ..	\$0.10
8097. Police Regulation (Amendment) ..	\$0.10
8098. Snowy Mountains Engineering Corporation (Victoria) ..	\$0.10
8099. Albert Park Land ..	\$0.10
8100. Local Government (Municipalities Assistance Fund) ..	\$0.10
8101. Health (Tuberculosis Arrangement) ..	\$0.10
8102. Presbyterian Church of Australia ..	\$0.20
8103. Marketing of Primary Products (Amendment) ..	\$0.10
8104. Gas and Fuel Corporation (Geelong Gas) ..	\$0.15
8105. Local Authorities Superannuation (Disability Benefits) (Commencement) ..	\$0.10
8106. Building Societies (Amendment) ..	\$0.20
8107. Survey Co-ordination (Place Names) ..	\$0.10
8108. Howard Florey Institute of Experimental Physiology and Medicine ..	\$0.30
8109. Superannuation (Transitional Provisions) ..	\$0.10
8110. New Broken Hill Consolidated Limited ..	\$0.15
8111. Litter (Proceedings for Offences) ..	\$0.10
8112. Justices (Service of Summonses) ..	\$0.10
8113. Stock (Artificial Breeding) (Amendment) ..	\$0.10
8114. Alcoa of Australia (W.A.) N.L. ..	\$0.40
8115. Victoria Institute of Colleges (Amendment) ..	\$0.10
8116. Cemeteries (Fawcner Crematorium and Memorial Park) ..	\$0.10
8117. Trustee Companies (Equity Trustees) ..	\$0.10
8118. Parliamentary Superannuation ..	\$0.10
8119. Ehrenhaus Retail Bottled Liquor Licence ..	\$0.10
8120. Melbourne University Land ..	\$0.10
8121. Forests (Bowater-Scott Agreement) ..	\$0.20
8122. Gas and Fuel Corporation (Pipelines) ..	\$0.15
8123. Coal Mines (Pensions) ..	\$0.10
8124. Crown Proceedings (Forfeited Recognisances) ..	\$0.10
8125. Public Trustee (Amendment) ..	\$0.15
8126. Geelong Waterworks and Sewerage (Rates) ..	\$0.10
8127. Subordinate Legislation (Powers) ..	\$0.10
8128. Barley Marketing ..	\$0.10
8129. Stamps (Credit Business) ..	\$0.15
8130. Land (Surrender to the Crown) ..	\$0.10
8131. Pipelines (Amendment) ..	\$0.10
8132. County Court (Jurisdiction) ..	\$0.10
8133. Grassmere Land ..	\$0.10
8134. Supply (Supplementary Estimates) ..	\$0.10
8135. Town and Country Planning (Amendment) ..	\$0.15
8136. Seeds ..	\$0.40
8137. Imperial Acts Application (Repeals) ..	\$0.10
8138. Audit (Recovery of Overpayments) ..	\$0.10

STATE ACTS 1971—continued.		CONTENTS	
No.	Price.		PAGE
8139. Evidence (Registration of Commissioners) ..	\$0.10	Acts of Parliament	3672
8140. Country Roads (Amendment) ..	\$0.15	Acts of Parliament on Sale at the Government	
8141. Protection of Animals (Rodeos) ..	\$0.10	Printing Office	3732
8142. Soil Conservation and Land Utilization		Appointments	3700
(Amendment)	\$0.15	Auction Sales Act	3682
8143. Motor Car (Driving Offences) ..	\$0.30	Cemeteries—Scale of Fees	3685
8144. Fisheries (Amendment) ..	\$0.15	Contracts	3687
8145. Appeal Costs Fund	\$0.10	Country Roads Board	3688
8146. Scaffolding	\$0.30	Estates of Deceased Persons	3687
8147. Liquor Control (Amendment) ..	\$0.15	Government Notices	3673
8148. Supply (July to September) ..	\$0.10	Impoundings	3732
8149. Local Government (Further Amendment) ..	\$0.40	Insolvency Notice	3731
		Lands	3712
		Melbourne and Metropolitan Board of Works—	
		Notice	3684
		Mining	3688
		Notice of Making of Statutory Rules	3732
		Orders in Council—	
		Acts—Country Roads; Land; Local Govern-	3702
		ment; Water; Sewerage Districts; et seq	
		Landlord and Tenant; Mines.	
		Police Sale	3677
		Private Advertisements	3717
		Proclamations	3672
		Publication of the "Victoria Government Gazette"	3671
		Public Service Notices	3715
		Resignations	3701
		State Rivers and Water Supply Commission ..	3678
		Tenders	3714
		Transport Regulation Board—Public Hearings ..	3674
		Waterworks Trusts	3673

C. H. RIXON,
Government Printer.

PUBLICATION OF OFFICIAL MATTER.

Attention is invited to the following procedure in relation to the publication of official matter in the *Government Gazette*:—

Publication will be facilitated by the submission of carbon copies for the use of the *Gazette Officer*.

1. *Matter submitted to the Executive Council.*

Matter submitted to the Executive Council which requires gazettal will normally be published in the issue of the following week.

Where urgent gazettal is required, special arrangements should be made with the *Gazette Officer*, Room 9, first floor, Old Treasury Building.

2. *Other matter.*

(a) All other matter duly certified by a responsible officer for publication should be lodged with the *Gazette Officer* not later than half-past Nine a.m. on Tuesday.

(b) Lengthy or involved notices should be forwarded several days before publication.

(c) Proofs, which will be supplied only when specifically requested or at the direction of the *Gazette Officer*, should be returned promptly to avoid delay in publication.

(d) No additions or amendments to matter for publication will be accepted by telephone.