



VICTORIA

GOVERNMENT GAZETTE

Published by Authority

No. 96]

WEDNESDAY, OCTOBER 20

[1971

PROCLAMATIONS

DANDENONG VALLEY AUTHORITY ACT 1963.
FLOOD-PLAIN AREA NUMBER 16.

PROCLAMATION

By His Excellency the Governor of the State of Victoria and its Dependencies in the Commonwealth of Australia, &c., &c., &c.

Whereas Section 27 of the *Dandenong Valley Authority Act 1963* provides that the Governor in Council may, at the request of the Dandenong Valley Authority, declare by proclamation any specified area or areas of land within the district of the Authority to be within the flood plain of any river or group of rivers within that district:

And whereas the said Authority has complied with the provisions of Section 27 of the aforementioned Act relative to the publication and service of notices in relation thereto:

Now therefore, I, the Governor of the State of Victoria, by and with the advice of the Executive Council thereof, do by this Proclamation declare that the area shown coloured pink on the plan number F28, approved by the Governor in Council and deposited in the office of the State Rivers and Water Supply Commission, Melbourne, is within the Bangholme North flood plain for the purposes of the said Act and shall be known as Flood-Plain Area Number 16.

Given under my Hand and Seal of the State of Victoria, aforesaid, at Melbourne, this nineteenth day of October, in the year of our Lord One thousand nine hundred and seventy-one, and in the twentieth year of the reign of Her Majesty Queen Elizabeth II.

(L.s.) ROHAN DELACOMBE.
By His Excellency's Command,
ROBERTS DUNSTAN,
Minister of Water Supply.
GOD SAVE THE QUEEN!

LOCAL AUTHORITIES SUPERANNUATION ACT 1958.

PROCLAMATION

By His Excellency the Governor of the State of Victoria and its Dependencies in the Commonwealth of Australia, &c., &c., &c.

Whereas by the *Local Authorities Superannuation Act 1958*, Section 3, it is among other things enacted that it shall be lawful for the Governor in Council to declare any body constituted for a joint purpose by two or more authorities within the meaning of that Act to be an authority for the purposes of the Act:

And whereas the Mordialloc-Chelsea Regional Library Service has requested that it be declared to be an authority:

Now therefore I, the Governor of the State of Victoria in the Commonwealth of Australia, by and with the advice of the Executive Council of the said State, do by this Proclamation declare that the Mordialloc-Chelsea Regional Library Service being an authority constituted for a joint purpose by the municipalities of the Cities of Mordialloc and Chelsea shall be an authority for the purpose of the said Act.

Given under my Hand and the Seal of the State of Victoria aforesaid, at Melbourne, this eleventh day of October, in the year of our Lord One thousand nine hundred and seventy-one, and in the twentieth year of the reign of Her Majesty Queen Elizabeth II.

(L.s.) ROHAN DELACOMBE.
By His Excellency's Command,
A. J. HUNT,
Minister for Local Government.
GOD SAVE THE QUEEN!

PUBLIC HALF-HOLIDAYS.

PROCLAMATION

By His Excellency the Governor of the State of Victoria and its Dependencies in the Commonwealth of Australia, &c., &c., &c.

In pursuance of the provisions contained in Part III. of the *Public Service Act 1958*, I, the Governor of the State of Victoria, in the Commonwealth of Australia, by and with the advice of the Executive Council of the said State, do by this my Proclamation appoint the days and dates hereunder mentioned to be observed as Public Half-Holidays at the places respectively specified, viz.:—

Public Half-Holidays from the Hour of Twelve o'clock noon:—

WEDNESDAY, THE 10TH NOVEMBER, 1971, in the West and South Ridings of the Shire of Huntly.

WEDNESDAY, THE 3RD NOVEMBER, 1971, within the Kyneton Riding of the Shire of Kyneton.

WEDNESDAY, THE 16TH FEBRUARY, 1972, within the Shire of Colac.

Given under my Hand and the Seal of the State of Victoria aforesaid, at Melbourne, this nineteenth day of October, in the year of our Lord One thousand nine hundred and seventy-one, and in the twentieth year of the reign of Her Majesty Queen Elizabeth II.

(L.S.) ROHAN DELACOMBE.

By His Excellency's Command,

R. J. HAMER,
Chief Secretary.

GOD SAVE THE QUEEN !

BANK HALF-HOLIDAYS.

PROCLAMATION

By His Excellency the Governor of the State of Victoria and its Dependencies in the Commonwealth of Australia, &c., &c., &c.

In pursuance of the provisions of the *Bank Holidays Act 1958*, I, the Governor of the State of Victoria, in the Commonwealth of Australia, do by this my Proclamation appoint the days and dates named hereunder special days to be observed as Bank Half-Holidays at the places respectively mentioned, that is to say:—

Bank Half-Holidays from the Hour of Eleven a.m.:—

WEDNESDAY, THE 3RD NOVEMBER, 1971, at Kyneton.

WEDNESDAY, THE 17TH NOVEMBER, 1971, at Learmonth.

Given under my Hand and the Seal of the State of Victoria aforesaid, at Melbourne, this nineteenth day of October, in the year of our Lord One thousand nine hundred and seventy-one, and in the twentieth year of the reign of Her Majesty Queen Elizabeth II.

(L.S.) ROHAN DELACOMBE.

By His Excellency's Command,

R. J. HAMER,
Chief Secretary.

GOD SAVE THE QUEEN !

Apprenticeship Act 1958.

VARIATION OF PROCLAMATION OF THE TEXTILE MECHANICS TRADE AS AN APPRENTICESHIP TRADE.

PROCLAMATION

By His Excellency the Governor of the State of Victoria and its Dependencies in the Commonwealth of Australia, &c., &c., &c.

Whereas section 13 of the *Apprenticeship Act 1958* provides, inter alia, that after the Minister has taken into consideration any recommendation made by the Apprenticeship Commission, the Governor in Council, for the purposes of the said Act, may from time to time by Proclamation proclaim any trade to be an apprenticeship trade and that the Governor in Council (whether with or without any recommendation of the said Commission) may by proclamation at any time revoke, amend or vary any such proclamation;

And whereas on the 12th August, 1969, the trade of Textile Mechanic was proclaimed to be an apprenticeship trade in so far as it is carried on in the cotton weaving section of the textile manufacturing industry anywhere in the State of Victoria:

And whereas on the 15th December, 1970, the said proclamation was varied by substituting for the words "Textile Mechanic" the words "Textile Mechanics":

And whereas the Apprenticeship Commission of Victoria has recommended to the Minister that the said proclamation be varied in the manner following:

And whereas the Minister has taken the said recommendation into consideration:

Now therefore, I, the Governor of the State of Victoria, in the Commonwealth of Australia, by and with the advice of the Executive Council of the said State, do by this my Proclamation vary the aforesaid proclamations by substituting for the trade proclaimed thereby the trade of Textile Mechanics in so far as it is carried on in the knitting section of the textile manufacturing industry and in the spinning and weaving sections of the carpet, cotton, woollen and worsted textile manufacturing industries anywhere in the State of Victoria.

Given under my Hand and the Seal of the State of Victoria aforesaid at Melbourne, this nineteenth day of October, in the year of our Lord, One thousand nine hundred and seventy-one, and in the twentieth year of the reign of Her Majesty, Queen Elizabeth II.

(L.S.) ROHAN DELACOMBE.

By His Excellency's Command,

J. A. RAFFERTY,
Minister of Labour and Industry.

GOD SAVE THE QUEEN !

Litter Act 1964.

APPLICATION OF THE PROVISIONS OF SECTION 3b TO THE MUNICIPAL DISTRICTS OF VARIOUS MUNICIPALITIES.

PROCLAMATION

By His Excellency the Governor of the State of Victoria and its Dependencies in the Commonwealth of Australia, &c., &c., &c.

Whereas by the *Litter Act 1964*, Section 3b it is provided that the Governor in Council on the application of the Council of a municipality may by proclamation published in the *Government Gazette* declare that the municipal district of the municipality or any part thereof shall be a district to which the said section applies.

And whereas the Councils of the municipalities herein-after mentioned have made application to have their respective municipal districts declared to be districts to which the said Section 3b shall apply.

Now therefore, I, the Governor of the State of Victoria in the Commonwealth of Australia, by and with the advice of the Executive Council of the said State do by this Proclamation declare that the municipal districts of the undermentioned municipalities shall be districts to which the provisions of Section 3b of the *Litter Act 1964* shall apply:—

Cities of Hamilton, Malvern and Maryborough.

Shires of Bellarine, Buninyong, Diamond Valley, Hampden, Newtown and Woodend and Tambo.

Given under my Hand and the Seal of the State of Victoria aforesaid, at Melbourne, this eleventh day of October, in the year of our Lord One thousand nine hundred and seventy-one, and in the twentieth year of the reign of Her Majesty Queen Elizabeth II.

(L.S.) ROHAN DELACOMBE.

By His Excellency's Command,

A. J. HUNT,
Minister for Local Government.

GOD SAVE THE QUEEN !

GOVERNMENT NOTICES

Police Regulation Act 1958, Section 122.

SALE OF UNCLAIMED MOTOR VEHICLE.

An owner is required for a 1955 Holden sedan motor car, registered No. Vic. KET-868, engine No. 106865.

This vehicle came into the possession of Police on the 30th January, 1971, and if not claimed, will be sold by public auction at the Burwood Police Station, corner of Scott-grove and Burwood-road, Burwood, at 10 a.m., on Friday, 5th November, 1971.

R. JACKSON,
Chief Commissioner of Police.

HOLIDAY.—MELBOURNE CUP DAY.

Notice is hereby given that on—

TUESDAY, THE 2ND NOVEMBER, 1971,

the Public Offices in the municipalities mentioned hereunder will be closed, that day being appointed by the Public Service Act 1958 to be observed as a holiday in the Public Offices:—

The Cities of Altona, Box Hill, Brighton, Broadmeadows, Brunswick, Camberwell, Caulfield, Chelsea, Coburg, Collingwood, Croydon, Dandenong, Doncaster and Templestowe, Essendon, Fitzroy, Footscray, Frankston, Hawthorn, Heidelberg, Keilor, Kew, Knox, Malvern, Melbourne, Moorabbin, Mordialloc, Northcote, Nunawading, Oakleigh, Port Melbourne, Prahran, Preston, Richmond, Ringwood, St. Kilda, Sandringham, South Melbourne, Springvale, Sunshine, Waverley and Williamstown; the Shires of Bacchus Marsh, Berwick, Bulla, Cranbourne, Diamond Valley, Etham, Gisborne, Hastings, Lillydale, Melton, Mornington, Newham and Woodend, Romsey, Sherbrooke, Werribee and Whittlesea.

This notice relates only to the closing of the State Public Offices. All inquiries regarding holidays in other offices and in shops and industry should be directed to the Department of Labour and Industry, 110 Exhibition-street, Melbourne. (Telephone 63 0321, Extensions 6158, 6721 or 6859.)

R. J. HAMER,
Chief Secretary.

Chief Secretary's Office,
Melbourne, 14th October, 1971.

**SHIRE OF PORTLAND.
ROAD DEVIATION ORDER.**

In pursuance of the powers conferred by sections 522 and 526 of the Local Government Act 1958, the Council of the Shire of Portland doth hereby direct that the land in the Parish of Merino shown hatched on the plan hereunder, which has been taken, purchased or acquired by it, shall be a public highway from and after the date of publication of this Order in the Government Gazette, and doth declare that such land shall be a public highway in lieu of the land in the said parish shown cross-hatched on the said plan.

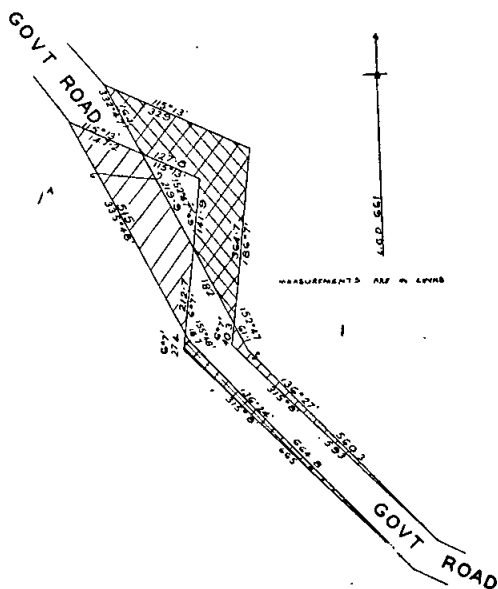

The common seal of the Shire of Portland was hereunto affixed this 10th day of September, 1971 in the presence of:

(SEAL) L. G. WALLIS, President.
M. McL. AYLMER, Councillor.
M. D. ALLARDICE, Secretary.

Confirmed by the Governor in Council, 11th October, 1971.—J. ROSSITER, Clerk of the Executive Council.

Commercial Goods Vehicles Act.

TRANSPORT REGULATION BOARD.

HEARING OF APPLICATIONS.

Notice is hereby given that the following applications will be considered by the Transport Regulation Board at its offices at the corner Lygon and Princes streets, Carlton, at 10.15 a.m., on Wednesday, 10th November, 1971.

ARMISTEAD, E. P. & R. J., Station-street, Forrest, 3236. One commercial goods vehicle (L/C. 246 cwt.) to operate: (a) Within a 25-mile radius of the post office at Forrest—general goods, provided that no goods shall be carried whether by one stage or by more than one stage between places within the above radius which are more than 30 road miles apart by the nearest practicable route. (b) From and to places within a 25-mile radius of the post office at Forrest to and from places outside that radius but wholly within a 50-mile radius of the said post office—livestock.

BRIGGS, R., 54 Queens-parade, Fawkner, 3060.—One commercial goods vehicle (L/C. 75 cwt.) to operate throughout the State of Victoria in the course of business as "Travelling Showman"—own sideshow equipment and novelty prizes.

CLARK & GREENWAY REFRIGERATED TRANSPORT PTY. LTD., Grant-road, Somerville, 3912. Two commercial goods vehicles (L/C. 62 and 65 cwt.) to operate throughout the State of Victoria in course of business as "Frozen Food Distributors" as a specially constructed refrigerated vehicle—frozen fish, frozen and fresh meat, ice-cream, frozen fruit juice, frozen processed vegetables, fresh cream and frozen poultry and up to 2 cwt of special cheese under refrigeration and up to 5 cwt. of yoghurt.

CROWN CONTROLS AUST. PTY. LTD., 26 Pickering-road, Glen Waverley, 3150. One commercial goods vehicle (L/C. 14 cwt.) to operate throughout the State of Victoria in the course of business as "Manufacturers of Mechanical Handling Equipment" for the purpose of servicing such equipment—tools of trade, spare parts and materials incidental to on-site servicing.

CURTIN, G. O., 14 Costa-street, Alexandra, 3714. Application to vary the conditions of licence number D.T.553/1 (L/C. 268 cwt.) by deleting the existing conditions and adding in lieu: (a) From forest landings situated within a 25-mile radius of the post office at Alexandra to sawmills at Marysville, Buxton, Narbethong and Healesville and to Casey's sawmill at Pakenham—sawmill logs. (b) Within a 25-mile radius of the post office at Alexandra—own tractor and logging equipment.

DALY, J. C., 36 High-street, Glen Iris, 3416. One commercial goods vehicle (L/C. 39 cwt.) to operate within a 50-mile radius of the premises of Ardare Pty. Ltd., at South Melbourne with a specially insulated vehicle exclusively on behalf of Ardare Dairy Foods—butter, cheese, cream and yoghurt.

EGAN, G. F. (trading as G. F. & D. M. Egan), 6 Anderson-street, Heyfield, 3858. One commercial goods vehicle (L/C. 300 cwt.) to operate: (a) From sawmills at Heyfield to the premises of Australian Paper Manufacturers Ltd. at Maryvale—bulk wood chips. (b) Within a 25-mile radius of the post office situated at Heyfield with the proviso that no goods shall be carried whether by one stage or by more than one stage between places within the above radius which are more than thirty (30) miles apart by the nearest practicable route—general goods.

FITZGERALD, M. J., Kepler-street, Warrnambool, 3280. One commercial goods vehicle (L/C. 199 cwt.) to operate within a 50-mile radius of each respective plant of Pioneer Concrete (Vic.) Pty. Ltd., at Terang, Warrnambool, Portland and Hamilton as a specially constructed agitator vehicle—premixed concrete on behalf of the said company.

GILLESPIE, J., 30 Mountain-crescent, Mulgrave, 3170. One commercial goods vehicle (L/C. 121 cwt.) to operate: (a) Within a 50-mile radius of the premises of A. V. Jennings Industries (Aust.) Ltd., at Mulgrave—tools of trade, builders' equipment and plant and sheds when being moved from site to site solely on behalf of the said company. (b) From a contract site to the nearest disposal point—excess building materials and rubbish.

GLADMAN, G. G. & G. J. (trading as G. Gladman & Son), Serpentine, 3517. Application to vary the conditions of licence number D.A.1154 (L/C. 150 cwt.) by deleting paragraph (e) from the existing conditions and adding in lieu as paragraph (e)—"To any property situated within a 50-mile radius of the post office at Serpentine from the railway station nearest thereto in the course of business as 'Bulk Superphosphate Spreader'—bulk superphosphate for spreading purposes only."

- GORST, K. R. & E. J. & P. K. (trading as Gorst Petroleum), Glenelg Highway, Wickliffe, 3291. Two commercial goods vehicles (L/C. 148 and 113 cwt.) to operate: (a) From own premises at Wickliffe to places within a 50-mile radius thereof and to and from Ballarat in the course of business as a "General Merchant"—own goods. (b) From and to Hamilton and Ballarat and to places within a 50-mile radius of own depot at Wickliffe—petroleum products in prescribed types of containers and empty returns on behalf of the Shell Company of Australia.
- GOUGE COUNTRY SERVICES PTY. LTD., 480 Glenhuntly-road, Elsternwick, 3185. One commercial goods vehicle (L/C. 25 cwt.) to operate between the township of Kerang and the City of Swan Hill—soiled linen for cleaning and laundering and linen for return after having been cleaned or laundered.
This application replaces licence No. D.A.1177/1 expiry date 19th June, 1971, held by Gouge Country Services Pty. Ltd.
- GRACE, S. O., 14 Jacqueline-road, Bundoora, 3083. One commercial goods vehicle (L/C. 40 cwt.) to operate within a 50-mile radius of the premises of Ardare Pty. Ltd., at South Melbourne with a specially insulated vehicle exclusively on behalf of Ardare Dairy Foods—butter, cheese, cream and yoghurt.
- HORTICO LTD., 327 Plummer-street, Port Melbourne, 3207. One commercial goods vehicle (L/C. 168 cwt.) to operate within a 50-mile radius of own premises at Port Melbourne in course of business as "Manufacturers of Agricultural and Horticultural Supplies"—own goods.
- HUNT, E. W., 23 Salisbury-street, Benalla, 3672. Application to vary the conditions of licence number D.A.63722 (L/C. 68 cwt.) by deleting "the Kooroora Chalet" from the existing conditions.
- HUXTABLE, K. J., 202 Station-street, Koo-Wee-Rup, 3981. One commercial goods vehicle (L/C. 147 cwt.) to operate: (a) Within a 20-mile radius of the post office at Koo-Wee-Rup—general goods. (b) Within a 50-mile radius of the post office at Koo-Wee-Rup—fresh fruit and vegetables and empty return containers. (c) To and from Victorian Egg Board, Melbourne and producers and depots in the Gippsland area—eggs and second-hand empty return containers. (d) Within a 50-mile radius respectively of own farms at Cardinia, Dalmore and French Island in the course of business as a "Primary Producer"—own goods.
- KEOGH, P., PTY. LTD., 371 Francis-street, Yarraville, 3013. One commercial goods vehicle (L/C. 12 cwt.) to operate throughout the State of Victoria in the course of business as "Erection Engineers and Contractors" for the purposes of servicing own equipment and supervising own contracts—tools of trade, spare parts, erection gear, equipment and materials incidental to servicing.
- WILKINSON, K. R. (trading as Mar Kei Tyre Service), 393 Allan-street, Kyabram, 3620. One commercial goods vehicle (L/C. 30 cwt.) to operate throughout the State of Victoria in the course of business as "Marine Dealer"—special wares, marine stores and old metals as designated in the *Marine Stores and Old Metals Act 1958* (No. 6303) Part I section 3 with the proviso that the combined load capacity of the vehicle and of any trailer hauled in conjunction therewith for the carriage of goods shall not at any time exceed one hundred and twenty (120) cwt. (6 tons).
- MIKAN, D., Main-road, Powelltown, 3797. One commercial goods vehicle (L/C. 180 cwt.) to operate from forest landings situated within a 5-mile radius of the Post Office at Noojee to the premises of the Australian Paper Manufacturers Ltd. at Maryvale—pulpwood.
- MCCLUSKEY, M. J., 195 Westblade-avenue, Kerang, 3579. One commercial goods vehicle (L/C. 200 cwt.) to operate: (a) Within a 50-mile radius from the post office at Kerang as a "Road Contractor"—road-making plant and materials. (b) Within a 25-mile radius from the post office at Kerang—general goods provided that no goods shall be carried whether by one stage or by more than one stage between places within the above radius which are more than 30 road miles apart by the nearest practicable route.
- MCNIECE, M., 205 Nicholson-street Carlton, 3053. One commercial goods vehicle (L/C. 12 cwt.) to operate throughout the State of Victoria in the course of business as "Caterers" for the purpose of attending shows and race-meetings—own catering equipment and own victuals.
- THE OLYMPIC TYRE & RUBBER CO. PTY. LTD., 102 Victoria-street, Carlton, 3053. One commercial goods vehicle (L/C. 13 cwt.) to operate throughout the State of Victoria in course of business as "Tyre Manufacturers and Repairers" for the purpose of maintaining and servicing own plant and equipment at branch premises—tools of trade, small items of plant and equipment for repair or having been repaired and a small quantity of spare parts incidental to such servicing and repair.
- PIZZEY LTD., 410 Whitehorse-road, Mitcham, 3132. One commercial goods vehicle (L/C. 14 cwt.) to operate: (a) Within a 50-mile radius of own premises at Mitcham in the course of business as "Merchants, Manufacturers and Distributors"—own goods. (b) Throughout the State of Victoria as "Manufacturers of Agricultural Machinery" for the purpose of servicing and demonstrating agricultural equipment—agricultural equipment for demonstration or for repair or having been repaired, also tools of trade, spare parts and materials incidental thereto.
- SMITH, L. B., 16 Regent-street, Shepparton, 3630. One commercial goods vehicle (L/C. 9 cwt.) to operate: (a) Within a 25-mile radius of the post office at Shepparton—general goods provided that no goods shall be carried whether by one stage or by more than one stage between places within the above radius which are more than 30 road miles apart by the nearest practicable route. (b) For the carriage of passengers not exceeding two at any one time along the route between Shepparton and Dookie Agricultural College and return.
- SPURRIER, W. K., Flat 3, 147 Glenhuntly-road, Elwood, 3184. One commercial goods vehicle (L/C. 39 cwt.) to operate within a 50-mile radius of the premises of Ardare Pty. Ltd. at South Melbourne with a specially insulated vehicle exclusively on behalf of Ardare Dairy Foods—butter, cheese, cream and yoghurt.
- WILSON, W. & D. FLORAL IMPORTS PTY. LTD., 439 Flemington-road, North Melbourne, 3051. One commercial goods vehicle (L/C. 5 cwt.) to operate throughout the State of Victoria in course of business as "Florist Supplies" for the purpose of sales promotion and booking orders—artificial flowers, dried flower arrangements, vases and floral decorations.
- YOUNG, B. S., 3 Rodda-place, Horsham, 3400. One commercial goods vehicle (L/C. 126 cwt.) to operate: (a) Within an 85-mile radius of the post office at Dimboola and/or 80 miles of the post office at Linga (Horsham Division of the Country Roads Board)—road contracting plant used in the construction or maintenance of a road, street, footpath, bridge, wharf, pier, weir or channel. (b) Within a 20-mile radius from site of construction or maintenance work performed pursuant to paragraph (a) above or from a railway station nearest thereto—materials required for such work. (c) Within a 25-mile radius of the post office at Horsham—general goods, provided that no goods shall be carried whether by one stage or by more than one stage between places within the above radius which are more than 30 road miles apart by the nearest practicable route.

TOW TRUCK.

- CARMAN, I. H., 11 Arnold-street, Horsham, 3400. One commercial goods vehicle (L/C. 120 cwt.) to operate throughout the State of Victoria as a "Heavy Duty Tow Truck" solely—(a) For the purpose of lifting and carrying or towing motor vehicles and the carriage of tools and equipment necessary for such purposes only and; (b) the carriage of spare parts necessary for the repair of a disabled motor to and from the place at which such disablement has occurred.

RENEWALS.

- Applications for renewal of licences as shown by persons listed hereunder to operate under the same terms and conditions from the expiry shown in each case.
- ALBION REID PTY. LTD., 83 Riversdale-road, Hawthorn, 3122; D.A.520/139; 25th March, 1972; 147 cwt.
- ALBION REID PTY. LTD., 83 Riversdale-road, Hawthorn, 3122; D.A.520/141; 25th March, 1972; 41 cwt.
- ANNETT, A. S., 4 Church-street, Coleraine, 3315; D.A.51446; 23rd March, 1972; 121 cwt.
- BEAUREPAIRE TYRE SERVICE PTY. LTD., 102 Victoria-street, Carlton, 3053; D.A.629/91; 23rd March, 1972; 15 cwt.
- BEAUREPAIRE TYRE SERVICE PTY. LTD., 102 Victoria-street, Carlton, 3053; D.A.629/92; 23rd March, 1972; 14 cwt.
- BEAUREPAIRE TYRE SERVICE PTY. LTD., 102 Victoria-street, Carlton, 3053; D.A.629/92; 23th March, 1972; 14 cwt.
- BLACKNEY, C. A. & SONS, Bass Highway, The Gurdies, 3984; D.A.683/4; 4th March, 1972; 258 cwt.
- BULLOCK, R. C., Great Western, 3378; D.A.32252/1; 28th March, 1972; 8 cwt.

- BURKE, R. W. E., PTY. LTD., 7-9 Culverlands-street, Heidelberg West, 3081; D.A.61155/2; 4th March, 1972; 30 cwt.
- BURR, A. W. & SONS PTY. LTD., 61 Madden-avenue, Mildura, 3500; D.A.39384; 28th March, 1972; 9 cwt.
- CANT, F. W., 8 Granya-grove, Morwell, 3840; D.A.60684/1; 4th March, 1972; 142 cwt.
- CIGARETTE SERVICE PTY. LTD., 171 Bridge-street, Bendigo, 3550; D.A.40870/8; 9th March, 1972; 22 cwt.
- CLARK KING & CO. PTY. LTD., 324 William-street, Melbourne, 3000; D.A.57019/5; 4th March, 1972; 223 cwt.
- CLARK KING & CO. PTY. LTD., 324 William-street, Melbourne, 3000; D.A.57019/6; 4th March, 1972; 236 cwt.
- COLONIAL GAS ASSOCIATION LTD., THE, 480 St. Kilda-road, Melbourne, 3004; D.A.25112; 20th March, 1972; 14 cwt.
- D'AGOSTIN, S. & R., 168A Firebrace-street, Horsham, 3400; D.A.51396; 23rd March, 1972; 140 cwt.
- DERITE (MORWELL) PTY. LTD., Commercial-road, Morwell, 3840; D.A.974/9; 4th March, 1972; 102 cwt.; D.A.974/10; 4th March, 1972; 66 cwt.
- ECLIPSE MOTORS PTY. LTD., 1-17 Albert-street, Sebastopol, 3356; D.A.1023/1; 15th March, 1972; 10 cwt.
- F.G.S. SERVICES PTY. LTD., 94 Errol-street, North Melbourne, 3051; D.A.61511; 4th March, 1972; 24 cwt.
- FALKENBERG, A. F., 6 Shaftesbury-parade, Thornbury, 3071; D.A.27416/4; 28th March, 1972; 124 cwt.
- GENERAL ENGINEERING SALES PTY. LTD., 21 Benalla-road, Shepparton, 3630; D.A.61532/1; 25th March, 1972; 11 cwt.
- GLADMAN, G. J., Serpentine, 3517; D.A.1154/1; 4th March, 1972; 124 cwt.
- GOLDEN CITY JOINERY PTY. LTD., Breen-street, Bendigo, 3550; D.A.61600; 4th March, 1972; 60 cwt.
- GREEN, F. L., Standish-street, Myrtleford, 3737; D.A.48511/5; 25th March, 1972; 152 cwt.
- GRIL, F., 13 Austral-avenue, West Preston, 3072; D.A.61539; 4th March, 1972; 157 cwt.
- GRUMMISCH, C. H., Bass, 3991; D.A.26319/4; 4th March, 1972; 14 cwt.
- HARRISON, L. B., 4 Cope-street, Preston, 3072; D.A.61587; 4th March, 1972; 8 cwt.
- HICKS, W. G., PTY. LTD., 562 City-road, South Melbourne, 3205; T.D.A.62469; 17th March, 1972; 14 cwt.; T.D.A.62469/1; 17th March, 1972; 79 cwt.
- HILLGROVE, A. D., P.O. Box 176, Birchip, 3483; D.A.1302/23; 19th February, 1972; 196 cwt.
- JENNINGS, A. V., INDUSTRIES (AUST.) LTD., 690 Springvale-road, Mulgrave, 3170; D.A.37756/2; 21st March, 1972; 98 cwt.
- KEOGH, P., PTY. LTD., 371 Francis-street, Yarraville, 3013; D.A.6989/8; 27th January, 1972; 297 cwt.
- KEOGH, P., PTY. LTD., 371 Francis-street, Yarraville, 3013; T.D.A.6989/6; 17th December, 1971; 245 cwt.
- KNOX SCHLAPP PTY. LTD., 49 Graham-street, Port Melbourne, 3207; D.A.25298/2; 20th October, 1971; 14 cwt.
- KOLACKO, I., 7 Kilby-court, Noble Park, 3174; T.D.A.63553; 2nd March, 1972; 132 cwt.
- LATROBE VALLEY CORDIAL & CONFECTIONERY CO. PTY. LTD., 31 Hotham-street, Traralgon, 3844; T.D.A.63078; 2nd March, 1972; 33 cwt.
- LINGHAM, R. J., Cromie-street, Rupanyup, 3388; D.A.61421; 12th February, 1972; 29 cwt.
- MALE, A. H. & Co., 21 Hilton-street, Beaumaris, 3193; T.D.A.60462; 6th March, 1972; 15 cwt.
- MANN, J., & SON, 120 High-street, Wodonga, 3690; D.A.51653; 23rd March, 1972; 110 cwt.
- MANN, J., & SON (PRODUCE) PTY. LTD., 120 High-street, Wodonga, 3690; D.A.51653/1; 4th March, 1972; 128 cwt.
- MASSEY FERGUSON AUST. LTD., 2 Devonshire-road, Sunshine, 3020; D.A.1252/16; 24th August, 1971; 14 cwt.
- MOBILCO LTD., 410 Whitehorse-road, Mitcham, 3132; D.A.48327/8; 9th March, 1972; 10 cwt.; D.A.48327/20; 4th March, 1972; 10 cwt.; D.A.48327/21; 4th March, 1972; 13 cwt.; D.A.48327/22; 4th March, 1972; 10 cwt.
- MYER SOUTHERN STORES LTD., 105-121 Malop-street, Geelong, 3220; D.A.61148/21; 18th December, 1971; 13 cwt.; D.A.61148/22; 18th December, 1971; 11 cwt.; D.A.61148/23; 18th December, 1971; 9 cwt.; D.A.61148/24; 18th December, 1971; 10 cwt.; D.A.61148/25; 18th December, 1971; 30 cwt.; D.A.61148/26; 18th December, 1971; 15 cwt.; D.A.61148/27; 18th December, 1971; 49 cwt.; D.A.61148/28; 18th December, 1971; 17 cwt.; D.A.61148/29; 18th December, 1971; 20 cwt.; D.A.61148/30; 18th December, 1971; 18 cwt.; D.A.61148/31; 18th December, 1971; 17 cwt.
- MYER SOUTHERN STORES LTD., 105-121 Malop-street, Geelong, 3220; D.A.61148/32; 4th March, 1972; 18 cwt.
- McTAGGARTS OF HAMILTON, Ballarat-road, Hamilton, 3300; D.A.60899/1; 4th March, 1972; 137 cwt.
- O'CONNOR, A. B., 125 Lime-avenue, Mildura, 3500; D.A.57210/2; 4th March, 1972; 10 cwt.
- PANAGIOTAKIS, K. & A., 7 Ryland-avenue, West Croydon, 3136; D.A.61536; 4th March, 1972; 265 cwt.
- PEGORARO, FRED, EXCAVATIONS PTY. LTD., 83 Palmerston-street, Carlton, 3053; D.A.61876; 25th March, 1972; 144 cwt.
- PETCH, A. S., Saviges-road, Moe, 3824; T.D.A.39031/3; 2nd March, 1972; 11 cwt.; T.D.A.39031/5; 2nd March, 1972; 63 cwt.; T.D.A.39031/6; 2nd March, 1972; 13 cwt.; T.D.A.39031/7; 2nd March, 1972; 11 cwt.
- PETERSVILLE AUST. LTD., Wellington-road, Clayton, 3168; D.A.1813/179; 4th March, 1972; 79 cwt.; D.A.1813/180; 4th March, 1972; 78 cwt.; D.A.1813/181; 25th March, 1972; 67 cwt.; D.A.1813/184; 25th March, 1972; 78 cwt.
- QUEEN'S BRIDGE MOTOR & ENG. CO. PTY. LTD., corner Salmon and Plummer streets, Port Melbourne, 3207; D.A.1783/55; 4th March, 1972; 156 cwt.
- READER, G. E., Tootala-road, Dingley, 3172; D.A.44551/3; 7th October, 1971; 80 cwt.
- RYAN, P. L., 10 Sadd-street, Oakleigh, 3166; D.A.1970; 15th March, 1972; 142 cwt.
- SCHLUMBERGER SEACO INC., 4 Darling-street, Sale, 3850; D.A.47778/2; 25th March, 1972; 26 cwt.
- SCHUBERT & STAFF PTY. LTD., 92 York-street, Sale, 3850; D.A.50110/1; 4th March, 1972; 20 cwt.
- SMITH, R. J., 16 Thompson-street, Sale, 3850; D.A.61573; 4th March, 1972; 33 cwt.
- STOCKDALE EXPLORATION LTD., 13th Floor, 60 Market-street, Melbourne, 3000; D.A.60407/11; 25th March, 1972; 18 cwt.
- SUPA-FLAME PTY. LTD., 32 Johnston-street, Collingwood, 3066; D.A.61619; 25th March, 1972; 14 cwt.
- TERRY, G. R., 25 Lamont-street, Wangaratta, 3677; D.A.61586; 4th March, 1972; 230 cwt.
- TOMLINSON STEEL LTD., 230 Lygon-street, East Brunswick, 3057; D.A.39628/3; 23rd March, 1972; 14 cwt.
- TOORALAC MILK PRODUCTS PTY. LTD., care of P.O. Box 13, Dandenong, 3175; D.A.56830/6; 4th March 1972; 208 cwt.
- TURTON, B., 6 Harley-street, Dingley, 3172; D.A.16518; 4th March, 1972; 12 cwt.
- VALENCIC, S. & V., 120 Chandler-road, Noble Park, 3174; D.A.61527; 4th March, 1972; 232 cwt.
- WALHOUT, J. & M., Lot 43, Sommerville-road, Hampton Park, 3976; D.A.61292; 9th March, 1972; 47 cwt.
- WARDELL, R., 14 Prince Andrew-avenue, Lalor, 3075; D.A.61599; 4th March, 1972; 120 cwt.
- WILSON, C. D., & SONS, 7 Carmen-street, Dandenong, 3175; D.A.27928/5; 15th March, 1972; 240 cwt.
- WRIGHT, WALTER H., PTY. LTD., Sudholz-street, West Melbourne, 3003; D.A.19947/1; 21st March, 1972; 306 cwt.
- YOU YANGS GRANITIC SAND SUPPLY PTY. LTD., 46 Maroondah Highway, Ringwood, 3134; D.A.51657; 23rd March, 1972; 130 cwt.
- YOUNG, W. H., & SONS (PLANT HIRE) PTY. LTD., 182 High-street, Shepparton, 3630; D.A.35594/40; 4th March, 1972; 128 cwt.
- YOUNG, W. H., & SONS (PLANT HIRE) PTY. LTD., 182 High-street, Shepparton, 3630; D.A.35594/41; 4th March, 1972; 302 cwt.

TOW TRUCK RENEWALS.

- PARKINSON, K. W., Meredith, 3333; D.A.61302; 4th March, 1972; 79 cwt.
- TURNER, C. R. (MOTORS) PTY. LTD., 347 Main-street, Mornington, 3931; D.A.35515/1; 23th March, 1972; 36 cwt.

RENEWALS WITH VARIATION.

Applications made by the persons listed hereunder for renewal of licences listed with variation of conditions in the manner set out opposite the names.

BEAUREPAIRE TYRE SERVICE PTY. LTD., 102 Victoria-street, Carlton, 3053; D.A.629/93; 23rd March, 1972; application to renew and vary the conditions of licence number D.A.629/93 (L/C. 14 cwt.) by deleting "Burwood" from the existing conditions and adding in lieu "Moorabbin".

DRAFFIN BROS., PTY. LTD., 45 City-road, South Melbourne, 3205; D.A.27827/5; 21st March, 1972; application to renew and vary the conditions of licence number D.A.27827/5 (L/C. 13 cwt.) by adding to the existing conditions "and electric stoves".

Notice of any objection should be forwarded to reach the Secretary of the Board not later than 3rd November, 1971.

Applicants are advised that it will not be necessary to appear on the hearing date specified above, unless advised in writing by the Board.

B. P. KAY,

Secretary.

Corner Lygon and Princes streets, Carlton, 3053, Wednesday, 20th October, 1971.

Transport Regulation Act.
TRANSPORT REGULATION BOARD.
HEARING OF APPLICATIONS.

Notice is hereby given that the following applications will be considered by the Transport Regulation Board at its offices at the corner of Princes and Lygon streets, Carlton, at 10.15 a.m., on Wednesday, 10th November, 1971.

CARMICHAEL, J. F. & B. L., Marine-parade, San Remo. One commercial passenger vehicle (S/C. 5) to operate as a country taxi cab at San Remo.

Application for renewal of licences as shown, by persons listed hereunder to operate under the same terms and conditions.

ARMSTRONG, G. W., 26 Kallioota-street, Alfredton; U.T.48.

CARR, J. F., 23 Caldwell's-road, Eaglehawk; U.H.312.

FOWLER, J. E. & M. J., "Jaru", 29 Swansea-road, Lilydale; C.T.330.

INVICTA COACHES PTY. LTD., P.O. Box 95, Croydon; C.O.22, C.O.150.

Notice of any objection should be forwarded to reach the Secretary of the Board not later than Wednesday, 3rd November, 1971.

Applicants are advised that it will not be necessary to appear on the hearing date specified above, unless advised in writing by the Board.

B. P. KAY,
Secretary.

Corner Lygon and Princes streets, Carlton, 3053, Wednesday, 20th October, 1971.

PUBLIC NOTICE.
DEPARTMENT OF AGRICULTURE.
Victoria.

It is hereby notified that the Farm Produce Merchants Licence issued to Delta Fruit Distributors Pty. Ltd., formerly trading at the Melbourne Wholesale Fruit and Vegetable Market, Footscray, Victoria, for the period 1st July, 1971 to 30th June, 1972, has been suspended in accordance with the provisions of section 15 (1) (c) of the *Farm Produce Merchants and Commission Agents Act 1965*.

A claim has been made against the Farm Produce Merchants and Commission Agents Guarantee Fund by a grower creditor of Delta Fruit Distributors Pty. Ltd., and all persons who as producers of farm produce have any claims against Delta Fruit Distributors Pty. Ltd., arising from any failure on the part of the said company to pay or account for any moneys payable to them for farm produce supplied are invited to forward particulars and proof of such claims to the Director of Agriculture, Treasury Place, Melbourne, on or before 17th November, 1971. (Postal Address, Department of Agriculture, Box 4041, G.P.O., Melbourne, Vic. 3001.)

D. S. WISHART,
Director of Agriculture.

The Constitution Act Amendment Act 1958.

APPOINTMENT OF A POLLING PLACE.

His Excellency the Governor of the State of Victoria, by and with the advice of the Executive Council thereof, doth by Order made on the 11th day of October, 1971, and pursuant to the provisions of the *Constitution Act Amendment Act 1958*, appoint—

SUNBURY WEST

as a Polling Place within and for the Sunbury Subdivision of the Melbourne West Province and the Electoral District of Gisborne.

J. ROSSITER,
Clerk of the Executive Council.

At the Executive Council Chamber,
Melbourne, 11th October, 1971.

The Constitution Act Amendment Act 1958.
REVOCATION OF APPOINTMENT OF A POLLING PLACE.

His Excellency the Governor of the State of Victoria by and with the advice of the Executive Council thereof doth by Order made on the 11th day of October, 1971, and pursuant to the provisions of the *Constitution Act Amendment Act 1958*, revoke the appointment of—

BUTTLEJORK

as a Polling Place within and for the Sunbury Sub-division of the Melbourne West Province and the Electoral District of Gisborne.

J. ROSSITER,
Clerk of the Executive Council.

At the Executive Council Chamber,
Melbourne, 11th October, 1971.

Stamps Act 1958.
STAMPS (EXEMPTIONS) REGULATIONS 1971.

NOTICE.

Pursuant to the provisions of the Stamps (Exemptions) Regulations 1971, I hereby declare the corporation listed in the Schedule hereto to be for the purposes of sub-division (13A) of Division 3 of Part II of the *Stamps Act 1958* a dealer in the unofficial short term money market.

SCHEDULE.

Brayburn & Co. Pty. Limited.

R. M. PHIBBS,
Comptroller of Stamps.

Stamp Duties Office,
Melbourne, 20th October, 1971.

Stamps Act 1958.

ANNUAL LICENCE.

NOTIFICATION PURSUANT TO SECTION 97.

I hereby notify that stamp duty has been paid for a licence under section 96 of the *Stamps Act* to carry on assurance and insurance business in Victoria for the year ending 31st December, 1971, by the following:—

BUSINESS MEN'S ASSURANCE COMPANY OF AUSTRALIA LIMITED.

R. M. PHIBBS,
Comptroller of Stamps.

Chief Office for Stamp Duties,
Melbourne, 20th October, 1971.

BENALLA WATERWORKS TRUST.

RATING BY-LAW FOR THE YEAR 1971-72.

That the Benalla Waterworks Trust in pursuance and exercise of the powers conferred by the Water Acts, doth hereby make a rate for the supply of water for domestic purposes of 5.5 cents in the dollar on the annual municipal valuations of lands and tenements liable to be rated within the Benalla Urban District.

Provided that in no case shall the amount of rate payable per annum in respect of any tenements (other than land on which there is no building) be less than Fifteen Dollars (\$15) and in respect of land on which there is no building less than Seven Dollars (\$7).

Such rates are made and shall be levied upon the occupiers or owners of the said lands and tenements for the twelve months commencing the first day of October, 1971, and shall be payable in one sum on the tenth day of December, 1971, at the Office of the said Trust.

The maximum quantity of water to be supplied in any one year without further charge to any property rated by the Trust is hereby fixed at the quantity which at charge of 20 cents per 1,000 gallons, would produce an amount equal to the amount of rate levied on such property for the said year.

The charge for water supplied by measure to any property rated by the Trust in excess of such maximum quantity computed as in the last preceding clause is hereby fixed at 20 cents per 1,000 gallons.

The charge for water supplied by measure to any property shall be payable on demand at the office of the said Trust.

Signed and sealed on the 20th day of September, 1971.

(L.S.) F. R. HARRISON, M.B.E., J.P., Chairman.
E. J. GUPPY, Commissioner.
C. A. BOYD, Acting Secretary.

Approved 11th October, 1971.—ROBERTS DUNSTAN,
Minister of Water Supply.

BEAUFORT WATERWORKS TRUST.

ANNUAL BALANCE.

His Excellency the Governor of the State of Victoria, by and with the advice of the Executive Council thereof, doth by Order made on the 19th day of October, 1971, and in pursuance of the provisions of the Water Act, fix the thirtieth day of September in each year as from 1st January, 1972, as the day to which the accounts of the Beaufort Waterworks Trust shall be balanced.

J. ROSSITER,
Clerk of the Executive Council.

At the Executive Council Chamber,
Melbourne, 19th October, 1971.

STATE RIVERS AND WATER SUPPLY COMMISSION.

LICENCES TO DIVERT WATER AND CUT RACES PURSUANT TO THE PROVISIONS OF SECTION 204 OF THE WATER ACT 1958
(AS AMENDED).

The Governor in Council has approved of the granting by the State Rivers and Water Supply Commission of licences as detailed hereunder for the term of years from the date specified in each case to the persons named in the following Schedule :—

SCHEDULE.

Licence No.	Term of Licence and Commencing Date.	Name and Address of Person to whom Licence is to be Granted.	Source of Supply.	Area Authorized to be Irrigated Per Annum.	Volume of Water Authorized to be Diverted Per Annum.	Annual Fee.
				acres.	ac. ft.	\$
596	Fifteen years from 1.7.71	Victor Albert William Peach, Myall	River Murray ..	178	356	445.00
600	Fifteen years from 1.7.70	Eric Andrew Wright, Nangiloc	River Murray ..	18	54	67.50
620	Fifteen years from 1.7.71	Reginald Leonard Keens, Noel Frederick Keens; Ian Leonard Keens and Lauris Gwenna Keens, Merbein	River Murray ..	97	291	363.75
623	Fifteen years from 1.7.71	James Arthur Stevens, Merbein	River Murray ..	29	87	108.75
785	Five years from 1.7.70	James Ceretti McMahon, Swan Hill	River Murray ..	141	282	352.50
957/1336	Fifteen years from 1.7.71	Graeme John Catto, Inglewood	Loddon River ..	40	80	100.00
966	Fifteen years from 1.7.71	Jessie Terrill and William John Terrill, Newbridge	Loddon River ..	11	24	30.50
987	Fifteen years from 1.7.71	Ralph Walter Sharp and Lauris Anne Sharp, Newbridge	Loddon River ..	4	8	15.00
991	Fifteen years from 1.7.71	Roy Cain, Laanecoorie ..	Loddon River ..	50	100	125.00
993	Four years from 1.7.71	Allen Brownbill, Laanecoorie ..	Loddon River ..	35	70	87.50
1015	Fifteen years from 1.7.71	Roy William Stewart, Newbridge	Loddon River ..	15	30	37.50
1045	Fifteen years from 1.7.71	John Thomas Raynes, St. Arnaud	Loddon River ..	10	20	25.00
1052	Fifteen years from 1.7.71	William George Cook, Bridge-water	Loddon River ..	20	40	50.00
1087	Fifteen years from 1.7.71	Alan Gillespie Long and Alice Evelyn Long, Serpentine ..	Loddon River ..	50	100	125.00
1355	Fifteen years from 1.7.71	John Arthur Barr, R.S.D. Bendigo East	Loddon River ..	30	60	75.00
1407	Fifteen years from 1.7.71	Alfred Ashley Lees and Iris Mary Lees, Mildura	River Murray ..	31	93	116.25
1750	Fifteen years from 1.7.70	J. H. Hards and G. E. Hards, Iraak	River Murray ..	33	99	123.75
1813	Eight years from 1.7.70	John Crosthwaite, Wodonga ..	Kiewa River ..	25	50	15.50
2064/1046	Fifteen years from 1.7.71	Andrew Norman McLeish, Keith Andrew McLeish and Ronald Norman McLeish, Eddington	Loddon River ..	20	40	50.00
2127	Fifteen years from 1.7.71	William Arthur Coad and Dorothy Alice Coad, Iraak	River Murray ..	50	150	187.50
2221	Fifteen years from 1.7.71	Francesco Gargiulo and Antonietta Gargiulo, Piangil	River Murray ..	25	75	93.75
2277	Fifteen years from 1.7.71	Peter Martyn Parkinson, Echuca	River Murray ..	100	200	250.00
2291	Fifteen years from 1.7.71	John Roscrow Hocking and Eileen Alexa Hocking, Piangil	River Murray ..	100	300	375.00
2377	Fifteen years from 1.7.71	William Alfred McCartney, Nyah	River Murray ..	7	16	22.00
2399/1548	Fifteen years from 1.7.71	Hurtle John Sinapius, George Robert Sinapius, Neville Percy Sinapius and Clarence Stanley Sinapius, Piangil	River Murray ..	100	300	375.00
2415	Fifteen years from 1.7.71	Grace Kathleen Dean, Echuca ..	River Murray ..	12	24	30.00
2575	Fifteen years from 1.7.71	M. and D. Briggs and Co., Colignan	River Murray ..	100	300	375.00
2607	Fifteen years from 1.7.71	Ian Terence Kneebone, Hansonville	Ovens River ..	15	22½	28.12
2662	Fifteen years from 1.7.71	Bridgewater Recreation Reserve Trustees, Bridgewater	Loddon River ..	6	12	7.50
2663	Fifteen years from 1.7.71	The Director of Agriculture, Melbourne	River Murray ..	10	20	25.00
3147	Four years from 1.7.70	Robert Henry Woodward, Swan Hill	Little Murray River	25	50	62.50
3165	Four years from 1.7.71	Samuel Carr Hordern, Mildura	River Murray ..	100	300	375.00
3177	Four years from 1.7.70	Ernest Edgar Parker, Thornton	Goulburn River ..	1	2	15.00
3178	Four years from 1.7.71	John Colville Garrity and Leicester Devenish Mearns, Mildura	River Murray ..	116	348	435.00

Private Agents Act 1966.

NOTICE OF RECEIPT OF APPLICATIONS FOR LICENCES UNDER THE PROVISIONS OF THE PRIVATE AGENTS ACT 1966.

THE Clerk(s) of the Magistrates' Court(s) as listed hereunder hereby give notice that applications, as under, have been lodged for hearing by the said Court(s) on the date(s) specified.

Any person desiring to object to any of such applications must—

- (a) lodge with the respective Clerk of the Magistrates' Court a notice in the prescribed form of his objection and of the grounds thereof;
- (b) cause a copy of such notice to be served personally or by post upon the applicant at least three days before the hearing of the application; and
- (c) send or deliver—
 - (i) where the objection is not made by the officer in charge of the police district in which the Court is situated—a copy of the notice to such officer; and
 - (ii) where the objection is not made by the Registrar or Deputy Registrar—a copy to the Registrar.

Full Name of Applicant or in the Case of a Firm or Corporation, of the Nominee.	Place of Abode of Applicant or Nominee.	Name of Firm or Corporation.	Address for Registration.	Type of Licence.	Date of Hearing of Application.
---	---	------------------------------	---------------------------	------------------	---------------------------------

MAGISTRATES' COURT, MELBOURNE.

Oversby, Stanley	60 Baratta-street, Blackburn South	Australian Watching Co. Pty. Ltd.	340 Abbotsford- street, North Mel- bourne	Watchman ..	3.11.71
Kilpatrick, Robert Campbell ..	Flat 12, 43 Royal- avenue, Glenhuntly	" "	" "	" "	" "

Dated at Melbourne this 11th day of October, 1971.

G. L. WEBSTER, Clerk of the Magistrates' Court.

MAGISTRATES' COURT, CAMBERWELL.

Tait, Alexander John ..	155 Through-road, Burwood	" "	155 Through-road, Burwood	Process Server ..	4.11.71
-------------------------	------------------------------	-----	------------------------------	-------------------	---------

Dated at Camberwell this 12th day of October, 1971.

J. C. TOBIN, Clerk of the Magistrates' Court.

MAGISTRATES' COURT, FOOTSCRAY.

Rosenthal, Samuel	19 Richards-street, Yarraville	" "	17 Richards-street, Yarraville	Watchman ..	3.11.71
---------------------------	-----------------------------------	-----	-----------------------------------	-------------	---------

Dated at Footscray this 13th day of October, 1971.

D. A. THOMPSON, Clerk of the Magistrates' Court.

MAGISTRATES' COURT, BALLARAT.

Davies, William Edward ..	411 Ligar-street, Bal- larat	" "	411 Ligar-street, Ballarat	Watchman ..	4.11.71
---------------------------	---------------------------------	-----	-------------------------------	-------------	---------

Dated at Ballarat this 13th day of October, 1971.

E. N. KINCHINGTON, Clerk of the Magistrates' Court.

Co-operation Act 1958.

DUNNSTOWN CO-OPERATIVE COMMUNITY SETTLEMENT SOCIETY LIMITED (IN LIQUIDATION).

Notice is hereby given in pursuance of section 78 (7) of the *Co-operation Act 1958* and section 308 (2) of the *Companies Act 1961* that, at the expiration of three months from the date hereof, the name of the afore-mentioned society will, unless cause is shown to the contrary, be struck off the register and the society will be dissolved.

Dated this 11th day of October, 1971.

R. F. SCOLLARD,
Deputy Registrar of Co-operative Societies.

Co-operation Act 1958.

NOTICE OF DISSOLUTION OF SOCIETY.

PARK DALE STATE SCHOOL CO-OPERATIVE LIMITED.

Notice is hereby given that I have this day registered the dissolution of the above-named society and cancelled its registration under the above-named Act.

Dated at Melbourne this 6th day of October, 1971.

R. F. SCOLLARD,
Deputy Registrar of Co-operative Societies.

Co-operation Act 1958.

NOTICE OF DISSOLUTION OF SOCIETY.

JORDANVILLE SOUTH STATE SCHOOL CO-OPERATIVE LIMITED.

Notice is hereby given that I have this day registered the dissolution of the above-named society and cancelled its registration under the above-named Act.

Dated at Melbourne this 6th day of October, 1971.

R. F. SCOLLARD,
Deputy Registrar of Co-operative Societies.

Co-operation Act 1958.

WARRACKNABEAL CO-OPERATIVE FARM ADVISORY SERVICE LIMITED.

Notice is hereby given in pursuance of section 78(7) of the *Co-operation Act 1958* and section (2) of the *Companies Act 1961* that, at the expiration of three months from the date hereof, the name of the afore-mentioned society will, unless cause is shown to the contrary, be struck off the register and the society will be dissolved.

Dated this 6th day of October, 1971.

R. F. SCOLLARD,
Deputy Registrar of Co-operative Societies.

Co-operation Act 1958.

NOTICE OF DISSOLUTION OF SOCIETY.

1ST SEAFORD BOY SCOUT CO-OPERATIVE LIMITED.

Notice is hereby given that I have this day registered the dissolution of the above-named society and cancelled its registration under the above-named Act.

Dated at Melbourne this 6th day of October, 1971.

R. F. SCOLLARD,
Deputy Registrar of Co-operative Societies.

Co-operation Act 1958.

NOTICE OF DISSOLUTION OF SOCIETY.

GOLDEN SQUARE HIGH SCHOOL DEVELOPMENT CO-OPERATIVE SOCIETY LIMITED.

Notice is hereby given that I have this day registered the dissolution of the above-named society and cancelled its registration under the above-named Act.

Dated at Melbourne this 6th day of October, 1971.

R. F. SCOLLARD,
Deputy Registrar of Co-operative Societies.

Co-operation Act 1958.

MACLEOD HIGH SCHOOL CO-OPERATIVE SOCIETY, LIMITED.

Notice is hereby given in pursuance of section 78 (7) of the Co-operation Act 1958 and section 308 (2) of the Companies Act 1961 that, at the expiration of three months from the date hereof, the name of the afore-mentioned society will, unless cause is shown to the contrary, be struck off the register and the society will be dissolved.

Dated this 12th day of October, 1971.

R. F. SCOLLARD,
Deputy Registrar of Co-operative Societies.

LAW DEPARTMENT.

COUNTY COURT SITTINGS—1972.

The Governor in Council having directed that the County Court be held at each of the under-mentioned places, I hereby appoint the following days of each month as the day on which the Court shall commence sitting at such place during the year 1972:—

ARARAT	Tuesday, 11th April.
		Tuesday, 5th September.
BAIRNSDALE	Tuesday, 18th April.
		Tuesday, 18th July.
		Tuesday, 21st November.
BALLARAT	Wednesday, 2nd February.
		Monday, 1st May.
		Tuesday, 1st August.
		Monday, 2nd October.
BENDIGO	Wednesday, 2nd February.
		Tuesday, 2nd May.
		Wednesday, 2nd August.
COLAC	Tuesday, 14th November.
		Tuesday, 18th April.
		Tuesday, 7th November.
GEELONG	Wednesday, 1st March.
		Thursday, 1st June.
		Monday, 4th September.
		Monday, 2nd October.
		Monday, 4th December.
HAMILTON	Tuesday, 7th March.
		Tuesday, 20th June.
		Tuesday, 17th October.
HORSHAM	Tuesday, 22nd February.
		Tuesday, 16th May.
		Tuesday, 21st November.
KERANG	Tuesday, 18th April.
		Tuesday, 18th July.
		Tuesday, 17th October.
KORUMBURRA	Monday, 20th March.
		Monday, 19th June.
		Monday, 2nd October.
MELBOURNE	Monday, 17th January.
		Tuesday, 1st February.
		Wednesday, 1st March.
		Thursday, 6th April.
		Monday, 1st May.
		Thursday, 1st June.
		Monday, 3rd July.
		Tuesday, 1st August.
		Friday, 1st September.
		Monday, 2nd October.
		Wednesday, 1st November.
		Friday, 1st December.
MILDURA	Monday, 20th March.
		Monday, 1st May.
		Monday, 14th August.
		Monday, 20th November.
MORWELL	Tuesday, 15th February.
		Tuesday, 16th May.
		Wednesday, 2nd August.
		Tuesday, 5th December.
SALE	Tuesday, 8th February.
		Tuesday, 2nd May.
		Tuesday, 19th September.
SHEPPARTON	Wednesday, 2nd February.
		Tuesday, 16th May.
		Tuesday, 19th September.
		Tuesday, 7th November.
WANGARATTA	Tuesday, 7th March.
		Tuesday, 6th June.
		Tuesday, 5th September.
		Tuesday, 5th December.
WARRAGUL	Monday, 10th April.
		Monday, 17th July.
		Monday, 2nd October.
WARRNAMBOOL	Tuesday, 7th March.
		Tuesday, 6th June.
		Tuesday, 5th September.
		Tuesday, 5th December.

G. L. DETHRIDGE,

Chairman of County Court Judges.
12th October, 1971.

Town and Country Planning Act 1961.

BARRABOOL PLANNING SCHEME 1966.

NOTICE OF AMENDMENT.

In pursuance of the powers conferred by sub-section 6 of section 32 of the Town and Country Planning Act 1961, the Governor in Council, by and with the advice of the Executive Council on the 11th October, 1971, amended the Barrabool Planning Scheme 1966, in so far as it refers to the extent of the Commercial "A" Zone fronting the Ocean-road, at Anglesea, and the building line applicable in this area.

A copy of the amendment may be inspected during office hours at the office of the Town and Country Planning Board, 235 Queen-street, Melbourne; at the office of the Council of the Shire of Barrabool, at Geelong; and when available at the Office of Titles, Melbourne; and at the Central Plan Office of the Department of Crown Lands and Survey, Melbourne.

W. H. CRAIG, Secretary,
Town and Country Planning Board.

Town and Country Planning Act 1961.

CITY OF ARARAT PLANNING SCHEME 1953.

AMENDMENT No. 12, 1970.

Notice of Approval.

In pursuance of the powers conferred by the Town and Country Planning Act 1961, the Governor in Council on the 11th October, 1971, approved a Planning Scheme entitled the City of Ararat Planning Scheme 1953, Amendment No. 12, 1970, in respect of part of the municipal district of the City of Ararat and such Planning Scheme comes into operation on the date this notice of approval is published in the Government Gazette.

A copy of the Planning Scheme as approved may be inspected free of charge during office hours at the office of the Town and Country Planning Board, 235 Queen-street, Melbourne; at the office of the Ararat Municipal Council; and when available, at the Office of Titles, Melbourne, and at the Central Plan Office of the Department of Crown Lands and Survey, Melbourne.

W. H. CRAIG, Secretary,
Town and Country Planning Board.

Town and Country Planning Act 1961.

SHIRE OF FLINDERS PLANNING SCHEME 1962.

AMENDMENT No. 28, 1970.

Notice of Approval.

In pursuance of the powers conferred by the Town and Country Planning Act 1961, the Governor in Council on the 11th October, 1971, approved a Planning Scheme entitled the Shire of Flinders Planning Scheme 1962, Amendment No. 28, 1970, in respect of part of the municipal district of the Shire of Flinders and such Planning Scheme comes into operation on the date this notice of approval is published in the Government Gazette.

A copy of the Planning Scheme as approved may be inspected free of charge during office hours at the office of the Town and Country Planning Board, 235 Queen-street, Melbourne; at the office of the Council of the Shire of Flinders, at Dromana; and when available, at the Office of Titles, Melbourne, and at the Central Plan Office of the Department of Crown Lands and Survey, Melbourne.

W. H. CRAIG, Secretary,
Town and Country Planning Board.

Town and Country Planning Act 1961.

SHIRE OF FLINDERS PLANNING SCHEME 1962.

AMENDMENT No. 32, 1970.

Notice of Approval.

In pursuance of the powers conferred by the Town and Country Planning Act 1961, the Governor in Council on the 11th October, 1971, approved a Planning Scheme entitled the Shire of Flinders Planning Scheme 1962, Amendment No. 32, 1970, in respect of part of the municipal district of the Shire of Flinders and such Planning Scheme comes into operation on the date this notice of approval is published in the Government Gazette.

A copy of the Planning Scheme as approved may be inspected free of charge during office hours at the office of the Town and Country Planning Board, 235 Queen-street, Melbourne; at the office of the Flinders Shire Council, at Dromana; and when available, at the Office of Titles, Melbourne, and at the Central Plan Office of the Department of Crown Lands and Survey, Melbourne.

W. H. CRAIG, Secretary,
Town and Country Planning Board.

Town and Country Planning Act 1961.
SHIRE OF WARANGA.

INTERIM DEVELOPMENT ORDER.

Notice of Approval.

In pursuance of the powers conferred by the Town and Country Planning Act 1961, the Governor in Council on the 11th day of October, 1971, approved an Interim Development Order made by the Council of the Shire of Waranga, for the whole of the municipal district of the said Shire of Waranga except the area included in the Corop Lakes Planning Scheme.

The Interim Development Order provides that the use, subdivision or development of any land within the area described, or the erection, construction or carrying out of any buildings, roads or other works thereon is prohibited except in accordance with the provisions of the Order.

A copy of the Interim Development Order, and a map showing the area affected may be inspected, free of charge, at the Shire Offices, High-street, Rushworth, and at the office of the Town and Country Planning Board, 235 Queen-street, Melbourne.

G. K. CALDER, Shire Secretary.

Town and Country Planning Act 1961.
CITY OF KNOX PLANNING SCHEME 1965.

AMENDMENT No. 81, 1971.

Notice of Approval.

In pursuance of the powers conferred by the Town and Country Planning Act 1961, the Governor in Council on the 11th October, 1971, approved a Planning Scheme entitled the City of Knox Planning Scheme 1965, Amendment No. 81, 1971, in respect of part of the municipal district of the City of Knox and such Planning Scheme comes into operation on the date this notice of approval is published in the *Government Gazette*.

A copy of the Planning Scheme as approved may be inspected free of charge during office hours at the office of the Town and Country Planning Board, 235 Queen-street, Melbourne; at the office of the Knox City Council, at Fern Tree Gully; and when available, at the Office of Titles, Melbourne, and at the Central Plan Office of the Department of Crown Lands and Survey, Melbourne.

W. H. CRAIG, Secretary,
Town and Country Planning Board.

Town and Country Planning Act 1961.
GEELONG PLANNING SCHEME 1959.

AMENDMENT No. 15, 1970.

(CITY OF GEELONG.)

Notice of Approval.

In pursuance of the powers conferred by the Town and Country Planning Act 1961, the Governor in Council on the 11th October, 1971, approved a Planning Scheme entitled the Geelong Planning Scheme 1959, Amendment No. 15, 1970, (City of Geelong), in respect of part of the municipal district of the City of Geelong and such Planning Scheme comes into operation on the date this notice of approval is published in the *Government Gazette*.

A copy of the Planning Scheme as approved may be inspected free of charge during office hours at the office of the Town and Country Planning Board, 235 Queen-street, Melbourne; at the office of the Council of the City of Geelong, at Geelong; and when available, at the Office of Titles, Melbourne, and at the Central Plan Office of the Department of Crown Lands and Survey, Melbourne.

W. H. CRAIG, Secretary,
Town and Country Planning Board.

Town and Country Planning Act 1961.
CITY OF KNOX PLANNING SCHEME 1965.

AMENDMENT No. 84, 1970.

Notice of Approval.

In pursuance of the powers conferred by the Town and Country Planning Act 1961, the Governor in Council on the 11th October, 1971, approved a Planning Scheme entitled the City of Knox Planning Scheme 1965, Amendment No. 84, 1970, in respect of part of the municipal district of the City of Knox and such Planning Scheme comes into operation on the date this notice of approval is published in the *Government Gazette*.

A copy of the Planning Scheme as approved may be inspected free of charge during office hours at the office of the Town and Country Planning Board, 235 Queen-street, Melbourne; at the office of the City of Knox, at Fern Tree Gully; and when available, at the Office of Titles, Melbourne, and at the Central Plan Office of the Department of Crown Lands and Survey, Melbourne.

W. H. CRAIG, Secretary,
Town and Country Planning Board.

Town and Country Planning Act 1961.
CITY OF KNOX PLANNING SCHEME 1965.

AMENDMENT No. 80, 1971.

Notice of Approval.

In pursuance of the powers conferred by the Town and Country Planning Act 1961, the Governor in Council on the 11th October, 1971, approved a Planning Scheme entitled the City of Knox Planning Scheme 1965, Amendment No. 80, 1971, in respect of part of the municipal district of the City of Knox and such Planning Scheme comes into operation on the date this notice of approval is published in the *Government Gazette*.

A copy of the Planning Scheme as approved may be inspected free of charge during office hours at the office of the Town and Country Planning Board, 235 Queen-street, Melbourne; at the office of the City of Knox; and when available, at the Offices of Titles, Melbourne, and at the Central Plan Office of the Department of Crown Lands and Survey, Melbourne.

W. H. CRAIG, Secretary,
Town and Country Planning Board.

Soil Conservation and Land Utilization Act 1958
(No. 6372).

NINE MILE NO. 2 GROUP CONSERVATION AREA.

Notice is hereby given that I, William Archibald Borthwick, Her Majesty's Minister for Conservation for the State of Victoria under powers conferred by Division 1A, Section 24A of the *Soil Conservation and Land Utilization Act 1958* (No. 6372), hereby declare to be a Group Conservation Area the land embraced by the Crown Allotments listed below, together with the Road Reserves in the Parish of Barrakee, as particularly designated in Drawing Nos. 2516A, 2517A and 2518, marked GA/14B and lodged at the office of the Soil Conservation Authority, 378 Cotham-road, Kew, and do further declare that it shall be known as the Nine Mile No. 2 Group Conservation Area.

Parish; Crown Allotments.

Barrakee; 49; 50c, D, F, G, H, Pt. 50m; 52A, B; 55; 66; 71A; 89; 90; Pt. 50k; 91; 92A; 93; 93A; 94; 94A; 95; 95A, 95B, 96, 96A, 96B, 96C, 96D, 100, 101, Pt. 103, Pt. 106A, 109, Pt. 109B, 110, Pt. 114, 115, 116, 116A, 116B, 116C, 117, 118, Pt. 119, 119A, Pt. 119c, 119d, Pt. 119E, 119F, 119G, 119H, 119J, 120, Pt. 120A, 120c, 120d, 120E, 120F, 120G, 120H, 120J, 121, Pt. 121A, 125, 125A, 125B, 125C, 125d, 125E, 125F, 127,

and those road reserves and Crown Land lying within the area designated in the above listed drawings.

13th October, 1971.

W. A. BORTHWICK,
Minister for Conservation.

Pipelines Act 1967, No. 7541.

APPLICATION FOR A PERMIT TO OWN AND USE
A SYSTEM OF PIPELINES.

MINISTRY OF FUEL AND POWER.

Notice.

1. In accordance with the provisions of section 11 (1) of the *Pipelines Act 1967*, notice is given that an application has been received by me from the Gas and Fuel Corporation of Victoria for a permit to own and use a system of pipelines for the purpose of conveying natural gas from Brooklyn to Ballarat and Bendigo via Ballan.

2. The proposed routes of the pipelines comprising the system are as follows:—

Line 1.—A steel pipeline 42.1 miles long with an internal diameter of 8 inches and designed to operate at a maximum pressure of 1,000 p.s.i.g. commencing at the Gas and Fuel Corporation of Victoria's metering and compressor station at Brooklyn located on allotment 12, section 10, Parish of Cut-Paw-Paw, and situated on the north side of the old Geelong-road approximately 400 yards west of the Princes Highway, Laverton North, and proceeding in a west-south-westerly direction across the old Geelong-road, and a road owned by the Shire of Braybrook, to pass through allotment A, section 10, Parish of Cut-Paw-

Paw; thence continuing along and parallel to the southern side of the Melbourne and Metropolitan Board of Works' Werribee outfall sewer, crossing Kororoit Creek en route, thence at a point approximately 15 feet north-east of Little Boundary-road turning to continue in a north-westerly direction through allotment 5, section 21, Parish of Truganina, owned by the Melbourne and Metropolitan Board of Works; thence crossing Boundary-road to pass through allotments 7 and 6, section 8, Parish of Derrimut, owned by the Melbourne and Metropolitan Board of Works, through lot 295, P/S.12795, Parish of Derrimut, across Fairbairn-road, through allotment C.P.2, section 8, owned by the Gas and Fuel Corporation of Victoria, allotment 4, section 7, and Crown land being allotments 4, 2 and 1, section 7, Parish of Derrimut, across Fitzgerald-road, through allotments 2 and 1, section 6, across Station-road, through allotments 2 and 1, section 5, across Robinsons-road, through allotments 2 and 1, section 4, across Christies-road, through allotments 2 and 1, section 3, across Clarke-road, through allotments 2 and 1, section 2, across Hopkins-road and through part allotment 2, section 1, and allotment 1, section 1, Parish of Derrimut to Mt. Atkinson-road; thence crossing such road and continuing in a generally westerly direction through allotments 2 and 1, section 5, Parish of Pywheijorck, across Troupes-road, through lot 12, P/S.82332 and lots 14, 15, 16 and 17, P/S.83082, across Downing-street, through allotments 2 and 1, section 3, across Faulkeners-road, through allotments 2 and 1, section 2 and across Mt. Cottrill-road and through allotment A, section 1, Parish of Pywheijorck; thence crossing the Werribee River, to pass through allotment 18, section A, Parish of Mooradoranook and enter Eynesbury-road; thence continuing within such road reserve for a distance of approximately 1 mile; thence leaving the road to continue in a generally west-north-westerly direction through allotment 17, section A, allotments 8, 9b and 9a, across Telephone-road, through allotments 10, 13 and 12b, across Nerowie-road, through allotment 12a, Parish of Mooradoranook; thence passing through allotments 13, 12 and 11, section 8, and allotment J, section 9, across Norton-road, through allotments K and H.2, across the Geelong-Bacchus Marsh-road, through allotments F.1, 38b and 38a, section 9, to enter and continue along Smiths-road for a distance of approximately 2,000 feet; thence through allotments 3 and 4, section B, across the Parwan Creek Reserve, through allotment 5, section B, and allotments 47, 47a, 48b and 48a, section 9 and part allotment B, section 3; thence crossing the Melbourne to Ballarat rail line to pass through part allotment B and 3, section 3, across Bacchus Marsh-Balliang-road, and through allotment 4, section 3, Parish of Parwan; thence continuing in a generally north-westerly direction to pass through part allotment 1, section 13, Parish of Gorrockburkghap across the Melbourne to Ballarat rail line through part allotment 1 and allotments 7, D.2 and D1, across Dogtrapgully-road, through allotment 11, section 11, allotment C, section 10, allotments 6 and 7, section 9, allotments E and A, section 7, Parish of Gorrockburkghap; thence continuing in a west-north-westerly direction through allotments 1a and 1b, section 16, Crown land being a Forest Reserve, allotment 1a, section 15, allotments 4, 3, 2, 1a and 1, section 14, Parish of Goorong; thence entering Ingleston-road, to continue in a westerly direction along the south side of such road for a distance of approximately 4 miles; thence continuing through allotment 25, section 4, allotments 21, 22, 23, 24, 25, 26, 27, 28, 29, 30, 31, 32, 33, 34, 35, 6, 5, 4, 3, 2 and 1, section 3, allotment 20, section 2, across the Geelong-Ballan-road, through part allotments 24, 8, 6, 5, 4, 3, 2 and 1, section 2, Parish of Gorong; thence passing through part allotments 1 and 2, section 1, Parish of Moorabool West, to cross the Melbourne-Ballarat rail line and terminate at a bifurcation located on part allotment 2, section 1, Parish of Moorabool West, and situated at a point north of the old Bradshaw Railway Station, and opposite the junction of the Western Highway and Racecourse-road, Bradshaw.

Line 2.—A steel pipeline 14.1 miles long with an internal diameter of 6 inches and designed to operate at a maximum pressure of 1,000 p.s.i.g. commencing at a bifurcation being the terminal point of Line 1 and proceeding in a generally westerly direction parallel to the Melbourne-Ballarat rail line, across an unnamed road and through part allotments 3a and 3, section 1, Parish of Moorabool West, across the Eastern Moorabool River and through Crown land being part allotment 3, section 1, and designated a quarry and water reserve; thence through allotment 6a and part allotment 4a, section 1, to enter the Western Highway

and continue in a westerly direction along the southern side of such highway for a distance of approximately 2.5 miles; thence through allotments 2, 1a2, 1a1 and 1a6, section 5, and allotments 8f and 8d, Parish of Moorabool West; thence entering and continuing along an unnamed road for a distance of approximately 1,500 feet, across the Gordon-Egerton-road, through allotments 2a and 1, section 34, (Village of Gordon), Parish of Kerit Bareet and an unnamed road, through allotments 4 and 5, section 12, Parish of Kerit Bareet; thence crossing Boundary-road, to pass through allotment 8, section 6, allotments 1, 2, 3, 10 and 11, section A, allotments 15, 16, 17, 18, 19 and 20, Parish of Kerit Bareet, allotments 1 and 2, section A2, across the Melbourne-Ballarat rail line and through part section A, (Urquhart PR), Parish of Kerit Bareet; thence crossing the Western Moorabool River to pass through allotment 1, section 14, across Wescotts-road, through allotments 4i and 4j, part allotment 3, allotments 2g, 2f, 2e, 2a, 1f, 1b and 1, section 12, Parish of Warrenheip, across Murphy-road, through allotments 2i, 2k, 2l, 2b and 2a, section 9, across the Lal Lal Creek, through allotment 1, section 9, across Lesters-road, through part allotment 1, section 4a, across the Melbourne-Ballarat rail line, through part allotment 1, across Two Mile Creek, through allotments 10a and 10, section 4a, across Torpys-road, through allotments 5, 4, 3a, 3e, 3d, 3c, 2, 1b, 1a, 1b1, and 1a, section 3a, across Forbes-road, through allotments 7b, 7a, 6, 8, 5, 4, 12, 3, 2, 13, 1 and 14, section 2, allotments 30, 31, 29, 32a, 32, 28, 21, 27, 22, 26, 23 and 25, section 1 and allotment 24, section 1, containing easements occupied by the Country Roads Board and the State Electricity Commission of Victoria, across the Warrenheip-road and through allotments 3 and 2, section 23, Parish of Warrenheip, to terminate at a pressure regulating station known as the Ballarat City Gate located on allotment 2, section 23, Parish of Warrenheip and situated on the northern side of Yenoan-road, midway between the junction of Warrenheip-road and the Western Highway, Warrenheip.

Line 3.—A steel pipeline 4.4 miles long with an internal diameter of 8 inches and designed to operate at a maximum pressure of 275 p.s.i.g. commencing at a pressure regulating station located at the terminal point of Line 2; thence proceeding in a southerly direction across Yenoan-road to pass through allotments 10 and 16, section 23, Parish of Warrenheip, to an unnamed road; thence turning to continue in a westerly direction along such road to the Melbourne-Ballarat rail line; thence turning to cross such line and continue in a southerly direction along the same unnamed road to Elford-street; thence turning to continue in a generally westerly direction along such street for a distance of approximately 2,500 feet; thence turning to enter Crown land reserved for public purposes, and continue in a generally westerly direction across such land to Turpie-street; thence turning to enter and continue in a south-westerly direction along such street to Eureka-street; thence turning to continue in a generally westerly direction along the north side of Eureka-street to Barkly-street, City of Ballarat; thence diverting to enter and cross Barkly-street in a northerly direction to Eastwood-street; thence turning to continue in a generally westerly direction along the north side of such street to Dana-street; thence turning to continue in a northerly direction along the north side of such street for approximately 200 feet to terminate at a valve located on allotment 1, section E, Parish of Ballarat, owned by the Gas and Fuel Corporation of Victoria.

Line 4.—A steel pipeline 55.1 miles long with an internal diameter of 6 inches and designed to operate at a maximum pressure of 1,000 p.s.i.g. commencing at a bifurcation being the terminal point of Line 1 and proceeding in a generally northerly direction across the Western Highway, to pass through allotment 7a, section 10, Parish of Moorabool West, and Crown land being allotments 7 and 10, parallel to the western side of Racecourse-road, and reserved for racecourse and recreation purposes, Bradshaw; thence through allotment 11, section 10, allotment A2, A1, A and 4, section 11, across the East Moorabool River, through allotment 5, section 11 and allotment 23, section 12, across Crown land vested in the Victorian Railways Commissioners, and the East Moorabool River; thence through allotments 21, 20a, 20, 14, 13, 6 and 5, section 12, allotments 8, 5, 4a and 1, section 13 and allotment 1, section 14; thence passing through a State Forest area, allotment 5, section 14, Parish of Moorabool West, and another State Forest area to cross the Daylesford to Ballan-road; thence passing through allotments 115, 114, 113, 112, 111, 73, 72, 71-

and 70, a State Forest area and allotments 31, 30, 29A, 18, 17, 16, 8 and 7, section 1A, a State Forest area, Parish of Korweinguboorra; thence continuing through a State Forest area, Parish of Wombat, allotments 6d, 6m, 6b and 6A, section 1A, another State Forest area, across Wombat Creek and through allotment 7e, section 16, to enter Lyman-street, Daylesford; thence proceeding in a northerly direction within the road reserve of such street across Knox-street to enter and pass through allotment 8, part allotment 3, across the Daylesford—Glenlyon-road, through part allotment 3, allotment 2, section 3, allotments 6, 5, 2, 1, 1A and 7A, section 8, a State Forest area, Parish of Wombat; thence across Middletons Creek, through allotments 4 and 2, section 9, Parish of Holcombe, allotments 20A4, 20A2, 20J, 20E and 20B, across Tarilta Creek, through allotments 20d, 20c and 7g, and allotments 3, 2a and 1A, section A, Parish of Holcombe; thence passing through a State Forest area, through allotment 11, section 5A, Parish of Yandoit, and a State Forest area, through allotment 19, section 4A, a State Forest area, allotments 8, 7 and 1, section 7A, a State Forest area, allotments 3A and 3B, section 7, and allotments 4e, 7 and 5, section 6; thence crossing the Midlands Highway to pass through allotment 1, section 6, Parish of Yandoit; thence through allotments 5 and 4A, section 13, Parish of Guildford, along an unnamed road for a distance of approximately half a mile; thence through allotments 12, 7, 7A and part allotment 5, across the Maryborough—Castlemaine rail line, through part allotment 5, across the Loddon River, through allotment 9, section 9, allotments 2A, 2B, 2d, 2c, 16A, 16b, 19, 11b and 11A, section 11, and allotments 14, 13, 10A, 7B and 18, section 12, Parish of Guildford; thence through allotments 56, 52, 50A, 50, 41, 32, 17, 8, 6, 3 and 2, section 7, allotments 40, 35, 31 and 27, section 8, Parish of Muckleford; thence crossing the Pyrenees Highway to pass through allotments 25, 22, 18, 14, 10, 7A, 6, 4 and 3A, across the Castlemaine—Maldon-road, through allotment 2b, across a State Electricity Commission of Victoria easement and through allotment 2c, section 8, allotments 13A, 27 and 3A and allotment 5, section 9A, occupied by Alexander Homes, Castlemaine, and allotment 21, section 9, formerly Crown land previously occupied by the Reformatory Prison and the Asylum Reserve now occupied by Alexander Homes, across the Maldon—Castlemaine rail line, and through allotments 16, 12 and 3, section 9, Parish of Muckleford; thence through allotments 7A and 11, section 6, allotments 9, 6A, 19c, 19A, 20, 21, 22A and 22c, section 7, allotments 19, 18b, 18A, 17 and 16, and land being part allotment 16, section 8, owned by the Shire of Maldon, across Fogarty's Gap-road and through allotments 13A and 13, section 8, Parish of Walmer; thence through allotments C and A, allotment 2A, Crown land being a former quarry reserve, allotment 4b and 4c, section 29; thence continuing in a northerly direction to enter and continue along an unmade and unused road reserve to Boundary-road; thence across such road, through allotment 1, section 16, allotments 9, 8b, 8A and 7A, section 7 and allotment 7, section 15, across the Black Stump-road; through allotment 1, section 6, Parish of Ravenswood; thence through allotments 2 and 1, section 4, across Bullock Creek and through allotments 5, 7, 8 and 9, section 4, Parish of Mandurang, to enter Crown land vested in the State Rivers and Water Supply Commission being the Sandhurst Water Supply Reserve, Parish of Mandurang, and terminate at a pressure regulating station known as the Bendigo City Gate, owned and operated by the Gas and Fuel Corporation of Victoria.

Line 5.—A steel pipeline 6.1 miles long with an internal diameter of 8 inches and designed to operate at a maximum pressure of 275 p.s.i.g. commencing at a pressure regulating station being the terminal point of Line 4 and proceeding in a north-westerly direction to the north-west corner of allotment 14A, section 1D, Parish of Mandurang containing the Sandhurst Water Supply Reserve; thence turning to enter an unnamed road and continue in a north-north-easterly direction along such road to the Calder Highway, to a point approximately 400 feet south of the junction of such highway with Phyllis-street; thence entering and continuing in a northerly direction along the highway to Phyllis-street; thence turning to enter and continue in a generally easterly direction along such street to pass through allotment 95c, section D, Parish of Mandurang, to Crown land containing an unmade and unused road; thence turning to continue in a generally northerly direction along such road to the corner of Taylor-street and Railway-street, Kangaroo Flat, Parish of Mandurang; thence diverting to enter and continue along the eastern side of Railway-street, to a point opposite Chapel-street; thence passing through

property owned by the Victorian Railways, and containing the Melbourne to Bendigo rail line; thence passing through Crown land situated on part section 20, Township of Kangaroo Flat, Parish of Sandhurst, and used as a public park, to the corner of Station-street and Short-street; thence at a point approximately 400 feet north of Station-street, turning to enter and continue in an easterly direction through property owned by the Victorian Railways, across the Melbourne—Bendigo rail line to Allingham-street; thence turning to enter and continue in a northerly and north-easterly direction along the west side of such street, and Breen-street to Thistle-street, City of Bendigo; thence turning to enter and continue in a south-south-easterly direction along the west side of such street to Abel-street; thence turning to enter and continue in an east-north-easterly direction along the south side of such street for a distance of approximately 200 feet; thence turning to enter allotment 20A, section C, Parish of Sandhurst, and terminate at a valve in a regulator station located on such property owned by the Gas and Fuel Corporation of Victoria.

3. Plans of the proposed route of the pipeline system may be inspected commencing Friday, 15th October, 1971, between the hours of 10 a.m. and 4 p.m., on Mondays to Fridays (excluding public holidays), at:—

- (1) Ministry of Fuel and Power,
15th Floor, 171 Flinders-street, Melbourne.
- (2) Gas and Fuel Corporation of Victoria's Offices
at—8th Floor, 171 Flinders-street, Melbourne,
and at Ballarat, Bendigo and Castlemaine.
- (3) Municipal Offices at—
Ballarat.
Buninyong.
Ballan.
Bacchus Marsh.
Werribee.
Melton.
Sunshine.
Bendigo.
Marong.
Maldon.
Newstead.
Daylesford and Glenlyon.
Strathfieldsaye.

in respect to that part of the pipeline(s) which passes through the particular municipality named.

Additional copies of plans are not available and detailed route plans can be seen only at the Gas and Fuel Corporation of Victoria's Drawing Office, 8th Floor, 171 Flinders-street, Melbourne.

4. Any objection to the proposed route of the pipeline must be addressed to me and reach the Office of the Ministry no later than Friday, 19th November, 1971.

J. C. M. BALFOUR,
Minister for Fuel and Power.

15th October, 1971.

AUCTION SALES ACT 1958.

KERANG.—Notice is hereby given that the Annual Meeting of Justices for the Licensing of Auctioneers will be held at the Law Courts, Kerang, on Tuesday, the 23rd day of November, 1971, at the hour of 10 o'clock in the forenoon. Dated at Kerang this 12th day of October, 1971.—K. T. RYAN, Clerk of the Magistrates' Court.

NHILL.—Notice is hereby given that the Annual Meeting of Justices for the Licensing of Auctioneers will be held at the Magistrates' Court, Nhill, on Tuesday, the 23rd day of November, 1971, at the hour of 10 o'clock in the forenoon. Dated at Nhill this 13th day of October, 1971.—T. J. SMALLEY, Clerk of the Magistrates' Court.

STAWELL.—Notice is hereby given that the Annual Meeting of Justices for the Licensing of Auctioneers will be held at the Court House, at Stawell, on Tuesday, the 22nd day of November, 1971, at 10 o'clock in the forenoon. Dated at Stawell this 8th day of October, 1971.—G. B. DALTON, Clerk of the Magistrates' Court.

AUCTION SALES ACT.

List of persons to whom Auctioneer's Licences have been issued during the month of September, 1971 and prior months.

Name.	Address.	Date of Issue.
Bridle, Sidney Ronald John	54 Menin-road, Forest Hill	12.8.71
Chester, James Norman	McEachern-street, East Bairnsdale	23.7.71
Clarke, Calvert John	8 Stawell-street, Kew	10.9.71
Constable, William James	Avoca	18.8.71
Craig, Ralph Gordon	73 Sutcliffe-street, Shepparton	6.8.71
Daw, Stanley Livingstone	22 Whitton-parade, East Coburg	14.9.71
Dickson, Roger Norman	9A Tooronga-street, Dandenong	7.9.71
Evison, Kenneth Robert	5 Sandy-court, Dandenong	10.9.71
Haass, Albert	3 Langley-street, Ardeer	23.8.71
Hamilton, Peter Edward	1029 Mate-street, North Albury, N.S.W.	15.7.71
Hewitt, John Stanislaus	56 Addison-street, Casterton	6.5.71
Hughes, Garth Balmer	55 Lemon-grove, Nunawading	9.9.71
Johnson, Henry Lynn	3 Louisville-avenue, Pascoe Vale South	3.8.71
Keily, Joseph Robert	28 Melville-road, Pascoe Vale South	7.7.71
King, Dennis Alfred	Clifton-street, Clifton Springs	9.6.71
Langsam, Victor Joseph	5 Florence-street, Carnegie	5.8.71
Levens, David	930 Centre-road, South Oakleigh	8.7.71
Lister, Howard John	1 Beaumont-road, Berwick	27.9.71
McGinley, Maxwell Francis	Lot 49, Eggleston-street, Ocean Grove	15.7.71
McGorlick, Kerry Graeme	Flat 3, 22 Rosella-street, Murrumbidgee	7.9.71
McKenna, Colin Bernard	"Yaltara" Grassmere	19.8.71
McNamara, David James	13 John-street, Shepparton	23.6.71
*Mahony, John	67 Baillie-street, Horsham	12.7.71
Murdoch, Robert Francis	9 Tiffany-street, Cheltenham	19.7.71
O'Keefe, James	572 Keilor-road, East Keilor	26.7.71
Passmore, Robert Edbrooke	875 Hampton-street, Brighton	13.9.71
Purtell, William Francis	776 Park-avenue, Albury, N.S.W.	25.8.71
Rowley, William Bailey	Flat 9, 13 Bertram-street, Gardenvale	1.9.71
Russo, Gennaro	33 Main-street, Coburg	9.7.71
Ryan, Andrew Francis	Woomelang	1.1.71
Smith, Raymond Francis	18A Stud-road, Dandenong	3.8.71
Stefanou, John Peter	Flat 6, 82 Warragul-road, Mentone	19.7.71
Stella, Giovanni	26 Warburton-street, Brunswick	9.7.71
Sullivan, Eugene Bernard	39 Celeste-avenue, East Doncaster	6.7.71
Sutton, David McIntosh	131 North-road, Reservoir	9.7.71
Szancer, Leslie	Flat 1, 22 Kendell-street, Elwood	7.7.71
Tamagno, Bruce	83 Panorama-drive, Mt. Martha	10.9.71
Thomas, Herbert Lloyd	9 The Avenue, East Malvern	12.7.71
Thomas, Peter Ronald	6 Montrose-court, Toorak	13.9.71
Thornton, Michael James	155 Hearn-street, Colac	7.7.71
Wallis, John Alfred	Stevenson-street, Murchison	20.9.71
Webb, Michael Richard	202 Noble-street, Geelong	24.8.71
Weel, Cornell	62 Tallangatta-road, Wodonga	26.8.71
Withers, Arthur Colville	197 Church-street, Brighton	9.9.71

The Treasury,
Melbourne, 3002.

* Licence transferred from Anthony P. Smith.

E. W. COATES,
Director of Finance.

PUBLIC TRUSTEE ACT 1958 (No. 6350), SECTION 17

I hereby give notice that on the 29th September, 1971, the Public Trustee filed elections to administer the following deceased persons' estates in accordance with section 17 of the Public Trustee Act 1958:—

BURDA, SILVESTER, late of 55 Graeme-street, Newport, retired labourer, died 17th May, 1971.

CARVER, CATHERINE HELEN DEWAR, late of Flat 7, 7 Hedgley-avenue, East Malvern, married woman, died 25th June, 1971.

CORNOCK, ELLEN CHARLOTTE, late of 100-104 Barnard-street, Bendigo, spinster, died 18th May, 1971.

FINCHETT, JOHN, late of Flat 8, 28 Patterson-street, Middle Park, toolmaker, died 13th June, 1971.

GREBNER, REX MALCOLM, late of Bundoora, pensioner, died 30th April, 1971.

HAYE, DE LA EDWARD JAMES, late of 254 Main-road, Upper Ferntree Gully, invalid pensioner, died 15th July, 1971.

JAMIESON, ANDREA MAY, late of 18 Narrawong-road, Caulfield, spinster, died 4th August, 1971.

JOHNSON, FRANCIS GUSTAV, also known as Johnson Francis Gustave, late of 19 (referred to in the will as 21) Hayden-road, Clayton, retired shoe repairer, died 14th August, 1971.

JORDAN, EMILY, also known as Johnstone Emily, late of 20 Wellington-street, Richmond, married woman, died 10th August, 1971.

KEARNEY, CHRISTOPHER WILLIAM, late of 116 Francis-street, Ascot Vale, retired cleaner, died 27th August, 1971.

MAES, ELSIE PRISCILLA, also known as Elsie Maes, formerly of Flat 1, 19 Palmer-street, Collingwood, but late of Caritas Christi Hospice, 104 Studley Park-road, Kew, retired presser, died 28th June, 1971.

McFARLANE, EMILY EVELINE ELIZABETH, late of Flat 3, 4 Norfolk-street, Yarraville, widow, died 6th July, 1971.

O'CONNOR, JAMES REGINALD, late of 1 Lincoln-street, Yarraville, retired foreman, died 17th July, 1971.

REED, JOHANNA, late of Horwood-drive, Breamlea, widow, died 7th September, 1968.

SHAW, ERIC JOHN, late of rear of 338 Burwood-road, Hawthorn, welder, died 12th June, 1970.

STEPHENSON, BASIL, late of 53 Fulton-street, Clayton (formerly of Lot 24 Fulton-street, East Oakleigh), storeman, died 30th June, 1971.

SYMONS, WILLIAM NICHOLAS, late of 21 York-street, East Ballarat, retired plumber, died 7th July, 1971.

THOMPSON, WINIFRED TYRRELL, (in the will called Thompson, Winifred Tyrell), late of Unit 2, Maranoa Court, 8 Parring-road, Balwyn, home duties, died 1st March, 1971.

THORNTON, ADELINA LINDA, late of 14 Rathmines-street, Fairfield, widow, died 23rd June, 1971.

TRUEMAN, JEANNIE, late 143 (in the will referred to as lot 52) Oak-street, Beaumaris, married woman, died 22nd July, 1971.

WEARNE, MYRTLE ANNIE MARIE, formerly of 7 Storey-avenue, Research, late of 66 Denham-street, Hawthorn, widow, died 7th July, 1971.

WEEDON, ALEXANDER ARTHUR, (in the will called Alexander Weedon), formerly of 53 Dunstan-parade, Port Melbourne, but late of Wandella Private Hospital, 97 Ormond-esplanade, Elwood, retired painter, died 13th April, 1971.

WILLIAMS, ALICE MAY, late of 102 Ascot-street, South Ballarat, widow, died 18th February, 1971.

I hereby give notice that on the 5th October, 1971, the Public Trustee filed elections to administer the following deceased persons' estates in accordance with section 17 of the *Public Trustee Act 1958*:—

BEACHAM, ALBERT, late of 220 Moreland-road, Brunswick, retired, died 27th July, 1971.

BORMAN, VIOLET LOUISA, also known as Violet Louisa Boreman, formerly of 82 Gwynne-street, Richmond, but late of 16 William-street, Hawthorn, retired cleaner, died 24th July, 1971.

DAVIES, ALFRED ERNEST, also known as Ernest Alfred Davies, late of 68 Church-street, Yallourn, 3838, electrical fitter, died 27th November, 1970.

GOOD, HELEN CURTIS, formerly of 72 Brewster-street, Essendon, but late of Henley-road, Kangaroo Ground, spinster, died 13th July, 1971.

GUNNYON, MARGUERITE MYRTLE, late of 128 Shaftesbury-street, West Coburg, widow, died 19th July, 1971.

SCHMIDT, GIRLIE, formerly of 46 Elizabeth-street, Malvern, but late of Studley Park Private Hospital, Kew, widow, died 13th July, 1971.

SHEPHERD, ROBERT, late of 276 Graham-street, Port Melbourne, cleaner, died 26th May, 1971.

TAYLOR, ALBERT EDWARD, formerly of 317A Geelong-road West Footscray, but late of Unit 3, 2 Kardella-street, East Malvern, retired industrial chemist, died 11th August, 1971.

WELLS, JAMES ALEXANDER, late of 737 Nepean Highway, East Brighton, cleaner, died 9th June, 1971.

N. P. BRODY,
Public Trustee.

256 Flinders-street, Melbourne, 3000, 13th October, 1971.

NOTICE.

Creditors, next of kin, and others having claims against the estate of any of the under-mentioned deceased persons are required to send particulars of their claims to the Public Trustee, 256 Flinders-street, Melbourne, Vic. 3000, the personal representative, on or before the 27th December, 1971, after which date the Public Trustee may convey or distribute the assets, having regard only to the claims of which the Public Trustee then has notice.

BARKER, HENRY JOHN, late of 20 Hoddle-street, Essendon, retired life assurance official, died 28th June, 1971.

BEACHAM, ALBERT, late of 220 Moreland-road, Brunswick, retired, died 27th July, 1971.

BORMAN, VIOLET LOUISA, also known as Violet Louisa Boreman, formerly of 82 Gwynne-street, Richmond, but late of 16 William-street, Hawthorn, retired cleaner, died 24th July, 1971.

BURDA, SILVESTER, late of 55 Graeme-street, Newport, retired labourer, died 17th May, 1971.

CARVER, CATHERINE HELEN DEWAR, late of Flat 7, 7 Hedgley-avenue, East Malvern, married woman, died 25th June, 1971.

CORNOCK, ELLEN CHARLOTTE, late of 100-104 Barnard-street, Bendigo, spinster, died 18th May, 1971.

DAVIES, ALFRED ERNEST, also known as Ernest Alfred Davies, late of 68 Church-street, Yallourn, 3838, electrical fitter, died 27th November, 1970.

FINCHETT, JOHN, late of Flat 8, 28 Patterson-street, Middle Park, toolmaker, died 13th June, 1971.

GOOD, HELEN CURTIS, formerly of 72 Brewster-street, Essendon, but late of Henley-road, Kangaroo Ground, spinster, died 13th July, 1971.

GREBNER, REX MALCOLM, late of Bundoora, pensioner, died 30th April, 1971.

GUNNYON, MARGUERITE MYRTLE, late of 128 Shaftesbury-street, West Coburg, widow, died 19th July, 1971.

GUY, PHILLIP RICHARD CHERGWIN, late of Finniston, Western Australia, storekeeper, died 26th April, 1971.

HAYE, DE LA EDWARD JAMES, late of 254 Main-road, Upper Ferntree Gully, invalid pensioner, died 15th July, 1971.

HENDERSON, DOUGLAS THOMAS, late of 58 View-street Clayton, retired engineer, died 4th July, 1971.

JAMIESON, ANDREA MAY, late of 18 Narrawong-road, Caulfield, spinster, died 4th August, 1971.

JOHNSON, FRANCIS GUSTAV, also known as Johnson Francis Gustave, late of 19 (referred to in the will as 21) Hayden-road, Clayton, retired shoe repairer, died 14th August, 1971.

JORDAN, EMILY, also known as Johnstone Emily, late of 20 Wellington-street, Richmond, married woman, died 10th August, 1971.

KEARNEY, CHRISTOPHER WILLIAM, late of 116 Francis-street, Ascot Vale, retired cleaner, died 27th August, 1971.

KINDER, SARAH MARY, late of Flat 4, 65 Park-street, St. Kilda, widow, died 29th April, 1971.

MAES, ELSIE PRISCILLA, also known as Elsie Maes, formerly of Flat 1, 19 Palmer-street, Collingwood, but late of Caritas Christi Hospice, 104 Studley Park-road, Kew, retired presser, died 28th June, 1971.

McFARLANE, EMILY EVELINE ELIZABETH, late of Flat 3, 4 Norfolk-street, Yarraville, widow, died 6th July, 1971.

O'CONNOR, JAMES REGINALD, late of 1 Lincoln-street, Yarraville, retired foreman, died 17th July, 1971.

POOLE, LEONARD ERNEST, late of Johns-crescent, Mount Evelyn, painter, died 13th June, 1971.

REED, JOHANNA, late of Horwood-drive, Breamlea, widow, died 7th September, 1968.

SCHMIDT, GIRLIE, formerly of 46 Elizabeth-street, Malvern, but late of Studley Park Private Hospital, Kew, widow, died 13th July, 1971.

SHAW, ERIC JOHN, late of rear of 338 Burwood-road, Hawthorn, welder, died 12th June, 1970.

SHEPHERD, ROBERT, late of 276 Graham-street, Port Melbourne, cleaner, died 26th May, 1971.

STEPHENSON, BASIL, late of 53 Fulton-street, Clayton (formerly of lot 24, Fulton-street, East Oakleigh), storeman, died 30th June, 1971.

SYMONS, WILLIAM NICHOLAS, late of 21 York-street, East Ballarat, retired plumber, died 7th July, 1971.

TAYLOR, ALBERT EDWARD, formerly of 317A Geelong-road West Footscray, but late of Unit 3, 2 Kardella-street, East Malvern, retired industrial chemist, died 11th August, 1971.

THOMAS, WILLIAM ERNEST, late of 17 Loch-street, St. Kilda, retired compositor, died 26th August, 1970.

THOMPSON, WINIFRED TYRRELL, (in the will called Thompson, Winifred Tyrell), late of Unit 2, Maranoa Court, 8 Parring-road, Balwyn, home duties, died 1st March, 1971.

THORTON, ADELINA LINDA, late of 14 Rathmines-street, Fairfield, widow, died 23rd June, 1971.

TRUEMAN, JEANNIE, late 143 (in the will referred to as lot 52) Oak-street, Beaumaris, married woman, died 22nd July, 1971.

WEARNE, MYRTLE ANNIE MARIE, formerly of 7 Storey-avenue, Research, but late of 66 Denham-street, Hawthorn, widow, died 7th July, 1971.

WEEDON, ALEXANDER ARTHUR, (in the will called Alexander Weedon), formerly of 53 Dunstan-parade, Port Melbourne, but late of Wandella Private Hospital, 97 Ormond-esplanade, Elwood, retired painter, died 13th April, 1971.

WELLS, JAMES ALEXANDER, late of 737 Nepean Highway, East Brighton, cleaner, died 9th June, 1971.

WILLIAMS, ALICE MAY, late of 102 Ascot-street, South Ballarat, widow, died 18th February, 1971.

WILLIS, LORNA MAUD, formerly of 183 Pickles-street, Port Melbourne and 35 Beaconsfield-parade, Thornbury, but late of 119A Mansfield-street, Thornbury, spinster, died 13th July, 1971.

N. P. BRODY,
Public Trustee.

Melbourne, 13th October, 1971.

COUNTRY ROADS BOARD.

RESOLUTIONS OF THE COUNTRY ROADS BOARD.

The Country Roads Board, in pursuance of the provisions of the *Country Roads Act 1958*, has passed Resolutions the dates whereof and the terms of which are Scheduled hereunder:—

SCHEDULE.

State Highways.

Resolution dated the Twenty-seventh day of September, One thousand nine hundred and seventy-one, made pursuant to sections 21 and 74 of the *Country Roads Act 1958*, declaring the widening of the Hume Highway in the Shire of Kilmore as shown hatched on Plan numbered G.P.6839A hereunder to be part of a State highway within the meaning and for the purposes of the said Act.

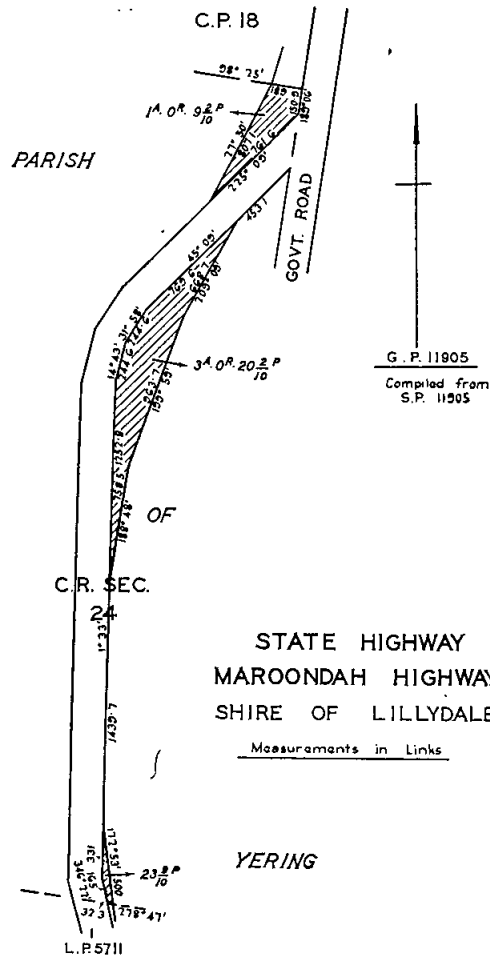
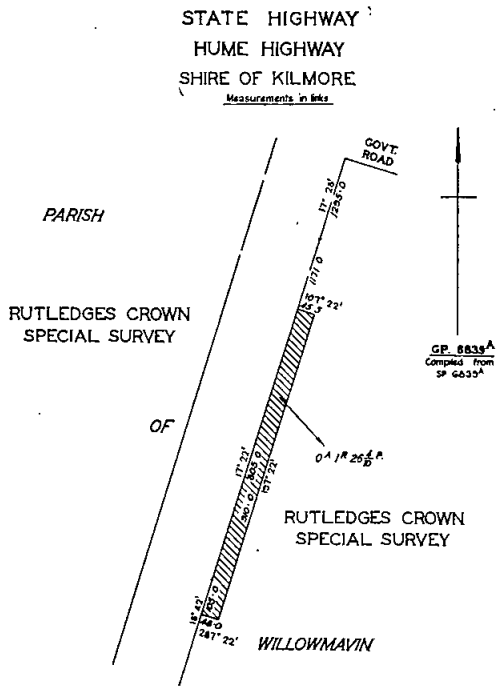

Resolution dated the Twenty-seventh day of September, One thousand nine hundred and seventy-one, made pursuant to sections 21 and 74 of the *Country Roads Act 1958*, declaring the widening of the Maroondah Highway in the Shire of Lillydale as shown hatched on Plans numbered G.P.11904, G.P.11905 and G.P.11906 hereunder to be part of a State highway within the meaning and for the purposes of the said Act.

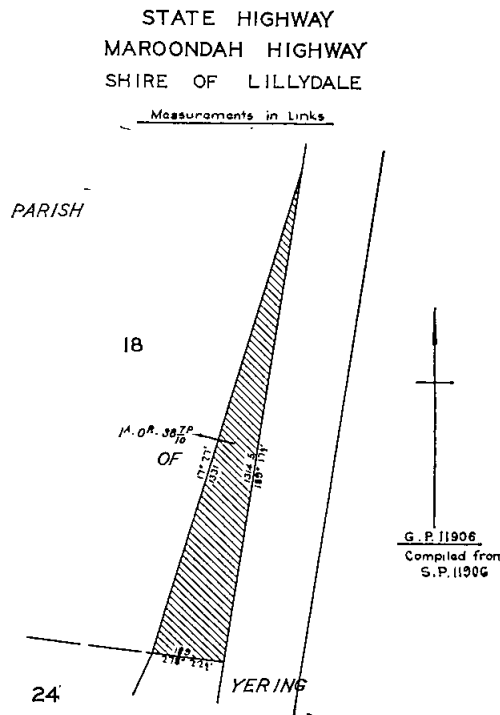
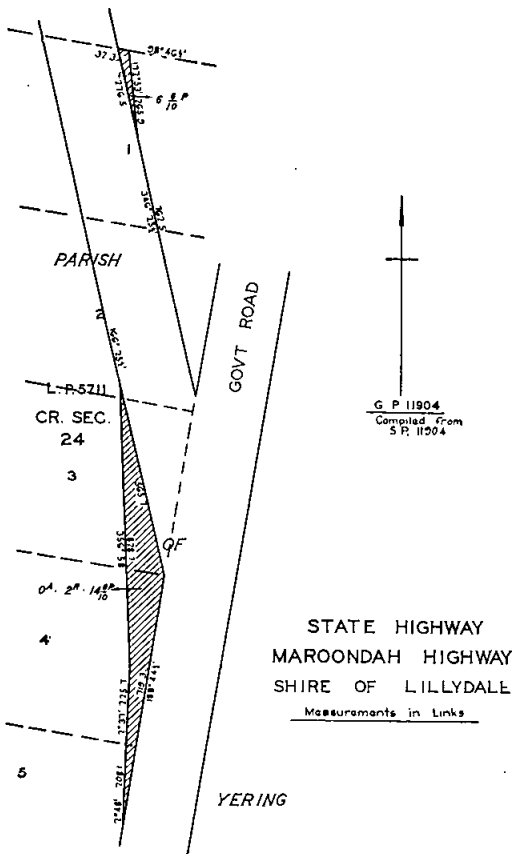

Resolution dated the Twenty-seventh day of September, One thousand nine hundred and seventy-one, made pursuant to sections 21 and 74 of the *Country Roads Act 1958*, declaring the widening of the Princes Highway in the City of Sunshine as shown hatched on Plans numbered G.P.7581 and G.P.7650 hereunder to be part of a State highway within the meaning and for the purposes of the said Act.

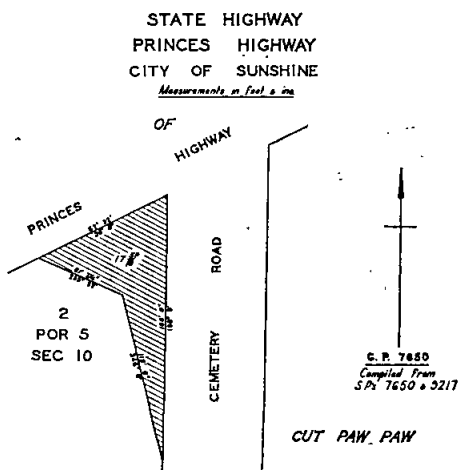
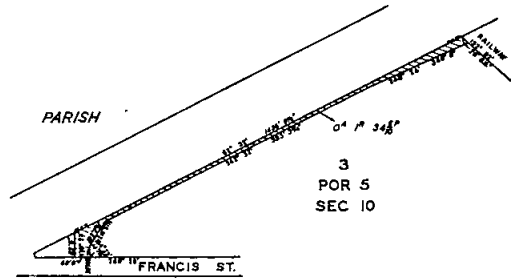
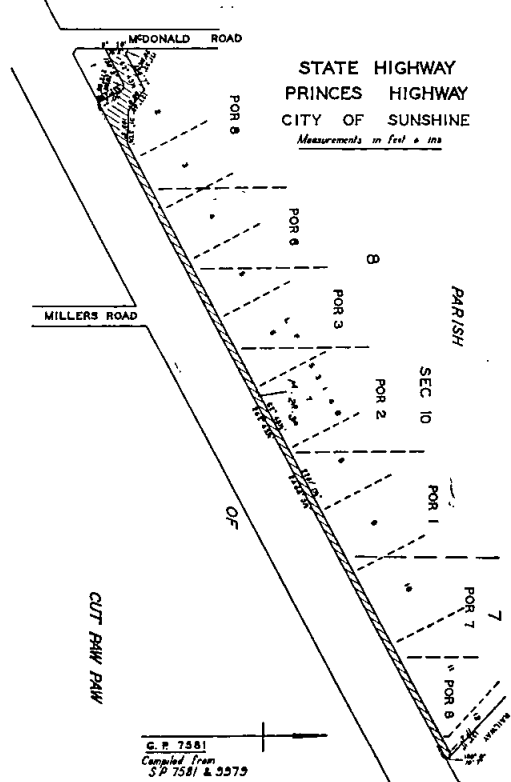

Resolution dated the Twenty-seventh day of September, One thousand nine hundred and seventy-one, made pursuant to sections 21 and 74 of the *Country Roads Act 1958*, declaring the widening of the Princes Highway in the City of Sunshine as shown hatched on Plan numbered G.P.10811B hereunder to be part of a State highway within the meaning and for the purposes of the said Act.

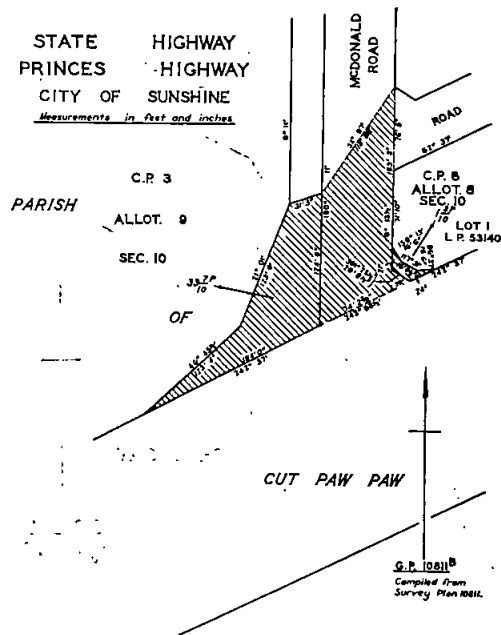

Main Roads.

Resolution dated the Twenty-seventh day of September, One thousand nine hundred and seventy-one, made pursuant to section 21 of the *Country Roads Act 1958*, declaring the widening of the Goorambat-Thoona road in the Shire of Benalla as shown hatched on Plan numbered G.P.7502 hereunder to be part of a main road within the meaning and for the purposes of the said Act.

**MAIN ROAD
GOORAMBAT - THOONA ROAD
SHIRE OF BENALLA**
Measurements in Links

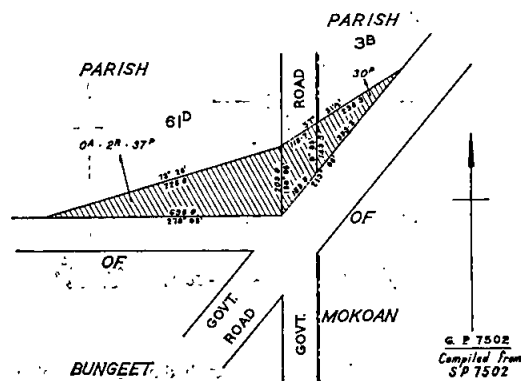

Resolution dated the Twenty-seventh day of September, One thousand nine hundred and seventy-one, made pursuant to section 21 of the *Country Roads Act 1958*, declaring the widening of the Healesville-Koo-Wee-Rup road in the Shire of Berwick as shown hatched on Plans numbered G.P.7514 and G.P.7515 hereunder to be part of a main road within the meaning and for the purposes of the said Act.

MAIN ROAD
HEALESVILLE - KOO-WEE-RUP ROAD
SHIRE OF BERWICK

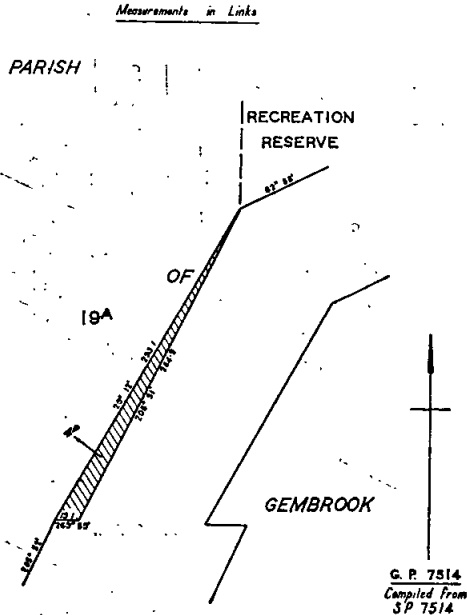

MAIN ROAD
BRIGHT - TAWONGA ROAD
SHIRE OF BRIGHT

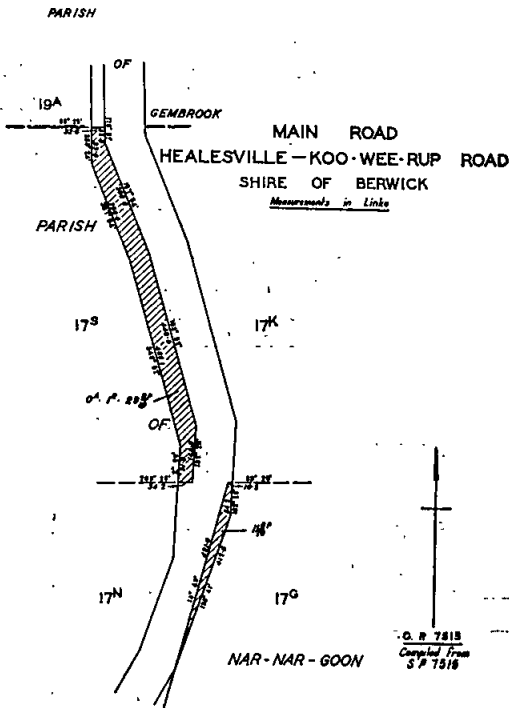
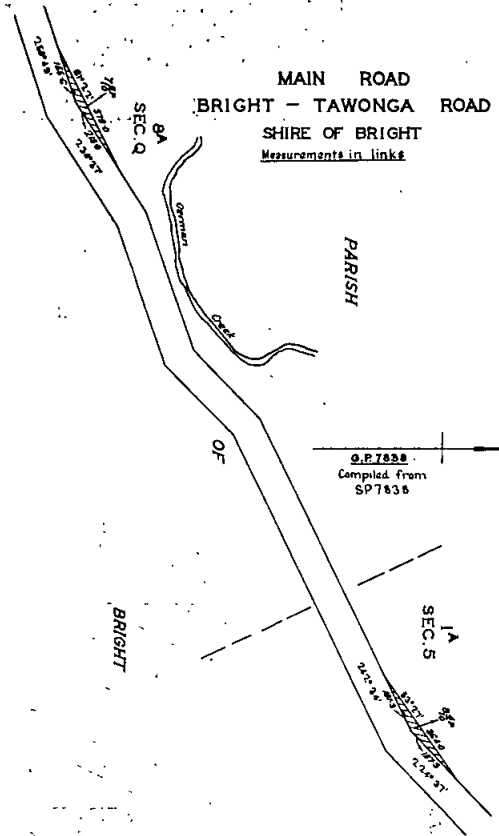

MAIN ROAD
NATHALIA - KATAMATITE ROAD
SHIRE OF COBRAM

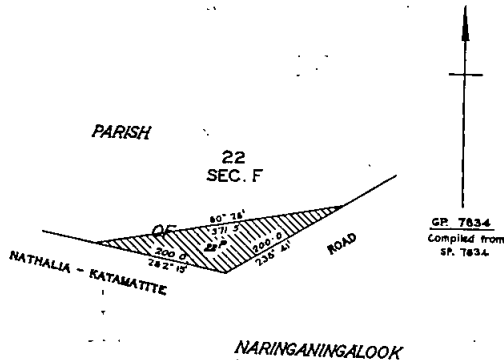

Resolution dated the Twenty-seventh day of September, One thousand nine hundred and seventy-one, made pursuant to section 21 of the Country Roads Act 1958, declaring the widening of the Bright-Tawonga road in the Shire of Bright as shown hatched on Plan numbered G.P.7838 hereunder to be part of a main road within the meaning and for the purposes of the said Act.

Resolution dated the Twenty-seventh day of September, One thousand nine hundred and seventy-one, made pursuant to section 21 of the Country Roads Act 1958, declaring the widening of the Nathalia-Katamatite road in the Shire of Cobram as shown hatched on Plan numbered G.P.7834 hereunder to be part of a main road within the meaning and for the purposes of the said Act.

Resolution dated the Twenty-seventh day of September, One thousand nine hundred and seventy-one, made pursuant to section 21 of the Country Roads Act 1958, declaring the widening of the Castlemaine-Ballarat road in the Shire of Creswick as shown hatched on Plan numbered G.P.12408 hereunder to be part of a main road within the meaning and for the purposes of the said Act.

MAIN ROAD
CASTLEMAINE - BALLARAT ROAD
SHIRE OF CRESWICK
Measurements in Links

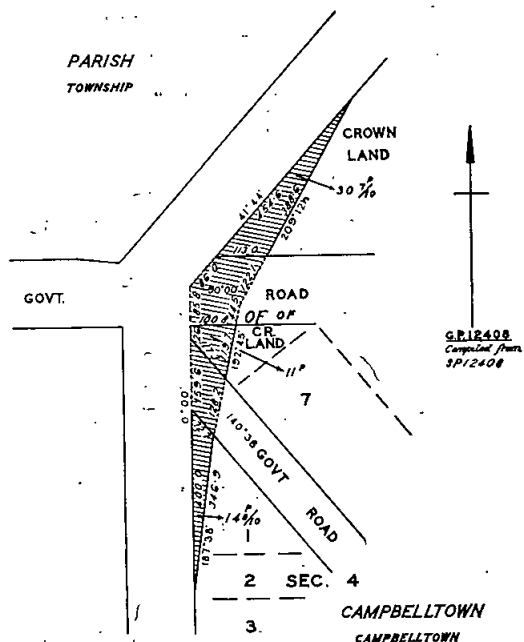

MAIN ROAD
HEIDELBERG - KINGLAKE ROAD
SHIRE OF ELTHAM
Measurements in Links

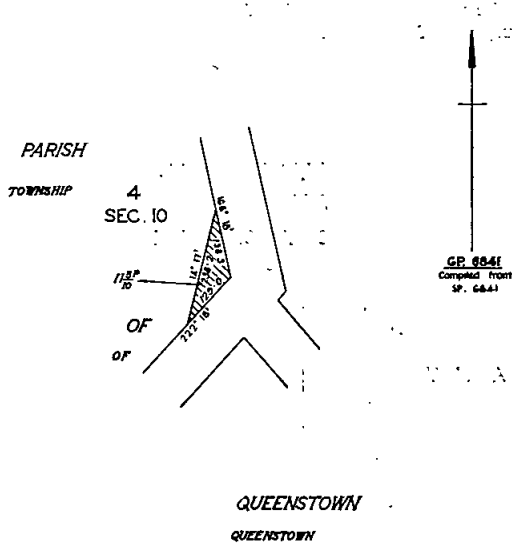

Resolution dated the Twenty-seventh day of September, One thousand nine hundred and seventy-one, made pursuant to section 21 of the Country Roads Act 1958, declaring the widening of the Heidelberg-Kinglake road in the Shire of Eltham as shown hatched on Plans numbered G.P.6840, G.P.6841 and G.P.7599 hereunder to be part of a main road within the meaning and for the purposes of the said Act.

MAIN ROAD
HEIDELBERG - KINGLAKE ROAD
SHIRE OF ELTHAM
Measurements in Links

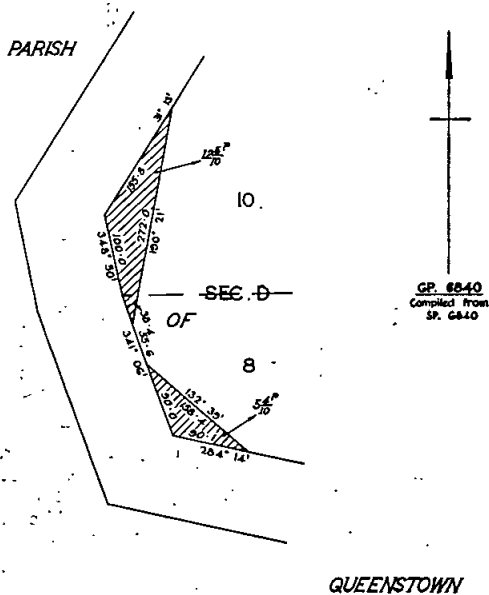

MAIN ROAD
HEIDELBERG - KINGLAKE ROAD
SHIRE OF ELTHAM
Measurements in Links

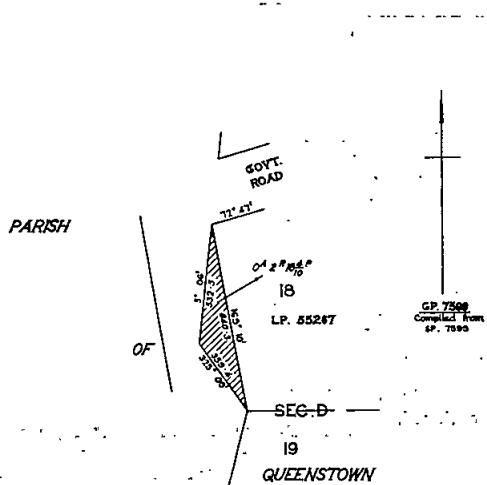

Resolution dated the Twenty-seventh day of September, One thousand nine hundred and seventy-one, made pursuant to section 21 of the *Country Roads Act 1958*, declaring the widening of Stud-road in the City of Knox as shown hatched on Plan numbered G.P.10641A hereunder to be part of a main road within the meaning and for the purposes of the said Act.

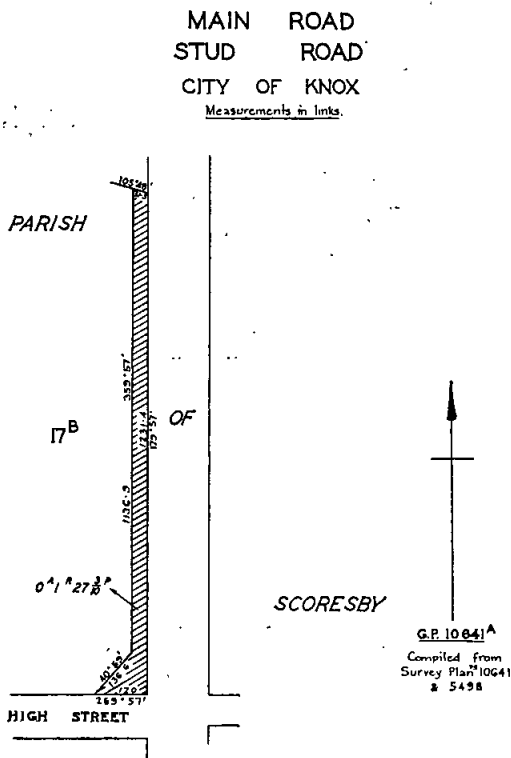

Resolution dated the Twenty-seventh day of September, One thousand nine hundred and seventy-one, made pursuant to sections 21 and 58 of the *Country Roads Act 1958*, declaring the deviation from the Korumburra-Wonthaggi road in the Shire of Korumburra as indicated by diagonal hatching on Plans numbered G.P.12200 and G.P.12201 hereunder to be part of a main road within the meaning and for the purposes of the said Act, and also declaring that such deviation shall be in lieu of the existing road or part thereof indicated by cross-hatching and horizontal hatching on Plan numbered G.P.12200 and cross-hatching on the said plans shall be discontinued.

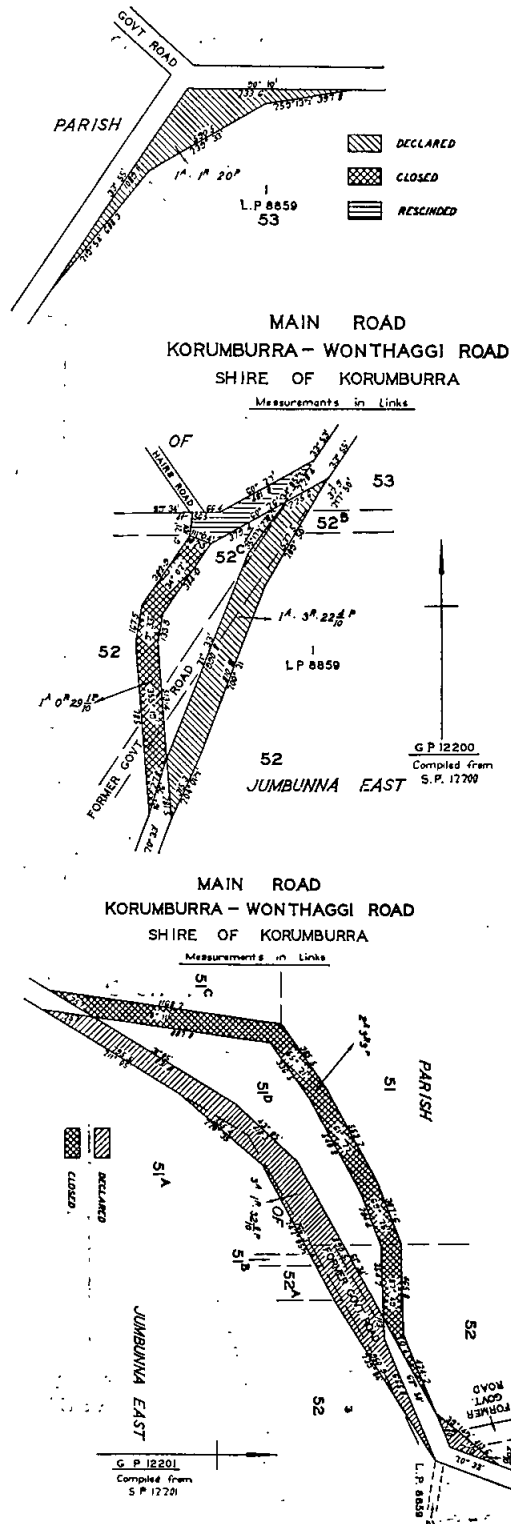

Resolution dated the Twenty-seventh day of September, One thousand nine hundred and seventy-one, made pursuant to section 21 of the *Country Roads Act 1958*, declaring the widening of Lorquon-road in the Shire of Lowan as shown hatched on Plan numbered G.P.7454 hereunder to be part of a main road within the meaning and for the purposes of the said Act.

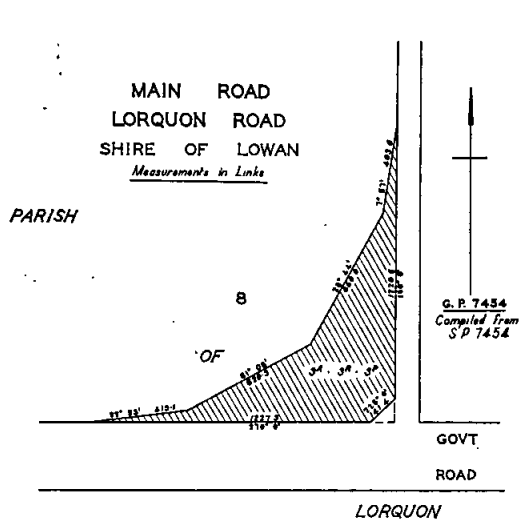

Resolution dated the Twenty-seventh day of September, One thousand nine hundred and seventy-one, made pursuant to section 21 of the *Country Roads Act 1958*, declaring the widening of Ventnor-road in the Shire of Phillip Island as shown hatched on Plans numbered G.P.7403 and G.P.7831 hereunder to be part of a main road within the meaning and for the purposes of the said Act.

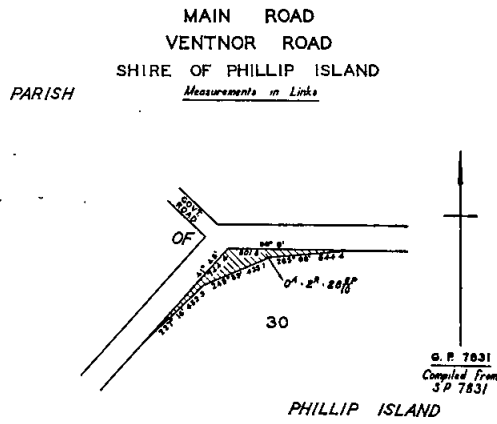

Resolution dated the Twenty-seventh day of September, One thousand nine hundred and seventy-one, made pursuant to sections 21 and 58 of the *Country Roads Act 1958*, declaring the deviation from Yabba-road in the Shire of Towong as indicated by diagonal hatching on Plan numbered G.P.12402 hereunder to be part of a main road within the meaning and for the purposes of the said Act, and also declaring that such deviation shall be in lieu of the existing road or part thereof indicated by cross-hatching on the said plan and that such part of the said existing road shall be discontinued.

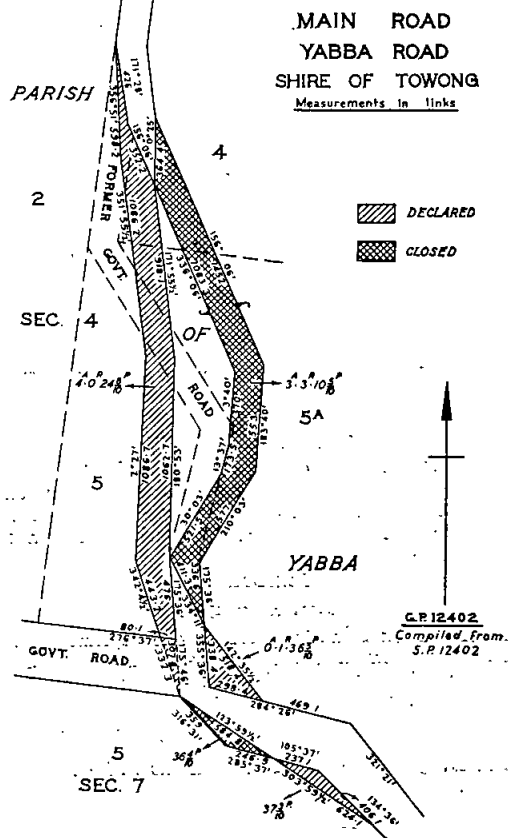
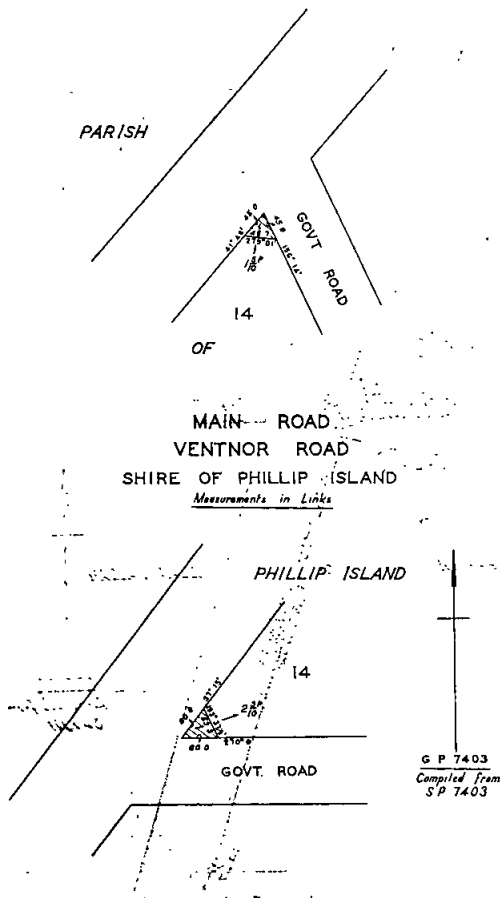

Unclassified Road

Resolution dated the Twenty-seventh day of September, One thousand nine hundred and seventy-one, made pursuant to sections 21 and 110 of the *Country Roads Act 1958*, declaring the widening of McDonald-road in the City of Sunshine as shown hatched on Plan numbered G.P.10811A hereunder to be part of a road within the meaning and for the purposes of the said Act.

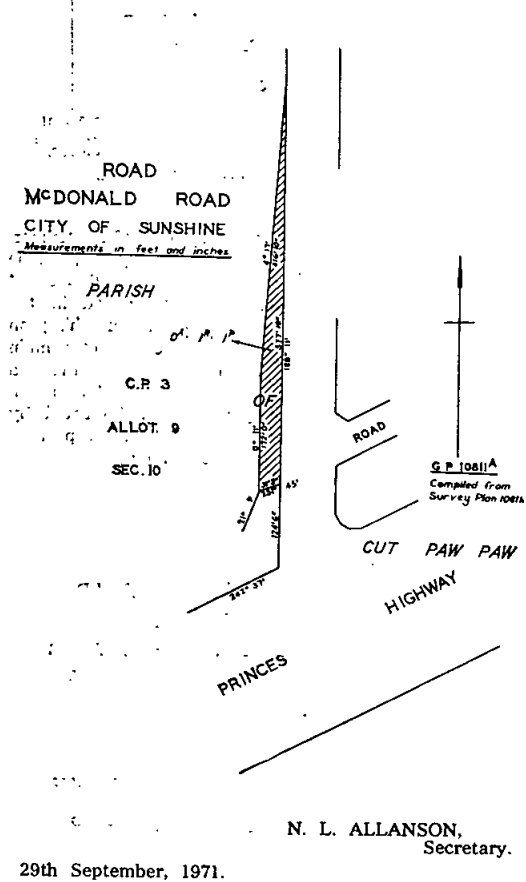

29th September, 1971.

COUNTRY ROADS BOARD.

RESOLUTIONS OF THE COUNTRY ROADS BOARD.

The Country Roads Board, in pursuance of the provisions of the *Country Roads Act 1958*, has passed Resolutions the dates whereof and the terms of which are Scheduled hereunder:—

SCHEDULE.

State Highways.

Resolution dated the Twentieth day of September, One thousand nine hundred and seventy-one, made pursuant to sections 21 and 74 of the *Country Roads Act 1958*, declaring the widening of the Borung Highway in the Shire of Donald as shown hatched on Plan numbered G.P.7705 hereunder to be part of a State highway within the meaning and for the purposes of the said Act.

STATE HIGHWAY
BORUNG HIGHWAY
SHIRE OF DONALD

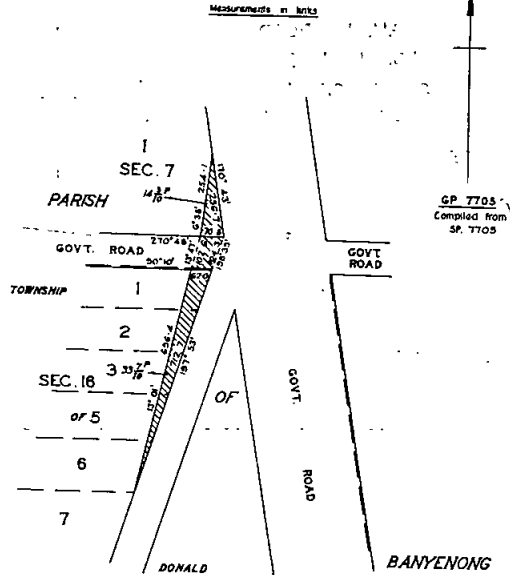

Resolution dated the Twentieth day of September, One thousand nine hundred and seventy-one, made pursuant to sections 21 and 74 of the *Country Roads Act 1958*, declaring the widening of the Hume Highway in the Shire of Kilmore as shown hatched on Plan numbered G.P.7071 hereunder to be part of a State highway within the meaning and for the purposes of the said Act.

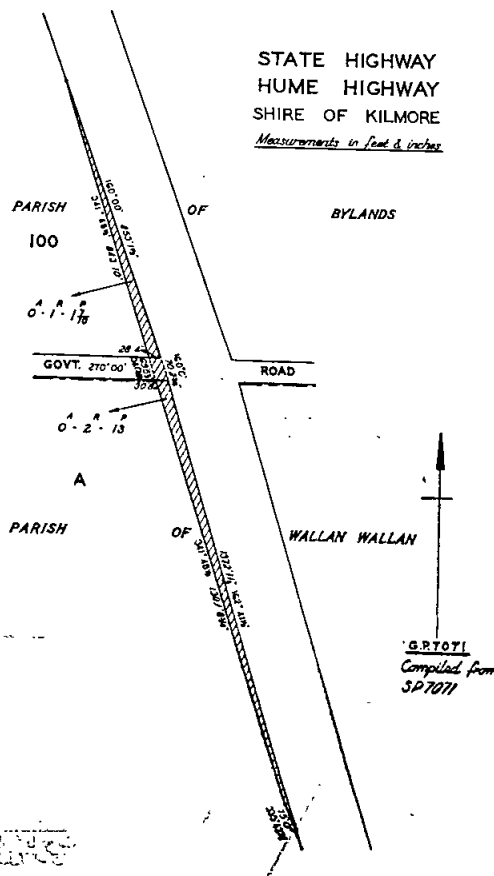

Resolution dated the Twentieth day of September, One thousand nine hundred and seventy-one, made pursuant to sections 21 and 74 of the *Country Roads Act 1958*, declaring the widening of the Murray Valley Highway in the Shire of Nathalia as shown hatched on Plan numbered G.P.7174 hereunder to be part of a State highway within the meaning and for the purposes of the said Act.

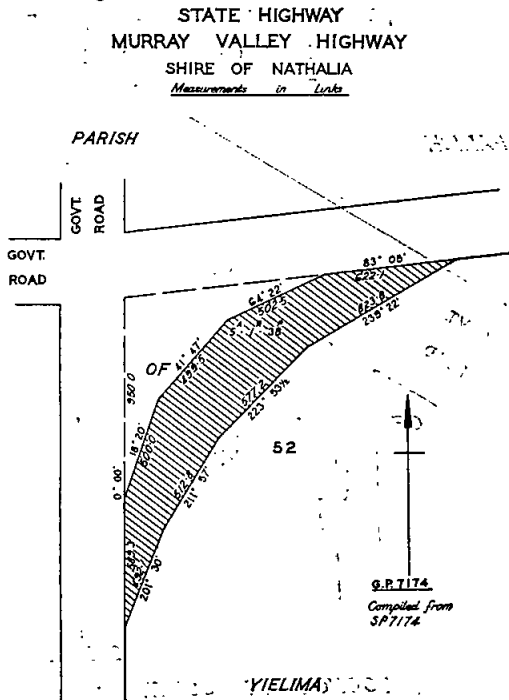

Resolution dated the Twentieth day of September, One thousand nine hundred and seventy-one, made pursuant to section 21 of the *Country Roads Act 1958*, declaring the widening of the Wedderburn-Boort road in the Shire of Korong as shown hatched on Plan numbered G.P.7224 hereunder to be part of a main road within the meaning and for the purposes of the said Act.

MAIN ROAD
WEDDERBURN - BOORT ROAD
SHIRE OF KORONG
Measurements in Links

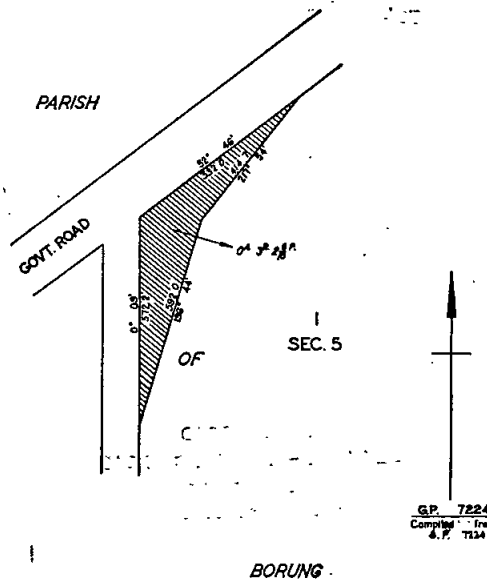

Resolution dated the Twentieth day of September, One thousand nine hundred and seventy-one, made pursuant to section 21 of the *Country Roads Act 1958*, declaring the widening of the Birchip-Sea Lake road in the Shire of Birchip as shown hatched on Plan numbered G.P.7585 hereunder to be part of a main road within the meaning and for the purposes of the said Act.

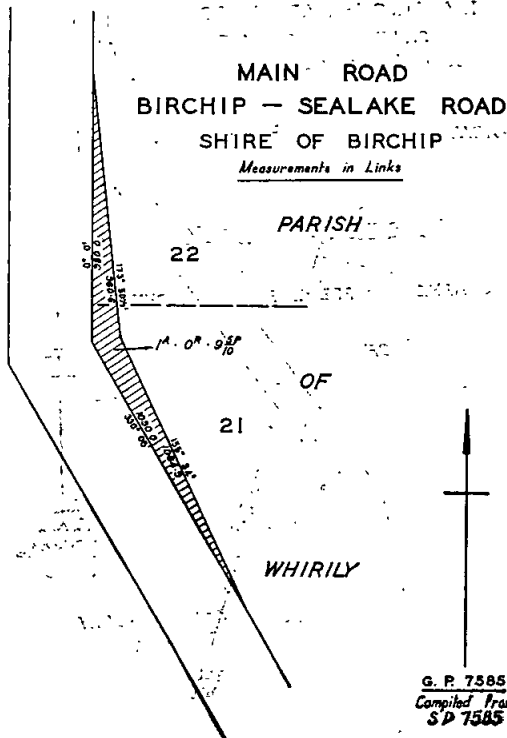

Resolution dated the Twentieth day of September, One thousand nine hundred and seventy-one, made pursuant to section 21 of the *Country Roads Act 1958*, declaring the widening of the Apsley-Natimuk road in the Shire of Kowree as shown hatched on Plan numbered G.P.7290 hereunder to be part of a main road within the meaning and for the purposes of the said Act.

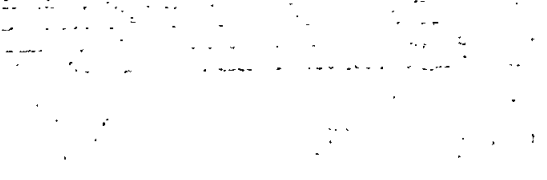

Resolution dated the Twentieth day of September, One thousand nine hundred and seventy-one, made pursuant to section 21 of the *Country Roads Act 1958*, declaring the widening of Traralgon Creek-road in the Shire of Traralgon as shown hatched on Plan numbered G.P.10399 hereunder to be part of a main road within the meaning and for the purposes of the said Act.

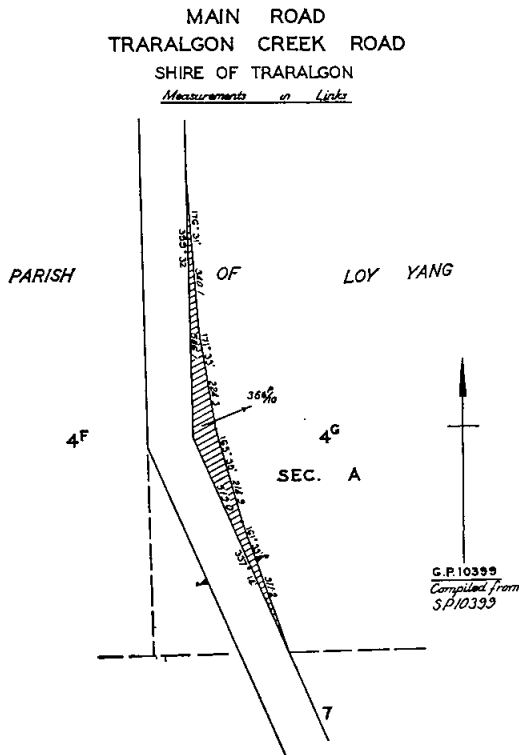

Resolution dated the Twentieth day of September, One thousand nine hundred and seventy-one, made pursuant to section 21 of the *Country Roads Act 1958*, declaring the widening of Nerrena-road in the Shire of Woorayl as shown hatched on Plan numbered G.P.7617 hereunder to be part of a main road within the meaning and for the purposes of the said Act.

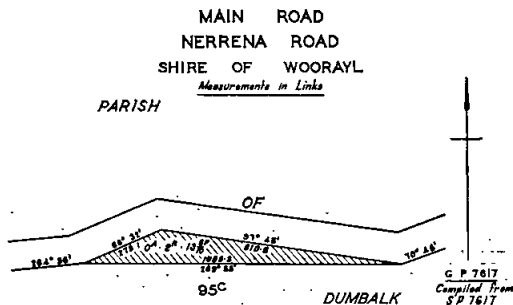

Resolution dated the Twentieth day of September, One thousand nine hundred and seventy-one, made pursuant to section 21 of the *Country Roads Act 1958*, declaring the widening of the Donald-Swan Hill road in the Shire of Wycheproof as shown hatched on Plan numbered G.P.7804 hereunder to be part of a main road within the meaning and for the purposes of the said Act.

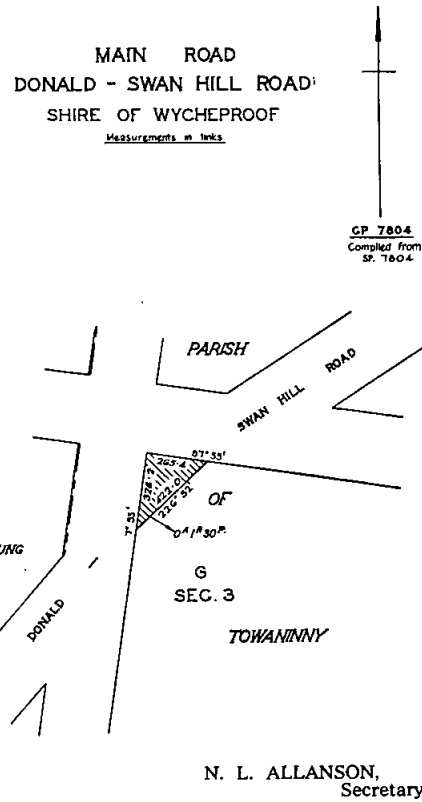

DEPARTMENT OF MINES.

Subject to any necessary excisions &c., it is proposed to grant the following mining lease:—
11401, Bendigo; North Deborah Mining Company No Liability; 0a. 1r. 0p., Parish of Sandhurst.

APPLICATION FOR MINING LEASES DECLARED ABANDONED.

- 8969, Mineral; George Milton; 640 acres, Parish of Loongelaat.
- 8970, Mineral; George Milton; 545 acres, Parish of Loongelaat.

APPLICATION FOR EXPLORATION LICENCE DECLARED ABANDONED.

- 376, Exploration Licence; Ausminco Services Pty. Ltd.; 200 square miles, Parishes of Thologolong, Bungil East, Koetong and Granya.

EXPLORATION LICENCES CANCELLED.

- 230, Exploration Licence; Stanley Irvine Lincoln, Ray Alan Borchers; 2 square miles, County of Gladstone.
- 380, Exploration Licence; Transouth Mining Proprietary Limited; 278 square miles, County of Gladstone.
- 391, Exploration Licence; Reef Oil N.L.; 300 square miles, County of Tatchera.

EXPLORATION LICENCES CANCELLED.

- 86, Exploration Licence; George Milton; 201 square miles, County of Croajingolong.
- 115, Exploration Licence; George Milton; 25 square miles, County of Tambo.
- 325, Exploration Licence; Comstock Minerals Limited; 464 square miles, Counties of Dargo and Wonnangatta.
- 326, Exploration Licence; Comstock Minerals Limited; 395 square miles, County of Croajingolong.

TAILINGS LICENCE EXPIRED.

- 3730, Tailings Licence; Bruhn's Quarries Pty. Ltd.; to remove tailings from "Devonshire Sand" dump, south of Bracewell-street in the Township of Eaglehawk.

APPLICATION FOR EXTRACTIVE INDUSTRY LICENCE REFUSED.

- 581, Extractive Industry Licence; Robert David Peck; 320 acres, Parish of Lillicur.

APPLICATION FOR EXTRACTIVE INDUSTRY LICENCES DECLARED ABANDONED.

- 213, Extractive Industry Licence; Ronald Lester Blake; 96 acres, Parish of Colongulac.
294, Extractive Industry Licence; Boulders Pty. Ltd.; 85 acres, Parish of Keelbundora.
480, Extractive Industry Licence; Boulders Pty. Ltd.; 46 acres, Parish of Keelbundora.

EXTRACTIVE INDUSTRY LICENCE GRANTED.

- 493, Extractive Industry Licence; Buninyong Gravel and Sand Proprietary Limited; 34a. Or. Op., Parish of Buninyong.

J. C. M. BALFOUR,
Minister of Mines.

CONTRACTS ACCEPTED.—(Series 1971-72.)

PUBLIC WORKS.

524. Melbourne, Public Offices, 632 Bourke-street, maintenance cleaning for the period 30th August, 1971, to approximately 31st August, 1974, \$3,900.00 per annum.—A. & B. Power Cleaning Service Pty. Ltd.
525. Melbourne, Public Offices, 278-282 Queen-street, maintenance cleaning for the period 9th August, 1971, to 8th August, 1974, \$9,399.00 per annum.—A. & B. Power Cleaning Service Pty. Ltd.
526. Warragul, Primary School 2104, plenum heating, class-room extensions, \$4,194.00.—Chadstone Air-conditioning Services Pty. Ltd.
527. Birchip, High School, site works, \$6,715.00.—S. T. Hamilton.
528. Corio, Technical School, science wing extensions, \$28,970.00.—E. J. Lyons & Sons Pty. Ltd.
529. Corio, Technical School, heating and hot water, science extensions, \$9,297.00.—L. F. Murray Pty. Ltd.
530. Templestowe, High School, mechanical services, science wing, \$14,437.00.—L. F. Murray Pty. Ltd.
531. South Yarra, Melbourne Boys' High School, rebuild fire-damaged pavilion, \$11,141.00.—A. & B. Oswald Pty. Ltd.
532. Oakleigh, Technical School, Library and science extensions, \$228,028.00.—Prentice Builders Pty. Ltd.
533. Boroondara North, Primary School 4960, site works, \$9,623.30.—Roy Senior & Son Pty. Ltd.
534. Altona, High School, restoration of oval, supply and delivery of sandy loam; original, \$3,480.00; additional, \$1,858.90; \$5,338.90.—V. F. Bird & Co. (W.138073.)
535. Deans Marsh, Primary School, internal renovations; original, \$3,777.00; additional \$350.00; \$4,127.00.—G. G. Hannah. (W.59157.)
536. Beechworth, Mental Hospital, electrical installation; original, \$678.00; additional, \$4,326.60; \$5,004.60.—Ian McGuffie. (N.151250.)
537. Lakeside Hospital, Ballarat, additional fire alarm system, \$7,398.00.—May Oatway Fire Alarms. (W.148131.)
538. Alexandra, Police Station Residences, renovations and painting; original, \$3,918.80; additional, \$188.48; \$4,107.28.—L. D. Singleton. (N.56981.)
539. Seymour, Police Station Residences, internal painting; original, \$1,993.50; additional, \$2,435.34; \$4,428.84.—L. D. Singleton. (N.116718.)
540. Lakeside Hospital, Ballarat, installation of hot-water calorifiers in wards 25 and 26; original, \$3,918.00; extras, \$1,008.96; \$4,926.96.—G. Stone & Sons (Vic.) Pty. Ltd. (W.154962.)
541. Horsham, Public Offices, cleaning up after fire damages, \$4,891.53.—P. & A. Coutts. Works Order 302411.
542. Walwa, Primary School No. 2806, site works; original, \$3,827.00; extra, \$304.40; \$4,131.40.—A. P. Delaney & Co. Pty. Ltd. File N.106969.

G. SERPELL, Director-General for Public Works. 13.10.71.

VICTORIAN RAILWAYS.

40. Erection and completion of locker, meal room, toilet and diesel locomotive maintenance facilities and tarpaulin repair workshop within the locomotive depot, shed at Bendigo, for the amount of \$68,499.00 (Contract 63673).—Royce Collier (Bendigo) Pty. Ltd. 41. Demolition and

reconstruction of front wall at the premises of the corporation at lot 43 Clarendon-street, South Melbourne, for the amount of \$6,126.77 (Contract 63710).—Brian M. Elms Pty. Ltd. 42. Manufacture, supply, delivery and erection of 30-ton travelling gantry cranes for Melbourne Goods Depot, for the amount of \$170,344.00 (Contract 63627).—Johns & Waygood Ltd. 43. Erection and completion of a brick addition to the Dimboola Station buildings for combined staff amenities for the amount of \$18,863.00 (Contract 63708).—Minyip Builders Pty. Ltd.

W. WALKER, Secretary. 15.10.71.

CONTRACTS ACCEPTED.—(Series 1971-72.)

TOOLS.

Gazette No. 38, 26th April, 1971, Schedule No. 52, Tools (General).—For Item No. 352, substitute, \$2.69 per dozen, as from 7th October, 1971.

PROVISIONS.

Gazette No. 57, 11th June, 1971, Schedule No. 1, Sub-schedule No. 7, Groceries, Metropolitan District.—For rates shown opposite the following items, substitute the rates as set out hereunder, as from 1st October, 1971:—Item No. 1, \$0.69; Item No. 2, \$0.70; Item No. 3, \$0.88; Item No. 33, \$0.70; Item No. 34, \$2.82; Item No. 67, \$0.36; Item No. 77, \$4.13; Item No. 85, \$0.75; Item No. 86, \$0.755; Item No. 116, \$9.10; Item No. 117, \$1.00; Item No. 118, \$4.84; Item No. 135, \$15.50; Item No. 201, \$5.70; Item No. 203, \$12.22; Item No. 208, \$2.48.

MEAT.

Gazette No. 88, 28th September, 1971, Schedule No. 16, Meat, Agricultural College, Glenormiston.—Delete Item No. 8, Chickens No. 5, as from 1st November, 1971.

GENERAL STORES.

Gazette No. 73, 10th August, 1971.—For rates shown opposite the following items, substitute the rates as set out hereunder, from the dates shown:—Schedule No. 43, Haberdashery, &c.—Item No. 63, \$2.64 per gross, as from 27th September, 1971. Schedule No. 46, General Industrial Goods, Item Nos. 16 and 17.—For name of contractor and rates shown, substitute The Goodyear Tyre & Rubber Co. (Australia) Ltd., at \$0.31 per foot, and \$0.38 per foot, respectively, as from 15th October, 1971. Schedule No. 56, Motor Spirit, Kerosene, &c.—For Esso Standard Oil (Australia) Ltd., substitute Esso Australia Ltd., as from 17th September, 1971. The following amendment has been made to the approved list of suppliers:—Glen Waverley, delete Esso Servicenter, 354 Springvale-road, substitute Esso Servicenter, Brandon Park, corner Ferntree Gully and Springvale roads.

SUPPLY OF SERVICES.

FUNERALS AND REMOVALS (COUNTRY TOWNS, &C.).

Gazette No. 77, 11th August, 1971.—For name of contractor and rates for Broadford, Nagambie, Seymour, Tallarook and Yea areas, substitute Drayton and Garson Pty. Ltd. Removal of Dead Bodies to Mortuaries, \$15, plus 70 cents per mile one way for excess over 10 miles; Burials of Destitute Persons, Coffin, Adult, \$25; Coffin, Child, \$12.50; Transfer to Cemetery, \$5, plus actual cemetery fees in each case.

PRISONERS' MEALS IN LOCK-UPS.

CONTRACTS ACCEPTED.

543. For the supply of Prisoners' Meals, at Camberwell, as from 1st October, 1971, Breakfast and Tea, 45 cents; Hot Dinner, 55 cents.—Filippos Giakoumis.
544. For the supply of Prisoners' Meals, at Geelong, as from 1st August, 1971, Breakfast and Tea, 65 cents; Hot Dinner, 85 cents.—Elly G. Zwiers.
545. For the supply of Prisoners' Meals, at Chelsea, as from 22nd September, 1971, Breakfast and Tea, 60 cents; Hot Dinner, 80 cents.—Mrs. M. W. Newman.

CONTRACTS CANCELLED.

Gazette No. 65, 14th July, 1971.—Prisoners' Meals, Camberwell. Contract No. 164 is hereby cancelled.
Gazette No. 65, 14th July, 1971.—Prisoners' Meals, Geelong. Contract No. 170 is hereby cancelled.

CEREALS.

Requirements under Sub-Schedule No. 10 of Schedule No. 1 for the period 1st November, 1971, to 30th June, 1972, are to be purchased from the under-mentioned firms at the rates per cwt. respectively indicated, viz., Ward McKenzie Pty. Ltd.:—Barley, pearl, \$5.75; Peas, split, yellow, \$8.75; deliveries under \$40.00, plus \$2.50 per delivery; Clifford Love & Co. Ltd.—Oatmeal, plain, \$7.00; Oatmeal, flaked, \$7.00; Rice, dressed, \$11.39; Waters Trading Co. Pty. Ltd.—Tapioca, seed, \$10.95 (in 56 lb. bags).

J. M. PAWSON, Acting Secretary to the Tender Board.
18.10.71.

CONTRACTS ACCEPTED.—(Series 1971-72.)

STATE RIVERS AND WATER SUPPLY COMMISSION.

517. Cleaning channels, Millewa Waterworks District, \$15,884.—A. D. Hillgrove.

Sealed by Commission, 1st July, 1971.

518. Supply and delivery of two removable houses to Rosslynne Dam Site, \$21,670.—M. Diedrich.

Sealed by Commission, 28th July, 1971.

519. Welding of 36-in. C.L.M.S. pipe-line at Bayview-road, McCrae, \$7,780.—Ilfred Pipe Welding.

Sealed by Commission, 12th August, 1971.

520. Cleaning of Head Office buildings, at Armadale, 1971-72, \$31,872.—Utility Cleaning Co. (Vic.) Pty. Ltd.

521. Construction of district office at Tatura, \$82,047.—G. G. Wright.

Sealed by Commission, 13th August, 1971.

522. Construction of access road and excavation of storage tank site at Portarlinton, \$7,277.—Moriac Bulldozers Pty. Ltd.

Sealed by Commission, 30th August, 1971.

523. Construction of brick veneer residence with office, garage and woodshed at Port Campbell, \$17,605.—Chenoweth & Downie Pty. Ltd.

Sealed by Commission, 8th September, 1971.

ORDERS IN COUNCIL.—(Series 1971-72.)

PUBLIC WORKS.

513. Carrum, Primary School 3385, construction of barrel drain, filling and levelling of school site, \$6,221.00.—City of Chelsea.—(E.4850.)

514. Melbourne, Public Offices, 436 Lonsdale-street, supply of furniture—

(a) \$21,117.75.—Brownbuilt Limited and;

(b) \$12,654.10.—Ron Barassi Office Furniture and Equipment.—(L.D.149282 "S".)

515. Portland, Dutton Way; supply, cartage and placing of stone and construction of groynes, \$11,500.00.—Portland Harbor Trust Commissioners.—(P. & H.86137.)

516. Westernport, supply and delivery of navigation lighting equipment, \$14,008.36.—A.G.A. Products Australia Pty. Ltd.—(P. & H.32801.)

Approved by the Governor in Council, 11th October, 1971.—J. ROSSITER, Clerk of the Executive Council.

APPOINTMENTS AND RESIGNATIONS

APPOINTMENTS.

His Excellency the Governor of the State of Victoria, by and with the advice of the Executive Council thereof, has, by Orders made on the 11th day of October, 1971, been pleased to make the under-mentioned appointments, viz.:—

CHIEF SECRETARY'S DEPARTMENT.

Chief Commissioner of Police.

REGINALD JACKSON, Q.P.M., pursuant to the provisions of the *Police Regulation Act 1958*, to be Chief Commissioner of Police, for a period of five years, as from 11th October, 1971; vice Noel Wilby, M.V.O., Q.P.M., retired.

Deputy Commissioner of Police.

ANGUS LINDSAY CARMICHAEL, Q.P.M., pursuant to the provisions of the *Police Regulation Act 1958*, to be Deputy Commissioner of Police, as from 11th October, 1971, vice Reginald Jackson, Q.P.M., promoted.

Assistant Commissioner (Operations).

SINCLAIR IMRIE MILLER, Q.P.M., pursuant to the provisions of the *Police Regulation Act 1958*, to be Assistant Commissioner (Operations), as from 11th October, 1971, vice Angus Lindsay Carmichael, Q.P.M., promoted.

CROWN LANDS AND SURVEY DEPARTMENT.

Bailiffs of Crown Lands.

LESLIE PERCIVAL BREWER

to be a bailiff of Crown lands, with respect to the reserved Crown land known as the "Port Welshpool Foreshore Reserve", pursuant to the provisions of section 30 of the *Land Act 1958*.

CLARENCE ROGER BOLDING

to be a bailiff of Crown lands, with respect to the reserved Crown lands known as the "Waratah Bay Foreshore Reserve", pursuant to the provisions of section 30 of the *Land Act 1958*.

Member of Committee of Management.

GERARD KENNETH GRANT

to be a member of the Elsternwick Park Committee of Management, provided that the said Gerard Kenneth Grant shall hold office as a member of the Committee of Management for so long only as he remains a Councillor and the elect of the City of Brighton, in place of John Ernest Bown (no longer a Councillor of the said City).

MINISTRY OF HEALTH.

Member of Committee of Management of Hospital.

ARTHUR WILLIAM McCracken

to be the Municipal nominee on the Committee of Management of the Stawell District Hospital for a period of three years, commencing the 7th October, 1971, pursuant to the provisions of paragraph (b) of the proviso to sub-section (1) of section 48 of the *Hospitals and Charities Act 1958*.

Official Visitors.

JOHN GLADSTONE CAMERON, M.B., B.S.,

NORVAL HENRY DOOLEY, LL.B.,

FLORENCE KATHLEEN NOBLE,

DORIS MARY DEAKIN,

WILLIAM LEE KELLY, and

DOROTHY ELIZABETH TWIST,

to be Official Visitors, Mont Park and Plenty Mental Hospitals, and Plenty Psychiatric Hospital, pursuant to section 66 of the *Mental Health Act 1959*, for the period ending the 31st October, 1972.

LAW DEPARTMENT.

Commissioners for Taking Declarations and Affidavits, &c.

ROBERT GEORGE BURNETT, care of Housing Commission, Victoria, 179 Queen-street, Melbourne, and

NEIL FRANCIS BROWN, care of Commonwealth Sub-Treasury, Commonwealth Bank Building, corner Elizabeth and Flinders streets, Melbourne,

to be Commissioners for taking Declarations and Affidavits, pursuant to the provisions of the *Evidence Act 1958*, to refrain from charging fees and to resign upon ceasing to occupy their present positions;

MURRAY THOMAS JONES, 159 Princes Highway East, Warrnambool, and

ALAN ERNEST TONER, 13 Stanhope-street, Daylesford, to be Commissioners for taking Declarations and Affidavits, pursuant to the provisions of the *Evidence Act 1958*, to resign upon removing from the neighbourhood of the addresses stated; and

RODNEY KEITH WHITMORE, care of B.F.C. Finance Limited, 725 Glenferrie-road, Hawthorn,

HUGH HAMILTON, care of Ships Chandler Corporation Pty. Ltd., 44-60 Stokes-street, Port Melbourne,

WILLIAM ERIC THOMPSON, care of The United Insurance Company Limited, 155 Queen-street, Melbourne,

JACK LEIGHTON DALY, care of Renault (Australia) Pty. Limited, Dougharty-road, West Heidelberg, and

GEORGE KERRY, care of George & Co. Pty. Ltd., 98 Somerville-road, Yarraville,

to be Commissioners for taking Declarations and Affidavits, pursuant to the provisions of the *Evidence Act 1958*, to resign upon ceasing to occupy their present positions.

Justices of the Peace.

ALLAN ALBERT DUNSTAN, Cope Cope, via Donald,
JOHN LAWRENCE CHRISTIAN, 107 Dunlop-street, Mort-
lake,
RONALD GRAEME STANLEY, 82 Ogilvy-street, Leongatha,
JOHN GILLAN MUNDY, 85 Gladstone-street, Orbost,
NORTON HALL BURSTON, 7 Foam-street, Hampton, and
CHARLES BLAKE JEWELL, 121 Church-street, Middle
Brighton,
to Keep the Peace in the State of Victoria.

J. ROSSITER,
Clerk of the Executive Council.
At the Executive Council Chamber,
Melbourne, 11th October, 1971.

Justice of the Peace.

CEDRIC JOHN SMART
from the Commission of the Peace for the State
of Victoria.

J. ROSSITER,
Clerk of the Executive Council.
At the Executive Council Chamber,
Melbourne, 11th October, 1971.

APPOINTMENTS.

His Excellency the Governor of the State of Victoria, by and with the advice of the Executive Council thereof, has, by Orders made on the 19th day of October, 1971, been pleased to make the under-mentioned appointments, viz.:

DEPARTMENT OF WATER SUPPLY.
Waterworks Trusts Commissioners.

WILLIAM IAN ROGERS
to be a Commissioner of the Balmoral Waterworks Trust, to hold such position for a period of four years from the date hereof, subject to the provisions of the Water Act.

PETER HUGH RANTON
to be a Commissioner of the Mount Beauty Waterworks Trust, to hold such position for the period from the date hereof until 2nd July, 1972, subject to the provisions of the Water Act.

J. ROSSITER,
Clerk of the Executive Council.
At the Executive Council Chamber,
Melbourne, 19th October, 1971.

Vermin and Noxious Weeds Act 1958.

APPOINTMENT OF INSPECTOR.

It is hereby notified that the Public Service Board, in exercise of its powers has appointed the under-mentioned person as an Inspector under the provisions of section 4 of the *Vermin and Noxious Weeds Act 1958*, without additional salary—

MACROBERT GRANT ANGUS.
A. J. HOLT,
Secretary for Lands.
Melbourne, 18th October, 1971.

Liquor Control Act 1968.

APPOINTMENT OF LICENSING INSPECTOR.

In accordance with the authority conferred upon me by section 6 of the *Police Regulation Act 1958*, I, Reginald Jackson, Deputy Commissioner of Police, do hereby appoint under sub-section (1) of section 22 of the *Liquor Control Act 1968*, the following Officer of Police as a Licensing Inspector for the Division of the Police District as shown:—

Division Number.	Police District.	Rank and Name.
1	Flinders	Inspector Norman Joseph Swan (from 6.9.71 to 6.11.71)
		R. JACKSON, Deputy Commissioner.
8.10.1971.		

RESIGNATIONS.

His Excellency the Governor of the State of Victoria, by and with the advice of the Executive Council thereof, has, by Orders made on the 11th day of October, 1971, accepted the resignations of the persons named hereunder of the offices mentioned, viz.:

LAW DEPARTMENT.
Commissioners for Taking Declarations and Affidavits, &c.
DANIEL HENRY MOLONEY, and
ROBERT DUNN WATSON,
as Commissioners for taking Declarations and Affidavits pursuant to the provisions of the *Evidence Act 1958*.

ORDERS IN COUNCIL

COUNTRY ROADS BOARD.

At the Executive Council Chamber, Melbourne, the
eleventh day of October, 1971.

PRESENT:

His Excellency the Governor of Victoria.
Mr. Balfour | Mr. Borthwick.
Mr. Rafferty

ORDER APPROVING OF LAND BEING ACQUIRED AND ROADS, DEVIATIONS OR WIDENING BEING MADE.

His Excellency the Governor of the State of Victoria by and with the advice of the Executive Council thereof, being satisfied that there are funds legally available for acquiring the land, doth hereby approve the acquiring of the land described in the schedule hereunder and the making of new roads and deviations from and widenings of existing roads referred to in the said schedule.

SCHEDULE.

Main roads.

The land shown hatched on Plan numbered G.P.12591 hereunder required for the deviation from the Buxton-Marysville road in the Shire of Alexandra and making of the deviation thereon.

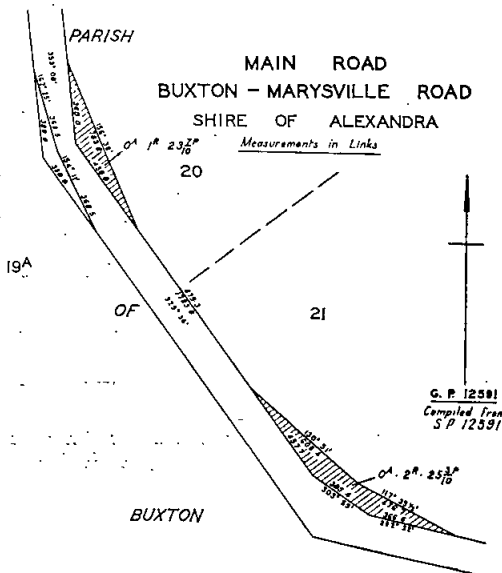

The land shown hatched on Plan numbered G.P.12744 hereunder required for the widening of Dorset-road in the City of Croydon and making of the widening thereon.

The land shown hatched on Plan numbered G.P.6738 hereunder required for the widening of Ferntree Gully-road in the City of Waverley and making of the widening thereon.

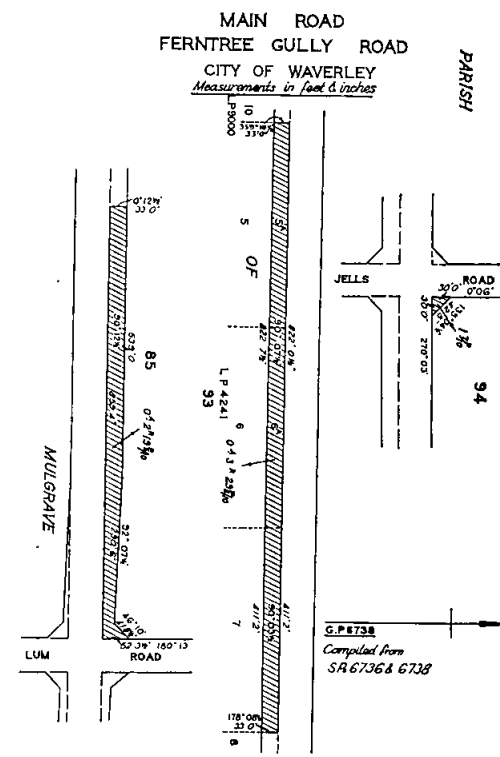
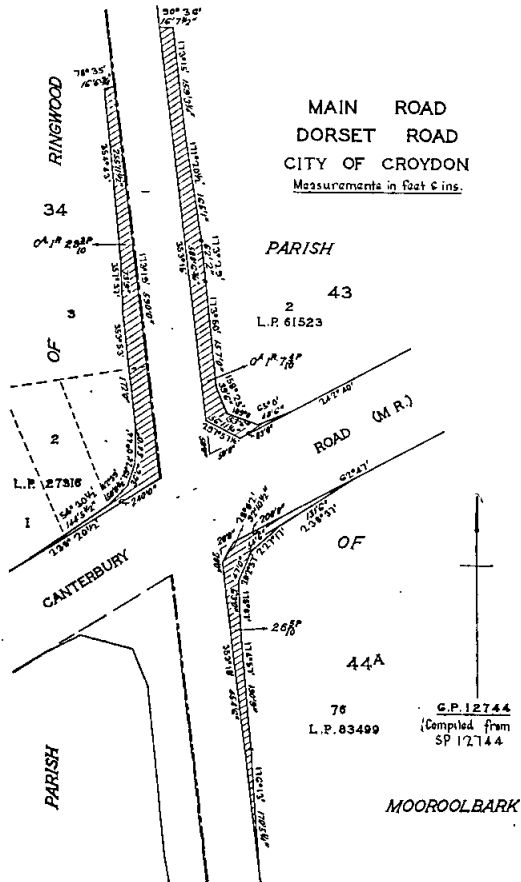

The land shown hatched on Plan numbered G.P.12732 hereunder required for the widening of the Woolsthorpe-Heywood road in the Shire of Warrnambool and making of the widening thereon.

And the Honorable Alan John Hunt, Her Majesty's Minister for Local Government for the State of Victoria, shall give the necessary directions herein accordingly.

J. ROSSITER,
Clerk of the Executive Council.

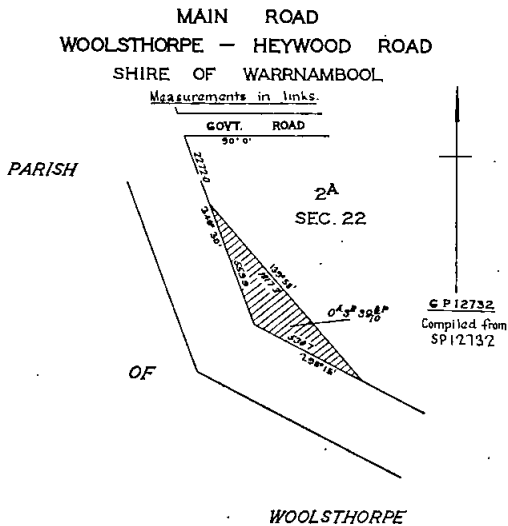

COUNTRY ROADS BOARD.

At the Executive Council Chamber, Melbourne, the eleventh day of October, 1971.

PRESENT:

His Excellency the Governor of Victoria.
Mr. Balfour
Mr. Rafferty
Mr. Borthwick.

ORDER APPROVING OF LAND BEING ACQUIRED AND ROADS, DEVIATIONS OR WIDENINGS BEING MADE.

His Excellency the Governor of the State of Victoria, by and with the advice of the Executive Council thereof, being satisfied that there are funds legally available for acquiring the land, doth hereby approve the acquiring of the land described in the schedule hereunder and the making of new roads and deviations from and widenings of existing roads referred to in the said schedule.

SCHEDULE.

State highways.

The land shown hatched on Plan numbered G.P.12745 hereunder required for the widening of the Northern Highway in the Shire of Pyalong and making of the widening thereon.

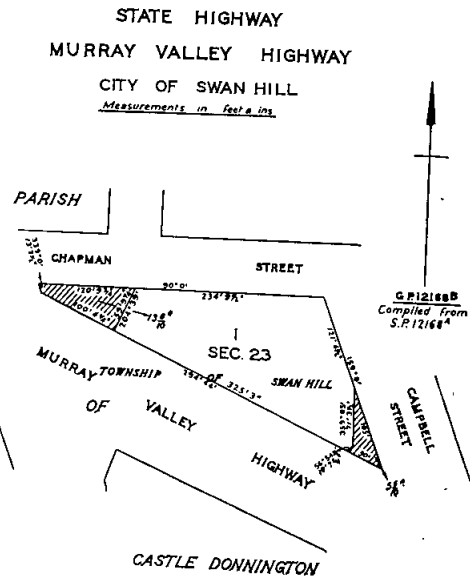
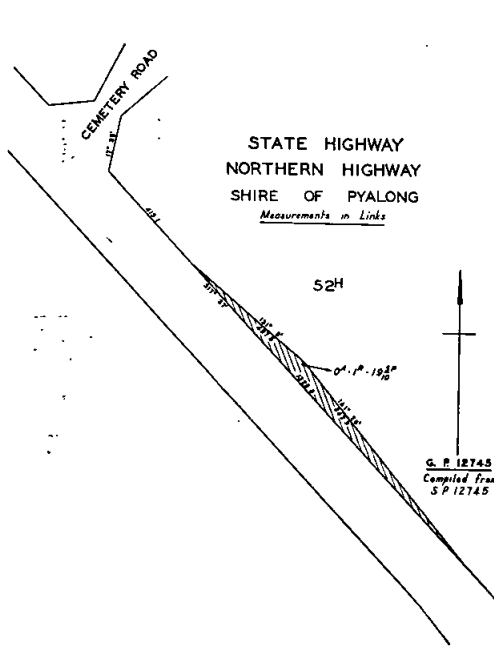

The land shown hatched on Plans numbered G.P.12168A and 12168B hereunder required for the widening of the Murray Valley Highway in the City of Swan Hill and making of the widening thereon.

Main Roads.
The land shown hatched on Plan numbered G.P.12735 hereunder required for the widening of Cheltenham-road in the City of Dandenong and making of the widening thereon.

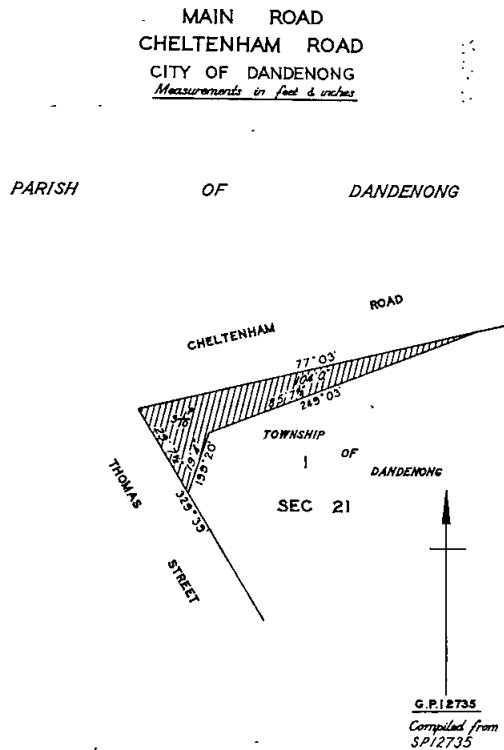
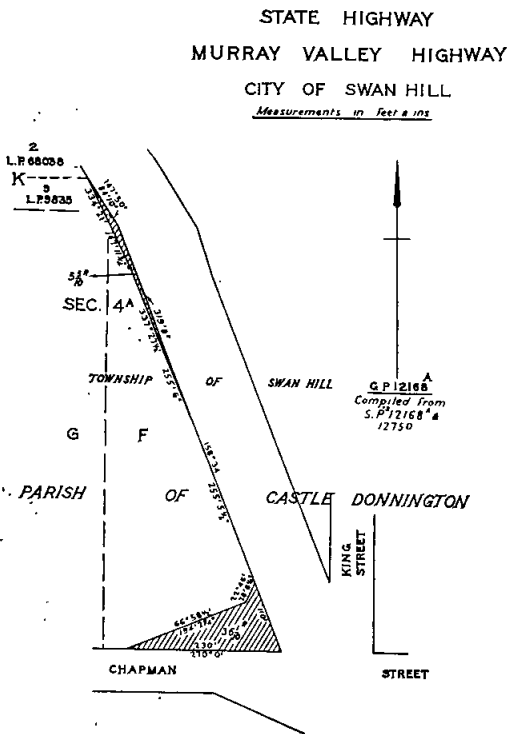

The land shown hatched on Plan numbered G.P.12678B hereunder required for the widening of the Wantima-Sassafras road in the City of Knox and making of the widening thereon.

The land shown hatched on Plan numbered G.P.12671B hereunder required for the widening of Bona Vista-road in the Shire of Warragul and making of the widening thereon.

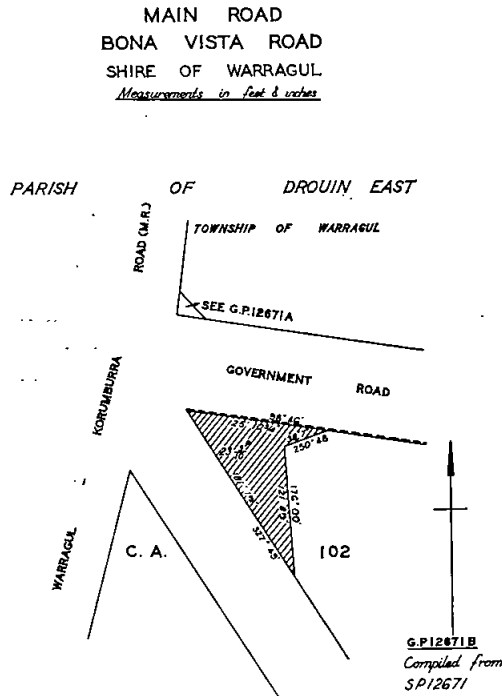
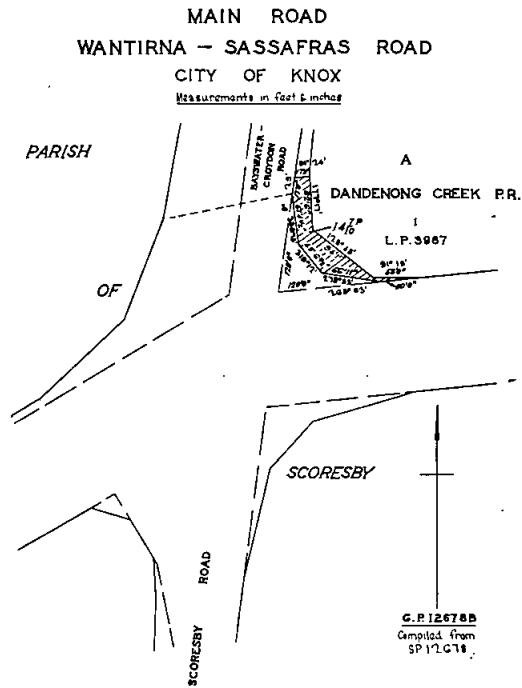

The land shown hatched on Plan numbered G.P.12671A hereunder required for the widening of the Warragul-Korumburra road in the Shire of Warragul and making of the widening thereon.

The land shown hatched on Plan numbered G.P.12687 hereunder required for the widening of Dederang-road in the Shire of Yackandandah and making of the widening thereon.

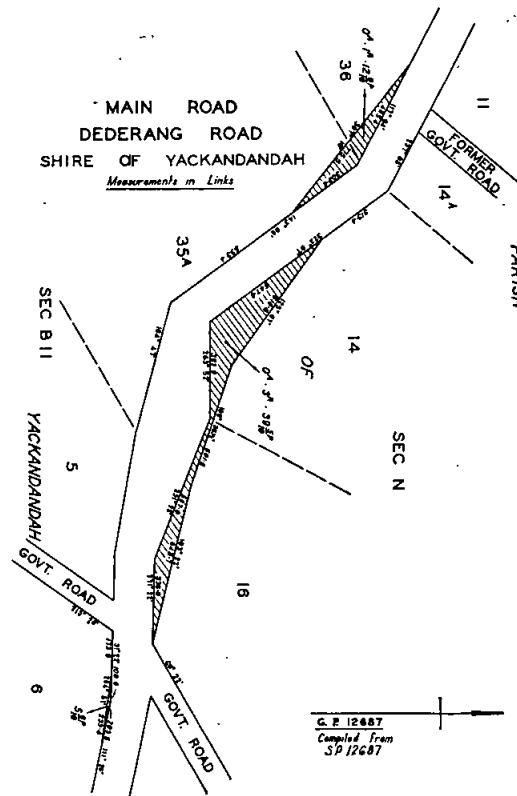
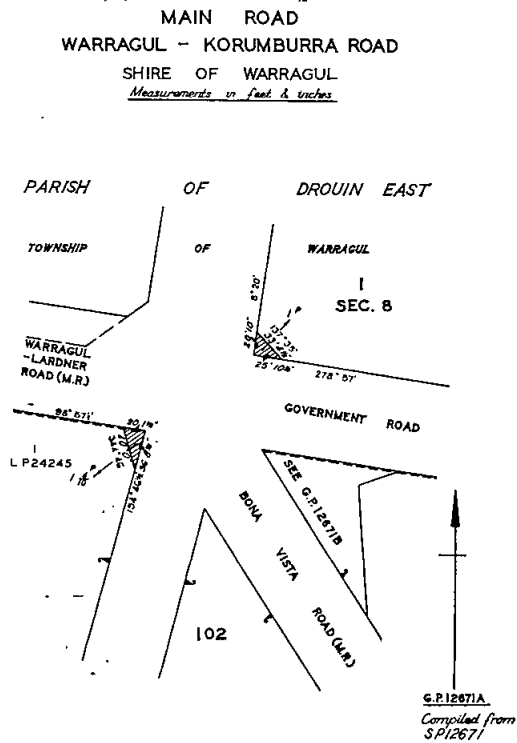

The land shown hatched on Plan numbered G.P.12688A hereunder required for the widening of Kiewa East-road in the Shire of Yackandandah and making of the widening thereon.

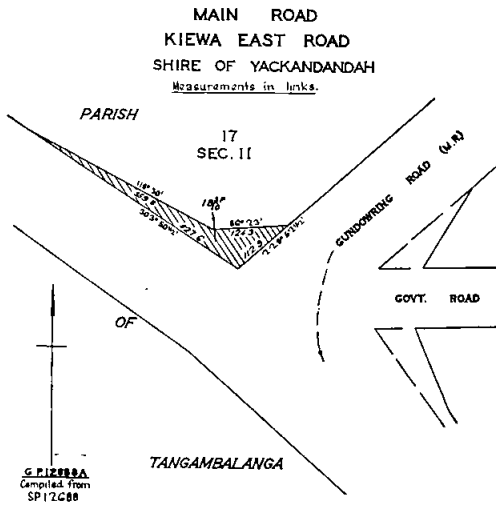

The land shown hatched on Plan numbered G.P.12688B hereunder required for the widening of Gundowring-road in the Shire of Yackandandah and making of the widening thereon.

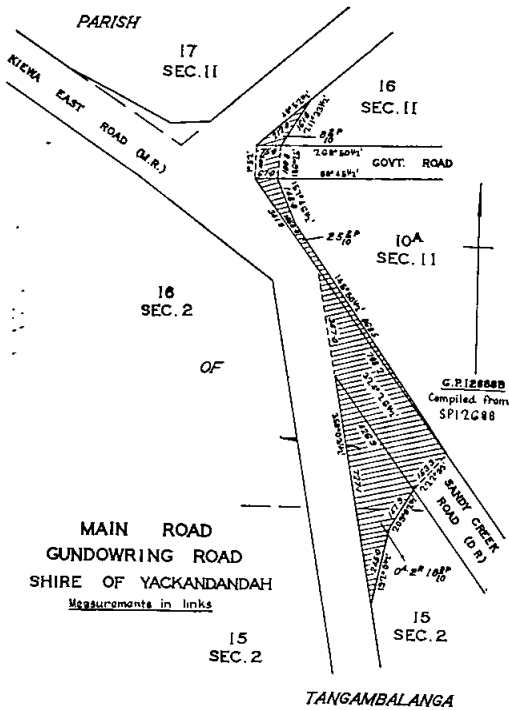

Freeway.

The land shown hatched on Plan numbered G.P.12747 hereunder required for the making of a new freeway (Western Freeway) in the Shire of Ballan.

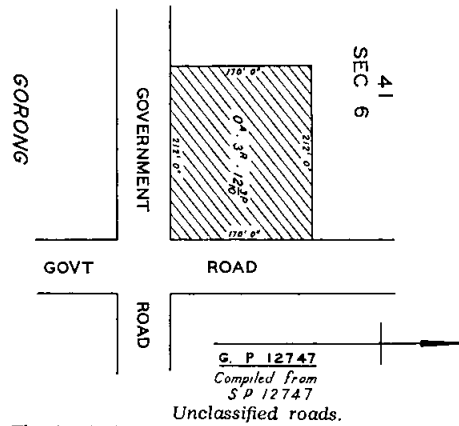
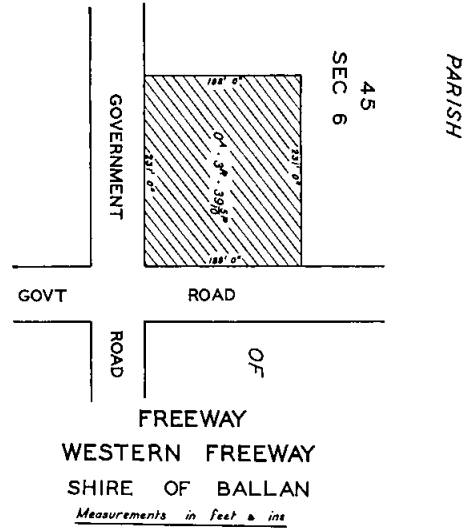

The land shown hatched on Plan numbered G.P.12730 hereunder required for the making of a new road in the Shire of Bacchus Marsh.

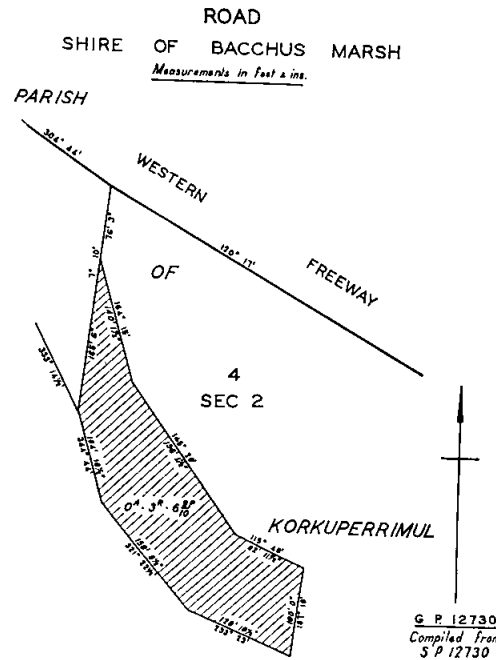

G. P. 12730
Compiled from
S. P. 12730

The land shown hatched on Plan numbered G.P.12678A hereunder required for the widening of the Bayswater-Croydon road in the City of Knox and making of the widening thereon.

which is shown hatched on the plan hereunder shall be discontinued and that the land may be sold by the Council of the City of Doncaster and Templestowe by agreement.

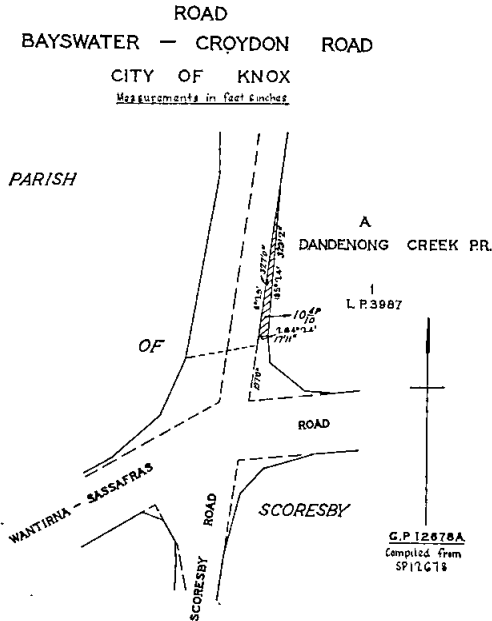

And the Honorable Alan John Hunt, Her Majesty's Minister for Local Government for the State of Victoria, shall give the necessary directions herein accordingly.

J. ROSSITER,
Clerk of the Executive Council.

LOCAL GOVERNMENT DEPARTMENT.

At the Executive Council Chamber, Melbourne, the eleventh day of October, 1971.

PRESENT:
His Excellency the Governor of Victoria.
Mr. Balfour | Mr. Borthwick.
Mr. Rafferty

ROAD DISCONTINUED.—CITY OF DONCASTER AND TEMPLESTOWE.

WHEREAS it is provided in section 528 (2) of the Local Government Act 1958, that where a road (whether or not a public highway but not being a road set out on land of the Crown) or any part thereof is not required for public use, the Governor in Council on the request of the Council of the municipality in which such road is situated made not less than one month after publishing in a newspaper generally circulating in the district and posting to the registered proprietor (if any) of the land and the owners and occupiers (if any) of the lands abutting or immediately adjacent to the road notice of intention to make such request may by Order published in the Government Gazette direct that such road or part shall be discontinued and thereupon such road or part shall be discontinued accordingly:

And whereas the Council of the City of Doncaster and Templestowe has requested that the Governor in Council direct that portion of Whitten's-lane, Doncaster, be discontinued and not less than one month previously has published in a newspaper generally circulating in the district and posted to the registered proprietor of lands abutting or immediately adjacent to the road notice of intention to make such request.

Now therefore, His Excellency the Governor of the State of Victoria, by and with the advice of the Executive Council thereof, hereby directs that the portion of the said road,

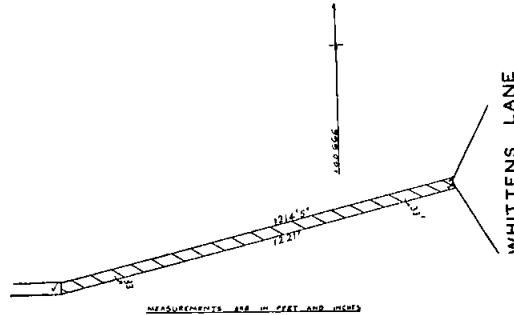

And the Honorable Alan John Hunt, Her Majesty's Minister for Local Government for the State of Victoria, shall give the necessary directions herein accordingly.

J. ROSSITER,
Clerk of the Executive Council.

LOCAL GOVERNMENT DEPARTMENT.

At the Executive Council Chamber, Melbourne, the eleventh day of October, 1971.

PRESENT:
His Excellency the Governor of Victoria.
Mr. Balfour | Mr. Borthwick.
Mr. Rafferty

CONSENT TO SALE OF A RESERVE BY THE SPRINGVALE CITY COUNCIL.

Whereas pursuant to the provisions of section 569A (1) of the Local Government Act 1958 certain land being the Reserve for Drainage Purposes on Plan of Subdivision No. 17712 lodged in the Office of Titles was vested in the Council of the City of Springvale by Order published in the Government Gazette, No. 65, dated 14th July, 1971 and the said Council is now of the opinion that the land is no longer required for the purpose for which it was reserved and has requested that consent be given to the sale of the land.

And whereas the said Council:

- (a) has published in a newspaper generally circulating in the municipal district a notice describing the land and the proposal for the sale of the land and stating that at the next ordinary meeting of the Council after the expiration of forty days after publication of the notice the Council would consider any objection to the proposal and would receive any representations.
- (b) has served a copy of the said notice upon the registered proprietor of the land and upon any registered mortgagee chargee or lessee thereof and upon those other persons upon whom the Council considered such notice should be served;
- (c) has posted a similar notice upon the land in question.

And whereas no person has objected to the proposed sale of the land and no representations have been made as to the disposal of any surplus purchase money.

Now therefore, His Excellency the Governor of the State of Victoria, by and with the advice of the Executive Council thereof and in pursuance of the provisions of section 569BA of the Local Government Act 1958 doth hereby consent to the Council of the City of Springvale selling by private treaty the Reserve for Drainage Purposes on Plan of Subdivision No. 17712 lodged in the Office of Titles.

And the Honorable Alan John Hunt, Her Majesty's Minister for Local Government for the State of Victoria, shall give the necessary directions herein accordingly.

J. ROSSITER,
Clerk of the Executive Council.

LOCAL GOVERNMENT DEPARTMENT.

At the Executive Council Chamber, Melbourne, the eleventh day of October, 1971.

PRESENT:

His Excellency the Governor of Victoria.
Mr. Balfour | Mr. Borthwick.
Mr. Rafferty

CONFIRMATION OF SEPARATE RATE.—CITY OF HEIDELBERG.

In pursuance of the provisions of section 287 of the *Local Government Act 1958*, His Excellency the Governor of the State of Victoria, by and with the advice of the Executive Council thereof, hereby confirms a separate rate of three point seven five (3.75) cents in the dollar on the Unimproved Capital Value of the rateable properties specified hereunder, which rate was made by the Council of the City of Heidelberg on the 6th September, 1971 for the purpose of providing off-street parking facilities for the Southern Road Shopping Centre.

Properties to be rated. All those rateable properties on the south side of Southern-road, Heidelberg, being Nos. 19 to 35 (both numbers inclusive).

And the Honorable Alan John Hunt, Her Majesty's Minister for Local Government for the State of Victoria, shall give the necessary directions herein accordingly.

J. ROSSITER,
Clerk of the Executive Council.

LOCAL GOVERNMENT DEPARTMENT.

At the Executive Council Chamber, Melbourne, the eleventh day of October, 1971.

PRESENT:

His Excellency the Governor of Victoria.
Mr. Balfour | Mr. Borthwick.
Mr. Rafferty

ROAD DISCONTINUED.—CITY OF FOOTSCRAY.

Whereas it is provided in section 528 (2) of the *Local Government Act 1958*, that where a road (whether or not a public highway but not being a road set out on land of the Crown) or any part thereof is not required for public use, the Governor in Council on the request of the Council of the municipality in which such road is situated made not less than one month after publishing in a newspaper generally circulating in the district and posting to the registered proprietor (if any) of the land and the owners and occupiers (if any) of lands abutting or immediately adjacent to the road notice of intention to make such a request may by Order published in the *Government Gazette* direct that such road or part shall be discontinued and thereupon such road or part shall be discontinued accordingly:

And whereas the Council of the City of Footscray has requested that the Governor in Council direct that portion of a road off Gamon-street, Yarraville be discontinued and not less than one month previously has published in a newspaper generally circulating in the district and posted to the registered proprietor of the land in the road and to the owners and occupiers of lands abutting or immediately adjacent to the road notice of intention to make such request.

Now therefore, His Excellency the Governor of the State of Victoria, by and with the advice of the Executive Council thereof, hereby directs:

- (a) that the portion of the said road, which is shown by hachure and cross-hachure on the plan hereunder, shall be discontinued;
- (b) that notwithstanding such discontinuance the State Electricity Commission of Victoria shall continue to have and possess the same right title power authority or interest in or in relation to the whole of the land shown by cross-hachure on the said plan as it had or possessed prior to such discontinuance with respect to or in connexion with any wires or cables laid or erected in on or over such land for the purpose of the supply of electricity; and

- (c) that, subject to any such right title power authority or interest the land in the said road may be sold by the Council of the City of Footscray by agreement.

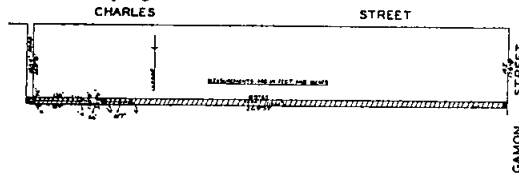

And the Honorable Alan John Hunt, Her Majesty's Minister for Local Government for the State of Victoria, shall give the necessary directions herein accordingly.

J. ROSSITER,
Clerk of the Executive Council.

DEPARTMENT OF CROWN LANDS AND SURVEY.

At the Executive Council Chamber, Melbourne, the eleventh day of October, 1971.

PRESENT:

His Excellency the Governor of Victoria.
Mr. Balfour | Mr. Borthwick.
Mr. Rafferty

LANDS TEMPORARILY RESERVED AS SITES.

His Excellency the Governor of the State of Victoria, by and with the advice of the Executive Council thereof, doth hereby, in pursuance of section 14 of the *Land Act 1958*, reserve temporarily from sale, from being leased and from having a licence granted in respect thereof, and also except from occupation for mining purposes under any miner's right, the land hereinafter described:—

BALLARAT EAST.—Site for Public Purposes (Historical Park), 1 acre 2 roods 35 perches, more or less, Township of Ballarat East, Parish of Ballarat, County of Grant, as indicated by hatching on plan hereunder.—(B.128(53) (Rs.9536).

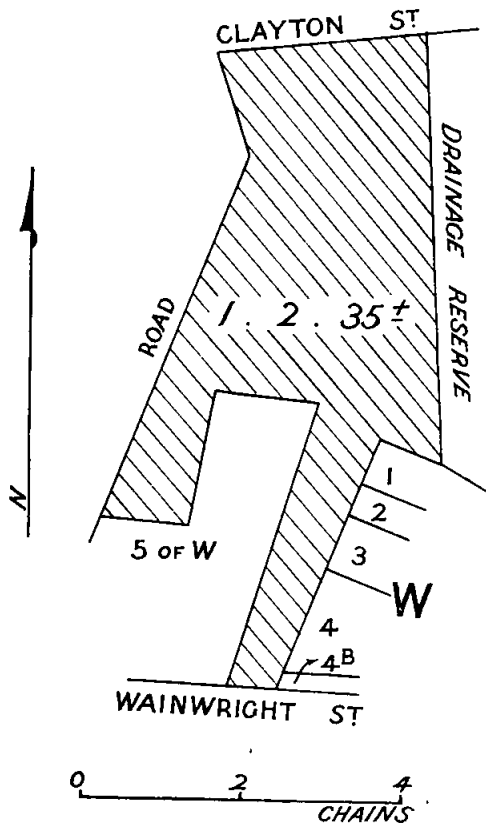

CORADJIL.—Site for Public Recreation, 8 acres 3 roods 25 perches, Parish of Coradjil, County of Heytesbury, as indicated by hatching on plan hereunder.—(C.428^(o)) (Rs.8635).

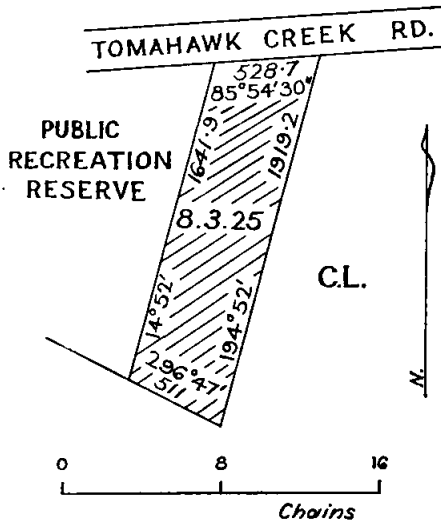

YAN YAN GURT.—Site for Public purposes (Preservation of Native Flora and Fauna), 40 acres, more or less, Parish of Yan Yan Gurt, County of Polwarth, as indicated by hatching on plan hereunder.—(Y.49⁽³⁾) (Rs.9534).

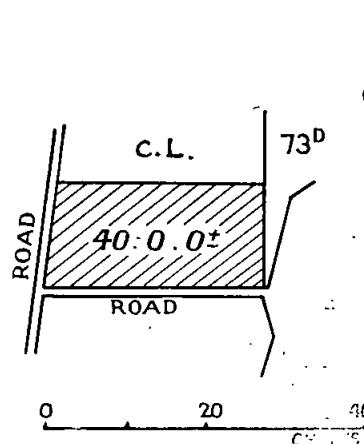

J. ROSSITER,
Clerk of the Executive Council.

And the Honorable William Archibald Borthwick, Her Majesty's Minister of Lands for the State of Victoria, shall give the necessary directions herein accordingly.

TARWIN.—Site for Public Park, 29 acres 2 roods 25 perches, Parish of Tarwin, County of Buln Buln, as indicated by hatching on plan hereunder.—(T.191⁽⁹⁾) (Rs.2634).

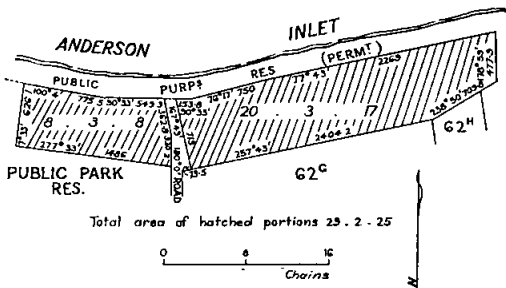

DEPARTMENT OF CROWN LANDS AND SURVEY.

At the Executive Council Chamber, Melbourne, the eleventh day of October, 1971.

PRESENT:

His Excellency the Governor of Victoria.
Mr. Balfour | Mr. Borthwick.
Mr. Rafferty

REVOCATION OF PERMANENT RESERVATION OF LAND.

In pursuance of the provisions of section 15 (2) (a) of the Land Act 1958, His Excellency the Governor of the State of Victoria, by and with the advice of the Executive Council thereof, doth hereby revoke the permanent reservation of land by Order in Council hereinafter referred to, viz.:

BRIDGEWATER.—The permanent reservation by Order in Council of the 23rd December, 1874, of 2 acres of land in the Parish of Bridgewater as a site for State School purposes.—(B.437⁽²⁾) (Rs.6789).

And the Honorable William Archibald Borthwick, Her Majesty's Minister of Lands for the State of Victoria, shall give the necessary directions herein accordingly.

J. ROSSITER,
Clerk of the Executive Council.

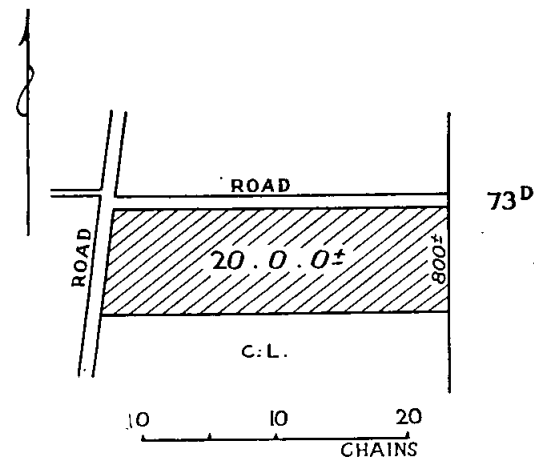

HOUSING ACT 1958.

At the Executive Council Chamber, Melbourne, the eleventh day of October, 1971.

PRESENT:

His Excellency the Governor of Victoria.
Mr. Balfour | Mr. Borthwick.
Mr. Rafferty

PARTIAL CLOSURE OF ROAD AND EXTINGUISHMENT OF EASEMENTS.—CITY OF NORTHCOTE.

Whereas by virtue and in exercise of the powers contained in the Housing Act 1958 (No. 6275) Housing Commission has recommended to the Governor in Council that the portion of road and easements described in the Schedule hereto be closed and extinguished.

Now therefore His Excellency the Governor of the State of Victoria in the Commonwealth of Australia by and with the advice of the Executive Council of the said State, doth in pursuance of the powers conferred by the said Act and upon such recommendation, consent and by this Order hereby close and extinguish such portion of road and easements.

SCHEDULE.

So much of Riley-street as set out on plans of subdivision Number 12167 and 12251 lodged in the Office of Titles as is delineated and hachured on the plan hereunder and being part of the land now comprised in Crown Grants volume 4703 folio 565 and volume 5263 folio 543.

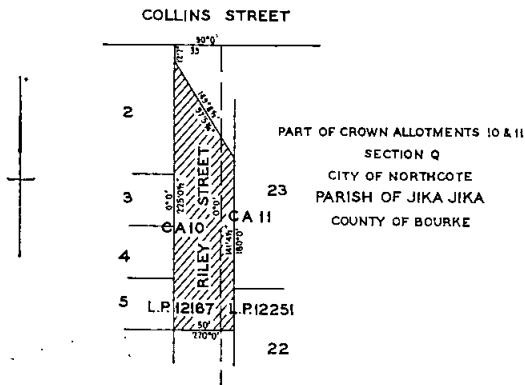

And the Honorable Edward Raymond Meagher, Her Majesty's Minister of Housing for the State of Victoria, shall give the necessary directions herein accordingly.

J. ROSSITER,
Clerk of the Executive Council.

HOUSING ACT 1958.

At the Executive Council Chamber, Melbourne, the eleventh day of October, 1971.

PRESENT:

His Excellency the Governor of Victoria.
Mr. Balfour | Mr. Borthwick
Mr. Rafferty

CLOSING OF ROADS AND EXTINGUISHMENT OF EASEMENTS AND RESTRICTIVE COVENANTS.—CITY OF RICHMOND.

Whereas by virtue and in exercise of the powers contained in the Housing Act 1958 (No. 6275) Housing Commission has recommended to the Governor in Council that the roads, easements and restrictive covenants described in the Schedule hereto to be closed and extinguished.

Now therefore His Excellency the Governor of the State of Victoria in the Commonwealth of Australia by and with the advice of the Executive Council of the said State, doth in pursuance of the powers conferred by the said Act and upon such recommendation, consent and by this Order hereby close and extinguish such roads, easements and restrictive covenants.

SCHEDULE.

All roads set out within, and any easements and restrictive covenants affecting all that piece of land situate within the municipality of the City of Richmond being part of Crown portions 39 and 46 Parish of Jika Jika and bounded by a line as follows:—

Commencing at a point on the southern alignment of Elizabeth-street being the intersection thereof with the eastern alignment of Lennox-street north; thence easterly by the southern alignment of Elizabeth-street to the intersection thereof with the western alignment of Church-street; thence southerly by the said western alignment of Church-street to the intersection thereof with the northern alignment of Risley-street; thence westerly by the said northern alignment of Risley-street and the northern boundaries of lot 2 and part lot 3 on plan of subdivision number 42698 and lot 3 on plan of subdivision number 55682 as are delineated and shown on certificate of title volume 8750 folio 185 and

the northern boundary of the land in certificate of title volume 8864 folio 014 to the north-west corner of the land in the said certificate of title volume 8864 folio 014 and further southerly by portion of the eastern boundary of the land comprised in certificate of title volume 4588 folio 414 to the south-eastern corner of the land comprised in said certificate of title volume 4588 folio 414; thence westerly by the northern boundary of the land comprised in certificate of title volume 7878 folio 005 to the intersection thereof within the eastern alignment of Lennox-street north and thence northerly by the said eastern alignment of Lennox-street north to the point of commencement.

And the Honorable Edward Raymond Meagher, Her Majesty's Minister of Housing for the State of Victoria, shall give the necessary directions herein accordingly.

J. ROSSITER,
Clerk of the Executive Council.

HOSPITALS AND CHARITIES ACT 1958.

SECTION 53.

At the Executive Council Chamber, Melbourne, the nineteenth day of October, 1971.

PRESENT:

His Excellency the Governor of Victoria.
Mr. Meagher | Mr. Smith.

ANNUAL GENERAL MEETING OF CONTRIBUTORS TO THE HELPING HAND ASSOCIATION FOR MENTALLY RETARDED CHILDREN, PRAHRAN—SOUTH YARRA BRANCH.

Pursuant to the powers conferred by Section 53 of the Hospitals and Charities Act 1958, and all other powers enabling him in that behalf, His Excellency the Governor of the State of Victoria, by and with the advice of the Executive Council of the said State, hereby fixes the 27th day of October, 1971, as the day prior to which the annual general meeting for 1971, of contributors to the Helping Hand Association for Mentally retarded Children, Prahran—South Yarra Branch, shall be held.

And the Honorable John Frederick Rossiter, Her Majesty's Minister of Health for the State of Victoria, shall give the necessary directions herein accordingly.

J. ROSSITER,
Clerk of the Executive Council.

DEPARTMENT OF CROWN LANDS AND SURVEY.

At the Executive Council Chamber, Melbourne, the nineteenth day of October, 1971.

PRESENT:

His Excellency the Governor of Victoria.
Mr. Meagher | Mr. Smith.

REDUCTION IN WIDTH OF ROAD IN THE TOWNSHIP AND PARISH OF DERRIMUT.

His Excellency the Governor of the State of Victoria, by and with the advice of the Executive Council thereof, in accordance with the provisions of and in exercise of the powers conferred by the Local Government Act 1958 (Section 532) doth, by this Order confirm the scheme for the reduction in width of the road in the Parish of Derrimut, Country of Bourke, in the State of Victoria as set out in an agreement deposited in the office of the Department of Crown Lands and Survey, Melbourne, the said scheme being under the seal of the Corporation of the Mayor, Councillors and Citizens of the City of Sunshine of the first part and the hand of the Minister of Lands of the second part and the hands of the persons whose signatures are subscribed to the said scheme and who are called the parties of the third part.—(G.71118.)

And the Honorable William Archibald Borthwick, Her Majesty's Minister of Lands for the State of Victoria, shall give the necessary directions herein accordingly.

J. ROSSITER,
Clerk of the Executive Council.

MARYBOROUGH SEWERAGE AUTHORITY.

At the Executive Council Chamber, Melbourne, the nineteenth day of October, 1971.

PRESENT:

His Excellency the Governor of Victoria.
Mr. Meagher | Mr. Smith.

EXTENT OF SEWERAGE DISTRICT INCREASED.

Under the powers conferred by the Sewerage Districts Act and all other powers enabling him in that behalf, His Excellency the Governor of the State of Victoria, by and with the advice of the Executive Council of the said State, doth hereby declare, order and direct that the extent of the Sewerage District of the Maryborough Sewerage Authority be increased by adding thereto the lands as shown on the plan approved by the Governor in Council, by and with this Order and deposited in the office of the State Rivers and Water Supply Commission, Melbourne (Corr. No. 59/1773/135), and as on and from the date hereof the extent of such District shall be and be deemed to be increased accordingly.

And the Honorable Roberts Christian Dunstan, Her Majesty's Minister of Water Supply for the State of Victoria, shall give the necessary directions herein accordingly.

J. ROSSITER,
Clerk of the Executive Council.

BALLARAT SEWERAGE AUTHORITY.

At the Executive Council Chamber, Melbourne, the nineteenth day of October, 1971.

PRESENT:

His Excellency the Governor of Victoria.
Mr. Meagher | Mr. Smith.

CONSENT TO BORROWING \$32,000.

Under the powers conferred by the Sewerage Districts Act and all other powers enabling him in that behalf, His Excellency the Governor of the State of Victoria, by and with the advice of the Executive Council of the said State, doth hereby consent to the Ballarat Sewerage Authority borrowing the sum of Thirty-two thousand dollars (\$32,000), for the conversion of Loan No. V.V.

And the Honorable Roberts Christian Dunstan, Her Majesty's Minister of Water Supply for the State of Victoria, shall give the necessary directions herein accordingly.

J. ROSSITER,
Clerk of the Executive Council.

COBRAM SEWERAGE AUTHORITY.

At the Executive Council Chamber, Melbourne, the nineteenth day of October, 1971.

PRESENT:

His Excellency the Governor of Victoria.
Mr. Meagher | Mr. Smith.

CONSENT TO BORROWING \$100,000.

Under the powers conferred by the Sewerage Districts Act and all other powers enabling him in that behalf, His Excellency the Governor of the State of Victoria, by and with the advice of the Executive Council of the said State, doth hereby consent to the Cobram Sewerage Authority borrowing the sum of One hundred thousand dollars (\$100,000) to meet the cost of sewerage works as set forth in the detailed statement bearing date 13th October, 1971.

And the Honorable Roberts Christian Dunstan, Her Majesty's Minister of Water Supply for the State of Victoria, shall give the necessary directions herein accordingly.

J. ROSSITER,
Clerk of the Executive Council.

DANDENONG SEWERAGE AUTHORITY.

At the Executive Council Chamber, Melbourne, the nineteenth day of October, 1971.

PRESENT:

His Excellency the Governor of Victoria.
Mr. Meagher | Mr. Smith.

CONSENT TO BORROWING \$90,000.

Under the powers conferred by the Sewerage Districts Act and all other powers enabling him in that behalf, His Excellency the Governor of the State of Victoria, by and with the advice of the Executive Council of the said State, doth hereby consent to the Dandenong Sewerage Authority borrowing the sum of Ninety thousand dollars (\$90,000) to meet the cost of sewerage works as set forth in the detailed statement bearing date 13th October, 1971.

And the Honorable Roberts Christian Dunstan, Her Majesty's Minister of Water Supply for the State of Victoria, shall give the necessary directions herein accordingly.

J. ROSSITER,
Clerk of the Executive Council.

MYRTLEFORD SEWERAGE AUTHORITY.

At the Executive Council Chamber, Melbourne, the nineteenth day of October, 1971.

PRESENT:

His Excellency the Governor of Victoria.
Mr. Meagher | Mr. Smith.

CONSENT TO BORROWING \$100,000.

Under the powers conferred by the Sewerage Districts Act and all other powers enabling him in that behalf, His Excellency the Governor of the State of Victoria, by and with the advice of the Executive Council of the said State, doth hereby consent to the Myrtleford Sewerage Authority borrowing the sum of One hundred thousand dollars (\$100,000), to meet the cost of sewerage works as set forth in the detailed statement bearing date 13th October, 1971.

And the Honorable Roberts Christian Dunstan, Her Majesty's Minister of Water Supply for the State of Victoria, shall give the necessary directions herein accordingly.

J. ROSSITER,
Clerk of the Executive Council.

PORT FAIRY SEWERAGE AUTHORITY.

At the Executive Council Chamber, Melbourne, the nineteenth day of October, 1971.

PRESENT:

His Excellency the Governor of Victoria.
Mr. Meagher | Mr. Smith.

CONSENT TO BORROWING \$100,000.

Under the powers conferred by the Sewerage Districts Act and all other powers enabling him in that behalf, His Excellency the Governor of the State of Victoria, by and with the advice of the Executive Council of the said State, hereby consents to the Port Fairy Sewerage Authority borrowing the sum of One hundred thousand dollars (\$100,000), to meet the cost of sewerage works as set forth in the detailed statement bearing date 13th October, 1971.

And the Honorable Roberts Christian Dunstan, Her Majesty's Minister of Water Supply for the State of Victoria, shall give the necessary directions herein accordingly.

J. ROSSITER,
Clerk of the Executive Council.

SALE SEWERAGE AUTHORITY.

At the Executive Council Chamber, Melbourne, the nineteenth day of October, 1971.

PRESENT:

His Excellency the Governor of Victoria.
Mr. Meagher | Mr. Smith.

CONSENT TO BORROWING \$63,000.

Under the powers conferred by the Sewerage Districts Act and all other powers enabling him in that behalf, His Excellency the Governor of the State of Victoria, by and with the advice of the Executive Council of the said State, doth hereby consent to the Sale Sewerage Authority borrowing the sum of Sixty-three thousand dollars (\$63,000) to meet the cost of sewerage works as set forth in the detailed statement bearing date 13th October, 1971.

And the Honorable Roberts Christian Dunstan, Her Majesty's Minister of Water Supply for the State of Victoria, shall give the necessary directions herein accordingly.

J. ROSSITER,
Clerk of the Executive Council.

PORT FAIRY SEWERAGE AUTHORITY.

At the Executive Council Chamber, Melbourne, the nineteenth day of October, 1971.

PRESENT:

His Excellency the Governor of Victoria.
Mr. Meagher | Mr. Smith.

EXTENT OF SEWERAGE DISTRICT INCREASED.

Under the powers conferred by the Sewerage Districts Act and all other powers enabling him in that behalf, His Excellency the Governor of the State of Victoria, by and with the advice of the Executive Council of the said State, doth hereby declare, order and direct that the extent of the Sewerage District of the Port Fairy Sewerage Authority be increased by adding thereto the land as shown on the plan approved by the Governor in Council by and with this Order and deposited in the office of the State Rivers and Water Supply Commission, Melbourne (Corr. No. 70/2893/25), and as on and from the date hereof the extent of such District shall be and be deemed to be increased accordingly.

And the Honorable Roberts Christian Dunstan, Her Majesty's Minister of Water Supply for the State of Victoria, shall give the necessary directions herein accordingly.

J. ROSSITER,
Clerk of the Executive Council.

GEELONG WATERWORKS AND SEWERAGE TRUST.

At the Executive Council Chamber, Melbourne, the nineteenth day of October, 1971.

PRESENT:

His Excellency the Governor of Victoria.
Mr. Meagher | Mr. Smith.

CONSENT TO BORROWING \$100,000.

Under the powers conferred by the Geelong Waterworks and Sewerage Act and all other powers enabling him in that behalf, His Excellency the Governor of the State of Victoria, by and with the advice of the Executive Council of the said State, doth hereby consent to the Geelong Waterworks and Sewerage Trust borrowing the sum of One hundred thousand dollars (\$100,000) for the conversion of Loan No. Q7.

And the Honorable Roberts Christian Dunstan, Her Majesty's Minister of Water Supply for the State of Victoria, shall give the necessary directions herein accordingly.

J. ROSSITER,
Clerk of the Executive Council.

GEELONG WATERWORKS AND SEWERAGE TRUST.

At the Executive Council Chamber, Melbourne, the nineteenth day of October, 1971.

PRESENT:

His Excellency the Governor of Victoria.
Mr. Meagher | Mr. Smith.

CONSENT TO BORROWING \$187,000.

Under the powers conferred by the Geelong Waterworks and Sewerage Act and all other powers enabling him in that behalf, His Excellency the Governor of the State of Victoria, by and with the advice of the Executive Council of the said State, doth hereby consent to the Geelong Waterworks and Sewerage Trust borrowing the sum of One hundred and eighty-seven thousand dollars (\$187,000) for the conversion of Loan No. D5.

And the Honorable Roberts Christian Dunstan, Her Majesty's Minister of Water Supply for the State of Victoria, shall give the necessary directions herein accordingly.

J. ROSSITER,
Clerk of the Executive Council.

DANDENONG VALLEY AUTHORITY.

At the Executive Council Chamber, Melbourne, the nineteenth day of October, 1971.

PRESENT:

His Excellency the Governor of Victoria.
Mr. Meagher | Mr. Smith.

CONSENT TO BORROWING \$190,000.

Under the powers conferred by the Dandenong Valley Authority Act and all other powers enabling him in that behalf, His Excellency the Governor of the State of Victoria, by and with the advice of the Executive Council of the said State, doth hereby consent to the Dandenong Valley Authority borrowing the sum of One hundred and ninety thousand dollars (\$190,000) in two amounts of One hundred thousand dollars (\$100,000) and Ninety thousand dollars (\$90,000) respectively, to meet the cost of river improvement and drainage works.

And the Honorable Roberts Christian Dunstan, Her Majesty's Minister of Water Supply for the State of Victoria, shall give the necessary directions herein accordingly.

J. ROSSITER,
Clerk of the Executive Council.

BRIAGOLONG WATERWORKS TRUST.

At the Executive Council Chamber, Melbourne, the nineteenth day of October, 1971.

PRESENT:

His Excellency the Governor of Victoria.
Mr. Meagher | Mr. Smith.

URBAN DISTRICT PROCLAIMED.

Under the powers conferred by the Water Act and all other powers enabling him in that behalf, His Excellency the Governor of the State of Victoria, by and with the advice of the Executive Council of the said State, proclaims that on and from the date hereof the Waterworks District of the Briagolong Waterworks Trust shall be an Urban District for the purposes of and within the meaning of the said Act and shall be known as the Briagolong Urban District.

And the Honorable Roberts Christian Dunstan, Her Majesty's Minister of Water Supply for the State of Victoria, shall give the necessary directions herein accordingly.

J. ROSSITER,
Clerk of the Executive Council.

LISMORE AND DERRINALLUM WATERWORKS TRUST.

At the Executive Council Chamber, Melbourne, the nineteenth day of October, 1971.

PRESENT:

His Excellency the Governor of Victoria.
Mr. Meagher Mr. Smith.

REPEAL OF ORDER AND FIXING LIMIT OF OVERDRAFT.

Under the powers conferred by the Water Act and all other powers enabling him in that behalf, His Excellency the Governor of the State of Victoria, by and with the advice of the Executive Council of the said State, hereby—

(a) repeals the Order fixing the limit of the amount that the Lismore and Derrinallum Waterworks Trust may owe at any time in respect of advances obtained by overdraft of current account with the National Bank of Australasia Ltd., Lismore, made on 3rd June, 1947, and published in the *Victoria Government Gazette* of 11th June, 1947; and

(b) specifies that the amount which the Lismore and Derrinallum Waterworks Trust may owe at any time in respect of advances obtained by overdraft of current account with the National Bank of Australasia Ltd., Lismore, pursuant to the provisions of section 288 of the Water Act 1958 shall not exceed Fifty thousand dollars (\$50,000).

And the Honorable Roberts Christian Dunstan, Her Majesty's Minister of Water Supply for the State of Victoria, shall give the necessary directions herein accordingly.

J. ROSSITER,
Clerk of the Executive Council.

Over \$40, and not exceeding \$100, 8 instalments.
Over \$100, and not exceeding \$200, 10 instalments.
Over \$200, and not exceeding \$400, 12 instalments.
Over \$400, and not exceeding \$600, 14 instalments.
Over \$600, and not exceeding \$800, 16 instalments.
Over \$800, and not exceeding \$1,000, 18 instalments.
Over \$1,000, 20 instalments.

Interest at the rate of 5% per annum is payable with all payments of residue, and is computed for each instalment from the date of sale to the date of such payment. Additional interest is charged if any instalment is not paid on or before the due date.

If paid off within 30 days of sale, no interest is payable.

FEES, ETC.:

Also payable at the sale, in addition to the deposit, are the survey fee and, if applicable, the valuation of improvements (if purchaser be not the owner thereof).

Payable with balance of purchase money—

Crown Grant fee—\$3.

Assurance Fund contribution.—One cent in every Five dollars or part thereof of purchase price. (This is a fund established to guarantee the validity of freehold titles.)

Transfer of interest prior to completion of payment may be allowed on payment of \$2 fee and subject to stamp duty.

If unable to attend personally, a prospective purchaser may arrange for another person to bid as his agent.

Attention is drawn to section 95, *Land Act 1958*, which provides that the purchaser shall be deemed to be the owner for the purposes of other Acts; also to an amendment to the Local Government Act providing for Government roads, in certain circumstances, to be declared "private streets", thus making the purchaser liable to contribute to the cost of street construction.

W. BORTHWICK,
Minister of Lands.

Office of Crown Lands and Survey,
Melbourne, 20th October, 1971.

LANDS DEPARTMENT NOTICES

APPROACHING LAND SALES.

Sales of Crown Lands, in fee-simple, will be held at the under-mentioned places and dates, viz.:—

	No. of Gazette.
Ballarat.—Thursday, 11th November, 1971 . .	90
Ballarat.—Thursday, 11th November, 1971 . .	87
Bannockburn.—Saturday, 23rd October, 1971 . .	84
Camperdown.—Thursday, 21st October, 1971 . .	84
Derrinallum.—Thursday, 21st October, 1971 . .	84
Inglewood.—Thursday, 25th November, 1971 . .	90
Kyabram.—Thursday, 18th November, 1971 . .	90
Red Cliffs.—Tuesday, 23rd November, 1971 . .	90
Rochester.—Thursday, 18th November, 1971 . .	90
Sale.—Thursday, 21st October, 1971 . .	83
St. Arnaud.—Thursday, 28th October, 1971 . .	87

SALE OF CLOSER SETTLEMENT LAND.

Tongala.—Thursday, 18th November, 1971 . . 90

SALE OF FREEHOLD LAND BY AUCTION.

Colac.—Thursday, 21st October, 1971 . . 84

SALE OF CROWN LAND BY AUCTION.

The land will be offered for sale in fee-simple, and subject to the provisions of the Land Act and Regulations thereunder.

The upset price is the sum at which bidding will start, and no bid below that sum can be accepted. The highest bidder at or above that sum shall be the purchaser, subject to signature of contract and any necessary payment.

TERMS:

A deposit of at least 12½% of the purchase price must be paid at the sale, either in cash or by cheque.

The residue is payable in half-yearly instalments, in accordance with the following scale, or may be paid off at any earlier time.

RED CLIFFS.—Sale (No. 12113) of Crown land in fee-simple, by auction, will be held at the LAND OFFICE, RED CLIFFS, on TUESDAY, the 23rd day of NOVEMBER, 1971, at HALF PAST ELEVEN o'clock a.m. To be conducted by N. J. FITZGERALD, Land Officer, Ballarat.
Lot 1.

TOWNSHIP OF PANITYA, PARISH OF CARINA, COUNTY OF WEEAH.

In the east of the Township fronting the north side of the Ouyen Highway and adjacent to the Recreation Reserve.

Upset price \$165 the lot. Survey fee \$120.

Area 13a. 2r. 21p. Allotment 8A of Section 1.

One month allowed for removal of fencing.—(M.62433.)

PROPOSED REVOCATIONS OF TEMPORARY RESERVATIONS OF LANDS BY ORDERS IN COUNCIL.

In pursuance of the provisions of the *Land Act 1958*, notice is hereby given that it is the intention of the Governor in Council to revoke the temporary reservations of lands by Orders in Council hereunder referred to, viz.:—

The following Notices were published 1° on the 29th September, 1971, pursuant to Orders of the 21st September, 1971.

HOME BUSH.—The temporary reservation by Order in Council of the 9th February, 1874, of 5 acres 0 roods 3 perches of land in the Township of Homebush as a site for State School purposes is about to be revoked.—(H.123(*) (74/N1055)).

LAKES ENTRANCE AND CUNNINGHAME.—The temporary reservation by Order in Council of the 19th January, 1971, of 11 acres 3 roods 29 perches of land in the Townships of Lakes Entrance and Cunninghame, as a site for Public purposes is about to be revoked.—(C.383(F³), C.486(F²)) (Rs.3353).

MOLIAGUL.—The temporary reservation by Order in Council of the 6th October, 1873, of 2 acres of land in the Parish of Moliagul, as a site for State School purposes is about to be revoked.—(M.131(*) (Rs.9525)).

MOREEP.—The temporary reservation by Order in Council of the 17th August, 1925, of 1,320 acres, more or less, of land in the Parish of Moreep, as a site for the Geelong Waterworks and Sewerage Trust is about to be revoked.—(M.486^(s)) (Rs.3168).

YALLOCK (BAYLES).—The temporary reservation by Order in Council of the 2nd July, 1912, of 2 acres of land in the Parish of Yallock, as a site for Supply of Material for Roadmaking is about to be revoked.—(Y.22^(s)) (12.C.55155).

YALLOCK (BAYLES).—The temporary reservation by Order in Council of the 20th June, 1932, of 3 acres 3 roods 36 perches of land in the Parish of Yallock, as a site for Public Gardens and Plantation, revoked as to part by various Orders, is about to be revoked so far as the balance thereof containing 3 acres 2 roods 25 8/10 perches is concerned.—(Y.22^(s)) (Rs.4214).

MANANGATANG.—The temporary reservation by Order in Council of the 20th October, 1914, of 3 acres 3 roods 31 3/10 perches of land in the Township of Manangatang, as a site for a State School, revoked as to part by various orders, is about to be revoked so far only as the portion containing 1 rood 20 perches, more or less, indicated by hatching on plan hereunder is concerned.—(M.571^(s)) (Rs.211).

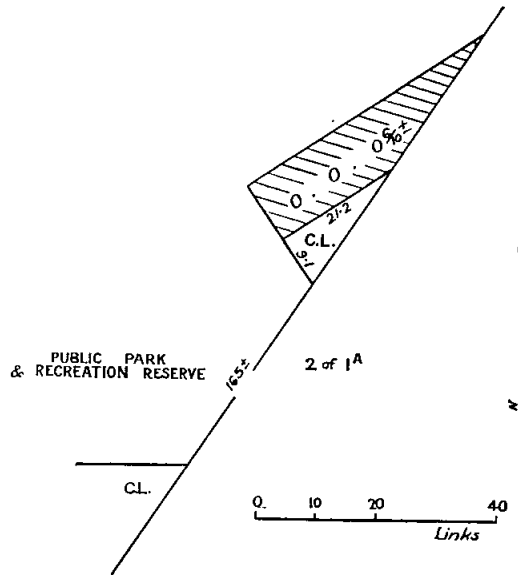

SANDHURST (EAGLEHAWK).—The temporary reservation by Order in Council of the 3rd February, 1885, of 53 acres 0 roods 10 perches of land at Eaglehawk, Parish of Sandhurst (named municipal district of Eaglehawk in Order) as a site for a Reservoir and Public Park, revoked as to part by Order of the 26th January, 1916, is about to be revoked so far only as the portion containing 34 perches, indicated by hatching on plan hereunder is concerned.—(S.371⁽²⁰⁾) (Rs.4219).

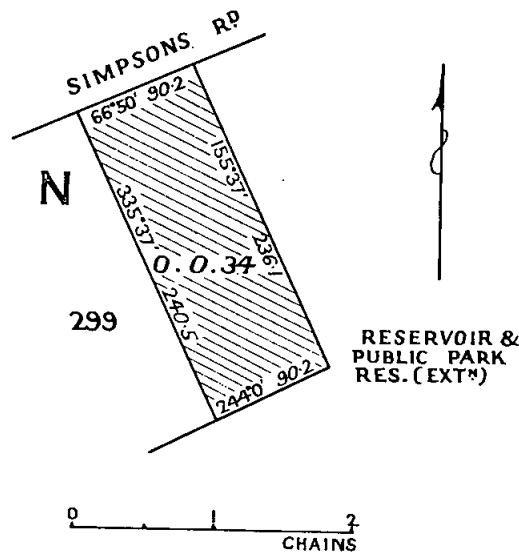
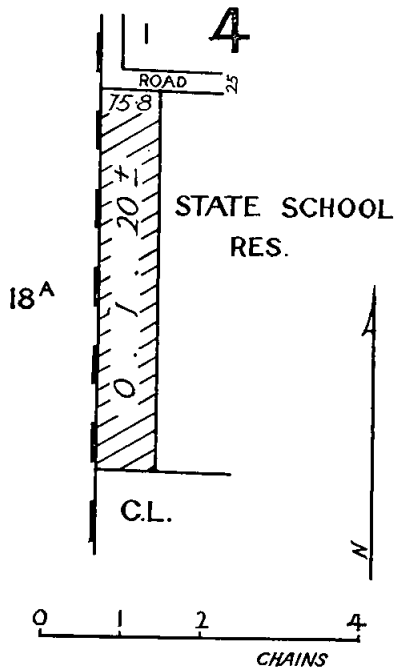

OAKLEIGH.—The temporary reservation by Order in Council of the 21st October, 1940, of 44 acres, more or less, of land in the Township of Oakleigh, as a site for a Public Park and Recreation, revoked as to part by various orders is about to be revoked so far only as the portion containing 0 6/10 of a perch, more or less, indicated by hatching on plan hereunder is concerned.—(O.1^(s)) (Rs.1121).

YAT NAT.—The temporary reservation by Order in Council of the 24th February, 1970, of 387 acres 2 roods 12 perches of land in the Parish of Yat Nat, as a site for Public Purposes (Supply of Gravel) is about to be revoked so far only as the portion containing 1 rood 2 perches, indicated by hatching on plan hereunder, is concerned.—(Y.106⁽⁷⁾) (Rs.9282).

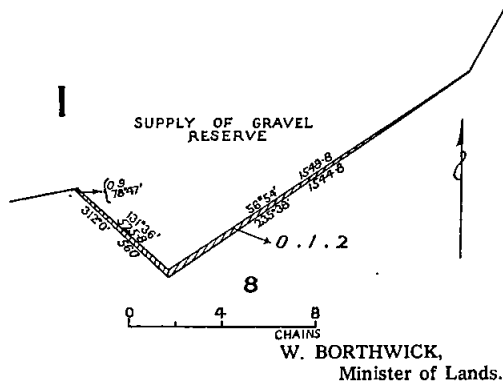

PROPOSED PERMANENT RESERVATION OF LAND AS A SITE.

In pursuance of sections 14 and 21 of the *Land Act 1958*, notice is hereby given that it is the intention of the Governor in Council to reserve permanently from sale, from being leased and from having a licence granted in respect thereof the land hereinafter described:—

The following Notice was published 1° on the 29th September, 1971, pursuant to Orders of the 21st September, 1971.

NARREE WORRAN.—Land proposed to be permanently reserved as a site for Public purposes, 2 acres 2 roods, Parish of Narree Worrان, County of Mornington, as indicated by hatching on plan hereunder.—(N.19⁽⁹⁾) (C.89844).

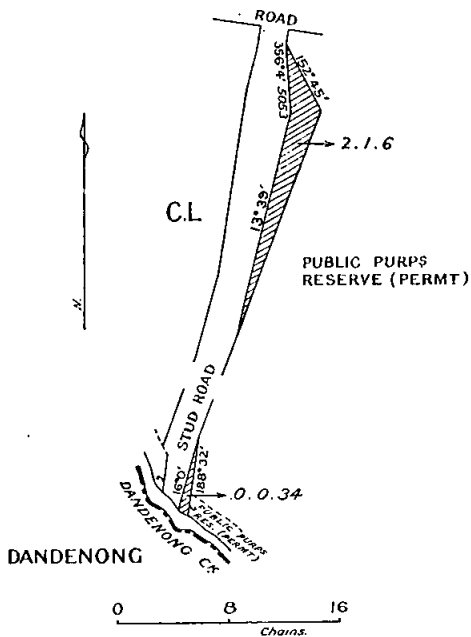

TOTAL AREA OF HATCHED PORTIONS : 2. 2. 0

W. BORTHWICK,
Minister of Lands.

PROPOSED PERMANENT RESERVATION OF LAND AS A SITE.

In pursuance of sections 14 and 21 of the *Land Act 1958*, notice is hereby given that it is the intention of the Governor in Council to reserve permanently from sale, from being leased and from having a licence granted in respect thereof the land hereinafter described:—

The following Notices were published 1° on the 6th October, 1971, pursuant to Orders of the 28th September, 1971.

NARREE WORRAN.—Land proposed to be permanently reserved as a site for Public Purposes (Conservation of Wildlife) 4 acres, Parish of Narree Worrان, County of Mornington as indicated by hatching on plan hereunder.—(N.19⁽¹⁰⁾) (Rs.9523).

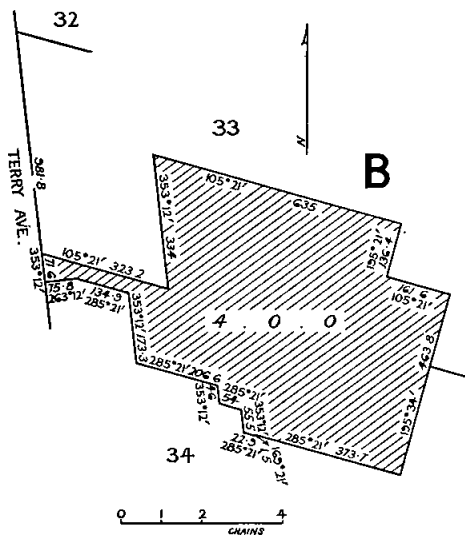

W. BORTHWICK,
Minister of Lands.

PROPOSED PERMANENT RESERVATION OF LAND AND REVOCATION AS TO PART.

In pursuance of section 15 of the *Land Act 1958*, notice is hereby given that it is the intention of the Governor in Council to reserve permanently, and to revoke as to part the permanent reservation of certain land hereunder referred to, viz.:—

The following Notice was published 1° on the 6th October, 1971, pursuant to Order of the 28th September, 1971.

SHEPPARTON.—Land to be permanently reserved for Public Purposes, Parish of Mooroopna, County of Rodney; Crown land forming the new bed of the Goulburn River, where the course of the said river has become altered since the 23rd May, 1881, together with the Crown land on the banks thereof, as indicated by hatching on plan hereunder.

ORDER IN COUNCIL TO BE REVOKED AS TO PART.

The Order in Council of the 23rd May, 1881 (see *Government Gazette* of the 27th May, 1881, Page 1389), by which the beds of certain lakes, rivers and creeks specified therein, and Crown lands on the margins and banks thereof respectively were permanently reserved for Public purposes, is about to be revoked so far only as it relates to that portion of the bed and banks of the Goulburn River in the Parish of Mooroopna, County of Rodney, and the Township of Shepparton, Parish of Shepparton, County of Moira, as indicated by cross-hatching on plan hereunder,

to which it is no longer applicable in consequence of the course of the said river having become altered after the date of the said Order.—(M.458⁽¹⁾) (S.283H.3) (C.77846).

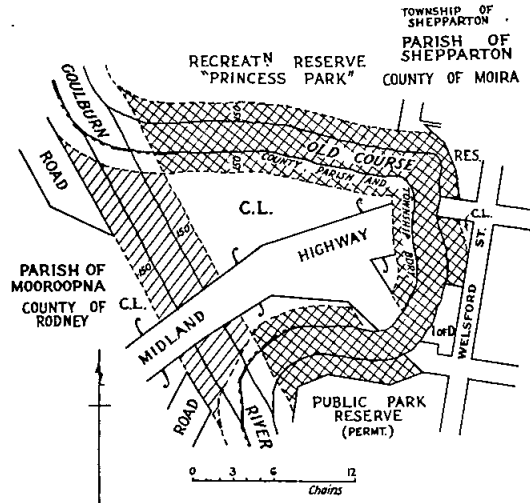

W. BORTHWICK,
Minister of Lands.

PROPOSED REVOCATIONS OF TEMPORARY RESERVATIONS OF LANDS BY ORDERS IN COUNCIL.

In pursuance of the provisions of the *Land Act 1958*, notice is hereby given that it is the intention of the Governor in Council to revoke the temporary reservations of lands by Orders in Council hereunder referred to, viz.:—

The following Notices were published 1° on the 20th October, 1971, pursuant to Orders of the 11th October, 1971.

WOOMELANG.—The temporary reservation, by Order in Council of the 20th January, 1970, of 11 acres 2 roods, more or less, of land in the Township of Woomelang as a site for Public purposes, municipal purposes, Storage of Water, is about to be revoked, so far only as the portion containing 26 perches, indicated by hatching on plan hereunder is concerned.—W.390⁽²⁾ (Rs.9248).

PROPOSED REVOCATION OF TEMPORARY RESERVATION OF LAND BY ORDER IN COUNCIL.

In pursuance of the provisions of the *Land Act 1958*, notice is hereby given that it is the intention of the Governor in Council to revoke the temporary reservation of land by Order in Council hereunder referred to, viz.:—
The following Notice was published 1° on the 6th October, 1971, pursuant to Orders of the 28th September, 1971.

WERRIGAR.—The temporary reservation, by Order in Council of the 17th February, 1885, of certain unappropriated Crown land in the Parishes of Kellalac and Werrigar for Water Supply purposes, revoked as to part by various Orders, is about to be revoked so far only as the portion in the Parish of Werrigar containing 12 acres, more or less, indicated by hatching on plan hereunder, is concerned.—(W.293⁽⁰⁾) (Rs.3749).

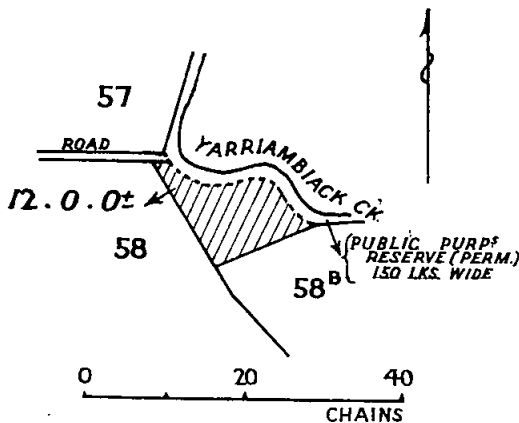
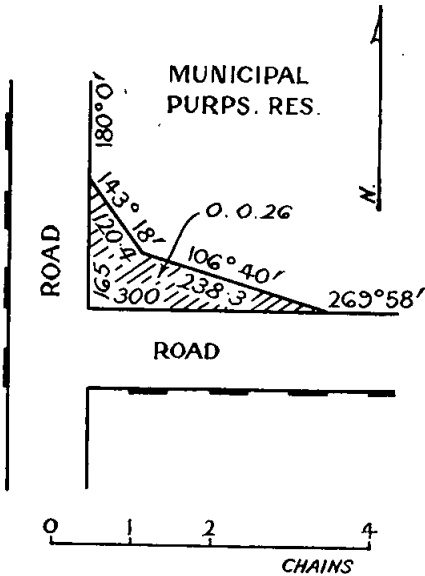

Minister of Lands.
W. BORTHWICK,

BEECHWORTH.—The temporary reservation, by Order in Council of the 27th November, 1962, of 278 acres 13 perches of land in the Parish of Beechworth, as a site for Social Welfare purposes, is about to be revoked, so far only as the portion containing 1 acre 2 roods 12 perches, indicated by hatching on plan hereunder is concerned.—(B.349⁽²²⁾) (Rs.8185).

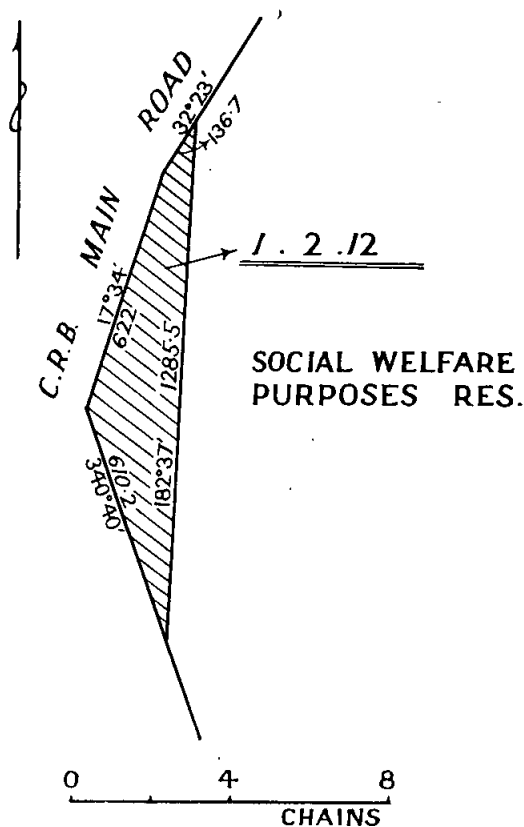

MOOROOLBARK.—The temporary reservation, by Order in Council of the 5th March, 1906, of 9 acres 1 rood 34 perches of land in the Parish of Mooroolbark, as a site for Public Recreation is about to be revoked, so far only as the portions containing 16 perches, indicated by hatching on plan hereunder, are concerned.—(M.152⁽⁵⁾) (Rs.310).

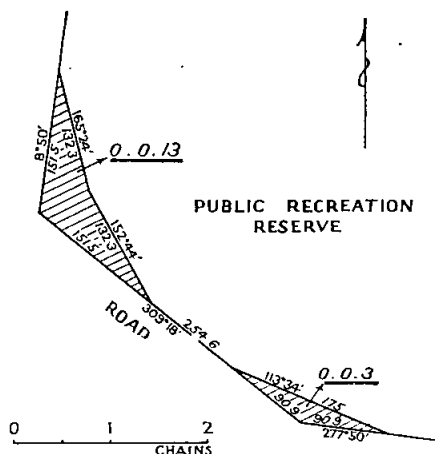

Total Area of Hatched Portions: 0.0.16

WODONGA.—The temporary reservation as a site for Public Park, and the withholding from sale, leasing and licensing by Order in Council of the 27th February, 1878, of 86 acres 1 rood 32 perches of land in the Township of Wodonga, revoked as to part by Order of the 22nd April, 1904, is about to be revoked, so far only as the portion containing 1 acre 1 rood 10 perches, more or less, indicated by hatching on plan hereunder is concerned.—(W.308⁽⁵³⁾) (Rs.4548).

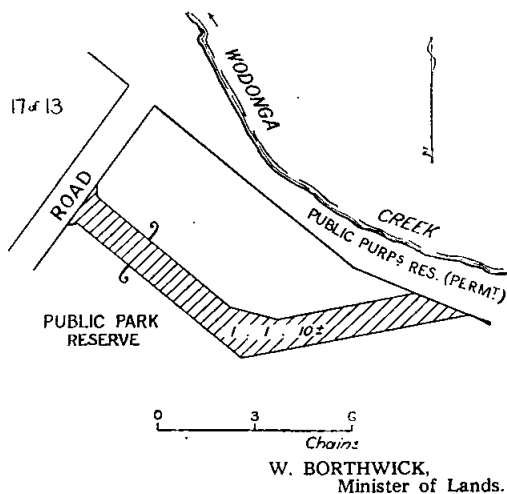

W. BORTHWICK,
Minister of Lands.

TENDERS

PUBLIC WORKS DEPARTMENT

Tenders will be received at Public Works Department, 2 Treasury-place, Melbourne, until **TWO** p.m. on dates shown and for purposes mentioned hereunder.

Particulars and tender forms available at Contracts Office, Room 8, Building Division, Parliament-place and at places indicated in brackets hereunder.

Abbreviations in brackets mean:—W.O.—Inspector of Works Office; P.S.—Police Station; C.S.—Consolidated School; H.E.S.—Higher Elementary School; H.S.—High School; S.S.—State School; T.S.—Technical School.

Tenders to be submitted on the Department's printed Tender Form and will not be received by telephone. All tenders must be on a "Firm Tender" basis. The lowest or any tender will not necessarily be accepted.

Address tenders to the Minister of Public Works, and endorse the envelope containing the tender "Tender for closing Tuesday,

Hand delivered tenders to be placed in the Tender Box of the Public Works Department, located on the wall of the centre entrance foyer, Ground Floor, 2 Treasury-place, Melbourne.

No preliminary deposit is required with any tender, but a successful tenderer will be required to pay a deposit for any accepted tender of \$4,000 or over.

Tuesday, 26th October, 1971.

Building, Electrical and Mechanical Works.

- BURWOOD.—External repairs and painting, H.S.
- ESSENDON.—External renovations, T.S.
- JANEFIELD.—Erection of Arts & Craft Centre, Training Centre.
- KILSYTH.—Exterior repairs and painting, Pr.S.3645.
- LYNDALE.—Erection of standard school hall type "800C", H.S.
- LYNDALE.—Electrical services, Hall, H.S.
- LYNDALE.—Mechanical services, Hall, H.S.
- OVERPORT.—Internal renovations, Infants Wing, Pr.S.4780.
- QUEENSCLIFF.—Design, fabrication and erection of Buoy Maintenance Depot (W.O., Geelong and Ports and Harbours Depot, Queenscliff). (Amended Specifications.)
- VARIOUS.—Additional classrooms Pr.S.'s, Western Region Bulk Contract 1971/72 (W.O., Ballarat, Geelong, Hamilton and Horsham.)
- YALLOURN.—Erection of standard school hall type "800". (W.O., Traralgon and Warragul.)
- YALLOURN.—Electrical services, Hall, Technical College. (W.O., Traralgon and Warragul.)
- YALLOURN.—Mechanical services, Hall, Technical College. (W.O., Traralgon and Warragul.)

Site Works.

- WOORANNA PARK.—Site Works, Pr.S.4989.

Thursday, 4th November, 1971.

Building, Electrical and Mechanical Works.

ALEXANDRA.—Erection of a new school, Pr.S.912. (W.O., Alexandra, Benalla, Shepparton and Wangaratta.)

ALEXANDRA.—Electrical services, new school, Pr.S.912. (W.O., Alexandra, Benalla, Shepparton and Wangaratta.)

ALEXANDRA.—Mechanical services, new school, Pr.S.912. (W.O., Alexandra, Benalla, Shepparton and Wangaratta.)

BALLARAT.—Repairs to windows, washing and drinking facilities, waterproofing, flyproofing, Girls' H.S. (W.O., Ballarat.) (Re-advertised.)

BORONIA.—Erection of brick library, H.S.

BORONIA.—Electrical services, library, H.S.

BORONIA.—Plenum heating and hot water services, library, H.S.

BURNLEY.—Erection of headhouse and glasshouse, Victorian Plant Research Institute.

BURNLEY.—Electrical services, headhouse and glasshouse, Victorian Plant Research Institute.

BURNLEY.—Mechanical services, headhouse and glasshouse, Victorian Plant Research Institute.

COBDEN.—Septic-humus tank and sewerage trickling filter installation, T.S. (W.O., Camperdown, Geelong and Warrambbool.)

COBURG.—Supply and installation of refrigeration system, new kitchen, H.M. Prison, Pentridge.

COLAC SOUTH-WEST.—Heating and hot water to four classroom wing, Pr.S.4775. (W.O., Ballarat, Geelong and Warrambbool.)

FAWKNER.—Erection of brick library, H.S.

FAWKNER.—Electrical services, library, H.S.

FAWKNER.—Plenum heating and hot water service, library, H.S.

FAWKNER.—Erection of brick library, T.S.

FAWKNER.—Electrical services, library, T.S.

FAWKNER.—Plenum heating and hot water service, library, T.S.

GROVEDALE.—Connect to sewer, renewal of water supply, &c., Pr.S.283. (W.O., Geelong.)

HAMILTON.—Heating, additional classrooms, Pr.S.4847. (W.O., Ballarat, Horsham and Warrambbool.)

WATSONIA.—Erection of brick library, H.S.

WATSONIA.—Electrical services, library, H.S.

WATSONIA.—Plenum heating and hot water service, library, H.S.

Furniture and Furnishings.

HEATHERTON.—Supply of furniture, male staff quarters, Sanatorium.

Site Works.

KANIVA.—Asphalt repairs, Con.S. (W.O., Horsham.)

LEONGATHA.—Construction of oval and playing fields, &c., H.S. (W.O., Korumburra.)

MOOROOLBARK.—Site works, P.S.

Miscellaneous.

PORTLAND.—Cartage of stone from P.H.T. quarry, to Dutton Way. (P.W.D. Depot, Port Fairy and Portland P.S.)

WILLIAMSTOWN.—Supply and delivery of electric motor driven air compressor, Dredging Depot. (Re-advertised.) Building, Electrical & Mechanical Works—

Tuesday, 9th November, 1971.

Building, Electrical and Mechanical Works.

BON BEACH.—External repairs and painting, H.S.

FRANKSTON.—External and internal renovations, H.S. (Re-advertised.)

GLENROY.—Erection of brick library, H.S.

GLENROY.—Electrical services, library, H.S.

GLENROY.—Plenum heating and hot water service, library, H.S.

MITCHAM.—Erection of brick library, H.S.

MITCHAM.—Electrical services, library, H.S.

MITCHAM.—Plenum heating and hot water service, library, H.S.

TECOMA.—Internal and external renovations, Pr.S.3356.

TEMPLESTOWE.—Erection of brick library, H.S.

TEMPLESTOWE.—Electrical services, library, H.S.

TEMPLESTOWE.—Plenum heating and hot water service, library, H.S.

WANGARATTA.—Erection of brick library, T.S. (W.O., Wangaratta.)

WANGARATTA.—Electrical services, library, T.S. (W.O., Wangaratta.)

WANGARATTA.—Plenum heating and hot water service, library, T.S. (W.O., Wangaratta.)

WAVERLEY.—Erection of brick library, H.S.

WAVERLEY.—Electrical services, library, H.S.

WAVERLEY.—Plenum heating and hot water service, library, H.S.

Site Works.

NARMARA.—Concreting, landscaping and associated drainage, Pr.S.4953.

MURRAY BYRNE,
Minister of Public Works.

Public Works Department,
Melbourne, 3002, 18th October, 1971.

PUBLIC SERVICE NOTICES

No. 84.

PUBLIC SERVICE ACT 1958.

The Public Service Board, in pursuance of the powers conferred by the *Public Service Act 1958*, hereby amends the *Public Service (Public Service Board) Regulations* as follows:—

PART III.—PROMOTIONS AND TRANSFERS.

DIVISION I.—GENERAL.

Regulation 71.

Sub-regulation (6) is deleted and the following sub-regulation is inserted in lieu thereof—

“(6) (a) Any applicant who feels aggrieved by the failure of the Permanent Head to recommend him for appointment may appeal in writing direct to the Board.

(b) The appellant shall state—

(i) the grounds of his appeal, and

(ii) whether he desires to appear in person before the Board—

and shall cause such appeal to be lodged with the Board not later than 9.30 a.m. on the day following the date ten days after the date on which the notification is signed by the Permanent Head.”

A. J. A. GARDNER, Chairman.

V. P. SCULLY, Secretary.

Office of the Public Service Board,
Melbourne, 8th October, 1971.

EXAMINATION OF APPLICANTS FOR LICENCE AS SHORTHAND WRITER.

It is hereby notified that an examination of applicants for licence as Shorthand Writer will be held at the Royal Melbourne Institute of Technology, 5th Floor, Casey Wing, Rooms C.519 and C.525, Swanston-street, Melbourne, on Saturday the 27th November, 1971, at 10 o'clock a.m.

Applications for permission to attend the examination together with an entry fee of four dollars (\$4.00) must be forwarded to reach the Secretary, Public Service Board, Treasury Place, Melbourne, 3002 (where a copy of the Regulations may be obtained), not later than Saturday the 13th November, 1971.

Satisfactory evidence of—

(1) Name in full.

(2) Having attained the age of twenty-one (21) years, and

(3) Good moral character, should be submitted with application.

By order,

V. P. SCULLY,
Secretary.

Office of the Public Service Board,
Melbourne, 11th October, 1971.

No. 86.

Public Service Act 1958, Section 39.

REGULATIONS.—PART IV.—SALARIES AND INCREMENTS.

The Public Service Board, in pursuance of the powers conferred by the *Public Service Act 1958*, hereby amends its Regulations as shown below :—

FOURTH SCHEDULE.

ADMINISTRATIVE DIVISION.

Amount of Salary Assigned to Offices in Class "A1"

Office.	Yearly Rate of Salary.
CHIEF SECRETARY'S DEPARTMENT.	
\$	
<i>Delete—</i> Assistant Secretary, Office of the Chief Commissioner of Police	10,280
<i>Add—</i> Senior Executive Officer, Office of the Chief Commissioner of Police	10,280

A. J. A. GARDNER, Chairman.
V. P. SCULLY, Secretary.

Office of the Public Service Board,
Melbourne, 8th October, 1971.

No. 85.

PUBLIC SERVICE ACT 1958.

The Public Service Board, in pursuance of the powers conferred by the *Public Service Act 1958*, hereby amends the Public Service (Public Service Board) Regulations as follows:—

PART III.—PROMOTIONS AND TRANSFERS.

DIVISION I.—GENERAL.

Regulation 72.

Sub-regulation (3) is deleted and the following sub-regulation is inserted in lieu thereof—

"(3) (a) Any officer may appeal in writing to the Board against any such recommendation.

(b) The appellant shall state—

- (i) the grounds of his appeal, and
(ii) whether he desires to appear in person before the Board—
and shall cause such appeal to be lodged with the Board not later than 9.30 a.m. on the day following the date ten days after the date of advertisement."

A. J. A. GARDNER, Chairman.
V. P. SCULLY, Secretary.

Office of the Public Service Board,
Melbourne, 8th October, 1971.

TEACHING SERVICE ACT 1958. SECTION 73.

PUBLIC SERVICE ACT 1958. SECTIONS 55 AND 56.

It is hereby notified that a charge of being absent without leave from 9th February, 1970 to 24th November, 1970 has been preferred against Mr. Kevin John Heath, Teacher, Assistant Class, Secondary School Division, Moe High School, Education Department, under Section 73 of the *Teaching Service Act 1958* which applies to the Teaching Service the provisions of Sections 55 and 56 of the *Public Service Act 1958* and that a certified letter asking him whether he admits or denies the truth of the charge (posted to his last known address, viz. 40 Alandale-road, Blackburn, 3130) has been returned unclaimed.

A further letter has been forwarded to the said Mr. Kevin John Heath at the last known address referred to, advising him that unless he admits or denies the truth of the charge in writing to the Tribunal by Sunday, 31st October, 1971 he shall be deemed to deny the truth of the charge and the investigation thereof will be proceeded with on Monday, 1st November, 1971 at 9.00 a.m. at the office of the Teachers Tribunal, Royal Mint Building, William-street, Melbourne, 3000.

By Order,

A. F. LE CLERCQ, Secretary.

Office of the Teachers Tribunal,
Melbourne, 18th October, 1971.

Teaching Service Act 1958.

TEACHING SERVICE (CLASSIFICATION, SALARIES AND ALLOWANCES) REGULATIONS.

AMENDMENT No. 213 (C.S. & A. 8).

The Teachers Tribunal, in pursuance of the powers conferred by the *Teaching Service Act 1958*, hereby amends the Teaching Service (Classification, Salaries and Allowances) Regulations in the manner following, that is to say:—

PART I.—PROFESSIONAL OFFICERS.

In sub-heading (a) of clause 5 after the expression "*Director of Special Services*" insert the expression "*Regional Directors of Education*" and under this sub-heading after the expression "*Director of Teacher Education and Director of Special Services .. \$13,900*" insert the expression "*Regional Director of Education .. \$13,000*".

W. E. SAMPSON, Chairman.
A. F. LE CLERCQ, Secretary.

Office of the Teachers Tribunal,
Melbourne, 8th October, 1971.

PRIVATE ADVERTISEMENTS

CITY OF ALTONA.

BY-LAW No. 44.

SEWERAGE CONNECTION BY-LAW.

Notice is given that the Council of the City of Altona has made a By-Law numbered 44 for the following purposes—

1. Repealing By-Law No. 36;
2. Regulating sewerage and drainage;
3. Providing for the health of the residents and against the spreading of contagious or infectious diseases; and
4. Suppressing nuisances.

The By-Law shall apply to and have operation throughout the whole of the municipal district of the City of Altona, but it shall not apply to any property in respect to which a general notice has been served by the Melbourne and Metropolitan Board of Works under Section 160 (2) of the *Melbourne and Metropolitan Board of Works Act 1958*.

A copy of the By-Law is open for inspection free of charge during office hours at the Civic Offices, 115 Civic Parade, Altona.

2941

S. FELL, Acting Town Clerk.

CITY OF BALLAARAT.

LOAN No. 27.

Notice of Intention to Borrow the Sum of \$10,000 for Permanent Works and Undertakings.

Notice is hereby given that the Council of the City of Ballarat proposes to borrow the principal sum of Ten thousand dollars (\$10,000), secured by a charge over the general rates of the municipality, such sum to be raised by the grant of a mortgage, in accordance with the provisions of the *Local Government Act 1958*.

1. The maximum rate of interest that may be paid is 7.4 per centum per annum.
2. The purpose for which the loan is to be applied is Caravan Park Development.
3. The period of the loan shall be 15 years.

4. The money borrowed shall be repayable by providing of the municipal fund 30 half-yearly instalments of \$557.43 each, including principal and interest, on the 1st day of June and the 1st day of December during the currency of the loan. The first instalment shall be payable on the 1st day of June, 1972.

Such moneys are to be repayable at the office of the Commonwealth Savings Bank of Australia, in Melbourne.

The plans and specifications and the estimate of the cost of the works and a statement showing the proposed expenditure of the moneys to be borrowed, are open for inspection at the Town Hall, Ballarat.

Dated 14th October, 1971.

2886

F. J. ROGERS, Town Clerk.

CITY OF BOX HILL.

LOAN No. 229.

Notice of Intention to Borrow the Sum of \$100,000 for Permanent Works and Undertakings.

Notice is hereby given that the Council of the City of Box Hill proposes to borrow the principal sum of \$100,000, secured by a charge over the general rates of the municipality, such sum to be raised by the grant of a mortgage in accordance with the provisions of the *Local Government Act 1958*.

1. The maximum rate of interest that may be paid is 7.4 per cent. per annum.
2. The purpose for which the loan is to be applied is:—

(a) *Road Reconstruction, &c.—*

Station-street, culvert over Gardiner's Creek ..	\$26,000
Burwood-road, Council's share of overpass near Burwood High School ..	25,000
Pendle-street, full length ..	24,000
	<hr/>
	\$75,000

(b) *Elgar Park, development of northern area, part cost ..*

25,000

\$100,000

3. The period of the loan shall be fifteen years.

4. The moneys borrowed shall be repayable by providing out of the municipal fund half-yearly instalments of approximately \$5,574.23 each, including principal and interest on the 1st day of February and the 1st day of August, during the currency of the loan. The first instalment shall be payable on the 1st day of February, 1972.

5. Such moneys shall be repayable to the Commissioners of the State Savings Bank of Victoria at the office of the said Commissioners, corner Elizabeth and Bourke streets, Melbourne.

The plans and specifications and the estimate of the cost of the proposed works and a statement showing the proposed expenditure of the moneys to be borrowed, are open for inspection at the office of the Council of the City of Box Hill, Victoria, at the Town Hall, Box Hill.

Dated 19th October, 1971.

2950

A. N. WALLS, Town Clerk.

CITY OF BOX HILL.

LOAN No. 230.

Notice of Intention to Borrow the Sum of \$50,000 for Permanent Works and Undertakings.

Notice is hereby given that the Council of the City of Box Hill intends to borrow \$50,000 (Fifty thousand dollars), secured by a charge over the general rates of the municipality by the grant of a mortgage in accordance with the provisions of the *Local Government Act*.

In connexion therewith, the following information is stated:—

- (a) The amount of the principal moneys which it is proposed to borrow is Fifty thousand dollars.
- (b) The maximum rate of interest that may be paid is 7.4 per centum per annum.
- (c) The times which the moneys borrowed are to be repayable are the 15th day of June, 1972, and the 15th days of December and June, during the years 1972-1985 inclusive, and a final payment on the 15th day of December, 1986, and that the place such moneys shall be repayable is at the Bank of New South Wales, Box Hill.
- (d) The purposes for which the loan is to be applied are:—

Road Reconstruction—

(a) Station-street—Carrington-road to Canterbury-road, part of Council's share of cost ..	\$20,000
(b) Middleborough-road - Whitehorse-road to Davey-street, part of Council's share of cost ..	5,000

Traffic Lights—

Installation at corner of Whitehorse-road and High-street .. 10,000

Erection of pavilion and dressing shed—

Wembly Park, Canterbury-road, part cost ..	15,000
	<hr/>
	\$50,000

- (e) The manner in which the loan is to be liquidated is by provision out of the municipal fund in each half-year during the currency of the loan of the sum of \$2,787.11, which includes principal and interest.

The plans and specifications and estimate of the cost of the works and a statement showing the proposed expenditure of the moneys to be borrowed, are open for inspection at the Town Hall.

Dated this 19th day of October, 1971.

2945

A. N. WALLS, Town Clerk.

CITY OF BOX HILL.

LOAN No. 228.

Notice of Intention to Borrow the Sum of \$25,000 for Permanent Works and Undertakings.

Notice is hereby given that the Council of the City of Box Hill proposes to borrow the principal sum of \$25,000, secured by a charge over the general rates of the municipality, such sum to be raised by the grant of a mortgage in accordance with the provision of the *Local Government Act 1958*.

1. The maximum rate of interest that may be paid is 7.4 per centum per annum.

2. The purpose for which the loan is to be applied is—
Councils's share of—

Road reconstruction and widening	\$21,000
Installation of Traffic Lights	4,000
	<u>\$25,000</u>

3. The loan is to be liquidated over a period of 15 years by 30 equal half-yearly instalments of approximately covering principal and interest, on the 10th days of the months of December and June in each year during the currency of the loan. The first instalment shall be payable on the 10th June, 1972.

4. Such moneys shall be repayable to the Commercial Savings Bank of Australia Ltd., Box Hill.

The plans and specifications and the estimate of the cost of the proposed works and a statement showing the proposed expenditure of the moneys to be borrowed are open for inspection at the office of the Council of the City of Box Hill, at Town Hall, Box Hill.

2858 A. N. WALLS, Town Clerk.

CITY OF BROADMEADOWS.

LOAN No. 63.

Notice of Intention to Borrow the Sum of \$100,000 for Permanent Works and Undertakings.

Notice is hereby given that the Council of the City of Broadmeadows proposes to borrow the sum of \$100,000 on the credit of the Mayor, Councillors and Citizens of the City of Broadmeadows, such sum to be raised by the grant of a mortgage in accordance with the provisions of the *Local Government Act 1958*.

1. The maximum rate of interest that may be paid is 7.3 per cent per annum.

2. The period of the loan shall be ten (10) years.

3. The purpose for which the loan is to be applied is:—

Broadmeadows-road deviation	\$50,000
Separate Rate—Augusta-avenue pedestrian crossing	1,200
Council proportion—Pascoe Vale-road reconstruction	11,000
Sewell Reserve pavilion construction	15,000
Reserves purchase—Broadmeadows ward	4,000
Road reconstruction — Broadmeadows ward	8,800
Clara-street construction	10,000

4. The principal repayments of the loan shall be repayable by providing out of the municipal fund twenty (20) equal amounts of \$7,131.95 principal and interest, payable half-yearly on the 1st day of June and the 1st day of December in each year, during the currency of the loan. The first instalment shall be due and payable on the 1st day of June, 1972.

5. Such moneys shall be repayable at the Offices of the Commonwealth Savings Bank, Glenroy, or such other place or places as the Bank may require.

The plans and specifications and the estimate of the cost of the proposed works and a statement showing the proposed expenditure of the moneys to be borrowed are open for inspection at the Offices of the Council of the City of Broadmeadows, Municipal Offices, Broadmeadows.

2873

E. F. SMILEY, Town Clerk.

CITY OF BROADMEADOWS.

LOAN No. 65.

Notice of Intention to Borrow the Sum of \$50,000 for Permanent Works and Undertakings.

Notice is hereby given that the Council of the City of Broadmeadows proposes to borrow the principal sum of \$50,000 by a charge over the general rates of the Municipality, such sum to be raised by the grant of a mortgage in accordance with the provisions of the *Local Government Act 1958*.

1. The maximum rate of interest that may be paid is 7.4 per cent per annum.

2. The period of the loan shall be fifteen (15) years.

3. The purpose for which the loan is to be applied is:—

Daley-street reconstruction	\$17,500
Barry-road reconstruction	15,000
Dallas Tennis Club pavilion	17,500
	<u>\$50,000</u>

4. The moneys borrowed shall be repayable by providing out of the municipal fund thirty (30) equal amounts of principal and interest payable half-yearly on the 1st day of June and the 1st day of December in each year, of \$2,787. The first instalment shall be due and payable on 1st June, 1972.

5. Such moneys shall be repayable to the Commissioners of the State Savings Bank of Victoria at the office of the said Commissioners, corner Elizabeth and Bourke streets, Melbourne, or such other place or places as the Bank may require.

The plans and specifications and the estimate of the cost of the proposed works and a statement showing the proposed expenditure of the moneys to be borrowed are open for inspection at the Offices of the Council of the City of Broadmeadows, Municipal Offices, Broadmeadows.

2872

E. F. SMILEY, Town Clerk.

CITY OF CAMBERWELL.

LOAN No. 88.

Notice of Intention to Borrow the Sum of \$40,000 for Permanent Works and Undertakings.

Notice is hereby given that the Council of the City of Camberwell proposes to borrow the principal sum of Forty thousand dollars (\$40,000), secured by a charge over the general rates of the municipality, such sum to be raised by the grant of a mortgage in accordance with the provisions of the *Local Government Act 1958*.

1. The maximum rate of interest that may be paid is 7.40 per centum per annum.

2. The purpose for which the loan is to be applied is—

Air Conditioning of City Hall	30,000.00
Parking Area Constructions—	
Ashburton	2,500.00
Yooralla Off-street Scheme	5,000.00
Albion-road	2,500.00
	<u>\$40,000.00</u>

3. That the period of the loan shall be fifteen years.

4. That moneys borrowed shall be repayable by providing out of the municipal fund half-yearly instalments of approximately \$2,229.70 each including principal and interest on the 10th day of June and the 10th day of December during the currency of the loan. The first instalment shall be payable on the 10th day of June, 1972.

5. Such moneys shall be payable at the Commercial Savings Bank of Australia Limited, 335 Collins-street, Melbourne.

The plans and specifications and the estimate of the cost of the proposed works and a statement showing the proposed expenditure of the moneys to be borrowed are open for inspection at the office of the Council of the City of Camberwell, at the Civic Centre, Camberwell.

11th October, 1971.

2868

L. F. CHEFFERS,
Town Clerk and Chief Administrator.

CITY OF CAULFIELD.

Notice under Section 696A (1A) of the Local Government Act 1958, as amended.

ARGENTINE ANT INFESTED AREA.

Notice is hereby given that the Council of the City of Caulfield, in exercise of the powers conferred by the provisions of section 696A (1A) of the *Local Government Act 1958*, as amended, hereby declares the area defined in the Schedule hereunder (such area being within the municipal district of the City of Caulfield), to be an Argentine ant infested area.

Schedule.

*Definition of Area.—Area No. 1.—*Commencing at a point being the south-eastern corner of Orrong-road and Dandenong-road; thence generally easterly and south-easterly along the southern boundary of Dandenong-road, to a point being the intersection of Normanby-road and Dandenong-road; thence farther south-easterly along the southern boundary of Normanby-road to a point being the north-west corner of Balaclava-road and Normanby-road; thence westerly along the northern boundary of Balaclava-road to a point being the north-east corner of Orrong-road and Balaclava-road; thence northerly along the eastern boundary of Orrong-road to the commencing point.

2879

CITY OF DONCASTER AND TEMPLESTOWE.

REVOCATION OF, AND ESTABLISHMENT OF, POUND SITE.
Pounds Act 1958, (Section 4).

Notice is hereby given that at a meeting of the Council of the City of Doncaster and Templestowe, held at the Council Chambers, Doncaster, on Monday, 11th October, 1971, the Council did:—

- (a) revoke the appointment as a pound, the property situated at Parker and Foote streets, Lower Templestowe, being Lots 9 and 10 of section 20 of Town of Templestowe, Parish of Bulleen, County of Bourke, and

(b) appoint as a pound that portion of land situated on the north-eastern corner of Blackburn-road and Heidelberg-Warrandyte-road and more particularly described as part of Crown Allotments 16T and 16U, Parish of Bulleen, County of Bourke.

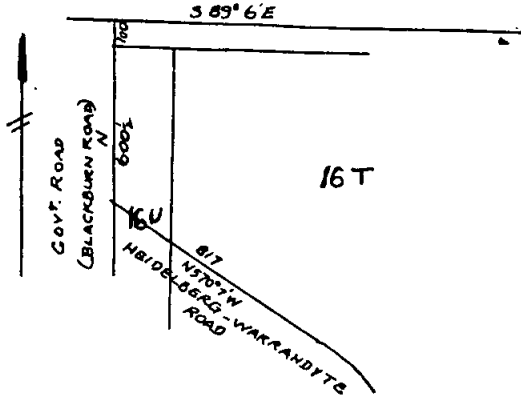

2857

J. W. THOMSON, Town Clerk.

CITY OF FRANKSTON.

ORDER CHANGING NAME OF STREET.

In accordance with the powers conferred by the Local Government Act 1958 (as amended), 15th Schedule, Part 1, clause 8, the Council of the City of Frankston does hereby make an Order changing the name of a street within the municipal district.

Old Name.—Wren-street.

New Name.—New-street.

Location Referred To.—Wren-street as created on lodged plan Nos. 14879 and 14916, being parts of Crown allotments 2 and 3, section B, Parish of Frankston.

G. C. PENTLAND, Town Clerk.

Civic Centre, Frankston. 2855

Town and Country Planning Act 1961.

CITY OF GEELONG.—GEELONG PLANNING SCHEME 1959.

NOTICE THAT A PLANNING SCHEME HAS BEEN PREPARED AND IS AVAILABLE FOR INSPECTION.

Amendment No. 19.

Notice is hereby given that the City of Geelong, in pursuance of its powers under the Town and Country Planning Act 1961, has prepared a Planning Scheme for—

(a) Crown allotments 1, 18, 19 and 20, section 1, Parish of Corio, County of Grant,

(b) Crown allotments 8, 9, 10 and 11, section 2, Parish of Corio, County of Grant,

for the purpose of rezoning the areas from Commercial "C" to Commercial "B".

A copy of the scheme has been deposited at the City Hall, Gheringhap-street, Geelong, and at the office of the Town and Country Planning Board, 235 Queen-street, Melbourne, and will be open for inspection during office hours by any person.

Any persons affected by the Planning Scheme are required to set forth, in writing, all objections they may have, addressed to the Town Clerk, City of Geelong, City Hall, Gheringhap-street, Geelong, on or before the 22nd November, 1971, and to state whether they wish to be heard in respect of their objection.

2854

L. L. WALTER, Town Clerk.

CITY OF KEW.

LOAN No. 66.

Notice of Intention to Resolve to Borrow Principal Moneys Amounting to \$100,000 for Permanent Works and Undertakings.

Notice is hereby given that the Council of the City of Kew proposes to resolve to borrow principal moneys amounting to \$100,000, secured by a charge over the general rates of the municipality, such moneys to be raised by the grant of a mortgage in accordance with the provisions of the Local Government Acts.

1. The maximum rate of interest that may be paid is 7.3 per centum per annum.

2. The period of the loan shall be ten years.

3. The moneys borrowed shall be repayable by providing out of the municipal fund ten yearly instalments of \$10,000 in repayment of principal on the 1st day of January, and twenty half-yearly instalments of interest on balance of principal outstanding from time to time on the 1st day of January and the 1st day of July, during the currency of the loan. The first instalment shall be payable on the 1st day of July, 1972.

4. Such moneys shall be repayable to the State Superannuation Board of Victoria at the office of the said Board for the time being, in Melbourne.

5. The purposes for which the loan is to be applied are:—

Erection of new Municipal Offices (part cost)	\$50,000
Construction of roads (C.R.B. Main) Denmark-street, Princess-street, Studley Park-road, Kew Junction	20,000
Reconstruction of streets (C.R.B. Unclassified) Burke-road (Dean-street-Cotham-road), Burke, Barkers and Mont Albert roads intersection, High-street	20,000
Places of resort and recreation, swimming pool	3,000
Traffic Lights, Kew Junction improvements, Studley Park-road, Gantry extensions, Charles-Wellington streets, others	7,000
	<hr/>
	\$100,000

The plans and specifications and the estimate of the cost of the proposed works and a statement showing the proposed expenditure of the moneys to be borrowed, are open for inspection at the Town Hall, Walpole-street, Kew.

Dated this 20th day of October, 1971.

2844

J. L. JOHNSON, Town Clerk.

CITY OF MORDIALLOC.

LOAN No. 79.

Notice of Intention to Borrow the Sum of \$50,000 for Permanent Works and Undertakings.

Notice is hereby given that the Council of the City of Mordialloc proposes to borrow the principal sum of Fifty thousand dollars (\$50,000) secured by a charge over the general rates of the municipality, such sum to be raised by the grant of a mortgage in accordance with the provisions of the Local Government Act 1958 (as amended).

1. The maximum interest that may be paid is 7.3 per centum per annum.

2. The purposes for which the loan is to be applied are:—

Purchase and establishment of a garbage disposal site (part).

3. The period of the loan shall be ten years.

4. The moneys borrowed shall be repayable by providing out of the municipal fund twenty half-yearly instalments of approximately \$3,565.97 each, including principal and interest on the first day of June and the first day of December, during the currency of the loan. The first instalment shall be payable on the first day of June, 1972.

5. Such moneys shall be repayable to the Australian and New Zealand Savings Bank Ltd., 394-396 Collins-street, Melbourne.

Plans and specifications and the estimate of the cost of the proposed works and a statement showing the proposed expenditure of the moneys to be borrowed are open for inspection at the office of the Council of the City of Mordialloc, at the corner of Mentone-parade and Brindisi-street, Mentone, Victoria.

J. GRUT, Town Clerk.

Council Chambers,

Mentone, 3194.

2849

CITY OF NUNAWADING.

No. 1587.

By-Law No. 79.

A By-Law of the City of Nunawading made under section 197 of the Local Government Act 1958 and numbered 79 for—

(a) regulating sewerage and drainage,

(b) providing for health of the residents in the municipal district and against the spreading of contagious or infectious diseases; and

(c) suppressing nuisances.

In pursuance of the powers conferred by the *Local Government Act 1958*, the Mayor, Councillors and Citizens of the City of Nunawading order as follows:

1. In this By-Law unless inconsistent with the context or subject matter—

"Board" means the Melbourne and Metropolitan Board of Works.

"Council" means the Council of the City of Nunawading.

"Property" includes any land upon which a house or other building is erected.

"Sewer" means a sewer laid by the Board.

"Sullage Water" includes household waste water, household slops and household liquid refuse from any property and other polluted water from stables, washing areas, manure bins, basements, cellars and yards and all such trade wastes which the Melbourne and Metropolitan Board of Works may agree to admit into any sewer.

2. (1) The owner of every property in respect of which a general notice has been given by the Board under section 160 (1) of the *Melbourne and Metropolitan Board of Works Act 1958*, shall—

(a) make provision to have the sewerage carried off from such property by the sewer laid by the Board; and

(b) provide such proper water closet or water closets and such drains, appliances, apparatus and connections with such sewer as may be prescribed by the Regulations of the Board—

within six months or such further time as the Council may allow from the date of the coming into operation of this By-Law where such a general notice has been given prior to the said date or within six months or such further time as aforesaid from the date of any such general notice given after the coming into operation of this By-Law as the case may be.

(2) All such sewerage works and the provision of all such water closet or water closets, drains, appliances, apparatus and connections with a sewer shall be carried out, fitted and laid in accordance with Regulations prescribed by the Board.

(3) Any owner desirous of an extension of time beyond the said period of six months shall,

(a) make application, in writing, to the Council; and

(b) in his application give—

(i) his full name and address,

(ii) particulars of his property,

(iii) the reasons why he requires an extension;

(iv) any other information the Council may require.

(4) Any owner to whom this By-Law applies who fails to provide for the sewerage from his property to be carried off by a sewer and to provide such water closet or water closets, drains, appliances, apparatus or connections as may be prescribed by the Regulations of the Board and cause the same to be connected to a sewer within the said period of six months or such further time as may be allowed by the Council shall be guilty of an offence against this By-Law.

3. No person shall allow, permit or suffer, after the expiration of six months or such further time as the Council may allow from the date of the coming into operation of this By-Law where a general notice under the said section 160 (1) has been given prior to the said date or after the expiration of six months or such further time as aforesaid from the date of any such general notice given after the coming into operation of this By-Law as the case may be, any sullage water to be discharged from any property affected by any such notice except into a sewer.

4. Any person guilty of a wilful act or default contrary to this By-Law shall be liable to a penalty of not less than \$10 or more than \$100 and to a further penalty of not more than \$10 for each day on which such offence is continued after a conviction or order by any Court.

5. This By-Law shall apply to and have operation throughout the whole of the municipal district of the City of Nunawading but it shall not apply to any property in respect to which a general notice has been served by the Board under section 160 (2) of the *Melbourne and Metropolitan Board of Works Act 1958*.

The corporate seal of the Mayor, Councillors and Citizens of the City of Nunawading, was hereunto affixed in the presence of:

D. P. GAWLER, Mayor.
K. E. ROONEY, Councillor.
J. H. BROWN, Town Clerk.

Resolution for passing this By-Law agreed to by the Council of the City of Nunawading, on the 20th day of September, 1971, and confirmed on the 11th day of October, 1971. 2865

CITY OF ST. KILDA.

BY-LAW No. 191.

A By-law of the City of St. Kilda made and passed under the provisions of the Local Government Acts and the Uniform Building Regulations (Victoria) and numbered 191 for amending By-law No. 184 of the said City.

In pursuance of the powers conferred by the Local Government Acts and the Uniform Building Regulations (Victoria) and every other power it thereunto enabling THE MAYOR, COUNCILLORS AND CITIZENS OF THE CITY OF ST. KILDA, with the approval of the Governor in Council, order as follows:—

By-law No. 184 of the City of St. Kilda shall be altered as follows:—

In the paragraph of the Second Schedule of By-law No. 184 relating to Raleigh Street for the words "From a point 120 feet east of St. Kilda Road" shall be substituted the words "From a point 252 feet east of St. Kilda Road."

This By-law shall come into operation on its publication in the *Victoria Government Gazette*.

Resolution for passing this By-law agreed to by the Council of the City of St. Kilda on the 2nd day of August, 1971, and confirmed on the 30th day of August, 1971.

The common seal of the Mayor, Councillors and Citizens of the City of St. Kilda has been hereto affixed by order of the Council of the said City, in the presence of—

I. B. TRAYLING, Mayor.
BRIAN ZOUCH, Councillor.
A. N. ISAAC, Town Clerk.

Approved by the Governor in Council, 21st September, 1971.—J. ROSSITER, Clerk of the Executive Council. 2851

CITY OF SUNSHINE.

LOAN No. 96.

Notice of Intention to Borrow the Sum of \$50,000 for Permanent Works and Undertakings.

Notice is hereby given that the Council of the City of Sunshine, proposes to borrow the principal sum of \$50,000, secured by a charge over the general rates of the municipality, such sum to be raised by the grant of a mortgage in accordance with the provisions of the *Local Government Act 1958*.

1. The maximum rate of interest that may be paid is 7.4 per cent. per annum.

2. The purpose for which the loan is to be applied is—

(a) Construction of Market-road ..	\$20,000
(b) Construction of Anderson-road ..	30,000
	\$50,000

3. The period of the loan shall be fifteen years.

4. The moneys borrowed shall be repayable by providing out of the municipal fund half-yearly instalments of approximately \$2,787.12 each, including principal and interest, on the 1st day of June, and the 1st day of December during the currency of the loan. The first instalment shall be payable on the 1st day of June, 1972.

5. Such moneys shall be repayable to the Commissioners of the State Savings Bank of Victoria, at the office of the said Commissioners, corner Elizabeth and Bourke streets, Melbourne.

The plans and specifications and the estimate of the cost of the proposed works and a statement, showing the proposed expenditure of the moneys to be borrowed, are open for inspection at the office of the Council of the City of Sunshine, at Municipal Offices, Alexandra-avenue, Sunshine.

Dated 6th October, 1971.

2940

T. W. DEUTSCHMANN, Town Clerk.

CITY OF SUNSHINE.

BY-LAW No. 106.

A By-law of the City of Sunshine made under Section 197 of the *Local Government Act 1958* and numbered 106 preventing and extinguishing fires.

In pursuance of the powers conferred by the *Local Government Act 1958* and of any and every other power it thereunto enabling the Mayor, Councillors and Citizens of the City of Sunshine orders as follows:—

1. For the purpose of preventing fires or minimising the possibility of the spread of fires the owner or occupier of any land may by notice in writing be directed by the Council to remove from such land in the manner and subject to the conditions specified in the notice and within the time specified therein all undergrowth scrub bracken fern weeds and grass (whether alive or dead and whether standing or not standing) and any other material (whether of a similar nature to the foregoing or not) which in the opinion of the Council constitute or are likely to constitute a fire menace to neighboring property.

2. If within the time specified in any such notice any owner or occupier to whom such notice is directed fails or neglects to remove in accordance with the notice such undergrowth scrub bracken fern weeds grass and material he shall be guilty of an offence against this By-Law.

3. Any person guilty of any wilful act or default contrary to this By-law shall be liable to a penalty of not less than \$40.00 nor more than \$100.00.

4. This By-law shall apply and have operation throughout the whole of the municipal district.

Resolution for passing this By-law was agreed to by the Council of the City of Sunshine on the thirteenth day of September, 1971 and confirmed on the twelfth day of October, 1971.

The corporate seal of the Mayor, Councillors and Citizens of the City of Sunshine was hereunto affixed in the presence of—

2884 (SEAL) D. EVANS, Mayor.
H. A. THOMAS, Councillor.
T. W. DEUTSCHMANN, Town Clerk.

CITY OF SUNSHINE.

PROSECUTING OFFICER.

Notice is hereby given that the Council of the City of Sunshine has appointed Sergeant Alan James Williams, No. 11528, as Prosecuting Officer, in lieu of Sergeant Patrick Hearn, No. 10387.

2963 T. W. DEUTSCHMANN, Town Clerk.

CITY OF WARRNAMBOOL.

APPOINTMENT OF PROSECUTING OFFICER.

Notice is hereby given that Sergeant Richard Albert Greinke, No. 11266, has been appointed Prosecuting Officer for the City of Warrnambool, in lieu of Sergeant Alan Coysh, No. 10150.

2944 K. L. ARNEL, Town Clerk.

CITY OF WAVERLEY.

PROSECUTING OFFICER.

Notice is hereby given that Sergeant William Eric Rowe, No. 10686, has been appointed Prosecuting Officer for the Council of the City of Waverley, in lieu of Sergeant Herbert Richard Rowe, No. 10512.

2949 F. S. BALES, Town Clerk.

Town and Country Planning Act 1961 (Twelfth Schedule).

EILDON SUB-REGIONAL PLANNING SCHEME.

NOTICE THAT A PLANNING SCHEME HAS BEEN PREPARED AND IS AVAILABLE FOR INSPECTION.

AMENDMENT No. 8, 1971.

Notice is hereby given that the Shire of Alexandra in pursuance of its powers under the *Town and Country Planning Act 1961* has prepared a Planning Scheme for the purpose of amending the Agricultural "A" and "B" Zones of the Eildon Sub-Regional Planning Scheme by replacing them with a Rural Forest Zone which specifies a 50-acre minimum subdivisional allotment size.

A copy of the scheme has been deposited at the Municipal Offices, Perkins-street, Alexandra and at the office of the Town and Country Planning Board, 235 Queen-street, Melbourne, and will be open for inspection during office hours by any person free of charge.

Any persons affected by the Planning Scheme are required to set forth in writing all objections they may have, addressed to Shire Secretary, Shire of Alexandra, P.O. Box 138, Alexandra, on or before the 21st day of November, 1971, and to state whether they wish to be heard in respect of their objections.

2952 DONALD O. McLEAN, Shire Secretary.

SHIRE OF BARRABOOL.

BY-LAW 26.

Notice is given that the Council at its Ordinary Meeting held on Wednesday July 21st 1971, did confirm By-Law No. 26 for preventing and extinguishing fires.

The contents of the By-law are:—

- Clause 1 Short Title
- Clause 2 Definitions
- Clause 3 Requirements for issue of permits
- Clause 4 Form of permits
- Clause 5 Matters to be observed in issue of permit
- Clause 6 Permit holder to comply with Permit
- Clause 7 Extent of operation of by-law
- Clause 8 Penalties

Schedules

Schedule A Form of Permit

Schedule B Conditions and Restrictions of Permit

A copy of the said By-law No. 26 is open for inspection, free of charge, during office hours at the office of the Council, 441 Moorabool Street, South Geelong.

2856 G. L. PEARCE, Shire Secretary.

Town and Country Planning Act 1961.—(Twelfth Schedule.)

SHIRE OF HASTINGS PLANNING SCHEME 1962.

NOTICE THAT A PLANNING SCHEME HAS BEEN PREPARED AND IS AVAILABLE FOR INSPECTION.

Amendment No. 58, 1971.

Notice is hereby given that the Council of the Shire of Hastings, in pursuance of its powers under the *Town and Country Planning Act, 1961*, has prepared a Planning Scheme for the following purpose:—

Land delineated on Map No. 1222, being Lot 2, of L.P. 60151 and Lot 3, of L.P. 83328, abutting Grant-road, Somerville, for the purpose of re-zoning the area from Industrial "B" Zone to Industrial "A" Zone.

A copy of the scheme has been deposited at the Shire Office, Marine-parade, Hastings, and at the office of the Town and Country Planning Board, 235 Queen-street, Melbourne, and will be open for inspection during office hours by any person, free of charge.

Any persons affected by the Planning Scheme are required to set forth in writing, all objections they may have, addressed to the Shire Secretary, Shire of Hastings, Post Office Box 55, Hastings on or before the 20th November 1971, and to state whether they wish to be heard in respect of their objections.

L. A. WALKER, Shire Secretary.

Municipal Offices, Hastings, 12th October, 1971. 2859

SHIRE OF LILLYDALE.

LOAN No. 108.

Notice of Intention to Borrow the Sum of \$70,000 for Permanent Works and Undertakings.

Notice is hereby given that the Council of the Shire of Lillydale proposes to borrow the sum of \$70,000, secured by a charge over the general rates of the municipality, such sum to be raised by the grant of a mortgage in accordance with the provisions of the *Local Government Act 1958*, for permanent works and undertakings within the municipality

1. The maximum rate of interest that may be paid is 7.4 per cent per annum.

2. The purposes for which the loan is to be applied are:—

Purchases of Reserves	\$35,000
Construction Works on Reserves	10,000
Plant Purchase	20,000
Drainage Works	5,000
	\$70,000

3. The period of the loan shall be 15 years.

4. The moneys borrowed shall be repayable by providing out of the municipal fund thirty (30) half-yearly instalments of approximately \$3,901.96 each, including principal and interest on the 1st day of June and the 1st day of December during the currency of the loan. The first instalment shall be payable on the 1st day of June, 1972.

5. Such moneys shall be repayable to the Commissioners of The State Savings Bank of Victoria, at the office of the said Commissioners, corner Elizabeth and Bourke streets, Melbourne.

The plans and specifications and the estimate of the cost of the proposed works, and a statement showing the proposed expenditure of the moneys to be borrowed, are open for inspection at the office of the Council of the Shire of Lillydale, at Shire Offices, Anderson-street, Lillydale.

2887

F. O. KENT, Shire Secretary.

Notice is hereby given that Lachen Lodge Ski Club has applied for a lease, pursuant to section 134 of the *Land Act 1958* for a term of 21 years in respect of allotment 12, section 1, Parish of Yertoo as a site for a Ski Club Lodge.—(H.034111.) 2616

ZERMATT SKI CLUB.

Notice is hereby given that Zermatt Ski Club has applied for a lease, pursuant to section 134 of the *Land Act 1958*, for a term of 21 years in respect of allotment 4, section 1, Parish of Yertoo, as a site for a Ski Club Lodge.

2573

I. E. WALDRON, Secretary.

Notice is hereby given that Raymond Russell Symmons, of 529 The Esplanade, Lakes Entrance, has applied for a lease under section 134 of the *Land Act 1958*, for a term of ten years in respect of an area of 2 perches, being allotment 25, section A, Township of Kalimna, as a site for a Camera Obscura.—H.031164.) 2720

Notice is hereby given that Austen Alpine Club has applied for a lease under section 134 of the *Land Act 1958* for a term of 21 years in respect of allotment 16, section 1, Parish of Yertoo, as a site for a Ski Club Lodge.—(H.O.34353.) 2878

Notice is hereby given that Royal Children's Hospital Ski Club has applied for a lease under section 134 of the *Land Act 1958* for a term of 21 years in respect of allotment 3, section B, Parish of Hotham, as a site for a Ski Club Lodge.—(H.O.34336.) 2843

NOTICE OF INTENTION TO APPLY FOR A LICENCE TO DIVERT WATER AND CUT RACE (RE-ISSUE) FROM THE KING RIVER, AT DOCKER.

I hereby give notice that I intend to apply for a licence empowering me to divert water for a term of four years to the extent of 67½ acre-feet per annum at a maximum rate of 3 acre-feet per day of 24 hours for the irrigation of tobacco and pasture, being part of allotment 1A and part 1, section XXVII, Parish of Laceby, and to occupy certain Crown lands for works of diversion, and to cut a race thereon.

Any objection to such application must be forwarded, in writing, to reach the State Rivers and Water Supply Commission, Melbourne, before 19th November, 1971, being 30 days from the first publication of this notice.

LUIGI CIARLO.

Whitfield Roadside, Docker.

2863

NOTICE OF INTENTION TO APPLY FOR A LICENCE TO DIVERT WATER AND CUT RACE FROM THE RIVER MURRAY, AT ROBINVALE.

We hereby give notice that we intend to apply for a licence empowering us to divert water for a term of four years to the extent of 180 acre-feet per annum at a maximum rate of 15 acre-feet per day of 24 hours for the irrigation of 60 acres of vines, trees, vegetables, cereal, crops and pasture, being lot 5 on plan of subdivision No. 89793, Parish of Bumbang, and to occupy certain Crown lands for works of diversion, and to cut a race thereon.

Any objection to such application must be forwarded, in writing to reach the State Rivers and Water Supply Commission, Melbourne, before the 14th of November, 1971, being 30 days from the first publication of this notice.

PANAGIOTIS GIANNOUKOS.
CHRISANTHI GIANNOUKOS.

Robinvale.

2882

NOTICE OF INTENTION TO APPLY FOR A LICENCE TO DIVERT WATER AND CUT RACE (RE-ISSUE) FROM THE WERRIBEE RIVER, AT WERRIBEE.

I hereby give notice that I intend to apply for a licence empowering me to divert water for a term of fifteen years to the extent of 17 acre-feet per annum at a maximum rate of 1.25 acre-feet per day of 24 hours for the purpose of

market garden, being part of allotment 1, section 16, Parish of Deutgam, County of Bourke and being the whole of the land described in indenture of conveyance register No. 71, book 712, register No. 72, book 556; register No. 73, book 556 and register No. 74, book 556, and to occupy certain Crown lands for works of diversion, and to cut a race thereon.

Any objection to such application must be forwarded, in writing, to reach the State Rivers and Water Supply Commission, Melbourne, before 19th November, 1971, being 30 days from the first publication of this notice.

GIUSEPPE MANTELLO.

Box 32 Walls-road, Werribee, 3030.

2964

ERRATUM.**DANDENONG VALLEY AUTHORITY.****DECLARATION OF ARTERIAL DRAINS.**

Paragraph 4 to read—

"4. Hampton Park East Drain No. 5534—

'Commencing at the north boundary of Crown portion 38, Parish of Berwick, approximately 3,600 feet east of the Parish boundary generally north-westerly to connect with the declared arterial drain at Hallam-road, near Hampton Park.'

(Published in lieu of notice appearing in *Victoria Government Gazette*, No. 87, 22nd September, 1971, pages 3161-2.) 2864

DROUIN SEWERAGE AUTHORITY.**GENERAL NOTICE.**

The above-mentioned Sewerage Authority having made provision for carrying off the sewage from each and every property, which or an part of which, is within the sewerage area hereinafter described, doth hereby declare that on and after the 18th day of October, 1971, each and every property, which, or any part of which, is within the said sewerage area, shall be deemed to be a seweraged property within the meaning of the *Sewerage Districts Act 1958*.

The said sewerage area shall be known as Sewerage Area No. 9.

The boundaries of Sewerage Area No. 9 are shown on drawing No. B-26-5867 which is available for inspection at the office of the Authority.

By order of the said Sewerage Authority,

K. L. NICKELL, Chairman.

2867

E. J. AUSTIN, Secretary.

NUMURKAH SEWERAGE AUTHORITY.***Sewerage Districts Act 1958.***

In accordance with section 111 (2) and (3) of the *Sewerage Districts Act* notice is hereby given that the Authority proposes to compulsorily acquire the ownership of the following land.

Commencing at the south-western angle of Crown allotment 13, section 2, Parish of Drumanure, County of Moira; thence easterly, northerly, westerly and northerly along the southern, eastern, northern and eastern boundaries of the said Crown allotment 13 to a point 1,861.6 links southerly from the north-eastern angle of the said Crown allotment 13; thence westerly through the said Crown allotment 13 by a line bearing 270 deg. 2 min. to a point on the western boundary of the said Crown allotment 13; thence southerly and south-westerly along the said western and the north-western boundaries of the said Crown allotment 13 to the point of commencement.

Description of Works.—Construction of Treatment Lagoons and associated plant for the treatment of Sewage.

Plan of Works.—A copy of the plan of the proposed works is available for inspection at the Shire Office, Numurkah between the hours of 9 a.m. to 5 p.m. each week day.

Area to be Acquired.—149 acres 3 roods 39 6/10 perches.

L. G. MITCHELL, Secretary.

Shire Office, Numurkah, 3636, 1st October, 1971. 2880

GEELONG WATERWORKS AND SEWERAGE TRUST.

GAZETAL OF WATER MAINS.

Notice to owners of tenements in the under-mentioned streets and private streets, lanes, courts and alleys opening thereto:—

Shire of Corio.

Martain-avenue, 109 feet north from lot 10 to lot 12.
 Korumburra-avenue, 195 feet north from lot 174 to lot 178.
 Tahara-street, 360 feet west from Sladen-street.
 Strathire Gardens, 973 feet north from Tahara-street.
 Walkers-road, 274 feet east from lot 8 to Turner-avenue.
 Turner-avenue, 91 feet north from lot 10 to Walkers-road.
 Jersey-road, 220 feet from Rollins-road to lot 71.
 Cheshire-street, 1,058 feet between Purnell-road and Carmarthen-drive.
 Durham-court, 436 feet east from Cheshire-street.
 Antrim-court, 419 feet west from Somerset-street.
 Somerset-street, 560 feet between Purnell-road and Caithness-crescent.
 Moray-court, 354 feet west from Caithness-crescent.
 Caithness-crescent, 1,561 feet between Cheshire-street and Purnell-road.
 Carmarthen-drive, 626 feet between Norfolk-crescent and Cheshire-street.
 Norfolk-crescent, 809 feet between Purnell-road and Carmarthen-drive.
 Wexford-court, 399 feet east from Norfolk-crescent.
 Darrwill-street, 116 feet west from lot 64 to Rollins-road.
 Baron-street, 540 feet east from Seabeach-parade to lot 117.
 Hinton-street, 280 feet north from Elmore-street to lot 114.
 Allowah-avenue, 402 feet north from Donnybrook-road to lot 210.
 Kildare-street, 583 feet north from existing dead end to north side of Inkerman-street.
 Mill-road, 2,967 feet north from lot 29 to Plains-road.
 Plains-road, 1,792 feet west from Mill-road to lot 89.
 Osborne-avenue, 181 feet north from lot 92 to Kerr-street.
 Fairy-street, 206 feet east from lot 45 to lot 41.
 Elmore-street, 312 feet east from lot 41 to lot 182.
 Korumburra-avenue, 173 feet south from lot 44 to Elmore-street.

Shire of Bellarine.

Durrant-street, 197 feet west from lot 41 to Boundary-road.
 Lindsay-street, 132 feet north from Richard-street to lot 17.

Shire of South Barwon.

Walpole-avenue, 183 feet east from Learmouth-street to lot 38.
 Belle Vue-avenue, 226 feet north from lot 3 to lot 2.
 Grosvenor-drive, 613 feet south from lot 6 to lot 13.
 Easement from Settlement-road to Grosvenor-drive, 290 feet (not supplying properties).
 Barwon Boulevard, 642 feet west from Standale-court to lot 73.
 Standale-court, 390 feet south from Barwon-boulevard.
 Fernhill-drive, 100 feet north from existing dead end to Barwon-boulevard.
 Keram-crescent, 578 feet north from Shoubra-drive to lot 8.
 Bieske-road, 179 feet north from lot 8 to lot 5.
 Walpole-avenue, 130 feet west from lot 44 to lot 41.
 Madigan-court, 213 feet west from lot 162.
 Gwyther-road, 223 feet west from lot 34 to lot 38.
 Torquay-road, 470 feet south from Lewis-court to lot 8.
 Matilda-street, 108 feet west from lot 2 to lot 1.

City of Geelong West.

Everett-close, 33 feet north from lot 17 to lot 18.
 Glenleith-court, 222 feet south from Glenleith-avenue to lot 5.

City of Geelong.

Denman-street, 183 feet east from existing dead end to Boundary-road.
 Boundary-road, 170 feet north from existing dead end to Denman-street.

The main pipe in the said streets being laid down the owners of all tenements situated above are hereby required on or before the 31st December, 1971, to cause a proper pipe and stop cocks to be laid so as to supply water within such tenements from the main pipe.

The common seal of the Geelong Waterworks and Sewerage Trust was hereunto affixed, this 18th day of October, 1971, in the presence of—

(SEAL) R. W. WHITESIDE, Chairman.
 B. C. HENSHAW, Secretary.

2943

PARTNERSHIP ACT 1958.

Notice is hereby given of the death of Mr. Richard Eric Breydon, of the firm R. E. & D. M. Breydon, on the 14th day of August, 1971. The partnership business will continue to be conducted by Mrs. Doris May Breydon, at 848 Toorak-road, East Hawthorn.

Dated the 6th day of October, 1971.

2922

D. M. BREYDON.

Notice is hereby given that the partnership heretofore subsisting between Rosario Cianci and Alessandro Nobile carrying on business of general engineers, at 297 Edward-street, Reservoir, under the style of firm name "R.A.A.M. Engineering Co." has been dissolved, as from the 27th day of September, 1971. Mr. Cianci is carrying on business under the same style of firm name at the same address.

ROSARIO CIANCI by his solicitors,

Scomparin Bernardi & Co., of 438 Queens-parade, Clifton Hill. 2871

H.I. HOME INSULATION.

Notice is hereby given that the partnership between Peter Edward John Mahon and Roy Leonard Anderson, insulation contractors, and carried on under the name of "H.I. Home Insulation", at Princes Highway, Clayton, was dissolved as at 30th September, 1971. The business will be carried on by the said Peter Edward John Mahon, of Piperita-road, Ferntree Gully.

PETER EDWARD JOHN MAHON.
 ROY LEONARD ANDERSON.

Wm. Murray & Son., solicitors, 422 Collins-street, Melbourne. 2930

Companies Act 1961.

AUSTRALIAN GROWTH INVESTMENTS COMPANY LIMITED (IN VOLUNTARY LIQUIDATION).

NOTICE OF FINAL MEETING.—(Pursuant to Section 272).

Notice is hereby given, pursuant to section 272 of the Companies Act, that the Final General Meeting of the members of the above-named company will be held at the offices of Fell & Starkey, chartered accountants, 351 Collins-street, Melbourne, on 1st December, 1971, at 10 a.m. for the purpose of having an account laid before it showing the manner in which the winding-up has been conducted and the property of the company disposed of and hearing any explanation that may be given by the liquidator.

Dated this 13th day of October, 1971.

2935

V. G. H. HARRISON, Liquidator.

Companies Act 1961.

EARLECOM PTY. LIMITED.

NOTICE OF RESOLUTION (PURSUANT TO SECTION 254 (2)).

At an Extraordinary General Meeting of the members of Earlecom Pty. Limited duly convened and held at 527 Glenferrie-road, Hawthorn, on the 13th day of October, 1971, the Special Resolution set out below was duly passed:—

"That this company be now voluntarily wound up and that Harold Frederick Day of 118 Queen-street, Melbourne, be appointed liquidator for the purpose of such winding up and that the liquidator be authorised to distribute in specie between the members entitled thereto such assets of the company as he may determine."

Dated this 18th day of October, 1971.

2936

JANE C. EARLE, Secretary.

NOBELIUS STATION ESTATE PTY. LTD. (IN VOLUNTARY LIQUIDATION).

NOTICE OF FINAL MEETING.

Notice is hereby given pursuant to section 272 of the Companies Act 1961 that a Final Meeting of the company will be held at the office of the liquidator, H. F. Day, 118 Queen-street, Melbourne, on the 23rd November, 1971, at twelve o'clock noon, for the purpose of having an account laid before it showing how the winding up of the company has been conducted, the property of the company disposed of, and giving any explanation required thereof.

Dated this 18th day of October, 1971.

2937

H. F. DAY, Liquidator.

Unclaimed Moneys Act 1962.

Register of Unclaimed Moneys held by the—

Name of Owner on Books and Last Known Address.	Total Amount Due to Owner.	Description of Unclaimed Moneys.	Date when Amount first became Payable.
§			
DAVIES COOP AND CO. LTD.			
Anderson, S. S., c/o Bank of N.S.W.	12.00	Dividend	— 9.69
Baalman, Monca I. (Mrs.), 10 The Circle, Avalon, N.S.W.	40.00	"	— 3.69
Bartsch, William A., G.P.O. Box 664K, Brisbane, Queensland	12.00	"	"
Bell Investments Pty. Ltd., G.P.O. Box 78, Newcastle, N.S.W.	60.00	"	"
Blackburn, Bryony H. C., Akaroa, Ayers Hill, Mount Lofty, S.A.	40.00	"	"
Bottomley, Roma J., c/o A.N.Z. Bank Ltd., 385 New South Head-road, Double Bay, N.S.W.	24.64	"	— 9.69
Bundy, Marion (Mrs.), 12 Crow's Nest-road, Waverton, N.S.W.	10.00	"	"
Cameron, Gladys E. (Mrs.), Presbyterian Ladies College, Pymble, N.S.W.	12.00	"	— 3.69
Campbell-Walker, Theodora J. (Miss), Mittagong, Winbourne-road, Mount Eliza	30.00	"	"
Carr, M. R. (Miss), (address unknown)	12.00	"	— 9.69
Carr, R. L., (address unknown)	20.00	"	"
Cutbush, Francis W., 20 Chandler-avenue, Floreat Park, W.A.	20.00	"	"
Cotterill, Albert A., 12 Henhan-street, Hawthorn	16.00	"	"
Crespin, Jervis S., c/o Mr. E. A. Cato, 56 Hopetoun-road, Toorak	467.50	"	— 3.69
Dixon, Elizabeth (Mrs.), 8 Milton-street, Canterbury	26.40	"	— 9.69
Doran, Mary (Miss), "Lachlan", St. Neotts-avenue, Potts Point, N.S.W.	20.00	"	— 3.69
Farmer, L. E. (Mrs.), (address unknown)	20.00	"	— 9.69
Foley, Wendy (Mrs.), 6 Vista-avenue, Bayview, N.S.W.	32.00	"	— 3.69
Goodfellow, W. D., (address unknown)	81.60	"	— 9.69
Graham, Kathleen F. (Mrs.), 21 Chester-street, Subiaco, W.A.	10.00	"	"
Griffiths, Mervyn L., 67 Botany-road, Waterloo, N.S.W.	20.00	"	— 3.69
Grosvenor, Vida A. (Mrs.), c/o Bank of N.S.W., Jannali, N.S.W.	40.00	"	"
Haddrell, D. H., (address unknown)	17.00	"	— 9.69
Larson, Ada M. (Mrs.), 6 Albion-street, Balaclava	12.00	"	— 3.69
Lind, J. (Mrs.), (address unknown)	80.00	"	— 9.69
Lloyd, Theodore R., 36 Darling-street, South Yarra	49.46	"	— 3.69
Lynch, A. J., (address unknown)	20.00	"	— 9.69
Mann, Jacqueline V., 8 Jenkins-street, Chatswood, N.S.W.	10.00	"	— 3.69
Moore, Arthur C., 409 Woollooware-road, Burraneer Bay, N.S.W.	47.00	"	"
Moran, G. W., 354 Harcourt-street, Hawthorn	10.00	"	— 9.69
MacDonald, Robert B., 18 Academy-street, Lithgow, N.S.W.	20.00	"	"
McGinnes, Avica A. (Mrs.), 109 Beatty-street, Ivanhoe	16.00	"	— 3.69
McGregor, Alfred G., 65 York-street, St. Kilda	12.00	"	"
Norman, Eldred D., Hope Valley, S.A.	21.08	"	"
Pritchard, Robert V., 16 Reid-street, Ashwood	20.00	"	"
Saunders, Nicholas J., Raglan-street, Daylesford	12.00	"	"
Shaw, E. M. (Miss), (address unknown)	86.00	"	— 9.69
Shaw, M. (Miss), (address unknown)	10.00	"	"
Sheridan-Lea, Phyllis E. (Mrs.), 10 Binjat Hill, Binjat Park, Duncarn-road, Singapore	62.00	"	— 3.69
Snow, Moses, 3 Bremerton-avenue, Caulfield	40.00	"	"
Spedding, Richard, 80 Hannan-street, North Williamstown	44.88	"	— 9.69
Tait, Cecilia C. (Mrs.), Holmesdale, Murchison	20.00	"	"
Talbot, A. M., (address unknown)	20.00	"	"
Thomas, Jack, c/o Dayleford Centenary Woollen Mills, Cnr. Nepean Highway and Thomas-street, Bentleigh	153.00	"	— 9.69
V.A.C.C. Insurance Co. Ltd., St. Kilda-road, Melbourne	39.80	"	"
Walford, G. P., 43 Austin-road, Oakleigh	20.00	"	"
Warmbrand, S. (Mrs.), 34 Cole-avenue, North Kew	20.00	"	"
Watkins, J. R., 173 Parramatta-road, Auburn, N.S.W.	20.00	"	"
Webb, David A., Flat 14, 5 Selwyn-court, Toorak	20.00	"	— 3.69
Wellsted, Susan V., 33 Albany-road, Toorak	12.00	"	"
Williamson, Peter J., Northbourne-avenue, Turner, A.C.T.	28.00	"	"
Williamson, Peter J., 416 Condamine-court, Turner, A.C.T.	12.00	"	— 9.69
Gillespie, Joan M., 2 Sutton-parade, Box Hill North	12.00	"	— 3.69
2811			
MACROBERTSON PTY. LTD.			
McCormack, Francis John (estate of), 499 George-street, Fitzroy	46.76	Dividend	9.2.70
Wagner, Doris, 99 Albo-avenue, Croydon	12.81	"	1.9.69
Bell, Joseph, 15 Gordon-street, Ringwood	17.29	"	25.8.69
Cooper, Mary Ann, 39 McNichol-road, Tecoma	11.96	"	30.6.69
2861			

The Companies Act 1961.—In the matter of J. R. BORRETT PTY. LIMITED (in Liquidation).

Notice is hereby given that pursuant to section 272 (2) of the Companies Act 1961, the Final Meeting of creditors and contributories of the above-named company will be held at the office of Bruce Fordham, chartered accountant, 170 Toorak-road, South Yarra, on Friday, November 26th 1971, at 9.30 in the forenoon.

Business.

To receive the liquidator's report and accounts.

Dated this 20th day of October, 1971.

BRUCE FORDHAM, Liquidator.

Bruce Fordham, chartered accountant, 170 Toorak-road, South Yarra, Vic. 2959

Companies Act 1961.

HELDEN PTY. LIMITED.

PURSUANT TO SECTION 254 (2).

At a General Meeting of the above-named company duly convened and held at 96 Rostrevor-parade, Box Hill North, Victoria, on the 16th day of October, 1971, the following Resolution was duly passed:—

"That the company be wound up voluntarily and that the assets of the company be distributed in specie and that John David Balmford, chartered accountant, of the firm of Fitzgerald Gunn & Partners, 470 Collins-street, Melbourne, be appointed liquidator of the company."

Dated this 16th day of October, 1971.

HELEN WEDD, Secretary.

A. L. HOCKING PROPRIETARY LIMITED:
SPECIAL RESOLUTION TO WIND UP, PURSUANT TO SECTION 254
OF THE COMPANIES ACT 1961.

At an Extraordinary General Meeting of the above-named company, duly convened and held at the offices of A. H. G. Clarke & Co., 460 Bourke-street, Melbourne, on the 15th day of October, 1971, the following Resolution was duly passed as a Special Resolution—

"That in accordance with the provisions of section 254 of the Companies Act 1961, the company be wound up voluntarily."

And at such last-mentioned meeting, Anthony Macavoy Locke, of 460 Bourke-street, Melbourne, was appointed liquidator for the purposes of the winding-up.

Dated this 15th day of October, 1971.

2942 A. M. LOCKE, Liquidator.

In the Supreme Court of Victoria.—1971 Co. No. 8206.—
In the matter of the Companies Act 1961; and in the matter of I. & P. MCKENZIE PTY. LTD.

Notice is hereby given that a petition for the winding-up of the above-named company by the Supreme Court was on the 8th day of October, 1971, presented by Scott Maurice Nunan, and that the said petition is directed to be heard before the Court sitting at Melbourne at the hour of 10.30 o'clock in the forenoon on Friday the 19th day of November, 1971, and any creditor or contributory of the said company desiring to support or oppose the making of an order on the said petition may appear at the time of hearing by himself or his counsel for that purpose; and a copy of the petition will be furnished to any creditor or contributory of the said company requiring the same by the undersigned on payment of the regulated charge for the same.

The petitioner's address is 254 Queen-street, Melbourne.

The petitioner's solicitors are Arthur Robinson & Co. of 447 Collins-street, Melbourne.

ARTHUR ROBINSON & CO.

NOTE.—Any person who intends to appear on the hearing of the said petition must serve on or send by post to the above-named Arthur Robinson & Co., notice in writing of his intention so to do. The notice must state the name and address of the person, or if a firm, the name and address of the firm, and must be signed by the person or firm or his or their solicitor (if any) and must be served or, if posted, must be sent by post in sufficient time to reach the above named not later than four o'clock in the afternoon of the 18th day of November, 1971.

ARTHUR ROBINSON & CO., solicitors, 447 Collins-street, Melbourne. 2961

In the Supreme Court of Victoria.—1971 Co. 8190.—In the matter of the Companies Act 1961; and in the matter of CONCRETE ROADS PROPRIETARY LIMITED.

Notice is hereby given a petition for the winding up of the above-named company by the Supreme Court was, on the 21st day of September, 1971, presented by Cyclone K. M. Products Pty. Ltd. Limited; And that the said petition is directed to be heard before the Court, sitting at the Fourteenth Court, Law Courts, William-street, Melbourne, on the 16th day of November, 1971, at the hour of 10.30 o'clock in the forenoon; and any creditor or contributory of the said company desiring to support or oppose the making of an order on the said petition may appear at the time of hearing by himself or his counsel for that purpose; and a copy of the petition will be furnished to any creditor or contributory of the said company requiring the same by the undersigned on payment of the regulated charge for the same.

The petitioner's address is 93 City-road, South Melbourne.

The petitioner's solicitors are Wundele, Couzens & Co., of 253 Lonsdale-street, Melbourne.

WUNDELE, COUZENS & CO., solicitors for the petitioner.

NOTE.—Any person who intends to appear on the hearing of the said petition must serve on or send by post to the above-named solicitors, notice, in writing, of his intention so to do. The notice must state the name and address of the person, or if a firm, the name and address of the firm and must be signed by the person or firm or his or their solicitors (if any) and must be served, or if posted, must be sent by post in sufficient time to reach the above named not later than 4 o'clock in the afternoon on the 15th day of November, 1971. 2846

YARRA GRANGE CO-OPERATIVE HOUSING SOCIETY
LIMITED (IN LIQUIDATION).

WINDING UP RESOLUTION.

Special Resolution.

Passed—13th October, 1971.

At a Special General Meeting of the above-named Society, duly convened and held at Elizabeth-street, Coburg, on the 13th day of October, 1971, at 1.30 p.m., the sub-joined Special Resolution was duly passed:—

That the Society having successfully completed its objectives 64 months ahead of its expected term be wound up voluntarily, and that John Peter Stanhope, of 18 Ivy-street, Parkdale, Victoria, 3194, be appointed honorary liquidator for the purpose of the winding up.

Dated the 14th day of October, 1971.

By order of the Board,

2934 R. DE ZILWA, Secretary.

In the matter of the Co-operative Housing Societies Act 1968, and the Companies Act 1961, and in the matter of YARRA GRANGE CO-OPERATIVE HOUSING SOCIETY LIMITED (in Liquidation).—Notice to Creditors.

Notice is hereby given that all persons having any claim against the above Society are required on or before the 3rd day of November, 1971, to send their names and addresses and particulars of their debts or claims to John Peter Stanhope, the liquidator of the said society, at his office, 173-199 Elizabeth-street, Coburg, 3058, and if so, required by notice in writing from the said liquidator, are personally, or by their solicitors, to come in and prove their said debts or claims at such time and place as shall be specified in such notice; or, in default thereof, they shall be excluded from the benefit of any distributions made before such debts or claims are so lodged or proved.

Dated at Coburg, this 14th day of October, 1971.

2933 J. P. STANHOPE, Liquidator.

The Companies Act 1961.—In the matter of YIN BUN LOW PTY. LTD.

Notice is hereby given that at a Meeting of the members of the above-named company held on 12th day of October, 1971, it was resolved that the company be wound up voluntarily and at a meeting of the creditors held on the same day pursuant to section 260, it was resolved that for such purpose D. J. Cougle, of 545 St. Kilda-road, Melbourne, public accountant, be appointed liquidator.

Notice is hereby given that at a Meeting of the members assets of the company. Creditors who do not lodge proof of debt by 15th November, 1971, will be excluded from any dividend.

BENT & COUGLE, public accountants, Suite 18, 545 St. Kilda-road, Melbourne, 3004. 2848

The Companies Act 1961.

ARMOND MFRS. & DISTRIBUTORS PTY. LTD.

(IN LIQUIDATION).

NOTICE CONVENING FINAL MEETING OF MEMBERS.

Notice is hereby given that a General Meeting of the members of the above-named company will be held in the registered office at 389 Brunswick-street, Fitzroy, on the 26th day of November, 1971, at 10.30 a.m., for the purpose of having an account laid before them showing the manner in which the winding up has been conducted and the property of the company disposed of and of hearing any explanation that may be given by the liquidator.

Dated the 15th day of October, 1971.

A. G. BLONDELL, Liquidator.

A. G. Blondell, A.A.S.A., 147 Bamba-road, Caulfield. 2874

PHIL MAYER PROPRIETARY LIMITED (IN LIQUIDATION).
NOTICE CONVENING FINAL MEETING.

Notice is hereby given in pursuance of section 272 of the Companies Act 1961 that a General Meeting of members of the above-named company will be held at 419 Lonsdale-street, Melbourne, on the 29th day of November, 1971, at 11.00 a.m., for the purpose of having an account laid before them showing the manner in which the winding up has been conducted and the property of the company disposed of, and of hearing any explanation that may be given by the liquidator.

Dated this 12th day of October, 1971.

2962 B. ETHERINGTON, Liquidator.

The Companies Act 1961.—In the matter of AUTO PREP PROPRIETARY LIMITED (in Voluntary Liquidation).

Notice is hereby given that at an Extraordinary Meeting of the members of the above-named company held on Wednesday, the 13th day of October, 1971, it was resolved that the company be wound up voluntarily and at a meeting of creditors held on the same day, it was resolved that for such purpose, Scott Maurice Nunan, of Hall & Rose, chartered accountants, 254 Queen-street, Melbourne, be appointed liquidator.

Notice is also given that after twenty-one days from this date I shall proceed to distribute the assets. All creditors having any claim against the company should furnish particulars of same by that date, otherwise I shall proceed to distribute the assets without regard to their claim.

Dated this 14th day of October, 1971.

S. M. NUNAN, Liquidator.

Hall & Rose, chartered accountants, 254 Queen-street, Melbourne. 2903

Companies Act 1961, Section 272.

SWAN FREIGHT LINE PTY. LTD. (IN LIQUIDATION).

NOTICE OF FINAL MEETING OF CREDITORS AND CONTRIBUTORIES.

Notice is hereby given that a Meeting of the Creditors and Contributories of Swan Freight Lines Pty. Ltd. (in Liquidation) will be held in the offices of Fell & Starkey, 19th Floor, 351 Collins-street, Melbourne, on the 23rd day of November, 1971, at 10 o'clock in the forenoon.

AGENDA.

To lay before the meeting of the liquidators account showing how the winding up has been conducted and the property of the company has been disposed of and to give any explanation of the account which may be required.

Dated this 15th day of October, 1971.

2902 R. W. ELLIS, Liquidator.

Companies Act 1961.

AUSTRALIAN GROWTH INVESTMENTS FINANCE COMPANY LIMITED (IN VOLUNTARY LIQUIDATION).

NOTICE OF FINAL MEETING.

Pursuant to Section 272.

Notice is hereby given, pursuant to section 272 of the Companies Act, that the Final General Meeting of the members of the above-named company will be held at the offices of Fell & Starkey, chartered accountants, 351 Collins-street, Melbourne, on 1st December, 1971, at 10.30 a.m. for the purpose of having an account laid before it showing the manner in which the winding-up has been conducted and the property of the company disposed of and hearing any explanation that may be given by the liquidator.

Dated this 13th day of October, 1971.

2901 V. G. H. HARRISON, Liquidator.

Under the Companies Act 1961.

NOTICE OF MEETING OF CREDITORS OF QUILTING PROPRIETARY LIMITED.

PURSUANT TO SECTION 260 (1) AND FORM 92 COMPANIES ACT REGULATION 28 (2) (b).

Registered Office: 2 Harper-street, Abbotsford.

Notice is hereby given that a Meeting of the creditors of Quilting Proprietary Limited will be held at the Palm Lake Motel, 52 Queens-road, Melbourne, on Thursday, the 28th day of October, 1971, at 3.30 o'clock in the afternoon.

AGENDA.

- (i) To consider a Special Resolution passed by the above-named company for winding up and the appointment of Ian Kenneth MacKinnon, registered liquidator; as the liquidator of the company.
- (ii) To consider a statement of the position of the company's affairs together with a list of creditors and the estimated amount of their claims.
- (iii) To confirm the appointment of the liquidator for the purpose of winding up the affairs and distributing the assets of the company.
- (iv) To fix the remuneration of the liquidator.
- (v) If thought fit to appoint a Committee of Inspection.
- (vi) To consider the persons and number thereof to be appointed to a Committee of Inspection.

Or alternatively:—

- (a) To consider the appointment by Special Resolution of Ian Kenneth MacKinnon as official manager of the company for such period and under such conditions as may be determined by the creditors at the meeting.
- (b) To determine the amount of the salary or remuneration of the official manager or delegate the fixing of the amount to a committee of management; and
- (c) If the creditors think it desirable so to do, to determine that a committee of management be appointed, being a committee comprising—
 - (i) three persons who are, and are to be appointed by creditors of the company by special resolution; and
 - (ii) two persons who are, and are to be appointed by, members of the company at a general meeting of the company.

NOTE.—A person is not entitled to vote as a creditor at the meeting unless he has lodged with the Chairman of the meeting a proof of the debt which he claims to be due to him from the company.

Dated this 19th day of October, 1971.

GEORGE CHAPMAN, Director.

John MacKinnon & Co., chartered accountants, Suite 12, 562 St. Kilda-road, Melbourne, 3004. Telephone: 51 2178, 51 2271. 2939

The Companies Act.—In the matter of J. E. SEARLS ENGINEERING PTY. LTD. (in Voluntary Liquidation).

Notice is hereby given that at an Extraordinary Meeting of the members of the above-named company held on Friday, the 15th day of October, 1971, it was resolved that the company be wound up voluntarily and at a meeting of creditors held on the same day it was resolved that for such purpose, Scott Maurice Nunan, of Hall & Rose, chartered accountants, 254 Queen-street, Melbourne, be appointed liquidator.

Notice is also given that after twenty-one days from this date I shall proceed to distribute the assets. All creditors having any claim against the company should furnish particulars of same by that date, otherwise I shall proceed to distribute the assets without regard to their claim.

Dated this 15th day of October, 1971.

S. M. NUNAN, Liquidator.

Hall & Rose, chartered accountants, 254 Queen-street, Melbourne. 2896

BAYSIDE INVESTMENTS PTY. LTD.

Notice is hereby given in accordance with section 254 (2) (b) of the Companies Act 1961, that at an Extraordinary General Meeting of Bayside Investments Pty. Ltd., held on the 18th October, 1971, the following Resolution was passed as a Special Resolution:—

That the company be wound up voluntarily and that Douglas Robinson, a partner in the firm of Kent, Brierley & Barraclough, of 440 Collins-street, Melbourne, be and is hereby appointed liquidator for the purposes of the winding up. 2955

The Companies Act 1961.—In the name of AERIAL ROPEWAYS PTY. LTD. (in Voluntary Liquidation).

Notice is hereby given that at an Extraordinary Meeting of the members of the above-named company held on Thursday, the 14th day of October, 1971, it was resolved that the company be wound up voluntarily and at a meeting of creditors held on the same day, it was resolved that for such purpose, Scott Maurice Nunan, of Hall & Rose, chartered accountants, 254 Queen-street, Melbourne, be appointed liquidator.

Notice is also given that after twenty-one days from this date I shall proceed to distribute the assets. All creditors having any claim against the company should furnish particulars of same by that date, otherwise I shall proceed to distribute the assets without regard to their claim.

Dated this 15th day of October, 1971.

S. M. NUNAN, Liquidator.

Hall & Rose, chartered accountants, 254 Queen-street, Melbourne. 2900

*Companies Act 1961, Section 254.***MCALLESTER BROS. PROPRIETARY LIMITED.**

Notice is hereby given that at an Extraordinary General Meeting of the members of the above-named company held on 11th October, 1971, the following Resolution was passed as a Special Resolution:—

“That this company be wound up as a members' voluntary liquidation and that Robert Arthur Waters, of 170 Queen-street, Melbourne, be appointed liquidator.”

2904 R. A. WATERS, Liquidator.

GODFREY PHILLIPS HOLDINGS LIMITED.

At an Extraordinary General Meeting of the above-named company on 12th October, 1971, a Special Resolution was passed to the effect that the company be wound up voluntarily and that Lance Stanger Dimsey, of 419 Lonsdale-street, Melbourne, be appointed liquidator for the purposes of the winding up.

Dated this 12th day of October, 1971.
2923 K. S. BATTEN, Secretary.

*Companies Act 1961, Section 254.***A. W. McDOUGALL PROPRIETARY LIMITED.**

Notice is hereby given that at a General Meeting of the members of A. W. McDougall Proprietary Limited duly convened and held at the offices of the National Trustees Executors & Agency Co. of Australasia Limited, 95 Queen-street, Melbourne, on the 11th day of October, 1971, the following Resolution was passed as a Special Resolution:—

“Resolved that the company be placed in voluntary liquidation and that Mr. Alan Edmondson Bainbridge be and is hereby appointed liquidator of the company.”

2925 A. E. BAINBRIDGE, Liquidator.

Companies Act 1961.—In the matter of PRESIDENT PLASTICS PTY. LTD.—Notice Re Meeting of Creditors Pursuant to Section 260.

Notice is hereby given that a Meeting of creditors of the above-named company will be held at the Board Room, Institute of Chartered Accountants, 23 McKillop-street, Melbourne, 3000, at 2.30 p.m. on the 25th day of October, 1971, the company having convened a meeting of its members for the same day for the purpose of considering a Resolution that the company be wound up voluntarily.

Dated this 14th day of October, 1971.
K. A. STEINMAN, Director.
A. Neville Bird & Co., chartered accountants, 289 Flinders-lane, Melbourne. Telephone No. 63 2874. 2926

Companies Act 1961.—In the matter of J. W. BYRNES PTY. LTD.—Notice Re Meeting of Creditors Pursuant to Section 260.

Notice is hereby given that a Meeting of creditors of the above-named company will be held at the Institute of Chartered Accountants, 23 McKillop-street, Melbourne, 3000, at 2.30 p.m. on the 27th day of October, 1971, the company having convened a meeting of its members for the same day for the purpose of considering a Resolution that the company be wound up voluntarily.

Dated this 14th day of October, 1971.
J. W. BYRNES, Director.
A. Neville Bird & Co., chartered accountants, 289 Flinders-lane, Melbourne. Telephone No. 63 2874. 2927

*The Companies Act 1961.***MURRAY NANKERVIS PTY. LTD.**

NOTICE TO CREDITORS OF INTENTION TO DECLARE A SECOND AND FINAL DIVIDEND.

A Second and Final Dividend is intended to be declared in the above matter. Creditors who have not proved their debt by the 1st day of November, 1971, will be excluded from this dividend.

Dated this 18th day of October, 1971.
A. NEVILLE BIRD, Trustee.
A. Neville Bird & Co., chartered accountants, 289 Flinders-lane, Melbourne. Telephone No. 63 2874. 2928

Notice of Winding-up Order.—In the matter of BLITHE FASHIONS PTY. LIMITED.

Winding-up order made the 12th day of October, 1971. Name and address of official liquidator, Jack Bastian, chartered accountant, 545 St. Kilda-road, Melbourne.

J. CANNY, Deputy Commissioner of Taxation of the Commonwealth of Australia. 2929

The Companies Act 1961.—In the matter of DOUBLE D APPAREL STORE PTY. LTD.—Notice Re Meeting of Creditors Pursuant to Section 260.

Notice is hereby given that a Meeting of creditors of the above-named company will be held at the offices of Kennedy, Smail & Middlemiss, 296 Little Lonsdale-street, Melbourne, at 11.30 a.m. on 28th day of October, 1971, the company having convened a meeting of its members for the same day for the purpose of considering a Resolution that the company be wound up voluntarily.

Dated this 18th day of October, 1971.
T. W. DOYLE, Director.
Kennedy, Smail & Middlemiss, 296 Little Lonsdale-street, Melbourne, 3000. 2931

MEWMORR MOTORS PROPRIETARY LIMITED.**SPECIAL RESOLUTION TO WIND UP.**

Pursuant to Section 254 of the Companies Act 1961.

At an Extraordinary General Meeting of the above-named company duly convened and held at 219 Millers-road, North Altona, on the 12th day of October, 1971, the following Resolution was duly passed as a Special Resolution.

“That the company be wound up voluntarily.”

And at such last-mentioned meeting William Keith Newton was appointed liquidator for the purpose of the winding up.

Dated this 12th day of October, 1971.
2932 TAXATION SERVICES OF AUST. PTY. LTD.

The Companies Act 1961.—In the matter of ATLAS CARPETS SALE PTY. LTD.

Notice is hereby given that at an Extraordinary General Meeting of the members of the above-named company, held on the 13th day of October, 1971, it was resolved that the company be wound up voluntarily, and at a meeting of creditors held on the same day pursuant to section 260 it was resolved that for such purpose Robert Eastaugh Ramsay, of 296 Little Lonsdale-street, Melbourne, accountant, be appointed liquidator.

Notice is also given that after 21 days from this date I shall proceed to distribute the assets. All creditors having any claims against the company should furnish particulars of same by that date, otherwise I shall proceed to distribute the assets, without regard to their claim.

Dated this 20th day of October, 1971.
R. E. RAMSAY, Liquidator.
Kennedy, Smail & Middlemiss, 296 Little Lonsdale-street, Melbourne. 2956

Creditors, next of kin and others having claims in respect of the estate of Hazel Myrtle Field, late of 15 Orchard-street, Brighton, home duties, deceased (who died on the 19th February, 1971), are required by the executor, Victor Henry Field, of 683 Toorak-road, Toorak, retired manager, to send particulars of their claims to him, care of the under-mentioned solicitors, by the 22nd day of December, 1971, after which date he will distribute the assets, having regard only to the claims of which he then has notice.

DARVALL & HAMBLETON, solicitors, 7th Floor, T. & G. Building, 147 Collins-street, Melbourne, 3000. 2912

Creditors, next of kin and others having claims in respect of the estate of Clive Meillon Statham, late of 5 Cusdin-street, Glen Iris, retired clergyman, deceased (who died on the 15th June, 1970), are required by the executrix, Evelyn Irene Gordon Statham, of 5 Cusdin-street, Glen Iris, widow, to send particulars of their claims to her, care of the under-mentioned solicitors, by the 22nd day of December, 1971, after which date she will distribute the assets, having regard only to the claims of which she then has notice.

DARVALL & HAMBLETON, solicitors, 7th Floor, T. & G. Building, 147 Collins-street, Melbourne, 3000. 2913

Creditors, next of kin and other persons having claims against the estate of Rose Isabel Goodhind, late of 18 White-street, Coburg, in the State of Victoria, widow, deceased (who died on the 16th day of January, 1970), are required to send particulars of their claims to the executrix, Mercia White, of 42 Union-street, East Brighton, in the said state by the 20th December, 1971, after which date the executrix will distribute the assets, having regard only for the claims of which she then has had notice.

SEDDON & WITT, solicitors, 75 Bridge-road, Richmond. 2938

NOTICE TO CLAIMANTS.

Pursuant to the Trustee Act 1958, creditors, next of kin and all other persons having claims in respect of the estate of any deceased person named below are required to send particulars to the legal personal representative or representatives at the addresses stated, after which date the representative or representatives will distribute the assets, having regard only to the claims of which notice has been received:—

Frederick George Glare, late of Willatook, farmer, deceased, died 18th day of February, 1971.—Claims to the executors, Kevin Stanley Glare and Howard Vincent Glare, both of Willatook, farmers, care of Conlan & Leishman, solicitors, 38 Bank-street, Port Fairy, by 22nd December, 1971. 2948

Pursuant to the Trustee Act 1958 notice is hereby given that creditors, next of kin and all other persons having claims against the estate of James Alexander Start, late of 28 Johnstone-street, Mentone, gentleman, deceased, intestate (who died on the 1st day of January, 1971), and letters of administration of the estate were on the 7th day of July, 1971, granted by the Supreme Court of Victoria, to Marie Evelyn Tilley, of 25 Neville-street, Mentone, married woman, a niece of the said deceased, are hereby required to send particulars in writing of such claims to the said administratrix, care of the under-mentioned solicitors, on or before the 29th day of December, 1971, after which date the administratrix will proceed to distribute the assets of the said deceased amongst the persons entitled thereto, having regard only to the claims of which she shall then have notice and will not be liable as regards the assets so distributed to any such person of whose claim she shall not then have had notice.

HERBERT, GEER AND RUNDLE, solicitors, 612-614 Balcombe-road, Black Rock. 2924

Creditors, next of kin and others having claims in respect of the estate of Valerie Petering, late of Flat 4, 218 Waiora-road, Macleod, married woman, deceased (who died on the 5th February, 1971), are required by the executors, Ian Frederick Petering, of 7 Arcadia-street, Box Hill, bank officer, and Douglas Paul Petering, of 13 Kevin-avenue, Blackburn, bank officer, to send particulars of their claims to them, care of the under-mentioned solicitors, by the 22nd day of December, 1971, after which date they will distribute the assets, having regard only to the claims of which they then have notice.

DARVALL & HAMBLETON, solicitors, 7th Floor, T. & G. Building, 147 Collins-street, Melbourne, 3000. 2914

Creditors, next of kin and others having claims in respect of the estate of Herbert Kilpatrick, late of 176 Victoria-avenue, Albert Park, retired, deceased (who died on the 29th June, 1971), are required by the executor, Reginald Herbert Donnington Kilpatrick, of 187 Blackburn-road, Blackburn, public servant, to send particulars of their claims to him, care of the under-mentioned solicitors, by the 22nd day of December, 1971, after which date he will distribute the assets, having regard only to the claims of which he then has notice.

DARVALL & HAMBLETON, solicitors, 7th Floor, T. & G. Building, 147 Collins-street, Melbourne, 3000. 2915

Creditors, next of kin and others having claims in respect of the estate of Eric Desmond John Doyle, late of 263 Domain-road, South Yarra, gentleman, deceased (who died on the 26th June, 1971), are required by the executors, Frank Combermere Cotton Doyle, of 26 Clendon-road, Toorak, real estate agent, and James McConnell Hambleton, of 147 Collins-street, Melbourne, solicitor, to send particulars of their claims to them, care of the under-mentioned solicitors, by the 22nd day of December, 1971, after which date they will distribute the assets, having regard only to the claims of which they then have notice.

DARVALL & HAMBLETON, solicitors, 7th Floor, T. & G. Building, 147 Collins-street, Melbourne, 3000. 2916

Creditors, next of kin and others having claims in respect of the estate of Dorothy Elaine Doyle, late of 263 Domain-road, South Yarra, widow, deceased (who died on the 20th January, 1971), are required by the executor, Frank Combermere Cotton Doyle, of 26 Clendon-road, Toorak, real estate agent, to send particulars of their claims to him, care of the under-mentioned solicitors, by the 22nd day of December, 1971, after which date he will distribute the assets, having regard only to the claims of which he then has notice.

DARVALL & HAMBLETON, solicitors, 7th Floor, T. & G. Building, 147 Collins-street, Melbourne, 3000. 2917

Creditors, next of kin and others having claims in respect of the will of Helen Muriel Wyatt, late of 32 Felix-grove, Mooroolbark, spinster, deceased (who died on the 11th day of August, 1971), are to send particulars of their claims to the executors, Rex Edward Haughton Wyatt, of 229 Main-street, Lilydale, estate agent, and Lilian Marcella Noble, of 30 Essex-road, Surrey Hills, company secretary, care of the under-mentioned solicitors, by the 31st day of December, 1971, after which date they will distribute the assets, having regard only to the claims of which they then have notice.

LLOYD P. GOODE & CO., solicitors, of 406 Lonsdale-street, Melbourne. 2918

Creditors, next of kin and others having claims in respect of the estate of Mabel Florence Davis, late of 127 South-road, Brighton, widow, deceased (who died on 23rd May, 1971), are required by the executors, Ralph Chelmsford Davis, of Flat 2, 37 Wallace-avenue, Toorak, director, and Joseph Charles Davis, of 38 Dendy-street, Brighton, manager, to send particulars to them, care of the under-mentioned solicitors, by 21st December, 1971, after which date they may convey or distribute the assets, having regard only to the claims of which they then have notice.

McCRACKEN & McCRACKEN, solicitors, 414 Collins-street, Melbourne. 2919

Creditors, next of kin and other persons having claims against the estate of Elsie Ann Stewart, formerly of 28 Orange-grove, Camberwell, in the State of Victoria, late of St. Omer Private Hospital, Camberwell, in the said state, widow, deceased (who died on 18th September, 1971), are required to send particulars of their claims to the executors, care of The Union-Fidelity Trustee Company of Australia Limited, of 100 Exhibition-street, Melbourne, by 20th December, 1971, after which date the executors will distribute the assets, having regard only for the claims of which it then has had notice. 2957

ARTHUR LESLIE WIDDY, late of "Omaha", Main-road, Queenscliff, in the State of Victoria, retired clerk, DECEASED.

Creditors, next of kin and others having claims in respect of the estate of the deceased (who died on the 15th day of December, 1970), are required by Ronald Frederick Stewart Crosbie, of 9 Maryvale-street, Sunshine, in the said state, public accountant, the executor to whom probate of the will of the said deceased was granted by the Supreme Court of Victoria, to send particulars to him by the 31st day of December, 1971, after which date the said executor may convey or distribute the assets, having regard only to the claims of which he then has notice.

PATRICK J. CANNON & TESTRO, solicitors, 117 Durham-road, Sunshine. 2951

Creditors, next of kin and others having claims against the estate of Francis Anthony Michael Cade, late of "Curramundi", Main-road, Mt. Macedon, in the State of Victoria, journalist, deceased (who died on the 29th day of August, 1970), are required to send particulars of their claims to the executors, care of R. G. Dunlop, solicitor, of 108 Queen-street, Melbourne, by the 30th day of December, 1971, after which date the executors will distribute the assets of the said deceased, having regard only to the claims of which they then have notice.

R. G. DUNLOP, solicitor, of 108 Queen-street, Melbourne. 2953

ELLEN MARGARET CARROLL, late of 10 Essex-road, Surrey Hills, married woman, DECEASED.

Creditors, next of kin and others having claims against the estate of the deceased (who died on 31st August, 1971), are required by the executor, The Trustees, Executors and Agency Company Limited, of 401 Collins-street, Melbourne, to send particulars of their claims to the said company on or before 22nd December, 1971, after which date it will convey or distribute the assets, having regard only to the claims of which it then has notice.

HOME, WILKINSON & LOWRY, solicitors, of 401 Collins-street, Melbourne. 2954

Creditors, next of kin and others having claims in respect of the estate of Douglas Mollet Greenwood, late of 5 Clarkstown-avenue, Mt. Eliza, builder, deceased (who died on the 4th January, 1971), are to send particulars of their claims to Ruby May Greenwood, care of the under-signed by the 24th day of December, 1971, after which date they will distribute the assets, having regard only to the claims of which they then have notice.

COOK & McCALLUM, solicitors, 506 Nepean-highway, Frankston. 2960

MARY BARTRUM WALKER, late of 67 Sutton-street, Warragul, widow, DECEASED.

Creditors, next of kin and others having claims in respect of the estate of the deceased (who died on the 11th of March, 1971), are required by the Trustees Alec Thomas Walker, of Buln Buln, farmer and Laurence Ernest Friend, of 64 Queen-street, Warragul, solicitor, to send particulars of their claims to them, care of the under-signed solicitors by the 29th day of December, 1971, after which date the trustees may convey or distribute the assets, having regard only to the claims of which they then have notice.

GRAY, FRIEND & LONG, solicitors, Warragul. 2885

JOSEPH SILVER COLLINGS, late of 118 Brown-street, Heidelberg, medical practitioner, DECEASED.

Creditors, next of kin and others having claims in respect of the estate of the above-named deceased (who died on the 6th day of February, 1971) are required by James Watson Wallman, of 3 Reid-street, Beaumaris, accountant and Gerald Martin Randall, of 401 Collins-street, Melbourne, solicitor, the executors of the will of the deceased to send particulars of their claims to the said executors care of the under-named solicitors by the 24th day of December, 1971, after which date they will convey or distribute the assets, having regard only to the claims of which they then have notice.

RUSSELL, KENNEDY & COOK, solicitors, 401 Collins-street, Melbourne. 2905

RUDOLPH CLUNES REID, late of "Riverlea", Oaklands Junction, grazier, DECEASED.

Creditors, next of kin and others having claims in respect of the estate of the above-named deceased (who died on the 22nd day of December, 1970), are required by Athol James Kennedy, of 401 Collins-street, Melbourne, solicitor and Victor Nicholls, of 13 Gulls Way, Frankston, accountant the executors of the will of the deceased to send particulars of their claims to the said executors care of the under-named solicitors by the 24 day of December, 1971, after which date they will convey or distribute the assets, having regard only to the claims of which they then have notice.

RUSSELL, KENNEDY & COOK, solicitors, 401 Collins-street, Melbourne. 2906

Creditors, next of kin and others having claims in respect of the estate of Annie Harding, formerly of 5 Lubrano-street, East Brighton, and Flat 2, 53 Kent-avenue, Croydon, but late of 229 Mont Albert-road, Surrey Hills, in the State of Victoria, widow, deceased (who died on the 22nd day of June, 1971), are to send particulars of their claims to The Equity Trustees Executors and Agency Company Limited, of 472 Bourke-street, Melbourne, by the 24th day of December, 1971, after which date it will distribute the assets, having regard only to the claims of which it then has notice.

SCHILLING, MISSEN & IMPEY, solicitors, 330 Little Collins-street, Melbourne. 2907

Creditors, next of kin and others having claims in respect of the estate of Alice Evelyn Burrows, late of 63 Hotham-street, East St. Kilda, widow, deceased (who died on the 7th day of September, 1971), are required by the executors Pamela Joyce Hamilton, married woman and Bob Hamilton, real estate agent, both of 36 St. Andrews-street, Brighton, and Valerie Claire Osborne, of 63 Hotham-street, East St. Kilda, married woman, to send particulars of their claims to the executors, care of the under-signed solicitors by the 24th day of December, 1971, after which date they will distribute the assets, having regard only to the claims of which they then have notice.

FREDERICK OWEN & ASSOCIATES, solicitors, 48 William-street, Melbourne. 2908

ARTHUR EDWARD JENNINGS, late of 35 Numerella-street, Mooroolbark, in the State of Victoria, carpenter, DECEASED.

Creditors, next of kin and others having claims in respect of the estate of the deceased (who died on the 30th day of July, 1971), are requested to send particulars of their claims to the administrator Arthur William Ernest Jennings, care of the under-signed solicitor by the 21st December, 1971, after which date the said administrator will proceed to distribute the estate having regard only to the claims of which he then has notice.

MARJORY C. COATES, solicitor, of 422 Collins-street, Melbourne, 3000. 2909

Creditors, next of kin and others having claims in respect of John Grant Clarke, late of 1 Luxton-road, Hawksburn, gentleman, deceased (who died on the 5th day of June, 1971), are to send particulars of their claims to Laurie Pearce Sinclair, care of K. P. Rees, solicitor, 118 Queen-street, Melbourne, by the 20th December, 1971, after which date he will distribute the assets, having regard only to the claims of which he then has notice.

K. P. REES, B.A. LL.B., solicitor, 118 Queen-street, Melbourne. 2910

Creditors, next of kin and others having claims in respect of the estate of Arthur Rosel Levy, formerly of 30 Aphrasia-street, Newtown, Geelong, in the State of Victoria, but late of Hotel Racine, 23 rue Racine, Paris, France, an interpreter attached to U.N.E.S.C.O., Paris, France (who died on the 15th March, 1969), are to send particulars of their claims to the administratrix Marjorie Vinegrad (in the will called Marjory), care of the undersigned by the 31st December, 1971, after which date she will commence to distribute the assets, having regard only to the claims of which she then has notice.

RENNICK & GAYNOR, solicitors, 481 Riversdale-road, Hawthorn East. 2911

Creditors, next of kin and others having claims against the estate of Ruby Louisa Smith, late of 39 Wattle-street, Bendigo, in the State of Victoria, widow, deceased (who died on the 26th day of June, 1971), are required to send particulars thereof to Sandhurst and Northern District Trustees, Executors and Agency Company Limited, of 18 View-street, Bendigo, aforesaid by the 20th day of December, 1971, after which date the said company will distribute the assets of the said deceased, having regard only to the claims of which it then has notice.

WATSON, JAMES & ROGERS, solicitors, 61 Bull-street, Bendigo. 2881

Creditors, next of kin and others having claims against the estate of Gennaro Favaloro, formerly of Barnard-street, Bendigo, in the State of Victoria, but late of Leni, in the province of Messina Republic of Italy, retired café proprietor, deceased (who died on the 6th day of November, 1968), are required to send particulars thereof, to the executor, National Trustees, Executors & Agency Company of Australasia Limited, of 46 Queen-street, Bendigo, aforesaid by the 18th day of December, 1971, after which date the said company may convey or distribute the assets, having regard only to the claims of which it then has notice.

ROBERT MORRISON McWILLIAM, late of 28 Windsor-avenue, McKinnon, builder, DECEASED.

Creditors, next of kin and others having claims against the estate of the above-named deceased (who died on the 30th day of July, 1971), are required to send particulars of their claims in writing to Henrietta Grace McWilliam (the executrix appointed by the deceased's will) care of her solicitors at their address set out below on or before the 24th day of December, 1971, after which date the said Henrietta Grace McWilliam will distribute the assets of the said deceased, having regard only to the claims of which she shall then have had notice. And notice is hereby further given that the said Henrietta Grace McWilliam will not be liable for assets so distributed or any part thereof to any person of whose claim she shall not have had notice as aforesaid.

Dated this 14th day of October, 1971.

JOHN MORAN & HAYES, 422 Collins-street, Melbourne, Solicitors for the said Henrietta Grace McWilliam. 2895

AMELIA ANNIE MILNER, late of 20 Jhonson-street, Pascoe Vale South, widow, DECEASED.

Creditors, next of kin and others having claims against the estate of the above-named deceased (who died on the 11th day of August, 1971), are required to send particulars of their claims in writing to Joyce Inez Appleby (the executrix appointed by the deceased's will), care of her solicitors at their address set out below on or before the 24th day of December, 1971, after which date the said Joyce Inez Appleby, will distribute the assets of the said deceased, having regard only to the claims of which she shall then have had notice. And notice is hereby further given that the said Joyce Inez Appleby will not be liable for the assets so distributed or any part thereof to any person of whose claim she shall not have had notice as aforesaid.

Dated this 14th day of October, 1971.

JOHN MORAN & HAYES, 422 Collins-street, Melbourne, solicitors for the said Joyce Inez Appleby. 2894

Creditors, next of kin and other persons having claims against the estate of Charles Edwin Tobin, late of 47 Maudstreet, North Balwyn, in the State of Victoria, gentleman, deceased (who died on the 24th day of August, 1971), are required to send particulars of their claims to the executor National Trustees Executors and Agency Company of Australasia Limited, of 95 Queen-street, Melbourne, by the 27th December, 1971, after which date the executor will distribute the assets, having regard only to the claims of which it then has had notice.

JAMES P. OGGE & CO., solicitors, 165 Greville-street,
Prahran. 2888

JOHN RICHARD BOWEN, late of 6 Cosham-street, Brighton, timber merchant, DECEASED (who died on the 9th day of May, 1971).

Creditors, next of kin and all other persons having claims against the estate of the deceased are required by the executors of his will and codicil Marie Beatrice Bowen, of 6 Cosham-street, Brighton, widow, Robert Alan Horsfall, of 27 Were-street, Brighton, civil engineer, John Richard Bowen (junior), of 33 Seymour-road, Elsternwick, company director and Ronald Moore, of 339 Collins-street, Melbourne, chartered accountant to send particulars thereof to them care of the under-mentioned solicitors before the 24th day of December, 1971, after which date they may distribute the assets of the deceased, having regard only to the claims of which they then have notice.

COLTMAN WYATT & ANDERSON, solicitors, of 379
Collins-street, Melbourne. 2897

LYDIA COX, late of Will H. Clay Nursing Home, Wahgool-road, Murrumbena, spinster, DECEASED (who died on the 26th day of August, 1971).

Creditors, next of kin and all other persons having claims against the estate of the deceased are required by the executors of her will and codicils Thomas Herbert Edward Mitchell (in the will called Thomas Henry Edward Mitchell), of 33 Berkeley-street, Hawthorn, director and William Tuxford Atkin, of 1A Campbell-grove, Northcote, minister of religion, to send particulars thereof to them care of the under-mentioned solicitors before the 24th day of December, 1971, after which date they may distribute the assets of the deceased, having regard only to the claims of which they then have notice.

COLTMAN WYATT & ANDERSON, solicitors, of 379
Collins-street, Melbourne. 2898

FREDERICK OCTAVIUS NEAL BROWN, late of 139 Atherton-road, Oakleigh, in the State of Victoria, retired farmer, DECEASED (who died on the 4th day of August, 1971).

Creditors, next of kin and all other persons having claims against the estate of the deceased, are required by the executor of his will William Tuxford Atkin, the secretary for the time being of The Christian Fellowship Association, of 217 Lonsdale-street, Melbourne, to send particulars thereof to him care of the under-mentioned solicitors before the 24th day of December, 1971, after which date he may distribute the assets of the deceased, having regard only to the claims of which he then has notice.

COLTMAN WYATT & ANDERSON, solicitors, of 379
Collins-street, Melbourne. 2899

Creditors, next of kin and others having claims in respect of the estate of Henry Thomas Bridge, late of Mt. Royal Hospital, Parkville, gentleman, deceased (who died on 11th July, 1971) are required by the executrix Doris Gilbert, of care of Messrs. Henderson and Ball, solicitors, of 430 Little Collins-street, Melbourne, to send particulars to her by the 21st December, 1971, after which date the executrix may convey or distribute the assets, having regard only to the claims which she then has notice.

HENDERSON AND BALL, solicitors, of 430 Little
Collins-street, Melbourne. 2893

Creditors, next of kin and others having claims in respect of the estate of Henry Warburton Sutton, late of 7 Avalon-road, Armadale, retired, deceased (who died on the 20th June, 1971), are to send the particulars of their claims to the trustee, The Trustees Executors and Agency Company Limited, of 401 Collins-street, Melbourne, by the 22nd December, 1971, after which date it will distribute the assets, having regard only to the claims of which it then has notice.

WHITING & BYRNE, solicitors, 166 Queen-street, Mel-
bourne. 2889

THOMAS GLADSTONE DOWSLEY, late of 43 Whitby-street, West Brunswick, in the State of Victoria, retired real estate agent, DECEASED.

Creditors, next of kin and others having claims in respect of the estate of the deceased (who died on the 20th April, 1971), are required by the trustees The Equity Trustees Executors and Agency Company Limited of 472 Bourke-street, Melbourne, and John Sydney Barrett of 28 Prendergast-street, Pascoe Vale South, accountant, to send particulars to the trustees by the 29th day of December, 1971, after which date the trustees may convey or distribute the assets, having regard only to the claims of which they then have notice.

W. E. PEARCEY & IVEY, solicitors, 526 Sydney-road,
Brunswick. 2847

DONALD McCOWAN, late of 30 Villamanta-street, Geelong West, in the State of Victoria, gentleman, DECEASED.

Creditors, next of kin and all persons having claims against the estate of the above-named are required by the executor of the will, Ian David McCowan, of 3 Cliff-street, North Geelong in the said State, shop proprietor, to send particulars to him care of the under-mentioned solicitors on or before the 29th day of December, 1971, after which date he will distribute the assets, having regard only to the claims of which he then has notice.

BIRDSEY, DEDMAN & BARTLETT, solicitors, of 166A
Ryrie-street, Geelong. 2866

JAMES MCGROUTHER FINCH, late of 27 Fraser-avenue,
Edithvale, farmer, DECEASED.

Creditors, next of kin and others having claims in respect of the estate of the deceased (who died on the 7th day of January, 1971), are required by the executors Bruce John Fletcher, of 714A Nepean Highway, Carrum, solicitor, and John Bryden Davis, of 2 Deanswood-road, Forest Hill, bank manager, to send particulars to them in the care of the undersigned by the 31st day of December, 1971, after which date the executors may convey or distribute the assets, having regard only to the claims of which they then have notice.

MACPHERSON & KELLEY, solicitors, 229 Thomas-street,
Dandenong. 2869

MARY JANE CATHERINE WINSTANLEY, (also known as Mary Kathleen Winstanley), late of Sunset House Private Hospital, 800 Mt. Dandenong-road, Montrose, spinster, DECEASED.

Creditors, next of kin and others having claims in respect of the estate of the deceased (who died on the 28th day of June, 1971), are required by the executor of her will, Henry Everard Winstanley, of 38 Marina-parade, Mentone, commonwealth public servant, to send particulars to him care of the undersigned by the 31st day of December, 1971, after which date the executor may convey or distribute the assets, having regard only to the claims of which he then has notice.

MACPHERSON & KELLEY, solicitors, 229 Thomas-street,
Dandenong. 2870

ARTHUR LEONARD POSTILL, late of 5 Darbyshire-road,
Mount Waverley, driver, DECEASED.

Creditors, next of kin and others having claims in respect of the estate of the deceased (who died on the 13th day of August, 1970), are required by the executor, Robert Noel Postill, of Alice Springs, Northern Territory, gentleman, to send particulars to him, care of the undersigned, on or before the 31st day of December, 1971, after which date he will distribute the assets, having regard to the claims of which he then has notice.

R. P. BAYLOR & CO., solicitors, Healesville. 2860

Creditors, next of kin and others having claims in respect of the estate of Lily Goodwin, late of Thomas-street, Geelong West, in the State of Victoria, widow deceased (who died on 26th June, 1971), are required by the executors of the will, Lloyd George Goodwin, of 3 Perry-court, Herne Hill, clerk, and Roy Davison Birdsey, of Ryrie-street, Geelong, solicitor, to send particulars to them care of the under-mentioned solicitors, on or before 20th December, 1971, after which date they will distribute the assets, having regard only to the claims of which they then have notice.

BIRDSEY, DEDMAN & BARTLETT, solicitors, of 166A
Ryrie-street, Geelong. 2845

Creditors, next of kin and others having claims in respect of the estate of Ronald Benjamin Bastin, late of 50 Gellibrand-crescent, Reservoir, retired, deceased (who died on the 9th June, 1971), are to send their claims to the executrix, care of Allan Moore, LL.B., 140 Queen-street, Melbourne, by the 20th December, 1971, after which date the executrix may convey or distribute the assets, having regard only to the claims of which she then has notice.

ALLAN MOORE, LL.B., 140 Queen-street, Melbourne.
2862

Creditors, next of kin and others having claims in respect of the estate of James Pelling, late of "Lyndoch", Warrnambool, in the State of Victoria, retired builder, deceased (who died on 24th October, 1970), are to send the particulars of their claims to The Equity Trustees, Executors & Agency Company Limited, of 472 Bourke-street, Melbourne, 3000, by the 20th day of December, 1971, after which date it will distribute the assets, having regard only to the claims of which it then has notice.

J. S. TAIT & CO., solicitors, Warrnambool. 2852

HUBERT STANLEY EUSTACE, late of 8 Charles-street, Belmont, gentleman, DECEASED.

Creditors, next of kin and others having claims in respect of the estate of the deceased (who died on the 18th day of May, 1971), are required by the personal representative, William Swallow, of 192 Autumn-street, Geelong West, electrician, to send particulars to him, care of the under-mentioned solicitors, by the 29th day of December, 1971 after which date the personal representative may convey or distribute the assets, having regard only to the claims of which he then has notice.

WHYTE, JUST & MOORE, solicitors, 27 Malop-street, Geelong. 2853

Creditors, next of kin and others having claims in respect of the estate of Arthur James Gregory, late of 212 Mary-street, Richmond, gentleman, deceased (who died on 6th August, 1971, are required by the applicants for probate, John Harold McCracken and Brian Darnton Bayston, both of 414 Collins-street, Melbourne, solicitors), to send particulars to them, by 21st December, 1971, after which date they may convey or distribute the assets, having regard only to the claims of which they then have notice.

McCRACKEN & McCRACKEN, solicitors, 414 Collins-street, Melbourne. 2920

Creditors, next of kin and others having claims in respect of the estate of Albert Marmaduke Meehl, late of 3 Little-avenue, Essendon, engineer, deceased (who died on 23rd June, 1971), are required by the executrix, Lorna Blanche Meehl, of Coronado, 511 St. Kilda-road, Melbourne, to send particulars to her, care of the under-mentioned solicitors, by 21st December, 1971, after which date she may convey or distribute the assets, having regard only to the claims of which she then has notice.

McCRACKEN AND McCRACKEN, solicitors, 414 Collins-street, Melbourne. 2921

After fourteen days application will be made to the Supreme Court of Victoria, that probate of the will dated the 5th day of August, 1970, of Harold Eric Catrina, late of 130 South-road, East Brighton, in the State of Victoria, retired, deceased, be granted to Ena Myrtle Maylands Catrina, of 130 South-road, East Brighton, in the said State, widow, the sole executrix named therein.

DAVID BRISTOL, LEVINE & CO., solicitors, of 549 Hampton-street, Hampton. 2850

In the Supreme Court of the State of Victoria.
SALE BY THE SHERIFF.

On Friday, the 19th of November, 1971, at 2 p.m., at the Police Station, Ferntree Gully (unless process be stayed or satisfied):—

All the estate and interest (if any) of Alfred Sime Pedley, brick cleaner, of 56 Eastgate-street, Oakleigh, as joint proprietor with Margaret Teresa Pedley of an estate in fee-simple in the land described in certificate of title, volume No. 8856, folio 575, upon which is erected a brick veneer dwelling known as No. 5 Ralph-court, Ferntree Gully.

Registered mortgage No. E.87313 affects the said estate and interest.

Terms: Cash only.

DOUGLAS S. HALL, Sheriff's Officer.
18th October, 1971. 2890

In the Supreme Court of the State of Victoria.

SALE BY THE SHERIFF.

On Friday, the 19th of November, 1971, at 10 a.m., at the Police Station, Fairfield (unless process be stayed or satisfied):—

All the estate and interest (if any) of Raffaello Cinel, contractor, and Franca Cinel, married woman, both of 8 Miller-street, Alphington, as joint proprietors of an estate in fee-simple in the land described in certificate of title, volume 4424, folio 706, upon which is erected a dwelling house known as No. 8 Miller-street, Alphington.

Registered mortgage No. C.778282 affects the said estate and interest.

Terms: Cash only.

DOUGLAS S. HALL, Sheriff's Officer.
14th October, 1971. 2891

In the Supreme Court of the State of Victoria.

SALE BY THE SHERIFF.

On Friday, the 26th of November, 1971, at 2 p.m., at the Police Station, Oakleigh (unless process be stayed or satisfied):—

All the estate and interest (if any) of Patrick David Coman, truck driver, of 7 Elora-road, South Oakleigh, as joint proprietor with Mavis Elizabeth Coman of an estate in fee-simple in the land described in certificate of title, volume No. 6982, folio 335, upon which is erected a dwelling house known as No. 7 Elora-road, South Oakleigh.

Registered mortgage No. A.859631 affects the said estate and interest.

Terms: Cash only.

DOUGLAS S. HALL, Sheriff's Officer.
20th October, 1971. 2892

IMPOUNDINGS

DERRINALLUM.—Impounded in Derrinallum Pound, on 26th September, 1971, from Hamilton Highway, by A. C. Wilson, C.R.B. Inspector.

2 ewes, blue brand on back, notch right ear
1 lamb, notch both ears, no visible brand

If not claimed and expenses paid, to be sold on 9th November, 1971.

A. M. McLENNAN,
2876—\$3.15 Poundkeeper.

LISMORE.—Impounded in Lismore Pound, on 23rd August, 1971, from Camperdown—Lismore road, by W. Sheedy.

1 ewe, no visible brand
1 ewe lamb, no visible brand

If not claimed and expenses paid, to be sold on 9th November, 1971.

J. A. SERGENT,
2875—\$2.80 Poundkeeper.

TEMPLESTOWE.—Impounded in Templestowe Pound.

1 bay mare, no visible brand
1 roan mare, no visible brand
1 grey filly, no visible brand

If not claimed and expenses paid, to be sold on 25th October, 1971.

T. M. PARKER,
2947—\$2.80 Poundkeeper.

TERANG.—Impounded in Terang Pound, from High-street. 5 ewe lambs, notch out of left ear, no visible brand

If not claimed and expenses paid, to be sold on 25th October, 1971.

DORIS M. KIDD,
2877—\$2.10 Poundkeeper.

SHEPPARTON.—Impounded in Shepparton pound.

1 white pig, no visible brand
1 old ewe, no visible brand

If not claimed and expenses paid, to be sold on 4th November, 1971.

C. L. MANSELL,
2946—\$2.45 Poundkeeper.

Subordinate Legislation Act 1962.

NOTICE OF MAKING OF STATUTORY RULES.

In pursuance of the provisions of the *Subordinate Legislation Act 1962* and the Regulations made thereunder, notice is given of the making of the following statutory rules:—

No.	Health Act 1958.	Price.
224/1971.	Night-soil and Sewage (Contamination of Land) Amendment Regulations 1971 No. 2	10c
<i>Vermin and Noxious Weeds Act 1958.</i>		
225/1971.	Vermin and Noxious Weeds Destruction Board (Appointed Members' Travelling Expenses) Regulations 1971	10c
<i>Motor Car Act 1958.</i>		
226/1971.	Motor Car (Transfer and Roadworthiness Amendment No. 3) Regulations 1971	10c
<i>Liquor Control Act 1968.</i>		
227/1971.	Liquor Control (Amendment No. 2) Regulations 1971	10c
<i>Country Fire Authority Act 1958.</i>		
228/1971.	Country Fire Authority (Meetings and Expenses of Members Amendment No. 1) Regulations 1971	10c
<i>Second-hand Dealers Act 1958.</i>		
229/1971.	Second-hand Dealers (Exemption No. 13) Regulations 1971	10c
<i>Motor Car Act 1958.</i>		
230/1971.	Motor Car (Transfer and Roadworthiness Amendment No. 2) Regulations 1971	10c

Copies of these statutory rules may be purchased at the Sale of Publications Section of the Government Printing Office, located at 7A Parliament-place, Melbourne, 3002. If ordered by mail, remittance should be addressed to "The Government Printer, Box 203, P.O., North Melbourne, 3051", and should include 7c extra for postage. If a credit account is held at this office, no remittance is required with the mail order.

The annual subscription rate for Statutory Rules (including Bound Volumes) is \$23, payable in advance. The subscription year commences on 1st January.

C. H. RIXON,
Government Printer.

STATE ACTS, 1969

Copies of the following Acts of Parliament of Victoria may be obtained at the Government Printing Office, Sale of Publications Branch, off Parliament-place, Melbourne, phone 63 0321, extension 6181, or from any accredited agent, at the price set opposite to each (these prices do not include postage).

No.	Price.
7786. Summary Offences (Sunday Newspapers) ..	\$0.10
7787. Town and Country Planning (Transitional Appeals)	\$0.10
7788. Discharged Servicemen's Preference (Amendment)	\$0.10
7789. Water (Amendment)	\$0.10
7790. Agricultural Education Cadetships	\$0.10
7791. Trustee (Amendment)	\$0.10
7792. Appeal Costs Fund (Amendment)	\$0.10
7793. Footscray (Lower Yarra Crossing Access Road) Land	\$0.10
7794. River Improvement (Amendment)	\$0.15
7795. Geelong Waterworks and Sewerage (Amendment)	\$0.15
7796. West Moorabool Water Board (Amendment) ..	\$0.10
7797. Sewerage Districts (Amendment)	\$0.15
7798. Drought Relief (Amendment)	\$0.10
7799. Legal Profession Practice (Amendment) ..	\$0.10
7800. Parliamentary Salaries and Superannuation (Administration)	\$0.10
7801. Protection of Animals (Penalties)	\$0.10
7802. Lotteries Gaming and Betting (Calcutta Sweepstakes)	\$0.10
7803. Belmont Common Recreation Ground Lands ..	\$0.10
7804. Listening Devices	\$0.10

STATE ACTS 1969—continued.

No.	Price.
7805. Coal Mines (Pensions)	\$0.10
7806. Marine (Amendment)	\$0.10
7807. Theatres (Amendment)	\$0.15
7808. Victorian Inland Meat Authority (Amendment)	\$0.10
7809. The Constitution Act Amendment (Electoral)	\$0.15
7810. Consolidated Revenue	\$0.10
7811. Gas and Fuel Corporation (Borrowing) ..	\$0.10
7812. Weights and Measures (Amendment) ..	\$0.10
7813. Health (Municipal Charges)	\$0.10
7814. Transfer of Land (Subdivision of Allotments)	\$0.15
7815. St. Vincent's Private Hospital (Guarantees)	\$0.10
7816. Strata Titles (Amendment)	\$0.15
7817. Sunday Entertainment (Evidence)	\$0.10
7818. Dried Fruits (Packing Houses)	\$0.10
7819. Town and Country Planning (Further Amendment)	\$0.10
7820. Milk Board (Amendment)	\$0.10
7821. Medical (Pharmaceutical Chemists)	\$0.10
7822. Melbourne Wholesale Fruit and Vegetable Market (Amendment)	\$0.10
7823. Education (Director-General)	\$0.10
7824. Wombat Bonuses	\$0.10
7825. Revocation and Excision of Crown Reservations	\$0.15
7826. Mildura Irrigation and Water Trusts ..	\$0.25
7827. South Melbourne (Roman Catholic Orphanage) Lands	\$0.15
7828. Racing (Amendment)	\$0.10
7829. Commercial Goods Vehicles (Tow Trucks) ..	\$0.10
7830. Stamps (Amendment)	\$0.15
7831. Gas and Fuel Corporation (Sale Undertaking)	\$0.15
7832. Melbourne (St. Kilda-road Underpass) ..	\$0.15
7833. Trustee (Authorized Investments)	\$0.10
7834. Consolidated Revenue	\$0.10
7835. Local Government	\$0.60
7836. Melbourne Wholesale Fruit and Vegetable Market (Advisory Committee)	\$0.10
7837. Teaching Service (Amendment)	\$0.10
7838. State Electricity Commission (Borrowing and Investing Powers)	\$0.10
7839. Motor Car (Amendment)	\$0.10
7840. Mines (Abolition of Courts)	\$0.30
7841. Manango (O'Shanessy River Watershed) Lands	\$0.10
7842. State Savings Bank (Amendment)	\$0.10
7843. Apprenticeship (Commission)	\$0.10
7844. Swan Hill Race-course and Golf-course Lands	\$0.15
7845. Imitation Milk	\$0.15
7846. Finance Brokers	\$0.25
7847. Local Government (Rating Exemptions) ..	\$0.15
7848. Labour and Industry (Amendment)	\$0.10
7849. Groundwater	\$0.30
7850. Consolidated Revenue	\$0.10
7851. Mental Health (Chairmanship)	\$0.10
7852. Instruments (Bills of Exchange Amendment)	\$0.10
7853. Supreme Court (Correction of Sentences) ..	\$0.10
7854. Summary Offences	\$0.10
7855. Church of England in Australia (Mount Shadwell Land)	\$0.10
7856. State Rivers and Water Supply Commission (Special Projects)	\$0.10
7857. Coal Mines (Pensions Increase)	\$0.10
7858. Trustee Companies (Burns Philp Trustee Company Limited)	\$0.10
7859. Latrobe Valley (Amendment)	\$0.10
7860. Maintenance (Amendment)	\$0.10
7861. Aboriginal Affairs (Amendment)	\$0.10
7862. Goods (Trade Descriptions)	\$0.10
7863. Marine Stores and Old Metals (Amendment)	\$0.15
7864. Fire Authorities (Borrowing Powers) ..	\$0.10
7865. Acts Interpretation (Time)	\$0.10
7866. Narre Worrnan Lands	\$0.10
7867. Moorpanyal Lands	\$0.10
7868. Juries (Amendment)	\$0.10
7869. Apprenticeship (Regulations)	\$0.10
7870. Portland Lands Exchange	\$0.10
7871. Melbourne University (Property)	\$0.10
7872. Latrobe Valley (Lands for Ambulance Services)	\$0.10
7873. Ministry of Transport (Director of Transport)	\$0.10
7874. Administration and Probate (Foreign Grants)	\$0.10
7875. Road Traffic (Amendment)	\$0.10
7876. Justices (Amendment)	\$0.35
7877. Country Fire Authority (Amendment) ..	\$0.15
7878. Coal Mines (Accidents Relief)	\$0.10
7879. Preston School of Design and Free Library Land	\$0.10
7880. Lands Compensation (Costs and Expenses)	\$0.10
7881. Evidence (Bankers' Books)	\$0.10
7882. Transport Regulation (Financial)	\$0.10
7883. Railways (Surplus Lands)	\$0.10

STATE ACTS 1969—continued.		STATE ACTS 1970—continued.	
No.	Price.	No.	Price.
7884. Abolition of Obsolete Offences	\$0.10	7950. Western Port (Steel Works)	\$0.25
7885. Fire Brigades (Contributions)	\$0.15	7951. Extractive Industries (Licences)	\$0.10
7886. Gas	\$0.30	7952. Stamps (Salary or Wages)	\$0.10
7887. Tobacco Leaf Industry Stabilization (Tobacco Quotas)	\$0.10	7953. Melbourne Lands Exchange	\$0.10
7888. The Constitution Act Amendment (Standing Appropriations)	\$0.10	7954. Public Officers Salaries and Allowances	\$0.15
7889. Legal Profession Practice	\$0.10	7955. Ballarat (Sovereign Hill) Land	\$0.15
7890. Navigable Waters (Oil Pollution) (Amendment)	\$0.15	7956. Wombat Bonuses	\$0.10
7891. Stamps (Mortgages)	\$0.10	7957. Richmond and Hawthorn Lands	\$0.15
7892. State Forests Loan Application	\$0.10	7958. Solicitor-General (Pensions)	\$0.10
7893. Melbourne and Metropolitan Board of Works (Amendment)	\$0.15	7959. Australia and New Zealand Banking Group (Amendment)	\$0.25
7894. Wheat Marketing	\$0.25	7960. Mildura Irrigation and Water Trusts	\$0.10
7895. Revenue Deficits Funding	\$0.15	7961. Land Settlement (Financial)	\$0.10
7896. Land Tax (Rates)	\$0.10	7962. Securities Industry	\$0.35
7897. Probate Duty	\$0.10	7963. Mildura College Lands (Amendment)	\$0.10
7898. Sale of Land (Amendment)	\$0.10	7964. Door to Door (Sales) (Amendment)	\$0.15
7899. Racing (Trotting Racing)	\$0.10	7965. Consumer Protection	\$0.10
7900. Crown Proceedings (Forfeited Recognisances)	\$0.15	7966. Justices (Alternative Procedure)	\$0.15
7901. Weights and Measures (Fees)	\$0.10	7967. Summary Offences	\$0.10
7902. Town and Country Planning (Compensation)	\$0.10	7968. Local Government (Amendment)	\$0.30
7903. Wheat Industry Stabilization (Amendment)	\$0.10	7969. Motor Car (Falsification of Mileage)	\$0.10
7904. Railway Loan Application	\$0.15	7970. Marketable Securities	\$0.25
7905. North Melbourne Lands (Loans to Lessees)	\$0.10	7971. Carriers and Innkeepers (Amendment)	\$0.10
7906. Theatres (Performance of Sacred Works)	\$0.10	7972. Cemeteries (Coburg Public Cemetery)	\$0.10
7907. Marketing of Primary Products (Amendment)	\$0.15	7973. Judges Pensions	\$0.10
7908. Water Supply Loan Application	\$0.25	7974. Victoria Institute of Colleges (Affiliated Colleges)	\$0.10
7909. Health (Amendment)	\$0.15	7975. Town and Country Planning (Responsible Authority)	\$0.10
7910. Superannuation (Amendment)	\$0.25	7976. Wheat Marketing (Special Quotas)	\$0.10
7911. Friendly Societies (Amendment)	\$0.15	7977. Joint Select Committee (Meat Industry)	\$0.10
7912. The Constitution Act Amendment (Conjoint Elections)	\$0.10	7978. Joint Select Committee (Road Safety)	\$0.10
7913. Labour and Industry (Long Service Leave)	\$0.10	7979. Consolidated Revenue (Supply—July to September 1969-70)	\$0.10
7914. Public Service (Amendment)	\$0.15	7980. Consolidated Revenue (Supplementary Estimates 1969-70)	\$0.10
7915. Motor Car (Traffic Offenders)	\$0.10	7981. Consolidated Revenue (Supply October to December, 1970)	\$0.10
7916. Motor Car	\$0.15	7982. Home Finance (Amendment)	\$0.10
7917. Farm Produce Merchants and Commission Agents (Amendment)	\$0.25	7983. Co-operative Housing Societies (Amendment)	\$0.10
7918. Education (Army Apprentices School)	\$0.10	7984. Soldier Settlement	\$0.10
7919. Legal Aid	\$0.15	7985. Judges' Pensions (Amendment)	\$0.10
7920. Educational Grants (Amendment)	\$0.10	7986. Civil Aviation (Carriers' Liability)	\$0.10
7921. Crown Reservations (Revocation and Ex-cision)	\$0.15	7987. Road Traffic (Amendment)	\$0.15
7922. Firearms (Amendment)	\$0.10	7988. West Melbourne Market Land (Amendment)	\$0.15
7923. Labour and Industry (Further Amendment)	\$0.10	7989. West Gate Bridge Royal Commission	\$0.10
7924. Forests (Softwood Timber Agreement)	\$0.15	7990. Motor Car (Amendment)	\$0.10
7925. Public Works Loan Application	\$0.15	7991. Discharged Servicemen's Preference (Amendment)	\$0.10
7926. Metropolitan Fire Brigades (Amendment)	\$0.15	7992. Labour and Industry (Shop Closing)	\$0.10
7927. Consolidated Revenue	\$0.10	7993. Country Fire Authority (Borrowing Powers)	\$0.10
7928. National Parks (Amendment)	\$0.25	7994. Crimes (Amendment)	\$0.10
7929. Railways (Offences)	\$0.10	7995. Lotteries Gaming and Betting (Amendment)	\$0.10
7930. Tourist	\$0.15	7996. River Improvement (Amendment)	\$0.10
7931. Country Roads (Amendment)	\$0.15	7997. Hospitals Superannuation (Amendment)	\$0.15
7932. Appropriation of Revenue	\$1.15	7998. Trustee Companies (Perpetual Trustees Australia Limited)	\$0.10
		7999. Gas and Fuel Corporation (Borrowing)	\$0.10
		8000. Victorian Inland Meat Authority (Amendment)	\$0.10
		8001. Auditor (Auditor-General)	\$0.10
		8002. Public Service (Amendment)	\$0.10
		8003. Evidence (Scientific Tests)	\$0.10
		8004. Boilers and Pressure Vessels	\$0.30
		8005. Coal Mines (Pensions Increase)	\$0.10
		8006. Stamps Act	\$0.15
		8007. Methodist Church (Victoria) Property Trust	\$0.20
		8008. Land Conservation	\$0.20
		8009. River Entrance Docks Railway Construction	\$0.10
		8010. Legal Profession Practice (Amendment)	\$0.15
		8011. Juries Compensation	\$0.10
		8012. Public Account	\$0.15
		8013. Sewerage Districts (Amendment)	\$0.10
		8014. Revocation and Ex-cision of Crown Reservations	\$0.15
		8015. State Forests Works and Services	\$0.10
		8016. Money Lenders (Prescribed Interest)	\$0.10
		8017. Gas and Fuel Corporation (The Gas Supply Company Limited)	\$0.30
		8018. Labour and Industry (Amendment)	\$0.10
		8019. Metropolitan Fire Brigades (Amendment)	\$0.15
		8020. Stamps (Receipt Duty Abolition)	\$0.10
		8021. Apprenticeship (Amendment)	\$0.10
		8022. Water (Amendment)	\$0.10
		8023. Melbourne Underground Rail Loop	\$0.40
		8024. Westernport Development	\$0.15
		8025. Vermin and Noxious Weeds (Amendment)	\$0.20
		8026. Commonwealth Places (Administration of Laws)	\$0.15
		8027. Hairdressers Registration (Amendment)	\$0.10
		8028. Lifts and Cranes (Amendment)	\$0.15
		8029. Wodonga Lands Exchange	\$0.10
		8030. Second-hand Dealers (Charity Collectors)	\$0.15
		8031. Water Supply Works and Services	\$0.25

C. H. RIXON,
Government Printer.

STATE ACTS. 1970

Copies of the following Acts of Parliament of Victoria may be obtained at the Government Printing Office, Sale of Publications Branch, off Parliament-place, Melbourne, phone 63 0321, extension 6181, or from any accredited agent, at the price set opposite to each (these prices do not include postage).

No.	Price.
7933. Evidence (Boards and Commissions)	\$0.10
7934. The Constitution Act Amendment	\$0.10
7935. Coroners (Amendment)	\$0.10
7936. Town and Country Planning (Appeals Tribunal)	\$0.10
7937. Melbourne (Veterinary Schools) Lands	\$0.10
7938. Board of Inquiry (Corrupt Practices)	\$0.10
7939. Cabrini Private Hospital (Guarantees)	\$0.10
7940. Judges' Salaries and Allowances	\$0.10
7941. Instruments (Amendment)	\$0.10
7942. La Trobe University (Amendment)	\$0.10
7943. Business Names (Amendment)	\$0.10
7944. Acts Interpretation (Nationality)	\$0.10
7945. Dairy Products (Board Membership)	\$0.10
7946. Melbourne Harbor Trust (Amendment)	\$0.10
7947. Aboriginal Affairs (Amendment)	\$0.10
7948. River Murray Waters	\$0.15
7949. River Murray Waters (Dartmouth Reservoir)	\$0.10

STATE ACTS 1970—continued.		Price.
No.		
8032.	East Melbourne Land	\$0.10
8033.	The Constitution Act Amendment (Responsible Ministers)	\$0.10
8034.	Justices (Bail and Appeals)	\$0.10
8035.	Forests (Amendment)	\$0.10
8036.	Maintenance (Amendment)	\$0.10
8037.	Hire Purchase (Insurance)	\$0.10
8038.	Marketable Securities (Amendment)	\$0.15
8039.	Mines (Compensation)	\$0.10
8040.	Railways Land	\$0.15
8041.	Probate Duty	\$0.10
8042.	Teaching Service (Tribunal)	\$0.10
8043.	Employers and Employés (Attachment of Wages)	\$0.10
8044.	Aboriginal Lands	\$0.25
8045.	Railway Works and Services	\$0.10
8046.	Water (Further Amendment)	\$0.15
8047.	Superannuation (Amendment)	\$0.20
8048.	Motor Car (Fees)	\$0.10
8049.	Public Works and Services	\$0.15
8050.	Western Port Steel Works (Development Control)	\$0.10
8051.	Housing (Amendment)	\$0.20
8052.	Urban Renewal	\$0.40
8053.	Wheat Marketing (Amendment)	\$0.10
8054.	Local Authorities Superannuation (Disability Benefits)	\$0.20
8055.	Land Tax	\$0.15
8056.	Environment Protection	\$0.50
8057.	Gas Franchises	\$0.15
8058.	Road Traffic (Road Safety and Traffic Authority)	\$0.15
8059.	Securities Industry (Amendment)	\$0.30
8060.	Land (Amendment)	\$0.10
8061.	Medical Practitioners	\$0.40
8062.	Teacher Housing	\$0.20
8063.	Criminal Appeals	\$0.10
8064.	Groundwater (Amendment)	\$0.10
8065.	Summary Offences (Trespass to Farms)	\$0.10
8066.	Registration of Births Deaths and Marriages (Amendment)	\$0.10
8067.	Tomato Processing Industry (Amendment)	\$0.15
8068.	Weights and Measures (Amendment)	\$0.10
8069.	Aerial Spraying Control (Amendment)	\$0.10
8070.	Science Museum of Victoria	\$0.20
8071.	Melbourne and Metropolitan Board of Works	\$0.15
8072.	National Museum of Victoria Council	\$0.20
8073.	Footwear Regulation	\$0.15
8074.	Motor Car (Safety)	\$0.10
8075.	Summary Offences	\$0.10
8076.	Fertilizers and Stock Foods (Labelling)	\$0.10
8077.	Architects (Amendment)	\$0.10
8078.	Stock Diseases (Amendment)	\$0.10
8079.	Dog Act	\$0.20
8080.	Racing (Amendment)	\$0.15
8081.	State Development	\$0.30
8082.	Statutory Salaries	\$0.10
8083.	National Parks	\$0.20
8084.	Workers Compensation	\$0.15
8085.	Summary Offences (Trespassers)	\$0.10
8086.	Parliamentary Salaries	\$0.10
8087.	Consolidated Revenue (Final Supplementary Estimates)	\$0.10
8088.	Appropriation	\$2.10
8089.	Social Welfare	\$1.10

C. H. RIXON,
Government Printer.

STATE ACTS, 1971

Copies of the following Acts of Parliament of Victoria may be obtained at the Government Printing Office, Sale of Publications Branch, off Parliament-place, Melbourne, phone 63 0321, extension 6181, or from any accredited agent, at the price set opposite to each (these prices do not include postage).

The annual subscription for State Acts 1971 et seq. is \$12.50 payable in advance.

Bound Volumes of State Acts are also available on a subscription basis of \$17.50 per annum.

No.		Price.
8090.	Municipal Association (Amendment)	\$0.10
8091.	Transfer of Land (Duplicate Certificates)	\$0.10
8092.	Firearms	\$0.10
8093.	Geelong Land (Special Grant)	\$0.10
8094.	Churchill Water and Sewerage Works	\$0.10
8095.	Superannuation (Railway Service)	\$0.10
8096.	Vermin and Noxious Weeds (Amendment)	\$0.10
8097.	Police Regulation (Amendment)	\$0.10

STATE ACTS 1971—continued.		Price.
No.		
8098.	Snowy Mountains Engineering Corporation (Victoria)	\$0.10
8099.	Albert Park Land	\$0.10
8100.	Local Government (Municipalities Assistance Fund)	\$0.10
8101.	Health (Tuberculosis Arrangement)	\$0.10
8102.	Presbyterian Church of Australia	\$0.20
8103.	Marketing of Primary Products (Amendment)	\$0.10
8104.	Gas and Fuel Corporation (Geelong Gas)	\$0.15
8105.	Local Authorities Superannuation (Disability Benefits) (Commencement)	\$0.10
8106.	Building Societies (Amendment)	\$0.20
8107.	Survey Co-ordination (Place Names)	\$0.10
8108.	Howard Florey Institute of Experimental Physiology and Medicine	\$0.30
8109.	Superannuation (Transitional Provisions)	\$0.10
8110.	New Broken Hill Consolidated Limited	\$0.15
8111.	Litter (Proceedings for Offences)	\$0.10
8112.	Justices (Service of Summonses)	\$0.10
8113.	Stock (Artificial Breeding) (Amendment)	\$0.10
8114.	Alcoa of Australia (W.A.) N.L.	\$0.40
8115.	Victoria Institute of Colleges (Amendment)	\$0.10
8116.	Cemeteries (Fawkner Crematorium and Memorial Park)	\$0.10
8117.	Trustee Companies (Equity Trustees)	\$0.10
8118.	Parliamentary Superannuation	\$0.10
8119.	Ehrenhaus Retail Bottled Liquor Licence	\$0.10
8120.	Melbourne University Land	\$0.10
8121.	Forests (Bowater-Scott Agreement)	\$0.20
8122.	Gas and Fuel Corporation (Pipelines)	\$0.15
8123.	Coal Mines (Pensions)	\$0.10
8124.	Crown Proceedings (Forfeited Recognisances)	\$0.10
8125.	Public Trustee (Amendment)	\$0.15
8126.	Geelong Waterworks and Sewerage (Rates)	\$0.10
8127.	Subordinate Legislation (Powers)	\$0.10
8128.	Barley Marketing	\$0.10
8129.	Stamps (Credit Business)	\$0.15
8130.	Land (Surrender to the Crown)	\$0.10
8131.	Pipelines (Amendment)	\$0.10
8132.	County Court (Jurisdiction)	\$0.10
8133.	Grassmere Land	\$0.10
8134.	Supply (Supplementary Estimates)	\$0.10
8135.	Town and Country Planning (Amendment)	\$0.15
8136.	Seeds	\$0.40
8137.	Imperial Acts Application (Repeals)	\$0.10
8138.	Audit (Recovery of Overpayments)	\$0.10
8139.	Evidence (Registration of Commissioners)	\$0.10
8140.	Country Roads (Amendment)	\$0.15
8141.	Protection of Animals (Rodeos)	\$0.10
8142.	Soil Conservation and Land Utilization (Amendment)	\$0.15
8143.	Motor Car (Driving Offences)	\$0.30
8144.	Fisheries (Amendment)	\$0.15
8145.	Appeal Costs Fund	\$0.10
8146.	Scaffolding	\$0.30
8147.	Liquor Control (Amendment)	\$0.15
8148.	Supply (July to September)	\$0.10
8149.	Local Government (Further Amendment)	\$0.40

C. H. RIXON,
Government Printer.

PUBLICATION OF OFFICIAL MATTER.

Attention is invited to the following procedure in relation to the publication of official matter in the *Government Gazette*:—

Publication will be facilitated by the submission of carbon copies for the use of the *Gazette* Officer.

1. Matter submitted to the Executive Council.

Matter submitted to the Executive Council which requires gazettal will normally be published in the issue of the following week.

Where urgent gazettal is required, special arrangements should be made with the *Gazette* Officer, Room 9, first floor, Old Treasury Building.

2. Other matter.

(a) All other matter duly certified by a responsible officer for publication should be lodged with the *Gazette* Officer not later than half-past Nine a.m. on Tuesday.

(b) Lengthy or involved notices should be forwarded several days before publication.

(c) Proofs, which will be supplied only when specifically requested or at the direction of the *Gazette* Officer, should be returned promptly to avoid delay in publication.

(d) No additions or amendments to matter for publication will be accepted by telephone.

THE "VICTORIA GOVERNMENT GAZETTE".

SUBSCRIPTIONS.—The subscription, including postage, is \$22.50 per annum, or \$11.25 per half year, payable in advance.

Subscriptions are required for whole months, and must cover at least a half year.

Single copies are 30 cents, posted 48 cents. Subscribers do not receive the Acts of Parliament with the GAZETTE.

GAZETTES are held in stock for five years only.

PRIVATE ADVERTISEMENTS.—The charge for insertion is 35 cents per line single column, and 70 cents per line double column. The title forms one or more lines as a heading. On an average ten words make a line of single column. Every signature must likewise be counted as a line. The final words of a paragraph, though only portion of a line, must be counted as one line. Signatures (in particular) and proper names must be written very plainly in the text; ONE SIDE ONLY of each sheet of paper should be WRITTEN UPON. The charge for a full page is \$50.

All documents illegibly written will be returned unpublished, and where brands occur unprovided for by the ordinary letters of the alphabet, a worded explanatory description must be furnished.

THE VICTORIA GOVERNMENT GAZETTE is published on WEDNESDAY EVENING in each week, and Notices for insertion will be received by the Government Printer at or before ONE p.m. at ordinary rates, and late advertisements between ONE p.m. and FOUR p.m. at double rates on the day preceding the day of publication.

PAYMENTS.—Unless the advertiser has a credit account, all payments are required in advance. Remittances should be made by cheque, postal order, or money order payable to "GOVERNMENT PRINTER".

ADDRESS.—All communications should be addressed to "The Government Printer, Box 203, P.O., North Melbourne", 3051.

CONTENTS

	PAGE
Acts of Parliament on Sale at the Government Printing Office	3415
Appointments	3381
Auction Sales Act	3367
Bank Half-Holidays	3356
Contracts	3361, 3380
Country Roads Board	3369
Courts	3364
Estates of Deceased Persons	3368
Government Notices	3356
Holiday—Melbourne Cup Day	3357
Impoundings	3414
Lands	3393
Mining	3379
Notice of Making of Statutory Rules	3415
Orders in Council—	
Acts—Country Roads Board; Local Government; Land; Housing; Hospitals and Charities; Land; Water.	3382 et seq
Police Sale	3356
Private Advertisements	3400
Proclamations	3355
Public Half-Holidays	3356
Public Service Notices	3398
Regulations—	
Act—Teaching Service	3399
Resignations	3382
State Rivers and Water Supply Commission	3361
Tenders	3397
Transport Regulation Board—Public Hearings	3357
Waterworks Trusts	3360