

[771]



VICTORIA

GOVERNMENT GAZETTE

Published by Authority

No. 20]

WEDNESDAY, MARCH 22

[1972

**PUBLICATION OF THE "VICTORIA
GOVERNMENT GAZETTE".**

Easter Holidays.

Because of the Easter Holidays, the Victoria Government Gazette will be published on Friday, the 7th April, 1972 instead of Wednesday, the 5th April, 1972.

All official matter for publication therein should be lodged with the Gazette Officer, Chief Secretary's Department (Telephone Extension 6282), not later than 9.30 a.m. on Thursday, the 6th April, 1972.

**C. H. RIXON,
Government Printer.**

PROCLAMATIONS

ROADS PROCLAIMED.

PROCLAMATION

By His Excellency the Governor of the State of Victoria and its Dependencies in the Commonwealth of Australia, &c., &c., &c.

In pursuance of the provisions of section 25 of the Land Act 1958, the Governor of the State of Victoria, by and with the advice of the Executive Council of the said State, do hereby proclaim as roads the under-mentioned lands:—

Parish of Rodborough, County of Talbot, being the land indicated by hatching on plan hereunder.—(R.28(*) (J.33965.)

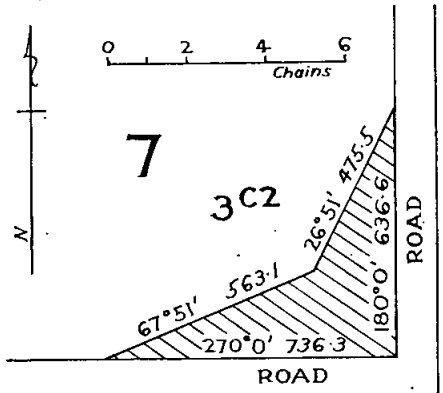

Parish of Eglinton, County of Talbot, being the land indicated by hatching on plan hereunder.—(E.18(*) (J.33965.)

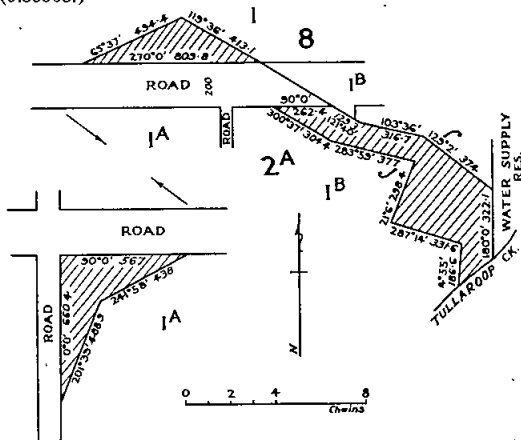

Given under my Hand and the Seal of the State of Victoria aforesaid, at Melbourne, this fifteenth day of March, in the year of our Lord One thousand nine hundred and seventy-two, and in the twenty-first year of the reign of Her Majesty Queen Elizabeth II.

(L.S.) ROHAN DELACOMBE.
By His Excellency's Command,
W. BORTHWICK,
Minister of Lands.

GOD SAVE THE QUEEN!

PUBLIC HALF-HOLIDAYS.

PROCLAMATION.

By His Excellency the Governor of the State of Victoria and its Dependencies in the Commonwealth of Australia, &c., &c., &c.

In pursuance of the provisions contained in Part III. of the Public Service Act 1958, I, the Governor of the State of Victoria, in the Commonwealth of Australia, by and with the advice of the Executive Council of the said State,

do by this my Proclamation appoint the days and dates hereunder mentioned to be observed as Public Half-Holidays at the places respectively specified, viz.:—

Public Half-Holidays from the Hour of Twelve o'clock noon:—

MONDAY, THE 20TH MARCH, 1972, throughout the Shire of Ballan.

WEDNESDAY, THE 12TH APRIL, 1972, throughout the Shire of Dundas.

Given under my Hand and the Seal of the State of Victoria aforesaid, at Melbourne, this fifteenth day of March, in the year of our Lord One thousand nine hundred and seventy-two, and in the twenty-first year of the reign of Her Majesty Queen Elizabeth II.

(L.S.) ROHAN DELACOMBE.

By His Excellency's Command,

R. J. HAMER,
Chief Secretary.

GOD SAVE THE QUEEN!

Public Service Act 1958.

QUEEN'S BIRTHDAY HOLIDAY 1973.

PROCLAMATION

By His Excellency the Governor of the State of Victoria and its Dependencies in the Commonwealth of Australia, &c., &c., &c.

In pursuance of the powers conferred by sub-section (1) of section 67 of the Public Service Act 1958, I, the Governor of the State of Victoria, in the Commonwealth of Australia, by and with the advice of the Executive Council of the said State, do by this my Proclamation appoint—

MONDAY, THE 11TH JUNE, 1973,

as the day upon which the Anniversary of the birthday of Her Majesty for the year 1973, shall be observed as a holiday in the public offices throughout the State of Victoria.

Given under my Hand and the Seal of the State of Victoria aforesaid, at Melbourne, this fifteenth day of March, in the year of our Lord One thousand nine hundred and seventy-two, and in the twenty-first year of the reign of Her Majesty Queen Elizabeth II.

(L.S.) ROHAN DELACOMBE.

By His Excellency's Command,

R. J. HAMER,
Chief Secretary.

GOD SAVE THE QUEEN!

CROWN PROCEEDINGS (FORFEITED RECOGNISANCES) ACT 1971, No. 8124.

DATE OF COMING INTO OPERATION.

PROCLAMATION

By His Excellency the Governor of the State of Victoria and its Dependencies in the Commonwealth of Australia, &c., &c., &c.

Whereas by an Act of Parliament of the State of Victoria passed in twentieth year of the reign of Her Majesty Queen Elizabeth II, intituled the Crown Proceedings (Forfeited Recognisances) Act 1971, No. 8124, it is amongst other things enacted that the said Act shall come into operation on a day to be fixed by Proclamation of the Governor in Council published in the Government Gazette:

Now therefore I, the Governor of the State of Victoria, acting by and with the advice of the Executive Council thereof, do by this my proclamation fix Thursday, the 1st day of June, One thousand nine hundred and seventy-two as the day upon which the Crown Proceedings (Forfeited Recognisances) Act 1971, No. 8124 shall come into operation.

Given under my Hand and the Seal of the State of Victoria aforesaid, at Melbourne, this fifteenth day of March in the year of our Lord One thousand nine hundred and seventy-two and in the twenty-first year of the reign of Her Majesty Queen Elizabeth II.

(L.S.) ROHAN DELACOMBE.

By His Excellency's Command,

G. O. REID,
Attorney-General.

GOD SAVE THE QUEEN!

VETERINARY SURGEONS (AMENDMENT) ACT
1971, No. 8221.

DATE OF COMING INTO OPERATION.

PROCLAMATION

By His Excellency the Governor of the State of Victoria and its Dependencies in the Commonwealth of Australia, &c., &c., &c.

Whereas by an Act of Parliament of the State of Victoria passed in the twentieth year of the reign of Her Majesty Queen Elizabeth II. entitled the *Veterinary Surgeons (Amendment) Act 1971* it is amongst other things enacted that the said Act shall come into operation on a day or the respective days to be fixed by Proclamation or successive Proclamations of the Governor in Council published in the *Government Gazette*:

Now therefore I, the Governor of the State of Victoria, in the Commonwealth of Australia, by and with the advice of the Executive Council of the said State, do by this my Proclamation fix Wednesday the twenty-second day of March, One thousand nine hundred and seventy-two as the day on which the said *Veterinary Surgeons (Amendment) Act 1971*, shall come into operation.

Given under my Hand and the Seal of the State of Victoria aforesaid, at Melbourne, this twenty-first day of March, in the year of Our Lord One thousand nine hundred and seventy-two, and in the twenty-first year of the reign of Her Majesty Queen Elizabeth II.

(L.S.) ROHAN DELACOMBE.

By His Excellency's Command,
G. L. CHANDLER,
Minister of Agriculture.

GOD SAVE THE QUEEN!

LANDLORD AND TENANT (AMENDMENT) ACT 1971,
No. 8208.

DATE OF COMING INTO OPERATION.

PROCLAMATION

By His Excellency the Governor of the State of Victoria and its Dependencies in the Commonwealth of Australia, &c., &c., &c.

Whereas by an Act of Parliament of the State of Victoria passed in twentieth year of the reign of Her Majesty Queen Elizabeth II. intituled the *Landlord and Tenant (Amendment) Act 1971, No. 8208*, it is amongst other things enacted that the several provisions of the said Act shall come into operation on a day or the respective days to be fixed by Proclamation or successive Proclamations of the Governor in Council published in the *Government Gazette*:

Now therefore I, the Governor of the State of Victoria, acting by and with the advice of the Executive Council thereof, do by this my Proclamation fix Monday the 1st day of May One thousand nine hundred and seventy-two as the day upon which all of the provisions of the *Landlord and Tenant (Amendment) Act 1971 No. 8208* shall come into operation.

Given under my Hand and the Seal of the State of Victoria aforesaid, at Melbourne, this fifteenth day of March, in the year of our Lord One thousand nine hundred and seventy-two, and in the twenty-first year of the reign of Her Majesty Queen Elizabeth II.

(L.S.) ROHAN DELACOMBE.

By His Excellency's Command,
G. O. REID,
Attorney-General.

GOD SAVE THE QUEEN!

GOVERNMENT NOTICES

VICE-CONSUL.

Notice is given that provisional recognition has been accorded Mr. Tsai Wan-Lien as Vice-Consul of the Republic of China at Melbourne, with jurisdiction throughout the States of Victoria, South Australia and Tasmania with effect from 22nd February, 1972.

K. D. GREEN,
Secretary to the Premier's Department.

EASTER HOLIDAYS.

It is hereby notified that on—

FRIDAY, THE 31ST MARCH,
SATURDAY, THE 1ST,
MONDAY, THE 3RD, and
TUESDAY, THE 4TH APRIL, 1972,

the Public Offices will be closed, such days being appointed by the *Public Service Act 1958* to be observed as holidays in the Public Offices throughout Victoria.

This notice relates only to the closing of the State Public Offices.

All inquiries regarding holidays in other offices and in shops and industry should be directed to the Department of Labour and Industry, 110 Exhibition-street, Melbourne, 3000. (Telephone 63 0321, Extensions 6158, 6859 or 6924.)

R. J. HAMER,
Chief Secretary.

Chief Secretary's Office,
Melbourne, 3002, 1st March, 1972.

Labour and Industry Act 1958.

ORDER OF EXEMPTION UNDER SECTION 80c.

Whereas pursuant to section 80c of the *Labour and Industry Act 1958* as amended by the *Labour and Industry (Further Amendment) Act 1968* the Council of the City of Maryborough has applied to the Minister for an order exempting certain shopkeepers of a shop in its municipal district from being required to close and keep closed their shop in accordance with the provisions of Part VI. of the said Act:

And whereas I have considered the report of the Minister for Tourism obtained in accordance with the provisions of sub-section (4) of section 80c of the said Act:

Now therefore I, Joseph Anstice Rafferty, Her Majesty's Minister of Labour and Industry in the State of Victoria do pursuant to the aforesaid section 80c of the *Labour and Industry Act 1958* make this order granting exemption to:

BARRY JAMES and JAYNE ANNE JAMES, of 214 High-street, Maryborough,

being shopkeepers within the City of Maryborough from being required to close and keep closed their shop on—

Saturdays, between the hours of 1 p.m. and 5.30 p.m.
Sundays and public holidays, between the hours of
9 a.m. and 5.30 p.m.

provided that such exemption shall not apply to Good Friday or Anzac Day.

Dated at Melbourne, this 10th day of March, 1972.

J. A. RAFFERTY,
Minister of Labour and Industry.

Labour and Industry Act 1958.

ORDER OF EXEMPTION UNDER SECTION 80c.

Whereas pursuant to section 80c of the *Labour and Industry Act 1958* as amended by the *Labour and Industry (Further Amendment) Act 1968* the Council of the Shire of Lillydale has applied to the Minister for an order exempting a certain shopkeeper of a shop in its municipal district from being required to close and keep closed the shop in accordance with the provisions of Part VI. of the said Act:

And whereas I have considered the report of the Minister for Tourism obtained in accordance with the provisions of sub-section (4) of section 80c of the said Act:

Now therefore I, Joseph Anstice Rafferty, Her Majesty's Minister of Labour and Industry in the State of Victoria do pursuant to the aforesaid section 80c of the *Labour and Industry Act 1958* make this order granting exemption to:

HENRY PATRICK GILL FITZHERBERT, of Main-road, Olinda,

being a shopkeeper within the Shire of Lillydale from being required to close and keep closed the shop on—

Saturdays between the hours of 1 p.m. and 6 p.m.,
and

Sundays between the hours of 9 a.m. and 6 p.m.,
provided that such exemption shall not apply to Anzac Day.

Dated at Melbourne, this 10th day of March, 1972.

J. A. RAFFERTY,
Minister of Labour and Industry.

Labour and Industry Act 1958.

ORDER OF EXEMPTION UNDER SECTION 80c.

Whereas pursuant to section 80c of the *Labour and Industry Act 1958* as amended by the *Labour and Industry (Further Amendment) Act 1968* the Council of the Shire of Lillydale has applied to the Minister for an order exempting a certain shopkeeper of a shop in its municipal district from being required to close and keep closed the shop in accordance with the provisions of Part VI of the said Act:

And whereas I have considered the report of the Minister for Tourism obtained in accordance with the provisions of sub-section (4) of section 80c of the said Act:

Now therefore, I, Joseph Anstice Rafferty, Her Majesty's Minister of Labour and Industry in the State of Victoria, do pursuant to the aforesaid section 80c of the *Labour and Industry Act 1958* make this order granting exemption to:

Nancy Sutch Taylor, of Sutch Nice Things, corner of Main-road and Monash-avenue, Olinda,

being a shopkeeper within the Shire of Lillydale from being required to close and keep closed the shop on—

Saturdays between the hours of 1 p.m. and 6 p.m., and Sundays between the hours of 9 a.m. and 6 p.m.

provided that such exemption shall not apply to Anzac Day.

Dated at Melbourne this 17th day of March, 1972.

J. A. RAFFERTY,
Minister of Labour and Industry.

Pipelines Act 1967-1971.

NOTICE OF VARIATION OF CONDITIONS OF A PIPELINE LICENCE.

Whereas sub-section (3) of section 30 of the *Pipelines Act 1967-1971* provides that the Minister may by notice published in the *Government Gazette* amend vary add to or revoke any conditions stated or included in a licence, I, George Oswald Reid, Acting Minister of Mines, do now hereby amend the conditions of Pipeline Licence No. 22, in the manner indicated in the Schedule hereto:—

SCHEDULE.

Replace section II (D) of the Schedule to the licence with the following:—

“(D) ALTERATIONS TO PIPELINE.

Except for emergencies, the licensee shall not effect any repairs or make any additions or alterations to the pipeline without prior approval in writing by the Director, Oil and Gas Division of the Mines Department.

Department of Mines,
Melbourne.

G. O. REID,
Acting Minister of Mines.

Pipelines Act 1967-1971.

NOTICE OF VARIATION OF CONDITIONS OF A PIPELINE LICENCE.

Whereas sub-section (3) of section 30 of the *Pipelines Act 1967-1971* provides that the Minister may by notice published in the *Government Gazette* amend vary add to or revoke any conditions stated or included in a licence, I, George Oswald Reid, Acting Minister of Mines, do now hereby amend the conditions of Pipeline Licence No. 32, in the manner indicated in the Schedule hereto:—

SCHEDULE.

Replace section II (D) of the Schedule to the licence with the following:—

“(D) ALTERATIONS TO PIPELINE.

Except for emergencies, the licensee shall not effect any repairs or make any additions or alterations to the pipeline without prior approval in writing by the Director, Oil and Gas Division of the Mines Department.

Department of Mines,
Melbourne.

G. O. REID,
Acting Minister of Mines.

MENTAL HEALTH ACT 1959, SECTION 26.

Notice is hereby given that the following appointment has been made pursuant to section 26 of the *Mental Health Act 1959*:—

JOHN FINCH
to be Deputy Secretary, Mental Hospital, Traralgon and Psychiatric Hospital, Traralgon, vice O. S. Foenander, transferred.

G. W. ROGAN, Secretary,
14th March, 1972. Department of Health.

Crimes Act 1958.

CURATOR OF CONVICT'S PROPERTY.

His Excellency the Governor of the State of Victoria, by and with the advice of the Executive Council thereof doth by Order made on the 15th day of March, 1972, and pursuant to the provisions of section 550 of the *Crimes Act 1958*, commit the custody and management of the property of the convict Bernhard Dunker, to John Ronald Ashmore Macmillan, care of Rennick and Gaynor, solicitors, 491 Bourke-street, Melbourne, as a Curator hereby appointed in that behalf.

J. ROSSITER,
Clerk of the Executive Council.

At the Executive Council Chamber,
Melbourne, 15th March, 1972.

PORT FAIRY SEWERAGE AUTHORITY.

AUDIT OF ACCOUNTS.

Fee Payable to Auditor.

His Excellency the Governor of the State of Victoria, by and with the advice of the Executive Council thereof doth by Order made on the 15th day of March, 1972, and in pursuance of the provisions of the *Sewerage Districts Act 1958*, (No. 6368), approve of the payment to V. Clayton, Esquire, of the sum of One hundred dollars (\$100) as remuneration for making an audit of the accounts of the Port Fairy Sewerage Authority for the year ended 30th September, 1971, he having been duly appointed by Order in Council made on 1st September, 1971, to make such audit.

J. ROSSITER,
Clerk of the Executive Council.

At the Executive Council Chamber,
Melbourne, 15th March, 1972.

BEAUFORT SEWERAGE AUTHORITY.

AUDIT OF ACCOUNTS.

Fee Payable to Auditor.

His Excellency the Governor of the State of Victoria, by and with the advice of the Executive Council thereof doth by Order made on 21st day of March, 1972, and in pursuance of the provisions of the *Sewerage Districts Act 1958*, (No. 6368), approve of the payment to G. B. Hayward, esquire, of the sum of Twenty-five dollars (\$25) as remuneration for making an audit of the accounts of the Beaufort Sewerage Authority, for the period from the constitution of the Authority to 30th September, 1971, he having been duly appointed by Order in Council made on 1st September, 1971, to make such audit.

J. ROSSITER,
Clerk of the Executive Council.

At the Executive Council Chamber,
Melbourne, 21st March, 1972.

ST. ARNAUD WATERWORKS TRUST.

FIXING THE LIMIT OF BANK OVERDRAFT.

His Excellency the Governor of the State of Victoria, by and with the advice of the Executive Council thereof doth by Order made on the 21st day of March, 1972, fix the total amount of the sums which the St. Arnaud Waterworks Trust may owe at any time in respect of moneys borrowed by overdraft of current account, pursuant to the provisions of section 286 of the *Water Act 1958*, at Twenty thousand dollars (\$20,000).

J. ROSSITER,
Clerk of the Executive Council.

At the Executive Council Chamber,
Melbourne, 21st March, 1972.

MELTON SEWERAGE AUTHORITY.

INCREASING THE LIMIT OF BANK OVERDRAFT.

His Excellency the Governor of the State of Victoria, by and with the advice of the Executive Council thereof doth by Order made on the 21st day of March, 1972, increase the total amount of the sums which the Melton Sewerage Authority may owe at any one time in respect of moneys borrowed by overdraft of the current account, pursuant to the provisions of section 79 of the *Sewerage Districts Act 1958*, and fixed by the Governor in Council on 7th December, 1971, at One hundred thousand dollars (\$100,000), to One hundred and twenty thousand dollars (\$120,000).

J. ROSSITER,
Clerk of the Executive Council.

At the Executive Council Chamber,
Melbourne, 21st March, 1972.

BRUTHEN WATERWORKS TRUST.

RATING BY-LAW No. 19.

The Bruthen Waterworks Trust, in pursuance and exercise of the powers conferred by the Water Act, doth hereby make the following rates for the supply of water for domestic purposes on land and tenements liable to be rated in the Bruthen Urban District.

On such land and tenements a rate of eighteen cents in the dollar on the amount of the annual municipal valuation not exceeding One hundred and twenty dollars and where the annual municipal valuation exceeds One hundred and twenty dollars a rate of eighteen cents in the dollar for the first One hundred and twenty dollars and three cents in the dollar for every dollar exceeding One hundred and twenty dollars of such valuation.

Provided that in no case shall the amount of rate payable per annum in respect of any tenement (other than land on which there is no building) be less than Twenty two dollars, and in respect of land on which there is no building less than three dollars.

Such rates are made and shall be levied upon the occupiers or owners of the said lands and tenements for the year commencing the 1st day of January, 1972, and shall be payable on the 23rd day of April, 1972, at the office of the said Trust.

The maximum quantity of water to be supplied in any one year without further charge to any property rated by the Trust is hereby fixed at the quantity which, at the charge of Twenty five cents per 1,000 gallons would produce an amount equal to the amount of the rate levied on such property for the said year.

The charge for water supplied by measure to any property rated by the Trust in excess of such maximum quantity computed as in the last preceding clause is hereby fixed at Twenty five cents per 1,000 gallons.

The charge for water supplied by measure shall be payable on demand, at the office of the Trust.

Passed this 23rd day of February, 1972.

(SEAL) IAN GEORGE INNES, Chairman.
JACK SLADE, Acting Secretary.
JOHN WALLIS POLLARD, Commissioner.

Approved, 1st March, 1972.—ROBERTS DUNSTAN,
Minister of Water Supply.

YEA WATERWORKS TRUST.

RATING BY-LAW 1972.

The Yea Waterworks Trust in pursuance of and in exercise of the powers conferred by the Water Act 1958 and of any and every other power it thereunto enabling doth hereby make a By-law as follows:—

1. The Trust hereby makes and levies a rate in respect of all the lands and tenements within the Yea Urban District of 8.3 cents in the dollar on the net annual value set out in the valuation at present in force of such lands and tenements for the purposes of the municipal rate of the Shire of Yea which is hereby adopted as the valuation of such lands and tenements respectively.

2. Such rate shall be made and levied upon the occupiers and owners of such lands and tenements for the year commencing on the 1st day of January, 1972, and shall be payable on the 31st day of March, 1972, at the office of the said Trust.

3. In no case shall the rate payable hereunder in respect of any land on which there is a building be less than thirteen dollars fifty cents and in respect of land on which there is no building be less than four dollars.

Passed on the 16th day of February, 1972.

(SEAL) K. D. BRYANT, Chairman.
F. F. BERKERY, Secretary.

Approved, 29th February, 1972.—ROBERTS DUNSTAN,
Minister of Water Supply.

WYCHEPROOF SEWERAGE AUTHORITY.

BY-LAW No. 4.

The Wycheproof Sewerage Authority in pursuance of the powers conferred by the Sewerage Districts Act 1958, doth hereby fix the following sums which shall be the minimum amount of rate to be paid annually by the owner or occupier of any rateable property on which there is a building or by the owner or occupier of any rateable property on which there is no building.

Rateable property on which there is a building \$30
Rateable property on which there is no building \$10

This by-law was passed by the Wycheproof Sewerage Authority on the 18th January, 1972, and confirmed on the 15th February, 1972.

The common seal of the Wycheproof Sewerage Authority was hereto affixed this 15th day of February, 1972.

(SEAL) D. P. SHEAHAN, Chairman.
E. J. MOLLOY, Member.
G. R. DRYDEN, Secretary.

Approved, 29th February, 1972.—ROBERTS DUNSTAN,
Minister of Water Supply.

YARRAWONGA SEWERAGE AUTHORITY.

RATING BY-LAW 1971-1972.

The Yarrowonga Sewerage Authority, in pursuance and exercise of the powers conferred by the Sewerage District Acts, doth hereby make a Sewerage Rate of Four cents in the Dollar on the Net Annual Valuation of all rateable seweraged property within the Yarrowonga Sewerage District, provided that the minimum amount of rate to be paid annually by the owner or occupier of any rateable seweraged property on which there is a building shall be Twelve Dollars and by the owner or occupier of any rateable seweraged property on which there is no building shall be Three Dollars.

Such rate is made and shall be levied upon the owners or occupiers of the said rateable property for the year commencing on the 1st October, 1971 and shall be due and payable on the 20th March, 1972 at the office of the said Authority, Shire Hall, Yarrowonga.

The foregoing By-law was made and passed by the Yarrowonga Sewerage Authority at a Special Meeting held on the 7th December, 1971 and confirmed at a subsequent meeting held on the 11th January, 1972.

In witness thereof the common seal of the said Authority was hereunto affixed in the presence of—

(SEAL) FRANK KEENAN, Chairman.
ALBERT E. CAMPBELL, Member.
D. J. PRESLEY, Secretary.

Approved, 15th March, 1972.—ROBERTS DUNSTAN,
Minister of Water Supply.

LISMORE AND DERRINALLUM WATERWORKS TRUST.

GENERAL RATING BY-LAW No. 2 FOR THE YEAR 1972 FOR THE LISMORE RURAL DISTRICT.

The Lismore and Derrinallum Waterworks Trust, in pursuance and exercise of the powers conferred by the Water Act doth hereby make a rate for the supply of water for domestic purposes of Two (2) cents in the dollar (2 cents in the \$1.00) of the annual municipal valuation of the lands and tenements liable to be rated within the Lismore Rural District.

Provided that in no case shall the amount of rate payable per annum in respect of lands or tenements (other than lands or tenements of less than five acres) be less than One hundred and thirty dollars (\$130.00) and in respect of any lands or tenements of Five (5) acres or less, be less than Sixty-five dollars (\$65.00).

Such rates are made and shall be levied on the occupiers or owners of the said lands or tenements for the year commencing the First of January 1972 and shall be payable on the First day of March 1972 at the Office of the said Trust.

The maximum quantity of water to be supplied in any one year without charge to any property rated by the Trust is hereby fixed at the quantity which at a charge of Forty-three cents (43 cents) per 1,000 gallons would produce an amount equal to the amount of rate levied on the property in the said year.

The charge for water supplied by measure to any property rated by the Trust in excess of the maximum quantity computed as in the last preceding clause is hereby fixed at Forty-three (43) cents per thousand gallons.

The charge for water supplied by measure shall be payable on demand at the Office of the Trust.

Passed this 16th day of December, 1971.

(SEAL) J. W. BAIRD, Chairman.
JOSEPH S. SMITH, Secretary.

Approved, 29th February, 1972.—ROBERTS DUNSTAN,
Minister of Water Supply.

Transport Regulation Act.
TRANSPORT REGULATION BOARD.

HEARING OF APPLICATIONS.

Notice is hereby given that the following applications will be considered by the Transport Regulation Board at its offices at the corner of Lygon and Princes streets, Carlton, at 10.15 a.m. on Wednesday, 12th April, 1972.

MOONEE VALLEY BUS LINES PTY. LTD., 73 Fletcher-street, Essendon. One commercial passenger vehicle with large seating capacity to operate as a metropolitan stage omnibus from Hampton to Middle Brighton on the following route:—Commencing from Hampton Railway Station; thence via Willis-lane, Willis, Hastings, Holyrood, New, Carpenter, Church and New streets to St. Kilda-street returning via St. Kilda, Park and Webb streets to normal route.

SECTIONS AND FARES.

Hampton Railway Station—Holyrood and New streets: Adults 10c, Child 5c. Holyrood and New streets—New and Dendy streets: Adults 15c, Child 9c, New and Dendy streets—St. Kilda street Terminus: Adults 18c, Child 10c.

TIME-TABLE.

Approximately 20 minute service.

PRESTON-COBURG BUS SERVICES PTY. LTD., 572 Murray-road, West Preston. Application for permit authority to operate for the carriage of the congregation of St. John's Church, Preston to St. Cecilia Church, Preston over a route from the corner of Gilbert and Murray roads via Murray-road, Elizabeth and Meadow streets, Connelly and Peterson-avenues, Jackson-parade, Boyne and Jacka streets, Gilbert-road, Bruce and Jessie streets, Austral-avenue, Oakover-road and Robeson-street to the corner of Kendall and Stafford streets.

TIME-TABLE.

Sundays Only.

Depart corner Gilbert and Murray roads—8.50 a.m.
Depart corner Kendall and Stafford streets—11.45 a.m.

REID'S, GRAEME, TRANSPORT SERVICE PTY. LTD., Colbinabbin. One commercial passenger vehicle (S/C. 20) to operate for the carriage of school children only between Colbinabbin West and Colbinabbin, under contract to the Education Department.

SHAVE BUS SERVICE PTY. LTD., 12 Ricketts-road, Mt. Waverley. One commercial passenger vehicle (S/C. 45) to operate as an additional metropolitan stage omnibus on Routes 622, 623, 624 and 625 under the same terms and conditions as M.O. licences at present held by the applicant.

Application for renewal of licences as shown, by persons listed hereunder to operate under the same terms and conditions.

AGUSSOL, C., 1/144 Booran-road, Glenhuntly; M.T.4530.
ANGELOPOULOS, I., 29 Alexander-street, Collingwood; M.T.4531.
ANDRIANOPOULOS, D., 11 Hartley-street, Northcote; M.T.4380.
APOSTOLIDIS, G., 97 Albert-street, Footscray; M.T.4475.
BARRASSO, G., 83 Neptune-street, Richmond; M.T.1998.
BERGER, J., 22 Newman-avenue, Carnegie; M.T.1762.
BORDONARO, P., 10 Chatham-street, Flemington; M.T.1981, M.T.4418.
CAMPBELL, J. A., 35 Macarthur-street, Moorabbin; M.T.4530.
CARIOTOGLOU, A., 4 Service-street, South Melbourne; M.T.4488.
CARR, E. J., 62 Roslyn-road, Belmont, Geelong; U.T.630.
CLARK, M., 9 Eva-street, Malvern; M.T.1335.
CONWAY, J., 1 Brennan-street, Bentleigh; M.T.4273.
CRANSTON, K. J. J., 15 Patrick-street, Glenroy; M.T.1428.
DICKINSON, D. E., 3 Dundas-street, Albert Park; M.T.1745.
DIMITROPOULOS, A., 145A Victoria-road, Northcote; M.T.1908.
DUDLEY, R. W., 1/851 Burke-road, Camberwell; M.T.3517.
EDWARDS, G. N., 15 Celeste-street, East Doncaster; M.T.4428.
ELLIOT, G., 10 Snell-grove, Pascoe Vale; M.T.4495.
EVANS MOTOR SERVICE PTY. LTD., 375 New-street, Brighton; M.T.3527, M.T.3528, M.T.3529.
FENWICK, J. P., 28 Outer-crescent, Brighton; M.T.1290.
FICKEN, E. R., 35 Baroda-street, Travencore; M.T.558.
FOSTER, H., 56 Through-road, Burwood; M.T.3502.
FILBY, S. G., 63 Orient-avenue, Mitcham; M.T.4148.
FREEMAN, M., 10 Ash-grove, East Malvern; M.T.4326.
GALVIN, L. M., 53 Bolingbroke-street, Pascoe Vale; M.T.1487.
GUERIN, L. E., 10 Kent-street, Hawthorn; M.T.3508.
HADEN, K., 37 Chaucer-street, Moonee Ponds; M.T.1970.
HAJICIC, S., 59 Bennett-street, North Fitzroy; M.T.4440.
KALEKS, I., 11 Washington-avenue, East Malvern; M.T.1930.

KAHWAGI, K., 12 Nicol-street, East Preston; M.T.4077.
KIRLIS, A., 87 Albion-street, Brunswick; M.T.4059.
KOUROS, E., 952 Lygon-street, North Carlton; M.T.4196.
LAKRINDIS, C., 32 Peers-street, Richmond; M.T.4479.
LICCIARDELLO, A., 8 Summerhill-road, Maidstone; M.T.4377.
LIDESTRI, A., 9 Canning-street, North Melbourne; M.T.4345.
LYTRA, G., 8 Peverill-street, Chadstone; M.T.1408.
MAHONEY, C. J., 436 Kooyong-road, South Caulfield; M.T.2497.
PAPETTAS, G., 40 Murawa-street, Frankston; M.T.4370.
PIERCE, C. T., 648 Riversdale-road, Box Hill; M.T.3518.
POPPE, K., 34 Badger Creek-road, Healesville; C.T.77, C.T.496.
REVELY, E. T., 23 Havelock-avenue, Bundoora; S.T.7533.
ROBERTS, E. W., 206 Waverley-road, East Malvern; M.T.2491.
ROWE, J. (Estate of the late), 72 Wellington-street, St. Kilda; M.T.2488.
SAVINOS, A., 60 Ramsden-street, Clifton Hill; M.T.4514.
SELBY, P. A., 28 Cheltenham-road, Black Rock; M.T.4416.
SKANTZOS, N., 12 Claremont-street, Fawkner; M.T.4007.
SPANO, P. N., 29 Larne-grove, Preston; M.T.1604.
STEWART, E. E. L., 317 Buckley-street, Essendon; M.T.3505, M.T.3503.
STRAIN, D. J., 36 Almond-street, Caulfield South; M.T.665.
TOLLEY, W., 39 Surrey-street, Pascoe Vale; M.T.4072.
THOMACOS, P., 27 Clements-street, East Bentleigh; M.T.1916.
WALLACE, G. J., 17 Foley-place, East Bentleigh; M.T.2496.
WEINBERGER, T., 2/12 Southey-street, Elwood; M.T.4478.
WOODHOUSE, A. P., 4 Colin-avenue, Frankston; C.T.375.
WOODMAN, W. H., 101 Cole-street, Gardenvale; M.T.4037.
YOUNG, K. K., 1 Waverley-road, Pascoe Vale South; M.T.3535.

Notice of any objection should be forwarded to reach the Secretary of the Board not later than Wednesday, 5th April, 1972.

Applicants are advised that it will not be necessary to appear on the hearing date specified above, unless advised in writing by the Board.

B. P. KAY,
Secretary.

Corner Lygon and Princes streets, Carlton, Wednesday, 22nd March, 1972.

Commercial Goods Vehicles Act.
TRANSPORT REGULATION BOARD.

HEARING OF APPLICATIONS.

Notice is hereby given that the following applications will be considered by the Transport Regulation Board at its offices at the corner of Lygon and Princes streets, Carlton, at 10 a.m. on Wednesday, 12th April, 1972.

DUMBRELL, N. (trading as Allbrell Auto Supplies), 28 Carson-street, Shepparton, 3630. One commercial goods vehicle (L/C. 15 cwt.) to operate within a 50-mile radius of own premises at Shepparton and to the Cities of Bendigo and Wangaratta and to the Township of Mansfield, and Towns en route in the course of business as "Auto Spares Agent and Distributors"—own goods, subject to the condition that all goods carried on the vehicle are to be initially consigned by rail to Shepparton.

AUTOCARE PTY. LTD., 117-119 Gilbert-road, Preston, 3072. One commercial goods vehicle (L/C. 64 cwt.) to operate throughout the State of Victoria as a specially constructed car carrying unit—second-hand motor cars, repossessed motor cars and damaged motor cars.

BURGESS, J., 16 Chippewa-avenue, Mitcham, 3132. One commercial goods vehicle (L/C. 204 cwt.) to operate within a 50-mile radius of the premises of Ready Mixed Concrete (Victoria) Pty. Ltd., at Richmond, solely on behalf of the said company—premixed concrete in a specially constructed agitator vehicle.

BUTLER, E. J., 14 Harrow-street, Blackburn South, 3130. One commercial goods vehicle (L/C. 202 cwt.) to operate within a 50-mile radius of the premises of Ready Mixed Concrete (Victoria) Pty. Ltd. at Nunawading solely on behalf of the said company—premixed concrete in a specially constructed agitator vehicle.

CARLILE BROS. PTY. LTD., Strickland-road, Bendigo, 3550. One commercial goods vehicle (L/C. 50 cwt.) to operate within a 50-mile radius of the post office at Ballarat and to and from own premises in the City of Bendigo in course of business as "Skin Merchants"—own goods.

DAFF, G. G., Old Dandenong-road, Heatherton, 3202. One commercial goods vehicle (L/C. 232 cwt.) to operate within a 35-mile radius of the G.P.O., Melbourne, on behalf of Consolidated Quarries Ltd.—sand, soil, screenings, premix and quarry products.

EDGE, R. H. (trading as R. H. & R. M. Edge), Road Side Delivery, McConnell's-road, Terang, 3264. One commercial goods vehicle (L/C. 140 cwt.) to operate: (a) Within a 25-mile radius of the post office at Terang—general goods, provided that no goods shall be carried whether in one or more stages between places within the above radius which are more than 30 road miles apart by the nearest practicable route. (b) Within a 50-mile radius of the post office at Terang—livestock. (c) Within a 50-mile radius of the post office at Terang as a "Primary Producer"—own goods.

FEIGLIN, M. & SONS PTY. LTD., Station-street, Nunawading, 3131. One commercial goods vehicle (L/C. 256 cwt.) to operate: (a) From forest landings in the Niagara and Upper Yarra forestry districts, the North Big River area and the Mt. Margaret and Taggerty Valley areas and points en route to: (i) Own sawmills at Narbethong, and Nunawading—logs. (ii) The Healesville Railway Station or to any sawmill or dump situated within a 20-mile radius either of the Healesville Railway Station or of any such forest landings specified above—logs. (iii) Any sawmill or timber yard situated within a 25-mile radius of the post office at the corner of Bourke and Elizabeth streets, Melbourne—logs. (iv) Between own orchards, sawmills, cool stores, canneries and markets—own fresh fruit and empty return cases. (b) From forest landings situated within a 50-mile radius of the post office at Mansfield to sawmills at Mansfield and Benalla—sawmill logs. (c) Between own sawmills at Mansfield, Narbethong and Nunawading and bush landings in the Mt. Buller, Mt. Margaret, Taggerty Valley and Jamieson areas—own logging equipment. (d) Between own mills, logging sites and own orchards—own logging and orchard equipment. (e) From own sawmill at Narbethong to—(i) The Healesville Railway Station. (ii) Any customer for delivery to an address within a 20-mile radius of the post office at the corner of Bourke and Elizabeth streets, Melbourne—sawn timber. (f) From own sawmill at Mansfield to the Mansfield Railway Station—sawn timber. (g) From own forest landings in the Millgrove area to own sawmills at Narbethong and Nunawading—logs and logging equipment.

FIRESTONE AUSTRALIA PTY. LTD., 36 Malua-street, Reservoir, 3073. One commercial goods vehicle (L/C. 14 cwt.) to operate within a 50-mile radius of own premises at Boort in course of business as "Tyre & Rubber Manufacturers"—tyres, tubes, batteries, motor accessories, polythene piping.

NOTE.—All new goods to be initially consigned by rail to Boort.

FIRESTONE AUSTRALIA PTY. LTD., 36 Malua-street, Reservoir, 3073. One commercial goods vehicle (L/C. 15 cwt.) to operate within 50-mile radius of own premises at Camperdown in course of business as "Tyre and Rubber Manufacturers"—tyres, tubes, batteries, motor accessories and polythene piping.

NOTE.—All new goods to be initially consigned by rail to Camperdown.

FIRESTONE AUSTRALIA PTY. LTD., 36 Malua-street, Reservoir, 3073. One commercial goods vehicle (L/C. 13 cwt.) to operate within a 50-mile radius of own premises at Morwell in course of business as "Tyre and Rubber Manufacturers"—tyres, tubes, batteries, motor accessories and polythene piping.

NOTE.—All new goods to be initially consigned by rail to Morwell.

FIRESTONE AUSTRALIA PTY. LTD., 36 Malua-street, Reservoir, 3073. One commercial goods vehicle (L/C. 14 cwt.) to operate within a 50-mile radius of own premises at Bendigo in course of business as "Tyre and Rubber Manufacturers"—tyres, tubes, batteries, motor accessories and polythene piping.

NOTE.—All new goods to be initially consigned by rail to Bendigo.

FIRESTONE AUSTRALIA PTY. LTD., 36 Malua-street, Reservoir, 3073. One commercial goods vehicle (L/C. 18 cwt.) to operate within a 50-mile radius of own premises at Shepparton in course of business as "Tyre and Rubber Manufacturers"—tyres, tubes, batteries, motor accessories and polythene piping.

NOTE.—All new goods to be initially consigned by rail to Shepparton.

FIRESTONE AUSTRALIA PTY. LTD., 36 Malua-street, Reservoir, 3073. Three commercial goods vehicles (L/C. 13, 17, 15 cwt.) to operate within a 50-mile radius of own premises at Geelong in course of business as "Tyre and Rubber Manufacturers"—tyres, tubes, batteries, motor accessories and polythene piping.

NOTE.—All new goods to be initially consigned by rail to Geelong.

FIRESTONE AUSTRALIA PTY. LTD., 36 Malua-street, Reservoir, 3073. Three commercial goods vehicles (L/C. 11, 12, 19 cwt.) to operate within a 50-mile radius of own premises at Wodonga in course of business as "Tyre and Rubber Manufacturers"—tyres, tubes, batteries, motor accessories and polythene piping.

NOTE.—All new goods to be initially consigned by rail to Wodonga.

HALLETT, M., 11 Vistula-court, Springvale South, 3172. One commercial goods vehicle (L/C. 204 cwt.) to operate within a 50-mile radius of the premises of Ready Mixed Concrete (Vic.) Pty. Ltd. at Sandown—solely on behalf of the said company—premixed concrete in a specially constructed agitator vehicle.

HATCHELL-BROWN, J. W., 16 North-street, Yea, 3717. Application to vary the conditions of licence No. D.A.64851 (L/C. 79 cwt.) by adding an additional paragraph (d)—"(d) From and to places situate within a 25-mile radius of the post office at Yea to and from places situate within a 50-mile radius of the post office at Yea—livestock."

HEATHS MOTORS PTY. LTD., 160 Little Malop-street, Geelong, 3220. One commercial goods vehicle (L/C. 15 cwt.) to operate: (a) Within a 50-mile radius of own premises in the City of Geelong in the course of business as "Farm Machinery Distributors"—own goods. (b) Throughout the State of Victoria for the purpose of servicing and maintaining tractors and farm machinery in the field only—tools of trade, spare parts and materials incidental to such servicing and maintenance.

HEAVY TRUCK SERVICES PTY. LTD., 66 Renver-road, Clayton, 3168. One commercial goods vehicle (L/C. 13 cwt.) to operate: (a) Within a 50-mile radius of own premises at Clayton in the course of business as "Truck Service Engineers"—own goods. (b) Throughout the State of Victoria in the course of business as "Truck Service Engineers"—tools of trade and spare parts incidental to on-site servicing in the field only.

INGLIS, J. C., 16 Crouch-street, Portland, 3305. Application to vary the conditions of licence No. D.T.819 (L/C. 255 cwt.) by adding an additional paragraph (d)—"(d) Within a 50-mile radius of the depot at Calteix Ltd. situated at Portland—bulk petroleum products."

K.M.M. PTY. LTD., 461 Bourke-street, Melbourne, 3000. One commercial goods vehicle (L/C. 199 cwt.) to operate: (a) Within a 50-mile radius from own premises at Kensington in the course of business as "Stockfeed and Flour Millers" in a specially constructed bulk vehicle—own goods in bulk. (b) From own premises at Kensington to places within that part of a 50-mile radius from the post office at the corner of Bourke and Elizabeth streets, Melbourne situated east of a line drawn due north and south through the City of Melbourne and to the City of Morwell—own bulk stockfeed in a specially constructed bulk unit.

MOTOR SPARES PTY. LTD., 547 Elizabeth-street, Melbourne, 3000. One commercial goods vehicle (L/C. 15 cwt.) to operate within a 50-mile radius of own branch premises at Mildura in the course of business as "Automotive and Spare Parts Distributor"—own goods.

OLIVER DAVEY GLASS CO. PTY. LTD., 35 Crockford-street, Port Melbourne, 3207. One commercial goods vehicle (L/C. 14 cwt.) to operate: (a) Within a 25-mile radius of own premises at Geelong in course of business as Glass Merchants—own goods. (b) Within a 50-mile radius of own premises at Geelong for the purpose of completing own glazing contracts—tools of trade, glass and materials incidental to the completion of own contracts.

PAHOR, R., 8 Canberra-avenue, Dandenong, 3175. One commercial goods vehicle (L/C. 200 cwt.) to operate within a 50-mile radius of the premises of Ready Mixed Concrete (Vic.) Pty. Ltd. Dandenong solely on behalf of the said company—premixed concrete in a specially constructed agitator vehicle.

PIZZEY LTD., 410 Whitehorse-road, Mitcham, 3132. One commercial goods vehicle (L/C. 10 cwt.) to operate: (a) Within a 50-mile radius from own premises at Mitcham in the course of business as "Merchants Manufacturers and Distributors"—own goods. (b) Throughout the State of Victoria as manufacturers of agricultural machinery, for the purpose of servicing and demonstrating Agricultural Equipment—Agricultural Equipment for demonstration or for repair or having been repaired, also tools of trade, spare parts and materials incidental thereto.

PASSIONA BOTTLING CO. (MELB.) PTY. LTD., 213-215 Chesterville-road, Moorabbin, 3189. One commercial goods vehicle (L/C. 70 cwt.) to operate within that part of the State of Victoria bounded on the east by a north/south line through Lismore and on the north by an east/west line through Glenthompson in the

course of business as Manufacturers and Distributors of Cottee's aerated waters and allied products—own aerated waters and allied manufactured products provided that all such goods are initially consigned by rail to Warrnambool.

- ROBERTSON, C. J. & Co. (HORSHAM) PTY. LTD., 85 Wilson-street, Horsham, 3400. Application to vary the conditions of licences numbered D.A.23358/5, 20, 21 (L/C. 14, 20 and 14 cwt.) by adding an additional paragraph (b)—“(b) Within a 50-mile radius of the G.P.O., Melbourne solely on behalf of the State Electricity Commission—tools of trade, creosote and chemicals for the treatment of posts on site.”
- SPILLER, H. H., 4 Mortoo-street, Swan Hill, 3585. One commercial goods vehicle (L/C. 13 cwt.) to operate within that part of the State of Victoria west of a line drawn north and south through the City of Echuca and north of a line drawn due east and west through the City of Bendigo in the course of business as “Refrigeration and Air Conditioning Engineer”—refrigerators and air conditioning units for installation or for repair, or having been repaired also tools of trade, equipment and spare parts incidental to the installation and servicing of refrigeration and air conditioning units.
- GERCOVICH, D. G. (trading as Stawell Concrete Co.) 10 Doyle-street, Stawell, 3380. One commercial goods vehicle (approx. 200 cwt.) to operate within a 50-mile radius of the post office at Stawell in course of business as “Premixed Concrete Manufacturer”—own premixed concrete in a specially constructed agitator vehicle.
- TROUTBECK, G., Mt. Ridley-road, Mickelham, 3047. One commercial goods vehicle (L/C. 139 cwt.) to operate: (a) Within a 25-mile radius of own premises at Mickelham—general goods provided that no goods shall be carried whether by one stage or by more than one stage between places within the above radius which are more than 30 road miles apart by the nearest practicable route. (b) From and to places in paragraph (a) above and from places within a 50-mile radius of own premises at Mickelham—livestock.
- WAITE, K. W., 101 Pearson-street, Bairnsdale, 3875. One commercial goods vehicle (L/C. 272 cwt.) to operate from forest landings situated within a 50-mile radius of Bairnsdale Post Office solely to sawmills operated by S. M. Collins Pty. Ltd. at Bairnsdale and Stratford—mill logs.
- WAKEFIELD, K. L. (trading as L. Wakefield & Co.), 3 Wainwright-street, Warrnambool, 3280. Application to vary the conditions of licence No. D.A.52402 (L/C. 76 cwt.) by deleting the existing conditions and adding in lieu—“Within the area of the State of Victoria bounded by Yambuk, Caramut, Lismore, Colac and Lavers Hill in course of business as ‘Distributors’ solely on behalf of Cohns Industries Ltd. at Bendigo—products manufactured by Cohns Industries Ltd. and agency lines.”
- MARSHALL FROZEN FOODS PTY. LTD. (trading as Western District Frozen Foods), Barwon Heads-road, Belmont, 3216. One commercial goods vehicle (L/C. 70 cwt.) to operate within that part of the State of Victoria situated west of a north/south line drawn through the City of Shepparton in a specially constructed refrigerated vehicle at a temperature not exceeding 10° Fahrenheit in the course of business as “Frozen Food Distributors”—frozen meat, frozen poultry, frozen fish, frozen seafoods, frozen vegetables, frozen pastries, frozen fruit juices, frozen pies, frozen chicken rolls, frozen prepared meals, frozen egg whites and ice-cream.
- YOUNG, W. H. & SONS PLANT HIRE PTY. LTD., 182 High-street, Shepparton, 3630. One commercial goods vehicle (L/C. 300 cwt.) to operate: (a) Within a 50-mile radius from the post office at Shepparton plant the property of a contractor and required by him for use in connexion with the construction or maintenance of some specific, existing or proposed road, street, footpath, bridge, pier, wharf, weir or channel and also the following materials, viz.: metal, stones, screenings, ashes, gravel, sand and earth. (b) Within a 25-mile radius from the site of any construction or maintenance work performed pursuant to paragraph (a) above, or from the railway station nearest thereto—any other materials required for such work. (c) Within a 25-mile radius of the post office at Shepparton—general goods provided that no goods shall be carried whether by one stage or by more than one stage between places within the above radius, which are more than 30 road miles apart by the nearest practicable route. (d) Within a 50-mile radius of Shepparton—hot asphalt and premix bituminous products. (e) Within a 100-mile radius of the post office at Shepparton but excluding operations

from places within a 25-mile radius of the G.P.O., Melbourne in the course of business as “Earth-moving Contractor”—own tools of trade, earth-moving plant and equipment.

TOW TRUCK.

- LOVELAND & LOADER PTY. LTD., 300 Dana-street, Ballarat, 3350. One commercial goods vehicle (to be purchased) to operate throughout the State of Victoria as a “Tow Truck” for the purpose of lifting and carrying or towing and/or repairing of wrecked or disabled vehicles—tools of trade, spare parts and materials incidental thereto.

RENEWALS.

Applications for renewal of licences as shown by persons listed hereunder to operate under the same terms and conditions from the expiry shown in each case.

- ABERFELDIE QUARRIES & SAND SUPPLY PTY. LTD., Knighton-avenue, East Keilor, 3042; D.A.37391/10; 7th July, 1972; 165 cwt.
- WILLIAM ADAMS TRACTORS PTY. LTD., Nantilla-road, North Clayton, 3168; D.A.512/13; 6th August, 1972; 13 cwt.
- ATHERTON, B. A., 36 Waverley-road, Chadstone, 3148; D.A.39868; 11th July, 1972; 57 cwt.
- BELL, I. J. A., 39 Benga-avenue, West Dandenong, 3175; D.A.47507/2; 29th July, 1972; 132 cwt.
- BUSH'S PRODUCE STORES PTY. LTD., 165 Williamson-street, Bendigo, 3550; D.A.53016; 17th August, 1972; 114 cwt.
- CONNOR, SHEA & Co. PTY. LTD., Fourth-avenue, Sunshine, 3020; D.A.40050; 1st August, 1972; 14 cwt.
- ELLSTED CONTRACTING Co. PTY. LTD., 23 Anderson-road, Thornbury, 3071; D.A.52740; 7th July, 1972; 11 cwt.
- EVERITT, C. A. D., Tone-road, Wangaratta, 3677; D.T.192/1; 5th August, 1972; 282 cwt.
- GLENTHOMPSON TRANSPORT PTY. LTD., Donald Forbes-street, Glenthompson, 3293; D.A.1157; 25th August, 1972; 196 cwt.
- HILL, C. J., 20 Acacia-street, East Doncaster, 3109; D.A.62003; 5th August, 1972; 161 cwt.
- HOLLAND, V. E., South Gippsland Highway, Five Ways Via Cranbourne, 3977; D.A.61823/1; 5th August, 1972; 224 cwt.
- INTERNATIONAL HARVESTER Co. OF AUST. PTY. LTD., The Esplanade, North Shore, Geelong, 3220; D.A.1351/58; 7th July, 1972; 20 cwt.
- JORGENSEN, D. A. E., Box 12, Portarlington, 3223; D.A.1397/1; 25th August, 1972; 116 cwt.
- JUDD CONSTRUCTIONS PTY. LTD., 34 Coghill-street, Yarrawonga, 3730; D.A.53009; 17th August, 1972; 306 cwt.
- JUDD, G. & SONS PTY. LTD., 34 Coghill-street, Yarrawonga, 3730; D.A.1403/6; 25th July, 1972; 158 cwt.
- KATOS FISH SUPPLY PTY. LTD., 32 Smythe-street, Geelong, 3220; D.A.64002; 15th July, 1972; 13 cwt.
- MAIN, K. J., 21 Stapley-crescent, Chadstone, 3148; D.A.39626; 1st August, 1972; 7 cwt.
- MAWSON, E. B. & SONS PTY. LTD., 141 King George-street, Cohuna, 3568; D.A.30119/7; 3rd August, 1972; 11 cwt.
- MILLER, W. & Co. PTY. LTD., Wills-street, Bright, 3741; T.D.A.14742/1; 19th August, 1972; 321 cwt.
- MOBILE QUARRIES (VIC.) PTY. LTD., 23 Anderson-road, Thornbury, 3071; D.A.39954; 25th July, 1972; 80 cwt.
- PAULKE, K. C., 1 George-street, Belmont, 3216; D.A.52888; 3rd August, 1972; 10 cwt.
- PETERSVILLE AUST. LTD., Wellington-road, Clayton, 3168; D.A.1813/185; 5th August, 1972; 79 cwt.
- PHILLIPS & WALKER, 9 Dalmahoy-street, Bairnsdale, 3875; D.A.30943/5; 17th August, 1972; 11 cwt.
- REYNOLDS FROZEN FREIGHT TRANSPORT PTY. LTD., 96 Wilsons-road, Newcomb, 3219; D.A.61975; 29th July, 1972; 147 cwt.
- ROCHE BROS. PTY. LTD., 22 Dynon-road, South Kensington, 3031; D.A.1941/18; 6th August, 1972; 7 cwt.
- RUSSELL, D. H. (trading as Russell & McDonald), Mt. Napier-road, Hamilton, 3300; D.A.60586/1; 26th August, 1972; 80 cwt.
- SPILLER, H. H., 2 George-street, Swan Hill, 3585; D.A.61953/1; 19th August, 1972; 11 cwt.
- BLACKNEY, W. A. (trading as Western District Frozen Foods), Station-road, Marshall, 3221; D.A.61986; 29th July, 1972; 47 cwt.
- WHITER PLANT HIRE PTY. LTD., 104 Union-street, Windsor, 3181; D.A.40199; 1st August, 1972; 103 cwt.
- WILSON, B. J. (trading as Wilson & Sheridan); 22 McCann-crescent, Kerang, 3579; D.A.47105/1; 19th August, 1972; 6 cwt. & 6 cwt. Trlr.

TOW TRUCKS.

ARNOLD, G. H. C., Molan-street, Ringwood, 3134; D.A.39609/3; 10th August, 1972; 43 cwt.
SHOWERS, R. A. (trading as Showers & Lowe), Gavan-street, Bright, 3741; D.A.62108; 26th August, 1972; 43 cwt.

RENEWALS WITH VARIATION.

Applications made by the persons listed hereunder for renewal of the licences listed with variation of conditions in the manner set out opposite the names.

SEARLE, NOEL PTY. LTD., 222 Williamson-street, Bendigo, 3550; D.A.39317; 20th June, 1972; Application to renew and vary the conditions of licence No. D.A.39317 (L/C. 37 cwt.) by deleting "between the City of Melbourne and the City of Bendigo" from the existing conditions and adding in lieu "Within a 25-mile radius of the G.P.O., Melbourne".
SULLIVAN, J. E., 23 Etko-avenue, East Keilor, 3042; D.A.61960; 29th July, 1972; Application to vary the conditions of licence No. D.A.61960 (L/C. 14 cwt.) by deleting "Dural Leeds Pty. Ltd." from the existing conditions and adding in lieu "Creighton Blinds Pty. Ltd."

Notice of any objection should be forwarded to reach the Secretary of the Board not later than 5th April, 1972.

Applicants are advised that it will not be necessary to appear on the hearing date specified above, unless advised in writing by the Board.

B. P. KAY,
Secretary.

Corner of Lygon and Princes streets, Carlton, 3053,
Wednesday, 22nd March, 1972.

Forests Act 1958, (No. 6254).

VARIATION OF PROHIBITED PERIOD.

In pursuance of the powers conferred by section 3 of the Forests Act 1958, I, Edward Raymond Meagher, Her Majesty's Minister of Forests in the State of Victoria, hereby vary the declarations of a prohibited period previously made by me and published in the *Government Gazette* of 15th December, 1971, in so far as they refer to the Municipalities specified in the Schedule hereto, and by this notice declare that in these specified Municipalities the prohibited period in respect of any fire protected area (other than a State Forest or National Park) shall end at midnight between the 24th and 25th March, 1972.

SCHEDULE.

The Shires of Alexandra, Yea.

E. R. MEAGHER,
Minister of Forests.

Survey Co-ordination Act 1958.

NOTICE OF THE ALTERATION OF A NAME.

Pursuant to the powers conferred under section 29 of the above Act, the Place Names Committee hereby gives notice of the following alteration to the name of the streams mentioned hereunder:—

Municipality.—Shire of Grenville.

Location.—From the source of the stream, north-westerly of the Township of Haddon, to its confluence with the existing Woody Yaloak River west of allotment 28b, section G, Parish of Clarkesdale.

Old Names.—Smythes Creek and Woody Yaloak Creek.

New Name.—Woody Yaloak River.

By order of the Committee,

C. E. E. BARLOW,
Secretary.

Survey Co-ordination Act 1958.

NOTICE OF THE ALTERATION OF NAMES.

Pursuant to the powers conferred under section 29 of the above Act, the Place Names Committee hereby gives notice of the following alteration to the names of the streams mentioned hereunder:—

Municipalities.—Shires of Leigh and Grenville.

Location.—The streams forming part of the common boundary of the Shires of Grenville and Leigh.

Old Names.—Mt. Misery Creek, Misery Creek, McMillans Creek and Little Woody Yaloak Creek.

New Name.—Mt. Misery Creek.

By order of the Committee,

C. E. E. BARLOW,
Secretary.

COMPANIES ACT 1961.

Notice is hereby given in pursuance of section 308 (2) and 308 (3) of the Companies Act 1961 that at the expiration of three months from the date hereof the names of the following Companies will, unless cause is shown to the contrary, be struck off the Register and the said Companies will be dissolved.

Dated this 16th day of March, 1972.

P. COMAN,
Assistant Registrar of Companies.

Companies Office,
Melbourne.

COMPANIES ABOVE REFERRED TO.

Name of Company.	Number of Registration.
W. E. Loft's Park Garage Pty. Ltd.	13811
A. Glover and Sons Pty. Ltd.	15546
Britannia Cycle Company Pty. Ltd.	25760
Woolcot Weaving Mills Pty. Ltd.	30677
Upper Yarra Transport Pty. Ltd.	33180
H. D. A. Vinall Pty. Ltd.	34447
Northcote Motors Pty. Ltd.	39493
J. Rahaley (Victoria) Pty. Ltd.	41027
Motormasters Pty. Ltd.	44091
P. J. B. Nominees Pty. Ltd.	49342
F. Baylis Pty. Ltd.	49475
Balzary Holdings Pty. Ltd.	49742
Dunric Pty. Ltd.	50459
Home Freezer-Foods Pty. Ltd.	50649
Amana Food Products Pty. Ltd.	51096
Ansell Distributors (S.A.) Pty. Ltd.	53125
Nutex Export Corporation Pty. Ltd.	53126
Acardo Pty. Ltd.	53679
Phoenix Ventilation Co. (Vic.) Pty. Ltd.	58427
Evergreen Memorial Park Pty. Ltd.	58459
T. J. Power's Engineering Pty. Ltd.	59695
Austalent Pty. Ltd.	61916
Robinson Field Welding Service Pty. Ltd.	64654
Bronhill Finny Productions Pty. Ltd.	64827
Elros Trading Pty. Ltd.	65244
George Wishart Investments Pty. Ltd.	66003
M.B.A. (Credits) Pty. Ltd.	68595
J. G. Rouda & Associates Pty. Ltd.	69870
Wilton Constructions Pty. Ltd.	69921
Continental Plastics (A'Asia) Pty. Ltd.	71090
Namrec Pty. Ltd.	71251
Aeroplan Airtel Pty. Ltd.	71746
Atsfatamp Pty. Ltd.	73731
Diamond Valley Taxis Ltd.	75275
Freeman and O'Loughlin Pty. Ltd.	77050
Coldhaul Transport Pty. Ltd.	77868
Adee Sportswear Pty. Ltd.	86437
Leets Pty. Ltd.	87682

Farm Produce Merchants and Commission Agents
Act 1965 (No. 7274).

LIST OF NAMES AND ADDRESSES OF PERSONS TO WHOM LICENCES HAVE BEEN GRANTED DURING FEBRUARY, 1972.

In accordance with the above Act, those issued with a Merchant's or Commission Agent's licence have paid the prescribed fee to the Farm Produce Merchants and Commission Agents Guarantee Fund. All licences, unless earlier cancelled, shall continue in force until 30th June, 1972.

D. S. WISHART,
Director of Agriculture.

MERCHANT.

Name; Principal Place of Business.

Mark Wilson Fruit; Store 10, Melbourne Wholesale Fruit and Vegetable Market, Footscray-road, Footscray. 3011.

COMMISSION AGENTS.

*Brown, D. A. & R. C.; Wyelangta. 3237.

Cichello, F.; "Bunga", Princes Highway, Lakes Entrance. 3909.

Piccolo, D.; Stand 253, Melbourne Wholesale Fruit and Vegetable Market, Footscray-road, Footscray. 3011.

SECONDARY WHOLESALER.

Crewes, B. G.; 10 Bowen-street, Windsor. 3181.

*Exempt from contribution to Guarantee Fund under Regulation 9 (1).

Private Agents Act 1966.

NOTICE OF RECEIPT OF APPLICATIONS FOR LICENCES UNDER THE PROVISIONS OF THE PRIVATE AGENTS ACT 1966.

The Clerk(s) of the Magistrates' Court(s) as listed hereunder hereby give notice that applications, as under, have been lodged for hearing by the said Court(s) on the date(s) specified.

Any person desiring to object to any of such applications must—

- (a) lodge with the respective Clerk of the Magistrates' Court a notice in the prescribed form of his objection and of the grounds thereof;
- (b) cause a copy of such notice to be served personally or by post upon the applicant at least three days before the hearing of the application; and
- (c) send or deliver—
 - (i) where the objection is not made by the officer in charge of the police district in which the Court is situated—a copy of the notice to such officer; and
 - (ii) where the objection is not made by the Registrar or Deputy Registrar—a copy to the Registrar.

Full Name of Applicant or in the Case of a Firm or Corporation, of the Nominee.	Place of Abode of Applicant or Nominee.	Name of Firm or Corporation.	Address for Registration.	Type of Licence.	Date of Hearing of Application.
MAGISTRATES' COURT, PORT MELBOURNE.					
MacLean, Ian Russell ..	189 Furlong-road, St. Albans	Mayne Nickless Limited	538 Williamstown-road, Port Melbourne	Watchman ..	30.3.72
Firmin, Alfred William ..	14 Westleigh-crescent, Narre Warren	" " "	" " "	" ..	"
Shiers, Charles Hood ..	21 Bognor-avenue, Seaford	" " "	" " "	" ..	6.4.72
McRae, Douglas William ..	Sergeants Mess, R.A.A.F. Laverton	" " "	" " "	" ..	"
Flye, Robert David ..	27 Beluga-street, Mt. Eliza	" " "	" " "	" ..	"

Dated at Port Melbourne this 9th day of March, 1972.

J. A. GIDLEY, Clerk of the Magistrates' Court.

MAGISTRATES' COURT, MELBOURNE.					
Robb, Thomas James ..	27 Hayman-avenue, Seaford	Australian Watching Company Pty. Ltd.	340 Abbotsford-street, North Melbourne	Process Server ..	29.3.72
" " " ..	" " "	" " "	" " "	Guard Agent ..	"

Dated at Melbourne this 8th Day of March, 1972.

G. L. WEBSTER, Clerk of the Magistrates' Court.

MAGISTRATES' COURT, MELBOURNE.					
Dudfield, Robin Clifford ..	3 Dangerfield-drive, Springvale	Australian Watching Company Pty. Ltd.	340 Abbotsford-street, North Melbourne	Watchman ..	29.3.72

Dated at Melbourne this 7th day of March, 1972.

G. L. WEBSTER, Clerk of the Magistrates' Court.

MAGISTRATES' COURT, MELBOURNE.					
Adam, Raymond Charles ..	Flat 3, 61 McPherson-street, Moonee Ponds	Australian Watching Company Pty. Ltd.	340 Abbotsford-street, North Melbourne	Watchman ..	29.3.72
Blom, Roger Lenard ..	Flat 2, 53 Lansdowne-road, East St. Kilda	" " "	" " "	" ..	"
Johnson, Brain Hurlston ..	89 Union-road, Surrey Hills	" " "	" " "	" ..	"
Jordon, Frederick Mark ..	41 Paget-avenue, Glenroy	" " "	" " "	" ..	"

Dated at Melbourne this 8th day of March, 1972.

G. L. WEBSTER, Clerk of the Magistrates' Court.

MAGISTRATES' COURT, MELBOURNE.					
Chapman, William Henry ..	56 Bellarine-drive, Lalor	Australian Watching Company Pty. Ltd.	340 Abbotsford-street, North Melbourne	Watchman ..	29.3.72
O'Loughlin, Lawrence Alphonse ..	19 Pine-avenue, Greensborough	" " "	" " "	" ..	"
Reeves, Raymond ..	13 Glenmer-street, Moorabbin	" " "	" " "	" ..	"

Dated at Melbourne this 8th day of March, 1972.

G. L. WEBSTER, Clerk of the Magistrates' Court.

MAGISTRATES' COURT, FERN TREE GULLY.					
Glen, Alan Heriot ..	Lawrence-court, The Patch	" " "	Lawrence-court, The Patch	Process Server ..	5.4.72

Dated at Fern tree Gully this 10th day of March, 1972.

F. J. DUTHIE, Clerk of the Magistrates' Court.

MAGISTRATES' COURT, SALE.					
Johnson, Geoffrey John ..	Thompson River Caravan Park, Sale	" " "	34 Hoddle-street, Sale	Watchman ..	11.4.72

Dated at Sale this 8th day of March, 1972.

D. R. WALKER, Clerk of the Magistrates' Court.

PRIVATE AGENTS—continued.

Full Name of Applicant or in the Case of a Firm or Corporation of the Nominee.	Place of Abode of Applicant or Nominee.	Name of Firm or Corporation.	Address for Registration.	Type of Licence.	Date of Hearing of Application.
MAGISTRATES' COURT, GEELONG.					
Robertson, Sydney Maxwell ..	79 Plume-street, Norlane	Geelong Armed and Security Service Company Pty.Ltd.	55 The Esplanade, North Shore	Watchman ..	29.3.72
Bodger, Robin Edward ..	44 Donnybrook-road, Norlane	" " "	" " "	Inquiry Agent ..	"
Dated at Geelong this 10th day of March, 1972.					
G. J. THOMPSON, Clerk of the Magistrates' Court.					
MAGISTRATES' COURT, BROADMEADOWS.					
Clarke, Anthony ..	8 King-street, Glenroy	Patrick Clarke	Greenvale - road, Oaklands Junction	Watchman ..	12.4.72
Dated at Broadmeadows this 14th day of March, 1972.					
P. J. LIVINGSTONE, Clerk of the Magistrates' Court.					
MAGISTRATES' COURT, MELBOURNE.					
McAdam, Peter Francis ..	5 Wellesley-street, Mont Albert	Mayne Nickless Limited	94 York-street, South Melbourne	Watchman ..	5.4.72
Dated at Melbourne this 14th day of March, 1972.					
G. L. WEBSTER, Clerk of the Magistrates' Court.					
MAGISTRATES' COURT, MELBOURNE.					
Johnson, Frank ..	115 Mascoma-street, Strathmore	Australian Watching Company Pty. Ltd.	340 Abbotsford-street, North Melbourne	Watchman ..	5.4.72
Dated at Melbourne this 14th day of March, 1972.					
G. L. WEBSTER, Clerk of the Magistrates' Court.					
MAGISTRATES' COURT, MORWELL.					
Bermingham, James Francis ..	377 Princes Highway, Morwell	Mayne Nickless Limited	94 York-street, South Melbourne	Watchman ..	7.4.72
Dated at Morwell this 15th day of March, 1972.					
D. M. CRANE, Clerk of the Magistrates' Court.					
MAGISTRATES' COURT, GEELONG.					
Walters, Bruce Paul ..	121 Fyans-street, Newtown	S.I.A. Mercantile Group Pty. Ltd.	121 Fyans-street, Newtown	Commercial Sub-Agent	7.4.72
Walters, Bruce Paul ..	" "	" "	" "	Watchman ..	"
Walters, Bruce Paul ..	" "	" "	" "	Inquiry Agent ..	"
Walters, Bruce Paul ..	" "	" "	" "	Process Server ..	"
Davis, Malcolm Walter ..	29 Swallow-crescent, Norlane	Geelong and Western District Investigations	29 Swallow-crescent, Norlane	Commercial Sub-Agent	"
Dated at Geelong this 15th day of March, 1972.					
J. E. REILLY, Clerk of the Magistrates' Court.					
MAGISTRATES' COURT, OAKLEIGH.					
Delahenty, Margaret Trevena ..	8 Hunter-street, Glen Waverley	" " "	8 Hunter-street, Glen Waverley	Inquiry Agent ..	7.4.72
Dated at Oakleigh this 16th day of March, 1972.					
J. A. BARNES, Clerk of the Magistrates' Court.					
MAGISTRATES' COURT, OAKLEIGH.					
Leitch, Dennis James ..	374 Springvale-road, Forest Hill	" " "	6 Hamilton-place, Mt. Waverley	Watchman ..	7.4.72
Dated at Oakleigh this 15th day of March, 1972.					
J. A. BARNES, Clerk of the Magistrates' Court.					

Cattle Compensation Act 1967 (No. 7615).

APPROVED AGENT.

NOTICE UNDER SECTION 14.

No. C.S. 39.

I hereby revoke the declaration made and published in the *Government Gazette*, No. 104, of 11th December, 1968, of Portland Wool Brokers Limited, as an "approved agent", for the purposes of Part II. of the *Cattle Compensation Act 1967*, with effect from 1st February, 1972.

Pursuant to the provisions of Regulation 81 of the Stamps Regulations 1960, I hereby state that the aforesaid revocation is being made at the request of the said Portland Wool Brokers Limited.

R. M. PHIBBS,
Comptroller of Stamps.

Stamp Duties Office,
Melbourne, 22nd March, 1972.

Cattle Compensation Act 1967 (No. 7615).

APPROVED AGENT.

NOTICE UNDER SECTION 14.

No. C.S. 36.

I hereby revoke the declaration made and published in the *Government Gazette*, No. 104, of 11th December, 1968, of Younghusband Limited as an "approved agent", for the purposes of Part II. of the *Cattle Compensation Act 1967*, with effect from 3rd March, 1972.

Pursuant to the provisions of Regulation 81 of the Stamps Regulations 1960, I hereby state that the aforesaid revocation is being made at the request of the said Younghusband Limited.

R. M. PHIBBS,
Comptroller of Stamps.

Stamp Duties Office,
Melbourne, 22nd March, 1972.

Swine Compensation Act 1967 (No. 7614).

APPROVED AGENT.

NOTICE UNDER SECTION 14.

No. C.S. 36.

I hereby revoke the declaration made and published in the *Government Gazette*, No. 104, of 11th December, 1968, of Younghusband Limited as an "approved agent", for the purposes of Part II. of the *Swine Compensation Act 1967*, with effect from 3rd March, 1972.

Pursuant to the provisions of Regulation 81 of the Stamps Regulations 1960, I hereby state that the aforesaid revocation is being made at the request of the said Younghusband Limited.

R. M. PHIBBS,
Comptroller of Stamps.

Stamp Duties Office,
Melbourne, 22nd March, 1972.

Swine Compensation Act 1967 (No. 7614).

APPROVED AGENT.

NOTICE UNDER SECTION 14.

No. C.S. 39.

I hereby revoke the declaration made and published in the *Government Gazette*, No. 104, of 11th December, 1968, of Portland Wool Brokers Limited, as an "approved agent", for the purposes of Part II. of the *Swine Compensation Act 1967*, with effect from 1st February, 1972.

Pursuant to the provisions of Regulation 81 of the Stamps Regulations 1960, I hereby state that the aforesaid revocation is being made at the request of the said Portland Wool Brokers Limited.

R. M. PHIBBS,
Comptroller of Stamps.

Stamp Duties Office,
Melbourne, 22nd March, 1972.

Health Act 1958.

VICTORIA—DEPARTMENT OF HEALTH.

NOTICE TO ATTEND FOR RADIOLOGICAL EXAMINATION.

To all persons aged twenty-one years and over enrolled or resident in the subdivisions specified hereunder in the State Electoral District of Oakleigh.

Take notice that you are required to attend at a Department of Health X-ray Unit sited in the public street at or as near as possible to the main entrance to the premises specified in this notice, at any time between the hours specified on one of the days specified and during the period specified in respect of those premises, and thereat to submit yourself to radiological examination of the chest for the purpose of ascertaining whether you may be suffering from pulmonary tuberculosis. If you have had a Chest X-ray within the last twelve months and for this reason do not wish to be examined now, you should attend the unit as directed and submit particulars of the previous examination.

SPECIFIED SUBDIVISION, PREMISES, PERIODS, DAYS AND HOURS.

Subdivision.	Premises.	Period.	Days.	Hours.
Clayton West	Car Park, cnr. Haughton and Clayton-roads, Clayton	Thursday, 6th April, 1972, to Monday, 17th April, 1972 (inclusive)	Each day during the period except Saturdays, Sundays and Public Holidays	From 10 a.m. to 8.30 p.m.
	Presbyterian Church, cnr. Shandean-avenue and Clayton-road, Clayton	Thursday, 6th April, 1972, to Tuesday, 11th April, 1972 (inclusive)	Each day during the period except Saturday, Sunday and Public Holidays	From 10 a.m. to 8.30 p.m.
	Kydas' Milk Bar, 36 Scotsburn-avenue, Clayton	Friday, 7th April, 1972, to Tuesday, 11th April, 1972 (inclusive)	Each day during the period except Saturday, Sunday and Public Holidays	From 10 a.m. to 8.30 p.m.
Oakleigh East	Golden Fleece Service Station, cnr. Dandenong-road and Surrey-crescent, Oakleigh	Wednesday, 12th April, 1972, to Monday, 17th April, 1972 (inclusive)	Each day during the period except Saturday, Sunday and Public Holidays	From 10 a.m. to 8.30 p.m.
	A. W. Wright's Pharmacy, 282A Huntingdale-road, Huntingdale	Wednesday, 12th April, 1972, to Wednesday, 19th April, 1972 (inclusive)	Each day during the period except Saturday, Sunday and Public Holidays	From 10 a.m. to 8.30 p.m.
Oakleigh	Council Chambers, Atherton road, Oakleigh	Tuesday, 18th April, 1972, to Thursday, 27th April, 1972 (inclusive)	Each day during the period except Saturday, Sunday and Public Holidays	From 10 a.m. to 8.30 p.m.
	Collinson's Fuel and Produce Store, 115 Poath-road, Murrumbena	Monday, 1st May, 1972, to Monday, 8th May, 1972 (inclusive)	Each day during the period except Saturday, Sunday and Public Holidays	From 10 a.m. to 8.30 p.m.
Oakleigh North	Liamprinas' Milk Bar, 51 Atkinson-parade, Oakleigh	Thursday, 20th April, 1972, and Friday, 21st April, 1972	Thursday, 20th April, 1972 Friday, 21st April, 1972	From 10 a.m. to 8.30 p.m. From 10 a.m. to 8.30 p.m.
	Eastern Taxi Service, cnr. Dandenong-road and Atkinson parade, Oakleigh	Monday, 24th April, 1972, and Wednesday, 26th April, 1972	Monday, 24th April, 1972 Wednesday, 26th April, 1972	From 10 a.m. to 8.30 p.m. From 10 a.m. to 8.30 p.m.
Oakleigh South	Play Ground, cnr. Pitt-street and Golf-road, Oakleigh South	Thursday, 27th April, 1972, and Friday, 28th April, 1972	Thursday, 27th April, 1972 Friday, 28th April, 1972	From 10 a.m. to 8.30 p.m. From 10 a.m. to 8.30 p.m.
	Northleigh Service Station, 94 North-road, Oakleigh	Friday, 28th April, 1972 to Thursday, 4th May, 1972 (inclusive)	Each day during the period except Saturday, Sunday and Public Holidays	From 10 a.m. to 8.30 p.m.
Murrumbena	Perry's Pharmacy, 448 Neerim-road, Murrumbena	Friday, 28th April, 1972, to Monday, 8th May, 1972 (inclusive)	Each day during the period except Saturdays, Sundays and Public Holidays	From 10 a.m. to 8.30 p.m.
	St. Patrick's School, Dalny-road, Murrumbena	Friday, 5th May, 1972, to Wednesday, 10th May, 1972 (inclusive)	Each day during the period except Saturday, Sunday and Public Holidays	From 10 a.m. to 8.30 p.m.

NOTE.—Any person to whom this notice applies and who without reasonable excuse fails to comply with the requirements of the notice shall be guilty of an offence, and shall be liable to a penalty of not more than forty dollars.

Dated this tenth day of February, One thousand nine hundred and seventy-two.

W. J. STEVENSON, Chief Health Officer.

Melbourne and Metropolitan

BOARD OF WORKS.

GENERAL NOTICE.

The Melbourne and Metropolitan Board of Works having made provision for carrying off the sewage of each and every property which or any part of which is situate in the Sewerage Areas hereinafter described doth hereby declare that on and after the 22nd day of April, 1972, each and every property so situate shall be deemed to be a sewerer property within the meaning of the *Melbourne and Metropolitan Board of Works Act 1958*.

The Sewerage Areas hereinbefore referred to are:—

Sewerage Area No. 2461.

Cities of Ringwood and Croydon.—Commencing at the junction of Oban-road and Maroondah Highway on the boundary of Sewerage Area No. 2210; thence south-westerly and north-westerly following the said area boundary to Mullum Mullum Creek, generally north-easterly along the said creek, south-easterly by a line to and along the north-eastern boundary of lot 16 Marcus-road, north-easterly along Marcus-road, south-easterly along Kallay-street, south-westerly along Maroondah Highway to the commencing point.

Sewerage Area No. 2462.

City of Sunshine.—Commencing at the junction of Oxford-street and Cumberland-street; thence southerly along Cumberland-street, westerly along Sussex-street, northerly along the western boundaries of lots 1 Sussex-street, 4 and 28 Middlesex-street and 23 Oxford-street, easterly along Oxford-street to the commencing point.

Sewerage Area No. 2463.

City of Ringwood.—Commencing at the junction of Hugh-street and Oban-road; thence easterly along Oban-road, southerly along the eastern boundaries of lots 2 Oban-road and 20 to 22 Jeffrey-drive, further southerly and south-westerly along the eastern and south-eastern boundaries of a reserve, southerly along the eastern boundary of lot 24 Jeffrey-drive, north-westerly along the south-western boundaries of lots 24 and 25 Jeffrey-drive, south-westerly along portion of the south-eastern boundary of lot 31 Rollington-drive, north-westerly along Rollington-drive, north-easterly along the north-western boundary of lot 34 Rollington-drive, north-westerly along portion of the south-western boundary of lot 12 Hugh-street, north-easterly and northerly along Hugh-street to the commencing point.

Sewerage Area No. 2464.

City of Ringwood.—Commencing at a point in Jeffrey-drive about 500 feet south-east of the south-eastern boundary of Mullum Mullum-road; thence south-easterly along Jeffrey-drive, south-westerly along the south-eastern boundary of lot 33 Jeffrey-drive, north-westerly along the south-western boundaries of lots 33 to 28 Jeffrey-drive, north-easterly along the north-western boundary of the said lot 28 to the commencing point.

Sewerage Area No. 2465.

City of Keilor.—Commencing at the junction of Esplanade East and Taylors-road; thence easterly along Taylors-road, southerly along the eastern boundary of lot 14 Taylors-road, easterly along portion of the northern boundary of lot 43 Graceburn-grove, southerly along the eastern boundary of the said lot 43, easterly along Graceburn-grove, northerly along Charles-street, easterly along the northern boundaries of lots 50 to 48 Taylors-road, southerly along the eastern boundary of the said lot 48, easterly along Helen-street, southerly along Theodore-street, westerly along the southern boundary of lot 24 Theodore-street, south-westerly along portion of the south-eastern boundary of lot 14 Peter-court, westerly along the southern boundary of the said lot 14, southerly along Peter-court, easterly along George-street, southerly along Theodore-street, easterly along the northern boundaries of lots 4 Theodore-street and 8 Conrad-street, northerly along the western boundary of lot 33 Fox-street, easterly along Fox-street, southerly along Alfreda-street, westerly along Henry-street, northerly along the western boundary of lot 7 Henry-street, westerly along the southern boundary of lot 13 Conrad-street, southerly along portion of the eastern boundary of lot 3 Theodore-street, westerly along the southern boundary of the said lot 3, southerly along Theodore-street, easterly along William-street, southerly along Alfreda-street to the boundary of Sewerage Area No. 2258 in Biggs-street, westerly, generally northerly, westerly and southerly following the said area boundary to the junction of Charles-street and Esplanade East, north-westerly along Esplanade East to the commencing point.

Sewerage Area No. 2466.

City of Coburg.—Commencing at a point in Newlands-road about 650 feet south of the municipal boundary of the City of Coburg; thence easterly along the northern boundary of lot 3 Newlands-road, south-westerly along the south-eastern boundary of the said lot 3 to the northern boundary of lot 2 Newlands-road, easterly, generally southerly, westerly and generally north-westerly along the boundaries of the said lot 2 to Newlands-road, northerly along Newlands-road to the commencing point.

Sewerage Area No. 2467.

City of Springvale.—Commencing at a point in Boundary-road 170 feet north of the northern boundary of Citrus-street; thence easterly along the northern boundaries of lots 1 Boundary-road and 19 to 21 Citrus-street, south-easterly along the north-eastern boundaries of the said lot 21 and lots 22 to 25 Hall-street, southerly along the eastern boundaries of lots 26 to 29 Hall-street, westerly along portion of the southern boundary of the said lot 29, southerly along the eastern boundary of lot 3 Mills-road, westerly along Mills-road, northerly along the western boundary of lot 2 Mills-road, westerly along the southern boundaries of lots 11 Hall-street and 10 Boundary-road, northerly along Boundary-road to the commencing point.

Sewerage Area No. 2468.

City of Ringwood.—Commencing at a point in Possum-lane about 485 feet east of the eastern boundary of Barnic-road; thence northerly along the western boundary of lot 3 Possum-lane, south-easterly along the north-eastern boundary of the said lot 3, north-easterly and easterly along the north-western and northern boundaries of lot 4 Possum-lane, southerly along the eastern boundaries of lots 4 and 7 Possum-lane and 8 Barrow-drive and a line in continuation to Dandenong Creek, generally westerly along the said creek, northerly along the western boundaries of a reserve, lots 15 and 10 Barrow-drive and 5 Possum-lane to the commencing point.

Sewerage Area No. 2469.

City of Oakleigh.—Commencing at the junction of Hillcrest-avenue and Huntingdale-road; thence southerly along Huntingdale-road, north-westerly along the south-western boundaries of lots 1 to 4 and 32 to 41 Oakpark-drive, westerly along the southern boundaries of lots 42 to 56 Oakpark-drive, northerly along the western boundaries of lots 56 and 3 Oakpark-drive, 28 and 27 Kalyrna-grove and 92 Hillcrest-avenue, easterly along Hillcrest-avenue to the commencing point.

Sewerage Area No. 2470.

City of Nunawading.—Commencing at the junction of Rickson-place and McClares-road; thence northerly along McClares-road, easterly along the northern boundaries of lots 1 McClares-road and 2 to 5 Rickson-place, southerly along the eastern boundaries of the said lot 5, a reserve and lot 6 Rickson-place, westerly along portion of the southern boundary of the said lot 6, southerly along the eastern boundary of lot 14 Sarah-court, westerly along Sarah-court, northerly along McClares-road to the commencing point.

By order of the Board,

W. C. S. ELLIS,
Secretary.

425 Collins-street, Melbourne, 3001, 21st March, 1972.

STATE RIVERS AND WATER SUPPLY COMMISSION.
BY-LAW No. 5666 AMENDING BY-LAW No. 5602 FOR PROTECTING WATERWORKS AND ALL LANDS UNDER THE CONTROL OR MANAGEMENT OF THE STATE RIVERS AND WATER SUPPLY COMMISSION AGAINST INTERFERENCE AND DAMAGE AND FOR MAINTAINING GOOD CONDUCT BY MEMBERS OF THE PUBLIC.

The State Rivers and Water Supply Commission (hereinafter called "the Commission") makes the following By-law pursuant to the provisions of the *Water Act 1958* and all other powers enabling it to make the By-law:

1. By-law No. 5602 made by the Commission on 18th August, 1969, is hereby amended by the inclusion of the following sub-clause:—

Clause 2 (6) "No person shall enter onto any Commission property where a notice or sign indicates that such entry is prohibited."

The foregoing By-law was made by the State Rivers and Water Supply Commission on the 28th February, 1972, and the common seal of the said Commission was hereunto affixed, on the 9th day of March, 1972, in the presence of—

(SEAL) A. L. TISDALL, Commissioner.
R. A. HORSFALL, Commissioner.

Approved by the Governor in Council, 15th March, 1972.
—J. ROSSITER, Clerk of the Executive Council.

STATE RIVERS AND WATER SUPPLY COMMISSION.

LICENCES TO DIVERT WATER AND CUT RACES PURSUANT TO THE PROVISIONS OF SECTION 204 OF THE WATER ACT 1958. (AS AMENDED).

The Governor in Council has approved of the granting by the State Rivers and Water Supply Commission of licences as detailed hereunder for the term of years from the date specified in each case to the persons named in the following Schedule :—

SCHEDULE.

Licence No.	Term of Licence and Commencing Date.	Name and Address of Person to whom Licence is to be granted.	Source of Supply.	Area Authorized to be Irrigated Per Annum.	Volume of Water Authorized to be Diverted Per Annum.	Annual Fee.
				acres.	ac. ft.	\$
607	Fifteen years from 1.7.71 ..	Oliver Hume and Co. Pty. Ltd., Melbourne	River Murray ..	150	300	375.00
617	Fifteen years from 1.7.70 ..	John Stamopoulos, Merbein ..	River Murray (Cowanna Bil- labong)	28	84	105.00
626	Fifteen years from 1.7.71 ..	Lloyd Bruce Donaldson, Nagambie	River Murray ..	28	84	105.00
627	Fifteen years from 1.7.71 ..	Henry Joseph Zoch and Elwyn Violet Zoch, Mildura West	River Murray ..	110	330	412.50
1386	Fifteen years from 1.7.71 ..	Raniero De Gregorio and Gennaro De Gregorio, Wood Wood	River Murray ..	46	138	172.50
1877	Nine years from 1.7.70 ..	Donald Alan Crosthwaite, Wodonga	Kiewa River ..	25	50	15.50
2065/962	Fifteen years from 1.7.71 ..	Elizabeth Caroline June Stephenson, Bridgewater	Loddon River ..	10	20	25.00
3191	Four years from 1.7.71 ..	Edward Raymond Porter and Sons, King Valley	King River ..	40	60	75.00
3198	Four years from 1.7.71 ..	The Estate of the late Henry George Porter, King Valley	King River ..	20	30	37.50
3248	Four years from 1.7.71 ..	Michele Liprino, Whitfield ..	King River ..	25	37½	46.87
3249	Four years from 1.7.71 ..	Rino Fontana, Danilo Fontana and Ernest Fontana, North Melbourne	King River ..	90	135	168.75
3257	Four years from 1.7.71 ..	Alan John Newton and Maria Therese Newton, Edi Upper	King River ..	25	37½	46.87
3260	Fifteen years from 1.7.71 ..	Keith Petersen, Cheshunt ..	King River ..	10	15	18.75
3262	Fifteen years from 1.7.71 ..	Mario Antonello, King Valley ..	King River ..	35	52½	65.62
3270	Four years from 1.7.71 ..	Pietro Martinelli, Cheshunt ..	King River ..	40	60	75.00
3271	Fours years from 1.7.71 ..	Francis Donald Burrowes, Wanga- ratta	King River ..	50	75	93.75
3273	Four years from 1.7.71 ..	Emmeline Reynolds, Edi ..	King River ..	50	75	93.75
3274	Fifteen years from 1.7.71 ..	James Bennett Newton, Whitfield ..	King River ..	7	10½	15.00
3275	Four years from 1.7.71 ..	Estate of the late Giovanni Liprino, Whitfield	King River ..	25	37½	46.87
3276	Four years from 1.7.71 ..	R. D. and M. J. Hancock and Co. Pty. Ltd., Robinvale	River Murray ..	83½	250	312.50

Office of the State Rivers and Water Supply Commission,
Melbourne, 15th March, 1972.G. W. LEWIS, Secretary,
State Rivers and Water Supply Commission.

STATE RIVERS AND WATER SUPPLY COMMISSION.

LICENCES TO DIVERT WATER PURSUANT TO THE PROVISIONS OF SECTION 204 OF THE WATER ACT 1958. (AS AMENDED).

The Governor in Council has approved of the granting by the State Rivers and Water Supply Commission of licences as detailed hereunder for the term of years from the date specified in each case to the persons named in the following Schedule :—

SCHEDULE.

Licence No.	Term of Licence and Commencing Date.	Name and Address of Person to whom Licence is to be granted.	Source of Supply.	Area Authorized to be Irrigated Per Annum.	Volume of Water Authorized to be Diverted Per Annum.	Annual Fee.
				acres.	ac. ft.	\$
1001	Fifteen years from 1.7.71 ..	Charles Ernest Cornwall, Laane- coorie	Loddon River ..	6	12	15.00
2298	Fifteen years from 1.7.71 ..	Willow Lea Pastoral Company, Gooramadda	River Murray (Ana-Branch)	50	100	125.00
3195	Four years from 1.7.71 ..	Alexander Grenville Simpson, Docker.	King River ..	16	24	30.00
3247	Four years from 1.7.71 ..	Norman Brett Vincent, Oxley ..	King River ..	20	30	37.50
3256	Fifteen years from 1.7.71 ..	Milford Co-operative Dairy Co. Ltd., Wangaratta	King River	4,500,000	20.00
3258	Four years from 1.7.71 ..	Alan John Newton (Jnr.), Edi Upper	King River ..	50	75	93.75

Office of the State Rivers and Water Supply Commission,
Melbourne, 15th March, 1972.G. W. LEWIS, Secretary,
State Rivers and Water Supply Commission.

Police Regulation Act 1958, Section 122.

SALE OF UNCLAIMED MOTOR VEHICLE.

An owner is required for a 1961 model pink and white Ford Falcon sedan motor car, ex-registered No. Vic. HKT-297, engine No. ZSH25656M.

The vehicle came into the possession of Police on the 9th April, 1971, and if not claimed, will be sold by public auction at the Fitzroy Police Station, 13 Condell-street, Fitzroy, at 2 p.m., on the 17th April, 1972.

R. JACKSON,
Chief Commissioner of Police.

LOCAL GOVERNMENT DEPARTMENT.

ORDER CONFIRMED.—SHIRE OF RODNEY.

The Minister of the Crown administering the *Local Government Act 1958*, on the seventeenth day of March, 1972, confirmed the Order hereinafter referred to in pursuance of section 514 of the Act namely:

An Order of the Council of the Shire of Rodney made on 28th February, 1972 directing the compulsory taking of Lot 4, Section M, on Plan of Subdivision No. 276 lodged at the Office of Titles for the realignment of Northgate-street, Mooroopna.

A. J. HUNT,
Minister for Local Government.

Local Government Department,
Melbourne. (3151311).

Country Fire Authority Act 1958.

VARIATION OF FIRE DANGER PERIOD IN RESPECT OF SPECIFIED PARTS OF THE COUNTRY AREAS OF VICTORIA.

Whereas by section 4 of the *Country Fire Authority Act 1958* it is enacted that the Chief Secretary of Victoria, after consultation with the Minister of Forests, may from time to time by declaration published in the *Government Gazette* declare any period to be the fire danger period in respect of the country area of Victoria, or any specified part or parts thereof and, without affecting the generality of the foregoing, may declare different periods to be the fire danger period in respect of different parts of the said country area:

And whereas by the said section it is further enacted that any declaration so published may be revoked, amended or varied by a subsequent declaration so published:

And whereas by declaration issued on the date stated in Schedule A annexed hereto, different fire danger periods expiring on the thirtieth day of April, 1972, were declared in respect of different parts of the country area of Victoria, situated within the municipal districts or parts of municipal districts specified in Schedule B hereunder:

And whereas the Chief Secretary and the Minister of Forests have consulted accordingly:

Now therefore I, the Chief Secretary of Victoria, do by this my declaration vary the aforesaid declaration by declaring that the fire danger period in respect of the parts of the country area of Victoria situated within the municipal districts or parts of municipal districts specified in Schedule B hereunder shall end at midnight on the 22nd March, 1972.

SCHEDULE A.

Date of Declaration; Date of Publication in Government Gazette.

31st December, 1971; 22nd December, 1971.

SCHEDULE B.

Town of Portland.
Shire of Portland.

R. J. HAMER,
Chief Secretary.

Chief Secretary's Office,
Melbourne, 21st March, 1972.

Country Fire Authority Act 1958.

VARIATION OF FIRE DANGER PERIOD IN RESPECT OF SPECIFIED PARTS OF THE COUNTRY AREAS OF VICTORIA.

Whereas by section 4 of the *Country Fire Authority Act 1958* it is enacted that the Chief Secretary of Victoria, after consultation with the Minister of Forests, may from time to time by declaration published in the *Government Gazette* declare any period to be the fire danger period in respect of the country area of Victoria, or any specified part or parts thereof and, without affecting the generality of the foregoing, may declare different periods to be the fire danger period in respect of different parts of the said country area:

And whereas by the said section it is further enacted that any declaration so published may be revoked, amended or varied by a subsequent declaration so published:

And whereas by declaration issued on the date stated in Schedule A annexed hereto, different fire danger periods expiring on the thirtieth day of April, 1972, were declared in respect of different parts of the country area of Victoria, situated within the municipal districts or parts of municipal districts specified in Schedule B hereunder:

And whereas the Chief Secretary and the Minister of Forests have consulted accordingly:

Now therefore I, the Chief Secretary of Victoria, do by this my declaration vary the aforesaid declaration by declaring that the fire danger period in respect of the parts of the country area of Victoria situated within the municipal districts or parts of municipal districts specified in Schedule B hereunder shall end at midnight on the 24th March, 1972.

SCHEDULE A.

Date of Declaration; Date of Publication in Government Gazette.

20th December, 1971; 15th December, 1971.
19th December, 1971; 15th December, 1971.

SCHEDULE B.

Shires of Beechworth, Myrtleford, Towong and Yea.

R. J. HAMER,
Chief Secretary.

Chief Secretary's Office,
Melbourne, 21st March, 1972.

DEPARTMENT OF MINES.

APPLICATION FOR MINING LEASE DECLARED ABANDONED.

8924, Mineral; Walwa Mining Company; 37a. 0r. 1p., Parish of Walwa.

MINING LEASES EXPIRED.

8560, Mineral; Altarama Minerals, 6a. 3r. 27p., Parish of Murrindal East.
8568, Mineral; Martin Stoneware Pipe Proprietary Limited; 29a. 1r. 36p., Parish of Ballarat.
8587, Mineral; Percival Alfred Mowat; 27a. 1r. 0p., Parish of Holey Plains.

EXPLORATION LICENCE GRANTED.

374, Exploration Licence; Canadian Tin Recovery Pty. Ltd.; 423 square miles, County of Benambra.

EXPLORATION LICENCE CANCELLED.

292, Exploration Licence; Henry Silberberg, Albert Francis Emphield; 49 square miles, County of Croajingolong.

EXPLORATION LICENCE EXPIRED.

92, Exploration Licence; Gippsland Minerals No Liability; 166 square miles, Counties of Croajingolong, Tambo.

TAILINGS LICENCES EXPIRED.

3612, Tailings Licence; State Rivers & Water Supply Commission; to remove tailings from the "Belltopper Hill" mine dump, Parish of Drummond.
3686, Tailings Licence; Stawell Brick Company Pty. Ltd.; to remove tailings from the tailings dump at the Kempston Mine Site, Parish of Illawarra.
3690, Tailings Licence; Albert William Trotter; to remove tailings from the old "Waterloo Dump" at Steiglitz, Parish of Durdidwarrah.
3695, Tailings Licence; Thomas William Needs; to remove tailings from Russell's No. 1 and Russell's No. 2 dumps at Lawriston, Parishes of Lawriston and Burke.
3698, Tailings Licence; West Moorabool Water Board; to remove 6,000 cubic yards from the "Mt. Egerton" and the "Sister Rose" dumps, Parish of Bungal.
3732, Tailings Licence; Bendigo Pottery Pty. Ltd.; to remove tailings from a deposit of slum situated at Collins-street, Golden Square.
3734, Tailings Licence; Leslie David Deas; to remove tailings from "Mona" tailings dump, Parish of Chiltern West.

- 3735, Tailings Licence; Alan Heywood Sutherland; to remove tailings from the Government-road between allotments 19b and 19c, Parish of Toora.
- 3736, Tailings Licence; Kelvin D. Donaldson; to remove tailings from the "South New Moon" shaft situated at Growlers-street, Eaglehawk.
- 3739, Tailings Licence; Brian Williams; to remove sand tailings from the "North Ajax" mine dump at Daylesford.
- 3741, Tailings Licence; F. K. Pierce; to remove tailings from the "Southern Consols" mine dump situated at Rutherglen.
- 3756, Tailings Licence; Malcolm John McClure; to remove tailings from the tailings dump known as "Ajax Shaft", situated at South Castlemaine.

EXTRACTIVE INDUSTRY LICENCES GRANTED.

- 159, Extractive Industry Licence; Lake Boga Quarries Pty. Limited; 31 acres more or less, Parish of Kunat Kunat.
- 219, Extractive Industry Licence; Bessie Wright, Frances Mary Keenan, Arthur Harold Wright; 10a. 0r. 2p., Parish of Mordialloc.
- 323, Extractive Industry Licence; Robert William Symons; 18a. 0r. 32p., Parish of Holey Plains.

G. O. REID,
Acting Minister of Mines.

MINING LEASES DECLARED VOID.

- 8217, Mineral; Anthony Malcolm Campbell Brown, Roger James Brown; 96a. 0r. 25p., Parish of Walwa.
- 8226, Mineral; Roland Walton; 101a. 0r. 0p., Parish of Burrowye.
- 8227, Mineral; Roland Walton; 134a. 3r. 0p., Parish of Burrowye.
- 8228, Mineral; Roland Walton; 67a. 3r. 30p., Parish of Burrowye.
- 8402, Mineral; Roland Walton; 624a. 2r. 24p., Parish of Boorgunyah.
- 8417, Mineral; Roland Walton; 598a. 2r. 20p., Parish of Boorgunyah.
- 8608, Mineral; Abraham David Hargreaves; 43a. 3r. 12p., Parish of Kerrit Bareet.

E. CONDON,
Secretary for Mines.

PUBLIC TRUSTEE ACT 1958 (No. 6350), SECTION 17.

I hereby give notice that on the 1st March, 1972, the Public Trustee filed elections to administer the following deceased person's estates in accordance with section 17 of the *Public Trustee Act 1958*.

BURNS, ANDREW THOMAS, late of 27 O'Loughlan-street, Ormond, retired watchman, died 28th October, 1971.

COTT, HELEN MAY, late of 13 Princess-street, Seddon, retired nurse, died 13th December, 1971.

PARKER-LAYOCK, SAMUEL, also known as Samuel Parker Layock and Samuel Parker, late of Lloyds-road, Powelltown, retired, died 30th October, 1971.

MICHELSSEN, IVAN ANDREW, late of 128 Morrell-street, Glenroy, catering officer, died 4th December, 1971.

MURRAY, ELLA JANE MAY, also known as Murray, Ella Jane, formerly of 9 Poplar-street, Box Hill, late of "Bethany", 222 Camberwell-road, Camberwell, married woman, died 9th October, 1971.

STEVENS, ANNIE LOUISA, formerly of 34 Clifton-street, Northcote and 14 Meadow-crescent, Montmorency, late of Kew, widow, died 10th March, 1971.

WADE, MARY LENA JANET, also known as Wade, Mary Lena, formerly of 12 William-street, Essendon, late of 60 Atkinson-street, Templestowe, widow, died 24th December, 1971.

WILLIAMS, AGNES, late of Beechworth, spinster, died 28th October, 1971.

WRIGHT, RUTH ELIZABETH, late of 20 Grace-street, Malvern, pensioner, died 9th August, 1971.

N. P. BRODY,
Public Trustee.

256 Flinders-street, Melbourne, 3000, 15th March, 1972.

NOTICE.

Creditors, next of kin, and others having claims against the estate of any of the under-mentioned deceased persons are required to send particulars of their claims to the Public Trustee, 256 Flinders-street, Melbourne, Vic. 3000, the personal representative, on or before the 29th May, 1972, after which date the Public Trustee may convey or

distribute the assets, having regard only to the claims of which the Public Trustee then has notice:—

ANDERSON, ELSIE ANNIE, formerly of Middleborough-road, Tally Ho and 1A Highett-street, West Richmond, but late of 18 Islington-street, Collingwood, widow, died 5th November, 1971.

BURNS, ANDREW THOMAS, late of 27 O'Loughlan-street, Ormond, retired watchman, died 28th October, 1971.

COTT, HELEN MAY, late of 13 Princess-street, Seddon, retired nurse, died 13th December, 1971.

FRANKS, GEORGE COCKERILL NICHOLAS, also known as Franks, George Cockerill, late of 47 Town Hall-avenue, Preston, retired clerk, died 3rd December, 1971.

HILL, LESLIE ROLAND, late of 6 Warida-avenue, East Malvern, gentleman, died 28th December, 1971.

HOCKING, DAVID JOHN, formerly of 6 Frier-avenue, Reservoir, late of Mount Royal Home for the Aged, Parkville, gentleman, died 25th November, 1971.

HOCKLEY, GEORGE FREDERICK, also known as Hockley, George, formerly of Stratford-road, Sale, and the Australian Imperial Force, late of Gippsland Base Hospital, Sale, Victoria, retired labourer, died 29th August, 1970.

PARKER-LAYOCK, SAMUEL, also known as Samuel Parker Layock and Samuel Parker, late of Lloyds-road, Powelltown, retired, died 30th October, 1971.

MERCER, HENRY LLOYD, late of 19 formerly 23 Brighton-street, Sandringham, retired accountant, died 21st October, 1971.

MICHELSSEN, IVAN ANDREW, late of 128 Morrell-street, Glenroy, catering officer, died 4th December, 1971.

MILLER, ANTONIO, late of Marysville-road, Buxton, farmer, died 29th November, 1971.

MURRAY, ELLA JANE MAY, also known as Murray, Ella Jane, formerly of 9 Poplar-street, Box Hill, late of "Bethany", 222 Camberwell-road, Camberwell, married woman, died 9th October, 1971.

MCFEE, MARGARET ADELINE, late of 32 Robinson-street, Moonee Ponds, spinster, died 28th December, 1971.

O'BRIEN, FRANCIS, late of 85 New-street, Brighton, retired civil servant, died 5th December, 1971.

OULD, HERBERT, late of 15 Clifton-street, South Oakleigh, retired fuel merchant, died 13th November, 1971.

SHEWAN, COLIN DAVID, formerly of 7 Larne-grove, Preston, late of 8 Graham-court, West Preston, clerk, died 21st December, 1971.

STEVENS, ANNIE LOUISA, formerly of 34 Clifton-street, Northcote and 14 Meadow-crescent, Montmorency, late of Kew, widow, died 10th March, 1971.

STEVENS, VERA NELLIE, late of Masterton, New Zealand, widow, died on or about 17th August, 1971.

SUTHERLAND, DUNCAN, late of 3 Sophia-grove, Parkdale, war pensioner, died 27th October, 1971.

WADE, MARY LENA JANET, also known as Wade, Mary Lena, formerly of 12 William-street, Essendon, late of 60 Atkinson-street, Templestowe, widow, died 24th December, 1971.

WILLIAMS, AGNES, late of Beechworth, spinster, died 28th October, 1971.

WRIGHT, RUTH ELIZABETH, late of 20 Grace-street, Malvern, pensioner, died 9th August, 1971.

N. P. BRODY,
Public Trustee.

Melbourne, 15th March, 1972.

CONTRACTS ACCEPTED.—(Series 1971-72.)

PUBLIC WORKS.

972. Heywood, High School, external and internal repairs and painting, \$22,400.00.—Hammond & Sons Contracting Pty. Ltd.

973. Dandenong, Special School, 4918, mechanical services, new school, \$34,350.00.—W. S. Atherton & Co. Pty. Ltd.

974. Watsonia, Special School 5027, mechanical services, new school, \$34,987.00.—W. S. Atherton & Co. Pty. Ltd.

975. Burwood East, Special School 5025, mechanical services, new school, \$35,823.00.—W. S. Atherton & Co. Pty. Ltd.

976. Burwood, Technical School, installation of fire service, \$5,432.00.—A. Bioye.

977. Donald, High School, electrical services, manual arts wing, \$4,463.00.—G. F. & J. D. Coutts.

978. Traralgon, High School, external and internal renovations, \$47,034.00.—E. Capaldo & Sons Pty. Ltd.

979. Manningham, Primary School 4940, internal and external renovations and painting, \$4,890.00.—E. Capaldo & Sons Pty. Ltd.

980. Glenroy, High School, erection of brick library, \$70,385.00.—A. F. Dewar Holdings Pty. Ltd.

981. Various, Dredging the mouth of Mordialloc Creek, Werribee River and Channel at Cresser Reserve, Altona, \$40,790.00.—Duncan & Russell Pty. Ltd.

982. Kew, Soil Conservation Authority, internal and external renovations, \$16,912.00.—Egeberg Building & Plumbing Service Pty. Ltd.

983. Burnley, Victorian Plant Research Institute, erection of headhouse and glasshouse, \$21,702.50.—Glasshouse Constructions.

984. Burnley, Victorian Plant Research Institute, electrical services, headhouse and glasshouse, \$6,749.00.—H.J.C. Contractors Pty. Ltd.

985. Murrumbidgee, High School, erection of sports club house, \$24,699.00.—Alfred W. Hunt.

986. Thomastown West, Primary School 4999, site works, \$16,313.00.—Infantino Constructions Pty. Ltd.

987. Strathmore North, Primary School 4821, site works, \$5,889.90.—Infantino Constructions Pty. Ltd.

988. Research, Primary School 2959, exterior and interior repairs and painting, \$4,741.00.—L. J. Jessop.

989. Chandler, High School, removal of covered way from Keilor Heights High School and re-erection at Chandler High School and provision of water, stormwater, fire and sewerage services to portable complex, \$15,130.00.—A. V. Jennings Industries (Aust.) Ltd.

990. Mitcham, Technical School, alterations, renovations and additions, \$887,582.00 (adjusted).—A. V. Jennings Industries (Aust.) Ltd.

991. St. Arnaud, High School, major renovations, \$26,540.00.—Z. Jovic.

992. Various Locations, Mental Hospitals, erection of proprietary type brick veneer residences at Larundel (2), Mont Park (1), Royal Park (2) and Kew (1), \$81,441.00.—Landall-Fulton Constructions Pty. Ltd.

993. Werribee, Research Farm, mechanical services, New Laboratory extensions (S.S. Cameron Laboratory), \$36,521.31.—H. A. Langmead Pty. Ltd.

994. Coburg, Pentridge Prison, erection of new kitchen, "D" Division, \$273,617.00.—McDougall-Ireland Pty. Ltd.

995. Colac, Training Centre, site works, \$100,063.00.—McDougall-Ireland Pty. Ltd.

996. Mansfield, High School, electrical services, manual arts wing, \$5,863.00.—G. & P. May.

997. Burnley, Victorian Plant Research Institute, mechanical services, headhouse and glasshouse, \$6,187.00.—Mech Engineering Pty. Ltd.

998. Glenroy, High School, electrical services, library, \$6,786.00.—H. C. Marshall & Co. Pty. Ltd.

999. West Melbourne, Primary School 1689, internal renovations, \$12,675.00.—L. Nallo.

1000. Mansfield, High School, mechanical services, manual arts wing, \$18,931.00.—A. J. Norton Pty. Ltd.

1001. Grovedale, Primary School 283, connexion to sewer, renewal of water supply, &c., \$9,164.00.—James Nott & Co.

G. SERPELL, Director-General of Public Works. 14.3.72.

VICTORIAN RAILWAYS.

83. Position and fix steel reinforcement for tunnel and ramp construction work associated with the Melbourne Underground Loop Connexions, at rates (Contract 63742).—P. J. McLean. 84. External painting of 60 number departmental residences (pre-cut), located at Sunshine area for the amount of \$13,750.00 (Contract 63753).—S. House. C. S. MORRIS, Secretary. 17.3.72.

SOIL CONSERVATION AUTHORITY.

CONTRACT No. 197101A.

971. Construction of 3 R. C. structures (22.96 cu. yds.)—Seven Mile No. 1 Group Conservation Area, \$1,936.80.—H. M. Sandow, Ararat.

P. J. McCALLUM, Secretary.

CONTRACT No. 257201.

969. Chisel Seeding—Eppalock Water Supply Catchment, 1972.

Tenderer; (a) Tractor H.P., (b) Chisel Seeder Size; Rate per Hour.

A. T. Campbell, Heathcote; (a) 52, (b) 9 feet; \$6.30.
W. D. Cameron, Kangaroo Flat; (a) 52, (b) 9 feet; \$6.30.
C. J. Boyer, Taradale; (a) 65, (b) 9 feet; \$6.30.
G. R. Cary, Heathcote; (a) 51, (b) 9 feet; \$6.30.

No. 20.—2382/72.—2

F. M. & D. M. Girvan, Taradale; (a) 43, (b) 7 feet; \$5.75.
K. N. Turner, Heathcote; (a) 55, (b) 9 feet; \$6.30.

All plus 60 cents a mile for travel between paddocks.

P. J. McCALLUM, Secretary.

ORDERS IN COUNCIL.—(Series 1971-72.)

PUBLIC WORKS.

970. Melbourne, Law Department, 221-231 Queen-street, reimbursement for partitioning costs, &c., in leased premises, \$201,100.68.—A.D.C. Properties (Vic.) Pty. Ltd.—(P.45).

Approved by the Governor in Council, 15th March, 1972.—J. ROSSITER, Clerk of the Executive Council.

APPOINTMENTS AND RESIGNATION

APPOINTMENTS.

His Excellency the Governor of the State of Victoria, by and with the advice of the Executive Council thereof, has, by Orders made on the 15th day of March, 1972, been pleased to make the under-mentioned appointments, viz.:

CROWN LANDS AND SURVEY DEPARTMENT.

Managers of Caramut Town Common.

JOHN HOULIHAN,
COLIN JACK BECKHAM,
REGINALD GRAEME SURKITT,
RONALD UNDERWOOD, and
RICHARD ALFRED HARDS,

in pursuance of the provisions of section 182 of the *Land Act 1958*, to be Managers of the Caramut Town Common, for a period ending the 31st December, 1974.

MINISTRY OF HEALTH.

Member of Committee of Management of Hospital.

PETER BARR

to be the Government Appointee on Committee of Management of Mansfield District Hospital, pursuant to subparagraph (ii) of paragraph (a) of sub-section (1) of section 48 of the *Hospitals and Charities Act 1958*.

LAW DEPARTMENT.

Commissioners for Taking Declarations, &c.

KEITH CHARLES BELL, care of J. J. Miller Printing Co. Pty. Ltd., 19-27 Grant-street, Clifton Hill,
ERIC BRUCE MILLSOM, care of BFC Finance Limited, 283 Springvale-road, Springvale,
CYRIL GORDON HICKS, care of Hicks and Allard Pty. Ltd., 1025 Doncaster-road, East Doncaster, and
NOEL STANLEY GRANT, care of Postal Institute Credit Co-operative Limited, 664 Bourke-street, Melbourne,

to be Commissioners for Taking Declarations and Affidavits, pursuant to the provisions of the *Evidence Act 1958*, to resign upon ceasing to occupy their present positions; and

ALLEN JOHN EVANS,
KEVIN NICHOLAS DAVIS, and
ROBIN VANDEGRAAFF, care of Department of Agriculture, Victoria, 3 Treasury-place, Melbourne,
to be Commissioners for Taking Declarations and Affidavits, pursuant to the provisions of the *Evidence Act 1958*, to refrain from charging fees and to resign upon ceasing to occupy their present positions; and

PETER STATHOPOULOS, 251 Hihett-street, Richmond, and
KARL KRISTOF MAY, 167 Thompson-road, North Geelong,

to be Commissioners for Taking Declarations and Affidavits, pursuant to the provisions of the *Evidence Act 1958*, to resign upon removing from the neighbourhood of the addresses stated.

Justices of the Peace.

THOMAS HENRY EDWARD SLEIGH, 40 Bulla-road, Strathmore,
HOWARD VINCENT GLARE, Willatook,
ROGER JOHN WILLIAM BAILEY, 14 Malua-road, Ferntree Gully,
PETER JOHN LEAKE, 5 Selwood-court, Mornington,
RONALD THEO COLSON; Wangaratta South,

JOHN WILLOUGHBY HUMPHRIS, 28 Morven-street, Mornington, and
JOHN STANLEY HEAD, 16 Osborne-street, Hawthorn, to Keep the Peace in the State of Victoria.

DEPARTMENT OF THE TREASURER.
Receivers of Revenue (Acting).

MAXWELL MAURICE SAUNDER to act temporarily as Receiver of Revenue, Mildura, vice J. Kearney, on leave; and
IAN JAMES BENNETT to act temporarily as Receiver of Revenue, Echuca, vice M. M. Saunder, transferred.

DEPARTMENT OF WATER SUPPLY.
Waterworks Trusts Commissioners.

WILLIAM JAMES CHILDE NORTH to be a Commissioner of The Ballarat Water Commissioners to hold such position for a period of four years from 16th March, 1972, subject to the provisions of the Water Act;

ALBERT NEVILLE SARGENT to be a Commissioner of the Bruthen Waterworks Trust to hold office from the date hereof until the fourth Thursday in the month of October in the year 1972, subject to the provisions of the Water Act;

CHARLES PERCY LANG to be a Commissioner of the Kerang Waterworks Trust, to hold such position for a period of four years from 19th March, 1972, subject to the provisions of the Water Act;

PERCY BOWEN MARTIN to be a Commissioner of the Toora Waterworks Trust to hold such position for a period of two years from the date thereof, subject to the provisions of the Water Act;

FRANK JOHN GRANT to be a Commissioner of the Wodonga Waterworks Trust, to hold such position for a period of four years from 19th March, 1972, subject to the provisions of the Water Act;

STANLEY EDWARD WOLFE to be a Commissioner of the Yarra Junction Waterworks Trust, to hold such position for a period from the date hereof until 16th December, 1972, subject to the provisions of the Water Act; and

FRANK DAVENPORT to be a Commissioner of the Yarra Junction Waterworks Trust, to hold such position from the date hereof until the date of expiry of the present term of office of Arthur Ronald Marr as a Councillor of the Shire of Upper Yarra, subject to the provisions of the Water Act.

J. ROSSITER,
Clerk of the Executive Council.

At the Executive Council Chamber,
Melbourne, 15th March, 1972.

APPOINTMENTS.

His Excellency the Governor of the State of Victoria, by and with the advice of the Executive Council thereof, has, by Orders made on the 21st day of March, 1972, been pleased to make the under-mentioned appointments, viz.:

DEPARTMENT OF WATER SUPPLY.
Waterworks Trust Commissioners.

DONALD HENRY ORR to be a Commissioner of the Cohuna Waterworks Trust, to hold office as such from the date hereof until 4th August, 1973, subject to the provisions of the Water Act;
CHARLES WILLIAM COOPER, and
LESLIE JOHN SAUNDERS

to be Commissioners of the Goorambat Waterworks Trust, to hold such position for a period of four years, as from the date hereof, subject to the provisions of the Water Act;

HARRY JOSEPH HENRY to be a Commissioner of the Shire of Mount Rouse Waterworks Trust, to hold such position for a period of four years from the date hereof, subject to the provisions of the Water Act; and

HUBERT STANER REILLY to be a Commissioner of the Tatura Waterworks Trust, to hold such position for a period of four years from 26th March, 1972, subject to the provisions of the Water Act.

J. ROSSITER,
Clerk of the Executive Council.

At the Executive Council Chamber,
Melbourne, 21st March, 1972.

RESIGNATION.

His Excellency the Governor of the State of Victoria, by and with the advice of the Executive Council thereof, has, by Order made on the 15th day of March, 1972, accepted the resignation of the person named hereunder of the office mentioned, viz.:

LAW DEPARTMENT.
Justice of the Peace.

ARNOLD THOMAS COULSTON, as a Justice of the Peace for the State of Victoria.

J. ROSSITER,
Clerk of the Executive Council.

At the Executive Council Chamber,
Melbourne, 15th March, 1972.

ORDERS IN COUNCIL

COUNTRY ROADS BOARD.

At the Executive Council Chamber, Melbourne, the
fifteenth day of March, 1972.

PRESENT:

His Excellency the Governor of Victoria.
Mr. Thompson | Mr. Rafferty.

ORDER APPROVING OF LAND BEING ACQUIRED AND ROADS, DEVIATIONS OR WIDENINGS BEING MADE.

His Excellency the Governor of the State of Victoria, by and with the advice of the Executive Council thereof, being satisfied that there are funds legally available for acquiring the land, doth hereby approve the acquiring of the land described in the Schedule hereunder and the making of new roads and deviations from and widenings of existing roads referred to in the said Schedule.

SCHEDULE.

State Highways.

The land shown hatched on Plan numbered G.P.12849A hereunder required for the widening of the Burwood Highway in the City of Knox and making of the widening thereon.

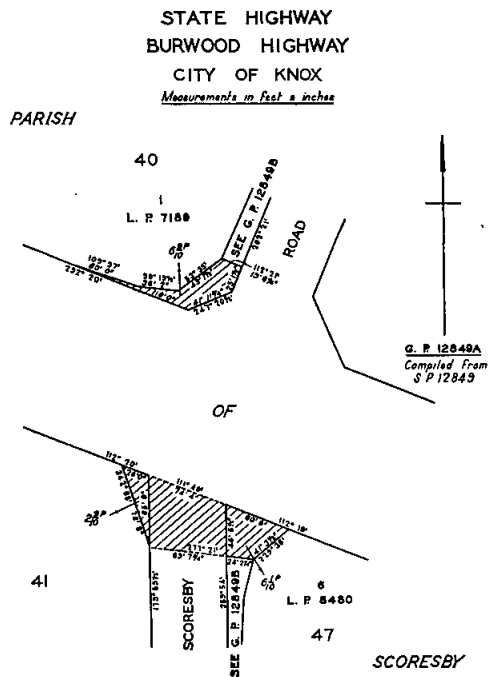

The land shown hatched on Plan numbered G.P.12870 hereunder required for the widening of the South Gippsland Highway in the Shire of Rosedale and making of the widening thereon.

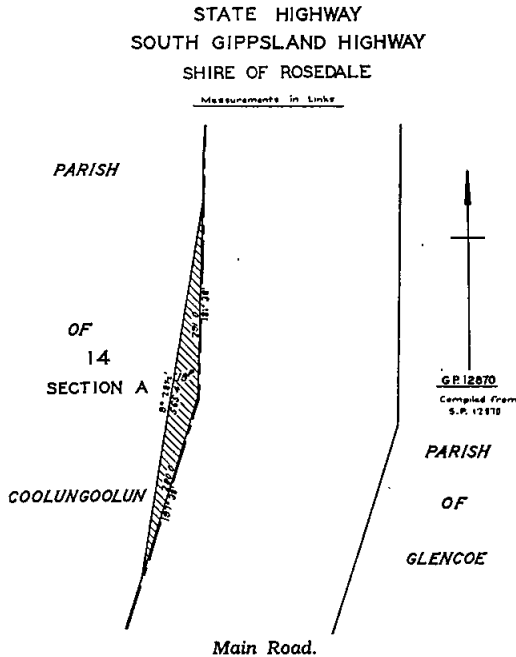

The land shown hatched on Plans numbered G.P.11998A, G.P.11998B, G.P.11998C, G.P.12177A, G.P.12178A, G.P.12379, G.P.12380, G.P.12381, G.P.12479A, G.P.12479B, G.P.12480, G.P.12481, G.P.12482A, G.P.12482B, G.P.12483 and G.P.12484 hereunder required for the widening of the Geelong-Portarlington road in the Shire of Bellarine and making of the widening thereon.

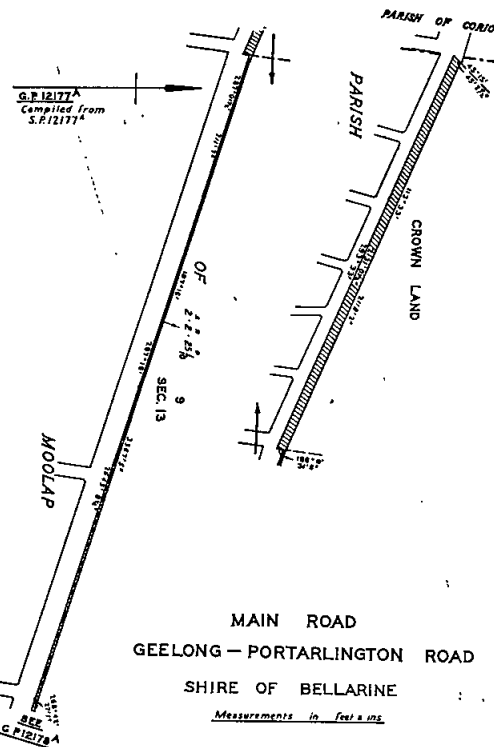
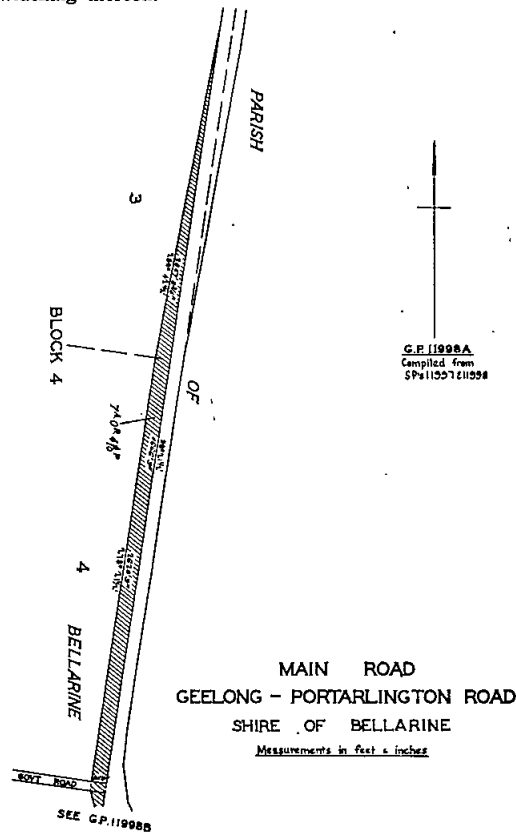
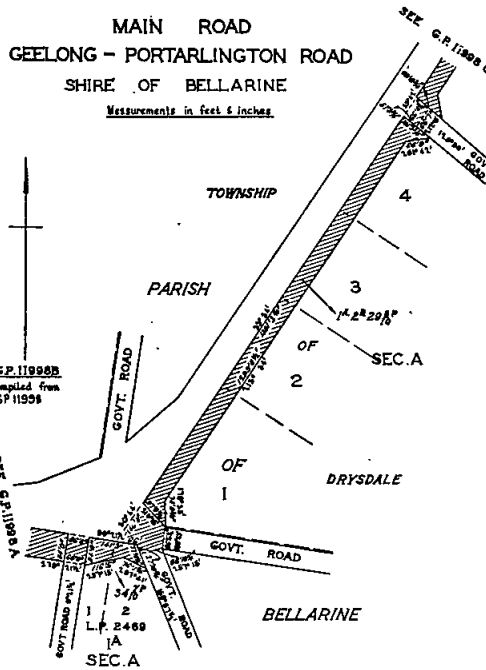

MAIN ROAD
GEELONG — PORTARLINGTON ROAD
SHIRE OF BELLARINE

Measurements in feet & ins

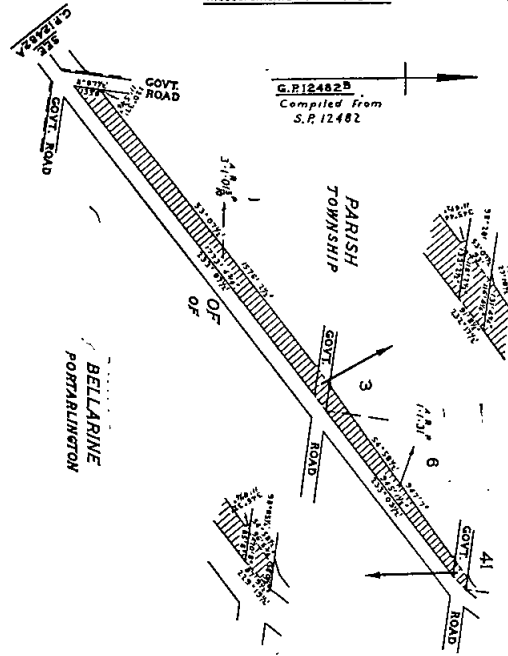

MAIN ROAD
GEELONG — PORTARLINGTON ROAD
SHIRE OF BELLARINE

Measurements in feet & inches

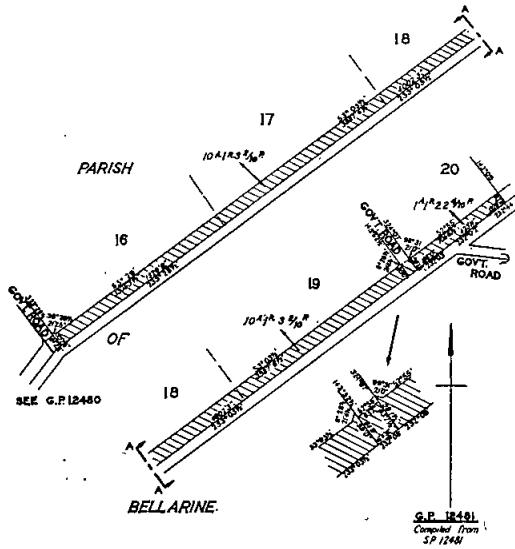

MAIN ROAD
GEELONG — PORTARLINGTON ROAD
SHIRE OF BELLARINE

Measurements in feet & inches

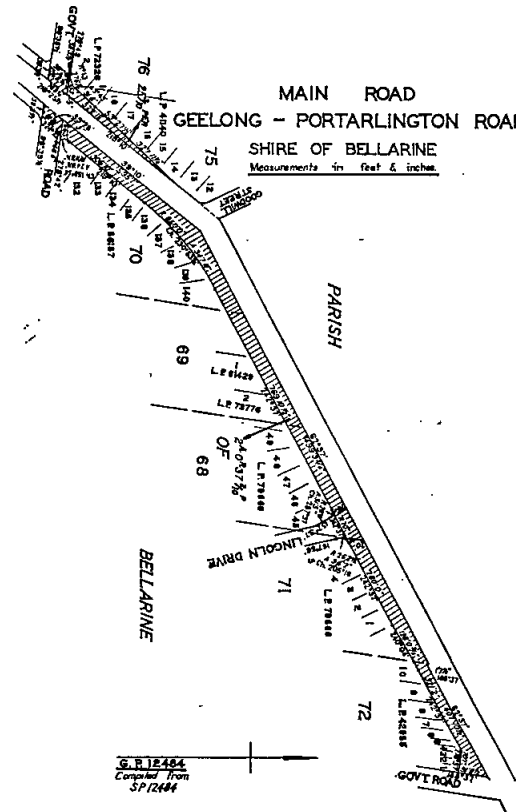

MAIN ROAD
GEELONG — PORTARLINGTON ROAD
SHIRE OF BELLARINE

Measurements in feet & ins

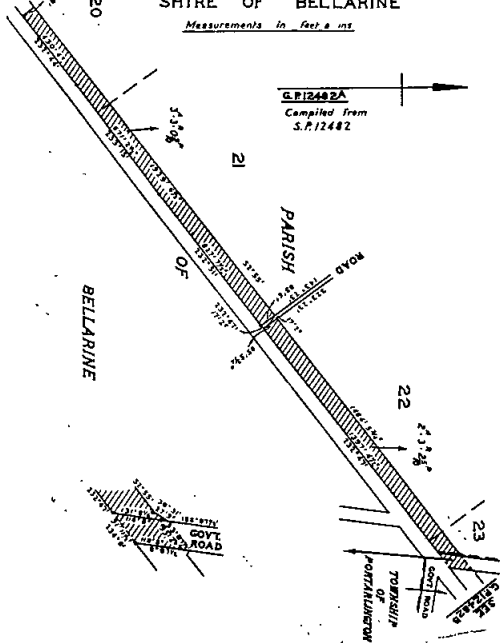

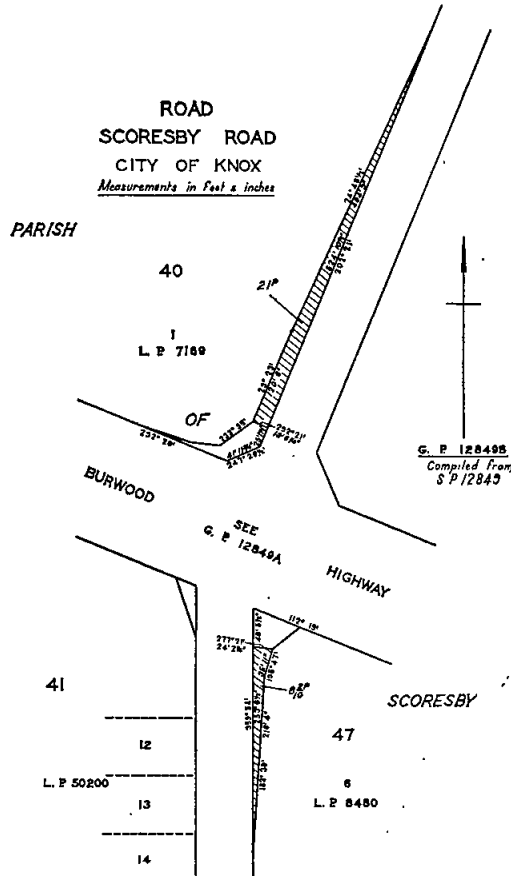
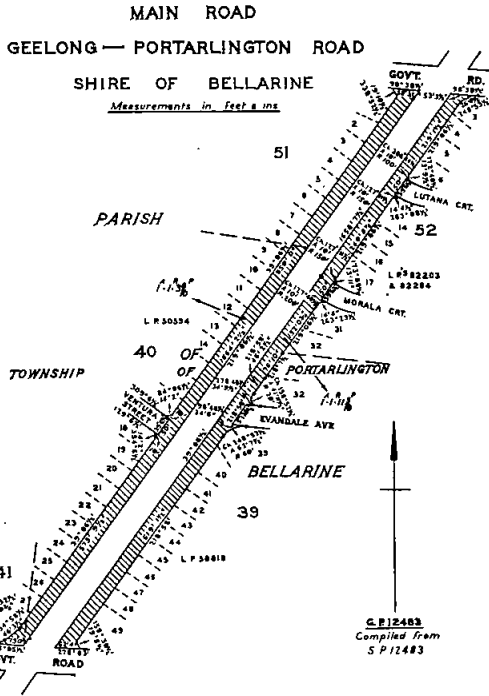

Freeway.
The land shown hatched on Plan numbered G.P.12857 hereunder required for the making of a new freeway (Mornington Peninsula Freeway) in the Shire of Flinders.

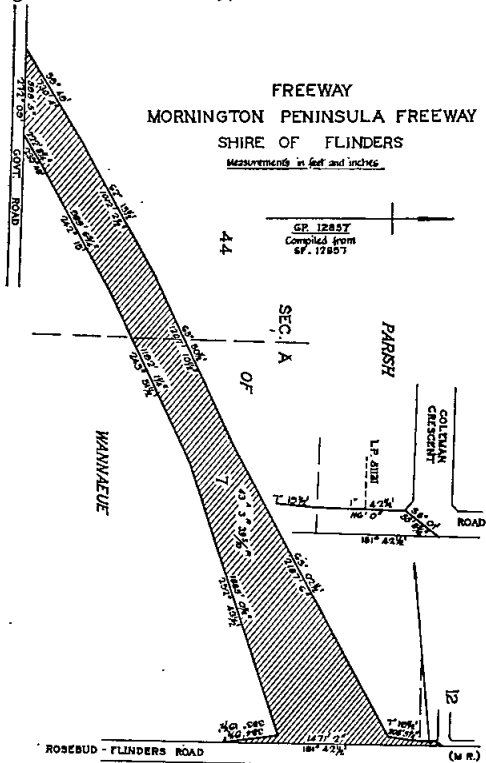

Tourists' Road.
The land shown hatched on Plan numbered G.P.12827 hereunder required for the widening of the Great Ocean-road, in the Shire of Barrabool, and making of the widening thereon.

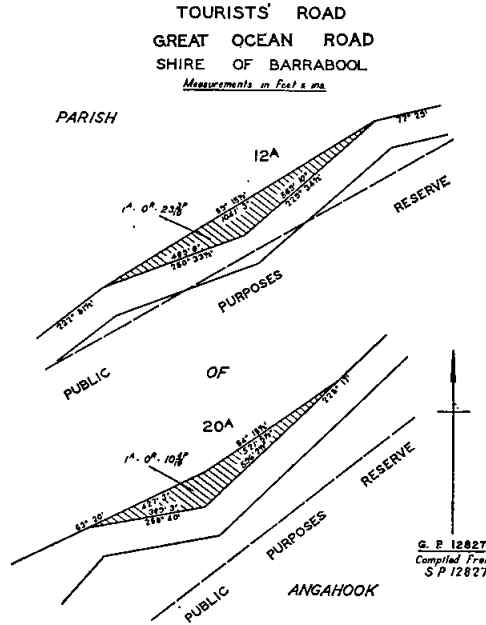

Unclassified Road.
The land shown hatched on Plan numbered G.P.12849B hereunder required for the widening of Scoresby-road in the City of Knox, and making of the widening thereon.

And the Honorable Alan John Hunt, Her Majesty's Minister for Local Government for the State of Victoria, shall give the necessary directions herein accordingly.
J. ROSSITER,
Clerk of the Executive Council.

LITTLE RIVER WATERWORKS TRUST.

At the Executive Council Chamber, Melbourne, the
fifteenth day of March, 1972.

PRESENT:

His Excellency the Governor of Victoria.
Mr. Thompson | Mr. Rafferty.

EXTENT OF WATERWORKS DISTRICT INCREASED.

Under the powers conferred by the Water Act and all other powers enabling him in that behalf, His Excellency the Governor of the State of Victoria, by and with the advice of the Executive Council of the said State, doth hereby declare, order and direct that the extent of the Little River Waterworks Trust be increased by adding to the same the lands comprised within the boundaries shown on the accompanying plan approved by the Governor in Council by and with this Order, and deposited in the office of the State Rivers and Water Supply Commission, Melbourne, (Corr. No. 63/1859/74), and as on and from the date hereof, the extent of such District shall be and be deemed to be increased accordingly.

And the Honorable Roberts Christian Dunstan, Her Majesty's Minister of Water Supply for the State of Victoria, shall give the necessary directions herein accordingly.

J. ROSSITER,
Clerk of the Executive Council.

LANDLORD AND TENANT ACT 1958.

At the Executive Council Chamber, Melbourne, the
fifteenth day of March, 1972.

PRESENT:

His Excellency the Governor of Victoria.
Mr. Thompson | Mr. Rafferty.

ORDER EXTENDING APPLICATION OF PART V. OF THE LANDLORD AND TENANT ACT 1958 TO CERTAIN PREMISES.

In pursuance of the powers conferred by section 44 of the *Landlord and Tenant Act 1958*, His Excellency the Governor of Victoria, by and with the advice of the Executive Council thereof, doth hereby declare that the application of part V. of the *Landlord and Tenant Act 1958* shall extend to the following premises:—

The premises known as Flat 4, 72 Withers-street,
Albert Park.

And the Honorable George Oswald Reid, Her Majesty's Attorney-General in and for the State of Victoria, shall give the necessary directions herein accordingly.

J. ROSSITER,
Clerk of the Executive Council.

LABOUR AND INDUSTRY ACT 1958.

At the Executive Council Chamber, Melbourne, the
fifteenth day of March, 1972.

PRESENT:

His Excellency the Governor of Victoria.
Mr. Thompson | Mr. Rafferty.

FIRE BRIGADE OFFICERS BOARD—NUMBER OF MEMBERS INCREASED.

In pursuance of the powers conferred by the *Labour and Industry Act 1958*, His Excellency the Governor of the State of Victoria, by and with the advice of the Executive Council thereof, doth hereby vary the Order made on the fourteenth day of December, 1954, in so far as it specified that the Fire Brigade Officers Board should consist of four members and a Chairman, and doth hereby specify that the said Fire Brigade Officers Board shall consist of six members and a Chairman.

And the Honorable Joseph Anstice Rafferty, Her Majesty's Minister of Labour and Industry for the State of Victoria, shall give the necessary directions herein accordingly.

J. ROSSITER,
Clerk of the Executive Council.

Land Act 1958.
DEPARTMENT OF CROWN LANDS AND SURVEY.

At the Executive Council Chamber, Melbourne, the
fifteenth day of March, 1972.

PRESENT:

His Excellency the Governor of Victoria.
Mr. Thompson | Mr. Rafferty.

REVOCATION OF TEMPORARY RESERVATIONS OF LANDS BY ORDERS IN COUNCIL.

His Excellency the Governor of the State of Victoria, by and with the advice of the Executive Council thereof, doth hereby, in pursuance of the provisions of the *Land Act 1958*, revoke the temporary reservations of lands by Orders in Council hereinafter referred to, viz.:—

BALLARAT EAST.—The temporary reservation by Order in Council of the 18th November, 1958, of 3 acres 1 rood 34 perches of land in the Township of Ballarat East, as a site for the Growth and Preservation of Timber and for Public Recreation.—(B.128⁽⁴⁴⁾) (Rs.1530).

HEYFIELD.—The temporary reservation as a site for the Supply of Gravel, and the withholding from sale, leasing and licensing by Order in Council of the 29th January, 1878 of 10 acres of land at Heyfieldbridge (now Township of Heyfield) in the Parish of Tinamba.—(H.110⁽⁸⁾) (Rs.2529).

MACARTHUR.—The temporary reservation by Order in Council of the 16th October, 1890, of 1 acre 2 roods 34 perches of land in the Parish of Macarthur, as a site for Drainage purposes.—(M.88⁽²⁾) (C.100802).

STAWELL.—The temporary reservation by Order in Council of the 11th January, 1955, of 1 acre 1 rood, more or less, of land in the Parish of Stawell, as a site for a Garbage Depot.—(S.329⁽¹⁶⁾) (Rs.7328).

WONGA WONGA SOUTH.—The temporary reservation by Order in Council of the 21st February, 1911 (see *Government Gazette* of the 1st March, 1911, page 1464) of 17 acres 14 perches of land in the Parish of Wonga Wonga South as a site for Supply of Gravel revoked as to part by Order of the 19th January, 1965, so far as the balance thereof containing 16 acres 16 perches is concerned.—(W.353⁽¹¹⁾) (Rs.3711).

WONGA WONGA SOUTH.—The temporary reservation by Order in Council of the 20th February, 1902, of 9 acres 3 roods 39 perches of land in the Parish of Wonga Wonga South as a site for Supply of Gravel.—(W.353⁽¹¹⁾) (Rs.3711).

WONGA WONGA SOUTH.—The temporary reservation by Order in Council of the 20th February, 1902 (see *Government Gazette*, 26th February, 1902, page 930), of 9 acres 2 roods 20 perches of land in the Parish of Wonga Wonga South as a site for Supply of Gravel, revoked as to part by various Orders, so far as the balance thereof containing 7 acres 3 roods, more or less, is concerned.—(W.353⁽¹¹⁾) (Rs.3711).

WURDI YOUANG.—The temporary reservation as a site for State School purposes, and the withholding from sale, leasing and licensing by Order in Council of the 5th July, 1875, of 5 acres of land in the Parish of Wurdí Youang.—(W.224⁽²⁾) (Rs.7177).

JIKA JIKA (ROYAL PARK).—The temporary reservation by Order in Council of the 12th January, 1932, of 60 acres 17 perches of land in the Parish of Jika Jika as a site for a Mental Hospital, revoked as to part by various Orders, is about to be revoked so far only as the portion containing 2 acres 15 perches, more or less as defined by the description published in the *Government Gazette* dated the 2nd February, 1972.—(M.314⁽¹⁶⁾) (Rs.4172).

SANDHURST (AT BENDIGO).—The temporary reservation by Order in Council of the 10th July, 1917, of 77 acres 3 roods more or less, of land at Bendigo, in the Parish of Sandhurst as a site for Supply of Gravel, revoked as to part by various Orders, so far only as the portion containing 1 acre 2 roods, more or less as defined by the description published in the *Government Gazette* dated the 17th November, 1971.—(S.372^(109.114)) (Rs.3837).

And the Honorable William Archibald Borthwick, Her Majesty's Minister of Lands for the State of Victoria, shall give the necessary directions herein accordingly.

J. ROSSITER,
Clerk of the Executive Council.

HOME FINANCE ACT 1962, No. 6933.

At the Executive Council Chamber, Melbourne, the
fifteenth day of March, 1972.

PRESENT:

His Excellency the Governor of Victoria.
Mr. Thompson | Mr. Rafferty.

Pursuant to the provisions of section 4 of the Home Finance Act 1962, His Excellency the Governor of the State of Victoria by and with the advice of the Executive Council thereof doth hereby appoint Sir Philip (Frederick) Jones, A.C.A., A.A.S.A., to be a member of the Home Finance Trust for the period from 1st April, 1972 to 31st March, 1975, both dates inclusive.

And the Honorable Sir Henry Edward Bolte, Her Majesty's Treasurer for the State of Victoria, shall give the necessary directions herein accordingly.

J. ROSSITER,
Clerk of the Executive Council.

OCEAN GROVE SEWERAGE AUTHORITY.

At the Executive Council Chamber, Melbourne, the
fifteenth day of March, 1972.

PRESENT:

His Excellency the Governor of Victoria.
Mr. Thompson | Mr. Rafferty.

CONSENT TO BORROWING \$100,000.

Under the powers conferred by the Sewerage Districts Act and all other powers enabling him in that behalf, His Excellency the Governor of the State of Victoria, by and with the advice of the Executive Council of the said State, doth hereby consent to the Ocean Grove Sewerage Authority borrowing the sum of One hundred thousand dollars (\$100,000), to meet the cost of sewerage works as set forth in the detailed statement bearing date 8th March, 1972.

And the Honorable Roberts Christian Dunstan, Her Majesty's Minister of Water Supply for the State of Victoria, shall give the necessary directions herein accordingly.

J. ROSSITER,
Clerk of the Executive Council.

MANSFIELD SEWERAGE AUTHORITY.

At the Executive Council Chamber, Melbourne, the
fifteenth day of March, 1972.

PRESENT:

His Excellency the Governor of Victoria.
Mr. Thompson | Mr. Rafferty.

CONSENT TO BORROWING \$25,000.

Under the powers conferred by the Sewerage Districts Act and all other powers enabling him in that behalf, His Excellency the Governor of the State of Victoria, by and with the advice of the Executive Council of the said State, doth hereby consent to the Mansfield Sewerage Authority borrowing the sum of Twenty-five thousand dollars (\$25,000), for the carrying out of works in accordance with the provisions of sections 95, 130 and 137 of the Sewerage Districts Act 1958. All moneys received by the said Authority in payment of costs and expenses of the said works, or any of them, shall be set aside for the purpose of and applied in repayment of the said sum so borrowed.

And the Honorable Roberts Christian Dunstan, Her Majesty's Minister of Water Supply for the State of Victoria, shall give the necessary directions herein accordingly.

J. ROSSITER,
Clerk of the Executive Council.

KYABRAM SEWERAGE AUTHORITY.

At the Executive Council Chamber, Melbourne, the
fifteenth day of March, 1972.

PRESENT:

His Excellency the Governor of Victoria.
Mr. Thompson | Mr. Rafferty.

EXTENSION OF SEWERAGE DISTRICT.

Under the powers conferred by the Sewerage Districts Act and all other powers enabling him in that behalf, His Excellency the Governor of the State of Victoria, by and with the advice of the Executive Council of the said State, doth hereby declare, order and direct that the extent of the Sewerage District of the Kyabram Sewerage Authority be increased by adding thereto the lands shown on a plan approved by the Governor in Council by and with this Order and deposited in the office of the State Rivers and Water Supply Commission, Melbourne, (Corr. No. 71/1203/17), and as on and from the date hereof the extent of such District shall be and be deemed to be increased accordingly.

And the Honorable Roberts Christian Dunstan, Her Majesty's Minister of Water Supply for the State of Victoria, shall give the necessary directions herein accordingly.

J. ROSSITER,
Clerk of the Executive Council.

GEELONG WATERWORKS AND SEWERAGE TRUST.

At the Executive Council Chamber, Melbourne, the
fifteenth day of March, 1972.

PRESENT:

His Excellency the Governor of Victoria.
Mr. Thompson | Mr. Rafferty.

CONSENT TO BORROWING \$47,000.

Under the powers conferred by the Geelong Waterworks and Sewerage Act and all other powers enabling him in that behalf, His Excellency the Governor of the State of Victoria, by and with the advice of the Executive Council of the said State, doth hereby consent to the Geelong Waterworks and Sewerage Trust borrowing the sum of Forty-seven thousand dollars (\$47,000), for the conversion of Loan No. 91.

And the Honorable Roberts Christian Dunstan, Her Majesty's Minister of Water Supply for the State of Victoria, shall give the necessary directions herein accordingly.

J. ROSSITER,
Clerk of the Executive Council.

GEELONG WATERWORKS AND SEWERAGE TRUST.

At the Executive Council Chamber, Melbourne, the
fifteenth day of March, 1972.

PRESENT:

His Excellency the Governor of Victoria.
Mr. Thompson | Mr. Rafferty.

CONSENT TO BORROWING \$636,000.

Under the powers conferred by the Geelong Waterworks and Sewerage Act and all other powers enabling him in that behalf, His Excellency the Governor of the State of Victoria, by and with the advice of the Executive Council of the said State, hereby consents to the Geelong Waterworks and Sewerage Trust borrowing the sum of Six hundred and thirty-six thousand dollars (\$636,000), in two amounts of Four hundred and thirty-six thousand dollars (\$436,000), and Two hundred thousand dollars (\$200,000), respectively, for the conversion of Loan Nos. L5, M5 and N5.

And the Honorable Roberts Christian Dunstan, Her Majesty's Minister of Water Supply for the State of Victoria, shall give the necessary directions herein accordingly.

J. ROSSITER,
Clerk of the Executive Council.

DEPARTMENT OF CROWN LANDS AND SURVEY.

At the Executive Council Chamber, Melbourne, the fifteenth day of March, 1972.

PRESENT:

His Excellency the Governor of Victoria.
Mr. Thompson | Mr. Rafferty.

UNUSED ROADS CLOSED.

His Excellency the Governor of the State of Victoria, by and with the advice of the Executive Council thereof, doth hereby direct that, in pursuance of the provisions of section 349 of the Land Act 1958, the unused roads referred to hereunder be closed, viz.:—

Township of Dartmoor, Parish of Dartmoor, County of Follett, being the portion of the width of the road indicated by hatching on plan hereunder.—(D.32⁽⁶⁾) (Rs.4933).

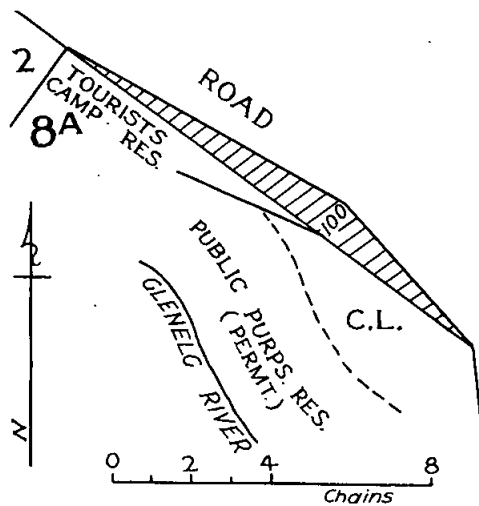

Township of Myrtleford, Parish of Myrtleford, County of Bogong, being the portion of the width of the road indicated by hatching on plan hereunder.—(M.294⁽⁴⁾) (H.033045).

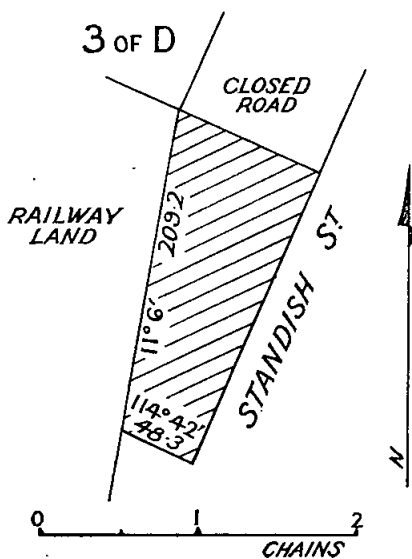

Township of Maldon, Parish of Maldon, County of Talbot, being the portion of the width of the road, indicated by hatching on plan hereunder.—(M.449⁽¹²⁾) (1862/171).

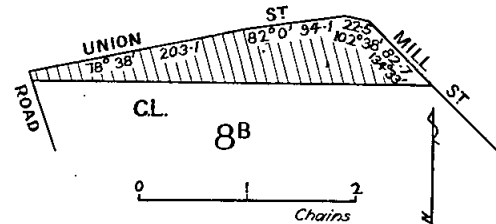

And the Honorable William Archibald Borthwick, Her Majesty's Minister of Lands for the State of Victoria, shall give the necessary directions herein accordingly.

J. ROSSITER,
Clerk of the Executive Council.

DEPARTMENT OF CROWN LANDS AND SURVEY.

At the Executive Council Chamber, Melbourne, the fifteenth day of March, 1972.

PRESENT:

His Excellency the Governor of Victoria.
Mr. Thompson | Mr. Rafferty.

LANDS TEMPORARILY RESERVED AS SITES.

His Excellency the Governor of the State of Victoria, by and with the advice of the Executive Council thereof, doth hereby, in pursuance of section 14 of the Land Act 1958, reserve temporarily from sale, from being leased and from having a licence granted in respect thereof, and also except from occupation for mining purposes under any miner's right, the land hereinafter described:—

BAIRNSDALE.—Site for Public purposes (Departmental Residence) 30 perches, Township of Bairnsdale, Parish of Bairnsdale, County of Tanjil, as indicated by hatching on plan hereunder.—(B.66⁽¹¹⁾) (Rs.9579).

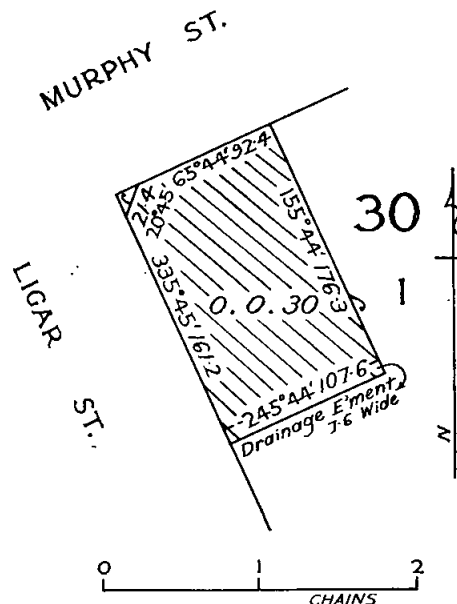

BARRARBOOL.—Site for a Cemetery, 10 acres 2 roods, more or less, Parish of Barrarbool, County of Grant, as indicated by hatching on plan hereunder.—(B.34⁽⁹⁾) (Rs.9584).

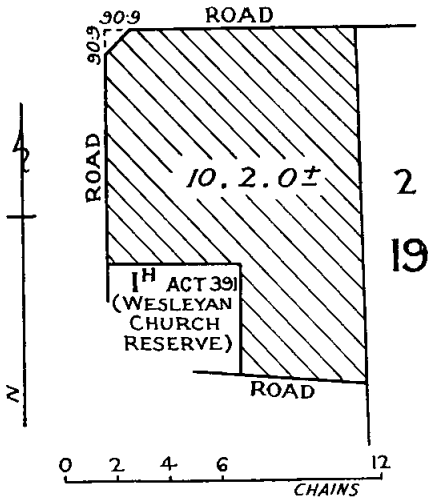

HAMILTON.—Site for State School purposes, 12 perches, Township of Hamilton, Parish of North Hamilton, County of Dundas, as indicated by hatching on plan hereunder.—(H.45^(*)) (Rs.2770).

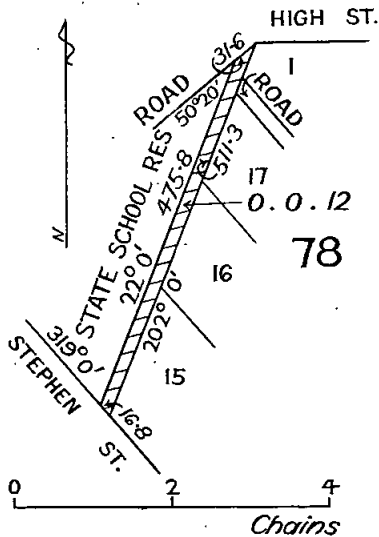

FRANKSTON.—Site for Public purposes, 1 acre, more or less, Parish of Frankston, County of Mornington, as indicated by hatching on plan hereunder.—(F.87^(*)) (Rs.3203).

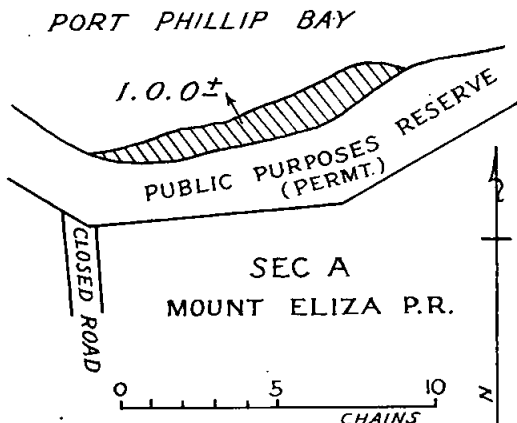

HOLEY PLAINS.—Site for Public purposes (Trigonometrical Survey Station), 7 acres 2 roods, Parish of Holy Plains, County of Buln Buln, as indicated by hatching on plan hereunder.—(H.121^(*)) (Rs.9590).

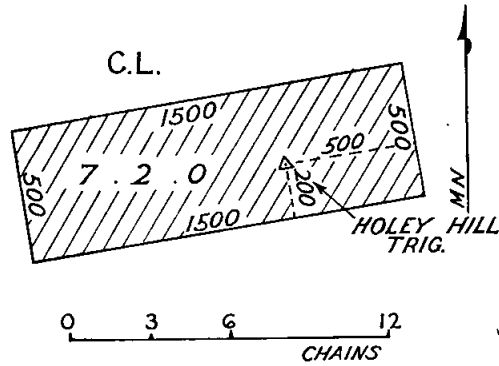

KANGERONG.—Site for Public Recreation, 72 acres 1 rood 29 perches, more or less, Parish of Kangerong, County of Mornington, as indicated by hatching on plan hereunder.—(K.7^(*)) (Rs.56).

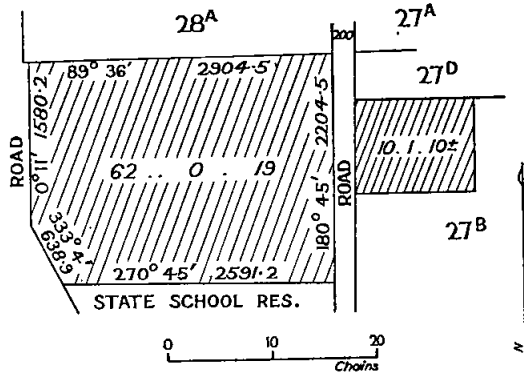

OUYEN.—Site for Public purposes (Trigonometrical Survey Station), 1 acre 1 rood 10 perches, Parish of Ouyen, County of Karkaroc, as indicated by hatching on plan hereunder.—(O.22^(*)) (Rs.9462).

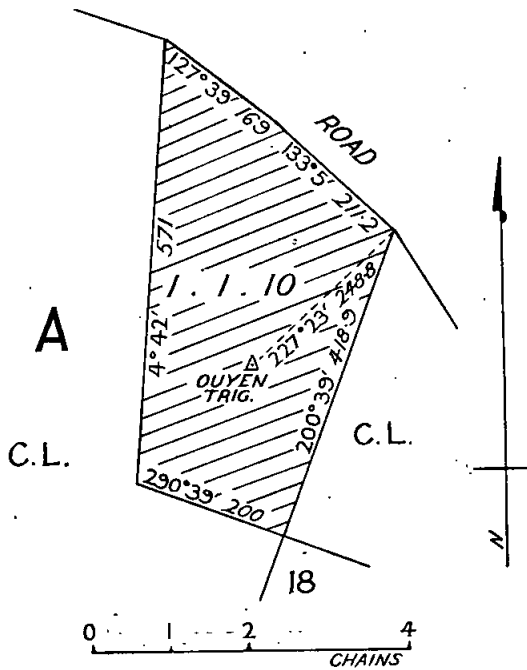

MACEDON.—Site for Public Recreation, 2 acres 3 roods, 38 perches, Parish of Macedon, County of Bourke, as indicated by hatching on plan hereunder.—(M.54⁽¹⁰⁾) (Rs.9400).

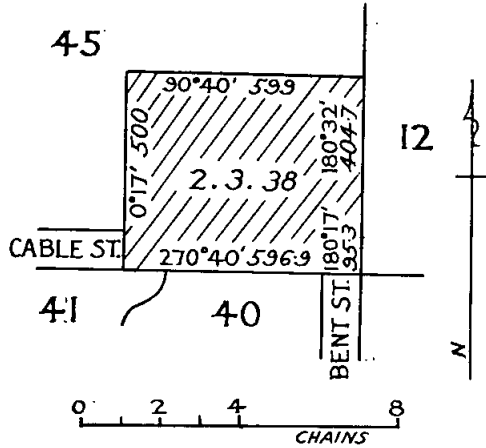

WONTHAGGI (CAPE PATERSON).—Site for Public Recreation, 68 acres, more or less, Parish of Wonthaggi, County of Mornington, as indicated by hatching on plan hereunder.—(W.345⁽¹⁸⁾) (Rs.4057).

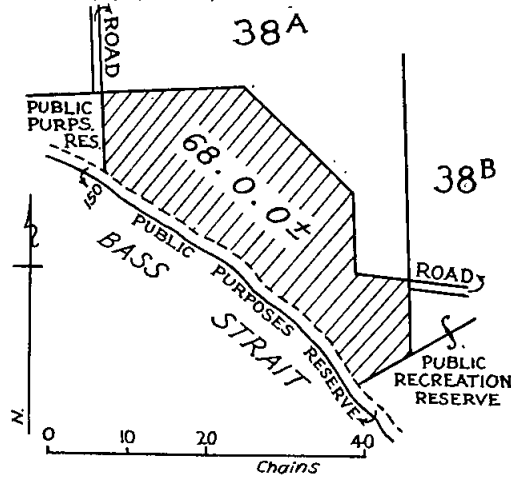

SANDHURST (AT BENDIGO).—Site for State School purposes, 6 acres 2 roods 34 perches, at Bendigo, Parish of Sandhurst, County of Bendigo, as indicated by hatching on plan hereunder.—(S.372⁽¹⁰⁸⁾) (Rs.9591).

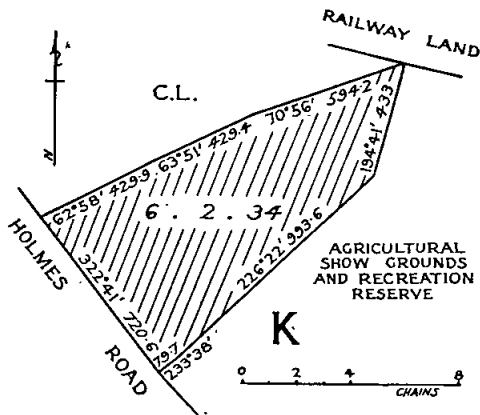

And the Honorable William Archibald Borthwick, Her Majesty's Minister of Lands for the State of Victoria, shall give the necessary directions herein accordingly.

J. ROSSITER,
Clerk of the Executive Council.

MORNINGTON SEWERAGE AUTHORITY.

At the Executive Council Chamber, Melbourne, the twenty-first day of March, 1972.

PRESENT:

His Excellency the Governor of Victoria.
Mr. Dickie | Mr. Borthwick.
Mr. Hunt

EXTENT OF SEWERAGE DISTRICT INCREASED.

Under the powers conferred by the Sewerage Districts Act and all other powers enabling him in that behalf, His Excellency the Governor of the State of Victoria, by and with the advice of the Executive Council of the said State, doth hereby declare, order and direct that the extent of the Sewerage District of the Mornington Sewerage Authority be increased by adding to the same the lands comprised within the boundaries shown by red colour on the plan approved by the Governor in Council, by and with this order, and deposited in the office of the State Rivers and Water Supply Commission, Melbourne (Corr. No. 72/594/2) and as on and from the date hereof, the extent of such District shall be and be deemed to be increased accordingly.

And the Honorable Roberts Christian Dunstan, Her Majesty's Minister of Water Supply for the State of Victoria, shall give the necessary directions herein accordingly.

J. ROSSITER,
Clerk of the Executive Council.

FRANKSTON SEWERAGE AUTHORITY.

At the Executive Council Chamber, Melbourne, the twenty-first day of March, 1972.

PRESENT:

His Excellency the Governor of Victoria.
Mr. Dickie | Mr. Borthwick.
Mr. Hunt

CONSENT TO BORROWING \$250,000.

Under the powers conferred by the Sewerage Districts Act and all other powers enabling him in that behalf, His Excellency the Governor of the State of Victoria, by and with the advice of the Executive Council of the said State, doth hereby consent to the Frankston Sewerage

WANGARATTA SOUTH.—Site for Public purposes (Police purposes), 8 acres 2 perches, Parish of Wangaratta South, County of Delatite, as indicated by hatching on plan hereunder.—(W.85⁽⁶⁾) (Rs.9593).

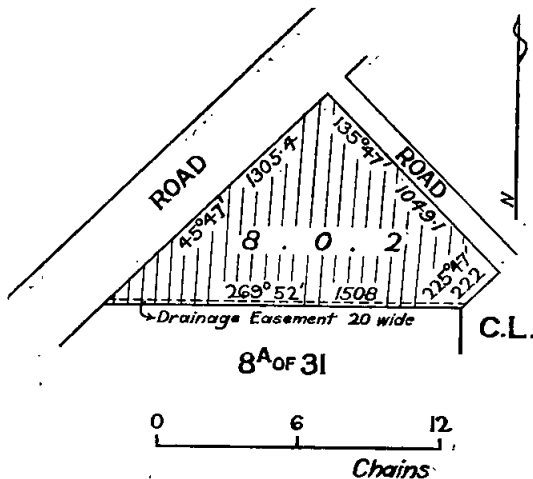

Authority borrowing the sum of Two hundred and fifty thousand dollars (\$250,000) for the carrying out of works in accordance with the provisions of sections 95, 130 and 137 of the *Sewerage Districts Act 1958*. All moneys received by the said Authority in payment of costs and expenses of the said works, or any of them, shall be set aside for the purpose of and applied in repayment of the said sum so borrowed.

And the Honorable Roberts Christian Dunstan, Her Majesty's Minister of Water Supply for the State of Victoria, shall give the necessary directions herein accordingly.

J. ROSSITER,
Clerk of the Executive Council.

GEELONG WATERWORKS AND SEWERAGE TRUST.

At the Executive Council Chamber, Melbourne, the twenty-first day of March, 1972.

PRESENT:

His Excellency the Governor of Victoria.
Mr. Dickie | Mr. Borthwick.
Mr. Hunt

CONSENT TO BORROWING \$47,000.

Under the powers conferred by the Geelong Waterworks and Sewerage Act and all other powers enabling him in that behalf, His Excellency the Governor of the State of Victoria, by and with the advice of the Executive Council of the said State, doth hereby consent to the Geelong Waterworks and Sewerage Trust borrowing the sum of Forty-seven thousand dollars (\$47,000), for the conversion of Loan No. 05.

And the Honorable Roberts Christian Dunstan, Her Majesty's Minister of Water Supply for the State of Victoria, shall give the necessary directions herein accordingly.

J. ROSSITER,
Clerk of the Executive Council.

LANDLORD AND TENANT ACT 1958.

At the Executive Council Chamber, Melbourne, the twenty-first day of March, 1972.

PRESENT:

His Excellency the Governor of Victoria.
Mr. Dickie | Mr. Borthwick.
Mr. Hunt

ORDER EXTENDING APPLICATION OF PART V. OF THE LANDLORD AND TENANT ACT 1958 TO CERTAIN PREMISES.

In pursuance of the powers conferred by section 44 of the *Landlord and Tenant Act 1958*, His Excellency the Governor of Victoria, by and with the advice of the Executive Council thereof, doth hereby declare that the application of Part V. of the *Landlord and Tenant Act 1958* shall extend to the following premises.

1. The premises known as No. 21 Packington-place Prahran.
 2. The premises known as No. 156 Corio-street, Geelong.
- And the Honorable George Oswald Reid, Her Majesty's Attorney-General in and for the State of Victoria, shall give the necessary directions herein accordingly.

J. ROSSITER,
Clerk of the Executive Council.

LANDS DEPARTMENT NOTICES

APPROACHING LAND SALES.

Sales of Crown Lands, in fee-simple, will be held at the under-mentioned places and dates, viz.:-

	No. of Gazette.
Bendigo.—Tuesday, 18th April, 1972 ..	17
Red Cliffs.—Wednesday, 19th April, 1972 ..	16

COMMON ABOUT TO BE DIMINISHED.

In pursuance of the provisions contained in the *Land Act 1958*, notice is hereby given that it is the intention of the Governor in Council to diminish the common hereinafter mentioned, viz.:-

The following Notice was published 1° on the 8th March, 1972, pursuant to Order of the 29th February, 1972.

The Broadford Common, proclaimed as such by the Governor in Council on the 30th August, 1886, is about to be diminished by the excision therefrom of the portion in the Township of Broadford containing 1 acre, indicated by hatching on plan hereunder.—(C.70447.)

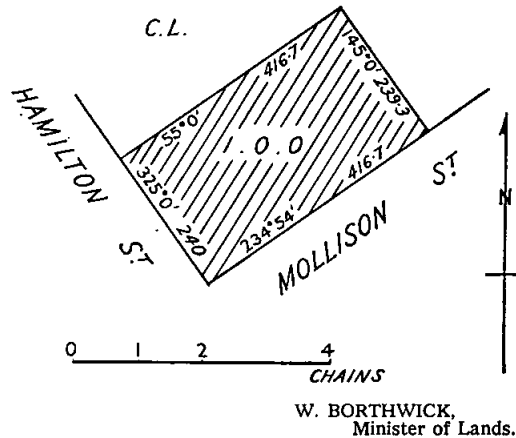

PROPOSED REVOCATIONS OF TEMPORARY RESERVATIONS OF LANDS BY ORDERS IN COUNCIL.

In pursuance of the provisions of the *Land Act 1958*, notice is hereby given that it is the intention of the Governor in Council to revoke the temporary reservations of lands by Orders in Council hereunder referred to, viz.:-

The following Notices were published 1° on the 22nd March, 1972, pursuant to Orders of the 15th March, 1972.

OXLEY.—The temporary reservation by Order in Council of the 30th November, 1948, of 3 roods 9 perches of land in two separate portions in the Township of Oxley as a site for an Ornamental Plantation and a Soldiers Memorial is about to be revoked so far only as the whole of the southern portion which contains 22 perches is concerned.—(O.16⁽²⁾) (Rs.6297).

MOREEP AND ANAKIE.—The temporary reservation as a site for a Pipe Track, Victorian Water Supply, and the withholding from sale, leasing and licensing by Order in Council of the 18th October, 1875 (see *Government Gazette* of the 22nd October, 1875, page 1995), of 168 acres of land in the Parishes of Moreep and Anakie are about to be revoked.—(M.468⁽⁸⁾), A.31⁽²⁾ (C.98135).

CARRARAGARMUNGEE.—The temporary reservation, by Order in Council of the 11th January, 1869, of 169 acres 3 roods 19 perches of land in the Parish of Carraragarmungee as a site for Watering purposes, revoked as to part by various authorized excisions is about to be revoked so far as the balance thereof containing 15 acres 2 roods 32 perches is concerned.—(C.188⁽⁸⁾) (Rs.1306).

FRAMLINGHAM EAST.—The temporary reservation, by Order in Council of the 6th November, 1876, of 5 acres of land in the Parish of Framlingham East as a site for Public purposes (State School) revoked as to part by Order of the 7th April, 1925, is about to be revoked so far as the balance thereof containing 2 acres 1 rood 8 perches is concerned, and the withholding from sale, leasing and licensing of the whole area included in the said Order of the 6th November, 1876, is about to be revoked.—(F.92⁽²⁾) (Rs.2415).

CROWLANDS.—The temporary reservation, by Order in Council of the 16th August, 1886 (see *Government Gazette* 20th August, 1886, page 2423) of 44 acres, more or less, of land in the Parish of Crowlands, County of Borung, as a site for Watering purposes, is about to be revoked, so far only as the portion containing 4 acres 2 roods 30 perches, more or less, indicated by hatching on plan hereunder, is concerned.—(C.324⁽⁸⁾) (C.100577).

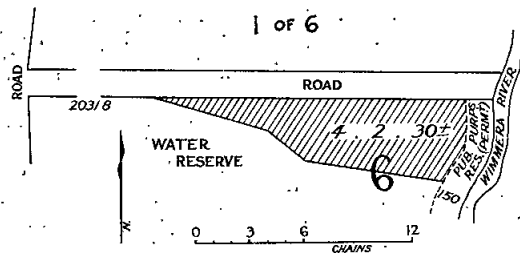

MORNINGTON.—The temporary reservation, by Order in Council of the 22nd June, 1971, of 2 acres 3 roods 30 perches, more or less, of land in the Township of Mornington, as a site for Public Park and for Public Recreation is about to be revoked so far only as the portion containing 1 rood 20 perches, more or less, indicated by hatching on plan hereunder, is concerned.—(M.162⁽²⁾) (Rs.5921).

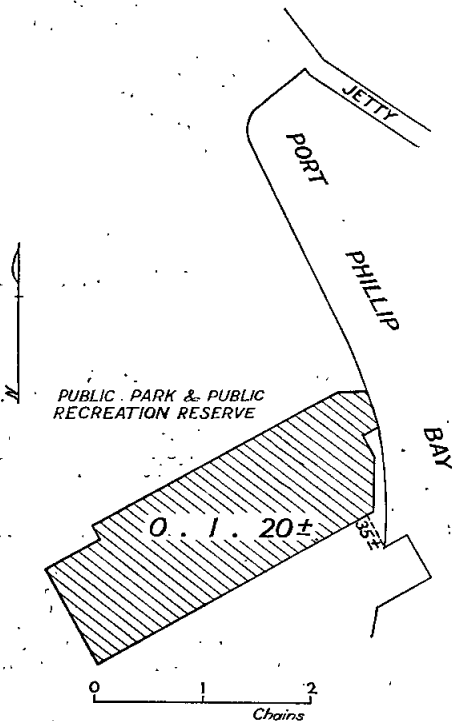

PYALONG.—The temporary reservation, by Order in Council of the 13th January, 1868, of 12 acres 1 rood 26 perches of land in the Parish of Pyalong (now in the Township of Pyalong) as a site for Police purposes, revoked as to part by various orders, is about to be revoked so far only as the portion containing 2 perches indicated by hatching on plan hereunder, is concerned.—(P.113⁽⁸⁾)—(Rs.1989).

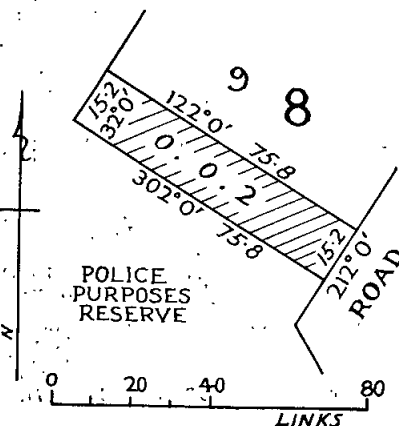

PUCKAPUNYAL.—The temporary reservation as a site for Camping and Watering purposes and the withholding from sale, leasing and licensing by Order in Council of the 15th April, 1878 (see *Government Gazette* 18th April, 1878, page 861) of 61 acres 35 perches of land in the Parish of Puckapunyal are about to be revoked save and except the area of 54 acres 3 roods 13 perches, indicated by hatching on plan hereunder.—(P.142⁽⁶⁾) (Rs.9587).

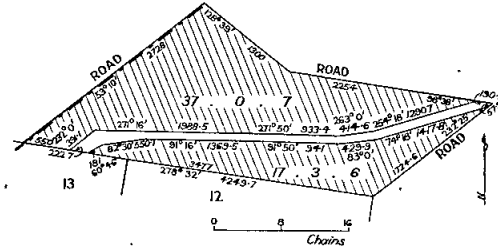

Total Area of Hatched Portions 54.3.13

W. BORTHWICK,
Minister of Lands.

TENDERS

PUBLIC WORKS DEPARTMENT

Tenders will be received at Public Works Department, 2 Treasury-place, Melbourne, until **TWO** p.m. on dates shown and for purposes mentioned hereunder.

Particulars and tender forms available at Contracts Office, Room 8, Building Division, Parliament-place and at places indicated in brackets hereunder.

Abbreviations in brackets mean:—W.O.—Inspector of Works Office; P.S.—Police Station; C.S.—Consolidated School; H.E.S.—Higher Elementary School; H.S.—High School; Pr.S.—Primary School; T.S.—Technical School.

Tenders to be submitted on the Department's printed Tender Form and will not be received by telephone. All tenders must be on a "Firm Tender" basis. The lowest or any tender will not necessarily be accepted.

Address tenders to the Minister of Public Works, and endorse the envelope containing the tender "Tender for closing Tuesday,

Hand delivered tenders to be placed in the Tender Box of the Public Works Department, located on the wall of the centre entrance foyer, Ground Floor, 2 Treasury-place, Melbourne.

No preliminary deposit is required with any tender, but a successful tenderer will be required to pay a deposit for any accepted tender of \$4,000 or over.

Tuesday, 28th March, 1972.

Building, Electrical and Mechanical Works.

ALEXANDRA.—External repairs and painting, H.S. (W.O., Alexandra.)

AXEDALE.—Erection of residential police station. (W.O., Bendigo.)

BLACKBURN.—Electrical services, Special School.

BLACKBURN SOUTH.—New brick veneer toilet block, extensions and renovations, Pr.S.4035.

BRUNSWICK.—General renovations to panel beating and machine shops, T.S.

COLLINGWOOD.—Replacement of steel frame windows, T.S. (Re-advertised.)

EDITHVALE.—External and internal repairs and painting, Pr.S.3790.

ELWOOD.—Erection of multi-purpose hall, type 800 "C", H.S. (Amended Specification.)

ELWOOD.—Electrical services, Hall, H.S. (Amended Specification.)

FITZROY.—Internal and external renovations, P.S. and Court House.

FITZROY.—Painting and renovations, H.S.

HAWKS BURN.—External renovations, Pr.S.1467.

MELBOURNE.—Supply, commissioning and testing of loudspeaking intercom. system, Police Headquarters.

ROKEWOOD.—Erection of residential police station. (W.O., Ballarat and Geelong.)

Site Works.

HEYWOOD.—Asphalt repairs, H.S. (W.O., Warrnambool.)

Thursday, 6th April, 1972.**Building, Electrical and Mechanical Works.**

ASCOT VALE WEST.—External renovations, Pr.S.4025. (Re-advertised.)

BEECHWORTH.—External repairs and painting, male wards 11/12, M.H. (W.O., Wangaratta.) (Re-advertised.)

BENDIGO.—Internal repairs and painting, Teachers College. (W.O., Bendigo.)

BROADMEADOWS.—Construction of Parasitology Building, Attwood Research Station.

CANTERBURY.—Mechanical services including service lifts—Science Block, Girls' H.S. (Re-advertised.)

CHILWELL.—Fencing and external repairs and painting, Pr.S.2061. (W.O., Geelong.)

FLEMINGTON.—Internal and external renovations, Pr.S.250.

IVANHOE.—Internal and external renovations, S.W.D. Hostel.

KARINGAL.—External and internal repairs and painting, H.S.

KORUMBURRA.—Internal and external renovations, H.S. (W.O., Korumburra.)

MAFFRA.—Erection of Police Station and Residence. (W.O., Bairnsdale.)

MARYBOROUGH.—Internal renovations, Pr.S.404. (W.O., Maryborough.)

MENTONE.—Repairs and painting, &c., Girls' H.S.

MOONEE PONDS.—Mechanical services—Court House. (Amended Specification.)

NIDDRIE.—Internal and external renovations, T.S.

PARKLANDS.—External painting, Pr.S.4738.

PRESTON EAST.—External and internal renovations, H.S.

ST. KILDA.—Internal renovations, Pr.S.1479.

THOMASTOWN EAST.—Connexion to M.M.B.W. sewerage, Pr.S.4827.

Site Works.

COBDEN.—Site works, T.S. (W.O., Camperdown.)

EDENHOPE.—Asphalt repairs, H.S. (W.O., Horsham.)

KEILOR PARK.—Site works, Pr.S.5030.

ST. ALBANS SOUTH.—Site works, Pr.S.4945.

YALLAMBIE.—Site works, Pr.S.5046.

Miscellaneous.

WILLIAMSTOWN.—Supply and delivery of fabricated mild steel pipe, Dredging Depot.

Tuesday, 11th April, 1972.**Building, Electrical and Mechanical Works.**

ASCOT VALE.—External and internal renovations, Travancore Developmental Centre, Residence.

BANYULE.—External painting and renovations, Pr.S.4746.

BAYVIEW.—External renovations, Pr.S.4752.

BOGONG VILLAGE.—Rewire of electrical installation &c., Camp School. (W.O., Wangaratta and Benalla.)

CHELSEA.—External and internal repairs and painting, Pr.S.3729.

DAYLESFORD.—Repairs and interior renovations, Pr.S.1609. (W.O., Bendigo and Ballarat.)

EDENHOPE.—Internal and external renovations, H.S. (W.O., Horsham.)

KEW.—External renovations, Wards 12, 13, 22, 24, Children's Cottages.

MELBOURNE.—Renovations to Third Floor, 107 Russell-street.

MOE.—Internal and external painting, replacement of boy's urinal &c., H.S. (H.S., Moe., W.O., Traralgon.)

STONEHAVEN.—Internal and external renovations, Pr.S.2199. (W.O. Geelong.)

TIDAL RIVER.—Sewerage reticulation &c., Wilsons Promontory N.P.S. (W.O., Korumburra and Warragul.)

TIDAL RIVER.—Construction of pumping well and pump house, N.P.S. Wilsons Promontory, (W.O., Korumburra and Warragul.)

Site Works.

BLACKBURN EAST.—Site works, Pr.S.4800.

Miscellaneous.

VARIOUS.—Supply of Engineers Lathes, period 1st July, 1972, to 30th June, 1973, Schools and Other Government Departments.

VARIOUS.—Supply of Engineers Machine Tools, period 1st July, 1972, to 30th June, 1973, Schools and Other Government Departments.

VARIOUS.—Supply of universal milling machines and shaping machine, period 1st July, 1972, to 30th June, 1973, Schools and Other Government Departments.

VARIOUS.—Supply of woodworking machines, period 1st July, 1972, to 30th June, 1973, Schools and Other Government Departments.

WILLIAMSTOWN.—Design, construction, supply and delivery of one hand operated wharf crane of two-ton capacity, Dredging Depot.

MURRAY BYRNE,
Minister of Public Works.

Public Works Department,
Melbourne, 3002, 20th March, 1972.

TENDERS FOR THE SERVICE, 1972-73-74.**GENERAL STORES.**

Tenders will be received until Eleven o'clock a.m., on Friday, the 14th April, 1972, from persons willing to supply the under-mentioned articles in such quantities as may be ordered by the Victorian Government during the periods commencing 1st July, 1972—

Schedule No.

1. Cotton Textiles.
2. Towels Turkish.
13. Acids and Chemicals.
18. Bolts, Nuts, Fixing Devices, &c.
19. Construction Materials, Lime, &c.
27. Piping and Fittings (Brass, Copper, Steel).
29. Cordage, Lines, Rope, Twine, &c.
32. Disinfectants.
36. Crockery, Cutlery and Kitchenware.
37. Electrical Goods (Appliances, Cables and Accessories).
48. Iron (Galvanised) Downpipe, Ridging, Spouting, &c.
49. Steel (Mild).
53. Leather, Chamois Skins, Shoe Laces, &c.
54. Metals, (Brass, Copper and Lead).
57. Nails, Rivets, Screws, &c.
61. Packing—Engine, &c.

The prices tendered must not include sales tax.

Security—Five per cent. of total amount of tender accepted, but in no case will security of less than \$6 be received.

Schedules as above, with full particulars, may be obtained from the Secretary to the Tender Board, 2nd Floor, South Building, New State Public Offices, Treasury-place, Melbourne, 3002, by whom also the samples will be shown and any information afforded to persons tendering.

In all cases the total cost of each item must be extended in the columns provided.

Security will be required either in Commonwealth Treasury Bonds, or approved bank guarantee, fixed deposit receipt, Savings Bank deposit book, or non-negotiable cheque in favour of the Secretary to the Tender Board, as the tenderer may elect.

The security must be completed and the contract signed within five days of acceptance of the tender, failing which the service may be again advertised, or another tender accepted.

The lowest or any tender will not necessarily be accepted.

In the event of tenderers withdrawing or attempting to withdraw their tenders before notification of acceptance of same, or failing to take up their accepted tenders within the prescribed period after notification of acceptance, they may be disqualified from tendering or holding any future contracts for Government supplies for a period of twelve months, such disqualification to date from the notification of acceptance of tender. It is also stipulated that, if a tenderer be a member of a firm and such firm be interested in the contract, the tender shall be in the name of the firm and not in that of the individual and that, for a breach of this condition, the tender will be declared informal.

Tenders enclosed in a separate envelope, and having the words "Tender for ———" (as the case may be) written thereon, must be deposited in the Tender-box at the Tender Board Offices, 2nd Floor, South Building, New State Public Offices, Treasury-place, Melbourne, 3002, or if sent by post, postage must be prepaid and the tenders addressed to the Chairman of the Tender Board, Tender Board Offices, 2nd Floor, South Building, New State Public Offices, Treasury-place, Melbourne, 3002, which office they must reach not later than by first post on the date of closing of tenders.

CONDITIONS OF CONTRACT.

1. For the purposes of these contracts the word "Government" shall mean the Government of the State of Victoria; and the word "Treasurer" shall mean the Treasurer of the said State.

2. Except where definite quantities are specified the Government will not be bound to order from the contractor all the articles enumerated in the schedule, but only those articles, and such quantities of those articles, as it may be found necessary to order. Should the Government, however, require a larger supply of any article than the estimated quantity stated in the schedule, the contractor will nevertheless be bound to supply the same at contract rates. The Government reserves the right to purchase otherwise than from the contractor articles of any of the several kinds enumerated in the schedule, the purchase of which is, in the opinion of the Tender Board, necessary in order to meet special circumstances or special requirements.

3. Under this contract goods may be ordered by any Department of the Commonwealth, but it shall be optional on the part of the contractor to supply.

4. Supplies must be of the kind ordered and of the particular manufacture accepted under contract. In the event of the tender having been accepted for goods manufactured within Australia or within any other part of the British Commonwealth, all such goods supplied shall, if required by the Government, bear evidence that they are of the particular manufacture tendered for and, in addition, the contractor may at any time during the currency of the contract be called on to furnish a statutory declaration as to the country of origin of the goods supplied.

5. Except where otherwise stated in the schedule, the value of all packages, cases, casks, &c., whether bulk be broken or not, must be included in the prices stated in the contractor's tender; all such packages, &c., shall be considered the property of the Government, and no charges or expenses whatsoever beyond the price tendered and set out in the schedule will be allowed to the contractor for any articles or packages, cases, casks, &c. The net weight or quantity only will be paid for. The contractor must provide, without extra charge, whatever labour may be required in the packing of stores.

6. Except where otherwise stated in the schedule all orders for supplies will emanate from the Departments requiring the goods, which shall be delivered as may be directed by the officer ordering the supply. At the time of delivering the supplies, the contractor shall produce the order for same to the officer authorized to accept delivery, and such officer shall acknowledge thereon the receipt of the stores accepted and return the order to the contractor, who will attach it to his claim for payment.

7. Supplies ordered for delivery in the Melbourne District are to be delivered free of all charges (whether cartage, freight, &c.) and, for the purposes of this contract, the Melbourne District, will include a radius of 20 miles from the Elizabeth-street Post Office. For supplies outside that radius the goods must be delivered free or free on rails at Flinders-street or Spencer-street Railway Stations as required.

8. Arrangements as to time of delivery and inspection of goods will be made by the officer ordering the supply.

9. Orders must receive prompt execution; in the event of the goods not being delivered within forty-eight hours after the specified delivery date shown on the order, it will be competent, after obtaining approval of the Tender Board, for the officer named in clause 8, or the head of the department to whom the goods are to be supplied, on giving the contractor twenty-four hours' notice, to purchase the supplies, or any like supplies that are suitable for the service, at the contractor's risk, and the extra expense incurred over and above the contract price (if any) will be deducted from the contractors' account or from the security money.

10. Delivery will not be deemed to have been made until the goods have been approved of. In the event of the rejection or return of any supplies, the contractor shall

bear the whole cost of replacing the supplies rejected or returned, otherwise purchases will be effected at the contractor's risk and the extra expense deducted as provided in clause 9.

11. The contractor will be required to furnish his account in the prescribed form as soon as possible after the delivery of the goods, the account to be accompanied by the receipted delivery orders on which it is based. Where practicable, the use of more than one account form for each Department or sub-Department must be avoided. The rates and the quantities quoted in the orders cannot be increased.

12. The acceptance of the supplies shall be subject to the approval of the officer authorized to take delivery of the stores, or such other officer as shall be named in the schedule. The contractor may, however, claim a survey on any goods objected to; but in that case, he must, within twenty-four hours after the objection is made, give notice thereof, in writing, to the officer rejecting the goods. If, after the delivery of the supplies has been taken, any deficiency or defect is discovered therein, such deficient or defective stores may be returned to the contractor.

13. The members of Boards of survey will be appointed by the Treasurer of the State for the time being, and the decision of the Board is to be considered as final. If the Board shall decide that the article is not of proper quality it must be immediately replaced by the contractor, failing which it, or any like supply that is suitable for the service, will be procured elsewhere, and the survey fees and extra expense (if any) will be charged as provided in clause 9.

14. A refusal to execute orders, irregularity in the quantity or quality of the supplies, delay in delivering or replacing them when required, or non-compliance with the terms of clauses 16 and 17 of these Conditions respecting the forwarding of consignment notes, &c., will subject the contractor, upon report from the Tender Board, to such mulct not exceeding Five hundred dollars as the Treasurer may direct, and the amount may be deducted as provided in clause 9. It will also be in the power of the said Treasurer upon such refusal, irregularity, or delay to terminate the contract forthwith and declare forfeit the whole or any portion of the security money; and, in addition, the contractor will be disqualified from tendering or holding any future contract or contracts for a period of not less than twelve months from the date of such disqualification.

15. All goods forwarded under this contract outside the Melbourne District shall, where railway facilities are available, be forwarded by rail, and all consignments shall bear the number of the consignment notes under which they are forwarded and also the name of the contractor by whom consigned, on a legibly-written business label.

16. When the contractor is required to make delivery of goods at a railway station for transmission by rail for any Department excepting Departments of the Commonwealth, he shall obtain a receipt for the goods in duplicate on the Stores and Transport consignment note, at the same time handing in a triplicate and quadruplicate of the form as an authority for the Railways to act as agent for, and charge the freight to, the Stores and Transport Office or such other Department as shall be named therein. He shall as soon as possible, and not later than twenty-four hours thereafter, deliver the original at the Tender Board Offices, the duplicate to be forwarded to the consignee in accordance with clause 17, and the quintuplicate to be retained by himself. Should the goods thus forwarded be rejected, the contractor must bear the cost of replacing such goods, for which service the departmental consignment note must not be used. Any infringement of this condition will subject the contractor to such mulct as is provided in clause 14.

17. Immediately after the consignment of the goods, the officer to whom they are forwarded shall be notified by the contractor, on the duplicate consignment note provided for the purpose, that the goods have been sent. On receipt of this document, the officer to whom it has been forwarded shall acknowledge thereon the receipt of the goods without delay to the Stores and Transport Office. In the event of loss through failure on the part of the contractor to comply with this condition he will be held responsible, and the amount of the loss incurred thereby will be deducted as provided in clause 9.

18. Should the order on the contractor specially provide that goods of a fragile character, or such as are liable to suffer loss by leakage, shall be consigned at the risk of the Railways Commissioners, under special freight conditions, the contractor shall in such instance provide,

in writing on the consignment note, an intimation to that effect failing which, in the event of loss, he shall bear the whole cost of replacing the goods, the amount thereof to be deducted from the contractor's account or from the security money.

19. The contractor is not at liberty to transfer his contract under cover of power of attorney, coupled with an interest or otherwise, and no such transfer will be recognized by the Government. Should it be found during the currency of the contract that the contractor has not conformed to the condition of advertisement—which stipulates that if a tenderer be a member of a firm and such firm be interested in the contract, the tender shall be in the name of the firm, and not in that of the individual—then the Treasurer may, on the recommendation of the Tender Board, determine the contract and forfeit the security money.

20. The contract entered into under these conditions is not to be considered as being broken, infringed, or vitiated by the importation of stores for the Government service, or by any contracts or purchases made by the Agent-General for Victoria, or by any contracts or agreements made for any works or supplies by the Department of Public Works or by the State Rivers and Water Supply, Forests, and Electricity Commissioners, or the Country Roads Board, or for the Railways Department, or for supplies for Technical Schools, or for connexions and fittings for Drills and Batteries, or by any article being made at and supplied for the use of any Government establishment, or by the consumption of the surplus stock of any Government establishment.

21. Notwithstanding anything to the contrary contained in section 152 of the Customs Act 1901-71, it is hereby expressly provided that upon any alteration of the duty collected affecting the goods included in this contract, the contract price shall not be altered, and the contract may be terminated at the option of either party by two months' notice, in writing, from the first day of the calendar month next ensuing and within the period for which the contract is made. The contract for the unaffected items shall remain in full force and effect. Any notice to be served under this condition shall be deemed to have been duly served if sent to the contractor in a registered letter to his last-known place of business or abode.

22. The foregoing provision shall not apply where the contract is for definite quantities of imported goods to be delivered at stated times, as stipulated in the schedule, and any alteration in the duty of Customs or Telegraphic Transfer rate of exchange affecting the goods included in such contract shall be to the accounts of the Government; adjustments to be based on the F.O.B. and C.L.F. prices of the goods, respectively, and the Telegraphic Transfer rate ruling at the time of delivery of the goods.

23. Under no circumstances, other than those mentioned in clause 21, will the contractor be permitted to abandon his contract. In the event of the contractor failing to carry on the contract, the contract security money will in that case be absolutely forfeited and, in addition, the contractor will be held liable for any loss which the Government may sustain in consequence of such failure.

24. Every person engaged in the service tendered for in this schedule shall be paid such wages and employed subject to such labour conditions as are or may be determined by any Federal Arbitration Court Award or any State Wages Board determination.

25. The contractor will be held liable for any damage to Government property occasioned by the contractor or any person engaged by the contractor during the performance of any service required under the contract.

14th March, 1972.

E. P. WATSON,
Secretary to the Tender Board.

The places for which tenders will be received and the security required for the due fulfilment of each contract are as follows:—

Schedule No. 1.	Melbourne Metropolitan and District	Kew Mental Hospital, Children's Cottages, Kew; Children's Welfare Depot, Royal Park; Psychiatric Hospital, Royal Park; Travancore Developmental Centre, Flemington; St. Nicholas Hospital, Carlton; "Winlaton" Juvenile School, 186 Springvale-road, Nunawading and "Allambie" Reception Centre, 70 Elgar-road, Burwood; Teachers' College, Grattan-street, Carlton; Teachers' College Hostels, 93 Drummond-street, Carlton, 470, and 372 St. Kilda-road, Melbourne, 19 Queen's-road, Melbourne, 152 Toorak-road West, South Yarra; Frank Tate House, 373 Dandenong-road Armadale; "Redcourt", No. 506 "Larnook", No. 519 and 13 Orrong-road, Armadale; 11 Patterson-street, Hawthorn; 174 Punt-road, Prahran; 221 Burwood-road, Burwood; John Cannon House, 32 Belmont-avenue, Kew; 23 Moule-avenue, Brighton and Hastings-road, Frankston; Police Hospital, St. Kilda-road, Melbourne; Mental Hygiene Clinic, 321 Glenferrie-road, Malvern, Mont Park, Bundoora, Larundel, Janefield, and Sunbury Mental Hospitals; Gresswell Rehabilitation Centre and Heatherton Sanatorium, Springvale.	Bread Flour Jams Tea Coffee Milk Cereals Potatoes Onions
Schedule No. 6	Ararat District		Breadstuffs Milk (Gaoi only) Potatoes
Schedule No. 7	Ballarat District		Breadstuffs Milk Potatoes and onions
Schedule No. 8	Beechworth District		Breadstuffs Milk (Gaoi only) Potatoes and onions
Schedule No. 9	Bendigo District		Bread Milk Potatoes and onions
Schedule No. 10	Castlemaine District		Bread Potatoes Breadstuffs
Schedule No. 11	School of Forestry, Creswick		Milk
Schedule No. 12	Shepparton District		Bread Milk Potatoes and onions
Schedule No. 13	McLeod Settlement, French Island		Bread Potatoes
Schedule No. 14	Geelong District		Bread Potatoes and onions
Schedule No. 15	Coorimungie Prison Camp, Heytesbury Forest		Bread Potatoes
Schedule No. 16	Agricultural College, Glenormiston		Bread
Schedule No. 17	Langi Kal Kal Training Centre		Bread
Schedule No. 18	Agricultural College, Longernong		Breadstuffs Potatoes and onions
Schedule No. 19	Research Station, Rutherglen		Bread
Schedule No. 20	Sale Gaoi		Bread Potatoes Breadstuffs
Schedule No. 21	Pleasant Creek Special School, Stawell		Milk Potatoes Breadstuffs
Schedule No. 23	Warrnambool District		Milk Breadstuffs
Schedule No. 24	Hobson Park Hospital, Traragon District		Milk
Schedule No. 25	Malmesbury Youth Training Centre		Bread Milk
Schedule No. 26	Morwell River Re-forestation Prison		Breadstuffs Milk Potatoes
Schedule No. 27	Tatura District		Breadstuffs Potatoes
Schedule No. 28	State Research Farm, Werribee		Bread Milk
Schedule No. 29	Wendouebie Re-forestation Prison		Bread Milk Potatoes

TENDERS FOR THE SERVICE, 1972-73.

PROVISIONS.

Tenders will be received until Eleven o'clock a.m., on Friday, 7th April, 1972, from persons willing to furnish the under-mentioned supplies, in such quantities as may be ordered by the Victorian Government—delivery to be made at the under-mentioned places—during the period from 1st July, 1972 to 30th June, 1973.

The prices tendered must not include sales tax.

In all cases, the total cost of each item must be extended in the columns provided.

No. 20.—2382/72.—3

Printed forms of tender and the conditions of contract may, in all cases, be obtained from the Secretary to the Tender Board, 2nd Floor, South Building, New State Public Offices, Treasury-place, Melbourne, 3002, by whom also any information or explanation will be afforded to persons tendering.

Security will be required either in Commonwealth Treasury Bonds or approved bank guarantee, fixed deposit receipt, Savings Bank deposit book, or non-negotiable cheque in favour of the Secretary to the Tender Board, as the tenderer may elect.

The security must be completed and the contract signed within ten days of acceptance of the tender, failing which the service may be again advertised, or another tender accepted.

Preference will be given by the Tender Board to tenders for articles manufactured within the Commonwealth, provided the quality of such articles is satisfactory and the prices tendered are considered reasonable.

The lowest or any tender will not necessarily be accepted.

In the event of tenderers withdrawing or attempting to withdraw their tenders before notification of acceptance of same, or failing to take up their accepted tenders within the prescribed period after notification of acceptance, they may be disqualified from tendering or holding any future contracts for Government supplies for a period of twelve months, such disqualification to date from the notification of acceptance of tender. It is also stipulated that, if a tenderer be a member of a firm and such firm be interested in the contract, the tender shall be in the name of the firm and not in that of the individual, and that, for a breach of this condition, the tender will be declared informal.

Tenders, enclosed in a separate envelope, and having the words "Tender for at (as the case may be) written thereon, must be deposited in the Tender-box at the Tender Board Office, 2nd Floor, South Building, New State Public Offices, Treasury-place, Melbourne, 3002, or if sent by post, postage must be prepaid, and the tenders addressed to the Chairman of the Tender Board, Tender Board Offices, 2nd Floor, South Building, New State Public Offices, Treasury-place, Melbourne, 3002, which office they must reach not later than by first post on the date of closing of tenders.

CONDITIONS OF CONTRACT.

1. For the purposes of these contracts the word "Government" shall mean the Government of the State of Victoria; and the word "Treasurer" shall mean the Treasurer of the said State.

2. All the articles are to be of the best quality of the several kinds, in the best conditions, and in conformity with the Health Acts, and to be delivered in sound packages, free from all charges for cartage, freight, &c. The goods shall be delivered as may be directed by the officer ordering the supply.

3. As the exact quantity of any article which may be required cannot be stated, the estimate being approximate only, the Government will not be bound by the quantity stated in the Schedule, but will be at liberty to order more or less, according to circumstances, and the contractor will be bound to supply the same as ordered.

4. The Government reserves the right to purchase otherwise than from the contractor any of the articles specified in the Schedule in the event of an emergency.

5. Supplies for country districts for which no local contract may have been taken, or for which the contract has been terminated, may be ordered under the Melbourne and Metropolitan contract.

6. The Melbourne and Metropolitan District will include places within a radius of 20 miles from the Elizabeth-street Post Office. Delivery must be made at the places, institutions, &c., named in the Schedules, or as directed by the officer ordering the supply.

7. Except where otherwise stated in the schedule, the value of all packages, cases, casks, &c., whether bulk be broken or not, must be included in the prices stated in the contractor's tender; all such packages, &c., shall be considered the property of the Government; and no charges or expenses whatsoever beyond the price tendered and set out in the schedule will be allowed to the contractor for any articles or packages, cases, casks, &c. The net weight or quantity only will be paid for. The contractor must provide, without extra charge, whatever labour may be required in the packing of stores. Butter boxes and soap boxes (not including fancy soaps), jam jars, flour, meal, and potato bags will remain the property of the contractor, the empty containers to be removed from the place of delivery at the contractor's expense.

8. Meat supplied under these conditions must be slaughtered and supplied in accordance with the provisions of the Health Act and Regulations. Any infringement of this condition will subject the contractor, on report from the Tender Board to such mulct, not exceeding One hundred dollars, as the Treasurer may direct, and the amount will be deducted from the contractor's account, or from the security money.

9. The supplies coming under the head of Rations and Medical Comforts are to be delivered direct to the establishment entitled thereto on the written order of the officer in charge. All other supplies will be ordered by the head of the Department concerned or any officer authorized by him, and shall be delivered as may be directed by the officer ordering the supply.

10. At the time of delivering the supplies, the contractor shall produce the order for the same to the officer authorized to accept delivery, and such officer shall acknowledge thereon the receipt of the stores accepted, and shall return the order to the contractor, who shall render his account as soon as possible after the delivery of the supplies, accompanied by the receipted delivery order. The rates or quantities quoted in the orders cannot be exceeded.

11. Where railway facilities are available, the contractor shall, except where delivery is required direct into institutions, use the Railways for the transport of the goods. When a contractor is required to make delivery of goods at a railway station for transmission by rail, except for Commonwealth Departments, he shall obtain a receipt for the goods in duplicate on the Stores and Transport consignment note at the same time handing in the triplicate and quadruplicate of the form as an authority for the Railways to act as agent for, and charge the freight to the Stores and Transport Office. He shall as soon as possible, and not later than twenty-four hours thereafter, deliver at the Tender Board Offices the original, the duplicate to be forwarded to the consignees and the quintuplicate retained by himself. Should the goods thus forwarded be rejected, the contractor must bear the cost of replacing such goods, for which services the departmental consignment note is not to be used. Any infringement of this condition may subject the contractor to such mulct as the Tender Board may recommend under clause 20 of these conditions.

12. Orders must receive prompt execution; in the event of the goods not being delivered at the time mentioned in the order or within such other time as the officer ordering the supply may specify for delivery, it will be competent for such officer, or the head of the Department to whom the goods are to be supplied, on giving the contractor twenty-four hours' notice, to purchase the supplies, or any like supplies that are suitable for the service, at the contractor's risk, and the extra expense incurred over and above the contract price (if any) will be deducted from the contractor's account or from the security money.

13. The acceptance of the supplies shall be subject to the approval of the officer authorized to take delivery of the stores, or such other officer as shall be named in the conditions.

14. If the officer in charge of stores be not satisfied as to the quantity or quality of the stores, or if, after taking delivery of any stores or material, he shall discover any deficiency or defect therein, he may return such deficient or defective stores or material to the contractor, and shall report the same to the head of his department and to the Tender Board.

15. In the event of a difference of opinion between the contractor and the officer receiving the supplies as to the quality, the same is to be decided, in cases where the article is not of a perishable nature, by a Board of Survey composed of persons named by the Treasurer of the State for the time being; and the decision of the Board is to be considered final. In the event of the decision being against the contractor, the survey fees and expenses (if any) will be deducted as in clause 12.

16. In cases where the article is of a perishable nature, or when from some other cause injury would be sustained either by the person to whom the rations or stores are due or by the contractor in waiting for a Board to survey, the head of the Department or officer authorized to take delivery will have power to reject such article or articles as are, obviously of inferior quality, it being understood that he will be responsible to the Government for so doing, and that the contractor must take back the rejected article and supply good in its stead; failing which it, or any like supply suitable for the Service, will be obtained by the officer requiring it as in clause 12. In case of the rejection or return of any supplies, the contractor shall bear the whole cost of replacing the supplies so rejected or returned.

17. If the Board shall decide that the article is not of proper quality it must be immediately replaced by the contractor; failing which it, or any like supply suitable for the Service, will be procured by the officer requiring it, and the expense charged as in clause 12.

18. In the case of supplies for Mental Hospitals, it will be competent for a Board of Survey, consisting of the medical superintendent (or, in his absence, of the medical officer) and any two officers named by him, to examine and reject any supplies that may be objected to. It must be

distinctly understood, however, that the contractor will have a right of appeal to the Treasurer of the State for the time being, such appeal to be made in writing within 24 hours of the rejection; but, pending such appeal, he must at once supply others of approved quality; failing which, the supplies required, or any like supplies suitable for the Service, may be obtained by the officer concerned, and the expense charged as in clause 12.

19. In the case of supplies for Mental Hospitals, it will also be competent for two or more of the official visitors, in conjunction with the medical superintendent, to reject any supplies that they may consider not in accordance with contract; and in such cases the reference to a Board of Survey will not be deemed to be necessary.

20. A refusal to execute orders, irregularity in the quantity or quality of the supplies, or delay in delivering or replacing them when required, will subject the contractor, upon report from the Tender Board, to such mulct, not exceeding One hundred dollars, as the said Treasurer may direct, and the amount may be deducted as in clause 12. It will also be in the power of the said Treasurer, upon such refusal, irregularity or delay, to terminate the contract forthwith, and forfeit the whole or any part of the security money; and, in addition, the contractor will be disqualified from tendering or holding any future contract or contracts for a period of not less than twelve months from the date of such disqualification.

21. Contractors are not at liberty to transfer their contracts under cover of power of attorney, coupled with an interest or otherwise, and no such transfer will be recognized by the Government. *If it is found during the currency of the contract that the contractor has not conformed to the condition of advertisement—which stipulates that if a tenderer be a member of a firm and such firm be interested in the contract, the tender shall be in the name of the firm and not in that of the individual—then the Treasurer may, on the recommendation of the Tender Board, determine the contract, and forfeit the security money.*

22. It will be competent for the Tender Board to terminate the contract, without notice, should there be reason to know that the contractor takes advantage of his contract to communicate with a prisoner.

23. The contract entered into under these conditions is not to be considered as being broken, infringed, or vitiated by the importation of stores for the Government service, or by any contracts or purchases made by the Agent General for Victoria; or by the consumption of the produce or surplus stock of any Government establishment, or by any article being made at and supplied for the use of any Government establishment.

24. Notwithstanding anything contained to the contrary in section 152 of the Customs Act 1901-71, it is hereby expressly provided that upon any alteration of the duty collected affecting the goods included in this contract, the contract price shall not be altered, and the contract may be terminated at the option of either party by two months' notice in writing from the first day of the calendar month next ensuing, and within the period for which the contract is made. The contract for the unaffected items shall remain in full force and effect. Any notice to be served under this condition shall be deemed to have been duly served if sent to the contractor in a registered letter to his last known place of business or abode.

25. Under no circumstances other than those mentioned in clause 24 will a contractor be permitted to abandon his contract. In the event of the contractor failing to carry on the contract; the contract security money will in that case be absolutely forfeited and, in addition, the contractor will be held liable for any loss which the Government may sustain in consequence of such failure.

26. Every person engaged in the service tendered for in this schedule shall be paid such wages and employed subject to such labor conditions as are or may be determined by any Federal Arbitration Court award or any State Wages Board determination.

27. The contractor will be held liable for any damage to Government property occasioned by the contractor or any person engaged by the contractor during the performance of any service required under the contract.

E. P. WATSON,
Secretary to the Tender Board.

14th March, 1972.

Teaching Service Act 1958.

TEACHING SERVICE (TEACHERS TRIBUNAL) REGULATIONS.

AMENDMENT No. 223 (T.T.37).

The Teachers Tribunal, in pursuance of the powers conferred by the Teaching Service Act 1958, hereby amends Regulation 3 of the Teaching Service (Teachers Tribunal) Regulations in the manner following, that is to say:—

REGULATION 3.

After the proviso to clause 7 add the following new proviso:—

“ Provided further that, in special circumstances, following a recommendation by the appropriate Committee of Classifiers, the Tribunal may, as an interim measure, authorize an alteration to the factors to which the Classifiers shall have regard in determining the relative positions on the classified roll of persons who have completed courses of training.”

W. E. SAMPSON, Chairman.
A. F. LE CLERCQ, Secretary.

Office of the Teachers Tribunal,
Melbourne, 9th March, 1972.

Teaching Service Act 1958.

TEACHING SERVICE (TEACHERS TRIBUNAL)
REGULATIONS.

AMENDMENT No. 224 (T.T.38).

The Teachers Tribunal, in pursuance of the powers conferred by the *Teaching Service Act 1958*, hereby amends Regulation 1 of the Teaching Service (Teachers Tribunal) Regulations in the manner following, that is to say:—

REGULATION 1.

1. In clause 15 for the amounts "\$1", "\$1.10" and "\$1.45", substitute the amounts "\$1.25", "\$1.35" and "\$1.80", respectively.

2. In clause 28 for the amount "\$1.45" substitute the amount "\$1.80".

W. E. SAMPSON, Chairman.
A. F. LE CLERCQ, Secretary.

Office of the Teachers Tribunal,
Melbourne, 14th March, 1972.

PUBLIC SERVICE NOTICES

No. 198.

Public Service Act 1958, Section 50.

REGULATIONS.—PART IV.—SALARIES AND INCREMENTS.

The Public Service Board, in pursuance of the powers conferred by the *Public Service Act 1958*, hereby amends its Regulations as shown below:—

SIXTH SCHEDULE.

TEMPORARY EMPLOYEES.

Designations of Positions and Rates of Salaries.

Department and Designation of Position.	Yearly Rate of Salary.		Increments (Annual).
	Minimum.	Maximum.	
	\$	\$	
<i>Delete the existing yearly rates of salary for the following positions and insert the rates shown hereunder in lieu thereof—</i>			
GENERAL.			
Gardener, Grade III. ..	3,532	3,861	Σ
Gardener, Grade II. ..	3,392	3,762	Σ
Gardener, Grade I.—Adult ..	3,210	3,551	Σ
DEPARTMENT OF CROWN LANDS AND SURVEY.			
<i>Royal Botanic Gardens.</i>			
Gardener, Grade IIa. ..	3,880	4,197	Σ
DEPARTMENT OF HEALTH.			
<i>Tuberculosis</i> φ			
<i>State Sanatoria</i> φ			
Gardener, Senior	3,940	4,295	Σ
SOCIAL WELFARE DEPARTMENT.			
<i>Family Welfare Division.</i>			
Gardener and General Assistant	3,210	3,551	Σ

This Regulation shall have effect as on and from the 5th March, 1972.

A. J. A. GARDNER, Chairman.
V. P. SCULLY, Secretary.

Office of the Public Service Board,
Melbourne, 6th March, 1972.

No. 197.

Public Service Act 1958, Section 50.

REGULATIONS.—PART IV.—SALARIES AND INCREMENTS.

The Public Service Board, in pursuance of the powers conferred by the *Public Service Act 1958*, hereby amends its Regulations as shown below:—

FIFTH SCHEDULE.

TEMPORARY EMPLOYEES.

DEPARTMENT OF HEALTH.

MENTAL HYGIENE.

Designations of Positions and Rates of Salaries.

Designation of Position.	Yearly Rate of Salary.£	
	Minimum.	Maximum.
	\$	\$
<i>Delete—</i>		
Gardener, Grade III.	3,290	3,627
Gardener, Grade II.	3,169	3,532
Gardener, Grade I.—Adult ..	2,983	3,331
<i>Add—</i>		
Gardener, Grade III.	3,532	3,861
Gardener, Grade II.	3,392	3,762
Gardener, Grade I.—Adult ..	3,210	3,551

Σ Annual increments shall be in accordance with those prescribed by Sub-Regulation 113 (2) and 113 (3) provided that in the case of the position of Assistant (Male), Administrative, the annual increments shall be in accordance with those prescribed by Part A of the Third Schedule.

This Regulation shall have effect as on and from the 5th March, 1972.

A. J. A. GARDNER, Chairman.

V. P. SCULLY, Secretary.

Office of the Public Service Board,
Melbourne, 14th March, 1972.

No. 199.

PUBLIC SERVICE ACT 1958.

The Public Service Board, in pursuance of the powers conferred by the *Public Service Act 1958*, hereby amends the Public Service (Public Service Board) Regulations as follows:—

PART V.—ALLOWANCES.

DIVISION V.—OTHER ALLOWANCES.

TREASURY—GOVERNMENT PRINTING OFFICE.

Regulation 183.

The amounts "5c", "7.1c", "14.0c" and "5c" are deleted and the amounts "7c", "7.5c", "15c" and "11c" are inserted in lieu thereof, respectively.

This regulation shall have effect as on and from the 5th March, 1972.

A. J. A. GARDNER, Chairman.

V. P. SCULLY, Secretary.

Office of the Public Service Board,
Melbourne, 6th March, 1972.

No. 195.

Public Service Act 1958, Section 50.
REGULATIONS.—PART IV.—SALARIES AND INCREMENTS.

The Public Service Board, in pursuance of the powers conferred by the *Public Service Act 1958*, hereby amends its Regulations as shown below :—

FIFTH SCHEDULE.
TEMPORARY EMPLOYEES.
DEPARTMENT OF HEALTH.
MENTAL HYGIENE.

Designations of Positions and Rates of Salaries.

Designation of Position.	Yearly Rate of Salary.£		Increments (Annual).
	Minimum.	Maximum.	
	\$	\$	
<i>Delete—</i>			
Tailoress, Grade II.	3,575	3,936	..
Tailoress, Grade I.	3,361	3,714	..
<i>Add—</i>			
Tailoress, Grade II.	3,724	4,100	A
Tailoress, Grade I.	3,513	3,880	A

A Increments in accordance with those prescribed for males and females in Part A of sub-regulation 113 (2).

£ Annual increments shall be in accordance with those prescribed by Sub-Regulations 113 (2) and 113 (3), provided that in the case of the position of Assistant (Male), Administrative, the annual increments shall be in accordance with those prescribed by Part A of the Third Schedule.

This Regulation shall have effect as on and from the 5th March, 1972.

A. J. A. GARDNER, Chairman.
V. P. SCULLY, Secretary.

Office of the Public Service Board,
Melbourne, 6th March, 1972.

No. 196.

Public Service Act 1958, Section 50.
REGULATIONS.—PART IV.—SALARIES AND INCREMENTS.

The Public Service Board, in pursuance of the powers conferred by the *Public Service Act 1958*, hereby amends its Regulations as shown below :—

SIXTH SCHEDULE.
TEMPORARY EMPLOYEES.

Designations of Positions and Rates of Salaries.

Department and Designation of Position.	Yearly Rate of Salary.		Increments (Annual).
	Minimum.	Maximum.	
	\$	\$	
EDUCATION DEPARTMENT.			
<i>Delete the existing yearly rate of salary for the following position and insert the rates shown hereunder in lieu thereof—</i>			
Graphic Artist—Adult	3,782	4,120	A

A Increments in accordance with those prescribed for males and females in Part A of Regulation 113 (2).

This Regulation shall have effect as on and from the 12th March, 1972.

A. J. A. GARDNER, Chairman.
V. P. SCULLY, Secretary.

Office of the Public Service Board,
Melbourne, 10th March, 1972.

PRIVATE ADVERTISEMENTS

CITY OF BENALLA.

LOAN No. 28.

Notice of Intention to Borrow.

Notice is hereby given that the Council of the City of Benalla intends to borrow Twenty thousand dollars (\$20,000), secured by charge over the general rates of the municipality by the grant of a mortgage in accordance with the provisions of the Local Government Acts.

In connexion therewith the following information is stated:—

- (a) The amount of the principal moneys which it is proposed to borrow: \$20,000 (Twenty thousand dollars).
- (b) The maximum rate of interest that may be paid is 6.4 per centum per annum.
- (c) The times which the moneys borrowed are to be repayable are the 1st day of January, 1973, and the 1st days of July and January, during the currency of the loan and that the place such moneys shall be repayable is at the National Bank of Australasia Limited, Benalla, or such other place or places as the bank from time to time may require.
- (d) The purpose for which the loan is to be applied is:—
Erection of Art Gallery—\$20,000.
- (e) The manner in which the loan is to be liquidated is by the provision out of the municipal fund in each half year during the currency of the loan of the sum of \$680.26 which includes principal and interest.
- (f) The loan will be for a period of forty (40) years.

The plans and specifications and estimate of the cost of the works and a statement showing the proposed expenditure of the moneys to be borrowed are open for inspection at the Town Hall, Benalla.

Dated this 15th day of March, 1972.

5195

L. A. HEMLEY, Town Clerk.

CITY OF BENALLA.

LOAN No. 29.

Notice of Intention to Borrow.

Notice is hereby given that the Council of the City of Benalla intends to borrow Fifty thousand dollars (\$50,000), secured by charge over the general rates of the municipality by the grant of a mortgage in accordance with the provisions of the Local Government Acts.

In connexion therewith the following information is stated:—

- (a) The amount of principal moneys which it is proposed to borrow: \$50,000 (Fifty thousand dollars).
- (b) The maximum rate of interest that may be paid is 6.2 per centum per annum.
- (c) The times which the moneys borrowed are to be repayable are the 1st day of January, 1973, and the 1st days of July and January, during the currency of the loan and that the place such moneys shall be repayable is at the National Bank of Australasia Limited, Benalla, or such other place or places as the bank from time to time may require.
- (d) The purpose for which the loan is to be applied is:—

Dog pound construction	\$2,529
Saleyards construction	7,294
Industrial land purchase	5,121
Town plan	5,703
Two-way radio	1,177
Kerb and channel construction	4,549
Drainage (Rocar)	4,000
New-street (Psaltis-parade)	5,000
Access road—Housing Commission	2,775
Office equipment and furniture	11,852
	\$50,000

- (e) The manner in which the loan is to be liquidated is by the provision out of the municipal fund in each half year during the currency of the loan of the sum of \$3,391.92 which includes principal and interest.
- (f) The loan will be for a period of ten (10) years.

The plans and specifications and estimate of the cost of the works and a statement showing the proposed expenditure of the moneys to be borrowed are open for inspection at the Town Hall, Benalla.

Dated this 15th day of March, 1972.
15196 L. A. HEMLEY, Town Clerk.

CITY OF ESSENDON.

LOAN No. 76.

Notice of Intention to Borrow the Sum of \$50,000 for Permanent Works and Undertakings.

Notice is hereby given that the Council of the City of Essendon proposes to borrow the principal sum of Fifty thousand dollars, secured by a charge over the general rates of the Municipality, such sum to be raised by the grant of a mortgage in accordance with the provisions of the *Local Government Act 1958* (as amended).

(1) The maximum rate of interest that may be paid is 6.20 per centum per annum.

(2) The purpose for which the loan is to be applied is as follows:—

Construction and reconstruction of roads.—\$50,000.

(3) The period of the loan shall be 10 years.

(4) The moneys borrowed shall be repayable by providing out of the municipal fund 20 half yearly instalments of approximately \$3,391.94 each, including principal and interest on the 1st day of November and the 1st day of May during the currency of the loan. The first instalment shall be payable on the 1st day of November, 1972.

(5) Such moneys shall be repayable at the office of the Commercial Bank of Sydney, Melbourne.

The plans and specifications and the estimates of the cost of the proposed works and a statement showing the proposed expenditure of the moneys to be borrowed, are open for inspection at the Town Hall, Moonee Ponds.

J. P. SCOTT, Town Clerk.
Town Hall, Moonee Ponds, 3039. 5258

Local Government Act 1958 (As Amended).

CITY OF MELBOURNE.

COMPULSORY TAKING OF THE LAND DESCRIBED BELOW.

Notice that Maps and Other Papers, &c., are Deposited for Inspection and the Place Where They are so Deposited.

Notice is hereby given that it is the intention of the Council of the City of Melbourne to compulsorily take the freehold land generally known as Nos. 15-19 Tyne-street, Carlton, and described in certificate of title, volume 3454, folio 745.

General description of the work or undertaking for which the land proposed to be taken is to be used—

For incorporation into the Lygon-street off-street car park project.

Such maps and other papers as may be necessary to show the general description of the work or undertaking for which the land proposed to be taken is to be used, the description of the land proposed to be taken and the names of the owners or reputed owners, lessees or reputed lessees, mortgagees and occupiers of such land so far as those names are known to or can be ascertained by the Council are deposited and will be open for inspection by all persons interested at the Office of the Town Clerk, First Floor, Town Hall, Swanston-street, Melbourne, between the hours of 9 a.m. and 4.30 p.m. on week-days, for the space of 40 clear days from the day of publication of this notice in the *Government Gazette*, within which time all persons affected by the proposed taking of the land set out above are hereby required to set forth, in writing, addressed to the Council or the Town Clerk, all objections which they may have to the taking of the land.

Dated this 20th day of March, 1972.
5243 F. H. ROGAN, Town Clerk.

Local Government Act 1958 (As Amended).

CITY OF MELBOURNE.

COMPULSORY TAKING OF THE LAND DESCRIBED BELOW.

Notice that Maps and Other Papers, &c., are Deposited for Inspection and the Place Where They are so Deposited.

Notice is hereby given that it is the intention of the Council of the City of Melbourne to compulsorily take the freehold land generally known as Nos. 197-199 Berkeley-street, Carlton, and described in certificate of title, volume 6154, folio 781.

General description of the work or undertaking for which the land proposed to be taken is to be used—

For incorporation into the City Council's off-street car park at Nos. 748-764 Elizabeth-street, Melbourne, running through to No. 203 Berkeley-street, Carlton, in order to provide a 66 feet wide parking module between Elizabeth-street and Berkeley-street for ultimate multi-storey development.

Such maps and other papers as may be necessary to show the general description of the work or undertaking for which the land proposed to be taken is to be used, the description of the land proposed to be taken and the names of the owners or reputed owners, lessees or reputed lessees, mortgagees and occupiers of such land so far as those names are known to or can be ascertained by the Council are deposited and will be open for inspection by all persons interested at the Office of the Town Clerk, First Floor, Town Hall, Swanston-street, Melbourne, between the hours of 9 a.m. and 4.30 p.m. on week-days, for the space of 40 clear days from the day of publication of this notice in the *Government Gazette*, within which time all persons affected by the proposed taking of the land set out above are hereby required to set forth, in writing, addressed to the Council or the Town Clerk, all objections which they may have to the taking of the land.

Dated this 20th day of March, 1972.
5244 F. H. ROGAN, Town Clerk.

CITY OF MOORABBIN.

LOAN No. 173.

Notice of Intention to Borrow the Sum of \$100,000 for Permanent Works and Undertakings.

Notice is hereby given that the Council of the City of Moorabbin proposes to borrow the principal sum of One hundred thousand dollars secured by a charge over the general rates of the municipality, such sum to be raised by the grant of a mortgage in accordance with the provisions of the *Local Government Act 1958*.

1. The maximum rate of interest that may be paid is 6.4 per cent. per annum.

2. The purposes for which the loan is to be applied are—

Extensions to Central Library	\$31,000
Installation of traffic lights	5,000
Improvements to reserves	8,000
Construction of roads	56,000
	<hr/>
	\$100,000

3. The period of the loan shall be 40 years.

4. The moneys borrowed shall be repayable by providing out of the municipal fund 80 equal half-yearly instalments of \$3,480.03 each including principal and interest on the 9th days of June and December during the currency of the loan. The first instalment shall be payable on the 9th day of December, 1972.

5. Such moneys shall be repayable to the Australian Mutual Provident Society, 535 Bourke-street, Melbourne, or at such other place as the Society may require.

The plans and specifications and the estimate of the cost of the proposed works and a statement showing the proposed expenditure of the moneys to be borrowed are open for inspection at the office of the Council of the City of Moorabbin, at Nepean Highway, Moorabbin.

Dated the 17th day of March, 1972.
5165 V. A. SMITH, Town Clerk.

CITY OF NUNAWADING.

LOAN No. 122.

Notice of Intention to Borrow.

Notice is hereby given that the Council of the City of Nunawading intends to borrow Forty-five thousand dollars (\$45,000) secured by a charge over the General rates of the municipality by the grant of a Mortgage in accordance with the provisions of the *Local Government Acts*.

In connexion therewith the following information is stated:—

(a) The amount of the principal moneys which it is proposed to borrow is \$45,000.00.

(b) The maximum rate of interest that may be paid is 6.3 per centum per annum.

(c) The times which the moneys borrowed are to be repayable are the 1st day of October, 1972, and the 1st days of April and October during the years of 1973 and 1986 inclusive and the 1st day of April 1987 and that the place at which such moneys shall be repayable is at the Bank of New South Wales, Mitcham.

(d) The purpose for which the loan is to be applied is: Providing places of public resort and recreation.

(e) The manner in which the loan is to be liquidated is by provision out of the Municipal Fund in each half-year during the currency of the loan of the sum of \$2,340.61, which includes principal and interest.

The plans and specifications and estimate of the cost of the works and a statement showing the proposed expenditure of the moneys to be borrowed are open for inspection at the Municipal Offices, White Horse-road, Nunawading.

Dated this 20th day of March, 1972.

5242 J. H. BROWN, Town Clerk.

TOWN OF STAWELL.

LOAN No. 48.

Notice of Intention to Borrow the Sum of \$100,000 for Permanent Works and Undertakings.

Notice is hereby given that the Council of the Town of Stawell proposes to borrow the principal sum of One hundred thousand dollars (\$100,000) secured by a charge over the general rates of the municipality, such sum to be raised by the grant of a mortgage in accordance with the provisions of the *Local Government Act 1958*.

1. The maximum rate of interest that may be paid is 6.4 per cent. per annum.

2. The purpose for which the loan is to be applied is—

Local contribution required for Historical Project.

3. The loan is to be liquidated over a period of twenty years by 40 equal half-yearly instalments of approximately \$4,467 each, covering principal and interest, on the 1st day of January and the 1st day of July in each year during the currency of the loan. The first instalment shall be repayable on the 1st day of January, 1973.

4. Such moneys shall be repayable to the A.M.P. Society, 535 Bourke-street, Melbourne.

The plans and specifications and the estimated cost of the proposed works and a statement showing the moneys to be borrowed, are open for inspection at the office of the Council of the Town of Stawell, Main-street, Stawell.

5160 D. H. HUTTON, Town Clerk.

BOROUGH OF QUEENSCLIFFE.

Notice of Intention to Borrow the Sum of \$20,250 for Permanent Works and Undertakings.

Notice is hereby given that the Council of the Borough of Queenscliffe intends to borrow the sum of \$20,250 (Twenty thousand two hundred and fifty dollars) secured by a charge over the general rates of the municipality, such sum to be raised by the grant of a mortgage in accordance with the provisions of the *Local Government Act 1958*.

1. The maximum rate of interest that may be paid is 6.3 per centum per annum.

2. The purposes for which the loan is to be applied are:—

Purchase of two houses	\$10,250
Historical Society Building	4,000
Boat ramp	6,000
	<u>\$20,250</u>

3. The period of the loan shall be fifteen (15) years.

4. The moneys borrowed shall be repayable by providing out of the municipal fund thirty (30) half-yearly instalments of \$1,053.28 each, including principal and interest, on the 1st day of May and the 1st day of November in each year during the currency of the loan. The first instalment shall be payable on the 1st day of November, 1972.

5. Such moneys shall be repayable to the C.B.C. Savings Bank Limited, Queenscliff, Victoria.

The plans and specifications and the estimate of the cost of the proposed works and a statement showing the proposed expenditure of the moneys to be borrowed, are open for inspection at the office of the Council, Town Hall, Queenscliff.

5193 R. T. FORBES, Town Clerk.

SHIRE OF BRIGHT.

PROSECUTING OFFICERS.

Notice is hereby given that Sergeant Charles Francis Side, No. 11799 and Sergeant Harold Leslie Parker, No. 12398 have been appointed prosecuting officers to the Shire of Bright in place of Senior Constable Thomas Ward Luscombe, No. 9602 and Senior Constable Bernard Danial O'Keeffe, No. 10159.

5200 H. G. HAYMES, Shire Secretary.

SHIRE OF CORIO.

LOAN No. 90.

Notice of Intention to Borrow the Sum of \$50,000 for Permanent Works and Undertakings.

Notice is hereby given that the Council of the Shire of Corio proposes to borrow the principal sum of \$50,000 secured by a charge over the general rates of the municipality, such sum to be raised by a grant of mortgage in accordance with the provisions of the *Local Government Act 1958*.

1. The maximum rate of interest that may be paid is 6.2 per cent. per annum.

2. The purpose for which the loan is to be applied is:—

Improvements to Pettitt Park and Youth Club	\$23,500
Land acquisition	\$15,000
Widening Mackay-street	\$5,000
Construct Infant Welfare Centre	\$5,000
Toilet block Hamlyn Park	\$1,500

3. The period of the loan shall be ten years.

4. The moneys borrowed shall be repayable by providing out of the municipal fund half-yearly instalments on the 10th day of October and the 10th day of April in each year, during the currency of the loan. The first instalment shall be payable on the 14th day of October, 1972.

5. Such moneys shall be repayable to the Commercial Savings Bank of Australia Ltd.

The plans and specifications and the estimate of the cost of the proposed works and a statement showing the proposed expenditure of the moneys to be borrowed are open for inspection at the office of the Council of the Shire of Corio, Osborne House, North Geelong.

5208 W. H. MYERS, Shire Secretary.

SHIRE OF FLINDERS.

LOAN No. 80.

Notice of Intention to Borrow the Sum of \$120,000 for Permanent Works and Undertakings.

Notice is hereby given that the Shire of Flinders proposes to borrow the principal sum of One hundred and twenty thousand dollars secured by a charge over the general rates of the municipality such sum to be raised by the grant of a mortgage in accordance with the provisions of the *Local Government Act 1958*.

1. The maximum rate of interest that may be paid is 6.3 per centum per annum.

2. The purposes for which the loan is to be applied are:—

(1) Shire contribution to C.R.B. Freeway Project—part	\$30,000
(2) Nepean Highway, Rosebud C.R.B. re-sealing parking lanes—Council contribution	2,500
(3) Refuse scheme Flinders hopper conversion—part	2,500
(4) Sorrento patrol depot construction—part	1,500
(5) Mornington—Dromana road, Safety Beach, drainage construction	25,000
(6) Dromana Technical School bus parking bay	3,000
(7) Flinders Post Office car parking improvements	2,000
(8) Flinders State School site beautification	1,500
(9) Shoreham public hall site improvement works	500
(10) Safety Beach toilet block at Tonkin-street, effluent system	2,700
(11) Nepean Highway, Dromana Old Caravan Park, parkland construction—part	2,000
(12) Elizabeth-drive, Rosebud, street construction, council proportion	10,000
(13) The Avenue, McCrae, drainage construction, council contribution	5,500
(14) Rosebud memorial hall, alterations and drainage	1,800
(15) Charles-street, McCrae, drainage outlet structure	3,000

(16) Colemans estate Rosebud—part construction reserve, stage 2 ..	\$1,000
(17) Truemans-road construction from Sandy-road, council contribution ..	6,000
(18) Melbourne-road, Sorrento, drainage works and pump—part ..	7,500
(19) Normanby-road, Sorrento, road construction ..	12,000
	\$120,000

3. The period of the loan shall be fifteen years.
4. The moneys borrowed shall be repayable by providing out of the municipal fund half-yearly instalments of \$6,241.61 each, including principal and interest on the 1st days of June and December, during the currency of the loan the first instalment shall be payable on the 1st day of December, 1972.
5. Such money shall be repayable to the office of the National Bank of Australasia Ltd., Collins-street, Melbourne.

The plans and specifications and the estimate of cost of the proposed works and undertakings and a statement showing the proposed expenditure of the money to be borrowed are open for inspection at the office of the Council of the Shire of Flinders, Nepean Highway, Dromana.

Dated the 15th day of March, 1972.
S. WILLIAMS, Shire Secretary.

SHIRE OF GISBORNE.

BY-LAWS NUMBERED 37, 38 AND 39.

Notice is hereby given that the Council of the Shire of Gisborne has made a by-law numbered 37 for the purpose of the collection, removal and disposal of refuse from a defined area of Gisborne and New Gisborne.

The resolution for making the by-law was passed by the Council on 3rd August, 1970, and confirmed on 7th September, 1970. By-law 37 was approved by the Governor in Council on 22nd December, 1970.

Notice is also given that the Council has made by-laws numbered 38 and 39 for the following purposes:—

By-law 38—Fixing the limits within which it shall be unlawful to keep swine or pig sties.

By-law 39—Regulating the keeping of dogs and limiting the number of dogs kept on any property to two except with a permit and requiring premises to be kept in a clean and sanitary condition.

The resolutions for making the by-laws were passed by the Council on 4th October, 1971, and confirmed on 6th December, 1971. By-laws 38 and 39 were approved by the Governor in Council on 15th February, 1972.

Copies of the by-laws are open for inspection free of charge during office hours at the Shire Office, 12 Hamilton-street, Gisborne.

5206 K. V. ROBINSON, Shire Secretary.

SHIRE OF WINCHELSEA.

BIRREGURRA POUND ABOLISHED.

Notice is given that in accordance with section 4 of the Pounds Act 1958 the Council at a meeting on 12th January, 1972, resolved to abolish the Birregurra Pound on allotments 1, 2, 3, 4 and 5, section A, Township of Birregurra.

5199 W. K. MATHISON, Shire Secretary.

SHIRE OF WINCHELSEA.

Notice is hereby given that at a Meeting, held on 12th January, 1972, the Council of the Shire of Winchelsea ordered that the name of the following road in the Parish of Tuteogong be changed:—

Old name.—Wurdale-road, from Winchelsea—Gherang road to Cape Otway-road.

New name.—Mathisons-road.

5263 W. K. MATHISON, Shire Secretary.

HORSHAM WATERWORKS TRUST.

EIGHTH SCHEDULE.

Notice to the owners of tenements in the under-mentioned streets and the private streets lanes courts and alleys opening thereto:—

Bolton, Carrol, Cathcart, Carter, Dougherty streets, Citrus, Farrar, Vine avenues, Culliver-place, Puls-place, and Osborne-road.

The main pipe in the said streets being laid down the owners of all tenements, situated as above, are hereby required on or before the 30th day of June next, to cause a proper pipe and stop cocks to be laid so as to supply water within such tenements from the main pipe.

A. R. CONN, Secretary, Horsham Waterworks Trust.

5163

NOTICE OF INTENTION TO APPLY FOR A LICENCE TO DIVERT WATER AND CUT RACE (RE-ISSUE) FROM THE RIVER MURRAY, AT NANGILOC.

We hereby give notice that we intend to apply for a licence empowering us to divert water for a term of fifteen years to the extent of 25½ acre-feet per annum at a maximum rate of 3 acre-feet per day of 24 hours for the purpose of irrigating 8½ acres of citrus, being part of allotment 1, section C, Parish of Colignan, and to occupy certain Crown lands for works of diversion, and to cut a race thereon.

Any objection to such application must be forwarded, in writing, to reach the State Rivers and Water Supply Commission, Melbourne, before 21st April, 1972, being 30 days from the first publication of this notice.

HANS COHRS.
BETTE COHRS.

Box 567, Red Cliffs, 3496.

5241

PARTNERSHIP ACT, SECTION 41.

Notice is hereby given that the partnership heretofore subsisting between Peter John Barton and Cynthia Ann Barton, both of 56 Roseman-road, Chirnside Park, Lilydale, 3140, and Richard John Longmore and Nola Marjorie Longmore, both of 1176 Kingswood-drive, Chirnside Park, Lilydale, 3140, carrying on business as taxation consultants at 56 Roseman-road, Chirnside Park, Lilydale, 3140, under the style or firm of Barton, Longmore & Associates, has been dissolved, as from 10th March, 1972. All debts due to and owing by the said firm will be received and paid respectively by Peter John Barton.

Dated the 13th March, 1972.

P. J. BARTON.
CYNTHIA BARTON.
R. J. LONGMORE.
NOLA M. LONGMORE.

Notice is hereby given that Peter John Barton, of 56 Roseman-road, Chirnside Park, Lilydale, 3140, will carry on the business of public accounting and taxation consulting, previously carried on under the style or firm of Barton, Longmore & Associates, at 56 Roseman-road, Chirnside Park, Lilydale, 3140.

Dated the 13th March, 1972.

5210

P. J. BARTON.

Notice is hereby given that the partnership heretofore subsisting between Lister Leung, Tony Lau, Yee Lew, and Gun Bond Lew, carrying on business as café proprietors, at 113 Little Bourke-street, Melbourne, under the style or firm of Hoon Lau Cafe has been dissolved by mutual consent as from the 28th day of February, 1972, so far as concerns the said Lister Leung who retires from the said firm.

Dated the 14th day of March, 1972.

LISTER LEUNG.
TONY LAU.
Y. LEW.
GUN BOND LEW.

Kirby & Co., solicitors, 224 Queen-street, Melbourne, Vic. 3000.

5235

NOTICE OF DISSOLUTION OF PARTNERSHIP.

Notice is hereby given that the Partnership heretofore subsisting between Russell Douglas Phillips, Janice Mary Phillips, John Sterrett Bell and Dawn Lesley Bell, carrying on business as Office Supply Retailers, at 3 Nevada-close, Mulgrave, under the firm name of Glen Office Supplies, has been dissolved as from the 30th day of November, 1971, and the said Russell Douglas Phillips and Janice Mary Phillips, shall as from that date recommence business under the same name as partners.

Dated this 15th day of March, 1972.

MACKENZIE & ROSS, solicitors, of 365 Burwood-road, Hawthorn.

5159

Notice is hereby given that the partnership heretofore subsisting between Charles Moylan, Charles Albert Lowe and Winifred Lowe, carrying on business as cartage contractors, at 39 Ascot-street, Ascot Vale, under the style or firm of Moylan & Lowe, has been dissolved as from the 10th day of March, 1972.

5219

Notice is hereby given that the partnership hereunto subsisting between Geoffrey David Hannon, and Anthony Gianstefani and Denis Conroy, carrying on the business as a restaurant, at 183 Elgin-street, Carlton, in the State of Victoria has been dissolved as from the 24th day of February, 1972.

Dated the 14th day of March, 1972.

E. L. RICHARDS & CO., solicitors, 346 Drummond-street, Carlton. 5167

Notice is hereby given that the partnership heretofore subsisting between Albert Casati and Triantafillos Servanis, carrying on business as Commercial Photographers, at 163 Nicholson-street, Carlton, and 237 Lonsdale-street, Melbourne, under the style of "Olympia Photography", has been dissolved as from the 29th day of February, 1972, so far as concerns the said Albert Casati.

All debts due to and owing by the said late firm will be received and paid by the said Triantafillos Servanis, who will continue to carry on the said business in the same name and at the same addresses.

Dated the 17th day of March, 1972.

5220 T. SERVANIS.
A. CASATI.

The partnership between R. and M. F. Bray and A. R. and D. I. Hibberd has been dissolved. 5259

Companies Act 1961.—In the matter of YINNAR CONSTRUCTIONS PTY. LTD. (In liquidation).

Notice is hereby given that at an Extraordinary Meeting of the members of the above-named company held on the 8th March, 1972, it was resolved that the company be wound up voluntarily and at a meeting of creditors held on the same day pursuant to section 260, it was resolved that for such purpose Everett Thomson Bent, of suite 18, 545 St. Kilda-road, Melbourne, public accountant, be appointed Liquidator.

Notice is also given that after 21 days from this date I shall proceed to distribute the assets. All creditors having any claims against the company should furnish particulars of same by that date, otherwise I shall proceed to distribute the assets without regard to their claim.

Dated this 8th day of March, 1972.

E. T. BENT, Liquidator.
Bent & Cogle, public accountants, suite 18, 545 St. Kilda-road, Melbourne, 3004. 5166

The Companies Act.—In the matter of BELMONT HOTELS PTY. LTD. (In voluntary liquidation).

NOTICE CONVENING FINAL MEETING OF MEMBERS.

Notice is hereby given as required by the Companies Act that a Meeting of the members of the above-named company will be held at the Office of the Liquidator, Ground Floor, 416 St. Kilda-road, Melbourne, on the 26th day of April, 1972, at 11 o'clock in the forenoon for the purpose of having an account before it showing the manner in which the winding up has been conducted and the property of the company disposed of and of hearing any explanations that may be given by the Liquidator.

Dated this 16th day of March, 1972.

5197 G. S. SWAINE, Liquidator.

FEDERAL FIBROUS PLASTER PTY. LTD.

At an Extraordinary Meeting of the above-named company duly convened and held at 20 Queen-street, Melbourne, on the 15th day of March, 1972, the following resolution was duly passed as a Special Resolution:—

"That the company be wound up voluntarily and that John Charles Couzens of 305 Upper Heidelberg-road, Ivanhoe, be appointed liquidator for the purposes of such winding up."

Notice is also given that after 21 days from this date, I shall proceed to distribute the assets. All creditors having any claims against the company shall furnish particulars of same by that date.

Notice is also given that pursuant to section 272 of the Companies Act, a Final Meeting of members of the above company will be held on Tuesday the 2nd day of May, 1972, in the offices of Messrs. Digby & Kellam, chartered accountants, third floor, 20 Queen-street, Melbourne, at 2 o'clock in the afternoon, to receive the liquidators accounts.

Dated this 15th day of March, 1972.

JOHN C. COUZENS, Liquidator—Phone 49-1878. 5233

The Companies Act 1961.—In the matter of STEPHEN CONDY ELECTRICS PROPRIETARY LIMITED.

Notice is hereby given that at an Extraordinary General Meeting of the members of the above-named company held on the 14th day of March, 1972, it was resolved that the company be wound up voluntarily, and at a meeting of creditors held on the same day pursuant to section 260 it was resolved that for such purpose John Martin Walsh of 296 Little Lonsdale-street, Melbourne, accountant, be appointed liquidator.

Notice is also given that after 21 days from this date I shall proceed to distribute the assets. All creditors having any claims against the company should furnish particulars of same by that date, otherwise I shall proceed to distribute the assets without regard to their claim.

Dated this 21st day of March, 1972.

J. M. WALSH, Liquidator.
Kennedy, Smail & Middlemiss, 296-304 Little Lonsdale-street, Melbourne, 3000. 5229

In the Supreme Court of Victoria.—1972, Co. 8307.—In the matter of the Companies Act 1961; and in the matter of M. J. NICHOLSON PTY. LTD.

Notice is hereby given that a petition for the winding up of the above-named company by the Supreme Court was on the 15th day of March, 1972, presented by Leo Thomas Fitzgerald, Deputy Commissioner of Taxation of the Commonwealth of Australia: And that the said petition is directed to be heard before the Court sitting at the Fourteenth Court, Law Courts, William-street, Melbourne, at the hour of 10.30 o'clock in the forenoon, on the 17th day of May, 1972, and any creditor or contributory of the said company desiring to support or oppose the making of an order on the said petition may appear at the time of hearing by himself or his counsel for the purpose; and a copy of the said petition will be furnished to any creditor or contributory of the said company requiring the same by the undersigned on payment of the regulated charge for the same.

The petitioner's official address is 350 Collins-street, Melbourne.

The petitioner's solicitor is Robert Burns Hutchison, Crown Solicitor for the Commonwealth, of 99 Queen-street, Melbourne.

R. B. HUTCHISON.

NOTE.—Any person who intends to appear on the hearing of the said petition must serve on or send by post to the above-named R. B. Hutchison, notice in writing of his intention so to do. The notice must state the name and address of the person, or, if a firm, the name and address of the firm, and must be signed by the person or firm, or his, or their solicitor (if any), and must be served or, if posted, must be sent by post in sufficient time to reach the above-named not later than Four o'clock in the afternoon of the 16th day of May, 1972. 5277

In the Supreme Court of Victoria.—1972, Co. 8298.—In the matter of the Companies Act 1961; and in the matter of CITY SITEMWORKS PROPRIETARY LIMITED.

Notice is hereby given that a petition for the winding up of the above-named company by the Supreme Court was on the 2nd day of March, 1972, presented by Leo Thomas Fitzgerald, Deputy Commissioner of Taxation of the Commonwealth of Australia: And that the said petition is directed to be heard before the Court sitting at the Fourteenth Court, Law Courts, William-street, Melbourne, at the hour of 10.30 o'clock in the forenoon, on the 19th day of April, 1972, and any creditor or contributory of the said company desiring to support or oppose the making of an order on the said petition may appear at the time of hearing by himself or his counsel for the purpose; and a copy of the said petition will be furnished to any creditor or contributory of the said company requiring the same by the undersigned on payment of the regulated charge for the same.

The petitioner's official address is 350 Collins-street, Melbourne.

The petitioner's solicitor is Robert Burns Hutchison, Crown Solicitor for the Commonwealth, of 99 Queen-street, Melbourne.

R. B. HUTCHISON.

NOTE.—Any person who intends to appear on the hearing of the said petition must serve on or send by post to the above-named R. B. Hutchison, notice in writing of his intention so to do. The notice must state the name and address of the person, or, if a firm, the name and address of the firm, and must be signed by the person or firm, or his, or their solicitor (if any), and must be served or, if posted, must be sent by post in sufficient time to reach the above-named not later than Four o'clock in the afternoon of the 18th day of April, 1972. 5278

In the Supreme Court of Victoria.—1972, Co. 8297.—In the matter of the *Companies Act 1961*; and in the matter of **TRUCKMASTER PROPRIETARY LIMITED**.

Notice is hereby given that a petition for the winding up of the above-named company by the Supreme Court was on the 2nd day of March, 1972, presented by Leo Thomas Fitzgerald, Deputy Commissioner of Taxation of the Commonwealth of Australia: And that the said petition is directed to be heard before the Court sitting at the Fourteenth Court, Law Courts, William-street, Melbourne, at the hour of 10.30 o'clock in the forenoon, on the 19th day of April, 1972, and any creditor or contributory of the said company desiring to support or oppose the making of an order on the said petition may appear at the time of hearing by himself or his counsel for the purpose; and a copy of the said petition will be furnished to any creditor or contributory of the said company requiring the same by the undersigned on payment of the regulated charge for the same.

The petitioner's official address is 350 Collins-street, Melbourne.

The petitioner's solicitor is Robert Burns Hutchison, Crown Solicitor for the Commonwealth, of 99 Queen-street, Melbourne.

R. B. HUTCHISON.

NOTE.—Any person who intends to appear on the hearing of the said petition must serve on or send by post to the above-named R. B. Hutchison, notice in writing of his intention so to do. The notice must state the name and address of the person, or, if a firm, the name and address of the firm, and must be signed by the person or firm, or his, or their solicitor (if any), and must be served or, if posted, must be sent by post in sufficient time to reach the above-named not later than Four o'clock in the afternoon of the 18th day of April, 1972. 5279

In the Supreme Court of Victoria.—1972, Co. 8299.—In the matter of the *Companies Act 1961*; and in the matter of **CRANEMASTER PROPRIETARY LIMITED**.

Notice is hereby given that a petition for the winding up of the above-named company by the Supreme Court was on the 2nd day of March, 1972, presented by Leo Thomas Fitzgerald, Deputy Commissioner of Taxation of the Commonwealth of Australia: And that the said petition is directed to be heard before the Court sitting at the Fourteenth Court, Law Courts, William-street, Melbourne, at the hour of 10.30 o'clock in the forenoon, on the 19th day of April, 1972, and any creditor or contributory of the said company desiring to support or oppose the making of an order on the said petition may appear at the time of hearing by himself or his counsel for the purpose; and a copy of the said petition will be furnished to any creditor or contributory of the said company requiring the same by the undersigned on payment of the regulated charge for the same.

The petitioner's official address is 350 Collins-street, Melbourne.

The petitioner's solicitor is Robert Burns Hutchison, Crown Solicitor for the Commonwealth, of 99 Queen-street, Melbourne.

R. B. HUTCHISON.

NOTE.—Any person who intends to appear on the hearing of the said petition must serve on or send by post to the above-named R. B. Hutchison, notice in writing of his intention so to do. The notice must state the name and address of the person, or, if a firm, the name and address of the firm, and must be signed by the person or firm, or his, or their solicitor (if any), and must be served or, if posted, must be sent by post in sufficient time to reach the above-named not later than Four o'clock in the afternoon of the 18th day of April, 1972. 5280

The *Companies Act 1961*.

V.I.P. CIBERNETICS PROPRIETARY LIMITED (IN LIQUIDATION).

NOTICE CONVENING FINAL MEETING OF MEMBERS AND CREDITORS PURSUANT TO SECTION 272.

Notice is hereby given pursuant to section 272 of the *Companies Act 1961*, that a General Meeting of the members and creditors of the above-named company will be held in the offices of Kennedy, Smail & Middlemiss, 296-304 Little Lonsdale-street, Melbourne, on Wednesday the 19th day of April, 1972, at 10.30 a.m., for the purpose of having an account laid before them showing the manner in which the winding up has been conducted and the property of the company disposed of and of hearing any explanations that may be given by the liquidator.

Dated this 14th day of March, 1972.

Kennedy, Smail & Middlemiss, 296-304 Little Lonsdale-street, Melbourne, 3000.

5230

E. R. SMAIL, Liquidator.

The *Companies Act 1961*.

F. MEYER & CO. PTY. LTD. (IN LIQUIDATION).

NOTICE TO CREDITORS OF INTENTION TO DECLARE DIVIDEND.

A First Dividend is intended to be declared in the above matter. Creditors who have not proved their debt by the 29th day of March, 1972, will be excluded from this dividend. The date of liquidation was the 25th day of January, 1972.

Dated this 16th day of March, 1972.

Lewis Luckins & Co., chartered accountants, 130 Flinders-street, Melbourne, 3000. Telephone No. 63 8827.

5231

LEWIS LUCKINS, F.C.A., Liquidator.

The *Companies Act 1961*.

FRANKSTON TRADING COMPANY PROPRIETARY LIMITED (IN LIQUIDATION).

NOTICE CONVENING FINAL MEETING OF MEMBERS AND CREDITORS PURSUANT TO SECTION 272.

Notice is hereby given pursuant to section 272 of the *Companies Act 1961*, that a General Meeting of the members and creditors of the above-named company will be held in the offices of Kennedy, Smail & Middlemiss, 296-304 Little Lonsdale-street, Melbourne, on Wednesday the 19th day of April, 1972, at 11.00 a.m., for the purpose of having an account laid before them showing the manner in which the winding up has been conducted and the property of the company disposed of and of hearing any explanations that may be given by the liquidator.

Dated this 15th day of March, 1972.

A. M. HORSBURGH, Liquidator.

Kennedy, Smail & Middlemiss, 296-304 Little Lonsdale-street, Melbourne, 3000. 5232

The *Companies Act 1961*.

JAY HAMILTON PROPRIETARY LIMITED (IN LIQUIDATION).

NOTICE CONVENING FINAL MEETING OF MEMBERS AND CREDITORS PURSUANT TO SECTION 272.

Notice is hereby given pursuant to section 272 of the *Companies Act 1961*, that a General Meeting of the members and creditors of the above-named company will be held in the offices of Kennedy, Smail & Middlemiss, 296 Little Lonsdale-street, Melbourne, on Wednesday the 19th day of April, 1972, at 11.30 a.m., for the purpose of having an account laid before them showing the manner in which the winding up has been conducted and the property of the company disposed of and of hearing any explanations that may be given by the liquidator.

Dated this 16th day of March, 1972.

E. R. SMAIL, Liquidator.

Kennedy, Smail & Middlemiss, 296-304 Little Lonsdale-street, Melbourne, 3000. 5234

In the Supreme Court of Victoria.—1972 Co. No. 8292.—In the matter of the *Companies Act 1961*; and in the matter of **COMPUTER HOUSE PROPRIETARY LIMITED**.

Notice is hereby given that a petition for the winding up of the above-named company by the Supreme Court was, on the 22nd day of February, 1972, presented by Warren Yates: And that the said petition is directed to be heard before the court sitting in the Fourteenth Court, Law Courts, William-street, Melbourne, at the hour of 10.30 o'clock in the forenoon on the 6th day of April, 1972, and any creditor or contributory of the said Computer House Proprietary Limited, desiring to support or oppose the making of an order on the said petition, may appear at the time of the hearing by himself or his counsel for that purpose; and a copy of the petition will be furnished to any creditor or contributory of the said Computer House Proprietary Limited, requiring the same by the undersigned on payment of the regulated charge for the same.

The petitioner's address is 47 Oswin-street, East Kew.

The petitioner's solicitors are Messrs. Clarence Smith & Co., of 536 Glenferrie-road, Hawthorn.

CLARENCE SMITH & CO., solicitors for the petitioner.

NOTE.—Any person who intends to appear on the hearing of the said petition must serve on or send by post to the above-named Messrs. Clarence Smith & Co., notice, in writing, of his intention so to do. The notice must state the name and address of the person, or if a firm, the name and address of the firm, and must be signed by the person or firm of his or their solicitor (if any) and must be served or, if posted, must be sent by post in sufficient time to reach the above named not later than the hour of 4 o'clock in the afternoon of the 5th day of April, 1972. 5271

Unclaimed Moneys Act 1962.

Register of Unclaimed Moneys held by the—

Name of Owner on Books and Last Known Address.	Total Amount Due to Owner.	Description of Unclaimed Moneys.	Date when Amount first became Payable.
\$			
VACC INSURANCE CO. LIMITED.			
Leech, Alfred G., 27 Kats-street, Maryborough	13.30	Dividend on Ordinary Shares	24.4.70
Dependable Motors Pty. Ltd., 151 Main North-road, Nailsworth, S.A. 4996	52.50	" " " "	30.10.70
HOTHLYN CORPORATION LIMITED.			
Freya Investments Pty. Ltd., P.O. Box 2755, Sydney, N.S.W. 4997	17.50	Dividend on 1,000 "A" shares	30.10.70
BRUCK (AUSTRALIA) LIMITED.			
Rawlinson, Gertrude (Miss), 1 Mayfair Court, 86 Milson-road, Cremorne, N.S.W.	15.00	Interim Dividend	30.3.70
Thorpe, Arthur F., 31 Pigott-street, Dulwich Hill, N.S.W.	52.50		
Rawlinson, Gertrude (Miss), 1 Mayfair Court, 86 Milson-road, Cremorne, N.S.W.	15.00	Final Dividend	12.10.70
O'Neill, Jeannette A. (Mrs.), 13 Fort View-road, Mount Claremont, W.A.	30.00	" " " "	"
Silberstein, Judith J. (Mrs.), 55 Hobbs-avenue, Dalkeith, W.A.	30.00	" " " "	"
Wicarr Nominees Limited, Garrard House, 31 Gresham-street, London, E.C.2. England 4998	63.75	" " " "	"
AUSTRALIAN GENERAL INVESTMENTS LIMITED.			
Miller, William, 16 Wudgong-street, Mosman, N.S.W.	15.08	Dividend	20.8.70
Orr, Ulric G., 17 Billyard-avenue, Elizabeth Bay, N.S.W. 4999	22.50	" " " "	"
A. V. JENNINGS INDUSTRIES (AUSTRALIA) LIMITED.			
Clare, Shirley, 20 Woodville-avenue, Wahroonga, N.S.W.	22.50	Dividend	31.3.70
Fisher, Patricia J., Oxford-street, Reynella, S.A.	50.61	" " " "	"
Trefield Estates Pty. Ltd., 224 Queen-street, Melbourne	28.11	" " " "	"
Harvey, Charles B. C., c/o Hong Kong and Shanghai Banking Corp., 9 Gracechurch-street, London, U.K.	25.50	" " " "	"
Taylor, Alexander F., 10 Edenhall-road, Birmingham, U.K.	15.30	" " " "	"
Beveridge, Daisy E., 2/174 Church-street, Middle Brighton	48.00	" " " "	22.10.70
Chartres, Geoffrey M., 580 Elizabeth-street, Melbourne	40.00	" " " "	"
Dougall, John K. and William R., 7/10 Hopetoun-road, Toorak	80.80	" " " "	"
Fisher, Roy A., 22 Oxford-street, Reynella, S.A.	67.48	" " " "	"
Hall, Hilary J., 3 Taylor-court, East Malvern	23.08	" " " "	"
Leembruggen, James I., 89 Nixon-street, Shepparton	20.00	" " " "	"
Lehrer, Alma, 3/39 Ross-street, Toorak	24.00	" " " "	"
Pell, Marjorie H., Montara, Hansonville	12.00	" " " "	"
Snowball, Emily M. and others, 22 Bayvie-terrace, Claremont, W.A.	12.00	" " " "	"
Short, James R., 30 Garrick Close, Walton on Thames, Surrey, U.K.	13.60	" " " "	"
Wright, Anthony J., 1470 Horseshoe Curve, Lake Oswega, Oregon, U.S.A.	12.72	" " " "	"
Allan, William D., 15 Colpin-avenue, Ballarat	28.11	" " " "	21.10.69
Alston, Rupert S., 25 Edward-street, Kew	59.04	" " " "	"
Clare, Shirley, 20 Woodville-avenue, Wahroonga, N.S.W.	22.50	" " " "	"
Little, Alma M., 183 Brooks-street, Newcastle, N.S.W.	36.00	" " " "	"
Long, Eric S., 6 Douglas-road, Moss Vale, N.S.W.	56.22	" " " "	"
Sibly, Arnold R., 8 Inverness-drive, East Kew	16.83	" " " "	"
Campbell, William P., Wisborough Green, Billingshurst, U.K.	15.30	" " " "	"
Taylor, Alexander F., 10 Edenhall-road, Quinton, Birmingham, U.K.	15.30	" " " "	"
Williams, Thomas F., c/o 43 High-street, Wrexham, U.K.	13.36	" " " "	"
Trefield Estates Pty. Ltd., 224 Queen-street, Melbourne	28.11	" " " "	"
ROBERT HARPER AND COMPANY LIMITED.			
MacPherson, K., 9 Titcher-road, Noble Park	14.47	Wages	13.11.70
Knight, J., 28 Coronon-del-crescent, Knoxfield	12.74	" " " "	20.11.70
Loft, E. D., 6 Walnut-court, Mulgrave	15.02	" " " "	11.12.70
Webb, G., 805 Dandenong-road, Springvale	10.48	" " " "	"
Llewellyn, M. M., 22 Rosehill-street, Scoresby	12.62	" " " "	8.1.71
COMALCO LIMITED.			
Owen, Denise (Miss), 7 Ethel-street, Condell Park, N.S.W. 5002	50.14	Pro rata annual leave due on termination of employment	24.7.70
THE SHELL COMPANY OF AUSTRALIA LIMITED.			
Spaulding, G., 32 Belmont-road, Glen Waverley	22.26	Duplicated payment	14.4.69
Mitchell, J., 31 Murray-road, Croydon	24.32	Unclaimed credit	10.7.69
Clements, B. I., 36 Spring-street, Preston	22.65	" " " "	0.7.69
Barnes, D., 40 Elizabeth-street, Malvern	27.70	Unclaimed Wages	0.5.68
Morell, J., Hobart, Tas.	30.26	" " " "	0.0.70
5003			

Unclaimed Moneys Act 1962.

Register of Unclaimed Moneys held by the—

Name of Owner on Books and Last Known Address.	Total Amount Due to Owner.	Description of Unclaimed Moneys.	Date when Amount first became Payable.
ICI AUSTRALIA LIMITED.			
Blows, Charles S., 28 Nellie-street, Seaholme	10.00	Preference Dividend 64	31.7.70
Gardner, Gladys (Mrs.) and Zohrab, James H., c/o Sainsbury, Logan and Williams, Box 151, Napier, N.Z.	21.25	" " "	"
Wilbur-Ham, Brian L. (Dr.), 1 Balfour-street, Toorak	21.70	" " "	"
Percival, Thomas A., 65 Pembroke-street, Hamilton, N.Z.	12.75	" " " 65	31.1.71
Reid, Marjorie W. (estate of), c/o Lawrence Roston and Son, 118 Queen-street, Melbourne	31.25	Interest 12.. "	31.5.70
Rossier, James H., 7 Cowper-street, Hawthorn East	12.50	" " "	"
Vine, Ethel (Mrs.), 10 The Boulevard, Cammeray, N.S.W.	32.50	" " "	"
Cook, Wayman M., 4 Walker-road, Bucklands Beach, N.Z.	12.15	" " "	"
Cowan, Lady Effie H. (estate of), c/o Executor Trustee and Agency Co. Ltd., 22 Grenfell-street, Adelaide, S.A.	38.50	" " "	"
Williams, Percy H. (estate of), c/o Clayton Utz and Co., 136 Liverpool-street, Sydney, N.S.W.	71.25	" " "	"
Barry, Jane M. (Miss), 77b Telegraph-road, Pymble, N.S.W.	14.00	" 13.. "	30.11.70
Bingham, Gertrude E. (Mrs.), 20 Bryson-street, Canterbury	39.75	" " "	"
Forsyth, John, 5 Briggs-street, Oakleigh	79.01	" " "	"
Jung, Reta R. (Mrs.), 29 Joffre-street, Regent	188.75	" " "	"
Keating, Alice M. (Mrs.), 47 Devon-street, Heidelberg	12.50	" " "	"
Lavis, Keith A., 42 Beanga-street, Greenslopes, Qld.	45.50	" " "	"
Reid, Marjorie W. (estate of), c/o Lawrence Rostron and Son, 118 Queen-street, Melbourne	31.25	" " "	"
Rosier, James H., 7 Cowper-street, Hawthorn East	12.50	" " "	"
Tait, Myrtle M. (Mrs.), 77 Braeside, Wahroonga, N.S.W.	28.00	" " "	"
Vine, Ethel (Mrs.), 10 The Boulevard, Cammeray, N.S.W.	32.50	" " "	"
Douglas, Gillespie W. A., 272 Queen-street, Melbourne	36.00	Dividend 39	2.3.70
Durcan, Thomas K., Sandilands Battery Co., Singapore	11.83	" " "	"
Kennard, Edwin A., The Chartered Bank, 2 Regent-street, London, U.K.	30.60	" " "	"
Lyon, Elizabeth A. (Mrs.), Reading-street, Broadstairs, Kent, U.K.	30.60	" " "	"
Lyon, Margaret (Mrs.) and Walter, Reading-street, Broadstairs, Kent, U.K.	10.20	" " "	"
Lyon, Walter, Reading-street, Broadstairs, Kent, U.K.	61.20	" " "	"
Lyon, Margaret (Mrs.), Reading-street, Broadstairs, Kent, U.K.	20.40	" " "	"
Martin, Josephine H., 87 Beatrice-street, Taringa, Qld.	49.80	" " "	"
Monahan, Peter D., 4 Torres-street, Red Hill, A.C.T.	12.00	" " "	"
Morton, Michael J., c/o National Bank of Australasia Ltd., 48 St. Georges-terrace, Perth, W.A.	36.00	" " "	"
Paul, Joan (Mrs.), 13 St. Andrews Walk, Cobham, Surrey, U.K.	12.75	" " "	"
Reid, Marjorie W. (estate of), c/o Lawrence Rostron and Son, 118 Queen-street, Melbourne	61.68	" " "	"
Swallow, Colin K. (estate of), Box 114, Palmerston, N.Z.	51.00	" " "	"
Wilcock, Frederick M., Mount Cochon-street, Jersey, Channel Islands	15.30	" " "	"
Wheeler, Ray and Cheryl, c/o Mahony Bros., Hokitika, N.Z.	10.20	" " "	"
Abbott, Alan G., Box 817, Auckland, N.Z.	20.40	" 40	1.9.70
Abbott, Gwenneth M. A. (Mrs.), Box 817, Auckland, N.Z.	68.00	" " "	"
Antonoff, Michael B. (estate of), c/o Mrd. D. Coyle, 449 Victoria-avenue Chatswood, N.S.W.	28.08	" " "	"
Borg, Gauden P., 75 St. Gregory-street, Zejtun, Malta	12.60	" " "	"
Bromhead, John (Major), Heaton-Renshaw, Olive D. (Mrs.) and Bromhead, Peter, c/o Westminster Bank Ltd., Piccadilly Circus, London, U.K.	48.48	" " "	"
Carroll, Hazel E. (Miss), 32 Rusden-street, Elsternwick	16.00	" " "	"
Cockburn, James P. (estate of), c/o Frank C. Kirkpatrick and Son, 66 Pitt-street, Sydney, N.S.W.	12.00	" " "	"
Durand, Mortimer H. M. (estate of), c/o Union-Fidelity Trustee Co., G.P.O. Box 493, Sydney, N.S.W.	24.00	" " "	"
Fennell, Myra M. (Mrs.), c/o Commercial Banking Co. of Sydney, 74 Castlereagh-street, Sydney, N.S.W.	28.00	" " "	"
Fuller, Mary L. (estate of), c/o Norman Thom Macdonald and Co., Box 111, Auckland, N.Z.	11.29	" " "	"
Handbury, Alan J., c/o Handbury Advertising Pty. Ltd., 224 Queen-street, Melbourne	24.00	" " "	"
Kennard, Edwin A., c/o The Chartered Bank, 2 Regent-street, London, U.K.	20.40	" " "	"
Knowles, James D., 9 Ballarat-street, Queenstown, N.Z.	13.60	" " "	"
Lowes, John C., Burfort House, The Green, Wrea Green, nr. Preston, U.K.	34.41	" " "	"
McArthur, Rachel E. (Mrs.), 11 Walshs-road, Ashburton, N.Z.	35.70	" " "	"
Reid, Marjorie W. (estate of), c/o Lawrence Rostron and Son, 118 Queen-street, Melbourne	41.12	" " "	"
Swallow, Colin K. (estate of), Box 114, Palmerston North, N.Z.	34.00	" " "	"
Ward, Anne E. (Mrs.), Mochau, Colville, N.Z.	17.00	" " "	"
Wigley, Jessie C. (estate of), c/o Tripp Rolleston and Co., Box 27, Timaru, N.Z.	42.43	" " "	"
Wong, George (Dr.), c/o Commonwealth Trading Bank, Martin-place, Sydney, N.S.W.	40.00	" " "	"
Archer, Hilda (Miss), 18 Norwich-road, Wavertree, Liverpool, Lancs., U.K.	200.00	Debentures/Notes matured	30.11.70
Badger, Margaret (Mrs.), 3 George-street, Walkerville, S.A.	400.00	" " "	"
Bowell, Bertram O. (estate of), c/o Hunter Boucaut and Ashton, 35 Grenfell-street, Adelaide, S.A.	2,000.00	" " "	"
Hatrick-Smith, Deidre (Mrs.), c/o Hamilton and Hamilton, Box 1036, Christchurch, N.Z.	400.00	" " "	"
Lodge, Florrie M. H. (estate of), c/o Colin D. Rowe and Co., Box 95, Maitland, S.A.	400.00	" " "	"

Unclaimed Moneys Act 1962.

Register of Unclaimed Moneys held by the—

Name of Owner on Books and Last Known Address.	Total Amount Due to Owner.	Description of Unclaimed Moneys.	Date when Amount first became Payable
§			
ICI AUSTRALIA LIMITED.—continued.			
Needham, Jessie K. (Mrs.), 12 Wellogate Gardens, South Shore, Blackpool, Lancs., U.K.	600.00	" " "	"
Nottle, Olive C. (estate of), c/o Cornwall Stodart and Co., G.P.O. Box 1466N, Melbourne	400.00	" " "	"
Webster, Frederick (estate of), c/o Wilkinson Throsby and Edwards, Box 2, Moss Vale, N.S.W.	2,000.00	" " "	"
White, Eliza K. (estate of), c/o M. W. Bednall and Co., 44 Grenfell-street, Adelaide, S.A.	1,200.00	" " "	"
Siruella, A., Box 251, Myrtleford	11.63	Wages	0 8.70
Westhead, D., 99 Park-street, South Yarra	14.90	"	21.11.70
Burns, P. J., 121 Hanbury-street, Kalgoorlie, W.A.	120.00	Contract work	23.9.70
5004			
CALTEX OIL (AUSTRALIA) PTY. LIMITED.			
P. M. Fraser Pty. Ltd., 3A Roosevelt-street, Coburg	12.07	Unpresented cheque	19.2.70
King, B. J., Rutherglen	25.70	" " "	20.8.70
Overseas Electrical Pty. Ltd., 31 Easton-street, Oakleigh	10.00	" " "	6.1.70
Overseas Electrical Pty. Ltd., 31 Easton-street, Oakleigh	30.00	" " "	18.3.70
Turner, N., Glen Waverley	20.44	" " "	19.11.70
Ward, D., P.O. Box 31, Kilmore	47.50	" " "	5.5.70
5005			
HUMES LIMITED.			
Cox, Kevin, P.O. Box 1560, Singapore	10.62	Dividend	6.10.70
English, James C., 520 Main-street, Mordialloc	12.50	"	"
Galbraith, Elizabeth A., Hockley Heath, Warwickshire, U.K.	13.28	"	"
5006			
NATIONAL CONSOLIDATED LIMITED.			
Wright, Walter, 5 Mt. Alexander-road, Flemington	22.50	Dividend No. 3	27.10.67
5007			
VEALLS SECURITIES AND FINANCE LIMITED.			
Scott, V. E. (Mrs.), 29A Glen Ebor-avenue, Blackburn	70.00	Dividend on 500 \$2 Preference Shares	{ 30.4.70 31.10.70
Kersey, A. V. (estate of), c/o R. B. Boyce, 2 Hector-street, Brighton	28.00	Dividend on 400 \$2 Preference Shares	
5008			
WM. HAUGHTON AND CO. LIMITED.			
Dixon, E. (Mrs.), 8 Milton-street, Canterbury	30.00	" " "	31.10.70
England, M. (Miss), 8 Milton-street, Canterbury	30.00	" " "	"
Sharp, I. C. (Mrs.), 1 Witchwood-close, South Yarra	140.00	" " "	"
5009			
SOUTH GIPPSLAND MILK INDUSTRIES LIMITED.			
Buckley, G. E., Fish Creek	23.80	Dividend	5.11.70
Chapman, H. K., 19 Edith-street, Dandenong	21.25	"	"
Fletcher, W. G., Buffalo	15.53	"	"
Pilkington, K., Sandy Point	58.00	"	"
Stone, H. B., 2A Manor-street, Brighton	10.37	"	"
Wilson, Ian, Bena	20.63	"	"
5010			
IAC (HOLDINGS) LIMITED.			
Hamilton, Bruce, 29 Roxby-street, Manifold Heights	21.24	Ordinary Dividend	—4.70
Ward, Doreen S. (Mrs.), 46 Hardmans-road, Whitefield, Manchester, U.K.	15.50	" " "	"
5024			
WHOLESALEERS LIMITED.			
King, Kevin Francis, 84 Latrobe-terrace, Geelong	12.50	Dividend cheque	1.5.70
5025			
LONDON REGISTER NORTH BROKEN HILL LIMITED.			
Bailey, Robin E. H., 3 Place Manor Cottages, Streatly-on-Thames, Reading, Berks.	10.28	Dividend	5.6.70
Bain, Andrew R., The Whins, 34 Park-terrace, Stirling, Scotland	305.50	"	11.12.70
Baker, Robin D. E., c/o Rodway Smith Ltd., 11 Lansdowne-road, Bournemouth, Hampshire	11.75	"	"
Blackwall, Elizabeth S., 34 Lansdowne-road, London	14.81	"	"
Bolton, Kathleen H., 10B Grove Hill Gardens, Tunbridge Wells, Kent	23.50	"	"
Burridge, Edith M., Glaslyn, 49 Quantock-road, Bridgewater, Somerset	12.34	"	"
Collison, Allan M., 203 Brooke-street, Preston, Lancashire	14.69	"	"
Dignam, Mona L., 15A Albert-court, Kensington Gore, London	23.50	"	"
Dollond, Jack, 260A Shirland-road, Paddington	11.75	"	"
Eggers, John C., Ockenden Manor, Cuckfield, Sussex	76.37	"	"
Ellis, Hedley V. (estate of), c/o National Westminster Bank Ltd., 41 Lothbury, London, E.C.2.	11.75	"	"
Evans, Robert B., 26 Greygates, Mount Merrion, Blackrock, Co. Dublin	14.00	"	5.6.70
Faber, Martin E., The Grange Cottage, Ickleton, Saffron Walden, Essex	11.75	"	11.12.70
Franken, Frances J., 25 Chaplin-crescent, Sunbury-on-Thames, Middlesex	17.63	"	"

Unclaimed Moneys Act 1962.

Register of Unclaimed Moneys held by the—

Name of Owner on Books and Last Known Address.	Total Amount Due to Owner.	Description of Unclaimed Moneys.	Date when Amount first became Payable.
S			
NORTH BROKEN HILL LIMITED.— <i>continued.</i>			
Gibbon, Austin K., Flat 2, The Anchorage, Route Du Fort, St. Helier, Jersey, Channel Islands	42.00	Dividend	5.6.70
Gibson, William N., Livilands Gate, Stirling, Scotland	11.75	" " " " "	11.12.70
Gourgey, Reginald E., c/o Midland Bank Ltd., 220 High Holborn, London, W.C.1.	23.50	" " " " "	"
Heffernan, Edna, National Bank House, Eyre Square, Galway, Ireland	18.20	" " " " "	5.6.70
Hogg, Geraldine S., 61 Roseberry-avenue, Colchester, Essex	29.38	" " " " "	11.12.70
Holbrook, Norman D. and Renshaw, Horatic H., c/o Laurence Keen and Gardner, Moor House, London Wall, E.C.2.	117.50	" " " " "	"
Loew, Wilhelm H. (estates of) Margaret F. Leischner, 32 Grange Hill, Edgware, London, HA 8, 9, PEM.	23.50	" " " " "	"
Macmillan, Edith J., Waterhead, Stewarton, Ayrshire	58.75	" " " " "	"
Mahdessian, Kevork, c/o Barclays Bank Ltd., Melbury Court Branch, 276/280 Kensington High-street, London, W.8.	11.75	" " " " "	"
Manley, Margherita E., c/o Drummonds Bank, Royal Bank of Scotland, 49 Charing Cross, London, S.W.1.	54.64	" " " " "	5.6.70
O'Fallon, Cynthia C. M., c/o Lloyds Bank Ltd., Princes, Risborough	35.25	" " " " "	11.12.70
Palmer, Edward M., Fernvale, Bloody Corner, Northam, Bideford, Devon	18.21	" " " " "	5.6.70
Phildrew Nominees Limited, Lee House, London Wall, London, E.C.2.	135.13	" " " " "	"
Pinkney, David B., 1 Lyndhurst-drive, Harpenden, Herts.	42.01	" " " " "	"
Pitcairn, John E., c/o Mardi Gras Ltd., 29 Harrington-road, London, S.W.7.	11.75	" " " " "	11.12.70
Roycroft, Patrick W., Glenfield, Dunmore East, Co. Waterford	28.00	" " " " "	"
Rucker, Ann P., Knowle Cottage, Crouch Lane, Sandhurst, Kent.	11.75	" " " " "	"
Rutter, John Aburi, Journey's End, Stoke Poges, Bucks.	16.45	" " " " "	"
Ryan, Eileen Desmond, 1c Sandy-Mount-avenue, Ballsbridge, Dublin	14.00	" " " " "	5.6.70
Schwabacher, Herta Haclenda, Chorley Wood-road, Rickmansworth, Herts.	35.25	" " " " "	11.12.70
Smith, Colin J. C., General Hospital, Kutching, Sarawak, Malaysia.	17.50	" " " " "	"
Sporne, Heather D., Hillocks, Ralliwod-road, Ashtead Park, Ashtead, Surrey	17.63	" " " " "	"
Stoop and Co. Nominees Limited, 3 London Wall Buildings, London, E.C.2.	70.50	" " " " "	5.6.70
Wood, S. R. C., Pear Tree Cottage, Silsoe, Bedfordshire	21.50	" " " " "	"
AUSTRALIAN REGISTER			
Babington, Hubert H. L., c/o Hong Kong and Shanghai Bank, P.O. Box 304, Juan Luna-street, Manila, Philippines	14.00	" " " " "	11.12.70
Bird, Aleyn H. and Ryan, John W., 51-53 Murray-street, Pyrmont, N.S.W.	30.00	" " " " "	5.6.70
Black, Robert K., 27 Denham-place, Toorak	25.00	" " " " "	11.12.70
Blades, Jeanette B., c/o J. Walsh, 23A Awaba-street, Mosman, N.S.W.	20.00	" " " " "	5.6.70
	40.00	" " " " "	11.12.70
Fifield, Bruce F., 161 Shaftesbury-road, Eastwood, N.S.W.	30.00	" " " " "	"
Finney, Dallas, 5/76 Lauderdale-avenue, Fairlight, N.S.W.	10.00	" " " " "	5.6.70
Griffiths, Georgia, 38 Malga-avenue, Roseville Chase, N.S.W.	48.90	" " " " "	"
Grove, Ina M., 1 Minns-road, Gordon, N.S.W.	52.00	" " " " "	11.12.70
Mackinnon, Colin C., R.D. 3, Whakatane, New Zealand	17.00	" " " " "	"
Murch, George D., c/o P.O. Box 17, Port Lincoln, S.A.	40.00	" " " " "	"
Rose, Jean H., 17 Marns-street, Wagga Wagga, N.S.W.	45.00	" " " " "	5.6.70
Slatter, Catherine M., c/o Williamsons Diamonds Ltd., Private Bag, Nairobi, Kenya	14.00	" " " " "	11.12.70
Wiggins, Nola M., 44 Briggs-street, East Oakleigh 5026	10.00	" " " " "	"
JOSEPH LUCAS (AUSTRALIA) PTY. LIMITED.			
Diggeden, Terence Allen, 15 Smith-road, Camberwell	27.70	Wages	23.3.70
Meyer, Maryse Chantal, 7/2 Woods-avenue, Mordialloc	15.60	"	19.7.70
Disselbark, Ronald William, P.O. Box 1002, Mt. Gambier, S.A.	25.90	"	31.1.71
Christopoulos, Rita, 22 Marshall-avenue, Highett 5028	17.90	"	30.8.70
INITIAL TOWEL SUPPLY (VIC.) PTY. LTD.			
Johnson, Gary Francis, 3 Coleman-street, Fitzroy	17.50	Wages	4.3.70
Freeman, Wayne, 72 Charles-street, Fitzroy 5029	14.25	"	25.3.70
HOWARD SMITH LIMITED.			
Bateman, Clarence D. (estate of), c/o A. D. Hickey and Co., 75 Mann-street, Gosford, N.S.W.	61.20	Final dividend	30.4.70
Orr, Ulric G., 17 Billyard-avenue, Elizabeth Bay, N.S.W.	63.75	" " " " "	"
Shaw, Kathleen E. (Mrs.), 10 High-street, Mordialloc	20.40	" " " " "	"
Bateman, Clarence D. (estate of), c/o A. D. Hickey and Co., 75 Mann-street, Gosford, N.S.W.	28.80	Interim dividend	30.10.70
Kenny, Bernard V. (Father) and McFadden, John H., Catholic Presbytery, Maclean, N.S.W.	10.00	" " " " "	"
Orr, Ulric G., 17 Billyard-avenue, Elizabeth Bay, N.S.W.	30.00	" " " " "	"
Stapleton, Rosa M. G. (Miss), 120 Carrington-road, Waverley, N.S.W. 5030	28.80	" " " " "	"
VULCAN INDUSTRIES LIMITED.			
Ogge, Marie Loreto (Mrs.), 3 Barnato-grove, Armadale	15.00	Dividend No. 17	24.4.70
" " " " "	30.00	" " " " "	23.10.70
Trehanne, Arthur Gwilym, 2A "Lake-street, Carnegie	18.70	" " " " "	"
Morrison, Aimee (Mrs.), c/o Union-Fidelity Trustee Co., G.P.O. Box 493, Sydney, N.S.W.	30.00	" " " " "	"
Cooper, Charles Gordon, 39 The Mall, South Hurstville, N.S.W. 5031	90.00	" " " " "	"

Notice is hereby given that at an Extraordinary General Meeting of J. W. Kennedy & Sons Pty. Ltd. held at Melbourne on Monday the 13th day of March, 1972, the following resolution was passed as a Special Resolution—

"That the company be placed in voluntary liquidation."

Dated this 14th day of March, 1972.

J. B. HUTCHINS, Liquidator.

Wilson, Bishop, Bowes & Craig, 191 Queen-street, Melbourne. 5249

Notice is hereby given that at an Extraordinary General Meeting of T. S. Nettlefold Sales Pty. Ltd. held at Melbourne on Monday the 13th day of March, 1972, the following resolution was passed as a Special Resolution—

"That the company be placed in voluntary liquidation."

Dated this 14th day of March, 1972.

J. B. HUTCHINS, Liquidator.

Wilson, Bishop, Bowes & Craig, 191 Queen-street, Melbourne. 5250

Companies Act 1961.

RANHOF PTY. LTD.

Notice is hereby given that at an Extraordinary General Meeting of the members of the company, held on the 16th day of March, 1972, special Resolutions were passed to voluntarily wind up the company and to appoint John Albert Hepworth, of 13 Mulgoa-street, Brighton, as liquidator with power to distribute the assets of the company in specie among the members.

Dated the 20th day of March, 1972.

5281 J. H. HEPWORTH, Liquidator.

LYNNLEA PTY. LTD.

At a General Meeting of the members of the above-named company, held at 1 Eden-court, Toorak, on 15th March, 1972, the Special Resolution set out below was duly passed—

That the company be wound up voluntarily and that Ronald Moore and Eric Maxwell Huggard, of the firm of Spry Walker & Co., chartered accountants, be appointed joint and several liquidators, at a fee to be determined in accordance with the normal professional scale rates for the time occupied by the said liquidators, and/or their staff, in carrying out their duties as liquidators.

Dated this 15th day of March, 1972.

5282 M. DAVIS, Secretary.

The Companies Act 1961.—In the matter of EDREX LEATHER PRODUCTS PTY. LTD. (In Liquidation).

Notice is hereby given that at an Extraordinary General Meeting of the members of the above-named company held on the 16th day of March, 1972, it was resolved that the company be wound up voluntarily, and at a meeting of creditors held on the same day, pursuant to section 260 (1), it was resolved that for such purpose, Bruce Edward Fordham, chartered accountant, be appointed Liquidator.

Dated this 20th day of August, 1972.

BRUCE FORDHAM & CO., chartered accountants, 170 Toorak-road, South Yarra, Vic., 3141. 5276

The Companies Act 1961.—In the matter of ARIEL SERVICES PROPRIETARY LIMITED.

Notice is hereby given that at an Extraordinary General Meeting of the members of the above-named company held on the 1st day of March, 1972, it was resolved that the company be wound up voluntarily, and that for such purpose, Edward Ronald Smail, of 296 Little Lonsdale-street, Melbourne, chartered accountant, be appointed liquidator.

Notice is also given that after 21 days from this date I shall proceed to distribute the assets. All creditors having any claims against the company should furnish particulars of same by that date otherwise I shall proceed to distribute the assets without regard to their claim.

Dated this 10th day of March, 1972.

E. R. SMAIL, Liquidator.

Kennedy, Smail & Middlemiss, 296 Little Lonsdale-street, Melbourne, Vic. 3000. 5294

Creditors, next of kin and others having claims against the estate of Harry Edwin Petrie, late of Napier-street, Creswick, in the State of Victoria, labourer, deceased (who died on the 30th day of August, 1971), are requested to send particulars of their claims to the executor, The Union-Fidelity Trustee Company of Australia Limited, of 101 Lydiard-street north, Ballarat, by the 23rd day of May, 1972, after which date the said executor will distribute the assets, having regard only to the claims of which it then has notice.

NEVETT, GLENN & COUTTS, solicitors, 205 Dana-street, Ballarat. 5247

MAX GORDON, late of 9 Irving-road, Toorak, gentleman, DECEASED.

Creditors, next of kin and others having claims in respect of the estate of the deceased (who died on the 8th day of November, 1971), are required by The Perpetual Executors and Trustees Association of Australia Limited, of 100-104 Queen-street, Melbourne, to send particulars of their claims to the said company, by the 7th day of June, 1972, after which date it will convey or distribute the assets, having regard only to the claims of which the company then has notice.

HENDERSON & BALL, solicitors, of 430 Little Collins-street, Melbourne. 5216

Creditors, next of kin and others having claims against the estate of Alfonsas Bikulcius (in the will incorrectly described as Alphonse Bikulcius), late of 88 Lyndhurst-street, Richmond, in the State of Victoria, fitter, deceased (who died on the 28th day of May, 1971), are required to send particulars of their claims to the executrix of his will, Terese Bikulcius, care of the under-mentioned solicitors, before the 1st day of July, 1972, after which date the said executrix will distribute the estate of the said deceased, having regard only to the claims of which she then had notice.

I. DIZGALVIS & CO., solicitors, 390 Lonsdale-street, Melbourne, Victoria, 3000. 5217

Creditors, next of kin and others having claims against the estate of Janis Skuja, late of 8 Boxleigh-grove, Box Hill North, in the State of Victoria, carpenter, deceased (who died on the 5th day of January, 1972), are required to send particulars of their claims to the executor of his will, Peteris Grundulis, care of the under-mentioned solicitors, before the 1st day of July, 1972, after which date the said executor will distribute the estate of the said deceased, having regard only to the claims of which he then had notice.

I. DIZGALVIS & CO., solicitors, 390 Lonsdale-street, Melbourne, Victoria, 3000. 5218

Creditors, next of kin and others having claims in respect of the estate of Ruby Lillian White, late of 13 The Avenue, Hampton, widow, deceased (who died on the 28th day of September, 1971), are to send particulars of their claims to The Equity Trustees, Executors and Agency Company Limited, of 472 Bourke-street, Melbourne, by the 31st day of May, 1972, after which date it will distribute the assets, having regard only to the claims of which it then has notice.

LEACH & THOMSON, solicitors, 472 Bourke-street, Melbourne. 5296

WILLIAM THOMAS DARLING, formerly of 611 Ripon-street, Ballarat, but late of 102 Ascot-street south, Ballarat, pensioner, DECEASED (who died on the 18th December, 1971).

Creditors, next of kin and all persons having claims against the estate of the deceased are required to send particulars to the executor, The Union-Fidelity Trustee Company of Australia Limited, of 101 Lydiard-street north, Ballarat, on or before the 23rd day of May, 1972, after which date it will distribute the assets, having regard only to the claims of which it shall then have notice.

HEINZ & GORDON, solicitors, 209 Dana-street, Ballarat. 5201

Creditors, next of kin and others having claims in respect of the estate of Walter Rupert Leith, late of 4 Oxford-street, Wendouree, retired farmer, deceased (who died on 19th October, 1971), are required to send particulars of their claims to the executors, The Union-Fidelity Trustee Company of Australia Limited and Elaine Jeanette Worthy, at the said company's address, 101 Lydiard-street north, Ballarat, by 23rd May, 1972, after which date the said executors will distribute the assets, having regard only to the claims of which they then have notice.

BAIRD & MCGREGOR, solicitors, Ballarat. 5202

GEORGE LUMSDEN, late of 78 Kerferd-road, Albert Park, film editor, DECEASED.

Creditors, next of kin and others having claims in respect of the estate of the above-named deceased (who died on 13th December, 1971), are required by the trustee, John Henry Lumsden, of 58 Allison-road, Elsternwick, retired salesman, to send particulars to his solicitors, Paul C. Nunan & Bloom, at their address below, by 31st May, 1972, after which date the trustee may convey or distribute the assets, having regard only to the claims of which he then has notice.

PAUL C. NUNAN & BLOOM, solicitors, 343 Little Collins-street, Melbourne. 5203

EMMA CONSTANCE LORDING (also known as Constance Emma Lording), formerly of 61 Barkly-street, Mordialloc, but late of flat 4, 18 John-street, Mordialloc, widow, DECEASED.

Creditors, next of kin and others having claims in respect of the estate of the deceased (who died on the 2nd September, 1971), are required to send particulars of their claims to National Trustees Executors and Agency Company of Australasia Limited, of 95 Queen-street, Melbourne, before the 30th day of May, 1972, after which date it will distribute the assets, having regard only to the claims of which it then has notice.

JOHN P. McCAFFREY & CO., solicitors, 24A Station-street, Moorabbin. 5204

ELIZABETH DOHERTY, late of Bethlehem Home for the Aged, of Taylor-street, Specimen Hill, Bendigo, (formerly of Ramsay-street, Rochester), spinster, DECEASED.

Creditors, next of kin and others having claims in respect of the estate of the deceased (who died on the 28th day of April, 1971), are required by the trustees, National Trustees Executors and Agency Company of Australasia Limited, of 95 Queen-street, Melbourne, and at 46 Queen-street, Bendigo, to send particulars to them, care of the under-mentioned solicitors, by the 29th day of May, 1972, after which date the trustee may convey and distribute the assets, having regard only to the claims of which they then have notice.

H. W. RALEIGH, ROBERTS & DICK, solicitors, Rochester. 5205

MONA JUDE, late of 39 Hampden-street, Mornington, in the State of Victoria, married woman, DECEASED (who died on the 7th day of September, 1971).

Creditors, next of kin and all other persons having claims against the estate of the deceased, are required by the surviving executrix of the will, Sadie Ray, to send particulars to her, care of the undersigned, on or before the 16th day of June, 1972, after which date they will distribute the assets, having regard only to the claims of which they then have notice.

GARDEN & GREEN, solicitors, 4 McCallum-street, Swan Hill. 5207

JACK STANLEY BLAKEY, late of 1445 Dandenong-road, Oakleigh, gentleman, DECEASED.

Creditors, next of kin and others having claims in respect of the estate of the deceased (who died on the 13th day of October, 1971), are required by The Perpetual Executors and Trustees Association of Australia Limited, of 100-104 Queen-street, Melbourne, to send particulars of their claims to the said company, by the 31st day of May, 1972, after which date it will convey or distribute the assets, having regard only to the claims of which the company then has notice.

MULLETT, LANGFORD & NEDOVIC, solicitor, 470 Bourke-street, Melbourne. 5224

Creditors, next of kin and others having claims in respect of the estate of Nicholas Evans Beveridge, late of 30 Scott-street, Preston, tanner (who died on the 6th day of October, 1971), are to send particulars of their claims to Royston Cahir, Martin & Dillon, solicitors of 17 Queen-street, Melbourne, by the 26th day of May, 1972, after which date the executor will distribute the assets of the estate, having regard only to claims of which he has notice.

ROYSTON CAHIR, MARTIN & DILLON, solicitors, of 17 Queen-street, Melbourne. 5285

Creditors, next of kin and others having claims in respect of the estate of Veronica Marie Taylor, late of 140 Williams-road, Prahran, married woman (who died on the 1st day of July, 1971), are to send particulars of their claims to Royston Cahir, Martin & Dillon, solicitors, of

17 Queen-street, Melbourne, by the 26th day of May, 1972, after which date the executor will distribute the assets of the estate, having regard only to claims of which he has notice.

ROYSTON CAHIR, MARTIN & DILLON, solicitors, of 17 Queen-street, Melbourne. 5286

Creditors, next of kin and others having claims against the estate of Ernst Kretz, late of 619 St. Kilda-road, Melbourne, engineer, deceased (who died on the 1st May, 1971), are required by the executors, Esther Kretz, of Flat 10, 18 Mercer-road, Malvern, widow, and Alfred Newton Super, of 374 Bourke-street, Melbourne, solicitor, to send particulars of such claims to them at the office of the undersigned solicitors, on or before the 23rd May, 1972, after which date they will distribute the assets, having regard only to the claims of which they shall then have had notice.

A. NEWTON SUPER & P. G. KOVACS, barristers and solicitors, 374 Bourke-street, Melbourne. 5295

COLIN ALFRED BROWNE, late of 12 Tarnet-street, East Bentleigh, in the State of Victoria, truck driver, DECEASED.

Creditors, next of kin and all others having claims in respect of the estate of the above-named deceased (who died on the 22nd day of November, 1971), are required to send particulars thereof to the executor care of the under-mentioned solicitor, on or before the 23rd day of May, 1972, after which date the said executor may convey or distribute the assets, having regard only to the claims of which he then has notice.

K. P. REES, B.A., LL.B., solicitor, 118 Queen-street, Melbourne. 5272

Creditors, next of kin and others having claims in respect of the estate of Beverley Margaret Stafford, late of 27 Coolibah-street, Doncaster, in the State of Victoria, married woman, deceased (who died on the 14th day of February, 1972), are requested to send particulars of their claims to the executor, Lloyd Pym Goode, solicitor, of 406 Lonsdale-street, Melbourne, in the said State, by the 31st day of May, 1972, after which date he will distribute the assets, having regard only to the claims of which he then has notice.

LLOYD P. GOODE & CO., solicitors, of 406 Lonsdale-street, Melbourne. 5225

RUDOLPH FREDERICK WHITE, late of Burnside Private Hospital, 7 Hartington-street, Elsternwick, pensioner, DECEASED.

Creditors, next of kin and others having claims in respect of the estate of the deceased (who died on the 29th day of September, 1971), are required by the trustee, The Equity Trustees, Executors and Agency Company Limited, of 472 Bourke-street, Melbourne, to send particulars to the said company at 472 Bourke-street, Melbourne, by the 31st day of May, 1972, after which date the trustee may convey or distribute the assets, having regard only to the claims of which it has notice.

CLEVERDON, REID & FINLAY, 118 Queen-street, Melbourne. 5226

Creditors, next of kin and others having claims in respect of the estate of Arthur Lionel Bridges Webb (sometimes known as Arthur Lionel Bridges-Webb), late of 26 Stradbroke-avenue, Heidelberg, medical practitioner, deceased (who died on the 1st November, 1971), are to send particulars of their claims to The Trustees, Executors and Agency Company Limited, of 401 Collins-street, Melbourne, by the 31st May, 1972, after which date it will distribute the assets, having regard only to the claims of which it then has notice.

MOULE, HAMILTON & DERHAM, 224 Queen-street, Melbourne. 5227

FRANCIS MICHAEL O'BRIEN, late of 35 Russell-street, Camberwell, civil servant, DECEASED.

Creditors, next of kin and others having claims in respect of the estate of the deceased (who died on the 31st day of August, 1971), are required by the personal representative, National Trustees, Executors and Agency Company of Australasia Limited, the registered office of which is at 95 Queen-street, Melbourne, to send particulars to it by the 26th day of May 1972, after which date the said company may convey or distribute the assets, having regard only to the claims of which it then has notice.

PAUL J. CAREY & CO., solicitors, 386 Flinders-lane, Melbourne. 5228

JOSEK SKURNIK, late of Flat 5, 3 Chomley-street, Windsor, businessman, DECEASED.

Creditors, next of kin and others having claims in respect of the estate of the deceased (who died on the 15th October, 1969), are required by the personal representatives, Lois Mary Skurnik, of Flat 5, 3 Chomley-street, Windsor, Arthur Skurnik, of 10 Meyer-court, East Brighton, and Michael David Firstenberg, of 452 Lonsdale-street, Melbourne, to send particulars to them, in care of the undersigned solicitor, by the 30th day of May, 1972, after which date the personal representatives may convey or distribute the assets, having regard only to the claims of which they then have notice.

Dated the 17th day of March, 1972.

M. DAVID FIRSTENBERG, LL.B., solicitor, 452 Lonsdale-street, Melbourne. 5211

ETHEL MAY JACOBSON, late of 298 Huntingdale-road, Chadstone, widow, DECEASED.

Creditors, next of kin and others having claims in respect of the estate of the deceased (who died on the 17th November, 1971), are required by Alfred Horace Jackson, of Benambra-street, Preston, clerk, the executor to whom probate of the will of the deceased was granted to send such claims to him, care of the under-mentioned solicitor, by the 31st May, 1972, after which date he will distribute the assets, having regard only to the claims of which he then has notice.

DAVID BULLARD, solicitor, 443 Little Bourke-street, Melbourne. 5212

Creditors, next of kin and others having claims against the estate of Agnes Bolton, late of Little Sisters of the Poor, St. Georges-road, Northcote, retired nurse, deceased (who died on 21st December, 1971), are required by Patrick Francis Toohey, the executor of the will of deceased, to send to him, care of the undersigned solicitors, particulars thereof by 31st May, 1972, after which date he will distribute the assets, having regard only to the claims of which he shall then have notice.

GAVAN DUFFY & KING, solicitors, 95 Queen-street, Melbourne. 5213

Creditors, next of kin and others having claims against the estate of Henrietta Newport, late of 47 Lincoln-street, Richmond, home duties, deceased (who died on 4th January, 1972), are required by Patrick Francis Toohey, the executor of the will of deceased, to send to him, care of the undersigned solicitors, particulars thereof by 31st May, 1972, after which date he will distribute the assets, having regard only to the claims of which he shall then have notice.

GAVAN DUFFY & KING, solicitors, 95 Queen-street, Melbourne. 5214

MALCOLM JOHN STEPHEN LIDDELL, late of Royal Hotel, Warrnambool, in the State of Victoria, retired post master, DECEASED.

Creditors, next of kin and others having claims in respect of the estate of the deceased (who died on the 14th July, 1970), are required by his administrator, Henry Patrick Liddell, of 53 Hackett-street, Pascoe Vale South, to send particulars to him by the 26th day of May, 1972, after which date the administrator may convey or distribute the assets, having regard only to the claims of which he then has notice.

CLEARY, ROSS & DOHERTY, solicitors, 406 Collins-street, Melbourne. 5215

RONALD ERNEST GRIFFIN, formerly of 25 White-street, Williamstown, in the State of Victoria, but late of Flat 1, 18 Station-road, Williamstown, in the said State, supervisor, DECEASED.

Creditors, next of kin and others having claims in respect of the estate of the above-named deceased (who died on the 9th day of November, 1971), are required by the executor, David Joseph Griffin, of 25 Churchill-road, Morwell, in the said State, accountant, to send particulars to him by the 25th day of May, 1972, after which date the executor may convey or distribute the assets, having regard only to the claims of which he then has notice.

DAVIES, CAMPBELL & PIESSE, solicitors, 401 Collins-street, Melbourne. 5273

JOHN ANDREW DAVIES, late of 27 Fyfe-drive, Lower Templestowe, sales representative, DECEASED, intestate.

Creditors, next of kin and others having claims in respect of the estate of the deceased (who died on 21st June, 1971), are required by the administratrix, Marlene

Agnes Davies, of 27 Fyfe-drive, Lower Templestowe, widow, to send particulars to the said administratrix, care of the under-mentioned solicitors, by the 22nd May, 1972, after which date she may distribute the assets, having regard only to the claims of which she then has notice.

BRENDAN MCGUINNESS & CO., solicitors, of 118 Queen-street, Melbourne. 5270

WALTER NICHOLAS JARRETT, late of The Queen Elizabeth Home, 102 Ascot-street, Ballarat, pensioner, DECEASED.

Creditors, next of kin and others having claims in respect of the estate of the deceased (who died on the 26th day of November, 1971), are required by Ewen Oliver Crossley Cameron, of Casterton, solicitor, the applicant for a grant of administration, to send particulars of his claims to the said applicant, in the care of Silvester & Silvester, solicitors, Casterton, before the 23rd day of May, 1972, after which date he will convey or distribute the assets, having regard only to the claims of which he then has notice. 5248

ELIZABETH CHARLOTTE RAYMOND, late of Flat 4, 22 Welsford-street, Shepparton, in the State of Victoria, widow, DECEASED.

Creditors, next of kin and all other persons having claims against the estate of the deceased, are required by the executor, John Finlay Anderson, solicitor, of 472 Bourke-street, Melbourne, to send particulars to him, care of the under-mentioned solicitors, on or before the 1st day of June, 1972, after which date he will distribute the assets, having regard only to the claims of which he then has notice.

J. ALLAN ANDERSON & SON, solicitors, of 472 Bourke-street, Melbourne. 5251

Creditors, next of kin and others having claims in respect of the estate of Joseph Alphonsus Valentine Stuart, late of Unit 8, 12 Marine-parade, St. Kilda, retired (who died on the 22nd day of May, 1971), are to send particulars of their claims to Royston Cahir, Martin & Dillon, solicitors, of 17 Queen-street, Melbourne, by the 26th day of May, 1972, after which date the executrix will distribute the assets of the estate, having regard only to claims of which she has notice.

ROYSTON CAHIR, MARTIN & DILLON, solicitors, of 17 Queen-street, Melbourne. 5284

Creditors, next of kin and other persons having claims against the estate of Isabella Augusta Burnett (also known as Isabella Augusta Berndt) late of 10 Murray-street, Prahran, in the State of Victoria, spinster, deceased (who died on the 26th January, 1972), are required to send particulars of their claims to the executor, Thomas Keith Burgin, care of the under-mentioned solicitors, by the 24th day of May, 1972, after which date the executor will distribute the assets, having regard only for the claims of which he then has had notice.

JAMES P. OGGE & CO., solicitors, 165 Greville-street, Prahran. 5283

ALEXANDER CLIFTON CROME, late of 76 High-street, South Kew, retired company director, DECEASED.

Creditors, next of kin and others having claims against the estate of the said deceased (who died on the 17th day of April, 1971), are to send particulars of their claims to Annie Margaret Crome and Bernard Gore Brett, care of Blake & Riggall, solicitors, 120 William-street, Melbourne, by the 26th day of May, 1972, after which date they will distribute the assets, having regard only to the claims of which they then have notice.

BLAKE & RIGGALL, solicitors, 120 William-street, Melbourne. 5275

ALFRED LANCELOT CHAMBERS, late of 4 Crest-avenue, Balwyn, company director, DECEASED.

Creditors, next of kin and others having claims in respect of the estate of the deceased (who died on the 15th day of September, 1971), are required by the trustees, The Trustees Executors and Agency Company Limited, of 401 Collins-street, Melbourne, Albert Victor Halligan, of 23 Parkdale-avenue, Balwyn, export manager and Gregory John Chambers, of Flat 4, 36 Auburn-road, Hawthorn, clerk, to send particulars to them, at the office of the said company, at 401 Collins-street, Melbourne, by the 25th day of May, 1972, after which date the trustees may convey or distribute the assets, having regard only to the claims of which they then have notice.

WEIGALL & CROWTHER, solicitors, 459 Little Collins-street, Melbourne. 5274

ERIC GORDON GUNSTONE, late of Neerim South, farmer, DECEASED.

Creditors, next of kin, and others having claims in respect of the estate of the deceased (who died on the 5th day of June, 1971), are required by the trustee, Elsie Gunstone, of Neerim South, widow, to send particulars of their claims to her, care of the under-mentioned solicitors, by the 31st day of May, 1972, after which date the trustee may convey or distribute the assets, having regard only to the claims of which she then has notice.

GRAY, FRIEND & LONG, solicitors, Warragul. 5185

Creditors, next of kin, and others having claims in respect of the estate of Arthur Bernard Sanders, late of 27 Rankins-road, Kensington, blacksmith, deceased, intestate (who died on the 26th day of January, 1972), are requested to send particulars of their claims to the administrator, Gavin Arthur Sanders, care of the under-mentioned solicitor, by the 31st day of May, 1972, after which date he will distribute the assets, having regard only as to the claims of which he then has notice.

JOHN STEWART, solicitor, of 290 Racecourse-road, Newmarket. 5169

Creditors, next of kin, and others having claims in respect of the estate of Joseph William Wright, late of St. Arnaud East, farmer, deceased (who died on the 29th November, 1971), are to send particulars of their claims to Margaret Mary Wright, widow, Maurice William Wright, farmer, and Brian Joseph Wright, farmer, all of St. Arnaud East, care of the under-mentioned solicitors, by the 1st June, 1972, after which date they will distribute the assets, having regard only to the claims of which they then have notice.

HEYTT & HEYTT, solicitors, 78 Napier-street, St. Arnaud. 5170

LESLIE GORDON HERD, late of 52 Fyans-street, Chilwell, Geelong, plumber, DECEASED.

Creditors, next of kin, and others having claims in respect of the estate of the said deceased (who died 4th January, 1972, are required by the applicant for grant of probate, Ivan James Lewis, of 89 Myers-street, Geelong, solicitor), to send particulars to him, at that address, by 24th May, 1972, after which date the said applicant may convey or distribute the assets, having regard only to the claims of which he then has notice.

WIGHTON & McDONALD, solicitors, 89 Myers-street, Geelong. 5162

Creditors, next of kin, and others having claims against the estate of Harold James Cayle, late of 32 Fisher-street, East Malvern, retired, deceased (who died on the 10th day of July, 1971), are required to send particulars of their claims to the executors, Graham James Cayley and Neville Ingham Cayley, care of the undersigned solicitors, before the 31st day of May, 1972, after which date they will distribute the assets, having regard only to the claims of which they then have notice.

LESTER, PEARN & FIELDEN, solicitors, 14 Haughton-road, Oakleigh. 5161

HENRY WILLIAM JACOBS, late of 642 Plenty-road, Preston, military pensioner.

Creditors, next of kin, and others having claims in respect of the estate of the deceased (who died on the 13th November, 1971), are required by executrix of the will of the said Henry William Jacobs, Vivienne Violet Jacobs, of 642 Plenty-road, Preston, home duties, to send particulars to her, care of her solicitor, James Kelleher, 235c Tyler-street, Preston, by the 31st day of May, 1972, after which date the executrix may convey or distribute the assets, having regard only to the claims of which she then has notice.

Dated the 15th day of March, 1972.

JAMES KELLEHER, barrister and solicitor, 235c Tyler-street, Preston. 5164

Creditors, next of kin, and others having claims in respect of the will of Edward John Fielder, late of 53 The Ridgeway, Kensington, gentleman (who died on the 20th day of August, 1970), are requested to send particulars of their claims to the executor, John Eudes Stewart, of 290 Racecourse-road, Newmarket, solicitor, by the 31st day of May, 1972, after which date he will distribute the assets, having regard only as to the claims of which he then has notice.

JOHN STEWART, solicitor, of 290 Racecourse-road, Newmarket. 5168

ANDREW BUCKLEY CROWE, late of 129 Cramer-street, Preston, formerly public servant, but late retired, DECEASED.

Creditors, next of kin, and others having claims in respect of the estate of the deceased (who died on the 24th day of November, 1971), are required to send particulars of their claims to National Trustees, Executors and Agency Company of Australasia Limited, of 95 Queen-street, Melbourne, before the 17th day of May, 1972, after which date it will distribute the assets, having regard only to the claims of which it then has notice.

F. P. & M. J. WALSH, solicitors, 452 High-street, Northcote. 5158

AMELIA ELSIE OLIVE VORBACH, late of 2 Leith-street, Newborough, in the State of Victoria, widow, DECEASED.

Creditors, next of kin, and others having claims in respect of the estate of the deceased (who died on the 7th day of January, 1971), are required by the executor, John Donald Vorbach, of 84 Monash-road, Newborough, dairyman, to send particulars to his solicitors, Messrs. F. X. O'Halloran, Davis & Co., Kirk-street, Moe, by the 29th day of May, 1972, after which date the executor may convey or distribute the assets, having regard only to the claims of which he then has notice.

Dated the 16th day of March, 1972.

F. X. O'HALLORAN, DAVIS & CO., solicitors, Moe. 5186

JAMES DYSON, late of Verner-street, South Geelong, engineer, DECEASED.

Creditors, next of kin, and others having claims in respect of the estate of the deceased (who died 1st November, 1971), are required by the personal representatives, Hubert Percy Bowman and Ian Robert Knox, both of 43 Yarra-street, Geelong, solicitors, to send particulars to them, by the 31st day of May, 1972, after which date they may convey or distribute the assets, having regard only to the claims of which they then have notice.

BOWMAN & KNOX, solicitors, 43 Yarra-street, Geelong. 5194

LINDSAY GEORGE TROUGHTON, late of Flat 9, 17 Burnett-street, St. Kilda, in the State of Victoria, State Electricity Commission officer, DECEASED, intestate.

Creditors, next of kin, and others having claims in respect of the estate of the deceased (who died on the 23rd December, 1971), are required by John Richard Troughton, of 30 Ruby-street, East Burwood, building supervisor, the administrator of the estate of the said deceased, to send particulars of their claims to Gregory Gray & Co., solicitors, of 635 Glenferrie-road, Hawthorn, by the 24th day of May, 1972, after which date the said administrator will convey or distribute the assets, having regard only to the claims of which he then has notice.

GREGORY GRAY & CO., solicitors, 635 Glenferrie-road, Hawthorn. 5198

ADELAIDE VICTORIA REYNOLDS, late of 100 Beveridge-street, Swan Hill in the State of Victoria, widow, DECEASED (who died on 2nd December, 1971).

Creditors, next of kin, and all other persons having claims against the estate of the deceased, are required by the executors of the will, William Reynolds and Shirley Reynolds, to send particulars to them, care of the under-mentioned, on or before the 16th day of June, 1972, after which date they will distribute the assets, having regard only to the claims of which they then have notice.

GARDEN & GREEN, solicitors, 4 McCallum-street, Swan Hill. 5187

MARY LOUISA MOSS, late of Swan Hill, in the State of Victoria, widow, DECEASED (who died on 11th February, 1972).

Creditors, next of kin and all other persons having claims against the estate of the deceased, are required by the executor of the will, Thomas Bridson Green, to send particulars to him, care of the under-mentioned, on or before the 16th day of June, 1972, after which date he will distribute the assets, having regard only to the claims of which he then has notice.

GARDEN & GREEN, solicitors, 4 McCallum-street, Swan Hill. 5188

In the Supreme Court of the State of Victoria.

SALE BY THE SHERIFF.

On Friday, the 28th of April, 1972, at 10 a.m., at the Police Station, Mentone (unless process be stayed or satisfied):—

All the estate and interest (if any) of Valdis Warke, horse-trainer, of 73 Robert-street, Mentone, as proprietor of an estate in fee-simple in the land described in certificate

of title, volume 8664, folio, 167, upon which is erected a weatherboard dwelling and outbuildings known as No. 73 Robert-street, Mentone.

Registered mortgage No. B.819486 affects the said estate and interest.

Terms: Cash only.

H. BUETTNER, Sheriff's Officer.

22nd March, 1972. 5287

In the Supreme Court of the State of Victoria.

SALE BY THE SHERIFF.

On Thursday, the 4th of May, 1972, at 10 a.m., at the Police Station, Toorak (unless process be stayed or satisfied):—

All the estate and interest (if any) of Dominic Morgado, solicitor, of 1 Lambert-road, Toorak, as joint proprietor with Sherrin Pennicott and Robin Garing, of an estate in fee-simple in the land described in certificate of title, volume 8375, folio 268, upon which is erected a brick veneer dwelling known as No. 1 Lambert-road, Toorak.

Registered mortgage No. D.768005 and Caveat E.40721 affects the said estate and interest.

Terms: Cash only.

H. BUETTNER, Sheriff's Officer.

22nd March, 1972. 5293

In the Supreme Court of the State of Victoria.

SALE BY THE SHERIFF.

On Friday, the 5th of May, 1972, at 10 a.m., at the Police Station, Murrumbena (unless process be stayed or satisfied):—

All the estate and interest (if any) of Dennis Skouris, taxi truck owner, and Konstantina Skouris, married woman, both of 24 Packer-street, Murrumbena, as joint proprietors of an estate in fee-simple in the land described in certificate of title, volume 4744, folio 604, upon which is erected a weatherboard dwelling known as No. 24 Packer-street, Murrumbena.

Registered mortgages Nos. D.763391 and caveat D.847211 affects the said estate and interest.

Terms: Cash only.

H. BUETTNER, Sheriff's Officer.

22nd March, 1972. 5289

In the Supreme Court of the State of Victoria.

SALE BY THE SHERIFF.

On Wednesday, the 3rd of May, 1972, at 11 a.m., at the Police Station, Burwood (unless process be stayed or satisfied):—

All the estate and interest (if any) of Allan Ridgway, foreman, of 26 Trent-court, East Burwood, as joint proprietor with Muriel Agnes Ridgway, of an estate in fee-simple in the land described in certificate of title, volume 8432, folio 708, upon which is erected a weatherboard dwelling known as No. 26 Trent-court, East Burwood.

Registered mortgages Nos. D.787612 and D.748308 affects the said estate and interest.

Terms: Cash only.

H. BUETTNER, Sheriff's Officer.

22nd March, 1972. 5290

In the Supreme Court of the State of Victoria.

SALE BY THE SHERIFF.

On Friday, the 5th of May, 1972, at 12 noon, at the Police Station, Springvale (unless process be stayed or satisfied):—

All the estate and interest (if any) of Cecil Edwin Heath, soil mechanic, of 20 Latrobe-street, Box Hill South, as proprietor of an estate in fee-simple in the land described in certificate of title, volume 8431, folio 987, upon which is erected a brick dwelling known as No. 30 Wanda-street, Mulgrave.

Registered mortgage Nos. C.184140 and D.783733 and Caveat D.671587 affects the said estate and interest.

Terms: Cash only.

H. BUETTNER, Sheriff's Officer.

22nd March, 1972. 5291

In the Supreme Court of the State of Victoria.

SALE BY THE SHERIFF.

On Friday, the 28th of April, 1972, at 12 noon, at the Police Station, Altona (unless process be stayed or satisfied):—

All the estate and interest (if any) of George Kalafatis, welder, and Christine Kalafatis, married woman, both of 123 Seventh-avenue, North Altona, as joint proprietors of

an estate in fee-simple in the land described in certificate of title, volume 8279, folio 160, upon which is erected a weatherboard dwelling known as No. 123 Seventh-avenue, North Altona.

Registered mortgages Nos. B.957890 and D.741595 affects the said estate and interest.

Terms: Cash only.

H. BUETTNER, Sheriff's Officer.

22nd March, 1972. 5288

In the Supreme Court of the State of Victoria.

SALE BY THE SHERIFF.

On Thursday, the 4th of May, 1972, at 11 a.m., at the Police Station, Doncaster (unless process be stayed or satisfied):—

All the estate and interest (if any) of Anthony John Zoch, public servant, and Elaine Agnes Marie Zoch, married woman, both of 12 Dunoon-street, Doncaster, as joint proprietors of an estate in fee-simple in the land described in certificate of title, volume 8489, folio 990A, upon which is erected a brick dwelling known as No. 12 Dunoon-street, Doncaster.

Registered mortgage No. D.794985 affects the said estate and interest.

Terms: Cash only.

H. BUETTNER, Sheriff's Officer.

22nd March, 1972. 5292

IMPOUNDINGS

ALEXANDRA.—Impounded in Alexandra Pound, on 10th March, 1972, from Goulburn Valley Highway, Alexandra.

1 ewe, long tail, full wool, no visible brand or earmarks
1 wether, long tail, full wool, no visible brand or earmarks

If not claimed and expenses paid, to be sold on 7th April, 1972.

G. MAUDOUIT,
Poundkeeper.

5189—\$2.80

CRANBOURNE.—Impounded in Cranbourne Pound, by Mr. D. Round of Pound-road, Clyde.

1 Jersey-Friesian cross cow, notched both ears, no visible brand

1 Jersey cow, notched both ears, no visible brand

1 Jersey cow, notched both ears and bob tailed, no visible brand

1 Jersey cow, notched one ear, no visible brand

If not claimed and expenses paid, to be sold on 12th April, 1972.

G. HALLISEY,
Poundkeeper.

5261—\$4.20

CRESWICK.—Impounded in Creswick Pound, by Ranger, on 11th March, 1972.

1 ram, no visible brand

1 ram lamb, no visible brand

If not claimed and expenses paid, to be sold on 6th April, 1972.

J. McNICOL,
Poundkeeper.

5191—\$2.80

DANDENONG.—Impounded in Dandenong Pound, by Ranger, City of Dandenong, from Brady-road, Dandenong.

1 Hereford steer, no visible brand

If not claimed and expenses paid, to be sold on 10th April, 1972.

L. S. MEAD,
Poundkeeper.

5222—\$2.45

DANDENONG.—Impounded in Dandenong Pound, by A. J. Follet, from Necropolis Paddock, Springvale.

1 Black Poll bull, no visible brand

If not claimed and expenses paid, to be sold on 11th April, 1972.

L. S. MEAD,
Poundkeeper.

5223—\$2.45

EAGLEHAWK.—Impounded in Eaglehawk Pound, from Arblaster-street, by the Borough Ranger.

1 black and white gelding with chain, no visible brand

If not claimed and expenses paid, to be sold on 4th April, 1972.

C. M. NANKERVIS,
Poundkeeper.

5264—\$2.45

JUNG.—Impounded in Jung Pound, by C.R.B. from Mockinya.

4 lambs, 2 ewes, 1 wether, no visible brands

If not claimed and expenses paid, to be sold on 8th April, 1972.

L. B. McRAE,
Poundkeeper.

5262—\$2.45

LAKE BENETOOK.—Impounded in Lake Benetook Pound.

1 Jersey bull, ring in nose, no visible brand
1 Friesian cow, dehorned, no visible brand
1 dark Jersey cow, no visible brand

If not claimed and expenses paid, to be sold on 6th April, 1972.

E. F. CURTIS,
Poundkeeper.

5221—\$2.80

PAKENHAM.—Impounded in Pakenham Pound.

1 black and white Hereford X heifer 6 months, mark right ear, green paint back, no visible brand

If not claimed and expenses paid, to be sold on 4th April, 1972.

H. SMITH,
Poundkeeper.

5192—\$2.45

WARRAGUL.—Impounded in Warragul Pound, on 10th March, 1972, from Mr. A. Robe's property at Princes Highway, Nilma.

1 crossbred ram, three-quarter tail, no visible brand

If not claimed and expenses paid, to be sold on 10th April, 1972.

D. GRAHAM,
Poundkeeper.

5190—\$2.80

YEA.—Impounded in Yea Pound, on 17th March, 1972, from Mr. McCormacks property, Flowerdale.

1 white polled bull, no visible brand or mark

1 red heifer, piece out of back of right ear, no visible brand

If not claimed and expenses paid, to be sold on 6th April, 1972.

H. RIDD,
Poundkeeper.

5260—\$3.15

Subordinate Legislation Act 1962.

NOTICE OF MAKING OF STATUTORY RULES.

In pursuance of the provisions of the *Subordinate Legislation Act 1962* and the Regulations made thereunder, notice is given of the making of the following statutory rules:—

No.	Extractive Industries Act 1966.	Price.
73/1972.	Extractive Industries (Board of Examiners for Quarry Managers) Regulations 1972	10c
<i>Geelong Waterworks and Sewerage Act 1958.</i>		
74/1972.	Geelong Waterworks and Sewerage (Long Service Leave) Regulations 1972	10c
<i>Health Act 1958.</i>		
75/1972.	Food and Drug Standards (Amendment) Regulations 1972	10c
<i>Apprenticeship Act 1958.</i>		
76/1972.	Apprenticeship (General) (Amendment No. 2) Regulations 1972	10c

Copies of these statutory rules may be purchased at the Sale of Publications Section of the Government Printing Office, located at 7A Parliament-place, Melbourne, 3002. If ordered by mail, remittance should be addressed to "The Government Printer, Box 203, P.O., North Melbourne, 3051", and should include 7c extra for postage. If a credit account is held at this office, no remittance is required with the mail order.

The annual subscription rate for Statutory Rules (including Bound Volumes) is \$23, payable in advance. The subscription year commences on 1st January.

C. H. RIXON,
Government Printer.

THE "VICTORIA GOVERNMENT GAZETTE".

SUBSCRIPTIONS.—The subscription, including postage, is \$22.50 per annum, or \$11.25 per half year, payable in advance.

Subscriptions are required for whole months, and must cover at least a half year

Single copies are 30 cents, posted 48 cents. Subscribers do not receive the Acts of Parliament with the GAZETTE.

GAZETTES are held in stock for five years only.

PRIVATE ADVERTISEMENTS.—The charge for insertion is 35 cents per line single column, and 70 cents per line double column. The title forms one or more lines as a heading. On an average ten words make a line of single column. Every signature must likewise be counted as a line. The final words of a paragraph, though only portion of a line, must be counted as one line. Signatures (in particular) and proper names must be written very plainly in the text; ONE SIDE ONLY of each sheet of paper should be WRITTEN UPON. The charge for a full page is \$50.

All documents illegibly written will be returned unpublished, and where brands occur unprovided for by the ordinary letters of the alphabet, a worded explanatory description must be furnished.

THE VICTORIA GOVERNMENT GAZETTE is published on WEDNESDAY EVENING in each week, and Notices for insertion will be received by the Government Printer at or before ONE p.m. at ordinary rates, and late advertisements between ONE p.m. and FOUR p.m. at double rates on the day preceding the day of publication.

PAYMENTS.—Unless the advertiser has a credit account, all payments are required in advance. Remittances should be made by cheque, postal order, or money order payable to "GOVERNMENT PRINTER".

ADDRESS.—All communications should be addressed to "The Government Printer, Box 203, P.O., North Melbourne", 3051.

CONTENTS

	PAGE
Appointments	787
Companies Act 1961—Notice	779
Contracts	786
Easter Holidays	773
Estates of Deceased Persons	786
Government Notices	773
Impoundings	821
Lands	799
Melbourne and Metropolitan Board of Works—	
Notice	783
Mining	785
Notice to attend for Radiological Examination	782
Notice of Making of Statutory Rules	821
Orders in Council—	
Acts—Country Roads; Water; Landlord and Tenant; Labour and Industry; Land; Home et seq Finance; Sewerage Districts; Geelong Waterworks and Sewerage; Landlord and Tenant.	788
Police Sale	785
Private Advertisements	807
Proclamations	772
Publication of the "Victoria Government Gazette"	771
Public Half-Holidays	772
Public Service Notices	806
Regulations—	
Acts—Teaching Service	805
Resignation	788
State Rivers and Water Supply Commission	783
Tenders	800
Transport Regulation Board—Public Hearings	776
Waterworks Trusts	774