

[2777]



VICTORIA GOVERNMENT GAZETTE

Published by Authority

No. 72]

WEDNESDAY, AUGUST 9

[1972

PROCLAMATIONS

ROADS PROCLAIMED.

PROCLAMATION

By His Excellency the Lieutenant-Governor of the State of Victoria and its Dependencies in the Commonwealth of Australia, &c., &c., &c.

In pursuance of the provisions of section 25 of the Land Act 1958, the Lieutenant-Governor of the State of Victoria, by and with the advice of the Executive Council of the said State, do hereby proclaim as roads the under-mentioned lands:

Township of Ballarat North, Parish of Ballarat, County of Grenville, being the land indicated by hatching on plan hereunder.—(B.128⁽⁹⁸⁾) (J.34128.)

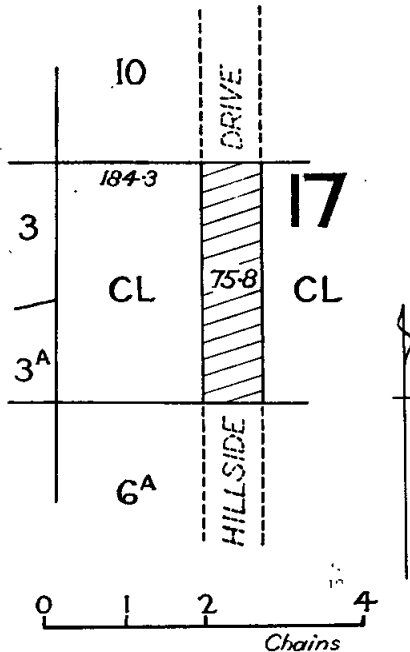

Township of Boort, Parish of Boort, County of Gladstone, being the land indicated by hatching on plan hereunder.—(B.654⁽¹³⁾) (C.100272.)

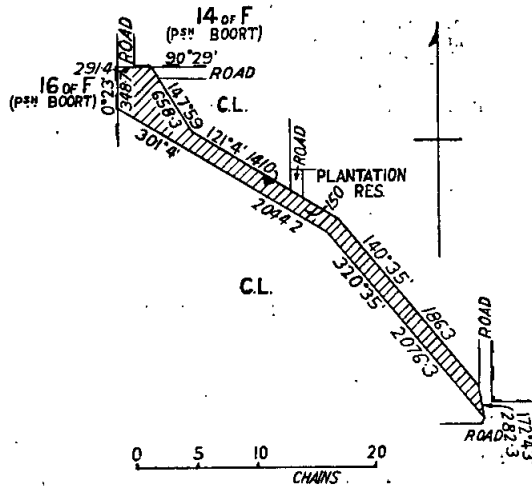

Given under my Hand and the Seal of the State of Victoria aforesaid, at Melbourne, this first day of August, in the year of our Lord One thousand nine hundred and seventy-two, and in the twenty-first year of the reign of Her Majesty Queen Elizabeth II.

(L.S.)

E. F. HERRING.

By His Excellency's Command,

W. BORTHWICK,
Minister of Lands.

GOD SAVE THE QUEEN!

MENTAL HEALTH ACT 1959.

PROCLAMATION

By His Excellency the Lieutenant-Governor of the State of Victoria and its Dependencies in the Commonwealth of Australia, &c., &c., &c.

Whereas by sub-section (1) of Section 24 of the Mental Health Act 1959 (No. 6605), it is provided that the Governor in Council may by proclamation published in the Government Gazette proclaim one or more buildings or places provided by the State for the treatment of the mentally ill or the intellectually defective or any part of such building or place to be—

- (a) a psychiatric hospital;
- (b) a mental hospital;
- (c) a training centre; or
- (d) a repatriation mental hospital;

And whereas by sub-section (3) of Section 24 it is provided that the Governor in Council may by proclamation published in the Government Gazette exempt from all or any of the provisions of Act No. 6605 any specified building forming part of an institution;

And whereas by Proclamation of the Governor in Council made pursuant to sub-section (1) of Section 24 of the Mental Health Act 1959 and dated the seventeenth day of May, 1966, and published in the Government Gazette of the twenty-fifth day of May, 1966, the whole of the area in the Parish of Keelbundora, County of Bourke, indicated by hachure on the plan attached to the said Proclamation dated the seventeenth day of May, 1966, was proclaimed as a mental hospital known as the Mental Hospital Mont Park:

Now therefore, I, the Lieutenant-Governor of the State of Victoria, in the Commonwealth of Australia by and with the advice of the Executive Council of the said State do, by this my Proclamation exempt from all of the provisions of the Mental Health Act 1959 as from the first day of September, 1972, the building, known as the General Surgical Unit and forming part of the Mont Park Mental Hospital, which is located in a south-easterly direction from Main Drive and at the rear of the Mont Park Psychiatric Hospital, proclaimed as such on the 1st day of December, 1971.

Given under my Hand and the Seal of the State of Victoria aforesaid, at Melbourne, this first day of August, in the year of our Lord One thousand nine hundred and seventy-two, and in the twenty-first year of the reign of Her Majesty Queen Elizabeth II.

(L.S.)

E. F. HERRING.

By His Excellency's Command,

J. F. ROSSITER,
Minister of Health.

GOD SAVE THE QUEEN!

GOVERNMENT NOTICES

Melbourne and Metropolitan
BOARD OF WORKS.

Town and Country Planning Act 1961.

MELBOURNE METROPOLITAN PLANNING SCHEME.

NOTICE THAT A PLANNING SCHEME HAS BEEN PREPARED
AND IS AVAILABLE FOR INSPECTION.

Amendment No. 27.

Notice is hereby given that the Melbourne and Metropolitan Board of Works in pursuance of its powers under the Town and Country Planning Act, 1961, has prepared a Planning Scheme for the purpose of amending and varying land use zoning and reservations of land within the Planning Area of the Melbourne Metropolitan Planning Scheme which was approved by the Governor in Council on the 30th day of April, 1968, and notice thereof published in the Government Gazette on the 22nd day of May, 1968.

A copy of the Amending Scheme has been deposited at the office of the Melbourne and Metropolitan Board of Works, Planning and Highways Branch, 60 Market-street, Melbourne, at the office of the Town and Country Planning Board, 235 Queen-street, Melbourne, and, as to so much of the Planning Scheme as relates to land within the municipal district of any municipality at the office of such municipality, and will be open for inspection during office hours free of charge.

Any persons affected by the Planning Scheme are required to set forth in writing all objections they may have addressed to the Secretary, Melbourne, and Metropolitan

Board of Works, 425 Collins-street, Melbourne, on or before the 10th November, 1972, and to state whether they wish to be heard in respect of their objections.

R. H. ENGELSMAN, Acting Secretary.

Melbourne and Metropolitan Board of Works,
425 Collins-street, Melbourne.

Melbourne and Metropolitan
BOARD OF WORKS.

NOTICE TO THE OWNERS OF TENEMENTS IN THE UNDER-MENTIONED STREETS AND THE PRIVATE STREETS, LANES, COURTS AND ALLEYS OPENING THERETO.

The main pipe in the said streets being laid down, the owners of all tenements situated as under are hereby required on or before the 21st August, 1972, to cause a proper pipe and stop cocks to be laid so as to supply water within such tenements from the main pipe.

R. H. ENGELSMAN,
Acting Secretary.

11th July, 1972.

STREET AND POSITION.

Broadmeadows.

Carrick-drive, from 520 feet north-east of Lancefield-road north-eastwards 600 feet.

Dandenong.

Galloway-street, from 250 feet west of Aberdeen-drive westwards 430 feet.

Ramsden-close, from Galloway-street south-westwards 170 feet.

Outlook-drive, from Towong-street north-westwards 170 feet.

Outlook-drive, from Towong-street southwards 1930 feet.

Towong-street, from 160 feet north-east of Waranga-street to Outlook-drive.

Mercer-court, from Outlook-drive westwards 440 feet.

Wingham-street, from Outlook-drive north-westwards 160 feet.

Murray-road, from Outlook-drive westwards 210 feet.

Heidelberg.

Harbourne-street, from 120 feet east of Janice-street eastwards 310 feet.

Jennifer-court, from Harbourne-street southwards 600 feet.

Keilor.

Rowan-drive, from 1070 feet north-east of Fox-road south-eastwards 460 feet.

Bundeena-avenue, from Rowan-drive southwards 820 feet.

Nerida-court, from Bundeena-avenue eastwards 370 feet.

Brazilia-avenue, from 130 feet east of Lantana-court to Bundeena-avenue.

Knox.

Phyllis-street, from 140 feet east of Susan-street eastwards 240 feet.

Warruga-avenue, from Phyllis-street southwards 1210 feet.

Terama-crescent, from Warruga-street eastwards 350 feet.

Welsh-court, from Warruga-street westwards 220 feet.

Bernard-street, from Warruga-street to Leonard-street.

Leonard-street, from 150 feet east of McKellar-street south-eastwards 630 feet.

Basil-court, from Leonard-street southwards 290 feet.

Lillydale.

Fardons-road, from Falls-road to Old Coach-road.

Old Coach-road, from Fardons-road to Helen-road.

Helen-road, from Old Coach-road north-westwards 220 feet.

Mount Dandenong-road, from Helen-road to Selwyn-lane.

Old Coach-road, from Mount Dandenong-road north-eastwards 80 feet.

Upaleng-road, from Mount Dandenong-road south-westwards 100 feet.

Montrose-road, from 220 feet north of Chestnut-court to Cambridge-road.

Walnut-drive, from Montrose-road to Fir-court.

Fir-court, from Walnut-drive southwards 410 feet.

Myoora-drive, from Erang-court to Woodville-road.

Wyuna-walk, from Myoora-drive northwards 200 feet.

Woodville-road, from 80 feet north-east of Avalon-street north-eastwards 740 feet.

Avalon-street, from 100 feet south of Woodville-road, southwards 620 feet.

Kinarra-court, from Avalon-street westwards 420 feet.

Lebunya-close, from Woodville-road north-eastwards 280 feet.

Maralinga-terrace, from McDermott-avenue north-westwards 370 feet.

Moorabbin.

Riddle-street, from 440 feet west of Hobart-street westwards 180 feet.
Carcoola-court, from Jasper-road eastwards 390 feet.

Nunawading.

Charlnet-drive, from Burwood-road southwards 990 feet.
Citrus-street, from Charlnet-drive eastwards 600 feet.
Janina-court, from Charlnet-drive westwards 330 feet.
Narracan-street, from Charlnet-drive eastwards 200 feet.
Alicia-court, from Charlnet-drive westwards 210 feet.
Huon-court, from Charlnet-drive eastwards 350 feet.
Tunstall-avenue, from O'Shannessy-street to Nicholson-street.

Oakleigh.

Aonach-street, from 400 feet south of Centre-road southwards 250 feet.
Keol-street, from Aonach-street north-westwards 40 feet.

Sunshine.

Capri-court, from Little-street eastwards 510 feet.
Porter-road, from 190 feet north of Billingham-road north-eastwards 390 feet.
Genoa-place, from Porter-road northwards 290 feet.

Waverley.

Wilton-crescent, from Waverley-road to Strickland-drive.
Letchworth-place, from Wilton-crescent south-westwards 120 feet.
Enfield-court, from Wilton-crescent southwards 120 feet.
Strickland-drive, from 140 feet west of Jells-road south-westwards 130 feet.
Sandhurst-court, from Wilton-crescent westwards 115 feet.
The Glades, from Wilton-crescent north-eastwards 190 feet.
Madigan-drive, from Finton-close northwards 610 feet.
Chapman-boulevard, from Madigan-drive eastwards 430 feet.
Kawana-crescent, from Madigan-drive westwards 180 feet.
Allure-court, from Madigan-drive westwards 280 feet.
Finton-close, from Madigan-drive north-eastwards 330 feet.
Bond-street, from 440 feet south of Wills-avenue to Regent-street.

Police Regulation Act 1958, Section 122.

SALE OF UNCLAIMED MOTOR VEHICLE.

An owner is required for a brown Ford Thames panel van, ex-registered No. GZF-006, engine No. 400E 16961.

This vehicle came into the possession of Police on 1st July, 1971, and if not claimed, will be sold by public auction at the Police Transport Branch, Dawson-street, Brunswick, at 2 p.m. on Monday, the 28th August, 1972.

Police Regulation Act 1958.

POLICE FORCE OF VICTORIA.

DETERMINATION NO. 193 OF THE POLICE SERVICE BOARD.

The Police Service Board, in pursuance of the powers in that behalf conferred by the *Police Regulation Act 1958*, hereby makes the following Determination (that is to say):—

1. The Determination No. 179 of the Police Service Board of 14th December, 1971, and published in the *Government Gazette* of 25th January, 1972, as amended, is hereby further amended as follows:—

In paragraph 47, sub-paragraph (3)—By deleting the amount "\$14.00" and substituting therefor the amount "\$16.00".

2. This Determination shall come into operation on the 6th day of August, 1972.

Dated this 31st day of July, 1972.

N. A. VICKERY,

A Judge of the County Court of Victoria,
Acting Chairman and Member of
the Police Service Board.

J. G. BROWN,

Member of the Police Service Board.

G. DAVIDSON,

Member of the Police Service Board.

Co-operation Act 1958.

WARRNAMBOOL HIGH SCHOOL CO-OPERATIVE LIMITED.

NOTICE OF DISSOLUTION OF SOCIETY.

Notice is hereby given that I have this day registered the dissolution of the above-named society and cancelled its registration under the above-named Act.

Dated at Melbourne this 26th day of July, 1972.

R. F. SCOLLARD,
Deputy Registrar of Co-operative Societies.

Co-operation Act 1958.

COLERAINE BOWLERS CO-OPERATIVE LIMITED.

NOTICE OF DISSOLUTION OF SOCIETY.

Notice is hereby given that I have this day registered the dissolution of the above-named society and cancelled its registration under the above-named Act.

Dated at Melbourne this 1st day of August, 1972.

R. F. SCOLLARD,
Deputy Registrar of Co-operative Societies.

Co-operation Act 1958.

DANDENONG TECHNICAL SCHOOL CO-OPERATIVE LIMITED.

Notice is hereby given in pursuance of section 78 (7) of the *Co-operation Act 1958* and section 308 (2) of the *Companies Act 1961* that, at the expiration of three months

from the date hereof, the name of the afore-mentioned society will, unless cause is shown to the contrary, be struck off the register and the society will be dissolved.

Dated this thirty-first day of July, 1972.

R. F. SCOLLARD,
Deputy Registrar.

Town and Country Planning Act 1961.

SHIRE OF MORNINGTON PLANNING SCHEME 1959.

AMENDMENT No. 68, 1971.

Notice of Approval.

In pursuance of the powers conferred by the *Town and Country Planning Act 1961*, the Governor in Council on the 1st August, 1972, approved a planning scheme entitled the Shire of Mornington Planning Scheme 1959, Amendment No. 68, 1971, in respect of part of the municipal district of the Shire of Mornington and such Planning Scheme comes into operation on the date this notice of approval is published in the *Government Gazette*.

A copy of the Planning Scheme as approved may be inspected, free of charge, during office hours, at the office of the Town and Country Planning Board, 235 Queen-street, Melbourne; at the office of the Shire of Mornington at Mornington and, when available, at the Office of Titles, Melbourne, and at the Central Plan Office of the Department of Crown Lands and Survey, Melbourne.

W. H. CRAIG, Secretary,
Town and Country Planning Board.

Transport Regulation Act.
TRANSPORT REGULATION BOARD.

HEARING OF APPLICATIONS.

Notice is hereby given that the following applications will be considered by the Transport Regulation Board at its offices at the corner of Lygon and Princes streets, Carlton, at 10.15 a.m. on Wednesday, 30th August, 1972.

GRENDAS BUS SERVICES, 9 Foster-street, Dandenong, 3175.
Application for variation of conditions of licences T.O.57 and T.O.58 to include the following day and half-day tours.

Full Day Tour: Ballarat and Sovereign Hill.

Route.—Bourke-street, Russell-street, Victoria-street, Elizabeth-street, Flemington-road, Racecourse-road, Ballarat-road, Western Highway to Ballarat. Tour of Ballarat City, to include Lake Wendouree and the Gardens, Eureka Stockade and Sovereign Hill. Return to Melbourne via the same route.

Fare.—\$5.50 Adult. \$3.75 Child.

Full Day Tour: Ballarat, Daylesford.

Route.—Bourke-street, Russell-street, Victoria-street, Elizabeth-street, Flemington-road, Racecourse-road, Ballarat-road, Western Highway to Ballarat. Tour of Ballarat City, to include Lake Wendouree and the Gardens, Eureka Stockade and Sovereign Hill. Return via Daylesford, Hepburn Springs, Trentham, Woodend, Calder Highway, Sunbury, Bulla-road, Tullamarine Freeway, Flemington-road, Elizabeth-street, Victoria-street, Exhibition-street, Bourke-street.

Fare.—\$5.50 Adult. \$3.75 Child.

Full Day Tour: Dandenong Ranges and Healesville.

Route.—Bourke-street, Russell-street, Flinders-street, Wellington-road, Brunton-avenue, Punt-road, South-Eastern Freeway, Toorak-road, Burwood-road to Fern-tree Gully. Tour the Dandenong Ranges; then to Lilydale, Maroondah Highway to Healesville. Visit Maroondah Reservoir and the Sir Colin MacKenzie Sanctuary. Return to Melbourne via Maroondah Highway, Whitehorse-road, High-street, Beresford-road, Mont Albert-road, Burke-road, Barkers-road, Victoria-street, Nicholson-street, Spring-street, Bourke-street.

Fare.—\$5.50 Adult. \$3.75 Child.

Full Day Tour: Walhalla.

Route.—Bourke-street, Russell-street, Flinders-street, Princes Bridge, St. Kilda-road, Dandenong-road, Princes Highway to Moe; then via Erica to Walhalla. Return via the same route.

Fare.—\$7.00 Adult. \$4.75 Child.

Half-Day Tour: Mt. Macedon.

Route.—Bourke-street, Russell-street, Victoria-street, Elizabeth-street, Flemington-road, Tullamarine Freeway, Bulla-road, Sunbury, Calder Highway to Gisborne; then to Mt. Macedon. Return via Gisborne, Bacchus Marsh, Western Highway, Ballarat-road, Racecourse-road, Flemington-road, Elizabeth-street, Victoria-street, Exhibition-street, Bourke-street.

Fare.—\$3.00 Adult. \$2.00 Child.

Full Day Tour: Maldon, Bendigo.

Route.—Bourke-street, Russell-street, Victoria-street, Elizabeth-street, Flemington-road, Tullamarine Freeway, Bulla-road, Sunbury, Calder Highway to Elphinstone; then to Castlemaine, Maldon and Bendigo. Return to Melbourne via Calder Highway, Tullamarine Freeway, Flemington-road, Elizabeth-street, Victoria-street, Exhibition-street, Bourke-street.

Fare.—\$6.00 Adult. \$4.00 Child.

Full-Day Tour: Tarra Valley.

Route.—Bourke-street, Russell-street, Flinders-street, Princes Bridge, St. Kilda-road, Dandenong-road, Princes Highway to Traralgon; then via Traralgon South and Balook to Tarra Valley. Return via Jumbuk to Morwell; then Princes Highway, Dandenong-road, Belgrave-road, Malvern-road, Tooronga-road, South-Eastern Freeway, Punt-road, Brunton-avenue, Wellington-road South, Exhibition-street.

Fare.—\$7.00 Adult. \$4.75 Child.

MIDLAND TOURS PTY. LTD., 907A High-street, Reservoir.
Application for one commercial passenger vehicle, to be purchased, to operate as an additional special service omnibus under the same terms and conditions as existing licences.

RESERVOIR BUS CO. PTY. LTD., 907A High-street, Reservoir.
One commercial passenger vehicle with large seating capacity to be purchased to operate a service from the corner of Robert-street and Mount View-road,

West Lalor to the corner of Deakin-avenue and Dalton-road, East Lalor via Robert-street, Edgars-road, Kingsway-drive, High and Station streets, Curtin-avenue, Dalton-road, Darebin-drive and Deakin-avenue—returning via Dalton-road and Curtin-avenue to Lalor Railway Station.

Time-table.

As detailed in application dated 21st July, 1972.

Sections and Fares.—To be determined.

SAVAGE, S. P., Goulburn Valley Highway, Eildon. One commercial passenger vehicle with seating capacity for five persons to operate as a Country Hire Car from the Goulburn Valley Highway, Eildon, subject to cancellation of licence No. C.T.116 held by the applicant.

VENTURA MOTORS PTY. LTD., 1037 Centre-road, South Oakleigh. Application for variation of M.O. licence conditions on Route 704 (Oakleigh—East Clayton) to include the ability to operate from the present terminus at Oakleigh Railway Station to Chadstone Shopping Centre via Johnson-street, Davey-avenue, Warrigal and Dandenong roads to Chadstone Centre. Trips from Chadstone to Oakleigh Railway Station are to operate via Dandenong-road, Warrigal-road, Davey-avenue and Haughton-road.

Fares.—Two additional sections.

Additional Section Points:

1. Oakleigh Railway Station to Neerim-road.
2. Neerim-road to Chadstone.

Applications for renewal of licences as shown, by persons listed hereunder to operate under the same terms and conditions.

CHASTON, J. W., 60 Progress-street, Kaniva; T.P.187.

CONNELLY, M. M. (Mrs.), 6 Dorothy-avenue, Thomastown; T.P.183.

HARD, B. J., Vernon-street, Korong Vale; T.P.105.

ROSS, H. E. (Miss), 8 Willow-grove, West Coburg; T.P.108.

STANTON PIPES OF AUST. PTY. LTD., P.O. Box 80, Coburg; T.P.58.

THOMAS, M. K., 54 Cruickshank-street, Port Melbourne; T.P.275.

WILLIAMS, E. J., Gunbower; T.S.553.

Notice of any objection should be forwarded to reach the Secretary of the Board not later than Wednesday, 23rd August, 1972.

Applicants are advised that it will not be necessary to appear on the hearing date specified above, unless advised in writing by the Board.

A. V. C. COOK,

Acting Secretary.

Corner Lygon and Princes streets, Carlton, Wednesday, 9th August, 1972.

Commercial Goods Vehicles Act.

TRANSPORT REGULATION BOARD.

HEARING OF APPLICATIONS.

Notice is hereby given that the following applications will be considered by the Transport Regulation Board at its offices at the corner Lygon and Princes streets, Carlton, at 10 a.m. on Wednesday, 30th August, 1972.

BRANCA, D. J., 58 Brunel-street, East Malvern, 3145. Application to vary the conditions of licence No. D.A.65212 (L/C. 240 cwt.) by adding an additional paragraph (d)—“(d) From Bacchus Marsh to own premises at Campbellfield—own river pebbles”.

COOPER, R. W. G. (trading as Bryant Plumbing Co.), 13 Dennis-street, Colac, 3250. One commercial goods vehicle (L/C. 140 cwt.) to operate within a 50-mile radius of the post office at Colac in the course of business as “Septic Tank Desludger”—own tools of trade and waste materials for disposal.

ASTON, F. (trading as Bulleen Drive Thru Nursery), 105 Banksia-street, Bulleen, 3105. Two commercial goods vehicles (L/C. 141, 138 cwt. to operate: (a) Within a 25-mile radius of own premises at Bulleen in course of business as “Soil, Screening, Garden Supply and Nurseryman”—own goods. (b) From Toolangi to own premises at Bulleen—own mountain soil. (c) From Gilderoy to own premises at Bulleen—own mountain

- soil. (d) From Bacchus Marsh to own premises at Bulleen—own river pebbles and honeycomb rock. (e) Between own premises at Bulleen and own nursery at Glenburn—own plants and own soil.
- CHEYNE, R. M. M. & S., Cooriemungle, via Timboon, 3268. One commercial goods vehicle (L/C. 239 cwt.) to operate: (a) Throughout the State of Victoria in course of business as "Earth-moving and Road-making Contractors"—own earth-moving equipment and own tools of trade. (b) To any construction site upon which the applicant is currently engaged within a 75-mile radius of the post office at Peshurst; from points within a 20-mile radius of the particular site—materials required for use at such site in connexion with a road-making or earth-moving contract. (c) Within a 25-mile radius of the post office at Timboon—general goods, provided that no goods shall be carried whether by one stage or by more than one stage between places within the above radius which are more than thirty (30) road miles apart by the nearest practicable route.
- Subject to the cancellation of licence No. D.A.54434/6 held in the name of R. Cheyne Pty. Ltd.
- CHEYNE, R. M. M. & S., Cooriemungle, via Timboon, 3268. One commercial goods vehicle (L/C. 325 cwt.) to operate: (a) Throughout the State of Victoria as a low loader in the course of business as "Land Clearing and Earth-moving Contractors"—own earth-moving equipment and tools of trade. (b) Within a 20-mile radius of the post office at Cooriemungle—earth-moving equipment on behalf of other contractors. (c) To any construction site upon which the applicant is currently engaged within a 75-mile radius of the post office at Peshurst from points within a 20-mile radius of the particular site—materials required for use at such site in connexion with a road-making or earth-moving contract. (d) Within a 25-mile radius of the post office at Timboon—general goods, provided that no goods shall be carried whether by one stage or by more than one stage between places within the above radius which are more than thirty (30) road miles apart by the nearest practicable route.
- Subject to the cancellation of licence No. D.A.54434/5 held in the name of R. Cheyne Pty. Ltd.
- COOPER, W. T., 16 Smith-street, Hampton, 3188. One commercial goods vehicle (L/C. approximately 170 cwt.) to operate within a 70-mile radius of the premises of Monier Roof Tiles at Springvale on behalf of the said company—roofing tiles, battens and tile fixing materials.
- FLICK, W. A., & Co. PTY. LTD., 1964 Princes Highway, Clayton, 3168. One commercial goods vehicle (L/C. 14 cwt.) to operate within a 50-mile radius of own branch premises at Traralgon in course of business as "Pest and Weed Control Specialists" for the purpose of executing own spraying contracts—own tools of trade, spraying equipment and spray chemicals but subject to the condition that all chemicals carried on the vehicle shall have been initially consigned by rail to Traralgon.
- FRANCIS, G. C. (trading as G. C. & A. M. Francis), Mitchell-street, Colbinabbin, 3559. One commercial goods vehicle (L/C. 199 cwt.) to operate: (a) Within a 50-mile radius from the post office at Colbinabbin—as a "Road Contractor"—road-making plant and materials. (b) Within a 25-mile radius of the post office at Colbinabbin—general goods, provided that no goods shall be carried whether by one stage or by more than one stage between places within the above radius which are more than thirty (30) road miles apart by the nearest practicable route.
- GUNN, L. J. (trading as Les Gunn's Farm Machinery), Timboon, 3268. One commercial goods vehicle (L/C. 124 cwt.) to operate: (a) Within a 25-mile radius of the post office at Timboon—general goods, provided that no goods shall be carried whether by one stage or by more than one stage between places within the above radius which are more than thirty (30) road miles apart by the nearest route. (b) From the depot of B.P. Aust. Ltd. at Colac to places situated within a 20-mile radius of the post office at Timboon—petroleum products in prescribed types of containers and empty containers for return. (c) From the City of Colac to own premises at Timboon in the course of business as "Produce Merchant and Machinery Agent"—own goods not exceeding a total aggregate weight of forty hundred weight (40 cwt.) on any one load. (d) From the City of Colac to own premises at Timboon in the course of business as "Produce Merchant"—Yanlen Liquid Stock Feed.
- HALL, G. W., 15 Callen-street, Seymour, 3660. Application to vary the conditions of licence No. T.D.A.24141/5 (L/C. 241 cwt.) by adding after the City of Shepparton in paragraph (b) of the existing conditions "from the railway station at Benalla to Glenmix Pty. Ltd. plants situated within the City of Benalla".
- HALL, G. W., 15 Callen-street, Seymour, 3660. Application to vary the conditions of licence No. T.D.A.24141/6 (L/C. 261 cwt.) by adding after the "City of Shepparton" in paragraph (b) of the existing conditions "from the railway station at Benalla to Glenmix Pty. Ltd. plants situated within the City of Benalla".
- INTERS BENDIGO PTY. LTD., 95-97 Mitchell-street, Bendigo, 3550. One commercial goods vehicle (L/C. 18 cwt.) to operate within that part of the State of Victoria bounded by straight lines drawn through the Cities and Townships of Koondrook, Kerang, Charlton, St. Arnaud, Avoca, Ballarat, Gisborne, Kilmore, Seymour, Shepparton and Echuca; thence by the River Murray to Koondrook in the course of business as "Truck, Tractor and Agricultural Machinery Agents and Distributors"—small quantities of agricultural machinery, spare parts incidental to servicing and for the purpose of towing agricultural implements.
- NOTE.—All agricultural machinery, implements and spare parts to be initially consigned by rail to Bendigo.
- JAMES, B. J., 836 Humffray-street South, Ballarat, 3350. One commercial goods vehicle (L/C. 15 cwt.) to operate throughout the State of Victoria in the course of business as "Auto Wrecker"—wrecked motor vehicles carried solely on a specially constructed car-carrying trailer and also used secondhand spare parts dismantled from wrecked vehicles in country areas but excluding the right to operate the vehicle from the scene or vicinity of any accident or collision for the purposes of removing therefrom any vehicle or parts of a vehicle involved in such accident or collision.
- KALARI PTY. LTD., Jessop-street, Hamilton, 3300. One commercial goods vehicle (L/C. 171 cwt.) to operate: (a) Within a 50-mile radius from the post office at Portland as a "Road Contractor"—road-making plant and materials. (b) Within a 25-mile radius of the post office at Portland—general goods, provided that no goods shall be carried whether by one stage or by more than one stage between places within the above radius which are more than thirty (30) road miles apart by the nearest practicable route.
- KENNEDY, P., PTY. LTD., Learmonth-road, Ballarat, 3350. One commercial goods vehicle (L/C. 14 cwt.) to operate: (a) Throughout the State of Victoria in the course of business as "Earth-moving and Excavation Contractors"—tools of trade, spare parts and fuel not exceeding 3 x 44 gallon drums for the operation of machinery on site but excluding the carriage of any spare parts from places within a 25-mile radius of Melbourne. (b) Within a 20-mile radius of the site of any contract currently engaged upon—materials for use in such contract.
- KINCAID, E. B., Hunters-road, Warragul South, 3820. One commercial goods vehicle (L/C. 148 cwt.) to operate: (a) Within a 50-mile radius from the post office at Warragul but excluding operations west of a north/south line drawn through Berwick as a "Road Contractor"—road-making plant and materials. (b) Within a 25-mile radius from the post office at Warragul—general goods, provided that no goods shall be carried whether by one stage or more than one stage between places within the above radius which are more than thirty (30) road miles apart by the nearest practicable route.
- LACY, D. J., 1 Flannery-court, Oak Park, 3046. One commercial goods vehicle (L/C. 156 cwt.) to operate within a 50-mile radius of the premises of Albion Reid Pty. Ltd. at North Melbourne solely on behalf of the said company—road-making plant, hot asphalt and premix and road-making materials excluding the carriage of cement and lime from the Geelong Urban District as defined in the Transport Regulation Act 1958.
- MARTIN, D. (trading as Martin's Sewing Service), 13 Murphy-street, Wangaratta, 3677. One commercial goods vehicle (L/C. 6 cwt.) to operate within a 50-mile radius of the post office at Wangaratta and to and from Corryong serving places en route in course of business as "Singer Sewing Machine Sales and Serviceman"—new sewing machines and knitting machines, secondhand sewing machines and knitting machines for repair or having been repaired also tools of trade, spare parts and accessories incidental to on-site servicing.

- MCKENZIE, N. A.**, Murchison-street, Marysville, 3779. Application to vary the conditions of licence No. D.T.1261 (L/C. 270 cwt.) by deleting "twenty-five (25) miles" from paragraph (a) of the existing conditions and adding in lieu "forty (40) miles".
- McMULLEN'S TRANSPORT PTY. LTD.**, Tyndall-street, Orbst, 3888. Application to vary the conditions of licence No. D.A.64331/4 (L/C. 316 cwt.) by adding after "eight (8) miles thereof" in paragraph (d) of the existing conditions "and towns on Princes Highway en route."
- OWENS, J. P.**, 16 Hammer-street, Bendigo, 3550. One commercial goods vehicle (L/C. 150 cwt.) to operate: (a) Within a 50-mile radius from the post office at Bendigo plant the property of a contractor and required by him for use in connexion with the construction or maintenance of some specific, existing or proposed road, street, footpath, bridge, pier, wharf, weir or channel and also the following materials viz: metal, stones, screenings, ashes, gravel, sand and earth. (b) Within a 20-mile radius from the site of any construction or maintenance work performed pursuant to paragraph (a) above, or from the railway station nearest thereto—any other materials required for such work. (c) Within a 25-mile radius from the post office at Bendigo—general goods excluding any plant or materials carried or to be carried pursuant to paragraphs (a) and (b) above.
- ROWLEY, R. J.**, Main-road, Harcourt, 3453. One commercial goods vehicle (L/C. 11 cwt.) to operate within a 25-mile radius of the post office at Castlemaine and to the City of Echuca as an employee of W. J. Stoneman Supermarkets—goods the property of the said firm.
- SLATER, R.** (trading as R. Slater & Sons), 57 Gravesend-street, Colac, 3250. Application to vary the conditions of licences numbered D.A.48284, D.A.48284/1, D.A.48284/2, D.A.48284/3 (L/C. 65, 137, 138, 229 cwt.) by deleting "or channel" from paragraph (a) of the existing conditions and adding in lieu "channel or trench in connexion with water, sewerage and drainage contracts."
- SOUTHERN PLANT HIRE CO. PTY. LTD.**, 1846 Princes Highway, Clayton, 3168. One commercial goods vehicle (L/C. 14 cwt.) to operate throughout the State of Victoria in the course of business as "Earth-moving Contractors and Plant and Mobile Crane Hirers" as a service vehicle—tools of trade and spare parts for the repair and servicing of own equipment on site.
- SPASOJEVIC, M.**, 66 Phillipson-street, Wangaratta, 3677. One commercial goods vehicle (L/C. 160 cwt.) to operate: (a) Within a 50-mile radius from the post office at Wangaratta as a "Road Contractor"—road-making plant and materials. (b) Within a 25-mile radius of the post office at Wangaratta—general goods, provided that no goods shall be carried whether by one stage or by more than one stage between places within the above radius which are more than thirty (30) road miles apart by the nearest practicable route.
- SUPER SPREAD AVIATION (AUST) PTY. LTD.**, P.O. Box 7, Cheltenham, 3192. One (Mobile Crane) to operate throughout the State of Victoria for the purpose of operating the vehicle as a "Mobile Crane" incidental to loading superphosphate into aircraft for dusting purposes with the ability also to carry excess aviation fuel and chemicals from property to property upon completion of a contract in the course of business as "Aerial Crop Dusters".
- THRELFALL, S. J.**, ROADSIDE DELIVERY, Myers Flat, 3556. One commercial goods vehicle (L/C. 143 cwt.) to operate: (a) Within a 25-mile radius of Myers Flat—general goods provided that no goods shall be carried by one stage or by more than one stage between places within the above radius which are more than thirty (30) road miles apart from the nearest practicable route. (b) Within a 50-mile radius of Myers Flat—livestock.
- TÖBIN BROS. PTY. LTD.**, 189 Boundary-road, North Melbourne, 3051. One commercial goods vehicle (L/C. 19 cwt.) to operate throughout the State of Victoria in the course of business as a "Funeral Director" as a mortuary-vehicle.
- GIBBONS, M. N.** (trading as Traralgon Metals), 63 Gwalia-street, Traralgon, 3844. One commercial goods vehicle (L/C. 20 cwt.) to operate throughout the State of Victoria in the course of business as "Marine Dealer"—special wares, marine stores and old metals as designated in the *Marine Stores and Old Metals Act 1958* (No. 6303), Part 1, section (3), but excluding the carriage of any such goods to wharves, docks, or ships for shipment or export purposes with the proviso that the combined load capacity of both prime mover and any trailer attached thereto shall not exceed 120 cwt.
- GIBBONS, M. N.** (trading as Traralgon Metals), 63 Gwalia-street, Traralgon, 3844. One commercial goods vehicle (L/C. 149 cwt.) to operate throughout the State of Victoria in the course of business as "Marine Dealer"—special wares, marine stores and old metals as designated in the *Marine Stores and Old Metals Act 1958* (No. 6303), Part 1, section (3), but excluding the carriage of any such goods to wharves, docks, or ships for shipment or export purposes with the proviso that no trailer shall be hauled in conjunction with this vehicle.
- UNITED ELECTRONIC SERVICING PTY. LTD.**, 161-173 Sturt-street, South Melbourne, 3205. Four commercial goods vehicles (L/C. 14 cwt. each) to operate throughout the State of Victoria in the course of business as "Electrical Engineers" for the purpose of installing, servicing and maintaining electrical appliances—electrical appliances for installation, tools of trade, spare parts and materials incidental to own contracts.
- WEATHERMASTER PTY. LTD.**, 2 Attenborough-street, Dandenong, 3175. One commercial goods vehicle (L/C. 77 cwt.) to operate within a 50-mile radius of own branch premises at Geelong in course of business as "Insulation Contractors"—tools of trade, insulation materials incidental to the completion of own contracts.
- WHITFIELD, T.**, 116 The Fairway, Kingsbury, 3083. One commercial goods vehicle (L/C. 140 cwt.) to operate within a 70-mile radius of the premises of Brick and Pipe Industries Ltd. at Northcote on behalf of the said company—bricks and empty pallets.

RENEWALS.

Applications for renewal of licences as shown by persons listed hereunder to operate under the same terms and conditions from the expiry shown in each case.

- ADAMS, WILLIAM, TRACTORS PTY. LTD.**, Nantilla-road, North Clayton, 3168; D.A.512/41; 14th December, 1972; 14 cwt.; D.A.512/40; 14th December, 1972; 15 cwt.
- AMERENA, V.**, 80 Heller-street, West Brunswick, 3055; D.A.62345; 1st December, 1972; 197 cwt.
- ANDERSON, R. W.** (trading as R. W. & M. M. Anderson), Davis-street, Warrnambool, 3280; D.A.62436; 17th December, 1972; 148 cwt.
- ANDERSON, R. W.** (trading as R. W. & M. M. Anderson), Davis-street, Warrnambool, 3280; D.A.62436/1; 16th December, 1972; 117 cwt.
- AUSTRALIA & NEW ZEALAND BANK LTD.**, 177 Toorak-road, South Yarra, 3141; D.A.4106/20; 1st December, 1972; 10 cwt.
- BERTINO, P. J.** (trading as Bairnsdale Tyre Service), corner Macleod and Buchanan streets, Bairnsdale, 3875; D.A.47121/3; 8th December, 1972; 28 cwt.; D.A.47121/6; 1st December, 1972; 10 cwt.
- BROWN, E. L.** (trading as Brown & Mitchell), Box 105, Harrow, 3317; D.A.5038/1; 17th December, 1972; 70 cwt.; D.A.5038/4; 17th December, 1972; 120 cwt.; D.A.5038; 17th December, 1972; 25 cwt.
- BROWN, E.**, 6 Greville-street, Huntingdale, 3166; D.A.38222/1; 1st December, 1972; 10 cwt.
- BUTCHER, W. A.**, 2 Prince-street, Moorabbin, 3189; D.A.40946; 14th November, 1972; 7 cwt.
- CAKEBREAD CONSTRUCTION CO. PTY. LTD.**, Nepean Highway, Mornington, 3931; D.A.31653/3; 1st December, 1972; 94 cwt.
- COLGATE PALMOLIVE PTY. LTD.**, 660 Footscray-road, West Melbourne, 3003; D.A.41727/32; 8th December, 1972; 10 cwt.; D.A.41727/33; 8th December, 1972; 12 cwt.
- COLLINS, E. B.**, 4 Meadow-court, Blackburn South, 3130; D.A.62353; 1st December, 1972; 16 cwt.
- ENGLISH ELECTRIC DIESELS AUST. LTD.**, 1852 Dandenong-road, Clayton, 3168; D.A.1965/4; 5th December, 1972; 14 cwt.
- FERRONATO, M. B.**, 33 Clarke-street, Northcote, 3070; D.A.62343; 1st December, 1972; 246 cwt.
- FOWLER, K. C.**, 18 Ervin-road, Kilsyth, 3137; D.A.62342; 1st December, 1972; 135 cwt.
- GAYWOOD, P.**, 38 Harbury-street, Reservoir, 3073; D.A.48820/1; 26th October, 1972; 11 cwt.
- GIBBS BRIGHT & CO. PTY. LTD.**, 559 Footscray-road, Footscray, 3011; D.A.60657/2; 9th December, 1972; 146 cwt.
- GORDON BROS. PTY. LTD.**, 110-120 Union-street, Brunswick, 3056; D.A.1172/8; 14th December, 1972; 10 cwt.
- HARBERGER, K. G.**, 194 Woods-street, Donald, 3480; T.D.A.64711; 16th August, 1972; 14 cwt.
- HOBBES, E. R., PTY. LTD.**, 177 Chesterville-road, Moorabbin, 3189; D.A.62265/1; 1st December, 1972; 128 cwt.

JONGBLOED, L., 34 Unitt-street, Melton, 3337; D.A.41259; 5th December, 1972; 270 cwt.

JURY, K. L., 4 Sturt-street, Ballarat, 3350; D.A.40930/1; 5th December, 1972; 10 cwt.

KEOGH, P., PTY. LTD., 371 Francis-street, Yarraville, 3012; T.D.A.6989/6; 17th December, 1972; 133 cwt.

LAYTON, H., 120 Main-street, Croydon, 3136; D.A.1478; 1st December, 1972; 17 cwt.

LOWNDES, J. W., 15 Alexandra-avenue, East Geelong, 3219; D.A.1526/1; 1st October, 1972; 11 cwt.

MAUDE, J. H., 109 Haldane-road, Niddrie, 3042; D.A.49973/1; 23rd November, 1972; 220 cwt.

MCFADDEN, J. A., 7 Salisbury-street, Werribee, 3030; D.A.54082; 14th December, 1972; 9 cwt.

NATIONAL CASH REGISTER CO. PTY. LTD., 124 Russell-street, Melbourne, 3000; D.A.1707/29; 21st December, 1972; 6 cwt.

PENSHURST EARTHMOVERS PTY. LTD., Walton-street, Penshurst, 3289; D.A.64467; 8th December, 1972; 156 cwt.

PETERSVILLE AUST. LTD., Wellington-road, Clayton, 3168; D.A.1813/80; 16th December, 1972; 77 cwt.

PETERSVILLE AUST. LTD., Wellington-road, Clayton, 3168; D.A.1813/81; 16th December, 1972; 75 cwt.; D.A.1813/188; 9th December, 1972; 73 cwt.; D.A.1813/189; 16th December, 1972; 76 cwt.

PHILPOTT, K., 4 York-street, Mont Albert, 3127; D.A.62349; 1st December, 1972; 125 cwt.

PORRECA, N. & A., PTY. LTD., 11A Warrigal-road, Oakleigh, 3166; D.A.44464/1; 16th December, 1972; 136 cwt.

REEVE, B. R., 62 Whiteman-street, South Melbourne, 3205; D.A.62264; 29th October, 1972; 11 cwt.

SPERRY, RAND AUST. LTD., 334-342 City-road, South Melbourne, 3205; D.A.828/12; 9th December, 1972; 13 cwt.; D.A.828/13; 9th December, 1972; 13 cwt.

SUNBEAM CORPORATION LTD., Sloane-street, Maribyrnong, 3032; D.A.14579/50; 16th December, 1972; 22 cwt.

TRETTEL, A., 2 Janice-grove, Dandenong, 3175; D.A.54060; 8th December, 1972; 185 cwt.

UNITED ELECTRONIC SERVICING PTY. LTD., 161-173 Sturt-street, South Melbourne, 3205; D.A.30374/23; 14th November, 1972; 14 cwt.

VALENTE, B., 9 Mullum-road, Ringwood, 3134; D.A.62359; 1st December, 1972; 191 cwt.

VICTORIAN OATGROWERS POOL & MARKETING CO. LTD., 406 Lonsdale-street, Melbourne, 3000; D.A.37995/6; 8th December, 1972; 14 cwt.

WEINERT, P. M., Meringur, 3501; D.A.2262; 17th December, 1972; 247 cwt.

WHITE, R., PTY. LTD., 69 Cromwell-street, Collingwood, 3066; D.A.31652/1; 1st December, 1972; 11 cwt.

TOW TRUCK RENEWALS.

HUSSEY, J. H. (trading as Allied Towing Service), 493 Spencer-street, West Melbourne, 3003; D.A.53177/2; 1st December, 1972; 29 cwt.

M.R.W. PTY. LTD. (trading as New Malvern Auto Service), 615 Dandenong-road, Armadale, 3143; D.A.46313/1; 1st December, 1972; 43 cwt.

RENEWAL WITH VARIATION.

Application made by the person listed hereunder for renewal of the licence listed with variation of condition in the manner set out opposite the name.

Dew, R. M., 58 Marshall-street, Newtown, 3220; D.A.53723; 21st December, 1972; Application to renew and vary the conditions of licence No. D.A.53723 (L/C. 318 cwt.) by deleting paragraph (b) from the existing conditions and adding in lieu a new paragraph (b) as follows: "Within a 70-mile radius from each of the operating companies of Clifton Brick Holdings Ltd. at Craigieburn, Oakleigh, Brunswick and Preston respectively—bricks and on return journeys, empty pallets and excess bricks to such of the above plants as may be appropriate".

Notice of any objection should be forwarded to reach the Secretary of the Board not later than 23rd August, 1972.

Applicants are advised that it will not be necessary to appear on the hearing date specified above, unless advised in writing by the Board.

A. V. C. COOK,
Acting Secretary.

Corner Lygon and Princes streets, Carlton, 3053, Wednesday, 9th August, 1972.

Transport Regulation Act.
TRANSPORT REGULATION BOARD.
NOTICE No. 100.

Appointment of Inspectors.

Take notice that, pursuant to the powers conferred on the Board by the provisions of the Transport Consolidated Regulations 1960, the Board hereby notifies in accordance with Regulation 5 of Part I. of the said Regulations, the appointment as Inspectors of—

JAMES KENNETH OLIVER,
EDWARD FENTON
LORENZO JOSEPH HUGHES,

while such persons are in uniform within the corporate limits of the City of Essendon during the period of their appointment as Traffic Officers of the said municipality, and

LIONEL WILFRED SEAL
JOHN, EDWARD GILES-CLARK,
KEVIN DENNIS MOULDAY
DONALD CARPENTER,

while such persons are in uniform within the corporate limits of the City of Moorabbin during the period of their appointment as Traffic Officers of the said municipality.

By order of the Transport Regulation Board,

A. V. C. COOK,
Acting Secretary.

DEPARTMENT OF MINES.

Subject to any excisions, &c., it is proposed to grant the following mining lease:—

8467, Beechworth; Patrick Manning Edema, Manfred Stern; 12a. Or. 19p., Parish of Lauraville.

MINING LEASE GRANTED.

8862, Mineral; Kaolin Australia Proprietary Limited; 79a. 3r. 8p., Parish of Argyle.

MINING LEASE TRANSFERRED.

8417, Beechworth; from Witold Boyar, Robert McGregor Dawson to Coopers Creek Mining & Exploration N.L.

MINING LEASE EXPIRED.

8860, Mineral; Arthur Vincent Marshall; 6a. 3r. 6p., Parish of Glenmaggie.

APPLICATION FOR EXPLORATION LICENCE REFUSED.

410, Exploration Licence; Ian Robert Marshall, John William Baulch; 25 square miles, Counties of Follett, Dundas.

MINERAL SEARCH LICENCE EXPIRED.

1079, Mineral Search Licence; Gippsland Minerals No Liability; 1,100 acres, Parish of Indi.

APPLICATION FOR EXTRACTIVE INDUSTRY LEASE REFUSED.

116, Extractive Industry Lease; William Gerrard Roache, Allan Bernard Roache; 100 acres, Parish of Angahook.

APPLICATIONS FOR EXTRACTIVE INDUSTRY LICENCES REFUSED.

280, Extractive Industry Licence; McGrath Sand and Stone Co. Proprietary Limited; 250 acres, Parish of Langwarrin.

281, Extractive Industry Licence; McGrath Sand and Stone Co. Proprietary Limited; 36 acres; Parish of Langwarrin.

EXTRACTIVE INDUSTRY LICENCE EXPIRED.

19, Extractive Industry Licence; I. R. Farrow & Co.; 34a. 2r. 18p., Parish of Koo-Wee-Rup East.

EXTRACTIVE INDUSTRY SEARCH PERMIT EXPIRED.

16, Extractive Industry Search Permit; Lindsay Gordon McRae, Keith McRae; 1,984 acres, more or less, Parish of Bindi.

J. C. McBALFOUR,
Minister of Mines.

Private Agents Act 1966.

NOTICE OF RECEIPT OF APPLICATIONS FOR LICENCES UNDER THE PROVISIONS OF THE PRIVATE AGENTS ACT 1966.

The Clerk(s) of the Magistrates' Court(s) as listed hereunder hereby give notice that applications, as under, have been lodged for hearing by the said Court(s) on the date(s) specified.

Any person desiring to object to any of such applications must—

- (a) lodge with the respective Clerk of the Magistrates' Court a notice in the prescribed form of his objection and of the grounds thereof;
- (b) cause a copy of such notice to be served personally or by post upon the applicant at least three days before the hearing of the application; and
- (c) send or deliver—
 - (i) where the objection is not made by the officer in charge of the police district in which the Court is situated—a copy of the notice to such officer; and
 - (ii) where the objection is not made by the Registrar or Deputy Registrar—a copy to the Registrar.

Full Name of Applicant or in the Case of a Firm or Corporation, of the Nominee.	Place of Abode of Applicant or Nominee.	Name of Firm or Corporation.	Address for Registration.	Type of Licence.	Date of Hearing of Application.
---	---	------------------------------	---------------------------	------------------	---------------------------------

MAGISTRATES' COURT, BOX HILL.

King, Owen Charles Richard	Main-road, Panton Hill	Centaur Security Service	78 Mahoneys-road, Forest Hill	Watchman	24.8.72
----------------------------	------------------------	--------------------------	-------------------------------	----------	---------

Dated at Box Hill this 28th day of July, 1972.

G. MURPHY, Clerk of the Magistrates' Court.

MAGISTRATES' COURT, MELBOURNE.

Betteridge, Edward George Henry	1/1129 Dandenong-road, Caulfield East	Australian Watching Co. Pty. Ltd.	340 Abbotsford-street, North Melbourne	Watchman	23.8.72
Etienne, Siegfried	13 Wilson-road, Melton	Australian Watching Co. Pty. Ltd.	340 Abbotsford-street, North Melbourne	Watchman	23.8.72
Gilberston, Vale Le Roy	20 Moore-avenue, Croydon	Australian Watching Co. Pty. Ltd.	340 Abbotsford-street, North Melbourne	Watchman	23.8.72
Holmes, Keith George	872 Centre-road, East Bentleigh	Australian Watching Co. Pty. Ltd.	340 Abbotsford-street, North Melbourne	Watchman	23.8.72
Louitt, Donald Russell	9 Highview-road, East Bentleigh	Australian Watching Co. Pty. Ltd.	340 Abbotsford-street, North Melbourne	Watchman	23.8.72
Payne, Samuel Henry	Unit 6, 4 Lyons-street, Williamstown	Australian Watching Co. Pty. Ltd.	340 Abbotsford-street, North Melbourne	Watchman	23.8.72
Schmidt, Karl Christian	20/57 Darling-street, South Yarra	Australian Watching Co. Pty. Ltd.	340 Abbotsford-street, North Melbourne	Watchman	23.8.72
Stewart, Warwick Dunbar	2 Taylor-court, Mount Waverley	Australian Watching Co. Pty. Ltd.	340 Abbotsford-street, North Melbourne	Watchman	23.8.72
Hoskin, Peter-Damian	1/33 Corrigan-road, Noble Park	Australian Watching Co. Pty. Ltd.	340 Abbotsford-street, North Melbourne	Inquiry Agent	23.8.72

Dated at Melbourne this 31st day of July, 1972.

G. L. WEBSTER, Clerk of the Magistrates' Court.

MAGISTRATES' COURT, OAKLEIGH.

Turner, Clement John	26 Moylan-street, East Bentleigh		26 Moylan-street, East Bentleigh	Process Server	25.8.72
----------------------	----------------------------------	--	----------------------------------	----------------	---------

Dated at Oakleigh this 1st day of August, 1972.

G. MEEHAN, Clerk of the Magistrates' Court.

MAGISTRATES' COURT, ELSTERNWICK.

Grace, Noah David	9 Merton-avenue, Elwood		9 Merton-avenue, Elwood	Process Server	24.8.72
-------------------	-------------------------	--	-------------------------	----------------	---------

Dated at Elsternwick this 2nd day of August, 1972.

G. J. CONDON, Clerk of the Magistrates' Court.

MAGISTRATES' COURT, ELSTERNWICK.

Thorpe, Fraser Richard	95 Wattle Valley-road, Camberwell		95 Wattle Valley-road, Camberwell	Process Server	24.8.72
------------------------	-----------------------------------	--	-----------------------------------	----------------	---------

Dated at Elsternwick this 1st day of August, 1972.

G. J. CONDON, Clerk of the Magistrates' Court.

MAGISTRATES' COURT, CARLTON.

Vasilios, Anenoglou	6 Amess-street, East Brunswick		6 Amess-street, East Brunswick	Inquiry Agent	30.8.72
---------------------	--------------------------------	--	--------------------------------	---------------	---------

Dated at Carlton this 2nd day of August, 1972.

M. J. QUIRK, Clerk of the Magistrates' Court.

MAGISTRATES' COURT, NUMURKAH.

Wood, Russell James	Katunga		Katunga	Process Server	24.8.72
---------------------	---------	--	---------	----------------	---------

Dated at Numurkah this 1st day of August, 1972.

J. L. COLLINS, Clerk of the Magistrates' Court.

PRIVATE AGENTS—continued.

Full Name of Applicant or in the Case of a Firm or Corporation, of the Nominee.	Place of Abode of Applicant or Nominee.	Name of Firm or Corporation.	Address for Registration.	Type of Licence.	Date of Hearing of Application.
MAGISTRATES' COURT, PRESTON.					
Fisher, Kevin James	Army Camp, 75 Camp-road, Broadmeadows		Army Camp, 75 Camp-road, Broadmeadows	Watchman	28.8.72
Adair, Ronald	27 Elliott-avenue, Broadmeadows		111E Spring-street, Reservoir	Watchman	21.8.72
Rowe, Martin Frederick	2 Emerald-street, Preston		2 Emerald-street, Preston	Guard Agent	21.8.72
Dated at Preston this 31st day of July, 1972.			F. J. TENNI, Clerk of the Magistrates' Court.		
MAGISTRATES' COURT, SHEPPARTON.					
Sherrin, Leslie Norman	51 Rae-street, Shepparton	Metropolitan Security Service	41 Nixon-street, Shepparton	Watchman	17.8.72
Dated at Shepparton this 31st day of July, 1972.			R. N. HOLLIS, Clerk of the Magistrates' Court.		
MAGISTRATES' COURT, MELBOURNE.					
Black, Kelvin Charles	3 Currawong-street, Noble Park	Security Watching Co. Pty. Ltd.	2nd Floor, 561 Bourke-street, Melbourne	Watchman	30.8.72
Dated at Melbourne this 4th day of August, 1972.			G. L. WEBSTER, Clerk of the Magistrates' Court.		
MAGISTRATES' COURT, BENALLA.					
Randell, Bruce	25 Waller-street, Benalla		25 Waller-street, Benalla	Watchman	15.8.72
Dated at Benalla this 1st day of August, 1972.			M. J. SHELTON, Clerk of the Magistrates' Court.		
MAGISTRATES' COURT, PORT MELBOURNE.					
Millar, Andrew James	5 Bailey-avenue, Preston	Mayne Nickless Limited	94 York-street, South Melbourne	Watchman	22.8.72
Bulled, Leslie William	15 Loongana-avenue, Glenroy	" " "	" " "	"	"
Parton, Vincent Ronnie	15 Waratah-street, Seaholm	" " "	" " "	"	"
Linton, Raymond Stewart	R.A.A.F. Base Tottenham	" " "	" " "	"	"
Cosell, Bert	16 Colac-street Broadmeadows	" " "	" " "	"	"
Thompson, David John	13 Stock-street, Coburg	" " "	" " "	"	"
Roberts, Maxwell Archibald	9 Nalad-avenue, Box Hill North	" " "	" " "	"	"
Sutherland, Donald William	47 South gateway, Avondale Heights	" " "	" " "	"	"
Blakiston, John Robert	c/o Airmen's Mess, R.A.A.F. Base, Tottenham	" " "	" " "	"	"
Deegan, John Garry	c/o Airmen's Mess, R.A.A.F. Base, Tottenham	" " "	" " "	"	"
Dated at Port Melbourne, this 3rd day of August, 1972.			J. A. GIDLEY, Clerk of the Magistrates' Court.		

KATAMATITE WATERWORKS TRUST.

RATING BY-LAW FOR THE YEAR 1972/73.

The Katamatite Waterworks Trust, in pursuance and exercise of the powers conferred by the Water Acts, doth hereby make a rate for the supply of water for domestic purposes, of Eleven Cents in the Dollar, on the annual municipal valuation of lands and tenements liable to be rated within the Katamatite Urban District.

Provided that in no case shall the amount of rate payable in respect of any tenements (other than land on which there is no building) be less than Fifteen Dollars, and in respect of land on which there is no building less than Six Dollars.

Such rates are made and shall be levied upon the occupiers or owners of the said lands and tenements, for the period of 1st day of October, 1972 to 30th day of September, 1973 and shall be payable on the 10th day of April, 1973, at the offices of the Trust, care of the Shire Offices, Cobram.

For every water trough, a minimum sum of Four Dollars per annum shall be charged.

The aforesaid charges shall be payable on demand.

Passed this 20th day of July, 1972.

The seal of the Trust was hereto affixed this 20th day of July, 1972, in the presence of—

(SEAL) JAMES LONGMUIR, Chairman.
J. T. MCPHERSON, Commissioner.
RONALD T. CUTTS, Secretary.

Approved, 25th July, 1972.—ROBERTS DUNSTAN, Minister of Water Supply.

OMEQ WATERWORKS TRUST.

RATING BY-LAW FOR THE TWELVE MONTHS ENDING 31ST DECEMBER, 1972.

The Omeo Waterworks Trust, in pursuance and exercise of the powers conferred by the Water Acts, doth hereby make a rate for the supply of water for domestic purposes of seventeen and one half cents in the dollar on the annual municipal valuation of lands and tenements liable to be rated within the Omeo Urban District.

Provided that in no case shall the amount of rate payable for the period in respect of any tenement (other than land on which there is not a building), be less than eighteen dollars (\$18.00) and in respect of land on which there is no building less than five dollars (\$5.00).

Such rates are made and shall be levied upon the occupiers or owners of the said lands and tenements for the period commencing 1st January, 1972, and ending 31st December, 1972, and shall be payable in one amount on the 9th August, 1972 at the Office of the said Trust, at Omeo.

The maximum quantity of water to be supplied for the twelve months period without further charge to any property rated by the Trust is hereby fixed at the quantity which, at a charge of thirty seven cents per 1,000 gallons, would provide an amount equal to the amount of the rate levied on such property for the said twelve months period.

The charge for water supplied by measure to any property rated by the Trust in excess of such maximum quantity, computed as in the last preceding clause, is hereby fixed at thirty seven cents per 1,000 gallons.

The charge for water supplied by measure shall be payable, on demand, at the Office of the Trust in Omeo.

Passed this 19th June, 1972.

The common seal of the Omeo Waterworks Trust was hereto affixed, in the presence of—

(SEAL) E. D'A. FITZGERALD, Chairman.
K. R. MCCOY, Commissioner.
V. W. WEBBER, Secretary.

Approved, 25th July, 1972.—ROBERTS DUNSTAN, Minister of Water Supply.

LINTON WATERWORKS TRUST.

BY-LAW NO. 19.

The Linton Waterworks Trust in pursuance of and in exercise of the powers conferred by the *Water Act 1958* and of any and every other power it thereunto enabling doth hereby make a By-Law as follows:

Snake Valley Urban District.

1. The Trust hereby makes and levies a rate in respect of all lands and tenements within the Snake Valley Urban District of Seventeen and One Half Cents in the Dollar on the Nett Annual Value, set out in the valuation at present in force of such lands and tenements for the purposes of the municipal rate of the Shire of Ripon which is hereby adopted as the valuation of such lands and tenements respectively.

2. Such rate shall be made and levied upon the occupiers and owners of such lands and tenements for the period 7th August, 1972 to 31st December, 1972 and shall be payable on the 7th day of August, 1972 at the office of the said trust.

3. In no case shall the rate payable hereunder in respect of any land on which there is a building be less than Twenty-two dollars and in respect of land on which there is no building be less than Six dollars.

Carngham Haddon Rural District.

4. The Trust hereby makes and levies a rate in respect of all lands and tenements within the Carngham Haddon Rural District in accordance with the following scale:—

- (a) An amount of Forty dollars for each building on a holding plus
- (b) An amount of Forty cents per acre for each of the first one hundred acres on the holding
- (c) An amount of Thirty cents per acre for each of the second one hundred acres on the holding
- (d) An amount of Twenty cents per acre for each of the third one hundred acres on the holding
- (e) An amount of Ten cents per acre for each of the fourth one hundred acres on the holding
- (f) An amount of Five cents per acre for the remainder of the area in excess of four hundred acres.

5. Such rate shall be made and levied upon the occupiers and owners of such lands and tenements for the period 7th August, 1972 to 31st December, 1972 and shall be payable on the 7th day of August, 1972 at the office of the said Trust.

6. In no case shall the rate payable hereunder in respect of any land on which there is no building be less than Six dollars.

Passed this 13th day of July, 1972.

(SEAL) I. S. GRIGG, Chairman.
W. S. GRIGG, Commissioner.
L. OLDHAM, Secretary.

Approved, 28th July, 1972.—ROBERTS DUNSTAN, Minister of Water Supply.

PUBLIC TRUSTEE ACT 1958 (No. 6350), SECTION 17.

I hereby give notice that on the 25th July, 1972, the Public Trustee filed elections to administer the following deceased persons' estates in accordance with section 17 of the *Public Trustee Act 1958*.

HARDING, GORDON STANLEY, formerly of Main-road, Silvan, late of 17 Arthur-street, Fairfield, retired labourer, died 12th May, 1972.

HARKNESS, MAUD ELIZABETH, late of 3 Charlotte-street, Yarraville, widow, died 21st April, 1972.

HOOKE, MAURICE WILLIAM, formerly of 21 Park-road, Middle Park, late of Flat 37, 150 Victoria-avenue, Albert Park, retired clerk, died 20th May, 1972.

LAWRENCE, MARY TERESA, also known as Teresa Mary Lawrence, late of Beechworth, pensioner, died 16th February, 1972.

TRATFORD, JAMES, formerly of 287 Neerim-road, Carnegie, late of 38 Jersey-parade, Carnegie, pensioner, died 9th May, 1972.

TURNBULL, GEORGE FREEMAN, late of 34 Hayes-street, Northcote, printer, died 17th February, 1972.

WATTS, WILLIAM, late of 31 Bank-street, Ascot Vale, pensioner, died 21st September, 1971.

WOOTEN, BERTRAM CHARLES, formerly of 11 Bear-street, Mordialloc, late of Bundoora, pensioner, died 28th January, 1972.

I hereby give notice that on the 24th July, 1972, the Public Trustee filed elections to administer the following deceased persons' estates in accordance with section 17 of the *Public Trustee Act 1958*.

BOLTON, STANLEY, late of 200 Albion-street, Brunswick, cleaner, died between the 1st and 3rd day of February, 1972.

NEMMIKS, JOHN, late of 8 Shirley-grove, Heidelberg, industrial chemist, died 13th April, 1972.

PANEK, JULIAN, late of 9 Drummond-street, Carlton, driver, died 7th May, 1972.

ROGERS, HILDA BERTHA VICTORIA, formerly of Home-street, Sunbury, but late of Kew, widow, died 26th July, 1971.

ROSE, MYRTLE JENNIE NAPLES, late of Beechworth, pensioner, died 14th March, 1972.

SILVA, SADIE ISABEL SARAH, in the will called Sadie Isabel Silva, late of Glenfern Hill, Healesville, widow, died 28th March, 1972.

TUME, REGINALD CUTHBERT, also known as Reginald Cuthbert Tume, late of 180 Page-street, Middle Park, clerk, died 26th or 27th April, 1972.

N. P. BRODY,

Public Trustee.

256 Flinders-street, Melbourne, 3000, 2nd August, 1972.

NOTICE.

Creditors, next of kin and others having claims against the estate of any of the under-mentioned deceased persons are required to send particulars of their claims to the Public Trustee, 256 Flinders-street, Melbourne, Vic. 3000, the personal representative, on or before the 16th October, 1972, after which date the Public Trustee may convey or distribute the assets, having regard only to the claims of which the Public Trustee then has notice:—

BEDFORD, MABEL GLADYS, formerly of 5 Fairfield-avenue, Camberwell, but late of 215 Dandenong-road, Windsor, spinster, died 6th December, 1971.

BOLTON, STANLEY, late of 200 Albion-street, Brunswick, cleaner, died between the 1st and 3rd day of February, 1972.

BRADY, CHRISTINA MARY, formerly of 18 Bowen-street, Kyneton, but late of Ballarat, widow, died 16th January, 1970.

BURKE, MARGARET MARY, late of 65 Dandenong-road, East Frankston, widow, died 21st April, 1972.

CAMPBELL, MARGARET ELIZABETH, late of Kew, widow, died 28th August, 1960.

CHANT, CATHERINE ADA, also known as Kaye Chant, late of St. Andrews Lodge, Flinders, cook, died 28th March, 1972.

EWALD, JEAN, also known as John Ewald, formerly of 141 Grey-street, East Melbourne, late of Bunyip, invalid pensioner, died 23rd June, 1970.

FIRINAUSKAS, JONAS, also known as Jonas Alexander Firinauskas and John Henry Alexander, late of Flat 2, 44 Burnett-street, St. Kilda, pensioner, died on or about 10th December, 1971.

FLYNN, HAVELOCK WILLIAM, late of 7 Seaview-crescent, Black Rock, retired salesman, died 11th April, 1972.

FYLAK, MIKALAJ, also known as Nick Fylak, formerly of 36 Grieve Highway, Altona, late of 9 Victoria-street, Footscray, machinist, died 20th April, 1971.

HARDING, GORDON STANLEY, formerly of Main-road, Silvan, late of 17 Arthur-street, Fairfield, retired labourer, died 12th May, 1972.

HARKNESS, MAUD ELIZABETH, late of 3 Charlotte-street, Yarraville, widow, died 21st April, 1972.

HIGGS, RICHARD ERNEST, late of 23 Omar-street, Maidstone, Commonwealth Police Officer, died 4th April, 1972.

HOOKE, MAURICE WILLIAM, formerly of 21 Park-road, Middle Park, late of Flat 37, 150 Victoria avenue, Albert Park, retired clerk, died 20th May, 1972.

IRELAND, CHARLOTTE JANE, late of West Cessnock, N.S.W., widow, died 15th December, 1953.

IRWIN, GEORGE RICHARD, formerly of 7 Showers-street, Sunshine, late of 34 Hall-street, Newport, electrical fitter, died 21st March, 1972.

KEANE, THOMAS, late of 7 Clifford-street, Warragul, retired seaman, died 9th July, 1971.

LAWRENCE, MARY TERESA, also known as Teresa Mary Lawrence, late of Beechworth, pensioner, died 16th February, 1972.

MURRAY, ERIC DANIEL, late of 40 Royal-avenue, North Essendon, retired clerk, died 22nd April, 1972.

MCCAMBRIDGE, ARCHIBALD GERALD, late of Flat 3, 5 Trentham-street, Sandringham, clerk, died 27th April, 1972.

MCGUIRE, ALLAN FRANCIS, also known as Allan Melville and Allan McKenzie Melville, late of 8 Braemar-street, Essendon, storeman, died 27th December, 1971.

NEAL, MURIEL THOMPSON, formerly of 47 Woolley-street, Essendon, late of Unit 2, 1 Grandview-road, Niddrie, widow, died 1st April, 1972.

NEMMIKS, JOHN, late of 8 Shirley-grove, Heidelberg, industrial chemist, died 13th April, 1972.

PAIGE, MARY DOROTHY, late of 140 Tennyson-street, Elwood, spinster, died 1st April, 1972.

PANEK, JULIAN, late of 9 Drummond-street, Carlton, driver, died 7th May, 1972.

POLJAK, ANDJELA, late of Varazdin, Yugoslavia, widow, died 17th December, 1969.

PRENDERGAST, JOHN WILLIAM, late of 20 Mulga-street, Altona, salesman, died 25th May, 1972.

PRESTON, CLARENCE VICTOR CRANE, late of 9 Cypress-avenue, Boronia, retired builder, died 13th March, 1972.

ROGERS, HILDA BERTHA VICTORIA, formerly of Horne-street, Sunbury, but late of Kew, widow, died 26th July, 1971.

ROSE, MYRTLE JENNIE NAPLES, late of Beechworth, pensioner, died 14th March, 1972.

SILVA, SADIE ISABEL SARAH, in the will called Sadie Isabel Silva, late of Glenfern Hill, Healesville, widow, died 28th March, 1972.

STEWART, BERTHA MENZIE, late of Flat 1, 10 Havelock-road, East Hawthorn, widow, died 3rd May, 1972.

TAYLOR, JOSEPH JAMES, late of 14 Connelly-street, Brunswick, clerk, died 4th April, 1972.

THOMPSON, GEORGE, also known as George Edward Thompson, late of 38 Cedar-street, South Caulfield, retired carpenter, died 25th May, 1972.

TRATFORD, JAMES, formerly of 287 Neerim-road, Carnegie, late of 38 Jersey-parade, Carnegie, pensioner, died 9th May, 1972.

TUME, REGINALD CUTHBERT, also known as Reginald Cuchbert Tume, late of 180 Page-street, Middle Park, clerk, died 26th or 27th April, 1972.

TURNBULL, GEORGE FREEMAN, late of 34 Hayes-street, Northcote, printer, died 17th February, 1972.

VEEVERS, MURRAY EDWARD, late of 18 Goodwin-street, West Preston, retired postal worker, died 21st April, 1972.

WATTS, WILLIAM, late of 31 Bank-street, Ascot Vale, pensioner, died 21st September, 1971.

WILLIAMS, ALAN WILLIAM, late of Christchurch, New Zealand, retired company manager, died 20th February, 1972.

WOOTEN, BERTRAM CHARLES, formerly of 11 Bear-street, Mordialloc, late of Bundoora, pensioner, died 28th January, 1972.

ZIAJA, FRANCISKEK, formerly of 3 Walker-street, Moonee Ponds and 17 Milverton-street, Moonee Ponds, late of Mont Park, spray painter, died 16th September, 1971.

N. P. BRODY,
Public Trustee.

Melbourne, 2nd August, 1972.

CONTRACTS ACCEPTED.—(Series 1971-72.)

PUBLIC WORKS.

1503. Fitzroy, High School, mechanical services—additions, \$10,100.00.—Chadstone Airconditioning Services Pty. Ltd.

1504. Kilmore, Social Welfare Department, erection of two (2) family group homes, \$52,132.00.—A. F. Dewar Holdings Pty. Ltd.

1505. East Geelong, Social Welfare Department, erection of two (2) family group homes, \$51,048.00.—A. F. Dewar Holdings Pty. Ltd.

1506. Watsonia Heights, Primary School 4935, external repairs and painting, \$4,700.00.—J. Grigg.

1507. Birregurra, Primary School 723, asphalt paving and drainage works, \$4,504.24.—J. Keen.

1508. Geelong East, Technical School, electrical services—trade wing, \$54,050.00.—C. W. Norris and Co. Pty. Ltd.

1509. Kilcunda, Primary School 2307, internal and external renovations, \$4,491.00.—N. B. & H. H. Schack.

1510. Melbourne, Crown Law Department, 221 Queen-street, maintenance cleaning for the period 15th May, 1972 to 14th May, 1975, \$16,005.52 per annum.—Samual-Kay Services Pty. Ltd.

1511. Studfield East, Primary School 5058, site works, \$28,503.00.—L. J. Towers.

1512. Montmorency, Primary School 4112, asphaltting, drainage, &c., \$10,500.00.—L. J. Towers.

G. SERPELL, Director-General. 27.7.72.

STATE RIVERS AND WATER SUPPLY COMMISSION.

1488. Cleaning of 28,000 chains of earthen channels in the Millewa, Yelta and Carwarp areas of the Millewa Waterworks District, \$16,406.50.—A. D. Hillgrove.

1489. Supply and erection of 2 transportable houses for Dartmouth Dam Project, \$22,666.00.—A. Dunstan & Sons.

1490. Construction, delivery and placing on site at Dartmouth Dam Project of 4 transportable site offices, \$6,000.00.—Kermac Modular Buildings Pty. Ltd.

Sealed by Commission, 13th June, 1972.

1491. Construction of S.N.4 type residence, at Dingee, \$16,198.00.—R. Holden.

1492. Construction of brick and concrete toilet block, at Robinvale, \$2,530.00.—F. E. Trickey.

Sealed by Commission, 26th June, 1972.

1493. Construction of brick pump house, at Red Cliffs, \$5,727.00.—H. C. Hudswell.

1494. Supply, delivery and erection of chain wire fencing, Beaconsfield pumping station and Cathodic Protection Plant, Officer, \$2,623.87.—Cyclone K.M. Products Pty. Ltd.

1495. Erection of S.N.4 type residence, at Koondrook, \$18,500.00.—T. J. & W. P. Laursen.

Sealed by Commission, 17th April, 1972.

1496. Construction of 2 brick pump houses, at South Otway, \$33,439.00.—N. A. Wooding.

1497. Construction of brick veneer house, Lake View-street, Boort, \$23,503.70.—T. J. & W. P. Laursen.

1498. Supply, erection, testing and protective coating of—(1) Additional 6-ft. strake on top of existing storage tank, Mt. Eliza. (2) Additional 1-ft. strake on top of existing surge tank at East Frankston, \$9,574.00.—Stoher & Pitt (Bayswater) Pty. Ltd.

Sealed by Commission, 2nd May, 1972.

1499. Welding of 36-in. C.L.M.S. pipeline, Cheltenham-road, Dandenong, \$3,345.00.—Ilfred Pipe Welding.

1500. Construction of S.N.4 type residence, at Bears Lagoon (including demolition of residence 85), \$18,574.00.—J. L. Cassidy & F. W. Harris.

Sealed by Commission, 8th May, 1972.

1501. Construction of a brick valve house, at Frankston Reservoir, \$2,641.00.—H. & W. Schipper Bros.

Sealed by Commission, 19th June, 1972.

1502. Construction of earthen storage, at Hopetoun, Urban Storage No. 4, \$13,923.74.—A. D. Hillgrove.

Sealed by Commission, 13th June, 1972.

CONTRACTS ACCEPTED.—(Series 1972-73.)**VICTORIAN RAILWAYS.**

11. Design of circuits and manufacture, supply, delivery, construction, erection and installation of automatic power signalling between Highett and Cheltenham and certain automatic boom barrier installations for the amount of \$97,920.00 (Contract 63782).—Westinghouse-McKenzie-Holland Pty. Ltd. 12. Installation of flashing lights at 8 railway level crossings for the amount of \$96,965.00 (Contract 63675).—Westinghouse-McKenzie-Holland Pty. Ltd.

C. S. MORRIS, Secretary for Railways. 4.8.72.

AUCTION SALE.

An Auction Sale of unclaimed and confiscated liquor in possession of the Police will be held at the premises at 193 Spring-street, Melbourne, at 10 a.m., on Wednesday, 23rd August, 1972, at 10 a.m.

APPOINTMENTS AND RESIGNATIONS**APPOINTMENTS.**

His Excellency the Lieutenant-Governor of the State of Victoria, by and with the advice of the Executive Council thereof, has, by Orders made on the 1st day of August, 1972, been pleased to make the under-mentioned appointments, viz.:

CROWN LANDS AND SURVEY DEPARTMENT.*Bailiffs of Crown Lands.*

ERIC THOMAS GEORGE CAULFIELD and
ALLAN MATTHEW EMMERSON,
Inspectors of Land Settlement, Department of
Crown Lands and Survey,
to be bailiffs of Crown lands, pursuant to section 30 of
the *Land Act 1958*.

MINISTRY OF HEALTH.*Members of Committees of Management of Hospitals.*

C. NORMAN WILLIAM PODGER
to be the Municipal nominee on the Committee of Management of Terang and District (Norah Cosgrove) Community Hospital, for a period of three (3) years pursuant to paragraph (b) of the proviso to sub-section (1) of section 48 of the *Hospitals and Charities Act 1958*;

JAMES KELSHAM FULLAGAR, F.I.C.A.A., A.A.S.A.
to be the Government appointee on the Committee of Management of Latrobe Valley Community Hospital (Moe), for a period of three (3) years pursuant to sub-paragraph (ii) of paragraph (a) of the proviso to sub-section (1) of section 48 of the *Hospitals and Charities Act 1958*;

JAMES GEORGE GILLESPIE, M.B.E.
to be the Government appointee on the Committee of Management of Greenvale Village for the Aged, re-appointed for a period of three (3) years commencing the 26th August, 1972, pursuant to the provisions of sub-paragraph (ii) of paragraph (a) of the proviso to sub-section (1) of section 48 of the *Hospitals and Charities Act 1958*, and

IAN LAURIE FULTON
to be the Government appointee on the Committee of Management of Rupanyup and District Hospital, re-appointed for a period of three (3) years commencing the 26th August, 1972, pursuant to the provisions of sub-paragraph (ii) of paragraph (a) of the proviso to sub-section (1) of section 48 of the *Hospitals and Charities Act 1958*.

Trustees of Public Cemeteries.

GRAEME MEDLYN
ANTHONY LLOYD and
JOHN DOUGLAS
to be Trustees of the Stuart Mill Public Cemetery, vice J. Romano, A. Frolich and C. Erwin resigned;

KEITH JUBB
to be a Trustee of the Hexham Public Cemetery, vice P. Jubb, deceased; and

PATRICK GEORGE MONAHAN and
FRANCIS CHARLES HEWESTON
to be Trustees of the Queenscliffe Public Cemetery, vice J. Monahan, deceased, and additional Trustee, pursuant to section 3 (1) of the *Cemeteries Act 1958*.

Superintendent of Mental Hospital.

GWENDOLINE RUTH NASH, M.B., B.S., M.A.N.Z.C.P.
to be Superintendent, Mental Hospital, Ararat and Training Centre, Ararat, pursuant to section 26 (1) of the *Mental Health Act 1959*, from the 24th July, 1972, to the 17th August, 1972, both dates inclusive, vice Dr. P. R. Wood, on annual leave.

LAW DEPARTMENT.*Commissioners for Taking Declarations, &c.*

RAYMOND ROGER JOHNSON, care of Companies Office,
451 La Trobe-street, Melbourne,
to be a Commissioner for taking Declarations and Affidavits under the *Evidence Act 1958*, to refrain from charging fees and to resign upon ceasing to occupy his present position.

ANGELO MARTINO, care of P. Inga Pty. Ltd., Real Estate and Business Agents, 444 Lygon-street, East Brunswick,

MICHAEL KENNETH O'BRIEN, care of Box Hill Credit Co-operative Ltd., 934 Whitehorse-road, Box Hill,

ERIC RAYMOND MASON, care of Phosphate Co-op. of Australia Ltd., 119 Whitehall-street, Yarraville, and

BARRY JOHN JOY, care of H. C. Sleigh Limited, 160 Queen-street, Melbourne,
to be Commissioners for taking Declarations and Affidavits under the *Evidence Act 1958*, to resign upon ceasing to occupy their present positions.

GEORGE BLOCKLEY, Lot 11, Allsops-road, Launching Place, and

LESTER JOSEPH HARRIS, 402 South-road, Moorabbin,
to be Commissioners for taking Declarations and Affidavits under the *Evidence Act 1958*, to resign upon leaving the neighbourhood of the addresses stated; and

NEVILLE ARTHUR PHILLIPS, care of Pilkington A.C.I. Ltd., 470 Collins-street, Melbourne,
to be a Commissioner for taking Declarations and Affidavits under the *Evidence Act 1958*, to resign upon ceasing to occupy his present position.

Justices of the Peace.

THOMAS JOSEPH WOOLLEY, Purnim via Warrnambool, and
VALMA NELLIE MCKENNA, 66 Station-street, Seymour,
to keep the Peace in the State of Victoria.

Judge of the County Court.

NUBERT SOLOMON STABEY, Q.C., a Barrister at Law who has practised as a Barrister in Victoria for a period of seven years,
to be a Judge of the County Court of Victoria, to take effect from the date of commencement of duty.

MINES DEPARTMENT.*Mining Registrars.*

MICHAEL JOSEPH SHELTON,
to act as Mining Registrar at Benalla for the Benalla Division of the Beechworth Mining District, vice Reginald John McAllister, transferred.

KEVIN GILBERT MASON,
to act as Mining Registrar at Bendigo for the Sandhurst Division of the Bendigo Mining District, vice Robert Neil Hollis.

DEPARTMENT OF THE TREASURER.*Collector of Imposts (Acting).*

PHILLIP ALBERT ROCKE
to act temporarily as Collector of Imposts, Chief Secretary's Department, vice D. H. McDermott, on leave.

Receivers of Revenue (Acting).

IAN JOHN COLLARD
to act temporarily as Receiver of Revenue, Warragul, vice K. J. Craddock, on leave.

JOHN MURPHY
to act temporarily as Receiver of Revenue, Korumburra, vice L. E. Breen, on leave

IAN JAMES BENNETT
to act temporarily as Receiver of Revenue, Horsham, vice P. W. Westmore, on leave.

J. ROSSITER*Acting Clerk of the Executive Council.*

At the Executive Council Chamber,
Melbourne, 1st August, 1972.

*Milk and Dairy Supervision Act 1958.***APPOINTMENTS.**

The Public Service Board, in exercise of its powers has by its certificate dated 11th July, 1972, appointed the under-mentioned officers, Department of Agriculture, as officers under the provisions of Part II. of the *Milk and Dairy Supervision Act 1958*, without additional salary:—

BOLITHO, STANLEY.

KING, JOHN FRANCIS.

HESSION, ROBERT JOHN.

JOHNSON, WILFRED ALBERT.
 NEWTON, ROBERT ALLAN.
 PONSFORD, LEONARD.
 RICHARDS, NORMAN EDWARD.
 WHITEHEAD, LORENCE GEORGE.
 WILSON, NORMAN KEITH.

D. S. WISHART,
 Director of Agriculture.

Marine Act 1958.

APPOINTMENT OF PORT OFFICER AND DEPUTY
 PORT OFFICER.

His Excellency the Lieutenant-Governor of the State of Victoria by and with the advice of the Executive Council thereof doth by Order made on the 1st day of August, 1972, revoke the Order in Council made on the 30th May, 1972, appointing David Philip Barkley and John Robert Ashworth as Port Officer and Deputy Port Officer in Victoria, respectively, and has appointed Albert John Wagglan and David Philip Barkley as Port Officer and Deputy Port Officer in Victoria, respectively, pursuant to section 7, Part II., of the *Marine Act 1958*.

J. ROSSITER,
 Acting Clerk of the Executive Council

At the Executive Council Chamber,
 Melbourne, 1st August, 1972.

Marine Act 1958.

APPOINTMENT OF ASSESSORS FOR COURTS OF
 MARINE INQUIRY.

His Excellency the Lieutenant-Governor of the State of Victoria by and with the advice of the Executive Council thereof doth by Order made on the 1st day of August, 1972, appoint the under-mentioned persons as Assessors for Courts of Marine Inquiry, pursuant to the provisions of section 178 of the *Marine Act 1958*, for the twelve months ending 30th June, 1973:—

COURTS OF MARINE INQUIRY.
 ASSESSORS.

Class 1—Masters.

GEORGE ARTHUR MOLYNEUX.
 WILLIAM HENRY UTTLEY.
 JAMES MURDOCH MACKAY SWANSON.
 ROBERT ERNEST BRETT.
 ROBERT STEPHENSON ALLEN.

Class 2—Engineers.

JOHN CHARLES ROBERT SUNDERCOMBE.
 DEREK NORMAN MOORE.
 JOHN HENRY MICHELL.
 ALFRED STANLEY DERRICK CLARKE.

Class 3—Pilots and Exempt Masters.

GEORGE ARTHUR MOLYNEUX.
 WILLIAM HENRY UTTLEY.

Class 4—Scientific.

JOHN CHARLES ROBERT SUNDERCOMBE.
 ARTHUR MAURICE CLARK.

J. ROSSITER,
 Acting Clerk of the Executive Council.

At the Executive Council Chamber,
 Melbourne, 1st August, 1972.

RESIGNATIONS.

His Excellency the Lieutenant-Governor of the State of Victoria, by and with the advice of the Executive Council thereof, has, by Orders made on the 1st day of August, 1972, accepted the resignations of the persons named hereunder of the offices mentioned, viz.:—

LAW DEPARTMENT.

Commissioners for Taking Declarations, &c.

RONALD BISHOP,
 GEORGE MYALL DOWNING,
 PETER BERNARD GILL, and
 COLIN EDWARD MORCOM

as Commissioners for taking Declarations and Affidavits pursuant to the provisions of the *Evidence Act 1958*.

J. ROSSITER,
 Acting Clerk of the Executive Council.

At the Executive Council Chamber,
 Melbourne, 1st August, 1972.

ORDERS IN COUNCIL

EXPLOSIVES ACT 1960.

At the Executive Council Chamber, Melbourne, the
 eighteenth day of July, 1972.

PRESENT:

His Excellency the Lieutenant-Governor of Victoria.
 Mr. Meagher | Mr. Dickie.

EXEMPTION OF THE STATE FORESTS DEPARTMENT
 FROM CERTAIN PROVISIONS OF THE EXPLOSIVES
 ACT 1960.

Whereas by paragraph (c) of section 3 of the *Explosives Act 1960* it is amongst other things enacted that the Governor in Council may from time to time by Order specify any department of the Government of Victoria as being exempted from all or any of the provisions of the *Explosives Act 1960*:

Now therefore, His Excellency the Lieutenant-Governor of the State of Victoria, in the Commonwealth of Australia, by and with the advice of the Executive Council of the said State, and in pursuance of the powers conferred by section 3 of the *Explosives Act 1960* and all other powers him thereunto enabling, doth hereby specify the State Forests Department as being exempted from the provisions of the *Explosives Act 1960* in relation to:—

1. the storage of explosives (Regulations 609–624 of the *Explosives Regulations 1962*, Statutory Rules No. 58/1962);
2. permits to purchase explosives (Regulation 704 (1) of the *Explosives Regulations 1962*, Statutory Rules No. 58/1962);
3. permits to use explosives (Regulation 1003 of the *Explosives (Use) Regulations 1967*, Statutory Rules No. 185/1967); and
4. the "Assembling and Blending of Ammonium Nitrate Explosives Mixture Order 1968" (Statutory Rules No. 18/1968).

And the Honorable James Charles Murray Balfour, Her Majesty's Minister of Mines for the State of Victoria, shall give the necessary directions herein accordingly.

J. ROSSITER,
 Acting Clerk of the Executive Council.

BENEFIT ASSOCIATIONS ACT 1958.

At the Executive Council Chamber, Melbourne, the
 first day of August, 1972.

PRESENT:

His Excellency the Lieutenant-Governor of Victoria.
 Mr. Balfour | Mr. Dunstan.

REVOCATION OF EXEMPTION FROM THE PROVISIONS
 OF THE BENEFIT ASSOCIATIONS ACT 1958.

In pursuance of the powers conferred by the *Benefit Associations Act 1958*, His Excellency the Lieutenant-Governor of the State of Victoria, in the Commonwealth of Australia, by and with the advice of the Executive Council of the said State, and after consideration by the Chief Secretary of a report in writing made by the Registrar of Sickness, Hospital, Medical and Funeral Benefit Associations and the Government Statist, doth by this Order revoke the Order in Council made on the 23rd day of March, 1965, and published in the *Government Gazette* of the 24th day of March, 1965, declaring the Association then known as the Hospitals Contribution Fund of New South Wales, and which said Association has since changed its name to the Hospital Contribution Fund of Australia, to be exempt from the provisions of the *Benefit Associations Act 1958*.

And the Honorable Rupert James Hamer, Her Majesty's Chief Secretary for the State of Victoria, shall give the necessary directions herein accordingly.

J. ROSSITER,
 Acting Clerk of the Executive Council.

CEMETERIES ACT 1958 (No. 6217), SECTION 36.

At the Executive Council Chamber, Melbourne, the first day of August, 1972.

PRESENT:

His Excellency the Lieutenant-Governor of Victoria.

Mr. Balfour | Mr. Dunstan.

Pursuant to section 36 of the *Cemeteries Act 1958*, His Excellency the Lieutenant-Governor of the State of Victoria, by and with the advice of the Executive Council of the said State, hereby directs that an amount not to exceed Fifteen thousand and thirty-six dollars (\$15,036), being part of the balance of funds in the hands of the Trustees of the Fawcner Crematorium and Memorial Park, be expended on extensions to the existing office block.

And the Honorable John Frederick Rossiter, Her Majesty's Minister of Health for the State of Victoria, shall give the necessary directions herein accordingly.

J. ROSSITER,
Acting Clerk of the Executive Council.

CEMETERIES ACT 1958 (No. 6217), SECTION 36.

At the Executive Council Chamber, Melbourne, the first day of August, 1972.

PRESENT:

His Excellency the Lieutenant-Governor of Victoria.

Mr. Balfour | Mr. Dunstan.

Pursuant to section 36 of the *Cemeteries Act 1958*, His Excellency the Lieutenant-Governor of the State of Victoria, by and with the advice of the Executive Council of the said State, hereby directs that the sum of Eight hundred dollars (\$800), being part of the balance of funds in the hands of the Trustees of the Franklinford Public Cemetery, be expended on the erection of an office and tool shed.

And the Honorable John Frederick Rossiter, Her Majesty's Minister of Health for the State of Victoria, shall give the necessary directions herein accordingly.

J. ROSSITER,
Acting Clerk of the Executive Council.

COUNTRY ROADS BOARD.

At the Executive Council Chamber, Melbourne, the first day of August, 1972.

PRESENT:

His Excellency the Lieutenant-Governor of Victoria.

Mr. Balfour | Mr. Dunstan.

ORDER APPROVING OF LAND BEING ACQUIRED AND ROADS, DEVIATIONS OR WIDENINGS BEING MADE.

His Excellency the Lieutenant-Governor of the State of Victoria, by and with the advice of the Executive Council thereof, being satisfied that there are funds legally available for acquiring the land, doth hereby approve the acquiring of the land described in the schedule hereunder and the making of new roads and deviations from and widenings of existing roads referred to in the said schedule.

SCHEDULE.

State Highway.

The land shown hatched on Plan numbered G.P.13015 hereunder required for the widening of the Wimmera Highway in the Shire of Kowree and making of the widening thereon.

STATE HIGHWAY
WIMMERA HIGHWAY
SHIRE OF KOWREE

Measurements in links

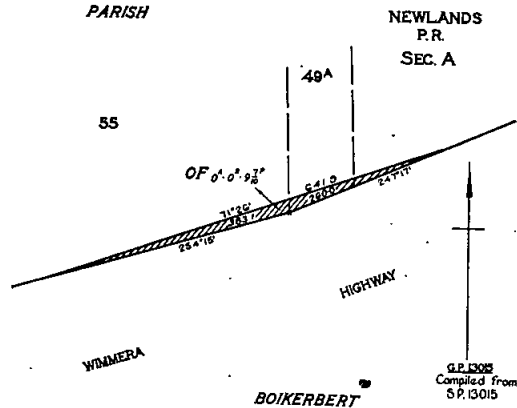

Main Roads.

The land shown hatched on Plan numbered G.P.12955 hereunder required for the widening of Barrabool-road in the Shire of Barrabool and making of the widening thereon.

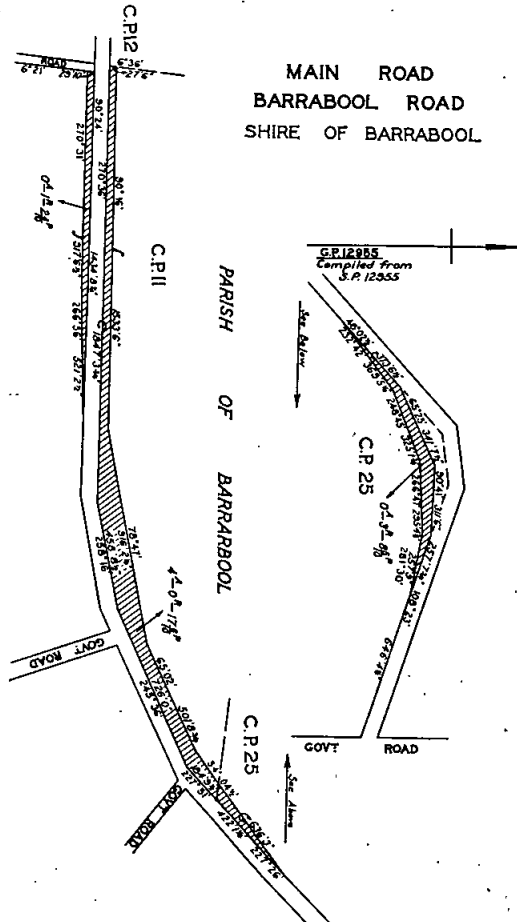

The land shown hatched on Plan numbered G.P.12966 hereunder required for the deviation from Rainbow-road in the Shire of Dimboola and making of the deviation thereon.

The land shown hatched on Plan numbered G.P.12863 hereunder required for the widening of Beach-road in the City of Sandringham and making of the widening thereon.

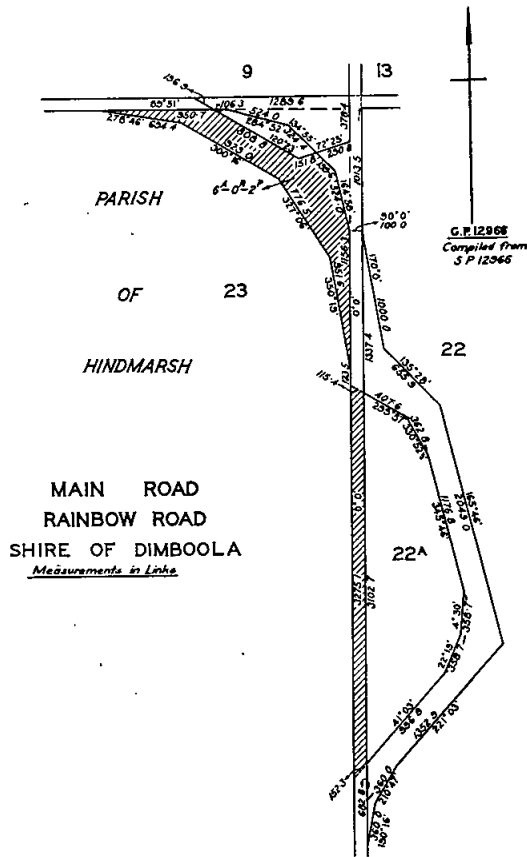

**MAIN ROAD
BEACH ROAD
CITY OF SANDRINGHAM**
Measurements in Feet & Inches

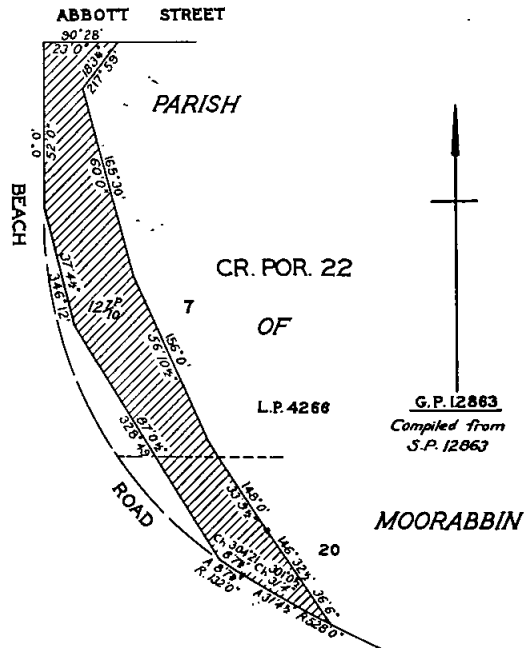

The land shown hatched on Plan numbered G.P.12708 hereunder required for the widening of the Euroa-Strathbogrie-road in the Shire of Euroa and making of the widening thereon.

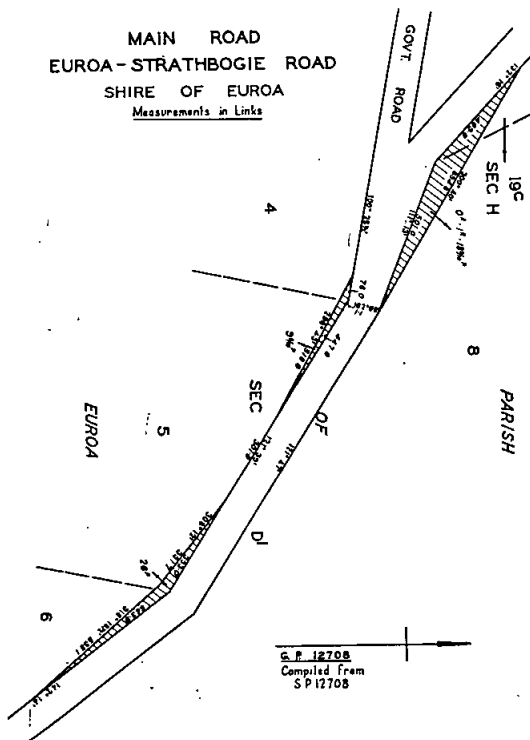

Freeway.

The land shown hatched on Plan numbered G.P.12986a hereunder required for the making of a new freeway (Mornington Peninsula Freeway) in the Shire of Flinders.

**FREWAY
MORNINGTON PENINSULA FREEWAY
SHIRE OF FLINDERS**
Measurements in Feet & Inches

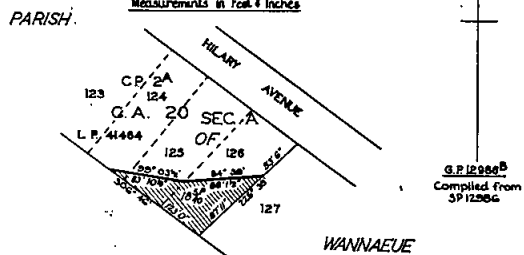

Unclassified Road.

The land shown hatched on Plans numbered G.P.12986A, G.P.12987A and G.P.12987B hereunder required for the making of a new road in the Shire of Flinders.

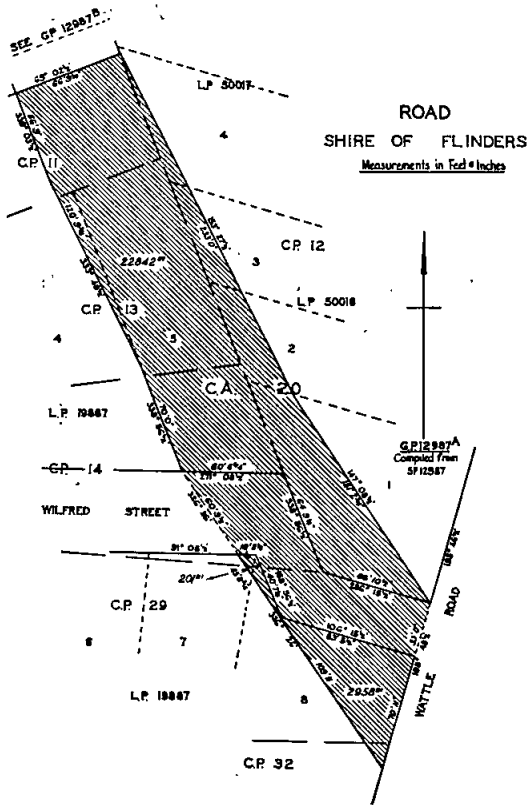
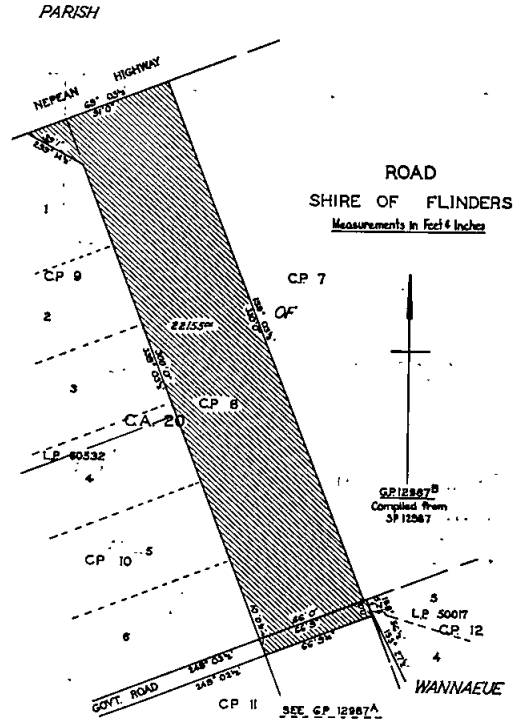
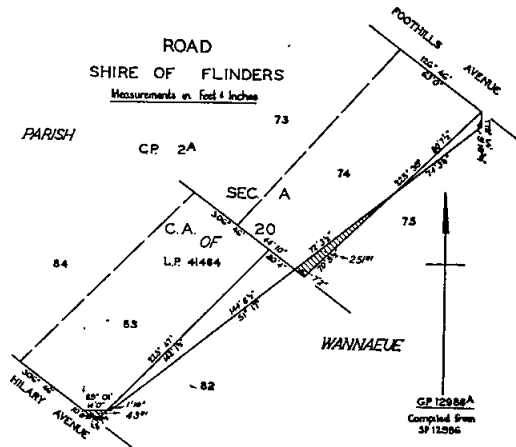

And the Honorable Alan John Hunt, Her Majesty's Minister for Local Government for the State of Victoria, shall give the necessary directions herein accordingly.

J. ROSSITER,
Acting Clerk of the Executive Council.

Land Act 1958.
DEPARTMENT OF CROWN LANDS AND SURVEY.

At the Executive Council Chamber, Melbourne, the first day of August, 1972.

PRESENT:
His Excellency the Lieutenant-Governor of Victoria.
Mr. Balfour | Mr. Dunstan.

LANDS TEMPORARILY RESERVED AS SITES.

His Excellency the Lieutenant-Governor of the State of Victoria by and with the advice of the Executive Council thereof, doth hereby in pursuance of the provisions of section 14 of the Land Act 1958, reserve temporarily from sale, from being leased and from having a licence granted in respect thereof, and also except from occupation for mining purposes under any miner's right the lands hereinafter described, viz.:-

CLUNES.—Site for Public purposes (Homes for the Elderly) 1 rood, more or less, Township of Clunes, Parish of Clunes, County of Talbot, as indicated by hatching on plan hereunder.—(C.394⁽⁵⁾) (Rs.9640).

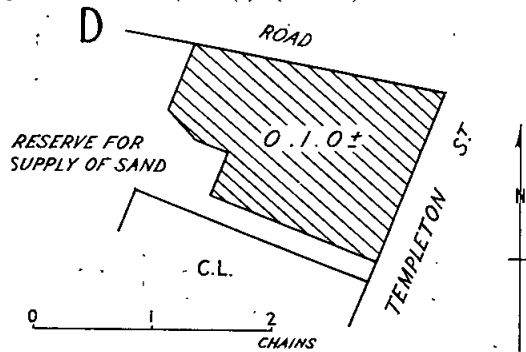

SUBJECT TO SURVEY

COBUNGRA.—Site for Public Recreation, 1 acre 33 perches, Parish of Cobungra, County of Benambra, as indicated by hatching on plan hereunder.—(C.372⁽⁶⁾) (Rs.9635).

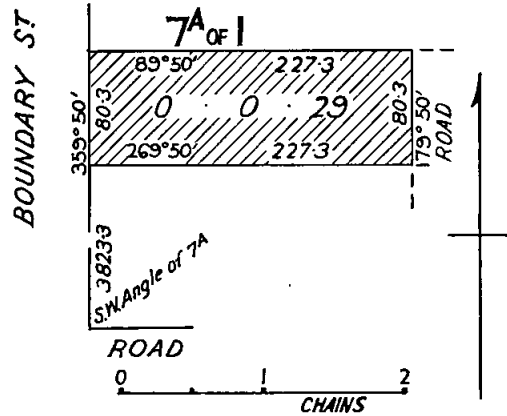
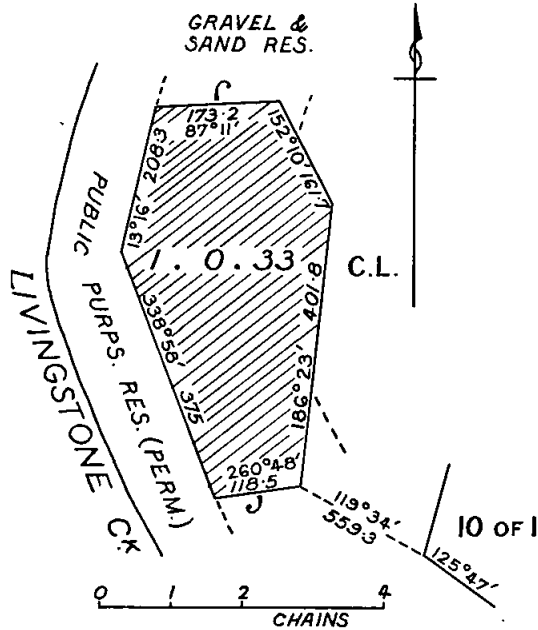

MILDURA.—Site for Public purposes (Departmental Residence), 24 perches, Parish of Mildura, County of Karkaroc, as indicated by hatching on plan hereunder.—(M.556⁽¹¹⁾) (Rs.9623).

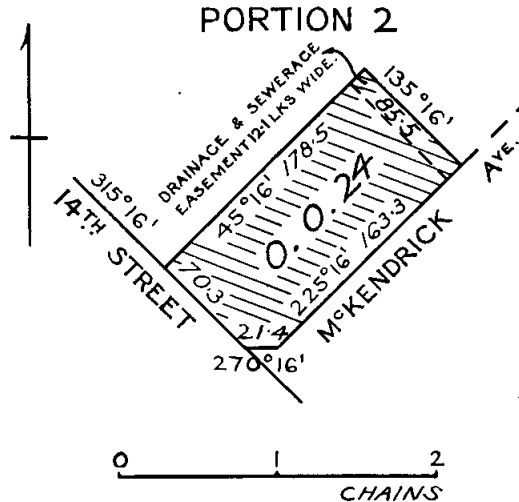

FLINDERS.—Site for Public purposes (Police Purposes), 2 roods, Township of Flinders, Parish of Flinders, County of Mornington, as indicated by hatching on plan hereunder.—(F.16^(A1)) (Rs.9610).

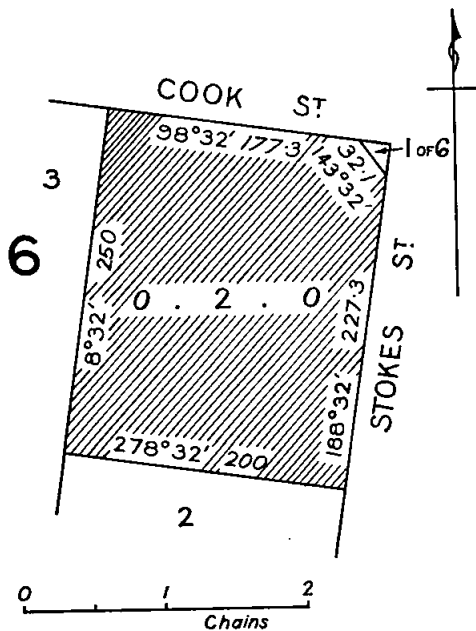

MURRABIT WEST (MYALL).—Site for State School purposes, 1 rood 15 perches, Parish of Murrabit West, County of Gunbower, as indicated by hatching on plan hereunder.—(M.474⁽⁷⁾) (Rs.8740).

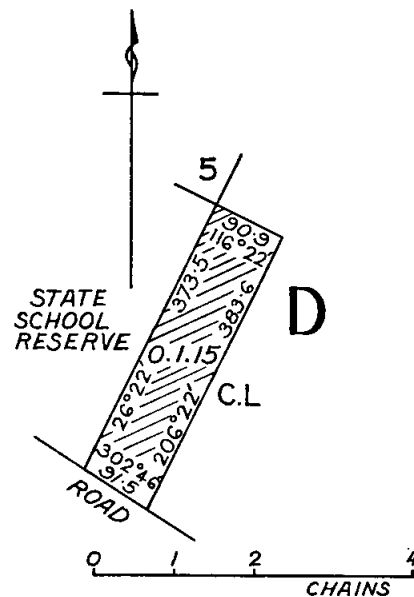

KERANG.—Site for Public purposes (Departmental Residence), 29 perches, Parish of Kerang, County of Gunbower, as indicated by hatching on plan hereunder.—(K.19⁽¹⁰⁾) (Rs.9620).

NAP-NAP-MARRA.—Site for Public purposes (Trigonometrical Survey Station), 4 acres 3 roods 8 perches, Parish of Nap-nap-marra, County of Tanjil, as indicated by hatching on plan hereunder.—(County Sheet 33) (Rs.9630).

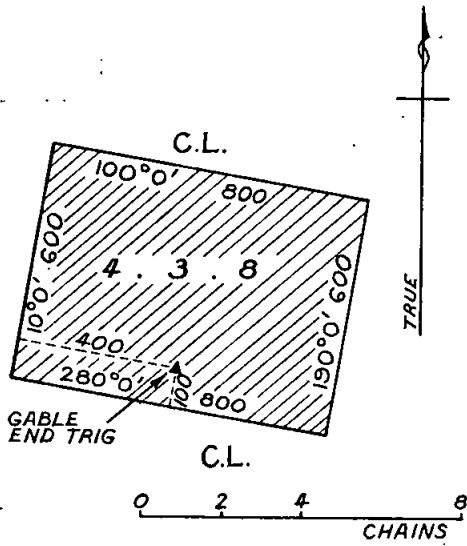

PAARATTE.—Site for Public Recreation, 3 acres, Parish of Paaratte, County of Heytesbury, as indicated by hatching on plan hereunder.—(P.160(A¹¹)) (Rs.4416).

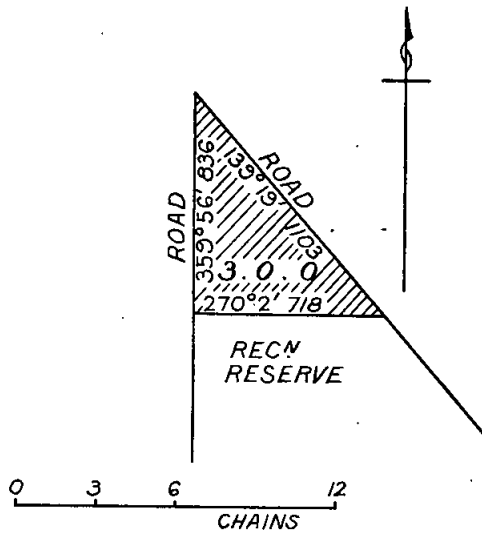

PORT CAMPBELL.—Site for Public Recreation, 4 acres 35 perches, Township of Port Campbell, Parish of Paaratte, County of Heytesbury, as indicated by hatching on plan hereunder.—(P.147(*) (Rs.4713).

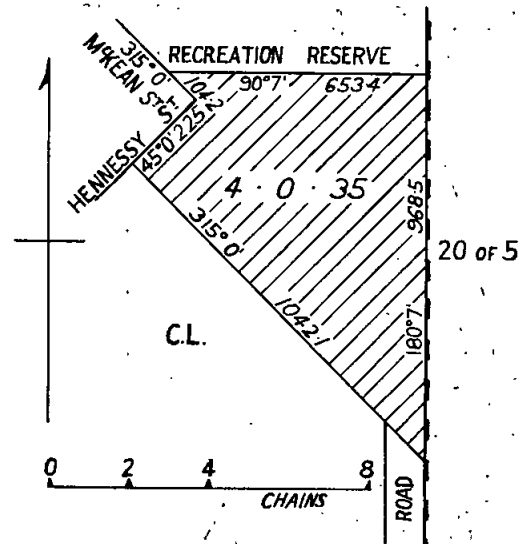

SEA LAKE.—Site for Public purposes (Departmental Depot), 2 roods 1 perch, Township of Sea Lake, Parish of Burupga, County of Karkaroc, as indicated by hatching on plan hereunder.—(S.452(*) (Rs.9626).

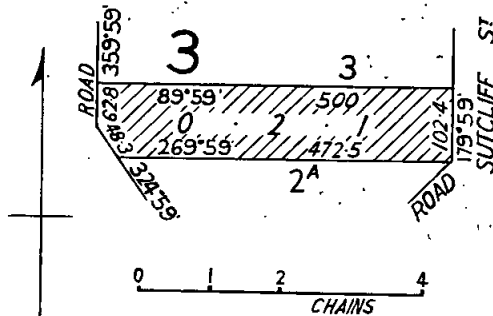

TRARALGON.—Site for Public purposes (Purposes of the Forests Acts), 24 perches, Parish of Traralgon, County of Buln Buln, as indicated by hatching on plan hereunder.—(T.115⁽¹¹⁾) (Rs.9638).

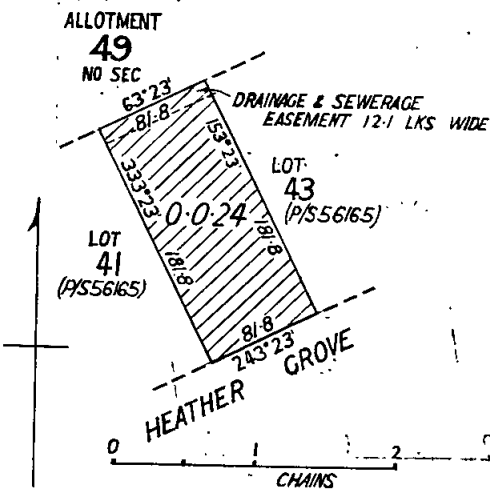

And the Honorable William Archibald Borthwick, Her Majesty's Minister of Lands for the State of Victoria, shall give the necessary directions herein accordingly.

J. ROSSITER,
Acting Clerk of the Executive Council.

DEPARTMENT OF CROWN LANDS AND SURVEY.

At the Executive Council Chamber, Melbourne, the first day of August, 1972.

PRESENT:

His Excellency the Lieutenant-Governor of Victoria.
Mr. Balfour | Mr. Dunstan.

UNUSED ROAD CLOSED.

His Excellency the Lieutenant-Governor of the State of Victoria, by and with the advice of the Executive Council thereof, doth hereby direct that, in pursuance of the provisions of section 349 of the Land Act 1958, the unused road referred to hereunder be closed, viz.:-

Parish of South Hamilton, County of Normanby, being the road indicated by hatching on plan hereunder.—(H.46⁽⁹⁾) (C.100743).

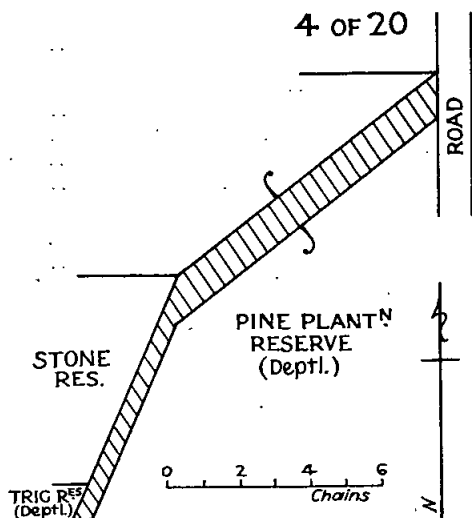

And the Honorable William Archibald Borthwick, Her Majesty's Minister of Lands for the State of Victoria, shall give the necessary directions herein accordingly.

J. ROSSITER,
Acting Clerk of the Executive Council.

LOCAL GOVERNMENT DEPARTMENT.

At the Executive Council Chamber, Melbourne, the first day of August, 1972.

PRESENT:

His Excellency the Lieutenant-Governor of Victoria.
Mr. Balfour | Mr. Dunstan.

VESTING OF RESERVES IN THE DIAMOND VALLEY SHIRE.

Whereas it is provided in section 569BA of the Local Government Act 1958, that where any map or plan has been lodged or deposited with the Registrar of Titles pursuant to section 97 of the Transfer of Land Act 1958, or any corresponding previous enactment (whether before or after the commencement of the Local Government Act 1963) and any allotment on that map or plan has been transferred, the Governor in Council on the request of the Council of the municipality may by Order published in the Government Gazette direct that the whole or any part of the land comprised in any reserve shown on that map or plan shall vest in the Council whereupon such land shall so vest freed and discharged from any mortgage charge lease or sub-lease.

And whereas the Council of the Shire of Diamond Valley has requested that reserves shown on plans of subdivision be vested in the Council and an allotment on each of those plans has been transferred.

Now therefore, His Excellency the Lieutenant-Governor of the State of Victoria, by and with the advice of the Executive Council thereof, doth by this Order vest in the Council of the Shire of Diamond Valley the following Reserves:—

- (a) The land coloured green reserved for drainage, sewerage and recreational purposes on plan of subdivision No. 42239 lodged in the Office of Titles;
- (b) the recreation, drainage and sewerage reserve coloured green on plan of subdivision No. 42413 lodged in the Office of Titles; and
- (c) the drainage, sewerage and recreational reserve coloured green on plan of subdivision No. 50493 lodged in the Office of Titles.

And the Honorable Alan John Hunt, Her Majesty's Minister for Local Government for the State of Victoria, shall give the necessary directions herein accordingly.

J. ROSSITER,
Acting Clerk of the Executive Council.

LOCAL GOVERNMENT ACT 1958.

At the Executive Council Chamber, Melbourne, the first day of August, 1972.

PRESENT:

His Excellency the Lieutenant-Governor of Victoria.
Mr. Balfour | Mr. Dunstan.

EXEMPTION OF THE MUNICIPALITY OF THE CITY OF MOE FROM THE OPERATION OF SECTION 249.

Whereas it is provided by sub-section (4) of section 249 of the Local Government Act 1958 that the Governor in Council may, at the request of the council of any municipality, by Order published in the Government Gazette, exempt the municipality from the operation of that section:

And whereas the Council of the City of Moe has requested that the municipality be exempted from the operation of the said section:

Now therefore, His Excellency the Lieutenant-Governor of the State of Victoria, by and with the advice of the Executive Council of the said State, hereby exempts the municipality of the City of Moe from the operation of section 249 of the Local Government Act 1958.

And the Honorable Alan John Hunt, Her Majesty's Minister for Local Government for the State of Victoria, shall give the necessary directions herein accordingly.

J. ROSSITER,
Acting Clerk of the Executive Council.

LOCAL GOVERNMENT DEPARTMENT.

At the Executive Council Chamber, Melbourne, the first day of August, 1972.

PRESENT:

His Excellency the Lieutenant-Governor of Victoria.
Mr. Balfour | Mr. Dunstan.

REVOCATION OF ORDER APPLYING REGULATIONS RELATING TO COMPULSORY VOTING TO ELECTIONS OF COUNCILLORS FOR THE SHIRE OF BAIRNSDALE.

His Excellency the Lieutenant-Governor of the State of Victoria, by and with the advice of the Executive Council thereof, in pursuance of the provisions of section 149 of the Local Government Act 1958, and in compliance with the prayer of a petition presented by the Council of the Shire of Bairnsdale hereby revokes an Order, published in the Government Gazette of the 9th February, 1966, applying the regulations relating to compulsory voting at municipal elections to elections of councillors for the said Shire.

And the Honorable Alan John Hunt, Her Majesty's Minister for Local Government for the State of Victoria, shall give the necessary directions herein accordingly.

J. ROSSITER,
Acting Clerk of the Executive Council.

LOCAL GOVERNMENT DEPARTMENT.

At the Executive Council Chamber, Melbourne, the first day of August, 1972.

PRESENT:

His Excellency the Lieutenant-Governor of Victoria.
Mr. Balfour | Mr. Dunstan.

ALTERATION OF TIME FOR CLOSING POLL AT MUNICIPAL ELECTIONS—SHIRE OF BACCHUS MARSH.

His Excellency the Lieutenant-Governor of the State of Victoria, by and with the advice of the Executive Council thereof, in pursuance of the powers conferred by section 134 of the *Local Government Act 1958*, and in compliance with the prayer of a petition presented by the Council of the Shire of Bacchus Marsh hereby declares that the hour for closing the poll at municipal elections for the said Shire shall be eight o'clock in the afternoon.

And the Honorable Alan John Hunt, Her Majesty's Minister for Local Government for the State of Victoria, shall give the necessary directions herein accordingly.

J. ROSSITER,
Acting Clerk of the Executive Council.

STAMPS ACT 1958, No. 6375.

At the Executive Council Chamber, Melbourne, the first day of August, 1972.

PRESENT:

His Excellency the Lieutenant-Governor of Victoria.
Mr. Balfour | Mr. Dunstan.

DECLARATION OF APPROVED VENDOR.

His Excellency the Lieutenant-Governor of the State of Victoria, by and with the advice of the Executive Council thereof, doth by this Order made pursuant to section 131C (1) of the *Stamps Act 1958*, declare the under-mentioned person carrying on business as a vendor of goods under instalment purchase agreements to be an "approved vendor" for the purposes of sub-division (14) of Division 3 of Part II. of the *Stamps Act 1958*.

271. BLACKWOOD FINANCE PTY. LTD.

And the Honorable Sir Henry Edward Bolte, Her Majesty's Treasurer for the State of Victoria, shall give the necessary directions herein accordingly.

J. ROSSITER,
Acting Clerk of the Executive Council.

Land Act 1958.

DEPARTMENT OF CROWN LANDS AND SURVEY.

At the Executive Council Chamber, Melbourne, the first day of August, 1972.

PRESENT:

His Excellency the Lieutenant-Governor of Victoria.
Mr. Balfour | Mr. Dunstan.

REVOCATION OF TEMPORARY RESERVATIONS OF LANDS BY ORDERS IN COUNCIL.

His Excellency the Lieutenant-Governor of the State of Victoria, by and with the advice of the Executive Council thereof, doth hereby, in pursuance of the provisions of the *Land Act 1958*, revoke the temporary reservations of lands by Orders in Council hereinafter referred to, viz.:

WARATAH NORTH.—The temporary reservation by Order in Council of the 20th November, 1939, of 145 acres, more or less, of land in the Parish of Waratah North as a site for Public purposes, so far only as regards the portion thereof comprised within the boundaries published in the *Government Gazette* of the 5th July, 1972 (page 2488) and containing 75 acres, more or less.—(W.365(r) (Rs.4799).

WARATAH NORTH.—The temporary reservation by Order in Council of the 11th August, 1879, of certain lands situated on the Shore of Bass Strait and the Indian Ocean

(named Southern Ocean in Order) as a site for Public purposes, revoked as to part by various Orders, so far only as regards the portion containing 35 acres, more or less, in the Parish of Waratah North, comprised within the boundaries published in the *Government Gazette* of the 5th July, 1972 (page 2488).—(W.365(r) (Rs.2362).

And the Honorable William Archibald Borthwick, Her Majesty's Minister of Lands for the State of Victoria, shall give the necessary directions herein accordingly.

J. ROSSITER,
Acting Clerk of the Executive Council.

LANDS DEPARTMENT NOTICES

APPROACHING LAND SALES.

Sale of Crown Land, in fee-simple, will be held at the under-mentioned places and dates, viz.:

	No. of Gazette.
Ballarat.—Wednesday, 27th September, 1972 ..	70
Cabbage Tree Creek.—Wednesday, 16th August, 1972 ..	61
Melbourne.—Wednesday, 13th September, 1972 ..	65
Numurkah.—Thursday, 14th September, 1972 ..	70
Robinvale.—Thursday, 31st August, 1972 ..	63
Wangaratta.—Thursday, 21st September, 1972 ..	69

SALE OF FREEHOLD LAND BY AUCTION.

Ararat.—Thursday, 21st September, 1972 .. 70

COMMITTEES OF MANAGEMENT OF RESERVES.

APPOINTMENTS.

Notice is hereby given that, in pursuance of section 221 of the *Land Act 1958*, the following appointments of Committees of Management of reserved Crown lands have been made by the Minister of Lands:—

"BARWO PUBLIC PURPOSES RESERVE."

Edward Patrick Bourke, Ronald George Hunter, Eric Loyd Musgrove, Frederick Grinter, Henry Thomas Vale, George Trevor Cobbedick, Athol John Reynolds and Royce Albert Ernest Hutchins as a Committee of Management for a period of three (3) years from the 14th July, 1972, of the land in the Parish of Barwo, temporarily reserved by Order in Council, dated the 21st January, 1937, as a site for Public purposes and known as the "Barwo Public Purposes Reserve".—(Corres. No. Rs.4646.)

"BIRREGURRA PUBLIC PARK AND RECREATION RESERVE."

Colin Cumming Campbell, John Savage Henderson, Peter Michael John Koop, Reginald George White, Arthur James Johnson, Francis Robert Lawrence, Keith Rollo Henderson and Alan David Pitkethly as a Committee of Management for a period of three (3) years from the 12th July, 1972, of the lands in the Township of Birregurra, temporarily reserved by Orders in Council, dated the 8th June, 1926, and 18th April, 1950, for Public Park and Public Recreation such lands being together known as the "Birregurra Public Park and Recreation Reserve".—(Corres. No. Rs. 3080.)

"CANNIBAL CREEK CAMPING, RECREATION AND WATER RESERVE."

Kenneth J. Coghill, Ross R. Walker, Keith J. C. McIlroy, David Simcocks, Stephen Nankervis, Leonard W. May, Alister Riddiford, Frederick Charles Cox and Charles William Parich as a Committee of Management for a period of three (3) years ending, the 30th June, 1975, of the remaining portion of the land in the Parish of Bunyip, temporarily reserved by Order in Council, dated the 22nd October, 1883, as a site for Camping and for affording access to water and by Order in Council dated the 23rd January, 1962, for the additional purpose of Public Recreation and known as the "Cannibal Creek Camping, Recreation and Water Reserve".—(Corres. No. Rs.6666.)

PUBLIC RECREATION PURPOSES RESERVE AT CARISBROOK.

The Corporation of the Shire of Tullaroop as the Committee of Management of the land in the Township of Carisbrook, temporarily reserved by Order in Council, dated the 11th July, 1972, as a site for Public Recreation Purposes.—(Corres. No. Rs.4463.)

SITE FOR PUBLIC PURPOSES (RECREATION), CASTERTON.

The Corporation of the Shire of Gleneig as the Committee of Management of the land in the Township and the Parish of Casterton, temporarily reserved by Order in Council, dated the 23rd May, 1972, as a site for Public Purposes (Recreation).—(Corres. No. Rs.9604.)

"CHATSWORTH RECREATION RESERVE."

Frederick Charles Williamson, Bernard Anthony Vaughan, Ian Arthur MacNaughton, Allan W. J. Edmonds, Alan James Shalders and James Hearne as a Committee of Management for a period of three (3) years from the 30th May, 1972, of the land in the Township of Chatsworth as is indicated by red colour on plan "C/30-5-56" attached to Lands Department correspondence Rs.7428 and known as the "Chatsworth Recreation Reserve".—(Corres. No. Rs.7428.)

"COBDEN RECREATION RESERVE."

Ian Campbell McArthur, John Sydney Sartori, Patrick John Northeast, Frank Hodgson, Graem Stuart Rix, James William Luker, John Stewart Blake and Francis Alexander Robertson as a Committee of Management for a period of three (3) years from the 28th June, 1972, of the land in the Township of Cobden, temporarily reserved as a site for Public Recreation and situated between section 18 and the Railway line and known as the "Cobden Recreation Reserve".—(Corres. No. Rs.1015.)

"COMBIENBAR PUBLIC RECREATION AND PUBLIC HALL RESERVE."

Stephen Keith Farmer, Samuel Albert Clay, Dulcie Ethel Clay, Raymond John Chester, Frank George Buteux, Robert A. Akeroyd and Wesley Ronald Morris as a Committee of Management for a period ending the 10th June, 1975, of the land in the Parish of Combiensbar, temporarily reserved by Orders in Council, dated the 20th July, 1925, and the 22nd December, 1953 as sites for Public Recreation and Public Hall and together known as the "Combiensbar Public Recreation and Public Hall Reserve".—(Corres. No. Rs.3150.)

"DINGEE RECREATION RESERVE."

Hugh Campbell Wallace, Raymond Victor Lawry, Ian Dudley Jackman, John Thompson, Ross Ormond Marwood, Graham Triplett, Ronald John Lawry, Dudley Fiske and William Melbourne Ryan as the Committee of Management for a period of three (3) years from the 20th June, 1972, of the remaining portion of the land, temporarily reserved by Order in Council, dated the 6th August, 1903, and of the lands, temporarily reserved by Orders in Council, dated 7th December, 1925, and 20th January, 1930, as sites for Public Recreation in the Parish of Dingee and known as the "Dingee Recreation Reserve".—(Corres. No. Rs.1979.)

"DARTMOOR TOURISTS CAMPING RESERVE."

Eric Holmes, Albert Neil Cameron, William Colin Thomas, Cyril Lindsay Bond, Robert Dallas, Roy Tomkins, Peter Andrew Roberts, Ronald Keith Barrett and Albert John Doueal as a Committee of Management for the period ending the 19th August, 1973, of the land in the Township of Dartmoor, temporarily reserved by Orders in Council, dated the 18th April, 1939, and the 30th May, 1972, as a site for Public purposes (Tourists Camp) and known as the "Dartmoor Tourists Camping Reserve".—(Corres. No. Rs.4933.)

"DOOKIE RACECOURSE AND RECREATION RESERVE."

Robert Walter Telford, Thomas Henry Cochran, Daniel Thomas O'Keefe, Thomas Joseph Ryan, Ronald Alan Ross, Calvin Stanley Kellow and Keith Robison Jeffery as a Committee of Management for a period of three (3) years from the 11th July, 1972, of the remaining portion of the land in the Parish of Pine Lodge, temporarily reserved by Order in Council, dated the 6th October, 1873, as a site for Racing and General Recreation purposes and known as the "Dookie Racecourse and Recreation Reserve".—(Corres. No. Rs.741.)

"GORDON PUBLIC PARK AND WATER RESERVE."

Jean Bourke, Patricia Catherine Carey, Ian Ronald Burns, Thomas Francis Clifford, Angus William Finlayson, Edwin Keith Sharrock, William Henry Barry, Cornelius Toohey

and Keith Russell Eastwood as a Committee of Management for a period of three (3) years from the 11th June, 1972, of the land in the Parish of Kerrit Bareet, temporarily reserved by Orders in Council, dated the 5th September, 1887, and the 12th December, 1930 as a site for a Public Park and Watering purposes and known as the "Gordon Public Park and Water Reserve".—(Corres. No. Rs.4060.)

PUBLIC RECREATION PURPOSES RESERVE AT KANGAROO FLAT.

The Corporation of the Shire of Marong as the Committee of Management of the land in the Township of Kangaroo Flat, temporarily reserved by Order in Council, dated the 11th July, 1972, as a site for Public Recreation Purposes.—(Corres. No. Rs.9629.)

"KOROIT MECHANICS' INSTITUTE, TEMPERANCE HALL AND FREE LIBRARY RESERVE."

Charles Henry Watson, Stuart Alexander Paton, and Nathan Clyde Gibson as a Committee of Management for a period of three (3) years from the 24th July, 1972, of the lands in the Town of Koroit, temporarily reserved by Orders in Council dated the 7th March, 1870, 3rd September, 1883, and 22nd September, 1884, as sites for Mechanics' Institute, Temperance Hall and Free Library.—(Corres. No. Rs.3291.)

"GRETA RECREATION RESERVE."

Evan Schubert, Eric Graham, Jack Graham, George Hillas, Hugh Evans, Alan Hughes, Noel Schubert, Jack Dinning and Ian Carmichael as a Committee of Management for a period of three (3) years from the 23rd May, 1972, of the land in the Parish of Greta, temporarily reserved by Order in Council, dated the 19th June, 1950, as a site for Public Recreation and known as the "Greta Public Recreation Reserve".—(Corres. No. Rs.4157.)

"LAKE TCHUM RESERVE", PARISH OF KARYRIE.

Arthur Duncan Hillgrove, William Edwin Lee, Richard Lee Bales, Keith McKenzie Mills, Robert John Lockwood, John James O'Connor, Stanley John Watson, Leo Julian Lowry and Colin Foster Russell as a Committee of Management for a period of three (3) years from the 14th July, 1972, of the land in the Parish of Karyrie reserved by Order in Council, dated the 21st January, 1937, as a site for Conservation of Water and Public Recreation and known as the "Lake Tchum Reserve".—(Corres. No. Rs.4636.)

"MOYHU RECREATION RESERVE."

Alan Kieth Sampson, Frederick Clyde Baker, David Maylor Evans, Maxwell James Baker, Martin Joseph Treacey, William Ivan Knight, Noel Russell McDonald, Walter Keith Frankling and Richard John Shanley as a Committee of Management for a period of three (3) years from the 9th July, 1972, of the land in the Parish of Moyhu, temporarily reserved by Order in Council, dated the 16th September, 1940, as a site for Public Recreation and known as the "Moyhu Recreation Reserve".—(Corres. No. Rs.5089.)

"MT. BUTE PUBLIC HALL RESERVE."

Angus James McDonald, James David Nicholls, Norman Robert Lindsay, Alexandra John Brett, Alan Frances Frost and Rupert Andrew McIntyre as a Committee of Management for a period of three (3) years from the 14th June, 1972, of the land in the Parish of Galla, temporarily reserved by Order in Council, dated the 15th April, 1947, as a site for Public Hall purposes and known as the "Mt. Bute Public Hall Reserve".—(Corres. No. Rs.5950.)

"NAGAMBIE RECREATION RESERVE."

John Charles Oliver, Robert Peter Fuhrmann, Francis Finnigan, John Edward Shells, Robert Stanley Perry, Norman James Boyer and Bernard Thomas Deane as a Committee of Management for a period of three (3) years from the 25th May, 1972, of the land in the Township of Nagambie, temporarily reserved by Order in Council, dated the 7th September, 1914, as a site for Public Recreation and known as the "Nagambie Recreation Reserve".—(Corres. No. Rs.58.)

"NEWBRIDGE RECREATION RESERVE."

Christopher James Metelmann, Leo James Lapidge, Francis Patrick Holland, Alfred John Holland, John Corry, Ralph Walter Sharp, John David Steel, John Frederick Heitmann, James Robert Chamberlain as a Committee of Management for a period of three (3) years from the 11th July, 1972, of the land at Newbridge, temporarily reserved by Order in Council, dated the 17th May, 1865, as a site for Public Recreation and known as the "Newbridge Recreation Reserve".—(Corres. No. Rs.1428.)

"MECHANICS' INSTITUTE AND PUBLIC HALL RESERVE",
RED HILL.

The Corporation of the Shire of Flinders as the Committee of Management of the land in the Township of Red Hill, Parish of Balnarring, temporarily reserved by Order in Council, dated the 29th May, 1923, as a site for a Mechanics' Institute and Public Hall.

This appointment is made in lieu of all previous appointments, with respect to the said land, which are hereby revoked.—(Corres. No. Rs.2740.)

"ST. ANDREWS MECHANICS' INSTITUTE AND FREE LIBRARY RESERVE" AND THE "ST. ANDREWS RECREATION RESERVE."

Rex Edward Dwight, Harold Roy Mayall, Robert Lodge Tucker, Robert Henry Mayall, William Thomas Rudge, Frank Trigg, Frank William Hollingsworth, Victor Thomas Roberts, and Lindsay Wright as a Committee of Management for a period of three (3) years from the 30th September, 1971, of the land in the Township of Queenstown (St. Andrews), temporarily reserved by Order in Council, dated the 2nd September, 1889, as a site for a Mechanics' Institute and Free Library and of the land in the said Township temporarily reserved by Order in Council, dated the 17th December, 1968, as a site for Public Recreation.—(Corres. Nos. Rs.1023; Rs.1460.)

"SEAFORD FORESHORE RESERVE."

George Raymond Pearson (for so long only as he continues to be a Councillor and the elect of the City of Frankston) in the place of Fay Nottage (no longer a Councillor) as a member of the Committee of Management of such portions of the Crown land in the Parishes of Frankston and Lyndhurst reserved for Public purposes as are indicated by red colour on plan marked "S/29.4.1937" attached to Department of Crown Lands and Survey correspondence Rs.4674, together with the area between the high and low water mark bordering such portions, all of which is known as the "Seaford Foreshore Reserve".—(Corres. No. Rs.4674.)

SITE FOR PUBLIC PURPOSES (SEWAGE PUMPING STATION),
SEA LAKE.

The Sea Lake Sewerage Authority as a Committee of Management of the land in the Township of Sea Lake, Parish of Burupga, temporarily reserved by Order in Council, dated the 11th July, 1972, as a site for Public purposes (Sewage Pumping Station).—(Corres. No. Rs.9612.)

"PUBLIC PURPOSES RESERVE", PARISH OF SHEPPARTON.

The Corporation of the City of Shepparton as the Committee of Management of the reserved Crown land in the Parish of Shepparton shown coloured red and green on plan S/25.7.72, attached to Lands Department correspondence Rs.8354.

This appointment is made in lieu of all previous appointments which are hereby rescinded.—(Corres. No. Rs.8354.)

"STRATFORD PUBLIC PURPOSES (SWIMMING POOL) RESERVE."

Leonard Francis Rule, John Clifford Brisbane, Thomas Alfred White, Brian Keith Smith, William Alan Rayner, Barry John Winzar and Peter Klaus Vranek as a Committee of Management for a period of three (3) years from the 14th July, 1972, of the land in the Township of Stratford, temporarily reserved by Order in Council, dated the 12th October, 1965, as a site for Public Purposes (Swimming Pool).—(Corres. No. Rs.8528.)

"TRAFALGAR RECREATION RESERVE."

Edward James Crowe, Francis James Fennell, Terence Ronald Brown, Charles Linton Henry Burgess, Herbert Frank Mynard, Allan Robert Erbs, Kevin James Jenkins,

Barry John McGrath and Leo John Donovan as a Committee of Management for a period of three (3) years from the 7th June, 1972, of the land in the Parish of Yarragon, temporarily reserved by Orders in Council, dated the 15th September, 1890, and 8th August, 1955, as a site for Public Recreation and known as the "Trafalgar Recreation Reserve".—(Corres. No. Rs.671.)

"WATCHEM RACECOURSE AND RECREATION RESERVE."

Roger B. Brennan, John E. Colbert, George R. Pickering, Alphonsis J. Noonan, Thomas P. Connellan, John A. Blair, Geoffrey Richmond, Norman W. Slocombe and Hector W. Dickie as a Committee of Management for a period of three (3) years from the 21st July, 1972, of the land in the Township of Watchem, temporarily reserved by Orders in Council, dated the 12th July, 1955, and 18th August, 1959, as sites for Racecourse and Public Recreation, in addition to and adjoining the site temporarily reserved therefor by Order in Council, dated the 8th December, 1931, and the whole being known as the "Watchem Racecourse and Recreation Reserve".—(Corres. No. Rs.4160.)

"WELSHPOOL PUBLIC HALL RESERVE."

Geoffrey George Linforth, Allan George Christensen, Eric Brooke Head, John Parry and William Tulloch Hendrie as a Committee of Management for a period of three (3) years from the 21st June, 1972, of the land in the Parish of Welshpool, temporarily reserved by Order in Council, dated the 24th February, 1947, as a site for Public Hall purposes and known as the "Welshpool Public Hall Reserve".—(Corres. No. Rs.5899.)

"JUBILEE PARK", WOODFORD.

Eric Carter, D. Carter, V. Mugavin, John Andrew Jellie, Alan James Wines, Clive Graham Wines, Oregon James Brodie, Basil Vivien Brodie, G. Mugavin as the Committee of Management for a period of three (3) years from the 8th July, 1972, of the land in the Parish of Wangoom, Township of Woodford, temporarily reserved by Order in Council, dated the 8th January, 1889, as a site for Public Park and Garden and temporarily reserved by Order in Council, dated the 28th July, 1959, for the additional purpose of Public Recreation and known as the "Jubilee Park".—(Corres. No. Rs.2486.)

"WOLLONABY (GLEN VALLEY) PUBLIC HALL RESERVE."

Cecil Cooper, John Batty, George B. Fitzgerald and James Denner as a Committee of Management for a period of three (3) years from the 9th July, 1972, of the land in the Parish of Wollonaby, temporarily reserved by Order in Council, dated the 30th June, 1941, as a site for a Public Hall and known as the "Wollonaby (Glen Valley) Public Hall Reserve".—(Corres. No. Rs.4627.)

"YARRABY RECREATION RESERVE."

Lynnton Charles Maple, Claude Henry Maple, Ian Kirby Watson and Verner Lancelot Watson as a Committee of Management for a period of three (3) years from the 27th June, 1972, of the land in the Township of Towan, temporarily reserved by Order in Council, dated the 14th December, 1972, as a site for Park and Recreation purposes and known as the "Yarraby Recreation Reserve".—(Corres. No. Rs.2669.)

JIM BALFOUR,
Acting Minister of Lands.

Department of Crown Lands and Survey,
Melbourne, 3rd August, 1972.

LOCAL LAND BOARDS.

In pursuance of the provisions of section 34 of the Land Act 1958, notice is hereby given that a public hearing at the following place and time will be conducted by the person mentioned, being duly appointed in that behalf.

W. BORTHWICK,
Minister of Lands.

Department of Crown Lands and Survey,
Melbourne.

SCHEDULE.

ROBINVALE, LAND INSPECTOR'S OFFICE, Thursday,
31st August, 1972, at 11 a.m.—T. A. Comte.

PROPOSED REVOCATIONS OF TEMPORARY RESERVATIONS OF LANDS BY ORDERS IN COUNCIL.

In pursuance of the provisions of the *Land Act 1958*, notice is hereby given that it is the intention of the Governor in Council to revoke the temporary reservations of lands by Orders in Council hereunder referred to, viz.:-

The following Notices were published 1° on the 19th July, 1972, pursuant to Orders of the 11th July, 1972.

OUYEN.—The temporary reservation by Order in Council of the 25th October, 1966, of 36 perches of land in the Parish of Ouyen as a site for a Municipal Saleyards is about to be revoked.—(O.22^(*)) (Rs.5930).

JERUK (GLENLOTH EAST).—The temporary reservation by Order in Council of the 14th February, 1939, of 2 acres 2 roods 26 perches of land in the Parish of Jeruk as a site for a State School, revoked as to part by Order of the 21st February, 1956, is about to be revoked so far as the balance thereof containing 1 acre 1 rood 36 perches, more or less, is concerned.—(J.35⁽²⁾) (Rs.4927).

SANDHURST.—The temporary reservation by Order in Council of the 13th August, 1946, of 272 acres, more or less, of land in the Parish of Sandhurst as a site for the Growth of Timber for the purpose of the manufacture or production of eucalyptus oil, revoked as to part by various Orders, is about to be revoked so far only as the portion containing 3 acres 1 rood 30 perches, more or less, indicated by hatching on plan hereunder, is concerned.—(S.371^(4*)) (Rs.5844).

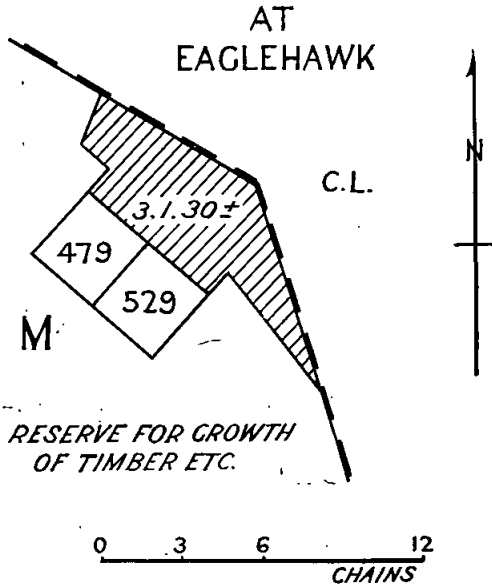

OUYEN.—The temporary reservation by Order in Council of the 21st December, 1960, of 3 acres 3 roods, more or less, of land in the Parish of Ouyen as a site for Municipal Saleyards is about to be revoked so far only as the portion containing 2 roods 7 perches, indicated by hatching on plan hereunder, is concerned.—(O.22^(*)) (Rs.5930).

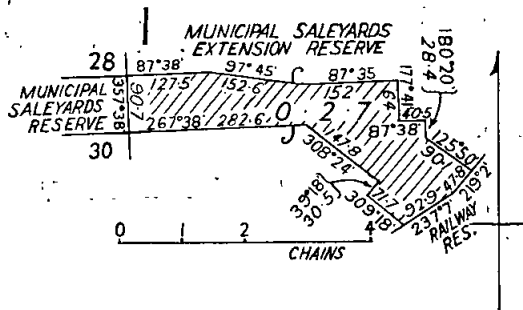

GANNAWARRA.—The temporary reservation by Order in Council of the 20th January, 1885, of 930 acres, more or less, of land in the Parish of Gannawarra as a site for Water Supply purposes, revoked as to part by Order of the 7th November, 1900, is about to be revoked so far only as the portion containing 8 acres 3 roods, more or less, indicated by hatching on plan hereunder, is concerned.—(G.211^(*)) (Rs.6543).

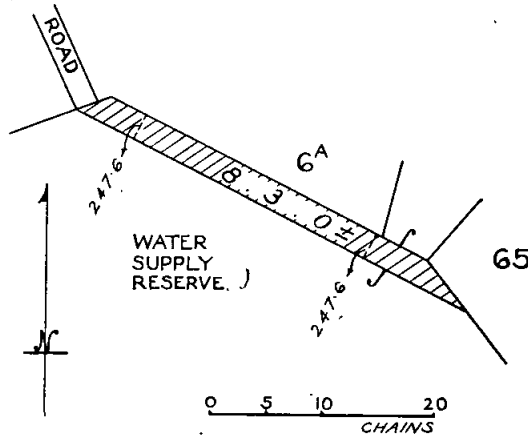

W. BORTHWICK,
Minister of Lands.

PROPOSED REVOCATIONS OF TEMPORARY RESERVATIONS OF LANDS BY ORDERS IN COUNCIL.

In pursuance of the provisions of the *Land Act 1958*, notice is hereby given that it is the intention of the Governor in Council to revoke the temporary reservations of lands by Orders in Council hereunder referred to, viz.:-

The following Notices were published 1° on the 9th August, 1972, pursuant to Orders of the 1st August, 1972.

DIMBOOLA.—The temporary reservation, by Order in Council of the 23rd June, 1936, of 6 acres 3 roods 7 perches of land in the Township of Dimboola, Parish of Dimboola, as a site for Supply of Gravel, is about to be revoked.—(D.150^(*)) (Rs.4580).

FLYNN.—The temporary reservation, by Order in Council of the 8th August, 1892, of 1 rood 19½ perches of land in the Township of Flinnstead (now Township of Flynn) as a site for a Mechanics Institute, is about to be revoked.—(F.102^(*)) (Rs.2151).

MARLO.—The temporary reservation, by Order in Council of the 25th November, 1952, of 5 acres 1 rood 20 perches of land in the Parish of Orbost East (now in the Township of Marlo) as a site for a Cemetery, is about to be revoked.—(M.538^(*)) (Rs.7051).

MARLO.—The temporary reservation, by Order in Council of the 14th November, 1967, of 6 acres 3 roods 13 perches of land in the Township of Marlo, as a site for PUBLIC purposes, is about to be revoked.—(M.538^(*)) (Rs.5157).

MOOLERR AND ST. ARNAUD.—The temporary reservation, as a site for Victorian Water Supply purposes and the withholding from sale, leasing and licensing, by Order in Council of the 29th September, 1879, of 317 acres 3 roods 5 perches of land in the Parishes of Moolerr and St. Arnaud are about to be revoked.—(S.366^(?)) (M.427^(*)) (Rs.2693).

NORTH HAMILTON.—The temporary reservation, as a site for Cemetery and the withholding from sale, leasing and licensing, by Order in Council of the 13th December, 1875 (see *Government Gazette*, 17th December, 1875, page 2332), of 3 acres 1 rood 30 perches of land in the Parish of North Hamilton, are about to be revoked.—(H.46^(*)) (C.100688).

SOUTH HAMILTON.—The temporary reservation, by Order in Council of the 6th July, 1927, of 2 acres 3 roods 38 perches of land in the Parish of South Hamilton, as a site for the Supply of Stone, is about to be revoked.—(H.46^(*)) (Rs.3507).

WHARPARILLA (ECHUCA).—The temporary reservation, by Order in Council of the 31st July, 1944, of 2 roods 30 perches of land in the Parish of Wharparilla, as a site for a Manure Depot is about to be revoked.—(W.132^(*)) (Rs.5515).

MARLO AND TABBARA.—The temporary reservation, by Order in Council of the 7th January, 1941, of 170 acres, more or less, of land in the Township of Marlo, and the Parish of Orbost East (now in the Township of Marlo and the Parish of Tabbara), as a site for Public purposes, revoked as to part by Order of the 23rd July, 1963, is about to be revoked so far as the balance thereof, containing 162 acres, more or less, is concerned.—(M.538 (5 & 6) (Rs.5157).

WHARPARILLA (ECHUCA).—The temporary reservation, by Order in Council of the 10th October, 1887 (see *Government Gazette*, 14th October, 1887, page 2978), of 10 acres 5 perches of land in the Parish of Wharparilla (named municipal district of Echuca in order) as a site for a Manure Depot, revoked as to part by Order of the 1st December, 1970, is about to be revoked, so far as the balance thereof, containing 8 acres 1 rood 14 perches, is concerned.—(W.132(3) (Rs.5515).

BALMORAL.—The temporary reservation, by Order in Council of the 27th July, 1966, of 11 acres 3 roods 16 perches of land in the Parish of Balmoral, as a site for Public Recreation is about to be revoked, so far only as the portion containing 1 rood 19 perches, indicated by hatching on plan hereunder is concerned.—(B.44(2) (Rs.8567).

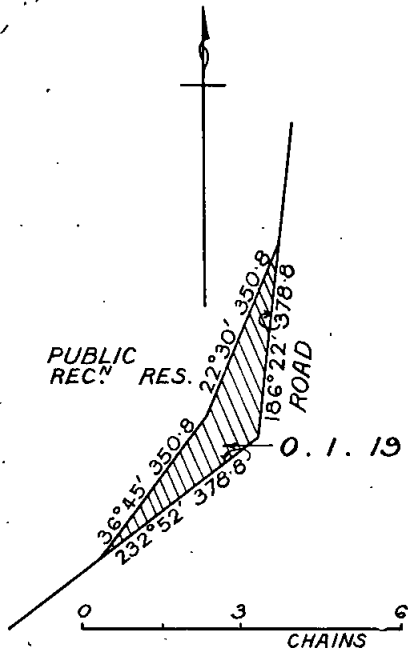

BOOLA BOLOKE.—The temporary reservation as a site for conservation of water and the withholding from sale, leasing and licensing, by Order in Council of the 20th February, 1882 (see *Government Gazette* 24th February, 1882, page 510), of 25 acres of land in the Parish of Boola Boloke are about to be revoked, so far only as the portion containing 2 acres 3 roods 4 perches indicated by hatching on plan hereunder, is concerned.—(B.81(2) (Rs.9489).

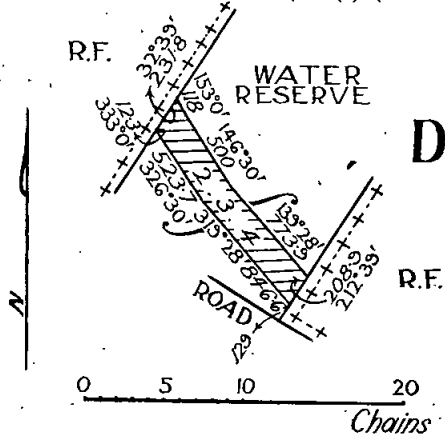

DARTMOOR.—The temporary reservation, by Order in Council of the 2nd July, 1957, of 2 acres 12 perches of land in the Township of Dartmoor, as a site for the purposes of the Forests Act revoked as to part, by Order of the 12th November, 1963, is about to be revoked so far only as the portion containing 1 rood 17 perches, indicated by hatching on plan hereunder, is concerned.—(D.32(2) (Rs.7613).

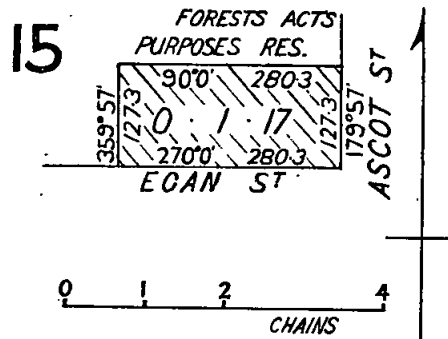

MARLO.—The temporary reservation, by Order in Council of the 7th May, 1889, of 14 acres, more or less, of land in the Parish of Orbost (now in the Township of Marlo and the Parish of Orbost East) as a site for a Lighthouse is about to be revoked, so far only as the portions in the Township of Marlo, containing 2 acres 1 rood, more or less, indicated by hatching on plan hereunder, are concerned.—(M.538(2) (Rs.7996).

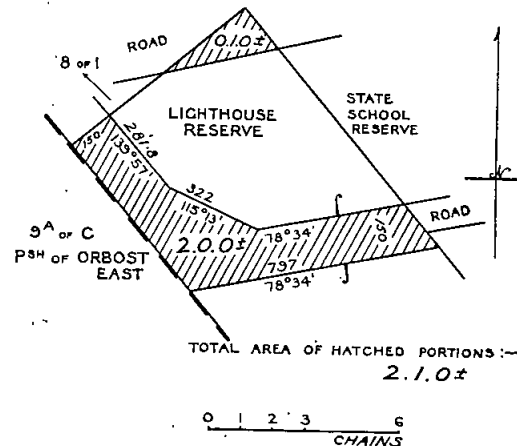

NATIMUK.—The temporary reservation, as a site whence Stone may be procured and the withholding from sale, leasing and licensing, by Order in Council of the 8th January, 1877, of 26 acres 3 roods 14 perches of land in the Parish of Natimuk, are about to be revoked, so far only as the portion containing 4 acres 1 rood 36 perches, indicated by hatching on plan hereunder, is concerned.—(N.117(2) (Rs.5143).

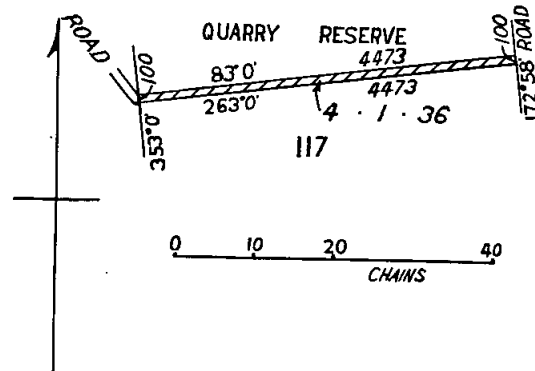

NEWMERELLA.—The temporary reservation, by Order in Council of the 18th July, 1927, of 103 acres 1 rood 25 perches of land in the Parish of Newmerella, as a site for a Racecourse and Public Recreation, revoked as to part by Order of the 22nd April, 1970, is about to be revoked so far only as the portion containing 1 acre 2 roods 33 perches, indicated by hatching on plan hereunder, is concerned.—(N.136⁽¹⁾) (Rs.3519).

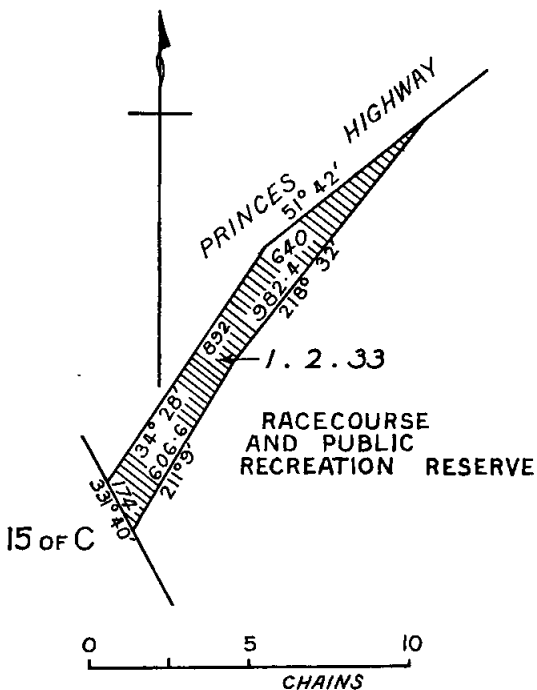

NYAH.—The temporary reservation, by Order in Council of the 22nd July, 1969, of 2 roods 8 perches of land in the Township of Nyah, as a site for Public Park and Recreation, is about to be revoked so far only as the portion containing 1 rood 2 perches, indicated by hatching on plan hereunder, is concerned.—(N.161⁽²⁾) (Rs.2051).

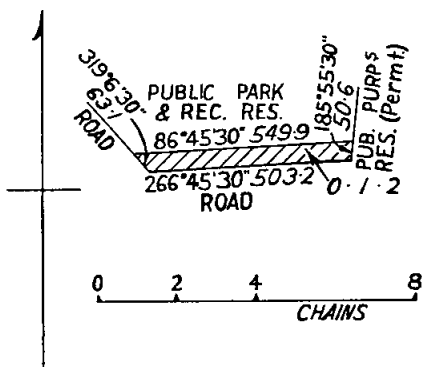

TABBARA.—The temporary reservation, by Order in Council of the 15th September, 1959, of 1,100 acres, more or less, of land in the Parish of Tabbara, as a site for an Aerodrome, is about to be revoked, so far only as the portion containing 1 acre 1 rood, more or less, indicated by hatching on plan hereunder, is concerned.—(T.261⁽³⁾) (Rs.7846).

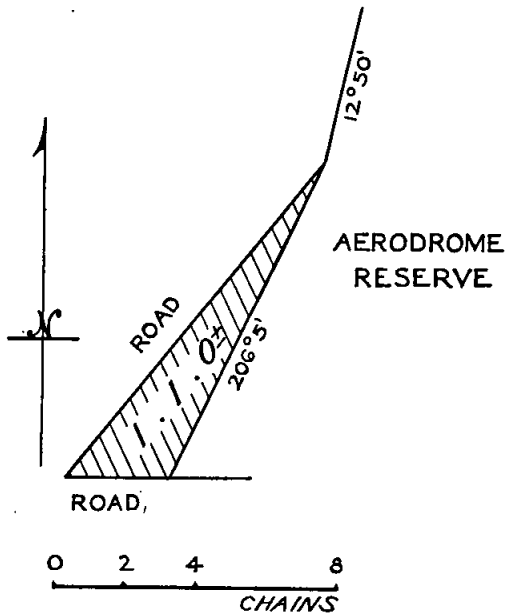

WINDHAM.—The withholding from sale, leasing and licensing by Order in Council of the 8th October, 1883 (see *Government Gazette*, 12th October, 1883, page 2372), of the unappropriated Crown lands on the banks of the Goulburn River in various parishes is hereby revoked, so far only as the portion in the Parish of Windham, containing 2 roods 21 perches, indicated by hatching on plan hereunder, is concerned.—(W.149⁽⁴⁾) (H.031198).

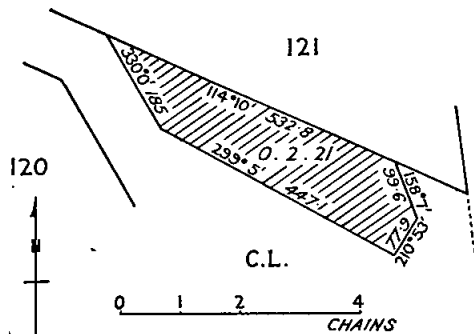

ST. ARNAUD AND MOOLERR.—The temporary reservation, by Order in Council of the 11th January, 1903, of 1,549 acres 1 rood 13 perches of land in the Parishes of St. Arnaud and Moolerr, as a site for the growth and preservation of Timber, revoked as to part by Order of the 12th March, 1909, is about to be revoked, so far as the balance thereof, containing 1,519 acres 3 roods 23 perches, is concerned.—(S.366⁽⁵⁾) (M.427⁽⁶⁾) (Rs.2693).

W. BORTHWICK,
Minister of Lands.

Land Act 1958.

PROPOSED PERMANENT RESERVATION OF CERTAIN LANDS AND THE REVOCATION AS TO PARTS OF THE PERMANENT RESERVATION OF CERTAIN OTHER LANDS.

In pursuance of section 15 (1) of the *Land Act 1958*, notice is hereby given that it is the intention of the Governor in Council to permanently reserve the lands, and to revoke as to parts the permanent reservation of other lands, herein referred to, viz:—

The following Notice was published 1^o on the 9th August, 1972, pursuant to Order of the 1st August, 1972.

MACORNA.—Land to be permanently reserved for Public purposes, Parish of Macorna, County of Gunbower: Crown land forming the bed of the new course, and on either side

thereof, of the Pyramid Creek between the points marked A and B and indicated by hatching on plan hereunder, save and except those portions lying within the hatched area which are already permanently reserved for Public purposes pursuant to the Order in Council of the 23rd May, 1881 (see Government Gazettes of the 18th March, 1881, page 817, and the 27th May, 1881, page 1389).

ORDER IN COUNCIL REVOKED AS TO PART.

The Order in Council of the 23rd May, 1881, permanently reserving certain Crown lands for Public purposes, is about to be revoked so far only as the said Order relates to those portions of the former bed, and Crown land on either side thereof, of the Pyramid Creek, in the Parish of Macorna, which lie between the points marked A and B, but which do not lie within the area indicated by hatching on plan hereunder.—(M.491(?) (Rs.9425).

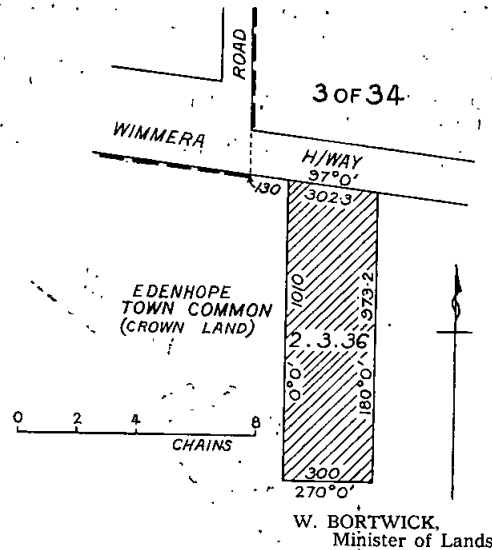
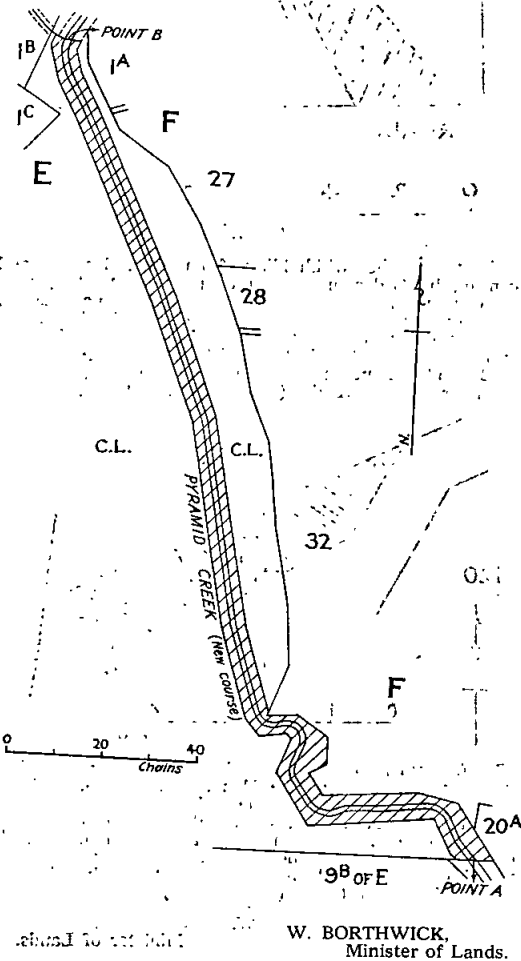

PUBLIC SERVICE NOTICE

No. 270. *Public Service Act 1958, Section 50.*

REGULATIONS.—PART IV.—SALARIES AND INCREMENTS.

The Public Service Board, in pursuance of the powers conferred by the *Public Service Act 1958*, hereby amends its Regulations as shown below:—

SECOND SCHEDULE.
TECHNICAL AND GENERAL DIVISION.
Grades and Salary Scales.
JUNIOR GRADES.
Females.

Grade.	Yearly Rate of Salary at Each Age in Years.				
	Under 17.	17.	18.	19.	20.
	\$	\$	\$	\$	\$
Add— JF-27			2,391	2,759	3,127

SIXTH SCHEDULE.
TEMPORARY EMPLOYEES.
Designations of Positions and Rates of Salaries.

Department and Designation of Position.	Yearly Rate of Salary.		Increments (Annual).
	Minimum.	Maximum.	
PREMIER'S DEPARTMENT.	\$	\$	
Add— <i>Audit Office.</i>			
Clerical Assistant (Female) (Audit), Grade II.	4,060	4,314	B
Clerical Assistant (Female) (Audit), Grade I.— Junior—			
At 18 years of age		2,391	
At 19 years of age		2,759	
At 20 years of age		3,127	
Adult.	3,679	3,758	B

COMMON ABOUT TO BE DIMINISHED.

In pursuance of the provisions contained in the *Land Act 1958*, notice is hereby given that it is the intention of the Governor in Council to diminish the common hereinafter mentioned, viz.:—

The following Notice was published on the 9th August, 1972, pursuant to Order of the 1st August, 1972.

The Edenhope Town Common, proclaimed as such by the Governor in Council on the 26th July, 1869, is about to be diminished by the excision therefrom of the portion in the Township of Edenhope containing 2 acres 3 roods 36 perches, as indicated by hatching on plan hereunder.—(Rs.666.)

A. J. A. GARDNER, Chairman.
R. H. DURRANT, Acting Secretary.

Office of the Public Service Board,
Melbourne, 24th July, 1972.

TENDERS**PUBLIC WORKS DEPARTMENT**

Tenders will be received at Public Works Department, 2 Treasury-place, Melbourne, until **TWO** p.m. on dates shown and for purposes mentioned hereunder.

Particulars and tender forms available at Contracts Office, Room 8, Building Division, Parliament-place and at places indicated in brackets hereunder.

Abbreviations in brackets mean:—W.O.—Inspector of Works Office; P.S.—Police Station; C.S.—Consolidated School; H.E.S.—Higher Elementary School; H.S.—High School; Pr.S.—Primary School; T.S.—Technical School.

Tenders to be submitted on the Department's printed Tender Form and will not be received by telephone. All tenders must be on a "Firm Tender" basis. The lowest or any tender will not necessarily be accepted.

Address tenders to the Minister of Public Works, and endorse the envelope containing the tender "Tender for _____", closing Tuesday,

Hand delivered tenders to be placed in the Tender Box of the Public Works Department, located on the wall of the centre entrance foyer, Ground Floor, 2 Treasury-place, Melbourne.

No preliminary deposit is required with any tender, but a successful tenderer will be required to pay a deposit for any accepted tender of \$4,000 or over.

Tuesday, 15th August, 1972.**Building, Electrical and Mechanical Works.**

ASCOT VALE.—External and internal renovations, Travancore Developmental Centre Residence. (Re-advertised.)

BENDIGO.—Erection of standard assembly hall, type 572c, Girls' H.S. (Re-advertised.) (Amended Specification.) (W.O., Bendigo.)

COWES.—Erection of four additional class-rooms, &c., Pr.S.1282. (W.O., Korumburra.)

KYABRAM.—Repairs and painting, Pr.S.4866. (W.O., Shepparton.)

PRESTON EAST.—External renovations, Pr.S.4316. (Amended Specification.)

PRESTON EAST.—Mechanical services—extensions, &c., T.S.

Site Works.

BACCHUS MARSH.—Asphalt repairs and site works, H.S. (W.O., Ballarat.)

CHELTENHAM HEIGHTS.—Site works, Pr.S.4930.

Tuesday, 22nd August, 1972.**Building, Electrical and Mechanical Works.**

BELLFIELD.—Erection of toilet block and breezeway, Pr.S.4656.

BURWOOD.—Electrical installation, Allambie Reception Centre. (Re-advertised.)

KYABRAM.—Internal and external repairs and painting, High School. (W.O., Shepparton.)

MOOMBA PARK.—Internal renovations, Pr.S.4876.

QUEENSCLIFF.—Additional class-rooms, &c., High School. (W.O., Geelong.)

QUEENSCLIFF.—Mechanical services, science wing, High School. (W.O., Geelong.)

VARIOUS.—Staff and administration improvements, &c., High Schools. Northern Region. (W.O., Shepparton and Wangaratta.)

VARIOUS.—Transfer and re-erection of Portable Buildings from 1st September, 1972 to 31st August, 1974, Schools. (Five Zone Contracts.) (W.O., Ballarat, Bendigo, Geelong, Horsham, Mildura, Shepparton and Traralgon.)

Site Works.

COBURG.—Site works, Technical School.

GLENORMISTON.—Site works, Agricultural College. (W.O., Camperdown.)

Tuesday, 29th August, 1972.**Building, Electrical and Mechanical Works.**

ABERFELDIE.—Renovations to toilet block, Pr.S.4220.

DONALD.—Erection of toilet block, Pr.S.1464. (Police Station Donald and W.O., Horsham and Maryborough.)

ESSENDON.—External repairs and painting—Roof renewal, Pr.S.483.

FOSTER.—Internal and external renovations, High School. (W.O., Korumburra.) (Re-advertised.)

HARCOURT.—External and internal repairs and painting, Pr.S.299. (W.O., Bendigo and Kyneton.)

MOUNT WAVERLEY.—Erection of science wing in B/V, High School.

MOUNT WAVERLEY.—Mechanical services—Science Wing, High School.

WOODEND.—Internal and external repairs and painting, Pr.S.647. (W.O., Kyneton.)

Site Works.

FAIRHILLS.—Site works, Pr.S.4906.

PARKDALE.—Asphalt repairs, Pr.S.4171.

MURRAY BYRNE,

Minister of Public Works.

Public Works Department,
Melbourne, 3002, 7th August, 1972.

TENDERS FOR GRAZING.

(Section 130, Land Act 1958.)

For the period 1st October, 1972, to 30th September, 1973, renewable annually for a further period where stated.

Tender forms and all particulars can be obtained on application to the Department of Crown Lands and Survey, Melbourne, or any of the Land Offices in the country.

Tenders endorsed "Tender for Grazing" must reach the Secretary for Lands, Department of Crown Lands and Survey Tender Box, State Treasury Buildings, Melbourne, 3002, at or before Noon on Wednesday, the 13th of September, 1972.

Tenders are invited and must be lodged at the Department of Crown Lands and Survey, Melbourne, at or before Noon on Wednesday, the 13th of September, 1972, for the right to depasture stock on the following unappropriated portions of lands, subject to the Regulations approved by the Governor in Council and also the subjoined conditions.

CONDITIONS.

1. The period of occupation will be from 1st October, 1972, to the 30th September, 1973, renewable annually for a further period where stated.

2. The rent for twelve months—for which the licence will be issued, and the licence fee of 75 cents, must accompany the tender; otherwise the offer of the next highest tenderer who complies with this condition may be accepted.

3. The licensee shall pay shire rates and all other charges for the period of occupation.

4. Separate tenders must be lodged for each block.

5. Tenders to be addressed to the Secretary for Lands (Department of Crown Lands and Survey Tender Box), Melbourne, 3002, and endorsed Tender for Grazing.

6. The highest or any tender not necessarily accepted.

7. Tenderers must give their full name, occupation and ordinary postal address.

8. Where permission to fence has been granted, the outgoing tenant has the option to remove any existing fencing owned by him within one month, or he may arrange with the incoming tenant to pay for it in accordance with the provisions of section 133, "Land Act 1958".

In all cases, the ingoing tenant will be held responsible for the care and maintenance of any improvements.

Licences issued will be for grazing only and will NOT authorize clearing or removal of timber or cultivation of the ground.

W. BORTHWICK,

Minister of Lands.

Department of Crown Lands and Survey,
Melbourne, 9th August, 1972.

Lot 1 (B.2116). Area 1,450 acres—

Parish of Budgee Budgee, County of Wonnangatta, being allotments 32, 33 and 34, together with Crown Land west of allotments 32 and 33. Period of occupation one (1) year from 1st October, 1972, renewable annually for four (4) years from 1st October, 1973.—(Sale 52/130.)

Lot 2 (B.2117). Area 261 acres—

Parish of Toombon, County of Tanjil, being allotment 5. Period of occupation one (1) year from 1st October, 1972, renewable annually for four (4) years from 1st October, 1973.—(Sale 115/130.)

- Lot 3 (B.2118). Area 2,900 acres—
Parishes of Mowamba and Jinderboine, County of Benambra, being grazing block 50. Period of occupation one (1) year from 1st October, 1972, renewable annually for four (4) years from 1st October, 1973.—(Omeo H.034591.)
- Lot 4 (B.2119). Area 7,000 acres—
Parish of Toonyarak, County of Croajingolong, being grazing block 57A. Period of occupation one (1) year from 1st October, 1972, renewable annually for four (4) years from 1st October, 1973.—(Bairnsdale 115/130.)
- Lot 5 (B.2120). Area 23,500 acres—
Parish of Deddick, County of Croajingolong, being grazing block 14. Period of occupation one (1) year from 1st October, 1972, renewable annually for four (4) years from 1st October, 1973.—(Bairnsdale 140/130.)
- Lot 6 (B.2121). Area 10,820 acres—
Parishes of Woongulmerang and Gelantipy East, County of Tambo, being grazing block 19. Period of occupation one (1) year from 1st October, 1972, renewable annually for four (4) years from 1st October, 1973.—(Bairnsdale 124/130.)
- Lot 7 (B.2122). Area 4,000 acres—
Parishes of Jilwain and Tabbara, County of Croajingolong, being grazing block 46. Period of occupation one (1) year from 1st October, 1972, renewable annually for four (4) years from 1st October, 1973.—(Bairnsdale 77/130.)
- Lot 8 (B.2123). Area 18,100 acres—
Parishes of Loongelaat and Orbst, County of Croajingolong, being grazing block 33. Period of occupation one (1) year from 1st October, 1972, renewable annually for four (4) years from 1st October, 1973.—(Bairnsdale 93/130.)
- Lot 9 (B.2124). Area 13,360 acres—
Parish of Ingeegoodbee, County of Tambo, being grazing block 2. Period of occupation one (1) year from 1st October, 1972, renewable annually for four (4) years from 1st October, 1973.—(Bairnsdale 265/130.)
- Lot 10 (B.2125). Area 18,400 acres—
Parish of Yalmy, County of Croajingolong, being grazing block 23. Period of occupation one (1) year from 1st October, 1972, renewable annually for four (4) years from 1st October, 1973.—(Bairnsdale 158/130.)
- Lot 11 (B.2126). Area 7,750 acres—
Parish of Jingallala, County of Croajingolong, being grazing block 3. Period of occupation one (1) year from 1st October, 1972, renewable annually for four (4) years from 1st October, 1973.—(Bairnsdale 14/130.)
- Lot 12 (B.2127). Area 18,000 acres—
Parish of Brindat, County of Croajingolong, being grazing block 76. Period of occupation one (1) year from 1st October, 1972, renewable annually for four (4) years from 1st October, 1973.—(Bairnsdale 271/130.)
- Lot 13 (B.2128). Area 513 acres—
Parish of Deddick, County of Croajingolong, being allotment 3A. Period of occupation one (1) year from 1st October, 1972, renewable annually for four (4) years from 1st October, 1973.—(Bairnsdale 333/130.)
- Lot 14 (B.2129). Area 11,700 acres—
Parish of Ingeegoodbee, County of Tambo, being grazing block 1. Period of occupation one (1) year from 1st October, 1972, renewable annually for four (4) years from 1st October, 1973.—(Bairnsdale 264/130.)
- Lot 15 (B.2130). Area 10,900 acres—
Parishes of Onyim and Bullumwaal, County of Dargo, being grazing block 33. Period of occupation one (1) year from 1st October, 1972, renewable annually for four (4) years from 1st October, 1973.—(Bairnsdale 0718/130.)
- Lot 16 (B.2131). Area 41,500 acres—
Parish of Tingaringy, County of Croajingolong, being grazing block 17. Period of occupation one (1) year from 1st October, 1972, renewable annually for four (4) years from 1st October, 1973.—(Bairnsdale 0714/130.)
- Lot 17 (B.2131). Area 75 acres—
Parish of Warmur, County of Borung, being Conservation of Water Reserve allotment 78A. Period of occupation one (1) year from 1st October, 1972.

NOTE.—The area occupied by the Country Fire Authority and the road on the east of the area are not included.—(St. Arnaud W.88926.)

- Lot 18 (B.2132). Area 3½ acres—
Township of Sebastopol, Parish of Ballarat, County of Grenville, being Crown Land adjoining allotment 1, section 3, formerly occupied by P. Block. Period of occupation one (1) year from 1st October, 1972, renewable annually for four (4) years from 1st October, 1973.—(Ballarat 491/130.)
- Lot 19 (B.2133). Area 570 acres—
Parish of Weecurra, County of Normanby, being allotment 42 of section A. Formerly occupied by S. T. Smith. Period of occupation one (1) year from 1st October, 1972, renewable annually for four (4) years from 1st October, 1973.—(Hamilton 02298/130.)
- Lot 20 (B.2134). Area 215 acres—
Parish of Murrandarra, County of Lowan, being allotment 16. Period of occupation one year from 1st October, 1972, renewable for one year from 1st October, 1973.—(Hamilton 02361/130.)
- Lot 21 (B.2135). Area 270 acres—
Parish of Yering, County of Evelyn, being allotment B2 of section 4. Formerly held by J. H. Roberts. Period of occupation one (1) year from 1st October, 1972, renewable annually for two (2) years from 1st October, 1973.

Permission to fence at licensee's risk will be given. One month allowed for outgoing licensee to remove fences erected by him.

The Department reserves the right to grant access to any person for the purpose of keeping existing drains clear.

The licensee agrees to pay for the Department's cost of vermin and noxious weeds control on the following scale:—

1st Year \$1,268.80.
2nd Year \$951.60.
3rd Year \$634.40.—

(Metropolitan 01645/130.)

PRIVATE ADVERTISEMENTS

CITY OF BENDIGO.

LOAN No. 66.

Notice of Intention to Borrow the Sum of \$50,000 for Permanent Works and Undertakings.

Notice is hereby given that the Council of the City of Bendigo proposes to borrow the principal sum of Fifty thousand dollars, secured by a charge over the general rates of the municipality, such sum to be raised by the grant of a mortgage in accordance with the provisions of the *Local Government Act 1958*.

1. The maximum rate of interest that may be paid is currently 6.3 per cent. per annum.

2. The loan is to be applied for the purpose of part cost of construction of a new Regional Library Building (total estimated cost \$420,000).

3. The period of the loan shall be fifteen years.

4. The moneys borrowed shall be repayable by providing out of the municipal fund thirty (30) equal amounts each of approximately \$2,600.67, principal and interest payable half-yearly. The first instalment shall be payable within six months of the loan being received, and subsequent half-yearly instalments will be payable at six monthly intervals thereafter.

5. Such moneys shall be payable to the Commonwealth Savings Bank of Australia, Bendigo.

The plans and specifications and estimate of the cost of the proposed works, and a statement showing the proposed expenditure of the moneys to be borrowed, are open for inspection at the Municipal Offices, Bendigo.

7674

V. G. ROBSON, Acting Town Clerk.

CITY OF CAMBERWELL.

LOAN No. 93.

Notice of Intention to Borrow the Sum of \$50,000.

Notice is hereby given that the Council of the City of Camberwell proposes to borrow the sum of \$50,000, secured by a charge over the general rates of the municipality, such sum to be raised by the grant of a mortgage in accordance with the provisions of the *Local Government Act 1958*.

1. The maximum rate of interest that may be paid is 6.30 per centum per annum.

2. The loan is to be applied to the liquidation of the principal moneys owing on account of a previous loan.

3. The period of the loan shall be fifteen years.

4. The moneys borrowed shall be repayable by providing out of the municipal fund 30 half-yearly instalments of approximately \$2,600.67 each, including principal and interest, on the 10th March and 10th September, during the currency of the loan. The first instalment shall be payable on the 10th March, 1973.

5. Such moneys shall be repayable to the Commercial Savings Bank of Australia Limited, at the Head Office of the Bank in Melbourne, or at such other place as the said Bank may require.

Dated 24th July, 1972.

7670

L. F. CHEFFERS, Chief Administrator.

CITY OF CAMBERWELL.

LOAN No. 92.

Notice of Intention to Borrow the Sum of \$100,000 for Permanent Works and Undertakings.

Notice is hereby given that the Council of the City of Camberwell proposes to borrow the sum of \$100,000, secured by a charge over the general rates of the municipality, such sum to be raised by the grant of a mortgage in accordance with the provisions of the *Local Government Act 1958*.

1. The maximum rate of interest that may be paid is 6.30 per centum per annum.

2. The purposes for which the loan is to be applied are as follows:—

(a) Council's Proportion C.R.B. Works, balance of "construction to Commence" costs, Camberwell Junction By-Pass. . .	\$28,498
(b) Myrtle Park Pavilion, balance of costs	12,000
(c) City Hall Air Conditioning, balance of costs	20,000
(d) New Pavilion, Howard Dawson Reserve	21,500
(e) Car Parks and Access Roads Construction, part cost	12,002
(i) Gordon Barnard Reserve, extension of parking area between pavilion and Youth Centre	
(ii) Completion of parking area/access road off Carrington-street, Stage 3	
(iii) Canterbury Sports Ground, part cost parking area adjacent to pavilion, Guildford-road	
(f) City Hall Public Address System, part cost	6,000
	\$100,000

3. The period of the loan shall be fifteen years.

4. The moneys borrowed shall be repayable by providing out of the municipal fund 30 half-yearly instalments of approximately \$5,201.35 each, including principal and interest, on the 10th March and 10th September, during the currency of the loan. The first instalment shall be payable on the 10th March, 1973.

5. Such moneys shall be repayable to the Commercial Savings Bank of Australia Limited at the Head Office of the Bank in Melbourne, or at such other place as the said Bank may require.

6. The plans and specifications and the estimate of the cost of the proposed expenditure of the moneys to be borrowed, are open for inspection at the Offices of the Council, City Engineer's Department, Camberwell and Inglesby roads, Camberwell, during office hours.

Dated 24th July, 1972.

7669

L. F. CHEFFERS, Chief Administrator.

CITY OF CAULFIELD.

CITY OF CAULFIELD BY-LAW No. 151.

A by-law of the City of Caulfield made under Section 197 of the *Local Government Act 1958* and numbered 151 for the purpose of regulating the proceedings of Council and Committee Meetings and other meetings conducted by the City of Caulfield, and for other purposes.

In pursuance of the powers conferred by the *Local Government Act 1958* and of any and every set power it thereunto enabling the Mayor Councillors and citizens of the City of Caulfield orders as follows:—

1. This By-Law is known as the Proceedings of Council By-Law.

2. By-Law No. 134 of the City of Caulfield is hereby repealed.

3. This By-Law shall apply to and have operation throughout the whole of the municipal district.

4. In this By-Law unless inconsistent with the context or subject matter—

"Committee" means a standing committee or an occasional committee of the Council and to the extent applicable includes the Council in committee of the whole; "Officer" means an officer appointed by the Council.

Business to be Considered.

5. No business shall be considered at any Ordinary or Special Meetings of the Council or any meetings of the Council's Standing Committees unless it appears on the agenda or in any report accompanying same except:—

- (a) if the matter has been referred to the Council by a Committee which has met earlier on the same day;
- (b) if the matter has arisen since the presentation of the agenda and reports and is of such importance that a decision of the Council cannot be delayed, and the matter submitted to Council is read either in the form of a supplementary agenda or report by the Town Clerk so that it may be incorporated in the Minutes of the Council which must resolve it to be urgent and therefore may be considered without notice.

6. A copy of the agenda paper for every Council and Standing Committee Meeting together with all reports to be considered at the Meeting, shall be delivered or sent by post or otherwise to the place of abode or to the usual place of business (if any) within the municipal district of each Councillor at least 48 hours before the time fixed for the holding of that particular meeting.

Admission of the Public.

7. The business of the Council shall be conducted at all Ordinary Meetings of the Council with open doors but the majority of the members present at such a Meeting may resolve that any question shall be considered in Committee of the whole and a motion to that effect may be moved without previous notice and if carried the Council shall thereupon resolve itself into Committee of the whole.

8. Members of the public shall be excluded from meetings of the Council as a Committee of the whole and from Committee meetings.

Council Meetings.

9. In all cases not provided for by this By-Law resort shall be had to the rules, forms and usages of parliament which shall be followed so far as the same are applicable to the proceedings of the Council.

Confirmation of Minutes.

10. At every meeting of the Council the first business shall subject to the proviso hereto be the reading of the minutes of the proceedings at the preceding meeting and putting a question for the confirmation thereof provided that if all councillors present indicate that they have received a copy of such minutes the reading thereof may be dispensed with.

11. No discussion shall be permitted on these Minutes except as to their accuracy as a record of the proceedings, and the said Minutes shall then be signed as required by Law.

Order of Business.

12. After the signing of the Minutes the order of business for an Ordinary Meeting of the Council shall be as follows, or as near thereto as may be practicable, but for the greater convenience of the Council at any particular Meeting thereof, it may be altered by resolution to that effect:—

- I. The resumption of debate on motions or Orders of the Day lapsed at previous Meeting.
- II. Declaration of Councillors of any direct or indirect pecuniary interests in items listed for consideration on the agenda.
- III. Considering and Ordering upon Inward Correspondence referred to in Clause 14 hereof.
- IV. The Reception and Reading of Petitions and Memorials.
- V. The presentation of Committee Reports.
- VI. Payment of Accounts.
- VII. Consideration of Ordinary Business.
- VIII. Questions with or without notice.
- IX. Orders of the Day, including subjects continued from proceedings of former meetings.

- X. Consideration of any matter or class of matters which might be delegated to a Committee or to an Officer.
 - XI. Extraordinary Business.
 - XII. Other motions of which previous notice has been given.
 - XIII. Notices of Motion.
13. The order of business at a Special Meeting of the Council shall be the order in which such business stands in the notice thereof.

Correspondence.

14. The Town Clerk shall prepare and place before each Meeting of the Council or the appropriate Committee a summary of the correspondence to be considered at such meeting.

Petitions and Memorials.

15. It shall be incumbent upon every Councillor presenting a petition to acquaint himself with the contents thereof and to ascertain that it does not contain language disrespectful to the Council and that the contents do not violate any By-Law or any provision thereof.

16. Every Councillor presenting a petition to the Council shall write his name at the beginning thereof.

17. Every petition shall be signed by the persons whose names are appended thereto by their names or marks and by no-one else except in cases of incapacity by sickness.

18. No letters, affidavits or other such documents shall be attached to any petition.

19. Every Councillor presenting a petition to the Council shall confine himself to a statement of the persons from whom it comes, of the number of signatures attached to it, of the material allegations contained in it and to the reading of the Prayer thereof.

20. No motion except that for receiving same shall, unless what the Council considers urgent circumstances, be made on any petition, memorial or other like application until the next Meeting of the Council after that at which it has been presented.

Committee Reports.

21. The Town Clerk shall cause a report of each Committee Meeting to be prepared prior to the holding of each Ordinary Meeting of the Council.

22. Meetings of all proceedings of Committee shall be entered in the Committees' Minute Book and signed by the Chairman of the Committee who shall present the Report to the next Ordinary Meeting of the Council.

23. Committee Reports presented to Council shall be submitted in two parts:—

- (a) A schedule of decisions made and acted upon in the exercise of any power delegated by the Council, and
- (b) A summary of items and recommendations therein where the decision is to be made by the Council.

24. (a) The Council shall formally ratify the decisions made by a Committee and included in its report pursuant to Clause 23 (a) hereof.

(b) The Council may adopt the whole of the recommendations made by a Committee pursuant to Clause 23 (b) hereof, and contained in its report or may adopt such recommendations other than that or those specified and may vary or reject any specified recommendation.

25. Upon the adoption of the Report by the Council, each decision made and acted upon and each recommendation contained in the Report as adopted, shall be treated in Law as being a resolution of the Council.

Ordinary Business.

26. A Councillor at any ordinary meeting of the Council may raise for the consideration of the Council a matter of which a notice of motion has not been given provided however that unless a majority of the Councillors present at such Meeting agree no such matter shall be raised if a resolution of the Council therein is to be sought.

Questions with and without Notice.

27. Every Councillor present at every Ordinary Meeting of the Council shall be given the opportunity of asking questions either with or without notice of any other Councillor present or any member of the Council's staff, and if such questions to such officers cannot be answered then it shall be incumbent upon the Town Clerk to ascertain the answer thereto in order that it may be read by the Chairman at the next Ordinary Meeting of the Council.

28. Questions upon Notice shall be notified to the Town Clerk at least five days before the time fixed for holding of the next Ordinary Meeting of the Council.

29. All questions and answers shall be as brief as possible and discussion on any question or answer may be allowed only at the discretion of the Chairman.

30. A question may be disallowed by the Chairman upon the ground that it:—

- (a) relates to a matter ultra vires the Council;
- (b) is defamatory, indecent, abusive or objectionable in language or obscene;
- (c) is repetitive of a question already answered whether at the same or an earlier Meeting;
- (d) is asked to embarrass a fellow Councillor or the Officer concerned.

Consideration of Matters of Delegation.

31. It shall be competent for any Committee or for the Town Clerk to submit for consideration by the Council the delegation (with or without direction or limitation) of any matter or class of matter to a Committee or to an Officer.

Notices of Motion.

32. All notices of motion (where notice of motion is required by Law to be given) shall be dated and numbered and given by the intending mover, to the Town Clerk at the close of the Meeting of Council or at such time before the next Ordinary Meeting of the Council as will permit the Town Clerk to give notice thereof in the manner and in the time required for Special Meetings, and the Town Clerk shall enter the same in the Notices of Motion Book in the order in which they are given.

Motions and Amendments.

33. A motion moved at a Meeting of the Council need not be reduced in writing by the mover unless the Chairman of the Meeting so directs.

34. The Town Clerk shall cause to be recorded in the Rough Minutes and the Minutes of the Council all motions given and seconded at a Meeting of the Council.

35. A motion or amendment shall be:

- (a) within the powers of the Council;
- (b) relevant to the item of business properly before the Council.

36. A motion or amendment which is not seconded lapses.

37. No motion or amendment shall be withdrawn without the leave of the Council.

38. No motion or amendment shall be discussed or put to the vote by the Council unless it is seconded, but a Councillor may require the endorsement of any Standing Order of the Council by directing the Chairman's attention to the infraction thereof.

39. A Councillor moving a motion shall be held to have spoken thereon but a Councillor merely seconding a motion shall not be held to have spoken upon it.

40. No Councillor shall speak a second time on the same question unless entitled to reply or in explanation when he has been misrepresented or misunderstood.

41. The mover of every original proposition or any amendment thereto shall have a right of reply, to be exercised at the conclusion of the debate.

42. The Councillors present at a Meeting of Council shall designate each other by their official titles and stand when addressing the Council.

43. If two or more Councillors rise to speak at the same time the Chairman shall decide which Councillor is entitled to priority.

Points of Order.

44. The Chairman when called upon to decide on points of order or practice, shall state the provision, rule or practice which he deems applicable to the case without discussing or commenting on same, and his decision as to order or explanation in each case shall be final.

45. No Councillor shall digress from the subject matter of the question under discussion and all imputations of improper motives and all personal reflections on Councillors shall be deemed highly disorderly, and such remarks shall be withdrawn by the offending Councillor when required by the Chairman and a satisfactory apology made to the Council.

46. A Councillor using offensive or disorderly language or having been twice called to order or to withdraw or apologise for such conduct and refusing so to do, shall be guilty of an offence.

Voting.

47. The Council shall vote by show of hands and any Councillor present and not voting, not being disabled by Law from so doing, shall be guilty of an offence.

48. The Chairman shall in taking the sense of the Council, put the question first in the affirmative then in the negative and the result thereof shall be recorded in the Minutes.

49. No second or subsequent amendment, whether upon the original proposition or on an amendment, shall be taken into consideration until the previous amendment is disposed of.

50. If an amendment be negatived, then a second may be moved to the question to which the first-mentioned amendment was moved.

Motion for Adjournment.

51. No discussion shall be allowed on any motion for adjournment of the Council but if on the question being put the motion is negatived, the subject then under discussion or next on the notice paper shall be discussed, or any other that may be allowed precedence before any subsequent motion for adjournment, be met.

Protests.

52. Any Councillor may protest against any resolution of the council and notice of intention to protest shall in every case be given forthwith on the adoption of the resolution protested against, and the protest shall specify the reason for protesting and shall be entered three days at least before the next Ordinary Meeting of the Council by the protesting Councillor in a book to be kept for that purpose in the office of the Town Clerk and signed by such Councillor and shall also be entered in the Minutes of the Meeting at which notice of intention to protest is given previously to the confirmation thereof but such protest may be expunged from the Minutes if declared by a majority of the Council to be not in accordance with truth or in its terms disrespectful to the Council.

Lapsed Question.

53. If a debate on any Motion or Order of the Day be interrupted by a number of Councillors present becoming insufficient for the transaction of business, such debate may be resumed at the next Meeting of the Council at the point where it was interrupted.

Committees.

54. The Council shall each year appoint Standing Committees and shall determine the number of Councillors (other than the Mayor) of which each such Standing Committee shall consist and the purposes of each such Standing Committee.

Committee Chairman.

55. Each such Committee shall appoint its own Chairman, and the Chairman or other member of the Committee acting as such for the occasion shall, in the case of an equality of votes, be entitled to a second or casting vote. In the event of the Council appointing more than one Standing Committee no Councillor shall be appointed Chairman of more than one such Committee.

56. The Town Clerk shall convene every Committee within 10 days of its first appointment or at any other time thereof by Order of the Council or on the written order of the Chairman or any two members of the Committee.

Common Seal.

57. The Common Seal of the Council shall be kept by the Town Clerk in a safe place and shall not be affixed to any document except by the authority of the Council and in the presence of one Councillor and the Town Clerk.

Staff.

58. No appointment to any senior position at the disposal of the Council shall take place until 7 clear days public notice has been given by advertisement in one or more newspapers circulating in the Municipal District, inviting applications from qualified candidates for such position.

59. The initial salary and/or allowance to be paid for such positions shall be fixed prior to the appointment of any person to fill that vacancy.

60. No Councillor or Officer of the Council and no auditor of the Municipality shall be received as a surety for any Officer appointed by the Council or for any work to be done for the Council.

61. A Council Officer may make a brief statement at a Council or Committee Meeting in respect of any statement (whether made at a Council Meeting or not) affecting him as an Officer or any Officer under his control.

62. A statement under Clause 61:—

- (i) in respect of a statement made by a Councillor or Officer at a Council or Committee Meeting shall be made immediately the Councillor or Officer resumes his seat; and
- (ii) in respect of a statement made other than at a Council or Committee Meeting shall be made at such time during the Meeting as the Chairman determines to be appropriate.

Disbursement of Monies.

63. It shall be lawful for the Accountant of the Municipality from time to time on a written order of the Town Clerk, to disburse such monies as have been appropriated by the Council for the purpose of this clause and as are required for any necessary occasion not exceeding in the whole in any interval between two Ordinary Meetings of the Council the sum of \$100.00.

Suspension of Standing Orders.

64. Any one or more of the rules or regulations contained in this By-Law may be suspended for a special purpose if notice of motion is duly given and shall not otherwise be suspended except by an unanimous vote by the whole of the Councillors present at the Meeting.

Public Works and Services.

65. (i) Subject as is hereinafter provided plans and specifications for any public work shall be laid before the Council at least 6 days prior to the same being considered and ordered upon and be open for inspection by any ratepayer during that time.

(ii) Notwithstanding anything hereinbefore provided plans and specifications for public works which the Council may resolve to be urgent may be considered and ordered upon at any Meeting of the Council.

Penalty.

66. Every person guilty of any wilful act or default contrary to this By-Law shall be liable to a penalty not exceeding \$100.00.

The Resolution for passing this By-Law was agreed to by the Council on the 4th July, 1972, and confirmed on the 1st August, 1972.

The common seal of the Mayor, Councillors and Citizens of the City of Caulfield was hereunto affixed in the presence of:

7668 F. A. ARDEN, Councillor.
B. MORAN, Town Clerk.

CITY OF ECHUCA.

LOAN No. 65.

Notice of Intention to Borrow.

Notice is hereby given that the Council of the City of Echuca intends to borrow Thirty-four thousand dollars (\$34,000), secured by a charge over the general rates of the municipality by the grant of a mortgage in accordance with the provisions of the *Local Government Act 1958*, as amended.

In connexion therewith the following information is stated:—

- (a) The amount of the principal moneys which it is proposed to borrow is \$34,000.
- (b) The maximum rate of interest that may be paid is \$6.3 per centum per annum.
- (c) The times at which the moneys borrowed are to be repayable are the 1st day of April and the 1st day of October during the years 1973 to 1987 inclusive, and the place where such moneys shall be repayable is the Bank of New South Wales, Echuca.
- (d) The purpose for which the loan is to be applied is:—
Purchase of land as authorized under section 393 of the *Local Government Act*.
- (e) The manner in which the loan is to be liquidated is by the provision out of the municipal fund in each half-year, during the currency of the loan of the sum of \$1,768.46, which includes principal and interest.

The plans and specifications and estimate of the cost of the works and a statement showing the proposed expenditure of the moneys to be borrowed are open for inspection at the office of the Council of the City of Echuca, at the corner of Hare and Heygarth streets, Echuca.

Dated this 4th day of August, 1972.

7690 K. F. McCARTNEY, Town Clerk.

CITY OF ESSENDON.

LOAN No. 77.

Notice of Intention to Borrow the Sum of \$40,000 for Permanent Works and Undertakings.

Notice is hereby given that the Council of the City of Essendon proposes to borrow the principal sum of Forty thousand dollars, secured by a charge over the general rates of the municipality, such sum to be raised by the grant of a mortgage in accordance with the provisions of the *Local Government Act 1958* (as amended).

(1) The maximum rate of interest that may be paid is 6.40 per centum per annum.

(2) The purpose for which the loan is to be applied is as follows:—

Improvement to Reserves—\$40,000.

(3) The period of the loan shall be twenty years.

(4) The moneys borrowed shall be repayable by providing out of the municipal fund 40 half-yearly instalments of approximately \$1,786.88 each, including principal and interest on the 10th day of September and the 10th day of March, during the currency of the loan. The first instalment shall be payable on the 10th day of March, 1973.

(5) Such moneys shall be repayable at the office of the Commercial Bank of Australia, Melbourne.

The plans and specifications and the estimate of the cost of the proposed works, and a statement showing the proposed expenditure of the moneys to be borrowed, are open for inspection at the Town Hall, Moonee Ponds.

J. P. SCOTT, Town Clerk.

Town Hall, Moonee Ponds, 3039.

7737

CITY OF ESSENDON.

LOAN No. 78.

Notice of Intention to Borrow the Sum of \$60,000 for Permanent Works and Undertakings.

Notice is hereby given that the Council of the City of Essendon proposes to borrow the principal sum of Sixty thousand dollars, secured by a charge over the general rates of the municipality, such sum to be raised by the grant of a mortgage in accordance with the provisions of the *Local Government Act 1958* (as amended).

(1) The maximum rate of interest that may be paid is 6.20 per centum per annum.

(2) The purpose for which the loan is to be applied is as follows:—

Construction of Infant Welfare Centre	\$30,000
Town Planning Land Purchase	30,000
	<u>\$60,000</u>

(3) The period of the loan shall be ten years.

(4) The moneys borrowed shall be repayable by providing out of the municipal fund 20 half-yearly instalments of approximately \$4,070.32 each, including principal and interest on the 10th day of September and the 10th day of March, during the currency of the loan. The first instalment shall be payable on the 10th day of March, 1973.

(5) Such moneys shall be repayable at the office of the Commercial Bank of Australia, Melbourne.

The plans and specifications and the estimate of the cost of the proposed works, and a statement showing the proposed expenditure of the moneys to be borrowed, are open for inspection at the Town Hall, Moonee Ponds.

J. P. SCOTT, Town Clerk.

Town Hall, Moonee Ponds, 3039.

7738

CITY OF FOOTSCRAY.

LOAN No. 115.

Notice of Intention to Borrow the Sum of \$25,000 for Permanent Works and Undertakings.

Notice is hereby given that the Council of the City of Footscray proposes to borrow the sum of Twenty-five thousand dollars (\$25,000), secured by a charge over the general rates of the municipality, such sum to be raised by the grant of a mortgage in accordance with the provisions of the *Local Government Act 1958*.

1. The maximum rate of interest that may be paid is 6.3 per centum per annum.

2. The period of the loan shall be fifteen (15) years.

3. The loan is to be liquidated by providing out of the municipal fund by 30 equal half-yearly instalments of \$1,300.34, including principal and interest, payable on

the 1st day of April and the 1st day of October in each year, during the currency of the loan. The first instalment shall be payable on the 1st day of April, 1973.

4. Such moneys shall be repayable at the office of the Commercial Bank of Australia Limited, Melbourne.

5. The purpose for which the loan is to be applied is part purchase of the under-mentioned land:—

First.—Lots 1 and 2 on plan of subdivision No. 69184 and being the whole of the land comprised in certificates of title, volume 8578, folio 697 and volume 8578, folio 696.

Secondly.—Part of lot 1 and part of lot 2 on plan of subdivision No. 51447 and being the whole of the land comprised in certificates of title, volume 8281, folio 431 and volume 8564, folio 685.

Thirdly.—Part of Crown allotment J, section 14 and being the whole of the land comprised in certificate of title, volume 7507, folio 057.

The plans and specifications and the estimate of the cost of the proposed works, and a statement showing the proposed expenditure of the moneys to be borrowed, are open for inspection at the Town Hall, Footscray.

Dated this 8th day of August, 1972.

7745

W. H. SWABY, Town Clerk.

CITY OF FOOTSCRAY.

LOAN No. 116.

Notice of Intention to Borrow the Sum of \$100,000 for Permanent Works and Undertakings.

Notice is hereby given that the Council of the City of Footscray proposes to borrow the sum of One hundred thousand dollars, secured by a charge over the general rates of the municipality, such sum to be raised by the grant of a mortgage in accordance with the provisions of the *Local Government Act 1958*.

1. The maximum rate of interest that may be paid is 6.4 per centum per annum.

2. The period of the loan shall be 40 years.

3. The loan is to be liquidated by providing out of the municipal fund 80 equal half-yearly instalments of \$3,480.03, including principal and interest, payable on the 21st day of January and the 21st day of July in each year, during the currency of the loan. The first instalment shall be payable on the 21st day of January, 1973.

4. Such moneys shall be repayable at the Office of Australian Mutual Provident Society, 535 Bourke-street, Melbourne.

5. The purpose for which the loan is to be applied is part purchase of the under-mentioned land:—

First.—Lots 1 and 2 on plan of subdivision No. 69184 and being the whole of the land comprised in certificates of title, volume 8578, folio 697 and volume 8578, folio 696.

Secondly.—Part of lot 1 and part of lot 2 on plan of subdivision No. 51447 and being the whole of the land comprised in certificates of title, volume 8281, folio 431 and volume 8564, folio 685.

Thirdly.—Part of Crown allotment J, section 14 and being the whole of the land comprised in certificate of title, volume 7507, folio 057.

The plans and specifications and the estimate of the cost of the proposed works, and a statement showing the proposed expenditure of the moneys to be borrowed, are open for inspection at the Town Hall, Footscray.

Dated this 8th day of August, 1972.

7746

W. H. SWABY, Town Clerk.

CITY OF KNOX.

Whereas the Council of the City of Knox deems it expedient to execute the work or undertaking of providing the land described hereunder for provision of a site for a pre-school and infant welfare centre and whereas for the purpose thereof the exercise of the power of taking land compulsorily will in the opinion of the Council be necessary and desirable and whereas the Council has caused to be prepared maps and other papers showing a general description of the work or undertaking for which the land proposed to be taken is to be used, a description of the lands proposed to be taken and the names of the owners or reputed owners lessees reputed lessees mortgagees occupiers of such lands so far as those names are known to or can be ascertained by the Council and whereas such maps and other papers are deposited at the office of the said Council situate at Fern Tree Gully and are open for inspection by all persons affected by the proposed taking of lands during normal office hours for the space of

40 clear days after the publication of this notice in the *Government Gazette*, now notice is hereby given to all persons affected by the proposed taking of the said land to set forth, in writing, addressed to the Council or the Town Clerk within 40 clear days of the publication of this notice in the *Government Gazette*, all objections which they may have to the taking of the said land.

THE LAND REFERRED TO:

Lots 148/149, lodged plan 24991, McIver-street, Fern Tree Gully.

Lots 183/184, lodged plan 24991, Roberts-street, Fern Tree Gully.

Dated this 2nd day of August, 1972.

By Order of the Council,

7679 N. G. HAYNES, Town Clerk.

CITY OF MELBOURNE.

Local Government Act 1958 (as amended).

COMPULSORY TAKING OF THE LAND DESCRIBED BELOW.

Notice that Maps and Other Papers, etc., are Deposited for Inspection and the Place where they are so Deposited.

Notice is hereby given that it is the intention of the Council of the City of Melbourne to compulsorily take the leasehold land generally known as No. 142 Swanston-street, Melbourne, and described in certificate of title, volume 7834, folio 037.

General description of the work or undertaking for which the land proposed to be taken is to be used:—

For incorporation into the City Council's Administrative Building Project to be constructed on land generally known as Nos. 134-142 Swanston-street, and Nos. 216-250 Little Collins-street.

Such maps and other papers as may be necessary to show the general description of the work or undertaking for which the land proposed to be taken is to be used, the description of the land proposed to be taken and the names of the owners or reputed owners lessees or reputed lessees mortgagees and occupiers of such land so far as those names are known to or can be ascertained by the Council are deposited and will open for inspection by all persons interested at the Office of the Town Clerk, 1st Floor, Town Hall, Swanston-street, Melbourne, between the hours of 9.00 a.m. and 4.30 p.m. on weekdays for the space of 40 clear days from the day of publication of this notice in the *Government Gazette*, within which time all persons affected by the proposed taking of the land set out above are hereby required to set forth, in writing, addressed to the Council or the Town Clerk, all objections which they may have to the taking of the land.

Dated this 8th day of August, 1972.

7744 F. H. ROGAN, Town Clerk.

No. 1666.

CITY OF NUNAWADING.

REGULATIONS FOR THE PROPER MANAGEMENT AND CONTROL OF LIBRARIES.

Regulation No. 3.

A Regulation of the City of Nunawading Numbered 3 made under Section 2 of Part IV of the Fifteenth Schedule of the *Local Government Act 1958* in force in the City of Nunawading by virtue of a bylaw of the Shire of Blackburn and Mitcham Numbered 4 for the proper management and control of libraries belonging to the City of Nunawading or under the management and control of the Council.

In pursuance of the powers conferred by the *Local Government Act 1958*, the Mayor Councillors and Citizens of the City of Nunawading makes the following regulation which shall apply to and have operation throughout the whole of the municipal district.

(1) In these Regulations unless inconsistent with the context or subject matter—

- (a) "Council" means the Council of the City of Nunawading.
- (b) "Municipality" means the municipal district of the City of Nunawading.
- (c) "Library" means any library or library vehicles belonging to the City of Nunawading or under the management or control of the Council and the several rooms, offices, passages, entrances and exits forming part thereof and adjacent thereto.
- (d) "Book" includes any book periodical newspaper pamphlet magazine picture print map chart photograph plan manuscript record tape film strip or slide or any other article of a like nature forming part of the contents of a library.

(e) "Registered Reader" or "Reader" means a person to whom a reader's card has been issued in accordance with these Regulations. The expression "Reader" unless the context otherwise requires also includes a person who enters any reference or reading room.

(f) "Librarian" means and includes the City Librarian or any person duly authorised on his or her behalf.

(2) Every library shall have as its aim the encouragement of all individuals and groups who seek information, inspiration or recreation from printed or recorded material. The Council subscribes to the Library Association of Australia's current "Statement of principles on freedom to read", the conditions of which are observed in the Library's acquisition policy.

(3) The Library shall be for the use of persons who pay rates to and/or who live, work or attend schools in the Municipality of Nunawading, provided that before borrowing any books or other material, they shall have completed an enrolment form prescribed by the Council and been issued with a reader's card.

(4) Books may be lent to other libraries within the provisions of the Municipal Inter-Library Committee (Victoria) or to registered readers visiting from other municipalities with reciprocal arrangements, at the discretion of the Librarian.

(5) The Librarian has the responsibility of administering the service equally and without favour to all eligible persons, according to Council's policy and within the scope of the above statements.

(6) No charge shall be made for the use or borrowing of library books or other material.

(7) The Library will be open at such times as the Council may determine. The Council reserves the right to amend as necessary the days and hours of opening.

(8) The Council, through the Librarian shall have the right to levy charges to cover stationery and mailing costs where postage is needed, e.g. the reservation of books. It may also charge for any extra service which may be provided from time to time, e.g. printed catalogues, photocopies, gramophone records. A charge may also be made for the replacement of any reader's ticket or token, or any other item used in the borrowing of books.

(9) (a) A book shall be for the exclusive use of the person to whom it is issued, and that person shall be responsible for the care and safe return of the book or other material to the library within the time specified by the rules then in force. Fines and the cost of any reminders sent may be charged for overdue books but there is no obligation on the Librarian to send any such reminders. If the Library property is not returned, or proper restitution made when requested, the Council reserves the right to take legal action, and authorise the Librarian to take any reasonable precaution to protect Council property.

(b) The issue of a book is a confidential transaction between the library and the reader.

(10) In the event of the loss of or damage to a book, the reader to whom the book was issued shall pay a charge based on the cost of replacement or shall compensate the Council for the damage or loss as assessed by the Librarian.

(11) Regardless of any amount paid in fines for overdue, damaged or lost books, the book shall remain the property of the Council.

(12) A book is not to be considered "returned" to the Library unless it has been handed to a Librarian and any records discharged. Although the Librarian will attempt to deal with books returned by post or messenger, the reader may still be held responsible in the event of loss.

(13) The condition of a book on its return to the library is the responsibility of the person who returns it. Readers should therefore report to the Librarian any damage to a book before borrowing it.

(14) To maintain good service and a pleasant atmosphere the co-operation of readers is sought, and the Librarian is authorised to exclude from the use of the library persons who default in the return and treatment of books or whose conduct in or around the library may cause annoyance to readers or staff.

Conduct specifically prohibited includes being offensively unclean, smoking, taking part in loud or objectionable conversation, bringing dogs (except a Guide for the Blind) or other animals into the library, eating or sleeping in the library; entering and remaining in areas provided for the staff and their work, or in the library after hours of closing, obstructing the staff or other readers, refusing to observe

routines for the correct borrowing and return of books, marking, soiling, tracing, or defacing in any way books, periodicals or other library property.

The decision as to whether or not a nuisance is being created shall be the responsibility of the Librarian and staff.

(15) The council shall have no responsibility for any mishap which may occur in or around the public toilets, or on the public approaches to the Library and the surrounding parkland.

(16) The Council shall have no responsibility for bicycles, prams or other property left outside the Library, nor for private property left in the Library.

(17) Special collections are provided for children to the age of 14, but no blame shall be attached to the library if they borrow books which in some opinions, are unsuitable for youth.

If parents believe that adolescents' reading should be censored, the parents must be the censors, not the Library.

Offence.

(18) Any person who commits any offence against these Regulations shall, on being requested by the Librarian to do so, leave the library, and shall not thereafter, without the permission of the Librarian, enter or use the Library.

(19) Notwithstanding any other provision of these Regulations any person who is in the Library shall give his name and address to the Librarian on being requested by the Librarian to do so.

Resolution for passing this Regulation was agreed to by the Council of the City of Nunawading on the 19th day of June, 1972, and confirmed on the 10th day of July, 1972.

The Corporate Seal of the Mayor, Councillors, and Citizens of the City of Nunawading was hereunto affixed in the presence of—

D. P. GAWLER, Mayor.
F. R. TAYLOR, Councillor.
J. H. BROWN, Town Clerk.

7661

CITY OF SALE.

LOAN No. 64.

Notice of Intention to Borrow.

Notice is hereby given that the Council of the City of Sale intends to borrow Six thousand five hundred dollars (\$6,500), secured by a charge over the general rates of the municipality by the grant of a mortgage in accordance with the provisions of the Local Government Acts.

In connexion therewith the following information is stated:—

(a) The amount of the principal moneys which it is proposed to borrow is \$6,500.

(b) The maximum rate of interest that may be paid is 6.2 per centum per annum.

(c) The times which the moneys borrowed are to be repayable are the 15th day of March and the 15th day of September during the years 1973-1982 inclusive, and that the place such moneys shall be repayable is at the Bank of New South Wales, Sale.

(d) The purpose for which the loan is to be applied is:—

Part cost of purchase of land for decentralised industry.

(e) The manner in which the loan is to be liquidated is by provision out of the municipal fund in each half-year during the currency of the loan of the sum of \$440.95, which includes principal and interest.

The plans and specifications and estimate of the cost of the works, and a statement showing the proposed expenditure of the moneys to be borrowed, are open for inspection at the Council Office, Sale.

Dated this 31st day of July, 1972.

7687

J. L. LOW, Town Clerk.

CITY OF SALE.

LOAN No. 62.

Notice of Intention to Borrow.

Notice is hereby given that the Council of the City of Sale intends to borrow One hundred and twelve thousand dollars (\$12,000), secured by a charge over the general rates of the municipality by the grant of a mortgage in accordance with the provisions of the Local Government Acts.

In connexion therewith the following information is stated:—

(a) The amount of the principal moneys which it is proposed to borrow is \$112,000.

(b) The maximum rate of interest that may be paid is 6.2 per centum per annum.

(c) The times which the moneys borrowed are to be repayable are the 15th day of March and the 15th day of September during the years 1973-1982 inclusive, and that the place such moneys shall be repayable is at the Bank of New South Wales, Sale.

(d) The purpose for which the loan is to be applied is:—

Construction of roads, drainage and associated works.

(e) The manner in which the loan is to be liquidated is by provision out of the municipal fund in each half-year during the currency of the loan of the sum of \$7,597.93, which includes principal and interest.

The plans and specifications and estimate of the cost of the works, and a statement showing the proposed expenditure of the moneys to be borrowed, are open for inspection at the Council Office, Sale.

Dated this 31st day of July, 1972.

7683

J. L. LOW, Town Clerk.

CITY OF SALE.

LOAN No. 63.

Notice of Intention to Borrow.

Notice is hereby given that the Council of the City of Sale intends to borrow Four thousand seven hundred dollars (\$4,700), secured by a charge over the general rates of the municipality by the grant of a mortgage in accordance with the provisions of the Local Government Acts.

In connexion therewith the following information is stated:—

(a) The amount of the principal moneys which it is proposed to borrow is \$4,700.

(b) The maximum rate of interest that may be paid is 6.0 per centum per annum.

(c) The times which the moneys borrowed are to be repayable are the 15th day of March and the 15th day of September during the years 1973-1977 inclusive, and that the place such moneys shall be repayable is at the Bank of New South Wales, Sale.

(d) The purpose for which the loan is to be applied is:—

Part cost of purchase of plant.

(e) The manner in which the loan is to be liquidated is by provision out of the municipal fund in each half-year during the currency of the loan of the sum of \$550.98, which includes principal and interest.

The plans and specifications and estimate of the cost of the works, and a statement showing the proposed expenditure of the moneys to be borrowed, are open for inspection at the Council Office, Sale.

Dated this 31st day of July, 1972.

7684

J. L. LOW, Town Clerk.

SHIRE OF DEAKIN.

Notice of Intention to Borrow the Sum of \$10,000 for Permanent Works and Undertakings.

Notice is hereby given that the Council of the Shire of Deakin proposes to borrow the principal sum of Ten thousand dollars, secured by a charge over the general rates of the municipality, such sum to be raised by the grant of a mortgage in accordance with the provisions of the Local Government Act 1958, as amended.

1. The maximum rate of interest that may be paid is 6.1 per cent.

2. The period of the loan shall be nine years.

3. The purpose for which the loan is to be raised is part cost of establishment of municipal depot on Finlay-road, Tongala.

4. The loan is to be liquidated by providing out of the municipal fund eighteen equal half-yearly instalments of principal and interest each of \$730.16, payable on the 1st days of April and October in each year, during the currency of the loan. The first repayment shall be made on the 1st day of April, 1973.

5. The repayments shall be made at the office of the Shire of Deakin Waterworks Trust, Mangan-street, Tongala.

The plans and specifications and estimate of costs of such works and a statement showing the proposed expenditure of moneys to be borrowed are open for inspection at the office of the Council of the Shire of Deakin, Mangans-street, Tongala.

Dated at Tongala, this 9th day of August, 1972.
7673 B. PEARL, Shire Secretary.

SHIRE OF HAMPDEN.

APPOINTMENT OF POLLING PLACES.

Notice is hereby given that the Council at its meeting held on the 21st July, 1972, abolished Polling Places of Duverney and Vite Vite and appointed the following places as Polling Places within its municipal district:—

For the East Riding—
Camperdown.
Derrinallum.
Foxhow.
Leslie Manor.
Lismore.
Pomborneit North.

For the North Riding—
Camperdown.
Berrybank.
Darlington.
Derrinallum.
Foxhow.
Lismore.
Mingay.
Mt. Bute.
Skipton.
Vite Vite North.

For the West Riding—
Camperdown.
Bookaar.
Boorcan.
Darlington.
Derrinallum.
Glenormiston North.
Naroghid.
Noorat.
Terang.

7680 S. J. GRIMMER, Shire Secretary.

SHIRE OF MANSFIELD.

LOAN No. 70.

Notice of Intention to Borrow the Sum of \$20,000 for Permanent Works and Undertakings.

Notice is hereby given that the Council of the Shire of Mansfield intends to borrow Twenty thousand dollars (\$20,000), secured by a charge over the general rates of the municipality by the grant of a mortgage in accordance with the provisions of the Local Government Acts.

In connexion therewith the following information is stated:—

- (a) The amount of the principal moneys which it is proposed to borrow is \$20,000.
- (b) The maximum rate of interest that may be paid is 6.4 per centum per annum.
- (c) The times which the moneys borrowed are to be repayable are the 28th day of March and the 28th day of September, during the years 1973-1992 inclusive, and that the place such moneys shall be repayable is at the Bank of New South Wales.
- (d) The purpose for which the Loan is to be applied is:—
Purchase of land for proposed depot, pound and sale-yards site.
- (e) The manner in which the loan is to be liquidated is by provision out of the municipal fund in each half-year during the currency of the loan of the sum of \$893.44, which includes principal and interest.

The plans and specifications and estimate of the cost of the works and a statement showing the proposed expenditure of the moneys to be borrowed are open for inspection at the Shire Office.

Dated this 3rd day of August, 1972.
7692 E. CAIRNS, Shire Secretary.

SHIRE OF MANSFIELD.

LOAN No. 69.

Construction of Private Streets and Drains.

Notice is hereby given that, at the meeting of the Council of the Shire of Mansfield, held at Mansfield, on 26th July, 1972, the said Council did agree to the following Resolution, that is to say:—

"That this Council, by Special Order, resolves to borrow on the credit of the general rates of the municipality the sum of \$13,600 (Thirteen thousand six hundred dollars), such sum to be secured by a charge over the general rates of the municipality by the grant of a mortgage in accordance with the provisions of the Local Government Act."

The rate of interest to be paid is 6.4 per centum per annum and the said loan shall be liquidated by 40 equal half-yearly re-payments of \$609.54 (principal and interest combined).

The time which the moneys borrowed are to be repayable are on the 1st days of March and September, during the years 1973 to 1992 (inclusive).

The place the moneys shall be repayable is at the Bank of New South Wales.

The purpose for which the said loan shall be applied are for the construction of private streets under the provisions of Division 10 of Part XIX. of the *Local Government Act 1958* and amendments, and the loan shall be liquidated from the receipts of money payable under schemes under the said division.

Notice is hereby further given that at the meeting of the said Council held at Mansfield, on the 23rd day of August, 1972, the said Resolution will be confirmed.

7681 E. CAIRNS, Shire Secretary.

Town and Country Planning Act.

SHIRE OF NEWHAM AND WOODEND PLANNING SCHEME.

INTERIM DEVELOPMENT ORDER AMENDMENT No. 1.

Notice that an amendment to the Shire of Newham and Woodend Interim Development Order is available for inspection.

Notice is hereby given that the Shire of Newham and Woodend, in accordance with the provisions of the *Town and Country Planning Act 1961*, proposes to request the Governor in Council to amend its Interim Development Order.

The amendment proposes to extend the Pink Area, as shown on the map which comprises the Schedule to the Interim Development Order, to include Crown portions 50, 56-58 inclusive, Parish of Woodend, and those parts of Crown portions 47 and 48, Parish of Woodend, which are not already included in such Pink Area.

A copy of the proposed amendment to the Interim Development Order has been deposited at the Shire Office, High-street, Woodend and at the offices of the Town and Country Planning Board, 235 Queen-street, Melbourne and will be open for inspection during office hours by any person, free of charge.

Any persons affected by the proposed amendment to the Interim Development Order are required to set forth, in writing, all objections they may have, addressed to the Shire Secretary, Shire of Newham and Woodend, Shire Offices, High-street, Woodend, on or before the 9th September, 1972, and state whether they wish to be heard in support of their objections.

7697 R. J. PEKIN, Shire Secretary.

Town and Country Planning Act 1961 (Twelfth Schedule).

SHIRE OF SEYMOUR.—SEYMOUR PLANNING SCHEME.

NOTICE THAT A PLANNING SCHEME HAS BEEN PREPARED AND IS AVAILABLE FOR INSPECTION.

Amendment No. 1, 1972.

Notice is hereby given that the Shire of Seymour, in pursuance of its powers under the *Town and Country Planning Act 1961*, has prepared an amending Planning Scheme for the purpose of—

Rezoning an area of land between Tallarook-street, Elizabeth-street and Bishop-street, Seymour to "Public purposes".

A copy of the Scheme has been deposited at the Shire Office, Seymour and at the Office of the Town and Country Planning Board, 235 Queen-street, Melbourne, and will be open for inspection during office hours by any person, free of charge.

Any persons affected by the Planning Scheme are required to set forth in writing all objections they may have, addressed to the Shire Secretary, Shire Office, Seymour on or before the 11th December, 1972, and to state whether they wish to be heard in respect of their objections.

7693

G. G. McWHINNEY, Municipal Clerk.

Town and Country Planning Act 1961 (Twelfth Schedule).
SHIRE OF SEYMOUR.—SHIRE OF SEYMOUR
PLANNING SCHEME.

NOTICE THAT A PLANNING SCHEME HAS BEEN PREPARED AND IS AVAILABLE FOR INSPECTION.

Amendment No. 1, 1972.

Notice is hereby given that the Shire of Seymour, in pursuance of its powers under the *Town and Country Planning Act 1961*, has prepared an amending Planning Scheme for the purpose of—

Permitting electricity generating works in the Rural A zone.

A copy of the Scheme has been deposited at the Shire Office, Seymour and at the Office of the Town and Country Planning Board, 235 Queen-street, Melbourne, and will be open for inspection during office hours by any person, free of charge.

Any persons affected by the Planning Scheme are required to set forth in writing all objections they may have, addressed to the Shire Secretary, Shire Office, Seymour on or before the 11th September, 1972, and to state whether they wish to be heard in respect of their objections.

7694

G. G. McWHINNEY, Municipal Clerk.

Town and Country Planning Act 1961 (Twelfth Schedule).
SHIRE OF SEYMOUR.—SEYMOUR PLANNING SCHEME.
NOTICE THAT A PLANNING SCHEME HAS BEEN PREPARED AND IS AVAILABLE FOR INSPECTION.

Amendment No. 2, 1972.

Notice is hereby given that the Shire of Seymour, in pursuance of its powers under the *Town and Country Planning Act 1961*, has prepared an amending Planning Scheme for the purpose of—

Including caravan park as a permitted use within the Highway Zone.

A copy of the Scheme has been deposited at the Shire Office, Seymour and at the Office of the Town and Country Planning Board, 235 Queen-street, Melbourne, and will be open for inspection during office hours by any person, free of charge.

Any persons affected by the Planning Scheme are required to set forth in writing all objections they may have, addressed to the Shire Secretary, Shire Office, Seymour on or before the 11th September, 1972, and to state whether they wish to be heard in respect of their objections.

7695

G. G. McWHINNEY, Municipal Clerk.

FRANKSTON SEWERAGE AUTHORITY.
SEWER CONSTRUCTION.

Notice is hereby given that it is the Authority's intention to construct sewers in the vicinity of Cranbourne-road, Culburra-avenue and Bunerong-drive, East Frankston.

Maps showing the precise location of the proposed sewers may be inspected at the Office of the Authority, Civic Centre, Frankston.

G. C. PENTLAND, Secretary.

Civic Centre, Frankston.

7703

NUMURKAH SEWERAGE AUTHORITY.

GENERAL NOTICE.

Sewerage Area 1.

The above-mentioned Sewerage Authority having made provision for the carrying off from each and every property which, or any part of which is within the sewerage area hereinafter described, doth hereby declare that on and after the 1st day of August, 1972, each and every property which, or any part of which is within the said Sewerage District, shall be deemed to be a seweraged property within the meaning of the *Sewerage Districts Act 1958*.

The boundaries of the Sewerage Area hereinafter referred to are:—

"The Railway Line, Saxton-street and Broken Creek."

By order of the Authority,

R. H. ROBINSON, Chairman.

L. G. MITCHELL, Secretary.

7666

MILDURA URBAN WATER TRUST.

CHARGES FOR SERVICE OUTSIDE DISTRICT OF TRUST.

For water supplied to properties outside the district of the Mildura Urban Water Trust, for the year ending 30th June, 1973, a minimum charge of Twenty-eight dollars (\$28), will be made for each connexion either directly or indirectly to the Trust's mains.

This charge is due and payable on the 31st August, 1972, and if not paid by the 30th November, 1972, will bear interest at the rate of eight per cent. (8%) per annum, from the 31st August, 1972, to the date of payment.

For water used in excess of the allowance for any service connexion outside the district there shall be a charge of fourteen cents (14c) per thousand gallons.

The allowance for any service connexion before such charge is made shall be 156,000 gallons for the full year, and shall be on a pro rata basis for any portion of the year.

11th July, 1972.

R. E. DUDLEY, Secretary.

Mildura Urban Water Trust, 7th Street, Mildura. 7689

GEELONG WATERWORKS AND SEWERAGE TRUST.

Pursuant to section 60 of the *Geelong Waterworks and Sewerage Act 1958* (No. 6263), the Trust has prepared plans to indicate the particulars of sewers and underground works in or adjacent to the following localities within the Drainage Area.

Linthwaite-close, Highton, Shire of South Barwon.

Lambert-avenue, Newtown, City of Newtown.

Strathire Gardens and Tahara-street, Hamlyn Heights, Shire of Corio.

Merinda-court and Ryong-street, Grovedale, Shire of South Barwon.

Pigdons-road, Highton, Shire of Barrabool.

Reigate-road, Highton, Shire of South Barwon.

Stanley-street, Chilwell, City of Newtown.

Notice is hereby given that the plans indicated above are open for public inspection at the Trust's Offices, Ryrie-street, Geelong, between the hours of 9 a.m. and 5 p.m., from Monday to Friday, Public Holidays excepted, by the owners and occupiers of land or premises within the Drainage Area.

7685

B. C. HENSHAW, Secretary.

Notice is hereby given that the Lorne Fishermen's Co-operative Society Limited has applied for a lease under section 134 of the *Land Act 1958*, for a term of twenty years over approximately 1 rood 9 perches of Crown land in the Township of Lorne, as a site for the purpose of Fish Freezing Works.

PRICE, HIGGINS & FIDGE, solicitors, "Douglas House", 47 Yarra-street, Geelong. 7307

Water Acts.

PROPOSED TAWONGA URBAN DISTRICT,
PROPOSED TAWONGA RURAL DISTRICT.

Notice is hereby given that the Mt. Beauty Waterworks Trust has made application to the Honorable the Minister of Water Supply for the extension of its Waterworks District and for the proclamation of an Urban District and a Rural District at Tawonga and the construction, maintenance, and continuance of Water Supply Works within those Districts under the provisions of the Water Acts.

A general plan and description of the proposed works have been submitted with the application, and copies of same may be seen at the Trust's office at Mt. Beauty.

Dated at Mt. Beauty, the 18th day of July, 1972.

7419

J. B. O'BRIEN, Secretary.

NOTICE OF INTENTION TO APPLY FOR A LICENCE TO DIVERT WATER AND CUT RACE FROM THE CAMPASPE RIVER, AT ROCHESTER.

I hereby give notice that I intend to apply for a licence empowering me to divert water for a term of fifteen years to the extent of 130 acre-feet per annum at a maximum rate of 8 acre-feet per day of 24 hours for the irrigation of 100 acres, being part of allotments 21, 22, and 23, Parish of Rochester, and to occupy certain Crown lands for works of diversion, and to cut a race thereon.

Any objection to such application must be forwarded, in writing, to reach the State Rivers and Water Supply Commission, Melbourne, before 8th September, 1972, being 30 days from the first publication of this notice.

GEORGE NEIL HUNTER.

"Riverside", Rochester.

7739

NOTICE OF INTENTION TO APPLY FOR A LICENCE TO DIVERT WATER AND CUT RACE FROM THE RIVER MURRAY, AT MERBEIN.

I hereby give notice that I intend to apply for a licence empowering me to divert water for a term of four years to the extent of 60 acre-feet per annum at a maximum rate of 6 acre-feet per day of 24 hours for the purpose of irrigating vines and vegetables (15 acres), being part of allotment 12B, section H, Parish of Merbein, and to occupy certain Crown lands for works of diversion, and to cut a race thereon.

Any objection to such application must be forwarded, in writing, to reach the State Rivers and Water Supply Commission, Melbourne, before 8th September, 1972, being 30 days from the first publication of this notice.

BRIAN ROBERT MUNRO.

Box 19, Merbein, 3505, Vic. 7735

NOTICE OF INTENTION TO APPLY FOR A LICENCE TO DIVERT WATER AND CUT RACE (RE-ISSUE) FROM THE RIVER MURRAY, AT BOUNDARY BEND.

I hereby give notice that I intend to apply for a licence empowering me to divert water for a term of fifteen years to the extent of 100 acre-feet per annum at a maximum rate of 4 acre-feet per day of 24 hours for the irrigation of market garden and fruit trees, being part of allotment 2, lot 13, L.P. 32772, Parish of Narrung, and to occupy certain Crown lands for works of diversion, and to cut a race thereon.

Any objection to such application must be forwarded, in writing, to reach the State Rivers and Water Supply Commission, Melbourne, before 8th September, 1972, being 30 days from the first publication of this notice.

RONALD CHARLES STOREY.

Post Office, Boundary Bend, 3599. 7686

After fourteen clear days application will be made to the Supreme Court that letters of administration of the estate of Frances Anne Lawler, formerly of Flat 6, 124 Glenhuntingly-road, Elwood, but late of The Royal Melbourne Hospital, Parkville, in the State of Victoria, invalid pensioner, deceased, intestate, be granted to Edmund Herbert Lawler, of 53 Lakeside-parade, The Entrance, in the State of New South Wales, retired pharmacist, the father of the said deceased.

JOHN D. MUSTOW & CO., solicitors, of 131 Queen-street, Melbourne. 7724

I, Alison Margaret Matters, of Flat 1, 13 Wattie-street, Swan Hill, in the State of Victoria, heretofore called and known by the name of Browne, do hereby give notice that on the 24th day of July, 1972, I renounced and abandoned the use of my said name of Browne, and assumed in lieu thereof the name Matters, for myself and my son, Martin John Matters, lately called Browne, and that such change of name is evidenced by a deed poll, dated the 17th day of July, 1972, deposited in the Registrar-General's Office No. 54225.

DELANY & DWYER, barristers and solicitors, 201 Campbell-street, Swan Hill. 7718

Domenic Salvetti, of 6 James-street, Hampton, and Leonard Neville Lary, of 1 Victoria-street, Sandringham, conducting business as builders, under the name of "Don & Len Builders", dissolved on the 31st day of March, 1972.

ROY L. YELLAND & CO., solicitors, 37 Swanston-street, Melbourne. 7730

Notice is hereby given that Charles Bernard Soward retired from partnership in the firm of Parsons Watson and Soward, chartered accountants, of 135 Canterbury-road, Toorak, on the 30th June, 1972. The said Charles Bernard Soward will not after the said date be responsible for any debts of the said firm. All debts due to and owing by the firm will be received and paid respectively by David Orchard-Parsons and Gavin Izett Ruthven Watson, who will continue to carry on the said business under the style or firm of "Parsons Watson & Co.", chartered accountants, at 135 Canterbury-road, Toorak.

Dated the 31st day of July, 1972.

D. O. PARSONS.
G. I. R. WATSON.
C. B. SOWARD.

7790

LANDSON PTY. LTD.

The above company was placed in liquidation by a meeting of members held on Monday, the 31st July, 1972.
G. E. MORGAN, liquidator, 290 La Trobe-street, Melbourne. 7721

GITA SCHOOL OF YOGA PTY. LIMITED.

Gita School of Yoga Pty. Limited gives notice that at a General Meeting of members held on the 31st day of July, 1972, it was resolved that the company be wound up voluntarily, and that Mr. Peter Follet Clarke, of the firm of Manning & Perry, of 175 King-street, Melbourne, be appointed liquidator of the company.

PETER BARKER, HARTY & CO., solicitors, 400 Lonsdale-street, Melbourne, 3000. 7717

In the matter of PIPER ELECTRONICS PTY. LIMITED.—Notice of Winding-up Order.

Winding-up Order made on Wednesday, the 26th day of July, 1972.

The liquidator is Harold Keith Cartledge, of 1 Palmerston-crescent, South Melbourne.

Dated the 2nd day of August, 1972.

7731 MALLESONS, solicitors for the petitioner.

Companies Act 1961.

MICHELL & REGOS PTY. LTD.

Notice is hereby given that at an Extraordinary General Meeting of the members of Michell & Regos Pty. Ltd. held at 106 Wellington-parade, East Melbourne, on 31st July, 1972, a Special Resolution was passed that the company be wound up voluntarily, and that James Regos, of 106 Wellington-parade, East Melbourne, be appointed liquidator for that purpose.

Dated this 31st July, 1972.

7734 J. REGOS, Liquidator.

In the matter of H.C.M.S. PTY. LTD.—Notice of Winding-up Order.

Winding-up Order made the 2nd day of August, 1972.

Name and address of official liquidator, Bruce Edward Fordham, chartered accountant, of 170 Toorak-road, South Yarra.

L. T. FITZGERALD, Deputy Commissioner of Taxation of the Commonwealth of Australia. 7785

In the matter of H.C. CONSTRUCTIONS PTY. LTD.—Notice of Winding-up Order.

Winding-up Order made the 2nd day of August, 1972.

Name and address of official liquidator, Bruce Edward Fordham, chartered accountant, of 170 Toorak-road, South Yarra.

L. T. FITZGERALD, Deputy Commissioner of Taxation of the Commonwealth of Australia. 7786

The Companies Act 1961.—In the matter of T. E. BUTLER & Co. Pty. Ltd. (in Voluntary Liquidation).

Notice is hereby given that at an Extraordinary General Meeting of shareholders of the above-named company held on the 31st day of July, 1972, it was resolved that the company be wound up voluntarily, and that Douglas Orson Oldfield and Roger James Gilchrist, chartered accountants, of 395 Collins-street, Melbourne, be and are hereby appointed liquidators for the purpose of such winding up.

Dated this 9th day of August, 1972.

D. O. OLDFIELD and R. J. GILCHRIST, liquidators, 395 Collins-street, Melbourne, 3000. 7787

Companies Act 1961.—In the matter of INITIAL ENTERPRISES No. 1 PROPRIETARY LIMITED (in Voluntary Liquidation).

Notice is hereby given, pursuant to section 254 (2) (b) of the Companies Act 1961 that at the General Meeting of the members of Initial Enterprises No. 1 Proprietary Limited duly convened and held at Suite 2, 162 Albert-road, South Melbourne, on the 3rd day of August, 1972, the following Resolutions were passed as Special Resolutions:—

"(1) That the company shall be wound up voluntarily, it not being further required, in accordance with the provisions of the Companies Act 1961 and that Eric Stanwell Field be appointed liquidator of the company for the purpose of winding up the affairs and distributing the assets of the company.

(2) That the liquidator be given power to divide amongst the members of the company in kind the whole of the assets of the company."

Dated this 3rd day of August, 1972.

7671 E. S. FIELD, Liquidator.

The Companies Act 1961.—In the matter of P. J. McMAHON, ADVANX TYRE SERVICE PROPRIETARY LIMITED (in Voluntary Liquidation).

Notice is hereby given that at an Extraordinary General Meeting of members of the above-named company held on 31st July, 1972, the following Special Resolution was duly passed:—

“That, as the main business activities of the company are now terminated, the company be wound up voluntarily, and that Allen Beavis Driscoll, be appointed liquidator of the company.”

Notice is also hereby given that after 21 days from this date I shall proceed to distribute the assets. All creditors having any claim against the company should furnish particulars of same by that date, otherwise I shall proceed to distribute the assets, without regard to their claim.

Dated this 31st day of July, 1972.

7707 ALLEN B. DRISCOLL, Liquidator.

Companies Act 1961.

LANDSCAPE PROPRIETARY LIMITED (IN MEMBERS' VOLUNTARY LIQUIDATION).

Notice is hereby given; in pursuance of section 272 of the Companies Act 1961, that the Final Meeting of members of the company will be held at 10 Cleeve-court, Toorak, on Thursday, 14th September, 1972, at 12.30 p.m., for the purpose of receiving the liquidator's account, showing how the winding up has been conducted and the property of the company has been disposed of and giving any explanation thereof.

Dated this 7th day of August, 1972.

7696 W. A. HUBBLE, Liquidator.

In the matter of the Companies Act 1961; and in the matter of S. E. MONTI PROPRIETARY LIMITED.

Notice is hereby given that at an Extraordinary General Meeting of the members of S. E. Monti Proprietary Limited, held at Bendigo, on the 2nd day of August, 1972, the following Special Resolution was duly passed:—

“That the company be wound up voluntarily and that for such purpose, Francis Brian Jennings, of 125 McCrae-street, Bendigo, be appointed Liquidator.”

Dated this 2nd day of August, 1972.

7691 F. B. JENNINGS, Liquidator.

Companies Act 1961, Section 254.

ANDERSON & BRIANT PTY. LTD.

Notice is hereby given that at a General Meeting of the members of Anderson & Briant Pty. Ltd., duly convened and held at 33 College-street, Wendouree, on 23rd July, 1972, the following Resolution was passed as a Special Resolution:—

“Resolved that the company be wound up as a Members' Voluntary Liquidation, and that Colin Richard Prowse, of 46 Lydiard-street south, Ballarat, be appointed liquidator.”

7706 C. R. PROWSE, Liquidator.

The Companies Act 1961.—In the matter of WATHEN & DOBSON PTY. LIMITED.—Notice Re Meeting of Creditors, Pursuant to Section 260.

Notice is hereby given that a meeting of creditors of the above-named company will be held at the offices of Kennedy, Smail & Middlemiss, 296 Little Lonsdale-street, Melbourne, at 4 p.m. on the 16th day of August, 1972, the company having convened a meeting of its members for the same day for the purpose of considering a Resolution that the company would be wound up voluntarily.

Dated this 8th day of August, 1972.

J. DOBSON, Director.

Kennedy, Smail & Middlemiss, 296 Little Lonsdale-street, Melbourne. 7789

Companies Act 1961.

MONTANA VAN LINES PTY. LTD.

NOTICE OF MEETING.

Notice is hereby given of a meeting of creditors of Montana Van Lines Pty. Ltd., to be held at the Honorary Justices Association, 3rd Floor, 528 Collins-street, Melbourne, on Friday, 18th August, 1972, at 2.30 p.m., for the purpose of considering and if thought fit, passing the following Resolution:—

“That the company be wound up voluntarily.”

W. COE, Director.

Care of Webster & Taylor, P.O. Box 138, St. Kilda, 3182. Tel. 94 0751. 7743

Companies Act 1961, Section 254 (2).

HERBORNE PTY. LTD. (IN LIQUIDATION) (FORMERLY HERBERT OSBORNE PTY. LTD.).

K.J.H.W. PTY. LTD. (IN LIQUIDATION) (FORMERLY L. B. STOCKDALE PTY. LTD.).

RENNBERG (AUSTRALIA) PTY. LTD. (IN LIQUIDATION).

TURNLEY PHOTO PROCESS EQUIPMENT PTY. LTD. (IN LIQUIDATION).

Notice is hereby given that at Extraordinary General Meetings of members of the above-named companies, duly held on Wednesday, 2nd August, 1972, the following Special Resolution was duly passed at each meeting:—

“That the company be and is hereby wound up as a Members' Voluntary Winding Up and that Phillip George Howard be and is hereby appointed Liquidator to wind the company up and attend to all matters relative thereto in accordance with the Companies Act 1961.”

P. G. HOWARD, Liquidator.

M. V. Anderson & Co., 277 William-street, Melbourne, 3000, Telephone 67 6245. 7677

Companies Act 1961.—In the matter of A.B.C. BLINDS (MELBOURNE) PTY. LTD.—Notice Re Meeting of Creditors, Pursuant to Section 260.

Notice is hereby given that a Meeting of Creditors of the above-named company will be held at the Board Room, Institute of Chartered Accountants, 140 Queen-street, Melbourne, at 10.30 a.m. on the 18th day of August, 1972, the company having convened a meeting of its members for the same day for the purpose of considering a Resolution that the company be wound up voluntarily.

Dated this 3rd day of August, 1972.

D. ACKERMAN, Director.

A. Neville Bird & Co., chartered accountants, 289 Flinders-lane, Melbourne, telephone No. 63 2874. 7728

Companies Act 1961.

ALLSIZE CARTONS PTY. LTD.

NOTICE OF MEETING OF CREDITORS, PURSUANT TO SECTION 260 OF THE COMPANIES ACT 1961.

Notice is hereby given that a meeting of the creditors of Allsize Cartons Pty. Ltd. will be held at the Office of Bruce Fordham & Co., chartered accountants, 170 Toorak-road, South Yarra, on Wednesday, 30th August, 1972, at 11 a.m., for the purpose of considering the company's affairs, the company having convened an Extraordinary General Meeting of its members to be held on the same day and for the purpose of considering, and if thought fit, passing a Special Resolution that the company be wound up voluntarily.

Dated this 2nd day of August, 1972.

7729 JAMES THOMAS, Director.

Companies Act 1961, Section 254 (2).

FLEXWRAP PTY. LTD. (IN LIQUIDATION).

Notice is hereby given that at an Extraordinary Meeting of members of the above-named company held on Friday, 28th July, 1972, the following Special Resolution was duly passed.

“That owing to the company being unable to meet its debts as and when they become due and payable that the company be and is hereby wound up voluntarily and that Maxwell George Gee, a Registered Liquidator, be and is hereby appointed liquidator to wind the company up and attend to all matters relative thereto in accordance with the Companies Act 1961.”

At a meeting of creditors held the same day, my appointment as liquidator was confirmed.

M. G. GEE, Liquidator.

Max Gee & Co., 325 Warrigal-road, Burwood, 3125, telephone 288 5109. 7663

The Companies Act 1961.—In the matter of JUNE SMITH ACCESSORIES PTY. LTD. (in Liquidation).

Notice is hereby given that at an Extraordinary General Meeting of the members of the above-named company, held on the 3rd day of August, 1972, it was resolved that the company be wound up voluntarily and at a meeting of creditors held on the same day, pursuant to section 260 (1), it was resolved that for such purpose, Bruce Edward Fordham, chartered accountant, be appointed liquidator.

Dated this 7th day of August, 1972.

BRUCE FORDHAM & CO., chartered accountants, 170 Toorak-road, South Yarra, Vic., 3141. 7788

In the Supreme Court of Victoria.—1972, CO. 8423.—In the matter of the *Companies Act 1961*; and in the matter of HUMPHREY OMEGA (VIC.) PTY. LTD.

Notice is hereby given that a petition for the winding up of the above-named company by the Supreme Court was on the 1st day of August, 1972, presented by Leo Thomas FitzGerald, Deputy Commissioner of Taxation of the Commonwealth of Australia; And that the said petition is directed to be heard before the Court sitting at the Fourteenth Court, Law Courts, William-street, Melbourne, at the hour of 10.30 o'clock in the forenoon on the 13th day of September, 1972, and any creditor or contributory of the said company desiring to support or oppose the making of an order on the said petition may appear at the time of hearing by himself or his Counsel for the purpose; and a copy of the said petition will be furnished to any creditor or contributory of the said company requiring the same by the undersigned on payment of the regulated charge for the same.

The petitioner's official address is 350 Collins-street, Melbourne.

The petitioner's solicitor is Robert Burns Hutchison, Crown Solicitor for the Commonwealth, of 99 Queen-street, Melbourne.

R. B. HUTCHISON.

NOTE.—Any person who intends to appear on the hearing of the said petition must serve on or send by post to the above-named R. B. Hutchison, notice in writing of his intention so to do. The notice must state the name and address of the person, or, if a firm, the name and address of the firm, and must be signed by the person or firm, or his, or their solicitor (if any), and must be served or, if posted, must be sent by post in sufficient time to reach the above-named not later than 4 o'clock in the afternoon of the 12th day of September, 1972.

7732

In the Supreme Court of Victoria.—1972, CO. 8424.—In the matter of the *Companies Act 1961*; and in the matter of BURNFIELD INVESTMENTS PTY. LTD.

Notice is hereby given that a petition for the winding up of the above-named company by the Supreme Court was on the 1st day of August, 1972, presented by Leo Thomas FitzGerald, Deputy Commissioner of Taxation of the Commonwealth of Australia; And that the said petition is directed to be heard before the Court sitting at the Fourteenth Court, Law Courts, William-street, Melbourne, at the hour of 10.30 o'clock in the forenoon on the 13th day of September, 1972, and any creditor or contributory of the said company desiring to support or oppose the making of an order on the said petition may appear at the time of hearing by himself or his Counsel for the purpose; and a copy of the said petition will be furnished to any creditor or contributory of the said company requiring the same by the undersigned on payment of the regulated charge for the same.

The petitioner's official address is 350 Collins-street, Melbourne.

The petitioner's solicitor is Robert Burns Hutchison, Crown Solicitor for the Commonwealth, of 99 Queen-street, Melbourne.

R. B. HUTCHISON.

NOTE.—Any person who intends to appear on the hearing of the said petition must serve on or send by post to the above-named R. B. Hutchison, notice in writing of his intention so to do. The notice must state the name and address of the person, or, if a firm, the name and address of the firm, and must be signed by the person or firm, or his, or their solicitor (if any), and must be served or, if posted, must be sent by post in sufficient time to reach the above-named not later than 4 o'clock in the afternoon of the 12th day of September, 1972.

7733

The *Companies Act 1961*.

FREYA PTY. LTD.

PURSUANT TO SECTION 260 OF THE COMPANIES ACT 1961.

Notice is hereby given that a meeting of creditors of Freya Pty. Ltd., will be held at the Institute of Chartered Accountants, 140 Queen-street, Melbourne, on Tuesday, the 15th day of August, 1972, at 3 o'clock in the afternoon, for the purpose of considering the company's affairs, the company having convened an Extraordinary General Meeting of its members to be held on the same day and for the purpose of considering and if thought fit, passing a Special Resolution that the company be wound up voluntarily.

Dated this 3rd day of August, 1972.

M. C. DICKSON, Director.

Hall & Rose, chartered accountants, 395 Collins-street, Melbourne.

7719

The *Companies Act 1961*.—In the matter of DOWELON INDUSTRIAL PLASTICS PTY. LTD. (In Voluntary Liquidation).

Notice is hereby given that at an Extraordinary Meeting of the members of the above-named company held on Thursday, the 27th day of July, 1972, it was resolved that the company be wound up voluntarily, and at a meeting of creditors held on the same day, it was resolved that for such purpose, Geoffrey Ormond Harrison, of Hall & Rose, chartered accountants, 395 Collins-street, Melbourne, be appointed liquidator.

Notice is also given that after 21 days from this date I shall proceed to distribute the assets. All creditors having any claim against the company should furnish particulars of same by that date, otherwise I shall proceed to distribute the assets without regard to their claim.

Dated this 31st day of July, 1972.

G. O. HARRISON, Liquidator.

Hall & Rose, chartered accountants, 395 Collins-street, Melbourne.

7720

The *Companies Act 1961*.

G. J. F. PTY. LTD. (IN LIQUIDATION).

NOTICE CONVENING FINAL MEETING OF MEMBERS AND CREDITORS, PURSUANT TO SECTION 272.

Notice is hereby given, in pursuance of section 272 of the *Companies Act 1961*, that a meeting of the members and creditors of the above-named company will be held on the 11th day of September, 1972, at the offices of Hall & Rose, 395 Collins-street, Melbourne, at 3 o'clock in the afternoon, for the purpose of having an account laid before them, showing the manner in which the winding up has been conducted and the property of the company disposed of and of hearing any explanations that may be given by the liquidator.

Dated this 7th day of August, 1972.

S. M. NUNAN, Liquidator.

Hall & Rose, chartered accountants, 395 Collins-street, Melbourne.

7751

The *Companies Act 1961*.—In the matter of ABLE DIACON CO. PROPRIETARY LIMITED.

Notice is hereby given that a meeting of creditors of the above-named company will be held at the offices of Bentley, Wheeler, Cartledge & Co., 1 Palmerston-crescent, South Melbourne, at 10 o'clock in the forenoon on Thursday, the 17th day of August, 1972, the company having convened a meeting of its members for the same day for the purpose of considering a Resolution that the company be wound up voluntarily.

Dated this 9th day of August, 1972.

H. ORR, Director.

Bentley, Wheeler, Cartledge & Co., chartered accountants, 1 Palmerston-crescent, South Melbourne, Vic., 3205.

7752

Companies Act 1961.

RINGWOOD MECHANICAL EQUIPMENT PTY. LTD.
(IN LIQUIDATION).

In accordance with section 272 of the *Companies Act* relating to Members' Voluntary Winding Up, notice is hereby given that a meeting of shareholders of Ringwood Mechanical Equipment Pty. Ltd. will be held at the office of Pascoe & Whitaker, 8 Station-street, Ringwood, on Friday, 15th September, 1972, to receive and consider the report and accounts of the winding up.

7766

B. H. WHITAKER, Liquidator.

In the matter of the *Companies Act 1961*; and in the matter of ASSOCIATED TEXTILE PRINTERS PTY. LIMITED (in Liquidation).

Notice is hereby given that at a General Meeting of the above-named company, duly convened and held at Bradmill House, Missenden-road, Camperdown, on the 28th day of July, 1972, the following Special Resolution was duly passed:—

"It was resolved that the company be wound up voluntarily, and that Kenneth Cross be and is hereby appointed liquidator for the purpose of winding up."

Dated this 31st day of July, 1972.

In the matter of the *Companies Act 1961*; and in the matter of ASSOCIATED TEXTILE PRINTERS PTY. LIMITED (in Liquidation).

Notice is hereby given that the Final Meeting of the members of the above-named company will be held at Bradmill House, Missenden-road, Camperdown, on the 15th day of November, 1972, at 2.30 p.m.

The purpose of the meeting is to receive the account of the liquidator showing how the winding up has been conducted and how the property of the company has been disposed of and to give any explanation of this account.

Dated this 31st day of July, 1972.

KENNETH CROSS, liquidator, 395 Collins-street, Melbourne, Vic., 3000. 7716

In the matter of the *Companies Act 1961*; and in the matter of DAVIES, COOP (FLAX INDUSTRIES) PTY. LIMITED (in Liquidation).

Notice is hereby given that at a General Meeting of the above-named company, duly convened and held at Bradmill House, Missenden-road, Camperdown, on the 28th day of July, 1972, the following Special Resolution was duly passed:—

"It was resolved that the company be wound up voluntarily, and that Kenneth Cross be and is hereby appointed liquidator for the purpose of winding up."

Dated this 31st day of July, 1972.

In the matter of the *Companies Act 1961*; and in the matter of DAVIES, COOP (FLAX INDUSTRIES) PTY. LIMITED (in Liquidation).

Notice is hereby given that the Final Meeting of the members of the above-named company will be held at Bradmill House, Missenden-road, Camperdown, on the 15th day of November, 1972, at 2.45 p.m.

The purpose of the meeting is to receive the account of the liquidator showing how the winding up has been conducted and how the property of the company has been disposed of and to give any explanation of this account.

Dated this 31st day of July, 1972.

KENNETH CROSS, liquidator, 395 Collins-street, Melbourne, Vic., 3000. 7722

In the matter of the *Companies Act 1961*; and in the matter of BRADFORD COTTON MILLS (AUSTRAL) PROPRIETARY LIMITED (in Liquidation).

Notice is hereby given that at a General Meeting of the above-named company, duly convened and held at Bradmill House, Missenden-road, Camperdown, on the 28th day of July, 1972, the following Special Resolution was duly passed:—

"It was resolved that the company be wound up voluntarily, and that Kenneth Cross be and is hereby appointed liquidator for the purpose of winding up."

Dated this 31st day of July, 1972.

In the matter of the *Companies Act 1961*; and in the matter of BRADFORD COTTON MILLS (AUSTRAL) PROPRIETARY LIMITED (in Liquidation).

Notice is hereby given that the Final Meeting of the members of the above-named company will be held at Bradmill House, Missenden-road, Camperdown, on the 15th day of November, 1972, at 3 p.m.

The purpose of the meeting is to receive the account of the liquidator showing how the winding up has been conducted and how the property of the company has been disposed of and to give any explanation of this account.

Dated this 31st day of July, 1972.

KENNETH CROSS, liquidator, 395 Collins-street, Melbourne, Vic., 3000. 7723

Creditors, next of kin and others having claims against the estate of Laurence Michael Foley, late of 11 Pine-grove, Malvern, retired, deceased (who died on 26th May, 1972), are required by Patrick Francis Toohey and Rose Veronica Foley, the executors of the will of deceased, to send to them, care of the undersigned solicitors, particulars thereof by 20th October, 1972, after which date they will distribute the assets, having regard only to the claims of which they shall then have notice.

GAVAN DUFFY & KING, solicitors, 95 Queen-street, Melbourne. 7750

SARAH WOOLEY, late of 57 Drummond-street, Carlton, widow, DECEASED.

Creditors, next of kin and others having claims in respect of the estate of the above-named deceased (who died on the 20th day of April, 1972), are required by the executrix, Elizabeth Pelon, of 10 Pender-street, Thornbury, widow, to send her particulars of such claims by the 19th day of October, 1972, after which date she may convey or distribute the assets, having regard only to the claims of which she then has notice.

ROCKMAN JANÓVER & FREEDMAN, solicitors, 224 Queen-street, Melbourne, 3000. 7736

Creditors, next of kin and others having claims in respect of the estate of Frederick James Wells Batt, late of 16 Mayfield-avenue, Malvern, retired company director, deceased (who died on the 22nd day of January, 1972), are required by the executor, John Michael Batt, of 55 Belford-avenue, Kew, barrister-at-law, to send particulars of their claims to him at the above address, by the 11th day of October, 1972, after which date he will distribute the assets, having regard only to the claims of which he then has notice.

Dated the 8th day of August, 1972.

OSWALD BURT & CO., solicitors, 389 Lonsdale-street, Melbourne. 7725

FRANCES LOUISE ROBERTS, late of Karana Baptist Home, 55 Walpole-street, Kew, spinster, DECEASED.

Creditors, next of kin and others having claims in respect of the estate of the above-named deceased (who died on the 21st day of October, 1971), are required by the executor, The Equity Trustees, Executors and Agency Company Limited, of 472 Bourke-street, Melbourne, to send particulars to it by the 11th day of October, 1972, after which date the executor will distribute the assets of the estate, having regard only to the claims of which they then have notice.

HALL & WILCOX, solicitors, 20 Queen-street, Melbourne. 7726

JOAN MARGARET PATON, late of Unit 3, 125 Park-road, Cheltenham, in the State of Victoria, dressmaker, DECEASED, intestate.

Creditors, next of kin and others having claims in respect of the estate of the deceased (who died on 8th May, 1972), are required by the trustee, Graeme Hamilton Paton, of 10 Powys-drive, Beaumaris, in the said State, manager, to send particulars to him by the 13th day of October, 1972, after which date the trustee will distribute the assets, having regard only to the claims of which he then has notice.

SLATER & GORDON, solicitors, 395 Collins-street, Melbourne, 3000. 7727

Trustee Act 1958.

NOTICE TO CLAIMANTS.

Pursuant to the *Trustee Act 1958*, creditors next of kin and all other persons having claims in respect of the estate of any deceased person named below are required to send particulars to the legal personal representative or representatives at the addresses stated, after which date the representatives will distribute the assets, having regard only to the claims of which notice has been received:—

Michael Samuel Thompson, late of 13 Woods-street, Newport, retired electric train driver, deceased, died on the 6th day of June, 1972.—Claims to the executrix, Irene Elizabeth Thompson, of 13 Wood-street, Newport, widow, care of John F. Carroll, of 4 Paisley-street, Footscray, solicitor, by the 4th day of October, 1972. John F. Carroll, LL.B., solicitor, 4 Paisley-street, Footscray. 7740

Eileen Rose Stevens, late of 2 Johnson-street, Footscray, widow, deceased, died on the 22nd day of May, 1972.—Claims to the executrix, Therese Mary Jones, of 43 Duthie-street, Ferryden Park in the State of South Australia, married woman, care of John F. Carroll, of 4 Paisley-street, Footscray, solicitor, by the 12th day of October, 1972. John F. Carroll, LL.B., solicitor, 4 Paisley-street, Footscray. 7741

Ida Freda Leaman, late of 6 Steele-street, Newport, married woman, deceased, died on the 11th day of May, 1972.—Claims to the executor, William John Leaman, of 6 Steele-street, Newport, retired hairdresser, care of John F. Carroll, of 4 Paisley-street, Footscray, solicitor, by the 12th day of October, 1972. John F. Carroll, LL.B., solicitor, 4 Paisley-street, Footscray. 7742

Creditors, next of kin and others having claims in respect of the estate of Stanley Gordon Miles, late of 620 Lower Plenty-road, East Rosanna, in the State of Victoria, gentleman, deceased (who died on 20th March, 1972), are to send the particulars of their claims to the executors, Arthur Charles Miles and Ethel Miles, in care of Colin Keon-Cohen, 472 Bourke-street, Melbourne, by the 11th October, 1972, after which date they will distribute the assets, having regard only to the claims of which they then have notice.

Dated the 4th August, 1972.

COLIN KEON-COHEN, solicitor, 472 Bourke-street, Melbourne. 7712

JAMES VICTOR JOSEPH RODDIS, late of 29 Queen-street, Ormond, in the State of Victoria, retired farmer, DECEASED (who died on 28th March, 1972).

Creditors, next of kin and all other persons having claims against the estate of the deceased are required by the executors of his will, Annie Georgina Buckley, of 29 Queen-street, Ormond, in the said State, nursing sister and Bruce Alexander Moore, of 33 Clark-road, Ivanhoe, in the said State, solicitor, to send particulars thereof to them, care of the under-mentioned solicitors, before 13th October, 1972, after which date they may distribute the assets of the deceased, having regard only to the claims of which they then have notice.

COLTMAN, WYATT & ANDERSON, solicitors, 379 Collins-street, Melbourne. 7711

Creditors, next of kin and others having claims against the estate of Florence Dorward, late of 260 Woodlands-street, Strathmore, in the State of Victoria, married woman, deceased (who died on the 24th day of June, 1972), are required to send particulars of their claims to Barbara Mary Gould and Dorothy Mary Moyle, the executrices of the will of the above-named deceased, care of the undersigned solicitor, before the 25th day of October, 1972, after which date they will distribute the assets, having regard only to the claims of which they then have notice.

JOHN F. CARROLL, solicitor, 118 Queen-street, Melbourne. 7713

BLASIUS WOLF, late of 26 Turner-street, Glen Iris, in the State of Victoria, gentleman, DECEASED.

Creditors, next of kin and others having claims in respect of the estate of the deceased (who died on the 22nd day of October, 1971), are required by the trustee, The Union-Fidelity Trustee Company of Australia Limited, of 100 Exhibition-street, Melbourne, in the said State, to send particulars to it by the 30th day of October, 1972, after which date the trustee may convey or distribute the assets, having regard only to the claims of which it then has notice.

KEITH HERCULES & SONS, solicitors, 443 Little Collins-street, Melbourne. 7714

JOHN MERRICK TEAGUE, late of "Strathardle", Riddells Creek, retired, DECEASED.

Creditors, next of kin and others having claims in respect of the estate of the deceased (who died on the 15th December, 1971), are to send particulars of their claims to National Trustees, Executors and Agency Company of Australasia Limited, of 95 Queen-street, Melbourne, by the 9th October, 1972, after which date it will distribute the assets, having regard only to the claims of which it then has notice.

CORR & CORR, solicitors, 290 Latrobe-street, Melbourne. 7715

Creditors, next of kin and others having claims against the estate of George Eli Killingbeck, late of unit 3, 184 Riversdale-road, Camberwell, T.P.I. pensioner, deceased (who died on the 7th May, 1972), are required by the executrix, Muriel Ida Ebdon, of unit 3, 184 Riversdale-road, Camberwell, widow, to send particulars of such claims to her at the office of the undersigned solicitors, on or before the 11th October, 1972, after which date she will distribute the assets, having regard only to the claims of which she shall then have had notice.

A. NEWTON SUPER & P. G. KOVACS, barristers and solicitors, 374 Bourke-street, Melbourne. 7667

JANET FULTON, late of 1313 Mair-street, Ballarat, spinster, DECEASED (who died on the 24th April, 1972).

Creditors, next of kin and persons having claims against the estate of the deceased, are required to send particulars to the executors, Doris May McKay and Walter Henry Heinz, of 209 Dana-street, Ballarat, on or before the 10th October, 1972, after which date they will distribute the assets, having regard only to the claims of which they shall then have notice.

HEINZ & GORDON, solicitors, 209 Dana-street, Ballarat. 7705

Creditors, next of kin and others having claims in respect of the estate of **WILLIAM ALBERT FLAVELL**, late of 23 Dalgetty-road, Beaumaris, gentleman (who died on 13th May, 1972), are to send particulars of their claims to NATIONAL TRUSTEES, EXECUTORS AND AGENCY COMPANY OF AUSTRALASIA LIMITED, 95 Queen-street, Melbourne, 3000, by the 11th day of October, 1972, after which date it will distribute the assets, having regard only to the claims of which it then has notice. 7708

Creditors, next of kin and others having claims in respect of the estate of George Panovski, late of 136 Stephens-street, Yarraville, in the State of Victoria, labourer, deceased (who died on the 7th day of April, 1972), are to send particulars of their claims to the administrator, Peco Stojanovski, of 2 Dane-street, Footscray, in the said State, leading hand, care of Loft & Associates, of 101 Nicholson-street, Footscray, by the 26th day of October, 1972, after which they will distribute the assets, having regard only to the claims of which they now have notice.

LOFT & ASSOCIATES, 101 Nicholson-street, Footscray. 7662

CHARLOTTE ANN BROWN, late of 19 Marston-street, Bentleigh, spinster, deceased.

Creditors, next of kin and others having claims in respect of the estate of the deceased (who died on the 25th day of March, 1972), are required by the executor and trustee, The Union-Fidelity Trustee Company of Australia Limited, of 100 Exhibition-street, Melbourne, to send particulars of their claims to the said trustee company by the 9th day of October, 1972, after which date the said trustee company may convey or distribute the assets, having regard only to the claims of which it then has notice.

LESTER, PEARN & FIELDEN, solicitors, 358 Centre-road, Bentleigh. 7664

Creditors, next of kin and others having claims in respect of the estate of Edwin Allen Sandell (sometimes known as Edwin Allen Sandles), late of Poplar-road, Parkville, in Victoria, retired labourer (who died on 29th March, 1972), are required by the executrix, Mina Hazel Martha Verrall, of Morwell, widow, to send particulars to her, care of the undersigned solicitor, by 20th October, 1972, after which date she may distribute the assets, having regard only to the claims of which she then has notice.

C. H. FORD, LL.M., solicitor, Princes-street, Traralgon. 7665

Creditors, next of kin and others having claims in respect of the estate of Frederick Allan Mitchell, formerly of 3 Melba-street, Wangaratta, but late of 8 Lofty-avenue, Camberwell in the State of Victoria, gentleman, deceased (who died on the 29th day of February, 1972), are to send particulars of their claims to The Equity, Trustees Executors and Agency Company Limited by the 30th day of October, 1972, after which date it will distribute the assets, having regard only to the claims of which it then has notice.

DAVID THOMAS & FRENKEL, of 303 Latrobe-street, Melbourne, solicitors for the company. 7709

ISABEL MAY STEWART, late of Warramunga Retirement Village, Kyabram, in the State of Victoria, widow, DECEASED.

Creditors, next of kin and others having claims in respect of the estate of the said deceased (who died on the 18th day of April, 1972), are to send particulars of their claims to the executor, namely Arthur James Stewart, care of the under-mentioned solicitors by the 12th day of October, 1972, after which date the said executor will distribute the assets in the said estate, having regard only to the claims of which he then has notice.

PAVEY, WILSON, COHEN & CARTER, solicitors, 390 Lonsdale-street, Melbourne. 7710

Creditors, next of kin and others having claims in respect of the estate of Ronald James May, late of Alpine Lodge, Healesville, cook, deceased, intestate (who died on the 17th day of May, 1972), are requested to send particulars of their claims to the administratrix, Melvis Gwendoline Baker, care of the under-mentioned solicitors, by the 12th day of October, 1972, after which date she will distribute the assets, having regard only to the claims of which she then has notice.

MAHONY, O'BRIEN & DUGGAN, solicitors, 37 Queen-street, Melbourne. 7778

Creditors, next of kin and others having claim in respect of the estate of John Thomas Tuttle, late of 64 Cramer-street, Preston, in the State of Victoria, waterside worker, deceased (who died on the 13th day of May, 1972), are to send particulars of their claims to Royston, Cahir, Martin & Dillon, solicitors, of 17 Queen-street, Melbourne, by the 16th day of October, 1972, after which date the executrix will distribute the assets of the estate, having regard only to claims of which she has notice.

ROYSTON CAHIR, MARTIN & DILLON, solicitors, of 17 Queen-street, Melbourne. 7779

DONALD CLIFFORD DUNSTAN, of 5 Balfour-street, Doncaster, in the State of Victoria, secretary-manager, DECEASED.

Creditors, next of kin and others having claim in respect of the estate of the above-named deceased (who died on the 6th day of February, 1972), are required to send particulars thereof to the executor, care of the under-mentioned solicitor, on or before the 10th day of October, 1972, after which date the said executor may convey or distribute the assets, having regard only to the claims of which he then has notice.

K. P. REES, B.A., LL.B., solicitor, 118 Queen-street, Melbourne. 7777

FREDERICK JOSEPH PEARSON, late of 63 Argyll-street, Chadstone, electroplater, DECEASED.

Creditors, next of kin and others having claims against the estate of the above-named deceased (who died on the 3rd day of December, 1971), are required to send particulars of their claims to Nancy Pearson, care of the under-mentioned solicitor, by the 10th day of October, 1972, after which date she may convey or distribute the assets, having regard only to the claims of which she then has notice.

IRVING S. PLOTKIN, LL.B., 388 Bourke-street, Melbourne. 7780

ALFRED IVANHOE ALLEN, late of 97 Stanley-street, West Melbourne, labourer, DECEASED.

Creditors, next of kin and others having claims against the estate of the above-named deceased (who died on the 23rd day of April, 1972), are required to send particulars of their claims to the executrix, Alma Allen, care of the under-mentioned solicitor, by the 10th day of October, 1972, after which date she may convey or distribute the assets, having regard only to the claims of which she then has notice.

IRVING S. PLOTKIN, LL.B., -solicitor, 502 Victoria-street, North Melbourne. 7781

JOHN EDGAR JONES, late of 70 Gatehouse-street, Parkville, retired, DECEASED.

Creditors, next of kin and others having claims against the estate of the above-named deceased (who died on the 19th day of May, 1972), are required to send particulars of their claims to the executor, Irving Samuel Plotkin, at the under-mentioned address, by the 10th day of October, 1972, after which date he may convey or distribute the assets, having regard only to the claims of which he then has notice.

IRVING S. PLOTKIN, LL.B., 502 Victoria-street, North Melbourne. 7782

ANNIE EMILY FRANCES MAGUIRE, late of 22 The Ridgeway, Kensington, home duties, DECEASED.

Creditors, next of kin and others having claims against the estate of the above-named deceased (who died on the 19th day of June, 1972), are required to send particulars of their claims to the executrix, May White, care of the under-mentioned solicitor, by the 10th day of October, 1972, after which date she may convey or distribute the assets, having regard only to the claims of which she then has notice.

IRVING S. PLOTKIN, LL.B., solicitor, 502 Victoria-street, North Melbourne. 7783

Creditors, next of kin and others having claims in respect of the estate of Ellen Sheehan, late of 219 Camberwell-road, Camberwell, retired school teacher (who died on the 29th day of February, 1972), are to send particulars of their claims to the executors, David Anthony Corrigan, and John Sheehan, care of the undersigned, by the 13th October, 1972, after which date they will commence to distribute the assets, having regard only to the claims of which they then have notice.

RENNICK & GAYNOR, solicitors, 481 Riversdale-road, Hawthorn East. 7784

Creditors, next of kin and others having claims against the estate of Alice Mary Thompson, late of 1187 Burke-road, East Kew, spinster, deceased (who died on 30th May, 1972), are required by Ellis Joseph Thompson, and Ellis Frank Thompson, the executors of the will of deceased, to send to them, care of the undersigned solicitors, particulars thereof, by 20th October, 1972, after which date they will distribute the assets, having regard only to the claims of which they shall then have notice.

GAVAN DUFFY & KING, solicitors, 95, Queen-street, Melbourne. 7748

MARDI BEARD, late of Marysville, widow, DECEASED.

Creditors, next of kin and others having claims in respect of the estate of the deceased (who died on the 5th day of March, 1972), are required by the executrix, Elizabeth Lillian Slater, of 5 Thompson-street, Ballarat East, widow, to send particulars to her, care of the undersigned, on or before the 22nd day of October, 1972, after which date she will distribute the assets, having regard only to the claims of which she then has notice.

R. P. BAYLOR & CO., solicitors, Healesville. 7676

Creditors, next of kin and others having claims against the estate of Abigail Mary Tuomy, late of 80 Nepean Highway, Mentone, widow, deceased (who died on 24th April, 1972), are required by Patrick Francis Toohey, and Joseph John Dynon, the executors of the will of deceased, to send to them, care of the undersigned solicitors, particulars thereof, by 20th October, 1972, after which date they will distribute the assets, having regard only to the claims of which they shall then have notice.

GAVAN DUFFY & KING, solicitors, 95 Queen-street, Melbourne. 7749

LENA MARGARET WILSON, late of Kinross Private Hospital, Broughton-road, Surrey Hills, widow, DECEASED.

Creditors, next of kin and others having claims in respect of the estate of the above-named deceased (who died on the 25th February, 1972), are required by the trustee, Geoffrey Campbell Wilson, of 13 Studley Park-road, Kew, medical practitioner, to send particulars to him, care of the undersigned by the 11th October, 1972, after which date the trustee may convey or distribute the assets, having regard only to the claims of which he then has notice.

WHITING & BYRNE, solicitors, 166 Queen-street, Melbourne. 7772

PERCY VANCE LANGMORE, late of 14 Langmore-lane, Berwick, retired medical practitioner, DECEASED.

Creditors, next of kin and others having claims in respect of the estate of the above-named deceased (who died on 1st June, 1972), are required by the trustee, Leonard Langmore, of 2 Lyndon Green, 2 Marlborough-street, Mont Albert, to send particulars to him, care of the undersigned, by the 11th October, 1972, after which date the trustee may convey or distribute the assets, having regard only to the claims of which he then has notice.

WHITING & BYRNE, solicitors, 166 Queen-street, Melbourne. 7773

WINIFRED MAY WARD, late of 45 Black-street, Middle Brighton in the State of Victoria, spinster, DECEASED.

Creditors, next of kin and others having claims in respect of the estate of the deceased (who died on the 25th January, 1972), are to send particulars of their claims to the executor, Geoffrey Thomas Parkes, of 38 Glassford-street, Armadale, in the said State, investment advisor, care of the under-mentioned solicitors; by 10th day of October, 1972, after which date he may distribute the assets, having regard only to the claims of which he then has notice.

AITKEN, WALKER & STRACHAN, solicitors, of 414 Collins-street, Melbourne. 7770

Creditors, next of kin and others having claims in respect of the estate of Mary Di Gilio, late of 2A Linden-court, Windsor, in the State of Victoria, spinster, deceased (who died on the 22nd day of March, 1972), are required to send particulars of all claims to The Trustees, Executors and Agency Company Limited, of 401 Collins-street, Melbourne, in the said State, by the 11th October, 1972, after which date the executors will distribute the assets of the estate, having regard only to the claims of which they have had notice.

NICHOLAS O'DONOHUE & CO., solicitors, 493 Law Courts-place, Melbourne, 3000. 7675

JOHN JOSEPH RYAN, formerly of "Talindert", Camperdown, stud master, but late of Camperdown, retired stud master, DECEASED.

Creditors, next of kin and others having claims in respect of the estate of the above-named deceased (who died on the 23rd November, 1971), are required by the executor, Patrick Joseph Sinnott, to send particulars to him, care of the under-mentioned solicitors, by the 31st day of October, 1972, after which date he may convey or distribute the assets, having regard only to the claims of which he shall then have had notice.

ARTHUR E. GEORGE & SONS, solicitors, 202 Manifold-street, Camperdown. 7747

ROSE FANNY ANTHONY, formerly of 276 Union-road, Balwyn, but late of 7 Hastings-street, Burwood in the State of Victoria, widow, DECEASED.

Creditors, next of kin and others having claims in respect of the estate of the deceased (who died on the 6th day of May, 1972), are to send particulars of their claims to the executor, Robert Russell Aitken, of 414 Collins-street, Melbourne in the said State, solicitor, care of the under-mentioned solicitors, by the 10th day of October, 1972, after which date he may distribute the assets, having regard only to the claims of which he then has notice.

AITKEN, WALKER & STRACHAN, solicitors, of 414 Collins-street, Melbourne. 7771

Creditors, next of kin and others having claims against the estate of Norma Salmon, late of "Windwhistle Farm", Mount Moriac, married woman, deceased (who died on the 18th day of April, 1972), are required by the executors, Ian, Hillhouse Salmon, of "Windwhistle Farm", Mount Moriac, company director, and Geoffrey Robin Westacott, of "Douglas House", 47 Yarra-street, Geelong, solicitor, to send particulars, care of the under-mentioned address, on or before the 16th day of November, 1972, after which date the executors may convey or distribute the assets, having regard only to the claims to which they then have notice of.

PRICE, HIGGINS & FIDGE, solicitors, "Douglas House", 47 Yarra-street, Geelong. 7672

SAMUEL DESMOND GOODWIN, late of 395 Maroondah Highway, Croydon, fuel merchant, DECEASED.

Creditors, next of kin and others having claims in respect of the estate of the above-named deceased (who died on the 13th day of May, 1972), are required by the executor of the will of the said deceased, John Francis Bell, of 100 Herbert-street, Dandenong, storeman, to send particulars to him, in the care of the undersigned, by the 27th day of October, 1972, after which date the executor may convey or distribute the assets, having regard only to the claims of which he then has notice.

MACPHERSON & KELLEY, solicitors, 229 Thomas-street, Dandenong. 7678

Creditors, next of kin and others having claims in respect of the estate of Robert Miller, formerly of 92 Hickford-street, East Brunswick, but late of 19 Bayview-street, Elsternwick, in the State of Victoria, retired gentleman, deceased (who died on the 23rd day of December, 1971), are to send particulars of their claims to Jane Miller, care of the under-mentioned solicitors, by the 9th day of October, 1972, after which date she will distribute the assets, having regard only to the claims to which she then has notice.

Dated this 3rd day of August, 1972.

REGINALD C. BUTLER & CO., solicitors, 312 Centre-road, Bentleigh. 7698

Creditors, next of kin and others having claims against the estate of William Benson, late of 349 Humffray-street north, Ballarat, retired contractor, deceased (who died on the 14th day of April, 1970), are requested to send particulars of their claims to the executor, John Benson Thurling, of 419A Humffray-street north, Ballarat, joiner, by the 3rd day of October, 1972, after which date the said executor will distribute the assets, having regard only to the claims of which he then has notice. Particulars of all payments to be forwarded, care of Nevett, Glenn & Courtts, 205 Dana-street, Ballarat.

NEVETT, GLENN & COURTTS, solicitors, 205 Dana-street, Ballarat. 7704

JAMES BRIGHT ELLINGHAM, late of 44 Pigdon-street, North Carlton, in the State of Victoria, pensioner, DECEASED.

Creditors, next of kin and all others having claims in respect of the estate of James Bright Ellingham, late of 44 Pigdon-street, North Carlton, pensioner, deceased (who died on the 12th day of February, 1972), are required by the executrix, Marion Frances Hefferman, of 44 Pigdon-street, North Carlton, widow, to send particulars of their claims to her, in the care of the under-mentioned solicitor, prior to the 10th day of October, 1972, after which date she will distribute the assets, having regard only to the claims of which she then has notice.

M. F. HUGHES, LL.B., 300 Barkly-street, Brunswick. 7700

PAUL RONALD DUNLOP, late of 6 Barnett-street, Swan Hill, in the State of Victoria, student, DECEASED, intestate (who died on the 22nd May, 1972).

Creditors, next of kin and all other persons having claims against the estate of the deceased are required by the administrator, Ronald Victor Dunlop, to send particulars to him, care of the undersigned, on or before the 2nd day of November, 1972, after which date he will distribute the assets, having regard only to the claims of which he then has notice.

GARDEN & GREEN, solicitors, 4 McCallum-street, Swan Hill. 7688

HORACE ALEXANDER MASTERS, late of Woorinen, in the State of Victoria, clerk, DECEASED.

Creditors, next of kin and others having claims in respect of the estate of the deceased (who died on the 27th day of May, 1972), are required by the executrix, Franciska Elizabeth Masters, of Woorinen aforesaid, widow, to send particulars to her, care of the undersigned, by the 17th day of October, 1972, after which date the executrix may convey or distribute the assets, having regard only to the claims of which she then shall have notice.

Dated this 31st day of July, 1972.

ALEC M. HAYES, solicitor, 148 Campbell-street, Swan Hill. 7682

Creditors, next of kin and others having claims in respect of the estate of Eva Rae, late of 797 Gilbert-road, Reservoir, in the State of Victoria, widow (who died on the 20th day of March, 1972), are to send the particulars of their claims to The Union-Fidelity Trustee Company of Australia Limited, of 100 Exhibition-street, Melbourne, by the 15th day of October, 1972, after which date the executor will distribute the assets of the estate of the said deceased, having regard only to the claims of which it has notice.

K. G. McINTYRE & TRUCANO, solicitors, 1039 Whitehorse-road, Box Hill, 3128. 7699

In the Supreme Court of the State of Victoria.

SALE BY THE SHERIFF.

On Friday, the 29th of September, 1972, at 10 a.m., at the Police Station, Thomastown (unless process be stayed or satisfied):—

All the estate and interest (if any) of Sharon Evans, school teacher, of 7 Manus-court, Lalor, as joint proprietor with Stanley Alfred Evans, of an estate in fee-simple in the land described in certificate of title, volume 8751, folio 489, upon which is erected a brick veneer house, known as No. 7 Manus-court, Lalor.

Registered mortgage Nos. D.598430 and D.612657 affect the said estate and interest.

Terms: Cash only.

DOUGLAS S. HALL, Sheriff's Officer.

9th August, 1972.

7774

In the Supreme Court of the State of Victoria.

SALE BY THE SHERIFF.

On Friday, the 29th of September, 1972, at 11 a.m., at the Police Station, Preston (unless process be stayed or satisfied):—

All the estate and interest (if any) of Vincent Gerard McGrath, manufacturer, of 487 Gilbert-road, West Preston, as joint proprietor with Josephine Mary McGrath, of an estate in fee-simple in the land described in certificate of title, volume 6573, folio 599, upon which is erected a dwelling-house, known as No. 487 Gilbert-road, West Preston.

Registered mortgage No. D.282770 affects the said estate and interest.

Terms: Cash only.

DOUGLAS S. HALL, Sheriff's Officer.

9th August, 1972.

7775

In the Supreme Court of the State of Victoria.

SALE BY THE SHERIFF.

On Friday, the 22nd of September, 1972, at 2 p.m., at the Police Station, Mordialloc (unless process be stayed or satisfied):—

All the estate and interest (if any) of Eric Matthews, business proprietor and Doreen Matthews, married woman, both of 17 Ardoyne-street, Black Rock, as joint proprietors

of an estate in fee-simple in the land described in certificate of title, volume 8685, folio 179, and volume 8721, folio 227, upon which is erected a factory building, known as Nos. 5-7 Beach-avenue, Mordialloc.

Registered mortgage No. D.881833 affects the said estate and interest.

Terms: Cash only.

DOUGLAS S. HALL, Sheriff's Officer.

9th August, 1972.

7776

INSOLVENCY NOTICES

Bankruptcy Act 1966, Part X.—In the matter of JOHN LESLIE ROGERS.

Notice is hereby given that a first and final dividend is intended to be declared in the above matter. Creditors who have not proved their debts by the 23rd day of August, 1972, may be excluded from this dividend.

Dated this 9th day of August, 1972.

I. K. MACKINNON, Registered Trustee.

John MacKinnon & Co., chartered accountants, Suite 12, 562 St. Kilda-road, Melbourne, 3004. Telephone: 51 2178.

7701

Bankruptcy Act 1966, Part X.—In the matter of ARTHUR EDWARD ROGERS.

Notice is hereby given that a first and final dividend is intended to be declared in the above matter. Creditors who have not proved their debts by the 23rd day of August, 1972, may be excluded from this dividend.

Dated this 9th day of August, 1972.

I. K. MACKINNON, Registered Trustee.

John MacKinnon & Co., chartered accountants, Suite 12, 562 St. Kilda-road, Melbourne, 3004. Telephone: 51 2178.

7702

IMPOUNDINGS

BENDIGO.—Impounded in Bendigo Pound on 4th August, 1972.

1 Jersey cow with Hereford cross calf at foot, 2 snips in right ear, no visible brand

If not claimed and expenses paid to be sold on 24th August, 1972.

7755—\$2.80 NORMAN L. HARRIS, Poundkeeper.

CAMPERDOWN.—Impounded in Camperdown Pound, seized in Adeney-street.

2 heifer calves, no visible brand

If not claimed and expenses paid, to be sold on 29th August, 1972.

7753—\$2.45 L. BREEN, Poundkeeper.

COBDEN.—Impounded in Cobden Pound.

1 Hereford Friesian crossbred steer, slit top of near ear, no visible brand

1 Hereford heifer, slit top of near ear, no visible brand
If not claimed and expenses paid, to be sold on 25th August, 1972.

7764—\$2.80 J. S. BRADD, Poundkeeper.

COHUNA.—Impounded in Cohuna Pound from Findlay's-lane.

2 Guernsey/Jersey crossbred heifers, no visible brand

If not claimed and expenses paid, to be sold on 17th August, 1972.

7756—\$2.45 R. E. KNOWLES, Municipal Clerk.

DONALD.—Impounded in Donald Pound on Wednesday, 2nd August, 1972, from North Western Highway, for being unattended at Cope Cope.

1 Jersey type steer, earmarks both ears (Poll), no visible brand

1 Shorthorn crossbred steer, earmarks both ears, no visible brand

1 poll Shorthorn crossbred cow, earmarks both ears, no visible brand

1 Hereford type cow, earmarks both ears, no visible brand
2 poll Hereford heifers, earmarks both ears, no visible brand

1 black and white poll steer, earmarks both ears, no visible brand

1 poll Shorthorn type steer, earmarks both ears, no visible brand

1 Jersey crossbred cow, earmarks both ears, no visible brand

1 Hereford steer, earmark both ears, no visible brand

1 poll Hereford crossbred steer, earmarks both ears, no visible brand

2 Shorthorn type heifers, earmarks both ears, no visible brand

1 poll shorthorn type steer, earmarks both ears, no visible brand

If not claimed and expenses paid, to be sold on 1st September, 1972.

7761—\$9.80 W. A. CAMERON, Poundkeeper.

DONCASTER.—Impounded in Doncaster East Pound, Warrandyte-road, by ranger.

1 Hereford crossbred bull, no visible brand

If not claimed and expenses paid, to be sold on 23rd August, 1972.

7758—\$2.45 H. M. F. MEARS, Acting Town Clerk.

DRYSDALE.—Impounded in Drysdale Pound from Hayes-road, Point Henry, by the Shire Ranger, Mr. N. R. Willis.

12 ewes, no visible brand

If not claimed and expenses paid, to be sold on 24th August, 1972.

7765—\$3.50 G. NORMAN, Poundkeeper.

KEILOR.—Impounded in Keilor Pound by City of Essendon.

1 lamb, ewe, off side horn broken, hole in off side ear, blue raddle mark on back

If not claimed and expenses paid, to be sold on 24th August, 1972.

7754—\$2.80 C. M. MISSEN, Poundkeeper.

KILMORE.—Impounded in Kilmore Pound.

1 aged bay gelding, no visible brand

If not claimed and expenses paid, to be sold on 24th August, 1972.

7763—\$2.10 I. Y. WRIGHT, Poundkeeper.

LAKE BENETOOK.—Impounded in Lake Benetook Pound.

23 ewes, varied earmarks, blurred brands

2 lambs, varied earmarks, blurred brands

If not claimed and expenses paid, to be sold on 17th August, 1972.

7762—\$2.45 E. F. CURTIS, Poundkeeper.

LARA.—Impounded in Lara Pound.

1 black and white steer, no visible brand

14 ewes and wethers, no visible brand

If not claimed and expenses paid, to be sold on 26th August, 1972, at noon.

7760—\$2.45 J. BAILEY, Poundkeeper.

MELTON.—Impounded in Melton Pound by Shire Ranger.

2 Dorset Horn rams, no visible brand

If not claimed and expenses paid, to be sold on 25th August, 1972.

7792—\$2.10 M. B. WATSON, Shire Secretary.

MT. MORIAC.—Impounded in Mt. Moriac Pound, Ervin's-road, by Council Ranger.

13 ewes, earmark "Sparrow Tail", no visible brand

7 lambs, no markings, no visible brand

If not claimed and expenses paid, to be sold on 24th August, 1972.

7759—\$2.80 W. D. HUTTON, Poundkeeper.

TERANG.—Impounded in Terang Pound from Ewing-street.
1 wether, no visible brand

If not claimed and expenses paid, to be sold on 28th August, 1972.

7757—\$2.10

DORIS M. KIDD,
Poundkeeper.

WHITTLESEA.—Impounded in Epping Pound by Ranger.
5 Merino crossbred ewes, with various earmarks, no visible brand

If not claimed and expenses paid, to be sold on 25th August, 1972.

7791—\$2.45

W. HERD,
Poundkeeper.

Subordinate Legislation Act 1962.

NOTICE OF MAKING OF STATUTORY RULES.

In pursuance of the provisions of the *Subordinate Legislation Act 1962* and the Regulations made thereunder, notice is given of the making of the following statutory rules:—

No.	Apprenticeship Act 1958.	Price.
209/1972.	Apprenticeship (Modular Courses No. 8) Regulations 1972	10c
<i>Education Act 1958.</i>		
210/1972.	Education Department (Amendment) Regulations 1972	20c
<i>Public Service Act 1958.</i>		
211/1972.	Public Service (Governor in Council) Regulations 1972	10c
<i>Marine Act 1958.</i>		
212/1972.	Marine (Pilots' Eyesight) Regulations 1972	10c

Copies of these statutory rules may be purchased at the Sale of Publications Section of the Government Printing Office, located at 7A Parliament-place, Melbourne, 3002. If ordered by mail, remittance should be addressed to "The Government Printer, Box 203, P.O., North Melbourne, 3051", and should include 7c extra for postage. If a credit account is held at this office, no remittance is required with the mail order.

The annual subscription rate for Statutory Rules (including Bound Volumes) is \$23, payable in advance. The subscription year commences on 1st January.

C. H. RIXON,
Government Printer.

STATE ACTS, 1972

Copies of the following Acts of Parliament of Victoria may be obtained at the Government Printing Office, Sale of Publications Branch, off Parliament-place, Melbourne, phone 63 0321, extension 6181, or from any accredited agent, at the price set opposite to each (these prices do not include postage).

The annual subscription for State Acts 1972 et seq. is \$12.50 payable in advance.

Bound Volumes of State Acts are also available on a subscription basis of \$17.50 per annum.

No.	Price.
8242. Seamen's (Amendment)	\$0.10
8243. Land (Greyhound Racing)	\$0.10
8244. Melbourne Land (Royal Melbourne Institute of Technology)	\$0.10
8245. Adoption of Children (Amendment)	\$0.10
8246. Disposal of Uncollected Goods (Amendment)	\$0.15
8247. Crimes (Powers of Arrest)	\$0.15
8248. Trustee Companies (Sandhurst and Northern District Trustees Executors and Agency Company Limited)	\$0.10
8249. Victorian Arts Centre	\$0.10
8250. Road Traffic (Amendment)	\$0.10
8251. Trustee Companies (National Trustees)	\$0.10
8252. Game Act	\$0.10
8253. Vermin and Noxious Weeds (Allowances)	\$0.10
8254. Leo Cussen Institute for Continuing Legal Education	\$0.15
8255. Revocation and Excision of Crown Reservations	\$0.10
8256. Dookie Agricultural College Land	\$0.15
8257. Country Fire Authority (Amendment)	\$0.15
8258. Select Committee (Ansett Transport Industries)	\$0.10

STATE ACTS, 1972—continued.

No.	Price.
8259. Legal Profession Practice (Amendment)	\$0.15
8260. Mt. Hotham Alpine Resort	\$0.20
8261. Nurses (Amendment)	\$0.10
8262. Films (Amendment)	\$0.10
8263. County Court (Jurisdiction)	\$0.10
8264. Soldier Settlement (Amendment)	\$0.10
8265. Government Buildings Advisory Council	\$0.10
8266. Poisons (Amendment)	\$0.10
8267. Police Offences	\$0.10
8268. Public Service (Amendment)	\$0.10
8269. Racing (Totalizator Commissions)	\$0.10
8270. Stamps (Bookmakers' Statements)	\$0.10
8271. Workers Compensation	\$0.10
8272. Liquor Control (Amendment)	\$0.15
8273. Archaeological and Aboriginal Relics Preservation	\$0.20
8274. Taxation Appeals	\$0.30
8275. Justices	\$0.20
8276. Consumer Protection	\$0.60
8277. Environment Protection (Amendment)	\$0.15
8278. Coal Mines (Pensions)	\$0.10
8279. Motor Car (Amendment)	\$0.15
8280. Crimes (Amendment)	\$0.15
8281. Melbourne and Metropolitan Board of Works (Reconstitution)	\$0.10
8282. Supply (Supplementary Estimates)	\$0.10
8283. Victoria Institute of Colleges (Affiliated Colleges)	\$0.10
8284. Supreme Court (Civil Appeals)	\$0.10
8285. Tattersall Consultations (Amendment)	\$0.10
8286. Parliamentary Committees (Take-over Offers)	\$0.15
8287. Dentists	\$0.40
8288. Firearms (Amendment)	\$0.30
8289. Sports Promotion	\$0.15
8290. Western Port (Steel Works)	\$0.10
8291. Local Government	\$0.30
8292. Supply (July to September)	\$0.10
8293. Marine	\$0.15

C. H. RIXON,
Government Printer.

ACTS REPRINTED IN ACCORDANCE WITH THE AMENDMENTS INCORPORATION ACT 1958 (No. 6422), AND FOR SALE AT THE SALE OF PUBLICATIONS BRANCH OF THE GOVERNMENT PRINTING OFFICE, MACARTHUR-STREET, MELBOURNE, 3002.

(These prices do not include postage.)

No.	Price.
6189. Acts Interpretation (Third Reprint—Incorporating amendments up to No. 7944)	\$0.35
6191. Administration and Probate (Fourth Reprint—Incorporating amendments up to No. 7874)	\$0.50
6194. Agricultural Colleges (First Reprint—Incorporating amendments up to No. 7302)	\$0.15
7117. Appeal Costs Fund Act 1964 (First Reprint—Incorporating amendments up to No. 7488)	\$0.25
6199. Apprenticeship (Second Reprint—Incorporating amendments up to No. 7869)	\$0.40
6201. Architects (First Reprint—Incorporating amendments up to No. 8077)	\$0.30
6203. Audit (First Reprint—Incorporating amendments up to No. 7377)	\$0.35
6208. Benefit Associations (First Reprint—Incorporating amendments up to No. 6961)	\$0.45
6529. Bread Industry Act 1959 (First Reprint—Incorporating amendments up to No. 7728)	\$0.30
6973. Building Contracts (Deposits) Act 1962 (First Reprint—Incorporating amendments from No. 7315)	\$0.10
6210. Building Societies (Second Reprint—Incorporating amendments up to No. 7911)	\$0.40
6213. Cancer (First Reprint—Incorporating amendments up to No. 7455)	\$0.35
6214. Carriers and Innkeepers (First Reprint—Incorporating amendments up to No. 7971)	\$0.15
6217. Cemeteries (First Reprint—Incorporating amendments up to No. 7672)	\$0.30
6218. Children's Court (Second Reprint—Incorporating amendments up to No. 8124)	\$0.45
6220. Clean Air (Second Reprint—Incorporating amendments up to No. 8196)	\$0.15
6221. Coal Mines (First Reprint—Incorporating amendments up to No. 7628)	\$1.05
6222. Commercial Goods Vehicles (Second Reprint—Incorporating amendments up to No. 7358)	\$0.22

ACTS REPRINTED IN ACCORDANCE WITH THE AMENDMENTS
INCORPORATION ACT 1958 (No. 6422)—*continued*.

No.	Price.
6223. Commonwealth Arrangements (<i>First Reprint</i> —Incorporating amendments from No. 7809)	\$0.10
6839. Companies Act 1961 (<i>Fourth Reprint</i> —Incorporating amendments up to Act No. 8185)	\$5.75
6224. The Constitution Act Amendment (<i>First Reprint</i> —Incorporating amendments up to No. 8086)	\$3.05
6225. Co-operation (<i>Second Reprint</i> —Incorporating amendments up to No. 7083)	\$0.42
6226. Co-operative Housing Societies (<i>Second Reprint</i> —Incorporating amendments up to No. 7575)	\$0.53
6227. Coroners (<i>First Reprint</i> —Incorporating amendments up to No. 7935)	\$0.35
6228. Country Fire Authority (<i>Second Reprint</i> —Incorporating Amendments up to No. 7476)	\$0.50
6229. Country Roads (<i>Third Reprint</i> —Incorporating amendments up to No. 8140)	\$1.05
6230. County Court (<i>Second Reprint</i> —Incorporating amendments up to No. 8132)	\$0.65
6231. Crimes (<i>Third Reprint</i> —Incorporating amendments up to No. 7884, but not including No. 7876)	\$1.60
6232. Crown Proceedings (<i>First Reprint</i> —Incorporating amendments up to No. 7900)	\$0.30
6233. Dairy Products (<i>First Reprint</i> —Incorporating amendments up to No. 7945)	\$0.20
7060. Dandenong Valley Authority Act 1963 (<i>First Reprint</i> —Incorporating amendments up to No. 7523)	\$0.35
4989. Discharged Servicemen's Preference Act 1943 (<i>First Reprint</i> —Incorporating amendments up to No. 7788)	\$0.20
6815. Disposal of Uncollected Goods Act 1961 (<i>First Reprint</i> —Incorporating amendments up to No. 7181)	\$0.15
6237. Drainage Areas (<i>First Reprint</i> —Incorporating amendments up to No. 7276)	\$0.35
6238. Drainage of Land (<i>First Reprint</i> —Incorporating amendments up to No. 7876)	\$0.15
6239. Dried Fruits Act 1968 (<i>First Reprint</i> —Incorporating amendments up to No. 7337)	\$0.25
6240. Education (<i>First Reprint</i> —Incorporating amendments up to No. 7533)	\$0.45
6241. Electric Light and Power (<i>First Reprint</i> —Incorporating amendments up to No. 7315)	\$0.30
6242. Employers and Employés (Incorporating amendments up to No. 6740)	\$0.18
6243. Entertainments Tax (<i>First Reprint</i> —Incorporating amendments up to No. 7315)	\$0.25
6245. Estate Agents (<i>Fourth Reprint</i> —Incorporating amendments up to No. 8181)	\$0.85
6246. Evidence (<i>Third Reprint</i> —Incorporating amendments up to No. 7933)	\$0.65
7499. Extractive Industries Act 1966 (<i>Second Reprint</i> —Incorporating amendments up to No. 7951)	\$0.40
6250. Fertilizers (Incorporating amendments up to No. 7142)	\$0.25
6468. Filled Milk (<i>First Reprint</i> —Incorporating amendments up to No. 6886)	\$0.15
6251. Firearms (<i>Third Reprint</i> —Incorporating amendments up to No. 8092)	\$0.65
6916. Foreign Judgments Act 1962 (<i>First Reprint</i> including amendments made by No. 7332)	\$0.15
6585. Forests (Pulpwood Agreement) (Incorporating amendments up to No. 6886)	\$0.15
6254. Forests (<i>First Reprint</i> —Incorporating amendments up to No. 7356)	\$0.60
6255. Friendly Societies (<i>First Reprint</i> —Incorporating amendments up to No. 7554)	\$0.60
6256. Fruit and Vegetables (<i>First Reprint</i> —Incorporating amendments up to No. 6944)	\$0.30
6258. Game (<i>First Reprint</i> —Incorporating amendments up to No. 7389)	\$0.30
6260. Gas and Fuel Corporation (<i>First Reprint</i> —Incorporating amendments up to No. 7422)	\$0.70
6262. Geelong Harbor Trust (<i>First Reprint</i> —Incorporating amendments up to No. 7547)	\$0.45
6263. Geelong Waterworks and Sewerage (<i>First Reprint</i> —Incorporating amendments up to No. 7547)	\$0.75
8176. Gift Duty Act 1971 (<i>First Reprint</i> —Incorporating amendments from No. 8202)	\$0.55
6265. Goods (<i>Fourth Reprint</i> —Incorporating amendments up to No. 7862)	\$0.55
6266. Grain Elevators (<i>First Reprint</i> —Incorporating amendments up to No. 7486)	\$0.35

ACTS REPRINTED IN ACCORDANCE WITH THE AMENDMENTS
INCORPORATION ACT 1958 (No. 6422)—*continued*.

No.	Price.
6269. Hawkers and Pedlers (<i>First Reprint</i> —Incorporating amendments up to No. 7876)	\$0.30
6270. Health (<i>Second Reprint</i> —Incorporating amendments up to No. 7490)	\$1.65
6267. Hairdressers Registration (<i>First Reprint</i> —Incorporating amendments up to Act No. 7659)	\$0.30
6531. Hire Purchase Act 1959 (<i>Second Reprint</i> —Incorporating amendments from Act No. 8232)	\$0.55
6933. Home Finance Act 1962 (<i>First Reprint</i> —Incorporating amendments up to No. 7363)	\$0.25
6274. Hospitals and Charities (<i>Second Reprint</i> —Incorporating amendments up to No. 7455)	\$0.50
6275. Housing (<i>Second Reprint</i> —Incorporating amendments up to No. 8052)	\$1.65
6276. Imprisonment of Fraudulent Debtors (<i>First Reprint</i> —Incorporating amendments up to No. 7876)	\$0.35
6277. Industrial and Provident Societies (<i>First Reprint</i> —Incorporating amendments up to No. 7547)	\$0.35
6279. Instruments (<i>Fourth Reprint</i> —Incorporating amendments up to No. 7941)	\$0.75
6280. Judicial Proceedings Reports (<i>First Reprint</i> —Incorporating amendments up to No. 7596)	\$0.15
6282. Justices (<i>Third Reprint</i> —Incorporating amendments up to No. 7966)	\$1.40
6283. Labour and Industry (<i>Fifth Reprint</i> —Incorporating amendments up to No. 8211)	\$1.55
6284. Land Act 1959 (<i>Second Reprint</i> —Incorporating amendments up to No. 8243)	\$3.15
6534. Land Settlement Act 1959 (<i>First Reprint</i> —Incorporating amendments up to No. 7328)	\$0.30
6288. Land Surveyors (<i>First Reprint</i> —Incorporating amendments up to Act No. 7065)	\$0.30
6289. Land Tax (<i>Second Reprint</i> —Incorporating amendments up to No. 7466)	\$0.40
6285. Landlord and Tenant (<i>Third Reprint</i> —Incorporating amendments up to No. 7332)	\$0.68
6286. Lands Compensation (<i>First Reprint</i> —Incorporating amendments up to No. 7332)	\$0.25
6290. Latrobe Valley (<i>First Reprint</i> —Incorporating amendments up to No. 7332)	\$0.35
6291. Legal Profession Practice (<i>Second Reprint</i> —Incorporating amendments up to No. 7539)	\$0.70
6292. Libraries (<i>First Reprint</i> —Incorporating amendments up to No. 7364)	\$0.15
6295. Limitation of Actions (<i>Second Reprint</i> —Incorporating amendments up to No. 7457)	\$0.25
7145. Litter Act 1964 (<i>First Reprint</i> —Incorporating amendments up to No. 7608)	\$0.15
7695. Liquor Control Act 1968 (<i>First Reprint</i> —Incorporating Amendments up to No. 7753)	\$0.80
6298. Local Authorities Superannuation (<i>Second Reprint</i> —Incorporating amendments up to No. 7161)	\$0.40
6299. Local Government (<i>Second Reprint</i> —Incorporating amendments up to No. 7689)	\$4.00
6299. Local Government. New Parts X. and XI. (being a reprint of portion of No. 7835, as amended by No. 7847)	\$0.50
6301. Margarine (<i>First Reprint</i> —Incorporating amendments up to No. 7714)	\$0.18
6302. Marine (Incorporating amendments up to No. 7350)	\$0.72
6303. Marine Stores and Old Metals (<i>First Reprint</i> —Incorporating amendments up to No. 7876)	\$0.35
6304. Marketing of Primary Products (<i>First Reprint</i> —Incorporating amendments up to No. 7491)	\$0.45
6305. Markets (<i>First Reprint</i> —Incorporating amendments up to No. 7705)	\$0.20
6306. Marriage (<i>First Reprint</i> —Incorporating amendments up to No. 6959)	\$0.25
6307. Masseurs (<i>First Reprint</i> —Incorporating amendments up to No. 7566)	\$0.20
6309. Medical (<i>Second Reprint</i> —Incorporating amendments up to No. 7408)	\$0.40
6310. Melbourne and Metropolitan Board of Works (<i>Third Reprint</i> —Incorporating amendments up to No. 8082)	\$1.85
6311. Melbourne and Metropolitan Tramways (<i>First Reprint</i> —Incorporating amendments up to No. 7622)	\$0.70
6312. Melbourne Harbor Trust (<i>First Reprint</i> —Incorporating amendments up to No. 7356)	\$0.48
6405. Melbourne University (<i>First Reprint</i> —Incorporating amendments up to No. 7871)	\$0.40

ACTS REPRINTED IN ACCORDANCE WITH THE AMENDMENTS
INCORPORATION ACT 1958 (No. 6422)—continued.

No.	Price.
6605. Mental Health (Incorporating amendments up to No. 7356)	\$0.45
6315. Metropolitan Fire Brigades (Incorporating amendments up to No. 6886)	\$0.28
6316. Mildura Irrigation and Water Trusts (First Reprint—Incorporating amendments up to No. 7448)	\$0.75
6317. Milk and Dairy Supervision (Incorporating amendments up to No. 6964)	\$0.40
6318. Milk Board (Incorporating amendments up to No. 7093)	\$0.22
6319. Milk Pasteurization (First Reprint—Incorporating amendments up to No. 7480)	\$0.15
6320. Mines (Second Reprint—Incorporating amendments up to No. 7876)	\$1.25
6184. Monash University (First Reprint—Incorporating amendments up to No. 7533)	\$0.30
6324. Money Lenders (Second Reprint—Incorporating amendments up to No. 8016)	\$0.55
6832. Motor Boating Act 1961 (Second Reprint—Incorporating amendments up to No. 6961)	\$0.30
6325. Motor Car (Fourth Reprint—Incorporating amendments up to No. 8143)	\$2.05
6705. Navigable Waters (Oil Pollution) Act 1960. (First Reprint—Incorporating amendments up to No. 7890)	\$0.30
6328. Nurses (Second Reprint—Incorporating amendments up to No. 7375)	\$0.45
6329. Opticians Registration (First Reprint—Incorporating amendments up to No. 7409)	\$0.30
6330. Partnership (Second Reprint—Incorporating amendments up to No. 7315)	\$0.30
6331. Patriotic Funds (First Reprint—Incorporating amendments up to No. 7338)	\$0.25
6332. Pawnbrokers (First Reprint—Incorporating amendments up to No. 7876)	\$0.35
6257. Pesticides Act 1968 (First Reprint—Incorporating amendments up to No. 7595)	\$0.15
6334. Petroleum (First Reprint—Incorporating amendments up to No. 7876)	\$0.65
6889. Poisons Act 1962 (Second Reprint—Incorporating amendments up to No. 7588)	\$0.50
6337. Police Offences (Second Reprint—Incorporating amendments up to No. 7678)	\$0.28
6338. Police Regulation (Second Reprint—Incorporating amendments up to No. 8179)	\$0.95
6340. Portland Harbor Trust (First Reprint—Incorporating amendments up to No. 7475)	\$0.35
6341. Pounds (First Reprint—Incorporating amendments up to No. 7315)	\$0.25
7498. Port Phillip Authority Act 1966 (First Reprint—Incorporating amendments from No. 8081)	\$0.15
6342. Printers and Newspapers (First Reprint—Incorporating amendments up to No. 7876)	\$0.15
7494. Private Agents Act 1966 (First Reprint—Incorporating amendments in No. 7646)	\$0.35
6890. Probate Duty (Third Reprint—Incorporating amendments up to No. 8072)	\$0.75
6344. Property Law (Second Reprint—Incorporating amendments up to No. 7750)	\$1.15
6345. Public Account (First Reprint—Incorporating amendments up to No. 8012)	\$0.20
6346. Public Authorities Marks (First Reprint—Incorporating amendments from No. 7315)	\$0.10
6349. Public Service (Second Reprint—Incorporating amendments up to No. 7356)	\$0.40
6350. Public Trustee (Incorporating amendments up to No. 6961)	\$0.35
6353. Racing (Third Reprint—Incorporating amendments up to No. 8080)	\$1.45
6355. Railways (First Reprint—Incorporating amendments up to No. 7475)	\$0.75
6564. Registration of Births Deaths and Marriages Act 1959 (First Reprint—Incorporating amendments up to No. 7332)	\$0.25
2596. River Murray Waters Act 1915 (First Reprint—Incorporating amendments up to No. 7061)	\$0.35
6359. Road Traffic (Third Reprint—Incorporating amendments up to No. 8192)	\$0.35

ACTS REPRINTED IN ACCORDANCE WITH THE AMENDMENTS
INCORPORATION ACT 1958 (No. 6422)—continued.

No.	Price.
6360. Rural Finance (First Reprint—Incorporating amendments up to No. 7328)	\$0.15
6846. Rural Finance and Settlement Commission Act 1961 (First Reprint—Incorporating amendments up to No. 7332)	\$0.30
6917. Sale of Human Blood Act 1962 (First Reprint—Incorporating amendments from No. 7332)	\$0.10
6975. Sale of Land Act 1962 (Second Reprint—Incorporating amendments up to No. 7898)	\$0.30
6363. Second-hand Dealers (First Reprint—Incorporating amendments up to No. 7529)	\$0.25
7962. Securities Industry Act 1970 (First Reprint—Incorporating amendments made by Act No. 8059)	\$0.65
6367. Settled Land (Second Reprint—Incorporating amendments up to No. 7065)	\$0.50
6368. Sewerage Districts (Second Reprint—Incorporating amendments up to No. 7547)	\$0.75
6369. Shearers Accommodation (Incorporating amendments up to Act No. 7876)	\$0.35
6809. Sheep Owners Protection Act 1961 (Second Reprint—Incorporating amendments up to No. 8179)	\$0.20
6372. Soil Conservation and Land Utilization (Second Reprint—Incorporating amendments up to No. 8142)	\$0.45
6373. Soldier Settlement (First Reprint—Incorporating amendments up to No. 7328)	\$0.42
6375. Stamps (Fourth Reprint—Incorporating amendments up to No. 7698)	\$1.18
6377. State Electricity Commission (Second Reprint—Incorporating amendments up to No. 7421)	\$0.65
6378. State Relief Committee (First Reprint—Incorporating amendments from No. 6886)	\$0.10
6379. State Savings Bank (Second Reprint—Incorporating amendments up to No. 8082)	\$0.95
6380. Statistics (First Reprint—Incorporating amendments up to No. 6961)	\$0.15
6383. Stock Foods (First Reprint—Incorporating amendments up to No. 7607)	\$0.28
6384. Stock Medicines (First Reprint—Incorporating amendments up to No. 7726)	\$0.20
7551. Strata Titles Act 1967 (Second Reprint—Incorporating amendments up to No. 8149)	\$0.65
6886. Subordinate Legislation (Incorporating amendments up to No. 6961)	\$0.15
7405. Summary Offences Act 1966 (First Reprint—Incorporating amendments up to Act No. 8226)	\$0.55
6386. Superannuation (Second Reprint—Incorporating amendments up to No. 7910)	\$0.75
6387. Supreme Court (First Reprint—Incorporating amendments up to No. 7522)	\$0.75
6388. Survey Co-ordination (First Reprint—Incorporating amendments up to Act No. 8107)	\$0.35
6391. Teaching Service (First Reprint—Incorporating amendments up to No. 7536)	\$0.35
6849. Town and Country Planning Act 1961 (Third Reprint—Incorporating amendments up to No. 7975)	\$0.65
6401. Trustee (Third Reprint—Incorporating amendments up to No. 7833)	\$0.55
6402. Trustee Companies (First Reprint—Incorporating amendments up to No. 7858)	\$0.35
7223. Tomato Processing Industry (Uniform Agreement) Act 1964 (First Reprint—Incorporating amendments up to No. 7342)	\$0.15
6397. Trade Unions (First Reprint—Incorporating amendments up to No. 6839)	\$0.20
6399. Transfer of Land (Third Reprint—Incorporating amendments up to No. 7551)	\$0.65
6400. Transport Regulation (First Reprint—Incorporating amendments up to No. 7358)	\$0.22
6879. Unclaimed Moneys (Incorporating amendments up to No. 6961)	\$0.12
7095. Underseas Mineral Resources Act 1963 (First Reprint—Incorporating amendments from No. 7591)	\$0.10

ACTS REPRINTED IN ACCORDANCE WITH THE AMENDMENTS INCORPORATION ACT 1958 (No. 6422)—continued.

No.	Price.
6653. Valuation of Land Act 1960 (Second Reprint—Incorporating amendments up to No. 7333)	\$0.22
6407. Vegetation and Vine Diseases (First Reprint—Incorporating amendments up to No. 7423)	\$0.30
6409. Vermin & Noxious Weeds (First Reprint—Incorporating amendments up to No. 7463)	\$0.35
6410. Veterinary Surgeons (First Reprint—Incorporating amendments up to No. 7343)	\$0.15
6411. Victorian Inland Meat Authority (First Reprint—Incorporating amendments up to No. 8000)	\$0.30
7291. Victoria Institute of Colleges Act 1965 (First Reprint—Incorporating amendments up to No. 7644)	\$0.25
6412. Warehousemen's Liens (First Reprint—Incorporating amendments up to No. 7876)	\$0.15
6413. Water (Second Reprint—Incorporating amendments up to No. 7590)	\$1.95
6414. Weights and Measures (Third Reprint—Incorporating amendments up to No. 8068)	\$1.05
6415. Wild Flowers and Native Plants Protection (First Reprint—Incorporating amendments up to No. 6976)	\$0.15
6416. Wills (First Reprint—Incorporating amendments up to No. 7238)	\$0.25
6417. Wire Netting (First Reprint—Incorporating amendments up to No. 7876)	\$0.45
6419. Workers Compensation (Fourth Reprint—Incorporating amendments up to No. 8084)	\$1.05

C. H. RIXON,
Government Printer.

- GULLAN'S NEWSAGENCY, 88 Bridge-street, Ballarat, Victoria 3350.
- HAMPTON, A. C., 243 Mitchell-street, Bendigo, Victoria 3550.
- HARSTON, PARTRIDGE & CO. PTY. LTD., 455 Little Collins-street, Melbourne, Victoria 3000.
- KYNETON GUARDIAN PTY. LTD., P.O. Box 18, Kyneton, Victoria 3444.
- LATIMER'S, Newsagents, 45 Station-street, Malvern, Victoria 3144.
- LIVINGSTON'S SHEPPARTON NEWSAGENCY, 246 Wyndham-street, Shepparton, Victoria 3630.
- THE MERCANTILE EXCHANGE, 34 Queen-street, Melbourne, Victoria, 3000.
- McGILL'S AUTHORIZED NEWSAGENCY, 183-5 Elizabeth-street, Melbourne, Victoria 3000.
- POWNEYS AUTHORIZED NEWSAGENCY, 293 Hargreaves-street, Bendigo, Victoria 3550.
- PURDIE, J., & CO., 138 Moorabool-street, Geelong, Victoria 3220.
- SALE AUTHORIZED NEWSAGENCY, 142 Raymond-street, Sale, Victoria 3850.
- SKINNER'S AUTHORIZED NEWSAGENCY, 49-51 Franklin-street, Traralgon, Victoria 3844.
- STEVENSON, A. C. & M., NEWSAGENTS, 132 Henty-street, Casterton, Victoria 3311.
- VANCE'S AUTHORIZED NEWSAGENCY, 83 Murray-street, Wangaratta, 3677.
- VERNONS OF RICHMOND, 162 Bridge-road, Richmond, Victoria 3121.
- VIEW POINT AUTHORIZED NEWSAGENCY, 4 View-Point, Bendigo, Victoria 3550.

A copy of the Gazette filed at each place for public reference.

AGENTS FOR THE "VICTORIA GOVERNMENT GAZETTE".

The following have been appointed agents to receive Advertisements and Subscriptions for the Victoria Government Gazette:—

- ARMSTRONG'S AGENCY, 217 Queen-street, Melbourne, Victoria 3000.
- ARNALL & JACKSON, 390 Barkly-street, Brunswick, Victoria, 3056
- BAIRNSDALE AUTHORIZED NEWSAGENCY, 132 Main-street, Bairnsdale, Victoria 3875.
- BICKNELL, M. J., Authorized Newsagent, 196 Timor-street, Warrnambool, Victoria 3280.
- BLANE'S AUTHORIZED NEWSAGENTS, 162 Murray-street, Colac, Victoria 3250.
- CARTER, R. G., ADVERTISING SERVICE PTY. LTD. Suite 24, 65 Queens-road, Melbourne, Victoria 3004.
- DAVIES, G. & M. V., 112 Gray-street, Hamilton, Victoria 3300
- DAVIS, WM. (MILDURA) PTY. LTD., 126 Eighth-street, Mildura, Victoria 3500.
- DIXON'S NEWSAGENCY, 89 Firebrace-street, Horsham, Victoria 3400.
- EASTHALL ASSOCIATES, 934 Whitehorse-road, Box Hill, Victoria 3128.
- EDGARS' AUTHORIZED NEWSAGENCY, 45 Bridge-street, Benalla, Victoria 3672.
- FRANKS, H. & CO., 184 Ryrie-street, Geelong, Victoria 3220.
- GATLEY, A. & J., 250 Lonsdale-street, Dandenong, Victoria 3175.
- GORDON & GOTCH AUSTRALASIA LTD., 434 St. Kilda-road, Melbourne, Victoria 3004.

CONTENTS

	PAGE
Acts of Parliament on Sale at the Government Printing Office	2820
Appointments	2788
Contracts	2787
Estates of Deceased Persons	2786
Government Notices	2778
Impoundings	2820
Insolvency Notices	2820
Lands	2796
Melbourne and Metropolitan Board of Works—Notices	2778
Mining	2783
Notice of Making of Statutory Rules	2820
Orders in Council—	
Acts—Explosives; Benefit Associations; Cemeteries; Country Roads; Land; Local Government; Stamps.	2789 et seq
Police Sales	2779, 2788
Private Advertisements	2804
Proclamations	2777
Public Service Notice	2802
Regulations—	
Acts—Police Regulation	2779
Resignations	2789
Tenders	2803
Transport Regulation Board—Public Hearings	2780
Waterworks Trusts	2785