



VICTORIA
GOVERNMENT GAZETTE

Published by Authority

No. 81

WEDNESDAY, FEBRUARY 2

[1972]

PROCLAMATIONS

Land Act 1958.

AREA OF LAND COMPRISED IN CERTAIN CLASSES DIMINISHED OR INCREASED.

PROCLAMATION

By His Excellency the Governor of the State of Victoria and its Dependencies in the Commonwealth of Australia, &c., &c., &c.

Whereas by the *Land Act 1958* it is amongst other things enacted that the Governor in Council may, by Proclamation to be published in the *Government Gazette*, at any time diminish or increase the area of land comprised in any of the classes mentioned in Part I., Division 1, Section 5, of the said *Land Act 1958*, but that the area of lands which may be sold by auction (Class 6), shall not be increased except as in certain cases in the said Act provided: Now therefore I, the Governor of the State of Victoria, in the Commonwealth of Australia, by and with the advice of the Executive Council of the said State, and in accordance with the provisions of Section 94 and 117 of the *Land Act 1958* aforesaid, do hereby diminish or increase (as the case may be) the areas of Crown lands comprised in Class 6 of the classes mentioned in Section 5 of the *Land Act 1958* aforesaid, to the extent set forth in the subjoined Schedule (that is to say):—

Schedule referred to.

CLASSES DIMINISHED OR INCREASED.

County.	Parish.	Allotment.	Section.	Area.	Diminished.	Increased.	Description.
					Class.	Class.	
				A. R. P.			
Karkaroc	Merbein	14	C	2 0 35	..	6	In the south-east of the parish (M61774)

Given under my Hand and the Seal of the State of Victoria, aforesaid, at Melbourne, this twenty-fifth day of January, in the year of Our Lord One thousand nine hundred and seventy-two, and in the twentieth year of the reign of Her Majesty Queen Elizabeth II.

(L.S.)

ROHAN DELACOMBE.

By His Excellency's Command,
W. BORTHWICK,
Minister of Lands.

GOD SAVE THE QUEEN!

PUBLIC HIGHWAY.—CITY OF SANDRINGHAM.

PROCLAMATION

By His Excellency the Governor of the State of Victoria and its Dependencies in the Commonwealth of Australia, &c., &c., &c.

Whereas by the *Local Government Act 1958*, Section 519 it is amongst other things enacted that it shall be lawful for the Governor in Council at any time and from time to time upon the request of the Council of any municipality by notice in the *Government Gazette* to proclaim any land reserved used or by purchase or exchange acquired for a street road highway thoroughfare bridge square court alley or right-of-way or any street road lane or passage made or laid out or proposed to be made or laid out on any land of which a plan of subdivision delineating that street road lane or passage has been sealed with the seal of the municipality under subdivision (3) of Division 9 of Part XIX of the *Local Government Act 1958*, or a corresponding previous enactment to be a public highway and that such land shall thereupon and thenceforth from the date of such proclamation become and be absolutely dedicated to the public as a public highway within the meaning of any law then or thereafter in force:

And whereas the Council of the City of Sandringham has requested that the land hereinafter mentioned, used for a street, road, lane or passage, be so declared to be a public highway.

Now therefore, I, the Governor of the State of Victoria in the Commonwealth of Australia, by and with the advice of the Executive Council of the said State, do by this Proclamation declare that the Drainage Reserve set out on Plan of Subdivision No. 4550 lodged in the Office of Titles and being the land shown by hachure on the diagram hereunder shall be a public highway within the meaning of the said Act.

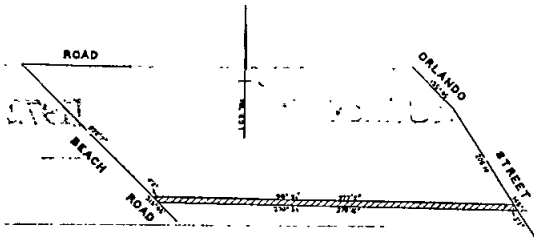

The measurements are in feet and inches.

Given under my Hand and the Seal of the State of Victoria aforesaid, at Melbourne, this twenty-fifth day of January, in the year of our Lord One thousand nine hundred and seventy-two, and in the twentieth year of the reign of Her Majesty Queen Elizabeth II.

(L.S.) ROHAN DELACOMBE.

By His Excellency's Command,
A. J. HUNT,
Minister for Local Government.

GOD SAVE THE QUEEN!

PUBLIC HIGHWAY.—CITY OF PRESTON.

PROCLAMATION

By His Excellency the Governor of the State of Victoria and its Dependencies in the Commonwealth of Australia, &c., &c., &c.

Whereas by the *Local Government Act 1958*, Section 519 it is amongst other things enacted that it shall be lawful for the Governor in Council at any time and from time to time upon the request of the Council of the municipality by notice in the *Government Gazette* to proclaim any land reserved used or by purchase or exchange acquired for a street, road, highway, thoroughfare, bridge, square, court, alley, or right-of-way or any street, road, lane or passage made or laid out or proposed to be made or laid out on any land of which a plan of subdivision delineating that street, road, lane or passage has been sealed with the seal of the municipality under subdivision (3) of Division 9 of Part XIX of the *Local Government Act 1958*, or a corresponding previous enactment to be a public highway

and that such land shall thereupon and thence forth from the date of such proclamation become and be absolutely dedicated to the public as a public highway within the meaning of any law then or thereafter in force.

And whereas the Council of the City of Preston has requested that the land hereinafter mentioned, being a street, road, lane, or passage made or laid out or proposed to be made or laid out on land of which a plan of subdivision delineating the street, road, lane or passage has been sealed with the seal of the municipality under subdivision (3) of Division 9 of Part XIX of the *Local Government Act 1958*, or a corresponding previous enactment, be so declared to be a public highway.

Now therefore, I, the Governor of the State of Victoria in the Commonwealth of Australia, by and with the advice of the Executive Council of the said State, do by this Proclamation declare that St. Georges Road Preston shown hatched on the plan hereunder shall be a public highway within the meaning of the said Act.

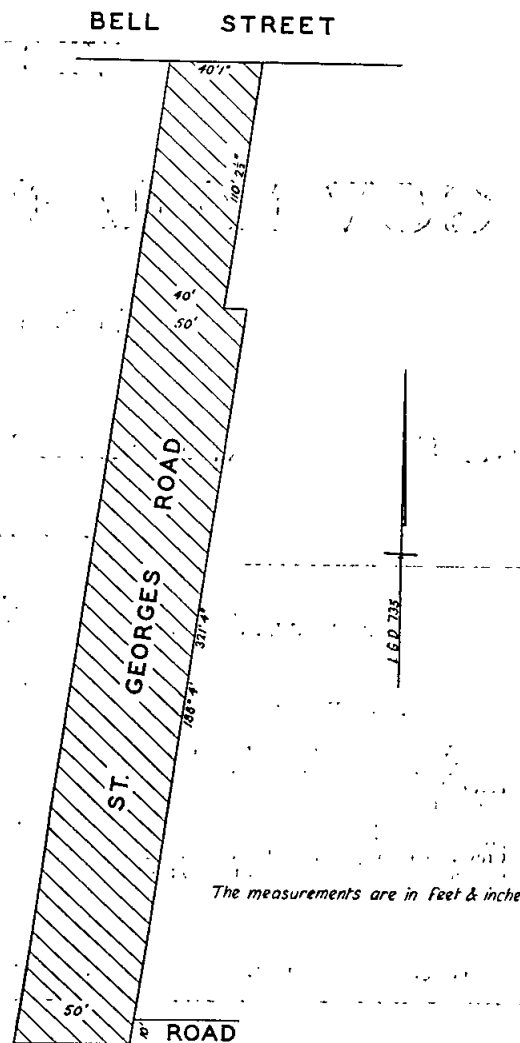

The measurements are in feet & inches

Given under my Hand and the Seal of the State of Victoria aforesaid, at Melbourne, this twenty-fifth day of January, in the year of our Lord One thousand nine hundred and seventy-two, and in the twentieth year of the reign of Her Majesty Queen Elizabeth II.

(L.S.) ROHAN DELACOMBE.

By His Excellency's Command,
A. J. HUNT,
Minister for Local Government.

GOD SAVE THE QUEEN!

Land Act 1958, Section 25.
ROAD PROCLAIMED.

PROCLAMATION

By His Excellency the Governor of the State of Victoria and its Dependencies in the Commonwealth of Australia, &c., &c., &c.

In pursuance of the provisions of Section 25.(3) (c) of the Land Act 1958, I, the Governor of the State of Victoria, by and with the advice of the Executive Council of the said State, do hereby, proclaim as a road the land in the Township of Manangatang, Parish of Manangatang, County of Karkaroc, as indicated by hatching on plan hereunder.—(M.571⁽²⁾) (M.61178).

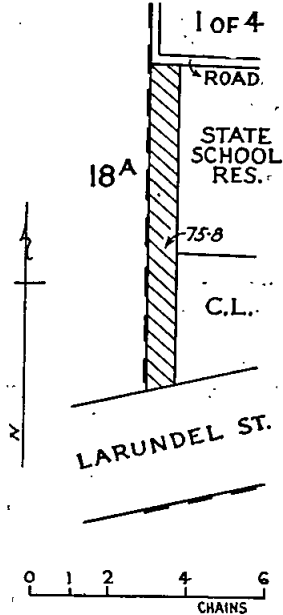

Given under my Hand and the Seal of the State of Victoria aforesaid, at Melbourne, this twenty-fifth day of January, in the year of our Lord One thousand nine hundred and seventy-two, and in the twentieth year of the reign of Her Majesty Queen Elizabeth II.

(L.S.) ROHAN DELACOMBE.

By His Excellency's Command,
W. BORTHWICK,
Minister of Lands.

GOD SAVE THE QUEEN!

GOVERNMENT NOTICES

Children's Court Act 1958.

CHILDREN'S COURT SITTINGS.—DAYS APPOINTED IN LIEU.

His Excellency the Governor of the State of Victoria, by and with the advice of the Executive Council thereof, doth by Order made on the 25th day of January, 1972, and pursuant to the provisions of section 8 (1) of the Children's Court Act 1958, appoint the days and hours contained in the Schedule below for the holding of Children's Courts at the places named in such Schedule in-lieu of the days and hours heretofore appointed.

SCHEDULE.

Place.	Days and Hours.
BALLARAT	Every Monday, Wednesday and Friday at 2 p.m. and every Tuesday and Thursday, at 9 a.m.
WARRNAMBOOL	Every Monday and Tuesday, at 9.30 a.m.
WHITTLESEA	Alternate Fridays, at 10.30 a.m., as from 4th February, 1972.

JOHN A. HORLOCK,
Acting Clerk of the Executive Council.

At the Executive Council Chamber,
Melbourne, 25th January, 1972.

COUNTRY ROADS BOARD.

RESOLUTIONS OF THE COUNTRY ROADS BOARD.

The Country Roads Board, in pursuance of the provisions of the Country Roads Act 1958, has passed Resolutions the dates whereof and the terms of which are scheduled hereunder:—

SCHEDULE.

State Highways.

Resolution dated the Seventeenth day of January, One thousand nine hundred and seventy-two, made pursuant to sections 21, 58 and 74 of the Country Roads Act 1958, declaring the deviation from the North Western Highway in the Shire of Avoca as indicated by diagonal hatching on Plan numbered G.P.12507 hereunder to be part of a State highway within the meaning and for the purposes of the said Act, and also declaring that such deviation shall be in lieu of the existing road or part thereof indicated by cross-hatching and horizontal hatching on the said plan, which part indicated by cross-hatching on the said plan shall be discontinued.

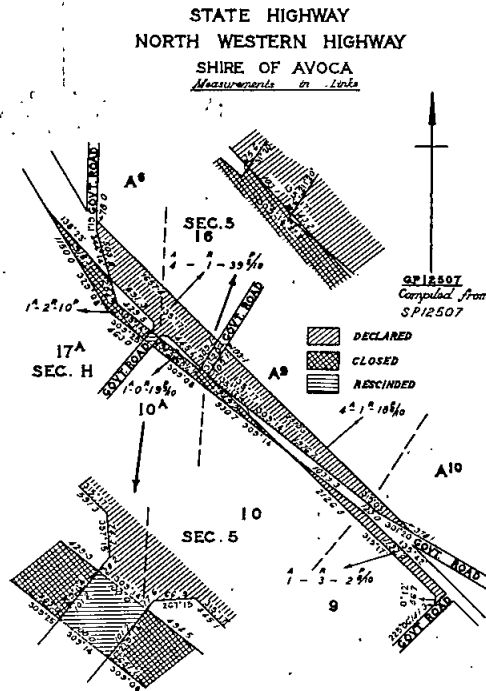

Resolution dated the Seventeenth day of January, One thousand nine hundred and seventy-two, made pursuant to sections 21, 58 and 74 of the Country Roads Act 1958, declaring the deviation from the Midland Highway in the Shire of Daylesford and Glenlyon as indicated by diagonal hatching on plans numbered G.P.12350, G.P.12351, G.P.12352B, G.P.12353A and G.P.12354 hereunder to be part of a State highway within the meaning and for the purposes of the said Act, and also declaring that such deviation shall be in lieu of the existing road or part thereof indicated by cross-hatching and horizontal hatching on Plans numbered G.P.12351 and G.P.12352B, and cross-hatching on Plan numbered G.P.12353A, which part indicated by cross-hatching on the said plans shall be discontinued.

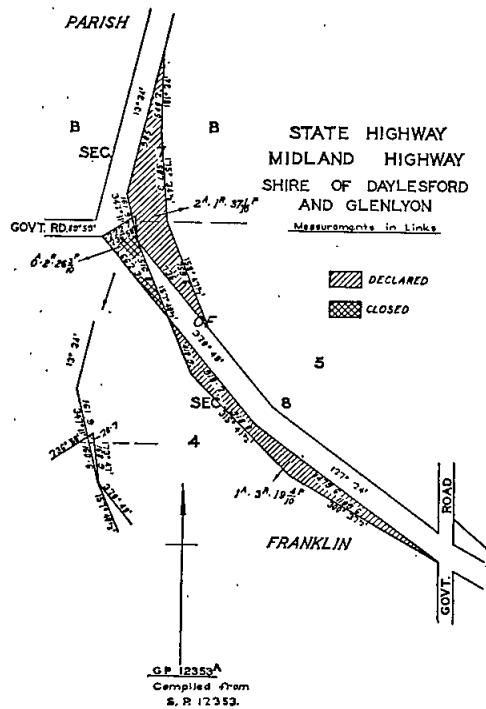
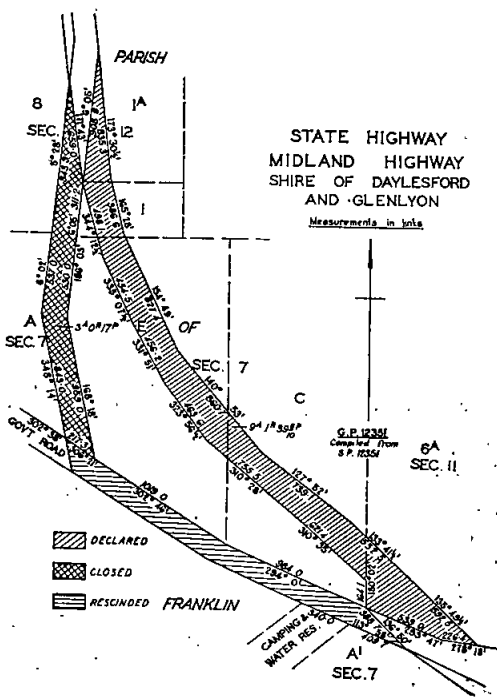
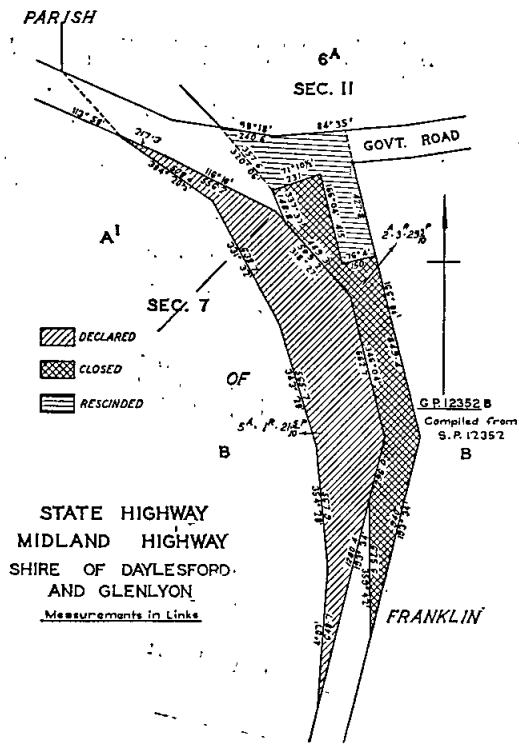
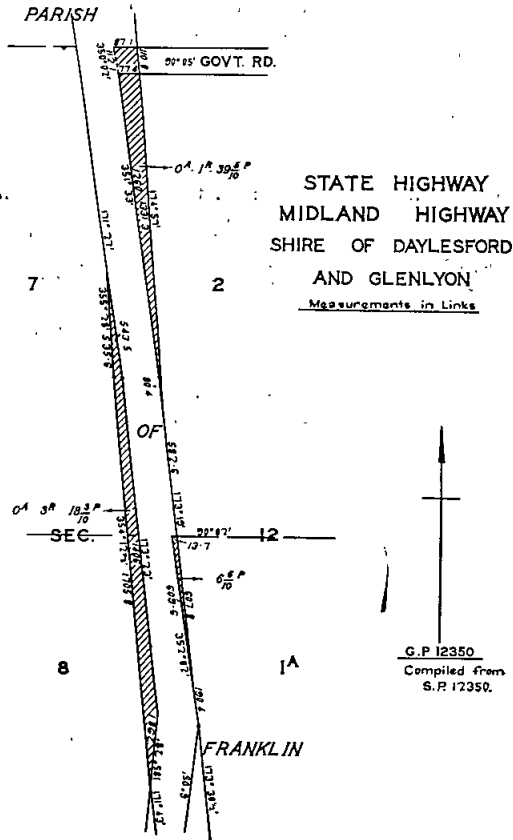

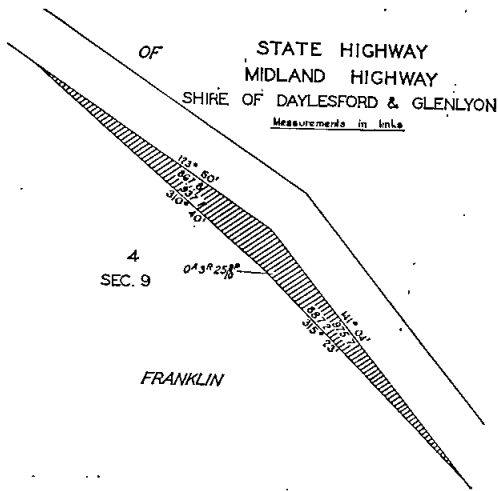
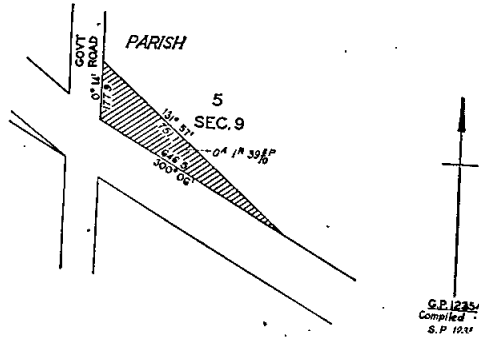

Resolution dated the Seventeenth day of January, One thousand nine hundred and seventy-two, made pursuant to sections 21, 58 and 74 of the *Country Roads Act 1958*, declaring the deviation from the Warburton Highway in the Shire of Lillydale as indicated by diagonal hatching on Plan numbered G.P.12027 hereunder to be part of a State highway within the meaning and for the purposes of the said Act, and also declaring that such deviation shall be in lieu of the existing road or part thereof indicated by cross-hatching on the said plan, and that such part of the said existing road shall be discontinued.

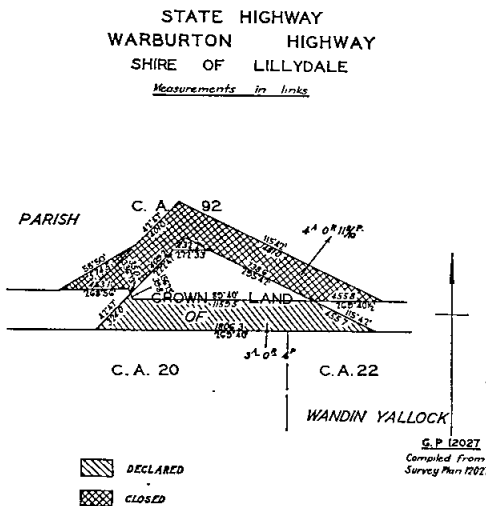

Resolution dated the Seventeenth day of January, One thousand nine hundred and seventy-two, made pursuant to sections 21 and 74 of the *Country Roads Act 1958*, declaring the widening of the Henty Highway in the Shire of Wimmera as shown hatched on Plan numbered G.P.8295A hereunder to be part of a State highway within the meaning and for the purposes of the said Act.

STATE HIGHWAY
HENTY HIGHWAY
SHIRE OF WIMMERA

Measurements in links

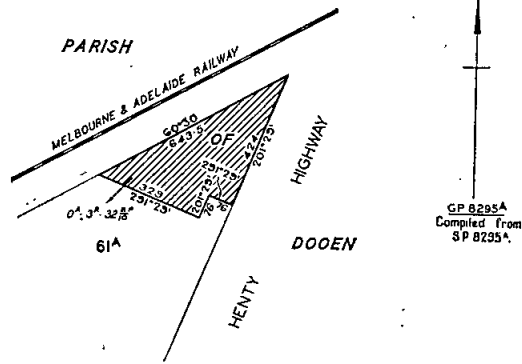

Main Roads.

Resolution dated the Seventeenth day of January, One thousand nine hundred and seventy-two, made pursuant to section 21 of the *Country Roads Act 1958*, declaring the widening of the Beaconsfield-Emerald road in the Shire of Berwick as shown hatched on Plan numbered G.P.10326 hereunder to be part of a main road within the meaning and for the purposes of the said Act.

MAIN ROAD
BEACONSFIELD - EMERALD ROAD
SHIRE OF BERWICK

Measurements in Links.

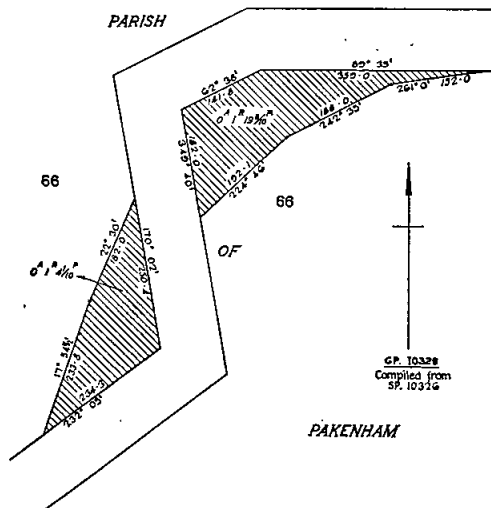

Resolution dated the Seventeenth day of January, One thousand nine hundred and seventy-two, made pursuant to section 21 of the Country Roads Act 1958, declaring the widening of Don-road in the Shire of Upper Yarra as shown hatched on Plan numbered G.P.10262 hereunder to be part of a main road within the meaning and for the purposes of the said Act.

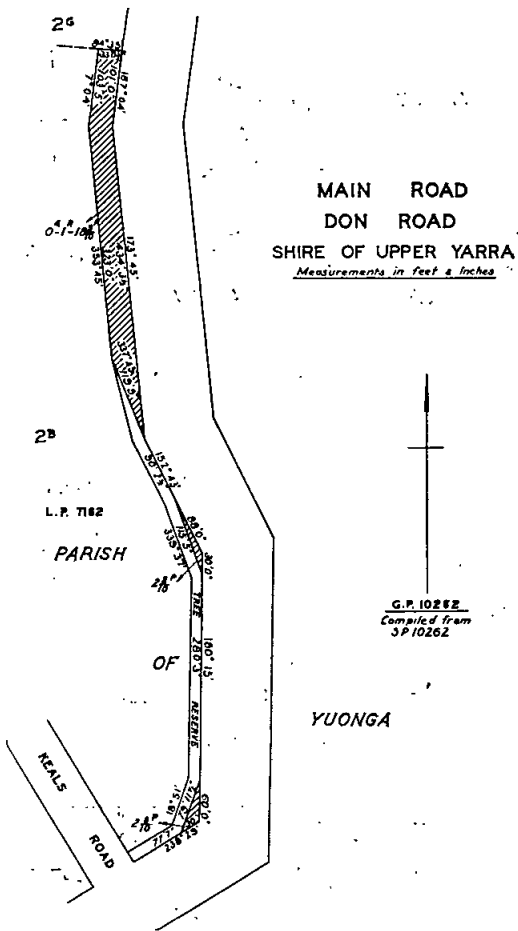

Resolution dated the Seventeenth day of January, One thousand nine hundred and seventy-two, made pursuant to section 21 of the Country Roads Act 1958, declaring the widening of the Warrnambool-Caramut road in the Shire of Warrnambool as shown hatched on Plans numbered G.P.8518, G.P.8519 and G.P.8520 hereunder to be part of a main road within the meaning and for the purposes of the said Act.

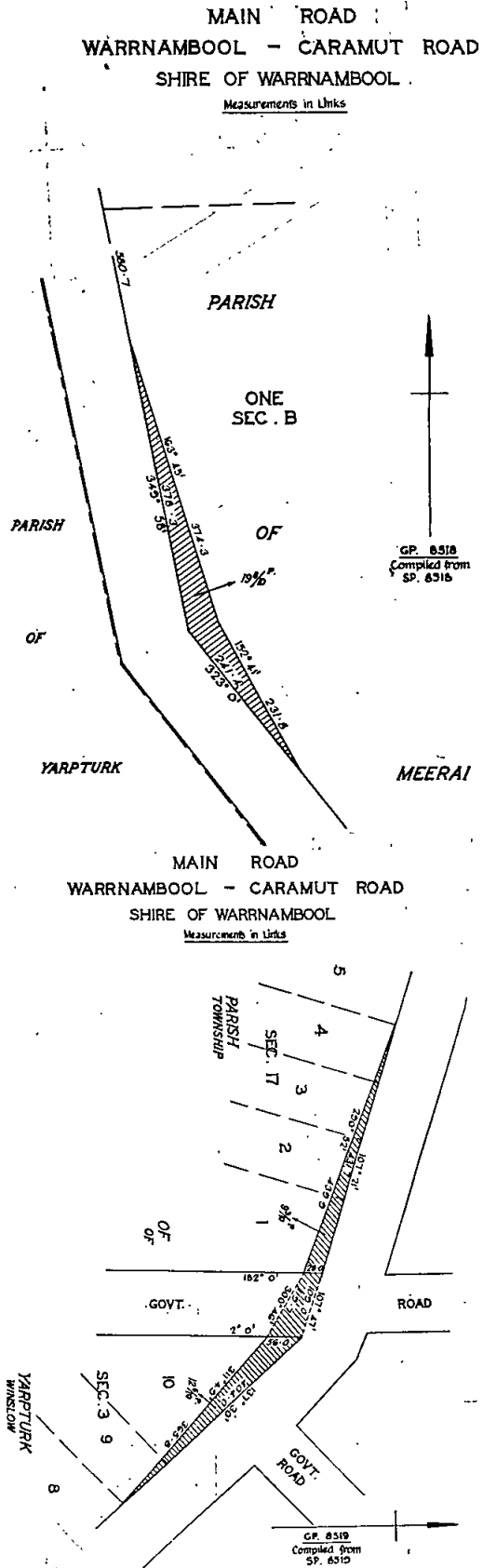

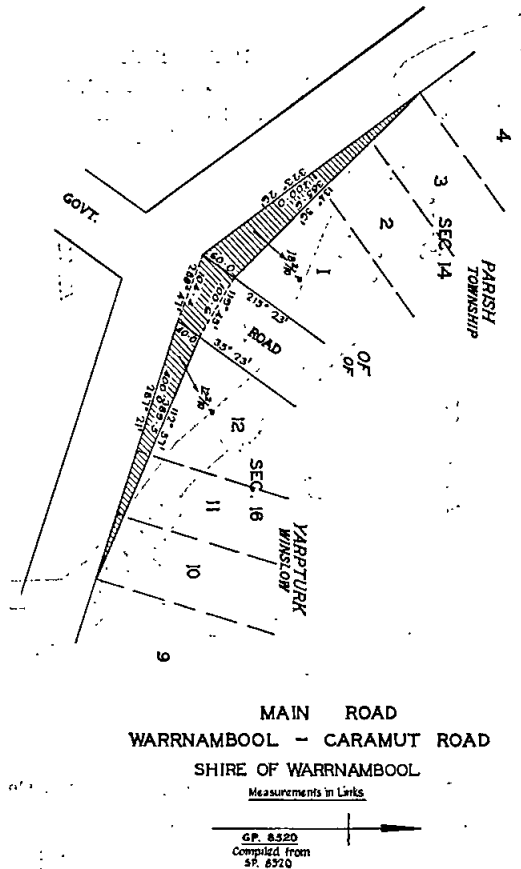

Resolution dated the Seventeenth day of January, One thousand nine hundred and seventy-two, made pursuant to section 21 of the Country Roads Act 1958, declaring the widening of High-street in the City of Waverley as shown hatched on Plan numbered G.P.8442 hereunder to be part of a main road within the meaning and for the purposes of the said Act.

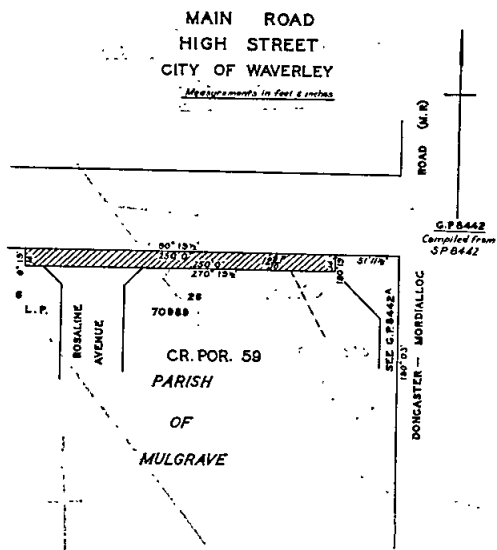

Resolution dated the Seventeenth day of January, One thousand nine hundred and seventy-two, made pursuant to section 21 of the Country Roads Act 1958, declaring the widening of the Doncaster-Mordialloc road in the City of Waverley as shown hatched on Plan numbered G.P.8442A hereunder to be part of a main road within the meaning and for the purposes of the said Act.

MAIN ROAD
DONCASTER - MORDIALLOC ROAD
CITY OF WAVERLEY

Measurements in feet & inches

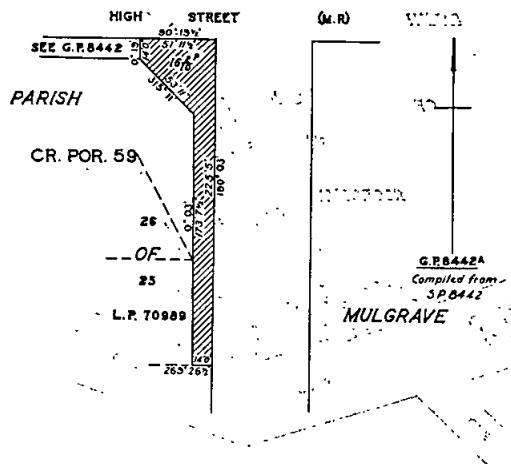

Resolution dated the Seventeenth day of January, One thousand nine hundred and seventy-two, made pursuant to section 21 of the Country Roads Act, 1958, declaring the widening of Nerrena-road in the Shire of Wooyal as shown hatched on Plan numbered G.P.8537 hereunder to be part of a main road within the meaning and for the purposes of the said Act.

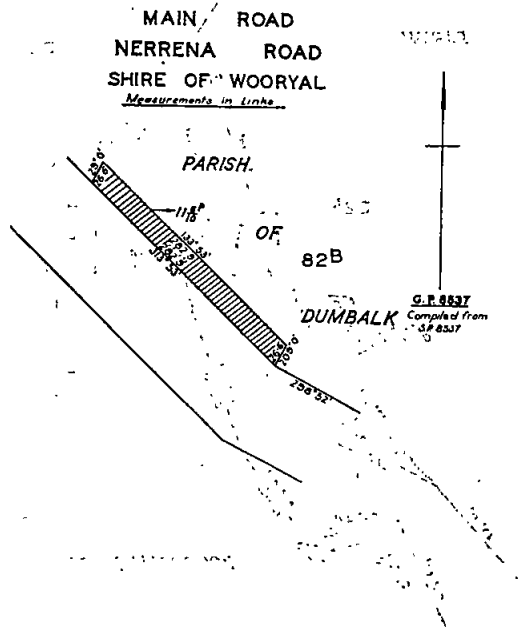

Resolution dated the Seventeenth day of January, One thousand nine hundred and seventy-two, made pursuant to section 21 of the Country Roads Act 1958, declaring the widening of Wild Dog Valley-road in the Shire of Woorayl as shown hatched on Plans numbered G.P.10307A, G.P.10307B and G.P.10307C hereunder to be part of a main road within the meaning and for the purposes of the said Act.

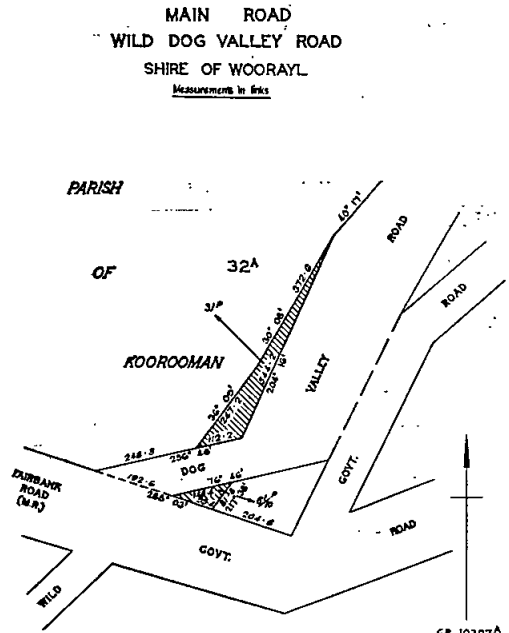

G.P. 10307A
Compiled from
SP. 10307

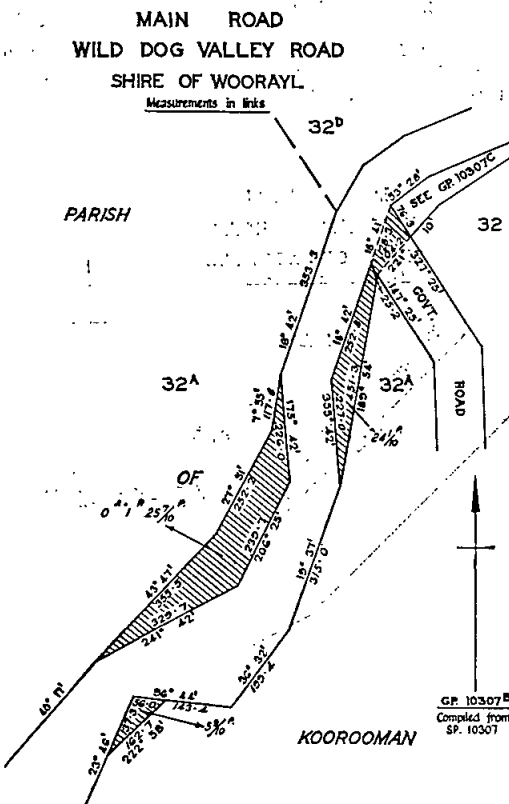

G.P. 10307B
Compiled from
SP. 10307

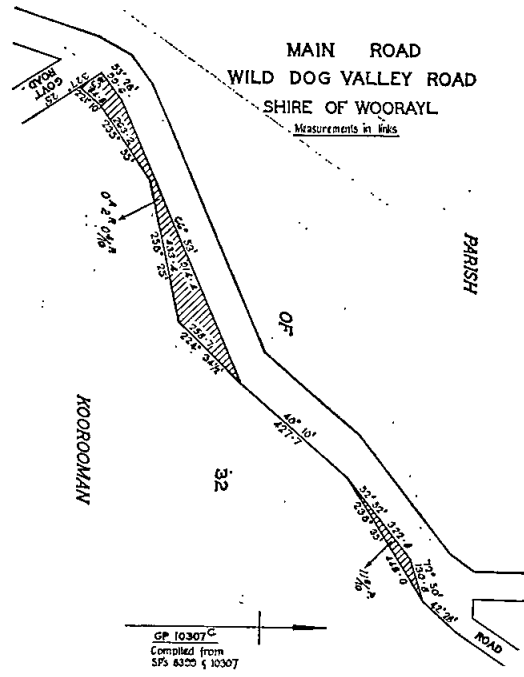

G.P. 10307C
Compiled from
SPs 8320 & 10307

Resolution dated the Seventeenth day of January, One thousand nine hundred and seventy-two, made pursuant to section 21 of the Country Roads Act 1958, declaring the widening of the Yarra Glen-Yea road in the Shire of Yea as shown hatched on Plan numbered G.P.7792 hereunder to be part of a main road within the meaning and for the purposes of the said Act.

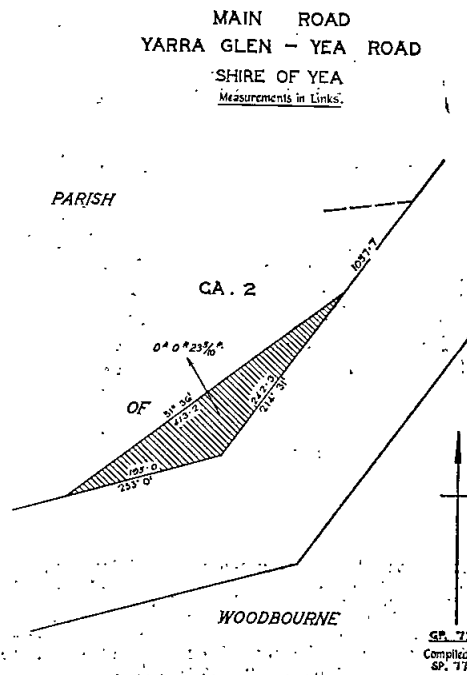

G.P. 7792
Compiled from
SP. 7752.

Unclassified Road.

Resolution dated the Seventeenth day of January, One thousand nine hundred and seventy-two, made pursuant to sections 21 and 110 of the *Country Roads Act 1958*, declaring the widening of Myrtle-street in the City of Bendigo as shown hatched on Plan numbered G.P.12228 hereunder to be part of a road within the meaning and for the purposes of the said Act.

ROAD
MYRTLE STREET
CITY OF BENDIGO
Measurements in links

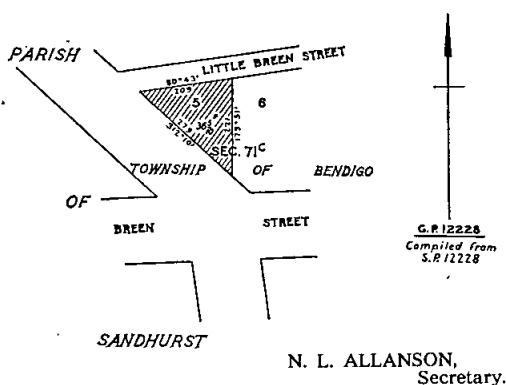

20th January, 1972.

ERRATUM.

In *Government Gazette* No. 4 of 19th January, 1972, page 139, 2nd column—

"RYAN, ALBERT BRUCE SHERIFF"

should read—

"RYAN, ALBERT BRUCE SHERRIFF"

and—

"RYAN, ALBERT BRUCE SHERRIFF, formerly of 1 William-Moonee Ponds."

should read—

"RYAN, ARTHUR LESLIE GEORGE, late of 28 Wilson-street, Moonee Ponds, retired fuel and ice merchant, died 11th October, 1971."

NOTICE.

Creditors, next of kin, and others having claims against the estate of any of the under-mentioned deceased persons are required to send particulars of their claims to the Public Trustee, 256 Flinders-street, Melbourne, Vic. 3000, the personal representative, on or before the 10th April, 1972, after which date the Public Trustee may convey or distribute the assets, having regard only to the claims of which the Public Trustee then has notice:—

ABBERTON, GEORGE ALBERT, also known as George Abberton, late of 12 Alma-terrace, North Williamstown, retired railway employee, died 19th September, 1971.

DIXON, TERRENCE EDWARD, formerly of Darwin in the Northern Territory, late of Swan Reach, Victoria, trader, died 7th September, 1971.

FAHEY, ALBERT CHARLES, late of 24 Wattle-avenue, Ringwood, retired engine driver, died 25th September, 1971.

GRIFFIN, THOMAS GERALD, also known as Gerald Thomas Griffin, late of 22 McGregor-street, Middle Park, retired clerk, died 2nd August, 1971.

HEGARTY, CATHERINE, late of Dunedin, New Zealand, spinster, died 8th June, 1971.

KENNEDY, MARGARET VERONICA, late of 2 Royal-parade, South Caulfield, widow, died 4th November, 1971.

MCADAM, GEORGE, late of 100 Osborne-street, Williamstown, boilermaker, died 28th May, 1963.

NEASON, ALBERT BURNLEY, formerly of 149 George-street, Fitzroy, late of 40 George-street, Fitzroy, builder, died 17th July, 1971.

PEARDON, VICTORIA JESSIE, late of 10 Alexandra-avenue, Surrey Hills, widow, died 23rd October, 1971.

PEEBLES, MARY ELLEN, late of 10 Duke-street, Richmond, widow, died 11th November, 1971.

PIKE, ALFRED JOHN, late of 249 Victoria-road, Northcote, retired compositor, died 15th September, 1971.

PURDIE, ARTHUR GARDNER, late of 69 Merton-street, Albert Park, retired clerk, died 18th March, 1971.

RAPKINS, MAY, formerly of 11 Willandra-avenue, Canterbury, late of Mildura Base Hospital, Mildura, spinster, died 24th October, 1971.

REES, OWEN, late of 2 Brunel-court, West Essendon, refrigeration engineer, died 6th November, 1971.

STEER, PERCIVAL, late of Warrnambool, pensioner, died 26th September, 1971.

TRELOAR, ETHEL MAY, late of 19 Denbigh-road, Armadale, spinster, died 10th December, 1970.

WARD, IRENE MAVIS, late of 291 Dandenong-road, Windsor, gentlewoman, died 18th December, 1970.

WHITE, JESSIE, late of Flat 2, 12 Lewisham-road, Windsor, married woman, died 7th July, 1971.

N. P. BRODY,
Public Trustee.

Melbourne, 26th January, 1972.

PUBLIC TRUSTEE ACT 1958 (No. 6350), SECTION 17.
I hereby give notice that on the 14th January, 1972, the Public Trustee filed elections to administer the following deceased persons' estates, in accordance with section 17 of the *Public Trustee Act 1958*.

DIXON, TERRENCE EDWARD, formerly of Darwin in the Northern Territory, late of Swan Reach, Victoria, trader, died 7th September, 1971.

FAHEY, ALBERT CHARLES, late of 24 Wattle-avenue, Ringwood, retired engine driver, died 25th September, 1971.

MCADAM, GEORGE, late of 100 Osborne-street, Williamstown, boilermaker, died 28th May, 1963.

NEASON, ALBERT BURNLEY, formerly of 149 George-street, Fitzroy, late of 40 George-street, Fitzroy, builder, died 17th July, 1971.

PEEBLES, MARY ELLEN, late of 10 Duke-street, Richmond, widow, died 11th November, 1971.

PIKE, ALFRED JOHN, late of 249 Victoria-road, Northcote, retired compositor, died 15th September, 1971.

RAPKINS, MAY, formerly of 11 Willandra-avenue, Canterbury, late of Mildura Base Hospital, Mildura, spinster, died 24th October, 1971.

REES, OWEN, late of 2 Brunel-court, West Essendon, refrigeration engineer, died 6th November, 1971.

STEER, PERCIVAL, late of Warrnambool, pensioner, died 26th September, 1971.

TRELOAR, ETHEL MAY, late of 19 Denbigh-road, Armadale, spinster, died 10th December, 1970.

WHITE, JESSIE, late of Flat 2, 12 Lewisham-road, Windsor, married woman, died 7th July, 1971.

N. P. BRODY,
Public Trustee.

256 Flinders-street, Melbourne, 3000, 26th January, 1972.

Stamps Act 1958.

STAMPS (EXEMPTIONS) REGULATIONS 1971.

NOTICE.

Pursuant to the provisions of the Stamps (Exemptions) Regulations 1971, I hereby declare—

BRAYBURN SECURITIES LIMITED

to be for the purpose of sub-division (13A) of Division 3 of Part II. of the *Stamps Act 1958* a dealer in the unofficial short term money market.

R. M. PHIBBS,
Comptroller of Stamps.

Stamp Duties Office,
Melbourne, 2nd February, 1972.

Country Fire Authority.

PERMISSION TO HOLD FIRE BRIGADE DEMONSTRATIONS.

In pursuance of the provisions of section 103 of the *Country Fire Authority Act 1958*, the Country Fire Authority has granted permission for the holding of fire brigade demonstrations as under:—

RURAL FIRE BRIGADES.

At Meenyan, on Friday, 25th February, 1972.

At Tolmie, on Monday, 13th March, 1972.

At Charlton, on Friday, 17th March, 1972.

J. L. ALLEN,
Secretary.

25th January, 1972.

Transport Regulation Act.
TRANSPORT REGULATION BOARD.

HEARING OF APPLICATIONS.

Notice is hereby given that the following applications will be considered by the Transport Regulation Board at its offices at the corner of Lygon and Princes streets, Carlton, 10.15 a.m. on Wednesday, 23rd February, 1972.

- HALL, J. E. (Mrs.), Box 131, Cohuna. One commercial passenger vehicle (S/C. 5) to operate as a country taxi-cab at Cohuna subject to the cancellation of licence CH. 47 in the name of the applicant.
- SKEHAN, P. F. & G. F., Foley-road, Yanakie. One commercial passenger vehicle (S/C. 41) to operate for the carriage of school children from Yanakie to Leongatha under contract to the Education Department.
- TAYLOR, E. I. & M. D., 3 Turner-street, Leongatha. One commercial passenger vehicle (S/C. 37) to operate for the carriage of school children from Korumburra to Leongatha Technical School under contract to the Education Department.
- TULLAMARINE BUS LINES PTY. LTD., 7 Louis-street, Airport West. Application for permit authority to operate either for an M.C. or M.O. licensed vehicle for the carriage of children from Airport West to Sokratis Greek Sunday School, Brunswick, via Louis-street, Dromana-avenue, Harper-street, Collier-crescent, Mascona-street, Pascoe Vale and Glenroy roads, Widford, Blair and Kaniva streets, Mildura-crescent, Echuca-street, Barrys-road, Dunstan-parade, Lydia-avenue, Hume Highway, Campbell and Clark streets, Somerset-road, Hume Highway, Anderson-road, Beccles, Lawson and Lanigan streets, Jukes-road, Bonwick-street, Major-road, Frederick-street, Lynch-road, Tyrrell-crescent, McBryde and Argyle streets, Sydney-road, Bell, Nicholson, Holmes, Nicholson and Albert streets to the Hall under contract to the Sokratis Greek Sunday School.

TIME-TABLE.
(Saturday Only.)

Depart Airport West—8.00 a.m.
Depart Sokratis Sunday School—1.00 p.m.

Application for renewal of licences as shown, by persons listed hereunder to operate under the same terms and conditions.

DEPARTMENT OF AGRICULTURE, Dookie Agricultural College, Dookie; T.P.56, T.P.174.

LAFFY, B. F., 35 Woonah-street, Chadstone; T.P.212.

Notice of any objection should be forwarded to reach the Secretary of the Board not later than Wednesday, 16th February, 1972.

Applicants are advised that it will not be necessary to appear on the hearing date specified above, unless advised in writing by the Board.

B. P. KAY,
Secretary.

Corner Lygon and Princes streets, Carlton, Wednesday, 2nd February, 1972.

Commercial Goods Vehicles Act.
TRANSPORT REGULATION BOARD.

HEARING OF APPLICATIONS.

Notice is hereby given that the following applications will be considered by the Transport Regulation Board at its offices at the corner Lygon and Princes streets, Carlton, at 10.15 a.m., on Wednesday, 23rd February, 1972.

- AIREY, R. G. & H. J., PTY. LTD., 106 Franklin-street, Traralgon, 3844. One commercial goods vehicle (L/C. 272 cwt.) to operate from own sawmill at Morwell to consignees situated within a 50-mile radius of the Morwell Post Office—sawn timber.
- ALEXANDER, J. M., Camperdown-road, Cobden, 3266. One commercial goods vehicle (L/C. 288 cwt.) to operate: (a) Within a 50-mile radius from the post office at Cobden—plant the property of a contractor and required by him for use in connexion with the construction or maintenance of some specific, existing or proposed road, street, footpath, bridge, pier, wharf, weir or channel and also the following materials, viz: metal, stones, screenings, ashes, gravel, sand and earth. (b) Within a 20-mile radius from the site of any construction or maintenance work performed pursuant to paragraph (a) above, or from the railway station nearest thereto—any other materials required for such work. (c) Within a 25-mile radius of the post office at Cobden—general goods, provided that no goods shall be carried whether by one stage or by more than one stage

between places within the above radius which are more than thirty (30) road miles apart by the nearest practicable route.

- ALLEN BROS. ASPHALTING CONTRACTORS PTY. LTD., Hovell-street, Wodonga, 3690. One commercial goods vehicle (L/C. 134 cwt.) to operate: (a) Within a 70-mile radius of own premises at Wodonga in the course of business as "Road-making and Asphaltting Contractors"—own road-making machinery. (b) Within a 70-mile radius of own premises at Wodonga—own road-making materials, viz.: sand, gravel, screenings, premix, bitumen and ashes.
- ANDY'S SALES PTY. LTD., 36 Tenth-street, Mildura, 3500. One commercial goods vehicle (L/C. 14 cwt.) to operate throughout the State of Victoria on behalf of Andy's Engineers Pty. Ltd., an approved Decentralized Industry—engineering supplies and equipment for display.
- BEATTIE, R. M. P., Box 42, Goroke, 3412. One commercial goods vehicle (L/C. 140 cwt.) to operate: (a) Within a 25-mile radius of the post office at Goroke—general goods, provided that no goods shall be carried whether by one stage or by more than one stage between places within the above radius which are more than thirty (30) road miles apart by the nearest practicable route. (b) Within a 50-mile radius of the post office at Goroke—bulk superphosphate for spreading purposes, from the railway station nearest to such spreading site.
- BEATTIE, R. M. P. (trading as Edenhope Super Spread), Box 98, Edenhope, 3318. Two commercial goods vehicles (L/C. 256, 240 cwt.) to operate: (a) Within a 25-mile radius of the post office at Edenhope—general goods, provided that no goods shall be carried whether by one stage or by more than one stage between places within the above radius which are more than thirty (30) road miles apart by the nearest practicable route. (b) From the bulk installation at Edenhope or from railway stations within a 50-mile radius of the post office at Edenhope nearest to spreading sites within the said radius—bulk superphosphate.
- FREEMAN, F. G. (trading as G. & D. Freeman amusements), 24 Whitby-street, Brunswick West, 3055. One commercial goods vehicle (L/C. 17 cwt.) to operate throughout the State of Victoria in the course of business as "Travelling Showman"—own sideshow equipment and novelty prizes.
- HEYFIELD SAWMILLERS LOGGING CO. PTY. LTD., Licola-road, Heyfield, 3858. One commercial goods vehicle (L/C. 121 cwt.) to operate within a 50-mile radius from own premises at Heyfield in the course of business as "Sawmillers and Logging Contractors"—tools of trade, equipment and materials incidental to the maintenance of roads for which this company is responsible.
- KEATHSON EARTHMOVERS PTY. LTD., 104 McBryde-street, Fawkner, 3060. One commercial goods vehicle (L/C. 139 cwt.) to operate: (a) Throughout the State of Victoria in the course of business as "Earth-moving and Road-making Contractor"—own earth-moving plant and equipment. (b) Within a 20-mile radius of any contract currently engaged upon or from the railway station nearest thereto—any materials required for work on such contract.
- M.C.Y. HAULAGE PTY. LTD., 39 Princes-street, Watsonia, 3087. One commercial goods vehicle (L/C. 143 cwt.) to operate: (a) Within a 25-mile radius of G.P.O., Melbourne, in course of business as "Soil, Screenings and Garden Supply"—own goods. (b) From Bacchus Marsh to own yard at Bundoora—own river pebbles. (c) From Toolangi to own yard at Bundoora—own mountain soil.
- MALLEYS LTD., Corner Cameron and Allen streets, Moreland, 3058. One commercial goods vehicle (L/C. 14 cwt.) to operate throughout the State of Victoria as a service vehicle for the purpose of servicing electrical refrigerators, washing machines and cookers—tools of trade, spare parts and materials incidental thereto.
- MAWSON, E. B., & SONS PTY. LTD., 141 King George-street, Cohuna, 3568. One commercial goods vehicle (semi-trailer) to operate: (a) Throughout the State of Victoria in the course of business as "Earth-moving Contractors"—own plant, tools of trade and equipment incidental to own contracts. (b) Within a 20-mile radius from site of construction or maintenance work performed pursuant to paragraph (a) above, or from the railway station nearest thereto—metal, stones, screenings, ashes, gravel, sand, earth and any other materials required for such work. (c) Within a 25-mile radius of the post office at Cohuna—general goods, provided that no goods shall be carried whether by one stage or by more than one stage between places within the above radius which are more than thirty (30) road miles apart by the nearest practicable route. (d) Within a 50-mile radius from own quarry

- at Pyramid Hill—screenings, stone dust, sand and rock.
(e) Within a 50-mile radius from own quarry at Corop—screenings, stone dust, sand and rock.
- MORROW, J. E., 8 Abernathy-street, Shepparton, 3630. Application to vary the conditions of licence No. D.A.41793/1 (L/C. 14 cwt.) by deleting "and Agent solely on behalf of Mackay and Green" from the existing conditions.
- CONWAY, L. R. (trading as Ormond Slate Supplies), 774 North-road, Ormond, 3204. One commercial goods vehicle (L/C. 122 cwt.) to operate in the course of business as "Sand, Screenings and Garden Suppliers" as follows: (a) Within a 25-mile radius of the post office situated at the corner of Bourke and Elizabeth streets, Melbourne—own goods. (b) From pits at Cranbourne to places within the radius specified in part (a) above—own sand. (c) From quarries at Chewton to places within the radius specified in part (a) above—own Castlemaine paving stone. (d) From quarries at Bacchus Marsh to places within the radius specified in part (a) above—own slate and pebbles. (e) From Healesville to places within the radius specified in part (a) above—own mountain soil. (f) From pits at Bacchus Marsh to places within the radius specified in part (a) above—own river pebbles. (g) From Bacchus Marsh, Melton and Balliang East to places within the radius specified in part (a) above—own honeycomb rock.
- PENDERGAST, R. G. (trading as W. A. Pendergast & Son), Benambra, 3900. Application to vary the conditions of licence No. D.T.1469 (L/C. 359 cwt.) by adding after "Damsinking" in the existing conditions "Road Construction".
- PICTON HOPKINS & SONS PTY. LTD., 130 Church-street, Richmond, 3121. One commercial goods vehicle (L/C. 10 cwt.) to operate in the course of business as "Plaster Craftsmen"—(a) Within a 25-mile radius of the post office at Richmond—own goods. (b) Throughout the State of Victoria—(i) Fibrous plaster sheeting, mouldings, sisal and a quantity of plaster sufficient only for the fixing of the said plaster sheets and mouldings; also battens, nails, and insulating materials, viz.:—insulwool and rockwool suspended ceilings, component parts and associated acoustic tiles and sprayed finishes. (ii) Terrazzo slabs and/or materials incidental to fixing of same, stone dust, sand and a quantity of cement sufficient only for setting purposes and associated materials necessary to carry out solid plastering contracts, vinyl and lino tiles and adhesives, scaffolding plant and tools of trade for use in own building contracts. (c) Within a 20-mile radius of own branch premises at Hernes Oak—own goods. (d) Within a 20-mile radius of the site of any contract currently engaged upon or to such site from the railway station nearest thereto—materials for use on such contract.
- PIZZEY LTD., 410 Whitehorse-road, Mitcham, 3132. Two commercial goods vehicles (L/C. 10, 19 cwt.) to operate:—(a) Within a 50-mile radius from own premises at Mitcham in the course of business as Merchants, Manufacturers and Distributors—own goods. (b) Throughout the State of Victoria as manufacturers of agricultural machinery, for the purpose of servicing and demonstrating agricultural equipment—agricultural equipment for demonstration or for repair or having been repaired, also tools of trade, spare parts and materials incidental thereto.
- 7X BEVERAGES (CENTRAL) PTY. LTD., 16 First-avenue, Sunshine, 3020. Application to vary the conditions of licences numbered T.D.A.61307/10, T.D.A.61307/11 (L/C. 65, 64 cwt.) by deleting the existing conditions and adding in lieu—"Within a 50-mile radius of licence holder's own premises at Bendigo in the course of business as 'Aerated Water Distributors'—aerated waters manufactured by Lowery Bros. Pty. Ltd. at its Maryborough factory and empty containers for return; also aerated waters and/or fruit juices manufactured at the 7X Beverages Pty. Ltd. factory at Morwell, an approved decentralized secondary industry".
- SILLERY ELECTRICS PTY. LTD., 7 Market-court, Reservoir, 3073. One commercial goods vehicle (L/C. 12 cwt.) to operate: (a) Within a 50-mile radius of the G.P.O., Melbourne in course of business as "Electrical Contractor"—tools of trade and electrical goods for repair or having been repaired. (b) Throughout the State of Victoria in course of business as "Electrical Contractor"—tools of trade, electrical switchboards for installation and a quantity of fittings and spare parts not exceeding 1 cwt. at any one time incidental to installation and repair work.
- VAN DER SLUYS, H., 23 Quentin-street, Forest Hill, 3131. One commercial goods vehicle (L/C. 176 cwt.) to operate within a 50-mile radius of the premises of Consolidated Quarries Ltd. at Oakleigh on behalf of the said company—premixed concrete in a specially constructed agitator vehicle.
- WALDEN, T. J., 109 Douro-street, North Geelong, 3215. One commercial goods vehicle (L/C. 16 cwt.) to operate within a 75-mile radius of the chief post office in the City of Geelong in the course of business as "Home Appliance Serviceman" for the purpose of installing and servicing heating units and electrical appliances—tools of trade, spare parts and materials incidental to own contracts and heating units and electrical appliances for installation, for repair or having been repaired but excluding all operations between Geelong and Melbourne.
- HALEY, E. M. (trading as White Top Taxi Trucks), 69 Colliver-road, Shepparton, 3630. One commercial goods vehicle (L/C. 34 cwt.) to operate: (a) Within a 25-mile radius of the post office at Shepparton—general goods, provided that no goods shall be carried whether by one stage or by more than one stage between places within the above radius which are more than thirty (30) road miles apart by the nearest practicable route. (b) Within a 70-mile radius of the post office at Shepparton—second-hand household furniture or personal effects of a householder or member of his family when being moved from residence to residence, from residence for storage or sale, from storage to residence, from a vendor to the residence of the purchaser.

TOW TRUCK.

SPYROU, K. (trading as Nationwide Motor Body Works), corner Webb-road and Harper-street, Airport West, 3042. One commercial goods vehicle (L/C. 27 cwt.) to operate throughout the State of Victoria as a "Tow Truck" solely—(a) For the purposes of lifting and carrying or towing of wrecked or disabled motor vehicles and the carriage of tools and equipment necessary for such purposes. (b) The carriage of spare parts necessary for the repair of a disabled motor vehicle to and from the place at which such disablement has occurred.

RENEWALS.

Applications for renewal of licences as shown by persons listed hereunder to operate under the same terms and conditions from the expiry shown in each case.

BEAUREPAIRE TYRE SERVICE PTY. LTD., 102 Victoria-street, Carlton, 3053; D.A.629/17; 27th June, 1972; 16 cwt.

BEAUREPAIRE TYRE SERVICE PTY. LTD., 102 Victoria-street, Carlton, 3053; D.A.629/49; 6th June, 1972; 14 cwt.

BORDER AVIATION AGRIC. PTY. LTD., 706 Yambala-avenue, Albury, N.S.W., 2640; D.A.61829; 3rd June, 1972; 80 cwt; D.A.61829/1; 3rd June, 1972; 80 cwt.

COWLING, K., 76 McKenzie-street West, Golden Square, 3555; D.A.61851; 11th June, 1972; 10 cwt.

HOGAN, K. F., Main-road, Emerald, 3782; D.A.7915; 18th June, 1972; 113 cwt.

LYTTON PLASTER PTY. LTD., Podmore-street, Dandenong, 3175; D.A.52479; 16th June, 1972; 194 cwt.

MASSEY-FERGUSON (AUST.) LTD. (trading as Massey Ferguson Ballarat), 801 Latrobe-street, Ballarat, 3350; D.A.1252/28; 1st June, 1972; 8 cwt; D.A.1252/29; 1st June, 1972; 8 cwt; D.A.1252/30; 1st June, 1972; 10 cwt; D.A.1252/31; 1st June, 1972; 79 cwt.

NORTHERN TYRE SERVICE PTY. LTD., 298 High-street, Shepparton, 3630; D.A.47685/3; 16th June, 1972; 10 cwt.

PEGORARO F., & B. CERVY PTY. LTD., 83 Palmerston-street, Carlton, 3053; D.A.10231/2; 6th June, 1972; 142 cwt.

RAMSAY & TREGANOWAN LTD., 475 La Trobe-street, Melbourne, 3000; D.A.31536/1; 23rd April, 1972; 12 cwt.

WEBSTER, JOHN, & Co. PTY. LTD., 18 High-street, Northcote, 3070; D.A.43803/3; 22nd June, 1972; 10 cwt.

RENEWAL WITH VARIATION.

Application made by the person listed hereunder for renewal of the licence listed with variation of conditions in the manner set out opposite the name.

CLEANAIR PTY. LTD. (trading as Gray & Wood), 19 Park-road, Cheltenham, 3192; D.A.47051/1; 16th June, 1972; Application to renew and vary the conditions of licence No. D.A.47051/1 (L/C. 16 cwt.) by deleting "Huntingdale" from the existing conditions and adding in lieu "Cheltenham".

Notice of any objection should be forwarded to reach the Secretary of the Board not later than 16th February, 1972.

Applicants are advised that it will not be necessary to appear on the hearing date specified above, unless advised in writing by the Board.

B. P. KAY,

Secretary.

Corner Lygon and Princes streets, Carlton, 3053, Wednesday, 2nd February, 1972.

Health Act 1958.

VICTORIA—DEPARTMENT OF HEALTH.

NOTICE TO ATTEND FOR RADIOLOGICAL EXAMINATION.

To all persons aged twenty-one years and over enrolled or resident in the subdivisions specified hereunder in the State Electoral District of Benambra.

Take notice that you are required to attend at a Department of Health X-ray Unit sited in the public street at or as near as possible to the main entrance to the premises specified in this notice, at any time between the hours specified on one of the days specified and during the period specified in respect of those premises, and thereat to submit yourself to radiological examination of the chest for the purpose of ascertaining whether you may be suffering from pulmonary tuberculosis. If you have had a Chest X-ray within the last twelve months and for this reason do not wish to be examined now, you should attend the unit as directed and submit particulars of the previous examination.

SPECIFIED SUBDIVISION, PREMISES, PERIODS, DAYS AND HOURS.

Subdivision.	Premises.	Period.	Days.	Hours.
Wangaratta..	Co-op Store, Corner Ovens and Reid streets, Wangaratta	Monday, 14th February, 1972, to Wednesday, 23rd February, 1972 (inclusive)	Monday, 14th February, 1972 All other days during the period except Saturday, Sunday and Public Holidays	From 7.30 p.m. to 9 p.m. From 10 a.m. to 6 p.m. and 7.30 p.m. to 9 p.m.
	Corner Vincent and Green roads, Wangaratta (Yarrunga)	Monday, 14th February, 1972, to Tuesday, 22nd February, 1972 (inclusive)	Monday, 14th February, 1972 All other days during the period except Saturday, Sunday and Public Holidays	From 7.30 p.m. to 9 p.m. From 10 a.m. to 6 p.m. and 7.30 p.m. to 9 p.m.
	Shopping Centre, Muntz-street, Wangaratta (West End)	Monday, 21st February, 1972, to Thursday, 24th February, 1972 (inclusive)	Monday, 21st February, 1972 All other days during the period except Public Holidays	From 11 a.m. to 6 p.m. and 7.30 p.m. to 9 p.m. From 10 a.m. to 6 p.m. and 7.30 p.m. to 9 p.m.
	Swimming Pool, Swan-street, Wangaratta	Wednesday, 23rd February, 1972, to Friday, 25th February, 1972 (inclusive)	Each day during the period except Public Holidays	From 10 a.m. to 6 p.m. and 7.30 p.m. to 9 p.m.
	Public Hall, Milawa	Thursday, 24th February, 1972, and Friday, 25th February, 1972	Thursday, 24th February, 1972 Friday, 25th February, 1972	From 11 a.m. to 6 p.m. and 7.30 p.m. to 9 p.m. From 10 a.m. to 6 p.m. and 7.30 p.m. to 9 p.m.
Beechworth..	Post Office, Eldorado ..	Friday, 25th February, 1972	Friday, 25th February, 1972	From 11 a.m. to 6 p.m. and 7.30 p.m. to 9 p.m.
	Library Hall, Whorouly	Thursday, 17th February, 1972, and Friday, 18th February, 1972	Thursday, 17th February, 1972 Friday, 18th February, 1972	From 2 p.m. to 6 p.m. and 7.30 p.m. to 9 p.m. From 10 a.m. to 6 p.m. and 7.30 p.m. to 9 p.m.
	Soldiers' Memorial Hall, Stanley Shire Offices, Beechworth	Thursday, 2nd March, 1972 Friday, 3rd March, 1972, to Tuesday, 7th March, 1972 (inclusive)	Thursday, 2nd March, 1972 Friday, 3rd March, 1972..	From 2 p.m. to 6 p.m. and 7.30 p.m. to 9 p.m. From 11 a.m. to 6 p.m. and 7.30 p.m. to 9 p.m.
Yackandandah	Public Hall, Yackandandah	Monday, 28th February, 1972, and Tuesday, 29th February, 1972	Monday, 28th February, 1972	From 7.30 p.m. to 9 p.m.
	Memorial Hall, Dederang	Wednesday, 1st March, 1972	Tuesday, 29th February, 1972	From 10 a.m. to 6 p.m. and 7.30 p.m. to 9 p.m.
	Community Centre, Mount Beauty	Thursday, 2nd March, 1972, and Friday, 3rd March, 1972	Wednesday, 1st March, 1972 Thursday, 2nd March, 1972	From 11 a.m. to 6 p.m. and 7.30 p.m. to 9 p.m. From 11 a.m. to 6 p.m. and 7.30 p.m. to 9 p.m.
	Memorial Hall, Tawonga	Monday, 6th March, 1972..	Friday, 3rd March, 1972	From 10 a.m. to 6 p.m. and 7.30 p.m. to 9 p.m.
	Coulston Park Pavilion, Tangambalanga	Tuesday, 7th March, 1972, and Wednesday, 8th March, 1972	Monday, 6th March, 1972 Tuesday, 7th March, 1972	From 11 a.m. to 6 p.m. and 7.30 p.m. to 9 p.m. From 2 p.m. to 6 p.m. and 7.30 p.m. to 9 p.m.
Tallangatta..	Public Hall, Eskdale ..	Monday, 28th February, 1972, and Tuesday, 29th February, 1972	Wednesday, 8th March, 1972 Monday, 28th February, 1972	From 10 a.m. to 6 p.m. and 7.30 p.m. to 9 p.m. From 7.30 p.m. to 9 p.m.
	Memorial Hall, Towong-street, Tallangatta	Wednesday, 1st March, 1972, to Friday, 3rd March, 1972 (inclusive)	Tuesday, 29th February, 1972 Wednesday, 1st March, 1972	From 10 a.m. to 6 p.m. and 7.30 p.m. to 9 p.m. From 11 a.m. to 6 p.m. and 7.30 p.m. to 9 p.m.
Corryong ..	Mechanics' Institute Cudgewa	Monday, 6th March, 1972..	All other days during the period except Public Holidays	From 10 a.m. to 6 p.m. and 7.30 p.m. to 9 p.m.
	R.S.L. Hall, Cnr. Donaldson and Hansen-streets, Corryong	Tuesday, 7th March, 1972, to Thursday, 9th March, 1972 (inclusive)	Monday, 6th March, 1972 Tuesday, 7th March, 1972	From 2 p.m. to 6 p.m. and 7.30 p.m. to 9 p.m. From 11 a.m. to 6 p.m. and 7.30 p.m. to 9 p.m.
	Soldiers' Memorial Hall, Walwa	Friday, 10th March, 1972..	All other days during the period except Public Holidays Friday, 10th March, 1972	From 10 a.m. to 6 p.m. and 7.30 p.m. to 9 p.m. From 11 a.m. to 6 p.m. and 7.30 p.m. to 9 p.m.

NOTE.—Any person to whom this notice applies and who without reasonable excuse fails to comply with the requirements of the notice shall be guilty of an offence, and shall be liable to a penalty of not more than forty dollars.

Dated this twelfth day of January, One thousand nine hundred and seventy-two.

W. J. STEVENSON, Chief Health Officer.

Private Agents Act 1966.

NOTICE OF RECEIPT OF APPLICATIONS FOR LICENCES UNDER THE PROVISIONS OF THE PRIVATE AGENTS ACT 1966.

The Clerk(s) of the Magistrates' Court(s) as listed hereunder hereby give notice that applications, as under, have been lodged for hearing by the said Court(s) on the date(s) specified.

Any person desiring to object to any of such applications must—

- (a) lodge with the respective Clerk of the Magistrates' Court a notice in the prescribed form of his objection and of the grounds thereof;
- (b) cause a copy of such notice to be served personally or by post upon the applicant at least three days before the hearing of the application; and
- (c) send or deliver—
 - (i) where the objection is not made by the officer in charge of the police district in which the Court is situated—a copy of the notice to such officer; and
 - (ii) where the objection is not made by the Registrar or Deputy Registrar—a copy to the Registrar.

Full Name of Applicant or in the Case of a Firm or Corporation, of the Nominee.	Place of Abode of Applicant or Nominee.	Name of Firm or Corporation.	Address for Registration.	Type of Licence.	Date of Hearing of Application.
MAGISTRATES' COURT, PRAHRAN.					
Holford, Dudley George ..	4 Churchill-street, Bairnsdale	Carol Furzer ..	Flat 12, 614 St. Kilda-road, Melbourne	Provisional Commercial Sub-Agent	7.2.72
Broadhurst, Norman Wisely ..	Flat 7, 44 Barkley-street, St. Kilda	" "	4.2.72
McKay, Ross Stuart ..	34 Box-street, Doveton	C. & C. Investigation and Security Service	Suite 5, 541 St. Kilda-road, Melbourne	Commercial Sub-Agent	8.2.72
Dated at Prahran this 28th day of January, 1972.					
J. F. PRESNELL, Clerk of the Magistrates' Court.					
MAGISTRATES' COURT, FRANKSTON.					
Hilton, Albert Trevor ..	" Kingston Lodge " Caravan Park, Car-rum Downs	8 Overport-road, Frankston	Watchman ..	11.2.71
Dated at Frankston this 20th day of January, 1972.					
J. W. DUNN, Clerk of the Magistrates' Court.					
MAGISTRATES' COURT, MELBOURNE.					
Rossi, Giovanni ..	58 Thackeray-road, Reservoir	Mayne Nickless Limited	94 York-street, South Melbourne	Watchman ..	16.2.71
Dated at Melbourne this 20th day of January, 1972.					
G. L. WEBSTER, Clerk of the Magistrates' Court.					
MAGISTRATES' COURT, FERNTREE GULLY.					
Toole, Roger Cleveland ..	24 Frudal-crescent, Knoxfield	Box 134, Ferntree Gully	Commercial Agent	14.2.72
" " " ..	" " "	" " " ..	Inquiry Agent ..	"
Dated at Ferntree Gully this 24th day of January, 1972.					
F. J. DUTHIE, Clerk of the Magistrates' Court.					
MAGISTRATES' COURT, MELBOURNE.					
Thiedeman, Maurice Walter Buchan	Flat 5, 80 Burke-road, East Malvern	Security Watching Company	2nd Floor, 561 Bourke-street, Melbourne	Watchman ..	9.2.72
Dated at Melbourne this 17th day of January, 1972.					
G. L. WEBSTER, Clerk of the Magistrates' Court.					
MAGISTRATES' COURT, MARYBOROUGH.					
Hendrickson, Joy Beverley ..	273 Gladstone-street, Maryborough	273 Gladstone-street, Maryborough	Process Server ..	14.2.72
Dated at Maryborough this 20th day of January, 1972.					
R. J. CANNING, Clerk of the Magistrates' Court.					
MAGISTRATES' COURT, GEELONG.					
Toseland, Clive ..	9 Osborne, avenue, North Geelong	S.I.A. Mercantile Group Pty. Ltd. [G. Hercus, Nominee]	Suite 29, 68 Yarra-street, Geelong	Commercial Sub-Agent	14.2.72
" " " ..	" " " ..	" " " ..	" " " ..	Process Server	"
Dated at Geelong this 24th day of January, 1972.					
J. E. REILLY, Clerk of the Magistrates' Court.					
MAGISTRATES' COURT, BOX HILL.					
Emery, Graham Edward ..	75 Husband-road, Forest Hill	Centaur Patrol Service	32 Milton-street, Nunawading	Watchman ..	18.2.72
Dated at Box Hill this 27th day of January, 1972.					
A. J. JOHNSON, Clerk of the Magistrates' Court.					
MAGISTRATES' COURT, OAKLEIGH.					
McKenzie, Clive Alexander ..	14 Maylands-crescent, Glen Waverley	14 Maylands-crescent, Glen Waverley	Inquiry Agent ..	18.2.72
" " " ..	" " "	" " " ..	Process Server ..	"
Dated at Oakleigh this 25th day of January, 1972.					
G. MEEHAN, Clerk of the Magistrates' Court.					

PRIVATE AGENTS—continued.

Full Name of Applicant or in the Case of a Firm or Corporation, of the Nominee.	Place of Abode of Applicant or Nominee.	Name of Firm or Corporation.	Address for Registration.	Type of Licence.	Date of Hearing of Application.
MAGISTRATES' COURT, BAIRNSDALE.					
Neal, Peter William	Princes Highway, Swan Reach		68 Main-street, Bairnsdale	Watchman	17.2.72
Dated at Bairnsdale this 25th January, 1972.					
G. H. SCHMIDT, Clerk of the Magistrates' Court.					
MAGISTRATES' COURT, PRAHRAN.					
Hyman, Margaret Ann	2 Studley-street, Doncaster		Suite 62, 145 Canterbury-road, Toorak	Commercial Agent Individual	11.2.72
Dated at Prahran this 21st day of January, 1972.					
J. F. PRESNELL, Clerk of the Magistrates' Court.					

DEPARTMENT OF MINES.
MINING LEASE EXPIRED.

11340, Bendigo; Edmond Francis McKenzie; 46a. 3r. 15p., Parish of Axedale.

APPLICATION FOR EXPLORATION LICENCE
DECLARED ABANDONED.

393, Exploration Licence; Planet Mining Company Pty. Ltd.; 320 square miles, Counties of Croajingolong, Tambo.

TAILINGS LICENCE GRANTED.

3707, Tailings Licence; John Lawrence Ward; to remove tailings from the "Great Southern" mining dump, Parish of Chiltern West.

APPLICATIONS FOR EXTRACTIVE INDUSTRY
LICENCES DECLARED ABANDONED.

123, Extractive Industry Licence; The Barkly Brick Company Proprietary Limited; 7 acres, more or less, Parish of Jika Jika.

128, Extractive Industry Licence; Fritsch Holzer & Co. Proprietary Limited; 21 acres, more or less, Parish of Booroodara.

APPLICATIONS FOR EXTRACTIVE INDUSTRY LEASES
DECLARED ABANDONED.

- 104, Extractive Industry Lease; R. T. Blake, P. N. Barton, N. Piera; 3 acres, Parish of Hotham.
- 125, Extractive Industry Lease; Alpha Minerals N.L.; 40 acres, Parish of Chewton.
- 126, Extractive Industry Lease; Alpha Minerals N.L.; 10 acres, Parish of Wedderburne.

EXTRACTIVE INDUSTRY LICENCES GRANTED.

- 61, Extractive Industry Licence; Brick and Pipe Industries Limited; 96a. 1r. 29p., more or less, Parish of Cranbourne.
- 68, Extractive Industry Licence; The Standard Brick Works (Box Hill) Proprietary Limited; 17a. 1r. 9p., more or less, Parish of Nunawading.
- 85, Extractive Industry Licence; Oakleigh Brick Company Proprietary Limited; 22a. 1r. 33p., more or less, Parish of Mulgrave.

EXTRACTIVE INDUSTRY SEARCH PERMIT GRANTED.

34, Extractive Industry Search Permit; B.A.M. & Associates Proprietary Limited; 602 acres, more or less, Parish of Dergholm.

J. C. M. BALFOUR,
Minister of Mines.

SHIRE OF ORBOST.
ROAD DEVIATION ORDER.

Pursuant to the provisions of sections 522 and 526 of the Local Government Act 1958, the Council of the Shire of Orbost hereby directs that the land in the Parish of Orbost indicated by hatching on the diagram hereunder which has been purchased, taken or acquired by it, shall be a public highway on and from the date of publication of this order in the *Government Gazette* and declares that such land shall be a public highway in lieu of the land indicated by cross-hatching on the said diagram.

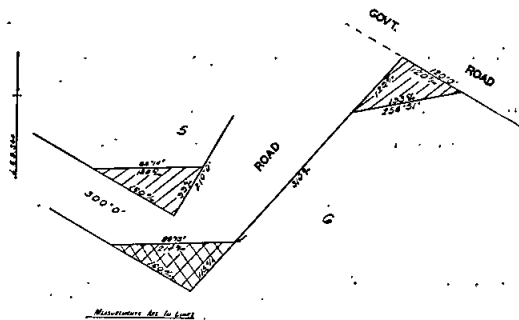

The common seal of the President, Councillors and Ratepayers of the Shire of Orbost was hereunto affixed this 11th day of June, 1971, in the presence of—

(SEAL) J. D. TORLEY, President.
L. G. SCOTT, Councillor.
R. K. SOULSBY, Secretary.

Confirmed by the Governor in Council, 25th January, 1972.—JOHN A. HORLOCK, Acting Clerk of the Executive Council.

Pipelines Act, 1967-1971.

NOTICE OF VARIATION OF CONDITIONS OF A
PIPELINE LICENCE.

Whereas sub-section (3) of section 30 of the Pipelines Act 1967-1971 provides that the Minister may by notice published in the *Government Gazette* amend vary add to or revoke any conditions stated or included in a licence, I, James Charles Murray Balfour, Minister of Mines, do now hereby amend vary and add to the conditions of Pipeline Licence No. 46 in the manner indicated in the Schedule hereto:—

SCHEDULE.

1. Add the following sub-clauses to Clause Ic of the Schedule to the licence:—

- (iii) *Meter Station.*
5 x 16 in., 1 x 6 in., and 3 x 10 in. positive replacement meters shall be installed down-stream of the pumping units referred to in Clause G of the Schedule in accordance with the details shown on Drawing No. 254-MF1-5 accompanying the application.
- (iv) *Connexion to W.A.G. Pipeline.*
A 24 in. pipeline connexion as described by drawing No. 254-MF1-5 shall be installed between the meter station referred to in sub-clause (iii) of this clause and a connexion located at the licensee's property boundary into the pipeline licensed by Pipeline Licence No. 65.

2. Amend Clause 1g (ii) of the Schedule to the licence to read:—

- (ii) *Transfer Pumps.*
Three vertical centrifugal crude oil pumps driven by 75 h.p. electric motors shall be connected into the delivery side of the pipeline in accordance with the details shown on Drawing No. 254-MF1-5 accompanying the application.

25th January, 1972.

JIM BALFOUR,
Minister of Mines.

NOTICE OF FIXING OF ALIGNMENTS OF THE HEALESVILLE FREEWAY IN THE CITY OF KNOX.

Notice is hereby given that the Country Roads Board under the powers conferred upon it by the Country Roads Act 1958 (No. 6229) has fixed an alignment for each side of the Healesville Freeway in the City of Knox as shown on survey plans numbered 11695, 11696, 11697 and 11699.

Copies of the said survey plans are lodged in the offices of the Country Roads Board, the municipality of the City of Knox, the Registrar of Titles and the Registrar-General respectively, and may be inspected by any person without a fee at any time at which such offices are open for business.

The locality in which the alignments have been fixed is indicated on the plans hereunder:—

BY-PASS ROAD HEALESVILLE FREEWAY BY-PASS ROAD SHIRE OF KNOX Measurements in feet & inches

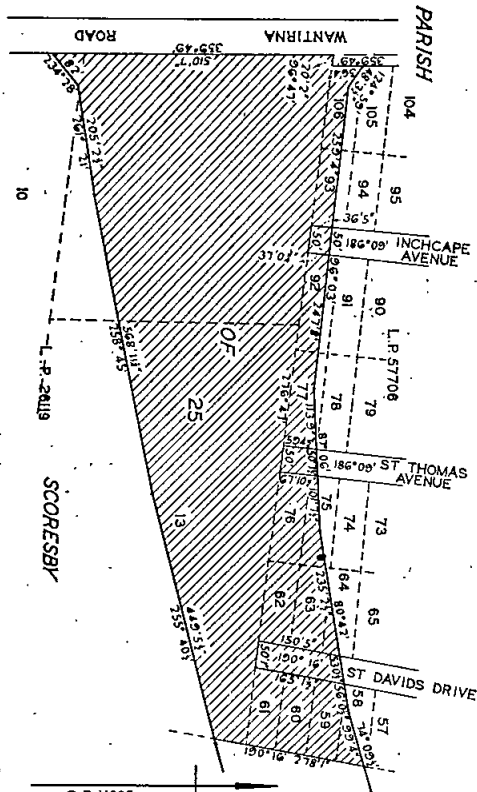

G.P. 11695 Compiled from S.P. 11695

BY-PASS ROAD HEALESVILLE FREEWAY BY-PASS ROAD SHIRE OF KNOX Measurements in feet & inches

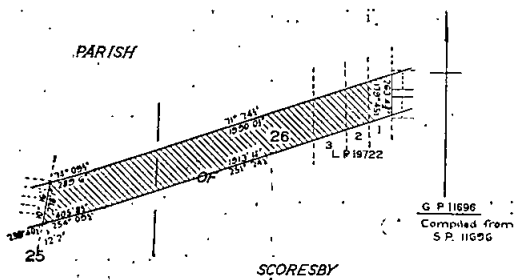

G.P. 11696 Compiled from S.P. 11696

BY-PASS ROAD HEALESVILLE FREEWAY BY-PASS ROAD SHIRE OF KNOX Measurements in feet & inches

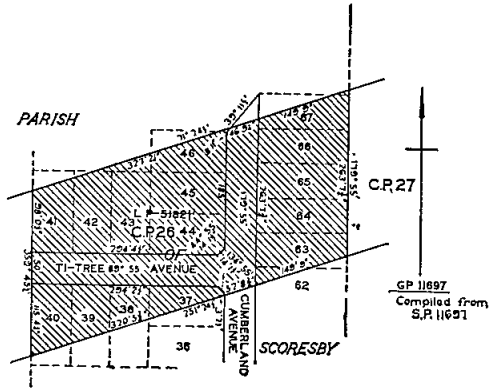

G.P. 11697 Compiled from S.P. 11697

BY-PASS ROAD HEALESVILLE FREEWAY BY-PASS ROAD SHIRE OF KNOX Measurements in feet & inches

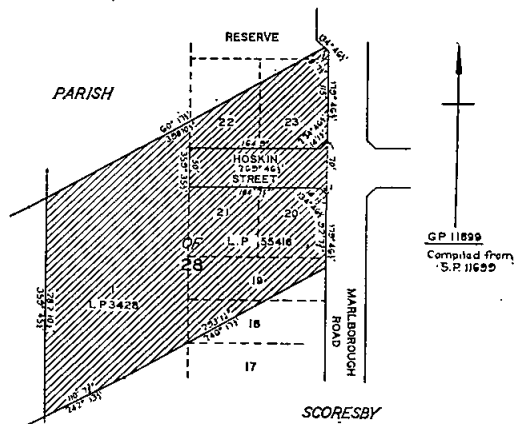

G.P. 11699 Compiled from S.P. 11699

N. L. ALLANSON, Secretary.

Country Roads Board, 60 Denmark-street, Kew, dated 21st January, 1972.

ORDERS IN COUNCIL.—(Series 1971-72.) PUBLIC WORKS.

800. Ballarat, 5 Lydiard-street south, partitioning, &c., of premises, \$5,779.00.—V.I.A. Ltd.—(P.851.)

801. Collingwood, High School, provision of sewerage, water supply and storm water drains to portable buildings, \$10,184.00.—F. R. Clark & Co. Pty. Ltd.—(C.26601 "H".)

802. Public Works, dredging the mouth of Mordialloc Creek, Werribee River and the Channel at Cresser Reserve, Altona, \$40,790.00.—Duncan and Russell Pty. Ltd.—(P. & H. 134043.)

Approved by the Governor in Council, 25th January, 1972.—JOHN A. HORLOCK, Acting Clerk of the Executive Council.

Medical Board of Victoria.

RECORD OF TEMPORARY MEDICAL REGISTRATION AS AT 31st DECEMBER, 1971.

Printed and published under the direction of the Medical Board of Victoria, pursuant to the provisions of Section 27 of the *Medical Practitioners Act 1970.*

Number of Certificate.	Date of Issue.	To Whom Issued.	Address.	Qualifications.	Limitations and Restrictions.
T. 74	10.4.69	Chirawong, Phisit ..	Dept. of Medicine, University of Melbourne	M.D. of the University of Medical Science Bangkok, 1962	Issued for a period not exceeding two (2) years and entitling the holder to work as a medical practitioner only in the service of University of Melbourne, Department of Medicine. This certificate was extended for a further period of one (1) year
T. 81	2.10.69	Lal, Kundan ..	Cancer Institute, William-street, Melbourne	M.B., B.S., Punjab, 1939. (Pakistan)	Issued for a period not exceeding two (2) years and entitling the holder to work as a medical practitioner only in the service of the Cancer Institute, Melbourne. This certificate was extended for a further period of one (1) year
T. 83	5.2.70	Thompson, Charles Derrick	Prince Henry's Hospital	M.D., Alberta, 1968 (Canada)	Issued for a period not exceeding one (1) year and entitling the holder to work as a medical practitioner only in the service of Prince Henry's Hospital. This certificate was extended for a further period of one (1) year
T. 89	7.5.70	Suzuki, Makoto ..	The Royal Melbourne Hospital	M.D., Keito (Japan), 1958	Issued for a period not exceeding two (2) years and entitling the holder to work as a medical practitioner only in the service of the Royal Melbourne Hospital
T. 93	14.9.70	Blamey, Roger Wallas	St. Vincent's Hospital..	M.A., M.B., B.Chir., Cambridge, 1961, F.R.C.S., 1965, M.D., 1969	Issued for a period not exceeding eighteen (18) months and entitling the holder to work as a medical practitioner only in the service of St. Vincent's Hospital
T. 100	10.12.70	Squires, Edward McIntosh	Prince Henry's Hospital	M.D., Queens University (Canada), 1968	Issued for a period not exceeding fifteen (15) months and entitling the holder to work as a medical practitioner only in service of Prince Henry's Hospital
T. 103	21.1.71	Maranetra, Nanter	Royal Melbourne Hospital	M.D. Mahidol (Thailand) 1965	Issued for a period not exceeding two (2) years and entitling the holder to work as a medical practitioner only in the service of The Royal Melbourne Hospital
T. 109	18.3.71	Benz, Ulrich Felix ..	Prince Henry's Hospital	M.D., Basal (Switzerland), 1968	Issued for a period not exceeding one (1) year and entitling the holder to work as a medical practitioner only in the service of the Prince Henry's Hospital
T. 110	18.3.71	Bunnag, Chaweewun	Eye and Ear Hospital..	M.D., University of Medical Sciences, Thailand, 1966	Issued for a period not exceeding two (2) years and entitling the holder to work as a medical practitioner only in the service of the Eye and Ear Hospital
T. 112	15.4.71	Pihl, Erik Axel Viktor	Department of Pathology, Monash University, Medical School	M.D., Umea (Sweden), 1963	Issued for a period not exceeding two (2) years and entitling the holder to work as a medical practitioner only in the service of Department of Pathology, Monash University Medical School
T. 114	20.5.71	Graham, Mary Frances Lyon	Mental Health Authority	M.D., Illinois (U.S.A.) 1951	Issued for a period not exceeding two (2) years and entitling the holder to work as a medical practitioner only in the service of the Mental Health Authority
T. 115	17.6.71	Sharma, Kesho Dutt	Royal Children's Hospital	D.S.M., Fiji, 1960 ..	Issued for a period not exceeding one (1) year and entitling the holder to work as a medical practitioner only in the service of the Royal Children's Hospital
T. 116	17.6.71	Yoshizawa, Hidezo	St. Vincent's Hospital ..	M.D., Keio (Japan), 1963	Issued for a period not exceeding one (1) year and entitling the holder to work as a medical practitioner only in the service of the St. Vincent's Hospital
T. 117	15.7.71	Gould, Sharon Ann	Prince Henry's Hospital	M.D., California, (U.S.A.), 1965	Issued for a period not exceeding one (1) year and entitling the holder to work as a medical practitioner only in the service of Prince Henry's Hospital

RECORD OF TEMPORARY MEDICAL REGISTRATION AS AT 31st DECEMBER, 1971.—Continued.

Number of Certificate.	Date of Issue.	To Whom Issued.	Address.	Qualifications.	Limitations and Restrictions.
T. 119	16.9.71	Blecher, Andrew Benjamin	Mental Health Authority	M.D., Budapest, 1955	Issued for a period not exceeding two (2) years and entitling the holder to work as a medical practitioner only in the service of the Mental Health Authority
T. 120	4.11.71	Lan, Nguyen Thanh	Alfred Hospital	M.D., Saigon, 1968..	Issued for a period not exceeding one (1) year and entitling the holder to work as a medical practitioner only in the service of the Alfred Hospital
T. 121	18.11.71	Bhalla, Surrender Kumar	St. Vincent's and Alfred Hospitals	M.B., B.S., Andhra (India), 1950	Issued for a period not exceeding six (6) months and entitling the holder to work as a medical practitioner only in the services of St. Vincent's and Alfred Hospitals
T. 122	20.12.71	Chong, Terry Min Sin	Austin Hospital	M.B., B.S., Malaya, 1969	Issued for a period not exceeding fourteen (14) months and entitling the holder to work as a medical practitioner only in the service of the Austin Hospital

STATE RIVERS AND WATER SUPPLY COMMISSION.

LICENCE TO DIVERT WATER PURSUANT TO THE PROVISIONS OF SECTION 204 OF THE WATER ACT (AS AMENDED).

The Schedule of one Licence as detailed hereunder to divert water has been revoked by the Governor in Council.

SCHEDULE.

Licence No.	Term of Licence and Commencing Date.	Name and Address of Person to whom Licence granted.	Source of Supply.
911/469	Fourteen and a half years from 1.1.56	Kenneth Leslie McNaughton, Little River	Little River

Office of the State Rivers and Water Supply Commission,
Melbourne, 25th January, 1972.G. W. LEWIS, Secretary,
State Rivers and Water Supply Commission.

STATE RIVERS AND WATER SUPPLY COMMISSION.

LICENCES TO DIVERT WATER AND CUT RACES PURSUANT TO THE PROVISIONS OF SECTION 204 OF THE WATER ACT 1958 (AS AMENDED).

The Schedule of Licences as detailed hereunder to divert water and cut races have been revoked by the Governor in Council.

SCHEDULE.

Licence No.	Term of Licence and Commencing Date.	Name and Address of Person to whom Licence granted.	Source of Supply.
2032/1662	Four years from 1.7.68 ..	Audrey Helen Young, Wemen	River Murray
2210	Four years from 1.7.66 ..	Audrey Helen Young, Wemen	River Murray

Office of the State Rivers and Water Supply Commission,
Melbourne, 25th January, 1972.G. W. LEWIS, Secretary,
State Rivers and Water Supply Commission.Town and Country Planning Act 1961.
PORTLAND PLANNING SCHEME 1957.

AMENDMENT No. 12, 1969.

(TOWN OF PORTLAND).

Notice of Approval.

In pursuance of the powers conferred by the Town and Country Planning Act 1961, the Governor in Council on the 25th January, 1972, approved a planning scheme entitled the Portland Planning Scheme 1957, Amendment No. 12, 1969 (Town of Portland), in respect of parts of the municipal district of the Town of Portland and such planning scheme comes into operation on the date this notice of approval is published in the *Government Gazette*.

A copy of the planning scheme as approved may be inspected free of charge during office hours at the office of the Town and Country Planning Board, 235 Queen-street, Melbourne; at the office of the Portland Town Council at Portland and when available, at the Office of Titles, Melbourne, and at the Central Plan Office of the Department of Crown Lands and Survey, Melbourne.

W. H. CRAIG, Secretary,
Town and Country Planning Board.

Town and Country Planning Act 1961.

CITY OF KNOX PLANNING SCHEME.

AMENDMENT No. 88.

Notice of Approval.

In pursuance of the powers conferred by the Town and Country Planning Act 1961, the Governor in Council on the 25th January, 1972, approved a planning scheme entitled the City of Knox Planning Scheme, Amendment No. 88, in respect of part of the municipal district of the City of Knox and such planning scheme comes into operation on the date this notice of approval is published in the *Government Gazette*.

A copy of the planning scheme as approved may be inspected free of charge during office hours at the office of the Town and Country Planning Board, 235 Queen-street, Melbourne; at the office of the City of Knox at Fern Tree Gully and when available, at the office of Titles, Melbourne, and at the Central Plan Office of the Department of Crown Lands and Survey, Melbourne.

W. H. CRAIG, Secretary,
Town and Country Planning Board.

METUNG WATERWORKS TRUST.**RATING BY-LAW No. 10.**

The Metung Waterworks Trust in pursuance and exercise of the powers conferred by the Water Act doth hereby make the following rates for the supply of water for domestic purposes on lands and tenements liable to be rated in the Metung Waterworks Trust District.

On such lands and tenements a rate of five cents in the dollar on the nett annual valuation of such properties. Provided that in no case shall the amount of rate payable per annum in respect of any tenements (other than land on which there is no building) be less than twenty-one dollars and in respect of land on which there is no building less than four dollars fifty cents.

Such rates are made and shall be levied upon the occupiers or owners of the said lands and tenements for the year commencing on the 1st day of October 1971 and shall be payable on the 31st day of March 1972 at the office of the Trust.

The maximum quantity of water to be supplied in any one year without further charge to any property rated by the Trust is hereby fixed at the quantity which at the charge of fifty cents per 1,000 gallons would produce an amount equal to the amount of the rate levied on such property for the said year. The Charge for water supplied by measure to any property rated by the Trust in excess of such maximum quantity computed as in the last preceding clause is hereby fixed at fifty cents per 1,000 gallons.

The charge for water supplied by measure shall be payable on demand at the office of the Trust.

Passed this 11th day of January, 1972.

(SEAL) ROBERT CLARENCE BULL, Chairman.
JACK SLADE, Acting Secretary.

Approved 25th January, 1972.—ROBERTS DUNSTAN,
Minister of Water Supply.

GEMBROOK COCKATOO AND EMERALD WATERWORKS TRUST.**By Law No. 11.**

The Gembrook Cockatoo & Emerald Waterworks Trust in pursuance of and in exercise of the powers conferred by the Water Act 1958 and of any and every other power it thereunto enabling doth hereby make a By Law as follows:—

1. The Trust hereby makes and levies a rate in respect of all the lands and tenements within the Gembrook Urban District and the Cockatoo Urban District of THIRTEEN CENTS in the dollar on the net annual value set out in the valuation at present in force of such lands and tenements for the municipal rate of the Shires of Berwick and Sherbrooke which is hereby adopted as the valuation of such lands and tenements respectively, and the Trust hereby makes and levies a rate in respect of all lands and tenements within the Emerald Urban District of ELEVEN AND ONE HALF CENTS in the Dollar on the net annual value set out in the valuation at present in force of such lands and tenements for the municipal rate of the Shires of Berwick and Sherbrooke which is hereby adopted as the valuation of such lands and tenements, respectively.

2. Such rate shall be made and levied upon the occupiers and owners of such lands and tenements for the year commencing on the 1st day of January 1972 and shall be payable on the 1st day of March 1972 at the office of the said Trust.

3. In no case shall the rate payable hereunder in respect of any land on which there is a building be less than TWENTY DOLLARS and in respect of land on which there is no building be less than EIGHT DOLLARS.

Passed this 19th day of January, 1972.

(SEAL) J. G. HOSKING, Chairman.
T. W. DALZIELL, Commissioner.
BEATRICE THOMAS, Secretary.

Approved 25th January, 1972.—ROBERTS DUNSTAN,
Minister of Water Supply.

ECHUCA SEWERAGE AUTHORITY.**By-Law No. 8.**

A By-Law of the Echuca Sewerage Authority made under the Sewerage Districts Act and every other Act or Regulation thereto enabling it in that behalf, and numbered 8 for the purposes of repealing By-Law No. 6 and for fixing minimum sewerage rates.

In pursuance of the powers conferred by the foregoing Act and every other Act or Regulation thereto enabling it in that behalf the Chairman and Members of the Echuca Sewerage Authority order as follows:—

1. The minimum amount of rate to be paid annually by the owner or occupier of any rateable sewered property on which there is a building shall be Twenty-Five Dollars.

2. The minimum amount of rate to be paid annually by the owner or occupier of any rateable sewered property on which there is no building shall be Ten Dollars.

Resolution for passing this By-Law was agreed to by the Authority on the 22nd day of November, 1971.

Confirmed on the 10th day of January, 1972.

(SEAL) F. C. McCARTNEY, Chairman.
D. B. TYLER, Commissioner.
K. F. McCARTNEY, Secretary.

Approved, 25th January, 1972.—ROBERTS DUNSTAN,
Minister of Water Supply.

MOOROOPNA WATERWORKS TRUST.**RATING BY-LAW FOR THE YEAR 1972.**

The Mooroopna Waterworks Trust, in pursuance and exercise of the powers conferred by the Water Act, doth hereby make a rate for the supply of water for domestic purposes of 3.0 cents in the dollar on the nett annual valuation of the lands and tenements liable to be rated within the Mooroopna Urban District.

Provided that in no case shall the amount of the rate payable per annum in respect of any tenement (other than land on which there is no building) be less than Twelve Dollars, and in respect of any land on which there is no building, less than Eight Dollars.

Such rates are made and shall be levied upon the occupiers or owners of the said lands and tenements for the year commencing on the 1st day of January, 1972, and shall be payable on the 1st day of February, 1972, at the office of the Trust.

Passed this 23rd day of December, 1971.

(SEAL) J. T. GRAHAM, Chairman.
R. F. FORSTER, Secretary.

Approved, 25th January, 1972.—ROBERTS DUNSTAN,
Minister of Water Supply.

APPOINTMENTS AND RESIGNATIONS**APPOINTMENTS.**

His Excellency the Governor of the State of Victoria, by and with the advice of the Executive Council thereof, has, by Orders made on the 25th day of January, 1972, been pleased to make the under-mentioned appointments, viz.:—

CHIEF SECRETARY'S DEPARTMENT.

Member and Chairman of Metropolitan Fire Brigades Appeal Tribunal.

WILLIAM JOHN CUTHILL, Chief Stipendiary Magistrate, pursuant to the provisions of the *Metropolitan Fire Brigades Act 1958*, to be a member and Chairman of the Metropolitan Fire Brigades Appeal Tribunal, for the period of two years from the 21st February, 1972.

Members of Metropolitan Fire Brigades Appeal Tribunal.

NEVILLE EDWARD VAN EVERY and
FREDERICK ROBERT TYSON,
pursuant to the provisions of the *Metropolitan Fire Brigades Act 1958*, to be members of the Metropolitan Fire Brigades Appeal Tribunal, for the period of two years from the 21st February, 1972.

MINISTRY OF HEALTH.

Member of Committee of Management of Hospital.

THOMAS EDMUND COSTELLO, J.P.,
to be the Government appointee on the Committee of Management of Rochester and District War Memorial Hospital, for a term of three years commencing the 3rd February, 1972, pursuant to the provisions of sub-paragraph (ii) of paragraph (a) of the proviso to sub-section (1) of section 48 of the *Hospitals and Charities Act 1958*.

Deputy Superintendent of Mental Hospital.

JENNIFER ANN BARRON, M.B., Ch.B., D.P.M.,
M.A.N.Z.C.P.,
to be Deputy Superintendent of Mental Hospital, Mont Park, and Psychiatric Hospital, Mont Park, pursuant to the provisions of section 26 (1) of the *Mental Health Act 1959*, from the 16th January, 1972, vice Dr. H. W. Hannah, promoted.

LAW DEPARTMENT.

Commissioners for Taking Declarations, &c.

DAVID GRENVILLE HINTON, care of Department of Agriculture, Victoria, 3 Treasury-place, Melbourne, ALEXANDER MCKENZIE PERKINS and ALBERT ARTHUR PHILPOTTS,

care of Motor Registration Branch, Lygon-street, Carlton,

PETER FRANCIS RENKIN, care of Ministry of Aboriginal Affairs, 105 King-street, Melbourne,

JEFFREY FRANK EDWARD TURNER, care of Office of the Industrial Registrar, 451 Little Bourke-street, Melbourne, and

DAVID MAUGHAN CHURCHILL, care of Department of Crown Lands and Survey, 2 Treasury-place, Melbourne,

to be Commissioners for taking Declarations and Affidavits, pursuant to the provisions of the *Evidence Act 1958*, to refrain from charging fees and to resign upon ceasing to occupy their present positions;

GEORGE AMENTAS, care of The Good Neighbour Council of Victoria, 32 Market-street, Melbourne,

WESLEY BERRILL PARSONS, care of S. B. Parsons and Son Pty. Ltd., Nolan-street, Maryborough,

PHILIP LEVY, care of Larwin-Shiff Development Corporation Pty. Ltd., 417 St. Kilda-road, Melbourne,

MAURICE SUGDEN care of Australian Motor Industries Ltd., 155 Bertie-street, Port Melbourne, and

THEODORE JOHN VAN EMBDEN, care of Embden Kurts, 526 Malvern-road, Prahran,

to be Commissioners for taking Declarations and Affidavits, pursuant to the provisions of the *Evidence Act 1958*, to resign upon ceasing to occupy their present positions; and

BRIAN KINGSLEY WOODS, 15 CherylInne-crescent, Kilsyth, DOMENIC ANTHONY CAVALLO, 37 Sydney-street, Avondale Heights,

LEONARD MORGAN POWELL, 16 Grandview-avenue, Pascoe Vale South,

LINDSAY WALTER BERNARD SMITH, 98 Bennett-road, Horsham, and

JOSEPH ROBLOTTA, 255 High-street, Northcote,

to be Commissioners for taking Declarations and Affidavits, pursuant to the provisions of the *Evidence Act 1958*, to resign upon removing from the neighbourhood of the addresses stated.

Justice of the Peace.

ALAN MACLELLAN LANE, Mirboo North, to Keep the Peace in the State of Victoria.

Deputy Prothonotary, Bendigo.

ALFRED THOMAS RYALL

to be Deputy Prothonotary at Bendigo, in the place of J. E. Wallace, promoted and transferred, to take effect from the date of commencement of duty.

PUBLIC WORKS DEPARTMENT.

Wharf Manager.

Sergeant KEITH CHARLES MACDONALD, No. 12024, to be Wharf Manager at Dromana, to carry out that portion of Part II. of the *Marine Act 1958* which relates to the Management of Public Wharves, and to be an officer under section 19 of such Act, to levy and collect wharfage rates thereat, vice Sergeant John Dean Booker, No. 10807, transferred.

DEPARTMENT OF THE TREASURER.

Collector of imposts (Acting).

JOHN ROBERT MORRIS

to act temporarily as Collector of Imposts, Fisheries and Wildlife Department, vice P. J. Walker, on leave.

Receiver of Revenue (Acting).

ALFRED THOMAS RYALL

to act temporarily as receiver of Revenue, Bendigo, vice J. E. Wallace, promoted.

JOHN A. HORLOCK,

Acting Clerk of the Executive Council.

At the Executive Council Chamber,

Melbourne, 25th January, 1972.

SUMMONING OFFICER.

Under section 5 of the *Education Act 1958*, I hereby appoint—

Senior Constable WILLIAM DONALD MARSHALL to summon parents within the State of Victoria.

IAN SMITH,

Minister for Social Welfare.

20th January, 1972.

RESIGNATIONS.

His Excellency the Governor of the State of Victoria, by and with the advice of the Executive Council thereof, has, by Orders made on the 25th day of January, 1972, accepted the resignations of the persons named hereunder of the offices mentioned, viz.:—

LAW DEPARTMENT.

Commissioner for Taking Declarations, &c.

ANTHONY JAMES MITHEN, as a Commissioner for taking Declarations and Affidavits, pursuant to the provisions of the *Evidence Act 1958*.

Justices of the Peace.

CHARLES WASHBURNE JOYCE,

FLORENCE ELLEN STILLMAN,

HAROLD CLEMENT BOND,

MERVYN JOSEPH McMILLAN, and

IAN WHITNEY GEER,

as Justices of the Peace for the State of Victoria.

JOHN A. HORLOCK,

Acting Clerk of the Executive Council.

At the Executive Council Chamber,

Melbourne, 25th January, 1972.

ORDERS IN COUNCIL

LOCAL GOVERNMENT DEPARTMENT.

At the Executive Council Chamber, Melbourne, the twenty-fifth day of January, 1972.

PRESENT:

His Excellency the Governor of Victoria.

Mr. Rossiter

Mr. Borthwick.

APPLICATION TO ELECTIONS OF COUNCILS FOR THE CITY OF COLAC AND SHIRE OF BULLA OF REGULATIONS RELATING TO COMPULSORY VOTING.

Whereas it is provided in section 149 of the *Local Government Act 1958*, that the Governor in Council on the petition of the Council of any municipality, may by Order published in the *Government Gazette*, apply to elections of councillors for such municipality with any modifications provided for in such Order, all or any of the Regulations relating to compulsory voting made under the said section 149.

Now therefore His Excellency the Governor of the State of Victoria, by and with the advice of the Executive Council thereof, and in pursuance of a petition of the Councils of the City of Colac and the Shire of Bulla, doth hereby Order that the Regulations relating to the compulsory voting at municipal elections made pursuant to the provisions of the said section 149 shall apply to elections of councillors for the said municipalities.

And the Honorable Alan John Hunt, Her Majesty's Minister for Local Government for the State of Victoria, shall give the necessary directions herein accordingly.

JOHN A. HORLOCK,

Acting Clerk of the Executive Council.

LOCAL GOVERNMENT DEPARTMENT.

At the Executive Council Chamber, Melbourne, the twenty-fifth day of January, 1972.

PRESENT:

His Excellency the Governor of Victoria.

Mr. Rossiter

Mr. Borthwick.

LAND VESTED IN THE MUNICIPALITY OF THE CITY OF OAKLEIGH TO BE RETAINED FOR MUNICIPAL PURPOSES.

Whereas in pursuance of the provisions of Division 7 of Part XII. of the *Local Government Act 1958*, certain land being the land described in certificate of title, volume 2008, folio 574, was vested in the municipality of the City of Oakleigh by an Order of the Minister published in the *Government Gazette* on the 8th December, 1971.

And whereas it is provided by sub-section (2) of section 526 of the said Act that any lands so vested in the municipality may with the approval of the Governor in Council be retained by the municipality for municipal purposes.

Now therefore, His Excellency the Governor of the State of Victoria, by and with the advice of the Executive Council thereof approves of the retention by the municipality of the City of Oakleigh for municipal purposes of the said land described in certificate of title, volume 2008, folio 574.

And the Honorable Alan John Hunt, Her Majesty's Minister for Local Government for the State of Victoria, shall give the necessary directions herein accordingly.

JOHN A. HORLOCK,
Acting Clerk of the Executive Council.

LOCAL GOVERNMENT DEPARTMENT.

At the Executive Council Chamber, Melbourne, the twenty-fifth day of January, 1972.

PRESENT:

His Excellency the Governor of Victoria.
Mr. Rossiter | Mr. Borthwick.

CONFIRMATION OF SEPARATE RATE.—CITY OF BALLAARAT.

In pursuance of the provisions of section 287 of the Local Government Act 1958, His Excellency the Governor of the State of Victoria, by and with the advice of the Executive Council thereof, hereby confirms the separate rate made by the Council of the City of Ballaarat on the 6th July, 1971, in respect of the properties described in Schedules "A", "B" and "C" hereunder for the purpose of providing off-street parking facilities for use in connexion with the Armstrong Street North Shopping Centre, subject to the variation that the properties described in Schedule "C" shall not be subject to the rate.

SCHEDULE "A".

Properties to be Rated at 3.3939 Cents in the Dollar on the Net Annual Value.

1. Sturt-street, No. 302.
2. Mair-street, No. 301.
3. Armstrong-street, Nos. 1, 1A, 3, 9, rear 9, 11, 13, 15, 15A, 17, 19, 21, rear 21, 23, 25, 27, 29, 31, 33, 35, 39, 48, 46, 44, 42, 40, 36, 34, 32, 30, 28, 24 to 26, 24 to 28 rear shop A, 24 to 28 rear shop B, 22, 20, 18, 16, 14, 12A, 12, 10, 8, 6 and 4.

SCHEDULE "B".

Properties to be Rated at 1.6970 Cents in the Dollar on the Net Annual Value.

1. Armstrong-street, No. 6 to 10 rear.
2. Sturt-street, Nos. 212, 214 basement shop, 214 ground floor shop and upstairs, 216 room 9 upstairs, 216 room 1 upstairs, 216 rooms 6 and 7 upstairs, 218, 304, 304A upstairs office No. 1, 304A upstairs storeroom, 304A upstairs office No. 2 and 306.
3. Mair-street, Nos. 211, 213, 215, 217, 219, 223 and 225.

SCHEDULE "C".

Properties Not to be Subject to the Rate.

1. Armstrong-street, Nos. 6 upstairs flat, 8 upstairs flat, 10 upstairs flat and 32A.
2. Sturt-street, No. 216 room 8 upstairs.

And the Honorable Alan John Hunt, Her Majesty's Minister for Local Government for the State of Victoria, shall give the necessary directions herein accordingly.

JOHN A. HORLOCK,
Acting Clerk of the Executive Council.

LOCAL GOVERNMENT DEPARTMENT.

At the Executive Council Chamber, Melbourne, the twenty-fifth day of January, 1972.

PRESENT:

His Excellency the Governor of Victoria.
Mr. Rossiter | Mr. Borthwick.

FIXATION AND DECLARATION OF BREADTHS OF CARRIAGEWAY AND FOOTWAYS.—CITY OF HEIDELBERG.

In pursuance of the provisions of section 520 of the Local Government Act 1958, His Excellency the Governor of the State of Victoria, by and with the advice of the Executive Council thereof, and in compliance with a request of the Council of the City of Heidelberg, hereby fixes and declares the breadths of the carriageway and footways of that portion of Mountain View-parade, Rosanna, shown on the plan hereunder, in the manner indicated on the said plan.

CITY OF HEIDELBERG

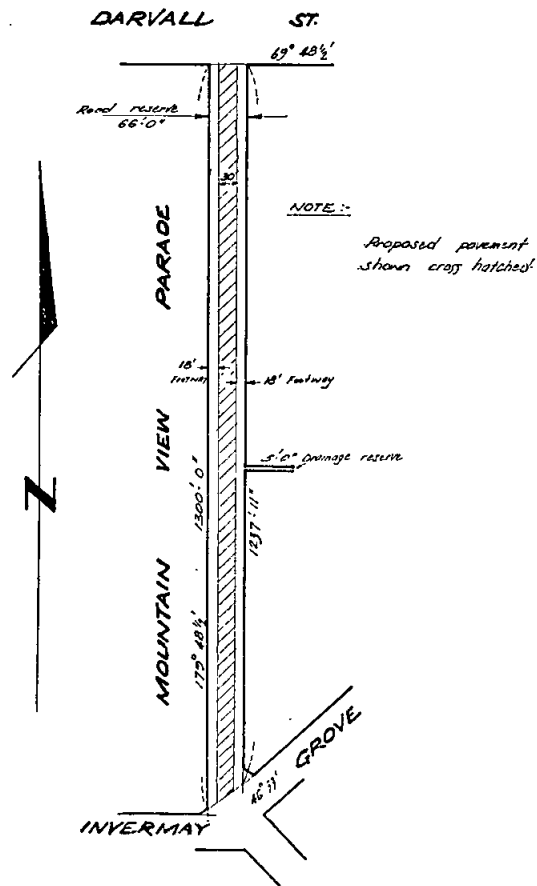

Scale = 160 ft to 1 in.

And the Honorable Alan John Hunt, Her Majesty's Minister for Local Government for the State of Victoria, shall give the necessary directions herein accordingly.

JOHN A. HORLOCK,
Acting Clerk of the Executive Council.

LOCAL GOVERNMENT DEPARTMENT.

At the Executive Council Chamber, Melbourne, the twenty-fifth day of January, 1972.

PRESENT:

His Excellency the Governor of Victoria.
Mr. Rossiter | Mr. Borthwick.

ROAD DISCONTINUED—CITY OF CROYDON.

Whereas it is provided in section 528 (2) of the Local Government Act 1958, that where a road (whether or not a public highway but not being a road set out on land of the Crown) or any part thereof is not required for public use, the Governor in Council on the request of the Council of the municipality in which such road is situated made not less than one month after publishing in a newspaper generally circulating in the district and posting to the registered proprietor (if any) of the land and the owners and occupiers (if any) of lands abutting or immediately adjacent to the road notice of intention to make such request may by Order published in the Government Gazette direct that such road or part shall be discontinued and thereupon such road or part shall be discontinued accordingly.

And whereas the Council of the City of Croydon has requested that the Governor in Council direct that portion of Alice-street, Croydon, be discontinued and not less than one month previously has published in a newspaper generally circulating in the district and posted to the registered proprietor of the land in the road and to the owners and occupiers of lands abutting or immediately adjacent to the road notice of intention to make such request.

Now therefore, His Excellency the Governor of the State of Victoria, by and with the advice of the Executive Council thereof, hereby directs that the portion of the said road, which is shown hatched on the plan hereunder, shall be discontinued and that the land may be sold by the Council of the City of Croydon by agreement.

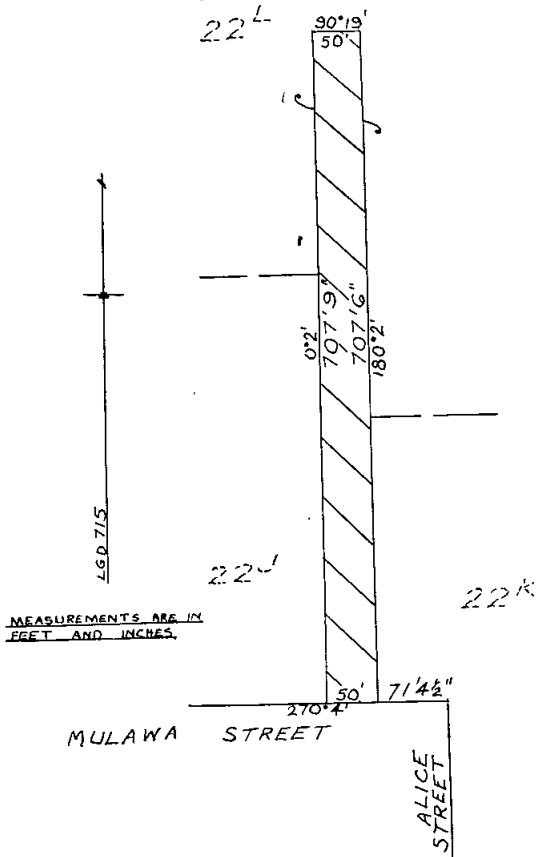

MEASUREMENTS ARE IN FEET AND INCHES.

And the Honorable Alan John Hunt, Her Majesty's Minister for Local Government for the State of Victoria, shall give the necessary directions herein accordingly.

JOHN A. HORLOCK,
Acting Clerk of the Executive Council.

LOCAL GOVERNMENT DEPARTMENT.

At the Executive Council Chamber, Melbourne, the twenty-fifth day of January, 1972.

PRESENT:

His Excellency the Governor of Victoria.
Mr. Rossiter | Mr. Borthwick.

ROAD DISCONTINUED—CITY OF HEIDELBERG.

Whereas it is provided in section 528 (2) of the Local Government Act 1958, that where a road (whether or not a public highway but not being a road set out on land of the Crown) or any part thereof is not required for public use, the Governor in Council on the request of the municipality in which such road is situated made not less than one month after publishing in a newspaper generally circulating in the district and posting to the registered proprietor (if any) of the land and the owners and occupiers (if any) of lands abutting or immediately adjacent to the road notice of intention to make such request may by Order published in the Government Gazette direct that such road or part shall be discontinued and thereupon such road or part shall be discontinued accordingly.

And whereas the Council of the City of Heidelberg has requested that portion of a road between Cherry and Dunstan streets, Macleod, be discontinued and not less than one month previously has published in a newspaper generally circulating in the district and posted to the registered proprietor of the land in the road and to the owners and occupiers of lands abutting or immediately adjacent to the said road notice of intention to make such request.

Now therefore, His Excellency the Governor of the State of Victoria, by and with the advice of the Executive Council thereof, hereby directs—

- (a) that the portion of the said road, which is shown by hachure on the plan hereunder, shall be discontinued.
- (b) that notwithstanding such discontinuance the Melbourne and Metropolitan Board of Works shall continue to have and possess the same right title power authority or interest in or in relation to the whole of the land shown by hachure on the said plan as it had or possessed prior to such discontinuance with respect to or in connexion with any drains or pipes laid or erected in on or over such lands for the purposes of drainage or sewerage; and
- (c) that, subject to any such right title power authority or interest the land in the said road may be sold by the Council of the City of Heidelberg by agreement.

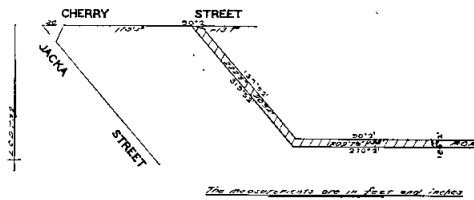

And the Honorable Alan John Hunt, Her Majesty's Minister for Local Government for the State of Victoria, shall give the necessary directions herein accordingly.

JOHN A. HORLOCK,
Acting Clerk of the Executive Council.

LOCAL GOVERNMENT DEPARTMENT.

At the Executive Council Chamber, Melbourne, the twenty-fifth day of January, 1972.

PRESENT:

His Excellency the Governor of Victoria.
Mr. Rossiter | Mr. Borthwick.

ROAD DISCONTINUED—CITY OF RINGWOOD.

Whereas it is provided in section 528 (2) of the Local Government Act 1958, that where a road (whether or not a public highway but not being a road set out on land of the Crown) or any part thereof is not required for public

use, the Governor in Council on the request of the Council of the municipality in which such road is situated made not less than one month after publishing in a newspaper generally circulating in the district and posting to the registered proprietor (if any) of the land and the owners and occupiers (if any) of the lands abutting or immediately adjacent to the road notice of intention to make such request may by Order published in the *Government Gazette* direct that such road or part shall be discontinued and thereupon such road or part shall be discontinued accordingly.

And whereas the Council of the City of Ringwood has requested that the Governor in Council direct that portion of Melbourne-street North, Ringwood, be discontinued and not less than one month previously has published in a newspaper generally circulating in the district and posted to the registered proprietor of the land in the said road and to the owners and occupiers of lands abutting or immediately adjacent to the road notice of intention to make such request.

Now therefore, His Excellency the Governor of the State of Victoria, by and with the advice of the Executive Council thereof, hereby directs—

- (a) that the portion of the said road, which is shown by hachure and cross-hachure on the plan hereunder, shall be discontinued;
- (b) that notwithstanding such discontinuance the Melbourne and Metropolitan Board of Works shall continue to have and possess the same right title power authority or interest in or in relation to the whole of the land shown by hachure marked "A" on the said plan as it had or possessed prior to such discontinuance with respect to or in connexion with any drains or pipes laid or erected in on or over such land for the purpose of drainage or sewerage;
- (c) that notwithstanding such discontinuance the State Electricity Commission of Victoria shall continue to have and possess the same right title power authority or interest in or in relation to the whole of the land shown by hachure marked "A" and cross-hachure on the said plan as it had or possessed prior to such discontinuance with respect to or in connexion with any wires or cables laid or erected in on or over such land for the purposes of the supply of electricity; and
- (d) that, subject to any such right title power authority or interest, the land in the said road shall be retained by the Council of the City of Ringwood for municipal purposes.

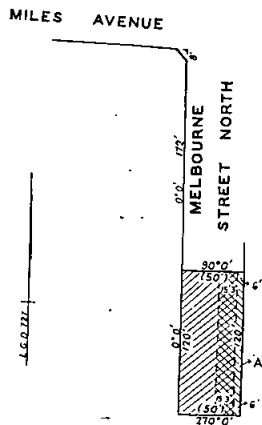

And the Honorable Alan John Hunt, Her Majesty's Minister for Local Government for the State of Victoria, shall give the necessary directions herein accordingly.

JOHN A. HORLOCK,
Acting Clerk of the Executive Council.

COUNTRY ROADS BOARD.

At the Executive Council Chamber, Melbourne, the twenty-fifth day of January, 1972.

PRESENT:

His Excellency the Governor of Victoria.
Mr. Rossiter | Mr. Borthwick.

ORDER APPROVING OF LAND BEING ACQUIRED AND ROADS, DEVIATIONS OR WIDENINGS BEING MADE.

His Excellency the Governor of the State of Victoria, by and with the advice of the Executive Council thereof, being satisfied that there are funds legally available for acquiring the land, doth hereby approve the acquiring of the land described in the Schedule hereunder and the making of new roads and deviations from and widenings of existing roads referred to in the said Schedule.

SCHEDULE.

Main Road.

The land shown hatched on Plan numbered G.P.12429 hereunder required for the widening of the Trafalgar-Thorpdale road in the Shire of Narracan and making of the widening thereon.

MAIN ROAD
TRAFALGAR - THORPDALE ROAD
SHIRE OF NARRACAN
Measurements in Links.

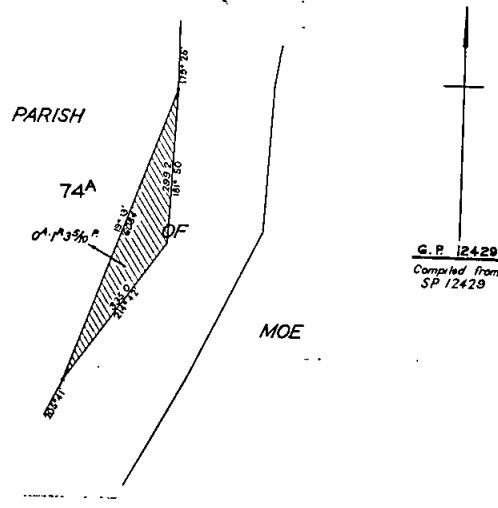

And the Honorable Alan John Hunt, Her Majesty's Minister for Local Government for the State of Victoria, shall give the necessary directions herein accordingly.

JOHN A. HORLOCK,
Acting Clerk of the Executive Council.

MARINE STORES AND OLD METALS ACT 1958.

At the Executive Council Chamber, Melbourne, the twenty-fifth day of January, 1972.

PRESENT:

His Excellency the Governor of Victoria.
Mr. Rossiter | Mr. Borthwick.

Whereas by section 4 of the *Marine Stores and Old Metals Act 1958*, it is enacted that the Governor in Council may from time to time upon the petition of any Shire Council within Victoria make an Order directing that the provisions of Part II. of the said Act shall be extended to that Shire:

And whereas the Council of the Shire of Waranga has petitioned the Governor in Council to extend the provisions of Part II. of the said Act to the Shire of Waranga:

Now therefore His Excellency the Governor of the State of Victoria in the Commonwealth of Australia by and with the advice of the Executive Council of the said State, doth

hereby direct that the provisions of Part II. of the *Marine Stores and Old Metals Act 1958* shall be extended to and shall be in force from the twenty-fifth day of January, 1972, within and throughout the boundaries of the Shire of Waranga.

And the Honorable Rupert James Hamer, Her Majesty's Chief Secretary for the State of Victoria, shall give the necessary directions herein accordingly.

JOHN A. HORLOCK,
Acting Clerk of the Executive Council.

DEPARTMENT OF CROWN LANDS AND SURVEY.

At the Executive Council Chamber, Melbourne, the twenty-fifth day of January, 1972.

PRESENT:

His Excellency the Governor of Victoria.
Mr. Rossiter | Mr. Borthwick.

UNUSED ROADS CLOSED.

His Excellency the Governor of the State of Victoria, by and with the advice of the Executive Council thereof, doth hereby direct that, in pursuance of the provisions of section 349 of the *Land Act 1958*, the unused roads referred to hereunder be closed, viz.:—

Township of Ballarat, Parish of Ballarat, County of Grenville, being the road indicated by hatching on plan hereunder.—(B.128(14) (J.33529).

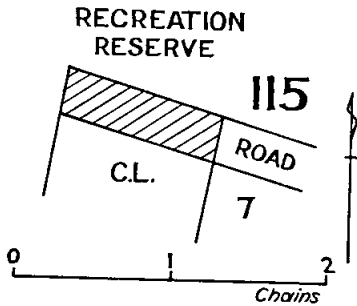

Township of Buninyong, Parish of Buninyong, County of Grant, being the portion of the width of the road indicated by hatching on plan hereunder.—(B.501(2) (Rs.4304).

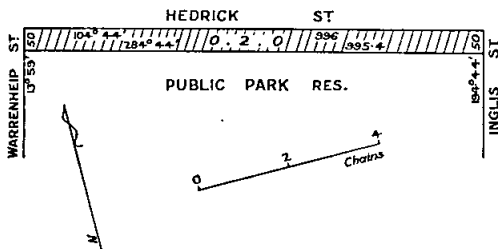

Township of Casterton, Parish of Casterton, County of Dundas, being the road indicated by hatching on plan hereunder.—(C.177(?) (Rs.6389).

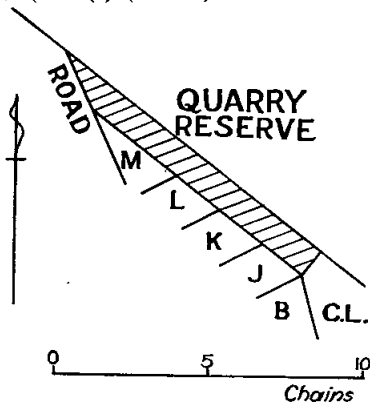

Parish of Mandurang, County of Bendigo, being the portion of the width of the road indicated by hatching on plan hereunder.—(M.29(9) (W.89030).

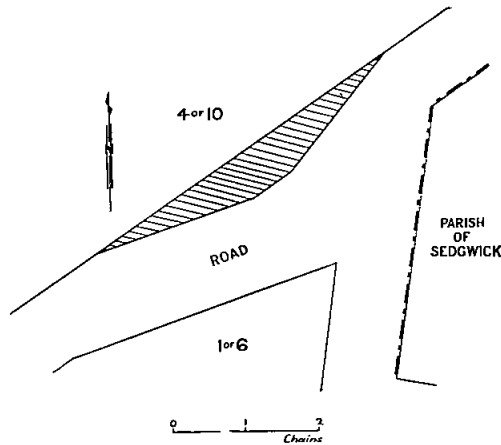

Parish of Wurdi Youang, County of Grant, being the road lying between the site reserved for State School purposes (Flinders Peak State School), by Order in Council of the 5th July, 1875, and Reserved Forest.—(W.224(2) (Rs.7177).

And the Honorable William Archibald Borthwick, Her Majesty's Minister of Lands for the State of Victoria, shall give the necessary directions herein accordingly.

JOHN A. HORLOCK,
Acting Clerk of the Executive Council.

DEPARTMENT OF CROWN LANDS AND SURVEY.

At the Executive Council Chamber, Melbourne, the twenty-fifth day of January, 1972.

PRESENT:

His Excellency the Governor of Victoria.
Mr. Rossiter | Mr. Borthwick.

LANDS TEMPORARILY RESERVED AS SITES.

His Excellency the Governor of the State of Victoria, by and with the advice of the Executive Council thereof, doth hereby, in pursuance of section 14 of the *Land Act 1958*, reserve temporarily from sale, from being leased and from having a licence granted in respect thereof, and also except from occupation for mining purposes under any miner's right, the land hereinafter described:—

BUNGAL.—Site for Public purposes (Public Hall and Recreation), 1 acre, Parish of Bungal, County of Grant as indicated by hatching on plan hereunder.—(B.548(4) (Rs.9571).

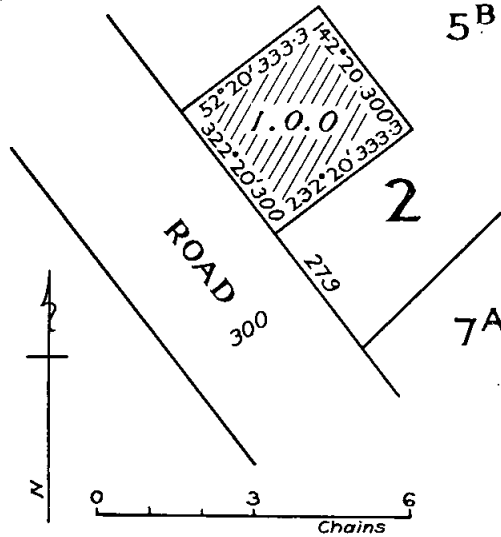

BUNINYONG.—Site for a Public Park, 2 roods, Township of Buninyong, Parish of Buninyong, County of Grant, as indicated by hatching on plan hereunder.—(B.501⁽²⁾) (Rs.4304).

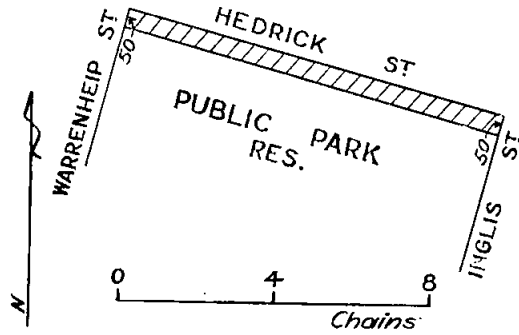

CHETWYND.—Site for Public Recreation, 1 acre 2 roods 30 perches, more or less, Township of Chetwynd, Parish of Ganoo Ganoo, County of Dundas, as indicated by hatching on plan hereunder.—(C.407⁽²⁾) (Rs.7404).

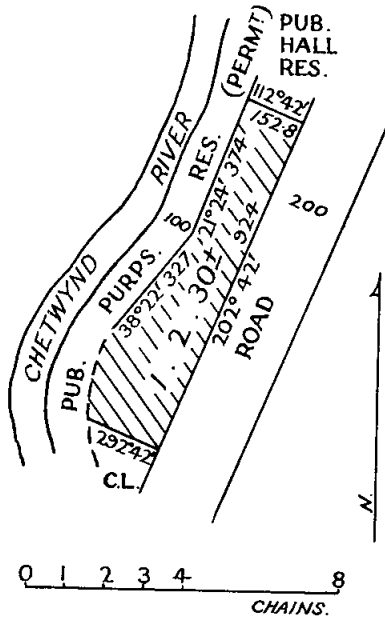

CRESWICK.—Site for Water Supply purposes, 1 rood 15 perches, Township of Creswick, Parish of Creswick, County of Talbot, as indicated by hatching on plan hereunder.—(C.318⁽¹²⁾) (Rs.9582).

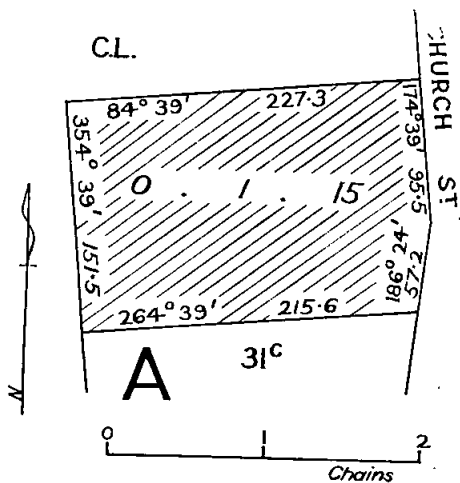

DIAMOND CREEK.—Site for Public purposes, 20 perches, more or less, Township of Diamond Creek, Parish of Nillumbik, County of Evelyn, as indicated by hatching on plan hereunder.—(N.69⁽¹²⁾) (Rs.7380).

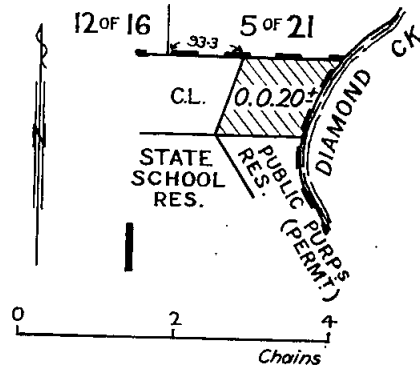

DIAMOND CREEK.—Site for State School purposes, 30 perches, more or less, Township of Diamond Creek, Parish of Nillumbik, County of Evelyn, as indicated by hatching on plan hereunder.—(N.69⁽¹²⁾) (Rs.7380).

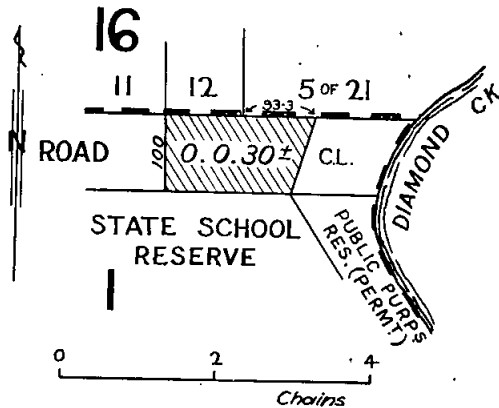

ELPHINSTONE.—Site for Water Supply and Road purposes, 1 acre 3 roods 13 perches, Township of Elphinstone, Parish of Elphinstone, County of Talbot, as indicated by hatching on plan hereunder.—(E.34⁽²⁾) (Rs.9581).

Total area of hatched portions :- 1.3.13

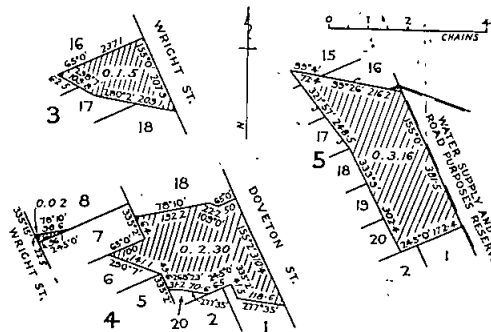

If unable to attend personally, a prospective purchaser may arrange for another person to bid as his agent.

Attention is drawn to section 95, *Land Act 1958*, which provides that the purchaser shall be deemed to be the owner for the purposes of other Acts; also to an amendment to the Local Government Act providing for Government roads, in certain circumstances, to be declared "private streets", thus making the purchaser liable to contribute to the cost of street construction.

W. BORTHWICK,
Minister of Lands.

Office of Crown Lands and Survey,
Melbourne, 2nd February, 1972.

YARRAM.—Sale (No. 12122) of Crown land in fee-simple, by auction, will be held at the LAND INSPECTOR'S OFFICE, YARRAM, on THURSDAY, the 16th day of MARCH, 1972, at ELEVEN o'clock a.m. To be conducted by W. J. MACKINTOSH, Land Officer, Melbourne.

Lot 1.

TOWNSHIP OF PORT WELSHPOOL, PARISH OF WELSHPOOL,
COUNTY OF BULN BULN.

Fronting the southern side of Townsend-street about 4 chains east of Turnbull-street.

Upset price \$4,500 the lot. Survey fee \$50.

Area 1 rood, allotment 4A of section 11. Improvements comprise weatherboard dwelling, outbuildings and fencing the valuation of which is included in the upset price.

SPECIAL CONDITIONS.—Until the purchase money has been paid in full, the following special conditions shall apply:—

- (i) The purchaser shall at his own expense maintain the property in good order and repair and keep all improvements thereon insured against fire in the name of the Secretary for Lands.
- (ii) A cover note for not less than \$4,000 for such insurance shall be lodged in the Lands Department by the purchaser, within one week of the date of sale, and the policy shall be lodged immediately on issue.
- (iii) The purchaser shall not remove or make any alterations to the improvements on the site without prior consent of the Secretary for Lands.

NOTE.—The purchaser, if not the present occupier, shall not be entitled to possession until one month from the date of sale.

The house will be open for inspection from 2 p.m. to 4 p.m. on Wednesday, the 8th March, 1972.—(G.72651.)

Lot 2.

TOWNSHIP OF WOODSIDE, PARISH OF WOODSIDE, COUNTY OF BULN BULN.

Fronting the western side of Princess-street about ¼ mile north of Bruthen Creek.

Upset price \$250 the lot. Survey fee \$17.

Area 2a. 3r. 18p., allotment 1 of section 29.—(G.69559.)

Lot 3.

TOWNSHIP OF PORT ALBERT, PARISH OF ALBERTON EAST,
COUNTY OF BULN BULN.

In the north-west of the Township.

Upset price \$175 the lot. Survey fee \$50.

Area 1a. 3r., allotment 8 of section 10.

NOTE.—Zoned agricultural in the Shire of Alberton Planning Scheme.—(G.72577.)

PROPOSED PERMANENT RESERVATION OF LAND AS A SITE.

In pursuance of sections 14 and 21 of the *Land Act 1958*, notice is hereby given that it is the intention of the Governor in Council to reserve permanently from sale, from being leased and from having a licence granted in respect thereof the land hereinafter described:—

The following Notice was published 1° on the 2nd February, 1972, pursuant to Order of the 25th January, 1972.

CARLTON.—Land proposed to be permanently reserved as a site for Public Educational purposes, 4 acres 2 roods 15 6/10 perches, at Carlton, Parish of Jika Jika, County of Bourke, as indicated by hatching on plan hereunder.—(M.314⁽¹⁴⁾) (Rs.9481).

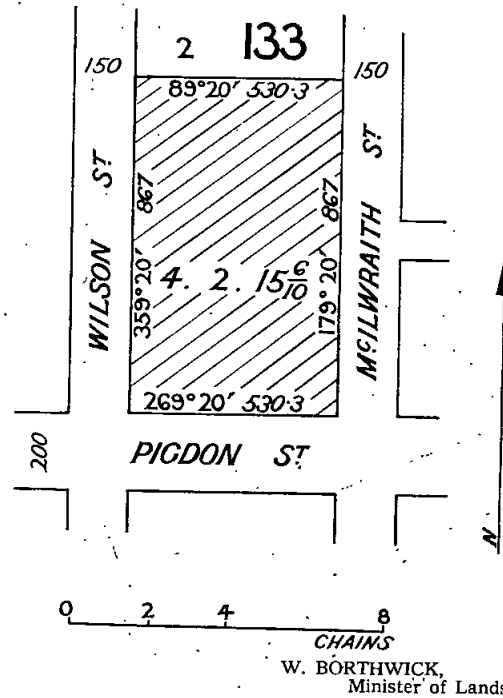

Land Act 1958.

LEASE CANCELLED.

Notice is hereby given that the Governor in Council has cancelled the Lease mentioned in the Schedule hereunder for the reason specified.

District.	Corr. No.	Name.	Section of Land Act under which Leased.	Parish.	Allotment.	Section.	Area.	Annual Rental.	Reason.
Geelong.	8/134	Commonwealth of Australia	134	Wongarra	2c		A. R. P. 0 0 4 1/8	\$ 20.00	Licence to issue in lieu of lease

Department of Crown Lands and Survey,
Melbourne, 24th January, 1972.

W. BORTHWICK,
Minister of Lands.

PROPOSED REVOCATIONS OF TEMPORARY RESERVATIONS OF LANDS BY ORDERS IN COUNCIL.

In pursuance of the provisions of the *Land Act 1958*, notice is hereby given that it is the intention of the Governor in Council to revoke the temporary reservations of lands by Orders in Council hereunder referred to, viz.:

The following Notices were published 1° on the 26th January, 1972, pursuant to Orders of the 14th December, 1971.

BOROONDARA (HAWTHORN).—The temporary reservation, by Order in Council of the 3rd of August, 1971, of 1 acre 0 roods 17 perches, more or less, of land in the Parish of Boroodara, as a site for Public purposes (Social Welfare Department purposes), is about to be revoked.—(B.415⁽²⁾) (Rs.9356).

GOROKE.—The temporary reservation, by Order in Council of the 8th October, 1888, of 2 roods 7 perches of land in the Township of Goroke, as a site for Water Supply purposes, is about to be revoked.—(G.214⁽²⁾) (Rs.708).

ULTIMA.—The temporary reservation, by Order in Council of the 11th February, 1936, of 1 rood 3 perches of land in the Parish of Ultima, as a site for Police purposes, is about to be revoked.—(U.63⁽¹⁾) (Rs.4526).

CUNNINGHAME AND LAKES ENTRANCE.—The temporary reservation, as a site for Public purposes and the withholding from sale, leasing and licensing by Order in Council of the 21st January, 1879, of three separate portions of land in the Parish of Colquhoun, revoked as to part by Order of the 18th July, 1924 (see *Government Gazette* of the 30th July, 1924, page 2561), are about to be revoked, so far only as the third portion cited in that order (now also within the Townships of Cunninghame and Lakes Entrance), is concerned.—C.486⁽⁵⁾, C.383^(F3, 10) (Rs.5532).

POOWONG.—The temporary reservation by Order in Council of the 22nd June, 1965, of 2 roods 20 perches, more or less, of land in the Parish of Poowong, as a site for Public purposes, is about to be revoked so far only as the portion containing 1 rood 10 perches, more or less, indicated by hatching on plan hereunder, is concerned.—P.154⁽⁷⁾ (Rs.8464).

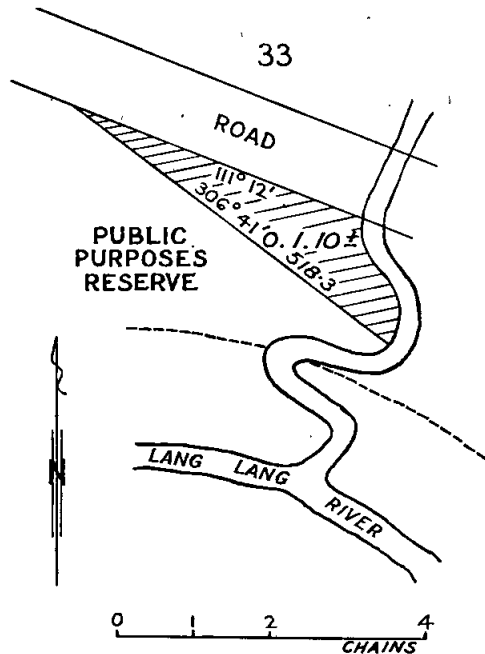

TIMBOON.—The temporary reservation, by Order in Council of the 25th February, 1941, of 8 acres 0 roods 23 perches of land in the Township of Timboon, as a site for Public purposes, revoked as to part by Order of the 22nd April, 1964, is about to be revoked, so far only as the portion containing 2 roods 20 perches, more or less, indicated by hatching on plan hereunder, is concerned.—(T.182⁽⁶⁾) (Rs.5161).

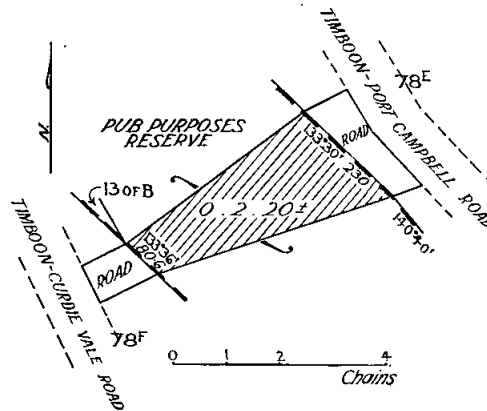

SEA LAKE.—The temporary reservation, by Order in Council of the 12th March, 1958, of 14 acres 0 roods 6 perches of land in the Township of Sea Lake, as a site for Public Recreation, is about to be revoked so far only as the portion containing 17 perches, indicated by hatching on plan hereunder, is concerned.—S.452⁽²⁾ (Rs.2623).

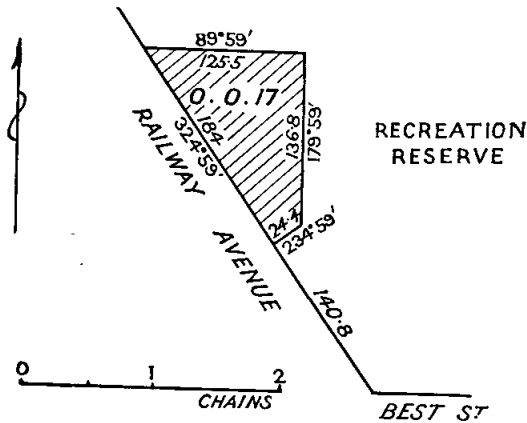

KANGAROO FLAT.—The temporary reservation, by Order in Council of the 1st July, 1969, of 1 rood 37 perches, of land in the Township of Kangaroo Flat, as a site for Public purposes (Police Department), is about to be revoked so far only as the portion containing 9 perches, more or less, indicated by hatching on plan hereunder, is concerned.—K.217⁽²⁾ (Rs.9104).

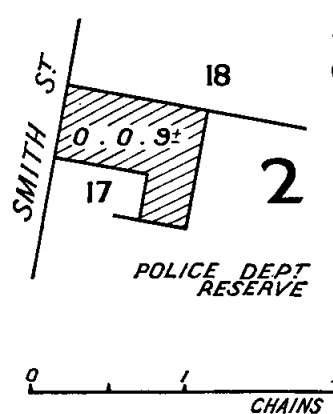

BUMBANG.—The temporary reservation by Order in Council of the 9th February, 1960, of 9 acres 1 rood 38 perches of land in the Parish of Bumbang as a site for Aborigines Welfare Board purposes is about to be revoked.—(B.660⁽¹⁾) (Rs.7859).

TANGAMBALANGA (UPPER SANDY CREEK).—The temporary reservation by Order in Council of the 17th March, 1891, of 4 acres 3 roods 39 perches, of land in the Parish of Tangambalanga as a site for a State School is about to be revoked so far only as the portions containing 34 perches indicated by hatching on plan hereunder, is concerned.—(T.35⁽¹¹⁾) (Rs.9572).

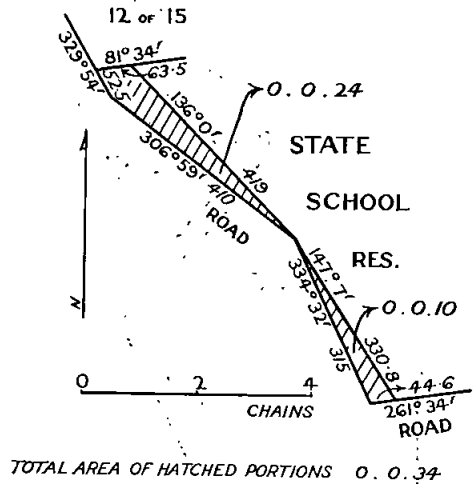

TOTAL AREA OF HATCHED PORTIONS 0.0.34

W. BORTHWICK,
Minister of Lands.

PROPOSED REVOCATIONS OF TEMPORARY RESERVATIONS OF LANDS BY ORDERS IN COUNCIL.

In pursuance of the provisions of the *Land Act 1958*, notice is hereby given that it is the intention of the Governor in Council to revoke the temporary reservations of lands by Orders in Council hereunder referred to, viz.:

The following Notices were published 1° on the 2nd February, 1972, pursuant to Orders of the 25th January, 1972.

BALLARAT EAST.—The temporary reservation by Order in Council of the 18th November, 1958, of 3 acres 1 rood 34 perches of land in the Township of Ballarat East, as a site for the Growth and Preservation of Timber and for Public Recreation, is about to be revoked.—(B.128⁽⁴⁾) (Rs.1530).

HEYFIELD.—The temporary reservation as a site for the Supply of Gravel, and the withholding from sale, leasing and licensing by Order in Council of the 29th January, 1878, of 10 acres of land at Heyfieldbridge (now Township of Heyfield) in the Parish of Tinamba, are about to be revoked.—(H.110⁽³⁾) (Rs.2529).

MACARTHUR.—The temporary reservation by Order in Council of the 16th October, 1890, of 1 acre 2 roods 34 perches of land in the Parish of Macarthur, as a site for Drainage purposes, is about to be revoked.—(M.88⁽²⁾) (C.100802).

WONGA WONGA SOUTH.—The temporary reservation by Order in Council of the 20th February, 1902, of 9 acres 3 roods 39 perches of land in the Parish of Wonga Wonga South, as a site for Supply of Gravel, is about to be revoked.—(W.353⁽¹¹⁾) (Rs.3711).

STAWELL.—The temporary reservation by Order in Council of the 11th January, 1955, of 1 acre 1 rood, more or less, of land in the Parish of Stawell, as a site for a Garbage Depot, is about to be revoked.—(S.329⁽¹⁵⁾) (Rs.7328).

WURDI YOUANG.—The temporary reservation as a site for State School purposes, and the withholding from sale, leasing and licensing by Order in Council of the 5th July, 1875, of 5 acres of land in the Parish of Wurdí Youang, are about to be revoked.—(W.224⁽²⁾) (Rs.7177).

WONGA WONGA SOUTH.—The temporary reservation by Order in Council of the 21st February, 1911 (see *Government Gazette*, 1st March, 1911, page 1464), of 17 acres 14 perches of land in the Parish of Wonga Wonga South,

as a site for Supply of Gravel, revoked as to part by Order of the 19th January, 1965, is about to be revoked so far as the balance thereof containing 16 acres 16 perches is concerned.—(W.353⁽¹¹⁾) (Rs.3711).

CURRAWA.—The temporary reservation as a site for a road, and the withholding from sale, leasing and licensing by Order in Council of the 22nd September, 1880, of 33 acres 3 roods 38 perches of land in the Township of Nalinga and Parish of Currawa (now wholly within the Parish of Currawa), are about to be revoked.—(C.412⁽²⁾) (Rs.5660).

WONGA WONGA SOUTH.—The temporary reservation by Order in Council of the 20th February, 1902 (see *Government Gazette*, 26th February, 1902, page 930), of 9 acres 2 roods 20 perches of land in the Parish of Wonga Wonga South, as a site for Supply of Gravel, revoked as to part by various Orders, is about to be revoked so far as the balance thereof containing 7 acres 3 roods, more or less, is concerned.—(W.353⁽¹¹⁾) (Rs.3711).

JIKA JIKA (ROYAL PARK).—The temporary reservation by Order in Council of the 12th January, 1932, of 60 acres 17 perches of land in the Parish of Jika Jika, as a site for a Mental Hospital, revoked as to part by various Orders, is about to be revoked so far only as the portion containing 2 acres 15 perches, more or less, indicated by hatching on plan hereunder, is concerned.—(M.314⁽¹⁵⁾) (Rs.4172).

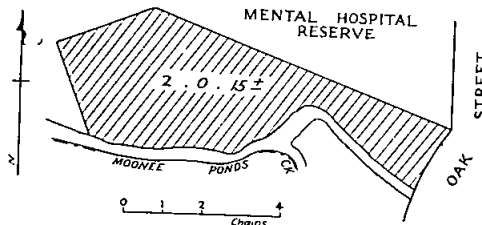

W. BORTHWICK,
Minister of Lands.

**COMMITTEE OF MANAGEMENT OF RESERVES.
APPOINTMENTS.**

Notice is hereby given that, in pursuance of section 221 of the *Land Act 1958*, the following appointments of Committees of Management of reserved Crown Lands have been made by the Minister of Lands:—

"BEEAC RECREATION RESERVE."

Francis Joseph Reilly, Earnest Edward Hanlon, George Duncan Gammick, Douglas George Grant, Geoffrey Thomas Grant, Ronald Francis Simpkin, and Bruce Watson as a Committee of Management for a period of three (3) years from the 26th November, 1971, of the land in the Parish of Ondit deemed permanently reserved for the recreation, convenience or amusement of the people, and known as the "Beac Recreation Reserve".—(Corres. No. Rs.8865.)

"BENDIGO AERODROME RESERVE."

John Henry Murray (for so long only as he continues to be a councillor and the elect of the Council of the City of Bendigo), in the place of Frederick William Clayton (no longer a councillor), as a member of the Committee of Management of the land in the Parish of Sandhurst, County of Bendigo temporarily reserved by Order in Council dated the 10th June, 1969, as a site for Aerodrome purposes; and known as the "Bendigo Aerodrome Reserve".—(Corres. No. Rs.1741.)

"BURKE'S FLAT PUBLIC HALL RESERVE."

James Gallacher, Ernest Rodger, John Rodger, Gaston A. C. Saint, Alexander Terence Perry, Norman R. Gallacher, and Rowland T. Martin as a Committee of Management for a period of three (3) years from the 16th December, 1971, of the land in the Township of Burke's Flat temporarily reserved by Order in Council dated the 15th July, 1895, as a site for a Mechanics' Institute and Free Library, and known as the "Burke's Flat Public Hall Reserve".—(Corres. No. Rs.7797.)

"CAVENDISH RECREATION RESERVE."

Leslie Douglas Cordy, Leslie Alan Brumley, Edward Vernon Lewis, Norman Brown Hearn, Ronald Graham Lewis, Cecil James Diprose and Lewis Rupert James Sharrock as a Committee of Management for a period of

three (3) years from the 9th October, 1971, of the land in the Township of Cavendish temporarily reserved by Orders in Council dated the 8th November, 1922, and 1st June, 1948, as a site for Public Recreation, and known as the "Cavendish Recreation Reserve".—(Corres. No. Rs.2635.)

SITE FOR PUBLIC PURPOSES (HISTORICAL PURPOSES), CRESWICK.

The Corporation of the Shire of Creswick as the Committee of Management of the land in the Township and the Parish of Creswick temporarily reserved by Order in Council dated the 7th December, 1971, as a site for Public purposes (Historical purposes).—(Corres. No. Rs.9566.)

"CUNNINGHAME RED BLUFF RESERVE."

E. Allan Gathercole, William G. Whelan, Ronald H. Deppeler, Allen Beveridge and John Whadcoat as a Committee of Management for a period of three (3) years from the 19th November, 1971, of the land in the Parish of Colquhoun, Township of East Cunninghame permanently reserved by Order in Council dated the 24th January, 1967, as a site for Camping and Public Recreation, and known as the "Cunninghame Red Bluff Reserve".—(Corres. No. Rs.5802.)

"CLEMATIS PARK" RESERVE AT EMERALD.

Gustaf Ryberg, Gwendoline Ammie Semmens, George S. C. Semmens, Keith William Dolling, Stanley John Turner, Stella Turner and Winifred Maude Wallace as a Committee of Management for a period of three (3) years from the 5th December, 1971, of the land in the Township of Emerald temporarily reserved by Order in Council dated the 5th September, 1950, as a site for Public Recreation, and known as "Clematis Park".—(Corres. No. Rs.6565.)

"HEATHCOTE SHOW GROUNDS RESERVE."

Edwin Alfred Kemp, Robert Hagan Perry, Keith Thomas Wilkie, James Louis Tranter, and Rodney McRobert as a Committee of Management for a period of three (3) years from the 3rd December, 1971, of the remaining portion of the land in the Parish of Heathcote temporarily reserved by Orders in Council dated the 4th January, 1883 and 28th January, 1905, as sites for Show Yards, and known as the "Heathcote Show Grounds Reserve".—(Corres. No. Rs.662.)

"KAMAROOKA RECREATION RESERVE."

Geoff Pedersen, Bruce Albert Cail, John Frederick Cail, William George Cail, John Alwyn Ludeman, John Joseph Demeo, John Home Hay, Barry Edward Ayres and Arthur Clement Evans as a Committee of Management for a period of three (3) years from the 21st August, 1971, of the land in the Parish of Kamarooka temporarily reserved by Order in Council dated the 18th April, 1950, as a site for Public Recreation, and known as the "Kamarooka Recreation Reserve".—(Corres. No. Rs.6529.)

"KATUNGA RECREATION RESERVE."

William John Adams, Brian Anthony Hansen, Thomas Shannon, Hugh Cameron Henderson, S. Paul Bianco, E. H. Caughey and Leslie Sewell Walkington as a Committee of Management for a period of three (3) years from the 21st December, 1971, of the land in the Parish of Strathmerton temporarily reserved by Orders in Council dated the 10th February, 1953 and 14th September, 1954, as sites for Public Recreation, and known as the "Katunga Recreation Reserve".—(Corres. No. Rs.7059.)

"LAKE PURRUMBETE FRONTAGE RESERVE."

William Stanley Marwood, Ronald Leslie Fryers, Jeffery William Everett, John James Boyd, Charles Wilfred Chamberlain, Frank Everit Bartlett, Hayden Arthur Jacka, Harold Thomas Fryers and Bernard Place as a Committee of Management for a period of three (3) years from the 31st November, 1971, of such portion of the frontage to Lake Purrumbete as is indicated by pink colour on plan marked "P/23 7.31", attached to Lands Department correspondence No. C.80169, and known as the "Lake Purrumbete Frontage Reserve".—(Corres. No. C.80169.)

"LAKE WARTOOK WATER RESERVE."

Valerie Charlotte Carter (in the place of Ernest Frederick Paul Gerlach), and Owen Thomas as members of the Committee of Management for the period ending the 25th November, 1974, of the reserved Crown Lands indicated

by blue colour on plan marked "W/19.8.1965", attached to Lands Department correspondence No. Rs.2326, and known as the "Lake Wartook Water Reserve".—(Corres. No. Rs.2326.)

"LETHBRIDGE RECREATION RESERVE."

Keith Henry Ackland, Raymond James Kelly, Patrick Scanlon, William Alan Miller, Eric McGillivray, Mervyn Laurence Anderson, Bernard Dooley, George Scanlon and Arthur Geoffrey Clarke as a Committee of Management for a period of three (3) years from the 8th December, 1971, of the land in the Township of Lethbridge, Parish of Wabdallah temporarily reserved by Order in Council dated the 29th July, 1930, as a site for Public Recreation, and known as the "Lethbridge Recreation Reserve".—(Corres. No. Rs.3268.)

"LLANELLY RECREATION RESERVE."

Albert Rienard Hurford, Harry William John Douglas, Eric Reginald Green, Noel William Alexander, Leslie Benjamin Dale, Robert Alexander Gray, Donald William Clark, George Hamilton Alexander and Kenneth George Clark as a Committee of Management for a period of three (3) years from the 4th November, 1971, of the land in the Township of Llanelly temporarily reserved by Order in Council dated the 15th July, 1913, as a site for Public Recreation, and known as the "Llanelly Recreation Reserve".—(Corres. No. Rs.423.)

"FRONTAGE ALONG THE MCKENZIE RIVER."

Valerie Charlotte Carter (in the place of Ernest Frederick Paul Gerlach), and Owen Thomas as members of the Committee of Management for the period ending the 25th November, 1974, of so much of the frontage reserve along the McKenzie River as lies between the Wartook Reservoir Reserve, and a line being the prolongation of the south-eastern boundary of allotment 18 in the Parish of Burrong North.—(Corres. No. C.85991.)

SITE FOR PUBLIC PURPOSES (PENAL MUSEUM) CITY OF MELBOURNE.

The National Trust of Australia (Victoria) as the Committee of Management of the land in the Parish of Melbourne North, City of Melbourne temporarily reserved by Order in Council dated the 7th December, 1971, as a site for Public purposes (Penal Museum).—(Corres. No. Rs.9452.)

"MOORNGAG PUBLIC HALL AND RECREATION RESERVE."

Frederick John Horsburgh, John Thomas Duffy, C. A. McCauley, Francis Reginald McCauley, A. G. Lewis, Daryl George Horsburgh, Dennis Keith McCauley, Leo Francis Ginnivan and George Edwin Exton as a Committee of Management for the period ending the 15th December, 1974, of the land in the Parish of Rothsay temporarily reserved by Order in Council dated the 21st November, 1887, as a site for Public Recreation and by Order in Council dated the 7th September, 1948, as a site for the additional purpose of a Public Hall, and known as the "Moornag Public Hall and Recreation Reserve".—(Corres. No. Rs. 2741.)

"MOUNTAIN VIEW MECHANICS' INSTITUTE RESERVE."

Donald Ronald Braham, James John O'Connor, Robert John Appleyard, Kenneth John Hallyburton, Lionel Wilfred Collins and Ernest Norman Ronald as a Committee of Management for a period of three (3) years from the 1st December, 1971, of the land in the Parish of Poowong East temporarily reserved by Order in Council dated the 29th April, 1886, as a site for a Mechanics' Institute, and known as the "Mountain View Mechanics' Institute Reserve".—(Corres. No. Rs.2852.)

"PAYNESVILLE FORESHORE RESERVE."

Dave John Baxter, Norman William Anderson, Francis Norman Gaffney, Arthur Alexander Freeman, Joseph William Dawes, Mervyn John Day, Arthur James Freeman, Colin P. Uppam and Keith Alexander Ferguson as a Committee of Management for a period of three (3) years from the 28th November, 1971, of such portions of the Reserve for Public purposes (Foreshore) at Paynesville, as are indicated in red colour on plans marked "P/12.10.1937", "P/6.7.1950" and "P/18.7.1957" attached to Lands Department correspondence C.79498, with the exception of the area in use for road purposes by the Country Roads Board, and known as the "Paynesville Foreshore Reserve".—(Corres. No. C.79498.)

"SANDFORD RACECOURSE AND RECREATION RESERVE."

Thomas Leo Doyle, Thomas Edward O'Dowd, Keith Tonkins, Edward Francis Doyle, Alan Richard Layley, Edward Norman Widdicombe, James Francis Widdicombe, William Robert Murrell, and George Henry Lawford as a Committee of Management for a period of three (3) years from the 23rd December, 1971, of the land in the Township of Sandford, Parish of Casterton temporarily reserved by Orders in Council dated the 11th October, 1886, 16th October, 1894, and 22nd June, 1965, as sites for Racecourse and other purposes of Public Recreation shown by red border on plan marked C/21.7.65, attached to Lands Department correspondence No. Rs.138, and known as the "Sandford Racecourse and Recreation Reserve".—(Corres. No. Rs.138.)

"SWAN HILL RACECOURSE & PUBLIC RECREATION RESERVE."

Keith Hillgrove, Bryan Esmond Dillon, George Murray Drummond, Donald Herbert Carne, Norman Sutton Fountain, Vernon Hug McKenzie and Alec Michael Hayes as a Committee of Management for the three (3) year period ending the 23rd November, 1974, of:—

(1) the remaining portion of land in the Township of Swan Hill temporarily reserved by Order in Council dated the 16th January, 1968, for the additional purpose of Public Recreation (excluding the portion of the reserve, known as the Racecourse and Golfcourse Pavilion Site), and

(2) the area of 1 acre, more or less, of land in the Township of Swan Hill temporarily reserved by Order in Council of 6th November, 1963, as a site for Public Recreation.—(Corres. Nos. Rs.1789, Rs.8275.)

"UPPER BEACONSFIELD PUBLIC HALL AND CHILDREN'S PLAYGROUND RESERVES."

Brenda Joyce Hopkins, Joan Trumper, Joyce Margaret Bumpstead, Keith Ewenson, Irene Rogers, Marleine Harvey, Ewart Arthur James, Paul H. Easton, Winifred Roynon and Frank E. Roynon as a Committee of Management for a period of one (1) year from the 15th October, 1971, of the lands in the Parish of Gembrook at Upper Beaconsfield temporarily reserved by Orders in Council dated the 29th July, 1940, and 23rd September, 1940, as sites for a Children's Playground and a Public Hall, respectively, and known as the "Upper Beaconsfield Public Hall and Children's Playground Reserves".—(Corres. Nos. Rs.5102, Rs.5066.)

"WAIL PUBLIC HALL AND RECREATION RESERVE."

Patrick Evan O'Connor, Thomas Hugh Crawford, Norman E. Barber, Ralph William Westendorf, J. R. Barker, Alick G. Stephan, Edward Archibald Watson, Arthur R. Barber and John Robert Porter as a Committee of Management for a period of three (3) years from the 21st December, 1971, of the land in the Township of Wail temporarily reserved by Order in Council dated the 11th July, 1923, as a site for Recreation purposes, and known as the "Wail Recreation Reserve".—(Corres. No. Rs.2779.)

SITE FOR PUBLIC PURPOSES (SUPPLY OF GRAVEL), PARISH OF YAT NAT.

The Corporation of the Shire of Kowree as the Committee of Management of the remaining portion of the land in the Parish of Yat Nat temporarily reserved by Order in Council dated the 24th February, 1970, as a site for Public purposes (Supply of Gravel).—(Corres. No. Rs.9282.)

W. BORTHWICK,
Minister of Lands.

Department of Crown Lands and Survey,
Melbourne, 24th January, 1972.

PUBLIC SERVICE NOTICES

No. 169.

PUBLIC SERVICE ACT 1958.

The Public Service Board, in pursuance of the powers conferred by the Public Service Act 1958, hereby amends the Public Service (Public Service Board) Regulations as follows:—

PART II.—APPOINTMENTS TO THE PUBLIC SERVICE.

DIVISION III.—PROFESSIONAL DIVISION.

Regulation 27.

Sub-regulation 4 is revoked.

A. J. A. GARDNER, Chairman.
V. P. SCULLY, Secretary.

Office of the Public Service Board,
Melbourne, 21st January, 1972.

No. 171.

Public Service Act 1958, Section 50.

REGULATIONS—PART IV.—SALARIES AND INCREMENTS.

The Public Service Board, in pursuance of the powers conferred by the Public Service Act 1958, hereby amends its Regulations as shown below:—

FIFTH SCHEDULE.

TEMPORARY EMPLOYEES.

DEPARTMENT OF HEALTH.

MENTAL HYGIENE.

Designations of Positions and Rates of Salaries.

Designation of Position.	Yearly Rate of Salary. £	
	Minimum.	Maximum.
	\$	\$
<i>Delete—</i>		
Storeman, Grade II.	3,250	3,627
Storeman, Grade I.	3,169	3,494
<i>Add—</i>		
Storeman, Grade II.	3,494	3,861
Storeman, Grade I.	3,351	3,685

Σ Annual increments shall be in accordance with those prescribed by Sub-Regulations 113 (2) and 113 (3), provided that in the case of the position of Assistant (Male), Administrative, the annual increments shall be in accordance with those prescribed by Part A of the Third Schedule.

This Regulation shall have effect as on and from the 16th January, 1972.

A. J. A. GARDNER, Chairman.
V. P. SCULLY, Secretary.

Office of the Public Service Board,
Melbourne, 10th January, 1972.

No. 172.

Public Service Act 1958, Section 50.

REGULATIONS—PART IV.—SALARIES AND INCREMENTS.

The Public Service Board, in pursuance of the powers conferred by the Public Service Act 1958, hereby amends its Regulations as shown below:—

SIXTH SCHEDULE.

TEMPORARY EMPLOYEES.

Designations of Positions and Rates of Salaries.

Department and Designation of Position.	Yearly Rate of Salary.		Increments (Annual).
	Minimum.	Maximum.	
	\$	\$	
GENERAL.			
<i>Delete—</i>			
Storeman, Grade II.	3,250	3,627	Σ
Storeman, Grade I.	3,169	3,494	Σ
<i>Add—</i>			
Storeman, Grade II.	3,494	3,861	Σ
Storeman, Grade I.	3,351	3,685	Σ

This Regulation shall have effect as on and from the 16th January, 1972.

A. J. A. GARDNER, Chairman.
V. P. SCULLY, Secretary.

Office of the Public Service Board,
Melbourne, 10th January, 1972.

No. 170.

PUBLIC SERVICE ACT 1958, SECTION 50.

REGULATIONS.—PART IV.—SALARIES AND INCREMENTS.

The Public Service Board, in pursuance of the powers conferred by the Public Service Act 1958, hereby amends its Regulations as shown below:—

THIRD SCHEDULE.

PART B.

PROFESSIONAL DIVISION.

Scale of Rates of Annual Salaries.

The heading "EXECUTIVE ASSISTANT, WATER SUPPLY DEPARTMENT" and the salary scale relating thereto are deleted.

A. J. A. GARDNER, Chairman.
V. P. SCULLY, Secretary.

Office of the Public Service Board,
Melbourne, 20th January, 1972.

TENDERS

PUBLIC WORKS DEPARTMENT

Tenders will be received at Public Works Department, 2 Treasury-place, Melbourne, until **TWO** p.m. on dates shown and for purposes mentioned hereunder.

Particulars and tender forms available at Contracts Office, Room 8, Building Division, Parliament-place and at places indicated in brackets hereunder.

Abbreviations in brackets mean:—W.O.—Inspector of Works Office; P.S.—Police Station; C.S.—Consolidated School; H.E.S.—Higher Elementary School; H.S.—High School; Pr.S.—Primary School; T.S.—Technical School.

Tenders to be submitted on the Department's printed Tender Form and will not be received by telephone. All tenders must be on a "Firm Tender" basis. The lowest or any tender will not necessarily be accepted.

Address tenders to the Minister of Public Works, and endorse the envelope containing the tender "Tender for , closing Tuesday,

Hand delivered tenders to be placed in the Tender Box of the Public Works Department, located on the wall of the centre entrance foyer, Ground Floor, 2 Treasury-place, Melbourne.

No preliminary deposit is required with any tender, but a successful tenderer will be required to pay a deposit for any accepted tender of \$5,000 or over.

Tuesday, 8th February, 1972.

Building, Electrical and Mechanical Works.

BALWYN.—Internal and external renovations, "Illoura" Children's Home.

BERRIWILLOCK.—Repairs and painting, Pr.S.3250. (W.O., Swan Hill.)

CARLTON.—Demolition of multi-storey building, St. Nicholas Hospital.

CRESWICK.—Alterations to main building, Victorian School of Forestry. (Re-advertised.) (W.O., Ballarat.)

DANDENONG WEST.—Internal and external repairs and painting, Pr.S.4217.

DIAMOND CREEK EAST.—Provision of canteen and covered play area, Pr.S.5037.

FAIRFIELD.—External repairs and painting and roof renewal, Pr.S.2711.

FOREST HILL.—External painting, Pr.S.4251.

FRANKSTON.—External and internal renovations, H.S. (Re-advertised.) (Amended Specification.)

JAMIESON.—Internal and external painting and repairs, Police Station and Residence. (Re-advertised.) (Amended Specification.) (W.O., Alexandra.)

LA TROBE.—External renovations, H.S.

MANNINGHAM.—Internal and external renovations and painting, Pr.S.4940.

MELBOURNE.—Supply, commissioning and testing of fire alarm system, Titles Office, 283 Queen-street.

MILDURA.—L.P. gas heating, H.S. (W.O., Mildura, Bendigo and Ballarat.)

MITCHAM.—Internal and external repairs and painting, H.S.

MONTMORENCY.—Exterior renovations and painting, &c., Pr.S.4112.

OAKLEIGH EAST.—Repairs and renovations, Pr.S.4327.

OLYMPIC VILLAGE.—External renovations and painting, Pr.S.4713.

QUAMBATOOK.—Erection of seven class-rooms, &c., in brick veneer, Pr.S.2443. (Re-advertised.) (Amended Specification.) (W.O., Swan Hill.)

RESEARCH.—Exterior and interior repairs and painting, Pr.S.2959.

TAWONGA.—Renovations, Pr.S.2282. (W.O., Wangaratta.)

TRARALGON.—Erection of standard school hall type "992 C", T.S. (Re-advertised.) (W.O., Traralgon.)

TRARALGON.—Erection of science wing, T.S. (W.O., Traralgon.)

TRARALGON.—Mechanical services, Science Wing, T.S. (W.O., Traralgon.)

UPPER YARRA.—Internal and external repairs and painting, H.S.

VARIOUS.—Maintenance of oil burners for the period 1st February, 1972, to 31st December, 1972, Schools, Northern Victoria.

VARIOUS.—Maintenance of oil burners for the period 1st February, 1972, to 31st December, 1972, Schools, Eastern Region.

WARRAWONG.—Internal painting, Pr.S.4835.

WATTLE PARK.—External painting, H.S.

WAVERLEY.—External renovations, H.S.

Site Works.

BEECHWORTH.—Road construction and associated works, Mental Hospital. (W.O., Wangaratta.)

FITZROY NORTH.—Site works, Pr.S.1490.

GLENORMISTON.—Site works, Agricultural College. (W.O., Camperdown.)

MORWELL.—Site works, H.S. (W.O., Traralgon and Warragul.)

WODONGA SOUTH.—Site works, Pr.S.5042. (W.O., Wangaratta.)

Tuesday, 15th February, 1972.

Building, Electrical and Mechanical Works.

BRIGHTON.—External renovations and painting, P.S.

BURNLEY.—Erection of an Insectary, Victorian Plant Research Institute.

BURNLEY.—Electrical services, Insectary, Victorian Plant Research Institute.

BURNLEY.—Mechanical services, Insectary, Victorian Plant Research Institute.

CAULFIELD.—External and internal renovations, T.S.

FRANKSTON.—External and internal renovations, Court House. (W.O., Mornington.)

JANEFIELD.—External and internal painting, Wards F.2-F.4, Training Centre.

MONT PARK.—External painting and renovations, Staff Hostel, Mental Hospital.

MOORABBIN.—Internal and external painting, Pr.S.4687.

NOBLE PARK.—Internal repairs and painting, H.S.

SOUTH YARRA.—Internal and external repairs and renovations, Pr.S.583 and Residence.

SUNSHINE HEIGHTS.—Internal and external renovations and repairs to roof, Pr.S.4744.

VARIOUS.—Maintenance of oil burners for the period 1st February, 1972, to 31st December, 1972, Schools, Central Region.

Site Works.

DANDENONG.—Asphalt repairs, T.S.

MAFFRA.—Asphalt repairs, H.S. (W.O., Bairnsdale and Traralgon.)

Miscellaneous.

PORT MELBOURNE.—Supply and delivery of eight (8) amenities caravans, Plant Depot.

Tuesday, 22nd February, 1972.

Building, Electrical and Mechanical Works.

BALLARAT NORTH.—Erection of multi-purpose hall, Type 800C, T.S. (W.O., Ballarat.)

BALLARAT NORTH.—Electrical services, hall, T.S. (W.O., Ballarat.)

BALLARAT NORTH.—Mechanical services, hall, T.S. (W.O., Ballarat.)

BENDIGO.—Mechanical services, Occupational Therapy Centre, Psychiatric Centre. (W.O., Bendigo.)
 BURNLEY.—Construction of a glass house/head house, Victorian Plant Research Institute.
 BURNLEY.—Mechanical services, glass house/head house, Victorian Plant Research Institute.
 COBRAM.—Connexion to sewer, C.S. (W.O., Benalla.)
 DANDENONG.—Internal and external repairs and painting, G.H.S. (Girls' High School, Dandenong.)
 EUROA.—External and internal renovations, Pr.S.1706. (W.O., Alexandra and Benalla.)
 GLENROY NORTH.—External renovations, Pr.S.4782.
 KEW.—Re-roofing, repairs and painting, Pr.S.1075 and Residence.
 PRESTON.—Remodelling of science rooms, Institute of Technology.
 PRESTON.—Electrical services, science rooms, Institute of Technology.
 PRESTON.—Mechanical services, science rooms, Institute of Technology.
 ST. ALBANS NORTH.—Internal and external painting, Pr.S.4811.
 WYCHEPROOF.—External repairs and painting, H.E.S. (W.O., Swan Hill.)

J. C. M. BALFOUR,
 Acting Minister of Public Works.

Public Works Department,
 Melbourne, 3002, 28th January, 1972.

PRIVATE ADVERTISEMENTS

MACEDON WATERWORKS TRUST.

Notice to owners of tenements in:—

- (a) Grandview-avenue, lots 23 to 28 inclusive, lodged plan 2093.
- (b) Marshall-avenue, lodged plan 2924 and lodged plan 1598.
- (c) Crombie-road, Dunne-street, and Norton-road, lots 16, 17, 18, lodged plan 1598.

The main pipe in the said streets having been laid down, the owners of all lands and tenements situated as above, may now cause a proper pipe and stopcocks to be laid so as to supply water within such lands and tenements from the main pipe.

4410

C. GOODWIN, Secretary.

BACCHUS MARSH SEWERAGE AUTHORITY.

The Bacchus Marsh Sewerage Authority has prepared maps and plans showing levels and locations of sewers, &c., in accordance with the *Sewerage District Act 1958*, for works to be undertaken as the Darley extension of the Bacchus Marsh Sewerage Scheme being generally the area bounded by High-street, Albert-street from 350 feet west of Nelson-street, and Grey-street.

The maps are now open for inspection at the Office of the Authority, Main-street, Bacchus Marsh and may be inspected during office hours by owners and occupiers of land or premises in the Sewerage District.

4453

B. E. LEACH, Secretary to Authority.

CITY OF BALLARAT.

LOAN No. 30.

Notice of Intention to Borrow.

Notice is hereby given that the Council of the City of Ballarat intends to borrow Fifty thousand dollars (\$50,000), secured by a charge over the general rates of the municipality by the grant of a mortgage in accordance with the provisions of the *Local Government Acts*.

In connexion therewith the following information is stated:—

- (a) The amount of the principal moneys which it is proposed to borrow is \$50,000.
- (b) The maximum rate of interest that may be paid is 7 per centum per annum.
- (c) The times which the moneys borrowed are to be repayable are the 15th day of September, 1972, and the 15th days of March, and September, during the years 1973–1987 inclusive and that the place such moneys shall be repayable is at the Bank of New South Wales, Ballarat.
- (d) The purpose for which the loan is to be applied is:—

Redevelopment of Town, Hall Building—part cost.

- (e) The manner in which the loan is to be liquidated is by provision out of the municipal fund in each half-year during the currency of the loan of the sum of \$2,004.43 and a final payment of \$38,870.04, which include principal and interest.

The plans and specifications and estimate of the cost of the works and a statement showing the proposed expenditure of the moneys to be borrowed are open for inspection at the Town Hall.

Dated this 28th day of January, 1972.

4450

F. J. ROGERS, Town Clerk.

CITY OF DANDENONG.

LOAN No. 58.

Notice of Intention to Borrow the Sum of \$100,000 for Permanent Works and Undertakings.

Notice is hereby given that the Council of the City of Dandenong proposes to borrow the principal sum of One hundred thousand dollars, secured by a charge over the general rates of the municipality, such sum to be raised by the grant of a mortgage in accordance with the provisions of the *Local Government Act 1958*.

- 1. The maximum rate of interest that may be paid is 7 per centum per annum.
- 2. The purpose for which the loan is to be applied is—

Library building (part cost)—\$100,000.

- 3. The period of the loan shall be fifteen years.
 - 4. The moneys borrowed shall be repayable by providing out of the municipal fund half-yearly instalments of approximately \$5,437.13 each, including principal and interest on the 1st day of April and the 1st day of October, during the currency of the loan. The first instalment shall be payable on the 1st day of October, 1972.
 - 5. Such moneys shall be repayable at the offices of the Local Authorities Superannuation Board, Rigby House, 15 Queens-road, Melbourne.
- The plans and specifications and the estimate of the cost of the proposed works, and a statement showing the proposed expenditure of the moneys to be borrowed, are open for inspection at the office of the Council of the City of Dandenong, 39 Clow-street, Dandenong.

4417

C. A. ELLIOTT, Town Clerk.

CITY OF DONCASTER AND TEMPLESTOWE.

LOAN No. 156.

Notice of Intention to Borrow the Sum of \$100,000 for Permanent Works and Undertakings.

Notice is hereby given that the Council of the City of Doncaster and Templestowe proposes to borrow the principal sum of One hundred thousand dollars (\$100,000), secured by a charge over the general rates of the municipality, such sum to be raised by the grant of a mortgage in accordance with the provisions of the *Local Government Act 1958*.

- 1. The maximum rate of interest that may be paid is 7 per cent. per annum.
- 2. The purpose for which the loan is to be applied is capital works in the Council's Electric Supply undertaking, namely—

Extensions to mains, provision of transformers and electrical equipment	\$80,000
Apparatus on consumers' premises—provision of meters and time switches, &c.	20,000
	\$100,000

- 3. The period of the loan shall be fifteen years.
- 4. The moneys borrowed shall be repayable by providing out of the municipal fund 30 half-yearly instalments of approximately \$5,438, including principal and interest on the 1st day of April and the 1st day of October, during the currency of the loan. The first instalment shall be payable on the 1st day of October, 1972.
- 5. Such moneys shall be repayable at the Australia and New Zealand Savings Bank Limited, 686 Doncaster-road, Doncaster.

The plans and specifications and the estimate of the cost of the proposed works and a statement showing the proposed expenditure of the moneys to be borrowed, are open for inspection at the office of the Council of the City of Doncaster and Templestowe at the Municipal Offices, Doncaster-road, Doncaster.

4413

J. W. THOMSON, Town Clerk.

CITY OF DONCASTER AND TEMPLESTOWE.

LOAN No. 158.

Notice of Intention to Borrow the Sum of \$75,000 for Permanent Works and Undertakings.

Notice is hereby given that the Council of the City of Doncaster and Templestowe proposes to borrow the principal sum of Seventy-five thousand dollars (\$75,000), secured by a charge over the general rates of the municipality, such sum to be raised by the grant of a mortgage in accordance with the provisions of the Local Government Act 1958.

1. The maximum rate of interest that may be paid is 7 per cent. per annum.

2. The purpose for which the loan is to be applied is capital works in the Council's Electric Supply undertaking, namely—

Extensions to mains, provision of transformers and electrical equipment	\$35,000
Apparatus on consumers' premises—provision of meters and time switches, &c.	30,000
Street lighting	10,000
	<u>\$75,000</u>

3. The period of the loan shall be fifteen years.

4. The moneys borrowed shall be repayable by providing out of the municipal fund 30 half-yearly instalments of approximately \$4,078, including principal and interest on the 1st day of April and the 1st day of October, during the currency of the loan. The first instalment shall be payable on the 1st day of October, 1972.

5. Such moneys shall be repayable at the Australia and New Zealand Savings Bank Limited, 686 Doncaster-road, Doncaster.

The plans and specifications and the estimate of the cost of the proposed works and a statement showing the proposed expenditure of the moneys to be borrowed, are open for inspection at the office of the Council of the City of Doncaster and Templestowe at the Municipal Offices, Doncaster-road, Doncaster.

4414 J. W. THOMSON, Town Clerk.

CITY OF HAMILTON.

Whereas the Council of the City of Hamilton deems it expedient to exercise its power of taking compulsorily the land delineated and hatched on the map at the foot hereof for development of the City of Hamilton Municipal Saleyards, pursuant to the Local Government Act 1958 and acquiring the said land for that purpose: And whereas the Council has caused to be prepared a map and other papers setting out the general description of the work or undertaking for which the land proposed to be taken is to be used the description of the land proposed to be taken and the names of the owners or reputed owners, lessees or reputed lessees, mortgagees and occupiers of that land so far as those names are known to or can be ascertained by the Council: And whereas the said map and other papers are deposited at the office of the said Council in Brown-street, Hamilton, and are and shall be open for inspection by all persons interested at all reasonable hours for the space of 40 clear days after the publication of this notice in the Government Gazette: Now notice is hereby given to all persons affected by the proposed taking of the said land to set forth, in writing, addressed to the Council or the Town Clerk within 40 clear days of the publication of this notice in the Government Gazette, all objections which they may have to the taking of the said land.

Part of allotment 20, Parish of South Hamilton, County of Normanby.

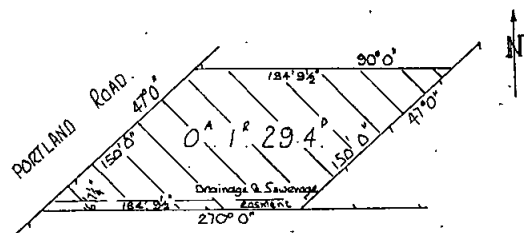

Dated this 1st day of February, 1972.

4451 By order of the Council, H. F. DONALD, Town Clerk.

CITY OF KEILOR.

NOTICE OF CHANGING NAMES OF STREETS.

In accordance with the provisions of the Local Government Act 1958, the Council of the City of Keilor hereby give notice that the said Council has made an Order changing the names of the following streets:—

- Old Name.—North-court.
New Name.—North-street.
Location.—Highlands-avenue to North-street.
- Old Name.—Bedford-court.
New Name.—Bedford-street.
Location.—Highlands-avenue to Bedford-street.
- Old Name.—Etzel-court.
New Name.—Etzel-street.
Location.—Highlands-avenue, to Etzel-street.
- Old Name.—South-court.
New Name.—South-road.
Location.—Highlands-avenue to South-road.
- Old Name.—Clydesdale-street.
New Name.—Clydesdale-road.
Location.—Roberts-road northwards to Clydesdale-road.

4401 R. F. B. KELLY, Town Clerk.

CITY OF SALE.

BY-LAW No. 60.

Swimming Complex.

Notice is hereby given that the Council of the City of Sale has made a By-Law Number 60, under the provisions of Section 756 of the Local Government Act 1958, for:—

- (a) Regulating the management and use of the Sale Swimming Complex situate in Guthridge Parade, Sale.
- (b) Imposing, collecting and receiving charges or entrance fees for Clubs, Associations or persons using or entering in or upon such Swimming Complex.
- (c) Regulating the conduct of persons using or being upon or in such Swimming Complex.

A copy of the By-Law may be inspected free of charge at the Council Chambers, Sale, during office hours (Mon.—Fri. 10 a.m.—4 p.m.)

Resolution agreed to on the 14th December, 1971, and confirmed on the 25th January, 1972.

4421 J. L. LOW, Town Clerk.

CITY OF SWAN HILL.

LOAN No. 58.

Notice of Intention to Borrow \$10,500 for Permanent Works and Undertakings.

Notice is hereby given that the Council of the City of Swan Hill proposes to borrow the principal sum of Ten thousand five hundred dollars (\$10,500), secured by a charge over the general rates of the municipality, such sum to be raised by the grant of a mortgage in accordance with the provisions of the Local Government Act 1958.

(a) The maximum rate of interest that may be paid is 6.9 per centum per annum.

(b) The period of the loan shall be ten (10) years.

(c) The times which the moneys borrowed are to be repayable are the 1st day of April and the 1st day of October in each year, during the currency of the loan, commencing on the 1st day of October, 1972, and such moneys shall be repayable to the Commissioners of the State Savings Bank of Victoria at the office of the said Commissioners, corner of Elizabeth and Bourke streets, Melbourne.

(d) The purpose for which the loan is to be applied is:—

Swan Hill Recreation Reserve, building extensions	\$6,250
Purchase of plant and equipment	3,600
Purchase of office equipment	650
	<u>\$10,500</u>

(e) The manner in which the loan is to be liquidated is by providing out of the municipal fund half-yearly instalments of approximately \$735.46 each, including principal and interest.

The plans and specifications and the estimates of the cost of the proposed works and a statement showing the proposed expenditure of the moneys to be borrowed, are open for inspection at the office of the Council of the City of Swan Hill, Town Hall, Swan Hill.

4403 Dated 26th January, 1972. J. W. KELLOCK, Town Clerk.

TOWN OF PORTLAND.

RESIGNATION OF PROSECUTING OFFICER.

Notice is hereby given that Senior Sergeant Maxwell Allen Oakley, No. 10904, has resigned as Prosecuting Officer to the Town of Portland as from 17th January, 1972.

4455

L. FELL, Town Clerk.

SHIRE OF BACCHUS MARSH.

PROSECUTING OFFICER.

Notice is hereby given that the Council of the Shire of Bacchus Marsh has appointed Sergeant William Ferris Burgess, No. 13003, as Prosecuting Officer for the Shire of Bacchus Marsh, in place of Sergeant Paul Highman, transferred.

4454

B. E. LEACH, Shire Secretary.

SHIRE OF GISBORNE.

LOAN No. 18.

Notice of Intention to Borrow the Sum of \$14,000 for Permanent Works and Undertakings.

Notice is hereby given that the Council of the Shire of Gisborne proposes to borrow the principal sum of \$14,000, secured by a charge over the general rates of the municipality, such sum to be raised by the grant of a mortgage in accordance with the provisions of the *Local Government Act 1958*.

1. The maximum rate of interest that may be paid is 6.7 per cent. per annum.
2. The purposes for which the loan is to be applied are:—

Underground drainage, Hamilton-street, Gisborne	\$5,000
Kerbing and channelling, Station-road, New Gisborne	4,000
Kindergarten building, Grant-crescent, Gisborne. Part cost	5,000
	<u>\$14,000</u>

3. The period of the loan shall be nine years.
4. The moneys borrowed shall be repayable by providing out of the municipal fund half-yearly instalments of approximately \$1,049 each, including principal and interest, on the 1st day of October and the 1st day of April during the currency of the loan. The first instalment shall be payable on the 1st day of October, 1972.
5. Such moneys shall be repayable to the Commissioners of the State Savings Bank of Victoria at the office of the said Commissioners, corner Elizabeth and Bourke streets, Melbourne.

The plans and specifications and the estimate of the cost of the proposed works and a statement showing the proposed expenditure of the moneys to be borrowed, are open for inspection at the office of the Council of the Shire of Gisborne, at the Shire Office.

Dated 2nd February, 1972.

4400

K. V. ROBINSON, Shire Secretary.

Water Act.

PROPOSED SHIRE OF GLENELG WATERWORKS TRUST.

SANDFORD WATER SUPPLY.

Notice is hereby given that the Glenelg Shire Council has made application to the Honorable the Minister of Water Supply for the constitution of a Waterworks Trust, and for the construction, maintenance and continuance of Water Supply Works at Sandford under the provisions of the Water Act.

A general plan and description of the proposed works have been submitted with the application, and copies of same may be seen at the Shire Office, at Casterton.

Dated at Casterton the 25th day of January, 1972.

4395

J. B. HANSEN, Secretary.

SHIRE OF KORUMBURRA.

NOTICE OF INTENTION TO ACQUIRE LAND COMPULSORILY.

Whereas the Council of the Shire of Korumburra deems it expedient to exercise its powers of taking land compulsorily for the purpose of deviating and widening Yannathan-road, such land being part of Crown allotments 14, 15 and 16, section 1, Township of Nyora, and part of Crown allotment 31, section 2, Township of Nyora, all such lots being in the Parish of Lang Lang East, and being more particularly described in certificate of title, volume 8366, folio 598, Crown grant, volume 2341, folio 038, certificate of title, volume 7167, folio 235, and Crown grant volume 6801, folio 098.

And whereas the Council has caused to be prepared maps and other plans setting out the general description of the work or undertaking for which the said land is proposed to be used together with the names of the owners or reputed owners, lessees or reputed lessees, mortgagees and occupiers of the said land as far as those names are known or can be ascertained.

And whereas the said maps and other papers are deposited at the Office of the said Council and are and shall be open for inspection by all persons interested at all reasonable hours, for the space of forty clear days after the publication of this notice in the *Government Gazette*.

Now notice is hereby given to all persons affected by the proposed taking of the said land to set forth in writing, addressed to the Shire Secretary, within forty clear days of publication of this notice in the *Government Gazette*, all objections which they may have to the taking of the said land.

4409

W. O. CLARK, Shire Secretary.

SHIRE OF RODNEY.

LOAN No. 68.

Notice of Intention to Borrow the Sum of \$80,000 for Permanent Works and Undertakings.

Notice is hereby given that the Council of the Shire of Rodney proposes to borrow the principal sum of Eighty thousand dollars, secured by a charge over the general rates of the municipality, such sum to be raised by the grant of a mortgage in accordance with the provisions of the *Local Government Act 1958*.

1. The maximum rate of interest that may be paid is 7.1 per centum per annum.
2. The purposes for which the loan is to be applied are:—

- (a) Redevelopment of Mooroopna Recreation Reserve including erection of indoor sports pavilion ... \$70,000
- (b) Mooroopna main drain reconstruction ... \$10,000

3. The period of the loan shall be twenty (20) years.
4. The moneys shall be repayable by providing out of the municipal fund 40 half-yearly instalments of \$3,775.29 each, including principal and interest on the 1st day of October and the 1st day of April, during the currency of the loan. The first instalment shall be payable on the 1st day of October, 1972.
5. Such moneys shall be repayable to the Local Authorities Superannuation Board at the office of the said Board, Rigby House, 15 Queens-road, Melbourne, or such other place or places as the Board from time to time may require.

The plans and specifications and the estimate of the cost of the proposed works and a statement showing the proposed expenditure of the moneys to be borrowed, are open for inspection at the office of the Council of the Shire of Rodney, at Tatura.

4456

R. PERRY, Shire Secretary.

SHIRE OF ROSEDALE.

LOAN No. 28.

Notice of Intention to Borrow the Sum of \$30,000 for Permanent Works and Undertakings.

Notice is hereby given that the Council of the Shire of Rosedale proposes to borrow the principal sum of Thirty thousand dollars (\$30,000), secured by a charge over the general rates of the municipality, such sum to be raised by the grant of a mortgage in accordance with the provisions of the *Local Government Act 1958*.

1. The amount of principal moneys which it is proposed to borrow is \$30,000.
2. The maximum rate of interest that may be paid is 6.9 per cent. per annum.
3. The moneys borrowed shall be repayable by providing out of the municipal fund half-yearly instalments on the 31st March and the 30th September in each year, commencing on 30th September, 1972, and concluding on 31st March, 1982, and payable at the office of the Australia and New Zealand Savings Bank Ltd., Melbourne.
4. The purpose of the loan is to be applied as follows:—

- (a) Sealing of roads at Nambrok and in the Townships of Wurruk and Rosedale.
- (b) Establishment of rubbish tip, Glengarry.
- (c) Drainage works, Township of Rosedale.
- (d) Fire plug installations, Township of Glengarry, Toongabbie and Rosedale.
- (e) Purchase of mobile radio equipment.
- (f) Purchase of land, Rosedale Township.

5. The manner in which the loan is liquidated is by provision out of the municipal fund in each half-year during the currency of the loan, the sum of approximately \$2,101, which includes principal and interest.

The plans and specifications and estimate of the cost of the proposed works and a statement showing the proposed expenditure of the moneys to be borrowed, are open for inspection at the office of the Council of the Shire of Rosedale.

Dated this 28th day of January, 1972.

4452 G. W. THOMSON, Shire Secretary.

SHIRE OF SOUTH BARWON.

CHANGE OF STREET NAMES.
Previous Name; New Name.

Belmont—

South-street; Cornish-avenue.
Union-street; Dargai-street.
Riverview-street; Bridgeview-street.
Colac-grove East; Deed-street.
Colac-grove West; Reynolds-road.
Albert-street; Batman-close.
Downside-close; Birnam-court.
Elizabeth-street; Mildren-street.

Grovedale—

Church-street; Jillong-street.

4321 H. W. S. JACKSON, Shire Secretary.

(Published in lieu of notice appearing in *Victoria Government Gazette*, No. 7, dated 26th January, 1972, page 254.)

SHIRE OF STRATHFIELDSAYE.

Notice is hereby given that an application and general plan and description of the "Spring Gully Reclamation Scheme" have been forwarded to the Minister for Local Government and that a copy of the general plan and description is open for inspection at the Strathfieldsaye Shire Office.

Any corporation or person having property or interest therein likely to be injuriously affected by the proposed scheme may forward to the Minister a petition to refuse or amend the application.

Dated 27th January, 1972.

4444 M. BRENNAN, Shire Secretary.

SHIRE OF UPPER MURRAY.

PROSECUTING OFFICER.

Notice is hereby given that the Council of the Shire of Upper Murray has appointed Senior Constable Leslie John O'Hagan, No. 11734 as Prosecuting Officer for the municipality in place of Senior Constable Joseph Draper, No. 10860, transferred.

4418 A. A. N. DEED, Shire Secretary.

SHIRE OF UPPER MURRAY.

LOAN No. 28.

Notice of Intention to Borrow the Sum of \$7,000 for Permanent Works and Undertakings.

Notice is hereby given that the Council of the Shire of Upper Murray proposes to borrow the principal sum of Seven thousand dollars, secured by a charge over the general rates of the municipality, such sum to be raised by the grant of a mortgage in accordance with the provisions of the *Local Government Act 1958*.

The maximum rate of interest that may be paid is 6.9 per centum per annum.

The loan is to be applied to payment of part of the Council's Contribution on Country Roads Board unclassified road works.

The period of the loan shall be ten years.

The money borrowed shall be repayable by providing out of the municipal fund nineteen half-yearly instalments of \$490.30, and one instalment of \$490.36 each, including principal and interest on the 31st day of March and the 30th day of September, during the currency of the loan. The first instalment shall be payable on the 30th day of September, 1972.

Such money shall be repayable to the Australia and New Zealand Savings Bank Limited, at Corryong.

The plans and specifications, and the estimate of the cost of the proposed works, and a statement showing the proposed expenditure of the moneys to be borrowed, are open for inspection at the offices of the Council of the Shire of Upper Murray, at 68-72 Hansen-street, Corryong, Victoria.

4419 A. A. N. DEED, Shire Secretary.

SHIRE OF WARANGA.

LOAN No. 43 (RE-ADVERTISED).

Notice of Intention to Borrow the Sum of \$23,000 for Permanent Works and Undertakings.

Notice is hereby given that the Council of the Shire of Waranga proposes to borrow the sum of Twenty-three thousand dollars (\$23,000), secured by a charge over the general rates of the municipality, such sum to be raised by the grant of a mortgage in accordance with the provisions of the *Local Government Act 1958*.

1. The maximum rate of interest that may be paid is 6.7 per centum per annum.

2. The purpose for which the loan is to be applied is as follows:—

Purchase of plant—\$23,000.

3. The period of the loan shall be eight years.

4. The moneys borrowed shall be repayable by sixteen half-yearly instalments of approximately \$1,880.39 each, including principal and interest, on the 1st day of October and the 1st day of April in each year during the currency of the loan. The first instalment shall be payable on the 1st October, 1972.

5. Such moneys shall be repayable to the C.B.C. Savings Bank Ltd., Melbourne.

The plans and specifications and the estimate of the cost of the proposed works and a statement showing the proposed expenditure of the moneys borrowed, are open for inspection at the Shire Offices, High-street, Rushworth, during office hours.

4406 G. K. CALDER, Shire Secretary.

SHIRE OF WARANGA.

LOAN No. 45.

Notice of Intention to Borrow the Sum of \$9,000 for Permanent Works and Undertakings.

Notice is hereby given that the Council of the Shire of Waranga proposes to borrow the sum of Nine thousand dollars (\$9,000), secured by a charge over the general rates of the municipality, such sum to be raised by the grant of a mortgage in accordance with the provisions of the *Local Government Act 1958*.

1. The maximum rate of interest that may be paid is 6.6 per centum per annum.

2. The purpose for which this loan is to be applied is as follows:—

Roadworks—\$9,000.

3. The period of the loan shall be six years.

4. The moneys borrowed shall be repayable by twelve half-yearly instalments of approximately \$920.43 each, including principal and interest, on the 1st day of October and the 1st day of April in each year during the currency of the loan. The first instalment shall be payable on 1st October, 1972.

5. Such moneys shall be repayable to the C.B.C. Savings Bank Ltd., Melbourne.

The plans and specifications and the estimate of the cost of the proposed works and a statement showing the proposed expenditure of the moneys borrowed, are open for inspection at the Shire Offices, High-street, Rushworth, during office hours.

4407 G. K. CALDER, Shire Secretary.

SHIRE OF WARANGA.

CHANGE OF STREET NAME.

Notice is hereby given that the Council of the Shire of Waranga did, at its meeting held on the 18th January, 1972, resolve to change the name of the following road, viz.:—

Old Name.—Mill-street.

New Name.—Meteorite-street.

Location.—The road forming the northern boundary of allotment 5, Town of Murchison, Parish of Murchison, County of Rodney.

4408 G. K. CALDER, Shire Secretary.

Town and Country Planning Act 1961 (Twelfth Schedule).

SHIRE OF WERRIBEE PLANNING SCHEME 1963.

NOTICE THAT A PLANNING SCHEME HAS BEEN PREPARED AND IS AVAILABLE FOR INSPECTION.

Amendment No. 15.

Notice is hereby given that the Shire of Werribee, in pursuance of its powers under the *Town and Country Planning Act 1961*, has prepared a Planning Scheme for the purpose of—

Rezoning from Public purposes, Melbourne and Metropolitan Board of Works Sewerage Farm and Main Sewer to Proposed Public Open Space Reserve G—Recreation Reserve being Crown allotments 10A and 24A, Township of Werribee, Parish of Nambourin, County of Bourke.

A copy of the scheme has been deposited at the Municipal Offices, Werribee, and at the office of the Town and Country Planning Board, 235 Queen-street, Melbourne, and will be open for inspection during office hours by any person, free of charge.

Any persons affected by the Planning Scheme are required to set forth, in writing, all objections they may have, addressed to the Shire Secretary, Municipal Offices, P.O. Box 197, Werribee, 3030, on or before Wednesday, 3rd May, 1972, and state whether they wish to be heard in respect of their objections.

Dated 24th January, 1972.

4398

J. T. KERR, Shire Secretary.

SHIRE OF WOORAYL.

LOAN No. 36.

Notice of Intention to Borrow the Sum of \$35,000 for Permanent Works and Undertakings.

Notice is hereby given that the Council of the Shire of Woorayl proposes to borrow the principal sum of \$35,000, secured by a charge over the general rates of the municipality, such sum to be raised by the grant of a mortgage in accordance with the provisions of the *Local Government Act 1958*.

1. The maximum rate of interest that may be paid is 7 per centum per annum.

2. The purpose for which the loan is to be applied is assistance to an approved decentralized industry.

3. The period of the loan shall be fifteen years.

4. The moneys borrowed shall be repayable by providing out of the municipal fund half-yearly instalments of \$1,903.00 each, including principal and interest on the 15th day of September and the 15th day of March each year during the currency of the loan. The first instalment shall be payable on the 15th day of September, 1972.

5. Such moneys shall be repayable at the office of the Commercial Savings Bank of Australia Ltd., 25 Bair-street, Leongatha.

Plans and specifications and the estimate of the costs of the proposed works and a statement showing the proposed expenditure of the moneys are open for inspection at the office of the Council of the Shire of Woorayl at Leongatha.

4449

R. G. STANLEY, Shire Secretary.

Notice is hereby given that the partnership heretofore subsisting between Johannes Adrianus Persons and Petronella Persons, carrying on business as manufacturers and contractors at Jesmond-road, Croydon, under the style or firm of "Eastern Suburbs Precast Tanks", has been dissolved by mutual consent as from the 22nd January, 1972. All debts due to and owing by the said firm will be received and paid respectively by Johannes Adrianus Persons, who will continue to carry on the said business under the same business name of "Eastern Suburbs Precast Tanks".

27th January, 1972.

R. W. HOLT & CLEMINSON, solicitors, 1 Ringwood-street, Ringwood, 3134.

4494

Notice is hereby given that the partnership heretofore subsisting between Frank Lloyd Swingler and Donald Bernard Wharrie, and carrying on the business of "Tricolor Litho", at 8 Corr-street, Moorabbin, has been dissolved as from the 31st day of January, 1972. The said Donald Bernard Wharrie will continue and carry on the said business at the same address under the said firm name.

Dated this 31st day of January, 1972.

FRANK LLOYD SWINGLER.
DONALD BERNARD WHARRIE.

Mollomby & Mollomby, solicitors.

4491

Notice is hereby given that the partnership heretofore subsisting between Norma Izatt and Jennifer Florence Izatt, carrying on the business of hairdressing, at 9E Anderson-street, Pascoe Vale, in the State of Victoria, under the style or firm name of "Jen-Nor Coiffure", has been dissolved as from the 25th day of January, 1972.

NORMA IZATT, by her solicitors Strugnell & Strugnell, 106 Bell-street, Coburg.

4415

Notice is hereby given that the partnership heretofore subsisting between Bruno Rigoni and Michele Buccellato, and carrying on business as plumbers at 55 Barton-street, Reservoir, under the style or firm name of "Ideal Building and Plumbing Co." has been dissolved as from 26th January, 1972.

The said Bruno Rigoni will continue and carry on the said business at the same address under the said firm name.

Dated this 26th day of January, 1972.

4437

Notice is hereby given that the partnership heretofore subsisting between the undersigned Garth Andrew Stockel and Robert Milne Robilliard, carrying on business as air charterers, at Sale and West Sale, under the style or firm of Oil City Air Charter, has been dissolved as from the 30th day of September, 1971.

Dated the 5th day of January, 1972.

GARTH A. STOCKEL.

Blake & Riggall, solicitors, 120 William-street, Melbourne.

4496

Companies Act 1961.—Section 272 (2).

MARASH HOLDINGS PTY. LTD. (IN VOLUNTARY LIQUIDATION).

The Final Meeting of the company will be held at the office of the liquidator on 28th February, 1972, at 10 a.m., for the purpose of receiving the liquidator's account showing how the winding up has been conducted and the property of the company disposed of.

W. A. BROWNE, Liquidator, 24 Jeffcott-street, Melbourne, 26th January, 1972.

4423

Companies Act 1961.—Section 272 (2).

FOURWAY HOLDINGS PTY. LTD. (IN VOLUNTARY LIQUIDATION).

The Final Meeting of the company will be held at the office of the liquidator on 28th February, 1972, at 10.30 a.m. for the purpose of receiving the liquidator's account showing how the winding up has been conducted and the property of the company disposed of.

W. A. BROWNE, Liquidator, 24 Jeffcott-street, Melbourne, 26th January, 1972.

4424

J. W. McGUIRE (MOORABBIN) PTY. LTD. (IN LIQUIDATION).

PURSUANT TO SECTION 254 (2) (b) OF THE COMPANIES ACT 1961.

At an Extraordinary General Meeting of the members of J. W. McGuire (Moorabbin) Pty. Ltd. duly convened and held at 112 Patterson-road, Moorabbin, on the 24th day of January, 1972, the following Special Resolution was duly passed:—

"That the company, being able to pay its debts in full, be wound up voluntarily forthwith and that Reginald Robert William Fox, whose office is situated at 112 Patterson-road, Moorabbin, be appointed liquidator."

Dated this 27th day of January, 1972.

4420

R. R. W. FOX, Liquidator.

The Companies Act 1961.—In the matter of KENLEIGH COURT PTY. LTD.

Notice is hereby given that at a meeting of the members held on 24th January, 1972, it was resolved that the company be wound up voluntarily and that Mr. D. J. Cogle, of 545 St. Kilda-road, Melbourne, be appointed liquidator.

Notice is also given that after 21 days the assets will be distributed. All creditors having claims should furnish particulars to the liquidator within this time or the assets will be distributed without regard to their claims.

Dated this 27th day of January, 1972.

4430

D. J. COUGLE, Liquidator.

Companies Act 1961.—Section 272 (2).
ENKER HOLDINGS PTY. LTD. (IN VOLUNTARY LIQUIDATION).

The Final Meeting of the company will be held at the office of the liquidator, on 28th February, 1972, at 11 a.m., for the purpose of receiving the liquidator's account showing how the winding up has been conducted and the property of the company disposed of.

W. A. BROWNE, Liquidator, 24 Jeffcott-street, Melbourne, 26th January, 1972. 4425

Companies Act 1961.—In the matter of MELVIC ENGINEERING PTY. LTD. (In Liquidation).

Notice is hereby given that, at an Extraordinary Meeting of the members of the above-named company, held on the 25th January, 1972, it was resolved that the company be wound up voluntarily, and at a meeting of creditors held on the same day pursuant to section 260, it was resolved that for such purpose, Everett Thomson Bent, of Suite 18, 545 St. Kilda-road, Melbourne, public accountant, be appointed liquidator.

Notice is also given that, after 21 days from this date, I shall proceed to distribute the assets. All creditors having any claims against the company should furnish particulars of same by that date, otherwise I shall proceed to distribute the assets without regard to their claim.

Dated this 25th day of January, 1972.

E. T. BENT, Liquidator.

Bent & Cogle, public accountants, Suite 18, 545 St. Kilda-road, Melbourne, 3004. 4402

Notice is hereby given pursuant to section 271 of the Companies Act 1961 that a meeting of creditors of Peninsula Marine & Land Services Pty. Ltd. (in liquidation) will be held at the Princes Gate Conference Centre (Room 311), 151 Flinders-street, Melbourne, on 17th February, 1972, at 10.30 a.m.

JOHN F. RUFFIN, liquidator, 100 Mount Eliza-way, Mt. Eliza. 4448

The Companies Act 1961.—In the matter of BIRRALEE BUILDERS PTY. LTD.—Notice Re Meeting of Creditors Pursuant to Section 260.

Notice is hereby given that a meeting of creditors of the above-named company will be held at Suite 18, 545 St. Kilda-road, Melbourne, on Wednesday, 16th February, 1972, at 10.30 a.m., the company having convened a meeting of its members for earlier the same day for the purpose of considering a Special Resolution that the company be wound up voluntarily.

Dated this 27th day of January, 1972.

F. BOSA, Director.

Bent & Cogle, public accountants, suite 18, 545 St. Kilda-road, Melbourne, 3004. 4441

The Companies Act 1961.

A. JAK CONSTRUCTORS PTY. LTD. (IN LIQUIDATION).

NOTICE CONVENING FINAL MEETING OF MEMBERS AND CREDITORS, PURSUANT TO SECTION 272 (2).

Notice is hereby given, in pursuance of section 272 of the Companies Act 1961, that a meeting of the members and creditors of the above-named company, will be held on the 28th day of February, 1972, at the office of A. Neville Bird & Co., chartered accountants, 289 Flinders-lane, Melbourne at 11.00 a.m. for the purpose of having an account laid before them showing the manner in which the winding up has been conducted and the property of the company disposed of and hearing any explanations that may be given by the liquidator.

Dated this 28th day of January, 1972.

A. NEVILLE BIRD, Liquidator.

A. Neville Bird & Co., chartered accountants, 289 Flinders-lane, Melbourne, 3000. Tel. 63 2874. 4495

The Companies Act 1961.

WATTLE VALLEY COURT PTY. LTD. (IN VOLUNTARY LIQUIDATION).

Notice is hereby given that pursuant to section 272 of the Companies Act, a Final Meeting of members of the above company, will be held at the office of Davey, Garcia & J. G. Davis, 3rd Floor, Nicholas Building, 37 Swanston-street, Melbourne, at 12.30 p.m. on Thursday, 2nd March, 1972, for the purpose of considering the final accounts.

4485

R. A. SEYMOUR, Liquidator.

The Companies Act 1961.

ORLOFF STAR PTY. LTD. (IN VOLUNTARY LIQUIDATION).

Notice is hereby given that pursuant to section 272 of the Companies Act, a Final Meeting of members of the above company, will be held at the office of Davey, Garcia & J. G. Davis, 3rd Floor, Nicholas Building, 37 Swanston-street, Melbourne, at 12 noon on Thursday, 2nd March, 1972, for the purpose of considering the final accounts.

4486

R. A. SEYMOUR, Liquidator.

Companies Act 1961.—In the matter of BRANKO ORIGINALS PTY. LTD (Under Official Management), Notice Re Meeting of Creditors, Pursuant to Section 203c (3).

Notice is hereby given that a meeting of creditors of the above-named company, will be held at the office of A. Neville Bird & Co., chartered accountants, 289 Flinders-lane, Melbourne, on Monday, 14th February, 1972, at 2.30 p.m., to consider, and if thought fit, pass a Special Resolution extending the official management for such further period not exceeding twelve months as is resolved.

A. NEVILLE BIRD, Official Manager.

Dated this 1st day of February, 1972.

A. Neville Bird & Co., chartered accountants, 289 Flinders-lane, Melbourne. Tel.: 63 2874. 4488

In the Supreme Court of Victoria.—1971 No. C.8282.—In the matter of the Companies Act 1961; and in the matter of CONSOLIDATED ALUMINIUM (AUST.) PROPRIETARY LIMITED.

Notice is hereby given that a petition for the winding up of the above-named company by the Supreme Court was, on the 11th day of January, 1972, presented by Indalex Pty. Limited: And that the said petition is directed to be heard before the Court sitting at the Fourteenth Court, Law Courts, William-street, Melbourne, on the 18th day of February, 1972, at the hour of 10.30 o'clock in the forenoon; and any creditor or contributory of the said company desiring to support or oppose the making of an order on the said petition may appear at the trial or hearing by himself or his counsel for that purpose; and a copy of the petition will be forwarded to any creditor or contributory of the said company requiring the same by the undersigned on payment of the regulated charge for the same.

The petitioner's address is Goldfields House, 1 Alfred-street, Sydney.

The petitioners solicitors are Messrs. Mallesons of 121 William-street, Melbourne.

MALESONS, solicitors for the petitioner.

NOTE.—Any person who intends to appear on the hearing of the said petition must serve on or send by post to the above-named solicitors, notice, in writing, of his intention so to do. The notice must state the names and address of the person, or, if a firm, the name and address of the firm and must be signed by the person or firm, or his or their solicitor (if any) and must be served, or if posted, must be sent by post in sufficient time to reach the above named not later than 4 o'clock in the afternoon of the 17th day of February, 1972. 4487

Companies Act 1961.

HELDEN PTY. LIMITED (IN VOLUNTARY LIQUIDATION).

NOTICE CONVENING FINAL MEETING OF MEMBERS PURSUANT TO SECTION 272.

Notice is hereby given that a General Meeting of the members of the company will be held on Wednesday, 8th March, 1972, at the office of Fitzgerald, Gunn & Partners, Tenth Floor, 470 Collins-street, Melbourne, Victoria, commencing at 9 a.m., for the purpose of having an account laid before the members showing the manner in which the winding up has been conducted and the property disposed of, and of hearing any explanations which may be given by the liquidator.

2nd February, 1972.

4489

J. D. BALMFORD, Liquidator.

KEITH ROWDEN PEARSON, late of Flat 8, 26 Warleigh-grove, Brighton, in the State of Victoria, retired sales representative, DECEASED, intestate.

Creditors, next of kin and all other persons having claims against the estate of the deceased are required by the administrators, The Trustees Executors and Agency Company Limited, of 401 Collins-street, Melbourne, to send particulars to its office at 401 Collins-street, Melbourne, before the 10th day of April, 1972, after which date it will distribute the assets, having regard only to the claims of which it then has notice.

J. ALLAN ANDERSON & SON, solicitors, of 472 Bourke-street, Melbourne. 4433

Companies Act 1961.

NIPPON ELECTRIC (AUSTRALASIA) PROPRIETARY LIMITED (IN VOLUNTARY LIQUIDATION).

Notice is hereby given that at an Extraordinary General Meeting of the members of the above-named company, held on the 18th day of January, 1972, it was resolved that the company be wound up and that Messrs. J. M. Poulton and D. A. Crawford be appointed joint and several liquidators.

Notice is also given that after 21 days from this date we shall proceed to distribute the assets. All creditors having any claims against the company should furnish particulars of same by that date, otherwise we shall proceed to distribute the assets without regard to their claim.

Dated this 25th day of January, 1972.

J. M. POULTON & D. A. CRAWFORD,
Joint and Several Liquidators.

Peat, Marwick, Mitchell & Co., 447 Collins-street, Melbourne, 3000. 4497

GLADYS MAY McGRATH, formerly of 10 Mitchell-street, Swan Hill, in the State of Victoria, married woman, but late of Lake Charm in the said State, home duties, DECEASED (who died on 7th November, 1971).

Creditors, next of kin and all other persons having claims against the estate of the deceased are required by the executors of the will, Thomas Bridson Green and Olga Patricia Gillingham, to send particulars to them, care of the undersigned on or before the 27th day of April, 1972, after which date they will distribute the assets, having regard only to the claims of which they then have notice.

GARDEN & GREEN, solicitors, 4 McCallum-street, Swan Hill. 4416

ADA DAWSON, late of 34 Gurner-street, St. Kilda, in the State of Victoria, gentlewoman, DECEASED.

Creditors, next of kin and all other persons having claims against the estate of the deceased are required by the executors, Joan Osborne Dark, of 13 Gillman-street, Cheltenham, widow, and Neill Finlay Anderson, of 472 Bourke-street, Melbourne, solicitor, to send particulars to them, care of the under-mentioned solicitors, on or before the 10th day of April, 1972, after which date they will distribute the assets, having regard only to the claims of which they then have notice.

J. ALLAN ANDERSON & SON, solicitors, of 472 Bourke-street, Melbourne. 4431

ETTIE DAWSON, late of 34 Gurner-street, St. Kilda, in the State of Victoria, gentlewoman, DECEASED.

Creditors, next of kin and all other persons having claims against the estate of the deceased are required by the executors, Joan Osborne Dark, of 13 Gillman-street, Cheltenham, widow, and Neill Finlay Anderson, of 472 Bourke-street, Melbourne, solicitor, to send particulars to them, care of the under-mentioned solicitors, on or before the 10th day of April, 1972, after which date they will distribute the assets, having regard only to the claims of which they then have notice.

J. ALLAN ANDERSON & SON, solicitors, of 472 Bourke-street, Melbourne. 4432

Creditors, next of kin and others having claims against the estate of Norman Patrick Stapleton Kerr, late of 1440A Sturt-street, West Ballarat, in the State of Victoria, garage proprietor, deceased (who died on the 1st day of September, 1971), are required to send particulars of their claims to The Union-Fidelity Trustee Company of Australia Limited, of 101 Lydiard-street north, Ballarat, in the said State, the executor of the will of the said deceased, by the 1st day of April, 1972, after which date the said executor will distribute the assets, having regard only to the claims of which it then has notice.

BYRNE, JONES & TORNEY, solicitors, Ballarat. 4445

Creditors, next of kin and others having claims against the estate of Lillie May Watson formerly of 208 Grant-street, Ballarat, but late of 102 Ascot-street south, Ballarat, widow, deceased (who died on 2nd November, 1971), are required by the executor, The Union-Fidelity Trustee Company of Australia Limited, 101 Lydiard-street north, Ballarat, to send detailed particulars of their claims to the said executor, by the 12th day of April, 1972, after which date it will proceed to distribute the said estate, having regard only to the claims of which it then has notice.

4447

FRANCIS JAMES MASKELL, late of 22 Oakwood-avenue, Brighton, in the State of Victoria, retired plumber, DECEASED.

Creditors, next of kin and all other persons having claims against the estate of the deceased are required by the executors, Ronald Francis Maskell, of 1 Agnes-street, Beaumaris, plumber, and Irene Boyce, of 62 Carpenter-street, North Brighton, married woman, to send particulars to them, care of the under-mentioned solicitors, on or before the 10th day of April, 1972, after which date they will distribute the assets, having regard only to the claims of which they then have notice.

J. ALLAN ANDERSON & SON, solicitors, of 472 Bourke-street, Melbourne. 4434

DOROTHY MAY CRELLIN, late of Flat 7, 273 Williams-road, South Yarra, in the State of Victoria, widow, DECEASED.

Creditors, next of kin and all other persons having claims against the estate of the deceased are required by the executors, Catherine Davis, of 41 Sussex-street, Brighton, widow, and Charles Bertram Crellin, of 236 Cotham-road, Kew, engineer, to send particulars to them, care of the under-mentioned solicitors, on or before the 10th day of April, 1972, after which date they will distribute the assets, having regard only to the claims of which they then have notice.

J. ALLAN ANDERSON & SON, solicitors, of 472 Bourke-street, Melbourne. 4435

SAMUEL SUNDERLAND GRIMSHAW, late of Old Dandenong-road, Heatherston, in the State of Victoria, retired builder, DECEASED.

Creditors, next of kin and all other persons having claims against the estate of the deceased are required by the executor, Neil Robert Burgess, of Old Dandenong-road, Heatherston, market gardener, to send particulars to him, care of the under-mentioned solicitors, on or before the 10th day of April, 1972, after which date he will distribute the assets, having regard only to the claims of which he then has notice.

J. ALLAN ANDERSON & SON, solicitors, of 472 Bourke-street, Melbourne. 4436

Trustee Act 1958.

NOTICE TO CLAIMANTS.

Pursuant to the Trustee Act 1958, creditors, next of kin and all other persons having claims in respect of the estate of any deceased person named below are required to send particulars to the legal personal representative or representatives at the addresses stated, after which date the representative or representatives will distribute the assets, having regard only to the claims of which notice has been received:—

John Stephen Upton, late of 18 Cranbrook-street, Spotswood, retired labourer, deceased, died on the 25th day of November, 1971.—Claims to the executors, William Joseph Upton, of 53 Khartoum-street, West Footscray, pensioner and Lucy Lillian Willingham, of 6 Old Heidelberg-road, Alphington, widow, care of John F. Carroll, of 4 Paisley-street, Footscray, solicitor, by the 4th day of April, 1972. John F. Carroll, LL.B., solicitor, 4 Paisley-street, Footscray. 4438

Kathleen Florence Gertrude Bradshaw, late of 3 Lindwood-avenue, West Altona, married woman, deceased, died on the 5th day of October, 1971.—Claims to the executrix, Alice Lillian Newton, of 57 Millers-road, Altona, married woman, care of John F. Carroll, of 4 Paisley-street, Footscray, solicitor, by the 4th day of April, 1972. John F. Carroll, LL.B., solicitor, 4 Paisley-street, Footscray. 4439

Bridget Ann Foley, late of 42 Home-road, Newport, widow, deceased, died on the 28th day of May, 1970.—Claims to the executrix, Kathleen O'Sullivan, of 42 Home-road, Newport, married woman, care of John F. Carroll, of 4 Paisley-street, Footscray, solicitor, by the 5th day of April, 1972. John F. Carroll, LL.B., solicitor, 4 Paisley-street, Footscray. 4440

JAMES WATSON, late of 208 Grant-street, Ballarat, water pipe tester, DECEASED, intestate (who died on the 5th June, 1961).

Creditors, next of kin and all other persons having claims against the estate are required by the administrator The Union-Fidelity Trustee Company of Australia Ltd., of 101 Lydiard-street north, Ballarat, to send detailed particulars of their claims to the said administrator on or before the 12th day of April, 1972, after which date it will proceed to distribute the said estate, having regard only to claims of which it then has notice. 4446

RUPERT WILLIAM NEWCOMBE, late of 71 George-street, Newtown, Geelong, gentleman, DECEASED.

Creditors, next of kin and others having claims in respect of the estate of the said deceased (who died 18th November, 1971), are required by the applicants for grant of probate of the will Kelvin Richmond, of 35 Herd-road, Belmont, Geelong, contractor and Roy Lindsay Bockholt, of 89 Myers-street, Geelong, solicitor, to send particulars to them care of the undersigned solicitors by 12th April, 1972, after which date the said applicants may convey or distribute the assets, having regard only to the claims of which they then have notice.

WIGHTON & McDONALD, solicitors, 89 Myers-street, Geelong. 4442

CORDELIA ALICE JULLIEN, late of 252A Myers-street, Geelong, married woman, DECEASED.

Creditors, next of kin and others having claims in respect of the estate of the deceased (who died on the 18th day of August, 1971), are required by the Trustees, Executors and Agency Company Limited, of 401 Collins-street, Melbourne, to send particulars of their claims to the said company by the 3rd of April, 1972, after which date it will convey or distribute the assets, having regard only to the claims of which it then has notice.

HARWOOD & PINCOTT, solicitors, 77 Moorabool-street, Geelong. 4443

All persons having claims against the estate of Ernest Robson Caygill, late of Christchurch, in the Dominion of New Zealand, retired public accountant, deceased (who died on the 21st March, 1971, and probate of whose will was on the 26th April, 1971, granted by the Supreme Court of New Zealand, Canterbury District Christchurch Registry to The Guardian Trust and Executors Company of New Zealand Limited, of Auckland, in the Dominion of New Zealand and Bruce Allott Caygill, of 254 Innes-road, Christchurch, in the said dominion and application to the Supreme Court of Victoria (probate jurisdiction) by The Perpetual Executors & Trustees Association of Australia Limited, to seal such probate having been granted on the 24th January, 1972), are hereby required to send particulars of such claims to The Perpetual Executors & Trustees Association of Australia Limited, at its Registered Office at 100-104 Queen-street, Melbourne, on or before the 4th April, 1972, after which date the said company will proceed to transfer, convey or distribute the said estate to or among the persons entitled thereto, having regard only to the claims of which it shall then have had notice and will not be liable for the assets so transferred, conveyed or distributed to any persons of whose claim it shall not then have had notice.

KEITH A. NESS & SON, solicitors, 411 Collins-street, Melbourne. 4475

THOMAS WILLIAM SCOTT, late of 4 Eades-place, West Melbourne, in the State of Victoria, driver, DECEASED.

Creditors, next of kin and others having claims against the estate of the above-named deceased (who died on the 13th day of August, 1971), are required to send particulars of their claims to the executor, Irving Samuel Plotkin, of 388 Bourke-street, Melbourne, by the 3rd day of April, 1972, after which date he may convey or distribute the assets, having regard only to the claims of which he has notice.

IRVING S. PLOTKIN, LL.B., 388 Bourke-street, Melbourne. 4480

ADA LUCIE EDITH LEWIS, formerly of Emmaus Rest Home, 41 Murrumbena-road, Murrumbena, but late of Will H. Clay Nursing Home, Wahgoo-street, Murrumbena, in the State of Victoria, widow, DECEASED.

Creditors, next of kin and others having claims in respect of the estate of the above-named deceased (who died on the 10th September, 1970), are required by the executors of the said deceased's will, Colin Frederick Lewis, of 866 Nepean Highway, Rosebud, gentleman, Enid Joyce Bowden, of 50 Deepdene-road, Balwyn, married woman and Marie Elizabeth Daly, of 403 Barkers-road, Kew, married woman, to send particulars to them by the 4th April, 1972, after which date the executors may convey or distribute the assets of the estate, having regard only to the claims of which they may have notice.

KEITH A. NESS & SON, solicitors, 411 Collins-street, Melbourne. 4474

PATRICK JAMES DOYLE, late of 23 Elm-street, North Melbourne, in the State of Victoria, retired, DECEASED.

Creditors, next of kin and others having claims against the estate of the above-named deceased (who died on the 30th day of May, 1971), are required to send particulars of their claims to the executrix, Veronica Teresa Grogan, care of the under-mentioned solicitor, by the 3rd day of April, 1972, after which date she may convey or distribute the assets, having regard only to the claims of which she has notice.

IRVING S. PLOTKIN, LL.B., 388 Bourke-street, Melbourne. 4482

JACK BLOOM, late of 3 Lambert-road, Caulfield, in the State of Victoria, manufacturer, DECEASED.

Creditors, next of kin and others having claims against the estate of the above-named deceased (who died on the 7th day of August, 1971), are required to send particulars of the claims to the executrix, Rachel Bloom, care of the under-mentioned solicitor, by the 3rd day of April, 1972, after which date she may convey or distribute the assets, having regard only to the claims of which she has notice.

IRVING S. PLOTKIN, LL.B., 388 Bourke-street, Melbourne. 4483

Creditors, next of kin and all others having claims against the estate of William Lee Murrell, late of 1 Dalgetty-road, Beaumaris, retired engineer, deceased (who died on 2nd September, 1971), are to send particulars of their claims to The Trustees, Executors and Agency Company Limited, of 401 Collins-street, Melbourne, and to Sibyl Murrell and Ronald William Murrell, care of the said company, the executors appointed by deceased's will, by the 3rd of April, 1972, after which date the said company will distribute the assets, having regard only to the claims of which it then has notice.

FOWLER & HICK, 17 Queen-street, Melbourne, solicitors for the executors. 4472

Creditors, next of kin and others having claims in respect of the estate of Norman Roth, late of 29 Adeney-avenue, Kew, in the State of Victoria, engineer, deceased (who died on the 12th day of June, 1971), are to send particulars of their claims to The Trustees, Executors & Agency Company Ltd., of 401 Collins-street, Melbourne, by the 9th day of April, 1972, after which date it will distribute the assets, having regard only to the claims of which it then has notice.

D. CONDON & CO., 83 William-street, Melbourne, proctors for the said company. 4476

Creditors, next of kin and others having claims in respect of the estate of James Arthur Turner, formerly of 9 Parestreet, Frankston, but late of Frankston Private Hospital, 2 Overton-road, Frankston, in the State of Victoria, gentleman, deceased (who died on the 22nd day of February, 1971), are required to send particulars of their claims to the executor of the estate, Darryl Alexander John Smith, care of Messrs. Corr & Kempson, solicitors, of 491 Bourke-street, Melbourne, by the 3rd of April, 1972, after which date the said executor may distribute the assets of the said estate, having regard only to claims of which he then has notice.

CORR & KEMPSON, solicitors, 491 Bourke-street, Melbourne. 4477

Creditors, next of kin and others having claims in respect of the estate of Mildred Annie Miles, late of 34 Elizabeth-street, Newport, married woman, deceased (who died on the 24th day of October, 1971), are required by the executor, The Union-Fidelity Trustee Company of Australia Limited, of 100 Exhibition-street, Melbourne, to send particulars of their claims to the executor, by the 7th day of April, 1972, after which date it will distribute the assets, having regard only to the claims of which it then has notice.

FREDERICK OWEN & ASSOCIATES, solicitors, 84 William-street, Melbourne. 4484

Creditors, next of kin and others having claims in respect of the estate of Ida Louise Juckert, late of 5 Grey-street, Balwyn, in the State of Victoria, spinster, deceased (who died on the 22nd day of August, 1971), are to send particulars of their claims to the executor, Eric Carl Juckert, care of the under-mentioned solicitors, on or before the 20th day of March, 1972, after which date the said executor will distribute the assets, having regard only to the claims of which notice has been received.

A. L. C. FLINT & MARRIE, of 511 Little Collins-street, Melbourne, the solicitors for the applicant. 4466

Creditors, next of kin and others having claims in respect to the estate of Maurice Delzoppo, late of 6 Herbert-street, Preston, in the State of Victoria, retired, deceased (who died on the 11th day of July, 1971), are required by the executors, to send particulars of their claims to Royston Cahir, Martin & Dillon, solicitors, of 17 Queen-street, Melbourne, by the 7th day of April, 1972, after which date the executors will distribute the assets of the estate, having regard only to claims to which they then have notice.

ROYSTON CAHIR, MARTIN & DILLON, solicitors, 17 Queen-street, Melbourne, 3000. 4457

Creditors, next of kin and others having claims in respect of the estate of Bonnie June Christie, late of Flat 7, 125 Separation-street, Northcote, spinster, deceased, intestate (who died on the 25th day of November, 1971), are required by the administrator, Colin James Christie, to send particulars of their claims to the said administrator, at the office of the under-mentioned solicitors, by the 17th day of April, 1972 after which date the administrator may convey or distribute the assets, having regard only to the claims of which he then has notice.

SEWELL & SEWELL, solicitors, 38 Murray-street, Colac. 4464

HENRY JAMES MARTIN, late of 12 Hillcrest-avenue, Kew, in the State of Victoria, gentleman, DECEASED.

Creditors, next of kin and others having claims in respect of the estate of the deceased (who died on the 18th September, 1971), are required by The Perpetual Executors and Trustees Association of Australia Limited, of 100-104 Queen-street, Melbourne, to send particulars of their claims to the said company, by the 7th day of April, 1972, after which date it will convey or distribute the assets, having regard only to the claims of which the company then has notice.

PRICE & CHAMBERLIN, solicitors, 443 Little Collins-street, Melbourne. 4465

JOHN WILLMOTT BENNETT, formerly of 27a Stanhope-grove, Camberwell, but late of 8 Stanhope-grove, Camberwell, in the State of Victoria, medical practitioner, DECEASED.

Creditors, next of kin and others having claims in respect of the estate of the deceased (who died on the 23rd day of July, 1971), are required by the executrix, Christina Bennett, of 8 Stanhope-grove, Camberwell, widow, to send particulars to her, care of the undersigned solicitors, by the 8th day of April, 1972, after which date she may convey or distribute the assets, having regard only to the claims of which she then has notice.

GIBSON McINTOSH & ASSOCIATES, 825 Burke-road, Camberwell. 4467

Creditors, next of kin or others having claims in respect of the estate of Alfred Morris Ronald Levi, late of 1371 Dandenong-road, Oakleigh, life assurance superintendent, deceased (who died on the 14th September, 1971), are to send particulars of their claims to The Equity Trustees, Executors and Agency Company Limited, of 472 Bourke-street, Melbourne, by the 6th April, 1972, after which date it will distribute the assets, having regard only to the claims of which it then has notice.

CORR & CORR, solicitors, 290 La Trobe-street, Melbourne. 4426

Creditors, next of kin and others having claims against the estate of Anthony Gerard Creane, late of 33 Pine-street, Surrey Hills, motor mechanic, deceased (who died on the 1st day of March, 1971), are required to send particulars of their claims to Laurence Creane, care of the under-signed solicitor, before the 5th day of April, 1972, after which date he will distribute the assets, having regard only to the claims of which he then has notice.

DAVID BULLARD, solicitor, of 443 Law Courts-place, Melbourne. 4427

Creditors, next of kin and others having claims against the estate of Myra Pearce Teasdale, late of 6 Burn-street, Golden Square, in the State of Victoria, gentlewoman, deceased (who died on the 24th day of October, 1971), are required to send particulars thereof to National Trustees, Executors and Agency Company of Australasia Limited, of 46 Queen-street, Bendigo, in the said State, by the 1st day of May, 1972, after which date the said company will distribute the assets of the said deceased, having regard only to the claims of which it then has notice.

WATSON, JAMES & ROGERS, solicitors, 61 Bull-street, Bendigo. 4422

JESSIE MURIEL HUTCHINSON, late of 59 Cookson-street, Camberwell, spinster, DECEASED.

Creditors, next of kin and others having claims in respect of the estate of the above-named deceased (who died on the 26th day of November, 1971), are required by the trustee, Mary Ethel Loughnan, of 59 Cookson-street, Camberwell, widow, to send particulars to her, care of the undersigned by the 4th day of April 1972, after which date the trustee may convey or distribute the assets, having regard only to the claims of which she then has notice.

WHITING & BYRNE, solicitors, 166 Queen-street, Melbourne. 4469

CHARLOTTE ELEANOR BORRMAN, late of 470 Campbell-street, Swan Hill, grazier, DECEASED.

Creditors, next of kin and others having claims in respect of the estate of the deceased (who died on the 29th June, 1971), are required by the trustees, Edwin Alfred Borrman, of 470 Campbell-street, Swan Hill, grazier, and Frank Frederick Dixon, of 2 John-street, Blackburn, accountant, to send particulars to them, care of the undersigned by the 7th day of April, 1972, after which date the trustees may convey or distribute the assets, having regard only to the claims of which they then have notice.

WHITING & BYRNE, of 166 Queen-street, Melbourne. 4468

Creditors, next of kin and others having claims in respect of the estate of Edith Blanche Prudence May, late of 14 Monckton-road, Bundoora, in the State of Victoria, married woman, deceased (who died on the 21st day of March, 1971), are required by the administratrix of the estate, Margaret Mary Girvan, of 14 Monckton-road, Bundoora, in the said State, to send particulars to N. C. Gay & Co., solicitors, of 136 Sydney-road, Brunswick, by the 31st day of March, 1972, after which date the said administratrix may distribute the assets, having regard only to claims of which she then has notice.

N. C. GAY & CO., solicitors, 136 Sydney-road, Brunswick. 4397

DONALD HENDRY, late of Swan Hill, in the State of Victoria, retired farmer, DECEASED (who died on 31st December, 1970).

Creditors, next of kin and all other persons having claims against the estate of the deceased are required by the executor of the will, Donald Hendry, to send particulars to him, care of the undersigned, on or before the 25th day of April, 1972, after which date he will distribute the assets, having regard only to the claims of which he then has notice.

GARDEN & GREEN, solicitors, 4 McCallum-street, Swan Hill. 4399

Creditors, next of kin and others having claims in respect of the estate of Francis Thomas Ellerton, late of 337 Swan-street, Richmond, retired welding specialist, deceased (who died on the 25th day of November, 1971), are requested to send particulars of their claims to Clement Vincent Ellerton, of 337 Swan-street, Richmond, welder, the executor of the will of the said deceased, in care of the under-mentioned firm of solicitors, by the 3rd day of April, 1972, after which date the executor will distribute the assets, having regard only to the claims of which he has notice.

CLEMENTS, MOTT & BETT, solicitors, 253-255 Glenhuntly-road, Elsternwick, 3185. 4411

Creditors, next of kin and others having claims in respect of the estate of John William Johnson, late of Modella-road, Longwarry, farmer (who died on the 26th day of February, 1971), are requested to send particulars of their claims to The Union-Fidelity Trustee Company of Australia Limited, of 100 Exhibition-street, Melbourne, by the 5th day of May, 1972, after which date the executor will distribute the assets, having regard only to the claims of which it then has notice.

M. DAVINE & CO., solicitors, Warragul. 4405

Creditors, next of kin and other persons having claims against the estate of Robert Ernest Legge, late of 50 Bendigo-street, Prahran, in the State of Victoria, glass-cutter, deceased, are required to send particulars of their claims to the executor, Arthur Legge, care of the under-mentioned solicitors, by the 26th March, 1972, after which date the executor will distribute the assets, having regard only to the claims of which he then has had notice.

JAMES P. OGG & CO., solicitors, 165 Greville-street, Prahran. 4470

Creditors, next of kin and others having claims in respect of the estate of Alice Hilda Badenach, late of 1038 Glenhantly-road, South Caulfield, widow, deceased (who died on the 23rd day of October, 1971), are requested to send particulars of their claims to John Randall Alexander, of 1038 Glenhantly-road, South Caulfield, painter and decorator and Jacquelyn de Jong, of 63 Bealiba-road, Caulfield, married woman, the executors of the will of the said deceased, in care of the under-mentioned firm of solicitors by the 3rd day of April, 1972, after which date the executors will distribute the assets, having regard only to the claims of which they have notice.

CLEMENTS, MOTT & BETT, solicitors, 253-255 Glenhantly-road, Elsterwick, 3185. 4412

ELLA MAY MCARTHUR, late of Kew Mental Hospital, Kew, married woman, DECEASED.

Creditors, next of kin and others having claims in respect of the estate of the deceased (who died on the 16th day of August, 1971), are required by The Perpetual Executors and Trustees Association of Australia Limited, of 100-104 Queen-street, Melbourne, to send particulars of their claims to the said company, by the 3rd day of April, 1972, after which date it will convey or distribute the assets, having regard only to the claims of which the company then has notice.

RICE, RATHJEN & WISELY, solicitors, Johnson-street, Maffra. 4404

Creditors, next of kin and others having claims in respect of the estate of Georgina Lucy Margaret Livingston, formerly of New Hospital, Mont Park, but late of Flat 7, 8 Mitchell-street, Mentone, retired nurse, deceased (who died on the 2nd day of November, 1971), are requested to send particulars of their claims to the executor, National Trustees, Executors and Agency Company of Australasia Limited, of 95 Queen-street, Melbourne, by the 4th day of April, 1972, after which date it will distribute the assets, having regard only to the claims of which it then has notice.

MAHONY, O'BRIEN & DUGGAN, solicitors, 37 Queen-street, Melbourne. 4492

Creditors, next of kin and others having claims in respect of the estate of Gladstone Goodwin Downey, formerly of 58 Leura-grove, East Hawthorn, but late of 104 Studley Park-road, Kew, gentleman, deceased (who died on the 15th day of December, 1971), are requested to send particulars of their claims to the executor, National Trustees, Executors and Agency Company of Australasia Limited, of 95 Queen-street, Melbourne, by the 4th day of April, 1972, after which date it will distribute the assets, having regard only to the claims of which it then has notice.

MAHONY, O'BRIEN & DUGGAN, solicitors, 37 Queen-street, Melbourne. 4493

MARY OLIVE SOPPET, formerly of 54 Mentone-road, Mentone, but late of Flat 5, 21 Florence-street, Mentone, widow, DECEASED.

Creditors, next of kin and others having claims in respect of the estate of the deceased (who died on the 20th day of November, 1971), are required by the National Trustees, Executors and Agency Company of Australasia Limited, of 95 Queen-street, Melbourne, to send particulars of their claims to the said company by the 5th day of May, 1972, after which date it will convey or distribute the assets, having regard only to the claims of which the company then has notice.

LLOYD P. GOODE & CO., solicitors, of 406 Lonsdale-street, Melbourne, 3000. 4490

ANGUS MUNRO ROBINSON, formerly of 240 Orrong-road, Toorak, in the State of Victoria, but late of 10 Howson-avenue, Glenhantly, in the said State, gentleman, DECEASED.

Creditors, next of kin and others having claims in respect of the estate of the above-named deceased (who died on the 24th day of May, 1971), are required to send particulars of their claims to the executors, Denise Mary Shannon, formerly of 60 Village High-road, Vaucluse, in the State of New South Wales, but now of Flat 11, 100 Birriga-road, Bellevue Hill, Sydney, in the State of New South Wales, married woman, and Ross Gibson MacFarlan and John Austin DeRavin, both formerly of 123 William-street, Melbourne, in the State of Victoria, but now of 414 Collins-street, Melbourne, in the said State, solicitors, care of the under-mentioned solicitors by the 4th day of April, 1972, after which date they may convey or distribute the assets, having regard only to the claims of which they then have notice.

AITKEN, WALKER & STRACHAN, solicitors, 414 Collins-street, Melbourne. 4471

Creditors, next of kin and others having claims in respect of the estate of James Munro, formerly of Staff College, Kungyung-road, Mount Eliza, but late of Granya-grove, Mount Eliza, in the State of Victoria, retired gardener, deceased (who died on the 25th November, 1971), are required to send particulars of their claims to Thomas Bernard Edward Phayre, of 8 Linden-avenue, Cheltenham, engineer, the sole executor of the will of the said deceased on or before the 5th April, 1972, after which date he will distribute the assets, having regard only to the claims of which he then has notice.

McNAB & McNAB, solicitors, of 17 Queen-street, Melbourne. 4473

VIOLET MAY KEANE, late of 489 Dryburgh-street, North Melbourne, in the State of Victoria, widow, DECEASED.

Creditors, next of kin and others having claims against the estate of the above-named deceased (who died on the 13th day of October, 1971), are required to send particulars of their claims to the executor, Irving Samuel Plotkin, of 388 Bourke-street, Melbourne, by the 3rd day of April, 1972, after which date he may convey or distribute the assets, having regard only to the claims of which he has notice.

IRVING S. PLOTKIN, LL.B., of 388 Bourke-street, Melbourne. 4481

ALICE MAY MOTT, late of 4 Milfoy-court, North Balwyn, in the State of Victoria, married woman, DECEASED.

Creditors, next of kin and others having claims against the estate of the above-named deceased (who died on the 11th day of June, 1971), are required to send particulars of their claims to the executor, Alan Eric Henry Mott, care of the under-mentioned solicitor, by the 3rd day of April, 1972, after which date he may convey or distribute the assets, having regard only to the claims of which he has notice.

IRVING S. PLOTKIN, LL.B., of 388 Bourke-street, Melbourne. 4479

BARTOLOMEO CASACELI, late of 90 Roden-street, West Melbourne, in the State of Victoria, fruiterer, DECEASED.

Creditors, next of kin and others having claims against the estate of the above-named deceased (who died on the 13th day of October, 1971), are required to send particulars of their claims to the executrix, Amalia Maria Domenica Casaceli, care of the under-mentioned solicitor, by the 3rd day of April, 1972, after which date she may convey or distribute the assets, having regard only to the claims of which she has notice.

IRVING S. PLOTKIN, LL.B., of 388 Bourke-street, Melbourne. 4478

In the Supreme Court of the State of Victoria.
SALE BY THE SHERIFF.

On Wednesday, the 8th day of March, 1972, at 2 p.m., at the Police Station, Geelong (unless process be stayed or satisfied):—

All the estate and interest (if any) of Edward Butwilowsky, television mechanic, and Beatrix Judith Butwilowsky, married woman, both of 446 Tatakan-avenue, Albury, as the last-registered owners of the land described in conveyance book 679 No. 24, subject to a memorandum having been filed in the Registrar-General's Office, No. 5876, pursuant to section 208 of the Property Law Act 1958, upon which is erected a brick veneer residence, known as No. 1, Fern-street, Newcomb.

Terms: Cash only.

Sergeant R. M. BARTROP, Sheriff's Officer.

2nd February, 1972. 4458

In the Supreme Court of the State of Victoria.
SALE BY THE SHERIFF.

On Friday, the 10th of March, 1972, at 10 a.m., at the Police Station, Moorabbin (unless process be stayed or satisfied), all the estate and interest (if any) of Walter John Miller, foreman, and Patricia Kathleen Miller, married woman, both of 41 Wilson-street, Highett, as joint proprietors of an estate in fee-simple in the land described in certificate of title, volume 5687, folio 201, upon which is erected a dwelling house, known as No. 41 Wilson-street, Highett.

Registered mortgages Nos. E.143191 and E.143192 affects the said estate and interest.

Terms: Cash only.

H. BUETTNER, Sheriff's Officer.

27th January, 1972. 4459

In the Supreme Court of the State of Victoria.

SALE BY THE SHERIFF.

On Friday, the 10th of March, 1972, at 11 a.m., at the Police Station, Mentone (unless process be stayed or satisfied):—

All the estate and interest (if any) of Sydney Charles Maber, carpenter, of 19 Acacia-avenue, Mentone, as joint proprietor with Evonne Maber of an estate in fee-simple in the land described in certificate of title, volume 8346, folio 768, upon which is erected a brick veneer residence, known as No. 19 Acacia-avenue, Mentone.

Registered mortgage Nos. B.185489, B.264251 and D.184522 and caveat No. D.980187 affects the said estate and interest.

Terms: Cash only.

DOUGLAS S. HALL, Sheriff's Officer.

27th January, 1972. 4460

In the Supreme Court of the State of Victoria.

SALE BY THE SHERIFF.

On Friday, the 17th of March, 1972, at 10 a.m., at the Police Station, Frankston, (unless process be stayed or satisfied):—

All the estate and interest (if any) of Gertrude Elizabeth Morris, married woman, of 32 Grange-road, Frankston, as joint proprietor with Gertrude Maude Newing, of an estate in fee-simple in the land described in certificate of title, volume 8501, folio 807, being a vacant block of land and the whole of lot 2 on plan of subdivision No. 88259, Parish of Frankston and being part of the land described in the above certificate of title. The land is known as No. 34 Grange-road, Frankston.

Terms: Cash only.

DOUGLAS S. HALL, Sheriff's Officer.

28th January, 1972. 4461

IMPOUNDINGS

COLERAINE.—Impounded in Coleraine Pound, by S. M. Templeton, from Tahara Bridge.

No. 14. Hereford stag, 12 to 15 months, key hole near ear, no visible brand

If not claimed and expenses paid, to be sold on 12th February, 1972.

GEO. SPONG,

4428—\$2.80

Poundkeeper.

CRANBOURNE.—Impounded in Cranbourne Pound, by Mrs. Lewer, from Pearceedale-road, Pearceedale.

3 black and white Friesian heifers, no visible brand

If not claimed and expenses paid, to be sold on 23rd February, 1972.

G. HALLISEY,

4463—\$2.45

Poundkeeper.

TATURA.—Impounded in Tatura Pound, from Undera.

1 Polled shorthorn cow, no visible brand

If not claimed and expenses paid, to be sold on 17th February, 1972.

J. H. MACTIER,

4462—\$2.10

Poundkeeper.

WODONGA.—Impounded in Wodonga Pound, from the Wodonga sale-yards, on 12th January, 1972.

1 Jersey cow, no visible brand or ear marks

If not claimed and expenses paid, to be sold on 1st February, 1972.

A. NUGENT,

4429—\$2.45

Poundkeeper.

Subordinate Legislation Act 1962.

NOTICE OF MAKING OF STATUTORY RULES.

In pursuance of the provisions of the *Subordinate Legislation Act 1962* and the Regulations made thereunder, notice is given of the making of the following statutory rules:—

No.	Valuation of Land Act 1960	Price.
10/1972.	Valuation of Land (Fees for Valuations) Regulations 1971	10c

No.	Apprenticeship Act 1958.	Price.
11/1972.	Apprenticeship (Pastrycooking Trade) (Amendment) Regulations 1972	10c
	<i>Health Act 1958</i> (No. 6270).	
12/1972.	Labelling of Hazardous Household Substances Regulations 1972 (No. 1)	10c
	<i>Metropolitan Fire Brigades Act 1958.</i>	
13/1972.	Metropolitan Fire Brigades (Loan No. 20) Regulations 1972	10c
	<i>Zoological Gardens Act 1967.</i>	
14/1972.	Zoological Gardens (Amendment) Regulations 1972	10c
	<i>Police Regulation Act 1958.</i>	
15/1972.	Police (Amendment No. 1) Regulations 1972	10c
	<i>Education Act 1958.</i>	
16/1972.	Adult Education (Salaries) Regulations 1972, No. 2	10c
	<i>Victoria Institute of Colleges Act 1965.</i>	
17/1972.	Statute 8.1.4—Degree of Master of Engineering and Other Degrees	10c
	<i>Nurses Act 1958.</i>	
18/1972.	Midwives (Amendment) Regulations 1971	10c

Copies of these statutory rules may be purchased at the Sale of Publications Section of the Government Printing Office, located at 7A Parliament-place, Melbourne, 3002. If ordered by mail, remittance should be addressed to "The Government Printer, Box 203, P.O., North Melbourne, 3051", and should include 7c extra for postage. If a credit account is held at this office, no remittance is required with the mail order.

The annual subscription rate for Statutory Rules (including Bound Volumes) is \$23, payable in advance. The subscription year commences on 1st January.

C. H. RIXON,
Government Printer.

STATE ACTS, 1968

Copies of the following Acts of Parliament of Victoria may be obtained at the Government Printing Office, Sale of Publications Branch, off Parliament-place, Melbourne, phone 63 0321, extension 6181, or from any accredited agent, at the price set opposite to each (these prices do not include postage).

No.		Price.
7656.	The Constitution Act Amendment (Governor's Salary)	\$0.10
7657.	Victorian Limbless Soldiers' Provident Fund (Closing)	\$0.15
7658.	Country Roads (Borrowing Powers)	\$0.10
7659.	Hairdressers Registration (Amendment)	\$0.10
7660.	Evidence (Attestations)	\$0.10
7661.	Melbourne Harbor Trust (Borrowing Powers)	\$0.10
7662.	Cheltenham Cemetery Lands Exchange	\$0.10
7663.	Administration and Probate (Amendment)	\$0.10
7664.	Road Traffic (Infringements)	\$0.10
7665.	Transport Regulation (Amendment)	\$0.10
7666.	Commercial Goods Vehicles (Amendment)	\$0.10
7667.	Tyabb to Long Island Railway Construction	\$0.10
7668.	Marriage (Liability in Tort)	\$0.10
7669.	La Trobe University (Amendment)	\$0.10
7670.	Children's Court (Procedure)	\$0.10
7671.	Labour and Industry (Amendment)	\$0.15
7672.	Cemeteries (Exhumation Licences)	\$0.10
7673.	Consolidated Revenue	\$0.10
7674.	Forests (Amendment)	\$0.10
7675.	Drought Relief	\$0.15
7676.	Town and Country Planning (Amendment)	\$0.35
7677.	Sunday Entertainment (Amendment)	\$0.10
7678.	Police Offences (Publications)	\$0.10
7679.	The Constitution Act Amendment	\$0.10
7680.	Portland Harbor Trust (Borrowing Powers)	\$0.10
7681.	Acts Interpretation (Prior Convictions)	\$0.10
7682.	Aerial Spraying Control (Amendment)	\$0.10
7683.	Shearers Accommodation (Amendment)	\$0.15
7684.	Racing (Amendment)	\$0.15
7685.	Health (Amendment)	\$0.10
7686.	State Electricity Commission (Amendment)	\$0.15
7687.	Kyneton Cattle Market Lands Exchange	\$0.15
7688.	Swine (Application of Fund)	\$0.10
7689.	Local Government (Amendment)	\$0.40

STATE ACTS, 1968—continued.

No.	Price.
7690. Royal Society for the Prevention of Cruelty to Animals	\$0.15
7691. Racing (Trotting Meetings)	\$0.10
7692. Labour and Industry (Shop Trading Hours)	\$0.10
7693. Justices (General Sessions Jurisdiction)	\$0.10
7694. Latrobe Valley (Amendment)	\$0.10
7695. Liquor Control	\$0.75
7696. Crimes (Amendment)	\$0.10
7697. Country Roads (Amendment)	\$0.10
7698. West Moorabool Water Board	\$0.35
7699. Melbourne and Metropolitan Board of Works (Borrowing Powers)	\$0.10
7700. Teaching Service (Amendment)	\$0.10
7701. Children's Welfare (Amendment)	\$0.10
7702. Consolidated Revenue	\$0.10
7703. Abolition of Bailiwicks	\$0.15
7704. Footscray (Recreation Ground) Lands	\$0.15
7705. County Court (Jurisdiction)	\$0.25
7706. Shrine of Remembrance Trustees (Powers)	\$0.10
7707. Margarine (Amendment)	\$0.10
7708. National Parks (Amendment)	\$0.10
7709. Revocation and Excision of Crown Reservations	\$0.15
7710. West Melbourne Lands	\$0.15
7711. Kew Lands (Grant Amendment)	\$0.10
7712. Agricultural Education (Amendment)	\$0.10
7713. Melbourne Sailors' Home (Powers of Trustees)	\$0.10
7714. Margarine (Penalties)	\$0.10
7715. State Coal Mines (Winding Up)	\$0.10
7716. Property Law (Amendment)	\$0.10
7717. Auction Sales (Night Auctions)	\$0.10
7718. Coal Mines (Pensions)	\$0.10
7719. Teaching Service (Amendment)	\$0.10
7720. State Forests Loan Application	\$0.10
7721. Aboriginal Affairs (Amendment)	\$0.10
7722. Police Assistance Compensation	\$0.10
7723. Parliamentary Salaries and Superannuation	\$0.25
7724. Stock Diseases	\$0.30
7725. Juries (Amendment)	\$0.10
7726. Stock Medicines (Amendment)	\$0.10
7727. Parliamentary Committees	\$0.25
7728. Bread Industry (Legal Proceedings)	\$0.10
7729. Sewerage Districts	\$0.15
7730. Municipalities (Commutation of Licensing Payments)	\$0.10
7731. Housing (Amendment)	\$0.10
7732. Second-hand Dealers (Amendment)	\$0.10
7733. Fences	\$0.25
7734. Melbourne Harbor Trust (Exchange of Yarraville Lands)	\$0.10
7735. Inflammable Liquids (Petrol Service Stations)	\$0.10
7736. Tomato Processing Industry (Amendment)	\$0.10
7737. Marketing of Primary Products (Egg and Egg Pulp Marketing Board)	\$0.10
7738. Children's Welfare (Prosecutions)	\$0.10
7739. Consumers Protection (Amendment)	\$0.10
7740. Forests (Amendment)	\$0.10
7741. State Electricity Commission	\$0.10
7742. Settlement Grants and Mortgages	\$0.10
7743. Water Supply Loan Application	\$0.25
7744. Door to Door (Sales) (Amendment)	\$0.10
7745. Medical (Organ Transplants)	\$0.15
7746. Public Works Loan Application	\$0.15
7747. Pesticides (Proclamations)	\$0.10
7748. Stock (Artificial Breeding) (Amendment)	\$0.10
7749. National Parks (Little Desert and Mount Richmond)	\$0.10
7750. Perpetuities and Accumulations	\$0.15
7751. Road Traffic (Crown Land)	\$0.10
7752. Lotteries Gaming and Betting (Penalties)	\$0.10
7753. Liquor Control (Amendment)	\$0.15
7754. Liquefied Gases	\$0.15
7755. Labour and Industry (Miscellaneous Provisions)	\$0.10
7756. Pounds (Amendment)	\$0.15
7757. Aerial Spraying Control (Security)	\$0.10
7758. Melbourne University (Council)	\$0.10
7759. Weights and Measures (Amendment)	\$0.15
7760. Melbourne Wholesale Fruit and Vegetable Market	\$0.15
7761. Mines (Amendment)	\$0.10
7762. Valuation of Land (Amendment)	\$0.15
7763. Dandenong Valley Authority (Amendment)	\$0.10
7764. Melbourne Harbor Trust Land	\$0.10
7765. Chiropodists	\$0.15
7766. Wheat Industry Stabilization	\$0.15
7767. Railway Loan Application	\$0.15
7768. Poultry Processing	\$0.15
7769. Country Roads (Declarations)	\$0.10
7770. Building Societies (Amendment)	\$0.10
7771. Goods (Textile Products)	\$0.10
7772. Alcoholics and Drug-dependent Persons	\$0.25

STATE ACTS, 1968—continued.

No.	Price.
7773. Land Tax	\$0.15
7774. Public Lands and Works (Amendment)	\$0.10
7775. Milk Board (Amendment)	\$0.10
7776. Married Women's Superannuation Fund	\$0.15
7777. Motor Car (Further Amendment)	\$0.15
7778. Melbourne and Metropolitan Board of Works (Amendment)	\$0.25
7779. Superannuation (Amendment)	\$0.15
7780. Fisheries	\$0.40
7781. Water	\$0.15
7782. Crimes (Evidence)	\$0.10
7783. Land (Special Land)	\$0.10
7784. Consolidated Revenue	\$0.10
7785. Appropriation of Revenue	\$1.00

C. H. RIXON,
Government Printer.

STATE ACTS, 1969

Copies of the following Acts of Parliament of Victoria may be obtained at the Government Printing Office, Sale of Publications Branch, off Parliament-place, Melbourne, phone 63 0321, extension 6181, or from any accredited agent, at the price set opposite to each (these prices do not include postage).

No.	Price.
7786. Summary Offences (Sunday Newspapers)	\$0.10
7787. Town and Country Planning (Transitional Appeals)	\$0.10
7788. Discharged Servicemen's Preference (Amendment)	\$0.10
7789. Water (Amendment)	\$0.10
7790. Agricultural Education Cadetships	\$0.10
7791. Trustee (Amendment)	\$0.10
7792. Appeal Costs Fund (Amendment)	\$0.10
7793. Footscray (Lower Yarra Crossing Access Road) Land	\$0.10
7794. River Improvement (Amendment)	\$0.15
7795. Geelong Waterworks and Sewerage (Amendment)	\$0.15
7796. West Moorabool Water Board (Amendment)	\$0.10
7797. Sewerage Districts (Amendment)	\$0.15
7798. Drought Relief (Amendment)	\$0.10
7799. Legal Profession Practice (Amendment)	\$0.10
7800. Parliamentary Salaries and Superannuation (Administration)	\$0.10
7801. Protection of Animals (Penalties)	\$0.10
7802. Lotteries Gaming and Betting (Calcutta Sweepstakes)	\$0.10
7803. Belmont Common Recreation Ground Lands	\$0.10
7804. Listening Devices	\$0.10
7805. Coal Mines (Pensions)	\$0.10
7806. Marine (Amendment)	\$0.10
7807. Theatres (Amendment)	\$0.15
7808. Victorian Inland Meat Authority (Amendment)	\$0.10
7809. The Constitution Act Amendment (Electoral)	\$0.15
7810. Consolidated Revenue	\$0.10
7811. Gas and Fuel Corporation (Borrowing)	\$0.10
7812. Weights and Measures (Amendment)	\$0.10
7813. Health (Municipal Charges)	\$0.10
7814. Transfer of Land (Subdivision of Allotments)	\$0.15
7815. St. Vincent's Private Hospital (Guarantees)	\$0.10
7816. Strata Titles (Amendment)	\$0.15
7817. Sunday Entertainment (Evidence)	\$0.10
7818. Dried Fruits (Packing Houses)	\$0.10
7819. Town and Country Planning (Further Amendment)	\$0.10
7820. Milk Board (Amendment)	\$0.10
7821. Medical (Pharmaceutical Chemists)	\$0.10
7822. Melbourne Wholesale Fruit and Vegetable Market (Amendment)	\$0.10
7823. Education (Director-General)	\$0.10
7824. Wombat Bonuses	\$0.10
7825. Revocation and Excision of Crown Reservations	\$0.15
7826. Mildura Irrigation and Water Trusts	\$0.25
7827. South Melbourne (Roman Catholic Orphanage) Lands	\$0.15
7828. Racing (Amendment)	\$0.10
7829. Commercial Goods Vehicles (Tow Trucks)	\$0.10
7830. Stamps (Amendment)	\$0.15
7831. Gas and Fuel Corporation (Sale Undertaking)	\$0.15
7832. Melbourne (St. Kilda-road Underpass)	\$0.15
7833. Trustee (Authorized Investments)	\$0.10
7834. Consolidated Revenue	\$0.10

STATE ACTS 1969—continued.

No.	Price.
7835. Local Government	\$0.60
7836. Melbourne Wholesale Fruit and Vegetable Market (Advisory Committee)	\$0.10
7837. Teaching Service (Amendment)	\$0.10
7838. State Electricity Commission (Borrowing and Investing Powers)	\$0.10
7839. Motor Car (Amendment)	\$0.10
7840. Mines (Abolition of Courts)	\$0.30
7841. Manango (O'Shanessy River Watershed) Lands	\$0.10
7842. State Savings Bank (Amendment)	\$0.10
7843. Apprenticeship (Commission)	\$0.10
7844. Swan Hill Race-course and Golf-course Lands	\$0.15
7845. Imitation Milk	\$0.15
7846. Finance Brokers	\$0.25
7847. Local Government (Rating Exemptions)	\$0.15
7848. Labour and Industry (Amendment)	\$0.10
7849. Groundwater	\$0.30
7850. Consolidated Revenue	\$0.10
7851. Mental Health (Chairmanship)	\$0.10
7852. Instruments (Bills of Exchange Amendment)	\$0.10
7853. Supreme Court (Correction of Sentences)	\$0.10
7854. Summary Offences	\$0.10
7855. Church of England in Australia (Mount Shadwell Land)	\$0.10
7856. State Rivers and Water Supply Commission (Special Projects)	\$0.10
7857. Coal Mines (Pensions Increase)	\$0.10
7858. Trustee Companies (Burns Philp Trustee Company Limited)	\$0.10
7859. Latrobe Valley (Amendment)	\$0.10
7860. Maintenance (Amendment)	\$0.10
7861. Aboriginal Affairs (Amendment)	\$0.10
7862. Goods (Trade Descriptions)	\$0.10
7863. Marine Stores and Old Metals (Amendment)	\$0.15
7864. Fire Authorities (Borrowing Powers)	\$0.10
7865. Acts Interpretation (Time)	\$0.10
7866. Narre Worrnan Lands	\$0.10
7867. Moorpanyal Lands	\$0.10
7868. Juries (Amendment)	\$0.10
7869. Apprenticeship (Regulations)	\$0.10
7870. Portland Lands Exchange	\$0.10
7871. Melbourne University (Property)	\$0.10
7872. Latrobe Valley (Lands for Ambulance Services)	\$0.10
7873. Ministry of Transport (Director of Transport)	\$0.10
7874. Administration and Probate (Foreign Grants)	\$0.10
7875. Road Traffic (Amendment)	\$0.10
7876. Justices (Amendment)	\$0.35
7877. Country Fire Authority (Amendment)	\$0.15
7878. Coal Mines (Accidents Relief)	\$0.10
7879. Preston School of Design and Free Library Land	\$0.10
7880. Lands Compensation (Costs and Expenses)	\$0.10
7881. Evidence (Bankers' Books)	\$0.10
7882. Transport Regulation (Financial)	\$0.10
7883. Railways (Surplus Lands)	\$0.10
7884. Abolition of Obsolete Offences	\$0.10
7885. Fire Brigades (Contributions)	\$0.15
7886. Gas	\$0.30
7887. Tobacco Leaf Industry Stabilization (Tobacco Quotas)	\$0.10
7888. The Constitution Act Amendment (Standing Appropriations)	\$0.10
7889. Legal Profession Practice	\$0.10
7890. Navigable Waters (Oil Pollution) (Amendment)	\$0.15
7891. Stamps (Mortgages)	\$0.10
7892. State Forests Loan Application	\$0.10
7893. Melbourne and Metropolitan Board of Works (Amendment)	\$0.15
7894. Wheat Marketing	\$0.25
7895. Revenue Deficits Funding	\$0.15
7896. Land Tax (Rates)	\$0.10
7897. Probate Duty	\$0.10
7898. Sale of Land (Amendment)	\$0.10
7899. Racing (Trotting Racing)	\$0.10
7900. Crown Proceedings (Forfeited Recognisances)	\$0.15
7901. Weights and Measures (Fees)	\$0.10
7902. Town and Country Planning (Compensation)	\$0.10
7903. Wheat Industry Stabilization (Amendment)	\$0.10
7904. Railway Loan Application	\$0.15
7905. North Melbourne Lands (Loans to Lessees)	\$0.10
7906. Theatres (Performance of Sacred Works)	\$0.10
7907. Marketing of Primary Products (Amendment)	\$0.15
7908. Water Supply Loan Application	\$0.25
7909. Health (Amendment)	\$0.15
7910. Superannuation (Amendment)	\$0.25

STATE ACTS 1969—continued.

No.	Price.
7911. Friendly Societies (Amendment)	\$0.15
7912. The Constitution Act Amendment (Conjoint Elections)	\$0.10
7913. Labour and Industry (Long Service Leave)	\$0.10
7914. Public Service (Amendment)	\$0.15
7915. Motor Car (Traffic Offenders)	\$0.10
7916. Motor Car	\$0.15
7917. Farm Produce Merchants and Commission Agents (Amendment)	\$0.25
7918. Education (Army Apprentices School)	\$0.10
7919. Legal Aid	\$0.15
7920. Educational Grants (Amendment)	\$0.10
7921. Crown Reservations (Revocation and Ex-cision)	\$0.15
7922. Firearms (Amendment)	\$0.10
7923. Labour and Industry (Further Amendment)	\$0.10
7924. Forests (Softwood Timber Agreement)	\$0.15
7925. Public Works Loan Application	\$0.15
7926. Metropolitan Fire Brigades (Amendment)	\$0.15
7927. Consolidated Revenue	\$0.10
7928. National Parks (Amendment)	\$0.25
7929. Railways (Offences)	\$0.10
7930. Tourist	\$0.15
7931. Country Roads (Amendment)	\$0.15
7932. Appropriation of Revenue	\$1.15

C. H. RIXON,
Government Printer.

STATE ACTS. 1970

Copies of the following Acts of Parliament of Victoria may be obtained at the Government Printing Office, Sale of Publications Branch, off Parliament-place, Melbourne, phone 63 0321, extension 6181, or from any accredited agent, at the price set opposite to each (these prices do not include postage).

No.	Price.
7933. Evidence (Boards and Commissions)	\$0.10
7934. The Constitution Act Amendment	\$0.10
7935. Coroners (Amendment)	\$0.10
7936. Town and Country Planning (Appeals Tribunal)	\$0.10
7937. Melbourne (Veterinary Schools) Lands	\$0.10
7938. Board of Inquiry (Corrupt Practices)	\$0.10
7939. Cabrini Private Hospital (Guarantees)	\$0.10
7940. Judges' Salaries and Allowances	\$0.10
7941. Instruments (Amendment)	\$0.10
7942. La Trobe University (Amendment)	\$0.10
7943. Business Names (Amendment)	\$0.10
7944. Acts Interpretation (Nationality)	\$0.10
7945. Dairy Products (Board Membership)	\$0.10
7946. Melbourne Harbor Trust (Amendment)	\$0.10
7947. Aboriginal Affairs (Amendment)	\$0.10
7948. River Murray Waters	\$0.15
7949. River Murray Waters (Dartmouth Reservoir)	\$0.10
7950. Western Port (Steel Works)	\$0.25
7951. Extractive Industries (Licences)	\$0.10
7952. Stamps (Salary or Wages)	\$0.10
7953. Melbourne Lands Exchange	\$0.10
7954. Public Officers Salaries and Allowances	\$0.15
7955. Ballarat (Sovereign Hill) Land	\$0.15
7956. Wombat Bonuses	\$0.10
7957. Richmond and Hawthorn Lands	\$0.15
7958. Solicitor-General (Pensions)	\$0.10
7959. Australia and New Zealand Banking Group	\$0.25
7960. Mildura Irrigation and Water Trusts (Amendment)	\$0.10
7961. Land Settlement (Financial)	\$0.10
7962. Securities Industry	\$0.35
7963. Mildura College Lands (Amendment)	\$0.10
7964. Door to Door (Sales) (Amendment)	\$0.15
7965. Consumer Protection	\$0.10
7966. Justices (Alternative Procedure)	\$0.15
7967. Summary Offences	\$0.10
7968. Local Government (Amendment)	\$0.30
7969. Motor Car (Falsification of Mileage)	\$0.10
7970. Marketable Securities	\$0.25
7971. Carriers and Innkeepers (Amendment)	\$0.10
7972. Cemeteries (Coburg Public Cemetery)	\$0.10
7973. Judges Pensions	\$0.10
7974. Victoria Institute of Colleges (Affiliated Colleges)	\$0.10
7975. Town and Country Planning (Responsible Authority)	\$0.10
7976. Wheat Marketing (Special Quotas)	\$0.10
7977. Joint Select Committee (Meat Industry)	\$0.10
7978. Joint Select Committee (Road Safety)	\$0.10
7979. Consolidated Revenue (Supply—July to September 1969-70)	\$0.10
7980. Consolidated Revenue (Supplementary Estimates 1969-70)	\$0.10

STATE ACTS 1970—continued.

No.	Price.
7981. Consolidated Revenue (Supply October to December, 1970)	\$0.10
7982. Home Finance (Amendment)	\$0.10
7983. Co-operative Housing Societies (Amendment)	\$0.10
7984. Soldier Settlement	\$0.10
7985. Judges' Pensions (Amendment)	\$0.10
7986. Civil Aviation (Carriers' Liability)	\$0.10
7987. Road Traffic (Amendment)	\$0.15
7988. West Melbourne Market Land (Amendment)	\$0.15
7989. West Gate Bridge Royal Commission	\$0.10
7990. Motor Car (Amendment)	\$0.10
7991. Discharged Servicemen's Preference (Amendment)	\$0.10
7992. Labour and Industry (Shop Closing)	\$0.10
7993. Country Fire Authority (Borrowing Powers)	\$0.10
7994. Crimes (Amendment)	\$0.10
7995. Lotteries Gaming and Betting (Amendment)	\$0.10
7996. River Improvement (Amendment)	\$0.10
7997. Hospitals Superannuation (Amendment)	\$0.15
7998. Trustee Companies (Perpetual Trustees Australia Limited)	\$0.10
7999. Gas and Fuel Corporation (Borrowing)	\$0.10
8000. Victorian Inland Meat Authority (Amendment)	\$0.10
8001. Auditor (Auditor-General)	\$0.10
8002. Public Service (Amendment)	\$0.10
8003. Evidence (Scientific Tests)	\$0.10
8004. Boilers and Pressure Vessels	\$0.30
8005. Coal Mines (Pensions Increase)	\$0.10
8006. Stamps Act	\$0.15
8007. Methodist Church (Victoria) Property Trust	\$0.20
8008. Land Conservation	\$0.20
8009. River Entrance Docks Railway Construction	\$0.10
8010. Legal Profession Practice (Amendment)	\$0.15
8011. Juries Compensation	\$0.10
8012. Public Account	\$0.15
8013. Sewerage Districts (Amendment)	\$0.10
8014. Revocation and Excision of Crown Reservations	\$0.15
8015. State Forests Works and Services	\$0.10
8016. Money Lenders (Prescribed Interest)	\$0.10
8017. Gas and Fuel Corporation (The Gas Supply Company Limited)	\$0.30
8018. Labour and Industry (Amendment)	\$0.10
8019. Metropolitan Fire Brigades (Amendment)	\$0.15
8020. Stamps (Receipt Duty Abolition)	\$0.10
8021. Apprenticeship (Amendment)	\$0.10
8022. Water (Amendment)	\$0.10
8023. Melbourne Underground Rail Loop	\$0.40
8024. Westernport Development	\$0.15
8025. Vermin and Noxious Weeds (Amendment)	\$0.20
8026. Commonwealth Places (Administration of Laws)	\$0.15
8027. Hairdressers Registration (Amendment)	\$0.10
8028. Lifts and Cranes (Amendment)	\$0.15
8029. Wodonga Lands Exchange	\$0.10
8030. Second-hand Dealers (Charity Collectors)	\$0.15
8031. Water Supply Works and Services	\$0.25
8032. East Melbourne Land	\$0.10
8033. The Constitution Act Amendment (Responsible Ministers)	\$0.10
8034. Justices (Bail and Appeals)	\$0.10
8035. Forests (Amendment)	\$0.10
8036. Maintenance (Amendment)	\$0.10
8037. Hire Purchase (Insurance)	\$0.10
8038. Marketable Securities (Amendment)	\$0.15
8039. Mines (Compensation)	\$0.10
8040. Railways Land	\$0.15
8041. Probate Duty	\$0.10
8042. Teaching Service (Tribunal)	\$0.10
8043. Employers and Employés (Attachment of Wages)	\$0.10
8044. Aboriginal Lands	\$0.25
8045. Railway Works and Services	\$0.10
8046. Water (Further Amendment)	\$0.15
8047. Superannuation (Amendment)	\$0.20
8048. Motor Car (Fees)	\$0.10
8049. Public Works and Services	\$0.15
8050. Western Port Steel Works (Development Control)	\$0.10
8051. Housing (Amendment)	\$0.20
8052. Urban Renewal	\$0.40
8053. Wheat Marketing (Amendment)	\$0.10
8054. Local Authorities Superannuation (Disability Benefits)	\$0.20
8055. Land Tax	\$0.15
8056. Environment Protection	\$0.50
8057. Gas Franchises	\$0.15

STATE ACTS 1970—continued.

No.	Price.
8058. Road Traffic (Road Safety and Traffic Authority)	\$0.15
8059. Securities Industry (Amendment)	\$0.30
8060. Land (Amendment)	\$0.10
8061. Medical Practitioners	\$0.40
8062. Teacher Housing	\$0.20
8063. Criminal Appeals	\$0.10
8064. Groundwater (Amendment)	\$0.10
8065. Summary Offences (Trespass to Farms)	\$0.10
8066. Registration of Births Deaths and Marriages (Amendment)	\$0.10
8067. Tomato Processing Industry (Amendment)	\$0.15
8068. Weights and Measures (Amendment)	\$0.10
8069. Aerial Spraying Control (Amendment)	\$0.10
8070. Science Museum of Victoria	\$0.20
8071. Melbourne and Metropolitan Board of Works	\$0.15
8072. National Museum of Victoria Council	\$0.20
8073. Footwear Regulation	\$0.15
8074. Motor Car (Safety)	\$0.10
8075. Summary Offences	\$0.10
8076. Fertilizers and Stock Foods (Labelling)	\$0.10
8077. Architects (Amendment)	\$0.10
8078. Stock Diseases (Amendment)	\$0.10
8079. Dog Act	\$0.20
8080. Racing (Amendment)	\$0.15
8081. State Development	\$0.30
8082. Statutory Salaries	\$0.10
8083. National Parks	\$0.20
8084. Workers Compensation	\$0.15
8085. Summary Offences (Trespassers)	\$0.10
8086. Parliamentary Salaries	\$0.10
8087. Consolidated Revenue (Final Supplementary Estimates)	\$0.10
8088. Appropriation	\$2.10
8089. Social Welfare	\$1.10

C. H. RIXON,
Government Printer.

STATE ACTS, 1971

Copies of the following Acts of Parliament of Victoria may be obtained at the Government Printing Office, Sale of Publications Branch, off Parliament-place, Melbourne, phone 63 0321, extension 6181, or from any accredited agent, at the price set opposite to each (these prices do not include postage).

The annual subscription for State Acts 1971 et seq. is \$12.50 payable in advance.

Bound Volumes of State Acts are also available on a subscription basis of \$17.50 per annum.

No.	Price.
8090. Municipal Association (Amendment)	\$0.10
8091. Transfer of Land (Duplicate Certificates)	\$0.10
8092. Firearms	\$0.10
8093. Geelong Land (Special Grant)	\$0.10
8094. Churchill Water and Sewerage Works	\$0.10
8095. Superannuation (Railway Service)	\$0.10
8096. Vermin and Noxious Weeds (Amendment)	\$0.10
8097. Police Regulation (Amendment)	\$0.10
8098. Snowy Mountains Engineering Corporation (Victoria)	\$0.10
8099. Albert Park Land	\$0.10
8100. Local Government (Municipalities Assistance Fund)	\$0.10
8101. Health (Tuberculosis Arrangement)	\$0.10
8102. Presbyterian Church of Australia	\$0.20
8103. Marketing of Primary Products (Amendment)	\$0.10
8104. Gas and Fuel Corporation (Geelong Gas)	\$0.15
8105. Local Authorities Superannuation (Disability Benefits) (Commencement)	\$0.10
8106. Building Societies (Amendment)	\$0.20
8107. Survey Co-ordination (Place Names)	\$0.10
8108. Howard Florey Institute of Experimental Physiology and Medicine	\$0.30
8109. Superannuation (Transitional Provisions)	\$0.10
8110. New Broken Hill Consolidated Limited	\$0.15
8111. Litter (Proceedings for Offences)	\$0.10
8112. Justices (Service of Summonses)	\$0.10
8113. Stock (Artificial Breeding) (Amendment)	\$0.10
8114. Alcoa of Australia (W.A.) N.L.	\$0.40

STATE ACTS 1971—continued.

No.	Price.
8115. Victoria Institute of Colleges (Amendment)	\$0.10
8116. Cemeteries (Fawkner Crematorium and Memorial Park)	\$0.10
8117. Trustee Companies (Equity Trustees)	\$0.10
8118. Parliamentary Superannuation	\$0.10
8119. Ehrenhaus Retail Bottled Liquor Licence	\$0.10
8120. Melbourne University Land	\$0.10
8121. Forests (Bowater-Scott Agreement)	\$0.20
8122. Gas and Fuel Corporation (Pipelines)	\$0.15
8123. Coal Mines (Pensions)	\$0.10
8124. Crown Proceedings (Forfeited Recognisances)	\$0.10
8125. Public Trustee (Amendment)	\$0.15
8126. Geelong Waterworks and Sewerage (Rates)	\$0.10
8127. Subordinate Legislation (Powers)	\$0.10
8128. Barley Marketing	\$0.10
8129. Stamps (Credit Business)	\$0.15
8130. Land (Surrender to the Crown)	\$0.10
8131. Pipelines (Amendment)	\$0.10
8132. County Court (Jurisdiction)	\$0.10
8133. Grassmere Land	\$0.10
8134. Supply (Supplementary Estimates)	\$0.10
8135. Town and Country Planning (Amendment)	\$0.15
8136. Seeds	\$0.40
8137. Imperial Acts Application (Repeals)	\$0.10
8138. Audit (Recovery of Overpayments)	\$0.10
8139. Evidence (Registration of Commissioners)	\$0.10
8140. Country Roads (Amendment)	\$0.15
8141. Protection of Animals (Rodeos)	\$0.10
8142. Soil Conservation and Land Utilization (Amendment)	\$0.15
8143. Motor Car (Driving Offences)	\$0.30
8144. Fisheries (Amendment)	\$0.15
8145. Appeal Costs Fund	\$0.10
8146. Scaffolding	\$0.30
8147. Liquor Control (Amendment)	\$0.15
8148. Supply (July to September)	\$0.10
8149. Local Government (Further Amendment)	\$0.40
8150. Supply (Supplementary Estimates)	\$0.10
8151. Supply (October to December)	\$0.10
8152. Police Regulation (Chief Commissioner)	\$0.10
8153. Groundwater	\$0.10
8154. Pay-Roll Tax	\$0.50
8155. Moonee Ponds (Queens Park) Land	\$0.10
8156. Commonwealth Places (Administration of Laws)	\$0.10
8157. Stamps	\$0.20
8158. Mercy Private Hospital (Guarantee)	\$0.10
8159. Daylight Saving	\$0.10

STATE ACTS 1971—continued.

No.	Price.
8160. Co-operative Housing Societies (Indemnities)	\$0.10
8161. Films	\$0.30
8162. Lotteries Gaming and Betting (Pre-Post Betting)	\$0.10
8163. Vegetation and Vine Diseases (Amendment)	\$0.10
8164. Melbourne and Metropolitan Board of Works (Amendment)	\$0.10
8165. Statutory Salaries	\$0.10
8166. Newhaven Land	\$0.10

C. H. RIXON,
Government Printer.

CONTENTS

	PAGE
Acts of Parliament on Sale at the Government Printing Office	308
Appointments	282
Contracts	279
Country Roads Board	267, 279
Courts	267
Estates of Deceased Persons	273
Government Notices	267
Impoundings	308
Lands	290
Mining	278
Notice to attend for Radiological Examination	276
Notice of Making of Statutory Rules	308
Orders in Council—	
Acts—Local Government; Country Roads; Marine Stores and Old Metals; Land	283 et seq
Private Advertisements	298
Proclamations	265
Public Service Notices	296
Resignations	283
State Rivers and Water Supply Commission	281
Tenders	297
Transport Regulation Board—Public Hearings	274
Waterworks Trusts	282



VICTORIA GOVERNMENT GAZETTE

Published by Authority

No. 9]

WEDNESDAY, FEBRUARY 2

[1972

State Electricity Commission Act 1958 (No. 6377).
STATE ELECTRICITY COMMISSION (PROTECTION
OF ELECTRICAL OPERATIONS) REGULATIONS 1966.

PROCLAMATION

By His Excellency the Governor of the State of Victoria and its Dependencies in the Commonwealth of Australia, &c., &c., &c.

Whereas by an Order in Council made on the twenty-fifth day of March One thousand nine hundred and seventy-one under the *State Electricity Commission Act 1958 (No. 6377)* in respect of Regulations cited as *State Electricity Commission (Protection of Electrical Operations) Regulations 1966*, it was proclaimed that an emergency had arisen at the whole of the electrical undertakings and works of or operated by the Commission, and that, for the protection of electrical works or lines of the Commission, and for the prevention of any interference therewith, it was necessary on and after the date of the publication in the *Government Gazette* of the said Proclamation, to prohibit or restrict the use of electricity by consumers: And whereas the said Proclamation was published in the *Government Gazette* on the twenty-fifth day of March, One thousand nine hundred and seventy-one: And whereas it was provided by the said Order in Council that such a state of emergency should be deemed, under the said Regulations, to continue until the publication in the *Government Gazette* of a Proclamation that such a state of emergency had ceased to exist: Now I, the Governor of the State of Victoria, by and with the advice of the Executive Council of the said State, do hereby proclaim that the said emergency has ceased to exist.

Given under my Hand and the Seal of the State of Victoria aforesaid, at Melbourne, this second day of February, in the year of our Lord One thousand nine hundred and seventy-two, and in the twentieth year of the reign of Her Majesty Queen Elizabeth II.

(L.s.) ROHAN DELACOMBE.

By His Excellency's Command,

JIM BALFOUR,
Minister for Fuel and Power.

GOD SAVE THE QUEEN!

State Electricity Commission Act 1958 (No. 6377).
STATE ELECTRICITY COMMISSION (PROTECTION OF
ELECTRICAL OPERATIONS) REGULATIONS 1966

PROCLAMATION

By His Excellency the Governor of the State of Victoria and its Dependencies in the Commonwealth of Australia, &c., &c., &c.

WHEREAS by Regulations cited as *State Electricity Commission (Protection of Electrical Operations) Regulations 1966* made by the Governor in Council on the twenty-third day of August One thousand nine hundred and sixty-six on the recommendation of the *State Electricity Commission of Victoria*, it is amongst other things provided that any person who, during a state of emergency as therein referred to, contravenes the provisions as to the use of electricity therein defined shall be guilty of an offence against the said Regulations: And whereas it is provided that a state of emergency shall be deemed to exist for the purpose of the said Regulations whenever the Governor in Council, by Proclamation published in the *Government Gazette*, proclaims that an industrial strike has occurred or other emergency has arisen at any portion of any undertaking or works of or operated by the Commission, or materially affecting any operations of the Commission or any or all of them, or the prevention of any interference therewith, or to secure the safe economical and effective supply of electricity in any area or areas in Victoria or throughout Victoria, it is necessary to prohibit or restrict the use of electricity by consumers: Now I, the Governor of the State of Victoria, with the advice of the Executive Council of the said State, do hereby proclaim that an emergency has arisen at the whole of the electrical undertakings and works of or operated by the Commission and that, for the protection of electrical works or lines of the Commission and the prevention of any interference therewith, it is necessary, on and after the date of publication in the *Government Gazette* of this, my Proclamation, to prohibit or restrict the use of electricity by consumers. Such state of emergency shall be deemed under the said Regulations to continue until the publication in the *Government Gazette* of a Proclamation that such state of emergency has ceased to exist.

Given under my Hand and the Seal of the State of Victoria aforesaid, at Melbourne, this second day of February, in the year of our Lord One thousand nine hundred and seventy-two, and in the twentieth year of the reign of Her Majesty Queen Elizabeth II.

(L.s.) ROHAN DELACOMBE.

By His Excellency's Command,

JIM BALFOUR,
Minister for Fuel and Power.

GOD SAVE THE QUEEN!

