

[3095]



# VICTORIA GOVERNMENT GAZETTE

Published by Authority

No. 841

WEDNESDAY, SEPTEMBER 13

[1972

## PROCLAMATIONS

### PUBLIC HALF-HOLIDAYS.

#### PROCLAMATION

By His Excellency the Governor of the State of Victoria and its Dependencies in the Commonwealth of Australia, &c., &c., &c.

In pursuance of the provisions contained in Part III. of the *Public Service Act 1958*, I, the Governor of the State of Victoria, in the Commonwealth of Australia, by and with the advice of the Executive Council of the said State, do by this my Proclamation appoint the days and dates hereunder mentioned to be observed as Public Half-Holidays at the places respectively specified, viz.:-

*Public Half-Holidays from the Hour of Twelve o'clock noon:-*

MONDAY, THE 2ND OCTOBER, 1972 in the township of Robinvale.

WEDNESDAY, THE 11TH OCTOBER, 1972 throughout the Shire of Cranbourne.

Given under my Hand and the Seal of the State of Victoria aforesaid, at Melbourne, this twelfth day of September, in the year of our Lord One thousand nine hundred and seventy-two, and in the twenty-first year of the reign of Her Majesty Queen Elizabeth II.

(L.S.) ROHAN DELACOMBE.

By His Excellency's Command,

E. R. MEAGHER,  
Chief Secretary.

GOD SAVE THE QUEEN !

### BANK HOLIDAYS.

#### PROCLAMATION

By His Excellency the Governor of the State of Victoria and its Dependencies in the Commonwealth of Australia, &c., &c., &c.

In pursuance of the provisions of the *Bank Holidays Act 1958*, I, the Governor of the State of Victoria, in the Commonwealth of Australia, do by this my Proclamation appoint the days and dates named hereunder special days

No. 84.—8120/72.—PRICE 30 cents; Half-Yearly \$11.25; Yearly \$22.50.

to be observed as Bank Holidays or Bank Half-Holidays (as the case may be) at the places respectively mentioned, that is to say:—

#### *Bank Holidays:—*

TUESDAY, THE 10TH OCTOBER, 1972 at Elmore.

TUESDAY, THE 7TH NOVEMBER, 1972 at Maryborough.

*Bank Half-Holidays from the Hour of eleven a.m.*

MONDAY, THE 2ND OCTOBER, 1972 at Robinvale.

FRIDAY, THE 6TH OCTOBER, 1972 at Lalbert.

WEDNESDAY, THE 25TH OCTOBER, 1972 at Geelong, Geelong West, North Geelong, East Geelong, Norlane and Shire of South Barwon.

Given under my Hand and the Seal of the State of Victoria aforesaid, at Melbourne, this twelfth day of September, in the year of our Lord One thousand nine hundred and seventy-two, and in the twenty-first year of the reign of Her Majesty Queen Elizabeth II.

(L.S.) ROHAN DELACOMBE.

By His Excellency's Command,

E. R. MEAGHER,  
Chief Secretary.

GOD SAVE THE QUEEN !

## GOVERNMENT NOTICES

### HOLIDAY—ROYAL AGRICULTURAL SHOW.

Notice is hereby given that on—

THURSDAY, THE 28TH SEPTEMBER, 1972,

the Public Offices in the municipalities mentioned hereunder will be closed, that day being appointed by the *Public Service Act 1958* to be observed as a holiday in the Public Offices:—

The Cities of Altona, Box Hill, Brighton, Broadmeadows, Brunswick, Camberwell, Caulfield, Chelsea, Coburg, Collingwood, Croydon, Dandenong, Doncaster and Templestowe, Essendon, Fitzroy, Footscray, Frankston, Hawthorn, Heidelberg, Keilor, Kew, Knox, Malvern, Melbourne, Moorabbin, Mordialloc, Northcote, Nunawading, Oakleigh, Port Melbourne, Prahran, Preston, Richmond, Ringwood, St. Kilda, Sandringham, South Melbourne, Springvale, Sunshine,

Waverley and Williamstown; the Shires of Berwick, Bulla, Cranbourne, Diamond Valley, Eltham, Hastings, Lillydale, Melton, Mornington, Sherbrooke, Werribee and Whittlesea.

This notice relates only to the closing of the State Public Offices. All inquiries regarding holidays in other offices and in shops and industry should be directed to the Department of Labour and Industry, 110 Exhibition-street, Melbourne, 3000. (Telephone 63-0321, Extensions 6158, 6859, and 6924.)

E. R. MEAGHER,  
Chief Secretary.

Chief Secretary's Office,  
Melbourne, 4th September, 1972.

*Cemeteries Act 1958.*

**SCALE OF FEES OF ENSAY PUBLIC CEMETERY.**

In pursuance of the powers conferred upon them by the Cemeteries Act the trustees of the Ensay Public Cemetery hereby make the following scale of fees, which shall come into operation upon publication in the *Government Gazette*, and from and after such publication every scale of fees heretofore made by the said trustees, shall be and is hereby rescinded to the extent to which it conflicts with this scale.

*Private Graves.*

Land, 8 ft. x 4 ft. . . . . \$6.00  
Own selection of land (extra) . . . . . \$6.00

*Public Graves.*

Interment in grave without exclusive right—  
stillborn child . . . . . \$10.00  
Interment in grave without exclusive right—  
others . . . . . \$17.00

*Sinking Charges for Private Graves.*

Sinking grave 6 feet deep . . . . . \$40.00  
Each additional foot . . . . . \$4.00  
Sinking oversize grave (extra) . . . . . \$12.00  
Cancellation of order to sink (if commenced) . . . . . \$6.00

*Reopening Charges.*

Reopening grave (no cover) . . . . . \$30.00  
Reopening grave (with cover) . . . . . \$35.00

*Extra Charges.*

Sinking grave outside prescribed hours or on  
Saturdays, Sundays or Public Holidays . . . \$12.00  
Interment in private grave without due notice . . \$12.00  
B. K. DUGGAN, Trustee.  
B. NEWCOMEN, Trustee.  
F. ANGUS, Trustee.

Approved by the Governor in Council, 5th September, 1972.—T. J. FORRISTAL, Clerk of the Executive Council.

*Cemeteries Act 1958.*

**SCALE OF FEES OF CASTLEMAINE PUBLIC CEMETERY.**

In pursuance of the powers conferred upon them by the Cemeteries Act the trustees of the Castlemaine Public Cemetery hereby make the following scale of fees, which shall come into operation upon publication in the *Government Gazette*, and from and after such publication every scale of fees heretofore made by the said trustees shall be and is hereby rescinded to the extent to which it conflicts with this scale.

*Private Graves.*

Land, 8 ft. x 4 ft. . . . . \$42.00  
Own selection of land . . . . . \$12.00

*Public Graves.*

Interment in grave without exclusive right—  
stillborn child . . . . . \$9.00  
Interment in grave without exclusive right—  
others . . . . . \$19.00  
Number peg or label . . . . . \$3.00

*Sinking Charges for Private Graves.*

Sinking grave 6 feet deep . . . . . \$36.00  
Each additional foot . . . . . \$4.00  
Sinking oversize grave (extra) . . . . . \$12.00  
Sinking oversize grave for American type casket  
(extra) . . . . . \$12.00  
Cancellation of order to sink (if commenced) . . \$6.00

*Reopening Charges.*

Reopening grave (no cover) . . . . . \$30.00  
Reopening grave (with cover or kerb) . . . . . \$35.00

*Extra Charges.*

Interment not in the prescribed hours or on  
Saturdays, Sundays or Public Holidays . . \$14.00  
Interment in private grave without due notice . . \$14.00  
Late fee (per half-hour or part thereof in excess  
of first fifteen minutes) . . . . . \$2.00

*Miscellaneous Charges.*

Interment fee . . . . . \$12.00  
Certificate of right of burial . . . . . \$1.00  
Number plate or brick . . . . . \$3.00  
Inspection of plan or register . . . . . \$1.00  
Annual maintenance (single grave) . . . . . \$12.00  
Permission to erect a headstone or monument—  
5 per cent. of cost, with a minimum of \$6.00.  
Permission to construct a brick grave or to erect  
any stone kerb, brick tilework or concrete . . \$5.00  
Grave renovations or additional inscription . . \$4.00  
Exhuming the remains of a body (when  
authorized) . . . . . \$30.00  
Interment of ashes in a private grave . . . . . \$12.00

*Lawn Cemetery (Udenominational).*

Lawn grave, 8 ft. x 4 ft. . . . . \$70.00  
For each interment therein . . . . . \$35.00  
Ashes buried in lawn . . . . . \$12.00  
Charge for erecting standard headstone . . . \$6.00

G. E. SHILL, Trustee.  
A. A. HEATHER, Trustee.  
W. L. SLINGO, Trustee.  
R. SEDDON, Trustee.

Approved by the Governor in Council, 5th September, 1972.—T. J. FORRISTAL, Clerk of the Executive Council.

*Labour and Industry Act 1958.*

**ORDER OF EXEMPTION UNDER SECTION 80c.**

Whereas pursuant to section 80c of the *Labour and Industry Act 1958* as amended by the *Labour and Industry (Further Amendment) Act 1969* the Council of the Shire of Maldon has applied to the Minister for an order exempting certain shopkeepers of shops in its municipal district from being required to close and keep closed their shops in accordance with the provisions of Part VI. of the said Act:

And whereas I have considered the report of the Minister for Tourism obtained in accordance with the provisions of sub-section (4) of section 80c of the said Act:

Now therefore I, Joseph Anstice Rafferty, Her Majesty's Minister of Labour and Industry in the State of Victoria, do, pursuant to the aforesaid section 80c of the *Labour and Industry Act 1958*, make this order granting exemption to:

BEVERLEY LORRAINE BUCKNELL and BARBARA ELIZABETH WILLIS, of Main-street, Maldon, and  
IAN RONALD HUXLEY, of Corner Reef and Templeton streets, Maldon,

being shopkeepers within the Township of Maldon from being required to close and keep closed their shops on—  
Saturdays between the hours of 1 p.m. and 6 p.m. and  
Sundays and public holidays between the hours of  
9 a.m. and 6 p.m.

provided that such exemption shall not apply to Good Friday or Anzac Day.

Dated at Melbourne this 5th day of September, 1972.

J. A. RAFFERTY,  
Minister of Labour and Industry.

**COUNTRY FIRE AUTHORITY ACT.**

**PERMISSION TO HOLD FIRE BRIGADE DEMONSTRATIONS.**

In pursuance of the provisions of section 103 of the *Country Fire Authority Act 1958*, the Country Fire Authority has granted permission for the holding of the fire brigade demonstrations as hereunder:—

*Urban Fire Brigades.*

At Maryvale, on Saturday, 18th November, 1972.  
At Morwell, on Saturday, 2nd December, 1972.  
At Bairnsdale, on Saturday, 16th December, 1972.  
At Sale, on Saturday, 20th January, 1973.  
At Moe, on Saturday, 10th February, 1973.  
At Yallourn, on Saturday, 24th February, 1973.

J. L. ALLEN,  
Secretary.

4th September, 1972.

Transport Regulation Act.  
TRANSPORT REGULATION BOARD.

## HEARING OF APPLICATIONS.

Notice is hereby given that the following applications will be considered by the Transport Regulation Board at its offices at the corner of Lygon and Princes streets, Carlton, at 10.15 a.m., on Wednesday, 4th October, 1972.

**BROADMEADOWS BUS CHARTER PTY. LTD.**, 145 Lynch-road, Fawkner. Application for one commercial passenger vehicle with seating capacity for 41 persons to operate as a special service omnibus, under the same terms and conditions as existing licences held by the applicant.

**CORNISH, R. J., & Co. PTY. LTD.**, P.O. Box 151, Cobram. Application for one commercial passenger vehicle with seating capacity for 22 persons to convey:—(i) Company employees free of charge from Cobram to the Company's properties, and between Company owned properties, as required. (ii) Members of the applicants Social Club on outings, as required, at no charge to the Social Club.

**CROYDON BUS SERVICE PTY. LTD.**, P.O. Box 95, Croydon. Application for one commercial passenger vehicle with seating capacity for 37 persons to operate as an additional metropolitan stage omnibus, under the same terms and conditions as existing licences held by the applicant.

**MASSEY-FERGUSON (AUST.) LTD.**, 2 Devonshire-road, Sunshine. Application for one commercial passenger vehicle with seating capacity for eight persons to operate free of charge for the carriage of employees and dealer personnel from hotels and motels in the Essendon, St. Albans, Tottenham and Sunshine areas to the "Wyeera" Company Training Centre at Taylors-road, St. Albans.

**MORELAND BUS LINES PTY. LTD.**, 25 Liverpool-street, West Coburg. Application for variation of M.O. licence conditions on Route 510 (Essendon-Ivanhoe) by deviating the 6.49 a.m. and 7.02 a.m. trips from Essendon Railway Station and the 4.27 p.m. and 4.37 p.m. trips from Ivanhoe Railway Station from the corner of Darebin-road and Sparks-avenue via Sparks-avenue, Christmas-street, Grange-road, Chingford-street and Fulham-road to normal route.

**MARSHALL, G.**, 60 Sherbourne-road, Montmorency. Application for one metropolitan Hire Car Licence to be issued in respect of a vehicle classified by the Board as a large car subject to the cancellation of licence S.T.5538.

**McMILLAN, H. F.**, 26 Benbow-street, Ararat. One commercial passenger vehicle with seating capacity for 33 persons for carriage of Victorian Railways construction workers within a 50-mile radius of Beaufort Railway Station, under contract to the Victorian Railways.

**REPCO ENGINE PARTS PTY. LTD.**, 87 Mitchell-street, Maidstone. Application for one commercial passenger vehicle with seating capacity for 14 persons to operate free of charge for the carriage of employees of Repco Engine Parts Pty. Ltd. between the applicants premises at 81 Burney-street, Richmond, and a subsidiary company in Mitchell-street, Maidstone via Buckingham, Church and Victoria streets, Dynon-road, Hopkins and Nicholson streets, Ballarat and Rosamond roads and Mitchell-street to the said premises at Maidstone subject to the cancellation of licence No. T.P.283 held in the name of Russell Manufacturing Co. Pty. Ltd.

## TIME-TABLE.

## Monday-Friday.

Depart Richmond 7.30 a.m.

Depart Maidstone 4.30 p.m.

NOTE.—Repco Engine Parts Pty. Ltd. have recently taken over Russell Manufacturing Co. Pty. Ltd. who operated T.P.283 under the same terms applied for above.

**WEDGE, D. E.**, 94 Victoria-street, Cobden. Application for one commercial passenger vehicle with large seating capacity, to be purchased, to operate—(i) In substitution for but not in addition to, any of the applicants 'T.S.' licensed vehicles operating school services. (ii) As a country special omnibus from Camperdown Post Office.

Applications for renewal of licences as shown, by persons listed hereunder to operate the same terms and conditions.

**ANAGOSTOU, D.**, 24 Bungay-street, Fawkner; M.T.4021.  
**ANGELUCCI, A.**, 21 Chappell-street, Thomastown; M.T.1892.  
**APSITE, J.**, 67 Gowrie-street, Glenroy; M.T.1954.  
**ARTHUR, J. G.**, 11 Peacock-street, West Brunswick; M.T.677.  
**BAKER, R. W.**, 19 Johnson-street, Pascoe Vale; M.T.2036.  
**BARBAGALLO, G.**, 54 Donne-street, West Coburg; M.T.1883.  
**BERGER, J.**, 22 Newman-avenue, Carnegie; M.T.1588.  
**BOVALINA, C.**, 107 Mitchell-street, Brunswick; M.T.1976.  
**BRENER, L.**, 441 Glen Eira-road, Caulfield; M.T.1511.  
**BRIGGS, H. R.**, 97 Hickford-street, Reservoir; T.P.73.  
**CALLAGHAN, B.**, 18 Aikman-crescent, Chadstone; M.T.1741.  
**CARMICHAEL, J. F. & B. L.**, Marine-parade, San Remo; C.T.363.  
**CHENEY, E.**, Lot 120, Koala-crescent, West Meadows; M.T.1817.  
**CHOUSSOS, S.**, 18 Hallone-street, South Oakleigh; M.T.1847.  
**CHYDIROTIS, J. J.**, 6 Loughnan-street, Richmond; M.T.4492.  
**CINCA, G.**, 150 Nicholson-street, East Coburg; M.T.4214.  
**COSTA, L.**, 104 Fenwick-street, North Carlton; M.T.1689.  
**DE IURE, G.**, 40 Golden-street, North Coburg; M.T.1501.  
**DE SANCTIS, F.**, 42 Collins-street, Bulleen; M.T.1792.  
**DIMITRAKAKIS, N.**, 13 Balwyn-road, Canterbury; M.T.4381.  
**EDGEcombe, R. L.**, 344 Nicholson-street, Fitzroy; M.T.947.  
**GALLI EQUIPMENT PTY. LTD.**, 15 Albert-street, East Brunswick; T.P.286.  
**FINNEGAN, T.**, Budge-street, Glen Thompson; T.S.417.  
**FREEMAN, F. G. & G. E.**, Waverley-street, Merrigum; T.S.686.  
**GILES, P. M.**, 101 Edgvale-road, Kew; M.T.1657.  
**GRANGER, N. F.**, 3 Gatis-street, Burwood; M.T.1581.  
**GUERRA, A.**, 14 Churchill-grove, Hawthorn; M.T.4374.  
**HANDLEY, R. F.**, rear 319 Clarendon-street, South Melbourne; M.T.2054.  
**HANNA, N.**, 212 Woodland-street, Strathmore; M.T.1478; M.T.1675.  
**HANNA, Y. A.**, 26 Sylvan-grove, Pascoe Vale; M.T.1597.  
**HAYES, W. S.**, 4 Kershaw-street, South Oakleigh; M.T.2060.  
**HRONIS, E.**, 29 Wall-street, Richmond; M.T.4529.  
**IBRAHIM, E.**, 498 Melbourne-road, Newport; M.T.1814.  
**JACKSON, E. W. P.**, Flat 11, 2 Selwyn-avenue, Elwood; M.T.1296.  
**KAYROOZ, J.**, 21 Vaness-street, Maribyrnong; M.T.1484.  
**KEAMY, R. W.**, 14 Keamy-avenue, Cheltenham; M.T.4395.  
**KOTSIMBAS, A.**, 130 Smith-street, Thornbury; M.T.1852.  
**LONERGAN, M. P.**, 60 Locksley-road, Ivanhoe; M.T.1769.  
**LUCAK, A.**, 35 Havelock-road, East Hawthorn; M.T.1816.  
**MAISEL, F.**, 50 Barkly-street, St. Kilda; M.T.4593.  
**MAKRIS, C.**, No. 4, Lot 55, Warraweena-road, Clayton; M.T.4335.  
**MAY, E. P.**, 49 Cecil-street, Kew; M.T.1548.  
**MEADOWS, C. D.**, 19 Melville-road, West Brunswick; M.T.2023.  
**MILLER, W. J. E.**, 6 Holberg-street, Moonee Ponds; M.T.1712.  
**MOORFIELD, R.**, 14 Ryot-street, Warrnambool; C.T.60.  
**MORABITO, G.**, 11 Lawson-street, Moonee Ponds; M.T.4224.  
**McNAMEE, (Mrs.) F. C.**, 48 Lansell-street, Bendigo; U.T.305T.  
**MACSWEENEY, J.**, 15 Organge-grove, Essendon; M.T.1766.  
**NIANAKOS, C.**, 83 Carter-street, Middle Park; M.T.1717.  
**O'BRIEN, M. J.**, 35 Salisbury-street, Moonee Ponds; M.T.1479.  
**PANAGISTOPOULOS, P.**, 15A Norfolk-road, Surrey Hills; M.T.1869.  
**PAPANICOLAOU, J.**, 53 Tanner-street, Richmond; M.T.1797.  
**POUMBOURIOS, N.**, 20 Keol-street, Clayton; M.T.4467.  
**RANIERI, V.**, 19 Cavalier-street, South Oakleigh; M.T.4286.  
**REVIS, T.**, 30 Fromhold-drive, Doncaster East; M.T.1523.  
**ROBERTS, E. C.**, 6 Ophir-street, Sebastopol; U.T.182.  
**ROBERTS, J. F.**, 25 McDonald-street, Beaumaris; M.T.4497.  
**ROSE, H.**, Flat 6, 348 Dandenong-road, East St. Kilda; M.T.1799.  
**ROVAS, P.**, 38 Brunel-street, East Malvern; M.T.1973.  
**SCULLI, P. A.**, 3 Thickers-street, Pascoe Vale; M.T.1578.  
**SEVASTOPOULOS, V.**, 7 Fairchild-street, Abbotsford; M.T.4328.  
**SHIELL, J. M.**, 7 Atkins-street, Bendigo; U.T.363.  
**STATHIS, J.**, Flat 8, 16A Cromwell-road, South Yarra; M.T.1857.  
**SULLIVAN, J. I.**, 7 Rosedale-grove, Ivanhoe; M.T.2008.  
**TRIGG, H.**, 201 Bell-street, Ballarat; U.T.163.  
**THEODOSIOU, K.**, 53 Clonaig-street, North Brighton; M.T.4407.  
**TIMPERIO, N.**, 71 Ward-street, Glenroy; M.T.4498.  
**TSATALBASSIS, E.**, 15 Lawes-street, Hawthorn; M.T.4006.  
**WATSON, L. M.**, 3A Spring Gully-road, Bendigo; U.T.336.  
**WHISTON, A. J.**, 39 Williams-road, Coburg; M.T.1504.  
**WHISTON, A. J.**, 39 Williams-road, Coburg; M.T.2005.  
**WILLIAMSON, V. M.**, 8 Wilson-grove, Camberwell; M.T.4144.

Notice of any objection should be forwarded to reach the Secretary of the Board not later than 27th September, 1972.

Applicants are advised that it will not be necessary to appear on the hearing date specified, unless advised in writing by the Board.

A. V. C. COOK,  
Acting Secretary.

Corner Lygon and Princes streets, Carlton, Wednesday, 13th September, 1972.

Commercial Goods Vehicles Act.  
TRANSPORT REGULATION BOARD.

HEARING OF APPLICATIONS.

Notice is hereby given that the following applications will be considered by the Transport Regulation Board at its offices at the corner Lygon and Princes streets, Carlton, at 10 a.m. on Wednesday, 4th October, 1972.

- AGOSTINI, M., 32 Towers-road, Lilydale, 3140. One commercial goods vehicle (L/C. 281 cwt.) to operate within a 35-mile radius of the G.P.O., Melbourne solely on behalf of Consolidated Quarries Ltd. at Oakleigh South—sand, soil, screenings, premix and other quarry products.
- ATKINS, C. A. & J. L., 5 Welwyn-court, Noble Park, 3174. One commercial goods vehicle (L/C. 196 cwt.) to operate within a 50-mile radius of the premises of Pioneer Concrete (Vic.) Pty. Ltd. at Croydon on behalf of the said company—premixed concrete in a specially constructed agitator vehicle.
- AVIS RENT-A-CAR SYSTEM PTY. LTD., 424 Elizabeth-street, Melbourne, 3000. One commercial goods vehicle (L/C. 53 cwt.) to operate throughout the State of Victoria in the course of business as "Motor Vehicle Rent-A-Car Proprietors" on a specially constructed car carrying trailer—own motor cars. This application replaces licence No. D.A.61012 held by the applicant.
- BRANCA, D. J., 58 Brund-street, East Malvern, 3145. Application to vary the conditions of licence No. D.A.65212 (L/C. 240 cwt.) by adding an additional paragraph (d)—(d) From Bacchus Marsh to own premises at Campbellfield—own river pebbles.
- COOMBS, A. G., PTY. LTD., 26 Cochranes-road, Moorabbin, 3189. One commercial goods vehicle (L/C. 14 cwt.) to operate throughout the State of Victoria in the course of business as "Heating Engineers"—tools of trade, spare parts and equipment incidental to the installation, servicing and maintenance of air conditioning units and heating systems.
- ECLIPSE RETAIL RENTAL PTY. LTD., 168 Chesterville-road, Moorabbin, 3189. One commercial goods vehicle (L/C. 14 cwt.) to operate within a 50-mile radius of own branch premises at Wangaratta in the course of business as "Electrical Retailers"—own goods, also electrical appliances for repair or having been repaired, provided that all new goods shall be initially consigned to Wangaratta by rail.
- ENSGN SERVICES VIC. PTY. LTD., 109 Archer-street, Shepparton, 3630. Two commercial goods vehicles (L/C. 67, 40 cwt.) to operate: (a) Within a 50-mile radius of the post office at Shepparton in the course of business as "Industrial Dry Cleaners"—clothing for cleaning or having been cleaned. (b) From and to own premises at Northcote and Richmond to and from the City of Shepparton and serving places en route—clothing for cleaning or having been cleaned also cleaning equipment for hire.
- ESSO AUST. LTD., 42 Raymond-street, Sale, 3850. Six commercial goods vehicles (L/C. 14 cwt. each) to operate throughout the State of Victoria in the course of business as "Oil and Gas Explorers" for the purpose of servicing own drilling and exploration projects—tools of trade, equipment and materials incidental thereto.
- FRENCH, J. C. D. (trading as J. C. French & Co.), 28 Mickle-street, Warrnambool, 3280. One commercial goods vehicle (L/C. 10 cwt. and 30 cwt. trailer) to operate in the course of business as "Roofing Paint and Brickboard Manufacturer" in the following areas:—(a) Within a 50-mile radius of applicant's premises at Warrnambool—own goods. (b) Within that part of the State of Victoria, south of a line drawn due east and west through the City of Horsham

and west of a line drawn due north and south through the City of Colac—own goods subject to the condition that all raw materials required in the manufacture of said goods shall have been initially forwarded by rail to Warrnambool. (c) Within that part of the State of Victoria, south of a line drawn due east and west through the City of Horsham and west of a line drawn due north and south through the City of Colac as distributors of Teagle Offset, Tractor Drawn Mower and Slasher—unassembled or complete mowers and slashers for delivery to farmers or for demonstration purposes subject to the condition that all such mowers and slashers carried on the vehicle shall have been initially consigned by rail to Warrnambool.

- K.M.M. PTY. LTD., 461 Bourke-street, Melbourne, 3000. One commercial goods vehicle (L/C. 155 cwt.) to operate within a 50-mile radius of own premises at Kensington in the course of business as "Flour Millers and Stockfeed Manufacturers"—own goods, excluding operations to places within an 8-mile radius of the chief post office in the City of Geelong. Subject to the cancellation of licence No. D.A.6317/8 in the name of W. S. Kimpton & Sons Pty. Ltd.
- K.M.M. PTY. LTD., 461 Bourke-street, Melbourne, 3000. One commercial goods vehicle (L/C. 241 cwt.) to operate within a 50-mile radius from own premises at Kensington in the course of business as "Flour Millers"—own goods but excluding operations to or from places within an 8-mile radius of the chief post office in the City of Geelong.
- MCNEECE, M. A., 205 Nicholson-street, Carlton, 3053. One commercial goods vehicle (L/C. 44 cwt.) to operate throughout the State of Victoria in the course of business as "Caterers" for the purpose of attending shows and race meetings—own catering equipment and victuals.
- NATIONAL BANK OF AUSTRALASIA LTD., 271 Collins-street, Melbourne, 3000. One commercial goods vehicle (L/C. 52 cwt.) to operate from and to own store premises in the City of Melbourne to and from various own branch bank premises throughout the State of Victoria in course of business as "Bankers"—used accounting machines, typewriters, office equipment, office furniture and tools of trade, solely for own use at such bank branches and also materials incidental to the servicing and maintenance of office equipment and bank property.
- PAUSMER, O. K., 2 Norfolk-street, Glen Waverley, 3150. One commercial goods vehicle (L/C. 200 cwt.) to operate within a 35-mile radius of the G.P.O., Melbourne on behalf of Consolidated Quarries Ltd.—sand, soil, screenings, premix and quarry products.
- QUINLIVAN, R. F., 18 Boyle-street, Echuca, 3625. One commercial goods vehicle (L/C. 203 cwt.) to operate within a 50-mile radius of the post office at Echuca and from Echuca to Swan Hill and towns en route in the course of business as "Concrete Manufacturers"—premixed concrete in a specially constructed agitator vehicle.
- QUIRKS ALL AUSTRALIAN REFRIGERATORS PTY. LTD., 113 Queensbridge-street, South Melbourne, 3205. Three commercial goods vehicles (L/C. 13 cwt. each) to operate throughout the State of Victoria in the course of business as "Refrigeration Engineers" as a service vehicle—tools of trade, equipment and spare parts required for installation and servicing refrigeration equipment in the field only.
- REED, K., 1 Caulson-avenue, Doveton, 3177. One commercial goods vehicle (L/C. 150 cwt.) to operate within a 70-mile radius of the premises of Vitclay Pipes Pty. Ltd. at Blackburn on behalf of the said company—earthenware pipes and fittings.
- REID, R. E., Little Yarra-road, Yarra Junction, 3797. One commercial goods vehicle (L/C. 240 cwt.) to operate: (a) From forest landings within a 20-mile radius of the post office at Yarra Junction to Reid Bros. Sawmill Pty. Ltd. at Yarra Junction—logs. (b) From forest landings within a 20-mile radius of the post office at Yarra Junction to the treatment works at Brooklyn—poles. (c) From the sawmill of Reid Bros. Sawmill Pty. Ltd. at Yarra Junction to timber yards and building sites within a 25-mile radius of the G.P.O., Melbourne—sawn timber.
- TOW TRUCK.
- JOHNSON, L. P. (trading as Murray Valley Auto Wreckers), Murray Valley Highway, Swan Hill, 3585. One commercial goods vehicle (to be purchased) to operate throughout the State of Victoria in the course of

business as "Motor Wrecker" as a Tow Truck for the purpose of collecting secondhand motor vehicles for wrecking purposes—own secondhand motor vehicles for return to own premises.

NOTE.—Excluding the ability to attend the scene of a motor car accident.

#### RENEWALS.

Applications for renewal of licences as shown by persons listed hereunder to operate under the same terms and conditions from the expiry shown in each case.

WILSON, R. H. (trading as Bairnsdale Bearing Supplies), 69 Main-street, Bairnsdale, 3875; D.A.60240/1; 13th January, 1973; 15 cwt.

WILTON, P. R. (trading as Baron Pest Exterminators), 166 Wantirna-road, Ringwood, 3134; D.A.62427; 16th December, 1972; 12 cwt.

BROWN'S OFFICE CLEANING SERVICES PTY. LTD., 367 High-street, Kew, 3101; D.A.750/5; 12th January, 1973; 8 cwt.

CIGARETTE SERVICE PTY. LTD., 171 Bridge-street, Bendigo, 3550; D.A.40870/7; 16th January, 1973; 35 cwt.

CLAVARINO, L. L. (trading as L. L. & G. N. Clavarino), 99 Station-road, Foster, 3960; D.A.60199/1; 13th January, 1973; 148 cwt.

CLODE, L. W., Bahgallah-road, Casterton, 3311; D.A.62178; 13th January, 1973; 112 cwt.

CONCRETE INDUSTRIES MONIER LTD., Frankston-road, Dandenong, 3175; D.A.62922/4; 26th January, 1973; 80 cwt.

DECKER, K. A., Lot 8, Princes Highway, Hallam, 3803; D.A.41538; 16th January, 1973; 212 cwt.

DOWLE, R. G., "Omaru", Derby-street, Warburton, 3799; D.A.53510/1; 13th January, 1973; 9 cwt.

DOYLE, J. & R. L., 52 Strickland-road, Bendigo, 3550; D.A.998; 21st January, 1973; 71 cwt.

ELLEN, E. M., 19 Selwyn-street, Canterbury, 3126; T.D.A.64265; 14th December, 1972; 135 cwt.

EMOLEUM (AUST.) LTD., 199 Arden-street, North Melbourne, 3051; D.A.1042/23; 13th January, 1973; 94 cwt.

FERGUSON, C., Flat 1, 23 Walker-street, West Brunswick, 3055; D.A.54456; 26th January, 1973; 195 cwt.

GIBSON, K. J., 127 Lorne-street, Fawkner, 3060; T.D.A.63391; 15th December, 1972; 126 cwt.

HADDEN, R. F. (trading as F. Hadden & Sons), 16 Ford-crescent, Thornbury, 3071; D.A.4096/3; 26th January, 1973; 137 cwt.

HARRISON, J., Haig-street, Mitiamo, 3573; D.A.54313; 26th January, 1973; 109 cwt.

HEALEY, C. P., & SONS, TRACTOR & FARM MACHINERY PTY. LTD., Murray Valley Highway, Echuca, 3625; D.A.62252; 13th January, 1973; 6 cwt.; D.A.62252/1; 13th January, 1973; 17 cwt.; D.A.62252/5; 13th January, 1973; 206 cwt.

HUTCHESON, M. J., Lockwood-road, Kangaroo Flat, 3555; D.A.62479; 28th January, 1973; 5 cwt.

JUDD, G., & SONS, PTY. LTD., 34 Coghill-street, Yarrowonga, 3730; D.A.1403/11; 11th January, 1973; 222 cwt.

LECHTE, R. G. & V. F., 11 Hunter-street, Murrumbena, 3163; D.A.54197; 21st December, 1972; 191 cwt.

LETIZIA, V., 24 Mario-street, Hamlyn Heights, 3215; D.A.41173; 23rd January, 1973; 152 cwt.

MANNIX, C. A., Shakespeare-street, Spring Gully, Bendigo, 3550; D.A.15992/1; 13th January, 1973; 121 cwt.

MARFLEET & WEIGHT MANUFACTURING PTY. LTD., Flockhart-street, Abbotsford, 3067; D.A.1552/3; 29th January, 1973; 17 cwt.

MARRINER, N. M., 105 Little Dodds-street, Ballarat, 3350; D.A.61332/1; 28th January, 1973; 10 cwt.

MASKELL & GRIBBEN PTY. LTD., 201 Corio-street, Shepparton, 3630; D.A.1566/4; 21st January, 1973; 114 cwt.

HOOPER, G. L. & J. L. (trading as Melbourne Scale & Repair Co.), 61 Arden-street, North Melbourne, 3051; D.A.62468/1; 13th January, 1973; 14 cwt.

MILROY, T., 5 Newton-street, Chadstone, 3148; D.A.38038/1; 23rd January, 1973; 48 cwt.

MITCHELL, R., 6 Claude-street, Shepparton, 3630; D.A.1614/2; 16th January, 1973; 75 cwt.

MORCOM, G. E., Box 45, Rupanyup, 3388; D.A.54286; 11th January, 1973; 91 cwt.

MOREILLON, R. H., Bannockburn, 3331; D.A.62372; 28th January, 1973; 113 cwt.

MOTORWAY TYRE SERVICE (WARRACKNABEAL) PTY. LTD., 161 Scott-street, Warracknabeal, 3393; D.A.50135/5; 21st January, 1973; 14 cwt.

McKNIGHT, W., 18 Doveton-street north, Ballarat, 3350; D.A.13665/2; 16th January, 1973; 11 cwt.

McWILLIAMS WINES PTY. LTD., 2187 Dandenong-road, Clayton, 3168; D.A.41537; 16th January, 1973; 13 cwt.; D.A.41537/1; 16th January, 1973; 13 cwt.

McWILLIAMS WINES PTY. LTD., 2187 Dandenong-road, Clayton, 3168; D.A.41537/3; 16th January, 1973; 10 cwt.

NATIONAL BANK OF AUSTRALASIA LTD., 271 Collins-street, Melbourne, 3000; D.A.1706; 14th January, 1973; 55 cwt.

PATERSONS PTY. LTD., 152 Bourke-street, Melbourne, 3000; D.A.1782/18; 29th January, 1973; 14 cwt.

PELOZA, J., 8 Colonsay-road, Springvale, 3171; D.A.54359; 26th January, 1973; 214 cwt.

PETERSVILLE LTD., Wellington-road, Clayton, 3168; D.A.1813/84; 27th January, 1973; 75 cwt; D.A.1813/192; 30th January, 1973; 79 cwt.

PETERSVILLE LTD., Wellington-road, Clayton, 3168; D.A.1813/85; 27th January, 1973; 77 cwt.

WALKER, R. A., (trading as Phillips & Walker), 9 Dalmahoy-street, Bairnsdale, 3875; D.A.30943/6; 18th November, 1972; 40 cwt.

PYE INDUSTRIES SALES PTY. LTD. (Davey-Dunlite Division), 22 Hargreaves-street, Huntingdale, 3166; D.A.64788; 29th January, 1973; 10 cwt.

QANTAS AIRWAYS LTD., 230 Collins-street, Melbourne, 3000; D.A.62506; 28th January 1973; 10 cwt.; D.A.62506/1; 28th January, 1973; 11 cwt.

READY MIXED CONCRETE (VIC.) PTY. LTD., 68 Burwood-road, Burwood, 3125; D.A.39437/17; 21st December, 1972; 290 cwt.

READY MIXED CONCRETE (VIC.) PTY. LTD., 68 Burwood-road, Burwood, 3125; T.D.A.48531/132; 18th January, 1973; 334 cwt.; T.D.A.48531/134; 25th January, 1973; 335 cwt.; T.D.A.48531/54; 18th December, 1972; 319 cwt.; T.D.A.48531/60; 18th December, 1972; 319 cwt.; T.D.A.48531/84; 22nd December, 1972; 337 cwt.; T.D.A.48531/147; 7th December, 1972; 334 cwt.; T.D.A.48531/148; 14th December, 1972; 335 cwt.

RITCHIE, R., Main-street, Gembrook, 3783; D.A.28100; 21st January, 1973; 38 cwt.

ROWE, A. L., 47 McDonald-street, Mordialloc, 3195; D.A.28255; 29th January, 1973; 8 cwt.

ROBERTSON C. J., & Co. (Horsham) PTY. LTD., 85 Wilson-street, Horsham, 3400; D.A.23358/15; 28th January, 1973; 14 cwt.

SALERNI, N., 6 Crookston-road, East Reservoir, 3073; D.A.62507; 28th January, 1973; 198 cwt.

SOUTHERN CROSS MACHINERY PTY. LTD., 133-135 McIntyre-road, Sunshine, 3020; D.A.52380/2; 11th January, 1973; 49 cwt.

SPERRY RAND AUST. LTD. REMINGTON RAND DIVISION, 334-342 City-road, South Melbourne, 3205; D.A.828/1; 29th January, 1973; 8 cwt.

STAWELL TIMBER INDUSTRIES PTY. LTD., Lake-road, Stawell, 3380; D.A.13328/14; 28th January, 1973; 16 cwt.; D.A.13328/15; 28th January, 1973; 9 cwt.

SUPER SPREAD AVIATION (AUST.) PTY. LTD., P.O. Box 7, Cheltenham, 3192; D.A.32508/26; 26th January, 1973; Mobile Crane.

WALLACE, E. D., Kergunyah, 3691; D.A.28192; 29th January, 1973; 277 cwt.

WATTS, D. H., 11 Ray-street, Dandenong, 3175; D.A.62516; 28th January, 1973; 39 cwt. & 40 cwt. trailer.

WOODS, P. W., 36 Tobin-street, Ararat, 3377; D.A.2327; 24th June, 1972; 190 cwt.

#### RENEWAL WITH VARIATION

Application made by the person listed hereunder for renewal of the licence listed with variation of conditions in the manner set out opposite the name.

HILL, C. T., Woomdoo, 3272; D.A.54095; 21st December, 1972; application to renew and vary the conditions of licence No. D.A.54095 (L/C. 145 cwt.) by deleting the existing conditions and adding in lieu—(a) Within a 25-mile radius of the post office at Woomdoo—general goods, provided that no goods shall be carried whether by one stage or by more than one stage between places within the above radius which are more than thirty (30) road miles apart by the nearest practicable route. (b) Within a 50-mile radius of the post office at Woomdoo—livestock. (c) From the depot of B.P. Australia Ltd. at Warrambool to places within the radius defined in part (a) of the document as agent for the said company—petroleum products in prescribed types of containers and empty return containers.

Notice of any objection should be forwarded to reach the Secretary of the Board not later than 27th September, 1972.

Applicants are advised that it will not be necessary to appear on the hearing date specified above, unless advised in writing by the Board.

A. V. C. COOK,  
Acting Secretary.

Corner Lygon and Princes streets, Carlton, 3053, Wednesday, 13th September, 1972.

*Private Agents Act 1966.*

## NOTICE OF RECEIPT OF APPLICATIONS FOR LICENCES UNDER THE PROVISIONS OF THE PRIVATE AGENTS ACT 1966.

The Clerk(s) of the Magistrates' Court(s) as listed hereunder hereby give notice that applications, as under, have been lodged for hearing by the said Court(s) on the date(s) specified.

Any person desiring to object to any of such applications must—

- (a) lodge with the respective Clerk of the Magistrates' Court a notice in the prescribed form of his objection and of the grounds thereof ;
- (b) cause a copy of such notice to be served personally or by post upon the applicant at least three days before the hearing of the application ; and
- (c) send or deliver—
- (i) where the objection is not made by the officer in charge of the police district in which the Court is situated— a copy of the notice to such officer ; and
- (ii) where the objection is not made by the Registrar or Deputy Registrar—a copy to the Registrar.

Full Name of Applicant or in the Case of a Firm or Corporation, of the Nominee.	Place of Abode of Applicant or Nominee.	Name of Firm or Corporation.	Address for Registration.	Type of Licence.	Date of Hearing of Application.
---	---	------------------------------	---------------------------	------------------	---------------------------------

## MAGISTRATES' COURT, GEELONG.

Keen, Warwick Bruce	9 Osborne-avenue, North Geelong		9 Osborne-avenue, North Geelong	Process Server (Individual)	29.9.72
---------------------	---------------------------------	--	---------------------------------	-----------------------------	---------

Dated at Geelong this 1st day of September, 1972.

J. E. REILLY, Clerk of the Magistrates' Court.

## MAGISTRATES' COURT, BOX HILL.

Wigren, Bo Sture	7 Roy-street, Donvale	Centaur Service Patrol	57 High-street, Glen Iris	Watchman	21.9.72
------------------	-----------------------	------------------------	---------------------------	----------	---------

Dated at Box Hill this 31st day of August, 1972.

G. MURPHY, Clerk of the Magistrates' Court.

## MAGISTRATES' COURT, MELBOURNE.

Shell, Robert Noel	1/2 Blair-street, Coburg	Australian Watching Co. Pty. Ltd.	340 Abbotsford-street, North Melbourne	Watchman	27.9.72
Smith, Peter Ronald	Pretty Hill-lane, Wattle Glen	" " "	" " "	"	"
Uren, Raymond Leo	31 Raleighs-road, Melton	" " "	" " "	"	"
Beever, Margaret Vera	15 Susan-street, Bayswater	" " "	" " "	Inquiry Agent	"
Bates, Peter Bernard	39 Edmond-street, Parkdale	" " "	" " "	Watchman	"
Derum, John Michael	96 Barrow-street, Coburg	" " "	" " "	"	"
Jones, Eric	34 Empress-avenue, West Footscray	" " "	" " "	"	"
Lo Ricco, John Anthony	7 Marne-street, Surrey Hills	" " "	" " "	"	"
McLaren, Alex Ernest	100 Empress-avenue, Kingsville	" " "	" " "	"	"
Moloney, Bryan Vincent	2 Edward-street, Toorak	" " "	" " "	"	"
Dickson, Frederick	42 Melon-street, Braybrook	" " "	" " "	"	"

Dated at Melbourne this 1st day of September, 1972.

G. L. WEBSTER, Clerk of the Magistrates' Court.

## MAGISTRATES' COURT, SUNSHINE.

Aalders, Geoffrey Alan	8 Dundalk-street, Sunshine		8 Dundalk-street, Sunshine	Process Server	11.10.72
------------------------	----------------------------	--	----------------------------	----------------	----------

Dated at Sunshine this 5th day of September, 1972.

OWEN BOURKE, Clerk of the Magistrates' Court.

## MAGISTRATES' COURT, COBURG.

Halton, Harold Gordon	6 Rolland-court, Montmorency		88 Bakers-road, Coburg	Watchman	3.10.72
-----------------------	------------------------------	--	------------------------	----------	---------

Dated at Coburg this 5th day of September, 1972.

G. G. WILLIAMSON, Clerk of the Magistrates' Court.

## MAGISTRATES' COURT, FRANKSTON.

Trebilcote, George Alan	5/18 Dunoon-street, Murrumbena		3 Leighton-court, Frankston	Watchman	26.9.72
-------------------------	--------------------------------	--	-----------------------------	----------	---------

Dated at Frankston this 5th day of September, 1972.

J. W. DUNN, Clerk of the Magistrates' Court.

## MAGISTRATES' COURT, CARLTON.

Griffin, John James William	43 Old Geelong-road, Laverton	Gryphon Investigations	196 Pelham-street, Carlton	Process Server	3.10.72
Griffin, John James William	43 Old Geelong-road, Laverton	Gryphon Investigations	196 Pelham-street, Carlton	Inquiry Agent	3.10.72

Dated at Carlton this 8th day of September, 1972.

M. J. QUIRK, Clerk of the Magistrates' Court.

COUNTRY ROADS BOARD.

RESOLUTIONS OF THE COUNTRY ROADS BOARD.

The Country Roads Board, in pursuance of the provisions of the *Country Roads Act 1958*, has passed Resolutions the dates whereof and the terms of which are scheduled hereunder:—

SCHEDULE.

State Highway.

Resolution dated the Twenty-eighth day of August, One thousand nine hundred and seventy-two made pursuant to sections 21 and 74 of the *Country Roads Act 1958*, declaring the widening of the Glenelg Highway in the Shire of Glenelg as shown hatched on Plans numbered G.P.12520 and G.P.12521 hereunder to be part of a State highway within the meaning and for the purposes of the said Act.

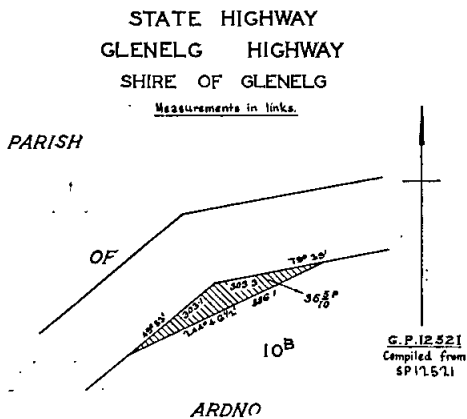
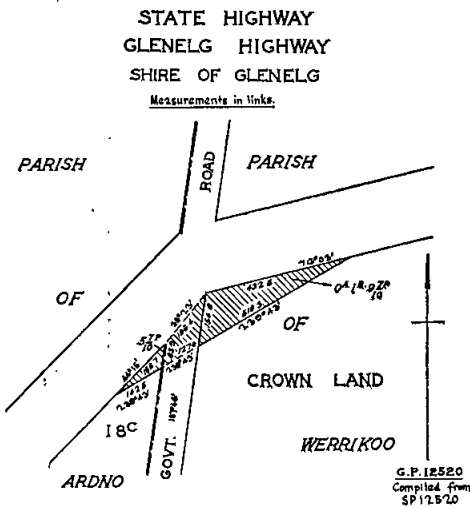

Main Roads.

Resolution dated the Twenty-eighth day of August, One thousand nine hundred and seventy-two made pursuant to section 21 of the *Country Roads Act 1958*, declaring the widening of the Warncoort-Birregurra road in the Shire of Colac as shown hatched on Plan numbered G.P.12505 hereunder to be part of a main road within the meaning and for the purposes of the said Act.

MAIN ROAD  
WARNCOORT - BIRREGURRA ROAD

SHIRE OF COLAC

Measurements in links

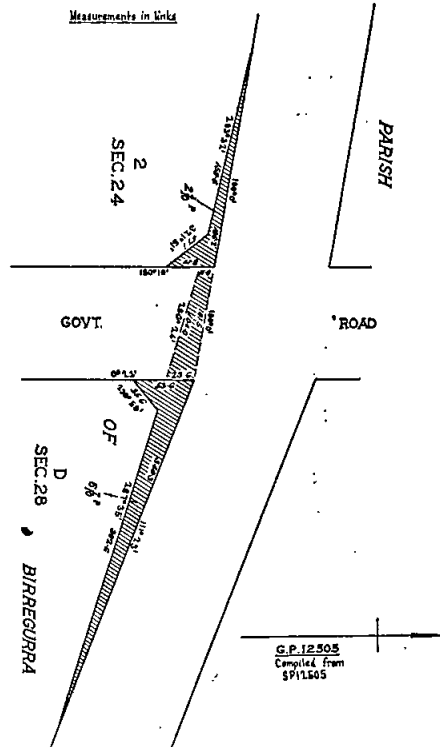

Resolution dated the Twenty-eighth day of August, One thousand nine hundred and seventy-two made pursuant to section 21 of the *Country Roads Act 1958*, declaring the widening of Mount Napier road in the Shire of Dundas as shown hatched on Plan numbered G.P.12374 hereunder to be part of a main road within the meaning and for the purposes of the said Act.

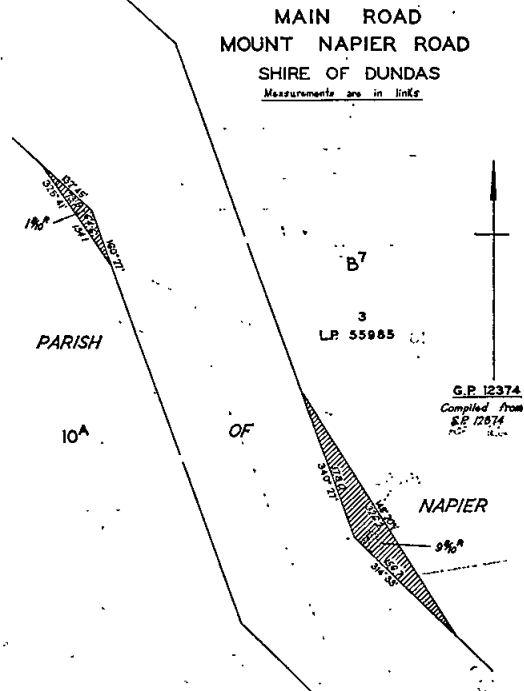

Resolution dated the Twenty-eighth day of August, One thousand nine hundred and seventy-two made pursuant to sections 21 and 58 of the *Country Roads Act 1958*, declaring the deviation from the Horsham-Lubeck road in the Shires of Dunmunkle and Wimmera as indicated by

diagonal hatching on Plan numbered G.P.12602 hereunder to be part of a main road within the meaning and for the purposes of the said Act, and also declaring that such deviation shall be in lieu of the existing road or part thereof indicated by cross-hatching on the said plan.

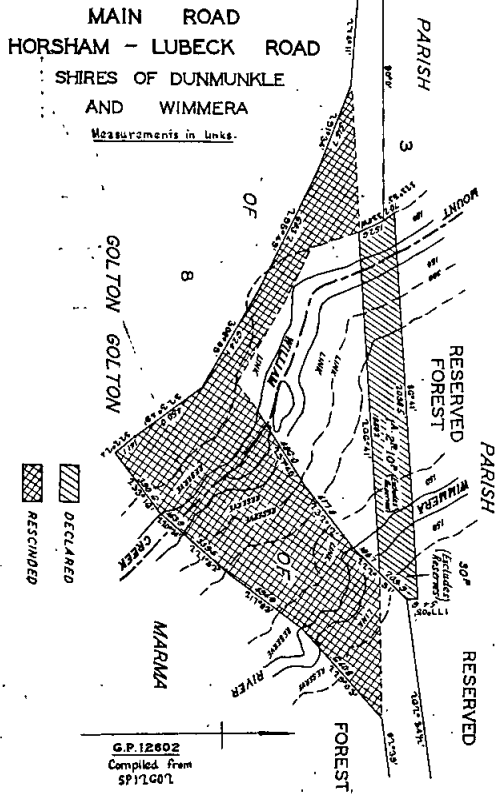

Resolution dated the Twenty-eighth day of August, One thousand nine hundred and seventy-two made pursuant to section 21 of the Country Roads Act 1958, declaring the widening of the Boort-Kerang road in the Shire of Gordon as shown hatched on Plan numbered G.P.12778 hereunder to be part of a main road within the meaning and for the purposes of the said Act.

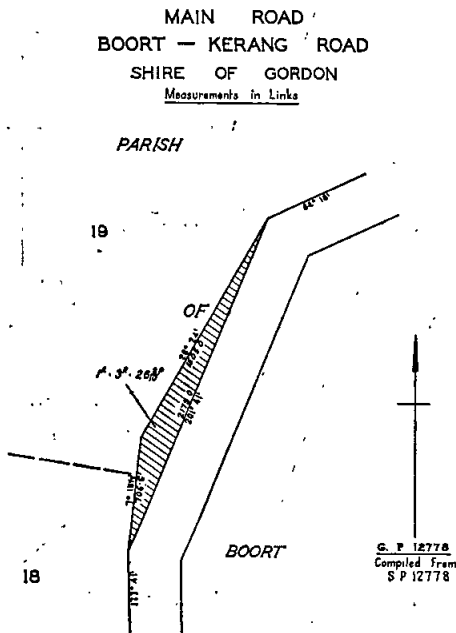

Resolution dated the Twenty-eighth day of August, One thousand nine hundred and seventy-two made pursuant to section 21 of the Country Roads Act 1958, declaring the widening of Springvale-road in the City of Nunawading as shown hatched on Plans numbered G.P.5986, G.P.5965A, G.P.5965B, G.P.5610 and G.P.10793 hereunder to be part of a main road within the meaning and for the purposes of the said Act.

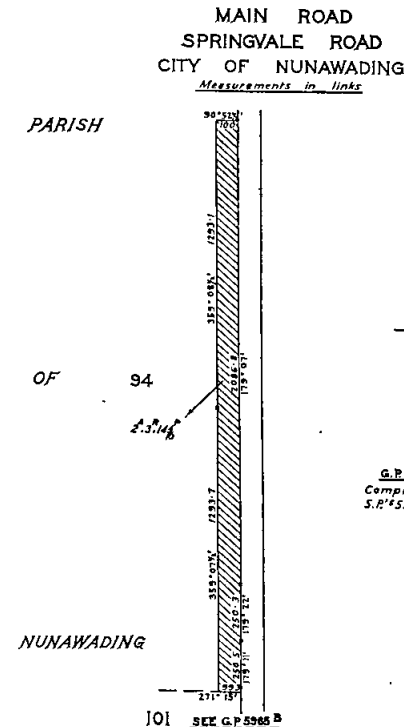
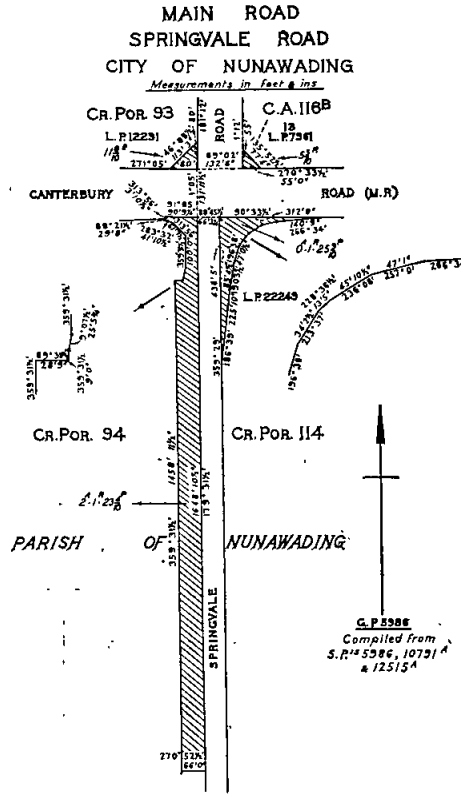



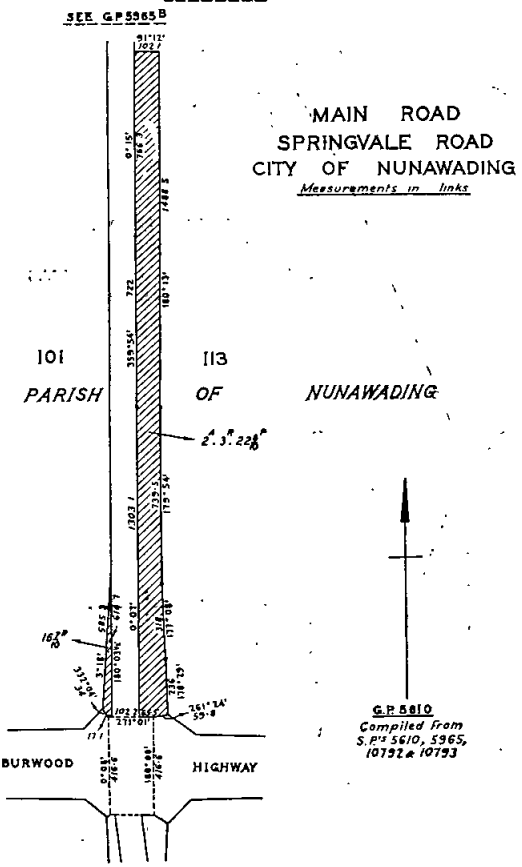
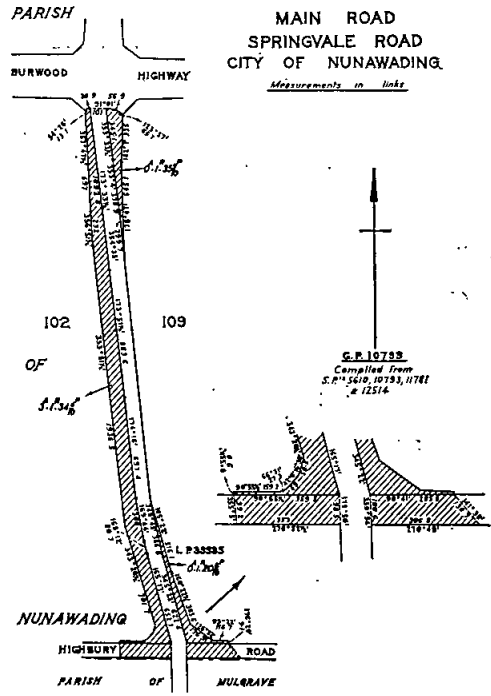
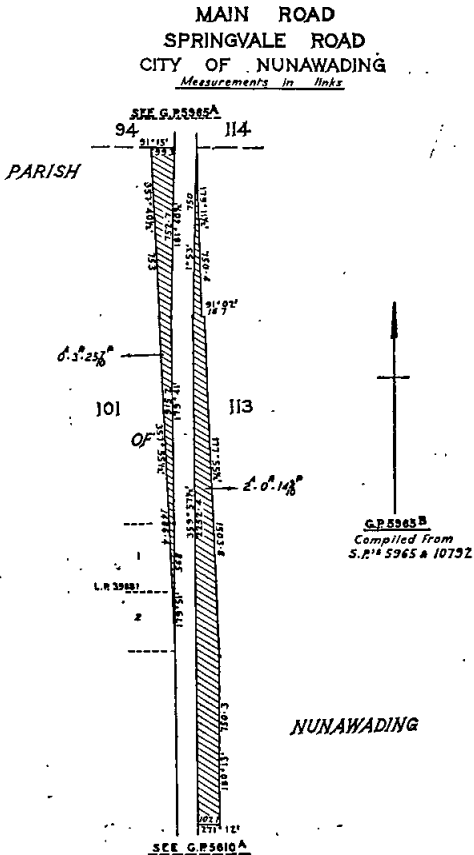

Resolution dated the Twenty-eighth day of August, One thousand nine hundred and seventy-two made pursuant to section 21 of the Country Roads Act 1958, declaring the widening of Bridgewater-road in the Shire of Portland as shown hatched on Plan numbered G.P.12526 hereunder to be part of a main road within the meaning and for the purposes of the said Act.

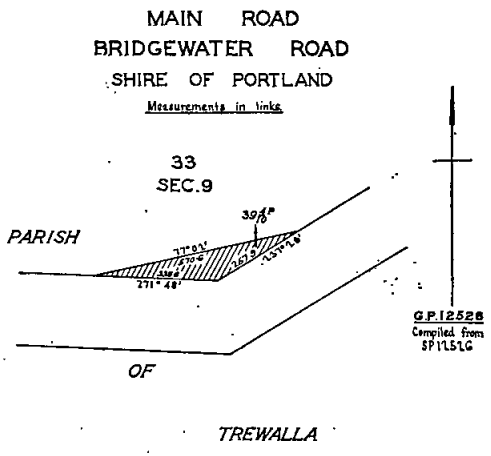

Resolution dated the Twenty-eighth day of August, One thousand nine hundred and seventy-two made pursuant to section 21 of the Country Roads Act 1958, declaring the widening of the Eurambeen-Streatham road in the Shire of Ripon as shown hatched on Plan numbered G.P.12772 hereunder to be part of a main road within the meaning and for the purposes of the said Act.

MAIN ROAD  
EURAMBEEN - STREATHAM ROAD  
SHIRE OF RIPON  
*Measurements in Links*

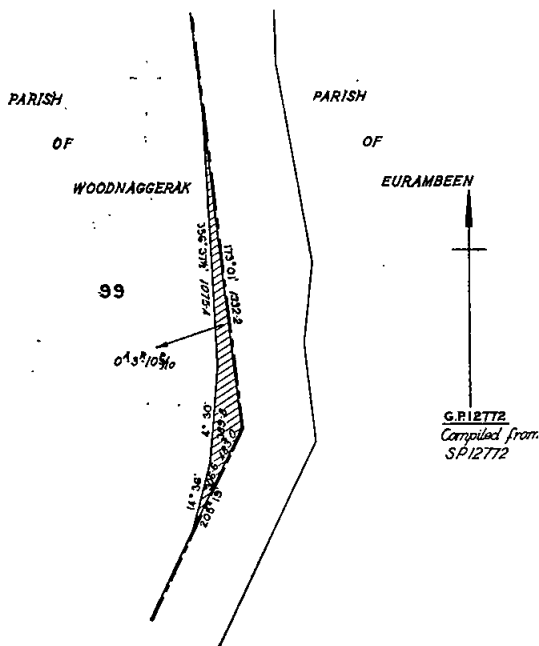

MAIN ROAD  
HAZELDEAN ROAD  
SHIRES OF WARRAGUL & NARRACAN  
*Measurements in Links*

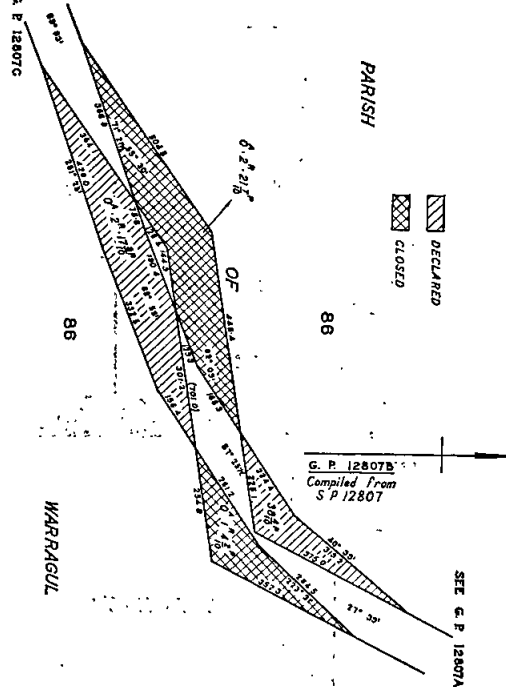

Resolution dated the Twenty-eighth day of August, One thousand nine hundred and seventy-two made pursuant to sections 21 and 58 of the *Country Roads Act 1958*, declaring the deviation from Hazeldean-road in the Shires of Warragul and Narracan as indicated by diagonal hatching on Plans numbered G.P.12807A, G.P.12807B and G.P.12807C hereunder to be part of a main road within the meaning and for the purposes of the said Act, and also declaring that such deviation shall be in lieu of the existing road or part thereof indicated by cross-hatching on Plans numbered G.P.12807A and G.P.12807B and that such part of the said existing road shall be discontinued.

MAIN ROAD  
HAZELDEAN ROAD  
SHIRES OF WARRAGUL & NARRACAN  
*Measurements in Links*

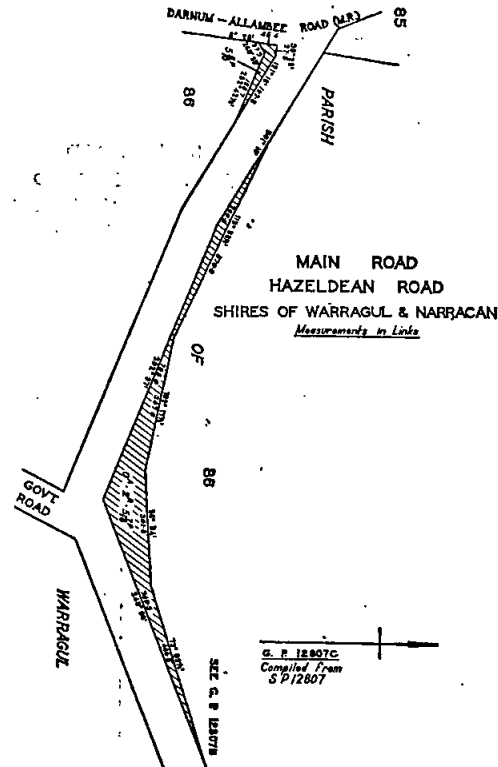

MAIN ROAD  
HAZELDEAN ROAD  
SHIRES OF WARRAGUL & NARRACAN  
*Measurements in Links*

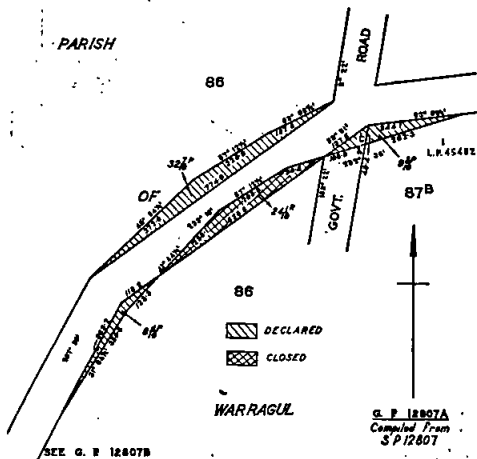

Resolution dated the Twenty-eighth day of August, One thousand nine hundred and seventy-two made pursuant to section 21 of the *Country Roads Act 1958*, declaring the widening of Kiewa East-road in the Shire of Yackandandah as shown hatched on Plan numbered G.P.12688A hereunder to be part of a main road within the meaning and for the purposes of the said Act.

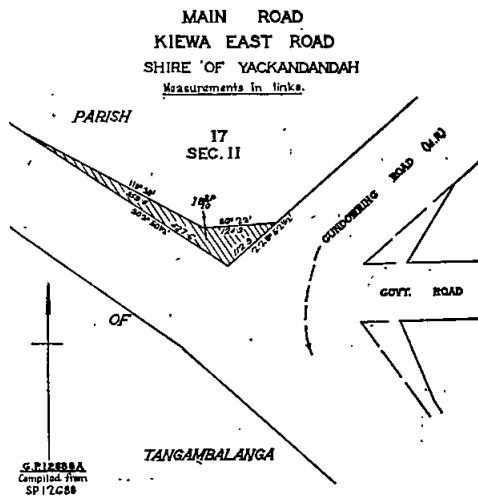

Resolution dated the Twenty-eighth day of August, One thousand nine hundred and seventy-two made pursuant to section 21 of the Country Roads Act 1958, declaring the widening of Gundowring-road in the Shire of Yackandandah as shown hatched on Plan numbered G.P.12688B hereunder to be part of a main road within the meaning and for the purposes of the said Act.

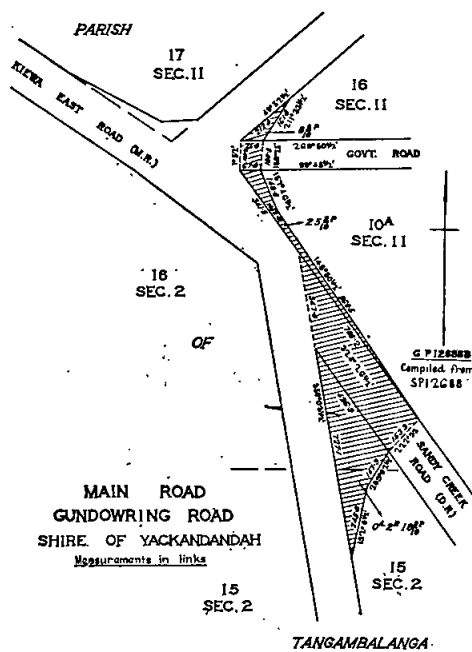

Freeway.

Resolution dated the Twenty-eighth day of August, One thousand nine hundred and seventy-two made pursuant to sections 21 and 101 of the Country Roads Act 1958, declaring the road in the Shires of Ballan and Buninyong as shown hatched on Plans numbered G.P.11735, G.P.11736, G.P.11737, G.P.11989, G.P.11990A, G.P.11991 and G.P.12292 hereunder to be a freeway (Western Freeway) within the meaning and for the purposes of the said Act.

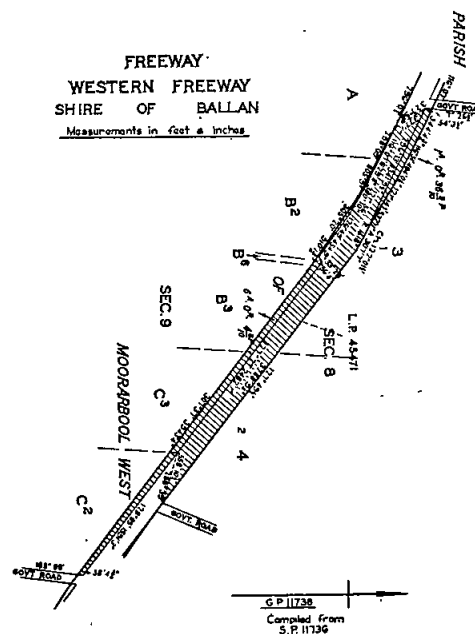
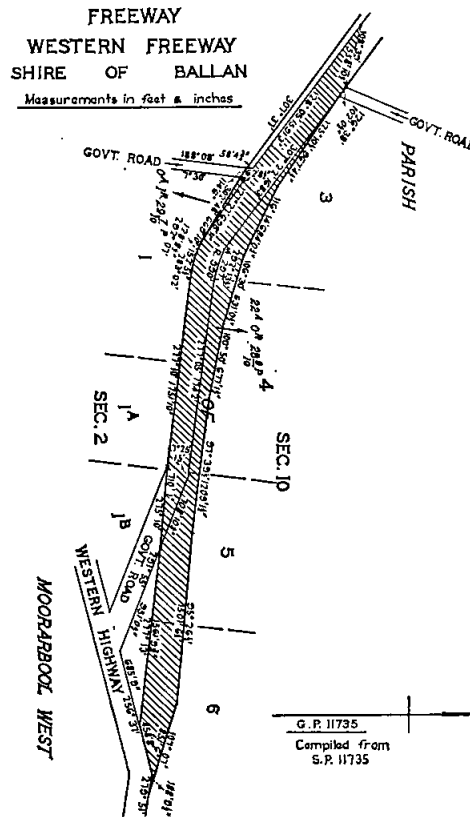

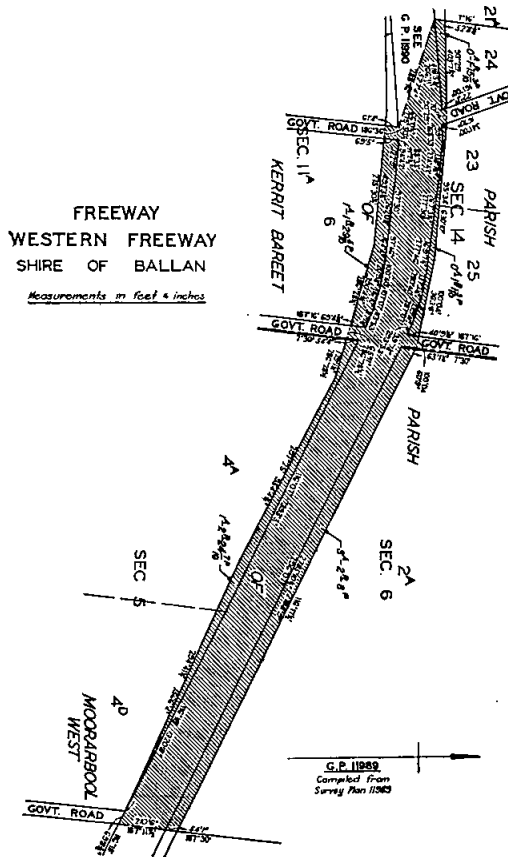
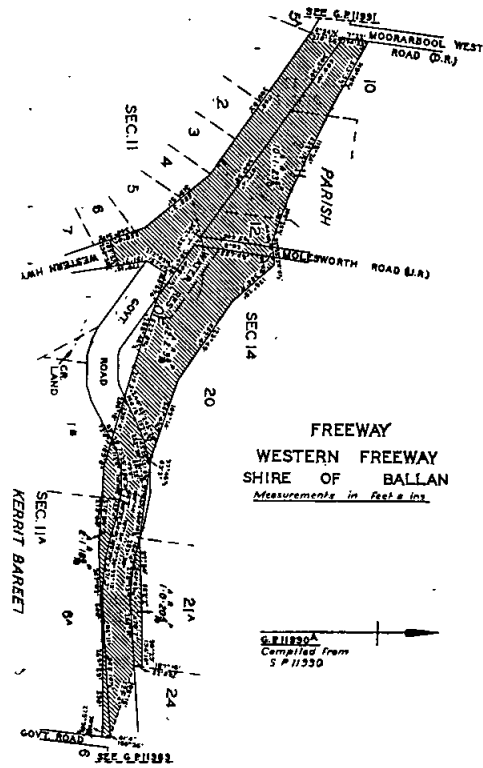
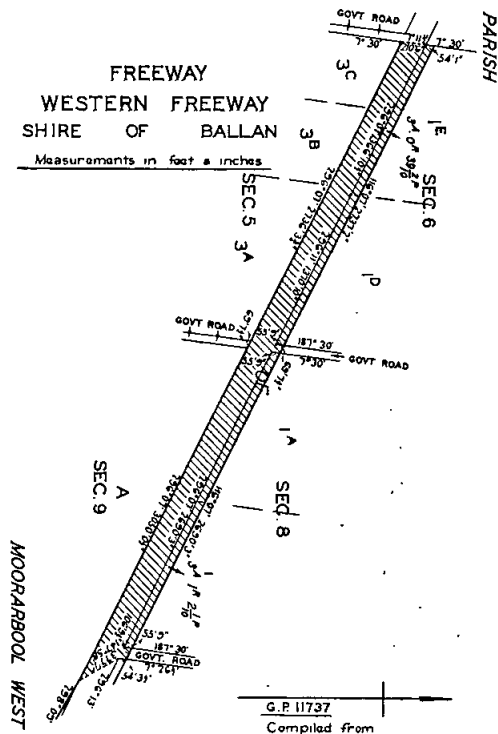

**FREWAY  
WESTERN FREWAY  
SHIRES OF BALLAN & BUNINYONG**  
Measurements in feet & inches

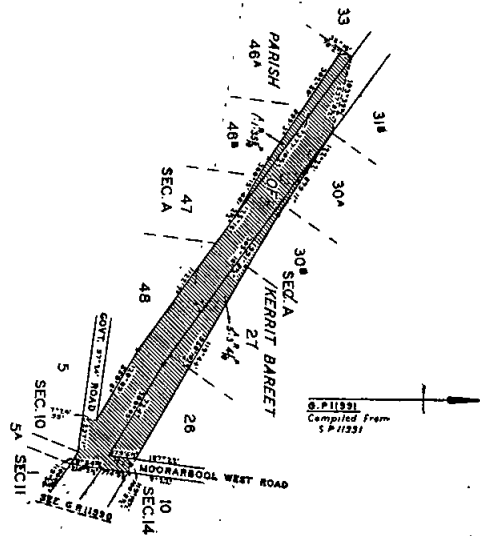

COUNTRY ROADS BOARD.

RESOLUTIONS OF THE COUNTRY ROADS BOARD.

The Country Roads Board, in pursuance of the provisions of the *Country Roads Act 1958*, has passed Resolutions the dates whereof and the terms of which are scheduled hereunder:—

SCHEDULE.

State Highways.

Resolution dated the Twenty-first day of August, One thousand nine hundred and seventy-two, made pursuant to sections 21 and 74 of the *Country Roads Act 1958*, declaring the widening of the Maroondah Highway in the City of Croydon as shown hatched on Plans numbered G.P.7348, G.P.7954 and G.P.10423 hereunder to be part of a State highway within the meaning and for the purposes of the said Act.

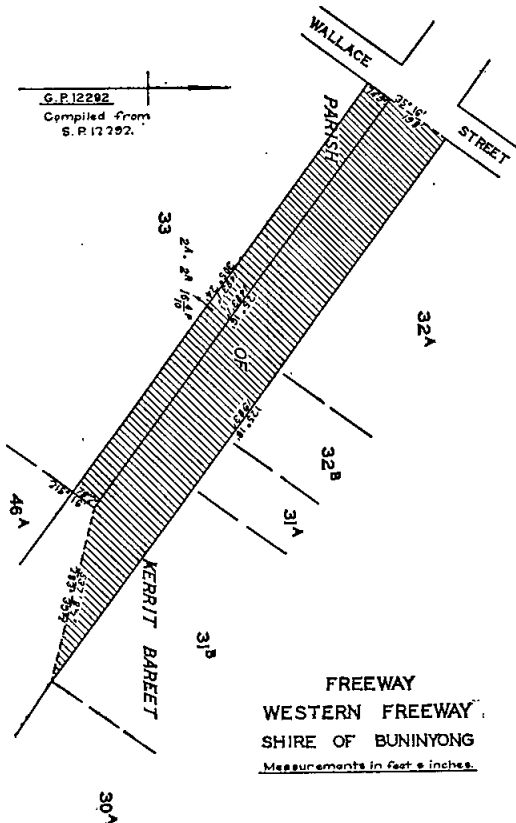

**FREEWAY**  
**WESTERN FREEWAY**  
SHIRE OF BUNINYONG  
*Measurements in feet & inches.*

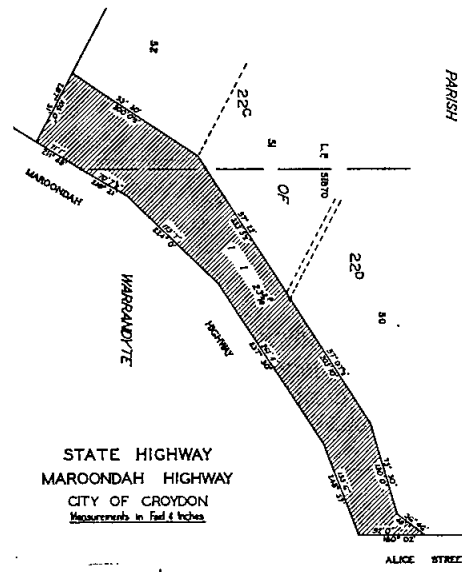

**STATE HIGHWAY**  
**MAROONDAH HIGHWAY**  
CITY OF CROYDON  
*Measurements in feet & inches.*

Tourists' Road.

Resolution dated the Twenty-eighth day of August, One thousand nine hundred and seventy-two made pursuant to sections 21 and 88 of the *Country Roads Act 1958*, declaring the widening of Arthurs Seat-road in the Shire of Flinders as shown hatched on Plan numbered G.P.12287 hereunder to be part of a tourists' road within the meaning and for the purposes of the said Act.

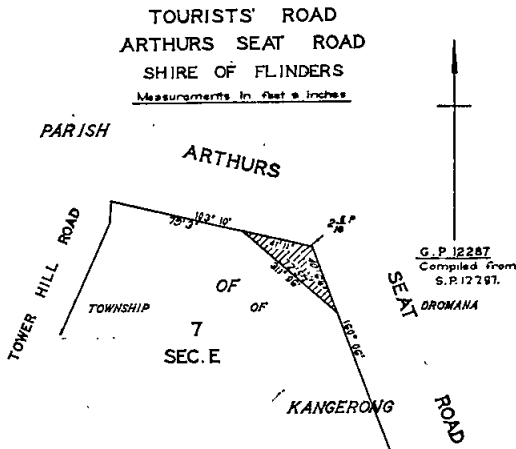

**TOURISTS' ROAD**  
**ARTHURS SEAT ROAD**  
SHIRE OF FLINDERS  
*Measurements in feet & inches.*

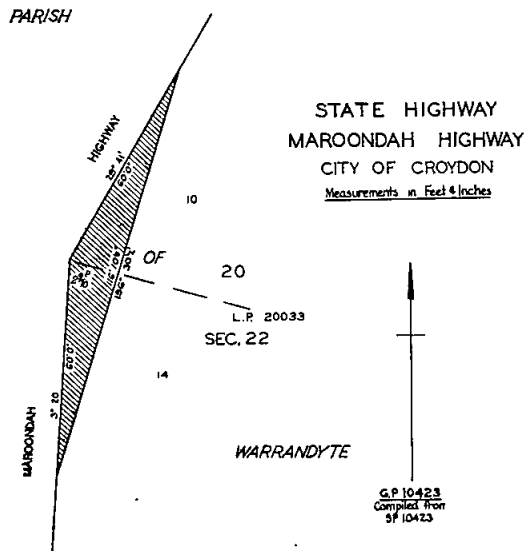

**STATE HIGHWAY**  
**MAROONDAH HIGHWAY**  
CITY OF CROYDON  
*Measurements in feet & inches.*

N. L. ALLANSON,  
Secretary.

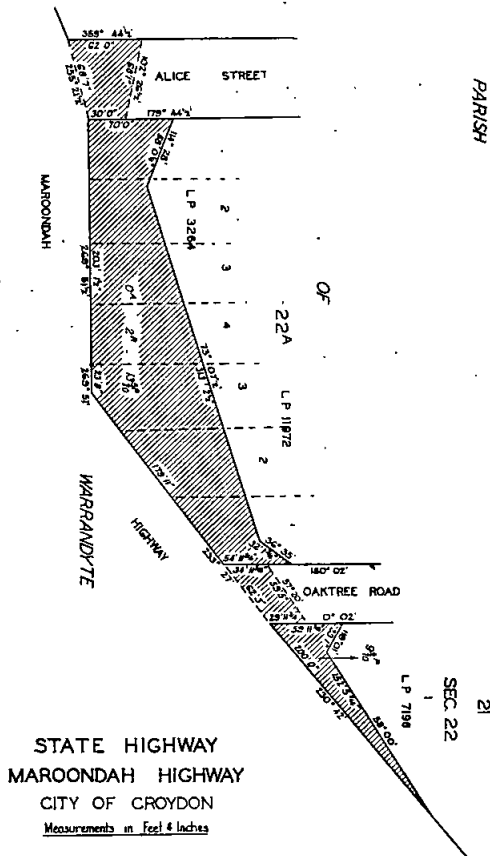

Resolution dated the Twenty-first day of August, One thousand nine hundred and seventy-two, made pursuant to sections 21 and 74 of the Country Roads Act 1958, declaring the widening of the Western Highway in the Town of Stawell as shown hatched on Plan numbered G.P.11389 hereunder to be part of a State highway within the meaning and for the purposes of the said Act.

**STATE HIGHWAY  
WESTERN HIGHWAY  
TOWN OF STAWELL**  
Measurements in links

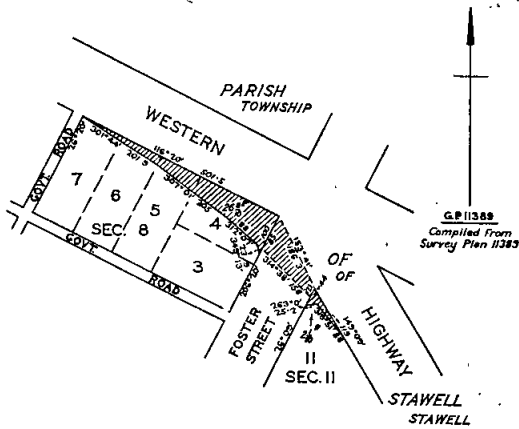

**Main Roads.**

Resolution dated the Twenty-first day of August, One thousand nine hundred and seventy-two, made pursuant to section 21 of the Country Roads Act 1958, declaring the widening of Anglesea-road in the Shire of Barrabool as shown hatched on Plan numbered G.P.12285 hereunder to be part of a main road within the meaning and for the purposes of the said Act.

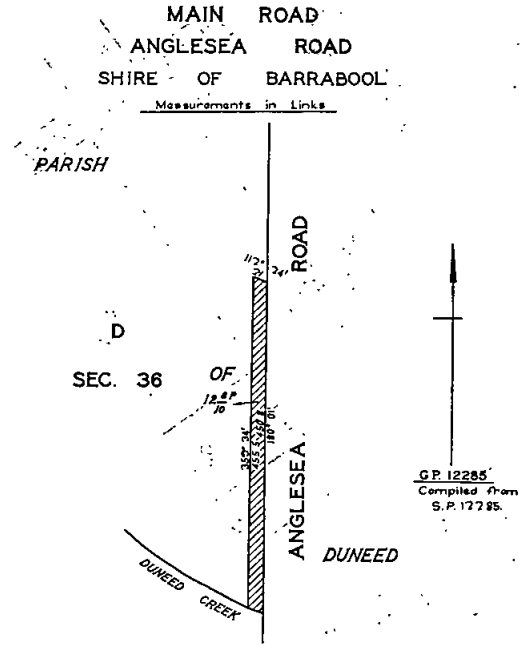

Resolution dated the Twenty-first day of August, One thousand nine hundred and seventy-two, made pursuant to sections 21 and 58 of the Country Roads Act 1958 declaring the deviation from the Dalyston-Glen Forbes road in the Shire of Bass as indicated by diagonal hatching on Plan numbered G.P.12548 hereunder to be part of a main road within the meaning and for the purposes of the said Act, and also declaring that such deviation shall be in lieu of the existing road or part thereof indicated by cross-hatching on the said plan and that such part of the said existing road shall be discontinued.

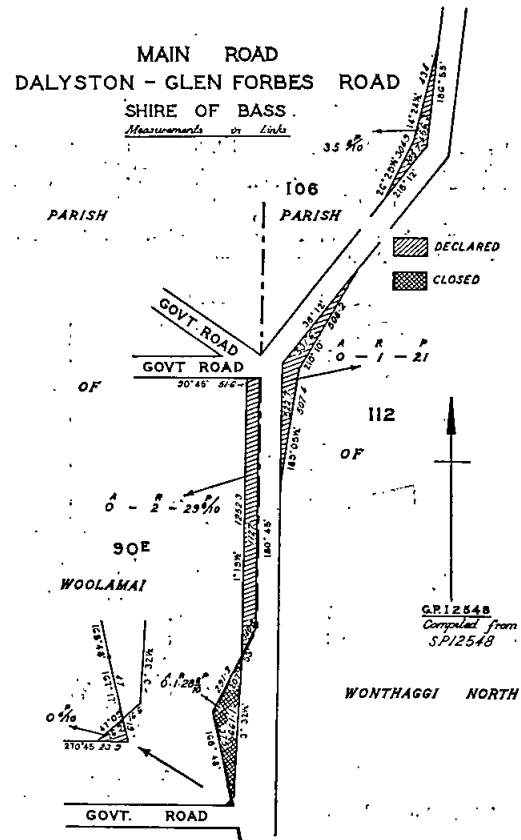

**WONTHAGGI NORTH**

Resolution dated the Twenty-first day of August, One thousand nine hundred and seventy-two, made pursuant to section 21 of the *Country Roads Act 1958*, declaring the widening of the Casterton-Edenhope road in the Shire of Glenelg as shown hatched on Plan numbered G.P.9603 hereunder to be part of a main road within the meaning and for the purposes of the said Act.

MAIN ROAD  
CASTERTON-EDENHOPE ROAD  
SHIRE OF GLENELG  
*Measurements in Links*

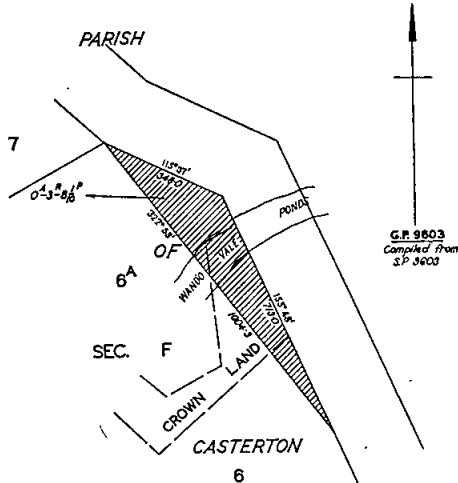

Resolution dated the Twenty-first day of August, One thousand nine hundred and seventy-two, made pursuant to section 21 of the *Country Roads Act 1958*, declaring the widening of the Belgrave-Gembrook road in the Shire of Sherbrooke as shown hatched on Plan numbered G.P.12318 hereunder to be part of a main road within the meaning and for the purposes of the said Act.

MAIN ROAD  
BELGRAVE-GEMBROOK ROAD  
SHIRE OF SHERBROOKE  
*Measurements in Feet & Ins*

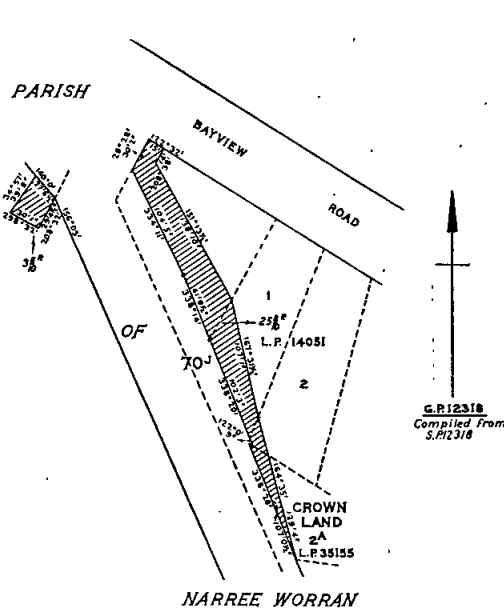

Resolution dated the Twenty-first day of August, One thousand nine hundred and seventy-two, made pursuant to section 21 of the *Country Roads Act 1958*, declaring the widening of the Wangaratta-Kilfeera road in the Shire of Oxley as shown hatched on Plan numbered G.P.12312 hereunder to be part of a main road within the meaning and for the purposes of the said Act.

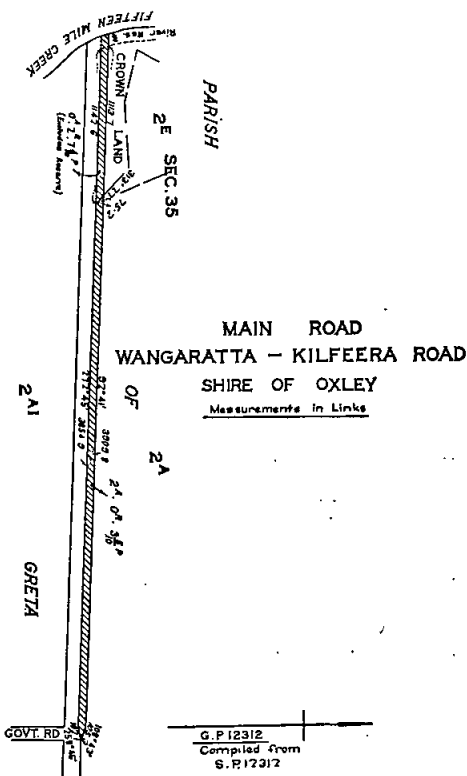

Resolution dated the Twenty-first day of August, One thousand nine hundred and seventy-two, made pursuant to section 21 of the *Country Roads Act 1958*, declaring the widening of the Rushworth-Stanhope road in the Shire of Waranga as shown hatched on Plan numbered G.P.12314 hereunder to be part of a main road within the meaning and for the purposes of the said Act.

MAIN ROAD  
RUSHWORTH-STANHOPE ROAD  
SHIRE OF WARANGA  
*Measurements in links*

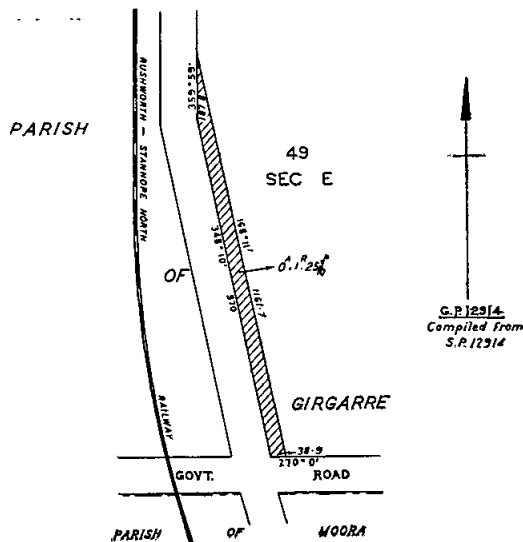

Unclassified Road.

Resolution dated the Twenty-first day of August, One thousand nine hundred and seventy-two, made pursuant to sections 21 and 110 of the Country Roads Act 1958, declaring the widening of Curtis-road in the Shire of Avoca as shown hatched on Plan numbered G.P.12795 hereunder to be part of a road within the meaning and for the purposes of the said Act.

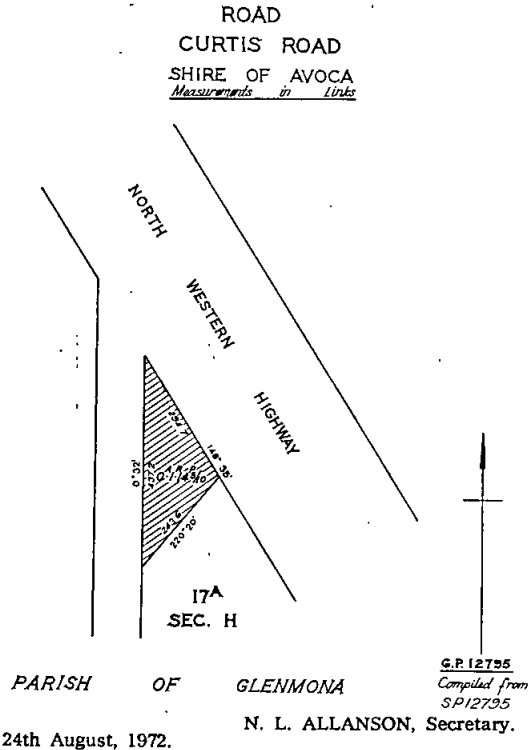

EXPLORATION LICENCE GRANTED.

397, Exploration Licence; Commonwealth Aluminium Corporation Ltd.; 300 square miles, County of Tambo.

EXPLORATION LICENCES CANCELLED.

191, Exploration Licence; Highland Gold Development N.L.; 212 square miles, County of Croajingolong.  
 192, Exploration Licence; Highland Gold Development N.L.; 343 square miles, County of Croajingolong.  
 269, Exploration Licence; Minefields Exploration N.L.; 483 square miles, Counties of Delatite and Bogong.

EXTRACTIVE INDUSTRY LICENCE GRANTED.

118, Extractive Industry Licence; Somerset Contracting Co. Pty. Ltd.; 11a. 0r. 23p., Parish of Tullamarine.

EXTRACTIVE INDUSTRY SEARCH PERMIT GRANTED.

26, Extractive Industry Search Permit; Marble Floors Pty. Ltd.; 553 acres, more or less, Parish of Enano.

APPLICATION FOR EXTRACTIVE INDUSTRY SEARCH PERMITS REFUSED.

10, Extractive Industry Search Permit; Rowlands Quarries Pty. Ltd.; 4,480 acres, more or less, Port Phillip Bay.  
 31, Extractive Industry Search Permit; Mountain View Quarry Pty. Ltd.; 5 square miles, Port Phillip Bay.

EXTRACTIVE INDUSTRY SEARCH PERMITS EXPIRED.

14, Extractive Industry Search Permit; The Victoria Portland Cement Co. Pty. Ltd.; 12.16 square miles, Parishes of Boodyarn, Mullungdung and Woodside.  
 24, Extractive Industry Search Permit; John Raymond Keith Edwards; 959 acres, more or less, Parish of French Island.

J. C. M. BALFOUR,  
 Minister of Mines.

Petroleum Act 1958.  
 MINES DEPARTMENT.

TERM OF PETROLEUM EXPLORATION PERMIT EXTENDED.

54. Petroleum Exploration Permit; Alliance Oil Development Australia No Liability; 380 square miles, Counties of Dundas and Normanby. Extended to 30th April, 1973.

J. C. M. BALFOUR,  
 Minister of Mines.

DEPARTMENT OF MINES.

Subject to any necessary excisions, &c., it is proposed to grant the following lease:—

9091, Mineral; The Colonial Sugar Refining Co. Ltd.; 543a. 3r. 16p., Parish of Goonegul.

APPLICATION FOR MINING LEASE DECLARED ABANDONED.

8965, Mineral; Stanley James Hewish; 12 acres, Parish of Merton.

APPLICATION FOR MINING LEASE REFUSED.

Gold Mining Lease No. 1; Lillian Thomas; 25 acres, Parish of Woosang.

MINING LEASE EXPIRED.

8648, Mineral; Rowlands Quarries Pty. Ltd.; 4a. 1r. 0p., Parish of Tanjil East.

APPLICATION FOR EXPLORATION LICENCE REFUSED.

373, Exploration Licence; William Lloyd Lange; 35 square miles, County of Benambra.

NOTICE TO MARINERS.

[No. 20(T) OF 1972.]

AUSTRALIA.—VICTORIA.

PORT PHILLIP.—CONSTRUCTION OF ETHANE GAS PIPELINE.

1. Further dredging operations.
2. Light to be established.

Reference Notices to Mariners Nos. 7 and 12(T) of 1972.

On or about 12th September, 1972.

(1) The trailing suction dredger "Geopotes V" will be dredging at the northern entrance to Symonds Channel and depositing the spoil along the route of the ethane gas pipeline being laid from Mordialloc to Altona. This dredger may also carry out some dredging along the pipeline route and will display appropriate lights and shapes as specified in the Rules for Preventing Collisions at Sea.

(2) An orange light showing one flash every three seconds, visible five miles, will be established on the single pile beacon at the northern entrance to Symonds Channel (Lat. 38 deg. 13 min. 40 sec. S., Long. 144 deg. 48 min. 40 sec. E. approx.) and a number of small marker buoys each equipped with a quick flashing white light will be laid south-westward of and within 2 miles of this beacon.

Charts Affected.—B.A. 309, 1171, Aus. 155.

A. J. WAGGLEN,  
 Port Officer.

Public Works Department,  
 Ports and Harbors Division,  
 2 Treasury-place, Melbourne, Vic. 3002.

4th September, 1972.



## NOTICE TO MARINERS.

[No. 21 of 1972.]

## AUSTRALIA.—VICTORIA.

## PORT PHILLIP.

Alteration in Station of Spoil Ground Light Buoy.

Date.—On or about 12th September, 1972.

Reference.—Timeball Tower Light (Williamstown Light-house).

Position.—Lat. 37 deg. 52 min. S., Long. 144 deg. 55 min. E. (approx.).

New Station of Light Buoy.—185 deg. 16 min. distant 7.21 miles from the reference position.

Depth at Buoy.—16m8 (55 ft.) mud.

Remarks.—Light characteristics and other details remain unchanged.

Spoil must not be dumped other than in the following area:—

Commencing in a position 192 degrees distant 2 cables from the new station of the light buoy, by a line bearing 102 degrees for 1½ cables; thence 192 degrees for 5 cables; thence 282 degrees for 2½ cables; thence 012 degrees for 5 cables; thence 192 degrees to point of commencement.

Charts Affected.—Aus. 155, B.A. 1171.

Publication.—Sailing Directions, Victoria, 1970, pages 290 and 291.

A. J. WAGGLEN,  
Port Officer.

Public Works Department,  
Ports and Harbors Division,  
2 Treasury-place, Melbourne, Victoria, 3002.  
6th September, 1972.

## Education Act 1958.

## SUMMONING OFFICER.

Under section 5 of the Education Act 1958, I hereby appoint—

Sergeant Graham Vincent Joyce,  
Sergeant Raymond Richard John Sheather, and  
Senior Constable Edmund Robert Capstick,  
to summon parents within the State of Victoria.

5th September, 1972.

IAN SMITH,  
Minister for Social Welfare.

## MENTAL HEALTH ACT 1959, SECTION 26.

Notice is hereby given that the following appointment has been made pursuant to section 26 of the Mental Health Act 1959, as from the 4th September, 1972:—

FRANCIS STEPHEN CLAREBROUGH, Secretary, Training Centre, Sunbury, vice Kenneth Milton Baird.

A. N. MATHIESON, Acting Secretary,  
Department of Health.

## Police Regulation Act 1958, Section 122.

## SALE OF UNCLAIMED MOTOR VEHICLE.

An owner is required for a blue Ford Mainline utility, unregistered, engine No. AVAR 1968.

This vehicle came into the possession of Police on the 30th January, 1972, and if not claimed, will be sold by public auction at the Brunswick Police Station, 620 Sydney-road, Brunswick, at 2 p.m., on Wednesday, the 20th September, 1972.

R. JACKSON,  
Chief Commissioner of Police.

## MUNICIPAL AUDITORS BOARD, VICTORIA.

The next examination for the Certificate of Competency as Municipal Auditor will be held in Melbourne on Wednesday, 23rd and Thursday 24th May, 1973.

Copies of the Regulations, syllabus and past examination papers may be obtained from the Board's Secretary, Local Government Department, 480 Collins-street, Melbourne, 3000. Telephone 6171-207.

Applications to sit should be forwarded on the appropriate form at least twenty-one days prior to the date of examination.

K. B. WILKINSON, Secretary,  
Municipal Auditors Board.

No. 84.—8120/72.—2

## COMPANIES ACT 1961.

Notice is hereby given in pursuance of section 308 (2) and 308 (3) of the Companies Act 1961 that at the expiration of three months from the date hereof the name of the following Companies will, unless cause is shown to the contrary, be struck off the Register and the said Companies will be dissolved.

Dated this 11th day of September, 1972.

E. B. MITCHAM,  
Deputy Registrar of Companies.Companies Office,  
Melbourne.

## COMPANIES ABOVE REFERRED TO.

Name of Company.	Number of Registration.
Ian H. Dancey Pty. Ltd. . . . .	27573
Radiological Services Pty. Ltd. . . . .	30617
Stanhill Consolidated Ltd. . . . .	33808
Pathological Services Pty. Ltd. . . . .	35508
P.L.M. Holdings Pty. Ltd. . . . .	35509
Radiological Services (Frankston) Pty. Ltd. . . . .	35510
Radiological Services (St. Kilda-road) Pty. Ltd. . . . .	35532
Chefmer Foundation Pty. Ltd. . . . .	39899
Dean Engineering Pty. Ltd. . . . .	41560
Radiological Services (Dandenong) Pty. Ltd. . . . .	43190
Radiological Services (Newtown) Pty. Ltd. . . . .	43253
Clinic Hire Car Service Pty. Ltd. . . . .	43463
Stanhill Development Finance Ltd. . . . .	44707
Radiological Services (Thornbury) Pty. Ltd. . . . .	47805
Gleaming Cleaners Pty. Ltd. . . . .	48762
Cartier Pty. Ltd. . . . .	48959
Eton Square Investments Pty. Ltd. . . . .	56605
Manor Quarries Pty. Ltd. . . . .	56971
Keath Quarries Pty. Ltd. . . . .	58095
Wimmera Liquid Cartage Pty. Ltd. . . . .	64783
Hartog Chisnall & Associates Pty. Ltd. . . . .	64959
Renewed Appliances Pty. Ltd. . . . .	68746
R.S.B. Surface Finishers Pty. Ltd. . . . .	70833
C.S.E. (Sales) Pty. Ltd. . . . .	72581

## PLACE NAMES COMMITTEE.

## NOTICE OF INTENTION TO ALTER A NAME.

Pursuant to the powers conferred under section 28 of the above Act the Place Names Committee hereby gives notice of its intention to alter the name of the Creek mentioned hereunder:—

Municipality.—Shire of Wannon.

Location.—From its source in allotment 1, Parish of Carrak to its junction with Bryan Creek.

Present Name.—Bryan Creek East Branch.

Proposed Name.—Chin Chap Creek.

Any person who objects to the above proposal, may give notice of objection, in writing, stating the reasons therefor, to the Secretary of the Committee not more than two (2) months following the publication of this notice.

By order of the Committee,

C. E. E. BARLOW,  
Secretary.

## LOCAL GOVERNMENT DEPARTMENT.

## ORDER CONFIRMED.—CITY OF KNOX.

The Minister for the Crown administering the Local Government Act 1958, on the 7th day of September, 1972, confirmed the Order hereinafter referred to in pursuance of section 514 of the said Act namely:—

An Order of the Council of the City of Knox made on the 16th May, 1972, directing the compulsory taking of the land described hereunder for the purpose of realigning Underwood-road, Fern Tree Gully.

(a) All that piece of land being part of lot 30 on Plan of Subdivision No. 10374 lodged at the Office of Titles commencing at a point being the intersection of the eastern alignment of Underwood-road and the northern alignment of Underwood-road, thence by a line bearing 35° 56' for 29 ft. 10 in., thence 73 ft. 2½ in. by the arc of a circle which has a radius of 244 ft. 10½ in. and a chord bearing 314° 30' 02" for 72 ft. 11½ in., thence by lines bearing 244° 50' for 0 ft. 8½ in. and 154° 50' for 82 ft. 9½ in. to the point of commencement.

(b) All that piece of land being part of lot 31 on Plan of Subdivision No. 10374 lodged at the Office of Titles commencing at a point being the intersection of the eastern alignment of Underwood-road and the northern alignment of Underwood-road, thence by a line bearing 97°

3' for 86 ft. 8 in., thence 77 ft. 2 in. by the arc of a circle which has a radius of 244 ft. 10½ in. and a chord bearing 296° 54' 23" for 76 ft. 0 in., thence by a line bearing 215° 56' for 29 ft. 10 in. to the point of commencement.

A. J. HUNT,  
Minister for Local Government.

Local Government Department,  
Melbourne (21813123).

lots 11 and 23, on plan of subdivision No. 160 lodged at the Office of Titles for the purpose of providing places of public resort and recreation.

A. J. HUNT,  
Minister for Local Government.

Local Government Department,  
Melbourne (1831947).

LOCAL GOVERNMENT DEPARTMENT.

ORDER CONFIRMED.—CITY OF NUNAWADING.

The Minister of the Crown administering the *Local Government Act 1958*, on the 7th day of September, 1972, confirmed the Order hereinafter referred to in pursuance of the provisions of section 514 of the *Local Government Act 1958*.

An Order of the Council of the City of Nunawading made on the 13th December, 1971, directing the compulsory taking of certain land being part of the land described in a Conveyance registered at the Office of the Registrar-General by Memorial No. 194, Book 89, and being the land shown by hachure on the plan hereunder for the purpose of providing a site for the erection of low rental housing units.

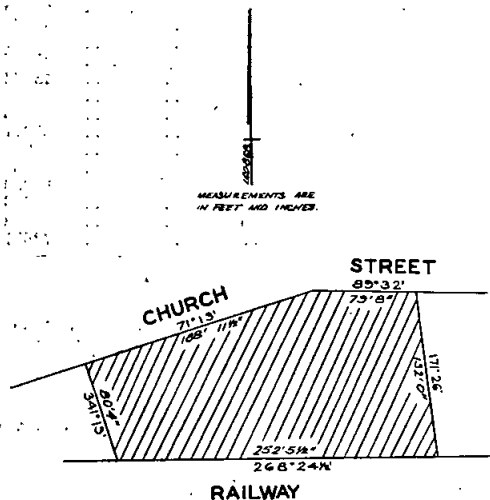

A. J. HUNT,  
Minister for Local Government.

Local Government Department,  
Melbourne (27813111).

LOCAL GOVERNMENT DEPARTMENT.

ORDER CONFIRMED.—SHIRE OF FLINDERS.

The Minister of the Crown administering the *Local Government Act 1958*, on the 7th day of September, 1972, confirmed the Order hereinafter referred to in pursuance of section 514 of the said Act namely:—

An Order of the Council of the Shire of Flinders made on the 5th July, 1972, directing the compulsory taking of a drainage easement over all that piece of land being part of the land described in certificate of title, volume 8094, folio 655, commencing at the southernmost corner of the said land; thence by lines bearing 0 deg. 48 min. for 151 ft. 3 in.; 55 deg. 53 min. for 9 ft. 9 in.; 180 deg. 48 min. for 151 ft. 3 in. and 235 deg. 53 min. for 9 ft. 9 in. to the point of commencement.

A. J. HUNT,  
Minister for Local Government.

Local Government Department,  
Melbourne (1831948).

LOCAL GOVERNMENT DEPARTMENT.

ORDER CONFIRMED.—SHIRE OF FLINDERS.

The Minister of the Crown administering the *Local Government Act 1958*, on the 7th day of September, 1972, confirmed the Order hereinafter referred to in pursuance of section 514 of the said Act namely:—

An Order of the Council of the Shire of Flinders made on the 5th July, 1972, directing the compulsory taking of

LOCAL GOVERNMENT DEPARTMENT.

ORDER CONFIRMED.—CITY OF KNOX.

The Minister of the Crown administering the *Local Government Act 1958*, on the 7th day of September, 1972, confirmed the Order hereinafter referred to in pursuance of section 514 of the said Act namely:—

An Order of the Council of the City of Knox made on the 1st August, 1972, directing the compulsory taking of lot 7, on plan of subdivision No. 9358, lodged at the Office of Titles for the purpose of providing a place of public resort and recreation.

A. J. HUNT,  
Minister for Local Government.

Local Government Department,  
Melbourne (21813125).

KERANG WATERWORKS TRUST.

By-Law No. 10.

Restrictions on the Use of Water—Stage three.

The Kerang Waterworks Trust (hereinafter referred to as "The Trust") in pursuance and exercise of the powers conferred by the *Water Act 1958* doth hereby make the By-Law following, restricting the use for other than domestic purposes of water supplied by the said Trust within its District.

1. This By-Law shall apply to and have force throughout the whole of the Kerang Waterworks District, and shall come into operation at such time or times as the Trust directs by notice published in a newspaper circulating generally within the Waterworks Trust District, and shall cease to operate at such time as the Trust by notice so published.

2. Notwithstanding anything contained in any other By-Law of the Trust, during the period of operation of this By-Law and subject to the provisions of clauses 3 and 4 of this By-Law no person shall, with water supplied by the Trust—

- (a) Water any garden, lawn, plantation, orchard, uncovered place, tree, plant or vegetation within the specified area except during the hours of 6 p.m. and 8 p.m. of each day and then only by means of a can or other vessel held in the hand.
- (b) Fill, add to or cleanse any private Swimming Pool within the specified area.

3. No person, shall, with water supplied by the Trust, water any land comprising sports grounds, golf courses, race courses, public and club bowling and croquet greens and public and club tennis courts within the specified area by means of fixed sprinklers except between the hours of 6 p.m. and 8 p.m. of each day. (Maximum of three sprinklers.)

4. No person shall, with water supplied by the Trust, water any commercial market gardens, commercial nurseries, or land used for growing green feed for commercial poultry farms within the specified area by means of fixed sprinklers except between the hours of 4 a.m. and 7 a.m. of each day. (Maximum of three sprinklers.)

5. No person shall, with water supplied by the Trust by means of a hose:

- (a) wash any vehicle, including cars, trailers, caravan & boats.
- (b) wash any paths, walks or buildings.

6. The occupier of any premises shall not permit or suffer any hose therein to be connected to any tap, stopcock or pipe supplied with water by the Trust other than during the approved times for the use of hoses set out in clauses 3 and 4 above.

7. Every person who uses or permits or suffers water supplied by the Trust to be used contrary to the provisions of this By-Law shall be guilty of a breach of this By-Law.

8. Every person guilty of a breach of this By-Law shall for every breach be liable to a penalty not exceeding one hundred dollars (\$100).

9. If any person supplied with water by the Trust wrongfully does or causes or permits to be done anything in contravention of this By-Law, the Trust may (without prejudice to any remedy in respect thereof) close or cut off any of the pipes by which water is supplied to him or for his use and may cease to supply him with water as provided by the *Water Act 1958*.

The foregoing By-Law was made and passed by the Commissioners of the Kerang Waterworks Trust, on the fifth day of July, 1972.

And the common seal of the said Trust was hereunto affixed the 2nd day of August, 1972, in the presence of—

(SEAL) D. H. H. JONES, Chairman.  
S. F. COUGHLAN, Commissioner.  
D. F. DREW, Secretary.

Approved by the Governor in Council, 12th September, 1972.—T. J. FORRISTAL, Clerk of the Executive Council.

#### KERANG WATERWORKS TRUST.

##### By-Law No. 11.

###### *Restrictions on the use of Water—Stage Four.*

The Kerang Waterworks Trust (hereinafter referred to as "The Trust") in pursuance and exercise of the powers conferred by the *Water Act 1958* doth hereby make the By-Law following, restricting the use for other than domestic purposes of water supplied by the said Trust within the district.

1. This By-Law shall apply to and have force throughout the whole of the Kerang Waterworks District, and shall come into operation at such time or times as the Trust directs by notice published in a newspaper circulating generally within the Waterworks District, and shall cease to operate at such time or times as the Trust may direct by notice so published.

2. Notwithstanding anything contained in any other By-Law of the Trust, during the period of operation of this By-Law and subject to the provisions of clauses 3 and 4 of this By-Law no person shall, with water supplied by the Trust—

(a) Water any garden, lawn, plantation, orchard, uncovered place, tree, plant or vegetation within the specified area.

(b) Fill, add to or cleanse any private Swimming Pool within the specified area.

3. No person shall with water supplied by the Trust, water any land comprising sports grounds, golf courses, race courses, public and club bowling and croquet greens and public and club tennis courts within the specified area.

4. No person shall, with water supplied by the Trust water any commercial market gardens, commercial nurseries, or land used for growing green feed for commercial poultry farms within the specified area.

5. No person shall, with water supplied by the Trust—

(a) wash any vehicle, including cars, trailers, caravans and boats.

(b) wash any paths, walks and buildings.

6. The occupier of any premises shall not permit or suffer any hose therein to be connected to any tap, stopcock or pipe supplied with water by the Trust.

7. Every person who uses or permits or suffers water supplied by the Trust to be used contrary to the provisions of this By-Law shall be guilty of a breach of this By-Law.

8. Every person guilty of a breach of this By-Law shall for every breach, be liable to a penalty not exceeding one hundred dollars (\$100).

9. If any person supplied with water by the Trust wrongfully does or causes or permits to be done anything in contravention of this By-Law, the Trust may (without prejudice to any remedy in respect thereof) close or cut off any of the pipes by or through which water is supplied to him or for his use and may cease to supply him with water as provided by the *Water Act 1958*.

The foregoing By-Law was made and passed by the Commissioners of the Kerang Waterworks Trust, on the fifth day of July, 1972.

And the common seal of the said Trust was hereunto affixed the 2nd day of August, 1972, in the presence of—

(SEAL) D. H. H. JONES, Chairman.  
S. F. COUGHLAN, Commissioner.  
D. F. DREW, Secretary.

Approved by the Governor in Council, 12th September, 1972.—T. J. FORRISTAL, Clerk of the Executive Council.

#### KERANG WATERWORKS TRUST.

##### By-Law No. 8.

###### *Restrictions on the use of water—Stage One.*

The Kerang Waterworks Trust (hereinafter referred to as "The Trust") in pursuance and exercise of the powers conferred by the *Water Act 1958* doth hereby make the By-Law following, restricting the use for other than domestic purposes of water supplied by the said Trust within its district.

1. This By-Law shall apply to and have force throughout the whole of the Kerang Waterworks District, and shall come into operation at such time or times as the Trust directs by notice published in a newspaper circulating generally within the Waterworks District, and shall cease to operate at such time or times as the Trust may direct by notice so published.

2. Subject to the provisions of Clauses 3 and 4 of this By-Law no person shall, with water supplied by the Trust—

(a) Water any garden, lawn, plantation, orchard, uncovered place, tree, plant or vegetation within the specified area except by means of a hose held in the hand, or by means of a can or other vessel held in the hand.

(b) Fill, add to or cleanse any private Swimming Pool within the specified area, except during periods in accordance with conditions stipulated by notice in writing to each of the proprietors, or bodies concerned following application to the Trust by such proprietors or bodies.

3. No person shall, with water supplied by the Trust, water any land comprising sports grounds, golf courses, race courses, public and club bowling and croquet greens and public and club tennis courts within the specified area by means of fixed sprinklers except between the hours of 4 a.m. and 10 a.m. of each day.

4. No person shall, with water supplied by the Trust water any commercial Market gardens, commercial nurseries, or land used for growing greenfeed for commercial poultry farms within the specified area by means of fixed sprinklers except between the hours of 4 a.m. and 10 a.m. of each day.

5. Every person who uses or permits or suffers water supplied by the Trust to be used contrary to the provisions of this By-Law shall be guilty of a breach of this By-Law.

6. Every person guilty of a breach of this By-Law, shall for every breach, be liable to a penalty not exceeding one hundred dollars (\$100).

7. If any person supplied with water by the Trust wrongfully does or causes or permits to be done anything in contravention of this By-Law, the Trust may (without prejudice to any remedy in respect thereof) close or cut off any of the pipes by or through which water is supplied to him or for his use and may cease to supply him with water as provided by the *Water Act 1958*.

8. The foregoing By-Law was made and passed by the Commissioners of the Kerang Waterworks Trust the fifth day of July, 1972.

And the common seal of the said Trust was hereunto affixed the 2nd day of August, 1972, in the presence of—

(SEAL) D. H. H. JONES, Chairman.  
S. F. COUGHLAN, Commissioner.  
D. F. DREW, Secretary.

Approved by the Governor in Council, 12th September, 1972.—T. J. FORRISTAL, Clerk of the Executive Council.

#### KERANG WATERWORKS TRUST.

##### By-Law No. 9.

###### *Restrictions on the use of Water—Stage Two.*

The Kerang Waterworks Trust (hereinafter referred to as "The Trust") in pursuance and exercise of the powers conferred by the *Water Act 1958* doth hereby make the By-Law following, restricting the use for other than domestic purposes of water supplied by the said Trust within its district.

1. This By-Law shall apply to and have force throughout the whole of the Kerang Waterworks District, and shall come into operation at such time or times as the Trust directs by notice published in a newspaper circulating generally within the Waterworks District, and shall cease to operate at such time or times as the Trust may direct by notice so published.

2. Notwithstanding anything contained in any other By-Law of the Trust, during the period of operation of this By-Law and subject to the provisions of clauses 3 and 4 of this By-Law no person shall, with water supplied by the Trust—

- (a) Water any garden, lawn, plantation, orchard, uncovered place, tree, plant or vegetation within the specified area except by means of a hose held in the hand, or by means of a can or other vessel held in the hand.
- (b) Fill, add to or cleanse any private Swimming Pool within the specified area, except during periods in accordance with conditions stipulated by notice in writing to each of the proprietors, or bodies concerned following application to the Trust by such proprietors or bodies.

3. No person, shall, with water supplied by the Trust, water any land comprising sports ground, golf courses, race courses, public and club bowling and croquet greens and public and club tennis courts within the specified area by means of fixed sprinklers except between the hours of 6 p.m. and 8 p.m. of each day. (Maximum of three sprinklers.)

4. No person shall, with water supplied by the Trust, water any commercial market gardens, commercial nurseries, or land used for growing greenfeed for commercial poultry farms within the specified area by means of fixed sprinklers except between the hours of 4 a.m. and 7 a.m. of each day. (Maximum of 3 sprinklers.)

5. No person shall, with water supplied by the Trust by means of a hose:

- (a) Wash any vehicle, including cars, trailers, caravans and boats.
- (b) Wash any paths, walks or buildings.

6. The occupier of any premises shall not permit or suffer any hose therein to be connected to any tap, stopcock or pipe supplied with water by the Trust other than during the approved times for the use of hoses set out in clauses 2, 3, and 4 above.

7. Every person who uses or permits or suffers water supplied by the Trust to be used contrary to the provisions of this By-Law shall be guilty of a breach of this By-Law.

8. Every person guilty of a breach of this By-Law; shall for every breach, be liable to a penalty not exceeding one hundred dollars (\$100).

9. If any person supplied with water by the Trust wrongfully does or causes or permits to be done anything in contravention of this By-Law, the Trust may (without prejudice to any remedy in respect thereof) close or cut off any of the pipes by or through which water is supplied to him or for his use and may cease to supply him with water as provided by the *Water Act 1958*.

The foregoing By-Law was made and passed by the Commissioners of the Kerang Waterworks Trust, on the fifth day of July, 1972.

And the common seal of the said Trust was hereunto affixed the 2nd day of August, 1972, in the presence of—

(SEAL) D. H. H. JONES, Chairman.  
S. F. COUGHLAN, Commissioner.  
D. F. DREW, Secretary.

Approved by the Governor in Council, 12th September, 1972.—T. J. FORRISTAL, Clerk of the Executive Council.

#### MINERS REST WATERWORKS TRUST. ANNUAL BALANCE.

His Excellency the Governor of the State of Victoria by and with the advice of the Executive Council thereof doth by Order made on the 12th day of September, 1972, and in pursuance of the provisions of the *Water Act*, fix the 31st day of December in each year as the day to which the accounts of the Miners Rest Waterworks Trust shall be balanced.

T. J. FORRISTAL,  
Clerk of the Executive Council.

At the Executive Council Chamber,  
Melbourne, 12th September, 1972.

#### PUBLIC TRUSTEE ACT 1958 (No. 6350), SECTION 17.

I hereby give notice that on the 23rd August, 1972, the Public Trustee filed elections to administer the following deceased persons' estates, in accordance with section 17 of the *Public Trustee Act 1958*.

PERRY, ROYDON JOHN GARNET, late of Kew, retired master mariner, died 7th February, 1972.

PRIEST, SYDNEY PHILLIP, formerly of West Camp, Yal-lourn, but late of 8 Gilsland-road, Murrumbidgee, retired plant attendant, died 14th May, 1972.

RODAKIS, IDA MINNIE, late of 42 Alamein-avenue, Ash-burton, married woman, died 29th December, 1971.

SOKOLOWSKI, WALTER, late of 5 Wynnstay-road, East Prahran, retired painter, died 12th February, 1972.

SPAULDING, REGINALD JOHN, late of Sonoma-street, Collins-ville, Queensland, shire council employee, died 11th July, 1971.

STOJNIC, LUCIANO, late of Ellerslie Estate, Myrree, labourer, died 24th December, 1971.

SYMONS, MARINA, late of Alexander Home and Hospital for the Aged, Castlemaine, spinster, died 13th May, 1972.

WALTER BERYL LAWRENCE, formerly of 10 Beresford-street, Pascoe Vale South, and 3 Thorne-court, Doncaster East, late of 47 Bennett-street, Forest Hill, married woman, died 27th May, 1972.

WILLIAMS, TRESSILLIAN CONSTANCE, late of 58 Medway-street, Box Hill, widow, died 21st April, 1972.

I hereby give notice that on the 28th August, 1972, the Public Trustee filed elections to administer the following deceased persons' estates, in accordance with section 17 of the *Public Trustee Act 1958*.

FREDRIKSEN, TOR FREDRIK, late of 47 King-street, Essen-don, design engineer, died on or about 3rd January, 1972.

GAUWITZ, KURT JOSEPH RICHARD, late of 2 Gloria-avenue, Dandenong, retired production engineer, died 10th June, 1972.

GAVAN, MICHAEL, also known as Michael Gavin, formerly of 29 Brunswick-street, Fitzroy, late of St. Joseph's Home, St. George's-road, Northcote, pensioner, died 8th May, 1972.

GLEESON, JOHN, late of 22 Alexandra-parade, Fitzroy, waterfront security guard, died 17th February, 1972.

GRANT, NORMAN GERALD, late of 74 Wales-street, West Footscray, toolmaker, died 15th May, 1972.

HILL, BEATRICE ALICE, late of 1 Dover-street, South Caul-field, widow, died 10th July, 1972.

JOHNSTON, GEORGE ALEXANDER, formerly of 21 Blessing-ton-street, St. Kilda, late of 9 Berwick-street, Reservoir, retired master pastry cook, died 10th July, 1972.

KRAUSE, HERMAN, late of 40 Chesterville-road, Chelten-ham, public servant, died 20th April, 1972.

LAWLEY, EILEEN GERTRUDE, late of 20 Wolseley-parade, Kensington, spinster, died 3rd May, 1972.

MCLELLAND, THOMAS CHRISTY, late of "Lumeah", 78 Bruce-street, West Preston, retired electoral officer, died 13th June, 1972.

MCMILLAN, REGINALD EDWARD, also known as Edward Reginald McMillan, late of 154 Queensberry-street, Carlton, retired ironworker, died 3rd or 4th July, 1972.

I hereby give notice that on the 30th August, 1972, the Public Trustee filed elections to administer the following deceased persons' estates, in accordance with section 17 of the *Public Trustee Act 1958*.

GAYLEARD, JAMES THEODORE, late of Kew, pensioner, died 19th December, 1970.

GILL, ALICE MARIE, formerly of Cheltenham Home and Hospital for the Aged, Cheltenham, late of 31 Percival-street, Preston, widow, died 5th May, 1972.

GRAVES, JOSEPH WALTER SYDNEY, late of 3 Paloma-street, South Oakleigh, retired army officer, died 6th July, 1972.

HAMILTON, DORIS ELEANOR, late of 69 King William-street, Fitzroy, home duties, died 2nd July, 1972.

HUGHES, DUDLEY ERNEST, late of 6 Jurang-street (in the will called road), Balwyn, retired house steward, died 28th May, 1972.

JOLLY, ERNEST WILLIAM, late of Flat 3, 705 Malvern-road, Toorak, retired caretaker and fireman, died 17th July, 1972.

KELLY, EDWARD LENNOX, late of 62 Grey-street, St. Kilda, pensioner, died 21st June, 1972.

I hereby give notice that on the 31st August, 1972, the Public Trustee filed elections to administer the following deceased persons' estates, in accordance with section 17 of the *Public Trustee Act 1958*.

BRUDEK, ALEXANDER, late of 177 Drummond-street, Carlton, waterside worker, died 12th January, 1972.

CAULFIELD, AGNES SHEPHERD, also known as Agnes Shephard Caulfield, late of 33 Brantome-street, Gisborne, widow, died 9th July, 1972.

GLANFIELD, EUNICE ISABEL, late of 122 Victoria-avenue, Albert Park, married woman, died 17th June, 1972.

HOEGH, JOHN, late of Mildura Homes for the Aged, Mildura, pensioner, died 25th March, 1972.

KENNEDY, ELLEN JANE, also known as Ellen Kennedy, late of 32 Abbotsford-street, Abbotsford, pensioner, died 5th June, 1972.

PERCY, SARAH JANE, also known as Sarah Percy, formerly of 13 Rango View-road, Boronia, but late of Station-street, Clarkefield, widow, died 31st May, 1972.

ROACHE, EDWARD, late of Kew, retired labourer, died 8th March, 1972.

N. P. BRODY,  
Public Trustee.

256 Flinders-street, Melbourne, 3000, 6th September, 1972.

#### NOTICE.

Creditors, next of kin and others having claims against the estate of any of the under-mentioned deceased persons are required to send particulars of their claims to the Public Trustee, 256 Flinders-street, Melbourne, Vic, 3000, the personal representative, on or before the 20th November, 1972, after which date the Public Trustee may convey or distribute the assets, having regard only to the claims of which the Public Trustee then has notice:—

ADDICOAT, ARTHUR ALFRED ERNEST, formerly of 478 Wellington-street, Clifton Hill, late of 34 Glover-street, South Melbourne, retired labourer, died 7th June, 1972.

AULD, AGNES RATTRAY, late of 155 The Avenue, Coburg East, widow, died 27th June, 1972.

BENNETT, HENRY BOULTON (in the will called Henry Bolton Bennett), late of 15 Holmes-street, East Brunswick, retired rubber manufacturer, died 14th June, 1972.

BRUDEK, ALEXANDER, late of 177 Drummond-street, Carlton, waterside worker, died 12th January, 1972.

CAULFIELD, AGNES SHEPHERD, also known as Agnes Shephard Caulfield, late of 33 Brantome-street, Gisborne, widow, died 9th July, 1972.

FITZGERALD, GEORGE, late of 30 Goulburn-avenue, Reservoir, retired tramway employee, died 24th August, 1969.

FREDRIKSEN, TOR FREDRIK, late of 47 King-street, Essendon, design engineer, died on or about 3rd January, 1972.

GAUWITZ, KURT JOSEPH RICHARD, late of 2 Gloria-avenue, Dandenong, retired production engineer, died 10th June, 1972.

GAVAN, MICHAEL, also known as Michael Gavin, formerly of 29 Brunswick-street, Fitzroy, late of St. Joseph's Home, St. George's-road, Northcote, pensioner, died 8th May, 1972.

GAYLEARD, JAMES THEODORE, late of Kew, pensioner, died 19th December, 1970.

GILL, ALICE MARIE, formerly of Cheltenham Home and Hospital for the Aged, Cheltenham, late of 31 Percival-street, Preston, widow, died 5th May, 1972.

GLANFIELD, EUNICE ISABEL, late of 122 Victoria-avenue, Albert Park, married woman, died 17th June, 1972.

GLEESON, JOHN, late of 22 Alexandra-parade, Fitzroy, waterfront security guard, died 17th February, 1972.

GRANT, NORMAN GERALD, late of 74 Wales-street, West Footscray, toolmaker, died 15th May, 1972.

GRAVES, JOSEPH WALTER SYDNEY, late of 3 Paloma-street, South Oakleigh, retired army officer, died 6th July, 1972.

HAMILTON, DORIS ELEANOR, late of 69 King William-street, Fitzroy, home duties, died 2nd July, 1972.

HILL, BEATRICE ALICE, late of 1 Dover-street, South Caulfield, widow, died 10th July, 1972.

HOBBS, THEODORE DAVID, late of Mont Park, retired soldier, died 9th May, 1972.

HOEGH, JOHN, late of Mildura Homes for the Aged, Mildura, pensioner, died 25th March, 1972.

HUGHES, DUDLEY ERNEST, late of 6 Jurang-street (in the will called road), Balwyn, retired house steward, died 28th May, 1972.

HUGHES, GERTRUDE IVY, late of 28 Glanfield-street, Northcote, widow, died 23rd May, 1972.

JEFFREY, KATHLEEN EMMA, late of 24 Tourello-avenue, East Hawthorn, retired stenographer, died 16th May, 1972.

JOHNSTON, GEORGE ALEXANDER, formerly of 21 Blessington-street, St. Kilda, late of 9 Berwick-street, Reservoir, retired master pastry cook, died 10th July, 1972.

JOLLY, ERNEST WILLIAM, late of Flat 3, 705 Malvern-road, Toorak, retired caretaker and fireman, died 17th July, 1972.

KELLY, EDWARD LENNOX, late of 62 Grey-street, St. Kilda, pensioner, died 21st June, 1972.

KENNEDY, ELLEN JANE, also known as Ellen Kennedy, late of 32 Abbotsford-street, Abbotsford, pensioner, died 5th June, 1972.

KRAUSE, HERMAN, late of 40 Chesterville-road, Cheltenham, public servant, died 20th April, 1972.

LACEY, GEORGE DAVID FREDERICK, late of 143 Rosanna-road, Rosanna, retired, died 21st June, 1972.

LAWLEY, EILEEN GERTRUDE, late of 20 Wolseley-parade, Kensington, spinster, died 3rd May, 1972.

MCLELLAND, THOMAS CHRISTY, late of "Lumeah", 78 Bruce-street, West Preston, retired electoral officer, died 13th June, 1972.

MCMILLAN, REGINALD EDWARD, also known as Edward Reginald McMillan, late of 154 Queensberry-street, Carlton, retired ironworker, died 3rd or 4th July, 1972.

PERCY, SARAH JANE, also known as Sarah Percy, formerly of 13 Rango View-road, Boronia, but late of Station-street, Clarkefield, widow, died 31st May, 1972.

PERRY, ROYDON JOHN GARNET, late of Kew, retired master mariner, died 7th February, 1972.

PRIEST, SYDNEY PHILLIP, formerly of West Camp, Yallowrn, but late of 8 Gilsland-road, Murrumbeena, retired plant attendant, died 14th May, 1972.

ROACHE, EDWARD, late of Kew, retired labourer, died 8th March, 1972.

RODAKIS, IDA MINNIE, late of 42 Alamein-avenue, Ashburton, married woman, died 29th December, 1971.

ROWE, DAVID BEATTY, late of 9 Biscop-road, Moorabbin, carpenter, died 8th May, 1972.

SOKOLOWSKI, WALTER, late of 5 Wynnstay-road, East Prahran, retired painter, died 12th February, 1972.

SPAULDING, REGINALD JOHN, late of Sonoma-street, Collinsville, Queensland, shire council employee, died 11th July, 1971.

STOJNIC, LUCIANO, late of Ellerslie Estate, Myrrhee, labourer, died 24th December, 1971.

SYMONS, MARINA, late of Alexander Home and Hospital for the Aged, Castlemaine, spinster, died 13th May, 1972.

WALTER, BERYL LAWRENCE, formerly of 10 Beresford-street, Pascoe Vale South, and 3 Thorne-court, Doncaster East, late of 47 Bennett-street, Forest Hill, married woman, died 27th May, 1972.

WILLIAMS, TRESSILLIAN CONSTANCE, late of 58 Medway-street, Box Hill, widow, died 21st April, 1972.

N. P. BRODY,  
Public Trustee.

Melbourne, 6th September, 1972.

#### CONTRACTS ACCEPTED.—(Series 1972-73.) PUBLIC WORKS.

292. Morwell, Primary School 2136, internal and external repairs and painting &c., \$15,700.00.—E. Capaldo and Sons Pty. Ltd.

293. Glendonald, School for Deaf Children 4683, mechanical services—new building, \$17,944.00.—W. S. Atherton and Co. Pty. Ltd.

294. Brown Hill, Primary School 35, renewal of slate roofing, \$4,154.00.—Atlas Industries Australia Ltd.

295. Watsonia, High School, internal and external repairs and painting, \$22,700.00.—C. B. Bramich Pty. Ltd.

296. West Melbourne, Primary School 1689, erection of new toilet block, \$12,650.00.—Ivan Bulat.

297. Sandringham, Primary School 267, external and internal renovations, \$13,381.50.—L. Brown.

298. Parkdale, Primary School 4171, repairs and painting, \$7,014.00.—R. Bendinelli Renovations and Painting.

299. Melbourne, 110 Exhibition-street, maintenance cleaning for the period 1st June, 1972 to 31st July, 1975, \$8,440.80 per annum.—Crothall and Co. Pty. Ltd.

300. Hawthorn, Road Safety and Traffic Authority, 801 Glenferrie-road, maintenance cleaning from 15th July, 1972 to 14th July, 1975, \$3,450.72 per annum.—D.P.C. Cleaning Service.

301. Manangatang, Consolidated-Higher Elementary School, installation of transportation bed, \$5,310.00.—Charles W. Gamble.

302. Preston East, Technical School, electrical services, extensions, \$8,100.00.—Electrite.

303. Bundoora, Kingsbury Training Centre, electrical services, remodelling, \$12,683.50.—Electrite.

304. Doncaster, High School, erection of sections G and MN, \$389,724.00.—A. V. Jennings Industries (Aust.) Ltd.

305. Preston, Alcoholics Assessment Centre, site works, \$27,935.60.—Wm. Loud Pty. Ltd.

306. Lilydale, Technical School, site works, \$22,390.50.—Guenther Mueller.

307. Mitta Mitta, Primary School 887, erection of toilet block, \$4,583.00.—Graeme Moncrieff.

308. Fawkner, High School, internal renovations, \$4,924.00.—J. P. McElligott (Sales) Pty. Ltd.

309. Newhaven, Primary School 3053, internal and external repairs and painting, \$5,145.00.—L. D. and H. T. Ollington.

310. Wyperfeld, National Park, erection of Ranger's house and office, \$17,920.00.—W. Phelan and Sons Pty. Ltd.

311. Sandringham, Technical School, asphalt repairs and concrete paving, \$7,934.50.—L. J. Towers.

312. Avondale Heights, High School, erection of Stage I, 691/900, \$221,667.00.—L. U. Simon Pty. Ltd.

313. Fitzroy, High School, additions to existing school, \$149,095.00.—L. U. Simon Pty. Ltd.

314. Glenroy, Social Welfare Department, corner Lytton-street and Pascoe Vale-road, maintenance cleaning for the period 1st August, 1972, to 31st July, 1975, \$580.00 per annum.—Utility Cleaning Co. (Vic.) Pty. Ltd.

315. Korumburra, High School, internal and external renovations, \$21,107.00.—Strykert and Bellingham.

316. Broadmeadows, Attwood Veterinary Research Station, construction of Parasitology building, \$38,840.00.—H. W. Willis.

317. Doveton, High School, staffroom and administration improvements, \$11,299.00.—D. B. Tincknell Pty. Ltd.

318. Karingal, High School, staffroom and administration improvements, \$10,524.00.—D. B. Tincknell Pty. Ltd.

319. Lyndale, High School, staffroom and administration improvements, \$13,810.00.—D. B. Tincknell Pty. Ltd.

320. Mentone, High School, staffroom and administration improvements, \$13,903.00.—D. B. Tincknell Pty. Ltd.

321. Chandler, erection of new high school type 691-900, \$210,181.00.—D. B. Tincknell Pty. Ltd.

322. Diamond Creek, Technical School, mechanical services, amenities block, \$26,628.00.—B. and S. Heating and Ventilation Pty. Ltd.

323. Bundoora, Kingsbury Training Centre, mechanical services, remodelling, \$4,610.00.—B. and S. Heating and Ventilation Pty. Ltd.

324. Melbourne, School Dental Clinic, maintenance cleaning for the period 1st August, 1972, to 31st July, 1975, \$3,049.00 per annum.—John Barry Contract Cleaning Pty. Ltd.

325. Highett, High School, staffroom and administration improvements, \$16,749.00.—A. F. Dewar Holdings Pty. Ltd.

326. Melbourne, State Public Offices, Treasury-place, supply and installation of P.A.B.X. telephone system, \$310,672.00.—L. M. Ericsson Pty. Ltd.

327. Monash, Teachers' College, supply and installation of P.A.B.X. telephone system, \$30,520.00.—L. M. Ericsson Pty. Ltd.

328. Burwood, High School, asphalt repairs and drainage works, \$9,471.45.—Wm. Loud Pty. Ltd.

329. Footscray, High School, site works, \$26,444.37.—Wm. Loud Pty. Ltd.

330. Banyule, Primary School 4746, site works, \$10,864.56.—Wm. Loud Pty. Ltd.

331. Birchip, High School, staff amenities extension and connexion to town sewerage, \$13,934.00.—H. J. and K. M. Onley.

G. SERPELL, Director-General. 5.9.72.

#### Milk Board Acts.

#### SCHEDULE XXI.—REGULATIONS.

#### CONSIDERATION OF APPLICATIONS FOR MILK CARRIERS' LICENCES.

Notice is hereby given that the application made by the person named hereunder for a Milk Carrier's Licence to operate upon the route and in the area set out opposite the name of the applicant will be considered by the Milk Board at its Offices, Domville-avenue, Hawthorn, on Wednesday, 20th September, 1972, commencing at 10.30 a.m.

Name and Address of Applicant.	Route and Area.
Metropolitan Dairies Pty. Ltd., 90 Railway-crescent, Broadmeadows	Whittlesea, Diamond Valley and Bulla to Melbourne.

8th September, 1972.

P. G. NUGENT,  
Secretary, Milk Board.

## APPOINTMENTS AND RESIGNATIONS

### APPOINTMENTS.

His Excellency the Governor of the State of Victoria, by and with the advice of the Executive Council thereof, has, by Orders made on the 5th day of September, 1972, been pleased to make the under-mentioned appointments, viz.:

#### CROWN LANDS AND SURVEY DEPARTMENT.

##### Bailiffs of Crown Lands.

RAYMOND ALBERT MCHENRY

to be a bailiff of Crown lands with respect to the Malla-coota Foreshore Reserve, pursuant to the provisions of section 30 of the *Land Act 1958*;

JAMES WILLIAM MULVEY

to be a Bailiff of Crown lands with respect to the Supreme Court and County Court buildings in the City of Melbourne, pursuant to the provisions of section 30 of the *Land Act 1958*; and

SINCLAIR IMRIE MILLER,  
FRANCIS GERALD HOLLAND, and  
JOHN O'CONNOR

to be bailiffs of Crown lands, pursuant to the provisions of section 30 of the *Land Act 1958*.

(The appointments of the first two gentlemen are made in the places of Gerald Joseph Hickey and Reginald Jackson, whose appointments are hereby revoked.)

#### MINISTRY OF HEALTH.

##### Members of Committees of Management of Hospitals.

ALLAN EDWARD McCORMACK

to be Government appointee on the Committee of Management of Myrtleford District War Memorial Hospital, for a further term of three years commencing the 23rd September, 1972, pursuant to the provisions of sub-paragraph (ii) of paragraph (a) of the proviso to sub-section (1) of section 48 of the *Hospitals and Charities Act 1958*.

MAX JOHN CLARK

to be Government appointee on the Committee of Management of Frankston Community Hospital, for a further term of three years commencing the 24th September, 1972, pursuant to the provisions of sub-paragraph (ii) of paragraph (a) of the proviso to sub-section (1) of section 48 of the *Hospitals and Charities Act 1958*; and

CHARLES FREDERICK RUSSELL

to be Government appointee on the Committee of Management of Mildura Base Hospital, for a further term of three years commencing the 29th September, 1972, pursuant to the provisions of sub-paragraph (ii) of paragraph (a) of the proviso to sub-section (1) of section 48 of the *Hospitals and Charities Act 1958*.

##### Trustees of Cemeteries.

NORMAN ERIC STANLEY ELLIOTT

to be a Trustee of the Harrow Public Cemetery, vice D. Calvert, resigned;

JOHN DOUGLAS BLACK

to be a Trustee of the Traralgon Public Cemetery, additional trustee;

KEITH PLOZZA

to be a Trustee of the Violet Town Public Cemetery, vice T. Hayes, deceased;

NORMAN DOUGLAS SPENCER, and

GEOFFREY GORDON BROWN

to be Trustees of the Hotspur Public Cemetery, additional trustees; and

LEO IGNATIUS LARKIN

to be a Trustee of the Yallourn Public Cemetery, vice D. Sullivan, resigned, pursuant to section 3 (1) of the *Cemeteries Act 1958*.

#### LAW DEPARTMENT.

##### Commissioners for Taking Declarations, &c.

REX GRAHAM MULLIGAN, care of Commonwealth Savings Bank of Australia, University of Melbourne, Parkville,

JONATHAN EDMONDS MAYNE, care of Roy E. Mayne & Son Pty. Ltd., 110 High-street, Preston,

BRUCE FERGUS GRANT, care of Consolidated Home Industries Ltd., 170 Thomas-street, Dandenong,

CHARLES FUERST, care of Spitzer & Fuerst, public accountants, 163 Glenferrie-road, Malvern,

RONALD LESLIE MALCOLM, care of Commonwealth Savings Bank of Australia, Migrant Information Centre, 227 Bourke-street, Melbourne,

IAN GEORGE MONOD, care of Dowd Associates Pty. Ltd., Hickory Rise, Highway-road, Burwood,  
 MERVYN JOHN MALLET, care of Sicree, Nixon, Watt & Co., chartered accountants, 38 Walsh-street, Melbourne,  
 CLIFFORD WILLIAM KILGOUR, care of Morrison & Teare, barristers and solicitors, P.O. Box 129, Numurkah,  
 STEPHEN CHARLES LAURENCE GRIFFIN, care of Ian M. Nisbet, chartered accountant, 243 Collins-street, Melbourne,  
 NOEL BRITTON HALFORD, care of Wrightcel Ltd., Cato-street, Auburn,  
 JACK ALLAN PRIOR, care of Commonwealth Banking Corporation, Elsternwick,  
 ROBERT CORNELIUS THOMAS, care of Swann Insurance Ltd., 212 King-street, Melbourne,  
 MICHAEL FRANCIS KEOGH, care of T. & K. Glass Co., 1076 Centre-road, South Oakleigh, and  
 LEONARD DOWELL GRATTIDGE, care of Sutex Pty. Ltd., 4 Croft-street, Huntingdale,  
 to be Commissioners for taking Declarations and Affidavits, pursuant to the provisions of the Evidence Act 1958, to resign upon ceasing to occupy their present positions; and  
 MARTIN LANE, 26 Libra-street, North Balwyn,  
 DESMOND JOHN McCORMACK, "Landscape", Milawa,  
 HARRY KELBERG, Mt. Dandenong-road, Montrose, and  
 GIUSEPPE CAROSELLI, 38 Ledger-avenue, Fawkner,  
 to be Commissioners for taking Declarations and Affidavits, pursuant to the provisions of the Evidence Act 1958, to resign upon leaving the neighbourhood of the addresses stated.

*Justices of the Peace.*

WESLEY GLEN EGGLESTON, 13 View-road, Springvale,  
 THOMAS EDWARD JOHNSTON, 39 Birdwood-street, Parkdale,  
 LAWRENCE JAMES NEWELL, care of Chief Commissioner's Office, Police Headquarters, Russell-street, Melbourne,  
 GERALD VINCENT O'DWYER, 41 Raglan-street, Maryborough, and  
 RONALD KEITH SOULSBY, Dawson-street, Stratford,  
 to Keep the Peace in the State of Victoria.

DEPARTMENT OF THE TREASURER.

*Collector of Imposts (Acting).*

PETER THOMAS SPENCER  
 to act temporarily as Collector of Imposts, Titles Office, Melbourne, vice C. P. Allen, on leave.

DEPARTMENT OF WATER SUPPLY.

*Waterworks Trust Commissioner.*

WILLIAM McCANN  
 to be a Commissioner of the Shire of Kowree Waterworks Trust, to hold such position for a period from the date hereof until 2nd December, 1972, subject to the provisions of the Water Act.

T. J. FORRISTAL,  
 Clerk of the Executive Council.

At the Executive Council Chamber,  
 Melbourne, 5th September, 1972.

APPOINTMENT.

His Excellency the Governor of the State of Victoria, by and with the advice of the Executive Council thereof, has, by Orders made on the 12th day of September, 1972, been pleased to make the under-mentioned appointments, viz.:-

MINISTRY OF HEALTH.

*Trustees of Cemetery.*

THE COUNCIL OF THE MUNICIPALITY OF THE CITY OF FOOTSCRAY

to be Trustee of the Footscray General Cemetery, pursuant to section 3 (2) of the Cemeteries Act 1958.

T. J. FORRISTAL,  
 Clerk of the Executive Council.

At the Executive Council Chamber,  
 Melbourne, 12th September, 1972.

FORESTS DEPARTMENT.

APPOINTMENT OF COMMITTEE OF MANAGEMENT OF "MT. BULLER ALPINE RESERVE".

Whereas pursuant to the provisions of section 50 of the Forests Act 1958 (No. 6254), a Committee of Management was appointed on the 9th November, 1970, of the land forming part of the reserved forest in the Parish of Changue, County of Wonnangatta, and known as the Mt. Buller Alpine Reserve, described in the First Schedule hereto.

And whereas pursuant to the provisions of the aforesaid section 50, an area of 2.5 acres, more or less, was set aside by the Forests Commission on the 6th June, 1972,

as an addition to the Mt. Buller Alpine Reserve: Now therefore, I, Edward Raymond Meagher, Her Majesty's Minister of Forests for the State of Victoria, on the recommendation of the Forests Commission, do hereby appoint the aforesaid Committee of Management until the 30th day of September, 1973, of the land forming part of the reserved forest described in the Second Schedule hereto, in lieu of the land described in the First Schedule.

FIRST SCHEDULE.

Parish of Changue, County of Wonnangatta, 2,357 acres, more or less, being the area shown within pink border on plan marked 18/11/60 over 58/2260, in file of correspondence No. 65/2273 of the Forests Department.

SECOND SCHEDULE.

Parishes of Changue and Mirimbah, Counties of Wonnangatta and Delatite, 2,359.5 acres, more or less, being the area shown within pink border on plan marked 18.11.60 over 58/2260 and the area shown coloured red on plan A66/682 in files of correspondence Nos. 65/2273 and 66/682 of the Forests Department.

Dated at Melbourne, the 4th day of September, 1972.

E. R. MEAGHER,  
 Minister of Forests.

FORESTS DEPARTMENT.

APPOINTMENT OF COMMITTEE OF MANAGEMENT OF LAL LAL BLAST FURNACE RESERVE.

Whereas by section 50 of the Forests Act 1958 (No. 6254), it is provided that the Minister of Forests may, on the recommendation of the Forests Commission, appoint any number of persons, not less than three, to be a Committee of Management of any land forming part of any reserved forest, such land being set aside as a recreational and historical reserve, and may remove any of those persons: Now, therefore, I, Edward Raymond Meagher, Her Majesty's Minister of Forests for the State of Victoria, on the recommendation of the Forests Commission, do hereby appoint—

ARCHIBALD JOHN FISKEN,  
 SYDNEY RICHARDSON BIRCH, O.B.E.,  
 THOMAS MAYO CONROY,  
 DONALD MURRAY THOMPSON, and  
 SYDNEY ERNEST RYAN,

as members of the Committee of Management until the 1st day of August, 1975, of the land described in the accompanying Schedule, and known as the "Lal Lal Blast Furnace Reserve".

SCHEDULE ABOVE REFERRED TO.

Parish of Lal Lal, County of Grant, 75 acres, more or less, being the area shown coloured yellow on plan A68/1564 in file of correspondence No. 72/463 of the Forests Department.

Dated at Melbourne the 4th day of September, 1972.

E. R. MEAGHER,  
 Minister of Forests.

FORESTS DEPARTMENT.

APPOINTMENT OF MEMBERS OF COMMITTEE OF MANAGEMENT OF THE KORWEINGUBOORA RECREATION RESERVE.

Whereas by section 50 of the Forests Act 1958 (No. 6254), it is provided that the Minister of Forests may, on the recommendation of the Forests Commission, appoint any number of persons, not less than three, to be a Committee of Management of land forming part of any reserved forest, such land being set aside and declared to be a recreation reserve, and may remove any of those persons. Now therefore I, Edward Raymond Meagher, Her Majesty's Minister of Forests for the State of Victoria, on the recommendation of the Forests Commission, do hereby appoint—

THOMAS COLIN HEDGES,  
 ARTHUR RONALD SUCKLING,  
 RICHARD PERCIVAL SUCKLING,  
 DAVID KINGSLEY PARNABY,  
 CHARLES ALBERT DEHNERT,  
 SANDRA ANN STOW, and  
 RHETT LEROY GRIFFITHS,

as members of the Committee of Management until the thirty-first day of August, 1975, of the land forming part of the reserved forest in the Parish of Korweinguboorra, County of Grant, comprising 10 acres, more or less, and shown by red hachure on plan marked A.63/70 over 5-8-63, in file of correspondence 63/70 of the Forests Department and known as the Korweinguboorra Recreation Reserve.

Dated at Melbourne, the sixth day of September, 1972.

E. R. MEAGHER,  
 Minister of Forests.

*National Parks Act 1970.*  
**AUTHORIZED OFFICERS.**

In accordance with section 23 of the *National Parks Act 1970*, I, Leonard Hart Smith, Director of National Parks, hereby appoint the following persons to be authorized officers for the purposes of the Act :—

Name.	Capacity/Address.	Area of Appointment.	Term of Appointment.
S. Watkins ..	Park Ranger, Wilson's Promontory National Park	Wilson's Promontory National Park	Until revoked or until he ceases to be employed by National Parks Service or National Park Committee of Management
A. Roadknight ..	Park Ranger, Wilson's Promontory National Park	Wilson's Promontory National Park	Until revoked or until he ceases to be employed by National Parks Service or National Park Committee of Management

L. H. SMITH,  
 Director of National Parks.

Office of National Parks Service,  
 Melbourne, 3002, 5th September, 1972.

*Liquor Control Act 1968.*

**APPOINTMENT OF LICENSING INSPECTOR.**

In accordance with the authority conferred upon me by sub-section (1) of section 22 of the *Liquor Control Act 1968*, I, Reginald Jackson, Chief Commissioner of Police, hereby appoint the following Officer of Police as Licensing Inspector for the Division of the Police District as shown :—

Division Number	Police District.	Rank and Name.
4	Flinders ..	Inspector Dennis Peter Reeves (from 21.8.72 to 18.9.72)

R. JACKSON,  
 Chief Commissioner of Police.

5.9.1972

*Liquor Control Act. 1968*

**APPOINTMENT OF LICENSING INSPECTORS.**

In accordance with the authority conferred upon me by sub-section (1) of section 22 of the *Liquor Control Act 1968*, I, Reginald Jackson, Chief Commissioner of Police, hereby appoint the following Officers of Police as Licensing Inspectors for the Divisions of the Police Districts as shown :—

Division Number.	Police District.	Rank and Name.
2	East Gippsland	Inspector John Thomas Ibbotson <i>vice</i> Inspector Brown
2	Mallee ..	Inspector Desmond John Suttie, V.B., <i>vice</i> Inspector Burns
2	Melbourne ..	Inspector Charles Raymond Mitchell
1	Moonee Ponds ..	Chief Superintendent Roy Henry Warne
1	" ..	Inspector Allan Henry Absalom
2	" ..	Superintendent Walter Gordon Perry
2	" ..	Inspector John William Tobin
3	" ..	Chief Inspector Stanley William Hanlon
3	" ..	Inspector Timothy Patrick Gilmore (from 4.9.72 to 31.12.72)
4	" ..	Inspector Thomas Weymouth Williams
5	" ..	Chief Inspector Ronald Arthur Kellett
3	Sunshine ..	Inspector Eric Raymond Janetzki

R. JACKSON,  
 Chief Commissioner of Police.

*Filled Milk Act 1958.*

**APPOINTMENT OF ADVISORY COMMITTEE.**

I, the undersigned, Sir Gilbert Lawrence Chandler, being the responsible Minister of the Crown for the time being administering the *Filled Milk Act 1958*, in accordance with section 3 of that Act, hereby appoint Herbert John Roberts,

who is a person deemed by me to be representative of dairy farmers in Victoria, to be a member of the Advisory Committee within the meaning of the said Act for the period ending on the 5th February, 1974, in lieu of Eric Gilbert Roberts, resigned.

Dated at Melbourne, this fifth day of September, 1972.

G. L. CHANDLER,  
 Minister of Agriculture.

*Imitation Milk Act 1969.*

**APPOINTMENT OF ADVISORY COMMITTEE.**

I, the undersigned, Sir Gilbert Lawrence Chandler, being the responsible Minister of the Crown for the time being administering the *Imitation Milk Act 1969*, in accordance with section 4 of that Act, hereby appoint Herbert John Roberts, who is a person deemed by me to be representative of dairy farmers in Victoria, to be a member of the Advisory Committee within the meaning of the said Act for the period ending on the 5th February, 1974, in lieu of Eric Gilbert Roberts, resigned.

Dated at Melbourne, this fifth day of September, 1972.

G. L. CHANDLER,  
 Minister of Agriculture.

*Melbourne Wholesale Fruit and Vegetable Market Act 1968.*

**APPOINTMENT OF FRUIT AND VEGETABLE MARKETING ADVISORY COMMITTEE.**

I, Sir Gilbert Lawrence Chandler, Minister of Agriculture for the State of Victoria hereby give notice that in accordance with the provisions of sections 14 and 15 of the *Melbourne Wholesale Fruit and Vegetable Market Act 1968*, I have appointed the under-mentioned persons as members of the Fruit and Vegetable Marketing Advisory Committee for a term of three years from and inclusive of the 1st September, 1972:—

ROBERT STANLEY HARPER, Chief of Division of Horticulture, Department of Agriculture (Chairman).

BARTOLOMEO FERLAZZO, of 47 McCarron-parade, Essendon (Representing the interests of wholesale fruit merchants).

MICHAEL TRICARICO, of 158 Mt. Dandenong-road, East Ringwood (Representing the interests of wholesale vegetable merchants).

AMATO VARAPODIO, of 325A Moreland-road, Coburg (Representing the interests of wholesale fruit and vegetable commission agents).

WILLIAM HENRY SHELTON, of Shelton-road, Pakenham, and BERNARD J. BURG, of Wandin North (Jointly representing the interests of fruitgrowers resident within a radius of 100 miles from the post office at the corner of Bourke and Elizabeth streets, Melbourne).

LESLIE WILLIAM ALLEN, of Fern Tree Gully-road, Wheeler's Hill and LEONARD GEORGE COCHRANE, of Cheltenham-road, Keysborough (Jointly representing the interests of vegetable growers resident within a radius of 100 miles from the post office at the corner of Bourke and Elizabeth streets, Melbourne).

ROCCO FRANZONI, of 1 Elora-road, South Oakleigh (Representing the interests of retail fruiterers and greengrocers).



ARTHUR JOSEPH JONAS, of 17 Torney-street, North Balwyn (Representing the interests of buyers of fruit and vegetables other than retail fruiterers and greengrocers).

WILLIAM JOHN BAIL, of Beverford (Representing the interests of fruit and vegetable growers resident beyond a radius of 100 miles from the post office at the corner of Bourke and Elizabeth streets, Melbourne).

STANLEY MATHERS, of Old Dandenong-road, Heather-ton (Representing the interests of flowergrowers and nurserymen).

I have appointed ROBERT ERNEST CHALK, an officer of the Department of Agriculture, to be Secretary to the Committee.

G. L. CHANDLER,  
Minister of Agriculture.

31st August, 1972.

#### RESIGNATIONS.

His Excellency the Governor of the State of Victoria, by and with the advice of the Executive Council thereof, has, by Orders made on the 5th day of September, 1972, accepted the resignation of the persons named hereunder of the offices mentioned, viz:—

#### LAW DEPARTMENT.

*Commissioner for Taking Declarations, &c.*

GORDON BARKER JOHNSON, as a Commissioner for taking Declarations and Affidavits, pursuant to the provisions of the Evidence Act 1958.

*Justice of the Peace.*

REA JOHNSTONE, as a Justice of the Peace for the State of Victoria.

T. J. FORRISTAL,  
Clerk of the Executive Council.

At the Executive Council Chamber,  
Melbourne, 5th September, 1972.

#### ORDERS IN COUNCIL

##### *Land Act 1958.*

#### DEPARTMENT OF CROWN LANDS AND SURVEY.

*At the Executive Council Chamber, Melbourne, the fifth day of September, 1972.*

#### PRESENT:

His Excellency the Governor of Victoria.

Sir George Reid	Mr. Wilcox
Mr. Dickie	Mr. Dunstan.
Mr. Scanlan	

#### REVOCATION OF TEMPORARY RESERVATIONS OF LANDS BY ORDERS IN COUNCIL.

His Excellency the Governor of the State of Victoria, by and with the advice of the Executive Council thereof, doth hereby in pursuance of the provisions of the *Land Act 1958*, revoke the temporary reservations of lands by Orders in Council hereinafter referred to, viz:—

BALMORAL.—The temporary reservation by Order in Council of the 27th July, 1966, of 11 acres 3 roods 16 perches of land in the Parish of Balmoral, as a site for Public Recreation, so far only as the portion containing 1 rood 19 perches, defined by description and plan published in the *Government Gazette* of 9th August, 1972.—(B.44<sup>(2)</sup>) (Rs.8567).

BOOLA BOLOKE.—The temporary reservation as a site for conservation of water and the withholding from sale, leasing and licensing by Order in Council of the 20th February, 1882 (see *Government Gazette* 24th February, 1882, page 510), of 25 acres of land in the Parish of Boola Boloke, so far only as the portion containing 2 acres 3 roods 4 perches, defined by description and plan published in the *Government Gazette* of 9th August, 1972.—(B.81<sup>(5)</sup>) (Rs.9489).

DARTMOOR.—The temporary reservation, by Order in Council of the 2nd July, 1957, of 2 acres 12 perches of land in the Township of Dartmoor, as a site for the purposes of the Forests Act revoked as to part, by Order of the 12th November, 1963, so far only as the portion containing 1 rood 17 perches, indicated by hatching on plan and description published in the *Government Gazette* of 9th August, 1972.—(D.32<sup>(9)</sup>) (Rs.7613).

MARLO AND TABBARA.—The temporary reservation, by Order in Council of the 7th January, 1941, of 170 acres, more or less, of land in the Township of Marlo, and the Parish of Orbost East (now in the Township of Marlo and the Parish of Tabbara), as a site for public purposes, revoked as to part by Order of the 23rd July, 1963, so far as the balance thereof, containing 162 acres, more or less.—(M.538<sup>(5 & 6)</sup>) (Rs.5157).

MARLO.—The temporary reservation, by Order in Council of the 7th May, 1889, of 14 acres, more or less, of land in the Parish of Orbost (now in the Township of Marlo and the Parish of Orbost East) as a site for a Lighthouse so far only as the portions in the Township of Marlo, containing 2 acres 1 rood, more or less, indicated by hatching on plan and description published in the *Government Gazette* of 9th August, 1972.—(M.538<sup>(9)</sup>) (Rs.7996).

NEWMERELLA.—The temporary reservation, by Order in Council of the 18th July, 1927, of 103 acres 1 rood 25 perches of land in the Parish of Newmerella, as a site for a Racecourse and Public Recreation, revoked as to part by Order of the 22nd April, 1970, so far only as the portion containing 1 acre 2 roods 33 perches, indicated by hatching on plan and description published in the *Government Gazette* of 9th August, 1972.—(N.136<sup>(7)</sup>) (Rs.3519).

NATIMUK.—The temporary reservation, as a site whence Stone may be procured and the withholding from sale, leasing and licensing, by Order in Council of the 8th January, 1877, of 26 acres 3 roods 14 perches of land in the Parish of Natimuk, so far only as the portion containing 4 acres 1 rood 36 perches, indicated by hatching on plan hereunder and description published in the *Government Gazette* of 9th August, 1972.—(N.117<sup>(8)</sup>) (Rs.5143).

NYAH.—The temporary reservation, by Order in Council of the 22nd July, 1969, of 2 roods 8 perches of land in the Township of Nyah, as a site for Public Park and Recreation, so far only as the portion containing 1 rood 2 perches, indicated by hatching on plan and description published in the *Government Gazette* of 9th August, 1972.—(N.161<sup>(2)</sup>) (Rs.2051).

ST. ARNAUD AND MOOLERR.—The temporary reservation, by Order in Council of the 11th January, 1903, of 1,549 acres 1 rood 13 perches of land in the Parishes of St. Arnaud and Moolerr, as a site for the growth and preservation of Timber, revoked as to part by Order of the 12th March, 1909, so far as the balance thereof, containing 1,519 acres 3 roods 23 perches, is concerned.—(S.366<sup>(7)</sup>) (M.427<sup>(8)</sup>) (Rs.2693).

TABBARA.—The temporary reservation, by Order in Council of the 15th September, 1959, of 1,100 acres, more or less, of land in the Parish of Tabbara, as a site for an Aerodrome, so far only as the portion containing 1 acre 1 rood, more or less, indicated by hatching on plan and description published in the *Government Gazette* of 9th August, 1972.—(T.261<sup>(9)</sup>) (Rs.7846).

WHARPARILLA (ECHUCA).—The temporary reservation, by Order in Council of the 10th October, 1887 (see *Government Gazette*, 14th October, 1887, page 2978), of 10 acres 5 perches of land in the Parish of Wharparilla (named municipal district of Echuca in order) as a site for a Manure Depot, revoked as to part by Order of the 1st December, 1970, so far as the balance thereof, containing 8 acres 1 rood 14 perches, is concerned.—(W.132<sup>(8)</sup>) (Rs.5515).

And the Honorable William Archibald Borthwick, Her Majesty's Minister of Lands for the State of Victoria, shall give the necessary directions herein accordingly.

T. J. FORRISTAL,  
Clerk of the Executive Council.

##### *Land Act 1958.*

#### DEPARTMENT OF CROWN LANDS AND SURVEY.

*At the Executive Council Chamber, Melbourne, the fifth day of September, 1972.*

#### PRESENT:

His Excellency the Governor of Victoria.	
Sir George Reid	Mr. Wilcox
Mr. Dickie	Mr. Dunstan.
Mr. Scanlan	

#### REVOCATION OF TEMPORARY RESERVATIONS OF LANDS BY ORDERS IN COUNCIL

His Excellency the Governor of the State of Victoria, by and with the advice of the Executive Council thereof, doth

hereby in pursuance of the provisions of the *Land Act 1958*, revoke the temporary reservations of lands by Orders in Council hereinafter referred to, viz.:

**DIMBOOLA.**—The temporary reservation, by Order in Council of the 23rd June, 1936, of 6 acres 3 roods 7 perches of land in the Township of Dimboola, Parish of Dimboola, as a site for Supply of Gravel.—(D.150<sup>(s)</sup>) (Rs.4580).

**FLYNN.**—The temporary reservation, by Order in Council of the 8th August, 1892, of 1 rood 19½ perches of land in the Township of Flinnstead (now Township of Flynn) as a site for Mechanics Institute.—(F.102<sup>(s)</sup>) (Rs.2151).

**MARLO.**—The temporary reservation, by Order in Council of the 25th November, 1952, of 5 acres 1 rood 20 perches of land in the Parish of Orbost East (now in the Township of Marlo) as a site for a Cemetery.—(M.538<sup>(s)</sup>) (Rs.7051).

**MARLO.**—The temporary reservation, by Order in Council of the 14th November, 1967, of 6 acres 3 roods 13 perches of land in the Township of Marlo, as a site for Public purposes.—(M.538<sup>(s)</sup>) (Rs.5157).

**MOOLERR AND ST. ARNAUD.**—The temporary reservation, as a site for Victorian Water Supply purposes and the withholding from sale, leasing and licensing, by Order in Council of the 29th September, 1879, of 317 acres 3 roods 5 perches of land in the Parishes of Moolerr and St. Arnaud.—(S.366<sup>(r)</sup>), (M.427<sup>(s)</sup>) (Rs.2693).

**NORTH HAMILTON.**—The temporary reservation, as a site for Cemetery and the withholding from sale, leasing and licensing, by Order in Council of the 13th December, 1875 (see *Government Gazette*, 17th December, 1875, page 2332), of 3 acres 1 rood 30 perches of land in the Parish of North Hamilton.—(H.46<sup>(s)</sup>) (C.100688).

**SOUTH HAMILTON.**—The temporary reservation, by Order in Council of the 6th July, 1927, of 2 acres 3 roods 38 perches of land in the Parish of South Hamilton, as a site for the Supply of Stone.—(H.46<sup>(s)</sup>) (Rs.3507).

**WHARPARILLA (ECHUCA).**—The temporary reservation, by Order in Council of the 31st July, 1944, of 2 roods 30 perches of land in the Parish of Wharparilla, as a site for a Manure Depot.—(W.132<sup>(s)</sup>) (Rs.5515).

And the Honorable William Archibald Borthwick, Her Majesty's Minister of Lands for the State of Victoria, shall give the necessary directions herein accordingly.

T. J. FORRISTAL,  
Clerk of the Executive Council.

*Land Act 1958.*  
DEPARTMENT OF CROWN LANDS AND SURVEY.

At the Executive Council Chamber, Melbourne, the fifth day of September, 1972.

PRESENT:  
His Excellency the Governor of Victoria.  
Sir George Reid | Mr. Wilcox  
Mr. Dickie | Mr. Dunstan.  
Mr. Scanlan

REVOCATION OF TEMPORARY RESERVATION OF LAND BY ORDER IN COUNCIL.

His Excellency the Governor of the State of Victoria, by and with the advice of the Executive Council thereof, doth hereby in pursuance of the provisions of the *Land Act 1958* revoke the temporary reservation of lands by Order in Council hereinafter referred to, viz.:

**WINDHAM.**—The withholding from sale, leasing and licensing by Order in Council of the 8th October, 1883 (see *Government Gazette*, 12th October, 1883, page 2372) of the unappropriated Crown lands on the banks of the Goulburn River in various parishes is hereby revoked, so far only as the portion in the Parish of Windham, containing 2 roods 21 perches, indicated by hatching on plan and description published in the *Government Gazette* of 9th August, 1972, is concerned.—(W.149<sup>(e)</sup>) (H.031198).

And the Honorable William Archibald Borthwick, Her Majesty's Minister of Lands for the State of Victoria, shall give the necessary directions herein accordingly.

T. J. FORRISTAL,  
Clerk of the Executive Council.

*Land Act 1958*, Section 15 (1).  
DEPARTMENT OF CROWN LANDS AND SURVEY.

At the Executive Council Chamber, Melbourne, the fifth day of September, 1972.

PRESENT:  
His Excellency the Governor of Victoria.  
Sir George Reid | Mr. Wilcox  
Mr. Dickie | Mr. Dunstan.  
Mr. Scanlan

PERMANENT RESERVATION OF LAND AND REVOCATION AS TO PART.

His Excellency the Governor of the State of Victoria, by and with the advice of the Executive Council thereof, doth hereby, in pursuance of the provisions of section 15 (1) of the *Land Act 1958*, reserve permanently and revoke, as to part, certain land hereunder referred to viz.:

**MACORNA.**—Land to be permanently reserved for Public purposes, Parish of Macorna, County of Gunbower; Crown land forming the bed of the new course, and on either side thereof, of the Pyramid Creek between the points marked A and B and indicated by hatching on plan hereunder, save and except those portions lying within the hatched area which are already permanently reserved for Public purposes pursuant to the Order in Council of the 23rd May, 1881 (see *Government Gazette*s of the 18th March, 1881, page 817 and the 27th May, 1881, page 1389).

ORDER IN COUNCIL REVOKED AS TO PART.

The Order in Council of the 23rd May, 1881, permanently reserving certain Crown lands for Public purposes is about to be revoked so far only as the said Order relates to those portions of the former bed, and Crown land on either side thereof, of the Pyramid Creek in the Parish of Macorna which lie between the points marked A and B but which do not lie within the area indicated by hatching on plan hereunder.—(M.491(7)) (Rs.9425).

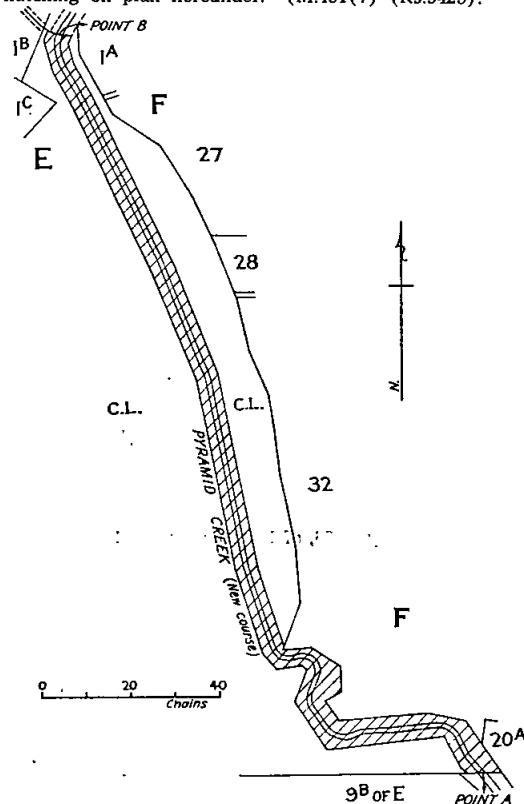

And the Honorable William Archibald Borthwick, Her Majesty's Minister of Lands for the State of Victoria, shall give the necessary directions herein accordingly.

T. J. FORRISTAL,  
Clerk of the Executive Council.

**SUPERANNUATION ACT 1958.**

At the Executive Council Chamber, Melbourne, the fifth day of September, 1972.

PRESENT:

His Excellency the Governor of Victoria.	
Sir George Reid	Mr. Wilcox
Mr. Dickie	Mr. Dunstan.
Mr. Scanlan	

Pursuant to the provisions of paragraph (ja) of subsection (1) of section 3 of the *Superannuation Act 1958*, His Excellency the Governor of the State of Victoria by and with the advice of the Executive Council thereof, doth by this Order declare that the provisions of the *Superannuation Act* shall apply to Reginald Thomas Borbridge, Deputy Chairman of the Vermin and Noxious Weeds Destruction Board constituted pursuant to the provisions of the *Vermin and Noxious Weeds Act 1958* No. 6409.

And the Honorable Rupert James Hamer, Her Majesty's Treasurer for the State of Victoria, shall give the necessary directions herein accordingly.

T. J. FORRISTAL,  
Clerk of the Executive Council.

**HOSPITALS AND CHARITIES ACT 1958, SECTION 6:**

At the Executive Council Chamber, Melbourne, the fifth day of September, 1972.

PRESENT:

His Excellency the Governor of Victoria.	
Sir George Reid	Mr. Wilcox
Mr. Dickie	Mr. Dunstan.
Mr. Scanlan	

**DECLARATION OF THE FAMILY PLANNING ASSOCIATION AS A BENEVOLENT SOCIETY.**

Pursuant to the provisions of section 6 of the *Hospitals and Charities Act 1958* (No. 6274), His Excellency the Governor of the State of Victoria by and with the advice of the Executive Council of the said State, doth by the present Order declare The Family Planning Association to be a benevolent society within the meaning of the said *Hospitals and Charities Act*.

And the Honorable John Frederick Rossiter, Her Majesty's Minister of Health for the State of Victoria, shall give the necessary directions herein accordingly.

T. J. FORRISTAL,  
Clerk of the Executive Council.

**ROAD TRAFFIC ACT 1958.**

At the Executive Council Chamber, Melbourne, the fifth day of September, 1972.

PRESENT:

His Excellency the Governor of Victoria.	
Sir George Reid	Mr. Wilcox
Mr. Dickie	Mr. Dunstan.
Mr. Scanlan	

In pursuance of the powers conferred by the *Road Traffic Act 1958*, His Excellency the Governor of the State of Victoria, in the Commonwealth of Australia, by and with the advice of the Executive Council of the said State, and at the request in writing of the Council of the City of Northcote, doth by this Order extend the provisions of the said Act to the land under the control of the City of Northcote such land having a frontage to the east side of Gillies-street, Fairfield, in the section between Wingrove and Duncan streets, Fairfield and known as the Gillies-street Car Park, as shown by hachure on the plan hereunder.

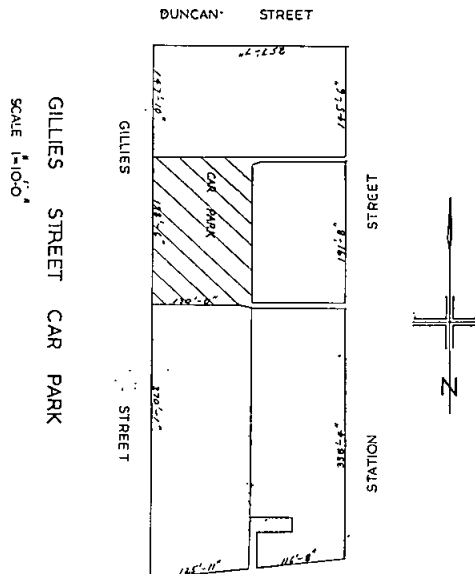

And the Honorable Edward Raymond Meagher, Her Majesty's Chief Secretary for the State of Victoria, shall give the necessary directions herein accordingly.

T. J. FORRISTAL,  
Clerk of the Executive Council.

**ROAD TRAFFIC ACT 1958.**

At the Executive Council Chamber, Melbourne, the fifth day of September, 1972.

PRESENT:

His Excellency the Governor of Victoria.	
Sir George Reid	Mr. Wilcox
Mr. Dickie	Mr. Dunstan.
Mr. Scanlan	

In pursuance of the powers conferred by the *Road Traffic Act 1958*, His Excellency the Governor of the State of Victoria, in the Commonwealth of Australia, by and with the advice of the Executive Council of the said State, and at the request in writing of the Council of the City of Frankston, doth by this Order extend the provisions of the said Act being the land in Playne-street, owned and controlled by the Council of the City of Frankston, as shown on the plan hereunder.

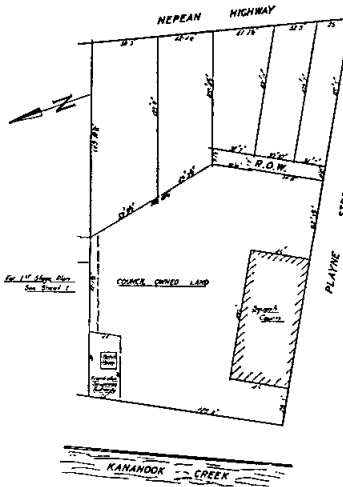

And the Honorable Edward Raymond Meagher, Her Majesty's Chief Secretary for the State of Victoria, shall give the necessary directions herein accordingly.

T. J. FORRISTAL,  
Clerk of the Executive Council.

COUNTRY ROADS BOARD.

At the Executive Council Chamber, Melbourne, the fifth day of September, 1972.

PRESENT:

His Excellency the Governor of Victoria.  
 Sir George Reid | Mr. Wilcox  
 Mr. Dickie | Mr. Dunstan.  
 Mr. Scanlan

ORDER APPROVING OF LAND BEING ACQUIRED AND ROADS, DEVIATIONS OR WIDENINGS BEING MADE.

His Excellency the Governor of the State of Victoria, by and with the advice of the Executive Council thereof, being satisfied that there are funds legally available for acquiring the land, doth hereby approve the acquiring of the land described in the schedule hereunder and the making of new roads and deviations from and widenings of existing roads referred to in the said schedule.

SCHEDULE.

State Highway.

The land shown hatched on Plan numbered G.P.13052 hereunder required for the deviation from the Princes Highway in the Shire of Portland and making of the deviation thereon.

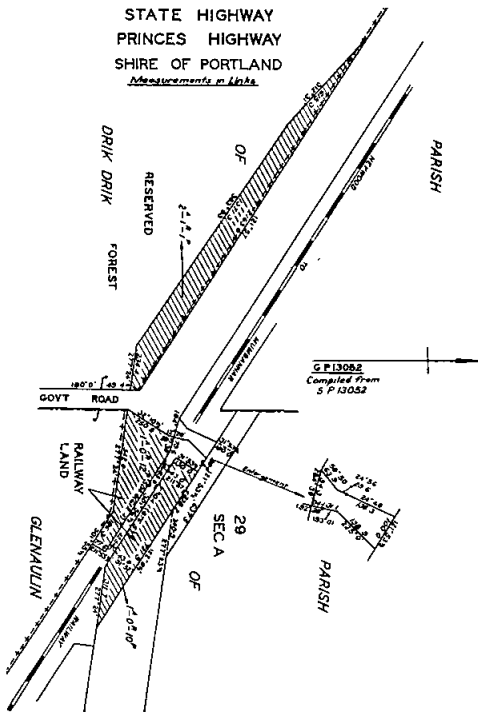

Main Roads.

The land shown hatched on Plan numbered G.P.13009 hereunder required for the widening of Millers-road in the City of Altona and making of the widening thereon.

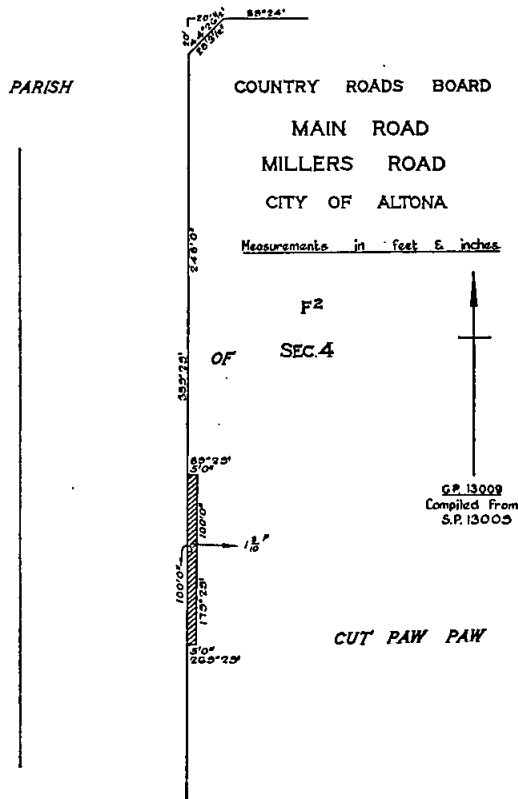

The land shown hatched on Plan numbered G.P.13010 hereunder required for the widening of the Kerang-Quambatook road in the Shire of Kerang and making of the widening thereon.

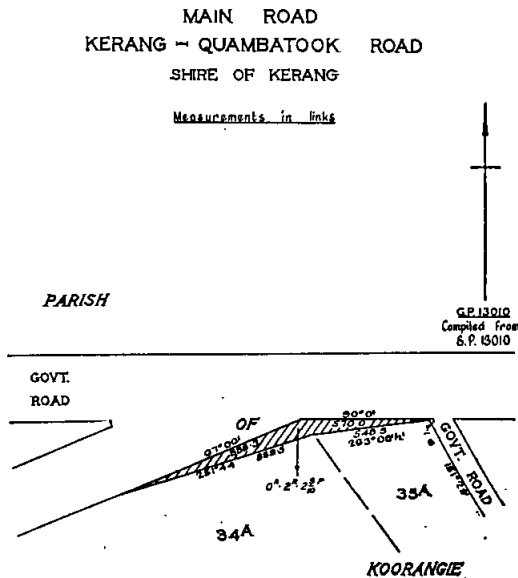

The land shown hatched on Plan numbered G.P.13069 hereunder required for the widening of the Natimuk-Hamilton road in the Shire of Kowree and making of the widening thereon.

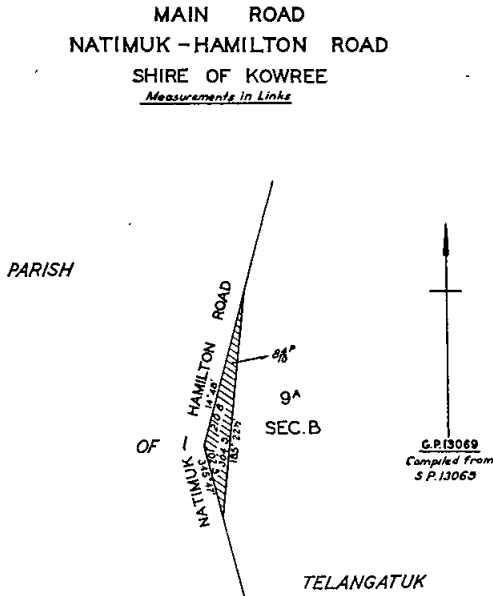

FOREST ROAD  
MEREDITH—STEIGLITZ—MAUDE ROAD  
SHIRE OF BANNOCKBURN  
Measurements in Links

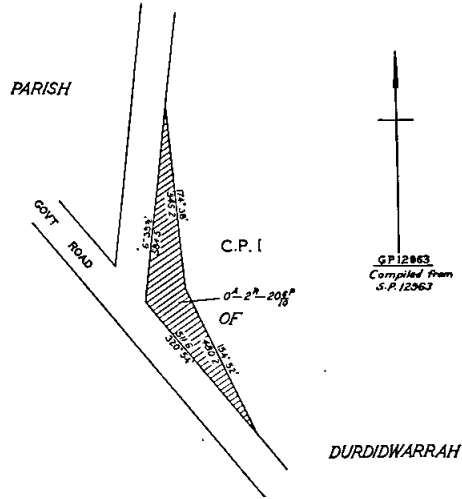

And the Honorable Alan John Hunt, Her Majesty's Minister for Local Government for the State of Victoria, shall give the necessary directions herein accordingly.

T. J. FORRISTAL,  
Clerk of the Executive Council.

HOUSING ACT 1958.

At the Executive Council Chamber, Melbourne, the fifth day of September, 1972.

PRESENT:

His Excellency the Governor of Victoria.  
Sir George Reid | Mr. Wilcox  
Mr. Dickie | Mr. Dunstan.  
Mr. Scanlan

The land shown hatched on Plan numbered G.P.12878 hereunder required for the widening of the Lilydale-Monbulk road in the Shire of Lillydale and making of the widening thereon.

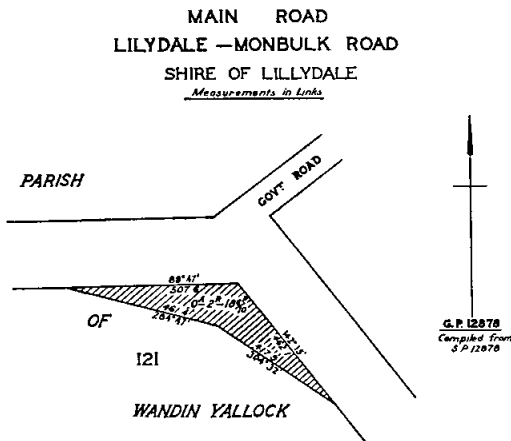

Forest Road.

The land shown hatched on Plan numbered G.P.12963 hereunder required for the widening of the Meredith-Steiglitz-Maude road in the Shire of Bannockburn and making of the widening thereon.

DECLARATION OF PRIVATE STREETS AS PUBLIC HIGHWAYS WITHIN THE CITY OF HORSHAM.

Whereas pursuant to section 107 of the Housing Act 1958 it is among other things enacted that where works have been carried out in accordance with an agreement for the full construction of any roads, pavements, culverts or drains made pursuant to the provisions of the said section 107 such roads, pavements, culverts or drains shall be under the care and management of the municipality which shall be liable for the cost of any maintenance, repair, alteration or reconstruction thereof and the Governor in Council may by order published in the Government Gazette declare any road so constructed to be a public highway.

And whereas by Order dated the 23rd December, 1969, the Governor in Council consented to an agreement between the Housing Commission and the City of Horsham regarding street and drainage construction in Puls-place in the Horsham Estate situate in the municipality of the City of Horsham and the carrying out of the works enumerated in the said Agreement.

And whereas the works of road pavements, culvert and drainage construction have now been carried out in accordance with the said agreement between the Housing Commission and the City of Horsham.

Now therefore, His Excellency the Governor of the State of Victoria by and with the advice of the Executive Council of the said State and in pursuance of the powers conferred by section 107 of the Housing Act and upon recommendation of the Housing Commission doth by this order declare the street more particularly delineated and shown hatched on the plan hereunder to be absolutely dedicated to the public as a Public Highway within the meaning of any law now or hereafter in force and that the Council of the municipality in which the streets are situate, shall hereafter be liable for all cost of any maintenance, repair, alteration or reconstruction thereof.

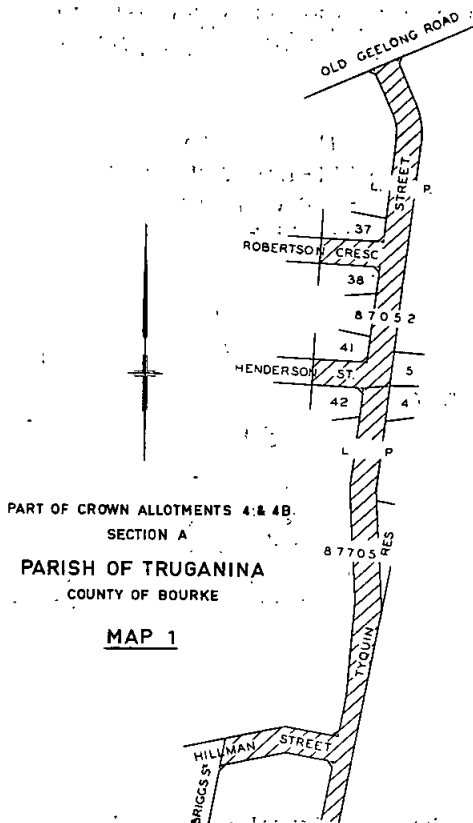
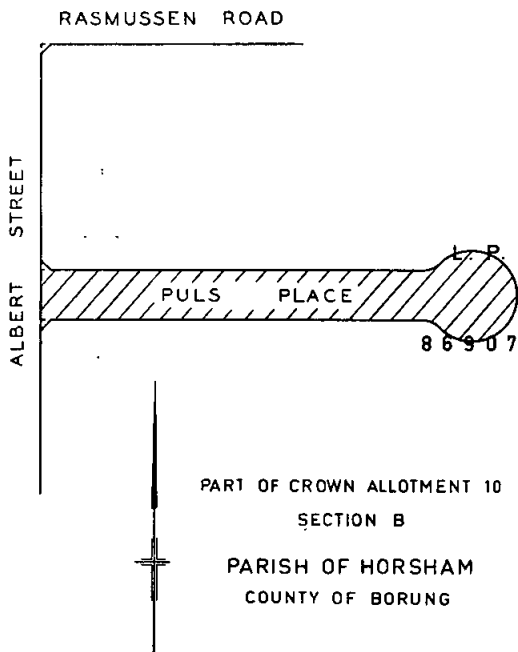

MAP 1

MAP 2

And the Honorable Vance Oakley Dickie, Her Majesty's Minister of Housing for the State of Victoria shall give the necessary directions herein accordingly.

T. J. FORRISTAL,  
Clerk of the Executive Council.

HOUSING ACT 1958.

At the Executive Council Chamber, Melbourne, the fifth day of September, 1972.

PRESENT:

His Excellency the Governor of Victoria.	
Sir George Reid	Mr. Wilcox
Mr. Dickie	Mr. Dunstan.
Mr. Scanlan	

DECLARATION OF PRIVATE STREETS AS PUBLIC HIGHWAYS WITHIN THE SHIRE OR WERRIBEE.

Whereas pursuant to section 107 of the *Housing Act 1958* it is among other things enacted that where works have been carried out in accordance with Agreements for the full construction of any roads, pavements, culverts or drains made pursuant to the provisions of the said section 107 such roads, pavements, culverts or drains shall be under the care and management of the municipality which shall be liable for the cost of any maintenance, repair, alteration or reconstruction thereof and the Governor in Council may by order published in the *Government Gazette* declare any road so constructed to be a public highway.

And whereas by Orders dated the Fourteenth day of January, 1969, and the Twelfth day of August, 1969, the Governor in Council consented to agreements between the Housing Commission and the Shire of Werribee regarding street and drainage construction in Tyquin-street, part Henderson-street, part Robertson-crescent, Watts-street, part Williams-road, part Jennings-street, part Campbell-street and part Hillman-street in the Laverton and Laverton North Estate situate in the municipality of the Shire of Werribee and the carrying out of the works enumerated in the said Agreements.

And whereas the works of road pavements, culvert and drainage construction have now been carried out in accordance with the said Agreements between the Housing Commission and the Shire of Werribee.

Now therefore His Excellency the Governor of the State of Victoria by and with the advice of the Executive Council of the said State and in pursuance of the powers conferred by section 107 of the *Housing Act* and upon recommendation of the Housing Commission doth by this order declare the streets more particularly delineated and shown hatched on the plans hereunder to be absolutely dedicated to the public as Public Highways within the meaning of any law now or hereafter in force; and that the Council of the municipality in which the streets are situate shall hereafter be liable for all cost of any maintenance, repair, alteration or reconstruction thereof.

And the Honorable Vance Oakley Dickie, Her Majesty's Minister of Housing for the State of Victoria shall give the necessary directions herein accordingly.

T. J. FORRISTAL,  
Clerk of the Executive Council.

## THE BALLARAT WATER COMMISSIONERS.

*At the Executive Council Chamber, Melbourne, the twelfth day of September, 1972.*

PRESENT:

His Excellency the Governor of Victoria.  
 Mr. Balfour | Mr. Rafferty.  
 Mr. Scanlan

## CONSENT TO BORROWING \$100,000.

Under the powers conferred by the Water Act and all other powers enabling him in that behalf, His Excellency the Governor of the State of Victoria, by and with the advice of the Executive Council of the said State, doth hereby consent to The Ballarat Water Commissioners borrowing the sum of One hundred thousand dollars (\$100,000), to meet the cost of water supply works.

And the Honorable Roberts Christian Dunstan, Her Majesty's Minister of Water Supply for the State of Victoria, shall give the necessary directions herein accordingly.

T. J. FORRISTAL,  
 Clerk of the Executive Council.

## LATROBE VALLEY ACT.

*At the Executive Council Chamber, Melbourne, the twelfth day of September, 1972.*

PRESENT:

His Excellency the Governor of Victoria.  
 Mr. Balfour | Mr. Rafferty.  
 Mr. Scanlan

## APPOINTMENT OF MEMBERS OF THE LATROBE VALLEY WATER AND SEWERAGE BOARD.

In exercise of the powers conferred on him by the Latrobe Valley Act, His Excellency the Governor of the State of Victoria, by and with the advice of the Executive Council thereof, hereby appoints Charles Bertram Crellin the member representing industry located in the Latrobe Valley on the Latrobe Valley Water and Sewerage Board for a period from the date hereof until 30th June, 1974.

And the Honorable Roberts Christian Dunstan, Her Majesty's Minister of Water Supply for the State of Victoria, shall give the necessary directions herein accordingly.

T. J. FORRISTAL,  
 Clerk of the Executive Council.

## GEMBROOK, COCKATOO AND EMERALD WATERWORKS TRUST.

*At the Executive Council Chamber, Melbourne, the twelfth day of September, 1972.*

PRESENT:

His Excellency the Governor of Victoria.  
 Mr. Balfour | Mr. Rafferty.  
 Mr. Scanlan

## URBAN DISTRICT PROCLAIMED.

Under the powers conferred by the Water Act and all other powers enabling him in that behalf, His Excellency the Governor of the State of Victoria, by and with the advice of the Executive Council of the said State, doth hereby by Order proclaim that on and from the date hereof that portion of the Waterworks District of the Gembrook, Cockatoo and Emerald Waterworks Trust

comprised within the area shaded red on the plan (Corr. No. 70/2556/23) shall be and become an Urban District for the purposes of and within the meaning of the said Act and shall be known as the Menzies Creek Urban District.

And the Honorable Roberts Christian Dunstan, Her Majesty's Minister of Water Supply for the State of Victoria, shall give the necessary directions herein accordingly.

T. J. FORRISTAL,  
 Clerk of the Executive Council.

## LANDLORD AND TENANT ACT 1958.

*At the Executive Council Chamber, Melbourne, the twelfth day of September, 1972.*

PRESENT:

His Excellency the Governor of Victoria.  
 Mr. Balfour | Mr. Rafferty.  
 Mr. Scanlan

## ORDER EXCLUDING CERTAIN PREMISES FROM THE OPERATION OF CERTAIN OF THE PROVISIONS CONTAINED IN PART V. OF THE LANDLORD AND TENANT ACT 1958.

The Fair Rents Board at Geelong having declared that the premises known as No. 156 Corio-street, Geelong, should cease to be prescribed premises and having sent its findings to the Minister for transmission to the Governor in Council for such action as the Governor in Council thinks fit, His Excellency the Governor of the State of Victoria, by and with the advice of the Executive Council thereof, doth declare that the said premises shall be excluded from the operation of the whole of the provisions contained in Divisions 2 and 3 of Part V. of the *Landlord and Tenant Act 1958*.

And the Honorable Sir George Oswald Reid, Her Majesty's Attorney-General in and for the State of Victoria, shall give the necessary directions herein accordingly.

T. J. FORRISTAL,  
 Clerk of the Executive Council.

## LANDLORD AND TENANT ACT 1958.

*At the Executive Council Chamber, Melbourne, the twelfth day of September, 1972.*

PRESENT:

His Excellency the Governor of Victoria.  
 Mr. Balfour | Mr. Rafferty.  
 Mr. Scanlan

## ORDER EXTENDING APPLICATION OF PART V. OF THE LANDLORD AND TENANT ACT 1958 TO CERTAIN PREMISES.

In pursuance of the powers conferred by sections 44 and 45 of the *Landlord and Tenant Act 1958*, His Excellency the Governor of Victoria, by and with the advice of the Executive Council thereof, doth hereby declare that the application of Part V. of the *Landlord and Tenant Act 1958*, shall extend to the following premises:—

The premises known as Number 43 Connell-street, Hawthorn, and to all premises forming part of such premises.

And the Honorable Sir George Oswald Reid, Her Majesty's Attorney-General in and for the State of Victoria, shall give the necessary directions herein accordingly.

T. J. FORRISTAL,  
 Clerk of the Executive Council.

## DAIRY PRODUCTS ACT 1958.

At the Executive Council Chamber, Melbourne, the twelfth day of September, 1972.

PRESENT:

His Excellency the Governor of Victoria.  
Mr. Balfour | Mr. Rafferty.  
Mr. Scanlan |

## APPOINTMENT OF MEMBER OF THE VICTORIAN DAIRY PRODUCTS BOARD.

In pursuance of the powers conferred by section 4 of the Dairy Products Act 1958 and all other powers him thereto enabling, His Excellency the Governor of the State of Victoria, by and with the advice of the Executive Council thereof, doth by this Order hereby appoint Doris Catherine Condon, nominated by the Minister as representing consumers of dairy products, as a member of the Victorian Dairy Products Board for the period ending on the 14th February, 1973, vice Hilda Imray, deceased.

And the Honorable Sir Gilbert Lawrence Chandler, Her Majesty's Minister of Agriculture for the State of Victoria, shall give the necessary directions herein accordingly.

T. J. FORRISTAL,  
Clerk of the Executive Council.

## LANDS DEPARTMENT NOTICES

## APPROACHING LAND SALES.

Sale of Crown Land, in fee-simple, will be held at the under-mentioned places and dates, viz.:—

	No. of Gazette
Ballarat.—Wednesday, 27th September, 1972 ..	70
Numurkah.—Thursday, 14th September, 1972 ..	70
Wangaratta.—Thursday, 21st September, 1972 ..	69

## SALE OF CLOSER SETTLEMENT LAND BY AUCTION.

Red Cliffs.—Wednesday, 18th October, 1972 .. 84

## SALE OF FREEHOLD LAND BY AUCTION.

Ararat.—Thursday, 21st September, 1972 .. 70

## SALE OF CLOSER SETTLEMENT LAND BY AUCTION.

The land will be offered for sale in fee-simple, and subject to the provisions of the Closer Settlement Act 1938.

The upset price is the sum at which bidding will start, and no bid below that sum can be accepted. The highest bidder at or above that sum shall be the purchaser, subject to signature of contract and any necessary payment.

## TERMS:—

A deposit of at least 12½% of the purchase price must be paid at the sale, either in cash or by cheque.

The residue is payable in half-yearly instalments, in accordance with the following scale, or may be paid off at any earlier time.

Over \$600, and not exceeding \$800, 16 instalments.
Over \$800, and not exceeding \$1,000, 18 instalments.
Over \$1,000, 20 instalments.

Interest at the rate of 5% per annum is payable with all payments of residue, and is computed on the unpaid balance. Additional interest is charged if any instalment is not paid on or before the due date.

If paid off within 30 days of sale, no interest is payable.  
FEES, ETC.:

Also payable at the sale, in addition to the deposit, are the survey fee and, if applicable, the valuation of improvements (if purchaser be not the owner thereof).

Payable with balance of purchase money—

Crown Grant fee—\$3.

Assurance Fund contribution.—One cent in every Five dollars or part thereof of purchase price. (This is a fund established to guarantee the validity of freehold titles.)

Transfer of interest prior to completion of payment may be allowed on payment of \$2 fee and subject to stamp duty.

If unable to attend personally, a prospective purchaser may arrange for another person to bid as his agent.

Attention is drawn to section 95, Land Act 1958, which provides that the purchaser shall be deemed to be the owner for the purposes of other Acts; also to an amendment to the Local Government Act providing for Government roads, in certain circumstances, to be declared "private streets", thus making the purchaser liable to contribute to the cost of street construction.

W. BORTHWICK,  
Minister of Lands.

Office of Crown Lands and Survey,  
Melbourne, 13th September, 1972.

RED CLIFFS.—A Sale of Closer Settlement land in fee-simple, by auction, will be held at the LAND OFFICE, RED CLIFFS, on WEDNESDAY, the 18TH day of OCTOBER, 1972, at ELEVEN o'clock a.m. To be conducted by R. F. JONES, Land Officer, Red Cliffs, Lot 1.

PARISH OF MILDURA, COUNTY OF KARKAROO.

At the western corner of Riverside-avenue and 15th-street.

Upset price \$770 the lot. Survey fee \$120.

Area 15a. 0r. 13p., allotment 11 of section 31 (Block E). One month allowed for the removal of fencing.

NOTE.—This land is within the operation of an Interim Development Order and is proposed to be zoned by the Shire of Mildura as "Industrial".

The State Rivers and Water Supply Commission has advised that water supply or drainage facilities are not available to this allotment.—(M.61560.)

## DEPARTMENT OF CROWN LANDS AND SURVEY.

Notice is hereby given that lot 12 of the Ballarat Sale (No. 12137), set down for Wednesday, 27th September, 1972, and published in *Government Gazette*, No. 70, of 2nd August, 1972, page 2758, has been withdrawn.

## APPOINTMENT OF COMMITTEE OF MANAGEMENT OF CERTAIN CROWN RESERVES AT ANGLESEA.

In pursuance of section 221 of the Land Act 1958, I hereby appoint The Corporation of the Shire of Barrabool as the Committee of Management of the reserved Crown land in the Township of Anglesea, Parish of Jan Juc, as is indicated by red colour on plan AH/4.9.72 attached to Lands Department correspondence No. Rs.1527.—(Corres. No. Rs.1527.)

W. BORTHWICK,  
Minister of Lands.

Department of Crown Lands and Survey,  
Melbourne, 8th September, 1972.

## PROPOSED REVOCATIONS OF TEMPORARY RESERVATIONS OF LANDS BY ORDERS IN COUNCIL.

In pursuance of the provisions of the Land Act 1958, notice is hereby given that it is the intention of the Governor in Council to revoke the temporary reservations of lands by Orders in Council hereunder referred to, viz.:—

The following Notices were published 1° on the 30th August, 1972, pursuant to Orders of the 22nd August, 1972.

BULGA (TARRA VALLEY).—The temporary reservation by Order in Council of the 28th October, 1912, of 13 3/10 perches of land in the Parish of Bulga as a site for a Public Hall, is about to be revoked.—(B.714<sup>(s)</sup>) (Rs.796).

GLEN WILLS.—The temporary reservation by Order in Council of the 15th July, 1895 (see *Government Gazette*, 19th July, 1895, page 2734) of 1 acre of land in the Township of Glen Wills as a site for Public purposes, is about to be revoked.—(G.225<sup>(s)</sup>) (Rs.1934).



GORDON.—The temporary reservation as a site for a Mechanics' Institute, Free Library and Public Hall, and the withholding from sale, leasing and licensing by Order in Council of the 20th November, 1882, of 3 roods 17 3/10 perches of land in the Township of Gordon, are about to be revoked.—(G.162<sup>(2)</sup>) (Rs.2821).

KILMORE.—The temporary reservation by Order in Council of the 7th November, 1906, of 33 8/10 perches of land in the Township of Kilmore as a site for a State School, is about to be revoked.—(K.47<sup>(8)</sup>) (Rs.4136).

PINE LODGE.—The temporary reservation as a site for Public purposes (State School) and the withholding from sale, leasing and licensing by Order in Council of the 6th October, 1879, of 2 acres of land in the Parish of Pine Lodge, are about to be revoked.—(P.151<sup>(4)</sup>) (C.100843).

YARRAGON (YULUNGAH).—The temporary reservation by Order in Council of the 8th January, 1902, of 1 acre of land in the Parish of Yarragon as a site for a State School, is about to be revoked.—(Y.109<sup>(10)</sup>) (Rs.9464).

KILMORE.—The temporary reservation by Order in Council of the 9th February, 1872, of 1 acre of land in the Township of Kilmore as a site for a Common School, is about to be revoked, so far only as the portion containing 2 roods 19 perches, indicated by hatching on plan hereunder, is concerned.—(K.47<sup>(8)</sup>) (Rs.4136).

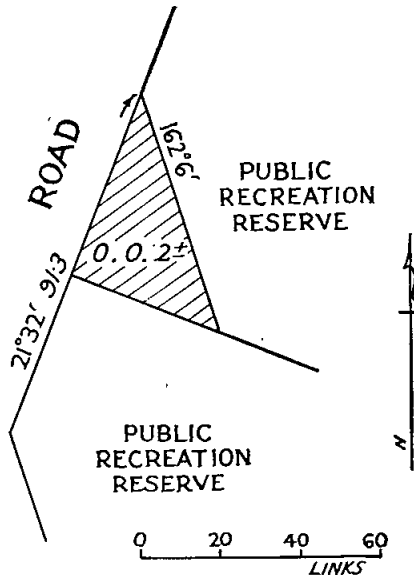
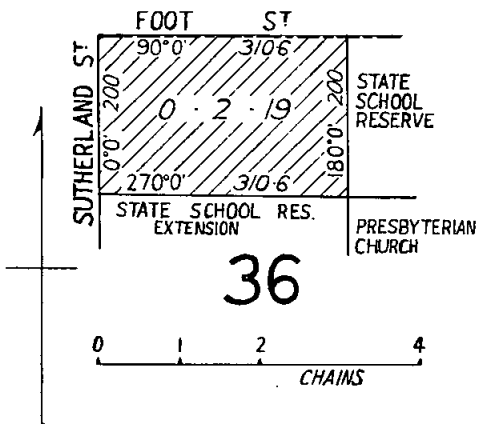

MANDURANG.—The temporary reservation by Order in Council of the 27th March, 1956, of 1 acre of land in the Parish of Mandurang as a site for Public Recreation, is about to be revoked so far only as the portion containing 1 rood 16 perches, more or less, indicated by hatching on plan hereunder, is concerned.—(M.29<sup>(9)</sup>) (Rs.5690).

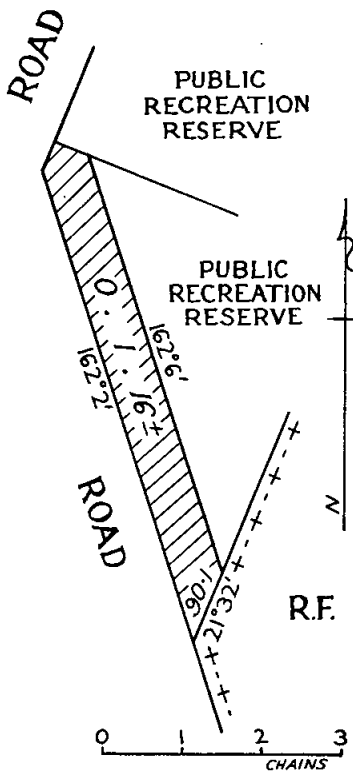

LORNE.—The temporary reservation by Order in Council of the 21st August, 1917, of 149 acres, more or less, of land in the Township of Lorne as a site for Public purposes, revoked as to part by various Orders, is about to be revoked so far only as the portion containing 32 perches, indicated by hatching on plan hereunder, is concerned.—(L.147<sup>(7)</sup>) (Rs.1690).

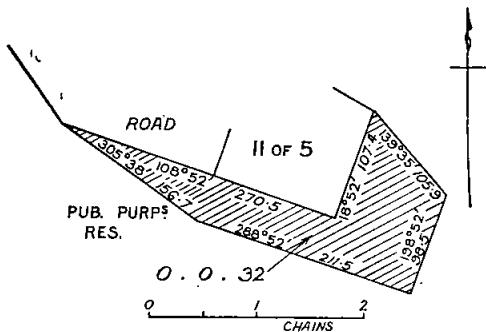

MANDURANG.—The temporary reservation by Order in Council of the 21st August, 1945, of 6 acres 1 rood 24 perches of land in the Parish of Mandurang as a site for Public Recreation is about to be revoked so far only as the portion containing 2 perches, more or less, indicated by hatching on plan hereunder, is concerned.—(M.29<sup>(9)</sup>) (Rs.5690).

TANGAMBALANGA.—The temporary reservation by Order in Council of the 21st February, 1928, of 9 acres, more or less, of land in the Parish of Tangambalanga as a site for Camping, Watering, and Recreation and Convenience of the People, is about to be revoked so far only as the portion containing 5 acres 3 roods 29 perches, indicated by hatching on plan hereunder, is concerned.—(T.35<sup>(12)</sup>) (Rs.3624).

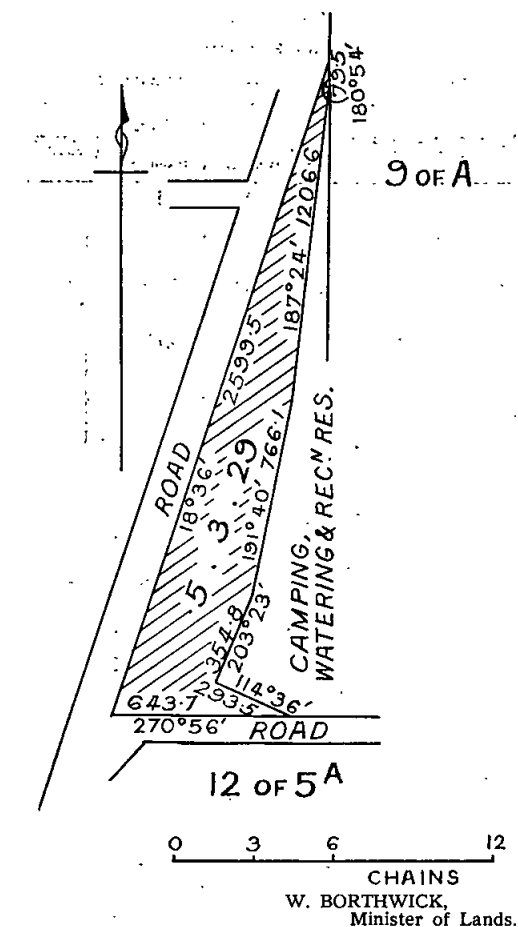

## TENDERS

### PUBLIC WORKS DEPARTMENT

Tenders will be received at Public Works Department, 2, Treasury-place, Melbourne, until **TWO** p.m. on dates shown and for purposes mentioned hereunder.

Particulars and tender forms available at Contracts Office, Room 8, Building Division, Parliament-place and at places indicated in brackets hereunder.

Abbreviations in brackets mean:—W.O.—Inspector of Works Office; P.S.—Police Station; C.S.—Consolidated School; H.E.S.—Higher Elementary School; H.S.—High School; Pr.S.—Primary School; T.S.—Technical School.

Tenders to be submitted on the Department's printed Tender Form and will not be received by telephone. All tenders must be on a "Firm Tender" basis. The lowest or any tender will not necessarily be accepted.

Address tenders to the Minister of Public Works, and endorse the envelope containing the tender "Tender for , closing Tuesday,

Hand delivered tenders to be placed in the Tender Box of the Public Works Department, located on the wall of the centre entrance foyer, Ground Floor, 2 Treasury-place, Melbourne.

No preliminary deposit is required with any tender, but a successful tenderer will be required to pay a deposit for any accepted tender of \$4,000 or over.

**Tuesday, 19th September, 1972.**

#### Building, Electrical and Mechanical Works.

BEECHWORTH.—Replacement of flooring and sheet vinyl covering Wards F6 and F7, M.H. (W.O., Wangaratta.)

BENDIGO.—Internal and external repairs and painting, Pr.S.877. (W.O., Bendigo and Kyneton.)

FLORA HILL.—External and internal renovations, Pr.S.4667. (W.O., Bendigo and Shepparton.)

HAWTHORN.—Internal and external repairs and painting, Milk Board.

HEATHMONT.—Exterior and interior renovations, Pr.S.4688.

HEIDELBERG.—Internal renovations, Girls H.S.

MARYBOROUGH EAST.—External renovations, Pr.S.2828. (W.O., Maryborough.)

MYRTLEFORD.—Exterior and interior renovations, C.S. (W.O., Benalla and Wangaratta.)

STRATHMORE NORTH.—External and internal renovations, Pr.S.4821.

THE BASIN.—L.T.C. classrooms, additions and alterations, Boys Special School.

TOOLANGI.—Erection of potato store, State Potato Research Station. (State Potato Research Station, Toolangi) (Re-advertised—Amend Specification).

TRENTHAM.—External and internal repairs and painting, Pr.S.1588. (W.O., Bendigo and Kyneton.)

VARIOUS.—Erection of classrooms, staff rooms etc., Bulk Contract (Western) 1972-73, Part I. (W.O., Ballarat and Geelong, Horsham and Warrnambool.)

VARIOUS.—Supply and delivery of Audio Visual Carrel Ducts and control room equipment, Schools.

WODONGA.—External renovations, T.S. (W.O., Wangaratta.)

#### Site Works.

ALTONA.—Site works, H.S.

BROOKLYN WEST.—Site works, Pr.S.4825.

BRUNSWICK SOUTH.—Site works, Pr.S.2743.

MILDURA WEST.—Site works, Pr.S.3983. (W.O., Mildura and Swan Hill.)

WILLIAMSTOWN.—Asphalt repairs, Girls H.S.

**Tuesday, 26th September, 1972.**

#### Building, Electrical and Mechanical Works.

BENTLEIGH.—External and internal repairs and painting, H.S.

BRIGHTON.—Renewal of timber floors, Pr.S.1542.

DANDENONG.—External and internal renovations, Pr.S.1403.

GLEN IRIS.—Internal and external repairs and painting, Pr.S.1148.

GLENORMISTON.—Additions and renovations, residence, Agricultural College. (Re-advertised.) (W.O., Camperdown, Geelong and Warrnambool.)

GREYTHORN.—External repairs and painting, Pr.S.4694.

HADFIELD.—Internal and external renovations, H.S.

KANGAROO FLAT.—External and internal renovations and painting, Pr.S.981. (W.O., Bendigo and Kyneton.)

RAINBOW.—Alterations and renovations, Trade Block, H.S. (W.O., Horsham.) (Amended Specification.)

STONY POINT.—Extensions to workshop and office, Buoy Depot. (Buoy Depot, Stony Point.)

STONY POINT.—Electrical installation—extensions Buoy Depot.

VICTORIA PARK.—Internal and external renovations, &c., Pr.S.2957.

#### Furniture and Furnishings.

MONASH.—Supply of furniture, Teachers College.

#### Site Works.

BACCHUS MARSH.—Asphalt works, Pr.S.28. (W.O., Ballarat.)

LAVERTON.—Concrete paving, drainage, kerbing, garden areas, &c., H.S.

McKINNON.—Site works, H.S.

MIRBOO NORTH.—Asphalt repairs, H.S. (W.O., Traralgon and Warragul.)

Tuesday, 3rd October, 1972.

**Building, Electrical and Mechanical Works.**

ABBOTSFORD.—Internal repairs and renovations, Pr.S.1886.

CROYDON.—Internal and external renovations, H.S.

MELBOURNE.—Air conditioning of P.A.B.X. rooms, Treasury Reserve.

MURTOA.—External and internal renovations, H.S. (W.O., Ararat.)

OAK PARK.—External and internal repairs and painting, H.S.

PYRAMID HILL.—External and internal renovations, Pr.S.1712. (W.O., Bendigo.)

RINGWOOD.—External and internal repairs and painting, Pr.S.2997.

TALLANGATTA.—External renovations, Pr.S.1365. (W.O., Wangaratta.)

VARIOUS.—Supply, delivery and assembly of timber-framed portable buildings 1972/73, Schools.

VARIOUS.—Electrical services, standard Primary classrooms 1972/73 Rates Contract, Primary Schools.

VARIOUS.—Mechanical services, standard Primary classrooms 1972/73 Rates Contract, Primary Schools.

**Site Works.**

BROADMEADOWS.—Site works, H.S.

CROYDON WEST.—Asphalting, concreting, drainage, &c., Pr.S.4879.

MOUNT BEAUTY.—Asphalt, concrete, drainage, &c., H.S. (W.O., Wangaratta.)

ROBERTS DUNSTAN,  
Minister of Public Works.

Public Works Department,  
Melbourne, 3002, 11th September, 1972.

**PUBLIC SERVICE NOTICES**

No. 284.

Public Service Act 1958, Section 50.

**REGULATIONS.—PART IV.—SALARIES AND INCREMENTS.**

The Public Service Board, in pursuance of the powers conferred by the Public Service Act 1958, hereby amends its Regulations as shown below:—

**FIFTH SCHEDULE.**

TEMPORARY EMPLOYEES.

DEPARTMENT OF HEALTH.

MENTAL HYGIENE.

Designations of Positions and Rates of Salaries.

Designation of Position.	Yearly Rate of Salary.		Increments (Annual).
	Minimum.	Maximum.	
	\$	\$	
<i>Delete—</i>			
Nurse, Student—			
Adult .. .. .	3,087	3,414	φ
Training Assistant, Sandhurst Boys' Centre .. .. .	3,044	3,374	φ
Ward Assistant—			
Adult .. .. .	3,044	3,374	φ
<i>Add—</i>			
Nurse, Student—			
Adult .. .. .	3,193	3,475	φ
Training Assistant, Sandhurst Boys' Centre .. .. .	3,193	3,475	φ
Ward Assistant—			
Adult .. .. .	3,193	3,475	φ

**SIXTH SCHEDULE.**

TEMPORARY EMPLOYEES.

Designations of Positions and Rates of Salaries.

Department and Designation of Position.	Yearly Rate of Salary.		Increments (Annual).
	Minimum.	Maximum.	
	\$	\$	
<b>GENERAL.</b>			
<i>Delete—</i>			
Animal Attendant .. .. .	3,129	3,294	A
<i>Add—</i>			
Animal Attendant= .. .. .	3,193	3,475	A
—Rates applicable for both males and females.			
<i>Delete the existing yearly rates of salary for the following positions and insert the rates shown hereunder in lieu thereof—</i>			
<b>DEPARTMENT OF AGRICULTURE</b>			
Cannery Operator, Horticultural Research Station, Tatura .. .. .	3,193	3,475	A
<b>DEPARTMENT OF HEALTH.</b>			
<i>General Health.</i>			
Physiotherapist's Assistant (Male) .. .. .	3,193	3,475	A
<i>Tuberculosis.</i>			
X-Ray Technician, Assistant—Adult .. .. .	3,294	3,475	A
<i>State Sanatoria.</i>			
Nursing Aide (Male), Trainee .. .. .		3,294	
<b>PUBLIC WORKS DEPARTMENT.</b>			
<i>Ports and Harbours.</i>			
Lightkeeper and Boatman .. .. .	3,273	3,475	A
<b>STATE FORESTS DEPARTMENT.</b>			
Engineering Surveyor, Grade I .. .. .	3,193	3,475	A

This Regulation shall have effect as on and from the 27th August, 1972.

A. J. A. GARDNER, Chairman,  
R. H. DURRANT, Acting Secretary.

Office of the Public Service Board,  
Melbourne, 4th September, 1972.

No. 281.

**PUBLIC SERVICE ACT 1958.**

The Public Service Board, in pursuance of the powers conferred by the Public Service Act 1958, hereby amends the Public Service (Public Service Board) Regulations as follows:—

**PART IV.—SALARIES AND INCREMENTS.**  
**DIVISION IV.—TECHNICAL AND GENERAL DIVISION.**

*Regulation 114.*

In paragraph (a) (iii), the expression "Grade F65" is substituted for the expression "Grade F60".

In paragraph (b) (ii), the expression "Grade F65" is substituted for the expression "Grade F60".

This Regulation shall have effect as on and from the 27th August, 1972.

A. J. A. GARDNER, Chairman,  
R. H. DURRANT, Acting Secretary.

Office of the Public Service Board,  
Melbourne, 4th September, 1972.

No. 279.

Public Service Act 1958, Section 50.

REGULATIONS.—PART IV.—SALARIES AND INCREMENTS.

The Public Service Board, in pursuance of the powers conferred by the Public Service Act 1958, hereby amends its Regulations as shown below:—

FIFTH SCHEDULE.  
TEMPORARY EMPLOYEES.  
DEPARTMENT OF HEALTH.  
MENTAL HYGIENE.

Designations of Positions and Rates of Salaries.

Designation of Position.	Yearly Rate of Salary.		Increments (Annual).
	Minimum.	Maximum.	
	\$	\$	
<i>Delete the existing yearly rates of salary for the following positions and insert the rates shown hereunder in lieu thereof—</i>			
Anaesthetic and Operating Theatre Technician	3,945	4,224	A
Bricklayer	4,601	4,970	A
Butcher	3,496	3,789	A
Carpenter	4,601	4,970	A
Cleaner (Male)	3,475	3,769	A
Cleaner (Female)	3,213	3,506	B
Cleaner and Labourer—Junior—			
At 20 years of age		3,165	
Adult	3,475	3,769	A
Cook	3,517	3,769	A
Craft Supervisor (Male), Grade IV.	4,994	5,401	A
Craft Supervisor (Male), Grade III.	4,810	4,947	A
Craft Supervisor (Male), Grade II.	3,984	4,184	A
Craft Supervisor (Male), Grade I.—Junior—			
At 20 years of age		3,347	
Adult	3,674	3,906	A
Craft Supervisor (Female), Grade IV.	3,899	4,040	B
Craft Supervisor (Female), Grade III.	3,738	3,838	B
Craft Supervisor (Female), Grade II.	3,327	3,385	B
Craft Supervisor (Female), Grade I.—Junior—			
At 20 years of age		2,893	
Adult	3,173	3,270	B
Dental Attendant (Female), Grade II.	3,251	3,506	B
Dental Attendant (Female), Grade I.—Junior—			
At 20 years of age		2,817	
Adult	3,072	3,347	B
Dental Mechanic	4,924	5,265	A
Drainer and Joiner	4,520	4,902	A
Electrical Mechanic	4,301	4,681	A
Engineer Mechanic, Grade I.	4,301	4,681	A
Farm Assistant—Junior—			
At 20 years of age		3,476	
Adult	3,809	4,084	A
Female Reliever	2,846	3,153	B
Fireman	3,731	4,024	A
Gardener, Grade III.	3,866	4,144	A
Gardener, Grade II.	3,731	4,044	A
Gardener, Grade I.—Junior—			
At 20 years of age		3,238	
Adult	3,557	3,828	A
General Assistant—Junior—			
At 20 years of age		3,110	
Adult	3,414	3,693	A
Hairdresser (Male)	3,945	4,301	A
Hairdresser (Female)	3,546	3,879	B
Kitchenman—Junior—			
At 20 years of age		3,110	
Adult	3,414	3,693	A

Designation of Position.	Yearly Rate of Salary.		Increments (Annual).
	Minimum.	Maximum.	
	\$	\$	
Kitchenmaid—Junior—			
At 20 years of age		2,557	
Adult	2,783	3,052	B
Kitchen and Wardsmaid—Junior—			
At 20 years of age		2,557	
Adult	2,783	3,052	B
Labourer	3,253	3,537	A
Laundress, Grade II.	2,951	3,251	B
Laundress, Grade I.—Junior—			
At 20 years of age		2,557	
Adult	2,783	3,052	B
Laundryman—Junior—			
At 20 years of age		3,110	
Adult	3,414	3,693	A
Messroom Attendant (Female)—Junior—			
At 20 years of age		2,557	
Adult	2,783	3,052	B
Mortuary Attendant	3,617	3,906	A
Motor Mechanic	4,301	4,681	A
Motor Truck Driver—Junior—			
At 20 years of age		3,861	
Adult	4,044	4,399	A
Painter	4,560	4,924	A
Plasterer	4,621	4,994	A
Plumber	4,702	5,039	A
Seamstress, Grade II.	2,910	3,193	B
Seamstress, Grade I.—Junior—			
At 20 years of age		2,575	
Adult	2,804	3,092	B
Shoemaker	4,301	4,681	A
Storeman, Grade II.	3,828	4,144	A
Storeman, Grade I.—Junior—			
At 20 years of age		3,365	
Adult	3,693	3,965	A
Supervisor and Caretaker (Male), Marlborough House	3,886	4,184	A
Tailor	3,847	4,164	A
Tailoress, Grade II.	4,184	4,560	A
Tailoress, Grade I.	3,847	4,164	A
Upholsterer	3,334	3,655	A
Watchman	3,655	3,926	A

SIXTH SCHEDULE.

TEMPORARY EMPLOYEES.

Designations of Positions and Rates of Salaries.

Department and Designation of Position.	Yearly Rate of Salary.		Increments (Annual).
	Minimum.	Maximum.	
	\$	\$	
<i>Delete the existing yearly rates of salary for the following positions and insert the rates shown hereunder in lieu thereof—</i>			
GENERAL			
Caretaker, Grade II.	4,379	4,745	A
Caretaker, Grade I.	3,886	4,184	A
Carpenter	4,601	4,970	A
Cleaner (Female)	3,213	3,506	B
Cleaner (Male)	3,475	3,769	A
Electrician	4,301	4,681	A
Field Assistant (Survey), Grade II.	4,243	4,520	A
Field Assistant (Survey), Grade I.—Junior—			
At 20 years of age		3,476	
Adult	3,809	4,104	A
Fireman	3,731	4,024	A
Garage Attendant—Junior—			
At 20 years of age		2,921	
Adult	3,193	3,475	A
Gardener, Grade III.	3,866	4,144	A
Gardener, Grade II.	3,731	4,044	A

SIXTH SCHEDULE—continued.

Department and Designation of Position.	Yearly Rate of Salary.		Increments (Annual).	Department and Designation of Position.	Yearly Rate of Salary.		Increments (Annual).
	Minimum.	Maximum.			Minimum.	Maximum.	
	\$	\$			\$	\$	
Gardener, Grade I.— Junior— At 20 years of age ..	..	3,238	..	Office of the Chief Commissioner of Police.	3,193	3,475	A
Adult ..	3,557	3,828	A				
General Assistant— Junior— At 20 years of age ..	..	3,110	..	Police Hospital.			
Adult ..	3,414	3,693	A	Cook .. .. .	3,750	4,044	A
General Hand— Junior— At 20 years of age ..	..	2,976	..	Housemaid .. .. .	2,783	3,052	B
Adult ..	3,253	3,537	A	Wardsman .. .. .	3,475	3,769	A
Laboratory Attendant— Junior— At 20 years of age ..	..	3,165	..	State Library, National Gallery, National Museum and Science Museum.			
Adult ..	3,475	3,769	A	General Hand, Senior ..	3,435	3,731	A
Labourer, Senior ..	3,435	3,731	A	Lavatory Attendant (Male)	3,314	3,617	A
Labourer ..	3,253	3,537	A	Lavatory Attendant (Female)	2,931	3,213	B
Lift Attendant ..	3,598	3,866	A	DEPARTMENT OF CROWN LANDS AND SURVEY.			
Motor Mechanic ..	4,301	4,681	A	Guide, Buchan Caves ..	3,809	4,084	A
Motor Truck Driver— Junior— At 20 years of age ..	..	3,861	..	Royal Botanic Gardens			
Adult ..	4,044	4,399	A	Gardener, Grade IIA ..	4,339	4,661	A
Painter ..	4,560	4,924	A	DEPARTMENT OF HEALTH.			
Plumber ..	4,702	5,039	A	General Health.			
Storeman, Grade II.	3,828	4,144	A	Attendant, Venereal Diseases Clinic .. .. .	3,557	3,847	A
Storeman, Grade I.— Junior— At 20 years of age ..	..	3,365	..	Exotic Diseases.			
Adult ..	3,693	3,965	A	Cook .. .. .	3,517	3,769	A
Watchman ..	3,655	3,926	A	Domestic .. .. .	2,783	3,052	B
DEPARTMENT OF AGRICULTURE							
Caretaker—Caterer (Female)				Maternal and Child Welfare.			
Horticultural Research Station, Tatura ..	3,465	3,698	B	Articulated Vehicle Driver (Maker's capacity, 10 Tons)	4,262	4,641	A
Caretaker and Overseer, Glenormiston ..	3,926	4,204	A	Dental Attendant (Female), Senior .. .. .	3,584	3,660	B
Farm Assistant— Junior— At 20 years of age ..	..	3,476	..	Dental Attendant (Female), Grade II. .. .. .	3,251	3,506	B
Adult ..	3,809	4,084	A	Dental Attendant (Female), Grade I.— Junior— At 20 years of age ..	..	2,817	..
Fitter ..	4,301	4,681	A	Adult ..	3,072	3,347	B
Maintenance Officer, Cool Stores ..	4,480	4,810	A	Tuberculosis.			
Stockman and Assistant ..	3,809	4,084	A	Dark Room Attendant (Male)— Junior— At 20 years of age ..	..	3,129	..
Dookie Agricultural College							
Blacksmith ..	4,320	4,702	A	Adult ..	3,435	3,731	A
Cook ..	4,084	4,439	A	Dark Room Attendant (Female)— Junior— At 20 years of age ..	..	2,605	..
Dairy Assistant ..	3,809	4,084	A	Adult ..	2,846	3,112	B
Farm Mechanic ..	4,301	4,681	A	State Sanatoria.			
Gardener, Head ..	4,399	4,766	A	Boiler Attendant .. .. .	3,731	4,024	A
Houseman, Senior ..	3,213	3,537	A	Chef .. .. .	4,262	4,621	A
Houseman, Waiter ..	3,193	3,475	A	Cook .. .. .	3,731	4,004	A
Piggery Assistant ..	3,945	4,224	A	Cook, Assistant .. .. .	3,517	3,769	A
Waitress ..	2,740	3,012	B	Cook, Second Assistant and Housemaid .. .. .	3,517	3,769	A
Housemaid, Senior ..	2,846	3,153	B	Engineer Mechanic, Grade II.	4,947	5,288	A
Longerenong Agricultural College							
Blacksmith-Instructor ..	4,480	4,833	A	Gardener, Senior .. .. .	4,399	4,766	A
Cook ..	4,084	4,439	A	Kitchenman .. .. .	3,414	3,693	A
CHIEF SECRETARY'S DEPARTMENT							
Fisheries and Wildlife.							
Hatchery Assistant, Snob's Creek— Junior— At 20 years of age ..	..	3,476	..	Laundryman, Grade II. ..	3,636	3,926	A
Adult ..	3,809	4,084	A	Laundress .. .. .	2,783	3,052	B
Liberation Officer— Junior— At 20 years of age ..	..	3,861	..	Laundress, Assistant and Housemaid .. .. .	2,783	3,052	B
Adult ..	4,044	4,399	A	Maid— Junior— At 20 years of age ..	..	2,557	..
				Adult .. .. .	2,783	3,052	B
				Seamstress and Housemaid ..	2,804	3,092	B

SIXTH SCHEDULE—continued.

Department and Designation of Position.	Yearly Rate of Salary.		Increments (Annual.)
	Minimum.	Maximum.	
Wardsmajd—			
Junior—			
At 20 years of age		2,557	
Adult .. .. .	2,783	3,052	B
Wardsmajd .. .. .	3,475	3,769	A
<b>LAW DEPARTMENT.</b>			
General Hand, Coroner's Court .. .. .	3,253	3,537	A
Mortuary Attendant, Assistant, Morgue .. .. .	3,496	3,789	A
<b>LOCAL GOVERNMENT DEPARTMENT.</b>			
<i>Weights and Measures.</i>			
Truck Driver and Assistant .. .. .	4,439	4,810	A
<b>MINES DEPARTMENT.</b>			
Bulldozer Operator (70-130 brake horsepower) .. .. .	4,540	4,878	A
Tradesman (Drilling Equipment) .. .. .		4,681	
Tradesman (Drilling Equipment), Leading Hand .. .. .		4,810	
<b>PUBLIC WORKS DEPARTMENT.</b>			
Electrical Fitter .. .. .	4,301	4,681	A
Electrical Mechanic .. .. .	4,301	4,681	A
Mechanic .. .. .	4,301	4,681	A
Polisher (Furniture) .. .. .	4,281	4,661	A
<i>Ports and Harbours.</i>			
Able Seaman .. .. .	3,866	4,164	A
Blacksmith's Striker .. .. .	3,193	3,475	A
Carpenter and Shipwright .. .. .	4,439	4,788	A
Cook .. .. .	4,520	4,878	A
Deckhand .. .. .	3,731	4,024	A
Dredge Engine Driver .. .. .	4,320	4,702	A
Dredge Operator, Grade I .. .. .	3,926	4,224	A
Engine Driver ("Fury") .. .. .	4,580	4,924	A
Engine Driver ("Goudie") .. .. .	4,320	4,702	A
Fireman, Marine .. .. .	3,965	4,224	A
Fitter and Turner .. .. .	4,301	4,681	A
Greaser and Storeman .. .. .	4,004	4,281	A
Master ("Fury") .. .. .	4,580	4,924	A
Master ("Goudie") .. .. .	4,320	4,702	A
Navigation Lights Officer, Assistant .. .. .	4,560	4,970	A
Steward .. .. .	4,520	4,878	A
Tradesman's Assistant .. .. .	3,193	3,475	A
Wharf Carpenter and Boatman .. .. .	4,601	4,970	A
<b>SOCIAL WELFARE DEPARTMENT.</b>			
<i>Family Welfare Division.</i>			
Cook, Grade III. .. .. .	3,617	3,906	A
Cook, Grade II. .. .. .	3,475	3,769	A
Cook, Grade I. .. .. .	3,294	3,578	A
Domestic—			
Junior—			
At 20 years of age .. .. .		2,502	
Adult .. .. .	2,740	3,012	B
Gardener and General Assistant .. .. .	3,557	3,828	A
General Reliever (Female)—			
Junior—			
At 20 years of age .. .. .		2,605	
Adult .. .. .	2,846	3,153	B
Kitchenman .. .. .	3,414	3,693	A
Laundress, Senior .. .. .	2,951	3,251	B
Laundress .. .. .	2,783	3,052	B
Seamstress .. .. .	2,804	3,092	B
<i>Youth Welfare Division.</i>			
Cook, Grade IV. .. .. .	4,084	4,439	A
Cook, Grade III. .. .. .	3,617	3,906	A
Cook, Grade II. .. .. .	3,475	3,769	A
Cook, Grade I. .. .. .	3,294	3,578	A
Domestic—			
Junior—			
At 20 years of age .. .. .		2,502	
Adult .. .. .	2,740	3,012	B
General Reliever (Female)—			
Junior—			
At 20 years of age .. .. .		2,605	
Adult .. .. .	2,846	3,153	B
Kitchenman .. .. .	3,414	3,693	A
Laundryman .. .. .	3,414	3,693	A

Department and Designation of Position.	Yearly Rate of Salary.		Increments (Annual.)
	Minimum.	Maximum.	
	\$	\$	
Laundress .. .. .	2,783	3,052	B
Patrolman "Winlaton" .. .. .	3,475	3,769	A
Seamstress .. .. .	2,804	3,092	B
<b>STATE FORESTS DEPARTMENT.</b>			
Mechanic, Leading Hand, Fire Protection .. .. .	4,480	4,810	A
Mechanic, Fire Protection .. .. .	4,301	4,681	A
Propagator, Forest Plants .. .. .	4,204	4,560	A
Transport Assistant .. .. .	4,480	4,810	A
<i>Central Workshops.</i>			
Electrical Fitter, Leading Hand .. .. .	4,480	4,810	A
Fitter, Leading Hand .. .. .	4,480	4,810	A
Fitter and Turner, Leading Hand .. .. .	4,480	4,810	A
Fitter .. .. .	4,301	4,681	A
Machinery Float Driver (20 tons) .. .. .	4,560	4,924	A
Mobile Crane Driver .. .. .	3,617	3,906	A
Welder, Special Class, Leading Hand .. .. .	4,560	4,924	A
Welder, Special Class .. .. .	4,399	4,766	A
Welder, Leading Hand .. .. .	4,480	4,810	A
Welder .. .. .	4,301	4,681	A
<b>WATER SUPPLY DEPARTMENT.</b>			
Mechanical Officer .. .. .	4,681	5,016	A
Mechanic, Senior .. .. .	4,601	4,970	A

This Regulation shall have effect as on and from the 27th August, 1972.

A. J. A. GARDNER, Chairman.  
R. H. DURANT, Acting Secretary.

Office of the Public Service Board,  
Melbourne, 4th September, 1972.

No. 283.

PUBLIC SERVICE ACT 1958.

The Public Service Board, in pursuance of the powers conferred by the Public Service Act 1958, hereby amends the Public Service (Public Service Board) Regulations as follows:—

PART IV.—SALARIES AND INCREMENTS.

DIVISION I.—GENERAL.

Regulation 99.

The expression "\$3,193" is substituted for the expression "\$2,962" in the proviso to this Regulation.

DIVISION IV.—TECHNICAL AND GENERAL DIVISION.

Regulation 113.

In paragraph (c) of sub-regulation (3) the expression "two annual increments of \$141" is substituted for the expression "one annual increment of \$187 and one annual increment of \$140".

In paragraph (d) of sub-regulation (3) the expression "\$141" is substituted for the expression "\$165".

PART V.—ALLOWANCES.

DIVISION IV.—SHIFT DUTY AND ROSTERED TIME OF ORDINARY DUTY PERFORMED BY OFFICERS DURING WEEK-ENDS OR ON PUBLIC HOLIDAYS.

DEPARTMENT OF HEALTH—MENTAL HYGIENE BRANCH.

Regulation 157.

In sub-regulation (1)—

Delete—

Yearly Rate of Allowance.

	\$
"Student Nurse—	
Junior .. .. .	373
Adult—1st year .. .. .	414
2nd year .. .. .	439
3rd and subsequent years .. .. .	458

Add—

	Yearly Rate of Allowance.
	\$
Student Nurse—	
Junior .. .. .	373
Adult—1st year .. .	429
2nd year .. .	447
3rd and subsequent years .. .	466

This Regulation shall have effect as on and from the 27th August, 1972.

A. J. A. GARDNER, Chairman.  
R. H. DURRANT, Acting Secretary.

Office of the Public Service Board,  
Melbourne, 4th September, 1972.

No. 282.

Public Service Act 1958, Section 50.

REGULATIONS—PART IV.—SALARIES AND INCREMENTS.

The Public Service Board, in pursuance of the powers conferred by the Public Service Act 1958, hereby amends its Regulations as shown below:—

SIXTH SCHEDULE.  
TEMPORARY EMPLOYEES.

Designations of Positions and Rates of Salaries.

Department and Designation of Position.	Yearly Rate of Salary.		Increments (Annual).
	Minimum.	Maximum.	
	\$	\$	
<i>Delete the existing yearly rates of salary for the following positions and insert the rates shown hereunder in lieu thereof—</i>			
EDUCATION DEPARTMENT.			
Graphic Artist .. .	4,004	4,460	A
Linotype Operator, Visual Education Centre .. .	4,460	4,902	A
TREASURY.			
<i>Government Printing Office.</i>			
Binder .. .	4,301	4,681	A
Binder, Quarter (Female) .. .	2,658	2,931	B
Binding Assistant .. .	3,193	3,475	A
Binding, Guillotine Operator .. .	4,301	4,681	A
Binding, Machine Folder .. .	3,213	3,496	A
Binding, Paper Ruler .. .	4,301	4,681	A
Book Folder (Female) .. .	2,617	2,889	B
Book Folder and Sewer (Female) .. .	2,658	2,931	B
Compositor .. .	4,301	4,681	A
Despatcher, Grade I .. .	3,414	3,712	A
Doorkeeper .. .	3,193	3,475	A
Electrician .. .	4,301	4,681	A
Engineer .. .	4,301	4,681	A
Engineer's Assistant .. .	3,193	3,475	A
Embossor (Female) .. .	2,658	2,931	B
Feeder (Female) .. .	2,617	2,889	B
Fork Lift Truck Operator .. .	3,496	3,809	A
General Assistant .. .	3,193	3,475	A
General Assistant, Cleaning .. .	3,193	3,475	A
Indexer (Female) .. .	2,658	2,931	B
Letterpress Assistant .. .	3,334	3,617	A
Linotype Assistant .. .	3,294	3,517	A
Machineman .. .	4,301	4,681	A
Machinist, Envelope (Female) .. .	2,658	2,931	B
Mechanic, Linotype .. .	4,301	4,681	A
Monotype Caster .. .	3,517	3,789	A
Operator, Linotype .. .	4,681	5,107	A
Operator, Monotype .. .	4,681	5,107	A
Photo Engraver .. .	4,399	4,788	A
Photo Lithographer .. .	4,399	4,788	A
Plumber, Mechanical Equipment .. .	4,301	4,681	A
Pressman .. .	4,301	4,681	A
Printer, Lithographic .. .	4,301	4,681	A
Printer, Lithographic, Assistant .. .	3,334	3,617	A
Printer, Small Offset .. .	3,906	4,399	A
Printer's Joiner .. .	4,301	4,681	A
Reader .. .	4,379	4,833	A
Reader's Assistant (Male) .. .	3,193	3,475	A
Reader's Assistant (Female) .. .	2,617	2,889	B
Stereotyper .. .	4,301	4,681	A
Storeman .. .	3,414	3,712	A
Ticket Printer .. .	3,557	3,847	A

No. 278.

Public Service Act 1958, Section 50.

REGULATIONS—PART IV.—SALARIES AND INCREMENTS.

The Public Service Board, in pursuance of the powers conferred by the Public Service Act 1958, hereby amends its Regulations as shown below:—

SIXTH SCHEDULE.  
TEMPORARY EMPLOYEES.

Designations of Positions and Rates of Salaries.

Department and Designation of Position.	Yearly Rate of Salary.		Increments (Annual).
	Minimum.	Maximum.	
	\$	\$	
GENERAL.			
<i>Delete—</i>			
Telephonist (Female)—			
Junior—			
Under 17 years of age .. .		1,817	
At 17 years of age .. .		1,983	
At 18 years of age .. .		2,137	
At 19 years of age .. .		2,452	
At 20 years of age .. .		2,765	
Adult .. .	3,251	3,506	B
<i>Add—</i>			
Telephonist (Female), Grade II .. .		3,641	
Telephonist (Female), Grade I.—			
Junior—			
Under 17 years of age .. .		1,817	
At 17 years of age .. .		1,983	
At 18 years of age .. .		2,137	
At 19 years of age .. .		2,452	
At 20 years of age .. .		2,765	
Adult .. .	3,251	3,506	B

This Regulation shall have effect as on and from the 27th August, 1972.

A. J. A. GARDNER, Chairman.  
R. H. DURRANT, Acting Secretary.

Office of the Public Service Board,  
Melbourne, 25th August, 1972.

This Regulation shall have effect as on and from the 27th August, 1972.

A. J. A. GARDNER, Chairman.  
R. H. DURRANT, Acting Secretary.

Office of the Public Service Board,  
Melbourne, 4th September, 1972.

No. 280.

Public Service Act 1958, Section 50.

REGULATIONS—PART IV.—SALARIES AND INCREMENTS.

The Public Service Board, in pursuance of the powers conferred by the Public Service Act 1958, hereby amends its Regulations as shown below:—

SECOND SCHEDULE.

TECHNICAL AND GENERAL DIVISION.

GRADES AND SALARY SCALES.

JUNIOR GRADES.

The salary scales shown for Males and Females are deleted and the following salary scales are inserted in lieu thereof:—

MALES.

Grade.	Yearly Rate of Salary at Each Age in Years.				
	Under 17.	17.	18.	19.	20.
	\$	\$	\$	\$	\$
JM—2 ..	1,382	1,657	1,934	2,210	2,921
JM—3 ..	1,412	1,694	1,977	2,259	2,976
JM—5 ..	1,487	1,783	2,081	2,378	3,110
JM—6 ..	1,497	1,796	2,096	2,395	3,129
JM—8 ..	1,517	1,820	2,124	2,427	3,165
JM—10 ..	1,558	1,869	2,181	2,492	3,238
JM—14 ..	1,690	2,027	2,366	2,703	3,476
JM—19 ..	..	..	3,266	3,266	3,861
JM—24 ..	..	..	2,279	2,605	3,365

FEMALES.

Grade.	Yearly Rate of Salary at Each Age in Years.				
	Under 17.	17.	18.	19.	20.
	\$	\$	\$	\$	\$
JF—5 ..	..	..	1,608	1,837	2,502
JF—6 ..	1,184	1,414	1,651	1,886	2,557
JF—7 ..	1,209	1,450	1,693	1,935	2,605
JF—11 ..	..	..	..	2,117	2,817

SEVENTH SCHEDULE.

TECHNICAL AND GENERAL DIVISION.

DEPARTMENT OF HEALTH.

MENTAL HYGIENE.

GRADES AND SALARY SCALES.

JUNIOR GRADES.

The salary scales shown for Males and Females are deleted and the following salary scales are inserted in lieu thereof:—

MALES.

Grade.	Yearly Rate of Salary at Each Age in Years.				
	Under 17.	17.	18.	19.	20.
	\$	\$	\$	\$	\$
JM—5 ..	1,487	1,783	2,081	2,378	3,110
JM—8 ..	1,517	1,820	2,124	2,427	3,165
JM—10 ..	1,558	1,869	2,181	2,492	3,238
JM—14 ..	1,690	2,027	2,366	2,703	3,476
JM—19 ..	..	..	3,266	3,266	3,861
JM—23 ..	..	..	2,265	2,589	3,347
JM—24 ..	..	..	2,279	2,605	3,365

FEMALES.

Grade.	Yearly Rate of Salary at Each Age in Years.				
	Under 17.	17.	18.	19.	20.
	\$	\$	\$	\$	\$
JF—6 ..	1,184	1,414	1,651	1,886	2,557
JF—11 ..	..	..	..	2,117	2,817
JF—27 ..	1,189	1,426	1,665	1,902	2,575
JF—28 ..	..	..	1,913	2,185	2,893

This Regulation shall have effect as on and from the 27th August, 1972.

A. J. A. GARDNER, Chairman.

R. H. DURRANT, Acting Secretary.

Office of the Public Service Board,  
Melbourne, 4th September, 1972.

No. 285.

Public Service Act 1958, Section 50.

REGULATIONS—PART IV.—SALARIES AND INCREMENTS.

The Public Service Board in pursuance of the powers conferred by the Public Service Act 1958, hereby amends its Regulations as follows:—

FIFTH SCHEDULE.

TEMPORARY EMPLOYEES.

DEPARTMENT OF HEALTH.

MENTAL HYGIENE.

Designations of Positions and Rates of Salaries.

Designation of Position.	Yearly Rate of Salary.		Increments (Annual).
	Minimum.	Maximum.	
	\$	\$	
<i>Delete the existing yearly rates of salary for the following position and insert the rates shown hereunder in lieu thereof—</i>			
Housekeeper .. ..	4,079	4,334	B

SIXTH SCHEDULE.

TEMPORARY EMPLOYEES.

Designations of Positions and Rates of Salaries.

Department and Designation of Position.	Yearly Rate of Salary.		Increments (Annual).
	Minimum.	Maximum.	
	\$	\$	
DEPARTMENT OF HEALTH.			
<i>Tuberculosis.</i>			
<i>State Sanatoria.</i>			
<i>Delete—</i>			
Housekeeper .. ..	2,379	2,597	B
<i>Delete the existing yearly rates of salary for the following positions and insert the rates shown hereunder in lieu thereof—</i>			
DEPARTMENT OF AGRICULTURE.			
Dairy Foreman, Glenormiston	3,828	4,004	A
Foreman, Government Cool Stores .. ..	5,221	5,424	A
Foreman, Viticultural Station, Rutherglen .. ..	4,580	4,833	A
Overseer, Government Cool Stores .. ..	6,062	6,334	A
<i>Dookie Agricultural College.</i>			
House Supervisor, Assistant	..	5,062	
CHIEF SECRETARY'S DEPARTMENT.			
<i>Office of the Chief Commissioner of Police.</i>			
Housekeeper, Police Officers' College .. ..	2,658	2,951	B
EDUCATION DEPARTMENT.			
Housekeeper, Grade III ..	3,818	3,939	B
Housekeeper, Grade II ..	3,641	3,679	B
Housekeeper, Grade I ..	3,465	3,526	B
DEPARTMENT OF HEALTH.			
<i>Tuberculosis.</i>			
<i>State Sanatoria.</i>			
Foreman .. ..	5,265	5,582	A



## SIXTH SCHEDULE—continued

Department and Designation of Position.	Yearly Rate of Salary.		Increments (Annual).
	Minimum.	Maximum.	
	\$	\$	
SOCIAL WELFARE DEPARTMENT.			
<i>Family Welfare Division.</i>			
Housekeeper, "Allambie" ..	4,079	4,334	B
STATE FORESTS DEPARTMENT.			
Construction Overseer, Senior Foreman, Field Workshop ..	5,993	6,484	A
Housekeeper, School of Forestry ..	5,902	6,334	A
	3,425	3,565	B
WATER SUPPLY DEPARTMENT.			
Inspector, Works ..	5,628	5,902	A
Mechanical Supervisor, Grade II. ..	5,764	5,902	A
Overseer ..	4,766	4,833	A

*This Regulation shall have effect as on and from the 27th August, 1972.*

A. J. A. GARDNER, Chairman.  
R. H. DURRANT, Acting Secretary.

Office of the Public Service Board,  
Melbourne, 4th September, 1972.

## Teaching Service Act 1958.

TEACHING SERVICE (TEACHERS TRIBUNAL)  
REGULATIONS.

## AMENDMENT No. 237 (T.T.44).

The Teachers Tribunal, in pursuance of the powers conferred by the *Teaching Service Act 1958*, hereby amends Regulation 23 of the Teaching Service (Teachers Tribunal) Regulations as follows:—

## Regulation 23.

After clause 20A insert the following new clause:—

"20B. (a) The Director-General may grant full-time leave of absence to any member nominated to undertake an approved full-time course of study under the Commonwealth Government's National Service Vocational Training Scheme.

(b) Such leave of absence shall be only for the actual duration of the appropriate course, but shall include any vacations occurring between the commencement of the course and the final examinations.

(c) During such period of leave the member shall be paid an allowance representing the difference between the salary to which he would normally have been entitled and the amount of the allowances paid to him under the National Service Vocational Training Scheme.

(d) If the Director-General is of the opinion that a member is failing to make satisfactory progress in the course, he may cancel the leave of absence."

W. E. SAMPSON, Chairman.  
A. F. LE CLERCQ, Secretary.

Office of the Teachers Tribunal,  
Melbourne, 5th September, 1972.

**PRIVATE ADVERTISEMENTS**

**CITY OF BENDIGO.**

**LOAN No. 66.**

*Notice of Intention to Borrow the Sum of \$100,000 for Permanent Works and Undertakings.*

Notice is hereby given that the Council of the City of Bendigo proposes to borrow the principal sum of One hundred thousand dollars, secured by a charge over the general rates of the municipality, such sum to be raised by the grant of a mortgage in accordance with the provisions of the Local Government Act 1958.

1. The maximum rate of interest that may be paid is 6.2 per cent. per annum.

2. The loan is to be applied for the purpose of:—

Road Construction .. .. .	\$52,000
Drainage Works .. .. .	10,000
Footpath Construction .. .. .	13,000
Kerb and Channel Construction and Associated Road Widening .. .. .	25,000
	<b>\$100,000</b>

3. The period of the loan shall be ten years.

4. The moneys borrowed shall be repayable by providing out of the municipal fund twenty equal amounts, of \$6,783.87 principal and interest, payable half-yearly on the 30th day of May, and the 30th day of November during the currency of the loan. The first instalment shall be payable on the 30th day of May, 1973.

5. Such moneys shall be payable to the Commonwealth Savings Bank of Australia, Bendigo.

The plans and specifications and estimate of the cost of the proposed works, and a statement showing the proposed expenditure of the moneys to be borrowed, are open for inspection at the Municipal Offices, Bendigo.

8310

A. J. WATTS, Town Clerk.

*Town and Country Planning Act 1961 (Twelfth Schedule).*

**CITY OF HORSHAM PLANNING SCHEME 1965.**

NOTICE THAT A PLANNING SCHEME HAS BEEN PREPARED AND IS AVAILABLE FOR INSPECTION.

*Amendment No. 15, 1972.*

Notice is hereby given that the Council of the City of Horsham, in pursuance of its powers under the *Town and Country Planning Act 1961*, has prepared a planning scheme for that part of the municipal district of the City of Horsham situated on the south side of Dimboola-road, 950 feet north-west of the intersection of Dimboola-road and Jenkinson-avenue, shown within a black border on planning scheme map No. 967/20/7 comprising an area of approximately 7/10th of an acre of land.

The purpose of the amendment is to re-zone the area from Rural "A" zone to Industrial "A" zone.

Copies of the scheme have been deposited at the office of the City of Horsham, Wilson-street, Horsham, and at the office of the Town and Country Planning Board, Fifth Floor, 235 Queen-street, Melbourne, and will be open for inspection during office hours by any person free of charge.

Any persons affected by the planning scheme are required to set forth in writing, all objections they may have addressed to the Town Clerk, City of Horsham, Postal Box 511, Horsham, on or before the 16th day of October, 1972, and to state whether they wish to be heard in respect of this objection.

8261

A. R. CONN, Town Clerk.

**CITY OF KNOX.**

**LOAN No. 97.**

*Notice of Intention to Borrow the Sum of \$50,000 for Permanent Works and Undertakings.*

Notice is hereby given that the Council of the City of Knox, in pursuance of powers conferred by the Local Government Acts, intends to borrow the sum of \$50,000, secured by a charge over the general rates of the municipality, such sum to be raised by the grant of a mortgage, in accordance with the said Acts and states:—

(a) The amount of principal moneys it is proposed to borrow is \$50,000.

(b) The maximum rate of interest that may be paid is 6.2 per cent. per annum.

(c) The period of the loan will be ten years and the time or times at which the moneys borrowed are to be repayable is on the 1st day of May and the 1st day of November in each year, during the currency of the loan commencing on the 1st day of May, 1973, until the final payment on the 1st day of November, 1982.

(d) The purpose for which the loan is to be applied is for permanent works and undertakings, viz:—

(1) Forest-road concrete kerb and channel and drainage, Old Forest-road to Mountain Highway .. .. .	\$14,300
(2) Burwood Highway, concrete kerb and channel, Austin-street to Acacia-road .. .. .	9,600
(3) Sasses-avenue construction, Orange-grove to south of Claude-street .. .. .	2,000
(4) Recreation Reserves Improvements: Glenfern Park Toilet Block and Pavilion, Wantirna South Tennis Court, Studfield Sports Centre Toilet Block .. .. .	9,800
(5) Tip Establishment .. .. .	14,300
	<b>\$50,000</b>

(e) The loan is to be liquidated by half-yearly payments of approximately \$3,391.93, including principal and interest, payable out of the municipal fund.

(f) The place of repayment will be The National Bank of Australasia Limited, 271-285 Collins-street, Melbourne, 3000.

Plans and specifications and an estimate of the cost of such works and undertakings, and a statement showing the proposed expenditure of the money to be borrowed, are open for inspection by ratepayers, during office hours, at the City Offices, Fern Tree Gully, for one month after the publication of this notice.

Dated at Fern Tree Gully this 30th day of August, 1972.

8254

N. G. HAYNES, Town Clerk.

*Town and Country Planning Act 1961.*

**CITY OF MOE PLANNING SCHEME 1966.**

NOTICE THAT A PLANNING SCHEME HAS BEEN PREPARED AND IS AVAILABLE FOR INSPECTION.

*Amendment No. 29.*

Notice is hereby given that the City of Moe in pursuance of its powers under the *Town and Country Planning Act 1961* has prepared a Planning Scheme to provide for the matters of Home Industries and Home Occupations.

A copy of the scheme may be inspected at the City Office, Albert-street, Moe, and at the office of the Town and Country Planning Board, 235 Queen-street, Melbourne, and will be open for inspection during office hours by any person free of charge.

Any persons affected by the Planning Scheme are required to set forth, in writing, all objections they may have, addressed to the Town Clerk, City of Moe, Albert-street, Moe, on or before the 13th day of October, 1972, and to state whether they wish to be heard in respect of their objections.

8255

R. J. PUGSLEY, Town Clerk.

*Town and Country Planning Act 1961 (Twelfth Schedule).*

**CITY OF SHEPPARTON PLANNING SCHEME 1953.**

NOTICE THAT A PLANNING SCHEME HAS BEEN PREPARED AND IS AVAILABLE FOR INSPECTION.

*Amendment No. 25, 1972.*

Notice is hereby given that the Council of the City of Shepparton, in pursuance of its power under the *Town and Country Planning Act 1961*, has prepared a Planning Scheme for the whole of the municipal district of the City of Shepparton for the purpose of:—

(a) Providing for all uses within the Residential Zone, with the exception of a house, to be subject to the grant of a permit by the Responsible Authority.

(b) Providing for the erection of flats in the Residential Zone (subject to the grant of a permit by the Responsible Authority).

(c) Excluding the word "Motel" from the definition of a "Guest House" in the Definitions' Clause of the Ordinance to the Planning Scheme.

A copy of the scheme has been deposited at the office of the Council, Civic Centre, Welsford-street, Shepparton, and at the office of the Town and Country Planning Board, 235 Queen-street, Melbourne, and will be open for inspection during office hours by any person free of charge.

Any persons affected by the Planning Scheme are required to set forth in writing all objections they may have, addressed to the Town Clerk, Civic Centre, Shepparton, on or before the 13th day of October, 1972, and to state whether they wish to be heard in respect of their objections.

8219

R. O'BRIEN, Town Clerk.

## TOWN OF PORTLAND.

## LOAN No. 101.

Notice of Intention to Borrow the Sum of \$30,000 for Permanent Works and Undertakings.

Notice is hereby given that the Council of the Town of Portland proposes to borrow the principal sum of \$30,000, secured by a charge over the general rates of the municipality, such sum to be raised by a grant of a mortgage in accordance with the provisions of the Local Government Act 1958.

1. The maximum rate of interest that may be paid is 6.3 per cent. per annum.

2. The purposes for which the loan is to be applied are:—

Roadworks—Cape Nelson-road (part cost)	\$18,000
Drainage Works within Town	\$12,000
	<u>\$30,000</u>

3. The period of the loan shall be fifteen years.

4. The moneys borrowed shall be repayable by providing out of the municipal fund half-yearly instalments of \$1,560.41 each, including principal and interest on the 1st day of June and the 1st day of December, during the currency of the loan. The first instalment shall be payable on the 1st day of June, 1973.

5. Such moneys shall be repayable to the Commissioners of the State Savings Bank of Victoria at the office of the said Commissioners, corner Elizabeth and Bourke streets, Melbourne.

The plans and specifications and estimate of the cost of the proposed works, and a statement showing the proposed expenditure of moneys to be borrowed, are open for inspection at the office of the Council of the Town of Portland, Gawler-street, Portland.

Dated this 13th day of September, 1972.

8217

L. FELL, Town Clerk.

## BOROUGH OF KYABRAM.

## LOAN No. 24.

Notice of Intention to Borrow the Sum of \$6,000 for Permanent Works and Undertakings.

Notice is hereby given that the Council of the Borough of Kyabram proposes to borrow the principal sum of \$6,000, secured by a charge over the general rates of the municipality, such sum to be raised by the grant of a mortgage in accordance with the provisions of the Local Government Act 1958.

1. The maximum rate of interest that may be paid is 6.2 per cent. per annum.

2. The purpose for which the loan is to be applied is:—

Purchase of Garbage Collection Vehicle—\$6,000

3. The period of the loan shall be ten years.

4. The moneys borrowed shall be repayable by providing out of the municipal fund half-yearly instalments of \$407.04 each, including principal and interest on the 1st day of May and the 1st day of November, during the currency of the loan. The first instalment shall be payable on the 1st day of May, 1973.

5. Such moneys shall be repayable to the Commonwealth Savings Bank of Australia, Melbourne.

The plans and specifications and estimate of the cost of the proposed works, and a statement showing the proposed expenditure of the moneys to be borrowed, are open for inspection at the office of the Council of the Borough of Kyabram, at Lake-road, Kyabram.

Dated this 8th day of September, 1972.

8215

E. T. CORNISH, Town Clerk.

## SHIRE OF BERWICK.

## BY-LAW No. 59.

## Abattoirs By-Law.

A By-Law of the Shire of Berwick made under Section 326 of the Health Act 1958 and Numbered 59 for:

(a) Fixing the rates of fees or dues payable to the Council under Part XV, of the Health Act 1958.

(b) Prescribing the times for slaughtering animals at public and private abattoirs.

(c) The feeding, watering and tending and the preventing of cruelty to and overcrowding of animals in abattoirs.

(d) Stopping temporarily the manufacture of and the sale of small goods in circumstances in which danger to the consumer is apprehended owing to uncleanness or to the presence of infection on or about the premises where such manufacture or sale is carried on.

In pursuance of the powers conferred by the Health Act 1958 and of any and every other power it thereunto enabling the President Councillors and Ratepayers of the Shire of Berwick orders as follows:

1. This By-Law shall be known as the Abattoirs By-Law.

2. By-Law No. 54 of the Shire of Berwick relating to Abattoirs is hereby repealed.

3. The fees and dues which shall be demanded and received by the Council for examining animals and examining and branding carcasses offal and meat by or under the direction of the Meat Inspector shall be as follows:

A. For examining any:

(i) Bull cow calf (other than a bobby calf) Heifer, ox or steer . . . 0.30c

(ii) Bobby calf goat kid lamb or sheep . . . 0.10c

(iii) Head of swine . . . 0.20c

B. For examining and branding any carcass or side of:

(i) Bull cow calf (other than a bobby calf) heifer ox or steer . . . 0.50c

(ii) Bobby calf goat kid lamb or sheep—

for the first 600 carcasses examined in any one month . . . 0.15c per carcass

for the next 400 carcasses examined in any one month . . . 0.10c per carcass

for all carcasses over the first 1,000 . . . 0.05c per carcass

(iii) Swine . . . 0.25c

C. Any quantity of meat (not including offal) fresh or cured in pieces less than a side per cwt. or part thereof . . . 0.10c

D. Any offal—per piece . . . 0.03c

In this By-Law "bobby calf" means a calf not more than six weeks old.

For any Certificate as to an examination made by a Meat Inspector 0.50c.

4. (a) The times for slaughtering animals at public or private abattoirs are hereby prescribed as being between the hours of 6 o'clock in the morning and 3 o'clock in the afternoon of any week day other than Saturday.

(b) No person shall slaughter any animals at any public or private abattoir at any time other than the times prescribed by this By-Law, except where in the opinion of the Meat Inspector it is necessary immediately to slaughter any animal.

5. The proprietor or person in charge of any abattoir:

(a) Shall at all times cause to be provided for and to be available to all animals therein adequate water and food for the use of such animals.

(b) Shall not suffer any animal or animals therein to be overcrowded or treated with cruelty.

6. Any person having the control or management of any animal or animals in any abattoir:

(a) Shall at all times cause to be provided for and to be available to such animal or animals adequate water and food for the use of such animal or animals.

(b) Shall not suffer any such animal or animals to be overcrowded or treated with cruelty.

7. If the Medical Officer of Health at any time apprehends that danger to the consumer will result owing to uncleanness or to the presence of infection on or about any premises where the manufacture of or the sale of small goods is carried on such Medical Officer of Health may by notice in writing under his hand to the owner occupier or person in charge of such premises direct such owner occupier and person in charge to stop the

manufacture and/or sale (as the case may be) of small goods from such premises until such time as such condition of uncleanness or such infection ceases and such owner occupier and person in charge of such premises shall comply with the terms of such notice.

8. This By-Law shall apply to and have operation throughout the whole of the Municipal district which has been constituted a meat area by proclamation of the Governor in Council.

Resolution for passing this By-Law agreed to by the Council of the Shire of Berwick on the Nineteenth day of June, 1972, and confirmed on the Twenty-fourth day of July, 1972.

The corporate seal of the President, Councillors and Ratepayers of the Shire of Berwick was hereunto affixed, in the presence of:

(SEAL)  
8312. T. B. KILVINGTON, President.  
B. D. SIMON, Councillor.  
B. J. WALLIS, Secretary.

SHIRE OF DIAMOND VALLEY.

LOAN No. 38.

Notice of Intention to Borrow the Sum of \$119,000 for Permanent Works and Undertakings.

Notice is hereby given that the Council of the Shire of Diamond Valley proposes to borrow the principal sum of \$119,000 secured by a charge over the general rates of the municipality, such sum to be raised by the grant of a mortgage in accordance with the provisions of the Local Government Act 1958.

1. The maximum rate of interest that may be paid is 6.3 per centum per annum.

2. The purposes for which the loan is to be applied are:—

Buildings—

Eltham North public hall (pt. prov.) .. .. .	\$16,500	
Gabonia-avenue reserve, pavilion & toilet block (pt. prov.) ..	5,000	
Coniston-street tennis courts, toilet block .. .. .	5,000	
Diamond Creek Bowling Club pavilion .. .. .	17,000	43,500
Public Works—		
C.R.B. works, Council's proportion (pt. prov.) .. .. .		14,300
Parks—		
Bundoora Park development ..		18,000
Traffic control—		
Greensborough-road south of Elder-street, pedestrian operated lights .. .. .	3,500	
Bent-street-Plenty-road, traffic signals (Council proportion)	4,700	8,200
Private street construction—		
Council's proportion .. .. .		35,000
		<u>\$119,000</u>

3. The period of the loan shall be 15 years.

4. The moneys borrowed shall be repayable by providing out of the municipal fund half-yearly instalments of \$6,189.61 each, including principal and interest on the 1st day of May and the 1st day of November during the currency of the loan. The first instalment shall be payable on 1st May, 1973.

5. Such moneys shall be repayable to the Commonwealth Savings Bank of Australia, Melbourne.

6. The plans and specifications and the estimate of the cost of the proposed works and a statement showing the proposed expenditure of the moneys to be borrowed are open for inspection at the office of the Council of the Shire of Diamond Valley, Civic Centre, Greensborough.

8262 B. J. MORGAN, Shire Secretary.

SHIRE OF DUNMUNKLE.

LOAN No. 33.

Notice of Intention to Borrow the Sum of \$35,000 for Permanent Works and Undertakings.

Notice is hereby given that the Council of the Shire of Dunmunkle proposes to borrow the principal sum of \$35,000, secured by a charge over the general rates of

the municipality, such sum to be raised by the grant of a mortgage in accordance with the provisions of the Local Government Act 1958.

1. The maximum rate of interest that may be paid is 6 per cent per annum.

2. The purpose for which the loan is to be applied is:—

Purchase of Roadmaking Plant—\$35,000.

3. The period of the loan shall be seven years.

4. The moneys borrowed shall be repayable by providing out of the municipal fund half-yearly instalments of \$3,098.42 each, including principal and interest on the 1st day of May and 1st day of November, during the currency of the loan. The first instalment shall be repayable on the 1st day of May, 1973.

5. Such moneys shall be repayable to the Commercial Savings Bank of Australia Ltd.

The plans and specifications and the estimate of the cost of the proposed works, and a statement showing the proposed expenditure of the moneys to be borrowed, are open for inspection at the office of the Council of the Shire of Dunmunkle, Cromie-street, Rupanyup.

8242 K. E. LIEBOLD, Shire Secretary.

SHIRE OF GORDON.

ALTERATION TO STREET NAME.

Notice is hereby given in accordance with the provisions of the Fifteenth Schedule of the Local Government Act 1958, of the following street name alteration:—

Old Name.—Church-street.

New Name.—Gregory-street.

Location.—Township of Pyramid Hill.

8257 D. D. WRIGHT, Shire Secretary.

Town and Country Planning Act 1961 (Twelfth Schedule).

SHIRE OF MORNINGTON PLANNING SCHEME 1959.

NOTICE THAT A PLANNING SCHEME HAS BEEN PREPARED AND IS AVAILABLE FOR INSPECTION.

Amendment No. 83, 1972.

Notice is hereby given that the Council of the Shire of Mornington in pursuance of its powers under the Town and Country Planning Act 1961, has prepared a Planning Scheme for the following areas and purposes:—

Land shown on Plan No. 237/PP/1 in the office of the Council, being lots Nos. 308 and 309 on Lodged Plan No. 12850 being land fronting Mountain View-road, Mount Eliza—Rezoning from Residential 'D' Zone to Proposed Public Purposes Reserve—(11) S. R. & W. S. C. Reserve.

A copy of the scheme has been deposited at the office of the Council, Queen-street, Mornington, and at the office of the Town and Country Planning Board, 235 Queen-street, Melbourne, and will be open for inspection during office hours by any person free of charge.

Any persons affected by the Planning Scheme are required to set forth in writing all objections they may have, addressed to the Shire Secretary, Mornington Shire Council, P.O. Box 78, Mornington, 3931, on or before the 13th day of December, 1972, and to state whether they wish to be heard in respect of their objections.

8231 D. G. COLLINGS, Shire Secretary.

Town and Country Planning Act 1961 (Twelfth Schedule).

SHIRE OF MORNINGTON PLANNING SCHEME 1959.

NOTICE THAT A PLANNING SCHEME HAS BEEN PREPARED AND IS AVAILABLE FOR INSPECTION.

Amendment No. 82, 1972.

Notice is hereby given that the Council of the Shire of Mornington in pursuance of its powers under the Town and Country Planning Act 1961, has prepared a Planning Scheme for the following areas and purposes:—

Land shown on Plan No. 236/PP/1 in the office of the Council, being land fronting Moomba-street, Mornington, opposite Flinders Park and being adjacent to rear of Residential allotments fronting Brent-street—Rezoning from Residential 'A' Zone to Proposed Public Purposes Reserve—(9) P.M.G. Reserve.

A copy of the scheme has been deposited at the office of the Council, Queen-street, Mornington, and at the office of the Town and Country Planning Board, 235 Queen-street, Melbourne, and will be open for inspection during office hours by any person free of charge.

Any persons affected by the Planning Scheme are required to set forth in writing all objections they may have, addressed to the Shire Secretary, Mornington Shire Council, P.O. Box 78, Mornington, 3931, on or before the 13th day of December, 1972, and to state whether they wish to be heard in respect of their objections.

8232 D. G. COLLINGS, Shire Secretary.

*Town and Country Planning Act 1961 (Twelfth Schedule).*  
LATROBE VALLEY SUB-REGIONAL PLANNING SCHEME  
1949.—SHIRE OF TRARALGON.

NOTICE THAT A PLANNING SCHEME HAS BEEN PREPARED AND IS AVAILABLE FOR INSPECTION.

*Amendment No. 24, 1972.*

Notice is hereby given that the Shire of Traralgon in pursuance of its powers under the *Town and Country Planning Act 1961*, has prepared a Planning Scheme for a portion of land within the area of the Latrobe Valley Sub-Regional Planning Scheme.

The purpose of the Scheme is:—

To rezone Crown allotment 14K, no section, Parish of Loy Yang as Agricultural "A" Zone.

A copy of the scheme has been deposited at the Shire Office, Kay-street, Traralgon, and at the office of the Town and Country Planning Board, 235 Queen-street, Melbourne, and may be inspected during office hours by any person free of charge.

Any persons affected by the Planning Scheme are required to set forth in writing all objections they may have, addressed to the Shire Secretary, Shire of Traralgon, P.O. Box 180, Traralgon, 3844, on or before Thursday, 26th October, 1972, and to state whether they wish to be heard in respect of their objections.

8263 W. TEASDALE, Shire Secretary.

*Town and Country Planning Act 1961.*  
SHIRE OF WODONGA PLANNING SCHEME.—INTERIM  
DEVELOPMENT ORDER.

NOTICE THAT AN AMENDMENT TO THE SHIRE OF WODONGA INTERIM DEVELOPMENT ORDER IS AVAILABLE FOR INSPECTION.

*Amendment No. 1.*

Notice is hereby given that the Wodonga Shire Council in accordance with the provisions of the *Town and Country Planning Act 1961* propose to request the Governor in Council to amend its interim development order.

The amendment to be requested is to delete paragraphs (a) and (b) from the Second Schedule and substitute the following:—

- (a) Town of Wodonga; section G; section H; section J; section 13; section 12; Crown allotment 1 of section 11; Crown allotments 1, 2 and 3, section 10; Crown allotments 1, 2A and 2B, section 14; part Crown allotments 6 and 4, Crown allotments 7, 8, 9, 11B and 12 of section 15; Crown allotment 6, part Crown allotments 13, 13A and 13B of section 1; section K; section L; Crown allotments 1, 2, 3, 4, 6, 7, 8, and 8A, section 5, Crown allotment 9, section 11; Crown allotment 1 of section 4 and part of Portion 3, section E.

- (b) Crown allotments 31 (part), 33 (part) 34, 82 and 82A (part), no section, Parish of Bonegilla.

A copy of the proposed amendment to the Interim Development Order has been deposited at the Wodonga Shire Offices, at Wodonga, and at the offices of the Town and Country Planning Board, 235 Queen-street, Melbourne, and will be open for inspection during office hours by any person free of charge.

Any persons affected by the proposed amendment to the Interim Development Order are required to set forth, in writing, all objections they may have, addressed to the Shire Secretary, Shire of Wodonga, Shire Offices, Wodonga, on or before the 13th October, 1972, and state whether they wish to be heard in support of their objections.

4th September, 1972.

8239 A. W. RUTKOWSKI,  
Shire Secretary.

THE BALLARAT SEWERAGE AUTHORITY.

Pursuant to section 119 (2) of the *Sewerage Districts Act 1958* (No. 6368), notice is hereby given of the intention to construct sewers to provide for properties situated in:—

*City of Ballarat.*—In the vicinity of Peady-street, between Trethowan and Cobden streets;

*Borough of Sebastopol.*—In the vicinity of Spencer and Vale streets, lot No. 3 and 4 Spencer-street;

*Shire of Ballarat.*—In the vicinity of Marie-crescent, John-street, Grandview-grove and Marilyn-street;

*Shire of Ballarat.*—Across the Western Highway, east of Ring-road;

and more particularly as shown on plans which are open for inspection at the office between the hours of 9 a.m. and 4 p.m. Monday to Friday inclusive.

30th August, 1972.

8268 CHAS. H. CLAMP, Secretary.

I, Janet Marie Campbell, of 304 Maude-street, Shepparton, in the State of Victoria, hereinbefore called and known by the name of Janet Marie Alexander, hereby give public notice that the Deed Poll dated the 15th day of August, 1972, duly executed and attested and deposited with the Registrar General of the said State on the 23rd day of August, 1972. I formally and absolutely renounced and abandoned the said name of Janet Marie Alexander and declared that I had assumed and adopted and intended thenceforth upon all occasions whatsoever to use and subscribe the name of Janet Marie Campbell, instead of the name of Janet Marie Alexander, and so as to be at all times thereafter called known and described by the said name of Janet Marie Campbell.

Dated the 15th day of August, 1972.

J. CAMPBELL.

WITNESS.—E. Rickson.

8251.

I, Raymond William Johns, of 12 Barram-street, Tatura, in the State of Victoria, hereinbefore called and known by the name of Raymond John O'Sullivan, hereby give public notice that the Deed Poll dated the 29th day of June, 1972, duly executed and attested and deposited with the Registrar General of the said State on the 15th day of August, 1972. I formally and absolutely renounced and abandoned the said name of Raymond John O'Sullivan, and declared that I had assumed and adopted and intended thenceforth upon all occasions whatsoever to use and subscribe the name of Raymond William Johns, instead of the name of Raymond John O'Sullivan, and so as to be at all times thereafter called known and described by the said name of Raymond William Johns.

Dated the 6th day of September, 1972.

COLLEEN CHERYL O'SULLIVAN, for Raymond William Johns.

WITNESS.—A. P. Sofra.

8252.

NOTICE OF INTENTION TO APPLY FOR A LICENCE  
TO DIVERT WATER AND CUT RACE (RE-ISSUE)  
FROM THE NARCOOYIA CREEK (RIVER MURRAY),  
AT NENANDIE.

We hereby give notice that we intend to apply for a licence empowering us to divert water for a term of fifteen years to the extent of 1,200 acre-feet per annum at a maximum rate of 15 acre-feet per day of 24 hours for the irrigation of pastures, citrus, almonds, market garden, being part of allotments 6A and 6, Parish of Nenandie, and to occupy certain Crown lands for works of diversion, and to cut a race thereon.

Any objection to such application must be forwarded, in writing, to reach the State Rivers and Water Supply Commission, Melbourne, before 13th October, 1972, being 30 days from the first publication of this notice.

E. G. CHISLETT.

G. D. M. CHISLETT.

W. J. SMITH.

S. J. SMITH.

Box 2, Boundary Bend, Vic., 3599.

8213

NOTICE OF INTENTION TO APPLY FOR A LICENCE  
TO DIVERT WATER AND CUT RACE FROM THE  
BULLAROOK CREEK, AT NEWLYN.

I hereby give notice that I intend to apply for a licence empowering me to divert water for a term of four years to the extent of 8 acre-feet per annum at a maximum rate of 1 acre-foot per day of 24 hours for the irrigation of 8 acres, being part of allotments 1, 1A and part of 2, section 3A, Parish of Bullarook, and to occupy certain Crown lands for works of diversion, and to cut a race thereon.

Any objection to such application must be forwarded, in writing, to reach the State Rivers and Water Supply Commission, Melbourne, before 13th October, 1972, being 30 days from the first publication of this notice.

EDWARD JAMES ENGLAND.

P.O. Box 56, Creswick, 3363.

8241.

**NOTICE OF INTENTION TO APPLY FOR A LICENCE TO DIVERT WATER AND CUT RACE FROM THE LAKE HUME, AT SANDY CREEK ARM.**

I hereby give notice that I intend to apply for a licence empowering me to divert water for a term of fifteen years to the extent of 80 acre-feet per annum at a maximum rate of 1 acre-foot per day of 24 hours for the irrigation of 40 acres, being part of allotments 10A and 13, sections 10 and 11, Parish of Tangambaianga, and to occupy certain Crown lands for works of diversion, and to cut a race thereon.

Any objection to such application must be forwarded, in writing, to reach the State Rivers and Water Supply Commission, Melbourne, before 13th October, 1972, being 30 days from the first publication of this notice.

M. J. TURNER.  
E. E. TURNER.

Red Bluff, via Huon, Vic., 3695

8221

on and after the 1st day of October, 1972, each and every property which is within the said Sewerage Area shall be deemed to be a seweraged property within the meaning of the Sewerage Districts Act.

The boundaries of the Sewerage Area hereinafter referred to are:—

**SEWERAGE AREA No. 14.**

All those pieces of land being lots 5, 6, 17 to 20 inclusive on lodged plan of subdivision No. 81194.

Lots 59 to 62 inclusive on lodged plan of subdivision No. 88090.

Lots 70 to 73 inclusive, lots 75, 78, 79 on lodged plan of subdivision No. 90854.

By order of the Mooroopna Sewerage Authority.

8229

J. T. GRAHAM, Chairman.  
R. F. FORSTER, Secretary.

**WOORI YALLOCK—LAUNCHING PLACE WATERWORKS TRUST.**

NOTICE TO THE OWNERS OF TENEMENTS IN THE UNDERMENTIONED STREETS AND THE PRIVATE STREETS, LANES, COURTS AND ALLEYS OPENING THERETO.

The main pipe in the said streets being laid down, the owners of all tenements situated as under are hereby required on or before the 20th October, 1972, to cause a proper pipe and stop cocks to be laid so as to supply water within such tenements from the main pipe.

J. N. EDDY,  
Secretary.

5th September, 1972.

*Street and Position.*

Elvians-road, from Warburton Highway 13.7 chains south and from Healesville-Koo-Wee-Rup road to School House-road 14.4 chains.

Warburton Highway and Old Warburton Highway, from Elvians-road to Launching Place Post Office 335.6 chains.

Healesville-Koo-Wee-Rup road, from Warburton Highway 29.5 chains north-east and 67.5 chains south-west.

Porters-road, from Healesville-Koo-Wee-Rup road 36.4 chains east.

Allsops-road, from Warburton Highway 64.4 chains.

Cairncroft-avenue, from Warburton Highway 21.2 chains.

Cairnview-court, from Cairncroft-avenue 4.6 chains.

Lester-street, from Warburton Highway 6.1 chains.

Carter-street, from Warburton Highway 24.3 chains.

Grieve-street, from 1.5 chains west of Carter-street to Ruthven-street 19.7 chains.

Ruthven-street, from Launching Place-Gembrook-road 7.6 chains.

Launching Place-Gembrook-road, from Warburton Highway 35.6 chains south.

Glenview-road, from Warburton Highway 15.2 chains, from Warburton Highway along the western boundary of the township of Launching Place, to and along a road running in a south-east direction joining Garden Hill-road 36.4 chains.

Garden Hill-road, 33.4 chains from Launching Place stand-pipe.

Don-road, from Warburton Highway 212.2 chains.

Dalry-road, from Don-road to Old Don-road 15.2 chains.

Williams-road, from Don-road 12.2 chains.

Ellen-grove, from Williams-road to Douglas-parade 21.2 chains.

Douglas-parade, from Ellen-grove 13.7 chains.

Harberts-road, from Ellen-grove 19.7 chains.

Old Don-road, from Don-road to Williams-road 50 chains.

Keals-road, from Don-road 20 chains.

Carroll-street, from Grieve-street to Wellman-street 20.5 chains.

Wellman-street, from Warburton Highway 4.6 chains.

8228

**MOORoopNA SEWERAGE AUTHORITY.**

The above-mentioned Sewerage Authority, having made provision for carrying off the sewage from each and every property which, or any part of which, is within the Sewerage Area hereinafter described, doth hereby declare that

**MOORoopNA SEWERAGE AUTHORITY.**

**LOCATION OF PROPOSED SEWAGE TREATMENT WORKS.**

Notice is hereby given that the Mooroopna Sewerage Authority has made application to the Honourable the Minister of Water Supply to locate a proposed sewage treatment works on land comprising part of Crown allotments 66 and 124, Parish of Mooroopna, County of Rodney, being an area of approximately 142.28 hectares (351 acres 2 roods and 10 perches).

A general plan and description of the proposed new sewage treatment works have been deposited for inspection at the office of the Mooroopna Sewerage Authority, McLennan-street, Mooroopna, during office hours.

Dated at Mooroopna the 6th day of September, 1972.

8248

R. F. FORSTER, Secretary.

**GEELONG WATERWORKS AND SEWERAGE TRUST.**

Pursuant to section 60 of the *Geelong Waterworks and Sewerage Act 1958* (No. 6263), the Trust has prepared plans to indicate the particulars of sewers and underground works in or adjacent to the following localities within the Drainage Area:—

Harcombe-street, and Rollins-road, Bell Post Hill, Shire of Corio.

Gwyther-road, Highton, Shire of South Barwon.

Strathire Gardens, Hamlyn Heights, Shire of Corio.

Notice is hereby given that the plans indicated above are open for public inspection at the Trust's Offices, Ryre-street, Geelong, between the hours of 9 a.m. and 5 p.m., from Monday to Friday, public holidays excepted, by the owners and occupiers of land or premises within the Drainage Area.

8304

B. C. HENSHAW, Secretary.

Victoria.

**ACT No. 391.—FIRST SCHEDULE.**

I, THE RIGHT REVEREND RONALD AUSTIN MULKEARNS, of Sturt-street, Ballarat, Bishop of Ballarat, Head or authorized representative of the denomination known as the Roman Catholic Church in the Diocese of Ballarat in Victoria, with the consent of the Corporation styled The Roman Catholic Trusts Corporation for the Diocese of Ballarat, of Sturt-street, Ballarat, the trustee of the land described in the subjoined statement of trusts, and of the Reverend James Conway, being the person entitled to minister in or occupy the said land, hereby apply to the Governor of the State of Victoria for leave to dispose of the said land by the means and for the purposes mentioned in the said statement of trust, and I hereby certify that the said land was reserved from sale by the Governor in Council as a site for Roman Catholic Church purposes by Order in Council, dated the 9th day of December, 1861. That the only trustee of the said land is the said Corporation styled The Roman Catholic Trusts Corporation for the Diocese of Ballarat: That there are no buildings upon the said land and the only person entitled to minister in or occupy the said land is the above-named James Conway.

Dated the 14th day of August, 1972.

Signature of head or authorized representative—RONALD A. MULKEARNS.

The Corporation styled The Roman Catholic Trusts Corporation for the Diocese of Ballarat hereby consents to this application.

The seal of the corporation styled the Roman Catholic Trusts Corporation for the Diocese of Ballarat

... was affixed hereto, in the presence of us being three of the trustees authorized to attest the affixing of such seal.

(SEAL) RONALD A. MULKEARNS, Trustee.  
W. P. McMAHON, Trustee.  
J. F. MADDEN, Trustee.

Signature of person entitled to minister in or occupy land.—JAMES CONWAY.

## STATEMENT OF TRUSTS.

*Description of Land.*—2 acres, Township of Stawell, Parish of Stawell, County of Borung, being allotment 3, section 18A: Commencing at the north-western angle of allotment 4; bounded thence by that allotment bearing 179° 19' 400 links, by Jones-street bearing 269° 19' 500 links, by allotments 5 and 1 bearing 359° 19' 400 links; and thence by Stone-street bearing 89° 19' 500 links to the point of commencement.

*Name of Trustees.*—The Trustees of the Roman Catholic Trusts Corporation for the Diocese of Ballarat of Sturt-street, Ballarat.

*Powers of Disposition.*—To permit and suffer so much of the lands as shall not be disposed of under the powers hereinafter specified to be used for the purposes for which it was promised or reserved from sale by the Crown. To let lease sell mortgage or exchange if concurred in by the said head or authorized representative for the time being, the said land or any portion thereof or any buildings thereon on such terms and conditions as shall be specified by such head or representative.

*Purposes to which Proceeds of Disposition are to be Applied.*—Moneys obtained from sale leases mortgages or exchanges to be paid to the Bishop to be dealt with for Roman Catholic Church purposes as shall be directed by the said trustees but to be subject nevertheless to the payment or deduction therefrom of all costs charges and expenses incurred by the trustee or for which it shall be liable in respect of the trust estate.

BRIGGS & O'DRISCOLL, 171 Main-street, Stawell, soli-  
8220-  
citors for the applicant.

Notice is hereby given that the partnership heretofore subsisting between Raymond John Cox, formerly of 23 March-street, Newborough, but now of 44 Chamberlain-road, Newborough, in the State of Victoria, and Ross Phillips Smith of Wattle-tree-road, Moe South, in the said State, carrying on the business of car sales and repair and carburettor services at 14 George-street, Moe, in the said State, under the name of Ross Cox Motors and Rite Carburettor Service, has been dissolved as on and from the 30th June, 1972. The aforesaid business as from that date shall be conducted at the last mentioned address by the said Ross Phillips Smith. All creditors having any claims against the business after this date should furnish particulars of same to the said Ross Phillips Smith.

Dated the 4th day of September, 1972.

8214 RAYMOND JOHN COX.  
ROSS PHILLIPS SMITH.

Notice is hereby given that the partnership heretofore subsisting between Dennis T. Sells, Gwenneth F. Sells, Christopher G. Wilson and Barryne K. Wilson, carried on under the firm name of Huntingdale Refrigeration, at the premises 251 Princes Highway, Dandenong, in Victoria, has been dissolved as from 31st August, 1972, and the partnership shall continue to be carried on by the said Dennis T. Sells and Gwenneth F. Sells.

All debts due and owing will be received and paid by said Dennis T. Sells and Gwenneth F. Sells.

8235 GWENNETH F. SELLS.  
DENNIS T. SELLS.

Take notice that Arthur Henry Weatherill junior and Ruth Ellen Weatherill, of 26 Foster-road, Toora, have withdrawn from the partnership carried on under the name of Toora Panel & Engineering Works, as from the 1st of June, 1972, and that the said partnership is continuing under the said name of Toora Panel & Engineering Works by the continuing partners Arthur Henry Weatherill senior, Edith Maud Weatherill and Robert Jame Weatherill.

8223

Notice is hereby given that the partnership heretofore subsisting between Herbert Edwin Mills, Patricia Christina Mills, Derek Clifford Tucker and Jeanne Freda Tucker,

carrying on business as authorized newsagents, at 15 Rose-street, Essendon, under the business name of "Essendon Authorized Newsagency", has been dissolved by mutual consent as from the 31st day of July, 1972.

8332 HERBERT EDWIN MILLS.  
PATRICIA CHRISTINA MILLS.  
DEREK CLIFFORD TUCKER.  
JEANNE FREDA TUCKER.

The Companies Act 1961—Regulations 28 (2) (b) and 46 (2).  
BENNETT HOLDINGS PTY. LTD.  
NOTICE OF MEETING OF CREDITORS.

Notice is hereby given that a meeting of creditors of Bennett Holdings Pty. Ltd. will be held at 77 Old Eltham-road, Lower Plenty, on the 30th day of September, 1972, at 4.15 p.m.

- (1) To receive statement of affairs of the company.
- (2) To consider and if thought fit pass the following Resolutions:—

- (a) that the company be placed in liquidation.
- (b) that section 10 (1) (a) and section 10 (1) (c) of the Companies Act should not apply to the appointment of a liquidator.
- (c) that Mr. W. D. Stannard, of 65 Queens-road, Melbourne, be appointed liquidator of the company, and that his remuneration for his duties be in accordance with scale of fees laid down by the Institute of Chartered Accountants.

8237

N. V. HERBERT, Director.

EMERY & HIRST PTY. LTD (IN VOLUNTARY LIQUIDATION).  
NOTICE OF FINAL MEETING.

Notice is hereby given pursuant to section 272 of the Companies Act 1961, that a Final Meeting of the company will be held at the office of the liquidator, H. F. Day, 118 Queen-street, Melbourne, on the 17th October, 1972, at twelve o'clock noon, for the purpose of having an account laid before it showing how the winding up of the company has been conducted, the property of the company disposed of, and giving any explanation required thereof.

Dated this 7th day of September, 1972.

8216

H. F. DAY, Liquidator.

Companies Act 1961.—In the matter of VOLTAGE PTY. LTD., of 541 St. Kilda-road, Melbourne.—Notice Re Meeting of Creditors, Pursuant to Section 260.

Notice is hereby given that a meeting of creditors of the above-named company will be held at the offices of Bent & Cogle, Suite 18, 545 St. Kilda-road, Melbourne, on Monday, 20th October, 1972, at 11.15 a.m., the company having convened a meeting of its members for the same day for the purpose of considering a Resolution that the company be wound up voluntarily.

Dated this 6th day of September, 1972.

I. HAM, Director.

Bent & Cogle, public accountants, Suite 18, 545 St. Kilda-road, Melbourne, 3004. 8234

Companies Act 1961, Section 272.

A. H. GRIFFITHS & SON PTY. LTD. (IN VOLUNTARY LIQUIDATION); and A. H. GRIFFITHS HOLDINGS PTY. LTD. (IN VOLUNTARY LIQUIDATION).

Notice is hereby given that a General Meeting of members of the above-named companies will be held at the office of William Buck & Co., 422 Collins-street, Melbourne, on Friday, 13th October, 1972, at 2.30 p.m., for the purpose of laying before the meeting an account showing how the winding up has been conducted and the property of the company has been disposed of and of hearing any explanation that may be given by the liquidators:

WALTER W. BUCK,  
DONALD HUTCHISON,  
Joint Liquidators.

8309

P.P.B. STEEL PRODUCTS PTY. LTD. (IN VOLUNTARY LIQUIDATION).

Notice is hereby given that at an Extraordinary General Meeting of P.P.B. Steel Products Pty. Ltd., held at Hawthorn, Victoria, on Wednesday, the 30th day of

August, 1972, the following Resolution was passed as a Special Resolution—

"That the company be wound up voluntarily and that Mr. John Heinrich Matthias Marcad, of 191 Queen-street, Melbourne, be appointed liquidator at a remuneration based on the scale of fees of the Institute of Chartered Accountants in Australia and that pursuant to section 269 of the Companies Act 1961, the liquidator be and is hereby authorized to exercise any of the powers given by virtue of paragraphs (b), (c) and (d) of sub-section (1) of section 236 of the Companies Act 1961, to a liquidator in a winding up by the Court."

Dated this 7th day of September, 1972.

J. H. M. MARCARD, Liquidator.

Wilson, Bishop, Bowes & Craig, 191 Queen-street, Melbourne. 8233

The Companies Act 1961.—In the matter of MERMDA INVESTMENTS PROPRIETARY LIMITED (IN LIQUIDATION).  
NOTICE OF MEETING OF MEMBERS AND CREDITORS PURSUANT TO SECTION 272.

Notice is hereby given that the Final Meeting of members and creditors of Mermda Investments Proprietary Limited (in liquidation) will be held at the offices of Messrs. Norman, Cartledge and Browne, 1 Palmerston-crescent, South Melbourne, on the 18th day of October, 1972, at 10 o'clock in the forenoon for the purpose of laying before the meeting the liquidator's final account and report.

Dated this 13th day of September, 1972.

H. K. CARTLEDGE, Liquidator.

Norman, Cartledge and Browne, chartered accountants, 1 Palmerston-crescent, South Melbourne, Vic. 3205. 8277

The Companies Act 1961.

FITZHERBERT GENERAL ELECTRIC PTY. LTD.  
(IN LIQUIDATION).

Notice is hereby given that a Second Dividend is intended to be declared in the above matter. Creditors who have not proved their debts by the 22nd day of September, 1972, may be excluded from this Dividend.

Dated this 6th day of September, 1972.

G. O. HARRISON, Liquidator.

Hall & Rose, chartered accountants, 395 Collins-street, Melbourne. 8278

The Companies Act 1961.

SEA LAKE TIMBER & HARDWARE CO. PTY. LTD.  
PURSUANT TO SECTION 260 OF THE COMPANIES ACT 1961.

Notice is hereby given that a Meeting of Creditors of Sea Lake Timber & Hardware Co. Pty., Ltd., will be held at The Institute of Chartered Accountants, 9th Floor, 140 Queen-street, Melbourne, on Wednesday, the 27th day of September, 1972, at 2.30 in the afternoon for the purpose of considering the company's affairs, the company having convened an Extraordinary General Meeting of its members to be held on the same day and for the purpose of considering and if thought fit, passing a Special Resolution that the company be wound up voluntarily.

Dated this 7th day of September, 1972.

J. C. JAMES, Director.

Hall & Rose, chartered accountants, 395 Collins-street, Melbourne, Vic. 3000. 8279

Companies Act 1961.

NOTICE OF MEETING OF CREDITORS OF PRIORITY MOTORS PROPRIETARY LIMITED.

Notice is hereby given that, pursuant to section 260 (1) of the Companies Act 1961, a meeting of the creditors of Priority Motors Proprietary Limited will be held at "The Windsor", 53 Princes Highway, Dandenong, on the 21st day of September, 1972, at 10.30 a.m. The company having convened a meeting of its members for the same day for the purpose of considering and if thought fit passing a Special Resolution that the company be wound up voluntarily and that Hudson Bernard Pitt, of 30 Queens-road, Melbourne, be appointed liquidator.

Dated this 11th day of September, 1972.

8308 K. B. PRIOR, Director.

The Companies Act 1961.—In the matter of HOLLOWAY HOLDINGS PTY. LTD. (in Voluntary Liquidation).—Members' Winding up.

Notice is hereby given that an Extraordinary General Meeting of the above company duly convened and held at 112 Salmon-street, Port Melbourne, Victoria, on 4th September, 1972, the following Resolution was proposed and passed as a Special Resolution:—

That the company be wound up voluntarily.

That subject to the payment of the debts and liabilities of the company the liquidator be and is hereby authorized to distribute the present-day value of assets of the company in specie or kind amongst the contributories of the company in accordance with their respective rights and interests therein.

That Mr. William Baillie Foy, of "Bryan Mawr", Coonara-road, Olinda, Victoria, be appointed liquidator for the purposes of the winding up of the company.

Dated 4th September, 1972.

L. J. S. GRAY, Secretary.

LIQUIDATION OF K. WILLS & COMPANY PTY. LTD.

At an Extraordinary General Meeting held on the 11th September, 1972, the members of K. Wills & Company Pty., Ltd. passed the following Special Resolution:—

"It was resolved that the company be wound up voluntarily by the members of the company, all of whom are present."

8301

L. ADAMS.

THE COMPANIES ACT 1961, SECTION 272.

Notice is hereby given that the Final Meetings of the under-mentioned companies will be held pursuant to section 272 of the Companies Act 1961 at the offices of R. H. Walford & Co., chartered accountants, 464 St. Kilda-road, Melbourne, on Friday the 20th of October, 1972, at the time set out below for the purpose of presenting the liquidator's accounts showing how the winding up of each company has been conducted and the property of each company has been disposed of, and of giving any explanation thereof.

C.S.S. Shoes Pty. Ltd. (In vol. liq.) 10 a.m.

G.X. Shoes Pty. Ltd. (In vol. liq.) 10.30 a.m.

Pinelli Shoes Pty. Ltd. (In vol. liq.) 11 a.m.

J. R. VIAL, Liquidator.

22 Fosbery-avenue, Caulfield:

8291.

Companies Act 1961.

CAWARRA HOLDINGS PTY. LIMITED.

(IN VOLUNTARY LIQUIDATION).

NOTICE OF FINAL MEETING.

Notice is hereby given pursuant to section 272 of the Companies Act 1961, that a Meeting of the members of the above-named company will be held at the office of Berg, Coleman & Partners, 9th Floor, 325 Collins-street, Melbourne, on the 12th day of October, 1972, at 9 a.m., for the purpose of having an account laid before the Meeting showing the manner in which the winding up has been conducted and the property of the company disposed of and of hearing any explanations that may be given by the liquidator.

Dated this 7th day of September, 1972.

8294

K. A. COLEMAN, Liquidator.

The Companies Act 1961.

LINLEY INVESTMENTS PROPRIETARY LIMITED

(IN LIQUIDATION).

NOTICE CONVENING FINAL MEETING OF MEMBERS AND CREDITORS PURSUANT TO SECTION 272.

Notice is hereby given pursuant to section 272 of the Companies Act 1961, that a General Meeting of the members and creditors of the above-named company will be held in the office of Kennedy, Small & Middlemiss, 296 Little Lonsdale-street, Melbourne, on Wednesday the 11th October, 1972, at 10.30 a.m., for the purpose of having an account laid before them showing the manner in which the winding up has been conducted and the property of the company disposed of and hearing any explanations that may be given by the liquidator.

Dated this 7th day of September, 1972.

E. R. SMAIL, Liquidator.

Kennedy, Small & Middlemiss, 296 Little Lonsdale-street, Melbourne, 3000. 8290



The Companies Act 1961.—In the matter of OLIVE OIL PRODUCTION LTD. (IN LIQUIDATION).

A First and Final Dividend is intended to be declared in the above-mentioned matter. Creditors who have not proved their debts by the 28th day of September, 1972, will be excluded from the dividend.

Dated this 7th day of September, 1972.

A. M. HORSBURGH, Liquidator.

Kennedy, Smail & Middlemiss, 296 Little Lonsdale-street, Melbourne, 3000. 8284

This day, 4th September, 1972, the directors resolved to voluntarily wind up the firm of King & George Motors Pty. Ltd. 8269

**DENFEY PROPRIETARY LIMITED.**

Notice is given that the following Special Resolution was passed on 31st August, 1972—

Resolved as a Special Resolution:—

- (a) that the company be placed into voluntary liquidation, and
- (b) that the assets of the company, after payment of debts, be transferred in specie to the shareholders, and
- (c) that Harry Wason McCutcheon be and is hereby appointed liquidator for the purpose of carrying out the requirements set out in paragraph (b) above.

8292

B. A. TAYLOR, Secretary.

**ZELWAT PROPRIETARY LIMITED.**

Notice is given that the following Special Resolution was passed on 31st August, 1972—

Resolved as a Special Resolution:—

- (a) that the company be placed into voluntary liquidation, and
- (b) that the assets of the company, after payment of debts, be transferred in specie to the shareholders, and
- (c) that Harry Wason McCutcheon be and is hereby appointed liquidator for the purpose of carrying out the requirements set out in paragraph (b) above.

8293

B. A. TAYLOR, Secretary.

In the Supreme Court of Victoria.—1972 Co. 8458.—In the matter of the Companies Act 1961; and in the matter of MINERAL INVESTMENT PORTFOLIOS PTY. LTD.

Notice is hereby given that a petition for the winding up of the above-named company by the Supreme Court was on the 8th day of September, 1972, presented by Leo Thomas FitzGerald, Deputy Commissioner of Taxation of the Commonwealth of Australia, and that the said petition is directed to be heard before the Court sitting at the Fourteenth Court, Law Courts, William-street, Melbourne, at the hour of 10.30 o'clock in the forenoon, on the 4th day of October, 1972, and any creditor or contributory of the said company desiring to support or oppose the making of an order on the said petition may appear at the time of hearing by himself or his counsel for the purpose; and a copy of the said petition will be furnished to any creditor or contributory of the said company requiring the same by the undersigned on payment of the regulated charge for the same.

The petitioner's official address is 350 Collins-street, Melbourne.

The petitioner's solicitor is Robert Burns Hutchison, Crown Solicitor for the Commonwealth, of 99 Queen-street, Melbourne.

R. B. HUTCHISON.

NOTE.—Any person who intends to appear on the hearing of the said petition must serve on or send by post to the above-named R. B. Hutchison, notice in writing of his intention so to do. The notice must state the name and address of the person, or, if a firm, the name and address of the firm, and must be signed by the person or firm, or his or their solicitor (if any), and must be served or, if posted, must be sent by post in sufficient time to reach the above named not later than 4 o'clock in the afternoon of the 3rd day of October, 1972. 8295

In the Supreme Court of Victoria.—1972. Co. 8459.—In the matter of the Companies Act 1961; and in the matter of CROSSFIELD INVESTMENTS PTY. LTD.

Notice is hereby given that a petition for the winding up of the above-named company by the Supreme Court was on the 8th day of September, 1972, presented by Leo

No. 84.—8120/72.—4

Thomas FitzGerald, Deputy Commissioner of Taxation of the Commonwealth of Australia and that the said petition is directed to be heard before the Court sitting at the Fourteenth Court, Law Courts, William-street, Melbourne, at the hour of 10.30 o'clock in the forenoon on the 4th day of October, 1972, and any creditor or contributory of the said company desiring to support or oppose the making of an order on the said petition may appear at the time of hearing by himself or his counsel for the purpose; and a copy of the said petition will be furnished to any creditor or contributory of the said company requiring the same by the undersigned on payment of the regulated charge for the same.

The petitioner's official address is 350 Collins-street, Melbourne.

The petitioner's solicitor is Robert Burns Hutchison, Crown Solicitor for the Commonwealth, of 99 Queen-street, Melbourne.

R. B. HUTCHISON.

NOTE.—Any person who intends to appear on the hearing of the said petition must serve on or send by post to the above-named R. B. Hutchison, notice in writing of his intention so to do. The notice must state the name and address of the person, or, if a firm, the name and address of the firm, and must be signed by the person or firm, or his or their solicitor (if any), and must be served or, if posted, must be sent by post in sufficient time to reach the above named not later than 4 o'clock in the afternoon of the 3rd day of October, 1972. 8296

In the Supreme Court of Victoria.—1972. Co. 8460.—In the matter of the Companies Act 1961; and in the matter of ART-CRAFT DECORATORS & UPHOLSTERERS PROPRIETARY LIMITED.

Notice is hereby given that a petition for the winding up of the above-named company by the Supreme Court was on the 8th day of September, 1972, presented by Leo Thomas FitzGerald, Deputy Commissioner of Taxation of the Commonwealth of Australia and that the said petition is directed to be heard before the Court sitting at the Fourteenth Court, Law Courts, William-street, Melbourne, at the hour of 10.30 o'clock in the forenoon on the 4th day of October, 1972, and any creditor or contributory of the said company desiring to support or oppose the making of an order on the said petition may appear at the time of hearing by himself or his counsel for the purpose; and a copy of the said petition will be furnished to any creditor or contributory of the said company requiring the same by the undersigned on payment of the regulated charge for the same.

The petitioner's official address is 350 Collins-street, Melbourne.

The petitioner's solicitor is Robert Burns Hutchison, Crown Solicitor for the Commonwealth, of 99 Queen-street, Melbourne.

R. B. HUTCHISON.

NOTE.—Any person who intends to appear on the hearing of the said petition must serve on or send by post to the above-named R. B. Hutchison, notice in writing of his intention so to do. The notice must state the name and address of the person, or, if a firm, the name and address of the firm, and must be signed by the person or firm, or his or their solicitor (if any), and must be served or, if posted, must be sent by post in sufficient time to reach the above named not later than 4 o'clock in the afternoon of the 3rd day of October, 1972. 8297

In the Supreme Court of Victoria.—1972. Co. 8457.—In the matter of the Companies Act 1961; and in the matter of ALIKI INVESTMENT PTY. LTD.

Notice is hereby given that a petition for the winding up of the above-named company by the Supreme Court was on the 8th day of September, 1972, presented by Leo Thomas FitzGerald, Deputy Commissioner of Taxation of the Commonwealth of Australia and that the said petition is directed to be heard before the Court sitting at the Fourteenth Court, Law Courts, William-street, Melbourne, at the hour of 10.30 o'clock in the forenoon on the 4th day of October, 1972, and any creditor or contributory of the said company desiring to support or oppose the making of an order on the said petition may appear at the time of hearing by himself or his counsel for the purpose; and a copy of the said petition will be furnished to any creditor or contributory of the said company requiring the same by the undersigned on payment of the regulated charge for the same.

The petitioner's official address is 350 Collins-street, Melbourne.

The petitioner's solicitor is Robert Burns Hutchison, Crown Solicitor for the Commonwealth, of 99 Queen-street, Melbourne.

R. B. HUTCHISON.

NOTE.—Any person who intends to appear on the hearing of the said petition must serve on or send by post to the above-named R. B. Hutchison, notice in writing of his intention so to do. The notice must state the name and address of the person, or, if a firm, the name and address of the firm, and must be signed by the person or firm or, his or their solicitor (if any), and must be served or, if posted, must be sent by post in sufficient time to reach the above named not later than 4 o'clock in the afternoon of the 3rd day of October, 1972. 8298

In the Supreme Court of Victoria.—1972 No. Co. 8421.—In the matter of the Companies Act 1961; and in the matter of HENRY B. SMITH, LIMITED.

Notice is hereby given that the Supreme Court of Victoria has by Order, dated the 23rd August, 1972, confirmed the reduction of the capital of the above-named company from \$800,000 (consisting of 600,000 ordinary stock units of \$1 each all of which had been issued and were fully paid up and 200,000 ordinary shares of \$1 each none of which had been issued) to \$500,000 (consisting of 600,000 ordinary stock units of 50 cents each all of which have been issued and are fully paid up and 400,000 ordinary shares of 50 cents each none of which have been issued). The said reduction was resolved upon and effected subject to the said Order by a Special Resolution passed at an Extraordinary General Meeting of the said company held on the 7th June, 1972. The Court declared the amount of the share capital as altered by the said Order is \$500,000 divided into 600,000 ordinary stock units of 50 cents each all of which have been issued and are fully paid up and 400,000 ordinary shares of 50 cents each none of which have been issued. An office copy of the said Order was lodged with the Registrar of Companies on the 6th September, 1972, pursuant to the terms of the said Order.

HEDDERWICK, FOKES & ALSTON, 121 William-street, Melbourne, 3000, solicitors for the company. 8333

MICHELL & REGOS PTY. LTD. (IN VOLUNTARY LIQUIDATION).

Notice is hereby given that, pursuant to section 272 of the Companies Act 1961; a Final Meeting of members and creditors of the above-named company will be held at the offices of James Regos, 106 Wellington-parade, East Melbourne, on the 16th day of October, 1972, at 10 a.m., for the purpose of laying before it accounts showing how the winding up has been conducted and the property of the company disposed of, and hearing any explanations of the liquidator.

Dated this 11th day of September, 1972.

JAMES REGOS, Liquidator.

J. Regos, 106 Wellington-parade, East Melbourne, 3002. Telephone 419 2827. 8313

The Companies Act 1961.—In the matter of LANCASHIRE HOUSE LIMITED (in Voluntary Liquidation).

Notice is hereby given, pursuant to section 272 of the Companies Act 1961, that the Final General Meeting of the members of the above-named company will be held at the office of Ian M. Nisbet, 2nd Floor, 243 Collins-street, Melbourne, on the 20th day of October, 1972, at 4 p.m., when I shall lay before the meeting an account showing how the winding up has been conducted and the property of the company disposed of.

30th August, 1972.

8329 IAN M. NISBET, Liquidator.

In the matter of SUNNINGHILL PTY. LIMITED.—Notice of Winding-up Order.

Winding-Up Order made the 6th day of September, 1972.

Name and Address of official liquidator, Michael Joseph O'Keefe, care of M. J. O'Keefe & Co., 162A High-street, Ashburton.

L. T. FITZGERALD, Deputy Commissioner of Taxation of the Commonwealth of Australia. 8330

The Companies Act 1961.—In the matter of EDREX LEATHER PRODUCTS PROPRIETARY LIMITED (in Liquidation).

Notice is hereby given that, pursuant to section 272 (2) of the Victorian Companies Act 1961, the Final Meeting of creditors and contributors of Edrex Leather Products Proprietary Limited (in-Liquidation), will be held at the office of Bruce Fordham & Co., chartered accountants, 170 Toorak-road, South Yarra, on Monday, 16th October, 1972, at 9.30 in the forenoon.

Business.

To lay before the meeting an account of the liquidator's acts and dealings and of the conduct of the winding up.

2. To obtain directions from the creditors, pursuant to section 284 (3) (c) of the Victorian Companies Act 1961, authorizing destruction of the books, documents and vouchers upon receipt, by the liquidator, of notice of final dissolution of the company.

Dated this 13th day of September, 1972.

BRUCE FORDHAM, Liquidator.

Bruce Fordham & Co., chartered accountants, 170 Toorak-road, South Yarra, 3141. Telephone 24 7511. 8331

CHARLES EDWARD JAMES WYATT, late of Macedon, retired, DECEASED, intestate.

Creditors, next of kin and others having claims in respect of the estate of the said deceased (who died on the 5th day of June, 1971), are required by the administrator, Charles William Wyatt, of 51 Hartington-street, Glenroy, to send particulars, in writing to him, at the office of the undersigned, at Kyneton, by the 15th day of November, 1972, after which date the administrator may convey or distribute the assets, having regard only to the claims of which he then has notice.

H. HURRY & SON, solicitors, Kyneton, and at Woodend. 8222

ESTHER JANE BRAUMAN, late of 35 Skene-street, Shepparton, in the State of Victoria, married woman, DECEASED.

Creditors, next of kin and others having claims in respect of the estate of the deceased (who died on the 16th November, 1971), are required by the executors, Victor Elman Brauman, of Numurkah-road, Shepparton, and Francis George Brauman, of 13 Coomboona-street, Shepparton, to send particulars of their claims to the said executors, by the 25th day of November, 1972, after which date the said executors may convey or distribute the assets, having regard only to the claims of which they then have notice.

Dated this 5th day of September, 1972.

P. V. FELTHAM & CO., Fryers-street, Shepparton, solicitors for the applicants. 8218

Creditors, next of kin and others having claims in respect of the estate of Ellen Brown, late of 127 Edward-street, Brunswick, in the State of Victoria, divorced woman (who died on the 23rd May, 1972), are to send particulars of their claims to the administrator of the said estate, care of the undersigned, by the 15th November, 1972, after which date the administrator will distribute the assets, having regard only to the claims of which he then has notice.

WM. MURRAY & SON, solicitors, 422 Collins-street, Melbourne. 8280

Creditors, next of kin and others having claims against the estate of Hassan Aziz, late of 373 Camp-road, Broadmeadows, cook, deceased (who died on 14th March, 1972), are required to send particulars of their claims to Fatima Hassan Aziz, formerly of 373 Camp-road, Broadmeadows, but now of 10 Woorite-place, East Keilor, widow, the administrator of the said deceased, on or before the 8th November, 1972, after which date she will distribute the assets, having regard only to the claims of which she then has notice.

TOLHURST DRUCE & EMMERSON, 357 Little Collins-street, Melbourne, 3000. 8289

Creditors, next of kin and others having claims against the estate of Westley James Wright (sometimes known as Wesley James Wright and sometimes known as Westy Wright), late of 27 Dorset-road, Ferntree Gully, in the State of Victoria, blacksmith, deceased (who died on the 21st day of November, 1971), are to send the particulars of their claims to the executors of the estate, in the care of the under-mentioned solicitors, by the 29th day of November, 1972, after which date the said executors will distribute the assets, having regard only to the claims of which they then have notice.

LAURENCE G. RALPH & MORREY, solicitors, 236 Dorset-road, Boronia, 3155. 8299

Creditors, next of kin and others having claims in respect of the estate of Awner Kantorowicz, late of 202 Booran-road, South Caulfield, sawmiller, deceased, intestate, are required to send particulars to the administrator, Salomon Kantorowicz, care of the under-mentioned solicitors, by the 15th day of November, 1972, after which date the administrator shall convey or distribute the assets, having regard only to the claims of which he then has notice.

SLONIM, VELIK & EMANUEL, solicitors, 374 Bourke-street, Melbourne. 8300

Trustee Act 1958.  
NOTICE TO CLAIMANTS.

Pursuant to the Trustee Act 1958, creditors, next of kin and all other persons having claims in respect of the estate of any deceased person named below are required to send particulars to the legal personal representative or representatives at the addresses stated, after which date the representative or representatives will distribute the assets, having regard only to the claims of which notice has been received:—

Isaac Roy Humphrys, formerly of "Ivanhoe", St. Helens, but late of Port Fairy, retired grazier, deceased, died 6th June, 1972.—Claims to the executors, Sylvie Eileen Humphrys, of Gipps-street, Port Fairy, widow, Moira Eileen Lindsey, married woman, and Thomas James William Lindsey, grazier, both of "Lynton", Bessiebelle, care of Conlan & Leishman, solicitors, 38 Bank-street, Port Fairy, by the 16th November, 1972. 8322

Alfred Theodore Uebergang, late of Port Fairy, retired farmer, deceased, died 4th May, 1972.—Claims to the executrices, Joan Cecilia Crowe, of Codrington, and Nola Ann McNamara, of Port Fairy, married women, care of Conlan & Leishman, solicitors, 38 Bank-street, Port Fairy, by the 16th November, 1972. 8323

EVA ELIZABETH MAY SPOONER, late of 27 Fulton-street, East St. Kilda, widow, DECEASED.

Creditors, next of kin and others having claims in respect of the estate of the said deceased (who died on 17th February, 1971), are required by Walter Rose Riddell, of 125 Central-road, Blackburn, public accountant, the executor of the will of the said deceased, to send particulars, in writing, to him, care of the under-mentioned solicitor, by 22nd November, 1972, after which date he may convey or distribute the assets of the estate, having regard only to the claims of which he then has notice.

THOMAS BURKE, solicitor, 152 Wattle-tree-road, Malvern. 8302

WILLIAM CHARLES SELWYN TOMPSITT, late of 19 Mitchell-road, Caulfield, retired, DECEASED.

Creditors, next of kin and others having claims in respect of the estate of the said deceased (who died on 16th May, 1972), are required by Essie Tompsitt, of 19 Mitchell-road, Caulfield, the executrix of the will of the said deceased, to send particulars, in writing, to her, care of the under-mentioned solicitor, by 24th November, 1972, after which date she may convey or distribute the assets of the estate, having regard only to the claims of which she then has notice.

THOMAS BURKE, solicitor, 152 Wattle-tree-road, Malvern. 8303

Creditors, next of kin and others having claims against the estate of Robert Vincent Michael, late of 176 Victoria-avenue, Albert Park, in the State of Victoria, gentleman, deceased (who died on the 8th February, 1972), are required to send particulars thereof to National Trustees, Executors and Agency Company of Australasia Limited, of 46 Queen-street, Bendigo, in the said State, by the 1st December, 1972, after which date the said Company will distribute the assets of the said deceased, having regard only to the claims of which it then has notice.

WATSON, JAMES & ROGERS, solicitors, 61 Bull-street, Bendigo. 8305

ETHLINE GRANT, late of Tucker-court, Lara, home duties, DECEASED.

Creditors, next of kin and others having claims in respect of the estate of the deceased (who died 29th July, 1971), are required by the personal representative, Hubert Percy Bowman, to send particulars to him, care of the under-mentioned solicitors, by the 30th November, 1972, after which date he may convey or distribute the assets, having regard only to the claims of which he then has notice.

BOWMAN & KNOX, solicitors, 43 Yarra-street, Geelong. 8307

Creditors, next of kin and others having claims in respect of the estate of George Alexander McGregor Hamilton, late of 11 Dickman-street, Richmond, in the State of Victoria, retired, deceased (who died on the 17th March, 1972), are hereby required to send particulars of their claims to Duncan McKercher, John Perrin Fraser and Burns Philp Trustee Company Limited, the executors of his estate, care of Burns Philp Trustee Company Limited, of 446 Collins-street, Melbourne, by the 30th November, 1972,

after which date they will distribute the assets, having regard only to the claims of which they then have had notice.

L'ESTRANGE & KENNEDY, solicitors, 291 Bridge-road, Richmond. 8314

Creditors, next of kin and others having claims in respect of the estate of Doreen Clare Sproule, late of "Yungundi", Tuck's-road, Shoreham, in the State of Victoria, married woman, deceased (who died on the 30th October, 1971), are required to send particulars of their claims to the executors, The Equity Trustees Executors and Agency Company Limited, of 472 Bourke-street, Melbourne, in the said State, and James Edward St. George Sproule, of "Yungundi", Tuck's-road, Shoreham, in the said State, grazier, care of the said company by the 14th November, 1972, after which date they may convey or distribute the assets, having regard only to the claims of which they then have notice.

AITKEN, WALKER & STRACHAN, solicitors, 414 Collins-street, Melbourne. 8315

HEDLEY OSWALD GREGORY, late of Unit 2, 35 Tennyson-street, Sandringham, in the State of Victoria, gentleman, DECEASED.

Creditors, next of kin and others having claims in respect of the estate of the above-mentioned deceased (who died on the 1st September, 1971), are requested by the trustee, Campbell McLeod, of 2 Wright-street, Middle Park, in the said State, to send particulars of their claims, care of the undersigned, by the 15th November, 1972, after which date the trustee may convey or distribute the assets, having regard only to the claims of which he then has notice.

NORRIS, NORRIS & BARRY JONES, solicitors, 407 Waverley-road, East Malvern. 8318

JAMES FREDERICK SINCLAIR, late of 9 Bales-street, Mount Waverley, in the State of Victoria, clerk, DECEASED.

Creditors, next of kin and others having claims in respect of the estate of the above-named deceased (who died on the 3rd January, 1972), are requested by the trustee, Beryl Joyce Sinclair, of 9 Bales-street, Mount Waverley, in the said State, to send particulars of their claims, care of the undersigned, by the 15th November, 1972, after which date the trustee may convey or distribute the assets, having regard only to the claims of which she then has notice.

NORRIS, NORRIS & BARRY JONES, solicitors, 407 Waverley-road, East Malvern. 8319

Creditors, next of kin and others having claims in respect of the estate of Marjorie Cullen, late of 10 Alcaia-avenue, Chadstone, widow, deceased (who died on the 27th June, 1972), are to send particulars of their claims to the executor, Kenneth McDonald Martin, care of the under-mentioned solicitors, on or before the 14th November, 1972, after which date the executor will distribute the assets, having regard only to the claims that he then has notice.

MARTIN & MARTIN, solicitors, 37 Queen-street, Melbourne. 8324

Creditors, next of kin and others having claims in respect of the estate of Albertina Emma Payne, late of 26 Rockley-road, South Yarra, in the State of Victoria, widow (who died on the 13th March, 1972), are to send particulars of their claims to the executors of the said estate, care of the undersigned, by the 15th November, 1972, after which date the executors will distribute the assets, having regard only to the claims of which they then have notice.

WM. MURRAY & SON, solicitors, 422 Collins-street, Melbourne. 8325

MARGARET CHRISTINA McDONALD, late of 9 Trafalgar-road, Camberwell, spinster, DECEASED.

Creditors, next of kin and others having claims in respect of the estate of the deceased (who died on 20th March, 1972), are required by The Perpetual Executors and Trustees Association of Australia Limited, of 100-104 Queen-street, Melbourne, to send particulars of their claims to the said Company by 13th March, 1973, after which date it will convey or distribute the assets, having regard only to the claims of which the Company then has notice.

HEDDERWICK, FOKES & ALSTON, 121 William-street, Melbourne. 8326

Creditors, next of kin and others having claims in respect of the estate of Sydney Vincent Nicholas, late of Flat 12, 14 Ashby-grove, Ivanhoe, director, deceased (who died on the 7th October, 1970), are to send particulars of their claims to Ellen Agnes Nicholas and John Watson

McCallum, care of the undersigned, by the 15th November, 1972, after which date they will distribute the assets, having regard only to the claims of which they then have notice.

COOK & McCALLUM, solicitors, 422 Collins-street, Melbourne. 8327

ALICE EMMA McDOUGALL, formerly of 2 Stephen-street, Carrum, but late of 64 Sackville-street, Collingwood, in the State of Victoria, widow, DECEASED.

Creditors, next of kin and others having claims in respect of the estate of the above-named deceased (who died on the 15th April, 1972), are required by the executor of the said deceased's will, Herbert George Jacobson, of 3 Fourth-avenue, Chelsea Heights, estate agent, to send particulars to him by the 15th November, 1972, after which date the executor may convey or distribute the assets of the estate having regard only to the claims of which he may have notice.

KEITH A. NESS & SON, solicitors, 411 Collins-street, Melbourne. 8328

STEPHEN GEORGE SMITH, late of Bright, in the State of Victoria, retired miner, DECEASED.

Creditors, next of kin and others having claims in respect of the estate of the deceased (who died on the 29th day of May, 1972), are required by the executor appointed by the will of the said deceased, to send particulars of their claims to him, care of Messrs. F. R. E. Dawson & Son, 84 William-street, Melbourne, by the 15th day of November, 1972, after which date he will convey or distribute the assets, having regard only to the claims of which he then has notice.

Dated the 13th day of September, 1972.  
F. R. E. DAWSON & SON, 84 William-street, Melbourne. 8273

MARGARET PAYNE, late of Myers Creek-road, Healesville, widow, DECEASED.

Creditors, next of kin and others having claims in respect of the estate of the deceased (who died on the 3rd day of May, 1972), are required by the executor, Richard Patrick Baylor, of 282 Maroondah Highway, Healesville, solicitor, to send particulars to him, care of the undersigned, on or before the 21st day of November, 1972, after which date he will distribute the assets, having regard only to the claims of which he then has notice.

R. P. BAYLOR & CO., solicitors, Healesville. 8264

REBECCA BABINGTON KEYS, late of "Frogmore House", Wahgoo-street, Murrumbena, spinster, DECEASED.

Creditors, next of kin and all others having claims in respect of the above-named deceased (who died on 20th October, 1943), are requested to send particulars of their claims in writing to the administrator, National Trustees, Executors and Agency Company of Australasia Limited, of 95 Queen-street, Melbourne, on or before the 13th November, 1972, after which date they will distribute the assets of the said estate, having regard only to the claims of which they then have notice as aforesaid.

DESMOND DUNNE & DWYER, solicitors, Warrnambool. 8265

JAMES LEONARD BRUMBY, late of Nirranda, farmer DECEASED.

Creditors, next of kin and all others having claims in respect of the above-named deceased (who died on 19th November, 1971), are requested to send particulars of their claims in writing to the administrator, National Trustees, Executors and Agency Company of Australasia Limited, of 95 Queen-street, Melbourne, on or before the 13th November, 1972, after which date they will distribute the assets of the said estate, having regard only to the claims of which they then have notice as aforesaid.

DESMOND DUNNE & DWYER, solicitors, Warrnambool. 8266

Creditors, next of kin and others having claims in respect of the estate of Henry Don, late of Timboon, pensioner, deceased (who died on the 22nd September, 1970), are required by the administrator, James Don, of Timboon, post master, to send particulars to him, care of the under-mentioned solicitors, by the 13th day of November, 1972, after which date he will distribute the assets, having regard only for the claims of which he then has notice.

ARTHUR E. GEORGE & SONS, solicitors, of Cobden. 8260

BESSIE ANN LINDSAY KEYS, late of "Frogmore House", Wahgoo-street, Murrumbena, spinster, DECEASED, intestate.

Creditors, next of kin and all others having claims in respect of the above-named deceased (who died on 9th March, 1942), are requested to send particulars of their claims in writing to the National Trustees, Executors and Agency Company of Australasia Limited, of 95 Queen-street, Melbourne, on or before the 13th November, 1972, after which date they will distribute the assets of the said estate, having regard only to the claims of which they then have notice as aforesaid.

DESMOND DUNNE & DWYER, solicitors, Warrnambool. 8267

LUCY ISABELLA MORRELL, late of 27 Main-street, Ballarat, spinster, DECEASED (who died on the 22nd May, 1972).

Creditors, next of kin and all persons having claims against the estate of the deceased, are required to send particulars to the executors, Robert Thomas Morrell and Thomas Charles Morrell, care of Messrs. Heinz & Gordon, solicitors, 209 Dana-street, Ballarat, on or before the 13th day of November, 1972, after which date it will distribute the assets, having regard only to the claims of which they shall then have notice.

HEINZ & GORDON, solicitors, 209 Dana-street, Ballarat. 8270

Creditors, next of kin and others having claims in respect of the estate of Frank Wavish, late of 16 Langs-road, Ascot Vale, in the State of Victoria, gentleman, deceased (who died on the 19th March, 1972), are to send particulars of their claims to The Union Fidelity Trustee Company of Australia Limited, of 100 Exhibition-street, Melbourne, in the said State, the executor of the said deceased, by the 31st day of October, 1972, after which date the executor may convey or distribute the assets, having regard only to the claims of which he then has notice.

DOOLAN, KEMP & TOWNSEND, solicitors, of 340 Collins-street, Melbourne. 8258

THOMAS O'CONNELL, late of 301 St. Georges-road, Northcote, in the State of Victoria, formerly foreman, but late retired, DECEASED.

Creditors, next of kin and others having claims in respect of the estate of the deceased (who died on the 20th day of January, 1972), are required by Harold Selwyn Astley, of 389 Flinders-lane, Melbourne, in the said State, solicitor, to send particulars to him by the 30th day of November, 1972, after which date he may convey or distribute the assets, having regard only to the claims of which he then has notice.

H. S. ASTLEY & CO., solicitors, 389 Flinders-lane, Melbourne. 8259

Creditors, next of kin and others having claims against the estate of Grace Ethel McCure, late of 333 Barkly-street, Ararat, pensioner, deceased (who died on the 1st day of June, 1972), are to send particulars of their claims to The Union-Fidelity Trustee Company of Australia Limited, of 101 Lydiard-street north, Ballarat, by the 17th day of November, 1972, after which date it will distribute the assets, having regard only to the claims of which it then has notice.

GRANO & McCARTHY, solicitors, Ararat. 8250

Creditors, next of kin and others having claims in respect of the will of Agnes Maud Hewett, late of Flat 1, 164 Wattle-tree-road Malvern, widow (who died on the 4th day of June, 1972), are requested to send particulars of their claims to the executors Harold Lawson Hewett and Edward Curmi, care of the under-mentioned solicitor, by the 20th day of November, 1972, after which date they will distribute the assets, having regard only to the claims of which they then have notice.

EDWARD CURMI, solicitor of 440 Victoria-street, North Melbourne. 8224

Creditors, next of kin and others having claims against the estate of Harriet Marshall, late of 14 Fallon-street, Caulfield, widow, deceased (who died on the 12th day of June, 1972), are required by the executor, William Graham Orr, of 406 Lonsdale-street, Melbourne, solicitor, to send particulars to him, by the 14th day of November, 1972, after which date the executor may convey or distribute the assets, having regard only to the claims of which he then has notice.

LEWIS, ORR & BRUSEY, solicitors, of 406 Lonsdale-street, Melbourne. 8225

Creditors, next of kin and others having claims in respect of the estate of Violet Elsie Worthy, formerly of 151 Don-street, Bendigo, in the State of Victoria, but late of Bendigo Home & Hospital for the Aged, Barnard-street, Bendigo aforesaid, widow (who died on the 2nd day of January, 1972), are to send particulars of their claim to National Trustees, Executors and Agency Company of Australasia Limited, of 46 Queen-street, Bendigo and 95 Queen-street, Melbourne, by the 8th day of November, 1972, after which date the executor will distribute the assets of the estate of the said deceased, having regard only to the claims of which it has notice.

EVERY & EVERY, solicitors, V.P.C. Building, Bull-street, Bendigo. 8226

Creditors, next of kin and others having claims in respect of the will of Catherine Hannah White, late of 71 Wellington-street, Flemington, widow (who died on the 24th day of July, 1972), are requested to send particulars of their claims to the executrix, Doreen Mary Curtin, care of the under-mentioned solicitor, by the 20th day of November, 1972, after which date she will distribute the assets, having regard only to the claims of which she then has notice.

JOHN STEWART, of 290 Racecourse-road, Newmarket. 8227

DELPHINE GABRIELLE ETHELDA SPEED, late of 6 Lawson-street, Elwood, widow, DECEASED.

Creditors, next of kin and others having claims in respect to the estate of the said deceased (who died on 8th May, 1972), are required by Harold Hector Speed, of 6 Lawson-street, Elwood, the executor of the Will of the said deceased, to send particulars in writing to him, care of the under-mentioned solicitor, by 17th November, 1972, after which date he may convey or distribute the assets of the estate, having regard only to the claims of which he then has notice.

THOMAS BURKE, solicitor, 152 Wattletree-road, Malvern. 8230

Creditors, next of kin and others having claims in respect of the estate of Charles Edward Dunn, late of Aviation-road, Werribee, farmer, deceased (who died on 29th May, 1970, and probate of whose will was granted by the Supreme Court of Victoria, on 7th August, 1970, to Rupert Nicholas Dunn, of Trentham, farmer, one of the executors therein named), are required to send particulars of their claims to the said executor, in care of the under-mentioned solicitors, before the 13th November, 1972, after which date he will distribute the assets, having regard only to the claims of which he shall then have had notice.

PALMER, STEVENS & RENNICK, solicitors, Kyneton. 8236

DANIEL BAKER, late of Marna Guest House, Maroondah Highway, Healesville, pensioner, DECEASED.

Creditors, next of kin and others having claims in respect of the estate of the deceased (who died on the 18th day of November, 1970), are required by the executor, Richard Patrick Baylor, of 282 Maroondah Highway, Healesville, solicitor, to send particulars to him, care of the under-mentioned, on or before the 21st day of November, 1972, after which date he will distribute the assets, having regard only to the claims of which he then has notice.

R. P. BAYLOR & CO., solicitors, Healesville. 8253

NELLIE McDONALD, late of 55 George-street, Hamilton, widow, DECEASED.

Creditors, next of kin and others having claims in respect of the estate of the above-named deceased (who died on the 6th day of June, 1972), are required by the executor, The Union-Fidelity Trustee Company of Australia Limited, to send particulars of their claims to it, care of the under-mentioned solicitors, by the 18th day of November, 1972, after which date it shall distribute the estate, having regard only to claims of which it then has notice.

MELVILLE, ORTON & LEWIS, solicitors, 66 Thompson-street, Hamilton. 8256

Creditors, next of kin and others having claims in respect of the estate of John William Carrodus, late of 317A Tyler-street, East Preston, in the State of Victoria, pensioner, deceased (who died on the 26th day of April, 1972), are to send particulars of their claims to Royston Cahir, Martin & Dillon, solicitors, of 17 Queen-street, Melbourne by the 17th day of November, 1972, after which date the administratrix will distribute the assets of the estate, having regard only to the claims of which she has notice.

ROYSTON CAHIR, MARTIN & DILLON, solicitors of 17 Queen-street, Melbourne. 8288

PLAYFAIR JOHN CAMPBELL GRACE, formerly of "Erindale", Stony Crossing, in the State of New South Wales, but late of 174 Overport-road, Frankston, in the State of Victoria, retired grazier, DECEASED (who died on 25th April, 1972).

Creditors, next of kin and all other persons having claims against the Estate of the deceased, are required by the executors of the will, Alvie Lesley Grace, Rosemary Beatrice Campbell Kennon, Lesley Jane Ashton and Angela Mary Campbell Powell, to send particulars to them, care of the undersigned, on or before the 6th December, 1972, after which date they will distribute the assets, having regard only to the claims of which they then have notice.

GARDEN & GREEN, solicitors, 4 McCallum-street, Swan Hill. 8238

Creditors, next of kin and others having claims against the estate of Robert James Slater, late of 5 Thompson-street, Brown Hill, log hauler, deceased (who died on the 29th day of February, 1972), are requested to send particulars of their claims to the executrix, Elizabeth Lilian Slater, of 5 Thompson-street, Brown Hill, widow, by the 15th day of December, 1972, after which date the said executrix will distribute the assets, having regard only to the claims of which she then has notice. Particulars of all payments to be forwarded care of Nevett Glenn & Coutts, 205 Dana-street, Ballarat.

NEVETT GLENN & COUTTS, solicitors, 205 Dana-street, Ballarat. 8271

Creditors, next of kin and others having claims against the estate of Mary Ann Rymer, formerly of 11 Princes-street north, Ballarat, in the State of Victoria, but late of 102 Ascot-street south, Ballarat, in the said State, widow, deceased (who died on the 14th day of June, 1972), are requested by the administrator of the estate of the said deceased, The Union-Fidelity Trustee Company of Australia Limited, of 101 Lydiard-street north, Ballarat, in the said State, to send particulars of their claims to the said company, on or before the 13th day of November, 1972, after which the administrator will distribute the assets, having regard only to the claims of which it shall have then had notice.

CUTHBERT, MORROW, MUST & SHAW, solicitors, Ballarat. 8272

MINNIE MUIR, late of 517 High Street-road, Mount Waverley, in the State of Victoria, widow, DECEASED.

Creditors, next of kin and others having claims in respect of the estate of the above-named deceased (who died on the 26th day of June, 1972), are required by the trustee William Muir, of 31 Cheviot-road, Mount Waverley, aforesaid director, to send particulars to the said trustee, by the 22nd day of November, 1972, after which date the trustee may convey and distribute the assets, having regard only to the claims of which he then has notice.

EGGLESTON, CLIFTON-JONES & CO., solicitors, of 20 Queen-street, Melbourne, Victoria, 3000. 8274

GEORGE WESLEY MORGAN, late of 30 Imbros-street, Hampton, gentleman, DECEASED.

Creditors, next of kin and others having claims in respect of the estate of the deceased (who died on 2nd March, 1972), are required by National Trustees, Executors and Agency Company of Australasia Limited, of 95 Queen-street, Melbourne, to send particulars of their claims to the said company, by the 15th November, 1972, after which date it will convey or distribute the assets, having regard only to the claims of which it then has notice.

CORR & CORR, solicitors, 290 Latrobe-street, Melbourne. 8275

GEORGE IVAN LEIGH MURRAY, late of 1 Selbourne-road, Kew, in the State of Victoria, retired bank official, DECEASED.

Creditors, next of kin and others having claims in respect of the estate of the above-named deceased (who died on the 3rd day of March, 1972), are required by the trustee, The Trustees, Executors and Agency Company Limited, of 401 Collins-street, Melbourne, in the State of Victoria, to send particulars to such company, by the 22nd day of November, 1972, after which date the said trustee may convey and distribute the assets, having regard only to the claims of which it then has notice.

EGGLESTON, CLIFTON-JONES & CO., solicitors, of 20 Queen-street, Melbourne, Victoria, 3000. 8276

Creditors, next of kin and others interested in the estate of Ethel Isa Beatrice Maud Bentley, formerly of 1 Sagamore-court, North Caulfield, in the State of Victoria, but late of 569 Glenhuntly-road, Elsternwick, in the said State, widow, deceased (who died on the 5th day of June, 1972), are to send particulars of their claims to her executor, The Equity Trustees Executors and Agency Company Limited, of 472 Bourke-street, Melbourne, by the 30th day of November, 1972, after which date it will distribute the assets, having regard only to the claims of which it then has notice.

JOHN W. McCOMAS & CO., 380 Bourke-street Melbourne, solicitors for the executor. 8281

Creditors, next of kin and others having claims against the estate of Frances Anne Lawler, formerly of Flat 6, 124 Glenhuntly-road, Elwood, in the State of Victoria, but late of The Royal Melbourne Hospital, Parkville, in the said State, invalid pensioner, deceased, are required by the administrator, Edmund Herbert Lawler, of 53 Lakeside-parade, The Entrance, in the State of New South Wales, retired pharmacist, to send particulars of their claims, care of the undersigned, by the 14th November, 1972, after which date he will distribute the estate, having regard only to the claims of which he then has notice.

JOHN D. MUSTOW & CO., solicitors, 131 Queen-street, Melbourne. 8285

Creditors, next of kin and others having claims in respect of the estate of Eileen Catherine Hutchinson, late of 163 Toorak-road, Camberwell, widow, deceased (who died on 10th day of October, 1971), are required to send particulars of their claims to Joseph David William Hutchinson, care of the under-mentioned solicitors, the executor of the will of the said deceased, by the 20th day of November, 1972, after which date the said executor will distribute the assets, having regard only to the claims of which he then has notice.

HERBERT, GEER & RUNDLE, solicitors, 612-614 Balcombe-road, Black Rock. 8286

Creditors, next of kin and others having claims in respect of the estate of Dorothy Sanders, formerly of "Eilerslie", 16 Harcourt-street, East Hawthorn, in the State of Victoria, but late of Baxter House Private Hospital, 62 Rowell-avenue, Camberwell, in the said State, spinster, deceased (who died on the 22nd June, 1972), are to send the particulars of their claims to The Union-Fidelity Trustee Company of Australia Limited, of 100 Exhibition-street, Melbourne, in the said State, by the 14th November, 1972, after which date it will distribute the assets, having regard only to the claims of which it then has notice.

HERBERT TURNER & DAVIS, solicitors, 411 Collins-street, Melbourne. 8287

In the Supreme Court of the State of Victoria.

SALE BY THE SHERIFF.

On Friday, the 17th of November, 1972, at 11 a.m., at the Police Station, Doncaster (unless process be stayed or satisfied):—

All the estate and interest (if any) of Bruno Kucko, carpenter, of 29 Worthing-avenue, East Doncaster, as joint proprietor with Wendy Dawn Kucko of an estate in fee-simple in the land described in certificate of title, volume 8693, folio 822, upon which is erected a brick veneer dwelling, known as No. 29 Worthing-avenue, East Doncaster.

Registered mortgage No. D.228522 and caveat E.207555 affects the said estate and interest.

Terms: Cash only.

H. BUETTNER, Sheriff's Officer.

13th September, 1972. 8316

In the Supreme Court of the State of Victoria.

SALE BY THE SHERIFF.

On Friday, the 24th of November, 1972, at 10 a.m., at the Police Station, Mooroolbark (unless process be stayed or satisfied):—

All the estate and interest (if any) of Melville John Smith, butcher, Flat 10, 18-32 Lennon-street, West Parkville, as joint proprietor with Nola Maureen Smith of an estate in fee-simple in the land described in certificate of title, volume 8437, folio 377, upon which is erected a dwelling, known as No. 121 Manchester-road, Mooroolbark.

Registered Caveat E.463855 affects the said estate and interest.

Terms: Cash only.

H. BUETTNER, Sheriff's Officer.

13th September, 1972. 8320

In the Supreme Court of the State of Victoria.

SALE BY THE SHERIFF.

On Friday, the 17th of November, 1972, at 10 a.m., at the Police Station, Canterbury (unless process be stayed or satisfied):—

All the estate and interest (if any) of Design Participation Pty. Ltd., of 461 Bourke-street, Melbourne, as proprietor of an estate in fee-simple in the land described in certificate of title, volume 8756, folio 042, upon which are erected four villa flats, known as No. 45 Canterbury-road, Canterbury.

Registered mortgages No. E.127563, E.373216 and E.418800 affect the said estate and interest.

Terms: Cash only.

H. BUETTNER, Sheriff's Officer.

13th September, 1972. 8321

INSOLVENCY NOTICE

BANKRUPTCY DISTRICT OF THE STATE OF VICTORIA.—No. 6 of 1967.—Part xi Scheme of Arrangement *re* Brian Dunn at present residing at Clegg-road, Mt. Evelyn, Victoria. —Notice of Intention to Declare Final Dividend.

A Final dividend in the above matter is about to be declared.

Creditors who have not lodged proofs of debt with me on or before 6th October, 1972, will be excluded from this dividend.

A. I. SINCLAIR, Trustee.

Duesbury & Johnston, 446 Collins-street, Melbourne, 3000. 8283

IMPOUNDINGS

COBDEN.—Impounded in Cobden Pound.

1 Hereford crossbred heifer, no visible brand or earmarks  
If not claimed and expenses paid, to be sold on 29th September, 1972.

8317—\$2.10 J. S. BRADD, Poundkeeper.

DONALD.—Impounded in Donald Pound from 3 miles east of Donald on 7th September, 1972.

1 black goat, 2 years, earmark point left ear.

If not claimed and expenses paid, to be sold on 29th September, 1972.

\$2.10—8334 W. A. CAMERON, Poundkeeper.

EAGLEHAWK.—Impounded in Eaglehawk Pound, from the Sebastian-Raywood road, Shire of Marong.

3 Shorthorn cows, no visible brand

1 Shorthorn bull, no visible brand

4 Shorthorn heifers, no visible brand

1 Friesian cow, no visible brand

6 vealers, no visible brand

If not claimed and expenses paid, to be sold on 3rd October, 1972.

8282—\$3.85 C. M. NANKERVIS, Poundkeeper.

HASTINGS.—Impounded in Hastings Pound, from Speedwell-street, Somerville, on the 28th August, 1972.

1 brindle heifer, no visible brand or markings

If not claimed and expenses paid, to be sold on 19th September, 1972.

8243—\$2.45 M. L. DICKINSON, Poundkeeper.

MANSFIELD.—Impounded in Mansfield Pound.

1 cream coloured female goat, no visible brand

If not claimed and expenses paid, to be sold on 29th September, 1972.

8246—\$2.10 M. PREST, Poundkeeper.

PYRAMID HILL.—Impounded in Pyramid Hill Pound.

1 Hereford cow, "D" brand, two notches right ear

1 Hereford cow, "D" brand, two notches right ear and silver tag left ear

If not claimed and expenses paid, to be sold on 28th September, 1972.

8245—\$2.80 A. E. TOEY, Poundkeeper.

TRARALGON.—Impounded in Traralgon Pound, from Minniedale-road.

1 Jersey heifer (horned), approximately eighteen months old, V out of point of near ear, no visible brand

If not claimed and expenses paid, to be sold on 27th September, 1972.

8244—\$2.80 M. J. LITTLE,  
Poundkeeper.

UPWEY.—Impounded in Upwey Pound on 31st August, 1972.

1 black bull, yellow tag on tail, silver ear tag, no visible brand

Impounded from Menzies Creek on 5th September, 1972.

1 black and white yearling bull, no visible brand

If not claimed and expenses paid, to be sold on 26th September, 1972.

\$3.15—8335 J. B. CLAYTON, Poundkeeper.

WANGARATTA.—Impounded in Wangaratta Pound, from Drovers Herd.

1 Poll Hereford steer, approx. 13-15 months old, piece out of top of left ear, no visible brand

If not claimed and expenses paid, to be sold on 28th September, 1972.

8240—\$2.80 B. SCHUBERT,  
Poundkeeper.

YINNAR.—Impounded in Yinnar Pound.

1 ram, no visible brand

1 ewe, no visible brand

1 lamb, no visible brand

If not claimed and expenses paid, to be sold on 27th September, 1972.

8247—\$2.80 J. E. HEESOM,  
Poundkeeper.

*Subordinate Legislation Act 1962.*

**NOTICE OF MAKING OF STATUTORY RULES.**

In pursuance of the provisions of the *Subordinate Legislation Act 1962* and the Regulations made thereunder, notice is given of the making of the following statutory rules:—

No.	Labour and Industry Act 1958.	Price.
251/1972.	Labour and Industry (Tractor Safety) Regulations 1972	10c
	<i>Marketable Securities Act 1970.</i>	
252/1972.	Marketable Securities (Further Authorised Trustee Corporations) Regulations 1972	10c
	<i>Railways Act 1958.</i>	
253/1972.	Victorian Railways Commissioners Amendment to Regulation No. 66, Clause 131	10c
	<i>Country Roads Act 1958 (No. 6229).</i>	
254/1972.	Western Freeway Gordon Section (Animals) By-law 1972	10c
	<i>Country Roads Act 1958 (No. 6229).</i>	
255/1972.	Western Freeway Gordon Section (Pedestrians, Bicyclists and Agricultural Machinery) By-law 1972	10c

Copies of these statutory rules may be purchased at the Sale of Publications Section of the Government Printing Office, located at 7A Parliament-place, Melbourne, 3002. If ordered by mail, remittance should be addressed to "The Government Printer, Box 203, P.O., North Melbourne, 3051", and should include 7c extra for postage. If a credit account is held at this office, no remittance is required with the mail order.

The annual subscription rate for Statutory Rules (including Bound Volumes) is \$23, payable in advance. The subscription year commences on 1st January.

C. H. RIXON,  
Government Printer.

**AGENTS FOR THE "VICTORIA GOVERNMENT GAZETTE".**

The following have been appointed agents to receive Advertisements and Subscriptions for the *Victoria Government Gazette*:—

ARMSTRONG'S AGENCY, 217 Queen-street, Melbourne, Victoria 3000.

ARNALL & JACKSON, 390 Barkly-street, Brunswick, Victoria 3056

BAIRNSDALE AUTHORIZED NEWSAGENCY, 132 Main-street, Bairnsdale, Victoria 3875.

BICKNELL, M. J., Authorized Newsagent, 196 Timor-street, Warrambool, Victoria 3280.

BLANE'S AUTHORIZED NEWSAGENTS, 162 Murray-street, Colac, Victoria 3250.

CARTER, R. G., ADVERTISING SERVICE PTY. LTD. Suite 24, 65 Queens-road, Melbourne, Victoria 3004.

DAVIES, G. & M. V., 112 Gray-street, Hamilton, Victoria 3300

DAVIS, WM. (MILDURA) PTY. LTD., 126 Eighth-street, Mildura, Victoria 3500.

DIXON'S NEWSAGENCY, 89 Firebrace-street, Horsham, Victoria 3400.

EASTHALL ASSOCIATES, 934 Whitehorse-road, Box Hill, Victoria 3128.

EDGARS' AUTHORIZED NEWSAGENCY, 45 Bridge-street, Benalla, Victoria 3672.

FRANKS, H. & CO., 184 Ryrie-street, Geelong, Victoria 3220.

GATLEY, A. & J., 250 Lonsdale-street, Dandenong, Victoria 3175.

GORDON & GOTCH AUSTRALASIA LTD., 434 St. Kilda-road, Melbourne, Victoria 3004.

GULLAN'S NEWSAGENCY, 88 Bridge-street, Ballarat, Victoria 3350.

HAMPTON, A. C., 243 Mitchell-street, Bendigo, Victoria 3550.

HARSTON, PARTRIDGE & CO. PTY. LTD., 455 Little Collins-street, Melbourne, Victoria 3000.

KYNETON GUARDIAN PTY. LTD., P.O. Box 18, Kyneton, Victoria 3444.

LATIMER'S, Newsagents, 45 Station-street, Malvern, Victoria 3144.

LIVINGSTON'S SHEPPARTON NEWSAGENCY, 246 Wyndham-street, Shepparton, Victoria 3630.

THE MERCANTILE EXCHANGE, 34 Queen-street, Melbourne, Victoria, 3000.

McGILL'S AUTHORIZED NEWSAGENCY, 183-5 Elizabeth-street, Melbourne, Victoria 3000.

POWNEYS AUTHORIZED NEWSAGENCY, 293 Hargreaves-street, Bendigo, Victoria 3550.

PURDIE, J., & CO., 138 Moorabool-street, Geelong, Victoria 3220.

SALE AUTHORIZED NEWSAGENCY, 142 Raymond-street, Sale, Victoria 3850.

SKINNER'S AUTHORIZED NEWSAGENCY, 49-51 Franklin-street, Traralgon, Victoria 3844.

STEVENSON, A. C. & M., NEWSAGENTS, 132 Henty-street, Casterton, Victoria 3311.

VANCE'S AUTHORIZED NEWSAGENCY, 83 Murray-street, Wangaratta, 3677.

VERNONS OF RICHMOND, 162 Bridge-road, Richmond, Victoria 3121.

VIEW POINT AUTHORIZED NEWSAGENCY, 4 View-Point, Bendigo, Victoria 3550.

A copy of the *Gazette* filed at each place for public reference.

**THE "VICTORIA GOVERNMENT GAZETTE".**

**SUBSCRIPTIONS.**—The subscription, including postage, is \$22.50 per annum, or \$11.25 per half year, payable in advance.

Subscriptions are required for whole months, and must cover at least a half year.

Single copies are 30 cents, posted 48 cents. Subscribers do not receive the Acts of Parliament with the *GAZETTE*.

*GAZETTES* are held in stock for five years only.

**PRIVATE ADVERTISEMENTS.**—The charge for insertion is 35 cents per line single column, and 70 cents per line double column. The title forms one or more lines as a heading. On an average ten words make a line of single column. Every signature must likewise be counted as a line. The final words of a paragraph, though only portion of a line, must be counted as one line. Signatures (in particular) and proper names must be written very plainly in the text; ONE SIDE ONLY of each sheet of paper should be WRITTEN UPON. The charge for a full page is \$50.

All documents illegibly written will be returned unpublished, and where brands occur unprovided for by the ordinary letters of the alphabet, a worded explanatory description must be furnished.

THE VICTORIA GOVERNMENT GAZETTE is published on WEDNESDAY EVENING in each week, and Notices for insertion will be received by the Government Printer at or before ONE p.m. at ordinary rates, and late advertisements between ONE p.m. and FOUR p.m. at double rates on the day preceding the day of publication.

PAYMENTS.—Unless the advertiser has a credit account, all payments are required in advance. Remittances should be made by cheque, postal order, or money order payable to "GOVERNMENT PRINTER".

ADDRESS.—All communications should be addressed to "The Government Printer, Box 203, P.O., North Melbourne", 3051.

**PUBLICATION OF OFFICIAL MATTER.**

Attention is invited to the following procedure in relation to the publication of official matter in the *Government Gazette*:—

Publication will be facilitated by the submission of carbon copies for the use of the Gazette Officer.

1. *Matter submitted to the Executive Council.*

Matter submitted to the Executive Council which requires gazettal will normally be published in the issue of the following week.

Where urgent gazettal is required, special arrangements should be made with the Gazette Officer, Room 9, first floor, Old Treasury Building.

2. *Other matter.*

(a) All other matter duly certified by a responsible officer for publication should be lodged with the Gazette Officer not later than half-past Nine a.m. on Tuesday.

(b) Lengthy or involved notices should be forwarded several days before publication.

(c) Proofs, which will be supplied only when specifically requested or at the direction of the Gazette Officer, should be returned promptly to avoid delay in publication.

(d) No additions or amendments to matter for publication will be accepted by telephone.

**CONTENTS**

**PAGE**

Appointments .. .. .	3116
Bank Holidays .. .. .	3095
Cemeteries—Scale of Fees .. .. .	3096
Companies Act 1961—Notice .. .. .	3111
Contracts .. .. .	3115
Country Roads Board .. .. .	3101
Estates of Deceased Persons .. .. .	3114
Government Notices .. .. .	3095
Holiday—Royal Agricultural Show .. .. .	3095
Impoundings .. .. .	3148
Insolvency Notice .. .. .	3148
Lands .. .. .	3126
Mining .. .. .	3110
Notice to Mariners .. .. .	3110
Notice of Making Statutory Rules .. .. .	3149
Orders in Council—	
Acts—Land; Superannuation; Hospitals and Charities; Road Traffic; Country Roads; Housing; Water; Latrobe Valley; Landlord and Tenant; Dairy Products.	3119 et seq
Police Sale .. .. .	3111
Private Advertisements .. .. .	3136
Proclamations .. .. .	3095
Public Half-Holidays .. .. .	3095
Public Service Notices .. .. .	3129
Regulations—	
Acts—Teaching Service .. .. .	3135
Resignations .. .. .	3119
Tenders .. .. .	3128
Transport Regulation Board—Public Hearings .. .. .	3097
Waterworks Trusts .. .. .	3112