



VICTORIA  
GOVERNMENT GAZETTE

Published by Authority

No. 108]

WEDNESDAY, NOVEMBER 7

[1973

PROCLAMATIONS

*Marine Act 1958.*  
AMENDMENT TO PORT RULE APPLICABLE TO  
WESTERNPORT HARBOR SERVICES (RATES AND  
CHARGES).

PORT RULE NO. 132.

PROCLAMATION

By His Excellency the Governor of the State of Victoria and its Dependencies in the Commonwealth of Australia, &c., &c., &c.

Whereas by Part II. of the *Marine Act 1958* it is amongst other things enacted that the Governor in Council by Proclamation published in the *Government Gazette*, may from time to time define the limits and boundaries of ports in Victoria and frame rules and regulations for the governance and preservation of the said ports respectively and for the regulation of shipping in the same (including the imposition of charges for the use of mooring sites and other facilities):

And that any such regulation may from time to time be in like manner altered, amended or repealed and other substituted in their stead:

Now therefore, I, the Governor of the State of Victoria in the Commonwealth of Australia by and with the advice of the Executive Council thereof and in the exercise of the powers conferred by the said Act, by this Proclamation do hereby amend the Proclamation dated the 13th day of February, 1973, as follows:—

Delete the proviso added at the end of Paragraph (A) of the schedule to Clause 2 by amendment dated 29th May, 1973, and substitute therefor the following:—

“Provided that during the period between the 8th November, 1973 and 31st May, 1974, both dates inclusive, the charges set forth in Paragraph (A) of this schedule shall be reduced by 30 per cent., unless the Governor in Council by proclamation determines otherwise.”

Delete the proviso added at the end of Paragraph (C) of the schedule to Clause 2 by amendment dated 29th May, 1973, and substitute therefor the following:—

“Provided that during the period between the 8th November, 1973, and the 31st May, 1974, both dates inclusive, the charges set forth in Paragraph (C) of this schedule shall be reduced by 50 per cent., unless the Governor in Council by proclamation determines otherwise.”

Given under my Hand and the Seal of the State of Victoria aforesaid, at Melbourne, this thirtieth day of October, in the year of our Lord One thousand nine hundred and seventy-three, and in the twenty-second year of the reign of Her Majesty Queen Elizabeth II.

(L.S.) ROHAN DELACOMBE.

By His Excellency's Command,

ROBERTS DUNSTAN,  
Minister of Public Works.

GOD SAVE THE QUEEN !

*Land Act 1958.*  
DEPARTMENT OF CROWN LANDS AND SURVEY.

PROCLAMATION

By His Excellency the Governor of the State of Victoria and its Dependencies in the Commonwealth of Australia, &c., &c., &c.

In pursuance of the provisions of section 22c (2) of the *Land Act 1958* (as amended by the *Surrender of Land Act 1972*, No. 8363): I, the Governor of the State of Victoria, by and with the advice of the Executive Council of the said State, upon receipt of certification of the clerk of the municipality concerned (City of Echuca) that the land is or has been used for any cultural sporting or recreational purposes, do hereby declare all that piece of land being part of Crown allotment 47, Town of Echuca, Parish of Echuca North, County of Rodney, comprising 10 acres 1 rood 19 perches, and being the land described in volume 8095, folio 109, to be land to which the said section 22c (2) applies.—(C.100716).

Given under my Hand and the Seal of the State of Victoria aforesaid, at Melbourne, this thirtieth day of October, in the year of our Lord One thousand nine hundred and seventy-three, and in the twenty-second year of the reign of Her Majesty Queen Elizabeth II.

(L.S.) ROHAN DELACOMBE.

By His Excellency's Command,

W. BORTHWICK,  
Minister of Lands.

GOD SAVE THE QUEEN !

Land Act 1958, Section 25.  
ROADS PROCLAIMED.

PROCLAMATION

By His Excellency the Governor of the State of Victoria and its Dependencies in the Commonwealth of Australia, &c., &c., &c.

In pursuance of the provisions of Section 25 of the Land Act 1958, I, the Governor of the State of Victoria by and with the advice of the Executive Council of the said State do hereby proclaim as roads the lands in the Parish of Koyuga County of Rodney as indicated by hatching on the plan hereunder.—(W.90831) (K.98<sup>(\*)</sup>).

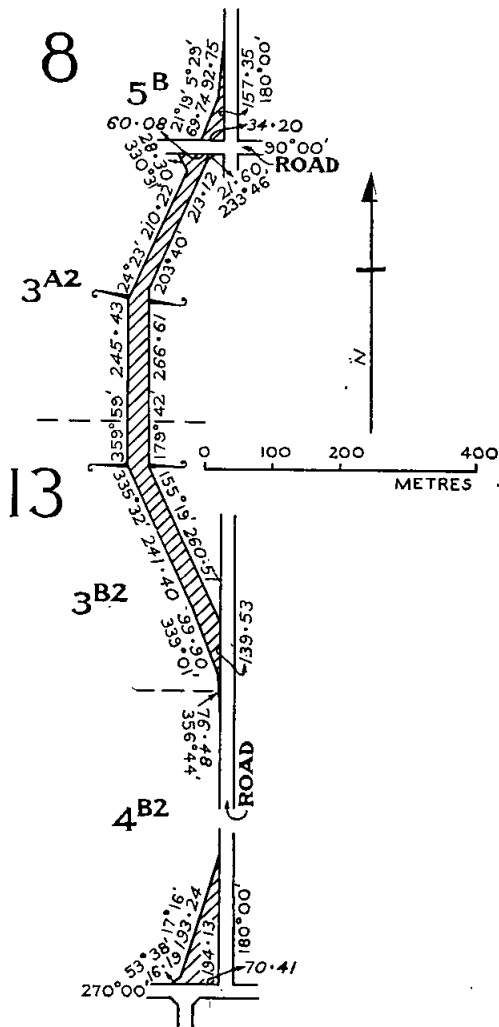

Given under my Hand and the Seal of the State of Victoria aforesaid, at Melbourne, this thirtieth day of October, in the year of our Lord One thousand nine hundred and seventy-three, and in the twenty-second year of the reign of Her Majesty Queen Elizabeth II.

(L.S.) ROHAN DELACOMBE.

By His Excellency's Command,

W. BORTHWICK,  
Minister of Lands.

GOD SAVE THE QUEEN!

GOVERNMENT NOTICES

Melbourne Cricket Ground Act 1933 (No. 4149).  
MELBOURNE CRICKET GROUND.

AMENDMENT OF REGULATION.

Whereas by Section 9 of the Melbourne Cricket Ground Act 1933 (No. 4149), the trustees appointed thereunder have power from time to time, with the approval of the Governor in Council, to make Regulations as therein provided, and with like approval to repeal or amend such Regulations: And whereas the said Act provides that the Regulations relating to the Metropolitan Cricket Ground in force immediately before the commencement of the said Act shall be deemed to have been made pursuant to the said Act and shall remain in force until repealed under the said Act: And whereas Regulations relating to the Melbourne Cricket Ground (hereinafter called the Ground) have been made from time to time both before and after the commencement of the said Act: And whereas it is in the opinion of a statutory majority of the said trustees necessary and expedient to amend one of such Regulations: Now therefore, we the undersigned, a statutory majority of the said trustees for the time being of the land described in the Fifth Schedule to the said Act, as enlarged pursuant to the provisions of the Melbourne Cricket Ground Acts (Nos. 5614 and 6854), together with all improvements thereon, do by virtue of all the powers thereunto us enabling hereby amend Regulation No. 20 (as notified in the Government Gazette of 11th July, 1973) by substituting therefor the following:—

REGULATION 20.

1. The maximum scale of fees which shall be charged and collected by the trustees for admission to the Second and Fourth Divisions of the Ground on such days as it may be set apart for cricket matches or football matches, shall (in addition to any tax payable under any law other than the said Act on or in respect of such fees or admissions) be as follows:—

- (a) For admission of every person on any such day such a sum as the trustees may from time to time determine not exceeding Three dollars (\$3.00).
- (b) For a reserved seat or reserved accommodation and the booking thereof on any such day such additional sum as the trustees may from time to time determine not exceeding Fifty cents (\$0.50).

2. The fees which shall be charged and collected by the trustees for admission to the Ground on such occasions as it may be set apart for outdoor games, sports, amusements or functions other than cricket matches or football matches shall (in addition to any tax payable under any law other than the said Act on or in respect of such fees or admissions) be such sums as the trustees may from time to time determine.

Dated at Melbourne, this eleventh day of October, 1973.

- L. J. HASSETT.
- P. J. KENNELLY.
- K. H. TURNBULL.
- A. C. ALLEN,  
deputy for C. E. Middleton.
- E. O. MCCUTCHAN,  
deputy for M. Nathan.
- R. C. STEELE.
- A. E. CHADWICK.
- L. H. S. THOMPSON.
- A. G. RYLAH.
- S. J. E. LOXTON.
- HENRY BOLTE.
- G. L. CHANDLER.

Approved by the Governor in Council, 30th October, 1973.  
—T. J. FORRISTAL, Clerk of the Executive Council.

LOCAL LAND BOARDS.

In pursuance of the provisions of section 34 of the Land Act 1958, notice is hereby given that a public hearing at the following place and time will be conducted by the person mentioned, being duly appointed in that behalf.

W. BORTHWICK,  
Minister of Lands.

Department of Crown Lands and Survey,  
Melbourne.

SCHEDULE.

ROBINVALE, LAND INSPECTOR'S OFFICE, Thursday,  
22nd November, 1973, at 9 a.m.—R. L. McMahon.

COUNTRY ROADS BOARD.

RESOLUTIONS OF THE COUNTRY ROADS BOARD.

The Country Roads Board, in pursuance of the provisions of the Country Roads Act 1958, has passed Resolutions the dates whereof and the terms of which are scheduled hereunder:—

SCHEDULE.

Main Roads.

Resolution dated the Twenty-ninth day of October, One thousand nine hundred and seventy-three, made pursuant to section 21 of the Country Roads Act 1958, declaring the widening of Koroop-road in the Shire of Kerang as shown hatched on plan numbered G.P.13011 hereunder to be part of a main road within the meaning and for the purposes of the said Act.

MAIN ROAD  
KOROOP ROAD  
SHIRE OF KERANG

Measurements in Links

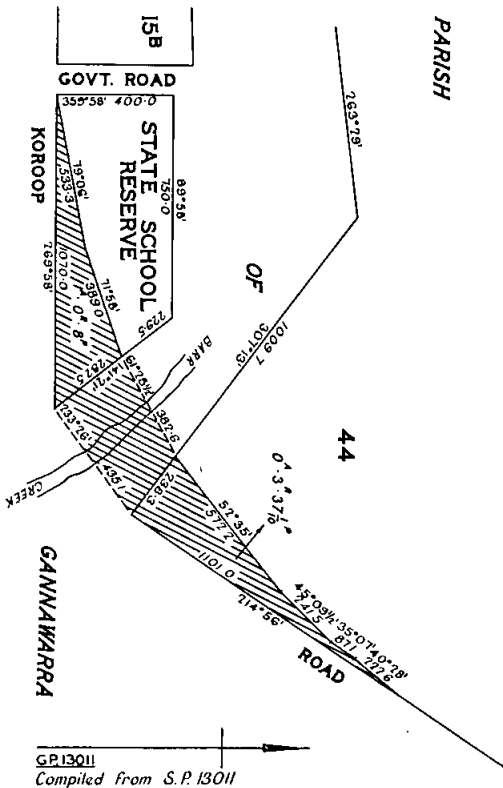

Resolution dated the Twenty-ninth day of October, One thousand nine hundred and seventy-three, made pursuant to section 21 of the Country Roads Act 1958, declaring the widening of Hazeldean-road in the Shire of Narracan as shown hatched on plan numbered G.P.12786A hereunder to be part of a main road within the meaning and for the purposes of the said Act.

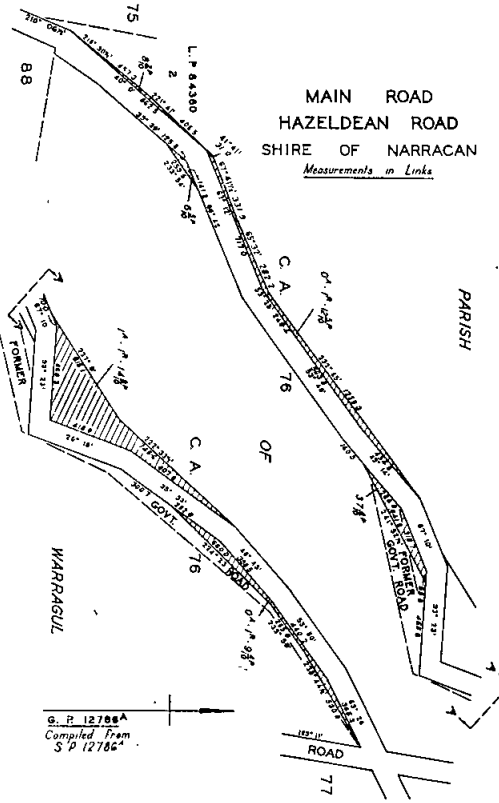

Resolution dated the Twenty-ninth day of October, One thousand nine hundred and seventy-three, made pursuant to section 21 of the Country Roads Act 1958, declaring the widening of the Yarragon-Leongatha road in the Shire of Narracan as shown hatched on plan numbered G.P.12742 hereunder to be part of a main road within the meaning and for the purposes of the said Act.

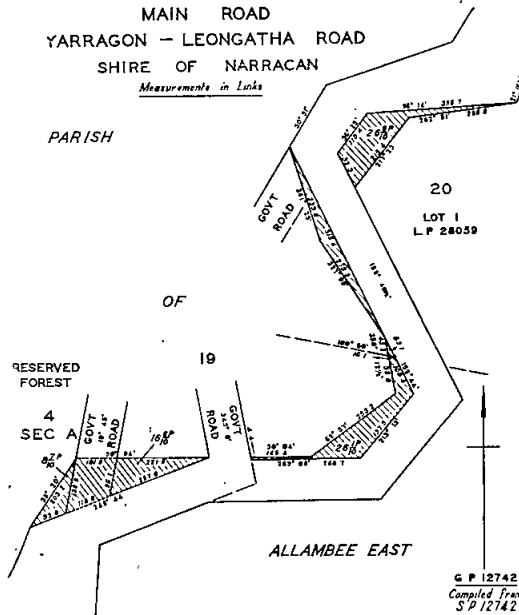

31st October, 1973.

N. L. ALLANSON,  
Secretary.

Transport Regulation Act.  
TRANSPORT REGULATION BOARD.  
HEARING OF APPLICATIONS.

Notice is hereby given that the following applications will be considered by the Transport Regulation Board at its office at the corner of Lygon and Princes streets, Carlton, at 10.15 a.m. on 21st November, 1973.

Application by each of the following for a commercial passenger vehicle with seating capacity for five persons to operate as a Country Taxi Cab from an approved depot in Zone X:—

ALBRECHT, C. E., 9 Lawson-road, Mooroolbark.  
ALBRECHT, R. L., 9 Lawson-road, Mooroolbark.  
ALEXANDER, P. C., 26 Diana-street, Croydon.  
AMARANT, D. P., 70 Ervin-road, Kilsyth.  
AMARANT, M. A., 8 Elgin-street, Hawthorn.  
ASHWORTH, J. J., 46 Stud-road, Dandenong.  
ASTON, A. H., 70 Burwood Highway, East Burwood.  
BETHAVAS, C., 30 Adele-avenue, Ferntree Gully.  
BLACKLOCK, R. A., 2 Surrey-court, Bayswater.  
BLYTHE, K. D., 49 Forest-road, Ferntree Gully.  
BURKE, J. H., Lot 130 Ferndale-road, Upwey.  
BUTTERS, A. E., 6 Royston-court, Boronia, 3153.  
CANN, T. J., 12 Veronica-street, Ferntree Gully.  
CHAPMAN, W. P., 9 Bourke-street, Mt. Evelyn.  
COGAN, M. G., 58 Balaclava-road, East St. Kilda.  
CURTAIN, M. J., 29 Byron-road, Kilsyth.  
DEHN, G. E., 121 Warren-road, Mordialloc.  
DOYLE, C., 15 Lansell-road, Mooroolbark.  
EDELSTEIN, A., 2/3 Halstead-street, Caulfield.  
FOWLER, J. E., "Jaru", 29 Swansea-road, Lilydale.  
GERMANOS, M., 247 Warrigal-road, South Oakleigh.  
GILL, F. L., 20 Moores-road, Monbulk.  
GORDON, P. N., 14/16 McIver-street, Ferntree Gully.  
HARRISS, H. C., 28 Tagell-road, Ringwood East.  
HEANEY, M. O., 6 Amelia-crescent, Doncaster.  
HOAD, R. C., Lot 36 Kardinia-crescent, Warrenwood.  
HOAD, W., Kardinia-crescent, Warrenwood.  
HOLT, M. K., 3/38 Begonia-avenue, Bayswater.  
HOSE, C. V. (Mrs.), 4 Meadowgate-drive, Lilydale.  
INNES, G. H., 2 McKeon-road, Mitcham.  
JAGO, F. E., 8 Allanfield-crescent, Wantirna.  
KEMPSON, D. A., 2/11 Hotham-street, Mont Albert.  
KHODER, J., 2 King-street, Lalor.  
LEACH, A. F., Lot 8, Leber-street, Warrandyte.  
LEASK, D. N., 63 Arbroath-road, Wantirna South.  
LITTLEWOOD, F. T., 5 Lake-avenue, Mitcham.  
LOFTHOUSE, P. G., 40 Beaver-street, East Malvern.  
LONG, J. R., 41 Third-avenue, Chelsea Heights.  
LOTHRINGER, J., 54 Barter-crescent, Forest Hill.  
LOTHRINGER, M., 54 Barter-crescent, Forest Hill.  
MALANE, L. J. J., 22 Hillview-drive, Kilsyth.  
MATTHES, R. A. J., 35 Sandells-road, Tecoma.  
MCCOMBE, J., 4 Barclay-avenue, Croydon.  
MCLEOD, N. C., Aitken-road, Seville.  
MCNAMARA, N. J., 27 Loretto-avenue, Ferntree Gully.  
MIELKE, R. W., 82B Stephenson's-road, Mt. Waverley.  
OXLEE, E. F., 32 Karingal-road, North Croydon.  
POWELL, F. C., 28 Alwyn-street, Croydon.  
PRITCHARD, R. G., 7 Verona-court, Bayswater.  
ROSENTHAL, H. S., Lot 48 Webb-street, Warrandyte.  
SCHREIBER, G. J., 82 Miller-road, The Basin.  
SCRIVENS, R. W., 2 Gibb-street, Dandenong.  
SHILIGO, S. M., 18 Ash-grove, Montrose.  
SHERRY, N. M., 5 Grandview-avenue, Croydon.  
SIMPSON, H. L., 5 Georges-road, Ringwood.  
SMITH, C. E., 62 Timms-street, Kilsyth.  
STEPHENSON, R. G., Lot 9 Mitchell-road, Lilydale.  
TSARDAKOS, G., 1 Melosa-avenue, Clayton.  
UNT-DEN-BOGAARD, A., 72 McGregor-street, Middle Park.  
UPSTILL, C. M., 7 Morris-road, Croydon.  
VAN DER HOPE, R., 15 Alpin-crescent, Kallista.  
VAN-OS, P., 31 Ronald-road, Croydon.  
WALL, D. J., 47 Lenna-street, East Burwood.  
WATERS, D. A., 7 Mathews-court, Ferntree Gully.  
WATSON, R. A., 230 Warrigal-road, Cheltenham.  
WILLIAMS, W., 4 Mulgoa-court, Noble Park.  
YATES, M., 3 Helena-road, Lilydale.

Notice of any objection should be forwarded to reach the Secretary of the Board not later than 14th November, 1973.

Applicants are advised that it will not be necessary to appear on the hearing date specified, unless advised in writing by the Board.

A. V. C. COOK,  
Secretary.

Corner Lygon and Princes streets, Carlton, 3053,  
Wednesday, 7th November, 1973.

Transport Regulation Act.  
TRANSPORT REGULATION BOARD.  
HEARING OF APPLICATIONS.

Notice is hereby given that the following applications will be considered by the Transport Regulation Board at its offices at the corner of Lygon and Princes streets, Carlton at 10.15 a.m. on 28th November, 1973.

HURSTBRIDGE BUS AND TAXI SERVICE PTY. LTD., 911 Main-road, Hurstbridge. Application for one commercial passenger vehicle with large seating capacity to operate as an additional metropolitan stage omnibus under the same terms and conditions as existing M.O. licences held by the applicant.

MAY, I. A. Arkaroola-Mt. Painter Sanctuary via Copley, S.A. Application for two commercial passenger vehicles (landrovers) each with seating capacity for 10 persons to operate as touring omnibuses on half-day, day, and two day tours from Bright to the Wonnangatta-Dargo High Plains area, to observe flora, fauna, bird-life, geological features and items of historical significance. It is intended to cater for interests of individual members of the living party but the tours would basically operate over Forest Commission fire access tracks known as Buckland-road, Ti Tree Spur Track, Water Spur Track, Rileys Track, Wonnangatta Track, Hardy Shepherd Track, Buffalo River-road, Wombat Spur Track, Pioneer Racecourse Track, Talbotville Track, Crooked River-road, Short Cut-road and Dargo High Plains-road, which are in the area in which tours are to operate.

FARES.—Approximately \$10 per full day on tour, including lunch.

MOOROPNA PASSENGER SERVICE PTY. LTD., 22 McLennan-street, Mooropna, Application for one commercial passenger vehicle with large seating capacity to operate in substitution for but not in addition to any "T.S." licensed vehicle held by the applicant company.

Applications for renewal of licences as shown by persons listed hereunder to operate under the same terms and conditions.

ARTHUR, D. W. & E. R., 53-55 Stud-road, Dandenong; T.P.70.

FORD MOTOR COMPANY OF AUSTRALIA LTD., North Shore-road, Norlane, Geelong; T.P.265.

HARRINGTON, V. C., 47 Bakewell-street, Bendigo; U.T.368.

HOLE, W. H., P.O. Box 27, Balmoral; T.S.399.

JOHNSON, W. C. & P. J., Marnoo; T.S.314.

MANSFIELD, G. A., 25 Collis-street, East Brighton; C.T.500.

PONYLAND PTY. LTD., Osborne's-road, Christmas Hills; T.P.277.

Notice of any objection should be forwarded to reach the Secretary of the Board not later than 21st November, 1973.

Applicants are advised that it will not be necessary to appear on the hearing date specified, unless advised in writing by the Board.

A. V. C. COOK,  
Secretary.

Corner Lygon and Princes streets, Carlton, 3053,  
Wednesday, 7th November, 1973.

Commercial Goods Vehicles Act.  
TRANSPORT REGULATION BOARD.  
HEARING OF APPLICATIONS.

Notice is hereby given that the following applications will be considered by the Transport Regulation Board at its offices at the corner of Lygon and Princes streets, Carlton, at 10 a.m., on Wednesday, 28th November, 1973.

ANDERSON J. G., Benambra Hotel, Benambra, 3900. One commercial goods vehicle (L/C. 15 cwt.) to operate between the Townships of Bairnsdale and Benambra in the course of business as "Hotel Keeper"—own goods.

ANNETT, P. J., 45 Hunter-street, Heywood, 3304. One commercial goods vehicle (L/C. 278 cwt.) to operate: (a) Within a 75-mile radius of the post office at Peshurst (Warrambool Division of the Country Roads Board)—road contracting plant used in the construction or maintenance of a road, street, foot-path, bridge, wharf, pier, weir or channel. (b) Within a 20-mile radius from site of construction or maintenance work performed pursuant to paragraph (a) above or from the railway station nearest thereto—materials required for such work. (c) Within a 25-mile radius of the post office at Heywood—general

- goods, with the proviso that no goods shall be carried whether by one stage or by more than one stage between places within the above radius which are more than 30 road miles apart by the nearest practicable route.
- DRUG HOUSES OF AUSTRALIA**, Cherry-lane Laverton North, 3028. Application to vary the conditions of licence number D.A.2414/4 (L/C. 10 cwt.) by adding to the existing conditions "and to and from Shepparton".
- ELLIOTS EARTHMOVING PTY. LTD.**, 477 Maroondah Highway, Ringwood, 3134. One commercial goods vehicle (L/C. 265 cwt.) to operate: (a) Within a 50-mile radius of own premises at Ringwood in course of business as "Earthmoving Contractors and Plant Hirers"—own excavation and earthmoving plant and equipment. (b) Within a 25-mile radius of own premises at Ringwood as a Low Loader—earth-moving plant and machinery on behalf of other contractors.
- ENSIGN SERVICES (VIC.) PTY. LTD.**, 24 Leinster-grove, Northcote, 3030. One commercial goods vehicle (L/C. 43 cwt.) to operate: (a) Within a 25-mile radius of own premises at Northcote in the course of business as "Launderers and Dry Cleaners"—articles for laundering or dry cleaning or having been laundered or dry cleaned. (b) From or to own premises at Northcote to or from own clients at Shepparton—articles for laundering or dry cleaning or having been laundered or dry cleaned.
- FIRESTONE AUSTRALIA PTY. LTD.**, 36 Malua-street, Reservoir, 3073. One commercial goods vehicle (L/C. 13 cwt.) to operate within a 50-mile radius from own premises at Kyneton in the course of business as "Tyre Manufacturers and Distributors"—new tyres and tubes for sale and delivery, secondhand tyres and tubes for repair or having been repaired or retreaded, batteries, polythene piping and motor car accessories, provided that all new goods are initially consigned by rail to Kyneton.
- HADLEY, J. R.** (trading as Hadley Bros.), 14 Elmhurst-street, Noble Park, 3174. One commercial goods vehicle (L/C. 17 cwt.) to operate throughout the State of Victoria in the course of business as "Boiler Makers and Refrigeration Engineers"—own tools of trade and equipment also spare parts and materials required for on site servicing in the field only.
- KELLY, D. W.**, 20 Leslie-street, Frankston, 3199. One commercial goods vehicle (L/C. 198 cwt.) to operate within a 50-mile radius of the premises of Pronto Mixed Concrete Co. Pty. Ltd., at Ringwood, solely on behalf of the said company—premixed concrete in a specially constructed agitator vehicle.
- KETTE, T. A.**, Yeodene via Colac, 3249. One commercial goods vehicle (L/C. 225 cwt.) to operate: (a) Within a 50-mile radius from own property at Yeodene in the course of business as "Primary Producer"—own goods. (b) Within a 50-mile radius of own place of business at Yeodene in the course of business as "Earthmoving Contractor"—own bulldozer, tools of trade, and fuel sufficient for the operation of such bulldozer.
- MACCIOCCA, A.**, 117 Brighton-street, Richmond, 3121. One commercial goods vehicle (L/C. 183 cwt.) to operate within a 50-mile radius of the plant of Pirotta Ready Mixed Concrete Pty. Ltd. at Springvale solely on behalf of the said company—premixed concrete in a specially constructed agitator vehicle.
- MARSDEN, G. E.**, 19 Ercil-street, Wendouree, 3355. One commercial goods vehicle (L/C. 54 cwt.) to operate throughout the State of Victoria in the course of business as "Marine Collector"—marine stores and old metals as defined in the *Marine Stores and Old Metals Act 1958* (No. 6303) but excluding the carriage of such goods to wharves, docks or ships for shipment or export purposes, and also excluding the use of a trailer in conjunction with the vehicle.
- MOTORWAY TYRE SERVICE PTY. LTD.**, 91 Wood-street, Donald, 3480. One commercial goods vehicle (L/C. 14 cwt.) to operate within a 75-mile radius of the post office at Donald in the course of business as "Tyre Dealers and Retreaders"—new tyres and tubes for delivery, used tyres and tubes for repair or retreading or having been repaired or retreaded and also batteries and motor car accessories subject to the condition that all goods carried on the vehicle (other than secondhand tyres and tubes for repair or having been repaired) shall have been initially consigned by rail to Donald.
- NICHOLAS, A. E.**, 2 O'Brien-street, Mooroopna, 3629. One commercial goods vehicle (L/C. 79 cwt.) to operate within a 100-mile radius of applicant's own premises at Mooroopna in the course of business as "House Remover"—houses, sheds, and outbuildings for removal and re-erection also tools of trade and equipment incidental thereto.
- PATTERSON, J.**, R.S.D. Drumborg, Heywood, 3304. One commercial goods vehicle (L/C. 106 cwt.) to operate: (a) Within a 50-mile radius of own property at Drumborg in the course of business as "Primary Producer"—own goods. (b) Within a 50-mile radius of Drumborg in the course of business as Contract Dam and Channel Cleaner—own contracting machinery, tractor, drag line, soil and gravel, incidental to own contracts.
- POLITES, S.**, 15 Raeburn-street, Pascoe Vale, 3044. One commercial goods vehicle (L/C. 199 cwt.) to operate within a 50-mile radius of the premises of Consolidated Quarries Ltd. at Tullamarine solely on behalf of the said company—premixed concrete in a specially constructed agitator vehicle.
- RAUSCHDORF, H.**, 30 Junier-street, Morwell, 3840. One commercial goods vehicle (L/C. 52 cwt.) to operate: (a) From the premises of Datsun Distribution Pty. Ltd. at Cheltenham and Clayton to the premises of Latrobe Valley Motors Pty. Ltd. at Morwell, Albroy Service Station Pty. Ltd. at Morwell and Traralgon and Tokyo Motors Pty. Ltd. at Sale—new Datsun motor vehicles. (b) From the premises of Renault (Australia) Pty. Ltd. at Heidelberg, Moorabbin and Richmond to the premises of Albroy Service Station Pty. Ltd. at Traralgon—new Renault and Peugeot motor vehicles. (c) From the premises of Volkswagen (Australia) Pty. Ltd. at Clayton to the premises of Albroy Service Station Pty. Ltd. at Morwell and Traralgon—new Volkswagen motor vehicles. Subject to the cancellation of licence No. D.A.65615.
- RAYNOL PTY. LTD.**, 199 Macleod-street, Bairnsdale, 3875. One commercial goods vehicle (L/C. 194 cwt.) to operate from any plant of Pioneer Concrete Pty. Ltd. at Morwell, Sale, Bairnsdale or Orbost to consignees situated within a 50-mile radius of the particular plant—premixed concrete in a specially constructed agitator vehicle solely on behalf of the said company.
- ROSENFELDT, M. F. G.**, 12 Stephen-street, Nunawading, 3131. One commercial goods vehicle (L/C. 200 cwt.) to operate: (a) Within a 25-mile radius of own premises at Nunawading in course of business as "Garden Supplies"—own goods. (b) From Bacchus Marsh to own premises at Nunawading—own river pebbles. (c) From You Yangs to own premises at Nunawading—own granolithic gravel.
- STRANGIS, P.**, 5 Minnie-street, Brunswick, 3056. One commercial goods vehicle (L/C. 195 cwt.) to operate within a 50-mile radius of the G.P.O. Melbourne on behalf of Apex Quarries Ltd.—premixed concrete in a specially constructed agitator vehicle.
- WAKEFIELD, K. L.** (trading as L. Wakefield & Co.), 3 Wainwright-street, Warrnambool, 3280. One commercial goods vehicle (L/C. 12 cwt.) to operate within the area east of a north/south line drawn through Yambuk and west of a north/south line drawn through Winchelsea and south of an east/west line drawn through Mortlake in the course of business as "Agents and Distributors" solely on behalf of Cohns Industries Ltd. of Bendigo (an approved decentralized secondary industry)—products manufactured by Cohns Industries Ltd. and Agency Lines.
- WHITE ENGINEERING PTY. LTD.**, 6 Sutton-court, Glen Waverley, 3150. One commercial goods vehicle (L/C. 15 cwt.) to operate throughout the State of Victoria in the course of business as "Refrigeration Engineers" as a service vehicle for the purpose of servicing and repairing of industrial refrigeration units—tools of trade and equipment also spare parts required for on site servicing and repairing of industrial refrigeration units on site.
- WITHAM, D. C.**, P.O. Box 1, Boolarra, 3870. One commercial goods vehicle (L/C. 157 cwt.) to operate from Dyer Brothers Timber Mills Pty. Ltd. at Boolarra to points within a 50-mile radius thereof—sawn timber.

## TOW TRUCKS.

- SERVIS PANEL WORKS PTY. LTD.**, 6 Levanswell-road, Moorabbin, 3189. Application to vary the conditions of licence No. D.A.47362/3 (L/C. 44 cwt.) by deleting "Within a 50-mile radius from the post office at Mentone" from the existing conditions and adding in lieu "Throughout the State of Victoria".
- MCGRATH, M. F.** (trading as St. Arnaud Panel Service), Napier-street, St. Arnaud, 3478. One commercial goods vehicle (to be purchased) to operate throughout the

State of Victoria as a "Tow Truck" for the purpose of lifting and carrying or towing and/or repairing of wrecked or disabled vehicles—tools of trade, spare parts and materials incidental thereto.

ANDERSON, M. K. & B. J. (trading as Tyabb Body Works), 546 Frankston—Flinders road Tyabb, 3913. One commercial goods vehicle (to be purchased) to operate throughout the State of Victoria as a "Tow Truck" solely—(a) For the purpose of lifting and carrying or towing motor vehicles and the carriage of tools and equipment necessary for such purposes only; and (b) the carriage of spare parts necessary for the repair of a disabled motor to and from the place at which such disablement has occurred.

#### RENEWALS.

Applications for renewal of licences as shown by persons listed hereunder to operate under the same terms and conditions from the expiry shown in each case.

ABBOTT, J. H., 49 Riverview-terrace, Belmont, 3216; D.A.3005; 14th April, 1974; 109 cwt.  
 ARTHUR'S DAIRY PTY. LTD., 146 Beach-street, Frankston, 3199; D.A.53906/6; 15th March, 1974; 95 cwt.  
 AUGER, W. D., 61 Stud-road, Dandenong, 3175; D.A.10376; 17th February, 1974; 144 cwt.  
 BURNS, J. C. (trading as Miller & Burns), 71 Vale-street, Nagambie, 3608; D.A.60711/1; 13th April, 1974; 139 cwt.  
 COBDEN & DISTRICT CO-OP PIONEER CHEESE & BUTTER FACTORY CO. LTD., THE, 229 Curdie-street, Cobden, 3266; D.A.61181/39; 13th April, 1974; 25 cwt.  
 COHNS INDUSTRIES PTY. LTD., Wills-street, Swan Hill, 3585; D.A.64484/28; 1st April, 1974; 295 cwt.  
 CUTTING, B. H. (trading as Bruce Cutting Electronic Service Centre), 98 Mitchell-street, Bendigo, 3550; D.A.63609; 16th March, 1974; 9 cwt.  
 ELLIOT, R. G., PTY. LTD., 37 Nolan-street, Maryborough, 3465; D.A.45800; 2nd April, 1974; 68 cwt.  
 GARNER BROS. PLANT HIRE PTY. LTD., 162 Rooks-road, Vermont, 3133; D.A.63608; 16th March, 1974; 195 cwt.  
 HANCOCK, A. W. & Co. PTY. LTD., 104 Armstrong-street, North Ballarat, 3350; D.A.42651/2; 18th April, 1974; 150 cwt.  
 HARRIS BROS. TRANSPORTS PTY. LTD., 78 Brougham-street, Geelong, 3220; D.A.1254/15; 28th March, 1974; 224 cwt.  
 HEALY, K. M., 20 Akuna-avenue, Tallangatta, 3700; D.A.24814; 24th March, 1974; 141 cwt.  
 HUTCHINSON, ROBERT LTD., Hartington-street, Glenroy, 3046; T.D.A.27836/4; 9th April, 1974; 136 cwt.; T.D.A.27836/20; 19th April, 1974; 128 cwt.  
 HUTCHINSON, ROBERT LTD., Hartington-street, Glenroy, 3046; T.D.A.27836/49; 13th April, 1974; 200 cwt.  
 HUTCHINSON, ROBERT LTD., Hartington-street, Glenroy, 3046; T.D.A.27836/52; 26th April, 1974; 138 cwt.  
 JENSEN, T. H., McGregor-avenue, Healesville, 3777; D.T.998/1; 18th April, 1974; 270 cwt.  
 JOLLY, K. M., Main-road, Anakie, 3221; D.A.58737; 4th April, 1974; 132 cwt.  
 JULIEN, J. R., McKillop-street, Geelong, 3220; D.A.2471; 14th April, 1974; 131 cwt.  
 KELLY, B. H., 48 Short-street, Portland, 3305; D.A.65577/1; 18th April, 1974; 40 cwt.  
 KERTON, W. K., Walpa, 3866; D.A.62606/1; 2nd March, 1974; 21 cwt.; D.A.62606/2; 2nd March, 1974; 21 cwt.  
 LANGSKAILL BROS., Buchan, 3892; D.A.1470/2; 20th March, 1974; 210 cwt.  
 MALADY & SONS, 42 Waterloo-road, Trafalgar, 3824; D.A.5192; 12th May, 1973; 256 cwt.  
 KENNEDY, J. (trading as Moree Quarries), Box 39, Harrow, 3317; D.A.40985/3; 5th March, 1974; 108 cwt.  
 PAYNTER, N. F. (trading as Paynter Berry Petroleum), Lindsay-street, Dennington, 3279; D.A.50727/1; 14th April, 1974; 103 cwt.  
 POWELL, G. F. O., 261 Ross-street, Port Melbourne, 3207; T.D.A.63830; 22nd June, 1973; 77 cwt.  
 RASH, K. E., 519 Humfray-street south, Ballarat, 3350; D.A.38933; 27th April, 1974; 8 cwt.  
 RETALLICK, L. A., 32 Ireland-road, Clayton, 3168; D.A.58484; 15th March, 1974; 43 cwt.  
 SHEEHAN, F. C., 16 Herbert-street, Northcote, 3070; D.A.26023/6; 10th March, 1974; 8 cwt.  
 SUNDALE DISTRIBUTORS, A DIVISION OF QUF IND. LTD., 99 Bell-street, Preston, 3072; D.A.65892/6; 7th March, 1974; 56 cwt.  
 SUNDALE DISTRIBUTORS, A DIVISION OF QUF IND. LTD., 99 Bell-street, Preston, 3072; D.A.65892/7; 7th March, 1974; 75 cwt.  
 SUPER SPREAD AVIATION (AUSTRALIA) PTY. LTD., P.O. Box 7, Cheltenham, 3192; D.A.32508/40; 2nd March, 1974; Mobile Crane.  
 TARAX DRINKS (GEELONG) PTY. LTD., 3-9 Douro-street,

North Geelong, 3215; D.A.2133/9; 2nd April, 1974; 10 cwt.

TRANS-WEST HAULAGE (MELBOURNE) PTY. LTD., 202 Station-street, Norlane 3214; D.A.65323/19; 27th April, 1974; 186 cwt.; D.A.65323/20; 13th April, 1974; 189 cwt.

VINCE, A. C., 8 Carrington-street, East Geelong, 3219; D.A.32249; 14th April, 1974; 160 cwt.

WITNISH & MILNER PTY. LTD., Yarra Junction 3797; D.T.400; 4th April, 1974; 220 cwt.

#### TOW TRUCK RENEWALS.

ARNOLD, G. H. C., 116A Mt. Dandenong-road, Ringwood East, 3135; D.A.39609/5; 23rd March, 1974; 133 cwt.

KLEIN, H. & K. C. HOPGOOD (trading as R.A.C.C. Rapid Auto Care), Chelsea, 321-325 Station-street, Chelsea, 3196; D.A.65886; 27th April, 1974; 93 cwt.

RIX MOTORS, 273 Nepean Highway, Parkdale, 3194; D.A.31029/1; 18th April, 1974; 39 cwt.

#### RENEWALS WITH VARIATION.

Applications made by the persons listed hereunder for renewal of the licences listed with variation of conditions in the manner set out opposite the names.

COOK, R. A. & Co., PTY. LTD., P.O. Box 15, Walwa, 3709; D.A.890/7; 31st December, 1973; Application to renew and vary the conditions of licence No. D.A.890/7 (L/C. 12 cwt.) by deleting paragraph (b) from the existing conditions and adding in lieu—“(b) throughout the State of Victoria—tools of trade, spare parts and equipment incidental to the servicing of own vehicles”.

COOK R. A., & Co., PTY. LTD., P.O. Box 15, Walwa, 3709; D.A.890/8; 31st December, 1973; Application to renew and vary the conditions of licence No. D.A.890/8 (L/C. 145 cwt.) by deleting paragraphs (a), (c) and (d) from the existing conditions and adding additional paragraph (a)—“(a) Within a 25-mile radius of the post office at Walwa—general goods subject to the condition that no goods shall be carried whether in one or more than one stage from any one point within the said radius to any other point within the said radius situated more than thirty (30) miles apart by the nearest and most practicable route.

KNAGGS, W., Wy Yung via Bairnsdale, 3875; D.A.55233/1; 28th March, 1974; Application to renew and vary the conditions of licence No. D.A.55233/1 (L/C. 163 cwt.) by deleting "Orbost" from paragraph (a) of the existing conditions and adding in lieu "Nowa Nowa" and by also deleting paragraph (c) and adding in lieu a new paragraph—“(c) Within a 25-mile radius of the post office at Bairnsdale—general goods provided that no goods shall be carried whether by one stage or by more than one stage between places within the above radius which are more than 30 road miles apart by the nearest practicable route.

Notice of any objection should be forwarded to reach the Secretary of the Board not later than 21st November, 1973.

Applicants are advised that it will not be necessary to appear on the hearing date specified above, unless advised in writing by the Board.

A. V. C. COOK,  
Secretary.

Corner Lygon and Princes streets, Carlton, 3053,  
Wednesday, 7th November, 1973.

#### Hospitals Superannuation (Board) Regulations 1970.

#### ELECTION OF REPRESENTATIVE AND DEPUTY REPRESENTATIVE OF CONTRIBUTORS AS MEMBERS OF THE HOSPITALS SUPERANNUATION BOARD.

In pursuance of the Hospitals Superannuation (Board) Regulations 1970, I hereby give notice that the under-mentioned nominations have been received for the election, to be held on the 5th December, 1973, of Representative of Contributors to the Hospitals Superannuation Board, viz.:

CLIFFORD CHARLES BUCHANAN  
ROBERT ARCHIBALD CAMPBELL  
GRANT PATTISON.

B. A. TIERNEY,  
Returning Officer.

Hospitals Superannuation Board Elections 1973.

*Health Act.*  
VICTORIA—DEPARTMENT OF HEALTH.

**NOTICE TO ATTEND FOR RADIOLOGICAL EXAMINATION.**

To all persons aged twenty-one years and over enrolled or resident in the subdivisions specified hereunder in the State Electoral District of DEER PARK.

Take notice that you are required to attend at a Department of Health X-ray Unit sited in the public street at or as near as possible to the main entrance to the premises specified in this notice, at any time between the hours specified on one of the days specified and during the period specified in respect of those premises, and thereat to submit yourself to radiological examination of the chest for the purpose of ascertaining whether you may be suffering from pulmonary tuberculosis. If you have had a Chest X-ray within the last twelve months and for this reason do not wish to be examined now, you should attend the unit as directed and submit particulars of the previous examination.

SPECIFIED SUBDIVISIONS, PREMISES, PERIODS, DAYS AND HOURS.

Subdivision.	Premises.	Period.	Days.	Hours.
Niddrie	Airwest Hardware, 28 Thomas-street, Airport West	Wednesday, 21st November, 1973 to Tuesday, 27th November, 1973 (inclusive)	Each day during the period except Saturday, Sunday and Public Holidays	From 10 a.m. to 8.30 p.m.
	State Savings Bank, 360 Keilor-road, Niddrie	Wednesday, 21st November, 1973 to Tuesday, 27th November, 1973 (inclusive)	Each day during the period except Saturday, Sunday and Public Holidays	From 10 a.m. to 8.30 p.m.
	Essendon Home Furnishers, 378 Keilor-road, Niddrie	Wednesday, 21st November, 1973, to Tuesday, 27th November, 1973 (inclusive)	Each day during the period except Saturday, Sunday and Public Holidays	From 10 a.m. to 8.30 p.m.
	Dempster's Milk Bar, 18 Hampton-road, Essendon West	Monday, 26th November, 1973 and Tuesday, 27th November, 1973	Monday, 26th November 1973 Tuesday, 27th November, 1973	From 10 a.m. to 8.30 p.m. From 10 a.m. to 8.30 p.m.
Keilor East	Post Office, The Centreway, Keilor East	Wednesday, 28th November, 1973 to Tuesday, 4th December, 1973 (inclusive)	Each day during the period except Saturday, Sunday and Public Holidays	From 10 a.m. to 8.30 p.m.
	Post Office, 49 Dinah-parade, Lincolnvillle	Wednesday, 28th November, 1973 to Monday, 3rd December, 1973 (inclusive)	Each day during the period except Saturday, Sunday and Public Holidays	From 10 a.m. to 8.30 p.m.
	Tralongo's Milk Bar, 1 Fosters-road, Keilor Park	Wednesday, 28th November, 1973 and Thursday, 29th November, 1973	Wednesday, 28th November, 1973 Thursday, 29th November, 1973	From 10 a.m. to 8.30 p.m. From 10 a.m. to 8.30 p.m.
	St. Peter's Catholic Church, cnr. Parkside and Eastleigh avenues, Keilor East	Friday, 30th November, 1973 and Monday, 3rd December, 1973	Friday, 30th November, 1973 Monday, 3rd December, 1973	From 10 a.m. to 8.30 p.m. From 10 a.m. to 8.30 p.m.
Avondale Heights	Woolworth's Car Park, Military-road, Avondale Heights	Wednesday, 28th November, 1973 to Wednesday, 5th December, 1973 (inclusive)	Each day during the period except Saturday, Sunday and Public Holidays	From 10 a.m. to 8.30 p.m.
	Ferraro's Hairdressing Salon, 143 Military-road, Avondale Heights	Wednesday, 28th November, 1973 to Monday, 3rd December, 1973 (inclusive)	Each day during the period except Saturday, Sunday and Public Holidays	From 10 a.m. to 8.30 p.m.

NOTE.—Any person to whom this notice applies and who without reasonable excuse fails to comply with the requirements of the notice shall be guilty of an offence, and shall be liable to a penalty of not more than five hundred dollars.

Dated this First day of October, One thousand nine hundred and seventy-three.

W. J. STEVENSON, Chief Health Officer.

*Town and Country Planning Act 1961.*  
SHIRE OF LILLYDALE PLANNING SCHEME 1958.  
AMENDMENT No. 36, 1973.  
INTERIM DEVELOPMENT ORDER.  
*Notice of Approval.*

In pursuance of the powers conferred by the *Town and Country Planning Act 1961*, the Governor in Council on the 30th day of October, 1973, approved the making of an Interim Development Order by the Council of the Shire of Lillydale for part of the municipal district of the Shire of Lillydale.

The Interim Development Order provides that the use, subdivision or development of any land within the area described or the erection, construction or carrying out of any building, roads or other works thereon is prohibited except that the Responsible Authority may permit such uses, subdivision, development, erection, construction or other works as it thinks proper.

A copy of the Interim Development Order and a map showing the area affected may be inspected, free of charge, at the office of the Council of the Shire of Lillydale at Lillydale, and at the office of the Town and Country Planning Board, 235 Queen-street, Melbourne.

F. O. KENT,  
Shire Secretary.

*Town and Country Planning Act 1961.*  
GEELONG PLANNING SCHEME 1959.  
AMENDMENT No. 12, 1972.  
(CITY OF NEWTOWN.)  
*Notice of Approval.*

In pursuance of the powers conferred by the *Town and Country Planning Act 1961*, the Governor in Council on the 30th October, 1973, approved a planning scheme entitled the Geelong Planning Scheme 1959, Amendment No. 12, 1972 (City of Newtown), in respect of part of the municipal district of the City of Newtown and such Planning Scheme comes into operation on the date this notice of approval is published in the *Government Gazette*.

A copy of the Planning Scheme as approved may be inspected, free of charge, during office hours at the office of the Town and Country Planning Board, 235 Queen-street, Melbourne; at the office of the Council of the City of Newtown at Newtown and, when available, at the Office of Titles, Melbourne, and at the Central Plan Office of the Department of Crown Lands and Survey, Melbourne.

W. H. CRAIG, Secretary,  
Town and Country Planning Board.

*Private Agents Act 1966.*

NOTICE OF RECEIPT OF APPLICATION FOR LICENCES UNDER THE PROVISIONS OF THE PRIVATE AGENTS ACT 1966.

The Clerk(s) of the Magistrates' Court(s) as listed hereunder hereby give notice that applications, as under, have been lodged for hearing by the said Court(s) on the date(s) specified.

Any person desiring to object to any of such applications must—

- (a) lodge with the respective Clerk of the Magistrates' Court a notice in the prescribed form of his objection and of the grounds thereof;
- (b) cause a copy of such notice to be served personally or by post upon the applicant at least three days before the hearing of the application; and
- (c) send or deliver—
  - (i) where the objection is not made by the officer in charge of the police district in which the Court is situated—a copy of the notice to such officer; and
  - (ii) where the objection is not made by the Registrar or Deputy Registrar—a copy to the Registrar.

Full Name of Applicant or in the Case of a Firm or Corporation, of the Nominee.	Place of Abode of Applicant or Nominee.	Name of Firm or Corporation.	Address for Registration.	Type of Licence.	Date of Hearing of Application.
---	---	------------------------------	---------------------------	------------------	---------------------------------

MAGISTRATES' COURT, FITZROY.

Demian, Jami Adly ..	300 Malvern-road, Prahran	.. .. .	75 Victoria-parade, Eastern Hill	Watchman ..	16.11.73
----------------------	---------------------------	---------	----------------------------------	-------------	----------

Dated at Fitzroy this 26th day of October, 1973.

D. LYNCH, Clerk of the Magistrates' Court.

MAGISTRATES' COURT, BRUNSWICK.

Halse, Kevin Roy ..	Unit 11, 84 Blythe-street Brunswick	.. .. .	Unit 11, 84 Blythe-street, Brunswick	Process Server ..	20.11.73
" " " ..	" " "	.. .. .	" " "	Inquiry Agent ..	"
" " " ..	" " "	.. .. .	" " "	Guard Agent ..	"

Dated at Brunswick this 30th day of October, 1973.

R. WHITE, Clerk of the Magistrates' Court.

MAGISTRATES' COURT, HEIDELBERG.

Zerial, Pietro ..	25 Sevenoaks-avenue, Heidelberg	.. .. .	.. .. .	Process Server ..	21.11.73
-------------------	---------------------------------	---------	---------	-------------------	----------

Dated at Heidelberg this 29th day of October, 1973.

M. QUIRK, Clerk of the Magistrates' Court.

MAGISTRATES' COURT, MALVERN.

Edmunds, Raymond ..	11 Goodwin-street, Richmond	.. .. .	21 Oak-grove, East Malvern	Watchman ..	3.12.73
---------------------	-----------------------------	---------	----------------------------	-------------	---------

Dated at Malvern this 30th day of October, 1973.

P. J. RODDA, Clerk of the Magistrates' Court.

MAGISTRATES' COURT, OAKLEIGH.

Burrows, Robert John ..	43 Castlewood-street, East Bentleigh	.. .. .	43 Castlewood-street, East Bentleigh	Process Server ..	29.11.73
-------------------------	--------------------------------------	---------	--------------------------------------	-------------------	----------

Dated at Oakleigh this 30th day of October, 1973.

G. F. MEEHAN, Clerk of the Magistrates' Court.

MAGISTRATES' COURT, FOOTSCRAY.

Stewart, Laurence ..	2A Alice-street, Yarraville	.. .. .	2A Alice-street, Yarraville	Process Server ..	26.11.73
----------------------	-----------------------------	---------	-----------------------------	-------------------	----------

Dated at Footscray this 30th day of October, 1973.

M. S. SAUNDER, Clerk of the Magistrates' Court.

STATE RIVERS AND WATER SUPPLY COMMISSION.

LICENCES TO DIVERT WATER PURSUANT TO THE PROVISIONS OF SECTION 204 OF THE WATER ACT 1958. (AS AMENDED).

The Governor in Council has approved of the granting by the State Rivers and Water Supply Commission of licences as detailed hereunder for the term of years from the date specified in each case to the persons named in the following Schedule :—

SCHEDULE.

Licence No.	Term of Licence and Commencing Date.	Name and Address of Person to whom Licence is to be granted.	Source of Supply.	Area Authorized to be Irrigated Per Annum.	Volume of Water Authorized to be Diverted Per Annum.	Annual Fee.
				hectares	megalitres	
1100	Fifteen years from 1.7.72..	Alan Gillespie Long, Serpentine ..	Serpentine Creek	20.7	124	125.00
1108/1337	Fifteen years from 1.7.72..	Thomas Mossop, Bears Lagoon ..	Serpentine Creek	16.5	99	100.00
1302	Fifteen years from 1.7.72..	Agostino Calvi, Lindenow ..	Mitchell River ..	10.3	62	50.00
2318	Fifteen years from 1.7.72..	John Percy Treasure and Floris Ethel Treasure, Lindenow South	Mitchell River ..	9.2	55	44.00
2325	Fifteen years from 1.7.72..	Alfred William Stewart and Annie Muriel McDonald, Hillside	Mitchell River ..	22.7	136	110.00
2336	Fifteen years from 1.7.72..	Edgar Filmer Freshwater, Lindenow	Mitchell River ..	15.7	94	76.00
2337	Fifteen years from 1.7.72..	Leslie David Hine, Walpa	Mitchell River ..	9.5	57	46.00
2398	Fifteen years from 1.7.72..	Charles Edward Joiner, Hillside ..	Mitchell River ..	8.3	50	40.00
3479	Four years from 1.7.73 ..	Serafino Giuseppe Peruzzo and Irma Peruzzo, Wangaratta	King River ..	13.4	56	56.00

Office of the State Rivers and Water Supply Commission, Melbourne, 30th October, 1973.

G. W. LEWIS, Secretary,  
State Rivers and Water Supply Commission.



## STATE RIVERS AND WATER SUPPLY COMMISSION.

LICENCES TO DIVERT WATER AND CUT RACES PURSUANT TO THE PROVISIONS OF SECTION 204 OF THE WATER ACT 1958 (AS AMENDED).

The Governor in Council has approved of the granting by the State Rivers and Water Supply Commission of licences as detailed hereunder for the term of years from the date specified in each case to the persons named in the following Schedule :—

## SCHEDULE.

Licence No.	Term of Licence and Commencing Date.	Name and Address of Person to whom Licence is to be granted.	Source of Supply.	Area Authorized to be Irrigated Per Annum.	Volume of Water Authorized to be Diverted Per Annum.	Annual Fee.
				hectares	megalitres	
2317	Fifteen years from 1.7.72..	Teresa Catherine Zagami, Bairnsdale	Mitchell River ..	23.5	141	114.00
2321	Fifteen years from 1.7.72..	Matthew Calvert, Hillside ..	Mitchell River ..	10.3	62	50.00
2329	Fifteen years from 1.7.72..	John William Clancy, Calulu ..	Mitchell River ..	10.3	62	50.00
2330	Fifteen years from 1.7.72..	Eric Campbell Ferguson, Lindenow South	Mitchell River ..	24.7	148	120.00
2331	Fifteen years from 1.7.72..	Robert Arnold Bruce Henderson, Bairnsdale	Mitchell River ..	8.3	50	40.00
2332	Fifteen years from 1.7.72..	Robert Whitbourne, Lindenow ..	Mitchell River ..	32.2	193	156.00
2345	Fifteen years from 1.7.72..	Lindsay George Clancy, Calulu ..	Mitchell River ..	8.3	50	40.00
2346	Four years from 1.7.72 ..	Agostino Calvi and Maria Calvi, Lindenow	Mitchell River ..	4.2	27.5	23.00
2349	Fifteen years from 1.7.72..	Francis Henry Grumley, Thea Grumley and Sons, Walpa ..	Mitchell River ..	14.5	87	70.00
2350	Fifteen years from 1.7.72..	Arthur Richard Lowe, Mervyn Arthur Lowe and Trevor Edward Lowe, Hillside	Mitchell River ..	8.3	50	40.00
2352	Fifteen years from 1.7.72..	M. J. Morton Iguana Creek ..	Mitchell River ..	4.2	25	20.00
2356	Fifteen years from 1.7.72..	Frederick Joseph Silvester, Iguana Creek	Mitchell River ..	6.2	37	30.00
2368	Fifteen years from 1.7.72..	Rodolfo Calvi and Ida Calvi, Lindenow South	Mitchell River ..	10.3	62	50.00
2383	Fifteen years from 1.7.72..	Francis Henry Grumley, Thea Grumley and Sons, Walpa	Mitchell River ..	11.5	69	56.00
2385	Fifteen years from 1.7.72..	Geoffrey Bryce Martin, Lindenow South	Mitchell River ..	22.7	136	110.00
2403	Fifteen years from 1.7.72..	Douglas Stanton, Rutherglen ..	River Murray ..	41.1	247	250.00
2409	Fifteen years from 1.7.73..	Colin MacDonald and Sylvia Lilian MacDonald, Buffalo River	Buffalo River ..	28.9	130	130.00
2427	Fifteen years from 1.7.73..	Carmine De Grazia, Ovens ..	Ovens River ..	3.3	15	15.00
2444	Fifteen years from 1.7.73..	Alexander John Armstrong, Porepun kah	Ovens River ..	8.2	37	29.60
2447	Fifteen years from 1.7.73..	Giuseppe Costenaro and Antonio Costenaro, Whorouly	Ovens River ..	12.4	56	56.00
2448	Fifteen years from 1.7.73..	Peter Pavone and Andy Pavone, Eurobin	Ovens River ..	10.4	47	47.00
2452	Fifteen years from 1.7.73..	Giuseppe Leggio, Ovens ..	Ovens River ..	11.5	52	52.00
2454	Fifteen years from 1.7.73..	Polecarpo Menegon, Myrtleford ..	Ovens River ..	3.3	15	15.00
2466	Fifteen years from 1.7.73..	Reginald Pretto and Dorothy June Pretto, Porepun kah	Ovens River ..	20.7	93	93.00
2472	Fifteen years from 1.7.73..	Luigi Veteri and Demetrio Veteri, Gapsted	Ovens River ..	8.2	37	37.00
2692	Fifteen years from 1.7.72..	Alan Rupert Johnstone, Tongala..	Goulburn River..	12.3	74	75.00
3469	Four years from 1.7.73 ..	John Horace Plant, Piangil ..	River Murray ..	20.6	187.5	151.00
3471	Four years from 1.7.72 ..	Robert John McClure, Mooroopna	Goulburn River..	26.8	161	162.50
3472	Four years from 1.7.73 ..	Estate of the Late Stuart Charles Hooper, Devenish	Broken Creek ..	16.5	99	99.00
3474	Four years from 1.7.71 ..	Dimitrios Rotsos and Helen Rotsos, Robinvale	River Murray ..	24.7	222	225.00
3475	Fifteen years from 1.7.71..	Salvatore Di Benedetto, King Valley	King River ..	..	34	33.75
3476	Eleven years from 1.7.73 ..	Thelma Lyle Hayden, Piangil ..	River Murray ..	..	47	37.60
3477	Eleven years from 1.7.73 ..	Donald William Hayden, Piangil..	River Murray ..	..	39.5	32.60
3480	Twelve years from 1.7.73 ..	John Alphonsus Weiss, Cobram ..	River Murray ..	5.8	35	35.00
3484	Fifteen years from 1.7.72..	Robinvale Golf Club, Robinvale ..	River Murray ..	6.2	56	45.00
3486	Four years from 1.7.73 ..	Bogong Park Pty. Ltd., Benalla ..	Broken River ..	36.2	217	217.00
3488	Four years from 1.7.72 ..	Keith Eddington Murray, Edi ..	King River ..	20.7	93	93.75
3490	Fifteen years from 1.7.72..	Costanzo Cacciavello, Piangil ..	River Murray ..	..	494	400.00
53	Fifteen years from 1.7.72..	Antonio Leone, Nyah ..	River Murray ..	3.3	20	20.00
58	Fifteen years from 1.7.72..	Barry Herbert Cleary, Boundary Bend	River Murray ..	30.9	278	225.00
92	Fifteen years from 1.7.72..	Pietro Gattuso, Cobram ..	River Murray ..	16.5	99	100.00
417	Fifteen years from 1.7.72..	Giuseppe Manna, Vincenzo Manna, and Antonio Manna, Robinvale	River Murray ..	20.6	185	150.00
887	Fifteen years from 1.7.72..	Stanley Ross Chislett, Boundary Bend	River Murray ..	30.9	278	225.00
1047	Fifteen years from 1.7.72..	Umberto Mancinelli and Maria Anna Mancinelli, Wood Wood	River Murray ..	10.3	95.5	78.00
1091	Fifteen years from 1.7.72..	Reginald Leonard Keens, Nellie May Keens, Noel Frederick Keens and Lauris Gwenna Keens, Merbein	River Murray ..	12.3	111	90.00
1098	Fifteen years from 1.7.72..	William Harold Long and Mary Naomi Long, Serpentine	Serpentine Creek	20.7	124	125.00
1112	Fifteen years from 1.7.72..	John Thomas Berrigan, Red Cliffs	River Murray ..	0.4	3.7	18.00
1120	Fifteen years from 1.7.72..	Colin Thomas Hickey, Goodnight, N.S.W.	River Murray ..	82.2	740	600.00
1121	Fifteen years from 1.7.72..	George William Le Brun, Colignan	River Murray ..	16.4	148	120.00
1139	Fifteen years from 1.7.72..	John Bell McMiken, Bairnsdale ..	Goulburn River..	18.5	113.5	115.50
1156	Fifteen years from 1.7.73..	Giuseppe Bruno Macri and Giuseppe Macri, Robinvale	River Murray ..	8.2	74	59.20
1210	Fifteen years from 1.7.73..	Wallace George Bruce and Alexia Bruce, Yarrawonga	River Murray ..	41.2	247	247.00
1447	Fifteen years from 1.7.72..	Valentino Audino (Jr.), Robinvale	River Murray ..	20.6	185	84.00
1666/541	Fifteen years from 1.7.70..	Nicolaos Katis, Robinvale ..	River Murray ..	10.3	93	93.75

SCHEDULE.—*continued.*

Licence No.	Term of Licence and Commencing Date.	Name and Address of Person to whom Licence is to be granted.	Source of Supply.	Area Authorized to be Irrigated Per Annum.	Volume of Water Authorized to be Diverted Per Annum.	Annual Fee.
				hectares	megalitres	\$
1938	Fifteen years from 1.7.72..	Carmela Lazzara, Robinvale ..	River Murray ..	1.2	11.1	18.00
1949	Fifteen years from 1.7.72..	Harold William Wilkinson and Dorothy Jean Wilkinson, Shepparton	River Murray (Ulupna Creek)	33.0	198	200.00
1952	Fifteen years from 1.7.72..	Walter Joseph Smith, Robinvale ..	River Murray ..	1.2	11.1	18.00
1954	Fifteen years from 1.7.72..	Olive Grace Richardson, Boundary Bend	River Murray ..	12.3	111	90.00
1955	Fifteen years from 1.7.72..	Alfredo Silverii, Amedeo Silverii and Filippo Silverii of Piangil	River Murray ..	24.7	222	180.00
1971	Fifteen years from 1.7.72..	John Strachan Bothroyd and John Julian Bothroyd, Colignan	River Murray ..	8.2	74	60.00
2018	Fifteen years from 1.7.72..	Oliveholme Limited, Robinvale ..	River Murray ..	116.6	1049	850.00
2031/1661	Fifteen years from 1.7.72..	Brian John McGinty and Lorraine Kay McGinty, Wemen	River Murray ..	8.2	76.5	63.00
203	Fifteen years from 1.7.72..	Malcolm George Browning, Yarrawonga	River Murray ..	41.1	247	250.00
2087	Fifteen years from 1.7.72..	Robert Alexander John Wilson, Mildura	River Murray ..	1.3	11.1	18.00
2304	Fifteen years from 1.7.72..	Richard Mainwaring Murphy, Lindenow	Mitchell River ..	24.7	148	120.00
2306	Fifteen years from 1.7.72..	George Thomas Bulmer and Barbara Rae Bulmer, Lindenow	Mitchell River ..	16.5	99	80.00
2307	Fifteen years from 1.7.72..	Ivy Alma Collins, Lindenow South	Mitchell River ..	7	42	34.00
2309	Fifteen years from 1.7.72..	Alan Hancock and Beverley Mary Hancock, Wy Yung	Mitchell River ..	3.3	20	16.00
2311	Fifteen years from 1.7.72..	Stephen Michael Dwyer, Hillside..	Mitchell River ..	18.5	111	90.00
2314	Fifteen years from 1.7.72..	Norman Dudley Kerton and Norman James Kerton, Walpa	Mitchell River ..	28.8	173	140.00
2316	Fifteen years from 1.7.72..	Howard Arthur Regan, Walpa ..	Mitchell River ..	14.5	89.5	74.50

Office of the State Rivers and Water Supply Commission,  
Melbourne, 30th October, 1973.

G. W. LEWIS, Secretary,  
State Rivers and Water Supply Commission.

*Police Regulation Act 1958.*

## POLICE FORCE OF VICTORIA.

## DETERMINATION No. 213 OF THE POLICE SERVICE BOARD.

The Police Service Board, in pursuance of the powers in that behalf conferred by the *Police Regulation Act 1958*, hereby makes the following Determination (that is to say):—

1. The Determination No. 179 of the Police Service Board of 14th December, 1971, and published in the *Government Gazette* of 25th January, 1972, as amended, is hereby further amended as follows:—

(a) By deleting paragraph 11, sub-paragraph (a), under the heading "Services Department—General" and substituting therefor the following paragraph:—

11. (a) There shall be paid to a member while occupying the position specified in the first column hereunder, an allowance at the rate set out in the second column:—

First Column. Rank or position	Second Column. Annual Allowance.
Chief Superintendent—Deputy to the Assistant Commissioner ..	\$ 450.00
Chief Technical Officer ..	450.00
	Allowance per day.
	\$
Assistant Chief Technical Officer	1.00
Sub-Officers ..	1.00
Senior Constables and Constables	0.75

2. This Determination shall come into operation as from the 11th November, 1973.

Dated the 30th day of October, 1973.

T. B. SHILLITO,

A Judge of the County Court of Victoria,  
Deputy Chairman and Member of the  
Police Service Board.

J. G. BROWN,  
Member of the Police Service Board.

G. DAVIDSON,  
Member of the Police Service Board.

## Police Regulation Act 1958.

## POLICE FORCE OF VICTORIA.

## DETERMINATION No. 212 OF THE POLICE SERVICE BOARD.

The Police Service Board, in pursuance of the powers in that behalf conferred by the *Police Regulation Act 1958*, hereby makes the following Determination (that is to say):—

1. The Determination No. 179 of the Police Service Board of 14th December, 1971, and published in the *Government Gazette* of 25th January, 1972, as amended, is hereby further amended as follows:—

- (a) In paragraph 42, under the heading "Travelling and Incidental Expenses"—
- (i) In sub-paragraph (1), clause (a) (i), by deleting the amount "\$20.00" and substituting therefor the amount "\$28.00".
  - (ii) In sub-paragraph (1), clause (a) (ii), by deleting the amount "\$13.60" and substituting therefor the amount "\$20.00".
  - (iii) In sub-paragraph (1), clause (b), by deleting the amount "\$15.00" and substituting therefor the amount "\$21.00".
  - (iv) In sub-paragraph (2), clause (a), by deleting the amount "\$20.00" and substituting therefor the amount "\$28.00".
  - (v) In sub-paragraph (3), clauses (a) and (b), by deleting the amounts "\$1.25", "\$1.35" and "\$1.80" and substituting therefor the amounts "\$1.35", "\$1.50" and "\$2.90" respectively.
  - (vi) In sub-paragraph 3, clause (c) by deleting the amount "\$4.00" and substituting therefor the amount "\$5.75".
  - (vii) In sub-paragraph 3, clause (d), by deleting the amount "\$8.00" and substituting therefor the amount "\$10.00".
  - (viii) In sub-paragraph 3, clause (e), by deleting the amounts "\$13.60" and "56 cents" and substituting therefor the amounts "\$20.00" and "83 cents" respectively.
  - (ix) In sub-paragraph 3, clause (f) by deleting the amount "56 cents" and substituting therefor the amount "83 cents".
  - (x) In sub-paragraph 4, clause (a), by deleting the amount "\$4.00" and substituting therefor the amount "\$5.75".
  - (xi) In sub-paragraph 5, clause (a), by deleting the amount "\$4.00" and substituting therefor the amount "\$5.25".
  - (xii) In sub-paragraph 5, clause (b), by deleting the amount "\$5.25" and substituting therefor the amount "\$6.90".
- (b) In paragraph 43 under the heading "Travelling expenses—Journey by rail", by deleting the amount "\$8.00" and substituting therefor the amount "\$10.00".
- (c) In paragraph 44 under the heading "Food and sleeping accommodation", by deleting the amount "75 cents" and substituting therefor the amount "\$1.00".
- (d) In paragraph 45 under the heading "Court", by deleting the amount "\$1.35" and substituting therefor the amount "\$1.50".
- (e) In paragraph 46 under the heading "Overtime—Meal allowance"—
- (i) In sub-paragraph 1, clause (a), by deleting the amount "\$1.25" and substituting therefor the amount "\$1.35".
  - (ii) In sub-paragraph 1, clause (b) by deleting the amount "\$1.35" and substituting therefor the amount "\$1.50".

- (iii) In sub-paragraph 1, clause (c), by deleting the amount "\$1.80" and substituting therefor the amount "\$2.90".
- (f) In paragraph 47 under the heading "Living away from home allowance"—
- (i) In sub-paragraph 1, by deleting the amount "\$14.00" and substituting therefor the amount "\$21.00".
- (ii) In sub-paragraph 4, clause (a), by deleting the amount "\$4.40" and substituting therefor the amount "\$5.75".
- (iii) In sub-paragraph 4, clause (b), by deleting the amount "\$1.80" and substituting and substituting therefor the amounts "\$1.35, \$1.50 and \$2.90", respectively.
- (iv) In sub-paragraph 4, clause (c), by deleting the amount "65 cents" and substituting therefor the amount "85 cents".

2. This Determination shall come into operation as from the 26th October, 1973.

Dated the 26th day of October, 1973.

N. A. VICKERY,  
A Judge of the County Court of Victoria,  
Chairman and Member of the Police  
Service Board.

J. G. BROWN,  
Member of the Police Service Board.

G. DAVIDSON,  
Member of the Police Service Board.

MOTOR CAR ACT 1958.

Whereas by notices in writing the under-mentioned authorized insurers under Part V. of the Motor Car Act 1958, namely:

Norwich Union Fire Insurance Society Limited,  
Royal Insurance Company Limited,  
Union Assurance Society of Australia Limited, and  
Commercial Union Assurance Company of Australia  
Limited,

have notified their intentions to withdraw from business in the terms of the aforesaid Part of the said Act:

Now therefore, I, John Frederick Rossiter, Her Majesty's Chief Secretary of the State of Victoria, in pursuance of section 41 of the said Act, do hereby fix the first day of January, One thousand nine hundred and seventy-four, as the day upon which such cessation of business shall have effect.

J. F. ROSSITER,  
Chief Secretary.

Chief Secretary's Office,  
Melbourne, 2nd November, 1973.

PLENTY-YARRAMBAT WATERWORKS TRUST.

FIXING THE LIMIT OF BANK OVERDRAFT.

His Excellency the Governor of the State of Victoria by and with the advice of the Executive Council thereof doth by Order made on the 30th day of October, 1973, fix the total amount of the sums which the Plenty-Yarrambat Waterworks Trust may owe at any time in respect of moneys borrowed by overdraft of current account, pursuant to the provisions of section 286 of the Water Act 1958, at Six thousand dollars (\$6,000).

T. J. FORRISTAL,  
Clerk of the Executive Council.

At the Executive Council Chamber,  
Melbourne, 30th October, 1973.

WOORI YALLOCK-LAUNCHING PLACE WATERWORKS TRUST.

RATING BY-LAW FOR YEAR 1973—No. 5.

The Woori Yallock-Launching Place Waterworks Trust, in pursuance and exercise of powers conferred by the Water Acts, doth hereby make a rate for the supply of water for domestic purposes of seventeen cents (17 cents)

in the dollar on the Municipal Valuation of all lands and tenements liable to be rated within the Woori Yallock-Launching Place Waterworks District.

Provided that in no case shall the amount of rate to be payable per annum in respect of any tenement (other than land on which there is no building) be less than Fifteen dollars (\$15.00) and in respect of any land on which there is no building) be less than Five dollars (\$5.00).

Such rate is made for the year commencing on the first day of January, 1973, and shall be payable on the seventh day of November, 1973, at the office of the Trust.

Where persons liable to pay the rate elect to pay such rate in instalments, the first instalment shall be due 14 days after posting of the demand for such rate and the remaining instalments shall be due respectively on 31st December, in the year 1973, and 31st January and 28th February in the year 1974.

Dated this 1st day of November, 1973.

(SEAL) H. G. GIRAUD, Chairman.  
D. A. REID, Commissioner.  
J. N. EDDY, Secretary.

Approved, 5th November, 1973.—F. J. GRANTER, Minister of Water Supply.

WOORI YALLOCK-LAUNCHING PLACE WATERWORKS TRUST.

RATING BY-LAW FOR YEAR 1972—No. 3 (AMENDED).

The Woori Yallock-Launching Place Waterworks Trust, in pursuance and exercise of its powers conferred by the Water Act, doth hereby amend rating By-law for year 1972—No. 3—by deleting the words "twelfth day of November, 1972" and inserting in lieu thereof the words "seventh day of November, 1973".

The foregoing Resolution was made by the Commissioners of the Woori Yallock-Launching Place Waterworks Trust on the 1st day of November, 1973, and the seal of the Trust affixed hereto in the presence of—

(SEAL) H. G. GIRAUD, Chairman.  
D. A. REID, Commissioner.  
J. N. EDDY, Secretary.

Approved, 5th November, 1973.—F. J. GRANTER, Minister of Water Supply.

## ERRATUM

In the notice published on page 3349 of *Government Gazette* No. 93, of 26th September, 1973, relating to Regulations for the care, protection and management of the "Phillip Island Koala Reserves", for the expression "the 41st April, 1958" appearing therein, substitute the expression "the 1st April, 1958".

## THE ONION MARKETING BOARD ELECTION.

I hereby appoint Kenneth Clarence Wheatland as Returning Officer for the poll of producers of Onions, to be taken on Wednesday, the 27th March, 1974, for the election of four (4) representatives of producers, to be elective members of The Onion Marketing Board constituted under the *Marketing of Primary Products Act 1958*.

IAN SMITH,  
Minister of Agriculture.

## THE CHICORY MARKETING BOARD ELECTION.

I hereby appoint Kenneth Clarence Wheatland as Returning Officer for the poll of producers of Chicory, to be taken on Wednesday, the 27th March, 1974, for the election of two representatives of producers, to be elective members of The Chicory Marketing Board constituted under the *Marketing of Primary Products Act 1958*.

IAN SMITH,  
Minister of Agriculture.

*Marketing of Primary Products Act 1958.*

## MARKETING OF PRIMARY PRODUCTS (POLLS AND ELECTIONS) REGULATIONS 1970.

## NOMINATIONS OF CANDIDATES FOR ELECTION OF ELECTIVE MEMBERS OF THE ONION MARKETING BOARD.

Notice is hereby given that I have appointed Tuesday, the 8th January, 1974, as the day for nominations of candidates for the election to be held on Wednesday, the 27th March, 1974, of four representatives of producers of onions, to be elective members of The Onion Marketing Board.

Nominations in the prescribed form will close at Noon on Nomination Day with Mr. K. C. Wheatland, Returning Officer, The Onion Marketing Board Election, Box 4105, G.P.O., Melbourne, Victoria, 3001. Nominations may be hand-delivered to the Returning Officer, Room 29, First Floor, Department of Agriculture, 3 Treasury-place, Melbourne, prior to the closing time for nominations.

Nomination forms are obtainable from the Returning Officer at the above postal address or location (Telephone 651 7376).

IAN SMITH,  
Minister of Agriculture.

*Marketing of Primary Products Act 1958.*

## MARKETING OF PRIMARY PRODUCTS (POLLS AND ELECTIONS) REGULATIONS 1970.

## NOMINATIONS OF CANDIDATES FOR ELECTION OF ELECTIVE MEMBERS OF THE CHICORY MARKETING BOARD.

Notice is hereby given that I have appointed Tuesday, the 8th January, 1974, as the day for nominations of candidates for the election to be held on Wednesday, the 27th March, 1974, of two representatives of producers of chicory, to be elective members of The Chicory Marketing Board.

Nominations in the prescribed form will close at Noon on Nomination Day with Mr. K. C. Wheatland, Returning Officer, The Chicory Marketing Board Election, Box 4105, G.P.O., Melbourne, Victoria, 3001. Nominations may be hand-delivered to the Returning Officer, Room 29, First Floor, Department of Agriculture, 3 Treasury-place, Melbourne, prior to the closing time for nominations.

Nomination forms are obtainable from the Returning Officer at the above postal address or location (Telephone 651 7376).

IAN SMITH,  
Minister of Agriculture.

## NOTICE.

Creditors, next of kin, and others having claims against the estate of any of the under-mentioned deceased persons are required to send particulars of their claims to the Public Trustee, 168 Exhibition-street, Melbourne, Vic. 3000, the personal representative, on or before the 14th January, 1974, after which date the Public Trustee may convey or distribute the assets, having regard only to the claims of which the Public Trustee then has notice:—

BROWN, JOHN CLIFFORD, late of 176 Gordon-street, Coburg, retired moulder, died 24th July, 1973.

CUMMINS, LAURA late of 46 Aspen-street, Moonee Ponds, widow, died on or about 14th July, 1973.

DUPUY, WILLIAM RUSSELL, late of 3 McGowan-avenue, Preston, retired labourer, died 29th July, 1973.

FIELD, ROSE, late of 9 Sutherland-street, Coburg, widow, died 9th July, 1973.

GEMMELL, JAMES HUGH, also known as Mathew James Patrick Gemmell, late of Flat 6, 48 Dalgety-street, St. Kilda, railway employee, died 28th April, 1973.

MUTTON, DORIS, late of Reubenville Private Hospital, 103 Holmes-road, Moonee Ponds, widow, died 21st June, 1973.

NICHOL, LINDA GRACE, late of 22 Alfred-road, Essendon, married woman, died 21st February, 1973.

PERRY, DAISY OLIVE, late of 21 Davis-street, Kew, widow, died 31st May, 1973.

SPENCER, MARGARET ELIZABETH, formerly of 40 Downshire-road, Elsternwick, but late of Kew, spinster, died 21st May, 1973.

WILLS, ERIC WILFRED, late of 804 Burke-road, Camberwell, retired dental surgeon, died 25th July, 1973.

N. P. BRODY,  
Public Trustee.

Melbourne, 31st October, 1973.

## ORDERS IN COUNCIL.—(Series 1973-74.)

## PUBLIC WORKS.

557. Avondale Heights, High School, supply and erection of chain mesh fencing, &c., \$5,145.00.—Diamond Fence & Gate Co. Pty. Ltd.—(C.27362 "D".)

558. Victoria, various sites, supply, delivery and assembly of thirty-seven (37) 24 ft. x 24 ft. Type "R" portable class-rooms, \$271,247.00.—Atco Structures Pty. Ltd.—(B.G.121117.)

Approved by the Governor in Council, 30th October, 1973.—T. J. FORRISTAL, Clerk of the Executive Council.

## CONTRACTS ACCEPTED.—(Series 1973-74.)

## PROVISIONS.

*Gazette* No. 42, 1st June, 1973, Schedule No. 1, Sub-schedule No. 18, Melbourne and Metropolitan District.—For rates shown opposite the following items, substitute the rates as set out below from the dates shown; Item No. 9, \$1.71; Item No. 13, \$2.95; Item No. 17, \$0.97; Item No. 74, \$5.90; Item No. 95, \$0.34; Item No. 97, \$0.36; Item No. 100, \$0.36; Item No. 119, \$2.20; Item No. 120, \$10.16; Item No. 132, \$5.43; Item No. 134, \$3.78; Item No. 135, \$4.22; Item No. 136, \$4.22; Item No. 156, substitute "Bendigo", as from 1st November, 1973.

## MOTOR SPIRIT ETC.

*Gazette* No. 22, 30th March, 1973.—The following amendment is to be made to the list for country areas. Warrnambool—Esso, Warrnambool Cordials, Raglan-parade and Fairy-street, Depot, 8 a.m.—5 p.m.

## GENERAL STORES.

*Gazette* No. 77, 30th July, 1973.—For rates shown opposite the following items, substitute the rates as set out below from the dates shown. Schedule No. 41—Glass. All prices in dollars per square metre—Item Nos. 1 to 4, \$2.26; Item Nos. 5 to 6, \$2.26; Item Nos. 7 to 8, \$3.44; Item No. 10, \$5.59; Item No. 11, \$5.59; Item No. 12, \$5.59; Item No. 13, \$6.88; Item No. 14, \$7.53; Item No. 15, \$7.75; Item No. 16, \$11.30; Item No. 17, \$11.30; Item No. 18, \$11.30; Item No. 19, \$16.57; Item No. 20, \$16.57; Item No. 21, \$16.57; Item No. 22, \$9.68; Item No. 23, \$10.76; Item No. 24, \$13.45; Item No. 25, 3 mm, \$3.10; 5 mm, \$3.87; 6 mm, \$5.22; Item No. 26, \$4.73; Item No. 27, \$5.92 as from 1st October, 1973. Schedule No. 48—Iron (Galvanized)—Item No. 2, \$22.08 to \$22.44; \$23.28 to \$23.64; \$15.46 to \$15.72; \$16.66 to \$16.92 as from 1st November, 1973.

E. P. WATSON, Secretary to the Tender Board. 5.11.73.

## APPOINTMENTS AND RESIGNATIONS

## APPOINTMENTS.

His Excellency the Governor of the State of Victoria, by and with the advice of the Executive Council thereof, has, by Orders made on the 30th day of October, 1973, been pleased to make the under-mentioned appointments, viz.:—

## MINISTRY OF HEALTH.

Member of Committee of Management of Hospital.

KEITH HAROLD LOVETT, F.I.M.A., to be Government appointee on Committee of Management, Wimmera Base Hospital, for a period of a further three years, commencing 15th November, 1973, pursuant to the

provisions of sub-paragraph (ii) of paragraph (a) of the proviso to sub-section (1) of section 48 of the *Hospitals and Charities Act 1958*.

LAW DEPARTMENT.

*Commissioners for Taking Declarations, &c.*

DOUGLAS RICHARD GLISSON, care of Municipal Offices, High-street, Heathcote,  
ALWYN JUDE HAYES, 6 Hutcheson-avenue, Highton,  
JOANNE VERONICA BIGLIN, 6 Thompson-street, Belmont,  
MAXWELL LESLIE PRATT, and  
DAVID JOHN COLLINS, care of Department of Crown Lands and Survey, State Public Offices, 2 Treasury-place, Melbourne,  
GEORGE LOWCOCK, 13 Flamingo-court, Norlane,  
ROY BEAL, 69 Pascoe-street, Burwood,  
COLIN NORMAN MCLEAN, 102 Robinson-road, Hawthorn,  
JOHN PATRICK JAMES, care of City of Fitzroy, Town Hall, 201 Napier-street, Fitzroy,  
KENNETH ROY HARRIS, care of A.G.C. (Advances) Ltd., 170 Queen-street, Melbourne,  
WOLFE COX, care of La Trobe University, Bundoora,  
MIKHAIL NAWAR, Flat 119, 125 Napier-street, Fitzroy,  
SANDRA WINIFRED DYNON, 36 Powell-street, Yarraville, and  
FRANCIS SALVATORE SPAGNOLO, care of Associated Securities Finance Ltd., 376 Sydney-road, Coburg, to be Commissioners for taking Declarations and Affidavits under the *Evidence Act 1958*.

*Justices of the Peace.*

JOHN EDWARD DELZOPPO, Main-road, Neerim South,  
STAVROS TOROSIDIS, 14 Sussex-street, Coburg, and  
KEITH RAYMOND WALTON, care of Village Drive-In Theatre, Settlement-road, Thomastown, to keep the Peace in the State of Victoria.

*Prosecutor for the Queen.*

FREDERICK CHARLES JAMES, LL.B., Owen Dixon Chambers, 205 William-street, Melbourne, to be a Prosecutor for the Queen, pursuant to the provisions of section 352 of the *Crimes Act 1958*, to take effect from the date of commencement of duty.

*Registrar of County Court.*

BARRY JOHN BOLTON to be Registrar of the County Court at Ararat, vice B. J. Clothier, absent on sick leave, to take effect from the date of commencement of duty.

T. J. FORRISTAL,

Clerk of the Executive Council.

At the Executive Council Chamber,  
Melbourne, 30th October, 1973.

FORESTS DEPARTMENT.

APPOINTMENT OF COMMITTEE OF MANAGEMENT OF "THE YOU YANGS FOREST PARK".

Whereas by section 50 of the *Forests Act 1958* (No. 6254), it is provided that the Minister of Forests may, on the recommendation of the Forests Commission, appoint any number of persons, not less than three, to be a Committee of Management of any land forming part of any reserved forest, such land being set aside as a Forest Park, and may remove any of those persons: Now, therefore, I, Frederick James Granter, Her Majesty's Minister of Forests for the State of Victoria, on the recommendation of the Forests Commission, do hereby appoint—

Ronald John Branch,  
Douglas Harold Seacombe,  
James Wilson Pettitt,  
John Russel Wheeler,  
Trevor Pescott,  
Frances Maude Poole, and  
Lloyd James Walker,

as members of the Committee of Management for the period until the 8th day of September, 1976, of the land forming part of the reserved forest in the Parish of Wurdri Youang, County of Grant, described in the accompanying Schedule, and known as "The You Yangs Forest Park".

SCHEDULE ABOVE REFERRED TO.

Parish of Wurdri Youang, County of Grant, 1,100 acres, more or less, being the area shown by blue border on plan marked A63.107 over 17.12.64 in file of correspondence 67/1238 of the Forests Department.

Dated at Melbourne, the 29th day of October, 1973.

F. J. GRANTER,  
Minister of Forests.

*Liquor Control Act 1968.*

APPOINTMENT OF LICENSING INSPECTOR.

In accordance with the authority conferred upon me by sub-section (1) of section 22 of the *Liquor Control Act 1968*, I, Reginald Jackson, Chief Commissioner of Police, hereby appoint the following Officer of Police as Licensing Inspector for the Division of the Police District as shown:—

Division Number.	Police District.	Rank and Name.
2	Westernport ..	Inspector Valentine William Quanchi (from 1.11.73 to 28.11.73).

30.10.1973. R. JACKSON,  
Chief Commissioner of Police.

*Liquor Control Act 1968.*

APPOINTMENT OF LICENSING INSPECTOR.

In accordance with the authority conferred upon me by sub-section (1) of section 22 of the *Liquor Control Act 1968*, I, Reginald Jackson, Chief Commissioner of Police, hereby appoint the following Officer of Police as Licensing Inspector for the Division of the Police District as shown:—

Division Number.	Police District.	Rank and Name.
1	Melbourne ..	Inspector Arthur Robert Smythe (from 28.10.73 to 30.11.73).

29.10.1973. R. JACKSON,  
Chief Commissioner of Police.

RESIGNATIONS.

His Excellency the Governor of the State of Victoria, by and with the advice of the Executive Council thereof, has, by Orders made on the 30th day of October, 1973, accepted the resignations of the persons named hereunder of the offices mentioned, viz.:—

LAW DEPARTMENT.

*Commissioners for Taking Declarations, &c.*

WILLIAM THOMAS KEITH ROBERTSON, and  
ROY HORACE TUCKETT,  
as Commissioners for taking Declarations and Affidavits under the *Evidence Act 1958*.

*Justices of the Peace.*

JAMES RAYMOND CLEWORTH,  
JACK LINDSAY KLASON, and  
HERBERT LESLIE POLGLASE,  
as Justices of the Peace for the State of Victoria.

T. J. FORRISTAL,

Clerk of the Executive Council.

At the Executive Council Chamber,  
Melbourne, 30th October, 1973.

ORDERS IN COUNCIL

LOCAL GOVERNMENT DEPARTMENT.

At the Executive Council Chamber, Melbourne, the thirtieth day of October, 1973.

PRESENT:

His Excellency the Governor of Victoria.  
Mr. Byrne | Mr. Dickie.  
Mr. Wilcox

ROADS DISCONTINUED.—CITY OF KNOX.

Whereas it is provided in section 528 (2) of the *Local Government Act 1958*, that where a road (whether or not a public highway but not being a road set out on land of the Crown) or any part thereof is not required for public use, the Governor in Council on the request of the Council of the municipality in which such road is situated made not less than one month after publishing in a newspaper generally circulating in the district and posting to

the registered proprietor (if any) of the land and the owners and occupiers (if any) of lands abutting or immediately adjacent to the road notice of intention to make such request may by Order published in the *Government Gazette*, direct that such road or part shall be discontinued and thereupon such road or part shall be discontinued accordingly.

And whereas the Council of the City of Knox has requested that the Governor in Council direct that the roads between Boronia-road and Margaret-avenue and Margaret-avenue and Wilhelma-avenue, Bayswater be discontinued and not less than one month previously has published in a newspaper generally circulating in the district and posted to the registered proprietors of the land in the roads and to the owners and occupiers of land abutting or immediately adjacent to the roads notice of intention to make such request.

Now therefore, His Excellency the Governor of the State of Victoria, by and with the advice of the Executive Council thereof, hereby directs that the said roads which are shown hatched on the plan hereunder shall be discontinued and that the land may be sold by the Council of the City of Knox by agreement.

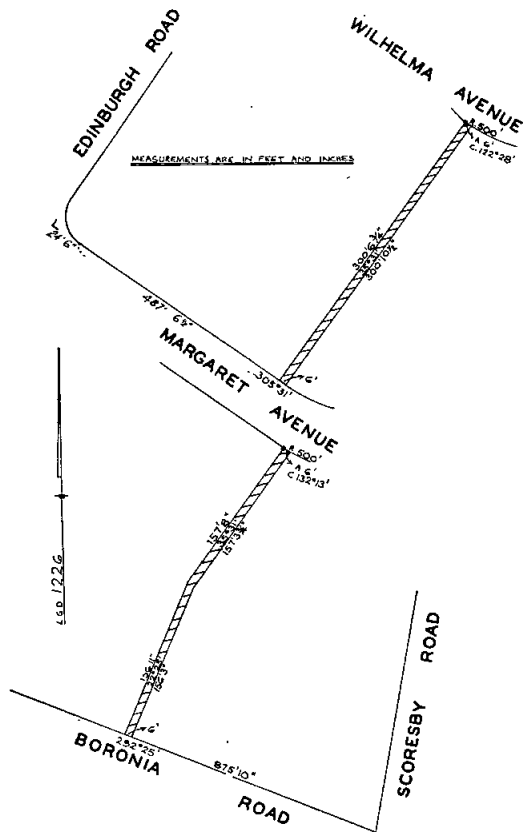

And the Honorable Alan John Hunt, Her Majesty's Minister for Local Government for the State of Victoria, shall give the necessary directions herein accordingly.

T. J. FORRISTAL,  
Clerk of the Executive Council.

COUNTRY ROADS BOARD.

At the Executive Council Chamber, Melbourne, the thirtieth day of October, 1973.

PRESENT:

His Excellency the Governor of Victoria.  
Mr. Byrne | Mr. Dickie.  
Mr. Wilcox |

ORDER APPROVING OF LAND BEING ACQUIRED AND ROADS, DEVIATIONS OR WIDENINGS BEING MADE.

His Excellency the Governor of the State of Victoria, by and with the advice of the Executive Council thereof, being satisfied that there are funds legally available for

acquiring the land, doth hereby approve the acquiring of the land described in the schedule hereunder and the making of new roads and deviations from and widenings of existing roads referred to in the said Schedule.

SCHEDULE.

State Highways.

The land shown hatched on plan numbered G.P.13397 hereunder required for the deviation from the Wimmera Highway in the Shire of Dunmunkle and making of the deviation thereon.

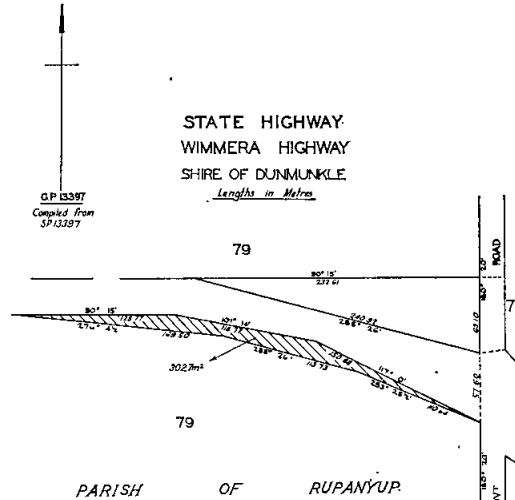

The land shown hatched on plans numbered G.P.13304A, G.P.13304B and G.P.13304C hereunder required for the deviation from the Omeo Highway in the Shire of Towong and making of the deviation thereon.

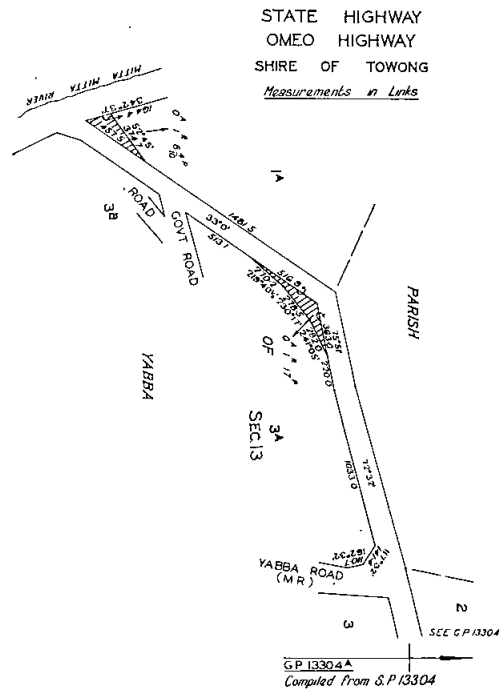

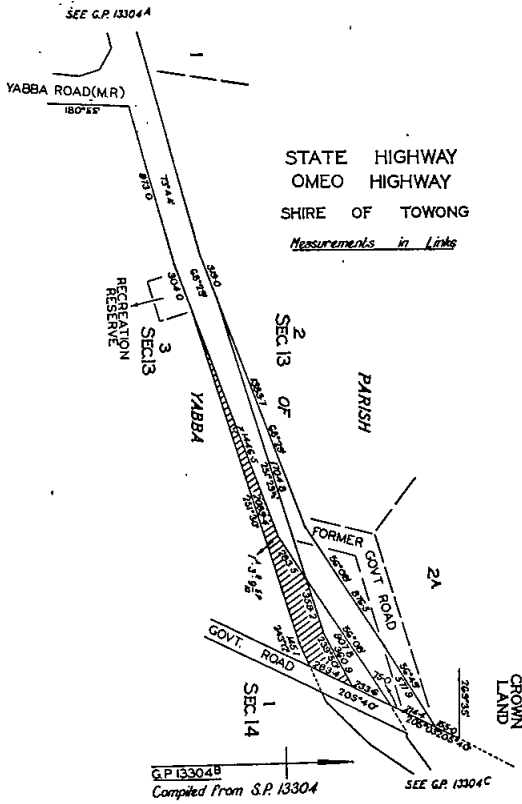

**Main Road.**  
The land shown hatched on plan numbered G.P.13195 hereunder required for the widening of the Woolsthorpe-Heywood road in the Shire of Minhamite and making of the widening thereon.

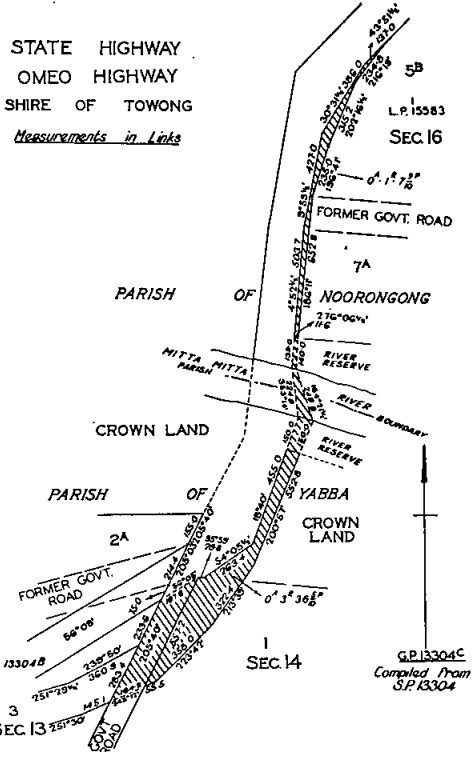
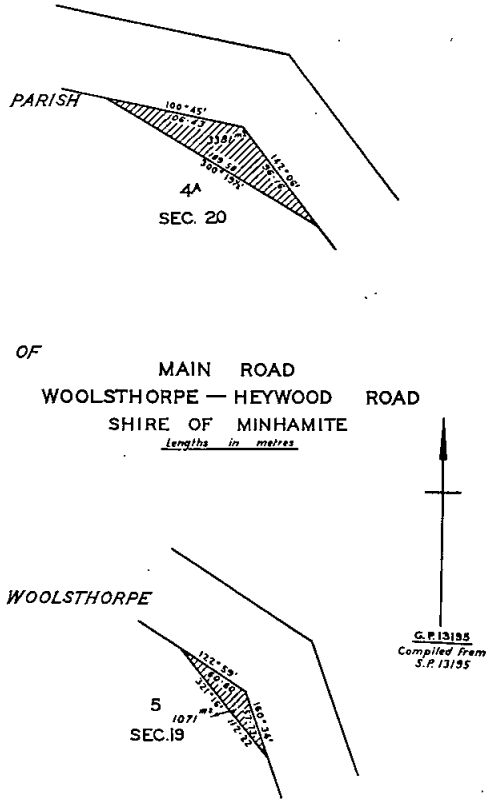

And the Honorable Edward Raymond Meagher, Her Majesty's Minister of Transport for the State of Victoria, shall give the necessary directions herein accordingly.

T. J. FORRISTAL,  
Clerk of the Executive Council.

COUNTRY FIRE AUTHORITY ACT 1958.

At the Executive Council Chamber, Melbourne, the thirtieth day of October, 1973.

PRESENT:

His Excellency the Governor of Victoria.  
Mr. Byrne | Mr. Dickie.  
Mr. Wilcox

CONSENT TO BORROWING TWO HUNDRED AND FIFTY THOUSAND DOLLARS BY THE COUNTRY FIRE AUTHORITY.

Whereas by section 82 of the Country Fire Authority Act 1958, it is enacted that the Country Fire Authority with the consent of the Governor in Council may, from time to time, borrow such moneys as it deems necessary in order to enable it to carry out and perform the powers, authorities and duties vested in or conferred or imposed upon it by the said Act:

And whereas the Country Fire Authority deems it necessary to borrow the sum of two hundred and fifty thousand dollars for the purposes aforesaid:

Now therefore, His Excellency the Governor of the State of Victoria, in the Commonwealth of Australia, by and with the advice of the Executive Council of the said State and in pursuance of the powers conferred by the said section 82 of the Country Fire Authority Act 1958, and all other powers him thereunto enabling, doth by this Order consent to the borrowing by the Country Fire Authority of the sum of \$250,000 (Two hundred and fifty thousand dollars) for a period of fourteen (14) years



to be liquidated by half-yearly repayments of the sum of \$14,234.80 (Fourteen thousand two hundred and thirty-four dollars and eighty cents), being proportion of the principal and interest at the rate of 7.1 per centum per annum, such sum being payable at the Australia and New Zealand Savings Bank Limited, Collins-street, Melbourne, on the first day of each half-year period during the term of the loan.

And the Honorable John Frederick Rossiter, Her Majesty's Chief Secretary for the State of Victoria, shall give the necessary directions herein accordingly.

T. J. FORRISTAL,  
Clerk of the Executive Council.

DEPARTMENT OF CROWN LANDS AND SURVEY.

At the Executive Council Chamber, Melbourne, the thirtieth day of October, 1973.

PRESENT:

His Excellency the Governor of Victoria.  
Mr. Byrne | Mr. Dickie.  
Mr. Wilcox |

LANDS TEMPORARILY RESERVED AS SITES.

His Excellency the Governor of the State of Victoria, by and with the advice of the Executive Council thereof, doth hereby, in pursuance of section 14 of the Land Act 1958, reserve temporarily from sale, from being leased and from having a licence granted in respect thereof, and also except from occupation for mining purposes under any miner's right, the land hereinafter described:—

MORANGHURK.—Site for Public purposes (Public Buildings), 3558 square metres, Parish of Moranghurk, County of Grant, as indicated by hatching on plan hereunder.—(M.205<sup>(4)</sup>) (Rs.9780).

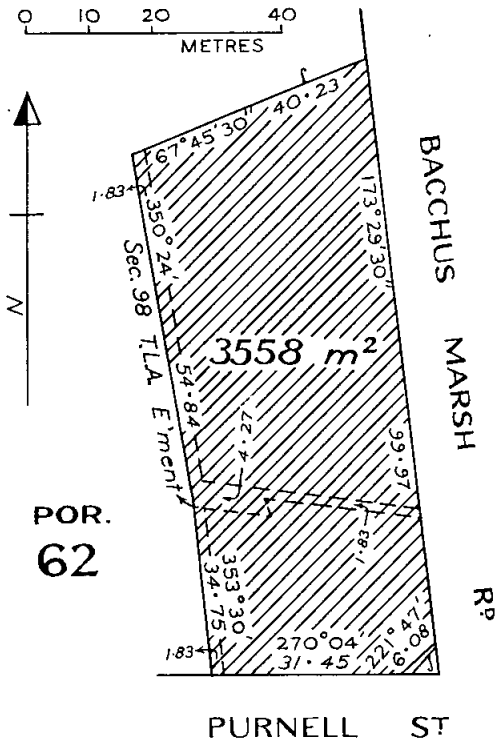

PORTLAND.—Site for Public purposes (Departmental Residence), 809 square metres, Township of Portland, Parish of Portland, County of Normanby, as indicated by hatching on plan hereunder.—(P.69<sup>(1)</sup>) (Rs.9773).

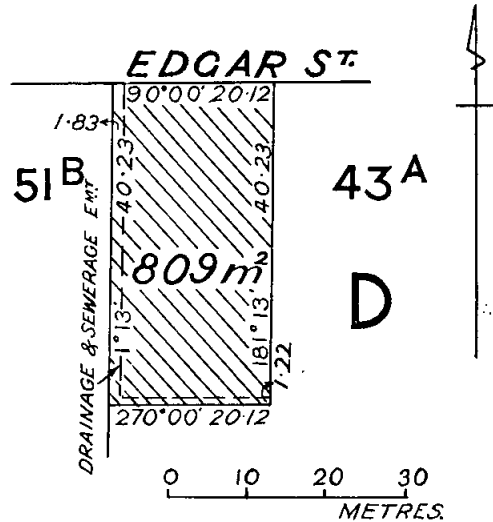

WODONGA.—Site for Public purposes (Departmental Residence), 707 square metres, Township of Wodonga, Parish of Wodonga, County of Bogong, as indicated by hatching on plan hereunder.—(W.308<sup>(5)</sup>) (Rs.9771).

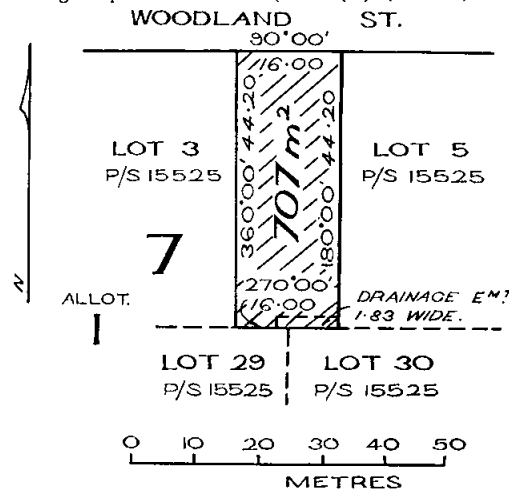

DANDENONG (NOBLE PARK).—Site for Public purposes (Social Welfare Department purposes), 643 square metres, Parish of Dandenong, County of Bourke, as indicated by hatching on plan hereunder.—(D.19<sup>(5)</sup>) (Rs.9781).

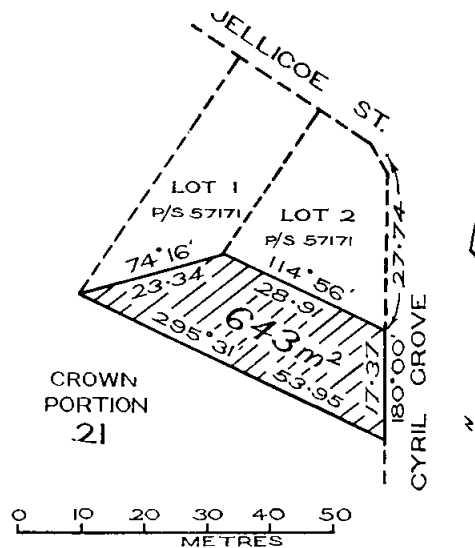

MOORABBIN (BENTLEIGH EAST).—Site for Public purposes (Public Buildings), 1071 square metres, being Crown allotment 60A, Parish of Moorabbin, County of Bourke, as indicated by hatching on plan hereunder.—(M.164<sup>(8)</sup>) (Rs.9770).

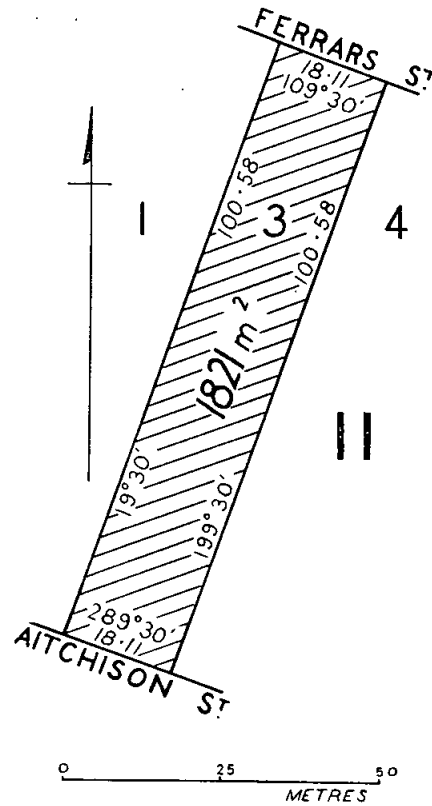
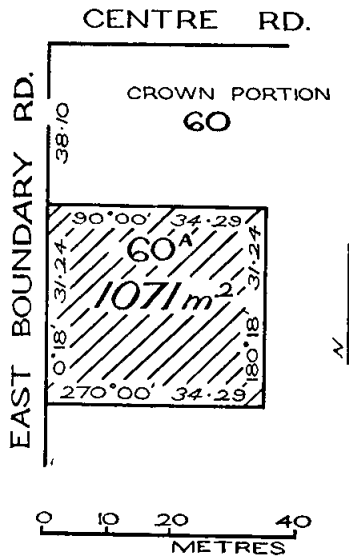

PRAHRAN.—Site for Public purposes (Social Welfare Department purposes), 1171 square metres, being Crown allotment 62A, Parish of Prahran, County of Bourke, as indicated by hatching on plan hereunder.—(P.81<sup>(12)</sup>) (Rs.9800).

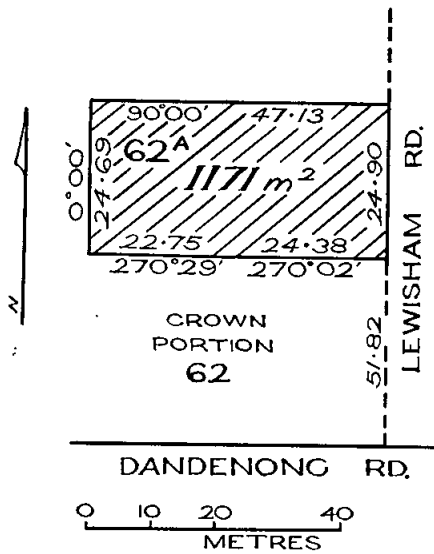

MELBOURNE SOUTH (ALBERT PARK).—Site for State School purposes, 306 square metres, City of South Melbourne, Parish of Melbourne South, County of Bourke, as indicated by hatching on plan hereunder.—(M.333<sup>(28)</sup>) (Rs.9786).

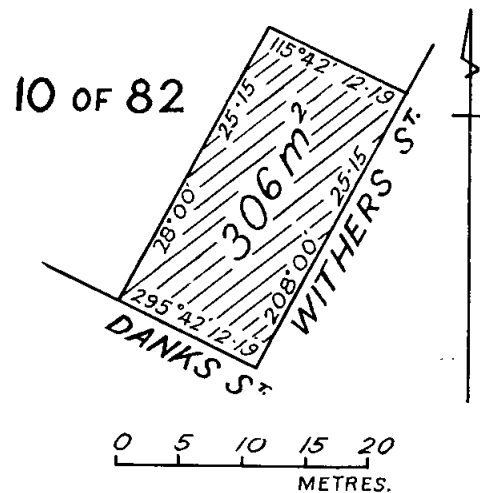

ROKEWOOD.—Site for Water Supply purposes, 1821 square metres, being Crown allotment 3, section 11, Township of Rokewood, Parish of Corindhap, County of Grenville, as indicated by hatching on plan hereunder.—(R.51<sup>(5)</sup>) (Rs.9820).

And the Honorable William Archibald Borthwick, Her Majesty's Minister of Lands for the State of Victoria, shall give the necessary directions herein accordingly.

T. J. FORRISTAL,  
Clerk of the Executive Council.

LAND ACT 1958.

At the Executive Council Chamber, Melbourne, the thirtieth day of October, 1973.

PRESENT:

His Excellency the Governor of Victoria.  
Mr. Byrne | Mr. Dickie.  
Mr. Wilcox

UNUSED ROAD CLOSED.

In pursuance of the provisions of section 349 of the Land Act 1958, His Excellency the Governor of Victoria, by and with the advice of the Executive Council thereof, and the concurrence in writing of the Council of the municipality concerned doth hereby close the unused road referred to hereunder, viz:—

Township of Stony Creek, Parish of Meenyan, County of Buln Buln, being the road as indicated by hatching on plan hereunder.—(D.200(6) (C.100634).

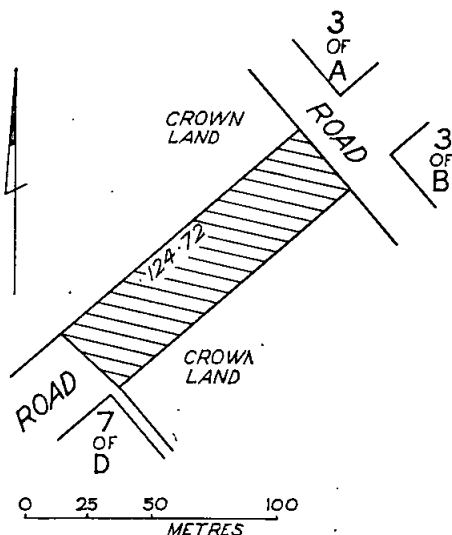

And the Honorable William Archibald Borthwick, Her Majesty's Minister of Lands for the State of Victoria, shall give the necessary directions herein accordingly.

T. J. FORRISTAL,  
Clerk of the Executive Council.

DEPARTMENT OF CROWN LANDS AND SURVEY.

At the Executive Council Chamber, Melbourne, the thirtieth day of October, 1973.

PRESENT:

His Excellency the Governor of Victoria.  
Mr. Byrne | Mr. Dickie.  
Mr. Wilcox

REVOCATION OF TEMPORARY RESERVATIONS OF LANDS BY ORDERS IN COUNCIL.

His Excellency the Governor of the State of Victoria, by and with the advice of the Executive Council thereof, doth hereby in pursuance of the provisions of the Land Act 1958, revoke the temporary reservations of lands by Orders in Council hereinafter described, viz:—

**COWES.**—The temporary reservation by Order in Council of the 13th June, 1870, of 6070 square metres (1 acre 2 roods) of land in the Township of Cowes as a site for Public purposes, revoked as to part by various Orders, so far only as the portion containing 859 square metres, as defined by description and hatching on plan published in the Government Gazette, dated the 3rd October, 1973.—(C.443(4) (Rs.6646).

**HARCOURT.**—The temporary reservation as a site for Public Recreation and the withholding from sale, leasing and licensing by Order in Council of the 13th February, 1884, of 13 hectares (32 acres 18 perches) of land in the

Township of Harcourt, revoked as to part by various Orders, so far only as the portion containing 2.428 hectares, more or less, as defined by description and hatching on plan published in the Government Gazette, dated the 3rd October, 1973.—(H.15(3) (Rs.1799).

And the Honorable William Archibald Borthwick, Her Majesty's Minister of Lands for the State of Victoria, shall give the necessary directions herein accordingly.

T. J. FORRISTAL,  
Clerk of the Executive Council.

SOIL CONSERVATION AND LAND UTILIZATION ACT.

At the Executive Council Chamber, Melbourne, the thirtieth day of October, 1973.

PRESENT:

His Excellency the Governor of Victoria.  
Mr. Byrne | Mr. Dickie.  
Mr. Wilcox

DISTRICT ADVISORY COMMITTEE.—WESTERN MALLEE SOIL CONSERVATION DISTRICT.

Whereas a vacancy exists on the Western Mallee Soil Conservation District Advisory Committee due to the transfer of David Llewelyn Hooke, being the person elected to represent the State Rivers and Water Supply Commission, now, therefore, I, the Governor of the State of Victoria, by and with the advice of the Executive Council thereof, and in pursuance of the provisions of section 15 of the Soil Conservation and Land Utilization Act do hereby remove the said David Llewelyn Hooke from office and appoint the following person to such vacancy for a period up to and including the nineteenth day of June, 1976:—

ZDZISLAW NICHOLAS KURKOWSKI, being the person appointed to represent the State Rivers and Water Supply Commission.

And the Honorable William Archibald Borthwick, Her Majesty's Minister for Conservation for the State of Victoria, shall give the necessary directions herein accordingly.

T. J. FORRISTAL,  
Clerk of the Executive Council.

TOWN AND COUNTRY PLANNING ACT 1961.

At the Executive Council Chamber, Melbourne, the thirtieth day of October, 1973.

PRESENT:

His Excellency the Governor of Victoria.  
Mr. Byrne | Mr. Dickie.  
Mr. Wilcox

REVOCATION IN PART OF THE EILDON SUB-REGIONAL PLANNING SCHEME, REVOCATION No. 4.

Whereas it is provided by sub-sections (4), (4A), (4B) and (4C) of section 32 of the Town and Country Planning Act 1961 that the Governor in Council, upon application of the Town and Country Planning Board or the Responsible Authority or of any other person or body of persons may revoke the whole or any part of any planning scheme if he thinks that in the special circumstances of the case it should be so revoked;

And whereas an application has been made by Messrs. I. Dizgalvis & Co., Barristers and Solicitors, of 213 Lonsdale-street, Melbourne, and the Minister has considered a report by the Town and Country Planning Board and has consulted the Responsible Authority;

And whereas it is provided by sub-section (5) of section 32 of the Town and Country Planning Act 1961, that the Governor in Council may by Order prohibit restrict or regulate the use or development of any land to which the revoked scheme or part related and shall specify that any use or development permitted under the Order is permitted only subject to the grant of a permit by the Responsible Authority enforcing and carrying out the part of the scheme so revoked;

Now therefore, His Excellency the Governor of the State of Victoria, by and with the advice of the Executive Council, doth hereby:—

- (i) revoke the Eildon Sub-Regional Planning Scheme in so far as it applies to all that land being lot 71 on plan of subdivision 44119, lodged at

the Office of Titles, being part of Crown allotment 26, section B, Parish of Eildon, and being land described in certificate of title, volume 8203, folio 408; and

- (ii) order that the said land, subject to the grant of a permit by the Council of the Shire of Alexandra, may be subdivided into not more than two allotments and may be used or developed for any purpose for which land in the Rural Forest Zone of the Eildon Sub-Regional Planning Scheme may be used or developed.

And the Honorable Alan John Hunt, Her Majesty's Minister for Local Government for the State of Victoria, shall give the necessary directions herein accordingly.

T. J. FORRISTAL,  
Clerk of the Executive Council.

**WORKERS COMPENSATION ACT 1958.**

At the Executive Council Chamber, Melbourne, the thirtieth day of October, 1973.

**PRESENT:**

His Excellency the Governor of Victoria.  
Mr. Byrne | Mr. Dickie.  
Mr. Wilcox

**PUBLIC BODY SPECIFIED.**

In pursuance of the powers conferred by the *Workers Compensation Act 1958*, His Excellency the Governor of the State of Victoria, in the Commonwealth of Australia, by and with the advice of the Executive Council of the said State, doth by this Order specify the Motor Accidents Board for the purposes of section 65 (1) (a) of the said Act.

And the Honorable John Frederick Rossiter, Her Majesty's Chief Secretary for the State of Victoria, shall give the necessary directions herein accordingly.

T. J. FORRISTAL,  
Clerk of the Executive Council.

**GEELONG HARBOR TRUST ACT 1958.**

At the Executive Council Chamber, Melbourne, the thirtieth day of October, 1973.

**PRESENT:**

His Excellency the Governor of Victoria.  
Mr. Byrne | Mr. Dickie.  
Mr. Wilcox

**APPOINTMENT OF A COMMISSIONER AND CHAIRMAN OF THE GEELONG HARBOR TRUST COMMISSIONERS.**

In accordance with the provisions of the *Geelong Harbor Trust Act 1958*, His Excellency the Governor of the State of Victoria, by and with the advice of the Executive Council thereof, doth by this Order re-appoint—

Sir ROY FIDGE, LL.B.,  
a Commissioner and Chairman of the Geelong Harbor Trust Commissioners for a period of three years, ending 31st December, 1976.

And the Honorable Roberts Christian Dunstan, Her Majesty's Minister of Public Works for the State of Victoria, shall give the necessary directions herein accordingly.

T. J. FORRISTAL,  
Clerk of the Executive Council.

**LANDS DEPARTMENT NOTICES**

**APPROACHING LAND SALES.**

Sale of Crown Land, in fee-simple, will be held at the under-mentioned places and dates, viz.:—

	No. of Gazette.
Ararat.—Thursday, 29th November, 1973	101
Ballarat.—Tuesday, 18th December, 1973	108
Bendigo.—Tuesday, 18th December, 1973	108
Daylesford.—Thursday, 13th December, 1973	101
Echuca.—Thursday, 15th November, 1973	98
Tongala.—Thursday, 15th November, 1973	98
Wonthaggi.—Tuesday, 27th November, 1973	101

**SALE OF CROWN LAND BY AUCTION.**

The land will be offered for sale in fee-simple, and subject to the provisions of the Land Act and Regulations thereunder.

The upset price is the sum at which bidding will start, and no bid below that sum can be accepted. The highest bidder at or above that sum shall be the purchaser, subject to signature of contract and any necessary payment.

**TERMS:—**

A deposit of at least 12½% of the purchase price must be paid at the sale, either in cash or by cheque.

The residue is payable in half-yearly instalments, in accordance with the following scale, or may be paid off at any earlier time.

- \$40 and under, 6 instalments.
- Over \$40, and not exceeding \$100, 8 instalments.
- Over \$100, and not exceeding \$200, 10 instalments.
- Over \$200, and not exceeding \$400, 12 instalments.
- Over \$400, and not exceeding \$600, 14 instalments.
- Over \$600, and not exceeding \$800, 16 instalments.
- Over \$800, and not exceeding \$1,000, 18 instalments.
- Over \$1,000, 20 instalments.

Interest at the rate of 5% per annum is payable, with all payments of residue, and is computed for each instalment from the date of sale to the date of such payment. Additional interest is charged if any instalment is not paid on or before the due date.

If paid off within 30 days of sale, no interest is payable.

**FEES, ETC.:**

Also payable at the sale, in addition to the deposit, are the survey fee and, if applicable, the valuation of improvements (if the purchaser be not the owner thereof).

**Payable with balance of purchase money—**

Crown Grant fee—\$3.

Assurance Fund Contribution—One cent in every Five dollars or part thereof of purchase price. (This is a fund established to guarantee the validity of freehold titles.)

Transfer of interest prior to completion of payment may be allowed on payment of \$2 fee and subject to stamp duty.

If unable to attend personally, a prospective purchaser may arrange for another person to bid as his agent.

Attention is drawn to section 95, *Land Act 1958*, which provides that the purchaser shall be deemed to be the owner for the purposes of other Acts; also to an amendment to the Local Government Act providing for Government roads, in certain circumstances, to be declared "private streets", thus making the purchaser liable to contribute to the cost of street construction.

W. BORTHWICK,

Minister of Lands.

Office of Crown Lands and Survey,  
Melbourne, 5th November, 1973.

**BALLARAT.**—Sale (No. 12158) of Crown land in fee-simple by auction, will be held at the Land Office, BALLARAT, on TUESDAY, the 18th day of DECEMBER, 1973, at TWO P.M. To be conducted by the Land Officer, Ballarat.

TOWNSHIP OF SEBASTOPOL, PARISH OF BALLARAT, COUNTY OF GRENVILLE.

Lot 1.

Fronting Tait and Kossuth streets approximately 3 chains south of Hertford-street (Gleneig Highway).

Upset price \$8,000 the lot. Survey fee \$90.

Area 1-625 hectares (4 acres) allotment 2 of section 1.—(J.34218.)

Lot 2.

On the corner of Vale and Spencer streets.

Upset price \$4,000 the lot. Survey fee \$70.

Area 3r. 19p., allotment 4 of section 39. One month allowed for removal of improvements (fencing).—(J.34175.)

**BENDIGO.**—Sale (No. 12157) of Crown land in fee-simple by auction, will be held at the Soldiers Memorial Hall, Pall Mall, BENDIGO, on TUESDAY, the 18th day of DECEMBER, 1973, at TEN A.M. To be conducted by the Land Officer, Bendigo.

PARISH OF SANDHURST, COUNTY OF BENDIGO.

Lot 1.

Situated on the corner of Cross and Bunker streets.

Upset price \$300 the lot. Survey fee \$55.

Area 1131 sq. metres (1r. 5p.), allotment 4H of section H<sup>1</sup>. One month for removal of improvements (fencing).—(W.90808.)

Lot 2.

Fronting the north side of Collins-street approximately  $\frac{1}{4}$  mile west of Olympic-parade.

Upset price \$450 the lot. Survey fee \$60.

Area 2r. 25p., allotment 74c of section 18.

NOTE.—Subject to Shire of Marong Planning Scheme.—(W.90461.)

PARISH OF MANDURANG, COUNTY OF BENDIGO.

Lot 3.

Fronting the east side of a government road approximately  $\frac{1}{4}$  mile south-east of Kangaroo Flat.

Upset price \$400 the lot. Survey fee \$60.

Area 1 acre, allotment 112G of section D.

NOTE.—Subject to S.E.C. easement and Shire of Strathfieldsaye Planning Scheme. One month allowed for removal of improvements.—(W.90354.)

Lot 4.

Approximately  $\frac{1}{4}$  mile north of Crusoe Reservoir.

Upset price \$100 the lot. Survey fee \$16.

Area 1a. 2r. 36p., allotment 7 of section A.—(W.88699.)

AT BENDIGO, PARISH OF SANDHURST, COUNTY OF BENDIGO.

Lot 5.

Fronting the north side of Wirrana-street approximately 2 chains east of Boyd-street.

Upset price \$400 the lot. Survey fee \$13.

Area 1r. 21p., allotment 10A of section 149c.

NOTE.—Subject to City of Bendigo Planning Scheme. One month allowed for removal of improvements.—(W.89648.)

Lot 6.

Fronting the south-eastern side of Holdsworth-road approximately 7 chains north-east of Wood-street.

Upset price \$765 the lot. Survey fee \$50.

Area 22p., allotment 485R of section K.

NOTE.—Subject to drainage easement.—(W.90780.)

Lot 7.

Fronting the east side of Adam-street approximately 3 chains north of Abel-street.

Upset price \$800 the lot. Survey fee \$50.

Area 18 perches, allotment 17 of section 120c. Valuation of improvements \$300 (Reclamation—City of Bendigo). Subject to SUBSIDENCE INDEMNITY CONDITION.

NOTE.—Area is crossed by a Sewerage main.—(W.89049.)

AT EAGLEHAWK, PARISH OF SANDHURST, COUNTY OF BENDIGO.

Lot 8.

Fronting the northern side of Buckie-street 1 chain west of Eagle-street.

Upset price \$300 the lot. Survey fee \$50.

Area 32 perches, allotment 141 of section M. Valuation of improvements \$750 (fowl shed, S. Jovanovic.)

NOTE.—Subject to Borough of Eaglehawk Planning Scheme.—(W.68716.)

Lot 9.

Fronting the west side of Youlden-street approximately  $7\frac{1}{2}$  chains north of Thorpe-street.

Upset price \$500 the lot. Survey fee \$55.

Area 1018 sq. metres (1 rood), allotment 439G of section M.

NOTE.—Subject to Borough of Eaglehawk Planning Scheme. (W.90692.)

Lot 10.

Fronting Kirkwood and Orlando streets approximately  $5\frac{1}{2}$  chains east of Burnside-street.

Upset price \$500 the lot. Survey fee \$60.

Area 4056 sq. metres (1 acre), allotment 11 of section 30.

NOTE.—Subject to Borough of Eaglehawk Planning Scheme.—(W.91042.)

Lot 11.

TOWNSHIP OF ELMORE, PARISH OF ELMORE,  
COUNTY OF BENDIGO.

At the south-west corner of Cardwell and Hervey streets. Upset price \$1,500 the lot. Survey fee \$50.

Area 32 perches, allotment 18A of section 9.

NOTE.—Improvements consist of a weatherboard dwelling with three bedrooms, separate office, sleepout, garage and other outbuildings, the valuation of which is included in the upset price.

Until the purchase money has been paid in full, the following special conditions shall apply:—

(i) The purchaser shall at his own expense maintain the property in good order and repair and keep all improvements thereon insured against fire in the name of the Secretary for Lands.

(ii) A cover note for not less than \$1,000 for such insurance shall be lodged in the Lands Department, by the purchaser, within one week of the date of sale, and the policy shall be lodged immediately on issue.

(iii) The purchaser shall not remove or make any alterations to the improvements on the site without the prior consent of the Secretary for Lands.—(W.90385.)

Lot 12.

TOWNSHIP OF DURHAM OX, PARISH OF YARROWALLA,  
COUNTY OF GUNBOWER.

Being part of the former Durham Ox State School Reserve abutting the south side of the Boort-Echuca road.

Upset price \$150 the lot. Survey fee \$60.

Area 3809 square metres (3r. 30p.), allotment 1 of section 4.

Improvements consist of a School Building and shed, the valuation of which is included in the upset price.—(W.90847.)

PROPOSED REVOCATIONS OF TEMPORARY RESERVATIONS OF LANDS BY ORDERS IN COUNCIL.

In pursuance of the provisions of the Land Act 1958, notice is hereby given that it is the intention of the Governor in Council to revoke the temporary reservations of lands by Orders in Council hereunder referred to, viz.:—

The following Notices were published 1<sup>o</sup> on the 7th November, 1973, pursuant to Orders of the 30th October, 1973.

SMEATON.—The temporary reservation by Order in Council of the 6th May, 1930, of 3.642 hectares (9 acres) of land in the Parish of Smeaton as a site for Public purposes is about to be revoked so far only as the portion containing 7000 square metres, more or less, indicated by hatching on plan hereunder, is concerned.—(S.298<sup>(1)</sup>) (Rs.3993).

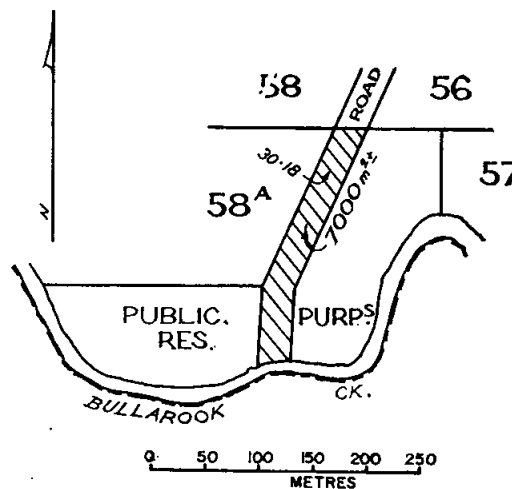

SPRING HILL.—The temporary reservation by Order in Council of the 6th May, 1930, of 4.047 hectares (10 acres) of land in the Parish of Spring Hill as a site for Public

purposes is about to be revoked so far only as the portion containing 5400 square metres, more or less, indicated by hatching on plan hereunder, is concerned.—(S.311<sup>(1)</sup>) (Rs.3835).

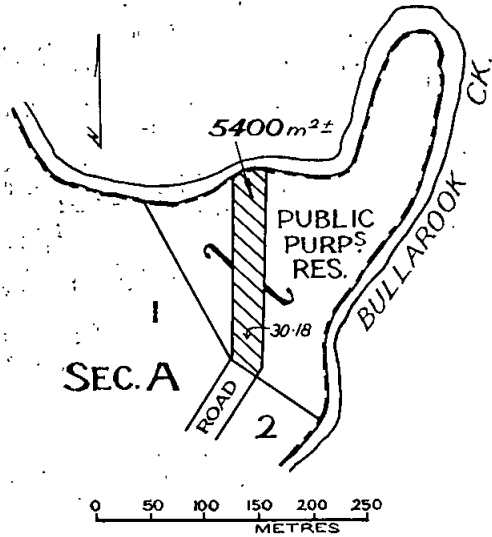

TARRAWINGEE.—The temporary reservation by Order in Council of the 17th January, 1870 (see *Government Gazette*, 1870, page 104), of 4047 square metres (1 acre) of land in the Parish of Tarrawingee West (now Parish of Tarrawingee) as a site for Common School purposes is about to be revoked so far only as the portion containing 2269 square metres, more or less, indicated by hatching on plan hereunder, is concerned.—(T.61<sup>(4)</sup>) (Rs.8963).

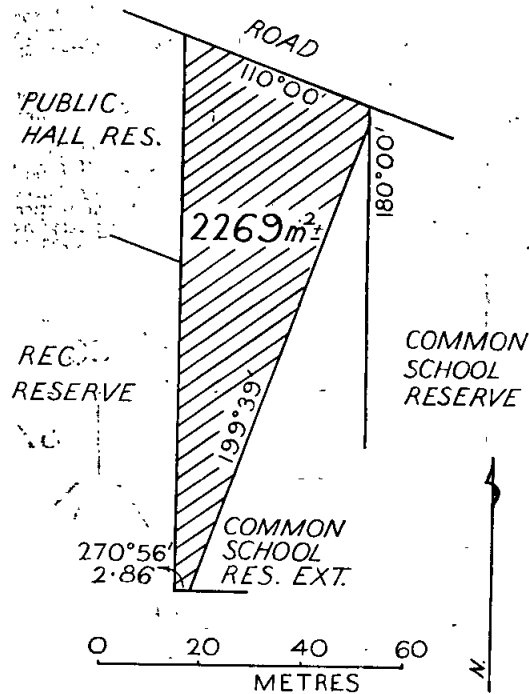

TARRAWINGEE.—The temporary reservation by Order in Council of the 22nd November, 1869 (see *Government Gazette* 1869, page 1922), of 4047 square metres (1 acre) of land in the Parish of Tarrawingee West (now Parish of Tarrawingee) as a site for Common School purposes

is about to be revoked so far only as the portion containing 1 square metre, more or less, indicated by hatching on plan hereunder, is concerned.—(T.61<sup>(4)</sup>) (Rs.8963).

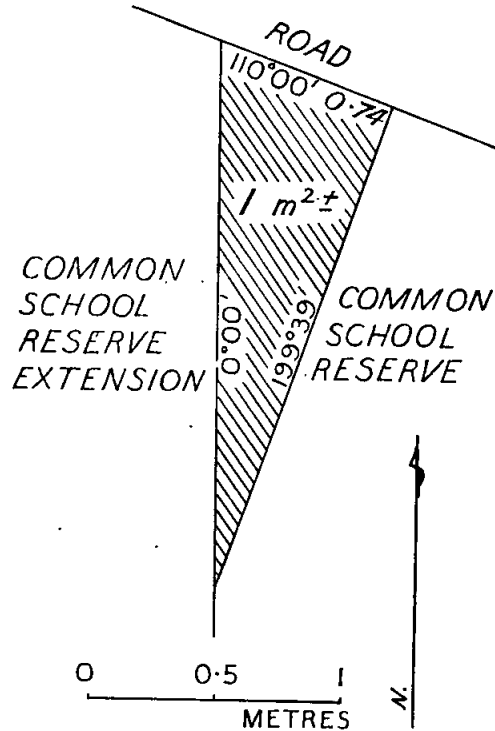

TARRAWINGEE.—The temporary reservation by Order in Council of the 29th June, 1868, of 18.39 hectares (45 acres 1 rood 32 perches) of land in the Parish of Tarrawingee West (now Parish of Tarrawingee) as a site for Recreative purposes, revoked as to part by Order of the 21st September, 1927, is about to be revoked, save and except, the area of 17 hectares, more or less, indicated by hatching on plan hereunder.—(T.61<sup>(4)</sup>) (Rs.1800).

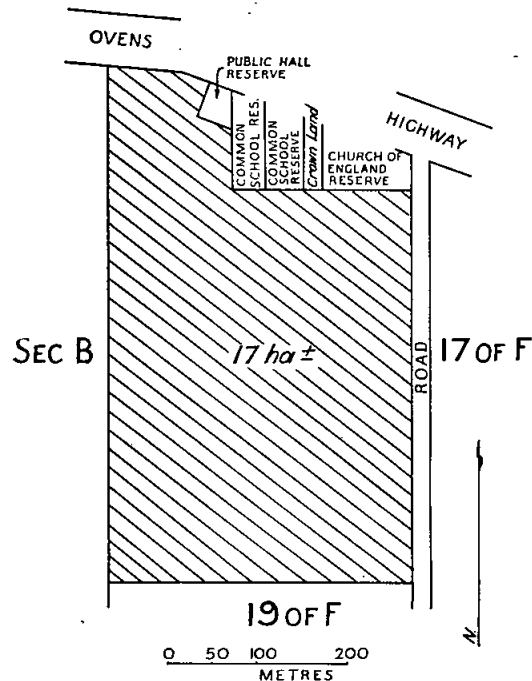

W. BORTHWICK,  
Minister of Lands.

**PROPOSED REVOCATIONS OF TEMPORARY RESERVATIONS OF LANDS BY ORDERS IN COUNCIL.**

In pursuance of the provisions of the *Land Act 1958*, notice is hereby given that it is the intention of the Governor in Council to revoke the temporary reservations of lands by Orders in Council hereunder referred to, viz.:-

The following Notices were published 1<sup>o</sup> on the 31st October, 1973, pursuant to Orders of the 23rd October, 1973.

**OMEQ.**—The temporary reservation by Order in Council of the 2nd December, 1969, of 1771 square metres (1 rood 30 perches) more or less, of land in the Township of Omeo as a site for Public purposes (Municipal purposes) is about to be revoked.—(O.19<sup>(8)</sup>) (Rs.4245).

**OMEQ.**—The temporary reservation by Order in Council of the 29th April, 1958, of 2479 square metres (2 roods 18 perches) of land in the Township of Omeo as a site for Municipal purposes is about to be revoked.—(O.19<sup>(8)</sup>) (Rs.4245).

**FRANKSTON.**—The temporary reservation by Order in Council of the 20th February, 1899 of 60.15 hectares (148 acres 2 roods 23 perches) of land in the Parish of Frankston as a site for Racecourse and Public Recreation is about to be revoked, so far only as the portion containing 1175 square metres indicated by hatching on plan hereunder, is concerned.—(F.87<sup>(8)</sup>) (Rs.3645).

**RACECOURSE AND RECREATION RESERVE**  
"Baxter Park"

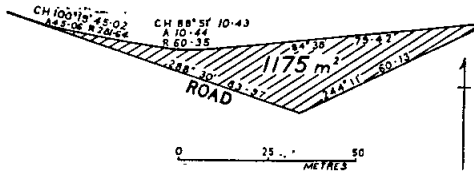

**SMYTHESDALE.**—The temporary reservation by Order in Council of the 18th July, 1938, of 1.065 hectares (2 acres 2 roods 21 perches) of land in the Township of Smythesdale as a site for Police purposes is about to be revoked, so far only as the portion containing 7621 square metres indicated by hatching on plan hereunder, is concerned.—(S.297<sup>(8)</sup>) (Rs.4784).

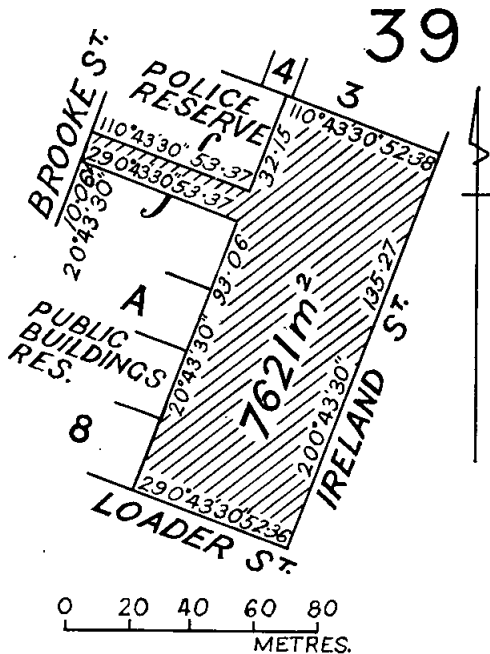

**OMEQ.**—The temporary reservation by Order in Council of the 29th April, 1958, of 2529 square metres (2 roods 20 perches) more or less, of land in the Township of

Omeo as a site for Public Gardens, revoked as to part by Order of the 14th October, 1969, is about to be revoked, save and except, the area of 1920 square metres indicated by hatching on plan hereunder.—(O.19<sup>(8)</sup>) (Rs.7707).

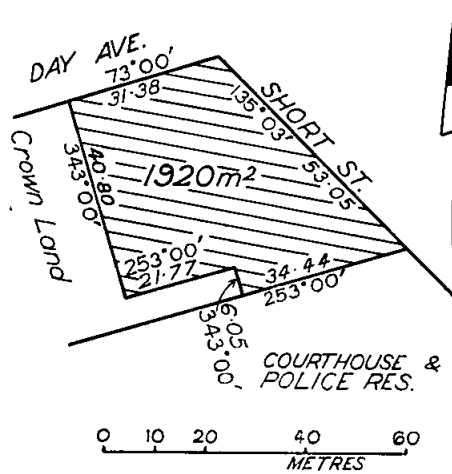

W. BORTHWICK,  
Minister of Lands.

**LOCAL GOVERNMENT ACT 1958.**

In pursuance of the powers conferred by sub-section 3A of section 575 of the *Local Government Act 1958*, I, William Archibald Borthwick, Her Majesty's Minister of Lands in the State of Victoria, hereby declare that the road set out on Crown land in the Parish of Sandhurst, County of Bendigo, as delineated and indicated by hachure on the plan hereunder be a private street within the meaning of and for the purposes of Division 10, Part XIX. of the said Act.—(Corres. No. W.91113.)

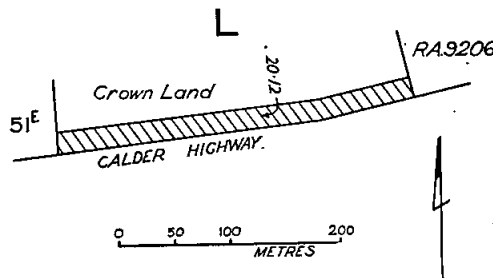

Dated at Melbourne this 26th day of October, 1973.

W. BORTHWICK,  
Minister of Lands.

**COMMITTEE OF MANAGEMENT OF RESERVE.**

**APPOINTMENT.**

Notice is hereby given that, in pursuance of section 221 of the *Land Act 1958*, the following appointment of a Committee of Management of reserved Crown land has been made by the Minister of Lands:—

"PORTLAND PUBLIC PURPOSES (KINDERGARTEN) RESERVE."

The Corporation of the Town of Portland as the Committee of Management of the land in the Township of Portland, temporarily reserved pursuant to Order in Council dated the 18th September, 1973, as a site for Public purposes (Kindergarten).—(Corres. No. Rs.8622.)

W. BORTHWICK,  
Minister of Lands.

Department of Crown Lands and Survey,  
Melbourne, 31st October, 1973.

**TENDERS****PUBLIC WORKS DEPARTMENT**

Tenders will be received at Public Works Department, 2 Treasury-place, Melbourne, until **TWO** p.m. on dates shown and for purposes mentioned hereunder.

Particulars and tender forms available at Contracts Office, Room 27, Ground Floor, No. 2, Treasury-place, and at places indicated in brackets hereunder.

Abbreviations in brackets mean:—W.O.—Inspector of Works Office; P.S.—Police Station; C.S.—Consolidated School; H.E.S.—Higher Elementary School; H.S.—High School; Pr.S.—Primary School; T.S.—Technical School.

Tenders to be submitted on the Department's printed Tender Form and will not be received by telephone. All tenders must be on a "Firm Tender" basis. The lowest or any tender will not necessarily be accepted.

Address tenders to the Minister of Public Works, and endorse the envelope containing the tender "Tender for closing Tuesday,

Hand delivered tenders to be placed in the Tender Box of the Public Works Department, located on the wall of the centre entrance foyer, Ground Floor, 2 Treasury-place, Melbourne.

No preliminary deposit is required with any tender, but a successful tenderer will be required to pay a deposit for any accepted tender of \$4,000 or over.

**Tuesday, 13th November, 1973.****Building, Electrical and Mechanical Works.**

BRAYBROOK.—Erection of Science block, H.S.

BRAYBROOK.—Electrical services, Science block, H.S.

BRAYBROOK.—Mechanical services, Science block, H.S.

ECHUCA.—Conversion of class-room to library and staff accommodation improvements, Pr.S.208. (W.O., Bendigo and Shepparton.) (Re-advertised.)

EAST LODDON.—Replacement of roofs, exterior and interior renovations, C.S. (W.O., Bendigo and Shepparton.) (Re-advertised.)

GLEN WAVERLEY.—Staff and administration improvements, Pr.S.2219.

LAKESIDE.—Erection of Science block, H.S.

LAKESIDE.—Electrical services, Science block, H.S.

LAKESIDE.—Mechanical services, Science block, H.S.

MONT PARK.—Alterations to Ward F.12, Mental Hospital.

NORWOOD.—Erection of library, H.S.

NORWOOD.—Electrical services, library, H.S.

NORWOOD.—Heating and hot water service, library, H.S.

NUMURKAH.—New toilet block and staff toilets, Pr.S.2134. (W.O., Benalla and Shepparton.) (Re-advertised.)

NUNAWADING.—External repairs and painting, H.S. (Re-advertised.)

ROYAL PARK.—External renovations, Mental Hospital.

SUNSHINE WEST.—Staff accommodation improvements, H.S. (Amended specification.) (Re-advertised.)

VARIOUS.—Electrical services in standard Primary Schools, Rates Contract 1973-74. (W.O., Geelong.)

VARIOUS.—Mechanical services in standard Primary Schools, Rates Contract 1973-74. (W.O., Geelong.)

**Site Works.**

ALTONA.—Site works, Pr.S.3923.

ASHBURTON.—Site works, Pr.S.4317.

BOROONDARA NORTH.—Site works, Pr.S.4960.

ELWOOD.—Site works, H.S.

**Miscellaneous.**

STONY POINT.—Re-charging, acetone and inspection of acetylene navigation light cylinders for the period 1st January, 1974, to 31st December, 1974, Buoy Depot.

WILLIAMSTOWN.—Re-charging, acetone and inspection of acetylene navigation light cylinders for the period 1st January, 1974, to 31st December, 1974, Dredging Depot.

**Tuesday, 20th November, 1973.****Building, Electrical and Mechanical Works.**

CARLTON.—Internal and external renovations, P.S.

DANDENONG.—Conversion of and extension to sports pavilion, T.S.

MELBOURNE.—Renovations to auditorium, Police Headquarters, Russell-street. (Re-advertised.)

**Site Works.**

EDI UPPER.—Site works, Pr.S.1422. (W.O., Wangaratta.) (Re-advertised.) (Amended Specification.)

RINGWOOD.—Site works, Pr.S.2997.

**Miscellaneous.**

BALLARAT.—Supply and delivery of one 100 lb. tumbler dryer, Lakeside Hospital.

BALLARAT.—Supply and delivery of one 600 lb. washer extractor, Lakeside Hospital.

BALLARAT.—Supply and delivery of one vibra steamer, Lakeside Hospital.

BEECHWORTH.—Supply and delivery of one vibra steamer, Mental Hospital.

BEECHWORTH.—Supply and delivery of two 100 lb. tumbler dryers, Mental Hospital.

PORT MELBOURNE.—Supply and delivery of five (5) only chassis and cabin with tray type body—capacity one ton, Plant Depot. (Re-advertised.)

**Tuesday, 27th November, 1973.****Building, Electrical and Mechanical Works.**

MARYBOROUGH.—Erection of library, H.S. (W.O., Ballarat and Maryborough.)

MARYBOROUGH.—Electrical installation—Library, H.S. (W.O., Ballarat and Maryborough.)

MARYBOROUGH.—Mechanical installation—Library, H.S. (W.O., Ballarat and Maryborough.)

SOMERS.—Electrical installation—New Dormitory Block, School Camp 4647. (W.O., Mornington.)

SOMERS.—Mechanical services—New Dormitory Block, School Camp 4647. (W.O., Mornington.)

SWAN HILL.—Electrical installation—Music and Classroom Wing, H.S. (W.O., Bendigo and Swan Hill.)

TIMBOON.—Erection of Library, H.S. (W.O., Geelong and Warrnambool.)

TIMBOON.—Electrical installation—Library, H.S. (W.O., Camperdown and Warrnambool.)

TIMBOON.—Mechanical installation—Library, H.S. (W.O., Camperdown and Warrnambool.)

TOTTENHAM.—New Art and Science Wing and New Fan Room, T.S.

TOTTENHAM.—Electrical services—Art and Science Wing and Fan Room, T.S.

TOTTENHAM.—Mechanical services—Art and Science Wing and Fan Room, T.S.

WODONGA WEST.—Staff accommodation improvements, Pr.S.4814. (W.O., Wangaratta.)

YARRUNGA.—Staff accommodation improvements, Pr.S.4761. (W.O., Wangaratta.)

**Site Works.**

BEAUMARIS.—Site works, Demonstration Unit.

WILLIAMSTOWN.—Site works, T.S.

**Miscellaneous.**

BEECHWORTH.—Connection to sewer, Training Prison. (W.O., Wangaratta.)

PORT MELBOURNE.—Supply and delivery of chassis and cabin—35 cwt. capacity with van body, Plant Depot. (Re-advertised.)

PORT MELBOURNE.—Supply and delivery of six (6) pile driving winches—3 tons capacity, Plant Depot.

ROBERTS DUNSTAN,

Minister of Public Works.

Public Works Department,  
Melbourne, 2nd November, 1973.



**PUBLIC SERVICE NOTICES**

No. 573.

*Public Service Act 1958, Section 50.*

**REGULATIONS.—PART IV.—SALARIES AND INCREMENTS.**

The Public Service Board, in pursuance of the powers conferred by the *Public Service Act 1958*, hereby amends the Public Service (Public Service Board) Regulations as follows :—

**SECOND SCHEDULE.**

TECHNICAL AND GENERAL DIVISION.

*Grades and Salary Scales.*

JUNIOR GRADES.

MALES.

Grade.	Yearly Rate of Salary at Each Age in Years.				
	Under 17.	17.	18.	19.	20.
	\$	\$	\$	\$	\$
Add— JM-28 ..	..	..	..	..	3,437(a)
	FEMALES.				
Add— JF-28 ..	..	..	..	..	3,437(a)

(a) 20 years of age and under

**SIXTH SCHEDULE.**

TEMPORARY EMPLOYEES.

*Designations of Positions and Rates of Salaries.*

Department and Designation of Position.	Yearly Rate of Salary.		Increments (Annual).
	Minimum.	Maximum.	
	\$	\$	
DEPARTMENT OF HEALTH.			
<i>Alcoholics and Drug Dependent Persons Services</i>			
Add— Nursing Assistant— Junior= —			
At 20 years of age and under .. ..	..	3,437	
Adult= .. ..	3,819	3,974	A

*This Regulation shall have effect as on and from the 28th October, 1973.*

A. J. A. GARDNER, Chairman.  
R. H. DURRANT, Acting Secretary.

Office of the Public Service Board,  
Melbourne, 26th October, 1973.

No. 572.

*Public Service Act 1958, Section 39.*

**REGULATIONS.—PART IV.—SALARIES AND INCREMENTS.**

The Public Service Board, in pursuance of the powers conferred by the *Public Service Act 1958*, hereby amends the Public Service (Public Service Board) Regulations as follows :—

**THIRD SCHEDULE.**

PART B.

PROFESSIONAL DIVISION.

*Scale of Rates of Annual Salaries.*

The heading "National Gallery Officers, Ministry for the Arts, Premier's Department" and the salary scale relating thereto are deleted and the following heading and salary scale are inserted in lieu thereof :—

LIAISON OFFICERS AND NATIONAL GALLERY OFFICERS, MINISTRY FOR THE ARTS, PREMIER'S DEPARTMENT.

Class.	Annual Salary of Each Subdivision of Each Class.					
	1.	2.	3.	4.	5.	6.
	\$	\$	\$	\$	\$	\$
NG-1 ..	5,078	5,217	5,312	5,589	..	..
NG-2 ..	6,519	6,782	7,014	..	..	..
NG-2A ..	7,217	7,480	7,750	8,022	..	..
NG-3 ..	7,373	7,644	7,804	8,290	8,449	8,764
NG-4 ..	8,290	8,449	8,764	9,324	..	..
NG-5 ..	11,008	..	..	..	..	..
NG-6 ..	12,010	..	..	..	..	..
NG-7 ..	14,414	..	..	..	..	..

A. J. A. GARDNER, Chairman.  
R. H. DURRANT, Acting Secretary.

Office of the Public Service Board,  
Melbourne, 26th October, 1973.

*Teaching Service Act 1958.*

**TEACHING SERVICE (TEACHERS TRIBUNAL) REGULATIONS.**

AMENDMENT No. 270 (T.T.58).

The Teachers Tribunal, in pursuance of the powers conferred by the *Teaching Service Act 1958*, hereby amends Regulation 7 of the Teaching Service (Teachers Tribunal) Regulations as follows:—

**REGULATION 7.**

In sub-clause 3 (a) for the expression "31st December, 1973" substitute the expression "1st January, 1974".

W. E. SAMPSON, Chairman.  
A. F. LE CLERCQ, Secretary.

Office of the Teachers Tribunal,  
Melbourne, 26th October, 1973.

*Teaching Service Act 1958.*  
TEACHING SERVICE (TEACHERS TRIBUNAL)  
REGULATIONS.

AMENDMENT No. 271 (T.T.59).

The Teachers Tribunal, in pursuance of the powers conferred by the *Teaching Service Act 1958*, hereby amends Regulation 1 of the Teaching Service (Teachers Tribunal) Regulations as follows:—

*Regulation 1.*

1. In clause 8, delete the scale of rates and substitute therefor the following scale:—

	For the First 5,000 Miles in a Financial Year.	Mileage Over 5,000 Miles in a Financial Year.
	cents a mile.	cents a mile.
Motor Cars—		
17 h.p. and over .. .. .	14·9	8·0
Under 17 h.p. .. .. .	12·5	6·6
Motor cycles, with side-cars .. .. .	6·3	3·3
Motor cycles .. .. .	5·4	2·8
Bicycles .. .. .	1·9 cents a mile irrespective of mileage	

2. In clause 21, delete the scale of rates and substitute therefor the following scale:—

Motor cars—

17 h.p. and over .. .. .	8·0 cents a mile
Under 17 h.p. .. .. .	6·6 cents a mile
Motor cycles .. .. .	2·8 cents a mile

W. E. SAMPSON, Chairman.  
A. F. LE CLERCQ, Secretary.

Office of the Teachers Tribunal,  
Melbourne, 1st November, 1973.

**PRIVATE ADVERTISEMENTS**

CITY OF BOX HILL.

LOAN No. 244.

*Notice of Intention to Borrow the Sum of \$100,000 for  
Permanent Works and Undertakings.*

Notice is hereby given that the Council of the City of Box Hill proposes to borrow the principal sum of One hundred thousand dollars (\$100,000), secured by a charge over the general rates of the municipality, such sum to be raised by the grant of a mortgage in accordance with the provisions of the *Local Government Act 1958* (as amended).

1. The maximum rate of interest that may be paid is 6·9 per centum per annum.
2. The loan will be applied towards capital works in the Electric Supply Undertaking.
3. The loan is to be liquidated over a period of 20 years, by providing out of the municipal fund 40 half-yearly instalments of \$4,646·48 each covering principal and interest, on the 30th day of the months of May and November in each year, during the currency of the loan. The first instalment shall be payable on the 30th May, 1974.
4. Such moneys shall be repayable to the Colonial Mutual Life Assurance Society Limited, 330 Collins-street, Melbourne.

The plans and specifications and the estimate of the cost of the proposed works, and a statement showing the proposed expenditure of the moneys to be borrowed, are open for inspection at the Municipal Offices, Whitehorse-road, Box Hill, during office hours.

Dated this 5th day of November, 1973.

5269 I. G. PORT, Town Clerk.

CITY OF BRUNSWICK.

Whereas the Council of the City of Brunswick deems it expedient to exercise its power of taking compulsorily the land described in the Schedule and delineated and hatched on the map at the foot hereof for providing same as a place of Public Resort and Recreation; And whereas the Council has caused to be prepared a map and other papers setting out the general description of the work or undertaking for which the land proposed to be taken is to be used, the description of the land proposed to be taken, and the names of the owners or reputed owners, lessees or reputed lessees, mortgagees and occupiers of that land so far as those names are known to or can be ascertained by the Council; And whereas the said map and other papers are deposited at the Office of the said Council at Brunswick and are and shall be open for inspection by all persons interested at all reasonable hours for the space of 40 clear days after the publication of this notice in the *Government Gazette*: Now notice is hereby given to all persons affected by the proposed taking of the said land to set forth, in writing, addressed to the Council or Town Clerk, within 40 clear days of the publication of this notice in the *Government Gazette* all objections which they may have to the taking of the said land.

SCHEDULE.

Commencing at a point at the south-west corner of the intersection of Blyth-street and Lygon-street, Brunswick; thence bearing 180 deg. 24 min. a distance 174 ft. 4½ in. along the west side of Lygon-street; thence bearing 269 deg. 43 min. a distance 136 feet; thence bearing 0 deg. 24 min. a distance 174 ft. 4½ in.; thence bearing 89 deg. 43

min. a distance 136 feet along the southern side of Blyth-street to the point of commencement and being the land described in certificate of title, volume 8909, folio 281.

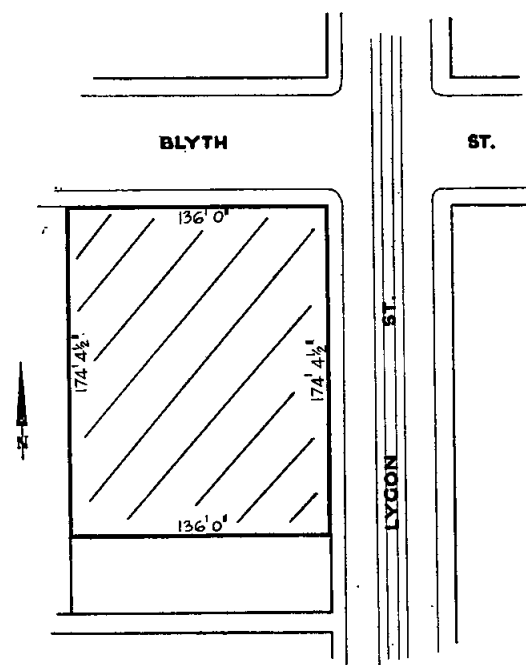

Dated the 31st of October, 1973.

By Order of the Council,  
K. D. WILSON, Town Clerk.

5238

CITY OF CAMBERWELL.

LOAN No. 101.

*Notice of Intention to Borrow the Sum of \$60,000 for Permanent Works and Undertakings.*

Notice is hereby given that the Council of the City of Camberwell proposes to borrow the sum of \$60,000, secured by a charge over the general rates of the municipality, such sum to be raised by the grant of a mortgage in accordance with the provisions of the *Local Government Act 1958*.

1. The maximum rate of interest that may be paid is 8.8 per centum per annum.
2. The purpose for which the loan is to be applied is:—  
For the purchase of land in the municipality, for municipal purposes including car parking and road works, in the following areas:

Camberwell Junction  
Ashburton (High-street)  
Canterbury (General)  
Allambee-avenue—Coolangatta-road.  
Como-avenue—Whitehorse-road  
Spencer-road—Matlock-street.

3. The period of the loan shall be fifteen years.
4. The moneys borrowed shall be repayable by providing out of the municipal fund thirty half-yearly instalments of approximately \$3,640.27, each including principal and interest, on the 10th day of June and the 10th day of December during the currency of the loan. The first instalment shall be payable on the 10th June, 1974.
5. Such moneys shall be repayable to the Commercial Savings Bank of Australia Limited at the head office of the Bank in Melbourne or at such other place as the said Bank may require.
6. The plans and estimate of the cost of the proposed expenditure of the money to be borrowed are open for inspection at the offices of the Council, City Engineer's Department, Camberwell and Inglesby roads, Camberwell, during office hours.

29th October, 1973.  
5191 L. F. CHEFFERS, Chief Administrator.

CITY OF CAMBERWELL.

LOAN No. 100.

*Notice of Intention to Borrow the Sum of \$100,000 for Permanent Works and Undertakings.*

Notice is hereby given that the Council of the City of Camberwell proposes to borrow the sum of \$100,000, secured by a charge over the general rates of the municipality, such sum to be raised by the grant of a mortgage in accordance with the provisions of the *Local Government Act 1958*.

1. The maximum rate of interest that may be paid is 8.9 per centum per annum.
2. The purpose for which the loan is to be applied is:—  
The Canterbury Memorial Basketball Stadium, including accommodation (meeting and clubrooms) for the R.S.A.I.L.A. Camberwell Sub-Branch. To be erected on the site of the Canterbury Memorial Hall, Canterbury-road, Canterbury. (Part Cost.) (Includes site clearance.)
3. The period of the loan shall be twenty years.
4. The moneys borrowed shall be repayable by providing out of the municipal fund forty half-yearly instalments of approximately \$5,395.59, each including principal and interest, on the 10th day of June and the 10th day of December during the currency of the loan. The first instalment shall be payable on the 10th June, 1974.
5. Such moneys shall be repayable to the Commercial Savings Bank of Australia Limited at the head office of the Bank in Melbourne or at such other place as the said Bank may require.
6. The plans and specifications and estimate of the cost of the proposed expenditure of the money to be borrowed are open for inspection at the offices of the Council, Building Surveyor's Department, Camberwell and Inglesby roads, Camberwell, during office hours.

29th October, 1973.  
5190 L. F. CHEFFERS, Chief Administrator.

CITY OF FOOTSCRAY.

LOAN No. 126.

*Notice of Intention to Borrow the Sum of \$68,000 for Permanent Works and Undertakings.*

Notice is hereby given that the Council of the City of Footscray proposes to borrow the sum of Sixty-eight thousand dollars, secured by a charge over the general rates of the municipality, such sum to be raised by the grant of a mortgage in accordance with the provisions of the *Local Government Act 1958*.

1. The maximum rate of interest that may be paid is 8.8 per centum per annum.
2. The period of the loan shall be fifteen years.
3. The loan is to be liquidated by providing out of the municipal fund 30 equal half-yearly instalments of \$4,125.65, including principal and interest, payable on the 31st day of January and the 31st day of July in each year during the currency of the loan. The first instalment shall be payable on the 31st day of July, 1974.
4. Such moneys shall be repayable at the Commonwealth Bank of Australia, Footscray.
5. The purpose for which the loan is to be applied is:—  
Part payment for the acquisition of property at 176/182 Nicholson-street, Footscray.

The plans and specifications and the estimate of the cost of the proposed works and a statement showing the proposed expenditure of the moneys to be borrowed, are open for inspection at the Town Hall, Footscray.

Dated this 7th day of November, 1973.  
5218 W. H. SWABY, Town Clerk.

CITY OF FOOTSCRAY.

LOAN No. 127.

*Notice of Intention to Borrow the Sum of \$100,000 for Permanent Works and Undertakings.*

Notice is hereby given that the Council of the City of Footscray proposes to borrow the sum of One hundred thousand dollars, secured by a charge over the general rates of the municipality, such sum to be raised by the grant of a mortgage in accordance with the provisions of the *Local Government Act 1958*.

1. The maximum rate of interest that may be paid is 8.9 per centum per annum.
2. The period of the loan shall be twenty years.
3. The loan is to be liquidated by providing out of the municipal fund 40 equal half-yearly instalments of \$5,395.59, including principal and interest payable on the

31st day of January and the 31st day of July in each year during the currency of the loan. The first instalment shall be payable on the 31st day of July, 1974.

4. Such moneys shall be repayable at the Bank of New South Wales, Footscray.

5. The purpose for which the loan is to be applied is:—  
Capital Expenditure—Electricity Undertaking.

The plans and specifications and the estimate of the cost of the proposed works and a statement showing the proposed expenditure of the moneys to be borrowed, are open for inspection at the Town Hall, Footscray.

Dated this 7th day of November, 1973.

5219

W. H. SWABY, Town Clerk.

## CITY OF FOOTSCRAY.

## LOAN No. 129.

*Notice of Intention to Borrow the Sum of \$25,000 for Permanent Works and Undertakings.*

Notice is hereby given that the Council of the City of Footscray proposes to borrow the sum of Twenty-five thousand dollars, secured by a charge over the general rates of the municipality, such sum to be raised by the grant of a mortgage in accordance with the provisions of the *Local Government Act 1958*.

1. The maximum rate of interest that may be paid is 8.9 per centum per annum.

2. The period of the loan shall be twenty years.

3. The loan is to be liquidated by providing out of the municipal fund 40 equal half-yearly instalments of \$1,349, including principal and interest, payable on the 1st day of February and the 1st day of August in each year, during the currency of the loan. The first instalment shall be payable on the 1st day of August, 1974.

4. Such moneys shall be repayable at the State Savings Bank of Victoria, corner Elizabeth and Bourke streets, Melbourne.

5. The purpose for which the loan is to be applied is:—  
Capital Expenditure—Electricity Undertaking—  
purchase of electricity poles.

The plans and specifications and the estimate of the cost of the proposed works and a statement showing the proposed expenditure of the moneys to be borrowed, are open for inspection at the Town Hall, Footscray.

Dated this 7th day of November, 1973.

5220

W. H. SWABY, Town Clerk.

## CITY OF HAMILTON.

## HOUSING SCHEME No. 1.

Notice is hereby given that a general plan and description of the City of Hamilton Housing Scheme No. 1 prepared in accordance with Part XXVIII. of the *Local Government Act 1958*, has been forwarded to the Minister for Local Government, together with an application for submission thereof to the Governor in Council for his approval.

Copies of such general plan and description have been deposited at the Municipal Offices of the City of Hamilton, Brown-street, Hamilton for inspection.

5216

T. J. NEVILLE, Town Clerk.

*Town and Country Planning Act 1961 (Twelfth Schedule).*

## CITY OF KNOX PLANNING SCHEME 1965.

NOTICE THAT A PLANNING SCHEME HAS BEEN PREPARED AND IS AVAILABLE FOR INSPECTION.

*Amendment No. 122, 1973.*

Notice is hereby given that the Council of the City of Knox, in pursuance of its powers under the *Town and Country Planning Act 1961*, has prepared a Planning Scheme for portion of the City of Knox for the purpose of amending the Principal Scheme by rezoning land on the south side of Fern Tree Gully-road, being part of Crown portion 4A, commencing 905 ft. 8 in. west of Stud-road, from Rural "A" to Light Industrial.

A copy of the scheme has been deposited at the office of the City of Knox, Spring-street, Fern Tree Gully, and at the office of the Town and Country Planning Board, 5th Floor, 235 Queen-street, Melbourne, and will be open for inspection during office hours by any person, free of charge.

Any persons affected by the Planning Scheme are required to set forth, in writing, all objections they may have addressed to the Town Clerk, City of Knox, Spring-

street, Fern Tree Gully, on or before the 7th day of December, 1973, and to state whether they wish to be heard in respect of their objections.

5234

N. G. HAYNES, Town Clerk.

## CITY OF MORDIALLOC.

## BYLAW No. 150.

A Bylaw of the City of Mordialloc made under the provisions of the *Local Government Act 1958* and numbered 150 for prohibiting the use of motorised vehicles for recreation purposes on certain land.

In pursuance of the powers conferred by the *Local Government Act 1958* and of every power it thereunto enabling the Mayor Councillors and Citizens of the City of Mordialloc orders as follows:—

1. In this Bylaw "motorised vehicles for recreational purposes" means and includes all mini-bikes, trail bikes, motor bikes, motor cars, motor scooters, go-carts and any other vehicle which may be propelled by a motor or a recreation vehicle within the meaning of the *Recreation Vehicles Act 1973* and which is normally used for recreational purposes.

2. No person shall use any motorised vehicle for recreation purposes on any land including any public place within the meaning of the *Recreation Vehicles Act 1973* within the Municipality of the City of Mordialloc not being a highway or private street or road or public land within the meaning of the *Land Conservation Act 1970* without the written consent of the Council first obtained.

3. Any person applying for such written consent from the Council under Clause 2 hereof shall—

- (a) make application in writing to the Council;
- (b) state the place of which such vehicle or vehicles is or are to be used;
- (c) The times during which such vehicle or vehicles will be used;
- (d) the names, addresses and age or ages of any person or persons who will be using such vehicle or vehicles at such time;
- (e) describe such vehicle or vehicles stating its make engine size and whether or not it is registered;
- (f) whether or not the consent of the owner of the land has been obtained;
- (g) supply such other information that the Council may require.

4. The Council in giving its consent under Clause 2 hereof can impose any condition which it considers appropriate to the use of such vehicles.

5. This Bylaw shall apply to and have operation throughout the whole of the Municipal district.

6. Any person guilty of a wilful act or default contrary to the provisions of this Bylaw shall be liable to a penalty of not less than \$10.00 nor more than \$100.00 and any person guilty of a continuing offence shall be liable to a penalty of not more than \$10.00 for each day on which an offence against this Bylaw is continued after a conviction or order by any Court.

Resolution for passing of this Bylaw was agreed to by the Council of the City of Mordialloc on the 8th day of October, 1973, and confirmed on the 29th day of October, 1973.

The common seal of the Mayor, Councillors and Citizens of the City of Mordialloc was hereunto affixed, in the presence of—

(SEAL) M. W. BUXTON, Mayor.  
5217 P. L. SCULLIN, Councillor.  
D. H. CORBEN, Town Clerk.

*Town and Country Planning Act 1961 (Twelfth Schedule).*

## CITY OF SHEPPARTON PLANNING SCHEME 1953.

NOTICE THAT A PLANNING SCHEME HAS BEEN PREPARED AND IS AVAILABLE FOR INSPECTION.

*Amendment No. 29, 1973.*

Notice is hereby given that the Council of the City of Shepparton, in pursuance of its powers under the *Town and Country Planning Act 1961*, has prepared a Planning Scheme for the whole of the municipal district of the City of Shepparton, for the purpose of rezoning land from "Agricultural" to "Industrial 'A'".

A copy of the Scheme has been deposited at the office of the Council, Civic Centre, Welsford-street, Shepparton, and at the office of the Town and Country Planning Board, 235 Queen-street, Melbourne, and will be open for inspection during office hours by any person free of charge.

Any persons affected by the Planning Scheme are required to set forth, in writing, all objections they may have, addressed to the Town Clerk, Civic Centre Shepparton, on or before the 7th day of December, 1973, and to state whether they wish to be heard in respect of their objection.

5275

R. O'BRIEN, Town Clerk.

CITY OF NORTHCOTE.

LOAN No. 113.

*Notice of Intention to Borrow the Sum of \$100,000 for Permanent Works and Undertakings.*

Notice is hereby given that the Council of the City of Northcote proposes to borrow the principal sum of One hundred thousand dollars (\$100,000), secured by a charge over the general rates of the municipality, such sum to be raised by the grant of a mortgage in accordance with the provisions of the *Local Government Act 1958* (as amended).

1. The maximum rate of interest that may be paid is 8.8 per centum per annum.

2. The purposes for which the loan is to be applied are:—

Construction of drains .. .. .	\$50,000
Capital expenditure in the Electric Supply Undertaking .. .. .	25,000
Improvements to parks and reserves .. .. .	20,000
Installation of traffic control signals .. .. .	5,000
	\$100,000

3. The period of the loan shall be fifteen (15) years.

4. The moneys borrowed shall be repayable by providing out of the municipal fund half-yearly instalments of \$6,067.13 each, including principal and interest, on the 1st day of January and the 1st day of July during the currency of the loan. The first instalment shall be payable on the 1st day of July, 1974.

5. Such moneys shall be repayable at the office of the Commonwealth Savings Bank of Australia, Northcote.

The plans and specifications and the estimate of the cost of the proposed works and a statement showing the proposed expenditure of moneys to be borrowed are open for inspection at the office of the Council of the City of Northcote, High-street, Northcote.

Dated the 2nd day of November, 1973.

5201

A. J. HILL, Town Clerk and City Manager.

CITY OF SOUTH MELBOURNE.

LOAN No. 82.

*Notice of Intention to Borrow the Sum of \$100,000 for Permanent Works and Undertakings.*

Notice is hereby given that the Council of the City of South Melbourne proposes to borrow the principal sum of One hundred thousand dollars (\$100,000), secured by a charge over the general rates of the municipality, such sum to be raised by the grant of a mortgage in accordance with the provisions of the *Local Government Act 1958*.

1. The maximum rate of interest that may be paid is 8.9 per centum per annum.

2. The purposes for which the loan is to be applied are:—

<i>Drainage—</i>	
St. Vincent-street — Nelson-road to Merton-street .. .. .	\$9,000
Harold-street — Canterbury-road to Hambleton-street, includes intersection drainage at Canterbury-place .. .. .	2,500
	\$11,500
<i>Street Construction—</i>	
<i>Kerbing and Channelling—</i>	
Hambleton-street (east side)—Wright-street to Harold-street .. .. .	9,000
Harold-street — Canterbury-road to Hambleton-street .. .. .	8,000
Napier-street (north side)—Eastern-road to Stead-street .. .. .	10,000
Raglan-street (south side)—Moray-street to Balmoral-place .. .. .	4,500
	31,500
<i>Road Reconstruction—</i>	
Queens-lane — Arthur-street for 500 feet northwards .. .. .	20,000
Bowen-lane—Kings-way for 475 feet northwards .. .. .	17,000
	37,000

*Market Redevelopment—*

Provision of part of Food Hall at York-street entrance .. .. .	20,000
	\$100,000

3. The period of the loan shall be twenty years.

4. The moneys borrowed shall be repayable by providing out of the municipal fund 40 half-yearly instalments of \$5,395.59 each, including principal and interest on the 15th day of February and the 15th day of August, during the currency of the loan. The first instalment shall be payable on the 15th day of August, 1974.

5. Such moneys shall be repayable to the Bank of New South Wales Limited, 269 City-road, South Melbourne, or such other place or places as the Bank from time to time may require.

The plans and specifications and the estimate of the cost of the proposed works and a statement showing the proposed expenditure of the moneys to be borrowed are open for inspection at the office of the Council of the City of South Melbourne, at the Town Hall, Bank-street, South Melbourne, during office hours.

18th October, 1973.

5203

J. J. COX, Town Clerk.

CITY OF SUNSHINE.

BYLAW No. 120.

*House Numbering Bylaw.*

A Bylaw of the City of Sunshine made under Section 197 of the *Local Government Act 1958* and numbered 120 for carrying out certain purposes provided for in the 15th Schedule to the said Act.

In pursuance of the powers conferred by the *Local Government Act 1958* and of any and every other power it thereunto enabling the Mayor Councillors and Citizens of the City of Sunshine orders as follows:—

1. This Bylaw shall be known as the House Numbering Bylaw.

2. In this Bylaw the words "Authorised Officer" means any officer of the Council authorised to exercise the powers and functions under Clause 3 hereof.

3. (a) The owners or occupiers of houses or buildings shall on the gate or gatepost or on such other conspicuous position as shall be determined by the Authorised Officer mark such houses or buildings with such numbers for the purpose of distinguishing the same as the Authorised Officer may from time to time direct or approve.

(b) In addition to complying with the requirements of paragraph (a) of this clause the owners or occupiers of buildings in which there are two or more separate dwellings shall on the front door of each such separate dwelling or in such other conspicuous place as the Authorised Officer determines mark such separate dwelling with such numbers for the purpose of distinguishing the same as the Authorised Officer may from time to time direct or approve.

(c) Such owners or occupiers shall renew the numbers of such houses buildings or separate dwellings as often as they are obliterated or defaced.

(d) If any owner or occupier of any such house building or separate dwelling neglects for one week after notice to him from the Authorised Officer to mark such house building or separate dwelling with such number as the Authorised Officer may direct or approve or to renew the number thereof as aforesaid he shall forfeit a sum not exceeding \$4.00 and the Council may cause such number to be so marked or renewed and recover the expense thereof from the owner or occupier of such house building or separate dwelling before any Justice and where such expense is paid by or recovered from the occupier he may deduct the same from any rent payable by him to the owner.

4. This Bylaw shall apply to and have operation throughout the whole of the municipal district.

Resolution for passing this Bylaw agreed to by the Council of the City of Sunshine on the sixth day of August 1973 and confirmed on the tenth day of September 1973.

The corporate seal of the Mayor, Councillors and Citizens of the City of Sunshine was hereunto affixed in the presence of—

V. C. PARSONS, Mayor.

(SEAL)

JOAN LOWE, Councillor.

T. W. DEUTSCHMANN, Town Clerk.

5195

## CITY OF SUNSHINE.

## LOAN No. 113.

*Notice of Intention to Borrow the Sum of \$100,000 for Permanent Works and Undertakings.*

Notice is hereby given that the Council of the City of Sunshine proposes to borrow the principal sum of One hundred thousand dollars (\$100,000), secured by a charge over the general rates of the municipality, such sum to be raised by the grant of a mortgage in accordance with the provisions of the *Local Government Act 1958*.

1. The maximum rate of interest that may be paid is 8.9 per centum per annum.
2. The purpose/s for which the loan is required are as follows:—

Kerb and Channel Construction—		
River Ward .. .. .	\$50,000	
Central Ward .. .. .	20,000	
		\$70,000
Construction of King Edward- avenue and Burnewang-street		30,000
		<u>\$100,000</u>

3. The period of the loan shall be twenty (20) years.
4. The moneys borrowed shall be repayable by providing out of the municipal fund half-yearly instalments of \$5,395.58, including principal and interest, on the 1st day of July and the 1st day of January, during the currency of the loan. The first instalment shall be payable on the 1st day of July, 1974.
5. Such moneys shall be repayable at the office of the Mutual Life and Citizen's Assurance Company Limited, Collins-street, Melbourne, or such other place or places as the company from time to time may require.

The plans and specifications and the estimate of the proposed work and a statement showing the proposed expenditure of the money to be borrowed, are open for inspection at the office of the Council of the City of Sunshine, at the Municipal Offices, Alexandra-avenue, Sunshine, 3020.

5211 T. W. DEUTSCHMANN, Town Clerk.

## CITY OF SUNSHINE.

## LOAN No. 115.

*Notice of Intention to Borrow the Sum of \$100,000 for Permanent Works and Undertakings.*

Notice is hereby given that the Council of the City of Sunshine proposes to borrow the principal sum of \$100,000, secured by a charge over the general rates of the municipality, such sum to be raised by the grant of a mortgage in accordance with the provisions of the *Local Government Act 1958*.

1. The maximum rate of interest that may be paid is 8.8 per centum per annum.
2. The purpose/s for which the loan is required is/are as follows:—

(i) Construction of the following roads and avenues:—		
Hertford-road .. .. .	\$45,800	
Furlong-road .. .. .	32,000	
Fitzgerald-road .. .. .	11,500	
Van Ness-avenue .. .. .	9,500	
		\$98,800
(ii) Construction of Pavilion at Skinner Reserve .. .. .		1,200
		<u>\$100,000</u>

3. The period of the loan shall be for fifteen (15) years.
4. The moneys borrowed shall be repayable by providing out of the municipal fund half-yearly instalments of \$6,067.12, including principal and interest, on the 1st day of July and the 1st day of January, during the currency of the loan. The first instalment shall be payable on the 1st day of July, 1974.
5. Such moneys shall be repayable at the office of the Bank of New South Wales, Hampshire-road, Sunshine, 3020, or such other place or places as the Bank from time to time may require.

The plans and specifications and the estimate of the proposed work and a statement showing the proposed expenditure of the money to be borrowed, are open for inspection at the office of the Council of the City of Sunshine, at the Municipal Offices, Alexandra-avenue, Sunshine, 3020.

5213 T. W. DEUTSCHMANN, Town Clerk.

## CITY OF SUNSHINE.

## LOAN No. 112.

*Notice of Intention to Borrow the Sum of \$50,000 for Permanent Works and Undertakings.*

Notice is hereby given that the Council of the City of Sunshine proposes to borrow the principal sum of \$50,000, secured by a charge over the general rates of the municipality, such sum to be raised by the grant of a mortgage in accordance with the provisions of the *Local Government Act 1958*.

1. The maximum rate of interest that may be paid is 8.8 per centum per annum.
2. The purpose/s for which the loan is required are as follows:—

Construction, Van Ness-avenue, roadway ..	\$28,000
Construction, Van Ness-avenue, drainage ..	8,000
Construction, off-street parking area ..	14,000
	<u>\$50,000</u>

3. The period of the loan shall be for fifteen (15) years.
4. The moneys borrowed shall be repayable by providing out of the municipal fund half-yearly instalments of \$3,033.57, including principal and interest on the 1st day of July and the 1st day of January, during the currency of the loan. The first instalment shall be payable on the 1st day of July, 1974.
5. Such moneys shall be repayable at the office of the Commonwealth Savings Bank of Australia, 242 Hampshire-road, Sunshine, or such other place or places as the Bank from time to time may require.

The plans and specifications and the estimate of the proposed work and a statement showing the proposed expenditure of the money to be borrowed, are open for inspection at the office of the Council of the City of Sunshine, at the Municipal Offices, Alexandra-avenue, Sunshine, 3020.

5214 T. W. DEUTSCHMANN, Town Clerk.

## CITY OF TRARALGON.

## LOAN No. 45.

*Notice of Intention to Borrow.*

Notice is hereby given that the Council of the City of Traralgon intends to borrow Fifty thousand dollars (\$50,000), secured by a charge over the general rates of the municipality by the grant of a mortgage in accordance with the provisions of the *Local Government Act*.

In connection herewith the following information is stated:—

- (a) The amount of the principal moneys which it is proposed to borrow is \$50,000 (Fifty thousand dollars).
- (b) The maximum rate of interest that may be paid is 8.8 per centum per annum.
- (c) The money borrowed shall be repayable by thirty (30) equal instalments of approximately \$3,033.57 each equal instalments including principal and interest, payable on the 14th days of June and December. The first instalment shall be payable on 14th June, 1974, and the final instalment on 14th December, 1988. Such moneys are repayable at the Commonwealth Savings Bank of Australia, Franklin-street, Traralgon.
- (d) The period of the loan shall be fifteen (15) years.
- (e) The purpose for which the loan is to be applied is:—

- (i) \$3,500—Council property development and permanent works.
- (ii) \$46,500—Repayment of balance of maturing Loan No. 19.

The plans and specifications and the estimate of cost of the proposed works and statement showing the proposed expenditure of the moneys borrowed are open for inspection at the office of the Council of the City of Traralgon, Kay-street, Traralgon.

Dated 30th October, 1973.

5212 K. J. SAUNDERS, Town Clerk.

## SHIRE OF ALEXANDRA.

## BY-LAW No. 55.

A By-law of the Shire of Alexandra made under Section 7 of the *Petrol Pumps Act 1958* and the *Local Government Act 1958* and numbered 55 for—

- (i) amending By-Law No. 15;

- (ii) prescribing fees on licences under By-Law No. 15; and
- (iii) prescribing minimum insurance to be taken out by licences under By-Law No. 15.

In pursuance of the powers conferred by the *Petrol Pumps Act 1958*, and the *Local Government Act 1958* and every other power enabling it in this behalf, the President, Councillors and Ratepayers of the Shire of Alexandra order as follows:—

1. Clauses (4) and (11) of By-law No. 15 shall be and the same are hereby repealed.

2. By-law No. 15 shall be amended as follows:—

I. After Clause (3) the following Clause shall be inserted—

“(4) (a) Every licence shall expire on the 30th day of September next following the date of issue of such licence, and shall thereafter be of no force or effect.

(b) There shall be paid to the Council in respect of every licence for a petrol pump whether portable or otherwise in or on any footway a fee of \$21.00.

(c) Provided that where a licence is granted for a period less than 12 months a proportionate reduction of the fee based on the number of months unexpired shall be made by the Council.”

II. After Clause (10) of By-law No. 15 the following Clause shall be inserted—

“(11) Every licensee under the provisions of this By-law shall, before the petrol pump in respect of which a licence was granted is erected, or if such petrol pump is erected prior to the application for a licence in respect thereof then before such petrol pump is used for the sale or supply of motor spirit, insure himself and thereafter keep himself insured at all times during the currency of such licence and any renewal thereof in an insurance company of good repute against liabilities which may be incurred by him in respect of such petrol pump and its use, control or possession by him for a minimum sum of \$200,000.00. Every licensee shall on demand produce to the Council or any duly authorised officer of the Council the said policy of insurance and the receipt for the premium for the then unexpired period of his licence PROVIDED that any licensee operating a petrol pump under a currently valid licence, and holding an insurance policy for less than the sum of \$200,000.00 may continue so to operate until the expiration of such permit, and shall show to Council's satisfaction that he has insured himself as aforesaid for the minimum sum of \$200,000.00 before any renewal of his permit is granted.

III. To the form in the Third Schedule by By-Law No. 15 there shall be added after the words “hereby apply for renewal of such licence for the year ending 30th September, 19 ” the following words:—

“and I/WE produce herewith a copy of my/our insurance policy with respect to such Petrol Pump for the sum of at least \$200,000.00 and the receipt for the premium for the period in respect of which this application is made”.

IV. This By-Law shall apply to and have operation throughout the whole of the municipal district.

Resolution for passing this By-Law agreed to by Council the 11th day of July, 1973.

Confirmed the 8th day of August, 1973.

(SEAL) E. E. SOUTHAM, Shire President.  
R. G. RENNIE, Councillor.  
DONALD O. McLEAN, Shire Secretary.

Approved by the Governor in Council, the 23rd day of October, 1973.—T. J. FORRISTAL, Clerk of the Executive Council. 5272

*Town and Country Planning Act 1961* (Twelfth Schedule).  
SHIRE OF BARRABOOL.—OCEAN ROAD PLANNING SCHEME 1966.

NOTICE THAT A PLANNING SCHEME HAS BEEN PREPARED AND IS AVAILABLE FOR INSPECTION.

Amendment No. 13.

Notice is hereby given that the Shire of Barrabool, in pursuance of its powers under the *Town and Country Planning Act 1961*, has prepared a Planning Scheme for the purpose of rezoning land from Residential Development to Special Uses Zone (3), Torquay.

A copy of the Scheme has been deposited at the Shire Office, 441 Moorabool-street, South Geelong, and at the office of the Town and Country Planning Board, 235 Queen-street, Melbourne, and will be open for inspection during office hours by any person, free of charge.

Any persons affected by the Planning Scheme are required to set forth, in writing, all objections they may have, addressed to the Shire Secretary, 441 Moorabool-street, South Geelong, on or before 7th December, 1973, and to state whether they wish to be heard in respect of their objections.

5202

G. L. PEARCE, Shire Secretary.

*Town and Country Planning Act 1961* (Twelfth Schedule).  
SHIRE OF BUNINYONG.—BALLAARAT AND DISTRICT PLANNING SCHEME 1966.

NOTICE THAT A PLANNING SCHEME HAS BEEN PREPARED AND IS AVAILABLE FOR INSPECTION.

Amendment No. 1.

Notice is hereby given that the Shire of Buninyong in pursuance of its powers under the *Town and Country Planning Act 1961* has prepared a Planning Scheme for the area comprising Crown allotments 35, 24, 36, 37, E, D, J, 1N, 1E, 1D, 1C, 1H, 1G, 1F, 1M, 1O, 1L, 1J, 1K, P, A1, A2 (and the closed Government roads abutting the said Crown allotments, in section 18, Parish of Warrenheip, County of Grant for the purpose of rezoning the said area from “Rural” to “Industrial B”.

A copy of the scheme has been deposited at the office of the Shire of Buninyong and at the office of the Town and Country Planning Board, 235 Queen-street, Melbourne, and will be open for inspection during office hours by any person free of charge.

Any persons affected by the Planning Scheme are required to set forth in writing all objections they may have, addressed to the Shire Secretary, Shire of Buninyong, Learmonth-street, Buninyong, 3357, on or before the 7th day of December, 1973, and to state whether they wish to be heard in respect of their objections.

Dated 2nd November, 1973.

5237

A. C. LORD, Shire Secretary.

SHIRE OF DEAKIN.

LOAN No. 31.

Notice of Intention to Borrow the Sum of \$26,000 for Permanent Works and Undertaking.

Notice is hereby given that the Council of the Shire of Deakin proposes to borrow the principal sum of Twenty-six thousand dollars, secured by a charge over the general rates of the municipality, such sum to be raised by the grant of a mortgage in accordance with the provisions of the *Local Government Act 1958*, as amended.

1. The maximum rate of interest that may be paid is 8.9 per cent. per annum.

2. The period of the loan shall be twenty years.

3. The purpose for which the loan is to be raised is part cost of the provisions of two bridges on the Warragul Creek (balance to be met by State Rivers and Water Supply Commission).

4. The loan is to be liquidated by providing out of the municipal fund 40 equal half-yearly instalments of principal and interest each of \$1,402.85, payable on the 1st days of January and July in each year, during the currency of the loan. The first repayment shall be made on the 1st day of July, 1974.

5. The repayments shall be made at the office of the C.B.C. Savings Bank Ltd., in Melbourne.

The plans and specifications and estimate of costs of the works and statement showing the proposed expenditure of moneys to be borrowed are open for inspection at the office of the Council of the Shire of Deakin, Mangan-street, Tongala.

Dated this 2nd day of November, 1973.

5193

B. PEARL, Shire Secretary.

SHIRE OF GOULBURN.

LOAN No. 18.

Notice of Intention to Borrow the Sum of \$30,000 for Permanent Works and Undertakings.

Notice is hereby given that the Council of the Shire of Goulburn intends to borrow the sum of Thirty thousand dollars (\$30,000), secured by a charge over the general rates of the municipality, such sum to be raised by a grant of a mortgage in accordance with the provisions of the *Local Government Act 1958*.

1. The maximum rate of interest that may be paid is 8.8 per cent. per annum.

2. The purpose for which the loan is to be applied is for the purchase of land for promoting or assisting the development of decentralized industry within the municipality in accordance with the provisions of sections 811a and 811b of the *Local Government Act 1958*.

3. The period of the loan shall be fifteen (15) years.

4. The moneys borrowed shall be repayable by providing out of the municipal fund thirty (30) half-yearly instalments of approximately \$1,820.14 each, including principal and interest, on the 10th days of June and December. The first instalment shall be payable on 10th June, 1974, and the final instalment on 10th December, 1988.

5. Such moneys shall be repayable to the Commercial Bank of Australia Limited, Melbourne.

The plans and specifications and the estimate of the cost of the proposed works and a statement showing the proposed expenditure of moneys to be borrowed are open for inspection at the office of the Council of the Shire of Goulburn, High-street, Nagambie.

Dated 30th October, 1973.

5194 J. L. MITCHELL, Shire Secretary.

SHIRE OF KORUMBURRA.

LOAN No. 65.

*Notice of Intention to Borrow the Sum of \$21,700 for Permanent Works and Undertakings.*

Notice is hereby given that the Council of the Shire of Korumburra proposes to borrow the principal sum of \$21,700, secured by a charge over the general rates of the municipality, such sum to be raised by the grant of a mortgage in accordance with the provisions of the *Local Government Act 1958*.

1. The maximum rate of interest that may be paid is 8.5 per cent. per annum.

2. The purpose for which the loan is to be applied is purchase of plant.

3. The period of the loan shall be five years.

4. The moneys borrowed shall be repayable by providing out of the municipal fund half-yearly instalments of principal and interest on the 20th day of June and the 20th day of December, during the currency of the loan. The first instalment shall be payable on the 20th day of June, 1974.

5. Such moneys shall be repayable to the Commonwealth Savings Bank of Australia.

The plans, specifications and estimates of the proposed expenditure of the moneys to be borrowed are open for inspection at the office of the Council, Commercial-street, Korumburra, during office hours.

5260 W. O. CLARK, Shire Secretary.

SHIRE OF KORUMBURRA.

LOAN No. 66.

*Notice of Intention to Borrow the Sum of \$78,000 for Permanent Works and Undertakings.*

Notice is hereby given that the Council of the Shire of Korumburra proposes to borrow the principal sum of \$78,000, secured by a charge over the general rates of the municipality, such sum to be raised by the grant of a mortgage in accordance with the provisions of the *Local Government Act 1958*.

1. The maximum rate of interest that may be paid is 8.8 per cent. per annum.

2. The purpose for which the loan is to be applied is:—

Off-street parking	.. .. .	\$6,000
Saleyards extension	.. .. .	7,000
Extensions to pre-school centre, Poowong	.. .. .	6,000
Industrial land development	.. .. .	30,000
Construction of pre-school centre, Loch	.. .. .	29,000
		\$78,000

3. The period of the loan shall be fifteen years.

4. The moneys borrowed shall be repayable by providing out of the municipal fund half-yearly instalments of principal and interest on the 20th day of June and the 20th day of December during the currency of the loan. The first instalment shall be payable on the 20th day of June, 1974.

5. Such moneys shall be repayable to the Commonwealth Savings Bank of Australia.

The plans, specifications and estimates of the proposed expenditure of the moneys to be borrowed are open for inspection at the office of the Council, Commercial-street, Korumburra, during office hours.

5259 W. O. CLARK, Shire Secretary.

SHIRE OF MANSFIELD.

By-Law No. 58.

A By-Law of the Shire of Mansfield made under Sections 198 (3), 212, 213 (1), 222 and 228 of the *Local Government Act 1958* as amended and Clause 815 of the Uniform Building Regulations, Victoria 1969, and numbered 58 for determining, applying, dispensing with or regulating such matters or things as are left to be determined, applied, dispensed with or regulated by, the Council of the Shire of Mansfield under the *Local Government Act 1958* as amended and the Uniform Building Regulations, Victoria, 1969.

In pursuance of the powers conferred by the *Local Government Act 1958* as amended and the Uniform Building Regulations, Victoria, 1969 and of any or every power it thereunto enabling, the President, Councillors and Ratepayers of the Shire of Mansfield order as follows:—

1. By-Laws numbered 30, 33, 35, 36 and 46 of the Shire of Mansfield are hereby repealed on the coming into operation of the By-Law.

2. This By-Law shall come into operation and have full effect on the day after publication of the notice of the making thereof in the *Victorian Government Gazette* after having received approval of the Governor in Council.

3. This By-Law shall apply to and have operation throughout the whole of the municipal district of the Shire of Mansfield.

4. The minimum area, depth and width of frontage etc., as specified in Column 4 of Table 804 of the Uniform Building Regulations, Victoria, 1969 (hereafter called the Regulations) are hereby adopted as the minimum area, width and depth of frontage etc., of land on which a building of Classes I and II occupancy shall be constructed throughout that portion (or those portions) of the municipal district of the Shire of Mansfield as defined in Clause 3 of this By-Law.

5. The maximum number of storeys, including the ground storey of a building of Classes II and III occupancy shall be three storeys except where the ground storey is devoted exclusively to the parking of wheeled vehicles, the building may contain four storeys.

6. In the case of a building on any land forming part of a subdivision approved by the Council and lodged with the Office of Titles prior to the date of commencement of the Regulations, the requirements of Clause 813 of the Regulations may be dispensed with, by resolution of the Council.

7. Any person or persons or members of bodies corporate or incorporate failing to comply with the provisions of the By-Law shall be deemed to have committed an offence against the By-Law and be subject to the following penalties:—

- (i) For a wilful act or default contrary to this By-Law be subject to a minimum penalty of \$10.00 and a maximum penalty of \$100.00.
- (ii) For a second offence a minimum penalty of \$40.00 and a maximum penalty of \$100.00.
- (iii) For any subsequent offence a minimum penalty of \$60.00 and a maximum penalty of \$100.00.
- (iv) In the case of a continuing offence be subject to a penalty of \$10.00 for each day on which any offence against the By-Law is continued after a conviction or order by any Court, provided that the maximum penalty for a continuing offence shall not exceed \$500.00.
- (v) In addition to penalties herein before prescribed any expense incurred by the Council in consequence of a breach of the By-Law or in the execution of work directed by the By-Law to be executed by any person and not executed by him shall be paid by the person committing such breach or failing to execute such work.

The Resolution for making and passing this By-Law was agreed to by the Council of the Shire of Mansfield on the 26th day of July, 1972.

Confirmed on the 23rd day of August, 1972.

The common seal of the President, Councillors and Ratepayers of the Shire of Mansfield was hereunto affixed in the presence of—

(SEAL) R. W. BOSTOCK, President.  
GEORGE CUMMINS, Councillor.  
E. CAIRNS, Secretary.

Approved by the Governor in Council this 31st day of July, 1973.—T. J. FORRISTAL, Clerk of the Executive Council. 5271



## SHIRE OF MIRBOO.

## LOAN No. 23.

*Notice of Intention to Borrow the Sum of \$21,000 for Permanent Works and Undertakings.*

Notice is hereby given that the Council of the Shire of Mirboo proposes to borrow the principal sum of \$21,000, secured by a charge over the general rates of the municipality, such sum to be raised by the grant of a mortgage in accordance with the provisions of the *Local Government Act 1958*.

1. The maximum rate of interest that may be paid is 8.5 per centum per annum.

2. The purpose for which the loan is to be applied is purchase of plant and equipment being 1 tipping truck, 1 utility, 1 front-end loader, 1 pump, 1 slasher, and two-way radio equipment.

3. The period of the loan shall be five (5) years.

4. The moneys borrowed shall be repayable by providing out of the municipal fund half-yearly instalments of approximately \$2,621.43 each, including principal and interest on the 1st day of July and the 1st day of January during the currency of the loan. The first instalment shall be payable on the 1st day of July, 1974.

5. Such moneys shall be repayable to the National Bank Savings Bank Limited, Melbourne.

The plans and specifications and the estimate of the cost of the proposed works and a statement showing the proposed expenditure of the moneys to be borrowed are open for inspection at the office of the Council of the Shire of Mirboo, Shire Offices, Mirboo North.

29th October, 1973.

5192 D. A. CARTLEDGE, Shire Secretary.

## Water Acts.

## BRIAGOLONG WATERWORKS TRUST.

## EXTENSION OF WATERWORKS DISTRICT AND CONSTRUCTION OF WORKS FOR THE SUPPLY OF WATER TO THE TOWNSHIP OF BOISDALE.

Notice is hereby given that the Briagolong Waterworks Trust has made application to the Honorable the Minister for Water Supply for the extension of its Waterworks District, and for the construction, maintenance and continuance of Water Supply Works within that district under the provisions of the Water Acts.

A general plan and description of the proposed works have been submitted with the application, and copies of same may be seen at Trust Office at Shire Office, Johnson-street, Maffra, 3860.

Dated at Maffra, the 18th day of October, 1973.

5032 J. RENNICK, Secretary.

## GEELONG WATERWORKS AND SEWERAGE TRUST.

Pursuant to section 60 of the *Geelong Waterworks and Sewerage Act 1958* (No. 6263), the Trust has prepared plans to indicate the particulars of sewers and underground works, the construction of which the Trust intends to begin at a date, not less than one month after publication of the notice, in or adjacent to the following localities within the Drainage Area.

Burdoo-drive, Mandama and Ainslie avenues, Gurley, Garie, Tomah, Marlee and Timbarra courts, and Corang-avenue, Grovedale, Shire of South Barwon.

Donnybrook-road and Page-street, Norlane, Shire of Corio.

Notice is hereby given that the plans indicated above are open for public inspection at the Trust's Offices, Ryrie-street, Geelong, between the hours of 9 a.m. and 5 p.m., from Monday to Friday (public holidays excepted), by the owners or occupiers of land or premises within the Drainage Area.

5204 B. C. HENSHAW, Secretary.

## SWAN HILL SEWERAGE AUTHORITY.

## GENERAL NOTICE.

The above-mentioned Sewerage Authority having made provision for carrying off the sewage from each and every property which or any part of which is within the sewerage area hereinafter described doth hereby declare that on and after the 1st day of October, 1973, each and every

property which or any part of which is within the said sewerage area shall be deemed to be a sewered property within the meaning of the *Sewerage Districts Act 1958*.

The boundaries of the sewerage area herein before referred to are:—

## Sewerage Area No. 8A.

Commencing at the south-eastern angle of Crown allotment E, section 7A, Township of Swan Hill, Parish of Castle Donnington, County of Tatchera, being a point on the boundary of the existing sewerage district; thence northerly along the eastern boundary of Crown allotments D and E, section 7A, to the north-eastern angle of Crown allotment D, section 7A; thence easterly by a line across a road to the south-western angle of Crown allotment A, section 6A; thence easterly along the southern boundary of said Crown allotment A, to its south-eastern angle; thence northerly along the western boundary of lot 12 on lodged plan No. 63067 being parts of Crown allotments B and D of section 6A, to its north-western angle; thence easterly along the northern boundary of said lot 12, to its north-eastern angle; thence southerly along the eastern boundary of said lot 12 to a point on the boundary of said lot 12 being the north-western angle of lot 11 on lodged plan No. 63067, being parts of Crown allotments B and D, section 6A; thence easterly along the northern boundary of said lot 11 to its north-eastern angle being also the north-western angle of lot 10 on lodged plan No. 63067, being parts of Crown allotments B, C and D, section 6A; thence north-easterly along the boundary of said lot 10 for a distance of 21 ft. 2½ in. at a bearing of 52 deg. 44 min.; thence easterly along the northern boundary of said lot 10, also lots 9, 8 and 7 on lodged plan No. 63067, being parts of Crown allotments C, D and K, section 6A, to the north-eastern angle of said lot 7; thence southerly along the eastern boundary of said lot 7 to its south-eastern angle; thence generally easterly by a line across a road to the north-western angle of lot 10 on lodged plan No. 63067, being part Crown allotment D, section 5A; thence easterly along the northern boundary of said lot 20 to its north-eastern angle; thence southerly along the eastern boundary of said lot 20 to its south-eastern angle being a point on the boundary of the existing sewerage district; thence generally westerly and southerly along the boundary of the existing sewerage district to the point of commencement.

## Sewerage Area No. 9A.

Commencing at the south-eastern angle of lot 1 on lodged plan No. 81955, being part of Crown allotment 11, section A, Parish of Castle Donnington, County of Tatchera; thence northerly along the eastern boundary of said Crown allotment 11, to its north-eastern angle; thence easterly by a line across a road to the north-western boundary of Crown allotment 7, section A; thence southerly along the western boundary of said Crown allotment 7 for a distance of 1,250 ft. 6 in. to a point on the point on the western boundary of said Crown allotment 7; thence easterly for a distance of 856 feet at a bearing of 92 deg. 13 min. to a point; thence southerly for a distance of 185 ft. 9 in. at a bearing of 19 deg. 40 min. 30 sec. to a point; thence south-westerly for a distance of 50 feet at a bearing of 38 deg. 7 min. 30 sec. to a point; thence westerly for a distance of 89 ft. 3 in. at a bearing of 117 deg. 54 min. to a point; thence south-westerly for a distance of 140 ft. 5½ in. at a bearing of 37 deg. 26 min. 30 sec. to a point being the north-eastern angle of lot 70, lodged plan No. 98896, being part Crown allotment 7, section A; thence south-westerly along the eastern boundary of said lot 70; thence southerly along the eastern boundary of Dowling-court to the north-eastern angle of lot 71, on lodged plan No. 98896, being part Crown allotment 7, section A; thence southerly along the boundary of said lot 71 and also lot 76 on lodged plan No. 98612, being part Crown allotment 7, section A to the south-eastern angle of said lot 76; thence by a line across a road to the eastern angle of lot 113, lodged plan No. 98612, being part Crown allotment 7, section A; thence south-westerly along the south-eastern boundary of said lot 113 to its south-eastern angle; thence westerly along its southern boundary to the north-eastern angle of lot 109 on lodged plan No. 98612, being part Crown allotment 7, section A; thence southerly along the eastern boundary of said lot 109 and also lots 108 and 107 on said lodged plan No. 98612 to the south-eastern angle of said lot 107; thence westerly along the southern boundary of said lot 107 and also lots 106 and 105 on said lodged plan No. 98612 and also lot 96 on lodged plan No. 93850, being part Crown allotment 7, section A to the south-western angle of said lot 96; thence by a line across a road to the point of commencement.

By order of the Swan Hill Sewerage Authority,

A. R. CLARK, Chairman.

J. W. KELLOCK, Secretary.

5273

LILYDALE SEWERAGE AUTHORITY.  
TEMPORARY SEWAGE TREATMENT PLANT.

Notice is hereby given that for the purpose of sewerage a portion of the Township of Montrose, a temporary sewage treatment plant will be constructed at the following location:—

Montrose—Part Lot 4, on L.P.5699 Moore-avenue, Montrose.

Further information may be obtained from the Officers of the Authority.

5067 F. O. KENT, Secretary.

Notice is hereby given that the partnership carried on under the firm name of "Honey De Sherrin" has been dissolved as from 1st October, 1973. Details of debts due and owing by the said business must be forwarded to the receiver and manager, John Martin Walsh, of 296 Little Lonsdale-street, Melbourne, within seven days of the date hereof.

Dated this 7th day of November, 1973.

J. M. WALSH, Receiver and Manager.

Kennedy, Smail & Middlemiss, 296 Little Lonsdale-street, Melbourne, 3000. 5251

Notice is hereby given that the partnership heretofore existing between Joseph Clarence Bull, Robert Clarence Bull, David James Bull and James Walter Bull, all of Metung, under the name of J. C. Bull & Staff, at Metung, was dissolved on the 26th day of October, 1973. All debts owing to and owing by the late firm will be collected and paid by Bull's Shipyards Pty. Ltd., of Main-road, Metung.

Dated the 26th day of October, 1973.

JOSEPH C. BULL.  
R. C. BULL.  
D. J. BULL.  
JAMES W. BULL.

J. Allan Anderson & Son, solicitors, 472 Bourke-street, Melbourne. 5210

Partnership between Reginald Alwyn Bird, of 7 Scott-street, Mitcham, and Robert Edwin Ketteridge, of 3 Magnolia-street, Wantirna, carried on at 30 Clarice-road, Box Hill South, under the name of Fibre-Fix, has been dissolved as from the 19th day of April, 1973, and the said business is now being carried on under the business name of Fibre-Fix by Reginald Alwyn Bird. 5235

Notice is hereby given that the partnership heretofore subsisting between Raymond John Harris and Philip Edward Arnold Hallum, carrying on the business of direct mail advertising at 166 Toorak-road, South Yarra, under the business name of "Harris Wilson & Associates", has been dissolved as from the 30th day of October, 1973. All debts due to and owing by the late partnership will be received and paid respectively by Raymond John Harris, who will continue to carry on the said business.

5285 RAYMOND JOHN HARRIS.  
PHILIP EDWARD ARNOLD HALLUM.

Notice is hereby given that Brooklands-Machins Proprietary Limited has applied for a lease, pursuant to sections 134 and 135 of the Land Act 1958, over allotment 12, section B, City of South Melbourne, Parish of Melbourne South, containing 3,855 square metres more or less, for a period of 35 years for commercial and industrial purposes.

4915 R. F. PURSER, Secretary.

Companies Act 1961.—In the matter of I. P. SHARP ASSOCIATES (AUST.) PROPRIETARY LIMITED (in Liquidation).

Notice is hereby given that, at an Extraordinary Meeting of the members of the above-named company, held on the 31st day of October, 1973, it was resolved that the company be wound up voluntarily, and at a meeting of creditors held on the same day pursuant to section 260, it was resolved that for such purpose, Philip Douglas George, of Arthur Young & Co., 440 Collins-street, Melbourne, be appointed liquidator.

Notice is also given that after 21 days from this date I shall proceed to distribute the assets. All creditors having any claim against the company should furnish particulars of same by that date, otherwise I shall proceed to distribute the assets without regard to their claim.

Dated this 31st day of October, 1973.

P. D. GEORGE, Liquidator.

Arthur Young & Company, chartered accountants, 440 Collins-street, Melbourne, 3000. 5252

The Companies Act 1961.

AURORA INVESTMENTS PROPRIETARY LIMITED (IN LIQUIDATION).

PURSUANT TO SECTIONS 254 AND 258.

At an Extraordinary General Meeting of the members of Aurora Investments Proprietary Limited, convened and held at the offices of Messrs. Wilson Danby Perry Johnson, 9th Floor, 461 Bourke-street, Melbourne, on 31st October, 1973, the following Special Resolution was duly passed:—

"That the company be wound up voluntarily in accordance with the Companies Act 1961, and that James Collier Benzie and Anthony Simpson Furze, chartered accountants, of 9th Floor, 461 Bourke-street, Melbourne, be appointed joint and several liquidators of the company, with the power to distribute the assets of the company in specie and at a fee calculated in accordance with the rates recommended by the Institute of Chartered Accountants in Australia."

5253 SUSAN ANSON, Director.

Companies Act 1961.

MARIGNY (W.A.) PROPRIETARY LIMITED (IN VOLUNTARY LIQUIDATION).

MEMBERS' WINDING UP.

Notice is hereby given that at the Extraordinary General Meeting of the above-named company, duly convened and held at 177 Collins-street, Melbourne, on the 31st day of October, 1973, the following Resolution was proposed and passed as a Special Resolution:—

"That the company be placed in liquidation and that the company secretary, Ronald Percy Beards, be appointed as liquidator."

Dated this 31st day of October, 1973.

5232 R. P. BEARDS, Liquidator.

The Companies Act 1961.

SWANCO DAIRYFARMERS LIMITED (IN VOLUNTARY LIQUIDATION).

NOTICE OF FINAL MEETING.

Notice is hereby given that, pursuant to section 272 of the Companies Act 1961, a Final Meeting of the members of the above-named company will be held at the office of the liquidator, 37 Queen-street, Melbourne, on the 3rd December, 1973, at 10 a.m., for the purpose of presenting the liquidator's account of the winding up.

Dated this 1st November, 1973.

R. R. CROZIER, Liquidator.

Leane & Crozier, chartered accountants, 7th Floor, 37 Queen-street, Melbourne, 3000. 5255

The Companies Act 1961.—In the matter of KRUSE & WEIR PTY. LTD. (in Liquidation).

Notice is hereby given that, at an Extraordinary General Meeting of the members of the above-named company, held on the 22nd October, 1973, it was resolved that the company be wound up voluntarily, and that Messrs. Peter William Harvey and Gavin John Hosking be nominated as joint and several liquidators for the purpose of such winding up; and that at a meeting of creditors held later on the same day our appointment as liquidators was confirmed.

Notice is also given that persons having claims against the company should lodge a proof of debt within 21 days at our office, at 447 Collins-street, Melbourne.

Dated this 28th day of October, 1973.

P. W. HARVEY,

G. J. HOSKING,

Joint and Several Liquidators.

Price Waterhouse & Co., chartered accountants, 447 Collins street, Melbourne. 5256

Companies Act 1961.

MAYCO (AUST.) PROPRIETARY LIMITED (IN VOLUNTARY LIQUIDATION).

MEMBERS' WINDING UP.

Notice is hereby given that at the Extraordinary General Meeting of the above-named company, duly convened and held at 177 Collins-street, Melbourne, on the 31st day of October, 1973, the following Resolution was proposed and passed as a Special Resolution:—

"That the company be placed in liquidation and that the company secretary, Ronald Percy Beards, be appointed as liquidator."

Dated this 31st day of October, 1973.

5233 R. P. BEARDS, Liquidator.

*Companies Act 1961, Section 272.***HUME HOLDINGS PROPRIETARY LIMITED (IN VOLUNTARY LIQUIDATION).**

Notice is hereby given that a Final Meeting of members of the above company will be held at the offices of Arthur Andersen & Co., 330 Collins-street, Melbourne, on 19th December, 1973, at 10.30 a.m., for the purpose of receiving an account showing how the winding up has been conducted and the property of the company disposed of.

Dated this 25th day of October, 1973.  
5199 JOHN B. BURROWS, Liquidator.

*Companies Act 1961.***H. & E. LLOYD PTY. LTD.****PURSUANT TO SECTION 254 (2).**

At an Extraordinary General Meeting of the above-named company, duly convened and held at 16 Mt. Pleasant-road, Monbulk, on the 25th day of October, 1973, the following Resolution was duly passed as a Special Resolution:—

“That the company be wound up voluntarily.”

And at such last-mentioned meeting, John Paul Fanning, of 406 Lonsdale-street, Melbourne, was appointed Liquidator for the purposes of the winding up.

Dated the 25th October, 1973.  
5198 H. I. LLOYD, Chairman.

**DANDENONG No. 2 CO-OPERATIVE HOUSING SOCIETY LIMITED (IN VOLUNTARY LIQUIDATION).**

Take notice that the affairs of the above-named society are now fully wound up and that, in pursuance of section 272 (1) of the *Companies Act 1961*, and of the *Co-operative Housing Societies Act 1958*, a General Meeting of the society will be held at Town Hall, Ground Floor, Lonsdale-street, Dandenong, on Monday, 10th December, 1973, at 8 p.m., for the purpose of—

- (1) laying before it an account showing how the winding up has been conducted and the property of the society disposed of and giving any explanations thereof; and
- (2) passing a Resolution that the books and papers of the said society and of the liquidator, relevant to the affairs of the society, to be destroyed after a period of twelve months from the date of the meeting.

Dated the 2nd day of November, 1973.  
5223 A. C. DOWNARD, Liquidator.

*Companies Act 1961.***MARIGNY (N.S.W.) PROPRIETARY LIMITED (IN VOLUNTARY LIQUIDATION).****MEMBERS' WINDING UP.**

Notice is hereby given that at the Extraordinary General Meeting of the above-named company, duly convened and held at 177 Collins-street, Melbourne, on the 31st day of October, 1973, the following Resolution was proposed and passed as a Special Resolution:—

“That the company be placed in liquidation and that the company secretary, Ronald Percy Beards, be appointed as liquidator.”

Dated this 31st day of October, 1973.  
5229 R. P. BEARDS, Liquidator.

In the matter of the *Companies Act 1961*; and in the matter of WRIGHTBILT (VICTORIA) PTY. LIMITED (in Liquidation).

Notice is hereby given that in pursuance of section 272 of the *Companies Act 1961*, a Final Meeting of the members of the above company will be held at the offices of Price Waterhouse & Co., 14th Floor, National Mutual Centre, 447 Collins-street, Melbourne, Victoria, on 5th December, 1973, at 9.45 a.m. This meeting is convened for the purpose of having an account laid before the members showing the manner in which the winding up has been conducted and the property of the company disposed of and of having any explanations that may be given by the liquidator and also of determining the manner in which the books, accounts and documents of the company and of the liquidator thereof shall be disposed of.

Dated this 2nd day of November, 1973.

RUSSELL EDWIN CHANCELLOR, liquidator, care of Price Waterhouse & Co., 14th Floor, National Mutual Centre, 447 Collins-street, Melbourne, Victoria. 5254

*Companies Act 1961.***MARIGNY (Q'LD.) PROPRIETARY LIMITED (IN VOLUNTARY LIQUIDATION).****MEMBERS' WINDING UP.**

Notice is hereby given that at the Extraordinary General Meeting of the above-named company, duly convened and held at 177 Collins-street, Melbourne, on the 31st day of October, 1973, the following Resolution was proposed and passed as a Special Resolution:—

“That the company be placed in liquidation and that the company secretary, Ronald Percy Beards, be appointed as liquidator.”

Dated this 31st day of October, 1973.  
5230 R. P. BEARDS, Liquidator.

*Companies Act 1961.***MARIGNY (S.A.) PROPRIETARY LIMITED (IN VOLUNTARY LIQUIDATION).****MEMBERS' WINDING UP.**

Notice is hereby given that at the Extraordinary General Meeting of the above-named company, duly convened and held at 177 Collins-street, Melbourne, on the 31st day of October, 1973, the following Resolution was proposed and passed as a Special Resolution:—

“That the company be placed in liquidation and that the company secretary, Ronald Percy Beards, be appointed as liquidator.”

Dated this 31st day of October, 1973.  
5231 R. P. BEARDS, Liquidator.

The *Companies Act 1961*.—In the matter of DUNSTAN'S ENGINEERING & TRANSPORT Co. PTY. LTD. (in Liquidation).

A Second and Final Dividend is intended to be declared in the above-mentioned matter. Creditors who have not proved their debts by the 21st day of November, 1973 will be excluded from the dividend.

Dated this 1st day of November, 1973.

EDWARD RONALD SMAIL, Liquidator.  
Kennedy, Smail & Middlemiss, 296 Little Lonsdale-street, Melbourne, 3000. 5250

*Companies Act 1961 Section 272 (2).***TIMONK INVESTMENTS PROPRIETARY LIMITED (MEMBERS' VOLUNTARY WINDING-UP).****NOTICE OF FINAL MEETING AND DISSOLUTION.**

Notice is hereby given that a General Meeting of the members of Timonk Investments Proprietary Limited will be held at 155 Wellington-parade south, Jolimont on the 30th November, 1973, at 10 a.m. for the purpose of laying before the meeting an account showing how the winding up has been conducted and the property of the company has been disposed of, and of giving any explanation of the account and also of determining by Extraordinary Resolution the manner in which the books, accounts and documents of the company and of the liquidator thereof shall be disposed of.

Dated this 31st day of October, 1973.  
5239 ALLAN NAHUM, Liquidator.

In the Supreme Court of Victoria.—Co. 8716 of 1973.—In the matter of the *Companies Act 1961*; and in the matter of R. D. HANNAH & SONS PTY. LTD.—Notice of Winding Up Order.

In the matter of R. D. Hannah & Sons Pty. Ltd., winding up order made 31st day of October, 1973. Bruce Henry Smith Liquidator, of 343 Little Collins-street, Melbourne.

LYNCH & MacDONALD, 118 Queen-street, Melbourne, 3000, solicitors for the petitioner. 5240

In the matter of the *Companies Act 1961*; and in the matter of MARBUT SAWMILLS PTY. LIMITED.

The Special Resolution set out hereunder was duly passed by Marbut Sawmills Pty. Limited, on the 2nd day of November, 1973: (a) That the company be wound up voluntarily; (b) That Mr. D. D. Carlisle, chartered accountant, of Suite 3916, 39th Level, Australia Square, Sydney, be appointed as the liquidator of the company.

Dated this 2nd day of November, 1973.  
5258 D. D. CARLISLE, Liquidator.

In the matter of the *Companies Act 1961*; and in the matter of UNITED KINGDOM GUARANTEE CORPORATION LIMITED (in Liquidation).

Notice is hereby given that, at an Extraordinary General Meeting of the members of the above-mentioned company, held on the 11th of October, 1973, it was resolved by Special Resolution that the company be wound up voluntarily.

Notice is also given that persons having claims against the company should lodge a proof of debt within 21 days at my office, at 447 Collins-street, Melbourne.

Dated this 17th day of October, 1973.

P. W. HARVEY, Liquidator.

Price Waterhouse & Co., chartered accountants, 447 Collins-street, Melbourne. 5282

**MINA PRODUCTIONS PTY. LIMITED.**

**NOTICE OF RESOLUTION.**

To the Registrar of Companies.

At a General Meeting of the members of Mina Productions Pty. Limited, duly convened and held at 10 Judith-street, Carnegie, on the 28th day of October, 1973, the Special Resolution set out below and signed by me for the purposes of identification was duly passed:—

"That Mina Productions Pty. Limited be voluntarily wound up under section 260 of the *Companies Act 1961*, and that Mr. R. Harari, of 39 Wellington-street, Windsor, registered liquidator, be appointed as liquidator of the company."

Dated this 29th day of October, 1973.

5263 MYER WEINSTOCK, Director.

In the matter of the *Companies Act 1961*; and in the matter of UNITED KINGDOM GUARANTEE CORPORATION LIMITED (in Liquidation).

Notice is hereby given that, pursuant to section 272 of the *Companies Act 1961*, the Final Meeting of the members and creditors of the company will be held at Price Waterhouse & Co., on the 3rd day of December, 1973, at 3 p.m., for the purpose of laying before the meeting the account of the winding up and any explanation thereof.

Dated this 31st day of October, 1973.

5283 P. W. HARVEY, Liquidator.

In the matter of the *Companies Act 1961*; and in the matter of GEPPETTO LEATHERWEARS PTY. LTD. (in Liquidation).

Notice is hereby given that, pursuant to section 272 of the *Companies Act 1961*, the Final Meeting of the members and creditors of the company will be held at the offices of Marquand & Co., 51 Queen-street, Melbourne, on the 14th day of January, 1974, at 9.30 a.m., for the purpose of laying before the meeting the account and any explanation thereof.

Dated this 5th day of November, 1973.

5284 V. K. REYNOLDS, Liquidator.

**The Companies Act 1961, Section 272 (1), Form 92.  
Companies Regulations.**

**MITCHELLS DRY CLEANING PROPRIETARY LIMITED  
(IN LIQUIDATION).**

**NOTICE OF MEETING OF CONTRIBUTORIES.**

Notice is hereby given that a Final Meeting of the contributories of Mitchells Dry Cleaning Proprietary Limited (in liquidation), will be held at 6th Floor, 470 Bourke-street, Melbourne, on Friday, 7th December, 1973, at 11 o'clock in the forenoon.

**Agenda.**

To receive the liquidator's account of his acts and dealings and of the conduct of the winding up and of hearing any explanations thereof.

Dated this 2nd of November, 1973.

5294 R. A. WATERS, Liquidator.

In the matter of the *Companies Act*; and in the matter of MALONGA SECURITIES PTY. LIMITED.

Notice is hereby given that at an Extraordinary General Meeting of the above-named company duly convened and held at the offices of Messrs. Gillott, Moir & Winneke, solicitors, of 95 Queen-street, Melbourne, on the 5th day of November, 1973, at 10.30 o'clock in the forenoon, the following Special Resolution was duly passed viz:—

That the company be wound up voluntarily and that John Barry Hutchins, of 81 Iona-street, Black Rock, in the State of Victoria, be appointed liquidator for the purpose of such winding up.

5287 D. M. HUTCHINSON, Chairman of Directors.

The *Companies Act 1961*.—In the matter of P.F. COPYING SERVICES PTY. LTD. (in Liquidation).

Notice is hereby given that at an Extraordinary General Meeting of the members of the above-named company held on the 24th October, 1973, it was resolved that the company be wound up voluntarily and that Messrs. Peter William Harvey and Gavin John Hosking, be nominated as joint and several liquidators for the purpose of such winding up and that at a meeting of creditors held later on the same day, our appointment as liquidators was confirmed.

Notice is also given that persons having claims against the company should lodge a proof of debt within 21 days, at our office, at 447 Collins-street, Melbourne.

Dated this 30th day of October, 1973.

P. W. HARVEY,  
G. J. HOSKING,

Joint and Several Liquidators.

Price, Waterhouse & Co., chartered accountants, 447 Collins-street, Melbourne. 5279

**AUSTAI TRADING COMPANY PROPRIETARY LIMITED.**

At a General Meeting of the members of Austai Trading Company Proprietary Limited, duly convened and held at 66 Sukhumvit 23, Bangkok, Thailand, on the 25th day of October, 1973, the following Special Resolution was duly passed:—

"That Austai Trading Company Proprietary Limited, be wound up voluntarily."

Dated this 25th day of October, 1973.

5265 C. BOONSOONG, Director.

The *Companies Act 1961*.—In the matter of FAWKNER TILES PTY. LTD. (in Liquidation).

Notice is hereby given that at an Extraordinary General Meeting of the members of the above-named company held on the 23rd October, 1973, it was resolved that the company be wound up voluntarily and that Messrs. Peter William Harvey and Gavin John Hosking, be nominated as joint and several liquidators for the purpose of such winding up and that at a meeting of creditors held later on the same day, our appointment as liquidators was confirmed.

Notice is also given that persons having claims against the company should lodge a proof of debt within 21 days, at our office, at 447 Collins-street, Melbourne.

Dated this 29th day of October, 1973.

P. W. HARVEY,  
G. J. HOSKING,

Joint and Several Liquidators.

Price, Waterhouse & Co., chartered accountants, 447 Collins-street, Melbourne. 5280

The *Companies Act 1961*.—In the matter of CAMERON CONSTRUCTIONS PTY. LTD. (in Liquidation).

Notice is hereby given that at an Extraordinary General Meeting of the members of the above-named company held on the 30th October, 1973, it was resolved that the company be wound up voluntarily and that Messrs. Peter William Harvey and Gavin John Hosking, be nominated as joint and several liquidators for the purpose of such winding up and that at a meeting of creditors held later on the same day, our appointment as liquidators was confirmed.

Notice is also given that persons having claims against the company should lodge a proof of debt within 21 days, at our office, 447 Collins-street, Melbourne.

Dated 1st day of November, 1973.

P. W. HARVEY,  
G. J. HOSKING,

Joint and Several Liquidators.

Price, Waterhouse & Co., chartered accountants, 447 Collins-street, Melbourne, 3000. 5281

**VICTORIAN TOBACCO GROWERS' CO-OPERATIVE  
SOCIETY LTD. (IN VOLUNTARY LIQUIDATION).**

At an Extraordinary General Meeting of shareholders of Victorian Tobacco Growers' Co-operative Society Ltd., duly convened and held at Myrtleford, on the 24th October, 1973, the following Special Resolution was duly passed:—

"That the company be wound up voluntarily and that Mr. Alexander Luxmoore Macgeorge, F.A.S.A., of 25 Ely-street, Wangaratta, be appointed liquidator."

Dated this 31st day of October, 1973.

5264 A. L. MACGEORGE.

Creditors, next of kin and others having claims against the estate of Annie Victoria Moore (also known as Anna Victoria Moore), late of 4 Riversdale-court, Hawthorn, in the State of Victoria, widow, deceased (who died on the

13th August, 1973), are requested by the executors of the will of the said deceased, The Equity Trustees, Executors and Agency Company Limited, of 472 Bourke-street, Melbourne, in the said State, Ian Heywood McKinnon, of 33 Barina-road, Glen Iris, in the said State, sharebroker, and Malcolm Stewart McKinnon, of 18 Gardenia-street, Blackburn, in the said State, accountant (Malcolm Stewart Moore, the other executor named therein having predeceased the testatrix), to send particulars of their claims to the executors, on or before 14th January, 1974, after which date the executors will distribute the assets, having regard only to the claims which it shall then have had notice.

ELLISON, HEWISON & WHITEHEAD, solicitors, 379 Collins-street, Melbourne, 3000. 5286

MARY MERITON, late of Flat 1, 73 Darebin-road, Northcote, widow, DECEASED.

Pursuant to the *Trustee Act 1958* notice is hereby given that all persons having claims against the estate of the said deceased (who died on the 26th day of July, 1973 and probate of whose will was granted by the Supreme Court of Victoria, on the 7th day of September, 1973, to Thomas McPherson Gibson, of 87 Armstrong-street, Middle Park, judge's associate) are hereby required to send particulars in writing of such claims to the solicitors hereunder mentioned on or before the 14th day of January, 1974, after which date the said Thomas McPherson Gibson, will proceed to distribute the assets of the said Mary Meriton deceased which so have come to his hands amongst the persons entitled thereto having regard only to the claims of which he shall then have had notice.

And notice is hereby further given that the said Thomas McPherson Gibson, will not be liable for the assets so distributed or any part thereof to any person of whose claim he shall not have had notice as aforesaid.

ALAN WAINWRIGHT & CO., solicitors, 397 Little Collins-street, Melbourne. 5248

DAISY EMILY DICKIE, late of 1 Carramar-avenue, Glen Waverley, in the State of Victoria, widow, DECEASED.

Creditors, next of kin and others having claims in respect of the estate of the deceased (who died on the 26th day of May, 1973), are required by the executrix, Gladys Morris, of 1 Carramar-avenue, Glen Waverley, to send particulars of their claims to her, in the care of the under-mentioned solicitor, by the 9th day of January, 1974, after which date she will distribute and/or convey the assets amongst the persons entitled thereto, having regard only to the claims of which she then has notice.

RICHARD K. PITMAN, solicitor, corner Kingsway and Railway-parade, Glen Waverley, 3150. 5221

JOHN APPLETON, late of 5 Monterey-avenue, Glen Waverley, in the State of Victoria, supervisor, DECEASED.

Creditors, next of kin and others having claims in respect of the estate of the deceased (who died on the 18th day of April, 1973), are required by the executrix, Ethel Appleton, of 5 Monterey-avenue, Glen Waverley, to send particulars of their claims to her, in the care of the under-mentioned solicitor, by the 9th day of January, 1974, after which date she will distribute and/or convey the assets amongst the persons entitled thereto, having regard only to the claims of which she then has notice.

RICHARD K. PITMAN, solicitor, corner Kingsway and Railway-parade, Glen Waverley, 3150. 5222

Creditors, next of kin and others having claims in respect of the will of Patrick Luke Thornton, late of 26 Wolseley-parade, Kensington, retired (who died on the 17th day of September, 1973), are requested to send particulars of their claims to the executors, Andrew William Blackwood and Ursula Anne Blackwood, care of the under-mentioned solicitor, by the 16th day of January, 1974, after which date they will distribute the assets, having regard only as to the claims of which they then have notice.

JOHN STEWART, solicitor, of 290 Racecourse-road, Newmarket. 5224

JOSEPH HARDY TURNER, late of 18 Harold-court, Whittlesea, retired, DECEASED.

Creditors, next of kin and others having claims against the estate of the said deceased (who died on the 17th February, 1973), are to send particulars of their claims to John William Turner, care of 591 Grimshaw-street, Bundoora, by the 11th January, 1974, after which date he will distribute the assets, having regard only to the claims of which he then has notice.

JOHNSTON & BURNES, solicitors, 591 Grimshaw-street, Bundoora. 5225

HANNAH VERONICA WOOLLEY, late of Main-road, Panton Hill, DECEASED.

Creditors, next of kin and others having claims against the estate of the said deceased (who died on the 16th April, 1973), are to send particulars of their claims to Liana Maureen Shaw and Allan Bruce Shaw, care of 591 Grimshaw-street, Bundoora, by the 11th day of January, 1974, after which date they will distribute the assets, having regard only to the claims of which they then have notice.

JOHNSTON & BURNES, solicitors, 591 Grimshaw-street, Bundoora. 5227

Creditors, next of kin and others having claims in respect of the estate of Alice Frances Blackburn, late of 5 Arthur-avenue, Brighton, spinster, deceased (who died on the 25th July, 1973), are required by National Trustees, Executors and Agency Company of Australasia Limited, of 95 Queen-street, Melbourne, to send particulars to this company, by the 17th day of January, 1974, after which date it will distribute the assets, having regard only to the claims of which it has then had notice.

D. L. McNAMARA, solicitor, 193 Fitzroy-street, St. Kilda. 5228

ETHEL VERA McLEOD, late of Flat 170, 159 Melrose-street, North Melbourne, married woman, DECEASED.

Creditors, next of kin and others having claims in respect of the estate of the deceased (who died on the 8th day of July, 1973), are requested to send particulars of their claims to the executors Thelma Joyce Hudson and Frederick Henry Hudson, care of the undersigned solicitor by the 2nd January, 1974, after which date the said executors will proceed to distribute the estate having regard only to the claims of which they then have notice.

MARJORY C. COATES, solicitor, of 422 Collins-street, Melbourne, 3000. 5249

EMILY ALLEN, formerly of 139 Carpenter-road, Brighton, but late of 568 Middleborough-road, Blackburn, widow, DECEASED.

Creditors, next of kin and others having claims against the estate of the said deceased (who died on the 18th February, 1973), are to send particulars of their claims to Emily Grace Dutton and Percival Arthur Allen, care of 882 Whitehorse-road, Box Hill, by the 11th day of January, 1974, after which date they will distribute the assets, having regard only to the claims of which they then have notice.

SALISBURY, WARDLAW & CO., solicitors, 882 Whitehorse-road, Box Hill. 5266

ROBIN BERNARD CLEMENTS, late of 30 Snowdon-avenue, South Caulfield, retired farmer, DECEASED.

Creditors, next of kin and others having claims in respect of the deceased (who died on the 14th day of May, 1973), are required by his trustees, Patrick John Larkin, clerk, of 30 Snowdon-avenue, South Caulfield, and Thomas Benjamin Larkin, toolmaker, of 17 Hawdon-street, Heidelberg, to send particulars to them, care of the under-mentioned firm of solicitors, by the 16th day of January, 1974, after which date the trustees may convey and distribute the assets, having regard only to the claims of which they then have notice.

MAL. RYAN & GLEN, 9 High-street, Mansfield, solicitors for the trustees. 5268

Creditors, next of kin and others having claims in respect of the will of Alfred James Cameron, late of 39 Glenbervie-road, Strathmore, retired (who died on the 28th day of September, 1973), are requested to send particulars of their claims to the executrix, Shirley Beatrice Cameron, care of the under-mentioned solicitor, by the 18th day of January, 1974, after which date she will distribute the assets, having regard only to the claims of which she then has notice.

JOHN STEWART, of 290 Racecourse-road, Newmarket. 5270

KENNETH LESLIE BIRTLES, late of 29 Rostrevor-parade, Mont Albert North, accountant, DECEASED.

Creditors, next of kin and others having claims against the estate of the said deceased (who died on the 30th September, 1972), are to send particulars of their claims to Ann Macphail Birtles, care of 882 Whitehorse-road, Box Hill, by the 11th day of January, 1974, after which date she will distribute the assets, having regard only to the claims of which she then has notice.

SALISBURY, WARDLAW & CO., solicitors, 882 Whitehorse-road, Box Hill. 5207

MICHAEL FRANCIS KEANE, late of 19 Myrning-grove, Hawthorn East, retired, DECEASED.

Creditors, next of kin and others having claims in respect of the estate of the deceased (who died on the 9th day of May, 1973), are required by the executrices, Veronica Ellen Keane, office supervisor and Margaret Mary Keane, secretary, both of 19 Myrning-grove, Hawthorn East, to send particulars to them care of the undersigned solicitors by the 2nd day of January, 1974, after which date the executrices may convey or distribute the assets, having regard only to the claims of which they then have notice.

FREDERICK OWEN & ASSOCIATES, solicitors, 84 William-street, Melbourne, 3000. 5243

GWENDOLINE MAUD LAIDLAW BEGGS, late of "Koorngang", Hamilton, in the State of Victoria, widow, DECEASED.

Creditors, next of kin and others having claims in respect of the estate of the above-named deceased (who died on the 29th day of July, 1973), are required by the executors, The Union-Fidelity Trustee Company of Australia Limited, of 100 Exhibition-street, Melbourne, in the State of Victoria (in the will referred to as The Fidelity Trustee Company Limited of 101 Lydiard-street north, Ballarat in the State of Victoria), and Kenneth Montgomery Beggs, of 37 Elizabeth-street, Aitkenville, Townsville, in the State of Queensland, grazier, to send particulars to them, care of the under-mentioned solicitors, by the 14th day of January, 1973, after which date they will distribute the assets, having regard only to the claims of which they then have notice.

AITKEN, WALKER & STRACHAN, solicitors, 414 Collins-street, Melbourne. 5261

ADA GERTRUDE HARTNELL, late of Alice Berry Hospital, Kings-road, Emerald, widow, DECEASED.

Creditors, next of kin and others having claims in respect of the estate of the above-named deceased (who died on the 1st of October, 1973), are required by the trustee, John Emery Hartnell, of Nobeliuss-street, Emerald, retired company director, to send particulars to him, care of the undersigned, by the 9th of January, 1974, after which date the trustee may convey or distribute the assets, having regard only to the claims of which he then has notice.

WHITING & BYRNE, of 440 Collins-street, Melbourne. 5262

In the will of RICHARD WESTALL BORBIDGE, late of 3 Bowen-road, Point Lonsdale, retired grazier, DECEASED.

Creditors, next of kin and others having claims in respect of the estate of the said deceased (who died on the 4th day of July, 1972), are requested by the executors of the will of the above-named deceased, Winifred June Temple Borbidge, of 3 Bowen-road, Point Lonsdale, widow, and John Peter Temple Miles, of 4 Hardy-crescent, Heathmont, communications officer, to send particulars, in writing, of such claims to them, care of the under-mentioned solicitors, by the 30th day of January, 1974, after which date the said executors may convey or distribute the assets, having regard only to the claims of which they have notice.

INGPEN & BENT, solicitors, 54 Malop-street, Geelong. 5266

In the will of MURDOCH HECTOR MATHESON, late of 46 Regent-street, Belmont, retired farmer, DECEASED.

Creditors, next of kin and others having claims in respect of the estate of the said deceased (who died on the 23rd day of August, 1972), are requested by the executors of the will of the above-named deceased, Ian Murray Matheson, of 11 Everett-close, Herne Hill, accountant, Graham Barber Matheson, of 24 Devon-street, North Geelong, engineer, and Lance Hector Matheson, of 26 Morton Bay-drive, Highton, bank manager, to send particulars, in writing, of such claims to them, care of the under-mentioned solicitors, by the 30th day of January, 1974, after which date the said executors may convey or distribute the assets, having regard only to the claims of which they have notice.

INGPEN & BENT, solicitors, 54 Malop-street, Geelong. 5267

GEORGE NELSON, late of 14 Patterson-avenue, Burwood, retired, DECEASED.

Creditors, next of kin and others having claims against the estate of the said deceased (who died on the 3rd June, 1973), are to send particulars of their claims to Nora Greenwood, care of 882 Whitehorse-road, Box Hill, by the 11th day of January, 1974, after which date she will distribute the assets, having regard only to the claims of which she then has notice.

SALISBURY, WARDLAW & CO., solicitors, 882 Whitehorse-road, Box Hill. 5205

Creditors, next of kin and others having claims in respect of the estate of George Laurence Riggall, late of 9 John-street, Traralgon, farmer, deceased (who died on the 2nd day of June, 1973, and probate of whose will was granted on the 29th day of October, 1973, to Mary Therese Day, of 9 John-street, Traralgon, married woman, and Joan Margaret Riggall, of 7 McGrath-street, Caulfield, typist), are to send particulars of their claims to the said executrices, care of the below-mentioned solicitors, by the 15th January, 1974, after which day they will distribute the assets of the deceased, having regard only to the claims of which they then have notice.

BRUCE, LITTLETON & HACKFORD, solicitors, Traralgon. 5274

PHYLLIS MARIE MAUGHAN, formerly of 12 Surrey Gardens, Bournemouth, Hampshire, England, formerly of 19 Martin-street, Brighton, in the State of Victoria, but late of 435 Chelsea Cloisters, Sloan-avenue, Chelsea, London, England, widow, DECEASED.

Creditors, next of kin and others having claims in respect of the estate of the deceased (who died on the 24th day of May, 1973) are required by The Perpetual Executors and Trustees Association of Australia Limited, of 50 Queen-street, Melbourne, to send particulars of their claims to the said company by the 21st day of January, 1974, after which date it will convey or distribute the assets, having regard only to the claims of which the company then has notice.

FORD, ASPINWALL & DE GRUCHY, solicitors, 100-104 Queen-street, Melbourne. 5246

Creditors, next of kin and others having claims in respect of the estate of Charles Albert Ford, late of 26 Peace-avenue, Warragul, in the State of Victoria, gentleman, deceased (who died on the 16th day of March, 1973), are to send particulars of their claims to the National Trustees, Executors and Agency Company of Australasia Limited, of 95 Queen-street, Melbourne, by the 15th day of February, 1974, after which date it will distribute the assets, having regard only to the claims of which it then has notice.

DUNN, STRACHAN & HARDIE, solicitors, 3 Smith-street, Warragul. 5188

JOHN ERSHUN TURNER, late of Chinkapook, farmer, DECEASED.

Creditors, next of kin and others having claims in respect of the estate of the deceased (who died on the 5th day of March, 1973), are required by the trustees, namely Herbert Ross Blair and William Ross Blair, both of Manangatang, solicitors, to send particulars to them, by the 14th day of January, 1974, after which date the trustees may convey or distribute the assets, having regard only to the claims of which they shall then have had notice.

Dated this 15th day of October, 1973. 5189

Creditors, next of kin and others having claims in respect of the will of Ettie Maud Murphy, late of Mont Park, Waiora-road, MacLeod, home duties (who died on the 27th day of August, 1973), are requested to send particulars of their claims to the executors, Warrick James Murphy and Patricia Sophia Little (formerly Patricia Sophia Bryant, in the will called Patricia Ann Bryant), care of the under-mentioned solicitor, by the 23rd day of January, 1974, after which date they will distribute the assets, having regard only as to the claims of which they then have notice.

JOHN STEWART, of 290 Racecourse-road Newmarket. 5208

STANLEY KEITH DOHNT, late of Gray-street, West Swan Hill, in the State of Victoria, linesman, DECEASED (who died on the 5th day of July, 1973).

Creditors, next of kin and all other persons having claims against the estate of the deceased are required by the executrix of the will, Marlene Joyce Dohnt, to send particulars to her, care of the undersigned, on or before the 29th of January, 1974, after which date they will distribute the assets, having regard only to the claims of which they then have notice.

GARDEN & GREEN, solicitors, 4 McCallum-street, Swan Hill. 5197

LINDA GRACE RAILEY, formerly of 3 Eric-avenue, Mordialloc, but late of "Overton", 17 Pakington-street, Kew, in the State of Victoria, married woman, DECEASED.

Creditors, next of kin, and others having claims in respect of the estate of the above-named deceased (who died on the 29th January, 1972), are required by the execu-

tors of the said deceased's will Arthur Lloyd Hargraves, of 3 Stonehaven-court, Toorak, airline executive, and Dora Ada Davis, of 25 Edward-street, Sandringham, married woman, to send particulars to them by the 10th January, 1974, after which date the executors may convey or distribute the assets of the estate, having regard only to the claims of which they may have notice.

KEITH A. NESS & SON, solicitors, 380 Collins-street, Melbourne, 3000. 5245

Creditors, next of kin and others having claims in respect of the estate of Joseph Maria Arena, late of 23/1225 Nepean Highway, Cheltenham, electrician, deceased intestate (who died on the 16th day of January, 1971), are required by the applicant for grant of administration, The Union-Fidelity Trustee Company of Australia Limited, of 100 Exhibition-street, Melbourne, to send particulars of their claims to it by the 9th day of January, 1974, after which date the applicant for grant of administration may convey or distribute the assets, having regard only to the claims of which it then has noted.

LOUIS S. LAZARUS, solicitor, 76 Spencer-street, Melbourne. 5241

MABEL MARTHA MOLLAND, late of 28 Grandview-Grove, Glen Iris, but formerly of 42 Bourne-road, Glen Iris, retired school teacher, DECEASED.

Creditors, next of kin, and others having claims in respect of the estate of the deceased (who died on the 6th day of July, 1973), are required by the personal representative, The Union-Fidelity Trustee Company of Australia Limited, of 100 Exhibition-street, Melbourne, to send particulars to it by the 9th day of January, 1974, after which date the personal representative may convey or distribute the assets, having regard only to the claims of which it then has notice.

LOUIS S. LAZARUS, solicitor, 76 Spencer-street, Melbourne. 5242

Creditors, next of kin and others having claims in respect of the estate of Lionel Frederick Robinson, late of 52 Cliff-road, Frankston, commander Royal Navy (retired), deceased (who died on the 29th day of July, 1973), are to send particulars of their claims to the executor of his will, namely National Trustees Executors and Agency Company of Australasia Limited, of 95 Queen-street, Melbourne, in the State of Victoria, by the 1st day of February, 1974, after which date the said company will distribute the assets in the said estate, having regard only to the claims of which it then has notice.

ARTHUR ROBINSON & CO., solicitors, 447 Collins-street, Melbourne. 5244

SUSAN ERSKINE HERRICK, late of 71 Windella-avenue, East Kew, widow, DECEASED.

Creditors, next of kin and others having claims against the estate of the said deceased (who died on 12th May, 1973), are to send particulars to Peter Robert Herrick, care of 591 Grimshaw-street, Bundoora, by the 11th day of January, 1974, after which date he will distribute the assets, having regard only to the claims of which he then has notice.

JOHNSTON & BURNES, solicitors, 591 Grimshaw-street, Bundoora. 5226

Creditors, next of kin and others having claims against the estate of Myrtle Buchanan, late of Corio Old Folks Home, Nelson-street, Warrnambool, widow, deceased (who died on the 2nd day of September, 1973), are required by the executor, Robert John Fewster, of the State Savings Bank, Castlemaine, bank manager, to send particulars of such claims to him, care of the under-mentioned solicitor, on or before the 14th day of January, 1974, after which date the said executor will distribute the assets, having regard only to the claims of which he then has notice.

DAVID E. TRICKETT, solicitor, High-street, Terang, solicitor to the estate. 5276

THEODORA MELVILLE, formerly of 280 Pascoe Vale-road, Essendon, in the State of Victoria, but late of Karinyah Private Hospital, 69 Broadway, Camberwell, in the said State, spinster, DECEASED.

Creditors, next of kin and others having claims in respect of the estate of the above-named deceased (who died on the 25th day of June, 1973), are required by the trustee, The Equity Trustees, Executors and Agency Company Limited, of 472 Bourke-street, Melbourne, aforesaid, to send particulars to such company, by the 16th day of January, 1974, after which date the said trustee may convey and distribute the assets, having regard only to the claims of which it then has notice.

EGGLESTON, CLIFTON-JONES & CO., solicitors, of 20 Queen-street, Melbourne, Victoria, 3000. 5289

Creditors, next of kin and others having claims in respect of the estate of Charles Ernest Pound, late of 35 Sylvester-grove, East Preston, storeman (who died on the 24th day of June, 1973), are to send particulars of their claims to Trevor Norman Pound, the executor to whom probate of the will of the said deceased was granted, care of the under-mentioned solicitor, by the 14th day of January, 1974, after which date he will distribute the assets, having regard only to the claims of which he shall then have had notice.

DAVID BULLARD, solicitor, of 443 Little Bourke-street, Melbourne. 5290

Creditors, next of kin and others having claims in respect of the estate of Thornton Newton, late of McMillan's-road, Korumburra, farmer, deceased (who died on the 7th day of March, 1973), are to send particulars of their claims to Robert Thornton Newton, care of the undersigned, by the 10th day of January, 1974, after which date he will distribute the assets, having regard only to the claims of which he then has notice.

BIRCH, ROSS & BARLOW, solicitors, Korumburra. 5236

Creditors, next of kin and others having claims in respect of the estate of John Chown, late of Lot 8 Kings-road, Emerald, retired fitter, deceased (who died on the 11th day of July, 1973) are to send the particulars of their claims to the Equity Trustees Executors and Agency Company Limited, of 472 Bourke-street, Melbourne, by the 9th day of January, 1974, after which date it will distribute the assets, having regard only to the claims of which it then has notice.

W. H. FLOOD & PERMEZEL, 388 Bourke-street, Melbourne, solicitors for the said company. 5247

ALBERT HENRY OLDMAN, late of 24 Rolland-street, Coburg, pensioner, DECEASED.

Creditors, next of kin and others having claims in respect of the estate of the deceased (who died on the 14th day of July, 1973), are required by National Trustees, Executors and Agency Company of Australasia Limited, of 95 Queen-street, Melbourne, to send particulars of their claims to the said company, by the 5th day of January, 1974, after which date it will convey or distribute the assets, having regard only to the claims of which the company then has notice.

HENDERSON & BALL, solicitors, of 430 Little Collins-street, Melbourne. 5288

Creditors, next of kin and others having claims in respect of the estate of Anna Plume, late of 24 South-street, Ascot Vale, married woman, deceased (who died on the 28th day of April, 1973), are requested to send particulars of their claims to the administrator of the estate, Janis Plume, care of the under-mentioned solicitor, by the 1st day of February, 1974, after which date he will convey and distribute the assets, having regard only to the claims of which he has then notice.

E. T. BRENNERS, solicitor, of 114 Princess-street, Kew. 5291

ETHEL TURNER STONEMAN, late of Ironbark-road, Diamond Creek, in the State of Victoria, retired medical practitioner, DECEASED.

Creditors, next of kin and all other persons having claims against the estate of the deceased are required by the executor of her will, The Equity Trustees, Executors and Agency Company Limited, of 472 Bourke-street, Melbourne, in the said State, to send particulars thereof to it, before the 11th January, 1974, after which date it may distribute the assets of the deceased, having regard only to the claims of which it then has notice.

COLTMAN, WYATT & ANDERSON, solicitors, 379 Collins-street, Melbourne. 5293

## INSOLVENCY NOTICES

Bankruptcy Act 1966-1970.

COMMONWEALTH OF AUSTRALIA.

A First and Final Dividend is intended to be declared in the under-mentioned estate. Creditors who have not proved their debts by the 22nd November, 1973, will be excluded from the dividend.

JESSIE IRENE LYDIA DUNSTAN.

Date of Assigned, 8th November, 1971, No. 123 of 1971.  
Dated this 2nd day of November, 1973.

J. M. WALSH, Trustee.

Kennedy, Smail & Middlemiss, 296 Little Lonsdale-street, Melbourne, 3000. 5277

*Bankruptcy Act 1966-1970.*  
**COMMONWEALTH OF AUSTRALIA.**  
 A First and Final Dividend is intended to be declared in the under-mentioned estate. Creditors who have not proved their debts by the 22nd November, 1973, will be excluded from the dividend.  
**RONALD WILLIAM DUNSTAN.**  
 Date of Assigned, 8th November, 1971, No. 128 of 1971.  
 Dated this 2nd day of November, 1973.  
 J. M. WALSH, Trustee.  
 Kennedy, Smail & Middlemiss, 296 Little Lonsdale-street, Melbourne, 3000.

**IMPOUNDINGS**

**DROUIN.**—Impounded in Drouin Pound from Albert-road, Drouin.  
 1 light brown Jersey heifer (3 days), no visible brand  
 If not claimed and expenses paid, to be sold on 26th November, 1973.  
 A. M. JONES,  
 5292—\$2.45 Poundkeeper.

**EPPING.**—Impounded in Epping Pound by Mr. K. Hall.  
 1 black and white Friesian bull, no visible brand  
 1 red roan Guernsey bull, no visible brand  
 If not claimed and expenses paid, to be sold on Friday, 23rd November, 1973.  
 W. HERD,  
 5257—\$2.45 Poundkeeper.

**MALDON.**—Impounded in Maldon Pound.  
 10 Merino ewes and wethers, branded with red D and blue raddle, also ear marked, no visible brand  
 If not claimed and expenses paid, to be sold on 15th November, 1973.  
 F. SHEPHERD,  
 5196—\$2.45 Poundkeeper.

**MORTLAKE.**—Impounded in Mortlake Pound, on 25th October, 1973, from Gordons-lane.  
 1 brown Jersey cow, slit out of end of each ear, no visible brand  
 If not claimed and expenses paid, to be sold on 16th November, 1973.  
 A. ROBERTSON,  
 5200—\$2.80 Poundkeeper.

**TRAFALGAR.**—Impounded in Trafalgar Pound from Shady Creek No. 6.  
 1 Hereford bull, earmark lower right ear, horned, between 12-18 months old, no visible brand  
 If not claimed and expenses paid, to be sold on 14th November, 1973.  
 V. A. KAYE,  
 5209—\$2.80 Poundkeeper.

*Subordinate Legislation Act 1962.*  
**NOTICE OF MAKING OF STATUTORY RULES.**

In pursuance to the provisions of the *Subordinate Legislation Act 1962* and the Regulations made thereunder, notice is given of the making of the following statutory rules:—

No.	Metric Conversion Act 1973.	Price.
307/1973.	Metric Conversion (Education Act) Regulations 1973	10c
<i>Aboriginal Affairs Act 1967.</i>		
308/1973.	Aboriginal Affairs (Cadetships) (Further Amendment) Regulations 1973	10c
<i>Education Act 1958.</i>		
309/1973.	Education Department (Teacher Registration Appeals) Regulations 1973 Amendment No. 30	10c
<i>Marine Act 1958</i>		
310/1973.	Port Phillip Pilot Sick and Superannuation Fund (Amendment) Regulations 1973	10c

<i>Forests Act 1958 (No. 6254).</i>		
311/1973.	Forests (Part IV.—Miscellaneous) (Amendment) Regulations 1973	10c
<i>Forests Act 1958 (No. 6254).</i>		
312/1973.	Forests (Part VI.—Diseases of Trees) Regulations 1973	10c
<i>Metric Conversion Act 1973.</i>		
313/1973.	Metric Conversion (Estate Agents Act) Regulations 1973	10c
<i>Estate Agents Act 1958.</i>		
314/1973.	Estate Agents (Metric Conversion) Regulations 1973	10c
<i>Metric Conversion Act 1973.</i>		
315/1973.	Metric Conversion (Stamps Act) Regulations 1973	10c
<i>Estate Agents Act 1958.</i>		
316/1973.	Estate Agents Committee (Metric Conversion) Rules 1973	10c
<i>Country Fire Authority 1958.</i>		
317/1973.	Country Fire Authority (Loan No. 96) Regulations 1973	10c
<i>Public Records Act 1973.</i>		
318/1973.	Public Records Regulations 1973	10c
<i>Police Regulation Act 1958.</i>		
319/1973.	Police (Authorized Strength No. 7) Regulations 1973	10c
<i>Marine Act 1958.</i>		
320/1973.	Amendment to Port Rule Applicable to Westernport Harbor Services (Rates and Charges)	10c

Copies of these statutory rules may be purchased at the Sale of Publications Section of the Government Printing Office, located at 7A Parliament-place, Melbourne, 3002. If ordered by mail, remittance should be addressed to "The Government Printer, Box 203, P.O., North Melbourne, 3051", and should include 7c extra for postage. If a credit account is held at this office, no remittance is required with the mail order.

The annual subscription rate for Statutory Rules (including Bound Volumes) is \$25, payable in advance. The subscription year commences on 1st January.

C. H. RIXON,  
 Government Printer.

<b>CONTENTS</b>		PAGE
Appointments	.. .. .	3703
Contracts	.. .. .	3703
Country Roads Board	.. .. .	3693
Estates of Deceased Persons	.. .. .	3703
Government Notices	.. .. .	3692
Impoundings	.. .. .	3730
Insolvency Notices	.. .. .	3729
Lands	.. .. .	3710
Notice to attend for Radiological Examination	.. .. .	3697
Notice of Making of Statutory Rules	.. .. .	3730
Orders in Council—		
Acts—Local Government; Country Roads; Country Fire Authority; Land; Soil Conservation and Land Utilization; Town and Country Planning; Workers Compensation; Geelong Harbor Trust.		3704 et seq
Private Advertisements	.. .. .	3716
Proclamations	.. .. .	3691
Public Service Notices	.. .. .	3715
Regulations—		
Acts—Police Regulation	.. .. .	3700
Teaching Service	.. .. .	3715
Resignations	.. .. .	3704
State Rivers and Water Supply Commission	.. .. .	3698
Tenders	.. .. .	3714
Transport Regulation Board—Public Hearings	.. .. .	3694
Waterworks Trusts	.. .. .	3702