

[3753]



VICTORIA GOVERNMENT GAZETTE

Published by Authority

No. 110] WEDNESDAY, NOVEMBER 14 [1973

PROCLAMATIONS

PUBLIC HOLIDAYS.

PROCLAMATION

By His Excellency the Governor of the State of Victoria and its Dependencies in the Commonwealth of Australia, &c., &c., &c.

In pursuance of the provisions contained in Part III. of the Public Service Act 1958, I, the Governor of the State of Victoria, in the Commonwealth of Australia, by and with the advice of the Executive Council of the said State, do by this my Proclamation appoint the days and dates hereunder mentioned to be observed as Public Holidays or Public Half-Holidays (as the case may be) at the places respectively specified, viz.:-

Public Holiday:—

SATURDAY, THE 23RD OF FEBRUARY, 1974 throughout the Shire of South Gippsland.

Public Half-Holiday from the Hour of Twelve o'clock noon:—

WEDNESDAY, THE 6TH OF FEBRUARY, 1974 within the City of Colac.

Given under my Hand and the Seal of the State of Victoria aforesaid, at Melbourne, this thirteenth day of November, in the year of our Lord One thousand nine hundred and seventy-three, and in the twenty-second year of the reign of Her Majesty Queen Elizabeth II.

(L.S.) ROHAN DELACOMBE,
By His Excellency's Command,

J. F. ROSSITER,
Chief Secretary.

GOD SAVE THE QUEEN!

STAMPS ACT 1973 (No. 8465).

PROCLAMATION.

By His Excellency the Governor of the State of Victoria and its Dependencies in the Commonwealth of Australia, &c., &c., &c.

Whereas by sub-section (3) of section 1 of the Stamps Act 1973 it is provided that the several provisions of the said Act shall come into operation on a day or respective days to be fixed by Proclamation of the Governor in Council published in the Government Gazette.

No. 110.—10670/73.—PRICE 30 cents; Half-Yearly \$11.25; Yearly \$22.50.

Now therefore, I, the Governor of the State of Victoria in the Commonwealth of Australia, by and with the advice of the Executive Council of the said State, do by this my Proclamation fix Saturday, the first day of December, One thousand nine hundred and seventy-three, as the day on which the several provisions of the said Act shall come into operation.

Given under my Hand and the Seal of the State of Victoria aforesaid, at Melbourne, this thirteenth day of November, in the year of our Lord One thousand nine hundred and seventy-three, and in the twenty-second year of the reign of Her Majesty Queen Elizabeth II.

(L.S.) ROHAN DELACOMBE.

By His Excellency's Command,

R. J. HAMER,
Treasurer.

GOD SAVE THE QUEEN!

PUBLIC HIGHWAY.—CITY OF OAKLEIGH.

PROCLAMATION

By His Excellency the Governor of the State of Victoria and its Dependencies in the Commonwealth of Australia, &c., &c., &c.

Whereas by the Local Government Act 1958, Section 519 it is amongst other things enacted that it shall be lawful for the Governor in Council at any time and from time to time upon the request of the Council of any municipality by notice in the Government Gazette to proclaim any land reserved used or by purchase or exchange acquired for a street, road, highway, thoroughfare, bridge, square, court, alley, or right-of-way or any street, road, lane or passage made or laid out or proposed to be made or laid out on any land of which a plan of subdivision delineating that street, road, lane or passage has been sealed with the seal of the municipality under subdivision (3) of Division 9 of Part XIX or a corresponding previous enactment to be a public highway and that such land shall thereupon and thenceforth from the date of such proclamation become and be absolutely dedicated to the public as a public highway within the meaning of any law then or thereafter in force.

And whereas the Council of the City of Oakleigh has requested that the land hereinafter mentioned, being a road laid out on land of which a plan of subdivision delineating

the street, road, lane or passage has been sealed with the seal of the municipality under subdivision (3) of Division 9 of Part XIX of the *Local Government Act 1958*, or a corresponding previous enactment, be so declared to be a public highway.

Now therefore, I, the Governor of the State of Victoria, in the Commonwealth of Australia, by and with the advice of the Executive Council of the said State, do by this Proclamation declare that Fairbank Road shown by hachure on the plan hereunder shall be a public highway within the meaning of the said Act.

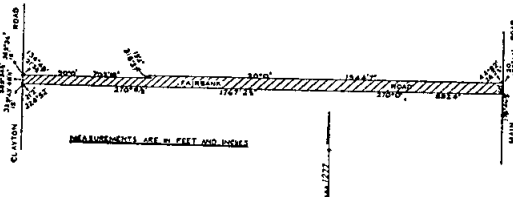

Given under my Hand and the Seal of the State of Victoria aforesaid, at Melbourne, this seventh day of November, in the year of our Lord One thousand nine hundred and seventy-three, and in the twenty-second year of the reign of Her Majesty Queen Elizabeth II.

(L.S.) ROHAN DELACOMBE.
By His Excellency's Command,
A. J. HUNT,
Minister for Local Government.
GOD SAVE THE QUEEN!

POISONS (FEES) ACT 1973.

PROCLAMATION

By His Excellency the Governor of the State of Victoria and its Dependencies in the Commonwealth of Australia, &c., &c., &c.

Whereas by an Act of Parliament of the State of Victoria passed in the twenty-second year of the reign of Her Majesty Queen Elizabeth II, entitled the *Poisons (Fees) Act 1973*, No. 8456, it is amongst other things enacted that the Act shall come into operation on a day to be fixed by proclamation of the Governor in Council published in the *Government Gazette*:

Now therefore, I, the Governor of the State of Victoria, in the Commonwealth of Australia, by and with the advice of the Executive Council of the said State, do by this my Proclamation fix Wednesday, the fourteenth day of November, One thousand nine hundred and seventy-three, as the day on which the said Act shall come into operation.

Given under my Hand and the Seal of the State of Victoria aforesaid, at Melbourne, this thirteenth day of November, in the year of our Lord One thousand nine hundred and seventy-three, and in the twenty-second year of the reign of Her Majesty Queen Elizabeth II.

(L.S.) ROHAN DELACOMBE.
By His Excellency's Command,
A. J. SCANLAN,
Minister of Health.
GOD SAVE THE QUEEN!

Land Act 1958.

DEPARTMENT OF CROWN LANDS AND SURVEY.

PROCLAMATION

By His Excellency the Governor of the State of Victoria and its Dependencies in the Commonwealth of Australia, &c., &c., &c.

In pursuance of the provisions of Section 22c (2) of the *Land Act 1958* (as amended by the *Surrender of Land Act 1972*, No. 8363), I, the Governor of the State of Victoria, by and with the advice of the Executive Council of the said State, upon receipt of certification of the clerk of the municipality concerned (Shire of Benalla) that the land is or has been used for any cultural sporting or recreational purposes (lawn bowls) do hereby declare all that piece of land containing 1 acre 2 roods 16 6/10 perches being Lot 1 on Plan of Subdivision No. 79850 and being

part of Crown allotment 43A, Section A, Parish of Lima, County of Delatite, to be land to which the said Section 22c (2) applies.—(C.101119.)

Given under my Hand and the Seal of the State of Victoria aforesaid, at Melbourne, this seventh day of November, in the year of our Lord One thousand nine hundred and seventy-three, and in the twenty-second year of the reign of Her Majesty Queen Elizabeth II.

(L.S.) ROHAN DELACOMBE.
By His Excellency's Command,
W. BORTHWICK,
Minister of Lands.
GOD SAVE THE QUEEN!

Land Act 1958.

DEPARTMENT OF CROWN LANDS AND SURVEY.

PROCLAMATION

By His Excellency the Governor of the State of Victoria and its Dependencies in the Commonwealth of Australia, &c., &c., &c.

In pursuance of the provisions of Section 22c (2) of the *Land Act 1958* (as amended by the *Surrender of Land Act 1972*, No. 8363), I, the Governor of the State of Victoria, by and with the advice of the Executive Council of the said State, upon receipt of certification of the Clerk of the municipality concerned (Shire of Mornington) that the land is or has been used for any cultural sporting or recreational purposes, do hereby declare those pieces of land described in certificates of title volume 3999 folium 698 volume 4544 folium 755 volume 5220 folium 942 volume 5234 folium 725 volume 5846 folium 062, less that piece of land described in Item 26 of Schedule TWO A to the said Act, in the Parish of Moorooduc to be land to which the said Section 22c (2) applies.—(C.89575.)

Given under my Hand and the Seal of the State of Victoria aforesaid, at Melbourne, this seventh day of November, in the year of our Lord One thousand nine hundred and seventy-three, and in the twenty-second year of the reign of Her Majesty Queen Elizabeth II.

(L.S.) ROHAN DELACOMBE.
By His Excellency's Command,
W. BORTHWICK,
Minister of Lands.
GOD SAVE THE QUEEN!

MONEY LENDERS (ADVERTISEMENTS) ACT 1973
No. 8454.

PROCLAMATION

By His Excellency the Governor of the State of Victoria and its Dependencies in the Commonwealth of Australia, &c., &c., &c.

Whereas by subsection (3) of Section 1 of the *Money Lenders (Advertisements) Act 1973*, No. 8454 it is provided that the said Act shall come into operation on a day to be fixed by proclamation of the Governor in Council published in the *Government Gazette*:

Now therefore, I, the Governor of the State of Victoria in the Commonwealth of Australia, by and with the advice of the Executive Council of the said State, do by this my Proclamation fix Saturday, the first day of December, One thousand nine hundred and seventy-three, as the day on which the said Act shall come into operation.

Given under my Hand and the Seal of the State of Victoria aforesaid, at Melbourne, this thirteenth day of November, in the year of our Lord One thousand nine hundred and seventy-three, and in the twenty-second year of the reign of Her Majesty Queen Elizabeth II.

(L.S.) ROHAN DELACOMBE.
By His Excellency's Command,
R. J. HAMER,
Treasurer.
GOD SAVE THE QUEEN!

AUCTION SALES (LICENCE FEES) ACT 1973 No. 8467.

PROCLAMATION

By His Excellency the Governor of the State of Victoria and its Dependencies in the Commonwealth of Australia, &c., &c., &c.

Whereas by subsection (3) of Section 1 of the Auction Sales (Licence Fees) Act 1973, No. 8467 it is provided that the said Act shall come into operation on a day to be fixed by proclamation of the Governor in Council published in the Government Gazette:

Now therefore, I, the Governor of the State of Victoria in the Commonwealth of Australia, by and with the advice of the Executive Council of the said State, do by this my Proclamation fix Wednesday, the Fourteenth day of November, One thousand nine hundred and seventy three, as the day on which the said Act shall come into operation.

Given under my Hand and the Seal of the State of Victoria aforesaid, at Melbourne, this thirteenth day of November, in the year of our Lord One thousand nine hundred and seventy-three, and in the twenty-second year of the reign of Her Majesty Queen Elizabeth II.

(L.S.) ROHAN DELACOMBE.

By His Excellency's Command,
R. J. HAMER,
Treasurer.

GOD SAVE THE QUEEN!

ESTATE AGENTS (FEES) ACT 1973 No. 8466.

PROCLAMATION

By His Excellency the Governor of the State of Victoria and its Dependencies in the Commonwealth of Australia, &c., &c., &c.

Whereas by subsection (3) of Section 1 of the Estate Agents (Fees) Act 1973, No. 8466 it is provided that the said Act shall come into operation on a day to be fixed by proclamation of the Governor in Council published in the Government Gazette:

Now therefore, I, the Governor of the State of Victoria in the Commonwealth of Australia, by and with the advice of the Executive Council of the said State do by this my Proclamation fix Wednesday, the fourteenth day of November, One thousand nine hundred and seventy three, as the day on which the said Act shall come into operation.

Given under my Hand and the Seal of the State of Victoria aforesaid, at Melbourne, this thirteenth day of November, in the year of our Lord One thousand nine hundred and seventy-three, and in the twenty-second year of the reign of Her Majesty Queen Elizabeth II.

(L.S.) ROHAN DELACOMBE.

By His Excellency's Command,
R. J. HAMER,
Treasurer.

GOD SAVE THE QUEEN!

Social Welfare Act 1970.
COORIEMUNGLE PRISON CAMP.

NOTICE.

By His Excellency the Governor of the State of Victoria and its Dependencies in the Commonwealth of Australia, &c., &c., &c.

Whereas by Part IV. of the Social Welfare Act 1970 provision is made whereby the Governor in Council may by notice in the Government Gazette proclaim all buildings, erections, houses, enclosed places, and premises to be prisons:

Now therefore I, the Governor of the State of Victoria, in the Commonwealth of Australia, by and with the advice of the Executive Council of the said State, do by this my notice proclaim all buildings, erections, houses, enclosed places, and premises comprised within the area described in the Schedule hereunder as a prison, under the title "Cooriemungle Prison Camp".

SCHEDULE.

WAARRE (COORIEMUNGLE).—Site for Public purposes (Prison Camp), 68.51 hectares, Parish of Waarre, County of Heytesbury, as indicated by hatching on plan hereunder.—(W.360(+)) (Rs.9762).

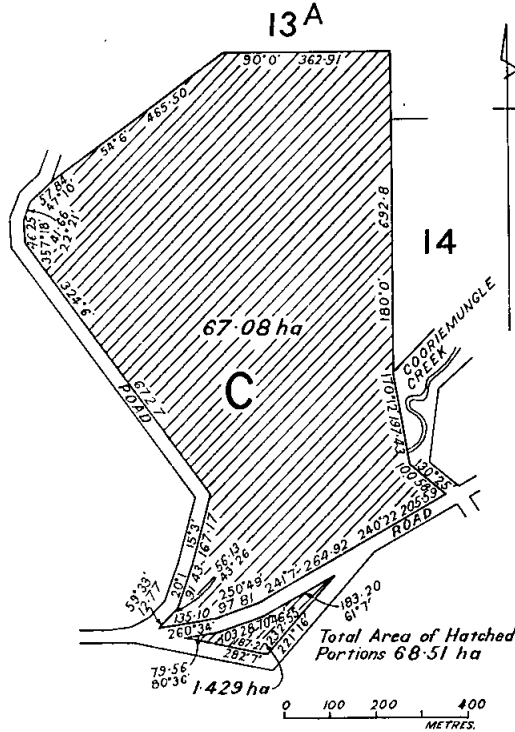

Given under my Hand and the Seal of the State of Victoria aforesaid, at Melbourne, this seventh day of November, in the year of our Lord One thousand nine hundred and seventy-three, and in the twenty-second year of the reign of Her Majesty Queen Elizabeth II.

(L.S.) ROHAN DELACOMBE.

By His Excellency's Command,
VASEY HOUGHTON,
Minister for Social Welfare.
GOD SAVE THE QUEEN!

GOVERNMENT NOTICES

Land Surveyors Act 1958.

SURVEYORS BOARD OF VICTORIA.

The Surveyors Board hereby gives notice that the next examination for the Board's Certificate of Competency will be held at the Engineering School, Melbourne University, from Monday, 18th February, 1974, to Monday, 25th February, 1974.

Applications for entry to this examination must be in the hands of the Secretary to the Board not later than Friday, 1st February, 1974. Late applications will be subject to Board approval.

The entry fee of \$10 is payable by every candidate each time he applies to enter for part or all of an examination. To this fee shall be added \$3 for each written subject taken.

On completion of written subjects at any examination, a candidate may enter for the Oral and Practical Section of that examination on payment of an additional fee of \$10.

Entry to any or all of the Oral and Practical subjects at a subsequent examination will require a fee of \$20.

Money Orders and Postal Notes should be made payable at the Collins-street East Post Office.

Cheques should be made payable to the Surveyors Board of Victoria.

A private address should be given in addition to any mailing address.

All addresses and names should be clearly set out, preferably in block letters.

M. J. DWYER,
Secretary.

Office of the Surveyors' Board,
Department of Crown Lands and Survey,
2 Treasury-place, Melbourne, 3002.

Transport Regulation Act.
TRANSPORT REGULATION BOARD.

HEARING OF APPLICATIONS.

Notice is hereby given that the following applications will be considered by the Transport Regulation Board at its office at the corner of Lygon and Princes streets, Carlton, at 10.15 a.m. on 5th December, 1973.

BENNETT, R. W., 41 Neimur-street, Barham. Application for three commercial passenger vehicles with large seating capacities to operate a service between Melbourne and Koondrook via Kilmore, Elmore, Echuca and Kerang subject to the condition that no passengers or parcels shall be picked up or set down between Melbourne and a point 5 miles west of Echuca on the Murray Valley Highway:

Timetable.

Mon.—Thur.; Fri.; Sat.; Sun.

Depart Melbourne 4.30 p.m.; 6.00 p.m.; 1.00 p.m.; 7.30 p.m.
Arrive Koondrook 10.00 p.m.; 11.30 p.m.; 6.30 p.m.; 12.50 a.m.
Depart Koondrook 7.40 a.m.; 7.40 a.m.; 7.10 a.m.; 1.40 p.m.
Arrive Melbourne 1.00 a.m.; 1.00 a.m.; 12.30 p.m.; 7.10 p.m.

Fares.

Melbourne to:

Koondrook, Kerang, Cohuna—

		Concession	
Single	Ret.	Single	Ret.
\$6.00	\$9.60	\$4.00	\$6.40

Leitchville, Gunbower—

		Concession	
Single	Ret.	Single	Ret.
\$5.50	\$8.80	\$3.70	\$5.90

Turrumbarry, Wharparilla—

		Concession	
Single	Ret.	Single	Ret.
\$5.00	\$8.00	\$3.40	\$5.40

NIXON, W. E., D. J. & W. B. (trading as Valley Buses), 324-326 Bell-street, Preston. Application for one commercial passenger vehicle with seating capacity for 30 persons to operate as an additional stage omnibus under the same terms and conditions as existing licences held by the applicant. (Subject to the transfer of licence M.O.90 to Hurstbridge Bus and Taxi Service Pty. Ltd.)

RINTOULE, R. A., P.O. Box 152, Nhill. Application for variation of licence T.S.815 to delete existing charter conditions from Diapur and instead operate under charter conditions with a 1 mile pick-up radius of Nhill.

MITCHELTON VINTNERS (AUST.) PTY. LTD., care of Mitchelton Vineyard, Mitchelstown. Application for one commercial passenger vehicle with seating capacity for 16 adults to be operated as follows:—1. Between Mitchelton Vineyard and Mangalore Airport carrying passengers and goods via Tabilk-road, Goulburn Valley Highway—Airport-road. (Distance 10 miles each way.) To be operated as and when required, fare 50 cents. 2. Between Mitchelton Vineyard and Nagambie carrying passengers and goods and mail via Tabilk-road, Goulburn Valley Highway. (Distance 8 miles each way.) To be operated as and when required, fare 50 cents. 3. Between Mitchelton Vineyard and Shepparton for the carriage of employees employed at the company's property and operated until such time as these employees are permanently residing in Nagambie. Homes are being erected in Nagambie for staff accommodation. No fares to be charged. Frequency of operation to be dependant on need, at any time to transport the company's employees.

Applications for renewal of licences as shown by persons listed hereunder to operate under the same terms and conditions:—

ELDRED, R. A. & J. M., 28 Parr-street, Leongatha; T.S.895.
MAURO, D., 64 Park-crescent, North Caulfield; M.T.4640.
REBLCO PTY. LTD., 22-30 Chifley-drive, Preston; T.P.205.
SMORGON CONSOLIDATED INDUSTRIES PTY. LTD., Somerville-road, Brooklyn; T.P.239.
TURNBULL, I. G., G. C. & A., 278 Commercial-road, Yarram; T.S.40. T.S.407. T.S.809.
VEITH, L. S., 52 Hunter-road, Camberwell; M.T.2517.

Notice of any objection should be forwarded to reach the Secretary of the Board not later than 28th November, 1973.

Applicants are advised that it will not be necessary to appear on the hearing date specified, unless advised in writing by the Board.

A. V. C. COOK,

Secretary.

Corner Lygon and Princes streets, Carlton, 3053,
Wednesday, 14th November, 1973.

Commercial Goods Vehicles Act.
TRANSPORT REGULATION BOARD.

HEARING OF APPLICATIONS.

Notice is hereby given that the following applications will be considered by the Transport Regulation Board at its offices at the corner of Lygon and Princes streets, Carlton, at 10 a.m., on Wednesday, 5th December, 1973.

ASCOM EQUIPMENT PTY. LTD., 63 Queen's Bridge-street, South Melbourne, 3205. One commercial goods vehicle (L/C. 8 cwt.) to operate in the course of business as "Civil Engineers and Contractors"—(a) Within a 25-mile radius of the post office at the corner of Bourke and Elizabeth streets in the City of Melbourne—own goods. (b) Throughout the State of Victoria—tools of trade and equipment. (c) To the site of any project upon which the applicant is currently engaged from points within a 20-mile radius of such site or from the railway station nearest thereto—materials for use on such project.

BROWN, L. H., 52 Bay-road, Sandringham, 3191. One commercial goods vehicle (L/C. 127 cwt.) to operate within a 50-mile radius of own premises at Sandringham in the course of business as "Tree Removing Contractor"—own tools of trade, own tree removing equipment and tree branches, stumps etc. for removal to nearest tip for disposal within the said radius.

CHAMBERLAIN, B., 34 Watson-street, Charlton, 3525. One commercial goods vehicle (L/C. 249 cwt.) to operate from Cook's Quarry at Charlton to places situated within a 70-mile radius from the post office at Charlton, but excluding places south of a line drawn east and west through the Township of St. Arnaud—screenings.

CUTTING, B. H. (trading as Bruce Cutting Electronic Service Centre), 98 Mitchell-street, Bendigo, 3550. One commercial goods vehicle (L/C. 9 cwt.) to operate within a 50-mile radius of the chief post office in the City of Bendigo and from and to Bendigo to and from the Township of Boort in the course of business as "Radio and Television Servicemen"—electrical equipment for repair or having been repaired, tools of trade, spare parts and materials incidental to the servicing and maintaining of such equipment.

DONEHUE, W. R., Markham-street, Heywood, 3304. One commercial goods vehicle (L/C. 119 cwt.) to operate: (a) Within a 25-mile radius of the post office at Heywood—general goods, provided that no goods shall be carried whether by one stage or by more than one stage between places within the above radius which are more than 30 road miles apart by the nearest practicable route. (b) Within a 50-mile radius of the post office at Heywood—superphosphate for spreading on own contract sites. (c) From Portland to the premises of Murray Goulburn Co-Operative Co. Ltd. at Koroit—fresh milk and fresh cream.

DOWNS, J. B., 1 Hughes-street, Hamilton, 3300. One commercial goods vehicle (L/C. 8 cwt.) to operate within a 70-mile radius of the post office at Hamilton in the course of business as "Wholesale Confectionery Supplier"—own confectionery, aerated waters, cordials and syrups, potato chips, nuts, wrapping paper, paper bags, paper plates and cups, groceries and products on behalf of I.C.I. Australia Ltd. and Kiwi Australia Ltd. provided that all goods carried on the vehicle are for use in an emergency only.

FOODLAND STORES PTY. LTD., 619 Springvale-road, Glen Waverley, 3150. Four commercial goods vehicles (L/C. approximately 200 cwt. each to be purchased) to operate throughout the State of Victoria in the course of business as "Food Distributors for the purpose of supplying own stores in a specially constructed refrigerated vehicle—(i) Dairy produce under refrigeration viz.: cream, yoghurt, cheese, margarine, butter, buttermilk, solid cooking oils, dripping, lard, eggs, fresh fruit juice, pastry, scones and rolls, shortening, cooked meats, sausages and canned hams. (ii) Frozen foods viz.: processed vegetables, meat, pastry, fruit, fish, cakes, ice-cream, poultry and frozen fruit juice concentrate. (iii) Fresh fruits and vegetables.

GREENFREIGHT PTY. LTD., Box 82, Myrtleford, 3707. Two commercial goods vehicles (to be purchased) to operate: (a) From the premises of Australian Forest

- Industries Pty. Ltd., an approved decentralized secondary industry at Myrtleford to the premises of Bowater-Scott Australia Ltd. at Box Hill—wood pulp. (b) From Melbourne to the premises of Australian Forest Industries Pty. Ltd., at Myrtleford—materials required in the manufacture of wood pulp.
- HILLIER, J. H., 23 Donaldson-street, Corryong, 3707. One commercial goods vehicle (L/C. 260 cwt.) to operate: (a) Within a 50-mile radius from the post office at Corryong as a "Road Contractor"—road-making plant and materials. (b) Within a 25-mile radius of the post office at Corryong—general goods, provided that no goods shall be carried whether by one stage or by more than one stage between places within the above radius which are more than the said 30 road miles apart by the nearest practicable route.
- JACKSON, W. C., (SEWING MACHINES) PTY. LTD., 169 Victoria-parade, Collingwood, 3066. One commercial goods vehicle (L/C. 19 cwt.) to operate: (a) Within a 50-mile radius of own premises at Collingwood in the course of business as "Textile Machinery Manufacturers"—own goods. (b) Throughout the State of Victoria—new industrial sewing machines for specialized installation, industrial sewing machines for repair or having been repaired, together with tools of trade and equipment incidental to the servicing or installation of industrial sewing machines.
- MORRISON, L. R., 93 Grey-street, Terang, 3264. One commercial goods vehicle (L/C. 116 cwt.) to operate: (a) Within a 50-mile radius of the post office at Terang—livestock. (b) Within a 50-mile radius of the post office at Terang as a "Primary Producer"—own goods.
- NEWTON, J. L. (trading as Newtons of Sale), 31 Cuninghame-street, Sale, 3850. One commercial goods vehicle (L/C. 14 cwt.) to operate: (a) Within a 50-mile radius of applicant's own premises at Sale in the course of business as "Boat Builder"—own goods. (b) From boat manufacturers and wholesalers in the metropolitan area (as defined in the Transport Regulation Act 1958) to applicant's own premises at Sale in the course of business as "Boat Retailer"—own boats on trailers.
- NOTE.—This application replaces licence No. T.D.A.63445 held in the name of J. C. McMillan.
- NOVAK, R., 44 Laurence-street, Myrtleford, 3737. One commercial goods vehicle (L/C. 146 cwt.) to operate: (a) Within a 50-mile radius of the post office at Myrtleford as a "Road Contractor"—road-making plant and materials. (b) Within a 25-mile radius of the post office at Myrtleford—general goods provided that no goods shall be carried whether by one stage or by more than one stage between places within the above radius which are more than 30 road miles apart by the nearest practicable route.
- PAINT SUPPLIES COMPANY PTY. LTD., 273 Edwardes-street, Reservoir, 3073. One commercial goods vehicle (L/C. 14 cwt.) to operate within a 50-mile radius of own branch premises at Leongatha in the course of business as "Paint Distributor"—own goods, provided that all goods are initially consigned to Leongatha by rail.
- PAINT SUPPLIES COMPANY PTY. LTD., 273 Edwardes-street, Reservoir, 3073. One commercial goods vehicle (L/C. 16 cwt.) to operate within a 50-mile radius of own branch premises at Bairnsdale in the course of business as "Paint Distributor"—own goods provided that all goods are initially consigned to Bairnsdale by rail.
- PRICE, R. C., Warrumyea-road, Panmure, 3265. One commercial goods vehicle (L/C. 252 cwt.) to operate within a 50-mile radius of the post office at Panmure in the course of business as "Earthmoving Contractor"—own earthmoving equipment, spare parts and materials incidental to own contracts.
- RANK XEROX (AUSTRALIA) PTY. LTD., 409 St. Kilda-road, Melbourne, 3004. One commercial goods vehicle (L/C. 14 cwt.) to operate within a 100-mile radius of the chief post office in the City of Bendigo in the course of business as "Business Machine Distributors"—tools of trade and spare parts incidental to the servicing and maintenance of office equipment in the field only.
- REDDAN, O. M. (trading as D. W. Reddan (Trust)), 32 North-street, Shepparton, 3630. One commercial goods vehicle (L/C. 42 cwt.) to operate within a 50-mile radius of own branch premises at Shepparton in the course of own business as "Wholesale Tobacco Merchants"—own goods subject to the condition that all such goods carried on the vehicle shall have been initially consigned to Shepparton by rail.
- ROBERTS, A. J., Box 473, Hamilton, 3300. One commercial goods vehicle (L/C. 138 cwt.) to operate: (a) Within a 50-mile radius of the post office at Hamilton in the course of business as "Cement Distributor"—bagged cement. (b) Within a 25-mile radius of the post office at Hamilton—general goods, provided that no goods shall be carried whether by one stage or more than one stage between places within the above radius which are more than 30 road miles apart by the nearest practicable route.
- ROLFO, J., 36 Bendoran-crescent, Bundoora, 3083. One commercial goods vehicle (L/C. 30 cwt.) to operate within a 70-mile radius of the premises of Wunderlich Ltd. at Vermont on behalf of the said company—roofing tiles, battens and tile fixing materials.
- STARBUCK, J. W. & J. A., 67 Hawdon-street, Heidelberg, 3084. One commercial goods vehicle (L/C. 350 cwt.) to operate within a 50-mile radius of the premises of Pioneer Concrete (Vic.) Pty. Ltd. at Bundoora on behalf of the said company—pre-mixed concrete in a specially constructed agitator vehicle.
- STEPHENS, G. G., 114 Cameron-parade, Bundoora, 3083. Two commercial goods vehicles (L/C. 192 cwt. each) to operate within a 70-mile radius of the premises of Glen Iris Brick Consolidated Ltd. at Bulleen on behalf of the said company—bricks.
- These applications replace licences numbered D.A.63015/9 and D.A.63015/10 previously held by R. T. Brick Co.

RENEWALS.

Applications for renewal of licences as shown by persons listed hereunder to operate under the same terms and conditions from the expiry shown in each case.

- ADAMS, K. & B., AGRICULTURAL SERVICES PTY. LTD., Amay-crescent, Ferntree Gully, 3156; D.A.63482; 13th April, 1974; 32 cwt.; D.A.63482/1; 13th April, 1974; 23 cwt.
- ALLISON, J., PTY. LTD., 788 Sydney-road, Brunswick, 3056; D.A.3455/6; 4th April, 1974; 10 cwt.
- AMEZDROZ & MENZIES PTY. LTD., Dennis-street, Colac, 3250; D.A.532/4; 7th March, 1974; 23 cwt.
- BRANCA, J. A., 454 Huntingdale-road, Chadstone, 3148; D.A.63160/1; 1st April, 1974; 65 cwt.
- C.W.S. PTY. LTD., 172 Bridge-street, Bendigo; D.A.57904; 18th April, 1974; 78 cwt.; D.A.57904/2; 18th April, 1974; 65 cwt.; D.A.57904/3; 18th April, 1974; 108 cwt.; D.A.57904/4; 4th April, 1974; 136 cwt.
- CALDOW, J. K., 48 Kitchener-street, Trafalgar, 3824; D.T.1284; 10th March, 1974; 411 cwt.
- CAMPBELL, B. G., 27 Hampshire-road, Glen Waverley, 3150; D.A.63642; 13th April, 1974; 112 cwt.
- COOPER, C. J., 59 Darcy-street, Stawell, 3380; D.T.859/1; 28th March, 1974; 256 cwt.
- CREASEY, F. C., 38 Dollar-avenue, Horsham, 3400; D.A.43540/2; 13th April, 1974; 450 cwt.
- CUDGEWA DAIRY CO. LTD., THE, Towong-road, Corryong, 3707; D.A.923/2; 27th April, 1974; 159 cwt.
- DONOHUE, W. & H., BROS. PTY. LTD., 123 Graham-street, Wonthaggi, 3995; D.A.37426/8; 13th April, 1974; 259 cwt.
- DUNSTAN, A., & SONS, 1-7 Tallangatta-road, Wodonga, 3690; D.T.185/3; 4th April, 1974; 263 cwt.
- EDEN, R. L., 48 Gertrude-street, Geelong West, 3218; D.A.45731; 2nd April, 1974; 156 cwt.
- FLANNER, L. E. & E. M., Cowley's Creek, via Timboon, 3268; D.A.45472; 2nd April, 1974; 21 cwt.
- FLEISNER, H., Jetty-road, Newhaven, Phillip Island, 3925; D.A.11250; 12th April, 1974; 77 cwt.
- GOYEN, K., PTY. LTD., 15 Eddington-street, Warrnambool, 3280; D.A.42286/1, 18th April, 1974; 72 cwt.
- HEMPHILL, J. D., Stanley-street, Wallan, 3654; D.A.53463/3; 4th November, 1973; 80 cwt.
- HILL, K. C., 82 Greta-road, Wangaratta, 3677; D.A.63656; 13th April, 1974; 146 cwt.
- LAWRENCE & HANSON PTY. LTD., 120 Maude-street, Shepparton, 3630; D.A.63607; 1st April, 1974; 10 cwt.; D.A.63607/1; 1st April, 1974; 10 cwt.; D.A.63607/2; 1st April, 1974; 10 cwt.
- LAWS, N. P. & A. V., 25 Waratah-street, Pascoe Vale South, 3044; D.A.63683; 27th April, 1974; 198 cwt.
- MCCCLUSKEY, B. A., Macarthur, 3286; D.A.63679; 27th April, 1974; 232 cwt.
- MCDIARMID, H., 220 Nicholson-street, Bairnsdale, 3875; D.T.547; 18th April, 1974; 274 cwt.
- MANSFIELD QUARRIES PTY. LTD., P.O. Box 11, Mansfield, 3722; D.A.63562; 2nd March, 1974; 239 cwt.
- MASKELL & GRIBBEN PTY. LTD., 201 Corio-street, Shepparton, 3630; D.A.1566/18; 13th April, 1974; 122 cwt.
- DUMBRELL, N. (trading as Mid North Auto Spares), 28 Carson-street, Shepparton, 3630; T.D.A.60769/1; 8th February, 1974; 36 cwt.
- MORELLI, S. (trading as S. & C. Morelli), 28 Morgan-street, Bairnsdale, 3875; D.T.800; 18th April, 1974; 398 cwt.
- MYERS, I., 170-172 Argyle-street, Traralgon, 3844; T.D.A.60234/2; 26th March, 1974; 96 cwt.
- NEILL, TED, MOTORS PTY. LTD., Princes Highway, Warragul, 3820; T.D.A.61001/1; 26th March, 1974; 51 cwt.

NESTLE CO. AUST. LTD., THE, Foster-street, Maffra, 3860; D.A.31378/52; 14th April, 1974; 12 cwt.
 NEVILL, J. L., Main-road, Hepburn Springs, 3461; D.T.446/3; 18th April, 1974; 216 cwt.
 NEWSOME, C. L. & R. E., 162 Corrigan-road, Noble Park, 3174; D.A.30931/1; 18th April, 1974; 8 cwt.
 PERRY, I. F., 1 Edgar-street, Tatura, 3616; D.A.57237/2; 27th April, 1974; 347 cwt.
 PERRY, I. F., 1 Edgar-street, Tatura, 3616; D.A.57237/3; 27th April, 1974; 17 cwt.
 PETERSVILLE LTD., Wellington-road, Clayton, 3168; D.A.1813/122; 26th April, 1974; 75 cwt.; D.A.1813/208; 27th April, 1974; 72 cwt.; D.A.1813/212; 27th April, 1974; 77 cwt.
 PIROTTA, G. & L., 2 Holly-avenue, Dandenong, 3175; D.A.58053; 24th January, 1974; 147 cwt.
 PLUM, LES, PTY. LTD., 125 McKellar-street, Benalla, 3672; D.T.1308; 19th May, 1973; 290 cwt.
 POTTER, A. A., Princes Highway, Longwarry North, 3816; T.D.A.63596; 16th March, 1974; 122 cwt.
 PREMIUM HAULAGE CO. PTY. LTD., 109 George-street, Morwell, 3840; D.T.1378; 1st April, 1974; 322 cwt.
 RIVER ROCK QUARRIES PTY. LTD., P.O. Box 122, Mansfield, 3722; D.A.57435/1; 13th April, 1974; 157 cwt.
 RIGONI, P. A., 45 Loco-street, Seymour, 3666; D.A.63644; 27th April, 1974; 140 cwt.
 ROBINSON, G. L., Queen-street, Port Albert, 3973; D.A.63382; 2nd March, 1974; 203 cwt.
 RYAN, J. F., 183 High-street, Northcote, 3070; D.A.62376/3; 27th April, 1974; 14 cwt.
 SNOWBALL, H. A., Irrewillipie, via Colac, 3250; D.A.45774; 2nd April, 1974; 216 cwt.
 SPENCELY, S. J., 152 Mt. Korong-road, Eaglehawk, 3556; D.A.58839; 18th April, 1974; 5 cwt.
 STONE BROS. PTY. LTD., 49 Rowan-street, Wangaratta, 3677; D.A.56703/1; 4th April, 1974; 10 cwt.; D.A.56703/2; 4th April, 1974; 8 cwt.
 SVANOSIO, N. L. & J. A., 129 Creek-street, Bendigo, 3550; D.A.36437/4; 19th March, 1974; 120 cwt.
 WAKEFIELD, K. L. (trading as L. Wakefield & Co.), 3 Wainwright-street, Warrnambool, 3280; D.A.52402/5; 1st April, 1974; 15 cwt.
 WATERS, S. H. & CO. PTY. LTD., 160 Firebrace-street, Horsham, 3400; T.D.A.2247/10; 6th April, 1974; 27 cwt.
 WIGHT, O. H., Box 3, Serpentine, 3517; D.A.58731; 4th April, 1974; 94 cwt.
 WOODALL, A. J., Wayside Delivery, Lyons, Heywood, 3304; D.A.2323/1; 15th April, 1974; 140 cwt.

TOW TRUCKS.

HUSSEY, J. H. (Junior) (trading as Kew Towing Service), 7 McCutcheon-street, Northcote, 3070; D.A.65671; 15th March, 1974; 25 cwt.
 MAHER, P. E. J., Loddon Valley Highway, Serpentine, 3517; D.A.63673; 25th April, 1974; 78 cwt.

RENEWAL WITH VARIATION.

Application made by the person listed hereunder for renewal of the licence listed with variation of conditions in the manner set out opposite the name.

REIDY, N., 92 Rupert-street, Bairnsdale, 3875; D.A.58364; 28th February, 1974; Application to renew and vary the conditions of licence No. D.A.58364 (L/C. 227 cwt.) by deleting the existing conditions and adding in lieu—(a) Within a 95-mile radius of the post office at Nowa Nowa (Bairnsdale Division of the Country Roads Board)—plant the property of a contractor and required for use in connection with the construction or maintenance of some specific, existing or proposed road, street, footpath, bridge, wharf, pier, weir or channel. (b) Within a 20-mile radius from site of construction or maintenance work performed pursuant to paragraph (a) above, or from the railway station nearest thereto—metal, stones, screenings, ashes, gravel, sand, earth and any other materials required for such work. (c) Within a 25-mile radius of the post office at Bairnsdale—general goods, provided that no goods shall be carried whether by one stage or by more than one stage between places within the above radius, which are more than 30 road miles apart by the nearest practicable route.

Notice of any objection should be forwarded to reach the Secretary of the Board not later than 28th November, 1973.

Applicants are advised that it will not be necessary to appear on the hearing date specified above, unless advised in writing by the Board.

A. V. C. COOK,
Secretary.

Corner Lygon and Princes streets, Carlton, 3053, Wednesday, 14th November, 1973.

Teaching Service (Teachers Tribunal) Regulations.

ELECTION OF A DEPUTY TO THE MEMBER OF THE COMMITTEE OF CLASSIFIERS FOR THE PRIMARY SCHOOLS DIVISION.

Pursuant to clause 20 of Regulation 2 of the Teaching Service (Teachers Tribunal) Regulations, I hereby declare that the election conducted by me on 8th November, 1973, resulted in JACK ELLIS REILLY (Croydon West Primary School), being elected as the deputy to the Member of the Committee of Classifiers for the Primary Schools Division.

J. T. MINTER,
Returning Officer.

Education Department,
Treasury-place,
Melbourne, 12th November, 1973.

LOCAL GOVERNMENT DEPARTMENT.

ORDER CONFIRMED.—SHIRE OF HUNTLY.

The Minister of the Crown administering the *Local Government Act 1958*, on the 9th day of November, 1973, confirmed the Order hereinafter referred to in pursuance of section 514 of the said Act namely:

An Order of the Council of the Shire of Huntly made on the 12th September, 1973, directing the compulsory taking of the land described in Crown Grants volume 8180 folio 298, volume 2494 folio 731, folio 361, for the purposes of providing a site for new Shire Offices.

A. J. HUNT,
Minister for Local Government.

Local Government Department,
Melbourne (209.131.1).

Town and Country Planning Act 1961.

BEECHWORTH PLANNING SCHEME.

(EXTENDED AREA).

INTERIM DEVELOPMENT ORDER.

Notice of Approval.

In pursuance of the powers conferred by the *Town and Country Planning Act 1961*, the Governor in Council on the 7th day of November, 1973, approved the making of an Interim Development Order by the United Shire of Beechworth for part of the municipal district of the United Shire of Beechworth.

The Interim Development Order provides that the use, subdivision or development of any land within the area described or the erection, construction or carrying out of any buildings, roads or other works thereon is prohibited except in accordance with the provisions of the Order.

A copy of the Interim Development Order and a map showing the area affected may be inspected, free of charge, at the office of the Council of the United Shire of Beechworth, at Beechworth; and at the office of the Town and Country Planning Board, 235 Queen-street, Melbourne.

W. H. CRAIG, Secretary,
Town and Country Planning Board.

Stamps Act 1958.

ANNUAL LICENCE.

NOTIFICATION PURSUANT TO SECTION 97.

I hereby notify that stamp duty has been paid for a licence under section 96 of the *Stamps Act*, to carry on assurance and insurance business in Victoria from 29th October, 1973, to 31st December, 1973, by the following:—

HIGHLANDS INSURANCE COMPANY.

R. M. PHIBBS,
Comptroller of Stamps.

Stamp Duties Office,
Melbourne, 7th November, 1973.

Stamps Act 1958.

ANNUAL LICENCE.

NOTIFICATION PURSUANT TO SECTION 97.

I hereby notify that stamp duty has been paid for a licence under section 110 of the *Stamps Act 1958* in respect of the year ending 30th September, 1974, by the following:—

BP AUSTRALIA LIMITED.

R. M. PHIBBS,
Comptroller of Stamps.

Stamp Duties Office,
Melbourne, 7th November, 1973.

Soil Conservation and Land Utilization Act 1958.

NOTICE IN RESPECT OF CHANGES IN LAND USE IN A SPECIFIED PART OF THE LAL LAL RESERVOIR WATER SUPPLY CATCHMENT.

(PROCLAIMED 6TH JUNE, 1973, VICTORIA GOVERNMENT GAZETTE No. 49, DATED 13TH JUNE, 1973.)

Notice is hereby given that the Soil Conservation Authority in pursuance of its powers under the Soil Conservation and Land Utilization Act 1958, as amended, has specified the changes in land use which may not be made without the prior approval of the Authority, in a specified part of the Lal Lal Reservoir Water Supply Catchment as defined on plan No. 2739, the original of which is kept at the Head Office of the Soil Conservation Authority at 378 Cotham-road, Kew.

The changes in land use which may not be made without the prior approval of the Soil Conservation Authority are:—

Within the area shaded on the plan No. 2739—

The burning or clearing of forest or scrub land, the ploughing or cultivation of land, and Within the whole specified area shown on plan No. 2739—

1. The erection of houses, the erection of or addition to buildings associated with enterprises which produce waste discharges.
2. The construction of roads or dams, the commencement of any extractive industry or earthworks.

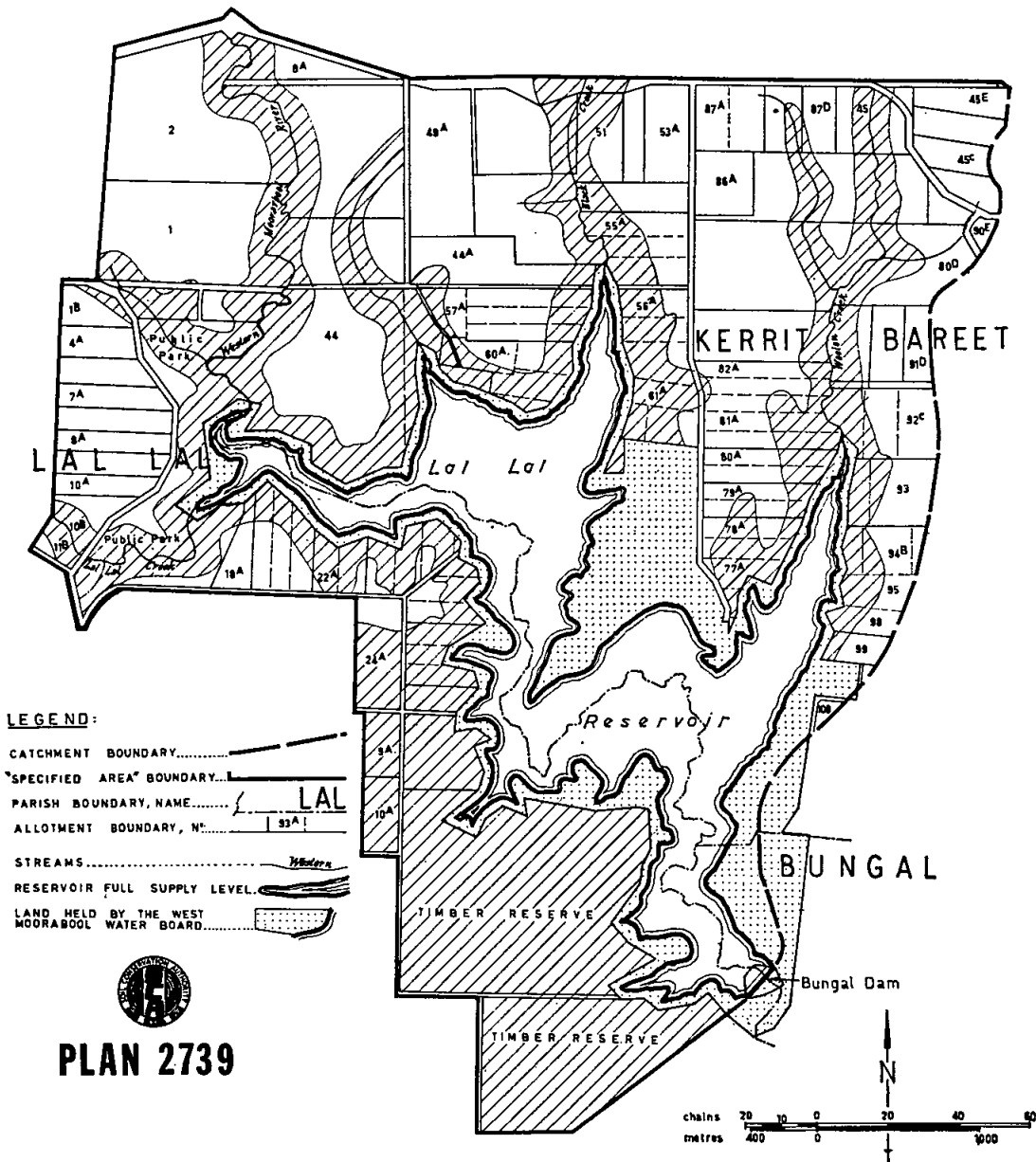

LEGEND:
 CATCHMENT BOUNDARY.....
 "SPECIFIED AREA" BOUNDARY.....
 PARISH BOUNDARY, NAME.....
 ALLOTMENT BOUNDARY, No.....
 STREAMS.....
 RESERVOIR FULL SUPPLY LEVEL.....
 LAND HELD BY THE WEST
 MOORABOOL WATER BOARD.....

PLAN 2739

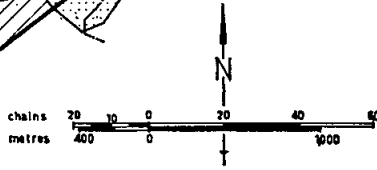

5th November, 1973.

R. A. FITT,
 Secretary.

Private Agents Act, 1966.

NOTICE OF RECEIPT OF APPLICATION FOR LICENCES UNDER THE PROVISIONS OF THE PRIVATE AGENTS ACT, 1966.

The Clerk(s) of the Magistrates' Court(s) as listed hereunder, hereby give notice that applications, as under, have been lodged for hearing by the said Court(s) on the date(s) specified.

Any person desiring to object to any of such applications must—

- (a) lodge with the respective Clerk of the Magistrates' Court a notice in the prescribed form of his objection and of the grounds thereof;
- (b) cause a copy of such notice to be served personally or by post upon the applicant at least three days before the hearing of the application; and
- (c) send or deliver—
 - (i) where the objection is not made by the officer in charge of the police district in which the Court is situated—a copy of the notice to such officer; and
 - (ii) where the objection is not made by the Registrar or Deputy Registrar—a copy to the Registrar.

Full Name of Applicant or in the Case of a Firm or Corporation, of the Nominee.	Place of Abode of Applicant or Nominee.	Name of Firm or Corporation.	Address for Registration.	Type of Licence.	Date of Hearing of Application.
---	---	------------------------------	---------------------------	------------------	---------------------------------

MAGISTRATES' COURT, CAMBERWELL.

Schumacher, Raymond John	187 Union-road, Surrey Hills		187 Union-road, Surrey Hills	Process Server	20.11.73
Wade, Kevin	43 Rix-street, Glen Iris		43 Rix-street, Glen Iris	Guard Agent	"

Dated at Camberwell this 31st day of October, 1973.

J. C. TOBIN, Clerk of the Magistrates' Court.

MAGISTRATES' COURT, CHELTENHAM.

Lowe, Ronald Stanley	1 Rowens-road, Highett		1 Rowens-road, Highett	Process Server (Individual)	23.11.73
----------------------	------------------------	--	------------------------	-----------------------------	----------

Dated at Cheltenham this 2nd day of November, 1973.

J. T. FERGUSON, Clerk of the Magistrates' Court.

MAGISTRATES' COURT, BOX HILL.

Watts, Max Allan	1 Leons-court, Blackburn		1 Leons-court, Blackburn	Process Server	30.11.73
Dick, Geoffrey Morrison	43 Station-street, Doncaster		" " "	" " "	"
Dick, Joyce Lillian	" " "		" " "	" " "	"

Dated at Box Hill this 1st day of November, 1973.

R. J. McALLISTER, Clerk of the Magistrates' Court.

MAGISTRATES' COURT, SOUTH MELBOURNE.

McMahon, Shane Francis	5/39 Alma-road, St. Kilda	Mayne Nickless Ltd.	94 York-street, South Melbourne	Watchman	14.11.73
------------------------	---------------------------	---------------------	---------------------------------	----------	----------

Dated at South Melbourne this 25th day of October, 1973.

F. J. TENNI, Clerk of the Magistrates' Court.

MAGISTRATES' COURT, BRUNSWICK.

Cauchi, Richard John	19 Glenlyon-road, Brunswick		19 Glenlyon-road, Brunswick	Process Server	29.11.73
----------------------	-----------------------------	--	-----------------------------	----------------	----------

Dated at Brunswick this 5th day of November, 1973.

R. WHITE, Clerk of the Magistrates' Court.

MAGISTRATES' COURT, CHELTENHAM.

Wieczorek, Jan	Flat 2, 5 Guernsey-street, Moorabbin.		Flat 2, 5 Guernsey-street, Moorabbin	Process Server (Individual)	27.11.73
----------------	---------------------------------------	--	--------------------------------------	-----------------------------	----------

Dated at Cheltenham this 5th day of November, 1973.

J. T. FERGUSON, Clerk of the Magistrates' Court.

MAGISTRATES' COURT, PORT MELBOURNE.

Dewar, John Alojzy	203 Lonsdale-street, Melbourne	Mayne Nickless Ltd.	94 York-street, South Melbourne	Watchman	27.11.73
Honig, Michael Edward	45 Gladstone-avenue, Northcote	" " "	" " "	" " "	"
Westwood, Donald George	122 Cowin-street, Diamond Creek	" " "	" " "	" " "	"
Allman, Geoffrey Russell	12/5 Brindisi-street, Mentone	" " "	" " "	" " "	"
Fitzgerald, Felix Joseph	969 Mt. Alexander-road, Essendon	" " "	" " "	" " "	"
Ruse, Ronald Gerald	3/6 Simmons-court, South Yarra	" " "	" " "	" " "	"
Moore, Ray Leslie	30 McMahons-road, Coburg	" " "	538 Williamstown-road, Port Melbourne	" " "	"
Glanville, Roy	291 Beaconsfield-parade, Middle Park	" " "	" " "	" " "	"
Kimber, Lindsay Robert	C/o Airmen's Mess, R.A.A.F., Tottenham	" " "	" " "	" " "	"

Dated at Port Melbourne this 5th day of November, 1973.

J. A. GIDLEY, Clerk of the Magistrates' Court.

MAGISTRATES' COURT, MALVERN.

Cable-Scott, William Frederick	1/115 Eskdale-road, Caulfield North		1/115 Eskdale-road, Caulfield	Process Server	5.12.73
--------------------------------	-------------------------------------	--	-------------------------------	----------------	---------

Dated at Malvern this 7th day of November, 1973.

P. J. RODDA, Clerk of the Magistrates' Court.

PRIVATE AGENTS—continued.

Full Name of Applicant or in the Case of a Firm or Corporation, of the Nominee.	Place of Abode of Applicant or Nominee.	Name of Firm or Corporation.	Address for Registration.	Type of Licence.	Date of Hearing of Application.
MAGISTRATES' COURT, SALE.					
Plant, Lionel Joseph	12 Hyland-court, Sale	Sale Security Agents	33 Cunninghame-street, Sale	Watchman	27.11.73
Smith, Graham Henry	12 Mathieson-street, Sale	Sale Burglar Protection	8 Elston-court, Sale	"	"
Trippett, Brian	R.A.A.F., East Sale	Sale Security Agents	33 Cunninghame-street, Sale	"	"
Wheeler, Barry John	Service Police Section, R.A.A.F. Base, East Sale	Sale Security Patrol	" " "	"	"

Dated at Sale this 5th day of November, 1973.

M. GERKENS, Clerk of the Magistrates' Court.

MAGISTRATES' COURT, PRAHRAN.					
Lewis, Allen Clarke	21 Queen-street, Nunawading	Security Pacific	Suite 1, 765 Punt-road, South Yarra	Watchman	7.12.73
Lewis, Allen Clarke	3 Sylvia-court, Black Rock	Carol Furzer	Suite 12, 614 St. Kilda-road, Melbourne	Inquiry Agent	"
Lease, Robert Charles Minto				Commercial Sub-Agent	"

Dated at Prahran this 7th day of November, 1973.

I. M. GRIFFITHS, Clerk of the Magistrates' Court.

MAGISTRATES' COURT, MALVERN.					
Malcolm, Reginald Charles	36 Teck-street, Jordanville	The Security Watching Co.	281 High-street, Ashburton	Watchman	14.12.73

Dated at Malvern this 8th day of November, 1973.

P. J. RODDA, Clerk of the Magistrates' Court.

MAGISTRATES' COURT, HORSHAM.					
Liston, Gerald Francis	Wayside Laharum-road, Horsham.		54 Roberts-avenue, Horsham	Commercial Sub-agent	5.12.73

Dated at Horsham this 5th day of November, 1973.

R. J. CUTHILL, Clerk of the Magistrates' Court.

MAGISTRATES' COURT, FRANKSTON.					
Lawson, Murray	2 Koala-court, Frankston		Clarke-road, Springvale.	Watchman	29.11.73

Dated at Frankston this 7th day of November, 1973.

M. J. DUFFY, Clerk of the Magistrates' Court.

Co-operation Act 1958.

BOX HILL PROGRESSIVE CO-OPERATIVE SOCIETY LIMITED.

MORTLAKE HIGH SCHOOL CO-OPERATIVE LIMITED.

NOTICE OF DISSOLUTION OF SOCIETIES.

Notice is hereby given that I have this day registered the dissolution of the above-named societies and cancelled their registrations under the above-named Act.

Dated at Melbourne this seventh day of November, 1973.

R. F. SCOLLARD,
Deputy Registrar of Co-operative Societies.

STATE RIVERS AND WATER SUPPLY COMMISSION.

BY-LAW No. 5708—RATES—NEWSTEAD URBAN DISTRICT.

The State Rivers and Water Supply Commission, in pursuance and exercise of the powers conferred by the Water Act, doth hereby make the By-law following:—

1. The following rates for the supply of water for domestic purposes are hereby made and shall be levied upon the owners or occupiers of lands and tenements within the Newstead Urban District:—

On all tenements in respect of which a notice has been given in accordance with the Eighth Schedule to the Water Act that a main pipe for the supply of water has been laid down—a rate of seventeen and one half cents in the dollar of the net annual value (NAV) as set out in the municipal valuation as at 30th June, 1973, of such tenements; provided that the total amount of the rate payable annually in respect of any such tenements (other than land on which there is no building) shall be not less than the sum of twenty dollars and in respect of any lands on which there is no building shall be not less than the sum of ten dollars.

2. Such rates are made and shall be levied for the year beginning with the 1st day of July, 1973, and ending with the 30th day of June, 1974, and shall be payable on the 1st day of December, 1973, at the office of the State Rivers and Water Supply Commission at Berdigo.

3. Interest at the rate of eight per cent per annum will be chargeable on all rates remaining unpaid after 15th April, 1974.

4. Such person or persons as the State Rivers and Water Supply Commission may from time to time appoint for that purpose shall be and is or are hereby authorized to demand, receive, collect and recover the said rates.

The foregoing By-law was made by the State Rivers and Water Supply Commission on the 16th day of October, 1973, and the common seal of the said Commission was hereunto affixed on the 5th day of November, 1973, in the presence of—

(SEAL) A. L. TISDALL, Commissioner.
W. E. BROMFIELD, Commissioner.

Approved, 8th November, 1973.—F. J. GRANTER, Minister of Water Supply.

STATE RIVERS AND WATER SUPPLY COMMISSION.
BY-LAW No. 5707.—RATES.—URBAN DISTRICT SUPPLIED WITH WATER FROM THE COLIBAN SYSTEM OF WATERWORKS.

The State Rivers and Water Supply Commission, in pursuance and exercise of the powers conferred by the Water Act, doth hereby make the By-law following:—

1. The following rates for the supply of water for domestic purposes are made and shall be levied upon the occupiers or owners of lands and tenements within the Urban District supplied with water from the Coliban System of Waterworks.

On all tenements in respect of which a notice has been given in accordance with the Eighth Schedule to the Water Act that a main pipe for the supply of water has been laid down—a rate of seven cents in the dollar of the net annual value (NAV) as set out in the municipal valuation as at 30th June, 1973, of such tenements; provided that the total amount of the rate payable annually in respect of any such tenements (other than land on which there is no building) shall be not less than the sum of twenty

dollars and in respect of any lands on which there is no building shall be not less than the sum of ten dollars.

2. Such rates are made and shall be levied for the year beginning with the 1st day of July, 1973, and ending with the 30th day of June, 1974, and shall be payable on the 1st day of December, 1973, at the office of the State Rivers and Water Supply Commission, at Bendigo.

3. Interest at the rate of eight per cent. per annum will be chargeable on all Rates remaining unpaid after 15th April, 1974.

4. Such person or persons as the State Rivers and Water Supply Commission may from time to time appoint for that purpose shall be and is or are hereby authorized to demand, receive, collect and recover the said rates.

The foregoing By-law was made by the State Rivers and Water Supply Commission on the 16th day of October, 1973, and the common seal of the said Commission was hereunto affixed on the 5th day of November, 1973, in the presence of—

(SEAL) A. L. FISDALL, Commissioner.
W. E. BROMFIELD, Commissioner.

Approved, 8th November, 1973.—F. J. GRANTER, Minister of Water Supply.

QUEENSLIFFE SEWERAGE AUTHORITY.

AUDIT OF ACCOUNTS.

Fees Payable to Auditor.

His Excellency the Governor of the State of Victoria by and with the advice of the Executive Council thereof doth by Order made on the 7th day of November, 1973, and in pursuance of the provisions of the Sewerage Districts Act 1958 (No. 6368) approve of the payment to R. C. MacTaggart, Esquire, of the sum of Seven hundred dollars (\$700) as remuneration for making audits of the accounts of the Queenscliffe Sewerage Authority, for the period from the date of constitution of the Authority until 30th September, 1972, he having been duly appointed by Orders in Council made on 6th October, 1970, 1st September, 1971, and 5th September, 1972, to make such audits.

T. J. FORRISTAL,
Clerk of the Executive Council.

At the Executive Council Chamber,
Melbourne, 7th November, 1973.

MINES DEPARTMENT.

APPLICATIONS FOR LEASES DECLARED ABANDONED.

- 9101, Mineral; New Yankee Metals Pty. Ltd.; 640 acres, Parishes of Trentham and Blackwood.
9121, Mineral; New Yankee Metals Pty. Ltd.; 640 acres, Parish of Blackwood.
49, Mining Lease; Erik Christian Sorensen; 51 acres, Parishes of Byawatha and Tarrawingee.

MINING LEASES GRANTED.

- 9048, Mineral; Commonwealth Aluminium Corporation Limited; 384a. 0r. 15p., Parishes of Walwa, Tintalra and Cudgewa.
107, Mining Lease; Donald Albert Grant; 33a. 1r. 37p., Parish of Koro-Ganeit.
123, Mining Lease; Albert Booth Clarke; 16a. 3r. 34p., Parish of Kooroon.

MINING LEASES TRANSFERRED.

- 9223, Ballarat; from Keith Juniper to Ready Mixed Concrete (Victoria) Pty. Limited.
9284, Castlemaine; from Ronald Dowell, Barry Lyons and Robert Henderson to Ronald Dowell, Barry Lyons and George Leggett.

TAILINGS LICENCES GRANTED.

- 3921, Tailings Licence; State Rivers and Water Supply Commission; to remove tailings from the "Victoria Proprietary Shaft" mine dump, Parish of Sandhurst.
3922, Tailings Licence; The Mayor, Councillors and Citizens of the City of Ballarat; to remove tailings from the "Imperial Heaps" mine dump, Parish of Buninyong.

EXTRACTIVE INDUSTRY LEASE GRANTED.

- 128, Extractive Industry Lease; Sure Quarries Pty. Ltd.; 18a. 3r. 25p., Parish of Tanjil East.

APPLICATION FOR EXTRACTIVE INDUSTRY LICENCE DECLARED ABANDONED.

- 640, Extractive Industry Licence; Ready Mixed Concrete (Victoria) Pty. Limited; 124 acres, Parish of Morang.

EXTRACTIVE INDUSTRY LICENCE GRANTED.

- 642, Extractive Industry Licence; Pirotta Industries Pty. Ltd.; 14a. 2r. 29p., Parish of Mordialloc.

EXTRACTIVE INDUSTRY LICENCE EXPIRED.

- 57, Extractive Industry Licence; Calvert Hartley King; 35 acres, Parish of Tonimbuk.

J. C. M. BALFOUR,
Minister of Mines.

NOTICE.

Creditors, next of kin and others having claims against the estate of any of the under-mentioned deceased persons are required to send particulars of their claims to the Public Trustee, 168 Exhibition-street, Melbourne, Vic. 3000, the personal representative, on or before the 21st January, 1974, after which date the Public Trustee may convey or distribute the assets, having regard only to the claims of which the Public Trustee then has notice:—

AULD, MARMA LILLIAN, late of Flat 8, 22 Roseberry-grove, Glenhuntly, home duties, died 17th July, 1973.

BEATON, CHARLES WILLIAM, formerly of 12 Edward-street, Footscray, but late of 9 Mervyn-street, Traralgon, retired boiler inspector, died 6th July, 1973.

BLACKMAN, CLARA LOUISA, formerly of 31 Laver-street, Kew, but late of 10 York-road, Berwick, widow, died 21st October, 1972.

BLISS, ETHEL MAY, formerly of 5 Swift-street, Northcote, but late of Arlington Private Hospital, 3 Collins-street, Thornbury, widow, died 9th September, 1973.

CAMERON, EVA MAUD, late of 25 Princes-street, North Williamstown, widow, died 22nd July, 1973.

CATTACH, DOROTHY, formerly of 8 The Avenue, Windsor, but late of Bundoora, widow, died 15th January, 1973.

KARSLAKE, HENRY GEORGE, formerly of Lexton, but late of Ballarat, pensioner, died 16th February, 1973.

MILLER, MERLE MAVIS, late of 162 Keele-street, Collingwood, spinster, died 27th July, 1973.

PEDERSEN, CHRISTINA, also known as Christina Pederson, late of 33 Wellington-road, Box Hill, widow, died 14th August, 1973.

SKELTON, MARY, also known as May Skelton, formerly of 24 Armadale-street, Thornbury, but late of 22 Delta-avenue, Merlynston, widow, died 10th July, 1973.

WALLACE, JACK JOSEPH, late of care of Spottiswoode Hotel, 59 Hudsons-road, Spotswood, driver, died 27th August, 1973.

WESTWOOD, TERESA JOSEPHINE, formerly of 282 Beaconsfield-parade, Middle Park, but late of Kew, married woman, died 28th March, 1973.

WILLIAMS, EDWIN BRAWDERS, late of 3 Hastings-road, Hawthorn East, gentleman, died 9th July, 1973.

YATES, FRANK GEORGE, formerly of 396 Huntingdale-road, Huntingdale, but late of Lightning Ridge, N.S.W., prospector, died 19th April, 1973.

N. P. BRODY,
Public Trustee.

Melbourne, 7th November, 1973.

CONTRACTS ACCEPTED.—(Series 1973-74.)

STATE RIVERS AND WATER SUPPLY COMMISSION.

607. Construction of amenities buildings 1 and 2; sullage, water collection points, log barriers and other items for Stage 1 of Dartmouth Caravan Park, \$94,704.—Bruni & Bisogni Pty. Ltd.

608. Construction of toilet block—dressing shed shelter and fuel store at Lake Mokoan, \$8,303.—S. C. Lewis.

609. Enlargement of earthen storages at Woomelang, involving 40,000 cubic yards of excavation, \$12,375.—A. D. Twigg & Sons.

Sealed by Commission, 3rd July, 1973.

610. Cleaning of Head Office buildings at Armadale for the year ending 30th June, 1974, \$36,404.—D.P.C. Cleaning Co.

Sealed by Commission, 16th July, 1973.

611. Construction of pumphouse at Dromana, \$12,500.—N.A.W.D. Building Pty. Ltd.

612. Supply and erection of 1,330 ft. of 8 ft. high chain wire fencing at Dromana, \$3,908.—Austral Wire Fence & Gate Co. Pty. Ltd.

613. Supply and erection of 420 ft. of 8 ft. high black P.V.C. coated chain wire fencing at Dromana, \$2,352.—Otter Fencing Co. Pty. Ltd.

Sealed by Commission, 23rd July, 1973.

614. Construction of six transportable houses at Dartmouth Dam, \$77,886.—K. G. Carson.

Sealed by Commission, 6th August, 1973.

615. Construction of combined toilet block—dressing shelter and six fireplaces at Lake William Hovell, \$9,190.—Stone Bros. Pty. Ltd.

616. Supply and installation of electrical services at Dartmouth Caravan Park, \$17,364.—O. C. Murphy & Co. Pty. Ltd.

617. Welding of third stage of 42-inch Tarago—Westernport Pipeline, \$25,000.—Samirlin Welding.

Sealed by Commission, 20th August, 1973.

618. Construction of SN4 residence in brick veneer at Point Lonsdale, \$18,613.—David J. Evans & Sons.

619. Supply, delivery and erection of chain wire fencing and gates at Rosslynne Reservoir—750 chains, \$159,794.—Cyclone K.M. Products Pty. Ltd.

Sealed by Commission, 28th August, 1973.

620. Cleaning of the Commission's Frankston office from 1st May, 1973, to 31st December, 1973, \$4,907.—John Barry Cleaning Group (Central) Pty. Ltd.

Sealed by Commission, 6th September, 1973.

PROVISIONS.

Gazette No. 42, 1st June, 1973.—For rates shown opposite the following items, substitute the rates as set out below from the dates shown. Schedule No. 6, Ararat District, Sub-schedule No. 4, Item No. 3, \$1.87; Item No. 4, \$12.68; Item No. 24, 32 Kg, \$7.92. Schedule No. 7, Ballarat District, Sub-schedule No. 4, Item No. 5, \$11.94; Item No. 51, 32 kg, \$7.48; Item No. 54, \$21.03; Item No. 92, 600 gm, \$7.32. Sub-schedule No. 5, Item No. 10, \$0.48; Item No. 22, 32 kg, \$7.48. Schedule No. 21, Pleasant Creek Special School, Stawell, Sub-schedule No. 4, Item No. 3, \$12.80; Item No. 36, \$2.42; as from 1st December, 1973. Schedule No. 22, Sunbury District, Sub-schedule No. 1, Item No. 41, \$7.20; Item No. 9, \$0.70; as from 1st November, 1973. Schedule No. 23, Warrnambool District, Sub-schedule No. 2, Item No. 2, \$0.90; Item No. 21, \$0.39; Item No. 27, \$0.75; Item No. 45, \$0.31; Item No. 49, \$0.25; as from 1st November, 1973.

TOOLS.

Gazette No. 19, 30th March, 1973. Schedule No. 52, Item No. 407 substitute \$10.80 from 9th November, 1973.

GENERAL STORES.

Gazette No. 77, 30th July, 1973. Schedule No. 32, Antiseptics, Disinfectants, Deodorants and Insecticides. For Item Nos. 15, 16, 17, 18 and 19 change of name of Contractor to Kiwi Australia Ltd.

MOTOR SPIRIT.

Gazette No. 22, 30th March, 1973. Distillate. Disregard amended rates shown for Items 13 and 14 published in *Gazette* dated 10th October, 1973. Rates remain as follows, Item No. 13, \$0.135, \$0.140; Item No. 14, \$0.127, \$0.132.

E. P. WATSON, Secretary to the Tender Board. 13.11.73.

PUBLIC WORKS.

621. Keilor Heights, High School, supply and fix shelving, \$4,942.25.—Westbury Timber Co. Pty. Ltd.

622. Kerang, High School, supply workshop equipment, \$8,620.00.—McPhersons Ltd.

623. Templestowe, Technical School, supply lathes, \$6,511.00.—Herbert Osborne.

624. Templestowe, Technical School, supply workshop equipment, \$7,784.00.—McPhersons Ltd.

625. Melbourne, Mental Health Authority, supply and install diabol power files, \$13,800.00.—Control Systems (A'asia) Pty. Ltd.

626. Blackburn, High School, supply tables, \$4,105.00.—G. & G. Shop & Office Fitters Pty. Ltd.

G. SERPELL, Director-General. 2.11.73.

ORDERS IN COUNCIL.—(Series 1973-74.)

PUBLIC WORKS.

598. Melbourne, 271 William-street, 9th Floor, Nubrick House, cost for partitioning and associated works, inclusive of professional fees, for leased premises for the Committee of Inquiry into Hospital and Health Services, \$31,947.00.—271 William Street Pty. Ltd.—(P.1997.)

Approved by the Governor in Council, 7th November, 1973.—T. J. FORRISTAL, Clerk of the Executive Council.

STATE ELECTRICITY COMMISSION.

599. For the supply and operation of drilling plant in the Melbourne, metropolitan and country areas for a period of two years with optional extension of three months, to Specification No. 73/110, at Schedule rates.—Watermore Boring Co. Pty. Ltd.

Approved by the Governor in Council, 11th September, 1973.—T. J. FORRISTAL, Clerk of the Executive Council.

600. For the supply and erection of one bucket wheel dredger for use in the Yallourn open cut, to Specification No. 72/318, \$4,449,936.—Krupp (Australia) Pty. Ltd.

601. For the supply of time switches in moulded cases for control of water/space heating and public lighting loads for a period of two years with optional extension of three months, to Specification No. 73/82, at Schedule rates.—Warburton Franki (Sydney) Pty. Ltd.

Approved by the Governor in Council, 18th September, 1973.—T. J. FORRISTAL, Clerk of the Executive Council.

602. For the supply of meter boards for a period of two years with optional extension of three months, to Specification No. 73/193, at Schedule rates.—Wycombe Industries Pty. Ltd.

Approved by the Governor in Council, 25th September, 1973.—T. J. FORRISTAL, Clerk of the Executive Council.

603. For the supply of desks, tables and wardrobes for Monash House, to Specification No. 73/228, at Schedule rates.—Feature Furniture Pty. Ltd.

Approved by the Governor in Council, 2nd October, 1973.—T. J. FORRISTAL, Clerk of the Executive Council.

604. For the supply of polyethylene heat shrink film for briquette packaging for a period of two years with optional extension of three months, to Specification No. 73/222A, at Schedule rates.—Renown and Pearlite Pty. Ltd.

605. For diversion of main drain, Morwell Open Cut, to Specification No. 73/230, \$306,000.—J. Jeffrey and Sons Pty. Ltd.

Approved by the Governor in Council, 16th October, 1973.—T. J. FORRISTAL, Clerk of the Executive Council.

606. For the provision of cleaning services of office premises at 122-138 Thomas-street, Dandenong, for the period 8th December, 1973, to 31st December, 1976, to Specification No. 73/229, \$62,860.—Dandenong Cleaning Service.

Approved by the Governor in Council, 23rd October, 1973.—T. J. FORRISTAL, Clerk of the Executive Council.

APPOINTMENTS AND RESIGNATIONS**APPOINTMENTS.**

His Excellency the Governor of the State of Victoria, by and with the advice of the Executive Council thereof, has, by Orders made on the 7th day of November, 1973, been pleased to make the under-mentioned appointments, viz.:

CHIEF SECRETARY'S DEPARTMENT.*Member of the Road Safety and Traffic Authority.*

GORDON WALGRAVE TRINCA, F.R.A.C.S. (nominated by the Royal Australasian College of Surgeons), pursuant to the provisions of the Road Traffic Act 1958, to be a member of the Road Safety and Traffic Authority, for the period ending the 15th February, 1974, vice Graeme Grove, deceased.

MINISTRY OF HEALTH.*Member of the Anti-Cancer Council of Victoria.*

ALAN THOMAS ROSE, M.B., B.S., M.R.A.C.G.P., to be a Member of the Anti-Cancer Council of Victoria, pursuant to the provisions of section 6 (b) of the Cancer Act 1958 for the remainder of the period ending the 11th March, 1977.

Deputy Superintendents.

BENJAMIN CHESLER, M.B., Ch.B., D.P.M., M.A.N.Z.C.P., to be Deputy Superintendent, Training Centre, Sunbury, appointed pursuant to section 26 (1) of the Mental Health Act 1959, from the 22nd October, 1973, vice Dr. Pillutia, resigned; and

JOHN MCLEOD GORDON GRIGOR, M.B., Ch.B., D.P.M., M.A.N.Z.C.P., Dip.Crim., to be Deputy Superintendent, Psychiatric Hospital, Royal Park, appointed pursuant to section 26 (1) of the Mental Health Act 1959, from the 22nd October, 1973, vice Dr. Chesler, transferred.

LAW DEPARTMENT.*Judge of the County Court.*

GORDON HENRY SPENCE, LL.B., a Barrister at Law who has practised as a Barrister in Victoria for a period of seven years, to be a Judge of the County Court of Victoria, to take effect from the date of commencement of duty.

Commissioners for Taking Declarations, &c.

GLORIA DAWN WADE, care of City of Heidelberg, Town Hall, Upper Heidelberg-road, Ivanhoe,
JUNE LESLEY HUGHES, care of St. Laurence Court Hostel, Upper-road, California Gully,
CAMPBELL FRASER JOHNSON, 175 Hotham-street, East St. Kilda,
ROBERT EDWARD BARTLETT, 26 Hillcrest-road, Nerrina,
ROBERT BLAIR STORK, care of Toplis and Harding, 53 Rosslyn-street, West Melbourne,
SYDNEY HAXTON GRAHAM THOMAS, care of Norwich Union Fire Insurance Society Ltd., 53-57 Queen-street, Melbourne, and
RALPH WINFIELD, 57 Davey-street, Parkdale,
to be Commissioners for taking Declarations and Affidavits under the Evidence Act 1958.

Justices of the Peace.

KEVIN PATRICK MCCARTHY, 22 Chauncey-street, Heathcote,
KATHLEEN MARY GAMBETTA, 193 San Mateo-avenue, Mildura,
LAWRENCE PERCIVAL BURGESS, 816 High-street, East Kew, and
MARGARET MARY JOAN DWYER, 28 River-avenue, Ascot Vale,
to Keep the Peace in the State of Victoria.

Queen's Counsel.

JOHN FRANCIS MOLONEY as one of Her Majesty's Counsel under the Regulations of 20th October, 1970, to have precedence next after The Honorable Vernon Francis Wilcox, Q.C.,

ALAN JAMES SCURRY as one of Her Majesty's Counsel under the Regulations of 20th October, 1970, to have precedence next after John Francis Moloney, Esquire,

FRANCIS XAVIER COSTIGAN as one of Her Majesty's Counsel under the Regulations of 20th October, 1970, to have precedence next after Alan James Scurry, Esquire,

GLENN ROYCE DONAL WALDRON as one of Her Majesty's Counsel under the Regulations of 20th October, 1970, to have precedence next after Francis Xavier Costigan, Esquire,

JOHN JOSEPH HEDIGAN as one of Her Majesty's Counsel under the Regulations of 20th October, 1970, to have precedence next after Glenn Royce Donal Waldron, Esquire,

JOHN EDWARD BARNARD as one of Her Majesty's Counsel under the Regulations of 20th October, 1970, to have precedence next after John Joseph Hedigan, Esquire; and

DOUGLAS GORDON MCGREGOR, Q.C., (N.S.W.), as one of Her Majesty's Counsel under the Regulations of 20th October, 1970, to have precedence next after John Edward Barnard, Esquire.

PUBLIC WORKS DEPARTMENT.*Members of the Marine Board of Victoria.*

ARTHUR WILLIAM STOVOLD to be re-appointed a Member of the Marine Board of Victoria, for a period of three (3) years from 21st December, 1973, as a representative of Merchants and Traders of Melbourne, pursuant to the provisions of the Marine Act 1958; and

ALBERT JOHN WAGGLEN, RONALD GEORGE WEBSTER, and JOHN HENRY COLES, to be re-appointed members of the Marine Board of Victoria, for a period of three years from 19th December, 1973; and that Albert John Wagglén be re-appointed President and Ronald George Webster be re-appointed Vice President of the said Board, for a period of three years from 19th December, 1973, pursuant to the provisions of the Marine Act 1958.

SOCIAL WELFARE DEPARTMENT.*Honorary Probation Officers.*

WILLIAM BELL ADRIAN (Rev.), 43 Cromie-street, Murtoa,
RUEBAN JAMES BERG, 26 McLennan-street, Braybrook,
MICHAEL DAVID BROOKS, 100 Ardle-street, Warrnambool,
TIMOTHY BELL CAFFIN, 127 Mt. Dandenong-road, Croydon,
ROBERT GEORGE DENHAM, Lot 34, Carmen-court, Lilydale,
BRIAN VINCENT FINNIGAN (Rev.), Catholic Presbytery, 117 Bentinck-street, Portland,
GEORGE ALBERT GOULDER, 3 A'Beckett-street, Kew,
HORACE HENRY GOWTHY (Rev.), 16 Alexander-avenue, Berriwillcock,
ROBERT GRIFFITHS, 21 Kingsley-road, Reservoir,
RICHARD JOSEPH HAIRE, 49 Carpenter-street, Bendigo,
EDWARD JOSEPH HOY, Ivine-road, Koroit,
BARBARA ANNE HUTTON (Miss), care of Dr. J. Fisher, P.O. Box 289, Warrnambool,
STUART ARMAND HURNALL, 88 Clifford-street, Warragul,
UTTLEY HUGA JENKIN, 189 Baillie-street, Horsham,
NORMAN JOHN KEILAR, 23 Edinburgh-road, Blackburn South,
DAWN KENNEALLY (Mrs.), 19 Nicholson-street, Warrnambool,
BARRIE FLETCHER KILPATRICK (Rev.), The Manse, Forest-street, Woodend,
CLIVE LYNN, Coast-road, Mirboo North,
BRIAN PATRICK McDERMOTT, Corpus Christi College, Bayview-avenue, Clayton,
CLIFFORD JOHNSON MILLER, Flat 5, 22 Highbury-grove, Kew,
ROBERT JOSEPH MYERS, 245 Timor-street, Warrnambool,
KEITH ANTHONY OATWAY, 48 Lydiard-street north, Ballarat,
GAVIN MELVILLE OTT, St. Peter's Rectory, Box 149, Dimboola,
ALLAN VICTOR POKE (Captain), 52 Short-street, Bendigo,
HELEN ELIZABETH SCRIVEN (Miss), Flat 2, 135 Anstruther-street, Echuca,
JOHN TREACY (Fr.), Sacred Heart Presbytery, Tatura,
LESLIE JAMES TULLY, 17 Lydford-road, Ferntree Gully, and
ROBERT R. WRIGHT, 27 Jukes-street, Warrnambool, pursuant to the provisions of section 507 (2) of the Crimes Act 1958 and section 10 (1) of the Children's Court Act 1958, to be Honorary Probation Officers for all Adult and Children's Courts in Victoria.

DEPARTMENT OF THE TREASURER.
Receiver of Revenue (Acting).

GRAEME MURPHY
to act temporarily as Receiver of Revenue, Korumburra,
vice D. J. Devlin, on leave.

T. J. FORRISTAL,
Clerk of the Executive Council.

At the Executive Council Chamber,
Melbourne, 7th November, 1973.

FORESTS DEPARTMENT.

APPOINTMENT OF COMMITTEE OF MANAGEMENT
OF "CRESWICK KOALA PARK".

Whereas by section 50 of the *Forests Act 1958* (No. 6254), it is provided that the Minister of Forests may, on the recommendation of the Forests Commission, appoint any number of persons, not less than three, to be a Committee of Management of any land forming part of any reserved forest, such land being set aside and declared to be a Koala Park, and may remove any of those persons: Now therefore, I, Frederick James Granter, Her Majesty's Minister of Forests for the State of Victoria, on the recommendation of the Forests Commission, do hereby appoint—

WILLIAM HENRY ROFE,
vice M. F. Hubbard resigned, as a member of the Committee of Management until the 30th day of June, 1976, of the land forming part of the reserved forest in the Parish of Creswick, County of Talbot, described in the accompanying Schedule, and known as "Creswick Koala Park".

SCHEDULE ABOVE REFERRED TO.

Parish of Creswick, County of Talbot, 23 acres, more or less, being the area shown by pink colour on plan marked A.41/746 over 15.7.42 on file of correspondence No. 67/57 of the Forests Department.

Dated at Melbourne, the 29th day of October, 1973.

F. J. GRANTER,
Minister of Forests.

FORESTS DEPARTMENT.

APPOINTMENT OF COMMITTEE OF MANAGEMENT OF
"ST. GEORGE'S LAKE SCENIC RESERVE".

Whereas by section 50 of the *Forests Act 1958* (No. 6254), it is provided that the Minister of Forests may, on the recommendation of the Forests Commission, appoint any number of persons, not less than three, to be a Committee of Management of any land forming part of any reserved forest, such land being set aside and declared to be a scenic reserve, and may remove any of those persons: Now therefore, I, Frederick James Granter, Her Majesty's Minister of Forests for the State of Victoria, on the recommendation of the Forests Commission, do hereby appoint—

WILLIAM HENRY ROFE,
vice M. F. Hubbard resigned, as a member of the Committee of Management until the 30th day of June, 1976, of the land forming part of the reserved forest in the Parish of Creswick, County of Talbot, described in the accompanying Schedule, and known as "St. George's Lake Scenic Reserve".

SCHEDULE ABOVE REFERRED TO.

Parish of Creswick, County of Talbot, 66 acres, more or less, being the area shown by pink colour on the plan marked 60/67 over 18.3.63, on file of correspondence No. 72/2288 of the Forests Department.

Dated at Melbourne, the fifth day of November, 1973.

F. J. GRANTER,
Minister of Forests.

FORESTS DEPARTMENT.

APPOINTMENT OF MEMBERS OF COMMITTEE OF
MANAGEMENT OF MOUNT ALEXANDER KOALA
PARK AND DOG ROCKS SCENIC RESERVE.

Whereas by section 50 of the *Forests Act 1958* (No. 6254), it is provided that the Minister of Forests may, on the recommendation of the Forests Commission, appoint any number of persons, not less than three, to be a Com-

mittee of Management of land forming part of any reserved forest, such lands being set aside as a Koala Park Reserve and a Scenic Reserve, and may remove any of those persons:

Now therefore I, Frederick James Granter, Her Majesty's Minister of Forests for the State of Victoria, on the recommendation of the Forests Commission, do hereby appoint—

EARLE KENNETH THOMAS,
vice K. D. White, resigned as a member of the Committee of Management until the thirtieth day of September, 1975, of the two areas of land forming parts of the reserved forests in the Parish of Harcourt, County of Talbot, described in the accompanying Schedules A and B, and known as the Mount Alexander Koala Park Reserve and Dog Rocks Scenic Reserve.

SCHEDULE A.

Parish of Harcourt, County of Talbot, 77.5 acres, more or less, being the area shown by pink colour on the plan marked 1.10.60 over 59/1751-59/2035, in file of correspondence No. 59/2035 of the Forests Department, and known as "Mount Alexander Koala Park".

SCHEDULE B.

Parish of Harcourt, County of Talbot, 5 acres, more or less, being the area shown by pink colour on the plan marked 1.10.60 over 59/1751-59/2035 in file of correspondence No. 65/2215, of the Forests Department, and known as "Dog Rocks Scenic Reserve".

Dated at Melbourne the fifth day of November, 1973.

F. J. GRANTER,
Minister of Forests.

Liquor Control Act 1968.

APPOINTMENT OF LICENSING INSPECTOR.

In accordance with the authority conferred upon me by sub-section (1) of section 22 of the *Liquor Control Act 1968*, I, Reginald Jackson, Chief Commissioner of Police, hereby appoint the following Officer of Police as Licensing Inspector for the Division of the Police District as shown:—

Division Number.	Police District.	Rank and Name.
3	Heidelberg	Inspector John Douglas Baker (from 29.10.73 to 8.12.73)
		R. JACKSON, Chief Commissioner of Police.
5.11.1973		

Liquor Control Act 1968.

APPOINTMENT OF LICENSING INSPECTOR.

In accordance with the authority conferred upon me by sub-section (1) of section 22 of the *Liquor Control Act 1968*, I, Reginald Jackson, Chief Commissioner of Police, hereby appoint the following Officer of Police as Licensing Inspector for the Division of the Police District as shown:—

Division Number.	Police District.	Rank and Name.
5	Moonee Ponds	Inspector Leslie William Cannon (from 9.12.73 to 31.12.73)
		R. JACKSON, Chief Commissioner of Police.
26.10.1973.		

RESIGNATIONS.

His Excellency the Governor of the State of Victoria, by and with the advice of the Executive Council thereof, has, by Orders made on the 7th day of November, 1973, accepted the resignations of the persons named hereunder of the offices mentioned, viz.:—

CHIEF SECRETARY'S DEPARTMENT.

Member of the Library Council of Victoria.

WILBY LAURENCE BROWN, A.L.A., A.L.A.A., a member of the Library Council of Victoria, pursuant to the provisions of the *Library Council of Victoria Act 1963*, from and inclusive of 23rd November, 1973.

LAW DEPARTMENT.
Justices of the Peace.
 JAMES HENRY CROMBIE, and
 LINDSAY CRAIG SILL,
 as Justices of the Peace for the State of Victoria.
 T. J. FORRISTAL,
 Clerk of the Executive Council.
 At the Executive Council Chamber,
 Melbourne, 7th November, 1973.

ORDERS IN COUNCIL

LAND ACT 1958.

At the Executive Council Chamber, Melbourne, the seventh day of November, 1973.

PRESENT:
 His Excellency the Governor of Victoria,
 Mr. Dickie | Mr. Wilcox.

UNUSED ROAD CLOSED.

In pursuance of the provisions of section 349 of the Land Act 1958, His Excellency the Governor of Victoria, by and with the advice of the Executive Council thereof and the concurrence in writing of the Council of the municipality concerned doth hereby close the unused road referred to hereunder, viz.:—

Township of Korumburra, Parish of Korumburra, County of Buln Buln, being the road as indicated by hatching on plan hereunder.—(K.172⁽¹⁵⁾) (G.70895).

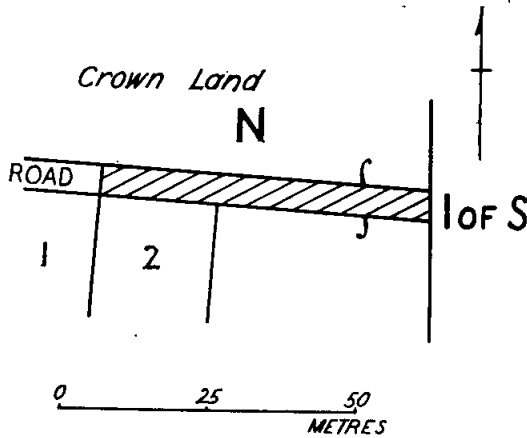

And the Honorable William Archibald Borthwick, Her Majesty's Minister of Lands for the State of Victoria, shall give the necessary directions herein accordingly.

T. J. FORRISTAL,
 Clerk of the Executive Council.

DEPARTMENT OF CROWN LANDS AND SURVEY.

At the Executive Council Chamber, Melbourne, the seventh day of November, 1973.

PRESENT:
 His Excellency the Governor of Victoria,
 Mr. Dickie | Mr. Wilcox.

LANDS TEMPORARILY RESERVED AS SITES.

His Excellency the Governor of the State of Victoria, by and with the advice of the Executive Council thereof, doth hereby, in pursuance of section 14 of the Land Act 1958, reserve temporarily from sale, from being leased and from having a licence granted in respect thereof and also except from occupation for mining purposes under any miner's right, the land hereinafter described:—

SUNBURY.—Site for Public purposes (Public Park and Children's Playground), 1619 square metres, being Crown allotment 5, section 30, Township of Sunbury, Parish of Buttletjorrk, County of Bourke, as indicated by hatching on plan hereunder.—(S.351⁽⁸⁾) (Rs.9810).

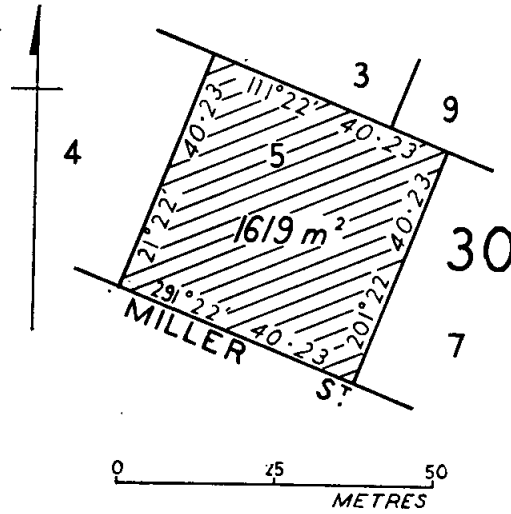

MILDURA.—Site for Public Recreation purposes, 103.1 hectares, Parish of Mildura, County of Karkaroc, as indicated by hatching on plan hereunder.—(M.556⁽¹⁸⁾) (Rs.9798).

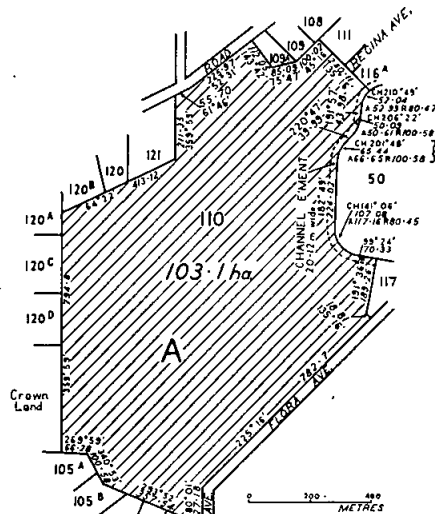

And the Honorable William Archibald Borthwick, Her Majesty's Minister of Lands for the State of Victoria, shall give the necessary directions herein accordingly.

T. J. FORRISTAL,
 Clerk of the Executive Council.

DEPARTMENT OF CROWN LANDS AND SURVEY.

At the Executive Council Chamber, Melbourne, the seventh day of November, 1973.

PRESENT:
 His Excellency the Governor of Victoria,
 Mr. Dickie | Mr. Wilcox.

REVOCATION OF TEMPORARY RESERVATION OF LAND BY ORDER IN COUNCIL.

His Excellency the Governor of the State of Victoria by and with the advice of the Executive Council thereof, doth hereby, in pursuance of the provisions of the Land Act 1958, revoke the temporary reservation of land by Order in Council hereinafter described, viz.:—

WIALI (HOPETOUN).—The temporary reservation by Order in Council of the 7th February, 1933, of 64.75 hectares (160 acres), more or less, of land in the Parishes of

Wiall and Goyura, as a site for Public purposes, so far only as the portion in the Parish of Wiall containing 1-643 hectares, as defined by description and hatching on plan published in the *Government Gazette* dated the 10th October, 1973.—(W.396^(a)) (Rs.4292).

And the Honorable William Archibald Borthwick, Her Majesty's Minister of Lands for the State of Victoria, shall give the necessary directions herein accordingly.

T. J. FORRISTAL,
Clerk of the Executive Council.

HOUSING ACT 1958.

At the Executive Council Chamber, Melbourne, the seventh day of November, 1973.

PRESENT:

His Excellency the Governor of Victoria.
Mr. Dickie | Mr. Wilcox.

EXTINGUISHMENT OF CERTAIN EASEMENTS—SHIRE OF BELLARINE.

Whereas by virtue and in exercise of the powers contained in the *Housing Act 1958* (No. 6275) Housing Commission has recommended to the Governor in Council that the easements described in the Schedule hereto be extinguished.

Now therefore His Excellency the Governor of the State of Victoria, in the Commonwealth of Australia, by and with the advice of the Executive Council of the said State, doth in pursuance of the powers conferred by the said Act and upon such recommendation, consent and by this Order hereby extinguish such easements.

SCHEDULE.

Any easements affecting the land comprised in certificate of title, volume 8844, folio 804.

And the Honorable Vance Oakley Dickie, Her Majesty's Minister of Housing for the State of Victoria shall give the necessary directions herein accordingly.

T. J. FORRISTAL,
Clerk of the Executive Council.

MARKETING OF PRIMARY PRODUCTS ACT 1958.

At the Executive Council Chamber, Melbourne, the seventh day of November, 1973.

PRESENT:

His Excellency the Governor of Victoria.
Mr. Dickie | Mr. Wilcox.

APPOINTMENT OF MEMBER OF THE TOBACCO LEAF MARKETING BOARD.

In pursuance of the powers conferred by section 35b of the *Marketing of Primary Products Act 1958* and all other powers him thereunto enabling His Excellency the Governor of the State of Victoria by and with the advice of the Executive Council thereof doth by this Order hereby appoint Harold Arthur White as a member of The Tobacco Leaf Marketing Board for the period ending on the 31st October, 1976.

And the Honorable Ian Winton Smith, Her Majesty's Minister of Agriculture for the State of Victoria, shall give the necessary directions herein accordingly.

T. J. FORRISTAL,
Clerk of the Executive Council.

COUNTRY ROADS BOARD.

At the Executive Council Chamber, Melbourne, the seventh day of November, 1973.

PRESENT:

His Excellency the Governor of Victoria.
Mr. Dickie | Mr. Wilcox.

ORDER APPROVING OF LAND BEING ACQUIRED AND ROADS, DEVIATIONS OR WIDENINGS BEING MADE.

His Excellency the Governor of the State of Victoria, by and with the advice of the Executive Council thereof, being satisfied that there are funds legally available for

acquiring the land, doth hereby approve the acquiring of the land described in the schedule hereunder and the making of new roads and deviations from and widenings of existing roads referred to in the said schedule.

SCHEDULE.

State Highway.

The land shown hatched on plans numbered G.P.12759A and G.P.12759B hereunder required for the widening of the Hume Highway in the Shire of Wangaratta and making of the widening thereon.

STATE HIGHWAY
HUME HIGHWAY
SHIRE OF WANGARATTA
Measurements in Links

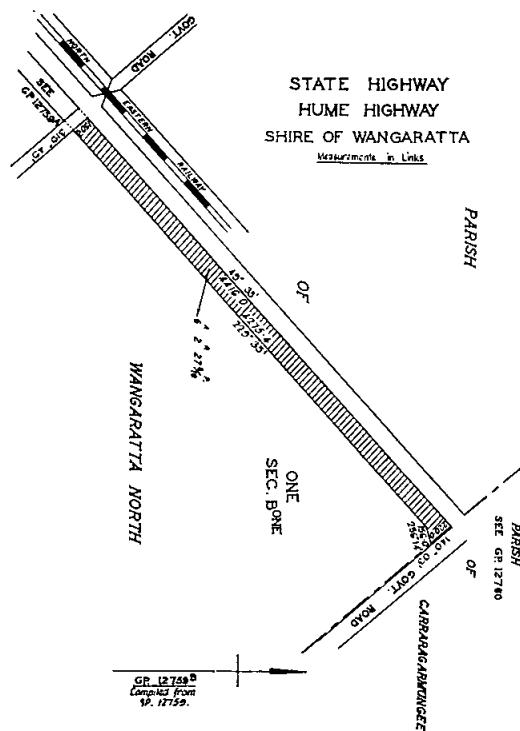
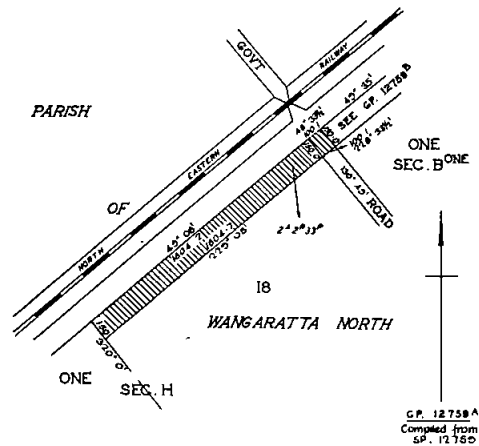

Main Roads.

The land shown hatched on plan numbered G.P.13343A hereunder required for the widening of High-street in the City of Waverley and making of the widening thereon.

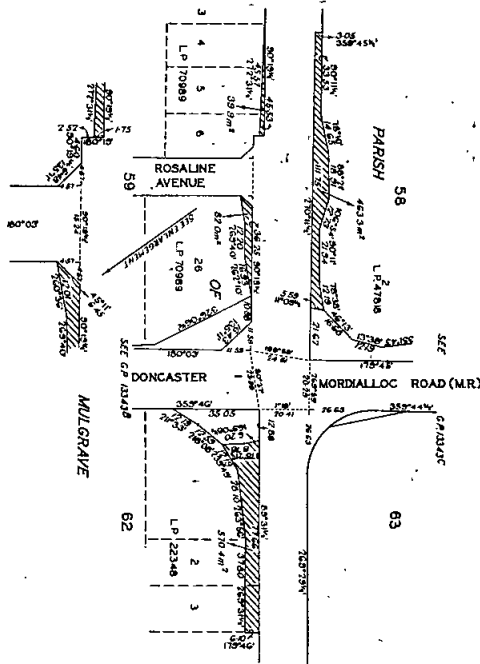

MAIN ROAD
HIGH STREET
CITY OF WAVERLEY

Lengths in Metres

G.P.13343A
Compiled from S.P.13343

The land shown hatched on plans numbered G.P.13343B and G.P.13343C hereunder required for the widening of the Doncaster-Mordialloc road in the City of Waverley and making of the widening thereon.

MAIN ROAD
DONCASTER - MORDIALLOC ROAD
CITY OF WAVERLEY

Lengths in Metres

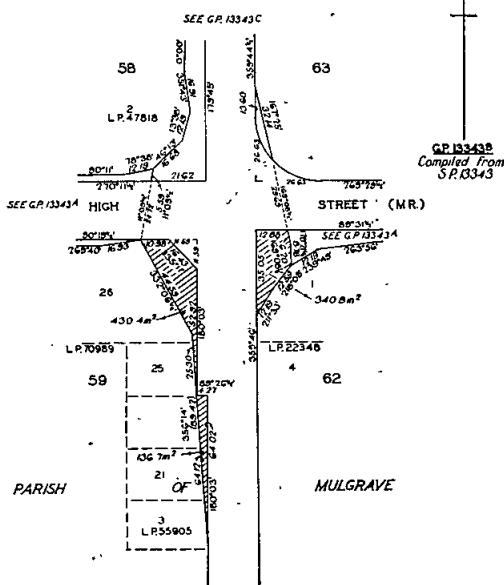

MAIN ROAD
DONCASTER - MORDIALLOC ROAD
CITY OF WAVERLEY

Lengths in Metres

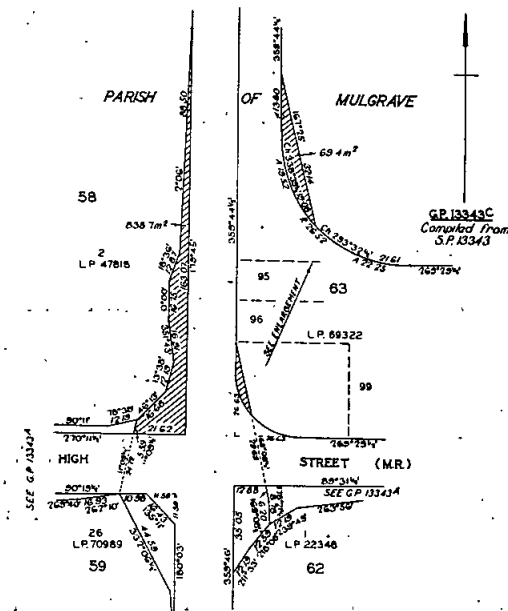

And the Honorable Edward Raymond Meagher, Her Majesty's Minister of Transport for the State of Victoria, shall give the necessary directions herein accordingly.

T. J. FORRISTAL,
Clerk of the Executive Council.

LOCAL GOVERNMENT DEPARTMENT.

At the Executive Council Chamber, Melbourne, the seventh day of November, 1973.

PRESENT:

His Excellency the Governor of Victoria.
Mr. Dickie | Mr. Wilcox.

ROADS DISCONTINUED.—CITY OF OAKLEIGH.

Whereas it is provided in section 528 (2) of the Local Government Act 1958, that where a road (whether or not a public highway but not being a road set out on land of the Crown) or any part thereof is not required for public use, the Governor in Council, on the request of the Council of the municipality in which such road is situated made not less than one month after publishing in a newspaper generally circulating in the district and posting to the registered proprietor (if any) of the land and the owners and occupiers (if any) of lands abutting or immediately adjacent to the road notice of intention to make such a request may by Order published in the Government Gazette direct that such road or part shall be discontinued and thereupon such road or part shall be discontinued accordingly.

And whereas the Council of the City of Oakleigh has requested that the Governor in Council direct that certain roads off Golf Links-avenue and Princes-street, Oakleigh, be discontinued and not less than one month previously, has published in a newspaper generally circulating in the district and posted to the registered proprietor of the land in the said roads and to the owners and occupiers of lands abutting or immediately adjacent to the roads notice of intention to make such request.

Now therefore, His Excellency the Governor of the State of Victoria, by and with the advice of the Executive Council thereof, hereby directs that the said roads which are shown hatched and cross-hatched on the plans hereunder shall be discontinued and that the lands may be sold by the Council of the City of Oakleigh by agreement.

LOCAL GOVERNMENT DEPARTMENT.

At the Executive Council Chamber, Melbourne, the seventh day of November, 1973.

PRESENT:

His Excellency the Governor of Victoria.
Mr. Dickie | Mr. Wilcox.

SEVERANCE OF A PORTION OF THE SHIRE OF OXLEY AND ANNEXATION THEREOF TO THE CITY OF WANGARATTA.

Pursuant to the provisions of Part II. of the Local Government Act 1958, His Excellency the Governor of the State of Victoria, by and with the advice of the Executive Council thereof hereby orders:—

- 1. That on and from 1st December, 1973, the portion of the municipal district of the Shire of Oxley described hereunder shall be severed from the West Riding of the said Shire and annexed to the City of Wangaratta.
- 2. That this Order shall not affect the retirement, in accordance with the provisions of Division 2 of Part III. of the said Act, of Councillors of the said municipalities.

Portion to be Severed from the Shire of Oxley and Annexed to the City of Wangaratta.

Commencing at a point on the Hume Highway at its intersection with the Three Mile Creek; thence generally northerly by that highway to the south-west angle of lot 4 on lodged plan 25070; thence easterly by the southern boundary of the said lot 4 and northerly by the eastern boundaries of lots 4, 3 and 2 on the said lodged plan to the southern boundary of the City of Wangaratta; thence easterly by that boundary being a direct line to a point on the western boundary of allotment 9, section 1A, Parish of Wangaratta South, distant 2 chains south of the north-western angle of the said allotment 9; thence along the western boundary of the said allotment to the said north-western angle; thence easterly along a direct line to the north-western angle of allotment 24, section 1A; thence easterly along the northern boundary of the said allotment 24 to the north-eastern angle of the said allotment 24; thence northerly by a road to the north-western angle of allotment 6, section 6A; thence along the northern boundary of the said allotment 6 to the King River; thence generally southerly along the King River to the south-eastern angle of allotment 7, section 6A; thence westerly along a road to the south-western angle of the said allotment 7; thence south-easterly by a road being the Wangaratta-Whitfield road to its intersection with a north-south road between allotments 5b and 21, section 1A and allotments 4 and 2 of section 4A; thence southerly by that north-south road to the south-eastern angle of allotment 21, section 1A; thence westerly along the road on the southern boundary of allotments 21, 20, 19, 18, section 1A and continuing westerly along the road on the southern boundary of allotment 11b and 11a, section 31 to the Hume Highway; thence northerly along the highway to the point of commencement. (Area 1,063 acres; 430.18 hectares.)

And the Honorable Alan John Hunt, Her Majesty's Minister for Local Government for the State of Victoria, shall give the necessary directions herein accordingly.

T. J. FORRISTAL,
Clerk of the Executive Council.

SUPREME COURT ACT 1958.

At the Executive Council Chamber, Melbourne, the seventh day of November, 1973.

PRESENT:

His Excellency the Governor of Victoria.
Mr. Dickie | Mr. Wilcox.

NOMINATION OF TWO PERSONS FOR THE PURPOSES OF DIVISION 9 OF PART VII. OF THE SAID ACT.

Whereas under the provisions of Division 9 of Part VII. of the Supreme Court Act 1958 it is enacted that two persons nominated by the Governor in Council, in conjunction with the Chief Justice or any other Judge of the Supreme Court nominated by him, and two members of the Council of the Law Institute of Victoria to be nominated by the said Council (hereinafter called "the Committee"), may from time to time exercise the powers set forth in the said Division: And whereas it is expedient to reconstitute the said Committee for the said purposes: Now

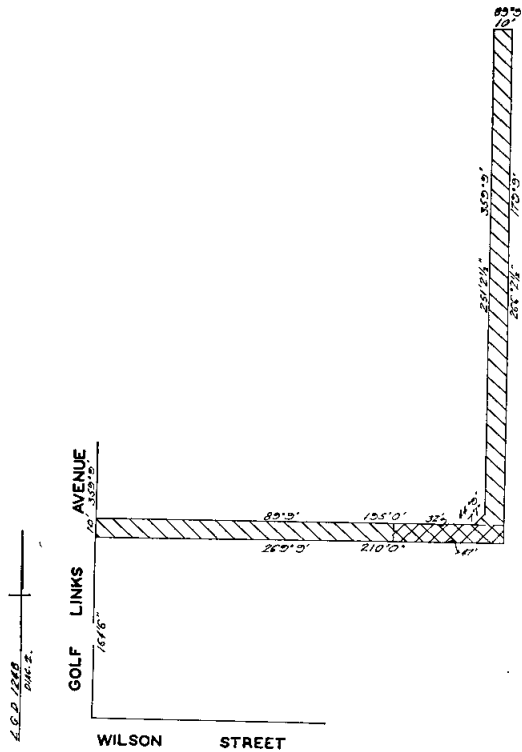

MEASUREMENTS ARE IN FEET AND INCHES

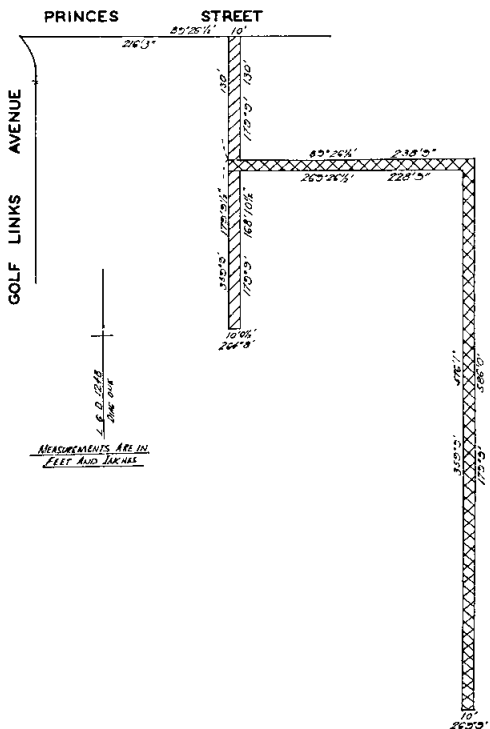

MEASUREMENTS ARE IN FEET AND INCHES

And the Honorable Alan John Hunt, Her Majesty's Minister for Local Government for the State of Victoria, shall give the necessary directions herein accordingly.

T. J. FORRISTAL,
Clerk of the Executive Council.

therefore the Governor of the State of Victoria, by and with the advice of the Executive Council thereof, in pursuance of the powers aforesaid, doth hereby nominate Victor Henry Arnold, Esquire, Actuary, and Thomas Peter Bruce, Esquire, Taxing Master of the Supreme Court, as members of the Committee empowered to exercise the said powers.

And the Honorable Vernon Francis Wilcox, Her Majesty's Attorney-General for the State of Victoria, shall give the necessary directions herein accordingly.

T. J. FORRISTAL,
Clerk of the Executive Council.

LANDLORD AND TENANT ACT 1958.

At the Executive Council Chamber, Melbourne, the seventh day of November, 1973.

PRESENT:

His Excellency the Governor of Victoria.
Mr. Dickie | Mr. Wilcox.

ORDER EXTENDING APPLICATION OF PART V. OF THE LANDLORD AND TENANT ACT 1958 TO CERTAIN PREMISES.

In pursuance of the powers conferred by sections 44 and 45 of the *Landlord and Tenant Act 1958*, His Excellency the Governor of Victoria, by and with the advice of the Executive Council, doth hereby declare that the application of Part V. of the *Landlord and Tenant Act 1958* shall extend to the following premises—

A dwelling on the first floor at 571 Lygon-street, North Carlton, which was on the 18th day of September, 1973, leased to Mr. Ian Pausacker together with the right to use the staircase and the laundry and lavatory in the rear yard.

And the Honorable Vernon Francis Wilcox, Her Majesty's Attorney-General in and for the State of Victoria, shall give the necessary directions herein accordingly.

T. J. FORRISTAL,
Clerk of the Executive Council.

DANDENONG VALLEY AUTHORITY.

At the Executive Council Chamber, Melbourne, the seventh day of November, 1973.

PRESENT:

His Excellency the Governor of Victoria.
Mr. Dickie | Mr. Wilcox.

CONSENT TO BORROWING \$300,000.

Under the powers conferred by the Dandenong Valley Authority Act and all other powers enabling him in that behalf, His Excellency the Governor of the State of Victoria, by and with the advice of the Executive Council of the said State, doth hereby consent to the Dandenong Valley Authority borrowing the sum of Three hundred thousand dollars (\$300,000), to meet the cost of river improvement and drainage works.

And the Honorable Frederick James Granter, Her Majesty's Minister of Water Supply for the State of Victoria, shall give the necessary directions herein accordingly.

T. J. FORRISTAL,
Clerk of the Executive Council.

BALLARAT WATER COMMISSIONERS.

At the Executive Council Chamber, Melbourne, the seventh day of November, 1973.

PRESENT:

His Excellency the Governor of Victoria.
Mr. Dickie | Mr. Wilcox.

APPROVAL TO ACQUISITION OF LAND.

Under the powers conferred by the Water Act and all other powers enabling him in that behalf, His Excellency the Governor of the State of Victoria, by and with the

advice of the Executive Council of the said State, doth hereby approve the acquisition of land being all that land coloured pink as shown on the plan approved by the Governor in Council, by and with this Order, and deposited in the office of the State Rivers and Water Supply Commission, Melbourne, together with all improvements situate thereon.—(Corr. No. 72/3065/113).

And the Honorable Frederick James Granter, Her Majesty's Minister of Water Supply for the State of Victoria, shall give the necessary directions herein accordingly.

T. J. FORRISTAL,
Clerk of the Executive Council.

INVERLOCH WATERWORKS TRUST.

At the Executive Council Chamber, Melbourne, the seventh day of November, 1973.

PRESENT:

His Excellency the Governor of Victoria.
Mr. Dickie | Mr. Wilcox.

AMENDMENT OF ORDER.

Under the powers conferred by the Water Act and all other powers enabling him in that behalf, His Excellency the Governor of the State of Victoria, by and with the advice of the Executive Council of the said State, hereby amends as follows the Order in Council constituting the Inverloch Waterworks Trust made on 8th July, 1947, and published in the *Government Gazette* dated 16th July, 1947, by deleting Clause No. 2 and substituting the following:—

"2. The Commissioners of the Trust shall comprise the Councillors for the time being of the South Riding of the Shire of Woorayl together with three other persons appointed by the Governor in Council."

And the Honorable Frederick James Granter, Her Majesty's Minister of Water Supply for the State of Victoria, shall give the necessary directions herein accordingly.

T. J. FORRISTAL,
Clerk of the Executive Council.

Water Act 1958.

STATE RIVERS AND WATER SUPPLY COMMISSION.

At the Executive Council Chamber, Melbourne, the seventh day of November, 1973.

PRESENT:

His Excellency the Governor of Victoria.
Mr. Dickie | Mr. Wilcox.

GOULBURN-MURRAY IRRIGATION DISTRICT—PORTION EXCISED.—TONGALA-STANHOPE IRRIGATION AREA—BOUNDARIES VARIED.

Under the powers conferred by the *Water Act 1958* and all other powers enabling him in that behalf, His Excellency the Governor of the State of Victoria, with the advice of the Executive Council of the said State, on the recommendation of the State Rivers and Water Supply Commission, doth hereby declare, order, and direct as follows:—

That there be excised from the Goulburn-Murray Irrigation District that portion of the same set out and described in the Schedule hereto and that the boundaries of the Tongala-Stanhope Irrigation Area be varied to excise from the said Area the aforesaid portion, which portion shall be deemed to be excised from the said Irrigation District and Irrigation Area as from the 30th day of November, 1973.

SCHEDULE.

The whole of lot 1 on lodged plan of subdivision No. 69915 and the whole of lot 1 on lodged plan of subdivision No. 74742 being parts of allotment 69, section C, Parish of Tongala.

The lands set out and described in the foregoing Schedule are shown on a plan approved by the Governor in Council, and deposited in the Office of the State Rivers and Water Supply Commission, Melbourne.—(Corr. No. 65/2380).

And the Honorable Frederick James Granter, Her Majesty's Minister of Water Supply for the State of Victoria, shall give the necessary directions herein accordingly.

T. J. FORRISTAL,
Clerk of the Executive Council.

Water Act 1958.

STATE RIVERS AND WATER SUPPLY COMMISSION.

At the Executive Council Chamber, Melbourne, the seventh day of November, 1973.

PRESENT:

His Excellency the Governor of Victoria.
Mr. Dickie | Mr. Wilcox.

MORNINGTON PENINSULA URBAN DISTRICT.—AREA OF DISTRICT INCREASED.

Under the powers conferred by the *Water Act 1958* and all other powers enabling him in that behalf, His Excellency the Governor of the State of Victoria, with the advice of the Executive Council of the said State, on the recommendation of the State Rivers and Water Supply Commission, doth hereby declare, order and direct that the area of the Mornington Peninsula Urban District be increased by adding to the same the lands shown by blue colour on plans numbered 1 and 2 approved by the Governor in Council and deposited in the office of the State Rivers and Water Supply Commission, Melbourne (Corr. No. 73/1981) and as on and from the first day of December, 1973, the area of such District shall be deemed to be so increased.

And the Honorable Frederick James Granter, Her Majesty's Minister of Water Supply for the State of Victoria, shall give the necessary directions herein accordingly.

T. J. FORRISTAL,
Clerk of the Executive Council.

WATER ACT 1958.

At the Executive Council Chamber, Melbourne, the seventh day of November, 1973.

PRESENT:

His Excellency the Governor of Victoria.
Mr. Dickie | Mr. Wilcox.

SHIRE OF DEAKIN WATERWORKS TRUST—EXTENT OF WATERWORKS DISTRICT INCREASED—AREA OF URBAN DISTRICT INCREASED.

Under the powers conferred by the *Water Act 1958* and all other powers enabling him in that behalf, His Excellency the Governor of the State of Victoria, with the advice of the Executive Council of the said State, doth hereby declare, order, and direct as follows:—

That the extent of the Waterworks District of the Shire of Deakin Waterworks Trust and the area of the Urban District of the Trust be increased by adding to such Districts the lands set out and described in the Schedule hereto, and as on and from the 1st day of December, 1973, the extent of the said Waterworks District and the area of the said Urban District shall be deemed to be so increased.

SCHEDULE.

The whole of lot 1 on lodged plan of subdivision No. 69915 and the whole of lot 1 on lodged plan of subdivision No. 74742 being parts of allotment 69, section C, Parish of Tongala.

The lands set out and described in the foregoing Schedule are shown on a plan approved by the Governor in Council, and deposited in the Office of the State Rivers and Water Supply Commission, Melbourne.—(Corr. No. 65/2380).

And the Honorable Frederick James Granter, Her Majesty's Minister of Water Supply for the State of Victoria, shall give the necessary directions herein accordingly.

T. J. FORRISTAL,
Clerk of the Executive Council.

STATE RIVERS AND WATER SUPPLY COMMISSION.

At the Executive Council Chamber, Melbourne, the seventh day of November, 1973.

PRESENT:

His Excellency the Governor of Victoria.
Mr. Dickie | Mr. Wilcox.

APPOINTMENT OF AUDITORS.—AMENDMENT OF ORDER.

Under the powers conferred by the Sewerage Districts Act and all other powers enabling him in that behalf, His Excellency the Governor of the State of Victoria, by and with the advice of the Executive Council of the said State, hereby amends as follows the Order in Council made on 4th September, 1973, appointing certain persons to audit and report upon the accounts of Sewerage Authorities for the years 1973 and 1974:—

For the name "G. T. Quinn" in column (3) opposite the name "Ocean Grove" in column (1) of the Schedule there shall be submitted the name "D. H. McDonald".

And the Honorable Frederick James Granter, Her Majesty's Minister of Water Supply for the State of Victoria, shall give the necessary directions herein accordingly.

T. J. FORRISTAL,
Clerk of the Executive Council.

WODONGA SEWERAGE AUTHORITY.

At the Executive Council Chamber, Melbourne, the seventh day of November, 1973.

PRESENT:

His Excellency the Governor of Victoria.
Mr. Dickie | Mr. Wilcox.

EXTENT OF SEWERAGE DISTRICT INCREASED.

Under the powers conferred by the Sewerage Districts Act and all other powers enabling him in that behalf, His Excellency the Governor of the State of Victoria, by and with the advice of the Executive Council of the said State, doth hereby declare, order and direct that the extent of the Sewerage District of the Wodonga Sewerage Authority be increased by adding thereto the lands shown within the red border on the plan approved by the Governor in Council, by and with this Order and deposited in the office of the State Rivers and Water Supply Commission, Melbourne (Corr. 68/2868/158), and as on and from the date hereof the extent of such District shall be deemed to be increased accordingly.

And the Honorable Frederick James Granter, Her Majesty's Minister of Water Supply for the State of Victoria, shall give the necessary directions herein accordingly.

T. J. FORRISTAL,
Clerk of the Executive Council.

HEYWOOD SEWERAGE AUTHORITY.

At the Executive Council Chamber, Melbourne, the seventh day of November, 1973.

PRESENT:

His Excellency the Governor of Victoria.
Mr. Dickie | Mr. Wilcox.

CONSENT TO BORROWING \$100,000.

Under the powers conferred by the Sewerage Districts Act and all other powers enabling him in that behalf, His Excellency the Governor of the State of Victoria, by and with the advice of the Executive Council of the said State, hereby consents to the Heywood Sewerage Authority borrowing the sum of One hundred thousand dollars (\$100,000), to meet the cost of sewerage works as set forth in the detailed statement bearing date 1st November, 1973.

And the Honorable Frederick James Granter, Her Majesty's Minister of Water Supply for the State of Victoria, shall give the necessary directions herein accordingly.

T. J. FORRISTAL,
Clerk of the Executive Council.

ENVIRONMENT PROTECTION ACT 1970.

At the Executive Council Chamber, Melbourne, the seventh day of November, 1973.

PRESENT:

His Excellency the Governor of Victoria.	
Mr. Dickie	Mr. Wilcox.

APPOINTMENT OF A MEMBER OF THE ENVIRONMENT PROTECTION COUNCIL.

In pursuance of the provisions of sections 7 (1) (c) and 11 (b) of the *Environment Protection Act 1970*, His Excellency the Governor of the State of Victoria, by and with the advice of the Executive Council thereof, doth by this order appoint—

JAMES COLIN FORBES WHARTON, being the Director of Fisheries and Wildlife, to be a member of the Environment Protection Council in lieu of Alfred Dunbavin Butcher, for the period ending 30th June, 1974, being the balance of the term of office of the said Alfred Dunbavin Butcher.

And the Honorable William Archibald Borthwick, Her Majesty's Minister for Conservation of the State of Victoria, shall give the necessary directions herein accordingly.

T. J. FORRISTAL,
Clerk of the Executive Council.

SUPERANNUATION ACT 1958.

At the Executive Council Chamber, Melbourne, the thirteenth day of November, 1973.

PRESENT:

His Excellency the Governor of Victoria.	
Mr. Rafferty	Mr. Smith
Mr. Houghton	Mr. Granter.

Pursuant to the powers conferred by the provisions of paragraph (ja) of sub-section (1) of section 3 of the *Superannuation Act 1958*, His Excellency the Governor of the State of Victoria, by and with the advice of the Executive Council thereof, doth by this Order declare that the provisions of the *Superannuation Act* shall apply to:—

Creed, Barbara Anne
Jones, Keith John
Jose, Terrence Murray
McAlley, Peter Philip
Thompson, Russell Maxwell

being officers of the State College of Victoria at Coburg constituted pursuant to the provisions of the *Education Act 1958* No. 6240.

And the Honorable Rupert James Hamer, Her Majesty's Treasurer for the State of Victoria, shall give the necessary directions herein accordingly.

T. J. FORRISTAL,
Clerk of the Executive Council.

SUPERANNUATION ACT 1958.

At the Executive Council Chamber, Melbourne, the thirteenth day of November, 1973.

PRESENT:

His Excellency the Governor of Victoria.	
Mr. Rafferty	Mr. Smith
Mr. Houghton	Mr. Granter.

Pursuant to the powers conferred by the provisions of paragraph (ja) of sub-section (1) of section 3 of the *Superannuation Act 1958*, His Excellency the Governor of the State of Victoria, by and with the advice of the Executive Council thereof, doth by this Order declare that the provisions of the *Superannuation Act* shall apply to Brian Raymond Davey an officer of the State College of Victoria at Bendigo constituted pursuant to the provisions of the *Education Act 1958* No. 6240.

And the Honorable Rupert James Hamer, Her Majesty's Treasurer for the State of Victoria, shall give the necessary directions herein accordingly.

T. J. FORRISTAL,
Clerk of the Executive Council.

SHEPPARTON URBAN WATERWORKS TRUST.

At the Executive Council Chamber, Melbourne, the thirteenth day of November, 1973.

PRESENT:

His Excellency the Governor of Victoria.	
Mr. Rafferty	Mr. Smith
Mr. Houghton	Mr. Granter.

CONSENT TO BORROWING \$100,000.

Under the powers conferred by the Water Act and all other powers enabling him in that behalf, His Excellency the Governor of the State of Victoria, by and with the advice of the Executive Council of the said State, hereby consents to the Shepparton Urban Waterworks Trust borrowing the sum of One hundred thousand dollars (\$100,000), to meet the cost of water supply works.

And the Honorable Frederick James Granter, Her Majesty's Minister of Water Supply for the State of Victoria, shall give the necessary directions herein accordingly.

T. J. FORRISTAL,
Clerk of the Executive Council.

WARBURTON WATERWORKS TRUST.

At the Executive Council Chamber, Melbourne, the thirteenth day of November, 1973.

PRESENT:

His Excellency the Governor of Victoria.	
Mr. Rafferty	Mr. Smith
Mr. Houghton	Mr. Granter.

APPROVAL OF PLAN OF SITES OF OFFTAKE WEIR, SETTLING TANK AND SUPPLY PIPELINE AND EXTENT OF WATERWORKS DISTRICT INCREASED.

His Excellency the Governor of the State of Victoria, by and with the advice of the Executive Council thereof, doth hereby in accordance with the provisions of the Water Act—

(a) approve the site of works comprising an offtake weir on Walkers Creek, settling tank and supply pipeline as shown on a plan deposited in the office of the State Rivers and Water Supply Commission, Melbourne (Corr. 59/2165/158); and

(b) doth hereby declare, order and direct that as on and from the date hereof the extent of the waterworks district of the Warburton Waterworks Trust be increased by adding to the same the lands as shown on the aforesaid plan deposited in the office of the State Rivers and Water Supply Commission, Melbourne (Corr. 59/2165/158).

And the Honorable Frederick James Granter, Her Majesty's Minister of Water Supply for the State of Victoria, shall give the necessary directions herein accordingly.

T. J. FORRISTAL,
Clerk of the Executive Council.

MILDURA SEWERAGE AUTHORITY.

At the Executive Council Chamber, Melbourne, the thirteenth day of November, 1973.

PRESENT:

His Excellency the Governor of Victoria.	
Mr. Rafferty	Mr. Smith
Mr. Houghton	Mr. Granter.

CONSENT TO BORROWING \$18,700.

Under the powers conferred by the Sewerage Districts Act and all other powers enabling him in that behalf, His Excellency the Governor of the State of Victoria, by and with the advice of the Executive Council of the said State, hereby consents to the Mildura Sewerage Authority borrowing the sum of Eighteen thousand seven hundred dollars (\$18,700), for the conversion of Loan No. 26.

And the Honorable Frederick James Granter, Her Majesty's Minister of Water Supply for the State of Victoria, shall give the necessary directions herein accordingly.

T. J. FORRISTAL,
Clerk of the Executive Council.

MORNINGTON SEWERAGE AUTHORITY.

At the Executive Council Chamber, Melbourne, the thirteenth day of November, 1973.

PRESENT:

His Excellency the Governor of Victoria.
 Mr. Rafferty | Mr. Smith
 Mr. Houghton | Mr. Granter.

CONSENT TO BORROWING \$300,000.

Under the powers conferred by the Sewerage Districts Act and all other powers enabling him in that behalf, His Excellency the Governor of the State of Victoria, by and with the advice of the Executive Council of the said State, hereby consents to the Mornington Sewerage Authority borrowing a sum of Three hundred thousand dollars (\$300,000), to meet the cost of sewerage works as set forth, in the detailed statement bearing date 8th November, 1973.

And the Honorable Frederick James Granter, Her Majesty's Minister of Water Supply for the State of Victoria, shall give the necessary directions herein accordingly.

T. J. FORRISTAL,
 Clerk of the Executive Council.

LANDS DEPARTMENT NOTICES

APPROACHING LAND SALES.

Sale of Crown Land, in fee-simple, will be held at the under-mentioned places and dates, viz.:-

	No. of Gazette.
Ararat.—Thursday, 29th November, 1973 ..	101
Ballarat.—Tuesday, 18th December, 1973 ..	108
Bendigo.—Tuesday, 18th December, 1973 ..	108
Daylesford.—Thursday, 13th December, 1973 ..	101
Wonthaggi.—Tuesday, 27th November, 1973 ..	101

PROPOSED REVOCATIONS OF TEMPORARY RESERVATIONS OF LANDS BY ORDERS IN COUNCIL.

In pursuance of the provisions of the Land Act 1958, notice is hereby given that it is the intention of the Governor in Council to revoke the temporary reservations of lands by Orders in Council hereunder referred to, viz.:-

The following Notices were published 1^o on the 7th November, 1973, pursuant to Orders of the 30th October, 1973.

SMEATON.—The temporary reservation by Order in Council of the 6th May, 1930, of 3.642 hectares (9 acres) of land in the Parish of Smeaton as a site for Public purposes is about to be revoked so far only as the portion containing 7000 square metres, more or less, indicated by hatching on plan hereunder, is concerned.—(S.298^(r)) (Rs.3993).

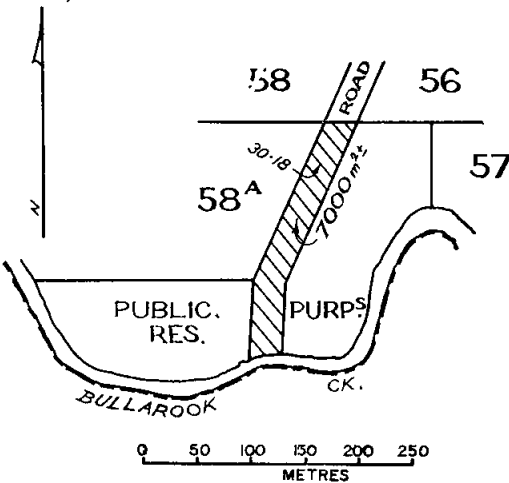

SPRING HILL.—The temporary reservation by Order in Council of the 6th May, 1930, of 4.047 hectares (10 acres) of land in the Parish of Spring Hill as a site for Public purposes is about to be revoked so far only as the portion

containing 5400 square metres, more or less, indicated by hatching on plan hereunder, is concerned.—(S.311^(r)) (Rs.3835).

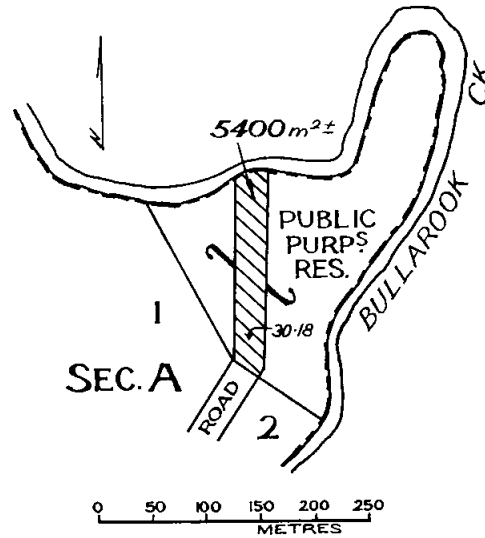

TARRAWINGEE.—The temporary reservation by Order in Council of the 17th January, 1870 (see Government Gazette, 1870, page 104), of 4047 square metres (1 acre) of land in the Parish of Tarrawingee West (now Parish of Tarrawingee) as a site for Common School purposes is about to be revoked so far only as the portion containing 2269 square metres, more or less, indicated by hatching on plan hereunder, is concerned.—(T.61^(*)) (Rs.8963).

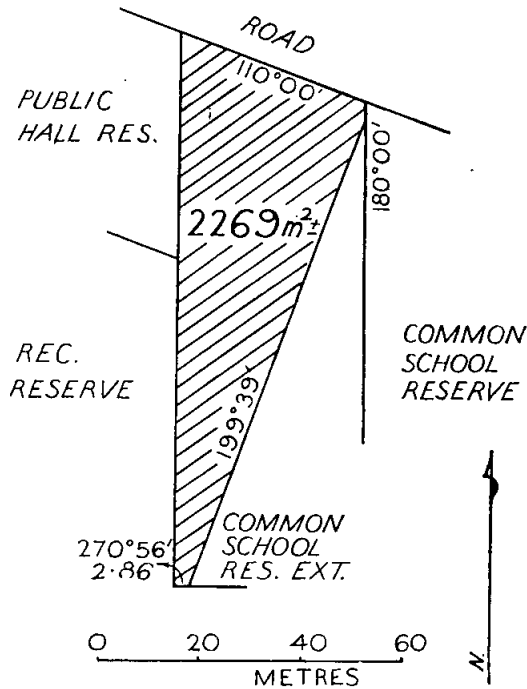

TARRAWINGEE.—The temporary reservation by Order in Council of the 22nd November, 1869 (see Government Gazette 1869, page 1922), of 4047 square metres (1 acre) of land in the Parish of Tarrawingee West (now Parish of Tarrawingee) as a site for Common School purposes

is about to be revoked so far only as the portion containing 1 square metre, more or less, indicated by hatching on plan hereunder, is concerned.—(T.61(*) (Rs.8963).

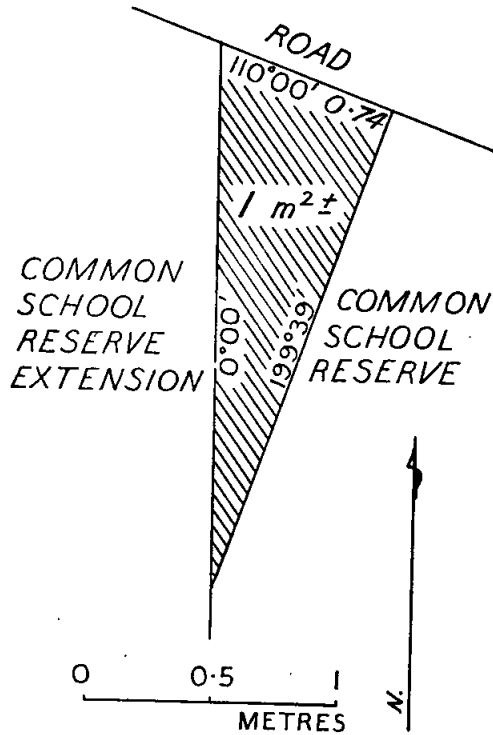

TARRAWINGEE.—The temporary reservation by Order in Council of the 29th June, 1868, of 18.39 hectares (45 acres 1 rood 32 perches) of land in the Parish of Tarrawingee West (now Parish of Tarrawingee) as a site for Recreative purposes, revoked as to part by Order of the 21st September, 1927, is about to be revoked, save and except, the area of 17 hectares, more or less, indicated by hatching on plan hereunder.—(T.61(*) (Rs.1800).

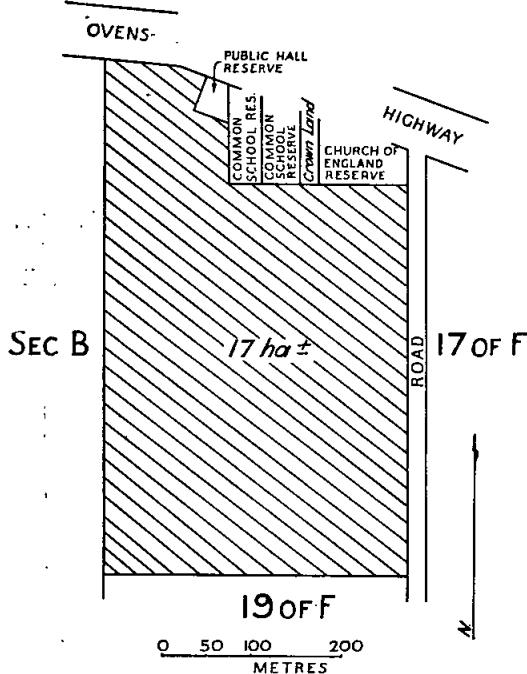

W. BORTHWICK,
Minister of Lands.

PROPOSED REVOCATIONS OF TEMPORARY RESERVATIONS OF LANDS BY ORDERS IN COUNCIL.

In pursuance of the provisions of the Land Act 1958, notice is hereby given that it is the intention of the Governor in Council to revoke the temporary reservations of lands by Orders in Council hereunder referred to, viz.:—

The following Notices were published 1° on the 31st October, 1973, pursuant to Orders of the 23rd October, 1973.

OMEQ.—The temporary reservation by Order in Council of the 2nd December, 1969, of 1771 square metres (1 rood 30 perches) more or less, of land in the Township of Omeo as a site for Public purposes (Municipal purposes) is about to be revoked.—(O.19(*) (Rs.4245).

OMEQ.—The temporary reservation by Order in Council of the 29th April, 1958, of 2479 square metres (2 roods 18 perches) of land in the Township of Omeo as a site for Municipal purposes is about to be revoked.—(O.19(*) (Rs.4245).

FRANKSTON.—The temporary reservation by Order in Council of the 20th February, 1899 of 60.15 hectares (148 acres 2 roods 23 perches) of land in the Parish of Frankston as a site for Racecourse and Public Recreation is about to be revoked, so far only as the portion containing 1175 square metres indicated by hatching on plan hereunder, is concerned.—(F.87(*) (Rs.3645).

RACECOURSE AND RECREATION RESERVE
"Baxter Park"

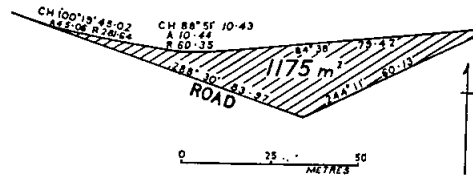

SMYTHESDALE.—The temporary reservation by Order in Council of the 18th July, 1938, of 1.065 hectares (2 acres 2 roods 21 perches) of land in the Township of Smythesdale as a site for Police purposes is about to be revoked, so far only as the portion containing 7621 square metres indicated by hatching on plan hereunder, is concerned.—(S.297(*) (Rs.4784).

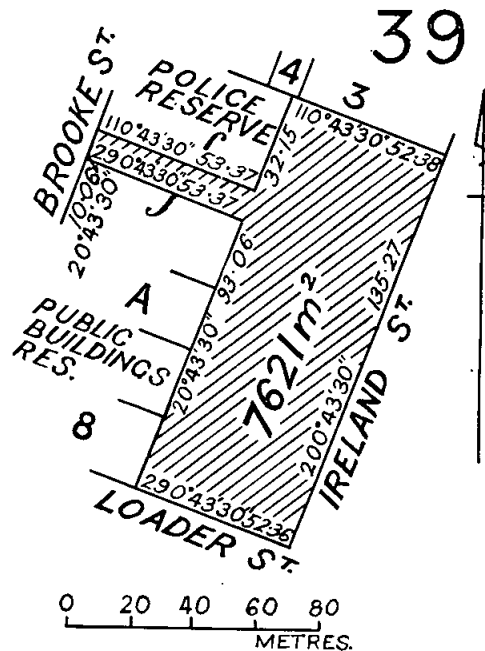

OMEQ.—The temporary reservation by Order in Council of the 29th April, 1958, of 2529 square metres (2 roods 20 perches) more or less, of land in the Township of

Omeo as a site for Public Gardens, revoked as to part by Order of the 14th October, 1969, is about to be revoked, save and except, the area of 1920 square metres indicated by hatching on plan hereunder.—(O.19^(*). (Rs.7707).

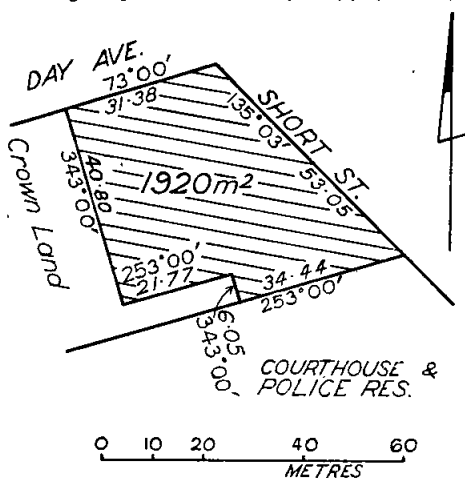

W. BORTHWICK,
Minister of Lands.

PROPOSED REVOCATIONS OF TEMPORARY RESERVATIONS OF LANDS BY ORDERS IN COUNCIL.

In pursuance of the provisions of the *Land Act 1958*, notice is hereby given that it is the intention of the Governor in Council to revoke the temporary reservations of lands by Orders in Council hereunder referred to, viz.:-

The following Notices were published 1^o on the 14th November, 1973, pursuant to Orders of the 7th November, 1973.

BULLA.—The temporary reservation by Order in Council of the 21st February, 1928, of 1.270 hectares (3 acres 22 perches) of land in the Township of Bulla, as a site for the supply of gravel is about to be revoked.—(B.522^(*)) (Rs.3439).

JEFFCOTT (JEFFCOTT SOUTH).—The temporary reservation as a site for Public purposes (State School) and the withholding from sale, leasing and licensing by Order in Council of the 14th October, 1878, of 8094 square metres (2 acres) in the Parish of Jeffcott are about to be revoked.—(J.38^(*)) (W.90849).

LAURAVILLE (GAFFNEYS CREEK).—The temporary reservation by Order in Council of the 17th May, 1960, of 2302 square metres (2 roods 11 perches) of land in the Parish of Lauraville, as a site for State School purposes is about to be revoked.—(K.116^(D1)) (Rs.5925).

W. BORTHWICK,
Minister of Lands.

TENDERS

PUBLIC WORKS DEPARTMENT

Tenders will be received at Public Works Department, 2 Treasury-place, Melbourne, until **TWO** p.m. on dates shown and for purposes mentioned hereunder.

Particulars and tender forms available at Contracts Office, Room 27, Ground Floor, No. 2, Treasury-place, and at places indicated in brackets hereunder.

Abbreviations in brackets mean:—W.O.—Inspector of Works Office; P.S.—Police Station; C.S.—Consolidated School; H.E.S.—Higher Elementary School; H.S.—High School; Pr.S.—Primary School; T.S.—Technical School.

Tenders to be submitted on the Department's printed Tender Form and will not be received by telephone. All tenders must be on a "Firm Tender" basis. The lowest or any tender will not necessarily be accepted.

Address tenders to the Minister of Public Works, and endorse the envelope containing the tender "Tender for , closing Tuesday,

Hand delivered tenders to be placed in the Tender Box of the Public Works Department, located on the wall of the centre entrance foyer, Ground Floor, 2 Treasury-place, Melbourne.

No preliminary deposit is required with any tender, but a successful tenderer will be required to pay a deposit for any accepted tender of \$4,000 or over.

Tuesday, 20th November, 1973.

Building, Electrical and Mechanical Works.

CARLTON.—Internal and external renovations, P.S.

DANDENONG.—Conversion of and extension to sports pavilion, T.S.

MELBOURNE.—Renovations to auditorium, Police Headquarters, Russell-street. (Re-advertised.)

Site Works.

EDI UPPER.—Site works, Pr.S.1422. (W.O., Wangaratta.) (Re-advertised.) (Amended Specification.)

RINGWOOD.—Site works, Pr.S.2997.

Miscellaneous.

BALLARAT.—Supply and delivery of one 100 lb. tumbler dryer, Lakeside Hospital.

BALLARAT.—Supply and delivery of one 600 lb. washer extractor, Lakeside Hospital.

BALLARAT.—Supply and delivery of one vibra steamer, Lakeside Hospital.

BEECHWORTH.—Supply and delivery of one vibra steamer, Mental Hospital.

BEECHWORTH.—Supply and delivery of two 100 lb. tumbler dryers, Mental Hospital.

PORT MELBOURNE.—Supply and delivery of five (5) only chassis and cabin with tray type body—capacity one ton, Plant Depot. (Re-advertised.)

Tuesday, 27th November, 1973.

Building, Electrical and Mechanical Works.

MARYBOROUGH.—Erection of library, H.S. (W.O., Ballarat and Maryborough.)

MARYBOROUGH.—Electrical installation—Library, H.S. (W.O., Ballarat and Maryborough.)

MARYBOROUGH.—Mechanical installation—Library, H.S. (W.O., Ballarat and Maryborough.)

SOMERS.—Electrical installation—New Dormitory Block, School Camp 4647. (W.O., Mornington.)

SOMERS.—Mechanical services—New Dormitory Block, School Camp 4647. (W.O., Mornington.)

SWAN HILL.—Electrical installation—Music and Classroom Wing, H.S. (W.O., Bendigo and Swan Hill.)

TIMBOON.—Erection of Library, H.S. (W.O., Geelong and Warrnambool.)

TIMBOON.—Electrical installation—Library, H.S. (W.O., Camperdown and Warrnambool.)

TIMBOON.—Mechanical installation—Library, H.S. (W.O., Camperdown and Warrnambool.)

TOTTENHAM.—New Art and Science Wing and New Fan Room, T.S.

TOTTENHAM.—Electrical services—Art and Science Wing and Fan Room, T.S.

TOTTENHAM.—Mechanical services—Art and Science Wing and Fan Room, T.S.

WODONGA WEST.—Staff accommodation improvements, Pr.S.4814. (W.O., Wangaratta.)

YARRUNGA.—Staff accommodation improvements, Pr.S.4761. (W.O., Wangaratta.)

Site Works.

ASHWOOD.—Site works, H.S.

BEAUMARIS.—Site works, Demonstration Unit.

WILLIAMSTOWN.—Site works, T.S.

Miscellaneous.

BEECHWORTH.—Connection to sewer, Training Prison. (W.O., Wangaratta.)

PORT MELBOURNE.—Supply and delivery of chassis and cabin—35 cwt. capacity with van body, Plant Depot. (Re-Advertised.)

PORT MELBOURNE.—Supply and delivery of six (6) pile driving winches—3 tons capacity, Plant Depot.

VARIOUS.—Supply of stoneware pipes and fittings for the period 1st December, 1973 to 30th November, 1974, Public Works Department.

Tuesday, 4th December, 1973.

Building, Electrical and Mechanical Works.

BELMONT.—Erection of Musical Instruments Teaching Block, H.S. (W.O., Geelong).

BELMONT.—Mechanical services—Musical Instruments Teaching Block, H.S. (W.O., Geelong.)

BENTLEIGH.—Mechanical services—Metalcraft Room, H.S.

BLACKBURN SOUTH.—Erection of 2 room Science Block, H.S.

BLACKBURN SOUTH.—Electrical services—Science Block, H.S.

BLACKBURN SOUTH.—Mechanical services—Science Block, H.S.

BURNLEY.—Erection of a screenhouse, Victorian Plant Research Institute. (Re-Advertised.)

CHELTENHAM NORTH.—Staff and Administration accommodation improvements, Pr.S.4763.

DARTMOOR.—Exterior painting and repairs, Residence, P.S. (W.O., Warrnambool.)

DROUIN.—Mechanical services—Metalcraft Room, H.S. (W.O., Traralgon.)

MOORABBIN.—Erection of 2 room Science Block, H.S.

MOORABBIN.—Electrical services—Science Block, H.S.

MOORABBIN.—Mechanical services—Science Block, H.S.

SANDRINGHAM EAST.—Staff accommodation improvements, Pr.S.4429.

WESTALL.—Erection of 2 room Science Block, H.S.

WESTALL.—Electrical services—Science Block, H.S.

WESTALL.—Mechanical services—Science Block, H.S.

Site Works.

YALLAMBIE.—Site works, Pr.S.5046.

Miscellaneous.

LARUNDEL.—Supply and delivery of one 600 lb. washer extractor, Mental Hospital.

ROBERTS DUNSTAN,
Minister of Public Works.

Public Works Department,
Melbourne, 12th November, 1973.

PUBLIC SERVICE NOTICES

No. 579.

Public Service Act 1958, Section 39.

REGULATIONS.—PART IV.—SALARIES AND INCREMENTS.

The Public Service Board, in pursuance of the powers conferred by the *Public Service Act 1958*, hereby amends its Regulations as shown below :—

FIRST SCHEDULE.

PROFESSIONAL DIVISION.

Amount of Salary Assigned to Offices in "Special" Class.

Office.	Yearly Rate of Salary.
CHIEF SECRETARY'S DEPARTMENT.	\$
Delete— Government Statist	19,918
Add— Government Statist and Actuary ..	19,918

A. J. A. GARDNER, Chairman.
R. H. DURRANT, Acting Secretary.

Office of the Public Service Board,
Melbourne, 26th October, 1973.

No. 580.

Public Service Act 1958, Section 50.

REGULATIONS.—PART IV.—SALARIES AND INCREMENTS.

The Public Service Board, in pursuance of the powers conferred by the *Public Service Act 1958*, hereby amends its Regulations as shown below :—

SIXTH SCHEDULE.

TEMPORARY EMPLOYEES.

Designations of Positions and Rates of Salaries.

Department and Designation of Position.	Yearly Rate of Salary.		Increments (Annual).
	Minimum.	Maximum.	
TREASURY.	\$	\$	
GOVERNMENT PRINTING OFFICE			
Delete— Apprentices— Metal Trades	†	*
All others	*	
Add— Apprentices— Metal Trades	†	‡
All others	* ‡	§
‡ In addition, an allowance at the annual rate indicated hereunder :— 1st year of apprenticeship \$225 2nd year of apprenticeship \$329 3rd year of apprenticeship \$433 4th or subsequent years of apprenticeship \$522.			

This Regulation shall have effect as on and from the 28th October, 1973.

A. J. A. GARDNER, Chairman.
R. H. DURRANT, Acting Secretary.

Office of the Public Service Board,
Melbourne, 29th October, 1973.

No. 582.

Public Service Act 1958, Section 50.

REGULATIONS.—PART IV.—SALARIES AND INCREMENTS.

The Public Service Board, in pursuance of the powers conferred by the *Public Service Act 1958*, hereby amends its Regulations as shown below :—

SIXTH SCHEDULE.

TEMPORARY EMPLOYEES.

Designations of Positions and Rates of Salaries.

Department and Designation of Position.	Yearly Rate of Salary.		Increments (Annual).
	Minimum.	Maximum.	
DEPARTMENT OF SOCIAL WELFARE.	\$	\$	
<i>Family Welfare Division.</i>			
Delete— Nurse, "Turana" †† ..	5,478	5,846	A
Add— Nurse, "Baltara" †† ..	5,478	5,846	A

A. J. A. GARDNER, Chairman.
R. H. DURRANT, Acting Secretary.

Office of the Public Service Board,
Melbourne, 26th October, 1973.

No. 583.

PUBLIC SERVICE ACT 1958.

The Public Service Board, in pursuance of the powers conferred by the *Public Service Act 1958*, hereby amends the Public Service (Public Service Board) Regulations as follows:—

PART V.—ALLOWANCES.

DIVISION V.—OTHER ALLOWANCES.

Regulation 166.

The heading "Chief Secretary's Department—Office of the Chief Commissioner of Police" immediately prior to Regulation 166 and Regulation 166 is deleted.

DEPARTMENT OF HEALTH—MENTAL HYGIENE BRANCH.
Regulation 170.

This Regulation is deleted.

Regulation 171.

This Regulation is deleted.

Regulation 174A.

The heading "Premier's Department—Ministry for the Arts, National Gallery" immediately prior to Regulation 174A and Regulation 174A is deleted.

Regulation 175.

The heading "Public Works Department" immediately prior to Regulation 175 and Regulation 175 is deleted.

GENERAL—PLUMBERS.

Immediately after Regulation 164 the following Regulation is inserted:—

"164A. A Plumber, Leading Hand or Plumber who is authorized by the Permanent Head to act on his plumber's licence by signing notices and assuming responsibility to relevant authorities shall be paid an allowance of 20 cents an hour while so authorized: Provided that where two or more plumbers are attached to the same headquarters the allowance shall not be paid to more than one plumber at the same time."

This Regulation shall have effect as on and from the 16th September, 1973.

A. J. A. GARDNER, Chairman.
R. H. DURRANT, Acting Secretary.

Office of the Public Service Board,
Melbourne, 26th October, 1973.

No. 581.

Public Service Act 1958, Section 50.

REGULATIONS.—PART IV.—SALARIES AND INCREMENTS.

The Public Service Board, in pursuance of the powers conferred by the *Public Service Act 1958*, hereby amends the Public Service (Public Service Board) Regulations as follows:—

SECOND SCHEDULE.

TECHNICAL AND GENERAL DIVISION.

Grades and Salary Scales.

JUNIOR GRADES.

MALES.

Delete the existing yearly rate of salary shown for the under-mentioned grade and insert the following rate in lieu thereof:—

Grade.	Yearly Rate of Salary at Each Age in Years.				
	Under 17.	17.	18.	19.	20.
JM-9	\$..	\$ 2,269(b)	\$ 2,661	\$ 3,054	\$ 3,498

(b) Under 18 years of age.

SIXTH SCHEDULE.

TEMPORARY EMPLOYEES.

Designations of Positions and Rates of Salaries.

Department and Designation of Position.	Yearly Rate of Salary.		Increments (Annual).
	Minimum.	Maximum.	
	\$	\$	
<i>Delete the existing yearly rates of salary for the following positions and insert the rates shown hereunder in lieu thereof:—</i>			
GENERAL.			
Laboratory Attendant—Junior—			
Under 18 years of age	2,269	
At 18 years of age	2,661	
At 19 years of age	3,054	
At 20 years of age	3,498	
Adult	3,839φ	4,135	A
CHIEF SECRETARY'S DEPARTMENT.			
OFFICE OF THE CHIEF COMMISSIONER OF POLICE.			
<i>Police Hospital.</i>			
Cook=	4,214	4,517	A
DEPARTMENT OF HEALTH.			
<i>Alcoholics and Drug Dependent Persons Services.</i>			
Cook, Grade II.=	4,740	5,106	A
Cook, Grade I.=	3,974	4,234	A
Laundryhand, Grade II.=	3,995	4,296	A
Seamstress, Grade I.	3,800	4,094	A
GENERAL HEALTH.			
<i>Exotic Diseases.</i>			
Cook=	3,974	4,234	A
TUBERCULOSISφ			
STATE SANATORIAφ			
Chef=	4,740	5,106	A
Cook=	4,194	4,477	A
Cook, Assistant=	3,974	4,234	A
Laundryhand, Grade II.=	3,995	4,296	A
Laundryhand, Grade I.=	3,758	4,035	A
Seamstress and Housemaid	3,800	4,094	A
SOCIAL WELFARE DEPARTMENT.			
<i>Family Welfare Division.</i>			
Laundryhand, Grade II.=	3,995	4,296	A
Laundryhand, Grade I.=	3,758	4,035	A
Seamstress	3,800	4,094	A
<i>Youth Welfare Division.</i>			
Laundryhand, Grade I.=	3,758	4,035	A
Seamstress	3,800	4,094	A

This Regulation shall have effect as on and from the 28th October, 1973.

A. J. A. GARDNER, Chairman.
R. H. DURRANT, Acting Secretary.

Office of the Public Service Board,
Melbourne, 26th October, 1973.

No. 577.

Public Service Act 1958, Section 50.
REGULATIONS.—PART IV.—SALARIES AND INCREMENTS.

The Public Service Board, in pursuance of the powers conferred by the *Public Service Act 1958*, hereby amends the Public Service (Public Service Board) Regulations as follows :—

FIFTH SCHEDULE.
TEMPORARY EMPLOYEES.
DEPARTMENT OF HEALTH.

MENTAL HYGIENE.

Designations of Positions and Rates of Salaries.

Designation of Position.	Yearly Rate of Salary.		Increments (Annual).
	Minimum.	Maximum.	
	\$	\$	
<i>Delete the existing yearly rates of salary for the following positions and insert the rates shown hereunder in lieu thereof :—</i>			
Anaesthetic and Operating Theatre Technician ..	4,316	4,597	A
Cook= ..	3,974	4,234	A
Laundryhand, Grade II.= ..	3,995	4,296	A
Laundryhand, Grade I.—			
Junior—			
Under 17 years of age	1,888	
At 17 years of age	2,220	
At 18 years of age	2,605	
At 19 years of age	2,989	
At 20 years of age	3,426	
Adult= ..	3,758φ	4,035	A
Seamstress, Grade II. ..	3,936	4,214	A
Seamstress, Grade I.—			
Junior—			
Under 17 years of age	1,909	
At 17 years of age	2,245	
At 18 years of age	2,634	
At 19 years of age	3,023	
At 20 years of age	3,463	
Adult ..	3,800φφ	4,094	A

SEVENTH SCHEDULE.

TECHNICAL AND GENERAL DIVISION.

DEPARTMENT OF HEALTH.

MENTAL HYGIENE.

Grades and Salary Scales.

JUNIOR GRADES.

MALES.

Grade.	Yearly Rate of Salary at Each Age in Years.				
	Under 17.	17.	18.	19.	20.
	\$	\$	\$	\$	\$
<i>Add—</i>					
JM-33 ..	1,888	2,220	2,605	2,989	3,426
<i>Delete—</i>					
JF-5 ..	1,811	2,127	2,497	2,865	3,288
JF-6 ..	1,822	2,140	2,512	2,883	3,308
<i>Add—</i>					
JF-6 ..	1,909	2,245	2,634	3,023	3,463
JF-33 ..	1,888	2,220	2,605	2,989	3,426

This Regulation shall have effect as on and from the 14th October, 1973.

A. J. A. GARDNER, Chairman.
R. H. DURRANT, Acting Secretary.

Office of the Public Service Board,
Melbourne, 29th October, 1973.

No. 576.

Public Service Act 1958, Section 50.
REGULATIONS.—PART IV.—SALARIES AND INCREMENTS.

The Public Service Board, in pursuance of the powers conferred by the *Public Service Act 1958*, hereby amends the Public Service (Public Service Board) Regulations as follows :—

FIFTH SCHEDULE.
TEMPORARY EMPLOYEES.
DEPARTMENT OF HEALTH.

MENTAL HYGIENE.

Designations of Positions and Rates of Salaries.

Designation of Position.	Yearly Rate of Salary.		Increments (Annual).
	Minimum.	Maximum.	
	\$	\$	
<i>Delete the existing yearly rates of salary for the following positions and insert the rates shown hereunder in lieu thereof :—</i>			
Laboratory Assistant (Male)—			
Junior—			
At 17 years of age	2,770	
At 18 years of age	3,232	
At 19 years of age	3,740	
At 20 years of age	4,201	
Adult ..	4,617	5,455	A
Laboratory Assistant (Female),	4,871	5,011	B
Grade II. ..			
Laboratory Assistant (Female),			
Grade I.—			
Junior—			
At 16 years of age	2,214	
At 17 years of age	2,657	
At 18 years of age	3,100	
At 19 years of age	3,587	
At 20 years of age	4,029	
Adult ..	4,428	4,615	B

SEVENTH SCHEDULE.

TECHNICAL AND GENERAL DIVISION.

DEPARTMENT OF HEALTH.

MENTAL HYGIENE.

Grades and Salary Scales.

JUNIOR GRADES.

MALES.

Delete the existing yearly rates of salary shown for the under-mentioned grades and insert the following rates in lieu thereof :—

Grade.	Yearly Rate of Salary at Each Age in Years.				
	Under 17.	17.	18.	19.	20.
	\$	\$	\$	\$	\$
JM-13	2,770	3,232	3,740	4,201
<i>FEMALES.</i>					
JF-17 ..	2,214	2,657	3,100	3,587	4,029

This Regulation shall have effect as on and from the 21st October, 1973,

A. J. A. GARDNER, Chairman.
R. H. DURRANT, Acting Secretary.

Office of the Public Service Board,
Melbourne, 29th October, 1973.

No. 574.

PUBLIC SERVICE ACT 1958.

The Public Service Board, in pursuance of the powers conferred by the Public Service Act 1958, hereby amends the Public Service (Public Service Board) Regulations as follows:—

PART VI.—TRAVELLING AND OTHER EXPENSES.

DIVISION IV.—OTHER EXPENSES.

Regulation 207.

The amount "\$100" is deleted and the amount "\$150" is inserted in lieu thereof.

A. J. A. GARDNER, Chairman.
R. H. DURRANT, Acting Secretary.

Office of the Public Service Board,
Melbourne, 15th October, 1973.

No. 584.

Public Service Act 1958, Section 39.

REGULATIONS.—PART IV.—SALARIES AND INCREMENTS.

The Public Service Board, in pursuance of the powers conferred by the Public Service Act 1958, hereby amends the Public Service (Public Service Board) Regulations as follows:—

FIRST SCHEDULE.

PROFESSIONAL DIVISION.

Amount of Salary Assigned to Offices in "Special" Class.

Office.	Yearly Rate of Salary.
CHIEF SECRETARY'S DEPARTMENT.	
<i>Delete—</i> State Librarian	18,796
PREMIER'S DEPARTMENT.	
<i>Add—</i> State Librarian, State Library, Ministry for the Arts	18,796

SIXTH SCHEDULE.

TEMPORARY EMPLOYEES.

Designations of Positions and Rates of Salaries.

Department and Designation of Position.	Yearly Rate of Salary.		Increments (Annual).
	Minimum.	Maximum.	
CHIEF SECRETARY'S DEPARTMENT.			
<i>The heading "State Library, National Museum and Science Museum" is deleted and the heading "National Museum and Science Museum" is inserted in lieu thereof.</i>			
<i>Delete—</i> Attendant, Library, Grade I.— Junior— Under 17 years of age At 17 years of age At 18 years of age At 19 years of age At 20 years of age Adult Cadet Attendant (Female)— Junior— Under 17 years of age At 17 years of age At 18 years of age At 19 years of age At 20 years of age Adult Field and Education Officer, Library Division = General Hand, Senior Librarian = Library Officer, Grade III. =	4,720	5,014	A
	3,943	4,251	B
	6,098	6,519	*
	4,035	4,336	A
	5,403	7,859	c
	5,630	6,098	1 of \$211 and 1 of \$257

SIXTH SCHEDULE.—continued.

Department and Designation of Position.	Yearly Rate of Salary.		Increments (Annual).
	Minimum.	Maximum.	
	\$	\$	
Library Officer, Grade II. = Library Officer, Grade I. = Junior = Under 17 years of age At 17 years of age At 18 years of age At 19 years of age At 20 years of age Adult =	5,032	5,449	1 (i)
	..	2,247	
	..	2,658	
	..	3,064	
	..	3,496	
	..	3,880	
	4,271	4,738	1 of \$188, 1 of \$138 and 1 of \$141
Map Librarian	8,129	
* Increments in accordance with the scale of rates of salaries as set out for Publications and Publicity Officer Class "PP-1" in Part B of the Third Schedule.			
c Increments in accordance with the scale of rates of salaries as set out for Librarian Class "L-1" in Part B of the Third Schedule.			
1 (i) Increments in accordance with the scale of rates of salaries as set out for Library Officer Class "LR-3" in Part B of the Third Schedule.			
PREMIER'S DEPARTMENT.			
<i>Add—</i> State Library. Attendant, Library, Grade I.— Junior— Under 17 years of age At 17 years of age At 18 years of age At 19 years of age At 20 years of age Adult Cadet Attendant (Female)— Junior— Under 17 years of age At 17 years of age At 18 years of age At 19 years of age At 20 years of age Adult Field and Education Officer, Library Division = General Hand, Senior Librarian = Library Officer, Grade III. = Library Officer, Grade II. = Library Officer, Grade I. = Junior = Under 17 years of age At 17 years of age At 18 years of age At 19 years of age At 20 years of age Adult = Map Librarian	4,720	5,014	A
	..	2,169	
	..	2,366	
	..	2,563	
	..	2,957	
	..	3,352	
	3,943	4,251	B
	6,098	6,519	*
	4,035	4,336	A
	5,403	7,859	c
	5,630	6,098	1 of \$211 and 1 of \$257
	5,032	5,449	1 (ii)
	..	2,247	
	..	2,658	
	..	3,064	
	..	3,496	
	..	3,880	
	4,271	4,738	1 of \$188, 1 of \$138 and 1 of \$141
	..	8,129	
* Increments in accordance with the scale of rates of salaries as set out for Publications and Publicity Officer Class "PP-1" in Part B of the Third Schedule.			
c Increments in accordance with the scale of rates of salaries as set out for Librarian Class "L-1" in Part B of the Third Schedule.			

This Regulation shall have effect as on and from the 11th November, 1973.

A. J. A. GARDNER, Chairman.
R. H. DURRANT, Acting Secretary.
Office of the Public Service Board,
Melbourne, 26th October, 1973.

No. 575.

PUBLIC SERVICE ACT 1958.

The Public Service Board, in pursuance of the powers conferred by the *Public Service Act 1958*, hereby amends the Public Service (Public Service Board) Regulations as follows:—

PART V.—ALLOWANCES.

DIVISION II.—OVERTIME AND STANDBY ALLOWANCES.

PUBLIC WORKS DEPARTMENT.—PORTS AND HARBOURS BRANCH.

Regulation 149.

In sub-regulation (3) the expression "\$800 or \$1,600 a year" is deleted and the expression "\$1,608 or \$3,216 a year" is inserted in lieu thereof.

A. J. A. GARDNER, Chairman.

R. H. DURRANT, Acting Secretary.

Office of the Public Service Board,
Melbourne, 15th October, 1973.

No. 578.

PUBLIC SERVICE ACT 1958.

The Public Service Board, in pursuance of the powers conferred by the *Public Service Act 1958*, hereby amends the Public Service (Public Service Board) Regulations as follows:—

PART III.—PROMOTIONS AND TRANSFERS.

DIVISION I.—GENERAL.

Immediately after Regulation 72 the following Regulation is inserted:—

"72A. The Board may enlarge the time appointed under this Division for doing any act or taking any proceeding upon such terms (if any) as the merits of the case may require and any such enlargement may be authorized although the time limited for the doing of the act or the taking of the proceeding has expired."

A. J. A. GARDNER, Chairman.

R. H. DURRANT, Acting Secretary.

Office of the Public Service Board,
Melbourne, 2nd November, 1973.

PRIVATE ADVERTISEMENTS*Town and Country Planning Act 1961.*

CITY OF BALLAARAT.—BALLAARAT AND DISTRICT PLANNING SCHEME 1966.

NOTICE THAT A PLANNING SCHEME HAS BEEN PREPARED AND IS AVAILABLE FOR INSPECTION.

Amendment No. 4, 1973.

Notice is hereby given that the City of Ballaarat, in pursuance of its powers under the *Town and Country Planning Act 1961*, has prepared a planning scheme for the following area:—

That portion of the Quarry Reserve, east of Learmonth-street and north of Leopold-street, to be rezoned from Public purposes Reserve Local Government to Residential A.

A copy of the scheme has been deposited at the Municipal Offices, Ballaarat, and at the office of the Town and Country Planning Board, 235 Queen-street, Melbourne, and will be open for inspection during office hours by any person, free of charge.

Any persons affected by the planning scheme are required to set forth, in writing, all objections they may have, addressed to the Town Clerk, City of Ballaarat, Municipal Offices, Ballaarat, on or before the 14th day of February, 1974, and to state whether they wish to be heard in respect of their objections.

8th November, 1973.

5318

F. J. ROGERS, Town Clerk.

Town and Country Planning Act 1961 (Twelfth Schedule).

CITY OF BENALLA PLANNING SCHEME.

NOTICE THAT A PLANNING SCHEME HAS BEEN PREPARED AND IS AVAILABLE FOR INSPECTION.

Amendment No. 4.

Notice is hereby given that the City of Benalla, in pursuance of its powers under the *Town and Country Planning Act 1961*, has prepared a planning scheme for the areas to which the City of Benalla Planning Scheme relates for the purposes of:—

- (a) Rezoning from Transitional to Proposed Public Purposes (Local Government) two small areas in Mair-street, Section 6A, Township of Benalla.

- (b) Rezoning from Transitional to Public Purposes (Local Government) a small area in Church-street, Section D, Township of Benalla.
- (c) Rezoning from Proposed Public Purposes to Public Purposes (Local Government) an area of land off Denny-street, Section D, Township of Benalla.
- (d) Rezoning from Public Purposes (Local Government) to Commercial A a small area of land in Bridge-street, Section C, Township of Benalla.
- (e) Rezoning from Restricted General Industrial and General Industrial to Public Purposes (Department of Agriculture) an area of land off the Hume Highway, Section R, Parish of Benalla.
- (f) Rezoning from Residential C to Public Purposes (Commonwealth of Australia) a small area of land off Arundel-street, Section L, Township of Benalla.

A copy of the scheme has been deposited at the Civic Centre, Benalla, and at the Office of the Town and Country Planning Board, 235 Queen-street, Melbourne, and will be open for inspection during office hours by any person, free of charge.

Any persons affected by the Planning Scheme are required to set forth, in writing all objections they may have addressed to the Town Clerk, City of Benalla, Fawckner-drive, Benalla, on or before the Fourteenth day of February, 1974, and to state whether they wish to be heard in respect of their objections.

5340

L. A. HEMLEY, Town Clerk.

Town and Country Planning Act 1961 (Twelfth Schedule).

CITY OF BENALLA PLANNING SCHEME.

NOTICE THAT A PLANNING SCHEME HAS BEEN PREPARED AND IS AVAILABLE FOR INSPECTION.

Amendment No. 3.

Notice is hereby given that the City of Benalla, in pursuance of its powers under the *Town and Country Planning Act 1961*, has prepared a planning scheme for the areas to which the City of Benalla Planning Scheme relates for the purposes of:—

- (a) Substitution of a new Ordinance for the Ordinance of the City of Benalla Planning Scheme in order to standardize in format Ordinances for the approval of the Governor in Council.
- (b) Deletion of the Transitional Zones in Carrier-street and Bridge-street and introduction of new zonings for the affected areas.
- (c) Rezoning from Commercial Zonings several areas throughout Bridge-street (Hume Highway) to Rural, Residential and Commercial C Zonings.
- (d) Rezoning from Light Industrial to Residential Zoning of a small area in Bridge-street west, Section 2, Township of Benalla.
- (e) Rezoning from Commercial B to Restricted Commercial a small area in Bridge-street west, Section K, Township of Benalla.
- (f) Rezoning from Transitional to Commercial A an area in Church-street, Section D, Township of Benalla.
- (g) Rezoning from Transitional to Residential B an area in Mair-street and Church-street, Section H, Township of Benalla.
- (h) Rezoning from Transitional to Residential B1 an area in Lowry-place, Smythe-street and Reilly-avenue, Sections Y and S, Township of Benalla.
- (i) Reclassification of an Environmental Area in Arundel-street to an area of Special Significance.
- (j) Rezoning from Residential A to Residential B1 an area in Salisbury-street, Ethel-street and Mackellar-street, Section IV, Parish of Benalla.
- (k) Rezoning from General Industrial to Restricted General Industrial an area in Witt-street, Section R, Parish of Benalla.
- (l) Rezoning from Residential A to General Industrial an area bounded by Anthony-street, Eric-street and Mackellar-street, Section IV, Parish of Benalla.
- (m) Rezoning from Rural to Offensive Industrial a small area, Section F, Parish of Benalla.
- (n) Rezoning from Residential A to General Industrial an area off Commercial-road, Section II, Parish of Benalla.

- (o) Rezoning from Residential A to Residential B1 areas in Mclvor-street, Maginness-street, Hannah-street, Ryan-street, Gillies-street, Holloway-street, Commercial-road and Roe-street, Section II, Parish of Benalla.
- (p) Rezoning from Restricted Commercial to Light Industrial a small area of land in Railway-place, Hannah-street and Commercial-road, Section 16, Township of Benalla and Section I, Parish of Benalla.
- (q) Rezoning from Restricted Commercial to Residential B a small area of land in Nunn-street and Mackellar-street, Section F, Township of Benalla.
- (r) Rezoning from Light Industrial to Residential B, a small area of land in Nunn-street and Mackellar-street, Section 10, Township of Benalla.
- (s) Rezoning from General Industrial to Rural an area of land, Section A, Parish of Benalla.
- (t) Rezoning from Light Industrial to Residential B1 an area of land Arundel-street, Section U, Township of Benalla.

A copy of the scheme has been deposited at the Civic Centre, Benalla, and at the Office of the Town and Country Planning Board, 235 Queen-street, Melbourne, and will be open for inspection during office hours by any person, free of charge.

Any persons affected by the Planning Scheme are required to set forth, in writing all objections they may have addressed to the Town Clerk, City of Benalla, Fawckner-drive, Benalla, on or before the Fourteenth day of December, 1973, and to state whether they wish to be heard in respect of their objections.

5339

L. A. HEMLEY, Town Clerk.

CITY OF BRIGHTON.

BY-LAW No. 206.

A By-law of the City of Brighton made under Sections 197, 799 and 800 of the Local Government Acts and every other power it thereunto enabling and numbered 206 for amending By-law No. 146 of the said City for preserving public decency for preserving good order and controlling and regulating the conduct of persons using or being upon or in those public reserves pleasure grounds or places of public resort or public recreation in the said City referred to in Clause 1 hereof:

In pursuance of the powers conferred by the Local Government Acts and every other power in that behalf enabling it the Mayor Councillors and Citizens of the City of Brighton order as follows:

1. By-law No. 146 of the City of Brighton is hereby amended by adding to the Second Schedule thereto the following land—

The land more particularly described in Certificate of Title Volume 5978 Folio 462 containing 4 acres and 18 perches or thereabouts situate at 26 Halifax Street Brighton and known as "Billilla".

2. On and after the coming into force of this By-law it shall form part of and be read as one with By-law 146.

3. This By-law shall apply to and have operation in that part of the Municipal District of Brighton set out in Clause 1 hereof.

Resolution for making and passing this By-law was agreed to by the Council at its meeting on the 16th day of July, 1973, and confirmed the 17th day of September, 1973.

The common seal of the Mayor, Councillors and Citizens of the City of Brighton was hereto affixed, in the presence of—

(SEAL) W. L. RAIT, Mayor.
K. DEVENPORT, Councillor.
A. C. G. DE GARIS, Town Clerk.

Approved by the Governor in Council on the 23rd day of October, 1973.—T. J. FORRISTAL, Clerk of the Executive Council. 5297

CITY OF BRIGHTON.

BY-LAW No. 207.

A By-law of the City of Brighton made under Section 228 of the Local Government Act and every other power it thereunto enabling and numbered 207 for repealing bylaws of the City of Brighton numbered 93, 99, 107, 116, 120, 124, 131, 140, 143, 152 and 158.

1. Bylaws of the City of Brighton numbered 93, 99, 107, 116, 120, 124, 131, 140, 143, 152 and 158 are hereby repealed.

Resolution for making and passing this Bylaw was agreed to by the Council at its meeting on the 16th day of July, 1973, and confirmed the 17th day of September, 1973.

The common seal of the Mayor, Councillors and Citizens of the City of Brighton was hereto affixed, in the presence of—

(SEAL) W. L. RAIT, Mayor.
K. DEVENPORT, Councillor.
A. C. G. DE GARIS, Town Clerk.

Approved by the Governor in Council on the 23rd day of October, 1973.—T. J. FORRISTAL, Clerk of the Executive Council. 5298

Town and Country Planning Act 1961.

CITY OF GEELONG.—GEELONG PLANNING SCHEME 1959.

NOTICE THAT A PLANNING SCHEME HAS BEEN PREPARED AND IS AVAILABLE FOR INSPECTION.

Amendment No. 22.

Notice is hereby given that the City of Geelong, in pursuance of its powers under the *Town and Country Planning Act 1961*, has prepared a Planning Scheme for the purpose of—

Amending Schedule 10—General Industrial Uses of the Geelong Planning Scheme 1959,

and a copy of the scheme has been deposited at the City Hall, Gheringhap-street, Geelong, and at the office of the Town and Country Planning Board, 235 Queen-street, Melbourne, and will be open for inspection during office hours by any person.

Any persons affected by the planning scheme are required to set forth, in writing, all objections they may have, addressed to the Town Clerk, City of Geelong, City Hall, Gheringhap-street, Geelong, on or before the 14th December, 1973, and to state whether they wish to be heard in respect of their objection.

5343 T. J. T. NEAL,
Town Clerk and Chief Administrative Officer.

CITY OF HAMILTON.

HOUSING SCHEME No. 1.

Notice is hereby given that a general plan and description of the City of Hamilton Housing Scheme No. 1 prepared in accordance with Part XXVIII. of the *Local Government Act 1958*, has been forwarded to the Minister for Local Government, together with an application for submission thereof to the Governor in Council for his approval.

Copies of such general plan and description have been deposited at the Municipal Offices of the City of Hamilton, Brown-street, Hamilton for inspection.

5216 T. J. NEVILLE, Town Clerk.

CITY OF HAMILTON.

LOAN No. 66.

Notice of Intention to Borrow the Sum of \$12,000 for Permanent Works and Undertakings.

Notice is hereby given that the Council of the City of Hamilton proposes to borrow the sum of Twelve thousand dollars (\$12,000) secured by a charge over the general rate of the municipality, such sum to be raised by the grant of a mortgage in accordance with the provisions of the *Local Government Act 1958*.

1. The maximum rate of interest that may be applied is 8.8 per centum per annum.

2. The purpose for which the loan is to be applied is extensions to factory buildings for Goulburn Knitting Mills Pty. Ltd.

3. The period of the loan shall be fifteen (15) years.

4. The money borrowed shall be repayable by Thirty (30) equal half-yearly instalments of approximately Seven hundred and twenty-eight dollars and five cents (\$728.05) each, including principal and interest on the 10th day of January and the 10th day of July during the currency of the loan. The first instalment shall be payable on the 10th day of July, 1974.

5. Such money shall be payable to the Commercial Savings Bank of Australia Ltd., Melbourne.

The plans and specifications and the estimates of the cost of the proposed works, and a statement showing the proposed expenditure of the money to be borrowed are open for inspection at the offices of the Council, Brown-street, Hamilton, during office hours.

5331

T. J. NEVILLE, Town Clerk.

CITY OF HORSHAM.

LOAN No. 83.

Notice of Intention to Borrow the Sum of \$30,000 for Permanent Works and Undertakings.

Notice is hereby given that the Council of the City of Horsham intends to borrow the principal sum hereinafter mentioned on the credit of the municipal revenues of the Mayor, Councillors and Citizens of the City of Horsham, by the grant of a mortgage in accordance with the provisions of the Local Government Acts.

1. The amount of the principal moneys which it is proposed to borrow is \$30,000.
2. The maximum rate of interest that may be paid is 8.9 per centum per annum.
3. The period of the loan shall be twenty years.
4. Moneys borrowed shall be repayable by providing out of the municipal fund 40 equal half-year instalments of approximately \$1,618.67 each, including principal and interest, on the 10th day of February and the 10th day of August, during the currency of the loan. The first instalment shall be payable on the 10th day of August, 1974.
5. Such moneys shall be repayable at the Commercial Savings Bank of Australia Limited, 335 Collins-street, Melbourne, or at the Council's Bankers for the time being in the City of Melbourne.
6. The purpose for which the loan is to be applied is:—

Construction of a basketball stadium (part cost) \$30,000

The plans, specifications and estimates for the cost of such work and the statement showing the proposed expenditure of the money to be borrowed are open for inspection at the office of the Council, Town Hall, Horsham, during office hours.

Dated the 7th day of November, 1973.

5311

A. R. CONN, Town Clerk.

CITY OF KEILOR.

BY-LAW No. 66.

Metropolitan Hawkers By-law.

A By-law of the City of Keilor made under the provisions of Section 197 (I) (xxxiii) (a) of the *Local Government Act 1958* and Section 36 of the *Hawkers and Pedlars Act 1958* and numbered 66 for prescribing the limits whether as to time or place within which a person holding a Metropolitan Hawkers Licence may sell or offer or expose for sale any articles specified in their licences in any street road or public place and for other purposes.

Pursuant to the powers conferred by the *Hawkers and Pedlars Act 1958* and of any and every other power it thereunto enabling the Mayor Councillors and Citizens of the City of Keilor orders as follows:—

1. This By-law may be known as the Metropolitan Hawkers By-Law.
2. By-Law No. 10 of the City of Keilor be and is hereby repealed.
3. In this By-Law the words "Metropolitan Hawker" mean the holder of a Metropolitan Hawkers Licence under the *Hawkers and Pedlars Act, 1958*.
4. The limits as to time within which the selling or offering or exposing for sale by a Metropolitan Hawker of any article specified in his licence issued under the *Hawkers and Pedlars Act 1958* is permitted within any street road or public place within the Municipal District of the City of Keilor are hereby prescribed as between the hours of 10.00 a.m. in the morning and 3.00 p.m. in the afternoon on any weekday other than Saturday, Sunday or a Public Holiday.
5. No Metropolitan Hawker shall so sell or offer or expose for sale any articles at any time other than a time permitted by the last preceding clause.
6. Any person guilty of any wilful act of default contrary to this By-Law shall be liable to a penalty of not less than \$20.00 nor more than \$50.00 and any person guilty of a continuing offence against this By-Law shall be liable for a penalty of not more than \$20.00 for each day in which an offence against this By-Law is continued after a conviction or order by any Court.

The resolution to make By-Law No. 66 was agreed to by the Council of the City of Keilor on 17th July, 1973. Confirmed on the 21st August, 1973.

The common seal of the Mayor, Councillors and Citizens of the City of Keilor was hereunto affixed this 6th day of September, 1973, in the presence of—

(SEAL) N. HEINZE, Mayor.
F. DINEEN, Councillor.
R. F. B. KELLY, Town Clerk.

Approved by the Governor in Council, 23rd October, 1973.—T. J. FORRISTAL, Clerk of the Executive Council.

5306

CITY OF MELBOURNE.

BY-LAW No. 497.

A By-law of the City of Melbourne made under section 12 of the *Melbourne Wholesale Fruit and Vegetable Market Act 1968* and numbered 497 to further amend By-Law No. 477*.

In pursuance of the powers conferred by the above-mentioned enactment and of every other Act or power enabling it in that behalf, the Council of the City of Melbourne ORDERS as follows:

1. (1) This By-law may be cited as the *City of Melbourne Wholesale Fruit and Vegetable Market (Amendment No. 2) By-law 1973*.
- (2) In this By-law, the *City of Melbourne Wholesale Fruit and Vegetable Market By-law 1969*, By-law No. 477, as amended by By-laws Nos. 478, 480, 485, 486, 490, and 496, is referred to as the Principal By-law.
2. Clause 10 of the Principal By-law is amended by inserting after the words "the periods" the expression "(not in any case exceeding three years)".
3. The form of the leasehold agreement set out in clause 16 of Part II—Stores of the Second Schedule to the Principal By-law is amended—
 - (a) in clause 1 in the definition of "term" by deleting the words "of four years";
 - (b) in clause 2 by substituting for the words "FOUR YEARS commencing on" the expression "the period beginning on the day of , 19 , and ending on the day of , 19 ,"; and
 - (c) in clause 7—
 - (i) by deleting paragraph (i); and
 - (ii) in paragraphs (j) and (k) by substituting for the expressions "(j)" and "(k)" the expressions "(i)" and "(j)" respectively.

Resolution for passing this By-law agreed to by the Council of the City of Melbourne, the 24th day of September, 1973, and confirmed the 15th day of October, 1973.

ALAN D. WHALLEY, Lord Mayor.
F. H. ROGAN, Town Clerk.

Approved by the Governor in Council the 30th day of October, 1973, so far as the provisions for which approval is required pursuant to the *Melbourne Wholesale Fruit and Vegetable Market Act 1958*.—T. J. FORRISTAL, Clerk of the Executive Council.

*By-law No. 477, as amended by By-laws Nos. 478, 480, 485, 486, 490, and 496. (73/4565/96.) 5388

Town and Country Planning Act 1961.

CITY OF MOE.—CITY OF MOE PLANNING SCHEME 1966.

NOTICE THAT A PLANNING SCHEME HAS BEEN PREPARED AND IS AVAILABLE FOR INSPECTION.

Amendment No. 37, 1973.

Notice is hereby given that the City of Moe, in pursuance of its powers under the *Town and Country Planning Act 1961*, has prepared a Planning Scheme to deal with the following matters:—

- (a) To extend the City of Moe Planning Scheme to include the area annexed from the Yallourn Works Area as published in the *Government Gazette*, on 4th April, 1973;
- (b) to reduce the width of Torres-street between Candy-street and Monash-road;
- (c) to close a section of a Government road at the eastern end of Shanahan-parade, between Shanahan-parade and Haunted Hills-road;

- (d) to close some existing roads in the area northward from Trend-street; and
- (e) to close a section of the lane and to rezone the land at the south-east corner of Mirboo-street and Booclarra-avenue to allow it also to be used for the construction of elderly citizens' flats and clubrooms.

A copy of the scheme may be inspected at the City Offices, Albert-street, Moe, and at the office of the Town and Country Planning Board, 235 Queen-street, Melbourne, and will be open for inspection during office hours by any person, free of charge.

Any persons affected by the Planning Scheme are required to set forth, in writing, all objections they may have addressed to the Town Clerk, City of Moe, Albert-street, Moe, on or before the 14th December, 1973, and to state whether they wish to be heard in respect of their objections.

5302

R. J. PUGSLEY, Town Clerk.

CITY OF PRAHRAN.

BY-LAW No. 259.

A By-law of the City of Prahran made under the provisions of the *Local Government Act 1958* and numbered 259 for the purpose of altering By-law No. 251.

In pursuance of the powers conferred by the *Local Government Act* and of any and every other power it thereunto enabling the Mayor, Councillors and Citizens of the City of Prahran order as follows:—

1. From and after the coming into operation of this By-law, By-law No. 251 made and passed by the Council on the 13th day of October, 1969 and confirmed by the Council on the 10th day of November, 1969 is hereby altered as follows:—

For clause 20 there shall be substituted the following clause—

- 20. No person shall bring into the Market any live animal, bird, fish or reptile and no occupier of any building, stall, standing, shop, enclosure or space in the Market shall keep or permit to remain thereon any live animal, bird, fish or reptile.

Resolution for the making and passing this By-law agreed to by the Council of the City of Prahran on the 24th day of September, 1973 and confirmed on the 5th day of November, 1973.

The common seal of the Mayor, Councillors and Citizens of the City of Prahran was hereunto affixed, in the presence of—

(SEAL) F. T. FARRALL, Mayor.
JOHN R. HOLDSWORTH, Councillor.
JOHN A. LUCAS, Town Clerk.

5395

SHIRE OF CRANBOURNE.

LOAN No. 45.

SPECIAL ORDER.

Private Streets Construction.

Notice is hereby given that the Council of the Shire of Cranbourne at a meeting of the Council, held on 9th November, 1973, confirmed the following Special Order:—

"That the Council of the Shire of Cranbourne does by Special Order hereby resolve to borrow the principal sum of \$50,000 secured by a charge over the general rates of the municipality, such sum to be raised by the grant of a mortgage in accordance with the provisions of section 585 of the *Local Government Act 1958*, as amended:—

- 1. The maximum rate of interest to be paid shall be 6.9 per cent. per annum.
- 2. The period of the loan shall be nine years.
- 3. The moneys borrowed shall be repayable by eighteen (18) half-yearly instalments of \$3,775.15 each, including principal and interest, on the 15th day of May and the 15th day of November, during the currency of the loan. The first instalment being payable on the 15th day of May, 1974.
- 4. The moneys shall be repayable at the Australia and New Zealand Savings Bank Limited, 394-396 Collins-street, Melbourne.
- 5. The loan is to be applied for the purpose of liquidating part of the amount due to the National Bank of Australasia Limited for which the Council has obtained an advance under section 583 of the *Local Government Act 1958*, by overdraft on current account."

5316

T. VICKERMAN, Shire Secretary.

SHIRE OF DIAMOND VALLEY.

LOAN No. 43.

Notice of Intention to Borrow the Sum of \$200,000 for Permanent Works and Undertakings.

Notice is hereby given that the Council of the Shire of Diamond Valley proposes to borrow the principal sum of \$200,000 secured by a charge over the general rates of the municipality, such sum to be raised by the grant of a mortgage in accordance with the provisions of the *Local Government Act 1958*.

1. The maximum rate of interest that may be paid is 8.8 per cent. per annum.

2. The purposes for which the loan is to be applied are—

Buildings—

Gabonia-avenue reserve pavilion (part provision)	\$11,000	
Civic Centre sporting complex (part provision)	25,000	
I.W. & P.S. centre, Eltham North (part provision)	18,000	
Greenhills Hall extensions	7,000	
		\$61,000

Parks development—

Willinda Park athletic track (part provision)	23,000	
Bent-street Reserve (part provision)	10,000	
		33,000

Public Works—

Private street construction—		
Council's proportion	50,000	
Country Roads Board works—		
Council's proportion	41,000	91,000

Plant—Purchase of skip truck, tractor, &c. .. .	15,000	
		\$200,000

3. The period of the loan shall be 15 years.

4. The moneys borrowed shall be repayable by providing out of the municipal fund half-yearly instalments of approximately \$12,134.25 each, including principal and interest on the 1st day of February and the 1st day of August during the currency of the loan. The first instalment shall be payable on the 1st day of August, 1974.

5. Such moneys shall be repayable to The Commissioners of the State Savings Bank of Victoria at the office of the said Commissioners, corner Elizabeth and Bourke streets, Melbourne.

The plans and specifications and the estimate of the cost of the proposed works and a statement showing the proposed expenditure of the moneys to be borrowed are open for inspection at the office of the Council of the Shire of Diamond Valley, Civic-drive, Greensborough.

5337

B. J. MORGAN, Shire Secretary.

SHIRE OF MORNINGTON.

LOAN No. 82.

Notice is hereby given that the Council of the Shire of Mornington proposes to borrow the principal sum of \$50,000, secured by a charge over the general rates of the municipality, such sum to be secured by the grant of a mortgage in accordance with the provisions of the *Local Government Act 1958*.

1. The maximum rate of interest is 8.7 per cent. per annum.

2. The moneys borrowed are to be repaid to the National Bank Savings Bank Limited at the head office of the said bank in Melbourne, or such other place or places as the bank from time to time may require.

3. The purposes for which the loan is to be applied are:—

Land acquisitions	\$50,000
Provision of connecting roads Queen, Albert and Empire streets, Mornington.	

4. The money borrowed shall be repayable by providing out of the municipal fund twenty half-yearly instalments of approximately \$3,793.50 each, including principal and interest, on the 16th days of December and June, during the period of the loan. The first instalment shall be payable on the 16th day of June, 1974.

5. The period of the loan shall be ten years from the 16th day of December, 1973.

The plans and specifications and the estimate of the cost of such works and undertakings and a statement of the proposed expenditure of the money to be borrowed, are open for inspection at the office of the Council of the Shire of Mornington, Queen-street, Mornington.

5314

D. G. COLLINGS, Shire Secretary.

Town and Country Planning Act 1961 (Twelfth Schedule).
**SHIRE OF MORWELL.—LATROBE VALLEY
 SUB-REGIONAL PLANNING SCHEME.**

NOTICE THAT A PLANNING SCHEME IS BEING PREPARED AND IS AVAILABLE FOR INSPECTION.

Amendment No. 28.

Notice is hereby given that the Council of the Shire of Morwell, in pursuance of its powers under the *Town and Country Planning Act 1961*, has prepared a Planning Scheme for the following area being the whole of the area of the Latrobe Valley Sub-Regional Planning Scheme which relates to the Shire of Morwell.

A copy of the scheme has been deposited at the Town Hall, Commercial-road, Morwell, and at the office of the Town and Country Planning Board, 235 Queen-street, Melbourne, and will be open for inspection during office hours by any person, free of charge.

Any persons affected by the Planning Scheme are required to set forth, in writing, all objections they may have, addressed to the Municipal Clerk, Shire of Morwell, Town Hall, Commercial-road, Morwell, on or before the 14th December, 1973, and to state whether they wish to be heard in respect of their objections.

5323 D. J. R. DUNTON, Shire Secretary.

Town and Country Planning Act 1961 (Twelfth Schedule).
**SHIRE OF MORWELL.—MORWELL PLANNING
 SCHEME 1954.**

NOTICE THAT A PLANNING SCHEME IS BEING PREPARED AND IS AVAILABLE FOR INSPECTION.

Amendment No. 42.

Notice is hereby given that the Council of the Shire of Morwell, in pursuance of its powers under the *Town and Country Planning Act 1961*, has prepared a Planning Scheme for the following area: lots 1-4, section 1, L.P.3219, Parish of Maryvale, north-west corner of Princes Highway and Hopetoun-avenue.

A copy of the scheme has been deposited at the Town Hall, Commercial-road, Morwell, and at the office of the Town and Country Planning Board, 235 Queen-street, Melbourne, and will be open for inspection during office hours by any person, free of charge.

Any persons affected by the Planning Scheme are required to set forth, in writing, all objections they may have, addressed to the Municipal Clerk, Shire of Morwell, Town Hall, Commercial-road, Morwell, on or before the 14th December, 1973, and to state whether they wish to be heard in respect of their objections.

5324 D. J. R. DUNTON, Shire Secretary.

Town and Country Planning Act 1961 (Twelfth Schedule).
**SHIRE OF MORWELL.—MORWELL PLANNING
 SCHEME 1954.**

NOTICE THAT A PLANNING SCHEME IS BEING PREPARED AND IS AVAILABLE FOR INSPECTION.

Amendment No. 46.

Notice is hereby given that the Council of the Shire of Morwell, in pursuance of its powers under the *Town and Country Planning Act 1961*, has prepared a Planning Scheme for the following area: being the whole of the area comprised in the Morwell Planning Scheme.

A copy of the scheme has been deposited at the Town Hall, Commercial-road, Morwell, and at the office of the Town and Country Planning Board, 235 Queen-street, Melbourne, and will be open for inspection during office hours by any person, free of charge.

Any persons affected by the Planning Scheme are required to set forth, in writing, all objections they may have, addressed to the Municipal Clerk, Shire of Morwell, Town Hall, Commercial-road, Morwell, on or before the 14th December, 1973, and to state whether they wish to be heard in respect of their objections.

5326 D. J. R. DUNTON, Shire Secretary.

Town and Country Planning Act 1961 (Twelfth Schedule).
**SHIRE OF MORWELL.—MORWELL PLANNING
 SCHEME 1954.**

NOTICE THAT A PLANNING SCHEME IS BEING PREPARED AND IS AVAILABLE FOR INSPECTION.

Amendment No. 45.

Notice is hereby given that the Council of the Shire of Morwell, in pursuance of its powers under the *Town and Country Planning Act 1961*, has prepared a Planning Scheme for the following area:—

Lot 1, L.P.23718, corner Margaret-street and Hopetoun-avenue; lots 1, 2, 3, 4, 5, 6, 7, 8, 9 and 10, L.P.2965, 255-261 Princes Highway; lot 1, L.P.20975, corner Jane

and Mary streets; lots 1, 2 and 3, L.P.20791, Jane-street; part lot 7, Block 2, L.P.1064, Princes Highway; part lots 8 and 7, Block 2, L.P.1064, Helen-street; part lots 3, 4 and 5, Block 4, L.P.878, Buckley-street.

A copy of the scheme has been deposited at the Town Hall, Commercial-road, Morwell, and at the office of the Town and Country Planning Board, 235 Queen-street, Melbourne, and will be open for inspection during office hours by any person, free of charge.

Any persons affected by the Planning Scheme are required to set forth, in writing, all objections they may have, addressed to the Municipal Clerk, Shire of Morwell, Town Hall, Commercial-road, Morwell, on or before the 14th December, 1973, and to state whether they wish to be heard in respect of their objections.

5325 D. J. R. DUNTON, Shire Secretary.

Town and Country Planning Act 1961 (Twelfth Schedule).
**SHIRE OF MORWELL.—HAZELWOOD PLANNING
 SCHEME.**

NOTICE THAT A PLANNING SCHEME IS BEING PREPARED AND IS AVAILABLE FOR INSPECTION.

Amendment No. 3.

Notice is hereby given that the Council of the Shire of Morwell, in pursuance of its powers under the *Town and Country Planning Act 1961*, has prepared a Planning Scheme for the following area, being that area of the Shire of Morwell contained in the Hazelwood Planning Scheme.

A copy of the scheme has been deposited at the Town Hall, Commercial-road, Morwell, and at the office of the Town and Country Planning Board, 235 Queen-street, Melbourne, and will be open for inspection during office hours by any person, free of charge.

Any persons affected by the Planning Scheme are required to set forth, in writing, all objections they may have, addressed to the Municipal Clerk, Shire of Morwell, Town Hall, Commercial-road, Morwell, on or before the 14th December, 1973, and to state whether they wish to be heard in respect of their objections.

5322 D. J. R. DUNTON, Shire Secretary.

Town and Country Planning Act 1961.
**SHIRE OF SHERBOOKE.—SHIRE OF SHERBROOKE
 PLANNING SCHEME 1965.**

AMENDMENT No. 67, 1973.

Notice is hereby given that the Council of the Shire of Sherbrooke in pursuance of its powers under the *Town and Country Planning Act 1961*, has prepared a planning scheme for portions of the Shire of Sherbrooke for the purpose of amending the Principal Scheme, as follows:—

Rezoning from Special Uses (B) to Residential Mountain, the land described as Lot 30, and Lot 31, L.P.20173, with frontage to Huon-road and Grandview-road, Belgrave Heights, also being the land within the black border on maps designated M (27).

A copy of the scheme has been deposited at the Shire Office, Glenfern-road, Upwey, and at the office of the Town and Country Planning Board, 235 Queen-street, Melbourne, and will be open for inspection during office hours by any person, free of charge.

Any persons affected by the Planning Scheme are required to set forth, in writing, any objections they may have, addressed to the Shire of Sherbrooke, Glenfern-road, Upwey 3158, on or before the 14th December, 1973, in respect of Amendment No. 67, 1973, and to state whether they wish to be heard in respect of their objections.

5334 K. E. MATSON, Shire Secretary.

SHIRE OF STAWELL.

ORDER DECLARING PUBLIC HIGHWAY.

In pursuance of the powers conferred by section 522 of the *Local Government Act 1958*, the Council of the Shire of Stawell doth hereby order:—

That the lands hereinafter described, which have been purchased by it, shall be public highways, viz.:—

All those pieces of land being parts of Crown allotments 44 and 57, section 15B, Parish of Ararat, as described in certificates of title, volume 8983, folio 398 and volume 8983, folio 637.

The common seal of the President, Councillors and Ratepayers of the Shire of Stawell was hereto affixed this 6th day of November, 1973, in the presence of:—

(SEAL) E. W. GILES, President.
 H. T. HARDING, Councillor.
 V. C. NIELSEN, Secretary.

5335

SHIRE OF WHITTLESEA.

LOAN No. G.34.

Notice of Intention to Borrow the Sum of \$55,000 for Permanent Works and Undertakings.

Notice is hereby given that the Council of the Shire of Whittlesea proposes to borrow the principal sum of \$55,000, secured by a charge over the general rates of the municipality, such sum to be raised by the grant of a mortgage in accordance with the provisions of the *Local Government Act 1958*.

1. The maximum rate of interest that may be paid is 8.8 per cent. per annum.

2. The purposes for which the loan is to be applied are:—

Main Drainage—

Johnsons-road—Schotters-road ..	\$10,000
Cooper-street, east of High-street; Memorial-avenue, west of High-street; Park-street, east of High-street; and Davison-street, north of Memorial-avenue ..	12,000
Plenty-road, south of Greenhill-road ..	13,000
Norris-crescent, south of Settlement-road ..	8,000
O'Herns-road, west of Epping-road ..	10,000
<i>Footpath—</i>	
Memorial-avenue, north side, west of High-street ..	2,000
	<hr/>
	\$55,000

3. The period of the loan shall be fifteen years.

4. The moneys borrowed shall be repayable by providing out of the municipal fund half-yearly instalments of approximately \$3,337 each, including principal and interest, on the 1st day of February and the 1st day of August, during the currency of the loan. The first instalment shall be payable on the 1st day of August, 1974.

5. Such moneys shall be repayable to the Commissioners of the State Savings Bank of Victoria at the office of the said commissioners, corner Elizabeth and Bourke streets, Melbourne.

The plans and specifications and the estimate of the cost of the proposed works and a statement showing the proposed expenditure of the moneys to be borrowed, are open for inspection at the office of the Council of the Shire of Whittlesea at High-street, Epping.

5303 R. G. C. COOK, Shire Secretary.

SHIRE OF WOORAYL.

LOAN No. 42.

Notice of Intention to Borrow.

Notice is hereby given that the Council of the Shire of Woorayl intends to borrow the sum of \$49,000 secured by a charge over the Separate Rate of the municipality by the grant of a mortgage in accordance with the provisions of the *Local Government Act*.

1. The amount of the principal sum to be borrowed is \$49,000.

2. The maximum rate of interest that is to be paid is 8.7 per centum per annum.

3. The purposes for which the loan is to be applied is—
Off-street Car Parking—\$49,000.

4. The loan shall be liquidated by provision for the municipal fund of twenty equal half-yearly payments each of \$3,718.13, including principal and interest on the 17th days of June and December of each year during the currency of the loan, the first payment to be made on the 17th day of June, 1974. The moneys shall be repayable at the Australia and New Zealand Banking Group, Leongatha.

The plans and specifications and estimate of the cost of the works and a statement showing the proposed expenditure of the moneys to be borrowed are open for inspection at the Shire Office, Leongatha.

5296 R. G. STANLEY, Shire Secretary.

TRARALGON SEWERAGE AUTHORITY.

The Traralgon Sewerage Authority having made provision for the carrying off of sewage from each and every property which or any part of which is within the sewerage area hereinafter described doth hereby declare that on and after the 1st day of May, 1973, each and every property which or any part of which is within the said sewerage area shall be deemed to be a seweraged property within the meaning of the *Sewerage Districts Act 1958*.

No. 110.—10670/73.—3

The boundaries of the sewerage area hereinbefore referred to are as follows:—

Sewerage Area No. 60.

Commencing at the south-east corner of lot 80, lodged plan 41396, being on the boundary of Declared Area No. 36; thence in a southerly direction along the boundary of Declared Area No. 36 to the northern boundary of the Railway Reserve; thence south-westerly along the northern boundary of the Railway Reserve to the south-east corner of Declared Area No. 13; thence northerly across Head-street along the boundary of Declared Area No. 13; thence easterly, northerly and easterly along the boundaries of Declared Areas No. 13 and No. 36 to the point of commencement.

All of which boundaries are shown on a plan which is open for inspection at the Office of the Traralgon Sewerage Authority.

By order of the said Sewerage Authority,

R. T. DUNBAR, Member.

5333

K. J. SAUNDERS, Secretary.

NOTICE OF INTENTION TO APPLY FOR A LICENCE TO DIVERT WATER AND CUT RACE (RE-ISSUE) FROM THE RIVER MURRAY, AT BOUNDARY BEND.

I hereby give notice that I intend to apply for a licence empowering me to divert water for a term of fifteen years to the extent of total 1,800 acre-feet per annum at a maximum rate of 24 acre-feet per day of 24 hours for the irrigation of 400 acres of almonds and 250 acres of improved pasture, being part of allotments 1, 1A and 1C, Parish of Yungera, and to occupy certain Crown lands for works of diversion, and to cut a race thereon.

Any objection to such application must be forwarded, in writing, to reach the State Rivers and Water Supply Commission, Melbourne, before 14th December, 1973, being 30 days from the first publication of this notice.

HORTICO LTD.

Box 105, Port Melbourne, 3207.

5341

Notice is hereby given that the partnership heretofore subsisting between Colin Trevor Molloy and David James Brockbank, carrying on business as automotive engineers, at 63 Heywood-street, Ringwood, in the State of Victoria, under the style or firm of "D. & C. Protectors", has been dissolved by mutual consent as from the 11th day of July, 1973.

R. W. HOLT & CURWOOD, solicitors, 1 Ringwood-street, Ringwood. 5315

Notice is hereby given that the partnership heretofore subsisting between Andrew Frank Millis and Paula Jane Millis, carrying on business as textile agents, at 72 Milton-street, Elwood, under the firm of "Andrew Millis Textiles", has been dissolved by mutual consent, as from the 30th day of June, 1973, and that the business shall continue to be carried on by Andrew Frank Millis only.

ANDREW FRANK MILLIS.

Neville & Co., solicitors, 1401 Malvern-road, Malvern. 5301

Notice is hereby given that the partnership heretofore subsisting between Sadie Sarah Simons, Harry Simons and Howard Stephen Simons, all of 9 Northcote-avenue, North Caulfield, and David Benge Motors Pty. Ltd., of 401 Little Bourke-street, Melbourne, carrying on business property investment and development, at 9 Northcote-avenue, North Caulfield; and 1404 High-street, Malvern, has been dissolved as from the 9th day of November, 1973.

Dated the 8th day of November, 1973.

RALPH BALL, as authorised by David Benge Motors Pty. Ltd. 5332

The Companies Act 1961.

CONWAY AGENCIES PTY. LTD. (IN MEMBERS' VOLUNTARY LIQUIDATION).

Notice is hereby given that at an Extraordinary Meeting of the members of the above-named company held on Friday, the 2nd day of November, 1973, it was resolved that the company be wound up voluntarily and that for such purpose Mr. John Kenneth Hall, chartered accountant of Hall & Rose, 395 Collins-street, Melbourne, be appointed liquidator.

Dated this 3rd day of November, 1973.

J. K. HALL, Liquidator.

HALL & ROSE, chartered accountants, 395 Collins-street, Melbourne, Vic. 3000. 5356

Companies Act 1961.—In the matter of BRUGALETTA PTY. LIMITED (in Liquidation).

Notice is hereby given that at an Extraordinary Meeting of the members of the above-named company, held on the 7th November, 1973, it was resolved that the company be wound up voluntarily and at a meeting of creditors held on the same day, pursuant to section 260, it was resolved that for such purpose, Everett Thomson Bent, of Suite 18, 545 St. Kilda-road, Melbourne, public accountant, be appointed liquidator.

Notice is also given that after 21 days from this date, I shall proceed to distribute the assets. All creditors having any claims against the company should furnish particulars of same by that date, otherwise I shall proceed to distribute the assets without regard to their claim.

Dated this 7th day of November, 1973.

E. T. BENT, Liquidator.

Bent & Cogle, public accountants, Suite 18, 545 St. Kilda-road, Melbourne, 3004. 5313

The Companies Act 1971.**M.A. FABRICS PTY. LTD. (IN VOLUNTARY LIQUIDATION):
NOTICE CONVENING FINAL MEETING OF MEMBERS, PURSUANT TO SECTION 272.**

Notice is hereby given, in pursuance to section 272 of the Companies Act 1971, that the Final Meeting of the members of the above-named company will be held at the office of N. Schindler, A. Darvas, B. T. Hodson, J. Sztajnmagen, public accountants, 14 Fitzroy-street, St. Kilda, on 10th day of December, 1973, at 3 p.m., to consider the liquidator's final accounts of the voluntary winding up.

Dated this 5th day of November, 1973.

5305 N. SCHINDLER, Liquidator.

NU VIEW CONSTRUCTIONS PTY. LTD.

Take notice that the affairs of the above-named company are now fully wound up, and that in pursuance of section 272 (1) of the Companies Act 1961, a General Meeting of the company and of the creditors will be held, at 143 Wells-street, South Melbourne, on 21st day of December, 1973, at 4 p.m., for the purpose of laying before it an account, showing how the winding up has been conducted, and the property of the company disposed of and giving any explanations thereof.

Dated the 5th day of November, 1973.

5308 R. J. GLOVER, Liquidator.

Companies Act 1961.—In the matter of KOORNANG INVESTMENTS PTY. LTD.

Notice is hereby given that at an Extraordinary Meeting of the members of the above-named company, held on the 24th October, 1973, it was resolved that the company be wound up voluntarily, pursuant to section 260, it was resolved that for such purpose, Everett Thomson Bent, of Suite 18, 545 St. Kilda-road, Melbourne, public accountant, be appointed liquidator.

Notice is also given that after 21 days from this date, I shall proceed to distribute the assets. All creditors having any claims against the company should furnish particulars of same by that date, otherwise I shall proceed to distribute the assets without regard to their claim.

Dated this 24th day of October, 1973.

E. T. BENT, Liquidator.

Bent & Cogle, public accountants, Suite 18, 545 St. Kilda-road, Melbourne, 3004. 5312

Hubbard Bros. Pty. Ltd. (42243), on the 3rd November, 1973, passed a Special Resolution that the company will be wound up voluntarily.

5300 F. L. ROCHE.

A.P.M. MINERALS PROPRIETARY LIMITED.

At a General Meeting of the members of the above-named company held at 4 South Gate, South Melbourne, on the 12th day of November, 1973, the Special Resolution set out below was duly passed:—

Resolved that the company be wound up voluntarily and that Eric Maxwell Huggard and Brian Argent Waters, of the firm of Spry Walker & Co., chartered accountants, be appointed joint and several liquidators at a fee to be determined in accordance with the normal professional scale rates for the time occupied by the said liquidators, and/or their staff, in carrying out their duties as liquidators.

Dated this 13th day of November, 1973.

5410 E. R. HARVEY, Secretary.

The Companies Act 1961.—in the matter of STEPHEN CONDY ELECTRICS PTY. LTD. (in Liquidation).

A Second and Final Dividend is intended to be declared in the above-mentioned matter. Creditors who have not proved their debts by the 4th day of December, 1973, will be excluded from the dividend.

Dated this 14th day of November, 1973.

JOHN MARTIN WALSH, Liquidator.

Kennedy, Small & Middlemiss, 296 Little Lonsdale-street, Melbourne, 3000. 5411

Companies Act 1961.—In the matter of I. P. SHARP ASSOCIATES PROPRIETARY LIMITED (in Liquidation).

Notice is hereby given that at an Extraordinary Meeting of the members of the above-named company held on the 31st of October, 1973, it was resolved that the company be wound up voluntarily and at a meeting of creditors held on the same day, pursuant to section 260, it was resolved that for such purpose, Philip Douglas George, of Arthur Young & Company, 440 Collins-street, Melbourne, 3000, be appointed liquidator.

Notice is also given that after 21 days from this date I shall proceed to distribute the assets. All creditors having any claim against the company should furnish particulars of same by that date, otherwise I shall proceed to distribute the assets without regard to their claim.

Dated this 6th day of November, 1973.

P. D. GEORGE, Liquidator.

Arthur Young & Company, chartered accountants, 440 Collins-street, Melbourne, 3000. 5412

Companies Act 1961.**49 BANK ST. PROPRIETARY LIMITED (IN LIQUIDATION).**

Notice is hereby given, in pursuance of section 272 of the Companies Act 1961, that a General Meeting of the members of the above-named company will be held at the offices of the liquidator, 12th Floor, 440 Collins-street, Melbourne, on 17th day of December, 1973, at 10 a.m., for the purpose of having the liquidator's account laid before them, showing the manner in which the winding up has been conducted and the property of the company disposed of and of hearing any explanation that may be given by the liquidator, and also of determining the manner in which the books, accounts and documents of the company and of the liquidator thereof shall be disposed of.

Dated this 12th day of November, 1973.

J. D. SPENCE, Liquidator.

Arthur Young & Company, chartered accountants, 440 Collins-street, Melbourne, 3000. 5413

The Companies Act 1961.**C.I.M. PTY. LTD.****PURSUANT TO SECTION 260 OF THE COMPANIES ACT 1961.**

Notice is hereby given that a meeting of creditors of C.I.M. Pty. Ltd., will be held at the offices of Hall & Rose, 395 Collins-street, Melbourne, on Monday, 3rd December, 1973, at 2.15 p.m., in the afternoon, for the purpose of considering the company's affairs, the company having convened an Extraordinary General Meeting of its members to be held on the same day, and for the purpose of considering and if thought fit, passing a Special Resolution that the company be wound up voluntarily.

Dated this 13th day of November, 1973.

G. MORGAN, Director.

Hall & Rose, chartered accountants, 395 Collins-street, Melbourne, Vic. 3000. 5381

The Companies Act 1961.**G.L.M. NOMINEES PTY. LTD.****PURSUANT TO SECTION 260 OF THE COMPANIES ACT 1961.**

Notice is hereby given that a meeting of creditors of G.L.M. Nominees Pty. Ltd., will be held at the offices of Hall & Rose, 395 Collins-street, Melbourne, on Monday, 3rd December, 1973, at 4 p.m., in the afternoon, for the purpose of considering the company's affairs, the company having convened an Extraordinary General Meeting of its members to be held on the same day, and for the purpose of considering and if thought fit, passing a Special Resolution that the company be wound up voluntarily.

Dated this 13th day of November, 1973.

G. MORGAN, Director.

Hall & Rose, chartered accountants, 395 Collins-street, Melbourne, Vic. 3000. 5382

AUSTRALIAN FOUNDATION INVESTMENT COMPANY LIMITED.

NATIONAL RELIANCE INVESTMENT COMPANY LIMITED.

CAPEL COURT INVESTMENT COMPANY (AUSTRALIA) LIMITED.

JASON INVESTMENT COMPANY (AUSTRALIA) LIMITED.

SHERBOURNE INVESTMENTS LIMITED.

BRENTON INVESTMENTS (AUSTRALIA) LIMITED.

CLONMORE INVESTMENTS (AUSTRALIA) LIMITED.

HALIBURTON INVESTMENTS (AUSTRALIA) LIMITED.

JONATHAN INVESTMENTS LIMITED.

Take notice that on the 26th day of October, 1973, the Supreme Court of Victoria made an order to the following effect:—

- (1) That the scheme of arrangement referred to the Supreme Court under reference No. C.O.8660, be and is approved and is declared to be binding on all stockholders of the above named companies and on those companies also.
- (2) That all the property rights and powers and all the liabilities of each of the above companies (except Australian Foundation Investment Company Limited) be transferred to Australian Foundation Investment Company Limited, subject to all charges then affecting the same and save for liquid assets sufficient to pay the respective interim dividends.
- (3) That on 26th April, 1974, all the above companies (except Australian Foundation Investment Company Limited) shall be dissolved without winding up.
- (4) That a copy of the order be lodged with the Registrar of Companies and that notice of the order be duly advertised in the *Government Gazette* and in the *Age* newspaper.

Dated this 12th day of November, 1973.

5386 IAN P. TAYLOR, Secretary of each company.

In the Supreme Court of Victoria.—1973, No. Co. 8745.—In the matter of the *Companies Act 1961*; and in the matter of WESTMELTON (VIC.) PTY. LIMITED.

Take notice that a petition for the winding up of West-melton (Vic.) Pty. Ltd., was presented on the 2nd day of November, 1973. The date and place appointed for the hearing of the petition are 10.30 o'clock in the forenoon on Monday, the 3rd day of December, 1973, in the Practice Court, Supreme Court, Law Courts, William-street, Melbourne.

The names and registered offices of the petitioners are as follows: Delphic Holdings Pty. Limited, at the office of R. A. Burnett & Co., Unit 1, 130 Albert-road, South Melbourne; and Kenneth A. Summons Pty. Limited, 21 Northcliffe-avenue, Edithvale.

The solicitor for the petitioners is Michael O'Brien, of the firm of Mahony, O'Brien & Duggan, 37 Queen-street, Melbourne.

Any person who intends to appear at the hearing of the petition, either to oppose or support, must send notice of his intention to the petitioners or to their solicitors, not later than Four o'clock on Friday, the 30th day of November, 1973.

MICHAEL O'BRIEN, solicitor for the petitioners.

Mahony, O'Brien & Duggan, solicitors, 37 Queen-street, Melbourne. 5372

In the Supreme Court.—1973, No. Co. 8725.—In the matter of the *Companies Act 1961*; and in the matter of HARRIS & LEWIN PTY. LTD.

BEFORE HIS HONOUR MR. JUSTICE GOWANS THE 26TH DAY OF OCTOBER, 1973.

Upon the petition of Geo. Thompson & Co. (Australia) Pty. Limited, of 447 Collins-street, Melbourne, a creditor of the above-named company on the 24th day of October, 1973, preferred unto the Court and on that day adjourned for hearing on this day; and upon hearing Doctor A. Endrey of counsel for the petitioner, on the 24th day of October, 1973, and this day; and upon reading the said petition, the affidavit of Malcolm Oliver Thompson, sworn on the 17th day of September, 1973, verifying the said petition, and the exhibit thereto, the affidavit of Timothy Russell Green sworn the 22nd day of October, 1973, the Victorian *Government Gazette* published on the 26th day of September, 1973, the *Age* newspaper published on the 27th day

of September, 1973, each containing an advertisement of the said petition, the several affidavits of Leslie Evan Evans sworn on the 24th day of September, 1973, and Graham Nelson, sworn on the 20th day of September, 1973, and each filed herein and the certificate of Master Collie, dated the 23rd day of October, 1973, this Court doth Order:—

1. That the above-named company, Harris & Lewin Pty. Ltd. be wound up on the ground that it is unable to pay its debts.

2. That Alan James Gairns, of 343 Little Collins-street, Melbourne, be appointed liquidator for the purposes of the said winding up.

3. That the Bank in which the liquidator is to open a trust account is the Australia and New Zealand Banking Group Limited, of 360 Collins-street, Melbourne.

4. That the costs of the petition be costs in the winding up.

By the Court,

S. H. COLLIE, Master.

Entered the 5th day of November, 1973.

P. S. MACBON, Prothonotary.

NOTE.—It will be the duty of such of the persons as are liable to make out or concur in making out a statement of affairs as the liquidator may require to attend on him at such time and place as he may appoint and to give him all information he may require. 5358

H.L. INVESTMENTS PTY. LTD. (IN VOLUNTARY LIQUIDATION).

At a meeting held on 5th November, 1973, the Special Resolution as follows was passed unanimously:—

"That H.L. Investments Proprietary Limited be placed in voluntary liquidation, and that Mr. Douglas Lindsay Cameron, be and is hereby appointed liquidator."

D. L. CAMERON, Liquidator.

K. J. Ackland & Co., public accountants, 114 Yarra-street, Geelong, 3220. 5336

EGITPRESS PTY. LIMITED (IN VOLUNTARY LIQUIDATION).

At an Extraordinary General Meeting of the above-named company, duly convened and held at 318 Darebin-road, Thornbury, on 2nd November, 1973, the following Resolutions were duly passed:—

That the company be wound up voluntarily. That Alan John Fookes, of 339 Collins-street, Melbourne, Victoria, be appointed liquidator.

Dated this 7th day of November, 1972.

5378

ALAN J. FOOKES, Liquidator.

The *Companies Act 1961*.—In the matter of PRYNTAR FABRICS PTY. LTD.—Notice Re Meeting of Creditors, Pursuant to Section 260.

Notice is hereby given that a meeting of creditors of the above-named company will be held at the offices of Kennedy, Smail & Middlemiss, 296 Little Lonsdale-street, Melbourne, at 3 p.m., on the 28th day of November, 1973, the company having convened a meeting of its members for the same day for the purpose of considering a Resolution that the company be wound up voluntarily.

Dated this 12th day of November, 1973.

S. WILTSHIRE, Director.

Kennedy, Smail & Middlemiss, 296 Little Lonsdale-street, Melbourne. 5379

The *Companies Act 1961*.

TOCKNELL APPLIANCES PROPRIETARY LIMITED (IN LIQUIDATION).

NOTICE CONVENING FINAL MEETING OF MEMBERS AND CREDITORS, PURSUANT TO SECTION 272.

Notice is hereby given pursuant to section 272 of the *Companies Act 1961*, that a General Meeting of the members and creditors of the above-named company will be held in the offices of Kennedy, Smail & Middlemiss, 296-304 Little Lonsdale-street, Melbourne, on Wednesday, the 5th day of December, 1973, at 10.30 a.m., for the purpose of having an account laid before them showing the manner in which the winding up has been conducted and the property of the company disposed of, and of hearing any explanations that may be given by the liquidator.

Dated this 2nd day of November, 1973.

EDWARD RONALD SMAIL, Liquidator.

Kennedy, Smail & Middlemiss, 296-304 Little Lonsdale-street, Melbourne, 3000. 5380

The Companies Act 1961.—In the matter of UNITED BISCUITS (AUSTRALIA) LIMITED (in Liquidation).

Notice is hereby given that at an Extraordinary Meeting of the members of the above-named company, held on the 9th day of November, 1973, it was resolved that the company be wound up voluntarily, and that Alan John Truett, be nominated as liquidator for the purpose of such winding up, and that at a meeting of creditors held on the same day my appointment as liquidator was confirmed.

Notice is also given that persons having any claim against the company should furnish particulars of same within 21 days, otherwise I shall proceed to distribute the assets without regard to their claim.

Dated this 12th day of November, 1973.

A. J. TRUETT, Liquidator.

Deloitte, Haskins & Sells, chartered accountants, 53 Queen-street, Melbourne. 5383

Companies Act 1961.

CRANE & ENGINEERING (VIC.) PTY. LIMITED.

NOTICE OF MEETING OF CREDITORS.

Companies Regulations, Regulations 28 (2) (b) and 46 (2).

Notice is hereby given that a meeting of the creditors of Crane & Engineering Pty. Limited, will be held at the Board Room, Institute of Chartered Accountants, 9th Floor, 140 Queen-street, Melbourne, on the 27th day of November, 1973, at 10.30 o'clock in the forenoon.

Agenda:

1. To receive a report from a director of the company nominated by a General Meeting of contributories to be held at Burwood, on the 27th day of November, 1973, at which a Special Resolution may be passed:—

"That the company be wound up voluntarily and that a liquidator be appointed for the purpose of winding up in view of the inability of the company by reason of its liabilities to continue its business."

2. In the event of the contributories in the General Meeting having resolved that the company go into voluntary liquidation to nominate a liquidator or if the contributories have nominated a liquidator to consider the confirmation of his appointment.

3. If thought fit to appoint a committee of inspection.

4. To fix the remuneration of the proposed liquidator or to delegate such power to the committee of inspection if appointed.

5. Any other business.

Dated this 13th day of November, 1973.

J. NOTTAGE, Director.

NOTES.—(a) No person is entitled to attend unless he is personally a creditor or unless he holds a proxy for a creditor. It is requested that both proxies and proofs, duly completed, be lodged at the office of Shepherd & Partners, 274 Melbourne-street, North Adelaide, S.A., 5006, or P.O. Box 101, Burwood, Vic., 3125, not later than 4.30 p.m., on the 23rd day of November, 1973.

(b) No person is entitled to vote as a creditor at the meeting unless he has lodged with the chairman of the meeting a proof of debt which he claims to be due to him from the company. 5393

The Companies Act 1961.—In the matter of MELBOURNE TRAILER SALES PROPRIETARY LIMITED (in Liquidation).—Notice of Meeting of Creditors and Members, Pursuant to Section 272.

Notice is hereby given that a Final Meeting of creditors and members of Melbourne Trailer Sales Proprietary Limited (in Liquidation), will be held at the offices of Messrs. Bentley, Wheeler, Cartledge & Co., 1 Palmerston-crescent, South Melbourne, on Monday, the 17th December, 1973, at 12 o'clock in the forenoon, for the purpose of laying before the meeting the liquidator's final account and report and giving any explanation thereof.

Dated this 13th day of November, 1973.

H. K. CARTLEDGE, Liquidator.

Bentley, Wheeler, Cartledge & Co., chartered accountants, 1 Palmerston-crescent, South Melbourne, Vic. 3205. 5409

YORK HOUSE PROPRIETARY LIMITED.

The above company was placed in voluntary liquidation by a Resolution of members passed on the 5th November, 1973.

5352

M. DEWAR, Liquidator.

The Companies Act 1961.—In the matter of W. R. ELSWORTH PTY. LTD. (in Voluntary Liquidation).—Members' Winding Up.

Notice is hereby given that at the Extraordinary General Meeting of W. R. Elsworth Pty. Ltd., duly convened and held at 536 Clayton-road, Clayton, in the State of Victoria, on the 5th day of November, 1973, the following Resolution was proposed and passed as a Special Resolution:—

"That the company be wound up voluntarily."

Dated this 8th day of November, 1973.

5320

R. W. BETTS, Liquidator.

ZELWAT PROPRIETARY LIMITED (IN VOLUNTARY LIQUIDATION).

Notice is hereby given that a General Meeting of the company will be held at the offices of Robertson, Darling & Wolfenden, 19th Floor, 535 Bourke-street, Melbourne, on Monday, the 10th day of December, 1973, at 12 o'clock noon, to receive an account showing how the winding up has been conducted and the property of the company disposed of.

Dated this 5th day of November, 1973.

5377

H. W. MCCUTCHEON, Liquidator.

The Companies Act 1961.—In the matter of SLEEPMAKERS (VIC.) PTY. LTD. (in Voluntary Liquidation).—Members' Winding Up.

Notice is hereby given that at the Extraordinary General Meeting of Sleepmakers (Vic.) Pty. Ltd., duly convened and held at 536 Clayton-road, Clayton, in the State of Victoria, on the 5th day of November, 1973, the following Resolution was proposed and passed as a Special Resolution:—

"That the company be wound up voluntarily."

Dated this 8th day of November, 1973.

5321

R. W. BETTS, Liquidator.

In the matter of the Companies Act 1961; and in the matter of RON'S STEAKHOUSE PTY. LTD. (in Liquidation).

Notice is hereby given that pursuant to section 272 of the Companies Act 1961, the Final Meeting of the members and creditors of the company will be held at the offices of Marquand & Co., 51 Queen-street, Melbourne, on the 17th day of December, 1973, at 9 a.m., for the purpose of laying before the meeting the account and any explanation thereof.

Dated this 8th day of November, 1973.

5365

L. P. SMART, Liquidator.

The Companies Act 1961.

ELECTRONSONICS PTY. LTD. (IN LIQUIDATION).

NOTICE CONVENING FINAL MEETING OF MEMBERS AND CREDITORS, PURSUANT TO SECTION 272.

Notice is hereby given in pursuance of section 272 of the Companies Act 1961, that a meeting of the members and Creditors of the above-named company will be held on the 10th day of December, 1973, at the offices of Hall & Rose, 395 Collins-street, Melbourne, at 10 a.m., for the purpose of having an account laid before them showing the manner in which the winding up has been conducted and the property of the company disposed of and of hearing any explanations that may be given by the liquidator.

Dated this 5th day of November, 1973.

J. K. HALL, Liquidator.

Hall & Rose, chartered accountants, 395 Collins-street, Melbourne. 5350

W.S.C. INVESTMENTS PTY. LTD.

The above company was placed in voluntary liquidation by a Resolution of members passed on the 5th November, 1973.

5351

M. DEWAR, Liquidator.

Companies Act 1961, Section 272 (2).

ROSE WATER LODGE PTY. LTD. (IN LIQUIDATION).

The Final Meeting of the company will be held at the offices of the liquidator on 14th December, 1973, at 10 a.m., for the purpose of receiving the liquidator's account showing how the winding up has been conducted and the property of the company disposed of.

5th November, 1973.

F. Y. RATTRAY, Liquidator, 24 Jeffcott-street, Melbourne. 5355

In the matter of CHASMEIL PROPRIETARY LIMITED.—Notice of Winding-up Order.

Winding-up Order made on the 7th day of November, 1973.

Mr. Alex. Neville Bird, liquidator, of 289 Flinders-lane, Melbourne.

CLEARY, ROSS & DOHERTY, solicitors, 406 Collins-street, Melbourne. 5357

ACSON LIMITED.

At a General Meeting of the members of the above-named company, held at 160 Fulham-road, Fairfield, on the 2nd day of November, 1973, the Special Resolution set out below was duly passed:—

Resolved that the company be wound up voluntarily and that Eric Maxwell Huggard and Brian Argent Waters of the firm of Spry Walker & Co., chartered accountants, be appointed joint and several liquidators, at a fee to be determined in accordance with the normal professional scale rates for the time occupied by the said liquidators, and/or their staff, in carrying out their duties as liquidators.

Dated this 6th day of November, 1973.

5373 C. D. LESCHEN, Secretary.

The Companies Act 1961.

WELD-N-SPRAY PTY. LTD. (IN LIQUIDATION).

NOTICE OF CONVENING FINAL MEETING OF MEMBERS AND CREDITORS, PURSUANT TO SECTION 272 (2).

Notice is hereby given in pursuance of section 272 of the Companies Act 1961 that a meeting of the members and creditors will be held on the 12th day of December, 1973, at the office of Neville Bird, Davies & Co., chartered accountants, 289 Flinders-lane, Melbourne, at 3 p.m., for the purpose of having an account laid before them showing the manner in which the winding up has been conducted and the property of the company disposed of and hearing any explanations that may be given by the liquidator.

Dated this 12th day of November, 1973.

NEVILLE BIRD, DAVIES & CO., chartered accountants, 289 Flinders-lane, Melbourne, 3000. Telephone: 63 2874. 5374

Companies Act 1961.

A. V. WEHL & CO. PROPRIETARY LIMITED (IN VOLUNTARY LIQUIDATION).

Notice is hereby given that at an Extraordinary General Meeting of the members of the above-named company held on the 24th day of October, 1973, it was resolved that the company be wound up voluntarily.

Notice is also given that after 21 days from this date, we shall proceed to distribute the assets. All creditors having any claims against the company should furnish particulars of same by that date, otherwise I shall proceed to distribute the assets without regard to their claim.

Dated this 7th day of November, 1973.

D. A. CRAWFORD, Liquidator.

Peat, Marwick, Mitchell & Co., 447 Collins-street, Melbourne, Vic. 3000. 5376

The Companies Act 1961.—In the matter of SEAFOAM PTY. LTD. (in Voluntary Liquidation).—Members' Winding Up.

Notice is hereby given that at the Extraordinary General Meeting of Seafoam Pty. Ltd., duly convened and held at 536 Clayton-road, Clayton, in the State of Victoria, on the 5th day of November, 1973, the following Resolution was proposed and passed as a Special Resolution:—

"That the company be wound up voluntarily."

Dated this 8th day of November, 1973.

5319 R. W. BETTS, Liquidator.

WILDON PTY. LTD. (IN VOLUNTARY LIQUIDATION).

Notice is hereby given, in pursuance of section 272 of the Companies Act 1961, that a General Meeting of the members of the above-named company will be held at the offices of Email Ltd., Joynton-avenue, Waterloo, N.S.W., on Thursday, the 13th day of December, 1973, at 3 p.m., for the purpose of having the liquidator's account laid before them showing the manner in which the winding up has been conducted and the property of the company disposed of and of hearing any explanation that may be given by the liquidator, and also of determining the manner in which the books, accounts and documents of the company and of the liquidator thereof shall be disposed of.

Dated the 9th day of November, 1973.

PETER J. JACKSON, Liquidator.

Brentnall Dale & Co., 351 Collins-street, Melbourne. 5375

Trustee Act 1958.

NOTICE TO CLAIMANTS.

Pursuant to the Trustee Act 1958, creditors next of kin and all other persons having claims in respect of the estate of any deceased person named below are required to send particulars to the legal personal representative or representatives at the addresses stated, after which date the representatives will distribute the assets, having regard only to the claims of which notice has been received:—

Joseph John Corby, formerly of Grant-street, Inglewood, but late of Bethlehem Home for the Aged, Taylor-street, Bendigo, retired farmer, who died on the 4th September, 1973.—Claims to the executor, James Patrick Nevins, in care of the under-signed solicitors, by the 14th day of January, 1974. Schleiger & Smalley, solicitors, 290 Williamson-street, Bendigo. 5304

JOHN STEWART LANG, late of 177 Farrell-street, Port Melbourne, in the State of Victoria, printer, DECEASED.

Creditors, next of kin and others having claims in respect of the estate of the deceased (who died on the 19th day of July, 1973), are required by The Trustees, Executors and Agency Company Limited, of 401 Collins-street, Melbourne, in the said State, the applicant for a grant of probate, to send particulars of their claims to the said applicant, at 401 Collins-street, Melbourne, in the said State, by the 15th day of January, 1974, after which date it will convey or distribute the assets, having regard only to the claims of which it then has notice.

H. G. HARRIS, solicitor, 422 Collins-street, Melbourne.

5394

Creditors, next of kin and others having claims in respect of the estate of Charles Rulczycki Smith, formerly of 27 Birdwood-street, Frankston, but late of 94 Cranbourne-road, Frankston, in the State of Victoria, retired french polisher, deceased (who died on the 3rd day of July, 1973), are to send particulars of their claims to the executor, Ellis John Richardson, care of the undersigned, by the 16th January, 1974, after which date he shall commence to distribute the assets, having regard only to the claims of which he then has notice.

RENNICK & GAYNOR, solicitors, 481 Riversdale-road, Hawthorn East. 5401

ADA DORIS HAYBALL, late of Hurlingham Hospital, East Brighton, spinster, DECEASED.

Creditors, next of kin and others having claims against the estate of the said deceased (who died on the 12th August, 1973), are to send particulars of their claims to The Union-Fidelity Trustee Company of Australia Limited, of 100 Exhibition-street, Melbourne, by the 21st day of January, 1974, after which date it will distribute the assets, having regard only to the claims of which it then has notice.

BLAKE & RIGGALL, solicitors, 140 William-street, Melbourne. 5402

Creditors, next of kin and others having claims in respect of the estate of Ada Gertrude Best, late of Croydon Private Hospital, 18 Hyton-crescent, Croydon, in the State of Victoria, widow, deceased (who died on the 1st day of September, 1973), are required by Malcolm James Anderson, to send particulars of their claims to the said Malcolm James Anderson, care of Martin & Martin, 37 Queen-street, Melbourne, by the 18th day of January, 1974, after which date he will convey or distribute the assets, having regard only to the claims of which he then has notice.

MARTIN & MARTIN, solicitors, 37 Queen-street, Melbourne. 5403

Creditors, next of kin and others having claims in respect to the estate of Eileen Agnes McCormack, late of 1 Knowles-street, Northcote, in the State of Victoria, nursing sister, deceased (who died on the 1st September, 1973), are to send particulars of their claims to Royston Cahir, Martin & Dillon, solicitors, of 17 Queen-street, Melbourne, by the 17th January, 1974, after which date the executors will distribute the assets of the estate, having regard only to claims to which they then have notice.

ROYSTON CAHIR, MARTIN & DILLON, solicitors, 17 Queen-street, Melbourne. 5404

MERSEY MYRTLE HENDERSON, late of Warrnambool Base Hospital, Warrnambool.

Creditors, next of kin and others having claims in respect of the estate of the deceased (who died on the 5th day of September, 1973), are required by The Perpetual Executors and Trustees Association of Australia Limited,

of 50 Queen-street, Melbourne, and Evalene Annie Henry, of 318 Upper Heidelberg-road, Ivanhoe, married woman, the applicants for a grant of administration, to send particulars of their claims to the said applicants in the care of the said company, by the 16th day of January, 1974, after which date they will convey or distribute the assets, having regard only to the claims of which they then have notice.

BEST, HOOPER, RINTOUL & SHALLARD, solicitors,
377 Little Collins-street, Melbourne, 3000. 5370

Creditors, next of kin and others having claims against the estate of Elizabeth Muriel Limerock, late of 18 Barry-street, Kew, spinster, deceased (who died on 19th August, 1973), are required to send particulars of their claims to The Union-Fidelity Trustee Company of Australia Limited, of 100 Exhibition-street, Melbourne, the administrator of the said deceased, on or before the 8th January, 1974, after which date the company will distribute the assets, having regard only to the claims of which the company then has notice.

TOLHURST, DRUCE & EMMERSON, solicitors, 357
Little Collins-street, Melbourne, 3000. 5371

MARIJA MIJUSKOVIC, late of 34 Wheeler-street, Ormond,
in the State of Victoria, widow, DECEASED.

Creditors, next of kin and all other persons having claims against the estate of the deceased are required by National Trustees, Executors and Agency Company of Australasia Limited, of 95 Queen-street, Melbourne, the executors of her will, to whom probate has been granted, to send particulars thereof to it before the 18th day of January, 1974, after which date it may distribute the assets of the deceased, having regard only to the claims of which it then has notice.

JOHN I. SULLIVAN CHISHOLM & ASSOCIATES,
solicitors, corner of Kooyong and Glenhenty roads,
Caulfield. 5330

ANNIE MAY EVERETT, late of 1 Ferncroft-avenue, East
Malvern, widow, DECEASED.

Creditors, next of kin and others having claims in respect of the estate of the deceased (who died on the 27th day of August, 1973), are required by The Trustees, Executors and Agency Company Limited, of 401 Collins-street, Melbourne, and Leslie John Viccars, of 1 Ferncroft-avenue, East Malvern, retired costing clerk, the applicants for a grant of administration, to send particulars of their claims to the said applicants, care of the said company, by the 18th day of January, 1974, after which date they will convey or distribute the assets, having regard only to the claims of which they then have notice.

RUSSELL, KENNEDY & COOK, solicitors, 401 Collins-
street, Melbourne. 5369

HILDA MAY BISH, formerly of 74 McCrae-street, Swan
Hill, but late of 33 Rutherford-street, Swan Hill, in the
State of Victoria, farmer, DECEASED.

Creditors, next of kin and other persons having claims against the estate of the said deceased (who died on the 3rd day of September, 1973), are required to send particulars of same to the executors, John Thomas Bish and Ivan Leslie Bish, in care of the undersigned, on or before the 21st day of January, 1974, after which date they will distribute the assets, having regard only to the claims of which they then have notice.

DELANY & DWYER, barristers and solicitors,
201 Campbell-street, Swan Hill. 5354

Pursuant to the Trustee Act 1958, notice is hereby given that all persons having claims against the estate of Emma Christina Elliott, late of 6 Rose-avenue, Surrey Hills, widow, deceased (who died on 7th July, 1973, and probate of whose will was granted by the Supreme Court of Victoria in its probate jurisdiction, on 26th October, 1973, to The Equity Trustees, Executors and Agency Company Limited, of 472 Bourke-street, Melbourne), are hereby required to send particulars, in writing, of such claims to the said The Equity Trustees, Executors and Agency Company Limited, at its above address on or before 10th January, 1974, after which date the said company will proceed to distribute the assets of the said Emma Christina Elliott, deceased, which shall have come to its hands amongst the persons entitled thereto having regard only to the claims of which it shall then have had notice. And notice is further given that the said company will not be liable for the assets so distributed or any part thereof to any person of whose claim it shall not have had notice as aforesaid.

Dated this 5th day of November, 1973.

G. F. PITCHER & BUTT, solicitors, 406 Lonsdale-street,
Melbourne. 5359

Creditors, next of kin and others having claims in respect of the estate of George Norman Alexander, late of 344 Plenty-road, Preston, retired produce merchant (who died on 23rd September, 1973), are to send the particulars of their claims to The Union-Fidelity Trustee Company of Australia Limited, of 100 Exhibition-street, Melbourne, by the 15th January, 1974, after which date it will distribute the assets, having regard only to the claims of which it then has notice.

RYLAH & RYLAH, solicitors, 349 Collins-street,
Melbourne. 5360

ROGER EASTWOOD, formerly of 11 Shady-grove Nuna-
wading, in the State of Victoria, but late of War
Veterans Home, Caboolture, in the State of Queensland,
soldier, DECEASED.

Creditors, next of kin and others having claims in respect of the estate of the deceased (who died on the 26th day of May, 1973), are required by the personal representative, The Trustees, Executors and Agency Company Limited, of 401 Collins-street, Melbourne, in the State of Victoria, to send particulars to it, by the 15th day of January, 1974, after which date it will distribute the assets, having regard only to the claims of which it then has notice.

E. P. JOHNSON & DAVIES, solicitors, 339 Collins-street,
Melbourne. 5361

Creditors, next of kin and others having claims in respect of the estate of Eva Powell Wilson, late of 11 Vickery-street, Bentleigh, home duties, deceased (who died on the 30th day of August, 1973), are to send particulars of their claims to The Union-Fidelity Trustee Company of Australia Limited, of 100 Exhibition-street, Melbourne, by the 15th January, 1974, after which date the said company will distribute the assets, having regard only to the claims of which it then has notice.

R. WADHAM & DOIG, solicitors, of 383 Flinders-lane,
Melbourne. 5362

JESSIE ISABEL WILSON, late of 5 Mincha-street, West
Brunswick, gentlewoman, DECEASED.

Creditors, next of kin and all other persons having claims against the estate of the said deceased are required by the executors, John Raymond Channon and Donald James Bainbridge, to send particulars to them, care of the undersigned, on or before 14th January, 1974, after which date they will distribute the assets of the said deceased, having regard only to the claims of which they then have notice.

RIDGEWAY, PEARCE & FREADMAN, solicitors, 419
Lonsdale-street, Melbourne. 5366

RAYMOND FARRIN WEBB, late of 16 Halford-street,
Inverloch, Victoria, retired sharebroker, DECEASED.

Creditors, next of kin and others having claims in respect of the estate of the deceased (who died on the 11th day of July, 1973), are required by The Perpetual Executors and Trustees Association of Australia Limited, of 50 Queen-street, Melbourne, and Jeannie Aureola Webb, of 16 Halford-street, aforesaid, the applicants for a grant of representation, to send particulars of their claims to the said applicants in the care of the said company, by the 16th day of January, 1974, after which date they will convey or distribute the assets, having regard only to the claims of which they then have notice.

HEDDERWICK, FOOKES & ALSTON, 121 William-street,
Melbourne. 5367

Creditors, next of kin and others having claims in respect of the estate of Eileen Marie McHenry, late of 43 Bowen-street, Camberwell, widow, deceased (who died on the 24th July, 1973), are to send particulars of their claims to the executors, John McHenry and Lily Veronica Bey, care of the undersigned, by the 14th day of January, 1974, after which date they will commence to distribute the assets, having regard only to the claims to which they then have notice.

RENNICK & GAYNOR, solicitors, 481 Riversdale-road,
Hawthorn East. 5368

DAVY EDWARD WEDGE, late of 92 Victoria-street,
Cobden, bus service proprietor, DECEASED.

Creditors, next of kin and all others having claims in respect of the above-named deceased (who died 1st October, 1973), are requested to send particulars of their claims in writing to the executors, Blanche Kathleen Wedge, of 92 Victoria-street, Cobden, Reginald Lawson Wedge, of 67 Wenborne-court, Mt. Eliza, and Robert Harvey O'Neill, of Manifold-street, Camperdown, care of

the undersigned on or before the 17th January, 1974, after which date they will distribute the assets of the said estate, having regard only to the claims of which they then have notice as aforesaid.

DESMOND DUNNE, & DWYER, solicitors, Warrnambool.
5338

WILFRED FORTESQUE HOLMES, late of 19 McKnight-street, Warrnambool, cleaner, DECEASED, intestate.

Creditors, next of kin and all others having claims in respect of the above-named deceased (who died 10th July, 1973), are requested to send particulars of their claims in writing to the administratrix, Ivy Margaret Holmes, of 19 McKnight-street, Warrnambool, care of the undersigned on or before the 17th January, 1974, after which date they will distribute the assets, having regard only to the claims of which they then have notice as aforesaid.

DESMOND DUNNE, & DWYER, solicitors, Warrnambool.
5342

Creditors, next of kin and others having claims against the estate of Minnie Dugan Nettle, formerly of 6 Boisdale-street, late of "Kinross" Private Hospital, 9 Broughton-road, both in Surrey Hills, widow, deceased (who died on 17th September, 1973), are required to send written notice of their claims to the executors (Messrs. N. D. Hooper and J. K. Proudfoot), care of the undersigned solicitors, by the 16th January, 1974, after which date the executors will distribute the assets, having regard only to the claims of which they then have notice.

PROUDFOOT, HORTON & COOKE, solicitors, 406 Lonsdale-street, Melbourne.
5345

Creditors, next of kin and others having claims against the estate of Edna Millicent Hardy, late of 2 Kirwanagrove, Montmorency, spinster, deceased (who died on 6th September, 1973), are required to send written notice of such claims to the executor, Mr. T. A. Egan, care of the undersigned solicitors, by the 16th January, 1974, after which date the executor will distribute the assets, having regard only to the claims of which he then has notice.

PROUDFOOT, HORTON & COOKE, solicitors, 406 Lonsdale-street, Melbourne.
5346

Creditors, next of kin and others having claims against the estate of Magdalena Elizabeth Carolina Kronhuber, commonly known as Lena Taylor, late of Flat 3, 51 Ormond-esplanade, Elwood, retired typist, deceased (who died on the 1st day of July, 1973), are to send particulars of their claims to the executor, The Equity Trustees, Executors and Agency Company Limited, at 472 Bourke-street, Melbourne, by the 23rd January, 1974, after which date it will distribute the assets, having regard only to the claims of which it then has notice.

PEARCE & WEBSTER, solicitors, 430 Little Collins-street, Melbourne.
5347

Creditors, next of kin and others having claims in respect of the estate of Mary Marjorie Foy Miller, late of 114 Burke-road, East Malvern, spinster, deceased (who died on 23rd July, 1973), are required to send particulars of such claims to the executors care of National Trustees, Executors and Agency Company of Australasia Limited, at its registered office at 95 Queen-street, Melbourne, by the 15th January, 1974, after which date they will distribute the assets, having regard only to the claims of which they then have notice.

DOYLE & KERR, solicitors, 450 Little Collins-street, Melbourne.
5348

Creditors, next of kin and others having claims in respect of the estate of Elvira Daisy Davis, late of 7 St. Kilda-avenue, Upwey, widow, deceased (who died on the 19th September, 1973), are required to send particulars of their claims to Anthony David Cooke, of 406 Lonsdale-street, Melbourne, by the 17th January, 1974, after which date the executor will distribute the assets, having regard only to the claims of which he then has notice.

PROUDFOOT, HORTON & COOKE, solicitors, of 406 Lonsdale-street, Melbourne.
5349

PERCIVAL JAMES WILLIAM MURFETT, late of 36 Main-street, Blackburn, retired architect, DECEASED.

Creditors, next of kin and others having claims in respect of the estate of the above-named Percival James William Murfett, deceased (who died on 14th June, 1973), are to send particulars of their claims to The Trustees Executors and Agency Company Limited, of 401 Collins-street, Melbourne, the executor to whom probate of the deceased's will have been granted by the Supreme Court

of Victoria, by 16th January, 1974, after which date the executor will distribute the assets, having regard only to the claims of which it shall then have notice.

H. L. YUNCKEN & YUNCKEN, solicitors, 443 Little Collins-street, Melbourne, 3000.
5353

EVELYN READ, late of corner of Atkinson and Anderson streets, Templestowe, in the State of Victoria, widow, DECEASED.

Creditors, next of kin and others having claims in respect of the estate of the above-named deceased (who died on the 27th July, 1972), are required by the executors of the said deceased's will, Sylvia Agnes Boon, of 60 Anderson-street, Templestowe, married woman, and Albert David Read, of 28 Bertram-street, Burwood, departmental manager, to send particulars to them, by the 15th January, 1974, after which date the executors may convey or distribute the assets of the estate, having regard only to the claims of which they may have notice.

KEITH NESS & SON, solicitors, 380 Collins-street, Melbourne, 3000.
5405

Creditors, next of kin and others having claims in respect of the estate of Annie Evelyn Adelaide Pratt, late of 22 Progress-street, Seymour, widow, deceased (who died on the 5th August, 1973), are required by the executor, The Union-Fidelity Trustee Company of Australia Limited, of 100 Exhibition-street, Melbourne, to forward particulars of their claims to it, care of the above company, by the 18th January, 1974, after which date it shall proceed to distribute the assets, having regard only to the claims of which it then has notice.

DARVALL & HAMBLETON, solicitors, of 147 Collins-street, Melbourne, 3000.
5406

Creditors, next of kin and others having claims in respect of the estate of Bruce Hugh Cannan, late of 49 Tennyson-street, Sandringham, in the State of Victoria, clerk, deceased (who died on the 20th February, 1973), are required by the administrator, The Union-Fidelity Trustee Company of Australia Limited, of 100 Exhibition-street, Melbourne, in the said State, to send particulars of their claims to the administrator, care of the undersigned solicitors, by the 18th January, 1974, after which date it will distribute the assets, having regard only to the claims of which it then has notice.

FREDERICK OWEN & ASSOCIATES, solicitors, 84 William-street, Melbourne.
5407

Creditors, next of kin and others having claims in respect of the estate of Clara Annie Smith, formerly of 27 Birdwood-street, Frankston, but late of 94 Cranbourne-road, Frankston, in the State of Victoria, married woman (who died on the 19th day of June, 1973), are to send particulars of their claims to the executor, Ellis John Richardson, care of the undersigned, by the 16th January, 1974, after which date he shall commence to distribute the assets, having regard only to the claims of which he then has notice.

RENNICK & GAYNOR, solicitors, 481 Riversdale-road, Hawthorn East.
5408

Creditors, next of kin and others having claims in respect of the estate of John Wills Thompson, late of Willung South, farmer, deceased, intestate (who died on the 19th day of March, 1973, and letters of administration of whose estate have been granted by the Supreme Court of the State of Victoria to Eliza Nora May Thompson, of Willung South, widow), are to send particulars of their claims to the below-mentioned solicitors, by the 15th January, 1974, after which date she will distribute the assets of the deceased, having regard only to the claims of which she then has notice.

BRUCE, LITTLETON & HACKFORD, solicitors, Traralgon.
5299

EMIL JOHN SHELDEN, late of 4 Walsh-street, Deepdene, retired bank manager, DECEASED.

Creditors, next of kin and others having claims in respect of the estate of the deceased (who died on the 3rd day of November, 1972), are required by the National Trustees, Executors and Agency Company of Australasia, the executor of the said estate, of 95 Queen-street, Melbourne, to send particulars of their claims to it, by the 14th January, 1974, after which date the executor may convey or distribute the assets, having regard only to the claims of which it then has notice.

JEFFREY SCOTT DOUBE, solicitor, 343 Little Collins-street, Melbourne.
5307

FRANCIS NOTMAN, late of Stockdales-road, Warragul, farmer, DECEASED.

Creditors, next of kin and others having claims in respect of the estate of the deceased (who died on the 23rd March, 1973), are required by the trustees, Lionel Francis Notman and Leslie Edwin Notman, to send particulars of their claims to them, care of the under-signed solicitors, by the 19th day of January, 1974, after which date the trustees may convey or distribute the assets, having regard only to the claims of which they then have notice.

GRAY, FRIEND & LONG, solicitors, Warragul. 5309

WILLIAM HENRY McLEAN, late of Nilma, farmer, DECEASED.

Creditors, next of kin and others having claims in respect of the estate of the deceased (who died on the 19th May, 1973), are required by the trustee, James Ferguson Robinson, to send particulars of their claims to him, care of the under-signed solicitors, by the 19th January, 1974, after which date the trustee may convey or distribute the assets, having regard only to the claims of which he then has notice.

GRAY, FRIEND & LONG, solicitors, Warragul. 5310

FLORENCE VIOLET SWAN, late of 24 Fyffe-street, Thornbury, widow, DECEASED.

Creditors, next of kin and others having claims in respect of the estate of the above-named deceased (who died on 1st September, 1973), are required by the trustee, Susy Friend, of 18 Tintern-avenue, Toorak, legal executive, to send particulars to her solicitors, Nunan & Bloom, at their address below, by 24th January, 1974, after which date the trustee may convey or distribute the assets, having regard only to the claims of which she then has notice.

NUNAN & BLOOM, solicitors, 343 Little Collins-street, Melbourne. 5317

ELLA ALICE MAUDE CALF, formerly of 15 Francis-street, Werribee, but late of 2 Marchant-street, Highett, widow, DECEASED.

Creditors, next of kin and others having claims against the estate of the said deceased (who died on the 9th August, 1973), are to send particulars of their claims to National Trustees, Executors and Agency Company of Australasia Limited, of 95 Queen-street, Melbourne, by the 25th January, 1974, after which date it will distribute the assets, having regard only to the claims of which it then has notice.

ADAMS & GARDE, solicitors, Central-avenue, Moorabbin. 5327

Creditors and next of kin and other persons having claims in respect of the estate of William Alfred Olney, late of Nhill, in the State of Victoria, retired farmer, deceased (who died on the 27th day of March, 1973), are required to send particulars of their claims to his executors, care of Messrs. Trumble & Palmer, solicitors, 45 Victoria-street, Nhill, in Victoria, on or before the 15th day of January, 1974, after which date the executors will distribute the assets, having regard only to the claims of which notice has been received.

TRUMBLE & PALMER, solicitors, 45 Victoria-street, Nhill. 5295

Creditors, next of kin and others having claims in respect of the estate of Joseph Gummow, late of 410 Macarthur-street, Ballarat, gentleman, deceased (who died on 27th June, 1973), are required to send particulars of their claims to the executor, The Union-Fidelity Trustee Company of Australia Limited, at its address 101 Lydiard-street north, Ballarat, by 15th January, 1974, after which date the said company will distribute the assets, having regard only to the claims of which it then has notice.

BAIRD, MCGREGOR & FOWLER, solicitors, Ballarat. 5384

Creditors, next of kin and others having claims in respect of the estate of Lloyd Selwyn Little, late of 266 Roslyn-road, Highton, insurance agent, deceased (who died on the 27th day of July, 1972), are required to send particulars of their claims to the executrix, Beryl Elsie Little, care of Males & Bell, solicitors, Geelong, by the 1st day of February, 1974, after which date she will distribute the assets, having regard only to the claims of which she then has notice.

MALES & BELL, solicitors, 76 Malop-street, Geelong. 5385

Creditors, next of kin and others having claims in respect of the estate of Mary Veronica McNamara, late of 3 Cecil-street, Benalla, spinster (who died on the 23rd day of June, 1973), are requested to send particulars of their claims in writing, to the under-mentioned solicitors, being the solicitors, for the executors, Trevor Turner Clarke, and Catherine Anne Carroll, by the 1st day of February, 1974, after which date the executors will distribute the assets, having regard only to the claims of which they then have notice.

HAMILTON CLARKE & CLARKE, solicitors, 55 Nunn-street, Benalla. 5387

Creditors, next of kin and others having claims in respect of the will of Una Myrtle Stephenson, late of 46 Gower-street, Kensington, widow, (who died on the 6th day of October, 1973), are requested to send particulars of their claims to the executor, William Jackson (in the will called William John Jackson), care of the under-mentioned solicitor, by the 30th day of January, 1974, after which date he will distribute the assets, having regard only as to the claims of which he then has notice.

JOHN STEWART, of 290 Racecourse-road, Newmarket. 5390

MARY CLELAND, formerly of 21 Shakespeare-street, Hamilton, but late of Cavendish, in the State of Victoria, spinster, DECEASED.

Creditors, next of kin and others having claims in respect of the estate of the deceased (who died on the 28th day of March, 1973), are required, by the executors of the estate, Ronald Lowenstern, solicitor, of Hamilton, and Alan James Dishon, of Cavendish, sawmiller, to send particulars to them, care of the under-mentioned solicitors, by the 24th day of January, 1974, after which date the executors may convey or distribute the assets, having regard to claims only of which they then have notice.

CAMERON & LOWENSTERN, solicitors, 62 Thompson-street, Hamilton. 5391

Creditors, next of kin and others having claims in respect of the estate of Viola Beatrice Jane Lake, formerly of 30 Blenheim-street, Balacava, but late of Queen Elizabeth Home, Ascot-street, Ballarat, both in the State of Victoria, spinster, deceased (who died on the 27th day of July, 1971), are required to send particulars of their claims to The Equity Trustees, Executors and Agency Company Limited, of 472 Bourke-street, Melbourne, by the 26th day of January, 1974, after which date it will distribute the assets, having regard only to the claims of which it then has notice.

LEACH & THOMSON, solicitors, 472 Bourke-street, Melbourne. 5392

In the Supreme Court of the State of Victoria.

SALE BY THE SHERIFF.

On Friday, the 21st of December, 1973, at 3 p.m., at the Police Station, Maffra (unless process be stayed or satisfied):—

All the estate and interest (if any) of Kurt Paschek, formerly of 49 Landy-street, Maffra, Victoria, but now of 4178 Kevelaer (Rhd) Wettenerstr. 37, in the Federal Republic of Germany (West Germany), carpenter, as proprietor of an estate in fee-simple in the land described in certificate of title, volume 8641, folio 429, upon which is erected a brick dwelling which is not fit for habitation, known as No. 49 Landy-street, Maffra.

Terms: Cash only.

N. GEMMILL, Sheriff's Officer.

14th November, 1973. 5396

In the Supreme Court of the State of Victoria.

SALE BY THE SHERIFF.

On Thursday, the 20th of December, 1973, at 10 a.m., at the Police Station, Frankston (unless process be stayed or satisfied):—

All the estate and interest (if any) of W. J. White, builder, shown in certificate of title as William James White, of 6 Burnett-crescent, Frankston, as joint proprietor with Sidonia Margaret White of an estate in fee-simple in the land described in certificate of title, volume 8332, folio 186, upon which is erected a white weatherboard dwelling with tiled roof, known as No. 6 Burnett-crescent, Frankston.

Registered mortgage No. C.842312 affects the said estate and interest.

Terms: Cash only.

DOUGLAS S. HALL, Sheriff's Officer.

14th November, 1973. 5397

In the Supreme Court of the State of Victoria.
SALE BY THE SHERIFF.

On Thursday, the 20th of December, 1973, at 2 p.m., at the Police Station, Clifton Hill (unless process be stayed or satisfied):—

All the estate and interest (if any) of Franco Lorenzi, gentleman, of 80 The Esplanade, Clifton Hill, as proprietor of an estate in fee-simple in the land described in certificate of title, volume 8210, folio 873, upon which is erected a dwelling-house, known as No. 80 The Esplanade, Clifton Hill.

Registered mortgages No. C.746692 and D.425783 affect the said estate and interest.

Terms: Cash only.

DOUGLAS S. HALL, Sheriff's Officer.

14th November, 1973. 5398

In the Supreme Court of the State of Victoria.
SALE BY THE SHERIFF.

On Thursday, the 20th of December, 1973, at 12 noon, at the Police Station, St. Albans (unless process be stayed or satisfied):—

All the estate and interest (if any) of Stuart Campbell Rowan, driver, and Alma Edith Rowan, married woman, both of 6 Harmon-avenue, St. Albans, as joint proprietors of an estate in fee-simple in the land described in certificate of title, volume 8179, folio 710, upon which is erected a weatherboard dwelling with tiled roof, known as No. 6 Harmon-avenue, St. Albans.

Caveat No. E.350525 affects the said estate and interest.

Terms: Cash only.

DOUGLAS S. HALL, Sheriff's Officer.

14th November, 1973. 5399

In the Supreme Court of the State of Victoria.
SALE BY THE SHERIFF.

On Friday, the 21st of December, 1973, at 10.30 a.m., at the Police Station, Port Melbourne (unless process be stayed or satisfied):—

All the estate and interest (if any) of Paraskevas Sahinis, labourer, and Antonia Sahinis, married woman, both of 35 Albert-street, Port Melbourne, as joint proprietors of an estate in fee-simple in the land described in certificate of title, volume 6653, folio 504, upon which is erected a dwelling, known as No. 35 Albert-street, Port Melbourne.

Registered mortgage No. E.695404 and caveat E.761762 affect the said estate and interest.

Terms: Cash only.

DOUGLAS S. HALL, Sheriff's Officer.

14th November, 1973. 5400

IMPOUNDINGS

BOX HILL.—Impounded in Box Hill Pound, by Ranger from Hawthorn area.

1 small goat with leather strap, no visible brand
 If not claimed and expenses paid, to be sold on 29th November, 1973.

R. KENNEDY,
 Poundkeeper.

5363—\$2.45

STAWELL.—Impounded in Stawell Pound, on 7th November, 1973.

2 lambs, indistinct brands
 If not claimed and expenses paid, to be sold on 23rd November, 1973.

A. N. PICKERING,
 Poundkeeper.

5364—\$2.45

SWAN HILL.—Impounded in Swan Hill Pound, on Wednesday, 31st October, 1973, from Murraydale.

1 polled brindle and white cow, nicks from both ears, no visible brand
 If not claimed and expenses paid, to be sold on 26th November, 1973.

F. G. BLAIR,
 Poundkeeper.

5329—\$2.80

UPWEY.—Impounded in Upwey Pound, found wandering at large in Hayseys-road, Narre Warren East.

1 Guernsey cow, brand marks H with S on side on rump, yellow tag right-hand ear
 If not claimed and expenses paid, to be sold on 28th November, 1973.

H. P. MEANEY,
 Poundkeeper.

5328—\$2.80

No. 110.—10670/73.—4

Subordinate Legislation Act 1962.

NOTICE OF MAKING OF STATUTORY RULES.

In pursuance of the provisions of the *Subordinate Legislation Act 1962* and the Regulations made thereunder, notice is given of the making of the following statutory rules:—

No.	Railways Act 1958.	Price.
321/1973.	By Law (Increased Charges) Amendments Apprenticeship Act 1958.	10c
322/1973.	Apprenticeship (Modular Courses No. 9) (Amendment) Regulations 1973 Metric Conversion Act 1973.	10c
323/1973.	Metric Conversion (Melbourne and Metropolitan Board of Works Act) Regulations 1973 Money Lenders Act 1958.	10c
324/1973.	Money Lenders (Prescribed Interest) Regulations 1973	10c

Copies of these statutory rules may be purchased at the Sale of Publications Section of the Government Printing Office, located at 7A Parliament-place, Melbourne, 3002. If ordered by mail, remittance should be addressed to "The Government Printer, Box 203, P.O., North Melbourne, 3051", and should include 7c extra for postage. If a credit account is held at this office, no remittance is required with the mail order.

The annual subscription rate for Statutory Rules (including Bound Volumes) is \$25, payable in advance. The subscription year commences on 1st January.

C. H. RIXON,
 Government Printer.

STATE ACTS, 1973

Copies of the following Acts of Parliament of Victoria may be obtained at the Government Printing Office, Sale of Publications Branch, off Parliament-place, Melbourne, phone 63 0321, extension 6181, or from any accredited agent, at the price set opposite to each (these prices do not include postage).

The annual subscription for State Acts 1972 et seq. is \$12.50 payable in advance.

Bound Volumes of State Acts are also available on a subscription basis of \$17.50 per annum.

No.		Price.
8385.	The Constitution Act Amendment (Qualifications)	\$0.10
8386.	Hungarian Reformed Church of Australia (Victoria District) Incorporation	\$0.20
8387.	Melbourne Family Care Organization	\$0.10
8388.	Gas and Fuel Corporation (Colonial Gas Holdings Limited)	\$0.10
8389.	Boilers and Pressure Vessels	\$0.10
8390.	State Electricity Commission (Yallourn Council)	\$0.10
8391.	Home Finance (Amendment)	\$0.10
8392.	Zoological Gardens (Amendment)	\$0.10
8393.	Melba Trust Fund	\$0.10
8394.	Hospitals and Charities (Guarantee)	\$0.10
8395.	Water (Amendment)	\$0.15
8396.	Geelong Harbor Trust (Lands)	\$0.10
8397.	Latrobe Valley (Amendment)	\$0.10
8398.	Maryborough Land	\$0.10
8399.	The Constitution Act Amendment (Presiding Officers)	\$0.10
8400.	Constitutional Convention (Alternate Members)	\$0.10
8401.	Ballarat (Sovereign Hill) Land	\$0.15
8402.	Taxation Appeals (Commencement)	\$0.10
8403.	Patriotic Funds (Amendment)	\$0.10
8404.	Abattoir and Meat Inspection	\$0.40
8405.	Valuation of Land (Valuers)	\$0.20
8406.	Egg Industry Stabilization	\$0.40
8407.	Recreation Vehicles	\$0.15
8408.	Motor Car Traders	\$0.50
8409.	Decentralized Industry (Housing)	\$0.15
8410.	Crimes (Amendment)	\$0.10
8411.	Cattle Compensation	\$0.10
8412.	Victorian Inland Meat Authority (Amendment)	\$0.10
8413.	Bendigo Aerodrome	\$0.10
8414.	Ombudsman	\$0.30
8415.	Public Service (Amendment)	\$0.10
8416.	Coal Mines (Pensions Increase)	\$0.10
8417.	Workers Compensation	\$0.10
8418.	Public Records	\$0.20
8419.	Joint Select Committee (Osteopathy, Chiropractic and Naturography)	\$0.10

STATE ACTS, 1973—continued.

No.	Price.
8420. Marketing of Primary Products (Citrus Fruit)	\$0.10
8421. Barley Marketing (Amendment)	\$0.10
8422. Margarine	\$0.10
8423. Metric Conversion	\$0.10
8424. Medical Practitioners (Amendment)	\$0.15
8425. Crimes (Theft)	\$0.30
8426. Social Welfare (Amendment)	\$0.20
8427. Magistrates' Courts (Jurisdiction)	\$0.60
8428. Victorian Development Corporation	\$0.40
8429. Motor Accidents	\$0.80
8430. Motor Car (Amendment)	\$0.15
8431. Teaching Service	\$0.10
8432. Lands Compensation	\$0.15
8433. Police Offences (Publications)	\$0.15
8434. The Constitution Act Amendment (Responsible Ministers)	\$0.10
8435. Supply (July to October)	\$0.10
8436. Supply (Supplementary Estimates)	\$0.10
8437. Joint Select Committee (Meat Industry)	\$0.10
8438. Joint Select Committee (Road Safety)	\$0.10
8439. Joint Select Committee (Osteopathy, Chiropractic and Naturopathy) Amendment	\$0.10
8440. Public Works Committee	\$0.10
8441. The Constitution Act Amendment (Qualifications Joint Select Committee)	\$0.10
8442. Ministry of Consumers Affairs	\$0.10
8443. Ministry for Planning	\$0.10

C. H. RIXON,
Government Printer.

ACTS REPRINTED IN ACCORDANCE WITH THE AMENDMENTS INCORPORATION ACT 1958 (No. 6422), AND FOR SALE AT THE SALE OF PUBLICATIONS BRANCH OF THE GOVERNMENT PRINTING OFFICE, MACARTHUR-STREET, MELBOURNE, 3002.

(These prices do not include postage.)

No.	Price.
6189. Acts Interpretation (Third Reprint—Incorporating amendments up to No. 7944)	\$0.35
6191. Administration and Probate (Fourth Reprint—Incorporating amendments up to No. 7874)	\$0.75
6194. Agricultural Colleges (First Reprint—Incorporating amendments up to No. 7302)	\$0.15
6198. Anzac Day (First Reprint—Incorporating amendments up to No. 8344)	\$0.15
7117. Appeal Costs Fund Act 1964 (First Reprint—Incorporating amendments up to No. 7488)	\$0.25
6199. Apprenticeship (Second Reprint—Incorporating amendments up to No. 7869)	\$0.40
6201. Architects (First Reprint—Incorporating amendments up to No. 8077)	\$0.30
6203. Audit (First Reprint—Incorporating amendments up to No. 7377)	\$0.35
6208. Benefit Associations (First Reprint—Incorporating amendments up to No. 6961)	\$0.45
6529. Bread Industry Act 1959 (First Reprint—Incorporating amendments up to No. 7728)	\$0.30
6973. Building Contracts (Deposits) Act 1962 (First Reprint—Incorporating amendments from No. 7315)	\$0.10
6210. Building Societies (Second Reprint—Incorporating amendments up to No. 7911)	\$0.40
6213. Cancer (First Reprint—Incorporating amendments up to No. 7455)	\$0.35
6214. Carriers and Innkeepers (First Reprint—Incorporating amendments up to No. 7971)	\$0.15
6217. Cemeteries (First Reprint—Incorporating amendments up to No. 7672)	\$0.30
6218. Children's Court (Second Reprint—Incorporating amendments up to No. 8124)	\$0.45
6220. Clean Air (Second Reprint—Incorporating amendments up to No. 8196)	\$0.15
6221. Coal Mines (First Reprint—Incorporating amendments up to No. 7628)	\$1.05
6222. Commercial Goods Vehicles (Second Reprint—Incorporating amendments up to No. 7358)	\$0.22
6223. Commonwealth Arrangements (First Reprint—Incorporating amendments from No. 7809)	\$0.10
6839. Companies Act 1961 (Fourth Reprint—Incorporating amendments up to Act No. 8185)	\$5.75
6224. The Constitution Act Amendment (First Reprint—Incorporating amendments up to No. 8086)	\$3.05
8276. Consumer Protection Act 1972 (First Reprint—Incorporating amendments up to No. 8382)	\$0.65

ACTS REPRINTED IN ACCORDANCE WITH THE AMENDMENTS INCORPORATION ACT 1958 (No. 6422)—continued.

No.	Price.
6225. Co-operation Act (Third Reprint—Incorporating amendments up to No. 8339)	\$0.85
6226. Co-operative Housing Societies (Second Reprint—Incorporating amendments up to No. 7575)	\$0.53
6227. Coroners (First Reprint—Incorporating amendments up to No. 7935)	\$0.35
6228. Country Fire Authority (Second Reprint—Incorporating Amendments up to No. 7476)	\$0.50
6229. Country Roads (Third Reprint—Incorporating amendments up to No. 8140)	\$1.05
6230. County Court (Second Reprint—Incorporating amendments up to No. 8132)	\$0.65
6231. Crimes (Fourth Reprint—Incorporating amendments up to Act No. 8338)	\$2.75
6232. Crown Proceedings (First Reprint—Incorporating amendments up to No. 7900)	\$0.30
6233. Dairy Products (First Reprint—Incorporating amendments up to No. 7945)	\$0.20
7060. Dandenong Valley Authority Act 1963 (First Reprint—Incorporating amendments up to No. 7523)	\$0.35
4989. Discharged Servicemen's Preference Act 1943 (First Reprint—Incorporating amendments up to No. 7788)	\$0.20
6815. Disposal of Uncollected Goods Act 1961 (First Reprint—Incorporating amendments up to No. 7181)	\$0.15
6237. Drainage Areas (First Reprint—Incorporating amendments up to No. 7276)	\$0.35
6238. Drainage of Land (First Reprint—Incorporating amendments up to No. 7876)	\$0.15
6239. Dried Fruits Act 1968 (First Reprint—Incorporating amendments up to No. 7337)	\$0.25
6240. Education (First Reprint—Incorporating amendments up to No. 7533)	\$0.45
6241. Electric Light and Power (First Reprint—Incorporating amendments up to No. 7315)	\$0.30
6242. Employers and Employés (Incorporating amendments up to No. 6740)	\$0.18
6243. Entertainments Tax (First Reprint—Incorporating amendments up to No. 7315)	\$0.25
8056. Environment Protection Act 1970 (First Reprint—Incorporating amendments up to No. 8277)	\$0.55
6245. Estate Agents (Fourth Reprint—Incorporating amendments up to No. 8181)	\$0.85
6246. Evidence (Fourth Reprint—Incorporating amendments up to No. 8228)	\$1.05
7499. Extractive Industries Act 1966 (Second Reprint—Incorporating amendments up to No. 7951)	\$0.40
6250. Fertilizers (Incorporating amendments up to No. 7142)	\$0.25
6468. Filled Milk (First Reprint—Incorporating amendments up to No. 6886)	\$0.15
6251. Firearms (Fourth Reprint—Incorporating amendments up to No. 8288)	\$0.75
6916. Foreign Judgments Act 1962 (First Reprint including amendments made by No. 7332)	\$0.15
6585. Forests (Pulpwood Agreement) (Incorporating amendments up to No. 6886)	\$0.15
6254. Forests (First Reprint—Incorporating amendments up to No. 7356)	\$0.60
6255. Friendly Societies (First Reprint—Incorporating amendments up to No. 7554)	\$0.60
6256. Fruit and Vegetables (First Reprint—Incorporating amendments up to No. 6944)	\$0.30
6258. Game (First Reprint—Incorporating amendments up to No. 7389)	\$0.30
6260. Gas and Fuel Corporation (First Reprint—Incorporating amendments up to No. 7422)	\$0.70
6262. Geelong Harbor Trust (First Reprint—Incorporating amendments up to No. 7547)	\$0.45
6263. Geelong Waterworks and Sewerage (First Reprint—Incorporating amendments up to No. 7547)	\$0.75
8176. Gift Duty Act 1971 (First Reprint—Incorporating amendments from No. 8202)	\$0.55
6265. Goods (Fifth Reprint—Incorporating amendments up to No. 8276)	\$0.45
6266. Grain Elevators (First Reprint—Incorporating amendments up to No. 7486)	\$0.35
7849. Groundwater (First Reprint—Incorporating amendments up to No. 8153)	\$0.45
6269. Hawkers and Pedlers (First Reprint—Incorporating amendments up to No. 7876)	\$0.30
6270. Health (Second Reprint—Incorporating amendments up to No. 7490)	\$1.65

ACTS REPRINTED IN ACCORDANCE WITH THE AMENDMENTS
INCORPORATION ACT 1958 (No. 6422)—continued.

No.	Price.
6267. Hairdressers Registration (First Reprint—Incorporating amendments up to Act No. 7659)	\$0.30
6531. Hire Purchase Act 1959 (Second Reprint—incorporating amendments from Act No. 8232)	\$0.55
6933. Home Finance Act 1962 (First Reprint—Incorporating amendments up to No. 7363)	\$0.25
6274. Hospitals and Charities (Second Reprint—Incorporating amendments up to No. 7455)	\$0.50
6275. Housing (Second Reprint—Incorporating amendments up to No. 8052)	\$1.65
6276. Imprisonment of Fraudulent Debtors (First Reprint—Incorporating amendments up to No. 7876)	\$0.35
6277. Industrial and Provident Societies (First Reprint—Incorporating amendments up to No. 7547)	\$0.35
6279. Instruments (Fourth Reprint—incorporating amendments up to No. 7941)	\$0.75
6280. Judicial Proceedings Reports (First Reprint—Incorporating amendments up to No. 7596)	\$0.15
6282. Justices (Third Reprint—Incorporating amendments up to No. 7966)	\$1.40
6283. Labour and Industry (Fifth Reprint—incorporating amendments up to No. 8211)	\$1.55
6284. Land Act 1959 (Second Reprint—incorporating amendments up to No. 8243)	\$3.15
6534. Land Settlement Act 1959 (First Reprint—Incorporating amendments up to No. 7328)	\$0.30
6288. Land Surveyors (First Reprint—Incorporating amendments up to Act No. 7065)	\$0.30
6289. Land Tax (Second Reprint—Incorporating amendments up to No. 7466)	\$0.40
6285. Landlord and Tenant (Third Reprint—Incorporating amendments up to No. 7332)	\$0.68
6286. Lands Compensation (First Reprint—Incorporating amendments up to No. 7332)	\$0.25
6290. Latrobe Valley (First Reprint—Incorporating amendments up to No. 7332)	\$0.35
6291. Legal Profession Practice Act (Third Reprint—Incorporating amendments up to No. 8259)	\$1.15
6292. Libraries (First Reprint—Incorporating amendments up to No. 7364)	\$0.15
6295. Limitation of Actions (Second Reprint—Incorporating amendments up to No. 7457)	\$0.25
7695. Liquor Control Act 1968 (Second Reprint—Incorporating amendments up to No. 8272)	\$1.35
7145. Litter Act 1964 (First Reprint—Incorporating amendments up to No. 7608)	\$0.15
6298. Local Authorities Superannuation (Second Reprint—Incorporating amendments up to No. 7161)	\$0.40
6299. Local Government. New Parts III. to IX. Section 51 to Section 250—Incorporating amendments up to No. 8291	\$1.70
6299. Local Government. New Parts X. and XI. (being a reprint of portion of No. 7835, as amended by No. 7847)	\$0.50
6301. Margarine (First Reprint—Incorporating amendments up to No. 7714)	\$0.18
6302. Marine (Incorporating amendments up to No. 7350)	\$0.72
6303. Marine Stores and Old Metals (First Reprint—Incorporating amendments up to No. 7876)	\$0.35
6304. Marketing of Primary Products (First Reprint—Incorporating amendments up to No. 7491)	\$0.45
6305. Markets (First Reprint—Incorporating amendments up to No. 7705)	\$0.20
6306. Marriage (First Reprint—Incorporating amendments up to No. 6959)	\$0.25
6307. Masseurs (First Reprint—Incorporating amendments up to No. 7566)	\$0.20
6309. Medical (Second Reprint—Incorporating amendments up to No. 7408)	\$0.40
6310. Melbourne and Metropolitan Board of Works (Third Reprint—Incorporating amendments up to No. 8082)	\$1.85
6311. Melbourne and Metropolitan Tramways (First Reprint—Incorporating amendments up to No. 7622)	\$0.70
6312. Melbourne Harbor Trust (First Reprint—Incorporating amendments up to No. 7356)	\$0.48
6405. Melbourne University (First Reprint—Incorporating amendments up to No. 7871)	\$0.40

ACTS REPRINTED IN ACCORDANCE WITH THE AMENDMENTS
INCORPORATION ACT 1958 (No. 6422)—continued.

No.	Price.
6605. Mental Health (Incorporating amendments up to No. 7135)	\$0.45
6315. Metropolitan Fire Brigades (Second Reprint—incorporating amendments up to No. 8165)	\$0.65
6316. Mildura Irrigation and Water Trusts (First Reprint—Incorporating amendments up to No. 7448)	\$0.75
6317. Milk and Dairy Supervision (Incorporating amendments up to No. 6964)	\$0.40
6318. Milk Board (Incorporating amendments up to No. 7093)	\$0.22
6319. Milk Pasteurization (First Reprint—Incorporating amendments up to No. 7480)	\$0.15
6320. Mines (Second Reprint—Incorporating amendments up to No. 7876)	\$1.25
6184. Monash University (First Reprint—Incorporating amendments up to No. 7533)	\$0.30
6324. Money Lenders (Third Reprint—Incorporating amendments up to No. 8181)	\$0.55
6832. Motor Boating Act 1961 (Second Reprint—Incorporating amendments up to No. 6961)	\$0.30
6325. Motor Car (Fourth Reprint—Incorporating amendments up to No. 8143)	\$2.05
6713. National Fitness Council of Victoria Act 1960 (First Reprint—Incorporating amendments up to No. 8344)	\$0.20
6705. Navigable Waters (Oil Pollution) Act 1960 (First Reprint—Incorporating amendments up to No. 7890)	\$0.30
6328. Nurses (Second Reprint—Incorporating amendments up to No. 7375)	\$0.45
6329. Opticians Registration (First Reprint—Incorporating amendments up to No. 7409)	\$0.30
6330. Partnership (Second Reprint—Incorporating amendments up to No. 7315)	\$0.30
6331. Patriotic Funds (First Reprint—Incorporating amendments up to No. 7338)	\$0.25
6332. Pawnbrokers (First Reprint—Incorporating amendments up to No. 7876)	\$0.35
6257. Pesticides Act 1968 (First Reprint—Incorporating amendments up to No. 7595)	\$0.15
6334. Petroleum (First Reprint—Incorporating amendments up to No. 7876)	\$0.65
6889. Poisons Act 1962 (Second Reprint—Incorporating amendments up to No. 7588)	\$0.50
6337. Police Offences (Second Reprint—Incorporating amendments up to No. 7678)	\$0.28
6338. Police Regulation (Second Reprint—Incorporating amendments up to No. 8179)	\$0.95
6340. Portland Harbor Trust (First Reprint—Incorporating amendments up to No. 7475)	\$0.35
6341. Pounds (First Reprint—Incorporating amendments up to No. 7315)	\$0.25
7498. Port Phillip Authority Act 1966 (First Reprint—Incorporating amendments from No. 8081)	\$0.15
6342. Printers and Newspapers (First Reprint—Incorporating amendments up to No. 7876)	\$0.15
7494. Private Agents Act 1966 (First Reprint—Incorporating amendments in No. 7646)	\$0.35
6890. Probate Duty (Third Reprint—Incorporating amendments up to No. 8072)	\$0.75
6344. Property Law (Third Reprint—Incorporating amendments up to No. 8181)	\$1.95
6345. Public Account (First Reprint—Incorporating amendments up to No. 8012)	\$0.20
6346. Public Authorities Marks (First Reprint—Incorporating amendments from No. 7315)	\$0.10
6349. Public Service (Second Reprint—Incorporating amendments up to No. 7356)	\$0.40
6350. Public Trustee (Incorporating amendments up to No. 6961)	\$0.35
6353. Racing (Third Reprint—Incorporating amendments up to No. 8080)	\$1.45
6355. Railways (First Reprint—Incorporating amendments up to No. 7475)	\$0.75
6564. Registration of Births Deaths and Marriages Act 1959 (First Reprint—Incorporating amendments up to No. 7332)	\$0.25
6358. River Improvement Act (First Reprint—Incorporating amendments up to No. 8342)	\$0.55
2596. River Murray Waters Act 1915 (First Reprint—Incorporating amendments up to No. 7061)	\$0.35
6359. Road Traffic (Third Reprint—Incorporating amendments up to No. 8192)	\$0.35
6360. Rural Finance (First Reprint—Incorporating amendments up to No. 7328)	\$0.15

ACTS REPRINTED IN ACCORDANCE WITH THE AMENDMENTS INCORPORATION ACT 1958 (No. 6422)—*continued*.

No.	Price.
6846. Rural Finance and Settlement Commission Act 1961 (<i>First Reprint</i> —Incorporating amendments up to No. 7332)	\$0.30
6917. Sale of Human Blood Act 1962 (<i>First Reprint</i> —Incorporating amendments from No. 7332)	\$0.10
6975. Sale of Land Act 1962 (<i>Second Reprint</i> —Incorporating amendments up to No. 7898)	\$0.30
6363. Second-hand Dealers (<i>First Reprint</i> —Incorporating amendments up to No. 7529)	\$0.25
7962. Securities Industry Act 1970 (<i>First Reprint</i> —Incorporating amendments made by Act No. 8059)	\$0.65
6367. Settled Land (<i>Second Reprint</i> —Incorporating amendments up to No. 7065)	\$0.50
6368. Sewerage Districts (<i>Second Reprint</i> —Incorporating amendments up to No. 7547)	\$0.75
6369. Shearers Accommodation (<i>First Reprint</i> —Incorporating amendments up to No. 7876)	\$0.35
6809. Sheep Owners Protection Act 1961 (<i>Second Reprint</i> —Incorporating amendments up to No. 8179)	\$0.20
6372. Soil Conservation and Land Utilization (<i>Second Reprint</i> —Incorporating amendments up to No. 8142)	\$0.45
6373. Soldier Settlement (<i>First Reprint</i> —Incorporating amendments up to No. 7328)	\$0.42
6375. Stamps (<i>Fifth Reprint</i> —Incorporating amendments up to No. 8274)	\$2.15
6377. State Electricity Commission (<i>Second Reprint</i> —Incorporating amendments up to No. 7421)	\$0.65
6378. State Relief Committee (<i>First Reprint</i> —Incorporating amendments from No. 6886)	\$0.10
6379. State Savings Bank (<i>Second Reprint</i> —Incorporating amendments up to No. 8082)	\$0.95
6380. Statistics (<i>First Reprint</i> —Incorporating amendments up to No. 6961)	\$0.15
6383. Stock Foods (<i>First Reprint</i> —Incorporating amendments up to No. 7607)	\$0.28
6384. Stock Medicines (<i>First Reprint</i> —Incorporating amendments up to No. 7726)	\$0.20
7551. Strata Titles Act 1967 (<i>Second Reprint</i> —Incorporating amendments up to No. 8149)	\$0.65
6886. Subordinate Legislation (Incorporating amendments up to No. 6961)	\$0.15
7405. Summary Offences Act 1966 (<i>First Reprint</i> —Incorporating amendments up to Act No. 8226)	\$0.55
6386. Superannuation (<i>Second Reprint</i> —Incorporating amendments up to No. 7910)	\$0.75
6387. Supreme Court (<i>First Reprint</i> —Incorporating amendments up to No. 7522)	\$0.75
6388. Survey Co-ordination (<i>First Reprint</i> —Incorporating amendments up to Act No. 8107)	\$0.33
6390. Tattersall Consultations (<i>First Reprint</i> —Incorporating amendments up to No. 8289)	\$0.15
6391. Teaching Service (<i>First Reprint</i> —Incorporating amendments up to No. 7536)	\$0.35
6849. Town and Country Planning Act 1961 (<i>Fourth Reprint</i> —Incorporating amendments up to No. 8380)	\$1.15
6401. Trustee (<i>Third Reprint</i> —Incorporating amendments up to No. 7833)	\$0.95
6402. Trustee Companies (<i>First Reprint</i> —Incorporating amendments up to No. 7858)	\$0.35
7223. Tomato Processing Industry (Uniform Agreement) Act 1964 (<i>First Reprint</i> —Incorporating amendments up to No. 7342)	\$0.15
6397. Trade Unions (<i>First Reprint</i> —Incorporating amendments up to No. 6839)	\$0.20
6399. Transfer of Land Act (<i>Fourth Reprint</i> —Incorporating amendments up to No. 8181)	\$1.15
6400. Transport Regulation (<i>First Reprint</i> —Incorporating amendments up to No. 7358)	\$0.22
6879. Unclaimed Moneys (Incorporating amendments up to No. 6961)	\$0.12

ACTS REPRINTED IN ACCORDANCE WITH THE AMENDMENTS INCORPORATION ACT 1958 (No. 6422)—*continued*.

No.	Price.
7095. Underseas Mineral Resources Act 1963 (<i>First Reprint</i> —Incorporating amendments from No. 7591)	\$0.10
6653. Valuation of Land Act 1960 (<i>Second Reprint</i> —Incorporating amendments up to No. 7333)	\$0.22
6409. Vermin & Noxious Weeds (<i>First Reprint</i> —Incorporating amendments up to No. 7423)	\$0.30
6410. Veterinary Surgeons (<i>First Reprint</i> —Incorporating amendments up to No. 7343)	\$0.35
6411. Victorian Inland Meat Authority (<i>First Reprint</i> —Incorporating amendments up to No. 8000)	\$0.15
7291. Victoria Institute of Colleges Act 1965 (<i>First Reprint</i> —Incorporating amendments up to No. 7644)	\$0.30
6412. Warehousemen's Liens (<i>First Reprint</i> —Incorporating amendments up to No. 7876)	\$0.25
6413. Water (<i>Second Reprint</i> —Incorporating amendments up to No. 7590)	\$0.15
6414. Weights and Measures (<i>Third Reprint</i> —Incorporating amendments up to No. 8068)	\$1.95
6415. Wild Flowers and Native Plants Protection (<i>First Reprint</i> —Incorporating amendments up to No. 6976)	\$1.05
6416. Wills (<i>First Reprint</i> —Incorporating amendments up to No. 7238)	\$0.15
6417. Wire Netting (<i>First Reprint</i> —Incorporating amendments up to No. 7876)	\$0.25
6419. Workers Compensation (<i>Fifth Reprint</i> —Incorporating amendments up to No. 8353)	\$0.45

FIRST NOTIFICATION OF REPRINT.

No.	Price.
8004. Boiler and Pressure Vessels Act 1970 (<i>First Reprint</i> —Incorporating amendments up to No. 8389)	\$0.45

C. H. RIXON,
Government Printer.

CONTENTS

	PAGE
Acts of Parliament on Sale at the Government Printing Office	3793
Appointments	3764
Contracts	3762
Estates of Deceased Persons	3762
Government Notices	3755
Impoundings	3793
Lands	3773
Mining	3762
Notice of Making of Statutory Rules	3793
Orders in Council—	
Acts—Land; Housing; Marketing of Primary Products Country Roads; Local Government; Supreme Court; Landlord and Tenant; Dandenong Valley Authority; Water; Sewerage Districts; Environment Protection; Superannuation; Water; Sewerage Districts.	3766 et seq
Private Advertisements	3780
Proclamations	3753
Public Holidays	3753
Public Service Notices	3776
Resignations	3765
State Rivers and Water Supply Commission	3761
Tenders	3775
Transport Regulation Board—Public Hearings	3756