



VICTORIA
GOVERNMENT GAZETTE

Published by Authority

No. 18]

WEDNESDAY, MARCH 28

[1973

**PUBLICATION OF THE "VICTORIA
GOVERNMENT GAZETTE".**

Easter and Anzac Day Holidays

All State Public Offices will be closed from Friday, the 20th April, 1973 until Wednesday, the 25th April, 1973, inclusive.

Following the publication of the normal weekly Gazette on Wednesday, the 18th April, the next Gazette will not be published until Wednesday, the 2nd May, 1973.

All official matter for publication in the Gazette of Wednesday, the 2nd May, must be lodged with the Gazette Officer, Chief Secretary's Department, not later than 9.30 a.m. on Tuesday, the 1st May, 1973.

**C. H. RIXON,
Government Printer.**

PROCLAMATIONS

Land Act 1958.

AREA OF LAND COMPRISED IN CERTAIN CLASSES DIMINISHED OR INCREASED.

PROCLAMATION

By His Excellency the Governor of the State of Victoria and its Dependencies in the Commonwealth of Australia, &c., &c., &c.

Whereas by the *Land Act 1958* it is amongst other things enacted that the Governor in Council may, by Proclamation to be published in the *Government Gazette*, at any time diminish or increase the area of land comprised in any of the classes mentioned in Part I., Division 1, Section 5, of the said *Land Act 1958*, but that the area of lands which may be sold by auction (Class 6), shall not be increased except as in certain cases in the said Act provided: Now therefore I, the Governor of the State of Victoria, in the Commonwealth of Australia, by and with the advice of the Executive Council of the said State, and in accordance with the provisions of Sections 94 and 117 of the *Land Act 1958* aforesaid, do hereby diminish or increase (as the case may be) the areas of Crown lands comprised in Class 6 of the classes mentioned in Section 5 of the *Land Act 1958* aforesaid, to the extent set forth in the subjoined Schedule (that is to say):—

Schedule referred to.

CLASSES DIMINISHED OR INCREASED.

County.	Parish.	Allotment.	Section.	Area.	Diminished.	Increased.	Description.
					Class.	Class.	
				A. R. P.			
Bogong.	Stanley	4	2	1 0 31	..	6	North of the Township of Stanley.—(H.033493)

Given under my Hand and the Seal of the State of Victoria aforesaid, at Melbourne, this twentieth day of March, in the year of our Lord One thousand nine hundred and seventy-three, and in the twenty-second year of the reign of Her Majesty Queen Elizabeth II.

(L.S.)

ROHAN DELACOMBE.

By His Excellency's Command,
W. BORTHWICK,
Minister of Lands.

GOD SAVE THE QUEEN !

Land Act 1958, Section 25.
ROAD PROCLAIMED.

PROCLAMATION

By His Excellency the Governor of the State of Victoria and its Dependencies in the Commonwealth of Australia, &c., &c., &c.

In pursuance of the provisions of Section 25 (3) (c) of the *Land Act 1958*, I, the Governor of the State of Victoria, by and with the advice of the Executive Council of the said State, do hereby proclaim as a road the land in the Township of Howqua, Parish of Changue, County of Wonnangatta, as indicated by hatching on plan hereunder.—(H.111^(1A)) (H.025358).

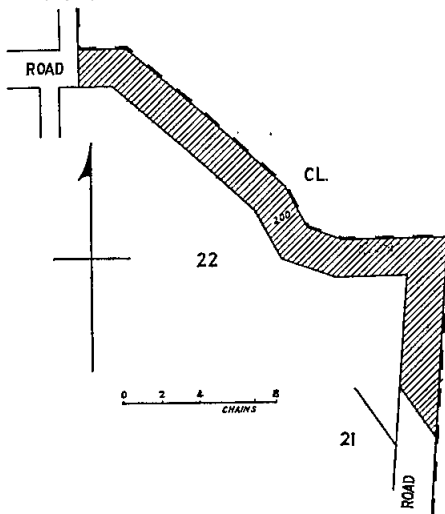

Given under my Hand and the Seal of the State of Victoria aforesaid, at Melbourne, this twentieth day of March, in the year of our Lord One

thousand nine hundred and seventy-three, and in the twenty-second year of the reign of Her Majesty Queen Elizabeth II.

(L.S.)

ROHAN DELACOMBE.

By His Excellency's Command,
W. BORTHWICK,
Minister of Lands.

GOD SAVE THE QUEEN !

PUBLIC SERVICE (APPEALS) ACT 1972, No. 8356.

PROCLAMATION

By His Excellency the Governor of the State of Victoria and its Dependencies in the Commonwealth of Australia, &c., &c., &c.

Whereas by an Act of Parliament of the State of Victoria passed in the twenty-first year of the reign of Her Majesty Queen Elizabeth II, entitled the *Public Service (Appeals) Act 1972, No. 8356*, it is amongst other things enacted that the Act shall come into operation on a day to be fixed by Proclamation of the Governor in Council published in the *Government Gazette*:

Now therefore, I, the Governor of the State of Victoria in the Commonwealth of Australia, by and with the advice of the Executive Council of the said State, do by this my Proclamation fix Wednesday, the twenty-eighth day of March, One thousand nine hundred and seventy-three as the day on which the said *Public Service (Appeals) Act 1972, No. 8356*, shall come into operation.

Given under my Hand and the Seal of the State of Victoria aforesaid, at Melbourne, this twenty-seventh day of March, in the year of our Lord One thousand nine hundred and seventy-three, and in the twenty-second year of the reign of Her Majesty Queen Elizabeth II.

(L.S.)

ROHAN DELACOMBE.

By His Excellency's Command,
R. J. HAMER,
Premier.

GOD SAVE THE QUEEN !

Mental Health Act 1959 (No. 6605).

REVOCATION OF PROCLAMATION OF A RECEIVING HOUSE.

PROCLAMATION

By His Excellency the Governor of the State of Victoria and its Dependencies in the Commonwealth of Australia, &c., &c., &c.

By virtue of the powers conferred by section 24 of the *Mental Health Act 1959 (No. 6605)* and all other powers enabling me in that behalf, I, the Governor of the State of Victoria in the Commonwealth of Australia by and with the advice of the Executive Council of the said State, hereby revoke as from the 28th March, 1973, Proclamation made on the twenty-ninth day of June, 1953, and published in the *Government Gazette* dated the first day of July, 1953, at page 3186, which declared certain land at Preston being part of portion 146 in the Parish of Jika Jika, County of Bourke, to be a Receiving House to be known as the Receiving House, Pleasant View.

Given under my Hand and the Seal of the State of Victoria aforesaid, at Melbourne, this 27th day of March, in the year of our Lord One thousand nine hundred and seventy-three and in the twenty-second year of the reign of Her Majesty Queen Elizabeth II.

(L.S.) ROHAN DELACOMBE.

By His Excellency's Command,
J. F. ROSSITER,
Minister of Health.

GOD SAVE THE QUEEN!

VETERINARY RESEARCH INSTITUTE ACT 1972.

PROCLAMATION FIXING SUNDAY THE 1ST APRIL, 1973 AS THE DAY ON WHICH THE CONTROL OF THE VETERINARY RESEARCH INSTITUTE SHALL BE TRANSFERRED TO THE MINISTER OF AGRICULTURE.

By His Excellency the Governor of the State of Victoria and its Dependencies in the Commonwealth of Australia, &c., &c., &c.

Whereas by section 2 of the *Veterinary Research Institute Act 1972*, it is amongst other things enacted that on a day to be fixed by Proclamation of the Governor in Council published in the *Government Gazette* the control of the Veterinary Research Institute in the University of Melbourne shall be transferred to the control of the Minister of Agriculture.

Now therefore I, the Governor of the State of Victoria, in the Commonwealth of Australia, by and with the advice of the Executive Council of the said State, do by this my Proclamation fix Sunday the first day of April, One thousand nine hundred and seventy-three as the day on and from which the control of the Veterinary Research Institute in the University of Melbourne shall be transferred to the control of the Minister of Agriculture.

Given under my Hand and the Seal of the State of Victoria aforesaid, at Melbourne, this twenty-seventh day of March, in the year of our Lord One thousand nine hundred and seventy-three, and in the twenty-second year of the reign of Her Majesty Queen Elizabeth II.

(L.S.) ROHAN DELACOMBE.

By His Excellency's Command,
G. L. CHANDLER,
Minister of Agriculture.

GOD SAVE THE QUEEN!

Vermin and Noxious Weeds Act.

SIMULTANEOUS DESTRUCTION OF NOXIOUS WEEDS.

PROCLAMATION

By His Excellency the Governor of the State of Victoria and its Dependencies in the Commonwealth of Australia, &c., &c., &c.

Whereas by Section 14, of the *Vermin and Noxious Weeds Act 1958, No. 6409*, it is enacted that the Governor in Council may from time to time by Proclamation specify a day being a day not less than thirty days after the publication of such proclamation from and after which any noxious weed specified in such proclamation shall be simultaneously destroyed by every owner and occupier of any land in Victoria or in any part of Victoria described in the proclamation:

Now therefore, I, the Governor of the State of Victoria, in the Commonwealth of Australia, by and with the advice of the Executive Council of the said State, do hereby specify the Thirtieth Day of April, One thousand nine hundred and seventy-three as the day from and after which the noxious weeds, *Echium lycopsis L. Syn. (E. plantagineum L.)* and *Echium vulgare L.*—Paterson's Curse or Purple Bugloss—shall be simultaneously destroyed by every owner and occupier of any land in the whole of Victoria excepting those parts of the State described in the schedule hereunder.

SCHEDULE.

The Parishes of Boroondara, Bulleen, Cut-paw-paw, Dandenong, Jika Jika, Melbourne North, Melbourne South, Moorabbin, Mordialloc, Mulgrave, Nunawading, Prahran, that part of the Parish of Doutta Galla within the municipal boundaries of the City of Essendon, that part of the Parish of Doutta Galla within the municipal boundaries of the City of Melbourne, that part of the Parish of Lyndhurst within the municipal boundaries of the City of Chelsea, and that part of the Parish of Keelbundoora situated south of Crown Allotments 8, 9, 10, 11, 12 and Mont Park Mental Hospital Reserve.

Given under my Hand and the Seal of the State of Victoria aforesaid, at Melbourne, this twenty-seventh day of March, in the year of our Lord One thousand nine hundred and seventy-three and in the twenty-second year of the reign of Her Majesty Queen Elizabeth II.

(L.S.) ROHAN DELACOMBE.

By His Excellency's Command,
W. BORTHWICK,
Minister of Lands.

GOD SAVE THE QUEEN!

Vermin and Noxious Weeds Act.

SIMULTANEOUS DESTRUCTION OF NOXIOUS WEEDS.

PROCLAMATION

By His Excellency the Governor of the State of Victoria and its Dependencies in the Commonwealth of Australia, &c., &c., &c.

In pursuance of the provisions of Section 14 of the *Vermin and Noxious Weeds Act 1958, I*, the Governor of the State of Victoria, in the Commonwealth of Australia, do by this my Proclamation specify the seventh day of May, One thousand nine hundred and seventy-three, as the day from and after which the noxious weed, *Senecio jacobaea L.*—Ragwort—shall be simultaneously destroyed by every owner and occupier of any land in the whole of Victoria excepting those parts of the State described in the schedule hereunder.

SCHEDULE.

The Parishes of Boroondara, Bulleen, Cut-paw-paw, Dandenong, Jika Jika, Melbourne North, Melbourne South, Moorabbin, Mordialloc, Mulgrave, Nunawading, Prahran, that part of the Parish of Doutta Galla within the municipal boundaries of the City of Essendon, that part of the Parish of Doutta Galla within the municipal boundaries of the City of Melbourne, that part of the Parish of Lyndhurst within the municipal boundaries of the City of Chelsea, and that part of the Parish of Keelbundoora situated south of Crown Allotments 8, 9, 10, 11, 12 and Mont Park Mental Hospital Reserve.

Given under my Hand and the Seal of the State of Victoria aforesaid, at Melbourne, this twenty-seventh day of March, in the year of our Lord One thousand nine hundred and seventy-three and in the twenty-second year of the reign of Her Majesty Queen Elizabeth II.

(L.S.) ROHAN DELACOMBE.

By His Excellency's Command,
W. BORTHWICK,
Minister of Lands.

GOD SAVE THE QUEEN!

HOUSING MINISTRY ACT 1972 (No. 8339).

DATE OF COMING INTO OPERATION.

PROCLAMATION

By His Excellency the Governor of the State of Victoria and its Dependencies in the Commonwealth of Australia, &c., &c., &c.

Whereas by an Act of Parliament of the State of Victoria passed in the twenty-first year of the reign of Her Majesty Queen Elizabeth II. intituled the *Housing Ministry Act 1972*

(No. 8339) it is among other things enacted that the said Act shall come into operation on a day to be fixed by Proclamation of the Governor in Council published in the *Government Gazette*:

Now therefore, I, the Governor of the State of Victoria acting by and with the advice of the Executive Council of the said State, do by this my Proclamation fix the second day of April, 1973, as the day upon which the provisions of the said Act No. 8339 shall come into operation.

Given under my Hand and the Seal of the State of Victoria aforesaid, at Melbourne, this twenty-seventh day of March, in the year of our Lord One thousand nine hundred and seventy-three and in the twenty-second year of the reign of Her Majesty Queen Elizabeth II.

(L.S.) ROHAN DELACOMBE.

By His Excellency's Command,
VANCE DICKIE,
Minister of Housing.

GOD SAVE THE QUEEN!

Public Service Act 1958.
QUEEN'S BIRTHDAY HOLIDAY 1974.

PROCLAMATION

By His Excellency the Governor of the State of Victoria and its Dependencies in the Commonwealth of Australia, &c., &c., &c.

In pursuance of the powers conferred by sub-section (1) of Section 67 of the *Public Service Act 1958*, I, the Governor of the State of Victoria, in the Commonwealth of Australia, by and with the advice of the Executive Council of the said State, do by this my Proclamation appoint—

Monday, the 17th June, 1974

as the day upon which the Anniversary of the birthday of Her Majesty for the year 1974, shall be observed as a holiday in the public offices throughout the State of Victoria.

Given under my hand and the Seal of the State of Victoria aforesaid, at Melbourne, this twenty-seventh day of March, in the year of our Lord One thousand nine hundred and seventy-three and in the twenty-second year of the reign of Her Majesty Queen Elizabeth II.

(L.S.) ROHAN DELACOMBE.

By His Excellency's Command,
E. R. MEAGHER,
Chief Secretary.

GOD SAVE THE QUEEN!

BANK HOLIDAY.

PROCLAMATION

By His Excellency the Governor of the State of Victoria and its Dependencies in the Commonwealth of Australia, &c., &c., &c.

In pursuance of the provisions of the *Bank Holidays Act 1958*, I, the Governor of the State of Victoria, in the Commonwealth of Australia, do by this my Proclamation appoint the day and date named hereunder a special day to be observed as a Bank Holiday, at the places mentioned that is to say:—

Bank Holiday:—

Monday, the 4th June, 1973 throughout the State of Victoria.

Given under my Hand and the Seal of the State of Victoria aforesaid, at Melbourne, this twenty-seventh day of March, in the year of our Lord One thousand nine hundred and seventy-three and in the twenty-second year of the reign of Her Majesty Queen Elizabeth II.

(L.S.) ROHAN DELACOMBE.

By His Excellency's Command,
E. R. MEAGHER,
Chief Secretary.

GOD SAVE THE QUEEN!

BANK HALF-HOLIDAY.

PROCLAMATION

By His Excellency the Governor of the State of Victoria and its Dependencies in the Commonwealth of Australia, &c., &c., &c.

In pursuance of the provisions of the *Bank Holidays Act 1958*, I, the Governor of the State of Victoria, in the Commonwealth of Australia, do by this my Proclamation appoint the day and date named hereunder a special day to be observed as a Bank Half-Holiday at the place mentioned, that is to say:—

Bank Half-Holiday from the Hour of Eleven o'clock:—

WEDNESDAY, 28TH MARCH, 1973, at Moe.

Given under my Hand and the Seal of the State of Victoria aforesaid, at Melbourne, this twenty-seventh day of March, in the year of our Lord One thousand nine hundred and seventy-three, and in the twenty-second year of the reign of Her Majesty Queen Elizabeth II.

(L.S.) ROHAN DELACOMBE.

By His Excellency's Command,
E. R. MEAGHER,
Chief Secretary.

GOD SAVE THE QUEEN!

GOVERNMENT NOTICES

EASTER AND ANZAC DAY HOLIDAYS.

It is hereby notified that on—

FRIDAY, THE 20TH,
SATURDAY, THE 21ST,
MONDAY, THE 23RD,
TUESDAY, THE 24TH, AND
WEDNESDAY, THE 25TH APRIL, 1973

the Public Offices will be closed, such days being appointed by the *Public Service Act 1958* to be observed as holidays in the Public Offices throughout Victoria.

This notice relates only to the closing of the State Public Offices. All inquiries regarding holidays in other offices and in shops and industry should be directed to the Department of Labour and Industry, 110 Exhibition-street, Melbourne, 3000. (Telephone 63 0321, Extensions 6158, 6859 or 6924.)

E. R. MEAGHER,
Chief Secretary.

Chief Secretary's Office,
Melbourne, 3002, 23rd March, 1973.

LOCAL GOVERNMENT DEPARTMENT.

ORDER CONFIRMED.—CITY OF MELBOURNE.

The Minister of the Crown administering the *Local Government Act 1958*, on the 23rd day of March, 1973, confirmed the Order hereinafter referred to in pursuance of the provisions of section 514 of the said Act namely:

An Order of the Council of the City of Melbourne made on the 15th March, 1972, directing the compulsory taking of the land described in certificate of title, volume 6154, folio 781, in order to provide a 66-ft. wide parking module between Elizabeth-street and Berkeley-street for ultimate multi-storey development.

A. J. HUNT,
Minister for Local Government.

Local Government Department,
Melbourne (247.131.9).

LOCAL GOVERNMENT DEPARTMENT.

ORDER CONFIRMED.—SHIRE OF BANNOCKBURN.

The Minister of the Crown administering the *Local Government Act 1958*, on the 23rd day of March, 1973, confirmed the Order hereinafter referred to in pursuance of section 514 of the said Act namely:

An Order of the Council of the Shire of Bannockburn made on the 8th February, 1973, directing the compulsory taking of the land described in Crown grant volume 2882, folio 357, for the provision of a place of public resort and recreation.

A. J. HUNT,
Minister for Local Government.

Local Government Department,
Melbourne (166.131.1).

Transport Regulation Act.
TRANSPORT REGULATION BOARD.

HEARING OF APPLICATIONS.

Notice is hereby given that the following applications will be considered by the Transport Regulation Board at its offices at the corner of Lygon and Princes streets, Carlton, at 10.15 a.m., on Wednesday, 18th April, 1973.

KASTORIA BUS LINES PTY. LTD., 3 Louis-street, Airport West. Application for variation of Route 475 (Moonee Ponds—East Keilor) to delete service between the corners of Milleara-road and Buckley-street and Milleara-road and The Crossway, and instead to operate via Buckley-street to The Crossway, Milleara-road and normal route.

VENTURA MOTORS PTY. LTD., 1037 Centre-road, South Oakleigh. One commercial passenger vehicle with large seating capacity to operate as a metropolitan stage omnibus on a new route as follows:—

Glen Waverley—Ringwood.

Commencing at Glen Waverley Railway Station via Springvale and Glen roads, The Outlook, Townsend-street, Gallaghers, High street and Westlands roads, Capital-avenue, Camelot-drive, Highbury-road, Weedendrive, Burwood Highway, Morack, Boronia, Centre and Heatherdale roads and Maroondah Highway to Ringwood Railway Station.

Sections fares and time-table to be determined.

Application by each of the following for a commercial passenger vehicle with seating capacity for five (5) persons to operate as a Suburban Taxi-Cab from an approved depot in Zone "T".

HARRIS, H. C., 7/17 Tiuna-grove, Elwood.
JONES, A. W. J., 35 Estelle-street, East Oakleigh.
KANTERS, J. P., 46 Elder-street, Blackburn.
O'RILEY, K. W., 24 Ashton-road, Ferntree Gully.
PENDERGAST, R. N., 13 Campbell-street, Ringwood.

Applications for renewal of licences as shown, by persons listed hereunder to operate under the same terms and conditions.

BORDONARO, P., 10 Chatham-street, Flemington; M.T.1981.
BRIAN, H. F., 14 Brown-street, Hamilton; C.T.418.
CAIRNS, D. A. E., Barker-street, Flinders; T.S.367.
CAPODANNO, L., 15 Talbot-street, Hampton; M.T.1931.
CASALE, V., 9 Bordeaux-street, East Doncaster; M.T.1770.

CASTLEMAINE BUS LINES PTY. LTD., Forest-street, Castlemaine; C.O.9; C.O.392; C.O.566; C.O.931; C.O.1080; T.S.1066; T.S.1068; T.S.1069; T.S.1070; T.S.1071; T.S.1072.

CHRISTENSEN, L. G., 32 Ellenvale-avenue, Pascoe Vale; M.T.2181.

CHRISTOPOULOS, G., 27 Dale-street, Bulleen; M.T.1945.
COBURG TAXIS PTY. LTD., 24 Cope-street, Coburg; M.T.2350.
CONWAY, J., 1 Brennan-street, Bentleigh; M.T.1982.

DACEY, K., 5 Nash-street, Northcote; M.T.2172.
DEDIC, C., 189 Kerferd-road, Albert Park; M.T.4592.
DE VALLE, E., 165 Richardson-street, North Carlton; M.T.1483.

DIXON, R. M., M. R. & M. G., Swann-street, Brim; T.S.408.
ELLIS, A. J. & F. M., 5 Appin-street, Wangaratta; C.T.400.
ENGLISH, F. F. & A. L., 3 Toledo-court, Wodonga; C.T.586.

EVANGELOU, A., 8 Frederick-street, Doncaster; M.T.1590.
FLEMING, J. W., 13 Harold-avenue, Glen Iris; M.T.4629.
FOX, J. P., 22 Hoddle-street, Warrnambool; C.T.463; C.T.542.

FRANET, P. J., 3/12 Gellibrand-street, South Kew; M.T.4513.
FRAZER, D. W. & S. M., 34 North-crescent, Somers; M.T.2348.

GIANNARIS, P., 27 Northcote-road, Armadale; M.T.4587.

GRAY, R. J., 305 Dowling-street, Ballarat; U.T.177.
HARVEY, J. E. (estate of the late), 21/350 Beaconsfield-parade, St. Kilda; M.T.2343.

HEATHCOTE, W. C., P.O. Box 163, Mansfield; C.O.262; C.O.264; C.O.266; C.O.267; C.O.268; C.O.302; C.O.321; C.O.327; C.O.1014; C.O.1015; C.O.1016.

HICKEY, J., 38 Vincent-street, Glen Iris; M.T.2353.

HOLE, W. H., P.O. Box 27, Balmoral; T.S.70.

HOWSON, E. M., 382 Napier-street, Fitzroy; M.T.1160.

IRELAND, J., 86 Argyll-street, Chadstone; M.T.1658.

IVKOVIC, B., Murray Valley Highway, Bonegilla; C.H.57.

JONES, F. E., Unit 4, 46 Brampton-street, Cheltenham; M.T.5574.

KEMPTON, E. J., 3 Hurd-street, Portland; T.S.572.

KOTSIIVOS, D., 60 Tudor-street, South Oakleigh; M.T.4245.

LITTLES GIPPSLAND COACHES PTY. LTD., corner Raglan and Patten streets, Sale; C.O.70; C.O.81; C.O.433; C.O.664; C.O.717; C.O.740; C.O.749; C.O.1033.

LITTLE, R. R., 124 Bastings-street, Northcote; M.T.2173.

LOCKWOOD, R. K. & G. J., 6 Honour-avenue, Werribee; C.T.452.

LUCAS, J. E., 1/108 George-street, East Melbourne; M.T.2341.

MACKIE, G. A., 8 Thompsons-court, Werribee; C.T.205.

MARLAND, F. J., PTY. LTD., 132 Chetwynd-street, North Melbourne; M.T.2346.

MEE'S BUS LINES PTY. LTD., 1 Percy-street, West Heidelberg; T.S.854.

MIHALAKOS, P., 357 Barkley-street, Brunswick; M.T.4185.

MIRABELLI, G., 27 Canning-street, Carlton; M.T.4213.

MUNRO TAXI SERVICE, 49 Harding-street, Coburg; M.T.2347.

MCMILLAN, R. J. & L. R., 58 McAdam-street, Maffra; C.T.593.

NISTOR, D., 82 Wattletree-road, Armadale; M.T.1844.

O'LEARY, D., 48 Talbot-street, Colac; C.T.365.

PHILLIPS, R., 38 Purnell-street, P.O. Box 49, Altona; M.T.2594.

PIAZZA, M., 1 Raeburn-street, Pascoe Vale; M.T.1564.

PITTOCK, F. J. J., 42 Gipps-street, East Melbourne; M.T.2166.

PLOWMAN, G. E. & E. N., 9 Market-street, Kyneton; C.T.152; C.T.159; C.T.442; C.T.381.

POSANTZIS, C., 62 Leichardt-street, Echuca; C.T.244.

PRODROMOU, T., 231 Bell-street, Coburg; M.T.1902.

R.J.R. TAXIS PTY. LTD., 12 Kent-avenue, Elwood; M.T.876.

ROZENBES, U. Z., 2/35 Westbury-street, East St. Kilda; M.T.2902.

RUTJENS, H., 23 Flora-grove, East Ivanhoe; M.T.1569.

SCHMIDT, A., 4 Glencoe-street, Caulfield; M.T.1780.

SELLARS, M., 49 Venice-avenue, Mitcham; M.T.1638.

STANSFIELD, H., 12 Menzies-street, Warrnambool; C.T.639.

THOMAS, V. H., 70 Alma-street, Maryborough; C.O.875; C.O.875.

TOWNSEND, W. P., 49 Hovell-street, Echuca; C.T.429.

TUCKERMAN, B. J., 151 Bell-street, Coburg; M.T.4134.

TYQUIN, B. T., 11 Doolan-street, Werribee; C.T.453; C.T.754.

UTTING, T. E., 16 Outlook-drive, Eaglemont; M.T.2340.

VILLANI, L., 204 Darebin-street, Northcote; M.T.2175.

WALTON, T. R., 51 Vears-road, Burwood; M.T.2185.

WILSON, T. & D., Findlay's-road, Bass; T.S.175.

WOODMAN, W. H., 101 Cole-street, Gardenvale; M.T.4221.

ZAGEL, I., Unit 6, 66 Kooyong-road, North Caulfield; M.T.4201.

Notice of any objection should be forwarded to reach the Secretary of the Board not later than 11th April, 1973.

Applicants are advised that it will not be necessary to appear on the hearing date specified, unless advised in writing by the Board.

A. V. C. COOK,

Secretary.

Corner Lygon and Princes streets, Carlton, 3053,
Wednesday, 28th March, 1973.

Commercial Goods Vehicles Act.
TRANSPORT REGULATION BOARD.

HEARING OF APPLICATIONS.

Notice is hereby given that the following applications will be considered by the Transport Regulation Board at its offices at the corner of Lygon and Princes streets, Carlton, at 10 a.m. on Wednesday, 18th April, 1973.

BONNEY'S PEST CONTROL PTY. LTD., 77 Lime-avenue, Mildura, 3500. Application to vary the conditions of licence No. D.A.62774/2 (L/C. 14 cwt.) by deleting "but excluding any operations to or from places within a 25-mile radius of the post office at the corner of Bourke and Elizabeth streets, Melbourne" from the existing conditions and adding in lieu "excluding the carriage of materials from places within a 25-mile radius of the G.P.O., Melbourne."

BOUTON, F. C., 52 Strathallan-road, Macleod, 3085. One commercial goods vehicle (L/C. 130 cwt.) to operate within a 70-mile radius of the premises of Clifton Brick Holdings Ltd. at Brunswick on behalf of the said Company—bricks.

COATES, I. G., 3 Bourke-street, Warragul, 3820. One commercial goods vehicle (L/C. 75 cwt.) to operate within a 30-mile radius of the post office situated at Warragul in course of business as "Post Supplier"—treated and untreated posts, droppers and stays.

COHNS INDUSTRIES PTY. LTD., 9 Wills-street, Swan Hill, 3585. One commercial goods vehicle (L/C. 20 cwt.) to operate: (a) in the course of business as "Soft Drink, Cordial, Sauce and Food Manufacturers" being an approved decentralized secondary industry with factories situated in Bendigo, Swan Hill and Wangaratta for the carriage of goods as follows:—(i) From points within the State of Victoria (but excluding the Gippsland area) to the said approved decentralized secondary industry factories at Bendigo, Swan Hill and Wangaratta—raw materials and goods associated with or required solely for use in the manufacturing or processing of such approved decentralized secondary industry, but provided that the majority

of raw sugar for use in the aforesaid industry at the said factories in each case shall be forwarded to the railway station nearest thereto, namely the railway stations at Bendigo, Swan Hill or Wangaratta as the case may be. (ii) From the premises of the aforesaid factories at Bendigo, Swan Hill and Wangaratta to points within the State of Victoria (but excluding the Gippsland area)—manufactured and/or processed products of such approved decentralized secondary industries. (b) In the course of business as "Soft Drink, Cordial, Sauce and Food Suppliers" in those parts of the State of Victoria and—(i) Bounded on the west by a line extending from the Township of Gunbower and the River Murray through the Township of Wycheproof and Rupanyup, the City of Horsham and the townships of Natimuk, Edenhope, and Apsley to the South Australian border and thence along the South Australian border to the sea coasts; and on the east by a line extending from the sea coast at the Township of Queenscliff, through the townships of Werribee, Melton, Gisborne, Kalkallo, Whittlesea, Lilydale, Warburton, Woods Point, Mansfield, Bonnie Doon, Merton, Numurkah and Nathalia to the River Murray and the New South Wales Border, or (ii) Bounded by and including the townships of Gunbower, Wycheproof and Rupanyup, the City of Horsham and the townships of Natimuk and Edenhope and thence via the main Naracoorte-road to the Victorian/South Australian border and thence via the Victoria/South Australian border to the River Murray or (iii) Bounded on the north by the River Murray and bounded on the south by a line drawn from Khancoban (N.S.W.) through Hotham Heights, Kevington, Merton, Locksley, Undera, Barham and Tocumwal (N.S.W.)—soft drinks, cordials, sauce and food lines not being manufactured products of the approved decentralized industries as specified in paragraph (a) above, together with empty return containers provided that goods shall not be carried on the vehicle from a place in one area as defined in paragraph (b) (i) or (b) (ii) or (b) (iii) to a place within another area, or for transfer and/or transshipment to any other vehicle for carriage of goods from places in one area to places within another area or to a destination outside the areas defined. (iv) All agency lines carried on the vehicle pursuant to paragraph (b) shall have been initially consigned by rail to either Swan Hill or Wangaratta, or Bendigo. (c) In the course of business as "Wine, Spirit and Intoxicating Liquor Suppliers" within a 50-mile radius of the chief post office in the City of Bendigo and from and to Bendigo and to and from the townships, towns or cities (as the case may be) of Kyabram, Tatura, Shepparton, Murchison, Nagambie, Mangalore, Broadford, Seymour, Yea, Alexandra, Narbethong, Flowerdale, Kilmore, Gisborne, St. Arnaud, Donald, Charlton and Boort—wines, spirits and intoxicating liquors (but excluding the carriage of any beer whatsoever outside a 50-mile radius of the chief post office in the City of Bendigo and subject to the condition that all wines, spirits and intoxicating liquors carried on the vehicle shall have been initially consigned by rail to Bendigo.

COHNS (SWAN HILL) PTY. LTD., 9 Wills-street, Swan Hill, 3585. One commercial goods vehicle (L/C. 248 cwt.) to operate: (a) In the course of business as "Soft Drink, Cordial, Sauce and Food Manufacturers" being an approved decentralized secondary industry with factories situated in Bendigo, Swan Hill and Wangaratta for the carriage of goods as follows:—(i) From points within the State of Victoria (but excluding the Gippsland area) to the said approved decentralized secondary industry factories at Bendigo, Swan Hill and Wangaratta—raw materials and goods associated with or required solely for use in the manufacturing or processing of such approved decentralized secondary industry, but provided that the majority of raw sugar for use in the aforesaid industry at the said factories in each case shall be forwarded to the railway station nearest thereto, namely the railway stations at Bendigo, Swan Hill or Wangaratta, as the case may be. (ii) From the premises of the aforesaid factories at Bendigo, Swan Hill and Wangaratta to points within the State of Victoria (but excluding the Gippsland area)—manufactured and/or processed products of such approved decentralized secondary industries. (b) In the course of business as "Soft Drink, Cordial, Sauce and Food Suppliers" in those parts of the State of Victoria and—(i) Bounded on the west by a line extending from the Township of Gunbower and the River Murray through the townships of Wycheproof and Rupanyup, the City of Horsham and the townships of Natimuk, Edenhope, and Apsley to the South Australian border

and thence along the South Australian border to the sea coasts; and on the east by a line extending from the sea coast at the Township of Queenscliff, through the Townships of Werribee, Melton, Gisborne, Kalkallo, Whittlesea, Lilydale, Warburton, Woods Point, Mansfield, Bonnie Doon, Merton, Numurkah and Nathalia to the River Murray and the New South Wales Border, or (ii) Bounded by and including the Townships of Gunbower, Wycheproof and Rupanyup, the City of Horsham and the Townships of Natimuk and Edenhope and thence via the main Naracoorte-road to the Victorian/South Australian border and thence via the Victoria/South Australian border to the River Murray, or (iii) Bounded on the north by the River Murray and bounded on the south by a line drawn from Khancoban (N.S.W.) through Hotham Heights, Kevington, Merton, Locksley, Undera, Barham and Tocumwal (N.S.W.)—soft drinks, cordials, sauce and food lines not being manufactured products of the approved decentralized industries as specified in paragraph (a) above, together with empty return containers provided that goods shall not be carried on the vehicle, from a place in one area as defined in paragraph (b) (i) or (b) (ii) or (b) (iii) to a place within another area, or for transfer and/or transshipment to any other vehicle for carriage of goods from places in one area to places within another area or to a destination outside the areas defined. (iv) All agency lines carried on the vehicle pursuant to paragraph (b) shall have been initially consigned by rail to either Swan Hill or Wangaratta or Bendigo. (c) In the course of business as "Wine, Spirit and Intoxicating Liquor Suppliers" within a 50-mile radius of the chief post office in the City of Bendigo and from and to Bendigo and to and from the townships, towns or cities (as the case may be) of Kyabram, Tatura, Shepparton, Murchison, Nagambie, Mangalore, Broadford, Seymour, Yea, Alexandra, Narbethong, Flowerdale, Kilmore, Gisborne, St. Arnaud, Donald, Charlton and Boort—wines, spirits and intoxicating liquors (but excluding the carriage of any beer whatsoever outside a 50-mile radius of the chief post office in the City of Bendigo and subject to the condition that all wines, spirits and intoxicating liquors carried on the vehicle shall have been initially consigned by rail to Bendigo.

DAWSON, CHAS., & SON PTY. LTD., 22 Wilson-street, Horsham, 3400. One commercial goods vehicle (L/C. 12 cwt.) to operate within a 50-mile radius of own premises at Horsham and to and from Beulah and Edenhope in course of business as "Plumber and Hot Water Engineer"—tools of trade, equipment and materials incidental to own contracts with proviso that all new materials be initially consigned by rail to Horsham.

DEIPENAU, H. E., PTY. LTD., 73 Victoria-street, East Brunswick, 3057. Application to vary the conditions of licence No. D.A.17846/2 (L/C. 298 cwt.) by adding an additional paragraph (b)—"(b) From the railway siding at North Melbourne to consignees within a 25-mile radius of the post office situated at the corner of Bourke and Elizabeth streets in the City of Melbourne in a specially constructed tanker—bulk cement.

DURAL LEEDS LTD., 504 Calder Highway, East Keilor, 3042. Two commercial goods vehicles (L/C. 10, and 14 cwt.) to operate throughout the State of Victoria in course of business as "Blind and Awning Manufacturers" for the purpose of sales promotion, repairing and measuring contracts—samples, display materials, tools of trade, blinds and awnings for repair, having been repaired and for specialized installation and materials incidental thereto.

EDWARDS CROMPTON PTY. LTD., Hamilton-street, Horsham, 3400. Application to vary the conditions of licence No. D.A.48136/2 (L/C. 62 cwt.) by deleting "own branch premises at Hamilton" from paragraph (a) of the existing conditions and adding in lieu "own branch premises at Horsham".

EDWARDS, G. N. (trading as Edwards Freighters), 1066 Bardia-street, Albury, 2640. One commercial goods vehicle (L/C. 80 cwt.) to operate along the route between Albury (N.S.W.) and/or Wodonga and the Township of Corryong via Tallangatta and places en route—"Sun" and "Age" and "Border Morning Mail" newspapers under contract to the proprietors of the newspapers concerned.

This application replaces licence No. T.D.A.16239/1 previously held by the applicant.

FOCHT, M., 35 Dennis-avenue, East Keilor, 3033. Application to vary the conditions of licence No. D.A.60155 (L/C. 155 cwt.) by deleting paragraph (a) of the existing conditions and adding in lieu—" (a) Within

- a 25-mile radius of own premises at East Keilor—general goods, provided that no goods shall be carried whether by one stage or by more than one stage between places within the above radius which are more than thirty (30) road miles apart by the nearest practicable route.”
- DINGLEY, F. W.** (trading as Geelong & District Windscreen Service), 41-47 Spring-street, Geelong West, 3218. One commercial goods vehicle (L/C. 6 cwt.) to operate: (a) Within a 50-mile radius of own premises in the City of Geelong West in the course of business as “Suppliers of Automotive Windcreens”—own goods. (b) From and to own premises in the City of Geelong West to and from the premises of Windscreen Supplies at Lilydale and the premises of Automotive Surplus Pty. Ltd. at Mitcham—own automotive windcreens. (c) From own premises in the City of Geelong West to the Township of Stoneyford serving places *en route* via the Princes Highway—own automotive windcreens solely for on site installation at clients premises where emergency breakages occur.
- GILBARCO AUST. LTD.**, 11 Anderson-road, Thornbury, 3071. Six commercial goods vehicles (L/C. 13, 13, 14, 13, 13 and 14 cwt.) to operate throughout the State of Victoria in the course of business as “Manufacturers of Petrol and Oil Pumping Equipment, Heating Equipment and Water Engineering Equipment—tools of trade, pumping equipment and materials incidental to the installation, servicing and maintenance of such equipment.
- GOLDING, S. W.**, Heriott-street, Buninyong, 3357. One commercial goods vehicle (L/C. approximately 140 cwt.) to operate within a 70-mile radius of the chief post office in the City of Ballarat—bricks, glazed bricks and glazed earthenware pipes and fittings on behalf of Vitclay Pipes Pty. Ltd.
- HALLAM, W. G., L. J. & R. C.** (trading as W. G. Hallam & Sons), 48 Lafayette-street, Traralgon, 3844; One commercial goods vehicle (L/C. approx. 400 cwt.) to operate: (a) Within that part of the State of Victoria situated east of a north/south line drawn through the City of Dandenong between own depot and own contract site in the course of own business as “Land Clearing and Dam Sinking Contractor”—own agricultural and earth-moving machinery, tools of trade, and up to 3 x 44 gallon drums of fuel and spare parts subject to the condition that all spare parts are initially received on rail at Traralgon. (b) Within a 50-mile radius of the post office situated at Traralgon—earthmoving equipment and agricultural implements the property of other contractors and being moved from site to site.
- LAGOUTATZIS, V. & N.**, 380 Dorcas-street, South Melbourne, 3205. One commercial goods vehicle (L/C. 350 cwt.) to operate within a 50-mile radius of the premises of Albion Reid Pty. Ltd., at North Melbourne solely on behalf of the said company—road-making plant, hot asphalt and premix and road-making materials excluding the carriage of cement and lime from the Geelong urban district as defined in the *Transport Regulation Act 1958*.
- LATROBE, T. R.**, care of Corindhap, P.O., 3352. One commercial goods vehicle (L/C. 139 cwt.) to operate within a 50-mile radius of the plant of Pioneer Concrete (Vic.) Pty. Ltd., at Ballarat solely on behalf of the said company—premixed concrete in a specially constructed agitator vehicle.
- MURRAY, E. F., PTY. LTD.**, 67 Riverine-street, Bairnsdale, 3875. One commercial goods vehicle (L/C. 129 cwt.) to operate within a 50-mile radius from the post office at Nowa Nowa, in the course of business as “Quarry Masters”—own plant and equipment, sand, gravel, screenings and road-making materials from own quarry at Nowa Nowa.
- NICHOLAS, PTY. LTD.**, 699 Warrigal-road, Chadstone, 3148. Four commercial goods vehicles (L/C. 10, 8, 10, 10 cwt.) to operate throughout the State of Victoria as a Traveller's Vehicle for display and sales promotion of own products and agency lines in the course of business as “Manufacturers and Distributors”—samples of own products and agency lines, also display materials relating to goods for sale with the right to leave an interim sample supply with a retailer pending despatch of normal supplies to such retailer.
- PACIFIC PHOTO SERVICE PTY. LTD.**, corner Haughton and Main roads, Clayton, 3168. One commercial goods vehicle (L/C. 7 cwt.) to operate within a 50-mile radius of own premises at Seymour and to Mansfield and Benalla in course of business as “Film Processors”—unexposed films for printing and printed films.
- PATERSONS PTY. LTD.**, 152 Bourke-street, Melbourne, 3000. Application to vary the conditions of licence No. D.A.1782 (L/C. 16 cwt.) by deleting “Warrnambool” from the existing conditions and adding in lieu “Colac”.
- PAYNE, T. I.**, Box 19, Edenhope, 3318. One commercial goods vehicle (L/C. 36 cwt.) to operate: (a) Within a 25-mile radius of the post office at Edenhope—general goods provided that no goods shall be carried whether by one or more stages between places within the above radius situated more than 30 road miles apart by the nearest practicable route. (b) Within a 50-mile radius of the post office at Edenhope and to and from the depot at Horsham of Amoco Aust. Pty. Ltd., as an agent on behalf of the said company—petroleum products in prescribed types of containers and empty return containers.
- PHOENIX BISCUIT CO. PTY. LTD.**, Grosvenor-street, Abbotsford, 3067. Application to vary the conditions of licence No. D.A.39491/11 (L/C. 78 cwt.) by deleting “Bendigo” where appearing in the existing conditions and adding in lieu “Echuca”.
- SIGMA CO. LTD.**, 589 Collins-street, Melbourne, 3000. One commercial goods vehicle (L/C. 14 cwt.) to operate within a 50-mile radius of own branch premises at Shepparton and to and from the City of Bendigo in the course of business as “Wholesale Manufacturing Chemists”—own goods subject to the condition that all goods carried on the vehicle shall have been initially consigned to Shepparton by rail.
- STRACHAN LIQUID FREIGHTERS PTY. LTD.**, McRoberts-street, Newport, 3015. One commercial goods vehicle (L/C. 14 cwt.) to operate throughout the State of Victoria in the course of business as “Bulk Liquid Haulage” for the purpose of servicing own equipment—tools of trade and spare parts for on site servicing in the field only.
- SUTER, D. J.**, 66 Gladstone-street, Orbost, 3888. One commercial goods vehicle (L/C. 77 cwt.) to operate: (a) Within a 50-mile radius of the post office at Orbost in course of business as “Dairy and Ice Proprietors”—milk, cream, butter, cheese, yoghurt, ice and ice-cream. (b) Within that part of the State of Victoria east of the Snowy River including the Township of Newmerella in the course of business as “Distributor and Agent” in a specially constructed insulated van—frozen fish, frozen chicko rolls, frozen dim sims, frozen hamburgers, frozen meats, frozen puff pastry, milk, cream, fruit juices, ice-cream and frozen prepared meals, frozen vegetables and poultry, meat pies, sausage rolls, yoghurt, ice, fresh fruit and vegetables and butter.
- TRAINOR TRANSPORT CO. PTY. LTD.**, Aberdeen-road, Sandringham, 3191. Five commercial goods vehicles (L/C. 40, 63, 58, 61, 63 cwt.) to operate within a 50-mile radius of own premises at Sandringham solely on behalf of associated companies Trainor Furniture and Importers Pty. Ltd. and Nepean Timber Company Pty. Ltd.—own goods and goods solely on behalf of associated companies.
- TYNAN, W. L.**, 6 Breed-street, Traralgon, 3844. One commercial goods vehicle (L/C. 248 cwt.) to operate from the premises of the State Electricity Commission of Victoria at Morwell to the following places for the carriage of bulk briquettes:—(i) West Gippsland Hospital—Warragul. (ii) Petersville Milk Products Pty. Ltd.—Warragul. (iii) Moe Co-operative Dairy Co.—Moe. (iv) Rice Bros. Pty. Ltd.—Moe. (v) Gippsland Cement Ltd.—Traralgon. (vi) Great Eastern Brick Co. Ltd.—Traralgon. This application replaces licence No. D.A.28095/4 previously held by the applicant.
- YOUNG, R. F.**, 83B Archer-street, Shepparton, 3630. One commercial goods vehicle (L/C. 10 cwt.) to operate (a) Within a 50-mile radius of own premises at Shepparton in course of business as “Light Fitting Agent and Merchant”—own goods. (b) Within a 100-mile radius of Shepparton as Interior Lighting Specialist for the purpose of installing, servicing and distributing light fittings—tools of trade, fragile electric light fittings for installation, repair or having been repaired and for distribution and materials incidental to the completion of own contracts.
- NOTE.**—Excluding the carriage of any fittings or materials from places within a 25-mile radius of the G.P.O., Melbourne.
- GRIFFIN, D. J.**, 178 Station-street, Norlane, 3214. One commercial goods vehicle (to be purchased) to operate within a 25-mile radius of the chief post office in the City of Geelong in the course of business as a “Panel Beater” to operate as a Tow Truck for the purpose of lifting and carrying or towing and/or repairing of wrecked or disabled vehicles—tools of trade, spare parts and materials incidental thereto, but excluding the right to operate the vehicle as a Tow Truck to or from the scenes of accidents or collisions.

RENEWALS.

Applications for renewal of licences as shown by persons listed hereunder to operate under the same terms and conditions from the expiry shown in each case.

- ABE, B. H., 178 Mundy-street, Bendigo, 3550; D.A.56436; 19th July, 1973; 11 cwt.; D.A.56436/1; 19th July, 1973; 11 cwt.
- ABREHART, R. E., 16 View-street, Hampton Park, 3976; D.A.62971; 21st July, 1973; 244 cwt.
- ADAMS, WILLIAM, TRACTORS PTY. LTD., Nantilla-road, North Clayton, 3168; D.A.512/46; 21st July, 1973; 16 cwt.
- ADDRESSOGRAPH MULTIGRAPH OF AUSTRALIA PTY. LTD., 411 Swanston-street, Melbourne, 3000; D.A.2118/1; 21st July, 1973; 8 cwt.; D.A.2118/2; 21st July, 1973; 8 cwt.; D.A.2118/3; 21st July, 1973; 8 cwt.
- BRAMBLES BRINKS LTD. (trading as Armoured Escorts), corner Arden and Lothian streets, North Melbourne, 3051; D.A.37566/8; 15th July, 1973; 14 cwt.
- ARNOTT BROCKHOFF GUEST PTY. LTD., 53 Huntingdale-road, Burwood, 3125; D.A.60213/34; 14th July, 1973; 10 cwt.
- ASCOM PTY. LTD., 63 Queensbridge-street, South Melbourne, 3205; D.A.34589/34; 26th July, 1973; 14 cwt.
- ASCOM PTY. LTD., 63 Queensbridge-street, South Melbourne, 3205; D.A.34589/37; 5th July, 1973; 91 cwt.
- ASCOM PTY. LTD., 63 Queensbridge-street, South Melbourne, 3205; D.A.34589/38; 19th July, 1973; 48 cwt.
- BARKER, N. A., 139 Main-street, Stawell, 3380; D.A.62871; 30th June, 1973; 11 cwt.
- BENNETT, K. D., 33 Cleveland-street, Thomastown, 3074; D.A.62951; 21st July, 1973; 122 cwt.
- BETTIOL, A., 13-15 Mullum-road, Ringwood, 3134; D.A.56450; 26th July, 1973; 197 cwt.
- BOWER, H. R., 15 Cumming-avenue, Birchip, 3483; D.A.41315; 12th December, 1973; 247 cwt.
- BOYER, W. L., 27 Yaldwin-street, Kyneton, 3444; D.A.56273; 5th July, 1973; 128 cwt.
- BROWN, F. S., (Estate of the late), 51 Lexton-road, Box Hill, 3129; D.A.28750/3; 5th July, 1973; 17 cwt.
- BURGESS, G. D., 46 Northcote-avenue, Balwyn, 3103; D.A.56423; 19th July, 1973; 139 cwt.
- CAMPBELL, C. J., Box 23, Balmoral, 3407; D.A.62660; 30th June, 1973; 143 cwt.
- CEDEL PRODUCTS A/ASIA PTY. LTD., 176 Commercial-road, Prahran, 3181; D.A.60276/9; 21st July, 1973; 10 cwt.
- CHARTER, C. J., Kaitlers-road, Lavington, New South Wales, 2641; T.D.A.63400/1; 24th May, 1973; 20 cwt.
- CHOROWICZ, I., 4 Tennyson-avenue, Caulfield, 3162; D.A.56422; 21st July, 1973; 65 cwt.
- COCK, G. MCG., 404 Doncaster-road, Doncaster, 3108; D.A.62807; 14th July, 1973; 222 cwt.
- COLDSTREAM REFRIGERATORS MELBOURNE PTY. LTD., 79 Lygon-street, East Brunswick, 3057; D.A.39871/7; 21st July, 1973; 14 cwt.
- CONCRETE TESTING PTY. LTD., 184 Kingsway, South Melbourne, 3205; D.A.62194/2; 28th July, 1973; 14 cwt.
- COOMBS, A. G., PTY. LTD., 26 Cochranes-road, Moorabbin, 3189; D.A.891/10; 5th July, 1973; 19 cwt.
- COOMBS, A. G., SERVICING PTY. LTD., 26 Cochranes-road, Moorabbin, 3189; D.A.891/11; 5th July, 1973; 13 cwt.
- DEIPENAU, H. E., PTY. LTD., 73 Victoria-street, East Brunswick, 3057; T.D.A.17846/36; 28th August, 1973; 242 cwt.
- DOODR, NORM, & SONS PTY. LTD., Creswick-road, Ballarat, 3350; D.A.24214/18; 21st July, 1973; 311 cwt.
- DOWLIN, J. P., Allansford, 3277; D.A.22568/1; 28th July, 1973; 19 cwt.
- DOWN INDUSTRIES PTY. LTD., 3 Cascade-drive, East Kew, 3102; T.T.D.1440; 15th June, 1973; 301 cwt.
- ECLIPSE MOTORS PTY. LTD., 84 High-street, Maryborough, 3465; D.A.1023/12; 14th July, 1973; 13 cwt.
- EDDINGTON, J. L., 28 Ormond-street, Mordialloc, 3195; D.A.62896; 30th June, 1973; 29 cwt.
- EMOLEUM AUST. LTD., Arden-street, North Melbourne, 3051; D.A.1042/27; 21st July, 1973; 230 cwt.
- EVERY, F. J., PTY. LTD., 14 King-street, Bendigo, 3550; D.A.56486; 26th July, 1973; 17 cwt.
- FACKAS, J., 6 Beleura-grove, Clayton, 3168; D.A.62889; 21st July, 1973; 210 cwt.
- FAGG, KEITH, PTY. LTD., 628 Canterbury-road, Vermont, 3133; D.A.56390; 13th July, 1973; 139 cwt.
- FAGG, KEITH, PTY. LTD., 628 Canterbury-road, Vermont, 3133; D.A.56390/1; 13th July, 1973; 141 cwt.
- FINGER, A. E., 106 Huntingdale-road, Mt. Waverley, 3149; D.A.30383; 8th July, 1973; 149 cwt.
- FULTON, J., 1387 Malvern-road, Malvern, 3144; D.A.62957; 21st July, 1973; 142 cwt.
- McKEON, E. J. (trading as Geelong Laundry Co.), 23-27 Austin-street, Newtown, 3220; D.A.30311; 22nd July, 1973; 21 cwt.
- GILBARCO AUST. LTD., 11 Anderson-road, Thornbury, 3071; D.A.1144/19; 9th July, 1972; 14 cwt.; D.A.1144/36; 15th May, 1973; 14 cwt.; D.A.1144/63; 21st April, 1972; 17 cwt.; D.A.1144/91; 11th August, 1973; 14 cwt.
- GILBEE, D. W., 16 Albert-road, Lilydale, 3140; D.A.61756/1; 21st July, 1973; 224 cwt.
- GLEN IRIS BRICK CONSOLIDATED LTD., Templestowe-road, Bulleen, 3105; D.A.34408/35; 23rd June, 1973; 92 cwt.; D.A.34408/36; 23rd June, 1973; 158 cwt.; D.A.34408/37; 9th June, 1973; 151 cwt.
- GLENMIX PTY. LTD., 141 King George-street, Cohuna, 3568; D.A.53997/2; 10th May, 1973; 181 cwt.
- GLENMIX PTY. LTD., 141 King George-street, Cohuna, 3568; D.A.53997/5; 30th June, 1973; 199 cwt.
- GRANT, J. E. & D. J., 32 Albert-street, Daylesford, 3460; D.A.52973/1; 13th July, 1973; 10 cwt.
- HADDEN, F., & SONS, 16 Ford-crescent, Thornbury, 3071; D.A.4096; 8th July, 1973; 145 cwt.
- HALL, G. W., 15 Callen-street, Seymour, 3660; T.D.A.24141/5; 13th July, 1973; 241 cwt.
- HUTCHINSON, ROBERT, LTD., Hartington-street, Glenroy, 3046; T.D.A.27836/62; 9th August, 1973; 197 cwt.
- HOUGHTON, LYN, & Co. PTY. LTD., 44 Hume-street, Huntingdale, 3166; T.D.A.62788/1; 9th June, 1973; 20 cwt.
- JENSEN, C. A., Warrenbayne, 3670; D.A.4380; 3rd July, 1973; 113 cwt.
- JONES, D. W., PTY. LTD., 126 Cecil-street, Williamstown, 3016; D.A.1392/6; 8th July, 1973; 147 cwt.
- K.M. PLASTER PRODUCTS PTY. LTD., Bald Hill-road, Pakenham East, 3810; D.A.31354/4; 5th July, 1973; 11 cwt.
- KENNEDY, E. J., Heatherton-road, Narre Warren North, 3804; D.A.62897; 30th June, 1973; 150 cwt.
- KING, H. C., PTY. LTD., Yinnar, 3869; D.A.28096/4; 21st July, 1973; 72 cwt.
- LEACH, E. S., Springcreek-road, Koroit, 3282; D.A.62965; 21st July, 1973; 12 cwt.
- LECHTE, G. R. & V. F., 11 Hunter-street, Murrumbena, 3163; D.A.54197/1; 13th July, 1973; 248 cwt.
- MCCARROLL, W. A., 4 Bruce's Creek-road, Whittlesea, 3757; D.A.19944/1; 21st July, 1973; 334 cwt.
- MCCONNELL, D. C., 194 Raglan-parade, Warrnambool, 3280; D.A.55093/2; 30th June, 1973; 11 cwt.
- MCGRATH, JOHN, TRAILERS PTY. LTD., 225 Brunswick-road, Brunswick, 3056; T.D.A.65455; 31st July, 1973; 26 cwt.
- MCPHERSON'S LTD., 546 Collins-street, Melbourne, 3000; D.A.43591; 3rd July, 1973; 230 cwt.; D.A.43591/2; 3rd July, 1973; 121 cwt.
- MARIANI, P., 2 Frank-street, Lalor, 3075; D.A.62961; 28th July, 1973; 203 cwt.
- MILLS, J. W., 15 Swallow-crescent, Norlane, 3214; D.A.62794; 30th June, 1973; 10 cwt.
- NOSEDA, A. C., care of B.P. Aust. Depot, Harris-street, Warrnambool, 3280; D.A.62937; 21st July, 1973; 145 cwt.; D.A.62937/1; 21st July, 1973; 109 cwt.; D.A.62937/2; 21st July, 1973; 18 cwt.; D.A.62937/3; 21st July, 1973; 145 cwt.
- PANZERA, F., 46 Norwich-crescent, Campbellfield, 3061; D.A.56425; 19th July, 1973; 122 cwt.
- PATERSONS PTY. LTD., 152 Bourke-street, Melbourne, 3000; D.A.1782/68; 21st July, 1973; 14 cwt.
- PETERSVILLE LTD., Wellington-road, Clayton, 3168; D.A.1813/99; 20th July, 1973; 37 cwt.; D.A.1813/124; 19th July, 1973; 79 cwt.
- PORTER, G. E., PTY. LTD., 15 Queens-parade, Clifton Hill, 3068; T.D.A.54561/2; 9th August, 1973; 206 cwt.; T.D.A.54561/3; 9th August, 1973; 218 cwt.
- POULTRYMEN & FARMERS' TRADING CO. PTY. LTD., 105 Hawthorn-road, Caulfield, 3162; D.A.1847/5; 21st November, 1972; 114 cwt.; D.A.1847/6; 21st November, 1972; 114 cwt.
- PRESTON, K. T. (trading as K. T. Preston & Sons), Napier-street, Creswick, 3363; D.A.62725; 21st July, 1973; 133 cwt.
- RAMSAY & TREGANOWAN LTD., 475 Latrobe-street, Melbourne, 3000; D.A.31536/9; 10th July, 1973; 10 cwt.
- RANK XEROX (AUSTRALIA) PTY. LTD., 377 Lonsdale-street, Melbourne, 3000; D.A.62652; 14th July, 1973; 14 cwt.
- RANK XEROX (AUSTRALIA) PTY. LTD., 377 Lonsdale-street, Melbourne, 3000; D.A.62652/1; 14th July, 1973; 14 cwt.
- RANK XEROX (AUSTRALIA) PTY. LTD., 377 Lonsdale-street, Melbourne, 3000; D.A.62652/3; 14th July, 1973; 14 cwt.
- SLOAN, J. H. (trading as Regal Cream Products), 27 Arden-street, North Melbourne, 3051; D.A.25421/6; 21st July, 1973; 54 cwt.
- ROSELLA FOODS PTY. LTD., 64 Balmain-street, Richmond, 3121; D.A.37710/12; 19th July, 1973; 11 cwt.; D.A.37710/14; 26th July, 1973; 8 cwt.; D.A.37710/15; 26th July, 1973; 10 cwt.
- RUBIN, J., 87 Oakleigh-road, Carnegie, 3163; D.A.56361; 13th July, 1973; 140 cwt.
- RUSSELL, S., 38 Abbroath-road, Wantirna South, 3152; D.A.56483; 26th July, 1973; 257 cwt.
- SALTER, W. S., 6 Perth-street, South Blackburn, 3130; D.A.62901; 30th June, 1973; 18 cwt.
- VAN SLAGEREN, S. (trading as Scientific Instrument Repair Service), 6 Holmes-street, North Geelong, 3215; D.A.62903; 30th June, 1973; 18 cwt.
- SHELLY, P. E., PTY. LTD., Labilliere-street, Bacchus Marsh, 3340; D.A.2022/5; 17th July, 1973; 304 cwt.; D.A.2022/7; 17th July, 1973; 143 cwt.

SHELLY, P. E., PTY. LTD., Labilliere-street, Bacchus Marsh, 3340; D.A.2022/6; 17th July, 1973; 158 cwt.
 SIMON CARVES (AUST.) PTY. LTD., Madden-street, Morwell, 3840; D.A.49137/7; 30th June, 1973; 63 cwt.
 SIMPSON POPE LTD., 128 Wellington-street, Collingwood, 3066; D.A.34725/38; 21st July, 1973; 13 cwt; D.A.34725/39; 21st July, 1973; 13 cwt; D.A.34725/40; 21st July, 1973; 13 cwt; D.A.34725/41; 21st July, 1973; 13 cwt.
 SIRONIC, S., 67 Rivett-crescent, Mulgrave, 3170; D.A.62865; 30th June, 1973; 225 cwt.
 STEVENSON, H. F., PTY. LTD., 10 Duffy-street, Burwood, 3125; T.D.A.2111/2; 7th August, 1973; 78 cwt.
 SUTHERLAND, E. J., 3 Mardi-court, Westall, 3169; D.A.62902; 30th June, 1973; 21 cwt.
 THOMSON, W., & SONS PTY. LTD., 10 Margaret-street, Huntingdale, 3166; D.A.43723; 10th July, 1973; 76 cwt.
 THOMSON, W., & SONS PTY. LTD., 10 Margaret-street, Huntingdale, 3166; D.A.43723/2; 10th July, 1973; 75 cwt.
 JONES, R. C. (trading as Timbertop Sawmills), 80 Malcolm-street, Mansfield, 3722; D.T.1301; 21st July, 1973; 266 cwt.
 TOWNSEND, F. R., 35-41 Union-road, Ascot Vale, 3032; D.A.56238; 5th July, 1973; 12 cwt.
 TRUMPER, R. W., "Kwama Lodge", Burton-road, Upper Beaconsfield, 3808; D.A.56426; 19th July, 1973; 197 cwt.
 TUCKER, F. H., & SON PTY. LTD., 55-77 Hope-street, Geelong West, 3218; D.A.3658; 17th July, 1973; 8 cwt.
 TUPPERWARE OF AUST. PTY. LTD., Lysterfield-road, Ferntree Gully, 3156; D.A.54379/27; 26th July, 1973; 10 cwt.
 WABCO DISTRIBUTION AUST. PTY. LTD., 1608 Sydney-road, Campbellfield, 3061; D.A.45971/3; 17th July, 1973; 14 cwt.
 WHITFORD, C., care of Post Office, Cann River, 3889; D.T.907; 21st July, 1973; 412 cwt.
 WILLIAMSON, L. M. & J. M., Alvie via Colac, 3253; D.A.58742/5; 21st July, 1973; 239 cwt.
 WILLIAMSON, L. M., Alvie Post Office via Colac, 3253; D.A.58742/6; 21st July, 1973; 162 cwt.
 WIMMERA LAUNDRY & DRY CLEANERS PTY. LTD., 19 Darlot-street, Horsham, 3400; D.A.62963; 21st July, 1973; 20 cwt.
 WISE, J. & R., Blake-street, Skipton, 3361; D.A.11396/1; 13th July, 1973; 154 cwt.
 YENCKEN WARRNAMBOOL PTY. LTD., 242 Timor-street, Warrnambool, 3280; D.A.41277/7; 5th July, 1973; 53 cwt.

TOW TRUCK RENEWALS.

DELANEY, VERN. & Co., Scott-street, Mortlake, 3550; D.A.56169; 7th July, 1973; 139 cwt.
 FULLARTON MOTORS, 235 Manifold-street, Camperdown, 3260; D.A.43724; 10th July, 1973; 75 cwt.
 ROGRAY PANELS PTY. LTD., 136 Weston-street, East Brunswick, 3056; D.A.50367/1; 17th August, 1973; 35 cwt.

RENEWALS WITH VARIATION.

Applications made by the persons listed hereunder for renewal of the licences listed with variation of conditions in the manner set out opposite the names.

Biggs, H. (trading as Contract Sprayers), 2 Reserve-street, Eaglehawk, 3556; D.A.53669/1; 26th July, 1973; Application to vary the conditions of licence No. D.A.53669/1 (L/C. 8 cwt.) by deleting "Between the Metropolitan area as defined in the *Transport Regulation Act 1958* and the Bendigo Urban District as also defined in the said Act" from the existing conditions and adding in lieu "from places within a 25-mile radius of the G.P.O., Melbourne."

DELOW, N. H. J., 4 Keck-street, Bendigo, 3550; D.A.62933; 14th July, 1973; Application to vary the conditions of licence No. D.A.62933 (L/C. 10 cwt.) by deleting "the Metropolitan area (as defined in the *Transport Regulation Act 1958*) from the existing conditions and adding in lieu "places within a 25-mile radius of the G.P.O., Melbourne".

IBBS, A. G., 12 Kirkham-road, Murrumbeena, 3163; D.A.47428/5; 21st July, 1973; Application to renew and vary the conditions of licence No. D.A.47428/5 (L/C. 199 cwt.) by adding after "Burnley" in the existing condition "and Clayton".

Notice of any objection should be forwarded to reach the Secretary of the Board not later than 11th April, 1973.

Applicants are advised that it will not be necessary to appear on the hearing date specified above, unless advised in writing by the Board.

H. SHEAHAN,
Acting Secretary.

Corner Lygon and Princes streets, Carlton, 3053, Wednesday, 28th March, 1973.

THE LIQUOR CONTROL ACT 1968.

Whereas the Hotelkeeper's Licence for licensed premises known as the Victoria Hotel, situate at Koroit, has been surrendered as from 10th December, 1972, notice is hereby given that the amount of compensation payable to the owners of such premises pursuant to the provisions of the *Liquor Control Act 1968*, is as under:—

Owners—\$21,500.00.

Dated this 20th day of March, 1973.

L. T. DUDLEY, Secretary,
Liquor Control Commission.

THE LIQUOR CONTROL ACT 1968.

Whereas the Hotelkeeper's licence for the licensed premises known as the Jung Hotel, situate at Jung, has been surrendered as from the 31st of December, 1972, notice is hereby given that the amount of compensation payable to the owner of such premises pursuant to the provisions of the *Liquor Control Act 1968* is as under:—

Owner—\$5,490.00.

Dated this 20th day of March, 1973.

L. T. DUDLEY, Secretary,
Liquor Control Commission.

Co-operation Act 1958.

THE MONASH CO-OPERATIVE LIMITED.

Notice is hereby given in pursuance of section 78 (7) of the *Co-operation Act 1958* and section 308 (2) of the *Companies Act 1961* that, at the expiration of three months from the date hereof, the name of the aforementioned society will, unless cause is shown to the contrary, be struck off the register and the society will be dissolved.

Dated this 20th day of March, 1973.

J. W. JUNGWIRTH,
Registrar.

Police Regulation Act 1958, Section 122.

SALE OF UNCLAIMED MOTOR VEHICLE.

An owner is required for a 1960 model, Holden station sedan; ex-registered No. N.S.W. DVS-962, engine No. B238716.

The vehicle has been in the possession of Police since the 15th July, 1972, and, if not claimed, will be sold by public auction at the Cann River Police Station, Cann Valley Highway, Cann River, at 2 p.m., on the 9th May, 1973.

A. L. CARMICHAEL,
Acting Chief Commissioner of Police.

Stamps Act 1958.

ANNUAL LICENCE.

NOTIFICATION PURSUANT TO SECTION 97.

I hereby notify that stamp duty has been paid for a licence under section 96 of the *Stamps Act* to carry on assurance and insurance business in Victoria from 1st March, 1973, to 31st December, 1973, by the following:—

GUARDALL INSURANCE CO. PTY. LTD.

R. M. PHIBBS,
Comptroller of Stamps.

Stamp Duties Office,
Melbourne, 28th March, 1973.

Electric Light and Power Act 1958.

ORDERS GRANTED BY THE GOVERNOR IN COUNCIL.

It is hereby notified that Orders, pursuant to the provisions of the *Electric Light and Power Act 1958* (No. 6241), as hereunder mentioned, have been granted by His Excellency the Governor in Council, viz.:—

Order No. 352.—Order under section 10 of the *Electric Light and Power Act 1958*, granted to the Mayor, Councillors and Citizens of City of Footscray, in respect of electricity supply to the South Kingsville area.

Order No. 353.—Order under section 10 of the *Electric Light and Power Act 1958*, granted to the Mayor, Councillors and Citizens of City of Footscray, in respect of electricity supply to the Kingsville area.

Order No. 354.—Order under section 10 of the *Electric Light and Power Act 1958*, granted to the Mayor, Councillors and Citizens of City of Williamstown, in respect of electricity supply to the West Newport—East Altona area.

J. C. M. BALFOUR,
Minister for Fuel and Power.

Private Agents Act 1966.

NOTICE OF RECEIPT OF APPLICATIONS FOR LICENCES UNDER THE PROVISIONS OF THE PRIVATE AGENTS ACT 1966.

The Clerk(s) of the Magistrates' Court(s) as listed hereunder hereby give notice that applications, as under, have been lodged for hearing by the said Court(s) on the date(s) specified.

Any person desiring to object to any of such applications must—

- (a) lodge with the respective Clerk of the Magistrates' Court a notice in the prescribed form of his objection and of the grounds thereof;
- (b) cause a copy of such notice to be served personally or by post upon the applicant at least three days before the hearing of the application; and
- (c) send or deliver—
 - (i) where the objection is not made by the officer in charge of the police district in which the Court is situated— a copy of the notice to such officer; and
 - (ii) where the objection is not made by the Registrar or Deputy Registrar—a copy to the Registrar.

Full Name of Applicant or in the Case of a Firm or Corporation, of the Nominee.	Place of Abode of Applicant or Nominee.	Name of Firm or Corporation.	Address for Registration.	Type of Licence.	Date of Hearing of Application.
MAGISTRATES' COURT, SUNSHINE.					
Bevz, Ihor	45 Oberon-avenue, St. Albans	45 Oberon-avenue, St. Albans	Process Server ..	11.4.73
Dated at Sunshine this 13th day of March, 1973.					
OWEN BOURKE, Clerk of the Magistrates' Court.					
MAGISTRATES' COURT, PRAHRAN.					
Atkinson, Victor Anthony ..	2/40 Bowman-street, Mordialloc	12/614 St. Kilda-road, Melbourne	Commercial Sub-Agent	6.4.73
Dated at Prahran this 16th day of March, 1973.					
J. PRESNELL, Clerk of the Magistrates' Court.					
MAGISTRATES' COURT, MALVERN.					
Strapp, Peter John Henry ..	11 Heatherbrae-avenue, Caulfield South	B.P.S. Business Protection Services	11 Heatherbrae-avenue, Caulfield South	Guard Agent ..	6.4.73
Jansz, Carl Lancelot ..	Flat 1, 18 Argyle-avenue, Chelsea	Security Watching Company Pty. Ltd.	281 High-street, Ashburton	Watchman ..	"
Dated at Malvern this 15th day of March, 1973.					
P. J. RODDA, Clerk of the Magistrates' Court.					
MAGISTRATES' COURT, RICHMOND.					
Panoutsos, Athanasios ..	288 Bridge-road, Richmond	288 Bridge-road, Richmond	Process Server ..	6.4.73
Panoutsos, Athanasios ..	" " " "	" " " "	Guard Agent ..	"
Panoutsos, Athanasios ..	" " " "	" " " "	Inquiry Agent ..	"
Dated at Richmond this 15th day of March, 1973.					
K. McDONALD, Clerk of the Magistrates' Court.					
MAGISTRATES' COURT, FITZROY.					
Entwistle, Thomas ..	27 Simpson-street, Northcote	Crothall and Co. Pty. Ltd.	75 Victoria-parade, Fitzroy	Watchman ..	6.4.73
Dated at Fitzroy this 16th day of March, 1973.					
J. B. RIES, Clerk of the Magistrates' Court.					
MAGISTRATES' COURT, FERNTREE GULLY.					
Harris, Lance Stanley Patrick Cronin	10 Beverly-street, Scoresby	10 Beverly-street, Scoresby	Commercial Agent	9.4.73
Dated at Ferntree Gully this 16th day of March, 1973.					
J. BALFA, Clerk of the Magistrates' Court.					
MAGISTRATES' COURT, SOUTH MELBOURNE.					
Koch, Graeme Edwin ..	1/264 Hope-street, West Brunswick	94 York-street, South Melbourne	Watchman ..	11.4.73
Dated at South Melbourne this 19th day of March, 1973.					
R. J. McALLISTER, Clerk of the Magistrates' Court.					
MAGISTRATES' COURT, PRAHRAN.					
Tootell, Sydney ..	3 Margaret-crescent, Braybrook	Factory Guard Service Pty. Ltd.	17/562 St. Kilda-road, Melbourne	Watchman ..	6.4.73
Dated at Prahran this 19th day of March, 1973.					
J. PRESNELL, Clerk of the Magistrates' Court.					
MAGISTRATES' COURT, YARRAM.					
Crotty, Ivy Margaret Helen ..	43 Growse-street, Yarram	43 Growse-street, Yarram	Process Server ..	6.4.73
Dated at Yarram this 16th day of March, 1973.					
LEN HANDLEY, Clerk of the Magistrates' Court.					
MAGISTRATES' COURT, MOE.					
Schutte, Franciscus Maria ..	c/o 15 Collins-street, Traralgon	Latrobe Security Services	71 Wirraway-street, Moe	Watchman ..	12.4.73
Dated at Moe this 20th day of March, 1973.					
S. G. MACKIE, Clerk of the Magistrates' Court.					

PRIVATE AGENTS—continued.

Full Name of Applicant or in the Case of a Firm or Corporation, of the Nominee.	Place of Abode of Applicant or Nominee.	Name of Firm or Corporation.	Address for Registration.	Type of Licence.	Date of Hearing of Application.
---	---	------------------------------	---------------------------	------------------	---------------------------------

MAGISTRATES' COURT, FITZROY.

Green, Geoffrey Seymour ..	10 Olympic-avenue, Cheltenham	Crothall and Co. Pty. Ltd.	75 Victoria-parade, Eastern Hill	Watchman ..	11.4.73
Pludek, Alec Zbynek ..	Flat 37, 95 Napier-street, Fitzroy	" "	" "	" ..	"

Dated at Fitzroy this 21st day of March, 1973.

J. B. RIES, Clerk of the Petty Sessions.

MAGISTRATES' COURT, SOUTH MELBOURNE.

Butler, Harvey Shawn ..	8 Turnbull-avenue, North Clayton	" "	94 York-street, South Melbourne	Watchman ..	10.4.73
Bramwell, Christopher John ..	Flat 5, 18 Shaftesbury-street, Essendon	" "	" "	" ..	13.4.73
Marshman, Ronald John ..	7 St. Ives-grove, Mount Martha	" "	" "	" ..	"

Dated at South Melbourne this 20th day of March, 1973.

R. J. McALLISTER, Clerk of the Magistrates' Court.

MAGISTRATES' COURT, BOX HILL.

Pope, Colin Ronald ..	114 Excelsior-drive, Frankston	Mayne Nickless Ltd.	114 Excelsior-drive, Frankston	Watchman ..	12.4.73
-----------------------	--------------------------------	---------------------	--------------------------------	-------------	---------

Dated at Box Hill this 21st day of March, 1973.

A. J. JOHNSON, Clerk of the Magistrates' Court.

MAGISTRATES' COURT, SALE.

Stergiopoulos, Peter ..	3 Hagenauer-street, Sale	Sale Security Patrol	P.O. Box 269, Sale 3850	Guard Agent (Individual)	10.4.73
Poulios, Alexander ..	1 Macarthur-street, Sale	" "	" "	" ..	"
Stergiopoulos, Peter ..	3 Hagenauer-street, Sale	" "	" "	(Firm)	"

Dated at Sale this 16th day of March, 1973.

G. MURPHY, Clerk of the Magistrates Court.

MAGISTRATES' COURT, CAMBERWELL.

Bellchambers, Roger Lindsay	117 Toorak-road, Camberwell	" "	5 Milton-street, Bentleigh	Process Server ..	10.4.73
-----------------------------	-----------------------------	-----	----------------------------	-------------------	---------

Dated at Camberwell this 20th day of March, 1973.

J. C. TOBIN, Clerk of the Magistrates Court.

MAGISTRATES' COURT, HAMILTON.

Burgess, Denzil John ..	Martin-street, Dunkeld	" "	Martin-street, Dunkeld	Process Server ..	5.4.73
-------------------------	------------------------	-----	------------------------	-------------------	--------

Dated at Hamilton this 16th day of March 1973.

A. CROFT, Clerk of the Magistrates' Court.

MAGISTRATES' COURT, MELBOURNE.

Medcalf, Terry John ..	Flat 3, 9 Lillimur-road, Ormond	" "	Flat 3, 9 Lillimur-road, Ormond	Process Server ..	4.4.73
Born, Jon Charles ..	10 Byron-street, Moonee Ponds	Mayne Nickless Limited	94 York-street, South Melbourne	Watchman ..	"
Andrews, Donald Arthur ..	121 Burke-road, Fern Tree Gully	Success Security Service	8th Floor, 500 Collins-street, Melbourne	" ..	"
Fitzsimmons, Peter James ..	82 Sellick-drive, Croydon	Armoured Escorts Pty. Ltd.	Cnr. Arden and Lothian streets, North Melbourne	" ..	"
Viergever, Ilja Johannes ..	61 Koonung-road Blackburn	" "	" "	" ..	"
Hobeika, Clement ..	6, D/12, Marine-parade, St. Kilda	W. I. Scammell Pty. Ltd.	148 Roden-street, West Melbourne	Inquiry Agent ..	11.4.73

Dated at Melbourne this 19th day of March, 1973.

G. L. WEBSTER, Clerk of the Magistrates' Court.

MAGISTRATES' COURT, CARLTON.

Burdett, Dennis Phillip James Francis	72 McPherson-street, North Carlton	" "	72 McPherson-street, North Carlton	Process Server ..	17.4.73
---------------------------------------	------------------------------------	-----	------------------------------------	-------------------	---------

Dated at Carlton this 21st day of March, 1973.

M. J. QUIRK, Clerk of the Magistrates' Court.

MAGISTRATES' COURT, OAKLEIGH.

Ashfield, Colin Robert ..	1 Damon-road, Mount Waverley	A.A.A. Ashfield and associates	1 Damon-road, Waverley	Process Server ..	17.4.73
" " " ..	" " " ..	" " "	" " "	Inquiry Agent ..	"

Dated at Oakleigh this 23rd day of March, 1973.

C. MEEHAN, Clerk of the Magistrates' Court.

MAGISTRATES' COURT, CAMBERWELL.

Butt, Peter Alan ..	5/312A Orrong-road, North Caulfield	" "	27 Morton-road, Burwood	Commercial Sub-Agent	10.4.73
---------------------	-------------------------------------	-----	-------------------------	----------------------	---------

Dated at Camberwell this 20th day of March, 1973.

J. C. TOBIN, Clerk of the Magistrates' Court.

PRIVATE AGENTS—continued.

Full Name of Applicant or in the Case of a Firm or Corporation, of the Nominee.	Place of Abode of Applicant or Nominee.	Name of Firm or Corporation.	Address for Registration.	Type of Licence.	Date of Hearing of Application.
MAGISTRATES' COURT, MALVERN.					
Scott, James Alexander ..	Flat 2, 22 Shoppes-road, Tullamarine	The Security Watching Pty. Ltd.	281 High-street, Ashburton	Watchman ..	9.4.73
Dated at Malvern this 19th day of March, 1973					
P. J. RODDA, Clerk of the Magistrates' Court.					
MAGISTRATES' COURT, MALVERN.					
Rose, William Edward ..	25 Sandgate-avenue, Glen Waverley	281 High-street, Ashburton	Watchman ..	30.4.73
Dated at Malvern this 21st day of March, 1973					
P. J. RODDA, Clerk of the Magistrates' Court.					
MAGISTRATES' COURT, BALLARAT.					
Golding, Raymond Francis ..	5A Corbett-street, Ballarat	46 Lydiard-street south, Ballarat	Watchman ..	12.4.73
Dated at Ballarat this 22nd day of March, 1973.					
E. N. KINCHINGTON, Clerk of the Magistrates Court.					

Cemeteries Act 1958.

SCALE OF FEES OF BOX HILL PUBLIC CEMETERY.

In pursuance of the powers conferred upon them by the Cemeteries Act the trustees of the Box Hill Public Cemetery hereby make the following scale of fees, which shall come into operation upon publication in the *Government Gazette*, and from and after such publication every scale of fees heretofore made by the said trustees shall be and is hereby rescinded to the extent to which it conflicts with this scale.

<i>Land.</i>	
Land for private graves	\$80.00
<i>Sinking Charges for Private Graves.</i>	
Sinking grave 7 feet or 8 feet	\$55.00
<i>Extra Charges.</i>	
Sinking grave over standard width (when permitted) over 2 ft. 3 in., at shoulders	\$15.00
For square caskets	\$15.00
<i>Miscellaneous Charges.</i>	
Reopening grave	\$55.00
Interment of ashes in a private grave	\$15.00
Exhumation of a body (when authorized)	\$100.00
<i>Grave Maintenance Charges.</i>	
First year	\$10.00
Each succeeding year	\$8.00
<i>Burial of Ashes.</i>	
Lawn plot and container	\$50.00
A. R. ALLINGHAM, Trustee. A. L. MCFARLANE, Trustee. R. V. COUCHE, Trustee.	

Approved by the Governor in Council, 20th March, 1973.
—T. J. FORRISTAL, Clerk of the Executive Council.

Cemeteries Act 1958.

SCALE OF FEES OF KANIVA AND LILLIMUR PUBLIC CEMETERY.

In pursuance of the powers conferred upon them by the Cemeteries Act the trustees of the Kaniva and Lillimur Public Cemetery hereby make the following scale of fees, which shall come into operation upon publication in the *Government Gazette*, and from and after such publication every scale of fees heretofore made by the said trustees shall be and is hereby rescinded to the extent to which it conflicts with this scale.

<i>Private Graves.</i>	
Sinking grave 6 feet deep	\$30.00
Sinking grave 8 feet deep	\$40.00
Sinking grave for child under twelve years	\$5.00
Removal of headstone	\$5.00
Land 8 ft. x 4 ft. (until 31st December, 1973)	\$4.00
Land 8 ft. x 4 ft. (from 1st January, 1974)	\$5.00
Interment fee	\$5.00

Burials on Saturdays, Sundays and Public Holidays—

Sinking grave 6 feet deep (extra)	\$5.00
Sinking grave 8 feet deep (extra)	\$5.00
Monumental work—5 per cent. of value.	

J. S. STEPHEN, Trustee.
D. J. MERRETT, Trustee.
D. WILSON, Trustee.

Approved by the Governor in Council, 20th March, 1973.—T. J. FORRISTAL, Clerk of the Executive Council.

Cemeteries Act 1958.

SCALE OF FEES OF CHELTENHAM PUBLIC CEMETERY.

In pursuance of the powers conferred upon them by the Cemeteries Act the trustees of the Cheltenham Public Cemetery hereby make the following scale of fees, which shall come into operation upon publication in the *Government Gazette*, and from and after such publication every scale of fees heretofore made by the said trustees shall be and is hereby rescinded to the extent to which it conflicts with this scale.

<i>Lawn Area.</i>		<i>Total Cost.</i>
Land, 8 ft. x 4 ft.	\$100	
Sinking fee (including use of mats and lowering machine)	\$55	\$155
Land, 8 ft. x 4 ft. facing drive	\$130	
Sinking fee (including use of mats and lowering machine)	\$55	\$185
Reopening fee (including use of mats and lowering machine)	\$55	
Grave sites purchased pre-need, plus 10 per cent.		
Bronze plaques and flower containers available on direct application to the cemetery		

Monumental Lawn Area.

Land, 12 ft. x 12 ft., sufficient for six interments	\$800
--	-------

Monumental Area.

Land, 8 ft. x 4 ft.	\$70
Land, 8 ft. x 4 ft., facing side drives and plantations	\$80
Land, 8 ft. x 4 ft., facing main drives and plantations	\$90
Sinking fee (adult)	\$55
Reopening fee (adult)	\$55
Sinking fee or reopening fee (child under twelve years)	\$20
Fees for exhumation (when authorized)	\$150
Monumental work (5 per cent. of value of work) minimum	\$3
Additional inscription	\$3
Grave sites purchased pre-need—plus 10 per cent.	

J. CAMPBELL, Trustee.
E. R. PEARSONS, Trustee.
W. M. SODING, Trustee.
W. F. THOMAS, Secretary.

Approved by the Governor in Council, 20th March, 1973.
—T. J. FORRISTAL, Clerk of the Executive Council.

Cemeteries Act 1958.

SCALE OF FEES OF CARNGHAM PUBLIC CEMETERY.

In pursuance of the powers conferred upon them by the Cemeteries Act the trustees of the Carngham Public Cemetery hereby make the following scale of fees, which shall come into operation upon publication in the *Government Gazette*, and from and after such publication every scale of fees heretofore made by the said trustees shall be and is hereby rescinded to the extent to which it conflicts with this scale.

Sinking grave 7 feet	\$33.00
Sinking grave 6 feet	\$28.00
Sinking grave 5 ft. 4 in.	\$23.00
Sinking grave for child under twelve years	\$23.00
Cost of marker peg	\$2.00

S. R. GREENBANK, Trustee.
K. V. O. DOHERTY, Trustee.
J. W. GARDNER, Trustee.

Approved by the Governor in Council, 20th March, 1973.
—T. J. FORRISTAL, Clerk of the Executive Council.

Cemeteries Act 1958.

SCALE OF FEES OF DROUIN PUBLIC CEMETERY.

In pursuance of the powers conferred upon them by the Cemeteries Act the trustees of the Drouin Public Cemetery hereby make the following scale of fees, which shall come into operation upon publication in the *Government Gazette*, and from and after such publication every scale of fees heretofore made by the said trustees shall be and is hereby rescinded to the extent to which it conflicts with this scale.

Monumental Section.

Land for graves 8 ft. x 4 ft.	\$30.00
Land for graves 8 ft. x 8 ft.	\$60.00
Sinking grave to 7 feet	\$20.00
Reopening graves	\$20.00

Extra Charges.

Interments without due notice	\$10.00
Interments on Sundays (double normal rates)	
Interments on Saturdays and holidays up to 11 a.m.	\$10.00
Annual maintenance of grave	\$10.00
Burial of ashes	\$10.00

Lawn Section.

Land, 8 ft. x 4 ft.	\$40.00
For each interment therein (including plaque and flower container)	\$70.00
Ashes in niche wall	\$45.00

N. G. HARPER, Trustee.
A. L. J. SAUNDERS, Trustee.
W. G. WHELLER, Trustee.

Approved by the Governor in Council, 20th March, 1973.
—T. J. FORRISTAL, Clerk of the Executive Council.

Cemeteries Act 1958.

SCALE OF FEES OF BRIGHTON GENERAL CEMETERY.

In pursuance of the powers conferred upon them by the Cemeteries Act the trustees of the Brighton General Cemetery hereby make the following scale of fees, which shall come into operation upon publication in the *Government Gazette*, and from and after such publication every scale of fees heretofore made by the said trustees shall be and is hereby rescinded to the extent to which it conflicts with this scale.

Private Graves.

Land, lawn graves, general areas R.O.B.	\$105.00
Land, lawn graves adjacent to entrances and special positions	\$140.00
Pre-need allotments, where applicable 12½ per cent. extra.	

Opening Adult Graves.

Sinking standard grave (6 ft. 9 in. x 2 ft. 3 in.) to 7 feet deep	\$55.00
Each additional foot	\$8.00

Reopening Adult Graves.

Reopening standard grave to depth of 6 feet	\$55.00
Reopening standard grave beyond 7 feet	\$63.00
Interment and registration of cremated remains	\$30.00
Exhumation (after 2 years) when authorized	\$150.00

Public Graves.

Interment of adult	\$30.00
Interment of child one year to thirteen years	\$17.50
Interment of child stillborn to one year	\$10.00

Extra Charges.

Interment on Saturday Morning	\$30.00
Interment on Sunday, Public Holiday or Picnic day	\$45.00
Sinking or reopening grave for oversize coffin	\$12.00
Sinking or reopening grave for oblong casket (small)	\$25.00
Sinking or reopening grave for oblong casket over 2 feet	\$30.00
Use of timbering in wet conditions	\$10.00
Copy of cemetery plan	\$0.50

Annual Grave Maintenance.

Single grave (4 ft. x 8 ft.) \$8.50; double (8 ft. x 8 ft.) \$12.00.	
Treble grave (12 ft. x 8 ft.) \$14.00; quadruple \$16.	
Larger areas by arrangement.	

Wall of Remembrance.

Position in existing wall "B"	\$30.00
Position reservation (extra)	\$5.00

Monumental Permits.

Permission to erect or alter a monument—7½ per cent. of retail price.	
Permission to cut extra inscription per burial	\$4.00
Permission to replace concrete top 4 ft. x 8 ft.	\$5.00
Permission to replace concrete top 8 ft. x 8 ft. (Inscriptions extra)	\$6.50

F. W. ALFORD, Trustee.
A. L. EDMONDS, Trustee.
R. CAINER, Trustee.
F. N. ALLEN, Secretary-Manager.

Approved by the Governor in Council, 20th March, 1973.
—T. J. FORRISTAL, Clerk of the Executive Council.

Cemeteries Act 1958.

SCALE OF FEES OF BALLAARAT GENERAL CEMETERIES.

In pursuance of the powers conferred upon them by the Cemeteries Acts the trustees of the Ballaarat General Cemeteries hereby make the following scale of fees, which shall come into operation upon publication in the *Government Gazette*, and from and after such publication every scale of fees heretofore made by the said trustees shall be and is hereby rescinded to the extent to which it conflicts with this scale.

Public Graves.

Single Interment—	
Stillborn child	\$10.00
Others	\$25.00

Private Graves.

Land, 9 ft. x 4 ft.—	
Denominational areas	\$55.00
Non-denominational areas	\$65.00
Old cemetery	\$75.00

Sinking—Reopening.

Sinking or reopening private graves	\$50.00
Extra charge for opening sealed graves	\$4.00

Lawn Area.

Site, including opening and memorial plate	\$180.00
Reopening of lawn grave and memorial plaque	\$90.00
Single Interment of—	
Child under three months (with memorial plate)	\$50.00
Child under three months (without memorial plate)	\$30.00
Child between three months and twelve years (with memorial plate)	\$75.00
Child between three months and twelve years (without memorial plate)	\$50.00

Miscellaneous Fees.

Pensioner's block, grave site (inclusive)	\$50.00
Pensioner, reopen	\$30.00
Exhumation of body (when authorized)	\$70.00
Burials on Saturdays or Gazetted holidays, additional	\$20.00
Oversize graves (coffins) additional	\$10.00
Oversize graves (caskets) additional	\$20.00
Burial of ashes in grave	\$20.00
Removal and replacement of ledger	\$10.00
Soldiers block (inclusive)	\$25.00
Burial right certificate or extract from register	\$2.00

Monumental Fees.

Costing under \$30.00	\$2.00
Costing \$30.00 and under \$60.00	\$4.00
Costing \$60.00 and under \$100.00	\$6.00
Costing \$100.00 and under \$200.00	\$10.00
Costing over \$200.00 and under \$400.00	\$20.00
Costing over \$400.00 and under \$800.00	\$40.00
Costing over \$800.00	\$60.00

Crematorium.

Cremation Fee.

Child up to the age of five (5) years	\$30.00
Person who was in receipt of an age, social service, or invalid pension under the Commonwealth Social Service Legislation (on production of Social Service Card).	

Or,

Person who was a discharged serviceman and has served outside Australia with an Australian Service force \$45.00

All others \$50.00

Saturdays.

Minimum Fee	\$50.00
Plus additional Saturday fee	\$20.00
	<hr/>
	\$70.00

Memorials.

Wall niche (with memorial plate)	\$50.00
Court yard niche (with memorial plate)	\$75.00
Rose garden niche (with memorial plate)	\$85.00
(In the foregoing niches the cremated remains are placed in a wall and covered by a bronze memorial plate 5½ in. wide by 4 in. deep; the inscription being limited to the name, date, of death and age.)	
Rose garden memorial	\$75.00
(memorial plates are placed in a position around the perimeter of a bed of selected bush roses)	
Individual rose trees or small shrubs	\$120.00
(which may have three memorials placed around them)	
Memorial trees	\$200.00
(which may have eight memorials placed around them)	
Additions to memorials already established	\$40.00
(each additional memorial placed at a memorial tree, shrub or rose tree)	
Fee for transfer of memorial to new position	\$5.00
Tenure of memorial.	
Niches are leased for a period of 50 years.	
Memorial trees, rose trees, shrubs and all other memorials are leased for a period of 25 years.	

E. G. LUDBROOK, Trustee.
M. STONE, Trustee.
F. R. PREST, Trustee.

Approved by the Governor in Council, 20th March, 1973.
—T. J. FORRISTAL, Clerk of the Executive Council.

Sinking oversize grave for American type casket (extra)	\$12.00
Cancellation of order to sink (if commenced)	\$5.00
Shelving	\$8.00

Reopening Charges.

Reopening grave (no cover)	\$30.00
Reopening grave (with cover or kerb)	\$36.00

Extra Charges.

Interment not in prescribed hours or on Saturday morning	\$20.00
Interment not in prescribed hours or on Saturday afternoon	\$28.00
Interment Sundays or Public Holidays	\$37.00
Interment in a private grave without due notice	\$8.00
Late fees (per half hour or part thereof in excess of first fifteen minutes)	\$3.00
Interment fee	\$12.00
Also in case of shelving	

Miscellaneous Charges.

Certificate of right of burial each allotment	\$1.00
Number plate or brick	\$1.00
Inspection of plan or register	\$1.00
Permission to erect a headstone, slab, fence or monument (plus 5 per cent. on the value of the work)	\$4.00
Permission to construct a brick grave or to erect any stone kerb, brick tilework, or concrete grave	\$4.00
Renovations	\$2.00
Alterations or additional inscriptions and minor renovations	\$1.00
Exhuming the remains of a body (when authorized)	\$30.00
Interment of ashes in a private grave	\$9.00
Monumental Mason's registration fee	\$2.00

Fees for Memorial Wall and Garden.

Standard memorial plate with three lines	\$10.00
Wall niche	\$30.00
Niche plates for additional lines over three	\$3.00
Niche plates for additional lines over three and Rising Sun	\$6.00
Flower containers with niche plate	\$7.00
Placing and fixing memorial plate	\$2.00
Placing and fixing memorial plate and flower container	\$3.00
Reservation of plate	\$7.00
Interment of ashes in memorial garden with standard memorial plate	\$30.00
Memorial garden plaque, 9 in. x 7 in.	\$40.00
Fixing	\$2.00

P. G. COLLYER, Trustee.
E. P. HYNES, Trustee.
S. M. BEGLEY, Trustee.
F. GAVENS, Trustee.

Approved by the Governor in Council, 20th March, 1973.
—T. J. FORRISTAL, Clerk of the Executive Council.

Cemeteries Act 1958.

SCALE OF FEES OF COLAC GENERAL CEMETERY.

In pursuance of the powers conferred upon them by the Cemeteries Act the trustees of the Colac General Cemetery hereby make the following scale of fees, which shall come into operation upon publication in the *Government Gazette*, and from and after such publication every scale of fees heretofore made by the said trustees shall be and is hereby rescinded to the extent to which it conflicts with this scale.

Private Graves.

Land, 8 ft. x 4 ft. adjoining or abutting a main road	\$70.00
Land, 8 ft. x 8 ft. adjoining or abutting a main road	\$140.00
Land, 8 ft. x 4 ft. other than above	\$35.00
Land, 8 ft. x 8 ft. other than above	\$70.00

Public Graves.

Interment in grave without exclusive right—stillborn child	\$8.00
Interment in grave without exclusive right—others	\$16.00
Number peg or label	\$1.00

Sinking Charges for Private Graves.

Sinking grave 5 ft. 6 in. deep	\$30.00
Each additional foot	\$4.00
Sinking oversize grave (extra)	\$8.00

Forests Act 1958, No. 6354.

VARIATION OF PROHIBITED PERIOD.

In pursuance of the powers conferred by Section 3 of the Forests Act, 1958, I, Edward Raymond Meagher, Her Majesty's Minister of Forests in the State of Victoria, hereby vary the declarations of a Prohibited Period previously made by me and published in the *Government Gazette* of 8th November, 1972, and 25th November, 1972, in so far as they refer to the Municipalities specified in the Schedule hereto, and by this notice declare that in these specified Municipalities the Prohibited Period in respect of any fire protected area (other than a State Forest or National Park) shall end at Midnight between the 28th and 29th March, 1973.

SCHEDULE.

The Shires of:

Ararat—that portion west of a line formed by the Hamilton-Ararat-Maryborough Railway Line.
Arapiles.
Dundas.
Glenelg.
Kowree.
Minhamite.
Mt. Rouse.
Portland.
Stawell.
Wannon.
Wimmera.

E. R. MEAGHER,
Minister of Forests.

Town and Country Planning Act 1961.
SHIRE OF BENALLA PLANNING SCHEME 1953.
AMENDMENT No. 5, 1972.

Notice of Approval.

In pursuance of the powers conferred by the *Town and Country Planning Act 1961*, the Governor in Council on the 20th March, 1973, approved a Planning Scheme entitled the Shire of Benalla Planning Scheme 1953, Amendment No. 5, 1972, in respect of part of the municipal district of the Shire of Benalla and such Planning Scheme comes into operation on the date this notice of approval is published in the *Government Gazette*.

A copy of the Planning Scheme as approved may be inspected free of charge during office hours at the office of the Town and Country Planning Board, 235 Queen-street, Melbourne; at the office of the Shire of Benalla, at Benalla, and when available, at the Office of Titles, Melbourne, and at the Central Plan Office of the Department of Crown Lands and Survey, Melbourne.

W. H. CRAIG, Secretary,
Town and Country Planning Board.

Town and Country Planning Act 1961.
COBRAM PLANNING SCHEME 1949.
AMENDMENT No. 12, 1971.

Notice of Approval.

In pursuance of the powers conferred by the *Town and Country Planning Act 1961*, the Governor in Council on the 20th March, 1973, approved a Planning Scheme entitled the Cobram Planning Scheme 1949, Amendment No. 12, 1971, in respect of part of the municipal district of the Shire of Cobram and such Planning Scheme comes into operation on the date this notice of approval is published in the *Government Gazette*.

A copy of the Planning Scheme as approved may be inspected free of charge during office hours at the office of the Town and Country Planning Board, 235 Queen-street, Melbourne; at the office of the Shire of Cobram, at Cobram, and when available, at the Office of Titles, Melbourne, and at the Central Plan Office of the Department of Crown Lands and Survey, Melbourne.

W. H. CRAIG, Secretary,
Town and Country Planning Board.

Town and Country Planning Act 1961.
SHIRE OF FLINDERS PLANNING SCHEME 1962.
AMENDMENT No. 44, 1972.

Notice of Approval.

In pursuance of the powers conferred by the *Town and Country Planning Act 1961*, the Governor in Council on the 20th March, 1973, approved a Planning Scheme entitled the Shire of Flinders Planning Scheme 1962, Amendment No. 44, 1972, in respect of part of the municipal district of the Shire of Flinders and such Planning Scheme comes into operation on the date this notice of approval is published in the *Government Gazette*.

A copy of the Planning Scheme as approved may be inspected free of charge during office hours at the office of the Town and Country Planning Board, 235 Queen-street, Melbourne; at the office of the Shire of Flinders, at Dromana, and when available, at the Office of Titles, Melbourne, and at the Central Plan Office of the Department of Crown Lands and Survey, Melbourne.

W. H. CRAIG, Secretary,
Town and Country Planning Board.

Town and Country Planning Act 1961.
CITY OF KNOX PLANNING SCHEME.
AMENDMENT No. 97, 1971.

Notice of Amendment.

In pursuance of the powers conferred by sub-section 6 of section 32 of the *Town and Country Planning Act 1961*, the Governor in Council, by and with the advice of the Executive Council on the 20th March, 1973, amended the City of Knox Planning Scheme, to allow variation in the size of allotments and set-backs from boundaries within part of the Residential Zone located on the west side of Stud-road between Burwood Highway and Boronia-road.

A copy of the amendment may be inspected during office hours at the office of the Town and Country Planning Board, 235 Queen-street, Melbourne; at the office of the Council of the City of Knox, at Fern Tree Gully, and when available at the Offices of Titles, Melbourne; and at the Central Plan Office of the Department of Crown Lands and Survey, Melbourne.

W. H. CRAIG, Secretary,
Town and Country Planning Board.

Town and Country Planning Act 1961.
CITY OF KNOX PLANNING SCHEME 1965.
AMENDMENT No. 114, 1972.

Notice of Approval.

In pursuance of the powers conferred by the *Town and Country Planning Act 1961*, the Governor in Council on the 20th March, 1973, approved a Planning Scheme entitled the City of Knox Planning Scheme 1965, Amendment No. 114, 1972, in respect of part of the municipal district of the City of Knox and such Planning Scheme comes into operation on the date this notice of approval is published in the *Government Gazette*.

A copy of the Planning Scheme as approved may be inspected free of charge during office hours at the office of the Town and Country Planning Board, 235 Queen-street, Melbourne; at the office of the City of Knox, at Fern Tree Gully and when available, at the Office of Titles, Melbourne, and at the Central Plan Office of the Department of Crown Lands and Survey, Melbourne.

W. H. CRAIG, Secretary,
Town and Country Planning Board.

Melbourne and Metropolitan.
BOARD OF WORKS.
GENERAL NOTICE.

The Melbourne and Metropolitan Board of Works having made provision for carrying off the sewage of each and every property which or any part of which is situate in the Sewerage Areas hereinafter described, doth hereby declare that on and after the 28th day of April, 1973, each and every property so situate shall be deemed to be a sewered property within the meaning of the *Melbourne and Metropolitan Board of Works Act 1958*.

The Sewerage Areas hereinbefore referred to are:—

Sewerage Area No. 2564.

City of Croydon.—Commencing at the southern extremity of Poulton-close; thence southerly along the eastern boundary of lot 2 Poulton-close, easterly along the northern boundaries of lots 3 View-court and 1 Miller-road, southerly along Miller-road, easterly and southerly along the northern and eastern boundaries of lot 1 Wayne-court, easterly along Wayne-court, southerly along the eastern boundary of lot 10 Wayne-court, westerly along the southern boundaries of lots 10 to 13 Wayne-court, southerly along Miller-road and the eastern boundary of lot 52 Coven-avenue, westerly along the southern boundaries of lots 52 to 49 Coven-avenue to the north-eastern angle of lot 22 Bungalook-road, southerly along the eastern boundary of the said lot 22 a distance of 190 feet, easterly by a line at right angles a distance of 97 feet, southerly by a line at right angles a distance of about 465 feet to Bungalook-road, westerly along Bungalook-road, northerly and easterly along the western and portion of the northern boundaries of the said lot 22, north-easterly along the north-western boundary of lot 47 Coven-avenue, northerly along Coven-avenue, westerly along the southern boundary of lot 36 Coven-avenue, northerly along the western boundaries of lots 36 to 34 Coven-avenue, further northerly along Coven-avenue, easterly along the northern boundary of lot 11 Coven-avenue, northerly and easterly and northerly along boundaries of lot 2 Poulton-close to the commencing point.

Sewerage Area No. 2565.

City of Nunawading.—Commencing at the junction of Centre-road and Heatherdale-road, thence southerly along Heatherdale-road, south-westerly along Abbey-walk, north-westerly and westerly along Culbara-drive, northerly along the western boundaries of lots 22 Culbara-drive, 28 and 29 Crisp-court, 31 to 38 Tulkara-grove and 39 Centre-road, easterly along Centre-road to the commencing point.

Sewerage Area No. 2566.

City of Springvale.—Commencing at a point in Downard-street 170 feet north of the northern boundary of Citrus-street; thence easterly along the northern boundary of lot 49 Downard-street; southerly along the eastern boundaries of lots 49 to 60 Downard-street, westerly along the southern boundaries of lots 60 and 30 Downard-street and a line in continuation to the boundary of Sewerage Area No. 2467, northerly and north-westerly along the said area boundary to the production of the northern boundary of lot 41 Citrus-street, easterly along the said production and the northern boundaries of lots 41 to 48 Citrus-street to the commencing point.

Sewerage Area No. 2567.

City of Nunawading.—Commencing at the junction of Pelham-drive and Hanover-road; thence northerly along Hanover-road, easterly and north-easterly along the northern boundaries of lots 63 Hanover-road and 61 to 55 Pelham-drive, southerly along the eastern boundaries of

lots 55 and 54 Pelham-drive, 37 and 36 Woodleigh-crescent, 19 and 18 Kiama-close and 1 Burwood Highway, westerly along Burwood Highway, northerly and easterly along the western and northern boundaries of lot 131 Hanover-road, northerly along Hanover-road to the commencing point.

Sewerage Area No. 2568.

City of Altona.—Commencing at the junction of Maidstone-street and Harrington-street; thence easterly and generally south-easterly following the boundary of Sewerage Area No. 2278 to the junction of Wren-street and Mulga-street, southerly, easterly and generally southerly following the boundary of Sewerage Area No. 2503 to the junction of Mulga-street and Queen-street, south-easterly along the production of the south-western boundary of Mulga-street to the foreshore of Port Phillip Bay, south-westerly along the said foreshore, north-westerly by a line to and along the south-western boundaries of lots 1 Esplanade and 19 Queen-street, south-westerly along Queen-street, north-westerly along Wilga-avenue, north-easterly along Myrtle-grove, north-westerly and northerly along Maidstone-street to the commencing point.

By order of the Board,

W. C. S. ELLIS,
Secretary.

425 Collins-street, Melbourne, 3001, 27th March, 1973.

Land Act 1958.—Melbourne and Metropolitan Board of Works Act 1958.

COMMITTEE OF MANAGEMENT OF THE SITE FOR PUBLIC PURPOSES (DRAINAGE PURPOSES), PARISH OF TRUGANINA (AT LAVERTON).

His Excellency the Governor of the State of Victoria, by and with the advice of the Executive Council thereof, has on the 20th day of March, 1973, appointed the Melbourne and Metropolitan Board of Works to be the Committee of Management of the land in the Parish of Truganina (at Laverton) temporarily reserved by Order in Council of the 9th January, 1973, and as was notified in the *Government Gazette* dated the 17th January, 1973, as a site for Public purposes (Drainage purposes), in pursuance of the provisions of section 221 of the *Land Act 1958*, and section 215 of the *Melbourne and Metropolitan Board of Works Act 1958*.—(Rs.9654).

T. J. FORRISTAL,
Clerk of the Executive Council.

At the Executive Council Chamber,
Melbourne, 20th March, 1973.

Metropolitan Fire Brigades Act 1958.

METROPOLITAN FIRE BRIGADES BOARD.

LIST OF FIRE INSURANCE COMPANIES CARRYING ON BUSINESS AND INSURING PROPERTY IN VICTORIA.

Pursuant to the provisions of the *Metropolitan Fire Brigades Act 1958* and the Metropolitan Fire Brigades General Regulations 1951, I, Edward Raymond Meagher, being the Chief Secretary of Victoria and the Minister administering the said Act, hereby publish the subjoined list of insurance companies carrying on business and insuring property in Victoria; and notify that any such insurance company omitted from such list may be inserted therein on application to me within seven days from the date of publication hereof; and that such list, with the name of any insurance company so added, shall be taken to be the roll of insurance companies entitled to vote at the forthcoming periodical election of insurance companies' representatives on the Metropolitan Fire Brigades Board.

E. R. MEAGHER,
Chief Secretary.

Chief Secretary's Office,
Melbourne, 23rd March, 1973.

LIST OF INSURANCE COMPANIES—MARCH, 1973.

1. A.C.I. Insurances Pty. Ltd.
2. A.F.G. Insurances Limited.
3. A.M.P. Fire & General Ins. Co. Ltd.
4. A.P.A. Fire & General Ins. Co. Ltd.
5. Accident Insurance Mutual Ltd.
6. Affiliated Reinsurances Pty. Ltd.
7. Victor Aghion & Sons Pty. Ltd.
8. Ajax Ins. Co. Ltd.
9. Albion Insurance Co. Ltd.
10. Allen-Duncan (Re-Insurances) Pty. Ltd.
11. Allen-Duncan Limited.
12. American Home Assurance Co.
13. American International.
14. Ansvar Insurance Co. Ltd.
15. Associated General Cont. Ins. Co. Ltd.

16. Associated Group Insurance Ltd.
17. Associated National Ins. Co. Ltd.
18. Atlas Assurance Co. Ltd.
19. The Australian Alliance Assurance Co. Ltd.
20. Australian & Eastern Ins. Co. Ltd.
21. The Australian Equitable Ins. Co. Ltd.
22. Australian General Ins. Co. Ltd.
23. Australian Marine Underwriting Agency Ltd.
24. Australian Mutual Fire Insurance Society Ltd.
25. Australian Motor Traders Ins. Ltd.
26. Australian & International Insurances Ltd.
27. Australian Natives Assn. Ins. Co. Ltd.
28. Australian Reinsurance Co. Ltd.
29. Baillieu Bowring (Vic.) Pty. Ltd.
30. Baillieu Bowring (Re-Insurances) Pty. Ltd.
31. Baltica Ins. Co. Ltd.
32. Bankers & Traders Ins. Co. Ltd.
33. The Bishopgate Ins. Co. Ltd.
34. Boral Insurance and Fund Management Ltd.
35. Bray Gibb Wrightson (Vic.) Pty. Ltd.
36. British Crown Assurance Corp. Ltd.
37. British & Foreign Marine Ins. Co. Ltd.
38. British Traders Insurance Co. Ltd.
39. British Equitable Assurance Co. Ltd.
40. British General Insurance Co. of Aust. Ltd.
41. C.G.A. Fire & Accident Insurance Co. Ltd.
42. C.M.L. Fire & General Ins. Co. Ltd.
43. Caledonian Insurance Co.
44. The Catholic Church Insurances Limited.
45. Cayzer Steel Bros. & Harlock Pty. Ltd.
46. The Central Insurance Co. Ltd.
47. The Century Ins. Co. Ltd.
48. The Chamber of Manufacturers Ins. Ltd.
49. City Mutual General Ins. Ltd.
50. T. P. Clark & Chapman Pty. Ltd.
51. T. P. Clark & Chapman (Re-Insurance) Pty. Ltd.
52. The Colonial Mutual Fire Ins. Co. Ltd.
53. Commercial & Industrial Insurance Ltd.
54. Commercial Union Assurance Company of Australia Ltd.
55. Consolidated Insurances of Aust. Ltd.
56. The Cooperative Ins. Co. of Aust. Ltd.
57. The Copenhagen Reinsurance Co. (Aust.) Ltd.
58. Cornhill Ins. Co. Ltd.
59. Cumis Insurance Society Inc.
60. The Derwent & Tamar Assurance Co. Ltd.
61. The Dominion Insurance Co. of Australia Ltd.
62. Eagle Star Ins. Co. Ltd.
63. Ecclesiastical Prop. Ins. Co. Pty. Ltd.
64. Economic Insurance Co. Ltd.
65. Employers Liability Ass. Corp of Aust. Ltd.
66. Excess Ins. Australia Ltd.
67. The Farmers & Graziers Co-operative Co. Ltd.
68. The Farmers & Settlers Co-operative Ins. Co. Ltd.
69. The Federation Ins. Ltd.
70. Fire & All Risks Insurance Co. Ltd.
71. John Forsaith (Aust.) Pty. Ltd.
72. Forsikringsaktieselskapet Vesta.
73. General Accident Fire & Life Ass. Corp. Ltd.
74. General Mutual Ins. Co. Ltd.
75. Glanvill Holland Pty. Ltd.
76. Greater Pacific General Ins. Ltd.
77. Gresham Fire & Accident Ins. Soc. Ltd.
78. Grieve & Irwin (Aust.) Pty. Ltd.
79. Guardian Assurance Co. Ltd.
80. The Guild Ins. Co. Ltd.
81. Hallmark General Ins. Co. Ltd.
82. The Hanover Ins. Co. New York.
83. Harris & Dixon (Ins.) Pty. Ltd.
84. Hartford Fire Insurance.
85. Harvey Trinder (Southern) Pty. Ltd.
86. Hogg Robinson & Gardiner Mountain (Aust.) Pty. Ltd.
87. Home Insurance Co.
88. Indemnity Marine Ass. Co. of Aust. Ltd.
89. Insurance Co. of North America.
90. Insurance Corp. of Ireland Ltd.
91. The Insurance Office of Aust. Ltd.
92. The Invincible Life & General Ins. Co. Ltd.
93. Law Union & Rock Ins. Co. Ltd.
94. Legal & General Ass. Soc. Ltd.
95. The Legal Insurance Co. Ltd.
96. L.E.P. Insurance Brokers Pty. Ltd.
97. The Licenses & General Ins. Co. Ltd.
98. Lombard Ins. Co. Ltd.
99. The Liverpool & London & Globe Ins. Co. Ltd.
100. London Guarantee & Accident Co. of Australia Ltd.
101. The London & Lancashire Ins. Co. Ltd.
102. London & Overseas Ins. Co. Ltd.
103. London & Scottish Ass. Corp of Aust. Ltd.
104. Edward Lumley & Sons (N.S.W.) Pty. Ltd.
105. Edward Lumley & Sons (Vic.) Pty. Ltd.
106. The M.L.C. Fire & General Ins. Co. Pty. Ltd.
107. Colin McDonald Pty. Ltd.
108. Manchester Unity Fire Ins. Co. of Vic. Ltd.
109. Maritime Ins. Co. Ltd.

110. The Mercantile & General Reinsurance Co. of Aust. Ltd.
 111. Mercantile Mutual Ins. Co. Ltd.
 112. Milford Ins. Co. Ltd.
 113. J. H. Minet & Co. (A.N.Z.) Pty. Ltd.
 114. Munich Reinsurance Co. of Aust.
 115. The Monarch Ins. Co. Ltd.
 116. N.C.I.S. Insurance Pty. Ltd.
 117. National Employers Mutual General Ins. Assn. Ltd.
 118. National & General Ins. Co. Ltd.
 119. The National Ins. Co. of New Zealand Ltd.
 120. National Mutual Fire Ins. Co. Ltd.
 121. New Reinsurance Geneva Pty. Ltd.
 122. The New Zealand Ins. Co. Ltd.
 123. The Nippon Fire & Marine Ins. Co. Ltd.
 124. Henry G. Nicholson (Aust.) Pty. Ltd.
 125. North British & Mercantile Ins. Co. of Aust. Ltd.
 126. Northumberland Ins. Co. Ltd.
 127. Northern Assurance Co. of Aust. Ltd.
 128. Norwich Union Fire Ins. Soc. Ltd.
 129. The Ocean Accident & Guarantee Corp. of Aust. Ltd.
 130. Omnibus & General Ins. Co. Pty. Ltd.
 131. Godfrey Orton Insurance Pty. Ltd.
 132. Orion Insurance Co. Ltd.
 133. Palatine Ins. Co. of Aust. Ltd.
 134. The Pacific Ins. Co. Ltd.
 135. Pearl Ass. Co. Ltd.
 136. Permanent Ins. Co. Ltd.
 137. Phoenix Ass. Co. of Aust. Ltd.
 138. H. G. Poland (Aust.) Pty. Ltd.
 139. Price Forbes Leslie Sedgwick Pty. Ltd. (Vic.).
 140. Price Forbes Leslie Sedgwick (N.S.W.) Pty. Ltd.
 141. P.F.L. Sedgwick (Reinsurance) Pty. Ltd.
 142. The Provident Fire Ins. Co. of Aust. Ltd.
 143. Provincial Ins. Co. Ltd.
 144. Prudential Ass. Co. Ltd.
 145. Queensland Ins. Co. Ltd.
 146. Reinsurance Co. of Australasia Ltd.
 147. Reliance Marine Ins. Co. Ltd.
 148. Royal Exchange Ass.
 149. Royal Ins. Co. Ltd.
 150. Rural Finance & Settlement Commission.
 151. The Scottish Union & National Ins. Co.
 152. The Security & General Ins. Co. Ltd.
 153. Security Life Ass. Ltd.
 154. Sirius Ins. Co. Ltd.
 155. Skandia Ins. Co. Ltd.
 156. South Aust. Ins. Co. Ltd.
 157. The South British Ins. Co. Ltd.
 158. The Southern Union Commercial Ins. Co. of Aust. Ltd.
 159. The State Assurance Co. Ltd.
 160. The State Savings Bank Ins. Trust Fund.
 161. Steeves Agnew & Co. (Vic.) Pty. Ltd.
 162. Stenhouse Reinsurance Pty. Ltd.
 163. Stenhouse Scott North Aust. Ltd.
 164. Stewart Smith & Co. (Aust.) Pty. Ltd.
 165. Sun Alliance Ins. Ltd.
 166. Surrey Ins. Co. Ltd.
 167. Swann Insurance Limited.
 168. Switzerland General Ins. Co. Ltd.
 169. T. & G. Fire & General Ins. Co. Ltd.
 170. Taisho Marine & Fire Ins. Co. Ltd.
 171. Stanley Taylor & Co.
 172. The Thames & Mersey Marine Ins. Co. Ltd.
 173. The Tokio Marine & Fire Ins. Co. Ltd.
 174. Traders Prudent Ins. Co. Ltd.
 175. Transport Industries Insurance Co. Pty. Ltd.
 176. Transport & General Ins. Co. Ltd.
 177. Triumph Insurance Co. (Aust.) Ltd.
 178. Triton Ins. Co. Ltd.
 179. Underwriting & Ins. Ltd.
 180. The United Ins. Co. Ltd.
 181. The Union Ass. Co. of Aust. Ltd.
 182. The Union Ins. Society of Canton Ltd.
 183. L' Union Des Assurances De Paris.
 184. Vanguard Insurance Co. Ltd.
 185. The Victoria Ins. Co. Ltd.
 186. V.A.C.C. Ins. Co. Ltd.
 187. The Victory Reinsurance Co. of Aust. Ltd.
 188. J. H. Wackerbarth (Aust.) Pty. Ltd.
 189. Western Assurance Co.
 190. The Western Aust. Ins. Co. (Canberra) Ltd.
 191. Westminster Insurance Co. Ltd.
 192. Wheatgrowers & General Ins. Co.
 193. Waltons Insurance Co. Ltd.
 194. Westchester Fire Insurance Co.
 195. Willis Faber Johnson & Higgins (Vic.) Pty. Ltd.
 196. Yasuda Fire & Marine Ins. Co. Ltd.
 197. The Yorkshire Ins. Co. Ltd.

No. 18.—2440/73.—2

Country Fire Authority Act.

PERMISSION TO HOLD FIRE BRIGADE
DEMONSTRATIONS.

In pursuance of the provisions of section 103 of the Country Fire Authority Act 1958, the Country Fire Authority has granted permission for the holding of fire brigades demonstrations as under:—

RURAL FIRE BRIGADES.

At Hopetoun on Sunday, 25th March, 1973.
 At Riddell, on Sunday, 1st April, 1973.

J. L. ALLAN,
 Secretary.

22nd March, 1973.

COMPANIES ACT 1961.

Notice is hereby given that in pursuance of section 308 (4) of the Companies Act 1961 the names of the companies referred to below have been struck off the register, and on publication of this notice in the Government Gazette the said companies will be dissolved.

Dated this 20th day of March, 1973.

E. B. MITCHAM,
 Deputy Register of Companies.

Companies Office,
 Melbourne.

COMPANIES ABOVE REFERRED TO.

Name of Company.	Number of Registration.
Acme Service Stations Pty. Ltd.	21807
Toroid Industrial Supplies Pty. Ltd.	23366
Viking Plumbing Company Pty. Ltd.	23973
Toroid Developments Pty. Ltd.	28638
R. Jackson & Sons Pty. Ltd.	32279
B. V. Hickey Pty. Ltd.	37985
Franco-Australian Constructions Pty. Ltd.	39283
Dorelaw Pty. Ltd.	45192
Atlas Meat Supply Pty. Ltd.	50262
Verduci Bros. Maintenance Pty. Ltd.	51072
Protos Superannuation Pty. Ltd.	52561
Rosenberg Holdings Pty. Ltd.	53537
United World Hotels Pty. Ltd.	53812
Esley Investments Pty. Ltd.	53855
Case Marine Services Pty. Ltd.	55479
Jamieson Transport Pty. Ltd.	61333
Architectural & Industrial Door Services Pty. Ltd.	62051
John James Distributors Pty. Ltd.	62348
Motorville Pty. Ltd.	65289
Toroid Holdings Pty. Ltd.	66200
Whitsunday Group Pty. Ltd.	66473
Subasco Pty. Ltd.	67972
Kingsbridge Library Service (Vic.) Pty. Ltd.	71490
W. Howard Cock & Associates Pty. Ltd.	73046
Queen's College Trust Corporation	74265
Toora Minerals No Liability	76677
E. A. K. Decorating Pty. Ltd.	76934
Aron Cabinets Pty. Ltd.	77278
Harris International Pty. Ltd.	78510
English Clays (Exploration) Pty. Ltd.	78769
Constellation Minerals No Liability	81753
G. & D. Athanasiadis Pty. Ltd.	82095
International Commodities Corporation Pty. Ltd.	82128
Island Woods Australia Pty. Ltd.	82532
G. & A. Sainato Pty. Ltd.	83911
Marrik Investments Pty. Ltd.	84202

Dairy Products Act.

QUOTAS FOR BUTTER AND CHEESE.

BUTTER QUOTA.

I, GILBERT LAWRENCE CHANDLER, Minister of Agriculture in the State of Victoria, after consultation with the Victorian Dairy Products Board, and after ascertaining that the supply and distribution of butter at reasonable prices to consumers thereof in Victoria will be ensured, hereby determine a quota for butter as follows:—

The proportion shall be Eighty-two point one two per centum.

The period for which this quota is to operate shall be the month of April, 1973.

CHEESE QUOTA.

I, GILBERT LAWRENCE CHANDLER, Minister of Agriculture in the State of Victoria, after consultation with the Victorian Dairy Products Board, and after ascertaining that the supply and distribution of cheese at

reasonable prices to consumers thereof in Victoria will be ensured, hereby determine a quota for cheese as follows:—

The proportion shall be Eighty-five point six seven per centum.

The period for which this quota is to operate shall be the month of April, 1973.

G. L. CHANDLER,
Minister of Agriculture.

WINCHELSEA WATERWORKS TRUST.

BY-LAW No. 8.

The Winchelsea Waterworks Trust in pursuance and in exercise of the powers conferred by the *Water Act 1958* and of any and every other power it thereunto enabling doth hereby make a By-law as follows:—

1. By-law No. 7 of the Winchelsea Waterworks Trust is hereby revoked.

2. The meter or meters measuring the supply of water to any land or tenement shall be read as near as practicable to twelve months from the date that it was read previously and the quantity of water so measured as having been supplied during the period between any two successive such readings (hereinafter called the meter year) shall be the basis of the calculating of charges payable under this By-law provided always that where a meter has been installed on any land or tenement during the course of a meter year the quantity of water measured as having been supplied during the period between the date of such installation and the date of the reading shall be the basis of calculating such charges.

3. Subject as is hereinafter provided in respect of any land or tenement rated by the Trust—

(a) The maximum quantity of water to be supplied in any meter year without charge is hereby fixed as a quantity which if charged at 30 cents per thousand gallons for any meter year would give an amount equal to the amount of the rate payable in respect of the land or tenement for the financial year in which the said meter year ended.

(b) For all water supplied in any meter year in excess of the maximum quantity referred to in paragraph (a) of this clause the charge is hereby fixed at 30 cents per thousand gallons for any meter year.

4. Subject as is hereinafter provided the charge for water supplied by measure to any property not rated by the Trust is hereby fixed at 30 cents per thousand gallons.

5. The minimum charge for measure to any property not rated by the Trust is hereby fixed at Two Dollars.

6. The aforesaid charges shall be payable within seven days of demand upon the owner or occupier at the office of the Trust during normal business hours.

7. The provisions of Clauses 3, 4 and 5 of this By-law shall not apply to any land tenement or property supplied with water by the Trust under a special agreement pursuant to Section 215 of the *Water Act 1958*.

Passed this 20th day of February, 1973.

(SEAL) G. S. TERRIER, Chairman.
S. M. MAWSON, Commissioner.
W. K. MATHISON, Secretary.

Approved 22nd March, 1973.—ROBERTS DUNSTAN,
Minister of Water Supply.

SHEPPARTON URBAN WATERWORKS TRUST.

RATING BY-LAW FOR THE YEAR 1973.

The Shepparton Urban Waterworks Trust, in pursuance and exercise of the powers conferred by the *Water Act*, doth hereby make a rate for the supply of water for domestic purposes of 3.5 cents in the Dollar of the annual municipal valuation of lands and tenements liable to be rated within the Shepparton Urban District.

Provided that in no case shall the amount of rate payable per annum in respect of any tenement (other than land on which there is no building) be less than Six Dollars, and in respect of any land on which there is no building less than Three Dollars.

Persons electing to pay rates by four equal instalments shall pay the first instalment on or before a date fourteen days after the posting of this demand, and subsequent payments shall be made on or before the last day of May, August and November respectively.

Such rates are made and shall be levied upon the occupiers or owners of the said lands and tenements for the year commencing on the 1st day of January, 1973, and shall be payable on the 17th day of April, 1973, at the office of the said Trust.

Passed this 13th day of March, 1973.

(SEAL) MAXWELL BROWN, Chairman.
NEIL P. HAYMES, Secretary.

Approved, 22nd March, 1973.—ROBERTS DUNSTAN,
Minister of Water Supply.

YARRAM WATERWORKS TRUST.

RATING BY-LAW FOR THE YEAR 1973.

The Yarram Waterworks Trust in pursuance of and in exercise of the powers conferred by the *Water Act 1958* and of any and every other power it thereunto enabling doth hereby make a By-Law as follows.

1. The Trust hereby makes and levies a rate in respect of all lands and tenements within the Yarram Urban District of Four Point Seventy Five Cents in the Dollar on the net annual value set out in the valuation at present in force of such lands and tenements for the purposes of the municipal rate of the Shire of Alberton which is hereby adopted as the valuation of such lands and tenements respectively.

2. Such rate shall be made and levied upon the occupiers and owners of such lands and tenements for the year commencing on the first day of January, 1973 and shall be payable on the 30th day of March, 1973 at the office of the said Trust.

3. In no case shall the rate payable in respect of any land on which there is a building be less than Fifteen Dollars and in respect of land on which there is no building be less than Six Dollars.

4. Water supplied by the Trust is in all cases subject to the right of the Trust by notice to prohibit or restrict the use of the same for all purposes (other than domestic purposes) during such period or at such time or from time to time as may be fixed by the Trust and stated in such notice, and such notice shall cease to have effect at such time the Trust from time to time directs by notice so published.

Such notice may be given by printed posters placed in a prominent position within the Trust District or by advertisement in some newspaper circulating in such district.

No person shall use or permit or suffer water supplied by the Trust to be used contrary to any such prohibitions or restrictions.

No person shall use or permit or suffer the use of a hose or any such other appliance to be attached to a tap or service pipe for the purpose of supplying water during such restricted periods.

Dated this 8th day of February, 1973.

(SEAL) I. S. CAMERON, Chairman.
G. G. SCOTT, Secretary.

Approved, 14th March, 1973.—ROBERTS DUNSTAN,
Minister of Water Supply.

HERNES OAK WATERWORKS TRUST.

RATING BY-LAW FOR THE YEAR 1973.

The Hernes Oak Waterworks Trust, in pursuance and exercise of the powers conferred by the *Water Acts*, doth hereby make a By-Law and direct as follows:—

1. The said Hernes Oak Waterworks Trust doth hereby make a rate for the supply of water for domestic purposes of three cents in the dollar on the annual municipal valuation of lands and tenements liable to be rated within the Hernes Oak Waterworks District.

Provided that in no case shall the amount of the rate payable per annum in respect of any tenement (other than land upon which there is no building) be less than Five Dollars, and in respect of land on which there is no building less than Two Dollars.

Such rates are made and shall be levied upon the occupiers or owners of the said lands and tenements for the year commencing on the 1st day of January, 1973, and shall be payable on the 31st day of March, 1973, at the office of the said Trust.

2. Where persons liable to pay the rate, elect to pay such rate in instalments, the first instalment shall be due 14 days after posting of the demand for such rate and the remaining instalments shall be due respectively on the 30th June, 31st August and 30th November in the year 1973.

3. The maximum quantity of water to be supplied in any one year without further charge to any property rated by the Trust is hereby fixed at the quantity which, at a charge of Twenty cents per 1,000 gallons would produce an amount equal to the amount of the rate levied on such property for the said year.

4. The charge for water supplied by measure to any property rated by the Trust in excess of such maximum quantity, computed as in the last preceding clause, is hereby fixed at Twenty cents per 1,000 gallons.

5. The charge for water supplied by measure, shall be payable on demand, at the office of the Trust.

6. The Secretary and/or Rate Collector of the Trust is hereby authorized to demand and receive, collect and recover the rates and charges aforesaid and each of them.

Passed this 7th day of March, 1973.

The common seal of the Hernes Oak Waterworks Trust was hereto affixed this 7th day of March, 1973, in the presence of—

(SEAL) L. W. BOND, Chairman.
W. J. PETTIGREW, Commissioner.
R. A. FLETCHER, Secretary.

Approved, 14th March, 1973.—ROBERTS DUNSTAN,
Minister of Water Supply.

WOODS POINT WATERWORKS TRUST.

RATING BY-LAW No. 7 FOR 1973.

The Woods Point Waterworks Trust in pursuance of and in exercise of the powers conferred by the *Water Act 1958* and of any and every other power it thereto enabling doth hereby make a By-law as follows:—

1. The Trust hereby makes and levies a rate in respect of all the lands and tenements within the Woods Point Urban District of Three and a half cents (3½c) in the dollar on the nett annual value set out in the valuation at present in force of lands and tenements for the purposes of the municipal rate of the Shire of Mansfield which is hereby adopted as the valuation of such lands and tenements respectively.

2. Such rate shall be made and levied upon the owners and occupiers of such lands and tenements for the year commencing on the first day of January, 1973, and shall be payable on the fifteenth day of March, 1973, at the office of the said Trust.

3. In no case shall the amount of rate payable in respect of any tenement (other than land on which there is no building) be less than Fifteen dollars (\$15.00) and in respect of land on which there is no building be less than One dollar (\$1.00).

4. Interest at a rate of 8 per centum per annum will be charged on any rates and other moneys accruing out of rates not paid by the fifteenth day of July, 1973.

Passed this 10th day of December, 1972.

(SEAL) H. R. W. STEWART, Chairman.
F. WICKHAM, Secretary.

Approved, 14th March, 1973.—ROBERTS DUNSTAN,
Minister of Water Supply.

TRARALGON WATERWORKS TRUST.

RATING BY-LAW 1972-73.

The Traralgon Waterworks Trust, in pursuance and exercise of the powers conferred by the *Water Act 1958* and of any and every other power it thereto enabling doth hereby make a By-Law as follows:

1. The Trust hereby makes and levies a rate in respect of all the lands and tenements within the Traralgon Urban District of three and one half tenth of a cent (0.35 cents) in the dollar on the unimproved capital value set out in the valuation at present in force of such lands and tenements for the purpose of the municipal rate of the City of Traralgon, which is hereby adopted as the valuation of such lands and tenements respectively.

2. Such rate shall be made and levied upon the owners or occupiers of such lands and tenements for the year commencing on the first day of October, 1972, and ending on the thirtieth day of September, 1973, and shall be payable on the tenth day of April, 1973, at the office of the said Trust.

3. In no case shall the rate payable hereunder in respect of any land on which there is a building be less than fourteen dollars (\$14.00) and in respect of land on which there is no building, be less than eight dollars (\$8.00).

The foregoing By-Law was made by the Traralgon Waterworks Trust on the first day of November, 1972, amended as to date that rate shall become due and payable on the eighth day of March,

1973; and sealed with the common seal of the said Trust this eighth day of March, 1973, in the presence of—

(SEAL) DONALD DUNBAR, Chairman.
B. A. S. WATKINS, Commissioner.
K. J. SAUNDERS, Secretary.

Approved, 16th March, 1973.—ROBERTS DUNSTAN,
Minister of Water Supply.

SUNBURY SEWERAGE AUTHORITY.

INCREASING THE LIMIT OF BANK OVERDRAFT.

His Excellency the Governor of the State of Victoria, by and with the advice of the Executive Council thereof doth by Order made on the 27th day of March, 1973, increase the total amount of the sums which the Sunbury Sewerage Authority may owe at any one time in respect of moneys borrowed by overdraft of the current account, pursuant to the provisions of Section 79 of the *Sewerage Districts Act 1958*, and fixed by the Governor in Council on 28th September, 1971, at Eighty thousand dollars (\$80,000), to Two hundred and forty thousand dollars (\$240,000).

T. J. FORRISTAL,
Clerk of the Executive Council.
At the Executive Council Chamber,
Melbourne, 27th March, 1973.

SEYMOUR SEWERAGE AUTHORITY.

INCREASING THE LIMIT OF BANK OVERDRAFT.

His Excellency the Governor of the State of Victoria, by and with the advice of the Executive Council thereof, doth by Order made on the 21st day of November, 1972, increase the total amount of the sums which the Seymour Sewerage Authority may owe at any one time in respect of moneys borrowed by overdraft of the current account, pursuant to the provisions of section 79 of the *Sewerage Districts Act 1958*, and fixed by the Governor in Council on 9th December, 1964, at Ten thousand dollars (\$10,000) to One hundred and twenty thousand dollars (\$120,000).

T. J. FORRISTAL,
Clerk of the Executive Council.
At the Executive Council Chamber,
Melbourne, 21st November, 1972.

Land Conservation Act 1970.

INVESTIGATION OF THE NORTH EAST AREA DISTRICTS, 3, 4 AND 5.

Notice is hereby given that in accordance with the provisions of the *Land Conservation Act 1970*, the Land Conservation Council proposes to carry out an investigation for the purpose of making recommendations on the uses of public land within the North East Area Districts 3, 4 and 5 depicted on the map hereunder, in order to provide for the balanced use of land in Victoria.

LAND CONSERVATION COUNCIL

VICTORIA

NORTH EASTERN AREA

DISTRICTS 3,4+5

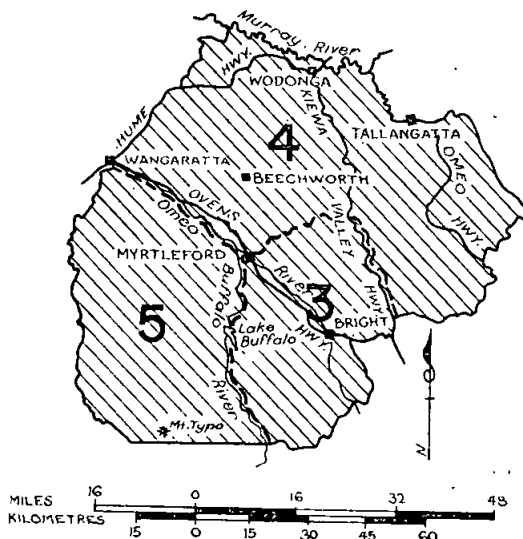

On completion of this investigation the Council shall publish a report of the investigation and will give notice in this newspaper of the publication and indicate where a copy may be inspected or obtained.

At the appropriate time the Council will invite any person or body to make submissions for the Council's consideration in respect of the use of public land in this area.

All inquiries concerning this investigation should be made direct to the undersigned at the offices of the Council, 464 St. Kilda-road, Melbourne, 3004.

W. J. McCORMACK,
Secretary.

Land Conservation Act 1970.
**INVESTIGATION OF THE EAST GIPPSLAND AREA
DISTRICTS 1 AND 2.**

Notice is hereby given that in accordance with the provisions of the *Land Conservation Act 1970*, the Land Conservation Council proposes to carry out an investigation for the purpose of making recommendations on the uses of public land within the East Gippsland area Districts 1 and 2 depicted on the map hereunder in order to provide for the balanced use of land in Victoria.

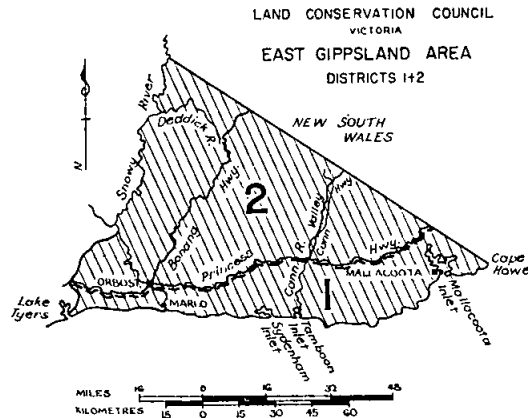

On completion of this investigation the Council shall publish a report of the investigation and will give notice in this newspaper of the publication and indicate where a copy may be inspected or obtained.

At the appropriate time the Council will invite any person or body to make submissions for the Council's consideration in respect of the use of public land in this area.

All inquiries concerning this investigation should be made direct to the undersigned at the offices of the Council, 464 St. Kilda-road, Melbourne, 3004.

W. J. McCORMACK,
Secretary.

PUBLIC TRUSTEE ACT 1958 (No. 6350), SECTION 17.

I hereby give notice that on the 6th March, 1973, the Public Trustee filed elections to administer the following deceased persons' estates in accordance with section 17 of the *Public Trustee Act 1958*.

BERRY, RAYMOND JAMES, formerly of 48 Barry-street, Carlton, but late of 3 Sunhill-court, Deer Park, technical officer, died 14th November, 1972.

BROWN, ALBERT WESTON, late of 12 Dunedin-street, Maidstone, retired electrical foreman, died 16th October, 1972.

BURGESS, MARGARET ELLEN, formerly of 42 Smith-street, Thornbury, but late of 25 Wingan-avenue, Camberwell, widow, died 1st January, 1973.

CLOWES, GERALD LEFROY, late of 200 O'Hea-street, Coburg, gentleman, died 20th December, 1972.

HOWELL, LILIAN, formerly of 8 Austin-street, Balwyn, late of Flat 3/8 Parring-road, Balwyn, married woman, died 26th November, 1972.

JOHANNESON, GUOMUNDUR PALL, also known as Gutmunder Pal Johannesson, and Gurmendur Pall Johannesson, formerly of 375 Barkly-street, Footscray, but late of Frances Creek, Northern Territory, electrician, died 5th May, 1971.

NOCKOLDS, HILDA, late of Bundoora, widow, died 14th August, 1972.

NORTHEY, JOSEPH THOMAS, late of 83 Moulder-street, Orange, N.S.W., pensioner, died 7th October, 1935.

OAKLEY, JOHN THOMAS, late of Flat 5, 24 Hawksburn-road, South Yarra, retired till maker, died 19th December, 1972.

ZEMAN, VASLAV, late of Cemetery-road, Nyah West, cook, died 27th May, 1971.

N. P. BRODY,
Public Trustee.

168 Exhibition-street, Melbourne, 3000, 21st March, 1973.

NOTICE.

Creditors, next of kin and others having claims against the estate of any of the under-mentioned deceased persons are required to send particulars of their claims to the Public Trustee, 168 Exhibition-street, Melbourne, Vic. 3000, the personal representative, on or before the 4th June, 1973, after which date the Public Trustee may convey or distribute the assets, having regard only to the claims of which the Public Trustee then has notice:—

ANDERSON, PERSIS ELEISE, late of 44 Fairview-avenue, Burwood, widow, died 31st December, 1972.

BERRY, RAYMOND JAMES, formerly of 48 Barry-street, Carlton, but late of 3 Sunhill-court, Deer Park, technical officer, died 14th November, 1972.

BONELL, WALTER HENRY WILLIAM, late of 1 Barker-street, Cheltenham, secretary, died 3rd December, 1972.

BROWN, ALBERT WESTON, late of 12 Dunedin-street, Maidstone, retired electrical foreman, died 16th October, 1972.

BURGESS, MARGARET ELLEN, formerly of 42 Smith-street, Thornbury, but late of 25 Wingan-avenue, Camberwell, widow, died 1st January, 1973.

CAPALDI, NORMA EILEEN, late of 273 Burke-road, Gardiner, married woman, died 29th September, 1972.

CASTLES, LESLIE BERNARD, late of 83 Elgar-road, Burwood, retired storeman, died 7th November, 1972.

CLOWES, GERALD LEFROY, late of 200 O'Hea-street, Coburg, gentleman, died 20th December, 1972.

DRUMMOND, DONALD CORNELIUS, late of 431 Victoria-street, West Melbourne, retired railway employee, died 23rd September, 1972.

FINCH, OLIVE MAY, late of 335 Park-street, North Carlton, widow, died 5th October, 1972.

FRASER, EVA ALICE, late of Ararat, widow, died 8th October, 1972.

HALLIFAX, SIDNEY JOHN, late of Ararat, pensioner, died 25th September, 1966.

HAMPSON, ELSIE MABEL, also known as Elsie Mabel Downing, late of 8 Noone-street, Clifton Hill, widow, died 29th October, 1972.

HOWELL, LILIAN, formerly of 8 Austin-street, Balwyn, late of Flat 3/8 Parring-road, Balwyn, married woman, died 26th November, 1972.

JOHANNESON, GUOMUNDUR PALL, also known as Gutmunder Pal Johannesson, and Gurmendur Pall Johannesson, formerly of 375 Barkly-street, Footscray, but late of Frances Creek, Northern Territory, electrician, died 5th May, 1971.

KEVAN, ALEXANDER JAMES, late of 44 John-street, Pakenham East, retired farmer, died 18th October, 1972.

NOCKOLDS, HILDA, late of Bundoora, widow, died 14th August, 1972.

NORTHEY, JOSEPH THOMAS, late of 83 Moulder-street, Orange, N.S.W., pensioner, died 7th October, 1935.

OAKLEY, JOHN THOMAS, late of Flat 5, 24 Hawksburn-road, South Yarra, retired till maker, died 19th December, 1972.

SPOTSWOOD, MARGARET, formerly of 30 Wentworth-avenue, Canterbury, but late of 764 Canterbury-road, Surrey Hills, spinster, died 12th December, 1972.

THOMAS, ALLEN ALEXANDER, late of Ballarat, retired labourer, died 4th October, 1972.

THOMAS, MARIAN ISOBEL ALICE, formerly of 13 Ormond-road, Ivanhoe, but late of Kenilworth Private Hospital, 3 Kenilworth-parade, Ivanhoe, widow, died 15th November, 1972.

ZEMAN, VASLAV, late of Cemetery-road, Nyah West, cook, died 27th May, 1971.

N. P. BRODY,
Public Trustee.

Melbourne, 21st March, 1973.

CONTRACTS ACCEPTED.—(Series 1972-73.)

PUBLIC WORKS.

992. Kew, Mental Hospital, renovations to Ward F5, \$37,240.00.—C. B. Bramich Pty. Ltd.

993. Swan Hill, Technical School, erection of multi-purpose hall type 800, \$125,200.00.—P. & A. Coutts Pty. Ltd.

994. Toorak, Trawalla Training Centre, 22 Lascelles-avenue, maintenance cleaning for the period 29th January, 1973 to 31st January, 1976, \$4,177.19 per annum.—Elisabetta Cleaning Service.

995. Hawthorn, Youth Welfare Service, 614 Glenferrie-road, maintenance cleaning for the period 29th January, 1973, to 31st January, 1976, \$1,668.17 per annum.—B. & M. Cleaning Service.

996. Melbourne. Alterations to ground floor and upper floors—car park, toilets, State Laboratories, 5 Parliament-place, \$4,834.00.—Frigite Industries Pty. Ltd.

997. Dookie, Agricultural College, supply and installation of water pump and pipework, \$4,242.00.—Calvin R. James.

998. Melbourne. Maintenance cleaning for the period 1st February, 1973, to 31st January, 1976, Agriculture Department, 19 Windsor-place, \$2,325.00 per annum.—K. & R. Building Services Maintenance.

999. Corio, Primary School 124, Drysdale, Primary School 1645, Geelong East, Primary School 541, Moolap, Primary School 1911, Winchelsea, Primary School 2015, erection of additional class-rooms, &c., bulk contract 1972-1973, Part 2, Sub Regional Contract 2, Western Region, \$69,947.00.—E. J. Lyons & Son Pty. Ltd.

1000. Stony Point, Buoy Depot, pavement and storm-water drainage works, \$24,819.50.—Richards Plant Hire Pty. Ltd.

1001. Aspendale, Technical School, Ferntree Gully, Technical School, Geelong East, Technical School Kyneton, Technical School, Templestowe, Technical School, supply and delivery of test panels for electrical practices and motor mechanics workshops, \$5,594.10.—H. T. Wheeler & Co. Pty. Ltd.

1002. Preston, Technical School, mechanical services—Stage II., \$9,037.00.—W. S. Atherton & Co. Pty. Ltd.

1003. Cockatoo, Primary School 3535, erection of brick veneer toilet block and breezeway, \$18,840.00.—A. Bloye.

1004. Donald, High School, site works, \$6,346.14.—R. Coffield.

1005. Footscray North, erection of a brick demonstration unit, \$110,040.00.—A. F. Dewar Holdings Pty. Ltd.

1006. Collingwood, erection of Education Centre, \$2,650,369.00.—Dillingham Constructions Pty. Ltd.

1007. Stony Point, Buoy Depot, extensions to office and workshop, \$63,888.00.—G. T. Constructions.

1008. Monterey, High School, mechanical services staff-room and administration improvements, \$4,134.00.—Gray & Wood.

1009. Heatherdale, Primary School 4904, site works, \$14,237.00.—Infantino Constructions Pty. Ltd.

1010. Footscray North, Electrical services—demonstration unit, \$9,086.00.—Jarrett & Crikis Pty. Ltd.

1011. Sunbury, Mental Hospital, external and internal renovations, administration building, \$7,250.00.—M. Jovetic.

1012. Mitcham, Technical School, site works, \$73,112.78.—Wm. Loud Pty. Ltd.

1013. Nathalia High School, erection of new toilet block, \$30,150.00.—D. J. McDonald.

1014. Wallarano, Primary School 5055, site works, \$17,120.90.—G. Mueller.

1015. Blackburn South, High School, Mitcham, High School, Vermont, High School, staff and administration improvements. Bulk Contract 1972/73, Part B, \$52,130.00.—T. & W. Melenhorst Pty. Ltd.

1016. Bentleigh, High School, external and internal repairs and painting, \$13,980.00.—"Melbourne Cup" Painting Service.

1017. Oak Park, Primary School 4721, erection of brick veneer toilet block, \$27,190.00.—G. & A. Power Pty. Ltd.

1018. Ballarat North, Primary School 4690, Alfredton, Primary School 1091, erection of additional class-rooms, &c. Bulk Contract 1972-1973, Part 2, Sub Regional Contract 3, Western Region, \$31,228.00.—Pascoe Vale Painters Construction Co.

1019. Beaumaris, Demonstration Unit, electrical services, \$9,244.00.—Read Electrical Service.

1020. Dandenong, Special School 4918, site works, \$16,443.30.—Sheffield Paving & Construction Co. Pty. Ltd.

1021. Monterey, High School, additional class-rooms, staffroom improvements, &c., \$45,362.00.—D. B. Tincknell Pty. Ltd.

G. SERPELL, Director-General of Public Works. 23.3.73.

PROVISIONS.

Gazette No. 43, 30th May, 1972.—For rates shown opposite the following items, substitute the rates set out hereunder as from the dates shown:—Schedule No. 21, Pleasant Creek, Stawell; Sub-schedule No. 4, Groceries.—Item No. 31, 79 cents, as from 20th February, 1973. Schedule No. 4, Traralgon, Sub-schedule No. 1, Bread and Flour.—Item No. 1, \$6.98; Item No. 2, \$6.98; Item No. 3, \$5.15, as from 2nd March, 1973.

ELECTRICAL GOODS.

Gazette No. 64, 17th July, 1972.—For rates shown opposite the following items, substitute the rates set out hereunder as from dates shown:—Schedule No. 37, Electrical Goods.—Item No. 63, substitute March 1973 Price Lists for "Clipsal", "Elmaco", "HPM" and "Ring-Grip", as from 19th March, 1973; Item No. 110, substitute "Autotune" price list of 12th March, 1973, as from 19th March, 1973; Item No. 111, substitute Nylex list No. A16, as from 5th March, 1973.

E. P. WATSON, Secretary to the Tender Board. 26.3.1974.

SOIL CONSERVATION AUTHORITY.

CONTRACT No. 37301.

1022. Shelbourne Hills No. 3 Group Conservation Area, Earthworks; Small Dam Construction.—J. W. Brook, Eaglehawk—2 T.D.9B (70-h.p.) dozers with equipment, \$10 per hour each; 1 model D scraper (7-9 cubic yard capacity), \$10 per hour; 1 truck and 1,500-gallon water tank, \$7.50 per hour; 1 vibrating sheepsfoot roller (66-in.), \$38 per day.

R. A. FITT, Secretary.

SOIL CONSERVATION AUTHORITY.

CONTRACT No. 47305.

987. Puckapunyal Project Area—Disc Cultivating and Seeding. Fiat 600 (60 H.P.) tractor with 14 plate International offset disc cultivator at \$3.30 per acre; Fiat 500 (50 H.P.) tractor with 9 ft. Connor Shea disc seeder at \$1.80 per acre. Total \$5.10 per acre.—I. Clark, Home-wood.

R. A. FITT, Secretary.

ORDERS IN COUNCIL.—(Series 1972-73.)

PUBLIC WORKS.

988. Broadmeadows, "Attwood" Veterinary Research Station; electrical services to new sub-station and modifications to electrical reticulation, \$8,350.00.—Lane & Roux Pty. Ltd.—(N.47437.)

989. Collingwood, Technical School, electrical services for remodelled offices and science room, \$5,212.60.—J. Newall Pty. Ltd.—(C.140793A.)

990. Frankston, Teachers' College, supply of lecture theatre seats, \$4,305.00.—Furniture Makers of Australia Pty. Ltd.—(P.E.192708F(I. & D.))

991. Shepparton, Technical School, reinstatement of fire damaged building, \$29,390.00.—G. E. Brown.—(N.49339.)

Approved by the Governor in Council, 20th March, 1973.—T. J. FORRISTAL, Clerk of the Executive Council.

APPOINTMENTS AND RESIGNATIONS

APPOINTMENTS.

His Excellency the Governor of the State of Victoria, by and with the advice of the Executive Council thereof, has, by Orders made on the 20th day of March, 1973, been pleased to make the under-mentioned appointments, viz.:—

MINISTRY OF HEALTH.

Members of Committees of Management of Hospitals.

RONALD BROWN TRAILL
to be the Government Appointee on Committee of Management of Orbst and District Hospital, for a further period of three years commencing the 14th April, 1973, pursuant to the provisions of sub-paragraph (ii) of paragraph (a) of the proviso to sub-section (1) of section 48 of the *Hospitals and Charities Act 1958*;

SILVESTER LAURENCE KILBY, J.P.,
to be the Government Appointee on Committee of Management of Westport Memorial Hospital (Koo-Wee-Rup), for a further period of three years commencing the 11th

April, 1973, pursuant to the provisions of sub-paragraph (ii) of paragraph (a) of the proviso to sub-section (1) of section 48 of the *Hospitals and Charities Act 1958*; and

THOMAS JOSEPH TEHAN
to be the Government Appointee on Committee of Management of Kyabram and District Memorial Community Hospital, for a period of three years pursuant to the provisions of sub-paragraph (ii) of paragraph (a) of the proviso to sub-section (1) of section 48 of the *Hospitals and Charities Act 1958*.

Trustees of Cemeteries.

COLIN BROWN
to be a Trustee of the Carngham Public Cemetery, vice R. Ringin, resigned;

DENNIS GREEN, and
LINDSAY PAGAN
to be Trustees of the Woorndoo Public Cemetery, vice S. Jervies and R. Jervies, resigned;

ALBERD HERMAN BOEHRINGER
to be a Trustee of the Yackandandah Public Cemetery, vice A. McKibbin, resigned;

ARTHUR LEONARD JAMES SAUNDERS
to be a Trustee of the Drouin Public Cemetery, vice C. Butterworth, deceased; and

LEONARD MORRIS
to be a Trustee of the Yarram Public Cemetery, vice M. Pearson, deceased, appointed pursuant to section 3 (1) of the *Cemeteries Act 1958*.

LAW DEPARTMENT.

Commissioners for Taking Declarations, &c.

GEOFFREY CLIVE HEPWORTH, care of Repco Forge Company, McNaughton-road, Clavton.

ERIC NOEL SIMONSON, care of Myer Melbourne Ltd., 314-336 Bourke-street, Melbourne.

WILLIAM JAMES WILLIAMS, care of Custom Credit Corporation Limited, 570 Bourke-street, Melbourne.

PETER LEON ISRAEL, 105 Hawthorn-road, Caulfield Junction.

WILLIAM EDWARD BROWN, 19 Howard-avenue, Churchill.

GEOFFREY KEITH McBEATH, care of John Lysaght (Aust.) Ltd., Bayview-road, Hastings.

FRANCIS JOSEPH FOX, and
LYN GIRDLESTONE, care of John Lysaght (Aust.) Ltd., Bavview-road, Hastings.

to be Commissioners for taking Declarations and Affidavits, under the *Evidence Act 1958*;

JOHN GARNET MARTIN, care of Gas and Fuel Corporation of Victoria, 171 Flinders-street, Melbourne.

JOHN THOMAS LYNCH, care of Victorian Railways, Railways Administrative Offices, 67 Spencer-street, Melbourne, and

FRANK ROBERT PEISLEY, care of Department of Agriculture, 3 Treasury-place, Melbourne.

to be Commissioners for taking Declarations and Affidavits, under the *Evidence Act 1958*, to refrain from charging fees; and

KEITH GEORGE DANIELS, 11 May-street, East Doncaster, to be Commissioners for taking Declarations and Affidavits, under the *Evidence Act 1958*, to resign upon leaving the neighbourhood of the address stated.

Justice of the Peace.

LESLIE CHARLES McLEOD, Post Office, Mallacoota, to keep the Peace in the State of Victoria.

Deputy Prothonotary.

IAN MICHAEL GRIFFITHS
to be Deputy Prothonotary at Mildura, vice G. H. Schmidt, absent on recreation leave, to take effect as from the 9th April, 1973.

Registrar of County Court, Ballarat.

JAMES PATRICK HANRAHAN,
to be Registrar of the County Court, at Ballarat, and Deputy Prothonotary at Ballarat, vice E. N. Kinchington, absent on recreation leave, to take effect as from the 2nd April, 1973.

MINES DEPARTMENT.

ROSS ALLAN BRAMLEY
to act as Mining Registrar at Maryborough for the Maryborough-Carlsbrook Division of the Maryborough Mining District, vice Richard John Canning, transferred.

DEPARTMENT OF WATER SUPPLY.
Waterworks Trusts Commissioners.

JOHN ERSKINE FRANCIS GRANT
to be a Commissioner of the Daylesford Waterworks Trust, to hold such position for a period of four years from the date hereof, subject to the provisions of the Water Act; and

ALBERT GEORGE SIDNEY BLOCK,
JOHN AUSTIN HUGHES, and
LEO IGNATIUS LARKIN,
to be Commissioners of the Hernes Oak Waterworks Trust, to hold such position for a period of four years from the date hereof, subject to the provisions of the Water Act.

T. J. FORRISTAL,
Clerk of the Executive Council.

At the Executive Council Chamber,
Melbourne, 20th March, 1973.

APPOINTMENTS.

His Excellency the Governor of the State of Victoria, by and with the advice of the Executive Council thereof, has, by Orders made on the 27th day of March, 1973, been pleased to make the under-mentioned appointments, viz.:-

CHIEF SECRETARY'S DEPARTMENT.

Electoral Returning Officers.

FRANCIS LEONARD GIULIANO,
to be Returning Officer for the Electoral District of Ballarat South, vice D. S. Cotton, resigned; and

IAN ALEXANDER STEWART,
to be Returning Officer for the Electoral District of Bellarine, vice H. B. Fittridge, resigned; and

ATHOL FRETHEROFF EGEBERG,
to be Returning Officer for the Electoral District of Evelyn, vice J. H. S. Worlley, resigned; and

STANLEY DAVID COCHRANE,
to be Returning Officer for the Electoral District of Rodney, vice J. A. White, resigned.

T. J. FORRISTAL,
Clerk of the Executive Council.

At the Executive Council Chamber,
Melbourne, 27th March, 1973.

Vegetation and Vine Diseases Act 1958.—Fruit and Vegetables Act 1958.

APPOINTMENT OF INSPECTOR.

The Public Service Board by certificate dated the 6th March, 1973, appointed the undermentioned officer to be an Inspector, under the provisions of the *Vegetation and Vine Diseases Act 1958*, and the *Fruit and Vegetables Act 1958*, without additional salary:—

ALLEN, ANTHONY DAVID, Agricultural Officer, Class "AO-1" Professional Division.

D. S. WISHART,
Director of Agriculture.

EDUCATION DEPARTMENT.

His Excellency the Governor of the State of Victoria, by and with the advice of the Executive Council thereof, doth by Order made on the 20th day of March, 1973, appoint Clarence Paul Handreck, duly elected deputy, to be a member of the Primary Teachers Registration Board, during the absence of Ian James Allan.

T. J. FORRISTAL,
Clerk of the Executive Council.

At the Executive Council Chamber,
Melbourne, 20th March, 1973.

Liquor Control Act 1968.

APPOINTMENT OF LICENSING INSPECTOR.

In accordance with the authority conferred upon me by Section 6 of the *Police Regulation Act 1958*, I, Angus Lindsay Carmichael, Deputy Commissioner of Police, do hereby appoint under sub-section (1) of Section 22 of the *Liquor Control Act 1968*, the following Officer of Police as a Licensing Inspector for the Division of the Police District as shown:—

Division Number.	Police District.	Rank and Name.
1	Melbourne	Inspector Robert Norman Hope (from 14.3.73 to 2.4.73).

A. L. CARMICHAEL,
Deputy Commissioner of Police.

Evidence Act 1958.

**COMMISSIONER FOR TAKING DECLARATIONS &c.—
APPOINTMENT REVOKED.**

His Excellency the Governor of the State of Victoria by and with the advice of the Executive Council thereof doth by Order made on the 20th day of March, 1973, revoke the appointment of Hendrik Vanderzee as a Commissioner for taking declarations and affidavits, pursuant to the provisions of the *Evidence Act 1958*.

T. J. FORRISTAL,
Clerk of the Executive Council.

At the Executive Council Chamber,
Melbourne, 20th March, 1973.

RESIGNATIONS.

His Excellency the Governor of the State of Victoria, by and with the advice of the Executive Council thereof, has, by Orders made on the 20th day of March, 1973, accepted the resignations of the persons named hereunder of the offices mentioned, viz.:—

LAW DEPARTMENT.

Commissioners for Taking Declarations, &c.

HUGH FAUX,
LIONEL DANIEL HARDY, and
JOHN MICHAEL KELLY,
as Commissioners for taking Declarations and Affidavits, pursuant to the provisions of the *Evidence Act 1958*.

T. J. FORRISTAL,
Clerk of the Executive Council.

At the Executive Council Chamber,
Melbourne, 20th March, 1973.

ORDERS IN COUNCIL

LOCAL GOVERNMENT DEPARTMENT.

At the Executive Council Chamber, Melbourne, the
twentieth day of March, 1973.

PRESENT:

His Excellency the Governor of Victoria.
Mr. Meagher | Mr. Hunt.

**APPOINTMENT OF MEMBERS OF THE LOCAL
GOVERNMENT ADVISORY BOARD.**

Pursuant to the provisions of section 17 (1) of the *Local Government Act 1958*, His Excellency the Governor of the State of Victoria, by and with the advice of the Executive Council thereof hereby appoints Louis Voumard and Albert Keith Lines, persons with a knowledge of local government to be members of the Local Government Advisory Board for a period of six months ending the 30th day of September, 1973.

And the Honorable Alan John Hunt, Her Majesty's Minister for Local Government for the State of Victoria, shall give the necessary directions herein accordingly.

T. J. FORRISTAL,
Clerk of the Executive Council.

LOCAL GOVERNMENT DEPARTMENT.

At the Executive Council Chamber, Melbourne, the
twentieth day of March, 1973.

PRESENT:

His Excellency the Governor of Victoria.
Mr. Meagher | Mr. Hunt.

**CONSENT TO SALE OF RESERVE BY THE HEIDELBERG
CITY COUNCIL.**

Whereas pursuant to the provisions of section 569BA of the *Local Government Act 1958*, certain land being portion of the Drainage Reserve on plan of subdivision No. 5585, lodged in the Office of Titles being the land shown by hachure on the plan hereunder was vested in the Council of the City of Heidelberg by Order published in the *Government Gazette*, No. 99, dated the 22nd November, 1972, and the Council of the City of Heidelberg is now of

the opinion that the land is no longer required for the purpose for which it was reserved and has requested that consent be given to the sale of the land.

And whereas the said Council—

- (a) has published in a newspaper generally circulating in the municipal district a notice describing the land and the proposal for the sale of the land and stating that the next ordinary meeting of the Council after the expiration of 40 days after publication of the notice the Council would consider any objection to the proposal and would receive any representations as to the disposal of any purchase money; and
- (b) has served a copy of the said notice on the registered proprietor of the land and those persons whom the Council considered such notice should be served; and
- (c) has posted a similar notice upon the land in question.

And whereas no person has objected to the proposed sale of the land.

Now therefore, His Excellency the Governor of the State of Victoria, by and with the advice of the Executive Council thereof, and in pursuance of the provisions of section 569BA of the *Local Government Act 1958*, hereby consents to the Council of the City of Heidelberg selling by agreement portion of Drainage Reserve on plan of subdivision No. 5585 lodged in the office of titles being the land shown by hachure on the plan hereunder.

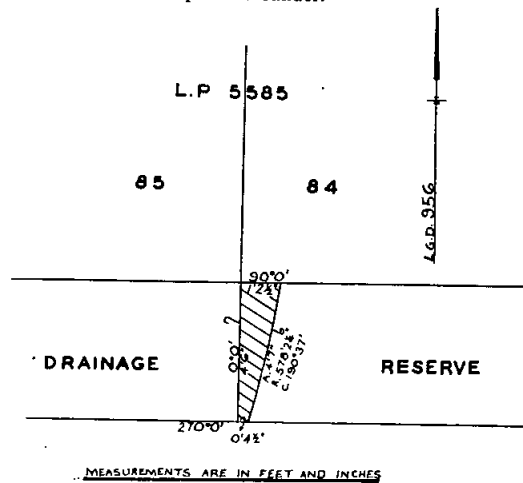

And the Honorable Alan John Hunt, Her Majesty's Minister for Local Government for the State of Victoria, shall give the necessary directions herein accordingly.

T. J. FORRISTAL,
Clerk of the Executive Council.

LOCAL GOVERNMENT DEPARTMENT.

At the Executive Council Chamber, Melbourne, the
twentieth day of March, 1973.

PRESENT:

His Excellency the Governor of Victoria.
Mr. Meagher | Mr. Hunt.

ROAD DISCONTINUED.—CITY OF MALVERN.

Whereas it is provided in section 528 (2) of the *Local Government Act 1958*, that where a road (whether or not a public highway but not being a road set out on land of the Crown) or any part thereof is not required for public use the Governor in Council on the request of the Council of the municipality in which such road is situated made not less than one month after publishing in a newspaper generally circulating in the district and posting to the registered proprietor (if any) of the land and the owners and occupiers (if any) of the lands abutting or immediately adjacent to the road notice of intention to make such request may by Order published in the *Government Gazette* direct that such road or part shall be discontinued and thereupon such road or part shall be discontinued accordingly.

And whereas the Council of the City of Malvern has requested that the Governor in Council direct that a road between Rothesay and Summerhill avenues, East Malvern, be discontinued and not less than one month previously has published in a newspaper generally circulating in the district and posted to the registered proprietor of the land in the said road and to the owners and occupiers of lands abutting or immediately adjacent to the road notice of intention to make such request.

Now therefore, His Excellency the Governor of the State of Victoria, by and with the advice of the Executive Council thereof, hereby directs:—

- (a) that the said road, which is shown by hachure on the plan hereunder shall be discontinued;
- (b) that notwithstanding such discontinuance the Council of the City of Malvern shall continue to have and possess the same right title power authority or interest in or in relation to the whole of the land shown by hachure on the said plan as it had or possessed prior to such discontinuance with respect to or in connexion with any drains or pipes laid or erected in on or over such land for the purpose of drainage; and
- (c) that, subject to any such right title power authority or interest the land in the said road may be sold by the Council of the City of Malvern by agreement.

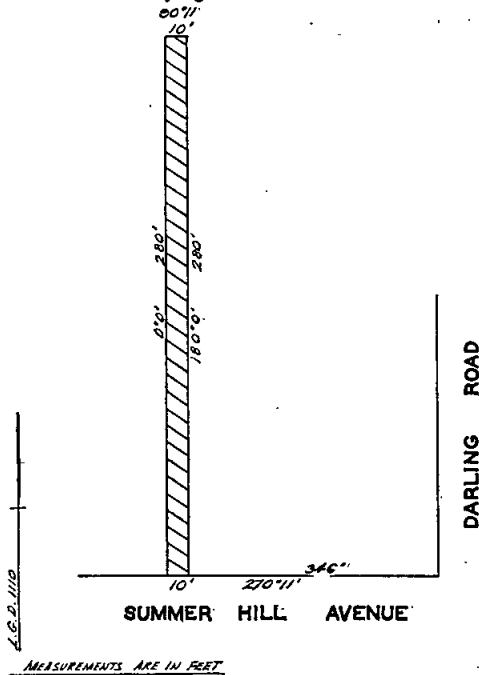

And the Honorable Alan John Hunt, Her Majesty's Minister for Local Government for the State of Victoria, shall give the necessary directions herein accordingly.

T. J. FORRISTAL,
Clerk of the Executive Council.

LOCAL GOVERNMENT DEPARTMENT.

At the Executive Council Chamber, Melbourne, the twentieth day of March, 1973.

PRESENT:
His Excellency the Governor of Victoria.
Mr. Meagher | Mr. Hunt.

ROAD DISCONTINUED.—CITY OF HEIDELBERG.

Whereas it is provided in section 528 (2) of the Local Government Act 1958, that where a road (whether or not a public highway but not being a road set out on land of the Crown) or any part thereof is not required for public use the Governor in Council on the request of the Council of the municipality in which such road is situated made

not less than one month after publishing in a newspaper generally circulating in the district and posting to the registered proprietor (if any) of the lands abutting or immediately adjacent to the road notice of intention to make such request may by Order published in the Government Gazette, direct that such road or part shall be discontinued and thereupon such road or part shall be discontinued accordingly.

And whereas the Council of the City of Heidelberg has requested that the Governor in Council direct that a road off Grove-road, Rosanna, be discontinued and not less than one month previously has published in a newspaper generally circulating in the district and posted to the registered proprietor of the land in the road and to the owner and occupiers of lands abutting or immediately adjacent to the road notice of intention to make such request.

Now therefore, His Excellency the Governor of the State of Victoria, by and with the advice of the Executive Council thereof, hereby directs:—

- (a) that the said road, which is shown by hachure on the plan hereunder, shall be discontinued;
- (b) that notwithstanding such discontinuance the Melbourne and Metropolitan Board of Works shall continue to have and possess the same right title power authority or interest in or in relation to the whole of the land shown by hachure on the said plan as it had or possessed prior to such discontinuance with respect to or in connexion with any drains or pipes laid or erected in on or over such lands for the purposes of drainage or sewerage; and
- (c) that, subject to any such right title power authority or interest, the land in the said road may be sold by the Council of the City of Heidelberg by agreement.

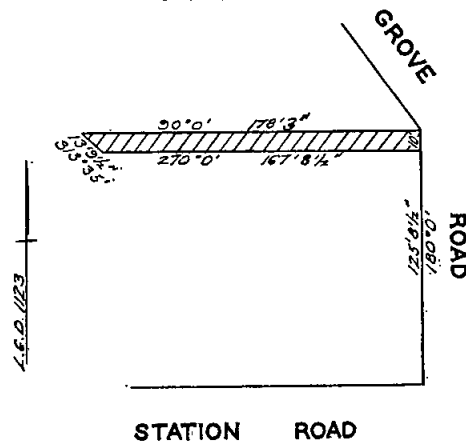

And the Honorable Alan John Hunt, Her Majesty's Minister for Local Government for the State of Victoria, shall give the necessary directions herein accordingly.

T. J. FORRISTAL,
Clerk of the Executive Council.

LOCAL GOVERNMENT DEPARTMENT.

At the Executive Council Chamber, Melbourne, the twentieth day of March, 1973.

PRESENT:
His Excellency the Governor of Victoria.
Mr. Meagher | Mr. Hunt.

ROAD DISCONTINUED.—CITY OF MELBOURNE.

Whereas it is provided in section 528 (2) of the Local Government Act 1958, that where a road (whether or not a public highway but not being a road set out on land of the Crown) or any part thereof is not required for public use the Governor in Council on the request of the Council of the municipality in which such road is situated made not less than one month after publishing in a newspaper generally circulating in the district and posting to the registered proprietor (if any) of the land and the owners and occupiers (if any) of the lands abutting or immediately adjacent to the road notice of intention to make

such request may by Order published in the *Government Gazette* direct that such road or part shall be discontinued and thereupon such road or part shall be discontinued accordingly.

And whereas the Council of the City of Melbourne has requested that the Governor in Council direct that a road off Jones-lane, Melbourne, be discontinued and not less than one month previously has published in a newspaper generally circulating in the district and posted to the registered proprietor of the land in the road and to the owners and occupiers of lands abutting or immediately adjacent to the road notice of intention to make such request.

Now therefore, His Excellency the Governor of the State of Victoria, by and with the advice of the Executive Council thereof, hereby directs that the portion of the said road, which is shown by hachure on the plan hereunder, shall be discontinued and that the land may be sold by the Council of the City of Melbourne by agreement.

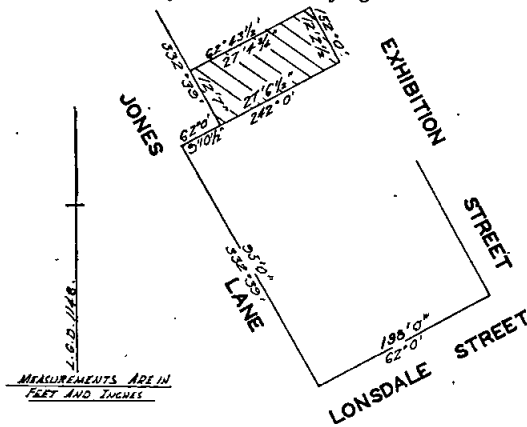

And the Honorable Alan John Hunt, Her Majesty's Minister for Local Government for the State of Victoria, shall give the necessary directions herein accordingly.

T. J. FORRISTAL,
Clerk of the Executive Council.

LOCAL GOVERNMENT DEPARTMENT.

At the Executive Council Chamber, Melbourne, the twentieth day of March, 1973.

PRESENT:

His Excellency the Governor of Victoria.
Mr. Meagher | Mr. Hunt.

ROAD DISCONTINUED.—CITY OF BOX HILL.

Whereas it is provided in section 528 (2) of the *Local Government Act 1958*, that where a road (whether or not a public highway but not being a road set out on land of the Crown) or any part thereof is not required for public use the Governor in Council on the request of the Council of the municipality in which such road is situated made not less than one month after publishing in a newspaper generally circulating in the district and posting to the registered proprietor (if any) of the land and the owners and occupiers (if any) of the lands abutting or immediately adjacent to the road notice of intention to make such request may by Order published in the *Government Gazette* direct that such road or part shall be discontinued and thereupon such road or part shall be discontinued accordingly.

And whereas the Council of the City of Box Hill has requested that the Governor in Council direct that portion of a road between Tennyson-street and Johnston-street, Burwood, be discontinued and not less than one month previously has published in a newspaper generally circulating in the district and posted to the registered proprietor of the land in the road and to the owners and occupiers of lands abutting or immediately adjacent to the road notice of intention to make such request.

Now therefore, His Excellency the Governor of the State of Victoria, by and with the advice of the Executive Council thereof, hereby directs—

- (a) that the portion of the said road, which is shown by hachure and cross-hachure on the plan hereunder, shall be discontinued;

- (b) that notwithstanding such discontinuance the Melbourne and Metropolitan Board of Works shall continue to have and possess the same right title power authority or interest in or in relation to the whole of the land shown by cross-hachure on the said plan as it had or possessed prior to such discontinuance with respect to or in connexion with any drains or pipes laid or erected in on or over such land for the purpose of drainage or sewerage; and
- (c) that, such to any such right title power authority or interest, the land in the said road may be sold by the Council of the City of Box Hill by agreement.

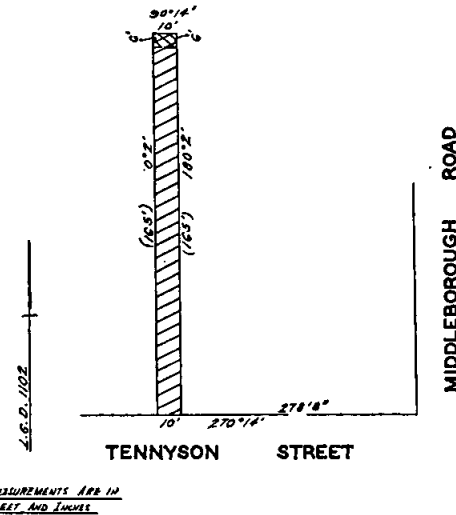

And the Honorable Alan John Hunt, Her Majesty's Minister for Local Government for the State of Victoria, shall give the necessary directions herein accordingly.

T. J. FORRISTAL,
Clerk of the Executive Council.

LOCAL GOVERNMENT DEPARTMENT.

At the Executive Council Chamber, Melbourne, the twentieth day of March, 1973.

PRESENT:

His Excellency the Governor of Victoria.
Mr. Meagher | Mr. Hunt.

ROAD DISCONTINUED.—CITY OF MELBOURNE.

Whereas it is provided in section 528 (2) of the *Local Government Act 1958*, that where a road (whether or not a public highway but not being a road set out on land of the Crown) or any part thereof is not required for public use the Governor in Council on the request of the Council of the municipality in which such road is situated made not less than one month after publishing in a newspaper generally circulating in the district and posting to the registered proprietor (if any) of the land and the owners and occupiers (if any) of the lands abutting or immediately adjacent to the road notice of intention to make such request may by Order published in the *Government Gazette* direct that such road or part shall be discontinued and thereupon such road or part shall be discontinued accordingly.

And whereas the Council of the City of Melbourne has requested that the Governor in Council direct that a road off Waterloo-street, Carlton, be discontinued and not less than one month previously has published in a newspaper generally circulating in the district and posted to the registered proprietor of the land in the road and to the owners and occupiers of lands abutting or immediately adjacent to the road notice of intention to make such request.

Now therefore, His Excellency the Governor of the State of Victoria, by and with the advice of the Executive Council thereof, hereby directs that the said road, which is shown hatched on the plan hereunder shall be discontinued and that the land may be sold by the Council of the City of Melbourne by agreement.

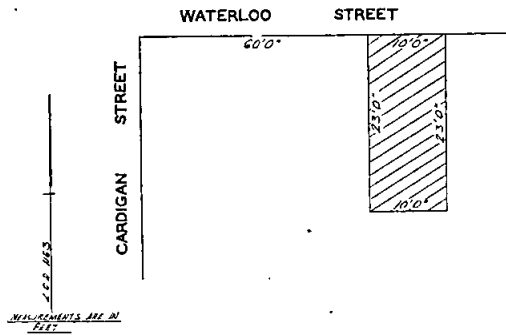

And the Honorable Alan John Hunt, Her Majesty's Minister for Local Government for the State of Victoria, shall give the necessary directions herein accordingly.

T. J. FORRISTAL,
Clerk of the Executive Council.

COUNTRY ROADS BOARD.

At the Executive Council Chamber, Melbourne, the twentieth day of March, 1973.

PRESENT:

His Excellency the Governor of Victoria.
Mr. Meagher | Mr. Hunt.

ORDER APPROVING OF LAND BEING ACQUIRED AND ROADS, DEVIATIONS OR WIDENINGS BEING MADE.

His Excellency the Governor of the State of Victoria, by and with the advice of the Executive Council thereof, being satisfied that there are funds legally available for acquiring the land, doth hereby approve the acquiring of the land described in the schedule hereunder and the making of new roads and deviations from and widenings of existing roads referred to in the said schedule.

SCHEDULE.

Main Roads.

The land shown hatched on plan numbered G.P.13210 hereunder required for the widening of the Hepburn-Newstead road in the Shire of Daylesford and Glenlyon and making of the widening thereon.

MAIN ROAD
HEPBURN - NEWSTEAD ROAD
SHIRE OF DAYLESFORD & GLENLYON

Measurements in Feet & Inches

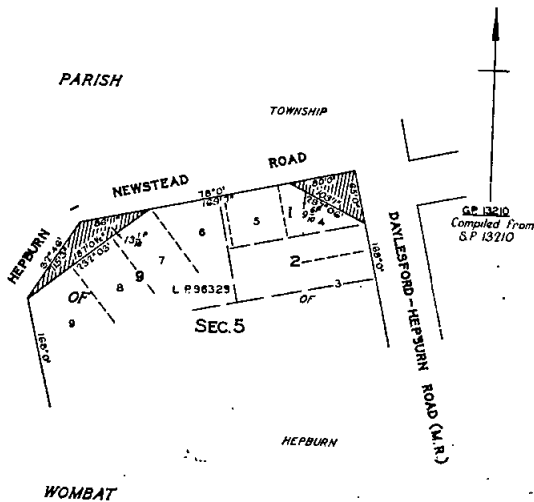

The land shown hatched on plan numbered G.P.13185 hereunder required for the widening of the Bittern-Dromana road in the Shire of Hastings and making of the widening thereon.

MAIN ROAD
BITTERN - DROMANA ROAD

SHIRE OF HASTINGS

Measurements in Links

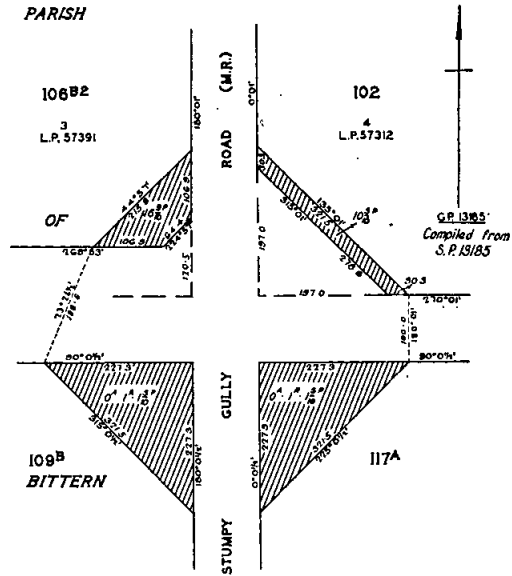

And the Honorable Alan John Hunt, Her Majesty's Minister for Local Government for the State of Victoria, shall give the necessary directions herein accordingly.

T. J. FORRISTAL,
Clerk of the Executive Council.

TOWN AND COUNTRY PLANNING ACT 1961.

At the Executive Council Chamber, Melbourne, the twentieth day of March, 1973.

PRESENT:

His Excellency the Governor of Victoria.
Mr. Meagher | Mr. Hunt.

REVOCATION IN PART OF THE CITY OF ECHUCA PLANNING SCHEME, REVOCATION NO. 1.

Whereas it is provided by sub-sections (4), (4A), (4B) and (4C) of section 32 of the Town and Country Planning Act 1961 that the Governor in Council, upon application of the Town and Country Planning Board or the responsible Authority or of any other person or body of persons may revoke the whole or any part of any planning scheme if he thinks that in the special circumstances of the case it should be so revoked;

And whereas an application has been made by Mr. R. B. Snow of Echuca and the Minister has considered a report by the Town and Country Planning Board and has consulted the Responsible Authority;

And whereas it is provided by sub-section (5) of section 32 of the Town and Country Planning Act 1961, that the Governor in Council may by Order prohibit restrict or regulate the use or development of any land to which the revoked scheme or part related and specify that any use or development permitted under the Order is permitted only subject to the grant of a permit by the Responsible Authority enforcing and carrying out the part of the scheme so revoked;

Now therefore, His Excellency the Governor of the State of Victoria by and with the advice of the Executive Council doth hereby—

- (i) revoke the City of Echuca Planning Scheme in so far as it applies to all that land being part of Crown allotments 32E and 32F, Parish of Echuca North, the boundaries of which are as follows:—

Commencing at the south-east corner of Crown allotment 32F; thence by a line bearing west along the northern alignment of an unnamed Government road for a distance of 2,300 links to the south-east corner of Crown allotment 31; thence by a line bearing north for a distance of 1,687 links; thence by a line bearing east along the northern boundary of Crown allotment 32E for a distance of 1,433 links; thence by a line bearing 152 deg. 49 min. along the westernmost alignment of the Murray Valley Highway for a distance of 1,896 links to the point of commencement; and

- (ii) specify that any use or development of any land described in (i) above is permitted only subject to the grant of a permit by the Council of the City of Echuca.

And the Honorable Alan John Hunt, Her Majesty's Minister for Local Government for the State of Victoria, shall give the necessary directions herein accordingly.

T. J. FORRISTAL,
Clerk of the Executive Council.

TOWN AND COUNTRY PLANNING ACT 1961.

At the Executive Council Chamber, Melbourne, the twentieth day of March, 1973.

PRESENT:

His Excellency the Governor of Victoria.
Mr. Meagher | Mr. Hunt.

REVOCATION IN PART OF THE SHIRE OF SHERBROOKE PLANNING SCHEME 1965, REVOCATION NO. 11.

Whereas it is provided by sub-sections (4), (4A), (4B) and (4C) of section 32 of the *Town and Country Planning Act 1961* that the Governor in Council, upon application of the Town and Country Planning Board or the responsible Authority or of any other person or body of persons may revoke the whole or any part of any planning scheme if he thinks that in the special circumstances of the case it should be so revoked;

And whereas an application has been made by the Council of the Shire of Sherbrooke and the Minister has considered a report by the Town and Country Planning Board and has consulted the Responsible Authority;

And whereas it is provided by sub-section (5) of section 32 of the *Town and Country Planning Act 1961*, that the Governor in Council may by Order prohibit, restrict or regulate the use or development of any land to which the revoked scheme or part related and specify that any use or development permitted under the Order is permitted only subject to the grant of a permit by the Responsible Authority enforcing and carrying out the part of the scheme so revoked;

Now therefore, His Excellency the Governor of the State of Victoria by and with the advice of the Executive Council doth hereby—

- (i) revoke the Shire of Sherbrooke Planning Scheme 1965 in so far as it applies to all that land being lot 58 on plan of subdivision 92432, lodged at the Office of Titles. The subject land is located at the south-east corner of Morris-road and Melaleuca-drive, Upwey;
- (ii) specify that any use or development of any land described in (i) above is permitted only subject to the grant of a permit by the Shire of Sherbrooke.

And the Honorable Alan John Hunt, Her Majesty's Minister for Local Government for the State of Victoria, shall give the necessary directions herein accordingly.

T. J. FORRISTAL,
Clerk of the Executive Council.

MELBOURNE UNDERGROUND RAIL LOOP ACT 1970, (No. 8023).

At the Executive Council Chamber, Melbourne, the twentieth day of March, 1973.

PRESENT:

His Excellency the Governor of Victoria.
Mr. Meagher | Mr. Hunt.

Whereas His Excellency the Governor of the State of Victoria, by and with the advice of the Executive Council thereof, has this day consented, pursuant to the provisions of the *Melbourne Underground Rail Loop Act 1970*, to the Melbourne Underground Rail Loop Authority raising by way of a loan the sum of Five hundred thousand dollars (\$500,000): And whereas His Excellency the Governor in Council is satisfied that a sufficient proportion of the loan to be raised will fall due and be repaid in each year during the currency of the proposed loan: Now therefore it is directed pursuant to the provisions of section 16 (3) of the said Act, that it shall not be necessary to provide a sinking fund in connexion with such loan.

And the Honorable Rupert James Hamer, Her Majesty's Treasurer for the State of Victoria, shall give the necessary directions herein accordingly.

T. J. FORRISTAL,
Clerk of the Executive Council.

HEALTH ACT 1958, (No. 6270).

At the Executive Council Chamber, Melbourne, the twentieth day of March, 1973.

PRESENT:

His Excellency the Governor of Victoria.
Mr. Meagher | Mr. Hunt.

EXTENSION UNDER SECTION 66 OF THE HEALTH ACT 1958, (No. 6270).

Under the powers conferred by section 66 (6) of the *Health Act 1958* (No. 6270), His Excellency the Governor of the State of Victoria, by and with the advice of the Executive Council of the said State, doth hereby order that the provisions of section 66 of the said Act shall be extended to include all areas and districts under the control of any water supply authority, administering a reticulated water supply within the State of Victoria.

And the Honorable John Frederick Rossiter, Her Majesty's Minister of Health for the State of Victoria, shall give the necessary directions herein accordingly.

T. J. FORRISTAL,
Clerk of the Executive Council.

DEPARTMENT OF CROWN LANDS AND SURVEY.

At the Executive Council Chamber, Melbourne, the twentieth day of March, 1973.

PRESENT:

His Excellency the Governor of Victoria.
Mr. Meagher | Mr. Hunt.

REVOCATION OF TEMPORARY RESERVATIONS OF LANDS BY ORDERS IN COUNCIL.

His Excellency the Governor of the State of Victoria, by and with the advice of the Executive Council thereof, doth hereby, in pursuance of the provisions of the *Land Act 1958*, revoke the temporary reservations of lands by Orders in Council hereinafter described, viz.:—

NETHERBY.—The temporary reservation by Order in Council of the 6th August, 1888, of 2 roods of land in the Township of Netherby as a site for Public Buildings.—(N.143^(*)) (Rs.2058).

OLINDA.—The temporary reservation by Order in Council of the 16th January, 1968, of 4 acres 3 roods 39 perches of land in the Township of Olinda as a site for State School purposes, so far only as regards the portion containing 2 roods 19 perches, comprised within the boundaries published in the *Government Gazette*, of the 21st February, 1973.—(O.25^(*)) (Rs.6866).

And the Honorable William Archibald Borthwick, Her Majesty's Minister of Lands for the State of Victoria, shall give the necessary directions herein accordingly.

T. J. FORRISTAL,
Clerk of the Executive Council.

DEPARTMENT OF CROWN LANDS AND SURVEY.

At the Executive Council Chamber, Melbourne, the twentieth day of March, 1973.

PRESENT:

His Excellency the Governor of Victoria.
Mr. Meagher | Mr. Hunt.

LANDS TEMPORARILY RESERVED AS SITES

His Excellency the Governor of the State of Victoria, by and with the advice of the Executive Council thereof, doth hereby, in pursuance of section 14 of the *Land Act* 1958, reserve temporarily from sale, from being leased and from having a licence granted in respect thereof, and also except from occupation for mining purposes under any miner's right, the land hereinafter described:—

DUNOLLY.—Site for Public purposes (Supply of Gravel) 43 acres 1 rood 24 perches, Parish of Dunolly, County of Gladstone as indicated by hatching on plan hereunder.—(D.125⁽¹²⁾) (Rs.9720).

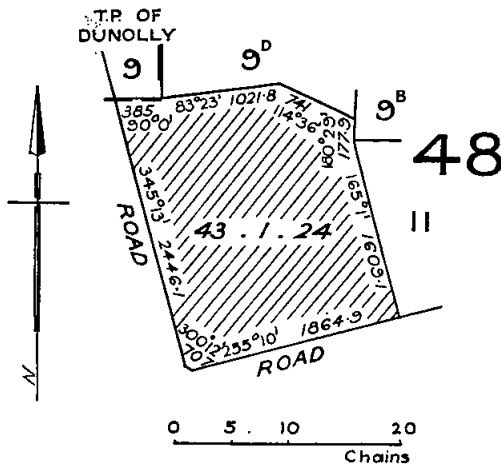

WAARRE.—Site for Water Supply purposes, 2 perches, Parish of Waarre, County of Heysbury, as indicated by hatching on plan hereunder.—(W.360^(E)) (Rs.9724).

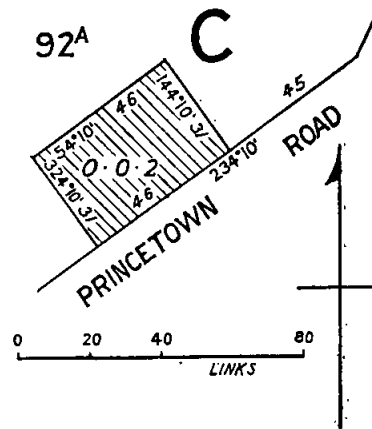

WERRIMULL.—Site for Public Purposes (General Health Centre), 1 rood 8 perches, Township of Werrimull, Parish of Werrimull, County of Millewa; as indicated by hatching on plan hereunder.—(W.423⁽⁴⁾) (Rs.8472).

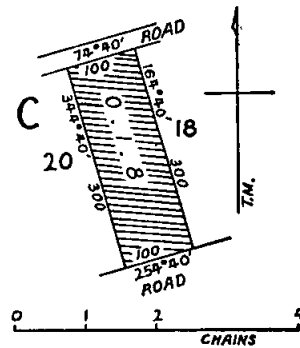

GEE LONG.—Site for Mental Health Authority purposes 15 acres 2 roods, City of Geelong, Parish of Corio, County of Grant as indicated by hatching on plan hereunder.—(C.272⁽⁶⁾) (Rs.8233).

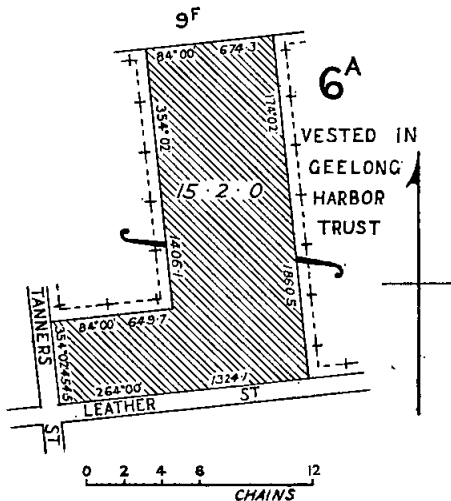

YANAKIE.—Site for Public Purposes (Native Flora and Public Recreation), 18 acres, Parish of Yanakie, County of Buln Buln, as indicated by hatching on plan hereunder.—(Y.117⁽⁴⁾) (Rs.9730).

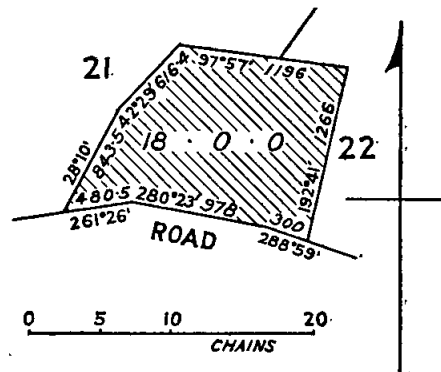

TRUGANINA (LAVERTON).—Site for Public Recreation, 59 acres 1 rood 11 perches, more or less, Parish of Truganina, County of Bourke, as indicated by hatching on plan hereunder.—(T.109⁽⁶⁾) (Rs.9726).

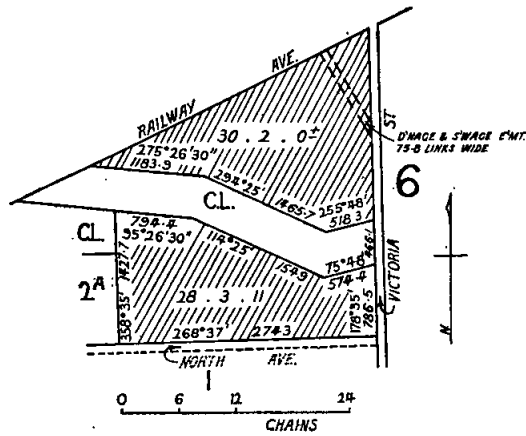

TOTAL AREA OF HATCHED PORTIONS
59.1.11²

TRUGANINA (LAVERTON).—Site for Public Recreation, 5 acres 3 roods 32 perches, Parish of Truganina, County of Bourke, as indicated by hatching on plan hereunder.—(T.109^(*) (Rs.9727).

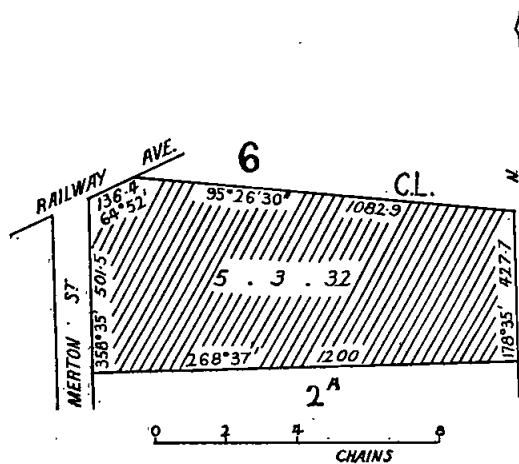

TRUGANINA (LAVERTON).—Site for Public purposes (Drainage purposes), 16 acres 1 rood 6 perches, Parish of Truganina, County of Bourke, as indicated by hatching on plan hereunder.—(T.109^(*) (Rs.9728).

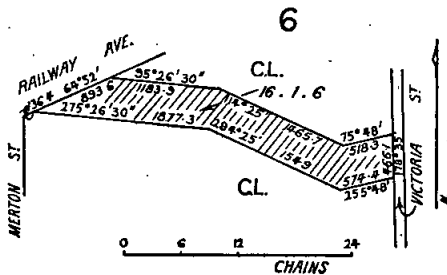

And the Honorable William Archibald Borthwick, Her Majesty's Minister of Lands for the State of Victoria, shall give the necessary directions herein accordingly.

T. J. FORRISTAL,
Clerk of the Executive Council.

LAND ACT 1958.

At the Executive Council Chamber, Melbourne, the twentieth day of March, 1973.

PRESENT:

His Excellency the Governor of Victoria.
Mr. Meagher | Mr. Hunt.

UNUSED ROAD CLOSED.

In pursuance of the provisions of section 349 of the Land Act 1958, His Excellency the Governor of Victoria, by and with the advice of the Executive Council thereof and the concurrence in writing of the Council of the municipality concerned doth hereby close the unused road referred to hereunder, viz:—

Township of Molesworth, Parish of Molesworth, County of Anglesey being the road as indicated by hatching on plan hereunder.—(M.163^(*) (H.032663).

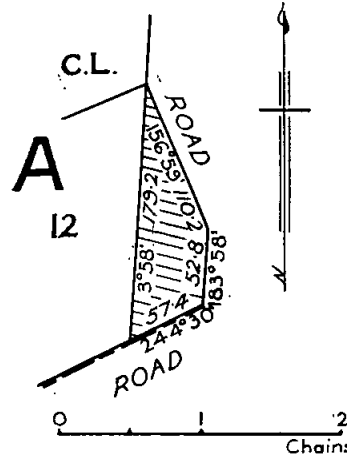

And the Honorable William Archibald Borthwick, Her Majesty's Minister of Lands for the State of Victoria, shall give the necessary directions herein accordingly.

T. J. FORRISTAL,
Clerk of the Executive Council.

LOCAL GOVERNMENT DEPARTMENT.

At the Executive Council Chamber, Melbourne, the twenty-seventh day of March, 1973.

PRESENT:

His Excellency the Governor of Victoria.
Mr. Rossiter | Mr. Smith.
Mr. Scanlan

CONFIRMATION OF SEPARATE RATE—SHIRE OF ELTHAM.

In pursuance of the provisions of section 287 of the Local Government Act 1958, His Excellency the Governor of the State of Victoria, by and with the advice of the Executive Council thereof hereby confirms a separate rate of two point nine three (2.93) cents in the dollar on the unimproved capital value of the properties described in Schedule "A" hereunder, one point seven zero seven (1.707) cents in the dollar on the unimproved capital value of property described in Schedule "B" hereunder and one point one nine one (1.191) cents in the dollar on the unimproved capital value of the property described in Schedule "C" hereunder, which rate was made by the Council of the Shire of Eltham on the 15th August, 1972, for the purpose of providing off-street parking facilities for use in connexion with the Montmorency (Were-street) Shopping Centre.

Schedule "A"—Properties to be Rated at 2.93 cents in the Dollar.

1. All rateable property fronting the western side of Were-street between Rattray-road and Station-street, Montmorency and on the eastern side between Rattray-road and Binns-street, Montmorency.

2. Nos. 53A, 55 and 57 Rattray-road, Montmorency.
3. Nos. 2 to 12 (inclusive) on the south side of Binns-street, Montmorency.
4. All rateable property fronting the south side of Station-road between Were-street and Wilson-avenue, Montmorency.

Schedule "B"—Property to be Rated at 1.707 Cents in the Dollar.

1. Rateable property at the north-west corner of the intersection of Were-street and Rattray-road, Montmorency.

Schedule "C"—Property to be Rated at 1.191 Cents in the Dollar.

1. No. 59 Rattray-road, Montmorency.

And the Honorable Alan John Hunt, Her Majesty's Minister for Local Government for the State of Victoria, shall give the necessary directions herein accordingly.

T. J. FORRISTAL,
Clerk of the Executive Council.

LOCAL GOVERNMENT DEPARTMENT.

At the Executive Council Chamber, Melbourne, the twenty-seventh day of March, 1973.

PRESENT:

His Excellency the Governor of Victoria.	
Mr. Rossiter	Mr. Smith.
Mr. Scanlan	

CONFIRMATION OF SEPARATE RATE—CITY OF MOORABBIN.

In pursuance of the provisions of section 287 of the *Local Government Act 1958*, His Excellency the Governor of the State of Victoria, by and with the advice of the Executive Council thereof, hereby confirms a separate rate of point six (0.6) cents in the dollar on the Unimproved Capital Value of the properties described hereunder, which rate was made by the Council of the City of Moorabbin on the 5th February, 1973 for the purpose of providing off-street parking facilities for the business and commercial area of Moorabbin, east of the Melbourne to Frankston Railway line, in the municipal district of Moorabbin.

Properties to be Rated.

1. All those rateable properties on the north side of South-road from Railway-crescent to Jasper-road.
2. All those rateable properties on the south side of South-road from Station-street to Taylor-street.
3. All those rateable properties on both sides of Station-street from South-road to Nepean Highway.
4. All those rateable properties on the north side of Central-avenue from Station-street to Taylor-street.
5. All those rateable properties on the south side of Central-avenue from Station-street to Tuck-street.
6. All those rateable properties on the west side of Tuck-street for a distance of 216 ft. 11 in. from Central-avenue.
7. All those rateable properties on the east side of Nepean Highway for a distance of 102 ft. 6 in. southerly from Station-street.
8. All those rateable properties on the west side of Taylor-street from South-road to Central-avenue.

And the Honorable Alan John Hunt, Her Majesty's Minister for Local Government for the State of Victoria, shall give the necessary directions herein accordingly.

T. J. FORRISTAL,
Clerk of the Executive Council.

LOCAL GOVERNMENT DEPARTMENT.

At the Executive Council Chamber, Melbourne, the twenty-seventh day of March, 1973.

PRESENT:

His Excellency the Governor of Victoria.	
Mr. Rossiter	Mr. Smith.
Mr. Scanlan	

VARIATION OF SEPARATE RATE DULY MADE AND CONFIRMED—CITY OF BRUNSWICK.

Whereas by Order published in the *Government Gazette* on the 26th May, 1971, the Governor in Council, pursuant to the provisions of section 287 of the *Local Government*

Act 1958, confirmed a separate rate made by the Council of the City of Brunswick for the purpose of providing off-street parking facilities for Sydney-road from Brunswick-road to Moreland-road.

And whereas it has been made to appear to the Governor in Council that certain properties included in that separate rate will not receive any benefit from the levying and expending of the separate rate.

Now therefore, His Excellency, the Governor of the State of Victoria, by and with the advice of the Executive Council thereof and in pursuance of the provisions of subsection 4A of section 290 of the *Local Government Act 1958* hereby varies the said separate rate by striking out any reference to the properties specified hereunder and to the persons liable to be rated in respect of the properties:—

SCHEDULE OF PROPERTIES.

1. 26 Stewart-street, Brunswick.
2. 21 Ballarat-street, Brunswick.

And the Honorable Alan John Hunt, Her Majesty's Minister for Local Government for the State of Victoria, shall give the necessary directions herein accordingly.

T. J. FORRISTAL,
Clerk of the Executive Council.

LOCAL GOVERNMENT DEPARTMENT.

At the Executive Council Chamber, Melbourne, the twenty-seventh day of March, 1973.

PRESENT:

His Excellency the Governor of Victoria.	
Mr. Rossiter	Mr. Smith.
Mr. Scanlan	

CONSENT TO INCLUSION OF ADDITIONAL PROPERTIES DURING THE CURRENCY OF A SEPARATE RATE—CITY OF BRUNSWICK.

Whereas—

- (a) By Order published in the *Government Gazette* on the 26th May, 1971, the Governor in Council, pursuant to the provisions of section 287 of the *Local Government Act 1958*, confirmed a separate rate made by the Council of the City of Brunswick for the purpose of providing off-street parking facilities for Sydney-road from Brunswick-road to Moreland-road;
- (b) the Council of the City of Brunswick is now of the opinion that certain properties, being the properties described in the schedule hereto, not being properties with respect to which the rate is levied would benefit from the works or undertakings carried out or to be carried out with the proceeds of the rate or with any monies borrowed on the security of the rate; and
- (c) the Council has not sooner than one month after serving written notice on the owners and occupiers of the said properties made and levied a rate of one cent (1.0) in the dollar on the unimproved capital value of these properties:—

SCHEDULE OF ADDITIONAL PROPERTIES REFERRED TO.

1. Albert-street Nos. 191-199 and 278.
2. Albion-street Nos. 183, 185, 187, 189, 203, 209 and 217.
3. Barkly-street Nos. 284, 286 and 294.
4. Black-street No. 14.
5. Blyth-street Nos. 1 and 4.
6. Breese-street Nos. 10, Rear 28, Rear 30, Rear 30A, Rear 32, Rear 34 and 34, and 37-39.
7. Cameron-street Nos. 1, 1A, 1B, 1C, 5, 6, 7, 27 and 29.
8. Charles-street Nos. 17, 19 and 19A.
9. Cozens-street Nos. 14, 17A, 18 and 20.
10. Dawson-street Nos. 5-7.
11. De Carle-street Nos. 34, Rear 49, and 74.
12. Dods-street No. 24.
13. Duckett-street Nos. 2-6, 5, 7, 8 and 10.
14. Edward-street Nos. 12-14 and 41.
15. Florence-street Nos. 1-3, 2, 4, 5 and 6.
16. Hope-street Nos. 1, 2, 9-11, 14 and 20-22.
17. Lobb-street Nos. 39 and 43.
18. McIvor-street Nos. 6-8.
19. Manallack-street Nos. 1-11.
20. Mitchell-street No. 4.
21. Moreland-road No. 204.
22. Ovens-street Nos. 30 and 38.
23. Phoenix-street No. 1.

- 24. Saxon-street Nos. 3 and 24.
- 25. Staley-street Nos. 2A and 2C.
- 26. Stewart-street No. 1.
- 27. Talbot-street Nos. 1, 3 and 11.
- 28. Thomas-street No. 27.
- 29. Tinning-street Nos. 23 and 25.
- 30. Union-street Nos. 5A, 11, 15A and 16.
- 31. Victoria-street Nos. 242, 248, 264, 274, 284, 287-291, 334 and 370.
- 32. West-street Nos. 1 and 3.
- 33. Western-street Nos. 6, 11, 19, 23, 24, 27 and 32.
- 34. Wilkinson-street No. 28.
- 35. William-street Nos. 1-3.
- 36. Wilson-avenue No. 17.

Now therefore, His Excellency the Governor of the State of Victoria, by and with the advice of the Executive Council thereof, and in pursuance of the provisions of section 290 of the said Act hereby consents to the rate so made and levied forming part of the separate rate confirmed by notice published in the *Government Gazette* as aforesaid.

And the Honorable Alan John Hunt, Her Majesty's Minister for Local Government for the State of Victoria, shall give the necessary directions herein accordingly.

T. J. FORRISTAL,
Clerk of the Executive Council.

CASTLEMAINE SEWERAGE AUTHORITY.

At the Executive Council Chamber, Melbourne, the twenty-seventh day of March, 1973.

PRESENT:

His Excellency the Governor of Victoria.
Mr. Rossiter | Mr. Smith.
Mr. Scanlan

CONSENT TO BORROWING \$8,400.

Under the powers conferred by the Sewerage Districts Act and all other powers enabling him in that behalf, His Excellency the Governor of the State of Victoria, by and with the advice of the Executive Council of the said State, hereby consents to the Castlemaine Sewerage Authority borrowing the sum of Eight thousand four hundred dollars (\$8,400), for the conversion of Loan No. 7.

And the Honorable Roberts Christian Dunstan, Her Majesty's Minister of Water Supply for the State of Victoria, shall give the necessary directions herein accordingly.

T. J. FORRISTAL,
Clerk of the Executive Council.

FRANKSTON SEWERAGE AUTHORITY.

At the Executive Council Chamber, Melbourne, the twenty-seventh day of March, 1973.

PRESENT:

His Excellency the Governor of Victoria.
Mr. Rossiter | Mr. Smith.
Mr. Scanlan

CONSENT TO BORROWING \$220,000.

Under the powers conferred by the Sewerage Districts Act and all other powers enabling him in that behalf, His Excellency the Governor of the State of Victoria, by and with the advice of the Executive Council of the said State, doth hereby consent to the Frankston Sewerage Authority borrowing the sum of Two hundred and twenty thousand dollars (\$220,000), in two amounts of Two hundred thousand dollars (\$200,000) and Twenty thousand dollars (\$20,000) respectively, to meet the cost of sewerage works as set forth in the detailed statement bearing date 22nd March, 1973.

And the Honorable Roberts Christian Dunstan, Her Majesty's Minister of Water Supply for the State of Victoria, shall give the necessary directions herein accordingly.

T. J. FORRISTAL,
Clerk of the Executive Council.

HEYWOOD SEWERAGE AUTHORITY.

At the Executive Council Chamber, Melbourne, the twenty-seventh day of March, 1973.

PRESENT:

His Excellency the Governor of Victoria.
Mr. Rossiter | Mr. Smith.
Mr. Scanlan

AMENDMENT OF ORDER.—EXTENT OF SEWERAGE DISTRICT INCREASED AND DIMINISHED AND LANDS TO BE ACQUIRED.

Under the powers conferred by the Sewerage Districts Act and all other powers enabling him in that behalf, His Excellency the Governor of the State of Victoria, by and with the advice of the Executive Council of the said State doth hereby:—

- (a) amend the site of a rising main as shown on a plan accompanying the Order in Council proclaiming the Sewerage Authority and constituting the Heywood Sewerage Authority made on 26th August, 1970, in accordance with the accompanying plan.
- (b) declare, order and direct that the Heywood Sewerage District be increased and diminished as shown on a plan accompanying this Order and as on and from the date hereof extent of such District shall be deemed to be increased and diminished accordingly.
- (c) consent to the Heywood Sewerage Authority acquiring lands as shown on the accompanying plan.

And the said plan is approved by the Governor in Council by and with the Order and deposited in the office of the State Rivers and Water Supply Commission, Melbourne.—(Corr. No. 69/845/87).

And the Honorable Roberts Christian Dunstan, Her Majesty's Minister of Water Supply for the State of Victoria, shall give the necessary directions herein accordingly.

T. J. FORRISTAL,
Clerk of the Executive Council.

FRANKSTON SEWERAGE AUTHORITY.

At the Executive Council Chamber, Melbourne, the twenty-seventh day of March, 1973.

PRESENT:

His Excellency the Governor of Victoria.
Mr. Rossiter | Mr. Smith.
Mr. Scanlan

CONSENT TO BORROWING \$400,000.

Under the powers conferred by the Sewerage Districts Act and all other powers enabling him in that behalf, His Excellency the Governor of the State of Victoria, by and with the advice of the Executive Council of the said State, hereby consents to the Frankston Sewerage Authority borrowing the sum of Four hundred thousand dollars (\$400,000) in two amounts of Two hundred thousand dollars (\$200,000) and One hundred thousand dollars (\$100,000) and two amounts each of Fifty thousand dollars (\$50,000) respectively, for the carrying out of works in accordance with the provisions of sections 95, 130 and 137 of the *Sewerage Districts Act 1958*. All moneys received by the said Authority in payment of costs and expenses of the said works, or any of them, shall be set aside for the purpose of and applied in repayment of the sum so borrowed.

And the Honorable Roberts Christian Dunstan, Her Majesty's Minister of Water Supply for the State of Victoria, shall give the necessary directions herein accordingly.

T. J. FORRISTAL,
Clerk of the Executive Council.

DROUIN SEWERAGE AUTHORITY.

At the Executive Council Chamber, Melbourne, the
twenty-seventh day of March, 1973.

PRESENT:

His Excellency the Governor of Victoria.	
Mr. Rossiter	Mr. Smith.
Mr. Scanlan	

EXTENT OF DISTRICT INCREASED.

Under the powers conferred by the Sewerage Districts Act and all other powers enabling him in that behalf, His Excellency the Governor of the State of Victoria, by and with the advice of the Executive Council of the said State, doth hereby declare, order and direct that the extent of the Sewerage District of the Drouin Sewerage Authority be increased by adding to the same the lands comprised within the boundaries shown on a plan approved by the Governor in Council and deposited in the office of the State Rivers and Water Supply Commission, Melbourne (Corr. No. 68/4162/152) and as on and from the date hereof the extent of such District shall be and be deemed to be increased accordingly.

And the Honorable Roberts Christian Dunstan, Her Majesty's Minister of Water Supply for the State of Victoria, shall give the necessary directions herein accordingly.

T. J. FORRISTAL,
Clerk of the Executive Council.

WEST MOORABOOL WATER BOARD.

At the Executive Council Chamber, Melbourne, the
twenty-seventh day of March, 1973.

PRESENT:

His Excellency the Governor of Victoria.	
Mr. Rossiter	Mr. Smith.
Mr. Scanlan	

CONSENT TO BORROWING \$50,000.

Under the powers conferred by the West Moorabool Water Board Act and all other powers enabling him in that behalf, His Excellency the Governor of the State of Victoria, by and with the advice of the Executive Council of the said State, hereby consents to the West Moorabool Water Board borrowing the sum of Fifty thousand dollars (\$50,000) to meet the cost of water storage works as set forth in the detailed statement bearing date 22nd March, 1973.

And the Honorable Roberts Christian Dunstan, Her Majesty's Minister of Water Supply for the State of Victoria, shall give the necessary directions herein accordingly.

T. J. FORRISTAL,
Clerk of the Executive Council.

MANSFIELD WATERWORKS TRUST.

At the Executive Council Chamber, Melbourne, the
twenty-seventh day of March, 1973.

PRESENT:

His Excellency the Governor of Victoria.	
Mr. Rossiter	Mr. Smith.
Mr. Scanlan	

EXTENT OF WATERWORKS DISTRICT INCREASED.

Under the powers conferred by the Water Act and all other powers enabling him in that behalf, His Excellency the Governor of the State of Victoria, by and with the advice of the Executive Council of the said State, doth hereby declare, order and direct that the extent of the Waterworks District of the Mansfield Waterworks Trust be increased by adding to the same the lands shown on plan approved by the Governor in Council, by and with this Order and deposited in the office of the State Rivers and Water Supply Commission, Melbourne (Corr. No.

64/1392/175), and as on and from the date hereof, the extent of such District shall be and be deemed to be increased.

And the Honorable Roberts Christian Dunstan, Her Majesty's Minister of Water Supply for the State of Victoria, shall give the necessary directions herein accordingly.

T. J. FORRISTAL,
Clerk of the Executive Council.

MITTA MITTA RIVER IMPROVEMENT TRUST.

At the Executive Council Chamber, Melbourne, the
twenty-seventh day of March, 1973.

PRESENT:

His Excellency the Governor of Victoria.	
Mr. Rossiter	Mr. Smith.
Mr. Scanlan	

CONSENT TO BORROWING \$5,000.

Under the powers conferred by the River Improvement Act and all other powers enabling him in that behalf, His Excellency the Governor of the State of Victoria, by and with the advice of the Executive Council of the said State, hereby consents to the Mitta Mitta River Improvement Trust borrowing the sum of Five thousand dollars (\$5,000), to meet the cost of river improvement and drainage works.

And the Honorable Roberts Christian Dunstan, Her Majesty's Minister of Water Supply for the State of Victoria, shall give the necessary directions herein accordingly.

T. J. FORRISTAL,
Clerk of the Executive Council.

HOUSING MINISTRY ACT 1972, No. 8339.

At the Executive Council Chamber, Melbourne, the
twenty-seventh day of March, 1973.

PRESENT:

His Excellency the Governor of Victoria.	
Mr. Rossiter	Mr. Smith.
Mr. Scanlan	

DATE OF COMING INTO OPERATION OF AMENDMENTS TO ACTS REFERRED TO IN SCHEDULE TWO OF THE HOUSING MINISTRY ACT 1972.

Whereas by section two of the *Housing Ministry Act 1972*, (No. 8339) it is among other things enacted that the Acts referred to in Schedule Two of the said Act No. 8339 shall be amended, as provided therein, as from the day or respective days fixed by Order of the Governor in Council published in the *Government Gazette*.

Now therefore, His Excellency the Governor of the State of Victoria, by and with the advice of the Executive Council of the said State, doth by this Order fix the second day of April, 1973, as the day upon and from which all of the Acts referred to in Schedule Two to the *Housing Ministry Act 1972*, shall be amended as provided therein.

And the Honorable Vance Oakley Dickie, Her Majesty's Minister of Housing for the State of Victoria, shall give the necessary directions herein accordingly.

T. J. FORRISTAL,
Clerk of the Executive Council.

METROPOLITAN FIRE BRIGADES ACT 1958.

At the Executive Council Chamber, Melbourne, the
twenty-seventh day of March, 1973.

PRESENT:

His Excellency the Governor of Victoria.	
Mr. Rossiter	Mr. Smith.
Mr. Scanlan	

PERIODICAL ELECTION OF MEMBERS OF THE METROPOLITAN FIRE BRIGADES BOARD.

Whereas amongst other things it is enacted by the *Metropolitan Fire Brigades Act 1958* that all elections of members of the Metropolitan Fire Brigades Board shall be conducted in all respects whatsoever in such manner as is prescribed by the Regulations and every such election

shall be held at such times and under the direction of such returning officers as the Governor in Council from time to time appoints:

And whereas the manner of conducting such elections is prescribed in the Metropolitan Fire Brigades General Regulations 1951:

And whereas pursuant to the said Act and the said Regulations it is necessary to conduct in the month of May, 1973, a periodical election of members of the said Board:

Now therefore His Excellency the Governor of the State of Victoria, by and with the advice of the Executive Council thereof, and in pursuance of the Metropolitan Fire Brigades Act 1958 and all other powers him thereunto enabling, doth by this Order appoint—

1. FRANCIS HENRY ROGAN, the Town Clerk of the City of Melbourne, to be the Returning Officer for the election of a member by the Council of the City of Melbourne.

2. (a) THURSDAY, 31ST MAY, 1973, to be the day for holding the election of one member by the Councils of the North Yarra Group and of one member by the Councils of the South Yarra Group of municipalities; and

(b) ERIC LAURENCE RICHARDSON, the Chief Electoral Officer for Victoria, to be the Returning Officer for such elections.

3. (a) THURSDAY, 31ST MAY, 1973, to be the day for holding the election of members by the insurance companies carrying on business and insuring property within Victoria; and

(b) RAYMOND PHILLIP SCHULTZ, the General Secretary of the Fire and Accident Underwriters' Association of Victoria, to be the Returning Officer for such election.

4. (a) THURSDAY, 31ST MAY, 1973, to be the day for holding the election of one member by the officers and employees of the said Board; and

(b) ERIC LAURENCE RICHARDSON, the Chief Electoral Officer for Victoria, to be the Returning Officer for such election.

And the Honorable Edward Raymond Meagher, Her Majesty's Chief Secretary for the State of Victoria, shall give the necessary directions herein accordingly.

T. J. FORRISTAL,
Clerk of the Executive Council.

LANDS DEPARTMENT NOTICES

APPROACHING LAND SALES.

Sale of Crown Land, in fee-simple, will be held at the under-mentioned places and dates, viz.:-

	No. of Gazette.
Ballarat.—Thursday, 3rd May, 1973	16
Bendigo.—Tuesday, 10th April, 1973	11

PROPOSED REVOCATION OF TEMPORARY RESERVATION OF LAND BY ORDER IN COUNCIL.

In pursuance of the provisions of the Land Act 1958, notice is hereby given that it is the intention of the Governor in Council to revoke the temporary reservation of land by Order in Council hereunder referred to viz.:-
The following Notices were published 1° on the 28th March, 1973, pursuant to Orders of the 20th March, 1973.

LINGA.—The temporary reservation by Order in Council of the 26th January, 1916, of 4 acres 3 roods 33 perches of land in the Township of Linga, as a site for a State School is about to be revoked.—(L.179⁽³⁾) (Rs.859).

W. BORTHWICK,
Minister of Lands.

PROPOSED REVOCATIONS OF TEMPORARY RESERVATIONS OF LANDS BY ORDERS IN COUNCIL.

In pursuance of the provisions of the Land Act 1958, notice is hereby given that it is the intention of the Governor in Council to revoke the temporary reservations of lands by Orders in Council hereunder referred to, viz.:-

The following Notices were published 1° on the 21st March, 1973, pursuant to Orders of the 14th March, 1973.

GANNAWARRA (KOROO).—The temporary reservation as a site for Public purposes (State School) and the withholding from sale, leasing and licensing by Order in

Council of the 4th November, 1878, of 3 acres 2 roods 22 perches of land in the Parish of Gannawarra, are about to be revoked, so far only as the portion containing 1 acre 8 perches indicated by hatching on plan hereunder, is concerned.—(G.211⁽⁴⁾) (Rs.9732).

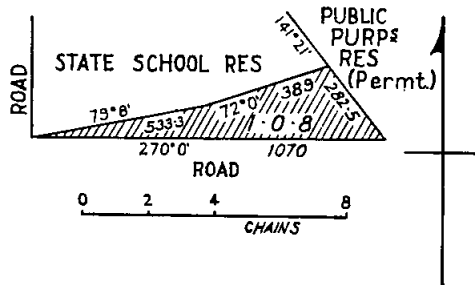

NARREE WORRAN.—The temporary reservation as a site for affording Access to Water and the withholding from sale, leasing and licensing by Order in Council of the 22nd April, 1879 (see Government Gazette 1879, page 928), of 92 acres, more or less, of land in the Parish of Narree Worrان, revoked as to part by Order of the 7th December, 1914 (see Government Gazette 1914, page 5643), are about to be revoked so far only as the portion containing 2 roods, more or less, indicated by hatching on plan hereunder, is concerned.—(N.19⁽¹⁰⁾) (Rs.863).

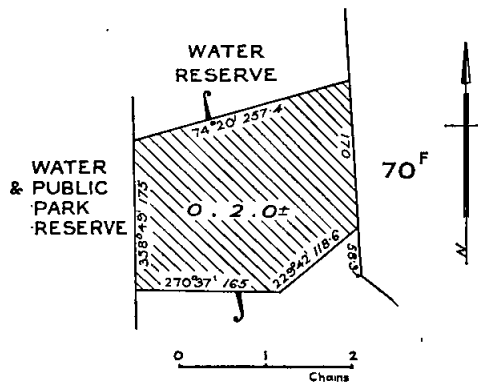

NARREE WORRAN.—The temporary reservation by Order in Council of the 11th July, 1938, of 1 acre, more or less, of land in the Parish of Narree Worrان as a site for Public purposes is about to be revoked so far only as the portion containing 15 perches, more or less, indicated by hatching on plan hereunder, is concerned.—(N.19⁽¹⁰⁾) (Rs.4839).

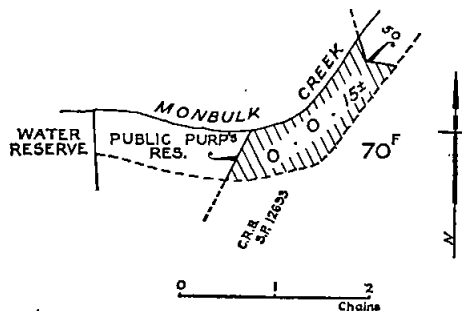

NARREE WORRAN.—The temporary reservation as a site for affording Access to Water and the withholding from sale, leasing and licensing by Order in Council of the 22nd April, 1879 (see Government Gazette 1879, page 928), of 92 acres, more or less, of land in the Parish of Narree Worrان, revoked as to part by Order of the 7th December, 1914 (see Government Gazette 1914, page 5643), and the temporary reservation for the additional purposes of a Public Park, by Order in Council of the 26th January, 1916, of 5 acres, more or less, (being part of the remaining land), are about to be revoked so far only as the portion

containing 2 roods 2 perches more or less, indicated by hatching on plan hereunder, is concerned.—(N.19⁽¹⁰⁾) (Rs.863).

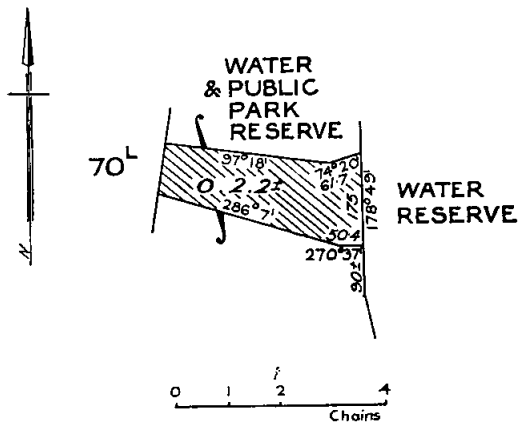

W. BORTHWICK,
Minister of Lands.

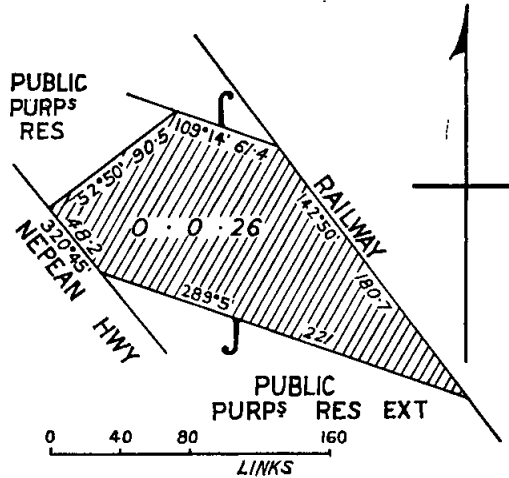

LYNDHURST (ASPENDALE).—The temporary reservation by Order in Council of the 30th October, 1939, of 1 acre 2 roods 28 perches of land in the Parish of Lyndhurst as a site for Public purposes revoked as to part by Order of the 10th December, 1968, is about to be revoked so far as the portion containing 31 perches, indicated by hatching on plan hereunder, is concerned.—(L.101⁽⁹⁾) (Rs.1365).

PROPOSED REVOCATIONS OF TEMPORARY RESERVATIONS OF LANDS BY ORDERS IN COUNCIL.

In pursuance of the provisions of the Land Act 1958, notice is hereby given that it is the intention of the Governor in Council to revoke the temporary reservations of lands by Orders in Council hereunder referred to, viz.:

The following Notices were published 1^o on the 7th March, 1973, pursuant to Orders of the 27th February, 1973.

DURHAM OX.—The temporary reservation as a site for Public purposes (State School) and the withholding from sale, leasing and licensing by Order in Council of the 18th September, 1876, of 5 acres of land in the Township of Durham Ox, Parish of Yarrowalla (called Parish of Yarrowalla, at Towan Gurr, in order) are about to be revoked.—(D.223⁽¹⁾) (Rs.7149).

NORTH HAMILTON.—The temporary reservation by Order in Council of the 28th March, 1871, of 118 acres, more or less, of land in the Parish of North Hamilton, as a site for Water Supply purposes, revoked as to part by Order of the 24th October, 1892, is about to be revoked so far as the balance thereof containing 97 acres 2 roods 16 perches, more or less, is concerned.—(H.46⁽⁶⁾) (Rs.7136).

TARCOMBE.—The temporary reservation as a site for Public purposes (State School) and the withholding from sale, leasing and licensing by Order in Council of the 9th July, 1883, of 4 acres 3 roods 1 perch of land in the Parish of Tarcombe are about to be revoked.—(T.240⁽⁵⁾) (C.95936).

YINNAR (YINNAR SOUTH).—The temporary reservation by Order in Council of 7th June, 1886, of 1 acre of land in the Parish of Yinnar as a site for a State School is about to be revoked.—(Y.113⁽⁴⁾) (Rs.9387).

LYNDHURST (ASPENDALE).—The temporary reservation as a site for Public purposes and the withholding from sale, leasing and licensing by Order in Council of the 23rd July, 1878, of 13 acres 35 perches of land in the Parish of Lyndhurst, revoked as to part by various Orders, are about to be revoked so far only as the portion containing 26 perches indicated by hatching on plan hereunder, is concerned.—(L.101⁽⁹⁾) (Rs.1365).

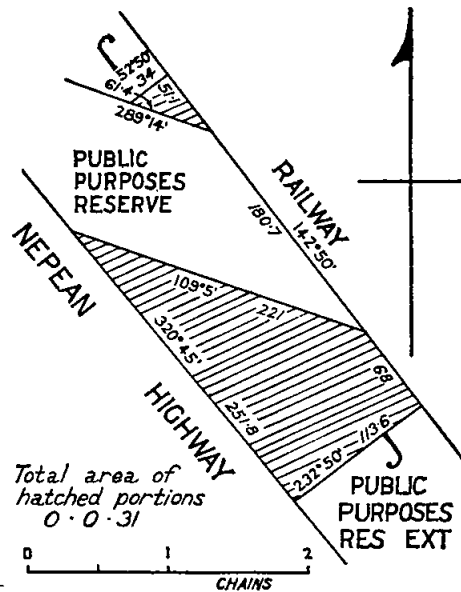

OME0.—The temporary reservation by Order in Council of the 13th January, 1862, of 3 acres 2 roods 16 perches of land in the Township of Omeo as a site for a Public Cemetery is about to be revoked so far only as the portion containing 16 perches indicated by hatching on plan hereunder, is concerned.—(O.19⁽⁸⁾) (Rs.9672).

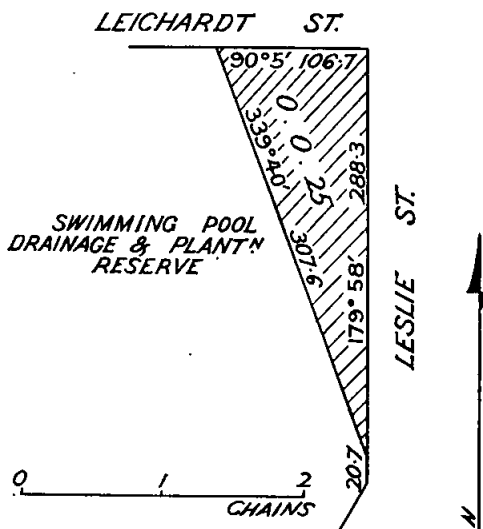
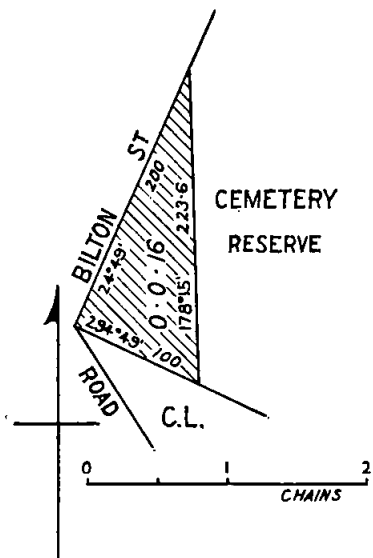

BEAUFORT.—The temporary reservation by Order in Council of the 22nd May, 1951, of 3 acres 2 roods 35 perches of land in the Township of Beaufort as a site for Swimming Pool, Drainage and Plantation purposes is about to be revoked, so far only as the portion containing 25 perches indicated by hatching on plan hereunder, is concerned.—(B.304⁽⁹⁾) (Rs.6662).

W. BORTHWICK,
Minister of Lands.

Land Act 1958.

LEASES SURRENDERED.

Notice is hereby given that the Governor in Council has accepted the surrender of the Leases mentioned in the Schedule hereunder for the reason specified in each case.

District.	Corr. No.	Name.	Section of Land Act under which Leased.	Parish.	Allotment.	Section.	Area.	Reason.
							A. R. P.	
Mallee ..	1232/241	G. W. Krause	241	Catiabrim ..	2	..	1559 1 16	Selection purchase lease to issue.
Mallee ..	1233/241	G. W. Krause	241	Catiabrim ..	1	..	759 0 18	Selection purchase lease to issue.

Department of Crown Lands and Survey,
Melbourne, 15th March, 1973

W. BORTHWICK,
Minister of Lands.

TENDERS

PUBLIC WORKS DEPARTMENT

Tuesday, 3rd April, 1973.

Tenders will be received at Public Works Department, 2 Treasury-place, Melbourne, until TWO p.m. on dates shown and for purposes mentioned hereunder.

Particulars and tender forms available at Contracts Office, Room 27, Ground Floor, No. 2, Treasury-place, and at places indicated in brackets hereunder.

Abbreviations in brackets mean:—W.O.—Inspector of Works Office; P.S.—Police Station; C.S.—Consolidated School; H.E.S.—Higher Elementary School; H.S.—High School; Pr.S.—Primary School; T.S.—Technical School.

Tenders to be submitted on the Department's printed Tender Form and will not be received by telephone. All tenders must be on a "Firm Tender" basis. The lowest or any tender will not necessarily be accepted.

Address tenders to the Minister of Public Works, and endorse the envelope containing the tender "Tender for .., closing Tuesday, ..".

Hand delivered tenders to be placed in the Tender Box of the Public Works Department, located on the wall of the centre entrance foyer, Ground Floor, 2 Treasury-place, Melbourne.

No preliminary deposit is required with any tender, but a successful tenderer will be required to pay a deposit for any accepted tender of \$4,000 or over.

Building, Electrical and Mechanical Works.

- BRUNSWICK.—Mechanical services—Workshops, T.S.
- GRESSWELL.—Stage 1—Hot water heating for wards 3, 4, 5 and 6, Stage 2—Extension of hot water heating for Administrative Building, Rehabilitation Centre.
- HAMILTON.—Additional bedrooms to Research Station Residence, No. 2. (W.O., Hamilton.)
- NORTH MELBOURNE.—Internal and external renovations—old building, Melbourne College of Printing and Graphic Arts.
- NORTH MELBOURNE.—Internal renovations, Melbourne College of Printing and Graphic Arts.
- MONT PARK.—Steam heating of store, Mental Hospital.
- MOUNT DANDENONG.—Laying of sewer drain, Observatory.
- MOUNT DANDENONG.—Packaged sewage treatment plant installation, Observatory.
- OBERON.—Additional L.T.C. class-room and remodelling of staff accommodation, H.S. (W.O., Geelong.)
- PENDERS GROVE.—Erection of timber framed staff-room and corridor extensions, Pr.S.3806.
- SUNSHINE WEST.—Staff and administration accommodation improvements, H.S.

Miscellaneous.

BENDIGO.—Installation of P.A.B.X. telephone system, Veterinary Laboratory and Regional Centre.

CARLTON.—Maintenance cleaning from 16th April, 1973, to 30th April, 1976, Central Licence and Registration Office.

DANDENONG.—Maintenance cleaning from 1st June, 1973, to 31st May, 1976, Court House.

ELSTERNWICK.—Maintenance cleaning from 1st June, 1973, to 30th June, 1976, Court House.

MELBOURNE.—Maintenance cleaning from 10th May, 1973, to 30th June, 1976, County Court.

MELBOURNE.—Maintenance cleaning from 1st June, 1973, to 31st May, 1976, Labour and Industry Department.

NORTH FITZROY.—Maintenance cleaning from 1st June, 1973, to 30th June, 1976, Dental Clinic.

OAKLEIGH.—Maintenance cleaning from 1st May, 1973, to 30th April, 1976, Court House.

PORT MELBOURNE.—Supply and delivery of four only 32-in. diameter tandem vibrating rollers and tilt bed trailers, Plant Depot.

Tuesday, 10th April, 1973.**Building, Electrical and Mechanical Works.**

ALTONA.—Internal renovations and painting, Pr.S.3923.

FAWKNER.—Internal and external repairs and painting, Pr.S.3590.

GREENWOOD.—Internal and external repairs and painting, Pr.S.4944.

KANIVA.—Internal and external repairs and painting, C.S. (W.O., Horsham.)

MILDURA.—Exterior renovations and painting, T.S. (W.O., Mildura.)

MONTEREY.—External and internal repairs and painting, T.S.

NULLAWIL.—Internal and external repairs and painting, Pr.S.3301. (W.O., Swan Hill.)

OUYEN.—Additions to staff accommodation, Pr.S.3615. (W.O., Mildura.) (Re-advertised.)

PORT MELBOURNE.—Extension to existing laboratory building, Marine Laboratory.

SHEPPARTON.—Three additional class-rooms in brick veneer construction and staff accommodation improvements, Pr.S.4943. (W.O., Shepparton, Bendigo and Benalla.)

SOUTHVALE.—Staff and administration accommodation alterations, Pr.S.4859.

STRATHMORE.—Repairs and painting, swimming pool, H.S.

VARIOUS.—Erection of timber class-rooms, stores, &c., Regional Bulk Contract (Northern) 1972/73 (Part One), Schools. (W.O., Bendigo and Shepparton.)

WANGARATTA.—Rewire of electrical installation, Adult Education Centre. (W.O., Wangaratta.)

Site Works.

FAIRFIELD NORTH.—Site works, Pr.S.4329.

MELBOURNE.—Site works, Secondary Teachers College.

VICTORIA PARK.—Site works, Pr.S.2957.

Miscellaneous.

BRIGHTON.—Maintenance cleaning from 1st June, 1973, to 31st May, 1976, Court House.

Tuesday, 17th April, 1973.**Building, Electrical and Mechanical Works.**

BELMONT.—Internal and external painting and repairs, H.S. (W.O., Geelong.)

CORIO.—Erection of a multi-purpose hall, T.S. (W.O., Geelong.)

CORIO.—Electrical services, Hall, T.S. (W.O., Geelong.)

CORIO.—Mechanical services, Hall, T.S. (W.O., Geelong.)

HUNTINGDALE.—Staff accommodation improvements and erection of two new classrooms, H.S.

LAKES ENTRANCE.—Additional classroom, new staff-room and toilets, Pr.S.2672. (W.O., Bairnsdale, Orbost and Traralgon.) (Re-advertised.)

MARYBOROUGH EAST.—External renovations, Pr.S. 2828. (W.O., Maryborough.) (Re-advertised.)

Site Works.

BLACKBURN.—Site works, Psychology and Speech Therapy Centre.

Miscellaneous.

DOOKIE.—Replacement of sewer mains, Agricultural College. (W.O., Benalla and Shepparton.)

VARIOUS.—Supply of grinding machines for the period 1st July, 1973, to 30th June, 1974, Schools and other Government Departments.

VARIOUS.—Supply of 13 mm ($\frac{1}{2}$ in.) drilling machines for the period 1st July, 1973, to 30th June, 1974, Schools and other Government Departments.

VARIOUS.—Supply of 150 mm (6 in.) hacksaw machine and marking off table for the period 1st July, 1973, to 30th June, 1974, Schools and other Government Departments.

VARIOUS.—Supply of 280 and 360 mm screw cutting lathes for the period 1st July, 1973, to 30th June, 1974, Schools and other Government Departments.

VARIOUS.—Supply of 230 mm (9 in.) swing engineers lathes for the period 1st July, 1973, to 30th June, 1974, Schools and other Government Departments.

VARIOUS.—Supply of universal turret head milling machine and shaping machine for the period 1st July, 1973, to 30th June, 1974, Schools and other Government Departments.

VARIOUS.—Supply of universal horizontal milling machine for the period 1st July, 1973, to 30th June, 1974, Schools and other Government Departments.

VARIOUS.—Supply of woodworking saw benches for the period 1st July, 1973, to 30th June, 1974, Schools and other Government Departments.

VARIOUS.—Supply of planning and jointing machines, and thicknesser for the period 1st July, 1973, to 30th June, 1974, Schools and other Government Departments.

VARIOUS.—Supply of woodturning lathes for the period 1st July, 1973, to 30th June, 1974, Schools and other Government Departments.

VARIOUS.—Supply of bandsaw machines, and spindle borer for the period 1st July, 1973, to 30th June, 1974, Schools and other Government Departments.

Tuesday, 1st May, 1973.**Miscellaneous.**

WESTERNPORT.—Sea bed investigations, (Ports and Harbours).

ROBERTS DUNSTAN,
Minister of Public Works.

Public Works Department,
Melbourne, 3002, 26th March, 1973.

PUBLIC SERVICE NOTICES

No. 391.

PUBLIC SERVICE ACT 1958.

The Public Service Board, in pursuance of the powers conferred by the *Public Service Act 1958*, hereby amends the Public Service (Public Service Board) Regulations as follows:—

PART V.—ALLOWANCES.**DIVISION II.—OVERTIME AND STAND-BY ALLOWANCES.***Department of Crown Lands and Survey.*

Regulation 147A.

The expression "Warden (Mount Hotham Alpine Reserve)" is deleted and the expression "Warden, Mount Hotham Alpine Resort" is inserted in lieu thereof.

A. H. RIGG, Acting Chairman.
P. CARRIGAN, Secretary.

Office of the Public Service Board,
Melbourne, 16th March, 1973.

No. 390.

PUBLIC SERVICE ACT 1958.

The Public Service Board, in pursuance of the powers conferred by the *Public Service Act 1958*, hereby amends the *Public Service (Public Service Board) Regulations* as follows:—

PART III.—PROMOTIONS AND TRANSFERS.

DIVISION III.—SPECIAL REQUIREMENTS.

Professional Division.

LAW DEPARTMENT—STIPENDIARY MAGISTRATES.

REGULATION 81.

Regulation 81 is revoked and the following regulation is inserted in lieu thereof—

81. (1) No officer shall be appointed to the office of Stipendiary Magistrate unless he has attained the age of 35 years and is willing (if required by the Permanent Head) to reside within the district to which he is from time to time assigned, and unless—

(a) Such officer—

(i) is an officer of the Professional Division who has passed the qualifying examination for appointment to the office of Clerk of a Magistrates' Court or Registrar of the County Court;

(ii) has been or is a Clerk of Magistrates' Courts or Registrar of the County Court or has been or is performing the duties of an office of Class "CC-2" or a higher class office (or, prior to the 26th day of February, 1967, of a Class "C1" or higher class office) of the Professional Division in the office of the Magistrates' Court at Melbourne, Ballarat, Bendigo or Geelong and has acted in any or all such capacities for an aggregate period of at least ten years; Provided that performance of duties of an office of Class "CC-2" or a higher class (or, prior to the 26th day of February, 1967 of Class "C1" or a higher class) of the Professional Division in any office of the County Court (other than as Registrar), the Children's Court or the Coroner's Court shall also be recognised for this purpose, but only to a maximum extent of two years; and

(iii) has passed the examinations hereinafter prescribed or is an officer to whom sub-regulation (15) of this regulation applies; or

(b) Such officer is a barrister and solicitor of the Supreme Court of Victoria who has been practising for a period of at least five years.

(2) Subject to the following sub-regulations of this regulation, the examinations prescribed for the purposes of sub-regulation (1)(a)(iii) of this regulation are—

(a) the examinations at the University of Melbourne in the subjects set out in Appendix AA; or

(b) the examinations at Monash University in the subjects set out in Appendix AA—

and an examination under this regulation in the operation of statute law as interpreted by superior courts.

(3) The examination in statute law under this regulation shall consist of two three-hour papers the respective scopes of which papers shall be as set out in Appendix A to these Regulations.

(4) Examinations in statute law under this regulation shall be held at such times and places as are from time to time determined by the Secretary to the Law Department.

(5) The examiner or examiners for any examination in statute law under this Regulation shall be the person or persons from time to time designated for the purpose by the Board.

(6) Every reference in Appendix A to these Regulations to any Commonwealth Act, or to any Victorian Act, or to any Part, Division, sub-division or section of any Commonwealth Act or of any Victorian Act, or to any Rules or Regulations shall be read and construed and take effect as a reference to the Commonwealth Act, Victorian Act, Part, Division, sub-division, section, Rules or Regulations (as the case may be) as re-enacted or re-made (whether with or without modification) or amended from time to time.

(7) An officer who has passed an examination in statute law under this Regulation or any corresponding previous Regulation shall not be required by reason of subsequent changes in or in connexion with the examination in statute law to pass a further examination in statute law.

(8) The passing of an examination or examinations in any subject or combination of subjects shown in any column of a table set out in Appendix AB (other than the column headed "Present Subjects") before the year shown in the heading to the column shall be taken as constituting the passing of the prescribed examination or examinations in any subject or combination of subjects shown opposite thereto in the column headed "Present Subjects".

(9) An examination in "Legal Process" shall be held in each year at such time and place as is determined by the Secretary to the Law Department. The syllabus for each such examination shall be the syllabus for the year in which the examination is held of the subject "Legal Process" at the University of Melbourne.

(10) An examination under sub-regulation (9) shall be upon one three-hour paper, but any written work from time to time submitted by the officer during the year preceding the examination in accordance with the requirements of the examiner, and the results of any mid-year test for which officers are required to sit by the examiner, shall be taken into account by the examiner in determining whether the officer has passed the examination.

(11) The examiner for any examination under sub-regulation (9) shall be the person from time to time designated for the purpose by the Board.

(12) The results of any examination in statute law under this regulation or of any examination in "Legal Process" held under sub-regulation (9) of this Regulation shall be reported in writing by the examiner to the Secretary to the Law Department, who shall thereupon inform the Board in writing of the names of any candidates who passed the examination and of the names of any candidates who failed to pass the examination.

(13) Any officer who is recorded by the Secretary to the Law Department as having passed a departmental or public service examination in "Introduction to Legal Method" held before the 31st day of December, 1969, shall be deemed for the purposes of this Regulation to have passed in the year in which the examination was held—

(a) an examination at the University of Melbourne in the subject "Introduction to Legal Method"; or

(b) an examination at Monash University in the subject "The Legal System"—

(as the case requires).

(14) Any officer who has passed an examination in "Legal Process" held under sub-regulation (9) shall for the purposes of this Regulation be deemed to have passed an examination in the subject "Legal Process" at the University of Melbourne or Monash University (as the case requires).

(15) An officer—

(a) who has been admitted after examination to, or who has qualified by examination to be admitted to, the degree of Bachelor of Laws in the University of Melbourne; or

(b) upon whom has been conferred after examination, or who has qualified by examination to have conferred upon him, the degree of Bachelor of Laws of Monash University; or

(c) who is a barrister and solicitor of the Supreme Court of Victoria; or

(d) who passed examinations held on or before the 31st day of December, 1965, at the University of Melbourne in the following subjects:—

(i) Introduction to Legal Method;

(ii) Principles of Contract;

(iii) Mercantile Law;

(iv) Tort;

(v) Criminal Law and Procedure;

(vi) Evidence; or

(e) who has at any time obtained from the Board a certificate stating that he has passed the examinations prescribed for the purposes of this Regulation at the time of the issue of the certificate—

shall not be required to pass the examinations prescribed for the purposes of sub-regulation (1)(a)(iii) of this Regulation.

(16) Where an officer who has passed the prescribed examination or examinations in any subject or subjects at the University of Melbourne or Monash University passes the prescribed examination or examinations in any further subject or subjects at Monash University or the University of Melbourne (as the case may be), the Board may determine that the passing of the prescribed examination or examinations in the subject or subjects at the University of Melbourne or Monash University shall for the purposes of this Regulation be taken as constituting the passing of the prescribed examination or examinations in any specified subject or subjects at Monash University or the University of Melbourne (as the case may be).

(17) For the purposes of this Regulation, any special or supplementary examination held following an annual examination shall be taken to be part of the annual examination.

APPENDIX 'A'.

EXAMINATION IN STATUTE LAW UNDER REGULATION 81.

Appendix 'A' is revoked and the following Appendices are inserted in lieu thereof—

APPENDIX 'A'.

EXAMINATION IN STATUTE LAW UNDER REGULATION 81.

Paper Number 1.

VICTORIAN LEGISLATION.

<i>Children's Court Act 1958</i>	The whole.
<i>and Regulations thereunder.</i>	
<i>Coroner's Act 1958</i>	.. The whole.
<i>Crimes Act 1958</i>	.. Sections 47, 49-53, 55, 70-73, 81-83, 85, 86, 89, 91, 94, 105-112, 152, 193, 250, 314-315, 318-320, 329-335, 379-380, 398-400, 408, 408A, 410-411, 440-442, 445, 457, 462-467, 470, 480-484, 506, 508, 510-517, 519-520, 534-535, 537A, 546.
<i>Justices Act 1958</i>	and The whole.
<i>Rules thereunder.</i>	
<i>Landlord and Tenant Act 1958.</i>	Parts IV. and V.
<i>Liquor Control Act 1968</i>	.. Sections 5, 45, 94-101, 110-136, 138-140, 143-145.
<i>Lotteries, Gaming and Betting Act 1966.</i>	and Section 3; Parts I., II. and III.; Divisions 1, 2 and 6 of Part IV.; Sections 43-48, 62-66, 68-78, 80, 85.
<i>Magistrates' Court Act 1971.</i>	Act The whole, except Part III.
<i>Maintenance Act 1965</i>	and The whole.
<i>Rules thereunder.</i>	
<i>Police Offences Act 1958</i>	Sections 164-167, 176, 180, 185.
<i>Protection of Animals Act 1966.</i>	Sections 3, 4, 5, 11-12, 18, 20-21.
<i>Summary Offences Act 1966.</i>	Act The whole.

Paper Number 2.

VICTORIAN LEGISLATION.

<i>Acts Interpretation Act 1958.</i>	Act The whole.
<i>Business Names Act 1962</i>	Sections 4, 14, 25, 27-30.
<i>Companies Act 1961</i>	.. Sections 344, 346, 351, 362-363, 372, 379-381.
<i>Consumer Protection Act 1972.</i>	Act The whole.
<i>Crown Proceedings Act 1958.</i>	Act Part I.
<i>Employers and Employees Act 1958.</i>	Act Part VII.
<i>Firearms Act 1958</i>	.. Sections 3, 13, 26-27, Part IIIA., Sections 40, 43, 47-48.
<i>Health Act 1958</i>	.. Sections 43-46, 100, 229, 231, 234-236, 239-240, 273-275, 277-282, 290-301, 303-304, 422-423, 425-432, 434-444.
<i>Instruments Act 1958</i>	.. Section 13.
<i>Labour and Industry Act 1958.</i>	Sections 46, 150-160; Division 2 of Part X.; Sections 200, 205.
<i>Limitation of Actions Act 1958.</i>	Sections 3-6, 20, 20A, 23-27, 34.

<i>Local Government Act 1958.</i>	Act Sections 154-155, 223, 226, 231-232; Divisions 1 and 2 of Part XII.; Sections 352, 386, 518, 519, 863-881, 890-894.
<i>Mental Health Act 1959</i>	Sections 45-51.
<i>Mines Act 1958.</i>	.. Subdivision 2 of Division 12 of Part I.; Sections 261, 326.
<i>Motor Car Act 1958</i>	.. Sections 3, 22B, 22C, 25, 25A, 26; Division 3 of Part IV., Sections 79-93.
<i>Navigable Waters (Oil Pollution) Act 1960.</i>	Act The whole.
<i>Poisons Act 1962</i>	.. Sections 3-4, 26, 28, 32, 34, 35, 54-57, 59-60.
<i>Social Welfare Act 1970</i>	Sections 3-5, 26, 31-35, 46-61, 70, 75, 76, 81-82, 95-99, 101, 104, 120, 123-124, 137-142, 145, 160, 171, 179.
<i>Stamps Act 1958</i>	.. Sections 9-10, 13-14, 20, 30, 41, 42, 44-45, 58, 159.

COMMONWEALTH LEGISLATION.

<i>Acts Interpretation Act 1901-1964.</i>	Act The whole.
<i>Crimes Act 1914-1960</i>	.. Part I., Part IA. Sections 24A-24C, 24E, 24F, 29, 29A, 29B, 29C, 71, 71A, 82, 85, 85A, 85B, 85C, 85E, 89, 89A.
<i>Customs Act 1901-1966</i>	.. Part I. Sections 233B, 236-243. Part XIV.
<i>Evidence Act 1905-1964.</i>	Act The whole.
<i>Excise Act 1901-1965</i>	.. Sections 4-5, 125-132; Part XI.
<i>Extradition (Commonwealth Countries) Act 1966.</i>	Act The whole.
<i>Extradition (Foreign States) Act 1966.</i>	Act The whole.
<i>Income Tax and Social Services Contribution Assessment Act 1936-1966.</i>	Sections 222-225, 227, 233-234, 238-239, 241-247, 250.
<i>Judiciary Act 1903-1966.</i>	Sections 2, 68-70, 78, 85.
<i>Marriage Act 1961</i>	.. Section 5, Part II., Sections 94-96, 115-117, 119.
<i>Migration Act 1958-1966</i>	Sections 5, 27, 38-41, 55-57, 66.
<i>Service and Execution of Process Act 1901-1963</i>	So far as relates to summary jurisdiction.
<i>State and Territorial Laws and Records Recognition 1901-1964.</i>	Act The whole.

APPENDIX 'AA'.

PRESCRIBED EXAMINATIONS.

- University of Melbourne:
 - Legal Process
 - Criminal Law
 - The Law of Torts
 - Principles of Contract
 - Administrative Law
 - Constitutional Law
 - Mercantile Law
 - Principles of Evidence
 - Family Law
- Monash University:
 - Legal Process
 - Common Law I
 - Common Law II
 - Constitutional Law
 - Criminal Law and Procedure
 - Administrative Law
 - Evidence
 - Family Law
 - Consumer Protection
 - Insurance
 - Urban Legal Problems.

APPENDIX 'AB'.

EQUIVALENTS OF PRESCRIBED EXAMINATIONS.

TABLE A—University of Melbourne.

Before 1966.	Before 1968.	Before 1969.	Before 1971.	Present Subjects.
..	Introduction to Legal Method	Legal Process
Criminal Law and Procedure	Criminal Law
Tort	The Law of Torts
..	Constitutional Law Part I.	Administrative Law
..	Evidence	Principles of Evidence
..	..	Domestic Relations	..	Family Law

TABLE B—Monash University.

Before 1972.	Before 1973.	Present Subjects.
..	The Legal System	Legal Process
{ The Law of Contracts The Law of Torts	..	{ Common Law I. Common Law II.
Criminal Law	..	Criminal Law and Procedure
Administrative Law	..	{ Administrative Law Urban Legal Problems
Commercial Law	{ Sales and Financing Insurance	{ Consumer Protection Insurance

A. J. A. GARDNER, Chairman.
P. CARRIGAN, Secretary.

Office of the Public Service Board,
Melbourne, 16th March, 1973.

No. 389.

Public Service Act 1958, Section 50.

REGULATIONS.—PART IV.—SALARIES AND INCREMENTS.

The Public Service Board, in pursuance of the powers conferred by the Public Service Act 1958, hereby amends the Public Service (Public Service Board) Regulations as follows :—

THIRD SCHEDULE.

PART B.

PROFESSIONAL DIVISION.

Scale of Rates of Annual Salaries.

VETERINARY OFFICERS.

The salary scale shown is deleted and the following salary scale is inserted in lieu thereof—

Class.	Annual Salary of Each Subdivision of Each Class.					
	1.	2.	3.	4.	5.	6.
VO-1 ..	\$ 6,692	\$ 7,313	\$ 8,000	\$ 8,623	\$ 9,408	\$ 10,119
VO-2 ..	11,484
VO-3 ..	12,029
VO-4 ..	12,506
VO-5 ..	13,036
VO-6 ..	13,564
VO-7 ..	14,004
VO-8 ..	14,704

SIXTH SCHEDULE.

TEMPORARY EMPLOYEES.

Designations of Positions and Rates of Salaries.

Department and Designation of Position.	Yearly Rate of Salary.		Increments (Annual).
	Minimum.	Maximum.	
DEPARTMENT OF AGRICULTURE	\$	\$	
Delete— Veterinary Officer ..	6,167	9,353	̄
Add— Veterinary Officer ..	6,692	10,119	̄

This Regulation shall have effect as on and from the 4th March, 1973.

A. J. A. GARDNER, Chairman.
P. CARRIGAN, Secretary.

Office of the Public Service Board,
Melbourne, 5th March, 1973.

PRIVATE ADVERTISEMENTS

CITY OF ALTONA.

PROSECUTING OFFICER.

Notice is given that the City of Altona has appointed Senior Sergeant Allan Collie, No. 10859, as Prosecuting Officer.

1304

S. FELL, Town Clerk.

CITY OF ALTONA.

LOAN No. 92.

Notice of Intention to Borrow the Sum of \$60,000 for Permanent Works and Undertakings.

Notice is hereby given that the Council of the City of Altona proposes to borrow the principal sum of Sixty thousand dollars, secured by a charge over the general rates of the municipality, such sum to be raised by the grant of a mortgage in accordance with the provisions of the Local Government Act 1958.

1. The maximum rate of interest to be paid is 5.7 per centum per annum.

2. The purpose for which the loan is to be applied is:—

The purchase of quarry holes for use as rubbish tips—\$60,000.

3. The period of the loan shall be four years.

4. The money borrowed shall be payable by providing out of the municipal fund eight equal half-yearly instalments of \$8,493.39 each, including principal and interest, on the 9th day of June and the 9th day of December in each year, during the currency of the loan. The first instalment shall be payable on the 9th day of December, 1973.

5. Such moneys shall be repayable at the office of the Commonwealth Savings Bank of Australia, Melbourne, or such other place or places which the bank may from time to time require.

The plans, specifications and estimate of the cost of the proposed works and a statement showing the proposed expenditure of the moneys to be borrowed are open for inspection at the Civic Offices, 115 Civic-parade, Altona.

1305

S. FELL, Town Clerk.

CITY OF ECHUCA.

LOAN No. 69.

Notice of Intention to Borrow.

Notice is hereby given that the Council of the City of Echuca intends to borrow Thirty-eight thousand (\$38,000) dollars, secured by a charge over the general rates of the municipality by the grant of a mortgage in accordance with the provisions of the Local Government Act 1958, as amended.

In connexion therewith the following information is stated:—

- (a) The amount of the principal moneys which it is proposed to borrow is \$38,000.
- (b) The maximum rate of interest that may be paid is 6.3 per centum per annum.
- (c) The times at which the moneys borrowed are to be repayable are the 1st day of December, 1973, and the 1st days of June and December, during the years 1974 to 1987, and the 1st day of June, 1988, and the place where such money shall be repayable is the Bank of New South Wales, Echuca.
- (d) The purpose for which the loan is to be applied is:—
Part cost of works proposed under Part XV., section 393 (11) of the *Local Government Act 1958*, as amended, namely, the Port of Echuca Restoration Project.
- (e) The manner in which the loan is to be liquidated is by the provision out of the municipal fund in each half-year during the currency of the loan of the sum of \$1,976.51, which includes principal and interest.

The plans and specifications and estimate of the cost of the works and a statement showing the proposed expenditure of the moneys to be borrowed are open for inspection at the office of the Council of the City of Echuca at the corner of Hare and Heygarth streets, Echuca.

Dated this 21st day of March, 1973.

1324

K. F. McCARTNEY, Town Clerk.

Pounds Act 1958.

CITY OF ECHUCA.

Take notice that the Council of the City of Echuca did on the 13th day of March, 1973, revoke the appointment of part of Suburban allotment 2, Parish of Echuca North, County of Rodney, as a pound site; and,

Take further notice that the Council of the City of Echuca did also on the 13th day of March, 1973, appoint the following as the site for a pound within the City of Echuca, viz.:—

All that piece or parcel of land comprising part of Section F¹ and being portion of the former Manure Depot Reserve Gazette page 2978, of 14th October, 1887, situated within the Parish of Wharparilla, County of Gunbower, commencing at a point on the south boundary of the section aforesaid at a point adjoining the Murrav Valley Highway Reserve and contained first by a line west from that point a distance of 816 links; thence north 1,324 links; thence east by a line 306.7 links to the western boundary of the Murrav Valley Highway and southward along that highway boundary first by a line bearing 144 deg. 9 min. being in length 511.9 links; and thence to the point of commencement by a line 913.1 links on a bearing of 166 deg. 37 min. the area contained within the boundaries so described comprising 8 acres 1 rood and 14 perches.

1325

K. F. McCARTNEY, Town Clerk.

CITY OF FOOTSCRAY.

LOAN No. 121.

Notice of Intention to Borrow the Sum of \$225,000 for Permanent Works and Undertakings.

Notice is hereby given that the Council of the City of Footscray proposes to borrow the sum of Two hundred and twenty-five thousand dollars, secured by a charge over the general rate of the municipality, such sum to be raised by the grant of a mortgage in accordance with the provisions of the *Local Government Act 1958*.

1. The maximum rate of interest that may be paid is 6.3 per centum per annum.

2. The period of the loan shall be fifteen years.

3. The loan is to be liquidated by providing out of the municipal fund 30 equal half-yearly instalments of \$11,703.03, including principal and interest, payable on the 1st day of April and the 1st day of October, in each year during the currency of the loan. The first instalment shall be payable on the 1st day of October, 1973.

4. Such moneys shall be repayable at the Commonwealth Bank of Australia, Footscray.

5. The purposes for which the loan is to be applied are:—

- (a) Road works, Alma and Severn streets \$62,000
(b) Drainage works, Saltley and Market streets 27,000

(c) Town Hall, capital expenditure ..	11,000
(d) Quarry purchase (part)	75,000
(e) Town Planning purposes, Nicholson-street Mall	50,000
	<hr/>
	\$225,000

The plans and specifications and the estimate of the cost of the proposed works and a statement showing the proposed expenditure of the moneys to be borrowed, are open for inspection at the Town Hall, Footscray.

Dated this 22nd day of March, 1973.

1298

W. H. SWABY, Town Clerk.

TOWN OF PORTLAND.

LOAN No. 104

Notice of Intention to Borrow the Sum of \$30,000 for Permanent Works and Undertakings.

Notice is hereby given that the Council of the Town of Portland proposes to borrow the principal sum of \$30,000 secured by a charge over the general rates of the municipality, such sum to be raised by the grant of a mortgage in accordance with the provisions of the *Local Government Act 1958*.

1. The maximum rate of interest that may be paid is 6.4 per cent. per annum.

2. The purpose for which the loan is to be applied is:—
Part cost construction of swimming pool complex—\$30,000.

3. The period of the Loan shall be 30 years.

4. The moneys borrowed shall be repayable by providing out of the municipal fund 59 half-yearly instalments of \$1,130.86, and a final instalment of \$1,130.79 each, including principal interest, on the 1st day of May and the 1st day of November, during the currency of the loan. The first instalment shall be payable on the 1st day of November, 1973.

5. Such moneys shall be repayable to the Portland Harbour Trust Commissioners.

The plans and specifications and the estimate of the proposed works and a statement showing the proposed expenditure of the moneys to be borrowed, are open for inspection at the office of the Council of the Town of Portland, at Gawler-street, Portland.

Dated this 23rd day of March, 1973.

1294

L. FELL,
Town Clerk.

SHIRE OF BULN BULN.

LOAN No. 53.

Notice of Intention to Borrow the Sum of \$23,000 for Permanent Works and Undertakings.

Notice is hereby given that the Council of the Shire of Buln Buln proposes to borrow the principal sum of \$23,000, secured by a charge over the general rates of the municipality, such sum to be raised by the grant of a mortgage in accordance with the provisions of the *Local Government Act 1958*.

1. The maximum rate of interest that may be paid is 6.2 per cent. per annum.

2. The purpose for which the loan is to be applied is the purchase of land and erection of buildings for a decentralised industry.

3. The period of the loan shall be fourteen years.

4. The moneys borrowed shall be repayable by providing out of the municipal fund 28 half-yearly instalments of approximately \$1,240.78 each, including principal and interest, on the 1st day of June and the 1st day of December, during the currency of the loan. The first instalment shall be payable on the 1st day of December, 1973.

5. Such moneys shall be repayable to the Australia and New Zealand Savings Bank Limited, 394-396 Collins-street, Melbourne.

The plans and specifications and the estimate of the cost of the proposed works, and a statement showing the proposed expenditure of the moneys to be borrowed, are open for inspection at the office of the Council of the Shire of Buln Buln, at Drouin.

Dated 28th March, 1973.

1310

K. A. PRETTY, Shire Secretary.

SHIRE OF BULN BULN.

LOAN No. 55.

Notice of Intention to Borrow the Sum of \$40,000 for Permanent Works and Undertakings.

Notice is hereby given that the Council of the Shire of Buln Buln proposes to borrow the principal sum of \$40,000, secured by a charge over the general rates of the municipality, such sum to be raised by the grant of a mortgage in accordance with the provisions of the *Local Government Act 1958*.

1. The maximum rate of interest that may be paid is 6.2 per cent. per annum.

2. The purpose for which the loan is to be applied is the purchase of land for municipal purposes.

3. The period of the loan shall be ten years.

4. The moneys borrowed shall be repayable by providing out of the municipal fund nineteen half-yearly instalments of approximately \$1,758.58 each, including principal and interest, on the 1st day of June and the 1st day of December, during the currency of the loan and one instalment of \$27,681.41 on 1st day of June, 1983. The first instalment shall be payable on the 1st day of December, 1973.

5. Such moneys shall be repayable to the Australia and New Zealand Savings Bank Limited, 394-396 Collins-street, Melbourne.

The plans and specifications and the estimate of the cost of the proposed works, and a statement showing the proposed expenditure of the moneys to be borrowed, are open for inspection at the office of the Council of the Shire of Buln Buln, at Drouin.

Dated 28th March, 1973.

1311

K. A. PRETTY, Shire Secretary.

SHIRE OF CRANBOURNE.

ORDER CHANGING NAME OF STREET.

Notice is hereby given that, pursuant to the powers conferred by the *Local Government 1958*, the Council of the Shire of Cranbourne at a meeting held on 9th March, 1973, made an order changing the name of the following road:—

Old Name.—Jenner-street.

New Name.—Jenner-court.

Location.—Runs off the south side of Somerville-road, Hampton Park, approximately 350 feet east of South Gippsland Highway.

By Order.

1322

T. VICKERMAN, Shire Secretary.

SHIRE OF DAYLESFORD AND GLENLYON.

LOAN No. 8.

Notice of Intention to Borrow the Sum of \$20,000 for Permanent Works and Undertakings.

Notice is hereby given that the Council of the Shire of Daylesford and Glenlyon proposes to borrow the sum of \$20,000 (Twenty thousand dollars), secured by a charge over the general rates of the municipality, such sum to be raised by the grant of a mortgage in accordance with the provisions of the *Local Government Act*, for permanent works and undertakings within the municipality.

1. The maximum rate of interest that may be paid is 5.7 per centum per annum.

2. The purpose for which the loan is to be applied is for the purchase of plant.

3. The period of the loan shall be six years.

4. The moneys borrowed shall be repayable by providing out of the municipal fund twelve (12) half-yearly instalments, including principal and interest of approximately \$1,991.34 each, in the 1st days of December and June, during the years 1973 to 1979. The first instalment shall be payable on the 1st day of December, 1973, and the final instalment shall be payable on the 1st day of June, 1979.

5. Such moneys shall be repayable at the office of the Australia and New Zealand Bank, Vincent-street, Daylesford, 3460.

The specifications and an estimate of the cost of the plant are available for inspection at the Shire Office, Vincent-street, Daylesford, during office hours.

1307

J. T. PEKIN, Shire Secretary.

SHIRE OF DONALD.

LOAN No. 52.

Notice of Intention to Borrow the Sum of \$12,000 for Permanent Works and Undertakings.

Notice is hereby given that the Council of the Shire of Donald proposes to borrow the sum of Twelve thousand dollars, on the credit of the municipal revenues of the President, Councillors and Ratepayers of the said Shire, such sum to be raised by the grant of a mortgage, in accordance with the provisions of the *Local Government Act 1958*.

1. The maximum rate of interest that may be paid is 5.7 per cent.

2. The purpose for which the loan is to be applied is purchase of plant.

3. The period of the loan shall be four years.

4. The moneys borrowed shall be repayable by providing out of the municipal fund eight half-yearly instalments of approximately \$1,698.68 each, including principal and interest, on the 1st days of April and of October in each year, during the currency of the loan. The first instalment shall be payable on the 1st day of October, 1973.

5. Such moneys shall be repayable at Australian and New Zealand Banking Group Limited, 351 Collins-street, Melbourne.

The Plans, specifications and the estimate of the cost of the proposed works, and a statement showing the proposed expenditure of the moneys to be borrowed, are open for inspection at the Shire Offices, Donald.

Dated at Donald, 21st March, 1973.

1253

T. H. BOWLES, Shire Secretary.

SHIRE OF ELTHAM.

PROSECUTING OFFICER.

Notice is hereby given that Sergeant Arthur Robert Traynor, No. 12748, has been appointed Prosecuting Officer for the Shire of Eltham, in lieu of Sergeant A. Fenton.

COLIN J. BOCK,

1260

Shire Secretary/Chief Administrative Officer.

Local Government Act 1958.

SHIRE OF HASTINGS.

NOTICE TO ALL WHOM IT MAY CONCERN.

Whereas the Council of the Municipality of the Shire of Hastings in the State of Victoria deems it expedient to execute a certain work or undertaking for the purpose of providing for a place for a Public Hall in the Township of Somerville, for the purposes whereof it is in the opinion of the said Council necessary and desirable that the Council exercise its power of taking land compulsorily within the municipal district of that said Council, as provided by the *Local Government Act 1958*, and the said Council has caused its surveyor to prepare a plan of the said work or undertaking as is necessary and in which is expressed the nature and extent of such work or undertaking and the exact site and admeasurements thereof and on and through what land the said work or undertaking is proposed to be placed and the names of the owners or reputed owners, lessees or reputed lessees and the occupiers of such land so proposed to be taken so far as known and the said plan so prepared has been approved by the said Council.

In pursuance of the provisions of the *Local Government Act 1958*, the said Council doth hereby publish notice that the description shortly of the purport of the said work or undertaking and of the said plan is as follows:—

“The provision of a place for a Public Hall on that piece of land being lot 10 on plan of subdivision No. 3165 and being part of Crown portion 57, Parish of Moorooduc, County of Mornington, certificate of title, volume 7972, folio 066.”

And the said Council doth hereby give further notice that the said plan is deposited at the office of the said Council, Shire Office, Hastings, and is there open for inspection and perusal on all the days and between the hours the municipal office is appointed to be open for the space of 40 clear days from the date of publication of this notice in the *Government Gazette*.

And the said Council doth hereby call upon all persons interested in or affected by the said proposed work or undertaking to set forth, in writing, addressed to the said Council or the Shire Secretary thereof, at the Shire Office, Hastings, within 40 clear days from the date of the publication of this notice as aforesaid, all objections which they may have to the said work or undertaking.

Dated this 20th day of March, 1973.

By Order of the Council of the Shire of Hastings—

L. A. WALKER,
Shire Secretary.

1297

SHIRE OF HUNTLY.

APPOINTMENT OF PROSECUTING OFFICER.

Notice is hereby given that the Council of the Shire of Huntly has appointed Senior Constable Leslie Alexander Hogg, No. 10616, Police Station, Goormong, in lieu of Senior Constable E. J. Simmonds, No. 9444, transferred, to be Prosecuting Officer of the Council of the Shire of Huntly.

1255 H. McK. SILKE, Shire Secretary.

SHIRE OF KARKAROOC.

Notice is hereby given that the Shire of Karkarooc, has appointed Senior Constable F. W. Primmer, No. 12488, Police Station, Woomelang, as Prosecuting Officer in lieu of Senior Constable L. A. Hogg, No. 10616, transferred. 1309

J. ANDREWARTHA, Shire Secretary.

SHIRE OF MAFFRA.

DOG ACT—SHOPPING AREA HEYFIELD.

In pursuance of the powers conferred by the Dog Act 1970, the Council of the Shire of Maffra hereby orders that the area hereinafter specified and described shall be a shopping area under the provisions of the said Act:—

Township of Heyfield—

Temple-street, full length.

George-street, between Davis-street and Clark-street.

By order of the Council.

1320 J. RENNICK, Shire Secretary.

SHIRE OF NEWSTEAD.

LOAN NO. 14.

Notice of Intention to Borrow the Sum of \$5,000 for Permanent Works and Undertakings.

Notice is hereby given that the Council of the Shire of Newstead proposes to borrow the principal sum of \$5,000, secured by a change over the general rates of the municipality, such sum to be raised by the grant of a mortgage in accordance with the provisions of the Local Government Act 1958.

1. The maximum rate of interest that may be paid is 5 per cent.

2. The purpose for which the loan is to be applied is the part construction of a Caretaker's Residence at the Welshman's Reef Tourist Area.

3. The period of the loan is to be four (4) years.

4. The moneys borrowed shall be repayable by providing out of the municipal fund half-yearly instalments of approximately \$697.34 each, including principal and interest, on the 1st day of June and the 1st day of December, during the currency of the loan, with the outstanding balance of principal being able to be repaid in full at anytime. The first instalment shall be payable on the 1st day of December, 1973.

5. Such moneys shall be repayable to the Ministry of Tourism, 276 Collins-street, Melbourne, Victoria.

The plans and specifications and the estimate of the cost of the proposed works, and a statement showing the proposed expenditure of the moneys to be borrowed, are open for inspection at the Shire Office, Newstead, during normal office hours.

1327 DAVID R. BROAD, Shire Secretary.

SHIRE OF ORBOST.

CHANGE OF STREET NAMES.

Notice is hereby given that, pursuant to the provisions of the Local Government Act 1958, the Council of the Shire of Orbost has caused the following alterations in street names in the Township of Marlo—

1. Old Name.—Unnamed.

New Name.—Perry-street.

2. Old Name.—Unnamed.

New Name.—Rodwell-street.

3. Old Name.—Unnamed.

New Name.—Sampson's-street.

4. Old Name.—Unnamed.

New Name.—Wakefield-street.

1323 R. E. VERNON, Shire Secretary.

SHIRE OF SHEPPARTON.

PROSECUTING OFFICER.

Notice is hereby given that Council has appointed Senior Constable Kenneth Bruce Bryant, No. 10062, as Prosecuting Officer for the Dookie Riding of the Shire of Shepparton.

1306 J. W. REED, Shire Secretary.

Town and Country Planning Act 1961.

SHIRE OF SHERBROOKE.—SHIRE OF SHERBROOKE PLANNING SCHEME.

AMENDMENT No. 53, 1972.

Notice is hereby given that the Council of the Shire of Sherbrooke, in pursuance of its powers under the Town and Country Planning Act 1961, has prepared a Planning Scheme for portions of the Shire of Sherbrooke for the purpose of amending the Principal Scheme by re-zoning lots 30, 31 and 32, L.P.5394, Belview Terrace, Upper Fern Tree Gully, from Forest Residential to Proposed Public Open Space D—National Park.

A copy of the Scheme has been deposited at the Shire Office, Glenfern-road, Upwey, and at the office of the Town and Country Planning Board, 235 Queen-street, Melbourne, and will be open for inspection during office hours by any person, free of charge.

Any persons affected by the Planning Scheme are required to set forth in writing, any objections they may have, addressed to the Shire Secretary, Shire of Sherbrooke, Glenfern-road, Upwey 3158, on or before the 28th June, 1973, in respect of Amendment No. 53, 1972, and to state whether they wish to be heard in respect of their objections.

1291 K. E. MATSON,
Shire Secretary.

Town and Country Planning Act 1961.

SHIRE OF SHERBROOKE.—SHIRE OF SHERBROOKE PLANNING SCHEME.

AMENDMENT No. 54, 1972.

Notice is hereby given that the Council of the Shire of Sherbrooke, in pursuance of its powers under the Town and Country Planning Act 1961, has prepared a Planning Scheme for portions of the Shire of Sherbrooke for the purpose of amending the Principal Scheme as follows:—

(i) Rezoning lots 20 and 21, L.P.9310, Talaskia-road —John-street, Upper Fern Tree Gully, from Residential General to Existing Public Purposes 3—Hospital,

(ii) Amending the Planning Scheme Ordinance to delete Residential Building as a use permitted without conditions in Residential General, Residential Medium and Residential Mountain zones, and include it as a use permitted subject to the grant of a permit and to any conditions imposed by such permit in the said zones.

A copy of the Scheme has been deposited at the Shire Office, Glenfern-road, Upwey, and at the office of the Town and Country Planning Board, 235 Queen-street, Melbourne, and will be open for inspection during office hours by any person, free of charge.

Any persons affected by the Planning Scheme are required to set forth in writing, any objections they may have, addressed to the Shire Secretary, Shire of Sherbrooke, Glenfern-road, Upwey 3158, on or before the 28th April, 1973, in respect of Amendment No. 54, 1972, and to state whether they wish to be heard in respect of their objections.

1292 K. E. MATSON,
Shire Secretary.

Town and Country Planning Act 1961.

SHIRE OF SOUTH GIPPSLAND.—WARATAH BAY PLANNING SCHEME.

NOTICE THAT A PLANNING SCHEME HAS BEEN PREPARED AND IS AVAILABLE FOR INSPECTION.

Amendment No. 3, 1973.

Notice is hereby given that the Council of the Shire of South Gippsland, in pursuance of its powers under the Town and Country Planning Act 1961, has prepared a Planning Scheme for lot 51, lodged plan 72745, Gale-street, Parish of Waratah North, for the purpose of re-zoning the said lot from "Special Usage" to "Residential, Commercial, Road Reserve and Recreation and Drainage".

A copy of the scheme has been deposited at the Shire Office, Pioneer-street, Foster, and at the office of the Town and Country Planning Board, 235 Queen-street, Melbourne, and will be open for inspection during office hours by any person free of charge.

Any persons affected by the Planning Scheme are required to set forth, in writing, all objections they may have, addressed to the Shire Secretary, Shire of South Gippsland, P.O. Box 14, Foster, on or before the 28th day of June, 1973, and to state whether they wish to be heard in respect of their objections.

23rd March, 1973.
1328 H. R. LOMAX, Shire Secretary.

SHIRE OF WARRAGUL.

LOAN No. 83.

Notice of Intention to Borrow the Sum of \$26,000 for Permanent Works and Undertakings.

Notice is hereby given that the Council of the Shire of Warragul proposes to borrow the principal sum of Twenty-six thousand dollars (\$26,000), secured by a charge over the general rates of the municipality, such sum to be raised by the grant of a mortgage in accordance with the provisions of the Local Government Act 1958.

1. The maximum rate of interest that may be paid is 6.2 per cent. per annum.
2. The purpose for which the loan is to be applied is:—
Purchase of land from Victorian Railways.
3. The period of the loan shall be ten years.
4. The moneys borrowed shall be repayable by providing out of the municipal fund half-yearly instalments of approximately \$1,763.81 each, including principal and interest, on the 6th day of June and the 6th day of December, during the currency of the loan. The first instalments shall be payable on the 6th day of December, 1973.
5. Such moneys shall be repayable to the Australian and New Zealand Savings Bank, Queen-street, Warragul.

The plans and specifications and the estimate of the cost of the proposed works and a statement showing the proposed expenditure of the moneys to be borrowed are open for inspection at the Municipal Offices, Warragul.

D. McADIE,
Shire Secretary.

1259

SHIRE OF WARRAGUL.

LOAN No. 82.

Notice of Intention to Borrow the Sum of \$5,000 for Permanent Works and Undertakings.

Notice is hereby given that the Council of the Shire of Warragul proposes to borrow the principal sum of Five thousand dollars (\$5,000), secured by a charge over the general rates of the municipality, such sum to be raised by the grant of a mortgage in accordance with the provisions of the Local Government Act 1958.

1. The maximum rate of interest that may be paid is 6.2 per cent. per annum.
2. The purpose for which the loan is to be applied is:—
Extensions to Ellinbank Hall.
3. The period of the loan shall be ten years.
4. The moneys borrowed shall be repayable by providing out of the municipal fund half-yearly instalments of approximately \$339.19 each, including principal and interest, on the 6th day of June and the 6th day of December, during the currency of the loan. The first instalment shall be payable on the 6th day of December, 1973.
5. Such moneys shall be repayable to the Australian and New Zealand Savings Bank, Queen-street, Warragul.

The plans and specifications and the estimate of the cost of the proposed works and a statement showing the proposed expenditure of the moneys to be borrowed are open for inspection at the Municipal Offices, Warragul.

D. McADIE,
Shire Secretary.

1258

SHIRE OF WERRIBEE.

LOAN No. 83.

Notice of Intention to Borrow the Sum of \$100,000 for Permanent Works and Undertakings.

Notice is hereby given that the Council of the Shire of Werribee proposes to borrow the principal sum of One hundred thousand dollars, secured by a charge over the general rates of the municipality, such sum to be raised by the grant of a mortgage in accordance with the provisions of the Local Government Act 1958.

1. The maximum rate of interest that may be paid is 6.2 per cent. per annum.
2. The purpose for which the loan is to be applied is:—
Part-construction of Private Street Construction Scheme, Pipe-road, Laverton North.
3. The period of the loan shall be ten years.
4. The moneys borrowed shall be repayable by providing out of the municipal fund half-yearly instalments of approximately \$6,783.87 each, including principal and interest, on the 1st day of June and the 1st day of December, during the currency of the loan. The first instalment shall be payable on the 1st day of December, 1973.
5. Such moneys shall be repayable to the Commissioners of the State Savings Bank of Victoria, at the office of the said commissioners, corner Elizabeth and Bourke streets, Melbourne.

The plans and specifications and the estimate of the cost of the proposed works and a statement showing the proposed expenditure of the moneys to be borrowed are open for inspection at the office of the Council of the Shire of Werribee, at Watton-street, Werribee.

Dated 19th March, 1973.

J. T. KERR,
Shire Secretary.

1290

Dog Act 1958.

SHIRE OF WARRNAMBOOL.

BATHING BEACH.

Notice is hereby given that the Warrnambool Shire Council, at a meeting held 14th day of March, 1973, ordered that a Bathing Beach area, for the purposes of section 16 (2) of the Dog Act 1958, be defined as followed:—

Bathing Beach—that area of the Peterborough Foreshore Reserve as indicated by hatching on the plan hereunder—

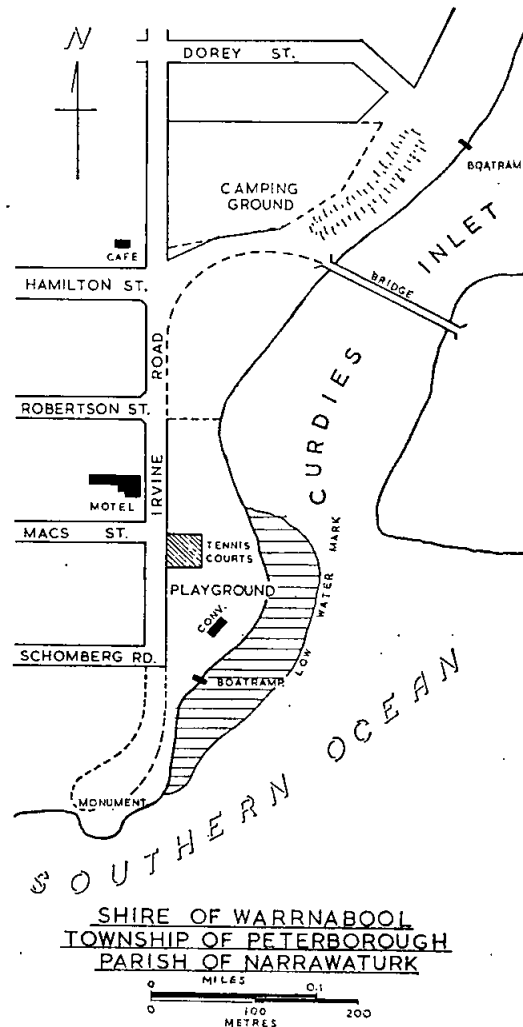

By order of the Council.

ALAN J. BOWES,
Shire Secretary.

1296

MOOROOPNA SEWERAGE AUTHORITY.

The Mooroopna Sewerage Authority, having obtained the consent of the Governor in Council, proposes to compulsorily acquire the land hereinafter described.

The nature of the works in respect of which it is proposed to use this land is to accept and treat sewage from the Mooroopna Sewerage District.

A plan of the proposed works will be available for inspection at the Authority's office, 35-37 McLennan-street, Mooroopna, during office hours.

The land to be acquired is Crown allotments 66 and 124, Parish of Mooroopna, County of Rodney, containing 351 acres 2 roods 10 perches (142.28 hectares) or thereabouts and being the whole of the land more particularly described in Certificate of Title, volume 5276, folio 174.

1210

R. F. FORSTER, Secretary.

SUNBURY SEWERAGE AUTHORITY.

COMPULSORY ACQUISITION OF LAND AND LEASE OF LAND.

In pursuance of the provisions of section 111 (2) of the *Sewerage Districts Act 1958*, notice is hereby given that the Sunbury Sewerage Authority intends to compulsorily acquire easement rights over the land shown by red colour on the plan approved by the Governor in Council at the Executive Council meeting held on 21st November, 1972, and to lease land shown by yellow colour on the said plan.

The work to be constructed on the land is a 30-in. diameter outfall sewer pipeline.

The land to be leased is 50 links wide and the land to be acquired is 100 links wide.

The length is 3079.1 links through Pt. lot 2, 3 and 4 L.P.7204 in Township of Sunbury, Parish of Buttlerjork and Parish of Holden.

A copy of the Order in Council plan is available for inspection at the Authority's Offices, Macedon-street, Sunbury between the hours of 9 a.m. and 4 p.m., Monday to Friday.

1349

JOHN M. KELLY, Secretary.

DANDENONG SEWERAGE AUTHORITY.

GENERAL NOTICE.

The above-mentioned Sewerage Authority having made provision for carrying off the sewage from each and every property which, or any part of which is within the Sewerage Areas hereinafter described, doth hereby declare that on and after the 1st day of April, 1973, each and every property which, or any part of which is within the said sewerage areas shall be deemed to be seweraged property within the meaning of the *Sewerage Districts Act 1958*.

The boundaries of the Sewerage Areas hereinafter referred to are:—

Sewerage Area No. 265.

All those pieces of land being lots 60 to 75 inclusive and 80 to 87 inclusive on lodged plan of subdivision No. 87178, lots 6 to 13 inclusive and lots 116 to 137 inclusive on lodged plan of subdivision No. 89560, lots 1 to 5 inclusive and 138 to 146 inclusive on lodged plan of subdivision No. 88362, lots 47 to 57 inclusive, 89 and 110 to 115 inclusive on lodged plan of subdivision No. 90523, lot 1 on lodged plan of subdivision No. 86475, lots 58 to 88 inclusive on lodged plan of subdivision No. 90524, lots 70 to 76 inclusive, 83 to 91 inclusive and 107 to 139 inclusive on lodged plan of subdivision No. 97255, lots 140 to 143 inclusive and 181 to 194 inclusive on lodged plan of subdivision No. 97256, lot 1 on lodged plan of subdivision No. 96473, lots 1 to 6 inclusive and 9 to 15 inclusive on lodged plan of subdivision No. 96474, lots 7, 8 and 16 to 69 inclusive on lodged plan of subdivision No. 96475, lot 1 on lodged plan of subdivision No. 86476.

Streets or parts thereof concerned in this area are Bakers-road, Jacksons-road, Kialla-court, Kernot-crescent, Estelle-court, Lower Terrace-crescent, Justin-drive, Silver-ton-drive, Reddington-drive, Pearce-court, Austin-close, Roscoe-court, Julius-crescent, Curtayne-court, Bellvue-court, Frogmal-drive, Templewood-avenue, Ellerdale-court, Arkwright-court, Shipton-court and Hartley-court.

Sewerage Area No. 266.

All those pieces of land being lots 88 and 89 Claredale-road on lodged plan of subdivision No. 10380.

The lodged plans of subdivision herein referred to shall be taken as those lodged at the Office of Titles, Melbourne.

By Order of the Dandenong Sewerage Authority.

L. K. DONNELLY, Chairman.

A. R. EDWARDS, Secretary.

1377

GEELONG WATERWORKS AND SEWERAGE TRUST.

The above-mentioned Trust, having made provision for carrying off the sewage from each and every property which or any part of which is within the sewerage area hereinafter described, doth hereby declare that on or after the 1st day of April, 1973, each and every property which or any part of which is within the said sewerage area shall be deemed and taken to be seweraged property within the meaning of the *Geelong Waterworks and Sewerage Act 1958*.

SEWERAGE AREA No. 551.

Shire of Corio, Parish of Moorpanyal, County of Grant.

Commencing at a point being the south-east corner of the intersection of Rollins-road and Wolsley-grove, Bell Post Hill, the said point being also on the boundary of Sewerage Area No. 435; thence easterly along the south side of Wolsley-grove to the south-west corner of the intersection of Wolsley-grove and Harcombe-street, which is also on the boundaries of Sewerage Areas Nos. 435 and 529; thence southerly, westerly, southerly and westerly following the boundaries of Sewerage Areas Nos. 529 and 435 to the east side of Rollins-road; thence northerly along the east side of Rollins-road to the point of commencement.

SEWERAGE AREA No. 552.

City of Newtown, Parish of Moorpanyal, County of Grant.

Commencing at a point being the south-east corner of the intersection of Gregory-avenue and Rutland-street, Marnock Vale, the said point being also on the boundary of Sewerage Area No. 59; thence westerly, southerly, westerly, southerly, easterly, southerly and south-westerly following the boundaries of Sewerage Areas Nos. 59 and 49, and crossing Gregory's-avenue to the prolongation of western boundary of allotment No. 28 Riversdale-road; thence northerly across Riversdale-road and continuing northerly along the western boundary of the said allotment No. 28 and western boundaries of allotments Nos. 29 to 34 inclusive, Lambert-avenue to the southern boundary of allotment No. 12 Lambert-avenue; thence westerly along the southern boundary of the said allotment No. 12 to the south-west corner of the said allotment No. 12; thence northerly along the western boundaries of allotments Nos. 12 to 8 inclusive, Lambert-avenue to the north-west corner of the said allotment No. 8; thence northerly by a line bearing 0 degrees to the south boundary of Sewerage Area No. 101; thence easterly following the boundary of Sewerage Area No. 101 and crossing Gregory's-avenue, to the east side of Gregory's-avenue; thence southerly along the east side of Gregory's-avenue and crossing Rutland-street to the point of commencement.

SEWERAGE AREA No. 553.

Shire of Corio, Parish of Moorpanyal, County of Grant.

Commencing at a point being the south-east corner of the intersection of Rollins-road and Darrivill-street, Bell Post Hill, the said point being also on the boundary of Sewerage Area No. 438; thence easterly along the south side of Darrivill-street to the north-east corner of allotment No. 63 Darrivill-street, which is also on the boundary of Sewerage Area No. 427; thence southerly, westerly, northerly and westerly following the boundaries of Sewerage Areas Nos. 427 and 437 to the east side of Rollins-road; thence northerly along the east side of Rollins-road to the point of commencement.

SEWERAGE AREA No. 554.

Shire of Corio, Parish of Moorpanyal, County of Grant.

Commencing at a point being the south-east corner of the intersection of Wolsley-grove and Beauford-avenue, Bell Post Hill, the said point being also on the boundaries of Sewerage Areas Nos. 428 and 436; thence easterly along the south side of Wolsley-grove to the north-east corner of allotment No. 138 Beauford-avenue, which is also on the boundaries of Sewerage Areas Nos. 436 and 537; thence southerly along the eastern boundaries of allotments Nos. 138 and 137 Beauford-avenue to the south-east corner of the said allotment No. 137; thence south-westerly along the eastern boundaries of allotments Nos. 136 to 134 inclusive, Beauford-avenue to the south-east corner of the said allotment 134; thence south-easterly across Shire of Corio Reserve approximately 222 feet to the north-east corner of allotment No. 132 Beauford-avenue; thence southerly along the eastern boundaries of allotments Nos. 132 and 131 Beauford-avenue to the south-east corner of the said allotment No. 131, which is also on the boundary of Sewerage Area No. 428; thence westerly, northerly, north-westerly, northerly and north-easterly following the boundary of Sewerage Area No. 428 to the point of commencement.

SEWERAGE AREA No. 555.

Shire of Corio, Parish of Moorpanyal, County of Grant.

Commencing at a point being the south-east corner of the intersection of Stonehaven and Donnybrook roads, Norlane, which is also on the boundary of Sewerage Area No. 306; thence westerly, southerly, south-easterly, southerly, westerly and southerly following the boundaries of Sewerage Areas Nos. 306 and 472 and crossing Stonehaven-road and R. O. W. to the north side of Page-street; thence westerly along the north side of Page-street and across Peacock-avenue on a straight line to the west side of Peacock-avenue; thence northerly along the west side

of Peacock-avenue and across Donnybrook-road on a straight line to the north side of Donnybrook-road, which is also on the boundary of Sewerage Area No. 491; thence easterly along the north side of Donnybrook-road and crossing Korumburra-avenue to the prolongation of the east side of Stonehaven-road; thence southerly across Donnybrook-road to the point of commencement.

Signed under seal of the Geelong Waterworks and Sewerage Trust, this 22nd day of March, 1973.

(SEAL) R. W. WHITESIDE, Chairman.
1301 B. C. HENSHAW, Secretary.

**GEMBROOK, COCKATOO AND EMERALD
WATERWORKS TRUST.**

PROPOSED EXTENSION OF WATERWORKS DISTRICT.

Notice is hereby given that the Gembrook, Cockatoo and Emerald Waterworks Trust has made application to the Honorable the Minister of Water Supply for the extension of its Waterworks District, and for the construction, maintenance and continuance of Water Supply Works within that extended District to supply the North Avonsleigh area under the provisions of the Water Act.

A general plan and description of the proposed works have been submitted with the application, and copies of same may be seen at the Trust's Office, Kings-road, Emerald.

Dated at Emerald, the 21st day of March, 1973.

1319 BEATRICE THOMAS, Trust Secretary.

**APPLICATION FOR DISPOSAL OF LAND PURSUANT
TO AN ACT TO PROVIDE FOR THE ABOLITION OF
STATE AID TO RELIGION.**

ACT 391.—FIRST SCHEDULE.

1. The Most Reverend Frank Woods of Cathedral Buildings, Flinders-lane, Melbourne, in the State of Victoria, Archbishop of the Church of England Diocese of Melbourne, head or authorized representative of the denomination known as The Church of England, in the Diocese of Melbourne, in Victoria, with the consent of the Church of England Trusts Corporation for the Diocese of Melbourne, of Flinders-lane, Melbourne, aforesaid, which is entitled to be registered as the trustee of the land described in the subjoined statement of trusts hereby applies to the Governor of the State of Victoria for leave to dispose of the said land by means and for the purposes mentioned in the said statement of trusts and I hereby certify that the said land was promised or reserved as a site for Church of England purposes on the 5th day of September, 1853.

2. That the Church of England Trusts Corporation for the Diocese of Melbourne is entitled to be registered as the only trustee of the said land.

3. There are a church, two halls, vicarage and garage erected upon the said land.

4. The only person entitled to minister or occupy same is the incumbent for the Parish of Leopold namely the Reverend H. H. Kiddier whose address is the Vicarage, Bellarine Highway, Leopold.

Dated this 5th day of October, 1972.

Signed sealed and delivered by the said The Most Reverend Frank Woods in Victoria in the presence of—
WILLIAM FELTHAM.

The common seal of the Church of England Trusts Corporation for the Diocese of Melbourne was hereunto affixed by authority of the trustees—

(SEAL) J. M. F. RELPH,
WILLIAM FELTHAM, Two of the Corporation
Trustees.

STATEMENT OF TRUST.

Description of the Land.—Two acres, permanently reserved for Church of England purposes by Order in Council of the 5th September, 1853.

Two acres, Parish of Moolap, County of Grant being Crown allotment 9C, section 5, block 1. Commencing at the most southern angle of Crown allotment 9B; bounded thence by that allotment bearing 472 links and 90 degrees 400 links; by a road bearing 180 degrees 528 links; and thence by the Bellarine Highway bearing 278 degrees 404 links to the point of commencement.

Name of Trustee.—The Church of England Trusts Corporation for the Diocese of Melbourne of Cathedral Buildings, Flinders-lane, Melbourne.

Power of Disposition.—Power to sell, lease, mortgage or exchange all or any part of such land subject to the approval of the Archbishop of Melbourne for the time being or during the absence of the Archbishop from the Diocese or the vacancy of the See to the approval of the person for the time being administering the affairs thereof.

The land until otherwise disposed of to be held for the purposes for which it was granted or reserved by the Crown.

Purposes to which Proceeds of Disposition are to be Applied.—To such purposes of the Church of England as may be agreed upon by—

(1) The Bishop or during his absence from his See or during the vacancy thereof by the person or persons for the time being administering the affairs of the Diocese.

(2) The trustees of the Church of England Trusts Corporation for the Diocese of Melbourne.

(3) The Minister entitled to occupy the aforesaid land.

HERBERT TURNER & DAVIS, solicitors, 411 Collins-street, Melbourne, 3000. 1360

**NOTICE OF INTENTION TO APPLY FOR A LICENCE
TO DIVERT WATER AND CUT RACE FROM THE
RIVER MURRAY (ANA-BRANCH), AT TYNTYNDER.**

I hereby give notice that I intend to apply for a licence empowering me to divert water for a term of four years to the extent of 40 acre-feet per annum at a maximum rate of 3 acre-feet per day of 24 hours for the irrigation of 20 acres of pasture, being part of allotment 24c, and 24d, section C, Parish of Tyntynder, and to occupy certain Crown lands for works of diversion, and to cut a race thereon.

Any objection to such application must be forwarded, in writing, to reach the State Rivers and Water Supply Commission, Melbourne, before 27th April, 1973, being 30 days from the first publication of this notice.

WILLIAM SCHMIDT.

Roadside Delivery, Swan Hill. 1361

**NOTICE OF INTENTION TO APPLY FOR A LICENCE
TO DIVERT WATER AND CUT RACE (RE-ISSUE)
FROM THE TULLAROOP CREEK, AT CARISBROOK.**

I hereby give notice that I intend to apply for a licence empowering me to divert water for a term of two years to the extent of 40 acre-feet per annum at a maximum rate of 4 acre-feet per day of 24 hours for the irrigation of 20 acres of lucerne, being part of allotment 14, section 9A, Parish of Carisbrook, and to occupy certain Crown lands for works of diversion, and to cut a race thereon.

Any objection to such application must be forwarded, in writing, to reach the State Rivers and Water Supply Commission, Melbourne, before 27th April, 1973, being 30 days from the first publication of this notice.

SOPHIA JEAN GALLAWAY.

Violet Hill, Carisbrook, 3464. 1366

I, Dianne Frances Anderson, of 88 Tone-road, Wangaratta, in the State of Victoria, shop assistant, do hereby give notice that I have assumed and intend henceforth upon all occasions and at all times to use and be called and known by the surname of Anderson, in lieu of the surname of Watson, and to use the name of Dianne Frances Anderson as my full name, and that such intended change is declared and evidenced by a deed poll dated the 15th day of March, 1973, and deposited in the office of the Registrar-General in the State of Victoria.

Dated the 20th day of March, 1973.

DIANNE FRANCES ANDERSON.

Arthur E. McSwiney, solicitor, Wangaratta. 1249

Notice is hereby given that the partnership subsisting between Arthur Ernest Rosendale, of 15 McKindlay-street, Echuca, builder, Elizabeth Weir Rosendale, of 15 McKindlay-street, Echuca, married woman and Emily Irene Rosendale, of 59 Eyre-street, Echuca, widow, carrying on the hardware and timber merchant's business at 132 Hare-street, Echuca, under the firm name of "Rosendale Hardware Coy." has been dissolved by mutual consent as from the 31st day of January, 1973, when the said Emily Irene Rosendale retired from the said firm and from such date the said business shall be carried on by the said Arthur Ernest Rosendale, and the said Elizabeth Weir Rosendale under the same firm name of "Rosendale Hardware Coy." All debts due to and owing by the said firm will be received and paid respectively by Arthur Ernest Rosendale and Elizabeth Weir Rosendale, of 15 McKindlay-street, Echuca, who will continue to carry on the said business under the same firm name as "Rosendale Hardware Coy."

Dated the 21st day of March, 1973.

ARTHUR ERNEST ROSENDALE.
ELIZABETH WEIR ROSENDALE.
EMILY IRENE ROSENDALE.

Mitchell, McKenzie & Co., solicitors, Echuca. 1378

Notice is hereby given that the partnership heretofore subsisting between the undersigned, Ian Raymond Roberts and Colin John Hudson, carrying on business as carriers, at Red Cliffs under the name of "Roberts & Hudson" has been dissolved by mutual consent, as from the 16th day of February, 1973.

Dated at Red Cliffs, the 22nd day of March, 1973.
1299 IAN RAYMOND ROBERTS.

Notice is hereby given that the partnership heretofore subsisting between Malcolm Frank Bryning and Robin Lalage Bryning, carrying on business as art designers, at 15 Park-crescent, Fairfield, under the firm name of M. F. & R. L. Bryning was dissolved by mutual consent, on the 31st day of December, 1972.

Dated the 21st day of March, 1973.
DARVALL & HAMBLETON, solicitors, 147 Collins-street, Melbourne. 1351

Notice is hereby given that the partnership heretofore subsisting between Arthur Ernest Rosendale, of 15 McKindlay-street, Echuca, builder, and Emily Irene Rosendale, of 59 Eyre-street, Echuca, widow, carrying on the building business at 132 Hare-street, Echuca, under the firm name of "A. E. Rosendale & Co." has been dissolved by mutual consent as and from the 31st day of January, 1973, when the said Emily Irene Rosendale, retired from the said firm and from such date the said business will be carried on by the said Arthur Ernest Rosendale and Elizabeth Weir Rosendale, of 15 McKindlay-street, Echuca, under the same firm name of "A. E. Rosendale & Co.". All debts due to and owing by the said firm will be received and paid respectively by Arthur Ernest Rosendale and Elizabeth Weir Rosendale, of 15 McKindlay-street, Echuca, who will continue to carry on the said business under the same firm name of "A. E. Rosendale & Co."

Dated the 21st day of March, 1973.
A. E. ROSENDALE.
E. I. ROSENDALE.
Mitchell, McKenzie & Co., solicitors, Echuca. 1379

Companies Act 1961.—In the matter of TURN STYLE (BENTLEIGH) PTY. LTD.—Notice Re Meeting of Creditors, pursuant to Section 260.

Notice is hereby given that a meeting of creditors of the above-named company will be held at the A.H.A. Conference Room, 4th Floor, 130 Flinders-street, Melbourne, on Monday, 2nd April, 1973, at 10.30 a.m., the company having convened an Extraordinary Meeting of its members for the same day for the purpose of considering a Special Resolution that the company be wound up voluntarily.

Dated this 23rd day of March, 1973.
ROBERT BAUMANN, Director.
Lewis Luckins and Co., chartered accountants, 130 Flinders-street, Melbourne, 3000. Telephone 63 8827. 1350

The Companies Act 1961.
CHURCH STREET MOTORS PTY. LTD. (IN VOLUNTARY LIQUIDATION).

Notice is hereby given that a First and Final Dividend is intended to be declared in the above matter. All creditors who have not proved their debts by 10th April, 1973, may be excluded from this dividend.

Dated this 27th day of March, 1973.
1380 K. C. HAMBLY, Liquidator.

Companies Act 1961.
B. & W. BUILDERS PTY. LTD. (IN MEMBER'S VOLUNTARY LIQUIDATION).

NOTICE OF RESOLUTION.

At an Extraordinary General Meeting of the members of B. & W. Builders Pty. Ltd., duly commenced and held at Traralgon, on the 7th day of March, 1973, the Special Resolution set out below was duly agreed to:—

"That the company be wound up voluntarily and that Kenneth Roy Downie, of 49 Victoria-street, Warragul, be appointed liquidator for the purpose of such winding up."

Creditors are required to lodge proofs of debt in order to participate in a First and Final Dividend declared and to be paid on 3rd April, 1973.

A Final Meeting will be held on that date.
1250 K. R. DOWNIE, Liquidator.

In the matter of the *Companies Act 1961*; and in the matter of FREEHOLD PROPERTIES PTY. LIMITED.

Notice is hereby given that at a Meeting of the Members of Freehold Properties Pty. Limited, on 22nd March, 1973, the following Resolution was passed as a Special Resolution:—

"That the company be wound up voluntarily".
1363 E. R. WHATMOUGH, Liquidator.

The Companies Act 1961.
A. R. CLELAND PROPRIETARY LIMITED (IN VOLUNTARY LIQUIDATION).
NOTICE CONVENING FINAL MEETING OF MEMBERS, PURSUANT TO SECTION 272.

Notice is hereby given in pursuance of section 272 of the *Companies Act 1961*, that the Final Meeting of the members of the above-named company will be held at the office of A. H. G. Clarke & Co., First Floor, 460 Bourke-street, Melbourne, on the 30th day of April, 1973, at 3 p.m., to consider the liquidator's final accounts of the voluntary winding up.

Dated this 26th day of March, 1973.
1303 T. L. PHILLIPS, Liquidator.

Companies Act 1961.
SZYKMAN (HOLDINGS) PTY. LTD. (IN VOLUNTARY LIQUIDATION).
NOTICE CONVENING FINAL MEETING OF MEMBERS, PURSUANT TO SECTION 272.

Notice is hereby given, in pursuance of section 272 of the *Companies Act 1961*, that a meeting of the members of the above-named company will be held on the 30th day of April, 1973, at the office of Messrs. John Rezak & Co., 66-68 Albert-road, South Melbourne, at 10 a.m., for the purpose of having an account laid before them, showing the manner in which the winding up has been conducted and the property of the company disposed of and of hearing any explanations that may be given by the liquidator.

Dated this 20th day of March, 1973.
JOHN REZAK, Liquidator.
John Rezak & Co., public accountants, 66-68 Albert-road, South Melbourne, 3205. 1257

The Companies Act 1961.
NOTICE OF FINAL MEETING OF SHAREHOLDERS OF MURRAY (A.N.Z.) PTY. LTD. (IN LIQUIDATION).

Notice is hereby given, in pursuance of section 272 of the *Companies Act 1961*, that a General Meeting of the members of Murray (A.N.Z.) Pty. Ltd. (in liquidation), will be held at 419 Lonsdale-street, Melbourne, on Monday, the 30th April, 1973, at 11 o'clock in the forenoon, for the purpose of laying before the meeting an account showing how the winding up has been conducted and the property of the company has been disposed of and of giving any explanation of the account.

1402 M. J. SCOTT, Liquidator.

HABER BROS. PTY. LIMITED (IN VOLUNTARY LIQUIDATION).

Notice is hereby given that the Final General Meeting of Members of the above company will be held at 11.30 a.m., on the 30th day of April, 1973, at 38 Walsh-street, Melbourne, for the purposes of laying before it the account of the liquidation and the liquidator's report.

1357 RONALD J. SICREE, Liquidator.

Companies Act 1961, Section 254 (2).
YARRA CREST SERVICES PTY. LTD. (IN VOLUNTARY LIQUIDATION).

NOTICE OF RESOLUTION.

At an Extraordinary General Meeting of the Members of Yarra Crest Services Pty. Ltd. duly convened and held at "Paringa", 35 Bradleys-lane, Warrandyte, Victoria, on the 23rd March, 1973, it was resolved that the company be wound up voluntarily as a members voluntary winding up in accordance with the provision of the *Companies Act 1961* and that Norman Martin be appointed liquidator.

Notice is also given that after 21 days from this date I shall proceed to distribute the assets. All creditors having any claims against the company should furnish particulars of same by that date otherwise I shall proceed to distribute the assets, without regard to their claim.

Dated this 26th day of March, 1973.
1358 N. MARTIN, Liquidator.

Unclaimed Moneys Act 1962.

Register of Unclaimed Moneys held by the—

Name of Owner on Books and Last Known Address.	Total Amount Due to Owner.	Description of Unclaimed Moneys.	Date when Amount first became Payable.
§			
THE NESTLE COMPANY (AUST.) LIMITED.			
Van Lier, J., Maffra	51.10	Wages	6.1.71
Reishjeck, H. F., Rutherglen-road, Newborough 973	184.11	Deferred Milk pay	15.10.71
MAYNE NICKLESS LIMITED.			
Kloch, Manfred, 13 Clement-street, Highett	23.20	Wages	21.3.71
Johnston, Frank, 41 Mary-street, Richmond	12.20	"	14.3.71
Warwick, Ronald, 35 Ford-avenue, Sunshine	12.60	"	2.5.71
Butler, Frederick George, 25 Carlisle-street, Preston	26.90	"	9.5.71
Briggs, William Dexter, 56 Cunningham-street, Northcote	22.80	"	9.5.71
Pontin, Shirley Yvonne, 21 Upper Esplanade, St. Kilda	10.10	"	13.12.71
Huet, Kevin John, 68 York-street, Carlton	22.70	"	13.6.71
Kelly, John, Whitelaws Track, Stony Creek	73.50	"	18.4.71
O'Brien, James, 38 George-street, Fitzroy	12.00	"	11.7.71
Daly, Irene M., 172 Rathmines-street, Northcote	24.50	"	11.7.71
Hardcastle, Barry, 118 Canterbury-road, Middle Park	25.30	"	18.7.71
Tattersall, Wayne J., 44 McGregor-street, East Malvern	35.20	"	23.5.71
Triffett, Gregory Philip, Spencer Private Hotel, Melbourne	22.90	"	25.7.71
Beasley, G., 93 Marshall-road, Airport	47.00	"	12.9.71
Simmons, R., 106 Canning-street, Carlton	15.10	"	26.9.71
Collard, Michael, 59 Lahinch-street, Broadmeadows	46.10	"	19.9.71
Gasparani, Antonio, 81 Cunningham-street, Northcote	11.60	"	15.8.71
Ford, Peter, 731 Rosstown-road, Carnegie	24.30	"	12.9.71
Wilmott, J. C. H., 3 Baxter-street, Elsternwick	63.00	"	31.10.71
Archer, P. R., 157 Ascot Vale-road, Ascot Vale	61.00	"	19.10.71
Ainger, Ron Edward, 159 Wellington-street, Flemington	13.50	"	12.12.71
Walker, Ronald Ernest, 41 View-street, Glenroy	27.50	Wages	12.12.71
Rosewall, R., 161 Gordon-street, Footscray	10.70	"	2.1.72
Jackson, J. F., 4 Strettle-street, Thornbury	19.40	"	9.1.72
Pollard, Ronnis Margaret, 5 Parkview-place, Doncaster	77.60	"	5.12.71
Valentine, Lloyd, 6/2A Robe-street, St. Kilda	12.60	"	11.7.71
McDonald, Alex, 1250 Sydney-road, Fawkner	35.00	"	13.2.72
Tawill, Solomon Mode, 5 Lawson-street, Blackburn	16.00	"	27.2.72
Wines, Kenneth Charles, 2/38 Burnley-street, Richmond	106.50	"	23.12.71
Crouch, Brian Charles, 5 Coombie-street, Preston	71.90	"	30.1.72
Weeks, Forster Brian, 5 Princes-road, Tamavua, Fiji	43.75	Dividend	30.4.71
Harvey, Margaret, 22 High-street, London	22.09	"	"
Darby, Geoffrey Cameron, 49 Virginia-street, Newtown	40.50	"	31.10.71
Isworth, Reginald Richard, c/o Bank of N.S.W., 368 Collins-street, Melbourne	27.00	"	"
Ryan, George Cardell Cardell, P.O., Korolevu, Fiji	47.25	"	"
Roberts, Florence Emily, 83 Locksley-road, Ivanhoe	11.69	"	30.4.71
Greenlaw, John, 74 Merriwa-street, Nedlands, W.A.	14.29	"	"
HENRY BERRY AND COMPANY (AUSTRALASIA) LIMITED.			
Coombes, Elizabeth M. (estate of), c/o Maclean and Wiseman, Suite 615, 107-109 Elizabeth-street, Sydney, N.S.W. 975	24.00	Interest	31.12.71
MOBIL OIL AUSTRALIA LIMITED.			
James, F. E., (address unknown)	75.04	Unclaimed Wages	—3.71
Gordon, H. G., (address unknown)	240.66	"	"
Andriopolis, G., 36 Salisbury-street, Coburg East	6.00	Drum Refund	—9.71
Kuttner and Lennerth, Edenhope	89.00	Refund of Cr. Balance	—11.71
Diamond, J., King and Hessells roads, Hartaway	32.20	"	—12.71
THE UNION-FIDELITY TRUSTEE COMPANY OF AUSTRALIA LIMITED.			
Ian Potter and Co., Melbourne	65.00	Dividends	—3.61
Ian Potter and Co., Melbourne	50.00	"	"
face value			
HOWARD SMITH LIMITED.			
McLennan, Colin C., 16 Clanalpine-street, Eastwood, N.S.W.	14.16	Final Dividend	29.4.66
McLennan, Colin C., 16 Clanalpine-street, Eastwood, N.S.W.	14.16	"	27.4.67
McLennan, Colin C., 16 Clanalpine-street, Eastwood, N.S.W.	17.70	"	26.4.68
McLennan, Colin C., 16 Clanalpine-street, Eastwood, N.S.W.	17.70	"	30.4.69
McLennan, Colin C., 16 Clanalpine-street, Eastwood, N.S.W.	20.06	"	"
Spurritt, Ian R., 218 Were-street, East Brighton	36.00	"	"
McLennan, Colin C., 16 Clanalpine-street, Eastwood, N.S.W.	21.24	"	"
Williams, Helena (estate of), c/o Hedley J. Proctor and Co., P.O. Box 268, Chatswood, N.S.W.	18.00	"	29.10.71
McLennan, Colin C., 16 Clanalpine-street, Eastwood, N.S.W.	11.80	"	"
Ross, Ian A., Uri East, Darlington Point, N.S.W.	25.00	"	"
Wilmar Investments Pty. Ltd., P.O. Box 129, Double Bay, N.S.W.	62.00	"	"
HOWARD SMITH INDUSTRIES PTY. LTD.			
Bracken, P. (address unknown)	10.00	Deposit for Travel	2.6.71
Streiker, H. (address unknown)	50.00	"	1.4.70
Keane, T. (address unknown)	11.00	Wages and Overtime	13.1.72

Unclaimed Moneys Act 1962.

Register of Unclaimed Moneys held by the—

Name of Owner on Books and Last Known Address.	Total Amount Due to Owner.	Description of Unclaimed Moneys.	Date when Amount first became Payable.
§			
MODEL DAIRY INDUSTRIES LIMITED.			
Fleetwood, E. D., 57 Trentwood-avenue, North Balwyn	12.50	Dividend	31.3.70
Sessanta Pty. Ltd., 92 Stanhope-street, Malvern	50.00	"	"
Simmons, H. R. and E. M., 225 McKinnon-road, Bentleigh	30.00	"	"
Wilson, C. R. and R. B., Karundel-street, Manangatang	12.50	"	"
Snelson, M. D. and J. M., 20 Grace-street, Watsonia	12.50	"	30.10.70
Wilson, C. R. and R. B., Karundel-street, Manangatang	15.63	"	"
Barber, A. H. (Miss), Flat 6, 28 Elliott-avenue, Carnegie	55.79	"	30.1.70
Wilson, C. R. and R. B., Karundel-street, Manangatang	10.00	"	31.3.71
Brens, W. J., 51 Leicester-street, Carlton	10.50	"	29.10.71
Snelson, M. D. and J. M., 20 Grace-street, Watsonia	10.50	"	"
Surridge, R. T. (Miss), Flat 4, 11 Hotham-street, Preston	10.50	"	"
979			
COATES AND CO. LTD.			
Green, Alice B., Flat 1, 76 Mont Albert-road, Canterbury	16.50	Dividend	30.9.71
982			
AUSTRALIAN GLASS MANUFACTURERS COMPANY.			
Novak, J., 46 Farm-street, Newport	72.21	Wages	31.3.71
Burda, S., 55 Graham-street, Newport	97.23	"	26.5.71
Schmidt, T., 36 Fourth-avenue, North Altona	24.12	"	31.1.72
Sterin, N., — N. Serin, Room 173, 125 Napier-street, Fitzroy	11.30	"	"
Atleparmak, B., Flat 115, 125 Napier-street, Fitzroy	16.77	"	"
Veznayer, L., 43 Lynch-street, Footscray	12.75	"	28.2.72
983			
VULCAN INDUSTRIES LIMITED.			
Allen, David James, c/o Bank of N.S.W., 368 Collins-street, Melbourne	15.00	Dividend	30.4.71
Allen, Patricia Margaret, c/o Bank of N.S.W., 368 Collins-street, Melbourne	15.00	"	"
Ogge, Marie Loreto, 3 Barnato-grove, Armadale	15.00	"	22.10.71
Allen, Patricia Margaret, c/o Bank of N.S.W., 368 Collins-street, Melbourne	36.00	"	"
Griffiths, Norman and David, 317½ Nepean Highway, Edithvale	27.00	"	"
Ogge, Marie Loreto, 3 Barnato-grove, Armadale	36.00	"	"
Thurecht, Alan William, c/o 61 Helles-road, Moorooka, Qld.	10.80	"	"
Treharne, Arthur Gwilym, 2A Lake-street, Carnegie	22.44	"	"
981			
AUSTRALIAN ASSOCIATED MOTOR INSURERS LTD.			
Torok, F., P.O. Kiah via Eden, N.S.W.	23.52	Refund of Premium	1.3.71
Shorter, R. E., Flat 1, 1A Salisbury-street, Moonee Ponds	20.21	"	18.3.71
Bereza, S., 40 Maple-crescent, Bell Park	21.40	"	4.5.71
Langley, J. T., 8/3 Blamey-street, Ascot Vale	13.82	"	5.5.71
Harvey, J. D., 54 North-road, Brighton	12.14	"	1.7.71
Clayton Body Repairs, 65 Whiteside-road, Clayton	134.15	Refund of Cost of Repairs	6.7.71
Nunawading Panel Service Pty. Ltd., 2 Nurlendi-road, Vermont	32.95	"	16.8.71
Palmieri, P., 75 Mayston-street, Hawthorn	20.00	Refund of Excess	23.8.71
Arbutnott, P. A., 3 Burdett-street, Frankston	11.06	Refund of Premium	2.9.71
Akrap, I., c/o Post Office, Cohuna	12.31	"	4.10.71
Herceg, M., 34 Stanhope-street, Footscray West	24.76	"	12.10.71
Gibbs, J., c/o V. Cooke, 373 Princes Highway, Morwell	26.05	Cancel of Policy	22.10.71
Stark, R. J., 73 Hargreaves-crescent, Braybrook	487.80	Settlement of Accident	24.11.71
Rennick and Gaynor, 491 Bourke-street, Melbourne	10.00	Legal Fees	20.1.72
Veal, G. D., 19/20 Sandown-road, Ascot Vale	26.31	Refund of Premium	24.1.72
984			
CLUB MOTOR INSURANCE AGENCY PTY. LTD.			
Rae, A. M., 14 Dudley-street, Belmont	15.00	Refund of Premium	7.6.71
Manthorpe, F., Greenacres Caravan Park, Princes Highway, Springvale	17.00	"	8.9.71
Mackie, I. M., c/o Chevron Hotel, 519 St. Kilda-road, Melbourne	27.46	"	17.11.71
985			
FRANKSTON GOLF LIMITED.			
Brookes, Sir Norman E. (estate of), c/o J. M. Smith and Emmerton, Solicitors, 170 Queen-street, Melbourne	400.00	Consideration on acquisition of shares	8.4.71
Fairbairn, Lorna B. (estate of), c/o Mrs. G. P. Robertson, 101 Mathoura-road, Toorak	400.00	"	"
Forrester, Alice Heather (Mrs.), 12 Reid-street, Beaumaris	100.00	"	"
Maxwell, Francis (estate of), c/o Best Hooper Rintoul and Shallard, Solicitors, 100 Queen-street, Melbourne	800.00	"	"
Sangwine, Elbert-Harold, 10A The Nook, North Balwyn	100.00	"	"
Trapp, Eleanor B. (estate of), c/o "Yalton" 13 Albany-road, Toorak	400.00	"	"
986			
BALLARAT AND WESTERN VICTORIA TELEVISION LIMITED.			
Campbell, G. J. A., 188 Main-road, Ballarat	28.00	Dividend	17.3.71
Campbell, G. J. A., 188 Main-road, Ballarat	35.00	"	15.9.71
Cole, K. M. (Miss), 4/246 Clovelly-road, Clovelly, N.S.W.	10.00	"	"
Faig, B. (Mrs.), 10 Munro-street, Ringwood	10.00	"	"
Farrell, E. M., 14 Wellington-street, Trafalgar	10.00	"	"
Rabach, W., P.O. Box 180, Warrnambool	17.50	"	"
987			

CONSULAR INVESTMENTS PTY. LIMITED (IN VOLUNTARY LIQUIDATION).

Notice is hereby given that the Final General Meeting of Members of the above company, for the purposes of laying before it the account of the liquidation and the liquidator's report, will be held at 10.30 a.m., on the 30th day of April, 1973, at 38 Walsh-street, Melbourne.

1354 RONALD J. SICREE, Liquidator.

E. E. & H. C. KIDD (HOLDINGS) PTY. LIMITED (IN VOLUNTARY LIQUIDATION).

Notice is hereby given that the Final General Meeting of Members of the above company, for the purposes of laying before it the account of the liquidation and the liquidator's report, will be held at 10.45 a.m., on the 30th day of April, 1973, at 38 Walsh-street, Melbourne.

1355 RONALD J. SICREE, Liquidator.

RAJON MANUFACTURING COMPANY PTY. LIMITED (IN VOLUNTARY LIQUIDATION).

Notice is hereby given that the Final General Meeting of Members of the above company, for the purposes of laying before it the account of the liquidation and the liquidator's report, will be held at 11 a.m., on the 30th day of April, 1973, at 38 Walsh-street, Melbourne.

1356 RONALD J. SICREE, Liquidator.

The Companies Act 1961.

BLAIR HAULAGE PROPRIETARY LIMITED (IN LIQUIDATION).

NOTICE CONVENING FINAL MEETING OF MEMBERS AND CREDITORS, PURSUANT TO SECTION 272.

Notice is hereby given pursuant to section 272 of the Companies Act 1961, that a General Meeting of the members and creditors of the above-named company will be held in the offices of Kennedy, Smail & Middlemiss, 296-304 Little Lonsdale-street, Melbourne, on Wednesday, the 2nd day of May, 1973, at 10.30 a.m., for the purpose of having an account laid before them showing the manner in which the winding up has been conducted and the property of the company disposed of and of hearing any explanations that may be given by the liquidator.

Dated this 22nd day of March, 1973.

ALAN MURRAY HORSBURGH, Liquidator.

Kennedy, Smail & Middlemiss, 296-304 Little Lonsdale-street, Melbourne, 3000. 1359

Companies Act 1961 (as Amended).

IVO HOLDING COMPANY PTY. LTD. (IN VOLUNTARY LIQUIDATION).

SECTION 272.

Notice is hereby given that a General Meeting of the company will be held at the offices of Stennett & Rooke, First Floor, 153 Upper Heidelberg-road, Ivanhoe, at 11 a.m., on Friday, 4th May, 1973, for the purposes of laying before it the liquidator's account showing how the winding up has been conducted and the property of the company disposed of and of giving any explanation thereof. 1382

Company No. 33250.—In the matter of the Companies Act 1961; and LYDHOLME PTY. LTD. (in Voluntary Liquidation).

Notice is hereby given that at a General Meeting of shareholders held on the 20th day of March, 1973, the following resolution was passed as a Special Resolution—

"That the company be wound up voluntarily as a Members Voluntary Winding Up in accordance with the provisions of the Companies Act 1961".

1383 R. L. EILENBERG, Director.

SOLORA PACKERS PROPRIETARY LIMITED. (Incorporated in South Australia.)

In the matter of the Companies Act 1962.—WILLIAM JOHN MURCHIE EWING, of 27 Leigh-street, Adelaide, in the State of South Australia, hereby gives notice that—

(a) He was appointed liquidator of Solora Packers Proprietary Limited by a Resolution of the Creditors and Members of Solora Packers Proprietary Limited passed on the 20th day of March, 1973.

(b) His office is situated at care of Thomas, Sara, Macklin & Co., 27 Leigh-street, Adelaide, S.A.

Dated this 22nd day of March, 1973.

1321 W. J. M. EWING.

No. 18.—2440/73.—4

Companies Act 1961.

A.A.W. PROPERTIES PROPRIETARY LIMITED.

At a General Meeting of members of A.A.W. Properties Proprietary Limited duly convened and held at 24 Jeffcott-street, Melbourne, on the 26th day of March, 1973, the following Special Resolution was duly passed:—

"That the company be wound up voluntarily and that Forbes Yorke Rattray, of 24 Jeffcott-street, Melbourne, in the State of Victoria, chartered accountant, be appointed liquidator of the company."

1389

F. Y. RATTRAY, Secretary.

COMPANIES ACT 1961.

Take notice that on the 21st day of March, 1973, an office copy of the Order of the Supreme Court of Victoria confirming the reduction of issued capital of Australian Factors (Victoria) Ltd. was lodged with the Registrar of Companies.

1391 CORR & CORR, Solicitors for the Petitioner.

The Companies Act 1961.—Notice of Final Meeting of Shareholders of BELL BRYANT (REFRIGERATION) PTY. LTD. (in Liquidation).

Notice is hereby given in pursuance of section 272 of the Companies Act 1961 that a General Meeting of the members of Bell Bryant (Refrigeration) Pty. Ltd. (in Liquidation) will be held at 419 Lonsdale-street, Melbourne, on Monday, the 30th April, 1973, at 10.30 in the forenoon, for the purpose of laying before the meeting an account showing how the winding up has been conducted and the property of the company has been disposed of and of giving any explanation of the account.

1400

M. J. SCOTT, Liquidator.

The Companies Act 1961.—Notice of Final Meeting of Shareholders of BELL BRYANT (TRADING) PTY. LTD. (in Liquidation).

Notice is hereby given in pursuance of section 272 of the Companies Act 1961 that a General Meeting of the members of Bell Bryant (Trading) Pty. Ltd. (in Liquidation) will be held at 419 Lonsdale-street, Melbourne, on Monday, the 30th April, 1973, at 11.30 in the forenoon, for the purpose of laying before the meeting an account showing how the winding up has been conducted and the property of the company has been disposed of and of giving any explanation of the account.

1401

M. J. SCOTT, Liquidator.

Companies Act 1961.—In the matter of W. SHAKESPEARE (AUST.) PTY. LTD.

Notice is hereby given that a meeting of creditors of the above-named company will be held at The Palm Lake Motel, 52 Queens-road, Melbourne, on the 9th day of April, 1973, at 12 noon, the company having convened a meeting of its members for the same day for the purpose of considering a Resolution that the company be wound up voluntarily.

Dated this 27th day of March, 1973.

W. A. ATWOOD.

T. D. Maclean and Company, consulting accountants, Suite 3, 545 St. Kilda-road, Melbourne. Telephone 51 1207.

1373

Companies Act 1961.—In the matter of HOWARD JACKETT AND CO. PTY. LTD. (in Liquidation).—Notice of Meeting of Contributors.

Notice is hereby given that, pursuant to section 272 of the Victorian Companies Act 1961, the Final Meeting of contributors of Howard Jackett and Co. Pty. Ltd. (in Liquidation) will be held at the office of Wilson Danby Perry Johnson, 9th Floor, 461 Bourke-street, Melbourne, on the 14th May, 1973, at 9 a.m.

BUSINESS.

1. To lay before the meeting the liquidator's account showing how the winding up has been conducted and the property of the company has been disposed of, and giving any explanation thereof.

2. To obtain directions from the contributors, pursuant to section 284 (3) (c) of the Victorian Companies Act 1961, authorizing destruction of the books, documents and vouchers upon receipt by the liquidator of notice of final dissolution of the company.

Dated this 23rd day of March, 1973.

1353

D. H. COCHRANE, Liquidator.

*Companies Act 1961.***LEW'S JUNCTION STORES PROPRIETARY LIMITED**
(IN VOLUNTARY LIQUIDATION).

Notice is hereby given that at an Extraordinary General Meeting of the members of the above-named company held on the 21st day of March, 1973, at Suite 1, 161 Fitzroy-street, St. Kilda, Melbourne, it was resolved that the company be wound up voluntarily, and that Robert David Fox, be appointed liquidator.

Notice is also given that after 21 days from this date we shall proceed to distribute the assets. All creditors having any claims against the company should furnish particulars of same by that date, otherwise I shall proceed to distribute the assets without regard to their claim.

Dated this 28th day of March, 1973.

R. D. FOX, Liquidator.

Greenfield & Fox, 161 Fitzroy-street, St. Kilda, 3182.

1295

*The Companies Act 1961.***EQUITY FACTORS CORPORATION LTD. (IN LIQUIDATION).**

Notice is hereby given that a First and Final Dividend is intended to be declared in the above matter. Creditors who have not proved their debts by the 9th day of April, 1973, will be excluded from this Dividend.

Dated this 22nd day of March, 1973.

S. M. NUNAN, Liquidator.

Hall & Rose, chartered accountants, 395 Collins-street, Melbourne. 1334

FIRTH CLEVELAND (AUSTRALASIA) PTY. LTD.

At a Meeting of the members of the company held on Friday, 23th March, 1973, the following Resolution was duly passed.

"That the company be wound up voluntarily."

R. F. FITZCLARENCE, Secretary.

Price Waterhouse & Co., chartered accountants, 447 Collins-street, Melbourne, 3000. 1336

The Companies Act 1961.—In the matter of GARTH ADHESIVES PTY. LTD.—Notice Re Meeting of Creditors, pursuant to Section 260.

Notice is hereby given that a Meeting of creditors of the above-named company will be held at the offices of Kennedy, Smail & Middlemiss, 296 Little Lonsdale-street, Melbourne, at 11.30 a.m., on the 29th day of March, 1973, the company having convened a Meeting of its members for the same day for the purpose of considering a Resolution that the company be wound up voluntarily.

Dated this 22nd day of March, 1973.

B. D. LEFEBVRE, Director.

Kennedy, Smail & Middlemiss, 296 Little Lonsdale-street, Melbourne, 3000. 1347

*Companies Act 1961, Section 272.***NOTICE OF FINAL MEETING OF SHAREHOLDERS OF W. BERNAL PROPRIETARY LIMITED (IN LIQUIDATION).**

Notice is hereby given that a General Meeting of the members of W. Bernal Proprietary Limited (in Liquidation) will be held at the offices of Rodda, Ballard and Vroland, solicitors, 695 Burke-road, Camberwell, on the 8th day of May, 1973, at 11 o'clock in the forenoon, for the purpose of laying before the meeting an account showing how the winding up has been conducted and the property of the company has been disposed of, and of giving any explanation of the account.

1352

R. M. McCOOK, Liquidator.

Companies Act 1961.—In the matter of SILVER SELF AID INSURANCE COMPANY LIMITED (in Liquidation).

Notice is hereby given that at an Extraordinary Meeting of the members of the above-named company held on the 23rd March, 1973, it was resolved that the company be wound up voluntarily, and at a meeting of creditors held on the same day, pursuant to section 260, it was resolved that for such purpose Barry Keith Taylor, of 545 St. Kilda-road, Melbourne, be appointed liquidator.

Notice is also given that after 21 days from this date, I shall proceed to distribute the assets. All creditors having any claims against the company should furnish particulars of same by that date, otherwise I shall proceed to distribute the assets without regard to their claim.

Dated this 28th day of March, 1973.

B. K. TAYLOR, Liquidator.

Bent & Cogle, public accountants, Suite 18, 545 St. Kilda-road, Melbourne, 3004. 1376

In the Supreme Court of Victoria.—1973 Co. No. 8589.—In the matter of the *Companies Act 1961*; and in the matter of ROCKBANK PROPRIETARY LIMITED.

Notice is hereby given that a petition for the winding up of the above-named company by the Supreme Court was on the 16th day of March, 1973, presented by B. & N. Brown Freighters Pty. Ltd.; and that the said petition is directed to be heard before the Court sitting at the Fourteenth Court, Law Courts, William-street, Melbourne, on the 27th day of April, 1973, at the hour of 10.30 o'clock in the forenoon; and any creditor or contributory of the said company desiring to support or oppose the making of an order on the said petition may appear at the time of hearing by himself or his counsel for that purpose; and a copy of the petition will be furnished to any creditor or contributory of the said company requiring the same by the undersigned on payment of the regulated charge for the same.

The petitioner's address is corner of Old Footscray-road and New Footscray-road, Footscray, in the State of Victoria.

The petitioner's solicitors are Messrs. G. A. Hilford & Co., of 406 Lonsdale-street, Melbourne.

G. A. HILFORD & CO.

NOTE.—Any person who intends to appear on the hearing of the said petition must serve on or send by post to the above-named solicitors notice, in writing, of his intention so to do. The notice must state the name and address of the person or, if a firm, the name and address of the firm, and must be signed by the person or firm, or his or their solicitors (if any) and must be served or, if posted, must be sent by post in sufficient time to reach the above-named solicitors not later than 4 o'clock in the afternoon of the 26th day of April, 1973. 1335

In the Supreme Court of Victoria.—1973 Co. No. 8568.—In the matter of the *Companies Act 1961*; and in the matter of a Petition for the Winding Up of A. S. JAMES PTY. LTD.

Notice is hereby given that a petition for the winding up of the above-named company by the Supreme Court was on the 14th day of February, 1973, presented by Diamond & Boart Products (Vic.) Pty. Ltd.; and that the said petition is directed to be heard before the Court sitting at the Practice Court, Supreme Court of Victoria, William-street, Melbourne, on the 18th day of April, 1973, at the hour of 10.30 o'clock in the forenoon; and any creditor or contributory of the said company desiring to support or oppose the making of an order on the said petition may appear at the time of hearing by himself or his counsel for the purpose; and a copy of the petition will be furnished to any creditor or contributory of the said company requiring the same by the undersigned on payment of the regulated charge for the same.

The petitioner's address is 71-73 Palmerston-crescent, South Melbourne, Victoria.

The petitioner's solicitors are Messrs. Darvall & Hambleton, 147 Collins-street, Melbourne.

DARVALL & HAMBLETON.

NOTE.—Any person who intends to appear on the hearing of the said petition must serve on or send by post to the above-named solicitors notice, in writing, of his intention so to do. The notice must state the name and address of the person or, if a firm, the name and address of the firm, and must be signed by the person or firm, or his or their solicitor (if any) and must be served or, if posted, must be sent by post in sufficient time to reach the above-named, not later than 4 o'clock in the afternoon of the 17th day of April, 1973. 1384

Pursuant to the *Trustee Act 1958*, notice is hereby given that all persons having claims against the estate of Elma Mary Stark, late of 47 Motherwell-street, Hawksburn, in the State of Victoria, spinster, deceased (who died on the 11th day of July, 1972, and probate of whose will was granted by the Supreme Court of the said State in its probate jurisdiction on the 8th day of December, 1972, to National Trustees, Executors and Agency Company of Australasia Limited, of 95 Queen-street, Melbourne, in the said State), are hereby required to send particulars in writing of such claims to the said National Trustees, Executors and Agency Company of Australasia Limited, at the above-mentioned address on or before the 30th day of May, 1973, after which date the said National Trustees, Executors and Agency Company of Australasia Limited, will proceed to distribute the assets of the said Elma Mary Stark, deceased, which shall have come to its hands amongst the persons entitled thereto, having regard only to the claims of which it shall then have had notice. And notice is hereby further given that the said National

Trustees Executors and Agency Company of Australasia Limited will not be liable for the assets so distributed or any part thereof to any person of whose claim it shall not have had notice as aforesaid.

Dated this 26th day of March, 1973.

F. J. REED, JOHNS & CO., solicitors, of 274 Bay-street, North Brighton, proctor for the said National Trustees, Executors and Agency Company of Australasia Limited.

1374

All persons having claims against the estate of Elsie Mabel Comer, late of 12 Challinor-crescent, Mount Albert, Auckland, in New Zealand, widow, deceased (who died on the 8th day of July, 1972, and probate of whose will was on the 30th day of October, 1972, granted by the Supreme Court of New Zealand, Northern District, Auckland Registry, to The Guardian Trust and Executors Company of New Zealand Limited, and application to the Supreme Court of Victoria, probate jurisdiction, by The Perpetual Executors & Trustees Association of Australia Limited, to seal such probate having been granted on the 9th day of March, 1973), are hereby required to send particulars of such claims to The Perpetual Executors & Trustees Association of Australia Limited, at its registered office, at 100-104 Queen-street, Melbourne, on or before the 6th day of June, 1973, after which date the said company will proceed to transfer, convey or distribute the said estate to or among the persons entitled thereto, having regard only to the claims of which it shall then have had notice and will not be liable for the assets so transferred, conveyed or distributed to any persons of whose claim it shall not then have had notice.

Dated this 28th day of March, 1973.

MADDEN, BUTLER, ELDER & GRAHAM, solicitors, of 500 Collins-street, Melbourne.

1344

Creditors, next of kin and others having claims in respect of the estate of John Garvan Hurley (in the will called John Patrick Garvan Hurley), late of 8 Florence-avenue, Kew, medical practitioner (who died on the 2nd day of April, 1972), are to send particulars of their claims to the executors, Francis Xavier Garvan Hurley, and John Garvan Hurley, care of the undersigned, by 8th June, 1973, after which date they will commence to distribute the assets, having regard only to the claims of which they then have notice.

RENNICK & GAYNOR, solicitors, 491 Bourke-street, Melbourne.

1342

Creditors, next of kin and others having claims in respect of the estate of Gwendoline Bertha Wareham, late of 53 York-street, North Fitzroy, in the State of Victoria, spinster, deceased (who died on the 20th day of April, 1972), are to send particulars of their claims to National Trustees, Executors and Agency Company of Australasia Limited, of 95 Queen-street, Melbourne, in the said State, within two clear months from the publication hereof, after which date it will distribute the assets, having regard only to the claims of which it then has notice.

SEPTIMUS JONES & LEE, solicitors, of 327 Collins-street, Melbourne.

1343

Creditors, next of kin and others having claims in respect of the will of Salvatore Patti, Senior, late of 19 Clyde-street, Maribymong, labourer (who died on the 15th day of February, 1973), are requested to send particulars of their claims to the executrix, Natalia Patti, care of the under-mentioned solicitor, by the 14th day of June, 1973, after which date she will distribute the assets, having regard only as to the claims of which she then has notice.

JOHN STEWART, of 290 Racecourse-road, Newmarket.

1256

Creditors, next of kin and others having claims in respect of the estate of William Ambrose Hogan, late of 120 Nicholson-street, Fitzroy, pensioner (who died on the 9th day of September, 1972), are to send particulars of their claims to Royston Cahir, Martin & Dillon, solicitors, of 17 Queen-street, Melbourne, by the 30th day of May, 1973, after which date the administratrix, will distribute the assets of the estate, having regard only to claims of which she has notice.

ROYSTON CAHIR, MARTIN & DILLON, solicitors, of 17 Queen-street, Melbourne.

1346

Creditors, next of kin and others having claims in respect of the estate of Arthur Edward Buckland, late of "Greenfields", North-road, Langwarrin, retired poultry farmer, deceased (who died on 29th November, 1972), are required by the executors, James McConnell Hambleton and Gordon William Duxbury, both of 7th Floor, T. & G. Building, corner Collins and Russell streets, Melbourne, solicitors, to send particulars of their claims to them, care of the under-mentioned solicitors, by the 31st day of May, 1973, after which date they will distribute the assets, having regard only to the claims of which they then have notice.

DARVALL & HAMBLETON, solicitors, 7th Floor, T. & G. Building, corner Collins and Russell streets, Melbourne.

1348

WALFORD STILWELL, formerly of 41 Williamson-street, Bendigo, but late of 3 Osborne-street, St. Marys, in the State of South Australia, Gentleman, DECEASED.

Creditors, next of kin and others having claims against the estate of the abovenamed deceased are required by the executor and executrix thereof, National Trustees, Executors and Agency Company of Australasia Limited, of 95 Queen-street, Melbourne, and at 46 Queen-street, Bendigo, and Muriel Mabel Stilwell, of 3 Osborne-street, St. Marys, widow, to forward particulars thereof to the said company, on or before the 1st day of June, 1973, after which date they will distribute the assets of the above said estate, having regard only to the claims of which they then have notice.

Dated this 21st day of March, 1973.

HYETT & HYETT, 51 Bull-street, Bendigo, solicitors for the applicants.

1251

ROSINA VICTORIA McCUBBIN, late of Lake Boga, in the State of Victoria, widow, DECEASED (who died on 1st February, 1973).

Creditors, next of kin and all other persons having claims against the estate of the deceased are required by the executrix of the will, Melba Caroline Barr, to send particulars to her, care of the undersigned, on or before the 21st day of June, 1973, after which date she will distribute the assets, having regard only to the claims of which she then has notice.

GARDEN & GREEN, solicitors, 4 McCallum-street, Swan Hill.

1252

GEORGE HENDERSON LEWIS, late of Alexandra, farmer, DECEASED.

Creditors, next of kin and others having claims in respect of the deceased (who died on 29th November, 1972), are required by his trustee, Alice May Victoria Lewis, of Alexandra, widow, to send particulars to her, care of the undermentioned firm of solicitors, by the 6th day of June, 1973, after which date the trustee may convey and distribute the assets, having regard only to the claims of which she then has notice.

MAL RYAN & GLEN, 9 High-street, Mansfield, solicitors for the trustee.

1254

JOHN FREDERICK SENNETT, late of St. Omer Private Hospital, 44 Prospect Hill-road, Camberwell, in the State of Victoria, gentleman, DECEASED.

Creditors, next of kin and others having claims in respect of the estate of the deceased (who died on 21st day of November, 1972), are required by The Equity Trustees, Executors and Agency Co. Ltd., of 472 Bourke-street, Melbourne, to send particulars of their claims to the said company by the 28th day of May, 1973, after which date it will convey or distribute the assets, having regard only to the claims of which the company then has notice.

GRANT & CO., solicitors, 108 Queen-street, Melbourne, 3000.

1326

ANNIE MACFARLANE, late of 4 Glenarm-road, Glen Iris, home duties, DECEASED.

Creditors, next of kin and others having claims in respect of the estate of the above-named deceased (who died on the 31st day of December, 1972), are required by John Cadwallader Jones, of 401 Collins-street, Melbourne, solicitor, the executor of the will of the said deceased, to send particulars of their claims to the said executor, care of the undernamed solicitors, by the 1st day of June, 1973, after which date he will convey or distribute the assets, having regard only to the claims of which he then has notice.

RUSSELL, KENNEDY & COOK, solicitors, 401 Collins-street, Melbourne.

1345

Creditors, next of kin and others having claims in respect of the estate of Francis Broughton Currie, late of 151 Nell-street, Greensborough, storeman, deceased (who died on 15th July, 1972), are required by National Trustees, Executors and Agency Company of Australasia Limited, of 95 Queen-street, Melbourne, the executor of the will of the above-named deceased to send particulars of their claim to it, by 31st May, 1973, after which date it will distribute the assets, having regard only to the claims of which it then has notice.

THOMAS BURKE, solicitor, 152 Wattle-tree-road, Malvern. 1289

Creditors, next of kin and others having claims against the estate of Harry Bardsley, late of 13 Wickham-street, Melton South, in the State of Victoria, retired gentleman, deceased (who died on the 10th day of November, 1972), are required by the executrix of his estate, Vera Bardsley, to send particulars of their claims to her, care of the under-mentioned solicitors, before the 4th day of June, 1973, after which date she will distribute the assets, having regard only to the claims of which she then has notice.

PEARCE & WEBSTER, solicitors, 430 Little Collins-street, Melbourne. 1330

MORRIS EDWIN HECKER, late of 78 Warrigal-road, Surrey Hills, retired grazier, DECEASED.

Creditors, next of kin and others having claims against the estate of the said deceased (who died on the 19th October, 1972), are to send particulars of their claim to the executors, The Union-Fidelity Trustee Company of Australia Limited, and Christine Helen Hecker, care of 100 Exhibition-street, Melbourne, by the 31st day of May, 1973, after which date they will distribute the assets, having regard only to the claims of which they have notice.

J. ROBERTSON, MACMILLAN & CO., solicitors, 191 Bank-street, South Melbourne. 1364

Creditors, next of kin and others having claims against the estate of Lillian Kate Peers, late of 29 Carters-avenue, Toorak, widow, deceased (who died on the 29th October, 1972), are required by the executor, Alfred Newton Super, of 374 Bourke-street, Melbourne, solicitor, to send particulars of such claims to him on or before 30th May, 1973, after which date he will distribute the assets, having regard only to the claims of which he shall then have had notice.

A. NEWTON SUPER & P. G. KOVACS, barristers and solicitors, 374 Bourke-street, Melbourne, 3000. 1369

Creditors, next of kin and others having claims against the estate of James Charles Coughlan, late of Unit 4, 27 Swansea-road, Chelsea, pensioner, deceased (who died on the 12th January, 1973), are required by the executrix, Sylvia Super, of 374 Bourke-street, Melbourne, solicitor, to send particulars of such claims to her on or before the 30th May, 1973, after which date she will distribute the assets, having regard only to the claims of which she shall then have had notice.

SYLVIA ROTHSTADT, M.A., LL.B., barrister and solicitor, 374 Bourke-street, Melbourne. 1370

Creditors, next of kin and others having claims in respect of the estate of Raimondo Antonio Marcolongo, late of 12 Matthews-street, Wonthaggi, postal clerk, deceased, intestate (who died on the 23rd day of October, 1971), are to send particulars of their claims to Guilio Marcolongo, care of the undersigned by the 31st day of May, 1973, after which date he will distribute the assets, having regard only to the claims of which he then has notice.

BIRCH, ROSS, BARLOW & WOJNARSKI, solicitors, Wonthaggi. 1362

DORIS MARY ABBIE McCRAE, late of "Corrabert", 210 Orrong-road, Toorak, in the State of Victoria, widow, DECEASED.

Creditors, next of kin and others having claims in respect of the estate of the said deceased (who died on the 12th day of September, 1972), are to send particulars of their claims to the executor, namely The Equity Trustees, Executors and Agency Company Limited, of 472 Bourke-street, Melbourne, by the 30th day of May, 1973, after which date the said executor will distribute the assets in the said estate, having regard only to the claims of which it then has notice.

PAVEY, WILSON, COHEN & CARTER, solicitors, 390 Lonsdale-street, Melbourne. 1331

Creditors, next of kin and others having claims in respect of the estate of Barbara Grant Williams, late of Tanwood, widow, deceased (who died on the 13th day of November, 1972), are to send the particulars of their claims to The Union-Fidelity Trustee Company of Australia Limited, of 100 Exhibition-street, Melbourne, on or before the 15th day of June, 1973, after which date it will distribute the assets, having regard only to the claims of which it has notice.

HERRING & BATHURST, solicitors, Maryborough.

1367

LEO FRANCIS FOWLER, late of 197 Camberwell-road, Hawthorn East, in the State of Victoria, gentleman, DECEASED.

Creditors, next of kin and others having claims in respect of the estate of the deceased (who died on the 11th day of September, 1972), are required by the executor The National Trustees, Executors and Agency Company of Australasia Limited, of 95 Queen-street, Melbourne, to send particulars of their claims to the said company by the 10th day of June, 1973, after which date the said company will convey or distribute the assets, having regard only to the claims of which the company then has notice.

T. A. RANK & ROBINSON, solicitors, 388 Bourke-street, Melbourne. 1375

Creditors, next of kin and others having claims in respect of the estate of Jean Gallienne Haig, late of 16 Sutherland-road, Armadale, spinster, deceased (who died on the 18th January, 1973), are to send particulars of their claims to The Union-Fidelity Trustee Company of Australia Limited, of 100 Exhibition-street, Melbourne, by the 29th May, 1973, after which date the said company will distribute the assets, having regard only to the claims of which it then has notice.

R. WADHAM & DOIG, solicitors, of 383 Flinders-lane, Melbourne. 1381

Creditors, next of kin and others having claims in respect of the estate of Leslie George Glew, late of 9 Martin-street, Sunshine, in the State of Victoria, patrolman, deceased (who died on or about 30th October, 1972), are required to send particulars of their claims to The Trustees, Executors and Agency Company Limited, of 401 Collins-street, Melbourne, by 31st May, 1973, after which date it will distribute the assets of the deceased, having regard only to the claims of which it then has notice.

DESMOND WILSON & CO., solicitors, Sunshine. 1368

Creditors, next of kin and others having claims in respect of the estate of Edward James Scarce, late of 25 Shipley-street, Box Hill, in the State of Victoria, inspector (who died on the 3rd day of January, 1973), are to send particulars of their claims to National Trustees, Executors and Agency Company of Australasia Limited, carrying on business at 95 Queen-street, Melbourne, in the said State the co-executor, with Joyce Olive Scarce, of the will of the deceased, by the 6th day of June, 1973, after which date it will distribute the assets, having regard only to the claims of which it then has notice.

COLE & O'HEARE, solicitors, 422 Little Collins-street, Melbourne. 1332

Creditors, next of kin and others having claims in respect of the estate of Elma Linda Durran, late of 25 Glendrive, Eaglemont, married woman, deceased (who died on the 14th October, 1972), are to send particulars of their claims to the executor, care of the under-mentioned solicitors, by the 30th May, 1973, after which date he will distribute the assets, having regard only to the claims of which he then has notice.

CORR & CORR, solicitors, 290 Latrobe-street, Melbourne. 1333

Creditors, next of kin and others having claims against the estate of Donald Miller Swanson Thomson, late of "Walton Cottage", Turnbull-street, Mornington, in the State of Victoria, grazier, deceased (who died on the 26th day of September, 1972), are required to submit particulars of their claims to the executor, The Equity Trustees, Executors and Agency Company Limited, of 472 Bourke-street, Melbourne, on or before the 30th day of June, 1973, after which the executor will distribute the assets of the estate, having regard only to the claims of which it shall have notice.

ANDERSON, RICE & NICOLL, of 51 Queen-street, Melbourne, solicitors for the executor. 1341

Creditors, next of kin and others having claims against the estate of Curt Edward Herman-Hauer, late of Unit 14, Lutheran Homes, Mountain View-road, Boronia, retired insurance officer, deceased (who died on the 11th day of October, 1972), are required to send particulars of their claims to the National Trustees, Executors and Agency Company of Australasia Limited, of 95 Queen-street, Melbourne, before the 1st day of June, 1973, after which date it will distribute the assets, having regard only to the claims of which it then has notice.

J. A. REDMOND & CO., solicitors, of 482 Bourke-street, Melbourne. 1337

Creditors, next of kin and others having claims in respect of estate of George Harris Griffith, late of 23 Moule-street, West Brunswick, retired tramway employee, deceased (who died on 4th November, 1972), are to send particulars of their claims to John Watson McCallum, care of the undersigned, by the 31st day of May, 1973, after which date he will distribute the assets, having regard only to the claims of which he then has notice.

COOK & McCALLUM, solicitors, 422. Collins-street, Melbourne. 1338

Creditors, next of kin and others having claims in respect of the estate of Ruby Gertrude Barber, late of 25 Childers-street, Kew, widow (who died on the 17th January, 1973), are to send particulars of their claims to The Union-Fidelity Trustee Company of Australia Limited, of 100 Exhibition-street, Melbourne, by the 30th day of May, 1973, after which date it will distribute the assets, having regard only to the claims of which it then has notice.

RYLAH & RYLAH, solicitors, 349 Collins-street, Melbourne. 1339

Creditors, next of kin and others having claims in respect to the estate of Elsie Maud Aldersea, late of 25 Swindon-road, Oakleigh, home duties, deceased (who died on 22nd September, 1972), are required by the executrix, Doris Nancy Lazer, of 6 Paddington-road, Oakleigh, home duties, to send particulars of their claims to her, care of the under-mentioned solicitors, by 31st May, 1973, after which date she will convey or deal with the assets, having regard only to the claims of which she then has notice.

UPTON & ETTIELSON, solicitors, 100 Queen-street, Melbourne. 1340

Creditors, next of kin and others having claims in respect of the estate of George Craven Cookson, late of 58 Kanooka-grove, Clayton, in the State of Victoria, printer, deceased (who died on the 18th September, 1972), are requested to send particulars of their claims to the executor, National Trustees, Executors and Agency Company of Australasia Limited, of 95 Queen-street, Melbourne, in the said State on or before 30th day of May, 1973, after which date the executor will distribute the assets, having regard only for the claims of which it has then had notice.

ALEXANDER WHITEHOUSE & CO., solicitors, 76 Jackson-court, Doncaster East. 1293

Creditors, next of kin and others having claims in respect of the estate of Alice Bertha Waite, formerly of 521 High-street, Prahran, married woman, but late of 22 Mackay-street, Essendon, widow, deceased (who died on the 8th day of November, 1972, and probate of whose will has been granted to The Equity Trustees, Executors and Agency Company Limited, of 472 Bourke-street, Melbourne), are required to send particulars of their claims to the said company, care of the undermentioned solicitors, by the 29th day of May, 1973, after which date they will distribute the assets, having regard only to the claims of which they then have notice.

PEARCE & WEBSTER, solicitors, 430 Little Collins-street, Melbourne. 1390

RUBY EVELYN GOFFIN, late of 7 Mossman-drive, Heidelberg, in the State of Victoria, married woman, DECEASED.

Creditors, next of kin and others having claims in respect of the estate of the deceased (who died on the 14th December, 1972), are required by the trustees, George Robert Goffin, civil engineer, and Elinor Caroline Goffin, school teacher, both of 7 Mossman-drive, Heidelberg, aforesaid, to send particulars to them, care of the undersigned, by the 30th May, 1973, after which date the trustees may convey or distribute the assets, having regard only to the claims of which they then have notice.

WHITING & BYRNE, 440 Collins-street, Melbourne. 1392

Creditors, next of kin and others having claims in respect of the estate of Percival Henry Judd, formerly of 40 Maribymong-road, Moonee Ponds, but late of 12 Gratten-road, Montrose, gentleman, deceased (who died on the 3rd day of October, 1972), are to send particulars of their claims to the executor, The Equity Trustees, Executors and Agency Company Limited, of 472 Bourke-street, Melbourne, by the 31st day of May, 1973, after which date the said executor will distribute the assets, having regard only to the claims of which it then has notice.

O'BRIEN & GALANTE, solicitors, 44 Pascoe Vale-road, Moonee Ponds. 1302

ERIC JOHN SPRIGG, late of Lockwood, farmer, DECEASED.

Creditors, next of kin and others having claims in respect of the above-named deceased (who died on the 26th December, 1972), are required by the executor, Thomas William Iser, care of the solicitors mentioned below, to send particulars to him, by the 30th June, 1973, after which date he may convey or distribute the assets, having regard only to the claims of which he then has notice.

COHEN, KIRBY, COSGRIFF & ISER, solicitors, corner Pall Mall and Bull-street, Bendigo. 1308

EMILY EWINS, formerly of 1 Menzie-grove, Ivanhoe, but late of 1 Delville-avenue, Mentone, in the State of Victoria, widow, DECEASED.

Creditors, next of kin and others having claims in respect of the estate of the deceased (who died on the 2nd day of August, 1972), are required by Donald Henry Ewins, of 104 Chute-street, Mordialloc, to send particulars to the said Donald Henry Ewins at his aforesaid address, by the 8th day of June, 1973, after which date he may convey or distribute the assets, having regard only to the claims of which he has had notice.

Dated this 27th day of March, 1973.

LOUGHREY & LOUGHREY, 118 Queen-street, Melbourne, solicitors for the administrator. 1385

Creditors, next of kin and others having claims against the estate of Edward Ernest Thomas Brown, formerly of 30 McMahons-road, Frankston, but late of Geriatric Centre, Jackson's-road, Frankston, gentleman, deceased (who died on the 29th day of December, 1972), should send particulars of their claims to the executor, The Equity Trustees Executors and Agency Company Limited, of 472 Bourke-street, Melbourne, by the 14th day of June, 1973, after which date the estate will be distributed, having regard only to the claims of which the executor then has notice.

PRENDERGAST & ROBINSON, PARKINSON & HART, solicitors, 406 Lonsdale-street, Melbourne. 1386

GEORGE ARROWSMITH, late of 289 St. George's-road, Northcote, engineer, DECEASED.

Creditors, next of kin and others having claims in respect of the estate of the above-named deceased (who died on the 6th day of December, 1972), are required to send particulars of their claims in writing to National Trustees, Executors and Agency Company of Australasia Limited, of 95 Queen-street, Melbourne (one of the executors appointed by the deceased's will) on or before the 20th day of June, 1973, after which date the company and its co-executor, Albert Charles Hodgkinson will distribute the assets of the deceased, having regard only to the claims of which they then have notice.

JOHN MORAN & HAYES, solicitors, 422 Collins-street, Melbourne. 1387

Creditors, next of kin and others having claims in respect of the estate of Christina Ann Peters, late of 37 Paul-street, Cheltenham, married woman, deceased (who died on the 22nd day of August, 1972, and probate of whose will has been granted to Alfred Leslie Peters, formerly of 37 Paul-street, Cheltenham, now of Unit 3, 4 Latona-street, Mentone, retired, and David John Peters, of 1 Port-street, Highett, Commonwealth public servant), are required to send particulars of their claims to the said executors, care of the under-mentioned solicitors, by the 29th day of May, 1973, after which date they will distribute the assets, having regard only to the claims of which they then have notice.

PEARCE & WEBSTER, solicitors, 430 Little Collins-street, Melbourne. 1388

Creditors, next of kin and other persons having claims against the estate of Mary Josephine Connors, late of 18 Leonard-street, Deepdene, in the State of Victoria, widow, deceased (who died on the 14th December, 1972), are required to send particulars of their claims to the executor, National Trustees Executors and Agency Company of

Australasia Limited, of 95 Queen-street, Melbourne, by the 21st day of May, 1973, after which date the executor will distribute the assets, having regard only for the claims of which it then has had notice.

JAMES P. OGG & CO., solicitors, 165 Greville-street, Prahran. 1393

MYRTLE JANE MARSDEN, late of St. Leonard's, spinster, DECEASED.

Creditors, next of kin and others having claims in respect of the estate of the said deceased (who died 18th September, 1972, are required by the applicant for grant of letters of administration with the will annexed, Rodger Stewart Marsden, of 88 Heyers-road, Grovedale, engineer), to send particulars to him, care of the undersigned solicitors, by 6th June, 1973, after which date the said applicant may convey or distribute the assets, having regard only to the claims of which he then has notice.

WIGHTON & McDONALD, solicitors, 89 Myers-street, Geelong. 1398

JESSIE DAWSON, late of Percy Baxter Lodge, Grace McKellar House, Ballarat-road, North Geelong, spinster, DECEASED.

Creditors, next of kin and others having claims in respect of the estate of the said deceased (who died 22nd January, 1973, are required by the applicants for grant of probate of the will, Colin Ernest Dawson, of 9 Wilson-road, Newcomb, tractor mechanic, and Arthur Sayce Beddome, of 43 West-street, Glenroy, process worker), to send particulars to them, care of the undersigned solicitors, by 6th June, 1973, after which date the said applicants may convey or distribute the assets, having regard only to the claims of which they then have notice.

WIGHTON & McDONALD, solicitors, 89 Myers-street, Geelong. 1399

In the Supreme Court of the State of Victoria.

SALE BY THE SHERIFF.

On Friday, the 4th of May, 1973, at 10 a.m., at the Police Station, South Yarra (unless process be stayed or satisfied):—

All the estate and interest (if any) of Erika Jansons (formerly known as Erika Smits), coffee lounge proprietor, of 26 Range-street, Camberwell, as joint proprietor with Harold Smits in 14 equal undivided forty-seventh parts or shares in all that piece of land being part of portion 3, Parish of Prahran, and being the land described in certificate of title, volume 8858, folio 072, on which is erected: (a) A building known as 95 Toorak-road, with a frontage of approximately 14 feet, currently being used as a coffee lounge. (b) A building known as 97 Toorak-road, with a frontage of approximately 22 feet, currently being used as a delicatessen. (c) A building known as 99 Toorak-road, with a frontage of approximately 11 feet, currently being used as a green grocer shop.

Registered mortgage No. D.858816 affects the said estate and interest.

Terms: Cash only.

DOUGLAS S. HALL, Sheriff's Officer.
28th March, 1973. 1394

In the Supreme Court of the State of Victoria.

SALE BY THE SHERIFF.

On Friday, the 11th of May, 1973, at 10 a.m., at the Police Station, Chelsea (unless process be stayed or satisfied):—

All the estate and interest (if any) of Mr. W. Patton, plumber (shown on certificate of title as William Charles Patton), of 63 The Broadway, Bonbeach, as joint proprietor with Heather Faye Patton, married woman, of an estate in fee-simple in the land described in certificate of title, volume 6533, folio 431, upon which is erected a contemporary style white weatherboard house, known as No. 63, The Broadway, Bonbeach.

Registered Mortgage No. D.887794 affects the said estate and interest.

Terms: Cash only.

DOUGLAS S. HALL, Sheriff's Officer.
28th March, 1973. 1395

In the Supreme Court of the State of Victoria.

SALE BY THE SHERIFF.

On Friday, the 11th of May, 1973, at 2 p.m., at the Police Station, Sunbury (unless process be stayed or satisfied):—

All the estate and interest (if any) of John Culleton, carpenter, of 6 Henty-court, Sunbury, as joint proprietor with Joyce Grace Culleton, married woman, of an estate in fee-simple in the land described in certificate of title, volume 8790, folio 927, upon which is erected a brick veneer dwelling, known as No. 6 Henty-court, Sunbury.

Registered mortgage Nos. D.661681 and E.661258 and caveat No. E.712158 affect the said estate and interest.

Terms: Cash only.

DOUGLAS S. HALL, Sheriff's Officer.
28th March, 1973. 1396

In the Supreme Court of the State of Victoria.

SALE BY THE SHERIFF.

On Friday, the 11th of May, 1973, at 10 a.m., at the Police Station, St. Kilda (unless process be stayed or satisfied):—

All the estate and interest (if any) of G. V. Tollis; travel agent (shown on certificate of title as George Vasil Tollis), of 5 Penleigh-court, East St. Kilda, as a tenant-in-common in equal shares with Georgina Tollis (formerly Georgina Kalisperatou), of the land described in certificate of title, volume 8623, folio 895, upon which is erected a block of four flats, known as 40 Park-street, St. Kilda.

Registered mortgage No. D.998942 affects the said estate and interest.

Terms: Cash only.

H. BUETTNER, Sheriff's Officer.
28th March, 1973. 1397

INSOLVENCY NOTICE

Bankruptcy Act 1966, Part X.—Bankruptcy District of the State of Victoria.—No. 17 of 1973, Part X.—Re: SYLVIA JOY SMITH, trading as A.D.O. Blinds & Floor Coverings.—Notice to Creditors.

At a meeting of creditors of the above-named debtor, held on 20th March, 1973, the following Special Resolution was duly passed:—

“That the debtor execute a deed of arrangement which shall contain the provisions contained in the draft deed produced to this meeting.”

It was resolved that Maxwell George Gee be appointed the trustee of the said deed, and a committee of inspection be appointed, comprising three persons, the first members to be Messrs. Webb, Barson & Sheppard.

The main provisions of the deed being as follows: The debtor is to pay to the trustee not less than \$400.00 per month until all priority and non-priority debts at the date of the execution of the deed are paid in full. The debtor shall continue to operate her business and shall be responsible for all debts incurred in the future operation of the business. All trade debts are assigned to the trustee, who shall immediately realise the amount of \$3,500. The balance of trade debtors, cash at bank, stock in trade, fixtures, fittings and floor coverings of the business are also assigned to the trustee, however, realisation shall be postponed as long as the debtor does not default in the terms of the deed, or the trustee forms the opinion that the results of the business are unsatisfactory. Drawings from the business by the debtor and her husband by way of salary, share of profits, allowances, &c., must not exceed the sum of \$150 per week in total, this does not include the payment of \$400 per month payable to the trustee previously referred to. Pursuant to section 218 of the Act, we advise that the debtor and the trustee executed the deed on 20th March, 1973.

M. G. GEE, Trustee.

Max Gee & Co., public accountants, 325 Warrigal-road, Burwood, Vic. 3125. 1300

IMPOUNDINGS

BENALLA.—Impounded in Benalla Pound by Mr. B. Hurley, on 15th March, 1973, at 10.30 a.m., found in Burnesses-road, Benalla.

1 cross-bred 4-tooth ewe, no visible brand or marks
If not claimed and expenses paid, to be sold on 12th April, 1973.

1314—\$2.80
C. H. WALLACE,
Poundkeeper.

BENALLA.—Impounded in Benalla Pound, by Mr. R. J. Hunter (Stock Inspector), on 20th March, 1973, at 4 p.m., from the Midland Highway near Stewarton.

1 wether, no visible brand
If not claimed and expenses paid, to be sold on 12th April, 1973.

1315—\$2.80
C. H. WALLACE,
Poundkeeper.

ELLIMINYT.—Impounded in Elliminyt Pound.

1 black bull calf, no visible brand or ear marks
If not claimed and expenses paid, to be sold on 5th April, 1973.

1317—\$2.10
G. J. DUNN,
Poundkeeper.

ELLIMINYT.—Impounded in Elliminyt Pound.

1 woolly wether, no visible brand or ear marks
If not claimed and expenses paid, to be sold on 5th April, 1973.

1313—\$2.10
G. J. DUNN,
Poundkeeper.

GISBORNE.—Impounded in Gisborne Pound, from Calder Highway, Macedon.

1 red and white heifer, no visible brand
If not claimed and expenses paid, to be sold on 13th April, 1973.

1316—\$2.45
K. V. ROBINSON,
Shire Secretary.

HAWKESDALE.—Impounded in Hawkesdale Pound, on 23rd March, 1973.

1 aged Polwarth ewe, plain blue tag, three notches right ear, no visible brand

1 Merino weaner lamb, two notches left ear, no visible brand

If not claimed and expenses paid, to be sold on 12th April, 1973.

1365—\$3.50
C. EDWARDS,
Poundkeeper.

KERANG.—Impounded in Kerang Pound, from Loddon Highway.

1 crossbred ewe, nick both ears, injured front leg, no visible brand

1 Merino ewe, indistinct blue mark on back, nick both ears like W

If not claimed and expenses paid, to be sold on 18th April, 1973.

1403—\$3.50
F. F. HASTIE,
Poundkeeper.

LAKE BENETOOK.—Impounded in Lake Benetook Pound.
6 black and white store-type vealers

1 brindle store-type vealer
If not claimed and expenses paid, to be sold on 12th April, 1973.

1312—\$2.45
E. F. CURTIS,
Poundkeeper.

MELTON.—Impounded in Melton Pound, on 26th March, 1973.

20 goats, various colours, male and female, no visible brand

If not claimed and expenses paid, to be sold on 12th April, 1973.

1372—\$2.80
M. B. WATSON,
Shire Secretary.

MELTON.—Impounded in Melton Pound, on 13th March, 1973.

1 dark-brown Shetland pony (stallion), no visible brand

If not claimed and expenses paid, to be sold on 6th April, 1973.

1371—\$2.45
M. B. WATSON,
Shire Secretary.

SMEATON.—Impounded in Smeaton Pound.

2 ewes, branded T S
2 ewes, no visible brand
1 wether, nick in right ear, no visible brand
2 wethers, no visible brand

If not claimed and expenses paid, to be sold on 12th April, 1973.

1329—\$3.15
I. E. TEASDALE,
Poundkeeper.

WINCHELSEA.—Impounded in Winchelsea Pound.

1 wether lamb, no visible brand
1 wether lamb, N inside circle on back

If not claimed and expenses paid, to be sold on 16th April, 1973.

1318—\$2.45
W. HOLE,
Poundkeeper.

Subordinate Legislation Act 1962.

NOTICE OF MAKING OF STATUTORY RULES.

In pursuance of the provisions of the *Subordinate Legislation Act 1962* and the Regulations made thereunder, notice is given of the making of the following statutory rules:—

No.	<i>The Constitution Act Amendment Act 1958.</i>	Price.
52/1973.	Victorian Parliamentary Elections (Amending) Regulations 1973	10c

No.	<i>The Constitution Act Amendment Act 1958.</i>	Price.
53/1973.	Electoral Rolls (Amending) Regulations 1973	10c

No.	<i>Metropolitan Fire Brigades Act 1958.</i>	Price.
54/1973.	Metropolitan Fire Brigades General (Amendment No. 1) Regulations 1973	10c

Copies of these statutory rules may be purchased at the Sale of Publications Section of the Government Printing Office, located at 7A Parliament-place, Melbourne, 3002. If ordered by mail, remittance should be addressed to "The Government Printer, Box 203, P.O., North Melbourne, 3051", and should include 7c extra for postage. If a credit account is held at this office, no remittance is required with the mail order.

The annual subscription rate for Statutory Rules (including Bound Volumes) is \$25, payable in advance. The subscription year commences on 1st January.

C. H. RIXON,
Government Printer.

AGENTS FOR THE "VICTORIA GOVERNMENT GAZETTE".

The following have been appointed agents to receive Advertisements and Subscriptions for the *Victoria Government Gazette*:—

ARMSTRONG'S AGENCY, 217 Queen-street, Melbourne, Victoria 3000

ARNALL & JACKSON, 390 Barkly-street, Brunswick, Victoria 3056.

BAIRNSDALE AUTHORIZED NEWSAGENCY, 132 Main-street, Bairnsdale, Victoria 3875.

BICKNELL, M. J., Authorized Newsagent, 196 Timor-street, Warrnambool, Victoria 3280.

BLANE'S AUTHORIZED NEWSAGENTS, 162 Murray-street, Colac, Victoria 3250.

CARTER, R. G., ADVERTISING SERVICE PTY. LTD., Suite 24, 65 Queens-road, Melbourne, Victoria 3004.

DAVIES, G. & M. V., 112 Gray-street, Hamilton, Victoria 3300.

DAVIS, WM. (MILDURA) PTY. LTD., 126 Eighth-street, Mildura, Victoria 3500.

DIXON'S NEWSAGENCY, 89 Firebrace-street, Horsham, Victoria 3400.

EASTHALL ASSOCIATES, 934 Whitehorse-road, Box Hill, Victoria 3128.

EDGAR'S AUTHORIZED NEWSAGENCY, 45 Bridge-street, Benalla, Victoria 3672.

FRANKS, H. & CO., 184 Ryrrie-street, Geelong, Victoria 3220.

	CONTENTS	PAGE
GATLEY, A. & J., 250 Lonsdale-street, Dandenong, Victoria 3175.	Appointments	669
GORDON & GOTCH AUSTRALASIA LTD., 434 St. Kilda-road, Melbourne, Victoria 3004.	Bank Half-Holiday	652
GULLAN'S NEWSAGENCY, 88 Bridge-street, Ballarat, Victoria 3350.	Bank Holiday	652
HAMPTON, A. C., 243 Mitchell-street, Bendigo, Victoria 3550.	Cemeteries—Scale of Fees	660
HARSTON, PARTRIDGE & CO. PTY. LTD., 455 Little-Collins-street, Melbourne, Victoria 3000.	Companies Act 1961—Notice	665
KYNETON GUARDIAN PTY. LTD., P.O. Box 18, Kyneton, Victoria 3444.	Contracts	668
LATIMER'S Newsagents, 45 Station-street, Malvern, Victoria 3144.	Easter and Anzac Day Holidays	652
LIVINGSTON'S SHEPPARTON NEWSAGENCY, 246 Wyndham-street, Shepparton, Victoria 3630.	Estates of Deceased Persons	668
THE MERCANTILE EXCHANGE, 34 Queen-street, Melbourne, Victoria, 3000.	Government Notices	652
MCGILL'S AUTHORIZED NEWSAGENCY, 183-5 Elizabeth-street, Melbourne, Victoria 3000.	Impoundings	702
POWNEY'S AUTHORIZED NEWSAGENCY, 293 Hargreaves-street, Bendigo, Victoria 3550.	Insolvency Notice	702
PURDIE, J., & CO., 138 Moorabool-street, Geelong, Victoria 3220.	Lands	681
SALE AUTHORIZED NEWSAGENCY, 142 Raymond-street, Sale, Victoria 3850.	Melbourne and Metropolitan Board of Works—Notice	663
SKINNER'S AUTHORIZED NEWSAGENCY, 49-51 Franklin-street, Traralgon, Victoria 3844.	Notice of Making of Statutory Rules	703
STEVENSON, A. C. & M., NEWSAGENTS, 132 Henty-street, Casterton, Victoria 3311.	Orders in Council—	
VANCE'S AUTHORIZED NEWSAGENCY, 83 Murray-street, Wangaratta, 3677.	Acts—Local Government; Country Roads; Town and Country Planning; Melbourne Underground Rail Loop; Health; Land; Local Government; Sewerage Districts; West Moorabool Water Board; Water; River Improvement; Housing Ministry; Metropolitan Fire Brigades.	671 et seq
VERNONS OF RICHMOND, 162 Bridge-road, Richmond, Victoria 3121.	Private Advertisements	687
VIEW POINT AUTHORIZED NEWSAGENCY, 4 View-Point, Bendigo, Victoria 3550.	Proclamations	650
	Publication of the "Victoria Government Gazette"	649
	Public Service Notices	684
	Resignations	671
	Tenders	683
	Transport Regulation Board—Public Hearings	653
	Waterworks Trusts	666

A copy of the Gazette is filed at each place for public reference.