

[1075].



VICTORIA GOVERNMENT GAZETTE

Published by Authority

No. 35]

WEDNESDAY, MAY 16

[1973

PROCLAMATIONS

Land Act 1958.

AREA OF LAND COMPRISED IN CERTAIN CLASSES DIMINISHED OR INCREASED.

PROCLAMATION

By His Excellency the Governor of the State of Victoria and its Dependencies in the Commonwealth of Australia, &c., &c., &c.

Whereas by the *Land Act 1958* it is amongst other things enacted that the Governor in Council may, by Proclamation to be published in the *Government Gazette*, at any time diminish or increase the area of land comprised in any of the classes mentioned in Part I., Division 1, Section 5, of the said *Land Act 1958*, but that the area of lands which may be sold by auction (Class 6), shall not be increased except as in certain cases in the said Act provided: Now therefore I, the Governor of the State of Victoria, in the Commonwealth of Australia, by and with the advice of the Executive Council of the said State, and in accordance with the provisions of Sections 94 and 117 of the *Land Act 1958* aforesaid, do hereby diminish or increase (as the case may be) the areas of Crown lands comprised in Class 6 of the classes mentioned in Section 5 of the *Land Act 1958* aforesaid, to the extent set forth in the subjoined Schedule (that is to say):—

Schedule referred to.

CLASSES DIMINISHED OR INCREASED.

County.	Parish.	Allotment.	Section.	Area.	Diminished.	Increased.	Description.
					Class.	Class.	
				A. R. P.			
Borong	Illawarra ..	136A	..	1 3 13	..	6	At the corner of Lake Road and Hines Road.— (M62997)
Borong	Illawarra ..	136D	..	2 2 4	” ” ”

Given under my Hand and the Seal of the State of Victoria aforesaid, at Melbourne, this eighth day of May, in the year of our Lord One thousand nine hundred and seventy-three, and in the twenty-second year of the reign of Her Majesty Queen Elizabeth II.

(L.S.)

ROHAN DELACOMBE.
By His Excellency's Command,
W. BORTHWICK,
Minister of Lands.

GOD SAVE THE QUEEN!

Health Act 1958 (No. 6270).

CONSTITUTION OF THE UPPER YARRA MEAT AREA.

PROCLAMATION

By His Excellency the Governor of the State of Victoria and its Dependencies in the Commonwealth of Australia, &c., &c., &c.

By virtue of the powers conferred by the Health Act 1958 (No. 6270), I, the Governor of the State of Victoria, in the Commonwealth of Australia, on the recommendation of the Commission of Public Health and by and with the advice of the Executive Council of the said State, do by this my Proclamation constitute as a Meat Area to be known as the Upper Yarra Meat Area, the area contained in the whole of the municipal district of the Shire of Upper Yarra.

Given under my Hand and the Seal of the State of Victoria, aforesaid, at Melbourne, this eighth day of May, in the year of our Lord One thousand nine hundred and seventy-three, and in the twenty-second year of the reign of Her Majesty Queen Elizabeth II.

(L.S.) ROHAN DELACOMBE.

By His Excellency's Command,

J. F. ROSSITER,
Minister of Health.

GOD SAVE THE QUEEN!

GOVERNMENT NOTICES

Cemeteries Act 1958.

SCALE OF FEES OF FERNTREE GULLY PUBLIC CEMETERY.

In pursuance of the powers conferred upon them by the Cemeteries Act, the trustees of the Ferntree Gully Public Cemetery hereby make the following scale of fees, which shall come into operation upon publication in the Government Gazette, and from and after such publication every scale of fees heretofore made by the said trustees shall be and is hereby rescinded to the extent to which it conflicts with this scale.

Private Graves (Including Sinking).

Monumental (beam type) lawn section graves (8 ft. x 4 ft.) .. \$130.00
All general denominational graves (8 ft. x 4 ft.) \$100.00

Reopening Charges.

Reopen lawn section graves .. \$50.00
Reopen general denominational (monumental graves) .. \$45.00

Exhumations.

Exhuming the remains of a body, when authorized .. \$100.00

Search of Records.

Search of records and providing written information .. \$3.00

Oversize Graves.

Oversize shaped graves (all sections) (extra) .. \$15.00
Rectangular opening (7 ft. x 2 ft. 3 in.) (extra) \$40.00

Monumental Fees.

Deposit of \$10.00 to apply in respect of each individual application to erect a memorial in addition to a minimum fee of \$5.00 for monumental value costing up to \$100.00, plus \$2.00 for each \$100.00 in excess of basic amount, or part thereof.

W. A. MACAULAY, Trustee.
A. OWEN, Trustee.
M. J. WHITE, Trustee.
R. E. READ, Secretary.

Approved by the Governor in Council, 8th May, 1973.—
T. J. FORRISTAL, Clerk of the Executive Council.

Cemeteries Act 1958.

SCALE OF FEES OF ALBERTON PUBLIC CEMETERY.

In pursuance of the powers conferred upon them by the Cemeteries Act, the trustees of the Alberton Public Cemetery hereby make the following scale of fees, which

shall come into operation upon publication in the Government Gazette, and from and after such publication every scale of fees heretofore made by the said trustees shall be and is hereby rescinded to the extent to which it conflicts with this scale.

Land, 8 ft. x 4 ft. .. \$14.00
Sinking grave to 6 feet .. \$42.00
Sinking grave to 7 feet .. \$47.00
Reopening grave (no cover) .. \$35.00
Reopening grave (with cover) .. \$41.00
Interment fee .. \$6.00
Interment on a Saturday, Sunday or Public Holiday .. \$5.00
Permission to erect a memorial—4 per cent. of cost of memorial with minimum charge .. \$6.00

W. T. DESSENT, Trustee.
H. D. MOWAT, Trustee.
S. J. FINLAY, Trustee.

Approved by the Governor in Council, 8th May, 1973.—
T. J. FORRISTAL, Clerk of the Executive Council.

Cemeteries Act 1958.

SCALE OF FEES OF MIRBOO NORTH PUBLIC CEMETERY.

In pursuance of the powers conferred upon them by the Cemeteries Act, the trustees of the Mirboo North Public Cemetery hereby make the following scale of fees, which shall come into operation upon publication in the Government Gazette, and from and after such publication every scale of fees heretofore made by the said trustees shall be and is hereby rescinded to the extent to which it conflicts with this scale.

Lawn Cemetery (Undenominational).

Lawn grave 8 ft. x 4 ft. .. \$60.00
Sinking charge .. \$28.00
Interment fee .. \$10.00
Bronze plaque for each interment (15 in. x 11 in.) \$28.00
Exhuming the remains of a body (when authorized) .. \$25.00
Interment of ashes in a grave .. \$10.00

A. M. LANE, Trustee.
A. K. JEPSON, Trustee.
J. A. NEWTON, Trustee.

Approved by the Governor in Council, 8th May, 1973.—
T. J. FORRISTAL, Clerk of the Executive Council.

Cemeteries Act 1958.

SCALE OF FEES OF ELMORE PUBLIC CEMETERY.

In pursuance of the powers conferred upon them by the Cemeteries Act, the trustees of the Elmore Public Cemetery hereby make the following scale of fees, which shall come into operation upon publication in the Government Gazette, and from and after such publication every scale of fees heretofore made by the said trustees shall be and is hereby rescinded to the extent to which it conflicts with this scale.

Land, 8 ft. x 4 ft. .. \$24.00
Interment fee .. \$7.00
Sinking grave to 7 feet .. \$40.00
Each additional foot .. \$4.00
Sinking oversize grave (extra) .. \$12.00
Digging in enclosure (extra) .. \$5.00
Reopening grave .. \$30.00
Interment on Sundays or Holidays (extra) .. \$12.00
Certificate of right of burial .. \$1.00
Number plate or label .. \$3.00
Permission to erect a headstone or monument .. \$6.00

J. A. TREWICK, Trustee.
J. C. GRAHAM, Trustee.
A. G. WEEKS, Trustee.

Approved by the Governor in Council, 8th May, 1973.—
T. J. FORRISTAL, Clerk of the Executive Council.

Cemeteries Act 1958.

SCALE OF FEES OF CORYYONG PUBLIC CEMETERY.

In pursuance of the powers conferred upon them by the Cemeteries Act, the trustees of the Coryyong Public Cemetery hereby make the following scale of fees, which shall come into operation upon publication in the Government Gazette, and from and after such publication every scale of fees heretofore made by the said trustees shall be and is hereby rescinded to the extent to which it conflicts with this scale.

Sinking Charges for Private Graves.

Sinking grave to 4 ft. 6 in.	\$23.00
Sinking grave to 6 feet	\$29.00
Sinking grave to 7 feet	\$35.00
A. B. LLOYD, Trustee. J. F. MONGAN, Trustee. W. I. HALES, Trustee.	

Approved by the Governor in Council, 8th May, 1973.—
T. J. FORRISTAL, Clerk of the Executive Council.

Cemeteries Act 1958.

SCALE OF FEES OF BARNAWARTHA PUBLIC CEMETERY.

In pursuance of the powers conferred upon them by the Cemeteries Act, the trustees of the Barnawartha Public Cemetery hereby make the following scale of fees, which shall come into operation upon publication in the *Government Gazette*, and from and after such publication every scale of fees heretofore made by the said trustees shall be and is hereby rescinded to the extent to which it conflicts with this scale.

Public Graves.

Interment in grave without exclusive right— stillborn child	\$8.00
Interment in grave without exclusive right— others	\$17.00

Private Graves.

Land, 8 ft. x 4 ft.	\$24.00
Own selection of land (extra)	\$6.00

Sinking Charges.

Sinking grave 6 feet deep	\$40.00
Each additional foot	\$5.00
Sinking oversize grave	\$10.00
Cancellation of order to sink	\$6.00
Reopening grave (no cover)	\$40.00
Reopening grave (with cover)	\$45.00

Extra Charges.

Interment outside prescribed hours or on Saturdays, Sundays or Public Holidays	\$14.00
Interment in private grave without due notice	\$14.00

Miscellaneous Charges.

Interment fee	\$14.00
Permission to erect a headstone	\$10.00
Exhuming the remains of a body when authorized	\$60.00
Interment of ashes in a private grave	\$10.00
Certificate of right of burial	\$1.00

W. F. TANNER, Trustee.
H. R. FISHER, Trustee.
B. T. GEHRIG, Trustee.
H. G. POOLEY, Trustee.

Approved by the Governor in Council, 8th May, 1973.—
T. J. FORRISTAL, Clerk of the Executive Council.

Cemeteries Act 1958.

SCALE OF FEES OF WARRNAMBOOL PUBLIC CEMETERY.

In pursuance of the powers conferred upon them by the Cemeteries Act, the trustees of the Warrnambool Public Cemetery hereby make the following scale of fees, which shall come into operation upon publication in the *Government Gazette*, and from and after such publication every scale of fees heretofore made by the said trustees shall be and is hereby rescinded to the extent to which it conflicts with this scale.

Land, 8 ft. x 4 ft.	\$50.00
Land for graves adjoining or abutting roads	\$60.00
Sinking grave to 7 feet	\$45.00
Sinking grave for a square coffin (extra)	\$15.00
Reopening grave (without cover)	\$36.00
Reopening grave (with cover)	\$42.00
Permission to erect a monument	\$20.00
Overtime fees (including Public Holidays and Saturdays)	\$15.00

H. J. BEARDSLEY, Trustee.
L. GERSCH, Trustee.
D. G. COLLINS, Trustee.

Approved by the Governor in Council, 8th May, 1973.—
T. J. FORRISTAL, Clerk of the Executive Council.

Cemeteries Act 1958.

SCALE OF FEES OF HAZELWOOD PUBLIC CEMETERY.

In pursuance of the powers conferred upon them by the Cemeteries Act, the trustees of the Hazelwood Public Cemetery hereby make the following scale of fees, which shall come into operation upon publication in the *Government Gazette*, and from and after such publication every scale of fees heretofore made by the said trustees shall be and is hereby rescinded to the extent to which it conflicts with this scale.

Public Graves.

Interment in grave without exclusive right— stillborn child	\$8.50
Interment in grave without exclusive right— others	\$17.00
Number peg or label	\$4.00

Private Graves.

Land, 8 ft. x 4 ft.	\$26.00
Own selection of land (extra)	\$10.00

Sinking Charges for Private Graves.

Sinking grave 6 feet deep	\$35.00
Each additional foot	\$5.00
Sinking oversize grave (extra)	\$14.00
Cancellation of order to sink (if commenced)	\$7.00

Reopening Charges.

Reopening grave (no cover)	\$30.00
Reopening grave (with cover)	\$35.00

Extra Charges.

Interment outside prescribed hours, or on Saturdays, Sundays or Public Holidays	\$14.00
Interment in a private grave without due notice	\$14.00

Miscellaneous Charges.

Interment fee	\$14.00
Certificate of right of burial	\$2.00
Number plate or brick	\$4.00
Permission to erect a headstone or monument— 5 per cent. of cost with a minimum of \$6.00.	
Permission to construct a brick grave or to erect any stone kerb, brick tile-work or concrete	\$6.00
Exhuming the remains of a body (when authorized)	\$60.00
Interment of ashes in a private grave	\$14.00

A. L. HARE, Trustee.
W. MORRISON, Trustee.
M. J. RYAN, Trustee.

Approved by the Governor in Council, 8th May, 1973.—
T. J. FORRISTAL, Clerk of the Executive Council.

Cemeteries Act 1958.

SCALE OF FEES OF CHEWTON PUBLIC CEMETERY.

In pursuance of the powers conferred upon them by the Cemeteries Act, the trustees of the Chewton Public Cemetery hereby make the following scale of fees, which shall come into operation upon publication in the *Government Gazette*, and from and after such publication every scale of fees heretofore made by the said trustees shall be and is hereby rescinded to the extent to which it conflicts with this scale.

Public Graves.

Interment in grave without exclusive right— stillborn child	\$8.50
Interment in grave without exclusive right— others	\$17.00
Number peg or label	\$4.00

Private Graves.

Land, 8 ft. x 4 ft.	\$20.00
Own selection of land (extra)	\$5.00

Sinking Charges for Private Graves.

Sinking grave 6 feet deep	\$42.00
Each additional foot	\$5.00
Sinking oversize grave (extra)	\$10.00
Cancellation of order to sink (if commenced)	\$7.00

Reopening Charges.

Reopening grave (no cover)	\$35.00
Reopening grave (with cover)	\$41.00

Extra Charges.

Interment outside prescribed hours, or on Saturdays, Sundays or Public Holidays	\$14.00
Interment in a private grave without due notice	\$14.00

Miscellaneous Charges.

Interment fee	\$14.00
Certificate of right of burial	\$2.00
Number plate or brick	\$4.00
Permission to erect a headstone or monument— 5 per cent. of cost with a minimum of \$6.00.	
Permission to construct a brick grave or to erect any stone kerb, brick tile-work or concrete	\$6.00
Exhuming the remains of a body (when authorized)	\$60.00
Interment of ashes in a private grave	\$14.00

A. W. BAGLIN, Trustee.
H. T. DAWE, Trustee.
A. J. COX, Trustee.

Approved by the Governor in Council, 8th May, 1973.—
T. J. FORRISTAL, Clerk of the Executive Council.

Cemeteries Act 1958.

**SCALE OF FEES OF FAWKNER CREMATORIUM AND
MEMORIAL PARK.**

In pursuance of the powers conferred upon them by the Cemeteries Act, the trustees of the Fawkner Crematorium and Memorial Park hereby make the following scale of fees, which shall come into operation upon publication in the *Government Gazette*, and from and after such publication every scale of fees heretofore made by the said trustees shall be and is hereby rescinded to the extent to which it conflicts with this scale.

*Purchase of Land in Denominational and
Undenominational Lawn Areas.*

Church of England Compartment S, 8 ft. x 4 ft.	\$115.00
Presbyterian Compartment E, 9 ft. x 4 ft. ..	\$115.00
Roman Catholic Compartment R, 9 ft. x 4 ft. ..	\$115.00
Roman Catholic Compartment S Extension, 9 ft. x 4 ft.	\$115.00
New lawn area east (adjacent to Sydney-road), 8 ft. x 4 ft.	\$130.00
7th Avenue lawn areas A to E inclusive, 8 ft. x 4 ft.	\$115.00

Purchase of Land in Traditional Areas.

Baptist Compartment C, 9 ft. x 4 ft. ..	\$80.00
Chinese Compartment B, 9 ft. x 4 ft. ..	\$80.00
Church of Christ Compartment C, 9 ft. x 4 ft.	\$80.00
Congregational Compartment C, 9 ft. x 4 ft. ..	\$80.00
Greek Compartment E, 8 ft. x 4 ft. ..	\$80.00
Jewish, 9 ft. x 4 ft.	\$90.00
Macedonian, 9 ft. x 4 ft.	\$80.00
Mohammedan Compartment B, 9 ft. x 4 ft. ..	\$80.00
Melbourne & East Melbourne Hebrew, Compartment B, 9 ft. x 4 ft.	\$95.00
Methodist Compartment E, 9 ft. x 4 ft. ..	\$80.00
Other Denominations Compartment B, 9 ft. x 4 ft.	\$80.00
Presbyterian Ordinary, 9 ft. x 4 ft.	\$80.00
Protestant Compartment E, 9 ft. x 4 ft. ..	\$80.00
Roman Catholic Compartment O, 9 ft. x 4 ft.	\$80.00
(extra charge if stone is encountered)	
Roman Catholic Compartment T, 9 ft. x 4 ft.	\$80.00
Salvation Army, 9 ft. x 4 ft.	\$80.00

Interment Fee.

Burial of cremated remains (maximum of four in any one grave)	\$25.00
--	---------

New Lawn Area.

Single ground niches	\$55.00
Companion ground niches	\$90.00
Single niches—4th Avenue	\$45.00
Scattering cremated remains in rose garden ..	\$4.00

Pine Ridge Memorial Park—Coburg (when available).

Traditional area, all denominations	\$80.00
Lawn areas	\$110.00

K. W. JOYCE, J.P., Trustee.
C. W. CRICK, Trustee.
A. C. VEREY, J.P., Trustee.
A. J. CORDELL, Trustee.
H. C. CURWEN-WALKER, Trustee.
H. J. CROWHURST, Administrator.

Approved by the Governor in Council, 8th May, 1973.—
T. J. FORRISTAL, Clerk of the Executive Council.

Town and Country Planning Act 1961.

COBRAM PLANNING SCHEME 1949.

AMENDMENT No. 11, 1971.

Notice of Approval.

In pursuance of the powers conferred by the *Town and Country Planning Act 1961*, the Governor in Council on the 8th May, 1973, approved a planning scheme entitled the Cobram Planning Scheme 1949, Amendment No. 11, 1971, in respect of part of the municipal district of the Shire of Cobram and such planning scheme comes into operation on the date this notice of approval is published in the *Government Gazette*.

A copy of the planning scheme as approved may be inspected free of charge during office hours at the office of the Town and Country Planning Board, 235 Queen-street, Melbourne; at the office of the Shire of Cobram at Cobram and when available, at the Office of Titles, Melbourne, and at the Central Plan Office of the Department of Crown Lands and Survey, Melbourne.

W. H. CRAIG, Secretary,
Town and Country Planning Board.

Town and Country Planning Act 1961.

SHIRE OF MORNINGTON PLANNING SCHEME 1959.

AMENDMENT No. 86, 1972.

Notice of Amendment.

In pursuance of the powers conferred by sub-section 6 of section 32 of the *Town and Country Planning Act 1961*, the Governor in Council, by and with the advice of the Executive Council on the 8th May, 1973, amended the Shire of Mornington Planning Scheme 1959, by introducing controls in relation to the use and development of land in the Industrial 'A' and 'B' Zones, requiring that all use and development including subdivision, shall be subject to grant of a permit by the Responsible Authority and to such conditions as the Responsible Authority may in its discretion include in the permit.

A copy of the amendment may be inspected during office hours at the office of the Town and Country Planning Board, 235 Queen-street, Melbourne; at the office of the Council of the Shire of Mornington at Mornington, and when available at the Office of Titles, Melbourne; and at the Central Plan Office of the Department of Crown Lands and Survey, Melbourne.

W. H. CRAIG, Secretary,
Town and Country Planning Board.

Public Service Act 1958.

PUBLIC SERVICE BOARD ELECTIONS REGULATIONS.

DEPUTY OF THE MENTAL HYGIENE REPRESENTATIVE.

Pursuant to the provisions of the Public Service Board Elections Regulations I declare—

WILLIAM JOSEPH KENNEDY, Department of Health, Mental Hygiene Branch, duly elected as the Deputy of the Mental Hygiene Representative Member of the Public Service Board for the remainder of the term of office of the previous Deputy, the said William Joseph Kennedy, being the only candidate duly nominated for election to the office specified.

E. L. RICHARDSON,
Returning Officer.

State Electoral Office,
Melbourne, 10th May, 1973.

DEPARTMENT OF CROWN LANDS AND SURVEY.

AERIAL PHOTOGRAPHY IN VICTORIA.

Quotations will be received until noon, 1st June, 1973, for aerial photography as required by the Department of Crown Lands and Survey, during the period, 1st July, 1973, to 30th June, 1974.

The lowest or any tender will not necessarily be accepted.

Full particulars may be obtained from—

The Surveyor-General,
Department of Crown Lands and Survey,
2 Treasury-place,
Melbourne, Vic. 3002.

Transport Regulation Act.
TRANSPORT REGULATION BOARD.

HEARING OF APPLICATIONS.

Notice is hereby given that the following applications will be considered by the Transport Regulation Board at its offices at the corner of Lygon and Princes streets, Carlton, at 10.15 a.m., on Wednesday, 6th June, 1973.

LA MODE INDUSTRIES PTY. LTD., Smith-road, Springvale North. Application for one commercial passenger vehicle with small seating capacity, to be purchased, to operate for the carriage of employees of La Mode Industries Pty. Ltd., free of charge, from the company's factory, to their homes, by a variable route within an 8-mile radius, terminating in the City of Dandenong.

TIME-TABLE.

(Monday—Friday.)

As and when required between 11.00 p.m. and 1.30 a.m.

LEYSHAN, F. C., 13 Pearson-street, Heyfield. Application for one commercial passenger vehicle with large seating capacity, to be purchased, to operate in substitution for, but not in addition to, existing T.S. licences held by the applicant.

MELBOURNE AND METROPOLITAN TRAMWAYS BOARD, 616 Little Collins-street, Melbourne.—Application for authority pursuant to section 33 (1) of the Transport Regulation Act No. 6400 to operate a stage omnibus service as follows:—Deer Park West—Westland via Ballarat-road. Commencing at the present terminus of the Deer Park West—City route (216) at Robinsons-road, via the normal route to the corner of Sydney-street and Western Highway; thence via Western Highway, Ballarat-road, Mitchell-street, Hampstead-road, Williamson-road and Rosamond-road to the Westland Shopping Centre.

NOTE.—Between Hampshire-road and Ashley-street, the proposed service will duplicate the Board's existing Sunshine—City via Ballarat-road service (Route 220).

Sections on Route.—1. Robinsons-road to Station-road. 2. Station-road to Fitzgerald-road. 3. Fitzgerald-road to Hulett-street. 4. Hulett-street to Sydney-street. 5. Sydney-street to Northumberland-road. 6. Northumberland-road to Vine-street. 7. Vine-street to Churchill-avenue. 8. Churchill-avenue to Westland Shopping Centre.

Fares.	Adults.	Children.
One section	10c	5c
Two sections	20c	10c
Three sections	25c	10c
Four or five sections ..	30c	15c
Six or seven sections ..	35c	15c
Eight sections (Through Fare)	35c	20c

Concession Fares.

Duke-street to Westland ..	20c	10c
Westmoreland-road to Westland ..	25c	10c

Period of Operation.

Weekdays (Public Holidays Excepted) 8.50 a.m. to 5.00 p.m. or as required.

Saturdays (Public Holidays Excepted) 8.50 a.m. to 12.10 p.m. or as required.

Sundays—No service.

TIME-TABLE.

Minimum service 60 minutes. A more frequent service will operate if required.

MELBOURNE AND METROPOLITAN TRAMWAYS BOARD, 616 Little Collins-street, Melbourne. Application for authority pursuant to section 33 (1) of the Transport Regulation Act No. 6400 to operate a stage omnibus service as follows:—

Sunshine Railway Station—Westland via South-road. Commencing at Sunshine Railway Station via Station-place, Monash-street, South-road, Ashley-street, Essex-street, Gordon-street, River-street and Rosamond-road to the Westland Shopping Centre.

NOTE.—Between Sunshine Railway Station and the corner of Essex and Gordon streets, the proposed service will duplicate the Board's existing Sunshine Park—City service (Route 219). It then duplicates the Board's existing Footscray—Moonee Ponds tram service (Route 82) between the corner of Ballarat-road and Gordon-street, and the corner of Williamson and Rosamond roads.

Sections on Route.—1. Sunshine Railway Station to Moama-street. 2. Moama-street to Ashley-street. 3. Ashley-street to Summerhill-road. 4. Summerhill-road to Ballarat-road. 5. Ballarat-road to River and Gordon streets corner. 6. River and Gordon streets corner to Westland Shopping Centre.

Fares.	Adults.	Children.
One section	10c	5c
Two sections	20c	10c
Three sections	25c	10c
Four or five sections ..	30c	15c
Six sections	35c	15c

Concession Fares.

Duke-street to Westland ..	30c	15c
----------------------------	-----	-----

Period of Operation.

Weekdays (Public Holidays Excepted) 8.50 a.m. to 5.00 p.m. or as required.

Saturdays (Public Holidays Excepted) 8.50 a.m. to 12.10 p.m. or as required.

Sundays—No service.

TIME-TABLE.

Minimum service 60 minutes. A more frequent service will operate if required.

MELBOURNE AND METROPOLITAN TRAMWAYS BOARD, 616 Little Collins-street, Melbourne. Application for authority pursuant to section 33 (1) of the Transport Regulation Act No. 6400 to operate a stage omnibus service as follows:—

Moonee Ponds—Westland.

Commencing at the central parking area in Mount Alexander-road, Moonee Ponds, the present terminus of the Board's existing special weekend service to Footscray via the normal route to the corner of Raleigh and Rosamond roads; thence via Rosamond road to the Westland Shopping Centre.

NOTE.—Between Moonee Ponds and the corner of Raleigh and Rosamond roads, the proposed service will duplicate the Board's existing Moonee Ponds—Footscray tram service (Route 82).

Fares.	Adults.	Children.
One section	10c	5c
Two sections	20c	10c
Three sections	25c	10c
Four or five sections ..	30c	15c
Six or seven sections ..	35c	15c
Eight sections (Through Fare)	35c	20c

Period of Operation.

Weekdays (Public Holidays Excepted) 8.50 a.m. to 5.00 p.m. or as required.

Saturdays (Public Holidays Excepted) 8.50 a.m. to 12.10 p.m. or as required.

Sundays—No service.

TIME-TABLE.

Minimum service 60 minutes. A more frequent service will operate if required.

MELBOURNE AND METROPOLITAN TRAMWAYS BOARD, 616 Little Collins-street, Melbourne. Application for authority pursuant to section 33 (1) of the Transport Regulation Act No. 6400 to extend the Williamstown—Footscray Railway Station—Ballarat-road route on trips ex Footscray Railway Station, from the existing terminus at the corner of Ballarat and Rosamond roads via Rosamond road to the Westland Shopping Centre.

NOTE.—The proposed extension will duplicate the Board's special weekend service in Rosamond-road between Ballarat-road and Williamson-road.

Sections on Route.—1. Williamstown and Somerville roads to Charles and Gamon streets. 2. Charles and Gamon streets to Footscray Railway Station. 3. Footscray Railway Station to Gordon-street and Ballarat-road. 4. Gordon-street and Ballarat-road to Rosamond-road and River-street. 5. Rosamond-road and River-street to Westland Shopping Centre.

Fares.	Adults.	Children.
One section	10c	5c
Two sections	20c	10c
Three sections	25c	10c
Four or five sections ..	30c	15c

Period of Operation.

Weekdays (Public Holidays excepted) at 8.50 a.m. to 5.00 p.m. or as required. Saturdays (Public Holidays excepted) 8.50 a.m. to 12.10 p.m. or as required.

Sundays—No service.

TIME-TABLE.

Minimum service 60 minutes. A more frequent service will operate if required.

REICHEL, B., Main-road, Millgrove. Application for one commercial passenger vehicle with seating capacity for five (5) persons to operate as a country taxi-cab at Yarra Junction.

SOUTHLAND BUS SERVICE PTY. LTD., corner Keys and Kilpa roads, Moorabbin. Application for one commercial passenger vehicle with large seating capacity to be purchased, to operate as an additional metropolitan stage omnibus, under the same terms and conditions as existing licences.

TRANS OTWAY LTD., corner Ryrie and Fenwick streets, Geelong. Application for one commercial passenger vehicle with seating capacity for 38 persons to operate as an additional Urban Stage Omnibus under the same terms and conditions as existing licences held by the company.

Applications for renewal of licences as shown, by persons listed hereunder to operate under the same terms and conditions.

KOOROORA CHALET PTY. LTD., Alpine Village, Mt. Buller; T.P.171.

MURRAY'S COACHES PTY. LTD., 38 Kingsville-street, West Footscray; M.O.292, M.O.454, M.O.674, M.O.391, M.O.255.

Notice of any objection should be forwarded to reach the Secretary of the Board not later than 30th May, 1973.

Applicants are advised that it will not be necessary to appear on the hearing date specified, unless advised in writing by the Board.

A. V. C. COOK,
Secretary.

Corner Lygon and Princes streets, Carlton, 3053, Wednesday, 16th May, 1973.

Commercial Goods Vehicles Act.
TRANSPORT REGULATION BOARD.

HEARING OF APPLICATIONS.

Notice is hereby given that the following applications will be considered by the Transport Regulation Board at its offices at the corner Lygon and Princes streets, Carlton, at 10 a.m., on Wednesday, 6th June, 1973.

AGER, L. W., Newham, via Woodend, 3442. Application to vary the conditions of licence No. D.T.105 (L/C. 220 cwt.) by deleting paragraph (b) from the existing conditions and adding in lieu a new paragraph (b)—“(b) From forest and private properties within a 25-mile radius of Woodend to the premises of Hardboards Aust. Ltd. at Bacchus Marsh—pulpwood.”

ANDERSON, W. J. (trading as W. J. & M. A. Anderson), Idyllwilde, Nirranda, 3277. One commercial goods vehicle (L/C. 329 cwt.) to operate: (a) Within a 50-fifty mile radius of the post office at Nirranda in the course of business as “Road Contractor, Quarry Masters and Earth-moving Contractors”—tools of trade, equipment and machinery, road-making materials, sandstone, limestone, sand and lime. (b) To any contract site where the applicant is currently engaged within the area specified in paragraph (a) from points within a 10-mile radius of such site—materials required in connexion with such contracts. (c) Within a 50-mile radius of the post office at Nirranda—own goods in course of business as “Primary Producer”. (d) Within a 50-mile radius of the post office at Nirranda—livestock.

ARNOTT BROCKHOFF GUEST PTY. LTD., 53 Huntingdale-road, Burwood, 3125. Four commercial goods vehicles (L/C. approximately 12 cwt. each) to operate throughout the State of Victoria in the course of business as “Biscuit Manufacturers” for the purpose of display and sales promotion of own products—tools of trade, merchandising and display equipment, materials and samples of own products.

AVERY, C. F., 64 Scott-street, Mortlake, 3272. Two commercial goods vehicles (L/C. 78, and 11 cwt.) to operate: (a) Within a 50-mile radius of the post office at Mortlake in the course of business as “Petroleum Agent”—petroleum products in prescribed types of containers and bulk tanks and empty farm and home storage tanks. (b) Within a 50-mile radius of the post office of Mortlake in the course of business as “Wool and Skins Agents”—wool and skins.

BAGGETT, G., 111 Service-road, Moe, 3825. One commercial goods vehicle (L/C. 40 cwt.) to operate from and to the premises of Latrobe Cake Supply at Moe

(an approved decentralized secondary industry) to and from consignees situated within a 30-mile radius of the post office at Moe solely on behalf of the said company—cakes, pastries and empty return containers.

BARNES, L. C., 62 Elgin-street, Berwick, 3806. One commercial goods vehicle (L/C. 246 cwt.) to operate: (a) Within a 25-mile radius of the premises of I. R. Farrow at North Clayton—sand, soil and screenings. (b) From the premises of I. R. Farrow's sand pits at Bunyip and North Garfield to places situated within a radius specified in paragraph (a) above—sand and soil. (c) To and from the premises of I. R. Farrow at North Clayton, Bunyip and North Garfield—front end loader, engines, pumps and spare parts for machinery repair, piping and timber bearers incidental to washing sand at the above mentioned sand pits.

BONNEY, F. L. & Co. (GROUP TRADING) PTY. LTD., 77 Lime-avenue, Mildura, 3500. One commercial goods vehicle (L/C. 15 cwt.) to operate throughout the State of Victoria in the course of business as “Pest Exterminators”—tools of trade, equipment and materials incidental to own contracts but excluding the carriage of materials from places within a 25-mile radius of the post office at the corner of Bourke and Elizabeth streets, Melbourne.

BROWELL, R. J., 4 Dimboola-road, Warracknabeal, 3393. One commercial goods vehicle (L/C. 32 cwt.) to operate from own premises at Warracknabeal to places within a 50-mile radius thereof in the course of business as “Distributor”—milk, cream and orange juice.

CAGGIATI, F., 37 Leighton-crescent, Fawkner, 3060. One commercial goods vehicle (L/C. 287 cwt.) to operate within a 50-mile radius of the premises of Albion Reid Pty. Ltd. at North Melbourne solely on behalf of the said company—road-making plant, hot asphalt and premix and road-making materials excluding the carriage of cement and lime from the Geelong Urban District as defined in the Transport Regulation Act 1958.

CALDWELL, G., Gormandale, via Traralgon, 3844. One commercial goods vehicle (L/C. 161 cwt.) to operate from bush sites within a 50-mile radius of Maryvale to the premises of Australian Paper Manufacturers Ltd. at Maryvale—pulpwood.

CARSON, K. J., Murravee, 3586. One commercial goods vehicle (L/C. 220 cwt.) to operate: (a) Within a 50-mile radius from the post office at Cohuna as a “Road Contractor”—road-making plant and materials. (b) Within a 25-mile radius of the post office at Cohuna—general goods, provided that no goods shall be carried whether by one stage or by more than one stage between places within the above radius situated more than thirty (30) road miles apart by the nearest practicable route.

CHAPMAN, J. A., 18 Birdwood-avenue, Norlane, 3214. One commercial goods vehicle (L/C. 226 cwt.) to operate: (a) Within a 25-mile radius of the chief post office in the City of Geelong—general goods. (b) From the premises of the Mountain View Quarries Pty. Ltd. at Point Wilson to the premises of Mountain View Quarries Pty. Ltd. at Sunshine—sand, scoria and screenings.

CLAPHAM, J. K., 180 Lava-street, Warrnambool, 3280. One commercial goods vehicle (L/C. 60 cwt.) to operate within a 50-mile radius of the post office at Warrnambool and to the Colac, Coleraine and Casterton areas serving places en route in the course of business as “Wholesale Confectioner”—confectionery and food-stuffs with proviso that all goods are initially consigned by rail to Warrnambool.

COOPER, M. D., 123 Channel-street, Cohuna, 3568. One commercial vehicle (L/C. 259 cwt.) to operate: (a) Within a 50-mile radius from the post office at Cohuna as a “Road Contractor”—road-making plant and materials. (b) Within a 25-mile radius of the post office at Cohuna—general goods provided that no goods shall be carried whether by one stage or by more than one stage between places within the above radius-situated more than thirty (30) road miles apart by the nearest practicable route.

DORRELL, J. W., 11 Durward-avenue, Glen Waverley, 3150. One commercial goods vehicle (L/C. 10 cwt.) to operate: (a) Within a 50-mile radius of own premises at Glen Waverley in the course of business as “Electrical Contractor”—own goods. (b) Throughout the State of Victoria in the course of business as “Electrical Contractor” solely on behalf of the Totalizer Agency Board—tools of trade and own equipment incidental to the completion of such contracts.

- HIGGINSON, A. J., care of P.O. Tawonga, 3697. One commercial goods vehicle (L/C. 109 cwt.) to operate: (a) Within a 50-mile radius from the post office at Tawonga as a "Road Contractor"—road-making plant and materials. (b) Within a 25-mile radius of the post office at Tawonga—general goods provided that no goods shall be carried whether by one stage or by more than one stage between places within the above radius which are more than thirty (30) road miles apart by the nearest practicable route.
- JULIEN, R. W., 34 Price-street, Torquay, 3228. One commercial goods vehicle (L/C. 80 cwt.) to operate throughout the State of Victoria in the course of business as "Waste Oil Collector"—waste oil in bulk and empty second-hand drums.
- LOVE, H. E. & J. M. (trading as Bert Love), Broadway-street, Cobram, 3644. Four commercial goods vehicles (L/C. 11, 11, 9, 6 cwt.) to operate within that part of the State of Victoria bounded on the east by a north/south line drawn through Rutherglen, on the south by an east/west line drawn through Nagambie and on the west by a north/south line drawn through Rochester in the course of business as "Farm Supply and Irrigation Contractor"—(i) Agricultural chemicals, fertilizers, irrigation and agricultural equipment. (ii) Earth-moving equipment and incidental materials required for the installation of irrigation equipment.
- LÜTZ, W. G., Box 16, Murrayville, 3512. One commercial goods vehicle (L/C. 242 cwt.) to operate within that part of the State of Victoria situated north of an east/west line drawn through the Township of Wyche-proof and west of a north/south line drawn through Sea Lake in the course of business as "Boring Contractor"—tools of trade and boring equipment incidental to the completion of own contracts.
- MONIER SERVICES PTY. LTD., Frankston-road, Dandenong, 3175. One commercial goods vehicle (L/C. 351 cwt.) to operate: (a) Within a 25-mile radius of the G.P.O., Melbourne in course of business as "Concrete Goods Manufacturers"—own goods. (b) From own pit at Broadford to own plants within a 25-mile radius of the G.P.O., Melbourne—quarry products and river sand. (c) From own pit at Anakie to own plants within a 25-mile radius of the G.P.O., Melbourne—own scoria. (d) From quarries at Anakie to own plants within a 25-mile radius of the G.P.O., Melbourne—crushed scoria. (e) From own plants at Broadford to premix concrete plants within a 25-mile radius of Broadford—quarry products and river sand.
- MOORE, D. H., 5 Scott-crescent, Mildura, 3500. Application to vary the conditions of licence numbers T.D.A.50951/4, (L/C. 143 and 138 cwt.) by deleting paragraph (a) of the existing conditions and adding in lieu—"(a) Within that part of the State of Victoria north of a line drawn due east and west through the Township of Sea Lake and west of a line drawn due south/south-west and north/north-east through the Townships of Sea Lake and West Piangil in the course of business as 'Wool and Skin Buyer'—wool and sheep skins".
- MOOROOPNA SAWMILLS PTY. LTD., P.O. Box 48, Mooroopna, 3629. Application to vary the conditions of licence No. D.T.372/3 (L/C. 270 cwt.) by adding an additional paragraph (e) to the existing conditions—"(e) From the Mansfield and Swanpool areas to own sawmill at Mooroopna—red gum logs."
- MOOROOPNA SAWMILLS PTY. LTD., P.O. Box 48, Mooroopna, 3629. Application to vary the conditions of licence No. D.T.372/5 (L/C. 270 cwt.) by adding an additional paragraph (c) to the existing conditions—"(c) From the Mansfield and Swanpool areas to own sawmill at Mooroopna—red gum logs."
- MOWAT, R. J. & L. J., Cranbourne-road, Narre Warren, 3805. One commercial goods vehicle (L/C. 209 cwt.) to operate within a 70-mile radius of the premises of Enco Concrete Masonry at Clayton on behalf of the said company—concrete masonry blocks not exceeding 40 lbs. each in weight.
- NEAVE, L. & B. M. (TRARALGON) PTY. LTD., P.O. Box 364, Traralgon, 3844. Two commercial goods vehicles (L/C. 303, 77 cwt.) to operate: (a) Within a 25-mile radius of the post office at Traralgon—general goods but subject to the condition that no journey shall be made from any one point within the said radius to any other point within the said radius situated more than thirty (30) miles apart by the nearest practical route. (b) Within a 70-mile radius of the premises of Rocla Pipes Ltd. at Traralgon solely on behalf of the said company—concrete pipes.
- O'DWYER, E. F. & M. O., 32 Indiana-avenue, Corio, 3214. One commercial goods vehicle (L/C. 240 cwt.) to operate within a 50-mile radius of the chief post office in the City of Geelong solely on behalf of Pioneer Concrete (Vic.) Pty. Ltd.—premixed concrete in a specially constructed agitator vehicle.
- PLATER, W. J., 61 Crawley-street, Warrnambool, 3280. One commercial goods vehicle (L/C. 9 cwt.) to operate throughout the State of Victoria in the course of business as "Household Pest Exterminator"—tools of trade and a small quantity of spraying materials incidental to the completion of own contracts but excluding the carriage of materials from places within a 25-mile radius of the G.P.O., Melbourne.
- RAWLINSON, G., 215 Nelson-place, Williamstown, 3016. One commercial goods vehicle (L/C. 11 cwt.) to operate throughout the State of Victoria in the course of business as "Electrical Contractor" for the purpose of servicing and maintaining electrical installations at service stations and bulk depots on behalf of H. C. Sleigh Ltd.—tools of trade and a small quantity of materials required for the on-site servicing and maintenance of such installations.
- RIDDELL, R. G. (trading as Riddell Haulage), Leane-drive, Eltham, 3095. Two commercial goods vehicles (L/C. 182, 183 cwt.) to operate within a 50-mile radius of the premises of Albion Reid Pty. Ltd., at North Melbourne solely on behalf of the said company—road-making plant, hot asphalt and premix and road-making materials excluding the carriage of cement and lime from the Geelong Urban District as defined in the *Transport Regulation Act 1958*.
- RYAN, L. M. (trading as Ryan Bros. (Wangaratta)), 72 Phillipson-street, Wangaratta, 3677. One commercial goods vehicle (L/C. 135 cwt.) to operate: (a) Within a 50-mile radius from the post office at Wangaratta as a "Road Contractor"—road-making plant and materials. (b) Within a 25-mile radius of the post office at Wangaratta—general goods, provided that no goods shall be carried whether by one stage or by more than one stage between places within the above radius which are more than thirty (30) road miles apart by the nearest practicable route.
- SKONTRA, B., 621 Barkly-street, Ballarat, 3350. One commercial goods vehicle (L/C. 15 cwt.) to operate: (a) Throughout the State of Victoria in the course of business as "Concrete Contractors"—tools of trade and boxing equipment. (b) Within a 20-mile radius from the site of any contract currently engaged upon or to such site from the railway station nearest thereto—materials incidental to the completion of such contract.
- SEYMOUR AGGREGATE PTY. LTD., P.O. Box 143, Seymour, 3660. One commercial goods vehicle (L/C. 198 cwt.) to operate within a 50-mile radius of own plant at Seymour in the course of business as "Premixed Concrete Suppliers"—own premixed concrete in a specially constructed agitator vehicle.
- SHIELDS, K. J., 47 Sullivan-street, Inglewood, 3517. One commercial goods vehicle (L/C. 8 cwt.) to operate in the course of business as "Motor Mechanic"—(i) Within a 50-mile radius of the post office at Inglewood. (ii) Within a 20-mile radius of the post office at 'Mystic Park. (iii) From the City of Bendigo to places within a 20-mile radius of the post office at Mystic Park—tools of trade and spare parts incidental to the completion of own servicing and repair contracts.
- SYKES PUMPS AUST. PTY. LTD., Dynon-road, Footscray, 3011. One commercial goods vehicle (L/C. 29 cwt.) to operate throughout the State of Victoria in the course of business as "Hirers of Pumps and Pumping Equipment"—tools of trade, pumps and pumping equipment for hire and also spare parts incidental to the servicing of pumps in the field only.
- TRANS-WEST HAULAGE (MELB.) PTY. LTD., 202 Station-street, Norlane, 3214. Five commercial goods vehicles (L/C. 215, 205, 204, 204 and 206 cwt.) to operate: (a) Within a 25-mile radius from the post office at Springvale—general goods provided that no goods shall be carried whether by one stage or by more than one stage between places within the above radius which are more than 30 road miles apart by the nearest practicable route. (b) Within a 70-mile radius from each of the plants of Brick and Pipe Industries Ltd., at Burwood, Northcote and Scoresby respectively—bricks and on return journeys empty pallets and excess bricks to such of the above plants as may be appropriate. (c) From Columbia Concrete Masonry Pty. Ltd. at Springvale to consignees within a 70-mile radius therefrom—concrete masonry and on return journeys empty pallets and excess concrete masonry to the said plant, provided that the concrete blocks shall not weigh more than 40 lb. each.

VALENTINE, G., 66 Crusoe-road, Kangaroo Flat, 3555. One commercial goods vehicle (L/C. 20 cwt.) to operate within a 100-mile radius of the chief post office in the City of Bendigo and to the townships of Warracknabeal and Sea Lake and to the City of Swan Hill in the course of business as "Plumber"—tools of trade, materials and equipment incidental to own contracts but excluding the carriage of materials and equipment from places within a 25-mile radius from the G.P.O., Melbourne.

MAAHS, H. S. & L. (trading as Valley Tanks), 60 McDonald-way, Churchill, 3842. One commercial goods vehicle (L/C. 115 cwt.) to operate within a 50-mile radius of the post office situated at Morwell in the course of own business as "Concrete Products Manufacturer"—own goods.

RENEWALS.

Applications for renewal of licences as shown by persons listed hereunder to operate under the same terms and conditions from the expiry shown in each case.

ALBION REID PTY. LTD., 83 Riversdale-road, Hawthorn, 3122; D.A.520/2; 16th September, 1973; 90 cwt.

ALBION REID PTY. LTD., 83 Riversdale-road, Hawthorn, 3122; D.A.520/3; 16th September, 1973; 88 cwt.

ANGELINI, S., 125 Seventh-avenue North Altona, 3018; D.A.6303/4; 8th September, 1973; 209 cwt.

BENNETT, W. H. & SONS PTY. LTD., 56 Hesse-street, Colac, 3250; D.T.127/4; 27th October, 1973; 278 cwt.; D.T.127/5; 27th October, 1973; 261 cwt.

CONMAC ASPHALT PTY. LTD., P.O. Box 242, Prahran, 3181. D.A.63103; 8th September, 1973; 68 cwt.

CONTRACT DRILLING (VIC.) PTY. LTD., 9 Salisbury-street, Sunshine, 3020; D.A.49565/3; 28th July, 1973; 245 cwt.

CONTRACT DRILLING (VIC.) PTY. LTD., 9 Salisbury-street, Sunshine, 3020; D.A.49565/4; 30th June, 1973; 130 cwt.

COOPER, J., Lawler-street, Meredith, 3333; D.A.60954/1; 26th October, 1973; 252 cwt.

CRAM, R. E., 18 Woorigoleen-drive, East Keilor, 3042; D.A.63127; 22nd September, 1973; 199 cwt.

DOWNES, J. B. & S. W., 1 Hughes-street, Hamilton, 3300; D.A.8395/6; 8th September, 1973; 50 cwt.

DUNLOP TYRE SERVICE (VIC.) PTY. LTD., SHEPPARTON BRANCH, 361 Wyndham-street, Shepparton, 3630; D.A.60416/20; 4th September, 1973; 18 cwt.

EWING, J. W., PTY. LTD., Penshurst, 3289; D.A.1054/3; 18th August, 1973; 135 cwt.; D.A.1054/4; 18th August, 1973; 197 cwt.; D.A.1054/5; 18th August, 1973; 200 cwt.

FOODLAND STORES PTY. LTD., 619 Springvale-road, Glen Waverley, 3150; D.A.56051/1; 9th August, 1973; 95 cwt.; D.A.56051/2; 9th August, 1973; 115 cwt.; D.A.56051/3; 9th August, 1973; 115 cwt.; D.A.56051/4; 9th August, 1973; 114 cwt.; D.A.56051/5; 9th August, 1973; 115 cwt.; D.A.56051/6; 9th August, 1973; 115 cwt.; D.A.56051/7; 9th August, 1973; 115 cwt.; D.A.56051/8; 9th August, 1973; 115 cwt.; D.A.56051/9; 9th August, 1973; 115 cwt.; D.A.56051/10; 9th August, 1973; 114 cwt.; D.A.56051/11; 9th August, 1973; 114 cwt.; D.A.56051/12; 9th August, 1973; 114 cwt.; D.A.56051/13; 9th August, 1973; 101 cwt.; D.A.56051/14; 9th August, 1973; 100 cwt.

FOODLAND STORES PTY. LTD., 619 Springvale-road, Glen Waverley, 3150; D.A.56051/11; 9th August, 1973; 96 cwt.; D.A.56051/12; 9th August, 1973; 97 cwt.; D.A.56051/13; 9th August, 1973; 96 cwt.

FREEMAN, G., 24 Whitby-street, Brunswick West, 3055; D.A.57018; 27th September, 1973; 74 cwt.

GEELOG FENCING SUPPLIERS PTY. LTD., 11 Douro-street, North Geelong, 3215; D.T.685; 18th October, 1973; 340 cwt.

HALL, C. H., 7 Lorima-street, Portland, 3305; D.A.56944; 14th September, 1973; 12 cwt.

HUTCHINSON, W. A., 177 Para-road, Greensborough, 3088; D.A.62876; 30th June, 1973; 109 cwt.

INGLIS, J. C., 16 Crouch-street, Portland, 3305; D.T.819; 15th September, 1973; 257 cwt.

JENKS, RAY, PTY. LTD., 118-120 High-street, Shepparton, 3630; D.A.60403/3; 15th September, 1973; 14 cwt.; D.A.60403/4; 15th September, 1973; 14 cwt.

KNOTT, D. J., P.O. Box 56, Bruthen, 3885; D.T.1539; 1st July, 1973; 266 cwt.

LUMSDEN, J. C., Whites-road, Warrnambool, 3280; D.A.33360/1; 27th September, 1973; 143 cwt.

MCCOLL, T. F., 47 Scott-grove, Kingsbury, 3083; D.A.65347; 15th September, 1973; 30 cwt.

MURRAY, A. A. & M. E., Popplewell-street, Moama, 2739; D.A.14330; 17th September, 1973; 130 cwt.

PANOFF, A., 1 Buna-avenue, Frankston, 3199; D.A.61170/1; 8th September, 1973; 120 cwt.

READY MIXED CONCRETE (VIC.) PTY. LTD., 68 Burwood-road, Burwood, 3125; T.D.A.48531/81; 22nd September, 1973; 242 cwt.; T.D.A.48531/81; 22nd September, 1973; 243 cwt.

READY MIXED CONCRETE (VIC.) PTY. LTD., 68 Burwood-road, Burwood, 3125; T.D.A.48531/99; 7th September, 1973; 343 cwt.

READY MIXED CONCRETE (VIC.) PTY. LTD., 68 Burwood-road, Burwood, 3125; T.D.A.48531/108; 17th August, 1973; 334 cwt.; T.D.A.48531/110; 7th September, 1973; 335 cwt.; T.D.A.48531/111; 7th September, 1973; 333 cwt.; T.D.A.48531/112; 7th September, 1973; 257 cwt.; T.D.A.48531/115; 21st September, 1973; 257 cwt.; T.D.A.48531/118; 21st September, 1973; 257 cwt.; T.D.A.48531/119; 5th October, 1973; 257 cwt.; T.D.A.48531/120; 5th October, 1973; 257 cwt.; T.D.A.48531/121; 12th October, 1973; 331 cwt.; T.D.A.48531/122; 12th October, 1973; 257 cwt.; T.D.A.48531/123; 12th October, 1973; 257 cwt.; T.D.A.48531/125; 19th October, 1973; 257 cwt.

READY MIXED CONCRETE (VIC.) PTY. LTD., 68 Burwood-road, Burwood, 3125; T.D.A.48531/129; 10th August, 1973; 334 cwt.

ROWE, F. C., Katunga, 3640; D.A.44441; 11th September, 1973; 84 cwt.

S.P.D., CARE OF UNILEVER AUST. PTY. LTD., 164 Ingles-street, Port Melbourne, 3207; D.A.46545/23; 6th September, 1973; 141 cwt.

SOUTHERN FARMERS CO-OP. LTD., Box 506, Hamilton, 3300; D.A.63001; 27th October, 1973; 10 cwt.

STINTON, C. R., 13 McKean-street, Bairnsdale, 3875; D.T.1540; 1st July, 1973; 260 cwt.

TONISSEN, L. J., Box 27, Tarrington, 3301; D.A.44068; 14th August, 1973; 329 cwt.

TOORALAC MILK PRODUCTS PTY. LTD., Bridge-road, Dandenong, 3175; D.A.56830; 6th September, 1973; 300 cwt.

TOORALAC MILK PRODUCTS PTY. LTD., Bridge-road, Dandenong, 3175; D.A.56830/1; 6th September, 1973; 200 cwt.; D.A.56830/2; 6th September, 1973; 256 cwt.

TOORALAC MILK PRODUCTS PTY. LTD., Bridge-road, Dandenong, 3175; D.A.56830/23; 16th August, 1973; 14 cwt.

TRANS-WEST HAULAGE (MELB.) PTY. LTD., 202 Station-street, Norlane, 3214; D.A.65323/23; 6th October, 1973; 211 cwt.; D.A.65323/25; 13th October, 1973; 211 cwt.

TRANS OTWAY LTD., corner Ryrie and Fenwick streets, Geelong, 3220; D.A.2179/6; 18th October, 1973; 75 cwt.

VAN SLAGAREN, S. (trading as Scientific Instrument Repair Service), 6 Holmes-street, North Geelong, 3215; D.A.62903/1; 13th October, 1973; 10 cwt.

YOUNG, W. R., 8 Peveril-street, Glen Waverley, 3150; D.A.63106; 15th September, 1973; 20 cwt.

YOUNG'S READY MIX PTY. LTD., 182 High-street, Shepparton, 3630; D.A.35594/6; 17th September, 1973; 209 cwt.

TOW TRUCK RENEWALS.

MELBOURNE TOWING SERVICE PTY. LTD., 169 City-road, South Melbourne, 3205; D.A.28169/13; 21st August, 1973; 74 cwt.; D.A.28169/14; 21st August, 1973; 29 cwt.; D.A.28169/15; 21st August, 1973; 76 cwt.; D.A.28169/16; 28th August, 1973; 79 cwt.

TOMKINS, R. (trading as R. & I. I. Tomkins), Dartmoor, 3304; D.A.63050; 18th August, 1973; 24 cwt.

RENEWALS WITH VARIATION.

Applications made by the persons listed hereunder for renewal of the licences listed with variation of conditions in the manner set out opposite the names.

ANSETT TRANSPORT INDUSTRIES (OPERATIONS) PTY. LTD., (trading as Ansett Motors), 210 Gray-street, Hamilton, 3300; D.A.64696/11; 13th October, 1973; application to renew and vary the conditions of licence No. D.A.64696/11 (L/C. 145 cwt.) by deleting paragraph (b) from the existing conditions.

MOORE, D. H., 5 Scott-crescent, Mildura, 3500; T.D.A.50951/2; 1st July, 1973; application to renew and vary the conditions of licence No. T.D.A.50951/2 (L/C. 15 cwt.) by deleting "due north and south through the Township of Sea Lake" from the existing conditions and adding in lieu "due south/south-west and north/north-east through the Townships of Sea Lake and West Piangil" and by also adding an additional paragraph (b)—"(b) Within that part of the State of Victoria west of a line drawn due north and south through the Township of Woomelang and north of a line drawn due east and west through the Township of Woomelang—wool and skins."

WILLIAMS, J. F., Main-street, Gembrook, 3783; D.T.532/5; 29th October, 1973; application to renew and vary the conditions of licence No. D.T.532/5 (L/C. 351 cwt.) by deleting the existing conditions and adding in lieu—"(a) From bush sites within a 20-mile radius of Gembrook and from Kinglake to own mill at Gembrook—logs. (b) From own mill at Gembrook

to places within a 25-mile radius of G.P.O., Melbourne—own sawn timber. (c) From own mill at Gembrook to Hicksons Timber Impregnation Co. (Aust.) Pty. Ltd. at Officer—own sawn timber. (d) From own mill at Gembrook to consignees within a 20-mile radius of Gembrook—own manufactured boxes."

Notice of any objection should be forwarded to reach the Secretary of the Board not later than 30th May, 1973.

Applicants are advised that it will not be necessary to appear on the hearing date specified above, unless advised in writing by the Board.

A. V. C. COOK,
Secretary.

Corner Lygon and Princes streets, Carlton, 3053, Wednesday, 16th May, 1973.

Melbourne and Metropolitan

BOARD OF WORKS.

GENERAL NOTICE.

The Melbourne and Metropolitan Board of Works, having made provision for carrying off the sewage of each and every property which or any part of which is situate in the Sewerage Areas hereinafter described, doth hereby declare that on and after the sixteenth day of June, 1973, each and every property so situate shall be deemed to be a seweraged property within the meaning of the *Melbourne and Metropolitan Board of Works Act 1958*.

The Sewerage Areas hereinbefore referred to are:—

Sewerage Area No. 2577.

City of Knox.—Commencing at the junction of Church-street and Mountain Highway; thence westerly along Mountain Highway, southerly along Birch-street to the southern boundary of the Bayswater Primary School property, westerly, northerly and westerly along boundaries of the said property to Begonia-avenue, northerly along Begonia-avenue, westerly along Lemon-grove, northerly along Kumala-road, westerly along Mountain Highway, northerly along the western boundaries of lots 51 Mountain Highway and 52 Larne-avenue, north-westerly by a line to the south-western angle of lot 144 Larne-avenue, north-easterly along the north-western boundary of the said lot 144, westerly along portion of the southern boundary of lot 142 Fallons-way, northerly along Fallons-way, further northerly along the western boundary of lot 1 Fallons-way to Dandenong Creek, generally easterly along the said creek to the boundary of Sewerage Area No. 2499, generally southerly along the said area boundary to the commencing point.

Sewerage Area No. 2578.

City of Springvale.—Commencing at the eastern extremity of Industrial-drive; thence southerly along the eastern boundary of lot 10 Industrial-drive, westerly along the southern boundaries of lots 10 to 12 Industrial-drive, southerly along portion of the eastern boundary of lot 8 Governor-road, westerly along Governor-road, northerly, westerly and northerly along the western boundaries of lot 6 Governor-road, further northerly along the western boundary of lot 5 Industrial-drive, westerly along Industrial-drive, northerly along Boundary-road, easterly along Malcolm-road, southerly along the production of the eastern boundaries of lots 22 to 27 Century-drive, further southerly along the said eastern boundaries and the eastern boundary of lot 28 Industrial-drive to the commencing point.

Sewerage Area No. 2579.

City of Ringwood.—Commencing at the junction of Pilgrim-court and Heatherdale-road; thence northerly along Heatherdale-road, easterly along the northern boundaries of lots 9 Heatherdale-road and 10 to 15 Pilgrim-court, further easterly along the northern boundaries of a reserve and lot 16 Pilgrim-court, northerly along the western boundary of land reserved for a proposed freeway to the boundary of Sewerage Area No. 2471, easterly along the said area boundary to the eastern boundary of the said reserved land, southerly along the said eastern boundary to Canterbury-road, westerly along Canterbury-road to the boundary of Sewerage Area No. 2069, northerly and westerly following the said area boundary to Heatherdale-road, northerly along Heatherdale-road to the commencing point.

Sewerage Area No. 2580.

City of Nunawading.—Commencing at the junction of Cavill-court and Burwood Highway; thence easterly along Burwood Highway; southerly along the eastern boundaries of lots 20 Burwood Highway and 18 to 12 Cavill-court, westerly along the southern boundaries of lots 12 to 9 Cavill-court, northerly along the western boundaries of lots 9 to 3 Cavill-court and 1 Burwood Highway, easterly along Burwood Highway to the commencing point.

Sewerage Area No. 2581.

Shire of Cranbourne.—Commencing at the junction of Mary-street and Karol-court; thence northerly along Karol-court, north-easterly along the north-western boundary of lot 14 Karol-court, northerly along the western boundary of lot 55 Vanessa-drive, further northerly along portion of the western boundary of lot 56 Pound-road, westerly and northerly along the southern and western boundaries of lot 16 Pound-road, easterly along Pound-road, southerly and south-westerly along the eastern and south-eastern boundaries of lot 70 Pound-road, easterly along the northern boundary of lot 73 Marshall-court, southerly along Marshall-court, south-easterly and westerly along the north-eastern and portion of the southern boundaries of lot 82 Marshall-court, southerly along the eastern boundary of lot 11 Mark-court and a line to the north-western angle of lot 10 Mark-court; easterly along the northern boundary of the said lot 10, southerly along the eastern boundaries of lots 10 to 4 Mark-court and 1 Somerville-road, westerly along Somerville-road, northerly along the western boundaries of lots 35 Somerville-road, 37 to 48 Vanessa-drive and 49 Mary-street, westerly along Mary-street to the commencing point.

Sewerage Area No. 2582.

City of Nunawading.—Commencing at the junction of Morack-road and Burwood Highway; thence westerly along Burwood Highway, northerly along the western boundaries of lots 326 Burwood Highway; 317 to 315 Dalwood-court, 312 and 311 Bundarra-court, 298 and 297 Barossa-avenue and 295 Great Western-drive, north-easterly along the north-western boundary of the said lot 295, north-westerly along Great Western-drive, northerly along the western boundaries of lots 16 to 3 Mildara-street and 1 Morack-road, easterly along Morack-road, southerly and westerly along the eastern and portion of the southern boundaries of lot 76 Morack-road, southerly along the eastern boundary of lot 90 Moyston-close, further southerly along Moyston-close, westerly along portion of the southern boundary of lot 91 Moyston-close, southerly along the eastern boundaries of lots 93 and 166 Minchinbury-drive, easterly along the northern boundaries of lots 136 and 137 Coonawarra-drive, southerly along the eastern boundary of the said lot 137, easterly along Coonawarra-drive, southerly along the eastern boundary of lot 194 Coonawarra-drive, easterly along the northern boundaries of lots 199 and 200 Yalumba-court, southerly along the eastern boundary of the said lot 200, south-easterly, south-westerly and north-westerly along the boundaries of lot 4 Morack-road, southerly along portion of the eastern boundary of lot 201 Yalumba-court, westerly along the southern boundary of the said lot 201, south-westerly along the south-eastern boundary of lot 227 Reynella-close, further south-westerly along Reynella-close and the south-eastern boundary of lot 224 Reynella-close, south-easterly along the north-eastern boundaries of lots 212 to 214 Great Western-drive, south-westerly along the south-eastern boundary of the said lot 214, south-easterly along Great Western-drive, north-easterly and south-easterly along the north-western and north-eastern boundaries of lot 217 Great Western-drive, easterly along the northern boundary of lot 218 Great Western-drive, southerly along Morack-road to the commencing point.

Sewerage Area No. 2583.

City of Broadmeadows.—Commencing at a point in Carrick-drive about 120 feet south of the southern boundary of Field-court on the boundary of Sewerage Area No. 2535; thence westerly and generally northerly following the said area boundary to Oldfield-grove, easterly and south-easterly along the northern and portion of the north-eastern boundaries of lot 2008 Oldfield-grove, north-easterly along the north-western boundary of lot 2003 Carrick-drive, south-easterly along Carrick-drive, easterly along Dingley-close, southerly and westerly along the eastern and portion of the southern boundaries of lot 2036 Dingley-close, south-easterly along the north-eastern boundary of lot 2146 Adam-court and a line to the north-eastern angle of lot 2144 Adam-court, southerly and westerly along the eastern and portion of the southern boundaries of the said lot 2144, southerly along the eastern boundary of lot 2138 Henley-drive, south-westerly by a line to the north-eastern angle of lot 2137 Henley-drive, southerly along the eastern boundaries of the said lot 2137 and lots 1940 and 1941 Carrick-drive, westerly along the southern boundary of the said lot 1941, northerly along Carrick-drive to the commencing point.

By order of the Board,

R. H. ENGELSMAN,
Acting Secretary.

425 Collins-street, Melbourne, 3001, 15th May, 1973.

STATE RIVERS AND WATER SUPPLY COMMISSION.

LICENCES TO DIVERT WATER AND CUT RACES PURSUANT TO THE PROVISIONS OF SECTION 204 OF THE WATER ACT 1958 (AS AMENDED).

The Governor in Council has approved of the granting by the State Rivers and Water Supply Commission of licences as detailed hereunder for the term of years from the date specified in each case to the persons named in the following Schedule :—

SCHEDULE.

Licence No.	Term of Licence and Commencing Date.	Name and Address of Person to whom Licence is to be granted.	Source of Supply.	Area Authorized to be Irrigated Per Annum.	Volume of Water Authorized to be Diverted Per Annum.	Annual Fee.
				acres.	ac. ft.	
820	Five years from 1.7.70 ..	George Harold Willox, Swan Hill ..	Little Murray River	59	118	236.00
3000/816	Five years from 1.7.70 ..	Ernest Ray Trethewie and Inez Marie Trethewie, Swan Hill	Little Murray River	50	100	200.00
3426	Four years from 1.7.72 ..	Thelma Jean Arnold, Strathmerton	Ulupna Creek ..	30	60	75.00
3437	Four years from 1.7.72 ..	Robert Wayne Driscoll and Julie Rose Driscoll, Stewart	River Murray ..	100	300	300.00
3449	Four years from 1.7.72 ..	Ronald Charles Storey, Boundary Bend	River Murray ..	33½	100	100.00
3451	Four years from 1.7.72 ..	Angelo Rigoni, Mt. Beauty ..	Kiewa River ..	25	50	50.00
3452	Four years from 1.7.72 ..	Ian Malcolm McPherson, Bundalong	River Murray (Lake Mulwala)	50	100	125.00

Office of the State Rivers and Water Supply Commission,
Melbourne, 8th May, 1973.

G. W. LEWIS, Secretary,
State Rivers and Water Supply Commission.

Soil Conservation and Land Utilization Act 1958.

TARAGO RIVER WATER SUPPLY CATCHMENT.

NOTICE OF DETERMINATION OF LAND USE—PLAN No. 2712.

Proclaimed 30th May, 1967, *Victoria Government Gazette*, No. 49, dated 7th June, 1967, pursuant to section 22, sub-section (1) of the *Soil Conservation and Land Utilization Act 1958*.

In pursuance of the provisions of section 23, sub-section (1) of the *Soil Conservation and Land Utilization Act 1958* (No. 6372), the Soil Conservation Authority after consultation with the Land Conservation Council has determined the land use for all that area of land in the Parishes of Jindivick, Neerim, Nayook and Nayook West within the boundaries of the Tarago River Water Supply Catchment delineated and marked on plan No. 1950, the original of which is lodged at the Head Office of the Soil Conservation Authority. All land within this area shall be used in accordance with the provisions of the particular category of land use to which each area has been assigned. The boundaries of land use categories shown on plan No. 2712 are intended as a guide to landholders, who should consult with the Soil Conservation Authority before making any changes in land use.

The provisions of each of the land use categories are set out hereunder:—

CATEGORY 1.

Land which shall be used primarily for the protection of streams and watercourses where:—

- (a) cultivation may be approved only for specific pasture improvement or weed and vermin control purposes;
- (b) no tree shall be removed, no drainage works undertaken, or any soil disturbed without the approval of the Soil Conservation Authority; and
- (c) if so required by the Authority, crossing shall be permitted only by means of crossings specifically approved for the particular site by the Soil Conservation Authority.

This category covers the marginal land around the reservoir and areas within half a chain, or one chain or such greater distance as the Authority may require from the edge of the banks of streams and watercourses shown on plan No. 2712 or specified where necessary by the Authority.

CATEGORY 2.

Land which shall be used for permanent forest or plantation purposes where forestry operations may be carried out only in accordance with management conditions made or approved by the Soil Conservation Authority.

The construction of roads, earthworks of any description or any other changes affecting catchment interests are subject to the approval of the Authority.

CATEGORY 3.

Land suitable for forest purposes, parts of which may be developed for grazing or cropping with the approval of the Soil Conservation Authority. Use of the land for any of these purposes is, where necessary, subject to conditions made or approved by the Authority and such conditions may include:—

- (a) Management prescriptions for forest areas.
- (b) The specification of areas which may be developed, and those areas which are to remain as forest.
- (c) The specification of conservation practices.

CATEGORY 4.

Land suitable for grazing. Cultivation for pasture maintenance purposes will be permitted subject to conditions imposed by the Authority. Such conditions may include the length of rotation and conservation practices where necessary.

CATEGORY 5.

Land suitable for grazing or cropping purposes, subject to conditions imposed by the Authority for particular circumstances.

CATEGORY 6.

6A. Land used for roads on which any changes in land use shall be made only after consultation with the Soil Conservation Authority.

68. Land reserved for roads on which any changes in land use shall be made only with the approval of the Soil Conservation Authority.

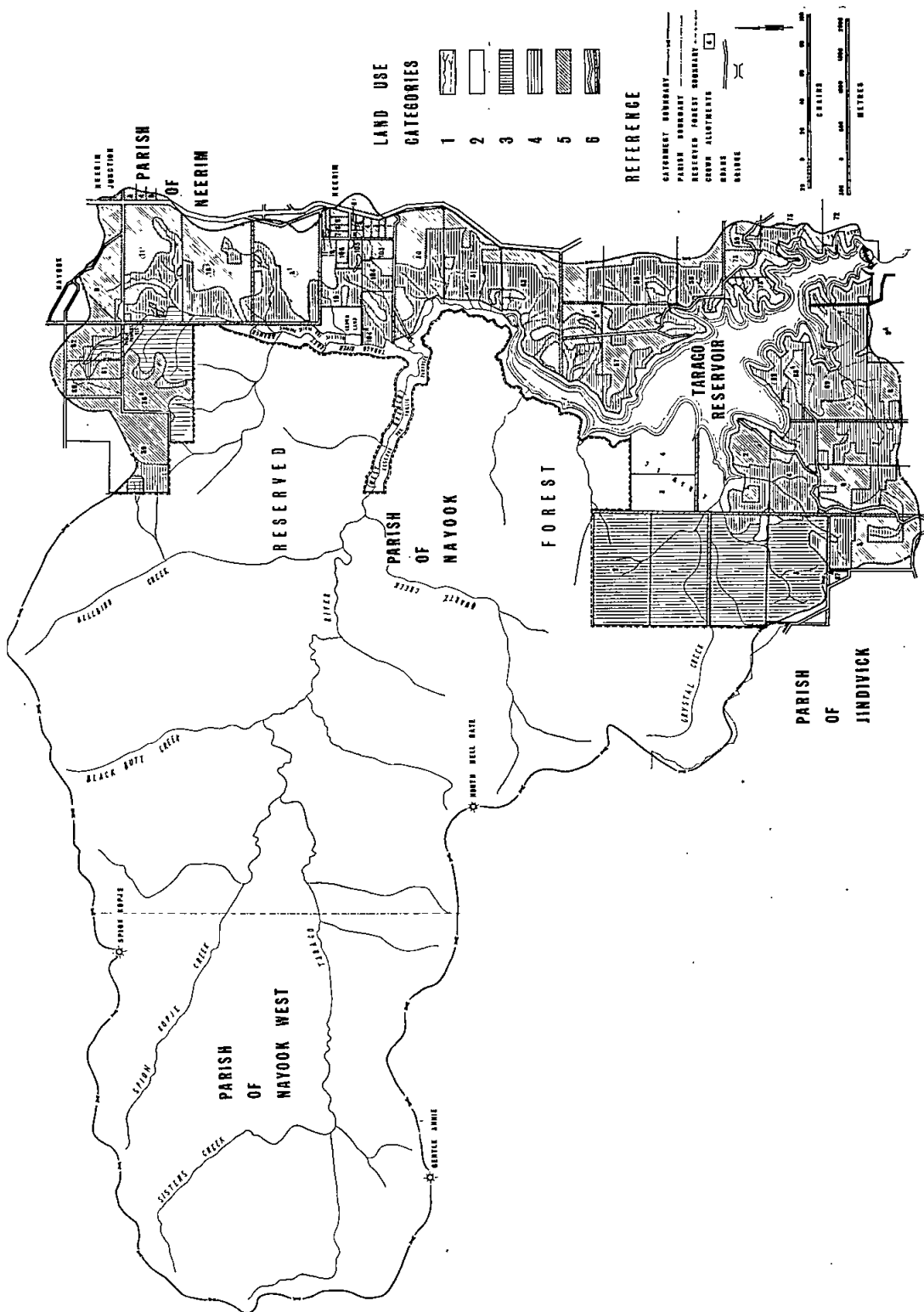

R. A. FITT, Secretary,
Soil Conservation Authority.

Private Agents Act 1966.

NOTICE OF RECEIPT OF APPLICATIONS FOR LICENCES UNDER THE PROVISIONS OF THE PRIVATE AGENTS ACT 1966.

The Clerk(s) of the Magistrates' Court(s) as listed hereunder hereby give notice that applications, as under, have been lodged for hearing by the said Court(s) on the date(s) specified.

Any person desiring to object to any of such applications must—

- (a) lodge with the respective Clerk of the Magistrates' Court a notice in the prescribed form of his objection and of the grounds thereof;
- (b) cause a copy of such notice to be served personally or by post upon the applicant at least three days before the hearing of the application; and
- (c) send or deliver—
 - (i) where the objection is not made by the officer in charge of the police district in which the Court is situated—a copy of the notice to such officer; and
 - (ii) where the objection is not made by the Registrar or Deputy Registrar—a copy to the Registrar.

Full Name of Applicant or in the Case of a Firm or Corporation, of the Nominee.	Place of Abode of Applicant or Nominee.	Name of Firm or Corporation.	Address for Registration.	Type of Licence.	Date of Hearing of Application.
---	---	------------------------------	---------------------------	------------------	---------------------------------

MAGISTRATES' COURT, PRAHRAN.

Murray, Rodney Paul ..	8/55 Filbert-street, South Caulfield	12/614 St. Kilda-road, Melbourne	Commercial Sub-Agent	1.6.73
------------------------	--------------------------------------	---------	----------------------------------	----------------------	--------

Dated at Prahran this 4th day of May, 1973.

J. PRESNELL, Clerk of the Magistrates' Court.

MAGISTRATES' COURT, PORT MELBOURNE.

Broadbent, James Edward ..	21 Barry-street, Brunswick	Mayne Nickless Limited	94 York-street, South Melbourne	Watchman	15.5.73
Mayo, Russell Ernest ..	11 Hartley-avenue, West Footscray	" " "	" " "	"	"
Burgemeestre, Reyer Willem Fulk	6 High-street, Kew	" " "	" " "	"	"
Lyons, Keith Hume ..	80 Broadway, Bon Beach	" " "	" " "	"	29.5.73
Hawkes, Alyn Robert ..	8 Russell-street, Ivanhoe	" " "	" " "	"	"

Dated at Port Melbourne, this 3rd day of May, 1973.

J. GIDLEY, Clerk of the Magistrates' Court.

MAGISTRATES' COURT, FOOTSCRAY.

Watkins, Graham Arthur ..	10 Eleanor-street, West Footscray	Mayne Nickless Limited	4 Cross-street, Footscray	Watchman	5.6.73
---------------------------	-----------------------------------	------------------------	---------------------------	----------	--------

Dated at Footscray this 4th day of May, 1973.

D. THOMPSON, Clerk of the Magistrates' Court.

MAGISTRATES' COURT, FITZROY.

Day, Michael James ..	54 York-street, North Fitzroy	54 York-street, North Fitzroy	Process Server	30.5.73
-----------------------	-------------------------------	---------	-------------------------------	----------------	---------

Dated at Fitzroy this 8th day of May, 1973.

J. B. RIES, Clerk of the Magistrates' Court.

MAGISTRATES' COURT, LEONGATHA.

Darby, John Maurice ..	Flat 10, Kenneny-street, Morwell	38 Russell-court, Leongatha	Commercial Sub-Agent	30.5.73
" " "	" " "	" " "	" " "	Process Server	"
" " "	" " "	" " "	" " "	Inquiry Agent	"

Dated at Leongatha this 3rd day of May, 1973.

D. J. DEVLIN, Clerk of the Magistrates' Court.

MAGISTRATES' COURT, COWES.

Gazan, Korstiaan Cornelis ..	Rhyll, Phillip Island	Rhyll, Phillip Island	Process Server	14.6.73
------------------------------	-----------------------	---------	-----------------------	----------------	---------

Dated at Cowes this 10th day of May, 1973.

R. A. ISON, Clerk of the Magistrates' Court.

MAGISTRATES' COURT, WILLIAMSTOWN.

Grant, Maurice V. ..	34 Carthy-street, Altona North	34 Carthy-street, Altona North	Process Server	31.5.73
----------------------	--------------------------------	---------	--------------------------------	----------------	---------

Dated at Williamstown this 9th day of May, 1973.

B. J. STOCKS, Clerk of the Magistrates' Court.

MAGISTRATES' COURT, BENDIGO.

Connaughton, John ..	220 Arnold-street, Bendigo	Bendigo Investments Limited	27 Queen-street, Bendigo	Watchman	11.6.73
Guest, John ..	Cook-street, Bendigo	" " "	" " "	"	"
Session, Glynn Phillip ..	76 Thistle-street, Bendigo	" " "	" " "	"	"
Tuckerman, Arthur Leigh ..	Calder Highway, Kangaroo Flat	" " "	" " "	"	"
Sutton, Hector Alfred ..	66 Mt. Kerang-road, Eaglehawk	" " "	" " "	"	"

Dated at Bendigo this 9th day of May, 1973.

R. N. HOLLIS, Clerk of the Magistrates' Court.

MAGISTRATES' COURT, WARBURTON.

McKay, Kevin Joseph ..	Hoddle-street, Yarra Junction	Hoddle-street, Yarra Junction	Process Server	6.6.73
" " "	" " "	" " "	" " "	Inquiry Agent	"

Dated at Warburton this 9th day of May, 1973.

D. C. HANNAN, Clerk of the Magistrates' Court.

PRIVATE AGENTS—continued.

Full Name of Applicant or in the Case of a Firm or Corporation, of the Nominee.	Place of Abode of Applicant or Nominee.	Name of Firm or Corporation.	Address for Registration.	Type of Licence.	Date of Hearing of Application.
MAGISTRATES' COURT, BOX HILL.					
Drew, Thomas Edward ..	16 Sandhurst-crescent, Bundoora	Mayne Nickless Limited	203 Elgar-road, Box Hill	Watchman ..	31.5.73
Dated at Box Hill this 10th day of May, 1973.					
A. J. JOHNSON, Clerk of the Magistrates' Court.					
MAGISTRATES' COURT, SPRINGVALE.					
Thomas, Raymond George ..	28 Wall-street, Noble Park	28 Wall-street, Noble Park	Inquiry Agent ..	31.5.73
Dated at Springvale this 9th day of May, 1973.					
J. B. DENNIS, Clerk of the Magistrates' Court.					
MAGISTRATES' COURT, SALE.					
Roberts, Colin Campbell ..	16 Overend-crescent, Sale	Sale Security Patrol	3 Hagenauer-street, Sale	Watchman ..	29.5.73
Dated at Sale this 8th day of May, 1973.					
M. W. GERKENS, Clerk of the Magistrates' Court.					
MAGISTRATES' COURT, MALVERN.					
Macrae, Duncan ..	2 Shelly-street, Heidelberg	The Security Watching Co. Pty. Ltd.	281 High-street, Ashburton	Watchman ..	11.6.73
Dated at Malvern this 11th day of May, 1973.					
P. J. RODDA, Clerk of the Magistrates' Court.					
MAGISTRATES' COURT, PRAHRAN.					
Kousal, Juri ..	74 Commercial-road, Prahran	80 Commercial-road, Prahran	Inquiry Agent ..	1.6.73
Dated at Prahran this 11th day of May, 1973.					
J. PRESNELL, Clerk of the Magistrates' Court.					
MAGISTRATES' COURT, RINGWOOD.					
Powers, Robert Charles ..	Lot 15 Waterloo-street, Heathmont	Lot 15 Waterloo-street, Heathmont	Process Server ..	7.6.73
Dated at Ringwood this 10th day of May, 1973.					
L. T. GOULD, Clerk of the Magistrates' Court.					
MAGISTRATES' COURT, MELBOURNE.					
House, Ronald Melfort ..	18 Cleve-road, Pascoe Vale	Mayne Nickless Limited	94 York-street, South Melbourne	Watchman ..	6.6.73
Gilbert, David George ..	5 Ralph-street, West Sunshine	" " "	" " "	Watchman ..	"
Dated at Melbourne this 10th day of May, 1973.					
G. L. WEBSTER, Clerk of the Magistrates' Court.					

Police Regulation Act 1958.

POLICE FORCE OF VICTORIA.

DETERMINATION NO. 205 OF THE POLICE SERVICE BOARD.

The Police Service Board, in pursuance of the powers in that behalf conferred by the *Police Regulation Act 1958*, hereby makes the following Determination (that is to say):—

1. The Determination No. 179 of the Police Service Board of 14th December, 1971, and published in the *Government Gazette* of 25th January, 1972, as amended, is hereby further amended as follows:—

In paragraph 12, sub-paragraph (j)—

(a) In clause (i)—

By inserting the expression "Other Officers attached to the Traffic and Patrol Division . . . 362.33" after the expression "Officer in Charge . . . 362.33".

(b) In clause (ii)—

By deleting the expression "Sub-Officer in Sub-Charge . . . 50", and in the following expression, by deleting the words "All other".

2. This Determination shall come into operation on the 13th day of May, 1973.

Dated the 2nd day of May, 1973.

T. B. SHILLITO,
A Judge of the County Court of Victoria,
Deputy Chairman and Member of the Police
Service Board.

J. G. BROWN,
Member of the Police Service Board.

G. DAVIDSON,
Member of the Police Service Board.

COUNTRY ROADS BOARD.

RESOLUTIONS OF THE COUNTRY ROADS BOARD.

The Country Roads Board, in pursuance of the provisions of the Country Roads Act 1958, has passed Resolutions the dates whereof and the terms of which are scheduled hereunder:—

SCHEDULE.

State Highways:

Resolution dated the Twenty-sixth day of April, One thousand nine hundred and seventy-three, made pursuant to sections 21 and 74 of the Country Roads Act 1958, declaring the widening of the South Gippsland Highway in the Shire of Cranbourne as shown hatched on plan numbered G.P.12414 hereunder to be part of a State highway within the meaning and for the purposes of the said Act.

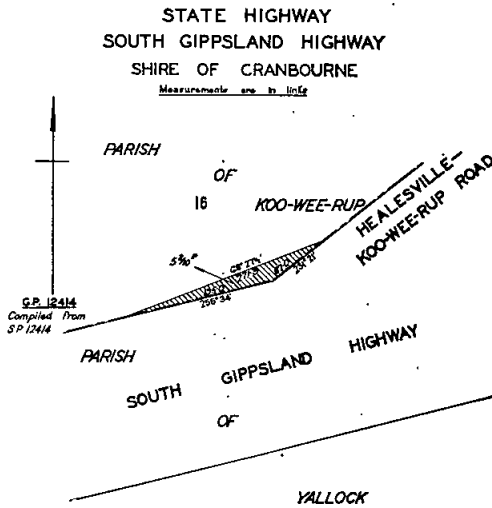

Resolution dated the Twenty-sixth day of April, One thousand nine hundred and seventy-three, made pursuant to sections 21 and 74 of the Country Roads Act 1958, declaring the widening of the Calder Highway in the Shire of Korong as shown hatched on plans numbered G.P.12116A and G.P.12116B hereunder to be part of a State highway within the meaning and for the purposes of the said Act.

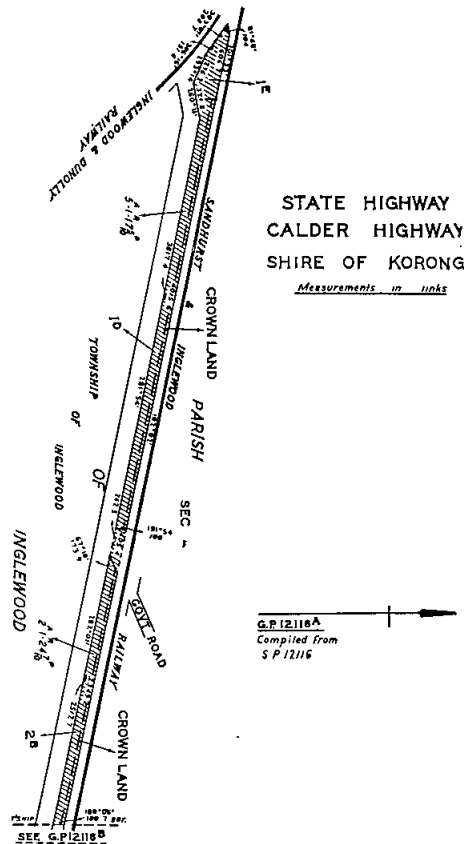
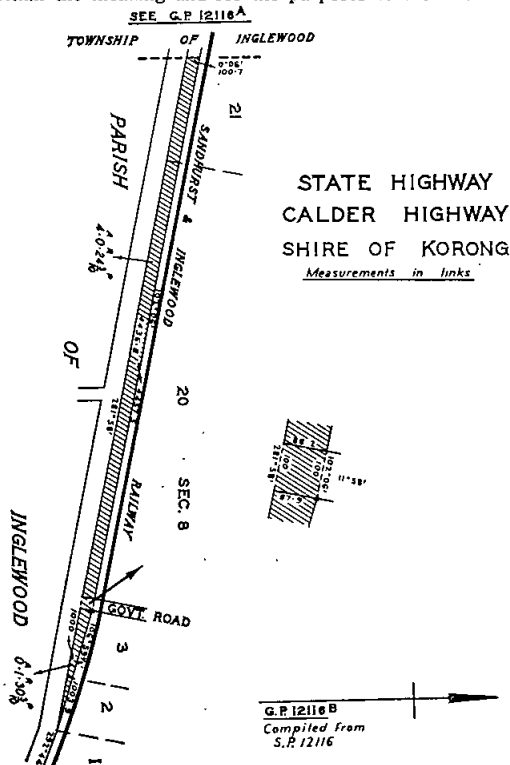

Main Roads.

Resolution dated the Thirtieth day of April, One thousand nine hundred and seventy-three, made pursuant to section 21 of the Country Roads Act 1958, declaring the widening of Epping-road in the City of Preston and Shire of Whittlesea as shown hatched on plan numbered G.P.12368A hereunder to be part of a main road within the meaning and for the purposes of the said Act.

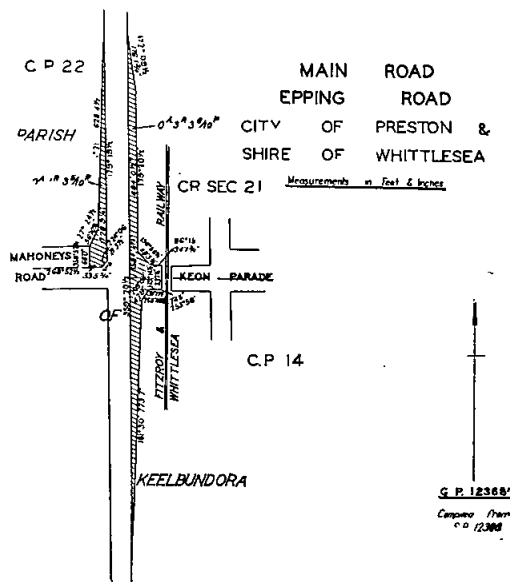

Resolution dated the Twenty-sixth day of April, One thousand nine hundred and seventy-three, made pursuant to section 21 of the Country Roads Act 1958, declaring the widening of the Ararat-Stawell road in the Town of

Stawell as shown hatched on plan numbered G.P.12634 hereunder to be part of a main road within the meaning and for the purposes of the said Act.

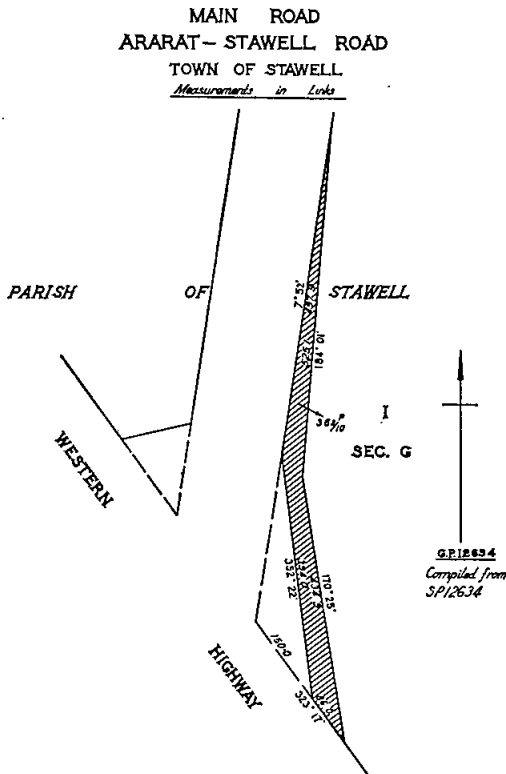

Resolution dated the Twenty-sixth day of April, One thousand nine hundred and seventy-three, made pursuant to section 21 of the Country Roads Act 1958, declaring the widening of Ballarat-road in the Shire of Tullaroop as shown hatched on plan numbered G.P.13055 hereunder to be part of a main road within the meaning and for the purposes of the said Act.

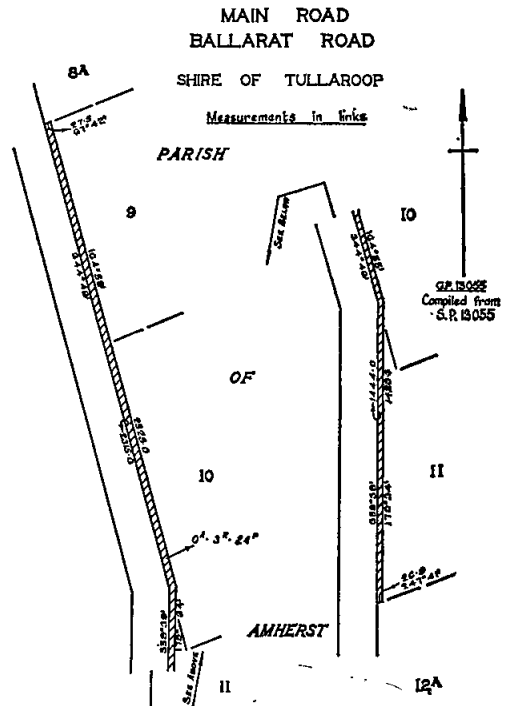

Unclassified Roads.

Resolution dated the Thirtieth day of April, One thousand nine hundred and seventy-three, made pursuant to sections 21 and 110 of the Country Roads Act 1958, declaring the road in the City of Preston and Shire of Whittlesea as shown hatched on plan numbered G.P.12368c hereunder to be a road (Keon-parade) within the meaning and for the purposes of the said Act.

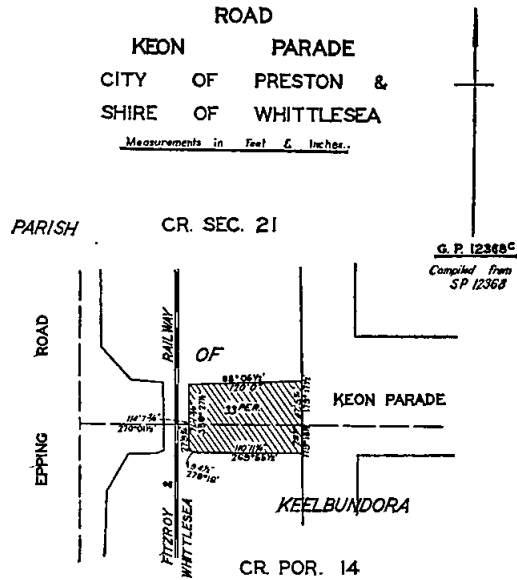

Resolution dated the Thirtieth day of April, One thousand nine hundred and seventy-three, made pursuant to sections 21 and 110 of the Country Roads Act 1958, declaring the widening of Mahoneys-road in the Shire of Whittlesea and City of Preston as shown hatched on plan numbered G.P.12368b hereunder to be part of a road within the meaning and for the purposes of the said Act.

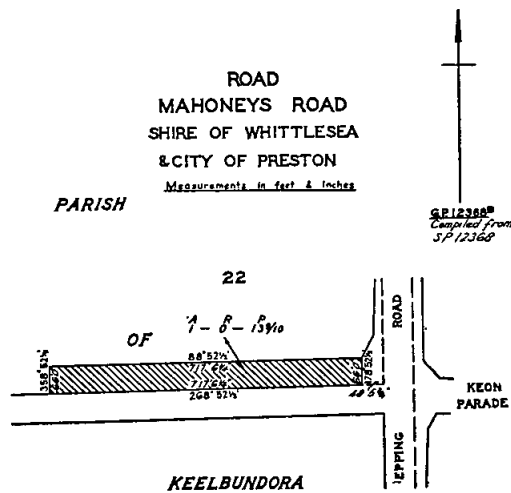

Tourists' Road.

Resolution dated the Twenty-sixth day of April, One thousand nine hundred and seventy-three, made pursuant to sections 21 and 88 of the Country Roads Act 1958, declaring the widening of Mount Dandenong-road in the

Shire of Lillydale as shown hatched on plan numbered G.P.8884 hereunder to be part of a tourists' road within the meaning and for the purposes of the said Act.

**TOURISTS' ROAD
MOUNT DANDENONG ROAD
SHIRE OF LILLYDALE**

Measurements in Feet and Inches

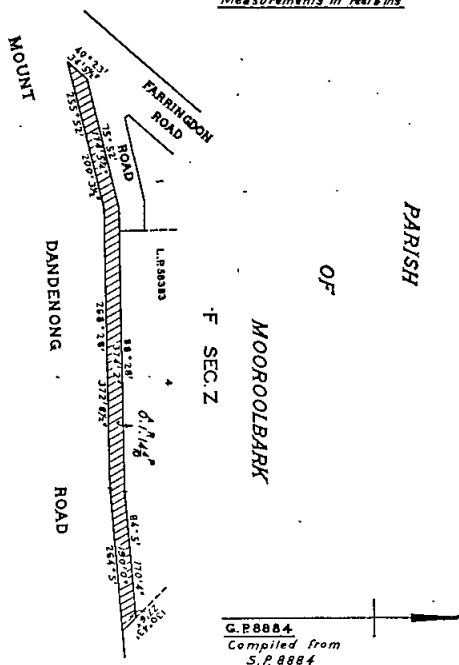

N. L. ALLANSON,
Secretary.

4th May, 1973.

State of Victoria.
MARINE BOARD OF VICTORIA.

NOTICE TO SHIPOWNERS, PILOTS, SHIPMASTERS, TUGMASTERS AND OTHERS CONCERNED.

Recommended Practice When Passing Bow Towlines Whilst Underway.

The Marine Board of Victoria strongly supports a recommendation of a recent Court of Marine Enquiry that in order to prevent misunderstanding on the part of the tug crews, to indicate to the tugmaster that those on the ship are ready to pass the towline and to speed up the operation of passing a bowline when the ship is underway, the eye of the tow-rope should be passed through the fairlead to be used and brought back on board in such a manner that it is clearly visible to those on the tug.

Tugmasters and crews should, however, bear in mind that conditions may be such that those in charge of the navigation of the ship may be unable to ensure that this recommendation has been carried out and should therefore contact the ship if any doubt exists.

R. G. WEBSTER, Vice President,
Marine Board of Victoria.

Co-operation Act 1958.

VALKSTONE STATE SCHOOL CO-OPERATIVE LIMITED.
Notice is hereby given, in pursuance of section 78 (7) of the Co-operation Act 1958 and section 308 (2) of the Companies Act 1961, that, at the expiration of three months from the date hereof, the name of the aforementioned society will, unless cause is shown to the contrary, be struck off the register and the society will be dissolved.

Dated this tenth day of May, 1973.

R. F. SCOLLARD,
Deputy Registrar.

HEYWOOD SEWERAGE AUTHORITY.

By-Law No. 2.

Relating to sewers, sewer manholes and the Planting of Trees, Shrubs or the like Within a Certain Distance Therefrom.

The Heywood Sewerage Authority, pursuant to and in the exercise of the powers and authorities conferred on it by the Sewerage Districts Act and of any and every other power or authority in any way enabling it on that behalf doth hereby make and prescribe the following By-Law (that is to say):

1. The owner or occupier of any premises shall not plant nor permit to be planted any trees, shrubs or plants of the varieties specified in Schedule A of this By-Law within a distance also specified in the said Schedule calculated from the centre line of any sewer or sewer manhole.
2. Any contravention of the preceding clause by act or omission shall be an offence against this By-Law.
3. Every person guilty of an offence against this By-Law shall be liable.
 - (a) to a penalty of not more than FORTY DOLLARS (\$40) and in the case of a continuing offence to a penalty of TEN DOLLARS (\$10) for each day on which the offence against this By-Law is continued after a conviction or order by any court, and
 - (b) to pay the Heywood Sewerage Authority any expense incurred by it in the removal of trees, shrubs or plants, the planting of which is prohibited by this By-Law.
4. Nothing in the preceding section shall in any way limit any right to any other action whatsoever at law which the Heywood Sewerage Authority may have against any person whomsoever for damages occasioned by lockage and/or obstruction to or in a sewer or sewer manhole.
5. This By-Law shall have force in and apply throughout the Sewerage District of the Heywood Sewerage Authority.

Resolution for adopting this By-Law was passed by the Heywood Sewerage Authority at a meeting on the 21st March, 1973, and confirmed at a subsequent meeting held on the 18th April, 1973.

The common seal of the Heywood Sewerage Authority was hereunto affixed this 18th day of April, in the year 1973, in the presence of—

E. SIBLEY, Chairman.
J. S. PORTER, Member.
M. D. ALLARDICE, Secretary.

SCHEDULE A.

Varieties of trees, shrubs or plants the planting of which is prohibited.	Distance from centre line of sewer or sewer manhole within which planting is prohibited.
SALIX trees—(more commonly known as WILLOW trees) all varieties	Sixty Feet (60')
ULMES trees—(more commonly known as ELM trees) all varieties	Forty Feet (40')
POPULUS trees—(more commonly known as POPLAR trees) all varieties.	Forty Feet (40')

Approved by the Governor in Council, 15th May, 1973.—
T. J. FORRISTAL, Clerk of the Executive Council.

THE LIQUOR CONTROL ACT, 1968.

Whereas the Hotelkeeper's Licence for the licensed premises known as the Nelson Hotel, situate at South Melbourne, has been surrendered as from the 31st of December, 1970, notice is hereby given that the amount of compensation payable to the owner of such premises pursuant to the provisions of the Liquor Control Act 1968 is as under:—

Owner—\$22,628.00.

Dated this 14th day of May, 1973.

L. T. DUDLEY, Secretary.
Liquor Control Commission.

PUBLIC TRUSTEE ACT 1958 (No. 6350), SECTION 17.

I hereby give notice that on the 17th April, 1973, the Public Trustee filed elections to administer the following deceased persons' estates in accordance with section 17 of the *Public Trustee Act 1958*.

CARPENTER, ERNEST RICHARD, late of Flat 4, 21 Riversdale-road, Hawthorn, secretary, died 15th August, 1971.

HAYES, SIDNEY, also known as Sydney Joseph Hayes, late of Warrnambool, retired driver, died 15th December, 1972.

I hereby give notice that on the 2nd May, 1973, the Public Trustee filed elections to administer the following deceased persons' estates in accordance with section 17 of the *Public Trustee Act 1958*.

BASSETT, RONALD GEOFFREY, also known as Ronald Bassett, formerly of Mitiamo, but late of 48 Latrobe-avenue, Yallourn, S.E.C. employee, died 5th December, 1972.

CUMMINS, AMY ALMA, late of 21 Laing-street, Mont Albert, married woman, died 25th February, 1973.

FISHER, CLARIBEL GORDON, formerly of 25 Goldsmith-avenue, Preston, but late of William H. Clay Nursing Home, Wahgoo-road, Murrumbeena, widow, died 28th December, 1972.

HAMER, JOHN JOSEPH, late of Sunbury, invalid pensioner, died 1st December, 1972.

MARRIOTT, AMIEL ANNIE LEONOWENS, late of 15 Jarvis-avenue, Croydon, spinster, died 26th February, 1973.

PROCTOR, ETHEL, late of Kew, widow, died 4th January, 1973.

RADCLIFFE, BERTRAM ALEXANDER, formerly of Flat 8, 10 Charnwood-grove, St. Kilda and Alfred Hospital, Commercial-road, Prahran, Castlemaine, retired shop keeper, died 6th December, 1972.

SMITH, LAURENCE WILLIAM, late of 336 Highett-street, Richmond, clock maker, died 1st March, 1973.

THOMPSON, NANCY ELIZABETH, late of lot 45, Avon-street, Rye, spinster, died 17th February, 1973.

TILINDIS, JONAS, late of 67 Walsgott-street, North Geelong, painter, died 12th August, 1972.

N. P. BRODY,
Public Trustee.

168 Exhibition-street, Melbourne, 3000, 9th May, 1973.

NOTICE.

Creditors, next of kin and others having claims against the estate of any of the under-mentioned deceased persons are required to send particulars of their claims to the Public Trustee, 168 Exhibition-street, Melbourne, Vic. 3000, the personal representative, on or before the 23rd July, 1973, after which date the Public Trustee may convey or distribute the assets, having regard only to the claims of which the Public Trustee then has notice.

ANDERSON, IDA MINNA, late of 127 St. Georges-road, Northcote, widow, died 28th July, 1972.

BASSETT, RONALD GEOFFREY, also known as Ronald Bassett, formerly of Mitiamo, but late of 48 Latrobe-avenue, Yallourn, S.E.C. employee, died 5th December, 1972.

CARPENTER, ERNEST RICHARD, late of Flat 4, 21 Riversdale-road, Hawthorn, secretary, died 15th August, 1971.

CREIGHTON, AUBREY, late of 24 Weymar-street, Cheltenham, retired electrical salesman, died 11th February, 1973.

CUMMINS, AMY ALMA, late of 21 Laing-street, Mont Albert, married woman, died 25th February, 1973.

DRAKARD, NELLIE SCOTT, late of 6 Kelvin-court, Prahran East, widow, died 24th February, 1973.

FISHER, CLARIBEL GORDON, formerly of 25 Goldsmith-avenue, Preston, but late of William H. Clay Nursing Home, Wahgoo-road, Murrumbeena, widow, died 28th December, 1972.

GLUYAS, ANNIE MARGUERITA, formerly of 13 Camroc-avenue, Blair Athol, South Australia, but late of Flat 2, 34 Castlebar-road, Oakleigh, Victoria, widow, died 9th December, 1972.

HAMER, JOHN JOSEPH, late of Sunbury, invalid pensioner, died 1st December, 1972.

HAYES, SIDNEY, also known as Sydney Joseph Hayes, late of Warrnambool, retired driver, died 15th December, 1972.

HIGGINS, THOMAS FRANCIS, late of 1 Carnarvon-street, Hawthorn, retired station master, died 19th January, 1973.

JACK, HELEN, late of 45 McGregor-street, East Malvern, widow, died 21st February, 1973.

No. 35.—3940/73.—2

MARRIOTT, AMIEL ANNIE LEONOWENS, late of 15 Jarvis-avenue, Croydon, spinster, died 26th February, 1973.

MCLEOD, BRUCE ATHOL, also known as Athol Bruce McLeod, late of 56 Baker-parade, Ashburton, departmental manager, died 29th December, 1972.

PERCIVAL, AMELIA, late of 1563 Nepean Highway, West Rosebud, spinster, died 30th November, 1972.

PROCTOR, ETHEL, late of Kew, widow, died 4th January, 1973.

RADCLIFFE, BERTRAM ALEXANDER, formerly of Flat 8, 10 Charnwood-grove, St. Kilda and Alfred Hospital, Commercial-road, Prahran, but late of Castlemaine, retired shop keeper, died 6th December, 1972.

RATTIGAN, PATRICK FRANCIS, also known as Patrick Rattigan, late of 11 Mimoso-road, Carnegie, labourer, died 2nd December, 1972.

REID, VIOLA EDITH, also known as Edith Viola Reid, late of 55 Nimmo-street, Middle Park, spinster, died 23rd November, 1972.

SMITH, LAURENCE WILLIAM, late of 336 Highett-street, Richmond, clock maker, died 1st March, 1973.

THOMPSON, NANCY ELIZABETH, late of lot 45, Avon-street, Rye, spinster, died 17th February, 1973.

TILINDIS, JONAS, late of 67 Walsgott-street, North Geelong, painter, died 12th August, 1972.

WHITE, JAMES WILLIAM, late of 319 Bell-street, Pascoe Vale South, retired plumber, died 11th February, 1973.

ZAJAC, PIOTR, late of 5 Berthandra-court, West Footscray, labourer, died between 18th and 20th November, 1972.

N. P. BRODY,
Public Trustee.

Melbourne, 9th May, 1973.

CONTRACTS ACCEPTED.—(Series 1972-73.)

PUBLIC WORKS.

1081. Carlton, Primary School 4980, site works, \$41,236.04.—S. J. Moran Construction Pty. Ltd.

1082. Elwood, High School, mechanical services—multi-purpose hall, \$7,157.00.—R. J. Weekes Pty. Ltd.

1083. Dandenong, Police Station, supply and installation of heating, \$6,780.40.—A.T. Heating & Plumbing Pty. Ltd.

1084. Glenroy, High School, mechanical services—standard type assembly hall type 800 "C", \$9,230.00.—W. S. Atherton & Co. Pty. Ltd.

1085. Beaumaris, Demonstration Unit, mechanical services, \$18,141.00.—Bruce Sheet Metal Service.

1086. Essendon, High School, extensions to existing mechanical services, \$11,832.00.—Bruce Sheet Metal Service.

1087. Glenroy, Primary School 3118, remodelling staff accommodation, \$4,217.00.—Brom Brothers.

1088. Shepparton, Technical School, rebuilding of four (4) class-rooms including store and central corridor, \$47,606.00.—G. E. Brown.

1089. Blackburn, Primary School 2933, external renovations, \$10,569.00.—R. Bendinelli Renovations & Painting.

1090. Collingwood, Technical School, mechanical services, \$14,441.00.—Bilstan Building Services.

1091. Newborough, Primary School 4650, internal and external repairs and renovations, \$4,650.00.—F. Boschini.

1092. Eaglehawk, High School, mechanical services—Stage 3, \$16,549.00.—B. R. Burns Pty. Ltd.

1093. Kangaroo Flat, Technical School, mechanical services—music and gymnasium block, \$29,900.00.—B. R. Burns Pty. Ltd.

1094. Eaglehawk North, Primary School 1428, internal and external repairs and painting, \$5,930.00.—E. Capaldo & Sons Pty. Ltd.

1095. Ararat, Aradale Training Centre, external renovations to male and female divisions, \$43,090.00.—E. Capaldo & Sons Pty. Ltd.

1096. Burwood Heights, Primary School 4932, provision of sewerage facilities, \$4,640.00.—N. Ciardulli.

1097. Melbourne, Melbourne School of Painting, Decorating and Signcrafts, renovations to second floor, \$71,299.00.—Egeberg Building & Plumbing Service Pty. Ltd.

1098. Glenroy, High School, erection of standard type assembly hall—type 800 "C", \$120,123.00.—A. F. Dewar Holdings Pty. Ltd.

1099. Melbourne, Fisheries and Wildlife Department, 632 Bourke-street, construction of 65-ft. fisheries research vessel, \$93,965.00.—C. H. Dusink.

1100. Hurstbridge, High School, electrical services, Stage 3, \$8,925.00.—Electrite.

1101. Altona, Primary School 3923, erection of male/female toilets in existing staff room, \$5,440.00.—A. Klimas.

1102. Various locations, Schools, maintenance of oil burners for the period 6th February, 1973, to 31st December, 1973, \$9,967.00.—Keystone Engineering Services.

1103. Various, Schools, maintenance of oil burners for the period 6th February, 1973, to 31st December, 1973, \$10,902.00.—Keystone Engineering Services.

1104. Various, Schools in Western Region, maintenance of oil burners in schools for the period 6th February, 1973, to 31st December, 1973, \$8,747.00.—Keystone Engineering Services.

1105. Melbourne, Mines Department, Explosives Branch, 427 and 467 Spencer-street, maintenance cleaning for the period 23rd March, 1973, to 31st March, 1976, \$2,700.60 per annum.—K. & R. Building Services Maintenance.

1106. Melbourne, Melbourne School of Hairdressing, additions and remodelling of the Vaccari building, \$397,655.00.—Lewis Construction Co. Pty. Ltd.

1107. Kingsbury, Training Centre, electrical services—remodelling wards S.8, S.9, S.10, and S.11, \$35,549.00.—Lane & Roux Pty. Ltd.

1108. Broadmeadows, "Attwood" Veterinary Research Station, electrical services to new sub-station and modifications to electrical reticulation, \$8,350.00.—Lane & Roux Pty. Ltd.

1109. Werribee, S.S. Cameron Laboratory, State Research Farm, site works, \$11,350.38.—Wm. Loud Pty. Ltd.

1110. Mornington, Primary School 2033, erection of brick veneer toilet block and covered way, \$34,096.00.—Lamb & Bell Pty. Ltd.

1111. Woodville, Primary School 5049, site works, \$20,375.02.—Wm. Loud Pty. Ltd.

1112. Frankston, High School, connexion to town sewerage, \$32,500.00.—Lamb & Bell Pty. Ltd.

1113. Frankston East, Primary School 4682, erection of brick veneer and timber toilet blocks, \$48,650.00.—Lamb & Bell Pty. Ltd.

1114. Carlton, Central Licence and Registration Office, corner Lygon-street and Cemetery-road, maintenance cleaning for the period 16th April, 1973, to 30th April, 1976, \$2,668.40 per annum.—R. M. Merkur.

1115. Maryvale, High School, site works, \$43,375.10.—P. & M. McNulty.

1116. Lalor, Technical School, site works, \$88,657.92.—Rainbow Construction Co. Pty. Ltd.

1117. Bendigo, Teachers Training College, supply and installation of stage lighting fittings, Assembly Hall, \$4,110.00.—Strand Electric (Australia) Pty. Ltd.

1118. Brunswick North, Primary School 3585, site works, \$5,609.25.—Sheffield Paving & Construction Co. Pty. Ltd.

1119. Glen Waverley Heights, Primary School 4836, site works, \$8,509.50.—Derek Saathoff.

1120. Broadmeadows, "Attwood" Research Station, erection of a new electrical sub-station, \$6,365.00.—Simmie & Co. Pty. Ltd.

1121. Langi Kal Kal, Youth Training Centre, renovations to 18 residences, \$24,874.00.—Peter K. Hauke.

1122. Cobram, Court House, exterior and interior renovations, new toilets and connexion to sewerage, \$13,130.00.—J. T. Hale.

1123. Red Cliffs, Primary School 4057, asphalt repairs and drainage works, \$5,224.70.—A.B. Asphalters.

1124. Rochester, Primary School 795, external and internal renovations and painting, \$8,950.00.—John C. Hunter.

1125. Burwood, Technical School, acid proofing roof areas, \$6,380.00.—Hosie Constructions Pty. Ltd.

1126. Westall, High School, additional class-rooms, \$11,128.00.—Hosie Constructions Pty. Ltd.

1127. Hurstbridge, High School, mechanical services, Stage 3, \$25,825.00.—Gommers & Fakkel.

1128. Heatherton, Sanatorium, plenum heating of Wing 3, \$6,806.00.—Ford-Swinton Industries Pty. Ltd.

1129. Drouin, High School, mechanical services—Staff and administration improvements, &c., \$10,726.00.—Ford-Swinton Industries Pty. Ltd.

1130. Burwood, Teachers' College, alterations to buildings, \$11,071.00.—R. & N. Fraser Pty. Ltd.

G. SERPELL, Director-General. 9.5.73.

ORDERS IN COUNCIL.—(Series 1972-73.)

PUBLIC WORKS.

1079. Portland, Dutton Way, extension of the eastern experimental rubble groyne, \$6,500.79.—Portland Harbor Trust Commissioners.—(P. & H.86137.)

1080. South Yarra, Weights and Measures Branch, supply and erection of a Terrapin unit building, \$5,395.00.—Willcroft-Terrapin Pty. Ltd.—(P.C.30705.)

Approved by the Governor in Council, 8th May, 1973.—T. J. FORRISTAL, Clerk of the Executive Council.

APPOINTMENTS AND RESIGNATIONS

APPOINTMENTS.

His Excellency the Governor of the State of Victoria, by and with the advice of the Executive Council thereof, has, by Orders made on the 8th day of May, 1973, been pleased to make the under-mentioned appointments, viz.:

CHIEF SECRETARY'S DEPARTMENT.

Members of the Zoological Board of Victoria.

ALFRED DUNBAVIN BUTCHER, M.Sc.,
DAVID MAUGHAN CHURCHILL, M.A., Ph.D., B.Sc.,
MAURICE RESS,
KENNETH VINCENT FINLAYSON JUBB, B.V.Sc., M.S.,
Ph.D.,
LESLIE JOHN RAY, M.B., B.S., Ph.D.,
RONALD SAMUEL DABSHECK,
LEON RESS,
HAROLD EDWARD ALBISTON, C.B.E., D.V.Sc.,
CHARLES KENNETH LUCAS, and
ALAN BRYCE NELSON,

pursuant to the provisions of the *Zoological Gardens Act 1967*, to be members of the Zoological Board of Victoria, for a period of four years from the 17th May, 1973.

MINISTRY OF HEALTH.

President of the Dental Board of Victoria.

DONALD FRANCIS SPRING, L.D.S., D.D.Sc.,
to be President of the Dental Board of Victoria, pursuant to the provisions of section 4 of the *Dentists Act 1972*, for the period ending the 28th February, 1974.

Member of Victorian Nursing Council.

JOAN HEATH, Dip.N.Ed., F.C.N.A.,
to be a Member of Victorian Nursing Council, pursuant to section 4 (2) (a) (v) of the *Nurses Act 1958*, for the remainder of the term ending the 28th September, 1974, vice Miss J. Murray, resigned.

Members of Committees of Management of Hospitals.

HUBERT JOHN PRISTON ELMS
to be the Government appointee on the Committee of Management of Waranga Memorial Hospital, for a period of three years commencing the 30th May, 1973, pursuant to the provisions of sub-paragraph (ii) of paragraph (a) of the proviso to sub-section (1) of section 48 of the *Hospitals and Charities Act 1958*;

KEVIN FRANCIS RIORDAN
to be the Government appointee on the Committee of Management of Mooroopna and District Base Hospital, for a period of three years commencing the 14th May, 1973, pursuant to the provisions of sub-paragraph (ii) of paragraph (a) of the proviso to sub-section (1) of section 48 of the *Hospitals and Charities Act 1958*; and

THOMAS MICHIE
to be the Government appointee on the Committee of Management of Dimboola District Hospital, for a period of three years commencing the 30th May, 1973, pursuant to the provisions of sub-paragraph (ii) of paragraph (a) of the proviso to sub-section (2) of section 48 of the *Hospitals and Charities Act 1958*.

Trustees of Cemeteries.

JAMES NEWALL
to be a Trustee of the Grays Bridge Public Cemetery, additional trustee;

ALAN COOK
to be a Trustee of the Kiewa Public Cemetery, vice W. J. Simmonds, deceased;

EDWARD VICTOR FOREST
CHARLES ALFRED HOLLAND
GRAHAM ALFRED HOLLAND
ANDREW WALLACE MCGLAISHIN
DOUGLAS ROY PEARCE

ROY THOMAS PEARCE
 SYDNEY HERBERT PEARSON
 GRAHAM WILLIAM RASHLEIGH
 RONALD ROBERTSON
 EWAN CAMPBELL ROHAN
 REX ALBERT SLOAN
 ARTHUR CLARENCE STEWART
 BRUCE WINTON WELLS, and
 HAROLD KEITH WINGRAVE
 to be Trustees of the Lockwood Public Cemetery, additional trustees;

LESLIE CHESTER HAW
 WILLIAM MAXWELL NIEMANN
 JOHN MAXWELL LEECH, and
 DONALD ALFORD PICKLES
 to be Trustees of the Mitiamo Public Cemetery, vice K. Rudkins and J. Ryan, resigned, and additional trustees;

KEITH RHOOK
 to be a Trustee of the Digby Public Cemetery, vice A. Heeman, resigned;

DAVID ASHTON
 to be a Trustee of the Katamatite Public Cemetery, vice J. Ashton, resigned;

JACK MONK
 to be a Trustee of the Nyah Public Cemetery, additional trustee;

TIMOTHY PELLY
 to be a Trustee of the Devenish Public Cemetery, vice J. Grogan, deceased;

TERENCE JOHN MILLER
 OTTO ROBERT HEINRICH SCHILLING
 CHARLES RICHARD NUSKE
 GORDON LAWRENCE JORGENSEN, and
 GRAEME PAUL SCHWARZ
 to be Trustees of the Katyl Public Cemetery, additional trustees;

NOEL FRYE
 to be a Trustee of the Taradale Public Cemetery, vice J. Reilly, resigned; and

RONALD JAMES COOPER
 to be a Trustee of the Fawknor Crematorium & Memorial Park, vice W. Newson, deceased, pursuant to section 3 (1) of the Cemeteries Act 1958; and

THE COUNCIL OF THE MUNICIPALITY OF THE SHIRE OF
 NEWHAM & WOODEND
 to be Trustees of the Carlsruhe Public Cemetery, pursuant to section 3 (2) of the Cemeteries Act 1958.

LAW DEPARTMENT.

Commissioners for Taking Declarations, &c.

KENNETH LAWRENCE NICKELL, Victoria-road, Drouin, to be a Commissioner for taking Declarations and Affidavits, under the Evidence Act 1958, to resign upon leaving the neighbourhood of the address stated; and

ROBERT DELACY BLACKMAN, 71 Leonard-street, Bayswater,

BAYLEY GEARING BEAUMONT, 28 Johnstone-street, Malvern,

STANLEY PAUL WARREN, 25 Plato-crescent, Mulgrave,
 ALEXANDER TABINER CLANCY, 170 Blackshaws-road,
 South Kingsville, and

ALAN HAROLD MCKENZIE, 380 Reynards-street, Pascoe Vale,

to be Commissioners for taking Declarations and Affidavits, under the Evidence Act 1958.

Deputy Prothonotary.

PETER CHARLES CLOTHIER
 to be Deputy Prothonotary at Hamilton, vice D. L. Croft, on recreation leave, to take effect as from the 14th May, 1973.

SOCIAL WELFARE DEPARTMENT.

Honorary Probation Officers.

IRENE CAPEK (Mrs.), 20 Norwood-road, Caulfield,
 NOLA JEAN CONTE (Mrs.), 24 Glen Tower-drive, Glen Waverley,

VALMA MARY FLINT (Mrs.), 33 Benambra-street, West Preston,

PATRICIA MARY FRASER (Mrs.), 31 Cameron-street, Regent,

MARY GIBLIN (Mrs.), 7 Pietro-road, Heatherton,
 MARGARET JEAN HAMPPEL (Mrs.), 56 Coventry-street, Montmorcency,

JAMES WILLIAM HICKEY, Herbert-street, Robinvale,
 MOLLY JEDWAB (Mrs.), 22 Byron-street, Brighton,
 CHARLOTTE RENEE KAT (Mrs.), 24 Thorpe-avenue, Werribee,

CONSTANCE LESLEY KENDRICK (Mrs.), 27 Wimmera-street, Dimboola,

LELLA FAZZALORI (Mrs.), 6 Park-street, Altona North,
 ELLEN FRANCES LUMSDEN (Mrs.), 25 Ellerslie-grove,
 Warrmambool,

GWENDOLINE BERYL MCPHEE (Mrs.), 40 Hart-street, Niddrie,

RITA ALMA PHEFLEY (Mrs.), 50 Parker-street, Williams-town,

MARY ELLEN RAWSON (Miss), 12 Wheatland-road, Malvern, and

MOIRA HELEN WATSON (Mrs.), 56 Cole-street, Brighton, pursuant to the provisions of section 507 (2) of the Crimes Act 1958, and section 10 (1) of the Children's Court Act 1958, to be Honorary Probation Officers for all Adult and Children's Courts in Victoria.

Stipendiary Probation Officers.

ELIZABETH ANNE AEBERLI (Mrs.),

WENDY ANNE MCINTYRE (Miss),

BETTY ANNE MONTGOMERY (Miss),

MAXWELL NORMAN WRIGHT,

THOMAS RICHARD THOMPSON,

SUSAN ELIZABETH GODING (Miss),

VICTOR CHARLES COULL,

ROBYN CUNNINGHAM (Mrs.),

MARGARET HELEN HUMPHREYS (Mrs.),

LILLIAN EVELYN KELLY (Miss),

MERRILYN GOULD (Miss), and

SUSAN LETITIA JOHNSON (Miss),

pursuant to the provisions of section 9 (2) of the Children's Court Act 1958, sections 507 (1) and 533 (3) of the Crimes Act 1958, and section 165 (1) of the Social Welfare Act 1970, to be Stipendiary Probation Officers for every Children's Court, Stipendiary Probation Officers and Stipendiary Parole Officers and Stipendiary Youth Parole Officers respectively.

Chaplains of Training Centres.

JOHN CORBY (Rev.), 13 Fitzgibbon-avenue, West Brunswick,
 to be Chaplain (full-time) at Turana Youth Training Centre.

MURRAY H. JOHN (Rev.), 19 Pantonn-street, Golden Square,
 to be Chaplain (part-time) at Malmsbury Youth Training Centre.

DEPARTMENT OF THE TREASURER.

Collector of Imposts (Acting).

DONALD MALCOLM WEEKS
 to act temporarily as Collector of Imposts, Central Firearms Registry, vice J. O. Condon, on leave.

Receiver of Revenue (Acting).

PETER CHARLES CLOTHIER
 to act temporarily as Receiver of Revenue, Hamilton, vice D. L. Croft, on leave.

T. J. FORRISTAL,

Clerk of the Executive Council.

At the Executive Council Chamber,

Melbourne, 8th May, 1973.

Marine Act 1958.

APPOINTMENT OF PORT OFFICER AND DEPUTY PORT OFFICER.

His Excellency the Governor of the State of Victoria by and with the advice of the Executive Council thereof doth by Order made on the 8th day of May, 1973, revoke the Order in Council made on the 1st August, 1972, appointing ALBERT JOHN WAGGLEN as Port Officer in Victoria and DAVID PHILIP BARKLEY as Deputy Port Officer in Victoria, as on and from 8th May, 1973, and that as on and from that date DAVID PHILIP BARKLEY be appointed Port Officer in Victoria during the absence from Victoria of ALBERT JOHN WAGGLEN, and that as on and from the same date JOHN ROBERT ASHWORTH be appointed Deputy Port Officer in Victoria, pursuant to section 7, Part II. of the Marine Act 1958.

T. J. FORRISTAL,

Clerk of the Executive Council.

At the Executive Council Chamber,

Melbourne, 8th May, 1973.

Education Act 1958.

SUMMONING OFFICER.

Under section 5 of the Education Act 1958, I hereby appoint—

Senior Constable RONALD ARTHUR COX,
 to summon parents within the State of Victoria.
 9th May, 1973.

IAN SMITH,

Minister for Social Welfare.

Vermin and Noxious Weeds Act 1958.

APPOINTMENT OF INSPECTORS.

It is hereby notified that the Public Service Board, in exercise of its powers has appointed the under-mentioned persons as Inspectors under the provisions of section 4 of the *Vermin and Noxious Weeds Act 1958*, without additional salary—

BRIAN JAMES RANKIN, and
KEITH IAN WHITEMAN.

C. E. MIDDLETON,
Secretary for Lands.

Melbourne, 11th May, 1973.

Liquor Control Act 1968.

APPOINTMENT OF LICENSING INSPECTORS.

In accordance with the authority conferred upon me by sub-section (1) of section 22 of the *Liquor Control Act 1968*, I, Reginald Jackson, Chief Commissioner of Police, hereby appoint the following Officers of Police as Licensing Inspectors for the Division of the Police District as shown :—

Division Number.	Police District.	Rank and Name.
1	Flinders ..	Chief Inspector Norman William Currie (<i>vice</i> Superintendent Slater).
1	Moonee Ponds ..	Inspector Anthony William Melbourne Snell (from 19.3.73 to 16.5.73).

R. JACKSON,
Chief Commissioner of Police.

4.5.1973

REVOCATION OF APPOINTMENTS.

His Excellency the Governor of the State of Victoria, by and with the advice of the Executive Council thereof, has, by Orders made on the 8th day of May, 1973, revoked the appointments of the persons named hereunder of the offices mentioned, viz.:—

SOCIAL WELFARE DEPARTMENT.

Honorary Probation Officers.

OLIVER INGRAM COLLIS (Rev.),
WILLIAM DARRYL DEARNALEY (Rev.), and
EDMUND BARRINGTON THOMAS,
as Honorary Probation Officers, pursuant to the provisions of section 507 (2) of the *Crimes Act 1958*, and section 10 (1) of the *Children's Court Act 1958*, for all Adult and Children's Courts in Victoria.

RAYMOND HENRY DAY COLYER (Rev.), St. Phillip's Church of England, Cowes, as Honorary Probation Officer, pursuant to the provisions of section 10 (1) of the *Children's Court Act 1958*, for all Children's Courts in Victoria.

T. J. FORRISTAL,
Clerk of the Executive Council.

At the Executive Council Chamber,
Melbourne, 8th May, 1973.

RESIGNATIONS.

His Excellency the Governor of the State of Victoria, by and with the advice of the Executive Council thereof, has, by Orders made on the 8th day of May, 1973, accepted the resignations of the persons named hereunder of the offices mentioned, viz.:—

CHIEF SECRETARY'S DEPARTMENT.

Member of the Police Discipline Board.

JOHN O'CONNOR, Q.P.M., a Chief Superintendent of Police, as a member of the Police Discipline Board, pursuant to the *Police Regulation Act 1958*.

LAW DEPARTMENT.

Commissioners for Taking Declarations, &c.

JOSEPH COX,
ROBERT GORDON MILLS,
WESLEY BYRON SPENCER, and
DONALD GORDON SUTTON,
as Commissioners for taking Declarations and Affidavits, under the *Evidence Act 1958*.

Justice of the Peace.

ARTHUR ALFRED WEIR
as a Justice of the Peace for the State of Victoria.

SOCIAL WELFARE DEPARTMENT.

Honorary Probation Officers.

FRANCIS JOHN HUMPHREY, 45 Canterbury-road, Warrnambool, and
HEATHER DAWN JACKSON (Mrs.), 354 Park-street, South Melbourne,
as Honorary Probation Officers, pursuant to the provisions of section 507 (2) of the *Crimes Act 1958*, and section 10 (1) of the *Children's Court Act 1958*, for all Adult and Children's Courts in Victoria.

Probation and Parole Officers.

MICHAEL DAVIES,
RAYMOND ALFRED ALWAY,
ROSLIN CALDER EDMOND (Miss), and
FREDERICK BURDETT WALLACE,
as Probation and Parole Officers, pursuant to the provisions of sections 507 (1) and 533 (3) of the *Crimes Act 1958*, and section 9 (2) of the *Children's Court Act 1958*, and section 165 (1) of the *Social Welfare Act 1970*.

Chaplains of Training Centres.

IAN ELLIS (Rev.),
as Chaplain (full-time) at Turana Youth Training Centre; and
KEITH PURDIE (Rev.),
as Chaplain (part-time) at Malmsbury Youth Training Centre.

T. J. FORRISTAL,
Clerk of the Executive Council.

At the Executive Council Chamber,
Melbourne, 8th May, 1973.

ORDERS IN COUNCIL

VICTORIAN DEVELOPMENT CORPORATION ACT 1973.

At the Executive Council Chamber, Melbourne, the eighth day of May, 1973.

PRESENT:

His Excellency the Governor of Victoria.
Sir George Reid | Mr. Borthwick.

APPOINTMENT OF MEMBERS AND CHAIRMAN OF THE VICTORIAN DEVELOPMENT CORPORATION.

In pursuance of the provisions of section 5 (1), (2) and (3) of the *Victorian Development Corporation Act 1973*, His Excellency the Governor of Victoria, by and with the advice of the Executive Council thereof, doth by this Order:—

- (a) Appoint IAN KENNETH MORTON, being a person experienced in banking finance and holding appropriate qualifications, to be a member of the Victorian Development Corporation for the period of five years commencing 8th May, 1973.
- (b) Appoint JOHN ALFRED NORTH, E.D., M.B.E., being a person with special knowledge of Tourism, to be a member of the Victorian Development Corporation for the period of three years commencing 8th May, 1973.
- (c) Appoint DONALD NEIL SYMONS, and GEOFFREY HAROLD ROBERTSON, to be members of the Victorian Development Corporation for the period of three years commencing 8th May, 1973.
- (d) Appoint FREDERICK GODFREY JAMES, to be a member of the Victorian Development Corporation for a period of two years commencing 8th May, 1973.
- (e) Appoint IAN KENNETH MORTON, to be Chairman of the said Corporation.

And the Honorable Murray Lewis Byrne, Her Majesty's Minister for State Development and Decentralization for the State of Victoria, shall give the necessary directions herein accordingly.

T. J. FORRISTAL,
Clerk of the Executive Council.

VICTORIAN DEVELOPMENT CORPORATION ACT 1973.

At the Executive Council Chamber, Melbourne, the eighth day of May, 1973.

PRESENT:

His Excellency the Governor of Victoria. Sir George Reid | Mr. Borthwick.

In accordance with the provisions of sub-section 5 (1) and (2) of the Victorian Development Corporation Act 1973, His Excellency the Governor of the State of Victoria by and with the advice of the Executive Council thereof, doth by this Order appoint:—

IAN KENNETH MORTON, a member and Chairman of the Victorian Development Corporation for a period of five years and doth hereby direct that this Order shall be construed as the consent of the Governor in Council within the meaning of sub-section (3) of section 5 of the Rural Finance and Settlement Commission Act 1961, No. 6846.

And the Honorable Murray Lewis Byrne, Her Majesty's Minister for State Development and Decentralization for the State of Victoria, shall give the necessary directions herein accordingly.

T. J. FORRISTAL, Clerk of the Executive Council.

PATRIOTIC FUNDS ACT 1958.

At the Executive Council Chamber, Melbourne, the eighth day of May, 1973.

PRESENT:

His Excellency the Governor of Victoria. Sir George Reid | Mr. Borthwick.

In pursuance of the provisions of the Patriotic Funds Act 1958 (No. 6331), His Excellency the Governor of Victoria, by and with the advice of the Executive Council thereof, doth by this Order appoint LESLIE ALBERT HYAMS, SYDNEY MERVYN STEVENS, COLONEL EDNA NELL DOIG and GEORGE PEARCE MACKENZIE, to be members of the Patriotic Funds Council of Victoria from the date of commencement of duty until and including the 21st day of December, 1973.

And the Honorable Sir George Oswald Reid, Her Majesty's Attorney-General for the State of Victoria, shall give the necessary directions herein accordingly.

T. J. FORRISTAL, Clerk of the Executive Council.

COUNTRY ROADS BOARD.

At the Executive Council Chamber, Melbourne, the eighth day of May, 1973.

PRESENT:

His Excellency the Governor of Victoria. Sir George Reid | Mr. Borthwick.

ORDER APPROVING OF LAND BEING ACQUIRED AND ROADS, DEVIATIONS OR WIDENINGS BEING MADE.

His Excellency the Governor of the State of Victoria, by and with the advice of the Executive Council thereof, being satisfied that there are funds legally available for acquiring the land, doth hereby approve the acquiring of the land described in the schedule hereunder and the making of new roads and deviations from and widenings of existing roads referred to in the said schedule.

SCHEDULE.

State Highways.

The land shown hatched on plans numbered G.P.13105B, G.P.13106B, G.P.13106C, G.P.13106D and G.P.13106E hereunder required for the widening of the Bass Highway in the Shire of Bass and making of the widening thereon.

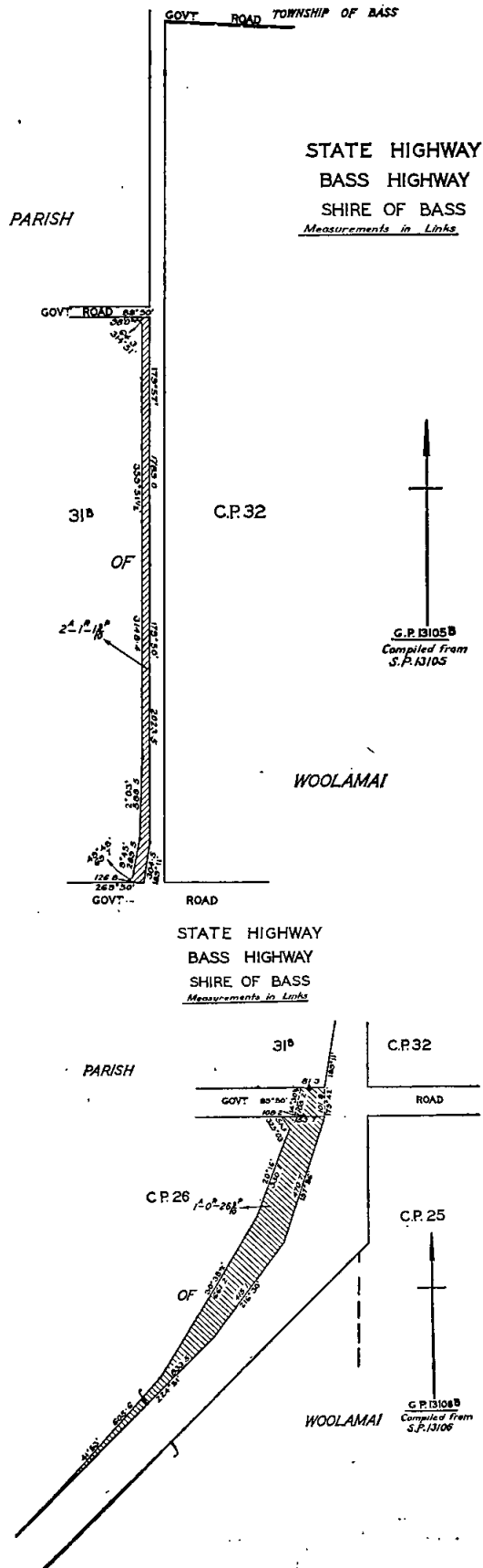

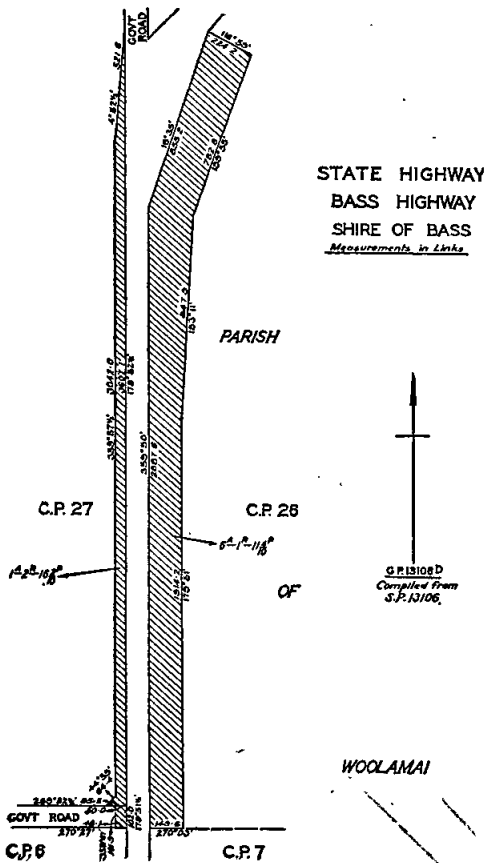
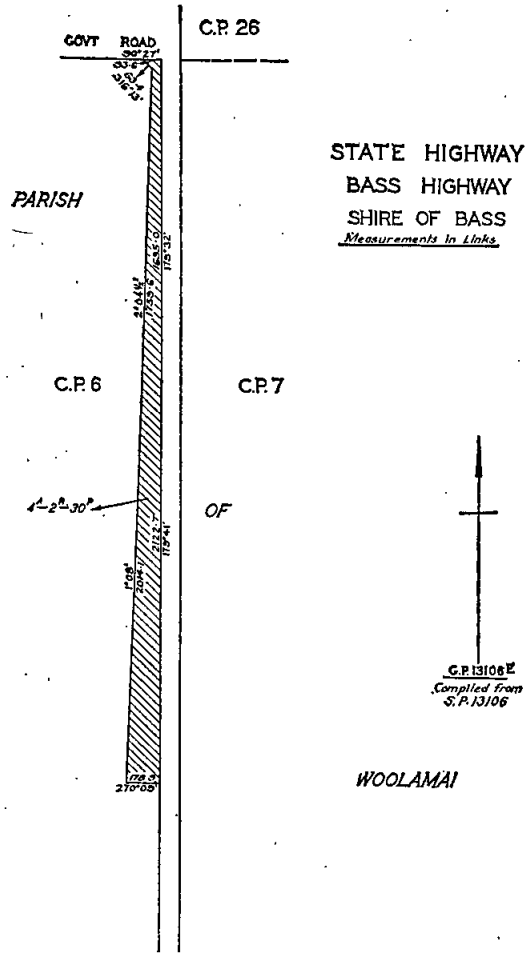
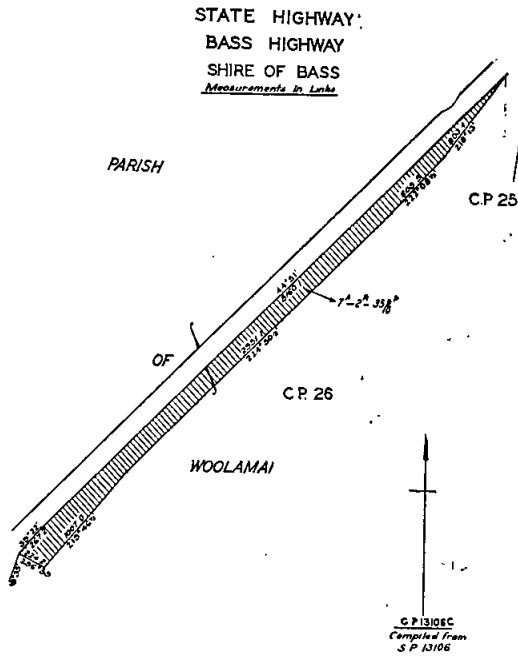

The land shown hatched on plan numbered G.P.13012 hereunder required for the deviation from the Murray Valley Highway in the Shire of Kerang and making of the deviation thereon.

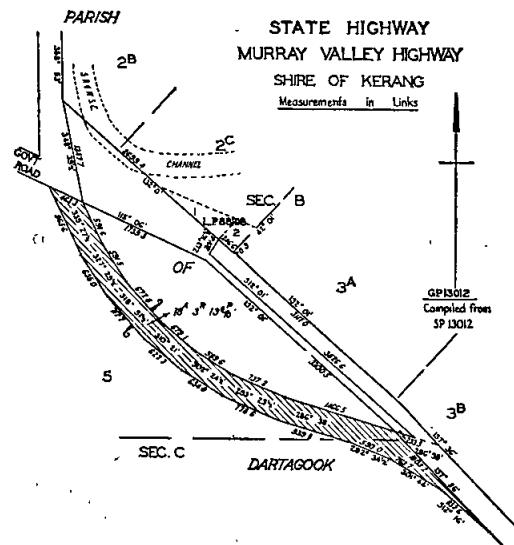

Main Roads.

The land shown hatched on plan numbered G.P.13220 hereunder required for the widening of the Hallam-Emerald road in the Shire of Berwick and making of the widening thereon.

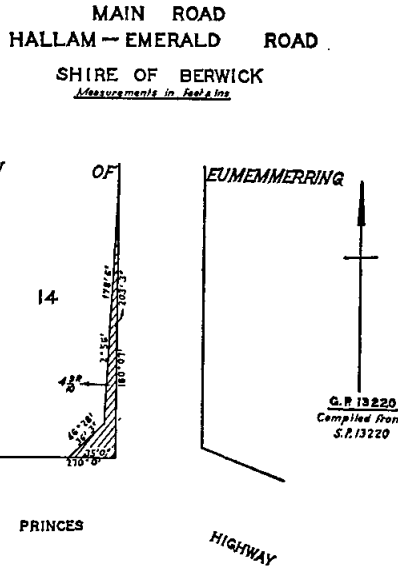

The land shown hatched on plans numbered G.P.13208A and G.P.13208B hereunder required for the deviation from Tarwin Lower-road in the Shire of Woorayl and making of the deviation thereon.

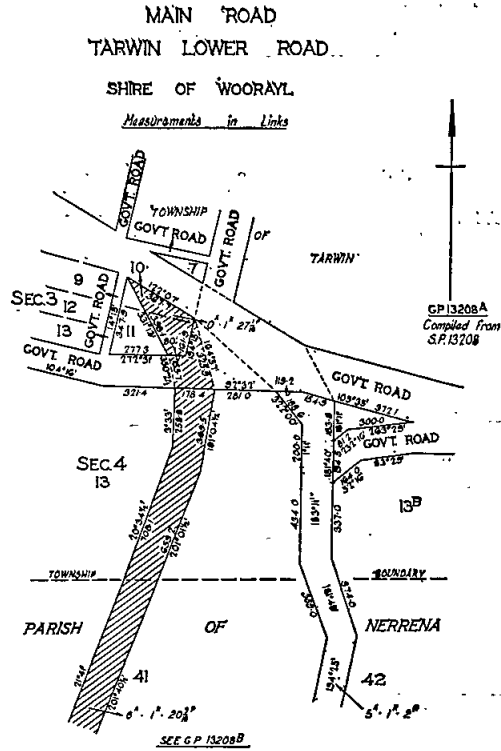

The land shown hatched on plan numbered G.P.13124 hereunder required for the deviation from Beach-road in the City of Port Melbourne and making of the deviation thereon.

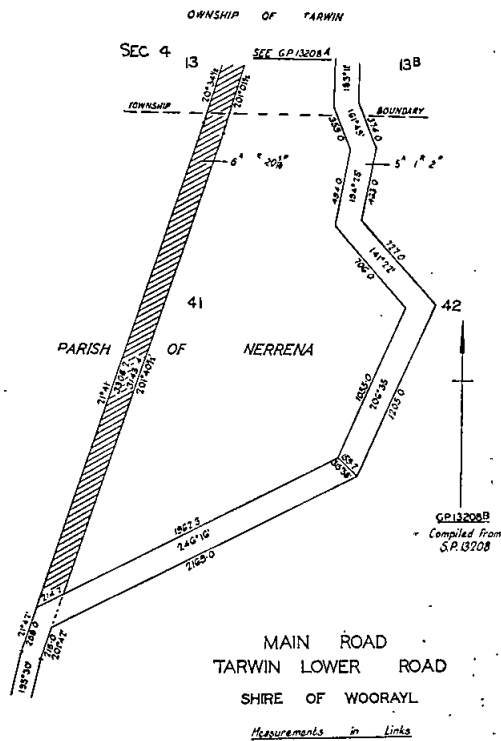
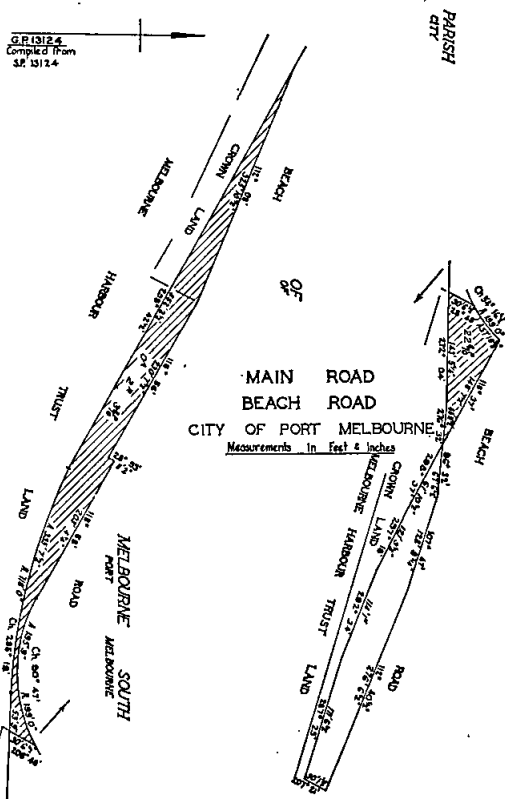

Freeway.

The land shown hatched on plan numbered G.P.13299 hereunder required for the making of a new freeway (Mornington Peninsula Freeway) in the Shire of Flinders.

**FREWAY
MORNINGTON PENINSULA FREWAY
SHIRE OF FLINDERS
Measurements in feet & inches**

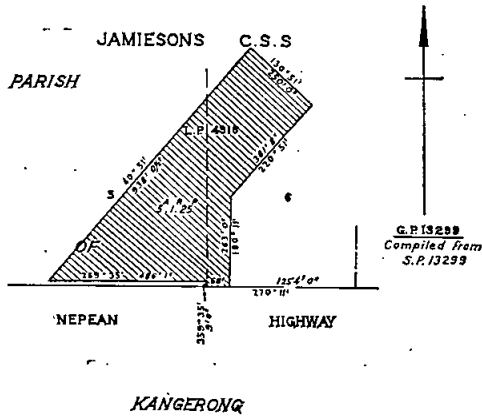

Medical Consulting Rooms Block at the Koroit and District Memorial Hospital, as Lessor, to Doctor Ramon Henry James Laurence, as Lessee, for a period of three years from the 1st July, 1973.

And the Honorable John Frederick Rossiter, Her Majesty's Minister of Health for the State of Victoria, shall give the necessary directions herein accordingly.

T. J. FORRISTAL,
Clerk of the Executive Council.

DEPARTMENT OF CROWN LANDS AND SURVEY.

At the Executive Council Chamber, Melbourne, the eighth day of May, 1973.

PRESENT:

His Excellency the Governor of Victoria.
Sir George Reid | Mr. Borthwick.

LANDS TEMPORARILY RESERVED AS SITES.

His Excellency the Governor of the State of Victoria, by and with the advice of the Executive Council thereof, doth hereby, in pursuance of section 14 of the Land Act 1958, reserve temporarily from sale, from being leased and from having a licence granted in respect thereof, and also except from occupation for mining purposes under any miner's right, the land hereinafter described:—

LETHBRIDGE.—Site for Recreation, Convenience and Amusement of the People, 12 acres 3 roods 30 perches, more or less, Township of Lethbridge, Parish of Wabdallah, County of Grant as indicated by hatching on plan hereunder.—(L.50⁽¹⁾) (Rs.9737).

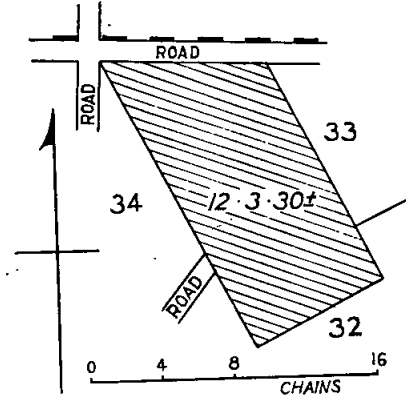

BALMORAL.—Site for Public purposes (Departmental Residence), 36 perches, Township of Balmoral, Parish of Balmoral, County of Dundas, as indicated by hatching on plan hereunder.—(B.43⁽⁵⁾) (Rs.9693).

And the Honorable Alan John Hunt, Her Majesty's Minister for Local Government for the State of Victoria, shall give the necessary directions herein accordingly.

T. J. FORRISTAL,
Clerk of the Executive Council.

DENTAL TECHNICIANS ACT 1972.

At the Executive Council Chamber, Melbourne, the eighth day of May, 1973.

PRESENT:

His Excellency the Governor of Victoria.
Sir George Reid | Mr. Borthwick.

Pursuant to the provisions of section 3 of the Dental Technicians Act 1972, His Excellency the Governor of the State of Victoria by and with the advice of the Executive Council of the said State, hereby appoints the following persons as members of the Dental Technicians Licensing Committee:—

- RICHARD DESMOND KENNEDY, J.P., who shall be Chairman
- JOHN MCFARLANE WARK, L.D.S., B.D.Sc., D.D.Sc.
- DOUGLAS CHARLES LOADER, L.D.S., B.D.Sc.
- JOHN ANTHONY O'NEILL
- MARK LEWIS
- RAYMOND JOHN WOODHARD
- ALLAN DAY PEAD, and
- DEREK MADEN.

And the Honorable John Frederick Rossiter, Her Majesty's Minister of Health for the State of Victoria, shall give the necessary directions herein accordingly.

T. J. FORRISTAL,
Clerk of the Executive Council.

HOSPITALS AND CHARITIES ACT 1958, SECTION 66.

At the Executive Council Chamber, Melbourne, the eighth day of May, 1973.

PRESENT:

His Excellency the Governor of Victoria.
Sir George Reid | Mr. Borthwick.

Pursuant to the provisions of section 66 of the Hospitals and Charities Act 1958 (No. 6274), His Excellency the Governor of the State of Victoria by and with the advice of the Executive Council of the said State, doth hereby approve of the granting of a lease of the whole of the

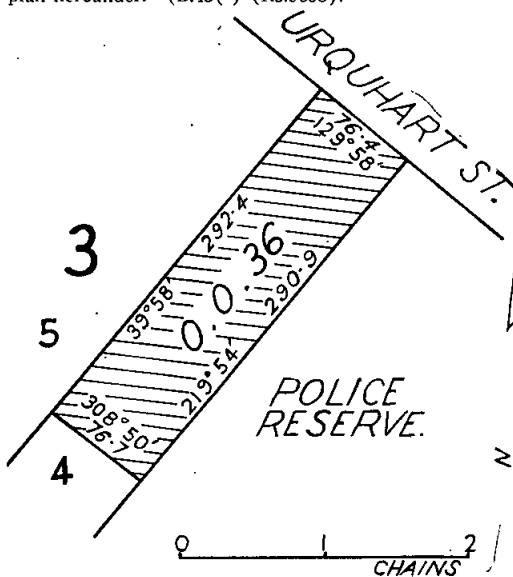

MACARTHUR.—Site for Public purposes (Infant Welfare and Pre-School Centre), 13 perches, Township of Macarthur, Parish of Macarthur, County of Normanby, as indicated by hatching on plan hereunder.—(M.88^(c)) (Rs.6720).

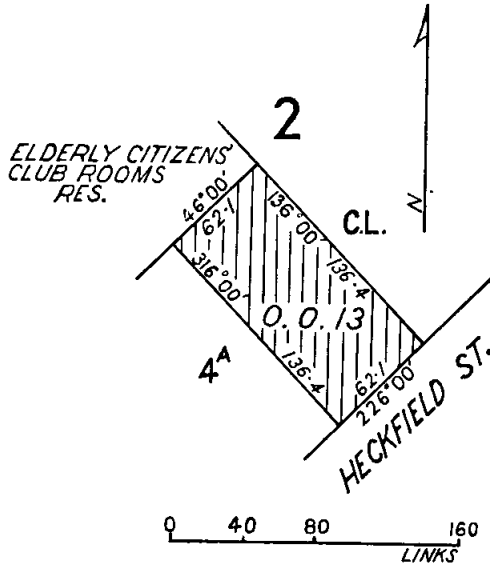

SANDHURST.—Site for Public purposes (Departmental Residence), 28 perches, Parish of Sandhurst, County of Bendigo, as indicated by hatching on plan hereunder.—(S.371^(1b)) (Rs.9738).

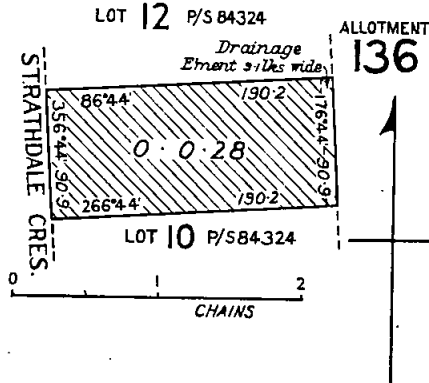

And the Honorable William Archibald Borthwick, Her Majesty's Minister of Lands for the State of Victoria, shall give the necessary directions herein accordingly.

T. J. FORRISTAL,
Clerk of the Executive Council.

Land Act 1958.
DEPARTMENT OF CROWN LANDS AND SURVEY.

At the Executive Council Chamber, Melbourne, the eighth day of May, 1973.

PRESENT:
His Excellency the Governor of Victoria.
Sir George Reid | Mr. Borthwick.

REVOCATION OF TEMPORARY RESERVATIONS OF LANDS BY ORDERS IN COUNCIL.

His Excellency the Governor of the State of Victoria, by and with the advice of the Executive Council thereof, doth hereby, in pursuance of the provisions of the Land Act 1958, revoke the temporary reservations of lands by Orders in Council hereinafter referred to, viz.:

NEWBURY (GARLICKS LEAD).—The temporary reservation by Order in Council of the 10th March, 1873, of 1

acre of land in the Parish of Trentham (now in the Township of Newbury, Parish of Trentham), as a site for State School purposes.—(N.189⁽¹⁾) (C.70195).

NEWBURY (GARLICKS LEAD).—The temporary reservation by Order in Council of the 1st December, 1908, of 1 rood 32 3/10 perches of land in the Township of Garlicks (now Township of Newbury), as a site for a State School.—(N.189⁽¹⁾) (C.70195).

And the Honorable William Archibald Borthwick, Her Majesty's Minister of Lands for the State of Victoria, shall give the necessary directions herein accordingly.

T. J. FORRISTAL,
Clerk of the Executive Council.

POLICE REGULATION ACT 1958.

At the Executive Council Chamber, Melbourne, the eighth day of May, 1973.

PRESENT:
His Excellency the Governor of Victoria.
Sir George Reid | Mr. Borthwick.

APPOINTMENT OF A MEMBER OF THE POLICE DISCIPLINE BOARD.

His Excellency the Governor of the State of Victoria, in the Commonwealth of Australia, by and with the advice of the Executive Council of the said State and in pursuance of the powers conferred by the Police Regulation Act 1958, and the Regulation made thereunder doth by this Order appoint:—

HARRY FORD, Q.P.M.,
a Chief Superintendent of Police, nominated by the Chief Commissioner of Police, to be a member of the Police Discipline Board for the period ending 30th April, 1975.

And the Honorable Edward Raymond Meagher, Her Majesty's Chief Secretary for the State of Victoria, shall give the necessary directions herein accordingly.

T. J. FORRISTAL,
Clerk of the Executive Council.

LABOUR AND INDUSTRY ACT 1958.

At the Executive Council Chamber, Melbourne, the eighth day of May, 1973.

PRESENT:
His Excellency the Governor of Victoria.
Sir George Reid | Mr. Borthwick.

EXTENSION OF THE POWERS OF THE HOSPITAL MEDICAL ANCILLARY SERVICES BOARD.

In pursuance of the powers conferred by section 20 of the Labour and Industry Act 1958, and all other powers him thereunto enabling, His Excellency the Governor of the State of Victoria, by and with the advice of the Executive Council thereof, doth hereby extend the powers of the Hospital Medical Ancillary Services Board so that in substitution for the powers heretofore conferred upon the said Hospital Medical Ancillary Services Board it shall have the power to determine any industrial matter in relation to the occupations of medical laboratory technician or technologist, physiotherapist, dietitian, radiographer, radiotherapy technician, hospital librarian, occupational therapist, orthoptist, speech therapist, medical photographer, medical illustrator and chiropodist (including trainees in any of these occupations) in or in connexion with any hospital or benevolent home registered pursuant to the Hospitals and Charities Act 1958, or the Cancer Institute constituted under the Cancer Act 1958.

And the Honorable Joseph Anstice Rafferty, Her Majesty's Minister of Labour and Industry for the State of Victoria, shall give the necessary directions herein accordingly.

T. J. FORRISTAL,
Clerk of the Executive Council.

Water Act 1958.

STATE RIVERS AND WATER SUPPLY COMMISSION.

At the Executive Council Chamber, Melbourne, the
fifteenth day of May, 1973.

PRESENT:

His Excellency the Governor of Victoria.
Mr. Meagher | Mr. Hunt.

WEST LODDON WATERWORKS DISTRICT.—PORTION
EXCISED.

Under the powers conferred by the Water Act 1958 and all other powers enabling him in that behalf His Excellency the Governor of the State of Victoria, with the advice of the Executive Council of the said State, on the recommendation of the State Rivers and Water Supply Commission, doth hereby declare, order and direct that there shall be excised from the West Loddon Waterworks District that portion of the same shown by green colour on a plan approved by the Governor in Council and deposited in the office of the State Rivers and Water Supply Commission, Melbourne (Corr. No. 69/59) and as on and from the 30th day of June, 1973, such portion shall be deemed to be excised accordingly.

And the Honorable Roberts Christian Dunstan, Her Majesty's Minister of Water Supply for the State of Victoria, shall give the necessary directions herein accordingly.

T. J. FORRISTAL,
Clerk of the Executive Council.

Water Act 1958.

STATE RIVERS AND WATER SUPPLY COMMISSION.

At the Executive Council Chamber, Melbourne, the
fifteenth day of May, 1973.

PRESENT:

His Excellency the Governor of Victoria.
Mr. Meagher | Mr. Hunt.

BAXTER-PEARCEDALE, BERWICK, BUNYIP, CENTRE-
VILLE-SOUTH LYNDHURST, CRANBOURNE, DEVON
MEADOWS-TOORADIN, DROMANA-PORTSEA,
FRANKSTON-MORNINGTON, GARFIELD, LONG-
WARRY, NARRE WARREN, PAKENHAM AND
WESTERNPORT URBAN DISTRICTS UNITED TO
FORM MORNINGTON PENINSULA URBAN DISTRICT.

Under the powers conferred by the Water Act 1958 and all other powers enabling him in that behalf, His Excellency the Governor of the State of Victoria, with the advice of the Executive Council of the said State, on the recommendation of the State Rivers and Water Supply Commission, doth hereby declare, order, and direct as follows:—

1. That as on and from 1st July, 1973, the Baxter-Pearcedale, Berwick, Bunyip, Centreville-South Lyndhurst, Cranbourne, Devon Meadows-Tooradin, Dromana-Portsea, Frankston-Mornington, Garfield, Longwarry, Narre Warren, Pakenham and Westernport Urban Districts be united so as to form one District to be known as the Mornington Peninsula Urban District.

2. The said Mornington Peninsula Urban District so formed shall comprise the lands which were within the boundaries of the aforesaid Baxter-Pearcedale, Berwick, Bunyip, Centreville-South Lyndhurst, Cranbourne, Devon Meadows-Tooradin, Dromana-Portsea, Frankston-Mornington, Garfield, Longwarry, Narre Warren, Pakenham and Westernport Urban Districts on 1st July, 1973.

3. That all property, income, assets, rights and liabilities standing in the name of the said Baxter-Pearcedale, Berwick, Bunyip, Centreville-South Lyndhurst, Cranbourne, Devon Meadows-Tooradin, Dromana-Portsea, Frankston-Mornington, Garfield, Longwarry, Narre Warren, Pakenham and Westernport Urban Districts shall upon the union of those districts as hereinbefore provided stand in the name of the Mornington Peninsula Urban District so formed.—(Corr. No. 73/273).

And the Honorable Roberts Christian Dunstan, Her Majesty's Minister of Water Supply for the State of Victoria, shall give the necessary directions herein accordingly.

T. J. FORRISTAL,
Clerk of the Executive Council.

Water Act 1958.

STATE RIVERS AND WATER SUPPLY COMMISSION.

At the Executive Council Chamber, Melbourne, the
fifteenth day of May, 1973.

PRESENT:

His Excellency the Governor of Victoria.
Mr. Meagher | Mr. Hunt.

GOULBURN-MURRAY IRRIGATION DISTRICT—DIS-
TRICT EXTENDED.—BOORT IRRIGATION AREA—
BOUNDARIES VARIED.

Under the powers conferred by the Water Act 1958 and all other powers enabling him in that behalf, His Excellency the Governor of the State of Victoria, with the advice of the Executive Council of the said State, on the recommendation of the State Rivers and Water Supply Commission, doth hereby declare, order and direct that the Goulburn-Murray Irrigation District be extended and the boundaries of the Boort Irrigation Area be varied by adding to the said District and Area the lands shown by blue colour on a plan approved by the Governor in Council and deposited in the office of the State Rivers and Water Supply Commission, Melbourne (Corr. No. 69/59) and as on and from the 1st day of July, 1973, such District shall be deemed to be so extended and the boundaries of such Area shall be so varied.

And the Honorable Roberts Christian Dunstan, Her Majesty's Minister of Water Supply for the State of Victoria, shall give the necessary directions herein accordingly.

T. J. FORRISTAL,
Clerk of the Executive Council.

Water Act 1958.

STATE RIVERS AND WATER SUPPLY COMMISSION.

At the Executive Council Chamber, Melbourne, the
fifteenth day of May, 1973.

PRESENT:

His Excellency the Governor of Victoria.
Mr. Meagher | Mr. Hunt.

GOULBURN-MURRAY IRRIGATION DISTRICT—DIS-
TRICT EXTENDED.—KERANG IRRIGATION AREA—
BOUNDARIES VARIED.

Under the powers conferred by the Water Act 1958 and all other powers enabling him in that behalf, His Excellency the Governor of the State of Victoria, with the advice of the Executive Council of the said State, on the recommendation of the State Rivers and Water Supply Commission, doth hereby declare, order and direct that the Goulburn-Murray Irrigation District be extended and the boundaries of the Kerang Irrigation Area be varied by adding to the said District and Area the lands shown by blue colour on a plan approved by the Governor in Council and deposited in the office of the State Rivers and Water Supply Commission, Melbourne (Corr. No. 69/2546) and as on and from the 1st day of July, 1973, such District shall be deemed to be so extended and the boundaries of such area shall be so varied.

And the Honorable Roberts Christian Dunstan, Her Majesty's Minister of Water Supply for the State of Victoria, shall give the necessary directions herein accordingly.

T. J. FORRISTAL,
Clerk of the Executive Council.

SEWERAGE DISTRICTS ACT 1958.

At the Executive Council Chamber, Melbourne, the
fifteenth day of May, 1973.

PRESENT:

His Excellency the Governor of Victoria.
Mr. Meagher | Mr. Hunt.

INVERLOCH SEWERAGE AUTHORITY CONSTITUTED.
—INVERLOCH SEWERAGE DISTRICT PROCLAIMED.

His Excellency the Governor of the State of Victoria, by and with the advice of the Executive Council thereof, doth hereby approve, in accordance with the provisions

of the Sewerage Districts Act, the construction of works for the sewerage of Inverloch, as set out in the description and general plan accompanying the Application of the Woorayl Shire Council for the proclamation of a Sewerage District and the constitution of a Sewerage Authority to construct, manage and maintain the said works in accordance with the provisions of the said Act and doth hereby order and appoint as follows:—

(1) That a Sewerage Authority is hereby constituted and its corporate name shall be the Inverloch Sewerage Authority.

(2) That the Members of the said Sewerage Authority shall comprise all the Commissioners for the time being of the Inverloch Waterworks Trust.

(3) That the lands within the boundary shown in red colour on the plan accompanying this Order are hereby proclaimed to be the Sewerage District (to be known as the Inverloch Sewerage District) of the said Sewerage Authority; such District being wholly within the Shire of Woorayl.

(4) That the principal works to be constructed or carried out by the said Sewerage Authority shall consist of reticulation sewers, main sewers, pumping stations, rising mains, treatment works and ocean outfall main.

(5) That the estimated cost of carrying out the proposed work is Five hundred and eighty-seven thousand seven hundred and fifty dollars (\$587,750).

(6) That the sites of the rising main, treatment works and ocean outfall main are as shown in orange colour, brown colour and green colour respectively on the plan accompanying this Order; such sites being wholly within the Shire of Woorayl.

(7) That the lands to be acquired by the Sewerage Authority outside the Sewerage District for the treatment works are as shown in brown colour on the plan accompanying this Order.

The location of the said rising main, treatment works, ocean outfall main and the boundaries of the said Sewerage District are shown on the plan approved by the Governor in Council by and with this Order and deposited in the office of the State Rivers and Water Supply Commission, Melbourne (64/967/25).

And the Honorable Roberts Christian Dunstan, Her Majesty's Minister of Water Supply for the State of Victoria, shall give the necessary directions herein accordingly.

T. J. FORRISTAL,
Clerk of the Executive Council.

APOLLO BAY SEWERAGE AUTHORITY.

*At the Executive Council Chamber, Melbourne, the
fifteenth day of May, 1973.*

PRESENT:

His Excellency the Governor of Victoria.
Mr. Meagher | Mr. Hunt.

EXTENT OF SEWERAGE DISTRICT INCREASED.

Under the powers conferred by the Sewerage Districts Act and all other powers enabling him in that behalf, His Excellency the Governor of the State of Victoria, by and with the advice of the Executive Council of the said State, doth hereby declare, order and direct that the extent of the Sewerage District of the Apollo Bay Sewerage Authority be increased by adding thereto lands as shown on the plan approved by the Governor in Council, by and with this Order and deposited in the office of the State Rivers and Water Supply Commission, Melbourne (Corr. No. 60/1216), and as on and from the date hereof the extent of such District shall be and be deemed to be increased accordingly.

And the Honorable Roberts Christian Dunstan, Her Majesty's Minister of Water Supply for the State of Victoria, shall give the necessary directions herein accordingly.

T. J. FORRISTAL,
Clerk of the Executive Council.

DROMANA-ROSEBUD SEWERAGE AUTHORITY.

*At the Executive Council Chamber, Melbourne, the
fifteenth day of May, 1973.*

PRESENT:

His Excellency the Governor of Victoria.
Mr. Meagher | Mr. Hunt.

CONSENT TO BORROWING \$150,000.

Under the powers conferred by the Sewerage Districts Act and all other powers enabling him in that behalf, His Excellency the Governor of the State of Victoria, by and with the advice of the Executive Council of the said State, hereby consents to the Dromana-Rosebud Sewerage Authority borrowing a sum of One hundred and fifty thousand dollars (\$150,000), to meet the cost of sewerage works as set forth in the detailed statement bearing date 10th May, 1973.

And the Honorable Roberts Christian Dunstan, Her Majesty's Minister of Water Supply for the State of Victoria, shall give the necessary directions herein accordingly.

T. J. FORRISTAL,
Clerk of the Executive Council.

MERBEIN SEWERAGE AUTHORITY.

*At the Executive Council Chamber, Melbourne, the
fifteenth day of May, 1973.*

PRESENT:

His Excellency the Governor of Victoria.
Mr. Meagher | Mr. Hunt.

CONSENT TO BORROWING \$100,000.

Under the powers conferred by the Sewerage Districts Act and all other powers enabling him in that behalf, His Excellency the Governor of the State of Victoria, by and with the advice of the Executive Council of the said State, hereby consents to the Merbein Sewerage Authority borrowing the sum of One hundred thousand dollars (\$100,000), to meet the cost of sewerage works as set forth in the detailed statement bearing date 15th March, 1973.

And the Honorable Roberts Christian Dunstan, Her Majesty's Minister of Water Supply for the State of Victoria, shall give the necessary directions herein accordingly.

T. J. FORRISTAL,
Clerk of the Executive Council.

GEELONG WATERWORKS AND SEWERAGE TRUST.

*At the Executive Council Chamber, Melbourne, the
fifteenth day of May, 1973.*

PRESENT:

His Excellency the Governor of Victoria.
Mr. Meagher | Mr. Hunt.

APPROVAL OF PLAN SHOWING SITE OF SERVICE BASIN.

Under the powers conferred by the Geelong Waterworks and Sewerage Act and all other powers enabling him in that behalf, His Excellency the Governor of the State of Victoria, by and with the advice of the Executive Council of the said State, doth hereby approve a plan showing the site of a service basin to be constructed by the Geelong Waterworks and Sewerage Trust, the said plan being deposited in the office of the State Rivers and Water Supply Commission, Melbourne.—(Corr. No. 72/3485/33).

And the Honorable Roberts Christian Dunstan, Her Majesty's Minister of Water Supply for the State of Victoria, shall give the necessary directions herein accordingly.

T. J. FORRISTAL,
Clerk of the Executive Council.

GEELONG WATERWORKS AND SEWERAGE TRUST.

At the Executive Council Chamber, Melbourne, the fifteenth day of May, 1973.

PRESENT:

His Excellency the Governor of Victoria.
Mr. Meagher | Mr. Hunt.

APPROVAL OF PLAN SHOWING SITE OF PIPELINE.

Under the powers conferred by the Geelong Waterworks and Sewerage Act and all other powers enabling him in that behalf, His Excellency the Governor of the State of Victoria, by and with the advice of the Executive Council of the said State, doth hereby approve a plan showing the site of a pipeline to be constructed by the Geelong Waterworks and Sewerage Trust, the said plan being deposited in the office of the State Rivers and Water Supply Commission, Melbourne.—(Corr. No. 67/2192/18).

And the Honorable Roberts Christian Dunstan, Her Majesty's Minister of Water Supply for the State of Victoria, shall give the necessary directions herein accordingly.

T. J. FORRISTAL,
Clerk of the Executive Council.

VICTORIAN INLAND MEAT AUTHORITY ACT 1958.

At the Executive Council Chamber, Melbourne, the fifteenth day of May, 1973.

PRESENT:

His Excellency the Governor of Victoria.
Mr. Meagher | Mr. Hunt.

APPOINTMENT OF A MEMBER OF THE VICTORIAN INLAND MEAT AUTHORITY.

In pursuance of the powers in that behalf conferred by the Victorian Inland Meat Authority Act 1958 and all other powers him thereunto enabling, His Excellency the Governor of the State of Victoria, by and with the advice of the Executive Council thereof, doth by this Order hereby appoint Robert John Scott to be a member of the Victorian Inland Meat Authority for the period ending on the 23rd April, 1976.

And the Honorable Sir Gilbert Lawrence Chandler, Her Majesty's Minister of Agriculture for the State of Victoria, shall give the necessary directions herein accordingly.

T. J. FORRISTAL,
Clerk of the Executive Council.

LANDS DEPARTMENT NOTICES

APPROACHING LAND SALES.

Sale of Crown Land, in fee-simple, will be held at the under-mentioned places and dates, viz.:—

	No. of Gazette.
Derrinallum.—Wednesday, 20th June, 1973 ..	33

PROPOSED REVOCATIONS OF TEMPORARY RESERVATIONS OF LANDS BY ORDERS IN COUNCIL.

In pursuance of the provisions of the Land Act 1958, notice is hereby given that it is the intention of the Governor in Council to revoke the temporary reservations of lands by Orders in Council hereunder referred to, viz.:—

The following Notices were published 1° on the 2nd May, 1973, pursuant to Orders of the 18th April, 1973.

WYCHEPROOF.—The temporary reservation by Order in Council of the 12th October, 1915, of 3 roods 7 perches of land in the Township of Wycheproof as a site for Police purposes is about to be revoked.—(W.287(?) (Rs.1557).

SANDHURST (BENDIGO).—The temporary reservation as a site for Water Channel and the withholding from sale, leasing and licensing by Order in Council of the 1st October, 1877, of 1 rood 14 4/10 perches of land in the City of Sandhurst (now at Bendigo, Parish of Sandhurst),

revoked as to part by various orders, are about to be revoked so far only as the portion containing 6 perches, indicated by hatching on plan hereunder, is concerned.—(S.372(118) (C.96931).

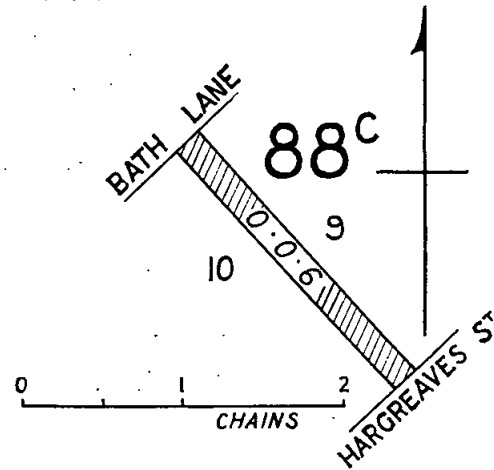

W. BORTHWICK,
Minister of Lands.

PROPOSED REVOCATIONS OF TEMPORARY RESERVATIONS OF LANDS BY ORDERS IN COUNCIL.

In pursuance of the provisions of the Land Act 1958, notice is hereby given that it is the intention of the Governor in Council to revoke the temporary reservations of lands by Orders in Council hereunder referred to, viz.:—

The following Notices were published 1° on the 16th May, 1973, pursuant to Orders of the 8th May, 1973.

WILLIAMSTOWN.—The temporary reservation by Order in Council of the 30th January, 1924, of 8 acres 1 rood 3 perches of land in the Township of Williamstown (named City of Williamstown in Order), as a site for Cricket and Public Recreation, is about to be revoked.—(W.163(5) (Rs.2075).

BURRAMBOOT.—The temporary reservation by Order in Council of the 10th June, 1969, of 1 acre 1 rood 10 perches, more or less, of land in the Parish of Burramboot, as a site for Public purposes (Trigonometrical Survey Station), is about to be revoked, so far only as the portion containing 2 roods 20 perches, more or less, indicated by hatching on plan hereunder is concerned.—(B.545(6) (Rs.9161).

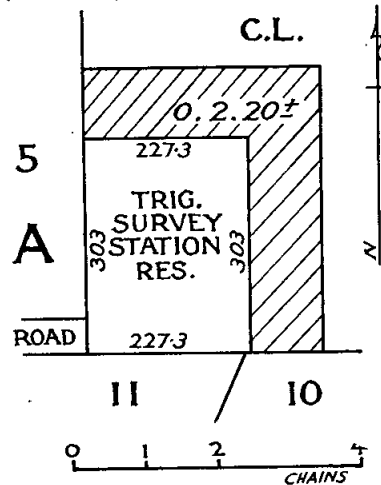

HEATHCOTE.—The temporary reservation as a site for Watering purposes and the withholding from sale, leasing and licensing by Order in Council of the 4th June, 1877 (see Government Gazette 1877, page 1097), of 7 acres 2 roods 11 perches of land in the Township of Heathcote (called Municipal district of Heathcote in Order), are

about to be revoked so far only as the portion containing 1 acre 15 perches, more or less, indicated by hatching on plan hereunder, is concerned.—(H.74(7) (Rs.5316).

therefrom of 14 acres, more or less, in the Township of Caramut, as indicated by hatching on plan hereunder.—(Rs.417.)

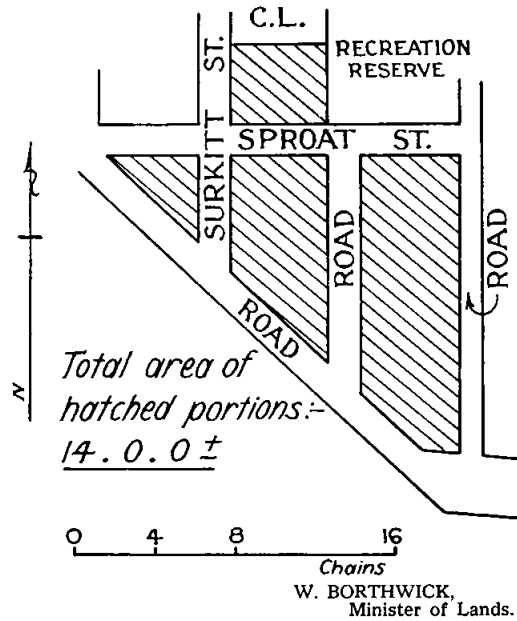
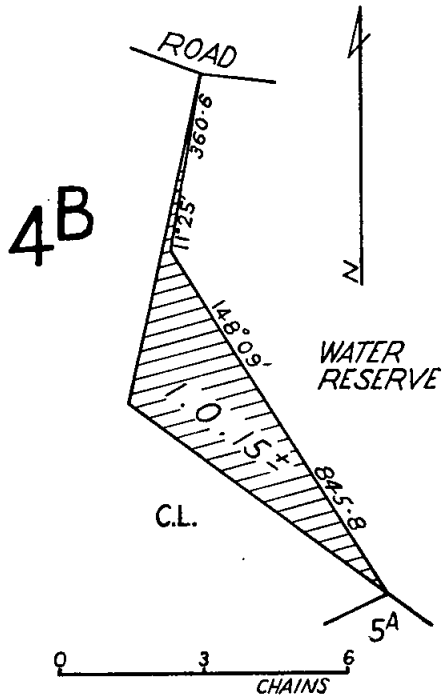

WILLIAMSTOWN.—The temporary reservation as a site for Public Park, and the withholding from sale, leasing and licensing by Order in Council of the 6th October, 1884, of 20 acres, more or less, of land in the Township of Williamstown (named Municipal district of Williamstown in Order), revoked as to part by various orders, are about to be revoked so far only as the portion containing 8 perches, more or less, indicated by hatching on plan hereunder, is concerned.—(W.163(6) (Rs.1381).

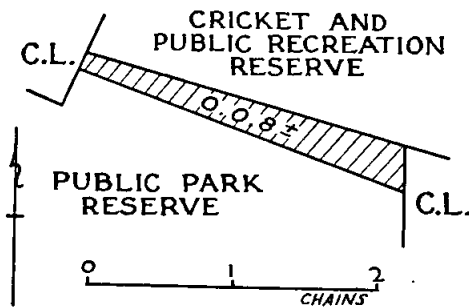

W. BORTHWICK,
Minister of Lands.

COMMON ABOUT TO BE DIMINISHED.

In pursuance of the provisions contained in the Land Act 1958, notice is hereby given that it is the intention of the Governor in Council to diminish the common herein-after mentioned, viz.:—

The following Notice was published 1^o on the 2nd May, 1973, pursuant to Order of the 18th April, 1973.

The Caramut Town Common, proclaimed as such by Proclamations of the 20th November, 1865, and the 14th October, 1867, is about to be diminished by the excision

TENDERS

PUBLIC WORKS DEPARTMENT

Tenders will be received at Public Works Department, 2 Treasury-place, Melbourne, until **TWO** p.m. on dates shown and for purposes mentioned hereunder.

Particulars and tender forms available at Contracts Office, Room 27, Ground Floor, No. 2, Treasury-place, and at places indicated in brackets hereunder.

Abbreviations in brackets mean:—W.O.—Inspector of Works Office; P.S.—Police Station; C.S.—Consolidated School; H.E.S.—Higher Elementary School; H.S.—High School; Pr.S.—Primary School; T.S.—Technical School.

Tenders to be submitted on the Department's printed Tender Form and will not be received by telephone. All tenders must be on a "Firm Tender" basis. The lowest or any tender will not necessarily be accepted.

Address tenders to the Minister of Public Works, and endorse the envelope containing the tender "Tender for , closing Tuesday,

Hand delivered tenders to be placed in the Tender Box of the Public Works Department, located on the wall of the centre entrance foyer, Ground Floor, 2 Treasury-place, Melbourne.

No preliminary deposit is required with any tender, but a successful tenderer will be required to pay a deposit for any accepted tender of \$4,000 or over.

Tuesday, 22nd May, 1973.

Building, Electrical and Mechanical Works.

AMPHITHEATRE.—Internal and external renovations, &c., Pr.S.1637. (W.O., Maryborough.)

BENDIGO.—Extensions to library and provision of lecture room, Teachers College. (W.O., Bendigo.)

BENDIGO.—Mechanical services—Extensions, Teachers College. (W.O., Bendigo.)

BROADFORD.—Erection of sick bays, H.S. (W.O., Benalla and Kyneton.)

CASTLEMAINE.—Repairs and renovations, Court House. (W.O., Bendigo and Kyneton.) (Re-advertised.)

KIEWA VALLEY.—Rewire of electrical installation, C.S. (W.O., Benalla and Wangaratta.)

MANSFIELD.—Erection of toilet block, staff toilets and connexion to sewerage, Pr.S.1112 (W.O., Alexandra, Benalla and Shepparton).

MELBOURNE.—Construction of one only glass reinforced plastic 43-ft. survey vessel. (P. & H.)

SUNSHINE EAST.—Staff accommodation improvements and new store, Pr.S.4645.

VARIOUS.—Supply and installation of radio trades bench supply panels, T.S's.

VERMONT.—Erection of new science wing in concrete veneer, H.S.

VERMONT.—Mechanical services, science wing, H.S.

WARRNAMBOOL.—Internal and external renovations and painting, Ward M.3, M.H. (W.O., Warrnambool.)

WARRNAMBOOL.—Internal and external renovations and painting, Ward 7, M.H. (W.O., Warrnambool.)

WERRIMULL.—Internal and external renovations and painting, C.S. (W.O., Mildura.)

Site Works.

BORONIA WEST.—Site works, Pr.S.4908.

SALE.—Site works, T.S. (W.O., Traralgon.)

Tuesday, 29th May, 1973.

Building, Electrical and Mechanical Works.

ARMADALE.—Internal renovations, Treloarwarren Hostel.

BALWYN.—Replacement of timber doors with aluminium, Yooralla Special School 4675.

BENDIGO.—Reglazing and screens to Trades Block, T.S. (W.O., Bendigo.)

KYABRAM.—New toilet block, store and sports store, H.S. (W.O., Benalla and Shepparton.)

MELBOURNE.—Provision of heating in two basements, State Library.

NUNAWADING.—External repairs and painting, H.S. (Re-advertised.)

TERANG.—Erection of new Police Station and Cell Block. (W.O., Camperdown.)

Furniture and Fittings.

ROYAL PARK.—Supply and installation of vinyl asbestos floor tiles and hardboard underlay, Psychiatric Hospital.

Site Works.

CLIFTON HILL.—Site works, Pr.S.3146.

FRANKSTON.—Site works, Special School 5080.

MITCHAM.—Site works, Pr.S.2904.

PARKTONE.—Site works, Pr.S.4843.

RAINBOW.—Site works, H.S. (W.O., Horsham, Swan Hill and Warracknabeal.)

STEVENSVILLE.—Site works, Pr.S.5047.

Wednesday, 6th June, 1973.

Building, Electrical and Mechanical Works.

BEAUFORT.—Erection of a brick toilet and internal and external renovations, Court House. (W.O., Ballarat.)

BROADMEADOWS.—Extensions and remodelling, T.S.

BROADMEADOWS.—Electrical services—Extensions and Remodelling, T.S.

BROADMEADOWS.—Mechanical services—Extensions and Remodelling, T.S.

HAMPTON.—Electrical installation for improved lighting, H.S.

MERINO.—Internal and external repairs and painting, C.S. (W.O., Hamilton and Warrnambool.)

Site Works.

MOOMBA PARK.—Site works, Pr.S.4876.

WARRAGUL.—Site works, T.S. (Re-advertised.) (W.O., Warragul.)

ROBERTS DUNSTAN,
Minister of Public Works.

Public Works Department,
Melbourne, 14th May, 1973.

PUBLIC SERVICE NOTICES

No. 436.

Public Service Act 1958, Section 50.

REGULATIONS.—PART IV.—SALARIES AND INCREMENTS.

The Public Service Board, in pursuance of the powers conferred by the *Public Service Act 1958*, hereby amends its Regulations as shown below :—

SIXTH SCHEDULE.

TEMPORARY EMPLOYEES.

Designations of Positions and Rates of Salaries.

Department and Designation of Position.	Yearly Rate of Salary.		Increments (Annual).
	Minimum.	Maximum.	
DEPARTMENT OF HEALTH.			
<i>Alcoholics and Drug Dependent Persons Services.</i>			
<i>Add—</i> Messroom Attendant (Female)	3,414	3,693	A

A. J. A. GARDNER, Chairman.

R. H. DURRANT, Acting Secretary.

Office of the Public Service Board,
Melbourne, 4th May, 1973.

No. 433.

Public Service Act 1958, Section 50.

REGULATIONS.—PART IV.—SALARIES AND INCREMENTS.

The Public Service Board, in pursuance of the powers conferred by the *Public Service Act 1958*, hereby amends the Public Service (Public Service Board) Regulations as follows :—

SEVENTH SCHEDULE.

TECHNICAL AND GENERAL DIVISION.

DEPARTMENT OF HEALTH.

MENTAL HYGIENE.

Grades and Salary Scales.

PART A.

Grade Number.	Yearly Rate of Salary.
	\$
<i>Add—</i>	
278	10,052
279	10,097
280	10,142
281	10,187
282	10,232
283	10,277
284	10,322
285	10,367
286	10,412
287	10,457
288	10,502
289	10,547
290	10,600
291	10,653
292	10,707
293	10,757
294	10,807
295	10,857
296	10,907
297	10,957
298	11,007
299	11,057
300	11,107

This Regulation shall have effect as on and from the 8th April, 1973.

A. J. A. GARDNER, Chairman.

R. H. DURRANT, Acting Secretary.

Office of the Public Service Board,
Melbourne, 30th April, 1973.

No. 435.

Public Service Act 1958, Section 50.

REGULATIONS.—PART IV.—SALARIES AND INCREMENTS.

The Public Service Board, in pursuance of the powers conferred by the *Public Service Act 1958*, hereby amends the Public Service (Public Service Board) Regulations as follows :—

SECOND SCHEDULE.

TECHNICAL AND GENERAL DIVISION.

Grades and Salary Scales.

JUNIOR GRADES.

MALES.

Grade.	Yearly Rate of Salary at Each Age in Years.				
	Under 17.	17.	18.	19.	20.
	\$	\$	\$	\$	\$
Add— JM-29	2,483	3,227
FEMALES.					
Add— JF-35	2,483	3,227

SIXTH SCHEDULE.

TEMPORARY EMPLOYEES.

Designations of Positions and Rates of Salaries.

Department and Designation of Position.	Yearly Rate of Salary.		Increments (Annual).
	Minimum.	Maximum.	
	\$	\$	
SOCIAL WELFARE DEPARTMENT. <i>Family Welfare Division.</i>			
Add— Cook, "Illoura"— Junior=			
At 19 years of age	..	2,483	
At 20 years of age	..	3,227	
Adult=	3,537	3,809	A

This Regulation shall have effect as on and from the 16th March, 1973.

A. J. A. GARDNER, Chairman.
R. H. DURRANT, Acting Secretary.

Office of the Public Service Board,
Melbourne, 30th April, 1973.

EXAMINATION OF APPLICANTS FOR LICENCE AS SHORTHAND WRITER.

It is hereby notified that an examination of applicants for licence as Shorthand Writer will be held at the Royal Melbourne Institute of Technology, 5th Floor, Casey Wing, Rooms C.519 and C.525, Swanston-street, Melbourne, on Saturday, the 30th June, 1973, at 10 o'clock a.m.

Applications for permission to attend the examination together with an entry fee of four dollars (\$4.00) must be forwarded to reach the Secretary, Public Service Board, Treasury-place, Melbourne, 3002 (where a copy of the Regulations may be obtained), not later than Saturday, the 13th June, 1973.

Satisfactory evidence of—

- (1) Name in full;
 - (2) having attained the age of twenty-one (21) years; and
 - (3) good moral character;
- should be submitted with application.

By order,

P. CARRIGAN,
Secretary.

Office of the Public Service Board,
Melbourne, 14th May, 1973.

No. 432.

Public Service Act 1958, Section 50.

REGULATIONS.—PART IV.—SALARIES AND INCREMENTS.

The Public Service Board, in pursuance of the powers conferred by the *Public Service Act 1958*, hereby amends the Public Service (Public Service Board) Regulations as follows :—

FIFTH SCHEDULE.

TEMPORARY EMPLOYEES.

DEPARTMENT OF HEALTH.

MENTAL HYGIENE.

Designations of Positions and Rates of Salaries.

Designation of Position.	Yearly Rate of Salary.		Increments (Annual).
	Minimum.	Maximum.	
	\$	\$	
<i>Delete the existing yearly rates of salary for the following positions and insert the rates shown hereunder in lieu thereof—</i>			
Dental Attendant (Female), Grade II.	3,506	3,758	B
Dental Attendant (Female), Grade I.— Junior—			
At 20 years of age	3,144	
Adult\$—	3,445	3,718	B
Dental Mechanic	5,175	5,514	A

SEVENTH SCHEDULE.

TECHNICAL AND GENERAL DIVISION.

DEPARTMENT OF HEALTH.

MENTAL HYGIENE.

Grades and Salary Scales.

JUNIOR GRADES.

Delete the existing yearly rates of salary shown for the under-mentioned grade and insert the following rates in lieu thereof—

FEMALES.

Grade.	Yearly Rate of Salary at Each Age in Years.				
	Under 17.	17.	18.	19.	20.
	\$	\$	\$	\$	\$
JF-11	2,410	3,144

This Regulation shall have effect as on and from the 15th April, 1973.

A. J. A. GARDNER, Chairman.
R. H. DURRANT, Acting Secretary.

Office of the Public Service Board,
Melbourne, 30th April, 1973.

No. 438.

Public Service Act 1958, Section 50.

REGULATIONS.—PART IV.—SALARIES AND INCREMENTS.

The Public Service Board, in pursuance of the powers conferred by the *Public Service Act 1958*, hereby amends its Regulations as shown below :—

SIXTH SCHEDULE.

TEMPORARY EMPLOYEES.

Designations of Positions and Rates of Salaries.

Department and Designation of Position.	Yearly Rate of Salary.		Increments (Annual).
	Minimum.	Maximum.	
	\$	\$	
DEPARTMENT OF HEALTH.			
<i>Alcoholics and Drug Dependent Persons Services.</i>			
Add—			
Seamstress, Grade I. . .	3,435	3,731	A

A. J. A. GARDNER, Chairman.
R. H. DURRANT, Acting Secretary.

Office of the Public Service Board,
Melbourne, 4th May, 1973.

No. 437.

Public Service Act 1958, Section 50.

REGULATIONS.—PART IV.—SALARIES AND INCREMENTS.

The Public Service Board, in pursuance of the powers conferred by the *Public Service Act 1958*, hereby amends its Regulations as shown below :—

SIXTH SCHEDULE.

TEMPORARY EMPLOYEES.

Designations of Positions and Rates of Salaries.

Department and Designation of Position.	Yearly Rate of Salary.		Increments (Annual).
	Minimum.	Maximum.	
	\$	\$	
DEPARTMENT OF HEALTH.			
<i>Alcoholics and Drug Dependent Persons Services.</i>			
Add—			
Domestic	3,414	3,693	A

A. J. A. GARDNER, Chairman.
R. H. DURRANT, Acting Secretary.

Office of the Public Service Board,
Melbourne, 4th May, 1973.

No. 431.

PUBLIC SERVICE ACT 1958.

The Public Service Board, in pursuance of the powers conferred by the *Public Service Act 1958*, hereby amends the Public Service (Public Service Board) Regulations as follows:—

PART IV.—SALARIES AND INCREMENTS.

DIVISION IV.—TECHNICAL AND GENERAL DIVISION.

Regulation 114.

In paragraph (b) (ii), the expression "Grade F85" is substituted for the expression "Grade, F65".

This Regulation shall have effect as on and from the 15th April, 1973.

A. J. A. GARDNER, Chairman.
R. H. DURRANT, Acting Secretary.

Office of the Public Service Board,
Melbourne, 30th April, 1973.

No. 434.

PUBLIC SERVICE ACT 1958.

The Public Service Board, in pursuance of the powers conferred by the *Public Service Act 1958*, hereby amends the Public Service (Public Service Board) Regulations as follows:—

PART V.—ALLOWANCES.

DIVISION II.—OVERTIME AND STANDBY ALLOWANCES.

Regulation 146.

In sub-regulation (11) delete the expression "other than sub-regulation (3)".

A. J. A. GARDNER, Chairman.
R. H. DURRANT, Acting Secretary.

Office of the Public Service Board,
Melbourne, 30th April, 1973.

Teaching Service Act 1958.

TEACHING SERVICE—SECONDARY SCHOOLS DIVISION (CLASSIFICATION, SALARIES, AND ALLOWANCES) REGULATION.

AMENDMENT No. 258 (SEC. C.S. & A.6).

The Teachers Tribunal, in pursuance of the powers conferred by the *Teaching Service Act 1958*, hereby amends the Teaching Service—Secondary Schools Division (Classification, Salaries, and Allowances) Regulation as follows:—

Rescind sub-clause (d) and paragraphs (iii) and (iv) of sub-clause (e) of clause 4.

(To take effect from and including the 1st January, 1974.)

W. E. SAMPSON, Chairman.
A. F. LE CLERCQ, Secretary.

Office of the Teachers Tribunal,
Melbourne, 19th April, 1973.

PRIVATE ADVERTISEMENTS

Town and Country Planning Act 1961.

CITY OF ARARAT.

NOTICE THAT A PLANNING SCHEME HAS BEEN PREPARED AND IS AVAILABLE FOR INSPECTION.

Amendment No. 13.

Notice is hereby given that the City of Ararat, in pursuance of its powers under the *Town and Country Planning Act 1961*, has prepared a Planning Scheme for the following area:—

1. All that area of land being allotment 10n, section M, Township and Parish of Ararat, containing an area of 2 acres 1 rood 6 perches, being reclassified from Public Reserve to Agricultural Zone.

A copy of the scheme has been deposited at the Municipal Offices, Ararat, and at the office of the Town and Country Planning Board, 235 Queen-street, Melbourne, and will be open for inspection during office hours by any person, free of charge.

Any persons affected by the Planning Scheme are required to set forth, in writing, all objections they may have, addressed to the Town Clerk, City of Ararat, Municipal Offices, Ararat, on or before the 16th day of August, 1973, and to state whether they wish to be heard in respect of their objections.

4th May, 1973.

2238

J. I. GRENFELL, Town Clerk.

Town and Country Planning Act 1961 (Twelfth Schedule).

CITY OF CROYDON PLANNING SCHEME 1961.

NOTICE THAT A PLANNING SCHEME HAS BEEN PREPARED AND IS AVAILABLE FOR INSPECTION.

Amendment No. 58, 1972.

Notice is hereby given that the City of Croydon, in pursuance of its powers under the *Town and Country Planning Act 1961*, has prepared a Planning Scheme for lot 1 as shown on plan of subdivision No. 41488, property being known as No. 112 Bayswater-road, Croydon, and lot 34 as shown on plan of subdivision No. 93476 and part of Crown allotment 30E, Parish of Ringwood, property being part of the Education Department's land at South Croydon for the purpose of re-zoning—

- (a) Lot 51 as shown on plan of subdivision No. 41488, property being known as No. 112 Bayswater-road, Croydon, from Residential to Proposed Public purposes—Municipal purposes (Car park) to enable the implementation of a Separate Rate Scheme to provide an off-street car parking area to serve the adjoining commercial premises and for
- (b) Lot 34 as shown on plan of subdivision No. 93476 and part of Crown allotment 30E, Parish of Ringwood, properties being part of the Education Department's property, South Croydon, from Residential and General Industrial to Existing Public purposes, the object being to consolidate zonings of the Croydon South State School site.

A copy of the scheme has been deposited at the City Offices, Foch-avenue, Croydon, and at the office of the Town and Country Planning Board, 235 Queen-street, Melbourne, and will be open for inspection during office hours by any person, free of charge.

Any persons affected by the Planning Scheme are required to set forth, in writing, all objections they may have, addressed to the Town Clerk, City Offices, Foch-avenue, Croydon, on or before the 16th day of August, 1973, and to state whether they wish to be heard in respect of their objections.

16th May, 1973.

2237

J. N. STEVENS, Acting Town Clerk.

CITY OF DONCASTER AND TEMPLESTOWE.

Whereas the Council of the City of Doncaster and Templestowe deems it expedient to exercise its power of taking compulsorily the land delineated and hatched on the map at the foot hereof for the purpose of providing a Pre-School Centre pursuant to the provisions of the *Local Government Act 1958* and acquiring the said land for that purpose: And whereas the Council has caused to be prepared maps and other papers setting out the general description of the work or undertaking for which the land proposed to be taken is to be used, the description of the

No. 35.—3940/73.—3

land proposed to be taken and the names of the owners or reputed owners, lessees or reputed lessees, mortgagees and occupiers, of the land so far as those names are known to or can be ascertained by the Council: And whereas the said plans and other papers are deposited at the office of the said Council at Doncaster and are and shall be open for inspection by all persons interested at all reasonable hours for the space of forty clear days after the publication of this notice in the *Government Gazette*: Now notice is hereby given to all persons affected by the proposed taking of the said land to set forth in writing addressed to the Council or Town Clerk within 40 clear days of the publication of this notice in the *Government Gazette* all objections which they may have to the taking of the said land.

THE LAND HEREBEFORE REFERRED TO:—

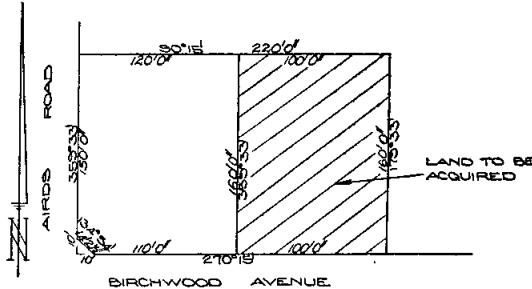

The land shown hatched on the above plan is part of the land contained in certificate of title, volume 8595, folio 933.

By order,

2195

J. W. THOMSON, Town Clerk.

CITY OF KNOX.

LOAN No. 106.

Confirmation of Special Order.

Notice is hereby given that the Council of the City of Knox, at a meeting held on the 8th day of May, 1973, did confirm the following Special Order:—

"That the Council of the City of Knox, in pursuance of powers conferred by the Local Government Acts, resolve to borrow the sum of \$765,000, secured on the general rates of the municipality, such sum to be raised by the grant of a mortgage, in accordance with the said Acts, and states:—

- (a) The amount of principal moneys it is proposed to borrow is \$765,000.
- (b) The maximum rate of interest that may be paid is 6.2 per cent. per annum.
- (c) The period of the loan will be ten years and the money borrowed is to be repayable in full at the expiration of the loan, on 16th May, 1983.
- (d) The purpose for which the loan is to be applied is to liquidate the whole or part of the overdraft on Council's Private Streets Bank Account at A.N.Z. Banking Group Ltd., Boronia.
- (e) The loan is to be liquidated by the establishment of a sinking fund pursuant to section 428A (1) of the Local Government Act with an annual appropriation of \$62,254.86, payable from the municipal fund.
- (f) The place of repayment will be Broken Hill Pty. Staff Superannuation Fund, 140 William-street, Melbourne."

2186

N. G. HAYNES, Town Clerk.

CITY OF KNOX.

Whereas the Council of the City of Knox deems it expedient to execute the work or undertaking of providing the land described hereunder for public open space: And whereas for the purpose thereof the exercise of the power of taking land compulsorily will in the opinion of the Council be necessary and desirable: And whereas the Council has caused to be prepared maps and other papers showing a general description of the work or undertaking for which the land proposed to be taken is to be used, a description of the lands proposed to be taken and the names of the owners or reputed owners, lessees, reputed lessees, mortgagees and occupiers of such lands so far as those names are known to or can be ascertained by the Council: And whereas such maps and other papers are deposited at the office of the said Council situate at Fern Tree Gully and are open for inspection by all persons affected by the proposed taking of lands during normal office hours for the space of 40 clear days after the publication of this

notice in the *Government Gazette*: Now notice is hereby given to all persons affected by the proposed taking of the said land to set forth, in writing, addressed to the Council or the Town Clerk within 40 clear days of the publication of this notice in the *Government Gazette*, all objections which they may have to the taking of the said land.

THE LAND REFERRED TO.

Lot 88, L.P.24991, Nathan-street, Fern Tree Gully.

Dated this 10th day of May, 1973.

By Order of the Council,

2230 N. G. HAYNES, Town Clerk.

CITY OF RICHMOND.

By-Law No. 182.

A By-Law of the City of Richmond made under the provisions of the *Health Act 1958* for repealing By-Law No. 176 and for fixing the fees or dues payable for services of Abattoirs and Meat Inspection Depots thereat.

In pursuance of the powers conferred by the *Health Acts* and every other Act or power enabling it on that behalf the Mayor Councillors and Citizens of the City of Richmond order as follows:

(1) By-Law No. 176 of the City of Richmond is hereby repealed.

(2) The following fees and dues which are hereby prescribed may be demanded and received by the Council for the services set out in Section 317 of the *Health Act 1958* and for specified services at the Abattoirs and Meat Inspection Depots:—

- (1) For examining and branding—
 - (i) Any carcass or side of—
 - (a) bull, cow, calf (other than a bobby calf) heifer, ox or steer 0.70
 - (b) bobby calf, goat, kid, lamb or sheep 0.15
 - (c) swine 0.25
 - (ii) Any quantity of meat (not including offal) fresh or cured in pieces less than a side, per cwt. or part thereof 0.10
 - (iii) Any offal, per piece 0.03

"Bobby-calf" means a calf not more than six weeks old.

This By-Law shall apply to and have application throughout the City of Richmond.

Resolution for passing this By-Law agreed to by the Council of the City of Richmond this 11th day of December, 1972.

Confirmed the 19th day of February, 1973.

Sealed with the common seal of the Mayor Councillors and Citizens of the City of Richmond this 28th day of March, 1973, in the presence of—

(SEAL) C. EVANS, Mayor.
J. A. LOUGHNAN, Councillor.
CHAS. C. EYRES, Town Clerk.

Submitted to the Commission of Public Health on the 3rd day of April, 1973.

Approved by the Governor in Council, the 10th day of April, 1973.—T. J. FORRISTAL, Clerk of the Executive Council: 2203

CITY OF SANDRINGHAM.

LOAN No. 113.

Notice of Intention to Borrow.

Notice is hereby given that the Council of the City of Sandringham intends to borrow Twenty thousand dollars (\$20,000), secured by a charge over the general rates of the municipality by the grant of a mortgage in accordance with the provisions of the *Local Government Acts*.

In connexion therewith the following information is stated:—

- (a) The amount of the principal moneys which it is proposed to borrow is \$20,000.
- (b) The maximum rate of interest that may be paid is 6.3 per centum per annum.
- (c) The times which the moneys borrowed are to be repayable are the 1st day of January, 1974, and the 1st days of July and January during the years 1974-1988 inclusive, and that the place such moneys shall be repayable is at the Bank of New South Wales, Sandringham.

(d) The purpose for which the loan is to be applied is:—

Improvement to places of public resort and recreation—an all-weather track at the Athletic Ground—\$20,000.

(e) The manner in which the loan is to be liquidated is by provision out of the municipal fund in each half-year, during the currency of the loan, of the sum of \$1,040.27, which includes principal and interest.

The plans and specifications and estimate of the cost of the works and a statement showing the proposed expenditure of the moneys to be borrowed are open for inspection at the Municipal Offices, Royal-avenue, Sandringham.

Dated this 9th day of May, 1973.

2196 J. L. ANDERSON, Town Clerk.

CITY OF SUNSHINE.

LOAN No. 105.

Notice of Intention to Borrow the Sum of \$50,000 for Permanent Works and Undertakings.

Notice is hereby given that the Council of the City of Sunshine proposes to borrow the principal sum of \$50,000, secured by a charge over the general rates of the municipality, such sum to be raised by the grant of a mortgage in accordance with the provisions of the *Local Government Act 1958*.

- 1. The maximum rate of interest that may be paid is 6.4 per cent. per annum.
- 2. The purposes for which the loan is required are as follows:—

Kerb and channel works—	
Western Ward	\$19,000
Southern Ward	28,000
Central Ward	3,000
	\$50,000

- 3. The period of the loan shall be for twenty (20) years.
- 4. The money borrowed shall be repayable by providing out of the municipal fund half-yearly instalments of \$2,233.60, including principal and interest, on the 1st day of January and the 1st day of July, during the currency of the loan. The first instalment shall be payable on the 1st day of January, 1974.

5. Such moneys shall be repayable at the office of The Mutual Life and Citizen's Assurance Company Limited, 303-317 Collins-street, Melbourne, or such other place or places as the Society from time to time may require.

The plans and specifications and the estimate of the proposed work and a statement showing the proposed expenditure of the money to be borrowed are open for inspection at the office of the Council of the City of Sunshine at the Municipal Offices, Alexandra-avenue, Sunshine.

2295 T. W. DEUTSCHMANN, Town Clerk.

CITY OF SUNSHINE.

LOAN No. 110.

Notice of Intention to Borrow the Sum of \$150,000 for Permanent Works and Undertakings.

Notice is hereby given that the Council of the City of Sunshine proposes to borrow the principal sum of \$150,000, secured by a charge over the general rates of the municipality, such sum to be raised by the grant of a mortgage in accordance with the provisions of the *Local Government Act 1958*.

- 1. The maximum rate of interest that may be paid is 6.3 per cent. per annum.
- 2. The purposes for which the loan is required are as follows:—

Construction Dobson Reserve	\$1,500
Construction Somerville-road Stage 5	16,500
Construction North Sunshine Drain	18,600
Installation of pedestrian signals at—	
Ballarat-road west of Northumberland-road; Ashley-street south of Churchill-avenue; Westmoreland-road north of Suffolk-road; Raleigh-road west of Warr's-road	7,400
Construction of pavilion at Kinder Smith Reserve	6,000
Construction of South-road, Rochester to Ashley-street	100,000
	\$150,000

- 3. The period of the loan shall be for fifteen (15) years.

4. The money borrowed shall be repayable by providing out of the municipal fund half-yearly instalments of \$7,802.02, including principal and interest, on the 1st day of January and the 1st day of July, during the currency of the loan. The first instalment shall be payable on the 1st day of January, 1974.

5. Such moneys shall be repayable at the office of The National Bank of Australasia Limited, Hampshire-road, Sunshine, or such other place or places as the Bank from time to time may require.

The plans and specifications and the estimate of the proposed work and a statement showing the proposed expenditure of the money to be borrowed are open for inspection at the office of the Council of the City of Sunshine at the Municipal Offices, Alexandra-avenue, Sunshine.

2296

T. W. DEUTSCHMANN, Town Clerk.

CITY OF WAVERLEY.

NOTICE OF INTENTION TO TAKE LAND COMPULSORILY.

Whereas the Council of the City of Waverley deems it expedient to exercise its power of taking compulsorily the land described in the Schedule hereto and shown hatched on the plan at the foot hereof for the work or undertaking of providing the same as pleasure grounds and places of public resort or recreation: And whereas the Council has caused to be prepared a map and other papers setting out the general description of the work or undertaking for which the land proposed to be taken is to be used the description of the land proposed to be taken and the names of the owners or reputed owners, lessees or reputed lessees, mortgagees and occupiers of that land so far as those names are known to or can be ascertained by the Council: And whereas the said map and other papers are deposited at the office of the said Council at Glen Waverley and are and shall be open for inspection by all persons interested at all reasonable hours for the space of 40 clear days after the publication of this notice in the *Government Gazette*: Now notice is hereby given to all persons affected by the proposed taking of the said land to set forth, in writing, addressed to the Council or the Town Clerk within 40 clear days of the publication of this notice in the *Government Gazette*, all objections which they may have to the taking of the said land.

THE SCHEDULE HEREINBEFORE REFERRED TO.

Technical description of land to be taken compulsorily by the City of Waverley being in two portions and being parts of Crown allotment 100 in the Parish of Mulgrave, County of Bourke and parts of the land described in certificates of title, volume 2969, folio 765, volume 8564, folio 541 and volume 8564, folio 542.

Portion 1.—All that portion of land containing 6 acres 2 roods 9 perches being part of Crown portion 100 in the Parish of Mulgrave, County of Bourke and being part of the land described in certificate of title, volume 2969, folio 765 as follows:—Commencing at a point bearing north distant 648 ft. 1½ in.; thence 270 deg. 8 min. 430 feet from the south-eastern corner of the said Crown portion 100; thence by lines bearing 270 deg. 8 min. distant 366 ft. 1 inch.; thence 0 deg. 15 min. 2 ft. 8 in.; thence 270 deg. 4 min. 126 ft. 5½ in.; thence 270 deg. 6 min. 631 ft. 10½ in.; thence 0 deg. 7 min. 55 feet; thence 19 deg. 49 min. 101 ft. 10½ in.; thence 359 deg. 47 min. 100 ft. 1½ in.; thence 89 deg. 47 min. 1,084 ft. 7 in.; thence 154 deg. 48½ min. 100 ft. 1½ in.; thence by the arc of a circle having a radius of 40 feet and length of 112 ft. 7½ in., the chord of which has a bearing 178 deg. 24 min. distant 78 ft. 11 in.; thence 203 deg. 29 min. 98 ft. 5½ in. to the point of commencement.

Portion 2.—All that portion of land containing 1 acre 2 roods 37/10 perches being part of Crown portion 100 in the Parish of Mulgrave, County of Bourke and being part of the land described in certificates of title, volume 8564, folio 541 and volume 8564, folio 542 as follows:—Commencing at a point bearing 89 deg. 49 min. distant 679 ft. 4 in.; thence 89 deg. 47 min. 342 feet; thence 90 deg. 0 min. 688 ft. 11 in.; thence 89 deg. 55 min. 60 feet; thence 2 deg. 58 min. 321 ft. 2½ in. from the south-western corner of the said Crown portion 100; thence by lines bearing 2 deg. 58 min. distant 327 ft. 1½ in.; thence 89 deg. 56 min. 222 ft. 2 in.; thence 179 deg. 43 min. 326 ft. 7½ in.; thence 269 deg. 55 min. 240 ft. 8½ in. to the point of commencement.

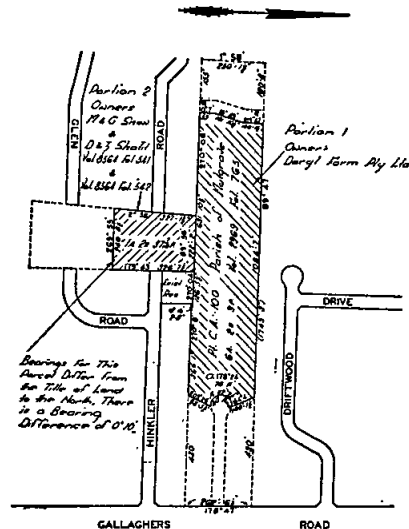

Dated the 8th day of May, 1973.

By order of the Council,

2233

F. S. BALES, Town Clerk.

SHIRE OF ARAPILES.

LOAN No. 28.

Notice of Intention to Borrow the Sum of \$50,000 for Permanent Works and Undertakings.

Notice is hereby given that the Council of the Shire of Arapiles proposes to borrow the principal sum of Fifty thousand dollars (\$50,000), secured by a charge over the general rates of the municipality, such sum to be raised by the grant of a mortgage in accordance with the provisions of the *Local Government Act 1958*.

1. The maximum rate of interest that may be paid is 5.7 per cent. per annum.

2. The purpose for which the loan is to be applied is purchase of road-making plant.

3. The period of the loan shall be five (5) years.

4. The moneys borrowed shall be repayable by providing out of the municipal fund ten half-yearly instalments of approximately \$5,800 each including principal and interest, on the 1st day of January and 1st day of July, during the currency of the loan. The first instalment shall be payable on the 1st day of January, 1974.

5. Such moneys shall be repayable to the Commissioners of the State Savings Bank of Victoria, at the office of the said commissioners, corner Elizabeth and Bourke streets, Melbourne.

The plans and specifications and the estimate of the cost of the proposed works, and a statement showing the proposed expenditure of the moneys to be borrowed, are open for inspection at the office of the Council of the Shire of Arapiles at the Shire Office, Natimuk.

11th May, 1973.

2247

C. J. WALKER, Shire Secretary.

SHIRE OF BACCHUS MARSH.

LOAN No. 26.

Notice of Intention to Borrow the Sum of \$15,000 for Permanent Works and Undertakings.

Notice is hereby given that the Council of the Shire of Bacchus Marsh proposes to borrow the principal sum of \$15,000, secured by a charge over the general rates of the municipality, such sum to be raised by the grant of a mortgage in accordance with the provisions of the *Local Government Act 1958*.

1. The maximum rate of interest that may be paid is 6.3 per cent. per annum.

2. The purpose for which the loan is to be applied is purchase of land for off street car parking in the area at the rear of Main-street, between Gisborne-road and Gell-street.

3. The period of the loan shall be fifteen years.

4. The moneys borrowed shall be repayable by providing out of the municipal fund half-yearly instalments of approximately \$780.21 each, including principal and

interest, on the 5th day of June and the 5th day of December, during the currency of the loan. The first instalment shall be payable on the 5th day of December, 1973.

5. Such moneys shall be repayable to Commonwealth Savings Bank of Australia, at Bacchus Marsh, 335 Collins-street, Melbourne, 3000.

The plans and specifications and the estimate of the cost of the proposed works, and a statement showing the proposed expenditure of the moneys to be borrowed, are open for inspection at the office of the Council of the Shire of Bacchus Marsh, at Main-street, Bacchus Marsh.
2225 B. E. LEACH, Shire Secretary.

SHIRE OF BIRCHIP.
PROSECUTING OFFICER.

Notice is hereby given that Sergeant John Maxwell Hanna, No. 12899, has been appointed Prosecuting Officer for the Shire of Birchip, vice Sergeant John Edwin Stevens, resigned.

2219 L. M. CONSTABLE, Shire Secretary.

SHIRE OF BROADFORD.

Notice is hereby given that Sergeant Desmond Thomas Usher, No. 11861, has been appointed Prosecuting Officer for the Shire of Broadford, as from 3rd May, 1973.

2221 M. D. WADE, Shire Secretary.

SHIRE OF CHARLTON.
PROSECUTING OFFICER.

Notice is hereby given that the Council of the Shire of Charlton appointed Sergeant R. H. Pearse, No. 13249, to the position of Prosecuting Officer, in lieu of Sergeant E. J. Manning, No. 11854, transferred.

2217 J. K. GIOVANETTI, Shire Secretary.

SHIRE OF CHILTERN.
PROSECUTING OFFICER.

Notice is hereby given that the Council of the Shire of Chiltern has appointed Senior Constable Brian Stewart Coleman, No. 15068, to the position of Prosecuting Officer for the Shire of Chiltern, to replace Senior Constable Rex Llewellyn Kent, transferred.

2202 T. H. FORBES, Shire Secretary.

SHIRE OF CRESWICK.
By Law No. 45.

Notice is hereby given that the Council of the Shire of Creswick has made By-Law No. 45 under the provisions of Section 93 (j) and (k) of the *Health Act 1958* for the purpose of the regulating or prohibiting the keeping of dogs within the whole of the Municipal District of the Shire of Creswick.

By-Law No. 45 provides that no person shall except with the written consent of the Council keep or cause or permit to be kept more than two dogs upon any premises having an area of less than 40 acres nor more than four dogs upon any premises having an area of more than 40 acres and also repeals By-Law No. 44.

The resolution for passing this By Law was agreed to by the Council of the Shire of Creswick on 13th day of November 1972 and confirmed on 11th day of December 1972.

The By-Law was submitted to the Commission of Public Health on 3rd April 1973 and approved by the Governor-in-Council on 10th April 1973.

A copy of the By Law is available for inspection, free of charge during office hours at the Municipal Office, 68 Albert Street, Creswick.

2214 B. C. REES, Shire Secretary.

Town and Country Planning Act 1961.

SHIRE OF LILLYDALE PLANNING SCHEME 1958.

NOTICE THAT A PLANNING SCHEME HAS BEEN PREPARED AND IS AVAILABLE FOR INSPECTION.

Amendment No. 38, 1973.

Notice is hereby given that the Council of the Shire of Lillydale, in pursuance of its powers under the *Town and Country Planning Act 1961*, has prepared a Planning Scheme for the whole of the Shire of Lillydale.

The Scheme proposes to introduce into the Shire of Lillydale Planning Scheme the following:—

(a) Residential 'G' Zone—

1. Child Minding Centres.
2. Service Premises.
3. Tourist Establishments.

(b) Rural Zone—

1. Catteries.

A copy of the Scheme has been deposited at the Shire Office, Anderson-street, Lilydale, and at the office of the Town and Country Planning Board, 235 Queen-street, Melbourne, and will be open for inspection during office hours, by any person, free of charge.

Any persons affected by the Planning Scheme are required to set forth, in writing, all objections they may have, addressed to the Shire Secretary, Shire Office, Lilydale, on or before the 16th day of June, 1973, and to state whether they wish to be heard in respect of their objections.

2245

F. O. KENT, Shire Secretary.

SHIRE OF MORNINGTON.
CHANGE OF STREET NAME.

Notice is hereby given that the Council of the Shire of Mornington has determined that the name of the street described hereunder within the Shire of Mornington at Mt. Eliza shall be changed as follows:—

Old Name.—Burong-street.

New Name.—Burong-court.

Effective date of name change, 1st July, 1973.

2215

D. G. COLLINGS, Shire Secretary.

SHIRE OF MORNINGTON.
CHANGE OF STREET NAME.

Notice is hereby given that the Council of the Shire of Mornington has determined that the name of the street described hereunder within the Shire of Mornington at Mt. Eliza shall be changed as follows:—

Old Name.—Kiata-street.

New Name.—Kiata-court.

Effective date of name change, 1st July, 1973.

2216

D. G. COLLINGS, Shire Secretary.

Water Act.

SHIRE OF OTWAY.

PROPOSED SKENES CREEK WATERWORKS TRUST.

Notice is hereby given that the Shire of Otway Council has made application to the Honorable the Minister of Water Supply for the constitution of a Waterworks Trust, and for the construction, maintenance, and continuance of water supply works within that District under the provisions of the Water Act.

A general plan and description of the proposed works have been submitted with the application, and copies of same may be seen at the Shire Office, Beech Forest, and Shire Engineer's Office, Apollo Bay.

Dated at Beech Forest, this 16th day of May, 1973.

2184

T. J. FRY, Shire Secretary.

SHIRE OF SOUTH BARWON.

LOAN No. 99—\$118,000.

Notice of Intention to Borrow.

Notice is hereby given that the Council of the Shire of South Barwon intends to borrow the sum of One hundred and eighteen thousand dollars, secured by a charge over the general rates of the municipality by the grant of a mortgage in accordance with the provisions of the *Local Government Act 1958*.

In connexion therewith the following information is stated:—

- (a) The amount of principal moneys which it is proposed to borrow is \$118,000.
- (b) The maximum rate of interest that may be paid is 6.3 dollars per centum per annum.
- (c) The times which the moneys borrowed are to be repayable are the 1st January and the 1st July, during the currency of the loan. The first instalment will be payable on the 1st January, 1974, and the final instalment shall be payable on 1st July, 1988.
- (d) The place such money shall be repayable is at the Bank of New South Wales, Belmont.
- (e) The period of the loan shall be fifteen years.

(f) The loan is to be applied for the following purposes:—

<i>Roads, Streets and Bridges—</i>	
1. Construction and re-construction ..	\$75,500
2. Traffic lights ..	4,800
3. Footpath, kerb and channel construction ..	9,900
4. Drainage construction ..	18,300
	\$108,500
<i>Council Properties—</i>	
Purchase of Land for Public purposes ..	9,500
	\$118,000

(g) The manner in which the loan is to be liquidated is by the provision out of the municipal fund in each half-year during the currency of the loan of the sum of approximately \$6,137.59 which includes principal and interest.

The plans and specifications and estimate of the cost of the works, and a statement showing the proposed expenditure of the moneys to be borrowed, are open for inspection at the Shire Office, Belmont.

2192 H. W. S. JACKSON, Shire Secretary.

SHIRE OF SOUTH BARWON.
LOAN No. 100, \$60,000.

Notice of Intention to Borrow.

Notice is hereby given that the Council of the Shire of South Barwon intends to borrow the sum of Sixty thousand dollars (\$60,000), secured by a charge over the general rates of the municipality by the grant of a mortgage in accordance with the provisions of the *Local Government Act, 1958*.

In connexion therewith the following information is stated:—

- (a) The amount of principal moneys which it is proposed to borrow is \$60,000.
- (b) The maximum rate of interest that may be paid is 6.2 dollars per centum per annum.
- (c) The times which the moneys borrowed are to be repayable are the 1st January and the 1st July, during the currency of the loan. The first instalment will be payable on the 1st January, 1974, and the final instalment shall be payable on 1st July, 1983.
- (d) The place such money shall be repayable is at the Bank of New South Wales, Belmont.
- (e) The period of the loan shall be ten years.
- (f) The loan is to be applied for the following purposes:—

<i>Council Properties—</i>	
1. Land purchase	\$1,500
2. Recreation reserves	10,000
3. Plant purchases	37,300
4. Municipal offices and depot	11,200
	\$60,000

(g) The manner in which the loan is to be liquidated is by the provision out of the municipal fund in each half-year during the currency of the loan of the sum of approximately \$4,070.32, which includes principal and interest.

The plans and specifications and estimate of the cost of the works, and a statement showing the proposed expenditure of the moneys to be borrowed, are open for inspection at the Shire Office, Belmont.

2193 H. W. S. JACKSON, Shire Secretary.

SHIRE OF STRATHFIELDSAYE.
LOAN No. 17.

Notice is hereby given that the municipality of the Shire of Strathfieldsaye borrowed \$5,000 from C.B.C. Savings Bank Limited, Melbourne, for the "Purchase of furniture and fittings for new municipal offices".

The Council are of opinion that the money is not required for the purpose for which it was borrowed and intend making an order declaring that all the unexpended money, \$5,000, be applied for:—

- Purchase of Office Equipment—
- (i) Cash Register.
 - (ii) Electronic Accounting Machine.
 - (iii) Typewriter.
 - (iv) Adding Machine.

M. BRENNAN, Shire Secretary.
Council Chambers, Kennington, 3550, 15th May, 1973.
2248

Town and Country Planning Act 1961 (Twelfth Schedule).

SHIRE OF WERRIBEE PLANNING SCHEME 1963.

NOTICE THAT A PLANNING SCHEME HAS BEEN PREPARED AND IS AVAILABLE FOR INSPECTION.

Amendment No. 29, 1973.

Notice is hereby given that the Shire of Werribee, in pursuance of its powers under the *Town and Country Planning Act 1961*, has prepared a Planning Scheme for the purpose of—

Rezoning from Agricultural Zone to Reserved Residential Zone: Crown allotments H, K, L, M and N, section vii, Parish of Tarneit, containing approximately 538 acres (Shire of Werribee Planning Scheme 1963, Amendment No. 29, 1973), in accordance with the *Town and Country Planning Act 1961*, and determines that the date of commencement of the preparation of such Planning Scheme shall be the 1st day of May, 1973.

A copy of the Scheme has been deposited at the Municipal Offices, Werribee, and at the office of the Town and Country Planning Board, 235 Queen-street, Melbourne, and will be open for inspection during office hours by any person, free of charge.

Any persons affected by the Planning Scheme are required to set forth, in writing, all objections they may have, addressed to the Shire Secretary, Municipal Offices, P.O. Box 197, Werribee, 3030, on or before the 16th day of June, 1973, and state whether they wish to be heard in respect of their objections.

11th May, 1973.

2236

J. T. KERR, Shire Secretary.

MYRTLEFORD SEWERAGE AUTHORITY.

Notice is hereby given that the above Authority intends to construct a Treatment Works and Rising Main.

Plans showing the works to be constructed are available for inspection at the Authority's office during normal office hours, Mondays to Fridays.

2223

K. S. LANE, Secretary.

MELTON SEWERAGE AUTHORITY.

LOCATION OF PROPOSED SEWAGE TREATMENT WORKS.

Notice is hereby given that the Melton Sewerage Authority has made application to the Honorable the Minister of Water Supply to locate a proposed sewage treatment works on land comprising Crown allotments 7 and 8, section XI, Parish of Pywhaitjorrk, being an area of approximately 320 acres.

A general plan and description of the proposed treatment works have been deposited at the Shire Offices, High-street, Melton, and may be inspected during office hours.

Any corporation or person likely to be injuriously affected may petition the Governor in Council for refusal or alteration of the proposals. All petitions must be verified by statutory declaration of one person signing the petition. The period during which objections may be lodged will expire on 16th June, 1973.

1901

M. B. WATSON, Secretary.

BEAUFORT SEWERAGE AUTHORITY.

BY-LAW No. 1.

Notice is hereby given of the making of a By-Law numbered 1 by the Beaufort Sewerage Authority relating to Consents, Licences, Levels, Dimensions, Construction, Maintenance, Ventilation and Cleansing of Sewers and other matters relating to House Connection Work.

The said By-Law No. 1 was passed by the Authority on 26th June 1972, confirmed by the Authority on 23rd August 1972, and approved by the Governor in Council on 1st May 1973.

A copy of the By-Law is available for inspection, free of charge, during office hours, at the office of the Authority, Shire Office, Beaufort.

2199

F. W. GLARE, Secretary.

MOE SEWERAGE AUTHORITY.

GENERAL NOTICE.

The above-mentioned Sewerage Authority, having made provision for carrying off the sewage from each and every property which or any part of which is within the Sewerage Area hereinafter described, doth hereby declare that on and after the 1st day of June, 1973, each and every property which or any part of which is within the said Sewerage Area shall be deemed to be a sewer property within the meaning of the *Sewerage Districts Act 1958*.

The Sewerage Area hereinbefore referred to shall be known as Sewerage Area No. 71.

The boundaries of the said Sewerage Area No. 71 are delineated on plan No. D.111-6520, which may be inspected at the office of the Moe Sewerage Authority.

By Order of the said Sewerage Authority,
J. S. TABUTEAU, Chairman.
A. DEWAR, Secretary.

2231

FRANKSTON SEWERAGE AUTHORITY.

COMMENCEMENT OF WORKS.

Notice is hereby given that the Authority intends to carry out sewer construction in the following areas:—
Culcairn-drive, lot 1 on L.P. 93032,

lots 2 and 3 on L.P. 95251.

Kimba-avenue, lots 128 to 136 on L.P. 85408.

Maps showing the precise location of the sewers may be inspected at the Civic Centre Annexe, Davey-street, Frankston.

2235

G. C. PENTLAND, Secretary.

CHARLTON WATERWORKS TRUST.

By-Law No. 100.

Notice is given that the Trust has adopted and the Governor in Council has approved By-Law No. 100 (Water Supply Services) relating to the following:—

1. Repealing By Law No. 72.
2. Licencing Plumbers.
3. Execution of Works of Water Supply.
4. Private extensions.
5. Connections to Main pipes and aqueducts.
6. Repairs.
7. Materials.
8. Meters.
9. Fire Services.
10. General.
11. Misuse and Waste of Water.
12. Penalties.

Notice is further given that copy of the said By-Law is open for inspection free of charge at the office of the Trust, High-street, Charlton, during normal office hours.

2220

J. K. GIOVANETTI, Shire Secretary.

GEELONG WATERWORKS AND SEWERAGE TRUST.

Pursuant to section 60 of the Geelong *Waterworks and Sewerage Act 1958* (No. 6263), the Trust has prepared plans to indicate the particulars of sewers and underground works in or adjacent to the following localities within the drainage area.

Bacchus Marsh-road, Teleta and Atami crescents, Corio; Shire of Corio.

Goldsworthy, Stapledon and Epsom roads, Wilkins and Ajax streets, Corio; Shire of Corio.

Princes and Goldsworthy roads, Corio; Shire of Corio.

Plantation-road, Lincoln-street, Browning-drive, Remington-street, Bren, Gallia and Owen courts, and Enfield-close, Corio; Shire of Corio.

Kalver-street and Talpa-crescent, Corio; Shire of Corio.

Purnell-road, Corio; Shire of Corio.

Douro-street, North Geelong; Shire of Corio.

Graylea-avenue, Herne Hill; Shire of Corio.

Tahara-street, Hamlyn Heights; Shire of Corio.

Donnybrook-road, Norlane, Shire of Corio.

Helms-street, Newcomb; Shire of Bellarine.

Notice is hereby given that the plans indicated above are open for public inspection at the Trust's Offices, Ryrie-street, Geelong, between the hours of 9 a.m. and 5 p.m., from Monday to Friday (public holidays excepted), by the owners or occupiers of land or premises within the drainage area.

2189

B. C. HENSHAW, Secretary.

NOTICE OF INTENTION TO APPLY FOR A LICENCE TO DIVERT WATER AND CUT RACE FROM THE RIVER MURRAY AT MOIRA.

We hereby give notice that we intend to apply for a licence empowering us to divert water for a term of four years to the extent of 120 acre-feet per annum at a maximum rate of 6 acre-feet per day of 24 hours for the irrigation

of 60 acres, being part of allotment 23, section B, Parish of Moira, and to occupy certain Crown lands for works of diversion, and to cut a race thereon.

Any objection to such application must be forwarded in writing to reach the State Rivers and Water Supply Commission, Melbourne, before 15th June, 1973, being 30 days from the first publication of this notice.

JAMES JOHN & CATHERINE MARY GREAD.

5 Madeline-street, Numurkah.

2232

NOTICE OF INTENTION TO APPLY FOR A LICENCE TO DIVERT WATER AND CUT RACE (RE-ISSUE) FROM THE RIVER MURRAY AT ECHUCA.

I hereby give notice that I intend to apply for a licence empowering me to divert water for a term of fifteen years to the extent of 15 acre-feet per annum at a maximum rate of 1 acre-foot per day of 24 hours for the watering of aquatic reserve lawns, being Crown land under control of Echuca City Council, Parish of Echuca North, and to occupy certain Crown lands for works of diversion, and to cut a race thereon.

Any objection to such application must be forwarded in writing to reach the State Rivers and Water Supply Commission, Melbourne, before 15th June, 1973, being thirty days from the first publication of this notice.

CITY OF ECHUCA.

P.O. Box 35, Echuca, 3625.

2239

NOTICE OF INTENTION TO APPLY FOR A LICENCE TO DIVERT WATER AND CUT RACE (RE-ISSUE) FROM THE RIVER MURRAY, AT WOOD WOOD.

We hereby give notice that we intend to apply for a licence empowering us to divert water for a term of fifteen years to the extent of 137 acre-feet per annum at a maximum rate of 10 acre-feet per day of 24 hours for the irrigation of 130 acres of vines, being part of allotments 148A and 149A, Parish of Piangil.

Any objection to such application must be forwarded, in writing, to reach the State Rivers and Water Supply Commission, Melbourne, before 15th June, 1973, being 30 days from the first publication of this notice.

HAMILTON'S EWELL VINEYARDS PTY. LTD.

165-175 Oaklands-road, Warradale, S.A., 5046.

2289

Notice is hereby given that David Hyland & Sons Proprietary Limited, has applied for a lease, pursuant to sections 134 and 135 of the *Land Act 1958*, for a term of 75 years in respect of allotment 6, section 58, City of Port Melbourne, containing 7 acres 0 roods 13 perches, as a site for general industrial purposes.

2094

Notice is hereby given that the partnership heretofore subsisting between Rose Fehr and Beverley Rose Lyon, carrying on business as poultry processors at 309 Boundary-road, Braeside, in the name of B. & R. Fehr, has been dissolved as and from the 4th day of May, 1973, as far as concerns the said Beverley Rose Lyon, who retired from the said business.

Dated the 16th day of May, 1973.

HASSALL & BILLINGS, solicitors for the retiring party.

2227

We, Peter John Bourke, of 4 Kalista-court, Burwood, in the State of Victoria, and James Edmond Bourke, of 15 Malakoff-street, Caulfield, in the said State, carrying on the business of carrier under the name of P. J. Bourke and Company, of 4 Kalista-court, Burwood, in the said State, hereby give notice that the said James Edmond Bourke has retired from partnership as from the 28th day of February, 1973, and take further notice that the said Peter John Bourke is continuing to operate the said business.

Dated this 7th day of May, 1973.

PETER BARKER, HARTY & CO., 400 Lonsdale-street, Melbourne.

2265

We, Peter John Bourke, of 4 Kalista-court, Burwood, in the State of Victoria, and James Edmond Bourke, of 15 Malakoff-street, Caulfield, in the said State, carrying on the business of carrier under the name of Auldcare, of 4 Kalista-court, Burwood, in the said State, hereby give notice that the said James Edmond Bourke has retired from partnership as from the 28th day of February, 1973, and take further notice that the said Peter John Bourke is continuing to operate the said business.

Dated this 7th day of May, 1973.

PETER BARKER, HARTY & CO., 400 Lonsdale-street, Melbourne.

2266

Notice is hereby given that the partnership heretofore subsisting between Lorenzo Follacchio and Santo Giovanni Dolcetta, carrying on a ready mix concrete business, at 17 Chenies-street, Reservoir, has been dissolved as from 30th day of April, 1973.

Dated the 30th day of April, 1973.

LORENZO FOLLACCHIO,
SANTO GIOVANNI DOLCETTA.

Messrs. Todd & Davide Yii, solicitors, 618 High-street,
Thornbury, 3071. 2197

Notice is hereby given that the partnership heretofore existing between June Lynette Fay and Kenneth Joseph Fay, carrying on business as boat builders, at 25 Nelson-street, Moorabbin, under the style or firm of "Paper Tiger Catamarans K. & J. Fay", has been dissolved as from the date hereof so far as concerns the said June Lynette Fay who retires from the said firm.

Dated the 9th day of May, 1973.

2204 JUNE LYNETTE FAY.

Notice is hereby given that the partnership heretofore subsisting between Catherine Murray Begehole, Arnold Mathaeus Faig, Esme Mildred Hall, Edith Florence Looker, Robert Scott Seaman, William Vestris, John Edward Windsor, Ilija Ilic, Olga Ilic, A. T. J. & M. A. Williams Pty. Ltd., Kevin Greig Peters, Merlene Myrtle Peters, Jan Svec, Karla Svec, J. P. S. Pty. Limited and Walter Frederick Urquhart, carrying on business in partnership under the style or name "Rathmines Street Fairfield Syndicate", has been dissolved as from the 31st day of March, 1973.

Dated the 7th day of May, 1973. 2200

Companies Act 1961.

W. L. INGPEN & SON PTY. LTD. (IN VOLUNTARY LIQUIDATION).

Notice is hereby given that at an Extraordinary Meeting of the members of the above-named company held on Tuesday, 1st May, 1973, it was resolved that the company be wound up voluntarily and at a meeting of creditors held on the same day, it was resolved that for such purpose Lewis Luckins, chartered accountant, of 130 Flinders-street, Melbourne, be appointed liquidator.

Notice is also given that after 21 days from this date I shall proceed to distribute the assets. All creditors who have any claim against the company should furnish particulars of same by that date, otherwise I shall proceed to distribute the assets without regard to their claim.

Dated this 11th day of May, 1973.

LEWIS LUCKINS, Liquidator.

Lewis Luckins & Co., chartered accountants, 130 Flinders-street, Melbourne, 3000. Telephone 63 8827. 2275

Companies Act 1961.

SARAH'S KITCHEN PTY. LTD. (IN VOLUNTARY LIQUIDATION).

Notice is hereby given that at an Extraordinary Meeting of the members of the above-named company held on Thursday, 3rd May, 1973, it was resolved that the company be wound up voluntarily and at a meeting of creditors held on the same day, it was resolved that for such purpose, Lewis Luckins, chartered accountant, of 130 Flinders-street, Melbourne, be appointed liquidator.

Notice is also given that after 21 days from this date I shall proceed to distribute the assets. All creditors who have any claim against the company should furnish particulars of same by that date, otherwise I shall proceed to distribute the assets without regard to their claim.

Dated this 11th day of May, 1973.

LEWIS LUCKINS, Liquidator.

Lewis Luckins & Co., chartered accountants, 130 Flinders-street, Melbourne, 3000. Telephone 63 8827. 2276

In the matter of FABRI-CELL PTY. LTD.—Notice of Winding-up Order.

Winding-up Order made the 8th day of May, 1973.

Name and Address of Liquidator, JOHN KENNETH HALL, of 395 Collins-street, Melbourne.

Cornwall Stodart & Co., of 222 Queen-street, Melbourne, solicitors for the petitioner. 2277

The Companies Act 1961.—In the matter of GEORGE RICE SURFBOARDS PROPRIETARY LIMITED (in Liquidation).

Notice is hereby given that at an Extraordinary General Meeting of the members of the above-named company held on the 7th day of May, 1973, it was resolved that the company be wound up voluntarily, and at a meeting of creditors held on the same day, pursuant to section 260, it was resolved that for such purpose, Robert Eastaugh Ramsay, of 296 Little Lonsdale-street, Melbourne, accountant, be appointed liquidator.

Notice is also given that after 21 days from this date I shall proceed to distribute the assets. All creditors having any claims against the company should furnish particulars of same by that date, otherwise I shall proceed to distribute the assets without regard to their claim.

Dated this 10th day of May, 1973.

R. E. RAMSAY, Liquidator.

Kennedy, Smail & Middlemiss, 296 Little Lonsdale-street, Melbourne, 3000, Victoria. 2278

Companies Act 1961.—In the matter of DUPLICATIONS PTY. LTD. (in Liquidation).

Notice is hereby given that a Final Meeting of members and creditors of the above-named company will be held at 3 p.m., on Friday, 15th June, 1973, at the office of Lewis Luckins & Co., 1st Floor, 130 Flinders-street, Melbourne, pursuant to section 272 of the Companies Act 1961, for the purpose of laying before the meeting an account showing how the winding up has been conducted and how the assets have been disposed of and also passing a Resolution in compliance with section 284 (2) of the Companies Act 1961.

Dated this 11th day of May, 1973.

LEWIS LUCKINS, F.C.A., Liquidator.

Lewis Luckins & Co., chartered accountants, 130 Flinders-street, Melbourne, Vic. 3000. Telephone 63 8827. 2279

The Companies Act 1961.—In the matter of JOHN W. POHL PTY. LTD.—Notice Re Meeting of Creditors, Pursuant to Section 260.

Notice is hereby given that a meeting of creditors of the above-named company will be held at the offices of Kennedy, Smail & Middlemiss, 296 Little Lonsdale-street, Melbourne, at 11 a.m., on the 23rd day of May, 1973, the company having convened a meeting of its members for the same day for the purpose of considering a Resolution that the company be wound up voluntarily.

Dated this 15th day of May, 1973.

J. W. POHL, Director.

Kennedy, Smail & Middlemiss, 296 Little Lonsdale-street, Melbourne, 3000, Victoria. 2280

BOURKE THEATRES PTY. LTD. (IN VOLUNTARY LIQUIDATION).

Notice is hereby given, in pursuance of section 272 (2) of the Companies Act 1961, that the Final Meeting of members of the above-named company will be held at 10th Floor, 271 William-street, Melbourne, at 10.30 a.m., Friday, 29th June, 1973, for the purpose of having an account laid before it showing the manner in which the winding up has been conducted and to hear any explanation that may be given by the liquidator.

Dated this 14th day of May 1973.

J. B. HUTCHINS, Liquidator.

Wilson, Bishop, Bowes & Craig, chartered accountants, 271 William-street, Melbourne, Victoria, 3000. 2290

The Companies Act 1961.

T. A. OSBORNE REFRIGERATION SERVICES PROPRIETARY LIMITED (IN VOLUNTARY LIQUIDATION).

NOTICE CONVENING FINAL MEETING OF MEMBERS, PURSUANT TO SECTION 272.

Notice is hereby given, in pursuance of section 272 of the Companies Act 1961, that the Final Meeting of the members of the above-named company will be held at the registered office of the company, 43 Elder-street, Watsonia, on Wednesday, 20th June, 1973, at 11 a.m., to consider the liquidator's final accounts of the voluntary winding up.

Dated this 14th day of May, 1973.

2302 J. P. MCGUINNESS, Liquidator.

*Companies Act 1961.***JEREMY HUGHES GRAPHIC SERVICES PROPRIETARY LIMITED (IN LIQUIDATION).**

Notice is hereby given, pursuant to section 254 (b) of the *Companies Act 1961*, that a Special Resolution was passed at a General Meeting of Jeremy Hughes Graphic Services Proprietary Limited, held on the 14th May, 1973, at Room 401, 4th floor, 20 Bank-place, Melbourne, 3000, to wind up the company.

D. J. FERGUSON, Liquidator.

2292

Companies Act 1961.—In the matter of CALOUNDRRA PASTORAL COMPANY PROPRIETARY LIMITED (in Voluntary Liquidation).—Notice of Special Resolution, Pursuant to Section 254.

Notice is hereby given that at an Extraordinary Meeting of the members of the above-named company duly convened and held at 24 Winter-street, Malvern, Victoria, on the 12th day of May, 1973, the following Resolution was passed:—

SPECIAL RESOLUTION.

"That the company be voluntarily wound up."

Notice is also given that after 21 days from this date I shall proceed to distribute the assets of the company. All creditors having any claim against the company should furnish particulars of same by that date, otherwise I shall proceed to distribute the assets without regard to their claim.

Dated this 14th day of May, 1973.

K. J. DALY, Liquidator.

Price Waterhouse & Co., chartered accountants, 447 Collins-street, Melbourne. 2301

Companies Act 1961.—In the matter of B. S. HOWARD PTY. LTD.—Notice of Meeting of Creditors, Pursuant to Section 260.

Notice is hereby given that a meeting of creditors of the above-named company will be held at the Conference Room, 4th Floor, 130 Flinders-street, Melbourne, on Tuesday, 22nd May, 1973, at 10.30 a.m., the company having convened an Extraordinary Meeting of its members for the same day for the purpose of considering a Special Resolution that the company be wound up voluntarily.

Dated this 15th day of May, 1973.

B. HOWARD, Director.

Lewis Luckins & Co., chartered accountants, 130 Flinders-street, Melbourne, 3000. Telephone 63 8827. 2311

*Companies Act 1961.***CAMERA ART PTY. LTD.**

WE HEREBY GIVE NOTICE OF THE MEETING OF CREDITORS OF CAMERA ART PTY. LTD. AS FOLLOWS.

Notice of Meeting of Creditors of Camera Art Pty. Ltd.

Notice is hereby given that, pursuant to section 260 of the *Companies Act 1961*, a meeting of the creditors of Camera Art Pty. Ltd., will be held at the offices of Kellett, Till & Associates, 1004 Doncaster-road, Doncaster East, on Tuesday, 29th May, 1973, at 10 a.m., the company having convened a meeting of its members on the same day at 9.30 a.m., for the purpose of considering and if thought fit passing a Special Resolution that the company be wound up voluntarily, and that Maurice John Kellett, public accountant and registered liquidator, of 1004 Doncaster-road, Doncaster East, be appointed liquidator. 2312

In the matter of the *Companies Act 1961*; and in the matter of AUTOMOTIVE & GENERAL INDUSTRIES LIMITED.

Notice is hereby given that a petition for the winding up of the above-named company by the Supreme Court was on the 11th day of May, 1973, presented by George Henry Vine Williams: That the said petition is directed to be heard before the Court sitting at the Fourteenth Court, Law Courts, William-street, Melbourne, on the 19th of June, 1973, at the hour of 10.30 o'clock in the forenoon: And any creditor or contributory of the said company desiring to support or oppose the making of an Order on the said petition may appear at the time of hearing by himself or his Counsel for that purpose: And a copy of the petition will be furnished to any creditor or contributory of the said company requiring the same by the undersigned on payment of the regulated charge for the same.

The petitioner's address is 2 Knox-street, Canterbury.

The petitioner's solicitors are Messrs. Madden, Butler, Elder & Graham, of 500 Collins-street, Melbourne.

MADDEN, BUTLER, ELDER & GRAHAM, solicitors for the petitioner.

NOTE.—Any person who intends to appear on the hearing of the said petition must serve on or send by post to the above-named solicitors, notice, in writing, of his intention to do so. The notice must state the name and address of the person, or, if a firm, the name and address of the firm and must be signed by the person or firm, or his or their solicitor if any, and must be served, or if posted, must be sent by post in sufficient time to reach the above-named not later than 4 o'clock in the afternoon of the 18th day of June, 1973. 2314

*Companies Act 1961.***J. ROY STEVENS PTY. LIMITED.**

At an Extraordinary General Meeting of J. Roy Stevens Pty. Limited, duly convened and held at 206 Capel-street, North Melbourne, on the 7th day of May, 1973.

The following Resolution was duly passed as a Special Resolution:—

"That the company be wound up voluntarily and that D. Ebsworth Cook, chartered accountant, of 48 Wilson-street, South Yarra, be appointed liquidator.

Dated this 7th day of May, 1973.

2205

D. EBSWORTH COOK, Liquidator.

*Companies Act 1961.***MILFORD CO-OPERATIVE DAIRY COMPANY LIMITED. MEMBERS' VOLUNTARY WINDING UP.**

Notice is hereby given that on the 11th day of May, 1973, the members of the company passed a Special Resolution to wind up the company by way of members' voluntarily winding up, and that Rockley Rex Crozier, chartered accountant, of 37 Queen-street, Melbourne, be appointed liquidator for the purpose of winding up the affairs and distributing the assets of the company.

R. R. CROZIER, Liquidator.

Leane & Crozier, chartered accountants, 37 Queen-street, Melbourne, 3000. 2313

*Companies Act 1961.***MELBOURNE ELECTRONIC COLOUR ETCHING PTY. LIMITED.**

At an Extraordinary General Meeting of Melbourne Electronic Colour Etching Pty. Limited, duly convened and held at 250 Spencer-street, Melbourne, on the 2nd day of May, 1973, at 10.40 a.m., the following Resolution was duly passed as a Special Resolution:—

"That the company be wound up voluntarily and that Mr. C. G. Roberts, of 66 Airlie-street, South Yarra, be and is hereby appointed liquidator."

Dated this 3rd day of May, 1973.

2213

C. G. ROBERTS, Liquidator.

*Companies Act 1961.***ROTAGRAVURE ETCHINGS PTY. LIMITED.**

At an Extraordinary General Meeting of Rotagravure Etchings Pty. Limited duly convened and held at 250 Spencer-street, Melbourne, on the 2nd day of May, 1973, at 10.45 a.m., the following Resolution was duly passed as a Special Resolution:—

"That the company be wound up voluntarily and that Mr. C. G. Roberts, of 66 Airlie-street, South Yarra, be and is hereby appointed liquidator."

Dated this 3rd day of May, 1973.

2207

C. G. ROBERTS, Liquidator.

*Companies Act 1961.***PATTERSON SHUGG PTY. LIMITED.**

At an Extraordinary General Meeting of Patterson Shugg Pty. Limited duly convened and held at 250 Spencer-street, Melbourne, on the 2nd day of May, 1973, at 10.50 a.m., the following Resolution was duly passed as a Special Resolution:—

"That the company be wound up voluntarily and that Mr. C. G. Roberts, of 66 Airlie-street, South Yarra, be and is hereby appointed liquidator."

Dated this 3rd day of May, 1973.

2212

C. G. ROBERTS, Liquidator.

Companies Act 1961.

DIRECTOPLATE LITHO PTY. LIMITED.

At an Extraordinary General Meeting of Directoplate Litho Pty. Limited duly convened and held at 250 Spencer-street, Melbourne, on the 2nd day of May, 1973, at 10.55 a.m., the following Resolution was duly passed as a Special Resolution:—

“That the company be wound up voluntarily and that Mr. C. G. Roberts, of 66 Airlie-street, South Yarra, be and is hereby appointed liquidator.”

Dated this 3rd day of May, 1973.

2211 C. G. ROBERTS, Liquidator.

Companies Act 1961.

ROBINSON TYPESETTERS PTY. LIMITED.

At an Extraordinary General Meeting of Robinson Type-setters Pty. Limited duly convened and held at 250 Spencer-street, Melbourne, on the 2nd day of May, 1973, at 11.00 a.m., the following Resolution was duly passed as a Special Resolution:—

“That the company be wound up voluntarily and that Mr. C. G. Roberts, of 66 Airlie-street, South Yarra, be and is hereby appointed liquidator.”

Dated this 3rd day of May, 1973.

2210 C. G. ROBERTS, Liquidator.

Companies Act 1961.

MCDIARMID BROS. PTY. LIMITED.

At an Extraordinary General Meeting of McDiarmid Bros. Pty. Limited duly convened and held at 250 Spencer-street, Melbourne, on the 2nd day of May, 1973, at 11.05 a.m., the following Resolution was duly passed as a Special Resolution:—

“That the company be wound up voluntarily and that Mr. C. G. Roberts, of 66 Airlie-street, South Yarra, be and is hereby appointed liquidator.”

Dated this 3rd day of May, 1973.

2209 C. G. ROBERTS, Liquidator.

Companies Act 1961.

P.E.A. (COLOUR ETCHING) PTY. LIMITED.

At an Extraordinary General Meeting of P.E.A. (Colour Etching) Pty. Limited duly convened and held at 250 Spencer-street, Melbourne, on the 2nd day of May, 1973, at 11.10 a.m., the following Resolution was duly passed as a Special Resolution:—

“That the company be wound up voluntarily and that Mr. C. G. Roberts, of 66 Airlie-street, South Yarra, be and is hereby appointed liquidator.”

Dated this 3rd day of May, 1973.

2208 C. G. ROBERTS, Liquidator.

Companies Act 1961.

PHOTO-ENGRAVING ASSOCIATES PTY. LIMITED.

At an Extraordinary General Meeting of Photo-engraving Associates Pty. Limited duly convened and held at 250 Spencer-street, Melbourne, on the 2nd day of May, 1973, at 11.15 a.m., the following Resolution was duly passed as a Special Resolution:—

“That the company be wound up voluntarily and that Mr. C. G. Roberts, of 66 Airlie-street, South Yarra, be and is hereby appointed liquidator.”

Dated this 3rd day of May, 1973.

2206 C. G. ROBERTS, Liquidator.

Companies Act 1961, Section 272 (1).

DEWEZ ROBERTSON PTY. LTD.

NOTICE OF MEETING OF CONTRIBUTORIES AND CREDITORS.

Notice is hereby given that a meeting of creditors and contributories of Dewez Robertson Pty. Limited, will be held at the offices of Fell & Starkey, 19th floor, 351 Collins-street, Melbourne, on the 20th day of June, 1973, at 2 o'clock in the afternoon.

Agenda:

To receive an account showing how the winding up has been conducted and the property of the company has been disposed of.

Dated this 16th day of May, 1973.

2224 R. W. ELLIS, Liquidator.

LOREL GEM CO. PTY. LTD. (IN VOLUNTARY LIQUIDATION).

Take notice that the affairs of the above-named company are now fully wound up and that, in pursuant of section 272 (1) of the *Companies Act 1961*, a General Meeting of the company will be held at Suite 2, 162 Albert-road, South Melbourne, on the 15th day of June, 1973, at 2 o'clock in the afternoon, for the purpose of laying before it an account showing how the winding up has been conducted and the property of the company disposed of and giving any explanation thereof.

Dated this 9th day of May, 1973.

2228 L. BRAUN, Liquidator.

OPAL DEN PTY. LTD. (IN VOLUNTARY LIQUIDATION).

Take notice that the affairs of the above-named company are now fully wound up and that, in pursuant of section 272 (1) of the *Companies Act 1961*, a General Meeting of the company will be held at Suite 2, 162 Albert-road, South Melbourne, on the 15th day of June, 1973, at 2 o'clock in the afternoon, for the purpose of laying before it an account showing how the winding up has been conducted and the property of the company disposed of and giving any explanation thereof.

Dated this 9th day of May, 1973.

2229 L. BRAUN, Liquidator.

Companies Act 1961, Section 254 (2).

ATTENT PTY. LTD. (IN LIQUIDATION).

Notice is hereby given that at an Extraordinary Meeting of members of the above-named company held on Monday, 14th May, 1973, the following Special Resolution was duly passed:—

“That owing to the company being unable to meet its debts as and when they become due and payable, that the company be and is hereby wound up voluntarily, and that Maxwell George Gee, a registered liquidator, be and is hereby appointed liquidator to wind the company up and attend to all matters relative thereto in accordance with the *Companies Act 1961*.”

At a meeting of creditors held the same day, my appointment as liquidator was confirmed.

M. G. GEE, Liquidator.

Max Gee & Co., 325 Warrigal-road, Burwood, 3125.
Telephone 288 5109. 2287

In the matter of the *Companies Act 1961*; and in the matter of DENCRAFT PRODUCTIONS PTY. LTD. (in Liquidation).

Notice is hereby given that at a General Meeting of the members of the above-named company duly convened and held at the offices of Messrs. Kent Brierley & Barraclough, 440 Collins-street, Melbourne, Victoria, on the 11th day of May, 1973, a Special Resolution in the words set out below was duly passed with respect to the said company:—

SPECIAL RESOLUTION.

“That the company be wound up voluntarily in accordance with the provisions of Division 3 of Part X. of the *Companies Act 1961*, and that Mr. H. A. B. McWilliam, chartered accountant, of Kent Brierley & Barraclough, 440 Collins-street, Melbourne, be appointed liquidator, and that his remuneration be fixed in accordance with the scale of fees of the Institute of Chartered Accountants.”

Dated this 14th day of May, 1973.

H. A. B. McWILLIAM, Liquidator.

Kent Brierley & Barraclough, 440 Collins-street, Melbourne. 2274

In the Supreme Court of Victoria.—1973 Co. 8632.—In the matter of the *Companies Act 1961*; and in the matter of WATERLAND WELL & ROCK DRILLERS PROPRIETARY LIMITED.

Notice is hereby given that a petition for the winding up of the above-named company by the Supreme Court was on the 10th day of May, 1973, presented by Leo Thomas FitzGerald, Deputy Commissioner of Taxation of the Commonwealth of Australia; and that the said petition is directed to be heard before the Court sitting at the Fourteenth Court, Law Courts, William-street, Melbourne, at the hour of 10.30 o'clock in the forenoon on the 6th day of June, 1973, and any creditor or contributory of the said company desiring to support or oppose the making of an order on the said petition may appear at the time of hearing by himself or his Counsel for the purpose; and a copy of the said petition will be furnished to any creditor or contributory of the said company requiring the same by the undersigned on payment of the regulated charge for the same.

The petitioner's official address is 350 Collins-street, Melbourne.

The petitioner's solicitor is Robert Burns Hutchison, Crown Solicitor for the Commonwealth, of 99 Queen-street, Melbourne.

R. B. HUTCHISON.

NOTE.—Any person who intends to appear on the hearing of the said petition must serve on or send by post to the above-named R. B. Hutchison, notice, in writing, of his intention so to do. The notice must state the name and address of the person, or, if a firm, the name and address of the firm, and must be signed by the person or firm, or his, or their solicitor (if any), and must be served or, if posted, must be sent by post in sufficient time to reach the above named not later than 4 o'clock in the afternoon of the 5th day of June, 1973.

2320

In the Supreme Court of Victoria.—1973 Co. 8633.—In the matter of the *Companies Act 1961*; and in the matter of MACKENZIE TYPESETTING SERVICES PROPRIETARY LTD.

Notice is hereby given that a petition for the winding up of the above-named company by the Supreme Court was on the 10th day of May, 1973, presented by Leo Thomas FitzGerald, Deputy Commissioner of Taxation of the Commonwealth of Australia; and that the said petition is directed to be heard before the Court sitting at the Fourteenth Court, Law Courts, William-street, Melbourne, at the hour of 10.30 o'clock in the forenoon on the 6th day of June, 1973, and any creditor or contributory of the said company desiring to support or oppose the making of an order on the said petition may appear at the time of hearing by himself or his Counsel for the purpose; and a copy of the said petition will be furnished to any creditor or contributory of the said company requiring the same by the undersigned on payment of the regulated charge for the same.

The petitioner's official address is 350 Collins-street, Melbourne.

The petitioner's solicitor is Robert Burns Hutchison, Crown Solicitor for the Commonwealth, of 99 Queen-street, Melbourne.

R. B. HUTCHISON.

NOTE.—Any person who intends to appear on the hearing of the said petition must serve on or send by post to the above-named R. B. Hutchison, notice, in writing, of his intention so to do. The notice must state the name and address of the person, or, if a firm, the name and address of the firm, and must be signed by the person or firm, or his, or their solicitor (if any), and must be served or, if posted, must be sent by post in sufficient time to reach the above named not later than 4 o'clock in the afternoon of the 5th day of June, 1973.

2321

In the Supreme Court of Victoria.—1973 Co. 8630.—In the matter of the *Companies Act 1961*; and in the matter of ASCOT PRESS PROPRIETARY LIMITED.

Notice is hereby given that a petition for the winding up of the above-named company by the Supreme Court was on the 10th day of May, 1973, presented by Leo Thomas FitzGerald, Deputy Commissioner of Taxation of the Commonwealth of Australia; and that the said petition is directed to be heard before the Court sitting at the Fourteenth Court, Law Courts, William-street, Melbourne, at the hour of 10.30 o'clock in the forenoon on the 6th day of June, 1973, and any creditor or contributory of the said company desiring to support or oppose the making of an order on the said petition may appear at the time of hearing by himself or his Counsel for the purpose; and a copy of the said petition will be furnished to any creditor or contributory of the said company requiring the same by the undersigned on payment of the regulated charge for the same.

The petitioner's official address is 350 Collins-street, Melbourne.

The petitioner's solicitor is Robert Burns Hutchison, Crown Solicitor for the Commonwealth, of 99 Queen-street, Melbourne.

R. B. HUTCHISON.

NOTE.—Any person who intends to appear on the hearing of the said petition must serve on or send by post to the above-named R. B. Hutchison, notice, in writing, of his intention so to do. The notice must state the name and address of the person, or, if a firm, the name and address of the firm, and must be signed by the person or firm, or his, or their solicitor (if any), and must be served or, if posted, must be sent by post in sufficient time to reach the above named not later than 4 o'clock in the afternoon of the 5th day of June, 1973.

2322

In the Supreme Court of Victoria.—1973 Co. 8631.—In the matter of the *Companies Act 1961*; and in the matter of M. J. NICHOLSON PTY. LTD.

Notice is hereby given that a petition for the winding up of the above-named company by the Supreme Court was on the 10th day of May, 1973, presented by Leo Thomas FitzGerald, Deputy Commissioner of Taxation of the Commonwealth of Australia; and that the said petition is directed to be heard before the Court sitting at the Fourteenth Court, Law Courts, William-street, Melbourne, at the hour of 10.30 o'clock in the forenoon on the 6th day of June, 1973, and any creditor or contributory of the said company desiring to support or oppose the making of an order on the said petition may appear at the time of hearing by himself or his Counsel for the purpose; and a copy of the said petition will be furnished to any creditor or contributory of the said company requiring the same by the undersigned on payment of the regulated charge for the same.

The petitioner's official address is 350 Collins-street, Melbourne.

The petitioner's solicitor is Robert Burns Hutchison, Crown Solicitor for the Commonwealth, of 99 Queen-street, Melbourne.

R. B. HUTCHISON.

NOTE.—Any person who intends to appear on the hearing of the said petition must serve on or send by post to the above-named R. B. Hutchison, notice, in writing, of his intention so to do. The notice must state the name and address of the person, or, if a firm, the name and address of the firm, and must be signed by the person or firm, or his, or their solicitor (if any), and must be served or, if posted, must be sent by post in sufficient time to reach the above named not later than 4 o'clock in the afternoon of the 5th day of June, 1973.

2323

In the Supreme Court of Victoria.—1973 Co. 8623.—In the matter of the *Companies Act 1961*; and in the matter of M. J. CLEANING SERVICE PTY. LTD.

Notice is hereby given that a petition for the winding up of the above-named company by the Supreme Court was on the 8th day of May, 1973, presented by Leo Thomas FitzGerald, Deputy Commissioner of Taxation of the Commonwealth of Australia; and that the said petition is directed to be heard before the Court sitting at the Fourteenth Court, Law Courts, William-street, Melbourne, at the hour of 10.30 o'clock in the forenoon on the 13th day of June, 1973, and any creditor or contributory of the said company desiring to support or oppose the making of an order on the said petition may appear at the time of hearing by himself or his Counsel for the purpose; and a copy of the said petition will be furnished to any creditor or contributory of the said company requiring the same by the undersigned on payment of the regulated charge for the same.

The petitioner's official address is 350 Collins-street, Melbourne.

The petitioner's solicitor is Robert Burns Hutchison, Crown Solicitor for the Commonwealth, of 99 Queen-street, Melbourne.

R. B. HUTCHISON.

NOTE.—Any person who intends to appear on the hearing of the said petition must serve on or send by post to the above-named R. B. Hutchison, notice, in writing, of his intention so to do. The notice must state the name and address of the person, or, if a firm, the name and address of the firm, and must be signed by the person or firm, or his, or their solicitor (if any), and must be served or, if posted, must be sent by post in sufficient time to reach the above named not later than 4 o'clock in the afternoon of the 12th day of June, 1973.

2285

In the Supreme Court of Victoria.—1973 Co. 8624.—In the matter of the *Companies Act 1961*; and in the matter of JOS ALEXANDER PROPRIETARY LIMITED.

Notice is hereby given that a petition for the winding up of the above-named company by the Supreme Court was on the 8th day of May, 1973, presented by Leo Thomas FitzGerald, Deputy Commissioner of Taxation of the Commonwealth of Australia; and that the said petition is directed to be heard before the Court sitting at the Fourteenth Court, Law Courts, William-street, Melbourne, at the hour of 10.30 o'clock in the forenoon on the 13th day of June, 1973, and any creditor or contributory of the said company desiring to support or oppose the making of an order on the said petition may appear at the time of hearing by himself or his Counsel for the purpose; and a copy of the said petition will be furnished to any

creditor or contributory of the said company requiring the same by the undersigned on payment of the regulated charge for the same.

The petitioner's official address is 350 Collins-street, Melbourne.

The petitioner's solicitor is Robert Burns Hutchison, Crown Solicitor for the Commonwealth, of 99 Queen-street, Melbourne.

R. B. HUTCHISON.

NOTE.—Any person who intends to appear on the hearing of the said petition must serve on or send by post to the above-named R. B. Hutchison, notice, in writing, of his intention so to do. The notice must state the name and address of the person, or, if a firm, the name and address of the firm, and must be signed by the person or firm, or his, or their solicitor (if any), and must be served or, if posted, must be sent by post in sufficient time to reach the above named not later than 4 o'clock in the afternoon of the 12th day of June, 1973. 2286

In the Supreme Court of Victoria.—1973 Co. 8628.—In the matter of the *Companies Act 1961*; and in the matter of KONSTANTINE JEWELLERY PROPRIETARY LIMITED.

Notice is hereby given that a petition for the winding up of the above-named company by the Supreme Court was on the 10th day of May, 1973, presented by Leo Thomas FitzGerald, Deputy Commissioner of Taxation of the Commonwealth of Australia; and that the said petition is directed to be heard before the Court sitting at the Fourteenth Court, Law Courts, William-street, Melbourne, at the hour of 10.30 o'clock in the forenoon on the 6th day of June, 1973, and any creditor or contributory of the said company desiring to support or oppose the making of an order on the said petition may appear at the time of hearing by himself or his Counsel for the purpose; and a copy of the said petition will be furnished to any creditor or contributory of the said company requiring the same by the undersigned on payment of the regulated charge for the same.

The petitioner's official address is 350 Collins-street, Melbourne.

The petitioner's solicitor is Robert Burns Hutchison, Crown Solicitor for the Commonwealth, of 99 Queen-street, Melbourne.

R. B. HUTCHISON.

NOTE.—Any person who intends to appear on the hearing of the said petition must serve on or send by post to the above-named R. B. Hutchison, notice, in writing, of his intention so to do. The notice must state the name and address of the person, or, if a firm, the name and address of the firm, and must be signed by the person or firm, or his, or their solicitor (if any), and must be served or, if posted, must be sent by post in sufficient time to reach the above named not later than 4 o'clock in the afternoon of the 5th day of June, 1973. 2318

In the Supreme Court of Victoria.—1973 Co. 8629.—In the matter of the *Companies Act 1961*; and in the matter of REHANDER PROPRIETARY LIMITED.

Notice is hereby given that a petition for the winding up of the above-named company by the Supreme Court was on the 10th day of May, 1973, presented by Leo Thomas FitzGerald, Deputy Commissioner of Taxation of the Commonwealth of Australia; and that the said petition is directed to be heard before the Court sitting at the Fourteenth Court, Law Courts, William-street, Melbourne, at the hour of 10.30 o'clock in the forenoon on the 6th day of June, 1973, and any creditor or contributory of the said company desiring to support or oppose the making of an order on the said petition may appear at the time of hearing by himself or his Counsel for the purpose; and a copy of the said petition will be furnished to any creditor or contributory of the said company requiring the same by the undersigned on payment of the regulated charge for the same.

The petitioner's official address is 350 Collins-street, Melbourne.

The petitioner's solicitor is Robert Burns Hutchison, Crown Solicitor for the Commonwealth, of 99 Queen-street, Melbourne.

R. B. HUTCHISON.

NOTE.—Any person who intends to appear on the hearing of the said petition must serve on or send by post to the above-named R. B. Hutchison, notice, in writing, of his intention so to do. The notice must state the name and address of the person, or, if a firm, the name and address of the firm, and must be signed by the person or firm, or his, or their solicitor (if any), and must be served or, if posted, must be sent by post in sufficient time to reach the above named not later than 4 o'clock in the afternoon of the 5th day of June, 1973. 2319

In the Supreme Court of Victoria.—1973 Co 8621.—In the matter of the *Companies Act 1961*; and in the matter of CO-ORDINATED EXHIBITORS PTY. LIMITED.

Notice is hereby given that a petition for the winding up of the above-named company by the Supreme Court was on the 8th day of May, 1973, presented by Leo Thomas FitzGerald, Deputy Commissioner of Taxation of the Commonwealth of Australia; and that the said petition is directed to be heard before the Court sitting at the Fourteenth Court, Law Courts, William-street, Melbourne, at the hour of 10.30 o'clock in the forenoon on the 13th day of June, 1973, and any creditor or contributory of the said company desiring to support or oppose the making of an order on the said petition may appear at the time of hearing by himself or his Counsel for the purpose; and a copy of the said petition will be furnished to any creditor or contributory of the said company requiring the same by the undersigned on payment of the regulated charge for the same.

The petitioner's official address is 350 Collins-street, Melbourne.

The petitioner's solicitor is Robert Burns Hutchison, Crown Solicitor for the Commonwealth, of 99 Queen-street, Melbourne.

R. B. HUTCHISON.

NOTE.—Any person who intends to appear on the hearing of the said petition must serve on or send by post to the above-named R. B. Hutchison, notice, in writing, of his intention so to do. The notice must state the name and address of the person, or, if a firm, the name and address of the firm, and must be signed by the person or firm, or his, or their solicitor (if any), and must be served or, if posted, must be sent by post in sufficient time to reach the above named not later than 4 o'clock in the afternoon of the 12th day of June, 1973. 2281

In the Supreme Court of Victoria.—1973 Co 8622.—In the matter of the *Companies Act 1961*; and in the matter of MAX RUSSELL PTY. LIMITED.

Notice is hereby given that a petition for the winding up of the above-named company by the Supreme Court was on the 8th day of May, 1973, presented by Leo Thomas FitzGerald, Deputy Commissioner of Taxation of the Commonwealth of Australia; and that the said petition is directed to be heard before the Court sitting at the Fourteenth Court, Law Courts, William-street, Melbourne, at the hour of 10.30 o'clock in the forenoon on the 13th day of June, 1973, and any creditor or contributory of the said company desiring to support or oppose the making of an order on the said petition may appear at the time of hearing by himself or his Counsel for the purpose; and a copy of the said petition will be furnished to any creditor or contributory of the said company requiring the same by the undersigned on payment of the regulated charge for the same.

The petitioner's official address is 350 Collins-street, Melbourne.

The petitioner's solicitor is Robert Burns Hutchison, Crown Solicitor for the Commonwealth, of 99 Queen-street, Melbourne.

R. B. HUTCHISON.

NOTE.—Any person who intends to appear on the hearing of the said petition must serve on or send by post to the above-named R. B. Hutchison, notice, in writing, of his intention so to do. The notice must state the name and address of the person, or, if a firm, the name and address of the firm, and must be signed by the person or firm, or his, or their solicitor (if any), and must be served or, if posted, must be sent by post in sufficient time to reach the above named not later than 4 o'clock in the afternoon of the 12th day of June, 1973. 2282

In the Supreme Court of Victoria.—1973 Co 8620.—In the matter of the *Companies Act 1961*; and in the matter of P. & M. MEAT SUPPLIES PROPRIETARY LTD.

Notice is hereby given that a petition for the winding up of the above-named company by the Supreme Court was on the 8th day of May, 1973, presented by Leo Thomas FitzGerald, Deputy Commissioner of Taxation of the Commonwealth of Australia; and that the said petition is directed to be heard before the Court sitting at the Fourteenth Court, Law Courts, William-street, Melbourne, at the hour of 10.30 o'clock in the forenoon on the 13th day of June, 1973, and any creditor or contributory of the said company desiring to support or oppose the making of an order on the said petition may appear at the time of hearing by himself or his Counsel for the purpose; and a copy of the said petition will be furnished to any creditor or contributory of the said company requiring the same by the undersigned on payment of the regulated charge for the same.

The petitioner's official address is 350 Collins-street, Melbourne.

The petitioner's solicitor is Robert Burns Hutchison, Crown Solicitor for the Commonwealth, of 99 Queen-street, Melbourne.

R. B. HUTCHISON.

NOTE.—Any person who intends to appear on the hearing of the said petition must serve on or send by post to the above-named R. B. Hutchison, notice, in writing, of his intention so to do. The notice must state the name and address of the person, or, if a firm, the name and address of the firm, and must be signed by the person or firm, or his, or their solicitor (if any), and must be served or, if posted, must be sent by post in sufficient time to reach the above named not later than 4 o'clock in the afternoon of the 12th day of June, 1973. 2283

In the Supreme Court of Victoria.—No. Co. 8571.—In the matter of the *Companies Act 1961*; and in the matter of MIDWAY ASSOCIATES PTY. LTD. (formerly James Cowan and Associates Pty. Ltd.).

Notice is hereby given that a petition for the winding up of the above-named company by the Supreme Court was on the 20th day of February, 1973 presented by G. Herring (Aust.) Pty. Ltd.: And that the said petition was directed to be heard before the Court on the 14th day of May, 1973, and that on the 10th day of May, 1973, the Court directed that the hearing of the petition be adjourned to be heard before the Court sitting at the Fourteenth Court, Law Courts, William-street, Melbourne, on the 11th day of June, 1973, at 10.30 o'clock in the forenoon; and any creditor or contributory of the said company desiring to support or oppose the making of an order on the said petition may appear at the time of the adjourned hearing by himself or his counsel for that purpose; and a copy of the petition will be furnished to any creditor or contributory of the said company requiring the same by the undersigned on payment of the regulated charge for the same.

The petitioner's address is care of Messrs. Mann, Judd & Co., Gold Fields House, 1 Alfred-street, Sydney Cove, in the State of New South Wales.

The petitioner's solicitors are Messrs. Weigall & Crowther, of 459 Little Collins-street, Melbourne, in the State of Victoria.

WEIGALL & CROWTHER.

NOTE.—Any person who intends to appear on the hearing of the said petition must serve on or send by post to the above-named solicitors, notice, in writing, of his intention to do so. The notice must state the name and address of the person, or if a firm the name and address of the firm and must be signed by the person or firm, or his or their solicitor (if any) and must be served, or if posted, must be sent by post in sufficient time to reach the above named not later than 4 o'clock in the afternoon of the 8th day of June, 1973. 2310

The *Companies Act 1961*.—In the matter of MAJOR PRINTING PTY. LTD. (in Liquidation).

A First and Final Dividend is intended to be declared in the above-mentioned matter. Creditors who have not proved their debts by the 1st day of June, 1973, will be excluded from the dividend.

Dated this 11th day of May, 1973.

R. E. RAMSAY, Liquidator.

Kennedy, Smail & Middlemiss, 296 Little Lonsdale-street, Melbourne, Vic. 3000. 2270

Companies Act 1961.

A.B.C. BLINDS (MELBOURNE) PTY. LTD. (IN LIQUIDATION).

NOTICE TO CREDITORS OF INTENTION TO DECLARE A FIRST DIVIDEND.

A First Dividend is intended to be declared in the above matter. Creditors who have not proved their debt by the 23rd day of May, 1973, will be excluded from this dividend.

Dated this 9th day of May, 1973.

A. NEVILLE BIRD, Liquidator.

A. Neville Bird & Co., chartered accountants, 289 Flinders-lane, Melbourne. Telephone No. 63 2874. 2273

PAKENHAM COOL STORES PROPRIETARY LIMITED (IN LIQUIDATION).

Notice is hereby given that a Final General Meeting of the shareholders of the above company will be held in the Coolstore, Bald Hill-road, Pakenham, on Thursday,

22nd June, 1973, at 8 p.m., when a full statement of accounts will be placed before the shareholders showing how the liquidation has been conducted.

A. A. KAY, Liquidator, 6 Waroona-court, Pakenham, Victoria. 2190

The *Companies Act 1961* (as amended).

FINGAL PTY. LTD.

At an Extraordinary General Meeting of the shareholders of the above-named company duly convened and held at the registered office, Nepean Highway, Dromana, on the 7th day of May, 1973, the following Special Resolution was duly passed:—

"That the company be wound up voluntarily and at such meeting, Harry Leslie Richardson, of 6th Floor, 37 Queen-street, Melbourne, was appointed liquidator for the purpose of the winding up."

Dated this 8th day of May, 1973.

2272 B. C. WILSON, Secretary.

The *Companies Act 1961* (as amended).

FLODAN GOLF COMPANY PTY. LTD.

At an Extraordinary General Meeting of the shareholders of the above-named company, duly convened and held at the registered office, Nepean Highway, Dromana, on the 7th day of May, 1973, the following Special Resolution was duly passed:—

"That the company be wound up voluntarily and at such meeting, Harry Leslie Richardson, of 6th Floor, 37 Queen-street, Melbourne, was appointed liquidator for the purpose of the winding up."

Dated this 8th day of May, 1973.

2271 B. C. WILSON, Secretary.

CHARLES ERNEST GROVES, late of 210 Maribyrnong-road, Moonee Ponds, retired, DECEASED.

Creditors, next of kin and others having claims in respect of the estate of the deceased (who died on the 3rd day of July, 1972), are required by the personal representative, The National Trustees, Executors and Agency Company of Australasia Limited, of 95 Queen-street, Melbourne, to send particulars to it, by the 19th day of July, 1973, after which date the personal representative may convey or distribute the assets, having regard only to the claims of which it has notice.

C. L. AUGUSTINUS, solicitor, of 102B Maribyrnong-road, Moonee Ponds. 2294

Creditors, next of kin and others having claims in respect of the estate of Jessie May Ling, late of 70 Lower Dandenong-road, Mordialloc, widow, deceased (who died on the 26th day of May, 1972), are to send particulars of their claims to The Union-Fidelity Trustee Company of Australia Limited, 100 Exhibition-street, Melbourne, by 31st July, 1973, after which date it will distribute the assets, having regard only to the claims of which it then has notice.

IVAN L. McDONALD, solicitor, 136 Balcombe-road, Mentone. 2300

Creditors, next of kin and other persons having claims against the estate of Elizabeth O'Grady, late of 130 Kooyong-road, Caulfield, in the State of Victoria, married woman, deceased (who died on the 20th October, 1972), are required to send particulars of their claims to the administrator, National Trustees, Executors and Agency Company of Australasia Limited, of 95 Queen-street, Melbourne, by the 23rd day of July, 1973, after which date the administrator will distribute the assets, having regard only to the claims of which it then has had notice.

JAMES P. OGGE & CO., solicitors, 165 Greville-street, Prahran. 2304

Creditors, next of kin and others having claims in respect of the estate of Annie Cameron Wigglesworth, late of 21 Highfield-road, Canterbury, in the State of Victoria, widow, deceased (who died on the 23rd day of December, 1972), are requested to send particulars of their claims to the executors, Howard Wilson Abbey, of Methodist Parsonage, 63 Anderson-street, Lilydale, in the State of Victoria, Minister of Religion, and Wemyss Helen Wigglesworth, of 21 Highfield-road, Canterbury, in the State of Victoria, spinster, care of the under-mentioned solicitors, by the 18th day of July, 1973, after which date they may convey or distribute the assets, having regard only to the claims of which they then have notice.

AITKEN, WALKER & STRACHAN, solicitors, 414 Collins-street, Melbourne. 2305

MARY MONICA MARRIOTT, late of 50 Mills-street, Hampton, in the State of Victoria, widow, DECEASED.

Creditors, next of kin and others having claims in respect of the estate of the above-named deceased (who died on the 25th day of December, 1972), are required by the executor, The Trustees, Executors and Agency Company Limited, of 401 Collins-street, Melbourne, in the said State, to send particulars to the executor by the 18th day of July, 1973, after which date the executor may convey or distribute the assets, having regard only to the claims of which it then has notice.

DAVIES, CAMPBELL & PIESSE, solicitors, of 401 Collins-street, Melbourne. 2315

ISABELLA WALKER VICTORIA DOYLE (usually known as Isabella Doyle), late of 16 Surf-avenue, Beaumaris, in the State of Victoria, widow, DECEASED.

Creditors, next of kin and others having claims in respect of the estate of the above-named deceased (who died between the 19th and 22nd days of January, 1973), are required by the executor, The Trustees, Executors and Agency Company Limited, of 401 Collins-street, Melbourne, in the said State, to send particulars to the executor, by the 18th day of July, 1973, after which date the executor may convey or distribute the assets, having regard only to the claims of which it then has notice.

DAVIES, CAMPBELL & PIESSE, solicitors, of 401 Collins-street, Melbourne. 2316

ELSIE EDITH RICHARDSON, late of Flat 1, 7 Rowell-avenue, Camberwell, in the State of Victoria, widow, DECEASED.

Creditors, next of kin and others having claims in respect of the estate of the above-named deceased (who died on the 24th day of January, 1973), are required by the executors, Melva Dorothy Horne, married woman, and George Reid Horne, gentleman, both of 6 Stirling-crescent, Glen Waverley, in the said State, to send particulars to the executors, by the 18th day of July, 1973, after which date the executors may convey or distribute the assets, having regard only to the claims of which they then have notice.

DAVIES, CAMPBELL & PIESSE, solicitors, of 401 Collins-street, Melbourne. 2317

WILLIAM JOHN SLACK, late of 106 Clyde-street, Box Hill, retired bank officer.

Creditors, next of kin and others having claims in respect of the estate of the deceased (who died on the 14th day of January, 1973), are required by The Perpetual Executors and Trustees Association of Australia Limited, of 100-104 Queen-street, Melbourne, to send particulars of their claims to the said company, by the 31st day of July, 1973, after which date it will convey or distribute the assets, having regard only to the claims of which the company then has notice.

MULLETT, NEDOVIC & CO., solicitors, 470 Bourke-street, Melbourne. 2324

LAWRENCE IAN COLLIE STEPHEN (also known as Lawrence Ian Stephen), late of 51 Ridge-street, South Perth, Western Australia, chartered civil engineer, DECEASED.

Creditors, next of kin and others having claims against the estate of the deceased (who died on 6th December, 1972), are required by the executor, The Trustees, Executors and Agency Company Limited, of 401 Collins-street, Melbourne, to send particulars of their claims to the said company, on or before 18th July, 1973, after which date it will convey or distribute the assets, having regard only to the claims of which it then has notice.

HOME, WILKINSON & LOWRY, solicitors, of 401 Collins-street, Melbourne. 2267

HUBERT MACKAY, late of 26 Canberra-street, Brunswick, plumber, DECEASED.

Creditors, next of kin and others having claims in respect of the estate of the deceased (who died on the 13th day of November, 1972), are required by Herbert Henry Clarke, of 12 Anketell-street, Coburg, gentleman (the executor to whom probate of the will of the said deceased has been granted), to send particulars of their claims to the said Herbert Henry Clarke, by the 20th day of July, 1973, after which date he will convey or distribute the assets, having regard only to the claims of which he then has notice.

HENDERSON & BALL, solicitors, of 430 Little Collins-street, Melbourne. 2293

Creditors, next of kin and all others interested in the estate of Emily Farmer, late of Westhaven Baptist Home, Paisley-street, Footscray, in the State of Victoria, widow, deceased (who died on the 25th day of February, 1973), are required to send particulars of their claims to Jack Meadows, care of John McComas & Co., solicitors, 380 Bourke-street, Melbourne, the executor by whom probate of the will of the deceased was proved in the Supreme Court, by the 21st day of July, 1973, after which date he will distribute the assets, having regard only to the claims of which he then has notice.

JOHN W. MCCOMAS & CO., 380 Bourke-street, Melbourne. 2269

Creditors, next of kin and others having claims in respect of the estate of Brian Kirwan Donaldson, late of 7 Turnbull-avenue, Toorak, and 290 Latrobe-street, Melbourne, solicitor, deceased (who died on the 25th May, 1972), are to send particulars of their claims to the executors, care of the under-mentioned solicitors, by the 18th July, 1973, after which date they will distribute the assets, having regard only to the claims of which they then have notice.

CORR & CORR, solicitors, 290 Latrobe-street, Melbourne. 2262

Creditors, next of kin and others having claims in respect of the estate of Frank Sydenham Einsiedel Tindall, formerly of Jells-road, Waverley, and 13 Prescott-avenue, Mount Martha, in the State of Victoria, but late of Mermaid Beach, Nursing Centre, 2424 Gold Coast Highway, Mermaid Beach, in the State of Queensland, retired, deceased (who died on the 19th May, 1972), are to send particulars of their claims to Vernon Manson Corr, care of the under-mentioned solicitors, by the 18th July, 1973, after which date he will distribute the assets, having regard only to the claims of which he then has notice.

CORR & CORR, solicitors, 290 Latrobe-street, Melbourne. 2261

Creditors, next of kin and others having claims in respect of the estate of James Stephen Maher, late of 207 Pascoe Vale-road, Essendon, in the State of Victoria, clerk (who died on the 7th day of December, 1972), are to send particulars of their claims to National Trustees, Executors and Agency Company of Australasia Limited, carrying on business at 95 Queen-street, Melbourne, in the said State, the executor of the will of the deceased, by the 18th day of July, 1973, after which date it will distribute the assets, having regard only to the claims of which it then has notice.

COLE & O'HEARE, solicitors, of 422 Little Collins-street, Melbourne. 2263

Creditors, next of kin and others having claims in respect of the estate of Alice Adams, late of 25 Leigh-road, Croydon, in the State of Victoria, widow (who died on the 17th day of December, 1972), are to send particulars of their claims to National Trustees, Executors and Agency Company of Australasia Limited, carrying on business at 95 Queen-street, Melbourne, in the said State, the substituted executor of the will of the deceased, the instituted executor, George Martin Adams, having predeceased the executrix, by the 23rd day of July, 1973, after which date it will distribute the assets, having regard only to the claims of which it then has notice.

COLE & O'HEARE, solicitors, 422 Little Collins-street, Melbourne. 2264

Creditors, next of kin and others having claims in respect of the estate of Agnes Davis, late of "Pinjarra", Main-road, Mount Macedon, widow, deceased (who died on the 20th day of December, 1972), are to send particulars of their claims to the executors of her estate, namely Richard Matheson Morgan and Hugh Matheson Morgan, care of the under-mentioned solicitors, by the 1st day of August, 1973, after which date the said executors will distribute the assets in the said estate, having regard only to the claims of which they then have notice.

ARTHUR ROBINSON & CO., solicitors, 447 Collins-street, Melbourne. 2268

JAMES ALEXANDER SMEAL, late of Flat 2, 25 Wynnstay-road, East Prahran, in the State of Victoria, medical practitioner, DECEASED.

Creditors, next of kin and others having claims in respect of the estate of the deceased (who died on the 31st day of December, 1972), are required by The Perpetual Executors and Trustees Association of Australia Limited, of 100-104 Queen-street, Melbourne, in the said State, and William Bruce Stafford, of 1083 North-road, Oakleigh, in the said State, medical practitioner, the applicants for a

grant of administration, to send particulars of their claims to the said applicants, in the care of the said company, by the 20th day of July, 1973, after which date they will convey or distribute the assets, having regard only to the claims of which they then have notice.

ABBOTT, STILLMAN & WILSON, solicitors, 406 Lonsdale-street, Melbourne. 2185

Creditors, next of kin and others having claims in respect of the estate of Ellen Gazina Issell, formerly of Terang, but late of St. Catherine's Hospital, 7 Collins-street, Mentone, widow, deceased, intestate (who died on the 12th day of December, 1972), are required by the Union Fidelity Trustee Company of Australia Limited, of 100 Exhibition-street, Melbourne, to send particulars of their claims to the said company, by the 25th day of July, 1973, after which date it will distribute the assets, having regard only to due claims of which it then has notice.

DAVID E. TRICKETT, High-street, Terang, solicitor for the said company. 2291

PANAYIOTA ANGELI, late of Numurkah, in the State of Victoria, business proprietor, DECEASED, intestate (died 17th September, 1972).

Creditors, next of kin and others having claims against the estate specified above are required to send particulars in writing, of such claims to the personal representatives of such estate, in care of Messrs. Morrison and Teare, solicitors, Numurkah, on or before the 16th August, 1973, after which date the assets of the estate will be conveyed, or distributed among the persons entitled thereto, having regard only to the claims to which the representatives shall then have had notice. 2240

Creditors, next of kin and others having claims against the estate of George Edward Digby, late of Church Hill, Creswick, retired timber worker, deceased (who died on the 3rd day of January, 1973), are requested to send particulars of their claims to the executor, The Union-Fidelity Trustee Company of Australia Limited, of 101 Lydiard-street north, Ballarat, by the 14th August, 1973, after which date the said executor will distribute the assets, having regard only to the claims of which it then has notice.

NEVETT, GLENN & COUTTS, solicitors, 205 Dana-street, Ballarat. 2234

RODNEY WAYNE JANETZKI, late of 2 Eyre-court, Swan Hill, in the State of Victoria, bank officer, DECEASED, intestate (who died on the 17th February, 1973).

Creditors, next of kin and all other persons having claims against the estate of the deceased, are required by the administrator, Stanley William Henry Janetzi, to send particulars to him, care of the undersigned, on or before the 10th day of August, 1973, after which date he will distribute the assets, having regard only to the claims of which he then has notice.

GARDEN & GREEN, solicitors, 4 McCallum-street, Swan Hill. 2241

Creditors, next of kin and all others having claims against the estate of William Alfred Nissen, late of Murchison East, in the State of Victoria, farmer, deceased, intestate, are required to send particulars thereof to Stewart Feltham & Co., solicitors, Tatura, on or before the 23rd day of July, 1973, otherwise they may be excluded when the assets are being distributed.

MESSRS. STEWART FELTHAM & CO., solicitors, Box 199, Tatura, 3616. 2243

Creditors, next of kin and others having claims against the estate of Adriana Brandsma, formerly Adriana Houben, late of 66 High-street, Kew, dress designer, deceased (who died on the 27th February, 1973), are required by the executor, Alfred Newton Super, of 374 Bourke-street, Melbourne, solicitor, to send particulars of such claims to him, on or before the 23rd July, 1973, after which date he will distribute the assets, having regard only to the claims of which he shall have had notice. 2246

Creditors, next of kin and others having claims in respect of the estate of Roy Peter Hague, late of 1 Canterbury-place, Brighton Beach, maintenance worker, deceased (who died on the 29th day of September, 1972), are requested to send particulars of their claims to William Rose, the executor named in the will of the said deceased in care of the under-mentioned solicitors, by the 1st day of August, 1973, after which date the executor will distribute the assets, having regard only to the claims of which he has notice.

CLEMENTS, MOTT & BETT, solicitors, 253-255 Glenhuntly-road, Elsternwick. 2198

WILLIAM JOSEPH YATES, late of Bairnsdale, gentleman, DECEASED.

Creditors, next of kin and others having claims in respect of the estate of the deceased (who died on the 9th day of October, 1972), are required by The Perpetual, Executors and Trustees Association of Australia Limited, of 100-104 Queen-street, Melbourne, to send particulars of their claims to the said company, by the 16th day of July, 1973, after which date it will convey or distribute the assets, having regard only to the claims of which the company then has notice.

WARREN, GRAHAM & MURPHY, solicitors, Bairnsdale, 3875. 2201

Creditors, next of kin and others having claims in respect of the estate of Hilda Taylor (also known as Hilda Harris), late of 23 Bena-street, Yarraville, in the State of Victoria, home duties, deceased (who died on the 12th November, 1972, and probate of whose will has been granted to Joseph Perillo, of 209 Nicholson-street, Footscray, in the said State, solicitor), are required to send particulars, in writing, of such claim to the said executor, at his address above referred to before the 26th July, 1973, after which date the executor will distribute the assets, having regard only to the claims of which he then has notice.

J. PERILLO, ADAMI & CO., solicitors, of 209 Nicholson-street, Footscray. 2222

WILLIAM WHALEN, late of 127 Moriah-street, Clayton, grocer, DECEASED.

Creditors, next of kin and others having claims in respect of the deceased (who died on the 6th day of January, 1973), are required by his trustees, Nola Doreen Whalen, of 127 Moriah-street, Clayton, widow, and Samuel Gordon Gray, of 3-5 Collopy-street, Mansfield, contractor, to send particulars to them, care of the under-mentioned firm of solicitors, by the 30th day of July, 1973, after which date the trustees may convey and distribute the assets, having regard only to the claims of which they then have notice.

MAL RYAN & GLEN, 9 High-street, Mansfield, solicitors for the trustees. 2226

Creditors, next of kin and others having claims in respect of the estate of Alexander James Smith, formerly of 186 Mont Albert-road, Canterbury, engineer, but late of 74 Barkly-street, East Brunswick, retired, deceased (who died on the 10th day of October, 1972), are requested to send particulars of their claims to David Ray Weston Smith (in the will called David Weston Smith), the executor named in the will of the said deceased, in care of the under-mentioned solicitors, by the 1st day of August, 1973, after which date the executor will distribute the assets, having regard only to the claims of which he has notice.

GREGORY GRAY & CO., solicitors, 635 Glenferrie-road, Hawthorn. 2242

JOHN ROSS RISCHBIETH, late of 60 The Esplanade, Maribymong, retired public servant, DECEASED.

Creditors, next of kin and others having claims in respect of the estate of the deceased (who died on the 15th November, 1972), are required by The Perpetual Executors and Trustees Association of Australia Limited, of 100-104 Queen-street, Melbourne, Olive Patricia Meiklejohn Rischbieth, widow, and Nicholas John Carl Rischbieth, technician, both of 60 The Esplanade, Maribymong, the applicants for a grant of probate of the will and codicil of the said applicants, in the care of the said company, by the 24th July, 1973, after which date they will convey or distribute the assets, having regard only to the claims of which they then have notice.

W. B. & O. MCCUTCHEON, solicitors, 150 Queen-street, Melbourne. 2256

STANLEY BARTON KILPATRICK, late of Cohuna, in the State of Victoria, retired motor mechanic, DECEASED.

Creditors, next of kin and all other persons having claims against the estate of the said deceased, are required by Raymond Stanley Kilpatrick, in the will called Stanley Ramond Kilpatrick, of 23 Deakin-street, Essendon, in the State of Victoria, agricultural officer, and Barry Neil Kilpatrick, of 997 Sylvania-avenue, North Albury, in the State of New South Wales, slaughterman, executors, of the estate of the said deceased, to send particulars of such claims to them, in care of the under-mentioned solicitors, on or before the 10th of July, 1973, after which date they will distribute the assets, having regard only to the claims of which they then have notice.

MITCHELL, MCKENZIE & CO., solicitors, Kerang, and at Cohuna and Echuca. 2258

Creditors, next of kin and others having claims in respect of the estate of Benjamin Charles Steen, late of Ararat, retired, deceased (who died on the 1st day of November, 1972, and probate of whose will was granted by the Supreme Court of Victoria, on the 20th day of March, 1973, to Stanley Reuben Harrison, merchant, and John Edward Joseph Briggs, solicitor, both of Ararat, the executors named in the said will), are to send particulars of their claims to the said executors, at their address, care of Briggs & O'Driscoll, solicitors, 94 Barkly-street, Ararat, by the 17th day of July, 1973, after which date they will distribute the assets, having regard only to the claims of which they then have notice.

BRIGGS & O'DRISCOLL, solicitors, Ararat. 2249

Creditors, next of kin and others having claims in respect of the estate of Rose Mary Ethel Webb, late of 8 Moreland Court, 546 Moreland-road, Brunswick West, widow, deceased (who died on the 27th day of December, 1972), are to send particulars of their claims to The Trustees, Executors and Agency Company Limited, by the 31st day of July, 1973, after which date it will distribute the assets, having regard only to the claims of which it then has notice.

DAVID THOMAS & FRENKEL, of 303 Latrobe-street, Melbourne, solicitors to the company. 2251

HENRY WILLIAM WELCH, late of 219 Dorking-road, Box Hill North, in the State of Victoria, gentleman, DECEASED.

Creditors, next of kin and others having claims in respect of the estate of the deceased (who died on the 12th day of August, 1972), are required by the executor, Jack Wilfred Dollman, of 45 Stroud-street, Balwyn, in the said State, knitting room manager, to send particulars to him, in care of the undersigned, by the 31st day of July, 1973, after which date the executor may convey or distribute the assets, having regard only to the claims of which he then has notice.

Dated the 9th day of May, 1973.

P. H. PIPPEY & SON, 1 Watts-street, Box Hill, solicitors for the executor. 2252

MARGARITE WOLF, late of 26 Turner-street, Glen Iris, in the State of Victoria, married woman, DECEASED.

Creditors, next of kin and others having claims in respect of the estate of the deceased (who died on the 24th July, 1971), are required by the trustees, The Union-Fidelity Trustee Company of Australia Limited, of 100 Exhibition-street, Melbourne, in the said State, to send particulars to it, by the 15th August, 1973, after which date the trustee may convey or distribute the assets, having regard only to the claims of which it then has notice.

KEITH HERCULES & SONS, solicitors, 443 Little-Collins-street, Melbourne. 2254

Trustee Act 1958.
NOTICE TO CLAIMANTS.

Pursuant to the *Trustee Act 1958*, creditors next of kin and all other persons having claims in respect of the estate of any deceased person named below are required to send particulars to the legal personal representative or representatives at the addresses stated, after which date the representatives will distribute the assets, having regard only to the claims of which notice has been received:—

Douglas Duncan, late of 37 Milford-street, Newport, retired engineer, deceased, died on the 21st day of January, 1973.—Claims to the executrix, Lillian Coralie Duncan, of 37 Milford-street, Newport, widow, care of John F. Carroll, of 4 Paisley-street, Footscray, solicitor, by the 25th day of July, 1973. John F. Carroll, LL.B., solicitor, 4 Paisley-street, Footscray. 2298

Elsie Elizabeth Baker, late of 43 Ryan-street, Footscray, widow, deceased, died on the 1st day of February, 1973.—Claims to the executrix, Mary Rose Clarke, of 125 Cowper-street, Footscray, married woman, care of John F. Carroll, of 4 Paisley-street, Footscray, solicitor, by the 25th day of July, 1973. John F. Carroll, LL.B., solicitor, 4 Paisley-street, Footscray. 2299

Hilda Mary Darby, late of 9 Home-road, Newport, widow, deceased, died on the 11th day of February, 1973.—Claims to the executors, Carmelita Ann Kelly, married woman, and Patrick John Kelly, teacher, both of 1 Kincumber-place, Engadine, New South Wales, care of John F. Carroll, of 4 Paisley-street, Footscray, solicitor, by the 25th day of July, 1973. John F. Carroll, LL.B., solicitor, 4 Paisley-street, Footscray. 2297

Pursuant to the provisions of the *Trustee Act 1958*, creditors, next of kin and all other persons having claims in respect of the estate of Edith May Lamond Muntz, formerly of 94 Overport-road, Frankston, but late of Unit 2, No. 24 Bembridge-avenue, Frankston, spinster (who died on the 3rd November, 1972), are required to send particulars of their claims to the executors, Judith Mary Dean, of 16 The Close, Frankston, married woman, and Donald Lyston Chisholm, of 339 Collins-street, Melbourne, solicitor, by the 18th July, 1973, after which date the executors will distribute the assets, having regard only to the claims of which they shall then have had notice.

MADDOCK, LONIE & CHISHOLM, solicitors, 339 Collins-street, Melbourne. 2255

CHARLES HORATIO BEAUCHAMP, late of 31 Thanet-street, Malvern, sworn valuer, DECEASED.

Creditors, next of kin and others having claims in respect of the estate of the deceased (who died on the 6th day of January, 1973), are required by The Perpetual Executors and Trustees Association of Australia Limited, of 100-104 Queen-street, Melbourne, to send particulars of their claims to the said company, by the 18th day of July, 1973, after which date it will convey or distribute the assets, having regard only to the claims of which the company then has notice.

CORR & CORR, solicitors, 290 La Trobe-street, Melbourne. 2257

MAVIS GLADYS MAY BARRINGTON, late of 9 Mayroscrescent, Brighton, in the State of Victoria, married woman, DECEASED.

Creditors, next of kin and others having claims in respect of the estate of the deceased (who died on the 16th March, 1973), are requested by the executrix, Erica Grace Greenwood, of 60 Rivett-crescent, Mulgrave, in the said State, married woman, to send particulars to her, care of the under-mentioned solicitor by the 15th July, 1973, after which date she may convey or distribute the assets, having regard only to the claims of which she then has notice.

JOHN M. BARRINGTON, solicitor, 42 Northcote-avenue, Caulfield. 2259

HENRY WEBB, late of Manor Court, Lodge, 144 Power-street, Hawthorn, gentleman, DECEASED.

Creditors, next of kin and others having claims in respect of the estate of the deceased (who died on the 4th day of February, 1973), are required by The Union-Fidelity Trustee Company of Australia Limited, of 100 Exhibition-street, Melbourne, to send particulars of their claims to the said company, by the 18th day of July, 1973, after which date it will convey or distribute the assets, having regard only to the claims of which it then has notice.

CORR & CORR, solicitors, 290 La Trobe-street, Melbourne. 2260

EVA FLORENCE UPTON, late of Sea Lake, in the State of Victoria, married woman, DECEASED.

Creditors, next of kin and others having claims against the estate of the above-named deceased (who died on the 3rd August, 1972), are required by the executors, Michael James Upton, James Thomas Upton, and John Douglas Upton, all care of H. R. Blair & Blair, solicitors, P.O. Box 24, Manangatang, to send to them at their said address, particulars of such claims, not later than 30th July, 1973, after which date the said executors may convey or distribute the assets, having regard only to the claims of which they shall then have had notice.

Dated this 12th April, 1973.

H. R. BLAIR & BLAIR, solicitors, Manangatang. 2187

HERBERT VICTOR McLEAN, late of Sea Lake, in the State of Victoria, farmer, DECEASED.

Creditors, next of kin and others having claims against the estate of the above-named deceased (who died on 30th July, 1972), are required by the executors, (Mrs.) Elva Christina McLean, and John Lillington Hanns, both care of H. R. Blair & Blair, solicitors, P.O. Box 24, Manangatang, to send to them at their said address, particulars of such claims, not later than 30th July, 1973, after which date the said executors may convey or distribute the assets, having regard only to the claims of which they shall then have had notice.

Dated this 12th April, 1973.

H. R. BLAIR & BLAIR, solicitors, Manangatang. 2188

Creditors, next of kin and others having claims in respect of the estate of John Walsh, formerly of 183 Kay-street, Traralgon, in the State of Victoria, but late of 92 Grey-street, Traralgon, aforesaid, contractor, deceased (who died on the 1st September, 1972), are required by the executrix Veronica Josephine Walsh, to send particulars to her, care of the under-mentioned solicitors, by the 16th July, 1973, after which date the executrix will distribute the assets, having regard only to the claims of which she then has notice.

RICHES & DAVINE, solicitors, 96 Hotham-street, Traralgon. 2194

In the Supreme Court of the State of Victoria.
SALE BY THE SHERIFF.

On Friday, the 22nd of June, 1973, at 10 a.m., at the Police Station, Moonee Ponds (unless process be stayed or satisfied):—

All the estate and interest (if any) of Lazaros Sideras, process worker, and Anthoula Sideras (shown on certificate of title as Athina Sideras), machinist, both of 16 Ngarveno-street, Moonee Ponds, as joint proprietors of an estate in fee-simple in the land described in certificate of title, volume 4368, folio 477, upon which is erected a dwelling-house, known as No. 16 Ngarveno-street, Moonee Ponds.

Registered mortgage No. E.667017 affects the said estate and interest.

Terms: Cash only.

DOUGLAS S. HALL, Sheriff's Officer.

16th May, 1973. 2306

In the Supreme Court of the State of Victoria.
SALE BY THE SHERIFF.

On Friday, the 29th of June, 1973, at 11 a.m., at the Police Station, Toorak (unless process be stayed or satisfied):—

All the estate and interest (if any) of John H. McKillop, pharmaceutical chemist, 17 May-road, Toorak, as proprietor of an estate in fee-simple in the land described in certificate of title, volume 6056, folio 196, upon which is erected a brick dwelling, known as No. 17 May-road, Toorak.

Registered mortgage No. E.569807 affects the said estate and interest.

Terms: Cash only.

H. BUETTNER, Sheriff's Officer.

16th May, 1973. 2307

In the Supreme Court of the State of Victoria.
SALE BY THE SHERIFF.

On Friday, the 29th of June, 1973, at 10 a.m., at the Police Station, Kew (unless process be stayed or satisfied):—

All the estate and interest (if any) of Mario Santoro, builder, of 187 Barkers-road, Kew, and Filipa Santoro, as joint proprietors of an estate in fee-simple in the land described in certificate of title, volume 7913, folio 033, upon which is erected a brick dwelling, known as No. 187 Barkers-road, Kew.

Registered mortgages Nos. E.267285, E.410801 and E.620479 affect the said estate and interest.

Terms: Cash only.

H. BUETTNER, Sheriff's Officer.

16th May, 1973. 2308

In the Supreme Court of the State of Victoria.
SALE BY THE SHERIFF.

On Tuesday, the 19th of June, 1973, at 3 p.m., at the Police Station, Doncaster (unless process be stayed or satisfied):—

All the estate and interest (if any) of Marion Campbell (shown in certificate of title as Marion Louise Karls), married woman, of Golden Fleece Service Station, Whittlesea, as proprietor of an estate in fee-simple in the land described in certificate of title, volume 8840, folio 234, upon which is erected a dwelling, known as No. 2 Botanic-drive, Doncaster.

Registered mortgage No. E.386180 affects the said estate and interest.

Terms: Cash only.

H. BUETTNER, Sheriff's Officer.

16th May, 1973. 2309

IMPOUNDINGS

CASTERTON.—Impounded in Casterton Pound, from Lake Mundi, by J. Maguire.

1 Hereford cross steer, no visible brand, top notched near ear

If not claimed and expenses paid, to be sold on 31st May, 1973.

W. R. FRANKS,

Poundkeeper.

2250—\$2.80

COLERAINE.—Impounded in Coleraine Pound, by the Shire Herdsman, from the Horsham-road, Balmoral.

Nos. 13 to No. 19. 7 head of mixed cattle, no visible brand or earmarks

If not claimed and expenses paid, to be sold on 2nd June, 1973.

GEO. SPONG,

Poundkeeper.

2288—\$2.80

LARA.—Impounded in Lara Pound, by Ranger.

1 bay mare, 10-12 hands, no visible brand

1 billy goat, no visible brand

2 does (goats), no visible brands

If not claimed and expenses paid, to be sold on 30th May, 1973.

J. BAILEY,

Poundkeeper.

2253—\$2.80

SKIPTON.—Impounded in Skipton Pound, by the Shire Ranger, from roads in Snake Valley, on Wednesday, 2nd May, 1973.

1 black bull, about 9 months of age, no visible brands or earmarks

If not claimed and expenses paid, to be sold on 28th May, 1973.

W. GOULD,

Poundkeeper.

2244—\$3.15

WYCHEPROOF.—Impounded in Wycheproof Pound, from Berrivillock, by R. Bath.

109 crossbred ewes, branded with blue S or blue 5, with black brand underneath

1 lamb, branded with blue S or blue 5, with black brand underneath

If not claimed and expenses paid, to be sold on 31st May, 1973.

J. C. HOMMELHOFF,

Poundkeeper.

2218—\$3.50

Subordinate Legislation Act 1962.

NOTICE OF MAKING OF STATUTORY RULES.

In pursuance of the provisions of the *Subordinate Legislation Act 1962* and the Regulations made thereunder, notice is given of the making of the following statutory rules:—

No.	Maintenance Act 1965.	Price.
85/1973.	Maintenance (Amendment) Rules 1973	10c
86/1973.	Hospitals Superannuation Act 1965 (No. 7354). Hospitals Superannuation (Fund) Regulations 1973	40c
87/1973.	Apprenticeship Act 1958. Apprenticeship (Furniture Trades) (Amendment) Regulations 1973	10c
88/1973.	Explosives Act 1960. Classification of Explosives	20c

No. *Criminal Injuries Compensation Act 1972.* Price.
89/1973. *Criminal Injuries Compensation Regulations* 15c
1973

Grain Elevators Act 1958.

90/1973. *Grain Elevators Board By-law (relating to the Conditions of Employment of Staff)* 10c
No. 47L

Copies of these statutory rules may be purchased at the Sale of Publications Section of the Government Printing Office, located at 7A Parliament-place, Melbourne, 3002. If ordered by mail, remittance should be addressed to "The Government Printer, Box 203, P.O., North Melbourne, 3051", and should include 7c extra for postage. If a credit account is held at this office, no remittance is required with the mail order.

The annual subscription rate for Statutory Rules (including Bound Volumes) is \$25, payable in advance. The subscription year commences on 1st January.

C. H. RIXON,
Government Printer.

STATE ACTS, 1972

Copies of the following Acts of Parliament of Victoria may be obtained at the Government Printing Office, Sale of Publications Branch, off Parliament-place, Melbourne, phone 63 0321, extension 6181, or from any accredited agent, at the price set opposite to each (these prices do not include postage).

The annual subscription for State Acts 1972 et seq. is \$12.50 payable in advance.

Bound Volumes of State Acts are also available on a subscription basis of \$17.50 per annum.

No.	Price.
8242. Seamen's (Amendment)	\$0.10
8243. Land (Greyhound Racing)	\$0.10
8244. Melbourne Land (Royal Melbourne Institute of Technology)	\$0.10
8245. Adoption of Children (Amendment)	\$0.10
8246. Disposal of Uncollected Goods (Amendment)	\$0.15
8247. Crimes (Powers of Arrest)	\$0.15
8248. Trustee Companies (Sandhurst and Northern District Trustees Executors and Agency Company Limited)	\$0.10
8249. Victorian Arts Centre	\$0.10
8250. Road Traffic (Amendment)	\$0.10
8251. Trustee Companies (National Trustees)	\$0.10
8252. Game Act	\$0.10
8253. Vermin and Noxious Weeds (Allowances)	\$0.10
8254. Leo Cussen Institute for Continuing Legal Education	\$0.15
8255. Revocation and Excision of Crown Reservations	\$0.10
8256. Dookie Agricultural College Land	\$0.15
8257. Country Fire Authority (Amendment)	\$0.15
8258. Select Committee (Ansett Transport Industries)	\$0.10
8259. Legal Profession Practice (Amendment)	\$0.15
8260. Mt. Hotham Alpine Resort	\$0.20
8261. Nurses (Amendment)	\$0.10
8262. Films (Amendment)	\$0.10
8263. County Court (Jurisdiction)	\$0.10
8264. Soldier Settlement (Amendment)	\$0.10
8265. Government Buildings Advisory Council	\$0.10
8266. Poisons (Amendment)	\$0.10
8267. Police Offences	\$0.10
8268. Public Service (Amendment)	\$0.10
8269. Racing (Totalizator Commissions)	\$0.10
8270. Stamps (Bookmakers' Statements)	\$0.10
8271. Workers Compensation	\$0.10
8272. Liquor Control (Amendment)	\$0.15
8273. Archaeological and Aboriginal Relics Preservation	\$0.20
8274. Taxation Appeals	\$0.30
8275. Justices	\$0.20
8276. Consumer Protection	\$0.60
8277. Environment Protection (Amendment)	\$0.15
8278. Coal Mines (Pensions)	\$0.10
8279. Motor Car (Amendment)	\$0.15
8280. Crimes (Amendment)	\$0.15
8281. Melbourne and Metropolitan Board of Works (Reconstitution)	\$0.10
8282. Supply (Supplementary Estimates)	\$0.10
8283. Victoria Institute of Colleges (Affiliated Colleges)	\$0.10
8284. Supreme Court (Civil Appeals)	\$0.10
8285. Tattersall Consultations (Amendment)	\$0.10
8286. Parliamentary Committees (Take-over Offers)	\$0.15

STATE ACTS, 1972—continued.

No.	Price.
8287. Dentists	\$0.40
8288. Firearms (Amendment)	\$0.30
8289. Sports Promotion	\$0.15
8290. Western Port (Steel Works)	\$0.10
8291. Local Government	\$0.30
8292. Supply (July to September)	\$0.10
8293. Marine	\$0.15
8294. Supply (October to December)	\$0.10
8295. Albert Park Land	\$0.10
8296. Yarraville (Recreation Ground) Lands (Amendment)	\$0.10
8297. Summer Time	\$0.10
8298. Co-operative Housing Societies	\$0.10
8299. State Rivers and Water Supply Commission (Special Projects)	\$0.10
8300. Limitation of Actions (Personal Injuries)	\$0.10
8301. Montrose Land	\$0.10
8302. Registration of Birth Deaths and Marriages	\$0.10
8303. State Electricity Commission (Borrowing Powers)	\$0.10
8304. Land (Residence Areas)	\$0.15
8305. Attorney-General and Solicitor-General	\$0.10
8306. Supreme Court (Judges)	\$0.10
8307. Constitutional Convention	\$0.10
8308. The Constitution Act Amendment (Conjoint Elections)	\$0.10
8309. Ringwood (Recreation Reserve) Land	\$0.10
8310. Land (Jetties and Marinas)	\$0.15
8311. Sandringham (Beach Oval) Land	\$0.10
8312. Mental Health (Admissions)	\$0.10
8313. Opticians Registration (Amendment)	\$0.10
8314. Superannuation	\$0.20
8315. Crown Grants (Removal of Conditions)	\$0.15
8316. Coal Mines (Pensions Increase)	\$0.10
8317. Sewerage Districts (Amendment)	\$0.10
8318. Gas and Fuel Corporation	\$0.10
8319. Boilers and Pressure Vessels (Registration)	\$0.10
8320. Lifts and Cranes (Amendment)	\$0.10
8321. Volunteer Civil Defence Workers Compensation	\$0.10
8322. Footscray (Bailey Reserve) Land	\$0.10
8323. Mildura Irrigation and Water Trusts (Amendment)	\$0.10
8324. Clean Air (Amendment)	\$0.10
8325. State Forests Works and Services	\$0.10
8326. Geelong Land Exchange	\$0.10
8327. Evidence	\$0.15
8328. State Electricity Commission (Dartmouth Hydro-Electric Power Station)	\$0.10
8329. State Electricity Commission (Yallourn W Power Station)	\$0.10
8330. Wrongs	\$0.10
8331. Crown Reservations (Revocation and Excision)	\$0.10
8332. Road Traffic	\$0.10
8333. Geelong Waterworks and Sewerage (Amendment)	\$0.20
8334. Navigable Waters (Oil Pollution) (Amendment)	\$0.20
8335. Melbourne College of Divinity	\$0.15
8336. Education (Amendment)	\$0.10
8337. Mines (Amendment)	\$0.10
8338. Crimes	\$0.10
8339. Housing Ministry	\$0.15
8340. National Gallery of Victoria	\$0.10
8341. The Constitution Act Amendment (Disqualification)	\$0.10
8342. River Improvement (Amendment)	\$0.10
8343. Health (Amendment)	\$0.30
8344. Youth, Sport and Recreation	\$0.30
8345. Motor Car (Learner Drivers' Permits)	\$0.15
8346. Veterinary Research Institute	\$0.10
8347. Cattle Compensation (Amendment)	\$0.10
8348. The Constitution Act Amendment (Appropriations)	\$0.10
8349. Motor Car (Miscellaneous Provisions)	\$0.10
8350. Victoria Conservation Trust	\$0.10
8351. Second-hand Dealers (Charitable Collectors)	\$0.10
8352. St. Vincent's Private Hospital (Guarantees)	\$0.10
8353. Railways (Amendment)	\$0.50
8354. Railway Works and Services	\$0.10
8355. Chiropodists (Amendment)	\$0.10
8356. Public Service (Appeals)	\$0.10
8357. Ministry for the Arts	\$0.15
8358. Wheat Marketing (Over-quota Wheat)	\$0.10
8359. Criminal Injuries Compensation	\$0.30
8360. The Constitution Act Amendment (Qualifications Joint Select Committee)	\$0.10
8361. Appropriation	\$2.20
8362. Water Supply Works and Services	\$0.30
8363. Surrender of Land	\$0.20
8364. Ministry for Conservation	\$0.15

STATE ACTS, 1972—continued

No.	Price.
8365. Public Works and Services	\$0.15
8366. Dental Technicians	\$0.30
8367. Land (Crown Bailiffs)	\$0.10
8368. Weights and Measures (Amendment)	\$0.20
8369. Metric Conversion (Agricultural Chemicals)	\$0.10
8370. Farm Produce Merchants and Commission Agents (Amendment)	\$0.10
8371. Milk and Dairy Supervision (Amendment)	\$0.10
8372. Pesticides (Amendment)	\$0.20
8373. Housing (Amendment)	\$0.10
8374. Local Government (Leases)	\$0.10
8375. Country Roads (Amendment)	\$0.10
8376. State College of Victoria	\$0.40
8377. State Electricity Commission (Amendment)	\$0.10
8378. Educational Grants	\$0.10
8379. Land Conservation (Vehicle Control)	\$0.10
8380. Town and Country Planning (Amendment)	\$0.40
8381. Land Tax	\$0.10
8382. Consumer Protection (Amendment)	\$0.15
8383. Decentralized Industry Incentives (Pay-roll Tax Rebates)	\$0.15
8384. Labour and Industry (Amendment)	\$0.15

C. H. RIXON,
Government Printer.

ACTS REPRINTED IN ACCORDANCE WITH THE AMENDMENTS INCORPORATION ACT 1958 (No. 6422), AND FOR SALE AT THE SALE OF PUBLICATIONS BRANCH OF THE GOVERNMENT PRINTING OFFICE, MACARTHUR-STREET, MELBOURNE, 3002.

(These prices do not include postage.)

No.	Price.
6189. Acts Interpretation (Third Reprint—Incorporating amendments up to No. 7944)	\$0.35
6191. Administration and Probate (Fourth Reprint—Incorporating amendments up to No. 7874)	\$0.75
6194. Agricultural Colleges (First Reprint—Incorporating amendments up to No. 7302)	\$0.15
6198. Anzac Day (First Reprint—Incorporating amendments up to No. 8344)	\$0.15
7117. Appeal Costs Fund Act 1964 (First Reprint—Incorporating amendments up to No. 7488)	\$0.25
6199. Apprenticeship (Second Reprint—Incorporating amendments up to No. 7869)	\$0.40
6201. Architects (First Reprint—Incorporating amendments up to No. 8077)	\$0.30
6203. Audit (First Reprint—Incorporating amendments up to No. 7377)	\$0.35
6208. Benefit Associations (First Reprint—Incorporating amendments up to No. 6961)	\$0.45
6529. Bread Industry Act 1959 (First Reprint—Incorporating amendments up to No. 7728)	\$0.30
6973. Building Contracts (Deposits) Act 1962 (First Reprint—Incorporating amendments from No. 7315)	\$0.10
6210. Building Societies (Second Reprint—Incorporating amendments up to No. 7911)	\$0.40
6213. Cancer (First Reprint—Incorporating amendments up to No. 7455)	\$0.35
6214. Carriers and Innkeepers (First Reprint—Incorporating amendments up to No. 7971)	\$0.15
6217. Cemeteries (First Reprint—Incorporating amendments up to No. 7672)	\$0.30
6218. Children's Court (Second Reprint—Incorporating amendments up to No. 8124)	\$0.45
6220. Clean Air (Second Reprint—Incorporating amendments up to No. 8196)	\$0.15
6221. Coal Mines (First Reprint—Incorporating amendments up to No. 7628)	\$1.05
6222. Commercial Goods Vehicles (Second Reprint—Incorporating amendments up to No. 7358)	\$0.22
6223. Commonwealth Arrangements (First Reprint—Incorporating amendments from No. 7809)	\$0.10
6839. Companies Act 1961 (Fourth Reprint—Incorporating amendments up to Act No. 8185)	\$5.75
6224. The Constitution Act Amendment (First Reprint—Incorporating amendments up to No. 8086)	\$3.05
6225. Co-operation (Second Reprint—Incorporating amendments up to No. 7083)	\$0.42
6226. Co-operative Housing Societies (Second Reprint—Incorporating amendments up to No. 7575)	\$0.53
6227. Coroners (First Reprint—Incorporating amendments up to No. 7935)	\$0.35

ACTS REPRINTED IN ACCORDANCE WITH THE AMENDMENTS INCORPORATION ACT 1958 (No. 6422)—continued.

No.	Price.
6228. Country Fire Authority (Second Reprint—Incorporating Amendments up to No. 7476)	\$0.50
6229. Country Roads (Third Reprint—Incorporating amendments up to No. 8140)	\$1.05
6230. County Court (Second Reprint—Incorporating amendments up to No. 8132)	\$0.65
6231. Crimes (Third Reprint—Incorporating amendments up to No. 7884, but not including No. 7876)	\$1.60
6232. Crown Proceedings (First Reprint—Incorporating amendments up to No. 7900)	\$0.30
6233. Dairy Products (First Reprint—Incorporating amendments up to No. 7945)	\$0.20
7060. Dandenong Valley Authority Act 1963 (First Reprint—Incorporating amendments up to No. 7523)	\$0.35
4989. Discharged Servicemen's Preference Act 1943 (First Reprint—Incorporating amendments up to No. 7788)	\$0.20
6815. Disposal of Uncollected Goods Act 1961 (First Reprint—Incorporating amendments up to No. 7181)	\$0.15
6237. Drainage Areas (First Reprint—Incorporating amendments up to No. 7276)	\$0.35
6238. Drainage of Land (First Reprint—Incorporating amendments up to No. 7876)	\$0.15
6239. Dried Fruits Act 1968 (First Reprint—Incorporating amendments up to No. 7337)	\$0.25
6240. Education (First Reprint—Incorporating amendments up to No. 7533)	\$0.45
6241. Electric Light and Power (First Reprint—Incorporating amendments up to No. 7315)	\$0.30
6242. Employers and Employés (Incorporating amendments up to No. 6740)	\$0.18
6243. Entertainments Tax (First Reprint—Incorporating amendments up to No. 7315)	\$0.25
8056. Environment Protection Act 1970 (First Reprint—Incorporating amendments up to No. 8277)	\$0.55
6245. Estate Agents (Fourth Reprint—Incorporating amendments up to No. 8181)	\$0.85
6246. Evidence (Fourth Reprint—Incorporating amendments up to No. 7933)	\$1.05
7499. Extractive Industries Act 1966 (Second Reprint—Incorporating amendments up to No. 7951)	\$0.40
6250. Fertilizers (Incorporating amendments up to No. 7142)	\$0.25
6468. Filled Milk (First Reprint—Incorporating amendments up to No. 6886)	\$0.15
6251. Firearms (Third Reprint—Incorporating amendments up to No. 8092)	\$0.65
6916. Foreign Judgments Act 1962 (First Reprint including amendments made by No. 7332)	\$0.15
6585. Forests (Pulpwood Agreement) (Incorporating amendments up to No. 6886)	\$0.15
6254. Forests (First Reprint—Incorporating amendments up to No. 7356)	\$0.60
6255. Friendly Societies (First Reprint—Incorporating amendments up to No. 7554)	\$0.60
6256. Fruit and Vegetables (First Reprint—Incorporating amendments up to No. 6944)	\$0.30
6258. Game (First Reprint—Incorporating amendments up to No. 7389)	\$0.30
6260. Gas and Fuel Corporation (First Reprint—Incorporating amendments up to No. 7422)	\$0.70
6262. Geelong Harbor Trust (First Reprint—Incorporating amendments up to No. 7547)	\$0.45
6263. Geelong Waterworks and Sewerage (First Reprint—Incorporating amendments up to No. 7547)	\$0.75
8176. Gift Duty Act 1971 (First Reprint—Incorporating amendments from No. 8202)	\$0.55
6265. Goods (Fifth Reprint—Incorporating amendments up to No. 8276)	\$0.45
6266. Grain Elevators (First Reprint—Incorporating amendments up to No. 7486)	\$0.35
6269. Hawkers and Pedlars (First Reprint—Incorporating amendments up to No. 7876)	\$0.30
6270. Health (Second Reprint—Incorporating amendments up to No. 7490)	\$1.65
6267. Hairdressers Registration (First Reprint—Incorporating amendments up to Act No. 7659)	\$0.30
6531. Hire Purchase Act 1959 (Second Reprint—Incorporating amendments from Act No. 8232)	\$0.55
6933. Home Finance Act 1962 (First Reprint—Incorporating amendments up to No. 7363)	\$0.25

ACTS REPRINTED IN ACCORDANCE WITH THE AMENDMENTS
INCORPORATION ACT 1958 (No. 6422)—continued.

No.	Price:
6274. Hospitals and Charities (Second Reprint—Incorporating amendments up to No. 7455)	\$0.50
6275. Housing (Second Reprint—Incorporating amendments up to No. 8052)	\$1.65
6276. Imprisonment of Fraudulent Debtors (First Reprint—Incorporating amendments up to No. 7876)	\$0.35
6277. Industrial and Provident Societies (First Reprint—Incorporating amendments up to No. 7547)	\$0.35
6279. Instruments (Fourth Reprint—Incorporating amendments up to No. 7941)	\$0.75
6280. Judicial Proceedings Reports (First Reprint—Incorporating amendments up to No. 7596)	\$0.15
6282. Justices (Third Reprint—Incorporating amendments up to No. 7966)	\$1.40
6283. Labour and Industry (Fifth Reprint—Incorporating amendments up to No. 8211)	\$1.55
6284. Land Act 1959 (Second Reprint—Incorporating amendments up to No. 8243)	\$3.15
6534. Land Settlement Act 1959 (First Reprint—Incorporating amendments up to No. 7328)	\$0.30
6288. Land Surveyors (First Reprint—Incorporating amendments up to Act No. 7065)	\$0.30
6289. Land Tax (Second Reprint—Incorporating amendments up to No. 7466)	\$0.40
6285. Landlord and Tenant (Third Reprint—Incorporating amendments up to No. 7332)	\$0.68
6286. Lands Compensation (First Reprint—Incorporating amendments up to No. 7332)	\$0.25
6290. Latrobe Valley (First Reprint—Incorporating amendments up to No. 7332)	\$0.35
6291. Legal Profession Practice (Second Reprint—Incorporating amendments up to No. 7539)	\$0.70
6292. Libraries (First Reprint—Incorporating amendments up to No. 7364)	\$0.15
6295. Limitation of Actions (Second Reprint—Incorporating amendments up to No. 7457)	\$0.25
7695. Liquor Control Act 1968 (Second Reprint—Incorporating amendments up to No. 8272)	\$1.35
7145. Litter Act 1964 (First Reprint—Incorporating amendments up to No. 7608)	\$0.15
6298. Local Authorities Superannuation (Second Reprint—Incorporating amendments up to No. 7161)	\$0.40
6299. Local Government. New Parts III. to IX. Section 51 to Section 250—Incorporating amendments up to No. 8291	\$1.70
6299. Local Government. New Parts X. and XI. (being a reprint of portion of No. 7835, as amended by No. 7847)	\$0.50
6301. Margarine (First Reprint—Incorporating amendments up to No. 7714)	\$0.18
6302. Marine (Incorporating amendments up to No. 7350)	\$0.72
6303. Marine Stores and Old Metals (First Reprint—Incorporating amendments up to No. 7876)	\$0.35
6304. Marketing of Primary Products (First Reprint—Incorporating amendments up to No. 7491)	\$0.45
6305. Markets (First Reprint—Incorporating amendments up to No. 7705)	\$0.20
6306. Marriage (First Reprint—Incorporating amendments up to No. 6959)	\$0.25
6307. Masseurs (First Reprint—Incorporating amendments up to No. 7566)	\$0.20
6309. Medical (Second Reprint—Incorporating amendments up to No. 7408)	\$0.40
6310. Melbourne and Metropolitan Board of Works (Third Reprint—Incorporating amendments up to No. 8082)	\$1.85
6311. Melbourne and Metropolitan Tramways (First Reprint—Incorporating amendments up to No. 7622)	\$0.70
6312. Melbourne Harbor Trust (First Reprint—Incorporating amendments up to No. 7356)	\$0.48
6405. Melbourne University (First Reprint—Incorporating amendments up to No. 7871)	\$0.40
6605. Mental Health (Incorporating amendments up to No. 7356)	\$0.45
6315. Metropolitan Fire Brigades (Second Reprint—Incorporating amendments up to No. 8165)	\$0.65
6316. Mildura Irrigation and Water Trusts (First Reprint—Incorporating amendments up to No. 7448)	\$0.75
6317. Milk and Dairy Supervision (Incorporating amendments up to No. 6964)	\$0.40

ACTS REPRINTED IN ACCORDANCE WITH THE AMENDMENTS
INCORPORATION ACT 1958 (No. 6422)—continued.

No.	Price.
6318. Milk Board (Incorporating amendments up to No. 7093)	\$0.22
6319. Milk Pasteurization (First Reprint—Incorporating amendments up to No. 7480)	\$0.15
6320. Mines (Second Reprint—Incorporating amendments up to No. 7876)	\$1.25
6184. Monash University (First Reprint—Incorporating amendments up to No. 7533)	\$0.30
6324. Money Lenders (Third Reprint—Incorporating amendments up to No. 8181)	\$0.55
6832. Motor Boating Act 1961 (Second Reprint—Incorporating amendments up to No. 6961)	\$0.30
6325. Motor Car (Fourth Reprint—Incorporating amendments up to No. 8143)	\$2.05
6705. Navigable Waters (Oil Pollution) Act 1960. (First Reprint—Incorporating amendments up to No. 7890)	\$0.30
6328. Nurses (Second Reprint—Incorporating amendments up to No. 7375)	\$0.45
6329. Opticians Registration (First Reprint—Incorporating amendments up to No. 7409)	\$0.30
6330. Partnership (Second Reprint—Incorporating amendments up to No. 7315)	\$0.30
6331. Patriotic Funds (First Reprint—Incorporating amendments up to No. 7338)	\$0.25
6332. Pawnbrokers (First Reprint—Incorporating amendments up to No. 7876)	\$0.35
6257. Pesticides Act 1968 (First Reprint—Incorporating amendments up to No. 7595)	\$0.15
6334. Petroleum (First Reprint—Incorporating amendments up to No. 7876)	\$0.65
6889. Poisons Act 1962 (Second Reprint—Incorporating amendments up to No. 7588)	\$0.50
6337. Police Offences (Second Reprint—Incorporating amendments up to No. 7678)	\$0.28
6338. Police Regulation (Second Reprint—Incorporating amendments up to No. 8179)	\$0.95
6340. Portland Harbor Trust (First Reprint—Incorporating amendments up to No. 7475)	\$0.35
6341. Pounds (First Reprint—Incorporating amendments up to No. 7315)	\$0.25
7498. Port Phillip Authority Act 1966 (First Reprint—Incorporating amendments from No. 8081)	\$0.15
6342. Printers and Newspapers (First Reprint—Incorporating amendments up to No. 7876)	\$0.15
7494. Private Agents Act 1966 (First Reprint—Incorporating amendments in No. 7646)	\$0.35
6890. Probate Duty (Third Reprint—Incorporating amendments up to No. 8072)	\$0.75
6344. Property Law (Third Reprint—Incorporating amendments up to No. 8181)	\$1.95
6345. Public Account (First Reprint—Incorporating amendments up to No. 8012)	\$0.20
6346. Public Authorities Marks (First Reprint—Incorporating amendments from No. 7315)	\$0.10
6349. Public Service (Second Reprint—Incorporating amendments up to No. 7356)	\$0.40
6350. Public Trustee (Incorporating amendments up to No. 6961)	\$0.35
6353. Racing (Third Reprint—Incorporating amendments up to No. 8080)	\$1.45
6355. Railways (First Reprint—Incorporating amendments up to No. 7475)	\$0.75
6564. Registration of Births Deaths and Marriages Act 1959 (First Reprint—Incorporating amendments up to No. 7332)	\$0.25
2596. River Murray Waters Act 1915 (First Reprint—Incorporating amendments up to No. 7061)	\$0.35
6359. Road Traffic (Third Reprint—Incorporating amendments up to No. 8192)	\$0.35
6360. Rural Finance (First Reprint—Incorporating amendments up to No. 7328)	\$0.15
6846. Rural Finance and Settlement Commission, Act 1961 (First Reprint—Incorporating amendments up to No. 7332)	\$0.30
6917. Sale of Human Blood Act 1962 (First Reprint—Incorporating amendments from No. 7332)	\$0.10
6975. Sale of Land Act 1962 (Second Reprint—Incorporating amendments up to No. 7898)	\$0.30
6363. Second-hand Dealers (First Reprint—Incorporating amendments up to No. 7529)	\$0.25
7962. Securities Industry Act 1970 (First Reprint—Incorporating amendments made by Act No. 8059)	\$0.65
6367. Settled Land (Second Reprint—Incorporating amendments up to No. 7065)	\$0.50

ACTS REPRINTED IN ACCORDANCE WITH THE AMENDMENTS INCORPORATION ACT 1958 (No. 6422)—continued.

No.	Price.
6368. Sewerage Districts (Second Reprint—Incorporating amendments up to No. 7547)	\$0.75
6369. Shearers Accommodation (First Reprint—Incorporating amendments up to No. 7876)	\$0.35
6809. Sheep Owners Protection Act 1961 (Second Reprint)—Incorporating amendments up to No. 8179	\$0.20
6372. Soil Conservation and Land Utilization (Second Reprint—Incorporating amendments up to No. 8142)	\$0.45
6373. Soldier Settlement (First Reprint—Incorporating amendments up to No. 7328)	\$0.42
6375. Stamps (Fifth Reprint—Incorporating amendments up to No. 8274)	\$2.15
6377. State Electricity Commission (Second Reprint—Incorporating amendments up to No. 7421)	\$0.65
6378. State Relief Committee (First Reprint—Incorporating amendments from No. 6886)	\$0.10
6379. State Savings Bank (Second Reprint—Incorporating amendments up to No. 8082)	\$0.95
6380. Statistics (First Reprint—Incorporating amendments up to No. 6961)	\$0.15
6383. Stock Foods (First Reprint—Incorporating amendments up to No. 7607)	\$0.28
6384. Stock Medicines (First Reprint—Incorporating amendments up to No. 7726)	\$0.20
7551. Strata Titles Act 1967 (Second Reprint—Incorporating amendments up to No. 8149)	\$0.65
6886. Subordinate Legislation (Incorporating amendments up to No. 6961)	\$0.15
7405. Summary Offences Act 1966 (First Reprint—Incorporating amendments up to Act No. 8226)	\$0.55
6386. Superannuation (Second Reprint—Incorporating amendments up to No. 7910)	\$0.75
6387. Supreme Court (First Reprint—Incorporating amendments up to No. 7522)	\$0.75
6388. Survey Co-ordination (First Reprint—Incorporating amendments up to Act No. 8107)	\$0.35
6390. Tattersall Consultations (First Reprint—Incorporating amendments up to No. 8289)	\$0.15
6391. Teaching Service (First Reprint—Incorporating amendments up to No. 7536)	\$0.35
6849. Town and Country Planning Act 1961 (Third Reprint—Incorporating amendments up to No. 7975)	\$0.65
6401. Trustee (Third Reprint—Incorporating amendments up to No. 7833)	\$0.95
6402. Trustee Companies (First Reprint—Incorporating amendments up to No. 7858)	\$0.35
7223. Tomato Processing Industry (Uniform Agreement) Act 1964 (First Reprint—Incorporating amendments up to No. 7342)	\$0.15
6397. Trade Unions (First Reprint—Incorporating amendments up to No. 6839)	\$0.20
6399. Transfer of Land Act (Fourth Reprint—Incorporating amendments up to No. 8181)	\$1.15
6400. Transport Regulation (First Reprint—Incorporating amendments up to No. 7358)	\$0.22
6879. Unclaimed Moneys (Incorporating amendments up to No. 6961)	\$0.12
7095. Underseas Mineral Resources Act 1963 (First Reprint—Incorporating amendments from No. 7591)	\$0.10
6553. Valuation of Land Act 1960 (Second Reprint—Incorporating amendments up to No. 7333)	\$0.22
6407. Vegetation and Vine Diseases (First Reprint—Incorporating amendments up to No. 7423)	\$0.30
6409. Vermin & Noxious Weeds (First Reprint—Incorporating amendments up to No. 7463)	\$0.35

ACTS REPRINTED IN ACCORDANCE WITH THE AMENDMENTS INCORPORATION ACT 1958 (No. 6422)—continued.

No.	Price.
6410. Veterinary Surgeons (First Reprint—Incorporating amendments up to No. 7343)	\$0.15
6411. Victorian Inland Meat Authority (First Reprint—Incorporating amendments up to No. 8000)	\$0.30
7291. Victoria Institute of Colleges Act 1965 (First Reprint—Incorporating amendments up to No. 7644)	\$0.25
6412. Warehousemen's Liens (First Reprint—Incorporating amendments up to No. 7876)	\$0.15
6413. Water (Second Reprint—Incorporating amendments up to No. 7590)	\$1.95
6414. Weights and Measures (Third Reprint—Incorporating amendments up to No. 8068)	\$1.05
6415. Wild Flowers and Native Plants Protection (First Reprint—Incorporating amendments up to No. 6976)	\$0.15
6416. Wills (First Reprint—Incorporating amendments up to No. 7238)	\$0.25
6417. Wire Netting (First Reprint—Incorporating amendments up to No. 7876)	\$0.45
6419. Workers Compensation (Fifth Reprint—Incorporating amendments up to No. 8353)	\$1.05

FIRST NOTIFICATION OF REPRINT.

No.	Price.
8276. Consumer Protection Act 1972 (First Reprint—Incorporating amendments up to No. 8382)	\$0.65

C. H. RIXON,
Government Printer.

CONTENTS

	PAGE
Acts of Parliament on Sale at the Government Printing Office	1123
Appointments	1092
Cemeteries—Scale of Fees	1076
Contracts	1091
Country Roads Board	1088
Estates of Deceased Persons	1091
Government Notices	1076
Impoundings	1122
Lands	1102
Melbourne and Metropolitan Board of Works—Notice	1083
Notice of Making of Statutory Rules	1122
Orders in Council—	
Acts—Victorian Development Corporation; Patriotic Funds; Country Roads; Dental Technicians; Hospitals and Charities; Land; Police Regulation; Labour and Industry; Water; Sewerage Districts; Geelong Waterworks and Sewerage; Victorian Inland Meat Authority.	1094 et seq
Private Advertisements	1107
Proclamations	1075
Public Service Notices	1104
Regulations—	
Acts—Public Service	1078
Police Regulation	1087
Teaching Service	1106
Resignations	1094
State Rivers and Water Supply Commission	1084
Tenders	1103
Transport Regulation Board—Public Hearings	1079