

[1821]



VICTORIA GOVERNMENT GAZETTE

Published by Authority

No. 45]

WEDNESDAY, JUNE 6

[1973

Government House,
Melbourne, Vic. 3004,
2nd June, 1973.

The Queen has been graciously pleased to signify Her Majesty's intention of conferring the following Honours and Awards in the Birthday Honours, 1973:—

TO BE KNIGHTS BACHELOR.

The Honourable Raymond William Garrett, A.F.C., A.E.A., M.L.C., F.Inst.D.
Clifton Vaughan Holland, Esquire, B.C.E., F.I.E. (Aust.), F.A.I.B., M.Inst.D.

THE MOST DISTINGUISHED ORDER OF SAINT MICHAEL AND SAINT GEORGE.

To be Companions of the said Most Distinguished Order:

Colonel Alfred Newcombe Kemsley, C.B.E., E.D., F.I.A.
The Honourable Ivan Archie Swinburne, M.L.C.

THE MOST EXCELLENT ORDER OF THE BRITISH EMPIRE.

To be Commanders of the said Most Excellent Order:

Professor Joseph Terrence Antony Burke, O.B.E., M.A., F.A.H.A.
The Honourable Arthur Robert Mansell, M.L.C.
The Honourable Mr. Justice Charles Augustine Sweeney, M.A., LL.B., Q.C.

To be Officers of the Civil Division of the said Most Excellent Order:

Doctor George Bankin Bearham, M.D., B.S., D.G.O.
Kenneth Thomas Blamey, Esquire, E.D., Dip.A.I.I.
James Douglas Butchart, Esquire, B.Econ., B.A.
Doctor John Kevin Clarebrough, F.R.A.C.S., F.R.C.S.
Maurice Cohen, Esquire, LL.M.
Howard Murray Lightfoot, Esquire, F.A.S.A., A.C.I.S., F.A.I.M.
Rabbi Doctor Izaak Rapaport, M.Phil., Ph.D.
Mother Mary Sebastian, M.A.
The Right Reverend Monsignor Kevin Michael Toomey.
The Right Reverend Monsignor Brian Walsh, A.L.C.M.
Councillor Kenneth Crago Webb, J.P.

To be Members of the Civil Division of the said Most Excellent Order:

Frederick Joseph Allen, Esquire, A.M.S.A.E. (Aust.).
Councillor William Michael Brady.
Mrs. Alice Josephine Butler.
Mrs. Elizabeth Cameron.
John Albert Cashmore, Esquire.
Arthur Roy Collins, Esquire.
Walter Connors, Esquire.
Reginald Keith Crow, Esquire, J.P., F.I.R.E.E. (Aust.).
Doctor Victor Hamilton French, B.D.Sc., L.D.S.
Councillor Archibald John Girdwood.
Reginald Edward Gregory, Esquire, J.P., F.A.S.A., F.C.I.S.
Mrs. Sylvia Ismay Hampson.

Mrs. Catherine McLeod Hemphill.
Councillor Edward Henry Jones.
Ronald Warren Jones, Esquire.
Henry Senior Kaye, Esquire.
John Watsford Lancaster, Esquire.
John Thomas Leed, Esquire.
Councillor Archibald Kingswell Lloyd, Ph.C., M.P.S.
John Francis O'Hagan, Esquire.
Councillor Alan Oswald Opie, Esquire.
Mrs. Jean Elizabeth Peart.
Mrs. Ellie Veronica Pullin.
Councillor Albert Leslie Roy, J.P.
Mrs. Mollie Sinclair.
Councillor Colin White Scott.
Councillor Bernard Milton Seebeck.
George Stewart Smale, Esquire, B.A., B.Com., Dip.Ed.
Mrs. Phyllis Ethel Vardy.
Edward McDonald Walker, Esquire, B.C.E., M.I.E. (Aust.).
John Harold Wass, Esquire, J.P., A.F.C.I.A.
Kenneth Wright, Esquire, J.P.

THE IMPERIAL SERVICE ORDER.

To be a Companion of the said Order:

Frederick Henry Brooks, Esquire, M.Sc., Dip.Ed., F.R.A.C.L., F.A.C.E.

AWARDS OF THE BRITISH EMPIRE MEDAL (CIVIL DIVISION).

Miss Dora Mary Armstrong.
Mrs. Louisa Moutray Arnoldt.
Geoffrey Austin, Esquire.
Ronald Elliott Barton, Esquire.
Robert Horne Bennie, Esquire.
Miss Bertha Brewer.
Stanley Laurence Butler, Esquire.
Mrs. Elizabeth Carter.
Walter Alfred Crompton, Esquire.
Ian Douglas Culliver, Esquire.
Norman Edward Duell, Esquire, E.D.
Ivor Herbert Evans, Esquire.
Albert Norman Field, Esquire.
Lewis Thomas Ford, Esquire, S.R.N.
Donald Lewis Garnham, Esquire.
William George Harrison, Esquire.
Alan Murray Holloway, Esquire, U.L.U.A., Dip.A.I.I.
Ewen Clarke Kirton, Esquire.
Raymond George Knight, Esquire.
Patrick Loftus, Esquire.
William Arthur Matthews, Esquire.
Miss Jean Gartrude Mole.
Mrs. Mary Isabel Mossenton.
Miss Dorothy Minnie Myers.
Miss Jean Sarah Nickell.
Thomas Francis Perrow, Esquire, F.A.S.A., A.C.I.S.
Walter Gordon Titheridge, Esquire.
Frank Wilson, Esquire.
William Wright, Esquire.

T. J. FORRISTAL,
Official Secretary to the Governor.

PROCLAMATIONS

Land Act 1958.

AREA OF LAND COMPRISED IN CERTAIN CLASSES DIMINISHED OR INCREASED.

PROCLAMATION

By His Excellency the Governor of the State of Victoria and its Dependencies in the Commonwealth of Australia, &c., &c., &c.

Whereas by the *Land Act 1958* it is amongst other things enacted that the Governor in Council may, by Proclamation to be published in the *Government Gazette*, at any time diminish or increase the area of land comprised in any of the classes mentioned in Part I., Division 1, Section 5, of the said *Land Act 1958*, but that the area of lands which may be sold by auction (Class 6), shall not be increased except as in certain cases in the said Act provided: Now therefore I, the Governor of the State of Victoria, in the Commonwealth of Australia, by and with the advice of the Executive Council of the said State, and in accordance with the provisions of Sections 94 and 117 of the *Land Act 1958* aforesaid, do hereby diminish or increase (as the case may be) the areas of Crown lands comprised in Classes 6 and 7 of the classes mentioned in Section 5 of the *Land Act 1958* aforesaid, to the extent set forth in the subjoined Schedule (that is to say) :—

Schedule referred to.

CLASSES DIMINISHED OR INCREASED.

County.	Parish.	Allotment.	Section.	Area.	Diminished.	Increased.	Description.
					Class.	Class.	
				A. R. P.			
Talbot	Castlemaine ..	6	G ²	0 2 16	7	6	Fronting Coles Road East of Moonlight Creek (W90905)

Given under my Hand and the Seal of the State of Victoria aforesaid, at Melbourne, this twenty-ninth day of May, in the year of our Lord One thousand nine hundred and seventy-three, and in the twenty-second year of the reign of Her Majesty Queen Elizabeth II.

(L.S.)

ROHAN DELACOMBE.
By His Excellency's Command,
W. BORTHWICK,
Minister of Lands.

GOD SAVE THE QUEEN!

Section 25, *Land Act 1958.*
ROAD PROCLAIMED.

PROCLAMATION

By His Excellency the Governor of the State of Victoria and its Dependencies in the Commonwealth of Australia, &c., &c., &c.

In pursuance of the provisions of Section 25 (3) (c) of the *Land Act 1958*, I, the Governor of the State of Victoria, by and with the advice of the Executive Council of the said State, do hereby proclaim as a road the land in the Parish of Cohuna, County of Gunbower, as indicated by hatching on plan hereunder.—(C.424^(s)) (W.91144).

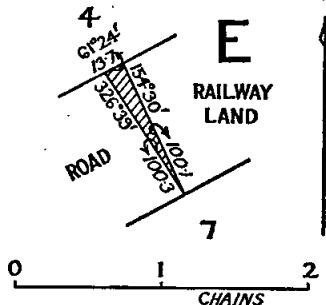

Given under my Hand and the Seal of the State of Victoria aforesaid, at Melbourne, this twenty-ninth day of May, in the year of our Lord One thousand nine hundred and seventy-three, and in the twenty-second year of the reign of Her Majesty Queen Elizabeth II.

(L.S.) ROHAN DELACOMBE.

By His Excellency's Command,
W. BORTHWICK,
Minister of Lands.

GOD SAVE THE QUEEN!

Firearms Act 1958.

APPLICATION OF PROVISIONS OF PART IIIA OF THE FIREARMS ACT 1958 TO THE SHIRE OF DUNMUNKLE.

PROCLAMATION

By His Excellency the Governor of the State of Victoria and its Dependencies in the Commonwealth of Australia, &c., &c., &c.

In pursuance of the powers conferred by the *Firearms Act 1958*, I, the Governor of the State of Victoria in the Commonwealth of Australia, by and with the advice of the Executive Council of the said State and on the application of the Council of the Shire of Dunmunkle do by this my Proclamation declare the municipal district of the Shire of Dunmunkle to be a district to which Part IIIA of the *Firearms Act 1958* applies.

Given under my Hand and the Seal of the State of Victoria aforesaid, at Melbourne, this twenty-ninth day of May, in the year of our Lord One thousand nine hundred and seventy-three, and in the twenty-second year of the reign of Her Majesty Queen Elizabeth II.

(L.S.) ROHAN DELACOMBE.

By His Excellency's Command,
E. R. MEAGHER,
Chief Secretary.

GOD SAVE THE QUEEN!

METRIC CONVERSION (AGRICULTURAL CHEMICALS) ACT 1972, No. 8369.

DATE OF COMING INTO OPERATION.

PROCLAMATION

By His Excellency the Governor of the State of Victoria and its Dependencies in the Commonwealth of Australia, &c., &c., &c.

Whereas by an Act of Parliament of the State of Victoria passed in the twenty-first year of the reign of Her Majesty Queen Elizabeth II entitled the *Metric Conversion*

(Agricultural Chemicals) Act 1972, No. 8369, it is amongst other things enacted that the several provisions of the said Act shall come into operation on a day or the respective days to be fixed by Proclamation or successive Proclamations of the Governor in Council published in the *Government Gazette*.

Now therefore I, the Governor of the State of Victoria, in the Commonwealth of Australia, by and with the advice of the Executive Council of the said State, do by this my Proclamation FIX Sunday, the first day of July, one thousand nine hundred and seventy-three as the day on which section 3 of the *Metric Conversion (Agricultural Chemicals) Act 1972, No. 8369*, shall come into operation.

Given under my Hand and the Seal of the State of Victoria aforesaid, at Melbourne, this twentieth day of May, in the year of our Lord One thousand nine hundred and seventy-three, and in the twenty-second year of the reign of Her Majesty Queen Elizabeth II.

(L.S.) ROHAN DELACOMBE.

By His Excellency's Command,
G. L. CHANDLER,
Minister of Agriculture.

GOD SAVE THE QUEEN!

GOVERNMENT NOTICES

Cemeteries Act 1958.

SCALE OF FEES OF WILLIAMSTOWN MEMORIAL PARK CEMETERY.

In pursuance of the powers conferred upon them by the Cemeteries Act the trustees of the Williamstown Memorial Park Cemetery hereby make the following scale of fees, which shall come into operation upon publication in the *Government Gazette*, and from and after such publication every scale of fees heretofore made by the said trustees shall be and is hereby rescinded to the extent to which it conflicts with this scale.

CREMATION.

Basic Fee.

Week days	\$55.00
Saturdays and Public Holidays—No concession rates	\$80.00

Concession Rates.

(a) Australian ex-service (with overseas service)	\$50.00
(b) Pensioner (invalid, old age, widow)	\$50.00
(c) Child—under five years of age	\$30.00

CEMETERY FEES.

Lawn Cemetery Plot.

"Pre-Need" inclusive of first interment fee	\$160.00
"At-Need" inclusive of first interment fee	\$134.00
Interment fees	\$70.00
Interments—Weekends and Public Holidays (additional fee)	\$30.00

B. HEATH, Trustee.
S. H. ROBINSON, Trustee.
B. R. MOORE, Trustee.
C. W. SIDWAY, Secretary.

Approved by the Governor in Council, 22nd May, 1973.—
T. J. FORRISTAL, Clerk of the Executive Council.

Cemeteries Act 1958.

SCALE OF FEES OF SEA LAKE PUBLIC CEMETERY.

In pursuance of the powers conferred upon them by the Cemeteries Act the trustees of the Sea Lake Public Cemetery hereby make the following scale of fees, which shall come into operation upon publication in the *Government Gazette*, and from and after such publication every scale of fees heretofore made by the said trustees shall be and is hereby rescinded to the extent to which it conflicts with this scale.

Sinking Charges for Private Graves.

Sinking child's grave to 4 feet	\$9.00
Sinking grave to 6 feet	\$20.00
Sinking grave to 7 feet	\$23.00

C. T. SCHODDE, Trustee.
F. J. CLOHESY, Trustee.
I. L. MCKENZIE, Trustee.

Approved by the Governor in Council, 22nd May, 1973.—
T. J. FORRISTAL, Clerk of the Executive Council.

Cemeteries Act 1958.

SCALE OF FEES OF HARCOURT PUBLIC CEMETERY.

In pursuance of the powers conferred upon them by the Cemeteries Act the trustees of the Harcourt Public Cemetery hereby make the following scale of fees, which shall come into operation upon publication in the *Government Gazette*, and from and after such publication every scale of fees heretofore made by the said trustees shall be and is hereby rescinded to the extent to which it conflicts with this scale.

Public Graves.

Interment in grave without exclusive right—stillborn child	\$8.50
Interment in grave without exclusive right—others	\$17.00
Number peg or label	\$4.00

Private Graves.

Land, 8 ft. x 4 ft.	\$20.00
Own selection of land (extra)	\$7.00

Sinking Charges for Private Graves.

Sinking grave 6 feet deep	\$40.00
Each additional foot	\$5.00
Sinking oversize grave (extra)	\$5.00
Cancellation of order to sink (if commenced)	\$7.00

Reopening Charges.

Reopening grave (no cover)	\$30.00
Reopening grave (with cover)	\$30.00

Extra Charges.

Interment outside prescribed hours, or on Saturdays, Sundays or Public Holidays	\$14.00
Interment in a private grave without due notice	\$14.00

Miscellaneous Charges.

Interment fee	\$10.00
Certificate of right of burial	\$2.00
Number plate or brick	\$4.00
Permission to erect a headstone or monument	\$6.00
Permission to construct a brick grave or to erect any stone kerb, brick tile-work or concrete	\$6.00
Exhuming the remains of a body (when authorized)	\$60.00
Interment of ashes in a private grave	\$14.00

C. H. JAMES, Trustee.
N. C. FISHER, Trustee.
W. GARTSIDE, Trustee.

Approved by the Governor in Council, 22nd May, 1973.—
T. J. FORRISTAL, Clerk of the Executive Council.

Cemeteries Act 1958.

SCALE OF FEES OF NELSON PUBLIC CEMETERY.

In pursuance of the powers conferred upon them by the Cemeteries Act the trustees of the Nelson Public Cemetery hereby make the following scale of fees, which shall come into operation upon publication in the *Government Gazette*, and from and after such publication every scale of fees heretofore made by the said trustees shall be and is hereby rescinded to the extent to which it conflicts with this scale.

Public Graves.

Interment in grave without exclusive right—stillborn child	\$8.50
Interment in grave without exclusive right—others	\$17.00
Number peg or label	\$4.00

Private Graves.

Land, 8 ft. x 4 ft.	\$28.00
Own selection of land (extra)	\$7.00

Sinking Charges for Private Graves.

Sinking grave 6 feet deep	\$42.00
Each additional foot	\$5.00
Sinking oversize grave (extra)	\$14.00
Cancellation of order to sink (if commenced)	\$7.00

Reopening Charges.

Reopening grave (no cover)	\$35.00
Reopening grave (with cover)	\$41.00

Extra Charges.

Interment outside prescribed hours, or on Saturdays, Sundays or Public Holidays	\$14.00
Interment in a private grave without due notice	\$14.00

Miscellaneous Charges.

Interment fee	\$14.00
Certificate of right of burial	\$2.00
Number plate or brick	\$4.00
Permission to erect a headstone or monument— five per cent. of cost with a minimum of \$6.00.	
Permission to construct a brick grave or to erect any stone kerb, tile-work or concrete	\$6.00
Exhuming the remains of a body (when authorized)	\$60.00
Interment of ashes in a private grave	\$14.00

J. LUNARDON, Trustee.
A. FOX, Trustee.
D. CAMERON, Trustee.

Approved by the Governor in Council, 22nd May, 1973.
—T. J. FORRISTAL, Clerk of the Executive Council.

Cemeteries Act 1958.

SCALE OF FEES OF CLUNES PUBLIC CEMETERY.

In pursuance of the powers conferred upon them by the Cemeteries Act the trustees of the Clunes Public Cemetery hereby make the following scale of fees, which shall come into operation upon publication in the *Government Gazette*, and from and after such publication every scale of fees heretofore made by the said trustees shall be and is hereby rescinded to the extent to which it conflicts with this scale.

Public Graves.

Interment in grave without exclusive right— stillborn child	\$7.00
Interment in grave without exclusive right— others	\$14.00
Number peg or label	\$3.00

Private Graves.

Land, 8 ft. x 4 ft.	\$15.00
Own selection of land (extra)	\$6.00

Sinking Charges for Private Graves.

Sinking grave 6 feet deep	\$36.00
Each additional foot	\$4.00
Sinking oversize grave (extra)	\$12.00
Cancellation of order to sink (if commenced)	\$6.00

Reopening Charges.

Reopening grave (no cover)	\$30.00
Reopening grave (with cover)	\$35.00

Extra Charges.

Interment outside prescribed hours, or on Satur- days, Sundays or Public Holidays	\$12.00
Interment in a private grave without due notice	\$12.00

Miscellaneous Charges.

Interment fee	\$12.00
Certificate of right of burial	\$1.00
Number plate or brick	\$3.00
Permission to erect a headstone or monument— five per cent. of cost with a minimum of \$6.00.	
Permission to construct a brick grave or to erect any stone kerb, brick tile-work or concrete	\$5.00
Exhuming the remains of a body (when authorized)	\$30.00
Interment of ashes in a private grave	\$12.00

R. DOLAN, Trustee.
W. B. J. COOK, Trustee.
H. TOOLE, Trustee.
W. J. FOLEY, Trustee.

Approved by the Governor in Council, 22nd May, 1973.
—T. J. FORRISTAL, Clerk of the Executive Council.

Cemeteries Act 1958.

SCALE OF FEES OF WILLIAMSTOWN PUBLIC CEMETERY.

In pursuance of the powers conferred upon them by the Cemeteries Act the trustees of the Williamstown Public Cemetery hereby make the following scale of fees, which shall come into operation upon publication in the *Government Gazette*, and from and after such publication every scale of fees heretofore made by the said trustees shall be and is hereby rescinded to the extent to which it conflicts with this scale.

INCREASE OF FEES.

Interment fee	\$60.00
Search fee (records)	\$12.50
Certificate of right of burial	\$4.00
Grave markers	\$5.00

MISCELLANEOUS.

Stone Masons' Fees.

Inscriptions on existing stonework	\$2.50
All memorials 12½ per cent.	

B. HEATH, Trustee.
S. H. ROBINSON, Trustee.
B. R. MOORE, Trustee.
C. W. SIDWAY, Secretary.

Approved by the Governor in Council, 22nd May, 1973.
—T. J. FORRISTAL, Clerk of the Executive Council.

Public Service Act 1958.

ELECTIONS OF MEMBERS AND DEPUTY MEMBERS OF THE PUBLIC SERVICE BOARD.

Pursuant to the Public Service Board Elections Regulations, I hereby give notice that for the purpose of the election of the—

Mental Hygiene Representative,
Public Service Representative,

as members of the Public Service Board for the term of office commencing on the 19th August, 1973, and also the election of a Deputy of each such Members, the following dates are fixed, namely:—

Nomination Day, Tuesday, 26th June, 1973;

Polling Day, Friday, 3rd August, 1973;

and I further give notice that Eric Lawrence Richardson be appointed as the Returning Officer to conduct the said elections and that he will receive nominations at his office, State Electoral Office, Old Treasury Building, Spring-street, Melbourne, 3002, not later than Twelve o'clock noon on Nomination Day.

Prescribed forms of nomination may be obtained from the Returning Officer.

R. J. HAMER,
Premier.

TEACHING SERVICE ACT 1958, SECTION 73.

PUBLIC SERVICE ACT 1958, SECTIONS 55 AND 56.

It is hereby notified that a charge of being absent without leave from 4th September, 1972, to 6th March, 1973, has been preferred against Miss Teresa Claire Davis, Record No. 860453, Teacher, Assistant Class, Secondary Schools Division, Collingwood Technical School, Education Department, under section 73 of the *Teaching Service Act 1958* which applies to the *Teaching Service Act 1958* and the provisions of sections 55 and 56 of the *Public Service Act 1958* and that a certified letter asking her whether she admits or denies the truth of the charge (posted to her last known address, viz., Griffiths House, Alice Springs, N.T., 5750) has not been replied to.

A further letter has been forwarded to the said Miss Teresa Claire Davis at the last known address referred to, advising her that unless she admits or denies the truth of the charge in writing to the Teachers Tribunal by the 11th June, 1973, she shall be deemed to deny the truth of the charge and the investigation thereof will be proceeded with at 9.30 a.m. on Tuesday, 12th June, 1973, at the office of the Teachers Tribunal, Royal Mint Building, corner William and La Trobe streets, Melbourne.

By order,

A. F. LE CLERCQ,
Secretary.

Office of the Teachers Tribunal,
Melbourne, 30th May, 1973.

LOCAL GOVERNMENT DEPARTMENT.

ORDER CONFIRMED.—TOWN OF STAWELL.

The Minister of the Crown administering the *Local Government Act 1958*, on the 1st day of June, 1973, confirmed the Order hereinafter referred to in pursuance of section 514 of the Act namely:—

An Order of the Council of the Town of Stawell made on 11th April, 1973, directing the compulsory taking of the land described in Crown grant, volume 859, folio 617 for the purpose of use as a site for development as a playground reserve.

A. J. HUNT,
Minister for Local Government.

Local Government Department,
Melbourne (3331313.)

Transport Regulation Act.
TRANSPORT REGULATION BOARD.

HEARING OF APPLICATIONS.

Notice is hereby given that the following applications will be considered by the Transport Regulation Board at its offices at the corner of Lygon and Princes streets, Carlton, at 10.15 a.m., on 27th June, 1973.

COULSTON, G. C. & H. M., 420 Kremur-street, Albury, N.S.W. Application for one commercial passenger vehicle with seating capacity for 2 persons, to operate as an additional stage omnibus from Wodonga to Mitta-Mitta under the same terms and conditions as licence No. C.O.857, with the ability to extend the service to the Dartmouth Dam site, for the carriage of mail, passengers, parcels, newspapers and foodstuffs.

PASSENGER FARES.

Wodonga—Tallangatta \$1.00.
Wodonga—Mitta Mitta \$2.00.
Wodonga—Dartmouth \$3.00.
Tallangatta—Mitta Mitta \$1.50.
Tallangatta—Dartmouth \$2.50.
Mitta-Mitta—Dartmouth \$1.00.

TIME-TABLE.

Depart Wodonga 7.20 a.m.
Depart Tallangatta 9.30 a.m.
Arrive Dartmouth 11.30 a.m.
Depart Dartmouth 12 noon.
Depart Tallangatta 1.45 p.m.
Arrive Wodonga 3.00 p.m.

HOGAN, W. J. & K. B., 16 Grant-street, Bacchus Marsh. Application for one commercial passenger vehicle to be purchased, with seating capacity for 5 persons to operate as a country taxi-cab at Bacchus Marsh.

KUPSCH, J. D., 21 Westbury-grove, East St. Kilda. One commercial passenger vehicle with seating capacity for five (5) persons to operate as a Metropolitan Private Hire Car from an address to be determined.

TAYNTON, P. T., Villa 2, 68 Schafer-road, Blackburn. One commercial passenger vehicle with seating capacity for five (5) persons to operate as a Metropolitan Private Hire Car from an address to be determined.

RENEWALS.

Applications for renewal of licences as shown, by persons listed hereunder to operate under the same terms and conditions.

ALCAN AUSTRALIA LTD., Barry-road, Campbellfield; T.P.103.
ATKINSON HOLLAND AUSTRALIA LTD., Upper Thomson via Warburton; T.P.128, T.P.288, T.P.289, T.P.290, T.P.291, T.P.292, T.P.293.

AUSTRALIAN PAPER MANUFACTURERS LTD., Hume Highway, Broadford; T.P.34.

BEACH TRANSPORT SERVICE PTY. LTD., 1037 Centre-road, South Oakleigh; M.O.929.

BENNETT, B. E., Kooloonong; T.S.879.

BUCETO, A. & F., 20 Houston-street, Epping; T.P.50.

CLARINDA TRANSPORT PTY. LTD., 1037 Centre-road, South Oakleigh; M.O.414.

MANIATIS, V., 14 Kerferd-road, Albert Park; M.T.1827.

MOONEE VALLEY BUS LINES PTY. LTD., 73 Fletcher-street, Essendon; M.C.517.

MCKEE, J. & M. J., 15 Maple-street, Shepparton; T.S.532.

PARKINSON, M. & D. R. (for the estate of the late T. Parkinson), Ford-street, Beechworth; C.O.198, C.O.236.

PETROLEUM REFINERIES AUSTRALASIA PTY. LTD., corner Millers-road and Kororoit Creek-road, Altona; T.P.95.

PROVINCIAL TRADERS PTY. LTD., Forsyth-road, Laverton; T.P.114.

RALSTON, M. J. (Mrs.), 299 High-street, Nagambie, T.P.181.

SWAN HILL BUS LINES PTY. LTD., 6 Chapman-street, Swan Hill; T.S.301, T.S.472, T.S.500, T.S.772.

VENTURA MOTORS PTY. LTD., 1037 Centre-road, South Oakleigh; M.O.784, M.O.800, M.O.806, M.O.807, M.O.819, M.O.821, M.O.831, M.O.837, M.O.838, M.O.839, M.O.843, M.O.847, M.O.853, M.O.856, M.O.1018, M.O.1019, M.O.426, M.O.860, M.O.785, M.O.786, M.O.787, M.O.788, M.O.789, M.O.790, M.O.791, M.O.792, M.O.793, M.O.794, M.O.795, M.O.796, M.O.797, M.O.798, M.O.799, M.O.801, M.O.802, M.O.803, M.O.804, M.O.805, M.O.808, M.O.809, M.O.810, M.O.811, M.O.812, M.O.813, M.O.814, M.O.815, M.O.816, M.O.817, M.O.818, M.O.820, M.O.822, M.O.823, M.O.824, M.O.825, M.O.826, M.O.827, M.O.828, M.O.829, M.O.830, M.O.833, M.O.834, M.O.836, M.O.840, M.O.841, M.O.842, M.O.844, M.O.845, M.O.846.

M.O.848, M.O.849, M.O.850, M.O.851, M.O.852, M.O.854, M.O.855, M.O.857, M.O.858, M.O.859, M.O.861, M.O.862, M.O.863, M.O.864, M.O.832.

WOODHALL PIPELINES PROPERTIES PTY. LTD., Bridge-road, Dandenong; T.P.284, T.P.285.

Notice of any objection should be forwarded to reach the Secretary of the Board not later than 20th June, 1973.

Applicants are advised that it will not be necessary to appear on the hearing date specified, unless advised in writing by the Board.

A. V. C. COOK,
Secretary.

Corner Lygon and Princes streets, Carlton, 3053,
Wednesday, 6th June, 1973.

Commercial Goods Vehicles Act.
TRANSPORT REGULATION BOARD.

HEARING OF APPLICATIONS.

Notice is hereby given that the following applications will be considered by the Transport Regulation Board at its offices at the corner of Lygon and Princes streets, Carlton, at 10 a.m. on Wednesday, 27th June, 1973.

AMENTA, S., 43 Marks-street, Coburg, 3058. One commercial goods vehicle (L/C. 380 cwt.) to operate within a 35-mile radius of the G.P.O., Melbourne, on behalf of Pioneer Quarries (Vic.) Pty. Ltd.—sand, soil, screenings, premix and quarry products.

ARNOLD, G. H. C., Molan-street, Ringwood, 3134. Application to vary the conditions of licence No. D.A.39609/4 (L/C. 10 cwt.) by deleting the existing conditions and adding in lieu—"Throughout the State of Victoria in the course of business as 'Motor Wrecker' for the purpose of collecting second-hand and wrecked vehicles with special car carrying trailer—own second-hand and wrecked vehicles for wrecking purposes."

ASQUITH, F. F., 278 White-road, Wonthaggi, 3995. One commercial goods vehicle (L/C. 13 cwt.) to operate: (a) Throughout the State of Victoria in the course of own business as "Apiarist"—own bees, bees wax and honey. (b) From own premises at Wonthaggi to the premises of Simsmetal (Australia) Pty. Ltd. at Noble Park—scrap metal and empty bottles.

BERGMEIER, R. J., Foster-road, Meeniyah, 3956. One commercial goods vehicle (L/C. 151 cwt.) to operate: (a) Within a 50-mile radius from the post office at Meeniyah—plant the property of a contractor and required by him for use in connexion with the construction or maintenance of some specific, existing or proposed road, street, wharf, weir or channel and also the following materials viz: metal, stones, screenings, ashes, gravel, sand and earth. (b) Within a 20-mile radius from the site of any construction or maintenance work performed pursuant to paragraph (a) above, or from the railway station nearest thereto—any other materials required for such work.

BERRY, J. W. (trading as Berry & Sprague), Gellibrand, 3239. Application to vary the conditions of licence No. D.T.770 (L/C. 280 cwt.) by deleting paragraph (b) from the existing conditions and adding in lieu a new paragraph (b)—"(b) From landings in the Warree Pine Plantation within a 10-mile radius of the post office at Newfield to Victree Timber Products Pty. Ltd. at Colac—pine logs."

BERRY, J. W. (trading as Berry & Sprague), Gellibrand, 3239. Application to vary the conditions of licence No. D.T.770/2 (L/C. 268 cwt.) by deleting paragraph (4) from the existing conditions and adding in lieu a new paragraph (4)—"(4) From landings in the Warree Pine Plantation within a 10-mile radius of the post office at Newfield to Victree Timber Products Pty. Ltd. at Colac—pine logs."

COBELAS, R., 33 Ethel-street, Traralgon, 3844. One commercial goods vehicle (L/C. 263 cwt.) to operate from forest and private landings situated within a 25-mile radius from the premises of Australian Paper Manufacturers Ltd. at Maryvale to the said premises at Maryvale—pulpwood. This application replaces licence No. D.T.1258 previously held by the applicant.

COOK & GREEN PTY. LTD., Flaxman-street, Warrnambool, 3280. One commercial goods vehicle (L/C. 201 cwt.) to operate within a 50-mile radius of the post office at Warrnambool in the course of business as "Agent" on behalf of Caltex Oil (Aust.) Pty. Ltd.—petroleum products in prescribed types of containers and bulk tanks and empty farm and home storage tanks.

D.S.M. TIMBER MILLS PTY. LTD., Box 11, Mansfield, 3722. Application to vary the conditions of licence No. D.T.834/1 (L/C. 406 cwt.) by adding an additional paragraph (d) to the existing conditions—" (d) Within

- a 50-mile radius of Mansfield on behalf of associate company Mansfield Quarries Pty. Ltd.—quarry products."
- DAWSON, J. E. & V. J.**, 33 Amiel-street, Springvale, 3171. One commercial goods vehicle (L/C. 121 cwt.) to operate: (a) Throughout the State of Victoria in the course of business as "Earth-moving Contractors"—own earth-moving equipment. (b) From contract sites to sites of disposal within a 20-mile radius of such contract site—overburden.
- DOWLIN, J. P.**, Allansford, 3277. Application to vary the conditions of licence No. D.A.22568/1 (L/C. 19 cwt.) by deleting "and veterinary" from paragraph (c) of the existing conditions.
- GEDDES, I. K.**, 27 Elmhurst-road, Tullamarine, 3043. Application to vary the conditions of licence No. D.A.61009/1 (L/C. 155 cwt.) by deleting "Clifton Brick Holdings Ltd. at Brunswick" and bricks" from the existing conditions and adding in lieu "Concrete Industries (Monier) Ltd. at Broadmeadows" and blocks".
- GIBBONS, M. N.**, 63 Gwalia-street, Traralgon, 3844. One commercial goods vehicle (L/C. 40 cwt.) to operate throughout the State of Victoria in the course of business as "Marine Collector"—special wares, marine stores and old metals as designated in the *Marine Stores and Old Metals Act 1958* (No. 6303), Part 1, section (3), but excluding the carriage of any such goods to wharves, docks or ships for shipment or export purposes with the proviso that the combined load capacity of the prime mover and any trailer attached thereto does not exceed 120 cwt.
- MOTOR TYRE SERVICE PTY. LTD.** (trading as Goodyear Tyre Service), corner Victoria-street and Muir-avenue, Kerang, 3578. One commercial goods vehicle (L/C. 15 cwt.) to operate within a 50-mile radius of the post office at Kerang in the course of business as "Tyre Repairers and Distributors"—new and second-hand tyres and tubes for delivery and second-hand tyres and tubes for repair or having been repaired and also batteries and motor car accessories.
- HALE, A. F.**, 6 Stirling-road, Blackburn South, 3130. One commercial goods vehicle (L/C. 134 cwt.) to operate throughout the State of Victoria as a "Water Tanker" for the purpose of spraying own road construction projects.
- KEVLEEN PTY. LTD.**, Princes Highway, Illowa, 3281. Two commercial goods vehicles (L/C. approximately 340 cwt. and 322 cwt.) to operate: (a) Within a 25-mile radius of the post office at Illowa—general goods provided that no goods shall be carried whether by one stage or by more than one stage between places within the above radius which are more than 30 road miles apart by the nearest practicable route. (b) Within a 50-mile radius of own premises at Illowa in the course of business as "Primary Producer"—own goods.
- RAMSDELL, P. F.**, 12 Jefferson-avenue, Lakes Entrance, 3909. One commercial goods vehicle (L/C. 262 cwt.) to operate from the Curlip logging unit solely to J. Ramsdell's sawmill at Nowa Nowa—sawmill logs.
- READY MIXED CONCRETE (VIC.) PTY. LTD.**, 68 Burwood-road, Burwood, 3125. Application to vary the conditions of licence No. D.A.39437/30 (L/C. 345 cwt.) by deleting the existing conditions and adding in lieu new conditions—"Within a 25-mile radius from the post office at the corner of Bourke and Elizabeth streets in the City of Melbourne and also from and to the Township of Hastings in the course of business as 'Concrete Manufacturers'—own bulk cement in a specially constructed bulk vehicle, provided that cement to Hastings is limited to Goliath Cement ex North Wharf only."
- SCOONES, A. R. & Co. (FERTILIZERS) PTY. LTD.**, 105 Archer-street, Shepparton, 3630. Ten commercial goods vehicles (L/C. 127, 159, 160, 157, 155, 300, 157, 164, 140, 156 cwt.) to operate: (a) For the carriage of bulk and bagged fertilizers from Yarraville and Geelong to the company's depots at Murchison, Shepparton, Kyabram, Numurkah, Nathalia and Yarraweyah, and bulk, bagged and locally blended fertilizers from those depots to farms within a 50-mile radius from each such depot. (b) The carriage from their places of purchase or arrival in Victoria to the said depots of materials for use in building, manufacturing and bagging fertilizers at any of the said depots. Replacing licences numbered D.A.61575, D.A.63687, D.A.63687/1, D.A.63687/2, D.A.63687/4, D.A.63687/5, D.A.63687/6, D.A.64485, D.A.64485/1, D.A.64485/2 held in the same name.
- SMITH, M. E.**, Box 11, Mansfield, 3722. Application to vary the conditions of licence No. T.D.30376 (L/C. 402 cwt.) by adding an additional paragraph (d) to the existing conditions—"d) Within a 50-mile radius of Mansfield on behalf of Mansfield Quarries Pty. Ltd.—quarry products."
- STRADFORD & FRANK PTY. LTD.**, 3-5 Ashburn-place, Blackburn, 3130. Application to vary the conditions of licence No. D.A.51991/1 (L/C. 35 cwt.) by deleting "Mansfield" from the existing conditions and adding in lieu "Wangaratta and Myrtleford".
- TEAGUE, R. M. & Y. L.**, 12 Lesley-grove, Noble Park, 3174. One commercial goods vehicle (L/C. 248 cwt.) to operate: (a) Within a 25-mile radius of own premises at Noble Park and to and from the Mornington Peninsula in course of business as "Garden Supplies and Landscape Gardeners"—own goods. (b) From Bacchus Marsh to own premises at Noble Park—own sand and own river pebbles. (c) From Beveridge to own premises at Noble Park—own scoria. (d) From Diggers Rest to own premises at Noble Park—own scoria and own rock. (e) From Castlemaine to own premises at Noble Park—own paving slate.
- WESTON, M. J.**, 5 Pender-street, Thornbury, 3071. One commercial goods vehicle (L/C. 126 cwt.) to operate within a 70-mile radius of the premises of The City Brick Works Co. Pty. Ltd. at Tooronga solely on behalf of the said company—bricks.
- WOODS & REEVES (MORWELL) PTY. LTD.**, Holmes-road, Morwell, 3840. One commercial goods vehicle (L/C. 13 cwt.) to operate within a 50-mile radius of the post office at Morwell in the course of own business as "Motor Truck and Farm Equipment Dealer"—new and used agricultural machinery, spare parts, agricultural machinery for demonstration and agricultural machinery for repair or having been repaired.

TOW TRUCK.

- O'BRIEN, E. P. & M. T. MOTORS PTY. LTD.**, Mansfield, 3722. Application to vary the conditions of licence No. D.A.63926/1 (L/C. 60 cwt.) by deleting "Within a 50-mile radius from the post office at Mansfield as a Tow truck solely"—from the existing conditions and adding in lieu "Throughout the State of Victoria as a Tow Truck solely".

RENEWALS.

- Applications for renewal of licences as shown by persons listed hereunder to operate under the same terms and conditions from the expiry shown in each case.
- ATKINSON VEHICLES (A'ASIA) PTY. LTD.**, 1948 Princes Highway, Clayton, 3168; D.A.61635/1; 27th October, 1973; 29 cwt.
- HOLLAND, V. E.** (trading as Balas & Holland), South Gippsland Highway, Five Ways, 3977; D.A.61823/2; 6th October, 1973; 283 cwt.
- BARTRAM, J.** (trading as J. & L. Bartram), Post Bag 148, Kerang, 3579; T.D.A.65403/1; 9th October 1973; 122 cwt.
- BLACKNEY'S FROZEN FOODS PTY. LTD.**, 34-36 Smythe-street, Geelong, 3220; D.A.36140/12; 4th November, 1973; 61 cwt.; D.A.36140/13; 4th November, 1973; 55 cwt.; D.A.36140/15; 4th November, 1973; 41 cwt.; D.A.36140/16; 4th November, 1973; 72 cwt.
- BOMBARDIERI, K. F.**, 12 Mellor-grove, Swan Hill, 3585; D.A.63149; 13th October, 1973; 205 cwt.
- BOYER, W. L. & Co. PTY. LTD.**, P.O. Box 209, Portland, 3305; D.A.31945/2; 4th October, 1973; 33 cwt.
- CAPPOLA, N.**, 3 Hotham-street, Preston, 3072; D.A.64143; 5th October, 1973; 196 cwt.
- COLAC AERATED WATER CO. PTY. LTD.**, P.O. Box 72, Colac, 3250; D.A.864/3; 19th November, 1973; 11 cwt.; D.A.864/6; 27th November, 1973; 67 cwt.
- COLAC AERATED WATER CO. PTY. LTD.**, 284-288 Murray-street, Colac, 3250; D.A.864/8; 4th November, 1973; 85 cwt.
- COLCOTT & STEPHENS PTY. LTD.**, 4 Hedderwick-street, Essendon, 3040; D.A.8164; 19th October, 1973; 18 cwt.
- COTTRILL, E. S. & G.**, Martin-street, Peshurst, 3289; D.A.6323; 9th November, 1973; 8 cwt.
- CROSS, W. J.**, 23 Clyde-lane, Ballarat, 3350; D.A.62592; 5th May, 1973; 14 cwt.
- CUMMINS, G. L.**, 462 Queensberry-street, North Melbourne, 3051; D.A.44585/1; 16th October, 1973; 111 cwt.
- DALLAS INDUSTRIES (VIC.) PTY. LTD.**, 215 Albion-street, Brunswick, 3056; D.A.48367/2; 27th October, 1973; 8 cwt.
- DIESEL FIELD SERVICE PTY. LTD.**, 90 Kildare-street, North Geelong, 3220; D.A.63075; 17th November, 1973; 76 cwt.

- DODGE, V. W. R., 13 Powlett-street, Broadford, 3658; D.T.1346; 27th October, 1973; 237 cwt.
- DODGE, V. W. R., 13 Powlett-street, Broadford, 3658; D.A.57525; 22nd November, 1973; 221 cwt.
- DUNLOP TYRE SERVICE (VIC.) PTY. LTD., Geelong Branch, corner Gheringhap and Little Myers streets, Geelong, 3220; D.A.60416/4; 4th October, 1973; 12 cwt.
- ENSIGN SERVICES (VIC.) PTY. LTD., 24 Leinster-grove, Northcote, 3070; D.A.1046/2; 18th October, 1973; 66 cwt.
- ENSIGN SERVICES (VIC.) PTY. LTD., 24 Leinster-grove, Northcote, 3070; D.A.1046/17; 4th October, 1973; 31 cwt.
- GAMES, A. R., Cora Lynn, 3814; D.A.44217/1; 21st August, 1973; 148 cwt.
- GEELONG CHURCH OF ENGLAND GRAMMAR SCHOOL, Corio, Geelong, 3214; D.A.30829; 19th November, 1973; 66 cwt.
- GIANOPOULOS, P., 23 Rushall-crescent, North Fitzroy, 3068; D.A.63142; 6th October, 1973; approximately 210 cwt.
- GRADY, F. W., P.O. Box 30, Kyneton, 3444; D.A.44774; 20th November, 1973; 60 cwt.
- GRANT, D. A., Box 566, Swan Hill, 3585; D.A.63344; 24th November, 1973, 259 cwt.
- GROUND SPRAY PTY. LTD., 23 Murray-street, Colac, 3250; D.A.60015/2; 4th November, 1973; 22 cwt.
- GUADAGNUOLO, F., 85 St. Vidgeons-road, Reservoir, 3073; D.A.63173; 27th October, 1973; 145 cwt.
- HAJEK, P., Whorouly, 3735; D.A.63194; 27th October, 1973; 7 cwt.
- HAMONO, P. & M. O., Box 26, Neerim South, 3831; D.A.56715; 6th September, 1973; 110 cwt.
- HARRIS BROS. TRANSPORTS PTY. LTD., Beaconsfield Upper, 3808; D.A.1254/23; 27th October, 1973; 248 cwt.; D.A.1254/24; 27th October, 1973; 30 cwt.
- HARRIS, J. T. & F. M., 61 Almurta-avenue, Coolaroo, 3048; T.D.A.65636; 27th November, 1973; 75 cwt.
- HENDERSON, R. O. (BEEHIVE) PTY. LTD., 18-20 Pall Mall, Bendigo, 3550; D.A.1285; 19th November, 1973; 8 cwt.
- HUTCHINSON, L. J., 16 Nimmo-street, Essendon, 3040; D.A.11668/2; 28th May, 1973; 6 cwt.
- HUTCHINSON, R. D., PTY. LTD., 29 Armstrong-street south, Ballarat, 3350; D.A.37280/1; 21st July, 1973; 11 cwt.
- JENKINS, J. P., Kiewa, via Wodonga, 3691; D.A.57127; 4th October, 1973; 135 cwt.
- KEFFORD, T. (care of L. Learey), Caravan Park, Private Bag 75, Colac, 3250; T.D.A.57447/1; 15th June, 1973; 45 cwt.
- LEYLAND MOTOR CORP. OF AUST. PTY. LTD., THE, Hume Highway, Wodonga, 3690. D.A.47736/1; 15th September, 1973; 11 cwt.
- MAHOMED, A. H., Beach-road, Foster, 3960; D.A.58631/5; 22nd September, 1973; 293 cwt.
- MATTHEWS, W. H., 121 Princes Highway, Trafalgar, 3824; D.A.1578; 18th October, 1973; 147 cwt.
- O'FLYNN, A. W., 62 Morris-road, Warrnambool, 3280; D.A.63212; 27th October, 1973; 9 cwt.
- ODGEN SAWMILLING CO., East-street, Daylesford, 3460; D.T.612; 18th October, 1973; 257 cwt.
- OLIVER, N. C., Lot 1, Mangans-road, Lilydale, 3140; D.A.31308; 18th October, 1973; 164 cwt.
- PATTINSON, R. J. & B. B., Yarram-street, Yarram, 3971; D.A.44291; 28th August, 1973; 153 cwt.
- PERMEWAN WRIGHT LTD., 657-677 Springvale-road, Mulgrave, 3170; D.A.1809/55; 4th October, 1973; 23 cwt.
- PERMEWAN WRIGHT LTD., 657-677 Springvale-road, Mulgrave, 3170; D.A.1809/57; 4th October, 1973; 62 cwt.
- PIDDINGTON, D. R., Port Albert-road, Alberton, 3970; D.A.52211/1; 18th August, 1973; 230 cwt.
- PRIMAL CHEMICALS, 26 Collins-street, Melbourne, 3000; D.A.63216; 27th October, 1973; 10 cwt.
- PRINCIOTTA, S., 29 Miller-street, Thornbury, 3071; T.D.A.64765; 2nd November, 1973; 42 cwt.
- RODGERS BROS. COLAC TYRE SERVICE PTY. LTD., 82 Gellibrand-street, Colac, 3250; D.A.49873/2; 8th November, 1973; 14 cwt.; D.A.49873/3; 8th November, 1973; 14 cwt.; D.A.49873/5; 8th November, 1973; 41 cwt.
- SELKIRK FREIGHT LINES PTY. LTD., 630 Howitt-street, Ballarat, 3350; D.A.11450/22; 17th November, 1973; 219 cwt.; D.A.11450/23; 17th November, 1973; 220 cwt.
- SHEPPARTON PLASTER WORKS PTY. LTD., 2-8 Mason-street, Shepparton, 3630; D.A.13047/12; 17th November, 1973; 10 cwt.
- SHIELDS, G. W., 22 Chenhall-crescent, Traralgon, 3844; D.T.902; 13th October, 1973; 152 cwt.
- SINCLAIR, R. J., Kinglake-road, Cottles Bridge, 3099; D.A.49736/1; 13th October, 1973; 12 cwt.
- SKYFARMERS PTY. LTD., 30 George-street, Morwell, 3840; D.A.56615; 14th September, 1973; 21 cwt.
- SMITH, W. F., 11 Gray-street, Leongatha, 3953; D.A.44523; 17th September, 1973; 70 cwt.
- STIRLING, D. H., 2 Phillip-street, Rosebud, 3939; D.A.7272; 12th October, 1973; 125 cwt.
- SUPERINA HAULAGE PTY. LTD., 67 Almond-street, North Balwyn, 3104; D.A.61033/6; 27th October, 1973; 267 cwt.
- TRANS-WEST HAULAGE (MELB.) PTY. LTD., 202 Station-street, Norlane, 3214; D.A.65323/22; 17th November, 1973; 212 cwt.; D.A.65323/27; 17th November, 1973; 211 cwt. D.A.65323/28; 17th November, 1973; 211 cwt. D.A.65323/17; 4th November, 1973; 183 cwt.; D.A.65323/26; 4th November, 1973; 212 cwt.
- WIFFEN, I. G., Lot 16, Kensington-road, Leopold, 3221; D.A.63187; 27th October, 1973; 194 cwt.
- WILSON, W. D. & L. M., PTY. LTD., 3 Fairview-street, Traralgon, 3844; D.A.47273/5; 30th June, 1973; 54 cwt.
- YARAMANIS, S., 12 Ulupna-road, Ormond, 3204; D.A.62928; 28th July, 1973; 141 cwt.
- TREWERN, R. W. (trading as Yarragon Motor Wreckers), Princes Highway, Yarragon, 3823; T.D.A.64688; 18th October, 1973; 34 cwt.

TOW TRUCK RENEWALS:

- DENT, J. A., 820 Sydney-road, North Coburg, 3058; D.A.65080; 20th November, 1973; 136 cwt.; D.A.65080/1; 20th November, 1973; 40 cwt.
- BARNETT, J. M. & A. D. (trading as New City Panels), New-street, Frankston, 3199; D.A.63081/1; 5th November, 1973; 45 cwt.
- OAKENFULL, G. P., 151 Stud-road, Dandenong, 3175; D.A.44960; 27th November, 1973; 50 cwt.
- PACE, V. J., Main-road, Seville, 3139; D.A.63557; 24th November, 1973; 80 cwt.
- CUBBINS, S. G. (trading as Sorrento Motor Garage), Main-street, Sorrento, 3943; D.A.66183; 16th June, 1973; 80 cwt.

RENEWALS WITH VARIATION.

Applications made by the persons listed hereunder for renewal of the licences listed with variation of conditions in the manner set out opposite the names:—

- POULSTON, R. & R. A., 67 Bridge-street, Bendigo, 3550; D.A.44662/1; 18th October, 1973; application to renew and vary the conditions of licence No. D.A.44662/1 (L/C. 15 cwt.) by deleting "but excluding the carriage of any goods whatsoever from or to the City of Melbourne" from the existing conditions and adding to the conditions "but excluding the carriage of any goods from any point within a 25-mile radius of the post office situated at the corner of Bourke and Elizabeth streets, in the City of Melbourne".
- SIDES, W. L. & SON PTY. LTD., Wellington-road, Clayton, 3168; D.A.28601/14; 9th October, 1973; application to renew and vary the conditions of licence No. D.A.28601/14 (L/C. 14 cwt.) by adding to the existing conditions "and also with the ability to carry samples of excavated minerals and earth for testing purposes, but excluding the carriage of bore casing other than that required for testing purposes only".

Notice of any objection should be forwarded to reach the Secretary of the Board not later than 20th June, 1973.

Applicants are advised that it will not be necessary to appear on the hearing date specified above, unless advised in writing by the Board.

A. V. C. COOK,
Secretary.

Corner Lygon and Princes streets, Carlton, Vic. 3053,
Wednesday, 6th June, 1973.

COUNTRY ROADS BOARD.

RESOLUTIONS OF THE COUNTRY ROADS BOARD.

The Country Roads Board, in pursuance of the provisions of the *Country Roads Act 1958*, has passed Resolutions the dates whereof and the terms of which are scheduled hereunder:—

SCHEDULE.

State Highways.

Resolution dated the Fourteenth day of May One thousand nine hundred and seventy-three, made pursuant to sections 21 and 74 of the *Country Roads Act 1958* declaring the widening of the Princes Highway in the Shire of Berwick as shown hatched on plan numbered G.P.11853 hereunder to be part of a State highway within the meaning and for the purposes of the said Act.

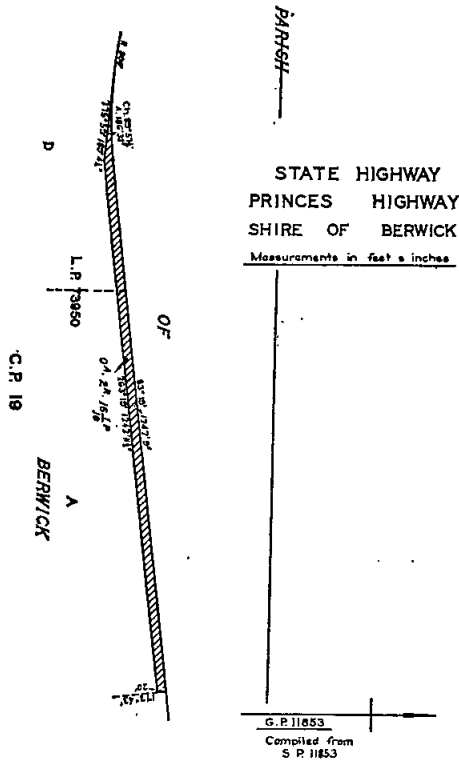

Resolution dated the Fourteenth day of May One thousand nine hundred and seventy-three, made pursuant to sections 21 and 74 of the *Country Roads Act 1958* declaring the widening of the Burwood Highway in the City of Knox as shown hatched on plan numbered G.P.12849A hereunder to be part of a State highway within the meaning and for the purposes of the said Act.

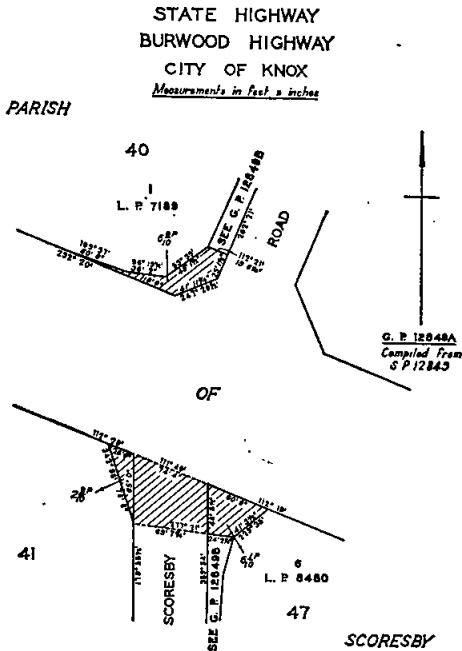

Resolution dated the Fourteenth day of May One thousand nine hundred and seventy-three, made pursuant to sections 21 and 74 of the *Country Roads Act 1958* declaring the widening of the Midland Highway in the Shire of Morwell as shown hatched on plan numbered G.P.13099 hereunder to be part of a State highway within the meaning and for the purposes of the said Act.

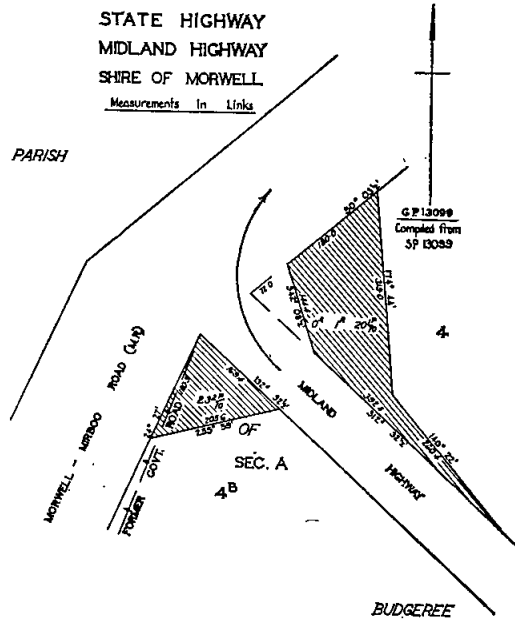

Resolution dated the Fourteenth day of May One thousand nine hundred and seventy-three, made pursuant to section 21 of the *Country Roads Act 1958* declaring the widening of the Bacchus Marsh-Balling road in the Shire of Bacchus Marsh as shown hatched on plan numbered G.P.12780 hereunder to be part of a main road within the meaning and for the purposes of the said Act.

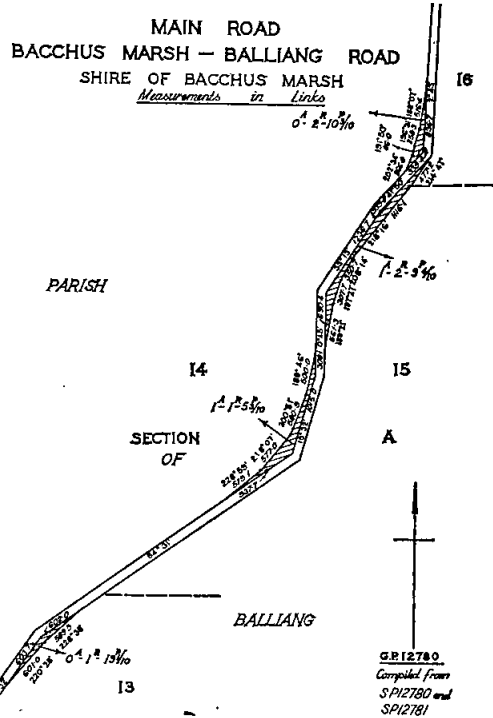

Resolution dated the Fourteenth day of May One thousand nine hundred and seventy-three, made pursuant to sections 21 and 110 of the *Country Roads Act 1958* declaring the widening of Scoresby-road in the City of Knox as shown hatched on plan numbered G.P.12849B hereunder to be part of a road within the meaning and for the purposes of the said Act.

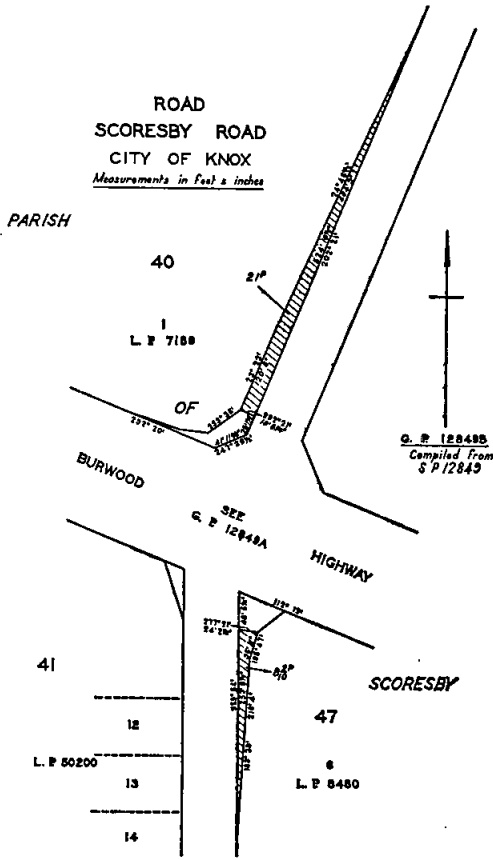

N. L. ALLANSON,
Secretary.

22nd May, 1973.

NOTICE TO MARINERS.

[No. 10 OF 1973.]

AUSTRALIA.—VICTORIA.

PORT PHILLIP.

1. Leading Lights Established.
2. Light Altered.

Date.—On or about 8th June, 1973.

Reference Position.—Werribee Triangulation Station Lat. 37 deg. 58 min. 27 sec. S., Long. 144 deg. 41 min. 53 sec. E.

1. Position of Leading Lights.—

Front—265 deg. 0.60 n miles.
Rear—270 deg. 0.68 n miles from reference position.

Characteristics.—

Front—flashing green every 2½ seconds;
flash 1 second, eclipse 1½ seconds;
visibility 3 n miles.

Rear—occluding green every 3 seconds;
flash 2 seconds, eclipse 1 second;
visibility 3 n miles.

Elevation.—

Front—5.2 metres.
Rear—7.0 metres.

Abridged Description.—

Front—Fl. G 2½ sec. 5.2 m. 3 M.
Rear—Occ. G 3 sec. 7 m. 3 M.

Details.—The lights are shown from wooden posts surmounted by white triangular topmarks.

Remarks.—The lights are in line on a bearing of 300 deg. 24 min., their distance apart being 164 metres.

2. The fixed red light at the entrance to Werribee River in position 265 deg., 966.5 metres from reference position has been raised to a height of 15.5 metres. Other details of the light remain unaltered.

Charts Affected.—Aus. 155, B.A.1171.

Publication Affected.—Sailing Directions, Victoria, 1970, pages 276, 627.

D. P. BARKLEY,
Port Officer.

Public Works Department,
Ports and Harbors Division,
2 Treasury-place, Melbourne, Vic., 3002.
25th May, 1973.

COMPANIES ACT 1961.

Notice is hereby given that in pursuance of section 308 (4) of the Companies Act 1961 the names of the Companies referred to below have been struck off the Register, and on publication of this notice in the Government Gazette the said Companies will be dissolved.

Dated this 29th day of May, 1973.

E. B. MITCHAM,
Deputy Register of Companies.

Companies Office,
Melbourne.

COMPANIES ABOVE REFERRED TO.

Name of Company.	Number of Registration.
Textint Pty. Ltd.	20398
Rodney Motors (Kyabram) Pty. Ltd.	26845
Martar Holdings Pty. Ltd.	26876
Jet Lighters Pty. Ltd.	27046
Moorabool Investments Pty. Ltd.	27900
Green Point Pty. Ltd.	28448
Federal Institute of Accountants Pty. Ltd.	31954
Mirza Pty. Ltd.	33005
Machinery Guaranteed Service Pty. Ltd.	33979
Harold Clark & Sons Pty. Ltd.	34693
Leacon Investments Pty. Ltd.	34704
Susan Bishop Gowns Pty. Ltd.	34834
Henry Richards Family Investments Pty. Ltd.	34875
Lee-Ann Clark Pty. Ltd.	35129
Marflex Utility Sales Pty. Ltd.	35274
H. & M. Holdings Pty. Ltd.	39264
Lodz Knitwear Pty. Ltd.	40264
Jonathan Brett Productions Pty. Ltd.	40512
Harold's Pty. Ltd.	40702
G. Weyl & Co. Pty. Ltd.	43616
PWA Transport Equipment Co. Pty. Ltd.	44785
MFV Farm Equipment Co. Pty. Ltd.	44786
TMD Equipment Pty. Ltd.	46065
Western Pastoral Co. Pty. Ltd.	46417
Nally (Vic.) Pty. Ltd.	47979
Hallmark Constructions Pty. Ltd.	49240
A. Yates Pty. Ltd.	54725
Hovell Joinery Pty. Ltd.	55079
S. E. Theobald Pty. Ltd.	57249
Maryanne Estates Pty. Ltd.	58960
Jolly Roger Food Stores Pty. Ltd.	60033
Rosebe Garments Pty. Ltd.	60102
Peter Wright Motors (Wholesale) Pty. Ltd.	60174
Golden King Scallops Pty. Ltd.	60249
Peter Gardiner & Co. (Australia) Pty. Ltd.	64003
N.B. Trading Pty. Ltd.	65022
M.V. Finance Corporation Pty. Ltd.	68198
Ahlco Pty. Ltd.	68719
Colin McDonald (Footscray) Pty. Ltd.	70109
Tirrikee Press Pty. Ltd.	70466
Beasley & Balfe Pty. Ltd.	72671
Timothy James (Food Division) Pty. Ltd.	75093
Dandenong Vacuum Cleaner Co. Pty. Ltd.	76333
World-Wide Goods Exchange Co. (Aust.) Pty. Ltd.	78084
Charles Anthony Holdings Pty. Ltd.	79633
Federated Mining Corporation (Australia) N.L.	81607
Worldair Corporation Pty. Ltd.	82822
Medical Radio Locum Society Ltd.	83326
Animal Medical Association of Australia Pty. Ltd.	84895

Private Agents Act 1966.

NOTICE OF RECEIPT OF APPLICATIONS FOR LICENCES UNDER THE PROVISIONS OF THE PRIVATE AGENTS ACT 1966.

The Clerk(s) of the Magistrates' Court(s) as listed hereunder hereby give notice that applications, as under, have been lodged for hearing by the said Court(s) on the date(s) specified.

Any person desiring to object to any of such applications must—

- (a) lodge with the respective Clerk of the Magistrates' Court a notice in the prescribed form of his objection and of the grounds thereof;
- (b) cause a copy of such notice to be served personally or by post upon the applicant at least three days before the hearing of the application; and
- (c) send or deliver—
 - (i) where the objection is not made by the officer in charge of the police district in which the Court is situated—a copy of the notice to such officer; and
 - (ii) where the objection is not made by the Registrar or Deputy Registrar—a copy to the Registrar.

Full Name of Applicant or in the Case of a Firm or Corporation, of the Nominee.	Place of Abode of Applicant or Nominee.	Name of Firm or Corporation.	Address for Registration.	Type of Licence.	Date of Hearing of Application.
MAGISTRATES' COURT, SPRINGVALE.					
MacTavish, Peter ..	22 Templewood-avenue, North Dandenong	Mayne Nickless Ltd.	94 York-street, South Melbourne	Watchman ..	12.6.73
Dated at Springvale this 21st day of May, 1973.					
J. B. DENNIS, Clerk of the Magistrates' Court.					
MAGISTRATES' COURT, MELBOURNE.					
Maslen, Ralph James ..	2 Heath-court, Noble Park North	180 Flinders-lane, Melbourne	Process Server ..	13.6.73
Armstrong, Thomas Fredrick	29 Clifton-grove, Coburg	Wormald International Security	340 Abbotsford-street, North Melbourne	Watchman ..	20.6.73
Holmes, John Melville ..	45 Alphington-street, Fairfield	" " "	" " "	" " "	" "
Larkin, Clement Roger ..	14 Dowling-street, Fawkner	" " "	" " "	" " "	" "
Murphy, Glen Walter ..	1 Treloar-crescent, Braybrook	" " "	" " "	" " "	" "
McPherson, Keith Desmond ..	259 The Boulevard, Garden City	" " "	" " "	" " "	" "
Terrill, Ernest Roy ..	2 Hillside-parade, Glen Iris	" " "	" " "	" " "	" "
Power, Robert William ..	19 Alta-street, Canterbury	" " "	" " "	" " "	" "
Towner, Leslie Wayne ..	52 Stanley-street, Glenroy	" " "	" " "	" " "	" "
Dated at Melbourne this 18th day of May, 1973.					
G. L. WEBSTER, Clerk of the Magistrates' Court.					
MAGISTRATES' COURT, FOOTSCRAY.					
Connolly, Joseph Peter ..	Flat 12, 13 Ormond-road, West Footscray	Flat 12, 13 Ormond-road, West Footscray	Guard ..	22.6.73
Dated at Footscray this 21st day of May, 1973.					
D. A. THOMPSON, Clerk of the Magistrates' Court.					
MAGISTRATES' COURT, MALVERN.					
Turner, Leslie Norman ..	Flat 2, 226 Maribyrnong-road, Moonee Ponds	The Security Watching Co. Pty. Ltd.	281 High-street, Ashburton	Watchman ..	25.6.73
Dated at Malvern this 22nd day of May, 1973.					
P. J. RODDA, Clerk of the Magistrates' Court.					
MAGISTRATES' COURT, MOONEE PONDS.					
Lane, James George ..	33 Roxburgh-street, Ascot Vale	33 Roxburgh-street, Ascot Vale	Process Server ..	21.6.73
Dated at Moonee Ponds this 25th day of May, 1973.					
H. KING, Clerk of the Magistrates' Court.					
MAGISTRATES' COURT, SPRINGVALE.					
Labutte, Serge Hedley ..	13 Warraweena-road, Clayton	94 York-street, South Melbourne	Watchman ..	15.6.73
Dated at Springvale this 24th day of May, 1973.					
J. B. DENNIS, Clerk of the Magistrates' Court.					
MAGISTRATES' COURT, FITZROY.					
Engelsmann, Michael ..	243 Maribyrnong-road, Ascot Vale	Crothall and Co. Pty. Ltd.	71 Victoria-parade, East Melbourne	Watchman ..	15.6.73
Dated at Fitzroy this 24th day of May, 1973.					
J. B. RIES, Clerk of the Magistrates' Court.					
MAGISTRATES' COURT, CAMBERWELL.					
Brown, Brian Francis ..	22 Van Ness-avenue, Glen Iris	22 Van Ness-avenue, Glen Iris	Process Server ..	14.6.73
Dated at Camberwell this 25th day of May, 1973.					
M. QUICK, Clerk of the Magistrates' Court.					

PRIVATE AGENTS—continued.

Full Name of Applicant or in the Case of a Firm or Corporation, of the Nominee.	Place of Abode of Applicant or Nominee.	Name of Firm or Corporation.	Address for Registration.	Type of Licence.	Date of Hearing of Application.
MAGISTRATES' COURT, CHELTENHAM.					
Kent, Frank Joseph	86 Chapel-road, Moorabbin		86 Chapel-road, Moorabbin	Process Server	19.6.73
Dated at Cheltenham this 29th day of May, 1973.					
J. A. FERGUSON, Clerk of the Magistrates' Court.					
MAGISTRATES' COURT, SPRINGVALE.					
Lyons, Denis John	1 Castleton-road, East Rosanna		Cnr. Fairview and Joyce streets, Springvale	Watchman	19.6.73
Dated at Springvale this 28th day of May, 1973.					
J. B. DENNIS, Clerk of the Magistrates' Court.					
MAGISTRATES' COURT, MELBOURNE.					
Runciman, Alan David	8 Page-court, Lalor	Mayne Nickless Limited	94 York-street, South Melbourne	Watchman	27.6.73
Murphy, Charles Robert	7 Arnold-street, Preston	E. S. Englander Pty. Ltd.	7 Arnold-street, Preston	Process Server	20.6.73
Dated at Melbourne this 28th day of May, 1973.					
G. L. WEBSTER, Clerk of the Magistrates' Court.					
MAGISTRATES' COURT, BOX HILL.					
Kontogouris, George	111 Lake-road, Nunawading		111 Lake-road, Nunawading	Guard Agent	21.6.73
Dated at Box Hill this 28th day of May, 1973.					
I. M. GRIFFITHS, Clerk of the Magistrates' Court.					
MAGISTRATES' COURT, HEIDELBERG.					
Rae, David Francis	180 Centre-road, Bentleigh		Braud Collection Agency, Summit-drive, Bulleen	Commercial Sub-agent	20.6.73
Dated at Heidelberg this 30th day of May, 1973.					
R. J. CUTHILL, Clerk of the Magistrates' Court.					
MAGISTRATES' COURT, MALVERN.					
Peet, Malcolm	83 Edina-road, Tree Gully	Fern Security Watching Co. Pty. Ltd.	281 High-street, Ashburton	Watchman	20.6.73
Dated at Malvern this 30th day of May, 1973.					
P. J. RODDA, Clerk of the Magistrates' Court.					
MAGISTRATES' COURT, BOX HILL.					
Ford, Malcolm James	18 Saxon-street, Doncaster		18 Saxon-street, Doncaster	Process Server	19.6.73
Dated at Box Hill this 29th day of May, 1973.					
I. M. GRIFFITHS, Clerk of the Magistrates' Court.					
MAGISTRATES' COURT, MOONEE PONDS.					
Kytrokas, George	33 Roxburgh-street, Ascot Vale		33 Roxburgh-street, Ascot Vale	Process Server	26.6.73
Dated at Moonee Ponds this 30th day of May, 1973.					
H. P. B. KING, Clerk of the Magistrates' Court.					
MAGISTRATES' COURT, FOOTSCRAY.					
Hamilton, Tomas Henry Milliken			Flat 3, 108 Summer- hill-road, Foots- cra	Process Server	26.6.73
Dated at Footscray this 29th day of May, 1973.					
D. THOMPSON, Clerk of the Magistrates' Court.					

DEPARTMENT OF LABOUR AND INDUSTRY.
DETERMINATION OF THE AMBULANCE SERVICES
BOARD (No. 3 of 1973).

Attention is drawn to the fact that notice of appeal to the Industrial Appeals Court has been lodged against clause 29 "Intensive Care Allowance" of Part 2 of the Determination of the Ambulance Services Board made on the 10th May, 1973.

Section 45 (1) (b) of Act 6283 provides that when an appeal is made in accordance with that Act, the parts of the Determination appealed against shall not come into operation until the appeal has been dealt with by the Court.

M. S. JEANS,
Secretary.

Labour and Industry Act 1958.

MINISTERIAL DIRECTION UNDER SECTION 175.

Whereas sub-section (5) of section 175 of the *Labour and Industry Act 1958* provides that a regulation made pursuant to the said section 175 requiring tractors to be

provided with protective frames shall not apply in any municipal district except by direction of the Minister made on the application of the council of the municipality.

And whereas the Council of the Shire of Bulla has applied to the Minister for a direction under the said sub-section (5) of section 175 in relation to the whole of its municipal district.

Now therefore I, Joseph Anstice Rafferty, Her Majesty's Minister of Labour and Industry in the State of Victoria, do pursuant to the provisions of the said section 175 hereby direct that Regulation 5 of the Labour and Industry (Tractor Safety) Regulations 1972 (S.R. No. 251/1972) shall apply to the whole of the municipal district of the Shire of Bulla.

Dated at Melbourne this 30th day of May, 1973.

J. A. RAFFERTY,
Minister of Labour and Industry.

Health Act 1958.

VICTORIA—DEPARTMENT OF HEALTH.

NOTICE TO ATTEND FOR RADIOLOGICAL EXAMINATION.

To all persons aged twenty-one years and over enrolled or resident in the subdivisions specified hereunder in the State Electoral District of IVANHOE.

Take notice that you are required to attend at a Department of Health X-ray Unit sited in the public street at or as near as possible to the main entrance to the premises specified in this notice, at any time between the hours specified on one of the days specified and during the period specified in respect of those premises, and thereat to submit yourself to radiological examination of the chest for the purpose of ascertaining whether you may be suffering from pulmonary tuberculosis. If you have had a Chest X-ray within the last twelve months and for this reason do not wish to be examined now, you should attend the unit as directed and submit particulars of the previous examination.

SPECIFIED SUBDIVISIONS, PREMISES, PERIODS, DAYS AND HOURS.

Subdivisions.	Premises.	Period.	Days.	Hours.
Ivanhoe	Reeves Pharmacy, 5 Stortford-avenue, Ivanhoe West	Monday, 18th June, 1973 to Wednesday, 20th June, 1973 (inclusive)	Each day during the period except Public Holidays	From 10 a.m. to 8.30 p.m.
	Car Park, rear of Town Hall, Ivanhoe-parade, Ivanhoe	Tuesday, 19th June, 1973 to Friday, 22nd June, 1973 (inclusive)	Each day during the period except Public Holidays	From 10 a.m. to 8.30 p.m.
	Cinderella Hairdressing Salon, 240 Waterdale-road, Ivanhoe	Thursday, 21st June, 1973 to Monday, 25th June, 1973 (inclusive)	Each day during the period except Saturday, Sunday and Public Holidays	From 10 a.m. to 8.30 p.m.
	Car Park, Pizza Hut, 1014 Heidelberg-road, Darebin	Monday, 25th June, 1973 and Tuesday, 26th June, 1973	Monday, 25th June, 1973 Tuesday, 26th June, 1973	From 10 a.m. to 8.30 p.m. From 10 a.m. to 8.30 p.m.
	Mobil Service Station, 220 Lower Heidelberg-road, Ivanhoe East	Monday, 25th June, 1973 to Monday, 2nd July, 1973 (inclusive)	Each day during the period except Saturday, Sunday and Public Holidays	From 10 a.m. to 8.30 p.m.
	Gough's Pharmacy, 81 Silverdale-road, Eagle-mont	Tuesday, 26th June, 1973 to Thursday, 28th June, 1973 (inclusive)	Each day during the period except Public Holidays	From 10 a.m. to 8.30 p.m.
Heidelberg	Ampol Service Station, 40 Burgundy-street, Heidelberg	Tuesday, 26th June, 1973 to Tuesday, 3rd July, 1973 (inclusive)	Each day during the period except Saturday, Sunday and Public Holidays	From 10 a.m. to 8.30 p.m.
Heidelberg West	Silvana Hair Stylist, 87 Bell-street, Heidelberg West	Tuesday, 26th June, 1973 to Thursday, 28th June, 1973 (inclusive)	Each day during the period except Public Holidays	From 10 a.m. to 8.30 p.m.
	Car Park, The Mall, cnr. Bell-street, and Oriel-road, Heidelberg West	Wednesday, 27th June, 1973 to Friday, 6th July, 1973 (inclusive)	Each day during the period except Saturday, Sunday and Public Holidays	From 10 a.m. to 8.30 p.m.
	McIntyre's Milk Bar, 25 Southern-road, Heidelberg West	Friday, 29th June, 1973 to Tuesday, 3rd July, 1973 (inclusive)	Each day during the period except Saturday, Sunday and Public Holidays	From 10 a.m. to 8.30 p.m.
	Cnr. Oriel-road and Banksia-street, Heidelberg West	Thursday, 5th July, 1973 and Friday, 6th July, 1973	Thursday, 5th July, 1973 Friday, 6th July, 1973	From 10 a.m. to 8.30 p.m. From 10 a.m. to 8.30 p.m.
Heidelberg North	Olympic Hall, Moresby-court, Heidelberg West	Friday, 29th June, 1973 to Wednesday, 4th July, 1973 (inclusive)	Each day during the period except Saturday, Sunday and Public Holidays	From 10 a.m. to 8.30 p.m.
	Evan's Milk Bar, 59B McEwan-road, Heidelberg West	Tuesday, 3rd July, 1973 and Wednesday, 4th July, 1973	Tuesday, 3rd July, 1973 Wednesday, 4th July, 1973	From 10 a.m. to 8.30 p.m. From 10 a.m. to 8.30 p.m.

NOTE.—Any person to whom this notice applies and who without reasonable excuse fails to comply with the requirements of the notice shall be guilty of an offence, and shall be liable to a penalty of not more than five hundred dollars.

Dated this Twenty-eighth day of April, One thousand nine hundred and seventy-three.

W. J. STEVENSON, Chief Health Officer.

MINES DEPARTMENT.

APPLICATIONS FOR LEASES DECLARED ABANDONED.

- 11393, Bendigo; George Heywood; 45 acres, Parish of Nerring.
- 11407, Bendigo; James Thomas Sullivan, Thomas Anthony Hennessy, Edward John Hynan, Rupert Emmanuel Giudice, Richard John Conroy, Joseph Andrew Grogan; 29a. Or. 34p., Parish of Toolleen.

APPLICATION FOR LEASE REFUSED.

- 9187, Mineral; Ray A. Borchers, Stanley I. Lincoln; 100 acres, Parish of Moongag.

MINING LEASES GRANTED.

- 8466, Beechworth; Stanley Clifford Thomas, Cecil Skinner; 103a. Or. 6p., Parish of Goulburn.
- 60, Mining Lease; Lindsay Gordon McRae, Keith McRae; 39a. 1r. 6p., Parish of Nowa Nowa South.
- 7145, Maryborough; William Arthur Burgess; 106a. 1r. 6p., Parish of Tarnagulla.

MINING LEASES EXPIRED.

- 8453, Mineral; Ian Alexander Dumesny; 10a. 3r. 26p., Parish of Wail.
- 8473, Mineral; Albert Arnold Clemann; 22a. 1r. 5p., Parish of Koorangie.
- 8488, Mineral; Rex Clifford McCann and Neville Eric McCann; 24 acres, Parish of Korrak Korrak.
- 8547, Mineral; Reginald Donald Evans; 135a. 1r. 1p., Parish of Angahook.

MINING LEASES TRANSFERRED.

- 8855, Mineral; From Gippsland Minerals No Liability to James Say.
- 8856, Mineral; From Gippsland Minerals No Liability to James Say.
- 8963, Mineral; From Gippsland Minerals No Liability to James Say.
- 9192, Mineral; From Gippsland Minerals No Liability to James Say.

TERM OF EXPLORATION LICENCE EXTENDED.

317, Exploration Licence; Coopers Creek Mining and Exploration N.L.; 33 square miles, Parishes of Matlock, Goulburn, Moolpah.

APPLICATIONS FOR TAILINGS LICENCES REFUSED.

3839, Tailings Licence; Ludbrooks Limited; to treat tailings, Parish of Berringa.
 3844, Tailings Licence; Ludbrooks Limited; to treat tailings, Parish of Berringa.
 3845, Tailings Licence; Ludbrooks Limited; to treat tailings, Parish of Berringa.
 3883, Tailings Licence; F. L. J. Sampson; to remove tailings, Parish of Sandhurst.

EXTRACTIVE INDUSTRY LICENCE GRANTED.

377, Extractive Industry Licence; Neil Edmund Price, 61a. 2r. Op., Parish of Mincha.

J. C. M. BALFOUR,
Minister of Mines.

PUBLIC TRUSTEE ACT 1958 (No. 6350), SECTION 17.

I hereby give notice that on the 23rd May, 1973, the Public Trustee filed elections to administer the following deceased persons' estates in accordance with section 17 of the *Public Trustee Act 1958*.

DICKSON, JESSIE ELIZABETH, formerly of 336 Albion-street, West Brunswick, but late of St. Kilda Private Hospital, 87 Chapel-street, East St. Kilda, widow, died 19th March, 1973.

DOOLAN, CHARLIE, also known as Charles Doolan, late of 25 Pamela-street, Mt. Waverley, retired gentleman, died 5th March, 1973.

FLETCHER, ALFRED ERNEST, late of Heatherton Sanatorium, Kingston-road, Heatherton, retired labourer, died 18th July, 1972.

MOORE, ERIC, late of Warrnambool, pensioner, died 31st January, 1973.

MCINNES, JAMES, formerly of Coleraine, but late of 131 King-street, Melbourne, retired farmer, died 11th November, 1970.

RICHARDSON, COLIN WILLIAM, formerly of 129 Boundary-street, Kerang, but late of Bendigo, herd tester, died 28th November, 1972.

YOOK, FRANCES ELIZABETH, also known as Frances Elizabeth Bishop, late of 64 Provost-street, North Melbourne, widow, died 20th January, 1973.

I hereby give notice that on the 25th May, 1973, the Public Trustee filed elections to administer the following deceased persons' estates in accordance with section 17 of the *Public Trustee Act 1958*.

AYLWARD, HENRY, late of Nikola House, 32 Marine-parade, Elwood, pensioner, died 1st December, 1972.

BOYLE, CHARLES, late of Mount Royal, Parkville, retired carpenter, died 29th January, 1973.

CUMMINGS, TASMAN GEORGE, late of 3 McGregor-street, Middle Park, pensioner, died 16th March, 1973.

PEARCE, DORA, formerly of 40 Durham-road, Kilsyth, but late of "Marna House", Maroondah Highway, Healesville, widow, died 5th April, 1973.

TOWSEY, STELLA MARION, late of 182 Barkly-street, St. Kilda, widow, died 30th October, 1972.

WILSON, EDNA, late of Beechworth, pensioner, died 16th August, 1972.

I hereby give notice that on the 22nd May, 1973, the Public Trustee filed elections to administer the following deceased persons' estates in accordance with section 17 of the *Public Trustee Act 1958*.

DENYER, WILLIAM JOHN, formerly of 2 Frederick-street, Fawkner, but late of Prince Henry's Hospital, St. Kilda-road, Melbourne, labourer, died 10th March, 1973.

GOODWIN, WILLIAM HENRY, late of 94 Cardinal-road, Glenroy, storeman, died 22nd January, 1973.

HEAD, ELSIE MAY, late of 28 Carrington-grove, East St. Kilda, widow, died 21st January, 1973.

MACKENZIE, WILLIAM FREDERICK, formerly of Aurukun Mission, via Thursday Island, but late of Unit 15, "Stathdon", Jolimont-road, Forest Hill, retired Presbyterian minister, died 29th June, 1972.

NAISMITH, JOHN GEORGE, late of 33 Meek-street, Brighton North, retired storekeeper, died 8th November, 1972.

SHEPHARD, ELIZABETH, late of Mont Park, widow, died 27th November, 1972.

I hereby give notice that on the 18th May, 1973, the Public Trustee filed elections to administer the following deceased persons' estates in accordance with section 17 of the *Public Trustee Act 1958*.

ALLISON, ARCHIBALD, late of 18 Heather-avenue, Thomastown, supervisor, died 28th March, 1971.

BASSETT, CLEMENT GEORGE, late of 15 Wright-street, Middle Park, invalid pensioner, died 19th February, 1973.

BERNAT, JAN, late of 19 Charles-street, Elsternwick, process worker, died 10th March, 1973.

BYRNE, RUBINA MAY, late of 143 Belford-road, East Kew, married woman, died 24th March, 1973.

DOWELL, ETHEL, formerly of The Old Colonist Home, Rushall-crescent, North Fitzroy, but late of Liscombe House, Leith Park, St. Helena-road, Eltham, spinster, died 6th March, 1973.

GRANT, MARY ALICE THERESIA, also known as Mary Alice Theresa Grant, and Mary Alice Teresa Grant, late of 86 Cowper-street, Footscray, widow, died 14th January, 1973.

NEANDER, STELLA RUTH, late of 7 Adelaide-street, McKinnon, widow, died 20th February, 1973.

SETFORD, HOWARD RICHARD, formerly of 11 Norbert-street, Balwyn, but late of 128 Humphries-road, Frankston, retired technical representative, died 31st January, 1973.

SMILLIE, LEONARD, late of Mangalore, cleaner, died 6th July, 1972.

WATSON, RONALD, late of Flat 9, 20 Kemp-street, Northcote, chef, died 11th February, 1973.

WOOD, GERTRUD (formerly Gertrud Ogi), in the will called Gertrude Wood, formerly of 2 Lockhart-street, Camberwell, but late of 89 Canterbury-road, South Blackburn, married woman, died 3rd March, 1973.

N. P. BRODY,
Public Trustee.

168 Exhibition-street, Melbourne, 3000, 30th May, 1973.

NOTICE.

Creditors, next of kin and others having claims against the estate of any of the under-mentioned deceased persons are required to send particulars of their claims to the Public Trustee, 168 Exhibition-street, Melbourne, Vic. 3000, the personal representative on or before the 13th August, 1973, after which date the Public Trustee may convey or distribute the assets, having regard only to the claims of which the Public Trustee then has notice:—

ALLISON, ARCHIBALD, late of 18 Heather-avenue, Thomastown, supervisor, died 28th March, 1971.

AYLWARD, HENRY, late of Nikola House, 32 Marine-parade, Elwood, pensioner, died 1st December, 1972.

BASSETT, CLEMENT GEORGE, late of 15 Wright-street, Middle Park, invalid pensioner, died 19th February, 1973.

BERNAT, JAN, late of 19 Charles-street, Elsternwick, process worker, died 10th March, 1973.

BOYLE, CHARLES, late of Mount Royal, Parkville, retired carpenter, died 29th January, 1973.

BYRNE, RUBINA MAY, late of 143 Belford-road, East Kew, married woman, died 24th March, 1973.

CUMMINGS, TASMAN GEORGE, late of 3 McGregor-street, Middle Park, pensioner, died 16th March, 1973.

DENYER, WILLIAM JOHN, formerly of 2 Frederick-street, Fawkner, but late of Prince Henry's Hospital, St. Kilda-road, Melbourne, labourer, died 10th March, 1973.

DICKSON, JESSIE ELIZABETH, formerly of 336 Albion-street, West Brunswick, but late of St. Kilda Private Hospital, 87 Chapel-street, East St. Kilda, widow, died 19th March, 1973.

DOOLAN, CHARLIE, also known as Charles Doolan, late of 25 Pamela-street, Mt. Waverley, retired gentleman, died 5th March, 1973.

DOWELL, ETHEL, formerly of The Old Colonist Home, Rushall-crescent, North Fitzroy, but late of Liscombe House, Leith Park, St. Helena-road, Eltham, spinster, died 6th March, 1973.

FLETCHER, ALFRED ERNEST, late of Heatherton Sanatorium, Kingston-road, Heatherton, retired labourer, died 18th July, 1972.

GOODWIN, WILLIAM HENRY, late of 94 Cardinal-road, Glenroy, storeman, died 22nd January, 1973.

GRANT, MARY ALICE THERESA, also known as Mary Alice Theresa Grant, and Mary Alice Teresa Grant, late of 86 Cowper-street, Footscray, widow, died 14th January, 1973.

HEAD, ELSIE MAY, late of 28 Carrington-grove, East St. Kilda, widow, died 21st January, 1973.

JOHNSON, HARRIET MARGUERITE, formerly of 30 Victoria-street, Mordialloc, but late of 11 Tennyson-street, Brighton, spinster, died 29th or 30th August, 1972.

MACKENZIE, WILLIAM FREDERICK, formerly of Aurukun Mission, via Thursday Island, but late of Unit 15, "Stathdon", Jolimont-road, Forest Hill, retired Presbyterian minister, died 29th June, 1972.

MOORE, ERIC, late of Warrnambool, pensioner, died 31st January, 1973.

MCINNES, JAMES, formerly of Coleraine, but late of 131 King-street, Melbourne, retired farmer, died 11th November, 1970.

NAISMITH, JOHN GEORGE, late of 33 Meek-street, Brighton North, retired storekeeper, died 8th November, 1972.

NEANDER, STELLA RUTH, late of 7 Adelaide-street, McKinnon, widow, died 20th February, 1973.

PEARCE, DORA, formerly of 40 Durham-road, Kilsyth, but late of "Marna House", Maroondah Highway, Healesville, widow, died 5th April, 1973.

RICHARDSON, COLIN WILLIAM, formerly of 129 Boundary-street, Kerang, but late of Bendigo, herd tester, died 28th November, 1972.

SETFORD, HOWARD RICHARD, formerly of 11 Norbert-street, Balwyn, but late of 128 Humphries-road, Frankston, retired technical representative, died 31st January, 1973.

SHEPHARD, ELIZABETH, late of Mont Park, widow, died 27th November, 1972.

SMILLIE, LEONARD, late of Mangalore, cleaner, died 6th July, 1972.

TOWSEY, STELLA MARION, late of 182 Barkly-street, St. Kilda, widow, died 30th October, 1972.

WATSON, RONALD, late of Flat 9, 20 Kemp-street, Northcote, chef, died 11th February, 1973.

WEIDENHOFER, LUCIA WILHELMINA, formerly of 37 Clynden-avenue, East Malvern, but late of 31 Thanet-street, Malvern, spinster, died 26th November, 1972.

WILSON, EDNA, late of Beechworth, pensioner, died 16th August, 1972.

WOOD, GERTRUD (formerly Gertrud Ogi), in the will called Gertrude Wood, formerly of 2 Lockhart-street, Camberwell, but late of 89 Canterbury-road, South Blackburn, married woman, died 3rd March, 1973.

YOOK, FRANCES ELIZABETH, also known as Frances Elizabeth Bishop, late of 64 Provost-street, North Melbourne, widow, died 20th January, 1973.

N. P. BRODY,
Public Trustee.

Melbourne, 30th May, 1973.

ORDERS IN COUNCIL.—(Series 1972-73.)

PUBLIC WORKS.

1184. Kew, Mental Hospital, supply and installation of 2 x 100 lb. capacity tumble dryers, \$10,006.40.—Broadbent Amott Pty. Ltd.—(C.31700.)

1185. Kew, Mental Hospital, supply and delivery of one small piece folder, \$5,670.00.—Hardie Trading Ltd.—(C.31736.)

1186. Larundel, Mental Hospital, supply of one Horscroft small piece folder, &c., \$5,650.00.—Hardie Trading Ltd.—(C.31703.)

1187. Larundel, Mental Hospital, supply and delivery of 2 x 100 lb. washing machines, \$11,406.00.—Hardie Trading Ltd.—(C.31733.)

1188. Larundel, Mental Hospital, supply and delivery of one vibra steamer, \$5,262.00.—Broadbent Amott Pty. Ltd.—(C.31735.)

1189. Public Offices, State Coat of Arms, supply of castings and transfers, \$5,496.00.—Amalgamated Panel Plates & Signs Pty. Ltd.—(G.158863.)

Approved by the Governor in Council, 29th May, 1973.—
T. J. FORRISTAL, Clerk of the Executive Council.

APPOINTMENTS AND RESIGNATIONS

APPOINTMENTS.

His Excellency the Governor of the State of Victoria, by and with the advice of the Executive Council thereof, has, by Orders made on the 29th day of May, 1973, been pleased to make the under-mentioned appointments, viz.:—

CROWN LANDS AND SURVEY DEPARTMENT.

Bailiffs of Crown Lands.

MERVYN JOHN MCALIECE, an officer of the Department of Crown Lands and Survey, to be a Bailiff of Crown Lands with respect to the whole of the State of Victoria and with authority to discharge and exercise all the duties and powers of bailiffs, pursuant to the provisions of section 30 of the *Land Act 1958*; and

KEITH IAN WHITEMAN, Inspector of Land Settlement, Department of Crown Lands and Survey, to be a Bailiff of Crown Lands, with respect to the whole of the State of Victoria and with authority to discharge and exercise all the duties and powers of bailiffs, pursuant to the provisions of section 30 of the *Land Act 1958*.

Land Officer.

MERVYN JOHN MCALIECE, an officer of the Department of Crown Lands and Survey, to be a Land Officer in and for the State of Victoria.

MINISTRY OF HEALTH.

Members of Committees of Management of Hospitals.

KENNETH CHARLES MAWSON to be the Government Appointee on the Committee of Management of Cohuna District Hospital, re-appointed pursuant to section 48 (1) (a) (ii) of the *Hospitals and Charities Act 1958*, for three years from and inclusive of the 25th June, 1973; and

JAMES SCOTT BELL to be the Government appointee on the Committee of Management of Springvale and District Community Hospital, re-appointed pursuant to section 48 (1) (a) (ii) of the *Hospitals and Charities Act 1958*, for three years from and inclusive of the 25th June, 1973.

Deputy Superintendent of Psychiatric Hospital, &c.

HARRY ALFRED DERHAM, M.B., B.S., M.R.A.C.P., D.P.M., to be the Deputy Superintendent of the Psychiatric Hospital and the Mental Hospital, Larundel, vice Dr. W. M. White, pursuant to section 26 (1) of the *Mental Health Act 1959*, as from the 14th May, 1973.

Superintendent of Mental Hospital, &c.

KEITH MCLEOD BENN, M.B., B.S., D.P.M., to be the Superintendent of the Mental Hospital and the Training Centre at Ararat, vice Dr. B. McC. Currie, on leave, pursuant to section 26 (1) of the *Mental Health Act 1959*, for the period 26th May, 1973, to the 10th June, 1973, both dates inclusive.

LAW DEPARTMENT.

Commissioners for Taking Declarations, &c.

JOHN WILLIAM IRELAND, 20 Dublin-avenue, Strathmore, CLARENCE ANGUS McDONALD, 28 Little Ryrie-street, Geelong,

KEITH IAN PARSONSON, 7 Rando-court, Frankston, EDWARD ARTHUR COLLINS, 11 Clivedon-place, Gladstone Park, Tullamarine, and

GEORGE STANLEY MOORE, 9 Lees-street, McKinnon, to be Commissioners for taking Declarations and Affidavits under the *Evidence Act 1958*, to resign upon leaving the neighbourhood of the addresses stated;

ALEXANDER NORMAN SILVA, care of Department of Crown Lands and Survey, State Public Offices, 2 Treasury-place, Melbourne,

KEVIN STANLEY JONES, GRAHAM GORDON FULLER, KENNETH RUSSELL MCALPINE, and

MAXWELL CHARLES STOREY, care of Repatriation Department, Victorian Branch, 169 Kings Way, South Melbourne, and

ARTHUR CHARLES FIELDER, care of Department of Social Security, Commonwealth Centre, corner La Trobe and Spring streets, Melbourne,

to be Commissioners for taking Declarations and Affidavits under the *Evidence Act 1958*, to refrain from charging fees; and

RAYMOND REX ADDICOAT, 380 Mountain Highway, Bayswater,

WILLIAM JOHN RALPH TOY, 36 Pine-avenue, Briar Hill,

KEITH GEORGE FULLER, 9 Bendigo-avenue, Bentleigh,

GEORGE PATRICK ATCHLEY HARDING, care of Sperry Rand Australia Ltd., 232 Princes Highway, Dandenong,

RONALD ALEXANDER MCKENZIE, Lancefield-road, Woodend,

GEOFFREY JAMES SPONG, 447 Collins-street, Melbourne,

KARL SIGVARD JONSSON, care of Karl Jonsson & Associates Pty. Ltd., 434 Nepean Highway, Chelsea,

FRANK CONSIGLIO, care of Malta High Commission, 343 Little Collins-street, Melbourne,

JOE MANCINI, 87 Cedar-street, Thomastown,

VALTON LEONARD DINES, "Nioka", Research-road, Warrandyte,

JOHN LAMBERT BRANDL, care of Royal Australian Navy, 331 Darley-road, H.M.A.S. Cerberus, Westernport,

JOHN FEIGL, 7 Wiltshire-street, North Sunshine,

WILLIAM MICHAEL DOYLE, 6 Carramar-avenue, Glen Waverley,

HENRY RAYMOND WILSON, 11 Clarence-street, East Bentleigh,

BERTHOLD STEINER, 143 Franklin-street, Melbourne,

MAURICE WILLIAM GEORGE BUTTERWORTH, care of Mobil Oil Australia Ltd., Francis-street, Yarraville,

PATRICK LAWRENCE CROZIER, 6 Miami-court, South Oakleigh,

JOAN LESLEY MCNAMARA, care of Gibby's Coffee Houses, 406 Lonsdale-street, Melbourne; and

MAXWELL HENRY FARR, 18 Jhonson-street, Pascoe Vale South,

to be Commissioners for taking Declarations and Affidavits under the Evidence Act 1958.

Justices of the Peace.

WILLIAM RICHARD GOUDIE, 268 Park-street, South Melbourne,

ALFRED ARTHUR KIMPTON, Post Office, Tutye,

ROY SEAMER VODDEN, care of Her Majesty's Prison, Pentridge,

WILLIAM JAMES HOBSON, 11 Ronald-street, Bruthen, and

EDWIN MARTIN BURR, School House-road, Woori Yallock,

to Keep the Peace in the State of Victoria.

Assistant Registrar of County Court.

KEVIN GEORGE McMAHON

to be Assistant Registrar at Traralgon for the County Court at Morwell, vice T. J. Wilson, to take effect as from the 6th June, 1973.

Clerk of the Magistrates' Court.

DAVID RICHARD SMITH

to be Clerk of the Magistrates' Court and Clerk of the Children's Court at Koroi, vice K. G. McMahon, transferred, to take effect as from the 29th May, 1973.

SOCIAL WELFARE DEPARTMENT.

Stipendiary Probation Officer.

JENNIFER ANNE VAUGHAN

pursuant to the provisions of section 9 (2) of the Children's Court Act 1958, sections 507 (1) and 533 (3) of the Crimes Act 1958 and section 165 (1) of the Social Welfare Act 1970, to be a Stipendiary Probation Officer for every Children's Court, Stipendiary Probation Officer and Stipendiary Parole Officer and Stipendiary Youth Parole Officer respectively.

DEPARTMENT OF THE TREASURER.

Receivers of Revenue (Acting).

GRAHAM JOSEPH COLLINS

to act temporarily as Receiver of Revenue, Hamilton, vice D. L. Croft, on leave; and

MAXWELL MAURICE SAUNDER

to act temporarily as Receiver of Revenue, Maryborough, vice R. A. Bramley, on leave.

T. J. FORRISTAL,
Clerk of the Executive Council.

At the Executive Council Chamber,
Melbourne, 29th May, 1973.

APPOINTMENTS.

His Excellency the Governor of the State of Victoria, by and with the advice of the Executive Council thereof, has, by Orders made on the 22nd day of May, 1973, been pleased to make the under-mentioned appointments, viz.:—

MINISTRY OF HEALTH.

Trustees of Cemeteries.

NOEL NEWTON SMITH
to be a Trustee of the Alberton Public Cemetery, vice N. Pearson, deceased;

WILLIAM JOHN READ
to be a Trustee of the Templestowe Public Cemetery, additional trustee;

HOWARD GOODALL
to be a Trustee of the Rainbow Public Cemetery, vice R. Wellington, deceased;

GEORGE BREMNER
to be a Trustee of the Wychitella Public Cemetery, vice J. Coghill, deceased; and

FRANK JOHNSON
to be a Trustee of the Eddington Public Cemetery, vice H. Gallagher, resigned, pursuant to section 3 (1) of the Cemeteries Act 1958.

T. J. FORRISTAL,
Clerk of the Executive Council.

At the Executive Council Chamber,
Melbourne, 22nd May, 1973.

FORESTS DEPARTMENT.

APPOINTMENT OF ADVISORY COMMITTEE OF MT. PILOT SCENIC RESERVE.

Whereas by section 50 of the Forests Act 1958 (No. 6254) it is provided that the Minister of Forests may, on the recommendation of the Forests Commission, appoint not less than three, to be an advisory committee of any land forming part of any reserved forest, such land being set aside and declared to be a scenic reserve, and may remove any of those persons: Now therefore, I, Edward Raymond Meagher, Her Majesty's Minister of Forests for the State of Victoria, on the recommendation of the Forests Commission, do hereby appoint—

FRANCES GLADSTONE,
JOHN ROY DOW,
RICHARD NANKERVIS,
ALAN MAXWELL FROST,
MALCOLM CHARLES O'MEARA,
IVAN LAWRENCE FRANKLIN,

as members of the advisory committee, until the 30th day of April, 1976, of the land forming part of the reserved forest in the Parish of El Dorado, County of Bogong, described in the accompanying Schedule, and known as the "Mt. Pilot Scenic Reserve".

SCHEDULE ABOVE REFERRED TO.

Parish of El Dorado, County of Bogong, comprising 630 acres, more or less, being the area shown coloured yellow on plan marked B over 66/823 on file of correspondence No. 72/2284, of the Forests Department.

Dated at Melbourne, the 28th day of May, 1973.

E. R. MEAGHER,
Minister of Forests.

Liquor Control Act 1968.

APPOINTMENT OF LICENSING INSPECTOR.

In accordance with the authority conferred upon me by sub-section (1) of section 22 of the Liquor Control Act 1968, I, Reginald Jackson, Chief Commissioner of Police, hereby appoint the following Officer of Police as Licensing Inspector for the Division of the Police District as shown:—

Division Number.	Police District.	Rank and Name.
2	Melbourne	Inspector Robert Norman Hope (from 6.5.73 to 15.6.73)

28.5.1973. R. JACKSON,
Chief Commissioner of Police.

Education Act 1958.
SUMMONING OFFICERS.

Under section 5 of the *Education Act 1958*, I hereby appoint—

Senior Constable Stanley William Webber,
Senior Constable Albert Thomas Morris,
Sergeant Frank Kenneth Walker,
Sergeant Francis Robert O'Shea,
Sergeant George Bourke-Finn, and
Senior Constable Brian Frank Bellinger,
to summon parents within the State of Victoria.

28th May, 1973.

IAN SMITH,
Minister for Social Welfare.

RESIGNATIONS.

His Excellency the Governor of the State of Victoria, by and with the advice of the Executive Council thereof, has, by Orders made on the 29th day of May, 1973, accepted the resignations of the persons named hereunder of the offices mentioned, viz.:—

LAW DEPARTMENT.

Commissioner for Taking Declarations, &c.
RAYMOND GREY ELLIOT, as a Commissioner for taking Declarations and Affidavits under the *Evidence Act 1958*.

Justice of the Peace.

DONALD MAXWELL, as a Justice of the Peace for the State of Victoria.

T. J. FORRISTAL,
Clerk of the Executive Council.

At the Executive Council Chamber,
Melbourne, 29th May, 1973.

ORDERS IN COUNCIL

SOCIAL WELFARE ACT 1970.

At the Executive Council Chamber, Melbourne, the twenty-ninth day of May, 1973.

PRESENT:

His Excellency the Governor of Victoria.
Sir Gilbert Chandler | Sir George Reid.

In pursuance of the powers conferred by the *Social Welfare Act 1970* and all other powers him thereunto enabling, His Excellency the Governor of the State of Victoria, in the Commonwealth of Australia, by and with the advice of the Executive Council of the said State, doth by this Order establish "Forsyth Home for Boys", 356 Springvale-road, Springvale, as a youth hostel for the purposes of the said Act.

And the Honorable Ian Winton Smith, Minister for Social Welfare for the State of Victoria, shall give the necessary directions herein accordingly.

T. J. FORRISTAL,
Clerk of the Executive Council.

SOIL CONSERVATION AND LAND UTILIZATION ACT 1958.

At the Executive Council Chamber, Melbourne, the twenty-ninth day of May, 1973.

PRESENT:

His Excellency the Governor of Victoria.
Sir Gilbert Chandler | Sir George Reid.

Whereas in pursuance of the powers conferred by section 15 of the *Soil Conservation and Land Utilization Act 1958* an Order constituting the Moorarbool Soil Conservation District was approved by His Excellency the Governor in Council on the sixth day of March, 1951.

Now therefore His Excellency the Governor of the State of Victoria upon the recommendation of the Soil Conservation Authority and with the advice of the Executive Council of the said State hereby varies the boundary of the Moorarbool Soil Conservation District by the addition of the Borough of Sebastopol to the hitherto existing Moorarbool Soil Conservation District.

And whereas His Excellency the Governor of the State of Victoria upon the recommendation of the Soil Conservation Authority and with the advice of the Executive Council of the said State did on the Fourth day of December, 1962 subdivide the aforesaid District.

Now therefore His Excellency the Governor of Victoria upon the recommendation of the Soil Conservation Authority by and with advice of the Executive Council of the said State doth hereby revoke the aforesaid subdivision and now subdivides the District thus:—

Subdivision No. 1—Comprising the Shires of Corio and Bannockburn.

Subdivision No. 2—Comprising the Shires of Ballan Buninyong and the Borough of Sebastopol.

Subdivision No. 3—Comprising the Shire of Grenville.

Subdivision No. 4—Comprising the Shire of Bacchus Marsh.

Subdivision No. 5—Comprising the Shire of Leigh.

And the Honorable William Archibald Borthwick, Her Majesty's Minister for Conservation in the State of Victoria, shall give the necessary directions herein accordingly.

T. J. FORRISTAL,
Clerk of the Executive Council.

STOCK DISEASES ACT 1968.

At the Executive Council Chamber, Melbourne, the twenty-ninth day of May, 1973.

PRESENT:

His Excellency the Governor of Victoria.
Sir Gilbert Chandler | Sir George Reid.

In pursuance of the powers conferred by section 5 of the *Stock Diseases Act 1968* and all other powers him thereunto enabling, His Excellency the Governor of the State of Victoria, by and with advice of the Executive Council thereof, doth hereby appoint WILLIAM KEVIN MULLIGAN as an Inspector of Stock for the purposes of the said Act, vice Senior Constable D. F. Hilton-Wood, resigned.

And the Honorable Sir Gilbert Lawrence Chandler, Her Majesty's Minister of Agriculture for the State of Victoria, shall give the necessary directions herein accordingly.

T. J. FORRISTAL,
Clerk of the Executive Council.

DEPARTMENT OF CROWN LANDS AND SURVEY.

At the Executive Council Chamber, Melbourne, the twenty-ninth day of May, 1973.

PRESENT:

His Excellency the Governor of Victoria.
Sir Gilbert Chandler | Sir George Reid.

REVOCATIONS OF TEMPORARY RESERVATIONS OF LANDS BY ORDERS IN COUNCIL.

His Excellency the Governor of the State of Victoria, by and with the advice of the Executive Council thereof, doth hereby, in pursuance of the provisions of the *Land Act 1958*, revoke the temporary reservations of lands by Orders in Council hereinafter described, viz.:—

WYCHEPROOF.—The temporary reservation by Order in Council of the 12th October, 1915, of 3 roods 7 perches of land in the Township of Wycheproof as a site for Police purposes.—(W.287(?) (Rs.2557).

SANDHURST (BENDIGO).—The temporary reservation as a site for Water Channel and the withholding from sale leasing and licensing by Order in Council of the 1st October, 1877, of 1 rood 14 4/10 perches of land in the City of Sandhurst (now at Bendigo, Parish of Sandhurst) revoked as to part by various orders, so far only as the portion containing 6 perches, as defined by the description published in the *Government Gazette* of the 2nd May, 1973, is concerned.—(S.372⁽¹¹⁸⁾ (C.96931).

And the Honorable William Archibald Borthwick, Her Majesty's Minister of Lands for the State of Victoria, shall give the necessary directions herein accordingly.

T. J. FORRISTAL,
Clerk of the Executive Council.

DEPARTMENT OF CROWN LANDS AND SURVEY.

At the Executive Council Chamber, Melbourne, the twenty-ninth day of May, 1973.

PRESENT:

His Excellency the Governor of Victoria.
Sir Gilbert Chandler | Sir George Reid.

UNUSED ROADS CLOSED.

His Excellency the Governor of the State of Victoria, by and with the advice of the Executive Council thereof, doth hereby direct that, in pursuance of the provisions of section 349 of the Land Act 1958, the unused roads referred to hereunder be closed, viz.:—

Township of Colac, Parish of Colac, County of Polwarth, being the road as indicated by hatching on plan hereunder.—(C.279⁽⁵⁾) (C.100870).

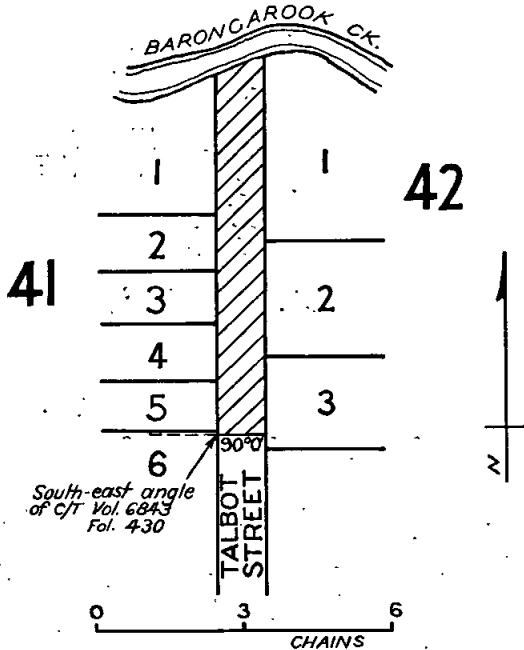

Parish of Mangalore, County of Anglesey, being the roads as indicated by hatching on plan hereunder.—(M.501⁽²⁾) (H.033687).

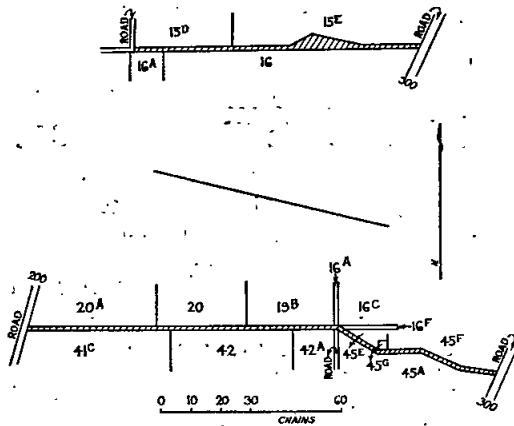

And the Honorable William Archibald Borthwick, Her Majesty's Minister of Lands for the State of Victoria, shall give the necessary directions herein accordingly.

T. J. FORRISTAL,
Clerk of the Executive Council.

Land Act 1958.

DEPARTMENT OF CROWN LANDS AND SURVEY.

At the Executive Council Chamber, Melbourne, the twenty-ninth day of May, 1973.

PRESENT:

His Excellency the Governor of Victoria.
Sir Gilbert Chandler | Sir George Reid.

LAND TEMPORARILY RESERVED AS A SITE.

His Excellency the Governor of the State of Victoria, by and with the advice of the Executive Council thereof, doth hereby, in pursuance of the provisions of section 14 of the Land Act 1958, reserve temporarily from sale, from being leased and from having a licence granted in respect thereof, and also except from occupation for mining purposes under any miner's right the land hereinafter described, viz.:—

KEELBUNDORA (BUNDOORA).—Site for Public purposes (Geriatric Hospital), 41 acres 2 roods 13 perches, Parish of Keelbundora, County of Bourke, as indicated by hatching on plan hereunder.—(K.25⁽⁶⁾) (Rs.9750).

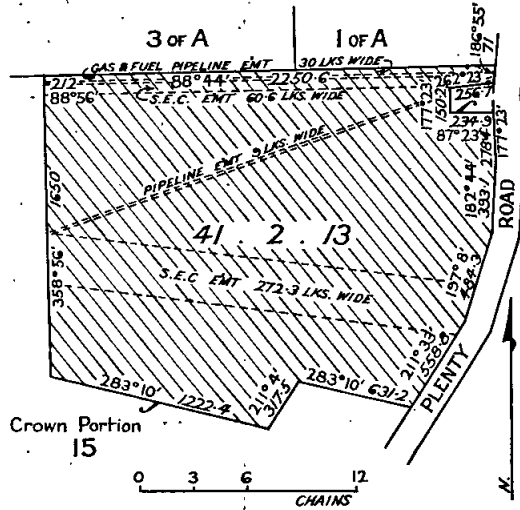

And the Honorable William Archibald Borthwick, Her Majesty's Minister of Lands for the State of Victoria, shall give the necessary directions herein accordingly.

T. J. FORRISTAL,
Clerk of the Executive Council.

SUPERANNUATION ACT 1958.

At the Executive Council Chamber, Melbourne, the twenty-ninth day of May, 1973.

PRESENT:

His Excellency the Governor of Victoria.
Sir Gilbert Chandler | Sir George Reid.

Pursuant to the powers conferred by the provisions of paragraph (ja) of sub-section (1) of section 3 of the Superannuation Act 1958, His Excellency the Governor of the State of Victoria, by and with the advice of the Executive Council thereof doth by this Order declare that the provisions of the Superannuation Act shall apply to John Neville Baldwin an officer of the Victoria Institute of Colleges constituted pursuant to the provisions of the Victoria Institute of Colleges Act 1957, No. 7291.

And the Honorable Rupert James Hamer, Her Majesty's Treasurer for the State of Victoria, shall give the necessary directions herein accordingly.

T. J. FORRISTAL,
Clerk of the Executive Council.

LANDS DEPARTMENT NOTICES

APPROACHING LAND SALES.

Sale of Crown Land, in fee-simple, will be held at the under-mentioned places and dates, viz.:-

	No. of Gazette.
Derrinallum.—Wednesday, 20th June, 1973 ..	33

PROPOSED REVOCATIONS OF TEMPORARY RESERVATIONS OF LANDS BY ORDERS IN COUNCIL.

In pursuance of the provisions of the *Land Act 1958*, notice is hereby given that it is the intention of the Governor in Council to revoke the temporary reservations of lands by Orders in Council hereunder referred to, viz.:-

The following Notices were published 1° on the 6th June, 1973, pursuant to Orders of the 29th May, 1973.

DRUMANURE.—The temporary reservation as a site for Public purposes (State School) and the withholding from sale, leasing and licensing by Order in Council of the 16th April, 1883, of 5 acres of land in the Parish of Drumanure, are about to be revoked.—(D.183(4) (Rs.7101).

REDBANK.—The temporary reservation by Order in Council of the 27th February, 1909, of 17 acres 2 roods 4 perches of land in the Parish of Redbank, as a site for Supply of Gravel, is about to be revoked.—(R.49(8) (Rs.6427).

TYNTYNDER NORTH.—The temporary reservation by Order in Council of the 4th December, 1923, of 1 acre 2 roods 16 perches of land in the Parish of Tyntynder North, as a site for Municipal purposes, is about to be revoked.—(T.244(13) (Rs.2868).

W. BORTHWICK,
Minister of Lands.

PROPOSED REVOCATIONS OF TEMPORARY RESERVATIONS OF LANDS BY ORDERS IN COUNCIL.

In pursuance of the provisions of the *Land Act 1958*, notice is hereby given that it is the intention of the Governor in Council to revoke the temporary reservations of lands by Orders in Council hereunder referred to, viz.:-

The following Notices were published 1° on the 16th May, 1973, pursuant to Orders of the 8th May, 1973.

WILLIAMSTOWN.—The temporary reservation by Order in Council of the 30th January, 1924, of 8 acres 1 rood 3 perches of land in the Township of Williamstown (named City of Williamstown in Order), as a site for Cricket and Public Recreation, is about to be revoked.—(W.163(6) (Rs.2075).

BURRAMBOOT.—The temporary reservation by Order in Council of the 10th June, 1969, of 1 acre 1 rood 10 perches, more or less, of land in the Parish of Burramboot, as a site for Public purposes (Trigonometrical Survey Station), is about to be revoked, so far only as the portion containing 2 roods 20 perches, more or less, indicated by hatching on plan hereunder is concerned.—(B.545(6) (Rs.9161).

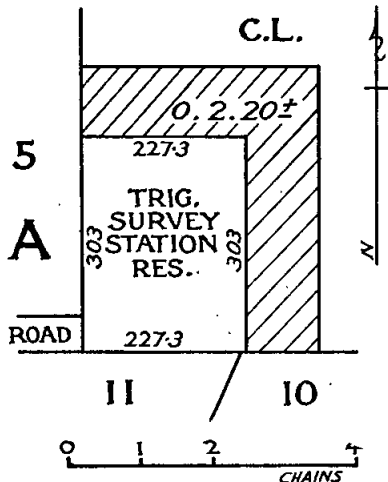

HEATHCOTE.—The temporary reservation as a site for Watering purposes and the withholding from sale, leasing and licensing by Order in Council of the 4th June, 1877 (see *Government Gazette 1877*, page 1097), of 7 acres 2 roods 11 perches of land in the Township of Heathcote (called Municipal district of Heathcote in Order), are about to be revoked so far only as the portion containing 1 acre 15 perches, more or less, indicated by hatching on plan hereunder, is concerned.—(H.74(7) (Rs.5316).

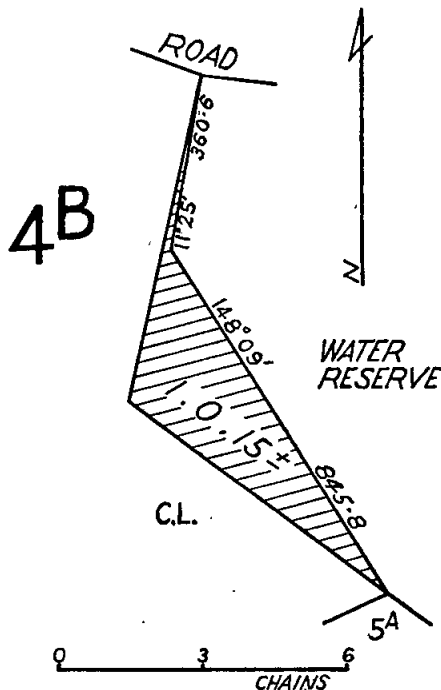

WILLIAMSTOWN.—The temporary reservation as a site for Public Park, and the withholding from sale, leasing and licensing by Order in Council of the 6th October, 1884, of 20 acres, more or less, of land in the Township of Williamstown (named Municipal district of Williamstown in Order), revoked as to part by various orders, are about to be revoked so far only as the portion containing 8 perches, more or less, indicated by hatching on plan hereunder, is concerned.—(W.163(6) (Rs.1381).

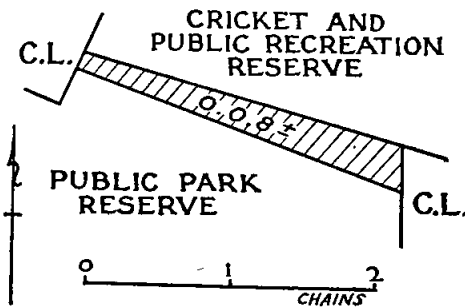

W. BORTHWICK,
Minister of Lands.

PROPOSED REVOCATION OF TEMPORARY RESERVATION OF LAND BY ORDER IN COUNCIL.

In pursuance of the provisions of the *Land Act 1958*, notice is hereby given that it is the intention of the Governor in Council to revoke the temporary reservation of land by Order in Council hereunder referred to, viz.:-

The following Notice was published 1° on the 23rd May, 1973, pursuant to Orders of the 15th May, 1973.

WARATAH NORTH (SANDY POINT).—The temporary reservation by Order in Council of the 14th January, 1964, of 1 rood 8 perches of land in the Parish of Waratah North as a site for a Public Hall is about to be revoked

so far only as the portion containing 10 perches, indicated by hatching on plan hereunder, is concerned.—(W.365(?) (Rs.8293).

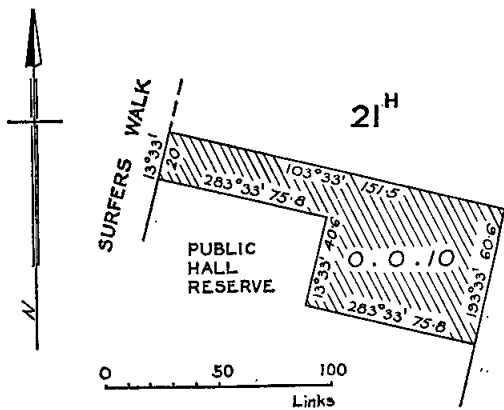

W. BORTHWICK,
Minister of Lands.

COMMITTEES OF MANAGEMENT OF RESERVES. APPOINTMENTS.

Notice is hereby given that, in pursuance of section 221 of the Land Act 1958, the following appointments of Committees of Management of reserved Crown lands have been made by the Minister of Lands:—

“BEACONSFIELD PUBLIC HALL RESERVE.”

The Corporation of the Shire of Berwick as the Committee of Management of the land in the Parish of Pakenham, temporarily reserved pursuant to Order in Council dated the 3rd April, 1973, as a site for Public purposes (Public Hall).—(Corres. No. Rs.5406.)

“PUBLIC PURPOSES (SEWERAGE PURPOSES) RESERVE, PARISH OF BEECHWORTH.”

The Beechworth Sewerage Authority as the Committee of Management of the land in the Parish of Beechworth, temporarily reserved pursuant to Order in Council dated the 12th September, 1972, as a site for Public purposes (Sewerage purposes).—(Corres. No. Rs.9606.)

“PRINCETOWN PUBLIC HALL RESERVE.”

The Corporation of the Shire of Otway as the Committee of Management of the land in the Township of Princetown, temporarily reserved pursuant to Order in Council dated the 13th July, 1885, as a site for a Public Hall.—(Corres. No. Rs.1898.)

“THE PUBLIC RECREATION RESERVE—PARISH OF TRUGANINA.”

The Corporation of the City of Altona as the Committee of Management of the land in the Parish of Truganina, temporarily reserved pursuant to Order in Council dated the 20th March, 1973, as a site for Public Recreation.—(Corres. No. Rs.9726.)

W. BORTHWICK,
Minister of Lands.

Department of Crown Lands and Survey,
Melbourne, 30th May, 1973.

TENDERS

PUBLIC WORKS DEPARTMENT

Tenders will be received at Public Works Department, 2 Treasury-place, Melbourne, until TWO p.m. on dates shown and for purposes mentioned hereunder.

Particulars and tender forms available at Contracts Office, Room 27, Ground Floor, No. 2, Treasury-place, and at places indicated in brackets hereunder.

Abbreviations in brackets mean:—W.O.—Inspector of Works Office; P.S.—Police Station; C.S.—Consolidated School; H.E.S.—Higher Elementary School; H.S.—High School; Pr.S.—Primary School; T.S.—Technical School.

Tenders to be submitted on the Department's printed Tender Form and will not be received by telephone. All tenders must be on a “Firm Tender” basis. The lowest or any tender will not necessarily be accepted.

Address tenders to the Minister of Public Works, and endorse the envelope containing the tender “Tender for , closing Tuesday,

Hand delivered tenders to be placed in the Tender Box of the Public Works Department, located on the wall of the centre entrance foyer, Ground Floor, 2 Treasury-place, Melbourne.

No preliminary deposit is required with any tender, but a successful tenderer will be required to pay a deposit for any accepted tender of \$4,000 or over.

Tuesday, 12th June, 1973.

Building, Electrical and Mechanical Works.

CHELTENHAM.—Erection of new brick veneer toilet block and new roof over existing senior toilet block, Pr.S.84.

GLEN WAVERLEY.—Roadway and security lighting, Police Academy.

HEATHERTON.—New brick veneer toilet block and covered way, Pr.S.938.

Site Works.

MILDURA.—Site works, High School. (W.O., Mildura, Swan Hill.)

Miscellaneous.

HAWTHORN.—Maintenance cleaning from 16th July, 1973, to 15th July, 1976, Court House.

Tuesday, 19th June, 1973.

Building, Electrical and Mechanical Works.

BENALLA.—Interior and exterior renovations and painting, H.S. (W.O., Benalla, Shepparton and Wangaratta.)

BENALLA.—Electrical installation, H.S. (W.O., Benalla, Shepparton and Wangaratta.)

COHUNA.—Mechanical services, H.S. (W.O., Bendigo and Wangaratta.) (Re-advertised.)

MAFFRA.—Extensions to Art/Craft Rooms, H.S. (W.O., Bairnsdale.)

PRAHRAN.—Internal and external renovations, T.S.

SOUTH MELBOURNE.—Alterations to canteen, T.S.

TOORAK.—External and internal renovations, Teacher's College Hostel.

Site Works.

SALE.—Site works, H.S. (W.O., Traralgon.)

STRATHMORE.—Site works, H.S.

Miscellaneous.

MELBOURNE.—Supply and installation of P.A.B.X. telephone system, Conservation and Environment Protection, 240 Victoria Parade.

MELBOURNE.—Supply and installation of intercommunication system, Conservation and Environment Protection, 240 Victoria Parade.

Tuesday, 26th June, 1973.

Building, Electrical and Mechanical Works.

MONT PARK.—Renovations to Deputy Chairman's Residence, Mental Hospital.

MOUNT DANDENONG.—New toilet block, Observatory Reserve.

PRINCES HILL.—Internal and external renovations, Pr.S.2955.

WARRNAMBOOL.—Internal and external renovations, High School (W.O., Warrnambool.) (Re-advertised.)

Miscellaneous.

PORT MELBOURNE.—Supply and delivery of twelve (12) amenities caravans, Plant Depot. (Re-advertised.)

ROBERTS DUNSTAN,
Minister of Public Works.

Public Works Department,
Melbourne, 3002, 1st June, 1973.

TENDERS FOR THE SERVICE, 1973-74.

GENERAL STORES.

Tenders will be received until Eleven o'clock a.m., on Friday, 29th June, 1973, from persons willing to supply the under-mentioned articles in such quantities as may be ordered by the Victorian Government from the 1st September, 1973, to the 31st August, 1974:—

Schedules as above, with full particulars, may be obtained from the Secretary to the Tender Board, by whom also the samples will be shown and any information afforded to persons tendering.

In all cases the total cost of each item must be extended in the columns provided.

Schedule No.

68. Stamps, Rubber.
69. Stationery (General) and Carbon Papers, Typewriter Ribbons, &c., Typograph Material.

The prices tendered must not include sales tax.

Security—Five per cent. of total amount of tender accepted, but in no case will security of less than \$6 be received.

Security will be required either in Commonwealth Treasury Bonds, or approved bank guarantee, fixed deposit receipt, Savings Bank deposit book, or non-negotiable cheque in favour of the Secretary to the Tender Board, as the tenderer may elect.

The security must be completed and the contract signed within five days of acceptance of the tender, failing which the contract may be again advertised, or another tender accepted.

The lowest or any tender will not necessarily be accepted.

In the event of tenderers withdrawing or attempting to withdraw their tenders before notification of acceptance of same, or failing to take up their accepted tenders within the prescribed period after notification of acceptance, they may be disqualified from tendering or holding any future contracts for Government supplies for a period of twelve months, such disqualification to date from the notification of acceptance of tender. It is also stipulated that, if a tenderer be a member of a firm and such firm be interested in the contract, the tender shall be in the name of the firm and not in that of the individual and that, for a breach of this condition, the tender will be declared informal.

Tenders enclosed in a separate envelope, and having the words "Tender for———" (as the case may be) written thereon, must be deposited in the Tender-box at the Tender Board Offices, 2nd Floor, South Building, New State Public Offices, Treasury-place, Melbourne, 3002, or if sent by post, postage must be prepaid and the tenders addressed to the Chairman of the Tender Board, Tender Board Offices, 2nd Floor, South Building, New State Public Offices, Treasury-place, Melbourne, 3002; which office they must reach not later than by first post on the date of closing of tenders.

The conditions of contract are those published in the Victoria Government Gazette, No. 14, dated 14th March, 1973.

E. P. WATSON,
Secretary to the Tender Board.

The Treasury,
Melbourne, 1st June, 1973.

TENDERS FOR THE SERVICE, 1973-74.

REQUISITES FOR EDUCATION DEPARTMENT.

Tenders will be received until Eleven o'clock a.m., on Friday, 29th June, 1973, from persons willing to supply the under-mentioned articles, in such quantities as may be ordered by the Victorian Government, from the 1st September, 1973, to the 31st August, 1974.

Schedule No.

2. Exercise Books and Requisites.

The prices tendered must not include sales tax.

Security—Five per cent. of total amount of tender accepted, but in no case will security of less than \$6 be received.

Schedules as above, with full particulars, may be obtained from the Secretary to the Tender Board, by whom also the samples will be shown and any information afforded to persons tendering.

Should the tenderer be in a position to supply a suitable substitute of Commonwealth production or manufacture in place of any sample exhibited that may be of imported origin, he may tender for such substitute, but must submit with his tender a sample of the article offered.

In all cases the country of origin of the articles tendered must be stated, and the total cost of each item extended in the columns provided.

Security will be required either in Commonwealth Treasury Bonds, or approved bank guarantee, fixed deposit receipt, Savings Bank deposit book, or non-negotiable cheque in favour of the Secretary to the Tender Board, as the tenderer may elect.

The security must be completed and the contract signed within five days of acceptance of the tender, failing which the contract may be again advertised, or another tender accepted.

The lowest or any tender will not necessarily be accepted.

In the event of tenderers withdrawing or attempting to withdraw their tenders before notification of acceptance of same, or failing to take up their accepted tenders within the prescribed period after notification of acceptance, they may be disqualified from tendering or holding any future contracts for Government supplies for a period of one year, such disqualification to date from the notification of acceptance of tender. It is also stipulated that, if a tenderer be a member of a firm and such firm be interested in the contract, the tender shall be in the name of the firm and not in that of the individual and that, for a breach of this condition the tender will be declared informal.

Tenders enclosed in a separate envelope, and having the words "Tender for———" (as the case may be) written thereon, must be deposited in the Tender-box at the Tender Board Offices, 2nd Floor, South Building, New State Public Offices, Treasury-place, Melbourne, 3002, or if sent by post, postage must be prepaid, and the tenders addressed to the Chairman of the Tender Board, Tender Board Offices, 2nd Floor, South Building, New State Public Offices, Treasury-place, Melbourne, 3002, which office they must reach not later than by first post on the date of closing of tenders.

CONDITIONS OF CONTRACT.

1. Except where definite quantities are specified the Government will not be bound to order from the contractor all the articles enumerated in the schedule, but only those articles, and such quantities of those articles, as it may be found necessary to order. Should the Government, however, require a larger supply of any article than the estimated quantity stated in the schedules, the contractor will nevertheless be bound to supply the same at contract rates.

The Government reserves the right to purchase otherwise than from the contractor articles of any of the several kinds enumerated in the schedules the purchase of which is, in the opinion of the Tender Board, necessary in order to meet special circumstances or special requirements.

2. The supplies are to be the same as sample where so stated, and of the particular manufacture indicated in the schedule of tenders. In the case of different makers' goods, the contractor will be required to supply the kind ordered. The supplies are to be the best quality of their several kinds or manufacture. In the event of the tender having been accepted for goods manufactured within the Commonwealth or manufactured within any other part of the British Empire (as the case may be), all such goods supplied shall, if required by the Government, bear evidence that they are of the particular manufacture tendered for, and, in addition, the contractor may at any time during the currency of the contract be called on to furnish a statutory declaration as to the country of origin of the goods supplied.

3. Except where otherwise stated in the schedule, the value of all packages, cases, casks, &c., whether bulk be broken or not, must be included in the prices stated in the contractor's tender; all such packages, &c., to be considered the property of the Government, and no charges or expenses whatsoever beyond the price tendered and set out in the schedule will be allowed to the contractor for any articles or packages, cases, casks, &c. The net weight or quantity only will be paid for. Contractors must provide, without extra charge, whatever labour may be required in the packing of stores, and the stores shall be packed in such a manner as shall secure them from injury during transit, and until delivery such stores shall be at the risk of the contractor.

4. All orders for supplies will emanate from the Education Department. The goods shall be delivered as may be directed by the officer ordering the supply.

5. Supplies ordered for delivery in the Melbourne District are to be delivered free of all charges (whether cartage, freight, &c.), and, for the purposes of these contracts, Melbourne District will include a radius of 12 miles from the Elizabeth-street Post Office. For supplies outside that radius the goods must be delivered free on rails at Flinders-street or Spencer-street Railway Stations as required.

6. Arrangements as to time of delivery and inspection of goods will be made by the Secretary, Education Department, or such other officer whom he may appoint.

7. Orders must receive prompt execution; and in the event of the goods not being delivered within forty-eight hours after the contractor shall have received the order, or within such other time as the order may specify for delivery, it will be competent for the officer named in clause 6, or the head of the department to whom the goods are to be supplied, on giving the contractor twenty-four hours' notice to purchase the supplies, or any like supplies that are suitable for the service, at the contractor's risk, and the extra expense incurred over and above the contract price (if any) will be deducted from the contractor's account or from the security money.

8. Delivery will not be deemed to have been made until the goods have been approved. In case of the rejection or return of any supplies, the contractor shall bear the whole cost of replacing the supplies rejected or returned, otherwise purchases will be effected at the contractor's risk and the extra expense deducted as in clause 7.

9. The official order issued by the Education Department shall be forwarded by the contractor to the officer authorized to accept delivery, who shall acknowledge thereon the receipt of the goods accepted and return the order to the contractor, who will attach same to his claim for payment.

10. All orders, duly receipted, shall be returned to the Education Department at the end of each month, accompanied by an account in the prescribed form for the articles supplied during the month, and, on receipt of same, the contractor shall be entitled to payment, due time to be allowed for the examination and verification of the claim.

11. The acceptance of the supplies shall be subject to the approval of the officer authorized to take delivery of the stores, or such other officer as shall be named in the schedules. Delivery of the articles will not be deemed to have been made until they have been handed in good order and condition to the head teacher of the school or such other person as may be authorized to accept delivery, &c. The contractor may, however, claim a survey on any goods objected to; but in that case he must, within twenty-four hours after objection is made give notice thereof, in writing, to the officer rejecting the goods. If, after the delivery of the supplies has been taken, any deficiency or defect is discovered therein, such deficient or defective stores may be returned to the contractor.

12. The members of Boards of survey will be appointed by the Treasurer of the State for the time being, and the decision of the Board is to be considered as final. If the Board shall decide that the article is not of proper quality it must be immediately replaced by the contractor, failing which it, or any like supply that is suitable for the service, will be procured elsewhere, and the survey fees and extra expense (if any) will be deducted as in clause 7.

13. All goods forwarded under these contracts shall, where practicable, be forwarded by rail, and all consignments shall bear the number of the consignment notes under which they are forwarded, and also the name of the contractor by whom consigned, on a legibly-written business label.

14. When the contractor is required to make delivery of goods at a railway station for transmission by rail, he shall obtain a receipt for the goods in duplicate on the Stores and Transport consignment note, at the same time handing in a triplicate and quadruplicate of the form as an authority for the Railways to act as agent for, and charge the freight to, the Stores and Transport Office or such other Department as shall be named therein. He shall as soon as possible, and not later than twenty-four hours thereafter, deliver the original at the Tender Board Offices, the duplicate to be forwarded to consignee in accordance with clause 15, and the quintuplicate to be retained by himself. Should the goods thus forwarded be rejected, the contractor must bear the cost of replacing such goods, for which service the departmental consignment note is not to be used. Any infringement of this condition will subject the contractor to such mulct as the Tender Board may recommend under clause 17 of these conditions. Such mulct may be deducted as in clause 7.

15. Immediately after the consignment of the goods, the officer to whom they are forwarded shall be notified by the contractor, on the duplicate consignment note provided for the purpose, that the goods have been sent. On receipt of

this document, the officer to whom it has been forwarded shall acknowledge thereon the receipt of the goods without delay to the Stores and Transport Office. In the event of loss through failure on the part of the contractor to comply with this condition he will be held responsible, and the amount of the loss incurred for same will be deducted as in clause 7.

16. Should the order on the contractor specially provide that goods of a fragile character, or such as are liable to suffer loss by leakage, shall be consigned at the risk of the Railways Commissioners under special freight conditions, the contractor shall in such instance provide in writing, on the consignment note an intimation to that effect, failing which, in the event of loss, he shall bear the whole cost of replacing the goods, the amount being deducted from the contractor's account or the security money.

17. A refusal to execute orders, irregularity in the quantity or quality of the supplies, delay in delivering or replacing them when required, or non-compliance with the terms of clauses 14 and 15 of these conditions respecting the forwarding of consignment notes, &c., will subject the contractor, upon report from the Tender Board, to such mulct not exceeding one hundred dollars as the said Treasurer may direct and the amount may be deducted as in clause 7. It will also be in the power of the said Treasurer upon such refusal, irregularity, or delay, to terminate the contract forthwith, and declare forfeit the whole or any portion of the security money; and, in addition, the contractor will be disqualified from tendering or holding any future contract or contracts for a period of one year from the date of such disqualification.

18. Contractors are not at liberty to transfer their contracts under cover of power of attorney, coupled with an interest or otherwise; and no such transfer will be recognized by the Government. If it is found during the currency of the contract that the contractor has not conformed to the condition of advertisement—which stipulates that if a tenderer be a member of a firm, and such firm be interested in the contract, the tender shall be in the name of the firm, and not in that of the individual—then the said Treasurer may, on the recommendation of the Tender Board, determine the contract, and forfeit the security money.

19. The contracts entered into under these conditions are not to be considered as being broken, infringed, or vitiated by the importation of stores for the Government service, or by any contracts or purchases made by the Agent-General for Victoria, or by any contracts or agreements made for supplies to Technical Schools, or by any article being made at any Government establishment and supplied for the use of the Education Department, or by the consumption of the surplus stock of any Government establishment.

20. Notwithstanding anything contained to the contrary in section 152 of the Customs Act 1901-36, it is hereby expressly provided that upon any alteration of the duty collected affecting the goods included in this contract, the contract price shall not be altered, and the contract may be terminated at the opinion of either party by two months' notice in writing from the first day of the calendar month next ensuing, and within the period for which the contract is made. The contract for the unaffected items shall remain in full force and effect. Any notice to be served under this condition shall be deemed to have been duly served if sent to the contractor in a registered letter to his last known place of business or abode.

21. Under no circumstances, other than those mentioned in clause 20, will a contractor be permitted to abandon his contract. In the event of the contractor failing to carry on the contract, the contract security money will in that case be absolutely forfeited; and, in addition, the contractor will be held liable for any loss which the Government may sustain in consequence of such failure.

22. Should the Minister of Education for the time being decide to discontinue the use of any book, map, or any other article in the schedule, or to direct that any book, map, or any other article other than those enumerated therein be taken into use, he shall at any time give six months' notice of such intention or decision to the contractor, and after the expiration of the period of such notice the Education Department shall not be bound to take any further supply of such book, map, or any other article, nor shall the contractor be bound to supply the same, and all books or maps not in the schedule, but which it may be decided to introduce, shall be supplied by the contractor after expiration of such notice at a price to be agreed on between the Minister of Education for the time being and the contractor.

E. P. WATSON,
Secretary to the Tender Board.

The Treasury,
Melbourne, 1st June, 1973.

PUBLIC SERVICE NOTICES

No. 452.

FIRST SCHEDULE—continued.

Public Service Act 1958; Section 39.

REGULATIONS.—PART IV.—SALARIES AND INCREMENTS.

The Public Service Board, in pursuance of the powers conferred by the *Public Service Act 1958*, hereby amends the Public Service (Public Service Board) Regulations as follows:—

FIRST SCHEDULE.

PROFESSIONAL DIVISION.

Amount of Salary Assigned to Offices in "Special" Class.

Office.	Yearly Rate of Salary.
Delete the existing yearly rates of salary for the following offices and insert the rates shown hereunder in lieu thereof—	
DEPARTMENT OF AGRICULTURE.	
Deputy Director of Agriculture	19,400
Chief Biologist	18,300
Chief of Division of Agricultural Education	18,300
Chief of Division of Agriculture	18,300
Chief of Division of Animal Health	18,300
Chief of Division of Animal Industry	18,300
Chief of Division of Dairying	18,300
Chief of Division of Horticulture	18,300
Chief of Division of Agricultural Chemistry and Chief Chemist.	17,400
CHIEF SECRETARY'S DEPARTMENT.	
Government Statist	19,400
State Librarian	18,300
MINISTRY FOR CONSERVATION.	
Director of Fisheries and Wildlife	19,400
DEPARTMENT OF CROWN LANDS AND SURVEY.	
Surveyor-General	18,300
Director, Royal Botanic Gardens and Government Botanist	17,400
DEPARTMENT OF HEALTH.	
Chief Health Officer	23,500
Deputy Chief Health Officer	20,600
Government Medical Officer	20,600
Chief Health Education Officer	18,300
<i>General Health Branch.</i>	
Assistant Chief Health Officer (Community Services)	19,400
Assistant Chief Health Officer (Public Health)	19,400
Chief Engineer	18,300
Chief Industrial Hygiene Officer	18,300
Health Officer (Venereal Diseases)	18,300
Senior District Health Officer	18,300
District Health Officer, Grade I.	17,400
Industrial Hygiene Medical Officer, Grade I.	17,400
Medical Officer, Poliomyelitis	17,400
<i>Maternal and Child Welfare Branch.</i>	
Director of Child Health (Dental)	18,300
Director of Child Health (Medical)	18,300
Director of Maternal, Infant and Pre-School Welfare	18,300
Senior Superintending Dental Officer	17,400
Superintending School Medical Inspector	17,400
<i>Tuberculosis Branch.</i>	
Deputy Director of Tuberculosis (Diagnostic Services)	18,300
Deputy Director of Tuberculosis (Radiology)	18,300
Deputy Director of Tuberculosis (Sanatoria and Chalets)	18,300
Clinical Tuberculosis Officer	17,400
Medical Superintendent, Sanatoria	17,400
Radiologist, Mass X-ray Surveys	17,400
Supervisor of Mass X-ray Surveys	17,400
Tuberculosis Officer	17,400

Office.	Yearly Rate of Salary.
MINISTRY OF HOUSING.	
Chief Technical Officer, Office of the Housing Commission	19,400
General Manager, Holmesglen Concrete House Factory, Office of the Housing Commission	17,400
LAW DEPARTMENT.	
Chief Parliamentary Counsel	23,500
Crown Solicitor	23,500
Registrar-General and Registrar of Titles	20,600
Assistant Crown Solicitor	18,300
Chief Stipendiary Magistrate	18,300
Deputy Chief Parliamentary Counsel	18,300
Deputy Chief Stipendiary Magistrate	17,400
LOCAL GOVERNMENT DEPARTMENT.	
Valuer-General	17,400
MINES DEPARTMENT.	
Director, Oil and Gas Branch	18,300
Director of Geological Survey	18,300
PREMIER'S DEPARTMENT.	
Director, National Gallery, Ministry for the Arts	17,400
PUBLIC WORKS DEPARTMENT.	
Director, Division of Building	20,600
Chief Architect	19,400
Director, Division of Ports and Harbours	19,400
Chief Engineer, Division of Building	18,300
Deputy Chief Architect	18,300
SOCIAL WELFARE DEPARTMENT.	
Deputy Director-General of Social Welfare	18,300
Director of Family Welfare	17,400
Director of Prisons	17,400
Director of Youth Welfare	17,400
STATE FORESTS DEPARTMENT.	
Chief of the Division of Forest Management	17,400
Chief of the Division of Forest Operations	17,400
TREASURY.	
Comptroller of Stamps	17,400
Government Printer	17,400
WATER SUPPLY DEPARTMENT.	
Chief Engineer, Major Works	19,400
Chief Engineer, Rural Water Supplies	19,400
Chief Engineer, Town Water Supplies and Local Authorities	19,400
Chief Constructional Engineer	18,300
Chief Designing Engineer	18,300
Chief Mechanical Engineer	18,300

THIRD SCHEDULE.

PART A.

ADMINISTRATIVE DIVISION.

Scale of Rates of Annual Salaries.

Delete the maximum annual salary amount of "\$20,054" in Class "A1" and insert the amount of "\$23,500" in lieu thereof.

PART B.

PROFESSIONAL DIVISION.

Scale of Rates of Annual Salaries.

OFFICERS CLASSIFIED IN "SPECIAL" CLASS.

Delete the minimum annual salary amount of "\$14,804" and the maximum annual salary amount of "\$20,054" and insert in lieu thereof the amounts of "\$17,400" and "\$23,500", respectively.

FOURTH SCHEDULE.
ADMINISTRATIVE DIVISION.

Amount of Salary Assigned to Offices in Class "A1".

Office.	Yearly Rate of Salary.
Delete the existing yearly rates of salary for the following offices and insert the rates shown hereunder in lieu thereof—	
CHIEF SECRETARY'S DEPARTMENT.	
Deputy Under Secretary	17,400
EDUCATION DEPARTMENT.	
Secretary	17,400
DEPARTMENT OF LABOUR AND INDUSTRY.	
Director of the Office of Industrial Relations Co-ordination (Public Employing Authorities) ..	17,400
LAW DEPARTMENT.	
Registrar of Companies	17,400
PREMIER'S DEPARTMENT.	
Assistant Auditor-General	18,300
Chief Public Service Inspector, Office of the Public Service Board	18,300
Deputy Secretary	17,400
TREASURY.	
Deputy Director of Finance	18,300
Commissioner, Land Tax and Probate Duties ..	17,400

This Regulation shall have effect as on and from the 3rd June, 1973.

A. J. A. GARDNER, Chairman.
P. CARRIGAN, Secretary.

Office of the Public Service Board,
Melbourne, 30th May, 1973.

No. 453.

Public Service Act 1958, Section 39.

REGULATIONS.—PART IV.—SALARIES AND INCREMENTS.

The Public Service Board, in pursuance of the powers conferred by the Public Service Act 1958, hereby amends its Regulations as shown below :—

THIRD SCHEDULE.

PART B.

PROFESSIONAL DIVISION.

Scale of Rates of Annual Salaries.

STIPENDIARY MAGISTRATES.

The salary scale shown is deleted and the following salary scale is inserted in lieu thereof—

Class.	Annual Salary of Each Class.
	\$
SM-1	14,804
SM-2	15,904

This Regulation shall have effect as on and from the 3rd June, 1973.

A. J. A. GARDNER, Chairman.
P. CARRIGAN, Secretary.

Office of the Public Service Board,
Melbourne, 30th May, 1973.

PRIVATE ADVERTISEMENTS

Local Government Act 1958, Part XVIII., Division 4.

CITY OF DANDENONG.

NOTICE OF INTENTION TO PURCHASE OR TAKE LANDS.

Notice is hereby given that—

- (a) The Council of the City of Dandenong deeming it expedient to provide land in Walker-street, Dandenong necessary for the provision of car-parking facilities and access thereto and other municipal purposes, intends to purchase or compulsorily take pursuant to the powers conferred on it by section 511 of the Local Government Act 1958 all that piece or parcel of land situate in the County of Bourke, Parish of Dandenong and State of Victoria, being part of allotment 10, section 2, Township of Dandenong and being the land described in conveyance No. 13, book 518.
- (b) The Council has prepared a map and other papers showing all necessary information as required by section 512 of the said Act.
- (c) The said map and other papers have been approved by the Council and are now deposited at the Office of the Council situate in Clow-street, Dandenong for inspection by any person during office hours free of charge.
- (d) All persons affected by the proposal for the taking of the said land are required to set forth in writing addressed to the Council or to the Municipal Clerk, City Offices, Clow-street, Dandenong within forty clear days from the 6th day of June, 1973, being the date of publication of this notice in the Government Gazette all objections which they may have to the taking of the said land; and
- (e) At the next ordinary meeting of the Council after the expiration of the said forty clear days the Council will consider any objections to the said taking.

Dated the 6th day of June, 1973.

By the Council,

2633

C. A. ELLIOTT, Town Clerk.

Local Government Act 1958, Part XVIII., Division 4.

CITY OF DANDENONG.

NOTICE OF INTENTION TO PURCHASE OR TAKE LANDS BEING EASEMENTS.

Notice is hereby given that—

- (a) The Council of the City of Dandenong deeming it expedient to provide drainage easements through land in Francis-street, Dandenong necessary for the adequate drainage of nearby land, intends to purchase or compulsorily take pursuant to the powers conferred on it by section 511 of the Local Government Act 1958, a six foot wide easement of drainage along and within the rear boundaries of lots 61 and 62 on L.P.11787 situate in Francis-street, Dandenong.
- (b) The Council has prepared maps and other papers showing all necessary information as required by section 512 of the said Act.
- (c) The said map and other papers have been approved by the Council and are now deposited at the Office of the Council situate in Clow-street, Dandenong for inspection by any person during office hours free of charge.
- (d) All persons affected by the proposal for the taking of the said land are required to set forth in writing addressed to the Council or to the Municipal Clerk, City Offices, Clow-street, Dandenong within forty clear days from the 6th day of June, 1973, being the date of publication of this notice in the Government Gazette all objections which they may have to the taking of the said land; and
- (e) At the next ordinary meeting of the Council after the expiration of the said forty clear days the Council will consider any objections to the said taking.

Dated the 6th day of June, 1973.

By the Council,

2634

C. A. ELLIOTT, Town Clerk.

CITY OF DONCASTER AND TEMPLESTOWE.

By-Law No. 63.

A By-Law of the City of Doncaster and Templestowe made under the Local Government Act 1968 and the Uniform Building Regulations 1969 and numbered 63 for determining, applying, dispensing with or regulating such matters or things as are left to be determined, applied, dispensed with, regulated by the Council of the said City under the Uniform Building Regulations 1969 for amending By-Law 62 of the City of Doncaster and Templestowe and for other purposes.

In pursuance of the powers conferred by the Local Government Act 1958 and the Uniform Building Regulations 1969 and of any and every other power it thereunto enabling the Mayor, Councillors and Citizens of the City of Doncaster and Templestowe order as follows:—

1. By-Law number 62 of the City of Doncaster and Templestowe is hereby amended as follows:—

(a) Immediately after the heading "Third Schedule" the words "That part of the municipal district cross hatched on the plan set out hereunder" shall be amended to read "That part of the municipal district cross hatched on the plans set out hereunder".

(b) Immediately after the plan appearing in the "Third Schedule" there shall be added the following additional plan—

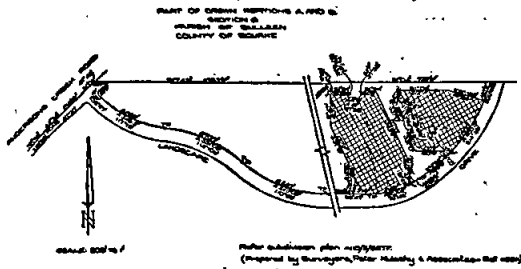

Resolution for passing of this By-Law was agreed to by the Council of the City of Doncaster and Templestowe on the 26th day of March, 1973, and confirmed by the Council on the 7th day of May, 1973.

The corporate seal of the Mayor, Councillors and Citizens of the City of Doncaster and Templestowe was hereunto affixed in the presence of—

W. R. DAVEY, Mayor.
 T. O. WILLASON, Councillor.
 M. MEARS, Deputy Town Clerk.

Approved by the Governor in Council on the 22nd day of May, 1973.—T. J. FORRISTAL, Clerk of the Executive Council. 2632

CITY OF KNOX.

LOAN No. 108.

Notice of Intention to Borrow.

Notice is hereby given that the Council of the City of Knox intends to borrow One hundred and fifty thousand dollars (\$150,000), secured by a charge over the general rates of the municipality by the grant of a mortgage in accordance with the provisions of the Local Government Acts.

In connexion therewith the following information is stated:—

- (a) The amount of the principal moneys which it is proposed to borrow is One hundred and fifty thousand dollars.
- (b) The maximum rate of interest that may be paid is \$6.90 per centum per annum.
- (c) The times which the moneys borrowed are to be repayable are the 20th day of January 1974 and the 20th days of January and July during the years 1974–1993 inclusive and that the place such moneys shall be repayable is at the Bank of New South Wales, Boronia.
- (d) The purpose for which the loan is to be applied is:—
 - (i) Construction of Pre School/Infant Welfare Centres.
 - (ii) Carrington Park Community Centre.
 - (iii) Land Acquisition.

(e) The manner in which the loan is to be liquidated is by provision out of the municipal fund in each half-year during the currency of the loan of the sum of \$6,969.71, which includes principal and interest.

The plans and specifications* and estimate of the cost of the works and a statement showing the proposed expenditure of the moneys to be borrowed are open for inspection at the City Offices, Fern Tree Gully, for one month after publication of this notice.

Dated this 1st day of June, 1973.

2640

N. G. HAYNES, Town Clerk.

CITY OF KNOX.

LOAN No. 109.

Notice of Intention to Borrow.

Notice is hereby given that the Council of the City of Knox intends to borrow One hundred and fifty thousand dollars (\$150,000), secured by a charge over the general rates of the municipality by the grant of a mortgage in accordance with the provisions of the Local Government Acts.

In connexion therewith the following information is stated:—

- (a) The amount of the principal moneys which it is proposed to borrow is One hundred and fifty thousand dollars.
- (b) The maximum rate of interest that may be paid is \$6.90 per centum per annum.
- (c) The times which the moneys borrowed are to be repayable are the 20th day of January 1974 and the 20th days of January and July during the years 1974–1993 inclusive and that the place such moneys shall be repayable is at the Bank of New South Wales, Bayswater.
- (d) The purpose for which the loan is to be applied is:—

Land acquisition for off-street parking in Bayswater Commercial Area.

(e) The manner in which the loan is to be liquidated is by provision out of the municipal fund in each half-year during the currency of the loan of the sum of \$6,969.71, which includes principal and interest.

The plans and specifications and estimate of the cost of the works and a statement showing the proposed expenditure of the moneys to be borrowed are open for inspection at the City Offices, Fern Tree Gully, for one month after publication of this notice.

Dated this 1st day of June, 1973.

2641

N. G. HAYNES, Town Clerk.

CITY OF KNOX.

LOAN No. 114.

Notice of Intention to Borrow the Sum of \$100,000 for Permanent Works and Undertakings.

Notice is hereby given that the Council of the City of Knox, in pursuance of powers conferred by the Local Government Acts, intends to borrow the sum of \$100,000, secured by a charge over the general rates of the municipality, such sum to be raised by the grant of a mortgage, in accordance with the said Acts and states:—

- (a) The amount of principal moneys it is proposed to borrow is \$100,000.
- (b) The maximum rate of interest that may be paid is 6.6 per cent. per annum.
- (c) The period of the loan will be ten years and the time or times at which the moneys borrowed are to be repayable is on the 10th day of June and the 10th day of December in each year, during the currency of the loan commencing on the 10th day of December, 1973, until the final payment on the 10th day of June, 1983.
- (d) The purpose for which the loan is to be applied is for permanent works and undertakings, viz:—

Land acquisition.

(e) The loan is to be liquidated by half-yearly payments of approximately \$6,909.38, including principal and interest, payable out of the municipal fund.

(f) The place of repayment will be the Commercial Bank of Australia Limited, Bayswater.

Plans and specifications and an estimate of the cost of such works and undertakings, and a statement showing the proposed expenditure of the money to be borrowed, are open for inspection by ratepayers, during office hours, at the City Offices, Fern Tree Gully, for one month after the publication of this notice.

Dated at Fern Tree Gully this 1st day of June, 1973.
2642 N. G. HAYNES, Town Clerk.

CITY OF KNOX.

LOAN No. 110.

Notice of Intention to Borrow the Sum of \$100,000 for Permanent Works and Undertakings.

Notice is hereby given that the Council of the City of Knox proposes to borrow the principal sum of \$100,000 secured by a charge over the general rates of the municipality, such sum to be raised by the grant of a mortgage in accordance with the provisions of the *Local Government Act 1958*.

1. The maximum rate of interest that may be paid is 6.4 per cent. per annum.
2. The purpose for which the loan is to be applied is:—

(a) Chandler-road, Boronia, land acquisition for widening	\$80,000
(b) Rowville. Recreation Reserve Pavilion (part cost)	20,000
	\$100,000

3. The period of the loan shall be twenty years.

4. The moneys borrowed shall be repayable by providing out of the municipal fund half-yearly instalments of approximately \$4,467 each including principal and interest on the 1st day of January and the 1st day of July during the currency of the loan. The first instalment shall be payable on the 1st day of January, 1974.

5. Such moneys shall be repayable to The Commissioners of The State Savings Bank of Victoria at the office of the said Commissioners, corner Elizabeth and Bourke streets, Melbourne.

The plans and specifications and the estimate of the cost of the proposed works and a statement showing the proposed expenditure of the moneys to be borrowed are open for inspection at the office of the Council of the City of Knox at Fern Tree Gully.

Dated 23rd May, 1973.
2585 N. G. HAYNES, Town Clerk.

CITY OF KNOX.

LOAN No. 115.

Notice of Intention to Borrow the Sum of \$75,000 for Permanent Works and Undertakings.

Notice is hereby given that the Council of the City of Knox proposes to borrow the principal sum of \$75,000 secured by a charge over the general rates of the municipality, such sum to be raised by the grant of a mortgage in accordance with the provisions of the *Local Government Act 1958*.

1. The maximum rate of interest that may be paid is 6.3 per cent. per annum.
2. The purpose for which the loan is to be applied is construction of Bayswater Community Centre (part cost).
3. The period of the loan shall be fifteen years.
4. The moneys borrowed shall be repayable by providing out of the municipal fund half-yearly instalments of approximately \$3,901 each including principal and interest on the 1st day of January and the 1st day of July during the currency of the loan. The first instalment shall be payable on the 1st day of January, 1974.

5. Such moneys shall be repayable to the Commissioners of The State Savings Bank of Victoria at the office of the said Commissioners, corner Elizabeth and Bourke streets, Melbourne.

The plans and specifications and the estimate of the cost of the proposed works and a statement showing the proposed expenditure of the moneys to be borrowed are open for inspection at the office of the Council of the City of Knox at Fern Tree Gully.

2586 N. G. HAYNES, Town Clerk.

CITY OF KNOX.

LOAN No. 107.

Notice of Intention to Borrow the Sum of \$220,000 for Permanent Works and Undertakings.

Notice is hereby given that the Council of the City of Knox in pursuance of the powers conferred by the *Local Government Acts*, intends to borrow the sum of \$220,000 secured by a charge over the general rates of the municipality, such sum to be raised by the grant of a mortgage, in accordance with the said Acts and states:—

- (a) The amount of principal moneys it is proposed to borrow is \$220,000.
- (b) The maximum rate of interest that may be paid is 6.8 per cent. per annum.
- (c) The period of the loan will be fifteen years and the time or times at which the moneys borrowed are to be repayable is on the 30th day of June, and the 30th day of December in each year during the currency of the loan commencing on the 30th day of December, 1973, until the final payment on the 30th day of June, 1988.
- (d) The purpose for which the loan is to be applied is for permanent works and undertakings, viz.:—
Construction of new city offices (part cost).
- (e) The loan is to be liquidated by half-yearly payments of approximately \$11,812.30 including principal and interest, payable out of the municipal fund.
- (f) The place of repayment will be A.N.Z. Banking Group Ltd., 206 Dorset-road, Boronia.

Plans and specifications and an estimate of the cost of such works and undertakings, and a statement showing the proposed expenditure of the moneys to be borrowed, are open for inspection by ratepayers, during office hours, at the City Offices, Fern Tree Gully, for one month after the publication of this notice.

Dated at Fern Tree Gully, this 30th day of May, 1973.
2594 N. G. HAYNES, Town Clerk.

CITY OF MOE.

LOAN No. 54.

Notice of Intention to Borrow the Sum of \$32,000 for Road Construction Works.

Notice is hereby given that the Council of the City of Moe proposes to borrow the sum of \$32,000 secured by a charge over the general rates of the municipality, such sum to be raised by the grant of a mortgage in accordance with the *Local Government Act*.

1. The maximum rate of interest that may be paid is 6.4 per cent. per annum.
2. The purpose for which the loan is to be applied is for construction of roads, and improvements to council properties.
3. The period of the loan shall be twenty years.
4. The moneys borrowed shall be repayable by providing out of the municipal fund 40 equal half-yearly instalments of approximately \$1,429.51 each including principal and interest.
5. Such moneys shall be repayable to the National Bank of Australasia Ltd., George-street, Moe, or at such other place as the bank may require.

The plans and specifications and the estimate of the cost of the proposed works, and a statement showing the proposed expenditure of the moneys to be borrowed are open for inspection at the City Offices, Albert-street, Moe, during office hours.

2588 R. J. PUGSLEY, Town Clerk.

CITY OF SPRINGVALE.

BY-LAW No. 193.

Municipal Buildings, Reserves and Playgrounds By-Law.
A By-law of the City of Springvale made under the provisions of Sections 197 and 800 of the *Local Government Act 1958* and numbered 193 for the purpose of:—

- (a) Preserving public decency.
- (b) Suppressing nuisances.
- (c) Controlling and managing and preserving commons and public reserves of which the management is vested in the Council.
- (d) Providing for the protection and control of—
 - (i) tree reserves and gardens, garden plots, lawns and ornamental plantations in or upon any street or road;

- (ii) trees shrubs and plants planted and tree guards statues monuments fountains and seats erected in or upon any street or road.
- (e) Preserving good order and decency in any building belonging to the municipality or under the control and management of the Council and preventing damage to such building and the furniture and fittings thereof.
- (f) Imposing collecting and receiving charges or entrance fees for clubs, associations or persons using or entering in or upon any pleasure grounds or places of public resort or public recreation on land purchased or rented or otherwise provided by or granted or given by any person to the Council for the providing of such grounds or places and also for the regulation of the conduct of persons using or being upon or in such grounds or places.

In pursuance of the powers conferred by the *Local Government Act 1958* and of any and every other power it thereunto enabling the Mayor Councillors and Citizens of the City of Springvale orders as follows:—

1. This By-law shall be known as the Municipal Buildings Reserves and Playgrounds By-Law.

2. By-laws Nos. 151 and 177 of the City of Springvale are hereby repealed.

3. In this By-law, unless inconsistent with the context or subject matter—

“Building” means a building belonging to the municipality or under the control and management of the Council.

“Council” means the Council of the City of Springvale.

“Children’s Playground” means and includes every reserve or portion of a reserve specified by notice on the same to be a Children’s Playground or set aside as playgrounds for children by the provision of swings slides and similar equipment.

“Fire prevention appliance” means any appliance, fixture, plant, machinery or thing whether attached to or placed in any building and used or intended to be used for the purpose of preventing controlling or extinguishing fire, and without affecting the generality of the foregoing includes hoses, taps, hydrants, sprinklers or portable fire extinguishers.

“Garden” means and includes any tree reserve, garden, garden plot, lawn or ornamental plantation in or upon any street or road and trees shrubs and plants planted and tree guards statues monuments and fountains and seats erected in or upon any street road or land.

“Reserve” means and includes any land purchased or rented or otherwise provided by or granted or given to the Council for the providing of pleasure grounds or places of public resort or public recreation.

“Sports Ground” means and includes every portion of the reserves described in the 1st Schedule hereto which are specified by notice on the same to be a sports ground or are declared from time to time by Council resolution to be a Sports Ground.

4. Except as hereinafter provided all reserves shall be open to the public every day from sunrise to sunset.

5. In the case of Sports Grounds the Council by Resolution may from time to time—

- (a) vary the days and hours during which the same shall be open,
- (b) determine the days and hours upon which charges or entrance fees may be collected and received for clubs, associations or persons using or entering in or upon the same.
- (c) determine the amount of deposit to be paid by any club association or person granted a permit to use the same,
- (d) determine the fee to be charged for a permit to use the same,
- (e) determine the fee to be charged for a permit to use any building upon the same,
- (f) determine the periods during which organised sport or forms of sport may be played upon the same.

6. No person other than members of the Council, persons authorised in writing by the Council, officers of the Council and employees of the Council on duty shall be entitled to

enter any sports ground during any time a charge authorised by the Council is made for admission thereto without first paying such charge.

7. (1) Every club, association or person to whom a permit to use a sports ground is granted shall be responsible to see that the sports ground is left in a clean and sanitary condition and that all refuse and rubbish deposited therein as a result of the use of the sports ground is removed to the satisfaction of the Engineer to the Council no later than by the end of the day following the day of such use.

(2) If such person fails to comply with the provisions of sub-clause (1) hereof then the Council shall be entitled to take all steps necessary to place the sports ground in a clean and sanitary condition and to deduct the cost of so doing from the deposit paid by the holder of the permit.

8. No person shall—

- (i) interfere with or break or damage or remove any tree plant shrub or flower in or upon any reserve or garden;
- (ii) walk on the flower beds or borders or climb jump or get upon or over any fence gate building or part thereof (other than seats set aside for the public) in or upon any reserve or garden;
- (iii) post bills or advertisements on any of the fences gates walls seats or other structures in or upon any reserve or garden;
- (iv) roll or throw stones or missiles in or upon any reserve or garden (except as may form part of the reasonable use of a sports ground);
- (v) leave in any reserve or garden or part thereof or building therein any bottle can broken glass paper fruit skins or peel or any refuse or rubbish whatsoever otherwise than in the receptacles provided.

9. Except with the written authority of the Council no person shall carry firearms in or through any reserve or shoot attempt to shoot snare attempt to snare destroy or attempt to destroy any bird or animal therein or thereon.

10. No person shall—

- (a) expectorate upon any passageway, stairway, floor or wall in; or
- (b) cut mark deface write or scribble on; or
- (c) otherwise damage or injure—
any building or any part thereof or the furniture and fittings thereof.

11. No person shall—

- (a) stand upon any chair seat or table in; or
- (b) stand or sit on any windowsill, parapet, roof, gutter, gable, exterior balcony or cornice of—
any building.

12. No person shall use the handrail of any stairway otherwise than for support or assistance by hand in ascending or descending such stairway.

13. No person shall in any way interfere with destroy damage or injure any fire prevention appliance in any building.

14. Except with the written authority of the Council no person shall attach fix or paint any bill device poster sign or advertisement on any of the buildings fences seats or other structures in any reserve or on any building.

15. (a) No person Club Association or group of persons shall engage play or practice in any organized game or practice session of cricket, football, bowls, tennis, lacrosse or golf or any like games or any other organized sport in or upon any reserve without the authority of the Council.

(b) No person shall play any type of ball game in a childrens playground which contains a notice erected by the Council announcing that ball games are not permitted.

16. No person shall play any unlawful game or make any wager for money or carry on any form of gambling in any reserve without the written authority of the Council and all other relevant authorities or by any unseemly or indecent conduct interfere with the comfort or enjoyment of other persons within any reserve.

17. No person shall interfere with or in any way hinder or interrupt any employee of the Council engaged in any duty in any reserve.

18. Except as may be provided under or pursuant to the *Hawkers and Pedlar’s Act 1958* no person shall sell expose or offer for sale within any reserve any article of food or drink or any other article or operate or cause to be operated any amusement for which a charge is made or make a collection of money for any purpose without the written authority of the Council.

19. No person shall behave in a disorderly manner or create any fight or disturbance or use any indecent or abusive language or commit any nuisance or in any way offend against decency by means of dress language or conduct in any reserve and no person shall enter or remain in any reserve whilst in a drunken or intoxicated condition or whilst under the influence of any drug to such an extent as to cause a disturbance to other persons in the reserve.

20. (1) Except as hereinafter provided no person other than an officer or servant of the Council shall ride or drive any horse or any motor vehicle motor cycle or bicycle into or upon any reserve.

(2) The provisions of this clause shall not apply to—

- (a) the driving in or upon any reserve of motor vehicles motor cycles or bicycles in accordance with the terms of any permit in writing by the Council under the hand of the Town Clerk authorising any club association or person upon conditions therein specified to allow the same;
- (b) the parking of motor vehicles motor cycles and bicycles in any parking area set aside for that purpose by the Council;
- (c) the wheeling of bicycles prams invalid wheel chairs child or baby carriages and children's toys along any delineated footpath in any reserve.

21. (1) No person shall—

- (a) fly any model aeroplane or any similar device;
- (b) use any turf cricket wicket provided by the Council—

in or on any reserve without the written permission of the Council.

(2) No person shall—

- (a) practice or engage in the game of golf; or
- (b) without the consent of the Council take any animal or allow or permit any animal to be;
- (c) take into or consume any intoxicating liquor except in accordance with the provisions of the Licensing Acts any permit thereunder)

in or on any reserve or building.

(3) No person shall use any reserve for—

- (a) the racing of any horse or any greyhound, whippet or other dog used for coursing;
- (b) motor car racing, motor cycle racing, go-kart racing, bicycle racing or similar sporting activities—

without the consent in writing of the Council.

(4) No person shall bring into or ride any bicycle motor cycle mini bike or horse in or on any reserve or within any building.

22. No person other than a player official or competitor at any sports match or sports gathering held in accordance with any permit to use a sports ground granted by the Council in accordance with the provisions of the By-law shall enter or remain within or upon the playing arena in any sports ground during the progress of such sports match or sports gathering or otherwise interfere with the same or interrupt or interfere with any employee of the Council in the proper execution of his duty or work.

23. Any person found offending against any of the provisions of this by-law who fails to obey a direction of any police officer or officer or employee of the Council to leave a reserve shall notwithstanding that a fee or charge for admission may have been paid by him, be guilty of an offence against this by-law.

24. No person other than an officer or employee of the Council shall enter any plots or areas which are set aside for the planting or growing of flowers trees or shrubs in any reserve.

25. (i) Except as hereinafter provided no person shall permit or suffer any animal owned by him or of which he is in charge to be in or upon any reserve.

(ii) No person shall bring allow or have any dog in any reserve unless such dog be controlled by a leash chain or cord or unless such dog is taking part in sheep dog trials or dog obedience trials or training sessions in accordance with the written authority of the Council for the use of the reserve for that purpose.

26. (i) No person above the age of fourteen years other than a person in charge of a child or children using the same shall enter any Children's Playground.

(ii) No person shall use any swing or other equipment erected in a Children's Playground for a longer period than five minutes if any other person is waiting to use such equipment.

27. No person shall ride lead train or exercise any horse or dog on any garden.

28. No person shall camp or pitch erect or occupy any camp tent or temporary shelter in or upon any reserve without the written consent of the Council.

29. No person shall without the written consent of the Council and the observance of all statutory restrictions which may be in force—

(i) light any fire or permit any fire to remain alight in any reserve save in a fire-place provided by Council;

(ii) let off any fireworks in any reserve
Provided that this clause shall not apply to the use of properly constructed gas bar-b-ques stoves or heaters which comply with any regulations affecting the same.

30. Any person guilty of any wilful act or default contrary to the provisions of this By-law shall be liable to a penalty of not more than \$100.00.

31. This By-law shall apply to and have operation throughout the whole of the municipal district of the City of Springvale.

FIRST SCHEDULE.

Burden Par
Frederick Wachter Reserve
Keysborough Reserve
Roth Hetherington Reserve
Dingley Reserve
Springvale Recreation Reserve
Edinburgh Road Reserve
Noble Park Reserve
Parkfield Reserve
Ross Reserve
Alex Nelson Reserve
Beazley Reserve
William Chadwick Reserve
Glendale Reserve
Norman Luth Reserve
Warner Reserve

Resolution for passing this By-law agreed to by the Council of the City of Springvale on the 16th April, 1973, and confirmed on the 28th May, 1973.

The common seal of the Mayor, Councillors and Citizens of the City of Springvale was hereto affixed, in the presence of—

(SEAL) H. C. BOX, Councillor.
2638 R. O. LUXFORD, Councillor.
K. MOODY, Acting Town Clerk.

CITY OF SUNSHINE.

BYLAW No. 114.

Street Reserves and Bus Shelters Protection Bylaw.
A Bylaw of the City of Sunshine made under Section 197 of the *Local Government Act 1958* and numbered 114 for:

- (a) Providing for the protection and control of:
 - (i) tree reserves and gardens garden plots lawns and ornamental plantations in or upon any street or road;
 - (ii) tree shrubs and plants and tree guards statues monuments fountains and seats erected in or upon any street or road.
 - (iii) posts fences raised pavings and places of refuge in or upon any street or road.
- (b) Preventing damage to any building belonging to the municipality or under the control and management of the Council.

In pursuance of the powers conferred by the *Local Government Act 1958* and of any and every other power it thereunto enabling the Mayor Councillors and Citizens of the City of Sunshine orders as follows:—

1. This Bylaw shall be known as the *Street Reserves and Bus Shelters Protection Bylaw*.

2. In this Bylaw the words "Bus Shelter" shall mean shelters for bus passengers which are provided by the Council pursuant to Subsection (7) of Section 244 of the *Local Government Act 1958* and which belongs to the municipality or under the control and management of the Council;

The word "Reserve" shall mean and include the reserves and gardens plots lawns and ornamental plantations in or upon any street or road.

The words "Traffic Control Structure" shall mean and include any post fence raised paving and place of refuge in or upon any street or road;

- (a) for protecting persons being on or passing along any street or road or footway; or
 - (b) for regulating traffic along any street or road or on footways; or
 - (c) for making the crossing of any street or road less dangerous to any such persons.
3. No person shall cut maim injure mutilate or destroy any tree shrub or plant planted or any tree guard statue monument fountain or seat erected in or upon any street or road.

4. No person shall drive or cause to be driven or ridden any vehicle, or animal or permit any hoofed animal of which he is the owner or in charge to be in or upon any reserve.

5. No person shall throw stones or other missiles in any reserve or place or leave therein any refuse or rubbish whatsoever save in a receptacle placed therein by the Council for the purpose.

6. No person shall without the previous consent in writing of the Council sell or offer for sale any goods wares or merchandise in or upon any reserve or conduct carry on or take part in any game sport entertainment performance or ceremony therein or thereon.

7. No person shall without the previous consent in writing of the Council light or attempt to light any fire or burn or attempt to burn any substance in or upon any reserve.

8. No person shall cut maim injure deface disfigure or destroy any traffic control structure or bus shelter or write paint print stencil place or affix any letter figure device poster sign or advertisement upon any traffic control structure or any statue monument fountain or seat in or upon any street or road.

9. This Bylaw shall apply to and have operation throughout the whole of the municipal district.

Resolution for passing this Bylaw agreed to by the Council of the City of Sunshine on the 19th day of June, 1972, and confirmed on the 31st day of July, 1972.

The corporate seal of the Mayor, Councillors and Citizens of the City of Sunshine was hereunto affixed in the presence of:

(SEAL) K. WHEELAHAN, Mayor.
2592 H. A. THOMAS, Councillor.
T. W. DEUTSCHMANN, Town Clerk.

BOROUGH OF WONTHAGGI

LOAN No. 31.

Notice of Intention to Borrow the Sum of \$17,000 for Permanent Works and Undertakings.

Notice is hereby given that the Council of the Borough of Wonthaggi proposes to borrow the sum of \$17,000, secured by a charge over the general rates of the municipality, such sum to be raised by the grant of a mortgage in accordance with the provisions of the Local Government Act 1958.

- 1. The maximum rate of interest that may be paid is 6 per cent. per annum.
- 2. The purposes for which the loan is to be applied are as follows:—

1. Recreation Reserve Clubrooms (part payment)	\$4,600
2. Water Service—Recreation Reserve	1,300
3. Industrial land	1,800
4. Plant	9,300
	\$17,000

- 3. The period of the loan shall be for seven (7) years.
- 4. The moneys borrowed shall be repayable by providing out of the municipal funds fourteen (14) half-yearly instalments of approximately \$1,504.95 each, including principal and interest due on the 16th day of January and of July in each year, during the currency of the loan. The first instalment shall be payable on the 16th January, 1974.

5. Such moneys shall be repayable at the National Bank Savings Bank Ltd., 64 McBride Avenue, Wonthaggi.

6. The plans and specifications and the estimate of the costs of the proposed works and a statement showing the proposed expenditure of the money to be borrowed, are open for inspection at the Office of the Council, Borough of Wonthaggi at the Town Hall, Wonthaggi.

Dated this 21st day of May, 1973.
2653 T. H. LARKINS, Town Clerk.

SHIRE OF BASS.

LOAN No. 37.

Notice of Intention to Borrow.

Notice is hereby given that the Council of the Shire of Bass proposes to borrow the sum of \$51,100, secured by a charge over the general rates of the municipality, such sum to be raised by a grant of a mortgage in accordance with the Local Government Act.

- (a) The maximum rate of interest that may be paid is 6.3 per cent. per annum.
- (b) The purpose for which the loan is to be applied is for:—
 - (i) the construction of an Infant Welfare and Pre-School Centre, North Wonthaggi .. \$27,500
 - (ii) the purchase of land, Dudley .. 23,600

\$51,100
- (c) The period of the loan shall be fifteen (15) years.
- (d) The moneys borrowed shall be repayable by 30 equal half-yearly instalments of \$2657.89 each, including principal and interest in each July and January, during the currency of the loan. The first instalment shall be payable during January, 1974.
- (e) Such moneys shall be repaid at the Savings Bank Branch of the National Bank of Australasia Limited, Wonthaggi, or at the Council's Bankers for the time being in Melbourne.

The plans and specifications and the estimates of the cost of the proposed works and a statement showing the proposed expenditure of moneys to be borrowed are open for inspection at the Shire Office, Dalyston, during office hours.

2645 G. J. HARLAND, Shire Secretary.

SHIRE OF DUNDAS.

ROAD DEVIATION ORDER.

Pursuant to the provisions of section 522 of the Local Government Act 1958, the Council of the Shire of Dundas hereby directs that the land in the Parish of Bochara indicated by hatching on the diagram hereunder, which has been purchased, taken or acquired by it, shall be a Public Highway on and from the date of publication of this Order in the Government Gazette.

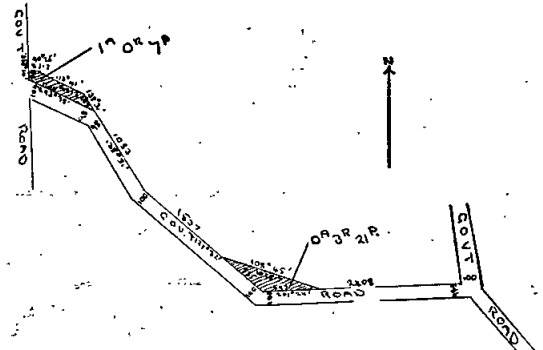

The common seal of the President, Councillors and Ratepayers of the Shire of Dundas was hereunto affixed this 5th day of April, 1973, in the presence of—

(SEAL) L. D. CORDY, President.
2580 J. R. MCKELLAR, Councillor.
J. R. MITCHELL, Secretary.

SHIRE OF ELTHAM.

BY-LAW No. 65.

Street Appeals By-Law.

A By-Law of the Shire of Eltham made under Section 197 (1) (xxxi) (a) of the Local Government Act 1958 and numbered 65 for prohibiting or regulating the soliciting or collection in any road or street or from house to house adjacent thereto of waste materials or of gifts of money or of subscriptions for any purpose.

In pursuance of the powers conferred by the Local Government Act 1958 and of any and every other power it thereunto enabling the President, Councillors and Ratepayers of the Shire of Eltham order as follows:

- 1. This By-law may be known as the Street Appeals By-Law.

2. No person shall without or otherwise than in accordance with the prior consent in writing of the Council of the Shire of Eltham solicit or collect in any road or street or from house to house adjacent thereto any waste materials or any gift or gifts of money or any subscription of subscriptions for any purpose without prior consent of the Council of the Shire of Eltham under the hand of the Shire Secretary.

3. This By-Law shall apply to and have operation throughout the whole of the Municipal District of the Shire of Eltham.

Resolution for passing this By-law was agreed to by the Council of the Shire of Eltham on the 19th day of March, 1973 and confirmed on the 21st day of May, 1973.

The common seal of the President, Councillors, Rate-payers of the Shire of Eltham was hereto affixed this 21st day of May, 1973, in the presence of—

J. O. WHITE, President.
A. S. KNOX, Councillor.
C. J. BOCK, Shire Secretary.

2649

Town and Country Planning Act 1961 (Twelfth Schedule).
SHIRE OF MORWELL.—MORWELL PLANNING SCHEME.



NOTICE THAT A PLANNING SCHEME IS BEING PREPARED AND IS AVAILABLE FOR INSPECTION.

Amendment No. 43.

Notice is hereby given that the Council of the Shire of Morwell, in pursuance of its powers under the *Town and Country Planning Act 1961*, has prepared a Planning Scheme for the following area of land, lot 41, L.P.52523, south-east corner of Laburnam and Franklin streets, Morwell, and shown on the plan hereunder for the purpose of zoning the area Residential "A".

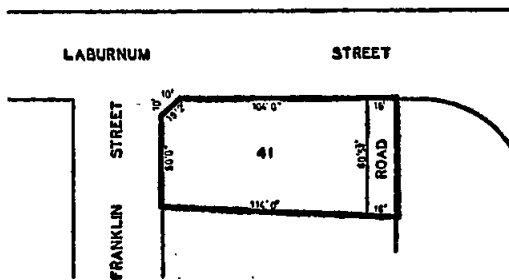
MORWELL PLANNING SCHEME
1954
AMENDMENT No. 43, 1972



REFERENCE
BOUNDARY OF SCHEME 
RESIDENTIAL "A" ZONE 

A copy of the scheme has been deposited at the Town Hall, Commercial-road, Morwell, and at the office of the Town and Country Planning Board, 235 Queen-street, Melbourne, and will be open for inspection during office hours by any person, free of charge.

Any persons affected by the Planning Scheme are required to set forth, in writing, all objections they may have addressed to the Municipal Clerk, Shire of Morwell, Town Hall, Commercial-road, Morwell, on or before the 6th July, 1973, and to state whether they wish to be heard in respect of their objections.

2629 D. J. R. DUNTON, Shire Secretary.

Town and Country Planning Act 1961 (Twelfth Schedule).
SHIRE OF MORWELL.—BOOLARRA PLANNING SCHEME.

NOTICE THAT A PLANNING SCHEME IS BEING PREPARED AND IS AVAILABLE FOR INSPECTION.



Amendment No. 5.

Notice is hereby given that the Council of the Shire of Morwell, in pursuance of its powers under the *Town and Country Planning Act 1961*, has prepared a Planning Scheme for the following area of land at Boolarra and shown on the plans hereunder for the purpose of extending the Residential and Rural "C" zone in the area.

BOOLARRA PLANNING SCHEME
1954
AMENDMENT No. 4, 1972

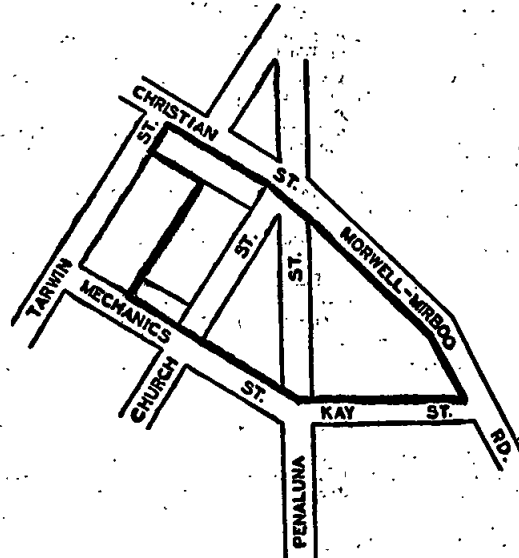
SHEET 1



REFERENCE
BOUNDARY OF SCHEME 
RESIDENTIAL 
PUBLIC PURPOSE 

BOOLARRA PLANNING SCHEME
1954
AMENDMENT No. 4, 1972
SHEET 2.

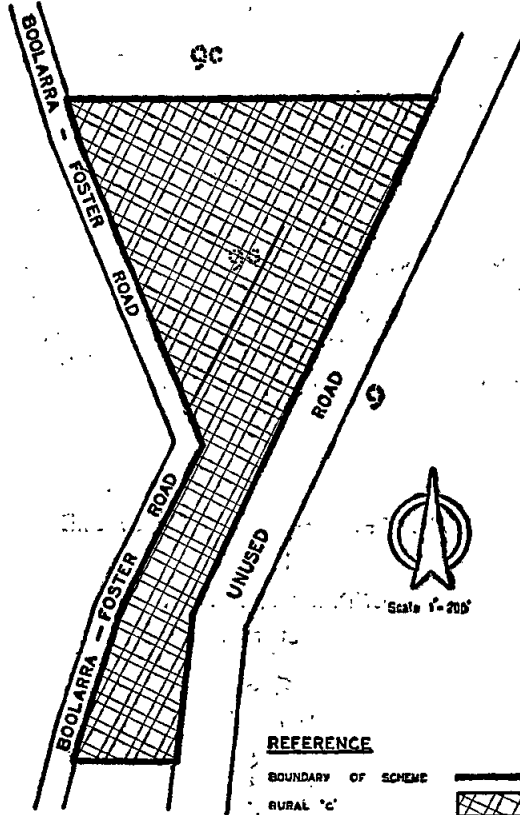

A copy of the scheme has been deposited at the Town Hall, Commercial-road, Morwell, and at the office of the Town and Country Planning Board, 235 Queen-street, Melbourne, and will be open for inspection during office hours by any person, free of charge.

Any persons affected by the Planning Scheme are required to set forth, in writing, all objections they may have addressed to the Municipal Clerk, Shire of Morwell, Town Hall, Commercial-road, Morwell, on or before the 6th September, 1973, and to state whether they wish to be heard in respect of their objections.

2630 D. J. R. DUNTON, Shire Secretary.

SHIRE OF OTWAY.
LOAN No. 23.

Notice of Intention to Borrow.

Notice is hereby given that the Council of the Shire of Otway intends to borrow the sum of \$30,000 (Thirty thousand dollars), on the credit of the municipal revenue of the President, Councillors, and Ratepayers of the said Shire, such sum to be raised by grant of mortgage, in accordance with the said Acts and states:—

1. The amount of principal moneys it is proposed to borrow is \$30,000.
2. The maximum rate of interest that may be paid is 6.6 per cent. per annum.
3. The period of the loan shall be for fourteen years and the times of which the moneys borrowed are to be repayable on the 10th day of March and the 10th day of September in each year, during the currency of the loan, commencing on the 10th day of March, 1974. The place of repayment will be the Commercial Savings Bank of Australia Ltd., Melbourne.
4. The purpose for which the loan is to be applied is for permanent works and undertakings, viz.:—

Construction of Shire Engineer's Offices, Workshops, Dog and Cattle Pounds.

5. The loan is to be liquidated by half-yearly payment of \$1,658.00 including principal and interest, payable out of the municipal fund.

Plans and specifications and estimate of cost of such works and undertakings, and a statement showing the proposed expenditure of the moneys to be borrowed, are open for inspection by ratepayers during office hours, at the Shire Office, Beech Forest, and the Shire Engineer's Office, Apollo Bay, for one month after publication of this notice.

Dated at Beech Forest this 18th day of May, 1973.

2639

T. J. FRY, Shire Secretary.

SHIRE OF WERRIBEE.

LOAN No. 84.

Notice of Intention to Borrow the Sum of \$100,000 for Permanent Works and Undertakings.

Notice is hereby given that the Council of the Shire of Werribee proposes to borrow the principal sum of One hundred thousand dollars secured by a charge over the general rates of the municipality, such sum to be raised by the grant of a mortgage in accordance with the provisions of the *Local Government Act 1958*.

1. The maximum rate of interest that may be paid is 6.2 per cent. per annum.
2. The purpose for which the loan is to be applied is:—

(i) Kerb and channel—Mortimer-street from Werribee-street to Greaves-street, Werribee	\$20,000
(ii) Kerb and channel—Mortimer-street from Werribee-street to Werribee River	5,000
(iii) Kerb and channel—Greaves-street from Werribee-street to Synnot-street, Werribee	6,000
(iv) Part construction of service road, Greens-road, Werribee	10,000
(v) Reconstruction of Werribee-street from Deutgam-street to Watton-street, Werribee	10,000
(vi) Part construction car park (area north of Station-street, Werribee)	9,000
(vii) Drainage and associated works, Thompson-court, Werribee	9,000
(viii) Road construction, Pipe-road, Laverton North (Council contribution)	31,000
	\$100,000
3. The period of the loan shall be ten years.
4. The moneys borrowed shall be repayable by providing out of the municipal fund half-yearly instalments of approximately \$6,783.87 each, including principal and interest, on the 1st day of August and the 1st day of February, during the currency of the loan. The first instalment shall be payable on the 1st day of February, 1974.
5. Such moneys shall be repayable to the Commissioners of the State Savings Bank of Victoria at the office of the said Commissioners, corner Elizabeth and Bourke streets, Melbourne.

The plans and specifications and the estimate of the proposed works and a statement showing the proposed expenditure of the moneys to be borrowed are open for inspection at the office of the Council of the Shire of Werribee, at Watton-street, Werribee.

Dated 28th May, 1973.

2579

J. T. KERR, Shire Secretary.

SIXTH SCHEDULE.

MORNINGTON SEWERAGE AUTHORITY.

GENERAL NOTICE.

Declaration of Sewerage Area No. 42.

The above-mentioned Sewerage Authority having made provision for carrying off the sewage from each and every property which or any part of which is within the Sewerage Area hereinafter described doth hereby declare that on and after the 1st day of July, 1973, each and every property which or any part of which is within the said Sewerage Area shall be deemed to be a seweraged property within the meaning of the *Sewerage Districts Act 1958*.

The boundaries of the Sewerage Area hereinbefore referred to are: Commencing at a point being the intersection of the northern boundary of lot No. 142 on lodged plan of subdivision No. 14204 and the western alignment of Nepean Highway (shown as Point Nepean-road on the said plan of subdivision); thence in a southerly direction by the said alignment of Nepean Highway to the south-eastern corner of lot No. 156 on lodged plan of subdivision No. 41478; thence in a westerly direction by the southern boundary of the said lot No. 156 to a point on the eastern

boundary of lot No. 143 on the last-mentioned plan of subdivision; thence southerly by the said eastern boundary to the south-eastern corner of the said lot No. 143; thence westerly by the southern boundary of the said lot No. 143 to the eastern alignment of Portrush-grove; thence by a line in a south-westerly direction across Portrush-grove to a point on its western alignment being the north-eastern corner of lot No. 166 on lodged plan of subdivision No. 41478; thence in a southerly direction by the western alignment of Portrush-grove and the prolongation thereof to the southern alignment of Dava-drive; thence easterly by the said alignment of Dava-drive to a point on the western alignment of Nepean Highway; thence southerly by the said alignment of Nepean Highway to a point being the prolongation of the northern boundary of lot No. 1 on lodged plan of subdivision No. 25023; thence easterly by the said prolongation across Nepean Highway and the northern boundaries of the said lot No. 1, the allotment on the lodged plan of consolidation No. C.P.100435, lot No. 24 on lodged plan of subdivision No. 25023, lots Nos. 1 to 4 inclusive on lodged plan of subdivision No. 50173, lots Nos. 1 to 11 inclusive on lodged plan of subdivision No. 52953 and lot No. 32 on lodged plan of subdivision No. 25023 to a point on the western alignment of Maxwell-street; thence southerly by the said alignment of Maxwell-street to a point on the northern alignment of Ruth-road; thence westerly by the northern alignment of Ruth-road and the prolongation thereof to a point on the western alignment of Nepean Highway; thence southerly by the said alignment of Nepean Highway to the south-eastern corner of lot No. 217 on lodged plan of subdivision No. 41478; thence westerly by the southern boundary of the said lot No. 217 to its south-western corner; thence northerly by the western boundaries of the said lot No. 217, lots Nos. 216 and 215 on the last-mentioned plan of subdivision to the south-eastern corner of lot No. 239 on the same plan of subdivision; thence westerly along the southern boundary of the said lot No. 239 to a point on the eastern alignment of Carnoustie-grove; thence northerly by the said alignment of Carnoustie-grove to the point of intersection of the prolongation of the southern boundary of lot No. 277 on lodged plan of subdivision No. 41478; thence westerly by the said prolongation and southern boundary of the said lot No. 277 to its south-western corner; thence southerly by the eastern boundaries of lots Nos. 296, 295, 294 and 293, across a footway, and the eastern boundaries of lots Nos. 292, 291, 290 and 288, all on lodged plan of subdivision No. 41478, to a point on the northern alignment of Sunningdale-avenue; thence southerly by a line across Sunningdale-avenue to a point on the southern alignment of Sunningdale-avenue, such point also being the north-western corner of lot No. 347 on the last-mentioned plan of subdivision; thence easterly by the said southern alignment of Sunningdale-avenue to a point on the western alignment of Carnoustie-grove; thence southerly by the said alignment of Carnoustie-grove to a point being the intersection of the prolongation of the northern boundary of lot No. 231 on lodged plan of subdivision No. 41478; thence easterly by the said prolongation and the northern boundary of the said lot No. 231 to its north-eastern corner; thence northerly by the western boundary of lot No. 221 on the last-mentioned plan of subdivision to its north-western corner; thence easterly by the northern boundary of the said lot No. 221 to the western alignment of Nepean Highway; thence southerly by the said alignment of Nepean Highway to a point being the intersection of the prolongation of the northern boundary of lot No. 5 on lodged plan of subdivision No. 93707; thence easterly by the said prolongation across Nepean Highway and the northern boundary of the said lot No. 5 to its northern-most corner; thence south-easterly by the north-eastern boundaries of the said lot No. 5 and lot No. 4 on the last-mentioned lodged plan of subdivision to the eastern-most corner of the said lot No. 4; thence easterly by the southern boundary of lot No. 9 to a point on the western boundary of lot No. 3 on lodged plan of subdivision No. 93707; thence northerly by the said western boundary of the said lot No. 3 to its north-western corner; thence easterly by the northern boundary of the said lot No. 3 and the prolongation thereof to the western alignment of Darcy-street; thence southerly by the said alignment of Darcy-street to the northern alignment of Bentons-road; thence westerly by the said alignment of Bentons-road across Nepean Highway and across Carnoustie-grove to the south-western corner of lot No. 338 on lodged plan of subdivision No. 41478; thence northerly by the western alignment of the said lot No. 338 to its north-western corner; thence westerly by the southern boundary of lot No. 352 on the last-mentioned plan of subdivision to its south-western corner; thence northerly by the western boundary of the said lot No. 352 to the southern alignment of Sunningdale-avenue; thence easterly by the said alignment of Sunningdale-avenue to a point being the intersection of same with the prolongation of the eastern alignment of Kooyonga-grove; thence northerly by the

said prolongation across Sunningdale-avenue and the said eastern alignment of Kooyonga-grove to the westernmost corner of lot No. 297 on lodged plan of subdivision No. 41478; thence northerly by the western boundary of the said lot No. 297 to the southern boundary of lot No. 273 on the last-mentioned plan of subdivision; thence westerly by the said southern boundary of the said lot No. 273 to its south-western corner; thence northerly by the western boundary of the said lot No. 273 to the southern alignment of Carnoustie-grove; thence by a line in a northerly direction across Carnoustie-grove to a point on the northern alignment of the said street being also the south-west corner of lot No. 255 on lodged plan of subdivision No. 41478; thence northerly by the western boundaries of the said lot No. 255 and lot No. 193 on the last-mentioned plan of subdivision and the prolongation thereof across Dava-drive to its northern alignment; thence westerly by the said alignment of Dava-drive to its intersection with the eastern alignment of Pender-avenue (shown as Nepean-avenue on the last-mentioned plan of subdivision); thence northerly by the said alignment of Pender-avenue to a point being the intersection of the prolongation of the southern boundary of lot No. 134 on lodged plan of subdivision No. 41478; thence by the said prolongation and the said southern boundary of lot No. 134 to its south-western corner; thence northerly by the western boundaries of lots Nos. 134 to 139 inclusive on the last-mentioned plan of subdivision to the northernmost corner of lot No. 119 on lodged plan of subdivision No. 41478; thence south-westerly by the south-eastern boundary of lot No. 118 on the last-mentioned plan of subdivision to the southernmost corner of lot No. 118; thence north-westerly and westerly by the abutments to Gleneagles-avenue of lots Nos. 118 and 117 on the last-mentioned plan of subdivision to the south-western corner of the said lot No. 117; thence northerly by the western boundary of the said lot No. 117 to its north-western corner; thence westerly by the northern boundary of the said lot No. 117 to the south-western corner of lot No. 126 on lodged plan of subdivision No. 14204; thence northerly by the western boundary of the said lot No. 126 to the southern alignment of Ti-tree-grove; thence easterly by the said alignment of Ti-tree-grove and the prolongation thereof across Pender-avenue (shown as Nepean-avenue in the last-mentioned plan of subdivision) to its eastern alignment; thence northerly by the said eastern alignment of Pender-avenue to the north-western corner of lot No. 136 on lodged plan of subdivision No. 14204; thence easterly by the northern boundary of the said lot No. 136 to its north-eastern corner; thence easterly by the northern boundary of lot No. 142 on lodged plan of subdivision No. 14204 home to the point of commencement.

Dated the 28th day of May, 1973.

By order of the said Authority,

C. R. G. TURNER, Chairman.
D. G. COLLINGS, Secretary.

2604

SIXTH SCHEDULE.

MORNINGTON SEWERAGE AUTHORITY.

GENERAL NOTICE.

Declaration of Sewerage Area No. 45.

The above-mentioned Sewerage Authority having made provision for carrying off the sewage from each and every property which or any part of which is within the Sewerage Area hereinafter described doth hereby declare that on and after the 1st day of July, 1973, each and every property which or any part of which is within the said Sewerage Area shall be deemed to be a sewered property within the meaning of the *Sewerage Districts Act 1958*.

The boundaries of the Sewerage Area hereinbefore referred to are:—Commencing at a point on the boundary of existing sewerage area No. 32, such point being the intersection of the northern alignment of Robertson-drive and the eastern alignment of Currawong-street; thence by a line southerly across Robertson-drive to its southern alignment; thence easterly by the said southern alignment of Robertson-drive to the western alignment of Hardy-street; thence southerly and south-easterly by the said western and south-western alignments of Hardy-street to the south-eastern corner of lot 256 on lodged plan of subdivision No. 94281; thence westerly by the southern boundary of the said lot 256 to the eastern alignment of Narambi-road; thence southerly and south-easterly by the said eastern and north-eastern alignments of Narambi-road and the north-eastern boundary of lot 901 on lodged plan of subdivision No. 94565 to the north-western boundary of the railway reserve; thence south-westerly and westerly by the said north-western and northern boundaries of the said railway reserve and the southern boundaries of lots 392 and 393 on the last-mentioned plan of subdivision to the south-western corner of the said lot 393; thence northerly by the western boundary of the said lot 393 to the south-

western alignment of Richardson-drive; thence by a line north-easterly across Richardson-drive to the westernmost corner of lot 320 on lodged plan of subdivision No. 94565; thence north-westerly by the north-eastern alignment of Richardson-drive to the south-western corner of a drainage and recreation reserve shown on the last-mentioned plan of subdivision; thence generally northerly by the western boundary of the said drainage and recreation reserve to the southern alignment of Gilga-street; thence easterly by the said alignment of Gilga-street to a point being on the prolongation of the eastern alignment of Jacana-street; thence northerly by the said prolongation across Gilga-street and the said eastern alignment of Jacana-street to the westernmost corner of lot 241 on lodged plan of subdivision No. 94281; thence north-easterly by the south-eastern alignment of Jacana-street and the prolongation thereof across Robertson-drive to its north-eastern alignment; thence south-easterly and easterly by the north-eastern and northern alignments of Robertson-drive home to the point of commencement.

Dated the 28th day of May, 1973.

By order of the said Authority,

C. R. G. TURNER, Chairman.
D. G. COLLINGS, Secretary.

2607

SIXTH SCHEDULE.
MORNINGTON SEWERAGE AUTHORITY.
GENERAL NOTICE.

Declaration of Sewerage Area No. 41.

The above-mentioned Sewerage Authority having made provision for carrying off the sewage from each and every property which or any part of which is within the Sewerage Area hereinafter described doth hereby declare that on and after the 1st day of July, 1973, each and every property which or any part of which is within the said Sewerage Area shall be deemed to be a sewered property within the meaning of the *Sewerage Districts Act 1958*.

The boundaries of the Sewerage Area hereinbefore referred to are:—Commencing at a point on the existing boundary of Sewerage Area No. 25, such point being on the eastern alignment of Lempriere-avenue and being the northernmost corner of lot No. 4 on plan of subdivision No. 7885; thence north-westerly across Lempriere-avenue to a point being the intersection of the western alignment of Lempriere-avenue with the southern alignment of the Esplanade being the prolongation of the northern and eastern boundaries of lot No. 3 on plan of subdivision No. 73765; thence north-westerly and westerly by the said alignment of the Esplanade turning south-westerly, southerly and finally south-easterly to the north-eastern alignment of Bridgford-avenue; thence south-easterly by the said alignment of Bridgford-avenue to the southernmost corner of lot No. 31 on plan of subdivision No. 73765; thence by the eastern boundaries of lots Nos. 31 to 44 inclusive and the recreation reserve on the said plan of subdivision to a point on the southern alignment of Two Bays-crescent; thence easterly by the said alignment of Two Bays-crescent to the westernmost corner of lot No. 6 on the said plan of subdivision; thence easterly by the southern boundaries of lots Nos. 6, 5 and 4 on the said plan of subdivision and the prolongation thereof across Lempriere-avenue to a point on the eastern alignment of Lempriere-avenue; thence northerly and north-easterly by the said alignment of Lempriere-avenue home to the point of commencement.

Dated the 28th day of May, 1973.

By order of the said Authority,

C. R. G. TURNER, Chairman.
D. G. COLLINGS, Secretary.

2603

SIXTH SCHEDULE.
MORNINGTON SEWERAGE AUTHORITY.
GENERAL NOTICE.

Declaration of Sewerage Area No. 44.

The above-mentioned Sewerage Authority having made provision for carrying off the sewage from each and every property which or any part of which is within the Sewerage Area hereinafter described doth hereby declare that on and after the 1st day of July, 1973, each and every property which or any part of which is within the said Sewerage Area shall be deemed to be a sewered property within the meaning of the *Sewerage Districts Act 1958*.

The boundaries of the Sewerage Area hereinbefore referred to are:—Commencing at a point being the northernmost corner of lot 66 on lodged plan of subdivision No. 23815; thence southerly by the eastern alignment of Kilburn-grove to the south-western corner of lot 61 on the said plan of subdivision; thence easterly by the southern

boundary of the said lot 61 to its south-eastern corner; thence southerly by the western boundary of lot 67 on the said plan of subdivision to the northern alignment of Somers-avenue; thence easterly and south-easterly by the said northern and north-eastern alignments of Somers-avenue to the southern corner of lot 71 on the said plan of subdivision; thence north-easterly by the south-eastern boundary of the said lot 71 to its eastern corner; thence north-westerly by the north-eastern boundaries of lots 71, 70, 69 and 68, and northerly by the eastern boundaries of lots 63 to 66 inclusive all on lodged plan of subdivision No. 23815, home to the point of commencement.

Dated the 28th day of May, 1973.

By order of the said Authority,

C. R. G. TURNER, Chairman.
D. G. COLLINGS, Secretary.

2606

SIXTH SCHEDULE.
MORNINGTON SEWERAGE AUTHORITY.
GENERAL NOTICE.

Declaration of Sewerage Area No. 46.

The above-mentioned Sewerage Authority having made provision for carrying off the sewage from each and every property which or any part of which is within the Sewerage Area hereinafter described doth hereby declare that on and after the 1st day of July, 1973, each and every property which or any part of which is within the said Sewerage Area shall be deemed to be a sewered property within the meaning of the *Sewerage Districts Act 1958*.

The boundaries of the Sewerage Area hereinbefore referred to are:—Commencing at a point on the boundary of the existing Sewerage Area No. 9, such point being the intersection of the north-eastern boundary of lot 11 on lodged plan of subdivision No. 17357 and the north-western alignment of Yuilles-road; thence north-easterly by the north-westerly alignment of Yuilles-road to its intersection with the south-western boundary of the railway reserve; thence north-westerly by the said south-western boundary of the railway reserve to the south-eastern alignment of Nepean Highway as defined in Country Roads Board plan No. S.P.5642; thence south-westerly and southerly by the said south-eastern and eastern alignments of Nepean Highway to its intersection with the north-eastern boundary of lot 2 on lodged plan of subdivision No. 17357; thence south-easterly by the said boundary of lot 2 and the north-eastern boundaries of lots 3 to 7 inclusive and lot 11 on the last-mentioned lodged plan of subdivision home to the point of commencement.

Dated the 28th day of May, 1973.

By order of the said Authority,

C. R. G. TURNER, Chairman.
D. G. COLLINGS, Secretary.

2608

SIXTH SCHEDULE.
MORNINGTON SEWERAGE AUTHORITY.
GENERAL NOTICE.

Declaration of Sewerage Area No. 47.

The above-mentioned Sewerage Authority having made provision for carrying off the sewage from each and every property which or any part of which is within the Sewerage Area hereinafter described doth hereby declare that on and after the 1st day of July, 1973, each and every property which or any part of which is within the said Sewerage Area shall be deemed to be a sewered property within the meaning of the *Sewerage Districts Act 1958*.

The boundaries of the Sewerage Area hereinbefore referred to are:—Commencing at a point on the existing Sewerage Area No. 13 being the southern corner of lot 25 on lodged plan of subdivision No. 25681; thence by a line south-easterly across Wood-street to the northernmost corner of lot 5 on the last-mentioned plan of subdivision; thence south-easterly by the north-eastern boundary of the said lot 5 and the prolongation thereof across Yuilles-road to its south-eastern alignment; thence south-westerly by the said alignment of Yuilles-road to a point on the prolongation of the south-western boundary of lot 16 on lodged plan of subdivision No. 25681; thence north-westerly by the said prolongation across Yuilles-road and the said south-western boundary of lot 16 and the prolongation thereof across Wood-street to its north-western alignment; thence north-easterly by the said alignment of Wood-street home to the point of commencement.

Dated the 28th day of May, 1973.

By order of the said Authority,

C. R. G. TURNER, Chairman.
D. G. COLLINGS, Secretary.

2609

SIXTH SCHEDULE.
MORNINGTON SEWERAGE AUTHORITY.
GENERAL NOTICE.

Declaration of Sewerage Area No. 48.

The above-mentioned Sewerage Authority having made provision for carrying off the sewage from each and every property which or any part of which is within the Sewerage Area hereinafter described doth hereby declare that on and after the 1st day of July, 1973, each and every property which or any part of which is within the said Sewerage Area shall be deemed to be a sewered property within the meaning of the *Sewerage Districts Act 1958*.

The boundaries of the Sewerage Area hereinbefore referred to are:—Commencing at a point on the boundary of the existing sewerage area No. 28, such point being the intersection of the northern boundary of lot 16 on lodged plan of subdivision No. 23815 and the western alignment of Kilburn-grove; thence southerly by the said alignment of Kilburn-grove to the south-eastern corner of lot 20 on the said plan of subdivision; thence westerly by the southern boundary of the said lot 20 to its south-western corner; thence northerly by the western boundaries of lots 20, 19, 18, 17 and 16 on lodged plan of subdivision No. 23815 to the north-western corner of the said lot 16; thence easterly by the northern boundary of the said lot 16 home to the point of commencement.

Dated the 28th day of May, 1973.

By order of the said Authority,

C. R. G. TURNER, Chairman.
D. G. COLLINGS, Secretary.

2610

SIXTH SCHEDULE.
MORNINGTON SEWERAGE AUTHORITY.
GENERAL NOTICE.

Declaration of Sewerage Area No. 39.

The above-mentioned Sewerage Authority having made provision for carrying off the sewage from each and every property which or any part of which is within the Sewerage Area hereinafter described doth hereby declare that on and after the 1st day of July, 1973, each and every property which or any part of which is within the said Sewerage Area shall be deemed to be a sewered property within the meaning of the *Sewerage Districts Act 1958*.

The boundaries of the Sewerage Area hereinbefore referred to are:—Commencing at a point on the boundary of the existing Sewerage Area No. 17, such point being the south-western corner of lot No. 14 on plan of subdivision No. 17880 lodged in the Office of Titles; thence in a northerly and north-westerly direction by the westerly and south-westerly boundaries of lots Nos. 14, 13, 12 and 11 on the said plan of subdivision to the westernmost corner of the said lot No. 11; thence by a line in a north-westerly direction across Kalimna-drive (shown as Esplanade on plan of subdivision No. 7120 lodged in the Office of Titles) to the southernmost corner of lot No. 170 on the said plan of subdivision No. 7120; thence in a north-westerly direction by the south-western boundary of the said lot No. 170 to the westernmost corner of the said lot; thence in a north-easterly direction by the north-western boundaries of lots Nos. 170 to 179 inclusive on the last-mentioned plan of subdivision to the northernmost corner of the said lot No. 279; thence by a line north-easterly across Warrain-avenue (shown as Beach-avenue on the last-mentioned plan of subdivision) to the westernmost corner of lot No. 4 on plan of subdivision No. 60245 lodged in the Office of Titles; thence in a north-easterly direction by the north-western boundaries of the said lot No. 4, lot No. 3 on plan of subdivision No. 51310 lodged in the Office of Titles, lot No. 183 on plan of subdivision No. 7120 lodged in the Office of Titles, and lot No. 2 on plan of subdivision No. 96040 lodged in the Office of Titles to the northernmost corner of the said lot No. 2, such point also being on the south-western alignment of Caraar Creek-lane; thence in a south-easterly direction by the said alignment of Caraar Creek-lane to the easternmost corner of lot No. 184 on plan of subdivision No. 7120 lodged in the Office of Titles; thence southerly by a line across Kalimna-drive to the north-eastern corner of lot No. 1 on plan of subdivision No. 17880 lodged in the Office of Titles; thence southerly by the western alignment of Caraar Creek-lane to the southernmost corner of lot No. 2 on plan of subdivision No. 44197 lodged in the Office of Titles; thence north-westerly by the south-western boundary of the said lot No. 2 to the northernmost corner of lot No. 1 on the last-mentioned plan of subdivision; thence southerly and south-westerly by the western and north-western boundaries of the said lot No. 1 to a point on the north-eastern alignment of Waratah-avenue; thence in a north-westerly direction by the said alignment of Waratah-avenue and the prolongation thereof across Silvan-grove to its

No. 45.—4670/73.—3

north-western alignment; thence north-easterly and northerly by the north-western and western alignments of Silvan-grove to the north-eastern corner of lot No. 3 on plan of subdivision No. 17880 lodged in the Office of Titles; thence westerly by the southern alignment of Kalimna-drive (shown as Esplanade on the last-mentioned plan of subdivision) to the westernmost corner of lot No. 4 on the last-mentioned plan of subdivision; thence south-easterly by the north-eastern boundary of lot No. 5 on the last-mentioned plan of subdivision to the easternmost corner of the said lot No. 5; thence south-westerly by the south-eastern boundaries of the said lot No. 5 and lots 6 to 10 inclusive and southerly by the eastern boundaries of lots 12 and 13 and the prolongation thereof across lot 14, all such lots being on plan of subdivision No. 17880 lodged in the Office of Titles, to a point on the southern boundary of the said lot 14; thence westerly along the said boundary of the said lot 14 home to the point of commencement.

Dated the 28th day of May, 1973.

By order of the said Authority,

C. R. G. TURNER, Chairman.
D. G. COLLINGS, Secretary.

2601

SIXTH SCHEDULE.
MORNINGTON SEWERAGE AUTHORITY.
GENERAL NOTICE.

Declaration of Sewerage Area No. 40.

The above-mentioned Sewerage Authority having made provision for carrying off the sewage from each and every property which or any part of which is within the Sewerage Area hereinafter described doth hereby declare that on and after the 1st day of July, 1973, each and every property which or any part of which is within the said Sewerage Area shall be deemed to be a sewered property within the meaning of the *Sewerage Districts Act 1958*.

The boundaries of the Sewerage Area hereinbefore referred to are:—Commencing at a point on the existing boundary of Sewerage Area No. 29, such point being the northernmost corner of lot No. 11 on plan of subdivision No. 14635; thence south-westerly by the north-western boundary of the said lot No. 11 and the prolongation thereof across Glenisla-drive to the southern alignment of Glenisla-drive; thence westerly and south-westerly by the said alignment to a point being the westernmost corner of lot No. 18 on plan of subdivision No. 68004; thence in a south-easterly direction by the south-western boundary of the said allotment to the southernmost corner of the said allotment; thence north-easterly and easterly by the south-eastern and southern boundaries of lots Nos. 18 to 9 inclusive on plan of subdivision No. 68004 to the south-eastern corner of the said allotment No. 9; thence southerly by the western boundary of lot No. 51 on plan of subdivision No. 80530 to the south-western corner of the said allotment; thence easterly by the southern boundary of the said allotment to the western alignment of Pindari-street; thence easterly by a line across Pindari-street to a point on the eastern alignment of Pindari-street such point being the south-western corner of lot No. 52 on plan of subdivision No. 80530; thence easterly by the southern boundary of the said allotment to the south-western corner of lot No. 5 on plan of subdivision No. 68004; thence easterly by the southern boundaries of lots Nos. 5, 4, 3, 2 and 1 to the easternmost corner of lot No. 1 on the said plan of subdivision, such point being on the south-western boundary of lot No. 1 on plan of subdivision No. 58545; thence south-easterly by the said south-western boundary to the southernmost corner of the said allotment; thence northerly by the eastern boundaries of lots Nos. 1, 2 and 3 to the south-western corner of lot No. 4 on the said plan of subdivision; thence easterly by the southern boundary of the said lot No. 4 to the easternmost corner of the said allotment; thence northerly by the eastern boundary of the said lot No. 4 to the southern alignment of Dominion-road; thence westerly by the said alignment to the westernmost corner of lot No. 4 on plan of subdivision No. 58545; thence westerly by a line across Glenisla-drive to the northernmost corner of lot No. 9 on plan of subdivision No. 14635; thence south-westerly by the north-western boundary of the said allotment to the westernmost corner of the said allotment; thence north-westerly by the north-eastern boundary of lot No. 11 on plan of subdivision No. 14635 home to the point of commencement.

Dated the 28th day of May, 1973.

By order of the said Authority,

C. R. G. TURNER, Chairman.
D. G. COLLINGS, Secretary.

2602

SIXTH SCHEDULE.
MORNINGTON SEWERAGE AUTHORITY.

GENERAL NOTICE.

Declaration of Sewerage Area No. 43.

The above-mentioned Sewerage Authority having made provision for carrying off the sewage from each and every property which or any part of which is within the Sewerage Area hereinafter described doth hereby declare that on and after the 1st day of July, 1973, each and every property which or any part of which is within the said Sewerage Area shall be deemed to be a sewered property within the meaning of the *Sewerage Districts Act 1958*.

The boundaries of the Sewerage Area hereinbefore referred to are:—Commencing at a point on the boundary of existing Sewerage Area No. 38, such point being the intersection of the eastern alignment of Esplanade and the northern alignment of Johns-road; thence easterly and northerly by the said northern and western alignment of Johns-road to a point being the northernmost corner of lot 5 on lodged plan of subdivision No. 19635; thence easterly by the prolongation of the northern alignment of Avalon-avenue across Johns-road and the said northern alignment of Avalon-avenue to the western alignment of Prince-street; thence by a line in an easterly direction across Prince-street to a point on the eastern alignment of Prince-street being also the southernmost corner of lot 3 on lodged plan of subdivision No. 14205; thence northerly by the eastern alignment of Prince-street to the westernmost corner of lot 1 on the last-mentioned plan of subdivision; thence north-easterly by the north-western boundary of the said lot 1 to the south-western alignment of Strachans-road; thence south-easterly by the said alignment of Strachans-road to a point being on the prolongation of the south-eastern alignment of Pine-avenue; thence north-easterly by the said prolongation across Strachans-road and the said south-eastern alignment of Pine-avenue to the northern corner of lot 20 on lodged plan of subdivision No. 52143; thence south-easterly by the north-eastern boundaries of lots 20, 19, 18, 17 and 16 on the said plan of subdivision to the eastern corner of the said lot 16; thence south-westerly by the south-eastern boundary of the said lot 16 and the prolongation thereof across Swansea-grove to the south-western alignment of Swansea-grove; thence south-easterly by the south-western alignment of Swansea-grove to the eastern corner of lot 30 on the last-mentioned plan of subdivision; thence easterly by a line across Swansea-grove to the north-western corner of lot 6 on lodged plan of subdivision No. 52143; thence continuing easterly by the northern boundary of the said lot 6 to its easternmost corner; thence south-westerly by the south-eastern boundaries of the said lot 6 and lots 5, 4, 3 and 1 of the last-mentioned plan of subdivision to the north-eastern alignment of Strachans-road; thence north-westerly by the said alignment of Strachans-road to a point on the prolongation across Strachans-road of the south-eastern boundary of lot 10 on lodged plan of subdivision No. 14205; thence south-westerly by the said prolongation and south-eastern boundary of the said lot 10 to its south-eastern corner; thence westerly by the southern boundary of the said lot 10 to its south-western corner; thence north-westerly by the south-western boundaries of lots 9, 8, 7, 6, 5 and 4 on lodged plan of subdivision No. 14205 to the south-eastern alignment of Short-street; thence south-westerly by the said alignment of Short-street and the prolongation thereof across Prince-street to its western alignment; thence southerly by the western alignment of Prince-street to the northern alignment of Coral-road; thence westerly by the northern alignment of Coral-road to a point on the prolongation across Coral-road of the eastern boundary of lot 5 on lodged plan of subdivision No. 94952; thence southerly by the said prolongation and eastern boundary of the said lot 5 to the northern boundary of lot 1 on the last-mentioned plan of subdivision; thence easterly, southerly and westerly by the northern, eastern and southern boundaries of the said lot 1 to the north-eastern corner of lot 149 on lodged plan of subdivision No. 15884; thence southerly by the eastern boundaries of the said lot 149 and lots 148 and 147 on the last-mentioned plan of subdivision to the northern boundary of lot 1 on lodged plan of subdivision No. 65367; thence easterly by the said northern boundary of the said lot 1 to its north-eastern corner; thence southerly by the eastern boundaries of the said lot 1 and lots 2 and 3 on the last-mentioned plan of subdivision to the northern boundary of lot 2 on lodged plan of subdivision No. 41478; thence easterly by the northern boundaries of lots 2 to 7 inclusive on the last-mentioned plan of subdivision to the north-western alignment of Prince-street; thence south-westerly and southerly by the said north-western and western alignments of Prince-street to the south-eastern corner of lot 54 on the last-mentioned plan of subdivision; thence westerly by the southern boundary of the said lot 54 to its south-western corner; thence southerly by the eastern boundaries of lots

35 to 39 inclusive on lodged plan of subdivision No. 41478 and the prolongation thereof across Bentons-road to the southern alignment of the said road; thence easterly by the said alignment of Bentons-road to the north-eastern corner of lot 5 on lodged plan of subdivision No. 86392; thence southerly by the eastern boundary of the said lot 5 to its south-eastern corner; thence westerly by the southern boundaries of lots 5 and 4 on the last-mentioned plan of subdivision to the eastern alignment of Benjamin-street; thence westerly by a line across Benjamin-street to the south-eastern corner of lot 3 on the last-mentioned plan of subdivision; thence westerly by the southern boundaries of the said lot 3 and lots 2 and 1 on lodged plan of subdivision No. 86392 to the south-western corner of the said lot 1; thence southerly by the eastern boundary of lot 1 on lodged plan of subdivision No. 80818 to the south-eastern corner of the said lot 1; thence westerly for a distance of 162 ft. 5½ in., northerly for a distance of 100 feet and westerly again for a distance of 300 feet, all by the southern boundary of the said lot 1 on the last-mentioned plan of subdivision to the eastern alignment of the Esplanade; thence generally northerly by the said alignment of the Esplanade to the north-western corner of lot 1 on lodged plan of subdivision No. 94952; thence easterly by the northern boundary of the said lot 1 to the south-western corner of lot 4 on the last-mentioned plan of subdivision; thence northerly by the western boundary of the said lot 4 and the prolongation thereof across Coral-road to the northern alignment of Coral-road; thence westerly along the said alignment of Coral-road to the eastern alignment of the Esplanade; thence northerly by the said alignment of the Esplanade home to the point of commencement.

Dated the 28th day of May, 1973:

By order of the said Authority,

2605

C. R. G. TURNER, Chairman.
D. G. COLLINGS, Secretary.

SIXTH SCHEDULE.
MOUNT ELIZA SEWERAGE AUTHORITY.

GENERAL NOTICE.

Declaration of Sewerage Area No. 33.

The above-mentioned Sewerage Authority having made provision for carrying off the sewage from each and every property which or any part of which is within the Sewerage Area hereinafter described doth hereby declare that on and after the 1st day of July, 1973, each and every property which or any part of which is within the said Sewerage Area shall be deemed to be a sewered property within the meaning of the *Sewerage Districts Act 1958*.

The boundaries of the Sewerage Area hereinbefore referred to are:—Commencing at a point on the existing boundary of Sewerage Area No. 6 being the intersection of the southern alignment of Bonito-street and the eastern boundary of lot No. 213 on lodged plan of subdivision No. 11510; thence in a southerly direction by the eastern boundary of the said lot No. 213 to the south-eastern corner of the said lot No. 213; thence in a westerly and south-westerly direction by the southern and south-eastern boundaries of the said lot No. 213 and the south-eastern boundary of lot No. 214 on the last-mentioned lodged plan of subdivision to the southernmost corner of the said lot No. 214; thence in a northerly direction by the western boundary of the said lot No. 214 to a point on the southern alignment of Bonito-street; thence in an easterly direction by the said alignment of Bonito-street home to the point of commencement.

Dated the 28th day of May, 1973.

By order of the said Authority,

2621

C. R. G. TURNER, Chairman.
D. G. COLLINGS, Secretary.

SIXTH SCHEDULE.
MOUNT ELIZA SEWERAGE AUTHORITY.

GENERAL NOTICE.

Declaration of Sewerage Area No. 34.

The above-mentioned Sewerage Authority having made provision for carrying off the sewage from each and every property which or any part of which is within the Sewerage Area hereinafter described doth hereby declare that on and after the 1st day of July, 1973, each and every property which or any part of which is within the said Sewerage Area shall be deemed to be a sewered property within the meaning of the *Sewerage Districts Act 1958*.

The boundaries of the Sewerage Area hereinbefore referred to are:—Commencing at a point on the existing boundary of Sewerage Area No. 21 being the intersection

of the north-western boundary of lot No. 16 on lodged plan of subdivision No. 18387 and the south-western alignment of Stewart-street; thence in a south-easterly direction by the said alignment of Stewart-street to the easternmost corner of lot No. 20 on the said lodged plan of subdivision; thence in a south-westerly direction by the south-eastern boundary of the said lot No. 20 to a point on the north-eastern boundary of lot No. 18 on lodged plan of subdivision No. 85499; thence in a south-easterly direction by the north-eastern boundary of the said lot No. 18 to a point on the north-western alignment of Grice-avenue; thence in a south-westerly direction by the said alignment of Grice-avenue to the southernmost corner of the said lot No. 18; thence in a north-westerly and north-easterly direction by the south-western and north-western boundaries of the said lot No. 18 to a point on the south-western boundary of lot No. 20 on lodged plan of subdivision No. 18387; thence in a north-westerly direction by the south-western boundaries of the said lot No. 20 and lots Nos. 19 to 16 inclusive, all on the last-mentioned lodged plan of subdivision, to the westernmost corner of the said lot No. 16; thence in a north-easterly direction by the north-western boundary of the said lot No. 16 home to the point of commencement.

Dated the 28th day of May, 1973.

By order of the said Authority,

2622 C. R. G. TURNER, Chairman.
D. G. COLLINGS, Secretary.

SIXTH SCHEDULE.

MOUNT ELIZA SEWERAGE AUTHORITY.

GENERAL NOTICE.

Declaration of Sewerage Area No. 35.

The above-mentioned Sewerage Authority having made provision for carrying off the sewage from each and every property which or any part of which is within the Sewerage Area hereinafter described doth hereby declare that on and after the 1st day of July, 1973, each and every property which or any part of which is within the said Sewerage Area shall be deemed to be a sewered property within the meaning of the *Sewerage Districts Act 1958*.

The boundaries of the Sewerage Area hereinbefore referred to are:—Commencing at a point on the existing boundary of Sewerage Area No. 21 being the intersection of the eastern boundary of lot No. 5 on lodged plan of subdivision No. 85499 and the north-western alignment of Lisa-court; thence in a south-westerly direction by the said alignment of Lisa-court and the north-western alignment of Gaskell-avenue to the westernmost point on the said alignment of Gaskell-avenue, all on the last-mentioned lodged plan of subdivision; thence in a south-westerly direction by the north-western alignment of Yewers-avenue to the southernmost corner of lot No. 36 on lodged plan of subdivision No. 56783; thence in a north-westerly, north-easterly and south-easterly direction by the south-western, north-western and north-eastern boundaries of the said lot No. 36 to a point on the north-eastern boundary of the said lot No. 36 being the westernmost corner of a recreation reserve on lodged plan of subdivision No. 85499; thence in a north-easterly direction by the north-western boundaries of the said recreation reserve and lot No. 5 on the last-mentioned lodged plan of subdivision to the northernmost corner of the said lot No. 5; thence in a southerly direction by the eastern boundary of the said lot No. 5 home to the point of commencement.

Dated the 28th day of May, 1973.

By order of the said Authority,

2623 C. R. G. TURNER, Chairman.
D. G. COLLINGS, Secretary.

SIXTH SCHEDULE.

MOUNT ELIZA SEWERAGE AUTHORITY.

GENERAL NOTICE.

Declaration of Sewerage Area No. 26.

The above-mentioned Sewerage Authority having made provision for carrying off the sewage from each and every property which or any part of which is within the Sewerage Area hereinafter described doth hereby declare that on and after the 1st day of July, 1973, each and every property which or any part of which is within the said Sewerage Area shall be deemed to be a sewered property within the meaning of the *Sewerage Districts Act 1958*.

The boundaries of the Sewerage Area hereinbefore referred to are:—

Commencing at a point on the existing boundary of Sewerage Area No. 2, being the intersection of the northern boundary of lot No. 153 on lodged plan of subdivision No. 10790 and the eastern alignment of Granya-grove;

thence in a southerly direction by the said alignment of Granya-grove to the northern alignment of Kanya-road; thence in an easterly direction by the said alignment of Kanya-road to the south-eastern corner of lot No. 131 on lodged plan of subdivision No. 10790; thence in a northerly direction by the eastern boundaries of the said lot No. 131 and lots Nos. 132 to 148 inclusive, all on the last-mentioned lodged plan of subdivision, to the southern alignment of Emu-road; thence by a line across Emu-road to the south-eastern corner of lot No. 149 on lodged plan of subdivision No. 10790; thence in a northerly direction along the eastern boundaries of the said lot No. 149 and lots Nos. 150 to 153 inclusive, all on the last-mentioned lodged plan of subdivision, to the north-eastern corner of the said lot No. 153; thence in a westerly direction along the northern boundary of the said lot No. 153 home to the point of commencement.

Dated the 28th day of May, 1973.

By order of the said Authority,

2614 C. R. G. TURNER, Chairman.
D. G. COLLINGS, Secretary.

SIXTH SCHEDULE.

MOUNT ELIZA SEWERAGE AUTHORITY.

GENERAL NOTICE.

Declaration of Sewerage Area No. 27.

The above-mentioned Sewerage Authority having made provision for carrying off the sewage from each and every property which or any part of which is within the Sewerage Area hereinafter described doth hereby declare that on and after the 1st day of July, 1973, each and every property which or any part of which is within the said Sewerage Area shall be deemed to be a sewered property within the meaning of the *Sewerage Districts Act 1958*.

The boundaries of the Sewerage Area hereinbefore referred to are:—

Commencing at a point on the existing boundary of Sewerage Area No. 11, being the intersection of the western alignment of Barmah-street and the prolongation of the southern boundary of lot No. 542 on lodged plan of subdivision No. 10791; thence easterly by the said prolongation and southern boundary of lot No. 542 to the south-eastern corner of the said allotment; thence northerly by the eastern boundaries of lots Nos. 542, 541, 540, 539 and 538, all on the last-mentioned lodged plan of subdivision, to the north-eastern corner of lot No. 538; thence westerly along the northern boundary of lot No. 538 and the prolongation thereof to a point on the western alignment of Barmah-street; thence southerly by the said alignment of Barmah-street home to the point of commencement.

Dated the 28th day of May, 1973.

By order of the said Authority,

2615 C. R. G. TURNER, Chairman.
D. G. COLLINGS, Secretary.

SIXTH SCHEDULE.

MOUNT ELIZA SEWERAGE AUTHORITY.

GENERAL NOTICE.

Declaration of Sewerage Area No. 28.

The above-mentioned Sewerage Authority having made provision for carrying off the sewage from each and every property which or any part of which is within the Sewerage Area hereinafter described doth hereby declare that on and after the 1st day of July, 1973, each and every property which or any part of which is within the said Sewerage Area shall be deemed to be a sewered property within the meaning of the *Sewerage Districts Act 1958*.

The boundaries of the Sewerage Area hereinbefore referred to are:—

Commencing at a point on the existing boundary of Sewerage Area No. 22, being the intersection of the eastern alignment of Roborough-avenue and the northern boundary of lot No. 602 on lodged plan of subdivision No. 10716; thence in an easterly direction by the said boundary to the north-eastern corner of lot No. 602; thence in a general southerly and south-easterly direction by the eastern and north-eastern boundaries of lots Nos. 602 to 597 inclusive, all on the last-mentioned lodged plan of subdivision, to the easternmost corner of the said lot No. 597; thence in a southerly direction by the eastern boundary of lot No. 596 in the last-mentioned lodged plan of subdivision and the prolongation thereof, to the south-western alignment of Roborough-avenue; thence in a south-easterly direction by the said Roborough-avenue alignment to the western alignment of Mount Eliza-way; thence in a southerly direction by the said Mount Eliza-way alignment to the southernmost corner of lot No. 666 on the last-mentioned lodged plan of subdivision; thence in a westerly direction by the

southern boundary of lot No. 666 to a point on the south-eastern boundary of lot No. 665 in the last-mentioned lodged plan of subdivision; thence in a south-westerly direction by the said boundary to the southernmost corner of lot No. 665; thence in a north-westerly direction by the south-western boundaries of lots Nos. 665 to 655 inclusive, all on the last mentioned lodged plan of subdivision, to the westernmost corner of lot No. 655; thence in a north-easterly direction by the north-western boundary of lot No. 655 and the prolongation thereof to the north-eastern alignment of Roborough-avenue; thence in a north-westerly and northerly direction by the north-eastern and eastern alignment of Roborough-avenue home to the point of commencement.

Dated the 28th day of May, 1973.

By order of the said Authority,

C. R. G. TURNER, Chairman.
D. G. COLLINGS, Secretary.

2616

SIXTH SCHEDULE.

MOUNT ELIZA SEWERAGE AUTHORITY.

GENERAL NOTICE.

Declaration of Sewerage Area No. 29.

The above-mentioned Sewerage Authority having made provision for carrying off the sewage from each and every property which or any part of which is within the Sewerage Area hereinafter described doth hereby declare that on and after the 1st day of July, 1973, each and every property which or any part of which is within the said Sewerage Area shall be deemed to be a sewered property within the meaning of the *Sewerage Districts Act 1958*.

The boundaries of the Sewerage Area hereinbefore referred to are:—

Commencing at a point on the existing boundary of Sewerage Area No. 22, being the south-eastern corner of lot No. 608 on lodged plan of subdivision No. 10716; thence in a northerly direction by the eastern boundaries of lots Nos. 608 to 616 inclusive, all on the last-mentioned lodged plan of subdivision, to the north-eastern corner of lot No. 616; thence in a westerly direction by the northern boundary of the said lot No. 616 and the prolongation thereof to a point on the western alignment of Roborough-avenue; thence in a southerly direction by the said Roborough-avenue alignment to a point being the prolongation of the southern boundary of lot No. 608 on lodged plan of subdivision No. 10716; thence in an easterly direction by the said prolongation and southern boundary of the said lot No. 608 home to the point of commencement.

Dated the 28th day of May, 1973.

By order of the said Authority,

C. R. G. TURNER, Chairman.
D. G. COLLINGS, Secretary.

2617

SIXTH SCHEDULE.

MOUNT ELIZA SEWERAGE AUTHORITY.

GENERAL NOTICE.

Declaration of Sewerage Area No. 31.

The above-mentioned Sewerage Authority having made provision for carrying off the sewage from each and every property which or any part of which is within the Sewerage Area hereinafter described doth hereby declare that on and after the 1st day of July, 1973, each and every property which or any part of which is within the said Sewerage Area shall be deemed to be a sewered property within the meaning of the *Sewerage Districts Act 1958*.

The boundaries of the Sewerage Area hereinbefore referred to are:—Commencing at a point on the existing boundary of Sewerage Area No. 19 being the intersection of the north-eastern alignment of Conway-street and the north-western boundary of lot No. 8 on lodged plan of subdivision No. 52780; thence in a north-easterly direction by the north-western boundaries of the said lot No. 8 and lot No. 4 on the said lodged plan of subdivision to the northernmost corner of the said lot No. 4; thence in a south-easterly direction by the north-eastern boundary of the said lot No. 4 and the prolongation thereof to a point on the south-eastern alignment of Grice-avenue; thence in a north-easterly direction by the said alignment of Grice-avenue to the northernmost corner of lot No. 12 on lodged plan of subdivision No. 53001; thence in a south-easterly direction by the north-eastern boundary of the said lot No. 12 to the easternmost corner of the said lot No. 12; thence in a south-westerly direction by the south-eastern boundaries of the said lot No. 12 and lots Nos. 11 and 10 on the said lodged plan of subdivision to the north-eastern alignment of Dalry-court; thence by the alignment of Dalry-court being the frontages of lots Nos. 14, 15 and 16 on lodged plan of subdivision No. 53001 to the easternmost corner of lot No. 9 on the said lodged plan of subdivision; thence in a south-westerly direction by the south-eastern

boundary of the said lot No. 9 to the southernmost corner of the said lot No. 9; thence in a north-westerly direction by the south-western boundary of the said lot No. 9 to the south-eastern alignment of Grice-avenue; thence in a north-easterly direction by the said alignment of Grice-avenue to a point being the prolongation of the south-western boundary of lot No. 4 on lodged plan of subdivision No. 52780; thence in a north-westerly direction by the said prolongation and south-western boundary of the said lot No. 4 to the easternmost corner of lot No. 8 on the said lodged plan of subdivision; thence in a south-westerly direction by the south-eastern boundary of the said lot No. 8 to a point on the north-eastern alignment of Conway-street; thence by the said alignment of Conway-street in a north-westerly direction home to the point of commencement.

Dated the 28th day of May, 1973.

By order of the said Authority,

C. R. G. TURNER, Chairman.
D. G. COLLINGS, Secretary.

2619

SIXTH SCHEDULE.

MOUNT ELIZA SEWERAGE AUTHORITY.

GENERAL NOTICE.

Declaration of Sewerage Area No. 32.

The above-mentioned Sewerage Authority having made provision for carrying off the sewage from each and every property which or any part of which is within the Sewerage Area hereinafter described doth hereby declare that on and after the 1st day of July, 1973, each and every property which or any part of which is within the said Sewerage Area shall be deemed to be a sewered property within the meaning of the *Sewerage Districts Act 1958*.

The boundaries of the Sewerage Area hereinbefore referred to are:—Commencing at a point on the existing boundary of Sewerage Area No. 3 being the intersection of the western boundary of lot No. 229 on lodged plan of subdivision No. 11510 and the southern alignment of Kogia-street; thence in an easterly direction by the said alignment of Kogia-street and the prolongation thereof to a point on the eastern alignment of Gannet-street; thence in a southerly direction by the said alignment of Gannet-street to a point on the prolongation of the south-eastern boundary of lot No. 219 on the last-mentioned lodged plan of subdivision; thence in a south-westerly direction by the said prolongation and south-eastern boundary of the said lot No. 219 to the southernmost corner of the said lot 219; thence in a northerly direction by the western boundaries of the said lot No. 219 and lots Nos. 220 to 229 inclusive, all on lodged plan of subdivision No. 11510, home to the point of commencement.

Dated the 28th day of May, 1973.

By order of the said Authority,

C. R. G. TURNER, Chairman.
D. G. COLLINGS, Secretary.

2620

SIXTH SCHEDULE.

MOUNT ELIZA SEWERAGE AUTHORITY.

GENERAL NOTICE.

Declaration of Sewerage Area No. 30.

The above-mentioned Sewerage Authority having made provision for carrying off the sewage from each and every property which or any part of which is within the Sewerage Area hereinafter described doth hereby declare that on and after the 1st day of July, 1973, each and every property which or any part of which is within the said Sewerage Area shall be deemed to be a sewered property within the meaning of the *Sewerage Districts Act 1958*.

The boundaries of the Sewerage Area hereinbefore referred to are:—Commencing at a point on the existing boundary of Sewerage Area No. 4 being the northernmost corner of lot No. 8 on lodged plan of subdivision No. 87852; thence in a southerly direction by the western boundaries of lots Nos. 8 to 3 inclusive and lot No. 1, all on the last-mentioned lodged plan of subdivision, to a point on the north-western alignment of Coonara-avenue; thence in a north-easterly direction by the said Coonara-avenue alignment to a point on the western alignment of Warana Way; thence by the alignment of Warana Way being abutments to lots Nos. 2 to 9 inclusive, all on lodged plan of subdivision No. 87852, to the easternmost corner of the said lot No. 9; thence in a north-westerly and south-westerly direction by the north-eastern and north-western boundaries of the said lot No. 9 home to the point of commencement.

Dated the 28th day of May, 1973.

By order of the said Authority,

C. R. G. TURNER, Chairman.
D. G. COLLINGS, Secretary.

2618

FRANKSTON SEWERAGE AUTHORITY.

DECLARATION OF SEWERED AREAS NOS. 57 TO 59 INCLUSIVE.

That the Frankston Sewerage Authority, having made provision for carrying off sewage from each and every property which, or any part of which, is within the Sewerage Areas hereinafter described, doth hereby declare that on and after the first day of June, 1973, each and every property which, or any part of which, is within the said Sewerage Areas shall be deemed to be a seweraged property within the meaning of the Sewerage Districts Act 1958.

The boundaries of the Sewerage Areas hereinbefore referred to are:—

Area No. 57.

Commencing at the corner of Seaford-road and TiTree-crescent, northerly along TiTree-crescent to the north-western corner of lot 222, easterly along the northern boundary of lot 222 TiTree-crescent, then southerly along the rear boundaries of lots 222 to 220 TiTree-crescent, then north-easterly along the rear boundaries of lots 35 to 37 L.P. 14084, then south-easterly along the north-eastern boundary of lot 37 to Dandenong-road, south-westerly along Dandenong-road to Seaford-road and westerly along Seaford-road to the point of commencement.

Area No. 58.

Commencing at the corner of Shaftesbury-street and Roberts-street at a point on the boundary of Declared Area No. 55, southerly along Roberts-street to Heatherhill-road, easterly along Heatherhill-road to Manly-avenue, southerly along Manly-avenue to Margate-avenue, then generally westerly, northerly and easterly along the boundaries of Declared Areas Nos. 48, 45 and 55 to the point of commencement.

Area No. 59.

Commencing at the corner of Naranga-crescent and Benong-place at a point on the boundary of Declared Area No. 50, south-easterly along Naranga-crescent to Karingal-drive, southerly along Karingal-drive to the south-western corner of lot 2204 Lucerne-crescent, then westerly along the rear boundaries of lots 2204 to 2200 Lucerne-crescent, lots 2197 and 2196 Gama-court, lots 2189 and 2188 Pepe-court and lots 2187 and 2185 Taketa-crescent, northerly along the eastern boundary of lot 2185 Taketa-crescent to Taketa-crescent, easterly along Taketa-crescent to the south-eastern corner of lot 2184 Taketa-crescent, then north-easterly along the eastern boundary of lot 2184 Taketa-crescent and along the rear boundaries of lots 2182 and 2181 Lamat-court, lots 2126 to 2124 Eula-court and lots 2122 to 2116 Lucerne-crescent to the south-western corner of lot 2084 Gomi-court, then south-easterly along the rear boundaries of lots 2084 to 2082 Gomi-court to Taketa-crescent and the southern boundary of lot 2081 Taketa-crescent, then northerly along the rear boundaries of lots 2081 to 2074 Taketa-crescent and lots 2072 to 2066 Sassafras-drive to the north-eastern corner of lot 2066 Sassafras-drive at a point on the boundary of Declared Area No. 50, then generally easterly along the boundary of Declared Area No. 50 to the corner of Lucerne-crescent and Pembroke-avenue, southerly along Pembroke-avenue to the south-western corner of lot 1868 Pembroke-avenue, then easterly along the southern boundary of lot 1868, then south-westerly along the rear boundaries of lots 2147 to 2145 Oleosa-court to the western corner of lot 2145, then south-easterly, southerly and south-westerly along the rear boundaries of lots 1795 to 1800 Nesbit-court to the north-eastern corner of lot 1811 Digby-court, then southerly and westerly along the rear and side boundaries of lot 1811 Digby-court to Digby-court, westerly along Digby-court to Pembroke-avenue, southerly along Pembroke-avenue to the north-eastern corner of lot 1826 Pembroke-avenue, westerly along the northern boundary of lot 1826, then northerly along the rear boundaries of lots 1821, 1820 and 1277 Karingal-drive, westerly along the northern boundary of lot 1277 to Karingal-drive, across Karingal-drive and westerly along the northern boundary of lot 1928 Karingal-drive, then northerly and westerly along the rear and side boundaries of lot 1923 Lomar-court to Lomar-court, northerly along Lomar-court to the eastern boundary of lot 1916 Lomar-court, north-westerly along the north-eastern boundary of lot 1916, then easterly and northerly along the rear and side boundaries of lot 1897 Benong-place, north-westerly along Benong-place to the point of commencement.

By order of the said Sewerage Authority,

B. AITKEN, Chairman.

G. C. PENTLAND, Secretary.

2590

GEELONG WATERWORKS AND SEWERAGE TRUST.

Pursuant to section 60 of the Geelong Waterworks and Sewerage Act 1958 (No. 6263), the Trust has prepared plans to indicate the particulars of sewers and underground works in or adjacent to the following localities within the Drainage Area.

Casaceli-court and Chapel-street, Whittington, Shire of Bellarine.

Barwon Boulevard, Challambra-crescent, Wynfield-drive and Highrise-court, North Highton, Shire of South Barwon.

Corner Helms and Glenburn streets, Newcomb, Shire of Bellarine.

Grayling-street, East Belmont, Shire of South Barwon.

Buckingham-road, Newtown, City of Newtown.

Notice is hereby given that the plans indicated above are open for public inspection at the Trust's Offices, Ryrie-street, Geelong, between the hours of 9 a.m. and 5 p.m., from Monday to Friday (public holidays excepted), by the owners or occupiers of land or premises within the Drainage Area.

2593

B. C. HENSHAW, Secretary.

THE BALLARAT SEWERAGE AUTHORITY.

GENERAL NOTICE.

The above-mentioned Sewerage Authority, having made provision for carrying off the sewage from each and every property which or any part of which is within the Sewerage Area hereinafter described, doth hereby declare that on and after the 1st day of July, 1973, each and every property which or any part of which is within the said Sewerage Area shall be deemed to be a seweraged property within the meaning of the Sewerage Districts Act 1958.

The boundaries of the Sewerage Area hereinbefore referred to are:—

Sewerage Area No. 348.

City of Ballarat.—Commencing at a point on the west building line of Larter-street, also being a point on the southern boundary of Sewerage Area No. 212; thence proceeding in a southerly direction along the said building line across a Government road to the south-west corner of the intersection of the said Government road and Larter street; thence continuing southerly along the said building line of Larter-street to the south-east corner of lot No. 2 of lodged plan No. 43920, westerly along the southern boundary and northerly along the western boundary of the said lot No. 2; thence continuing northerly along the western boundaries of lot No. 3 and lot No. 4 of the said L.P. to the north-west corner of the said lot No. 4; thence continuing in line across the said Government road and across a drainage reserve to a point on the southern boundary of Sewerage Area No. 212; thence proceeding easterly along the said Sewerage Area boundary to the point of commencement.

Further particulars regarding the streets or parts of streets in which sewers have been laid may be ascertained on inquiry at the Authority's Office.

By Order of the said Sewerage Authority.

A. W. NICHOLSON, Chairman.

CHAS. H. CLAMP, Secretary.

2644

Water Act 1958.

DROUIN WATERWORKS TRUST.

Notice to the owners of tenements in Acacia, Albert, Armstrong, Balmoral, Bank, Bennett, Bertram, Beverley, Bright, Brynwood, Buln Buln, Charles, Church, Civic, Colin, Darnum, Edward, Fairchild, Ferris, Francis, Gerrard, Gould, Grant, Hearn, Hopetoun, Johnson, Kraft, Kraft-crescent, Lampards, Lardner, Longwarry, Main Neerim, Main South, Monaghan, Montague, Morton, Murrell, McClure, McKindlay, McLean, McNeilly, Neerim, Normans, Oddy, Park, Paterson, Princes-avenue, Princes Highway, Railway, Ramsden, Ronalds, Russell, Sinclair, Smethurst, Thomas, Viaduct, Victoria, Viking, Wade, Weebar, Williamson, Wood, Young streets and the private streets, lanes, courts and alleys opening thereto.

The main pipe in the said streets being laid down the owners of all tenements situated as above are hereby required on or before the 1st day of July next, to cause a proper pipe and stop cocks to be laid so as to supply water within such tenements from the main pipe.

2635

E. J. AUSTIN, Secretary.

NOTICE OF INTENTION TO APPLY FOR A LICENCE TO DIVERT WATER AND CUT RACE. (RE-ISSUE) FROM THE RIVER MURRAY, AT PIANGIL.

I hereby give notice that I intend to apply for a licence empowering me to divert water for a term of fifteen years to the extent of 125 acre-feet per annum at a maximum rate of 19 acre-feet per day of 24 hours for the irrigation of 42 acres of pasture, being part of allotment 130, Parish of Piangil, and to occupy certain Crown lands for works of diversion, and to cut a race thereon.

Any objection to such application must be forwarded, in writing, to reach the State Rivers and Water Supply Commission, Melbourne, before 6th July, 1973, being 30 days from the first publication of this notice.

DAVID ROBERT KENTISH.

Box 74, Piangil, 3597.

2612

NOTICE OF INTENTION TO APPLY FOR A LICENCE TO DIVERT WATER AND CUT RACE. (RE-ISSUE) FROM THE RIVER MURRAY, AT PIANGIL.

I hereby give notice that I intend to apply for a licence empowering me to divert water for a term of fifteen years to the extent of 75 acre-feet per annum at a maximum rate of 19 acre-feet per day of 24 hours for the irrigation of 25 acres of pasture, being part of allotment 132, Parish of Piangil, and to occupy certain Crown lands for works of diversion, and to cut a race thereon.

Any objection to such application must be forwarded, in writing, to reach the State Rivers and Water Supply Commission, Melbourne, before 6th July, 1973, being 30 days from the first publication of this notice.

MARGARET JULIA KENTISH.

Box 74, Piangil, 3597.

2613

NOTICE OF INTENTION TO APPLY FOR A LICENCE TO DIVERT WATER AND CUT RACE FROM THE KING RIVER, AT EDI.

I hereby give notice that I intend to apply for a licence empowering me to divert water for a term of four years to the extent of 75 acre-feet per annum at a maximum rate of 7 1/2 acre-feet per day of 24 hours for the irrigation of 50 acres of pasture being part of Edi, pre-emptive right, Parish of Moyhu, and to occupy certain Crown lands for works of diversion, and to cut a race thereon.

Any objection to such application must be forwarded, in writing, to reach the State Rivers and Water Supply Commission, Melbourne, before 6th July, 1973, being 30 days from the first publication of this notice.

KEITH EDDINGTON MURRAY.

Edi, via Wangaratta, 3678.

2626

Notice is hereby given that Grimwade Castings Proprietary Limited, has applied for a lease, pursuant to sections 134 and 135 of the Land Act 1958, for a term of 45 years in respect of allotment 2, section 60, City of Port Melbourne, containing 1 acre 3 roods 24 8/10 perches, as a site for general industrial purposes.

2438

Notice is hereby given that the partnership hereinbefore subsisting between Johannes Arnoldus Herman Boers and Doreen Margaret Boers, both of 20 Greenhills-avenue, Montrose, and Harold Ivan Wilkinson and Sandra Roberta Wilkinson, both of 5 Forest Park-road, Upwey, carrying on business at 20 Greenhills-avenue, Montrose, under the firm name of "B. & W. Bricklaying Contractors", has been dissolved by mutual consent.

HENDERSON & BALL, solicitors, of 430 Little Collins-street, Melbourne.

2681

The Companies Act 1961.

ALLIED BUSINESS SYSTEMS PTY. LTD. (IN LIQUIDATION):

NOTICE CONVENING FINAL MEETING OF MEMBERS AND CREDITORS, PURSUANT TO SECTION 272.

Notice is hereby given, in pursuance of section 272 of the Companies Act 1961, that a meeting of the members and creditors of the above-named company will be held on the 6th day of July, 1973, at 3 o'clock in the afternoon, at the offices of Hall & Rose, 395 Collins-street, Melbourne, for the purpose of having an account laid before them, showing the manner in which the winding up has been conducted and the property of the company disposed of, and of hearing any explanations that may be given by the liquidator.

Dated this 1st day of June, 1973.

G. O. HARRISON, Liquidator.

Hall & Rose, chartered accountants, 395 Collins-street, Melbourne.

2682

Co-operation Act 1958.

NOTICE OF FINAL MEETING OF MEMBERS OF CO-OPERATIVE DEVELOPMENT SOCIETY LIMITED (IN MEMBERS' VOLUNTARY LIQUIDATION).

Notice is hereby given that a meeting of the members of Co-Operative Development Society Limited, will be held at the offices of Gartner Walker & Co., chartered accountants, 422 Collins-street, Melbourne, on 6th July, 1973, at 10.00 o'clock in the forenoon.

Agenda:

To lay before the meeting the liquidator's account showing how the winding up has been conducted and the property of the society has been disposed of and giving any explanation thereof.

Dated this 4th day of June, 1973.

2677

J. S. WALKER, Liquidator.

Companies Act 1961.—In the matter of J. & M. HOLDEN (BALWYN) PTY. LTD. (IN LIQUIDATION).—Notice to Creditors of Intention to Declare a First and Final Dividend.

A First and Final Dividend is intended to be declared in the above matter.

Creditors who have not proved their debt by 20th June, 1973, will be excluded from the dividend.

Dated this 6th day of June, 1973.

H. CHAPMAN, Liquidator.

Chapman, Rowe & Co., chartered accountants, 267 Collins-street, Melbourne.

2678

Companies Act 1961, Section 206 (3).

BELROSE BUSINESS SUPPLIES PTY. LTD.

NOTICE OF MEETING OF CREDITORS.

Notice is hereby given that a meeting of creditors of the above-named company will be held at the Victorian Employers' Federation, Eastern Tower, Princes Gate Building, 151 Flinders-street, Melbourne, on the 15th day of June, 1973, at 9.30 in the forenoon. The company having convened a meeting of its members for the same day for the purpose of considering a Resolution that the company be wound up voluntarily.

Dated this 15th day of June, 1973.

LIONEL STONE, Director.

T. D. Maclean and Company, Suite 3, 545 St. Kilda-road, Melbourne, Vic. 3004. Telephone 51 1207.

2655

Companies Act 1961, Section 206 (3).

BELROSE AGENCIES PTY. LTD.

NOTICE OF MEETING OF CREDITORS.

Notice is hereby given that a meeting of creditors of the above-named company will be held at the Victorian Employers' Federation, Eastern Tower, Princes Gate Building, 151 Flinders-street, Melbourne, on the 15th day of June, 1973, at 9.30 in the forenoon. The company having convened a meeting of its members for the same day for the purpose of considering a Resolution that the company be wound up voluntarily.

Dated this 5th day of June, 1973.

LIONEL STONE, Director.

T. D. Maclean and Company, Suite 3, 545 St. Kilda-road, Melbourne, Vic. 3004. Telephone 51 1207.

2656

The Companies Act 1961.

INDEPENDENT CREATIVE WORKSHOP PTY. LTD. (IN LIQUIDATION).

NOTICE CONVENING FINAL MEETING OF MEMBERS AND CREDITORS, PURSUANT TO SECTION 272 (2).

Notice is hereby given, in pursuance of section 272 of the Companies Act 1961, that a meeting of the members and creditors of the above-named company will be held on the 4th day of July, 1973, at the office of A. Neville Bird & Co., chartered accountants, 289 Flinders-lane, Melbourne, at 3 p.m., for the purpose of having an account laid before them showing the manner in which the winding up has been conducted and the property of the company disposed of, and hearing any explanations that may be given by the liquidator.

Dated this 4th day of June, 1973.

A. NEVILLE BIRD, Liquidator.

A. Neville Bird & Co., chartered accountant, 289 Flinders-lane, Melbourne, 3000. Telephone 63 2874.

2668

The Companies Act 1961.

Re HARISROB PROPRIETARY LIMITED.

NOTICE OF APPOINTMENT OF LIQUIDATOR IN MEMBERS' VOLUNTARY WINDING UP.

Notice is hereby given that at Extraordinary General Meetings of the above company, held on 21st May, 1973, Cedric Lyle Carr, public accountant, of 157 Moorabool-street, Geelong, was appointed liquidator for the purposes of the winding up of the company.

CEDRIC LYLE CARR, Liquidator.

West, Carr & Harvey, public accountants, P.O. Box 216, Geelong, 3220. 2591

The Companies Act 1961.—In the matter of JOSU PTY. LIMITED (IN VOLUNTARY LIQUIDATION).—Members' Winding Up.

Notice is hereby given that at the Extraordinary General Meeting of Josu Pty. Limited, duly convened and held at 408 Collins-street, Melbourne, in the State of Victoria, on the 23rd day of May, 1973, the following Resolution was proposed and passed as a Special Resolution:—

"That the company be wound up voluntarily."

Dated this 29th day of May, 1973.

2596 R. W. BETTS, Liquidator.

The Companies Act 1961.—In the matter of AVOCA SANDS PTY. LIMITED (IN VOLUNTARY LIQUIDATION).—Members' Winding Up.

Notice is hereby given that at the Extraordinary General Meeting of Avoca Sands Pty. Limited, duly convened and held at 408 Collins-street, Melbourne, in the State of Victoria, on the 23rd day of May, 1973, the following Resolution was proposed and passed as a Special Resolution:—

"That the company be wound up voluntarily."

Dated this 29th day of May, 1973.

2597 R. W. BETTS, Liquidator.

The Companies Act 1961.—In the matter of ADDISCOT PASTORAL COMPANY PTY. LTD.—Members' Voluntary Winding Up.

Notice is hereby given that at an Extraordinary General Meeting of Addiscot Pastoral Company Pty. Ltd., duly convened and held at 16 Dudley-street, Brighton, on the 31st day of May, 1973, the following Special Resolution was duly passed:—

Resolved that the purpose of the company as graziers for which purpose the company was formed, being completed it is proposed and passed as a Special Resolution that the company be wound up voluntarily.

Dated this 31st day of May, 1973.

P. I. McNAUGHTON, Liquidator, 16 Dudley-street, Brighton, 2600

The Companies Act 1961.

GEOMETRIC BUILDING CONSTRUCTION PTY. LTD. (MEMBERS' VOLUNTARY LIQUIDATION).

NOTICE OF FINAL MEETING OF MEMBERS, PURSUANT TO SECTION 272.

Notice is hereby given, in pursuance of section 272 of the Companies Act 1961, that a meeting of the members of the above-named company will be held on the 6th day of July, 1973, at 45 Johnson-street, Keon Park, at 11 o'clock a.m., for the purpose of having an account laid before them showing the manner in which the winding up has been conducted and the property of the company disposed of and of hearing any explanation that may be given by the liquidator.

Dated this 1st day of June, 1973.

LETIZIA BARCO, Liquidator, 106 Hughes-parade, Reservoir, Vic., 3073. 2658

The Companies Act 1961.

INDUSTRIAL TIMBER SALES PTY. LTD. (IN LIQUIDATION).

NOTICE TO CREDITORS OF INTENTION TO DECLARE FIRST DIVIDEND.

A First Dividend is intended to be declared in the above matter:

Creditors who have not lodged a proof of debt by the 22nd day of June, 1973, will be excluded from the dividend.

M. J. O'KEEFFE, Liquidator.

M. J. O'Keefe & Co., 162A High-street, Ashburton, 3147. 2589

The Companies Act 1961.

MERCURY INTERNATIONAL HOLDINGS PTY. LIMITED (IN VOLUNTARY LIQUIDATION).

Notice is hereby given that, pursuant to section 272 (2) of the Companies Act 1961, a Final Meeting of the members of Mercury International Holdings Pty. Limited (in Voluntary Liquidation), will be held at 3rd Floor, 415 Bourke-street, Melbourne, on Monday, 9th July, 1973, at 10 a.m., in the forenoon, for the purpose of laying before the meeting an account showing how the winding up has been conducted and the property of the company disposed of, and of hearing any explanation that may be given by the Liquidator; and to pass a resolution to destroy the company's books and papers, pursuant to section 284 (3) (b) of the Companies Act 1961.

Dated this 1st day of June, 1973.

C. G. ROBERTS, Liquidator.

Messrs. Mann Judd & Co., 3rd Floor, 415 Bourke-street, Melbourne, Vic., 3000. 2624

Companies Act 1961.—In the matter of ROLLERINK PROPRIETARY LIMITED (in Liquidation).

Notice is hereby given that at an Extraordinary Meeting of the members of the above-named company, held on the 30th May, 1973, it was resolved that the company be wound up voluntarily and at a meeting of creditors held on the same day, pursuant to section 260, it was resolved that for such purpose, Brendan John O'Connor, of Suite 19, 562 St. Kilda-road, Melbourne, accountant, be appointed liquidator.

Notice is also given that after 21 days from this date I shall proceed to distribute the assets. All creditors having any claims against the company should furnish particulars of same by that date, otherwise I shall proceed to distribute the assets without regard to their claim.

Dated this 7th day of June, 1973.

B. J. O'CONNOR, Liquidator.

Taylor O'Connor & Co., accountants, 562 St. Kilda-road, Melbourne, 3004. Telephone 51 1388. 2643

PARKLANDS INVESTMENTS PROPRIETARY LIMITED (IN VOLUNTARY LIQUIDATION).

Notice is hereby given, pursuant to section 272 (2) of the Companies Act 1961, that a General Meeting of members of the above-named company will be held at the offices of Offner, Hadley and Company, 395 Collins-street, Melbourne, on Monday, 16th July, 1973, commencing at 11 a.m., for the purpose of having an account laid before them showing the manner in which the winding up has been conducted and the property of the company disposed of, and of hearing of any explanations that may be given by the liquidator.

Dated this 31st day of May, 1973.

2636 K. CROSS, Liquidator.

SMIT LLOYD (VICTORIA) PTY. LIMITED (IN LIQUIDATION).

MEMBERS' VOLUNTARY LIQUIDATION.

Notice is hereby given that at an Extraordinary General Meeting of the above-named company duly convened and held at 4th Floor, 261 George-street, Sydney, on the 28th day of May, 1973, the following Special Resolution was passed:—

"That the company be wound up voluntarily, that the assets be divided amongst the members in specie, and that Evan Philip Groombridge, of 6-10 O'Connell-street, Sydney, be appointed liquidator for the purposes of such winding up." 2637

Companies Act 1961.

GITA SCHOOL OF YOGA PROPRIETARY LTD. (IN VOLUNTARY LIQUIDATION).

MEMBER'S VOLUNTARY WINDING UP.

Notice is hereby given that, pursuant to section 272 of the Companies Act 1961, the Final Meeting of members of the above-named company will be held at the office of Manning & Perry, chartered accountants, 175 King-street, Melbourne, on the 20th June, 1973, at 10.30 a.m., for the purpose of receiving the liquidator's account and his report upon the winding up.

Dated this 31st day of May, 1973.

P. F. CLARKE, Liquidator.

Manning & Perry, chartered accountants, 175 King-street, Melbourne, 67 6861. 2651

LONERGAN AUTOS PROPRIETARY LIMITED.

SPECIAL RESOLUTION TO WIND UP, PURSUANT TO SECTION 254 OF THE COMPANIES ACT 1961.

At an Extraordinary General Meeting of the above-named company, duly convened and held at Cobram, on the 26th day of May, 1973, the following Resolution was duly passed as a Special Resolution:—

"That the company be wound up voluntarily."

And at such last-mentioned meeting, Victor Francis Selwyn McGrath, was appointed liquidator for the purpose of the winding up.

Notice is hereby given that after 21 days from this date I shall proceed to distribute the assets. All creditors having any claims against the company should furnish particulars of same by that date, otherwise I shall proceed to distribute the assets without regard to their claim.

Dated this 26th day of May, 1973.

V. F. S. MCGRATH, Liquidator.

200 Little Lonsdale-street, Melbourne, Victoria, 3000.

2650

Companies Act 1961.—In the matter of ALL SEASONS INTERIORS PTY. LTD.—Notice Re Meeting of Creditors, Pursuant to Section 260.

Notice is hereby given that a meeting of creditors of the above-named company, will be held at Princes Gate Conference Centre, Room 314, Third Floor, 151 Flinders-street, Melbourne, on Thursday, 21st June, 1973, at 10.30 a.m., the company having convened a meeting of its members for the same day for the purpose of considering a Resolution that the company be wound up voluntarily.

Dated this 29th day of May, 1973.

CHRISTEL HIMSTEDT, Secretary.

Bent & Cogle, public accountants, Suite 18, 545 St. Kilda-road, Melbourne, 3004.

2583

Companies Act 1961.—In the matter of CONTRACT WINDOW COVERINGS PTY. LTD., of 79-81 Coppin-street, Richmond.—Notice Re Meeting of Creditors, Pursuant to Section 260.

Notice is hereby given that a meeting of creditors of the above-named company will be held at Princes Gate Conference Centre, Room 314, Third Floor, 151 Flinders-street, Melbourne, on Thursday, 21st June, 1973, at 11.15 a.m., the company having convened a meeting of its members for the same day for the purpose of considering a Resolution that the company be wound up voluntarily.

Dated this 29th day of May, 1973.

W. F. POTTER, Director.

J. D. HUNT, Director.

Bent & Cogle, public accountants, Suite 18, 545 St. Kilda-road, Melbourne, 3004.

2584

Companies Act 1961.

STEGWIN PTY. LTD. (IN VOLUNTARY LIQUIDATION).

PURSUANT TO SECTION 272 (2).

Notice is hereby given that the Final Meeting of the shareholders of Stegwin Pty. Ltd. (in Voluntary Liquidation), will be held at the office of F. & T. Industries Limited, 8 Nicholson-street, Melbourne, Victoria, on Friday, 6th July, 1973, at 10 a.m., for the purpose of having an account laid before it showing how the winding up of the company has been conducted and the property of the company has been disposed of and to pass a Resolution to destroy the company's books and papers, pursuant to section 284(3)(b) of the Companies Act.

Dated the 5th June, 1973.

2671 R. A. BERRY, Liquidator.

Companies Act 1961.—In the matter of B. & S. HEATING & VENTILATION PTY. LIMITED.—Notice of Meeting of Creditors, Pursuant to Section 260.

Notice is hereby given that a meeting of creditors of the above-named company will be held at the Conference Room, 4th Floor, 130 Flinders-street, Melbourne, on Wednesday, 13th June, 1973, at 2.30 p.m., the company having convened an Extraordinary Meeting of its members for the same day for the purpose of considering a Special Resolution that the company be wound up voluntarily.

Dated this 1st day of June, 1973.

J. B. HOWARD, Director.

Lewis Luckins & Co., chartered accountants, 130 Flinders-street, Melbourne, 3000. Telephone. 63 8827.

2672

THE NEW BRUNSWICK BRICK & POTTERY CO. PTY. LTD. (IN VOLUNTARY LIQUIDATION).

Notice is hereby given in pursuance to section 272 (2) of the Companies Act 1961, that the Final Meeting of members of the above company, will be held at the offices of Wilson, Bishop, Bowes & Craig, 12th Floor, 271 William-street, Melbourne, on Friday, 6th July, 1973, at 11 a.m., for the purpose of having an account laid before it showing the manner in which the winding up has been conducted and to hear any explanation that may be given by the liquidator.

Dated this 6th day of June, 1973.

D. C. PETLEY, Liquidator.

Wilson, Bishop, Bowes & Craig, chartered accountants, 12th Floor, 271 William-street, Melbourne. 3000. 2676

Companies Act 1961, Section 272 (2).

R.W.R. PROPRIETARY LIMITED (IN VOLUNTARY LIQUIDATION).

NOTICE OF FINAL MEETING.

Notice is hereby given that a General Meeting of the members of the above-named company will be held at the office of Hosking Quinn & Partners, 9th Floor, 422 Collins-street, Melbourne, on Thursday, 19th July, 1973, at 2.30 p.m., for the purpose of having an account laid before them showing the manner in which the winding up has been conducted and the property of the company disposed of.

2670

C. C. RIVINGTON, Liquidator.

Companies Act 1961.

CAMERA ART PTY. LTD. (IN VOLUNTARY LIQUIDATION).

Notice is hereby given that at an Extraordinary Meeting of the members of the above-named company held on Tuesday, 29th May, 1973, it was resolved that the company be wound up voluntarily and at a meeting of creditors held on the same day it was resolved that for such purpose, Maurice John Kellett, public accountant, of 1004 Doncaster-road, Doncaster East, be appointed liquidator.

Notice is also given that after 21 days from this date I shall proceed to distribute the assets.

All creditors having any claim against the company should furnish particulars of the same by that date, otherwise I shall proceed to distribute the assets without regard to their claim.

Dated this 31st day of May, 1973.

MAURICE J. KELLETT, Liquidator.

Kellett, Till & Associates, public accountants, 1004 Doncaster-road, Doncaster East, 3109. Telephone 842 4222. 2673

Companies Act 1961.

E. CRAIG INVESTMENTS PROPRIETARY LIMITED (IN VOLUNTARY LIQUIDATION).

Notice is hereby given that at an Extraordinary General Meeting of shareholders of the above-mentioned company held on the 28th day of May, 1973, the following Resolution was passed as a Special Resolution:—

"All members having agreed it was hereby resolved that the company be wound up voluntarily."

N. B. DOWDLE, the appointed Liquidator, 7th Floor, 401 Collins-street, Melbourne, 3000. 2674

In the matter of the Corporation Act 1958; and in the matter of CO-OPERATIVE DEVELOPMENT SOCIETY LIMITED.

Notice is hereby given that at an Extraordinary General Meeting of the above-named Society duly convened and held at the Registered Office on the 1st day of June, 1973, the following Special Resolution was passed:—

"Resolved that the Co-operative Development Society Limited be wound up voluntarily and that John Stuart Walker, chartered accountant, of 422 Collins-street, Melbourne, being a registered company liquidator acceptable to the Registrar under the Corporation Act 1958, for the purpose of such winding up and that the remuneration of the liquidator be fixed in accordance with average scale of fees laid down by the Institute of Chartered Accountants."

Dated this 1st day of June, 1973.

2675

M. RUNDLE, Chairman.

In the matter of the *Companies Act 1961*; and in the matter of **SHANKS AND COMPANY PTY. LTD.**

Notice is hereby given that at a meeting of the members of Shanks and Company Pty. Ltd., held at 31-49 Queens, Bridge-street, South Melbourne, on 14th May, 1973, the following Resolution was passed as a Special Resolution:—

That the company be wound up voluntarily and that Mr. Leslie Philip Smart, chartered accountant, of Marquand & Co., 51 Queen-street, Melbourne, 3000, be and is hereby appointed liquidator for the purpose of such winding up.

2669

L. P. SMART, Liquidator.

All persons having claims against the estate of John Percival Rhys, late of 7 Guinions-road, High Wycombe, Buckinghamshire, retired surveyor, deceased (who died on the 30th December, 1969, and probate of whose will was on the 12th March, 1970, granted by the High Court of Justice, at Oxford, in England, to Midland Bank Executor Company and Trustee Company Limited, of 27-32 Poultry, in the City of London, and William Henry David Crawford, of 10 Euston-street, Wycombe, in the County of Buckinghamshire, solicitor, and application to the Supreme Court of Victoria (Probate Jurisdiction) by Perpetual Trustee Company Limited to seal such probate having been granted on the 15th of May, 1973), are hereby required to send particulars of such claims to the Perpetual Trustee Company Limited, at its registered office, 29-32 Hunter-street, Sydney, New South Wales, on or before the 1st August, 1973, after which date the said company will proceed to transfer, convey or distribute the estate to or among the persons entitled thereto, having regard only to the claims of which it shall then have had notice and will not be liable for the assets so transferred, conveyed or distributed to any persons of whose claim it shall not then have had notice.

RYLAH & RYLAH, solicitors, 349 Collins-street, Melbourne. 2661

Pursuant to *Trustee Act 1958* (Victoria), W. M. Ferguson being duly authorized by the trustees of Metal Manufacturers' Staff Provident Fund, hereby gives notice that any dependants of Leslie Murray Strurgiss, are required to send particulars of their claims to the said trustees, at Box 7047 G.P.O., Sydney, on or before 1st August, 1973, at the expiration of which time the said trustees will proceed, pursuant to the Rules of the said fund having regard only to the claims of which they then have notice.

Dated the 25th day of May, 1973.

ALLEN ALLEN & HEMSLEY, solicitors, 2 Castlereagh-street, Sydney. 2625

Pursuant to the *Trustee Act 1958*, notice is hereby given that creditors, next of kin and all other persons having claims against the estate of John Charles Purvis, late of 6 Seaview-crescent, Black Rock, engraver, deceased (who died on the 12th day of August, 1973, and letters of administration were granted by the Supreme Court of Victoria to Vera Elizabeth Purvis, of 6 Seaview-crescent, Black Rock, widow, the administratrix appointed by the said Court), are hereby required to send particulars, in writing, of such claims to the said administratrix, care of the under-mentioned solicitors, on or before the 15th day of August, 1973, after which date the administratrix will proceed to distribute the assets of the said deceased amongst the persons entitled thereto, having regard only to the claims of which she shall then have notice and will not be liable as regards the assets so distributed to any such person of whose claim she shall not then have had notice.

G. R. HERBERT & CO., solicitors, 612-614 Balcombe-road, Black Rock. 2663

AIMEE SOPHIE KEYNES, late of 3 Younger-court, Kew, Victoria, spinster, DECEASED.

Creditors, next of kin and others having claims in respect of the estate of the said deceased (who died on 4th October, 1972), are required by the personal representatives, Robert George Andry, of 44 Cholmeley-crescent, Highgate, London, England, psychologist, and Peter Edward Andry, of 95 Hampstead Way, Hampstead, London, England, musical director, to send particulars to them in care of their solicitors Hedderwick, Fookes & Alston, of 121 William-street, Melbourne, by 10th August, 1973, after which date they may convey or distribute the assets, having regard only to the claims of which they then have notice.

HEDDERWICK, FOOKES & ALSTON, 121 William-street, Melbourne. 2660

No. 45.—4670/73.—4

Creditors, next of kin and others having claims in respect of the estate of Winifred Maud Austin Dawborn, formerly of 1318 High-street, Malvern, in the State of Victoria, but late of 2 Beaver-street, Malvern, in the said State, widow, deceased (who died on the 7th November, 1972), are to send the particulars of their claims to The Union-Fidelity Trustee Company of Australia Limited, of 100 Exhibition-street, Melbourne, in the said State, by the 7th day of August, 1973, after which date it will distribute the assets, having regard only to the claims of which it then has notice.

HERBERT TURNER & DAVIS, solicitors, 411 Collins-street, Melbourne. 2659

Creditors, next of kin and others having claims in respect of the estate of Jessie North, late of Flat 4, 84 Blessington-street, St. Kilda, married woman, deceased (who died on the 8th day of March, 1973), are required to send particulars of their claims to the executor, Tasman Thomas Rigney, care of the under-mentioned solicitors, by the 9th day of August, 1973, after which date he will distribute the assets, having regard only to the claims of which he then has notice.

MAHONY, O'BRIEN & DUGGAN, solicitors, 37 Queen-street, Melbourne. 2662

Creditors, next of kin and others having claims in respect of the estate of Grace Tabiatha Born, late of Unit 1, No. 10 Brisbane-street, Murrumbidgee, widow, deceased (who died on the 26th December, 1972), are required by the executor, The Trustees, Executors and Agency Company Limited, of 401 Collins-street, Melbourne, to send particulars of their claims, in writing, in care of the said company, prior to the 15th August, 1973, after which date the said executor will distribute the assets, having regard only to the claims of which it then shall have had notice.

ROGERS & GAYLARD, solicitors, 51 Queen-street, Melbourne. 2664

ALICE MARTHA SMITH, late of Swan Hill, in the State of Victoria, married woman, DECEASED (who died on 29th November, 1972).

Creditors, next of kin and all other persons having claims against the estate of the deceased, are required by the executors of the will, William Murray Smith and Judith Evelyn Wood, to send particulars to them, care of the undersigned, on or before the 28th day of August, 1973, after which date they will distribute the assets, having regard only to the claims of which they then have notice.

GARDEN & GREEN, solicitors, 4 McCallum-street, Swan Hill. 2581

MARIE THERESE JONES, late of Swan Hill, in the State of Victoria, widow, DECEASED (who died on the 9th day of February, 1973).

Creditors, next of kin and all other persons having claims against the estate of the deceased, are required by the executors of the will, Veronica May Riordan and Nestor Webb, to send particulars to them, care of the undersigned, on or before the 29th day of August, 1973, after which date they will distribute the assets, having regard only to the claims of which they then have notice.

GARDEN & GREEN, solicitors, 4 McCallum-street, Swan Hill. 2598

WILLIAM WHITTAKER, late of Manangatang, retired farmer, DECEASED.

Creditors, next of kin and others having claims in respect of the estate of the deceased (who died on the 21st September, 1971), are required by the trustee, The National Trustees, Executors and Agency Company of Australasia Limited, of 46 Queen-street, Bendigo, to send particulars to it, by the 15th day of August, 1973, after which date the trustee may convey or distribute the assets, having regard only to the claims of which it then has notice.

MACOBOY, TAYLOR & TAYLOR, solicitors, 32 View-street, Bendigo. 2595

Creditors, next of kin and others having claims in respect of the estate of Vera May MacDonald, late of 2 Peterson-street, Highett, in the State of Victoria, process worker, deceased, intestate (who died on the 21st day of January, 1973), are to send particulars of their claims to George MacDonald, care of the under-mentioned solicitors, by the 6th day of July, 1973, after which date he will distribute the assets, having regard only to the claims to which he then has notice.

Dated this 30th day of May, 1973.

REGINALD C. BUTLER & CO., solicitors, 312 Centre-road, Bentleigh. 2582

MARY CATHERINE CLOSE, late of Booroolite, married woman, DECEASED.

Creditors, next of kin and others having claims in respect of the deceased (who died on the 15th day of August, 1972), are required by her trustees, Vincent Joseph Close and Kelvin Frances Close, both of Booroolite, graziers, and Kevin Charles Bock, of Mansfield, P.M.G. technician, to send particulars to them, care of the under-mentioned firm of solicitors by the 15th day of August, 1973, after which date the trustees may convey and distribute the assets, having regard only to the claims of which they then have notice.

MAL RYAN & GLEN, 9 High-street, Mansfield, solicitors for the trustees. 2587

MARTIN HENRY PRICE, formerly of "Coobool", Mallan, in the State of New South Wales, but late of 26 Mitchell-street, Swan Hill, in the State of Victoria, grazier, DECEASED (who died on the 30th day of June, 1972).

Creditors, next of kin and all other persons having claims against the estate of the deceased, are required by the executors of the will, Dorothy Florence Price (in the will called Dorothy Price), Edward James Price and George Richard Price, to send particulars to them, care of the undersigned, on or before the 29th day of August, 1973, after which date they will distribute the assets, having regard only to the claims of which they then have notice.

GARDEN & GREEN, solicitors, 4 McCallum-street, Swan Hill. 2599

Creditors, next of kin and others having claims in respect of the estate of James Seefield Grant (usually known as James Grant), formerly of 118 New-street, Middle Brighton, but late of Villa Madonna Nursing Home, 310 High-street, Windsor, in the State of Victoria, retired caretaker, deceased (who died on the 26th day of December, 1972), are to send particulars of their claims to the National Trustees, Executors and Agency Company of Australasia Limited, of 95 Queen-street, Melbourne, by the 6th day of August, 1973, after which date it will distribute the assets, having regard only to the claims of which it then has notice.

PATRICIA CLANCY, solicitor, of 710 Burke-road, Camberwell. 2611

Creditors, next of kin and others having claims in respect of the estate of Norman Ian Byron, late of Willaura, farmer and grazier, deceased (who died on the 13th day of January, 1973, and probate of whose will was granted by the Supreme Court, on the 23rd day of May, 1973, to Francis Mervyn Byron, of Willaura, farmer and grazier, and John Edward Joseph Briggs, of Ararat, solicitor, the executors named in the said will), are to send particulars of their claims to the said executors, at their address, care of Briggs & O'Driscoll, solicitors, 94 Barkly-street, Ararat, by the 10th day of August, 1973, after which date they will distribute the assets, having regard only to the claims of which they then have notice.

BRIGGS & O'DRISCOLL, solicitors, Ararat. 2627

JOHN WILLIAM THOMPSON (also known as John William Thomson), late of 70A Stradbroke-avenue, Swan Hill, in the State of Victoria, T.P.I. pensioner, DECEASED.

Creditors, next of kin and others having claims in respect of the estate of the deceased (who died on the 31st day of January, 1973), are required by the executor, Elijah James Simms, of 40 Hamilton-street, Shepparton, in the said State, to send particulars to him, care of the undersigned, by the 30th day of July, 1973, after which date the executor may convey or distribute the assets, having regard only to the claims of which he then has notice.

ALEC M. HAYES, solicitor, 148 Campbell-street, Swan Hill. 2628

Creditors, next of kin and others having claims in respect of the estate of William George Dennis, late of Bundalaguah, grazier, deceased (who died on the 17th day of February, 1973), are requested to send particulars of their claims to The National Trustees, Executors and Agency Company of Australasia Limited, of 95 Queen-street, Melbourne, one of the executors appointed by deceased's will, by the 19th day of August, 1973, after which date the above-named executor will distribute the assets, having regard only to the claims of which it then has notice.

J. CROFTON LEE & MOIR, solicitors, of 69A Raymond-street, Sale. 2631

HENRY PATRICK BRITTON, late of Mansfield, pensioner, DECEASED.

Creditors, next of kin and others having claims in respect of the deceased (who died on the 24th day of September, 1972), are required by his trustees, Doreen Coleman (formerly Britton), of 24 Finlason-street, Mansfield, married woman, and William Darcy Britton, formerly of 1 New-street, Hawthorn, but now of 24 Finlason-street, Mansfield, labourer, to send particulars to them, care of the under-mentioned firm of solicitors, by the 20th day of August, 1973, after which date the trustees may convey and distribute the assets, having regard only to the claims of which they then have notice.

MAL. RYAN & GLEN, 9 High-street, Mansfield, solicitors for the trustees. 2652

JAMES JOSEPH DUKE, late of 219 Macleod-street, Bairnsdale, grazier, DECEASED.

Creditors, next of kin and others having claims in respect of the estate of the deceased (who died on the 24th day of January, 1973), are required by The Perpetual Executors and Trustees Association of Australia Limited, of 100-104 Queen-street, Melbourne, and Maurice Patrick Duke, of 62 Bambridge-street, Weetangerra, A.C.T., public servant, the applicants for a grant of administration, to send particulars of their claims to the said applicants in the care of the said company, by the 9th day of August, 1973, after which date they will convey or distribute the assets, having regard only to the claims of which they then have notice.

WARREN, GRAHAM & MURPHY, solicitors, Bairnsdale, 3875. 2654

MARGARET ANNIE NICHOLAS EDGAR, late of 21 Glen-road, Toorak, in the State of Victoria, married woman, DECEASED.

Creditors, next of kin and other persons having claims against the estate of the deceased (who died on the 7th June, 1972), are required by the executors, Michael John Edgar, of 138 Mont Albert-road, Canterbury, in the State of Victoria, sharebroker, and Andrew Campbell Edgar, of 2b Mathoura-road, Toorak, in the said State, marketing executive, to send particulars to them, care of the under-mentioned solicitors, on or before the 6th day of August, 1973, after which date they will distribute the assets, having regard only to the claims of which they then have notice.

AITKEN, WALKER & STRACHAN, solicitors, of 414 Collins-street, Melbourne. 2657

JOHN FRANCIS RODONI, late of 21 Kay-street, Mount Waverley, engineer, DECEASED.

Creditors, next of kin and others having claims in respect of the estate of the above-named deceased (who died on 10th July, 1972), are required by the executor, Watson James and Rogers, of 61 Bull-street, Bendigo, to send particulars of their claims to the said executor, care of the under-mentioned solicitors, by the 9th August, 1973, after which date the executor may convey or distribute the assets, having regard only to the claims of which it then has notice.

RODDA, BALLARD & VROLAND, solicitors, 695 Burke-road, Camberwell. 2667

Creditors, next of kin and others having claims in respect of the estate of Aileen Edna Mary Forsyth, late of 25 Webster-street, Burwood, in the State of Victoria, spinster, deceased (who died on 21st December, 1972), are to send the particulars of their claims to the executor, Francis Alexander Jenkin, in care of Colin Keon-Cohen, 472 Bourke-street, Melbourne, by the 15th August, 1973, after which date he will distribute the assets, having regard only to the claims of which he then has notice.

Dated the 7th May, 1973.

COLIN KEON-COHEN, solicitors, 472 Bourke-street, Melbourne. 2679

GEORGE TURNER, late of 10 Farleigh-grove, Brighton, customs agent, DECEASED.

Creditors, next of kin and others having claims in respect of the estate of the deceased (who died on the 10th day of February, 1973), are required by The Equity Trustees, Executors and Agency Company Limited, of 472 Bourke-street, Melbourne, to send particulars of their claims to the said company, by the 8th day of August, 1973, after which date it will convey or distribute the assets, having regard only to the claims of which it then has notice.

CORR & CORR, solicitors, 290 La Trobe-street, Melbourne. 2680

GEORGE CHARLES REEVES, late of 2 Erica-street, Canterbury, gentleman, DECEASED.

Creditors, next of kin and others having claims in respect of the estate of the above-named deceased (who died on the 21st day of January, 1973), are required by Athol James Kennedy, of 401 Collins-street, Melbourne, solicitor, Raymond George Reeves, of 21 Frederick-street, Balwyn, company director, and Phillip Robilliard Reeves, of 115 Holland-road, Blackburn South, company director, the executors of the will of the deceased, to send particulars of their claims to the said executors, care of the under-named solicitors, by the 10th day of August, 1973, after which date they will convey or distribute the assets, having regard only to the claims of which they then have notice.

RUSSELL, KENNEDY & COOK, solicitors, 401 Collins-street, Melbourne. 2665

Creditors, next of kin and others having claims in respect of the estate of Eleanor Emilie Allen, late of 30 Prospect Hill-road, Camberwell, spinster (who died on the 18th December, 1972), are to send particulars of their claims to the executor, The Trustees, Executors and Agency Company Ltd., of 401 Collins-street, Melbourne, by the 13th August, 1973, after which date it will distribute the assets, having regard only to the claims of which it then has notice.

RENNICK & GAYNOR, solicitors, 491 Bourke-street, Melbourne. 2666

ESKEL HERBERT HYMAN, late of Unit 3, No. 420 Dandenong-road, Caulfield, merchant, DECEASED.

Creditors, next of kin and others having claims in respect of the estate of the said deceased (who died on 1st April, 1973), are required by the executors, Hyman Hyman, of 406A Dandenong-road, Caulfield, and Simon Hyman, of 10 Eumeralla-road, Caulfield, merchants, to send particulars to them, care of their solicitors, Messrs. Keith Hercules & Sons, of 443 Little Collins-street, Melbourne, by the 30th August, 1973, after which date they may convey or distribute the assets, having regard only to the claims of which they then have notice.

MESSRS. KEITH HERCULES & SONS, solicitors, of 443 Little Collins-street, Melbourne. 2683

JOSEPH ADOLPH MOODY, late of 22 Laura-street, Moonee Ponds, gentleman, DECEASED.

Creditors, next of kin and others having claims in respect of the estate of the above-named deceased (who died on the 29th April, 1973), are required by the executors Evangeline Moody, of 22 Laura-street, Moonee Ponds, widow, and Elaine Joyce Collis, of 19 Clapperton-street, Bentleigh, married woman, to send particulars to them, care of their solicitors, Messrs. Keith Hercules & Sons, of 443 Little Collins-street, Melbourne, by the 31st day of August, 1973, after which date they may convey or distribute the assets, having regard only to the claims of which they then have notice.

MESSRS. KEITH HERCULES & SONS, solicitors, of 443 Little Collins-street, Melbourne. 2684

IMPOUNDINGS

PLENTY.—Impounded in Yan Yean-road, Plenty Pound, on 10th May, 1973.

1 ram, no visible brand

If not claimed and expenses paid, to be sold on 21st June, 1973.

2647—\$2.45

B. J. MORGAN,
Shire Secretary.

UPWEY.—Impounded in Upwey Pound, from Bayview-road, Upwey, on 25th May, 1973.

1 Sussex sheep, black face, clipped ear, no visible brand

If not claimed and expenses paid, to be sold on 22nd June, 1973.

2646—\$2.45

J. B. CLAYTON,
Poundkeeper.

WARRAGUL.—Impounded in Warragul Pound, from Railway Trucking yards, Warragul.

1 red brindle steer, no visible brand

2 red steers, no visible brand

If not claimed and expenses paid, to be sold on 22nd June, 1973.

2648—\$2.80

D. P. GRAHAM,
Poundkeeper.

Subordinate Legislation Act 1962.

NOTICE OF MAKING OF STATUTORY RULES.

In pursuance to the provisions of the *Subordinate Legislation Act 1962* and the Regulations made thereunder, notice is given of the making of the following statutory rules:—

No.	State Electricity Commission Act 1958.	Price.
108/1973.	Yallourn Town Advisory Council Elections (Amendment) Regulations 1973	10c
	Fertilizers Act 1958.	
109/1973.	Fertilizers (Metric Conversion) Regulations 1973	10c
	Marine Act 1958.	
110/1973.	Amendment to Port Rule Applicable to Westernport Harbor Services (Rates and Charges)	10c
	Road Traffic Act 1958.	
111/1973.	Road Traffic (Amendment No. 1) Regulations 1973	10c
	Discharged Servicemen's Preference Act 1943.	
112/1973.	Discharged Servicemen's Preference Act 1943—Salaries Regulations 1973	10c
	State Savings Bank Act 1958.	
113/1973.	State Savings Bank (Provident Fund) General Orders 1973	20c
	Legal Profession Practice Act 1958.	
114/1973.	Rules Relating to the Qualification and Admission of Candidates	10c

Copies of these statutory rules may be purchased at the Sale of Publications Section of the Government Printing Office, located at 7A Parliament-place, Melbourne, 3002. If ordered by mail, remittance should be addressed to "The Government Printer, Box 203, P.O., North Melbourne, 3051", and should include 7c extra for postage. If a credit account is held at this office, no remittance is required with the mail order.

The annual subscription rate for Statutory Rules (including Bound Volumes) is \$25, payable in advance. The subscription year commences on 1st January.

C. H. RIXON,
Government Printer.

AGENTS FOR THE "VICTORIA GOVERNMENT GAZETTE".

The following have been appointed agents to receive Advertisements and Subscriptions for the *Victoria Government Gazette*:—

- ARMSTRONG'S AGENCY, 217 Queen-street, Melbourne, Victoria 3000
- ARNALL & JACKSON, 390 Barkly-street, Brunswick, Victoria 3056.
- BAIRNSDALE AUTHORIZED NEWSAGENCY, 132 Mam-street, Bairnsdale, Victoria 3875.
- BICKNELL, M. J., Authorized Newsagent, 196 Timor-street, Warrambool, Victoria 3280.
- BLANE'S AUTHORIZED NEWSAGENTS, 162 Murray-street, Colac, Victoria 3250.
- CARTER, R. G., ADVERTISING SERVICE PTY. LTD., Suite 24, 65 Queens-road, Melbourne, Victoria 3004.
- DAVIES, G. & M. V., 112 Gray-street, Hamilton, Victoria 3300.
- DAVIS, WM. (MILDURA) PTY. LTD., 126 Eighth-street, Mildura, Victoria 3500.
- DIXON'S NEWSAGENCY, 89 Firebrace-street, Horsham, Victoria 3400.
- EASTHALL ASSOCIATES, 934 Whitehorse-road, Box Hill, Victoria 3128.
- EDGAR'S AUTHORIZED NEWSAGENCY, 45 Bridge-street, Benalla, Victoria 3672.
- FRANKS, H. & CO., 184 Ryrie-street, Geelong, Victoria 3220.
- GATLEY, A. & J., 250 Lonsdale-street, Dandenong, Victoria 3175.
- GORDON & GOTCH AUSTRALASIA LTD., 434 St. Kilda-road, Melbourne, Victoria 3004.
- GULLAN'S NEWSAGENCY, 88 Bridge-street, Ballarat, Victoria 3350.
- HAMPTON, A. C., 243 Mitchell-street, Bendigo, Victoria 3550.

HARSTON, PARTRIDGE & CO. PTY. LTD., 455 Little-Collins-street, Melbourne, Victoria 3000.

KYNETON GUARDIAN PTY. LTD., P.O. Box 18, Kyneton, Victoria 3444.

LATIMER'S NEWSAGENTS, 45 Station-street, Malvern, Victoria 3144.

LIVINGSTON'S SHEPPARTON NEWSAGENCY, 246 Wyndham-street, Shepparton, Victoria 3630.

THE MERCANTILE EXCHANGE, 34 Queen-street, Melbourne, Victoria, 3000.

MCGILL'S AUTHORIZED NEWSAGENCY, 183-5 Elizabeth-street, Melbourne, Victoria 3000.

POWNEY'S AUTHORIZED NEWSAGENCY, 293 Hargreaves-street, Bendigo, Victoria 3550.

PURDIE, J. & CO., 138 Moorabool-street, Geelong, Victoria 3220.

SALE AUTHORIZED NEWSAGENCY, 142 Raymond-street, Sale, Victoria 3850.

SKINNER'S AUTHORIZED NEWSAGENCY, 49-51 Franklin-street, Traralgon, Victoria 3844.

STEVENSON, A. C. & M., NEWSAGENTS, 132 Henty-street, Casterton, Victoria 3311.

VANCE'S AUTHORIZED NEWSAGENCY, 83 Murray-street, Wangaratta, 3677.

VERNONS OF RICHMOND, 162 Bridge-road, Richmond, Victoria 3121.

VIEW POINT AUTHORIZED NEWSAGENCY, 4 View-Point, Bendigo, Victoria 3550.

A copy of the Gazette is filed at each place for public reference.

PUBLICATION OF OFFICIAL MATTER.

Attention is invited to the following procedure in relation to the publication of official matter, in the *Government Gazette*:—

Publication will be facilitated by the submission of carbon copies for the use of the *Gazette Officer*.

1. Matter submitted to the Executive Council.

Matter submitted to the Executive Council which requires gazettal will normally be published in the issue of the following week.

Where urgent gazettal is required, special arrangements should be made with the *Gazette Officer*, Room 9, first floor, Old Treasury Building.

2. Other matter.

(a) All other matter duly certified by a responsible officer for publication should be lodged with the *Gazette Officer* not later than half-past Nine a.m. on Tuesday.

(b) Lengthy or involved notices should be forwarded several days before publication.

(c) Proofs, which will be supplied only when specifically requested or at the direction of the *Gazette Officer*, should be returned promptly to avoid delay in publication.

(d) No additions or amendments to matter for publication will be accepted by telephone.

CONTENTS	PAGE
Appointments	1834
Cemeteries—Scale of Fees	1823
Companies Act 1961—Notice	1829
Contracts	1834
Country Roads Board	1827
Estates of Deceased Persons	1833
Government Notices	1823
Impoundings	1863
Lands	1838
Mining	1832
Notice to attend for Radiological Examination	1832
Notice to Mariners	1829
Notice of Making of Statutory Rules	1863
Orders in Council—	
Acts—Social Welfare; Soil Conservation and Land Utilization; Stock Diseases; Land; Superannuation.	1836 et seq
Private Advertisements	1843
Proclamations	1822
Public Service Notices	1842
Queen's Birthday Honours	1821
Resignations	1836
Tenders	1839
Transport Regulation Board—Public Hearings	1825