



VICTORIA GOVERNMENT GAZETTE

Published by Authority

No. 65]

WEDNESDAY, JULY 11

[1973

PROCLAMATIONS

COUNTRY FIRE AUTHORITY (AMENDMENT) ACT 1972, No. 8257. DATE OF COMING INTO OPERATION.

PROCLAMATION

By His Excellency the Governor of the State of Victoria and its Dependencies in the Commonwealth of Australia, &c., &c., &c.

Whereas by an Act of Parliament of the State of Victoria in the Commonwealth of Australia passed in the twenty-first year of the reign of Her Majesty Queen Elizabeth II entitled the *Country Fire Authority (Amendment) Act 1972* (No. 8257) it is amongst other things enacted that the several provisions of the said Act shall come into operation on a day or respective days to be fixed by proclamation or successive proclamations of the Governor in Council published in the *Government Gazette*:

Now therefore I, the Governor of the State of Victoria in the Commonwealth of Australia, by and with the advice of the Executive Council of the said State do by this my proclamation fix the eleventh day of July, One thousand nine hundred and seventy-three as the day on which sections 2, 3, 5, 6 and 15 of the said *Country Fire Authority (Amendment) Act 1972* shall come into operation.

Given under my Hand and the Seal of the State of Victoria aforesaid, at Melbourne, this tenth day of July, in the year of our Lord One thousand nine hundred and seventy-three, and in the twenty-second year of the reign of Her Majesty Queen Elizabeth II.

(L.S.) ROHAN DELACOMBE.

By His Excellency's Command,
J. F. ROSSITER,
Chief Secretary.

GOD SAVE THE QUEEN!

Milk and Dairy Supervision Act 1958.

MUNICIPAL DISTRICTS PROCLAIMED TO BE SUBJECT TO THE PROVISIONS OF PART II.

PROCLAMATION

By His Excellency the Governor of the State of Victoria and its Dependencies in the Commonwealth of Australia, &c., &c., &c.

Whereas by paragraph (c) of sub-section (1) of section 55 of the *Milk and Dairy Supervision Act 1958* it is provided that Part II of the said Act shall have effect as

regards any municipal district outside any milk area on such date as such district at any time is proclaimed by the Governor in Council to be subject to the provisions of the said Part II: And whereas by paragraph (b) of sub-section (2) of section 55 of the said Act it is provided that the Governor in Council may revoke, amend or vary any such proclamation: Now, therefore I, the Governor of the State of Victoria by and with the advice of the Executive Council thereof do by this my proclamation—

I. Revoke on and after the eleventh day of July, One thousand nine hundred and seventy-three the proclamations made in accordance with the provisions of paragraph (c) of sub-section (1) of section 55 of the said Act on the 6th August, 1968, the 8th October, 1968 and the 22nd August, 1972, and published in the *Government Gazette* of the 7th August, 1968, the 16th October, 1968, and the 23rd August, 1972, respectively; and

II. Proclaim the municipal districts set out in the Schedule hereto to be subject to the provisions of Part II of the said Act on and after the eleventh day of July, One thousand nine hundred and seventy-three on which date all Regulations and Orders made thereunder now in operation shall be of full force and effect in such municipal districts:—

SCHEDULE.

The Cities of Altona, Ararat, Benalla, Box Hill, Broadmeadows, Chelsea, Colac, Croydon, Dandenong, Doncaster and Templestowe, Echuca, Frankston, Hamilton, Heidelberg, Horsham, Keilor, Knox, Maryborough, Mildura, Moe, Moorabbin, Mordialloc, Nunawading, Ringwood, Sale, Sandringham, Shepparton, Springvale, Sunshine, Swan Hill, Traralgon, Wangaratta, Warrnambool and Waverley.

The Rural City of Wodonga.

The Towns of Bairnsdale, Camperdown, Kyabram, Portland, St. Arnaud and Stawell.

The Boroughs of Kerang, Koroit, Queenscliffe, Sebastopol and Wonthaggi.

The Shires of Alberton, Alexandra, Ararat, Avon, Bacchus Marsh, Bairnsdale, Ballan, Ballarat, Bannockburn, Barrabool, Bass, Belfast, Bellarine, Benalla, Berwick, Bright, Broadford, Bulla, Buln Buln, Bungaree, Buninyong, Chiltern, Cobram, Cohuna, Colac, Corio, Cranbourne, Creswick, Daylesford and Glenlyon, Deakin, Diamond Valley, Donald, Dundas, Dunmunkle, East Loddon, Eltham, Euroa, Flinders, Gisborne, Glenelg, Gordon, Goulburn, Grenville, Hampden, Hastings, Healesville, Heytesbury, Huntly, Kerang, Kilmore, Korong, Korumburra, Kowree, Kyneton, Leigh, Lillydale, Maffra, Maldon, Mansfield, Marong, Melton, Metcalfe, Mildura, Minhamite Mirboo,

Mornington, Mortlake, Morwell, Mount Rouse, Myrtleford, Mclvor, Narracan, Nathalia, Newham and Woodend, Newstead, Numurkah, Orbost, Otway, Oxley, Phillip Island, Portland, Pyalong, Ripon, Rochester, Rodney, Romsey, Rosedale, Rutherglen, Seymour, Shepparton, Sherbrooke, South Barwon, South Gippsland, Strathfieldsaye, Swan Hill, Talbot and Clunes, Tambo, Towong, Traralgon, Tullaroop, Tungamah, Upper Murray, Upper Yarra, Violet Town, Wangaratta, Wannon, Waranga, Warragul, Warrnambool, Werribee, Whittlesea, Winchelsea, Woorayl, Yackandandah, Yarrawonga, Yea.

The United Shire of Beechworth.

Given under my Hand and the Seal of the State of Victoria aforesaid, at Melbourne, this tenth day of July, in the year of our Lord One thousand nine hundred and seventy-three, and in the twenty-second year of the reign of Her Majesty Queen Elizabeth II.

(L.S.) ROHAN DELACOMBE.

By His Excellency's Command,
VASEY HOUGHTON,
Acting Minister of Agriculture.
GOD SAVE THE QUEEN!

Milk and Dairy Supervision Act 1958.
MILK AREAS PROCLAIMED.

PROCLAMATION

By His Excellency the Governor of the State of Victoria and its Dependencies in the Commonwealth of Australia, &c., &c., &c.

Whereas by sub-section (1) of section 65 of the *Milk and Dairy Supervision Act 1958* it is provided that on the recommendation of the Minister any portion of Victoria may be proclaimed a milk area by the Governor in Council: And whereas by paragraph (b) of sub-section (2) of section 65 of the said Act it is provided that the Governor in Council on the recommendation of the Minister may revoke, amend or vary any such proclamation: And whereas by paragraph (b) of sub-section (1) of section 55 of the said Act it is provided that Part II of the said Act shall have effect as regards any milk area other than the Metropolitan Milk Area and the milk areas of Ballarat, Bendigo, Geelong, Castlemaine and Port Fairy on such day after the constitution thereof as is fixed by the Governor in Council: Now, therefore, I, the Governor of the State of Victoria by and with the advice of the Executive Council thereof and on the recommendation of the Honorable the Minister of Agriculture of the said State do by this my proclamation—

I. Revoke on and after the eleventh day of July, One thousand nine hundred and seventy-three the proclamations made in accordance with the provisions of sub-section (1) of section 65 of the said Act on the 6th August, 1968, the 7th October, 1969, the 25th May, 1971, the 18th April, 1972, and the 22nd August, 1972 and published in the *Government Gazette* of the 7th August, 1968, the 15th October, 1969, the 2nd June, 1971, the 19th April, 1972 and the 23rd August, 1972, respectively;

II. Declare the portions of Victoria set out in the Schedule hereto to be milk areas as specified; and

III. I do further declare that the eleventh day of July, One thousand nine hundred and seventy-three shall be the day on which Part II of the said Act shall have effect in such milk areas and all regulations and Orders made thereunder now in operation shall be of full force and effect in such milk areas.

SCHEDULE.

| Name of Milk Area. | Portion of Victoria. |
|--------------------|---|
| Arapiles .. | All those portions of the Municipal District of the Shire of Arapiles within the Parishes of Bungallaly, Horsham and Vectis East. |
| Birchip .. | The Township of Birchip. |
| Charlton .. | The Central Riding of the Municipal District of the Shire of Charlton. |
| Dimboola .. | All those portions of the Municipal District of the Shire of Dimboola within the Parishes of Dimboola and Watchegatcheca. |
| French Island .. | French Island. |
| Lowan .. | All those portions of the Municipal District of the Shire of Lowan within the Parishes of Balrootan and Kinimakatka. |

- Omeo .. All that portion of the Municipal District of the Shire of Omeo comprising the Parishes of Yambulla, Eumana, Angora, Numbie Munjie, Tongio-Munjie West, Tongio-Munjie East, Omeo, Bingo-Munjie, Cobungra, Bingo-Munjie North and Hinnomunjie.
- Walpeup .. All that portion of the Municipal District of the Shire of Walpeup within the Parishes of Ouyen, Tiega and Walpeup.
- Warracknabeal .. All that portion of the Municipal District of the Shire of Warracknabeal within the Parish of Werrigar.
- Wimmera .. All those portions of the Municipal District of the Shire of Wimmera within the Parishes of Bungallaly, Dooen, Drung Drung, Horsham, Quantong and Vectis East.
- Yallourn .. The Yallourn Works Area.

Given under my Hand and the Seal of the State of Victoria aforesaid, at Melbourne, this tenth day of July, in the year of our Lord One thousand nine hundred and seventy-three, and in the twenty-second year of the reign of Her Majesty Queen Elizabeth II.

(L.S.) ROHAN DELACOMBE.

By His Excellency's Command,
VASEY HOUGHTON,
Acting Minister of Agriculture.
GOD SAVE THE QUEEN!

POISONS ACT 1962 (No. 6889).

PROCLAMATION

By His Excellency the Governor of the State of Victoria and its Dependencies in the Commonwealth of Australia, &c., &c., &c.

Whereas by Section 4 of the *Poisons Act 1962* it is amongst other things enacted that the Governor in Council may, by Proclamation published in the *Government Gazette*, amend any of Schedules One, Two, Three, Four, Five, Six, Seven or Eight to such Act by adding to any such Schedules or removing therefrom any item:

Now therefore, I, the Governor of the State of Victoria in the Commonwealth of Australia, by and with the advice of the Executive Council of the said State, by virtue of the provisions of the said Section and all other enabling powers, do by this Proclamation:—

1. Amend Schedule Three to the said Act by adding thereto the following item:

HEXACHLOROPHANE in preparations, other than preparations for use on infants, containing 3 per centum or less of hexachlorophane for skin cleansing purposes when such preparations are labelled with the following warnings.

- (i) Do not use internally or on areas of burnt or damaged skin.
- (ii) Do not use on infants except under medical direction.
- (iii) Wash off the skin immediately after use.

2. Amend Schedule Four to the said Act by adding thereto the following item:

HEXACHLOROPHANE except—
(a) when included in Schedule Three; or
(b) in preparations, other than for use on infants, containing 0.1 per centum or less of hexachlorophane as a preservative.

Given under my Hand and the Seal of the State of Victoria aforesaid, at Melbourne, this third day of July in the year of our Lord One thousand nine hundred and seventy-three, and in the twenty-second year of the reign of Her Majesty Queen Elizabeth II.

(L.S.) ROHAN DELACOMBE.

By His Excellency's Command,
A. H. SCANLAN,
Minister of Health.

GOD SAVE THE QUEEN!

Vegetation and Vine Diseases Act 1958.
**REVOKING PROCLAMATION DECLARING A
 PROCLAIMED AREA FOR THE CONTROL OF
 FRUIT FLY.**

PROCLAMATION

By His Excellency, the Governor of the State of Victoria and its Dependencies in the Commonwealth of Australia, &c., &c., &c.

Whereas by the *Vegetation and Vine Diseases Act 1958* it is amongst other things enacted that any proclamation made under section 25 of the said Act may be amended or revoked by a subsequent proclamation: Now therefore, I, the Governor of the State of Victoria, in the Commonwealth of Australia, by and with the advice of the Executive Council thereof, do by this my Proclamation hereby revoke:—

The proclamation made under the said section on the seventh day of March, 1972, declaring a portion of Victoria within the Parishes of Wimbirchip and Karyrie in the County of Karkarook and the Parish of Narraport within the County of Borung to be a proclaimed area.

Given under my Hand and the Seal of the State of Victoria aforesaid, at Melbourne, this tenth day of July, in the year of our Lord One thousand nine hundred and seventy-three, and in the twenty-second year of the reign of Her Majesty Queen Elizabeth II.

(L.S.) ROHAN DELACOMBE.

By His Excellency's Command,
 VASEY HOUGHTON,
 Acting Minister of Agriculture.
 GOD SAVE THE QUEEN!

GOVERNMENT NOTICES

Country Fire Authority Act.
**PERMISSION TO HOLD FIRE BRIGADE
 DEMONSTRATION.**

In pursuance of the provisions of section 103 of the *Country Fire Authority Act 1958*, the Country Fire Authority has granted permission for the holding of a fire brigade demonstration as under:—

Region 13 Council—Victorian Rural Fire Brigades Association.

At Rowville Recreation Reserve, Stud-road, Rowville, on Sunday, 2nd December, 1973.
 3rd July, 1973.

J. L. ALLEN,
 Secretary.

Town and Country Planning Act 1961.
SHIRE OF KILMORE PLANNING SCHEME.

NOTICE OF APPROVAL.

In pursuance of the powers conferred by the *Town and Country Planning Act 1961*, the Governor in Council on the 3rd July, 1973, approved a planning scheme entitled the Shire of Kilmore Planning Scheme in respect of the municipal district of the Shire of Kilmore and such planning scheme comes into operation on the date this notice of approval is published in the *Government Gazette*.

A copy of the planning scheme as approved may be inspected free of charge during office hours at the office of the Town and Country Planning Board, 235 Queen-street, Melbourne; at the office of the Shire of Kilmore at Kilmore; and when available, at the Office of Titles, Melbourne, and at the Central Plan Office of the Department of Crown Lands and Survey, Melbourne.

W. H. CRAIG, Secretary,
 Town and Country Planning Board.

NUMURKAH SEWERAGE AUTHORITY.

AUDIT OF ACCOUNTS.

Fee Payable to Auditor.

His Excellency the Governor of the State of Victoria, by and with the advice of the Executive Council thereof, doth by Order made on the 10th day of July, 1973, and in pursuance of the provisions of the *Sewerage Districts Act 1958* (No. 6368) approve of the payment to J. T. Coutts, Esquire, of the sum of Ninety dollars (\$90), as

remuneration for making an audit of the accounts of the Numurkah Sewerage Authority for the year ended 30th September, 1972, he having been duly appointed by Order in Council made 5th September, 1972, to make such audit.

T. J. FORRISTAL,
 Clerk of the Executive Council.

At the Executive Council Chamber,
 Melbourne, 10th July, 1973.

Transport Regulation Act.

TRANSPORT REGULATION BOARD.

HEARING OF APPLICATIONS.

Notice is hereby given that the following applications will be considered by the Transport Regulation Board at its offices at the corner of Lygon and Princes streets, Carlton, at 10.15 a.m. on 1st August, 1973.

HAHNE, H. A. J., 72 Regent-street, Preston. One commercial passenger vehicle with seating capacity for 8 persons to operate on weekends only for the carriage of anglers on fishing journeys throughout the State of Victoria.

Fares.—\$30—\$35 per day.

Additional charge to be made for the hire of fishing and camping equipment.

MARTYR, H., PTY. LTD., Main-street, Warburton. Application for one commercial passenger vehicle with seating capacity for 49 persons to operate as an additional country stage omnibus under the same terms and conditions as existing licences.

RAMSEY, W. M., Main-street, Buchan. Application for one commercial passenger vehicle with seating capacity for five persons to operate as follows:—

(i) For the carriage of passengers and parcels from Buchan to Bairnsdale via Bruthen.

TIME-TABLE.

Friday.

Depart Buchan—9.30 a.m.

Arrive Bairnsdale—11 a.m.

Depart Bairnsdale—3.30 p.m.

Arrive Buchan 5 p.m.

Fares.—Bairnsdale to Buchan \$2 single, \$4 return.

South Buchan \$1.75 single, \$3.50 return.

Restriction.—(a) On journeys from Buchan to Bairnsdale, no passengers or parcels are to be picked up nearer to Bairnsdale than a point two miles east of the Bruthen Post Office. (b) On journeys from Bairnsdale to Buchan no passengers or parcels shall be set down nearer to Bairnsdale than a point 2 miles east of the Bruthen Post Office.

(ii) As a country hire car from Buchan.

THIESS BROS. PTY. LTD., Dartmouth Dam, via Mitta Mitta. Application for one commercial passenger vehicle with seating capacity for 39 persons to operate for the carriage of construction workers, free of charge, from the Dartmouth Village to the Dartmouth Dam Diversion Tunnel project.

TIME-TABLE.

As and when required.

WALKERS, B. M., BUS SERVICE PTY. LTD., 132 Spring Gully-road, Bendigo. Application for one commercial passenger vehicle with seating capacity for 35 persons to operate as an additional country stage omnibus under the same terms and conditions as existing licences.

Applications for renewal of licences as shown, by persons listed hereunder to operate under the same terms and conditions:—

DOYLE, PATRICK, 118 Vaughan-street, Shepparton; C.O.51, C.O.53, C.O.223, C.O.618, C.O.763, C.O.876, C.O.1000.

MCKENZIE'S TOURIST SERVICES PTY. LTD., 53 Barkers-road, Kew; M.C.426.

SINCLAIRS COACHES PTY. LTD., 983 North-road, Murrumbidgee; M.C.279.

Notice of any objection should be forwarded to reach the Secretary of the Board not later than 25th July, 1973.

Applicants are advised that it will not be necessary to appear on the hearing date specified, unless advised in writing by the Board.

A. V. C. COOK,
 Secretary.

Corner Lygon and Princes streets, Carlton, 3053, Wednesday, 11th July, 1973.

COUNTRY ROADS BOARD.

RESOLUTIONS OF THE COUNTRY ROADS BOARD.

The Country Roads Board, in pursuance of the provisions of the Country Roads Act 1958, has passed Resolutions the dates whereof and the terms of which are scheduled hereunder:—

SCHEDULE.

State Highways.

Resolution dated the Eighteenth day of June, One thousand nine hundred and seventy-three, made pursuant to sections 21 and 74 of the Country Roads Act 1958, declaring the widening of the Midland Highway in the Shire of Buninyong as shown hatched on plan numbered G.P.9821 hereunder to be part of a State highway within the meaning and for the purposes of the said Act.

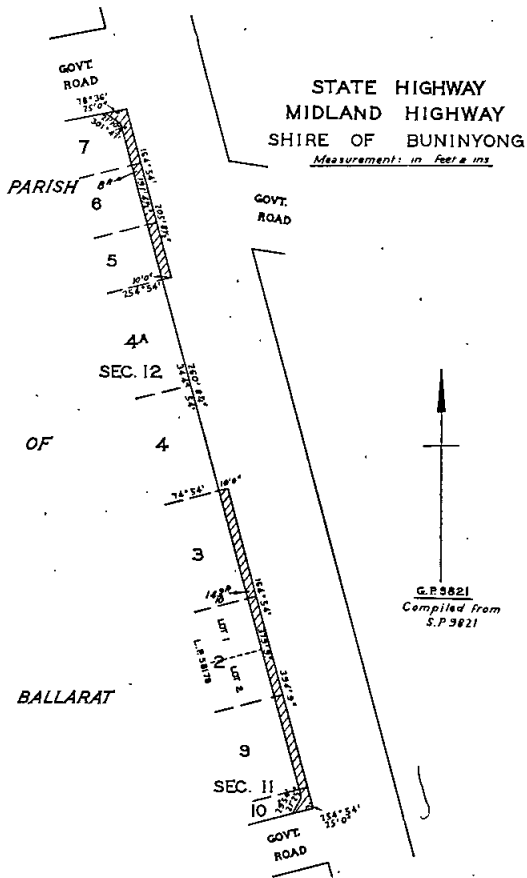

Resolution dated the Eighteenth day of June, One thousand nine hundred and seventy-three, made pursuant to sections 21 and 74 of the Country Roads Act 1958, declaring the widening of the Nepean Highway in the City of Frankston as shown hatched on plans numbered G.P.6739 and G.P.12005 hereunder to be part of a State highway within the meaning and for the purposes of the said Act.

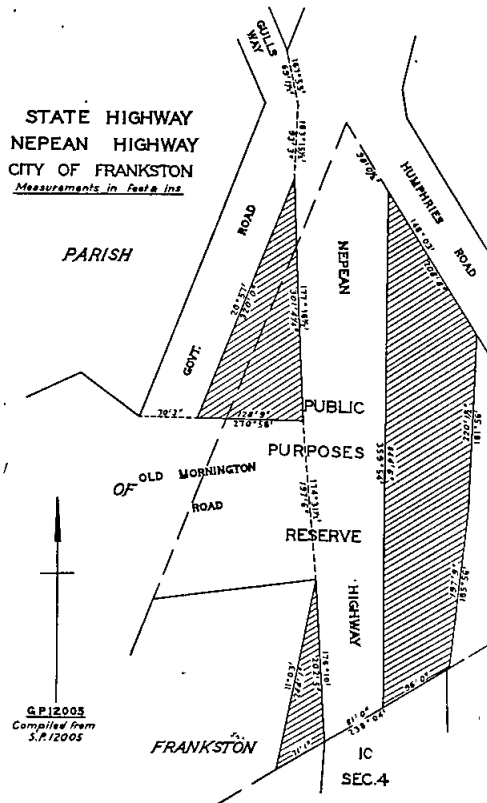
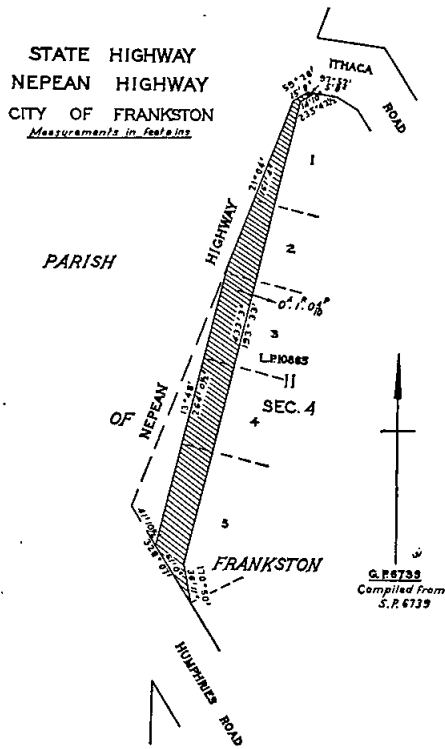

Resolution dated the Eighteenth day of June, One thousand nine hundred and seventy-three, made pursuant to sections 21 and 74 of the Country Roads Act 1958, declaring the widening of the South Gippsland Highway in the Shire of Korumburra as shown hatched on plan numbered G.P.13282 hereunder to be part of a State highway within the meaning and for the purposes of the said Act.

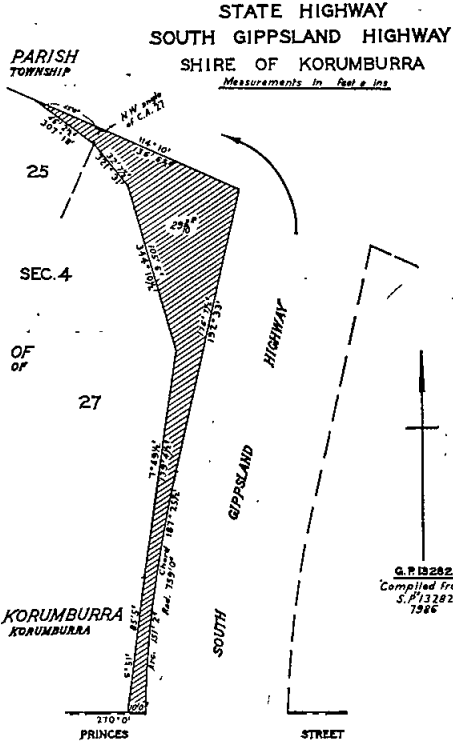

of Narracan and City of Moe as shown hatched on plans numbered G.P.5883A, G.P.5883B, G.P.5883C, G.P.5883D and G.P.5883E hereunder to be part of a State highway within the meaning and for the purposes of the said Act.

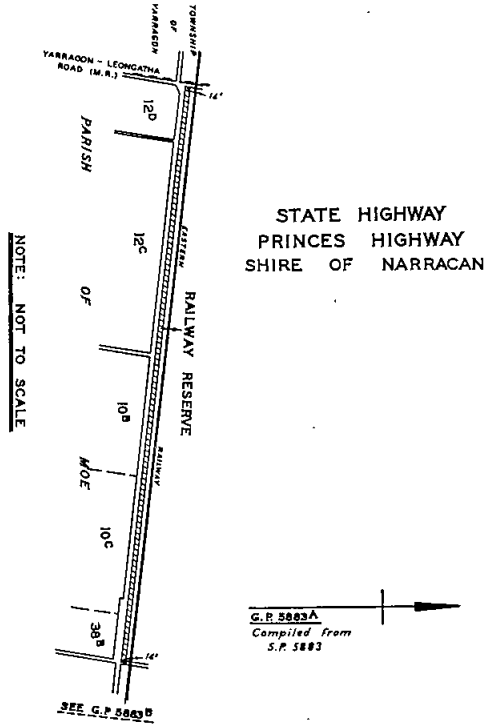

Resolution dated the Eighteenth day of June, One thousand nine hundred and seventy-three, made pursuant to sections 21 and 74 of the Country Roads Act 1958, declaring the widening of the Wimmera Highway in the Shire of Kowree as shown hatched on plan numbered G.P.13015 hereunder to be part of a State highway within the meaning and for the purposes of the said Act.

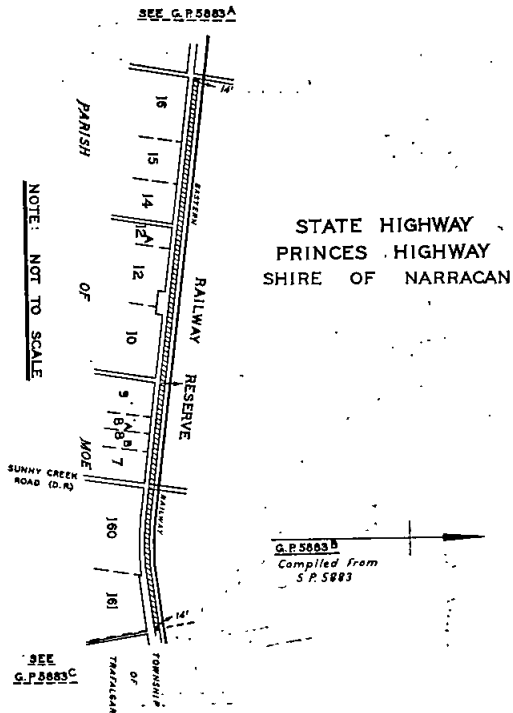
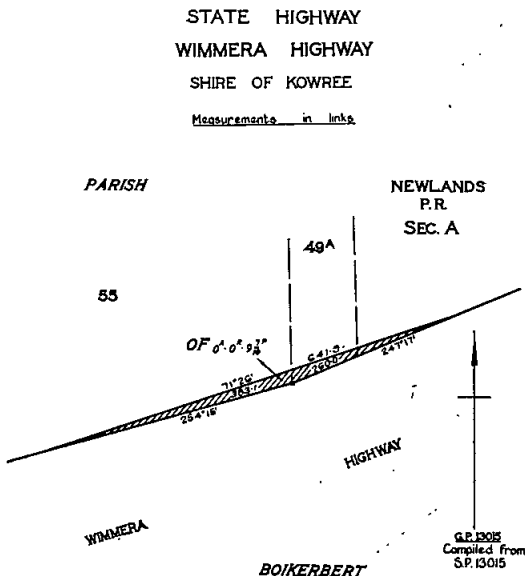

Resolution dated the Eighteenth day of June, One thousand nine hundred and seventy-three, made pursuant to sections 21 and 74 of the Country Roads Act 1958, declaring the widening of the Princes Highway in the Shire

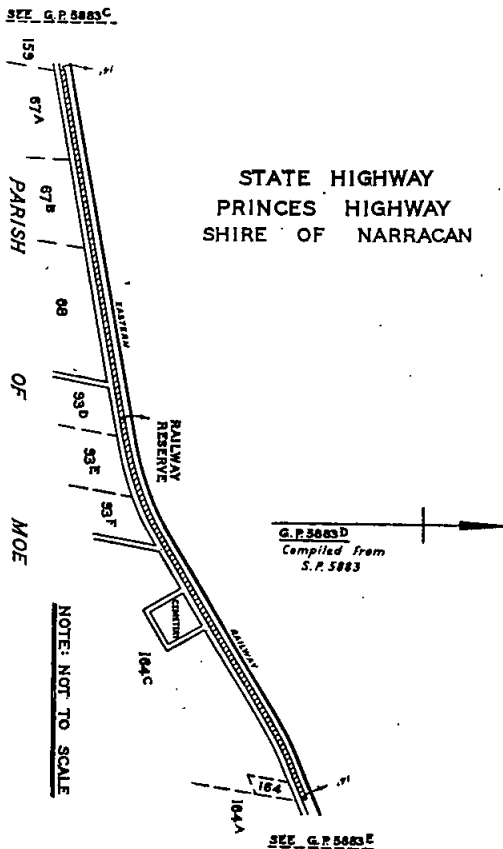
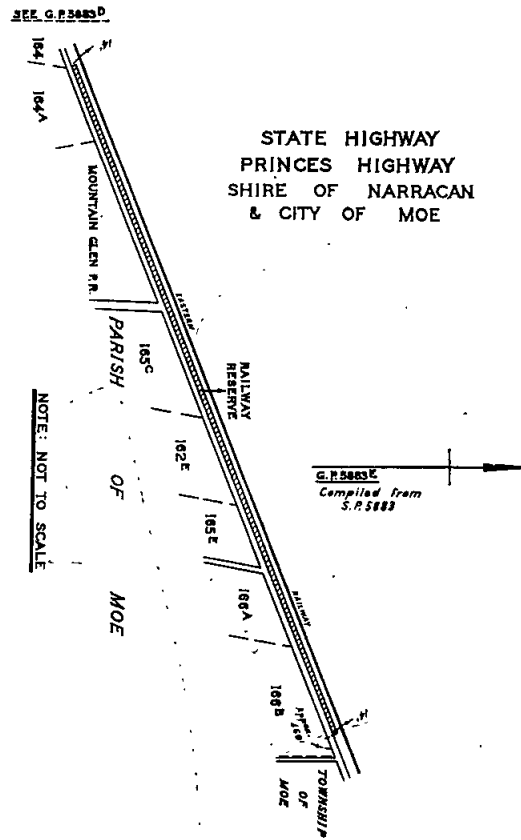
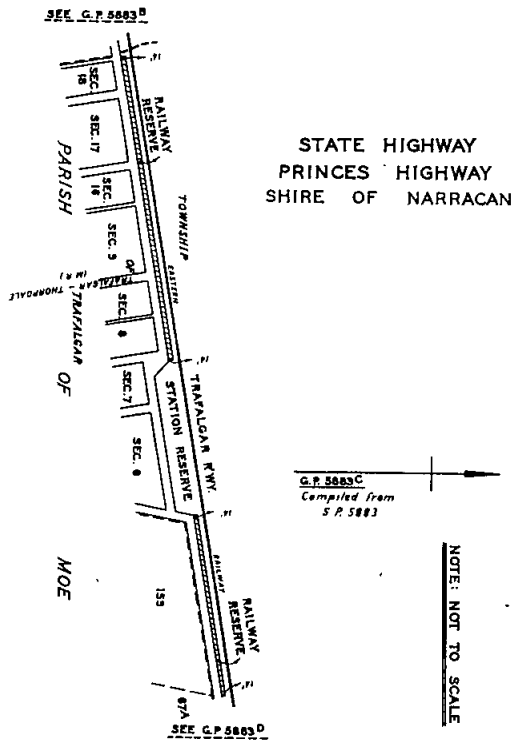

Resolution dated the Eighteenth day of June, One thousand nine hundred and seventy-three, made pursuant to sections 21 and 74 of the Country Roads Act 1958, declaring the widening of the Murray Valley Highway in the Shire of Swan Hill as shown hatched on plans numbered G.P.11433, G.P.11434 and G.P.11435 hereunder to be part of a State highway within the meaning and for the purposes of the said Act.

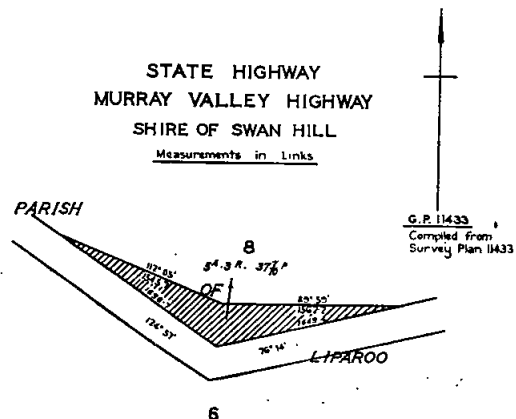

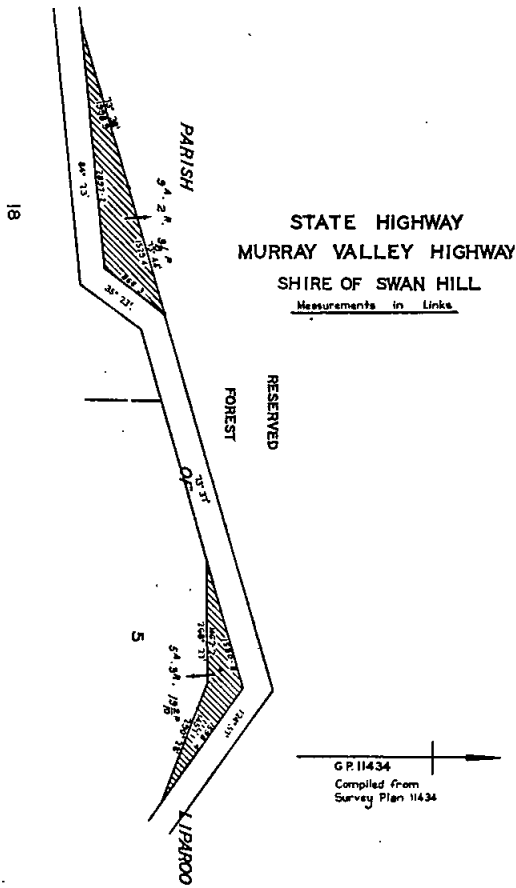

Main Roads.

Resolution dated the Eighteenth day of June, One thousand nine hundred and seventy-three, made pursuant to sections 21 and 58 of the *Country Roads Act 1958*, declaring the deviation from the Wonthaggi-Loch road in the Shire of Bass as indicated by diagonal hatching on plans numbered G.P.12669A, G.P.12669B and G.P.12670 hereunder to be part of a main road within the meaning and for the purposes of the said Act, and also declaring that such deviation shall be in lieu of the existing road or part thereof indicated by cross hatching on plans numbered G.P.12669B and G.P.12670 and that such part of the said existing road shall be discontinued.

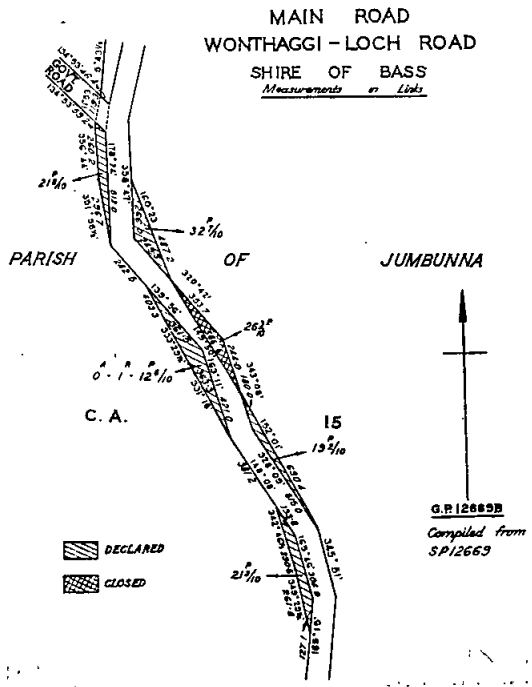
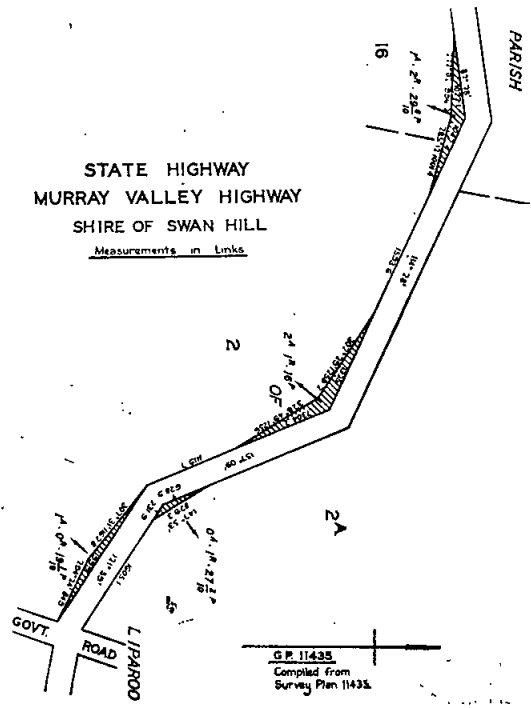
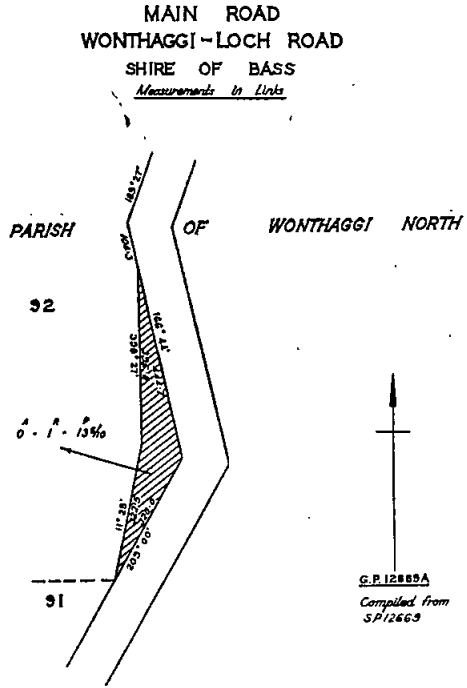

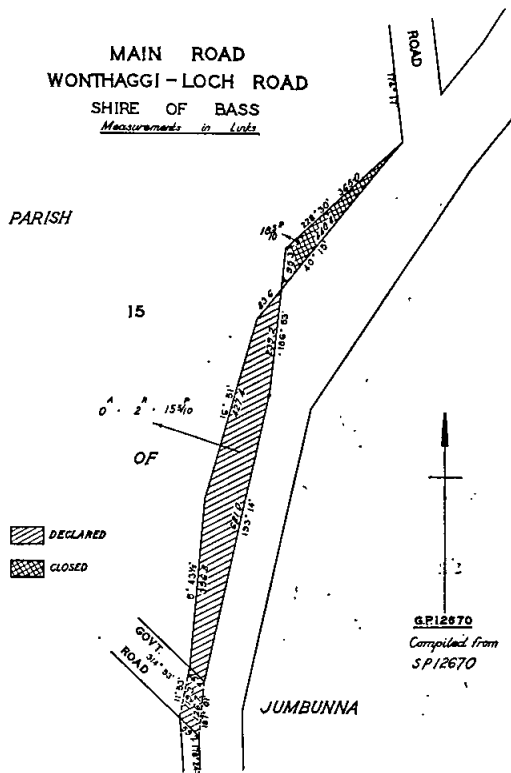

Resolution dated the Eighteenth day of June, One thousand nine hundred and seventy-three, made pursuant to section 21 of the *Country Roads Act 1958*, declaring the widening of Wandiligong-road in the Shire of Bright as shown hatched on plan numbered G.P.13060 hereunder to be part of a main road within the meaning and for the purposes of the said Act.

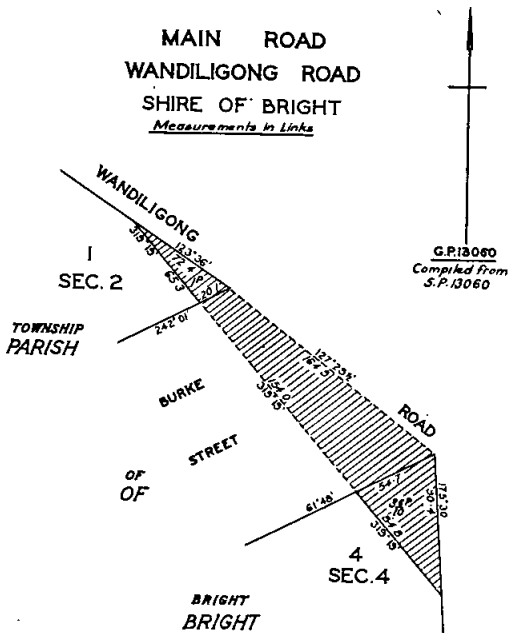

Resolution dated the Eighteenth day of June, One thousand nine hundred and seventy-three, made pursuant to section 21 of the *Country Roads Act 1958*, declaring the widening of the Mornington-Flinders road in the Shire of Flinders as shown hatched on plan numbered G.P.12460 hereunder to be part of a main road within the meaning and for the purposes of the said Act.

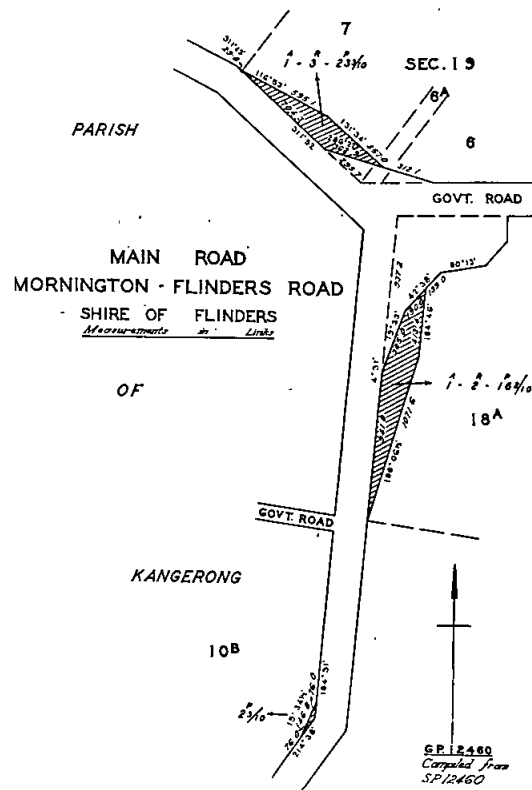

Resolution dated the Eighteenth day of June, One thousand nine hundred and seventy-three, made pursuant to section 21 of the *Country Roads Act 1958*, declaring the widening of the Natimuk-Hamilton road in the Shire of Wannon as shown hatched on plan numbered G.P.12828 hereunder to be part of a main road within the meaning and for the purposes of the said Act.

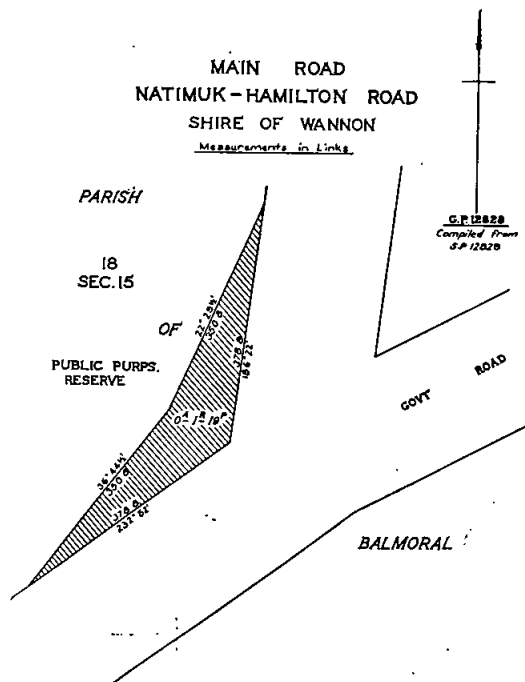

Resolution dated the Eighteenth day of June, One thousand nine hundred and seventy-three, made pursuant to sections 21 and 58 of the *Country Roads Act 1958*, declaring the deviation from the Goornong-Murchison road in the Shire of Waranga as indicated by diagonal hatching on plan numbered G.P.12624 hereunder to be part of a main road within the meaning and for the purposes of the said Act, and also declaring that such deviation shall be in lieu of the existing road or part thereof indicated by cross-hatching on the said plan.

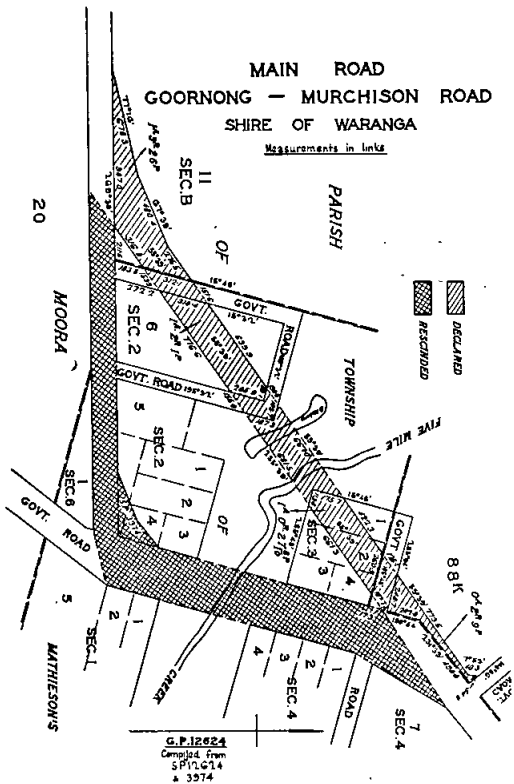

Resolution dated the Eighteenth day of June, One thousand nine hundred and seventy-three, made pursuant to section 21 of the *Country Roads Act 1958*, declaring the widening of Aviation-road in the Shire of Werribee as shown hatched on plan numbered G.P.12674 hereunder to be part of a main road within the meaning and for the purposes of the said Act.

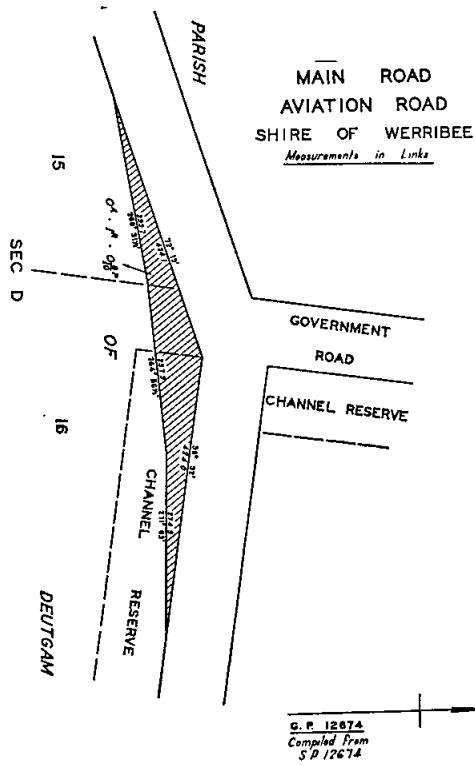

Resolution dated the Eighteenth day of June, One thousand nine hundred and seventy-three, made pursuant to section 21 of the *Country Roads Act 1958*, declaring the widening of Farmers-road in the Shire of Woorayl as shown hatched on plans numbered G.P.12903A and G.P.12903B hereunder to be part of a main road within the meaning and for the purposes of the said Act.

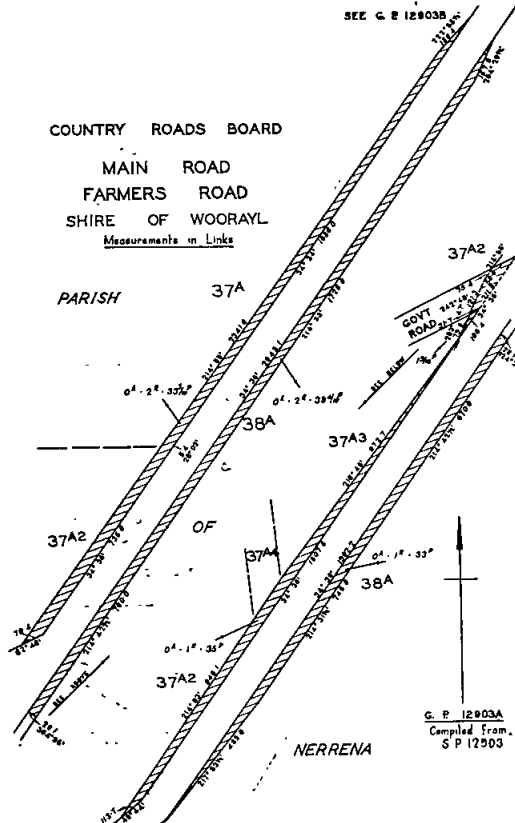

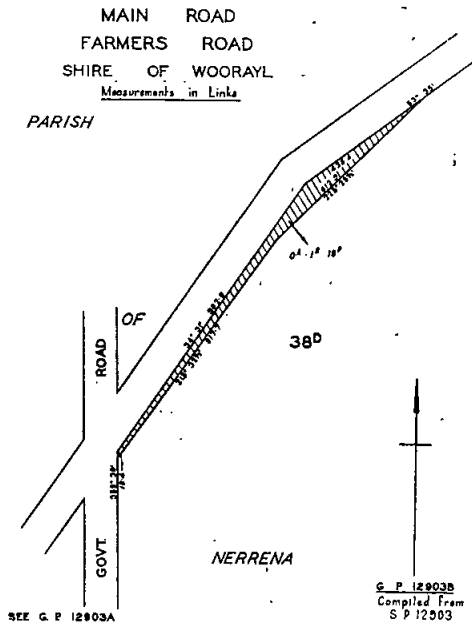

Resolution dated the Eighteenth day of June, One thousand nine hundred and seventy-three, made pursuant to section 21 of the *Country Roads Act 1958*, declaring the widening of the Whittlesea-Yea road in the Shire of Yea as shown hatched on plan numbered G.P.13128 hereunder to be part of a main road within the meaning and for the purposes of the said Act.

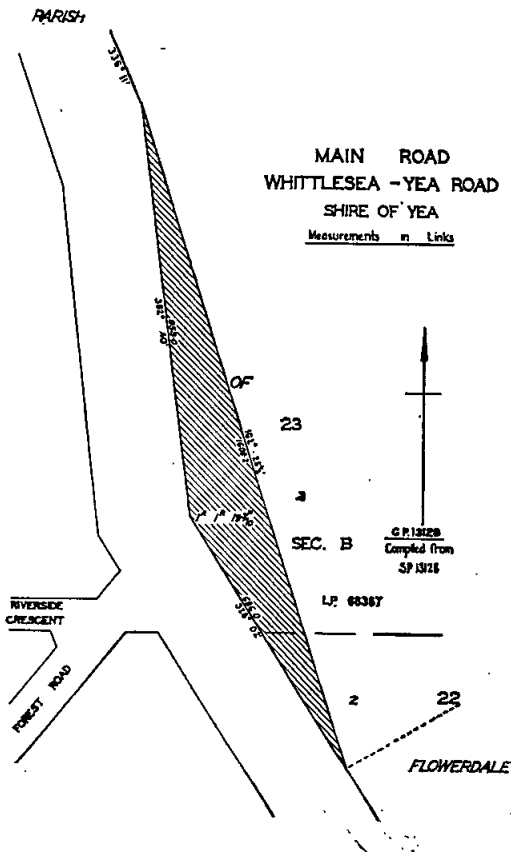

Unclassified Roads.

Resolution dated the Eighteenth day of June, One thousand nine hundred and seventy-three, made pursuant to sections 21, 58 and 110 of the *Country Roads Act 1958*, declaring the deviation from Station-street in the City of Chelsea as indicated by diagonal hatching on plan numbered G.P.13038 hereunder to be part of a road within the meaning and for the purposes of the said Act, and also declaring that such deviation shall be in lieu of the existing road or part thereof indicated by cross-hatching on the said plan and that such part of the said existing road shall be discontinued.

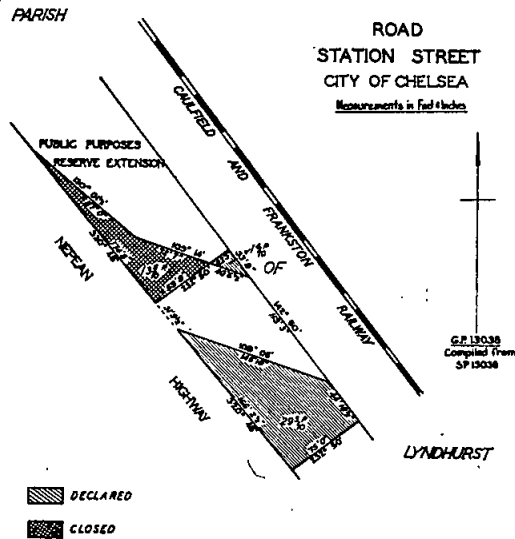

Resolution dated the Eighteenth day of June, One thousand nine hundred and seventy-three, made pursuant to sections 21 and 110 of the *Country Roads Act 1958*, declaring the widening of the Old Mornington-road in the City of Frankston as shown hatched on plan numbered G.P.9998 hereunder to be part of a road within the meaning and for the purposes of the said Act.

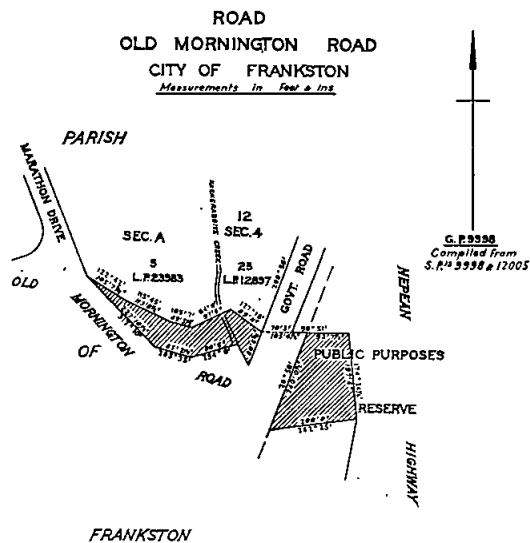

N. L. ALLANSON,
Secretary.

26th June, 1973.

GEELONG WATERWORKS AND SEWERAGE TRUST.

BY-LAW NUMBER 126.

A By-law for the Amendment of Water Supply By-law 104.

Geelong Waterworks and Sewerage Trust (hereinafter called the Trust) in pursuance of and in exercise of the powers conferred on such Trust by the *Geelong Waterworks and Sewerage Act 1958* and of any other powers and authorities in any wise enabling the said Trust in that behalf hereby makes the following By-law for the area supplied with water by the Geelong Water Supply Works or any extension of such works.

1. Sub-Clauses 4 (a), (b), (c), (d), (e), (f), (g) and (h) 5 (a) and (b), Clause 6 and Sub-Clauses 9 (b) and (c) are deleted and the following Clauses substituted.

4. (a) To the Geelong Harbor Trust for use in shipping other than that owned by the said Trust at the rate of 8.8 cents per kilolitre.

4. (b) For parks (but excluding areas used at football or cricket ovals or sports grounds) gardens and rockeries under municipal control or the control of the Geelong Harbor Trust at the rate of 3.3 cents per kilolitre.

4. (c) For sports grounds, football and cricket ovals to which no charge for admission is made at the rate of 3.3 cents per kilolitre provided that the minimum charge in any one year shall in no case be less than fifteen dollars.

4. (d) For swimming pools under municipal or public control at the rate of 4.4 cents per kilolitre for the first 2,200,000 kilolitres consumed, 2.2 cents per kilolitre for the next 6,800,000 kilolitres consumed and 4.4 cents per kilolitre for all consumption above 9,000,000 kilolitres in any one year.

4. (e) To public benevolent institutions not conducted for private profit but maintained for the charitable care of diseased, aged, infirm, incurable or delinquent persons at the rate of 4.4 cents per kilolitre for such quantity of water consumed in any one year as shall exceed an agreed allowance free of charge.

4. (f) For churches at the rate of 4.4 cents per kilolitre provided that the minimum charge in any one year shall in no case be less than fifteen dollars.

4. (h) In all cases other than the foregoing and those dealt with in clauses 5 and 9 herein at the rate of 7.7 cents per kilolitre.

5. (a) For the purpose of calculating the quantity of water supplied by measure for domestic purposes to be charged in accordance with the previous clause a deduction relative to the net annual value of the property to which water was supplied shall be made from the measured quantity of water used in that year in accordance with the following table.

| Deduction Kilolitres. | N.A.V. | Deduction Kilolitres. | N.A.V. |
|-----------------------|-----------|-----------------------|---------|
| | \$ | | \$ |
| 227 .. | Up to 300 | 364 .. | 515-525 |
| 232 .. | 301-312 | 368 .. | 526-536 |
| 236 .. | 313-321 | 373 .. | 537-547 |
| 241 .. | 322-330 | 377 .. | 548-558 |
| 245 .. | 331-340 | 382 .. | 559-569 |
| 250 .. | 341-350 | 386 .. | 570-580 |
| 255 .. | 351-360 | 391 .. | 581-591 |
| 259 .. | 361-366 | 396 .. | 592-600 |
| 264 .. | 367-372 | 400 .. | 601-609 |
| 268 .. | 373-378 | 405 .. | 610-618 |
| 273 .. | 379-384 | 409 .. | 619-627 |
| 277 .. | 385-390 | 414 .. | 628-636 |
| 282 .. | 391-395 | 418 .. | 637-645 |
| 286 .. | 396-400 | 423 .. | 646-654 |
| 291 .. | 401-405 | 427 .. | 655-663 |
| 295 .. | 406-410 | 432 .. | 664-673 |
| 300 .. | 411-415 | 436 .. | 674-683 |
| 305 .. | 416-422 | 441 .. | 684-693 |
| 309 .. | 423-429 | 446 .. | 694-703 |
| 314 .. | 430-436 | 450 .. | 704-713 |
| 318 .. | 437-443 | 455 .. | 714-723 |
| 323 .. | 444-450 | 459 .. | 724-733 |
| 327 .. | 451-457 | 464 .. | 734-743 |
| 332 .. | 458-463 | 468 .. | 744-753 |
| 336 .. | 464-471 | 473 .. | 754-763 |
| 341 .. | 472-479 | 477 .. | 764-773 |
| 345 .. | 480-487 | 482 .. | 774-783 |
| 350 .. | 488-495 | 486 .. | 784-793 |
| 355 .. | 496-503 | 491 .. | 794-803 |
| 359 .. | 504-514 | 496 .. | 804-813 |

| Deduction Kilolitres. | N.A.V. | Deduction Kilolitres. | N.A.V. |
|-----------------------|-----------|-----------------------|-----------|
| | \$ | | \$ |
| 500 .. | 814-823 | 682 .. | 1286-1301 |
| 505 .. | 824-833 | 686 .. | 1302-1317 |
| 509 .. | 834-843 | 691 .. | 1318-1333 |
| 514 .. | 844-852 | 696 .. | 1334-1360 |
| 518 .. | 853-861 | 700 .. | 1361-1387 |
| 523 .. | 862-870 | 705 .. | 1388-1414 |
| 527 .. | 871-881 | 709 .. | 1415-1440 |
| 532 .. | 882-892 | 714 .. | 1441-1466 |
| 536 .. | 893-903 | 718 .. | 1467-1500 |
| 541 .. | 904-914 | 723 .. | 1501-1533 |
| 546 .. | 915-925 | 727 .. | 1534-1567 |
| 550 .. | 926-936 | 732 .. | 1568-1600 |
| 555 .. | 937-947 | 736 .. | 1601-1633 |
| 559 .. | 948-958 | 741 .. | 1634-1667 |
| 564 .. | 959-969 | 746 .. | 1668-1700 |
| 568 .. | 970-980 | 750 .. | 1701-1733 |
| 573 .. | 981-991 | 755 .. | 1734-1767 |
| 577 .. | 992-1002 | 759 .. | 1768-1800 |
| 582 .. | 1003-1012 | 764 .. | 1801-1833 |
| 586 .. | 1013-1022 | 768 .. | 1834-1867 |
| 591 .. | 1023-1032 | 773 .. | 1868-1900 |
| 596 .. | 1033-1042 | 777 .. | 1901-1933 |
| 600 .. | 1043-1052 | 782 .. | 1934-1967 |
| 605 .. | 1053-1062 | 786 .. | 1968-2000 |
| 609 .. | 1063-1071 | 791 .. | 2001-2027 |
| 614 .. | 1072-1080 | 796 .. | 2028-2054 |
| 618 .. | 1081-1089 | 800 .. | 2055-2081 |
| 623 .. | 1090-1100 | 805 .. | 2082-2107 |
| 627 .. | 1101-1111 | 809 .. | 2108-2133 |
| 632 .. | 1112-1126 | 814 .. | 2134-2167 |
| 636 .. | 1127-1141 | 818 .. | 2168-2200 |
| 641 .. | 1142-1157 | 823 .. | 2201-2233 |
| 646 .. | 1158-1173 | 827 .. | 2234-2267 |
| 650 .. | 1174-1189 | 832 .. | 2268-2300 |
| 655 .. | 1190-1205 | 836 .. | 2301-2333 |
| 659 .. | 1206-1221 | 841 .. | 2334-2367 |
| 664 .. | 1222-1237 | 846 .. | 2368-2400 |
| 668 .. | 1238-1253 | 850 .. | 2401-2433 |
| 673 .. | 1254-1269 | 855 .. | 2434-2467 |
| 677 .. | 1270-1285 | 859 .. | 2468-2500 |

5. (b) For the purpose of calculating the amount payable for water supplied by measure for industrial, commercial and rural purposes a deduction shall be made from the amount of water used in any one year of 1 kilolitre for each 7.7 cents of water rate paid in respect of that year. The charge for water used in excess of any such deduction shall be 7.7 cents for each 1 kilolitre.

6. For the purpose of calculating the amount payable for water supplied by measure a deduction of 46 kilolitres in respect of 1 water closet, 78 kilolitres in respect of 2 water closets and 96 kilolitres in respect of 3 water closets shall be made from the annual consumption measured; provided however that the total deduction allowed shall not in any case exceed 96 kilolitres.

9. (b) Standpipes

The Trust may grant supplies of water for standpipes to municipalities within its water supply area for which a charge of 6.6 cents per kilolitre with a minimum annual charge of fifteen dollars shall be payable.

9. (e) Tappings

The following charges shall be payable in respect of tapping of the Trust's mains.

(i) Cast Iron mains of all sizes under pressure—4 dollars

Cast Iron mains not under pressure:

MM

75—5 dollars 50 cents

100—5 dollars 50 cents

150—7 dollars

225—9 dollars

300—10 dollars

(ii) Asbestos cement mains under pressure:

100—8 dollars

150—8 dollars

225—10 dollars

300—10 dollars

Asbestos cement mains not under pressure:

75—5 dollars 50 cents

100—5 dollars 50 cents

150—7 dollars

225—9 dollars

300—10 dollars

- (iii) Steel mains under pressure:
 - 150 with tapping saddle—8 dollars
 - 225 with tapping saddle—8 dollars
 - 150 steel plate welded—10 dollars
 - 225 steel plate welded—10 dollars
- (iv) 40 and 50 Galvanised mains—4 dollars

The foregoing By-law was made and passed by the Geelong Waterworks and Sewerage Trust on the 20th day of June, 1973.

The common seal of the Geelong Waterworks and Sewerage Trust was hereto affixed, in the presence of—

(SEAL) R. W. WHITESIDE, Chairman.
L. W. SPRAGUE, Commissioner.
B. C. HENSHAW, Secretary.

Approved by the Governor in Council, 10th July, 1973.—
T. J. FORRISTAL, Clerk of the Executive Council.

GEELONG WATERWORKS AND SEWERAGE TRUST.

By-LAW NUMBER 127.

A By-Law to Amend Sewerage By-Law Number 97.

The Geelong Waterworks and Sewerage Trust (hereinafter called the Trust) in pursuance of and in exercise of the powers and authorities conferred on such Trust by the *Geelong Waterworks and Sewerage Act 1958*, the *Sewerage Districts Act 1958* and every other power enabling it in that behalf hereby amends Sewerage By-Law number 97 as follows:

1. Sub-Clauses 4 (c) (i), 18 (5) (a), 18 (5) (v) (a), and 18 (5) (b) (v) (c) of Sewerage By-Law number 97 are deleted and the following sub-clauses are substituted:

4 (c) (i) For the supply of a block plan, a fee of Two dollars fifty cents (\$2.50).

For tenements exceeding 400 square metres in ground floor area and/or properties exceeding 1 hectare in extent, an additional fee of One dollar twenty five cents (\$1.25) shall be charged for each additional 400 square metres, or part thereof, and/or for each additional 1 hectare, or part thereof.

18 (5) (a) In Addition to the rates normally levied by the Trust in respect of any sewered property, the occupier of any premises from which is discharged trade waste which the Trust, pursuant to the provisions of this by-law has agreed to admit into its sewers shall, unless certain agreements made hereunder with the present occupiers of certain properties abutting the Barwon River and formerly constituting the Special Areas shall otherwise provide, pay on demand the amount of 5 cents for each kilolitre so admitted, but in any case not less than the total amount of twenty dollars in any one year: Provided that where an approved meter or approved apparatus for limiting the maximum possible rate of discharge is installed on any property and is maintained at all times in an efficient working condition by the occupier a discount of 5% will be allowed for every 5% by which the ratio of the maximum hourly discharge to the mean hourly discharge is less than four to one (4 : 1): Provided however, that the allowable discount in any case shall not exceed 50 per cent. For the purposes of this sub-clause, the maximum hourly discharge shall be either that permitted by the limiting apparatus installed, or where a meter is installed calculated by averaging the maximum hourly discharge recorded by the meter in each calendar month in the period for which charge is being made, and the mean hourly discharge shall be calculated by dividing the total volume discharged in the period for which the charge is being made by 160 times the number of weeks contained in such period.

18 (5) (b) (v) (a)

(v) For the purposes of any calculation or determination to be made under this sub-clause:—

(a) where there is a common discharge of both trade waste and ordinary domestic sewage, domestic sewage shall be allowed for at the rate of

140 kilolitres per annum for each water closet on the property contributing to such discharge, and

(c) where the total quantity of water from all sources supplied to any property does not exceed 700 kilolitres per annum the assessment and charge shall be the minimum as set forth in clause 18 (5) (a) hereinbefore and no detailed measurement of effluent shall be required.

The foregoing By-law was made and passed by the Geelong Waterworks and Sewerage Trust on the 20th day of June, 1973.

R. W. WHITESIDE, Chairman.
L. W. SPRAGUE, Commissioner.
B. C. HENSHAW, Secretary.

Approved by the Governor in Council, 10th July, 1973.—
T. J. FORRISTAL, Clerk of the Executive Council.

Cemeteries Act 1958.

SCALE OF FEES OF MOONDARRA PUBLIC CEMETERY.

In pursuance of the powers conferred upon them by the *Cemeteries Act*, the trustees of the Moondarra Public Cemetery hereby make the following scale of fees, which shall come into operation upon publication in the *Government Gazette*, and from and after such publication every scale of fees heretofore made by the said trustees shall be and is hereby rescinded to the extent to which it conflicts with this scale.

Public Graves.

| | |
|---|---------|
| Interment in grave without exclusive right— | |
| stillborn child | \$7.00 |
| Interment in grave without exclusive right— | |
| others | \$14.00 |
| Number peg or label | \$3.00 |

Private Graves.

| | |
|---------------------------------------|---------|
| Land, 8 ft. x 4 ft. | \$24.00 |
| Own selection of land (extra) | \$6.00 |

Sinking Charges for Private Graves.

| | |
|--|---------|
| Sinking grave 6 feet deep | \$36.00 |
| Each additional foot | \$4.00 |
| Sinking oversize grave (extra) | \$12.00 |
| Cancellation of order to sink (if commenced) | \$6.00 |

Reopening Charges.

| | |
|--------------------------------------|---------|
| Reopening grave (no cover) | \$30.00 |
| Reopening grave (with cover) | \$35.00 |

Extra Charges.

| | |
|---|---------|
| Interment outside prescribed hours, or on Saturdays, Sundays or Public Holidays | \$12.00 |
| Interment in a private grave without due notice | \$12.00 |

Miscellaneous Charges.

| | |
|---|---------|
| Interment fee | \$12.00 |
| Certificate of Right of Burial | \$1.00 |
| Number plate or brick | \$3.00 |
| Permission to erect a headstone or monument— | |
| 5 per cent. of cost with a minimum of \$6.00. | |
| Permission to construct a brick grave or to erect any stone kerb, brick tile-work or concrete | \$5.00 |
| Exhuming the remains of a body (when authorized) | \$30.00 |
| Interment of ashes in a private grave | \$12.00 |

B. THOMSON, Trustee.
E. J. KEATING, Trustee.
A. L. VICKERY, Trustee.

Approved by the Governor in Council, 3rd July, 1973.—
T. J. FORRISTAL, Clerk of the Executive Council.

Cemeteries Act 1958.

SCALE OF FEES OF SUNBURY PUBLIC CEMETERY.

In pursuance of the powers conferred upon them by the *Cemeteries Act*, the trustees of the Sunbury Public Cemetery hereby make the following scale of fees, which shall come into operation upon publication in the *Government Gazette*, and from and after such publication every scale of fees heretofore made by the said trustees shall be and is hereby rescinded to the extent to which it conflicts with this scale.

Public Graves.

| | |
|---|---------|
| Interment in grave without exclusive right— | |
| stillborn child | \$8.50 |
| Interment in grave without exclusive right— | |
| others | \$17.00 |
| Number peg or label | \$4.00 |

Private Graves.

| | |
|---|---------|
| Land, 8 ft. x 4 ft. | \$28.00 |
| Own selection of land (extra) | \$7.00 |

Sinking Charges for Private Graves.

| | |
|--|---------|
| Sinking grave 6 feet deep | \$42.00 |
| Each additional foot | \$5.00 |
| Sinking oversize grave (extra) | \$14.00 |
| Cancellation of order to sink (if commenced) | \$7.00 |

Reopening Charges.

| | |
|--|---------|
| Reopening grave (no cover) | \$35.00 |
| Reopening grave (with cover) | \$41.00 |

Extra Charges.

| | |
|---|---------|
| Interment outside prescribed hours, or on Saturdays, Sundays or Public Holidays | \$14.00 |
| Interment in a private grave without due notice | \$14.00 |

Miscellaneous Charges.

| | |
|---|---------|
| Interment fee | \$14.00 |
| Certificate of Right of Burial | \$2.00 |
| Number plate or brick | \$4.00 |
| Permission to erect a headstone or monument—5 per cent. of cost with a minimum of \$6.00. | |
| Permission to construct a brick grave or to erect any stone kerb, brick tile-work or concrete | \$6.00 |
| Exhuming the remains of a body (when authorized) | \$60.00 |
| Interment of ashes in a private grave | \$14.00 |

H. C. RICHARDS, Trustee.
R. F. BUCKLAND, Trustee.
C. E. COOK, Trustee.

Approved by the Governor in Council, 3rd July, 1973.—
T. J. FORRISTAL, Clerk of the Executive Council.

Cemeteries Act 1958.

SCALE OF FEES OF FLINDERS PUBLIC CEMETERY.

In pursuance of the powers conferred upon them by the Cemeteries Act, the trustees of the Flinders Public Cemetery hereby make the following scale of fees, which shall come into operation upon publication in the *Government Gazette*, and from and after such publication every scale of fees heretofore made by the said trustees shall be and is hereby rescinded to the extent to which it conflicts with this scale.

Public Graves.

| | |
|--|---------|
| Interment in grave without exclusive right—stillborn child | \$8.50 |
| Interment in grave without exclusive right—others | \$17.00 |
| Number peg or label | \$4.00 |

Private Graves.

| | |
|---|---------|
| Land, 8 ft. x 4 ft. | \$28.00 |
| Own selection of land (extra) | \$7.00 |

Sinking Charges for Private Graves.

| | |
|--|---------|
| Sinking grave 6 feet deep | \$42.00 |
| Each additional foot | \$5.00 |
| Sinking oversize grave (extra) | \$14.00 |
| Cancellation of order to sink (if commenced) | \$7.00 |

Reopening Charges.

| | |
|--|---------|
| Reopening grave (no cover) | \$35.00 |
| Reopening grave (with cover) | \$41.00 |

Extra Charges.

| | |
|---|---------|
| Interment outside prescribed hours, or on Saturdays, Sundays or Public Holidays | \$14.00 |
| Interment in a private grave without due notice | \$14.00 |

Miscellaneous Charges.

| | |
|---|---------|
| Interment fee | \$14.00 |
| Certificate of Right of Burial | \$2.00 |
| Number plate or brick | \$4.00 |
| Permission to erect a headstone or monument—5 per cent. of cost with a minimum of \$6.00. | |
| Permission to construct a brick grave or to erect any stone kerb, brick tile-work or concrete | \$6.00 |
| Exhuming the remains of a body (when authorized) | \$60.00 |
| Interment of ashes in a private grave | \$14.00 |

M. HORNE, Trustee.
B. A. CAIRNS, Trustee.
B. A. TRAHAIR, Trustee.

Approved by the Governor in Council, 3rd July, 1973.—
T. J. FORRISTAL, Clerk of the Executive Council.

Cemeteries Act 1958.

SCALE OF FEES OF HAMILTON PUBLIC CEMETERY.

In pursuance of the powers conferred upon them by the Cemeteries Act, the trustees of the Hamilton Public Cemetery hereby make the following scale of fees, which shall come into operation upon publication in the *Government Gazette*, and from and after such publication every scale of fees heretofore made by the said trustees shall be and is hereby rescinded to the extent to which it conflicts with this scale.

Private Graves.

| | |
|-----------------------------|---------|
| Land, 8 ft. x 4 ft. | \$60.00 |
|-----------------------------|---------|

Sinking Charges for Private Graves.

| | |
|-------------------------------------|---------|
| Sinking grave 6 feet deep | \$52.00 |
| Sinking grave 7 feet deep | \$55.00 |

Reopening Charges.

| | |
|---|---------|
| Reopening grave (no cover) up to 6 feet | \$45.00 |
| Reopening grave (with cover or kerb) up to 6 feet | \$52.00 |
| Reopening, each additional foot | \$7.00 |

Extra Charges.

| | |
|---|---------|
| Interment on Public Holidays (extra) | \$22.00 |
| Digging fee for burial of destitute persons | \$12.00 |

Lawn Cemetery, Non-denominational.

| | |
|---|----------|
| Land, 8 ft. x 4 ft. inclusive of first interment | \$160.00 |
| Second interment in same grave | \$70.00 |
| Rectangular casket (extra) | \$7.00 |
| Exhumation fee (minimum period of two years after burial and when authorized) | \$35.00 |
| Additional fee for Saturday, Sunday and Holidays | \$22.00 |
| Late fee (for every half-hour or part thereof) | \$5.00 |
| Certificate of right of burial | \$2.00 |
| Flower container for grave | \$7.00 |

H. N. MALLINSON, Trustee.
B. V. MAYFIELD, Trustee.
R. H. DYSON, Trustee.

Approved by the Governor in Council, 3rd July, 1973.—
T. J. FORRISTAL, Clerk of the Executive Council.

Cemeteries Act 1958.

SCALE OF FEES OF SHELFORD PUBLIC CEMETERY.

In pursuance of the powers conferred upon them by the Cemeteries Act, the trustees of the Shelford Public Cemetery hereby make the following scale of fees, which shall come into operation upon publication in the *Government Gazette*, and from and after such publication every scale of fees heretofore made by the said trustees shall be and is hereby rescinded to the extent to which it conflicts with this scale.

Public Graves.

| | |
|--|---------|
| Interment in grave without exclusive right—stillborn child | \$8.50 |
| Interment in grave without exclusive right—others | \$17.00 |

Private Graves.

| | |
|---|---------|
| Land, 9 ft. x 4 ft. | \$28.00 |
| Own selection of land (extra) | \$7.00 |

Sinking Charges for Private Graves.

| | |
|--|---------|
| Sinking grave 6 feet deep | \$42.00 |
| Each additional foot | \$5.00 |
| Sinking oversize grave (extra) | \$14.00 |
| Cancellation of order to sink (if commenced) | \$7.00 |

Reopening Charges.

| | |
|--|---------|
| Reopening grave (no cover) | \$35.00 |
| Reopening grave (with cover) | \$41.00 |

Extra Charges.

| | |
|---|---------|
| Interment outside prescribed hours, or on Saturdays, Sundays or Public Holidays | \$14.00 |
| Interment in a private grave without due notice | \$14.00 |

Miscellaneous Charges.

| | |
|--|---------|
| Interment fee | \$14.00 |
| Certificate of right of burial | \$2.00 |
| Permission to construct a brick grave or to erect any stone kerb, brick tile-work or concrete or headstone | \$6.00 |
| Exhuming the remains of a body (when authorized) | \$60.00 |
| Interment of ashes in a private grave | \$14.00 |

H. M. ROSS, Trustee.
A. E. WILSON, Trustee.
J. E. BARRIE, Trustee.

Approved by the Governor in Council, 3rd July, 1973.—
T. J. FORRISTAL, Clerk of the Executive Council.

Cemeteries Act 1958.

SCALE OF FEES OF GUILDFORD PUBLIC CEMETERY.

In pursuance of the powers conferred upon them by the Cemeteries Act, the trustees of the Guildford Public Cemetery hereby make the following scale of fees, which shall come into operation upon publication in the *Government Gazette*, and from and after such publication every scale of fees heretofore made by the said trustees shall be and is hereby rescinded to the extent to which it conflicts with this scale.

| | |
|--|---------|
| <i>Public Graves.</i> | |
| Interment in grave without exclusive right— stillborn child | \$8.50 |
| Interment in grave without exclusive right— others | \$17.00 |
| Number peg or label | \$4.00 |
| <i>Private Graves.</i> | |
| Land, 8 ft. x 4 ft. | \$28.00 |
| Own selection of land (extra) | \$7.00 |
| <i>Sinking Charges for Private Graves.</i> | |
| Sinking grave 6 feet deep | \$42.00 |
| Each additional foot | \$5.00 |
| Sinking oversize grave (extra) | \$14.00 |
| Cancellation of order to sink (if commenced) .. | \$7.00 |
| <i>Reopening Charges.</i> | |
| Reopening grave (no cover) | \$35.00 |
| Reopening grave (with cover) | \$40.00 |
| <i>Extra Charges.</i> | |
| Interment outside prescribed hours, or on Satur- days, Sundays or Public Holidays | \$14.00 |
| Interment in a private grave without due notice .. | \$14.00 |
| <i>Miscellaneous Charges.</i> | |
| Interment fee | \$14.00 |
| Certificate of right of burial | \$2.00 |
| Number plate or brick | \$4.00 |
| Permission to erect a headstone or monument— 5 per cent. of cost with a minimum of \$6.00. | |
| Permission to construct a brick grave or to erect any stone kerb, brick tile-work or concrete | \$6.00 |
| Exhuming the remains of a body (when authorized) | \$60.00 |
| Interment of ashes in a private grave | \$14.00 |

R. L. SIMMS, Trustee.
J. P. DAVIS, Trustee.
A. HOLLAND, Trustee.
F. PASSALAUQA, Trustee.

Approved by the Governor in Council, 3rd July, 1973.—
T. J. FORRISTAL, Clerk of the Executive Council.

PUBLIC NOTICE.

DEPARTMENT OF AGRICULTURE.

It is hereby notified that a claim has been made against the Farm Produce Merchants and Commission Agents Guarantee Fund by a grower creditor of Philip Chen and Company, wholesale fruit and vegetable merchant, formerly operating at the Melbourne Wholesale Fruit and Vegetable Market, and in accordance with the provisions of the *Farm Produce Merchants and Commission Agents Act 1965*, all persons who as producers of farm produce have any claim against Philip Chen and Company arising from any failure of the Company to pay or account for any moneys payable to them for farm produce supplied, are invited to forward particulars and proof of such claims to the Director of Agriculture, Treasury-place, Melbourne, to be received no later than 8th August, 1973. (Postal Address, Department of Agriculture, Box 4041, G.P.O., Melbourne, Vic., 3001).

D. S. WISHART,
Director of Agriculture.

STATE RIVERS AND WATER SUPPLY COMMISSION.

LICENCE TO DIVERT WATER AND CUT RACE PURSUANT TO THE PROVISIONS OF SECTION 204 OF THE WATER ACT 1958 (AS AMENDED).

The Schedule of one Licence as detailed hereunder to divert water and cut race has been revoked by the Governor in Council.

SCHEDULE.

| Licence No. | Term of Licence and Commencing Date. | Name and Address of Person to whom Licence Granted. | Source of Supply. |
|-------------|--------------------------------------|---|-------------------|
| 3389 | Four years from 1.7.72 | Tara Syndicate, Melbourne | River Murray |

Office of the State Rivers and Water Supply Commission,
Melbourne, 3rd July, 1973.

MINISTRY OF FUEL AND POWER.

Notice.

Pipelines Act 1967, No. 7541.

APPLICATION FOR A PERMIT TO OWN AND USE A PIPELINE.

1. In accordance with the provisions of section 11 (1) of the *Pipelines Act 1967*, notice is given that an application has been received by me from the Gas and Fuel Corporation of Victoria for a permit to own and use a pipeline for the purpose of conveying natural gas from Exford to Melton.

2. The proposed route of the pipeline is as follows—a steel pipeline 8.13 km (5 miles) in length and 168 mm OD (6½ inches) and designed to operate at a maximum pressure of 2,758 kPa (400 psig) commencing at a valve on the Brooklyn-Ballararat transmission pipeline situated near the eastern boundary of allotment 16, section A, Parish of Mooradoranook; thence proceeding in a northerly direction for approximately 20 m (66 feet) to the proposed Melton metering and regulating station (City Gate); thence turning to continue in an easterly direction across Eynesbury-road to a point approximately 5 m (16 feet) within allotment 19, section A; thence turning to continue in a northerly direction parallel to Eynesbury-road across allotments 20, 21 and 22, section A; thence diverting in a north-north-easterly direction to a point approximately 290 m (951 feet) west of the Exford-road bridge, Exford, across the Werribee River; thence crossing such road to continue in a north-easterly direction across allotment A, section 16, and allotment C, section 17, to the Werribee River; thence crossing the river at a point approximately 380 m (1,247 feet) below the Melton Reservoir dam wall; thence turning to continue in a generally north-westerly direction parallel to the eastern bank of the reservoir across allotments D and C, section 4 and allotment 3, section B, Parish of Djerriwarrh to Coburns-road also known as Rees-road, Melton; thence crossing such road to enter allotment 1, section B and turn to continue in a northerly direction parallel to Coburns-road through allotments 1 and 2, section B and allotment B, section 3, crossing the Melbourne-Ballararat rail line en route; thence at a point approximately 40 m (131 feet) south of the junction of Brooklyn-avenue and Coburns-road turning to cross Coburns-road and terminate at a distribution depot owned and operated by The Colonial Gas Association Ltd. (a subsidiary of the Gas and Fuel Corporation of Victoria) and situated on lot 1, plan of subdivision No. 54125, Township of Melton, Parish of Djerriwarrh.

The proposed route of the pipeline lies wholly within an area covered by Interim Development Orders of the Melbourne and Metropolitan Board of Works and the Melton Shire Council and an Approved Planning Scheme of the Werribee Shire Council.

3. Plans of the proposed route of the pipeline may be inspected, commencing Monday, 9th July, 1973, between the hours of 10.00 a.m. and 4.00 p.m. on Mondays to Fridays (excluding public holidays) at—

- (a) Ministry of Fuel and Power, 15th Floor, 171 Flinders-street, Melbourne.
- (b) Plan Room, Gas and Fuel Corporation of Victoria, 8th floor, 171 Flinders-street, Melbourne.
- (c) Shire Offices at Werribee and Melton.

Additional copies of plans are not available from the Ministry and detailed route plans can be seen only at the Gas and Fuel Corporation's Plan Room, 8th floor, 171 Flinders-street, Melbourne.

4. Any objections to the proposed route of the pipeline must be addressed to me and reach the Office of the Ministry no later than Friday, 10th August, 1973.

9th July, 1973.

J. C. M. BALFOUR,
Minister for Fuel and Power.

G. W. LEWIS, Secretary,
State Rivers and Water Supply Commission.

Private Agents Act 1966.

NOTICE OF RECEIPT OF APPLICATION FOR LICENCES UNDER THE PROVISIONS OF THE PRIVATE AGENTS ACT 1966.

The Clerk(s) of the Magistrates' Court(s) as listed hereunder hereby give notice that applications, as under, have been lodged for hearing by the said Court(s) on the date(s) specified.

Any person desiring to object to any such applications must—

- (a) lodge with the respective Clerk of the Magistrates' Court a notice in the prescribed form of his objection and of the grounds thereof;
- (b) cause a copy of such notice to be served personally or by post upon the applicant at least three days before the hearing of the application; and
- (c) send or deliver—
 - (i) where the objection is not made by the officer in charge of the police district in which the Court is situated—a copy of the notice to such officer; and
 - (ii) where the objection is not made by the Registrar or Deputy Registrar—a copy to the Registrar.

| Full Name of Applicant or in the Case of a Firm or Corporation, of the Nominee. | Place of Abode of Applicant or Nominee. | Name of Firm or Corporation. | Address for Registration. | Type of Licence. | Date of Hearing of Application. |
|---|---|------------------------------|---------------------------|------------------|---------------------------------|
|---|---|------------------------------|---------------------------|------------------|---------------------------------|

MAGISTRATES' COURT, FITZROY.

| | | | | | |
|------------------------|----------------------------------|---------------------|----------------------------------|-------------|---------|
| Ienco, Charles Michael | 137 Barkly-street, North Fitzroy | Hershiri Electronic | 137 Barkly-street, North Fitzroy | Guard Agent | 25.7.73 |
|------------------------|----------------------------------|---------------------|----------------------------------|-------------|---------|

Dated at Fitzroy this 2nd day of July, 1973.

D. LYNCH, Clerk of the Magistrates' Court.

MAGISTRATES' COURT, MELBOURNE.

| | | | | | |
|-----------------------------------|--|--------------------------------|--|----------|--------|
| Adamson, Dale H. | 2/19 Cabena-crescent, Chadstone | Wormald International Security | 340 Abbotsford-street, North Melbourne | Watchman | 1.8.73 |
| Archer, Colin Eric | 46 Haley-street, Diamond Creek | " " " | " " " | " | " |
| Brain, George | 5 Mary-street, Hawthorn | " " " | " " " | " | " |
| Cork, Adrian John | 74 Cramer-street, Preston | " " " | " " " | " | " |
| Creasy, William James | 4 Ashe-avenue, Mitcham | " " " | " " " | " | " |
| Debenham, Lester Horry | 11/557 Glenferrie-road, Hawthorn | " " " | " " " | " | " |
| Edwards, Richard John | 33 Hazel-street, Camberwell | " " " | " " " | " | " |
| Hutcheon, Maxwell Norman | 20 Garnsworthy-street, Springvale | " " " | " " " | " | " |
| Kolar, Frank | 17 Oak-street, Hawthorn | " " " | " " " | " | " |
| Lacey, Harold Clifford | Flat 12, 82 Coorigil-road, Murrumbeena | " " " | " " " | " | " |
| Marriott, Eric Arthur Douglas | 9 Marmal-court, Tullamarine | " " " | " " " | " | " |
| McCarton, Malcolm John | 16 Fuschia-street, Ferntree Gully | " " " | " " " | " | " |
| Pile, Donald Henry | 13 Aminga-court, Croydon | " " " | " " " | " | " |
| Smith, Clive Edgar | 6/11 Maxwell-court, Moorabbin | " " " | " " " | " | " |
| Stoodley, Edward Ben | 5 Little-street, Werribee | " " " | " " " | " | " |
| Voutsas, Nikolaos | 24 Forest-street, Collingwood | " " " | " " " | " | " |
| Wellings, Wallace James | 20A Wimmera-street, Box Hill | " " " | " " " | " | " |
| Wilkinson, George Marnie Coventry | 21 Springvale-road, Springvale | " " " | " " " | " | " |

Dated at Melbourne, this 4th day of July, 1973.

G. L. WEBSTER, Clerk of the Magistrates' Court.

MAGISTRATES' COURT, COBURG.

| | | | | | |
|--------------------------|----------------------------|-------|---------------------------------|----------|---------|
| Williamson, David Walter | 175 Anderson-road, Fawkner | " " " | 94 York-street, South Melbourne | Watchman | 31.7.73 |
|--------------------------|----------------------------|-------|---------------------------------|----------|---------|

Dated at Coburg this 4th day of July, 1973.

G. G. WILLIAMSON, Clerk of the Magistrates' Court.

MAGISTRATES' COURT, MELBOURNE.

| | | | | | |
|-----------------------------|-----------------------------------|-----------------|---|----------------|--------|
| Saltearn, Thomas Edward | 59 Owens-street, Doncaster East | Brambles Brinks | Cnr. Arden and Lothian streets, North Melbourne | Watchman | 1.8.73 |
| Dowal, Robert | 76 Station-street, Melton South | " " " | " " " | " | " |
| Minns, Wayne John | Bullmans-road, Melton | " " " | " " " | " | " |
| Quartermain, Roderick Keith | Unit 1, 43A Mary-street, Hawthorn | Bailiffs Office | 223 William-street, Melbourne | Process Server | " |

Dated at Melbourne, this 5th day of July, 1973.

G. L. WEBSTER, Clerk of the Magistrates' Court.

MAGISTRATES' COURT, FERNTREE GULLY.

| | | | | | |
|------------------------|--------------------------------|-------|-------------------------------|----------------------|---------|
| Robertson, Ian Malcolm | 13 Doonbrae-avenue, Noble Park | " " " | 24 Frudal-crescent, Knoxfield | Commercial Sub-Agent | 30.7.73 |
|------------------------|--------------------------------|-------|-------------------------------|----------------------|---------|

Dated at Ferntree Gully this 6th day of July, 1973.

T. BEDOHAZY, Clerk of the Magistrates' Court.

MAGISTRATES' COURT, FRANKSTON.

| | | | | | |
|---------------------------|----------------------------|-------|----------------------------|----------------------|---------|
| Hinchcliffe, Geowal James | 5 Frank-street, Noble Park | " " " | 5 Frank-street, Noble Park | Commercial Sub-Agent | 31.7.73 |
|---------------------------|----------------------------|-------|----------------------------|----------------------|---------|

Dated at Frankston this 5th day of July, 1973.

J. DUFFY, Clerk of the Magistrates' Court.

COMPANIES ACT 1961.

Notice is hereby given in pursuance of section 308 (2) and 308 (3) of the Companies Act 1961 that at the expiration of three months from the date hereof the names of the following companies will, unless cause is shown to the contrary, be struck off the Register and the said companies will be dissolved.

Dated this 3rd day of July, 1973.

E. B. MITCHAM,
Deputy Registrar of Companies.

Companies Office,
Melbourne.

COMPANIES ABOVE REFERRED TO.

| Name of Company. | Number of Registration. |
|---|-------------------------|
| Austex Sales Company Proprietary Limited | 36029 |
| A. Bell Constructions Pty. Ltd. | 72089 |
| Castlereagh Insurance Brokers Pty. Ltd. | 91888 |
| Davie & Bottomer Proprietary Limited | 58296 |
| E.F.S. Investments Proprietary Limited | 56434 |
| Fent Textiles Proprietary Limited | 31947 |
| Norman J. Field (Holdings) Pty. Limited | 59991 |
| Finlay Bros. Holdings Proprietary Limited | 31638 |
| Hapco Proprietary Limited | 26455 |
| Daryl Humphreys & Associates Pty. Limited | 88792 |
| Marcus Financial Services Pty. Ltd. | 82240 |
| Marsal of Paris (Perfumes) Pty. Limited | 49533 |
| The Melody Music Publishing Company Proprietary Limited | 21077 |
| Nolten Proprietary Limited | 84690 |
| Pica Bros. Constructions Proprietary Limited | 51503 |
| Pinafore Motors Proprietary Limited | 69539 |
| Race International Proprietary Limited | 84143 |
| S.I.A. Mercantile Group Pty. Limited | 36817 |
| Spaulding Investments Pty. Ltd. | 77060 |
| Webb's Developments Proprietary Limited | 48307 |
| Webb's Guarantee Company Proprietary Limited | 38921 |
| Webb's Radio Pty. Ltd. | 22461 |
| Webb's Radio and Electrical Proprietary Limited | 32989 |
| Webb's Radio Investments Limited | 40669 |
| Wentworth Holdings Proprietary Limited | 58310 |
| Zareeba Holdings Proprietary Limited | 79496 |

Melbourne and Metropolitan
BOARD OF WORKS.

NOTICE TO THE OWNERS OF TENEMENTS IN THE UNDER-MENTIONED STREETS AND THE PRIVATE STREETS, LANES, COURTS AND ALLEYS OPENING THERETO.

The main pipe in the said streets being laid down, the owners of all tenements situated as under are hereby required on or before the 13th August, 1973, to cause a proper pipe and stop cocks to be laid so as to supply water within such tenements from the main pipe.

W. C. S. ELLIS,
Secretary.

3rd July, 1973.

STREET AND POSITION.

Broadmeadows.

Mickleham-road (east side), from Gladstone Park-drive northwards 230 feet.
Carrick-drive, from 100 feet north of Pyke-drive northwards 880 feet.
Henley-drive, from Carrick-drive eastwards 110 feet.
Field-court, from Carrick-drive westwards 330 feet.
Dunfield-drive, from Townsend-avenue to Carrick-drive.
Cousen-place, from Dunfield-drive northwards 400 feet.
Rodda-court, from Dunfield-drive southwards 270 feet.
Townsend-avenue, from Grentley-drive to Dunfield-drive.
Hoctor-close, from Townsend-avenue westwards 340 feet.

Dandenong.

Highland-court, from Seventh-avenue northwards 460 feet.
Aberdeen-drive, from Koonung-street southwards 120 feet.
Aberdeen-drive, from Koonung-street northwards 490 feet.
Koonung-street, from Aberdeen-drive eastwards 620 feet.
Binya-court, from Koonung-street northwards 290 feet.
Severn-court, from Koonung-street northwards 335 feet.

Doncaster and Templestowe.

Reynolds-road (south side), from Tindals-road westwards 1,520 feet.
Pambara-court, from Reynolds-road south-westwards 1,780 feet.
Greenridge-avenue, from King-street north-westwards 590 feet.
King-street, from Greenridge-avenue eastwards 370 feet.
Noral-court, from Greenridge-avenue northwards 640 feet.

Trevinden-close, from Greenridge-avenue northwards 470 feet.
Eastern-avenue, from High-street eastwards 640 feet.
Golf Hill-avenue, from Eastern-avenue southwards 830 feet.
Stutt-avenue, from High-street eastwards 560 feet.

Eltham.

Toorac-drive, from Sherbourne-road northwards and eastwards 910 feet.
Wembley-close, from Sherbourne-road northwards 640 feet.

Heidelberg.

Kylta-road, from 80 feet north of Lillimur-avenue to Northern-road.
Northern-road, from Kolora-road westwards 520 feet.
Crissane-street, from 330 feet west of Korong-road westwards 390 feet.

Kew.

High-street, from Gladstone-street to Hartington-street.
Right of Way 200 feet north-east of Gladstone-street, from High-street northwards 150 feet.

Lilydale.

Morrison-crescent, from 950 feet southwards and eastwards of Cambridge-road eastwards 200 feet.
Clancy-road, from 300 feet east of Spring-road eastwards 440 feet.

Sherbrooke.

Sherbrooke-road, from 460 feet east of Georges-road to Monbulk-road.
Kallista-Emerald-road, from Monbulk-road to Church-street.
McIntosh-road, from Church-street to Baringa-avenue.
Roberts-road, from Baringa-avenue to Kallista-Emerald road.
Grantulla-road, from Kallista-Emerald road south-eastwards 70 feet.

Sunshine.

McKechnie-street, from Andrea-street northwards 250 feet.

Waverley.

Hansworth-street, from Police-road northwards 1,340 feet.
Currie-avenue, from 50 feet east of Romilly-crescent eastwards 440 feet.
Abbeydale-court, from Hansworth-street westwards 490 feet.
Locarno-court, from Hansworth-street westwards 510 feet.
Andover-court, from Hansworth-street westwards 500 feet.

Werribee.

Linden-street, from 580 feet north of North-avenue northwards 180 feet.

LOCAL GOVERNMENT DEPARTMENT.

NOTICE OF APPROVAL OF AGREEMENT TO FORM THE WARRNAMBOOL VALUATION GROUP.

In pursuance of the provisions of section 254 (10) of the Local Government Act 1958, the Governor in Council on the 3rd day of July, 1973, approved an agreement made on the 27th April, 1973, between the Mayors, Presidents, Councillors and Ratepayers of the Borough of Koroiit, City of Warrnambool and Shires of Belfast, Minhamite and Warrnambool, to form a valuation group to be known as the Warrnambool Valuation Group, to make valuations under Part X. of the said Act for the municipalities which are members of the group.

T. J. FORRISTAL,
Clerk of the Executive Council.

At the Executive Council Chamber,
Melbourne, 3rd July, 1973.

LOCAL GOVERNMENT DEPARTMENT.

ORDER CONFIRMED.—SHIRE OF ELTHAM.

The Minister of the Crown administering the Local Government Act 1958, on the 3rd day of July, 1973, confirmed the Order hereinafter referred to in pursuance of section 514 of the said Act namely:—

An Order of the Council of the Shire of Eltham made on the 21st May, 1973, directing the compulsory taking of the balance of the land described in certificates of title, volume 8376, folio 066 and volume 8376, folio 067, for the purpose of providing a place of public resort and recreation.

A. J. HUNT,
Minister for Local Government.

Local Government Department,
Melbourne (1581315).

LOCAL GOVERNMENT DEPARTMENT.

ORDER CONFIRMED.—SHIRE OF ELTHAM.

The Minister for the Crown administering the *Local Government Act 1958*, on the 5th day of July, 1973, confirmed the Order hereinafter referred to in pursuance of section 514 of the said Act namely:—

An Order of the Council of the Shire of Eltham made on the 21st May, 1973, directing the compulsory taking of the land described hereunder for the purpose of providing a place of public resort and recreation.

All that piece of land being part of lot 8 on plan of subdivision No. 5096 lodged at the Office of Titles commencing at the north-west corner of the said lot; thence by lines bearing 109 deg. 54 min. for 441 feet; 81 deg. 21 min. for 92 feet; 180 deg. for 240 feet; 253 deg. 23½ min. for 183 ft. 7½ in.; 270 deg. for 180 feet; 306 deg. for 185 feet and 360 deg. for 320 feet to the point of commencement.

A. J. HUNT,

Minister for Local Government.

Local Government Department,
Melbourne (17413114).

LOCAL GOVERNMENT DEPARTMENT.

ORDER CONFIRMED.—CITY OF KNOX.

The Minister for the Crown administering the *Local Government Act 1958*, on the 5th day of July, 1973, confirmed the Order hereinafter referred to in pursuance of section 514 of the said Act namely:—

An Order of the Council of the City of Knox made on the 19th June, 1973, directing the compulsory taking of an easement for drainage purposes over the land described hereunder:

All that piece of land being an eight (8) foot wide strip along the western boundary of lot 119 on lodged plan No. 6712, Bayview-crescent, The Basin.

A. J. HUNT,

Minister for Local Government.

Local Government Department,
Melbourne (21813130).

LOCAL GOVERNMENT DEPARTMENT.

ORDER CONFIRMED.—CITY OF PRESTON.

The Minister for the Crown administering the *Local Government Act 1958*, on the 5th day of July, 1973, confirmed the Order hereinafter referred to in pursuance of section 514 of the said Act namely:—

An Order of the Council of the City of Preston made on the 19th March, 1973, directing the compulsory taking of lots 2736, 2737, 2738, 2739, 2740, 2741 and 2742, on plan of subdivision No. 8653, lodged at the Office of Titles, for the purpose of providing a place of public resort and recreation.

A. J. HUNT,

Minister for Local Government.

Local Government Department,
Melbourne (2971315).

LOCAL GOVERNMENT DEPARTMENT.

ORDER CONFIRMED.—CITY OF DONCASTER AND TEMPLESTOWE.

The Minister for the Crown administering the *Local Government Act 1958*, on the 5th day of July, 1973, confirmed the Order hereinafter referred to in pursuance of the provisions of section 514 of the said Act namely:—

An Order of the Council of the City of Doncaster and Templestowe made on the 12th May, 1973, directing the compulsory taking of certain land being the balance of the land described in certificate of title, volume 3388, folio 540.

A. J. HUNT,

Minister for Local Government.

Local Government Department,
Melbourne (16713130)

Melbourne Cricket Ground Act 1933 (No. 4149).

MELBOURNE CRICKET GROUND.

AMENDMENT OF REGULATION.

Whereas by section 9 of the *Melbourne Cricket Ground Act 1933 (No. 4149)*, the trustees appointed thereunder have power from time to time, with the approval of the Governor in Council, to make Regulations as therein provided, and with like approval to repeal or amend such Regulations: And whereas the said Act provides that the Regulations relating to the Metropolitan Cricket Ground in force immediately before the commencement of the said Act shall be deemed to have been made pursuant to the said Act and shall remain in force until repealed under

No. 65.—6150/73.—2

the said Act: And whereas Regulations relating to the Melbourne Cricket Ground have been made from time to time both before and after the commencement of the said Act: And whereas it is in the opinion of a statutory majority of the said trustees necessary and expedient to amend one of such Regulations: Now therefore, we, the undersigned, a statutory majority of the said trustees for the time being of the land described in the Fifth Schedule to the principal Act as enlarged, pursuant to the provisions of the Melbourne Cricket Ground Acts (Nos. 5614 and 6854), together with all improvements thereon, do by virtue of all the powers thereunto us enabling hereby amend Regulation No. 20 (as notified in the *Government Gazette* of 23rd February, 1972) by substituting therefor the following:—

Regulation 20.

The maximum scale of fees which shall be charged and collected by the trustees for admission to the Second and Fourth Divisions of the Reserve on such days as it may be set apart for cricket matches or football matches, or any other outdoor game or sports or amusements, shall (in addition to any tax payable under any law other than the said Act on or in respect of such fees or admissions) be as follows:—

- (a) For admission of every person on any such day such a sum as the trustees may from time to time determine not exceeding three dollars (\$3.00).
- (b) For a reserved seat or reserved accommodation and the booking thereof on any such day such additional sum as the trustees may from time to time determine not exceeding Fifty cents (\$0.50).

Dated at Melbourne on this 12th day of June, 1973.

G. L. CHANDLER.

L. J. HASSETT.

S. J. E. LOXTON.

R. C. STEELE, deputy for

W. J. DOWLING.

M. NATHAN.

A. E. CHADWICK.

K. H. TURNBULL.

C. E. MIDDLETON.

JOHN A. LITTLE.

P. J. KENNELLY.

L. H. S. THOMPSON.

HENRY BOLTE.

Approved by the Governor in Council, 3rd July, 1973.—
T. J. FORRISTAL, Clerk of the Executive Council.

Stamps Act 1958.

ANNUAL LICENCE.

NOTIFICATION PURSUANT TO SECTION 97.

I hereby notify that stamp duty has been paid for a licence under section 96 of the *Stamps Act* to carry on assurance and insurance business in Victoria, from 1st January, 1973, to 31st December, 1973, by the following:—

ADAM & ADAM (AUST.) PTY. LTD.

AUSTRALIAN INSURANCE BROKERS (VIC.) PTY. LTD.

C. E. HEATH UNDERWRITING (AUSTRALIA) PTY. LTD.

DOMINION INSURANCE COMPANY OF AUSTRALIA LTD.

INVINCIBLE LIFE & GENERAL INSURANCE CO. LTD.

R. M. PHIBBS,

Comptroller of Stamps.

Stamp Duties Office,

Melbourne, 11th July, 1973.

Police Regulation Act 1958, Section 122.

SALE OF UNCLAIMED MOTOR VEHICLE.

An owner is required for a green Chrysler "Royal" sedan motor vehicle, ex-registered No. (Vic.) GRV-213, engine No. KEW 2 PF5284.

The vehicle came into the possession of Police on the 1st March, 1973, and if not claimed will be sold by Public Auction at the Albert Park Police Station, corner Danks and Withers streets, Albert Park, at 2 p.m. on the 16th August, 1973.

A. L. CARMICHAEL,

Acting Chief Commissioner of Police.

Police Regulation Act 1958, Section 122.

SALE OF UNCLAIMED MOTOR VEHICLE.

An owner is required for a 1957 model, brown Holden sedan motor vehicle, registered No. (W.A.) UHU-098.

The vehicle came into the possession of Police on the 14th October, 1972, and, if not claimed, will be sold by public auction at the Ascot Vale Crime Car Squad Office, corner Union-road and Munro-street, Ascot Vale, 3032, at 2 p.m., on the 29th August, 1973.

A. L. CARMICHAEL,

Acting Chief Commissioner of Police.

Teaching Service Act 1958.

ERRATUM.

In *Government Gazette*, No. 51, of 20th June, 1973, page 2080, Teaching Service (Teachers Tribunal Elections) Regulations, paragraph (b), for "John Neil Harris" to represent technical school teachers substitute "John Neil Harris" to represent secondary school teachers

Town and Country Planning Board.
CITY OF HORSHAM PLANNING SCHEME.

NOTICE OF APPROVAL.

Erratum.

In the Notice of Approval of the City of Horsham Planning Scheme appearing on page 2202 of *Government Gazette*, No. 57, dated 27th June, 1973, the expression "in respect of part of the municipal district" appearing in the first paragraph should be amended to read "in respect of the municipal district".

W. H. CRAIG,
Secretary.

PUBLIC TRUSTEE ACT 1958 (No. 6350), SECTION 17.

I hereby give notice that on the 27th June, 1973, the Public Trustee filed elections to administer the following deceased persons' estates in accordance with section 17 of the *Public Trustee Act 1958*.

BIRD, ISABELL MARY, late of 73 Sir Garnet-road, Surrey Hills, married woman, died 7th May, 1973.

CAMPBELL, CHARLES, late of Hotel Hollyford, 650 Elizabeth-street, Melbourne, pensioner, died 11th October, 1972.

CHRISTIE, MARY AGNES, late of 'Mayflower' 7 Centre-road, East Brighton, spinster, died 21st January, 1973.

KILPATRICK, JAMES WILLIAM, also known as James Kilpatrick, late of Foster-road, Boolarra, pensioner, died 28th April, 1973.

LANE, ETHEL AGNES, late of 5 Rosslyn-street, Hawthorn, spinster, died 7th April, 1973.

LOVECKY, HENRY, late of Club Hotel, Orbost, pensioner, died 2nd April, 1973.

MARSDEN, TOM ARTHUR, late of 41 Wooddale-grove, Mitcham, retired manager, died 25th April, 1973.

RUTLEDGE, ELIZABETH ANNIE, formerly of 237 Station-street, Fairfield, but late of 12 Hanslope-avenue, Alphington, widow, died 27th March, 1973.

I hereby give notice that on the 20th June, 1973, the Public Trustee filed an election to administer the following deceased person's estate in accordance with section 17 of the *Public Trustee Act 1958*.

COVELA, JESUS LOPEZ, also known as Jesus Lopez and Jesus Lopez Cobela, late of Transfield Camp, Gove, Northern Territory, labourer, died 31st July, 1971.

N. P. BRODY,
Public Trustee.

168 Exhibition-street, Melbourne, 3000, 4th July, 1973.

NOTICE.

Creditors, next of kin, and others having claims against the estate of any of the under-mentioned deceased persons are required to send particulars of their claims to the Public Trustee, 168 Exhibition-street, Melbourne, Vic., 3000, the personal representative, on or before the 18th September, 1973, after which date the Public Trustee may convey or distribute the assets, having regard only to the claims of which the Public Trustee then has notice:—

ANDERSON, NEAL THOMAS, formerly of 18 Banool-street, East Preston, but late of Flat 3, 34 Wellington-street, St. Kilda, electrician, died 5th November, 1972.

BIRCH, HAROLD, formerly of 127 Station-street, Port Melbourne, but late of "Abbey Lodge" 645 High-street, Armadale, war pensioner, died 18th November, 1972.

BIRD, ISABELL MARY, late of 73 Sir Garnet-road, Surrey Hills, married woman, died 7th May, 1973.

BIGGS, EMILY FLORENCE, late of Ararat, spinster, died 30th January, 1973.

CAMPBELL, CHARLES, late of Hotel Hollyford, 650 Elizabeth-street, Melbourne, pensioner, died 11th October, 1972.

CHRISTIE, MARY AGNES, late of 'Mayflower' 7 Centre-road, East Brighton, spinster, died 21st January, 1973.

COVELA, JESUS LOPEZ, also known as Jesus Lopez and Jesus Lopez Cobela, late of Transfield Camp, Gove, Northern Territory, labourer, died 31st July, 1971.

DAWES, OLIVE LETITIA, late of 47 Dalny-road, Murrumbidgee, widow, died 12th March, 1973.

FITZGERALD, MARIA (better known as Marie) JOSEPHINE, formerly of 202 Park-street, West Brunswick, but late of 14 Taylor-street, East Brighton, spinster, died 13th April, 1973.

HALL, GEORGE ALEXANDER, late of Broken Hill, New South Wales, bus proprietor, died 10th July, 1972.

HEYWARD, MARGARET JANE, also known as Margaret Jane Heywood, formerly of 1 Fulton-street, East St. Kilda, but late of Caulfield Hospital, 294 Kooyong-road, Caulfield, widow, died 9th April, 1972.

KILPATRICK, JAMES WILLIAM, also known as James Kilpatrick, late of Foster-road, Boolarra, pensioner, died 28th April, 1973.

LANE, ETHEL AGNES, late of 5 Rosslyn-street, Hawthorn, spinster, died 7th April, 1973.

LOVECKY, HENRY, late of Club Hotel, Orbost, pensioner, died 2nd April, 1973.

MARSDEN, TOM ARTHUR, late of 41 Wooddale-grove, Mitcham, retired manager, died 25th April, 1973.

MARSHALL, THOMAS ANDREAS, late of 61 Park-street, South Melbourne, retired clerk, died 12th April, 1973.

PARRY, MABEL ETHEL, late of 177 Hudson-road, Spotswood, widow, died 14th February, 1973.

RUTLEDGE, ELIZABETH ANNIE, formerly of 237 Station-street, Fairfield, but late of 12 Hanslope-avenue, Alphington, widow, died 27th March, 1973.

SKARDON, EDNA LOUISA, formerly of 104 Melville-road, West Brunswick, but late of 77 Balmoral-avenue, Pascoe Vale South, spinster, died 18th October, 1972.

N. P. BRODY,
Public Trustee.

Melbourne, 4th July, 1973.

CONTRACTS ACCEPTED.—(Series 1972-73.)

STATE RIVERS AND WATER SUPPLY COMMISSION.

1329. Construction of brick veneer residence, at Bamawm, \$17,215.—R. Holden.

Sealed by Commission, 3rd January, 1973.

1330. Investigation and design of Dartmouth Dam, \$1,177,600.—Snowy Mountains Engineering Corporation.

Sealed by Commission, 17th January, 1973.

1331. Construction of brick veneer residence at Benjeroop (Kerang), \$18,462.—T. J. & W. P. Laursen.

1332. Construction of office, kitchen and messes, health centre and shopping centre, Dartmouth Township, \$260,920.—Bruni & Bisogni Pty. Ltd.

1333. Construction of testing laboratory, fire, police and ambulance stations, public hall, sports pavilions and bus shelter, Dartmouth Township, \$222,593.—Bruni & Bisogni Pty. Ltd.

Sealed by Commission, 5th February, 1973.

1334. Supply, delivery and installation of twin submersible pumpsets for sewage manhole pumping station, Dartmouth Township, \$7,539.—Trans Australasia Services & Construction Pty. Ltd.

Sealed by Commission, 12th February, 1973.

1335. Construction of roads, storm water drainage, sewerage and water supply reticulation, landscaping, Dartmouth Township, \$589,828.—E. B. Mawson & Sons Pty. Ltd.

Sealed by Commission, 20th February, 1973.

1336. Construction of 10 brick veneer houses and a 19-room timber hostel, Dartmouth Township, \$324,355.—R. & G. F. Zauner.

Sealed by Commission, 22nd February, 1973.

1337. Construction of excavated storage, 22 million gallons, at Port Campbell, \$137,592.—Wal Henning Earthworks Pty. Ltd.

Sealed by Commission, 26th February, 1973.

1338. Supply, delivery, erection and repair of fencing at Beaconsfield Reservoir, Bittern Reservoir, Carrum Downs and Langwarrin, \$4,328.—Austral Wire Fence & Gate Co. Pty. Ltd.

Sealed by Commission, 5th March, 1973.

1339. Supply, delivery, installation and testing of 246,205 lineal feet (75,043 metres) of 12 in. pipeline and fittings, Millewa Pipeline Stage 3, \$383,744.—Macmahon Construction Pty. Ltd.

1340. Making of 16-mm. motion picture colour sound film of 30 minutes duration on Dartmouth Dam Project, \$23,850.—Kestrel Film Productions Pty. Ltd.

Sealed by Commission, 19th March, 1973.

1341. Grout filling of 2,468 feet of abandoned 21-in. wood main, Noble Park, \$10,131.—Cementation Coy. (Aust.) Ltd.

1342. Construction of brick pumphouse, at Flora Hill, Bendigo, \$9,250.—G. B. Lee.

Sealed by Commission, 2nd April, 1973.

1343. Supply, erection and protective coating of a 300,000-gallon steel storage tank, South Otway Pipeline Project, \$28,454.—Stothert & Pitt (Bayswater) Pty. Ltd.

Sealed by Commission, 16th April, 1973.

1344. Sand or grit blasting, metal spraying and/or painting of interior, together with exterior coating repair of 2 steel storage tanks—(a) 500,000-gallon tank, at St. Leonards; (b) 800,000-gallon tank, at Clifton Springs, \$66,877.—Gardner Bros. (Vic.) Pty. Ltd.

Sealed by Commission, 19th April, 1973.

1345. Construction of diversion tunnel, intake shaft, valve chamber and access tunnel, Dartmouth Dam, \$4,312,294.—Thiess Bros. Pty. Ltd.

Sealed by Commission, 16th May, 1973.

1346. Supply of steel pipes, 42-in. I.D., for Tarago, Westernport Pipeline, 5,250 pipes (40 miles), \$4,132,590.—Steel Mains Pty. Ltd.

1347. Supply of steel pipes, 18-in. I.D., for South Otway Pipeline, 2,288 pipes (13 miles), \$437,169.—Steel Mains Pty. Ltd.

Sealed by Commission, 28th May, 1973.

1348. Supply, delivery, installation and testing of 138,974 lineal feet (42,359 metres) of 8 in. to 1½ in. diameter pipe and fittings, Millewa Waterworks District, Contract No. 1, \$227,618.—Macmahon Construction Pty. Ltd.

1349. Supply, delivery, installation and testing of 63,302 lineal feet (19,295 metres) of 4 in. to 2 in. diameter pipe and fittings, Millewa Waterworks District, Contract No. 2, \$62,600.—Macmahon Construction Pty. Ltd.

1350. Construction of brick toilet block, dressing shed and launching ramp, Lake Eppalock, \$9,410.—R. L. House.

Sealed by Commission, 30th May, 1973.

1351. Construction of internal roads at Frankston Storeyard, \$19,089.—Paoletti Bros. Pty. Ltd.

Sealed by Commission, 31st May, 1973.

1352. Construction of earthen storage, at Lalbert, involving about 14,860 cubic yards (10,825 cubic metres) of excavation, \$5,358.—A. D. Hillgrove.

1353. Welding approximately 25,200 feet (8,966 metres) of 42 inch (1,050 mm) diameter cement-lined steel pipe, Tarago—Westernport Pipeline, \$16,327.—Samirlin Welding Services.

1354. Supply, erection, protective coating and testing of steel storage tank, 250,000 gallons, at Dromana, \$32,940.—J. F. Thomson Pty. Ltd.

1355. Cleaning of 20,000 chains (449,856 metres) of earthen channels in the Millewa Waterworks District, \$17,376.—A. D. Hillgrove.

1356. Erection of toilet block—dressing shelter and fuel store, at Waranga Reservoir, \$6,193.—H. Lloyd.

1357. Construction of mechanical workshop, office and services block, Dartmouth, \$35,742.—Bruni & Bisogni Pty. Ltd.

Sealed by Commission, 20th June, 1973.

CONTRACTS ACCEPTED.—(Series 1973-74.)

VICTORIAN RAILWAYS.

3. Manufacture, supply and delivery of steel re-inforcement for tunnel construction work associated with the Melbourne Underground Rail Loop Connexions, at rates (Contract No. 63901).—Dominion Reinforcements Division of Humes Limited. 4. Cartage services as required, during the period 1st July, 1973, to 30th June, 1975, at rates (Contract No. 63928).—Mayne Nickless Limited. 5. Cartage services as required during the period 1st July, 1973, to 30th June, 1975, at rates (Contract No. 63918).—Fleetexpress (The Transport Division of Fleetways Holdings Limited). 6. Supply and delivery of bread and bread rolls as required during the period 1st July, 1973, to 30th June, 1975, at rates (Contract No. 63913).—Sunicrust Bakeries Pty. Ltd.

C. S. MORRIS, Secretary. 6.7.1973.

ORDERS IN COUNCIL.—(Series 1973-74.)

PUBLIC WORKS.

130. Geelong East, Technical School, supply of a sheet-metal forming machine, \$4,385.00.—Norman N. Benson & Co. Pty. Ltd.—(P.W.63288j).

Approved by the Governor in Council, 3rd July, 1973.—T. J. FORRISTAL, Clerk of the Executive Council.

APPOINTMENTS AND RESIGNATIONS

APPOINTMENTS.

His Excellency the Governor of the State of Victoria, by and with the advice of the Executive Council thereof, has, by Orders made on the 3rd day of July, 1973, been pleased to make the under-mentioned appointments, viz.:

CHIEF SECRETARY'S DEPARTMENT.

Members of Premiums Committee.

LESLIE WILLIAM CARVER,
the person for the time being holding the office of Insurance Commissioner,

NORMAN ERIC MUTTON, and
DOUGLAS ALBERT HODGMAN,
persons representing the interests of authorized insurers,

KEITH WESTBURY BEISSEL, and
DAVID CLAUDE TOWNSEND ROBERTSON,
persons representing the interests of owners of motor cars,

pursuant to the provisions of the *Motor Car Act 1958*, to be members of the Premiums Committee, for the period ending 23rd June, 1976.

MINISTRY OF HEALTH.

Members of Committees of Management of Hospitals.

ERNEST JOHN ROBBINS
to be Government Appointee on Committee of Management of Colac District Hospital, reappointed for a period of three years commencing the 7th July, 1973, pursuant to the provisions of sub-paragraph (ii) of paragraph (a) of the proviso to sub-section (1) of section 48 of the *Hospitals and Charities Act 1958*; and

GEORGE STEPHEN MITCHELL
to be Government Appointee on Committee of Management of Donald District Hospital, reappointed for a period of three years commencing the 26th July, 1973, pursuant to the provisions of sub-paragraph (ii) of paragraph (a) of the proviso to sub-section (1) of section 48 of the *Hospitals and Charities Act 1958*.

Official Visitor.

ROLAND McNAUGHTON BRAZIER
to be Official Visitor, Mental Hospital and Children's Cottages, Kew, pursuant to section 66 of the *Mental Health Act 1959*, for the remainder of the period ending 31st October, 1977, *vice* Mr. W. D. Birrell, resigned.

Trustee of Cemetery.

STUART FRASER
to be a Trustee of the Natta Yallock Public Cemetery, additional trustee, pursuant to section 3 (1) of the *Cemeteries Act 1958*.

Public Vaccinator.

THOMAS DESMOND HOBAN, M.B., B.S.,
to be Public Vaccinator for the municipality of the Shire of Whittlesea, pursuant to section 151 of the *Health Act 1958*.

LAW DEPARTMENT.

Commissioners for Taking Declarations, &c.

HOWARD JOHN MITCHELL, 33 Nottingham-street, Glen Waverley,

JOHN HAMILTON BARNIER, 127 North-road, Brighton,
TERENCE JAMES LYNCH, 10 Manooka-court, Noble Park,
KATHLEEN KRUSS, care of Wodonga District Hospital,
132 Brockley-street, Wodonga,

HERBERT MAURICE MARSHALL, 33 Kent-road, Surrey Hills,

PATRICIA MARGARET GULLEY, 26 Rowan-street, Doncaster East,

JAMES JOSEPH HAWE, 27 Rob Roy-road, Chadstone,
GERALD JOSEPH QUIGLEY, 8/18 Roselea-street, South Caulfield, and

GIUSEPPE TODARO, 113 Rushall-crescent, North Fitzroy, to be Commissioners for taking Declarations and Affidavits under the *Evidence Act 1958*.

Deputy Prothonotary.

ROBERT JOHN CUTHILL

to be Deputy Prothonotary at Horsham, vice P. W. Westmore, transferred, to take effect as from the 24th July, 1973.

Justices of the Peace.

CHARLES GILBERT SEARIES, care of Postmaster-General's Department, 374 Bourke-street, Melbourne,
GRAEME LAWRENCE ELVEY, Shire Office, Marong, and
LASZLO BENYEI, 39 Barnard-grove, North Kew, to keep the Peace in the State of Victoria.

SOCIAL WELFARE DEPARTMENT.

Special Magistrates.

DAVID WATKINS DE GRAAFF,
RAYMOND GORDON PEEBLES, and
MARTIN SIEGFRIED SCHMIDT,
pursuant to the provisions of section 24 (1) of the *Social Welfare Act 1970*, to be Special Magistrates.

DEPARTMENT OF THE TREASURER.

Collector of Imposts.

HECTOR SHEAHAN
to be Collector of Imposts, Transport Regulation Board, vice A. V. C. Cook, transferred.

Collectors of Imposts (Acting).

EDWARD NORMAND MANSFIELD
to act temporarily as Collector of Imposts, Workers Compensation Board, vice A. J. Wenn, promoted;

RUSSELL GARNER FRENCH
to act temporarily as Collector of Imposts, Lands Department, vice A. L. Peverill, on leave;

VINCENT THOMAS HARVEY
to act temporarily as Collector of Imposts, Law Department, vice D. W. Neville, promoted.

T. J. FORRISTAL,
Clerk of the Executive Council.

At the Executive Council Chamber,
Melbourne, 3rd July, 1973.

Vermin and Noxious Weeds Act 1958.

APPOINTMENT OF INSPECTOR.

It is hereby notified that the Public Service Board in exercise of its powers has appointed the undermentioned person as an Inspector under the provisions of section 4 of the *Vermin and Noxious Weeds Act 1958*, without additional salary:

CYRIL RAYMOND GILBY.

A. C. ALLEN,
Acting Secretary for Lands.

Melbourne, 9th July, 1973.

BAILIFFS OF CROWN LANDS.

His Excellency the Governor of the State of Victoria by and with the advice of the Executive Council thereof doth by Order made on the 3rd day of July, 1973; and pursuant to the provisions of section 30 of the *Land Act 1958* appoint—

DESMOND HENRY BOYD,
FRANK CHARLES BANCROFT,
PETER WILLIAM MORRIS,
ERIC HADLOW BAKER, and
NORMAN WILLIAM WITTICK,
as Bailiffs of Crown Lands, with respect to the reserved Crown lands in the Township of Rosebud and the Parish of Wannaeue as are indicated by red color on plan marked

"A/11.2.1937" attached to Lands Department correspondence Rs.3351, known as the "Rosebud Foreshore Reserve", and with authority to discharge and exercise all the duties and powers of bailiffs.

T. J. FORRISTAL,
Clerk of the Executive Council.

At the Executive Council Chamber,
Melbourne, 3rd July, 1973.

FORESTS DEPARTMENT.

APPOINTMENT OF COMMITTEE OF MANAGEMENT OF "LERDERDERG GORGE FOREST PARK".

Whereas by section 50 of the *Forests Act 1958* (No. 6254), it is provided that the Minister of Forests may, on the recommendation of the Forests Commission, appoint any number of persons not less than three to be a Committee of Management of any land forming part of any reserved forest, such land being set aside as a forest park, and may remove any of those persons: Now therefore, I, Frederick James Granter, Her Majesty's Minister of Forests for the State of Victoria, on the recommendation of the Forests Commission, do hereby appoint—

ALAN WALLACE BYRNES,

as an additional member of the Committee of Management until the 5th day of June, 1975, of the land forming part of the reserved forest in the Parishes of Blackwood, Coimadai, Coornmill and Myrmiong, County of Bourke, described in the accompanying Schedule, and known as the "Lerderderg Gorge Forest Park".

SCHEDULE ABOVE REFERRED TO.

Parishes of Blackwood, Coimadai, Coornmill and Myrmiong, County of Bourke, containing 9,930 acres, more or less, being the area shown by yellow and red borders on the plan marked A67/1020 over 25.1.63, on file of correspondence No. 67/1020 of the Forests Department.

Dated at Melbourne, the second day of July, 1973.

F. J. GRANTER,
Minister of Forests.

Liquor Control Act 1968.

APPOINTMENT OF LICENSING INSPECTORS.

In accordance with the authority conferred upon me by section 6 of the *Police Regulation Act 1958*, I, Angus Lindsay Carmichael, Deputy Commissioner of Police, do hereby appoint under subsection (1) of section 22 of the *Liquor Control Act 1968*, the following Officers of Police as Licensing Inspectors for the Divisions of the Police Districts as shown:—

| Division Number. | Police District. | Rank and Name. |
|------------------|------------------|--|
| 1 | Henty | Inspector George Frederick Earl (from 1.7.73 to 8.7.73). |
| 2 | Westernport .. | Inspector John Augustus Costelloe (from 8.7.73 to 28.7.73). |

A. L. CARMICHAEL,
2.7.1973. Deputy Commissioner of Police.

REVOCATION OF APPOINTMENTS.

His Excellency the Governor of the State of Victoria, by and with the advice of the Executive Council thereof, has, by Orders made on the 3rd day of July, 1973, revoked the appointments of the persons named hereunder of the offices mentioned, viz.:—

CROWN LANDS AND SURVEY DEPARTMENT.

Bailiff of Crown Lands.

HENRY JOHN SUTCLIFFE,
a bailiff of Crown lands with respect to the Royal Botanic Gardens (Melbourne), pursuant to section 30 (1) of the *Land Act 1958*.

SOCIAL WELFARE DEPARTMENT.

Honorary Probation Officers.

JOYCE COPEMAN LEMAN,
FLORENCE ELIZABETH McCRAE, (Mrs.), and
KEITH OTTO DOUGLAS NAGEL, (Rev.),
Honorary Probation Officers pursuant to the provisions of section 507 (2) of the *Crimes Act 1958* and section 10 (1) of the *Children's Court Act 1958* for all Adult and Children's Courts in Victoria.

T. J. FORRISTAL,
Clerk of the Executive Council.
At the Executive Council Chamber,
Melbourne, 3rd July, 1973.

RESIGNATIONS.

His Excellency the Governor of the State of Victoria, by and with the advice of the Executive Council thereof, has, by Orders made on the 3rd day of July, 1973, accepted the resignations of the persons named hereunder of the offices mentioned, viz.:—

LAW DEPARTMENT.
Justices of the Peace.

JOHN HAROLD BARTLETT BINDON,
KENNETH GRAHAM LEE, and
JAMES REGINALD RAE LINDSEY,
as Justices of the Peace for the State of Victoria.

T. J. FORRISTAL,
Clerk of the Executive Council.

At the Executive Council Chamber,
Melbourne, 3rd July, 1973.

ORDERS IN COUNCIL

COUNTRY ROADS BOARD.

At the Executive Council Chamber, Melbourne, the
third day of July, 1973.

PRESENT:

His Excellency the Governor of Victoria.
Mr. Dickie | Mr. Dunstan.

**ORDER APPROVING OF LAND BEING ACQUIRED AND
ROADS, DEVIATIONS OR WIDENINGS BEING MADE.**

His Excellency the Governor of the State of Victoria, by and with the advice of the Executive Council thereof, being satisfied that there are funds legally available for acquiring the land, doth hereby approve the acquiring of the land described in the schedule hereunder and the making of new roads and deviations from and widenings of existing roads referred to in the said schedule.

SCHEDULE.
Freeway.

The land shown hatched on plan numbered G.P.13335 hereunder required for the making of a new freeway (Greensborough Freeway) in the Shire of Diamond Valley.

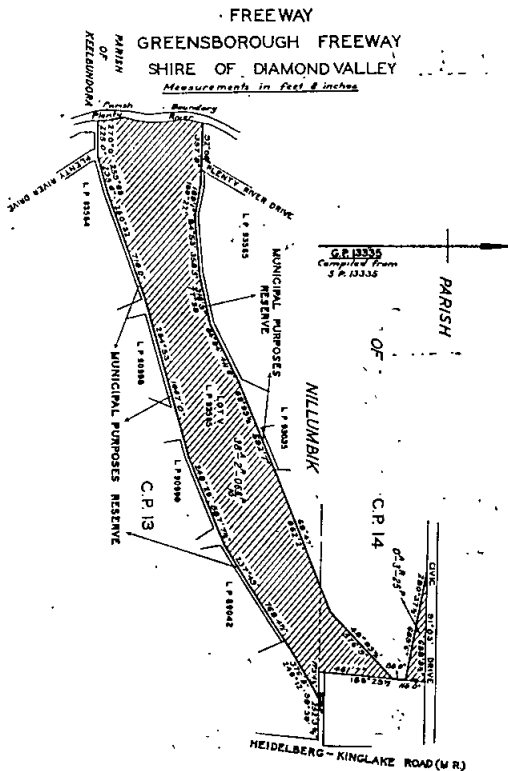

Forest Road.

The land shown hatched on plan numbered G.P.13081 hereunder required for the deviation from the Bairnsdale-Dargo road in the Shire of Bairnsdale and making of the deviation thereon.

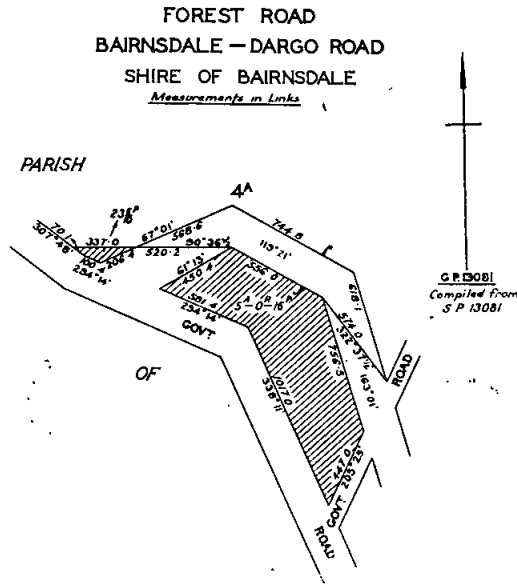

And the Honorable Edward Raymond Meagher, Her Majesty's Minister of Transport for the State of Victoria, shall give the necessary directions herein accordingly.

T. J. FORRISTAL,
Clerk of the Executive Council.

DEPARTMENT OF CROWN LANDS AND SURVEY.

At the Executive Council Chamber, Melbourne, the
third day of July, 1973.

PRESENT:

His Excellency the Governor of Victoria.
Mr. Dickie | Mr. Dunstan.

**REVOCATION OF TEMPORARY RESERVATIONS OF
LANDS BY ORDERS IN COUNCIL.**

His Excellency the Governor of the State of Victoria, by and with the advice of the Executive Council thereof, doth hereby, in pursuance of the provisions of the Land Act 1958, revoke the temporary reservations of lands by Orders in Council hereinafter described, viz.:

DRUMANURE.—The temporary reservation and the withholding from sale leasing and licensing by Order in Council of the 16th April, 1883 of 5 acres of land in the Parish of Drumanure as a site for Public purposes (State School).—(D.183⁽⁴⁾) (Rs.7101).

REDBANK.—The temporary reservation by Order in Council of the 27th February, 1909 of 17 acres 2 roods 4 perches of land in the Parish of Redbank as a site for Supply of Gravel.—(R.49⁽³⁾) (Rs.6427).

TYNTYNDER NORTH.—The temporary reservation by Order in Council of the 4th December, 1923, of 1 acre 2 roods 16 perches of land in the Parish of Tyntynder North as a site for Municipal purposes.—(T.244⁽¹³⁾) (Rs.2868).

And the Honorable James Charles Murray Balfour, Her Majesty's Acting Minister of Lands for the State of Victoria, shall give the necessary directions herein accordingly.

T. J. FORRISTAL,
Clerk of the Executive Council.

DEPARTMENT OF CROWN LANDS AND SURVEY.

At the Executive Council Chamber, Melbourne, the third day of July, 1973.

PRESENT:

His Excellency the Governor of Victoria.
Mr. Dickie | Mr. Dunstan.

LANDS TEMPORARILY RESERVED AS SITES.

His Excellency the Governor of the State of Victoria, by and with the advice of the Executive Council thereof, doth hereby, in pursuance of section 14 of the *Land Act 1958*, reserve temporarily from sale, from being leased and from having a licence granted in respect thereof, and also except from occupation for mining purposes under any miner's right, the land hereinafter described:—

SANDHURST (BENDIGO).—Site for Public purposes (Children's Playground) 782 square metres, at Bendigo, Parish of Sandhurst, County of Bendigo, as indicated by hatching on plan hereunder.—(S.372⁽¹²⁵⁾) (Rs.9749).

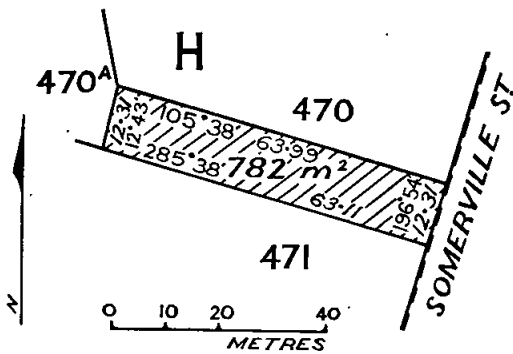

BUNINYONG.—Site for Public purposes (Public Recreation and Cultural purposes) 1.432 hectares, Township of Buninyong, Parish of Buninyong, County of Grant as indicated by hatching on plan hereunder.—(B.501⁽²⁾) (Rs.9692).

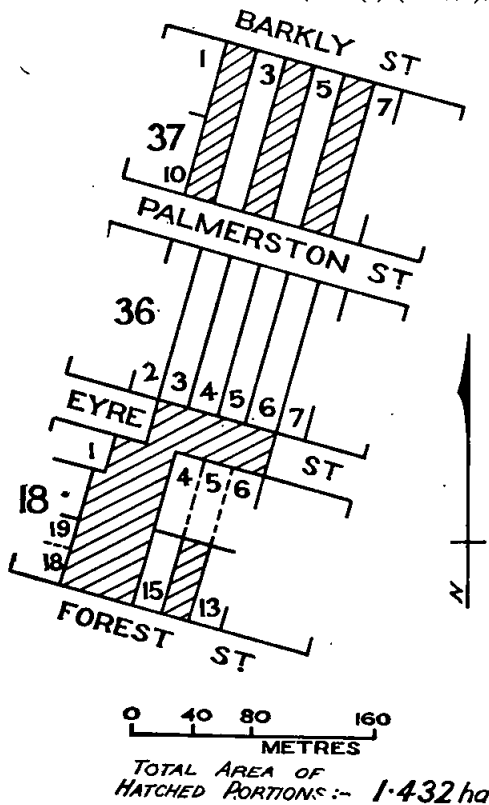

TOTAL AREA OF HATCHED PORTIONS:— 1.432 ha

KANGAROO FLAT.—Site for Public purposes (Park and Drainage Works) 4 acres 1 rood 18 perches, more or less, Township of Kangaroo Flat, Parish of Sandhurst, County of Bendigo as indicated by hatching on plan hereunder.—(K.217⁽²⁾) (Rs.9605).

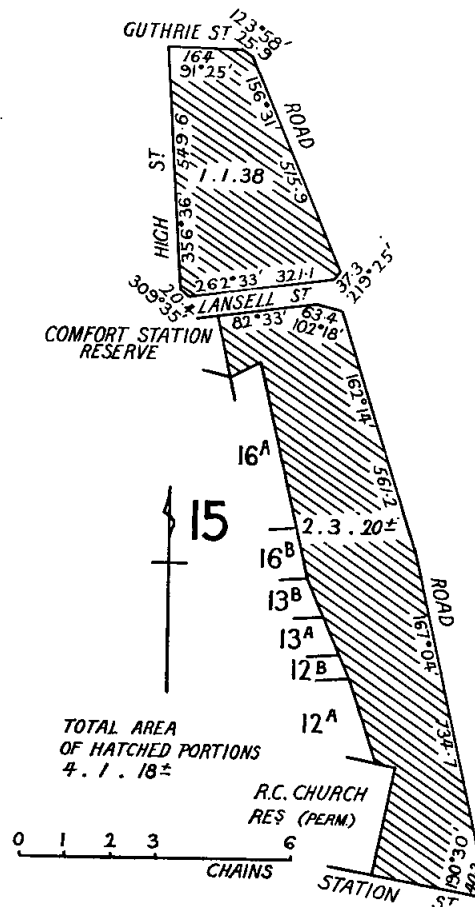

KEELBUNDORA (GREENSBOROUGH).—Site for Public purposes (Public Buildings) 2 roods 27 perches, Parish of Keelbundora, County of Bourke as indicated by hatching on plan hereunder.—(K.25⁽⁶⁾) (Rs.9745).

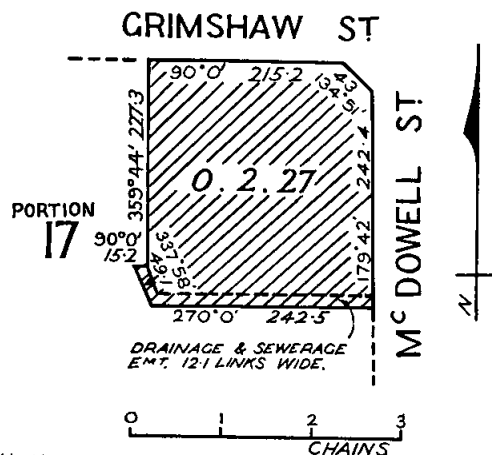

KOORANGIE.—Site for Public purposes, 29 acres, more or less, Parish of Koorangie, County of Tatchera, as indicated by hatching on plan hereunder.—(K.188⁽¹⁾) (Rs.8109)

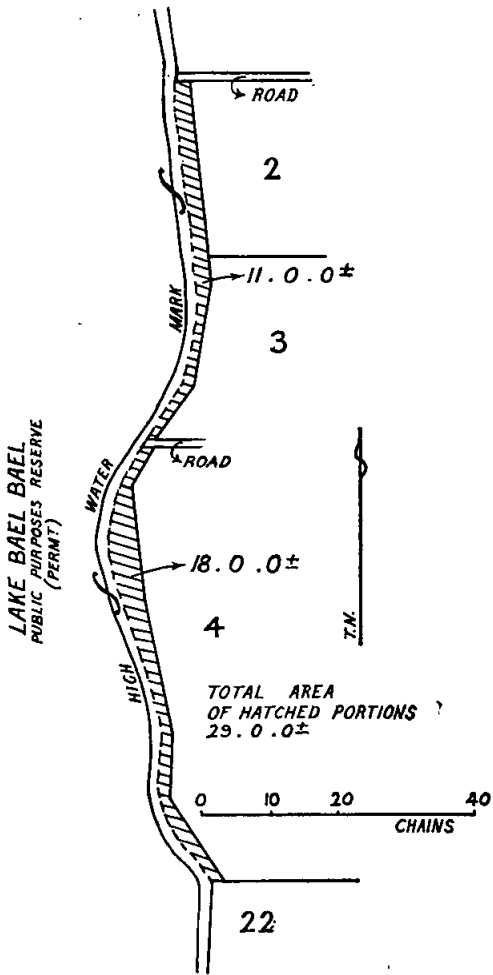

LONGWARRY.—Site for State School purposes, 3,800 square metres, more or less, Parish of Longwarry, County of Mornington, as indicated by hatching on plan hereunder.—(L.162⁽¹⁾) (Rs.9751).

MARYBOROUGH.—Site for Public purposes (Soil Conservation Authority purposes), 557 square metres, Parish of Maryborough, County of Talbot as indicated by hatching on plan hereunder.—(M.66⁽¹⁸⁾) (Rs.9748).

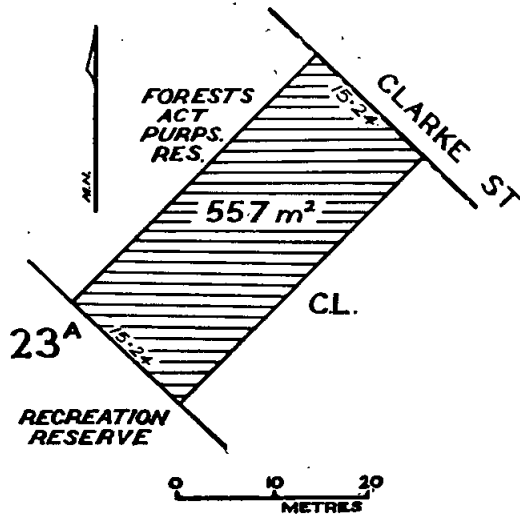

WARRNAMBOOL.—Site for Public purposes (Departmental Residence) 613 square metres, Township of Warrnambool, Parish of Wangom, County of Villiers, as indicated by hatching on plan hereunder.—(W.99⁽⁸⁾) (Rs.9747).

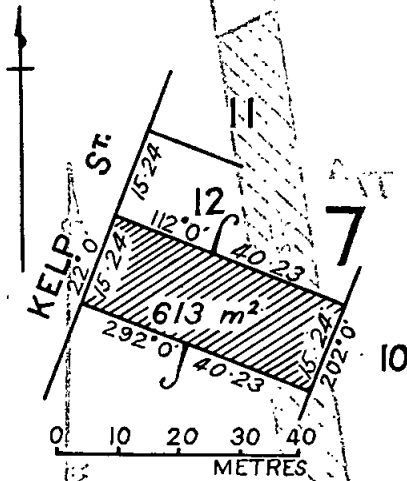

WARUNG.—Site for Public Recreation purposes, 3,500 square metres, more or less, Parish of Warung, County of Borung, as indicated by hatching on plan hereunder.—(W.405⁽³⁾) (Rs.9746).

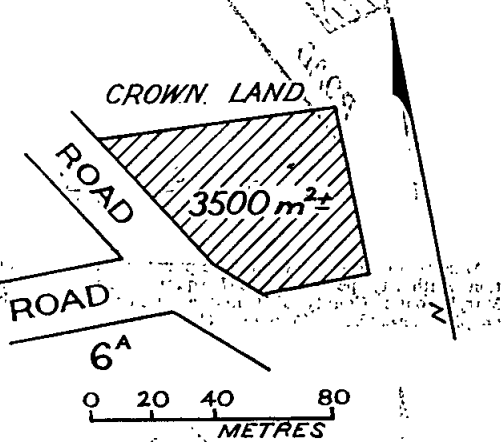

And the Honorable James Charles Murray Balfour, Her Majesty's Acting Minister of Lands for the State of Victoria, shall give the necessary directions herein accordingly.

T. J. FORRISTAL,
Clerk of the Executive Council.

LAND ACT 1958

At the Executive Council Chamber, Melbourne, the third day of July, 1973.

PRESENT:

His Excellency the Governor of Victoria
Mr. Dickie | Mr. Dunstan

UNUSED ROAD CLOSED.

In pursuance of the provisions of section 349 of the Land Act 1958, His Excellency the Governor of Victoria, by and with the advice of the Executive Council thereof and the concurrence in writing of the Council of the Municipality concerned doth hereby close the unused road referred to hereunder, viz.:

Township of Cowes, Parish of Phillip Island, County of Mornington—being parts of the road indicated by hatching on plan hereunder.—(C.443⁽⁴⁾) (Rs.5133A).

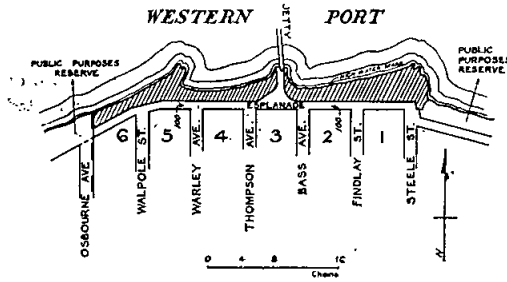

And the Honorable William Archibald Borthwick Her Majesty's Minister of Lands for the State of Victoria, shall give the necessary directions herein accordingly.

T. J. FORRISTAL,
Clerk of the Executive Council.

LOCAL GOVERNMENT DEPARTMENT.

At the Executive Council Chamber, Melbourne, the third day of July, 1973.

PRESENT:

His Excellency the Governor of Victoria.
Mr. Dickie | Mr. Dunstan

APPOINTMENT OF MEMBERS OF THE MUNICIPAL VALUATION FEES COMMITTEE.

Pursuant to the provisions of section 254 (6A) of the Local Government Act 1958, His Excellency the Governor of the State of Victoria, by and with the advice of the Executive Council thereof, hereby appoints the following persons to be members of the Municipal Valuation Fees Committee for the periods specified hereunder and such persons, together with the Valuer-General who shall be chairman shall form the said Committee:—

- (a) Ebenezer William Giles, one of three persons whose names were submitted by the governing body of the Municipal Association of Victoria, for a period ending the 20th day of May, 1974.
- (b) John Clarence Burnham, one of six persons whose names were submitted by the governing body of the Victorian Division of the Commonwealth Institute of Valuers, for a period ending the 24th day of June, 1976.

And the Honorable Alan John Hunt, Her Majesty's Minister for Local Government for the State of Victoria, shall give the necessary directions herein accordingly.

T. J. FORRISTAL,
Clerk of the Executive Council.

LOCAL GOVERNMENT DEPARTMENT.

At the Executive Council Chamber, Melbourne, the third day of July, 1973.

PRESENT:

His Excellency the Governor of Victoria.
Mr. Dickie | Mr. Dunstan

ROAD DISCONTINUED.—CITY OF OAKLEIGH.

Whereas it is provided in section 528 (2) of the Local Government Act 1958, that where a road (whether or not a public highway but not being a road set out on land of the Crown) or any part thereof is not required for public use, the Governor in Council, on the request of the Council of the municipality in which such road is situated made not less than one month after publishing in a newspaper generally circulating in the district and posting to the registered proprietor (if any) of the land and the owner and occupiers (if any) of lands abutting or immediately adjacent to the road notice of intention to make such request may by Order published in the Government Gazette direct that such road or part shall be discontinued and thereupon such road or part shall be discontinued accordingly.

And whereas the Council of the City of Oakleigh has requested that the Governor in Council direct that portion of a road off Burlington-street, Oakleigh, be discontinued and not less than one month previously has published in a

newspaper generally circulating in the district and posted to the registered proprietor of the land in the road and to the owners and occupiers of lands abutting or immediately adjacent to the road notice of intention to make such request.

Now therefore, His Excellency the Governor of the State of Victoria, by and with the advice of the Executive Council thereof, hereby directs that the said portion of road, which is shown by hachure on the plan hereunder, shall be discontinued and that the land may be sold by the Council of the City of Oakleigh by agreement.

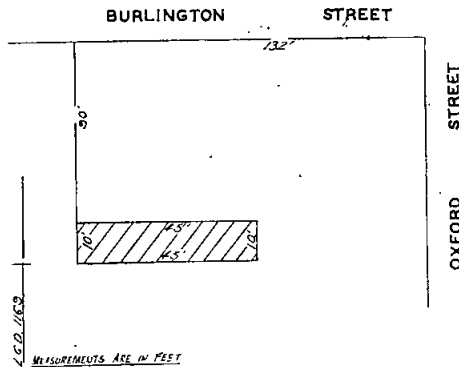

And the Honorable Alan John Hunt, Her Majesty's Minister for Local Government for the State of Victoria, shall give the necessary directions herein accordingly.

T. J. FORRISTAL,
Clerk of the Executive Council.

LOCAL GOVERNMENT DEPARTMENT.

At the Executive Council Chamber, Melbourne, the third day of July, 1973.

PRESENT:
His Excellency the Governor of Victoria.
Mr. Dickie | Mr. Dunstan.

APPROVAL OF RATING AGREEMENT BETWEEN THE BOROUGH OF EAGLEHAWK AND TONY TUCKS WINDOWS AND BUILDING SUPPLIES.

Whereas—

- (a) Tony Tucks Windows and Building Supplies is liable to be rated in respect of certain land being Crown allotment 259b, section M, Parish of Sandhurst and has established a joinery factory on the said land, which land is not within the metropolitan area within the meaning of the *Town and Country Planning Act 1961*;
- (b) The Council of the Borough of Eaglehawk is of the opinion that the establishment and maintenance of the industry within the municipality is making and will continue to make a substantial contribution to the industrial development of the municipality and encourage the decentralization of industry in Victoria; and
- (c) The Mayor, Councillors and Burgesses of the Council of the Borough of Eaglehawk and Tony Tucks Windows and Building Supplies on the seventeenth day of May, 1973, entered into an agreement in respect of the above described land as to the amount of rates that will be payable thereon by the said firm under the *Local Government Act 1958*, and copies of such agreement have been submitted to the Minister for Local Government.

Now therefore, His Excellency the Governor of the State of Victoria, by and with the advice of the Executive Council thereof and in pursuance of the provisions of the said section 811BA of the *Local Government Act 1958*, hereby approves the said agreement.

And the Honorable Alan John Hunt, Her Majesty's Minister for Local Government for the State of Victoria, shall give the necessary directions herein accordingly.

T. J. FORRISTAL,
Clerk of the Executive Council.

MELBOURNE AND METROPOLITAN BOARD OF WORKS ACT 1958.

At the Executive Council Chamber, Melbourne, the third day of July, 1973.

PRESENT:
His Excellency the Governor of Victoria.
Mr. Dickie | Mr. Dunstan.

FIXING OF THE MINIMUM AMOUNT OF THE WATER RATE TO BE PAID FOR CERTAIN TENEMENTS.

In pursuance of the provisions of section 99 (b) of the *Melbourne and Metropolitan Board of Works Act 1958*, His Excellency the Governor of the State of Victoria, by and with the advice of the Executive Council thereof, by this Order provides that the minimum amount of the rate to be paid for any tenements being land included in the metropolis pursuant to the powers conferred by section 3 (5) of the said Act shall be Twenty-two dollars and fifty cents (\$22.50) per annum.

And the Honorable Alan John Hunt, Her Majesty's Minister for Local Government for the State of Victoria, shall give the necessary directions herein accordingly.

T. J. FORRISTAL,
Clerk of the Executive Council.

STAMPS ACT 1958, No. 6375.

At the Executive Council Chamber, Melbourne, the third day of July, 1973.

PRESENT:
His Excellency the Governor of Victoria.
Mr. Dickie | Mr. Dunstan.

DECLARATION OF APPROVED VENDOR.

His Excellency the Governor of the State of Victoria, by and with the advice of the Executive Council thereof, doth by this Order made pursuant to section 131c (1) of the *Stamps Act 1958*, declare the under-mentioned person carrying on business as a vendor of goods under instalment purchase agreements to be an "approved vendor" for the purposes of subdivision (14) of Division 3 of Part II. of the *Stamps Act 1958*.

280. ECLIPSE INVESTMENTS PTY. LTD.

And the Honorable Rupert James Hamer, Her Majesty's Treasurer for the State of Victoria, shall give the necessary directions herein accordingly.

T. J. FORRISTAL,
Clerk of the Executive Council.

SUPERANNUATION ACT 1958.

At the Executive Council Chamber, Melbourne, the third day of July, 1973.

PRESENT:
His Excellency the Governor of Victoria.
Mr. Dickie | Mr. Dunstan.

Pursuant to the powers conferred by the provisions of paragraph (a) of sub-section (1) of section 3 of the *Superannuation Act 1958*, His Excellency the Governor of the State of Victoria, by and with the advice of the Executive Council thereof, doth by this Order declare that the provisions of the *Superannuation Act* shall apply to Philip Henry Napoleon Opas, Q.C., Chairman of the Environment Protection Appeal Board constituted pursuant to the provisions of the *Environment Protection Act 1970*, No. 8056.

And the Honorable Rupert James Hamer, Her Majesty's Treasurer for the State of Victoria, shall give the necessary directions herein accordingly.

T. J. FORRISTAL,
Clerk of the Executive Council.

SUPERANNUATION ACT 1958.

At the Executive Council Chamber, Melbourne, the third day of July, 1973.

PRESENT:

His Excellency the Governor of Victoria.
Mr. Dickie | Mr. Dunstan.

Pursuant to the powers conferred by the provisions of paragraph (ja) of sub-section (1) of section 3 of the Superannuation Act 1958, His Excellency the Governor of the State of Victoria, by and with the advice of the Executive Council thereof doth by this Order declare that the provisions of the Superannuation Act shall apply to:—

JOHNSTON, KARL JAMES,
TYERS, ROSEMARY ANNE,
being officers of The Victorian College of the Arts constituted pursuant to the provisions of the Victoria Institute of Colleges Act 1965, No. 7291.

And the Honorable Rupert James Hamer, Her Majesty's Treasurer for the State of Victoria, shall give the necessary directions herein accordingly.

T. J. FORRISTAL,
Clerk of the Executive Council.

COUNTRY ROADS BOARD.

At the Executive Council Chamber, Melbourne, the tenth day of July, 1973.

PRESENT:

His Excellency the Governor of Victoria.
Mr. Balfour | Mr. Hunt.

ORDER APPROVING OF LAND BEING ACQUIRED AND ROADS, DEVIATIONS OR WIDENINGS BEING MADE.

His Excellency the Governor of the State of Victoria, by and with the advice of the Executive Council thereof, being satisfied that there are funds legally available for acquiring the land, doth hereby approve the acquiring of the land described in the schedule hereunder and the making of new roads and deviations from and widenings of existing roads referred to in the said schedule.

SCHEDULE.

State Highways.

The land shown hatched on plans numbered G.P.12945A, G.P.12946A and G.P.12946B hereunder required for the deviation from the Princes Highway in the City and Shire of Colac and making of the deviation thereon.

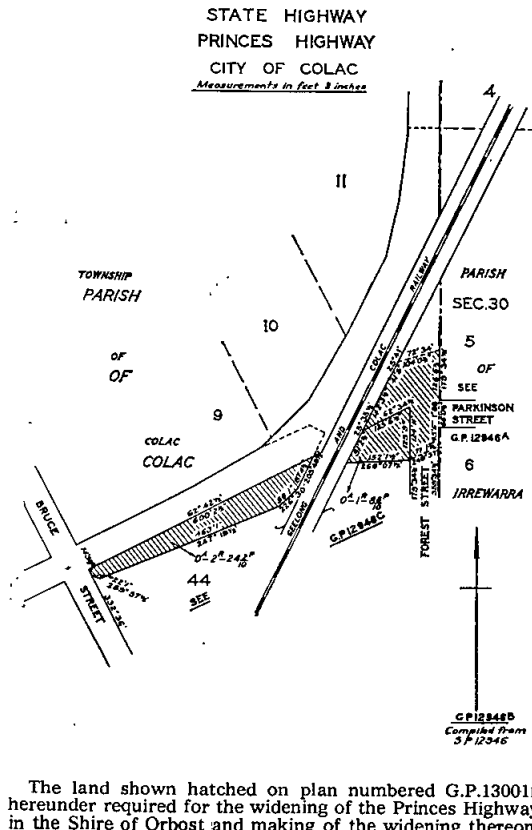
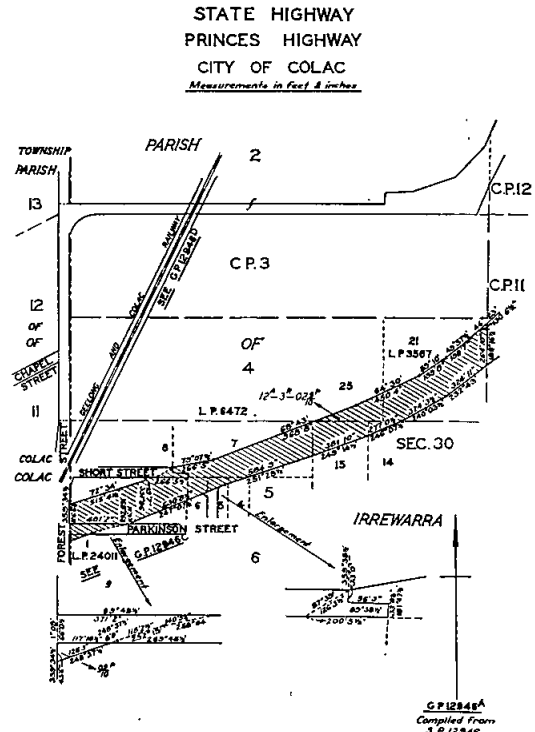
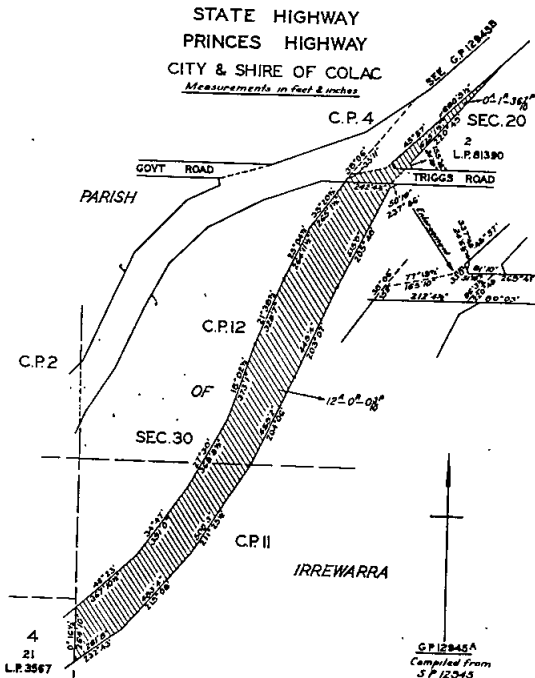

The land shown hatched on plan numbered G.P.13001B hereunder required for the widening of the Princes Highway in the Shire of Orbst and making of the widening thereon.

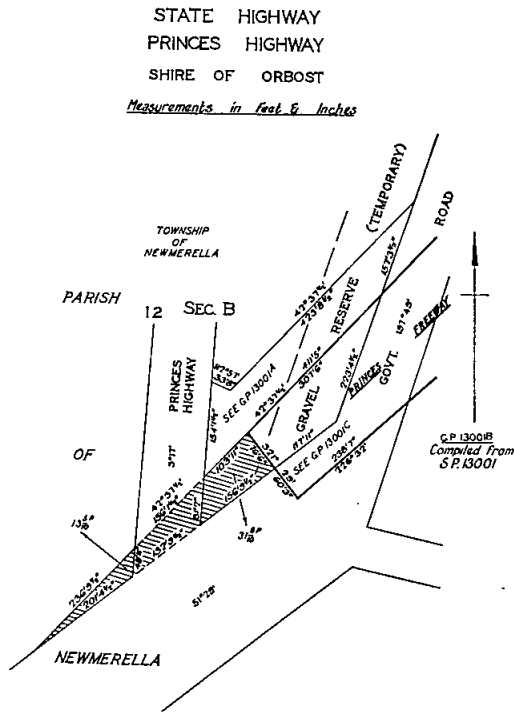

MAIN ROAD
HAMILTON - PORT FAIRY ROAD

SHIRE OF BELFAST

Measurements in Links

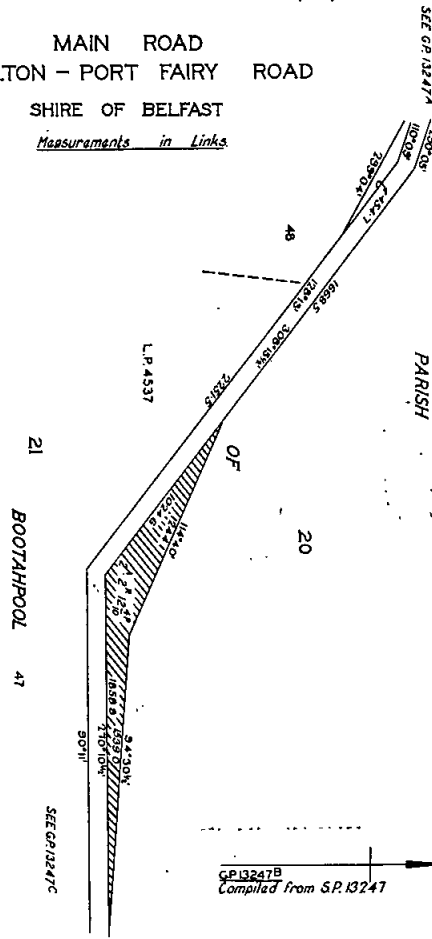

Main Roads.

The land shown hatched on plans numbered G.P.13247A, G.P.13247B, G.P.13247C and G.P.13247D hereunder required for the deviation from the Hamilton-Port Fairy Road in the Shire of Belfast and making of the deviation thereon.

MAIN ROAD
HAMILTON - PORT FAIRY ROAD

SHIRE OF BELFAST

Measurements in Links

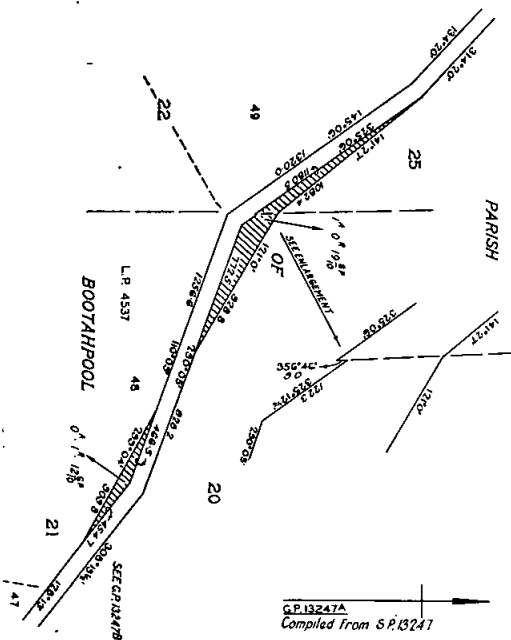

MAIN ROAD
HAMILTON - PORT FAIRY ROAD

SHIRE OF BELFAST

Measurements in Links

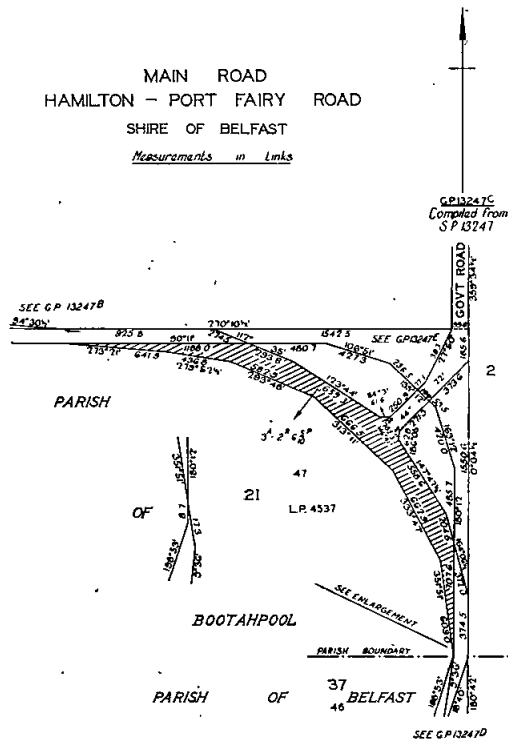

MAIN ROAD
HAMILTON - PORT FAIRY ROAD

SHIRE OF BELFAST

Measurements in Links

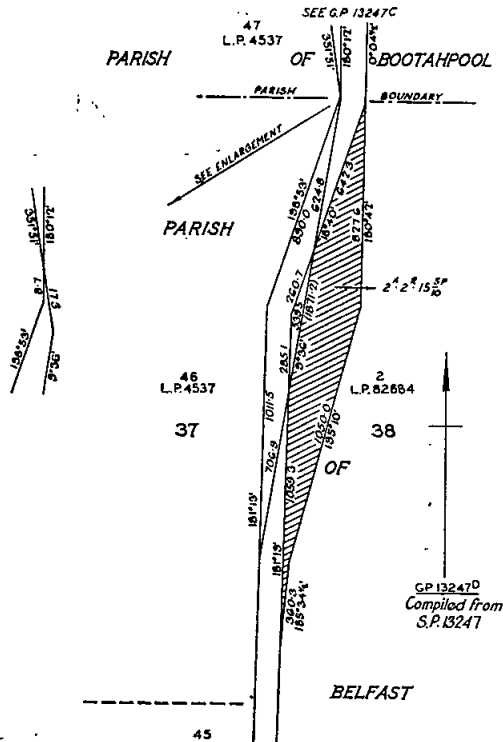

The land shown hatched on plan numbered G.P.13288 hereunder required for the widening of Navarre-road in the Shire of Stawell and making of the widening thereon.

MAIN ROAD
NAVARRE ROAD

SHIRE OF STAWELL

Measurements in Links

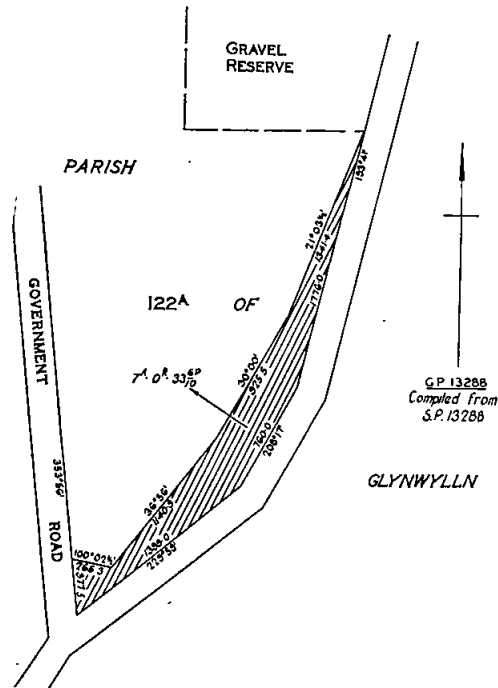

The land shown hatched on plan numbered G.P.13270 hereunder required for the widening of Cheltenham-road in the City of Dandenong and making of the widening thereon.

MAIN ROAD
CHELTENHAM ROAD

CITY OF DANDENONG

Lengths in Metres

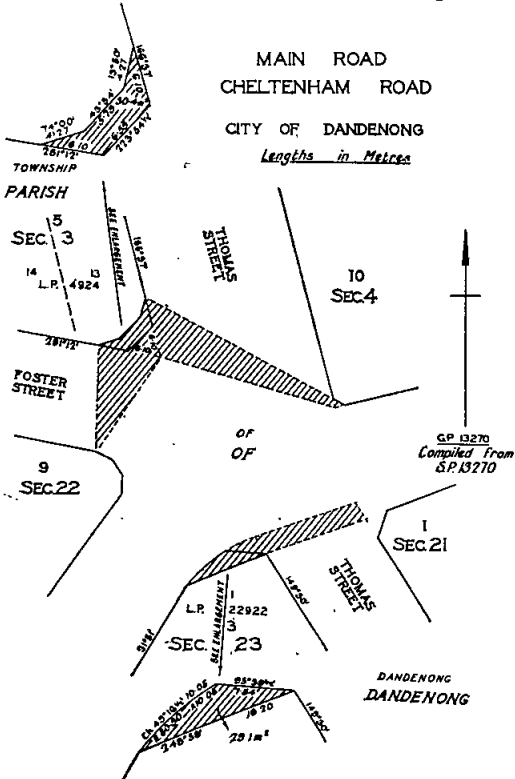

The land shown hatched on plans numbered G.P.13274A, G.P.13274B and G.P.13274C hereunder required for the deviation from the Cavendish-Coleraime road in the Shire of Wannon and making of the deviation thereon.

MAIN ROAD
CAVENDISH - COLERAINE ROAD

SHIRE OF WANNON

Lengths in Metres

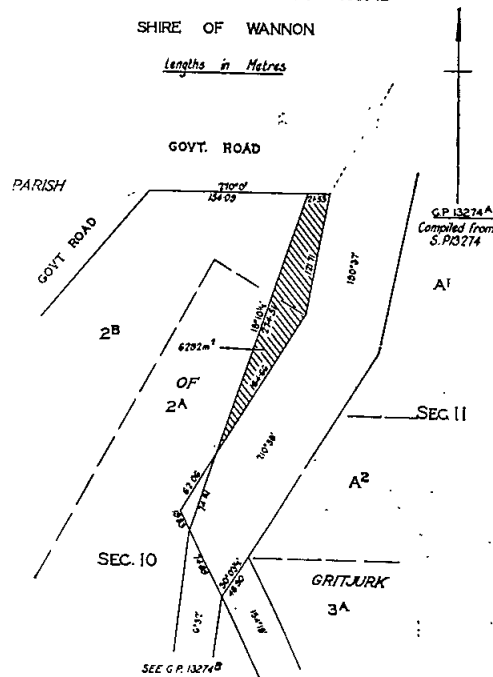

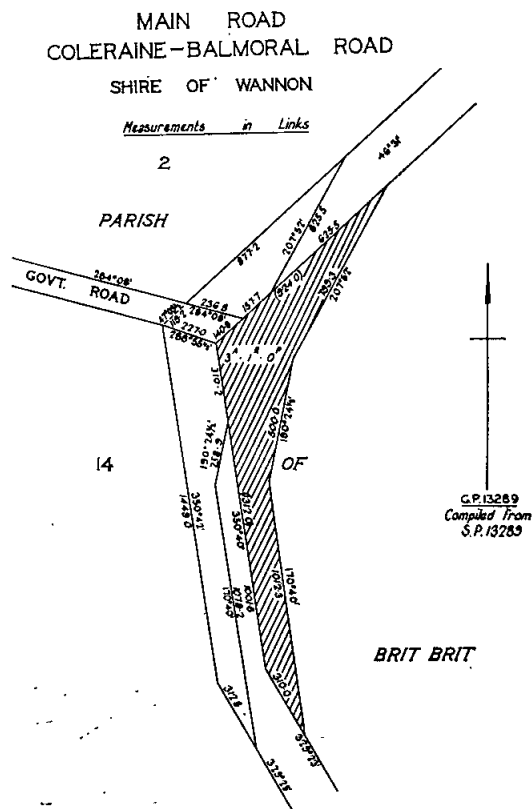
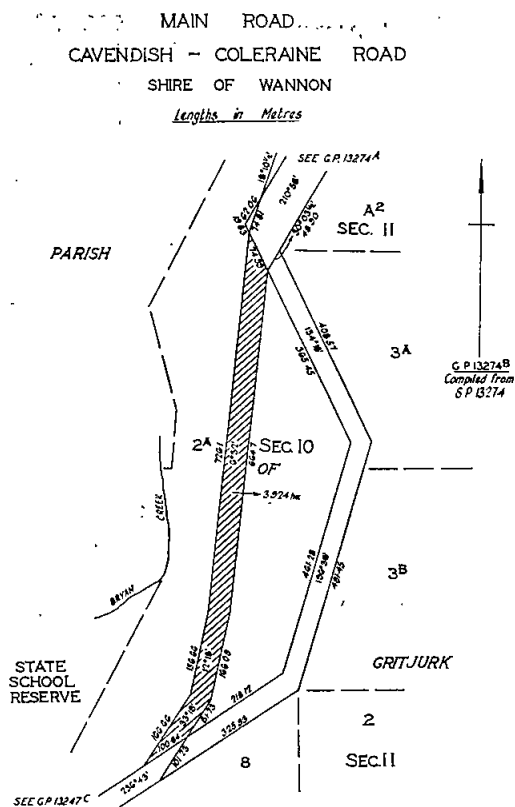

Freeway.
The land shown hatched on plans numbered G.P.13001c, G.P.13001d, G.P.13001e, G.P.13002a and G.P.13002b hereunder required for the making of a new freeway (Princes Freeway) in the Shire of Orbost.

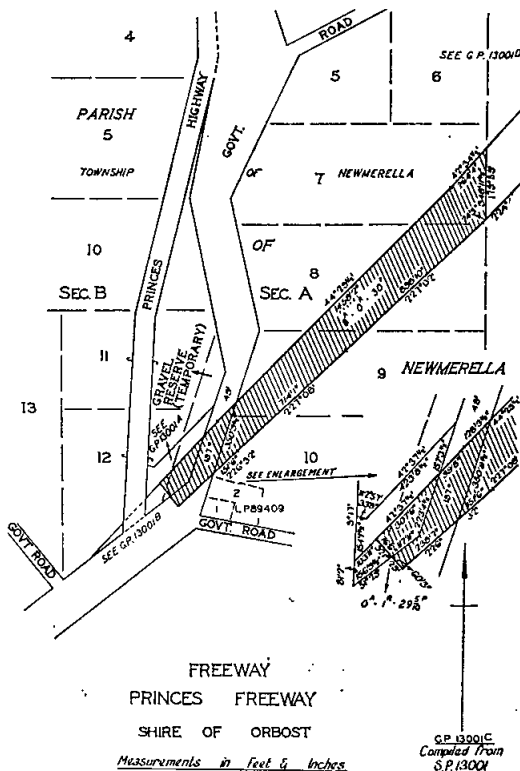
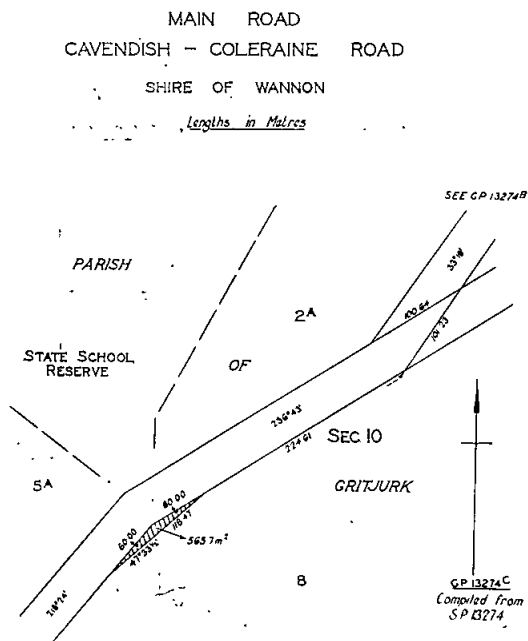

The land shown hatched on plan numbered G.P.13289 hereunder required for the deviation from the Coleraine-Balmoral road in the Shire of Wannon and making of the deviation thereon.

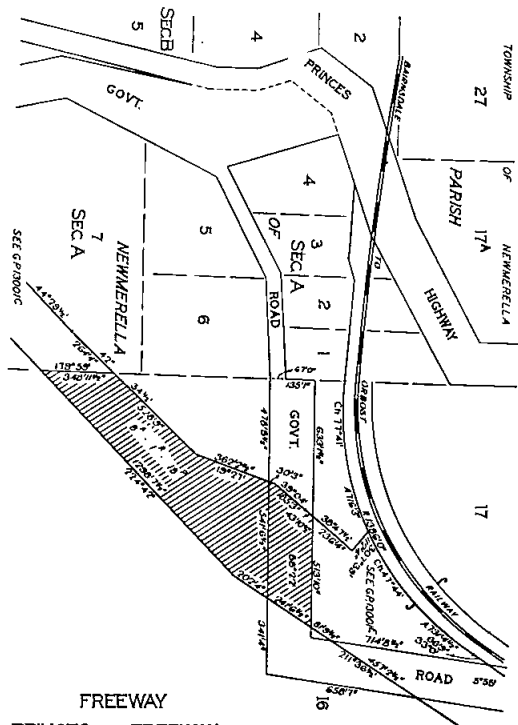

FREWAY
PRINCES FREEWAY
SHIRE OF ORBOST

Measurements in Feet & Inches

G.P. 13001B
Compiled from S.P. 13001

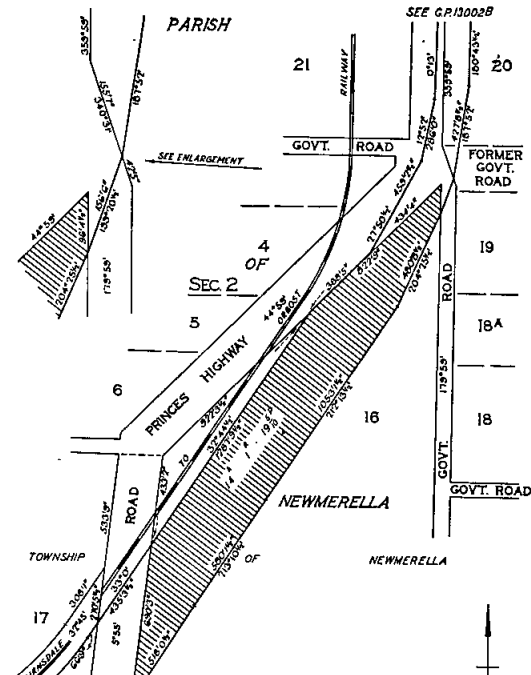

FREWAY
PRINCES FREEWAY
SHIRE OF ORBOST

Measurements in Feet & Inches

G.P. 13002A
Compiled from S.P. 13002

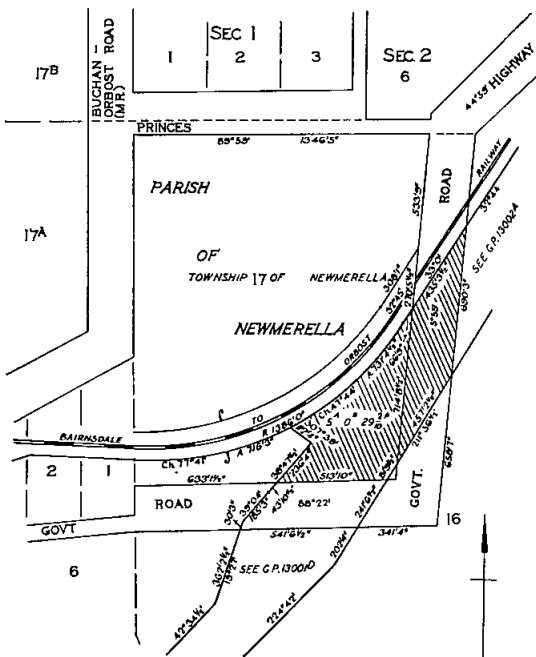

FREWAY
PRINCES FREEWAY
SHIRE OF ORBOST

Measurements in Feet & Inches

G.P. 13001E
Compiled from S.P. 13001

FREWAY
PRINCES FREEWAY
SHIRE OF ORBOST

Measurements in Feet & Inches

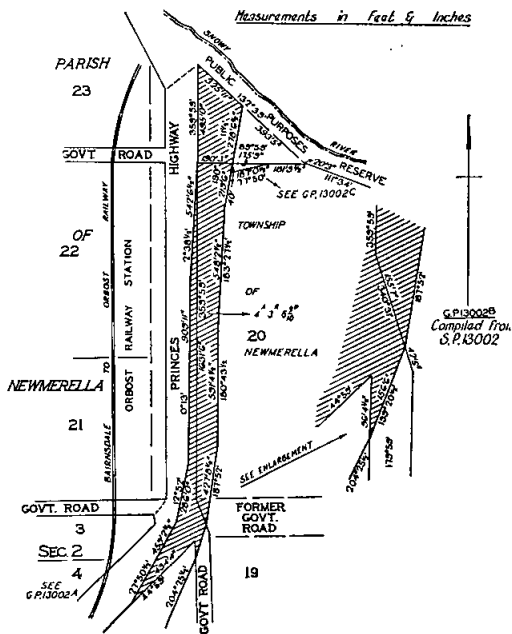

G.P. 13002B
Compiled from S.P. 13002

Unclassified Roads.

The land shown hatched on plan numbered G.P.13247E hereunder required for the making of a new road in the Shire of Belfast.

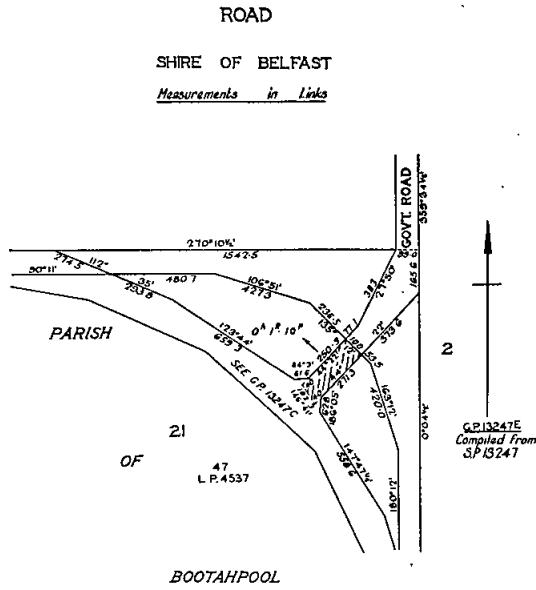

The land shown hatched on plans numbered G.P.12946c and G.P.12946d hereunder required for the making of new roads in the City of Colac.

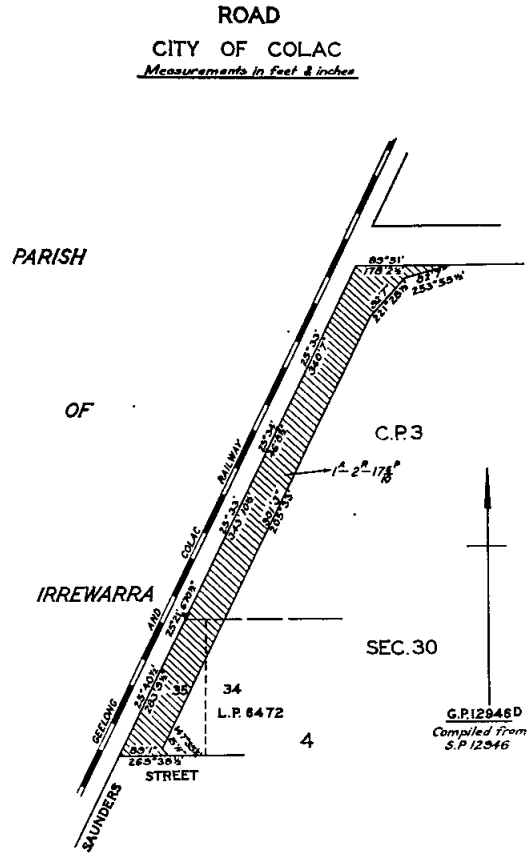
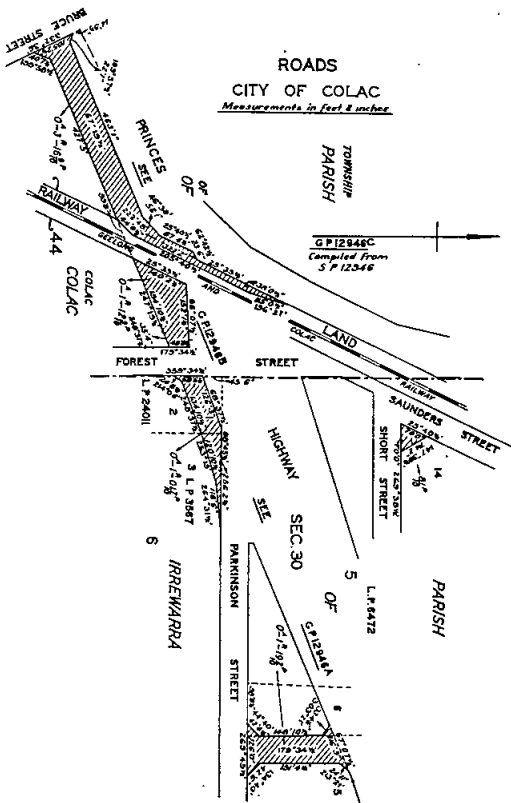

The land shown hatched on plans numbered G.P.13001A and G.P.13002c hereunder required for the making of new roads in the Shire of Orbost.

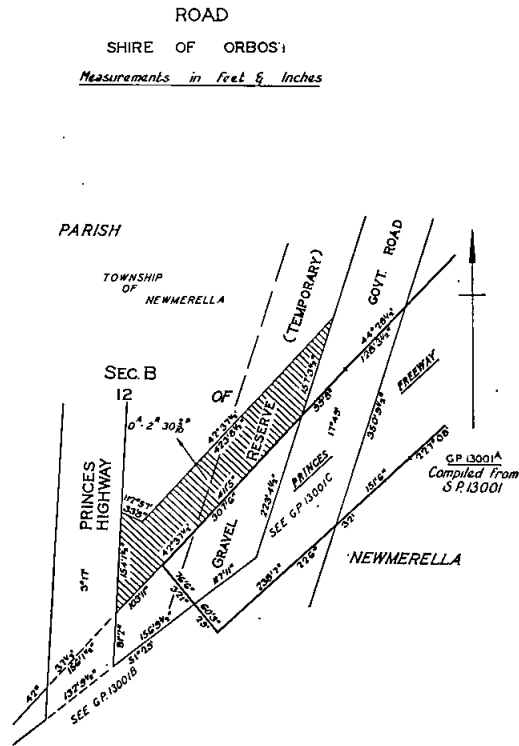

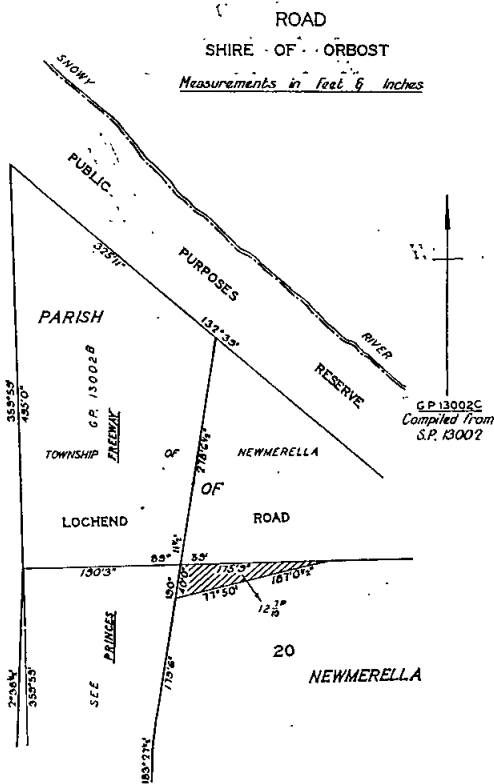

And the Honorable Edward Raymond Meagher, Her Majesty's Minister of Transport for the State of Victoria, shall give the necessary directions herein accordingly.

T. J. FORRISTAL,
Clerk of the Executive Council.

GEMBROOK, COCKATOO AND EMERALD WATERWORKS TRUST.

At the Executive Council Chamber, Melbourne, the tenth day of July, 1973.

PRESENT:
His Excellency the Governor of Victoria.
Mr. Balfour | Mr. Hunt.

EXTENT OF EMERALD URBAN DISTRICT INCREASED.

Under the powers conferred by the Water Act and all other powers enabling him in that behalf, His Excellency the Governor of the State of Victoria, by and with the advice of the Executive Council of the said State, doth hereby declare, order and direct that the extent of the Emerald Urban District of the Gembrook, Cockatoo and Emerald Waterworks Trust be increased by adding to the same the lands shown in red colour on the accompanying plan approved by the Governor in Council and deposited in the office of the State Rivers and Water Supply Commission, Melbourne (Corr. No. 73/1170/9), and as on and from the date hereof, the extent of such District shall be deemed to be increased.

And the Honorable Frederick James Granter, Her Majesty's Minister of Water Supply for the State of Victoria, shall give the necessary directions herein accordingly.

T. J. FORRISTAL,
Clerk of the Executive Council.

MELTON WATERWORKS TRUST.

At the Executive Council Chamber, Melbourne, the tenth day of July, 1973.

PRESENT:
His Excellency the Governor of Victoria.
Mr. Balfour | Mr. Hunt.

CONSENT TO BORROWING \$100,000.

Under the powers conferred by the Water Act and all other powers enabling him in that behalf, His Excellency the Governor of the State of Victoria, by and with the advice of the Executive Council of the said State, hereby consents to the Melton Waterworks Trust borrowing the sum of One hundred thousand dollars (\$100,000), to meet the cost of water supply works.

And the Honorable Frederick James Granter, Her Majesty's Minister of Water Supply for the State of Victoria, shall give the necessary directions herein accordingly.

T. J. FORRISTAL,
Clerk of the Executive Council.

METUNG WATERWORKS TRUST.

At the Executive Council Chamber, Melbourne, the tenth day of July, 1973.

PRESENT:
His Excellency the Governor of Victoria.
Mr. Balfour | Mr. Hunt.

CONSENT TO BORROWING \$2,700.

Under the powers conferred by the Water Act and all other powers enabling him in that behalf, His Excellency the Governor of the State of Victoria, by and with the advice of the Executive Council of the said State, hereby consents to the Metung Waterworks Trust borrowing the sum of Two thousand seven hundred dollars (\$2,700), for the conversion of Loan No. 1.

And the Honorable Frederick James Granter, Her Majesty's Minister of Water Supply for the State of Victoria shall give the necessary directions herein accordingly.

T. J. FORRISTAL,
Clerk of the Executive Council.

WOODEND WATERWORKS TRUST.

At the Executive Council Chamber, Melbourne, the tenth day of July, 1973.

PRESENT:
His Excellency the Governor of Victoria.
Mr. Balfour | Mr. Hunt.

CONSENT TO BORROWING \$6,000.

Under the powers conferred by the Water Act and all other powers enabling him in that behalf, His Excellency the Governor of the State of Victoria, by and with the advice of the Executive Council of the said State, hereby consents to the Woodend Waterworks Trust borrowing the sum of Six thousand dollars (\$6,000), to meet the cost of water supply works.

And the Honorable Frederick James Granter, Her Majesty's Minister of Water Supply for the State of Victoria, shall give the necessary directions herein accordingly.

T. J. FORRISTAL,
Clerk of the Executive Council.

WONTHAGGI SEWERAGE AUTHORITY.

At the Executive Council Chamber, Melbourne, the tenth day of July, 1973.

PRESENT:

His Excellency the Governor of Victoria.
Mr. Balfour | Mr. Hunt.

CONSENT TO BORROWING \$100,000.

Under the powers conferred by the Sewerage Districts Act and all other powers enabling him in that behalf, His Excellency the Governor of the State of Victoria, by and with the advice of the Executive Council of the said State, doth hereby consent to the Wonthaggi Sewerage Authority borrowing the sum of One hundred thousand dollars (\$100,000), in two amounts each of Fifty thousand dollars (\$50,000), to meet the cost of sewerage works as set forth in the detailed statement bearing date 4th July, 1973.

And the Honorable Frederick James Granter, Her Majesty's Minister of Water Supply for the State of Victoria, shall give the necessary directions herein accordingly.

T. J. FORRISTAL,
Clerk of the Executive Council.

TORQUAY SEWERAGE AUTHORITY.

At the Executive Council Chamber, Melbourne, the tenth day of July, 1973.

PRESENT:

His Excellency the Governor of Victoria.
Mr. Balfour | Mr. Hunt.

EXTENT OF SEWERAGE DISTRICT INCREASED.

Under the powers conferred by the Sewerage Districts Act and all other powers enabling him in that behalf, His Excellency the Governor of the State of Victoria, by and with the advice of the Executive Council of the said State, doth hereby declare, order and direct that the extent of the Sewerage District of the Torquay Sewerage Authority be increased by adding thereto land as shown on the plan approved by the Governor in Council, by and with this Order and deposited in the office of the State Rivers and Water Supply Commission, Melbourne, (Corr. No. 70/2931), and as on and from the date hereof the extent of such District shall be and be deemed to be increased accordingly.

And the Honorable Frederick James Granter, Her Majesty's Minister of Water Supply for the State of Victoria, shall give the necessary directions herein accordingly.

T. J. FORRISTAL,
Clerk of the Executive Council.

LANDS DEPARTMENT NOTICES

APPROACHING LAND SALES.

Sale of Crown Land, in fee-simple, will be held at the under-mentioned places and dates, viz.:-

| | No. of Gazette. |
|------------------------------------|-----------------|
| Wonthaggi.—Monday, 30th July, 1973 | 51 |

PROPOSED PERMANENT RESERVATION OF LAND AS A SITE.

In pursuance of sections 14 and 21 of the Land Act 1958, notice is hereby given that it is the intention of the Governor in Council to reserve permanently from sale, from being leased and from having a licence granted in respect thereof the land hereinafter described:—

The following Notice was published 1^o on the 20th June, 1973, pursuant to Order of the 12th June, 1973.

LAKES ENTRANCE.—Land proposed to be permanently reserved as a site for Public Purposes, 20 perches, more or less, Township of Lakes Entrance, Parish of Colquhoun, County of Tambo, as indicated by hatching on plan hereunder.—(C.383(F²)) (Rc.5532).

No. 65.—6150/73.—3

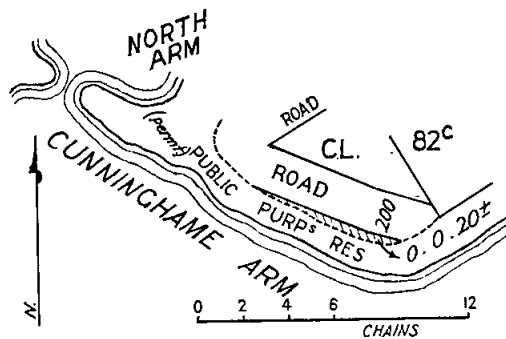

W. BORTHWICK,
Minister of Lands.

COMMONS ABOUT TO BE DIMINISHED.

In pursuance of the provisions contained in the Land Act 1958, notice is hereby given that it is the intention of the Governor in Council to diminish the commons herein-after mentioned, viz.:-

The following Notices were published 1^o on the 4th July, 1973, pursuant to Orders of the 26th June, 1973.

The Broadford Common, proclaimed as such by the Governor in Council on the 30th August, 1886, is about to be diminished by the excision therefrom of allotment 21, section 17, Township of Broadford and containing 1 rood 20 perches.—(C.70447).

The Amherst United Town and Gold Field Common, now designated the Amherst United Borough and Gold Field Common, proclaimed as such on the 17th October, 1862, the 13th November, 1862, and the 10th November, 1863, is about to be diminished by the excision therefrom of the portion in the Parish of Amherst containing 19 acres, more or less, indicated by hatching on plan hereunder.—(Rs.35).

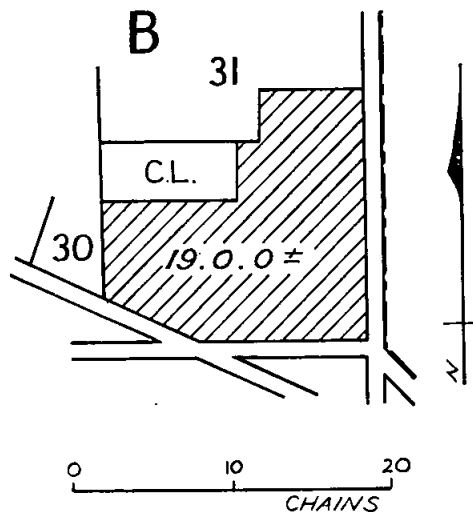

W. BORTHWICK,
Minister of Lands.

PROPOSED REVOCATIONS OF TEMPORARY RESERVATIONS OF LANDS BY ORDERS IN COUNCIL.

In pursuance of the provisions of the Land Act 1958, notice is hereby given that it is the intention of the Governor in Council to revoke the temporary reservations of lands by Orders in Council hereunder referred to, viz.:-

The following Notices were published 1^o on the 4th July, 1973, pursuant to Orders of the 26th June, 1973.

MARYBOROUGH.—The temporary reservation by Order in Council of the 11th April, 1967, of 3 roods 9 perches of land in the Township of Maryborough as a site for Public purposes (Government and Municipal purposes) is about to be revoked.—(M.66(15)) (Rs.5729).

WONTHAGGI.—The temporary reservation by Order in Council of the 14th January, 1964, of 4 acres 1 rood, more or less, of land in the Township of Wonthaggi as a site for Public purposes is about to be revoked.—(K.217⁽²⁾) (Rs.7476).

ARARAT.—The temporary reservation, as a site for Supply of Gravel and the withholding from sale, leasing and licensing by Order in Council of the 25th September, 1906 (see *Government Gazette*, 1906, page 4066), of 8.951 hectares (22 acres 19 perches) of land in the Township of Ararat (called Municipal district of Ararat in Order) revoked as to part by Order of the 4th February, 1969 (see *Government Gazette*, 1969, page 296) are about to be revoked so far as the balance thereof containing 8.041 hectares (19 acres 3 roods 19 perches) is concerned.—(A.148⁽⁸⁾) (C.82343).

W. BORTHWICK,
Minister of Lands.

PROPOSED REVOCATIONS OF TEMPORARY RESERVATIONS OF LANDS BY ORDERS IN COUNCIL.

In pursuance of the provisions of the *Land Act 1958*, notice is hereby given that it is the intention of the Governor in Council to revoke the temporary reservations of lands by Orders in Council hereunder referred to, viz.:—

The following Notices were published 1° on the 20th June, 1973, pursuant to Orders of the 12th June, 1973.

BYLANDS (KILMORE).—The temporary reservation by Order in Council of the 31st August, 1915, of 3 acres 1 rood 5 perches of land in the Parishes of Bylands and Glenburnie (now only in the Parish of Bylands) as a site for a Public Park and Gardens is about to be revoked so far only as the portion containing 16 perches indicated by hatching on plan hereunder is concerned.—(B.563⁽³⁾) (Rs.692).

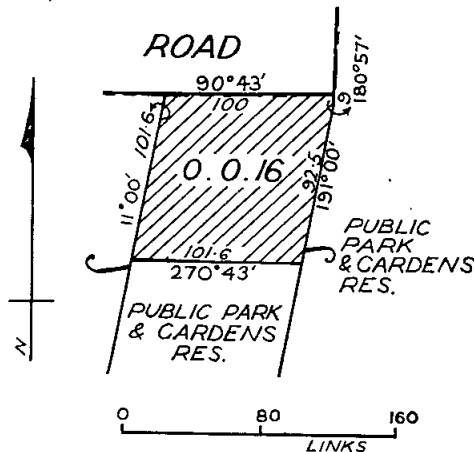

BYLANDS (KILMORE).—The temporary reservation by Order in Council of the 24th January, 1911, of 214 acres of land in the Township of Kilmore and the Parishes of Bylands and Glenburnie (now only in the Township of Kilmore and the Parish of Bylands) as a site for Public Park and Gardens, revoked as to part by Order of the 22nd November, 1960, is about to be revoked so far only as the portion in the Parish of Bylands containing 2 acres 2 roods 11 perches indicated by hatching on plan hereunder is concerned.—(B.563⁽³⁾) (Rs.692).

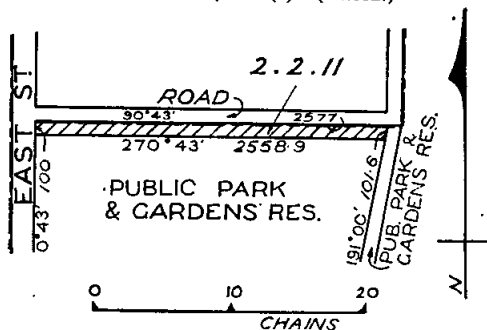

W. BORTHWICK,
Minister of Lands.

PROPOSED PERMANENT RESERVATION OF LAND AS A SITE.

In pursuance of sections 14 and 21 of the *Land Act 1958*, notice is hereby given that it is the intention of the Governor in Council to reserve permanently from sale, from being leased and from having a licence granted in respect thereof the land hereinafter described:—

The following Notice was published 1° on the 11th July, 1973, pursuant to Order of the 3rd July, 1973.

WILLIAMSTOWN.—Land proposed to be permanently reserved as a site for Public Recreation, 8 acres 2 roods 13 perches, Township of Williamstown, Parish of Cut-paw-paw, County of Bourke, as indicated by hatching on plan hereunder.—(W.163⁽²⁾) (Rs.2075).

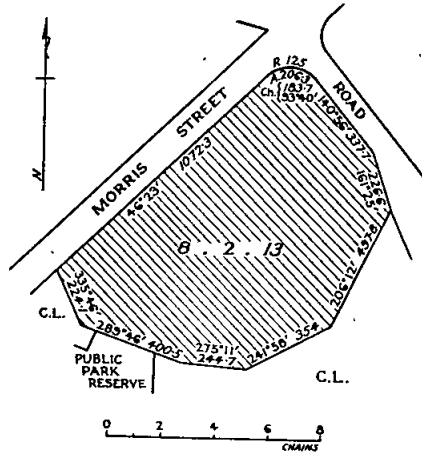

JIM BALFOUR,
Acting Minister of Lands.

PROPOSED REVOCATIONS OF TEMPORARY RESERVATIONS OF LANDS BY ORDERS IN COUNCIL.

In pursuance of the provisions of the *Land Act 1958*, notice is hereby given that it is the intention of the Governor in Council to revoke the temporary reservations of lands by Orders in Council hereunder referred to, viz.:—

The following Notices were published 1° on the 11th July, 1973, pursuant to Orders of the 3rd July, 1973.

BROADFORD.—The temporary reservation by Order in Council of the 10th February, 1947, of 1,770 square metres (1 rood 30 perches) of land in the Township of Broadford, as a site for Swimming Pool, is about to be revoked.—(B.443⁽⁴⁾) (Rs.5926).

BRUCKNELL.—The temporary reservation by Order in Council of the 18th June, 1888, of 8,094 square metres (2 acres) of land in the Parish of Brucknell, as a site for a Cemetery, is about to be revoked.—(B.100⁽³⁾) (C.100864).

COWES.—The temporary reservation as a site for a Road and the withholding from sale, leasing and licensing by Order in Council of the 18th December, 1882 (see *Government Gazette*, 22nd December, 1882, page 3150), of 11 acres, more or less, of land in the Township of Cowes, are about to be revoked.—(C.443⁽⁴⁾) (Rs.5133A).

GEMBROOK (DEWHURST).—The temporary reservation by Order in Council of the 7th August, 1945, of 6,070 square metres (1 acre 2 roods), of land in the Parish of Gembrook, as a site for a Public Hall, is about to be revoked.—(G.206⁽¹³⁾) (Rs.5674).

ROCHESTER.—The temporary reservation by Order in Council of the 20th May, 1947, of 1.416 hectares (3 acres 2 roods) of land in the Township of Rochester, as a site for Rubbish Depot, is about to be revoked.—(R.32⁽²⁾) (Rs.5963).

THARANBEGGA (TUNGAMAH).—The temporary reservation as a site for Public purposes (State School) and the withholding from sale, leasing and licensing by Order in Council of the 28th July, 1879, of 4,047 square metres (1 acre) of land in the Parish of Tharanbeggia, are about to be revoked.—(T.216⁽³⁾) (C.100994).

YARPTURK.—The temporary reservation by Order in Council of the 10th August 1868 (see *Government Gazette* 1868, page 1529) of 8,094 square metres (2 acres) of land in the Parish of Yarpurk as a site for Common School purposes is about to be revoked.—(Y.54⁽³⁾) (G.75061)

MURMUNGEE (GAPSTED).—The temporary reservation by Order in Council of the 10th December, 1888 of 3.986 hectares (9 acres 3 roods 16 perches) of land in the Parish of Murmungee as a site for Public Recreation is about to be revoked so far only as the portion containing 233 square metres, indicated by hatching on plan hereunder, is concerned.—(M.285⁽³⁾) (Rs.2625).

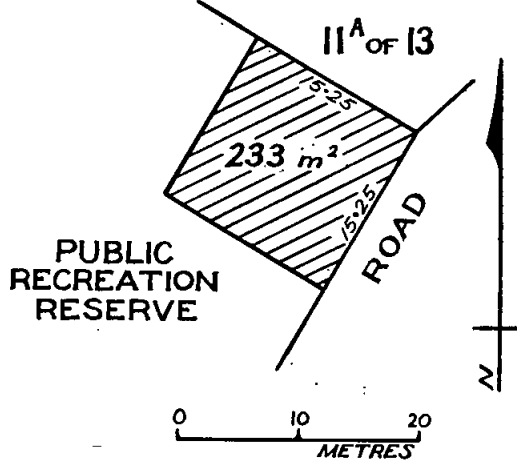

PHILLIP ISLAND (COWES).—The temporary reservation by Order in Council of the 30th April, 1957, of certain land in the Parish of Phillip Island as a site for Public purposes is about to be revoked so far only as the portion containing 20 perches, indicated by hatching on plan hereunder, is concerned.—(P.136⁽³⁾) (Rs.5133A).

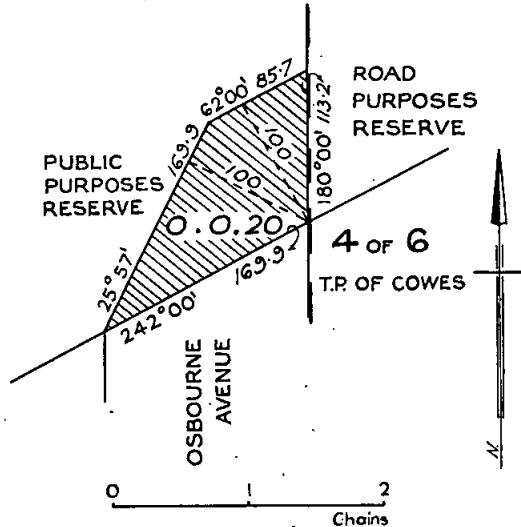

JIM BALFOUR,
Acting Minister of Lands.

PROPOSED REVOCATION OF TEMPORARY RESERVATION OF LAND BY ORDER IN COUNCIL.

In pursuance of the provisions of the Land Act 1958, notice is hereby given that it is the intention of the Governor in Council to revoke the temporary reservation of land by Order in Council hereunder referred to, viz.:—
The following Notice was published 1^o on the 11th July, 1973, pursuant to Orders of the 10th July, 1973.

MIRNEE.—The temporary reservation by Order in Council of the 11th August, 1873 of 2.023 hectares (5 acres) of land in the Parish of Mirnee, as a site for a Pound, is about to be revoked.—(M.118⁽³⁾) (W.7648).

JIM BALFOUR,
Acting Minister of Lands.

TENDERS

PUBLIC WORKS DEPARTMENT

Tenders will be received at Public Works Department, 2 Treasury-place, Melbourne, until **TWO** p.m. on dates shown and for purposes mentioned hereunder.

Particulars and tender forms available at Contracts Office, Room 27, Ground Floor, No. 2, Treasury-place, and at places indicated in brackets hereunder.

Abbreviations in brackets mean:—W.O.—Inspector of Works Office; P.S.—Police Station; C.S.—Consolidated School; H.E.S.—Higher Elementary School; H.S.—High School; Pr.S.—Primary School; T.S.—Technical School.

Tenders to be submitted on the Department's printed Tender Form and will not be received by telephone. All tenders must be on a "Firm Tender" basis. The lowest or any tender will not necessarily be accepted.

Address tenders to the Minister of Public Works, and endorse the envelope containing the tender "Tender for , closing Tuesday,

Hand delivered tenders to be placed in the Tender Box of the Public Works Department, located on the wall of the centre entrance foyer, Ground Floor, 2 Treasury-place, Melbourne.

No preliminary deposit is required with any tender, but a successful tenderer will be required to pay a deposit for any accepted tender of \$4,000 or over.

Tuesday, 17th July, 1973.

Building, Electrical and Mechanical Works.

BROADFORD.—External and part internal repairs and painting, H.S. (W.O., Kyneton, Bendigo and Shepparton.)

TEMPLESTOWE.—New brick veneer toilet block, additional class-room, sick bay and staff toilets, Pr.S.1395.

Miscellaneous.

PORT MELBOURNE.—Two-barrow (120-ft. lift) builders platform hoist, Plant Depot.

Tuesday, 24th July, 1973.

Building, Electrical and Mechanical Works.

BEAUFORT.—Erection of a brick toilet and internal renovations, Court House. (W.O., Ballarat.) (Re-advertised.)

GEE LONG.—External painting and repairs, "Ariston", Teachers' College Hostel. (W.O., Geelong.)

MELBOURNE.—New suspended ceilings, 2nd and 3rd floors, 2 Treasury-place.

MONT PARK.—Remodelling of ward F4, M.H.

MONT PARK.—Electrical services, remodelling ward F4, M.H.

PIANGIL.—Internal repairs and painting, Pr.S.4164. (W.O., Swan Hill.)

WERRIBEE.—Replace existing G.S.I. roof with new roof decking, H.S.

Site Works.

KIEWA VALLEY.—Site works, C.S. (W.O., Wangaratta.)

Miscellaneous.

PRAHRAN.—Supply and installation of metal shelving, State Library.

OUYEN.—Non-party fencing, H.S. (W.O., Mildura.)

Tuesday, 31st July, 1973.

Building, Electrical and Mechanical Works.

COBRAM.—Sewerage connexion, H.S. (W.O., Shepparton.)

FOOTSCRAY NORTH.—Mechanical services, demonstration unit, Pr.S.4160. (Re-advertised.) (Amended Specification.)

KEON PARK.—Interior renovations, T.S. (Re-advertised.)
 MONT PARK.—Mechanical services, remodelling Ward F4, M.H.
 MOUNT DANDENONG.—New toilet block, Observatory Reserve. (Re-advertised.)

Site Works.

BORONIA.—Site works, T.S.
 MILLEARA.—Site works, Pr.S.4969.

ROBERTS DUNSTAN,
 Minister of Public Works.

Public Works Department,
 Melbourne, 3002, 9th July, 1973.

PUBLIC SERVICE NOTICES

No. 476. *Public Service Act 1958, Section 39.*

REGULATIONS—PART IV.—SALARIES AND INCREMENTS.

The Public Service Board, in pursuance of the powers conferred by the *Public Service Act 1958*, hereby amends the Public Service (Public Service Board) Regulations as follows :—

THIRD SCHEDULE.

PART B.

PROFESSIONAL DIVISION.

Scale of Rates of Annual Salaries.

PUBLICATIONS AND PUBLICITY OFFICERS.

The salary scale shown is deleted and the following salary scale is inserted in lieu thereof—

| Class. | Annual Salary of Each Subdivision of Each Class. | | |
|--------------|--|-------|-------|
| | 1. | 2. | 3. |
| | \$ | \$ | \$ |
| PP-1 | 6,098 | 6,272 | 6,519 |
| PP-2 | 7,697 | 7,859 | 8,183 |
| PP-3 | 8,710 | 8,871 | 9,094 |
| PP-4 | 9,499 | .. | .. |
| PP-5 | 10,396 | .. | .. |

SIXTH SCHEDULE.

TEMPORARY EMPLOYEES.

Designations of Positions and Rates of Salaries.

| Department and Designation of Position. | Yearly Rate of Salary. | | Increments (Annual). |
|--|------------------------|----------|----------------------|
| | Minimum. | Maximum. | |
| | \$ | \$ | |
| CHIEF SECRETARY'S DEPARTMENT. | | | |
| <i>State Library, National Museum and Science Museum.</i> | | | |
| Delete— Field and Education Officer (Female), Library Division= | 5,589 | 5,967 | * |
| Add— Field and Education Officer, Library Division= | 6,098 | 6,519 | * |

This Regulation shall have effect as on and from the 1st July, 1973.

A. J. A. GARDNER, Chairman.
 P. CARRIGAN, Secretary.

Office of the Public Service Board,
 Melbourne, 29th June, 1973.

No. 477.

Public Service Act 1958, Section 50.

REGULATIONS—PART IV.—SALARIES AND INCREMENTS.

The Public Service Board, in pursuance of the powers conferred by the *Public Service Act 1958*, hereby amends its Regulations as shown below.

SIXTH SCHEDULE.

TEMPORARY EMPLOYEES.

Designations of Positions and Rates of Salaries.

| Department and Designation of Position. | Yearly Rate of Salary. | | Increments (Annual). |
|---|------------------------|----------|----------------------|
| | Minimum. | Maximum. | |
| | \$ | \$ | |
| DEPARTMENT OF HEALTH. | | | |
| ALCOHOLICS AND DRUG DEPENDENT PERSONS SERVICES. | | | |
| Add— Kitchenman | 3,654 | 3,936 | A |

A. J. A. GARDNER, Chairman.
 P. CARRIGAN, Secretary.

Office of the Public Service Board,
 Melbourne, 29th June, 1973.

No. 475.

Public Service Act 1958, Section 50.

REGULATIONS—PART IV.—SALARIES AND INCREMENTS.

The Public Service Board, in pursuance of the powers conferred by the *Public Service Act 1958*, hereby amends the Public Service (Public Service Board) Regulations as follows :—

SIXTH SCHEDULE.

TEMPORARY EMPLOYEES.

Designations of Positions and Rates of Salaries.

| Department and Designation of Position. | Yearly Rate of Salary. | | Increments (Annual). |
|---|------------------------|----------|----------------------|
| | Minimum. | Maximum. | |
| | \$ | \$ | |
| SOCIAL WELFARE DEPARTMENT. | | | |
| FAMILY WELFARE DIVISION. | | | |
| Delete— Field Officer (Female), Senior | 5,127 | 5,544 | B |
| Field Officer (Female) | 5,127 | 5,267 | B |
| Field Officer (Foster Care and Adoption) (Female)†† | 5,127 | 5,267 | B |
| Welfare Officer (Female) | 4,148 | 4,230 | B |
| Add— Field Officer, Senior | 5,662 | 6,291 | A |
| Field Officer | 5,662 | 6,009 | A |
| Field Officer (Foster Care and Adoption)†† | 5,662 | 6,009 | A |
| Welfare Officer= | 5,662 | 6,009 | A |
| YOUTH WELFARE DIVISION. | | | |
| Delete— Welfare Officer (Female) | 4,148 | 4,230 | B |
| Add— Welfare Officer= | 5,662 | 6,009 | A |

This Regulation shall have effect as on and from the 17th June, 1973.

A. J. A. GARDNER, Chairman.
 P. CARRIGAN, Secretary.

Office of the Public Service Board,
 Melbourne, 18th June, 1973.

No. 474.

Public Service Act 1958, Section 50.

REGULATIONS—PART IV.—SALARIES AND INCREMENTS.

The Public Service Board, in pursuance of the powers conferred by the Public Service Act 1958, hereby amends its Regulations as shown below :—

SIXTH SCHEDULE.

TEMPORARY EMPLOYEES.

Designations of Positions and Rates of Salaries.

| Department and Designation of Position. | Yearly Rate of Salary. | | Increments (Annual). |
|---|------------------------|----------|----------------------|
| | Minimum. | Maximum. | |
| | \$ | \$ | |
| <i>Delete the existing yearly rates of salary for the following positions and insert the rates shown hereunder in lieu thereof—</i> | | | |
| SOCIAL WELFARE DEPARTMENT. | | | |
| PRISONS DIVISION. | | | |
| Dressmaking Instructor (Female) | 4,871 | 5,360 | B |
| Handcraft Instructor (Female) | 4,871 | 5,360 | B |
| Overseer, Grade II. | 6,544 | 6,706 | A |
| Prison Officer= | 4,991 | 5,119 | A |
| Trade Instructor | 6,544 | 6,706 | A |

This Regulation shall have effect as on and from the 17th June, 1973.

A. J. A. GARDNER, Chairman.
P. CARRIGAN, Secretary.

Office of the Public Service Board,
Melbourne, 25th June, 1973.

CORRIGENDUM.

PUBLIC SERVICE BOARD OF VICTORIA.

Public Service Act 1958.

REGULATIONS.—PART IV.—SALARIES AND INCREMENTS.

In Serial No. 454 published in Government Gazette No. 47 dated 8th June, 1973—

THIRD SCHEDULE.

PART B.

PROFESSIONAL DIVISION.

Scale of Rates of Annual Salaries.

GEOLOGISTS.

| Class. | Annual Salary of Each Subdivision of Each Class. | | | | | | |
|----------------------|--|-------|-------|-------|-------|----|----|
| | 1. | 2. | 3. | 4. | 5. | 6. | 7. |
| | \$ | \$ | \$ | \$ | \$ | \$ | \$ |
| For— G-2 | 8,290 | 8,605 | 9,151 | 9,382 | 9,690 | .. | .. |
| Read— G-2 | 8,290 | 8,605 | 9,151 | 9,382 | 9,670 | .. | .. |

By Order,

P. CARRIGAN,
Secretary.

Office of the Public Service Board,
Melbourne, 4th July, 1973.

EXAMINATION FOR LICENCE AS SHORTHAND WRITER.

It is hereby notified that the under-mentioned persons passed the examination, held on the 30th June, 1973, for licence as shorthand writers under the Evidence Act:—

- BENCIC, MARINA ROSA,
- BUDARICK, BRENTON JOHN,
- CUMMINS, LESLEY KAYE (Mrs.),
- GILLESPIE, KAREN MARY ALICE (Mrs.),
- HILL, JOAN DOROTHY (Mrs.), and
- HUMPHREYS, JOAN MILLICENT (Mrs.).

By Order,

P. CARRIGAN,
Secretary.

Office of the Public Service Board,
Melbourne, 3rd July, 1973.

PRIVATE ADVERTISEMENTS

CITY OF BENALLA.

LOAN No. 31.

Notice of Intention to Borrow.

Notice is hereby given that the Council of the City of Benalla intends to borrow Fifty thousand dollars (\$50,000), secured by charge over the general rates of the municipality by the grant of a mortgage in accordance with the provisions of the Local Government Acts.

In connexion therewith the following information is stated:—

- (a) The amount of the principal moneys which it is proposed to borrow is \$50,000 (Fifty thousand dollars).
- (b) The maximum rate of interest that may be paid is 6.9 per centum per annum.
- (c) The times which the moneys borrowed are to be repayable are the 1st day of March, 1974, and the 1st days of September and March, during the currency of the loan and that the place such moneys shall be repayable is at the Bank of New South Wales, Benalla, Victoria.
- (d) The purpose for which the loan is to be applied is:—

Underground drains—

| | |
|--|-----------------|
| Kent-street to main drain .. | \$1,000 |
| Clarke-street to Waller-street | 8,000 |
| Wedge-street to main drain .. | 6,000 |
| | <u>\$15,000</u> |

Kerb and Channel—

| | |
|---------------------------------|--------------|
| Thomas-street, east side .. | \$500 |
| Gillies-street, west side .. | 900 |
| Coster-street, north side .. | 500 |
| Shadforth-street, south side .. | 1,300 |
| Gay-street, south side .. | 500 |
| Waller-street, north side .. | 500 |
| Clarke-street, both sides .. | 2,800 |
| | <u>7,000</u> |

Traffic lights—

| | |
|--|-------|
| Salisbury-street and Clarke-street (Hume Highway) .. | 3,000 |
|--|-------|

Saleyards construction—

| | |
|---------------------|-----------------|
| Cattle pens | 25,000 |
| | <u>\$50,000</u> |

- (e) The manner in which the loan is to be liquidated is by provision out of the municipal fund in each half-year during the currency of the loan the sum of \$1,847.50, which includes principal and interest, with a final payment of \$41,609.10 on 1st September, 1993.
- (f) The loan will be for a period of twenty (20) years.

The plans and specifications and estimate of the cost of the works and a statement showing the proposed expenditure of the moneys to be borrowed are open for inspection at the Civic Centre, Benalla.

Dated this 11th day of July, 1973.

3342

L. A. HEMLEY, Town Clerk.

CITY OF CROYDON.

LOAN No. 118.

Notice of Intention to Borrow the Sum of \$100,000 for Permanent Works and Undertakings.

Notice is hereby given that the Council of the City of Croydon proposes to borrow the principal sum of One hundred thousand dollars (\$100,000) secured by a charge

over the general rates of the municipality, such sum to be raised by the grant of a mortgage in accordance with the provisions of the *Local Government Act 1958*.

1. The maximum rate of interest that may be paid is 6.9 per centum per annum.

2. The purpose for which the loan is to be applied is—
1. Purchase of land for Public Open Space (Amending Planning Scheme No. 2).

3. The period of the loan shall be 40 years.

4. The moneys borrowed shall be repayable by 80 half-yearly instalments of approximately \$3,695.00, including principal and interest, on the 17th day of February and the 17th day of August during the currency of the loan. The first instalment shall be repayable on the 17th day of February, 1974.

5. Such moneys shall be repayable at Australian Mutual Provident Society, 535 Bourke-street, Melbourne.

The plans and specifications and the estimate of the cost of the proposed works and a statement showing the proposed expenditure of the moneys to be borrowed, are open for inspection at the office of the Council of the City of Croydon at City Offices, Foch-avenue, Croydon.
3250 R. BURTON, Town Clerk.

CITY OF FITZROY.

LOAN No. 43.

Notice of Intention to Borrow the Sum of \$20,000 for Permanent Works and Undertakings.

Notice is hereby given that the Council of the City of Fitzroy proposes to borrow the principal sum of \$20,000 secured by a charge over the general rates of the municipality, such sum to be raised by the grant of a mortgage in accordance with the provisions of the *Local Government Act 1958* and its amendments.

(1) The maximum rate of interest that may be paid is 6.6 per centum per annum.

(2) The period of the loan shall be ten years and the times at which the moneys borrowed are to be repayable will be on the 1st day of March and the 1st day of September in each year, during the currency of the loan, commencing on the 1st day of March, 1974. The place of repayments shall be the Commonwealth Savings Bank of Australia, Melbourne.

(3) The purposes for which the loan is to be applied are:—

Construction of a Community Youth Centre (part cost) \$20,000

(4) The manner in which the loan is to be liquidated is by provision out of the Municipal Fund in each half year during the currency of the loan of the sum of \$1,381.88 approximately which includes principal and interest.

(5) Plans and specifications and the estimated cost of the proposed works and a statement showing the proposed expenditure of the moneys to be borrowed are open for inspection at the Office of the Council, Town Hall, Fitzroy, during office hours.

3245

J. JAMES, Town Clerk.

Town and Country Planning Act 1961 (Twelfth Schedule).

CITY OF GEELONG WEST.—GEELONG PLANNING SCHEME 1959 (AMENDING SCHEME No. 12).

NOTICE THAT A PLANNING SCHEME HAS BEEN PREPARED AND IS AVAILABLE FOR INSPECTION.

Notice is hereby given that the City of Geelong West, in pursuance of its powers under the *Town and Country Planning Act 1961*, has prepared a Planning Scheme for all land within the City of Geelong West.

The purpose of the Scheme is—

1. Amend the Non Conforming Use provisions of the Ordinance.

A copy of the scheme has been deposited at the Town Hall, 153 Pakington-street, Geelong West, and at the Office of the Town and Country Planning Board, 235 Queen-street, Melbourne, and will be open for inspection during office hours by any person, free of charge.

Any persons affected by the Planning Scheme are required to set forth in writing all objections they may have, addressed to the Town Clerk, Town Hall, 153 Pakington-street, Geelong West, on or before the 11th day of August, 1973, and state whether they wish to be heard in respect of these objections.

Dated 3rd July, 1973.

3234

R. J. HAMMETT, Town Clerk.

CITY OF KEILOR.

LOAN No. 122.

Notice of Intention to Borrow the Sum of \$250,000 for Permanent Works and Undertakings.

Notice is hereby given that the Council of the City of Keilor intends to borrow the principal sum of two hundred and fifty thousand dollars (\$250,000) secured by a charge over the general rates of the municipality, such sum to be raised by the grant of a mortgage in accordance with the provisions of the *Local Government Act 1958*.

1. The maximum rate of interest that may be paid is 6.9 per cent per annum.

2. Such moneys shall be repayable at Local Authorities Superannuation Board, Queens-road, Melbourne.

3. The loan is to be liquidated by providing out of the municipal fund 40 half yearly instalments of approximately \$11,616.19 each including principal and interest on the 1st day of August and the 1st day of February during the currency of the loan. The first instalment shall be payable on the 1st day of February, 1974.

4. The purpose for which the loan is to be applied is—

| | |
|---|----------|
| (a) Development of Reserves | \$50,000 |
| (b) Establishment of Branch Libraries | 40,000 |
| (c) Purchase of Land for Municipal Purposes | 160,000 |

5. The period of the loan shall be twenty years.

The plans, specifications and an estimate of the cost of the proposed works and a statement showing the proposed expenditure of the moneys to be borrowed are open for inspection at the Municipal Offices, Keilor.

3286

R. F. B. KELLY, Town Clerk.

CITY OF KNOX.

LOAN No. 111.

Notice of Intention to Borrow the Sum of \$250,000 for Permanent Works and Undertakings.

Notice is hereby given that the Council of the City of Knox in pursuance of powers conferred by the *Local Government Acts*, intends to borrow the sum of \$250,000 secured by a charge over the general rates of the municipality, such sum to be raised by the grant of a mortgage, in accordance with the said Acts and states:—

(a) The amount of principal moneys it is proposed to borrow is \$250,000.

(b) The maximum rate of interest that may be paid is 6.6 per cent. per annum.

(c) The period of the loan will be ten years and the time or times at which the moneys borrowed are to be repayable is on the 1st day of February and the 1st day of August in each year during the currency of the loan commencing on the 1st day of February, 1974, until the final payment on 1st day of August, 1983.

(d) The purpose for which the loan is to be applied is for permanent works and undertakings, viz.:

| | |
|--|-----------|
| 1. Fairpark Reserve Pavilion | \$6,000 |
| 2. Traffic Lights | 40,000 |
| 3. Toilet Block—Guy Turner Reserve | 5,000 |
| 4. Playground Construction | 5,000 |
| 5. New City Offices (part cost) | 50,000 |
| 6. Contribution to C.R.B. Burwood Highway works | 20,000 |
| 7. Dobson Park Pavilion | 31,000 |
| 8. Recreation Reserves improvements—Bayswater Ward | 31,000 |
| 9. Road and path improvements and Recreation Reserve improvements—Boronia Ward | 31,000 |
| 10. Road improvements and Recreation Reserve improvements—Rowville/Scoresby Ward | 31,000 |
| | \$250,000 |

(e) The loan is to be liquidated by half-yearly payments of approximately \$17,273.45 including principal and interest, payable out of the municipal fund.

(f) The place of repayment will be Australia and New Zealand Banking Group Limited, 206 Dorset-road, Boronia.

Plans and specifications and an estimate of the cost of such works and undertakings, and a statement showing the proposed expenditure of the money to be borrowed, are open for inspection by ratepayers, during office hours, at the City Offices, Fern Tree Gully, for one month after the publication of this notice.

Dated at Fern Tree Gully, this 5th day of July, 1973.

3308

N. G. HAYNES, Town Clerk.

CITY OF NUNAWADING.

BY-LAW No. 82.

Adoption of Fifteenth Schedule By-law.

A By-law of the City of Nunawading made under Section 197 of the *Local Government Act 1958* and numbered 82 for adopting certain of the provisions of the Fifteenth Schedule to the said Act and carrying out the purpose provided for in the said schedule.

In pursuance of the powers conferred by the *Local Government Act 1958* and of any and every other power it thereunto enabling the Mayor Councillors and Citizens of the City of Nunawading orders as follows:

1. This By-law may be known as the Adoption of Fifteenth Schedule By-law.

2. So much of By-law No. 4 of the Shire of Blackburn and Mitcham relating to the adoption of certain of the provisions of the Thirteenth Schedule of the *Local Government Act 1928* as has not already been repealed is hereby repealed.

3. Such of the provisions of the Fifteenth Schedule to the *Local Government Act 1958* as are set out hereunder are hereby adopted, namely—

Part I—Streets and Footways:

- (1) Porticos and projections, etc.—Clauses 1, 2, 5, 6 and 7.
- (2) Naming streets, exhibiting traffic control signs and numbering houses—Clauses 8, 8A, 10 and 11.
- (3) Spouts and drains from houses, etc.—Clauses 12–14 both inclusive.
- (4) Crossings over footways and channels—Clauses 15–26 both inclusive.
- (6) Depositing building materials excavations, etc.—Clauses 29–37 inclusive.
- (7) Lighting etc. of obstructions generally—Clauses 38 and 39.
- (8) Houses, etc. encroaching on streets—Clause 40.
- (9) Obstructions, etc. to streets etc. by cattle, etc.—Clauses 41–45 both inclusive.
- (11) Miscellaneous—Clauses 47–49 both inclusive.

Part II—Waterworks, drains, etc.—Clause 6.

Part VI.—Buildings, etc. for public meetings, etc. Clauses 1–4 both inclusive.

4. (a) The owners or occupiers of houses or buildings shall on the gate or gatepost or on such other conspicuous position as the Council determines or approves mark such houses or buildings with such numbers for the purpose of distinguishing the same as the Council may from time to time direct or approve.

(b) In addition to complying with the requirements of paragraph (a) of this clause the owners or occupiers of buildings in which there are two or more separate dwellings shall on the front door of each such separate dwelling or on such other conspicuous position as the Council determines or approves mark such separate dwelling with such number for the purpose of distinguishing the same as the Council may from time to time direct or approve.

(c) Such owners or occupiers shall renew the numbers of such houses buildings or separate dwellings as often as they are obliterated or defaced.

(d) If any owner or occupier of any such house building or separate dwelling shall neglect for one week after notice to him from the Council so to mark such house building or separate dwelling with such number as the Council may direct or approve or to renew the number thereof as aforesaid he shall forfeit a sum not exceeding \$4.00 and the Council may cause such number to be so marked or renewed and recover the expense thereof from the owner or occupier of such house building or separate dwelling before any justice and where such is paid by or recovered from the occupier he may deduct the same from any rent payable by him to the owner.

5. This By-law shall apply to and have operation throughout the municipal district.

Resolution for passing this By-law agreed to by the Council of the City of Nunawading on the twenty-eighth day of May 1973 and confirmed on the eighteenth day of June 1973.

The corporate seal of the Mayor Councillors and Citizens of the City of Nunawading was hereunto affixed in the presence of:

(SEAL) F. R. TAYLOR, Mayor.
C. P. C. JAMES, Councillor.
E. J. JANE, Town Clerk.

3302

CITY OF NUNAWADING.

Whereas the Council of the City of Nunawading deems it expedient to exercise its power of taking compulsorily the land described in the Schedule at the foot hereof for the purpose of providing a site for a Pre-School Centre: and whereas the Council has caused to be prepared a map and other papers setting out the general description of the work or undertaking, for which the land proposed to be taken is to be used the description of the land proposed to be taken and the names of the owners or reputed owners, lessees or reputed lessees, mortgagees and occupiers of that land so far as those names are shown to or can be ascertained by the Council: and whereas the said map and other papers are deposited at the office of the said Council at Nunawading and are and shall be open for inspection by all persons interested at all reasonable hours for the space of 40 clear days after the publication of this notice in the *Government Gazette*: now notice is hereby given to all persons affected by the proposed taking of the said land to set forth, in writing, addressed to the Council or the Town Clerk within 40 clear days of the publication of this notice in the *Government Gazette*, all objections which they may have to the taking of the said land.

SCHEDULE HEREINBEFORE REFERRED TO.

All that piece of land being part of Crown allotment 105, Parish of Nunawading, County of Bourke, and being allotment 49 on plan of subdivision 33849, lodged in the Office of Titles, Melbourne, contained within a boundary line commencing at the north-westerly corner of the said allotment 49; thence on a bearing of 88 deg. 45 min. for a distance of 123 ft. 5 in.; thence on a bearing of 178 deg. 57½ min. for a distance of 54 feet; thence on a bearing of 268 deg. 45 min. for a distance of 123 ft. 3 in.; thence on a bearing of 358 deg. 45 min. for a distance of 54 feet to the point of commencement.

Dated the 9th day of July, 1973.

By Order of the Council,

3353 E. J. JANE, Town Clerk.

CITY OF NUNAWADING.

Whereas the Council of the City of Nunawading deems it expedient to exercise its power of taking compulsorily the land described in the Schedule at the foot hereof for the purpose of providing a site for a Pre-School Centre: and whereas the Council has caused to be prepared a map and other papers setting out the general description of the work or undertaking, for which the land proposed to be taken is to be used the description of the land proposed to be taken and the names of the owners or reputed owners, lessees or reputed lessees, mortgagees and occupiers of that land so far as those names are known to or can be ascertained by the Council: and whereas the said map and other papers are deposited at the office of the said Council at Nunawading and are and shall be open for inspection by all persons interested at all reasonable hours for the space of 40 clear days after the publication of this notice in the *Government Gazette*: now notice is hereby given to all persons affected by the proposed taking of the said land to set forth, in writing, addressed to the council or the Town Clerk within 40 clear days of the publication of this notice in the *Government Gazette*, all objections which they may have to the taking of the said land.

SCHEDULE HEREINBEFORE REFERRED TO.

All that piece of land being part of Crown allotment 105, Parish of Nunawading, County of Bourke, and being allotment 52 on plan of subdivision 33849, lodged in the Office of Titles, Melbourne, contained within a boundary line commencing at the north-westerly corner of the said allotment 52; thence on a bearing of 88 deg. 45 min. for a distance of 123 ft. 3 in.; thence on a bearing of 178 deg. 57½ min. for a distance of 54 feet; thence on a bearing of 268 deg. 45 min. for a distance of 123 ft. ½ in.; thence on a bearing of 358 deg. 45 min. for a distance of 54 feet to the point of commencement.

Dated the 9th day of July, 1973.

By Order of the Council,

3354 E. J. JANE, Town Clerk.

CITY OF PRAHRAN.

BY-LAW No. 256.

A By-law of the City of Prahran made under Section 198 of the *Local Government Act 1958* and numbered 256 for the purpose of regulating or prohibiting the erection construction conversion or alteration and of any addition to buildings.

In pursuance of the powers conferred by Section 198 of the *Local Government Act 1958* as amended the Mayor, Councillors and Citizens of the City of Prahran order as follows—

1. That By-law 252 of the said City is hereby repealed.
2. The erection construction conversion or alteration of any new or existing building or erection in any area within the Municipality of Prahran without the written permission of the Council of the said Municipality or the Building Surveyor of the said Municipality is prohibited from midnight on any Saturday to midnight on the following Sunday. Provided that this By-law shall not be applicable—
 - (a) to any person who himself performs any work as aforesaid on his own property or
 - (b) to any person who without material reward himself performs any work as aforesaid on any property in which he resides,
 - (c) to any such work performed by or under the direction of the Mayor Councillors and Citizens of the City of Prahran.

3. This By-law shall apply to and have operation throughout the City of Prahran.

4. Any wilful contravention of this By-law shall be an offence against this By-law.

5. Any person guilty of an offence against this By-law shall be liable—

- (a) to a penalty of not less than \$20 and not more than \$100, and
- (b) to a further penalty of not more than \$10 for each day on which the offence is continued after conviction or order by any Court.

Resolution for the making and passing this By-law agreed to by the Council of the City of Prahran on the 4th day of December, 1972, and confirmed on the 5th day of February, 1973.

The common seal of the Mayor, Councillors and Citizens of the City of Prahran was hereunto affixed in the presence of—

(SEAL) W. M. DANE, Mayor.
JOHN R. HOLDSWORTH, Councillor.
JOHN A. LUCAS, Town Clerk.

Approved by the Governor in Council on the 3rd day of July, 1973.—T. J. FORRISTAL, Clerk of the Executive Council. 3365

CITY OF PRAHRAN.

BY-LAW No. 257.

A By-law of the City of Prahran made under Part VII Division I of the *Local Government Act 1958* and numbered 257 for:—

- (a) Controlling and regulating the use of premises with a view to preventing objectionable noise at unreasonable times.
- (b) Suppressing nuisances, and
- (c) Prohibiting or minimizing noises in any public highway.

In pursuance of the powers conferred by Part VII Division I of the *Local Government Act 1958* and every other Act or powers enabling it in that behalf the Council of the City of Prahran doth order as follows—

1. By-law No. 245 of the said City is hereby repealed.
2. In this By-law unless the context otherwise requires 'Clause' means clause of this By-law.

'Council' means the Council of the City of Prahran.
'Instrument' means any instrument, device or thing whatsoever capable of making or transmitting or being used for making or transmitting any noise and without affecting the generality of the foregoing includes any loud-speaker amplified, broadcasting set, wireless, receiving set, television set, radio, gramophone, musical instrument or any similar device.

'Person' includes a corporation.

Words importing the masculine gender include the feminine and the singular number includes the plural and the plural the singular.

3. No person shall cause or permit or suffer any objectionable noise at an unreasonable time to emanate from any land or premises of which he is the owner, occupier or person in charge so as to materially interfere with the reasonable comfort of any person in any premises adjacent thereto.

4. No person shall in or adjacent to or in or on any premises or land adjacent to any public highway cause or permit or suffer any loud noise in such public highway by—

- (a) using operating or working any instrument, or
- (b) shouting or making any loud outcry, or
- (c) singing or haranguing.

5. Notwithstanding anything contained in Clause 4—

- (a) any member of—
 - (i) the police force
 - (ii) any fire brigade
 - (iii) any ambulance service, or
 - (iv) any first aid or civil defence organisation,

or

- (b) any officer or employee of—
 - (i) any public utility or
 - (ii) the corporation of the City of Prahran,
 who is performing any of the duties he is lawfully permitted or required to perform may use, operate or work any instrument in or adjacent to any public highway in the performance of his duties.

6. Any person guilty of a wilful act or default contrary to this By-law shall be liable on conviction—

- (a) to a penalty of not less than \$20 and not more than \$100 and
- (b) to a further penalty of not more than \$10 for each day on which the offence is continued after a conviction or order by any court.

7. This By-law shall apply and have operation throughout the whole of the municipal district of the City of Prahran.

Resolution for making and passing this By-law agreed to by the Council of the said City the 5th day of March, 1973, and confirmed the 16th April, 1973.

The common seal of The Mayor, Councillors and Citizens of the City of Prahran was hereunto affixed in the presence of—

(SEAL) W. M. DANE, Mayor.
F. T. FARRALL, Councillor.
JOHN A. LUCAS, Town Clerk.

Approved by the Governor in Council on the 3rd day of July, 1973.—T. J. FORRISTAL, Clerk of the Executive Council. 3366

CITY OF RINGWOOD.

CHANGE OF STREET NAME.

Notice is hereby given that the Council of the City of Ringwood did resolve at a meeting of the Council held on the 2nd July, 1973, to rename the following street:

That the name of the street heretofore known as—
Park-street, Heathmont (running east off Marlborough-road),
be now known as—
Waters-grove, Heathmont.

3296

A. W. HALL, Town Clerk.

TOWN OF PORTLAND.

CHANGE OF NAME OF STREETS.

Notice is hereby given that in pursuance of the powers conferred by the *Local Government Act 1958*, as amended the Council of the Town of Portland at a meeting on the 26th June, 1973, did resolve to make the following alterations to street names:—

Old Name; New Name; Location.

Government-road; Amity-road; from Barkly-street easterly between Crown allotments 19 and 84A to north-west corner of Crown allotment 84, section 13, Parish of Portland.

Government-road; Barton-place; from Cliff-street, northerly.

Government-road; Burnis'-road; from north end of Parker's-road westerly to north end of Pitts'-road.

Government-road; Burville's-road; from Parker's-road westerly through Crown allotments 8 and 9, section 6, to Pitts'-road.

Government-road; Corney-street; from Tipping-street westerly between sections 6A and 7A, Township of Portland, to Railway Reserve.

Government-road; Derril-road; from Cape Nelson-road westerly between Crown allotment 60b, Township of Portland, and Plantation Reserve, then north-westerly through Public Park; then northerly and westerly between Public Park and Crown allotment 5, section 5 to Maling's-road.

Government-road; Marie-road; from Aerodrome, southerly between Crown allotments 17 and 23, 16 and 86, section 13, to Coastal Reserve.

Government-road; Kerr's-road; from intersection of Lalor and Wyatt streets, south-westerly through Crown allotments 14, 13 and 12, section 6, to Town Boundary.

Government-road; Maling's-road; from south end of West Boundary-road, south-westerly between Public Park and Crown allotment 3 of section 7 to intersection of Derril-road at Town Boundary.

Government-road; Marie-road; from Aerodrome, southerly, between Crown allotments 23 and 88A, 24 and 86, section 13, to Coastal Reserve.

Government-road; Myrtle-road; from Cape Nelson-road easterly, north-easterly and northerly along boundaries of New Cemetery and Crown allotments 10, 4 and 3, section 13, to Derril-road.

Government-road; Nestor-road; from Aerodrome northerly and north-easterly between eastern boundary of Aerodrome and Crown allotment 88, then easterly between Crown allotment 88 and Quarantine Station Reserve to Coastal Reserve.

Government-road; Olearia-road; from Sheoke-road easterly between Crown allotments 1, 2, 9, 11 and 13, section 13, to Tecoma-road.

Government-road; Orana-drive; (extension) from Wellington-road and Orana-drive intersection westerly between Crown allotments 15, 8 and 12, then northerly between Crown allotments 5A, 3B and 3A, section 13, to Derril-road.

Government-road; Rebecca-road; from Barkly-street, westerly between Crown allotments 79, 18 and 78 to north-east corner of Crown allotment 81, section 13.

Government-road; Sheoke-road; from Cape Nelson-road southerly between sections 11 and 13 to Coastal Reserve.

Government-road; Smith-street; from Wyatt-street, northerly between Camping Reserve and Crown allotments 32 and 34, section 6A, to Bridgewater-road.

Government-road; Tamar-road; from east end of Orana-drive, southerly and northerly along west boundary of Aerodrome and Crown allotments 87 and 43B3 of section 13.

Government-road; Tecoma-road; from Orana-drive, south-westerly between Crown allotments 11, 12 and 14, then southerly between Crown allotments 13 and 14, section 13, to Coastal Reserve.

Government-road; Thistle-road; from Orana-drive, south-easterly between Crown allotments 15, 17 and 16, section 13, to Coastal Reserve.

Dated this 11th day of July, 1973.

3236 L. FELL, Town Clerk.

SHIRE OF BRIGHT.

BY-LAW No. 33.

A By-law of the Shire of Bright (hereinafter referred to as the "Municipality") made under and in pursuance of the Local Government Acts and the Uniform Building Regulations, Victoria, and numbered thirty-three, for determining, applying, dispensing with or regulating such matters or things as are left to be determined, applied or dispensed with, or required by the Council of the Shire of Bright under the Uniform Building Regulations, Victoria.

In pursuance of the powers conferred by the Local Government Acts and the Uniform Building Regulations, Victoria, or of any and every other power enabling them in that behalf, the President, Councillors and Ratepayers of the Shire of Bright order as follows:—

OPERATION AND DATE OF COMING INTO FORCE.

1. This By-law shall apply to and have operation in the Bright Riding of the municipal district of the Shire of Bright and shall be read in conjunction with the Uniform Building Regulations, Victoria.

2. This By-law shall come into operation and have effect immediately upon publication of the notice of the making hereof in the *Victoria Government Gazette*.

MINIMUM DISTANCE FROM FRONTAGE.

3. Notwithstanding anything contained in the Regulations, the minimum distance of the outer walls of any building in Class I, or Class II, Occupancy from the frontage of an allotment of land on which the building is constructed shall be twenty-five (25) feet.

Resolution for passing this By-law was agreed to by the Council of the Shire of Bright on the 8th day of March, 1973, and the same was confirmed on the 10th day of May, 1973.

The common seal of the President, Councillors and Ratepayers of the Shire of Bright was hereto affixed by order of the Council of the said Shire on the 10th day of May, 1973.

(SEAL) C. W. MACGILL, President.
J. H. WALLACE, Councillor.
H. G. HAYMES, Shire Clerk.

Approved by the Governor in Council, the 12th day of June, 1973.—T. J. FORRISTAL, Clerk of the Executive Council. 3309

SHIRE OF COBRAM.

SPECIAL ORDER.

Private Street Loan No. 36.

Notice is hereby given that a meeting held on 2nd July, 1973, the Council of the Shire of Cobram did by Special Order resolve to borrow the sum of \$9,200 for the period of 5 years at the rate of 6.2 per cent to be repaid by making half-yearly payments of principal and interest amounting to \$1,084.03 to the A.N.Z. Banking Group, 394 Collins-street, Melbourne, on 1st March and 1st September each year, during the period of the loan.

The purpose of the loan is to repay the balance of Loan No. 16 borrowed in 1963, for financing private street schemes then under construction.

And further notice is given that this Resolution will be confirmed at a meeting to be held in the Council Chambers, Cobram, on Monday, 6th August, 1973, commencing at 8 p.m.

3266 R. T. CUTTS, Shire Secretary.

Pounds Act 1958.

SHIRE OF DUNMUNKLE.

Take notice that the Shire of Dunmunkle did on the 26th day of June, 1973, appoint the following as the site for a pound in the Shire of Dunmunkle:—

All that piece of land comprising two (2) acres three (3) roods fourteen (14) perches in the south-west corner of the Public Park, Racecourse and Recreation Reserve, situated in the Parish of Lallat, County of Borung, set aside as Sheep Dip and Pound, for which the Council was granted permissive occupancy.

3240 K. E. LIEBOLD, Shire Secretary.

SHIRE OF DUNMUNKLE.

Notice is hereby given of the appointment of Messrs. Wayne John Yole, 32 Breen-street, Murtoa, and Barry Roy Jackson, 3 Petering-street, Minyip, as proper officers under the *Dog Act 1970*, in place of Leon Charles Connor.

3238 K. E. LIEBOLD, Shire Secretary.

SHIRE OF ELTHAM.

LOAN No. 98.

Notice of Intention to Borrow.

Notice is hereby given that the Council of the Shire of Eltham, intends to borrow Seventy thousand dollars (\$70,000) secured by a charge over the General rates of the municipality by the grant of a Mortgage in accordance with the provisions of the Local Government Acts.

In connection therewith the following information is stated:—

- The amount of the principal moneys which it is proposed to borrow is Seventy thousand dollars.
- The maximum rate of interest that may be paid is 6.3 per centum per annum.
- The times which the moneys borrowed are to be repayable are the 26th day of December, 1973, and the 26th days of June and December, during the Years 1973–1988 inclusive and that the place such moneys shall be repayable is at the Bank of New South Wales, Eltham.
- The purpose for which the loan is to be applied is:

Erection of pavilion for tennis courts at Montmorency Park.

Erection of Infant Welfare Centre at Research (net cost after Government Grant).

Erection of 3 pre-school centres being at Montmorency, Eltham, Hurstbridge (net cost after Government Grants and contributions by the Shire of Diamond Valley).

Total sum required \$70,000.

- (e) The manner in which the loan is to be liquidated is by provision out of the Municipal Fund in each half-year during the currency of the loan of the sum of \$2,611.14 plus a final payment of \$52,812.42 which includes principal and interest.

The plans and specifications and estimate of the cost of the works and a statement showing the proposed expenditure of the moneys to be borrowed are open for inspection at the Shire Office.

Dated this 6th day of July, 1973.

COLIN J. BOCK, Shire Secretary/Chief Administrative Officer. 3285

SHIRE OF ELTHAM.

NOTICE OF INTENTION TO TAKE LAND COMPULSORILY.

Notice is hereby given that—

1. The Council of the Shire of Eltham intends to establish a reserve in Main-road (Eltham-Yarra Glen-road) for the provision of:—

- (a) a drainage reserve;
(b) a place of public resort and recreation.

2. For the purpose of executing such work the Council deems it expedient to exercise its power of taking compulsorily, a portion of land being part of Crown portion 13, section 4, Parish of Nillumbik, County of Evelyn, commencing at a point 223 ft. 9 in. in a southerly direction from the intersection of the prolongations of the eastern building line of Eltham-Yarra Glen road and the southern building line of Elsa-court and thence 40 ft. 6 in. bearing 169 deg. 1½ min.; thence 92 ft. 8½ in. easterly bearing 66 deg. 16 min.; thence 38 ft. 3 in. bearing 353 deg. 48 min. with the remaining side being a creek Title boundary running in a westerly direction to the commencement point, such land being situated adjacent to lot 1 on L.P.33351, and abutting onto a drainage reserve on L.P.33351 and being part of the land more particularly described in certificate of title, volume 8122, folio 097.

3. The Council has caused to be prepared maps and other papers describing the proposed work or undertaking and this land proposed to be taken, together with the names of every owner or reputed owner, every lessee or reputed lessee, every mortgagee, and the occupier thereof as far as such names can be ascertained by the Council.

4. Such maps and other papers are deposited at the Shire Offices, Main-road, Eltham, where they are and will remain open for inspection by all persons interested, at all reasonable hours for the space of 40 clear days after publication of this notice in the *Government Gazette*.

5. All persons affected by the proposed work or undertaking are hereby called upon to set forth, in writing, addressed to the Council, or the Shire Secretary, of the Shire of Eltham, within 40 clear days from the publication of this notice in the *Government Gazette*, viz., 11th July, 1973, all objections which they may have to the said work or undertaking.

Dated this 11th day of July, 1973.

COLIN J. BOCK, Shire Secretary/Chief Administrative Officer. 3281

Water Acts.

SHIRE OF GLENELG WATERWORKS TRUST.

PROPOSED EXTENSION OF WATERWORKS DISTRICT AND PROCLAMATION OF AN URBAN DISTRICT.

Notice is hereby given that the Shire of Glenelg Waterworks Trust has made application to the Honorable the Minister of Water Supply for the extension of its Waterworks District, and for the proclamation of an Urban District at Merino, and the construction maintenance and continuance of Water Supply Works within that district under the provisions of the Water Acts.

A general plan and description of the proposed works have been submitted with the application, and copies of same may be seen at the Trust Office, Town Hall, Casterton.

Dated at Casterton this 6th day of April, 1973.

3295

J. B. HANSEN, Secretary.

Town and Country Planning Act 1961.

SHIRE OF GISBORNE.—SHIRE OF GISBORNE PLANNING SCHEME.

NOTICE THAT A PLANNING SCHEME HAS BEEN PREPARED AND IS AVAILABLE FOR INSPECTION.

Notice is hereby given that the Shire of Gisborne in pursuance of its powers under the *Town and Country Planning Act 1961*, has prepared a Planning Scheme for the Shire of Gisborne for the purpose of controlling development in an orderly manner, and that after consideration of the Adopted Scheme with modifications and alterations, the Minister has determined that the Scheme shall be placed upon public exhibition for a period of three months.

A copy of the Scheme has been deposited at the Shire Office, Gisborne and at the Town and Country Planning Board, 235 Queen-street, Melbourne, and will be open for inspection during office hours by any person free of charge.

Any persons affected by the Planning Scheme are required to set forth in writing all objections they may have addressed to the Shire Secretary, Shire Office, Gisborne, on or before the 16th day of October, 1973, and to state whether they wish to be heard in respect of their objections.

Dated the 11th day of July, 1973.

3299

K. V. ROBINSON, Shire Secretary.

SHIRE OF GISBORNE.

Whereas the Council of the Shire of Gisborne deems it expedient to execute the work or undertaking of providing the land described hereunder for municipal property and whereas for the purpose thereof the exercise of the power of taking land compulsorily will in the opinion of the Council be necessary and desirable and whereas the Council has caused to be prepared maps and other papers showing a general description of the work or undertaking for which the land proposed to be taken is to be used, a description of the lands proposed to be taken and the names of the owners or reputed owners lessees or reputed lessees mortgagees occupiers of such lands so far as those names are known to or can be ascertained by the Council and whereas such maps and other papers are deposited at the office of the said Council situate at Gisborne and are open for inspection by all persons affected by the proposed taking of lands during normal office hours for the space of forty clear days, after the publication of this notice in the *Government Gazette*, now notice is hereby given to all persons affected by the proposed taking of the said land to set forth in writing addressed to Council or the Shire Secretary within forty clear days of the publication of this notice in the *Government Gazette* all objections which they may have to the taking of the said land.

All that part of Crown allotment 6, section 6, Township and Parish of Gisborne situated westerly of the eastern boundary of the pitched open drain through Crown allotment 6.

Dated this 6th day of July, 1973.

3300

By Order of the Council,

K. V. ROBINSON, Shire Secretary.

SHIRE OF HUNTLY.

Whereas the Council of the Shire of Huntly deems it expedient to execute its powers of taking compulsorily the land described in the Schedule hereto for the purpose of erecting new Council Chambers and developing Municipal gardens, pursuant to section 511 of the *Local Government Act 1958*, and acquiring the said land for that purpose: And whereas the Council has caused to be prepared plans setting out the general description of the work or undertaking for which the land proposed to be taken is to be used, the description of the land proposed to be taken and the names of the owners or reputed owners, lessees or reputed lessees, mortgagees and occupiers of that land so far as those names are known or can be ascertained by the Council: And whereas the said plan and other papers are deposited at the office of the said Council at Huntly and are and shall be open for inspection by all persons interested at all reasonable hours for the space of 40 clear days after publication of this notice: Now it is hereby given to all persons affected by the proposed taking of the said land to set forth, in writing, addressed to the Council or the Shire Secretary within 40 clear days of the publication of this notice, all objections which they may have to the taking of the said land.

THE SCHEDULE HEREINBEFORE REFERRED TO.

Crown allotments 25, 27 and 28, Township and Parish of Huntly.

Dated the 5th day of July, 1973.

3351

H. McK. SILKE, Shire Secretary.

SHIRE OF LILLYDALE.

APPOINTMENT OF PROSECUTING OFFICER.

Notice is hereby given that Senior Sergeant Keva Lewis Barnard, No. 11579, has been appointed Prosecuting Officer for the Shire of Lillydale, in lieu of Senior Sergeant I. N. Hanrahan, No. 11174, transferred.

3348 F. O. KENT, Shire Secretary.

SHIRE OF OTWAY.

Notice is hereby given that Aileen Daffy of Gellibrand River, has been appointed poundkeeper of the Gellibrand River Pound.

2nd July, 1973.

By Order of the Council,

3239

T. J. FRY, Shire Secretary.

SHIRE OF SOUTH BARWON.

LOAN NO. 101.

Private Streets Construction.

Notice is hereby given that at the meeting of the Council of the Shire of South Barwon, held at the South Barwon Council Chamber, Thompson-street, Belmont, on Tuesday, 15th May, 1973, the said Council did agree to the following Resolution—

“That this Council by special order resolve to borrow Eighty thousand dollars (\$80,000), to be secured by a charge over the general rates of the municipality by the grant of a mortgage in accordance with the provisions of the Local Government Act.

In connection therewith the following information is stated—

- The amount of the principal moneys which it is proposed to borrow is \$80,000.
- The rate of interest to be paid is 6.2 per centum per annum.
- The times which the moneys borrowed are to be repayable are the 1st day of January and the 1st day of July, during the currency of the loan. The first instalment shall be payable on the 1st January, 1974, and the final instalment shall be payable on the 1st July, 1983. The place the moneys shall be repayable is the Bank of New South Wales, Belmont.
- The purpose for which the said loan shall be applied is for the construction of private streets under the provision of Division 10 of Part XIX. of the Local Government Act 1958 as amended.
- The loan shall be liquidated from the receipts of money payable under schemes under Division 10 of Part XIX. of the Local Government Act 1958 by twenty half-yearly repayments of approximately \$5,427.09 which includes principal and interest.”

Notice is further given that at the meeting of the said Council, held at the South Barwon Council Chamber, Thompson-street, Belmont, on Tuesday, 3rd July, 1973, the said resolution was confirmed.

3276 H. W. S. JACKSON, Shire Secretary.

SHIRE OF STAWELL.

RE-NAMING OF STREET.

Notice is hereby given that the Council of the Shire of Stawell has renamed the following street located at Marnoo in the said municipality:—

Old Name.—Main-street.

New Name.—Newall-street.

3301 V. C. NIELSON, Shire Secretary.

BRIAGOLONG WATERWORKS TRUST.

Notice to the owners of tenements in the streets listed hereunder and in the private streets, lanes, courts and alleys opening thereto:—

Cahill-street, from 7.3 chains to 13.5 chains west of Forbes-street.

Rostrevor-avenue, from McLean-street to 6 chains eastwards.

The main pipe in the said street being laid down the owners of all tenements situated as above are hereby required on or before the 31st day of August next, to cause a proper pipe and stop cocks to be laid as to supply water within such tenements from the main pipe.

J. RENNICK, Secretary, Briagolong Waterworks Trust. 3267

Sewerage Districts Act 1958.

CASTLEMAINE SEWERAGE AUTHORITY.

GENERAL NOTICE.

Sewerage Area No. 59.—Winters Flat, Castlemaine.

The Castlemaine Sewerage Authority having made provision for carrying off the sewage from each and every property which or any part of which is within the sewerage area hereinafter described doth hereby declare that on and after the 1st day of July, 1973, each and every property which or any part of which is within the said sewerage area shall be deemed to be a seweraged property within the meaning of the Sewerage Districts Act 1958.

The boundaries of the sewerage area hereinbefore referred to are:—

Sewerage Area No. 59.

Commencing at a point being the intersection of the western boundary of Farnsworth-street and the southern boundary of Brown-street; thence westerly along the southern boundary of Brown-street to the north-western extremity of Crown allotment 4, section D6, Parish of Castlemaine; thence southerly along the western boundary of the said Crown allotment 4 for a distance of 282 links; thence due west to the eastern boundary of Butterworth-street; thence in a direct line to the north-eastern extremity of lot 2, lodged plan 93769; thence westerly along the northern boundaries of lot 2 and lot 1, lodged plan 93769 to the eastern boundary of Crown allotment 10, section D6, Parish of Castlemaine; thence northerly along the said boundary to the southern boundary of Brown-street; thence westerly along the said boundary to the north-western extremity of Crown allotment 13, section D6, Parish of Castlemaine; thence southerly along the western boundary of the said Crown allotment 13 to the northern boundary of Ray-street; thence south-westerly along the northern boundaries of Ray-street and of the Pyrenees Highway to the north-western boundary of Gaffney-street; thence northerly along the eastern boundary of Crown allotment 17, section D7, Parish of Castlemaine, to the north-eastern extremity of the said Crown allotment 17; thence westerly along the northern boundaries of Crown allotments 17, 16, 15, section D7, Parish of Castlemaine; thence southerly along the western boundary of the said Crown allotment 15 to the northern boundary of the Castlemaine-Shellbourne Railway Line reserve; thence south-easterly along the said boundary to the south-eastern extremity of lot 1, lodged plan 58457; thence northerly along the eastern boundary of the said lot 1; thence easterly along the southern boundaries of lots 2, 3 and 4, lodged plan 58457; thence southerly along the western boundary of lot 1, lodged plan 41327; thence easterly along the southern boundary of lots 1, 2, 3, 4 and 5, lodged plan 41327; thence northerly to the south-western extremity of lot 1, lodged plan 26391; thence south-easterly along the southern boundaries of lots 1, 2, 3, 4, 5, 6, 7 and 8, lodged plan 26391, and lots 1, 2, 3 and 4, lodged plan 23182, to the south-eastern extremity of lot 4, lodged plan 23182; thence in a direct line to the south-western extremity of Crown allotment 16, section D2, Parish of Castlemaine; thence south-easterly along the southern boundaries of Crown allotments 16, 17, 19, 20, 21, 22, 23, 24, 25, 26, 27, 28, 29 and 30, section D2, Parish of Castlemaine, to the south-eastern extremity of the said Crown allotment 30; thence southerly along the western boundaries of Crown allotments 37, 38, 39, 40, 41, 42, 43, 44, 45, 46, 47 and 48, section D2, Parish of Castlemaine; thence easterly to the south-eastern extremity of the said Crown allotment 48; thence in a direct line to the south-western extremity of Crown allotment 17A, section D1, Parish of Castlemaine; thence north-easterly along the eastern boundary of Johnstone-street to the northern extremity of Crown allotment 1, section D1, Parish of Castlemaine; thence northerly along the western boundary of Roberts-avenue to the north-eastern extremity of Crown allotment 1, section D5, Parish of Castlemaine; thence north-westerly along the northern boundary of Crown allotments 1, 2, 3, 58, 59, 60, 61, 62, 63, 64, 65, 9A and 10, section D5, Parish of Castlemaine, to the northern extremity of the said Crown allotment 10; thence in a direct line to the north-eastern extremity of Crown allotment 12, section D5, Parish of Castlemaine; thence along the northern boundary of Crown allotments 12 and 13, section D5, Parish of Castlemaine; thence south along the western boundary of the said Crown allotment 13 to the northern boundary of Elizabeth-street; thence westerly along the said boundary to the southern extremity of Crown allotment 11, section D5, Parish of Castlemaine; thence along the south-eastern boundary of Crown allotment 11 and 10, section D5, Parish of Castlemaine, to the south-eastern

extremity of the said Crown allotment 10; thence northerly to the southern boundary of Ray-street; thence easterly along the said boundary to the western boundary of Roberts-avenue and Farnsworth-street; thence northerly along the said boundary to the point of commencement.

By order of the Castlemaine Sewerage Authority,
JOHN HARCUS, Commissioner.
S. A. STEVENS, Secretary.

Dated this 25th day of June, 1973. 3271

FRANKSTON SEWERAGE AUTHORITY.

DECLARATION OF SEWERED AREAS NOS. 60 AND 61.

That the Frankston Sewerage Authority, having made provision for carrying off sewage from each and every property, which or any part of which is within the sewerage areas hereinafter described, doth hereby declare that on and after the 1st day of July, 1973, each and every property, which or any part of which is within the said sewerage areas shall be deemed to be a sewerage property within the meaning of the *Sewerage Districts Act 1958*.

The boundaries of the sewerage areas hereinbefore referred to are:—

Area No. 60.

Commencing at the corner of Hillcrest-road and Heatherhill-road, westerly and northerly along the boundary of declared area No. 58 and continuing northerly along Roberts-street and northerly and easterly along the boundary of declared area No. 45 to Hillcrest-road, then southerly along Hillcrest-road to the point of commencement.

Area No. 61.

Commencing at the corner of Kenilworth-avenue and Gulwa-avenue, easterly along Kenilworth-avenue to the Railway, south-easterly along the Railway Reserve to the rear boundary of lot 7 Kenilworth-avenue, then westerly along the rear boundaries of lots 7 to 1 L.P.87150 and lots 5 and 4 L.P.51311 Kenilworth-avenue to the north-eastern corner of lot 83 Gulwa-avenue, then south-westerly along the rear boundaries of lots 83 to 75 Gulwa-avenue and the side boundary of No. 57 Highview-road to Highview-road, then continuing south-westerly along Valley-road to Heatherhill-road, north-westerly along Heatherhill-road to Outlook-road, north-easterly along Outlook-road and continuing along the western side boundary of lot 1 L.P.80642 to the boundary of declared area No. 54, then generally north-westerly and easterly along the boundary of declared area No. 54 to the point of commencement.

By Order of the said Sewerage Authority,
B. AITKEN, Chairman.
G. C. PENTLAND, Secretary.

3244

GEMBROOK, COCKATOO AND EMERALD WATERWORKS TRUST.

NOTICE TO OWNERS OF TENEMENTS IN THE STREETS LISTED HEREUNDER.

The main pipes in the said streets being laid down the owners of all tenements in these streets are required on or before the 1st day of August, 1974, to cause a proper pipe and stop cocks to be laid so as to supply water within such tenements from the main pipe.

Emerald Urban District.

- Anne-street, from Church-street to Ogilvy-road.
- Belgrave-Gembrook road, from west end of Ogilvy-road to boundary of Urban District.
- Emerald Lake-road, from the end of the existing main opposite lot 33, lodged plan 43563, 250 feet easterly to a point opposite lot 30 lodged plan 43563.
- Jacka-road, whole length from Grieve-road to Wright-road.
- Ogilvy-road, whole length from Anne-street to Belgrave-Gembrook road.
- Wright-road, from Jacka-road 70 feet south-westerly to a point opposite lot 60.

Cockatoo Urban District.

- Allenby-street, from Kitchener-parade 700 feet northerly to a point opposite lot 145.
- Kitchener-parade, from end of existing main opposite lot 70, 200 feet easterly to a point opposite lot 67.

Menzies Creek Urban District.

- Belgrave-Gembrook road, from Urban District boundary to Menzies Creek-Clematis road.
- Menzies Creek-Clematis road, from Belgrave-Gembrook road to Aura Vale-road.

3270

BEATRICE THOMAS, Trust Secretary.

SEWERAGE DISTRICTS ACT.

PROPOSED SEWERAGE AUTHORITY.

Notice is hereby given that the Riddell's Creek Waterworks Trust has made application to the Honorable the Minister of Water Supply for the constitution of a Sewerage Authority and for the Proclamation of a Sewerage District at Riddell's Creek, and for the construction, maintenance and continuance of sewerage works within that district under the provisions of the Sewerage Districts Act.

A general plan and description of the proposed works have been submitted with the application and copies of same may be seen at Romsey Shire Office, and the vicinity of Riddell's Creek Post Office.

Dated at Riddell's Creek, the 3rd day of July, 1973.

3275 UNA I. WRIGHT, Trust Secretary.

NOTICE OF INTENTION TO APPLY FOR A LICENCE TO DIVERT WATER AND CUT RACE (RE-ISSUE) FROM LAKE HUME, AT TALGARNO.

We hereby give notice that we intend to apply for a licence empowering us to divert water for a term of four years to the extent of 30 acre-feet per annum at a maximum rate of 15 acre-feet per day of 24 hours for the irrigation of pasture, being part of allotment part 5 and 5A, section D, Parish of Talgarno, and to occupy certain Crown lands for works of diversion, and to cut a race thereon.

Any objection to such application must be forwarded, in writing, to reach the State Rivers and Water Supply Commission, Melbourne, before 9th August, 1973, being 30 days from the first publication of this notice.

ANGELA ROSE LEHMAN.
ALAN LEHMAN.

R.M.B. 4016, Wodonga, 3600. 3346

NOTICE OF INTENTION TO APPLY FOR A LICENCE TO DIVERT WATER AND CUT RACE FROM THE RIVER MURRAY, AT ROBINVALE.

I hereby give notice that I intend to apply for a licence empowering me to divert water for a term of four years to the extent of 204 acre-feet (252 ml.) per annum at a maximum rate of 6 acre feet (7.4 ml.) per day of 24 hours for the irrigation of 68 acres (28 ha.) of market garden, olives and vines, being allotment 3A, Parish of Tol Tol, and to occupy certain Crown lands for works of diversion, and to cut a race thereon.

Any objection to such application must be forwarded, in writing, to reach the State Rivers and Water Supply Commission, Melbourne, before 9th August, 1973, being 30 days from the first publication of this notice.

EFSTATHIOS VAVARIS.

P.O. Box 171, Robinvale. 3377

Notice is hereby given that Lusteroid (Victoria) Proprietary Limited has applied for a lease pursuant to sections 134 and 135 of the *Land Act 1958*, for a term of 25 years, in respect of allotments 1 and 2, section 101A, City of South Melbourne, containing 981.3 square metres as a site for commercial and industrial purposes. 3160

Notice is hereby given of the termination and dissolution of the partnership now carried on under the firm name of M. Noonan & Sons between Michael Joseph Noonan (Senior) and Michael Joseph Noonan (Junior) and Robert James Noonan which pursuant to a notice of dissolution and termination dated the 15th day of June, 1973, were given by the said Michael Joseph Noonan (Junior), dated the 15th day of June, 1973, will be dissolved on and from 30th June, 1973.

CORR & CORR, solicitors, Melbourne. 3319

Notice is hereby given that the partnership heretofore subsisting between Harry Wason McCutcheon, Ronald Harold Thorn, Keith William George Watson, Harold Edward Touzel, John Harold McCutcheon, John Sutherland Bell, David Kingsley Lindly, James William Milroy Campbell and Ian Robert Anderson, carrying on business under the style or firm of Robertson Darling & Wolfenden, of Horwath & Horwath and of H. G. McCutcheon & Co., has been dissolved with effect from the 14th March, 1973.

Dated the 28th day of June, 1973.

3328

H. W. McCUTCHEON.

Notice is hereby given that the partnership between International Marketing Consultants Pty. Ltd., J. Taal, H. Geddes and G. Cooper was terminated and dissolved as at the 6th day of June, 1973. The partnership was carried on in the name of "Complete Decor of Australia". 3330

Notice is hereby given that the partnership heretofore subsisting between John Henry Carrick Brown, late of 6 Cecil-street, Eltham, pharmaceutical chemist, deceased, and Norman Ernest Charles Williams, of 121 Mount Pleasant-road, Eltham, pharmaceutical chemist, carrying on business as pharmaceutical chemists under the business name of Thompson's Pharmacy, at 964 Main-road, Eltham; 1022 Main-road, Eltham; 97 Main-road, Lower Plenty, and 88 Station-street, Fairfield, has been dissolved by reason of the death of the said John Henry Carrick Brown, as from the 29th day of May, 1973. The business is being carried on by the said Norman Ernest Charles Williams.

Dated the 28th day of June, 1973.

Signed in Victoria by Felon Ronald Avis, as executor of the estate of the said John Henry Carrick Brown in the presence of Heather De Henptinne. Signed in Victoria by the said Norman Ernest Charles Williams in the presence of B. T. Charlton.

3341 F. R. AVIS.
N. E. C. WILLIAMS.

Notice is hereby given that the partnership heretofore subsisting between Margery Annie Kiernan, John Bernard Amery Kiernan, Robert George Kiernan and Beryl Jean Kiernan, carrying on business under the style or firm name of "Kiernan & Sons", has been dissolved as from the 1st day of July, 1972, as far as concerns the said Robert George Kiernan and the said Beryl Jean Kiernan, who both retire from the said firm.

Dated this 26th day of June, 1973.

3230 MARGERY A. KIERNAN.
JOHN B. KIERNAN.
R. G. KIERNAN.
BERYL J. KIERNAN.
Doyle & Kerr, solicitors, Terang.

Notice is hereby given that the partnership heretofore subsisting between the undersigned Joyce Veronica McDonald and Graham James Mitchell, carrying on the business of ladies hairdressers, at 84A Wyndham-street, Shepparton, under the name of Hair-Tis' Salon has been dissolved by mutual consent as from the 1st day of February, 1973. All debts due to and owing by the said late firm will be received and paid by Graham James Mitchell who will continue to carry on the business at the same place.

Dated this 29th day of June, 1973.

3268 GRAHAM MITCHELL.
JOYCE V. McDONALD.

Notice is hereby given that the partnership heretofore subsisting between the undersigned Charles Patrick Tobin, Mary Eris Tobin, James Ignatius Tobin and Kathleen May Tobin, all of Eskdale in Victoria, carrying on business as farmers and graziers at Eskdale, under the name of "C. & J. Tobin & Co." has been dissolved by mutual consent as from 30th day of June, 1973.

All debts due to and owing by the said late firm will be received and paid from 90 High-street, Wodonga.

Dated at Wodonga the 2nd day of July, 1973.

3265 C. P. TOBIN.
J. I. TOBIN.
M. E. TOBIN.
K. TOBIN.

Notice is hereby given that the partnership heretofore subsisting between Raymond Lindsay Prince and Marie Joan Prince, both of 27 Thomas-street, Benalla, and Robert William Holmes and Cynthia Dawn Holmes, both of 6 Samaria-road, Benalla, carrying on business at 43 Bridge-street, Benalla, under the style or firm name of "Benalla Fashion House", has been dissolved as from the 30th June, 1973, so far as concerns the said Raymond Lindsay Prince and the said Marie Joan Prince who retire from the said firm. The business will be carried on as and from the 1st of July, 1973, at the same address under the same firm name by the said Robert William Holmes and the said Cynthia Dawn Holmes.

Dated the 3rd day of July, 1973.

3272 R. L. PRINCE.
M. J. PRINCE.
R. W. HOLMES.
C. D. HOLMES.

Notice is given that the partnership between Helmut Willi Holz, of 7 Kay-street, Mount Waverley, butcher, and Johanna Holz, of 7 Kay-street, Mount Waverley, married woman, carrying on business as butchers, delicatessen and small goods manufacturers, at 167 Acland-street, St. Kilda, under the name of "Village Belle Butchery & Delicatessen", has been dissolved as from the 1st day of July, 1973.

J. A. REDMOND & CO., solicitors. 3374

Notice is hereby given that the partnership in the Kwong Tung Café heretofore subsisting between Chung Peng, Chao Chen Tung and Chao Chen Leung, carrying on business at 16 Bourke-street, Melbourne, has been dissolved as from the 31st day of December, 1972, in so far as concerns the said Chung Peng, who retires from the said partnership.

3370 CHUNG PENG.
CHAO CHEN TUNG.
CHAO CHEN LEUNG.

PASCOE PLASTER PRODUCTS PROPRIETARY LIMITED.
SPECIAL RESOLUTION TO WIND UP.

Pursuant to Section 254 of the Companies Act 1961.

At an Extraordinary General Meeting of the above-named company, duly convened and held at 111 St. Andrews-street, Brighton, on the 30th day of June, 1973, the following Resolution was duly passed as a Special Resolution:—

"That the company be wound up voluntarily."

And at such last-mentioned meeting Victor Francis Selwyn McGrath was appointed liquidator for the purpose of the winding up.

Notice is hereby given that after 21 days from this date I shall proceed to distribute the assets. All creditors having any claims against the company should furnish particulars of same by that date, otherwise I shall proceed to distribute the assets without regard to their claim.

Dated this 2nd day of July, 1973. 3251

Form 7.
Companies Act 1961.
BOX HILL CONTAINERS PTY. LIMITED.

NOTICE OF RESOLUTION.

Section 146 (1), Section 254 (2).

To the Registrar of Companies:

At the General Meeting of members of Box Hill Containers Pty. Limited duly convened and held at McCauley-street, Matraville, N.S.W., on the 29th day of June, 1973, the Special Resolution set out below was duly passed.

"(a) That the company be wound up voluntarily and that Alfred Barclay Cleland, a chartered accountant and a registered company liquidator, residing at 54 Addison-avenue, Roseville, in the State of New South Wales, and having an office at 15-19 Bent-street, Sydney, in the said State, be and he is hereby appointed liquidator for the purposes of such winding up.

(b) That the liquidator be and he is hereby authorized when and so soon as the debts and liabilities of the company shall have been paid, satisfied or duly provided for to distribute in specie or kind amongst the members of the company in accordance with their respective rights and interests therein the whole or any part of the assets of the company as he shall think fit."

Dated this 4th day of July, 1973. 3252

Form 7.
Companies Act 1961.
JOHNELL PTY. LIMITED.

NOTICE OF RESOLUTION.

Section 146 (1), Section 254 (2).

To the Registrar of Companies:

At a General Meeting of members of Johnell Pty. Limited duly convened and held at McCauley-street, Matraville, N.S.W., on the 29th day of June, 1973, the Special Resolution set out below was duly passed.

"(a) That the company be wound up voluntarily and that Alfred Barclay Cleland, a chartered accountant and a registered company liquidator, residing at 54 Addison-avenue, Roseville, in the State of New South Wales, and having an office at 15-19 Bent-street, Sydney, in the said State, be and he is hereby appointed liquidator for the purposes of such winding up.

(b) That the liquidator be and he is hereby authorized when and so soon as the debts and liabilities of the company shall have been paid, satisfied or duly provided for to distribute in specie or kind amongst the members of the company in accordance with their respective rights and interests therein the whole or any part of the assets of the company as he shall think fit."

Dated this 4th day of July, 1973. 3253

Form 7.

Companies Act 1961.

CARLTON BOX (HOLDINGS) PTY. LIMITED.

NOTICE OF RESOLUTION.

Section 146 (1), Section 254 (2).

To the Registrar of Companies:

At a General Meeting of members of Carlton Box (Holdings) Pty. Limited duly convened and held at McCauley-street, Matraville, N.S.W., on the 29th day of June, 1973, the Special Resolution set out below was duly passed.

"(a) That the company be wound up voluntarily and that Alfred Barclay Cleland, a chartered accountant and a registered company liquidator, residing at 54 Addison-avenue, Roseville, in the State of New South Wales, and having an office at 15-19 Bent-street, Sydney, in the said State, be and he is hereby appointed liquidator for the purposes of such winding up.

(b) That the liquidator be and he is hereby authorized when and so soon as the debts and liabilities of the company shall have been paid, satisfied or duly provided for to distribute in specie or kind amongst the members of the company in accordance with their respective rights and interests therein the whole or any part of the assets of the company as he shall think fit.

(c) That Article 27 of the Company's Articles of Association be amended by inserting the figures '66' between the figures '64' and '69'."

Dated this 4th day of July, 1973.

3254

Form 7.

Companies Act 1961.

PRAHRAN BOX CO. PTY. LIMITED.

NOTICE OF RESOLUTION.

Section 146 (1), Section 254 (2).

To the Registrar of Companies:

At a General Meeting of members of Prahran Box Co. Pty. Limited duly convened and held at McCauley-street, Matraville, N.S.W., on the 29th day of June, 1973, the Special Resolution set out below was duly passed.

"(a) That the company be wound up voluntarily and that Alfred Barclay Cleland, a chartered accountant and a registered company liquidator, residing at 54 Addison-avenue, Roseville, in the State of New South Wales, and having an office at 15-19 Bent-street, Sydney, in the said State, be and he is hereby appointed liquidator for the purposes of such winding up.

(b) That the liquidator be and he is hereby authorized when and so soon as the debts and liabilities of the company shall have been paid, satisfied or duly provided for to distribute in specie or kind amongst the members of the company in accordance with their respective rights and interests therein the whole or any part of the assets of the company as he shall think fit."

Dated this 4th day of July, 1973.

3255

Form 7.

Companies Act 1961.

SPECIALTY CONTAINERS PROPRIETARY LIMITED.

NOTICE OF RESOLUTION.

Section 146 (1), Section 254 (2).

To the Registrar of Companies:

At a General Meeting of members of Specialty Containers Proprietary Limited duly convened and held at McCauley-street, Matraville, N.S.W., on the 29th day of June, 1973, the Special Resolution set out below was duly passed.

"(a) That the company be wound up voluntarily and that Alfred Barclay Cleland, a chartered accountant and a registered company liquidator, residing at 54 Addison-avenue, Roseville, in the State of New South Wales, and having an office at 15-19 Bent-street, Sydney, in the said State, be and he is hereby appointed liquidator for the purposes of such winding up.

(b) That the liquidator be and he is hereby authorized when and so soon as the debts and liabilities of the company shall have been paid, satisfied or duly provided for to distribute in specie or kind amongst the members of the company in accordance with their respective rights and interests therein the whole or any part of the assets of the company as he shall think fit."

Dated this 4th day of July, 1973.

3256

Form 7.

Companies Act 1961.

Section 146 (1), Section 254 (2).

SAF-PAK BOXES (VIC.) PROPRIETARY LIMITED.

NOTICE OF RESOLUTION.

To the Registrar of Companies:

At a General Meeting of members of Saf-Pak Boxes (Vic.) Proprietary Limited duly convened and held at McCauley-street, Matraville, N.S.W., on the 29th day of June, 1973, the Special Resolution set out below was duly passed.

"(a) That the company be wound up voluntarily and that Alfred Barclay Cleland, a chartered accountant and a registered company liquidator, residing at 54 Addison-avenue, Roseville, in the State of New South Wales and having an office at 15-19 Bent-street, Sydney, in the said State, be and he is hereby appointed liquidator for the purposes of such winding up.

(b) That the liquidator be and he is hereby authorized when and so soon as the debts and liabilities of the company shall have been paid, satisfied or duly provided for to distribute in specie or kind amongst the members of the company in accordance with their respective rights and interests therein the whole or any part of the assets of the company as he shall think fit."

Dated this 4th day of July, 1973.

3257

Form 7.

Companies Act 1961.

Section 146 (1), Section 254 (2).

CARLTON BOX CO. (S.A.) PTY. LIMITED.

NOTICE OF RESOLUTION.

To the Registrar of Companies:

At a General Meeting of members of Carlton Box Co. (S.A.) Pty. Limited duly convened and held at McCauley-street, Matraville, N.S.W., on the 29th day of June, 1973, the Special Resolution set out below was duly passed.

"(a) That the company be wound up voluntarily and that Alfred Barclay Cleland, a chartered accountant and a registered company liquidator, residing at 54 Addison-avenue, Roseville, in the State of New South Wales and having an office at 15-19 Bent-street, Sydney, in the said State, be and he is hereby appointed liquidator for the purposes of such winding up.

(b) That the liquidator be and he is hereby authorized when and so soon as the debts and liabilities of the company shall have been paid, satisfied or duly provided for to distribute in specie or kind amongst the members of the company in accordance with their respective rights and interests therein the whole or any part of the assets of the company as he shall think fit.

(c) That Article 27 of the Company's Articles of Association be amended by inserting the figures '66' between the figures '64' and '69'."

Dated this 4th day of July, 1973.

3258

Form 7.

Companies Act 1961.

Section 146 (1), Section 254 (2).

CARLTON BOX INDUSTRIES PROPRIETARY LIMITED.

NOTICE OF RESOLUTION.

To the Registrar of Companies:

At a General Meeting of members of Carlton Box Industries Proprietary Limited duly convened and held at McCauley-street, Matraville, N.S.W., on the 29th day of June, 1973, the Special Resolution set out below was duly passed.

"(a) That the company be wound up voluntarily and that Alfred Barclay Cleland, a chartered accountant and a registered company liquidator, residing at 54 Addison-avenue, Roseville, in the State of New South Wales and having an office at 15-19 Bent-street, Sydney, in the said State, be and he is hereby appointed liquidator for the purposes of such winding up.

(b) That the liquidator be and he is hereby authorized when and so soon as the debts and liabilities of the company shall have been paid, satisfied or duly provided for to distribute in specie or kind amongst the members of the company in accordance with their respective rights and interests therein the whole or any part of the assets of the company as he shall think fit."

Dated this 4th day of July, 1973.

3260

Form 7.

Companies Act 1961.

Section 146 (1), Section 254 (2).

NOTICE OF RESOLUTION.

CARLTON BOX CO. PROPRIETARY LIMITED.

To the Registrar of Companies:

At a General Meeting of members of Carlton Box Co. Proprietary Limited duly convened and held at McCauley-street, Matraville, N.S.W., on the 29th day of June, 1973, the Special Resolution set out below was duly passed.

"(a) That the company be wound up voluntarily and that Alfred Barclay Cleland, a chartered accountant and a registered company liquidator, residing at 54 Addison-avenue, Roseville, in the State of New South Wales and having an office at 15-19 Bent-street, Sydney, in the said State, be and he is hereby appointed liquidator for the purposes of such winding up.

(b) That the liquidator be and he is hereby authorized when and so soon as the debts and liabilities of the company shall have been paid, satisfied or duly provided for to distribute in specie or kind amongst the members of the company in accordance with their respective rights and interests therein the whole or any part of the assets of the company as he shall think fit."

Dated this 4th day of July, 1973. 3261

Form 7.

Companies Act 1961.

Section 146 (1), Section 254 (2).

CARLTON CONTAINERS (MANFG.) CO. PROPRIETARY LIMITED.

NOTICE OF RESOLUTION.

To the Registrar of Companies:

At a General Meeting of members of Carlton Containers (Manfg.) Co. Proprietary Limited duly convened and held at McCauley-street, Matraville, N.S.W., on the 29th day of June, 1973, the Special Resolution set out below was duly passed.

"(a) That the company be wound up voluntarily and that Alfred Barclay Cleland, a chartered accountant and a registered company liquidator, residing at 54 Addison-avenue, Roseville, in the State of New South Wales and having an office at 15-19 Bent-street, Sydney, in the said State, be and he is hereby appointed liquidator for the purposes of such winding up.

(b) That the liquidator be and he is hereby authorized when and so soon as the debts and liabilities of the company shall have been paid, satisfied or duly provided for to distribute in specie or kind amongst the members of the company in accordance with their respective rights and interests therein the whole or any part of the assets of the company as he shall think fit."

Dated this 4th day of July, 1973. 3262

Form 7.

Companies Act 1961.

Section 146 (1), Section 254 (2).

CARLTON BOX (MANFG.) CO. PTY. LIMITED.

NOTICE OF RESOLUTION.

To the Registrar of Companies:

At a General Meeting of members of Carlton Box (Manfg.) Co. Pty. Limited duly convened and held at McCauley-street, Matraville, N.S.W., on the 29th day of June, 1973, the Special Resolution set out below was duly passed.

"(a) That the company be wound up voluntarily and that Alfred Barclay Cleland, a chartered accountant and a registered company liquidator, residing at 54 Addison-avenue, Roseville, in the State of New South Wales and having an office at 15-19 Bent-street, Sydney, in the said State, be and he is hereby appointed liquidator for the purposes of such winding up.

(b) That the liquidator be and he is hereby authorized when and so soon as the debts and liabilities of the company shall have been paid, satisfied or duly provided for to distribute in specie or kind amongst the members of the company in accordance with their respective rights and interests therein the whole or any part of the assets of the company as he shall think fit."

Dated this 4th day of July, 1973. 3263

Companies Act 1961, Section 254 (2) (b).

NORMAN CROOME PTY. LIMITED.

Notice is hereby given that at an Extraordinary General Meeting of the members of the above-named company held on the 29th day of June, 1973, it was resolved that the company be wound up voluntarily and that Donald Robertson, F.A.S.A., of 1 High-street, Windsor, public accountant, be appointed liquidator.

Notice is also given that after 21 days from this date the liquidator shall proceed to distribute the assets. All creditors having any claims against the company should furnish particulars of the same by that date otherwise the assets will be distributed without regard to their claim.

Dated the 6th day of July, 1973.

WM. R. HUNT, M.A., LL.B., solicitor, 358 Lonsdale-street, Melbourne. 3343

Companies Act 1961.

NOTICE OF MEETING OF CREDITORS OF HOADLEYS CABINETS PROPRIETARY LIMITED (IN LIQUIDATION).

PURSUANT TO SECTIONS 232 (3) (b), 237 (2) AND 241 (1) AND FORM 92 OF THE COMPANIES REGULATIONS 28 (2) (b) AND 46 (2).

Notice is hereby given that a meeting of the creditors of Hoadleys Cabinets Proprietary Limited will be held at the Palm Lake Motel, 52 Queens-road, Melbourne, on Friday, 20th day of July, 1973, at 2 o'clock in the afternoon.

Agenda:

(i) To receive the company's statement of affairs together with a list of creditors and the estimated amount of their claims.

(ii) To fix the remuneration of the liquidator.

(iii) If thought fit to appoint a committee of inspection.

NOTE.—That a person is not entitled to vote as a creditor at the meeting unless he has lodged with the chairman of the meeting a proof of debt which he claims to be due to him from the company.

Dated this 17th day of July, 1973.

IAN KENNETH MacKINNON, Official Liquidator.

John MacKinnon & Co., chartered accountants, Suite 12, 562 St. Kilda-road, Melbourne, 3004 3344

The Companies Act 1961—In the matter of the following companies (in Voluntary Liquidation).—Members' Winding Up.

ROBISON BROTHERS & CO. PTY. LTD.
KENT PLATE PRODUCTS PTY. LTD.
ROBBIES DOMESTIC APPLIANCES PTY. LTD.

Notice is hereby given that at the Extraordinary General Meeting of each of the above-named companies duly convened and held at 406 Collins-street, Melbourne, in the State of Victoria, on the 27th day of June, 1973, the following Resolution was proposed and passed as a Special Resolution.

"That the company be wound up voluntarily".

Dated this 5th day of July, 1973.

3288 R. W. BETTS, liquidator.

MAXMARNIA PROPRIETARY LIMITED.

SPECIAL RESOLUTION TO WIND UP, PURSUANT TO SECTION 254 OF THE COMPANIES ACT 1961.

At an Extraordinary General Meeting of the above-named company, duly convened and held at the offices of A. H. G. Clarke & Co., 460 Bourke-street, Melbourne, on the 29th day of June, 1973, the following Resolution was duly passed as a Special Resolution:—

"That in accordance with the provisions of section 254 of the Companies Act 1961, the company be wound up voluntarily."

And at such last mentioned meeting, Percival Russell Devenish, of 460 Bourke-street, Melbourne was appointed liquidator for the purpose of the winding up.

Dated this 29th day of June, 1973.

3283 P. R. DEVENISH, Liquidator.

E.M.P. HOLDINGS PTY. LTD.

At the Meeting of Members of E.M.P. Holdings Pty. Ltd., held on 30th June, 1973, the following Resolution was passed as a Special Resolution:—

"That the company be wound up voluntarily and that a liquidator be appointed for the purposes of winding up."

3264 M. B. CRABB, Liquidator.

L. E. ELLIOTT PROPRIETARY LIMITED.
SPECIAL RESOLUTION TO WIND UP, PURSUANT TO SECTION 254
OF THE COMPANIES ACT 1961.

At an Extraordinary General Meeting of the above-named company, duly convened and held at 328 Alma-road, North Caulfield, on the 30th day of June, 1973, the following Resolution was duly passed as a Special Resolution:—

“That the company be wound up voluntarily.”

And at such last-mentioned meeting Mr. Victor Francis Selwyn McGrath was appointed liquidator for the purpose of the winding up. Notice is hereby given that after 21 days from this date I shall proceed to distribute the assets. All creditors having any claims against the company should furnish particulars of same by that date, otherwise I shall proceed to distribute the assets without regard to their claims.

Dated this 2nd day of July, 1973. 3249

Companies Act 1961, Section 254.
J. H. WILLIAMS & CO. PTY. LTD.

Notice is hereby given that an Extraordinary Meeting of members of the above-named company, held on Tuesday, the 3rd July, 1973, the following Resolution was passed as a Special Resolution:—

It was resolved by Special Resolution that the company be wound up voluntarily as a members' winding up and that John William Dwyer be appointed liquidator.

3243 J. W. DWYER, Liquidator.

T. C. GLEESON & SON PTY. LTD. (IN LIQUIDATION).

Notice is hereby given pursuant to section 272 of the Companies Act 1961 that a general meeting of the members of T. C. Gleeson & Son Pty. Ltd., will be held on 25th August, 1973, at 9.30 a.m., at the office of R. A. Budge, Suite 2, 34 Swan-street, Richmond, for the purpose of having an account laid before them showing the manner in which the winding up of the company has been conducted, the property disposed of, and the giving of any explanations by liquidator.

Dated 30th June, 1973.

3237 R. A. BUDGE, Liquidator.

Companies Act 1961.

BURNETS PTY. LTD. (IN VOLUNTARY LIQUIDATION).
NOTICE OF LIQUIDATOR'S FINAL MEETING.

Take notice that the Final Meeting of members of Burnets Pty. Ltd. (in Voluntary Liquidation) is called for 10 o'clock in the forenoon of Monday, the 13th day of August, 1973, at the office of the liquidator, Geoffrey Lyon, 1st Floor, 3 Lyon-street, Leongatha, when the final accounts of the liquidation will be presented.

Dated this 28th day of June, 1973.

3280 GEOFFREY LYON, Liquidator.

CHER INVESTMENTS PROPRIETARY LIMITED.

At an Extraordinary General Meeting of the above-mentioned company duly convened and held at 125 Kepler-street, Warrnambool, on Monday, 9th July, 1973, the following Resolution was duly passed as a Special Resolution:—

“That the company be wound up voluntarily.”

At the same meeting John Vincent Coffey, whose office is at 119 Kepler-street, Warrnambool, was appointed liquidator for the purposes of the winding up.

Dated the 10th day of July, 1973.

J. V. COFFEY, Liquidator.
J. S. Tait & Co., solicitors, Warrnambool. 3273

In the matter of the Companies Act 1961; and in the matter of NAREEN INVESTMENTS PTY. LIMITED (in Voluntary Liquidation).—Notice of Final Meeting of Members pursuant to section 272.

Notice is hereby given in pursuance of section 272 of the Companies Act 1961 that a General Meeting of the members of the company will be held at the office of N. M. Randall, Room 802A, 150 Queen-street, Melbourne, on the 17th day of August, 1973, at 4.30 o'clock in the afternoon for the purpose of having an account laid before it showing the manner in which the winding up has been conducted and the property of the company disposed of, and hearing any explanation that may be given by the liquidator.

Dated this 5th day of July, 1973.

3274 N. M. RANDALL, Liquidator.

Company No. 43316.—Companies Act 1961.—In the matter of EDWAL PROPRIETARY LIMITED (in Voluntary Liquidation).

Notice is hereby given that at an Extraordinary General Meeting of the members of the above-named company held on the 29th day of June, 1973, it was resolved that the company be wound up voluntarily and that Mr. Robert Gordon Cameron, of 162 Albert-road, South Melbourne, chartered accountant, be appointed liquidator.

Notice is also given that after 21 days from this date I shall proceed to distribute the assets. All creditors having any claims against the company should furnish particulars of same by that date otherwise I shall proceed to distribute the assets without regard to their claim.

Dated this 4th day of July, 1973.

3277 R. GORDON CAMERON, Liquidator.

The Companies Act 1961.—In the matter of NEWMORR MOTORS PROPRIETARY LIMITED.—Notice of Final Meeting.

Notice is hereby given that, pursuant to section 272 of the Companies Act 1961, a General Meeting of the members of the above-named company will be held at 219 Millers-road, North Altona, on Wednesday, 15th August, 1973, at 12 noon, for the purpose of having an account laid before them showing the manner in which the winding up has been conducted and the property of the company disposed of, and of hearing any explanation that may be given by the liquidator.

Dated the 28th day of June, 1973.

3278

The Companies Act 1961.—In the matter of GARTH ADHESIVES PTY. LTD. (in Liquidation).

A First Dividend is intended to be declared in the above-mentioned matter. Creditors who have not proved their debts by the 31st day of July, 1973, will be excluded from the dividend.

Dated this 10th day of July, 1973.

J. M. WALSH, Liquidator.

Kennedy, Smail & Middlemiss, 296 Little Lonsdale-street, Melbourne. 3334

Companies Act 1961.

EMELL INVESTMENTS PTY. LIMITED (IN VOLUNTARY LIQUIDATION).

Notice is hereby given that in pursuance of section 272 of the Companies Act 1961, a general meeting of the members of the company will be held at the office of Fitzgerald, Gunn & Partners, Tenth Floor, 470 Collins-street, Melbourne, on Wednesday, the 15th day of August, 1973, at 12 noon, for the purpose of receiving the liquidator's final account of the winding up of the company and of hearing any explanation that may be given by the liquidator and to determine the period after which the books and papers of the company and of the liquidator may be destroyed.

Dated this 5th day of July, 1973.

3335 J. R. BALLANTYNE, Liquidator.

Companies Act 1961.

SWAN HILL MILK PRODUCTS LIMITED.
MEMBERS' VOLUNTARY WINDING UP.

Notice is hereby given that on the 27th June, 1973, the members of the company passed a Special Resolution to wind up the company by way of members' voluntary winding up, and that Rockley Rex Crozier, of 37 Queen-street, Melbourne, be appointed liquidator for the purpose of winding up the affairs and distributing the assets of the company.

R. R. CROZIER, Liquidator.

Leane & Crozier, chartered accountants, 37 Queen-street, Melbourne. 3336

Companies Act 1961.

SWANCO DAIRYFARMERS LIMITED.
MEMBERS' VOLUNTARY WINDING UP.

Notice is hereby given that on the 27th June, 1973, the members of the company passed a Special Resolution to wind up the company by way of members' voluntary winding up, and that Rockley Rex Crozier, of 37 Queen-street, Melbourne, be appointed liquidator for the purpose of winding up the affairs and distributing the assets of the company.

R. R. CROZIER, Liquidator.

Leane & Crozier, chartered accountants, 37 Queen-street, Melbourne. 3337

The Companies Act 1961.—In the Matter of the Following Companies (in Voluntary Liquidation).—Members' Winding Up:—

FIRST KLIM PTY. LTD.
SECOND KLIM PTY. LTD.
THIRD KLIM PTY. LTD.
CRANBOURNE DAIRIES HOLDINGS LTD.
GOLDEN PURA DAIRY PTY. LTD.
ATLAS IMPORT & EXPORT CO. PTY. LTD.
NORTH MELBOURNE DAIRIES PTY. LTD.
BELLETT & COOK PTY. LTD.
BENSON HOLDINGS PTY. LTD.
FOURTH KLIM PTY. LTD.
NINTH KLIM PTY. LTD.
FIFTH KLIM PTY. LTD.
THIRTEENTH KLIM PTY. LTD.
DOVETON DAIRY PTY. LTD.
SIXTEENTH KLIM PTY. LTD.
HATHERLEIGH DAIRY PTY. LTD.
HOLLYHILL DAIRY PTY. LTD.
TENTH KLIM PTY. LTD.
SIXTH KLIM PTY. LTD.
KILMORE—BROADFORD DAIRY CO. PTY. LTD.
SEVENTH KLIM PTY. LTD.
ELEVENTH KLIM PTY. LTD.
FOURTEENTH KLIM PTY. LTD.
MOOROOLBARK DAIRY PTY. LTD.
ORMOND DAIRY PTY. LTD.
FIFTEENTH KLIM PTY. LTD.
SUNBEAM DAIRIES PTY. LTD.
TEMPLESTOWE DAIRY PTY. LTD.
TOWT'S ROSEHILL DAIRY PTY. LTD.
EIGHTH KLIM PTY. LTD.
TWELFTH KLIM PTY. LTD.
YORK BUTTER FACTORIES PTY. LTD.

Notice is hereby given that, at the Extraordinary General Meeting of each of the above-named companies, duly convened and held at Railway-crescent, Broadmeadows, in the State of Victoria, on the 30th day of June, 1973, the following Resolution was proposed and passed as a Special Resolution:—

"That the company be wound up voluntarily."

Dated this 3rd day of July, 1973.

3287 R. W. BETTS, Liquidator.

Under the Companies Act 1961.—Notice of a Meeting of Creditors and Members of ADAMS EARTHMOVING PROPRIETARY LIMITED, Pursuant to Section 203A (1) of the Companies Act.

Notice is hereby given that a meeting of creditors and members of the above company will be held at the Palm Lake Motel, 52 Queens-road, Melbourne, on 20th July, 1973, at 10.30 in the forenoon.

Agenda.

(i) To lay before the creditors and members a statement of assets and liabilities and receipts and payments of the company as at 22nd June, 1973, and to receive a report in regard thereto from the official manager.

(ii) To consider a Resolution as to whether the official management of the company should be continued.

(iii) To consider what legal action should be authorized for the official manager to undertake on behalf of the company concerning moneys that are considered due to the company.

(iv) To consider a resolution that the official manager commence legal action to obtain the recovery of such moneys as may be considered by him to be recoverable, and to obtain unlimited indemnities from the creditors to cover all costs of such legal action.

The above-mentioned statements and report will be available for inspection at the office of John MacKinnon & Co., chartered accountants, on the 19th day of July, 1973, between the hours of 9 a.m. and 5 p.m.

Dated this 11th day of July, 1973.

IAN KENNETH MACKINNON, Official Manager.

John MacKinnon & Co., chartered accountants, Suite 12, 562 St. Kilda-road, Melbourne, 3004. 3304

W. J. YOUNG & SONS PROPRIETARY LIMITED (IN LIQUIDATION).

Notice is hereby given that at a meeting held on 22nd June, 1973, at 1063 Centre-road, South Oakleigh, the above-named company passed a Special Resolution to wind up, the winding up to be a members voluntary winding up.

3269 J. K. LAND, Liquidator.

Under the Companies Act 1961.—Notice of a Meeting of Creditors and Members of JAMES S. ADAMS & Co. PROPRIETARY LIMITED, Pursuant to Section 203A (1) of the Companies Act.

Notice is hereby given that a meeting of creditors and members of the above company will be held at the Palm Lake Motel, 52 Queens-road, Melbourne, on 20th July, 1973, at 10.30 in the forenoon.

Agenda.

(i) To lay before the creditors and members a statement of assets and liabilities and receipts and payments of the company as at 22nd June, 1973, and to receive a report in regard thereto from the official manager.

(ii) To consider a Resolution as to whether the official management of the company should be continued.

(iii) To consider what legal action should be authorized for the official manager to undertake on behalf of the company concerning moneys that are considered due to the company.

(iv) To consider a resolution that the official manager commence legal action to obtain the recovery of such moneys as may be considered by him to be recoverable, and to obtain unlimited indemnities from the creditors to cover all costs of such legal action.

The above-mentioned statements and report will be available for inspection at the office of John MacKinnon & Co., chartered accountants, on the 19th day of July, 1973, between the hours of 9 a.m. and 5 p.m.

Dated this 11th day of July, 1973.

IAN KENNETH MACKINNON, Official Manager.

John MacKinnon & Co., chartered accountants, Suite 12, 562 St. Kilda-road, Melbourne, 3004. 3305

Companies Act 1961.

THE PENSHURST & DISTRICT BUTTER & CHEESE CO. LIMITED.

MEMBERS' VOLUNTARY WINDING UP.

Notice is hereby given that on the 27th June, 1973, the members of the company passed a Special Resolution to wind up the company by way of members' voluntary winding up, and that Rockley Rex Crozier, of 37 Queen-street, Melbourne, be appointed liquidator for the purpose of winding up the affairs and distributing the assets of the company.

R. R. CROZIER, Liquidator.

Leane & Crozier, chartered accountants, 37 Queen-street, Melbourne. 3338

Companies Act 1961.

ESKDALE ENTERPRISES PTY. LIMITED.

MEMBERS' VOLUNTARY WINDING UP.

Notice is hereby given that on the 27th June, 1973, the members of the company passed a Special Resolution to wind up the company by way of members' voluntary winding up, and that Rockley Rex Crozier, of 37 Queen-street, Melbourne, be appointed liquidator for the purpose of winding up the affairs and distributing the assets of the company.

R. R. CROZIER, Liquidator.

Leane & Crozier, chartered accountants, 37 Queen-street, Melbourne. 3339

Companies Act 1961.

THE CONDAH CO-OPERATIVE BUTTER & CHEESE FACTORY CO. LIMITED.

MEMBERS' VOLUNTARY WINDING UP.

Notice is hereby given that on the 27th June, 1973, the members of the company passed a Special Resolution to wind up the company by way of members' voluntary winding up, and that Rockley Rex Crozier, of 37 Queen-street, Melbourne, be appointed liquidator for the purpose of winding up the affairs and distributing the assets of the company.

R. R. CROZIER, Liquidator.

Leane & Crozier, chartered accountants, 37 Queen-street, Melbourne. 3340

Companies Act 1961, Section 254 (2).

JACK MILLER & SONS PROPRIETARY LIMITED (IN VOLUNTARY LIQUIDATION).

Notice is hereby given that at an Extraordinary General Meeting of the above-named company held on 2nd July, 1973, the following Special Resolution was duly passed:—

"That the company would be wound up voluntarily".

P. F. CLARKE, Liquidator.

Manning & Perry, chartered accountants, 175 King-street, Melbourne. Telephone 67 6861. 3306

Companies Act 1961.

STARK'S DEVELOPMENT PROPRIETARY LIMITED (IN VOLUNTARY LIQUIDATION).

NOTICE CONVENING FINAL MEETING OF MEMBERS PURSUANT TO SECTION 272.

Notice is hereby given, in pursuance of section 272 of the *Companies Act 1961*, that a meeting of the members of the above-named company will be held on the 13th of August, 1973, at the office of John Rezak and Co., 66-68 Albert-road, South Melbourne, at 11 a.m. for the purpose of having an account laid before them showing the manner in which the winding up has been conducted and the property of the company disposed of, and hearing any explanations that may be given by the liquidator.

Dated this 4th day of July, 1973.

JOHN REZAK, Liquidator.

John Rezak and Co., public accountants, 66-68 Albert-road, South Melbourne, 3205. 3307

Companies Act 1961, Section 254.

F. E. PARKINSON PTY. LTD.

Notice is hereby given that at an Extraordinary General Meeting of the members of the above-named company held on 3rd July, 1973, the following resolution was passed as a Special Resolution:—

"That this company be wound up as a members' voluntary liquidation and that Robert Arthur Waters, of 470 Bourke-street, Melbourne, be appointed liquidator."

3318

R. A. WATERS, Liquidator.

In the matter of HOUGHTON & BYRNE (VIC.) PTY. LIMITED (in Voluntary Liquidation).

Notice is hereby given that at an extraordinary general meeting of the above-named company duly convened and held at the offices of Mr. Maxwell James Scott, care of J. S. Eastwood & Etherington, 450 Little Collins-street, Melbourne, Victoria, on the 4th July, 1973, the following Special Resolutions were duly passed—

"That the company be wound up voluntarily, and that the company appoint Maxwell James Scott, care of J. S. Eastwood & Etherington, 450 Little Collins-street, Melbourne, Victoria, as liquidator of the company".

Dated this 4th day of July, 1973.

3329

M. J. SCOTT, Liquidator.

Companies Act 1961.—In the matter of APARTMENTS PTY. LTD. (in Liquidation).

Notice is hereby given that a final meeting of members of the above-named company will be held at 2.00 p.m. on Monday, 6th August, 1973, at the office of Lewis Luckins & Co., 1st Floor, 130 Flinders-street, Melbourne, pursuant to section 272 of the *Companies Act 1961*, for the purpose of laying before the meeting an account showing how the winding up has been conducted and how the assets have been disposed of and also passing a resolution in compliance with section 284 (2) of the *Companies Act 1961*.

Dated this 9th day of July, 1973.

LEWIS LUCKINS, F.C.A., Liquidator.

Lewis Luckins & Co., chartered accountants, 130 Flinders-street, Melbourne, 3000. Telephone 63 8827. 3331

TURNER LUFKIN PTY. LTD. (IN LIQUIDATION):

NOTICE OF FINAL GENERAL MEETING.

Notice is hereby given, pursuant to section 272 of the *Companies Act 1961*, that the affairs of the company have been fully wound up and that a Final Meeting of shareholders will be held at the office of Edwin V. Nixon & Partners, 440 Collins-street, Melbourne, on Monday, 13th August, 1973, at 11 a.m., for the purpose of laying before it the liquidators account showing the manner in which the winding up has been conducted and the property of the company disposed of and to hear any explanation that may be given by the liquidator.

3382

P. D. GEORGE, Liquidator.

Companies Act 1961.—In the matter of CRAIGIE PROPRIETARY LIMITED (in Voluntary Liquidation).—Members' Winding Up.

NOTICE OF FINAL MEETING.

Notice is hereby given, pursuant to section 272 of the *Companies Act 1961*, that the Final General Meeting of the members of the above-named company will be held at 10th Floor, 44 Market-street, Melbourne, on the 19th August, 1973, when I shall lay before the meeting an account how the winding up has been conducted and the property of the company has been disposed of.

Dated this 4th day of July, 1973.

3303

E. H. NIEMANN, Liquidator.

Companies Act 1961.

ALPINE DEVELOPMENTS (SKI TOWS) PROPRIETARY LIMITED.

Notice is hereby given that by a Special Resolution passed at a meeting of shareholders of Alpine Developments (Ski Tows) Proprietary Limited held on the 5th July, 1973, it was resolved that the company be wound up voluntarily.

Dated this 5th day of July, 1973.

NORMAN HARRIS, Liquidator.

Hughes, Fincher & Rodda, chartered accountants, 343 Little Collins-street, Melbourne, Vic. 3000. 3332

Companies Act 1961.

Notice is hereby given that the capital of the Squatting Investment Company Limited has been reduced by Order of the Supreme Court of Victoria, made on the 6th day of July, 1973, which confirmed the special resolution of the company passed at its Ordinary General Meeting held on the 18th day of April, 1973, which resolved:—

"That the capital of the company be reduced from \$5,000,000 divided into 5,000,000 shares of \$1 each to \$2,800,142.40 divided into 2,250,178 shares of \$1 each and 2,749,822 shares of 20c each and that such reduction be effected by returning to the holders of each of the 2,749,822 shares of \$1 each which are issued and are fully paid-up capital to the extent of 80c per share and by reducing the nominal amount of each of the said 2,749,822 shares from \$1 to 20c."

And that an office copy of the Order of the Supreme Court of Victoria was lodged with the Registrar of Companies on the 6th day of July, 1973.

BLAKE & RIGGALL, solicitors for the petitioner. 3333

TURNER INDUSTRIES LTD. (IN LIQUIDATION).

NOTICE OF FINAL GENERAL MEETING.

Notice is hereby given, pursuant to section 272 of the *Companies Act 1961*, that the affairs of the company have been fully wound up and that a Final Meeting of shareholders will be held at the office of Edwin V. Nixon & Partners, 440 Collins-street, Melbourne, on Monday, 13th August, 1973, at 11.15 a.m., for the purpose of laying before it the liquidators account showing the manner in which the winding up has been conducted and the property of the company disposed of, and to hear any explanation that may be given by the liquidator.

3378

P. D. GEORGE, Liquidator.

TURNER MANUFACTURING CO. PTY. LTD. (IN LIQUIDATION).

NOTICE OF FINAL GENERAL MEETING.

Notice is hereby given, pursuant to section 272 of the *Companies Act 1961*, that the affairs of the company have been fully wound up and that a Final Meeting of shareholders will be held at the office of Edwin V. Nixon & Partners, 440 Collins-street, Melbourne, on Monday, 13th August, 1973, at 10 a.m., for the purpose of laying before it the liquidators account showing the manner in which the winding up has been conducted and the property of the company disposed of and to hear any explanation that may be given by the liquidator.

3379

P. D. GEORGE, Liquidator.

TURNER ATKINS SAWS PTY. LTD. (IN LIQUIDATION).

NOTICE OF FINAL GENERAL MEETING.

Notice is hereby given, pursuant to section 272 of the *Companies Act 1961*, that the affairs of the company have been fully wound up and that a Final Meeting of shareholders will be held at the office of Edwin V. Nixon & Partners, 440 Collins-street, Melbourne, on Monday, 13th

August, 1973, at 10.30 a.m., for the purpose of laying before it the liquidators account showing the manner in which the winding up has been conducted and the property of the company disposed of and to hear any explanation that may be given by the liquidator.

3380

P. D. GEORGE, Liquidator.

TURNER INTERNATIONAL PTY. LTD. (IN LIQUIDATION).

NOTICE OF FINAL GENERAL MEETING.

Notice is hereby given, pursuant to section 272 of the Companies Act 1961, that the affairs of the company have been fully wound up and that a Final Meeting of shareholders will be held at the office of Edwin V. Nixon & Partners, 440 Collins-street, Melbourne, on Monday, 13th August, 1973, at 10.15 a.m., for the purpose of laying before it the liquidators account showing the manner in which the winding up has been conducted and the property of the company disposed of and to hear any explanation that may be given by the liquidator.

3381

P. D. GEORGE, Liquidator.

FORGECRAFT MANUFACTURING CO. PTY. LTD. (IN LIQUIDATION).

NOTICE OF FINAL GENERAL MEETING.

Notice is hereby given, pursuant to section 272 of the Companies Act 1961, that the affairs of the company have been fully wound up and that a Final Meeting of shareholders will be held at the office of Edwin V. Nixon & Partners, 440 Collins-street, Melbourne, on Monday, 13th August, 1973, at 10.45 a.m., for the purpose of laying before it the liquidators account showing the manner in which the winding up has been conducted and the property of the company disposed of and to hear any explanation that may be given by the liquidator.

3383

P. D. GEORGE, Liquidator.

In the matter of the Companies Act 1961; and in the matter of R. & G. FINANCES PTY. LIMITED (in Liquidation).

Notice is hereby given that, pursuant to section 272 of the Companies Act 1961, a Final Meeting of members of the above-named company will be held at the offices of Messrs. Fell & Starkey, chartered accountants, Level 25, Australia Square, Sydney, on Monday, 20th August, 1973, at 9 a.m., for the purpose of having an account laid before them, showing the manner in which the winding up has been conducted and the property of the company disposed of, and of hearing any explanations which may be given by the liquidator, and also of determining the manner in which the books, accounts and documents of the company and of the liquidator thereof shall be disposed of.

Dated at Melbourne this 3rd day of July, 1973.

3345

R. D. EVANS, Liquidator.

The Companies Act 1961.—In the matter of ANGOR HOLDINGS PTY. LTD. (in Liquidation).

Notice is hereby given that, pursuant to section 272 (2) of the Companies Act 1961, a Final Meeting of members of the above-mentioned company (in liquidation), will be held at 9.30 a.m., 13th August, 1973, at F. A. & W. A. Coghlan, 192 King-street, Melbourne, 3000, for the purpose of laying before the meeting an account showing the manner in which the winding up has been conducted and the property of the company disposed of and of hearing any explanation that may be given by the liquidator.

B. S. ROBERTSON, Liquidator.

F. A. & W. A. Coghlan, 192 King-street, Melbourne, 3000.

3349

GOLDEN AGE INVESTMENTS PTY. LTD. (IN LIQUIDATION).

Notice is hereby given, pursuant to section 272 of the Companies Act, that the affairs of the company have been fully wound up and that a Final Meeting of shareholders will be held at the offices of Coleman, McClure & Wilby, 495 Bourke-street, Melbourne, on 17th August, 1973, at 3 p.m., for the purpose of laying before it an account showing how the winding up has been conducted and the property of the company disposed of and giving any explanation thereof.

L. G. CHALKLEY, Liquidator, care of Coleman, McClure & Wilby, 495 Bourke-street, Melbourne. 3358

G.G.C. HOLDINGS PTY. LTD. (IN LIQUIDATION).

Notice is hereby given, pursuant to section 272 of the Companies Act, that the affairs of the company have been fully wound up and that a Final Meeting of shareholders will be held at the offices of Coleman, McClure & Wilby, 495 Bourke-street, Melbourne, on 17th August, 1973, at 2 p.m., for the purpose of laying before it an account showing how the winding up has been conducted and the property of the company disposed of and giving any explanation thereof.

L. G. CHALKLEY, Liquidator, care of Coleman, McClure & Wilby, 495 Bourke-street, Melbourne. 3359

BREAN INVESTMENTS PTY. LTD. (IN LIQUIDATION).

Notice is hereby given, pursuant to section 272 of the Companies Act, that the affairs of the company have been fully wound up and that a Final Meeting of shareholders will be held at the offices of Coleman, McClure & Wilby, 495 Bourke-street, Melbourne, on 17th August, 1973, at 2.30 p.m., for the purpose of laying before it an account showing how the winding up has been conducted and the property of the company disposed of and giving any explanation thereof.

L. G. CHALKLEY, Liquidator, care of Coleman, McClure & Wilby, 495 Bourke-street, Melbourne. 3360

Companies Act 1961.

LUMAC HOMES PROPRIETARY LIMITED.

NOTICE OF MEETING OF CREDITORS, PURSUANT TO SECTION 260 OF THE COMPANIES ACT 1961.

Notice is hereby given that a meeting of creditors of the above-named company will be held in the National Mutual Theatre, Lower Ground Floor, 447 Collins-street, Melbourne, on Friday, the 20th day of July, 1973, at 10 a.m., the company having convened a meeting of its members to be held on the same day and for the purpose of considering a Special Resolution, that the company be wound up voluntarily.

Dated this 10th day of July, 1973.

H. D. McCULLOCH, Director.

Messrs. Peat, Marwick, Mitchell & Co., 447 Collins-street, Melbourne, Vic., 3000. 3371

SAFEGUARD INVESTMENT TRUST PTY. LTD. (IN VOLUNTARY LIQUIDATION).

Notice is hereby given that, pursuant to section 272 (2) of the Companies Act 1961, a Final Meeting of the members of Safeguard Investment Trust Pty. Ltd. (in voluntary liquidation), will be held at 11th Floor, 271 William-street, Melbourne, on Thursday, 9th August, 1973, at 10 a.m. in the forenoon, for the purpose of laying before the meeting an account showing how the winding up has been conducted and the property of the company disposed of, and of hearing any explanation that may be given by the liquidator, and to pass a Resolution to destroy the company's books and papers, pursuant to section 284 (3) (b) of the Companies Act 1961.

Dated this 4th day of July, 1973.

R. B. VANCE, Liquidator.

Wilson, Bishop, Bowes & Craig, 11th Floor, 271 William-street, Melbourne, Vic., 3000. 3372

In the matter of the Companies Act 1961; and in the matter of M. G. HOMES PTY. LIMITED.

Notice is hereby given that at an Extraordinary General Meeting of members, held at 51 Queen-street, Melbourne, and at a meeting of creditors, held at 60 Market-street, Melbourne, on 6th July, 1973, the following Resolution was passed as a Special Resolution:—

That the company be wound up voluntarily and that Messrs. Leslie Philip Smart and Douglas Ewart Tonkin, chartered accountants, of Marquand & Co., 51 Queen-street, Melbourne, be and are hereby appointed liquidators to act jointly or severally for the purpose of such winding up.

Notice is given that creditors of the above-mentioned company are required on or before the 1st day of August, 1973, to send their names and addresses and particulars of the debts or claims and the names and addresses of their solicitors, if any, to us at the address before, and if so required to prove their said debts and claims or they will be excluded from the benefit of any distribution made before such debts are proved.

Dated this 10th day of July, 1973.

D. E. TONKIN, Liquidator.

L. P. SMART, Liquidator.

Marquand & Co., 51 Queen-street, Melbourne, Vic., 3000. 3376

Unclaimed Moneys Act 1962.

Register of Unclaimed Moneys held by the—

| Name of Owner on Books and Last Known Address. | Total Amount Due to Owner. | Description of Unclaimed Moneys. | Date when Amount first became Payable |
|---|----------------------------|----------------------------------|---------------------------------------|
| \$ | | | |
| CARLTON BREWERY LIMITED. | | | |
| Blaxland, G. H. G., 6 Collings-street, Wahroonga, N.S.W. | 123.06 | Dividend | 23.3.71 |
| Bradley, F. S., 11 Luxton-road, South Yarra | 16.50 | " | " |
| Brownrigg, G. M., 34 Carnarvon-road, Roseville, N.S.W. | 595.74 | " | 1.10.71 |
| Cowman, M. P., c/o Mr. J. M. Cowman, 37 Jean-street, McKinnon | 11.70 | " | " |
| English, M. E., Redbank, Deniliquin, N.S.W. | 32.55 | " | 22.3.71 |
| Fulcher, M. C., 1 Honey Hill Bury-street, Edmunds, Suffolk, England | 15.30 | " | 1.10.71 |
| Griffin, J. L., 22 Flowerdale-road, Moorabbin | 24.75 | " | 22.3.71 |
| Holmes, C. M., 16 Canfield Gardens, London, N.W.16, U.K. | 18.59 | " | " |
| Heily, A., 127 Booth-street, Annandale, Sydney | 82.46 | " | " |
| Ireland, R. J., 7 Bond-street, Mount Waverley | 19.35 | " | " |
| Johns, R. O., 22 Lansell-crescent, Camberwell | 21.70 | " | " |
| Mereweather, M. G. (estate of), c/o M. Myob, Oley-street, Campbelltown, N.S.W. | 134.40 | " | 1.10.71 |
| Marks, C. (estate of), c/o Royston L. Cahir and Martin, 17 Queen-street, Melbourne | 40.38 | " | 22.3.71 |
| Manning, M. D. E., Flowing Water, Mtung | 12.60 | " | 1.10.71 |
| McCann, P. F., 47 Stirling Gardens, Belfast, Ireland | 17.53 | " | 22.3.71 |
| Oliphant, E., 6 Elmgrade-road, Springfield, S.A. | 44.70 | " | 1.10.71 |
| Quarrel, U. L., 11 Waverton-avenue, Waverton, N.S.W. | 10.02 | " | " |
| 3226 | | | |
| CARLTON AND UNITED BREWERIES LIMITED. | | | |
| Hendry, P., 279 Moreland-road, Coburg | 76.78 | Wages | 13.4.71 |
| Mulholland, W. R., 295 Punt-road, Richmond | 123.78 | " | 23.4.71 |
| Connolly, G., 480 Lygon-street, Carlton | 36.32 | " | 10.6.71 |
| Hayes, C. E., c/o Empire Hotel, La Trobe-street, Melbourne | 10.82 | " | 17.9.71 |
| Ritchie, L., c/o P.O., Darwin | 22.44 | " | 13.10.71 |
| Lee, R., 50 Alura-road, St. Kilda | 44.81 | " | 29.11.71 |
| Torun, E., 9 Alura-street, St. Kilda | 16.50 | " | 10.12.71 |
| Wall, R. A., 34 Cambridge-road, Middle Park | 24.57 | " | 24.1.72 |
| Alexander, E., 71 Rankins-road, Kensington | 12.32 | " | 8.2.72 |
| Musson, S., 162 Londridge-street, Collingwood | 108.93 | " | 22.2.72 |
| Dally, R. T., 11 Contala-avenue, Caulfield North | 15.55 | Retiring Allowance | " |
| Jeparit Urban Fire Brigade, P.O. Box 142, Jeparit | 12.40 | Creditor's Balance | 17.12.71 |
| Abraham, G. E. G. and G. E. Abraham, P.O. Box 14, Nullawil | 12.00 | Dividend | " |
| Allen, J. L., c/o R. M. Blonchard and Co., P.O. Box R333, Sydney, N.S.W. | 11.95 | " | " |
| Lathbury, General Sir, G. W., c/o Lloyds Bank Ltd., 6 Pall Mall, London, S.W.1 | 10.20 | " | " |
| Lord, D. A., 4 Marlborough-avenue, Camberwell | 14.60 | " | " |
| McCaul, A. C. (estate of), 12/47 Kars-street, Frankston | 58.40 | " | " |
| Morris, P. M., 17/14 Roberts-street, Strathfield, N.S.W. | 22.50 | " | " |
| O'Meara, M. (estate of), c/o P. C. Ceast, 255 Darling-street, Balmain, N.S.W. | 19.20 | " | " |
| Richards, K. L., 7/27 Armond-road, Elwood | 29.20 | " | " |
| Byrne, E. L., 67 Markwell-street, Hamilton, Queensland | 12.00 | " | " |
| McMurray, B. K., c/o A. H. Cormie, cnr. Jesmond-road, and Raedoen-street, Figtree Pocket, Q'ld. | 16.90 | " | " |
| Storrien, M. T., 1/263 Gregory-terrace, Brisbane, Q'ld. | 70.36 | " | " |
| Coorong Investments Pty. Ltd., c/o 19 North Terrace, St. Peters, S.A. | 96.00 | " | 6.10.71 |
| McCormack, P., 11 Givenda-avenue, Moorabbin | 23.68 | " | " |
| Robinson, B. S., Queens Park, Lowesdale, via Corawa, N.S.W. | 19.20 | " | " |
| Sadler, L. I. B. (estate of), 11/1231 Malvern-road, Malvern | 4.80 | " | " |
| Turner, D., 50 Stonton-road, Haberfield, N.S.W. | 19.30 | " | " |
| Warnes Gap Pty. Ltd., 134 Waymouth-street, Adelaide, S.A. | 46.08 | " | " |
| Wong, P. K., 3/15 Chandos-street, Ashfield, N.S.W. | 11.20 | " | " |
| O'Donnell, T. F., 71 Sedcole-street, Pahiatia, N.Z. | 11.50 | " | " |
| Brownrigg, G. M., 34 Carnarvon-road, Roseville, N.S.W. | 63.52 | " | " |
| Burke, A. P., Barker-street, New Farm, Q'ld. | 322.88 | " | " |
| Hunter, A. R., Hambridge-street, Aspley, Q'ld. | 23.04 | " | " |
| Patterson, J. C. (estate of), c/o George B. Patterson, 22 Butler-street, Albion Heights, Q'ld. | 27.20 | " | " |
| 3227 | | | |
| HOLEPROOF LIMITED. | | | |
| Van Der Linden, M., Box Hill | 46.90 | Wages | 2.9.70 |
| Bywaters, P., Flat 4, 18 Oak-avenue, Boronia | 13.10 | " | 19.5.71 |
| Ambrosini, L., 10 Patricia-street, Fawkner | 46.40 | " | 3.9.71 |
| Lord, S., 188 Canterbury-road, Canterbury | 23.45 | " | 10.9.71 |
| Daminco, M., 41 Meaken-street, Fitzroy | 10.00 | " | 30.7.71 |
| Bacopolyloy, G., 19 Walker-street, Brunswick | 74.80 | " | 15.10.71 |
| Groves, E., c/o Mrs. S. Green, 4 Marshall-street, Rye | 131.44 | " | 22.12.71 |
| 3228 | | | |
| WESTERN MINING CORPORATION LTD. | | | |
| Colman, Hon. Victoria H., c/o National Westminster Bank, 161 Brompton-road, London | 11.75 | Dividend | 5.3.71 |
| George Henderson Nominees Limited, 11 Old Jewry, London | 24.38 | " | " |
| Jones, David T., c/o National Provincial Bank Ltd., 156 Fleet-street, London | 35.25 | " | " |
| The Steamship Mutual Underwriting Assoc. Ltd., 18 London-street, London, E.C.3. | 14.69 | " | " |
| 3229 | | | |

Unclaimed Moneys Act 1962.

Register of Unclaimed Moneys held by the—

| Name of Owner on Books and Last Known Address. | Total Amount Due to Owner. | Description of Unclaimed Moneys. | Date when Amount first became Payable |
|---|----------------------------|----------------------------------|---------------------------------------|
| \$ | | | |
| THE MOUNT LYELL MINING AND RAILWAY COMPANY LIMITED. | | | |
| Bennett, Elizabeth, G. (Mrs.), 52 Raglan-street, Mosman, N.S.W..... | 12.00 | Dividend | 16.9.71 |
| Eden, Gwendoline, I. M. (Mrs.), 457-469 Little Collins-street, Melbourne | 22.50 | " | " |
| Ford, Emil, E. J., 310 George-street, Sydney, N.S.W. | 156.00 | " | " |
| Gibson, Margaret, (Miss), c/o Mr. L. R. Jacques, 123 Ryrie-street, Geelong | 19.80 | " | " |
| Gillies, Robin, M., Flat 3, 3 Cromley-street, Windsor | 45.00 | " | " |
| Greville, Anthony R. and Mrs. Sandra A., 52 Station-road, Indooroopilly, Q'ld. | 19.80 | " | " |
| Hodge, Sydney, R. (estate of), c/o S. T. Hodge and Co., 16 Loftus-street, Sydney, N.S.W. | 11.25 | " | " |
| Laby, Betty, E. (Miss), 24 Stawell-street, Kew | 29.70 | " | " |
| Laby, Jean, E., Dr. 24 Stawell-street, Kew | 29.70 | " | " |
| Lazarus, Jack, M., 13 Dunraven-avenue, Toorak | 19.80 | " | " |
| Liberto, Pam, (Mrs.), 18 Kensington-road, South Yarra | 22.50 | " | " |
| Malloch, Peter, Pinnaroo, S.A. | 15.00 | " | " |
| Minter, Adeline, C. (Miss.), 49 Cotswold-road, Strathfield, N.S.W. | 29.70 | " | " |
| Moir, James, T., 4 Weripi-street, Noraville via Toukley, N.S.W. | 39.60 | " | " |
| Moir, Nora (estate of), 27 Hazelbank-road, Wollstone Craft, N.S.W. | 19.80 | " | " |
| Murray, Clarice, G. (Mrs.), 46 Bryson-street, Canterbury | 45.00 | " | " |
| Porter, Reginald, K., Villa No. 2, Upper Neal-street, Teneriffe, Qld. | 36.00 | " | " |
| Prineas, Peter, J. (estate of), c/o T. J. McMahon and Meagher, 363-367 Pitt-street, Sydney, N.S.W. | 15.00 | " | " |
| Robinson, David M. and Richard, E. Eastway, 28 Beatrice-street, Clontarf, N.S.W. | 49.50 | " | " |
| Salisbury, Charles, V., Dr. 185 Macquarie-street, Sydney, N.S.W. | 39.60 | " | " |
| Scanlon, Nanna, M. (Mrs.), 50 Beaufort-street, Woodville, S.A. | 12.00 | " | " |
| Stewart, Violet, H. (Mrs.), Flat 1, 55 Caroline-street, South Yarra | 150.00 | " | " |
| Van Den Hout, Leander, N., (M/s) 33 Dalrymple-avenue, Chatswood, N.S.W. | 31.50 | " | " |
| Whitbread, Doris, M. (Miss), 23A Bay-road, New Town, Hobart, Tas. | 15.00 | " | " |
| White, Frances, M. (Mrs.), Mullins-street, Hamilton, Q'ld. | 15.00 | " | " |
| Williams, Gladys (Mrs.), 26 Greenhill-street, Castlemaine | 157.50 | " | " |
| Wilson, Robert, R., 135 Brougham-street, Fairfield, Q'ld. | 15.00 | " | " |
| Wood, Janet, A. (Miss), 24 Wattle-street, West Ryde, N.S.W. | 15.60 | " | " |
| Mitchell, John, A., 50 Brodford-street, Dunedin, N.Z. | 25.50 | " | " |
| Murray, Marie, B. (Miss), 184 Pampunui-road, Christchurch, N.Z. | 120.49 | " | " |
| O'Shea, Thomas (estate of), c/o P.O. Box 381, Dunedin, N.Z. | 25.50 | " | " |
| Wightman, Elizabeth, M. (Mrs.), 57 Melanestia-road, Kohimarama, Auckland, N.Z. | 10.94 | " | " |
| Bowes, Charles, H. G., Dr., 8 Yarm-road, Stockton-on-Tees, Co. Durham, England, U.K. | 109.78 | " | " |
| Chaney, Walter, A., Foresters Arms, Main-street, Grassington, Skipton, Yorks, U.K. | 15.94 | " | " |
| Clark, Beatrice, E. (Mrs.), Dewar, Heriot, Midlothian, U.K. | 17.68 | " | " |
| Coleman, Alan, J. P., 20 Buxton Gardens, Acton Hill, W 3, U.K. | 16.83 | " | " |
| Craig, Margaret (estate of), c/o Miss Janet Craig, Kents Farm, West Hanningfield, Chelmsford, Essex, U.K. | 25.50 | " | " |
| Farnworth, David E. A., 10 West Cliff, Preston, Lancs., U.K. | 31.88 | " | " |
| Gardiner, Catherine G. (Miss), Gort House, Petersham, Surrey, U.K. | 12.63 | " | " |
| Hilbourne, Barbara M. (Mrs.), 15 Takbit House, 98 St. Martin-lane, London, WC 2, U.K. | 33.66 | " | " |
| Hodman Nominees Ltd., The Stock Exchnage, London, EC 2, U.K. | 57.38 | " | " |
| Innishannon Investment Co., Innishannon House, Innishannon, Co. Cork, Eire | 26.25 | " | " |
| Jarvis, Nora (Mrs.), (estate of), 27 Westward Ho., Bargate, Grimsby, Lincs, U.K. | 26.78 | " | " |
| Mountain, Ross S., 21 Ave Du Mail, Geneva, 1205 Switzerland | 18.49 | " | " |
| Muirhead, Ehlen J. (estate of), c/o William Muirhead, 46 Grove-road, Newbury, Berks, U.K. | 10.20 | " | " |
| McCue, Alexander, 31 Broomberry-drive, Gourock, Renfrewshire, U.K. | 16.83 | " | " |
| Otto, Audrey (Mrs.), c/o British Political Agency, Dubai, Trucial States, Arabian Gulf. | 16.80 | " | " |
| Ratcliffe, Alfred, 3 Beamish-lane, Codsall Wood, Wolverhampton, Staffs, U.K. | 33.66 | " | " |
| Stoop and Co. Nominees Ltd., 3 London Wall Buildings, London, EC 2, U.K. | 12.75 | " | " |
| Templer, Martin, c/o Zenith Enterprises, P.O. Box 84041, Mombasa, Kenya | 10.50 | " | " |
| Underwood, Helen (Miss), Flat 10, 105 Westbourne-terrace, London, SW 1, U.K. | 12.75 | " | " |
| Chong Ec Wah, Eva (Miss) c/o The Chartered Bank, Tanglin Branch, Shaw House, Orchard Road, Singapore, 9 | 12.75 | " | " |
| Weaver, Richard L., Lenham, Milford, Carlow, Irish Republic | 22.05 | " | " |
| Chivers, Bronwyn A., (M/s) 67 Raglan-street, Mosman, N.S.W. | 15.00 | " | " |
| Haney, Thomas G., 21 Grange-road, Lower Mitcham, S.A. | 37.50 | " | " |
| Pratt, Olive Marie, (M/s) RMB 686, Mangrove Mountain, N.S.W. | 11.25 | " | " |
| Brewer, Jeremy R., Brockhill, Bidborough, Tunbridge Wells, Kent, U.K. | 19.13 | " | " |
| Leaton, John H. (estate of), c/o John E. Leaton, c/o Barclays Bank Ltd., 86 High-street, Birmingham, 4 U.K. | 40.16 | " | " |
| Milton, William B., c/o T. T. Curwen and Sons, Friars House, 39-41 New Broad-street, London, EC 2, U.K. | 42.08 | " | " |
| Surgenor, Eileen (Miss), c/o Post Office, Cornwallis, Auckland, N.2, N.Z. | 20.73 | " | " |
| Chai, Loen T., c/o Miss Tsui Chai Peng, 33 Fort-street, North Point, Hong Kong | 52.50 | " | " |

Unclaimed Moneys Act 1962.

Register of Unclaimed Moneys held by the—

| Name of Owner on Books and Last Known Address. | Total Amount Due to Owner. | Description of Unclaimed Moneys. | Date when Amount first became Payable. |
|--|----------------------------|----------------------------------|--|
| TARGET SUPERMARKETS PTY. LTD. | | | |
| Wyatt, Shirley Anne, 14 Lancaster-avenue, Valley View, S.A. | 34.70 | Dividend | 27.10.71 |
| Doody, Patricia, 14 Somerset-avenue, Hilton, S.A. | 12.57 | " | 7.7.71 |
| Strong, Elaine, 3.E5 Pennington Hostel, Pennington, S.A. | 20.44 | " | 27.1.71 |
| Porrovecchio, Peter (address unknown) | 25.80 | " | 14.10.70 |
| Price, Neillie, Flat 7, 393 Anzac-Highway, Plympton, S.A. | 19.48 | " | 28.10.70 |
| Simons, Theo, 154 Payneham-road, Evandale, S.A. | 123.00 | " | 10.2.71 |
| Denouden, Thomas (address unknown) | 131.80 | " | 21.10.71 |
| Giffen, Joan, 17 Durham-avenue, Lockley's, S.A. | 13.19 | " | " |
| Radis, Klara (address unknown) | 13.19 | " | " |
| Cheesman, Joan, 265 Esplanade, Henley-beach, S.A. | 13.19 | " | " |
| Howse, Yvonne, 1417 South-road, Bedford Park, S.A. | 13.19 | " | 18.11.70 |
| Ianni, Tina, 53 Stradbroke-road, Athelstone, S.A. | 36.20 | " | 8.9.71 |
| Peat, Helmutrud, 17 Albert-street, Clarence Gardens, S.A. | 18.69 | " | 26.1.72 |
| Mandorlo, Joe, 7 Teak-street, Campbelltown, S.A. | 16.96 | " | 23.2.72 |
| Rennie, C. (address unknown) | 15.60 | " | 9.2.72 |
| Wiegold, Joan, 28 Botanic-grove, Campbelltown, S.A. | 14.55 | " | 1.3.72 |
| Billingsley, P. (address unknown) | 12.79 | " | 31.5.72 |
| Ianni, Joan, 14 Devon-avenue, Newton, S.A. | 36.20 | " | 13.11.71 |
| Angrove, J. (address unknown) | 22.62 | " | 3.5.72 |
| Case, Helen, 109 Railway-terrace, Ascot Park, S.A. | 10.92 | " | 6.9.72 |
| Modra, Janine, 8 Alexander-avenue, Magill, S.A. | 16.68 | " | 2.8.72 |
| Modistach, Margaret, Flat 4, 38 Wear-street, Marden, S.A. | 24.17 | " | 23.8.72 |
| Carney, Kathleen, 12 Leeds-avenue, Hope Valley, S.A. | 11.25 | " | 6.9.72 |
| 1264 | | | |
| THE MOUNT LYELL MINING AND RAILWAY COMPANY LIMITED. | | | |
| Prinz, Karl Armin, Queenstown, Tas. | 58.75 | Unclaimed Wages | 17.3.71 |
| Lovell, Sydney Ellis, Queenstown, Tas. | 28.12 | " | 14.4.71 |
| Jones, Kevin John, Queenstown, Tas. | 29.25 | " | " |
| Brown, Robert John, Queenstown, Tas. | 13.50 | " | 26.5.71 |
| Tybusch, Klaus, Queenstown, Tas. | 52.41 | " | " |
| Simoncic, Dominik, Queenstown, Tas. | 56.26 | " | 18.8.71 |
| Walker, Leslie David, Queenstown, Tas. | 126.02 | " | 1.9.71 |
| McNeill, Alastair James, Queenstown, Tas. | 42.28 | " | 15.9.71 |
| Kennedy, Alan George, Queenstown, Tas. | 20.00 | " | 13.10.71 |
| Triffett, Kenneth James, Queenstown, Tas. | 180.25 | " | 27.10.71 |
| Taylor, John Micheal, Queenstown, Tas. | 33.89 | " | 10.11.71 |
| Cooper, James, Queenstown, Tas. | 12.80 | " | 22.12.71 |
| Ralph, Colin Alway, Queenstown, Tas. | 17.21 | " | 19.1.72 |
| Cooper, James, Queenstown, Tas. | 41.42 | " | 2.2.72 |
| Kerkez, Stevan, Queenstown, Tas. | 15.75 | " | " |
| 3231 | | | |
| THE MOUNT LYELL MINING AND RAILWAY COMPANY LIMITED. | | | |
| Colton, Dr. Robert S., 9 Hainesworth-street, Westmead, N.S.W. | 13.20 | Dividend | 20.4.71 |
| Murray, Clarice, G. (Mrs.), 46 Bryson-street, Canterbury | 15.00 | " | " |
| Revie, Elizabeth, (Miss), 60 Augusta-road, Hobart, Tas. | 12.50 | " | " |
| Robinson, John Michael, 30 Carcoola-crescent, Normanhurst, N.S.W. | 12.50 | " | " |
| Stewart, Violet, M. (Mrs.), Flat 1, 55 Caroline-street, South Yarra | 50.00 | " | " |
| Bowes, Charles, H. G., Dr., 8 Yaram-road, Stockton-on-Tees, Co. Durham, England, U.K. | 36.60 | " | " |
| Kennard, Allington, c/o The Straits Times Press Ltd. Jalan Pudu, Kuala Lumpur, Malaysia | 36.75 | " | " |
| Milton, William B., c/o T. T. Curwen and Sons, Friars House, 39-41 New Broad-street, London EC 2 | 14.02 | " | " |
| Searby, Lorna, R. (Mrs.), 38 Derby-street, Vacluse, N.S.W. | 13.20 | " | " |
| 3232 | | | |

MAY SEAMER SLEEMAN, late of 16 Park-street, Middle Brighton, in the State of Victoria, widow, DECEASED (who died on 23rd May, 1973).

Creditors, next of kin and all other persons having claims against the estate of the deceased, are required by the executors of the will, James Rupert Sleeman and Betty Garden Haddon, to send particulars to them, care of the undersigned, on or before the 9th day of October, 1973, after which date they will distribute the assets, having regard only to the claims of which they then have notice.

GARDEN & GREEN, solicitors, 4 McCallum-street, Swan-Hill. 3350

Creditors, next of kin and others having claims against the estate of Charles Rudolph Stoneman, late of 36 Shasta-avenue, Brighton, in the State of Victoria, accountant, deceased (who died on the 11th October, 1972), are requested by the executrix of the will of the said deceased, Jean Doris Lambert Stoneman, of 36 Shasta-avenue,

Brighton, in the said State, widow, to send particulars of their claims to the said executrix, on or before 25th September, 1973, after which date the executrix will distribute the assets, having regard only to the claims of which it shall then have had notice.

ELLISON, HEWISON & WHITEHEAD, solicitors, 379 Collins-street, Melbourne, 3000. 3322

Creditors, next of kin and others having claims in respect of the estate of Albert George Begbie, late of 25 Serrell-street, East Malvern, gentleman, deceased (who died on the 30th day of October, 1972, and probate of whose will has been granted to Ivy Begbie, of 25 Serrell-street, East Malvern, widow), are required to send particulars of their claims to the said executrix, care of the under-mentioned solicitors, by the 17th day of September, 1973, after which date she will distribute the assets, having regard only to the claims of which she then has notice.

PEARCE & WEBSTER, solicitors, of 430 Little Collins-street, Melbourne. 3316

MAURICE JOSEPH LASRY, formerly of 605 St. Kilda-road, Melbourne, in the State of Victoria, and formerly of Florence Nightingale Private Hospital, 85 Wilson-street, Brighton aforesaid, but late of Unit 2, 50 Black-street, Brighton aforesaid, gentleman, DECEASED.

Creditors, next of kin and others having claims in respect of the estate of the above-named deceased (who died on the 29th day of March, 1973), are required by the trustees, Ian Joseph Charles Lasry, of 59 Church-street, Brighton, in the State of Victoria, solicitor, and The Equity Trustees, Executors and Agency Company Ltd., of 472 Bourke-street, Melbourne aforesaid, to send particulars to such company by the 19th day of September, 1973, after which date the said trustees may convey and distribute the assets, having regard only to the claims of which they then have notice.

EGGLESTON, CLIFTON-JONES & CO., solicitors, of 20 Queen-street, Melbourne, Victoria, 3000. 3310

Creditors, next of kin and others having claims in respect of the estate of Raymond Percy Quinlan, late of 31 Almurta-road, East Bentleigh, retired railway employee, deceased (who died on the 7th day of March, 1973, and probate of whose will has been granted to Kevin Percy Quinlan, of Stella Maris Club, 600 Little Collins-street, Melbourne, port chaplain, Brian Raymond Quinlan, of 29 Miller-crescent, Mount Waverley, garage proprietor, and Elizabeth Mary Cummins, of 31 Almurta-road, East Bentleigh, married woman, the substituted executors and executrix respectively named therein, Ellen Quinlan, the instituted executrix appointed by the said will having predeceased the said deceased), are required to send particulars of their claims to the said executors and executrix, care of the under-mentioned solicitors, by the 17th day of September, 1973, after which date they will distribute the assets, having regard only to the claims of which they then have notice.

PEARCE & WEBSTER, solicitors, of 430 Little Collins-street, Melbourne. 3315

Creditors, next of kin and others having claims in respect to the estate of Percival Warren, late of 3 Marie-street, Boronia, retired, deceased (who died on 3rd October, 1972), are required by the executrix, Lucy Myrtle Warren, of 3 Marie-street, Boronia, widow, to send particulars of their claims to her, care of the under-mentioned solicitors, by 19th September, 1973, after which date she will convey or deal with the assets, having regard only to the claims of which she then has notice.

UPTON & ETTIELSON, solicitors, 100 Queen-street, Melbourne. 3320

Creditors, next of kin and others having claims in respect of the estate of Eileen Monkhouse Walle, late of 88 Prospect Hill-road, Camberwell, married woman, deceased (who died on the 19th day of March, 1973), are to send particulars of their claims to Royston Cahir, Martin & Dillon, solicitors, of 17 Queen-street, Melbourne, by the 12th day of September, 1973, after which date the executor will distribute the assets of the estate, having regard only to claims of which he has notice.

ROYSTON CAHIR, MARTIN & DILLON, solicitors, of 17 Queen-street, Melbourne. 3321

Creditors, next of kin and others having claims in respect of the estate of Pierce James Brennan, late of 15 Peters-street, Watsonia, gentleman, deceased (who died on the 26th day of April, 1973), are to send particulars of their claims to Royston Cahir, Martin & Dillon, solicitors, of 17 Queen-street, Melbourne, by the 13th day of September, 1973, after which date the executor will distribute the assets of the estate, having regard only to claims of which he has notice.

ROYSTON CAHIR, MARTIN & DILLON, solicitors, of 17 Queen-street, Melbourne. 3323

RUBY EDITH ARGALL, late of 88 Faith-street, Dimboola, in the State of Victoria, widow, DECEASED.

Creditors, next of kin and others having claims in respect of the estate of the deceased (who died on the 1st day of October, 1972), are required by the trustees, Maxwell Donald Argall, of 15 English-street, Bordertown, in the State of South Australia, salesman, and John Mercer Hobday, of 30 Victoria-street, Nhill, in the said State of Victoria, solicitor, to send particulars to them, care of the undersigned, by the 18th day of September, 1973, after which date the trustees may convey or distribute the assets, having regard only to the claims of which they then have notice.

Dated the 4th day of July, 1973.

TURNER & HOBDDAY, 30 Victoria-street, Nhill, solicitors for the said trustees. 3324

REUBEN GEORGE ANDERSON, late of Nhill, in the State of Victoria, farmer and grazier, DECEASED.

Creditors, next of kin and others having claims in respect of the estate of the deceased (who died on the 22nd day of August, 1957), are required by the trustee, Graham Bruce Keam, of Woorak, farmer, to send particulars to him, care of the undersigned, by the 20th day of September, 1973, after which date the trustee may convey or distribute the assets, having regard only to the claims of which he then has notice.

Dated the 2nd day of July, 1973.

TURNER & HOBDDAY, 30 Victoria-street, Nhill, solicitors for the said trustee. 3325

Creditors, next of kin and others having claims in respect of the estate of Earl Treffry Kersey, formerly of 213 Danks-street, Albert Park, in the State of Victoria, but late of 44 Howe-street, South Melbourne, in the said State, retired linesman, deceased (who died on the 14th day of March, 1973), are to send particulars of their claims to the executor, The Equity Trustees, Executors and Agency Company Limited, care of the undersigned solicitors, by the 12th day of September, 1973, after which date it will distribute the assets, having regard only to the claims of which it then has notice.

HALL & WILCOX, solicitors, 20 Queen-street, Melbourne. 3326

Creditors, next of kin and others having claims in respect of the estate of Leopold Brandner, late of 6 Cleek-avenue, Oakleigh, in the State of Victoria, retired chef (who died on the 23rd day of May, 1973), are requested to send particulars of their claims to the executor, Lloyd Pym Goode, solicitor, of 406 Lonsdale-street, Melbourne, by the 14th day of September, 1973, after which date he will distribute the assets, having regard only to the claims of which he then has notice.

LLOYD P. GOODE & CO., solicitors, of 406 Lonsdale-street, Melbourne. 3327

Creditors, next of kin and others having claims in respect of the estate of Alfred George Robinson, late of 37 Fenwick-street, Geelong, deceased (who died on the 7th January, 1973), are to send particulars of their claims to the executor, Edward Haig Robinson, care of the under-mentioned solicitors, on or before the 11th September, 1973, after which date the said executor will distribute the assets, having regard only to the claims of which notice has been received.

WIGHTON & McDONALD, solicitors, 89 Myers-street, Geelong. 3347

LUIGI DUTTO, late of Tyntynder Central, in the State of Victoria, farmer, DECEASED.

Creditors, next of kin, and others having claims in respect of the estate of the deceased (who died on the 25th day of August, 1972), are required by the executors, Flavia Dutto and Paul Dutto, both of Tyntynder Central, in the said State, to send particulars to them, care of the undersigned, by the 11th day of September, 1973, after which date the executors may convey or distribute the assets, having regard only to the claims of which they then have notice.

ALEC M. HAYES, solicitor, 148 Campbell-street, Swan Hill. 3279

Creditors, next of kin, and others having claims in respect of the estate of Archibald James Milligan MacPherson, late of 34 Gray-street, Hamilton, gentleman, deceased (who died on the 14th day of January, 1973), are to send the particulars of their claims to The Union Fidelity Trustee Company of Australia Limited, of 100 Exhibition-street, Melbourne, by the 15th day of September, 1973, after which date it will distribute the assets, having regard only to the claims of which it then has notice.

HULL, NEWNS & LORD, solicitors, 58 Gray-street, Hamilton. 3235

AGNES MARIA MACKAY, late of 61 Central-avenue, Torquay, married woman, DECEASED (who died on the 2nd day of April, 1973).

Creditors, next of kin, and all persons having claims against the estate of the deceased, are required to send particulars to the executors, The Union-Fidelity Trustee Company of Australia Limited, of 8 Malop-street, Geelong, on or before the 12th September, 1973, after which date it will distribute the assets, having regard only to the claims of which it shall then have notice.

HEINZ & GORDON, solicitors, 209 Dana-street, Ballarat. 3241

Creditors, next of kin and others having claims in respect of the estate of Patrick William Nolan, late of 1 Murdoch-road, Wangaratta, grazier, deceased (who died on the 3rd day of March, 1973), are required by the executors, Alice Annie Nolan, of 1 Murdoch-road, Wangaratta, widow, and NATIONAL TRUSTEES EXECUTORS AND AGENCY COMPANY OF AUSTRALASIA LIMITED, of 95 Queen-street, Melbourne, to send particulars of such claims to the said executors, care of NATIONAL TRUSTEES EXECUTORS AND AGENCY COMPANY OF AUSTRALASIA LIMITED, at 95 Queen-street, Melbourne aforesaid, before the expiration of two clear months from the date hereof after which date the said executors will convey or distribute the assets, having regard only to the claims of which they then have notice.

CONNELL, McKENNA & WEARNE, solicitors,
117 Murphy-street, Wangaratta. 3284

Creditors, next of kin and others having claims in respect of the estate of Thomas Alexander Ballintine, late of "Ballantrae", Goorambat, grazier (who died on the 12th day of July, 1972), are required to send particulars of their claims in writing, to the under-mentioned solicitors, being the solicitors for the executors, Jessie Belle Ballintine and James Alexander Forsyth, by the 17th day of September, 1973, after which date the executors will distribute the assets, having regard only to the claims of which they then have notice.

HAMILTON, CLARKE & CLARKE, solicitors, 55 Nunn-street, Benalla. 3297

ROBERT FOX, late of Meatian, in the State of Victoria, farmer, DECEASED (who died on 6th March, 1973).

Creditors, next of kin and all other persons having claims against the estate of the deceased are required by the executors of the will, Harry Fox and Thomas Bridson Green, to send particulars to them, care of the undersigned, on or before the 6th day of October, 1973, after which date they will distribute the assets, having regard only to the claims of which they then have notice.

GARDEN & GREEN, solicitors, 4 McCallum-street, Swan Hill. 3298

Creditors, next of kin and others having claims in respect of the estate of Monica Ida Josephine Connolly, late of 146 High-street, Ashburton, in the State of Victoria, spinster (who died on the 24th day of April, 1973), are to send particulars of their claim to National Trustees, Executors and Agency Company of Australasia Limited, carrying on business at 95 Queen-street, Melbourne, in the said State, the surviving executor of the will of the deceased, the appointed co-executor, Marie Perpetua Eileen Connolly, having predeceased the testatrix, by the 10th day of September, 1973, after which day it will distribute the assets, having regard only to the claims of which it then has notice.

COLE O'HEARE, solicitors, 422 Little Collins-street, Melbourne. 3311

Creditors, next of kin and others having claims in respect of the estate of William Robert Frost, late of 2 Cobden-street, Caulfield, in the State of Victoria, retired, deceased (who died on the 20th day of June, 1972), are required by The Union-Fidelity Trustee Company of Australia Limited, of 100 Exhibition-street, Melbourne, Jessie Frost, of 2 Cobden-street, Caulfield, widow, and Russell Ernest Bergin, of Flat 1, 1475 Heatherton-road, Dandenong, storeman, the executors appointed by the deceased's last will, to send particulars of their claims to the said executors, care of the said company, at its registered office, 100 Exhibition-street, Melbourne, by the 18th day of September, 1973, after which date the said executors may convey or distribute the assets, having regard only to the claims of which it and they shall then have had notice.

HOAD & BONELLA, 114 Hawthorn-road, Caulfield, solicitors for the said executors. 3312

HERMAN SEDAL, late of 10 Dickens-street, Elwood, in the State of Victoria, DECEASED.

Creditors, next of kin and others having claims in respect of the estate of the deceased (who died on the 27th day of March, 1973), are required by the executors, Jewel Okno, of 213 Lonsdale-street, Melbourne, and Martin Katz, of "The Block", Elizabeth-street, Melbourne, to send particulars to them, care of the undersigned, by the 15th day of September, 1973, after which day the executors may convey or distribute the assets, having regard only to the claims of which they then shall have notice.

J. OKNO & CO., solicitors, of 312 Lonsdale-street, Melbourne. 3313

Creditors, next of kin and others having claims in respect of the estate of May Elizabeth Morris, late of 67 South-road, Rosebud, widow, deceased (who died on 10th March, 1973), are to send particulars of their claims to the executrix, Nesta May McCullagh, care of the under-mentioned solicitors, by the 14th day of September, 1973, after which date the said executrix will distribute the assets, having regard only to the claims of which she then has notice.

O'BRIEN & GALANTE, solicitors, 44 Pascoe Vale-road, Moonee Ponds. 3282

GEORGE PHILBROOK, late of 64 Geelong-road, Ballarat, pensioner, DECEASED.

Creditors, next of kin, and all persons having claims against the estate of the deceased, are required to send particulars to the executors, The Union-Fidelity Trustee Company of Australia Limited, of 101 Lydiard-street north, Ballarat, on or before the 11th day of September, 1973, after which date it will distribute the assets, having regard only to the claims of which it shall then have notice.

3242

Creditors, next of kin, and others having claims in respect of the estate of Edith Emily Dolan, late of 14 Newington-grove, Caulfield, widow, deceased (who died on the 9th November, 1972), are to send their claims to the executrices, care of Allan Moore, LL.B., 140 Queen-street, Melbourne, by the 11th October, 1973, after which date the executrices may distribute or convey all assets, having regard only to the claims of which they then have notices.

ALLAN MOORE, LL.B., 140 Queen-street, Melbourne.

3246

Creditors, next of kin, and others having claims in respect of the estate of John Henry Ferguson, late of Murrumgee, in the State of Victoria, farmer and grazier, deceased (who died on the 19th May, 1972), are to send their claims to the executor, care of Allan Moore, LL.B., 140 Queen-street, Melbourne, by the 11th October, 1973, after which date the executor may distribute or convey all assets, having regard only to the claims of which they then have notice.

ALLAN MOORE, LL.B., 140 Queen-street, Melbourne.

3247

WALTER BRACHER SCOTT, late of 19 Church-street, Eaglehawk, manager, DECEASED.

Creditors, next of kin and others having claims against the estate of the above-named deceased, are required by the executor thereof, National Trustees Executors and Agency Company of Australasia Limited, of 95 Queen-street, Melbourne, and at 46 Queen-street, Bendigo, to forward particulars thereof, care of the said company, on or before the 17th day of September, 1973, after which date it will distribute the assets of the above said estate, having regard only to the claims of which it then have notice.

HYETT & HYETT, 51 Bull-street, Bendigo, solicitors for the executor. 3248

Pursuant to the provisions of the Trustee Act 1958, creditors, next of kin and all other persons having claims in respect of the estate of Edith Hamilton Gabsch, late of 36 Sargood-street, Hamilton, married woman (who died on the 1st day of September, 1972), are required to send particulars of their claims to the executor, The Union-Fidelity Trustee Company of Australia Limited, the registered office of which is situate at 100 Exhibition-street, Melbourne, by the 20th September, 1973, after which date the company will distribute the assets, having regard to the claims of which it shall then have had notice.

MADDOCK, LONIE & CHISHOLM, solicitors, of 339 Collins-street, Melbourne. 3314

Creditors, next of kin and others having claims in respect of the estate of Alice Veronica Greenway, late of 27 Nicholson-street, South Yarra, widow, deceased (who died on the 20th November, 1972), are to send particulars of their claims to The Union-Fidelity Trustee Company of Australia Limited, of 100 Exhibition-street, Melbourne, by the 20th day of September, 1973, after which date the said company, the administrator of the will and estate of the said deceased, will distribute the assets, having regard only to the claims of which the said company then has notice.

BEST, HOOPER, RINTOUL & SHALLARD, solicitors, 377 Little Collins-street, Melbourne, 3000. 3375

Creditors, next of kin and others having claims in respect of the estate of William George Howard, late of lot 15, Devon-road, Devon Meadows, poultry farmer, deceased (who died on the 12th day of June, 1972), are required by the administrator, Brian William Howard, of 9 Graham-road, Rosanna, clerk, to send particulars of their claims to him, care of the under-mentioned solicitor, by the 25th September, 1973, after which date the said administrator will distribute the assets of the deceased, having regard only to the claims of which he then shall have notice.

B. J. WILLIAMS, LL.B., solicitor, 129 Lower Plenty-road, Rosanna. 3355

ELLEN FLORENCE QUINLIVAN, late of 8 Kelvin-grove, Thornbury, widow, DECEASED.

Creditors, next of kin and others having claims in respect of the estate of the above-mentioned deceased (who died on the 7th day of July, 1972), are required by the administratrix, Jeanette Alicia Howie, of 35 Fricker-avenue, Greensborough, married woman, to send particulars of their claims to her, care of the under-mentioned solicitor, by the 25th September, 1973, after which date the said administratrix will distribute the assets of the deceased, having regard only to the claims to which she then shall have notice.

B. J. WILLIAMS, LL.B., solicitor, 129 Lower Plenty-road, Rosanna. 3356

JOHN STEPHEN FILLIPONI, formerly of Numurkah, and late of Ovens and Murray Home for the Aged, Beechworth, retired, DECEASED.

Creditors, next of kin and other persons having claims against the estate of deceased (who died on 7th March, 1973), are required to send particulars of such claims to the executors, James Filliponi, of 14 Hume-court, Thurgoona-street, Albury, New South Wales, and Malachi Daniel Filliponi, of 18 Bond-street, Benalla, retired, in care of the undersigned, at his address Box 13, Numurkah, by the 15th day of September, 1973, after which date the executors will distribute the assets, having regard only to the claims of which they shall have notice.

S. W. E. STIFE, LL.B., solicitor, Numurkah. 3357

Creditors, next of kin and others having claims against the estate of May Tonkin, formerly of The Manse, Beac, in the State of Victoria, but late of Darlot-street, Meekatharra, in the State of Western Australia, widow, deceased, are required by the executor, John Duncan Mustow, to send particulars of their claims, care of the undersigned, by the 30th day of September, 1973, after which date he will proceed to distribute the estate, having regard only to the claims of which he then has notice.

JOHN D. MUSTOW & CO., solicitors, of 131 Queen-street, Melbourne. 3373

TRUSTEE ACT 1958.

Creditors, next of kin and others having claims against the estates specified below, are required to send particulars, in writing, of such claims to the personal representatives of such estates, in care of Messrs. Morrison and Teare, solicitors, Numurkah, on or before 11th October, 1973, after which date the assets of the estates will be conveyed or distributed among the persons entitled thereto, having regard only to the claims to which the representatives shall then have had notice:—

Annie Edith Christie, late of Numurkah, in the State of Victoria, spinster, deceased (died 24th March, 1973).

Ethel Beatrice Laidlaw, late of Numurkah, in the State of Victoria, widow, deceased (died 8th April, 1973).

Alice Lavinia Sutton, late of Numurkah, in the State of Victoria, married woman, deceased (died 21st January, 1973).

David Andrew Sutton, late of Strathmerton, in the State of Victoria, farmer, deceased (died 25th October, 1972).

Maud Beatrice Dunstan, late of 459 Wyndham-street, Shepparton, in the State of Victoria, widow, deceased (died 14th December, 1972).

Arthur Thomas Harris, late of Numurkah, in the State of Victoria, farmer, deceased (died 30th September, 1972).

Herbert Reginald Hunt, late of Wunghnu, in the State of Victoria, farmer, deceased (died 11th February, 1973).

Eleanor Eliza Sutton, late of Cobram, in the State of Victoria, widow, deceased (died 1st November, 1972).

Martha McPherson, late of Katamatite, in the State of Victoria, widow, deceased (died 19th November, 1972).

Henry Blake Howard, late of Katandra West, in the State of Victoria, farmer, deceased (died 17th March, 1973). 3352

In the Supreme Court of the State of Victoria.

SALE BY THE SHERIFF.

On Friday, the 24th of August, 1973, at 10.30 a.m., at the Police Station, St. Albans (unless process be stayed or satisfied):—

All the estate and interest (if any) of Gregory Frendo, skin classer, and Anne Frendo, married woman, both of 35 Grace-street, St. Albans, as joint proprietors of an estate in fee-simple in the land described in certificate of title, volume 8286, folio 615, upon which is erected a brick veneer dwelling, known as No. 35 Grace-street, St. Albans.

Registered mortgages Nos. D.807226 and E.620478 and caveat No. E.358822 affect the said estate and interest.

Terms: Cash only.

DOUGLAS S. HALL, Sheriff's Officer.

11th July, 1973.

3367

In the Supreme Court of the State of Victoria.

SALE BY THE SHERIFF.

On Friday, the 17th of August, 1973, at 10 a.m., at the Police Station, St. Albans (unless process be stayed or satisfied):—

All the estate and interest (if any) of Theodore Zafropoulos, engineer, of 32 Lister-street, Kew, as proprietor of an estate in fee-simple in the land described in certificate of title, volume 8939, folio 649, upon which is erected a factory building, known as No. 140 McIntyre-road, North Sunshine.

Covenant contained in transfer No. 1336522 affects the said estate and interest.

Terms: Cash only.

H. BUETTNER, Sheriff's Officer.

11th July, 1973.

3368

In the Supreme Court of the State of Victoria.

SALE BY THE SHERIFF.

On Friday, the 17th of August, 1973, at 10.30 a.m., at the Police Station, Greensborough (unless process be stayed or satisfied):—

All the estate and interest (if any) of Joseph Bongiorno, mechanic, of No. 1 Miriam-court, Bundoora, as joint proprietor with Dulcie June Bongiorno, married woman, of an estate in fee-simple in the land described in certificate of title, volume 8651, folio 719, upon which is erected a red brick house with flat roof, known as No. 1 Miriam-court, Bundoora.

Registered mortgage No. D.289521 and the covenant described in instrument of transfer D.289519 affects the said estate and interest.

Terms: Cash only.

DOUGLAS S. HALL, Sheriff's Officer.

11th July, 1973.

3369

INSOLVENCY NOTICE

The Bankruptcy Act 1966-70.

Commonwealth of Australia.

W. A. T. & S. POWNEY, 26 Lawtons-road, Lakes Entrance.

NOTICE OF MEETING OF CREDITORS.

Take notice that William Anthony Thomas Powney, has, on the 27th day of June, 1973, and Sandra Powney, has, on the 2nd day of July, 1973, signed an authority under subsection (1) of section 188 of the Bankruptcy Act 1966, authorizing Geoffrey Ormond Harrison, of 395 Collins-street, Melbourne, to call a meeting of their creditors (and to take over control of their property), and that, in pursuance of section 194 of the Bankruptcy Act 1966, a meeting of the creditors of the above-named debtors will be held at the Conference Room, Motel Marlin, 45 Main-street, Bairnsdale, on Thursday, the 12th day of July, 1973, at 9.30 a.m.

Dated this 3rd day of July, 1973.

G. O. HARRISON, Controlling Trustee.

Hall & Rose, chartered accountants, 395 Collins-street; Melbourne, Vic. 3000. 3317

IMPOUNDINGS

BAIRNSDALE.—Impounded in Bairnsdale Pound, on 25th June, 1973.

1 Hereford steer, V notch points of both ears, no visible brand

1 Hereford steer, slice top of near ear, notch top off ear, no visible brand

1 Hereford steer, notch bottom both ears, no visible brand
If not claimed and expenses paid, to be sold on 27th July, 1973.

3363—\$3.85 W. WALKER, Poundkeeper.

BROADMEADOWS.—Impounded in Broadmeadows Pound.

1 skewbald gelding (mostly white), no visible brand

If not claimed and expenses paid, to be sold on 26th July, 1973.

3364—\$2.10 C. M. MISSEN, Poundkeeper.

CASTERTON.—Impounded in Casterton Pound, from Six Chain-road, by Mr. J. Gill.

1 Poll Hereford steer, two back notches off ear, no visible brand

If not claimed and expenses paid, to be sold on 26th July, 1973.

3291—\$2.80 W. R. FRANKS, Poundkeeper.

COLAC.—Impounded in Colac Pound.

6 Jersey heifers, 3 punch holes and slit in ear, no visible brand

If not claimed and expenses paid, to be sold on 19th July, 1973.

3290—\$2.45 G. J. DUNN, Poundkeeper.

DANDENONG.—Impounded in Dandenong Pound by Ranger, City of Springvale, from Browns-road, Harrisfield.

1 black heifer, no visible brand

If not claimed and expenses paid, to be sold on 30th July, 1973.

3293—\$2.45 R. M. HARDY, Poundkeeper.

DONALD.—Impounded in Donald Pound, from P. Campbell's, at Avon Plains, on 5th July, 1973.

1 dehorned, black and white Friesian cow, 3 punch holes top of left ear, one yellow tag No. 73 bottom of left ear, no visible brand

If not claimed and expenses paid, to be sold on 1st August, 1973.

3292—\$3.15 W. A. CAMERON, Poundkeeper.

DROUIN.—Impounded in Drouin Pound, from McKenzie-road, Neerim East, on 29th June, 1973.

1 brown and white Jersey heifer, dehorned, 2 years old, no visible brand

Impounded from Main Neerim-road, Rokeby, on 10th July, 1973.

1 black baldy steer, 2 years old, no visible brand

1 Hereford steer, off-side ear mark, 2 years old, no other visible brand

If not claimed and expenses paid, to be sold on 2nd August, 1973.

3384—\$4.55 A. M. JONES, Poundkeeper.

KERANG.—Impounded in Kerang Pound, from Koondrook.

1 white billy goat (polled)

If not claimed and expenses paid, to be sold on 25th July, 1973.

3294—\$2.10 F. HASTIE, Poundkeeper.

PAKENHAM.—Impounded in Pakenham Pound, from Princes Highway, Doveton.

1 Black Poll heifer, notch right ear, no visible brand

If not claimed and expenses paid, to be sold on 25th July, 1973.

3362—\$2.45 H. SMITH, Poundkeeper.

TATURA.—Impounded in Tatura Pound, from Dhurringile. 1 brindle baldy steer, no visible brand

If not claimed and expenses paid, to be sold on 26th July, 1973.

3361—\$2.10 J. H. MACTIER, Poundkeeper.

Subordinate Legislation Act 1962.

NOTICE OF MAKING OF STATUTORY RULES.

In pursuance to the provisions of the *Subordinate Legislation Act 1962* and the Regulations made thereunder, notice is given of the making of the following statutory rules:—

| No. | State Electricity Commission Act 1958. | Price. |
|-----------|--|--------|
| 145/1973. | State Electricity Commission Electrical Contractors' Registration Regulations 1973 | 20c |
| | <i>Health Act 1958 (No. 6270).</i> | |
| 146/1973. | Lead Workers (Medical Examination) Regulations 1973 | 15c |
| | <i>Geelong Harbor Trust Act 1958.</i> | |
| 147/1973. | Geelong Harbor Trust (Inscribed Stock and Debentures) Regulations 1973 | 40c |
| | <i>The Constitution Act Amendment Act 1958.</i> | |
| 148/1973. | Supreme Court (Disputed Elections and Returns) Rules 1973 | 10c |
| | <i>Motor Accidents Act 1973.</i> | |
| 149/1973. | Motor Accidents Tribunal (References) Rules 1973 | 10c |
| | <i>Ombudsman Act 1973.</i> | |
| 150/1973. | Ombudsman (Jurisdiction) Rules 1973 | 10c |

Copies of these statutory rules may be purchased at the Sale of Publications Section of the Government Printing Office, located at 7A Parliament-place, Melbourne, 3002. If ordered by mail, remittance should be addressed to "The Government Printer, Box 203, P.O., North, Melbourne, 3051", and should include 7c extra for postage. If a credit account is held at this office, no remittance is required with the mail order.

The annual subscription rate for Statutory Rules (including Bound Volumes) is \$25, payable in advance. The subscription year commences on 1st January.

C. H. RIXON,
Government Printer.

STATE ACTS, 1971

Copies of the following Acts of Parliament of Victoria may be obtained at the Government Printing Office, Sale of Publications Branch, off Parliament-place, Melbourne, phone 63 0321, extension 6181, or from any accredited agent, at the price set opposite to each (these prices do not include postage).

The annual subscription for State Acts 1971 et seq. is \$12.50 payable in advance.

Bound Volumes of State Acts are also available on a subscription basis of \$17.50 per annum.

| No. | Price. |
|---|--------|
| 8090. Municipal Association (Amendment) | \$0.10 |
| 8091. Transfer of Land (Duplicate Certificates) | \$0.10 |
| 8092. Firearms | \$0.10 |
| 8093. Geelong Land (Special Grant) | \$0.10 |
| 8094. Churchill Water and Sewerage Works | \$0.10 |
| 8095. Superannuation (Railway Service) | \$0.10 |
| 8096. Vermin and Noxious Weeds (Amendment) | \$0.10 |
| 8097. Police Regulation (Amendment) | \$0.10 |
| 8098. Snowy Mountains Engineering Corporation (Victoria) | \$0.10 |
| 8099. Albert Park Land | \$0.10 |
| 8100. Local Government (Municipalities Assistance Fund) | \$0.10 |
| 8101. Health (Tuberculosis Arrangement) | \$0.10 |
| 8102. Presbyterian Church of Australia | \$0.20 |
| 8103. Marketing of Primary Products (Amendment) | \$0.10 |
| 8104. Gas and Fuel Corporation (Geelong Gas) | \$0.15 |
| 8105. Local Authorities Superannuation (Disability Benefits) (Commencement) | \$0.10 |

| STATE ACTS, 1971—continued. | |
|-----------------------------|---|
| No. | Price. |
| 8106. | Building Societies (Amendment) .. \$0.20 |
| 8107 | Survey Co-ordination (Place Names) .. \$0.10 |
| 8108. | Howard Florey Institute of Experimental Physiology and Medicine .. \$0.30 |
| 8109. | Superannuation (Transitional Provisions) .. \$0.10 |
| 8110. | New Broken Hill Consolidated Limited .. \$0.15 |
| 8111. | Litter (Proceedings for Offences) .. \$0.10 |
| 8112. | Justices (Service of Summonses) .. \$0.10 |
| 8113. | Stock (Artificial Breeding) (Amendment) .. \$0.10 |
| 8114. | Alcoa of Australia (W.A.) N.L. .. \$0.40 |
| 8115. | Victoria Institute of Colleges (Amendment) .. \$0.10 |
| 8116. | Cemeteries (Fawcner Crematorium and Memorial Park) .. \$0.10 |
| 8117. | Trustee Companies (Equity Trustees) .. \$0.10 |
| 8118. | Parliamentary Superannuation .. \$0.10 |
| 8119. | Ehrenhaus Retail Bottled Liquor Licence .. \$0.10 |
| 8120. | Melbourne University Land .. \$0.10 |
| 8121. | Forests (Bowater-Scott Agreement) .. \$0.20 |
| 8122. | Gas and Fuel Corporation (Pipelines) .. \$0.15 |
| 8123. | Coal Mines (Pensions) .. \$0.10 |
| 8124. | Crown Proceedings (Forfeited Recognisances) .. \$0.10 |
| 8125. | Public Trustee (Amendment) .. \$0.15 |
| 8126. | Geelong Waterworks and Sewerage (Rates) .. \$0.10 |
| 8127. | Subordinate Legislation (Powers) .. \$0.10 |
| 8128. | Barley Marketing .. \$0.10 |
| 8129. | Stamps (Credit Business) .. \$0.15 |
| 8130. | Land (Surrender to the Crown) .. \$0.10 |
| 8131. | Pipelines (Amendment) .. \$0.10 |
| 8132. | County Court (Jurisdiction) .. \$0.10 |
| 8133. | Grassmere Land .. \$0.10 |
| 8134. | Supply (Supplementary Estimates) .. \$0.10 |
| 8135. | Town and Country Planning (Amendment) .. \$0.15 |
| 8136. | Seeds .. \$0.40 |
| 8137. | Imperial Acts Application (Repeals) .. \$0.10 |
| 8138. | Audit (Recovery of Overpayments) .. \$0.10 |
| 8139. | Evidence (Registration of Commissioners) .. \$0.10 |
| 8140. | Country Roads (Amendment) .. \$0.15 |
| 8141. | Protection of Animals (Rodeos) .. \$0.10 |
| 8142. | Soil Conservation and Land Utilization (Amendment) .. \$0.15 |
| 8143. | Motor Car (Driving Offences) .. \$0.30 |
| 8144. | Fisheries (Amendment) .. \$0.15 |
| 8145. | Appeal Costs Fund .. \$0.10 |
| 8146. | Scaffolding .. \$0.30 |
| 8147. | Liquor Control (Amendment) .. \$0.15 |
| 8148. | Supply (July to September) .. \$0.10 |
| 8149. | Local Government (Further Amendment) .. \$0.40 |
| 8150. | Supply (Supplementary Estimates) .. \$0.10 |
| 8151. | Supply (October to December) .. \$0.10 |
| 8152. | Police Regulation (Chief Commissioner) .. \$0.10 |
| 8153. | Groundwater .. \$0.10 |
| 8154. | Pav-Roll Tax .. \$0.50 |
| 8155. | Moonee Ponds (Queens Park) Land .. \$0.10 |
| 8156. | Commonwealth Places (Administration of Laws) .. \$0.10 |
| 8157. | Stamps .. \$0.20 |
| 8158. | Mercy Private Hospital (Guarantee) .. \$0.10 |
| 8159. | Daylight Saving .. \$0.10 |
| 8160. | Co-operative Housing Societies (Indemnities) .. \$0.10 |
| 8161. | Films .. \$0.30 |
| 8162. | Lotteries Gaming and Betting (Pre-Post Betting) .. \$0.10 |
| 8163. | Vegetation and Vine Diseases (Amendment) .. \$0.10 |
| 8164. | Melbourne and Metropolitan Board of Works (Amendment) .. \$0.10 |
| 8165. | Statutory Salaries .. \$0.10 |
| 8166. | Newhaven Land .. \$0.10 |
| 8167. | Land Tax .. \$0.10 |
| 8168. | Water Authorities Accident Insurance .. \$0.10 |
| 8169. | Building Societies (Special Advances) .. \$0.10 |
| 8170. | Juries (Compensation) .. \$0.10 |
| 8171. | Coal Mines (Pensions Increase) .. \$0.10 |
| 8172. | Exhibition (Borrowing Powers) .. \$0.10 |
| 8173. | Sunday Entertainment (Cinematograph Films) .. \$0.10 |
| 8174. | Apprenticeship (Amendment) .. \$0.15 |
| 8175. | Labor and Industry (Shop Trading Hours) .. \$0.10 |
| 8176. | Gift Duty .. \$0.50 |
| 8177. | Aboriginal Lands (Amendment) .. \$0.10 |
| 8178. | Lutheran Church of Australia, Victoria District Incorporation .. \$0.40 |
| 8179. | Police Regulations (Amendment) (No. 2) .. \$0.20 |
| 8180. | Railways (Amendment) .. \$0.10 |
| 8181. | Statute Law Revision .. \$0.40 |
| 8182. | State Electricity Commission (Newport Power Station) .. \$0.10 |
| 8183. | Judges Salaries and Allowances .. \$0.10 |
| 8184. | Magistrates' Courts .. \$0.30 |
| 8185. | Companies .. \$2.10 |
| 8186. | Water (Amendment) .. \$0.20 |
| 8187. | Essendon (Recreation Ground) Land .. \$0.10 |
| 8188. | Brotherhood of St. Laurence (Incorporation) .. \$0.30 |
| 8189. | State Forests Works and Services .. \$0.10 |

| STATE ACTS 1971—continued. | |
|----------------------------|---|
| No. | Price. |
| 8190. | Evidence (Boards and Commissions) .. \$0.10 |
| 8191. | Public Authorities (Contributions) (Amendment) .. \$0.10 |
| 8192. | Road Traffic (Penalties) .. \$0.10 |
| 8193. | Grain Elevators (Amendment) .. \$0.10 |
| 8194. | Flinders-street Station Area Redevelopment .. \$0.20 |
| 8195. | Buninyong (Recreation Reserve) Land .. \$0.10 |
| 8196. | Health Services (Fees and Penalties) .. \$0.15 |
| 8197. | Motor Car (Breath Tests) .. \$0.10 |
| 8198. | Instruments (Amendment) .. \$0.15 |
| 8199. | Melbourne Harbor Trust (Amendment) .. \$0.15 |
| 8200. | Revocation and Excision of Crown Reservations .. \$0.15 |
| 8201. | Yarragon Lands Exchange .. \$0.10 |
| 8202. | Gift Duty (Rates and Rebates) .. \$0.15 |
| 8203. | Stamps (Gifts and Settlements) .. \$0.10 |
| 8204. | Eastern Freeway Lands .. \$0.15 |
| 8205. | Land (Surrenders) .. \$0.10 |
| 8206. | Housing (Amendment) .. \$0.15 |
| 8207. | Land (Amendment) .. \$0.10 |
| 8208. | Landlord and Tenant (Amendment) .. \$0.20 |
| 8209. | Racing (Amendment) .. \$0.30 |
| 8210. | National Parks (Amendment) .. \$0.30 |
| 8211. | Labor and Industry (Amendment) .. \$0.15 |
| 8212. | Public Works and Services .. \$0.15 |
| 8213. | Wheat Marketing .. \$0.15 |
| 8214. | Public Works and State Development Committees .. \$0.10 |
| 8215. | Water Supply Works and Services .. \$0.30 |
| 8216. | Bees .. \$0.20 |
| 8217. | Agricultural Colleges (Amendment) .. \$0.10 |
| 8218. | Chiropodists (Registration) .. \$0.10 |
| 8219. | Portland Harbor Trust (Amendment) .. \$0.10 |
| 8220. | Harbor Boards (Amendment) .. \$0.10 |
| 8221. | Veterinary Surgeons (Amendment) .. \$0.10 |
| 8222. | Scaffolding (Amendment) .. \$0.10 |
| 8223. | Stock Diseases (Composite Licences) .. \$0.10 |
| 8224. | Justices (Civil Proceedings) .. \$0.10 |
| 8225. | Closer Settlement .. \$0.10 |
| 8226. | Summary Offences (Amendment) .. \$0.10 |
| 8227. | Sewerage Districts (Amendment) .. \$0.10 |
| 8228. | Evidence (Documents) .. \$0.20 |
| 8229. | Mildura Irrigation & Water Trusts (Amendment) .. \$0.10 |
| 8230. | Farm Produce Merchants & Commission Agents (Employment) .. \$0.10 |
| 8231. | Latrobe Valley (Amendment) .. \$0.10 |
| 8232. | Hire Purchase (Form) .. \$0.10 |
| 8233. | Poisons (Amendment) .. \$0.10 |
| 8234. | Geelong Harbor Trust (Amendment) .. \$0.10 |
| 8235. | Eastern Railway Construction .. \$0.15 |
| 8236. | Milk and Dairy Supervision (Amendment) .. \$0.10 |
| 8237. | Educational Grants (Amendment) .. \$0.10 |
| 8238. | Railway Works and Services .. \$0.10 |
| 8239. | Education (Teacher Registration) .. \$0.15 |
| 8240. | Supply (Final Supplementary Estimates) .. \$0.10 |
| 8241. | Appropriation .. \$2.20 |

C. H. RIXON,
Government Printer.

STATE ACTS, 1972

Copies of the following Acts of Parliament of Victoria may be obtained at the Government Printing Office, Sale of Publications Branch, off Parliament-place, Melbourne, phone 63 0321, extension 6181, or from any accredited agent, at the price set opposite to each (these prices do not include postage).

The annual subscription for State Acts 1972 et seq. is \$12.50 payable in advance.

Bound Volumes of State Acts are also available on a subscription basis of \$17.50 per annum.

| No. | Price. |
|-------|---|
| 8242. | Seamen's (Amendment) .. \$0.10 |
| 8243. | Land (Greyhound Racing) .. \$0.10 |
| 8244. | Melbourne Land (Royal Melbourne Institute of Technology) .. \$0.10 |
| 8245. | Adoption of Children (Amendment) .. \$0.10 |
| 8246. | Disposal of Uncollected Goods (Amendment) .. \$0.15 |
| 8247. | Crimes (Powers of Arrest) .. \$0.15 |
| 8248. | Trustee Companies (Sandhurst and Northern District Trustees Executors and Agency Company Limited) .. \$0.10 |
| 8249. | Victorian Arts Centre .. \$0.10 |
| 8250. | Road Traffic (Amendment) .. \$0.10 |
| 8251. | Trustee Companies (National Trustees) .. \$0.10 |
| 8252. | Game Act .. \$0.10 |
| 8253. | Vermin and Noxious Weeds (Allowances) .. \$0.10 |

STATE ACTS, 1972—continued.

| No. | Price. |
|---|--------|
| 8254. Leo Cussen Institute for Continuing Legal Education | \$0.15 |
| 8255. Revocation and Excision of Crown Reservations | \$0.10 |
| 8256. Dookie Agricultural College Land | \$0.15 |
| 8257. Country Fire Authority (Amendment) | \$0.15 |
| 8258. Select Committee (Ansett Transport Industries) | \$0.10 |
| 8259. Legal Profession Practice (Amendment) | \$0.15 |
| 8260. Mt. Hotham Alpine Resort | \$0.20 |
| 8261. Nurses (Amendment) | \$0.10 |
| 8262. Films (Amendment) | \$0.10 |
| 8263. County Court (Jurisdiction) | \$0.10 |
| 8264. Soldier Settlement (Amendment) | \$0.10 |
| 8265. Government Buildings Advisory Council | \$0.10 |
| 8266. Poisons (Amendment) | \$0.10 |
| 8267. Police Offences | \$0.10 |
| 8268. Public Service (Amendment) | \$0.10 |
| 8269. Racing (Totalizator Commissions) | \$0.10 |
| 8270. Stamps (Bookmakers' Statements) | \$0.10 |
| 8271. Workers Compensation | \$0.10 |
| 8272. Liquor Control (Amendment) | \$0.15 |
| 8273. Archaeological and Aboriginal Relics Preservation | \$0.20 |
| 8274. Taxation Appeals | \$0.30 |
| 8275. Justices | \$0.20 |
| 8276. Consumer Protection | \$0.60 |
| 8277. Environment Protection (Amendment) | \$0.15 |
| 8278. Coal Mines (Pensions) | \$0.10 |
| 8279. Motor Car (Amendment) | \$0.15 |
| 8280. Crimes (Amendment) | \$0.15 |
| 8281. Melbourne and Metropolitan Board of Works (Reconstitution) | \$0.10 |
| 8282. Supply (Supplementary Estimates) | \$0.10 |
| 8283. Victoria Institute of Colleges (Affiliated Colleges) | \$0.10 |
| 8284. Supreme Court (Civil Appeals) | \$0.10 |
| 8285. Tattersall Consultations (Amendment) | \$0.10 |
| 8286. Parliamentary Committees (Take-over Offers) | \$0.15 |
| 8287. Dentists | \$0.40 |
| 8288. Firearms (Amendment) | \$0.30 |
| 8289. Sports Promotion | \$0.15 |
| 8290. Western Port (Steel Works) | \$0.10 |
| 8291. Local Government | \$0.30 |
| 8292. Supply (July to September) | \$0.10 |
| 8293. Marine | \$0.15 |
| 8294. Supply (October to December) | \$0.10 |
| 8295. Albert Park Land | \$0.10 |
| 8296. Yarraville (Recreation Ground) Lands (Amendment) | \$0.10 |
| 8297. Summer Time | \$0.10 |
| 8298. Co-operative Housing Societies | \$0.10 |
| 8299. State Rivers and Water Supply Commission (Special Projects) | \$0.10 |
| 8300. Limitation of Actions (Personal Injuries) | \$0.10 |
| 8301. Montrose Land | \$0.10 |
| 8302. Registration of Birth Deaths and Marriages | \$0.10 |
| 8303. State Electricity Commission (Borrowing Powers) | \$0.10 |
| 8304. Land (Residence Areas) | \$0.15 |
| 8305. Attorney-General and Solicitor-General | \$0.10 |
| 8306. Supreme Court (Judges) | \$0.10 |
| 8307. Constitutional Convention | \$0.10 |
| 8308. The Constitution Act Amendment (Conjoint Elections) | \$0.10 |
| 8309. Ringwood (Recreation Reserve) Land | \$0.10 |
| 8310. Land (Jetties and Marinas) | \$0.15 |
| 8311. Sandringham (Beach Oval) Land | \$0.10 |
| 8312. Mental Health (Admissions) | \$0.10 |
| 8313. Opticians Registration (Amendment) | \$0.10 |
| 8314. Superannuation | \$0.20 |
| 8315. Crown Grants (Removal of Conditions) | \$0.15 |
| 8316. Coal Mines (Pensions Increase) | \$0.10 |
| 8317. Sewerage Districts (Amendment) | \$0.10 |
| 8318. Gas and Fuel Corporation | \$0.10 |
| 8319. Boilers and Pressure Vessels (Registration) | \$0.10 |
| 8320. Lifts and Cranes (Amendment) | \$0.10 |
| 8321. Volunteer Civil Defence Workers Compensation | \$0.10 |
| 8322. Footscray (Bailey Reserve) Land | \$0.10 |
| 8323. Mildura Irrigation and Water Trusts (Amendment) | \$0.10 |
| 8324. Clean Air (Amendment) | \$0.10 |
| 8325. State Forests Works and Services | \$0.10 |
| 8326. Geelong Land Exchange | \$0.10 |
| 8327. Evidence | \$0.15 |
| 8328. State Electricity Commission (Dartmouth Hydro-Electric Power Station) | \$0.10 |
| 8329. State Electricity Commission (Yallourn W Power Station) | \$0.10 |

STATE ACTS, 1972—continued.

| No. | Price. |
|--|--------|
| 8330. Wrongs | \$0.10 |
| 8331. Crown Reservations (Revocation and Excision) | \$0.10 |
| 8332. Road Traffic | \$0.10 |
| 8333. Geelong Waterworks and Sewerage (Amendment) | \$0.20 |
| 8334. Navigable Waters (Oil Pollution) (Amendment) | \$0.20 |
| 8335. Melbourne College of Divinity | \$0.15 |
| 8336. Education (Amendment) | \$0.10 |
| 8337. Mines (Amendment) | \$0.10 |
| 8338. Crimes | \$0.10 |
| 8339. Housing Ministry | \$0.15 |
| 8340. National Gallery of Victoria | \$0.10 |
| 8341. The Constitution Act Amendment (Disqualification) | \$0.10 |
| 8342. River Improvement (Amendment) | \$0.10 |
| 8343. Health (Amendment) | \$0.30 |
| 8344. Youth, Sport and Recreation | \$0.30 |
| 8345. Motor Car (Learner Drivers' Permits) | \$0.15 |
| 8346. Veterinary Research Institute | \$0.10 |
| 8347. Cattle Compensation (Amendment) | \$0.10 |
| 8348. The Constitution Act Amendment (Appropriations) | \$0.10 |
| 8349. Motor Car (Miscellaneous Provisions) | \$0.10 |
| 8350. Victoria Conservation Trust | \$0.10 |
| 8351. Second-hand Dealers (Charitable Collectors) | \$0.10 |
| 8352. St. Vincent's Private Hospital (Guarantees) | \$0.10 |
| 8353. Railways (Amendment) | \$0.50 |
| 8354. Railway Works and Services | \$0.10 |
| 8355. Chiropodists (Amendment) | \$0.10 |
| 8356. Public Service (Appeals) | \$0.10 |
| 8357. Ministry for the Arts | \$0.15 |
| 8358. Wheat Marketing (Over-quota Wheat) | \$0.10 |
| 8359. Criminal Injuries Compensation | \$0.30 |
| 8360. The Constitution Act Amendment (Qualifications Joint Select Committee) | \$0.10 |
| 8361. Appropriation | \$2.20 |
| 8362. Water Supply Works and Services | \$0.30 |
| 8363. Surrender of Land | \$0.20 |
| 8364. Ministry for Conservation | \$0.15 |
| 8365. Public Works and Services | \$0.15 |
| 8366. Dental Technicians | \$0.30 |
| 8367. Land (Crown Bailiffs) | \$0.10 |
| 8368. Weights and Measures (Amendment) | \$0.20 |
| 8369. Metric Conversion (Agricultural Chemicals) | \$0.10 |
| 8370. Farm Produce Merchants and Commission Agents (Amendment) | \$0.10 |
| 8371. Milk and Dairy Supervision (Amendment) | \$0.10 |
| 8372. Pesticides (Amendment) | \$0.20 |
| 8373. Housing (Amendment) | \$0.10 |
| 8374. Local Government (Leases) | \$0.10 |
| 8375. Country Roads (Amendment) | \$0.10 |
| 8376. State College of Victoria | \$0.40 |
| 8377. State Electricity Commission (Amendment) | \$0.10 |
| 8378. Educational Grants | \$0.10 |
| 8379. Land Conservation (Vehicle Control) | \$0.10 |
| 8380. Town and Country Planning (Amendment) | \$0.40 |
| 8381. Land Tax | \$0.10 |
| 8382. Consumer Protection (Amendment) | \$0.15 |
| 8383. Decentralized Industry Incentives (Pay-roll Tax Rebates) | \$0.15 |
| 8384. Labour and Industry (Amendment) | \$0.15 |

C. H. RIXON,
Government Printer.

STATE ACTS, 1973

Copies of the following Acts of Parliament of Victoria may be obtained at the Government Printing Office, Sale of Publications Branch, off Parliament-place, Melbourne, phone 63 0321, extension 6181, or from any accredited agent, at the price set opposite to each (these prices do not include postage).

The annual subscription for State Acts 1972 et seq. is \$12.50 payable in advance.

Bound Volumes of State Acts are also available on a subscription basis of \$17.50 per annum.

| No. | Price. |
|--|--------|
| 8385. The Constitution Act Amendment (Qualifications) | \$0.10 |
| 8386. Hungarian Reformed Church of Australia (Victoria District) Incorporation | \$0.20 |
| 8387. Melbourne Family Care Organization | \$0.10 |
| 8388. Gas and Fuel Corporation (Colonial Gas Holdings Limited) | \$0.10 |
| 8389. Boilers and Pressure Vessels | \$0.10 |
| 8390. State Electricity Commission (Yallourn Council) | \$0.10 |
| 8391. Home Finance (Amendment) | \$0.10 |

STATE ACTS, 1973—continued.

| No. | Price. |
|--|--------|
| 8392. Zoological Gardens (Amendment) | \$0.10 |
| 8393. Melba Trust Fund | \$0.10 |
| 8394. Hospitals and Charities (Guarantee) | \$0.10 |
| 8395. Water (Amendment) | \$0.15 |
| 8396. Geelong Harbor Trust (Lands) | \$0.10 |
| 8397. Latrobe Valley (Amendment) | \$0.10 |
| 8398. Maryborough Land | \$0.10 |
| 8399. The Constitution Act Amendment (Presiding Officers) | \$0.10 |
| 8400. Constitutional Convention (Alternate Members) | \$0.10 |
| 8401. Ballarat (Sovereign Hill) Land | \$0.15 |
| 8402. Taxation Appeals (Commencement) | \$0.10 |
| 8403. Patriotic Funds (Amendment) | \$0.10 |
| 8404. Abattoir and Meat Inspection | \$0.40 |
| 8405. Valuation of Land (Valuers) | \$0.20 |
| 8406. Egg Industry Stabilization | \$0.40 |
| 8407. Recreation Vehicles | \$0.15 |
| 8408. Motor Car Traders | \$0.50 |
| 8409. Decentralized Industry (Housing) | \$0.15 |
| 8410. Crimes (Amendment) | \$0.10 |
| 8411. Cattle Compensation | \$0.10 |
| 8412. Victorian Inland Meat Authority (Amendment) | \$0.10 |
| 8413. Bendigo Aerodrome | \$0.10 |
| 8414. Ombudsman | \$0.30 |
| 8415. Public Service (Amendment) | \$0.10 |
| 8416. Coal Mines (Pensions Increase) | \$0.10 |
| 8417. Workers Compensation | \$0.10 |
| 8418. Public Records | \$0.20 |
| 8419. Joint Select Committee (Osteopathy, Chiropractic and Naturography) | \$0.10 |
| 8420. Marketing of Primary Products (Citrus Fruit) | \$0.10 |
| 8421. Barley Marketing (Amendment) | \$0.10 |
| 8422. Margarine | \$0.10 |
| 8423. Metric Conversion | \$0.10 |
| 8424. Medical Practitioners (Amendment) | \$0.15 |
| 8425. Crimes (Theft) | \$0.30 |
| 8426. Social Welfare (Amendment) | \$0.20 |
| 8427. Magistrates' Courts (Jurisdiction) | \$0.60 |
| 8428. Victorian Development Corporation | \$0.40 |
| 8429. Motor Accidents | \$0.80 |
| 8430. Motor Car (Amendment) | \$0.15 |
| 8431. Teaching Service | \$0.10 |
| 8432. Lands Compensation | \$0.15 |
| 8433. Police Offences (Publications) | \$0.15 |

C. H. RIXON,
Government Printer.

ACTS REPRINTED IN ACCORDANCE WITH THE AMENDMENTS INCORPORATION ACT 1958 (No. 6422), AND FOR SALE AT THE SALE OF PUBLICATIONS BRANCH OF THE GOVERNMENT PRINTING OFFICE, MACARTHUR-STREET, MELBOURNE, 3002.

(These prices do not include postage.)

| No. | Price. |
|---|--------|
| 6189. Acts Interpretation (Third Reprint—Incorporating amendments up to No. 7944) | \$0.35 |
| 6191. Administration and Probate (Fourth Reprint—Incorporating amendments up to No. 7874) | \$0.75 |
| 6194. Agricultural Colleges (First Reprint—Incorporating amendments up to No. 7302) | \$0.15 |
| 6198. Anzac Day (First Reprint—Incorporating amendments up to No. 8344) | \$0.15 |
| 7117. Appeal Costs Fund Act 1964 (First Reprint—Incorporating amendments up to No. 7488) | \$0.25 |
| 6199. Apprenticeship (Second Reprint—Incorporating amendments up to No. 7869) | \$0.40 |
| 6201. Architects (First Reprint—Incorporating amendments up to No. 8077) | \$0.30 |
| 6203. Audit (First Reprint—Incorporating amendments up to No. 7377) | \$0.35 |
| 6208. Benefit Associations (First Reprint—Incorporating amendments up to No. 6961) | \$0.45 |
| 6529. Bread Industry Act 1959 (First Reprint—Incorporating amendments up to No. 7728) | \$0.30 |
| 6973. Building Contracts (Deposits) Act 1962 (First Reprint—Incorporating amendments from No. 7315) | \$0.10 |
| 6210. Building Societies (Second Reprint—Incorporating amendments up to No. 7911) | \$0.40 |
| 6213. Cancer (First Reprint—Incorporating amendments up to No. 7455) | \$0.35 |
| 6214. Carriers and Innkeepers (First Reprint—Incorporating amendments up to No. 7971) | \$0.15 |
| 6217. Cemeteries (First Reprint—Incorporating amendments up to No. 7672) | \$0.30 |

ACTS REPRINTED IN ACCORDANCE WITH THE AMENDMENTS INCORPORATION ACT 1958 (No. 6422)—continued.

| No. | Price. |
|---|--------|
| 6218. Children's Court (Second Reprint—Incorporating amendments up to No. 8124) | \$0.45 |
| 6220. Clean Air (Second Reprint—Incorporating amendments up to No. 8196) | \$0.15 |
| 6221. Coal Mines (First Reprint—Incorporating amendments up to No. 7628) | \$1.05 |
| 6222. Commercial Goods Vehicles (Second Reprint—Incorporating amendments up to No. 7358) | \$0.22 |
| 6223. Commonwealth Arrangements (First Reprint—Incorporating amendments from No. 7809) | \$0.10 |
| 6839. Companies Act 1961 (Fourth Reprint—Incorporating amendments up to Act No. 8185) | \$5.75 |
| 6224. The Constitution Act Amendment (First Reprint—Incorporating amendments up to No. 8086) | \$3.05 |
| 8276. Consumer Protection Act 1972 (First Reprint—Incorporating amendments up to No. 8382) | \$0.65 |
| 6225. Co-operation Act (Third Reprint—Incorporating amendments up to No. 8339) | \$0.85 |
| 6226. Co-operative Housing Societies (Second Reprint—Incorporating amendments up to No. 7575) | \$0.53 |
| 6227. Coroners (First Reprint—Incorporating amendments up to No. 7935) | \$0.35 |
| 6228. Country Fire Authority (Second Reprint—Incorporating Amendments up to No. 7476) | \$0.50 |
| 6229. Country Roads (Third Reprint—Incorporating amendments up to No. 8140) | \$1.05 |
| 6230. County Court (Second Reprint—Incorporating amendments up to No. 8132) | \$0.65 |
| 6231. Crimes (Third Reprint—Incorporating amendments up to No. 7884, but not including No. 7876) | \$1.60 |
| 6232. Crown Proceedings (First Reprint—Incorporating amendments up to No. 7900) | \$0.30 |
| 6233. Dairy Products (First Reprint—Incorporating amendments up to No. 7945) | \$0.20 |
| 7060. Dandenong Valley Authority Act 1963 (First Reprint—Incorporating amendments up to No. 7523) | \$0.35 |
| 4989. Discharged Servicemen's Preference Act 1943 (First Reprint—Incorporating amendments up to No. 7788) | \$0.20 |
| 6815. Disposal of Uncollected Goods Act 1961 (First Reprint—Incorporating amendments up to No. 7181) | \$0.15 |
| 6237. Drainage Areas (First Reprint—Incorporating amendments up to No. 7276) | \$0.35 |
| 6238. Drainage of Land (First Reprint—Incorporating amendments up to No. 7876) | \$0.15 |
| 6239. Dried Fruits Act 1968 (First Reprint—Incorporating amendments up to No. 7337) | \$0.25 |
| 6240. Education (First Reprint—Incorporating amendments up to No. 7533) | \$0.45 |
| 6241. Electric Light and Power (First Reprint—Incorporating amendments up to No. 7315) | \$0.30 |
| 6242. Employers and Employés (Incorporating amendments up to No. 6740) | \$0.18 |
| 6243. Entertainments Tax (First Reprint—Incorporating amendments up to No. 7315) | \$0.25 |
| 8056. Environment Protection Act 1970 (First Reprint—Incorporating amendments up to No. 8277) | \$0.55 |
| 6245. Estate Agents (Fourth Reprint—Incorporating amendments up to No. 8181) | \$0.85 |
| 6246. Evidence (Fourth Reprint—Incorporating amendments up to No. 8228) | \$1.05 |
| 7499. Extractive Industries Act 1966 (Second Reprint)—Incorporating amendments up to No. 7951) | \$0.40 |
| 6250. Fertilizers (Incorporating amendments up to No. 7142) | \$0.25 |
| 6468. Filled Milk (First Reprint—Incorporating amendments up to No. 6886) | \$0.15 |
| 6251. Firearms (Fourth Reprint—Incorporating amendments up to No. 8288) | \$0.75 |
| 6916. Foreign Judgments Act 1962 (First Reprint including amendments made by No. 7332) | \$0.15 |
| 6585. Forests (Pulpwood Agreement) (Incorporating amendments up to No. 6886) | \$0.15 |
| 6254. Forests (First Reprint—Incorporating amendments up to No. 7356) | \$0.60 |
| 6255. Friendly Societies (First Reprint—Incorporating amendments up to No. 7554) | \$0.60 |
| 6256. Fruit and Vegetables (First Reprint—Incorporating amendments up to No. 6944) | \$0.30 |

ACTS REPRINTED IN ACCORDANCE WITH THE AMENDMENTS
INCORPORATION ACT 1958 (No. 6422)—*continued*.

| No. | Price. |
|---|--------|
| 6258. Game (<i>First Reprint</i> —Incorporating amendments up to No. 7389) | \$0.30 |
| 6260. Gas and Fuel Corporation (<i>First Reprint</i> —Incorporating amendments up to No. 7422) | \$0.70 |
| 6262. Geelong Harbor Trust (<i>First Reprint</i> —Incorporating amendments up to No. 7547) | \$0.45 |
| 6263. Geelong Waterworks and Sewerage (<i>First Reprint</i> —Incorporating amendments up to No. 7547) | \$0.75 |
| 8176. Gift Duty Act 1971 (<i>First Reprint</i> —Incorporating amendments from No. 8202) | \$0.55 |
| 6265. Goods (<i>Fifth Reprint</i> —Incorporating amendments up to No. 8276) | \$0.45 |
| 6266. Grain Elevators (<i>First Reprint</i> —Incorporating amendments up to No. 7486) | \$0.35 |
| 6269. Hawkers and Pedlers (<i>First Reprint</i> —Incorporating amendments up to No. 7876) | \$0.30 |
| 6270. Health (<i>Second Reprint</i> —Incorporating amendments up to No. 7490) | \$1.65 |
| 6267. Hairdressers Registration (<i>First Reprint</i> —Incorporating amendments up to Act No. 7659) | \$0.30 |
| 6531. Hire Purchase Act 1959 (<i>Second Reprint</i> —Incorporating amendments from Act No. 8232) | \$0.55 |
| 6933. Home Finance Act 1962 (<i>First Reprint</i> —Incorporating amendments up to No. 7363) | \$0.25 |
| 6274. Hospitals and Charities (<i>Second Reprint</i> —Incorporating amendments up to No. 7455) | \$0.50 |
| 6275. Housing (<i>Second Reprint</i> —Incorporating amendments up to No. 8052) | \$1.65 |
| 6276. Imprisonment of Fraudulent Debtors (<i>First Reprint</i> —Incorporating amendments up to No. 7876) | \$0.35 |
| 6277. Industrial and Provident Societies (<i>First Reprint</i> —Incorporating amendments up to No. 7547) | \$0.35 |
| 6279. Instruments (<i>Fourth Reprint</i> —Incorporating amendments up to No. 7941) | \$0.75 |
| 6280. Judicial Proceedings Reports (<i>First Reprint</i> —Incorporating amendments up to No. 7596) | \$0.15 |
| 6282. Justices (<i>Third Reprint</i> —Incorporating amendments up to No. 7966) | \$1.40 |
| 6283. Labour and Industry (<i>Fifth Reprint</i> —Incorporating amendments up to No. 8211) | \$1.55 |
| 6284. Land Act 1959 (<i>Second Reprint</i> —Incorporating amendments up to No. 8243) | \$3.15 |
| 6534. Land Settlement Act 1959 (<i>First Reprint</i> —Incorporating amendments up to No. 7328) | \$0.30 |
| 6288. Land Surveyors (<i>First Reprint</i> —Incorporating amendments up to Act No. 7065) | \$0.30 |
| 6289. Land Tax (<i>Second Reprint</i> —Incorporating amendments up to No. 7466) | \$0.40 |
| 6231. Crimes Act 1958 (<i>Fourth Reprint</i> —Incorporating amendments up to Act No. 8338) | \$2.75 |
| 6285. Landlord and Tenant (<i>Third Reprint</i> —Incorporating amendments up to No. 7332) | \$0.68 |
| 6286. Lands Compensation (<i>First Reprint</i> —Incorporating amendments up to No. 7332) | \$0.25 |
| 6290. Latrobe Valley (<i>First Reprint</i> —Incorporating amendments up to No. 7332) | \$0.35 |
| 6291. Legal Profession Practice Act (<i>Third Reprint</i> —Incorporating amendments up to No. 8259) | \$1.15 |
| 6292. Libraries (<i>First Reprint</i> —Incorporating amendments up to No. 7364) | \$0.15 |
| 6295. Limitation of Actions (<i>Second Reprint</i> —Incorporating amendments up to No. 7457) | \$0.25 |
| 7695. Liquor Control Act 1968 (<i>Second Reprint</i> —Incorporating amendments up to No. 8272) | \$1.35 |
| 7145. Litter Act 1964 (<i>First Reprint</i> —Incorporating amendments up to No. 7608) | \$0.15 |
| 6298. Local Authorities Superannuation (<i>Second Reprint</i> —Incorporating amendments up to No. 7161) | \$0.40 |
| 6299. Local Government. New Parts III. to IX. Section 51 to Section 250—Incorporating amendments up to No. 8291 | \$1.70 |
| 6299. Local Government. New Parts X. and XI. (being a reprint of portion of No. 7835, as amended by No. 7847) | \$0.50 |
| 6301. Margarine (<i>First Reprint</i> —Incorporating amendments up to No. 7714) | \$0.18 |
| 6302. Marine (Incorporating amendments up to No. 7350) | \$0.72 |
| 6303. Marine Stores and Old Metals (<i>First Reprint</i> —Incorporating amendments up to No. 7876) | \$0.35 |
| 6304. Marketing of Primary Products (<i>First Reprint</i> —Incorporating amendments up to No. 7491) | \$0.45 |

ACTS REPRINTED IN ACCORDANCE WITH THE AMENDMENTS
INCORPORATION ACT 1958 (No. 6422)—*continued*.

| No. | Price. |
|---|--------|
| 6305. Markets (<i>First Reprint</i> —Incorporating amendments up to No. 7705) | \$0.20 |
| 6306. Marriage (<i>First Reprint</i> —Incorporating amendments up to No. 6959) | \$0.25 |
| 6307. Masseurs (<i>First Reprint</i> —Incorporating amendments up to No. 7566) | \$0.20 |
| 6309. Medical (<i>Second Reprint</i> —Incorporating amendments up to No. 7408) | \$0.40 |
| 6310. Melbourne and Metropolitan Board of Works (<i>Third Reprint</i> —Incorporating amendments up to No. 8082) | \$1.85 |
| 6311. Melbourne and Metropolitan Tramways (<i>First Reprint</i> —Incorporating amendments up to No. 7622) | \$0.70 |
| 6312. Melbourne Harbor Trust (<i>First Reprint</i> —Incorporating amendments up to No. 7356) | \$0.48 |
| 6405. Melbourne University (<i>First Reprint</i> —Incorporating amendments up to No. 7871) | \$0.40 |
| 6605. Mental Health (Incorporating amendments up to No. 7135) | \$0.45 |
| 6315. Metropolitan Fire Brigades (<i>Second Reprint</i> —Incorporating amendments up to No. 8165) | \$0.65 |
| 6316. Mildura Irrigation and Water Trusts (<i>First Reprint</i> —Incorporating amendments up to No. 7448) | \$0.75 |
| 6317. Milk and Dairy Supervision (Incorporating amendments up to No. 6964) | \$0.40 |
| 6318. Milk Board (Incorporating amendments up to No. 7093) | \$0.22 |
| 6319. Milk Pasteurization (<i>First Reprint</i> —Incorporating amendments up to No. 7480) | \$0.15 |
| 6320. Mines (<i>Second Reprint</i> —Incorporating amendments up to No. 7876) | \$1.25 |
| 6184. Monash University (<i>First Reprint</i> —Incorporating amendments up to No. 7533) | \$0.30 |
| 6324. Money Lenders (<i>Third Reprint</i> —Incorporating amendments up to No. 8181) | \$0.55 |
| 6832. Motor Boating Act 1961 (<i>Second Reprint</i> —Incorporating amendments up to No. 6961) | \$0.30 |
| 6325. Motor Car (<i>Fourth Reprint</i> —Incorporating amendments up to No. 8143) | \$2.05 |
| 6705. Navigable Waters (Oil Pollution) Act 1960. (<i>First Reprint</i> —Incorporating amendments up to No. 7890) | \$0.30 |
| 6328. Nurses (<i>Second Reprint</i> —Incorporating amendments up to No. 7375) | \$0.45 |
| 6329. Opticians Registration (<i>First Reprint</i> —Incorporating amendments up to No. 7409) | \$0.30 |
| 6330. Partnership (<i>Second Reprint</i> —Incorporating amendments up to No. 7315) | \$0.30 |
| 6331. Patriotic Funds (<i>First Reprint</i> —Incorporating amendments up to No. 7338) | \$0.25 |
| 6332. Pawnbrokers (<i>First Reprint</i> —Incorporating amendments up to No. 7876) | \$0.35 |
| 6257. Pesticides Act 1968 (<i>First Reprint</i> —Incorporating amendments up to No. 7595) | \$0.15 |
| 6334. Petroleum (<i>First Reprint</i> —Incorporating amendments up to No. 7876) | \$0.65 |
| 6889. Poisons Act 1962 (<i>Second Reprint</i> —Incorporating amendments up to No. 7588) | \$0.50 |
| 6337. Police Offences (<i>Second Reprint</i> —Incorporating amendments up to No. 7678) | \$0.28 |
| 6338. Police Regulation (<i>Second Reprint</i> —Incorporating amendments up to No. 8179) | \$0.95 |
| 6340. Portland Harbor Trust (<i>First Reprint</i> —Incorporating amendments up to No. 7475) | \$0.35 |
| 6341. Pounds (<i>First Reprint</i> —Incorporating amendments up to No. 7315) | \$0.25 |
| 7498. Port Phillip Authority Act 1966 (<i>First Reprint</i> —Incorporating amendments from No. 8081) | \$0.15 |
| 6342. Printers and Newspapers (<i>First Reprint</i> —Incorporating amendments up to No. 7876) | \$0.15 |
| 7494. Private Agents Act 1966 (<i>First Reprint</i> —Incorporating amendments in No. 7646) | \$0.35 |
| 6890. Probate Duty (<i>Third Reprint</i> —Incorporating amendments up to No. 8072) | \$0.75 |
| 6344. Property Law (<i>Third Reprint</i> —Incorporating amendments up to No. 8181) | \$1.95 |
| 6345. Public Account (<i>First Reprint</i> —Incorporating amendments up to No. 8012) | \$0.20 |
| 6346. Public Authorities Marks (<i>First Reprint</i> —Incorporating amendments from No. 7315) | \$0.10 |
| 6349. Public Service (<i>Second Reprint</i> —Incorporating amendments up to No. 7356) | \$0.40 |
| 6350. Public Trustee (Incorporating amendments up to No. 6961) | \$0.35 |
| 6353. Racing (<i>Third Reprint</i> —Incorporating amendments up to No. 8080) | \$1.45 |

ACTS REPRINTED IN ACCORDANCE WITH THE AMENDMENTS INCORPORATION ACT 1958 (No. 6422)—*continued*.

| No. | Price. |
|--|--------|
| 6355. Railways (First Reprint—Incorporating amendments up to No. 7475) .. | \$0.75 |
| 6564. Registration of Births Deaths and Marriages Act 1959 (First Reprint—Incorporating amendments up to No. 7332) .. | \$0.25 |
| 2596. River Murray Waters Act 1915 (First Reprint—Incorporating amendments up to No. 7061) .. | \$0.35 |
| 6359. Road Traffic (Third Reprint—Incorporating amendments up to No. 8192) .. | \$0.35 |
| 6360. Rural Finance (First Reprint—Incorporating amendments up to No. 7328) .. | \$0.15 |
| 6846. Rural Finance and Settlement Commission Act 1961 (First Reprint—Incorporating amendments up to No. 7332) .. | \$0.30 |
| 6917. Sale of Human Blood Act 1962 (First Reprint—Incorporating amendments from No. 7332) .. | \$0.10 |
| 6975. Sale of Land Act 1962 (Second Reprint—Incorporating amendments up to No. 7898) .. | \$0.30 |
| 6363. Second-hand Dealers (First Reprint—Incorporating amendments up to No. 7529) .. | \$0.25 |
| 7962. Securities Industry Act 1970 (First Reprint—Incorporating amendments made by Act No. 8059) .. | \$0.65 |
| 6367. Settled Land (Second Reprint—Incorporating amendments up to No. 7065) .. | \$0.50 |
| 6368. Sewerage Districts (Second Reprint—Incorporating amendments up to No. 7547) .. | \$0.75 |
| 6369. Shearers Accommodation (First Reprint—Incorporating amendments up to No. 7876) .. | \$0.35 |
| 6809. Sheep Owners Protection Act 1961 (Second Reprint—Incorporating amendments up to No. 8179) .. | \$0.20 |
| 6372. Soil Conservation and Land Utilization (Second Reprint—Incorporating amendments up to No. 8142) .. | \$0.45 |
| 6373. Soldier Settlement (First Reprint—Incorporating amendments up to No. 7328) .. | \$0.42 |
| 6375. Stamps (Fifth Reprint—Incorporating amendments up to No. 8274) .. | \$2.15 |
| 6377. State Electricity Commission (Second Reprint—Incorporating amendments up to No. 7421) .. | \$0.65 |
| 6378. State Relief Committee (First Reprint—Incorporating amendments from No. 6886) .. | \$0.10 |
| 6379. State Savings Bank (Second Reprint—Incorporating amendments up to No. 8082) .. | \$0.95 |
| 6380. Statistics (First Reprint—Incorporating amendments up to No. 6961) .. | \$0.15 |
| 6383. Stock Foods (First Reprint—Incorporating amendments up to No. 7607) .. | \$0.28 |
| 6384. Stock Medicines (First Reprint—Incorporating amendments up to No. 7726) .. | \$0.20 |
| 7551. Strata Titles Act 1967 (Second Reprint—Incorporating amendments up to No. 8149) .. | \$0.65 |
| 6886. Subordinate Legislation (Incorporating amendments up to No. 6961) .. | \$0.15 |
| 7405. Summary Offences Act 1966 (First Reprint—Incorporating amendments up to Act No. 8226) .. | \$0.55 |
| 6386. Superannuation (Second Reprint—Incorporating amendments up to No. 7910) .. | \$0.75 |
| 6387. Supreme Court (First Reprint—Incorporating amendments up to No. 7522) .. | \$0.75 |
| 6388. Survey Co-ordination (First Reprint—Incorporating amendments up to Act No. 8107) .. | \$0.30 |
| 6390. Tattersall Consultations (First Reprint—Incorporating amendments up to No. 8289) .. | \$0.15 |
| 6391. Teaching Service (First Reprint—Incorporating amendments up to No. 7536) .. | \$0.35 |
| 6849. Town and Country Planning Act 1961 (Third Reprint—Incorporating amendments up to No. 7975) .. | \$0.65 |
| 6401. Trustee (Third Reprint—Incorporating amendments up to No. 7833) .. | \$0.95 |
| 6402. Trustee Companies (First Reprint—Incorporating amendments up to No. 7858) .. | \$0.35 |
| 7223. Tomato Processing Industry (Uniform Agreement) Act 1964 (First Reprint—Incorporating amendments up to No. 7342) .. | \$0.15 |
| 6397. Trade Unions (First Reprint—Incorporating amendments up to No. 6839) .. | \$0.20 |
| 6399. Transfer of Land Act (Fourth Reprint—Incorporating amendments up to No. 8181) .. | \$1.15 |
| 6400. Transport Regulation (First Reprint—Incorporating amendments up to No. 7358) .. | \$0.22 |

ACTS REPRINTED IN ACCORDANCE WITH THE AMENDMENTS INCORPORATION ACT 1958 (No. 6422)—*continued*.

| No. | Price. |
|--|--------|
| 6879. Unclaimed Moneys (Incorporating amendments up to No. 6961) .. | \$0.12 |
| 7095. Underseas Mineral Resources Act 1963 (First Reprint—Incorporating amendments from No. 7591) .. | \$0.10 |
| 6653. Valuation of Land Act 1960 (Second Reprint—Incorporating amendments up to No. 7333) .. | \$0.22 |
| 6407. Vegetation and Vine Diseases (First Reprint—Incorporating amendments up to No. 7423) .. | \$0.30 |
| 6409. Vermin & Noxious Weeds (First Reprint—Incorporating amendments up to No. 7463) .. | \$0.35 |
| 6410. Veterinary Surgeons (First Reprint—Incorporating amendments up to No. 7343) .. | \$0.15 |
| 6411. Victorian Inland Meat Authority (First Reprint—Incorporating amendments up to No. 8000) .. | \$0.30 |
| 7291. Victoria Institute of Colleges Act 1965 (First Reprint—Incorporating amendments up to No. 7644) .. | \$0.25 |
| 6412. Warehousemen's Liens (First Reprint—Incorporating amendments up to No. 7876) .. | \$0.15 |
| 6413. Water (Second Reprint—Incorporating amendments up to No. 7590) .. | \$1.95 |
| 6414. Weights and Measures (Third Reprint—Incorporating amendments up to No. 8068) .. | \$1.05 |
| 6415. Wild Flowers and Native Plants Protection (First Reprint—Incorporating amendments up to No. 6976) .. | \$0.15 |
| 6416. Wills (First Reprint—Incorporating amendments up to No. 7238) .. | \$0.25 |
| 6417. Wire Netting (First Reprint—Incorporating amendments up to No. 7876) .. | \$0.45 |
| 6419. Workers Compensation (Fifth Reprint—Incorporating amendments up to No. 8353) .. | \$1.05 |

FIRST NOTIFICATION OF REPRINT.

| No. | Price. |
|--|--------|
| 7849. Groundwater (First Reprint—Incorporating amendments up to No. 8153) .. | \$0.45 |
| 6358. River Improvement Act (First Reprint—Incorporating amendments up to No. 8342) .. | \$0.55 |

C. H. RIXON,
Government Printer.

THE "VICTORIA GOVERNMENT GAZETTE".

SUBSCRIPTIONS.—The subscription, including postage, is \$22.50 per annum, or \$11.25 per half year, payable in advance.

Subscriptions are required for whole months, and must cover at least a half year.

Single copies are 30 cents, posted 48 cents. Subscribers do not receive the Acts of Parliament with the GAZETTE.

GAZETTES are held in stock for five years only.

PRIVATE ADVERTISEMENTS.—The charge for insertion is 35 cents per line single column, and 70 cents per line double column. The title forms one or more lines as a heading. On an average ten words make a line of single column. Every signature must likewise be counted as a line. The final words of a paragraph, though only portion of a line, must be counted as one line. Signatures (in particular) and proper names must be written very plainly in the text; ONE SIDE ONLY of each sheet of paper should be WRITTEN UPON. The charge for a full page is \$50.

All documents illegibly written will be returned unpublished, and where brands occur unprovided for by the ordinary letters of the alphabet, a worded explanatory description must be furnished.

PUBLICATION.—Unless otherwise advertised, the VICTORIA GOVERNMENT GAZETTE is published on WEDNESDAY EVENING in each week, and Notices for insertion will be received by the Government Printer at or before ONE p.m. at ordinary rates, and late advertisements between ONE p.m. and half-past THREE p.m. at double rates on the day preceding the day of publication.

PAYMENTS.—Unless the advertiser has a credit account, all payments are required in advance. Remittances should be made by cheque, postal order, or money order payable to "GOVERNMENT PRINTER".

ADDRESS.—All communications should be addressed to "The Government Printer, Box 203, P.O., North Melbourne, 3051."

AGENTS FOR THE "VICTORIA GOVERNMENT
GAZETTE".

The following have been appointed agents to receive Advertisements and Subscriptions for the *Victoria Government Gazette*:—

- ARMSTRONG'S AGENCY, 217 Queen-street, Melbourne, Victoria 3000.
- ARNALL & JACKSON, 390 Barkly-street, Brunswick, Victoria 3056.
- BAIRNSDALE AUTHORIZED NEWSAGENCY, 132 Main-street, Bairnsdale, Victoria 3875.
- BICKNELL, M. J., Authorized Newsagent, 196 Timor-street, Warrambool, Victoria 3280.
- BLANE'S AUTHORIZED NEWSAGENTS, 162 Murray-street, Colac, Victoria 3250.
- CARTER, R. G., ADVERTISING SERVICE PTY. LTD., Suite 24, 65 Queens-road, Melbourne, Victoria 3004.
- DAVIES, G. & M. V., 112 Gray-street, Hamilton, Victoria 3300.
- DAVIS, WM. (MILDURA) PTY. LTD., 126 Eighth-street, Mildura, Victoria 3500.
- DIXON'S NEWSAGENCY, 89 Firebrace-street, Horsham, Victoria 3400.
- EASTHALL ASSOCIATES, 934 Whitehorse-road, Box Hill, Victoria 3128.
- EDGAR'S AUTHORIZED NEWSAGENCY, 45 Bridge-street, Benalla, Victoria 3672.
- FRANKS, H. & CO., 184 Ryrie-street, Geelong, Victoria 3220.
- GATLEY, A. & J., 250 Lonsdale-street, Dandenong, Victoria 3175.
- GORDON & GOTCH AUSTRALASIA LTD., 434 St. Kilda-road, Melbourne, Victoria 3004.
- GULLAN'S NEWSAGENCY, 88 Bridge-street, Ballarat, Victoria 3350.
- HAMPTON, A. C., 243 Mitchell-street, Bendigo, Victoria 3550.
- HARSTON, PARTRIDGE & CO. PTY. LTD., 455 Little-Collins-street, Melbourne, Victoria 3000.
- KYNETON GUARDIAN PTY. LTD., P.O. Box 18, Kyneton, Victoria 3444.
- LATIMER'S NEWSAGENTS, 45 Station-street, Malvern, Victoria 3144.
- LIVINGSTON'S SHEPPARTON NEWSAGENCY, 246 Wyndham-street, Shepparton, Victoria 3630.
- THE MERCANTILE EXCHANGE, 34 Queen-street, Melbourne, Victoria, 3000.
- MCGILL'S AUTHORIZED NEWSAGENCY, 183-5 Elizabeth-street, Melbourne, Victoria 3000.
- POWNEY'S AUTHORIZED NEWSAGENCY, 293 Hargreaves-street, Bendigo, Victoria 3550.
- PURDIE, J. & CO., 138 Moorabool-street, Geelong, Victoria 3220.
- SALE AUTHORIZED NEWSAGENCY, 142 Raymond-street, Sale, Victoria 3850.
- SKINNER'S AUTHORIZED NEWSAGENCY, 49-51 Franklin-street, Traralgon, Victoria 3844.
- STEVENSON, A. C. & M., NEWSAGENTS, 132 Henty-street, Casterton, Victoria 3311.
- VANCE'S AUTHORIZED NEWSAGENCY, 83 Murray-street, Wangaratta, 3677.
- VERNSONS OF RICHMOND, 162 Bridge-road, Richmond, Victoria 3121.
- VIEW POINT AUTHORIZED NEWSAGENCY, 4 View-Point, Bendigo, Victoria 3550.

A copy of the *Gazette* is filed at each place for public reference.

CONTENTS

PAGE

| | |
|---|-------------|
| Acts of Parliament on Sale at the Government Printing Office | 2468 |
| Appointments | 2429 |
| Cemeteries—Scale of Fees | 2422 |
| Companies Act 1961—Notice | 2426 |
| Contracts | 2428 |
| Country Roads Board | 2414 |
| Estates of Deceased Persons | 2428 |
| Government Notices | 2413 |
| Impoundings | 2468 |
| Insolvency Notice | 2467 |
| Lands | 2443 |
| Melbourne and Metropolitan Board of Works—Notice | 2426 |
| Notice of Making of Statutory Rules | 2468 |
| Orders in Council— | |
| Acts—Country Roads; Land; Local Government; Melbourne and Metropolitan Board of Works; Stamps; Superannuation; Water; Sewerage Districts. | 2431 et seq |
| Police Sale | 2427 |
| Private Advertisements | 2447 |
| Proclamations | 2411 |
| Public Service Notices | 2446 |
| Resignations | 2431 |
| State Rivers and Water Supply Commission | 2424 |
| Tenders | 2445 |
| Transport Regulation Board—Public Hearings | 2413 |