

[3753]



VICTORIA GOVERNMENT GAZETTE

Published by Authority

No. 103]

WEDNESDAY, OCTOBER 23

[1974

PROCLAMATIONS

BANK HOLIDAYS.

PROCLAMATION

By His Excellency the Governor of the State of Victoria and its Dependencies in the Commonwealth of Australia, &c., &c., &c.

In pursuance of the provisions of the *Bank Holidays Act 1958, I*, the Governor of the State of Victoria, in the Commonwealth of Australia, do by this my Proclamation appoint the days and dates named hereunder special days to be observed as Bank Holidays or Bank Half-Holidays (as the case may be) at the places respectively mentioned, that is to say:—

Bank Holidays:—

TUESDAY, THE 5TH NOVEMBER, 1974, at Bendigo, Eaglehawk and Kangaroo Flat.
TUESDAY, THE 5TH NOVEMBER, 1974, at Maryborough.

Bank Half-Holidays from the Hour of Eleven a.m.:—

TUESDAY, THE 29TH OCTOBER, 1974, at Hamilton.
TUESDAY, THE 5TH NOVEMBER, 1974, at Donald, Litchfield and Corack East.
WEDNESDAY, 13TH NOVEMBER, 1974, at Bendigo, Eaglehawk and Kangaroo Flat.
MONDAY, THE 28TH OCTOBER, 1974, at Kilmore.
TUESDAY, THE 5TH NOVEMBER, 1974, at Wedderburn.
TUESDAY, THE 5TH NOVEMBER, 1974, at Manangatang.

Given under my Hand and the Seal of the State of Victoria aforesaid, at Melbourne, this twenty-second day of October, in the year of our Lord One thousand nine hundred and seventy-four, and in the twenty-third year of the reign of Her Majesty Elizabeth the Second, Queen of Australia.

(L.S.) HENRY WINNEKE.

By His Excellency's Command,

J. F. ROSSITER,
Chief Secretary.

GOD SAVE THE QUEEN!

PUBLIC HOLIDAYS.

PROCLAMATION

By His Excellency the Governor of the State of Victoria and its Dependencies in the Commonwealth of Australia, &c., &c., &c.

In pursuance of the provisions contained in Part III. of the *Public Service Act 1958, I*, the Governor of the State of Victoria, in the Commonwealth of Australia, by and with the advice of the Executive Council of the said State, do by this my Proclamation appoint the days and dates hereunder mentioned to be observed as Public Holidays or Public Half-Holidays (as the case may be) at the places respectively specified, viz.:—

Public Holidays:—

TUESDAY, THE 5TH NOVEMBER, 1974, throughout the City of Bendigo.

TUESDAY, THE 5TH NOVEMBER, 1974, throughout the Borough of Eaglehawk.

Public Half-Holidays from the Hour of Twelve o'clock noon:—

WEDNESDAY, THE 13TH NOVEMBER, 1974, in the West and South Ridings of the Shire of Huntly.

WEDNESDAY, THE 13TH NOVEMBER, 1974, throughout the Shire of Strathfieldsaye.

Given under my Hand and the Seal of the State of Victoria aforesaid, at Melbourne, this twenty-second day of October, in the year of our Lord One thousand nine hundred and seventy-four, and in the twenty-third year of the reign of Her Majesty Elizabeth the Second, Queen of Australia.

(L.S.) HENRY WINNEKE.

By His Excellency's Command,

J. F. ROSSITER,
Chief Secretary.

GOD SAVE THE QUEEN!

Milk and Dairy Supervision Act 1958.
MUNICIPAL DISTRICT PROCLAIMED TO BE SUBJECT
TO THE PROVISIONS OF PART II.

PROCLAMATION.

By His Excellency the Governor of the State of Victoria and its Dependencies in the Commonwealth of Australia, &c., &c., &c.

Whereas by paragraph (c) of sub-section (1) of section 55 of the *Milk and Dairy Supervision Act 1958* it is provided that Part II. of the said Act shall have effect as regards any municipal district outside any milk area on such date as such district at any time is proclaimed by the Governor in Council to be subject to the provisions of the said Part II.: Now therefore I, the Governor of the State of Victoria by and with the advice of the Executive Council thereof do hereby Proclaim the municipal district of the Shire of Kaniva to be subject to the provisions of Part II. of the said Act on and after the first day of November, One thousand nine hundred and seventy-four on which date all Regulations and Orders made thereunder now in operation shall be of full force and effect in such municipal district.

Given under my Hand and the Seal of the State of Victoria aforesaid, at Melbourne, this twenty-second day of October, in the year of our Lord One thousand nine hundred and seventy-four, and in the twenty-third year of the reign of Her Majesty Elizabeth the Second, Queen of Australia.

(L.s.) HENRY WINNEKE.

By His Excellency's Command,
IAN SMITH,
Minister of Agriculture.

GOD SAVE THE QUEEN!

Milk and Dairy Supervision Act 1958.
DEFINED URBAN DISTRICTS.

PROCLAMATION

By His Excellency the Governor of the State of Victoria and its Dependencies in the Commonwealth of Australia, &c., &c., &c.

In pursuance of the powers conferred by section 99 of the *Milk and Dairy Supervision Act 1958* and all other powers enabling me in that behalf, I, the Governor of the State of Victoria, in the Commonwealth of Australia, by and with the advice of the Executive Council of the said State, do by this my Proclamation hereby define the Shire of Kaniva as an urban district on and after the first day of November, 1974.

Given under my Hand and the Seal of the State of Victoria aforesaid, at Melbourne, this twenty-second day of October, in the year of our Lord One thousand nine hundred and seventy-four, and in the twenty-third year of the reign of Her Majesty Elizabeth the Second, Queen of Australia.

(L.s.) HENRY WINNEKE.

By His Excellency's Command,
IAN SMITH,
Minister of Agriculture.

GOD SAVE THE QUEEN!

GOVERNMENT NOTICES

HOLIDAY.—MELBOURNE CUP DAY.

Notice is hereby given that on—

TUESDAY, THE 5TH NOVEMBER, 1974,

the Public Offices in the municipalities mentioned hereunder will be closed, that day being appointed under the provisions of the *Public Service Act 1958* to be observed as a holiday in the Public Offices:—

The Cities of Altona, Berwick, Box Hill, Brighton, Broadmeadows, Brunswick, Camberwell, Caulfield, Chelsea, Coburg, Collingwood, Croydon, Dandenong, Doncaster and Templestowe, Essendon, Fitzroy, Footscray, Frankston, Hawthorn, Heidelberg, Keilor, Kew, Knox, Malvern, Melbourne, Moorabbin, Mordialloc, Northcote, Nunawading, Oakleigh, Port Melbourne, Prahran, Preston, Richmond, Ringwood, St. Kilda, Sandringham, South Melbourne, Springvale, Sunshine, Waverley and Williamstown; the Shires of Bacchus

Marsh, Bulla, Cranbourne, Diamond Valley, Eltham, Gisborne, Hastings, Lillydale, Melton, Mornington, Pakenham, Romsey, Sherbrooke, Werribee and Whittlesea.

This notice relates only to the closing of the State Public Offices. All inquiries regarding holidays in other offices and in shops and industry should be directed to the Department of Labour and Industry, 110 Exhibition Street, Melbourne. (Telephone 651 6158 or 651 6859.)

J. F. ROSSITER,
Chief Secretary.

Chief Secretary's Office,
Melbourne, 27th September, 1974.

Securities Industry Act 1970.

PARTNERSHIP PACIFIC LIMITED.

I hereby give notice that on the 8th day of October, 1974, the following Notice of Cessation of Business under the above-mentioned Act was served on me:—

Form 9.

Victoria.

Securities Industry Act 1970 (Section 17A (1)).

NOTICE OF CESSATION OF BUSINESS.

Name of Licensee: Partnership Pacific Limited.

Notice is hereby given that on the 7th day of October, 1974, business ceased to be carried on in Victoria by the above-mentioned licensee in respect of which it was licensed to carry on business.

Signed at Melbourne by Alan James Barker, Agent of Partnership Pacific Limited on the 7th day of October, 1974.

A. J. BARKER.

B. J. WALDRON, Commissioner for Corporate Affairs.

SECURITIES INDUSTRY ACT 1970.

I, Brian Joseph Waldron, Commissioner for Corporate Affairs of the State of Victoria, hereby give notice that:—

1. On 8th October, 1974, I was served with a notice in the prescribed form that Partnership Pacific Limited had ceased to carry on business as a dealer in this State as from 7th October, 1974.

2. Under the above Act it is provided that I may release the security lodged with me by a dealer in accordance with the said Act:—

- on the expiration of three months after service on me of a notice in writing duly signed by or on behalf of the dealer stating that the dealer has ceased to carry on the business of a dealer in this State;
- on my being satisfied that the dealer has not from the date of service of the notice carried on such business in the State; and
- on my being satisfied that all the liabilities of the dealer in this State in respect of such business are fully liquidated or provided for.

3. Any person having any objection to the release of the said security should send particulars of such objection addressed to me at the Corporate Affairs Office, P.O. Box 4567, Melbourne.

B. J. WALDRON,
Commissioner for Corporate Affairs.

Victoria.

DEPARTMENT OF AGRICULTURE.

PUBLIC NOTICE.

It is hereby notified that a claim has been lodged against the Farm Produce Merchants and Commission Agents Guarantee Fund by a grower creditor of Sun Sui Wah Villa-Ma Pty. Ltd., wholesale fruit and vegetable merchant, formerly operating at the Melbourne Wholesale Fruit and Vegetable Market, and in accordance with the provisions of the *Farm Produce Merchants and Commission Agents Act 1965*, all persons who as producers of farm produce have any claim against Sun Sui Wah Villa-Ma Pty. Ltd. arising from any failure on the part of the said Company to pay or account for any moneys payable to them for farm produce supplied are invited to forward particulars and proof of such claim to the Director of Agriculture, Treasury Place, Melbourne, on or before 27th November, 1974. (Postal Address: Department of Agriculture, Box 4041, G.P.O., Melbourne, Vic. 3001).

Transport Regulation Act.
TRANSPORT REGULATION BOARD.

HEARING OF APPLICATIONS.

Notice is hereby given that the following applications will be considered by the Transport Regulation Board on 12th November, 1974.

GOLDSWORTHY, J. L. & C. W. & AUSTIN, N. S., 82 Commercial Street, Kaniva. Application for one commercial passenger vehicle with seating capacity for 39 persons to operate in substitution for but not in addition to T.S. licensed vehicles currently in the name of the applicant.

GRIFFITHS, W. R., WERNER, I. C. and ARMSTRONG, J., 64 Lloyd Street, Dimboola. Application for variation of conditions of licence S.V.44 to include the ability to operate additional tours as follows:—(i) Horsham—Grampians; (ii) Horsham—Warracknabeal Museum and locale; (iii) Horsham—Mt. Arapiles and District; (iv) Horsham—Naracoorte Caves; (v) Horsham—Little Desert.

HUTCHINSON, J. G., 16 Tennis Grove, North Caulfield. Application for one commercial passenger vehicle with seating capacity for five persons to operate as a Suburban Taxi under composite conditions from an approved depot in Zone "E" subject to cancellation of M.H.4115 expiring 22/7/79 at present held by the applicant.

McKENZIE, L., & G. G., 17 O'Callaghan's Parade, Horsham. Application for one commercial passenger vehicle with small seating capacity, to operate day and half day tours from Horsham as follows:—(i) Zumsteins, McKenzies Falls, various lookouts, Halls Gap, Lake Bellfield, and Stawell returning to Horsham. (ii) Mount Arapiles, Edenhope, Naracoorte Caves, returning to Horsham via Harrow and Wonwondah. (iii) Warracknabeal Museum, Jeparit Pioneers Museum, Old Mission Station at Antwerp returning to Horsham. (iv) Wyperfeld National Park, returning via Hoptoun. (v) Tour to Dimboola, thence to Little Desert (in conjunction with Griffiths, Werners and Armstrong). (vi) Sightseeing of Horsham.

Application for renewal of licences as shown by the person listed hereunder to operate under the same terms and conditions:—

SANDLANT, G. D., 7 McKinley Avenue, Landsborough; C.O.1088, T.S.490, T.S.666.

Notice of any objections should be forwarded to reach the Secretary of the Board not later than 6th November, 1974.

Applicants are advised that it will not be necessary to appear on the hearing date specified, unless advised in writing by the Board.

A. V. C. COOK,
Secretary.

Corner Lygon and Princes Streets, Carlton, 3053,
Wednesday, 23rd October, 1974.

Commercial Goods Vehicles Act.
TRANSPORT REGULATION BOARD.

HEARING OF APPLICATIONS.

Notice is hereby given that the following applications will be considered by the Transport Regulation Board on 12th November, 1974.

WATSON, A. K. (trading as Alpine Services), 239 Campbell Street, Swan Hill, 3585. One commercial goods vehicle (L/C. 0.75 tonne) to operate within an 80-km radius from own premises at Swan Hill and to and from the townships of Robinvale, Ouyen, Patchewollock, Lascelles, Hoptoun and Birchip in the course of business as "Electrical Retailers and Servicemen"—tools of trade, equipment, spare parts and materials incidental to servicing and also electrical appliances for delivery, for repair or having been repaired.

ANSWER, W. J., Dingley Dell Road, Thorpdale, 3835. One commercial goods vehicle (L/C. 14.15 tonne) to operate: (a) From forest and private landings within a 40-km radius of the post office at Traralgon to saw-mills situated within the said radius—mill logs. (b) From the area specified in paragraph (a) above to the premises of Australian Paper Manufacturers Ltd. at Maryvale—pulpwood on pallets and the return of empty pallets.

ASSOCIATED PRODUCTS DISTRIBUTORS, 8-20 King Street, Oakleigh, 3166. One commercial goods vehicle (L/C. 1.65 tonne) to operate within an 80-km radius of own

branch depot at Wodonga in the course of business as "Snack Food Manufacturers and Distributors"—own snack foods.

NOTE.—All goods to be initially consigned by rail to Wodonga.

BENNETT, W. A., & CO., PTY. LTD., 197 High Street Road, Ashwood, 3147. One commercial goods vehicle (L/C. 6.55 tonne) to operate: (a) Within a 40-km radius of the post office situated at the corner of Bourke and Elizabeth Streets in the City of Melbourne in the course of business as "Garden and Building Suppliers"—own goods. (b) From Castlemaine and Chewton to own premises situated at Ashwood—own paving slate. (c) From Bacchus Marsh to own premises situated at Ashwood—own river pebbles. (d) From places situated in the Geelong district and from places en route, to own premises situated at Ashwood—own honeycomb rock.

BRUNT, A. J., 9 Grayling Street, Belmont, 3216. One commercial goods vehicle (L/C. 0.50 tonne) to operate within an 80-km radius of the chief post office in the City of Geelong in the course of business as "Electrical Serviceman"—television sets, radios and electrical appliances for installation repair or having been repaired and also tools of trade and materials incidental to the installation, servicing and maintenance of such appliances.

CARPENTER, M. G., 5 Hills Street, Hernes Oak, 3836. One commercial goods vehicle (L/C. 7.40 tonne) to operate: (a) Within an 80-km radius of the post office at Hernes Oak—plant the property of a contractor and required by him for use in connection with the construction or maintenance of some specific existing or proposed road, street, footpath, bridge, pier, wharf, weir or channel and also the following materials viz.: metal, stones, screenings, ashes, gravel, sand and earth. (b) Within a 32-km radius from the site of any construction or maintenance work performed pursuant to paragraph (a) above, or from the railway station nearest thereto—any other materials required for such work. (c) Within a 40-km radius of the post office at Hernes Oak—general goods. (d) From own sand pit at Gormandale to consignees situated within the area specified in paragraph (a) above—sand.

CARRACHER, C. P., Minimay, 3413. One commercial goods vehicle (L/C. 7.80 tonne) to operate: (a) Within a 32-km radius of the post office at Minimay—general goods. (b) From the premises of Ampol Petroleum at Horsham to own premises at Minimay—petroleum products and empty return containers. (c) Throughout the State of Victoria—livestock.

OWEN, G. R. & R. J. (trading as Combined Roof Trusses & Prefabricated Houses), 159 Princes Highway, Warrnambool, 3280. One commercial goods vehicle (L/C. 1.90 tonne) to operate: (a) Within an 80-km radius of own premises at Warrnambool in the course of business as "Building Contractor"—own goods. (b) Within an 80-km radius of own premises at Warrnambool as a "Distributor of Plaster Board"—victor plaster board. (c) To own approved decentralized secondary industry premises (prefabricated houses) at Warrnambool from points within that part of Victoria south of an east/west line drawn through Ararat and west of a north/south line drawn through Geelong and from mills within an 80-km radius of Mansfield—sawn hardwood timber and sawn pine timber.

DAHLSEN, J. C., PTY. LTD., 90-120 Nicholson Street, Bairnsdale, 3875. One commercial goods vehicle (L/C. 0.75 tonne) to operate within an 80-km radius from the post office at Bairnsdale and/or within that part of the State of Victoria east of a line drawn due north and south through the Township of Fernbank in the course of business as "General Merchants"—own goods and goods the property of J. C. Dahlsen Building and Farm Supplies Pty. Ltd. an associate company.

DUTSON QUARRYING CO. PTY. LTD., Frankston Road, Dandenong, 3175. One commercial goods vehicle (L/C. 0.70 tonne) operate throughout the State of Victoria in the course of business as "Earthmoving Contractors" for the purpose of servicing own equipment—tools of trade, spare parts and materials incidental to on-site servicing.

EVERLAST CONCRETE TANKS, 48 Fallon Street, Albury, N.S.W., 2640. One commercial goods vehicle (L/C. 5.40 tonne) to operate: (a) Throughout the State of Victoria in the course of business as "Manufacturers of Concrete Tanks"—tools of trade and equipment. (b) Within an 80-km radius of any current contract

- site or from the nearest railway station thereto—materials for use on such contract. (c) Within a 112-km radius from each of own plants at Bendigo, Pakenham and Ballarat respectively—own prefabricated concrete tanks on a specially constructed vehicle with own lifting and winching equipment.
- FERGUSON, L.**, 113 High Street, Heathcote, 3606. One commercial goods vehicle (L/C. 0.75 tonne) to operate within a 40-km radius of own premises at Heathcote and from Bendigo and Melbourne to own premises at Heathcote in course of business as "General Storekeeper"—own goods.
- GALLI EQUIPMENT PTY. LTD.**, 15 Albert Street, East Brunswick, 3057. One commercial goods vehicle (L/C. 8.00 tonne) to operate within an 80-km radius of the G.P.O., Melbourne, in the course of business as "Road Construction Contractors" for the purpose of operating the vehicle as a "Water Tanker" for spraying own road construction projects.
- GORMAN, R. W.**, Maroondah Highway, Alexandra, 3714. One commercial goods vehicle (L/C. 10.30 tonne) to operate from forest landings and private properties situated within an 80-km radius of the post office at Alexandra to Sawmills at Alexandra and Benalla—sawmill logs.
- GOSENS, G.**, Sand Road, Longwarry, 3816. One commercial goods vehicle (L/C. 3.00 tonne) to operate: (a) Within an 80-km radius from the post office at Longwarry—plant the property of a contractor and required by him for use in connection with the construction or maintenance of some specific, existing or proposed road, street, footpath, bridge, pier, wharf, weir or channel and also the following materials viz.: metal, stones, screenings, ashes, gravel, sand and earth. (b) Within a 32-km radius from the site of any construction or maintenance work performed pursuant to paragraph (a) above, or from the railway station nearest thereto—any other materials required for such work. (c) Within a 40-km radius of the post office at Longwarry—general goods, provided that no goods shall be carried whether by one stage or by more than one stage between places within the above radius, which are more than 48-km apart by the nearest practicable route.
- HARCOURT CO-OPERATIVE LTD.**, Harcourt, 3453. One commercial goods vehicle (L/C. 12.05 tonne) to operate: (a) Within a 40-km radius of Harcourt—general goods. (b) From Harcourt to Melbourne—pine boxes, bins and apple juice. (c) From Melbourne and Fyansford to Harcourt—superphosphate, wrapping paper and cardboard. (d) From plantations at Harcourt and Castlemaine to Ballarat—docked pulp logs. (e) From plantations at Harcourt and Castlemaine to Melbourne—docked peeler logs. (f) From Harcourt to Melbourne—case shooks. (g) From Melbourne to Harcourt—septic tanks, aluminium irrigation pipes and fittings. (h) From Harcourt to Melbourne—fruit with return empty containers.
- HARCOURT CO-OPERATIVE LTD.**, Harcourt, 3453. One commercial goods vehicle (L/C. 8.30 tonne) to operate: (a) From plantations situated in the Harcourt, Castlemaine and Daylesford areas to own sawmill and case factory (an approved decentralized industry) at Harcourt—pine logs for use in manufacturing fruit boxes, bins and shooks. (b) From plantations at Harcourt and Castlemaine to Melbourne—docked peeler logs.
- HERITAGE, FRANK & SONS PTY. LTD.**, P.O. Box 7, Healesville, 3777. One commercial goods vehicle (L/C. 0.80 tonne) to operate throughout the State of Victoria in the course of business as a "Funeral Director" as a mortuary vehicle.
- HORTIN, L. E.**, 49 Francis Street, Traralgon, 3844. One commercial goods vehicle (L/C. 7.45 tonne) to operate: (a) Within an 80-km radius of the post office at Traralgon—plant the property of a contractor and required by him for use in connection with the construction or maintenance of some specific, existing or proposed road, street, footpath, bridge, pier, wharf, weir or channel and also the following materials viz.: metal, stones, screenings, ashes, gravel, sand and earth. (b) Within a 32-km radius from the site of any construction or maintenance work performed pursuant to paragraph (a) above or from the railway station nearest thereto—any other materials required for such work. (c) Within a 40-km radius of the post office situated at Traralgon—general goods.
- JEFFREY, J. & SONS PTY. LTD.**, Princes Highway, Morwell, 3840. Two commercial goods vehicles (L/C. 11.30 and 11.00 tonne) to operate: (a) Throughout the Traralgon and Bairnsdale divisions of the Country Roads Board in the course of own business as "Civil and Construction Engineers"—plant the property of a contractor and required by him for use in connection with the construction or maintenance of some specific, existing or proposed road, street, footpath, bridge, pier, wharf, weir or channel and also the following materials viz.: metal, stones, screenings, ashes, gravel, sand and earth. (b) Within a 30-km radius from the site of any construction or maintenance work performed pursuant to paragraph (a) above or from the railway station nearest thereto—any other materials required for such work. (c) Within a 40-km radius of the post office at Morwell—general goods.
- KELLY, B. F. & B. P.**, 32 Bruce Street, Heyfield, 3858. One commercial goods vehicle (L/C. 6.30 tonne) to operate from forest landings within that part of an 80-km radius of the post office at Licola which is situated north of Licola to sawmills at Heyfield—mill logs.
- MARSHALL, R. R.**, Ensay, 3895. One commercial goods vehicle (L/C. 0.30 and 1.70 tonne trailer) to operate: (a) Between Bairnsdale and places on or reached from the road between Bairnsdale and a point on the Omeo Highway 500 metres near to Omeo than The Township of Ensay South—general goods. (b) Within an 80-km radius of Ensay—livestock.
- MITTING, F. E.** care of Post Office, Jarklin, 3517. Application to vary the conditions of licence No. D.A.49430 (L/C. 10.15 tonne) by deleting "Within an 80-km radius of Jarklin" and adding in lieu "throughout the State of Victoria".
- MUSGROVE, A. T.**, 64 Alice Street, Clayton, 3168. Two commercial goods vehicles (L/C. 7.50 tonne and 11.60 tonne) to operate: (a) Within a 40-km radius of own premises at Clayton in course of business as "Sand and Soil Supply"—own goods. (b) From Lang Lang to own customers within a 40-km radius of own premises at Clayton—own soil.
- MCANINLY, A. J.**, Stacey's Bridge, via Yarram, 3971. One commercial goods vehicle (L/C. 7.00 tonne) to operate within an 80-km radius of the post office at Alberton in the course of business as "Timber Treatment and Fencing Contractor"—own goods.
- MACPHERSON EQUIPMENT LTD.**, 340 Dudley Street, West Melbourne, 3003. One commercial goods vehicle (L/C. 0.90 tonne) to operate throughout the State of Victoria in the course of business as "Forklift Distributors" as a service vehicle—tools of trade, spare parts and materials incidental to servicing forklifts on site only.
- NATION, D. L.**, Hillend, via Moe, 3825. One commercial goods vehicle (L/C. 1.05 tonne) to operate throughout that part of the State of Victoria situated east of a north/south line drawn through the City of Melbourne in the course of business as "Logging Bulldozing Contractor"—own tools of trade, equipment and fuel and lubricants for the operational requirements of own equipment but not exceeding 3 x 200 litre drums.
- O'CONNOR, J. P.**, Willung South, 3844. One commercial goods vehicle (L/C. 10.95 tonne) to operate: (a) From any one of own pits situated at Merryman's Creek, Longford, Yanakie and Bairnsdale to any consignee within an 80-km radius respectively of each such pit—own bulk lime excluding the carriage of lime between the said pits. (b) Throughout the total area of the combined 80-km radii from each of the pits specified in paragraph (a) above in the course of business as "Lime Contractor"—own equipment.
- PASQUALE, A.**, 118 Michael Street, North Fitzroy, 3068. One commercial goods vehicle (L/C. 16.60 tonne) to operate within a 56-km radius of the G.P.O., Melbourne, on behalf of the Readymix Group (Vic.)—sand, soil, screenings, premix and quarry products.
- RISDALE, J. & A., & L. PLAIN** (trading as Plains-Dale Nursery & Garden Supplies), 2 Mitchell Court, Noble Park, 3174. One commercial goods vehicle (L/C. 7.85 tonne) to operate: (a) Within a 40-km radius of G.P.O., Melbourne, in course of business as "Sand, Screening and Garden Supply"—own goods. (b) From Bacchus Marsh to own premises at Dandenong—own honeycomb rock. (c) From Lang Lang and Cranbourne to own premises at Dandenong—own sand and soil. (d) From Powelltown to own premises at Dandenong—own mountain soil. (e) From Yea to own premises at Dandenong—own river pebbles. (f) From Koo-wee-rup to own premises at Dandenong—own pine chips. (g) From Dromana to own premises at Dandenong—own granite screenings.
- REEVES, D. H.**, 7 Dynon Road, South Kensington, 3031. One commercial goods vehicle (L/C. 3.70 tonne) to operate throughout the State of Victoria in the course of business as "Marine Collector"—special wares,

marine stores and old metals as defined in the *Marine Stores and Old Metals Act 1958*, Part I, section 3, provided that the combined load capacity of the prime mover and any trailer attached thereto does not exceed 6.00 tonnes.

RIDLEY, W. G., 15 Mills Street, Heyfield, 3858. One commercial goods vehicle (L/C. 13.90 tonne) to operate from forest landings within that part of an 80-km radius of the post office at Licola which is situated north of Licola to sawmills at Heyfield—mill logs.

SHERWELL, A. V., 54 Watson Street, Charlton, 3525. One commercial goods vehicle (L/C. 3.00 tonne) to operate: (a) Within an 80-km radius of the post office at Charlton in the course of business as "Septic Tank Cleaner" for the purpose of emptying and cleaning septic tanks and for disposing of the residue from the emptied tanks. (b) Throughout the State of Victoria in the course of business as "Marine Collector"—marine stores as designated in the *Marine Stores and Old Metals Act 1958*, No. 6303, Part I, paragraph (3) but excluding the carriage of any such goods to wharves, docks or ships for shipment or export purposes.

NOTE.—That the combined load capacities of the prime mover and any trailer used in conjunction with it does not exceed 6.00 tonnes. This application replaces licence No. D.A.60389 previously held by the applicant.

STEVENSON, H. F., PTY. LTD., 10 Duffy Street, Burwood, 3125. One commercial goods vehicle (L/C. 3.95 tonne) to operate: 1. Within a 40-km radius from the G.P.O., Melbourne—general goods. 2. Within an 80-km radius of the depot installation of Gas & Fuel Corporation at Dandenong—(a) Liquid petroleum gas (Porta Gas and Heatane) and allied gas appliances for direct delivery to householders and/or (when required) to agents and also empty containers for return. (b) The following electrical appliances solely on behalf of Gas & Fuel Corporation—refrigerators, deep freeze units, drink dispensers, micro wave ovens, icemaking machines, glass washing machines, washing machines and clothes dryers.

SUPER SPREAD AVIATION (AUST.) PTY. LTD., P.O. Box 7, Cheltenham, 3192. One commercial goods vehicle (L/C. 1.15 tonne) to operate throughout the State of Victoria in the course of business as "Aerial Crop Dusters" for the purpose of supervising own contracts—tools of trade, equipment and small quantities of fuel for carriage from spraying site to spraying site for completion of own contracts.

TIEMAN INDUSTRIES PTY. LTD., 4-10 Keon Parade, Keon Park, 3073. One commercial goods vehicle (L/C. 4.15 tonne) to operate throughout the State of Victoria in the course of business as "Materials Handling Engineers" for the purpose of servicing and installing materials handling equipment—tools of trade, spare parts, materials handling equipment for specialised installation and materials incidental to on-site servicing.

VALLANCE, L. J., 58 Main Street, Bacchus Marsh, 3340. One commercial goods vehicle (L/C. 12.85 tonne) to operate from sawmills at Ballarat, Colac, Seymour, Korweinguboorra and Whittlesea to the mill of Hardboards Aust. Ltd. at Bacchus Marsh—waste timber on behalf of the said company.

WARD, E. A., PRODUCE MERCHANT PTY. LTD., Station Street, Lang Lang, 3984. One commercial goods vehicle (L/C. 7.80 tonne) to operate within an 8-km radius of own premises at Lang Lang and to Nyora and from and to the City of Melbourne in the course of business as "General Produce Merchant"—own goods.

WATERS, S. H. & Co. PTY. LTD., 160 Firebrace Street, Horsham, 3400. Application to vary the conditions of licence No. D.A.2247/2 (L/C. 3.00 tonne) by adding an additional paragraph (b)—"(b) From Coleraine to Horsham—own sheepskins".

WATERS, S. H. & Co. PTY. LTD., 160 Firebrace Street, Horsham, 3400. Application to vary the conditions of licence No. T.D.A.2247/11 (L/C. 3.10 tonne) by adding an additional paragraph (b)—"(b) From Warrnambool to Hamilton and Horsham—own sheepskins".

WHITE ENGINEERING PTY. LTD., corner Malvern & Edellaier Streets, Bayswater, 3153. One commercial goods vehicle (L/C. 0.75 tonne and 1.55 tonne trailer) to operate throughout the State of Victoria in the course of business as "Refrigeration Engineers" as a service vehicle for the purpose of servicing and repairing of industrial refrigeration units—tools of trade and equipment also spare parts required for on site servicing and repairing of industrial refrigeration units on site.

WHITE WAY SIGN & LIGHTING CO. LTD., 1-9 Cecil Street, South Melbourne, 3205. One commercial goods vehicle (L/C. 2.30 tonne) to operate throughout the State of Victoria in the course of business as "Advertising Sign Manufacturers"—tools of trade also advertising signs for erection together with a small quantity of materials incidental to erection of such signs.

EDWARDS DUNLOP & Co. LTD. (trading as Wrappings, Bendigo), Thistle Street South, Bendigo, 3550. One commercial goods vehicle (L/C. 3.00 tonne) to operate within that part of the State of Victoria east of a line drawn north to south through the Township of Sea Lake, north of a line drawn east to west through the Township of Daylesford and west of a line drawn north to south through the Township of Dookie—paper, wrappings, school supplies from Bendigo—all goods are initially consigned by rail to Bendigo.

TOW TRUCKS.

DANDENONG PANELS PTY. LTD., 10 Gladstone Road, Dandenong, 3175. One commercial goods vehicle (L/C. 2.10 tonne) to operate throughout the State of Victoria as a Tow Truck for the purposes of lifting and carrying or towing and/or repairing of wrecked or disabled vehicles—tools of trade, spare parts and materials incidental thereto.

NOTE.—This application replaces licence No. D.A.65821 held in the name of C.N. Panels Pty. Ltd.

CORCORAN, V. (trading as Douro Auto Specialists), 116-118 Douro Street, North Geelong, 3215. One commercial goods vehicle (L/C. 2.10 tonne) to operate throughout the State of Victoria as a Tow Truck solely—(a) For the purpose of lifting and carrying or towing motor cars and the carriage of tools and equipment necessary for such purposes only. (b) The carriage of spare parts necessary for the repair of a disabled motor to and from the place at which such disablement has occurred.

Subject to cancellation of licence No. D.A.58449/1 in the name of the applicant.

RENEWALS.

Applications for renewal of licences as shown by persons listed hereunder to operate under the same terms and conditions from the expiry shown in each use.

BAYER AUSTRALIA LTD., 633-647 Springvale Road, Glen Waverley, 3150; D.A.48044/2; 14th January, 1975; 0.50 tonne.

BENDIGO QUICK FROZEN FOODS PTY. LTD., 109 Garsed Street, Bendigo, 3550; D.A.47899/2; 8th February, 1975; 2.25 tonne; D.A.47899/3; 8th February, 1975; 3.25 tonne; D.A.47899/5; 8th February, 1975; 0.95 tonne.

BENNETT, A., 25 Edina Road, Ferntree Gully, 3156; D.A.64304; 25th January, 1975; 3.85 tonne.

BOLTON BROS. PTY. LTD., Mitchell Street, Bendigo, 3550; D.A.45891/2; 27th February, 1975; 0.80 tonne.

CRELLIN, K. P. C., 12 Mountain View Road, Kilsyth, 3137; D.A.66840; 14th January, 1975; 4.85 tonne.

DALTON, K. D., 4 Princes Street, Port Fairy, 3284; D.A.60028/1; 3rd October, 1974; 0.60 tonne and 0.85 tonne trailer.

ELLIS, C. R., Manks Road, Dalmore, 3981; D.A.41693/2; 14th January, 1975; 7.80 tonne.

FOX, ALBERT H. PTY. LTD., 6 Regent Court, Warragul, 3820; D.A.35038/7; 18th January, 1975; 0.70 tonne.

GLEESON, G. M., Curdie Vale, 3268; D.A.62781/1; 18th January, 1975; 12.65 tonne.

MOORE, D. H., 5 Scott Crescent, Mildura, 3500; T.D.A.50951; 1st December, 1974; 15.55 tonne.

PAPATRAIANOS, J., 158 Rossmoyne Street, Thornbury, 3071; D.A.64176; 12th October, 1974; 10.25 tonne.

RAWLINSON, G., 215 Nelson Place, Williamstown, 3016; D.A.35099, 28th January, 1975; 0.70 tonne; D.A.35099/1; 28th January, 1975; 0.70 tonne.

THOMAS, R. M. & D. E. (trading as Rosiland Floor Coverings), 2 Sailors Gully Road, Eaglehawk, 3556; D.A.64402; 22nd February, 1975; 0.65 tonne.

SWIFT, D. H. & SONS PTY. LTD., P.O. Box 172, Mornington, 3931; D.A.63931/1; 25th January, 1975; 3.45 tonne.

TOW TRUCK RENEWALS.

BOYD, I. D., 30 McGibbony Street, Ararat, 3377; D.A.35094; 28th January, 1975; 2.00 tonne.

DOWLINGS MOTOR SERVICE PTY. LTD., 322 Campbell Street, Swan Hill, 3585; D.A.46899/1; 9th February, 1975; 3.05 tonne.

RIVERFERN DECOR & LANDSCAPING PTY. LTD., Lot 3, Canterbury Road, Kilsyth, 3137; D.A.65780/2; 1st November, 1974; 2.35 tonne.

SQUIRES, L. R., Lot 5, Frankston Road, Dandenong, 3175; D.A.33313; 14th January, 1975; 1.35 tonne and 1.65 tonne trailer.

RENEWALS WITH VARIATION.

Applications made by the persons listed hereunder for renewal of the licences listed with variation of conditions in the manner set out opposite the names.

DALE, C. W., 16-18 Elizabeth Street, Castlemaine, 3450; T.D.A.60156; 12th December, 1974. Application to renew and vary the conditions of licence No. T.D.A.60156 by deleting the Special Condition.

JAMIESON, B. H., LOWER BENDOC, via Delegate, 3888; D.A.64284; 18th January, 1975. Application to renew and vary the conditions of licence No. D.A.64284 (L/C. 4.75 tonne) by deleting paragraph (c) and adding in lieu as paragraph (c)—(c) Within a radius of 40-km of the post office at Bendoc—general goods.

Notice of any objection should be forwarded to reach the Secretary of the Board not later than 6th November, 1974.

Applicants are advised that it will not be necessary to appear on the hearing date specified above, unless advised in writing by the Board.

A. V. C. COOK,
Secretary.

Corner Lygon and Princes Streets, Carlton, 3053,
Wednesday, 23rd October, 1974.

TEACHING SERVICE ACT 1958, SECTION 73.

PUBLIC SERVICE ACT 1958, SECTIONS 55 AND 56.

It is hereby notified that a charge of being absent without leave from the 4th February, 1974, to the 5th July, 1974, has been preferred against Mr. David Terence Mastin, Record No. 905851, Assistant, Primary Schools Division, Education Department, under section 73 of the Teaching Service Act 1958, which applies to the Teaching Service, the provisions of sections 55 and 56 of the Public Service Act 1958, and that a certified letter asking him whether he admits or denies the truth of the charge (posted to his last-known address, viz., Kirkland Avenue, Euroa, 3666) has not been replied to.

A further letter has been forwarded to the said David Terence Mastin at the last known address referred to advising him that unless he admits or denies the truth of the charge in writing to the Teachers Tribunal by the 8th November, 1974, he shall be deemed to deny the truth of the charge and the investigation thereof will be proceeded with at 11.15 a.m. on the 11th November, 1974, at the office of the Teachers Tribunal, Royal Mint Building, corner William and La Trobe Streets, Melbourne.

By Order,

A. F. LE CLERCQ,
Secretary.

Office of the Teachers Tribunal,
Melbourne, 17th October, 1974.

TEACHING SERVICE ACT 1958, SECTION 73.

PUBLIC SERVICE ACT 1958, SECTIONS 55 AND 56.

It is hereby notified that a charge of being absent without leave from the 11th February, 1974, to the 5th July, 1974, has been preferred against Mr. Darryl Rodney Milich, Record No. 848354, Teacher, Assistant Class, Primary Schools Division, Education Department, under section 73 of the Teaching Service Act 1958, which applies to the Teaching Service the provisions of sections 55 and 56 of the Public Service Act 1958, and that a certified letter asking him whether he admits or denies the truth of the charge (posted to his last known address, viz., Twitt's Road, Moolap, 3221) has not been replied to.

A further letter has been forwarded to the said Darryl Rodney Milich at the last known address referred to, advising him that unless he admits or denies the truth of the charge in writing to the Teachers Tribunal by the 8th November, 1974, he shall be deemed to deny the truth of the charge and the investigation thereof will be proceeded with at 11.45 a.m. on the 11th November, 1974, at the office of the Teachers Tribunal, Royal Mint Building, corner William and La Trobe Streets, Melbourne.

By Order,

A. F. LE CLERCQ,
Secretary.

Office of the Teachers Tribunal,
Melbourne, 17th October, 1974.

AUCTION SALES ACT 1958.

COLAC.—Notice is hereby given that the Annual Meeting of Justices for the Licensing of Auctioneers will be held at the Court House at Colac, on Tuesday, the 26th day of November, 1974, at ten o'clock in the forenoon. Dated at Colac, this 17th day of October, 1974.—R. W. DeGRUCHY, Clerk of the Magistrates' Court.

ECHUCA.—Notice is hereby given that the Annual Meeting of Justices for the Licensing of Auctioneers will be held at the Magistrates' Court, Echuca, on Tuesday, 26th November, 1974, at 10 o'clock in the forenoon. Dated at Echuca this 11th day of October, 1974.—R. T. WARNE, Clerk of the Magistrates' Court.

GEELONG.—Notice is hereby given that the Annual Meeting of Justices for the Licensing of Auctioneers will be held at the Law Courts, Geelong, on Tuesday, the 26th day of November, 1974, at the hour of ten o'clock in the forenoon. Dated at Geelong this 14th day of October, 1974.—J. E. REILLY, Clerk of the Magistrates' Court.

NUMURKAH.—Notice is hereby given that the Annual Meeting of Justices for the Licensing of Auctioneers will be held at the Magistrates' Court, Numurkah, on Tuesday, the 26th day of November, 1974, at Ten o'clock in the forenoon. Dated at Numurkah the 14th day of October, 1974.—J. L. COLLINS, Clerk of the Magistrates' Court.

STAWELL.—Notice is hereby given that the Annual Meeting of Justices for the Licensing of Auctioneers will be held at the Magistrates' Court, Traralgon, on Tuesday, the 26th day of November, 1974, at ten o'clock in the forenoon.—G. B. DALTON, Clerk of the Magistrates' Court.

TRARALGON.—Notice is hereby given that the Annual Meeting of Justices for the Licensing of Auctioneers will be held at the Magistrates' Court Traralgon, on Tuesday, the 26th day of November, 1974, at ten o'clock in the forenoon. Dated at Traralgon this 14th day of October, 1974.—K. G. McMAHON, Clerk of the Magistrates' Court.

Survey Co-ordination Act 1958.

NOTICE OF ASSIGNMENT OF A NAME.

Pursuant to the powers conferred under section 29 of the above Act, the Place Names Committee hereby gives notice of the assignment of the following name to the place mentioned hereunder:—

Municipality.—Shire of Oxley.

Location.—As shown on plan hereunder.

Name Assigned.—Wild Horse Gap.

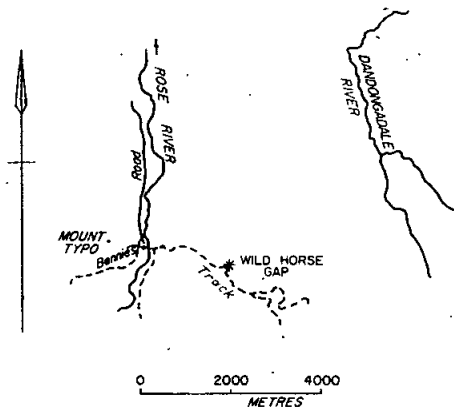

By Order of the Committee,

M. J. DWYER,
Secretary.

Office of the Place Names Committee,
Department of Crown Lands and Survey,
Melbourne, 3002.

Health Act 1958.

VICTORIA—DEPARTMENT OF HEALTH.

NOTICE TO ATTEND FOR RADIOLOGICAL EXAMINATION.

To all persons aged twenty-one years and over enrolled or resident in the subdivisions specified hereunder in the State Electoral District of KEW.

Take notice that you are required to attend at a Department of Health X-ray Unit sited in the public street at or as near as possible to the main entrance to the premises specified in this notice, at any time between the hours specified on one of the days specified and during the period specified in respect of those premises, and thereat to submit yourself to radiological examination of the chest for the purpose of ascertaining whether you may be suffering from pulmonary tuberculosis. If you have had a Chest X-ray within the last twelve months and for this reason do not wish to be examined now, you should attend the unit as directed and submit particulars of the previous examination.

SPECIFIED SUBDIVISIONS, PREMISES, PERIOD, DAYS AND HOURS.

Subdivision.	Premises.	Period.	Days.	Hours.
Kew South	Near B. S. Stillwells Used Cars, cnr. Charles Street and Cotham Road, Kew	Thursday, 7th November, 1974 to Wednesday 13th November, 1974 (inclusive)	Each day during the period except Saturday, Sunday and Public Holidays	From 10 a.m. to 8.30 p.m.
	Near St. Hilary's Church, cnr. Rowlands and Johns Streets, Kew	Thursday, 7th November, 1974 to Tuesday, 12th November, 1974 (inclusive)	Each day during the period except Saturday, Sunday and Public Holidays	From 10 a.m. to 8.30 p.m.
	Cnr. Parkhill Road and Wimba Avenue, Kew	Friday, 8th November, 1974 and Monday, 11th November, 1974	Friday, 8th November, 1974 Monday, 11th November, 1974	From 10 a.m. to 8.30 p.m. From 10 a.m. to 8.30 p.m.
Kew	At Safeway Car Park, Walpole Street, Kew	Tuesday, 12th November, 1974 to Thursday, 21st November, 1974 (inclusive)	Each day during the period except Saturday, Sunday and Public Holidays	From 10 a.m. to 8.30 p.m.
	Near Xavier College, cnr. Nolan Avenue and Studley Park Road, Kew	Wednesday, 13th November, 1974 to Friday, 15th November, 1974 (inclusive)	Each day during the period except Public Holidays	From 10 a.m. to 8.30 p.m.
	Near Eglinton Reserve, cnr. Eglinton and Derby Streets, Kew	Thursday, 14th November, 1974 to Monday, 18th November, 1974 (inclusive)	Each day during the period except Saturday, Sunday and Public Holidays	From 10 a.m. to 8.30 p.m.
Kew North	Near Carson's Pharmacy, cnr. Belford Road and Kilby Street, Kew East	Monday, 18th November, 1974 to Wednesday, 20th November, 1974 (inclusive)	Each day during the period except Public Holidays	From 10 a.m. to 8.30 p.m.
	Car Park, cnr. Earl Street and Willsmere Road, Kew	Tuesday, 19th November, 1974 to Thursday, 21st November, 1974 (inclusive)	Each day during the period except Public Holidays	From 10 a.m. to 8.30 p.m.
	Near Post Office, cnr. Station and High Streets, Kew East	Thursday, 21st November, 1974 to Wednesday, 27th November, 1974 (inclusive)	Each day during the period except Saturday, Sunday and Public Holidays	From 10 a.m. to 8.30 p.m.
	Near L. J. Hooker, Arnold and Sandor Pty. Ltd., 146 Harp Road, Kew North	Friday, 22nd November, 1974 and Monday, 25th November, 1974	Friday, 22nd November, 1974 Monday, 25th November, 1974	From 10 a.m. to 8.30 p.m. From 10 a.m. to 8.30 p.m.
Balwyn North	Car Park, Hawkins Pharmacy, 12 Doncaster Road, Balwyn North	Friday, 22nd November, 1974 to Wednesday, 27th November, 1974 (inclusive)	Each day during the period except Saturday, Sunday and Public Holidays	From 10 a.m. to 8.30 p.m.
	Car Park, cnr. Bulleen and Doncaster Roads, Balwyn North	Tuesday, 26th November, 1974 to Monday, 2nd December, 1974 (inclusive)	Each day during the period except Saturday, Sunday and Public Holidays	From 10 a.m. to 8.30 p.m.
	Near Walton's Pharmacy, 119 Bulleen Road, Balwyn North	Thursday, 28th November, 1974 to Monday, 2nd December, 1974 (inclusive)	Each day during the period except Saturday, Sunday and Public Holidays	From 10 a.m. to 8.30 p.m.
	Car Park, Bowling Club, Buchanan Avenue, Balwyn North	Thursday, 28th November, 1974 to Monday, 2nd December, 1974 (inclusive)	Each day during the period except Saturday, Sunday and Public Holidays	From 10 a.m. to 8.30 p.m.

NOTE: Any person to whom this notice applies and who without reasonable excuse fails to comply with the requirements of the notice shall be guilty of an offence, and shall be liable to a penalty of not more than five hundred dollars.

Dated this twelfth day of September, One thousand nine hundred and seventy-four.

B. P. McCLOSKEY, Acting Chief Health Officer.

Private Agents Act 1966.

NOTICE OF RECEIPT OF APPLICATIONS FOR LICENCES UNDER THE PROVISIONS OF THE PRIVATE AGENTS ACT 1966.

The Clerk(s) of the Magistrates' Court(s) as listed hereunder hereby give notice that applications, as under, have been lodged for hearing by the said Court(s) on the date(s) specified.

Any person desiring to object to any of such applications must—

(a) lodge with the respective Clerk of the Magistrates' Court a notice in the prescribed form of his objection and of the grounds thereof;

(b) cause a copy of such notice to be served personally or by post upon the applicant at least three days before the hearing of the application; and

(c) send or deliver—

(i) where the objection is not made by the officer in charge of the police district in which the Court is situated a copy of the notice to such officer; and

(ii) where the objection is not made by the Registrar or Deputy Registrar—a copy to the Registrar.

Full Name of Applicant or in the Case of a Firm or Corporation, of the Nominee.	Place of Abode of Applicant or Nominee.	Name of Firm or Corporation.	Address for Registration.	Type of Licence.	Date of Hearing of Application.
---	---	------------------------------	---------------------------	------------------	---------------------------------

MAGISTRATES' COURT, FOOTSCRAY.

Blakeman, Philip Roy	R.A.A.F. Laverton		4 Cross Street, Footscray	Watchman	31.10.74
----------------------	-------------------	--	---------------------------	----------	----------

Dated at Footscray this 9th day of October, 1974.

J. KEARNEY, Clerk of the Magistrates' Court.

MAGISTRATES' COURT, BRIGHTON.

Pinchas, Peer	95 Asling Gardenvale		5 Milton Street, Bentleigh	Process Server	1.11.74
---------------	----------------------	--	----------------------------	----------------	---------

Dated at Brighton this 8th day of October, 1974.

R. A. BRUCKNER, Clerk of the Magistrates' Court.

MAGISTRATES' COURT, MOONEE PONDS.

Halemba, Walter Jan	25 Waverley Street, Essendon		25 Waverley Street, Essendon	Guard Agent	8.11.74
"	"	"	"	Process Server	"

Dated at Moonee Ponds this 11th day of October, 1974.

IAN J. SIMMONS, Clerk of the Magistrates' Court.

MAGISTRATES' COURT, PORT MELBOURNE.

Hale, Graham Lloyd	Sergeants Mess, R.A.A.F. Base, Tottenham	Mayne Limited	Nickless	538 Williamstown Road, Port Melbourne	Watchman	29.10.74
Pronasky, Hugh Gordon	6 Held Vermont Street	"	"	"	"	"
Reed, Leslie John	76A Beaconsfield Parade, Albert Park	"	"	"	"	12.11.74
Meadows, Arnold James	9 Armstrong Street, Laverton	"	"	"	"	"
Collyer, Colin John	4 Lyndhurst Crescent, Box Hill North	"	"	"	"	"

Dated at Port Melbourne this 4th day of October, 1974.

JOHN ARDLIE, Clerk of the Magistrates' Court.

MAGISTRATES' COURT, MELBOURNE.

Keenan, Gordon John	5 Leighton Court, Toorak	Mayne Limited	Nickless	94 York Street, South Melbourne	Watchman	20.11.74
---------------------	--------------------------	---------------	----------	---------------------------------	----------	----------

Dated at Melbourne this 8th day of October, 1974.

G. L. WEBSTER, Clerk of the Magistrates' Court.

MAGISTRATES' COURT, OAKLEIGH.

Habel, Arthur	9 Love Street, Black Rock	Argus Night Patrol Pty. Ltd.		19A Portman Street, Oakleigh	Watchman	1.11.74
---------------	---------------------------	------------------------------	--	------------------------------	----------	---------

Dated at Oakleigh this 11th day of October, 1974

A. J. JOHNSON, Clerk of the Magistrates' Court.

MAGISTRATES' COURT, FOOTSCRAY.

Simonides, Simon	88 Wiltonvale Avenue, Hoppers Crossing			4 Cross Street, Footscray	Watchman	4.11.74
------------------	--	--	--	---------------------------	----------	---------

Dated at Footscray this 11th day of October, 1974.

J. KEARNEY, Clerk of the Magistrates' Court.

MAGISTRATES' COURT, PORT MELBOURNE.

Walsh, Brian Benedict Higgins	29 Pine Frankston Street	Mayne Limited	Nickless	538 Williamstown Road, Port Melbourne	Watchman	12.11.74
-------------------------------	--------------------------	---------------	----------	---------------------------------------	----------	----------

Dated at Port Melbourne this 10th day of October, 1974.

JOHN ARDLIE, Clerk of the Magistrates' Court.

MAGISTRATES' COURT, HAWTHORN.

Lowerson, Raymond James	27 Miller Sandringham Street	Security Watching Co. Pty. Ltd.		330 Auburn Road, Hawthorn	Watchman	1.11.74
-------------------------	------------------------------	---------------------------------	--	---------------------------	----------	---------

Dated at Hawthorn this 11th day of October, 1974

I. M. GRIFFITHS, Clerk of the Magistrates' Court.

PRIVATE AGENTS—*continued.*

Full Name of Applicant or in the Case of a Firm or Corporation, of the Nominee.	Place of Abode of Applicant or Nominee.	Name of Firm or Corporation.	Address for Registration.	Type of Licence.	Date of Hearing of Application.
MAGISTRATES' COURT, PORT MELBOURNE.					
Carroll, Terence Maxwell ..	20 Wolai Avenue, South Oakleigh	Mayne Nickless Limited	538 Williamstown Road, Port Melbourne	Watchman ..	12.11.74
Gelder, Norman Cleland ..	6 Poplar Court, St. Albans	" "	" "	" ..	"
Highfield, John Oakley ..	11 Elamo Road, Healesville	" "	" "	" ..	"
Mackney, George Frederick Hare	81/56 Derby Street, Kensington	" "	" "	" ..	"
Mathers, Allan Keith ..	Main Road, Launching Place	" "	" "	" ..	"

Dated at Port Melbourne this 14th day of October, 1974.

JOHN ARDLIE, Clerk of the Magistrates' Court.

MAGISTRATES' COURT, ELTHAM.

Robinson, Peter ..	46 Albion Crescent, Greensborough	" ..	46 Albion Crescent, Greensborough	Inquiry Agent ..	7.11.74
--------------------	-----------------------------------	------	-----------------------------------	------------------	---------

Dated at Eltham this 15th day of October, 1974.

JOHN M. WALSH, Clerk of the Magistrates' Court.

MAGISTRATES' COURT, COBURG.

Mordaunt, Stanley Dennis ..	21 Wattle Street, West Footscray	" ..	94 York Street, South Melbourne	Watchman ..	6.11.74
-----------------------------	----------------------------------	------	---------------------------------	-------------	---------

Dated at Coburg this 14th day of October, 1974.

G. G. WILLIAMSON, Clerk of the Magistrates' Court.

MAGISTRATES' COURT, FOOTSCRAY.

Moodie, Robert James Arthur	78 Daley Street, Glenroy	" ..	4 Cross Street, Footscray	Watchman ..	7.11.74
-----------------------------	--------------------------	------	---------------------------	-------------	---------

Dated at Footscray this 14th day of October, 1974.

R. BOURKE, Clerk of the Magistrates' Court.

MAGISTRATES' COURT, HAWTHORN.

Guilfoyle, Desmond Michael	22 Sunnyside Avenue, Nunawading	Security Watching Company Pty. Ltd.	330 Auburn Road, Hawthorn	Watchman ..	4.11.74
----------------------------	---------------------------------	-------------------------------------	---------------------------	-------------	---------

Dated at Hawthorn this 14th day of October, 1974.

K. O'HARE, Clerk of the Magistrates' Court.

MAGISTRATES' COURT, MELBOURNE.

Allan, James ..	88 Ella Grove, Chelsea	Wormald International Security	340 Abbotsford Street, North Melbourne	Watchman ..	15.1.75
Campbell, W. T. ..	335 Waterdale Road, West Heidelberg	" "	" "	" ..	"
Chisholm, F. S. ..	2/5 Stonnington Place, Toorak	" "	" "	" ..	"
Davies, S. J. ..	12 Hedgeley Road, Keilor	" "	" "	" ..	"
Gould, James ..	5 Lyell Street, Gisborne	" "	" "	" ..	"
Howarth, M. ..	5/376 Victoria Parade, East Melbourne	" "	" "	" ..	"
Hutchindoh, Brian W. ..	Flat 6, 79 Walter Street, Ascot Vale	" "	" "	" ..	"
Ibbetson, K. W. ..	5 Wilson Street, Fawkner	" "	" "	" ..	"
Armstrong-Reid, J. ..	15 Iond Avenue, Toorak	" "	" "	" ..	"
Stolzenberg, F. ..	54/189 Beaconsfield Parade, Middle Park	" "	" "	" ..	"
Winch, C. M. H. ..	5 Rowell Court, Melton South	" "	" "	" ..	"
Wood, M. E. ..	5/35 Byron Street, Ringwood	" "	" "	" ..	"

Dated at Melbourne this 15th day of October, 1974.

G. L. WEBSTER, Clerk of the Magistrates' Court.

Police Regulation Act 1958, Section 122.

SALE OF UNCLAIMED MOTOR VEHICLE.

An owner is required for a blue and white model 850 Morris sedan, ex-registered number (S.A.) RXU-546, engine number 1OYA/TA/H6219.

The vehicle came into the possession of Police on 10th January, 1973, and if not claimed, will be sold by public auction at the Stawell Police Station, 9 Patrick Street, Stawell, at 10.30 a.m. on 28th November, 1974.

R. JACKSON,
Chief Commissioner of Police.

Police Regulation Act 1958, Section 122.

SALE OF UNCLAIMED MOTOR VEHICLE.

An owner is required for a white 1969 model Chrysler Valiant sedan, ex-registered No. KET-622, engine No. VE 6.9743.

The vehicle came into the possession of Police on the 26th May, 1974, and if not claimed, will be sold by public auction at the Pyalong Police Station, Northern Highway, Pyalong at 4.30 p.m., on the 28th November, 1974.

R. JACKSON,
Chief Commissioner of Police.

ROAD DEVIATION ORDER.—SHIRE OF BELFAST.

Pursuant to the provisions of section 522 and section 526 of the Local Government Act 1958, the Council of the Shire of Belfast hereby directs that the land through Crown allotment 17, section E, Parish of Yambuk indicated by hatching on the diagram hereunder which has been purchased taken or acquired by it, shall be a public highway on and from the date of publication of this order in the Government Gazette and declares that such land shall be a public highway in lieu of the land indicated by cross-hatching on the said diagram.

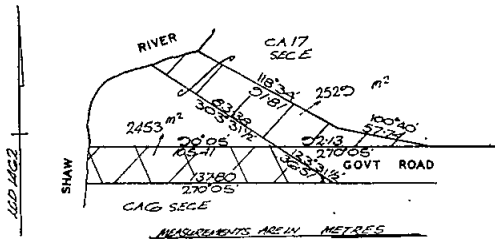

The common seal of the President, Councillors and Ratepayers of the Shire of Belfast was hereunto affixed this 9th day of August, 1974.

(SEAL) S. M. PHYLAND, President. DES B. BARKER, Councillor. BRIAN MOLONEY, Secretary.

Confirmed by the Governor in Council, 15th October, 1974.—TOM FORRISTAL, Clerk of the Executive Council.

ROAD DEVIATION ORDER.—SHIRE OF MANSFIELD.

Pursuant to the provisions of sections 522 and 526 of the Local Government Act 1958, the Council of the Shire of Mansfield hereby directs that the land in the Parish of Wappan indicated by hatching on the diagram hereunder, which has been acquired by it, shall be a public highway on and from the date of publication of this order in the Government Gazette and declares that such land shall be a public highway in lieu of the land indicated by cross-hatching on the said diagram.

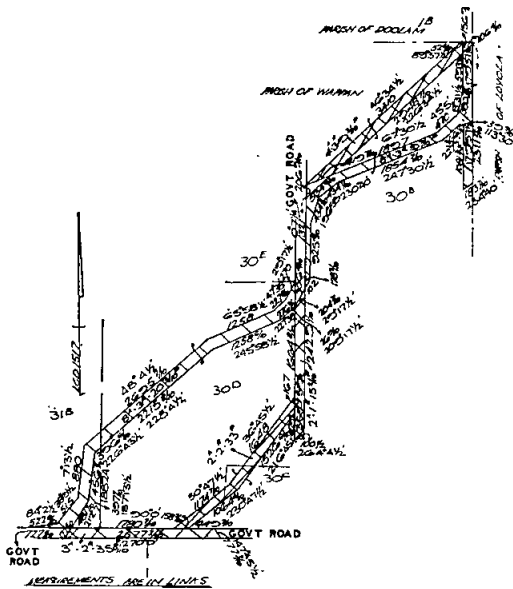

The common seal of the President, Councillors and Ratepayers of the Shire of Mansfield was hereunto affixed this 24th day of July, 1974.

(SEAL) J. W. REDFERN, President. R. M. RICHARDSON, Councillor. E. CAIRNS, Secretary.

Confirmed by the Governor in Council, 15th October, 1974.—TOM FORRISTAL, Clerk of the Executive Council.

LOCAL GOVERNMENT DEPARTMENT.

ORDER CONFIRMED.—SHIRE OF TAMBO.

The Minister of the Crown administering the Local Government Act 1958, on the 10th day of October, 1974, confirmed an Order hereinafter referred to in pursuance of the provisions of section 514 of the said Act namely:

An Order of the Council of the Shire of Tambo made on the 20th August, 1974, directing the compulsory taking of certain land in the Parish of Colquhoun being the land shown by hachure on the plan hereunder for the purpose of promoting and assisting decentralized industries.

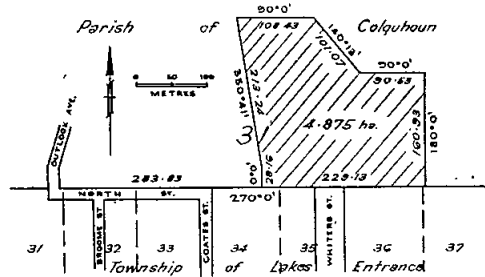

Note: the area shown hatched is the area intended to be acquired by Council.

R. DUNSTAN, Acting Minister for Local Government.

COUNTRY ROADS BOARD.

NOTICE OF FIXING NEW ALIGNMENTS OF THE MIDLAND HIGHWAY IN THE SHIRE OF DAYLESFORD AND GLENLYON.

Notice is hereby given that the Country Roads Board under the powers conferred upon it by the Country Roads Act 1958 (Act No. 6229) has fixed a new alignment for the west side of the Midland Highway in the Shire of Daylesford and Glenlyon as shown on Survey Plan Numbered 8637.

Copies of the said Survey Plan are lodged in the offices of the Country Roads Board, the municipality of the Shire of Daylesford and Glenlyon, the Registrar of Titles and the Registrar-General respectively, and may be inspected by any person without a fee at any time at which such offices are open for business.

The locality in which the alignment has been fixed is indicated on the plan hereunder—

STATE HIGHWAY MIDLAND HIGHWAY SHIRE OF DAYLESFORD & GLENLYON

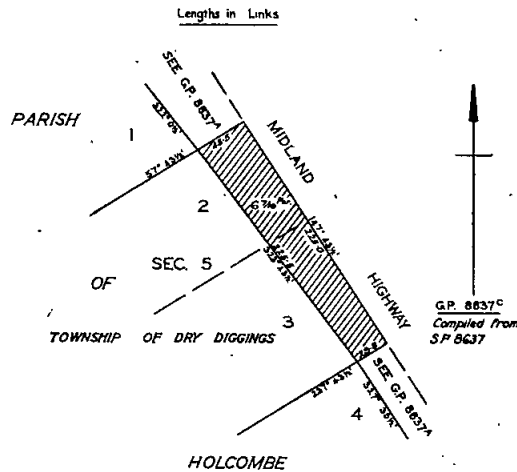

N. L. ALLANSON, Secretary.

Country Roads Board, 60 Denmark Street, Kew, 16th October, 1974

Melbourne and Metropolitan

BOARD OF WORKS.

GENERAL NOTICE.

The Melbourne and Metropolitan Board of Works having made provision for carrying off the sewage of each and every property which or any part of which is situate in the Sewerage Areas hereinafter described doth hereby declare that on and after the twenty-eighth day of October, 1974, each and every property so situate shall be deemed to be a sewerer property within the meaning of the *Melbourne and Metropolitan Board of Works Act 1958*.

The Sewerage Areas hereinbefore referred to are:—

Sewerage Area No. 2755.

City of Nunawading.—Commencing at a point in Stradella Avenue about 31.40 metres south of the southern boundary of Weeden Drive; thence easterly along the northern boundary of lot 29 Stradella Avenue, northerly along the western boundaries of lots 23 and 22 Weeden Drive, easterly along the northern boundary of the said lot 22 to the western boundary of lot 21 Weeden Drive, northerly and easterly along the western and northern boundaries of the said lot 21 to the boundary of Sewerage Area No. 2533, southerly and south-westerly along the said area boundary to its junction with Sewerage Area No. 2599 in Licola Street, generally westerly along the last-mentioned area boundary to Stradella Avenue, northerly along Stradella Avenue to the commencing point.

Sewerage Area No. 2756.

City of Doncaster and Templestowe.—Commencing in Dellfield Drive near the northern boundary of Sinclair Avenue; thence easterly along the northern boundary of lot 33 Dellfield Drive, northerly along portion of the western boundary of lot 1 Eumeralla Avenue, generally south-easterly along the north-eastern boundaries of the said lot 1, southerly and south-easterly along Eumeralla Avenue, westerly along the southern boundary of lot 9 Eumeralla Avenue, southerly along the eastern boundaries of a reserve and lots 107 and 106 Dellfield Drive, north-westerly along portion of the south-western boundary of the said lot 106, south-westerly along the south-eastern boundaries of lots 105 to 103 and 95 to 93 Dellfield Drive to the northern boundary of the Templestowe Heights Technical School property, easterly, southerly, westerly, generally northerly and easterly along the boundaries of the said property and the Templestowe Heights Primary School property to the south-western angle of lot 91 Dellfield Drive, northerly along the western boundary of the said lot 91, generally north-easterly along Dellfield Drive to the commencing point.

Sewerage Area No. 2757.

City of Altona.—Commencing at a point on the eastern boundary of John Street, 97.64 metres south of the southern boundary of Blackshaws Road; thence easterly and southerly along the northern and eastern boundaries of lot 130 John Street, south-easterly and south-westerly along the north-eastern and south-eastern boundaries of lot 131 John Street, south-easterly along John Street, south-westerly along the south-eastern boundary of lot 153 John Street, north-westerly along the south-western boundaries of lots 153 to 160 John Street, easterly along the northern boundary of the said lot 160, north-easterly by a line to the commencing point.

Sewerage Area No. 2758.

City of Knox.—Commencing at the junction of Mountain Highway and King Street; thence north-westerly along King Street to Dandenong Creek, generally easterly along the said creek to Bayswater Road, southerly along Bayswater Road, easterly and generally southerly along the northern and eastern boundaries of properties of title description vol. 8154 fol. 416, vol. 7868 fol. 116 and vol. 4730 fol. 886, westerly along Mountain Highway, southerly along the western boundary of lot 4 Mountain Highway, easterly along portion of the northern boundary of lot 16 Scoresby Road, southerly along the eastern boundaries of the said lot 16 and lots 1, 2 and an adjoining lot 2 Scoresby Road, westerly along portion of the southern boundary of the adjoining lot 2, southerly along the eastern boundaries of lots 3 and 19 to 21 Scoresby Road, easterly and southerly along the northern and portion of the eastern boundaries of lot 2 Malvern Street, easterly along the northern boundaries of lots 1 and 2 Malvern Street, southerly along portion of the eastern boundary of the last-mentioned lot 2, easterly along the northern boundaries of lots 3 and 4 Malvern Street, northerly along Jersey Road to a point about 75 metres north of the northern boundary of Malvern Street, easterly along the northern boundary of lot 1 Jersey Road to the eastern boundary of crown allotment 60A, Parish of Scoresby, southerly along the said crown allotment boundary to

Barry Street, westerly along Barry Street, northerly along Jersey Road, westerly along the southern boundary of lot 45 Jersey Road, northerly along the western boundaries of lots 45 to 48 Jersey Road, westerly along portion of the southern boundary of lot 47 Jersey Road, further westerly along the southern boundaries of lots 4 to 1 Malvern Street, northerly along portion of the western boundary of the said lot 1, westerly along the southern boundary of an adjoining lot 1 Malvern Street, northerly along Edelmair Street, westerly and northerly along the southern and portion of the western boundaries of lot 3 Malvern Street, westerly along the southern boundaries of lots 14 to 1 Malvern Street, southerly along the eastern boundaries of lots 4 Malvern Street, 54 and 55 Scoresby Road and 56 Power Road, north-westerly along Power Road, northerly along Scoresby Road, north-westerly along the south-western boundaries of lots 1 and 2 Scoresby Road to the boundary of Sewerage Area No. 2693, generally northerly, generally north-westerly and south-westerly along the said area boundary to the commencing point.

Sewerage Area No. 2759.

City of Altona.—Commencing at the intersection of Sargood Street and Blyth Street on the boundary of Sewerage Area No. 2575; thence westerly, southerly, westerly, northerly, westerly and northerly following the said area boundary to a point in Railway Street North about 34 metres west of the western boundary of David Street, easterly along Railway Street North, southerly along McBain Street, easterly along Railway Street South, southerly along Sargood Street to the commencing point.

Sewerage Area No. 2760.

Shire of Whittlesea and City of Preston.—Commencing at the junction of Aylward Avenue and Mahoneys Road; thence westerly along the southern boundary of Mahoneys Road, southerly and westerly along the eastern and portion of the southern boundaries of lot 5 Mahoneys Road, south-easterly along the north-eastern boundary of lot 1906 Bedwell Street, south-westerly along Bedwell Street, south-easterly and south-westerly along the north-eastern and south-eastern boundaries of lot 1855 Bedwell Street, south-easterly along the north-eastern boundary of lot 1887 Callander Street, south-westerly along Callander Street, south-easterly along the north-eastern boundary of lot 1816 Callander Street, north-easterly along portion of the north-western boundary of lot 1849 Dredge Street, south-easterly along the north-eastern boundary of the said lot 1849, north-easterly along Dredge Street, south-easterly along the north-eastern boundary of lot 1782 Dredge Street, north-easterly along the north-western boundaries of lots 1811 and 1810 Pallant Avenue, south-easterly along the north-eastern boundary of the said lot 1810, north-easterly along Pallant Avenue, south-easterly along the north-eastern boundary of lot 92 Pallant Avenue and a line in continuation to Edgars Creek, generally south-westerly along Edgars Creek, north-westerly and northerly along Hughes Parade, easterly along portion of the northern boundary of lot 6 Hughes Parade, northerly along the western boundary of lot 3 Mahoneys Road, easterly along Mahoneys Road, northerly along the western boundaries of lots 1 Mahoneys Road and 7 to 13 Aylward Avenue, easterly along the northern boundary of the said lot 13, northerly along the western boundaries of lots 17 to 23 Aylward Avenue and 86 Lipton Drive, easterly along the northern boundaries of the said lot 86 and lots 24 to 42 Lipton Drive, southerly along the eastern boundaries of lots 42 to 49 and 83 to 85 Lipton Drive, further southerly along the eastern boundary of Lipton Drive, westerly by a line to and along the southern boundaries of lots 4 Lipton Drive, 2 and 3 and 5 to 13 Norwich Avenue and 16 Aylward Avenue, southerly and westerly along the eastern and portion of the southern boundaries of lot 1 Aylward Avenue, southerly along the eastern boundaries of lots 17 to 20 Aylward Avenue, westerly along the southern boundary of the said lot 20, southerly along Aylward Avenue to the commencing point.

Sewerage Area No. 2761.

City of Croydon.—Commencing at the junction of Mount Dandenong Road and Haig Avenue; thence southerly along Haig Avenue, westerly along Birdwood Road, southerly along the eastern boundaries of lots 1 to 5 Lusher Road, easterly along the northern boundary of lot 2 Lusher Road, southerly along the eastern boundaries of the said lot 2 and lot 24 Lusher Road, south-westerly and westerly along the south-eastern and southern boundaries of the said lot 24, northerly along Lusher Road, south-westerly and westerly along Mount Dandenong Road to the railway line, north-easterly along the said railway line to Main Street, southerly along Main Street, easterly along Hewish Road, southerly along the eastern boundaries of lots 2 and 1 Hewish Road, westerly along the southern

boundary of the said lot 1 and a line in continuation to the eastern boundary of lot 3 Main Street, southerly along the eastern boundaries of properties on the east side of Main Street to a point 52.70 metres north of the northern boundary of Mount Dandenong Road, easterly by a line at right angles for a distance of 43.30 metres, southerly by a line at right angles for a distance of about 49.40 metres to Mount Dandenong Road, westerly along Mount Dandenong Road to the commencing point.

Sewerage Area No. 2762.

Shire of Diamond Valley.—Commencing at the junction of Civic Drive and Bullanoo Court; thence southerly along Bullanoo Court, easterly along the northern boundary of lot 373 Bullanoo Court, southerly along the eastern boundaries of the said lot 373 and lots 2 and 374 Bullanoo Court, westerly along the southern boundaries of lots 374 to 376 Bullanoo Court and a line in continuation to the south-eastern angle of lot 681 Goonyah Court, further westerly along the southern boundaries of lots 681 to 676 Goonyah Court, 675 to 673 Wala Place, 663 to 661 Tallerk Close, 649 to 645 Tuta Court and 643 Plenty River Drive, again further westerly along Booyan Crescent to Plenty River, generally northerly and north-easterly along the said river to the production of the northern boundary of lot 204 Corowa Crescent, easterly along the said production and lot boundary, further easterly along the northern boundaries of lots 773 and 772 Kowa Court, 181 to 184 Doowi Court and 444 Plenty River Drive, again further easterly along Civic Drive to the commencing point.

Sewerage Area No. 2763.

City of Waverley.—Commencing at the southern end of Montrose Close; thence southerly, westerly and northerly along the eastern, southern and portion of the western boundaries of lot 96 Montrose Close, westerly along the southern boundary of lot 46 Watsons Road, northerly along Watsons Road, easterly along the northern boundaries of lots 1 Watsons Road, 3 to 5 Mannering Drive and 7 and 8 Talisman Rise, southerly along the eastern boundaries of lots 9 and 10 Talisman Rise and 12 to 19 Mannering Drive, south-easterly along the north-eastern boundary of lot 101 Mannering Drive, south-westerly along the south-eastern boundary of the said lot 101, north-westerly along Mannering Drive, south-westerly along the south-eastern boundary of lot 100 Mannering Drive, south-easterly along portion of the north-eastern boundary of lot 98 Montrose Close, southerly along Montrose Close to the commencing point.

By order of the Board,

R. H. ENGELSMAN,
Secretary.

625 Little Collins Street, Melbourne, 3001, 22nd
October, 1974.

Cemeteries Act 1958 (No. 6217).

SCALE OF MISCELLANEOUS CHARGES OF THE
NECROPOLIS SPRINGVALE.

In pursuance of the powers conferred upon them by the *Cemeteries Act 1958*, the Trustees of The Necropolis Springvale, hereby make the following scale of miscellaneous charges which shall come into operation on the 1st day of November, 1974, and on and from such date, any scale of miscellaneous charges previously made by the Trustees shall be and is hereby rescinded to the extent to which it conflicts with the said following scale.

1. *Flower Containers—Cremation Memorial Gardens—*
 - (a) Wall Niche \$10.00
 - (b) Small rectangular (95 mm x 45 mm) .. \$16.00
 - (c) Large rectangular (170 mm x 50 mm) \$20.00
 - (d) Vase for Columbarium Niches .. \$10.00
2. *Plaques—Cremation Memorial Gardens—*
 - (a) Small Bronze (4 lines of inscription) \$20.00
 - (b) Small Bronze (with inbuilt rectangular 95 mm x 45 mm flower container) .. \$36.00
 - (c) Large Bronze (10 lines of inscription) \$35.00
 - (d) Large Bronze (with inbuilt rectangular 170 mm x 50 mm flower container) .. \$50.00
 - (e) Variation to an inscription or reconditioning of plaque. Removal and relocation charge of \$7.00 plus actual quoted cost from engraving company \$7.00

3. *Photograph of a Plaque or Memorial—*
Polaroid print 107 mm x 85 mm each .. \$5.00
 4. *Administration Charges—*
 - (a) Collection of cremated remains from office (48 hours notice required) .. \$5.00
 - (b) Postage of cremated remains within Australia .. \$8.00
 - (c) Postage of cremated remains overseas by Seamail .. \$13.00
 - (d) Postage of cremated remains overseas by Airmail .. \$18.00
 - Transfer/Cancellation Charges—*
 - (a) Transfer—Relocation of a plaque within The Necropolis, plus charge for past maintenance (see below) .. \$6.00
 - (b) Cancellation charge if cancelling an allocated or reserved memorial location, cremation deed, certificate of right of burial .. \$6.00
Plus collection or postage charge, detailed above, if applicable; and/or
 - (c) Maintenance Charge—Refunds due in respect of cancelled memorials or reserved locations, are subject to a charge for maintenance based on elapsed years of tenure.
 5. *Cemetery Plaques—*
 - (i) Special dual decorative design—to commemorate one or two persons with the same surname. Includes first attachment and inbuilt flower container .. \$120.00
 - (ii) Second attachment to special decorative plaque .. \$15.00
 - (iii) Standard lawn with decorative design and inbuilt flower container .. \$85.00
 - (iv) Standard lawn—with inbuilt flower container .. \$75.00
 - (v) Standard lawn—without flower container \$65.00
 6. *Flower Containers—Separate—*
Small—Rectangular 95 mm x 45 mm .. \$16.00
Large—Rectangular 170 mm x 50 mm .. \$20.00
 7. *Maintenance of Grave—Upkeep Service—*
Denominational monumental areas:
Annual charge .. \$10.00
Annual charge with monumental ledger or slab .. \$5.00
50 year period .. \$200.00
 8. *Interment of Cremated Remains—*
(Written authority from holder of Right of Burial required) .. \$20.00
 9. *Issue of duplicate Certificate of Right of Burial* .. \$2.00
 10. *Monumental Permit Charge—*
Administration charge to issue permit:
(a) for an additional inscription on a headstone .. \$5.00
(b) new, additional or renovation of a monument .. \$15.00
 11. *Jewish Memorial Headstone Inscriptions Lettering—*52 cents per letter
Star of David or Menorah .. \$3.50
 12. *Scatter at Sea* .. \$15.00
 13. *Use of Chapel—Memorial Service only* .. \$15.00
 14. Additional fee for inscriptions other than in English—as quoted by engraving company
- The common seal of the Trustees of The Necropolis Springvale was hereto affixed on the authority of a resolution of Trustees and in the presence of—
- (SEAL) M. A. R. SYNNOTT, Trustee.
R. G. O. WILSON, Trustee.
A. C. DOWNARD, Trustee.
R. A. BLAIN, Secretary.
- Signed and sealed at Springvale on the 1st October, 1974.
- Approved by the Governor in Council, 15th October, 1974.—TOM FORRISTAL, Clerk of the Executive Council.

Cemeteries Act 1958.

SCALE OF FEES OF THE WARRINGAL PUBLIC CEMETERY.

In pursuance of the powers conferred upon them by the Cemeteries Act the trustees of the Warringal Public Cemetery hereby make the following scale of fees, which shall come into operation upon publication in the *Government Gazette*, and from and after such publication every scale of fees heretofore made by the said trustees shall be and is hereby rescinded to the extent to which it conflicts with this scale.

Private Graves.

	<i>Heidelberg Burial Grounds.</i>	<i>Eltham Burial Grounds.</i>
Childrens Lawn Cemetery grave ..		\$80.00
Lawn cemetery grave inclusive of land 8 ft x 4 ft. ..		\$120.00
Land for private graves 8 ft. x 4 ft.—		
Lining roadways or pathways ..	\$150.00	\$90.00
Elsewhere ..	\$125.00	\$75.00
Sinking same to 6 feet ..	\$60.00	\$60.00
Sinking same to 7 feet ..	\$70.00	\$70.00
Sinking same to 8 feet ..	\$80.00	\$80.00
For each inch over 2 feet width ..	\$10.00	\$10.00
For each interment ..	\$15.00	\$15.00
Remove concrete or cement top to sink or reopen grave ..	\$15.00	\$15.00
Remove ledger or slab top to sink or reopen grave and replace ..	\$15.00	\$15.00
Reopen grave for additional interment	\$50.00	\$50.00

Miscellaneous Charges.

Label ..	\$5.00	\$5.00
Certificate of right of burial or transfer	\$5.00	\$5.00
Saturday interments (extra) ..	\$50.00	\$50.00
Charge for permission to erect a monu- ment to grave up to \$100 ..	\$10.00	\$10.00
Plus 10c on each \$1 over \$100		
For inspecting plan or copy of register	\$4.00	\$4.00
Exhumation of body (when authorized)	\$100.00	\$100.00
Cancellation of order ..	\$10.00	\$10.00
Additional inscription on headstone ..	\$5.00	\$5.00
Upkeep of single grave per annum ..	\$15.00	\$15.00
Charge for maintenance of perpetuity 8 ft. x 4 ft. ..	\$250.00	\$250.00
Interment of ashes ..	\$20.00	\$20.00
American type casket ..	\$40.00	\$40.00

P. S. BARBETA, Trustee.
C. G. BAIRD, Trustee.
F. G. JONES, Trustee.

Approved by the Governor in Council, 15th October, 1974.—TOM FORRISTAL, Clerk of the Executive Council.

Cemeteries Act 1958.

SCALE OF FEES OF THE COBRAM PUBLIC CEMETERY.

In pursuance of the powers conferred upon them by the Cemeteries Act the trustees of the Cobram Public Cemetery hereby make the following scale of fees, which shall come into operation upon publication in the *Government Gazette*, and from and after such publication every scale of fees heretofore made by the said trustees shall be and is hereby rescinded to the extent to which it conflicts with this scale.

Private Graves.

Sinking a grave ..	\$30.00
--------------------	---------

W. R. DENSON, Trustee.
R. W. BLACK, Trustee.
P. A. CORBETT, Trustee.

Approved by the Governor in Council, 15th October, 1974.—TOM FORRISTAL, Clerk of the Executive Council.

Cemeteries Act 1958.

SCALE OF FEES OF THE WARRNAMBOOL PUBLIC CEMETERY.

In pursuance of the powers conferred upon them by the Cemeteries Act the trustees of the Warrnambool Public Cemetery hereby make the following scale of fees, which shall come into operation upon publication in the *Government Gazette*, and from and after such publication every scale of fees heretofore made by the said trustees shall be and is hereby rescinded to the extent to which it conflicts with this scale.

Land 8 ft. x 4 ft. ..	\$95.00
Sinking new grave 7 feet ..	\$80.00
Sinking new grave 8 feet ..	\$90.00

Re-opening grave (without cover) ..	\$60.00
Re-opening grave (with cover) ..	\$75.00
Sinking grave for a square coffin (extra) ..	\$40.00
Land for graves adjoining or abutting roads ..	\$110.00
Interments on Saturdays, Sundays and Public Holidays (extra) ..	\$60.00
Exhumation (when authorized) ..	\$130.00
Niche in wall memorial for ashes (without plaque)	\$40.00
Interment of a stillborn child (for other children adult fees are payable) ..	\$25.00
Inspection of plans ..	\$3.00
Permission to erect a memorial ..	\$30.00

H. J. BEARDSLEY, Trustee.
J. S. LARK, Trustee.
D. G. COLLINS, Trustee.

Approved by the Governor in Council, 15th October, 1974.—TOM FORRISTAL, Clerk of the Executive Council.

Stamps Act 1958.

STAMPS (EXEMPTIONS) REGULATIONS 1971.

NOTICE.

Pursuant to the provisions of the Stamps (Exemptions) Regulations 1971, I hereby declare—

HOTHLYN CORPORATION LIMITED,
to be for the purpose of subdivision (13A) of Division 3 of Part II. of the Stamps Act 1958, a dealer in the unofficial short-term money market.

R. M. PHIBBS,
Comptroller of Stamps.

Stamp Duties Office,
Melbourne, 23rd October, 1974.

Victoria.

Co-operation Act 1958.

NOTICE OF AMALGAMATION OF SOCIETIES.

Notice is hereby given that, pursuant to the provisions of the *Co-operation Act 1958*, OVENS VALLEY ARTIFICIAL BREEDERS CO-OPERATIVE LIMITED, BENALLA AND DISTRICT ARTIFICIAL BREEDERS CO-OPERATIVE SOCIETY LIMITED and MOYHU & DISTRICT 'AB.' CO-OPERATIVE LIMITED were amalgamated into one society under the name of NORTH EASTERN HERD IMPROVEMENT CO-OPERATIVE LIMITED, on the fourteenth day of October, 1974.

Dated at Melbourne, this fourteenth day of October, 1974.

E. P. LIDDELL,
Deputy Registrar of Co-operative Societies.

Co-operation Act 1958.

VICTORIAN GROUP STAFF CO-OPERATIVE SOCIETY LIMITED.

NOTICE OF DISSOLUTION OF SOCIETY.

Notice is hereby given that I have this day registered the dissolution of the above-named society and cancelled its registration under the above-named Act.

Dated at Melbourne, this eleventh day of October, 1974.

E. P. LIDDELL,
Deputy Registrar of Co-operative Societies.

Co-operation Act 1958.

B.W.S.S. LIBRARY CO-OPERATIVE LIMITED.

Notice is hereby given in pursuance of section 78 (7) of the *Co-operation Act 1958* and section 308 (2) of the *Companies Act 1961* that, at the expiration of three months from the date hereof, the name of the aforementioned society will, unless cause is shown to the contrary, be struck off the register and the society will be dissolved.

Dated this eleventh day of October, 1974.

E. P. LIDDELL,
Deputy Registrar.

Co-operation Act 1958.

1ST BORONIA SCOUT GROUP CO-OPERATIVE LIMITED.

Notice is hereby given in pursuance of section 78 (7) of the *Co-operation Act 1958* and section 308 (2) of the *Companies Act 1961* that, at the expiration of three months from the date hereof, the name of the aforementioned society will, unless cause is shown to the contrary, be struck off the register and the society will be dissolved.

Dated this eleventh day of October, 1974.

E. P. LIDDELL,
Deputy Registrar.

STATE RIVERS AND WATER SUPPLY COMMISSION.

LICENCE TO DIVERT WATER PURSUANT TO THE PROVISIONS OF SECTION 204 OF THE WATER ACT (AS AMENDED).
The Schedule of Licence as detailed hereunder to divert water has been revoked by the Governor in Council.

SCHEDULE.

Licence No.	Term of Licence and Commencing Date.	Name and Address of Person to whom Licence is Granted.	Source of Supply.
3362	Four years from 1.7.72 ..	Ian Harold Sands and Beverley Ann Sands of Oxley..	King River

Office of the State Rivers and Water Supply Commission,
Melbourne, 15th October, 1974.

G. W. LEWIS, Secretary,
State Rivers and Water Supply Commission.

MOUNT ELIZA SEWERAGE AUTHORITY.

INCREASING THE LIMIT OF BANK OVERDRAFT.

His Excellency the Governor of the State of Victoria, by and with the advice of the Executive Council thereof, doth by Order made on the 22nd day of October, 1974, increase the total amount of the sums which the Mount Eliza Sewerage Authority may owe at any time in respect of moneys borrowed by overdraft of current account, pursuant to the provisions of section 78 of the *Sewerage Districts Act 1958*, fixed by the Governor in Council on 7th September, 1965, at Twenty thousand dollars (\$20,000) to Thirty-six thousand dollars (\$36,000).

TOM FORRISTAL,
Clerk of the Executive Council.

At the Executive Council Chamber,
Melbourne, 22nd October, 1974.

MOUNT ELIZA SEWERAGE AUTHORITY.

INCREASING THE LIMIT OF BANK OVERDRAFT.

His Excellency the Governor of the State of Victoria, by and with the advice of the Executive Council thereof, doth by Order made on the 22nd day of October, 1974, increase the total amount of the sums which the Mount Eliza Sewerage Authority may owe at any time in respect of moneys borrowed by overdraft of current account, pursuant to the provisions of section 79 of the *Sewerage Districts Act 1958*, fixed by the Governor in Council on 14th January, 1969, at Sixty thousand dollars (\$60,000) to One hundred thousand dollars (\$100,000).

TOM FORRISTAL,
Clerk of the Executive Council.

At the Executive Council Chamber,
Melbourne, 22nd October, 1974.

MOUNT ELIZA SEWERAGE AUTHORITY.

INCREASING THE LIMIT OF BANK OVERDRAFT.

His Excellency the Governor of the State of Victoria, by and with the advice of the Executive Council thereof, doth by Order made on the 22nd day of October, 1974, increase the total amount of the sums which the Mount Eliza Sewerage Authority may owe at any time in respect of moneys borrowed by overdraft of current account, pursuant to the provisions of section 79A of the *Sewerage Districts Act 1958*, fixed by the Governor in Council on 28th September, 1965, at Forty thousand dollars (\$40,000) to Sixty thousand dollars (\$60,000).

TOM FORRISTAL,
Clerk of the Executive Council.

At the Executive Council Chamber,
Melbourne, 22nd October, 1974.

COHUNA WATERWORKS TRUST.

INCREASING THE LIMIT OF BANK OVERDRAFT.

His Excellency the Governor of the State of Victoria, by and with the advice of the Executive Council thereof, doth by Order made on the 22nd day of October, 1974, increase the total amount of the sums which the Cohuna Waterworks Trust may owe at any time in respect of moneys borrowed by overdraft of current account pursuant to the provisions of section 286 of the *Water Act 1958*, fixed by the Governor in Council on 24th July, 1973, at Four thousand dollars (\$4,000) to Ten thousand dollars (\$10,000).

TOM FORRISTAL,
Clerk of the Executive Council.

At the Executive Council Chamber,
Melbourne, 22nd October, 1974.

ROSEDALE WATERWORKS TRUST.

FIXING THE LIMIT OF BANK OVERDRAFT.

His Excellency the Governor of the State of Victoria, by and with the advice of the Executive Council thereof, doth by Order made on the 22nd day of October, 1974, fix the total amount of the sums which the Rosedale Waterworks Trust may owe at any one time in respect of moneys borrowed by overdraft of current account, pursuant to the provisions of section 286 of the *Water Act 1958* at Fifteen thousand dollars (\$15,000).

TOM FORRISTAL,
Clerk of the Executive Council.

At the Executive Council Chamber,
Melbourne, 22nd October, 1974.

Town and Country Planning Act 1961.

CITY OF MOE PLANNING SCHEME 1966.

REVOCATION No. 4.

Notice of Revocation.

In pursuance of the provisions of section 32 of the *Town and Country Planning Act 1961* the Governor in Council on the 15th October, 1974, made an Order:—

- (i) revoking the City of Moe Planning Scheme 1966, in so far as it applies to approximately 83 ha of land known as the Monash Estate, and which is more particularly described on the maps annexed to the said Order; and
- (ii) subject to the grant of a permit by the Council of the City of Moe and to any conditions it may include in a permit.

A copy of the Order may be inspected during office hours at the Office of the Town and Country Planning Board, 235 Queen Street, Melbourne; and at the office of the City of Moe, at Moe.

W. H. CRAIG, Secretary,
Town and Country Planning Board.

Town and Country Planning Act 1961.

BALLAARAT AND DISTRICT PLANNING SCHEME, 1966.

(CITY OF BALLAARAT).

REVOCATION No. 2.

Notice of Revocation.

In pursuance of the provisions of section 32 of the *Town and Country Planning Act 1961* the Governor in Council on the 15th October, 1974, made an Order:—

- (i) Revoking the Ballaarat and District Planning Scheme 1966, in so far as it applies to an area of the Principal Scheme between Victoria and Little Bridge Streets in the City of Ballaarat to provide for a new road alignment and more particularly described in Crown allotments 1 to 7 and 26 to 35 of Section G and Crown allotments 1 to 11 and 41 and 42 of Section H in the Township of Ballarat East, Parish of Ballarat.
- (ii) That the said land may, subject to the grant of a permit by the Council of the City of Ballaarat and to any conditions it may include in the permit, be used only for those uses permitted in the Commercial "A" Zone or as a Reserve for New Road in the Ballaarat and District Planning Scheme 1966.

A copy of the Order may be inspected during office hours at the Office of the Town and Country Planning Board, 235 Queen Street, Melbourne; at the Office of the City of Ballaarat, Ballarat.

W. H. CRAIG, Secretary,
Town and Country Planning Board.

Town and Country Planning Act 1961.
CITY OF KNOX PLANNING SCHEME 1965.
AMENDMENT No. 142, 1974.

Notice of Amendment.

In pursuance of the powers conferred by sub-section 6 of section 32 of the *Town and Country Planning Act 1961*, the Governor in Council, on the 15th October, 1974, amended the City of Knox Planning Scheme, 1965 to convert all lineal and areal dimensions from imperial to metric units and to amend all reference to the "Shire of Knox" to the "City of Knox".

A copy of the amendment may be inspected during office hours at the office of the Town and Country Planning Board, 235 Queen Street, Melbourne; at the office of the council of the City of Knox at Fern Tree Gully, and when available at the Office of Titles, Melbourne; and at the Central Plan Office of the Department of Crown Lands and Survey, Melbourne.

W. H. CRAIG, Secretary,
Town and Country Planning Board.

Town and Country Planning Act 1961.
BARRABOOL PLANNING SCHEME 1966.
AMENDMENT No. 17, 1973.

Notice of Approval.

In pursuance of the powers conferred by the *Town and Country Planning Act 1961*, the Governor in Council on the 15th October, 1974, approved a planning scheme entitled the Barrabool Planning Scheme 1966, Amendment No. 17, 1973, in respect of part of the municipal district of the Shire of Barrabool and such planning scheme comes into operation on the date this notice of approval is published in the *Government Gazette*.

A copy of the planning scheme as approved may be inspected free of charge during office hours at the office of the Town and Country Planning Board, 235 Queen Street, Melbourne; at the office of the Council of the Shire of Barrabool at Geelong, and when available, at the Office of Titles, Melbourne and at the Central Plan Office of the Department of Crown Lands and Survey, Melbourne.

W. H. CRAIG, Secretary,
Town and Country Planning Board.

Town and Country Planning Act 1961.
SHIRE OF SHERBROOKE PLANNING SCHEME 1965.
AMENDMENT No. 61, 1973.

Notice of Approval.

In pursuance of the powers conferred by the *Town and Country Planning Act 1961*, the Governor in Council on the 15th October, 1974, approved a planning scheme entitled the Shire of Sherbrooke Planning Scheme 1965, Amendment No. 61, 1973, in respect of the municipal district of the Shire of Sherbrooke and such planning scheme comes into operation on the date this notice of approval is published in the *Government Gazette*.

A copy of the planning scheme as approved may be inspected free of charge during office hours at the office of the Town and Country Planning Board, 235 Queen Street, Melbourne; at the office of the Shire of Sherbrooke at Upwey, and when available, at the Office of Titles, Melbourne, and at the Central Plan Office of the Department of Crown Lands and Survey, Melbourne.

W. H. CRAIG, Secretary,
Town and Country Planning Board.

Town and Country Planning Act 1961.
SHIRE OF SHERBROOKE PLANNING SCHEME 1965.
AMENDMENT No. 56, 1973.

Notice of Approval.

In pursuance of the powers conferred by the *Town and Country Planning Act 1961*, the Governor in Council on the 15th October, 1974, approved a planning scheme entitled the Shire of Sherbrooke Planning Scheme 1965, Amendment No. 56, 1973, in respect of Part of the municipal district of the Shire of Sherbrooke and such planning scheme comes into operation on the date this notice of approval is published in the *Government Gazette*.

A copy of the planning scheme as approved may be inspected free of charge during office hours at the office of the Town and Country Planning Board, 235 Queen Street, Melbourne; at the office of the Council of the Shire of Sherbrooke at Upwey, and when available, at the Office of Titles, Melbourne, and at the Central Plan Office of the Department of Crown Lands and Survey, Melbourne.

W. H. CRAIG, Secretary,
Town and Country Planning Board.

LAW DEPARTMENT.

County Court Act 1958.

COUNTY COURT SITTINGS 1975.

Notice is hereby given that the Sittings of the County Court at Sale will commence at 10 a.m. on Tuesday, 4th March, 1975, in lieu of Tuesday, 4th February, 1975, as was previously appointed.

G. L. DETHRIDGE, Chairman,
County Court Judges.

18th October, 1974.

PUBLIC TRUSTEE ACT 1958 (No. 6350), SECTION 17.

I hereby give notice that on the 7th October, 1974, the Public Trustee filed elections to administer the following deceased persons' estates, in accordance with section 17 of the *Public Trustee Act 1958*:—

ADAM, JACK, late of 132 Cochrane Street, Gardenvale, retired, died 29th May, 1974.

CARTER, RICHARD, 40 George Street, Fitzroy, clerk, died 4th July, 1974.

CHAMBERS, ALICE MAY, late of 9 Gayle Street, Watsonia, widow, died 20th June, 1974.

CURTIS, NORMAN, also known as Norman James Curtis, late of "Ashleigh" Private Hospital, 58 Cochrane Street, North Brighton, pensioner, died 9th August, 1974.

DONALDSON, WILLIAM JAMES, late of Bundoora, pensioner, died 10th June, 1974.

FOWLER, LESLIE COLIN, late of Beechworth, pensioner, died 16th July, 1974.

HAWKINS, EDWARD FRANK, late of 11 Jubilee Avenue, Frankston, pensioner, died 25th June, 1974.

HEWITT, JOHN, late of Alexander Home and Hospital for the Aged, Castlemaine, pensioner, died 19th September, 1972.

PATTISON, MARY CUNNINGHAM, late of Bundoora, widow, died 4th February, 1974.

WILMS, HENRY FRANCIS, late of Plenty Road, Bundoora, pensioner, died 16th March, 1974.

N. P. BRODY,
Public Trustee.

168 Exhibition Street, Melbourne, 3000, 16th October, 1974.

NOTICE.

Creditors, next of kin and others having claims against the estate of any of the under-mentioned deceased persons are required to send particulars of their claims to the Public Trustee, 168 Exhibition Street, Melbourne, Vic. 3000, the personal representative, on or before the 30th December, 1974, after which date the Public Trustee may convey or distribute the assets having regard only to the claims of which the Public Trustee then has notice:—

ADAM, JACK, late of 132 Cochrane Street, Gardenvale, retired, died 29th May, 1974.

BAIN, HAROLD BIRCHWOOD, formerly of War Veterans Home, Overport Road, Frankston, but late of Kew, retired farmer, died 12th April, 1974.

BRENS, ANGUS, formerly of 65 Fitzroy Street, Fitzroy, but late of 217 A'Beckett Street, Melbourne, retired labourer, died 17th May, 1968.

CARTER, RICHARD, late of 40 George Street, Fitzroy, clerk, died 4th July, 1974.

CHAMBERS, ALICE MAY, late of 9 Gayle Street, Watsonia, widow, died 20th June, 1974.

COOK, GEORGE ARTHUR, late of 4 Steele Street, Moonee Ponds, retired bricklayer, died 17th June, 1974.

CROWE, MARTIN LEO, late of 4 McGowan Avenue, West Preston, retired industrial chemist, died 7th August, 1974.

CURTIS, NORMAN, also known as Norman James Curtis, late of "Ashleigh" Private Hospital, 58 Cochrane Street, North Brighton, pensioner, died 9th August, 1974.

DAVIS, MARK EDWARD, formerly of 41 Wheatshaf Road, Glenroy, but late of Kew, retired drover, died 20th April, 1974.

DE ROSS, HUBERT LESLIE DALMORE, late of 63 Rae Avenue, Edithvale, retired gentleman, died 26th August, 1974.

DONALDSON, WILLIAM JAMES, late of Bundoora, pensioner, died 10th June, 1974.

FOWLER, LESLIE COLIN, late of Beechworth, pensioner, died 16th July, 1974.

GILLIES, CLYDE KENNETH, late of 28 Stanley Street, Northcote, retired boot trade worker, died 8th July, 1974.

GUEST, LEO MARK, formerly of 8 Scott Street, Croxton, but late of Bundoora, retired clerk, died 15th June, 1974.

HANDLEY, GORDON ELLIJAH, late of 54 Elsie Street, Boronia, retired nursery man, died 25th June, 1974.

HAWKINS, EDWARD FRANK, late of 11 Jubilee Avenue, Frankston, pensioner, died 25th June, 1974.

HEWITT, JOHN, late of Alexander Home and Hospital for the Aged, Castlemaine, pensioner, died 19th September, 1972.

HORNE, DANIEL, late of Karawinna, farmer, died 24th January, 1974.

HULTGREN, IDA OTTOLINE, late of 71 Dowling Street, Arncliffe, N.S.W., spinster, died 3rd August, 1967.

MERRILEES, ALEXANDER McCORMACK (in the will called Alexander Merrilees), formerly of "Burnside Hospital", 7 Hartington Street, Elsternwick, but late of "Belvedere Hospital", Princes Highway, Noble Park, retired spray painter, died 30th December, 1973.

McCOY, ILLA MARY, formerly of 4 Lobb Street, Coburg, but late of Greenvale Geriatric Centre, Greenvale, spinster, died 13th January, 1974.

McKENZIE, GEORGE, late of 4 Minto Street, East Kew, retired, died 27th August, 1974.

PATTISON, MARY CUNNINGHAM, late of Bundoora, widow, died 4th February, 1974.

RAIDAL, REIN, late of 9 Lacey Street, Lalor, draftsman, died 9th August, 1974.

SHADE, ELLEN MARGARET, also known as Ellen Margaret Caroline Shade, late of 2 Lincoln Parade, Aspendale, widow, died 20th July, 1974.

WILLCOCKS, EMMA MAY, formerly of 48 The Esplanade, Maribyrnong, but late of 13 Bayview Street, Northcote, widow, died 16th August, 1974.

WILMS, HENRY FRANCIS, late of Plenty Road, Bundoora, pensioner, died 16th March, 1974.

WILSON, ISABELLA KATE, also known as Bella Wilson, late of 155 Aitken Street, Williamstown, home duties, died 18th June, 1974.

N. P. BRODY,
Public Trustee.

Melbourne, 17th October, 1974.

MINES DEPARTMENT.

Subject to any necessary excisions &c., it is proposed to grant the following lease:—

No. 256; Roger Keith Watson Steedman, Keith Watson Steedman, Stuart Norman Smith; 32 ha, Parish of Mellick-Munjie.

MINING LEASE EXPIRED.

8325 Beechworth; William James Hannan, Samuel Frank Bolitho, Archibald Cope; 40a. 1r. 38p., Parish of Tawanga.

EXPLORATION LICENCES GRANTED.

No. 528; Western Mining Corporation Limited; 275 square miles, Counties of Talbot and Grant.

No. 529; Western Mining Corporation Limited; 275 square miles, Counties of Talbot, Ripon, Grenville and Grant.

No. 532; Geosearch Pty. Ltd., Pierra Investments Pty. Ltd.; 25 square miles, County of Benambra.

EXPLORATION LICENCE TERM EXTENDED, WITH AREA REDUCED.

No. 432; Western Mining Corporation Limited; reduced from 175 square miles to 100 square miles comprising graticules 765, 766, 767 and 768, Melbourne Map Sheet.

REDUCTION OF AREA OF EXPLORATION LICENCE.

No. 495; ICI Australia Limited, Newmont Proprietary Limited; reduced from 50 square miles to 25 square miles, now comprising graticule 322, Melbourne Map Sheet.

EXPLORATION LICENCES CANCELLED.

No. 477; Commonwealth Aluminium Corporation Limited; 296 square miles, County of Benambra.

No. 499; Metals Exploration No Liability; 150 square miles, Counties of Gladstone and Kara Kara.

No. 507; Commonwealth Aluminium Corporation Limited; 186 square miles, County of Benambra.

MINERAL SEARCH LICENCE EXPIRED.

No. 1098; Harold Jack Helms, Huon Stevens, Peter Crowe; 6.1 ha, Parish of Nerran.

TAILINGS LICENCES GRANTED.

3949 Tailings Licence; Forests Commission of Victoria; to remove tailings from a deposit known as "Russells" mine dump, situated in the Parish of Creswick.

3952 Tailings Licence; Forests Commission of Victoria; to situated in a gully north of the Wallaby Mine, Parish of Stanley.

TAILINGS LICENCES EXPIRED.

3768 Tailings Licence; The President, Councillors and Ratepayers of the Shire of Maldon; to remove tailings from the "Daydawn, South German Extended and South Parkins" mine dumps situated at Maldon.

3882 Tailings Licence; Lyle George Elmer; to remove dredged tailings from the dump situated south of Crown allotment 4A, Parish of El Dorado.

EXTRACTIVE INDUSTRY LICENCE GRANTED.

No. 451; Stanley Alexander Fenton, Nancy Jean Fenton; 6.4 ha, Parish of Terang.

EXTRACTIVE INDUSTRY LICENCE TRANSFERRED.

No. 662; From James Erskine Page to Praznovszky Carriers Proprietary Limited.

EXTRACTIVE INDUSTRY LICENCE REVOKED.

No. 279; McGrath Sand and Stone Co. Pty. Ltd.; 127 ha, Parish of Langwarrin.

CORRIGENDUM.

The item under the heading "Mining Lease Granted" on Page 3708 of *Government Gazette* of 16th October, 1974, should have read 9143 Mineral and not 7143 Mineral.

J. C. M. BALFOUR,
Minister of Mines.

CONTRACTS ACCEPTED.—(Series 1974-75.)

VICTORIAN RAILWAYS.

72. Supply and Delivery of Copper Cable 2200 Volt, Two Core for Power Signalling, at \$4,030.40 per mile F.I.S. Spotswood (Contract No. 64039).—Cablemakers (A.C.T.) Pty. Ltd. 73. Painting and Maintenance of the Metalwork of Railway Bridges over the Avon River at Stratford; the Mitchell River at Bairnsdale; the Nicholson River at Nicholson and the Tambo River at Bruthen, over a ten year period, for the amount of \$121,628.00 (Contract No. 64009).—Miles Industrial Painting Services Pty. Ltd. 74. Ten year Maintenance Painting Contract of the Metalwork of the old and new Railway Bridges at Flemington Road, Flemington, for the amount of \$12,683.60 (Contract No. 64012).—Miles Industrial Painting Services Pty. Ltd. 75. Internal and External Painting, &c. over a ten year period, of Station Buildings and Associated Structures at Camberwell, at rates (Contract No. 64021).—Miles Industrial Painting Services Pty. Ltd. 76. Ten year Maintenance of the Paintwork of the Railway Bridge over City Road, South Melbourne, for the amount of \$4,920.00 (Contract No. 64041).—Miles Industrial Painting Services Pty. Ltd.

C. W. MILLER, Secretary for Railways. 18.10.74.

APPOINTMENTS AND RESIGNATIONS

APPOINTMENTS.

His Excellency the Governor of the State of Victoria, by and with the advice of the Executive Council thereof, has, by Orders made on the 15th day of October, 1974, been pleased to make the under-mentioned appointments, viz.:

MINISTRY OF HEALTH.

Member of Committee of Management of Hospital.

RUGBY WINTER LARMOUR, to be Government Appointee on Committee of Management of Wycheproof Hospital, for a period of three years commencing the 27th October, 1974, pursuant to the provisions of sub-paragraph (ii) of paragraph (a) of the proviso to sub-section (1) of section 48 of the *Hospitals and Charities Act 1958*.

Deputy Superintendent of Hospital.

HARI DASS CHOPRA, M.B., B.S., D.P.M., M.D., to be Deputy Superintendent, Lakeside Hospital, Ballarat, pursuant to the provisions of section 26 (1) of the *Mental Health Act 1959*, from the 7th October, 1974, vice Dr. G. D. Wilkins, transferred.

Superintendent of Hospital.

DILEEP SINGH RASTOGI, M.B., B.S., M.D. (Psychiatry), to be Superintendent, Royal Park Psychiatric Hospital, pursuant to the provisions of section 26 (1) of the *Mental Health Act 1959*, for the period 18th October, 1974, to the 5th November, 1974, vice Dr. Cade, on leave overseas.

Trustees of Public Cemeteries.

RAYMOND EXCELL, to be a Trustee of the Harkaway Public Cemetery, vice H. Wanke, deceased;

FREDERICK RAE, to be a Trustee of the Harkaway Public Cemetery, vice P. Aurisch, deceased; and

STANLEY JOHN FORD, to be a Trustee of the Shepparton Public Cemetery, vice W. Rimes, resigned, pursuant to section 3 (1) of the *Cemeteries Act 1958*; and

THE COUNCIL OF THE MUNICIPALITY OF THE SHIRE OF TULLAROOP, to be Trustees of the Alma Public Cemetery, pursuant to section 3 (2) of the *Cemeteries Act 1958*.

LAW DEPARTMENT.

Commissioners for Taking Declarations, &c.

WILLIAM JOHN GILHAM, 79 Numurkah Road, Shepparton,

LESTER GORDON HAWES, 83 Rowena Parade, Richmond,

GEORGE LEONARD LEDWITCH, 19 Ormond Road, Elwood,

PETER ALEXANDER LYNCH, care of Frankton Co-operative Credit Society Ltd., 1 Balmoral Street, Frankton,

MICHAEL ANDREW MIMMO, 252 Mt. Alexander Road, Flemington,

CLEMENT JOSEPH QUINLAN, care of Stores and Transport Branch, Department of Manufacturing Industry, Marybymong,

RODERICK JOHN ROWNNEY, care of Department of Crown Lands and Survey, Melbourne, and

GORDON STANLEY TAYLOR, 7 Fahey Street, Shepparton,

to be Commissioners for taking Declarations and Affidavits under the *Evidence Act 1958*.

Justices of the Peace.

GEOFFREY THOMAS EVANS, 21 Watson Street, Echuca,

SYDNEY JAMES GELLIE, Gellie's Road, Sunbury,

LAWRENCE STEPHEN ROGERS, W.S.D. Cashmore, Portland,

WESLEY WILLIAM SHARROCK, Wickliffe,

WILLIAM GEORGE CRAPPER, Elmora Road, Raywood,

PETER WILLIAM WEST, Katandra West,

EDWARD ROY WHITEHEAD, 20 Esmond Street, Rushworth, and

COLIN GEORGE TUTCHELL, 155 Warrigal Road, Burwood,

to keep the Peace in the State of Victoria.

Clerk of Courts.

JAMES WILLIAM KEE,

to be Clerk of the Magistrates' Court and Clerk of the Children's Court at Beech Forest, Birregurra, Cressy, Rokewood, Apollo Bay and Winchelsea, vice R. E. Lyneham, on extended sick leave.

Deputy Prothonotary.

KENNETH McDONALD,

to be Deputy Prothonotary at Horsham, vice G. J. Collins, transferred.

No. 103.—10300/74.—2

DEPARTMENT OF WATER SUPPLY.

Sewerage Authority Members.

GRAHAM STANLEY ELLIS, **WILLIAM BERNARD TELLEFSON**, and **WILLIAM ALFRED NORMAN TAYLOR**, to be Members of the Merbein Sewerage Authority, to hold such positions for a period of four years from the date hereof, subject to the provisions of the Sewerage Districts Act.

TOM FORRISTAL,

Clerk of the Executive Council.

At the Executive Council Chamber, Melbourne, 15th October, 1974.

Vermin and Noxious Weeds Act 1958.

APPOINTMENT.

It is hereby notified that the Public Service Board, in exercise of its powers, has appointed **TREVOR MAGNUS LAGSTROM**, an officer of the Department of Crown Lands and Survey, as Secretary to the Vermin and Noxious Weeds Destruction Board, without additional salary.

C. E. MIDDLETON,
Secretary for Lands.

Melbourne, 16th October, 1974.

MENTAL HEALTH ACT 1959, SECTION 26.

Notice is hereby given that the following appointment has been made pursuant to section 26 of the *Mental Health Act 1959*, as from the 2nd July, 1974:—

JAMES GORDON HYATT, Secretary, Dandenong Psychiatric Hospital.

G. W. ROGAN, Secretary,
Department of Health.

MENTAL HEALTH ACT 1959, SECTION 26.

Notice is hereby given that the following appointments have been made pursuant to section 26 of the *Mental Health Act 1959*, as from the 4th August, 1974:—

WAYNE ROBERT RALPH DOBSON, Secretary, Kingsbury Training Centre.

BAYLEE WILLIAM ROGERS, Deputy Secretary, Kingsbury Training Centre.

G. W. ROGAN, Secretary,
Department of Health.

MENTAL HEALTH ACT 1959, SECTION 26.

Notice is hereby given that the following appointment has been made pursuant to section 26 of the *Mental Health Act 1959*, as from the 22nd August, 1974:—

GORDON NICHOLAS VINCENT, Deputy Secretary, Lakeside Hospital, Ballarat, during the absence of David Thomas Dennett.

G. W. ROGAN, Secretary,
Department of Health.

MENTAL HEALTH ACT 1959, SECTION 26.

Notice is hereby given that the following appointment has been made pursuant to section 26 of the *Mental Health Act 1959*, as from the 22nd August, 1974:—

DAVID THOMAS DENNETT, Secretary, Mental Hospital and Training Centre, Warrnambool, during the absence of Colin Eugene Hay, on sick leave.

G. W. ROGAN, Secretary,
Department of Health.

Liquor Control Act 1968.

APPOINTMENT OF LICENSING INSPECTORS.

In accordance with the authority conferred upon me by sub-section (1) of Section 22 of the *Liquor Control Act 1968*, I, Reginald Jackson, Chief Commissioner of Police, hereby appoint the following Officers of Police as Licensing Inspectors for the Divisions of the Police Districts as shown:—

Division Number	Police District	Rank and Name
4	Dandenong	Inspector Albert Clifton Thompson (from 13.10.1974 to 3.11.1974)
1	Maroondah	Inspector James Ernest Pryor (from 1.10.1974 to 20.10.1974)

R. JACKSON,
Chief Commissioner of Police.

10.10.1974.

RESIGNATIONS:

His Excellency the Governor of the State of Victoria, by and with the advice of the Executive Council thereof, has, by Orders made on the 15th day of October, 1974, accepted the resignations of the persons named hereunder of the offices mentioned, viz.:—

LAW DEPARTMENT.

Commissioners for Taking Declarations, &c.

GRAEME FREDERICK DAVEY,
JOHN BRIAN DENMAN,
SYDNEY JAMES GELLIE,
ADRIAN CHRISTOPHER HARRIS, and
CYRIL LAURENCE MALONEY,
as Commissioners for taking Declarations and Affidavits under the Evidence Act 1958.

Justices of the Peace.

WILLIAM DELLAVEDOVA,
THOROLD BALSER ERLANDSEN,
MEYER HERMAN LEVEE,
THOMAS JAMES LOADER,
JESSE LOGAN, and
ALBERT ALEXANDER MORRISON,
as Justices of the Peace for the State of Victoria.

TOM FORRISTAL,
Clerk of the Executive Council.

At the Executive Council Chamber,
Melbourne, 15th October, 1974.

ORDERS IN COUNCIL

STAMPS ACT 1958, No. 6375.

*At the Executive Council Chamber, Melbourne, the
fifteenth day of October, 1974.*

PRESENT:

His Excellency the Governor of Victoria.
Mr. Rossiter | Mr. Rafferty
Mr. Smith | Mr. Granter.

His Excellency the Governor of the State of Victoria by and with the advice of the Executive Council thereof, doth by this Order made pursuant to Section 131c of the Stamps Act 1958 (No. 6375) revoke the declarations made on the dates shown in the first column of the schedule set out hereunder and published in the *Government Gazette* on the dates shown in the second column of the said schedule, declaring certain persons to be "approved vendors" for the purposes of sub-division (14) of Division 3 of Part II. of the said Stamps Act 1958 in so far as each declaration respectively refers to the person named in the third column of the said schedule.

THE SCHEDULE.

<i>First Column.</i> Date of Declaration.	<i>Second Column.</i> Date of Gazette.	<i>Third Column.</i> Name of Person.
9th December, 1958	10th December, 1958	41 Traders Finance Corporation Ltd.
8th December, 1959	9th September, 1959	110 Maples Pty. Ltd.
17th October, 1967	18th October, 1967	237 Woolworths (Victoria) Limited, trading as "Foy's-Big W"
19th October, 1971	27th October, 1971	260 Collins Trading Company Pty. Ltd.

And the Honorable Rupert James Hamer, Her Majesty's Treasurer for the State of Victoria, shall give the necessary directions herein accordingly.

TOM FORRISTAL,
Clerk of the Executive Council.

STAMPS ACT 1958, No. 6375.

*At the Executive Council Chamber, Melbourne, the
fifteenth day of October, 1974.*

PRESENT:

His Excellency the Governor of Victoria.
Mr. Rossiter | Mr. Rafferty
Mr. Smith | Mr. Granter.

DECLARATION OF APPROVED VENDOR.

His Excellency the Governor of the State of Victoria, by and with the advice of the Executive Council thereof, doth by this Order made pursuant to Section 131c (1) of the Stamps Act 1958, declare the under-mentioned person carrying on business as a vendor of goods under instalment purchase agreements to be an "approved vendor" for the purposes of sub-division (14) of Division 3 of Part II. of the Stamps Act 1958.

231. R. Rechner & Co.

And the Honorable Rupert James Hamer, Her Majesty's Treasurer for the State of Victoria, shall give the necessary directions herein accordingly.

TOM FORRISTAL,
Clerk of the Executive Council.

STATE ELECTRICITY COMMISSION ACT 1958, No. 6377.

*At the Executive Council Chamber, Melbourne, the
fifteenth day of October, 1974.*

PRESENT:

His Excellency the Governor of Victoria.
Mr. Rossiter | Mr. Rafferty
Mr. Smith | Mr. Granter.

Whereas His Excellency the Governor of the State of Victoria by and with the advice of the Executive Council thereof has this day consented pursuant to the provisions of the State Electricity Commission Act 1958 to the State Electricity Commission of Victoria raising by way of loan the sum of Four hundred and twenty-two thousand two hundred dollars (\$422,200); and whereas the Governor in Council is satisfied that a sufficient proportion of the loan to be raised will fall due and be repaid in each year during the currency of the proposed loan; now therefore it is directed pursuant to the provisions of Section 91 (3) of the said Act, that it shall not be necessary to provide a sinking fund in connection with such loan.

And the Honorable Rupert James Hamer, Her Majesty's Treasurer for the State of Victoria, shall give the necessary directions herein accordingly.

TOM FORRISTAL,
Clerk of the Executive Council.

Land Act 1958.
DEPARTMENT OF CROWN LANDS AND SURVEY.

At the Executive Council Chamber, Melbourne, the
fifteenth day of October, 1974.

PRESENT:
His Excellency the Governor of Victoria.
Mr. Rossiter | Mr. Rafferty
Mr. Smith | Mr. Granter.

LANDS TEMPORARILY RESERVED AS SITES.

His Excellency the Governor of the State of Victoria, by and with the advice of the Executive Council thereof, doth hereby in pursuance of the provisions of section 14 of the Land Act 1958, reserve temporarily from sale, from being leased and from having a licence granted in respect thereof, and also except from occupation for mining purposes under any miner's right the lands hereinafter described, viz.:-

BERRINGA.—Site for Water Supply purposes, 20.26 hectares being Crown allotment 5c section 2A, Parish of Berringa, County of Benambra, as indicated by hatching on plan hereunder.—(B.634(?) (Rs.9959).

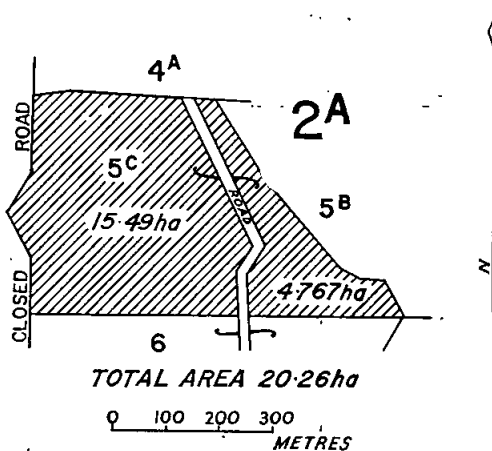

BROADWATER.—Site for Public purposes (Preservation of Native Flora and Fauna), 3.66 hectares, more or less, being Crown allotment 76A, Parish of Broadwater, County of Villiers, as indicated by hatching on plan hereunder.—(B.577(*) (Rs.9996).

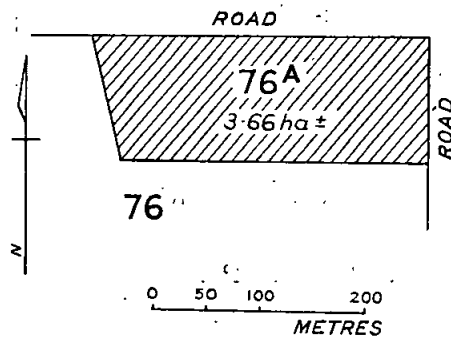

DINGEE.—Site for Public purposes (Public Hall), 951 square metres, being Crown allotment 140A, Parish of Dingee, County of Bendigo, as indicated by hatching on plan hereunder.—(D.166(2) (Rs.7528).

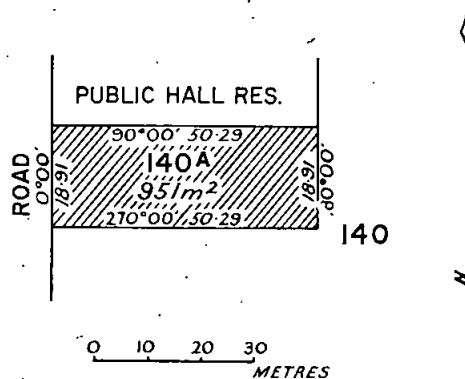

GEE LONG.—Site for Public purposes (Park and Childrens Playground), 5740 square metres, more or less, being Crown allotment 2 section 17A, City of Geelong, Parish of Corio, County of Grant, as indicated by hatching on plan hereunder.—(G.29(10) (Rs.10012).

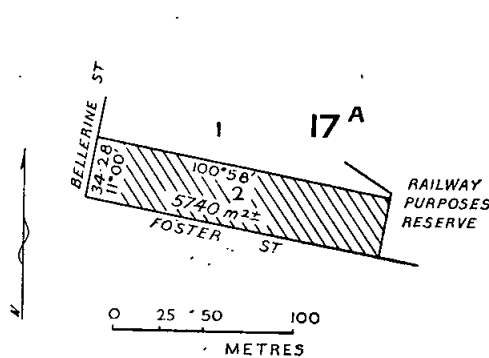

MILDURA.—Site for Public purposes (Horticultural Research Station), 56.85 hectares, being Crown allotment 15B section 95, Block F, Parish of Mildura, County of Karkaroc, as indicated by hatching on plan hereunder.—(M.556(15) (Rs.9991).

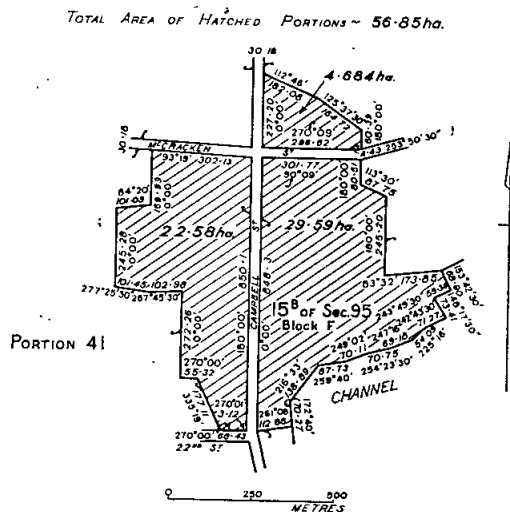

MORTLAKE.—Site for Public purposes (Public Hall), 3237 square metres, being Crown allotment 4 section 10, Township of Mortlake, Parish of Mortlake, County of Hampden, as indicated by hatching on plan hereunder.—(M.210⁽²⁾) (Rs.2194).

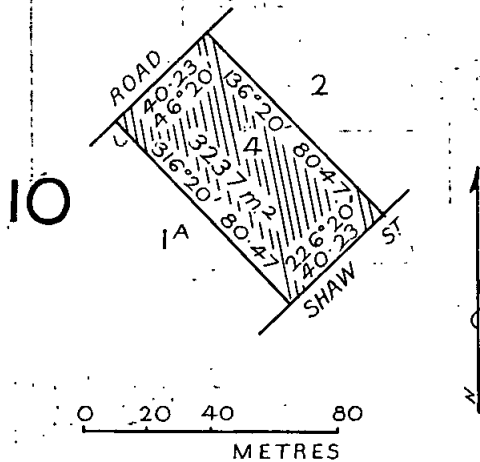

WHISKEY CREEK.—Site for Public purposes (Public Hall), 2024 square metres, being Crown allotment 31 section B, Township of Whiskey Creek, Parish of Drouin West, County of Buln Buln, as indicated by hatching on plan hereunder.—(W.433⁽²⁾) (Rs.9993).

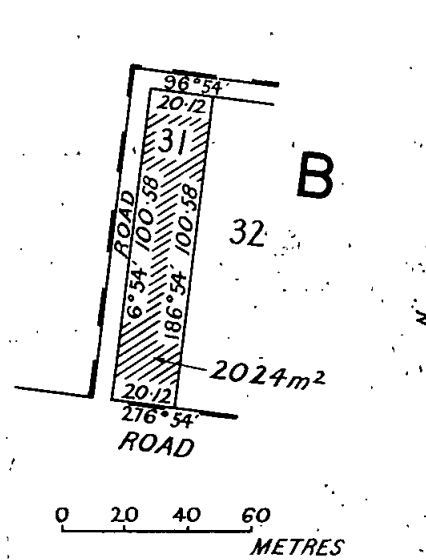

SOUTH HAMILTON.—Site for Public purposes (Racecourse and Recreation), 21.75 hectares, being Crown allotment 6 section 7, Parish of South Hamilton, County of Normandy, as indicated by hatching on plan hereunder.—(H.46⁽²⁾) (Rs.9994).

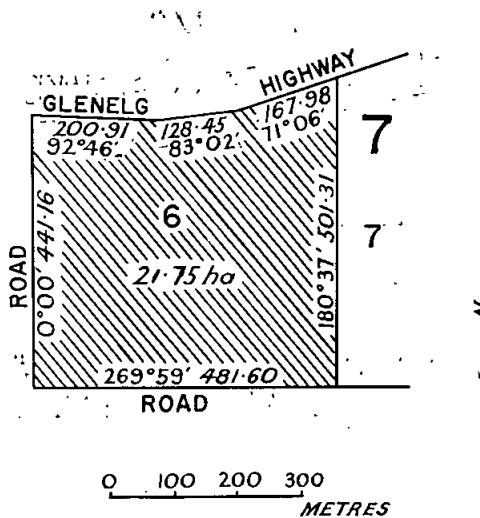

WILL-WILL-ROOK.—Site for Cemetery purposes, 1.28 hectares, being Crown allotment 4C, Parish of Will-will-rook, County of Bourke, as indicated by hatching on plan hereunder.—(W.151⁽²⁾) (Rs.8641).

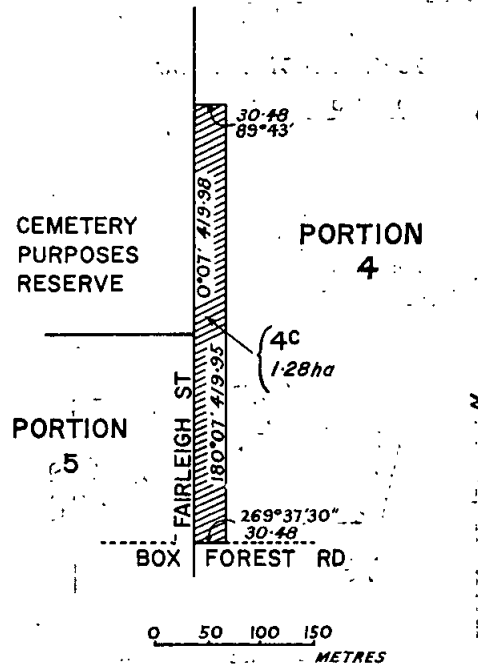

TOOLLEEN.—Site for Public purposes (State School Forest Plantation), 1.416 hectares, being Crown allotment 11 section 29, Township of Toolleen, Parish of Toolleen, County of Rodney, as indicated by hatching on plan hereunder.—(T.98⁽²⁾) (Rs.10009).

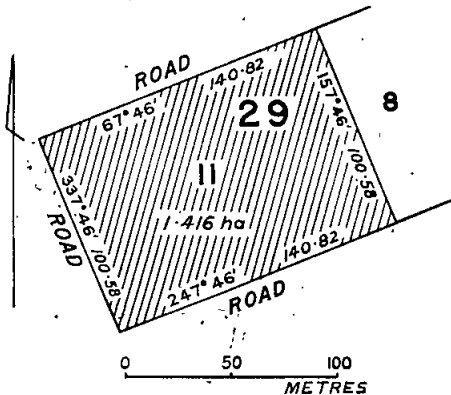

And the Honorable William Archibald Borthwick, Her Majesty's Minister of Lands for the State of Victoria, shall give the necessary directions herein accordingly.

TOM FORRISTAL,
Clerk of the Executive Council.

LOCAL GOVERNMENT DEPARTMENT.

At the Executive Council Chamber, Melbourne, the
fifteenth day of October, 1974.

PRESENT:

His Excellency the Governor of Victoria.
Mr. Rossiter | Mr. Rafferty
Mr. Smith | Mr. Granter.

ROAD DISCONTINUED.—CITY OF WILLIAMSTOWN.

Whereas it is provided in section 528 (2) of the *Local Government Act 1958*, that where a road (whether or not a public highway but not being a road set out on land of the Crown) or any part thereof is not required for public use, the Governor in Council on the request of the council of the municipality in which such road is situated made not less than one month after publishing in a newspaper generally circulating in the district and posting to the registered proprietor (if any) of the land and the owners and occupiers (if any) of lands abutting or immediately adjacent to the road notice of intention to make such request may by Order published in the *Government Gazette* direct that such road or part shall be discontinued and thereupon such road or part shall be discontinued accordingly.

And whereas the Council of the City of Williamstown has requested that a road off Ford Street, Newport be discontinued and not less than one month previously has published in a newspaper generally circulating in the district and posted to the registered proprietor of the land in the road and to the owners and occupiers of the lands abutting or immediately adjacent to the said road notice of intention to make such request.

Now therefore, His Excellency the Governor of the State of Victoria, by and with the advice of the Executive Council thereof hereby directs:

- (a) that the said road, which is shown by hachure on the plan hereunder, shall be discontinued;
- (b) that notwithstanding such discontinuance the Melbourne and Metropolitan Board of Works shall continue to have and possess the same right title power authority or interest in or in relation to the whole of the land shown by hachure on the said plan as it had or possessed prior to such discontinuance with respect to or in connection with any drains or pipes laid or erected in on or over such lands for the purposes of drainage or sewerage; and
- (c) that, subject to any such rights title power authority or interest, the land in the said road may be sold by the Council of the City of Williamstown by agreement.

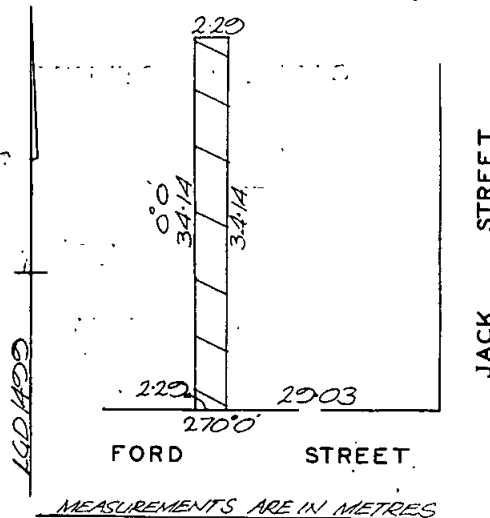

And the Honorable Alan John Hunt, Her Majesty's Minister for Local Government for the State of Victoria, shall give the necessary directions herein accordingly.

TOM FORRISTAL,
Clerk of the Executive Council.

LOCAL GOVERNMENT DEPARTMENT.

At the Executive Council Chamber, Melbourne, the
fifteenth day of October, 1974.

PRESENT:

His Excellency the Governor of Victoria.
Mr. Rossiter | Mr. Rafferty
Mr. Smith | Mr. Granter.

ROAD DISCONTINUED.—CITY OF FOOTSCRAY.

Whereas it is provided in section 528 (2) of the *Local Government Act 1958*, that where a road (whether or not a public highway but not being a road set out on land of the Crown) or any part thereof is not required for public use, the Governor in Council on the request of the council of the municipality in which such road is situated made not less than one month after publishing in a newspaper generally circulating in the district and posting to the registered proprietor (if any) of the land and the owners and occupiers (if any) of lands abutting or immediately adjacent to the road notice of intention to make such request may by Order published in the *Government Gazette* direct that such road or part shall be discontinued and thereupon such road or part shall be discontinued accordingly.

And whereas the Council of the City of Footscray has requested that the Governor in Council direct that a road between Francis and Taylor Streets, Footscray be discontinued and not less than one month previously has published in a newspaper generally circulating in the district and posted to the registered proprietor of the land in the road and to the owners and occupiers of land abutting or immediately adjacent to the road notice of intention to make such request.

Now therefore, His Excellency the Governor of the State of Victoria, by and with the advice of the Executive Council thereof, hereby directs:

- (a) that the said road which is shown by hachure and cross-hachure on the plan hereunder shall be discontinued;
- (b) that notwithstanding such discontinuance the Melbourne and Metropolitan Board of Works shall continue to have and possess the same right title power authority or interest in or in relation to the whole of the land shown by cross-hachure on the said plan as it had or possessed prior to such discontinuance with respect to or in connection with any drains or pipes laid or erected in on or over such lands for the purposes of drainage or sewerage; and
- (c) that subject to any such right title power authority or interest, the land in the said road may be sold by the Council of the City of Footscray by agreement.

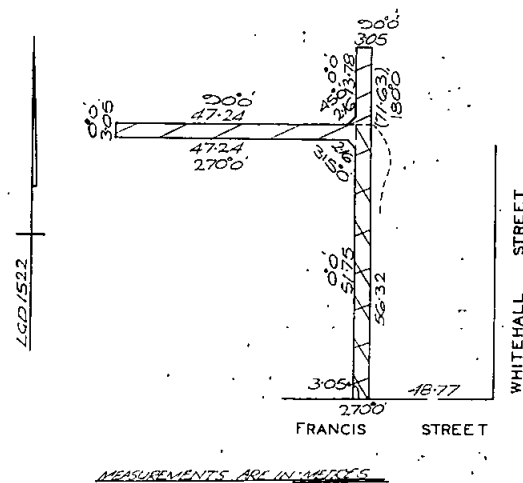

And the Honorable Alan John Hunt, Her Majesty's Minister for Local Government for the State of Victoria, shall give the necessary directions herein accordingly.

TOM FORRISTAL,
Clerk of the Executive Council.

LOCAL GOVERNMENT DEPARTMENT.

At the Executive Council Chamber, Melbourne, the
fifteenth day of October, 1974.

PRESENT:

His Excellency the Governor of Victoria.	
Mr. Rossiter	Mr. Rafferty
Mr. Smith	Mr. Granter.

APPROVAL OF RATING AGREEMENT BETWEEN THE
BOROUGH OF EAGLEHAWK AND CLARKE'S
CRUSHING WORKS.

Whereas:

- (a) Clarkes Crushing Works is liable to be rated in respect of certain land, in the Parish of Nerring and uses the said land for industrial purposes which land is not within the metropolitan area within the meaning of the *Town and Country Planning Act 1961*;
- (b) The Council of the Borough of Eaglehawk is of the opinion that the establishment and maintenance of the industry within the municipality will make a substantial contribution to the industrial development of the municipality and encourages decentralization of industry in Victoria; and
- (c) The Mayor, Councillors and Burgesses of the Council of the Borough of Eaglehawk and the Clarkes Crushing Works on the 21st June, 1973, entered into an agreement in respect of the above described land as to the amount of rates that will be payable thereon by the said Company under the *Local Government Act 1958* and a copy of such agreement has been submitted to the Minister for Local Government.

Now therefore, His Excellency the Governor of the State of Victoria, by and with the advice of the Executive Council thereof, and in pursuance of the provisions of section 811BA of the *Local Government Act 1958* hereby approves the said agreement.

And the Honorable Alan John Hunt, Her Majesty's Minister for Local Government for the State of Victoria, shall give the necessary directions herein accordingly.

TOM FORRISTAL,
Clerk of the Executive Council.

LOCAL GOVERNMENT DEPARTMENT.

At the Executive Council Chamber, Melbourne, the
fifteenth day of October, 1974.

PRESENT:

His Excellency the Governor of Victoria.	
Mr. Rossiter	Mr. Rafferty
Mr. Smith	Mr. Granter.

ROAD DISCONTINUED.—CITY OF PRAHRAN.

Whereas it is provided in section 528 (2) of the *Local Government Act 1958*, that where a road (whether or not a public highway but not being a road set out on land of the Crown) or any part thereof is not required for public use, the Governor in Council on the request of the council of the municipality in which such road is situated made not less than one month after publishing in a newspaper generally circulating in the district and posting to the registered proprietor (if any) of the land and the owners and occupiers (if any) of lands abutting or immediately adjacent to the road notice of intention to make such request may by Order published in the *Government Gazette* direct that such road or part shall be discontinued and thereupon such road or part shall be discontinued accordingly.

And whereas the Council of the City of Prahran has requested that the Governor in Council direct that a portion of a road off Cassell Street, South Yarra be discontinued and not less than one month previously has published in a newspaper generally circulating in the district and posted to the registered proprietor (if any) of the land in the portion of road and to the owners and occupiers (if any) of land abutting or immediately adjacent to the portion of road notice of intention to make such request.

Now therefore, His Excellency the Governor of the State of Victoria, by and with the advice of the Executive Council thereof hereby directs:

- (a) that the said portion of road which is shown by hachure on the plan hereunder, shall be discontinued;
- (b) that notwithstanding such discontinuance the Melbourne and Metropolitan Board of Works shall continue to have and possess the same right title power authority or interest in or in relation to the whole of the land shown by hachure on the said plan as it had or possessed prior to such discontinuance with respect to or in connection with any drains or pipes laid or erected in on or over such lands for the purposes of drainage or sewerage; and.
- (c) that subject to any such right title power authority or interest, the land in the said road may be sold by the Council of the City of Prahran by agreement.

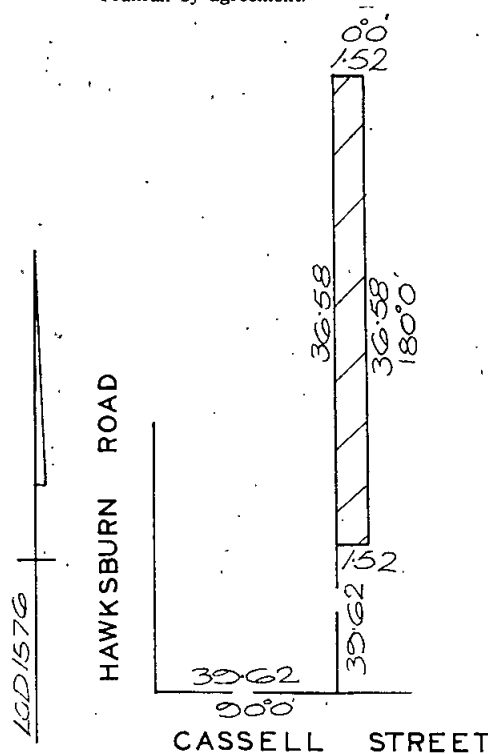

MEASUREMENTS ARE IN METRES

And the Honorable Alan John Hunt, Her Majesty's Minister for Local Government for the State of Victoria, shall give the necessary directions herein accordingly.

TOM FORRISTAL,
Clerk of the Executive Council.

LOCAL GOVERNMENT DEPARTMENT.

At the Executive Council Chamber, Melbourne, the
fifteenth day of October, 1974.

PRESENT:

His Excellency the Governor of Victoria.	
Mr. Rossiter	Mr. Rafferty
Mr. Smith	Mr. Granter.

ROAD DISCONTINUED.—SHIRE OF CORIO.

Whereas it is provided in section 528 (2) of the *Local Government Act 1958*, that where a road (whether or not a public highway but not being a road set out on land of the Crown) or any part thereof is not required for public use the Governor in Council on the request of the

council of the municipality in which such a road is situated made not less than one month after publishing in a newspaper generally circulating in the district and posting to the registered proprietor (if any) of the land and the owners and occupiers (if any) of the lands abutting or immediately adjacent to the road notice of intention to make such a request may by Order published in the *Government Gazette* direct that such road or part shall be discontinued and thereupon such road or part shall be discontinued accordingly.

And whereas the Council of the Shire of Corio has requested that the Governor in Council direct that a road off Wesley Court, Corio, be discontinued and not less than one month previously has published in a newspaper generally circulating in the district and posted to the registered proprietor of the land in the road and to the owners and occupiers of lands abutting or immediately adjacent to the road notice of intention to make such request.

Now therefore, His Excellency the Governor of the State of Victoria, by and with the advice of the Executive Council thereof hereby directs that the said road, which is shown by hachure on the plan hereunder shall be discontinued and that the land may be sold by the Council of the Shire of Corio by agreement.

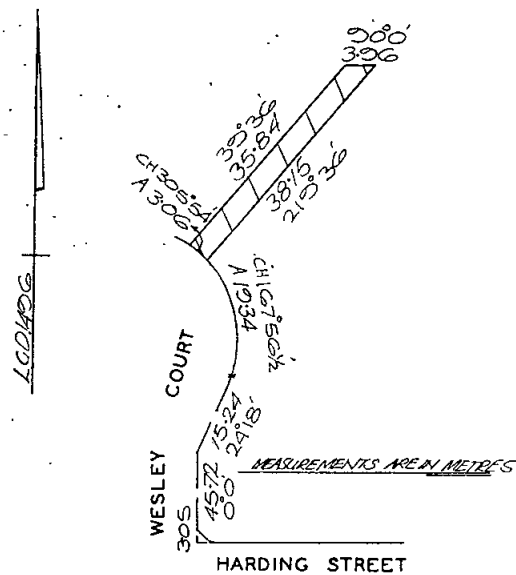

And the Honorable Alan John Hunt, Her Majesty's Minister for Local Government for the State of Victoria, shall give the necessary directions herein accordingly.

TOM FORRISTAL,
Clerk of the Executive Council.

LOCAL GOVERNMENT DEPARTMENT.

At the Executive Council Chamber, Melbourne, the
fifteenth day of October, 1974.

PRESENT:

His Excellency the Governor of Victoria.
 Mr. Rossiter | Mr. Rafferty
 Mr. Smith | Mr. Granter.

ROAD DISCONTINUED.—SHIRE OF CORIO.

Whereas it is provided in section 528 (2) of the *Local Government Act 1958*, that where a road (whether or not a public highway but not being a road set out on land of the Crown) or any part thereof is not required for public use the Governor in Council on the request of the council of the municipality in which such road is situated made not less than one month after publishing in a newspaper generally circulating in the district and posting to the registered proprietor (if any) of the land and to the owners and occupiers (if any) of the lands abutting or immediately adjacent to the road notice of intention

to make such request may by Order published in the *Government Gazette* direct that such road or part shall be discontinued and thereupon such road or part shall be discontinued accordingly.

And whereas the Council of the Shire of Corio has requested that the Governor in Council direct that a road off The Centreway, Norlane, be discontinued and not less than one month previously has published in a newspaper generally circulating in the district and posted to the registered proprietor of the land in the road and to the owners and occupiers of lands abutting or immediately adjacent to the road notice of intention to make such request.

Now therefore, His Excellency the Governor of the State of Victoria, by and with the advice of the Executive Council thereof, hereby directs:—

- (a) that the said road which is shown by hachure and cross-hachure on the plan hereunder shall be discontinued;
- (b) that notwithstanding such discontinuance the Geelong Waterworks and Sewerage Trust shall continue to have and possess the same right title power authority or interest in or in relation to the land shown by cross-hachure on the said plan as it had or possessed prior to such discontinuance with respect to or in connection with any drains or pipes laid or erected in on or over such land for the purposes of drainage or sewerage.
- (c) that subject to any such right title power authority or interest, the land in the said road may be sold by the Council of the Shire of Corio by agreement.

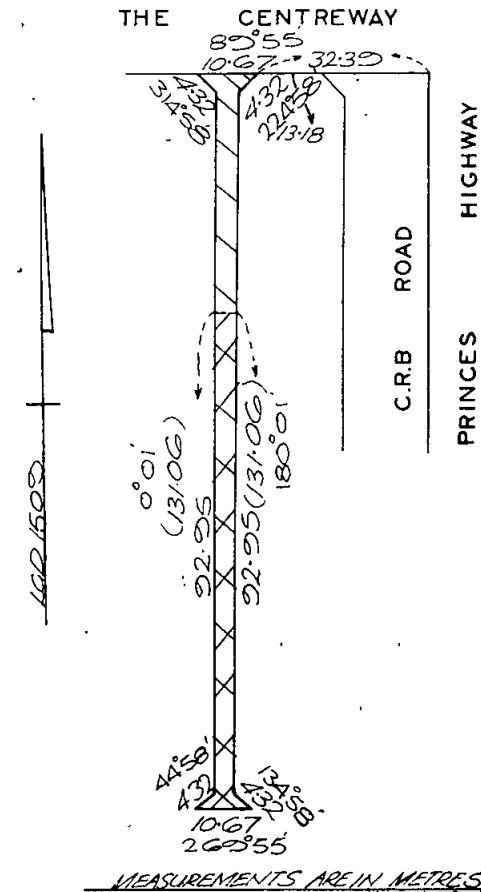

And the Honorable Alan John Hunt, Her Majesty's Minister for Local Government for the State of Victoria, shall give the necessary directions herein accordingly.

TOM FORRISTAL,
Clerk of the Executive Council.

And whereas the Council of the City of Footscray has requested that the Governor in Council direct that a road between Tarrengower and Ovens Streets Yarraville be discontinued and not less than one month previously has published in a newspaper generally circulating in the district and posted to the registered proprietor of the land in the road and to the owners and occupiers of lands abutting or immediately adjacent to the road notice of intention to make such request.

Now therefore, His Excellency the Governor of the State of Victoria, by and with the advice of the Executive Council thereof hereby directs:

- (a) that the said road, which is shown by hachure on the plan hereunder, shall be discontinued.
- (b) that notwithstanding such discontinuance the Melbourne and Metropolitan Board of Works shall continue to have and possess the same right title power authority or interest in or in relation to the whole of the land shown by hachure as it had or possessed, prior to such discontinuance with respect to or in connection with any drains or pipes laid or erected in on or over such land for the purposes of drainage or sewerage; and
- (c) that subject to any such right title power authority or interests, the land in the said road may be sold by the Council of the City of Footscray by agreement.

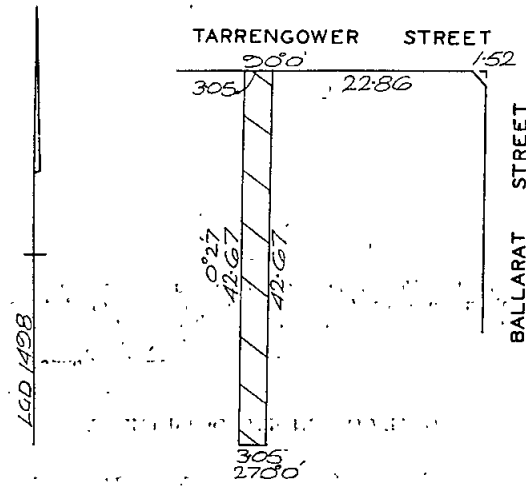

MEASUREMENTS ARE IN METRES

And the Honorable Alan John Hunt, Her Majesty's Minister for Local Government for the State of Victoria, shall give the necessary directions herein accordingly.

TOM FORRISTAL,
Clerk of the Executive Council.

LOCAL GOVERNMENT DEPARTMENT.

At the Executive Council Chamber, Melbourne, the fifteenth day of October, 1974.

PRESENT:

His Excellency the Governor of Victoria.
Mr. Rossiter | Mr. Rafferty
Mr. Smith | Mr. Granter.

ROAD DISCONTINUED.—CITY OF NORTHCOTE.

Whereas it is provided in section 528 (2) of the Local Government Act 1958, that where a road (whether or not a public highway but not being a road set out on land of the Crown) or any part thereof is not required for public use, the Governor in Council on the request of the council of the municipality in which such road is situated made not less than one month after publishing in a newspaper generally circulating in the district and posting to the registered proprietor (if any) of the land and the owners and occupiers (if any) of lands abutting or immediately

adjacent to the road notice of intention to make such a request may by Order published in the *Government Gazette* direct that such road or part shall be discontinued accordingly.

And whereas the Council of the City of Northcote has requested that the Governor in Council direct that portion of Perry Street, Fairfield be discontinued and not less than one month previously, has published in a newspaper generally circulating in the district and posted to the registered proprietor of the land in the portion of road and to the owners and occupiers of lands abutting or immediately adjacent to the portion of road notice of intention to make such request.

Now therefore, His Excellency the Governor of the State of Victoria, by and with the advice of the Executive Council thereof, hereby directs that the said portion of road which is shown by hachure on the plan hereunder shall be discontinued and that the land may be sold by the Council of the City of Northcote by agreement.

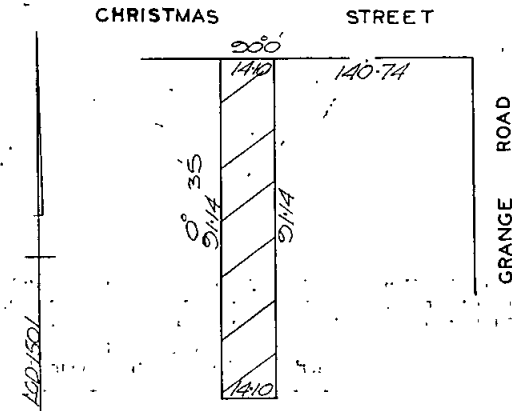

MEASUREMENTS ARE IN METRES

And the Honorable Alan John Hunt, Her Majesty's Minister for Local Government for the State of Victoria, shall give the necessary directions herein accordingly.

TOM FORRISTAL,
Clerk of the Executive Council.

LOCAL GOVERNMENT DEPARTMENT.

At the Executive Council Chamber, Melbourne, the fifteenth day of October, 1974.

PRESENT:

His Excellency the Governor of Victoria.
Mr. Rossiter | Mr. Rafferty
Mr. Smith | Mr. Granter.

ROADS DISCONTINUED.—CITY OF MELBOURNE.

Whereas it is provided in section 528 (2) of the Local Government Act 1958, that where a road (whether or not a public highway but not being a road set out on land of the Crown) or any part thereof is not required for public use, the Governor in Council on the request of the council of the municipality in which such road is situated made not less than one month after publishing in a newspaper generally circulating in the district and posting to the registered proprietor (if any) of the land and the owners and occupiers (if any) of the lands abutting or immediately adjacent to the road notice of intention to make such request may by Order published in the *Government Gazette* direct that such road or part shall be discontinued and thereupon such road or part shall be discontinued accordingly.

And whereas the Council of the City of Melbourne has requested that the Governor in Council direct that a portion of Hetford Place, Melbourne be discontinued and not less than one month previously has published in a newspaper generally circulating in the district and posted to the registered proprietor of the land in the portion of road and to the owners and occupiers of land abutting or immediately adjacent to the portion of road notice of intention to make such request.

Now therefore, His Excellency the Governor of the State of Victoria, by and with the advice of the Executive Council thereof, hereby directs that the said portion of road shown by hachure on the plan hereunder shall be discontinued and that the land in the portion of road may be sold by the Council of the City of Melbourne by agreement.

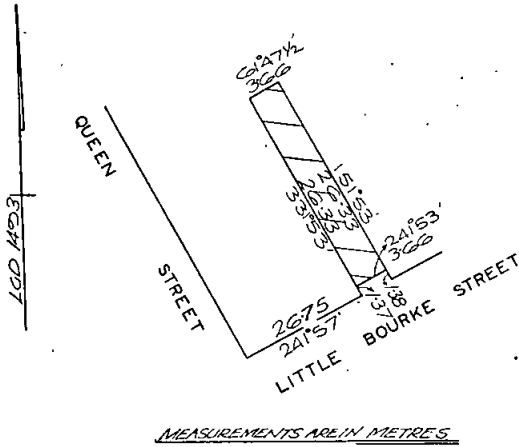

And the Honorable Alan John Hunt, Her Majesty's Minister for Local Government for the State of Victoria, shall give the necessary directions herein accordingly.

TOM FORRISTAL,
Clerk of the Executive Council.

LOCAL GOVERNMENT DEPARTMENT.

At the Executive Council Chamber, Melbourne, the fifteenth day of October, 1974.

PRESENT:

His Excellency the Governor of Victoria.
Mr. Rossiter | Mr. Rafferty
Mr. Smith | Mr. Granter.

ROAD DISCONTINUED.—CITY OF COBURG.

Whereas it is provided in section 528 (2) of the Local Government Act 1958, that where a road (whether or not a public highway but not being a road set out on land of the Crown) or any part thereof is not required for public use the Governor in Council on the request of the council of the municipality in which such road is situated made not less than one month after publishing in a newspaper generally circulating in the district and posting to the registered proprietor (if any) of the land and the owners and occupiers (if any) of lands abutting or immediately adjacent to the road notice of intention to make such request may by Order published in the Government Gazette direct that such road shall be discontinued and thereupon such road or part shall be discontinued accordingly.

And whereas the Council of the City of Coburg has requested that the Governor in Council direct that portions of Pallett Street, Coburg be discontinued and not less than one month previously has published in a newspaper generally circulating in the district and posted to the registered proprietors of the land in the portions of road and to the owners and occupiers of lands abutting or immediately adjacent to the portions of road notice of intention to make such request.

Now therefore, His Excellency the Governor of the State of Victoria, by and with the advice of the Executive Council thereof, hereby directs:

- (a) that the said portions of road which are shown by hachure and cross-hachure on the plan hereunder shall be discontinued;
- (b) that notwithstanding such discontinuance the Melbourne and Metropolitan Board of Works shall continue to have and possess the same right title power authority or interest in or in relation to the whole of the land shown by cross-hachure on the said plan as it had or possessed prior to such discontinuance with respect to

- or in connection with any drains or pipes laid or erected in, on or over such lands for the purposes of drainage or sewerage; and
- (c) that subject to any such right title power authority or interest, the land in the said portions of road may be sold by the Council of the City of Coburg by agreement.

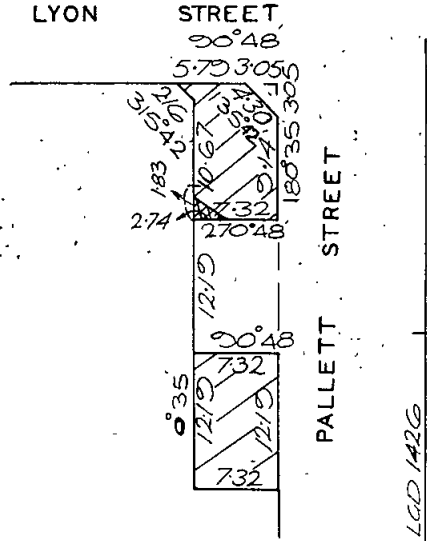

And the Honorable Alan John Hunt, Her Majesty's Minister for Local Government for the State of Victoria, shall give the necessary directions herein accordingly.

TOM FORRISTAL,
Clerk of the Executive Council.

LOCAL GOVERNMENT DEPARTMENT.

At the Executive Council Chamber, Melbourne, the fifteenth day of October, 1974.

PRESENT:

His Excellency the Governor of Victoria.
Mr. Rossiter | Mr. Rafferty
Mr. Smith | Mr. Granter.

ROAD DISCONTINUED.—CITY OF CAMBERWELL.

Whereas it is provided in section 528 (2) of the Local Government Act 1958, that where a road (whether or not a public highway but not being a road set out on land of the Crown) or any part thereof is not required for public use the Governor in Council on the request of the council of the municipality in which such road is situated made not less than one month after publishing in a newspaper generally circulating in the district and posting to the registered proprietor (if any) of the land and the owners and occupiers (if any) of the lands abutting or immediately adjacent to the road notice of intention to make such request may by Order published in the Government Gazette direct that such road or part shall be discontinued and thereupon such road or part shall be discontinued accordingly.

And whereas the Council of the City of Camberwell has requested that the Governor in Council direct that a road off Station Street, Camberwell be discontinued and not less than one month previously has published in a newspaper generally circulating in the district and posted to the registered proprietor of the land in the road and to the owners and occupiers of land abutting or immediately adjacent to the road notice of intention to make such request.

Now therefore, His Excellency the Governor of the State of Victoria, by and with the advice of the Executive Council thereof, hereby directs:

- (a) that the said road which is shown by hachure and cross-hachure on the plan hereunder shall be discontinued;
- (b) that notwithstanding such discontinuance the Melbourne and Metropolitan Board of Works shall continue to have and possess the same right title power authority or interest in or in relation to the whole of the land shown by hachure and cross-hachure on the said plan as it had or possessed prior to such discontinuance with respect to or in connection with any drains or pipes laid or erected in on or over such lands for the purposes of drainage or sewerage; and
- (c) that subject to any such right title power authority or interest, the land in the road shown by cross-hachure may be sold by the council of the City of Camberwell by agreement and the land in the road shown by hachure shall be retained by the Council of the City of Camberwell for municipal purposes.

PROSPECT HILL ROAD

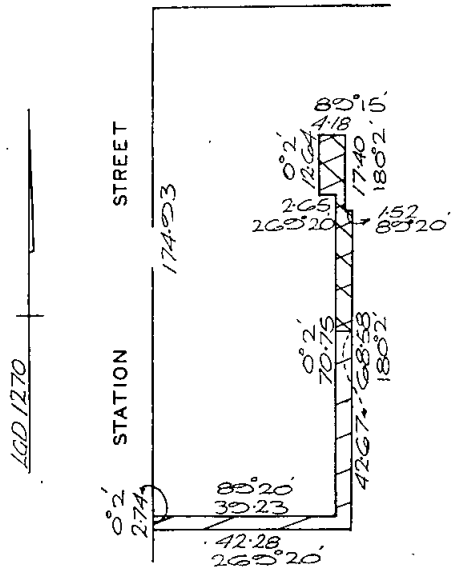

MEASUREMENTS ARE IN METRES

And the Honorable Alan John Hunt, Her Majesty's Minister for Local Government for the State of Victoria, shall give the necessary directions herein accordingly.

TOM FORRISTAL,
Clerk of the Executive Council.

LOCAL GOVERNMENT DEPARTMENT.

At the Executive Council Chamber, Melbourne, the fifteenth day of October, 1974.

PRESENT:

His Excellency the Governor of Victoria.
Mr. Rossiter | Mr. Rafferty
Mr. Smith | Mr. Granter.

ROADS DISCONTINUED.—CITY OF FOOTSCRAY.

Whereas it is provided in section 528 (2) of the Local Government Act 1958, that where a road (whether or not a public highway but not being a road set out on land of the Crown) or any part thereof is not required for public use, the Governor in Council on the request of the council of the municipality in which such road is situated made not less than one month after publishing in a newspaper generally circulating in the district and posting to the registered proprietor (if any) of the land and the owners and occupiers (if any) of lands abutting or immediately adjacent to the road notice of intention to make such request may by Order published in the Government Gazette

direct that such road or part shall be discontinued and thereupon such road or part shall be discontinued accordingly.

And whereas the Council of the City of Footscray has requested that roads at the rear of properties abutting Barton, Hope and Essex Streets, Footscray be discontinued and not less than one month previously has published in a newspaper generally circulating in the district and posted to the registered proprietor of the land in the roads and to the owners and occupiers of the lands abutting or immediately adjacent to the said roads notice of intention to make such request.

Now therefore, His Excellency the Governor of the State of Victoria, by and with the advice of the Executive Council thereof, hereby directs:

- (a) that the said roads, which are shown by hachure on the plan hereunder, shall be discontinued;
- (b) that notwithstanding such discontinuance the Melbourne and Metropolitan Board of Works shall continue to have and possess the same right title power authority or interest in or in relation to the whole of the land shown by hachure on the said plan as it had or possessed prior to such discontinuance with respect to or in connection with any drains or pipes laid or erected in on or over such lands for the purposes of drainage or sewerage; and
- (c) that, subject to any such rights title power authority or interest, the land in the said roads may be sold by the Council of the City of Footscray by agreement.

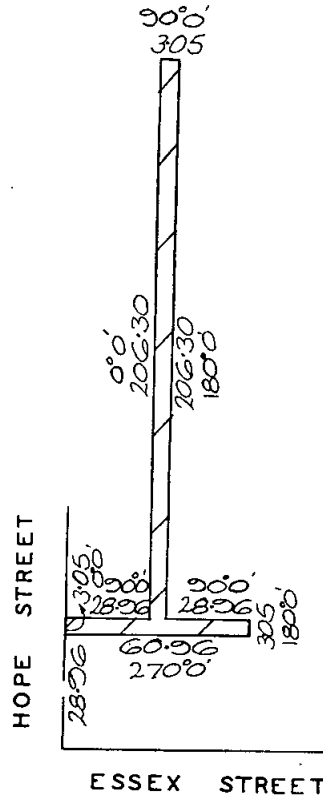

MEASUREMENTS ARE IN METRES

And the Honorable Alan John Hunt, Her Majesty's Minister for Local Government for the State of Victoria, shall give the necessary directions herein accordingly.

TOM FORRISTAL,
Clerk of the Executive Council.

LOCAL GOVERNMENT DEPARTMENT

At the Executive Council Chamber, Melbourne, the
fifteenth day of October, 1974.

PRESENT:

His Excellency the Governor of Victoria.
Mr. Rossiter Mr. Rafferty
Mr. Smith Mr. Granter.

ALTERATION OF TIME FOR CLOSING POLL AT
MUNICIPAL ELECTIONS.—SHIRE OF GOULBURN.

His Excellency the Governor of the State of Victoria, by and with the advice of the Executive Council thereof, in pursuance of the powers conferred by section 134 of the Local Government Act 1958, and in compliance with the prayer of a petition presented by the Council of the Shire of Goulburn, hereby declares that the hour for closing the poll at municipal elections for the said Shire shall be seven o'clock in the afternoon.

And the Honorable Alan John Hunt, Her Majesty's Minister for Local Government for the State of Victoria, shall give the necessary directions herein accordingly.

TOM FORRISTAL,
Clerk of the Executive Council.

LOCAL GOVERNMENT DEPARTMENT

At the Executive Council Chamber, Melbourne, the
fifteenth day of October, 1974.

PRESENT:

His Excellency the Governor of Victoria.
Mr. Rossiter Mr. Rafferty
Mr. Smith Mr. Granter.

ROAD DISCONTINUED.—CITY OF OAKLEIGH.

Whereas it is provided in section 528 (2) of the Local Government Act 1958; that where a road (whether or not a public highway but not being a road set out on land of the Crown) or any part thereof is not required for public use, the Governor in Council on the request of the council of the municipality in which such road is situated made not less than one month after publishing in a newspaper generally circulating in the district and posting to the registered proprietor (if any) of the land and the owners and occupiers (if any) of lands abutting or immediately adjacent to the road, notice of intention to make such request may by Order published in the Government Gazette direct that such road or part shall be discontinued and thereupon such road or part shall be discontinued accordingly.

And whereas the Council of the City of Oakleigh has requested that the Governor in Council direct that a portion of a road off Dunstan Street, Oakleigh, be discontinued and not less than one month previously has published in a newspaper generally circulating in the district and posted to the registered proprietor (if any) of the land in the portion of road and to the owners and occupiers (if any) of land abutting or immediately adjacent to the portion of road notice of intention to make such request.

Now therefore, His Excellency the Governor of the State of Victoria, by and with the advice of the Executive Council thereof hereby directs:

- (a) that the said portion of road which is shown by hachure and cross-hachure on the plan hereunder, shall be discontinued;
- (b) that notwithstanding such discontinuance the Melbourne and Metropolitan Board of Works shall continue to have and possess the same right title power authority or interest in or in relation to the whole of the land shown by hachure and cross-hachure on the said plan as it had or possessed prior to such discontinuance with respect to or in connection with any drains or pipes laid or erected in on or over such lands for the purposes of drainage or sewerage and;
- (c) that notwithstanding such discontinuance the Gas and Fuel Corporation of Victoria shall continue to have and possess the same right title power authority or interest in or in relation to the whole of the land shown by cross-hachure on the said plan as it had or possessed prior to such discontinuance with respect to or in con-

nection with any pipes, fixtures or fittings laid or erected in on or over such land for the purposes of the supply of gas; and

- (d) that subject to any such right title power authority or interest, the land in the said road shall be retained by the Council of the City of Oakleigh for municipal purposes.

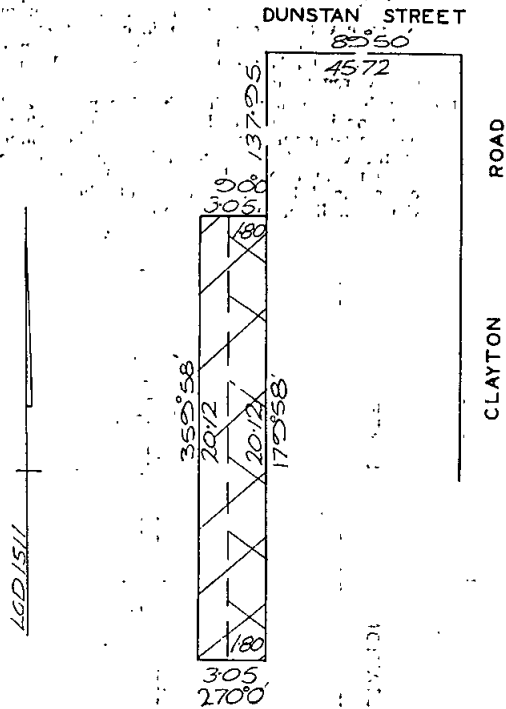

MEASUREMENTS ARE IN METRES

And the Honorable Alan John Hunt, Her Majesty's Minister for Local Government for the State of Victoria, shall give the necessary directions herein accordingly.

TOM FORRISTAL,
Clerk of the Executive Council.

LOCAL GOVERNMENT DEPARTMENT

At the Executive Council Chamber, Melbourne, the
fifteenth day of October, 1974.

PRESENT:

His Excellency the Governor of Victoria.
Mr. Rossiter Mr. Rafferty
Mr. Smith Mr. Granter.

ROAD DISCONTINUED.—CITY OF RICHMOND.

Whereas it is provided in section 528 (2) of the Local Government Act 1958, that where a road (whether or not a public highway but not being a road set out on land of the Crown) or any part thereof is not required for public use the Governor in Council on the request of the council of the municipality in which such road is situated made not less than one month after publishing in a newspaper generally circulating in the district and posting to the registered proprietor (if any) of the land and to the owners and occupiers (if any) of the lands abutting or immediately adjacent to the road notice of intention to make such request may by Order published in the Government Gazette direct that such road or part shall be discontinued and thereupon such road or part shall be discontinued accordingly.

And whereas the Council of the City of Richmond has requested that the Governor in Council direct that a road off Carroll Street, Richmond be discontinued and not less than one month previously has published in a newspaper generally circulating in the district and posted to the

registered proprietor of the land in the road and to the owners and occupiers of lands abutting or immediately adjacent to the road notice of intention to make such request.

Now therefore, His Excellency the Governor of the State of Victoria, by and with the advice of the Executive Council, thereof, hereby directs that the said road which is the land coloured brown on the map in the margin of certificate of title, volume 5088, folio 516, shall be discontinued and that the land may be sold by the Council of the City of Richmond by agreement.

And the Honorable Alan John Hunt, Her Majesty's Minister for Local Government for the State of Victoria, shall give the necessary directions herein accordingly.

TOM FORRISTAL,
Clerk of the Executive Council.

HOSPITALS AND CHARITIES ACT 1958, SECTION 52.

At the Executive Council Chamber, Melbourne, the
fifteenth day of October, 1974.

PRESENT:

His Excellency the Governor of Victoria.
Mr. Rossiter | Mr. Rafferty
Mr. Smith | Mr. Granter.

EXTENSION OF THE OBJECTS OR PURPOSES OF
WEST GIPPSLAND HOSPITAL.

Whereas West Gippsland Hospital is an incorporated institution within the meaning of the Hospitals and Charities Act 1958;

And whereas the Board of Management of the said institution has agreed that the objects or purposes of the said institution should be extended;

And whereas the Hospitals and Charities Commission after enquiry has recommended that the objects or purposes should be extended;

Now therefore His Excellency the Governor of the State of Victoria, by and with the advice of the Executive Council of the said State, and by virtue of the powers conferred on him by Section 52 of the Hospitals and Charities Act 1958, and all other powers enabling him in that behalf, hereby extends the objects or purposes of West Gippsland Hospital by adding the following:—

"(d) To provide facilities for the training of nurses."

And the Honorable Alan Henry Scanlan, Her Majesty's Minister of Health for the State of Victoria, shall give the necessary directions herein accordingly.

TOM FORRISTAL,
Clerk of the Executive Council.

HOSPITALS AND CHARITIES ACT 1958, SECTION 52.

At the Executive Council Chamber, Melbourne, the
fifteenth day of October, 1974.

PRESENT:

His Excellency the Governor of Victoria.
Mr. Rossiter | Mr. Rafferty
Mr. Smith | Mr. Granter.

EXTENSION OF THE OBJECTS OR PURPOSES OF
KYNETON DISTRICT HOSPITAL.

Whereas the Kyneton District Hospital is an incorporated institution within the meaning of the Hospitals and Charities Act 1958;

And whereas the Board of Management of the said institution has agreed that the objects or purposes of the said institution should be extended;

And whereas the Hospitals and Charities Commission after enquiry has recommended that the objects or purposes should be extended;

Now therefore His Excellency the Governor of the State of Victoria, by and with the advice of the Executive Council of the said State, and by virtue of the powers conferred on him by Section 52 of the Hospitals and Charities Act 1958,

and all other powers enabling him in that behalf, hereby extends the objects or purposes of Kyneton District Hospital by adding the following:—

"(c) To provide facilities for the training of nursing aides."

And the Honorable Alan Henry Scanlan, Her Majesty's Minister of Health for the State of Victoria, shall give the necessary directions herein accordingly.

TOM FORRISTAL,
Clerk of the Executive Council.

COUNTRY ROADS BOARD ACT No. 6229.

At the Executive Council Chamber, Melbourne, the
fifteenth day of October, 1974.

PRESENT:

His Excellency the Governor of Victoria.
Mr. Rossiter | Mr. Rafferty
Mr. Smith | Mr. Granter.

ORDER APPROVING OF LAND BEING ACQUIRED AND
ROADS, DEVIATIONS OR WIDENINGS BEING MADE
TOGETHER WITH ALL ANCILLARY WORKS
REQUIRED TO BE EXECUTED IN CONJUNCTION
THEREWITH.

His Excellency the Governor of the State of Victoria, by and with the advice of the Executive Council thereof, being satisfied that there are funds legally available for acquiring the land, doth hereby approve the acquiring of the land described in the schedule hereunder and the making of new roads and deviations from and widenings of existing roads, together with all ancillary works required to be executed in conjunction therewith, referred to in the said schedule.

SCHEDULE.

State Highways.

The land shown hatched on plan numbered G.P.13785 hereunder required for the widening of the Kiewa Valley Highway in the Shire of Bright and making of the widening thereon.

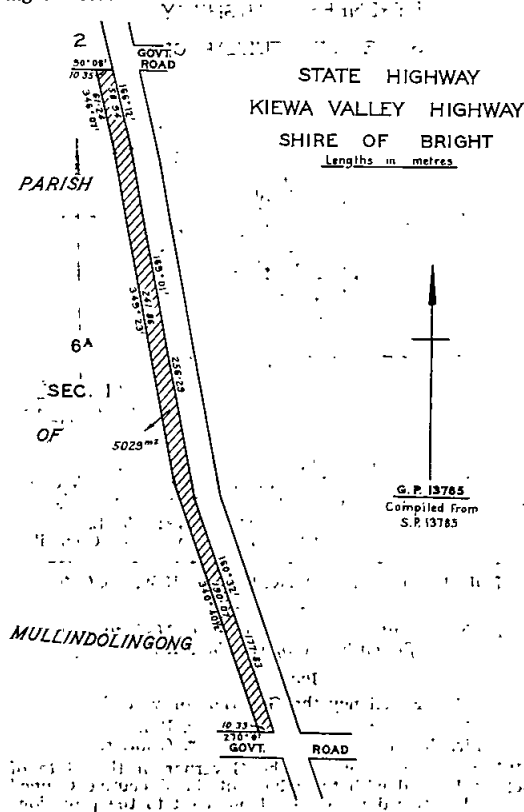

The land shown hatched on plans numbered G.P.13196E and G.P.13196F hereunder required for the deviation from the Pyrenees Highway in the Shire of Tullaroop and making of the deviation thereon.

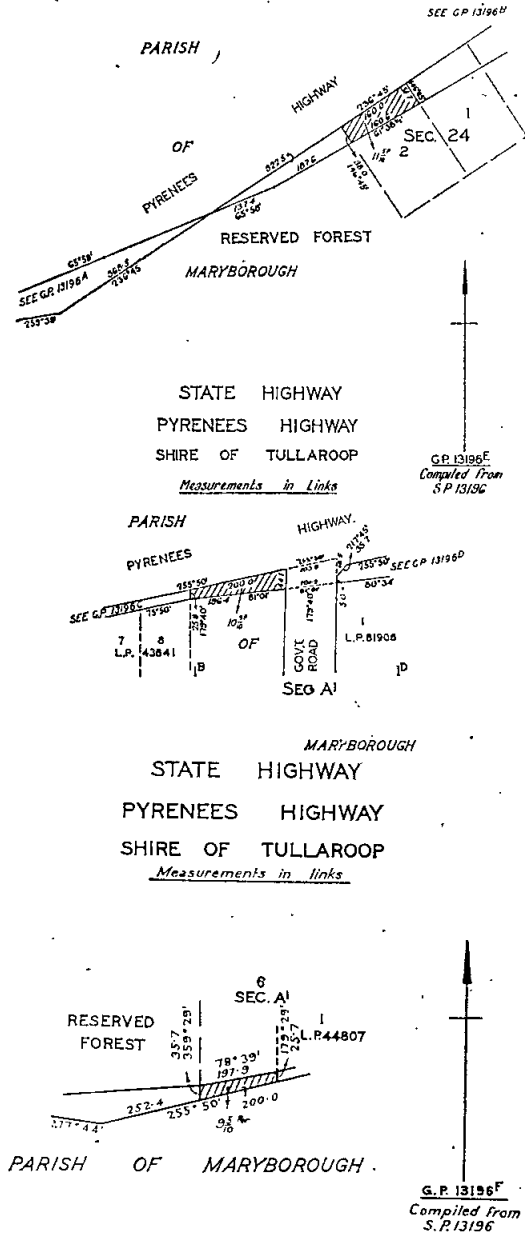

And the Honorable Edward Raymond Meagher, Her Majesty's Minister of Transport for the State of Victoria, shall give the necessary directions herein accordingly.

TOM FORRISTAL,
Clerk of the Executive Council.

PORTLAND HARBOR TRUST ACT 1958, No. 6340.

At the Executive Council Chamber, Melbourne, the fifteenth day of October, 1974.

PRESENT:

His Excellency the Governor of Victoria.

Mr. Rossiter | Mr. Rafferty
Mr. Smith | Mr. Granter.

Whereas His Excellency the Governor of the State of Victoria by and with the advice of the Executive Council thereof has this day consented pursuant to the provisions

of the Portland Harbor Trust Act 1958 to the Portland Harbor Trust Commissioners raising by way of a loan the sum of Two hundred and forty-five thousand dollars (\$245,000); and whereas the Governor in Council is satisfied that a sufficient proportion of the loan to be raised will fall due and be repaid in each year during the currency of the proposed loan; now therefore it is directed pursuant to the provisions of Section 33 (3) of the said Act, that it shall not be necessary to provide a sinking fund in connection with such loan.

And the Honorable Rupert James Hamer, Her Majesty's Treasurer for the State of Victoria, shall give the necessary directions herein accordingly.

TOM FORRISTAL,
Clerk of the Executive Council.

SUPERANNUATION ACT 1958.

At the Executive Council Chamber, Melbourne, the fifteenth day of October, 1974.

PRESENT:

His Excellency the Governor of Victoria.

Mr. Rossiter | Mr. Rafferty
Mr. Smith | Mr. Granter.

Pursuant to the powers conferred by the provisions of paragraph (ja) of sub-section (1) of Section 3 of the Superannuation Act 1958, His Excellency the Governor of the State of Victoria, by and with the advice of the Executive Council thereof, doth by this Order declare that the provisions of the Superannuation Act shall apply to Enid Jessie Hallister, being an officer of the State College of Victoria at Melbourne, constituted pursuant to the provisions of the Education Act 1958, No. 6240.

And the Honorable Rupert James Hamer, Her Majesty's Treasurer for the State of Victoria, shall give the necessary directions herein accordingly.

TOM FORRISTAL,
Clerk of the Executive Council.

SUPERANNUATION ACT 1958.

At the Executive Council Chamber, Melbourne, the fifteenth day of October, 1974.

PRESENT:

His Excellency the Governor of Victoria.

Mr. Rossiter | Mr. Rafferty
Mr. Smith | Mr. Granter.

Pursuant to the powers conferred by the provisions of paragraph (ja) of sub-section (1) of Section 3 of the Superannuation Act 1958, His Excellency the Governor of the State of Victoria, by and with the advice of the Executive Council thereof, doth by this Order declare that the provisions of the Superannuation Act shall apply to:—

JOHN CHARLES OOSTERMEYER,
BENJAMIN WILLIAM ROENNFELDT,
REGINALD JOHN HOGAN,
being officers of the State College of Victoria, Rusden, constituted pursuant to the provisions of the Education Act 1958, No. 6240.

And the Honorable Rupert James Hamer, Her Majesty's Treasurer for the State of Victoria, shall give the necessary directions herein accordingly.

TOM FORRISTAL,
Clerk of the Executive Council.

SUPERANNUATION ACT 1958.

At the Executive Council Chamber, Melbourne, the fifteenth day of October, 1974.

PRESENT:

His Excellency the Governor of Victoria.

Mr. Rossiter | Mr. Rafferty
Mr. Smith | Mr. Granter.

Pursuant to the powers conferred by the provisions of paragraph (ja) of sub-section (1) of Section 3 of the Superannuation Act 1958, His Excellency the Governor of

the State of Victoria, by and with the advice of the Executive Council thereof, doth by this Order declare that the provisions of the Superannuation Act shall apply to Alan Henry Winch, being an officer of the State College of Victoria at Hawthorn, constituted pursuant to the provisions of the Education Act 1958, No. 6240.

And the Honorable Rupert James Hamer, Her Majesty's Treasurer for the State of Victoria, shall give the necessary directions herein accordingly.

TOM FORRISTAL,
Clerk of the Executive Council.

WODONGA SEWERAGE AUTHORITY.

At the Executive Council Chamber, Melbourne, the
fifteenth day of October, 1974.

PRESENT:

His Excellency the Governor of Victoria.	
Mr. Rossiter	Mr. Rafferty
Mr. Smith	Mr. Granter.

EXTENT OF SEWERAGE DISTRICT INCREASED.

Under the powers conferred by the Sewerage Districts Act and all other powers enabling him in that behalf, His Excellency the Governor of the State of Victoria, by and with the advice of the Executive Council of the said State, doth hereby declare, order and direct that the extent of the Sewerage District of the Wodonga Sewerage Authority be increased by adding thereto the lands shown coloured red on the plan approved by the Governor in Council, by and with this Order and deposited in the office of the State Rivers and Water Supply Commission, Melbourne, (Corr. 73/3924/38), and as on and from the date hereof the extent of such district shall be deemed to be increased accordingly.

And the Honorable Frederick James Granter, Her Majesty's Minister of Water Supply for the State of Victoria, shall give the necessary directions herein accordingly.

TOM FORRISTAL,
Clerk of the Executive Council.

MENTAL HEALTH ACT 1959 (No. 6605).

At the Executive Council Chamber, Melbourne, the
fifteenth day of October, 1974.

PRESENT:

His Excellency the Governor of Victoria.	
Mr. Rossiter	Mr. Rafferty
Mr. Smith	Mr. Granter.

Pursuant to the provisions of Sections 5 and 6 of the Mental Health Act 1959 (No. 6605) and all other powers enabling him in that behalf, His Excellency the Governor of the State of Victoria, by and with the advice of the Executive Council of the said State, hereby appoints Dr. Alan Stoller, M.R.C.S., L.R.C.P., F.A.N.Z.C.P., D.P.M. as a Member and Chairman of the Mental Health Authority for the period from the 21st October, 1974 until the 25th May, 1976.

And the Honorable Alan Henry Scanlan, Her Majesty's Minister of Health for the State of Victoria, shall give the necessary directions herein accordingly.

TOM FORRISTAL,
Clerk of the Executive Council.

STATE RIVERS AND WATER SUPPLY COMMISSION.

At the Executive Council Chamber, Melbourne, the
twenty-second day of October, 1974.

PRESENT:

His Excellency the Governor of Victoria.	
Mr. Byrne	Mr. Meagher
Mr. Scanlan	Mr. Dixon.

APPOINTMENT OF AUDITORS.—AMENDMENT OF ORDER.

Under the powers conferred by the Sewerage Districts Act and all other powers enabling him in that behalf, His Excellency the Governor of the State of Victoria, by

and with the advice of the Executive Council of the said State, hereby amends as follows the Order in Council made on 4th September, 1973, appointing certain persons to audit and report upon the accounts of Sewerage Authorities for the years 1973 and 1974:—

For the name "K. W. Dixon" in column (3) opposite the name "Bendigo" in column (1) of the Schedule there shall be substituted the name "G. B. Hayward".

And the Honorable Frederick James Granter, Her Majesty's Minister of Water Supply for the State of Victoria, shall give the necessary directions herein accordingly.

TOM FORRISTAL,
Clerk of the Executive Council.

LABOUR AND INDUSTRY ACT 1958.

At the Executive Council Chamber, Melbourne, the
twenty-second day of October, 1974.

PRESENT:

His Excellency the Governor of Victoria.	
Mr. Byrne	Mr. Meagher
Mr. Scanlan	Mr. Dixon.

ALTERATION OF THE SHORT TITLE AND EXTENSION OF THE POWERS OF THE WIREWORKING (RYLANDS) BOARD AND VARIATION OF THE POWERS OF THE NAILMAKERS BOARD AND THE WIREWORKERS BOARD.

In pursuance of the powers conferred by section 20 of the Labour and Industry Act 1958, and all other powers him thereunto enabling, His Excellency the Governor of the State of Victoria, by and with the advice of the Executive Council thereof doth hereby—

1. Alter the short title of the Wireworking (Rylands) Wages Board so that it may be hereafter described as the Wireworking (Rylands and Nastan) Board.

2. Extend the powers of the Wireworking (Rylands and Nastan) Board so that in substitution for the powers heretofore conferred on the said Wireworking (Rylands and Nastan) Board it shall be appointed for the occupations of wire drawing and galvanizing, wire rope making and fence dropper making in the factory of Rylands Brothers (Australia) Pty. Ltd. situated in the Shire of Corio, and for the occupations associated with wire tyre cord making and the making of kindred products in the factory of Nastan (Australia) Pty. Ltd. also situated in the Shire of Corio.

3. Vary the powers of the Nailmakers Board so that in substitution for the powers heretofore conferred on the said Nailmakers Board it shall be appointed for any person (including storemen, packers and sorters) employed in the occupations of:—

- making nails;
- weaving wire-netting or barbed wire;
- galvanizing; and
- drawing wire—

but excluding any occupation subject to the Non-Ferrous Metals Board and the Wireworking (Rylands and Nastan) Board.

4. Vary the powers of the Wireworkers Board so that in substitution for the powers heretofore conferred on the said Wireworkers Board it shall be appointed for the occupations of wireworking, using six gauge or smaller wire, but excluding making wire-netting, barbed wire, wire nails, or wire mattresses, and excluding any occupation subject to the Wireworking (Rylands and Nastan) Board.

And the Honorable Joseph Anstice Rafferty, Her Majesty's Minister of Labour and Industry for the State of Victoria, shall give the necessary directions herein accordingly.

TOM FORRISTAL,
Clerk of the Executive Council.

LANDS DEPARTMENT NOTICES

APPROACHING LAND SALES.

Sale of Crown Land, in fee-simple, will be held at the under-mentioned places and dates, viz.:—

	No. of Gazette.
Red Cliffs.—Wednesday, 20th November, 1974	100
Swan Hill.—Wednesday, 6th November, 1974	95

PROPOSED REVOCATIONS OF TEMPORARY RESERVATIONS OF LANDS BY ORDERS IN COUNCIL.

In pursuance of the provisions of the Land Act 1958, notice is hereby given that it is the intention of the Governor in Council to revoke the temporary reservations of lands by Orders in Council hereunder referred to viz.:—

The following Notices were published 1° on the 16th October, 1974, pursuant to Orders of the 8th October, 1974.

LETHBRIDGE.—The temporary reservation by Order in Council of the 8th May, 1973, of 5.236 hectares (12 acres 3 roods 30 perches, more or less) of land in the Township of Lethbridge as a site for Recreation, Convenience and Amusement of the People is about to be revoked.—(L.50⁽¹⁾) (Rs.9737).

MALDON.—The temporary reservation by Order in Council of the 17th June, 1861, of 2023 square metres (2 roods) of land in the Township of Maldon as a site for Powder Magazine is about to be revoked.—(M.449⁽¹²⁾) (Rs.9875).

MERBEIN.—The temporary reservation by Order in Council of the 5th September, 1961, of 2175 square metres (2 roods 6 perches) of land in the Parish of Merbein as a site for State School purposes is about to be revoked.—(M.572⁽⁹⁾) (Rs.8066).

MIRBOO SOUTH.—The temporary reservation by Order in Council of the 23rd April, 1974, of 110 hectares, more or less, of land in the Parish of Mirboo South as a site for a Public Park is about to be revoked.—(M.517⁽¹⁰⁾) (Rs.9870).

OMEQ.—The temporary reservation by Order in Council of the 4th November, 1889, of certain unappropriated Crown land situate within a distance of 60.35 metres (3 chains) from the banks of the Livingstone Creek for the supply of Gravel and Sand, revoked as to part by various Orders, is about to be revoked so far only as the portion in the Parish of Omeo containing 2.5 hectares, more or less, indicated by hatching on plan hereunder, is concerned.—(O.19⁽¹⁹⁾) (C.86890).

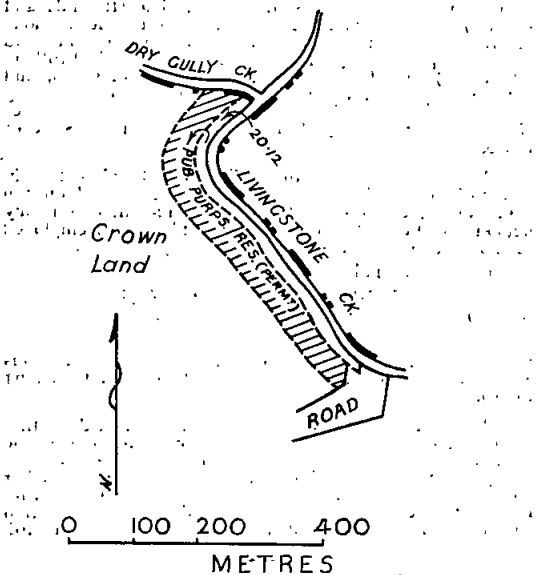

AREA OF HATCHED PORTION
2.5 ha ±

W. BORTHWICK,
Minister of Lands.

PROPOSED REVOCATIONS OF TEMPORARY RESERVATIONS OF LANDS BY ORDERS IN COUNCIL.

In pursuance of the provisions of the Land Act 1958, notice is hereby given that it is the intention of the Governor in Council to revoke the temporary reservations of lands by Orders in Council hereunder referred to, viz.:—

The following Notices were published 1° on the 2nd October, 1974, pursuant to Orders of the 25th September, 1974.

BULLEEN (DONCASTER EAST).—The temporary reservation by Order in Council of the 27th February, 1968, of 1568 square metres (1 rood 22 perches) of land in the Parish of Bulleen as a site for Public purposes (Public Buildings) is about to be revoked so far only as the portion containing 47 square metres indicated by hatching on plan hereunder is concerned.—(B.526⁽⁸⁾) (Rs.8931).

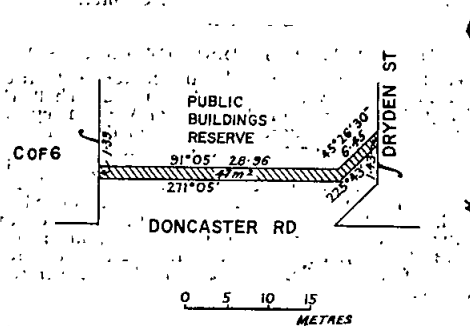

NHILL.—The temporary reservation by Order in Council of the 23rd April, 1974, of 3300 square metres, more or less, of land in the Township of Nhill as a site for Public purposes (Municipal Offices and Car Park), is about to be revoked so far only as the portion containing 37 square metres, more or less, indicated by hatching on plan hereunder, is concerned.—(N.102⁽⁴⁾) (Rs.9844).

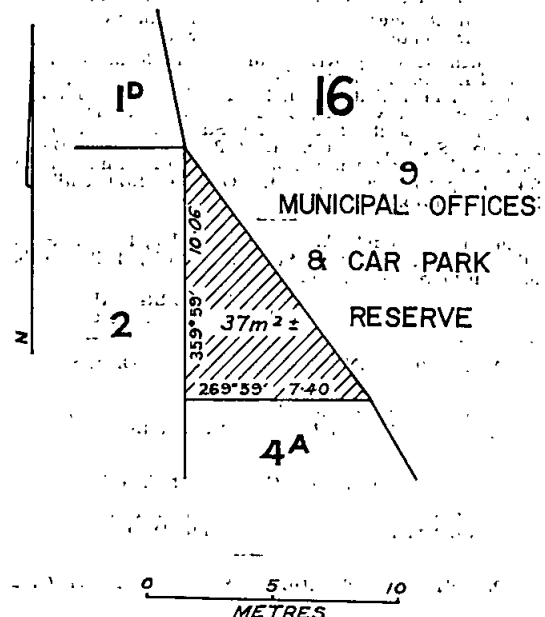

W. BORTHWICK,
Minister of Lands.

COMMON ABOUT TO BE DIMINISHED.

In pursuance of the provisions contained in the Land Act 1958, notice is hereby given that it is the intention of the Governor in Council to diminish the common herein-after mentioned viz:—

The following Notice was published 1° on the 23rd October, 1974, pursuant to Order of the 15th October, 1974.

The Maldon Shire Common, proclaimed as such by the Governor in Council on the 2nd April, 1889, and altered by Order in Council of the 23rd April, 1912, is about to be diminished by the excision therefrom of the portion in the Township of Maldon containing 1012 square metres, indicated by hatching on plan hereunder.—(Rs.353.)

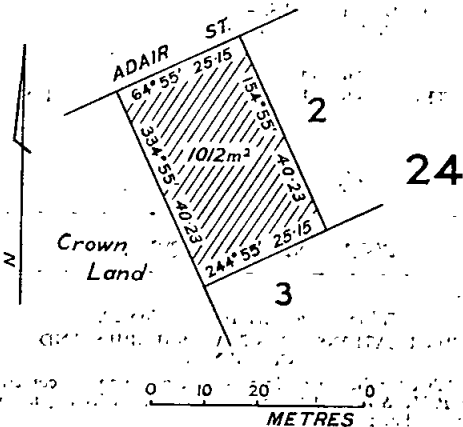

W. BORTHWICK,
Minister of Lands.

PUBLIC HEARINGS BY A PERSON APPOINTED UNDER THE 34TH SECTION OF THE LAND ACT 1958.

Notice is hereby given that at the time and place mentioned in the Schedule hereunder, applications for leases and licences under the Land Acts, objections to such applications, additions, diminutions, revocations or unions of commons, and reasons against forfeiture of any leases or licences under the Land Acts deemed liable to forfeiture, will be publicly heard by the person whose name is set opposite such place in such Schedule, being the person appointed by me, the responsible Minister of the Crown administering the Land Acts, to hear the same and report thereon, in writing, to me.

W. BORTHWICK,
Minister of Lands.

11th October, 1974.

SCHEDULE.

MARYBOROUGH, Monday in each week, at 9.00 a.m.,
by the Land Officer (Bendigo).

COMMITTEES OF MANAGEMENT OF RESERVES:

APPOINTMENTS.

Notice is hereby given that, in pursuance of section 221 of the Land Act 1958, the following appointments of Committees of Management of reserved Crown lands have been made by the Minister of Lands:—

PHILLIP ISLAND PUBLIC PURPOSES RESERVE.

The Corporation of the Shire of Phillip Island as the Committee of Management of the land in the Township of Ventnor temporarily reserved pursuant to Order in Council dated the 11th December, 1973, as a site for Public purposes.—(Corres. No. Rs.5133.)

"WOODEND SPORTS ARENA."

The Corporation of the Shire of Newham and Woodend as the Committee of Management of the land in the Township of Woodend reserved for Public Park, Gardens and Recreation purposes, as is indicated by hatching on plan marked "W/28.9.66" attached to Lands Department correspondence Rs.112a.—(Corres. No. Rs.112a.)

W. BORTHWICK,
Minister of Lands.

Department of Crown Lands and Survey,
Melbourne, 17th October, 1974.

No. 103.—10300/74.—3

TENDERS

PUBLIC WORKS DEPARTMENT

Tenders will be received at Public Works Department, 2 Treasury Place, Melbourne, until TWO p.m. on dates shown and for purposes mentioned hereunder.

Particulars and tender forms available at Contracts Office, Room 27, Ground Floor, No. 2, Treasury Place, and at places indicated in brackets hereunder.

Abbreviations in brackets mean:—W.O.—Inspector of Works Office; P.S.—Police Station; C.S.—Consolidated School; H.E.S.—Higher Elementary School; H.S.—High School; Pr.S.—Primary School; T.S.—Technical School.

Tenders to be submitted on the Department's printed Tender Form and will not be received by telephone. All tenders must be on a "Firm Tender" basis. The lowest or any tender will not necessarily be accepted.

Address tenders to the Minister of Public Works, and endorse the envelope containing the tender "Tender for , closing Tuesday,

Hand delivered tenders to be placed in the Tender Box of the Public Works Department, located on the wall of the centre entrance foyer, Ground Floor, 2 Treasury-place, Melbourne.

No preliminary deposit is required with any tender, but successful tenderer will be required to pay a deposit for any accepted tender of \$10,000 or over.

Tuesday, 29th October, 1974.

Building, Electrical and Mechanical Works.

BALLARAT.—Conversion of boilers to gas, Lakeside Hospital. (W.O., Ballarat.)

BENTLEIGH EAST.—Staff accommodation improvements, Pr.S.2083.

BROADMEADOWS.—Internal renovations, T.S.

COLAC.—Internal and external renovations, H.S. (W.O., Geelong.)

CORRYONG.—Erection of Library, H.S. (W.O., Benalla and Wangaratta.)

CORRYONG.—Electrical services, Library, H.S. (W.O., Benalla and Wangaratta.)

CORRYONG.—Heating and hot water service, Library, H.S. (W.O., Bendigo and Wangaratta.)

DONCASTER.—General repairs and external and internal painting, Pr.S.197.

DROUIN.—Erection of two (2) classrooms, store room, art/craft room, toilet shower block and covered way, Pr.S.1924. (W.O., Warragul.)

EASTMOOR.—External renovations, Pr.S.4790.

FRANKSTON.—Alterations to L.T.C. block, H.S. (Re-advertised.) (Amended Specification.)

HEATHERTON.—Staff accommodation improvements and additional classroom, Pr.S.938.

KEW.—Renovations of ablution block, Ward F.3, Mental Hospital.

KOONUNG HEIGHTS.—Staff and Administration accommodation improvements, Pr.S.4727.

LALOR.—Exterior and interior renovations, H.S.

MALVERN.—Alterations and additions to Out Patients' Clinic.

MOE.—Re-roofing main school building, Pr.S.4740. (W.O., Traralgon.)

MOE.—Erection of Science Block, H.S. (W.O., Traralgon.) (Re-advertised.) (Amended Specification.)

MOE.—Mechanical services, Science Block, H.S. (W.O., Traralgon.) (Re-advertised.) (Amended Specification.)

MONT PARK.—Alterations to existing vegetable store, Mental Hospital.

MOORABBIN.—Replacement of roof covering, T.C.

NORTH MELBOURNE.—Extensions and alterations to store, Government Printing Office.

OBERON.—Internal and external painting and repairs, H.S. (W.O., Geelong.)

WENDOUREE WEST.—Art/craft room, library, staff accommodation improvements and general purpose room, Pr.S.4701. (W.O., Ballarat.)

Miscellaneous.

MELBOURNE.—Supply and delivery of one (1) only 2 ton double-cabin utility, 2 Treasury Place, Public Works Department.

MELBOURNE.—Supply and delivery of one (1) only 2 ton double-cabin utility, 2 Treasury Place, Public Works Department.

MELBOURNE.—Supply and delivery of three (3) only 30 cwt. capacity vans, 2 Treasury Place, Public Works Department. (Re-advertised.)

MELBOURNE.—Maintenance cleaning for the period 1st December, 1974, to 30th November, 1977, Titles Office, 283 Queen Street.

MELBOURNE.—Provision and installation of P.A.B.X. system, Head Office, 45 Swanston Street, Social Welfare Department.

MELBOURNE.—Maintenance cleaning for the period 1st December, 1974, to 30th November, 1977, Police Headquarters, Russell Street.

PORT MELBOURNE.—Supply and delivery of 23 foot-26 foot glass reinforced plastic boat, Marine Laboratory, Salmon Street, Ports and Harbors Division. (Re-advertised.) (Amended Specification.)

VARIOUS.—Supply of stoneware pipes and fittings for the period 1st December, 1974, to 30th November, 1975, Public Works Department.

Wednesday, 6th November, 1974.

Building, Electrical and Mechanical Works.

BALLARAT NORTH.—Additional classrooms and Staff accommodation improvements, T.S. (W.O., Ballarat.) (Re-advertised.) (Amended Specification.)

BAXTER.—Erection of Art/Craft Room and Library, Pr.S.3023. (W.O., Mornington.)

CAMPBELLFIELD.—Provision of a General Purpose Room, Art/Craft Room, Library, Staff accommodation improvements and covered play area, Pr.S.143.

EUROA.—Conversion of Woolclassing Room to Library and construction of Art-Craft Room, H.S. (W.O., Alexandra, Benalla and Shepparton.)

GLENHUNTLY.—Erection of Library and Staff accommodation improvements, Pr.S.3703.

MONBULK.—Exterior and interior renovations, Pr.S.3265.

PARKDALE.—Erection of Science Block, H.S.

PARKDALE.—Mechanical services—Science Block, H.S.

PORT FAIRY.—Internal and external repairs and painting, C.S. (W.O., Hamilton and Warrnambool.)

SHEPPARTON.—Erection of two store rooms, Ambergere Psychiatric Centre. (W.O., Shepparton.)

SUNVALE.—Erection of Art/Craft Room, Library and Staff and Administration improvements, Pr.S.4818.

TEMPLESTOWE.—External and internal repairs and painting, H.S.

TRARALGON.—Internal and external repairs and painting, Pr.S.4699. (W.O., Traralgon.)

WARRNAMBOOL NORTH.—Administration remodelling and extension, T.S. (W.O., Warrnambool.)

WARRNAMBOOL NORTH.—Mechanical services, T.S. (W.O., Warrnambool.)

Furniture and Furnishings.

VARIOUS.—Supply of contract furniture for the period 1st January, 1975, to 31st December, 1975, Schools and other Government Departments.

Miscellaneous.

MELBOURNE.—Supply of one (1) two ton chassis and cabin with container van body, 2 Treasury Place, Public Works Department.

Tuesday, 12th November, 1974.

Building, Electrical and Mechanical Works.

BALLARAT.—Remodelling of Science Rooms, T.S. (W.O., Ballarat.) (Re-advertised.)

COLLINGWOOD.—Internal and external repairs and painting, Pr.S.1895.

HUNTINGDALE.—Staff accommodation improvements, &c., Pr.S.4716.

MALVERN.—Mechanical services, Outpatients Clinic, 521 Glenferrie Road.

SEBASTOPOL.—Electrical services, T.S. (W.O., Ballarat.)

ST. ALBANS EAST.—External and internal renovations, Pr.S.4741.

SUNSHINE NORTH.—Internal and external painting and repairs, T.S.

THOMASTOWN EAST.—Internal and external painting and repairs, Pr.S.4827.

WATTLE PARK.—Erection of Science Block, H.S.

WATTLE PARK.—Mechanical services—Science Block, H.S. (Amended Specification.)

Site Works.

ASPENDALE.—Asphalt and concrete pavements, drainage, beautification and associated works, T.S.

RINGWOOD HEIGHTS.—Asphalt paving, concrete retaining walls, &c., Pr.S.4911.

Furniture and Furnishings.

HAWTHORN.—Supply and fix built in fittings, H.S.

ROBERTS DUNSTAN,
Minister for Public Works.

Public Works Department,
Melbourne, 21st October, 1974.

PUBLIC SERVICE NOTICES

No. 175. *Public Service Act 1958, Section 50.*

REGULATIONS.—PART IV.—SALARIES AND INCREMENTS.

The Public Service Board, in pursuance of the powers conferred by the *Public Service Act 1958*, hereby amends its Regulations as shown below:—

FIFTH SCHEDULE.

TEMPORARY EMPLOYEES.

DEPARTMENT OF HEALTH.

MENTAL HYGIENE.

Designations of Positions and Rates of Salaries.

Designation of Position.	Designation Code.	Yearly Rate of Salary.		Salary/Increment Code.
		Minimum.	Maximum.	
		\$	\$	
Delete—Cook	GA	4,986	5,267	AA
Add—Cook, Grade II.	GA	5,647	6,024	AA
Cook, Grade I.	GA	4,986	5,267	AA

A. J. A. GARDNER, Chairman.
L. R. BROWN, Secretary.

Office of the Public Service Board,
Melbourne, 7th October, 1974.

No. 179. **PUBLIC SERVICE ACT 1958.**

The Public Service Board, in pursuance of the powers conferred by the *Public Service Act 1958*, hereby amends the Public Service (Public Service Board) Regulations as follows:—

PART V.—ALLOWANCES.

DIVISION II.—OVERTIME AND STANDBY ALLOWANCES.

WATER SUPPLY DEPARTMENT.

Regulation 163.

In sub-regulation (1) immediately prior to the heading "Inspector (Diversions), Grade II." insert the following:—

Office or Position.	Stand-by a Year.	Commuted Overtime Percentage.
	\$	%
<i>Inspector (Diversions), Grade III.</i>		
Lilydale	106	10

A. J. A. GARDNER, Chairman.
L. R. BROWN, Secretary.

Office of the Public Service Board,
Melbourne, 14th October, 1974.

No. 182.

Public Service Act 1958, Section 39.

REGULATIONS.—PART IV.—SALARIES AND INCREMENTS.

The Public Service Board, in pursuance of the powers conferred by the Public Service Act 1958, hereby amends the Public Service (Public Service Board) Regulations as follows—

THIRD SCHEDULE.

PART B.

PROFESSIONAL DIVISION.

Scale of Rates of Annual Salaries.

THERAPISTS—OCCUPATIONAL THERAPISTS, PHYSIOTHERAPISTS AND SPEECH THERAPISTS.

The salary scale shown is deleted and the following salary scale is inserted in lieu thereof—

Class.	Annual Salary of each Subdivision of Each Class.					
	1.	2.	3.	4.	5.	6.
	\$	\$	\$	\$	\$	\$
T-1 ..	6,527	6,930	7,440	7,816	8,422	8,748
T-2 ..	6,729	7,225	7,706	8,146	8,640	8,961
T-3 ..	9,178	9,464	9,760	10,051
T-4 ..	9,640	9,877	10,220	10,564
T-5 ..	12,324	12,552	12,778

SIXTH SCHEDULE.

TEMPORARY EMPLOYEES.

Designations of Positions and Rates of Salaries.

Department and Designation of Position.	Designation Code.	Yearly Rate of Salary.		Salary/Increment Code.
		Minimum.	Maximum.	
		\$	\$	
<i>Delete the existing yearly rates of salary for the following positions and insert the rates shown hereunder in lieu thereof—</i>				
GENERAL.				
Occupational Therapist, Grade III.	GA	9,178	10,051	BZ
Occupational Therapist, Grade II.	GA	6,729	8,961	BY
Occupational Therapist, Grade I.	GA	6,527	8,748	BX
DEPARTMENT OF HEALTH.				
<i>General Health.</i>				
Physiotherapist, Grade I.	GA	6,527	8,748	BX
<i>Mental Hygiene.</i>				
Music Therapist		6,527	8,748	BX
Physiotherapist, Grade III.	GA	9,178	10,051	BZ
Physiotherapist, Grade II.	GA	6,729	8,961	BY
Physiotherapist, Grade I.	GA	6,527	8,748	BX
Speech Therapist, Grade II.	GA	6,729	8,961	BY
Speech Therapist, Grade I.	GA	6,527	8,748	BX

This Regulation shall have effect from 13th October, 1974.

A. J. A. GARDNER, Chairman.
L. R. BROWN, Secretary.

Office of the Public Service Board,
Melbourne, 14th October, 1974.

No. 177.

Public Service Act 1958, Section 50.

REGULATIONS.—PART IV.—SALARIES AND INCREMENTS.

The Public Service Board, in pursuance of the powers conferred by the Public Service Act 1958, hereby amends its Regulations as shown below :—

SIXTH SCHEDULE.

TEMPORARY EMPLOYEES.

Designations of Positions and Rates of Salaries.

Department and Designation of Position.	Designation Code.	Yearly Rate of Salary.		Salary/Increment Code.
		Minimum.	Maximum.	
		\$	\$	
DEPARTMENT OF HEALTH.				
<i>Tuberculosis.</i>				
	GY			
<i>State Sanatoria.</i>				
	GY			
<i>Add—</i>				
Cleaner and Labourer—				
Junior	GC		1-14	
Adult		4,839	5,155	AA, AG

A. J. A. GARDNER, Chairman.
L. R. BROWN, Secretary.

Office of the Public Service Board,
Melbourne, 11th October, 1974.

No. 181.

Public Service Act 1958, Section 50.

REGULATIONS.—PART IV.—SALARIES AND INCREMENTS.

The Public Service Board, in pursuance of the powers conferred by the Public Service Act 1958, hereby amends its Regulations as shown below :—

SIXTH SCHEDULE.

TEMPORARY EMPLOYEES.

Designations of Positions and Rates of Salaries.

Department and Designation of Position.	Designation Code.	Yearly Rate of Salary.		Salary/Increment Code.
		Minimum.	Maximum.	
		\$	\$	
PUBLIC WORKS DEPARTMENT.				
<i>Ports and Harbours.</i>				
	HB, HC, HD			
<i>Delete—</i>				
Carpenter and Shipwright	HH	6,403	6,781	AA
<i>Add—</i>				
Carpenter and Shipwright	HH	6,875	7,240	AA

This Regulation shall have effect from 20th October, 1974.

A. J. A. GARDNER, Chairman.
L. R. BROWN, Secretary.

Office of the Public Service Board,
Melbourne, 18th October, 1974.

No. 178.

Public Service Act 1958, Section 50.

REGULATIONS.—PART IV.—SALARIES AND INCREMENTS.

The Public Service Board, in pursuance of the powers conferred by the Public Service Act 1958, hereby amends its Regulations as shown below:

SIXTH SCHEDULE.

TEMPORARY EMPLOYEES.

Designations of Positions and Rates of Salaries.

Department and Designation of Position.	Designation Code.	Yearly Rate of Salary.		Salary/Increment Code.
		Minimum.	Maximum.	
<i>Delete the existing yearly rates of salary for the following positions and insert the rates shown hereunder in lieu thereof:—</i>				
GENERAL.				
Computer Operator, Senior	GA.	7,568	7,776	AA
Computer Operator, Grade III.	GA	6,970	7,279	AA
Computer Operator, Grade II...	GA	6,380	6,689	AA

This Regulation shall have effect from 6th October, 1974.

A. J. A. GARDNER, Chairman.
L. R. BROWN, Secretary.

Office of the Public Service Board,
Melbourne, 8th October, 1974.

No. 174.

PUBLIC SERVICE ACT 1958.

The Public Service Board, in pursuance of the powers conferred by the Public Service Act 1958, hereby amends the Public Service (Public Service Board) Regulations as follows—

PART II.—APPOINTMENTS TO THE PUBLIC SERVICE.

DIVISION VI.—EMPLOYMENT OF CADETS.

Regulation 65.

The scale of allowances in clause (1) of paragraph (a) of sub-regulation (1) is deleted and the following scale is inserted in lieu thereof—

Years of Age	Living at Home	Living Away from Home
At 17 years and under	2,280	2,541
At 18 years	2,526	2,787
At 19 years	2,771	3,032
At 20 years	3,053	3,314
Adult—	3,332	3,593
and—		

This Regulation shall have effect from 1st January, 1975.

A. J. A. GARDNER, Chairman.
L. R. BROWN, Secretary.

Office of the Public Service Board,
Melbourne, 14th October, 1974.

No. 176.

Public Service Act 1958, Section 39.

REGULATIONS.—PART IV.—SALARIES AND INCREMENTS.

The Public Service Board, in pursuance of the powers conferred by the Public Service Act 1958, hereby amends the Public Service (Public Service Board) Regulations as follows—

THIRD SCHEDULE.

PART B.

PROFESSIONAL DIVISION.
Scale of Rates of Annual Salaries.

ARCHIVISTS.

The salary scale shown is deleted and the following salary scale is inserted in lieu thereof—

Class.	Annual Salary of Each Subdivision of Each Class.						
	1.	2.	3.	4.	5.	6.	7.
	\$	\$	\$	\$	\$	\$	\$
AV-1	6,879	7,225	7,650	8,090	8,532	9,014	9,406
AV-2	9,640	9,993	10,164
AV-3	10,621	11,017	11,471
AV-4	13,053	13,549
AV-5	16,289

LIAISON OFFICERS AND NATIONAL GALLERY OFFICERS, MINISTRY FOR THE ARTS, PREMIER'S DEPARTMENT.

The salary scale shown is deleted and the following salary scale is inserted in lieu thereof—

Class.	Annual Salary of Each Subdivision of Each Class.					
	1.	2.	3.	4.	5.	6.
	\$	\$	\$	\$	\$	\$
NG-1	6,626	6,779	6,879	7,166
NG-2	8,257	8,532	8,855
NG-2A	9,069	9,346	9,640	9,993
NG-3	9,234	9,523	9,700	10,280	10,449	10,790
NG-4	10,280	10,449	10,790	11,415
NG-5	13,329
NG-6	14,448
NG-7	17,225

LIBRARIANS.

The salary scale shown is deleted and the following salary scale is inserted in lieu thereof—

Class.	Annual Salary of Each Subdivision of Each Class.							
	1.	2.	3.	4.	5.	6.	7.	8.
	\$	\$	\$	\$	\$	\$	\$	\$
L-1	6,990	7,225	7,491	7,871	8,257	8,696	9,178	9,760
L-2A	10,107
L-2	10,280	10,621	11,017
L-3	11,471	11,926	12,324
L-4	13,053	13,549
L-5	13,248
L-6	16,289

LIBRARY OFFICERS.

The salary scale shown is deleted and the following salary scale is inserted in lieu thereof—

Class.	Annual Salary of Each Subdivision of Each Class.					
	1.	2.	3.	4.	5.	6.
	\$	\$	\$	\$	\$	\$
LR-1	3,416	3,872	4,308	4,837	5,263	5,736
LR-2	5,916	6,088	6,262
LR-3	6,577	6,829	7,048
LR-4	6,829	7,048	7,225	7,491	7,760	..
LR-5	7,871	8,146	8,422	8,532
LR-6A	10,107
LR-6	10,280	10,621	11,017

SIXTH SCHEDULE.

TEMPORARY EMPLOYEES.

Designations of Positions and Rates of Salaries.

Department and Designation of Position.	Designation Code.	Yearly Rate of Salary.		Salary/Increment Code.
		Minimum.	Maximum.	
<i>Delete the existing yearly rates of salary for the following positions and insert the rates shown hereunder in lieu thereof:—</i>				
CHIEF SECRETARY'S DEPARTMENT.				
National Museum and Science Museum.				
Curator Assistant	GA	..	8,257	..
PREMIER'S DEPARTMENT.				
Ministry for the Arts, State Library.				
Librarian	GA	6,990	9,760	CX
Library Officer, Grade III.	GA	7,225	7,760	AV
Library Officer, Grade II.	GA	6,577	7,048	CY
Library Officer, Grade I.—Adult	..	5,756	6,262	AW
Map Librarian	10,107	..

This Regulation shall have effect from 13th October, 1974.

A. J. A. GARDNER, Chairman.
L. R. BROWN, Secretary.

Office of the Public Service Board,
Melbourne, 14th October, 1974.

No. 180.

Public Service Act 1958, Section 50.
REGULATIONS.—PART IV.—SALARIES AND INCREMENTS.

The Public Service Board, in pursuance of the powers conferred by the Public Service Act 1958, hereby amends its Regulations as shown below :—

SECOND SCHEDULE.

TECHNICAL AND GENERAL DIVISION.

Grades and Salary Scales.

JUNIOR GRADES (NOT CLASSIFIED IN EIGHTH SCHEDULE.)

Delete the existing yearly rates of salary shown for the undermentioned grades and insert the following rates in lieu thereof :—

Grade.	Yearly Rate of Salary at Each Age in Years.				
	Under 17.	17.	18.	19.	20.
	\$	\$	\$	\$	\$
J-36	6,170	6,232	6,650
J-33	6,076	6,138	6,305
J-30	5,975	6,037	6,204

FIFTH SCHEDULE.

TEMPORARY EMPLOYEES.

DEPARTMENT OF HEALTH.

MENTAL HYGIENE.

Designations of Positions and Rates of Salaries.

Designation of Position.	Designation Code.	Yearly Rate of Salary.		Salary/Increment Code.
		Minimum.	Maximum.	
		\$	\$	
<i>Delete the existing yearly rates of salary for the following positions and insert the rates shown hereunder in lieu thereof :—</i>				
Motor Driver, Grade III.—Adult	..	6,853	7,240	AA, AG
Motor Driver, Grade II.—Adult	..	6,425	6,733	AA, AG
Motor Driver, Grade I.—Adult	..	6,332	6,641	AA, AG

SIXTH SCHEDULE.

TEMPORARY EMPLOYEES.

Designations of Positions and Rates of Salaries.

Department and Designation of Position.	Designation Code.	Yearly Rate of Salary.		Salary/Increment Code.
		Minimum.	Maximum.	
		\$	\$	
<i>Delete the existing yearly rates of salary for the following positions and insert the rates shown hereunder in lieu thereof :—</i>				
GENERAL.				
Motor Driver, Grade III.—Adult	..	6,853	7,240	AA, AG
Motor Driver, Grade II.—Adult	..	6,425	6,733	AA, AG
Motor Driver, Grade I.—Adult	..	6,332	6,641	AA, AG
MINISTRY FOR CONSERVATION.				
<i>Fisheries and Wildlife Division.</i>				
Liberation Officer—Adult	..	6,853	7,240	AA, AG
DEPARTMENT OF HEALTH.				
<i>Maternal and Child Welfare.</i>				
Articulated Vehicle Driver (Maker's capacity 10 tons)	..	7,085	7,527	AA
LOCAL GOVERNMENT DEPARTMENT.				
<i>Weights and Measures.</i>				
Truck Driver and Assistant	..	7,320	7,735	AA
STATE FORESTS DEPARTMENT.				
<i>Central Workshop.</i>				
Machinery Float Driver (30 tons)	..	7,610	8,028	AA

SEVENTH SCHEDULE.

TECHNICAL AND GENERAL DIVISION.

DEPARTMENT OF HEALTH.

MENTAL HYGIENE.

Grades and Salary Scales.

JUNIOR GRADES (NOT CLASSIFIED IN EIGHTH SCHEDULE.)

Delete the existing yearly rates of salary shown for the undermentioned grades and insert the following rates in lieu thereof—

Grade.	Yearly Rate of Salary, at Each Age in Years.				
	Under 17.	17.	18.	19.	20.
	\$	\$	\$	\$	\$
J-30	5,975	6,037	6,204
J-33	6,076	6,138	6,305
J-36	6,170	6,232	6,650

This Regulation shall have effect from 6th October, 1974.

A. J. A. GARDNER, Chairman.
L. R. BROWN, Secretary.

Office of the Public Service Board,
Melbourne, 7th October, 1974.

No. 173.

Public Service Act 1958, Section 50.

REGULATIONS.—PART IV.—SALARIES AND INCREMENTS.

The Public Service Board, in pursuance of the powers conferred by the Public Service Act 1958, hereby amends its Regulations as shown below :—

FIFTH SCHEDULE.

TEMPORARY EMPLOYEES.

DEPARTMENT OF HEALTH—MENTAL HYGIENE.

Designations of Positions and Rates of Salaries.

Designation of Position.	Designation Code.	Yearly Rate of Salary.		Salary/Increment Code.
		Minimum.	Maximum.	
		\$	\$	
<i>Add—</i>				
Director of Nursing, Grade III.	GA	..	12,182	AC
Director of Nursing, Grade II.	GA	..	11,001	AC
Director of Nursing, Grade I.	GA	..	10,393	AC
Assistant Director of Nursing	GA	..	10,393	AC
Supervisory Nurse	GA	..	8,622	..

This Regulation shall have effect from 6th October, 1974.

A. J. A. GARDNER, Chairman.
L. R. BROWN, Secretary.

Office of the Public Service Board,
Melbourne, 7th October, 1974.

PRIVATE ADVERTISEMENTS

CITY OF KEILOR.

NOTICE OF CHANGING NAMES OF STREETS.

In accordance with the provisions of the Local Government Act 1958, the Council of the City of Keilor hereby gives notice that the said Council has made orders changing the names of the following streets.

Old Name.—Woorite Place.

New Name.—Keilor Road.

Location.—The Avenue to Woorite Place Interchange.

Old Name.—Oleander Street.

New Name.—Rex Street.

Location.—Taylors Road to Magnolia Avenue.

Old Name.—Kurrajong Street.

New Name.—Alan Street.

Location.—Kings Road to Rex Street (formally Oleander Street).

Old Name.—Lantana Court.

New Name.—Betson Court.

Location.—Off Brazilia Avenue.

Old Name.—Willow Drive.

New Name.—Cecelia Drive.

Location.—Sterling Drive to Arcade Way.

Old Name.—Norman Street.

New Name.—Moffat Street.

Location.—Main Road West to McLeod Road.

Old Name.—Clydesdale Street.

New Name.—Clydesdale Road.

Location.—Bedford Street to McNamara Avenue.

Old Name.—Gum Street or Gum Avenue.
 New Name.—Gum Road.
 Location.—Main Road West to Gillespie Road.
 Old Name.—Ross Court.
 New Name.—Ross Street.
 Location.—Treadwell Road to Matthews Avenue.
 Old Name.—(New Road.)
 New Name.—Fullarton Road.
 Location.—Matthews Avenue to the Woorite Place Interchange.
 Old Name.—The Centreway.
 New Name.—Clough Street.
 Location.—Intervale Drive to North Road.
 Old Name.—Fox Road.
 New Name.—Fox's Road.
 Location.—St. Albans Road to Stenson Road.

1381 R. F. B. KELLY, Town Clerk.

CITY OF KEW.

WHEREAS the Council of the City of Kew deems it expedient to exercise its power of taking compulsorily the land delineated and hatched on the map at the foot hereof for the work or undertaking of providing land for public recreational purposes AND WHEREAS the Council has caused to be prepared a map and other papers setting out the general description of the work or undertaking for which the land proposed to be taken and the names of the owners or reputed owners lessees or reputed lessees mortgagees and occupiers of that land so far as those names are known to or can be ascertained by the Council AND WHEREAS the said map and other papers are deposited at the office of the said Council at Kew and are and shall be open for inspection by all persons interested at all reasonable hours for the space of forty clear days after the publication of this notice in the *Government Gazette* NOW NOTICE IS HEREBY GIVEN to all persons affected by the proposed taking of the said land to set forth in writing addressed to the Council or the Town Clerk within forty clear days of the publication of this notice in the *Government Gazette* all objections which they may have to the taking of the said land.

The land referred to—all that parcel of land described in Certificate of Title Volume 7131 Folio 1426147 being Lot 198 on Plan of Subdivision 11839 and Part of Crown Allotment 53, Parish of Boroondara, County of Bourke.

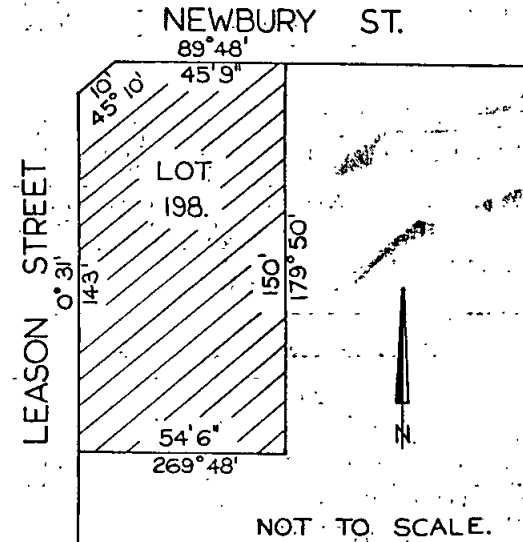

NOT TO SCALE.

Dated the 23rd day of October, 1974.

By Order of the Council,
 B. H. ROBINSON, Town Clerk.

1382

CITY OF KEW.

WHEREAS the Council of the City of Kew deems it expedient to exercise its power of taking compulsorily the land delineated and hatched on the map at the foot hereof for the work or undertaking of providing land for public recreational purposes AND WHEREAS the Council has caused to be prepared a map and other papers setting out the general description of the work or undertaking for which the land proposed to be taken and the names of the owners or reputed owners lessees or reputed lessees mortgagees and occupiers of that land so far as those names are known to or can be ascertained by the Council AND WHEREAS the said map and other papers are

deposited at the office of the said Council at Kew and are and shall be open for inspection by all persons interested at all reasonable hours for the space of forty clear days after the publication of this notice in the *Government Gazette* NOW NOTICE IS HEREBY GIVEN to all persons affected by the proposed taking of the said land to set forth in writing addressed to the Council or the Town Clerk within forty clear days of the publication of this notice in the *Government Gazette* all objections which they may have to the taking of the said land.

The land referred to—all that parcel of land described in Certificate of Title Volume 6630 Folio 1325842 being Lot 197 on Plan of Subdivision 11839 and Part of Crown Allotment 53, Parish of Boroondara, County of Bourke.

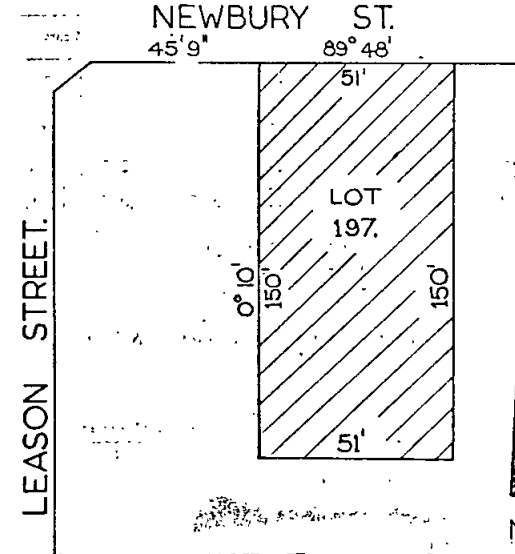

NOT TO SCALE.

Dated the 23rd day of October, 1974.

By Order of the Council,
 B. H. ROBINSON, Town Clerk.

1408

CITY OF MORDIALLOC.

BYLAW No. 151.

A Bylaw of the City of Mordialloc made under Part III of Chapter 8 of the Uniform Building Regulations of Victoria and the *Local Government Act 1958* and Numbered 151 for altering Bylaw No. 114 of the City of Mordialloc.

In pursuance of the powers conferred by the Uniform Building Regulations of Victoria and the *Local Government Act 1958* and of any and every other power it thereunto enabling the Mayor, Councilors and Citizens of the City of Mordialloc orders as follows:—

1. Bylaw No. 114 entitled the Mordialloc Building Control Bylaw as altered by Bylaws Nos. 139 and 143 shall be further altered by adding at the end of the brick areas schedule the following areas, namely:—

20. The whole of the area enclosed by a line commencing at a point on the South East intersection of the street alignments of McDonald Street and Golf Avenue, then following the Northern alignment of McDonald Street in an Easterly direction to the intersection of McDonald Street and Myrtle Street, then following the Western alignment of Myrtle Street to the intersection of Myrtle Street and White Street, then following the Southern alignment of White Street in a Westerly direction to the intersection of White Street and Golf Avenue, then following the Eastern alignment of Golf Avenue to the commencing point.

21. The whole of the area enclosed by a line commencing at a point at the South Eastern intersection of McDonald Street and Myrtle Street, then following the Northern and Western alignments of McDonald Street to the Western intersection of McDonald Street and White Street, then following the Southern alignment of White Street in a Westerly direction to the Eastern intersection of White Street and Myrtle Street, then following the Eastern alignment of Myrtle Street to the commencing point.

22. The whole of the area enclosed by a line commencing at the South West intersection of McDonald Street and Golf Avenue, then following the Northern alignment of McDonald Street in a Westerly direction to a point 283 feet West of the Intersection of McDonald Street and Golf Avenue, then along the Western boundaries of Lot 110 McDonald Street and Lots 120, 121, 122, 123 and 124 Golf Avenue to a point 521 feet 2 inches North of McDonald Street, then Easterly along the North boundary of Lot 124 Golf Avenue to the Western alignment of Golf Avenue, then along the Western alignment of Golf Avenue to the commencing point.

23. The whole of the area enclosed by a line commencing at the North West intersection of White Street and Bradshaw Street, then North along the West alignment of Bradshaw Street for a distance of 300 feet, then Westerly along the Southern boundary of Lot 205 White Street for a distance of 140 feet 8 inches, then Northerly for a distance of 170 feet along the rear boundaries of Lots 205, 204 and part of 203 Bradshaw Street, then Westerly along the Northern boundary of Lot 5 Bradshaw Street for a distance of 228 feet $\frac{1}{2}$ inch to a Drainage and Sewerage Reserve, then South Easterly along the Westerly boundary of Lots 5, 6, 2 and 1 Bradshaw Street for a distance of 566 feet 7 inches to the Northern alignment of White Street, then Easterly along the Northern alignment of White Street to the commencing point.

24. The whole of the area enclosed by a line commencing at a point of the South East corner of Nepean Highway and White Street, then following the street alignment of Nepean Highway in Southerly direction to the North intersection of Nepean Highway and Ashmore Avenue, then following the North alignment of Ashmore Avenue for a distance of 120 feet, then proceeding in a general Northerly direction following parallel to and at a constant distance of 120 feet from the Eastern alignment of Nepean Highway to the Southern alignment of White Street, then following the Southern alignment of White Street in a Westerly direction to the commencing point.

Resolution for passing of this Bylaw was agreed to by the Council of the City of Mordialloc on the Twenty-third day of September, 1974, and confirmed on the Eighteenth day of October, 1974.

The common seal of the Mayor, Councillors and Citizens of the City of Mordialloc was hereunto affixed in the presence of—

1456

(SEAL)

PETER L. SCULLIN, Mayor.
MAL. W. BUXTON, Councillor.
D. H. CORBEN, Town Clerk.

CITY OF MORDIALLOC.

BYLAW No. 149.

A Bylaw of the City of Mordialloc made under Section 197 of the *Local Government Act 1958* and numbered 149 for:

- (a) Suppressing Nuisances;
- (b) Controlling and regulating the use of premises with a view to preventing objectionable noises at unreasonable times;
- (c) Generally maintaining the good rule and government of the Municipality;
- (d) Prohibiting or minimizing noises in any public highway;
- (e) Repealing Bylaws Nos. 78, 89 and 120.

In pursuance of the powers conferred by the *Local Government Act 1958* and of any and every other power it thereunto enabling the Mayor Councillors and Citizens of the City of Mordialloc orders as follows:—

1. This Bylaw may be known as the Nuisances Bylaw.

2. In this Bylaw unless inconsistent with the context—

“Apparatus” includes radio, record player, tape player, amplifier, loud speaker, or any other appliance or device by which any sound may be produced or amplified.

“Council” means the Council of the City of Mordialloc.

“Essential Public Utility” shall mean Victorian Police, Victorian Civil Ambulance, Fire Brigades Board, Gas & Fuel Corporation, Melbourne and Metropolitan Board of Works and State Electricity Commission and the City of Mordialloc.

“Public Highway” means any road, street, footpath, reservation and shall include any inland lake whether natural or artificial, and any navigable water vested in the Council upon which boats are used to ply for hire.

“Public Place” includes any Public Highway, park, garden reserve and other place of public resort.

“Vehicle” shall include boat.

3. Bylaw No. 78 for the purpose of suppressing nuisances and generally for maintaining the good rule of the Municipality, Bylaw No. 89 for suppressing nuisances and prohibiting or minimising noises in public highways and generally for maintaining the good rule and government of the Municipality and Bylaw No. 120 for suppressing nuisances, are hereby repealed.

4. No person shall have, keep or allow within or about any house, building or premises any noisy animal or bird which shall cause a nuisance or annoyance to any person residing in the neighbourhood of such house, building or premises.

5. No person shall in any premises between the hours of 10.00 p.m. to 6.00 a.m. on any day or at any time on a Sunday use operate or work any plant machinery, equipment or apparatus or carry on any activities in such a manner to produce any objectionable noise audible to persons outside such premises.

6. (i) No person shall in any public highway, without the consent in writing of the Council of the City of Mordialloc, use or allow to be operated any apparatus excluding the horn or any other warning device fitted to a vehicle by which any sound may be produced or amplified.

(ii) For the purpose of this clause an apparatus shall be deemed to be in a public highway if it is in or over the public highway, or is in, upon or attached to any vehicle in the public highway.

(iii) The Council in its absolute discretion—

(a) May, give its consent, subject to such conditions as it thinks fit, with respect to all or any of the following matters, that is to say—the quality or degree of amplification or loudness of the sounds produced or amplified by the apparatus, information to be given by the sounds if they are in words, the nature of any music or other sound to be produced or amplified, the times of use or operation of the apparatus; or

(b) may refuse its consent—

to the use or operation, in specified places in public highways, or in specified public highways or in all public highways within the Municipality, of any apparatus for producing or amplifying any sounds, or any sounds which the Council specifies, or sounds of any description which it specifies.

(iv) After the Council has given consent, subject to conditions specified by it, to the use or operation of any apparatus, if any person in any public highway uses or allows to be operated that apparatus or any other apparatus without observing all the conditions specified by the Council, he shall be deemed to have used or operated the apparatus without the consent in writing of the Council.

(v) This clause shall not apply to persons employed by or engaged in activities on behalf of an essential public utility whilst in the performance of their duties for such public utility.

7. No person shall in any public highway within the Municipal district cause or permit or suffer to be caused any noise so as to be an annoyance or nuisance to any other person:

(a) by shouting, calling out, haranguing or singing;

or

(b) by using, operating, controlling, sounding or playing any device or instrument;

without having first obtained the written consent of the Council of the City of Mordialloc.

8. No person shall in or upon any premises use or operate any instrument or any machinery or plant in such manner as to cause any objectionable noise at any unreasonable time.

9. (i) This clause shall not apply to the use or operation of apparatus in connection with any public or patriotic purpose in any park or reserve under the control or management of the Council during any period of time for which the Council has authorised the use of the park or reserve for that purpose.

(ii) Subject to sub-clause (i) of this clause, no person shall in any public place, or in any premises abutting on or adjacent to any public place, use or allow to be operated any apparatus in such way that any sound is produced or amplified by it, so as to be a nuisance to members of the public in the public place or to persons in neighbouring premises.

(iii) For the purposes of this clause, an apparatus shall be deemed to be in a public place if it is in or over the public place, or is in, upon or attached to any vehicle in the public place.

10. (i) Any consent given by the Council for the purposes of any clause of this Bylaw may be expressed to be limited so as to remain in effect only for a specified time, or only until a notice that it has been withdrawn is served on the person to whom it was given; and any consent, whether expressed to be so limited or not, may be withdrawn, by notice served on the person to whom it was given, and after the service of such a notice any person who wilfully allows anything that is prohibited by the Clause under which the consent was given shall be deemed to have been guilty of a wilful act or default contrary to that Clause as if no consent under that Clause had ever been given.

(ii) Any consent hereunder may be given under the hand of the Town Clerk of the City of Mordialloc.

11. (a) Every person shall in the construction of any roadworks or the grading and levelling of any land or the carrying on of any land developmental works take or cause to be taken all necessary precautions to prevent the dust from such works being carried by the wind so as to be a nuisance to persons outside the premises in which the works are being performed.

(b) No person shall permit to be left any earthworks in such a state as to be likely to cause or to become likely to cause a nuisance to persons outside the premises in which such works are being performed.

(c) This clause shall not apply to the employees of the City of Mordialloc whilst engaged in the performance of their duties as such or Contractors with the City of Mordialloc whilst engaged in the performance of a Contract between the City of Mordialloc and the Contractor.

12. No person shall carry on a trade, manufacturing process or business which, in its operation is likely to cause a nuisance to persons outside the premises on which business is carried on by reason of the emission of noise, vibration, smell, fumes, smoke, vapour, steam, soot, ash, dust, waste products, grit or oil.

13. Every person who fails to comply with the provisions of this Bylaw shall be guilty of an offence against this Bylaw.

14. Every person guilty of an offence against this Bylaw shall be liable on conviction to a penalty of not more than One Hundred Dollars (\$100.00) and in the case of a continuing offence to a further daily penalty of not more than Ten Dollars (\$10.00).

15. This Bylaw shall apply to and have operation throughout the whole of the Municipal District of the City of Mordialloc.

Resolution for passing this Bylaw agreed to by the Council of the City of Mordialloc on the Nineteenth day of November, 1973, and confirmed on the Tenth day of December, 1973.

The common seal of the Mayor, Councillors and Citizens of the City of Mordialloc was hereunto affixed in the presence of—

(SEAL) MAL. W. BUXTON, Mayor.
PETER L. SCULLIN, Councillor.
D. H. CORBEN, Town Clerk.

Approved by the Governor in Council on the 1st day of October, 1974.—TOM FORRISTAL, Clerk of the Executive Council. 1404

CITY OF ST. KILDA.

CHANGE OF NAME OF STREET.

Notice is hereby given that the Council of the City of St. Kilda, in pursuance of the power conferred by the Local Government Act 1958, resolved to change the name of the undermentioned Street:—

Location.—The Street connecting St. Kilda Road with Brighton Road.

Old Name.—High Street, St. Kilda.

New Name.—St. Kilda Road, St. Kilda.

1383

A. N. ISAAC, Town Clerk.

SHIRE OF BELFAST.

LOAN No. 28.

Notice of Intention to Borrow the Sum of \$11,500 for Permanent Works and Undertakings.

Notice is hereby given that the Council of the Shire of Belfast proposes to borrow the principal sum of \$11,500 secured by a charge over the general rates of the municipi-

ality, such sum to be raised by the grant of a mortgage in accordance with the provisions of the Local Government Act 1958.

1. The maximum rate of interest to be paid is 9.85 per centum per annum.

2. The purpose for which the loan is to be applied is:—

Part contribution to the purchase of and alterations to buildings and land in Bank Street, Port Fairy, to be used as a Youth and Recreation complex.

3. The period of the loan shall be ten years.

4. The moneys borrowed shall be repayable by providing out of the municipal fund half-yearly instalments of approximately \$916.93 including principal and interest, on the 1st day of February and the 1st day of August, during the currency of the loan. The first instalment will be repayable on the 1st day of August, 1975.

5. Such moneys will be repayable to the National Bank of Australasia Limited, Melbourne.

6. The plans and specifications, and the estimate of the cost of the proposed works, and a statement showing the proposed expenditure of the moneys so borrowed, are open for inspection at the office of the Council of the Shire of Belfast, Cox Street, Port Fairy, during office hours.

15th October, 1974.

1378

BRIAN MOLONEY, Shire Secretary.

SHIRE OF BENALLA.

By-Law, No. 59.

Camping and Caravans By-law.

A By-law of the Shire of Benalla made under Part VII of the Local Government Act and every other power enabling it in that behalf for:—

(a) prohibiting or regulating camping on roads;

(b) regulating, or restricting or prohibiting the use of caravans;

(c) prohibiting or regulating the leaving standing of caravans on streets or roads and the placing of caravans and the establishment of camps on private property.

In pursuance of the powers conferred by the Local Government Act and every other power enabling it in that behalf the President Councillors and Ratepayers of the Shire of Benalla order as follows:—

1. In this By-Law:—

“caravan” includes any structure having the general characteristics of a caravan notwithstanding that any of its wheels or axles have been removed or that it is resting directly on the ground or on blocks;

Definition.

“proprietor” includes the owner, occupier or any person having the management of any land used or lands which a permit has been obtained hereunder for use thereof as a caravan or camping park site or for the placing thereon of a caravan or camp;

“the Council” shall mean the Council of the Shire of Benalla.

Proprietor to hold licence for caravan or camp.

2. No proprietor of any land shall cause or permit the said land to be used for the purpose of placing thereon any caravan or camp or for a caravan site unless he or any other proprietor of the said land shall be the holder of a current permit in writing from the Council authorising such use;

Application for licence.

3. Any proprietor desirous of obtaining a permit for the use of land of which he is the owner, manager or occupier for the purposes set out in Clause 2 hereof shall make application in writing therefor to the Council in the form of the First Part of the Schedule hereto setting out the land which he desires to so use, the number of caravans or camps to be placed thereon, the number of persons who will use such camps, the water, washing, and sewerage facilities available and such other information as the Council may, from time to time require.

Permit for use of land as a caravan or camping site.

4. The Council may issue the permit referred to in clauses 2 and 3 hereof subject to such conditions and limitations as it thinks fit and any person including any proprietor causing or permitting the use of the land in respect of which the permit is granted otherwise than in compliance with the said conditions and limitations shall be

guilty of a breach of this By-Law. Such permit shall be in the form or to the effect of the Second Part of the Schedule hereto;

Renewal.

5. Subject to the provisions of clause 8 hereof any permit issued by the Council hereunder shall unless renewed expire on the 30th day of September next after the issue or previous renewal thereof unless otherwise revoked by notice in writing by the Council served on the proprietor by leaving the same at his usual place of residence or business or by prepaid registered letter addressed to him at the address set out in the application for permit.

Fees.

6. The Council may in respect of the issue of the permit hereunder charge a sum of one dollar.

7. The proprietor of land in respect of which a permit hereunder has been obtained shall at all times during the currency of the permit—

(a) cause to be provided thereon suitable and adequate sanitary conveniences in accordance with the General Sanitary Regulations made under the Health Acts;

Requirements to be provided by Proprietor.

(b) cause to be kept the said sanitary conveniences in an orderly and sanitary condition and in good repair so as to comply with the applicable regulations under the Health Acts;

(c) cause to be provided a sufficient supply of fresh water for the use of persons occupying caravans or camps thereon;

(d) ensure that no nuisance or offensive conditions exist on the said land;

(e) erect and maintain in good repair thereon such bathrooms, shower rooms, washrooms, laundry or laundries, lavatories, kitchens and other conveniences as the Council may from time to time require;

(f) whilst the said land shall be used as a caravan or camping park or site ensure that there shall be in charge thereof a responsible adult person who shall exercise continuous control and supervision thereof.

Period during which caravan or camp may remain restricted.

8. No proprietor or person being the owner or in charge of any caravan or camp shall allow the said caravan or camp to remain on any land in respect of which a permit hereunder has been granted for more than twelve weeks whether consecutive or not during the period of twelve months next ensuing after the date when such caravan or camp was first brought onto or set up on the said land (but where a residence exists nothing herein shall apply to a caravan owned by the proprietor or a member of his household which at all times is kept on the said land for the purposes of storage only).

Caravan on roads.

9. No person shall leave or cause to be left standing any caravan of which he is in charge on any road for a period exceeding twenty-four hours;

Camping on roads.

10. No person shall camp or cause or permit any camp to be established or erected on any road for a period exceeding twenty-four hours.

Obstruction by caravans or camps.

11. No person shall leave or cause to be left standing any caravan of which he is in charge or erect or establish any camp on any road so as to obstruct the same or so as to restrict the view of users of the roadway or of any corner or intersection.

Revocation of permit.

12. Any permit or notice of revocation of permit given by the Council under this By-Law may be given under the hand of the Shire Secretary or Shire Engineer or any other duly authorised officer.

Operation of By-Law.

13. This By-Law shall have operation throughout the Municipal District of the Shire of Benalla.

Penalties.

14. Any person who shall wilfully offend against any of the provisions of this By-Law shall on conviction be liable to a penalty of not more than \$40.00 and in the case of

a continuing offence shall be liable to a penalty of not more than \$4.00 for each day on which an offence against this By-Law is continued after a conviction or order by any Court.

SCHEDULE

PART I

SHIRE OF BENALLA

BY-LAW No. 59

Camping and Caravans Regulations.

Application for Camping Permit

Name of Applicant:

Address (usual residence):

State if Applicant the owner, occupier or manager:

Land (give description):

Area:

Number of camps:

Number of persons:

Number of caravans:

Water facilities available:

Washing facilities:

Sewerage facilities:

Period of permit sought:

Commencing:

Terminating:

Date of Application:

Signature of Applicant:

PART II

SHIRE OF BENALLA

BY-LAW No. 59

Camping and Caravans Regulations.

Permit

Holder:

Address:

Date of Application:

Land:

Number of camps:

Number of persons who may use such camps:

Number of caravans:

Period of permit: The day of 19
to the day of 19

Conditions of issue: This permit is issued to the holder hereof providing the facilities set out in the application hereof and in the Special Conditions herewith and to the observance of the provisions of By-Law No. ; the Health Act and Regulations made thereunder.

Special Conditions:

Dated this day of 19

By Order of the Council

Authorised Officer

Resolution for passing this By-law agreed to by the Council on the Fifteenth day of July, 1974, and confirmed this Nineteenth day of August, 1974.

The common seal of the President, Councillors and Ratepayers of the Shire of Benalla was affixed hereto in the presence of—

W. J. SAMMON, President.

(SEAL)

ROY T. HILL, Councillor.

R. C. McDIARMID, Shire Secretary.

Approved by the Governor in Council, 25th September, 1974.—TOM FORRISTAL, Clerk of the Executive Council.

1406

SHIRE OF BRIGHT.

LOAN No. 55.

Notice of Intention to Borrow the Sum of \$32,000 for Permanent Works and Undertakings.

Notice is hereby given that the Council of the Shire of Bright proposes to borrow the principal sum of \$32,000 secured by a charge over the general rates of the municipality, such sum to be raised by the grant of a mortgage in accordance with the provisions of the *Local Government Act 1958*.

1. The maximum rate of interest that may be paid is 9.9 per cent. per annum.

2. The purpose for which the loan is to be applied is

Plant Purchase	\$23,000
Land Acquisition	6,000
Construction of Roads	3,000

3. The period of the loan shall be 7 years.

4. The moneys borrowed shall be repayable by providing out of the municipal fund half-yearly instalments of approximately \$3,222 each including principal and interest on the first day of June and the first day of December during the currency of the loan. The first instalment shall be payable on the first day of June 1975.

5. Such moneys shall be repayable to The Commissioners of The State Savings Bank of Victoria at the office of the said Commissioners, Corner Elizabeth and Bourke Streets, Melbourne.

The plans and specifications and the estimate of the cost of the proposed works and a statement showing the proposed expenditure of the moneys to be borrowed are open for inspection at the office of the Council of the Shire of Bright, at Ireland Street, Bright.

1457 T. J. RITSON, Shire Secretary.

SHIRE OF BRIGHT.

LOAN No. 56.

Notice of Intention to Borrow the Sum of \$32,000 for Permanent Works and Undertakings.

Notice is hereby given that the Council of the Shire of Bright proposes to borrow the principal sum of \$32,000 secured by a charge over the general rates of the municipality, such sum to be raised by the grant of a mortgage in accordance with the provisions of the *Local Government Act 1958*.

1. The maximum rate of interest that may be paid is 9.85 per cent. per annum.

2. The purpose for which the loan is to be applied is
Construction of Roads \$32,000

3. The period of the loan shall be 20 years.

4. The moneys borrowed shall be repayable by providing out of the municipal fund half-yearly instalments of approximately \$1,845 each including principal and interest on the first day of June and the first day of December during the currency of the loan. The first instalment shall be payable on the first day of December, 1975.

5. Such moneys shall be repayable to The Commissioners of The State Savings Bank of Victoria at the office of the said Commissioners, Corner Elizabeth and Bourke Streets, Melbourne.

The plans and specifications and the estimate of the cost of the proposed works and a statement showing the proposed expenditure of the moneys to be borrowed are open for inspection at the office of the Council of the Shire of Bright, at Ireland Street, Bright.

1458 T. J. RITSON, Shire Secretary.

SHIRE OF BULLA.

By-Law No. 48.

For the purpose of amending By-Law No. 45 (Garbage Collection), Notice is hereby given that the Council of the Shire of Bulla, on the 12th day of August 1974, made a By-Law of the Shire of Bulla under the provisions of the *Health Act 1958* and numbered 48 for the purpose of amending By-Law No. 45 of the said Shire, being a By-Law made on the 15th day of October 1973, for the purpose of regulating garbage collection.

Notice is further given that a copy of the By-Law is open for inspection free of charge during office hours at the office of the Council, Macedon Street, Sunbury.

1379 JOHN M. KELLY, Shire Secretary.

Town and Country Planning Act 1961 (Twelfth Schedule).

SHIRE OF BULLA PLANNING SCHEME 1959

NOTICE THAT A PLANNING SCHEME HAS BEEN PREPARED AND IS AVAILABLE FOR INSPECTION.

Amendment No. 46, 1974.

Notice is hereby given that the Shire of Bulla in pursuance of its powers under the *Town and Country Planning Act 1961*, has prepared a Planning Scheme for:—

That portion of land described as Crown Allotments 42, 43, 50, 51, 58 and 59, Parish of Buttletjork, and being approximately 62a 0r 34p in area.

For the purpose of:—

Rezoning 62a, 0r 34p described as Crown Allotments 42, 43, 50, 51, 58 and 59, Parish of Buttletjork from "Rural" zone to "Residential" zone.

Copy of the Scheme has been deposited at the Municipal Offices, Macedon Street, Sunbury, and at the office of the Town and Country Planning Board, 235 Queen Street, Melbourne, and will be open for inspection during office hours by any person free of charge.

Any persons affected by the Planning Scheme are required to set forth in writing all objections they may have, addressed to the Shire Secretary, Shire of Bulla, Municipal Offices, Macedon Street, Sunbury, on or before the 24th November, 1974, and state whether they wish to be heard in respect of their objections.

Dated 14th October, 1974.

1380 JOHN M. KELLY, Shire Secretary.

SHIRE OF HEYTESBURY.

LOAN No. 36.

Notice of Intention to Borrow the Sum of \$40,000 for Permanent Works and Undertakings.

Notice is hereby given that the Council of the Shire of Heytesbury proposes to borrow the principal sum of \$40,000 secured by a charge over the general rates of the municipality, such sum to be raised by the grant of a mortgage in accordance with the provisions of the *Local Government Act 1958*.

1. The maximum rate of interest that may be paid is 9.85 per cent. per annum.

2. The purpose for which the loan is to be applied is to pay for part cost of erecting a sporting complex at Port Campbell.

3. The period of the loan shall be 20 years.

4. The moneys borrowed shall be repayable by providing out of the municipal fund half-yearly instalments of approximately \$2,307.24 each including principal and interest on the first day of January and the first day of July during the currency of the loan. The first instalment shall be payable on the first day of July 1975.

5. Such moneys shall be repayable to The Commissioners of The State Savings Bank of Victoria at the office of the said Commissioners, Corner Elizabeth and Bourke Streets, Melbourne.

The plans and specifications and the estimate of the cost of the proposed works and a statement showing the proposed expenditure of the moneys to be borrowed are open for inspection at the office of the Council of the Shire of Heytesbury, at Municipal Offices, Cobden.

1405 M. L. WHELAN, Shire Secretary.

SHIRE OF WERRIBEE.

NOTICE is hereby given that the President, Councillors and Ratepayers of the Shire of Werribee have applied for a Lease under Section 134 of the *Land Act 1958*, for a term of twenty-one years in respect of an area of Crown land between Watton Street and the Werribee River, Werribee as a site for amusement and recreation.

1091 P. R. JORDAN, Acting Shire Secretary.

BAIRNSDALE WATERWORKS TRUST.

NOTICE TO OWNERS OF TENEMENTS IN THE UNDERMENTIONED STREETS AND PRIVATE STREETS, LANES, COURTS AND ALLEYS OPENING THERETO.

Albert Street, Anderson Street, Bailey Street, Bent Street, Bredt Street, Bridge Street, Buchanan Street, Bull Street, Calvert Street, Charles Street, Churchill Street, Combay Street, Crooke Street, Dahlsen Crescent, Dalmahoy Street, Davies Street, Dawson Street, Day Street, Dean Street, Drevermann Street, Enid Street, Evelyn Street, Francis Street, Freeman Street, Glenda Court, Goodman Street, Gould Street, Grant Street, Grant Street South, Gray Street, Grosvenor Court, Hadfield Street, High Street, Hodgson Street, James Court, Jefferson Street, Jennings Street, Ligar Street, Lucknow Street, Macarthur Street, Macleod Street, Macrae Street, Main Street, McCulloch Street, McKean Street, McLean Street, McMillan Street, Mitchell Street, Morgan Street, Murphy Street, Nicholson Street, O'Brien Street, Park Street, Payne Street, Pearson Street, Pinnock Street, Potter Street, Power Street, Pyke Street, Riverine Street, Robb Street, Ross Street, Rupert Street, Service Street, Sharpe Street, Smith Street, Stavely Street, Swan Street, Swan Street Lucknow, Taylor Street, Turnbull Street, Victoria Street, Wallace Street, Warde Street, Williams Parade, Wood Street;

Ballantyne Street, 132 feet north from Drevermann Street, 396 feet north from Wallace Street, 330 feet south from Wallace Street.

Burns Street, Freeman Street to Albert Street.

Doherty Street, Wallace Street to Moroney Street, Williams Parade to Drevermann Street.

Forge Creek Road, Princes Highway to Bairnsdale Cemetery.

Hosie Street, McKean Street to O'Brien Street.

McEacharn Street, Princes Highway to Croke Street.

Omeo Highway, Princes Highway to Lanes Road.

Maude Street, 924 feet east from Charles Street.

Mitchell Street East Bairnsdale, 990 feet east from Hadfield Street.

Moroney Street, Dawson Street to Ballantyne Street.

Pope Street, Bredt Street to Doherty Street.

Pound Swamp Hill Road, 198 feet north from Riverine Street.

Princes Highway, from Bengworden Road along Highway to Phillips Lane East Bairnsdale.

Riley Street, Wallace Street to 132 feet north of Ross Street.

Bairnsdale—Paynesville Road, 8,448 feet south from Princes Highway.

Scott Street, Morgan Street to Potter Street.

Garden Avenue, 132 feet north from Moroney Street.

Greene Street, 1,452 feet west from Calvert Street.

The main pipe in the said streets being laid down the owner of all tenements situated above are hereby required on or before the first day of January 1975, to cause a proper pipe and stop cocks to be laid so as to supply water within such tenements from the main pipe.

The common seal of the Bairnsdale Waterworks Trust was hereunto affixed this 21st day of October, 1974, in the presence of—

1455 (SEAL) A. W. WYNDHAM, Chairman.
J. B. NEALE, Secretary.

Water Act.

KYNETON SHIRE WATERWORKS TRUST.

PROCLAMATION OF RURAL DISTRICT AND CONSTRUCTION OF WORKS FOR THE SUPPLY OF WATER AT KYNETON WEST.

NOTICE is hereby given that the Kyneton Shire Waterworks Trust has made application to the Honorable the Minister of Water Supply for the proclamation of a Rural District, and for the construction, maintenance, and continuance of Water Supply Works within that Rural District to supply West Kyneton under the provisions of the Water Act.

A general plan and description of the proposed works have been submitted with the application, and copies of same may be seen at the Shire Office, Shire Hall, Kyneton.

Dated at Kyneton, this 2nd day of October, 1974.

1167 S. G. PORTER, Secretary.

GEELONG WATERWORKS AND SEWERAGE TRUST.

Pursuant to Section 60 of the *Geelong Waterworks and Sewerage Act 1958* (No. 6263) the Trust has prepared plans to indicate the particulars of sewers and underground works, the construction of which the Trust intends to begin at a date, not less than one month after publication of the notice, in or adjacent to the following localities within the Drainage Area.

Merlin Crescent, Corio. Shire of Corio
Leopold Sewerage Scheme. Shire of Bellarine

450 mm diameter Rising Main, south of, Geelong—Queenscliff Railway Reserve, from Melaluka Road, crossing Bellarine Highway at Grinter Street, thence crossing Wilsons Road and along Regent Street and Boundary Road.

NOTICE IS HEREBY GIVEN that the plans indicated above are open for inspection at the Trust's Offices, Rynie Street, Geelong, between the hours of 9.00 a.m. and 5.00 p.m. from Monday to Friday (public holidays excepted) by the owners or occupiers of land or premises within the Drainage Area.

1459 B. C. HENSHAW, Secretary.

NOTICE IS HEREBY GIVEN that the partnership heretofore subsisting between PAMELA WINIFRED BRAMLEY and JUDITH BLAKE carrying on business as Real Estate Developers at Knox under the style or firm of P. W. BRAMLEY & J. BLAKE has been dissolved by mutual consent as from the 7th day of October 1974.

Dated this 16th day of October, 1974.

P. W. BRAMLEY by her Solicitors and Agents RODDA, BALLARD & VROLAND. 1360

I, DELLMA ANNE MURRAY of 439 Campbell Street, Swan Hill in the State of Victoria home duties heretofore called and known by the name of DELLMA ANNE LE PAGE HEREBY GIVE NOTICE that on the 14th day of October, 1974 I renounced and abandoned the use of my said surname of LE PAGE and assumed in lieu the surname of MURRAY AND further that such change is evidenced by a deed dated the 14th day of October, 1974 duly executed by me and attested and filed in the Office of the Registrar General Melbourne.

Dated this 14th day of October, 1974.

1358 DELLMA ANNE MURRAY,
formerly known as DELLMA ANNE LE PAGE.

Notice is hereby given that the Partnership previously subsisting between Malcolm Roderick Charles Wackett and Patrick James Gibson both of Warracknabeal carrying on business as Solicitors at 152 Scott Street, Warracknabeal under the firm name of Griffiths & Wackett has been dissolved as from the Thirteenth of October 1974. Malcolm Roderick Charles Wackett will henceforth carry on the said business of Solicitor under the name of Griffiths & Wackett as sole trader, in conjunction with Mr. J. N. Griffiths.

MALCOLM RODERICK CHARLES WACKETT.
PATRICK JAMES GIBSON.

Griffiths & Wackett, solicitors, 152 Scott Street,
Warracknabeal. 1359

NOTICE is hereby given that the partnership subsisting between KEVIN JOHN DUFF, MARGARET MARY DUFF, KEVIN JOHN DUFF as Trustee for WARREN JAMES DUFF and KEVIN JOHN DUFF as Trustee for STEWART JOHN DUFF under the firm name of "K. & M. Duff" and carrying on business at Traralgon was dissolved as from the 30th day of November, 1971.

Dated the 16th day of October, 1974.

Signed by Margaret Mary Duff and Kevin John Duff for himself and as Trustee for Warren James Duff and Stewart John Duff.

RYAN, MACKEY & KELLY, solicitors of 65 Main Street,
Greensborough. 1364

NOTICE is hereby given that the partnership heretofore subsisting between us the undersigned carrying on business as Wholesale Merchants at 296 Collins Street Melbourne under the name of Buchanan Hemingway Distributors has been dissolved by mutual consent as from the 4th day of October, 1974. The said business will be continued at the same postal address under the sole proprietorship of Lorna Dorothea Hemingway.

LORNA HEMINGWAY.
JOHN BUCHANAN.

1431

NOTICE IS HEREBY GIVEN that the partnership heretofore subsisting between GIOVANNI ZOLLO (also known as JOHNNY ZOLLO) LIVIO LUNELLI, RINALDO PANARA and VICTORI ZULICKI of Coffee Lounge proprietors under the name of IL MONDO ESPRESSO BAR on the premises situate at and known as 130 Lygon Street, Carlton in the State of Victoria has been dissolved as from the 3rd day of October One thousand nine hundred and seventy-four by the retirement of the said Giovanni ZOLLO and LIVIO LUNELLI from that partnership. All debts due and owing by the business as at the date of dissolution shall be received and paid by all partners and the said RINALDO PANARA and VICTOR ZULICKI will continue to carry on the said business in the said name at the said premises. 1432

NOTICE IS HEREBY GIVEN that the partnership heretofore subsisting between GIOVANNI (also known as JOHNNY) ZOLLO, LIVIO LUNELLI and RINALDO PANARA of Coffee Lounge Proprietors on the premises situate at and known as 144 and 146 Lygon Street, Carlton in the State of Victoria has been dissolved as from the 20th day of September, One thousand nine hundred and seventy-four by the retirement of the said GIOVANNI ZOLLO and RINALDO PANARA from that partnership. All debts due and owing by the business shall be received and paid by the said LIVIO LUNELLI who will continue to carry on the said business at the said premises. 1433

NOTICE is hereby given that the Partnership heretofore subsisting between WILLIAM JOHN PYPERS of 6 Mayo Street, Sunshine in the State of Victoria, Sales Representative, and DAVID WINSTON WHITE of 5 Willow Street, Box Hill North in the said State, Electronic Technician,

carrying on business in selling electronic goods at 966-968 High Street, Armadale, under the style of the firm of GEO. HAWTHORN ELECTRONICS has been dissolved as from the 10th day of September, 1974, so far as concerns the said William John Pypers who retires from the said firm as at that date. 1464

Companies Act 1961.—In the matter of **KENLINE CONSTRUCTIONS PROPRIETARY LIMITED** (in Liquidation).

NOTICE is hereby given that at an extraordinary Meeting of the Members of the abovenamed Company held on the 11th October 1974, it was resolved that the Company be wound up voluntarily and at a Meeting of Creditors held on the same day pursuant to Section 260, it was resolved that for such purpose, **BRENDAN JOHN O'CONNOR** of Taylor O'Connor & Co., 562 St. Kilda Road, Melbourne be appointed Liquidator.

NOTICE is also given that after twenty-one days from this date I shall proceed to distribute the assets. All creditors having any claims against the Company should furnish particulars of same by that date, otherwise I shall proceed to distribute the assets without regard to their claims.

Dated this 18th day of October, 1974.

B. J. O'CONNOR, Liquidator.

Taylor O'Connor & Co., accountants, 562 St. Kilda Road, Melbourne, 3004. Telephone: 51 1388. 1377

James W. Mann, Public Accountant, of 370 Blackshaws Road, North Altona was appointed "LIQUIDATOR" of Ben Williams Pty. Ltd. in a Members Voluntary Winding-up on the 15th October 1974.

1401 **JAMES W. MANN**.

SUTTON THOMPSON PTY. LTD. (IN VOLUNTARY LIQUIDATION)

NOTICE OF FINAL MEETING.

Notice is hereby given pursuant to Section 272 of the Companies Act 1961 that a Final Meeting of the Company will be held at the office of the Liquidator, **J. K. BEE**, Ground Floor, 140 Flinders Street, Melbourne on the 27th November 1974 at 10 a.m., for the purpose of having an account laid before it showing how the winding up of the Company has been conducted, the property of the Company disposed of, and giving any explanation required thereof.

Dated this 18th day of October, 1974.

1402 **J. K. BEE**, Liquidator.

Companies Act 1961, Section 260.

MATHEWS & GRAVENER PTY. LIMITED.

NOTICE OF MEETING OF CREDITORS.

Notice is hereby given that a meeting of creditors of Mathews & Graveney Pty. Limited, will be held at the office of Hebard & Gunning, 2 Station Street, Moorabbin, on Tuesday the 29th October, 1974, at 3.00 p.m., the Company having convened a meeting of its members for the same day for the purpose of considering a resolution that the Company be wound up voluntarily.

Dated this 18th day of October, 1974.

R. P. MATHEWS, Director.

Hebard & Gunning, chartered accountants, 2 Station Street, Moorabbin, 3189. 1407

In the matter of the **Companies Act 1961**; and in the matter of **SPORTS MARINE PTY. LTD.** (in Liquidation).

Notice is hereby given that pursuant to Section 272 of the Companies Act 1961, the final meeting of the members of the Company will be held at 234 Albert Road, South Melbourne on the 27th day of November, 1974, at 2.00 p.m., for the purpose of laying before the meeting the account of the winding up and any explanation thereof.

Dated this 18th day of October, 1974.

C. G. CONDON, Liquidator.

Condon, Hamilton & Co., chartered accountants, 234 Albert Road, South Melbourne, 3205. 1395

In the matter of the **Companies Act 1961**; and in the matter of **CATHEDRAL INVESTMENTS PTY. LTD.** (in Liquidation).

Notice is hereby given that pursuant to Section 272 of the Companies Act 1961, the final meeting of the members of the Company will be held at 234 Albert Road, South Melbourne on the 27th day of November, 1974, at

2.15 p.m., for the purpose of laying before the meeting the account of the winding up and any explanation thereof.

Dated this 18th day of October, 1974.

C. G. CONDON, Liquidator.

Condon, Hamilton & Co., chartered accountants, 234 Albert Road, South Melbourne, 3205. 1396

In the matter of the **Companies Act 1961**; and in the matter of **MENZIES ESTATES PTY. LTD.** (in Liquidation).

Notice is hereby given that pursuant to Section 272 of the Companies Act 1961, the final meeting of the members of the Company will be held at 234 Albert Road, South Melbourne on the 27th day of November, 1974, at 2.30 p.m., for the purpose of laying before the meeting the account of the winding up and any explanation thereof.

Dated this 18th day of October, 1974.

C. G. CONDON, Liquidator.

Condon, Hamilton & Co., chartered accountants, 234 Albert Road, South Melbourne, 3205. 1397

In the matter of the **Companies Act 1961**; and in the matter of **A.B.T. PTY. LTD.** (in Liquidation).

Notice is hereby given that pursuant to Section 272 of the Companies Act 1961, the final meeting of the members of the Company will be held at 234 Albert Road, South Melbourne on the 27th day of November, 1974, at 2.45 p.m., for the purpose of laying before the meeting the account of the winding up and any explanation thereof.

Dated this 18th day of October, 1974.

C. G. CONDON, Liquidator.

Condon, Hamilton & Co., chartered accountants, 234 Albert Road, South Melbourne, 3205. 1398

In the matter of the **Companies Act 1961**; and in the matter of **FINANCE MANAGEMENT PTY. LTD.** (in Liquidation).

Notice is hereby given that pursuant to Section 272 of the Companies Act 1961, the final meeting of the members of the Company will be held at 234 Albert Road, South Melbourne on the 27th day of November, 1974, at 3.00 p.m., for the purpose of laying before the meeting the account of the winding up and any explanation thereof.

Dated this 18th day of October, 1974.

C. G. CONDON, Liquidator.

Condon, Hamilton & Co., chartered accountants, 234 Albert Road, South Melbourne, 3205. 1399

In the matter of the **Companies Act 1961**; and in the matter of **85 WELLS STREET PTY. LTD.** (in Liquidation).

Notice is hereby given that pursuant to Section 272 of the Companies Act 1961, the final meeting of the members of the Company will be held at 234 Albert Road, South Melbourne on the 27th day of November, 1974, at 3.15 p.m., for the purpose of laying before the meeting the account of the winding up and any explanation thereof.

Dated this 18th day of October, 1974.

C. G. CONDON, Liquidator.

Condon, Hamilton & Co., chartered accountants, 234 Albert Road, South Melbourne, 3205. 1400

Companies Act 1961, Section 260.

RADIAL IMPORTS (AUSTRALIA) PTY. LIMITED.

NOTICE OF MEETING OF CREDITORS.

NOTICE IS HEREBY GIVEN that a meeting of creditors of Radial Imports (Australia) Pty. Limited will be held at the Fitzgerald Room, Accountants' House, 49 Exhibition Street, Melbourne on Friday 8th November, 1974, at 10.00 a.m., the company having convened a meeting of its members for the same day for the purpose of considering a resolution that the company be wound up voluntarily.

Dated this 18th day of October, 1974.

S. K. DAVIS, Director.

Michael W. E. Hosking, public accountant, 96 High Street, St. Kilda, 3182, telephone: 94 1932. 1475

In the matter of the **Companies Act 1961**; and in the matter of **THE LEVIATHAN LIMITED** (in Voluntary Liquidation).

NOTICE IS HEREBY GIVEN that creditors of the abovenamed company (which is being wound up voluntarily) are required on or before the 15th day of November 1974 to send in their names and addresses and particulars of their debts or claims, and the names and addresses of their solicitors (if any), to the undersigned, the Liquidator of the said company, and if so required in writing from the said Liquidator are by their solicitors or personally required

to come in and prove the said debts or claims at such time and place as shall be specified in such notice, or in default thereof they will be excluded from the benefit of any distribution made before such debts are proved.

Dated this 18th day of October, 1974.

M. J. SCOTT, Liquidator.

J. S. Eastwood & Etherington, chartered accountants,
450 Little Collins Street, Melbourne, 3000. 1476

N.C.J.S. PTY. LTD.

NOTICE OF RESOLUTION.

Notice is hereby given that at an Extraordinary General Meeting of the members of N.C.J.S. Proprietary Limited duly convened, and held at 207 Nelson Place, Williamstown on the 10th day of October 1974 the following special resolution was duly passed.

"That the Company be wound up voluntarily and that in view of the Declaration of Solvency made by the Directors the liquidation be conducted as a Members' Voluntary Winding Up."

Also take notice that Mr. Keith Lewis Paroissien of 280 Church Street, Richmond was appointed Liquidator of the Company and that all Creditors having a claim against the Company must lodge details of the same with him within 21 days otherwise he shall proceed to distribute the assets without regard to their claims.

1444

K. L. PAROISSIEN, Liquidator.

In the matter of the Companies Act; and in the matter of S.B.W. PROPRIETARY LIMITED.

NOTICE IS HEREBY GIVEN that at an Extraordinary General Meeting of the abovenamed Company duly convened and held at 271 William Street, Melbourne on the 27th September, 1974 at 10.00 o'clock in the forenoon the following special resolution was duly passed, viz:

That the Company be wound up voluntarily and that Kenneth William Scott of 13 Glenroy Road, Hawthorn in the State of Victoria be appointed liquidator for the purpose of such winding up.

1445

S.B.W. PROPRIETARY LIMITED,
D. M. HUTCHINSON.

The Companies Act 1961.—In the matter of CARPET & RUG STEAM CLEANERS PTY. LTD.

NOTICE is hereby given that at a meeting of the members of the abovenamed company held on the 11th day of October, 1974, it was resolved that the company be wound up voluntarily and at a meeting of creditors held on the same day pursuant to Section 260, it was resolved that for such purpose, Ronald Dennis Widdows, of 703 South Road, Moorabbin, Public Accountant, be appointed Liquidator.

Dated this 15th day of October, 1974.

R. D. WIDDOWS, public accountant, Office 2, 703 South Road, Moorabbin, Vic. 3189. 1446

Companies Act 1961.—J. F. CLEMENTSON PTY. LIMITED (in Liquidation).—Notice Covering Final Meeting of Members, Pursuant to Section 272.

Notice is hereby given that the Final Meeting of Members of J. F. Clementson Pty. Limited (In Liquidation) will be held at the Office of Edwards, Pearl & Associates, 372 South Road, Moorabbin, at 5 p.m. on Monday the 25th November 1974 for the purpose of laying before the Meeting the Liquidators Final Account and report and giving any explanation thereof.

Dated this 10th day of October, 1974.

1447

R. A. EDWARDS, Liquidator.

In the Supreme Court of Victoria.—1974 No. Co. 8940.—In the matter of the Companies Act 1961; and in the matter of FEATHEROCK INDUSTRIES PTY. LTD.; and in the matter of a Petition Dated the 1st Day of October, 1974.

ADVERTISEMENT OF PETITION.

NOTICE is hereby given that a Petition for the winding up of the abovenamed company by the Supreme Court was, on the 2nd day of October 1974, presented by A. HOFFMANN (INSURANCES) PTY. LTD. And that the said Petition is directed to be heard before the Court sitting at the Law Courts, William Street, Melbourne at the hour of 10.30 o'clock in the forenoon on the 12th day of November 1974, and any creditor or contributory of the said company desiring to support or oppose the making of an order on the said petition may appear at the time of hearing by himself or his counsel for that purpose; and a copy of the

petition will be furnished to any creditor or contributory of the said company requiring the same by the undersigned on payment of the regulated charge for the same.

The Petitioner's address is Suite 209, 343 Little Collins Street, Melbourne.

The Petitioner's solicitors are Messrs. Madgwick & Madgwick of 491 Bourke Street, Melbourne.

MESSRS. MADGWICK & MADGWICK.

NOTE: Any person who intends to appear on the hearing of the said petition must serve on or send by post to the abovenamed solicitors notice in writing of his intention so to do. The notice must state the name and address of the person, or if a firm, the name and address of the firm, and must be signed by the person or firm, or his or their solicitor (if any), and must be served, or, if posted, must be sent by post in sufficient time to reach the abovenamed not later than four o'clock in the afternoon of the 11th day of November 1974. 1448

In the matter of the Companies Act 1961; and in the matter of GNOVOOK HOLDINGS PTY. LTD. (in Liquidation).

Notice is hereby given that pursuant to Section 272 of the Companies Act 1961, the final meeting of the members of the Company will be held at 4/795 Glenferrie Road, Hawthorn, 3122, on the 28th day of November, 1974, at 2 p.m., for the purpose of laying before the meeting the account of the winding up and any explanation thereof.

Dated this 21st day of October, 1974.

1453

H. G. STEVENS, Liquidator.

BRIAN LANE AIR CONDITIONING (VIC.) PTY. LTD. (IN VOLUNTARY LIQUIDATION).

NOTICE CONVENING FINAL MEETING, PURSUANT TO SECTION 272 OF THE COMPANIES ACT 1961.

Pursuant to Section 272 of the Companies Act 1961 a General Meeting of members and creditors of the abovementioned company will be held at the office of the liquidator, 13th Floor, 257 Collins Street, Melbourne on Wednesday the 27th day of November, 1974 at 9.15 a.m. for the purpose of having an account laid before them showing the manner in which the winding up has been conducted and the property of the company disposed of, and of hearing any explanations that may be given by the liquidator.

Dated this 21st day of October, 1974.

1454

N. A. ROGERS, Liquidator.

The Companies Act 1961.—In the matter of BROOKLYN HIDE & SKIN PROCESSORS PROPRIETARY LIMITED (Receiver Manager Appointed).—Notice of Meeting of Creditors, Pursuant to Section 260.

NOTICE is hereby given that a Meeting of Creditors of the abovenamed company will be held at The Institute of Chartered Accountants 140 Queen Street, Melbourne on 7th day of November, 1974 at 10.00 a.m., the company having convened a meeting of its members for the same day for the purpose of considering a Resolution that the company be wound up voluntarily.

Dated this 21st day of October, 1974.

L. REILLY, Director.

Arthur Young & Company, chartered accountants, 440 Collins Street, Melbourne, 3000. 1472

SUMMERLEIGH INVESTMENT PROPRIETARY LIMITED.

NOTICE is hereby given, pursuant to section 254 (2) (b) of the Companies Act 1961, that at an extraordinary general meeting of members of SUMMERLEIGH INVESTMENT PROPRIETARY LIMITED, duly convened and held at 20 Norman Street, McKinnon on the 18th day of October 1974, the special resolution set out below was duly passed—

"That the company be wound up voluntarily and that Bruce Etherington of 450 Little Collins Street, Melbourne be appointed liquidator for the purpose of winding up."

Dated this 18th day of October, 1974.

1473

B. ETHERINGTON; Liquidator.

Companies Act 1961.

NOTICE OF FINAL MEETING OF SHAREHOLDERS OF MELWEST ENGINEERING COMPANY PROPRIETARY LIMITED (IN LIQUIDATION).

Notice is hereby given that, pursuant to Section 272 of the Companies Act 1961, a general meeting of the members of MELWEST ENGINEERING COMPANY PROPRIETARY LIMITED (IN LIQ.) will be held at 450 Little Collins Street, Melbourne on Friday the 29th day of November

1974 at 3 o'clock in the afternoon, for the purpose of laying before the meeting an account showing how the winding up has been conducted and the property of the Company has been disposed of, and of giving any explanation of the account.

1474

I. M. PEEL, Liquidator.

NOTICE OF WINDING UP ORDER.

In the matter of OWEN THOMAS PTY. LTD. Winding up order made 15th October 1974. Name and address of liquidator Leslie Philip Smart, of 51 Queen Street, Melbourne.

BRIAN DAVID KEWLEY, of the firm of Messrs. Moule, Hamilton & Derham, solicitors for the petitioner. 1429

Companies Act 1961, New South Wales.
CHEMVIRON (AUSTRALIA) PTY. LTD.

NOTICE OF MEETING OF CREDITORS.

NOTICE is hereby given that, pursuant to Section 260 of the Companies Act 1961, as amended, a meeting of creditors of Chemviron (Australia) Pty. Limited will be held at the offices of Messrs. Norman Waterhouse & Mutton, 153 Flinders Street, Adelaide in the State of South Australia on Monday the 4th day of November 1974, at 10.30 o'clock in the forenoon for the following purposes:—

1. To receive a report from a director of the company nominated by a general meeting of shareholders to be held at the offices of Messrs. Norman Waterhouse & Mutton, 153 Flinders Street, Adelaide aforesaid on Monday the 4th day of November 1974 at 10.15 o'clock in the forenoon at which meeting the following resolution will be considered—

"That the company be wound up voluntarily and that a liquidator be appointed for the purpose of winding up in view of the inability of the company by reason of its liabilities to continue its business."

2. In the event of the shareholders in the general meeting having resolved to liquidate to consider and confirm the appointment of the liquidator nominated by the general meeting or to appoint an alternative liquidator.

3. If thought fit to appoint a committee of inspection pursuant to Section 262 of the said Act.

4. To fix the remuneration of the proposed liquidator or to delegate such power to the committee of inspection if appointed.

5. To consider any other business.

Dated this 18th day of October, 1974.

K. J. TOOHEY, Secretary.

Davies Campbell & Piesse, solicitors, 401 Collins Street, Melbourne, 3000. 1430

Companies Act 1961.—In the matter of FARMERS PEANUT PRODUCTS PTY. LIMITED.

At an Extraordinary General Meeting of the abovenamed Company, duly convened and held at 351 Collins Street, Melbourne on the 21st October, 1974 the following resolution was duly passed as a special resolution:—

"That the company be wound up voluntarily."

And at such meeting, John Edward Howard, Chartered Accountant of 351 Collins Street, Melbourne was appointed Liquidator for the purposes of the winding up.

Dated this 21st day of October, 1974.

1437

J. E. HOWARD, Liquidator.

Companies Act 1961, Section 254.

LE GUY PTY. LTD.

Notice is hereby given that at an Extraordinary General Meeting of the members of the abovenamed company held on 16th October 1974 the following resolution was passed as a Special Resolution:—

"That this company be wound up as a members' voluntary liquidation and that Robert Arthur Waters, of 470 Bourke Street, Melbourne be appointed liquidator."

1438

R. A. WATERS, Liquidator.

Companies Act 1961, Section 254.

OILENE SUPREMA PTY. LTD.

Notice is hereby given that at an Extraordinary General Meeting of the members of the abovenamed company held on 16th October 1974 the following resolution was passed as a Special Resolution:—

"That this company be wound up as a members' voluntary liquidation and that Robert Arthur Waters, of 470 Bourke Street, Melbourne be appointed liquidator."

1439

R. A. WATERS, Liquidator.

In the matter of the Companies Act 1961; and in the matter of L. & H. HOMES PROPRIETARY LIMITED.—Notice of Appointment of Provisional Liquidator.

An Order for the appointment of an Official Liquidator as Provisional Liquidator was made on the 14th October, 1974.

PROVISIONAL LIQUIDATOR: GEOFFREY ORMOND HARRISON of 398 Collins Street, Melbourne Victoria 3000.
CORR & CORR, solicitors for the petitioner. 1442

In the matter of the Companies Act 1961; and in the matter of P. & J. GYOPAR PROPRIETARY LIMITED.

WINDING-UP ORDER MADE:—the 27th day of September, 1974.

NAME AND ADDRESS OF LIQUIDATOR:—John Kenneth Hall of 395 Collins Street, Melbourne.

G. A. HILFORD & CO., solicitors for petitioner. 1443

In the Supreme Court of Victoria.—1974, No. C.8945.—In the matter of the Companies Act 1961; and in the matter of L. & H. HOMES PROPRIETARY LIMITED.

NOTICE IS HEREBY GIVEN that a Petition for the winding up of the abovenamed Company by the Supreme Court was on the 10th day of October, 1974 presented by OSCAR CLEMENT HOCHKINS and JUNE BEATRICE HOCHKINS; AND THAT the said Petition is directed to be heard before the Court sitting at the Law Courts William Street, Melbourne on the 28th day of November, 1974 at the hour of 10.30 o'clock in the forenoon; and any Creditor or Contributory of the said Company desiring to support or oppose the making of an Order on the said Petition may appear at the time of hearing by himself or his Counsel for that purpose; and a copy of the Petition will be furnished to any Creditor or Contributory of the said Company requiring the same by the undersigned on payment of the regulated charge for the same.

THE PETITIONER'S ADDRESS: 11 Kitchener Road, Croydon, Victoria.

THE PETITIONER'S SOLICITORS: Messrs. Corr & Corr, 290 La Trobe Street, Melbourne (Reference: 74/107/235).

CORR & CORR, solicitors for the petitioners.

NOTE.—Any person who intends to appear on the hearing of the said Petition must serve on or send by post to the abovenamed Solicitors, Notice in writing of his intention so to do. The Notice must state the name and address of the person, or, if a firm, the name and address of the firm and it must be signed by the person or firm, or his or their Solicitor (if any) and must be served, or if posted, must be sent by post in sufficient time to reach the abovenamed not later than 4.00 o'clock in the afternoon of the 27th of November, 1974. 1441

FINAL MEETING.

The Companies Act 1961 —In the matter of CHARLES POTTS PTY. LTD. (in Voluntary Liquidation).—Notice of Final Meeting.

Notice is hereby given that, pursuant to section 272 of the Companies Act 1961, a General Meeting of the members of the above-named company will be held at 200 Little Lonsdale Street, Melbourne on 25th November, 1974 at 11 a.m. for the purpose of having an account laid before them showing the manner in which the winding up has been conducted and the property of the company disposed of, and of hearing any explanation that may be given by the liquidator.

Dated the 21st day of October, 1974.

1409

MR. G. T. EASTON, Liquidator.

In the matter of the Companies Act 1961; and in the matter of STEELEX HOLDINGS.

WINDING UP ORDER MADE: 15th day of October, 1974.

NAME AND ADDRESS OF LIQUIDATOR: Ernest Harding Niemann, of 44 Market Street, Melbourne.

WEIGALL & CROWTHER, solicitors for the petitioner.

1421

In the matter of the Companies Act 1961; and in the matter of FURNLEIGH FURNITURE PTY. LTD.

WINDING UP ORDER MADE: 15th day of October, 1974.

NAME AND ADDRESS OF LIQUIDATOR: Ernest Harding Niemann, of 44 Market Street, Melbourne.

WEIGALL & CROWTHER, solicitors for the petitioner.

1422

*Companies Act 1961, Section 254 (2).***KADROS PROPRIETARY LIMITED (IN LIQUIDATION).****NOTICE OF RESOLUTION.**

At an extraordinary general meeting of the members of Kadros Proprietary Limited duly convened and held at 1 Palmerston Crescent, South Melbourne on the 14th day of October, 1974, the special resolution set out below was duly passed.

"THAT the company be wound up voluntarily as a members' voluntary winding up in accordance with the provisions of the *Companies Act 1961*."

"THAT Kevin James Browne be and is hereby appointed liquidator."

Notice is also given that after twenty-one days from this date, I shall proceed to distribute the assets. All creditors having any claims against the company should furnish particulars of same by that date, otherwise, I shall proceed to distribute the assets without regard to their claim.

Dated this 17th day of October, 1974.

1423 K. J. BROWNE, Liquidator.

In the matter of **SUMMIT HOLDINGS PROPRIETARY LIMITED.—**
Notice of Winding Up Order.

Winding Up Order made the 11th day of October, 1974.

Name and address of official Liquidator—

Everett Thomson Bent,
 545 St. Kilda Road,
 Melbourne.

GRANT & CO., solicitors for the petitioner. 1424

*Companies Act 1961, Section 254 (2).***JENNINGS INVESTMENTS PTY. LTD. (IN VOLUNTARY LIQUIDATION).****NOTICE OF RESOLUTION.**

At an Extraordinary General Meeting of the Members of JENNINGS INVESTMENTS PTY. LTD., duly convened and held at the office of Carrick Bossence & Partners, 330 Collins Street, Melbourne on the 16th October, 1974 it was resolved that the Company be wound up voluntarily as a Members voluntary winding up in accordance with the provision of the *Companies Act 1961*, and that Norman Martin be appointed Liquidator.

Notice is also given that after twenty one days from this day, I shall proceed to distribute the assets. All creditors having any claims against the Company should furnish particulars of same by that date, otherwise I shall proceed to distribute the assets without regard to their claim.

Dated this 17th day of October, 1974.

1425 N. MARTIN, Liquidator.

The *Companies Act 1961*.—In the matter of **KYABRAM PETROLEUM SUPPLIES PTY. LTD. (in Liquidation).**

A SECOND DIVIDEND is intended to be declared in the above-mentioned matter. Creditors who have not proved their debts by the 11th day of November, 1974 will be excluded from the dividend.

Dated this 21st October, 1974

ROBERT EASTAUGH RAMSAY, Liquidator.

Kennedy Smail, 296 Little Lonsdale Street, Melbourne, 1426
 3000.

In the matter of **TRANS LINK PROPRIETARY LIMITED.—**Notice of Winding Up Order.

Winding Up Order made the 11th day of October, 1974.

Name and address of official Liquidator—

Everett Thomson Bent,
 545 St. Kilda Road,
 Melbourne.

GRANT & CO., solicitors for the petitioner. 1427

*Companies Act 1961.***R. ROBERTSON INVESTMENTS PTY. LTD.**

Notice is hereby given that at an Extraordinary Meeting of the abovenamed company duly convened and held at 422 Collins Street, Melbourne at 10 a.m. on the 15th day of October, 1974, the following Special Resolution was duly passed—

"That the Company would be wound up voluntarily and that John Stuart Walker, Chartered Accountant of 422 Collins Street, Melbourne be appointed Liquidator for the purpose of such winding up."

Dated the 15th day of October, 1974.

1428 ROBERT ROBERTSON, Chairman.

Companies Act 1961.—In the matter of **J. F. CLEMENTSON PTY. LTD. (in Liquidation).**

Notice is hereby given that at an extraordinary Meeting of the Members of the abovenamed Company held on the 7th October, 1974 it was resolved that the Company be wound up voluntarily and it was resolved that for such purpose Robin Arthur Edwards of 372 South Road, Moorabbin, Public Accountant, be appointed Liquidator.

Dated this 7th day of October, 1974.

1372 R. A. EDWARDS, Liquidator.

Companies Act 1961.—In the matter of **LAUNCESTON INVESTMENTS PTY. LTD. (in Liquidation).**

At a general meeting of the Company held on 21st October 1974 the following resolution was passed—

"That the Company be wound up voluntarily and that Thomas Neal Duncan Stevens of 422 Collins Street Melbourne Chartered Accountant be appointed Liquidator."

T. N. D. STEVENS, Liquidator.

21st October, 1974. 1462

Companies Act 1961.—In the matter of **EXVIC INVESTMENTS PTY. LTD. (in Liquidation).**

At a general meeting of the Company held on 21st October 1974 the following resolution was passed—

"That the Company be wound up voluntarily and that Thomas Neal Duncan Stevens of 422 Collins Street Melbourne Chartered Accountant be appointed Liquidator."

T. N. D. STEVENS, Liquidator.

21st October, 1974. 1463

*The Companies Act 1961.***MONTROSE PTY. LTD. (IN VOLUNTARY LIQUIDATION).****NOTICE CONVENING FINAL MEETING OF MEMBERS, PURSUANT TO SECTION 272.**

NOTICE is hereby given in pursuance of Section 272 of the *Companies Act 1961* that a Final Meeting of the Members of the abovenamed Company will be held on the 6th day of December, 1974, at 2 p.m., at the Offices of Gordon Quinn & Co., 2nd Floor, 325 Collins Street, Melbourne, for the purpose of having an account laid before them, showing the manner in which the winding up has been conducted and of hearing any explanations that may be given by the Liquidator.

Dated this 10th day of October, 1974.

G. T. QUINN, Liquidator.

Gordon Quinn & Co., chartered accountants, 325 Collins Street, Melbourne, Vic. 3000. 1371

Companies Act 1961.—In the matter of **B. B. N. INVESTMENTS PTY. LTD. (in Liquidation).**

NOTICE is hereby given that at an extraordinary Meeting of the Members of the abovenamed Company held on the 17th October, 1974 it was resolved that the Company be wound up voluntarily and at a Meeting of Creditors held on the same day pursuant to Section 260, it was resolved that for such purpose EVERETT THOMSON BENT of Suite 18, 545 St. Kilda Road, Melbourne, Public Accountant, be appointed Liquidator.

NOTICE is also given that after twenty-one days from this date I shall proceed to distribute the assets. All creditors having any claims against the Company should furnish particulars of same by that date, otherwise I shall proceed to distribute the assets without regard to their claim.

Dated this 17th day of October, 1974.

E. T. BENT, Liquidator.

Bent & Cogle, public accountants, Suite 18, 545 St. Kilda Road, Melbourne, 3004. 1373

Companies Act 1961.—In the matter of **WILLSTAR PTY. LTD.,** Reg. Office 20th Floor, 351 Collins Street, Melbourne.—
Notice Re Meeting of Creditors, Pursuant to Section 260.

NOTICE is hereby given that a Meeting of Creditors of the abovenamed Company will be held at:—the offices of Bent & Cogle, Public Accountants, Suite 18, 545 St. Kilda Road, Melbourne on Tuesday, 19th November, 1974 at 10.30 a.m., the Company having convened a Meeting of its Members for the same day for the purpose of considering a Resolution that the Company be wound up voluntarily.

Dated this 16th day of October, 1974.

P. B. LAWRENCE, Director.

Bent & Cogle, public accountants, Suite 18, 545 St. Kilda Road, Melbourne, 3004. 1374

Companies Act 1961, Section 254.
OSLO HOLDINGS LIMITED.

Notice is hereby given that at a general meeting of members of the above-named company, held on the 11th day of October, 1974, the following resolution was passed as a special resolution:

"That the company be wound up voluntarily."
1375 J. A. COLEMAN, Secretary

Companies Act 1961.—In the matter of ASHTRONICS PROPRIETARY LIMITED.—Notice Re Meeting of Creditors, Pursuant to Section 260.

NOTICE is hereby given that a Meeting of Creditors of the abovenamed Company will be held at the Meeting Room, Taylor O'Connor & Co., 562 St. Kilda Road Melbourne on Wednesday 20th November 1974, at 3.30 p.m., the Company having convened a Meeting of its Members for the same day for the purpose of considering a Resolution that the Company be wound up voluntarily.

Dated this 18th day of October, 1974.

J. M. McDONALD, Director.

Taylor O'Connor & Co., accountants, 562 St. Kilda Road, Melbourne, 3004. Telephone 51 1388. 1376

CECILIA MITCHELL, late of McGregor Road, Warrnambool, spinster, DECEASED.

CREDITORS, next-of-kin and all others having claims in respect of the abovenamed deceased (who died 25th May 1974) are requested to send particulars of their claims in writing to the Executor REGINALD FRANK ROW-BOTTOM C/o the undersigned, on or before the 23rd December 1974, after which date he will distribute the assets having regard only to the claims of which he then has notice as aforesaid.

DESMOND DUNNE & DWYER, solicitors, Warrnambool. 1394

CREDITORS, Next of Kin and others having claims in respect of the Estate of KEITH DONALD GREIG late of 29 Huddersfield Road, Deer Park, Carpenter and Joiner, deceased, intestate, who died on the Fifteenth day of March One thousand nine hundred and seventy-four, are required to send particulars of their claims to the Administrator, Stephen Greig, care of the undermentioned Solicitors by the Thirtieth day of December One thousand nine hundred and seventy-four after which date the said Administrator will distribute the assets of the said Estate having regard only to the claims of which he then has notice.

MARTIN & MARTIN, solicitors, 37 Queen Street, Melbourne. 1410

CREDITORS Next of Kin and others having claims in respect of the Estate of BERTHA MARY LOGAN late of 11 Larch Street, Blackburn North, Spinster deceased, who died on the Twenty-third day of May One thousand nine hundred and seventy-four, are required to send particulars of their claims to the Executors, Elizabeth Margaret Harrison and Alfred Leslie Harrison, care of the undermentioned Solicitors by the Thirtieth day of December One thousand nine hundred and seventy-four after which date the said Executors will distribute the assets of the said Estate having regard only to the claims of which they then have notice.

MARTIN & MARTIN, solicitors, 37 Queen Street, Melbourne. 1411

JOHN KUPSCH, late of 44 Ruby Street, Preston, retired, DECEASED.

CREDITORS, next-of-kin and others having claims in respect of the Estate of the deceased who died on the 10th day of September, 1974 are requested to send particulars of their claims to the Executrix MARY BEATON KUPSCH C/o the undersigned Solicitor by the 24th day of December, 1974 after which date the said Executrix will proceed to distribute the Estate having regard only to the claims of which she then has notice.

MARJORY C. COATES, 422 Collins Street, Melbourne, 3000. 1412

VIDA ALICE LUGG, formerly of 20 Albert Street; North Caulfield, but late of Plenty Road, Bundoora, spinster, DECEASED.

Creditors, next of kin and others having claims in respect of the estate of the deceased (who died on the twenty-second day of May, 1974) are required by THE PERPETUAL EXECUTORS AND TRUSTEES ASSOCIATION OF AUSTRALIA LIMITED, of 50 Queen Street, Melbourne, to send particulars of their claims to the said Company by

the twenty-seventh day of December, 1974 after which date it will convey or distribute the assets, having regard only to the claims of which the Company then has notice.

KEITH & IAN NESS, solicitors, of 380 Collins Street, Melbourne, solicitors for the said company. 1413

EDNA NEWELL NELSON, late of 11 Kalimna Street, Essendon, in the State of Victoria, widow, DECEASED.

CREDITORS next-of-kin and others having claims in respect of the Estate of the abovenamed deceased who died on the 25th day of June 1974 are required to send particulars thereof to the Executor care of the undermentioned Solicitors on or before the 24th day of December 1974 after which date the said Executor may convey or distribute the assets having regard only to the claims of which he then has notice.

K. P. REES & CO., solicitors, 118 Queen Street, Melbourne. 1414

BERTHA LILIAN BREWER, late of 27 Rose Street, Box Hill, in the State of Victoria, spinster, DECEASED.

CREDITORS next-of-kin and others having claims in respect of the Estate of the abovenamed deceased who died on the 16th day of July 1974 are required to send particulars thereof to the Executor care of the undermentioned Solicitors on or before the 24th day of December 1974 after which date the said Executor may convey or distribute the assets having regard only to the claims of which he then has notice.

K. P. REES & CO., solicitors, 118 Queen Street, Melbourne. 1415

CREDITORS next of kin and others having claims in respect of the ESTATE OF ELIZABETH JANE BURNS formerly of 73 Paisley Street Footscray but late of "Nazareth House" Cornell Street Camberwell Widow deceased who died on the 13th July, 1974, are to send particulars of their claims to the Executor BERNARD FRANCIS O'CONNOR (In the Will called Bernard O'Connor) care of the undersigned by the 31st day of December, 1974, after which date he will commence to distribute the assets having regard only to the claims of which he then has notice.

RENNICK & GAYNOR, solicitors, 481 Riversdale Road, Hawthorn East, Victoria, 3123. 1416

CREDITORS next of kin and others having claims in respect of the ESTATE OF VERA MAY ARBER late of 12 Adams Street, Murrumbeena Widow deceased who died on the 12th February 1974 are to send particulars of their claims to the Executors STUART MICHAEL ARBER and BERNARD WILLIAM GAYNOR care of the undersigned by the 31st day of December, 1974, after which date they will commence to distribute the assets having regard only to the claims to which they then have notice.

RENNICK & GAYNOR, solicitors, 491 Bourke Street, Melbourne. 1417

Creditors, next of kin and others having claims in respect of the Estate of MYRLE MABEL ELLEN HILLAS late of Flat 6, 22 Pickett Street, Footscray in the State of Victoria Saleswoman deceased Intestate who died on the 16th day of August, 1974 are required to send particulars of their claims to the Administrator, FRANCIS ALEXANDER HILLAS c/o the undermentioned solicitors by the 24th day of December 1974 after which date the Administrator will distribute the assets of the deceased having regard only to the claims of which he then has had notice.

J. McDONALD SMITH & CO., solicitors, 59-61 Irving Street, Footscray. 1418

CREDITORS, next of kin, and others having claims in respect of the Estate of ROSARIO CUCIA late of Euston in the State of New South Wales Market Gardener deceased who died on the 29th December, 1960 are required by VENZENCA GABELLONE (formerly VENZENCA CUCIA) of 58 Roseberry Street, Ascot Vale Married Woman the Administratrix of the Estate of the said deceased to send particulars of their claims to the said Administratrix care of the undermentioned Solicitors by the 23rd December, 1974 after which date the Administratrix will convey or distribute the assets, having regard only to the claims of which she then has notice.

HILLARDS, solicitors, 71 Deakin Avenue, Mildura. 1385

CREDITORS, next of kin, and others having claims in respect of the Estate of MICHAEL FRANCIS O'CALLAGHAN late of Fuller Street Ouyen Contractor deceased who died on the 3rd September, 1972 are required by MICHAEL BRIAN O'CALLAGHAN of Scott

Street Ouyen Contractor the Executor of the Will of the said deceased to send particulars of their claims to the said Executor care of the undermentioned Solicitors by the 23rd December, 1974 after which date the said Executor will convey or distribute the assets, having regard only to the claims of which he then has notice.

HILLARDS, solicitors, 71 Deakin Avenue, Mildura. 1386

JAMES THOMAS NORRIS, late of Moran House, 2 Raheen Drive, Kew, catholic priest, DECEASED.

Creditors, next-of-kin and others having claims in respect of the estate of the abovenamed deceased who died on 8th November 1973 are to send particulars of their claims to NATIONAL TRUSTEES EXECUTORS AND AGENCY COMPANY OF AUSTRALASIA LIMITED of 95 Queen Street, Melbourne by 22nd December 1974 after which date it will distribute the assets having regard only to the claims of which it then has notice.

NUNAN & BLOOM, solicitors, 343 Little Collins Street, Melbourne. 1387

OLIVE WINIFRED PETERSEN, late of Kiama Nursing Home, 155 Staniland Avenue, Malvern, in the State of Victoria, spinster, DECEASED.

CREDITORS, next of kin, and others having claims in respect of the estate of the deceased, who died on the 23rd day of July 1974, are required by the Executor The Union-Fidelity Trustee Company of Australia Limited of 100 Exhibition Street Melbourne to send particulars of their claims to it at its said address by the 24th day of December 1974 after which date it will distribute and/or convey the assets amongst the persons entitled thereto having regard only to the claims of which it then has notice.

RICHARD K. PITMAN, solicitor, corner Kingsway and Railway Parade, Glen Waverley, 3150. 1388

ELIZABETH NORRY HUGHES (also known as ELIZABETH NORRIE HUGHES), late of Flat 6, 13 Belmont Avenue, Kew, in the State of Victoria, retired sister tutor, DECEASED.

CREDITORS, next of kin, and others having claims in respect of the estate of the deceased, who died on the 4th day of July 1974, are required by the Executor The Union-Fidelity Trustee Company of Australia Limited of 100 Exhibition Street Melbourne to send particulars of their claims to it at its said address by the 24th day of December 1974 after which date it will distribute and/or convey the assets amongst the persons entitled thereto having regard only to the claims of which it then has notice.

RICHARD K. PITMAN, solicitor, corner Kingsway and Railway Parade, Glen Waverley, 3150. 1389

LESLIE JAMES ROWE, late of 47 Bridge Street, Sebastopol, retired fitter, DECEASED (who died on the 15th July, 1974).

Creditors next of kin and all persons having claims against the estate of the deceased are required to send particulars to the Executors THE UNION-FIDELITY TRUSTEE COMPANY OF AUSTRALIA LIMITED of 101 Lydiard Street North Ballarat on or before the 24th December 1974 after which date it will distribute the assets having regard only to the claims of which it shall then have notice.

HEINZ & GORDON, solicitors, 209 Dana Street, Ballarat. 1390

CREDITORS next-of-kin and all others having claims against the Intestate Estate of ALBERT ANDREW CAMPBELL late of 1011 Howitt Street Wendouree in the State of Victoria Retired Railways Employee deceased who died on the 5th day of May 1973 are hereby required to send particulars of their claims to WILLIAM EDWARD CAMPBELL of 1011 Howitt Street Wendouree aforesaid Pensioner the Administrator in the deceased's Estate care of the undermentioned solicitors by the 21st day of January 1975 after which date he will distribute the assets having regard only to claims of which he then has notice.

CUTHBERTS, solicitors, Ballarat. 1391

MARICE GERALD RATCLIFFE, late of Racecourse Road, Marysville, in the State of Victoria, pensioner, DECEASED.

Creditors, next of kin and others having claims in respect of the estate of the deceased (who died on the 24th day of May, 1974) are required by the Executor RICHARD PATRICK BAYLOR of Healesville, Solicitor to send particulars to him, care of the undersigned, on or before the

10th day of January, 1975 after which date he will distribute the assets having regard only to the claims of which he then has notice.

R. P. BAYLOR & CO., solicitors, Healesville. 1392

HELEN MAY WILSON, late of 15 Glance Street, Flemington, in the State of Victoria, married woman, DECEASED.

Creditors Next-of-kin and others who have claims in respect of the Estate of the Deceased who died on the 11th day of July, 1974 are required by the Trustee JULIE ANN WATTERSON of 12 Deakin Street, Essendon West to send particulars of their claims to the Trustee care of DENT CANNON & AUGUSTINUS, of 5-7 Hall Street, Moonee Ponds by the 10th day of January, 1975 after which day the Trustee may convey or distribute the assets having regard only to the claims of which it then had notice.

Dated this 18th day of October, 1974.

DENT CANNON & AUGUSTINUS, solicitors, of 5-7 Hall Street, Moonee Ponds. 1393

HERBERT WILLIAM DICKER, late of 102 Mortlake Road, Warrnambool, labourer, DECEASED, intestate.

CREDITORS, next-of-kin and all others having claims in respect of the abovenamed deceased (who died on 29th July 1974) are requested to send particulars of their claims in writing to the administrator NATIONAL TRUSTEES, EXECUTORS AND AGENCY COMPANY OF AUSTRALASIA LIMITED of 95 Queen Street Melbourne, on or before the 23rd December 1974, after which date they will distribute the assets having regard only to the claims of which they then have notice as aforesaid.

DESMOND DUNNE & DWYER, solicitors, Warrnambool. 1361

CREDITORS next of kin and others having claims against the estate of JOSEPH HENRY BURGESS late of 21 Rowe Street, Euroa, Retired Farmer, deceased who died on the 23rd April 1974 are required to send particulars of their claims to THE TRUSTEES EXECUTORS AND AGENCY COMPANY LIMITED of 401 Collins Street, Melbourne, the Executor of the said deceased on or before the 31st December 1974 after which date the said Executor will distribute the assets having regard only to the claims of which notice shall have been given.

LANDER & ROGERS, solicitors, 140 Queen Street, Melbourne. 1362

MARY BEATRICE DOUGLAS, late of Croydon Park Hospital, Croydon, widow, DECEASED.

Creditors, next of kin and others having claims in respect of the estate of the deceased (who died on 30th June, 1974) are required by THE UNION FIDELITY TRUSTEE COMPANY OF AUSTRALIA LIMITED of 100 Exhibition Street, Melbourne, to send particulars of their claims to the said Company by 31st December, 1974, after which date it will convey or distribute the assets, having regard only to the claims of which the Company then has notice.

ROSS, GREEN & CO., solicitors, Main Street, Croydon. 1363

MYRA SMITH, late of Swan Hill, in the State of Victoria, married woman, DECEASED.

CREDITORS, next of kin, and others having claims in respect of the estate of the deceased (who died on the 6th day of July 1974) are required by the Executor PETER JAMES SMITH of Swan Hill to send particulars to him care of the undersigned by the 31st day of December 1974, after which date the Executor may convey or distribute the Assets, having regard only to the claims of which he then shall have notice.

ALEC M. HAYES, solicitor, 148 Campbell Street, Swan Hill. 1365

JOHN ALBERT JOBLING, late of Swan Hill, in the State of Victoria, retired farmer, DECEASED.

CREDITORS next of kin, and others having claims in respect of the estate of the deceased (who died on the 9th day of February 1974) are required by the Executors ALBERT HENRY JOBLING of Koroop Via Kerang, IAN JOHN JOBLING of Swan Hill and ERIC BRUCE JOBLING of Lalbert to send particulars to them care of the undersigned by the 31st day of December 1974, after which date the Executors may convey or distribute the Assets, having regard only to the claims of which they then shall have notice.

ALEC M. HAYES, solicitor, 148 Campbell Street, Swan Hill. 1366

CREDITORS NEXT-OF-KIN and others having claims in respect of the Estate of WILLIAM SEYMOUR LARKAN late of 11 Renown Street Bentleigh in the State of Victoria Retired Bank Officer T.P.I. deceased who died on the 7th day of May 1974, are to send particulars of their claims to ROMA VERONICA OLIVER care of the undermentioned Solicitors by the 23rd day of December 1974 after which date she will distribute the assets having regard only to the claims of which she then has notice.

REGINALD C. BUTLER & CO., solicitors, 312 Centre Road, Bentleigh. 1367

CREDITORS NEXT-OF-KIN and others having claims in respect of the Estate of THOMAS CROSBY late of 10 Whitmuir Road Bentleigh in the State of Victoria formerly Caretaker but then Gentleman deceased who died on the 13th day of December 1973, are to send particulars of their claims to KEVIN CROSBY care of the undermentioned Solicitors by the 23rd day of December 1974 after which date he will distribute the assets having regard only to the claims of which he then has notice.

REGINALD C. BUTLER & CO., solicitors, 312 Centre Road, Bentleigh. 1368

RODERICK EDWARD PETER JOHN, late of Bungower Road, Mornington, in the State of Victoria and also of 131 Main Street, Mornington, aforesaid, pharmaceutical chemist, DECEASED.

CREDITORS, next of kin and other having claims in respect of the Estate of the above named Deceased who died on the 9th day of July, 1973 are required by the EXECUTOR, PETER MASON JOHN, of 5 Inglewood Avenue, Forest Hill in the said State Supply Manager to send particulars of such claims to him at the office of his Solicitors MESSRS. NEVILLE D. KELLY GRAINGER & CO., of 437 Centre Road, Bentleigh in the said State by the 27th day of December, 1974 after which date the said Executor may convey or distribute the assets of the Deceased having regard only to the claims of which the Executor then has notice.

Dated 15th October, 1974.

NEVILLE D. KELLY GRAINGER & CO., 437 Centre Road, Bentleigh, 3204, solicitors for the said Executor. 1369

CREDITORS next of kin and others having claims against the Estate of LILIAN JEAN SILKE late of Lockwood in the State of Victoria Spinster deceased intestate who died on the Seventh day of May 1972 are required to send particulars thereof to NATIONAL TRUSTEES EXECUTORS AND AGENCY COMPANY OF AUSTRALASIA LIMITED of 95 Queen Street Melbourne and 46 Queen Street Bendigo in the said State by the Twentieth day of December 1974 after which date the said Company will distribute the assets of the said deceased having regard only to the claims of which it then has notice.

WATSON JAMES & ROGERS, solicitors, 61 Bull Street, Bendigo. 1370

Creditors next of kin and others having CLAIMS in respect of the estate of KATHLEEN DOROTHY ADAMS late of 4 View Street Hawthorn in the State of Victoria Widow deceased who died on the 12th day of July 1974 are to send particulars of their claims to the proving executors of her will namely THE EQUITY TRUSTEES EXECUTORS AND AGENCY COMPANY LIMITED and FRANCIS SYDNEY WRIGHT care of the said Company at 472 Bourke Street Melbourne in the said State by the 1st day of January 1975 after which date the said executors will distribute the assets in the said estate having regard only to the claims of which it and he then have notice.

ARTHUR ROBINSON & CO., solicitors, 447 Collins Street, Melbourne. 1419

CREDITORS next of kin and all other persons having claims against the Estate of VIOLET MAY ASHTON (also called MAYSIE ASHTON) late of 783 (formerly 271) Riversdale Road Camberwell Widow deceased who died on 27th March 1974 are required by the Executors KEITH CHARLES BATTLE of 4 Winnmalee Road Balwyn Retired and JOHN WINTER ASHTON of 36 Alma Road Camberwell Medical Practitioner to send particulars of their claims to them C/- the undersigned by the 24th day of December 1974 after which date they will proceed to distribute the estate having regard only to the claims of which they then have notice.

JOHN D. MUSTOW & CO., solicitors, of 131 Queen Street, Melbourne. 1420

CREDITORS next of kin and others having claims in respect of the estate of ALBERT MELFORD HODGETTS late of 1206 (in the Will called 306) Heatherton Road Noble Park who died on the 1st August 1974 are to send particulars of their claims to the executor Harold Percival Carter care of the undermentioned firm by the 24th day of December 1974 after which date the said executor will distribute the assets having regard only to the claims of which he then has notice.

McINTYRE & CARTER, solicitors, 414 Collins Street, Melbourne. 1434

CREDITORS next of kin and others having claims in respect of the estate of JANKO STEFAN MLAKA late of 41 Settlement Road Bundoora (formerly of 18 Braidhill Road Macleod) who died on the 5th day of August 1974 are to send particulars of their Claims to the Executor Ian Michael Carter care of the undermentioned firm by the 24th day of December 1974 after which date the said executor will distribute the assets having regard only to the claims of which he then has notice.

McINTYRE & CARTER, solicitors, 414 Collins Street, Melbourne. 1435

CREDITORS NEXT-OF-KIN AND OTHERS having claims in respect of the estate of FRITHJOF HASSELBY late of 14 Clairmont Avenue, Bentleigh Victoria, Retired deceased who died on the 14th September, 1973 are to send particulars of their claims to the Executor Charles Frederick Broadbent care of Prendergast & Robinson, Parkinson & Hart, Solicitors of 406 Lonsdale Street, Melbourne by the 6th day of January, 1975, after which date the said Executor will distribute the estate having regard only to the claims of which he then has notice.

PRENDERGAST & ROBINSON, PARKINSON & HART, solicitors, 406 Lonsdale Street, Melbourne. 1436

All persons having claims against the Estate of the late His Highness SAID BIN TAIMUR late of care of The British Bank of the Middle East Muscat and Oman former Sultan of Muscat and Oman deceased who died on the 20th day of October, 1972 and Letters of Administration of whose Estate was on the 18th day of March, 1974 granted by The High Court of Justice in England to BARRY DAVID STUART LOCK and RICHARD MURRAY COLEMAN both of Royex House Aldermanbury Square London Solicitors and application to the Supreme Court of Victoria (Probate Jurisdiction) by THE PERPETUAL EXECUTORS AND TRUSTEES ASSOCIATION OF AUSTRALIA LIMITED the duly constituted Attorney to seal a Sealed and Certified copy of the Letters of Administration are hereby required to send particulars of such claims to The Perpetual Executors & Trustees Association of Australia Limited at its Registered Office at 50 Queen Street, Melbourne on or before the 23rd December, 1974 after which date the said Company will proceed to transfer, convey or distribute the said Estate to or among the persons entitled thereto having regard only to the claims of which it shall then have had notice and will not be liable for the assets so transferred, conveyed or distributed to any persons of whose claim it shall not then have had notice.

CORR & CORR, solicitors, 290 La Trobe Street, Melbourne, Victoria. 1440

HILDA NEA WORTHY, late of 14 Mandowie Road, Glen Waverley, in the State of Victoria, widow, DECEASED.

CREDITORS, next of kin and others having claims in respect of the estate of the deceased, who died on the 8th day of June 1974, are required by the Executors ROBERT FRANK WORTHY of Broadgully Road Diamond Creek and CLIVE GADSEN ROSSITER of 4 Arna Street Blackburn to send particulars of their claims to them in the care of the undermentioned Solicitor by the 24th day of December 1974 after which date they will distribute and/or convey the assets amongst the persons entitled thereto having regard only to the claims of which they then have notice.

RICHARD K. PITMAN, solicitor, of corner Kingsway and Railway Parade, Glen Waverley, 3150. 1449

WILLIAM JOHNS, late of 18 Andromeda Way, Lower Templestowe, in the State of Victoria, retired insurance manager, DECEASED.

CREDITORS, next of kin, and others having claims in respect of the estate of the deceased, who died on the 12th day of August 1974, are required by the Executors WILLIAM MAXWELL JOHNS of 280 Elgar Road Box Hill and NOEL REID JOHNS of 18 Andromeda Way Lower Templestowe to send particulars of their claims to them

in the care of the undermentioned Solicitor by the 24th day of December 1974 after which date they will distribute and/or convey the assets amongst the persons entitled thereto having regard only to the claims of which they then have notice.

RICHARD K. PITMAN, solicitor, of corner Kingsway and Railway Parade, Glen Waverley, 3150. 1450

EILEEN JANE MANLEY, late of 97 Dundas Street, Preston, in the State of Victoria, widow, DECEASED.

CREDITORS next of kin and all others having claims in respect of the estate of EILEEN JANE MANLEY late of 97 Dundas Street, Preston Widow deceased who died on the 14th day of July, 1974 are required by the Executor THOMAS FRANCIS MANLEY of 5 Rocklea Crescent, Sylvania Heights in the State of New South Wales Gentleman to send particulars of their claims to him in the care of the undermentioned Solicitor prior to the 20th day of January, 1975 after which date he will distribute the assets having regard only to the claims of which he then has notice.

M. F. HUGHES, LL.B., solicitor, 300 Barkly Street, Brunswick. 1451

THOMAS BRIGHT, late of Pental Island, via Swan Hill, in the State of Victoria, farmer, DECEASED.

CREDITORS, next of kin, and others having claims in respect of the estate of the deceased (who died on the 1st day of May, 1974) are required by the executor ERNEST THOMAS BRIGHT of Pental Island via Swan Hill aforesaid, to send particulars to him care of the undersigned by the 31st day of December, 1974, after which date the executor may convey or distribute the assets, having regard only to the claims of which he then has notice.

ALEC M. HAYES, solicitor, 148 Campbell Street, Swan Hill. 1452

CREDITORS next of kin and other persons having claims against the estate of MONICA VIOLET WEAVER formerly of Flat 1, 314 Inkerman Street East St. Kilda but late of Flat 4, 225 Canterbury Road St. Kilda in the State of Victoria Widow deceased who died on the first day of May 1974 ARE REQUIRED to send particulars of their claims to the Executor NATIONAL TRUSTEES EXECUTORS AND AGENCY COMPANY OF AUSTRALASIA LIMITED of 95 Queen Street Melbourne by the 31st day of December 1974 after which date the Executor will distribute the assets having regard only for the claims of which it then has had notice.

JAMES P. OGGE & CO., solicitors, 165 Greville Street, Prahran. 1460

CREDITORS NEXT OF KIN AND OTHERS having claims in respect of the Estate of LAWRENCE CUTAJAR late of 74 Hubert Avenue Glenroy Millhand deceased intestate who died on the 26th August 1974 are to send particulars of their claims to the Administrator Anthony Laurence Cutajar care of the undermentioned Solicitors by the 24th December 1974 after which date the said Administrator will distribute the assets having regard only to the claims of which he then has notice.

R. WADHAM & DOIG, solicitors, of 383 Flinders Lane, Melbourne. 1465

CREDITORS NEXT OF KIN AND OTHERS having claims in respect of the Estate of HELENOR DAVEY late of 134 Edgevale Road Kew Spinster deceased intestate who died on the 27th July 1974 are to send particulars of their claims to the Administrator Walter Davey care of the undermentioned Solicitors by the 24th December 1974 after which date the said Administrator will distribute the assets having regard only to the claims of which he then has notice.

R. WADHAM & DOIG, solicitors, of 383 Flinders Lane, Melbourne. 1466

CREDITORS NEXT OF KIN AND OTHERS having claims in respect of the Estate of LILIAN ROSE PARSONS late of 11 James Avenue Highett Widow deceased who died on 24th March 1974 are to send particulars of their claims to the Executrix ELAINE EVELYN PARSONS care of the undermentioned Solicitors by the 24th December 1974 after which date the Executrix will distribute the assets having regard only to the claims of which she then has notice.

R. WADHAM & DOIG, solicitors, 383 Flinders Lane, Melbourne. 1467

CREDITORS NEXT OF KIN AND OTHERS having claims in respect of the Estate of HOWARD ARTHUR SMITH late of 9 Preston Road Hughesdale Engineer deceased intestate are to send particulars of their claims to the Administratrix Alma Gertrude Smith care of the undermentioned Solicitors by the 24th December 1974 after which date the Administratrix will distribute the assets having regard only to the claims of which she then has notice.

R. WADHAM & DOIG, solicitors, 383 Flinders Lane, Melbourne. 1468

CREDITORS NEXT OF KIN AND OTHERS having claims against the Estate of ALICE LILLIAN GRAHAM late of 19 Watson Street East Preston Widow deceased who died on the 27th July 1974 are to send particulars of their claims to the Executors Malcolm Frank Fleming and Delma Jill Madin care of the undermentioned Solicitors by the 24th December 1974 after which date the Executors will distribute the assets having regard only to the claims of which they then have notice.

R. WADHAM & DOIG, solicitors, 383 Flinders Lane, Melbourne. 1469

EDWIN HENRY KIRBY, formerly of 51 Malvern Road, Malvern, but late of 8 Burgess Street, Beaumaris, gentleman, DECEASED.

Creditors, next of kin and others having claims in respect of the estate of the deceased (who died on the 17th day of July, 1974) are required by THE EQUITY TRUSTEES EXECUTORS AND AGENCY COMPANY LIMITED of 472 Bourke Street, Melbourne to send particulars of their claims to the said company by the 24th day of December 1974 after which date it will convey or distribute the assets, having regard only to the claims of which the company then has notice.

HEDDERWICK, FOOKES & ALSTON, 121 William Street, Melbourne, 3000. 1470

CREDITORS, next of kin and others having claims in respect of the estate of RONALD GILLESPIE late of 4 Young Street, Preston in the State of Victoria, Greenkeeper deceased who died on the 16th day of November, 1972 are required by MARY EDITH GILLESPIE of 1 Holmes Street, Northcote, Administratrix who was granted letters of Administration on the 27th day of August, 1974 to send particulars in writing to her care of her solicitors mentioned below by the 3rd day of January, 1975 after which date the Administratrix may convey or distribute the assets of the said deceased having regard only to the claims of which she then has notice.

AKEHURST, FRIEND & HAACK, solicitors, 10 Queen Street, Melbourne, 3000. 1471

In the Supreme Court of the State of Victoria.

SALE BY THE SHERIFF.

ON FRIDAY the 29TH of NOVEMBER 1974 at 10.00 a.m. AT THE POLICE STATION OAKLEIGH (unless process be stayed or satisfied).

ALL the Estate and Interest (if any) of GRAHAM McISAAC, salesman and BERNICE McISAAC, married woman (shown on Certificate of Title as Graeme Thomas McIsaac and Bernice Fay McIsaac) both of 3 Chauvel Street, South Oakleigh as joint proprietors of an estate in fee simple in the land described in Certificate of Title Volume 5089 Folio 639 upon which is erected a brick dwelling known as No. 3 Chauvel Street South Oakleigh.

Registered Mortgages No. E.142507 and E.158198 and Caveat E.754847 affect the said estate and interest.

TERMS—CASH ONLY.

H. BUETTNER, Sheriff's Officer.

23rd October, 1974.

1461

IMPOUNDINGS

SHIRE OF HEYTESBURY.

COBDEN.—Impounded at the Cobden Pound.

1 black and white Friesian bull, indistinct brand on off rump, slit at bottom on off ear

If not claimed and expenses paid to be sold, by Denny Lascelles Ltd. at the Camperdown Sale Yard on 5th November, 1974.

J. S. BRADD,
Poundkeeper.

1356—\$3.15

CITY OF KNOX.

FERN TREE GULLY.—Impounded in Fern Tree Gully Pound on 25th September, 1974.

1 Hereford calf, no visible brand

If not claimed and expenses paid, to be sold on the 8th November, 1974, at 12 noon.

1355—\$2.80 J. WILLIAMS, Poundkeeper.

CITY OF BERWICK.

NARRE WARREN NORTH.—Impounded in Narre Warren North Pound, from Golf Links Road, Berwick.

14 head of cattle, consisting of 9 heifers and 5 steers, mixed breeds

If not claimed and expenses paid, to be sold at Dandenong Market on Monday 28th October, 1974.

1357—\$3.15 A. DUNCAN, Poundkeeper.

SHIRE OF FLINDERS.

ROSEBUD.—Impounded in Rosebud Pound.

1 Hereford crossbred calf, red, no visible brands

If not claimed and expenses paid by 4th November, 1974, calf to be sold at noon on that day by auction.

1384—\$2.45 J. MILBOURN, Poundkeeper.

Subordinate Legislation Act 1962.

NOTICE OF MAKING OF STATUTORY RULES.

In pursuance of the provisions of the *Subordinate Legislation Act 1962* and the Regulations made thereunder, notice is given of the making of the following statutory rules:—

No.	Stock Foods Act 1958.	Price.
455/1974.	Stock Foods (Fees) Regulations 1974 ..	10c
	<i>Pesticides Act 1958.</i>	
456/1974.	Pesticides (Fees) Regulations 1974 ..	10c
	<i>Port Phillip Authority Act 1966.</i>	
457/1974.	Port Phillip Authority (Metric Conversion) Regulations 1974 ..	10c
	<i>Abattoir and Meat Inspection Act 1973.</i>	
458/1974.	Abattoir and Meat Inspection Regulations 1974 ..	60c
	<i>Tattersall Consultations Act 1958.</i>	
459/1974.	Tattersall Consultations (Soccer Football Pools) Regulations 1974 ..	10c

Copies of these statutory rules may be purchased at the Sale of Publications Section of the Government Printing Office, located at 7A Parliament Place, Melbourne, 3002. If ordered by mail, remittance should be addressed to "The Government Printer, Box 203, P.O., North Melbourne, 3051", and should include 7c extra for postage. If a credit account is held at this office, no remittance is required with the mail order.

The annual subscription rate for Statutory Rules (including Bound Volumes) is \$28, payable in advance. The subscription year commences on 1st January.

C. H. RIXON,
Government Printer.

PUBLICATION OF OFFICIAL MATTER.

Attention is invited to the following procedure in relation to the publication of official matter in the *Government Gazette*:—

Publication will be facilitated by the submission of carbon copies for the use of the Gazette Officer.

1. *Matter submitted to the Executive Council.*

Matter submitted to the Executive Council which requires gazettal will normally be published in the issue of the following week.

Where urgent gazettal is required, special arrangements should be made with the Gazette Officer, Room 9, first floor, Old Treasury Building.

2. *Other matter.*

(a) All other matter duly certified by a responsible officer for publication should be lodged with the Gazette Officer not later than half-past Nine a.m. on Tuesday.

(b) Lengthy or involved notices should be forwarded several days before publication.

(c) Proofs, which will be supplied only when specifically requested or at the direction of the Gazette Officer, should be returned promptly to avoid delay in publication.

(d) No additions or amendments to matter for publication will be accepted by telephone.

CONTENTS	PAGE
Appointments	3769
Auction Sales Act	3758
Bank Holidays	3753
Cemeteries—Scale of Fees	3764
Contracts	3768
Country Roads Board	3762
Courts	3767
Estates of Deceased Persons	3767
Government Notices	3754
Impoundings	3803
Lands	3784
Melbourne and Metropolitan Board of Works— Notice	3763
Mining	3768
Notice to attend for Radiological Examination ..	3759
Notice of Making of Statutory Rules	3804
Orders in Council—	
Acts—Stamps; State Electricity Commission; Land; Local Government; Hospital and Charities; Country Roads; Port- land Harbor Trust; Superannuation; Sewerage Districts; Mental Health; Sewerage Districts; Labour and Industry.	3770 et seq
Police Sales	3761
Private Advertisements	3789
Proclamations	3753
Public Holiday—Melbourne Cup Day	3754
Public Holidays	3753
Public Service Notices	3786
Resignations	3770
State Rivers and Water Supply Commission ..	3766
Tenders	3785
Transport Regulation Board—Public Hearings ..	3755



VICTORIA GOVERNMENT GAZETTE

Published by Authority

No. 104]

WEDNESDAY, OCTOBER 30

[1974

PROCLAMATIONS

LOCAL AUTHORITIES SUPERANNUATION ACT 1958.

PROCLAMATION

By His Excellency the Governor of the State of Victoria and its Dependencies in the Commonwealth of Australia, &c., &c., &c.

Whereas by the *Local Authorities Superannuation Act 1958*, section 3, it is among other things enacted that it shall be lawful for the Governor in Council to declare any body constituted for a joint purpose by two or more authorities within the meaning of that Act to be an authority for the purposes of the Act.

And whereas the Wimmera Regional Tourist Authority has requested that it be declared to be an authority.

Now therefore, I, the Governor of the State of Victoria in the Commonwealth of Australia, by and with the advice of the Executive Council of the said State, do by this Proclamation declare that the Wimmera Regional Tourist Authority being an authority constituted for a joint purpose by the Councils of the City of Horsham and the Shires of Arapiles, Dimboola, Dunmunkle, Kaniva, Karkaroc, Kowree, Lowan, Warracknabeal and Wimmera shall be an authority for the purpose of the said Act.

Given under my Hand and the Seal of the State of Victoria aforesaid, at Melbourne, this twenty-second day of October, in the year of Our Lord One thousand nine hundred and seventy-four, and in the twenty-third year of the reign of Her Majesty Queen Elizabeth II.

(L.S.) HENRY WINNEKE.

By His Excellency's Command,
A. J. HUNT,
Minister for Local Government.
GOD SAVE THE QUEEN!

ACTS OF PARLIAMENT.

PROCLAMATION

By His Excellency the Governor of the State of Victoria and its Dependencies in the Commonwealth of Australia, &c., &c., &c.

I, the Governor of the State of Victoria, in the Commonwealth of Australia, do hereby, declare that I have this day assented; in Her Majesty's name, to the Bills passed

No. 104.—10550/74.—Price 30 cents; Half-Yearly \$11.25; Yearly \$22.50.

by the Parliament of the said State, the titles whereof are hereunder set forth, together with the short titles, that is to say:—

No. 8581. "An Act to provide for the Promotion and Conduct in Victoria of Soccer Football Pools, for that and other purposes to amend the '*Tattersall Consultations Act 1958*', to amend the '*Lotteries Gaming and Betting Act 1966*' and the '*Youth, Sport and Recreation Act 1972*', and for other purposes." (*Tattersall Consultations (Soccer Football Pools) Act 1974.*)

No. 8582. "An Act to authorize the Grant of certain land in the City of Geelong to The Geelong Harbor Trust Commissioners to amend the '*Geelong Lands Exchange Act 1972*' and the '*Geelong Harbor Trust Act 1958*' and for other purposes." (*Geelong Land Act 1974.*)

No. 8583. "An Act relating to certain Crown Lands in the City of Melbourne." (*Melbourne (Alexandra Gardens) Land Act 1974.*)

No. 8584. "An Act to enable the Surrender to Her Majesty of the Property of the Terang Mechanics Institute and Free Library Trust free of the Trust and of a certain mortgage, to facilitate the Appointment of the Shire of Hampden as a Committee of Management thereof under the '*Land Act 1958*', and for Purposes connected therewith." (*Terang Mechanics Institute and Free Library Trust Act 1973.*)

Given under my Hand and the Seal of the State of Victoria aforesaid, at Melbourne, this twenty-second day of October, in the year of our Lord One thousand nine hundred and seventy-four; and in the twenty-third year of the reign of Her Majesty Queen Elizabeth II.

(L.S.) HENRY WINNEKE.

By His Excellency's Command,
R. J. HAMER,
Premier.

GOD SAVE THE QUEEN!

NOTE.—Act Nos. 8581, 8582, 8583 and 8584 shall come into operation on the date of Royal Assent, i.e., 22nd October, 1974.

Land Act 1958.
DEPARTMENT OF CROWN LANDS AND SURVEY.

PROCLAMATION

By His Excellency the Governor of the State of Victoria and its Dependencies in the Commonwealth of Australia, &c., &c., &c.

In pursuance of the provisions of Section 25 (3) (c) of the Land Act 1958, I, the Governor of the State of Victoria, by and with the advice of the Executive Council of the said State, do hereby proclaim as road the Crown land at Bendigo and at Eaglehawk in the Parish of Sandhurst, County of Bendigo, being the land indicated by hatching on the plan hereunder.—(S.371⁽²⁶⁾. (S.372⁽¹⁰¹⁾) (W.89894).

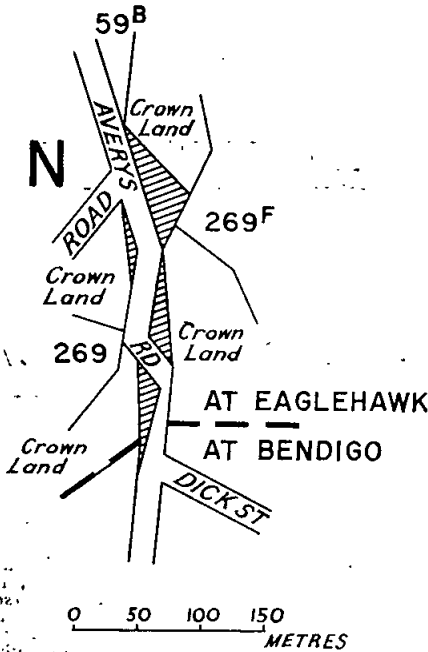

Given under my Hand and the Seal of the State of Victoria aforesaid, at Melbourne, this twenty-second day of October, in the year of our Lord One thousand nine hundred and seventy-four, and in the twenty-third year of the reign of Her Majesty Queen Elizabeth II.

(L.s.) HENRY WINNEKE.
By His Excellency's Command.

W. BORTHWICK,
Minister of Lands.

GOD SAVE THE QUEEN!

PUBLIC HIGHWAY.—CITY OF DONCASTER AND TEMPLESTOWE.

PROCLAMATION

By His Excellency the Governor of the State of Victoria and its Dependencies in the Commonwealth of Australia, &c., &c., &c.

Whereas by the Local Government Act 1958, section 519 it is amongst other things enacted that it shall be lawful for the Governor in Council at any time and from time to time upon the request at the Council of any municipality by notice in the Government Gazette to proclaim any land reserved used or by purchase or exchange acquired for a street road highway thoroughfare bridge square court alley or right-of-way or any street road land or passage has been sealed with the seal of the municipality under subdivision (3) of Division 9 of Part XIX of the Local Government Act 1958, or a corresponding previous enactment be a public highway and that such land shall thereupon and thenceforth from the date of such proclamation become and be absolutely dedicated to the public as a public highway within the meaning of any law then or thereafter in force.

And whereas the Council of City of Doncaster and Templestowe requested that the land hereinafter mentioned, used for a street to be so declared to be a public highway.

Now therefore, I, the Governor of the State of Victoria in the Commonwealth of Australia, by and with the advice of the Executive Council of the said State, do by this proclamation declare that the land shown by hachure on the plan hereunder shall be a public highway within the meaning of the said Act.

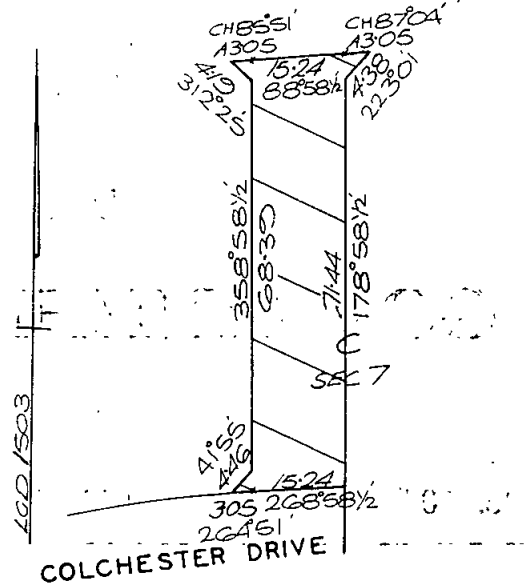

MEASUREMENTS ARE IN METRES

Given under my Hand and the Seal of the State of Victoria aforesaid, at Melbourne, this twenty-second day of October, in the year of Our Lord One thousand nine hundred and seventy-four, and in the twenty-third year of the reign of Her Majesty Queen Elizabeth II.

(L.s.) HENRY WINNEKE.
By His Excellency's Command,

A. J. HUNT,
Minister for Local Government.
GOD SAVE THE QUEEN!

GOVERNMENT NOTICES

HOLIDAY.—MELBOURNE CUP DAY.

Notice is hereby given that on—

TUESDAY, THE 5TH NOVEMBER, 1974,

the Public Offices in the municipalities mentioned hereunder will be closed, that day being appointed under the provisions of the Public Service Act 1958 to be observed as a holiday in the Public Offices:—

The Cities of Altona, Berwick, Box Hill, Brighton, Broadmeadows, Brunswick, Camberwell, Caulfield, Chelsea, Coburg, Collingwood, Croydon, Dandenong, Doncaster and Templestowe, Essendon, Fitzroy, Footscray, Frankston, Hawthorn, Heidelberg, Kew, Knox, Malvern, Melbourne, Moorabbin, Mordialloc, Northcote, Nunawading, Oakleigh, Port Melbourne, Prahran, Preston, Richmond, Ringwood, St. Kilda, Sandringham, South Melbourne, Springvale, Sunshine, Waverley and Williamstown; the Shires of Bacchus Marsh, Bulla, Cranbourne, Diamond Valley, Eltham, Gisborne, Hastings, Lilydale, Melton, Mornington, Pakenham, Romsey, Sherbrooke, Werribee and Whittlesea.

This notice relates only to the closing of the State Public Offices. All inquiries regarding holidays in other offices and in shops and industry should be directed to the Department of Labour and Industry, 110 Exhibition Street, Melbourne. (Telephone 651 6158 or 651 6859.)

J. F. ROSSITER,
Chief Secretary.
Chief Secretary's Office,
Melbourne, 27th September, 1974.

Transport Regulation Act.
TRANSPORT REGULATION BOARD.
HEARING OF APPLICATIONS.

Notice is hereby given that the following applications will be considered by the Transport Regulation Board on 19th November, 1974.

COLUMBIA CARPET MILLS PTY. LTD., Hartnett Drive, Seaford. Application for one commercial passenger vehicle, a Toyota Coaster with seating capacity for fourteen persons to operate free of charge for the carriage of employees between their homes and the company's carpet mills on a round route from the premises as follows: Commencing at Seaford via Hartnett Drive, Seaford Road, Frankston-Dandenong Road, Kirkham Road, Hammond Road, Cheltenham Road, Chandler Road, Princes Highway, Gladstone Road, Heatherton Road to Watson Street, returning via same route to Gladstone Road then via Gladstone Road to Carlton Road, return via same route to Princes Highway, then via Princes Highway and Power Road to Kidds Road, Doveton. The return journey to Seaford is via Power Road, Princes Highway, Frankston-Dandenong Road, Seaford Road and Hartnett Drive.

Timetable (Monday-Friday).

Depart Seaford, 6.00 a.m.
Arrive Seaford, 7.00 a.m.
Depart Seaford, 3.30 p.m.
Arrive Doveton, 4.50 p.m.

FALLON, L. F. & F. W., 40 Shamrock Street, Alexandra. Application for variation of conditions of licence T.S.1458 to include the ability to undertake charter hirings from Alexandra.

HAYES, W. S., 82 Beach Road, Mentone. Application for one commercial passenger vehicle with seating capacity for four persons, namely a Mercedes Benz sedan to operate as a metropolitan private hire car from the depot of South Suburban Taxis Co-operative Society Ltd.

SINCLAIR COACHES PTY. LTD., 983 North Road, Murrumbidgee. Application for one commercial passenger vehicle with large seating capacity to be purchased to operate as an additional metropolitan special service omnibus.

TRANSFIELD PTY. LTD., 100 Arthur Street, North Sydney. Application for one commercial passenger vehicle with seating capacity for 33 persons to operate, free of charge, for the carriage of the applicant's own construction workers from its camp site on the Barry's Beach Road to the platform construction works area situated 2.4 kilometres into the Esso Marine Terminal area at Barry's Beach. This service is to operate on an as and when required basis.

Applications for renewal of licences as shown by the persons listed hereunder to operate under the same terms and conditions:—

BRIEN, J. H. & Co. PTY. LTD., 2 Whitehall Street, Footscray; T.S.734.

HOLLAND, W. R. & J. I., 60 Wimmera Street, Dimboola; T.S.639.

MOLONEY, R. W., 21 Henty Street, Pakenham East; T.S.589, T.S.651, T.S.1393, T.S.1394, C.O.604, C.O.702.

NORTH WESTERN BUS SERVICE PTY. LTD., 935 Pascoe Vale Road, Glenroy; M.O.699.

SIMCOCKS, C. G., Garfield; T.S.494, T.S.1388.

Notice of any objections should be forwarded to reach the Secretary of the Board not later than 13th November, 1974.

Applicants are advised that it will not be necessary to appear on the hearing date specified, unless advised in writing by the Board.

A. V. C. COOK,
Secretary.

Corner Lygon and Princes Streets, Carlton, 3053,
Wednesday, 30th October, 1974.

Commercial Goods Vehicles Act.
TRANSPORT REGULATION BOARD.
HEARING OF APPLICATIONS.

Notice is hereby given that the following applications will be considered by the Transport Regulation Board on 19th November, 1974.

A.B.C. HIRE CO. PTY. LTD., Lot 2, Ordish Road, Dandenong, 3175. One commercial goods vehicle (L/C. 16.95 tonne) to operate within an 80-km radius of the

G.P.O., Melbourne in the course of business as liquid waste disposal contractors in a specially constructed vehicle for the purpose of collecting liquid waste from various industries within the said radius to the point of disposal also within the said radius—liquid waste.

ATTENBOROUGH, A. R., 76 York Street, Sale, 3875. One commercial goods vehicle (L/C. 3.25 tonne) to operate: (a) From and to auction rooms within a 40-km radius of Melbourne to and from own premises at Sale in the course of business as "Secondhand Furniture Renovator and Dealer"—secondhand furniture. (b) Within an 80-km radius of Sale in the course of business as "Secondhand Furniture Renovator and Dealer"—secondhand furniture and personal effects.

BALKIN, J. T., P.O. Box 38, Casterton, 3311. One commercial goods vehicle (L/C. 7.90 tonne) to operate: (a) Within a 40-km radius of the post office at Casterton—general goods. (b) Within an 80-km radius of own property at Myaring in the course of business as primary producer—own goods.

BEER, M. G. & A. H., Lancefield Road, Sunbury, 3429. Two commercial goods vehicles (L/C. 11.85 tonne and 5.45 tonne) to operate: (a) Within a 40-km radius of the post office at Sunbury excluding the carriage of goods between places which are more than 48 km apart—general goods. (b) From Heathcote to own premises at Sunbury in course of business as fencing post supplier—own fencing posts. (c) Within an 80-km radius of Sunbury—livestock.

BLOOM, S. R., 65 Whitehorse Road, Deepdene, 3103. One commercial goods vehicle (L/C. 6.10 tonne) to operate: (a) Within a 40-km radius of own premises at Deepdene in the course of business as sand, soil screening and garden supply—own goods. (b) From Cranbourne and Toolangi to own premises at Deepdene—own soil. (c) From Cranbourne to own premises at Deepdene—own sand. (d) From Bacchus Marsh to own premises at Deepdene—own river pebbles and rocks.

BOORAN MOTORS PTY. LTD., 1049 Glenhantly Road, Caulfield, 3162. One commercial goods vehicle (L/C. 11.85 tonne) to operate: (a) Within a 40-km radius of the premises of Peninsula Paving Co. Pty. Ltd. at Rye in course of business as Paving Contractors—goods the property of the said company. (b) From pits at Cranbourne and South Oakleigh to premises of Peninsula Paving Co. Pty. Ltd. at Rye—sand. (c) Within a 40-km radius of any contract site within 80-km radius of Rye—sand, soil and overburden.

BROND, R. D. & J. E., 19 Elvin Street, Mansfield, 3722. One commercial goods vehicle (L/C. to be purchased—approximately 2 tonne) to operate between Mansfield and Melbourne via Bonnie Doon, Merton, Yarck, Alexandra, Cathkin and Yea—general goods.

COOK, D. A. (trading as CNG Plant Hire), Flaxman Street, Warrnambool, 3280. One commercial goods vehicle (L/C. 11.75 tonne) to operate: (a) Within a 40-km radius from the post office at Warrnambool—general goods. (b) Within that part of the State of Victoria west of a line drawn due north and south through the City of Colac and south of a line drawn due east and west through the City of Ararat for the purpose of servicing own plant and equipment under hire in the field only also tools of trade and spare parts incidental to servicing such plant and equipment and also own plant and equipment for delivery to or return from hirer. (c) Within an 80-km radius from the depot of Caltex Oil (Aust.) Pty. Ltd. at Warrnambool—petroleum products in prescribed types of containers and empty containers for return. (d) Within an 80-km radius of the post office at Warrnambool—hay. (e) From Pontings Sawmills situated at Portland and Heywood to Pontings Warrnambool—sawn timber. (f) From the C.R.B. Warrnambool to within this division of the C.R.B.—prefabricated concrete piles, beams and sections required for construction and completion of C.R.B. projects. (g) From Daviesway Pty. Ltd. Colac to within an 80-km radius of Warrnambool as Agent and Distributor—bulk yanlen in a specially constructed bulk tank. (h) From the Korot and Tower Hill areas to the Cities of Ballarat, Melbourne and Geelong—potatoes and onions. (i) From Pivot Portland to within an 80-km radius of such works—superphosphate.

CASH'S (DANDENONG) PTY. LTD., Cheltenham Road, South Dandenong, 3175. One commercial goods vehicle (L/C. 2.70 tonne) to operate within an 80-km radius of own premises at Dandenong and to Leongatha in course of business as wholesale hardware merchants—own goods.

- CASAL MOULDING SAND PTY. LTD.**, 1041 Centre Road, South Oakleigh, 3167. One commercial goods vehicle (L/C. 10.65 tonne) to operate: (a) From own sand pits at Cranbourne to places within a 40-km radius of G.P.O., Melbourne and to Geelong in course of business as "Moulding Sand Processors and Suppliers"—own moulding sand. (b) From own premises at South Oakleigh to Ballarat, Shepparton and Castlemaine—own moulding sand.
- DAWSON, J. A.** (trading as Central Victorian Removals), Sandhurst Road, Raywood, 3570. Two commercial goods vehicles (L/C. 1.00 tonne and 3.25 tonne) to operate: (a) Within a 40-km radius of Bendigo—general goods. (b) For the carriage of household furniture or personal effects of a householder or a member of his family when being moved from residence to residence; from residence for storage or sale; from storage to residence; from vendor to the residence of the purchaser. (c) From Melbourne to Bendigo for the carriage of goods as listed per new furniture list.
- CHESTER, J.**, 4/6 Thistle Grove, Highett, 3190. One commercial goods vehicle (L/C. 3.10 tonne) to operate throughout the State of Victoria in the course of business as a Travelling Showman—own sideshow equipment and novelty prizes.
- CLARK EQUIPMENT AUST. LTD.**, 881 Princes Highway, Springvale North, 3170. One commercial goods vehicle (L/C. 1.55 tonne) to operate throughout the State of Victoria in the course of business as Distributors of Earthmoving and Materials Handling Equipment for the purpose of sales promotion only—own earthmoving equipment for demonstration purposes only.
- COLES, K. G. & Co. PTY. LTD.**, 134 Dougharty Road, West Heidelberg, 3081. One commercial goods vehicle (L/C. 1.00 tonne) to operate throughout the State of Victoria in the course of business as materials handling equipment manufacturers for the purpose of servicing such equipment—tools of trade, spare parts and materials incidental to onsite servicing.
- COOMBS, A. G., SERVICING PTY. LTD.**, 26 Cochranes Road, Moorabbin, 3189. One commercial goods vehicle (L/C. 0.75 tonne) to operate throughout the State of Victoria in the course of business as "Heating Engineers"—tools of trade, spare parts and equipment incidental to the installation, servicing and maintenance of air conditioning units and heating systems.
- COOPER, M.**, 123 Channel Street, Cohuna, 3568. One commercial goods vehicle (L/C. 14.90 tonne) to operate: (a) Within an 80-km radius from the post office at Corop—plant the property of a contractor and required by him for use in connection with the construction or maintenance of some specific, existing or proposed road, street, footpath, bridge, pier, wharf, weir or channel and also the following materials, viz.: metal, stones, screenings, ashes, gravel, sand and earth. (b) Within a 40-km radius from the site of any construction or maintenance work performed pursuant to paragraph (a) above, or from the railway station nearest thereto—any other materials required for such work.
- CUDMORE, K.** (trading as Cudmore Bros.), Moonambel, 3467. One commercial goods vehicle (L/C. 5.15 tonne) to operate: (a) Within a 40-km radius of Moonambel—general goods. (b) From own premises at Moonambel to consignees at Ballarat, Geelong and Melbourne—own firewood.
- DAVIES INDUSTRIAL EQUIPMENT PTY. LTD.**, 39 Connell Road, Oakleigh, 3166. One commercial goods vehicle (L/C. 0.75 tonne) to operate throughout the State of Victoria in the course of business as Forklift Manufacturers—tools of trade, also spare parts, and materials required for the onsite servicing and maintenance of forklifts.
- DAVIES, W. D.**, 39 Grimshaw Street, Greensborough, 3088. One commercial goods vehicle (L/C. 7.50 tonne) to operate within a 112-km radius of the premises of Brick and Pipe Industries Ltd. at Northcote—bricks solely on behalf of the said company.
- SHAMBARA PTY. LTD.** (trading as Deep Frozen Foods), 21 Carrier Street, Benalla, 3672. One commercial goods vehicle (L/C. 6.55 tonne) to operate within a 146-km radius of own premises at Benalla and from and to Benalla to and from the City of Melbourne in the course of business as "Frozen Food Distributors" in a specially constructed refrigerated van—frozen vegetables, frozen fish, frozen meat, frozen poultry, frozen prepared meals, frozen hamburgers, frozen dim sims, frozen chicken rolls, frozen pastry and ice-cream at a temperature not exceeding minus five degrees celsius.
- HORNE, L. K.** (trading as Donald Savage), 3 Camp Street, Donald, 3480. One commercial goods vehicle (L/C. 12.25 tonne) to operate: (a) Within a 50-km radius of Donald—general goods. (b) Within an 80-km radius of Donald—waste paper. (c) Within an 80-km radius of Donald in the course of business as "Marine Collector"—special wares, marine stores and old metals as defined in the *Marine Stores and Old Metals Act 1958*, No. 6303, Part 1, Section (3).
- DYSON, M. L.**, Broadwater, via Port Fairy, 3285. One commercial goods vehicle (L/C. 7.15 tonne) to operate: (a) Within a 32-km radius from the post office at Broadwater—general goods. (b) From and to places situated within a 16-km radius from the post office at Broadwater to and from towns or townships which are situated on the main railway lines between Warrnambool and Port Fairy, Warrnambool and Hamilton and Portland and Hamilton respectively—general goods. (c) From and to places situated within the radius as described in paragraph (a) above to and from places situated within an 80-km radius from the post office at Broadwater—livestock.
- FALKENBERG, A. F.**, 6 Shaftsbury Parade, Thornbury, 3071. Two commercial goods vehicles (L/C. 11.80 tonne and 12.05 tonne) to operate: (a) Within a 40-km radius from the post office situated at the corner of Bourke and Elizabeth Streets, in the City of Melbourne in the course of business as sand, soil and garden supply. (b) From pits situated at Cranbourne and Longwarry, to own premises at Thornbury—own sand. (c) From Toolangi and Powelltown to own premises at Thornbury—own mountain soil. (d) From Bacchus Marsh to own premises at Thornbury—own river pebbles and own sand. (e) From Yea and Seymour to own premises at Thornbury—own river pebbles.
- NOTE.—Replacing licence No. D.A.274165/5 in the same name.
- FEELEY, E. C.**, 42 Johnson Street, Maffra, 3860. One commercial goods vehicle (L/C. 3.60 tonne) to operate: (a) From and to auction rooms within a 40-km radius of Melbourne to and from own premises at Maffra in the course of business as "Secondhand Furniture Renovator and Dealer"—second-hand furniture. (b) Throughout the State of Victoria as Furniture Removalists—second-hand furniture and personal effects.
- FISCHER, D. J.**, 49 Montrose Avenue, Apollo Bay, 3233. Two commercial goods vehicles (L/C. 7.15 tonne and 7.85 tonne) to operate: (a) Within a 40-km radius of the post office at Apollo Bay—general goods. (b) From and to places situated within the radius as described in paragraph (a) above to and from the Birregurra Railway Station—general goods. (c) From the Townships of Apollo Bay and Lorne to the Cities of Geelong and Melbourne—fish on behalf of the Apollo Bay Fishermen's Co-operative Society Ltd. and the Lorne Fishermen's Co-operative Society Ltd. (d) From the fish market in the City of Melbourne to the Township of Apollo Bay—empty return fish boxes, fishermen's gear and requisites having been delivered to the fishmarket by fish-carrying vehicles operated by either Hancocks of Lakes Entrance or Safcol of South Australia, but only when fish has been carried to the fish market on the forward journey. (e) To and from the City of Geelong from and to the Township of Apollo Bay—livestock, primary producers' requirements from which livestock has been consigned, bricks on pallets or in strapped packs, earthenware pipes, garage requirements on behalf of M. E. Fisher, garage proprietor of Apollo Bay, and road contracting plant on behalf of the Shire of Otway. (f) From the City of Ballarat to the Township of Apollo Bay—bagged stock feed, earthenware pipes, and roofing tiles. (g) From and to places within a 16-km radius of the G.P.O., Melbourne to and from the Townships of Apollo Bay and Lorne—bricks on pallets or in strapped packs, uncrated cement sheets, waxed cartons for fish packing, road contracting plant on behalf of the Shire of Otway. (h) From the sawmills of A. Coutts and K. Schaaf at Apollo Bay, to the Cities of Geelong and Melbourne—sawn timber. (i) From and to the City of Colac to and from the Township of Apollo Bay—general goods.
- FREIGHTER INDUSTRIES LTD.**, 579 Footscray Road, Footscray, 3011. One commercial goods vehicle (L/C. 12.70 tonne) to operate: (a) Within a 40-km radius of the G.P.O., Melbourne in the course of business as trailer, containers and caravan manufacturers—own goods. (b) From own premises at Footscray to own approved decentralized secondary industry (trailer and caravan manufacture) at Ballarat—raw materials used solely in the manufacture of trailers, caravans

- and containers. (c) From own premises at Ballarat to own premises at Footscray—own manufactured trailers, containers and caravans.
- FULTON, J., 1387 Malvern Road, Malvern, 3144. One commercial goods vehicle (L/C. 11.55 tonne) to operate: (a) Within a 40-km radius of the post office at the corner of Bourke and Elizabeth Streets, Melbourne and also to places outside that radius situated on the Mornington Peninsula in the course of business as "Sand, Soil and Screening Supplier and Landscape Gardeners"—own goods. (b) From pits at Cranbourne to own premises at Malvern—own sand and soil. (c) From Bacchus Marsh to own premises at Malvern—own river gravel and pebbles. (d) From pits at Toolangi and Marysville to own premises at Malvern—own mountain soil.
- GEMBROOK POTATO GROWERS PTY. LTD., Main Road, Gembrook, 3783. One commercial goods vehicle (L/C. 12.10 tonne) to operate: (a) From own premises at Gembrook to consignees within a 40-km radius of the post office at the corner of Bourke and Elizabeth Streets in the City of Melbourne in the course of business as "Potato Growers and Packers"—own pre-packaged potatoes and own pre-packaged onions and vegetables returning with packaging materials incidental only to own business. (b) From own premises at Gembrook to consignees at Bairnsdale and places en route—own potatoes, onions and vegetables.
- GILLMAN, G. J., High Street, Rutherglen, 3685. Application to vary the conditions of licence No. D.A.66355 (L/C. 4.95 tonne) by deleting from paragraph (b) "Within a 100-mile radius" and adding in lieu "Within an 80-km radius of".
- GOODWIN, L. J. (trading as L. J. & J. E. Goodwin), 10 Main South Road, Drouin, 3818. One commercial goods vehicle (L/C. 6.95 tonne) to operate: (a) From G. C. Morgan's sawmill at Drouin to consignees situated within an 80-km radius of the post office at Drouin—sawn timber. (b) From G. C. Morgan's sawmill at Drouin to consignees situated within a 40-km radius of the post office situated at the corner of Bourke and Elizabeth Streets in the City of Melbourne—sawn timber. (c) From the premises of the State Electricity Commission of Victoria at Morwell to consignees situated within a 5-km radius of the post office at Drouin—bagged briquettes. (d) From consignees situated within a 250-km radius of the post office situated at the corner of Bourke and Elizabeth Streets in the City of Melbourne to the premises of R. Gregory at Scoresby—bagged potatoes. (e) From the premises of C.C. Stockfeeds Pty. Ltd. at Dandenong to consignees situated within a 5-km radius of the post office at Drouin—bagged stockfeed. (f) From the premises of Phosphate Co-Op. Ltd. (Pivot) at Yarraville to consignees situated within a 30-km radius from the post office at Drouin—bagged superphosphate and superphosphate-based agricultural fertilizers. (g) From the premises of Victor Board Pty. Ltd. at Oakleigh and the premises of K.M. Plaster Products Pty. Ltd. at Pakenham to the premises of Ferguson and Puglese Pty. Ltd. at Warragul—plaster board. (h) From the premises of Gippsland Cement Ltd. at Traralgon to consignees situated within a 5-km radius of the post office at Drouin—bagged cement. (i) From the premises of I. J. Hardie at Neerim South to the premises of Australian Estates Co. Ltd. at Braybrook—skins, hides and drums of tallow. (j) From consignees situated within a 5-km radius of the post office at Drouin to the premises of Australian Estates Co. Ltd. at Braybrook—drums of tallow. (k) From the premises of Wunderlich Ltd. at Sunshine to consignees situated within a 5-km radius of the post office at Drouin—cement sheet. (l) Within a 40-km radius of the post office at Drouin—general goods.
- GUDGEON, B. W., 18 Mathilda Street, Wendouree, 3355. One commercial goods vehicle (L/C. 1.70 tonne) to operate: (a) Within an 80-km radius of own premises at Wendouree in the course of business as "Builders"—own goods. (b) Throughout the State of Victoria—tools of trade and builder's equipment. (c) Within a 32-km radius of any contract the applicant is currently engaged upon or from the railway station nearest thereto—materials for use on such contract.
- HIBBERD, W. N. G. (trading as Hibberd's Nursery), 38 Alfred Street, Sebastopol, 3356. One commercial goods vehicle (L/C. 1.25 tonne) to operate from plant nurseries situated within a 40-km radius of Melbourne to own nursery at Sebastopol—concrete plant pots, shrubs and seedlings.
- IRWIN, P. B., 12 Kalimna Avenue, Horsham, 3400. One commercial goods vehicle (L/C. 13.10 tonne) to operate from forest landings and private landings within an 80-km radius of Horsham to G., B. & N. Sawmill at Horsham—logs.
- LEECH, J. J., & SONS PTY. LTD., 314 Barker Street, Castlemaine, 3450. Five commercial goods vehicles (L/C. 16.75, 15.35, 18.00, 14.25, 18.40 tonne) to operate: (a) Within a 40-km radius of the chief post office in Castlemaine—general goods. (b) From Melbourne to places within a 40-km radius of Castlemaine—bricks. (c) From Melbourne to Castlemaine—uncrated cement products. (d) From within a 40-km radius of Castlemaine to Melbourne—empty return pallets and reject bricks.
- LEECH, J. J., & SONS PTY. LTD., 314 Barker Street, Castlemaine, 3450. One commercial goods vehicle (L/C. 6.75 tonne) to operate: (a) Within a 40-km radius of the chief post office in Castlemaine—general goods. (b) From the premises of A. Gianarelli & Sons, an approved decentralized secondary industry (monumental mason and granite crushing) at Harcourt to the premises of A. Gianarelli & Sons at Melbourne—granite blocks and kerbing. (c) From the premises of A. Gianarelli & Sons at Harcourt, being an approved decentralized secondary industry—goods and materials used solely in the manufacturing processes of such industry.
- MCCULLAGH, A. E. (trading as McCullagh Bros.), 169-171 Fairy Street, Warrnambool, 3280. One commercial goods vehicle (L/C. 0.40 tonne and 0.80 tonne trailer) to operate: (a) Within an 80-km radius of own premises at Warrnambool in the course of business as "Sawmiller"—own goods. (b) Within a 112-km radius of own premises at Warrnambool in the course of business as "Farm Machinery and Chain Saw Distributor and Servicing Specialist"—tools of trade and spare parts incidental thereto, farm machinery and chain saws for repair or having been repaired, secondhand traded in machinery and chain saws and new machinery and chain saws for delivery or installation, provided that all new goods from Melbourne are consigned to Warrnambool by rail.
- MCGLASHAN, D. K., Hassel Street, Irymple, 3498. One commercial goods vehicle (L/C. 2.50 tonne) to operate throughout the State of Victoria in the course of business as "Marine Collector"—marine stores and old metals as defined in the *Marine Stores and Old Metals Act 1958*, No. 6303, but excluding the carriage of such goods to wharves docks or ships for shipment or export purposes, providing the combined load capacities of the vehicle and any trailer used does not exceed five (5) tonnes.
- MCMAHON, T. K., South Heathcote, 3606. Two commercial goods vehicles (L/C. 12.25 and 12.05 tonne) to operate: (a) Within a 40-km radius of Heathcote—general goods. (b) From Melbourne to places within a 40-km radius of Heathcote—bricks and empty pallets for return. (c) From Heathcote to places within a 60-km radius of Dandenong—own fencing posts, own grain and own hay. (d) From Melbourne to places within a 40-km radius of Heathcote—superphosphate.
- NUNN, G. G., 77 Holmes Road, Morwell, 3840. One commercial goods vehicle (L/C. 0.70 tonne) to operate within an 80-km radius of the post office at Morwell in the course of business as carpet layer—own tools of trade and carpets subject to the condition that all carpets are initially received on rail at Morwell.
- RAMSDALL, P. F., 12 Jefferson Avenue, Lakes Entrance, 3909. One commercial goods vehicle (L/C. 19.50 tonne) to operate: (a) From places within a 24-km radius of Combiobar to the Combiobar Sawmill—sawmill logs. (b) From the Curlip logging unit to J. Ramsdall's Sawmill at Nowa Nowa—sawmill logs.
- OULD, T. D. & E. C. (trading as Rice Hull Supplies), Mountain Highway, Bayswater, 3153. One commercial goods vehicle (L/C. 7.50 tonne) to operate in the course of business as fowl manure supply, from poultry farms within an 80-km radius of own premises at Bayswater to market gardens and nurserymen within the said radius—own fowl manure.
- RICH, E. E. (trading as E. E. & S. J. Rich), 20 Gearing Street, Maryborough, 3465. One commercial goods vehicle (L/C. 3.30 tonne) to operate: (a) Within a 40-km radius of Maryborough—general goods. (b) From Melbourne to Maryborough and towns en route—new furniture as per T.R.B. Schedule. (c) For the carriage of household furniture, being furniture or personal effects of a householder or a member of his family when being moved from residence to residence, from residence for storage or sale, from storage to residence; from a vendor to the residence of the purchaser.

- ROGERSON, R. D.**, Derrinallum, 3325. One commercial goods vehicle (L/C. 7.85 tonne) to operate: (a) Within a 40-km radius from the post office at Derrinallum—general goods. (b) Throughout the State of Victoria—livestock. (c) From Pivot at Geelong to various primary producers' properties within 161 km of Geelong—bagged and bulk superphosphate. (d) From and to the City of Ballarat to and from the Townships of Derrinallum and Mingay and places on or most conveniently reached from the road between the two townships aforesaid—general goods.
- RUGGERI, M.**, 13 Elcho Street, Newtown, 3220. One commercial goods vehicle (L/C. 9.50 tonne) to operate within an 80-km radius of the chief post office in the City of Geelong—premixed concrete in a specially constructed agitator vehicle on behalf of Local Mix Concrete Pty. Ltd.
- SANTARIUM HEALTH FOOD CO.**, 118 Union Street, Windsor, 3181. One commercial goods vehicle (L/C. 6.35 tonne) to operate in the course of business as Manufacturers of Health Food Products within the following areas: (a) Within an 80-km radius of the G.P.O., Melbourne and from the City of Melbourne to Gordon, Wallace and Bungaree—own goods. (b) From the railhead at Ballarat to consignees. (i) Within the City of Ballarat. (ii) Within the Boroughs of Daylesford, Creswick, Clunes and Burrumbeet—own goods.
- SCHILTZ, N. M.**, 7 Pickford Street, Wendouree, 3355. One commercial goods vehicle (L/C. 0.40 tonne and 0.50 tonne trailer) to operate within an 80-km radius of the post office at Ballarat in the course of business as "Carpet and Linoleum Layers"—tools of trade and small quantities of carpet and linoleum and floor tiles for laying purposes only.
- SENDEK, R.** (trading as R. & P. S. Sendek), 3 Parry Street, Korumburra, 3950. One commercial goods vehicle (L/C. 0.70 tonne) to operate: (a) Throughout the State of Victoria in the course of business as floor covering contractor—own tools of trade. (b) Within an 80-km radius of any contract site engaged upon—carpet, vinyl flooring, and floor tiles provided that all such goods are initially received on rail at the premises from which they are sold.
- SINCLAIR & DUNCAN FOUNDRIES PTY. LTD.**, Industrial Avenue, Thomastown, 3074. Two commercial goods vehicles (L/C. 6.60 and 15.95 tonne) to operate: (a) Within a 40-km radius of the G.P.O., Melbourne—own goods. (b) From own premises at Thomastown to own approved decentralized secondary industry premises at White Hills (Iron and Steel Founding)—raw materials, semi-processed castings and goods used solely in the manufacturing processes of such industry. (c) From own premises at White Hills to own premises at Thomastown—manufactured and semi manufactured articles and machinery for repair.
- SPRAYPAVE PTY. LTD.**, P.O. Box 373, Clayton, 3168. One commercial goods vehicle (L/C. 2.05 tonne and 0.85 tonne trailer) to operate throughout the State of Victoria in the course of business as "Household Pest contractor for the purpose of line marking on roads—special road-marking equipment, tools of trade, and small quantity of road marking materials incidental to the completion of own contracts.
- PLATTER, W. J.** (trading as Tedman's Pest Control), 61 Crawley Street, Warrnambool, 3280. One commercial goods vehicle (L/C. 0.40 tonne and 0.30 tonne trailer) to operate throughout the State of Victoria in the course of business as "Household Pest Exterminators"—tools of trade and a small quantity of spray materials incidental to the completion of contracts undertaken but excluding the carriage of materials from places within a 40-km radius of the G.P.O., Melbourne.
- THOMAS, C. J.** (trading as Thomas Garden Supplies), 64 Loongana Avenue, Glenroy, 3046. One commercial goods vehicle (L/C. 11.40 tonne) to operate in a specially constructed bulk vehicle solely on behalf of Hortopine Products Pty. Ltd. an approved decentralized secondary industry at Ballarat—(a) From sawmills at Colac, Stawell, and Ballarat to the said decentralized industry at Ballarat—bulk pine bark. (b) From the said decentralized industry at Ballarat and from sawmills at Colac and Stawell to the Melbourne metropolitan area and to those places within an 8-km radius of Geelong, Warrnambool, Bendigo, Shepparton, Swan Hill and Wodonga—bulk treated pine bark. (c) From Ulina to own customers within a 40-km radius of G.P.O., Melbourne—own light-weight honeycomb garden rock.
- THOMPSON, L. J.**, 55 Kays Avenue, Hallam, 3803. One commercial goods vehicle (L/C. 16.55 tonne) to operate within a 56-km radius of the G.P.O., Melbourne on behalf of "The Ready Mix Group (Vic.)"—sand, soil, screenings, premix and quarry products.
- TIZARD, E. D.**, 228 Beech Avenue, Mildura, 3500. One commercial goods vehicle (L/C. 0.85 tonne) to operate throughout the State of Victoria in the course of business as "Carpet and Linoleum Layers"—tools of trade and small quantities of carpet and linoleum and floor tiles for laying purposes only.
- TOMLINSON STEEL LTD.**, 230 Lygon Street, East Brunswick, 3056. One commercial goods vehicle (L/C. 0.75 tonne) to operate throughout the State of Victoria in the course of business as "Manufacturing Engineers"—tools of trade and spare parts incidental to the servicing and maintenance of boilers and generating plants.
- TURNER, T. J.**, 22 Sabine Avenue, Dandenong North, 3175. One commercial goods vehicle (L/C. 0.80 tonne and 0.75 tonne trailer) to operate throughout the State of Victoria in the course of business as "Contract Carpet Layers"—tools of trade, floor coverings for laying purposes only also a small quantity of fixing materials.
- WASHINGTON, S. M.**, 89 Bruce Street, Colac, 3250. One commercial goods vehicle (L/C. 13.40 tonne) to operate:—(a) Within a 40-km radius of the chief post office in the City of Colac—general goods. (b) Within a 40-km radius of the Township of Forrest—logs.
- WILLIAMS, K. E.**, Esmond, via Yarrowonga, 3730. One commercial goods vehicle (L/C. 0.85 tonne) to operate within an 80-km radius of Esmond and to and from Kerang and Nagambie serving places en route in the course of business as "Marine and water ski supply"—Boating accessories, equipment and water skiing equipment.
- WRIGHT, S. R.**, Maryborough Road, Carisbrook, 3464. One commercial goods vehicle (L/C. 15.55 tonne) to operate: (a) Within a 40-km radius of Carisbrook—general goods. (b) From own premises at Carisbrook to the Melbourne metropolitan area as defined in the *Transport Regulation Act 1958*—own firewood. (c) From Carisbrook to Warragul, Shepparton, Rochester, Kerang, Kilmore and Swan Hill—baled grass and lucerne hay. (d) From Carisbrook to Stramit Board at Bendigo—baled straw. (e) Wooden fencing posts from bush locations situated within a 10-km radius of Carisbrook to various places within an 80-km radius of Carisbrook. (f) Bagged fowl manure from poultry farmers in Carisbrook to Werribee and Mildura. (g) Bagged superphosphate from I.C.I. Yarraville to primary producers' properties situated within 161 km of such works. (h) Bagged superphosphate from Pivot Geelong to primary producers' properties situated within 161 km of such works. (i) Livestock throughout the State of Victoria.

TOW TRUCKS.

- BROOKS, R. J.**, 2233 Nepean Highway, Rye, 3941. One commercial goods vehicle (to be purchased) to operate within an 80-km radius of own premises at Rye as a tow truck: (a) For the purpose of lifting and carrying or towing of wrecked or disabled motor vehicles and the carriage of tools and equipment necessary for such purpose. (b) The carriage of spare parts necessary for the repair of a disabled motor vehicle to and from the place at which such disablement has occurred.

NOTE.—(i) That the operation shall only occur from the scene of a motor car accident if the licensed owner or certificated driver of the said tow truck has been previously bespoken, but not at the scene of such accident, by the owner of the damaged or disabled motor car, or his agent or the person in charge of the said damaged motor car or disabled motor car. (ii) The licensed vehicle shall at all times exhibit a black plate 23 cm x 6.5 cm on which appears in white letters 4.00 cm high the word "RESTRICTED" to be affixed above the front and rear registration plates.

- MAFFESIONI, P. J.**, 70 High Street, Maryborough, 3465. One commercial goods vehicle (L/C. 3.00 tonne) to operate throughout the State of Victoria as a Tow Truck solely—(a) for the purpose of lifting and carrying or towing motor vehicles and the carriage of tools and equipment necessary for such purposes only. (b) The carriage of spare parts necessary for the repair of a disabled motor vehicle to and from the place at which such disablement has occurred.

NOTE.—This application replaces tow truck licence No. D.A.63605 previously held by the applicant.

NOTE.—This application replaces previous application gazetted on 7th February, 1974.

MANSFIELD MOTOR PANEL REPAIRS PTY. LTD., Early Street, Mansfield, 3722. Application to vary the conditions of licence No. D.A.45861 (L/C. 2.95 tonne) by deleting "Within a 100-mile radius" and adding in lieu "Throughout the State of Victoria".

VARDY, G. D. & V. L., Gormandale, 3873. Application to vary the conditions of licence No. D.A.67081 (L/C. 4.10 tonne) by deleting "Throughout the State of Victoria" and adding in lieu "Within an 80-km radius of the post office at Gormandale".

RENEWALS.

Applications for renewal of licences as shown by persons listed hereunder to operate under the same terms and conditions from the expiry shown in each case.

ADAMS, B. W., Ballarat Street, Talbot, 3371; D.A.60582; 27th February, 1975; 6.15 tonne.

BEISSOUNDAS, J., 126 Albert Street, Brunswick, 3056; D.A.64195; 19th October, 1974; 11.90 tonne.

BULLER, G. S., P.O. Box 82, Warburton, 3799; D.A.64295; 18th January, 1975; 3.20 tonne.

CARDELL, A. J., Elaine, 3334; D.A.45544; 18th February, 1975; 6.35 tonne.

CHESTER, W. J., 20 Rolland Street, Sale, 3850; D.A.62950/3; 2nd February, 1975; 2.42 tonne.

COLLINS, S. M., PTY. LTD., 603-613 Princes Highway, Bairnsdale, 3875; D.A.65088; 15th February, 1975; 2.40 tonne; D.A.65088/2; 15th February, 1975; 0.70 tonne.

COTTEES GENERAL FOODS, 160 Whitehorse Road, Blackburn, 3130; D.A.30358/7; 18th February, 1975; 0.70 tonne.

DALGETY AUST. LTD., 461 Bourke Street, Melbourne, 3000; D.A.46170/96; 22nd February, 1975; 0.50 tonne.

DUNLOP TYRE SERVICE (VIC.) PTY. LTD., GEELONG BRANCH, 107 Gheringhap Street, Geelong, 3220; D.A.60416; 27th February, 1975; 0.70 tonne.

DUNLOP TYRE SERVICE (VIC.) PTY. LTD., COLAC BRANCH, 108 Flinders Street, Melbourne, 3000; D.A.60416/38; 14th January, 1975; 0.80 tonne.

FULTON, J., 1387 Malvern Road, Malvern, 3144; D.A.60514; 22nd October, 1974; 2.05 tonne.

GREENWAYS REFRIGERATED TRANSPORT PTY. LTD., Grant Road, Somerville, 3912; D.A.66062/3; 2nd February, 1975; 5.25 tonne.

HANCOCK, M. J. & H. S., 35 Kett Street, Nunawading, 3131; D.A.64368; 8th February, 1975; 7.85 tonne.

HERDMAN, K. J., 2 McGowan Street, Eaglehawk, 3556; D.A.60108/1; 27th February, 1974; 0.50 tonne.

BATTERS, R. G. (trading as Hubber & Batters), Mollison Street, Kyneton, 3446; D.A.35042; 23rd February, 1975; 5.10 tonne.

JENKS, RAY, PTY. LTD., 118-120 High Street, Shepparton, 3630; D.A.60403/6; 22nd February, 1975; 0.65 tonne.

JUICELAND PTY. LTD., 217 Wade Avenue, Mildura, 3550; D.A.64297; 18th January, 1975; 2.45 tonne.

KENNEDY, P., PTY. LTD., P.O. Box 11, Wendouree, 3355; D.A.64290; 18th January, 1975; 16.20 tonne.

KOLMANIC, M. M., 77 Spring Road, Drysdale, 3222; D.A.47956; 10th December, 1974; 7.75 tonne and 7.15 tonne trailer.

LAIRD, R. J., Anakie, 3221; D.A.60534; 27th February, 1975; 7.05 tonne and 6.50 tonne trailer.

MALONE, W. J., 15 Albert Street, Port Fairy, 3284; D.A.60491/1; 6th February, 1975; 7.95 tonne and 3.00 tonne trailer; D.A.60491/2; 6th February, 1975; 8.05 tonne and 3.00 tonne trailer.

MAY, S. F., 6 Sutherland Street, Chadstone, 3148; D.A.64301; 18th January, 1975; 0.30 tonne.

METROPOLITAN DAIRIES PTY. LTD., 90 Railway Crescent, Broadmeadows, 3047; T.D.A.38202/3; 12th February, 1975; 6.50 tonne.

MCPHERSON, N. J., New Dookie Road, Shepparton, 3630; D.A.64373; 8th February, 1975; 1.50 tonne.

NANGLE, L. A., PTY. LTD., 5 Peel Street, Collingwood, 3066; D.A.40349/4; 27th February, 1975; 1.05 tonne.

NEWTON, J. L. (trading as Newton's of Sale), 99-109 Raymond Street, Sale, 3850; T.D.A.66512; 11th February, 1975; 0.70 tonne.

NOLAN, J. P., 6 Campbells Crescent, Ballarat, 3350; D.A.64133; 28th September, 1974; 0.55 tonne.

ORR, J. A., 7 McFarlane Crescent, Dandenong, 3175; D.A.34592; 27th January, 1975; 7.25 tonne.

PETERSVILLE LTD., Wellington Road, Clayton, 3168; D.A.1813/217; 18th January, 1975; 3.80 tonne; D.A.1813/219; 25th January, 1975; 3.75 tonne.

PETERSVILLE LTD., Wellington Road, Clayton, 3168; D.A.1813/218; 18th January, 1975; 3.80 tonne; D.A.1813/159; 16th January, 1975; 3.80 tonne.

PEWTRESS, K. E., 123 View Street, Bendigo; D.A.65018/2; 15th February, 1975; 0.75 tonne.

RAFFERTY, F. T., PTY. LTD., 2 Nicholas Street, Lilydale, 3140; D.T.323/3; 14th September, 1974; 11.25 tonne.

RODGERS BROS. COLAC TYRE SERVICE, 82 Gellibrand Street, Colac, 3250; D.A.4973/12; 2nd February, 1975; 0.70 tonne.

ROSE, W. D., & SON PTY. LTD., 221 Charman Road, Cheltenham, 3192; D.A.36617/2; 6th February, 1975; 1.05 tonne.

SCULLI, D., 8A Tuppal Place, East Keilor, 3033; D.A.62056/1; 25th January, 1975; 12.20 tonne.

THOR INDUSTRIES PTY. LTD., Slater Parade, East Keilor, 3033; D.A.41614/19; 22nd February, 1975; 1.45 tonne.

TOMAINO, S. (trading as Tomaino's), 4 Buffalo River Road, Myrtleford, 3737; D.A.53055/12; 8th February, 1975; 1.45 tonne.

TOWNSEND, R. C., Collins Street, Bairnsdale, 3875; D.T.1426; 8th February, 1975; 14.25 tonne.

TRANS WEST HAULAGE (MELB.) PTY. LTD., 202 Station Street, Norlane, 3214; D.A.65323/45; 2nd February, 1975; 12.90 tonne.

TUTT BRYANT (VIC.) PTY. LTD., Gwelo Street, Tottenham, 3012; D.A.2187/19; 14th January, 1975; 0.75 tonne; D.A.2187/20; 14th January, 1975; 0.75 tonne; D.A.2187/21; 14th January, 1975; 0.75 tonne.

VIOLET TOWN CARTAGE PTY. LTD., P.O. Box 16, Shepparton, 3630; D.A.64237/4; 8th February, 1975; 8.05 tonne.

TOW TRUCK RENEWALS.

LITTLETON, A. (trading as Carron Motors), 197 Albion Street, Brunswick, 3056; D.A.59818; 16th May, 1974; 2.45 tonne.

MCCORMACK, T. M. (trading as Gardiner Panel Works), 286 Burke Road, Glen Iris, 3146; D.A.66372; 6th November, 1974; 1.75 tonne.

GORING, L. J. & SONS (trading as Hospital Service Station), 45 Flemington Road, North Melbourne, 3051; D.A.47050; 18th February, 1975; 3.20 tonne.

KENNEDY, L., 25 Main Road, Ballarat, 3350; D.A.36192/1; 6th February, 1975; 2.80 tonne.

MAROONDAH TOWING SERVICE PTY. LTD., 18 Molan Street, Ringwood, 3134; D.A.64182; 2nd February, 1975; 6.05 tonne.

MIKES MOTOR BODY WORKS PTY. LTD., 118-124 Nicholson Street, East Brunswick, 3057; D.A.65449/2; 27th February, 1975; 2.15 tonne.

SOUTH GIPPSLAND MILK INDUSTRIES LTD., 55 Walsh Street, North Melbourne, 3051; D.A.29347/1; 14th January, 1975; 3.50 tonne.

ROGERS, W. A., & J. M. WEST (trading as Rogers & West), 784 Ballarat Road, Deer Park, 3023; D.A.47168; 18th February, 1975; 1.45 tonne.

TIMMS, M. J., Broadway Street, Cobram, 3644; D.A.45951; 18th February, 1975; 2.00 tonne.

UNITED TOWING SERVICE PTY. LTD., 628 High Street, Thornbury, 3071; D.A.58930/7; 18th February, 1975; 1.90 tonne; D.A.58930/3; 16th May, 1974; 2.05 tonne; D.A.58930/5; 16th May, 1974; 3.40 tonne.

WAUGH, V. A., 13 Douro Street, North Geelong, 3215; T.D.A.2257/5; 12th February, 1975; 1.50 tonne.

RENEWALS WITH VARIATION.

Applications made by the persons listed hereunder for renewal of the licences listed with variation of conditions in the manner set out opposite the names.

SHANAHAN, C. P. & J. F. (trading as P. T. Shanahan), 158 Princes Highway, Bairnsdale, 3875; D.A.19269/2; 28th February, 1975. Application to renew and vary the conditions of licence No. D.A.19269/2 (L/C. 7.10 tonne) by deleting paragraph (c) and adding in lieu as paragraph (c)—"Within a 40-km radius of the post office at Bairnsdale—general goods".

SHINGLES, C. G. (estate of the late), 10 Boisdale Street, Maffra, 3860; D.A.60568; 13th February, 1975; D.A.60568/2; 13th February, 1975; D.A.60568/3; 13th February, 1975. Application to renew and vary the conditions of licences numbered D.A.60568 (L/C. 11.55 tonne), D.A.60568/3 (L/C. 11.60 tonne) and D.A.60568/2 (L/C. 12.10 tonne) by deleting paragraph (c) and adding in lieu as paragraph (c)—"Within a radius of 40-km of the post office at Maffra—general goods".

Notice of any objection should be forwarded to reach the Secretary of the Board not later than Tuesday, 6th November, 1974.

Applicants are advised that it will not be necessary to appear on the hearing date specified above, unless advised in writing by the Board.

A. V. C. COOK,
Secretary.

Corner Lygon and Princes Streets, Carlton, 3053,
Wednesday, 30th October, 1974.

Stamps Act 1958.

ANNUAL LICENCE.

NOTIFICATION PURSUANT TO SECTION 97.

I hereby notify that stamp duty has been paid for a licence under section 96 of the Stamps Act to carry on assurance and insurance business in Victoria from 1st October, 1974 to 31st December, 1974, by the following:—

GILMAN WELLER AUSTRALIA PTY. LTD.

R. M. PHIBBS,
Comptroller of Stamps.

Stamp Duties Office,
Melbourne, 23rd October, 1974.

Police Regulation Act 1958, Section 122.

SALE OF UNCLAIMED MOTOR VEHICLE.

An owner is required for a 1966 model fawn Chrysler Valiant Safari station wagon, engine No. B2250609.

The vehicle came into the possession of Police on the 1st April, 1974, and if not claimed, will be sold by public auction at the Coleraine Police Station, Macleod Street, Coleraine at 2 p.m., on the 28th November, 1974.

R. JACKSON,
Chief Commissioner of Police.

COUNTRY ROADS BOARD.

RESOLUTIONS OF THE COUNTRY ROADS BOARD.

The Country Roads Board, in pursuance of the provisions of the Country Roads Act 1958, has passed Resolutions the dates whereof and the terms of which are scheduled hereunder:

SCHEDULE.

State highway.

Resolution dated the Fourteenth day of October, One thousand nine hundred and seventy-four, made pursuant to sections 21 and 74 of the Country Roads Act 1958, declaring the widening of the Bellarine Highway in the Shire of Bellarine as shown hatched on plans numbered G.P.12182, G.P.12183, G.P.12184, G.P.12185, G.P.12186 and G.P.12187 hereunder to be part of a State highway within the meaning and for the purposes of the said Act.

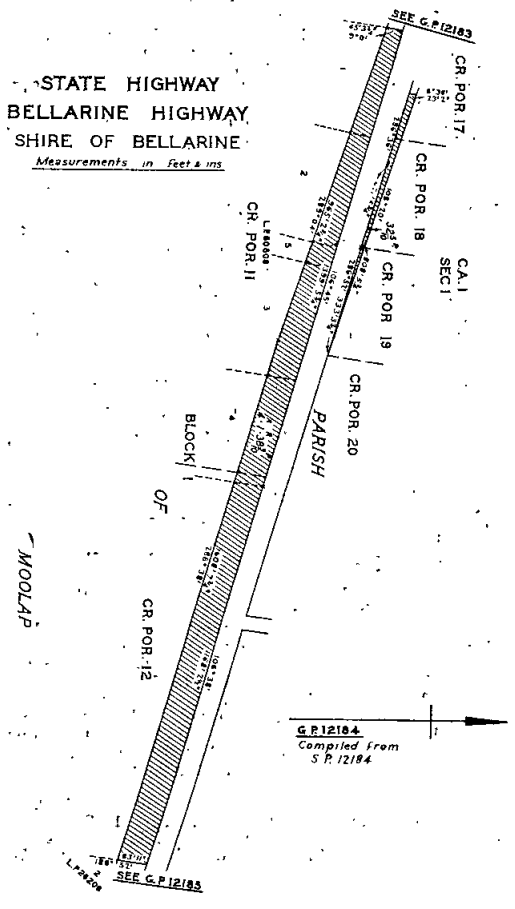
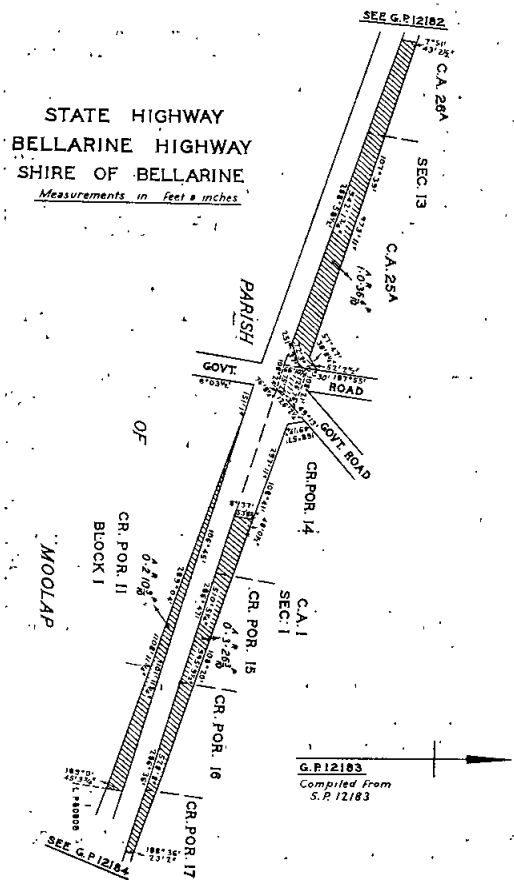
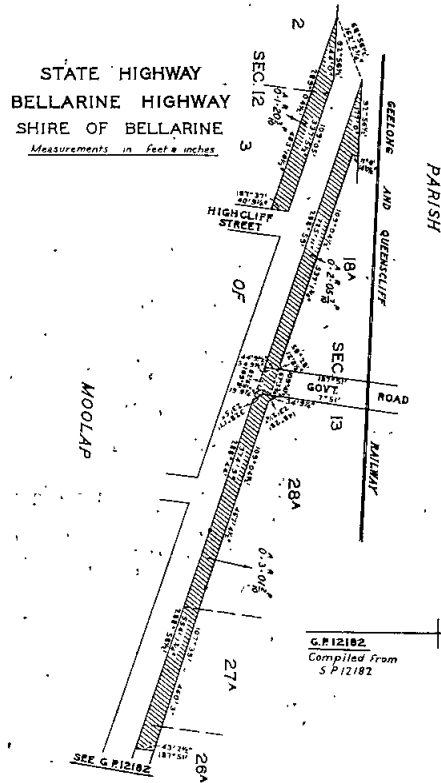

STATE HIGHWAY
BELLARINE HIGHWAY
SHIRE OF BELLARINE
Measurements in feet & ins.

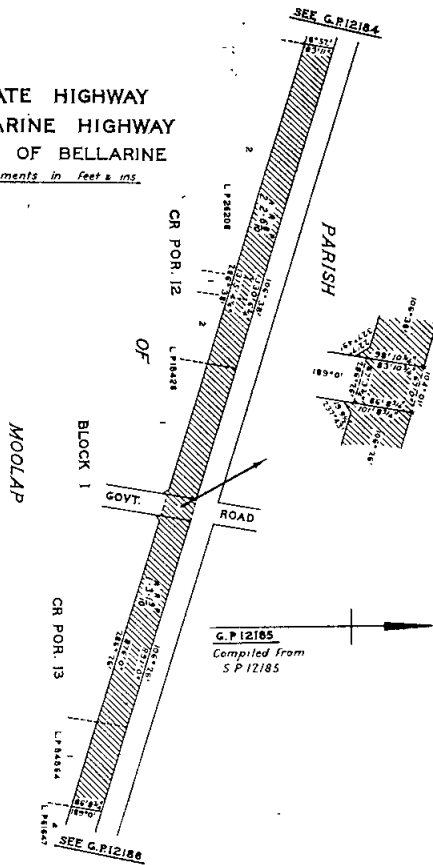

STATE HIGHWAY
BELLARINE HIGHWAY
SHIRE OF BELLARINE
Measurements in feet & ins.

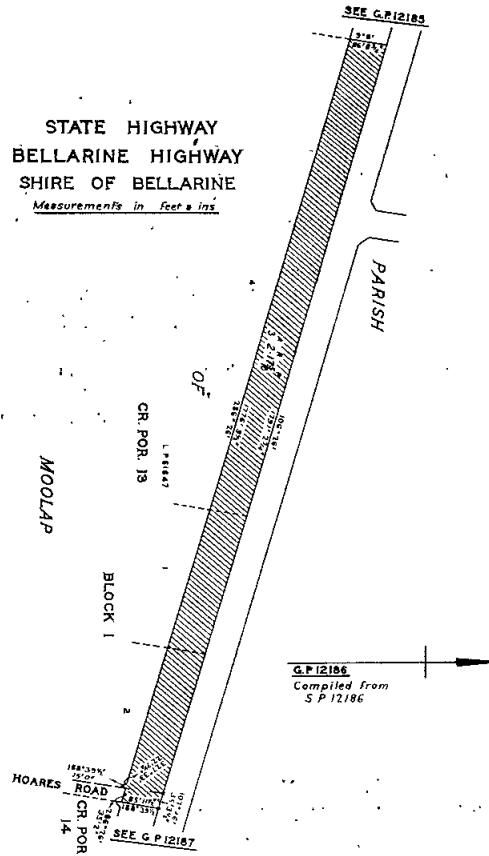

STATE HIGHWAY
BELLARINE HIGHWAY
SHIRE OF BELLARINE
Measurements in feet & inches.

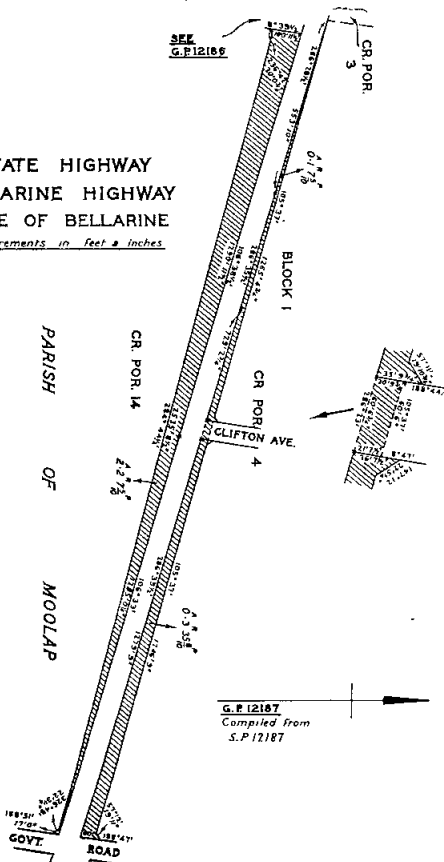

Main roads.
Resolution dated the Fourteenth day of October, One thousand nine hundred and seventy-four, made pursuant to section 21 of the Country Roads Act 1958, declaring the widening of the Doncaster-Mitcham Road in the City of Doncaster and Templestowe as shown hatched on plan numbered G.P.11482 hereunder to be part of a main road within the meaning and for the purposes of the said Act.

MAIN ROAD
DONCASTER—MITCHAM ROAD
CITY OF DONCASTER & TEMPLESTOWE
Measurements in feet & inches.

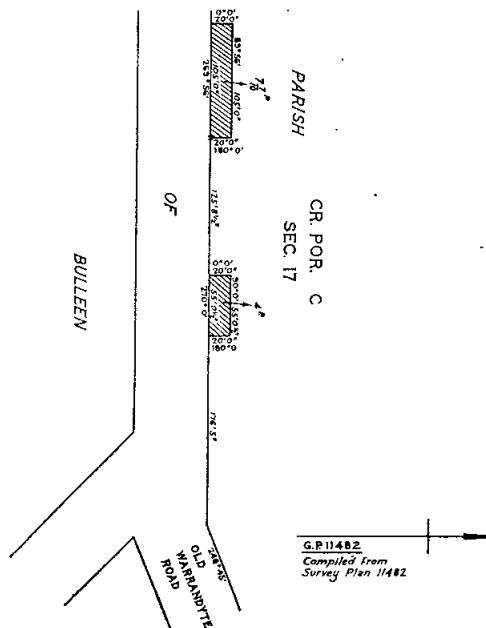

Resolution dated the Fourteenth day of October, One thousand nine hundred and seventy-four, made pursuant to sections 21 and 58 of the Country Roads Act 1958 declaring the deviation from the Healesville-Kinglake Road in the Shires of Healesville and Yea as indicated by diagonal hatching on plans numbered G.P.13108, G.P.13109, G.P.13110, G.P.13111A and G.P.13111B hereunder to be part of a main road within the meaning and for the purposes of the said Act, and also declaring that such deviation shall be in lieu of the existing road or part thereof indicated by cross-hatching on plans numbered G.P.13111A and G.P.13111B and vertical hatching on plans numbered G.P.13108 and G.P.13109 which part indicated by cross-hatching on plans numbered G.P.13111A and G.P.13111B shall be discontinued.

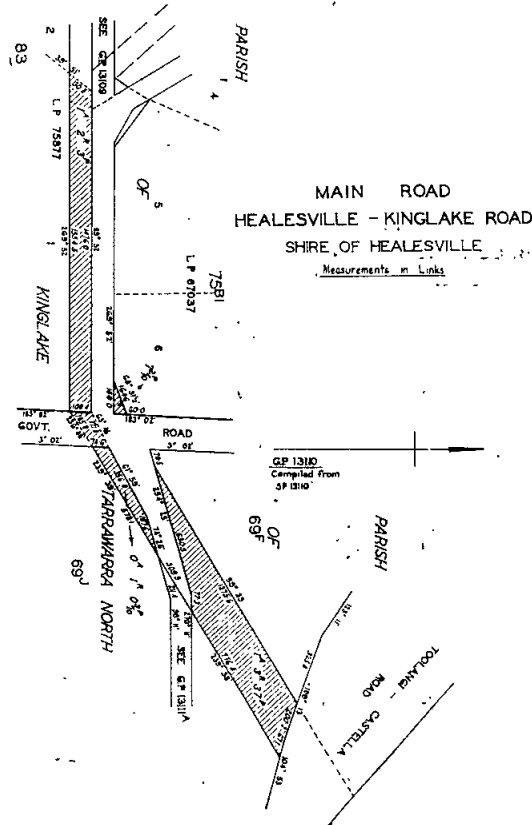
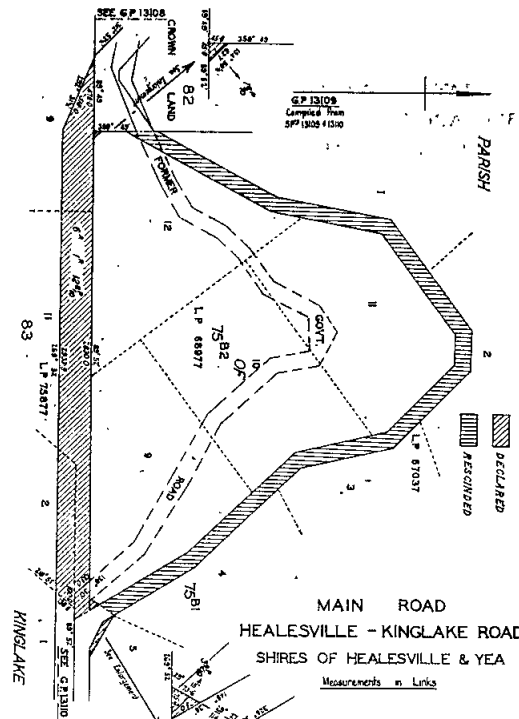
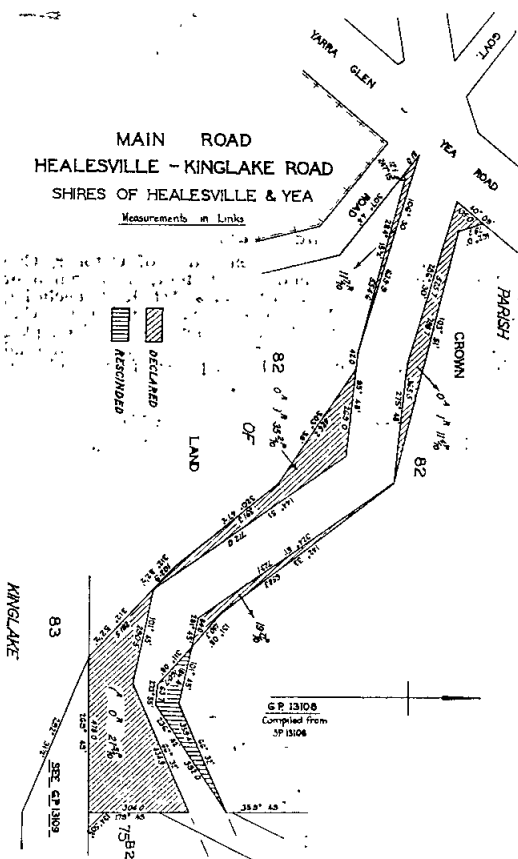

widening of the Emerald—Monbulk Road in the Shire of Sherbrooke as shown hatched on plan numbered G.P.12677 hereunder to be part of a main road within the meaning and for the purposes of the said Act.

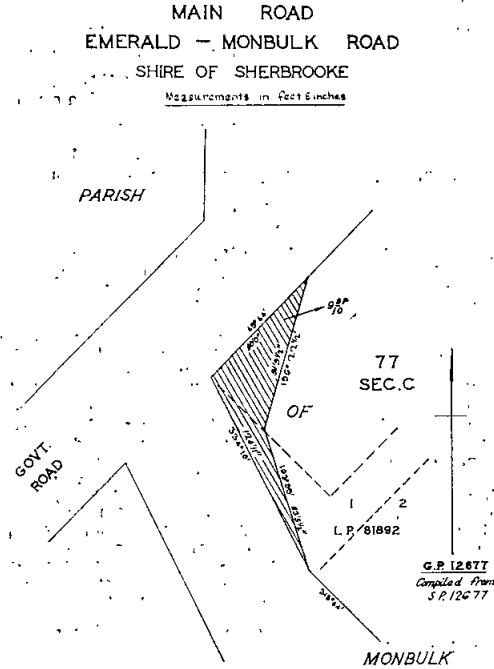
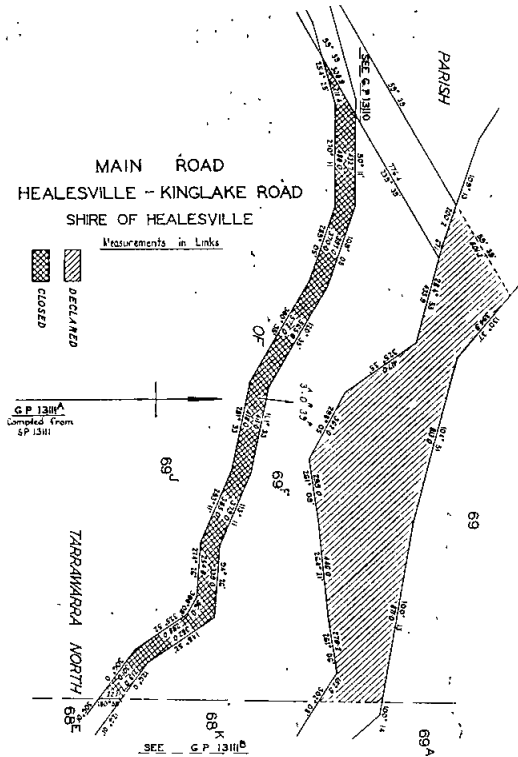

21st. October, 1974.

N. L. ALLANSON,
Secretary.

LOCAL GOVERNMENT ACT 1958.

In pursuance of the powers conferred by sub-section 3A of Section 575 of the Local Government Act 1958, I, William Archibald Borthwick, Her Majesty's Minister of Lands in the State of Victoria hereby declare that the road set out on Crown land in the City of Maryborough Parish of Maryborough, Country of Talbot, as delineated and indicated by hachure on the plan hereunder to be a private street within the meaning of and for the purposes of Division 10 Part XIX of the said Act.—(Corres. No. W.91476A.)

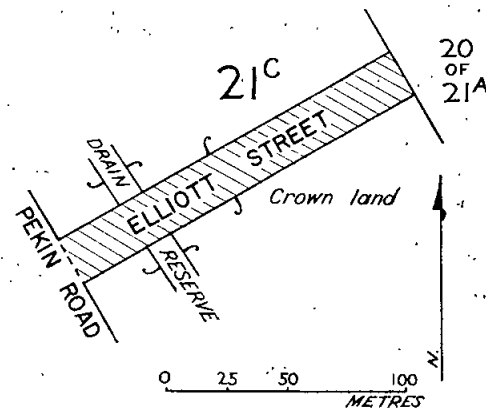
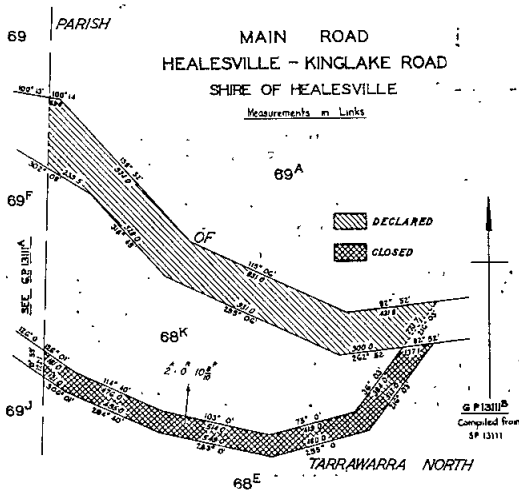

Dated at Melbourne this twenty-third day of October, 1974.

W. BORTHWICK,
Minister of Lands.

Resolution dated the Fourteenth day of October, One thousand nine hundred and seventy-four, made pursuant to section 21 of the Country Roads Act 1958, declaring the

Town and Country Planning Act 1961.
BALLAARAT AND DISTRICT PLANNING SCHEME 1966.

(BOROUGH OF SEBASTOPOL.)
AMENDMENT No. 1, 1973.

Notice of Approval.

In pursuance of the powers conferred by the *Town and Country Planning Act 1961*, the Governor in Council on the 22nd October, 1974, approved a planning scheme entitled the Ballarat and District Planning Scheme 1966 (Borough of Sebastopol) Amendment No. 1, 1973, in respect of part of the municipal district of the Borough of Sebastopol and such planning scheme comes into operation on the date this notice of approval is published in the *Government Gazette*.

A copy of the planning scheme as approved may be inspected free of charge during office hours at the office of the Town and Country Planning Board, 235 Queen Street, Melbourne; at the office of the Council of the Borough of Sebastopol at Sebastopol and when available, at the Office of Titles, Melbourne, and at the Central Planning Office of the Department of Crown Lands and Survey, Melbourne.

W. H. CRAIG, Secretary,
Town and Country Planning Board.

Town and Country Planning Act 1961.
SHIRE OF ALEXANDRA PLANNING SCHEME 1969.

INTERIM DEVELOPMENT ORDER.

AMENDMENT No. 2.

Notice of Amendment.

In pursuance of the powers conferred by section 26 of the *Town and Country Planning Act 1961*, the Governor in Council on the 22nd October, 1974, amended the Shire of Alexandra Planning Scheme 1969 Interim Development Order to permit the subdivision of part Crown allotment 10C, Parish of Yarck, into 3 allotments.

A copy of the amendment may be inspected during office hours at the office of the Town and Country Planning Board, 235 Queen Street, Melbourne; at the office of the Council of the Shire of Alexandra at Alexandra.

W. H. CRAIG, Secretary,
Town and Country Planning Board.

Town and Country Planning Act 1961.
SHIRE OF ALEXANDRA PLANNING SCHEME 1969.

INTERIM DEVELOPMENT ORDER.

AMENDMENT No. 3.

Notice of Amendment.

In pursuance of the powers conferred by section 26 of the *Town and Country Planning Act 1961*, the Governor in Council on the 22nd October, 1974, amended the Shire of Alexandra Planning Scheme Interim Development Order by increasing the minimum subdivision size in the Rural A and B Zones from 50 acres to 50 hectares (123.5 acres).

A copy of the amendment may be inspected during office hours at the office of the Town and Country Planning Board, 235 Queen Street, Melbourne; at the office of the Council of the Shire of Alexandra at Alexandra.

W. H. CRAIG, Secretary,
Town and Country Planning Board.

Town and Country Planning Act 1961.
SHIRE OF AVON PLANNING SCHEME.

INTERIM DEVELOPMENT ORDER.

AMENDMENT No. 1.

Notice of Amendment.

In pursuance of the powers conferred by section 26 of the *Town and Country Planning Act 1961*, the Governor in Council on the 22nd October, 1974, amended the Shire of Avon Planning Scheme Interim Development Order to allow the subdivision of Crown allotment 7, section 9, Parish of Bundalaguiah, County of Tanjil, into two allotments only, having areas of 1,114.96 square metres and 5.959 hectares.

A copy of the amendment may be inspected during office hours at the office of the Town and Country Planning Board, 235 Queen Street, Melbourne; at the office of the Council of the Shire of Avon at Stratford.

W. H. CRAIG, Secretary,
Town and Country Planning Board.

Town and Country Planning Act 1961.
SHIRE OF AVON PLANNING SCHEME.

INTERIM DEVELOPMENT ORDER.

AMENDMENT No. 2.

Notice of Amendment.

In pursuance of the powers conferred by section 26 of the *Town and Country Planning Act 1961*, the Governor in Council on the 22nd October, 1974, amended the Shire of Avon Planning Scheme Interim Development Order to allow the subdivision of part of Crown allotment 15, section E, Parish of Sale, County of Tanjil, into two allotments having areas of 4.047 square metres and 13.03 hectares.

A copy of the amendment may be inspected during office hours at the office of the Town and Country Planning Board, 235 Queen Street, Melbourne; at the office of the Council of the Shire of Avon at Stratford.

W. H. CRAIG, Secretary,
Town and Country Planning Board.

Town and Country Planning Act 1961.
SHIRE OF BACCHUS MARSH PLANNING SCHEME.

INTERIM DEVELOPMENT ORDER.

AMENDMENT No. 9.

Notice of Amendment.

In pursuance of the powers conferred by section 26 of the *Town and Country Planning Act 1961*, the Governor in Council on the 22nd October, 1974, amended the Shire of Bacchus Marsh Planning Scheme Interim Development Order to allow a subdivision of land situated at the corner of Vallence Road and the main Geelong-Bacchus Marsh Road and forms part of Crown allotment 42, section A, Parish of Parwan, County of Grant.

A copy of the amendment may be inspected during office hours at the office of the Town and Country Planning Board, 235 Queen Street, Melbourne; at the office of the Council of the Shire of Bacchus Marsh at Bacchus Marsh.

W. H. CRAIG, Secretary,
Town and Country Planning Board.

Town and Country Planning Act 1961.
SHIRE OF ROMSEY PLANNING SCHEME.

INTERIM DEVELOPMENT ORDER.

AMENDMENT No. 5A.

Notice of Amendment.

In pursuance of the powers conferred by section 26 of the *Town and Country Planning Act 1961*, the Governor in Council on the 22nd day of October, 1974, amended the Shire of Romsey Planning Scheme Interim Development Order to extend existing controls over tree-felling to the whole of the land included in the rural areas of the municipality.

A copy of the amendment may be inspected during office hours at the office of the Town and Country Planning Board, 235 Queen Street, Melbourne; at the office of the Council of the Shire of Romsey, at Romsey.

W. H. CRAIG, Secretary,
Town and Country Planning Board.

Town and Country Planning Act 1961.
SHIRE OF ROMSEY PLANNING SCHEME.

INTERIM DEVELOPMENT ORDER.

AMENDMENT No. 5.

Notice of Amendment.

In pursuance of the powers conferred by section 26 of the *Town and Country Planning Act 1961*, the Governor in Council on the 22nd October, 1974, amended the Shire of Romsey Planning Scheme Interim Development Order to extend the Township Zone at Riddell, to extend existing control over tree-felling, and to exempt the routine operations of public authorities and municipalities from the necessity of applying for a planning permit.

A copy of the amendment may be inspected during office hours at the office of the Town and Country Planning Board, 235 Queen Street, Melbourne; at the office of the Council of the Shire of Romsey at Romsey.

W. H. CRAIG, Secretary,
Town and Country Planning Board.

Private Agents Act 1966.

NOTICE OF RECEIPT OF APPLICATIONS FOR LICENCES UNDER THE PROVISIONS OF THE PRIVATE AGENTS ACT 1966.

The Clerk(s) of the Magistrates' Court(s) as listed hereunder hereby give notice that applications, as under, have been lodged for hearing by the said Court(s) on the date(s) specified.

Any person desiring to object to any of such applications must—

(a) lodge with the respective Clerk of the Magistrates' Court a notice in the prescribed form of his objection and of the grounds thereof ;

(b) cause a copy of such notice to be served personally or by post upon the applicant at least three days before the hearing of the application ; and

(c) send or deliver—

(i) where the objection is not made by the officer in charge of the police district in which the Court is situated a copy of the notice to such officer ; and

(ii) where the objection is not made by the Registrar or Deputy Registrar—a copy to the Registrar.

Full Name of Applicant or in the Case of a Firm or Corporation, of the Nominee.	Place of Abode of Applicant or Nominee.	Name of Firm or Corporation.	Address for Registration.	Type of Licence.	Date of Hearing of Application.
MAGISTRATES' COURT, SUNSHINE.					
Cotterill, Karen Mereline	1 Barclay Street, Albion		1 Barclay Street, Albion	Process Server	8.11.74
Dated at Sunshine this 17th day of October, 1974.					
M. F. MOLONEY, Clerk of the Magistrates' Court.					
MAGISTRATES' COURT, RICHMOND.					
Rahaley, John Lawrence	37 Arcadia Avenue, The Basin		271 Bridge Road, Richmond	Process Server and Inquiry Agent	22.11.74
Dated at Richmond this 17th day of October, 1974.					
N. T. DAVIDSON, Clerk of the Magistrates' Court.					
MAGISTRATES' COURT, HASTINGS.					
Depasquale, Nicola	43 Church Street, Hastings		340 Abbotsford Street, North Melbourne	Watchman	27.11.74
Dated at Hastings this 17th day of October, 1974.					
T. O'KEEFE, Clerk of the Magistrates' Court.					
MAGISTRATES' COURT, FRANKSTON.					
Buntrock, Dieter	4 Francis Street, Frankston		4 Francis Street, Frankston	Guard Agent	7.11.74
"	"	"	"	Process Server	"
Dated at Frankston this 17th day of October, 1974.					
J. BOUNDY, Clerk of the Magistrates' Court.					
MAGISTRATES' COURT, FRANKSTON.					
Buntrock, Dieter	4 Francis Street, Frankston		4 Francis Street, Frankston	Inquiry Agent	7.11.74
Dated at Frankston this 16th day of October, 1974.					
E. MCGOWAN, Clerk of the Magistrates' Court.					
MAGISTRATES' COURT, OAKLEIGH.					
Kent, Raoul Alexander Anthony	523 Neerim Road, Murrumbena		523 Neerim Road, Murrumbena	Guard Agent	8.11.74
Dated at Oakleigh this 21st day of October, 1974.					
A. J. JOHNSON, Clerk of the Magistrates' Court.					
MAGISTRATES' COURT, MALVERN.					
Batley, Robert Albert	Flat 1, 24 Harrison Street, Mitcham		1389 High Street, Glen Iris	Commercial Sub-Agent	18.11.74
Dated at Malvern this 21st day of October, 1974.					
P. J. RODDA, Clerk of the Magistrates' Court.					
MAGISTRATES' COURT, MELBOURNE.					
Gaulton, Walter Bryce	48 Fawkner Street, West Essendon	Mayne Nickless Limited	94 York Street, South Melbourne	Watchman	27.11.74
Dated at Melbourne this 22nd day of October, 1974.					
G. L. WEBSTER, Clerk of the Magistrates' Court.					
MAGISTRATES' COURT, MELBOURNE.					
Daemen, Louis Jan Peter	36 Princess Springvale Avenue, Springvale	Wormald International Security	340 Abbotsford Street, North Melbourne	Watchman	22.1.75
Kerr, Maxwell Gordon	7 York Street, St. Kilda	"	"	"	"
Maynard, Roy David	248 Pascoe Vale Road, Essendon	"	"	"	"
Morton, Harry	92 Anderson Street, Newport	"	"	"	"
O'Brien, Patrick	47 Guy's Road, Korumburra	"	"	"	"
Robertson, Neil James	22 Shelley Street, West Heidelberg	"	"	"	"
Van Helfteren, Christianus Josephus	43 Edgar Street, Werribee	"	"	"	"
Walton, George	53 Settlement Road, Bundoora	"	"	"	"
Glén, Alan Heriot	Lawrence Court, The Patch	Mayne Nickless Limited	94 York Street, South Melbourne	"	"

Dated at Melbourne this 23rd day of October, 1974.

G. L. WEBSTER, Clerk of the Magistrates' Court.

PRIVATE AGENTS—continued.

Full Name of Applicant or in the Case of a Firm or Corporation, of the Nominee.	Place of Abode of Applicant or Nominee.	Name of Firm or Corporation.	Address for Registration.	Type of Licence.	Date of Hearing of Application.
MAGISTRATES' COURT, COBURG.					
Barnes, Roy Valentine	2 Beaumont Street, Watsonia		94 York Street, South Melbourne	Watchman	13.11.74
Dated at Coburg this 21st day of October, 1974.					
G. G. WILLIAMSON, Clerk of the Magistrates' Court.					

COMMONWEALTH OF AUSTRALIA.
Petroleum (Submerged Lands) Act 1967-1974.

STATE OF VICTORIA.
Petroleum (Submerged Lands) Act 1967.

NOTICE OF GRANT OF RENEWAL OF PERMIT.

A renewal of permit numbered VIC/PI has been granted to Hematite Petroleum Proprietary Limited of 140 William Street, Melbourne, in respect of each of the blocks constituted by a graticular section described hereunder. This renewal has effect for a period of five years commencing on the day after the day on which the last previous permit in respect of the blocks described herein ceased to have effect.

Description of Graticular Sections.

The graticular sections numbered 1778, 1779, 1784, 1785, 1847, 1848, 1849, 1850, 1851, 1852, 1856, 1857, 1858, 1920, 1921, 1928, 1992, 1998, 1999, 2000, 2064, 2065, 2066, 2067, 2071, 2072, 2130, 2131, 2132, 2133, 2134, 2135, 2136, 2137, 2138, 2139, 2143, 2144, 2200, 2201, 2202, 2204, 2205, 2206, 2207, 2208, 2215, 2216, 2277, 2278, 2279, 2280, 2284, 2285, 2286, 2287, 2350, 2356, 2357, 2358, and those portions of graticular sections numbered 1775, 1776, 1777, 1845, 1846, 1916, 1917, 2129, which fall on the southerly side of the line comprised of geodesics consecutively joining points as follows:—

- From the point defined—
- by latitude 38 deg. 36 min. south, longitude 147 deg. 07 min. east,
- to the point defined—
- by latitude 38 deg. 12 min. south, longitude 147 deg. 38 min. east,
- thence to the point defined—
- by latitude 38 deg. 05 min. south, longitude 147 deg. 49 min. east,
- by latitude 38 deg. 02 min. south, longitude 147 deg. 56 min. east,
- by latitude 38 deg. 00 min. south, longitude 148 deg. 02 min. east;

shown on the plan hereunder.

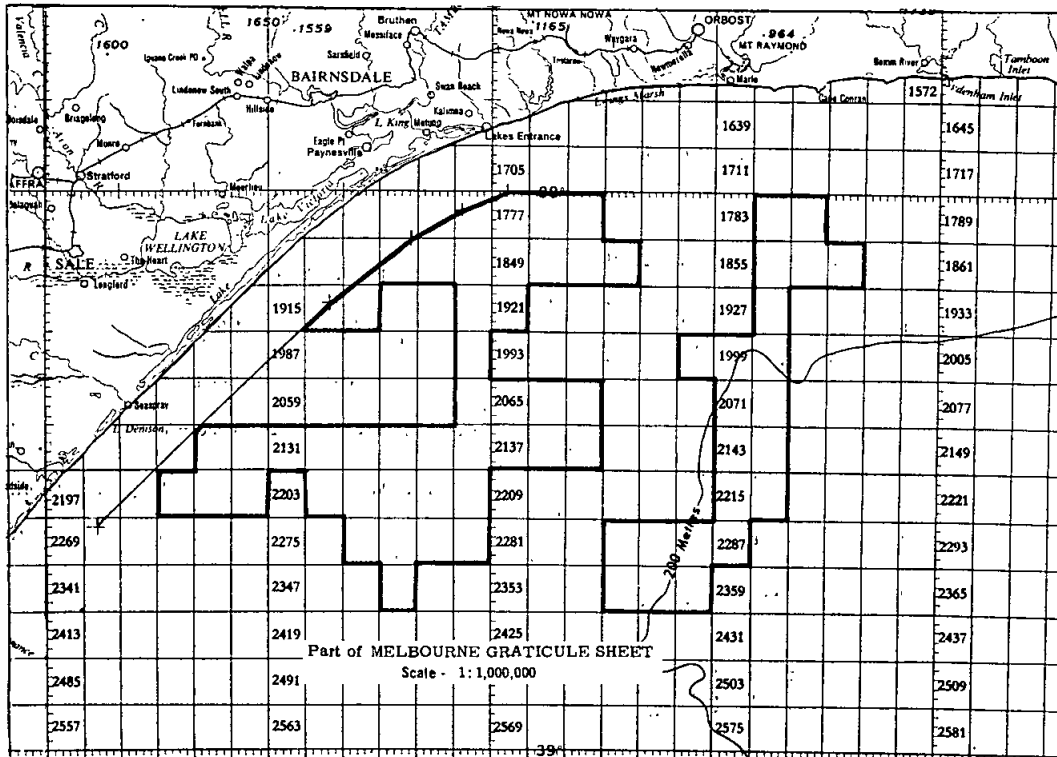

Dated this 24th day of October, 1974.

Made under the Petroleum (Submerged Lands) Act 1967-1974 of the Commonwealth of Australia.

Made under the Petroleum (Submerged Lands) Act 1967 of the State of Victoria.

J. C. M. BALFOUR,
Designated Authority.

COMMONWEALTH OF AUSTRALIA:
Petroleum (Submerged Lands) Act 1967-1974.

STATE OF VICTORIA.
Petroleum (Submerged Lands) Act 1967.

NOTICE OF GRANT OF RENEWAL OF PERMIT.

A renewal of permit numbered VIC/P2 has been granted to Hematite Petroleum Proprietary Limited of 140 William Street, Melbourne, in respect of each of the blocks constituted by a graticular section described hereunder.

This renewal has effect for a period of five years commencing on the day after the day on which the last previous permit in respect of the blocks described herein ceased to have effect.

Description of Graticular Sections.

The graticular sections numbered 2424, 2425, 2426, 2427, 2428, 2429, 2430, 2496, 2497, 2498, 2499, 2500, 2501, 2502, 2573, 2574, shown on the plan hereunder.

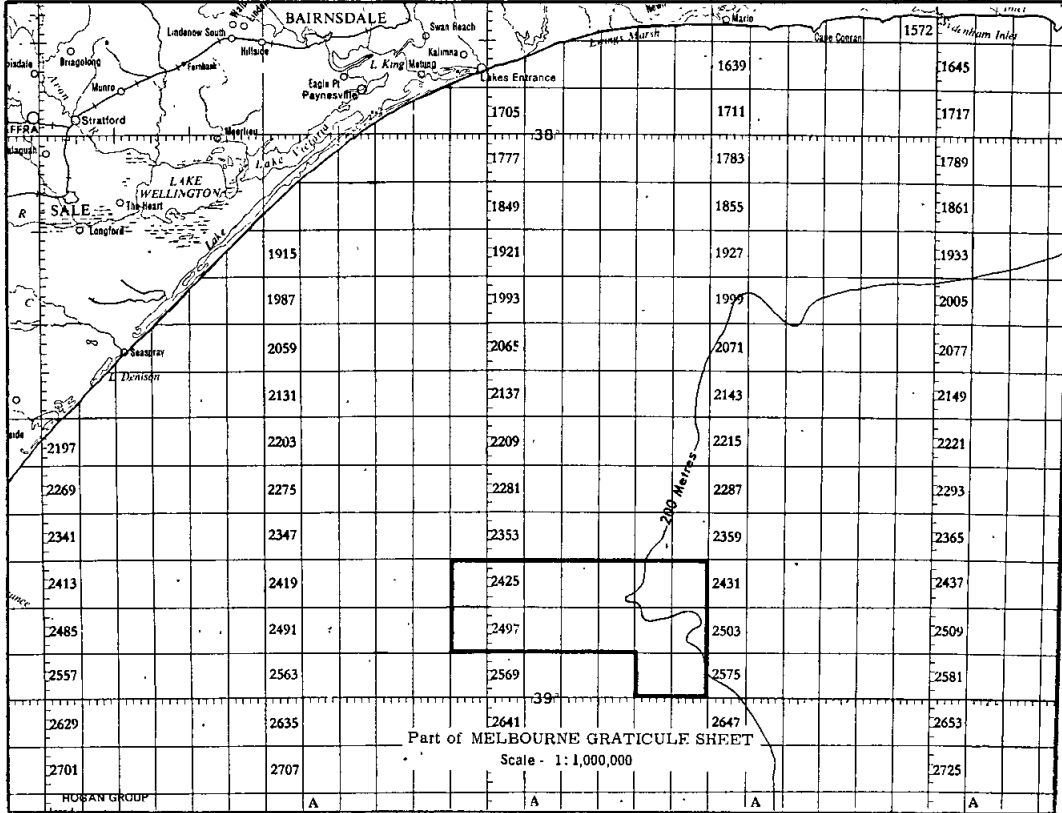

Dated this 24th day of October, 1974.

Made under the Petroleum (Submerged Lands) Act 1967-1974 of the Commonwealth of Australia. Made under the Petroleum (Submerged Lands) Act 1967 of the State of Victoria.

J. C. M. BALFOUR,
Designated Authority.

State Electricity Commission Acts.
ELECTRICAL APPROVALS BOARD.

Pursuant to Regulation 16 of the Electrical Approvals Regulations—Approval of Equipment, 1953, the State Electricity Commission of Victoria hereby gives notice that it has withdrawn approval of the undermentioned articles:—

Applicant.	Article and Reference Number.	Date of Certificate of Approval.	Date of Withdrawal of Approval.	Approvals Marking.
Kingsley Radio Pty. Ltd., 58A Gipps Street, Collingwood	Room Heater, Cat. No. KR11, Ref. No. BM/B5E/01	5.1.66	24.9.74	V/B5E/KR11
Kingsley Radio Pty. Ltd., 58A Gipps Street, Collingwood	Room Heater, Cat. No. KR15, Ref. No. BM/B5E/04	5.4.67	24.9.74	V/B5E/KR15
S. Luka, 3 York Street, Caulfield	Cord Line Switch, Cat. No. 2180, Ref. No. AZ/JD/01	20.6.67	19.9.74	V/JD/2180
S. Luka, 3 York Street, Caulfield	Wall Switch, Cat. No. S151, Ref. No. AR/JD/03	22.7.52	19.9.74	V/JD/S151
S. Luka, 3 York Street, Caulfield	Wall Switch Ref. No. AR/JD/04	13.8.53	19.9.74	
S. Luka, 3 York Street, Caulfield	Wall Switch, Cat. No. K6/7, Ref. No. AR/JD/05	28.9.53	19.9.74	
S. Luka, 3 York Street, Caulfield	Lampholder Adaptor, Cat. No. RTO120, Ref. No. AA/JD/09	10.7.51	2.10.74	
Linda Corporation, 139 Chetwynd Street, North Melbourne	Room Heater (warming slipper), Cat. No. FS1, Ref. No. BM/XF/01	1.8.66	16.10.74	V/XF/FS1

G. A. MCINTYRE,
Acting Secretary.

Seeds Act 1971.

REGISTERED SEED CLEANERS 1974-75.

REGISTRATIONS EFFECTIVE 1ST OCTOBER, 1974-30TH
SEPTEMBER, 1975.

C-COMMERCIAL; P-PRIVATE; B-BUILDING; M-MOBILE.

Register No.; Name and Address; Classification.

- V.10; Smyth & Murphy Pty. Ltd., Gillies Street, Benalla, 3672; C; B. All kinds and varieties of seed. All classes and varieties of seed Certified.
- V.11; Ray McPherson Pty. Ltd., Hume Highway, Benalla, 3672; C; B. All kinds and varieties of seed. All classes and varieties of seed Certified.
- V.11A; Ray McPherson Pty. Ltd., Ethel Street, Benalla, 3672; C; B. All kinds and varieties of seed. All classes and varieties of seed Certified.
- V.12; R. & Smart, "Kelvin View", R.S.D. 419 Euroa, 3666; C; B. All kinds and varieties of seed. All classes and varieties of seed Certified.
- V.13; Wright Stephenson, Meggitt (Vic.) Pty. Ltd., McConachy Street, Box 28, Winchelsea, 3241; C; B. All kinds and varieties of seed. All classes and varieties of seed Certified.
- V.14; J. F. Roberts, Warncoort, Vic. 3243; C; B. All kinds and varieties of grasses, cereals, linseed. All Certified Grasses.
- V.15; S. K. & E. M. Powell, Skene Street, Birregurra, 3242; C; B. Ryegrass; Oats. Certified Ryegrass.
- V.16; L. J. Whitehead, Colac Road, Birregurra, 3242; C; B. All kinds and varieties of seed. All classes of Grasses Certified.
- V.17; Pasture Seed Supply, (I. R. Hope), Edenhope Road, Harrow, Vic. 3317; C; B. Certified Phalaris.
- V.18; W. Mizzeni & Sons, Kooroocheang, Vic. 3364; C; B. All kinds and varieties of seed. All classes and varieties of Seed Certified.
- V.19; F. E. S. & B. M. Kinnersley, Mt. Beckworth via Creswick, 3363; C; B. All kinds and varieties of seed. All classes and varieties of seed Certified.
- V.20; A. J. Sewell, Kooroocheang, Vic. 3364; C; B. Ryegrass, Phalaris Cocksfoot. Certified Ryegrass.
- V.21; A. F. & M. I. Toose, Smeaton, 3364; C; B. Ryegrass Mother and Certified Ryegrass.
- V.22; Revell Seeds Pty. Ltd.; 121 Lloyd Street, Dimboola, Vic. 3414; C; B. All kinds and varieties of seed. All Classes and varieties of Seed Certified.
- V.23; G. Hendy, Kokoda Road, Naring, Vic. (Rural Delivery, Numurkah), 3636; C; B. Subterranean Clover, Millet, Ryegrass. Mother and Certified Clovers.
- V.24; W. J. & W. L. Ryan, 45 R.S.D., Katamatite Road, Yarrowonga, Vic. 3730; C; B. All kinds and varieties of seed. All classes and varieties of seed Certified.
- V.25; J. D. Roberts & Son, Byrne Street, Moyhu (Whitfield Roadside), Wangaratta, 3677; C; B. All kinds and varieties of seeds. All classes and varieties of Seed Certified.
- V.26; Wright Stephenson & Co. (Aust.) Pty. Ltd., 15 Ascot Vale Road, Flemington, Vic., P.O. Box 209, Moonee Ponds, 3039; C; B. All kinds and varieties of seed. All classes and varieties of seed Certified.
- V.27; F. H. Brunning Pty. Ltd., 22 Kingsway, South Melbourne, Vic. 3205; C; B. All kinds and varieties of seed. All varieties of Certified Seed. Seed coating, mixing and packaging, cleaning of seed under Quarantine restriction.
- V.28; Valley Seeds Pty. Ltd., Mansfield Road, Cathkin, Vic. 3714; C; B. All kinds and varieties of seed. All classes and varieties of seed Certified. Seed Drying; Seed coating, mixing and packaging.
- V.29; E. B. H. James, Yarrowalla via Pyramid Hill, Vic. 3575; C; B. All kinds and varieties of uncertified seed. Mother and Certified perennial clovers and lucerne.
- V.30; A. C. May & Son, "Grassmere", Smeaton R.S.D. via Creswick, Vic. 3363; C; B. Ryegrass Mother and Certified Ryegrass.
- V.31; J. F. Evans, "Redcamp", Moyhu, 3732; C; B. Cocksfoot, Phalaris and Ryegrass. All classes of Grasses Certified.
- V.32; H. G. Walter, "May Park", Dookie, 3646; C; B. Clovers, lucerne, phalaris. Mother and Certified Clovers, Certified Lucerne.
- V.33; C. & S. Elliott, Roadside via Maryborough, Vic. 3465; C; B. Uncertified Lucerne, Certified Lucerne.
- V.34; L. H. & V. L. Parks, "Parkdale", Olivers Road, Mansfield, Vic. 3722; C; B. All kinds and varieties of seed. All classes and varieties of seed certified.
- V.35; E. G. Baker & Co., "Old Paroo", Springvale Road, Rutherglen, Vic. (P.O. Box 75), 3685; P; B. Subterranean clover. Mother and Certified Subterranean clovers.
- V.36; G. M. Crocker, "Woodlands", Murchison Road, Violet Town, (P.O. Box 33), 3669; P; B. Grasses, Rape, Cereals, Certified Phalaris.
- V.39; C. F. & J. T. Thomas, "Wild Pines", Dingee, Vic. 3571; C; B. Uncertified grasses and clovers.
- V.40; J. W. Wrigley, "Sunnybank", Clunes, 3370; P; B. Uncertified Ryegrass.
- V.41; J. J. Roach & Sons, Larpent R.S.D., 42 Colac, Vic. 3249; P; B. Uncertified Ryegrass.
- V.42; N. R. Craig & Son, "Rocklea", Box 41, Winchelsea, Vic. 3241; P; B. Uncertified Ryegrass, Peas, Rape, Linseed, Onion and Cereals.
- V.43; Gippsland & Northern Co. Ltd., Laurens Street, North Melbourne, Vic. (P.O. Box 4513, G.P.O.), 3001; C; B. All kinds and varieties of Uncertified seed. Seed mixing; packaging.
- V.45; Graham White Investments Pty. Ltd., & R. L. Jackson, "Claremont", Woolsthorpe, Vic. 3729; P; B. Uncertified Ryegrass.
- V.46; Adolph Schurmann, "Kingaroy", Strathkellar, Vic. 3292; P; B. Uncertified Rape, Wheatgrass, Ryegrass and Lucerne.
- V.47; W. S. Banham, Cressy Road, Winchelsea, Vic. 3241; P; B. Uncertified Ryegrass, Mustard, Cereals.
- V.48; Victorian Oatgrowers Pool, & Marketing Co. Ltd., Stawell, (Box 4303, G.P.O., Melbourne), 3001; C; B. Uncertified Cereals.
- V.49; L. G. Wallis, "Sunnybrae", Lillimur, Vic. 3415; P; B. Uncertified Ryegrass.
- V.52; A. W. Farthing, Western District, Scarified Seeds, Lismore, Vic. 3324; C; B. Uncertified Linseed, Rape, Phalaris, Dunn Pea, Tick Beans, Cereals.
- V.53; Buckholz Bros., "Coree", Lismore, 3324; P; B. Uncertified Ryegrass and Cocksfoot.
- V.54; H. F. & M. A. Klemm, "Eumanna", Londrigan R.S.M. via Wangaratta, Vic. 3628; P; B. Uncertified Ryegrass and Lucerne.
- V.55; E. L. Ellis, R.S.D. 19, Creek Junction, Boho South, Vic. 3669; P; B. Uncertified Ryegrass and phalaris.
- V.57; F. Spiers, Nalangil Road, P.B.I. Colac, 3250; P; B. Uncertified Ryegrass.
- V.58; Junah Pty. Ltd., "Kiwarrick", Woorndoo, Vic. 3272; P; B. Uncertified Ryegrass, Cocksfoot, Rape, Phalaris.
- V.60; K. J. & E. Crawford, Moutajup, Vic. 3292; P; B. Uncertified Linseed, Phalaris, Ryegrass and Cereals.
- V.61; N. D. & M. E. Mundy, 43 Scott Street, Orbost, Vic., (Box 86), Orbost, 3888; P; B. Uncertified and Certified Beans.
- V.62; Henderson Seed Co., Templestowe Road, Lower Templestowe, (Box 118, Bulleen), Vic. 3105; P; B. Uncertified Vegetable Seeds.
- V.63; W. Emphield, Cabbage Tree Creek, 3889; P; B. Certified Beans.
- V.64; D. M. & C. T. Hurley, "Morning Glory", Dargo, Vic. 3862; P; B. Uncertified and Certified Beans.
- V.M.65; A. Phillips Seed Service, 52 Shadforth Street, Kerang, Vic. 3579; C. Mobile; Vehicle Reg. No. LEL 105. Uncertified Millett; Cereals.
- V.M.65b; A. Phillips Seed Service, 52 Shadforth Street, Kerang, Vic. 3579; C. Mobile; Vehicle Reg. No. LHX 911. Uncertified Millett; Cereals.
- V.M.66a; F. E. Bridgewater, "Currong", Echuca Village, Echuca, 3625; C. Mobile; Vehicle Reg. No. JUR 931. Uncertified Ryegrass, Peas and Millett.
- V.M.66b; F. E. Bridgewater "Currong", Echuca Village, Echuca, 3625; C. Mobile; Vehicle Reg. No. GKM 334. Uncertified Ryegrass, Peas and Millett.
- V.M.67; N. J. Greenbank, Snake Valley, 3551; C. Mobile. Trailer No. H64036. Uncertified phalaris, Ryegrass, Cocksfoot, Rape and Cereals.

Country Fire Authority Act.
PERMISSION TO HOLD FIRE BRIGADE
DEMONSTRATIONS.

In pursuance of the provisions of section 103 of the Country Fire Authority Act 1958, the Country Fire Authority has granted permission for the holding of the fire brigade demonstration as under:—

URBAN FIRE BRIGADES.

Number 10 Regional Council — Junior Reserve Competition:—

At Myrtleford, on Sunday 17th November, 1974.

J. L. ALLEN,
Secretary.

MINES DEPARTMENT.

Subject to any necessary excisions, &c., it is proposed to grant the following mining lease:—

7154, Maryborough; Lindsay Gordon Robertson, Albert Robertson; 4.7 ha, Parish of Borung.

APPLICATION FOR MINING LEASE DECLARED
ABANDONED.

No. 124; Lone Star Exploration N.L.; 50 acres, Parish of Maldon.

EXPLORATION LICENCE GRANTED.

No. 530; Western Mining Corporation Limited; 250 square miles, Counties of Bendigo and Talbot.

TERM OF EXPLORATION LICENCE EXTENDED.

No. 230; Stanley Irvine Lincoln, Ray Alan Borchers; 2 square miles, County of Gladstone.

APPLICATION FOR TAILINGS LICENCE DECLARED
ABANDONED.

3931, Tailings Licence; Lone Star Exploration N.L.; to treat tailings, Parish of Maldon.

EXTRACTIVE INDUSTRY LICENCES GRANTED.

No. 220; John Richard Westbury; 6.0 ha, Parish of Barongarook.

No. 661; Ivan Walkinshaw Pty. Limited; 27 ha, Parish of Warragul.

No. 724; Apex Quarries Limited; 170 ha, Parish of Glenburnie.

EXTRACTIVE INDUSTRY SEARCH PERMIT
CANCELLED.

No. 29; Gippsland Minerals N.L.; 12.55 square miles, Parish of Bindi.

J. C. M. BALFOUR,
Minister of Mines.

MINING LEASE DECLARED VOID.

8902, Mineral; Reginald Albert Earl Trevithick; 40a. 0r. 8p., Parish of Warburton.

E. CONDON,
Secretary for Mines.

NOTICE TO MARINERS.

[No. 7 of 1974.]

AUSTRALIA.—VICTORIA.

PORT PHILLIP.—WAVE MEASURING BUOY TO BE ESTABLISHED.

Date.—On or about 6th November, 1974.

Position of Buoy.—38 deg. 20 min. 00 sec. S., Long. 144 deg. 55 min. 42 sec. E.

Description.—A spherical unpainted stainless steel buoy surmounted by a 2 metre whip aerial and showing a group flashing white light, 3 flashes every 20 seconds.

Abridged Description.—Gp. Fl. (3) 20 sec.

Charts affected.—AUS 158; 143.

D. P. BARKLEY,
Deputy Port Officer.

Public Works Department,
Ports and Harbors Division,
168 Exhibition Street,
Melbourne, Vic. 3000, 22nd October, 1974.

NOTICE TO MARINERS.

[No. 8 of 1974.]

AUSTRALIA.—VICTORIA.

PORT ALBERT APPROACH.—BUOY MISSING FROM STATION.

The black and white conical buoy known as the northern fairway buoy and previously stationed 126 deg. 20 min. distant 2.64 miles from the front main leading light (Lat. 38 deg. 44.3 min. S., Long. 146 deg. 39.5 min. E. approximately) has been washed ashore.

A further notice will issue on re-establishment.

Charts affected.—AUS 801; 357.

D. P. BARKLEY,
Deputy Port Officer.

Public Works Department,
Ports and Harbors Division,
168 Exhibition Street,
Melbourne, Vic. 3000, 22nd October, 1974.

FARM PRODUCE MERCHANTS AND COMMISSION
AGENTS ACT 1965 (No. 7274).

List of names and addresses of licence holders to whom licences have been issued during September, 1974. In accordance with the above Act, those issued with a Merchant's or Commission Agent's licence have paid the prescribed fee to the Farm Produce Merchants and Commission Agents Guarantee Fund. All licences, unless earlier cancelled, shall continue in force until 30th June, 1975.

D. S. WISHART,
Director of Agriculture.

MERCHANTS.

Name; Principal Place of Business.

Adams, L. G.; Army Road, Pakenham, 3810.

Daffy's Wholesale Fruit and Vegetables; 36 Leming Road, Deer Park, 3023.

Farquhar, Stan, Pty. Ltd.; Learmonth Road, Wendouree, 3355.

Viva La Fruit Pty. Ltd.; Store 287, Melbourne Wholesale Fruit and Vegetable Market, Footscray Road, Footscray, 3011.

COMMISSION AGENT.

Kennedy, W. K., and Sons; 54 Wellington Street, Kerang, 3579.

SECONDARY WHOLESALER.

Malane, W. E.; 22 Moncoe Street, Boronia, 3155.

ABORIGINAL AFFAIRS ACT 1967.

APPOINTMENT OF LIONEL ROSE CENTRE COMMITTEE,
MORWELL.

In accordance with the provisions of section 38 of the Aboriginal Affairs Act 1967, I, Vance Oakley Dickie, Her Majesty's Minister for Aboriginal Affairs for the State of Victoria, do hereby constitute a Special Purpose Committee to be known as the Lionel Rose Centre Committee, Morwell, comprising the following persons who have knowledge and experience suitable for the management of the affairs of the Hostels and Recreation Centre at the Lionel Rose Centre, Buckley Street, Morwell.

Mr. GRAHAM JOHN BENSON, of Wittams Road, Yinnar.

Mrs. ANN DRAKE, of 3 McMillan Street, Traralgon;
Mr. GRAHAM WILLIAM GORDON, of 51 Tarwin Street, Morwell.

Mr. JOHN GORRIE, of 160 Mary Street, Morwell.
Mrs. REGINA HOPE, of 18 Margaret Street, Moe.
Mr. MAXWELL WALLACE HOPPER, of Jumbuk Road, Yinnar South.

Mr. HENRY JOHNSTON, of 19 Haunted Hills Road, Newborough.

CANON FRANK MCLEAN RHODES LOWE, of 8 Latrobe Road, Morwell.

Mr. JAMES PETER MACPHERSON, of Lionel Rose Centre, Buckley Street, Morwell.

Mr. MURRAY JOHN TUCKER, of 3 Tobruk Court, Traralgon.

Dated this 17th day of October, 1974.

VANCE DICKIE, M.L.C.,
Minister for Aboriginal Affairs.

Ministry of Aboriginal Affairs,
Melbourne.

State Savings Bank Act 1958, Section 30.
THE STATE SAVINGS BANK OF VICTORIA.
ESTABLISHMENT OF BRANCH.

The Commissioners of The State Savings Bank of Victoria hereby give notice of the establishment of Hoppers Crossing Branch of the Bank at Shop 13, Woodville Park Shopping Centre, Woodville Park Drive, Werribee, 3030, on 31st October, 1974.

D. ROSS,
General Manager.

EXAMINATION OF APPLICANTS FOR LICENCE AS
SHORTHAND WRITER.

It is hereby notified that an examination of applicants for licence as Shorthand Writer will be held at the Royal Melbourne Institute of Technology, Fifth Floor, Casey Wing, Rooms C.519 and C.525; Swanston Street, Melbourne, on Saturday, 30th November, 1974, at 10 o'clock a.m.

Applications for permission to attend the examination must be forwarded to reach the Secretary, Public Service Board, Treasury Place, Melbourne, 3002 (where a copy of the Regulations may be obtained), not later than Saturday, 16th November, 1974.

By Order,
L. R. BROWN, Secretary.

Office of the Public Service Board,
Melbourne, 28th October, 1974.

Melbourne and Metropolitan
BOARD OF WORKS.

NOTICE TO THE OWNERS OF TENEMENTS IN THE UNDER-
MENTIONED STREETS AND THE PRIVATE STREETS, LANES
COURTS AND ALLEYS OPENING THERETO.

The main pipe in the said streets being laid down, the owners of all tenements situated as under are hereby required on or before the 2nd December, 1974, to cause a proper pipe and stopcocks to be laid so as to supply water within such tenements from the main pipe.

R. H. ENGELSMAN,
Secretary.

22nd October, 1974.

STREET AND POSITION.

Altona.

Doherty's Road, from Princes Highway eastwards 376 metres.

Box Hill.

Gracefield Drive, from 61 metres south of Woodhouse Grove southwards 67 metres.

Berry Street, from 67 metres west of Trainor Street westwards 67 metres.

Broadmeadows.

Cooper Street, from Rex Road westwards 216 metres.

Rex Road, from 97 metres north of Northbourne Road to Cooper Street.

Sages Road, from 434 metres north of Box Forest Road northwards 174 metres.

Camberwell.

Kawarren Street, from 24 metres north of Ventnor Street to Carron Street.

Ventnor Street, from Kawarren Street to Wilburton Parade.

Wilburton Parade, from Ventnor Street to Kelvinside Street.

Dandenong.

Police Road, from 46 metres east of Buckley Street eastwards 250 metres.

Blaxland Drive, from Police Road southwards 223 metres.

Garfield Court, from Blaxland Drive eastwards, northwards and southwards 238 metres.

Taft Close, from Blaxland Drive eastwards 90 metres.

Madison Avenue, from Blaxland Drive southwestwards 220 metres.

Hayes Court, from Madison Avenue northwestwards 45 metres.

Doncaster and Templestowe.

Warrock Avenue, from Anglemere Crescent eastwards 220 metres.

Anglemere Crescent, from Warrock Avenue northwards and westwards 302 metres.

Ridgeway Street, from Dellfield Drive southwards 43 metres.

Keilor.

Atheldene Drive, from 50 metres west of Cordelia Grove westwards 93 metres.

Libra Place, Atheldene Drive southwards 76 metres.

Meads Court, from Cordelia Grove northwards 90 metres.

Charlebury Grove, from Kings Road southeastwards 424 metres.

Somerton Crescent, from Corunna Avenue to Charlebury Grove.

Lambolle Court, from Somerton Crescent southwards 183 metres.

Kings Road (east side), from 290 metres south of Taylors Road southwards 307 metres.

Ascot Court, from Charlebury Grove northwards 38 metres.

Corunna Avenue, from Charlebury Grove southwards 274 metres.

Shannon Court, from Corunna Avenue southeastwards 162 metres.

Knox.

Frederick Street, from 230 metres north of Hunter Street northwards 202 metres.

Mountain Highway (north side), from Michellan Court westwards 62 metres.

Mountain Highway (north side), from Michellan Court eastwards 63 metres.

Michellan Court, from Mountain Highway northwards 340 metres.

Lillydale.

Upalong Road, from Mount Dandenong Tourist Road southwards and westwards 272 metres.

Yarrabee Road, from Upalong Road southwards 189 metres.

Jones Street, from Anderson Street westwards 43 metres.

Moorabbin.

Nellburn Road, from 372 metres southwards and eastwards of South Road eastwards 17 metres.

Nunawading.

Simpson Street, from Percy Street to Creek Road.

Eastcote Court, from 38 metres east of Stradella Avenue eastwards 30 metres.

Moran Court, from 104 metres west of Topwood Drive southeastwards 152 metres.

Whittlesea.

Fore Street, from Paddock Street to Sherwin Street.

Sherwin Street, from Fore Street eastwards 122 metres.

PUBLIC TRUSTEE ACT 1958 (No. 6350), SECTION 17.

I hereby give notice that on the 11th October, 1974, the Public Trustee filed elections to administer the following deceased persons' estates in accordance with section 17 of the *Public Trustee Act 1958*:—

BARNES, BERTHA CHARLOTTE, formerly of 52 Francis Street, Clarence Park, South Australia, but late of Alimar Private Hospital, 34 Scott Street, Essendon, widow, died 15th June, 1974.

BRACKS, ALEXANDER, late of Flat 2, 10 Kelvin Grove, East Prahran, retired storeman clerk, died 13th August, 1974.

BUTT, RONALD HENRY, late of Bermingham Hotel, Smith Street, Fitzroy, hospital employee, died 17th March, 1974.

FILER, WILLIAM EDWARD, also known as William Filer, and William Edwards, formerly of 222 Inkerman Street, St. Kilda, but late of 960 Glenhuntly Road, Caulfield South, retired furniture manufacturer, died 8th July, 1974.

IZZARD, GEORGE, late of Mount Royal, Parkville, T.P.I. pensioner, died 20th July, 1974.

JOEGI, VOLDERMAR, also known as Valdemar Zoegi, late of 37 Foote Street, Albert Park, process worker, died 17th August, 1974.

KEMP, GEORGE ROBERT DANIEL, also known as Daniel Kemp, and George Robert Kemp, late of 508 Barkly Street, West Footscray, retired council employee, died 3rd August, 1974.

KENDALL, GEORGE HENRY, late of Elanora Home & Hospital, 7 Main Street, Brighton Beach, retired gardener, died 2nd July, 1974.

MOTHERWELL, CATHERINE MAY, late of 63 Gower Street, Kensington, widow, died 3rd February, 1967.

ROADKNIGHT, EVELYN MERRICK, formerly of 11 Sumner Avenue, Old Colonists' Homes, Rushall Crescent, North Fitzroy, but late of Liscombe House, Leith Park, St. Helena Road, Greensborough, spinster, died 3rd June, 1974.

SAVAGE, MYRTLE GERTRUDE, late of Flat 11, 76 Church Street, Richmond, widow, died 15th July, 1974.

SEARSON, JAMES PATRICK, late of 147 Park Road, Cheltenham, storeman, died 5th August, 1974.

SIELDS, EILEEN DORIS, formerly of 249 Blyth Street, East Brunswick, but late of Ararat, spinster, died 4th May, 1974.

I hereby give notice that on the 16th October, 1974, the Public Trustee filed elections to administer the following deceased persons' estates in accordance with section 17 of the Public Trustee Act 1958:—

BODEY, HOPE LYLE, formerly of "Lumeah", Bruce Street, West Preston, but late of Greenvale Geriatric Centre, Providence Road, Greenvale, spinster, died 4th August, 1974.

BROWN, VICTORIA ESTHER, late of 173 Bellerine Street, Geelong, widow, died 17th April, 1974.

CLAYTON, MARY VERONICA, late of Flat 22, 3 Surrey Road, South Yarra, widow, died 19th August, 1974.

HARTSHORN, VIOLET LOUISA, formerly of Station Street, Lower Ferntree Gully, but late of Mont Park, gentlewoman, died 1st May, 1974.

McHUGH, FRANK, formerly of 89 Shaftsbury (in the will called Shaftsbury) Street, West Coburg, but late of 9 Devon Avenue, Heathmont, retired postal worker, died 30th June, 1974.

McMAHON, ETHEL MAY, late of 23 Carroll Street, North Melbourne, widow, died 22nd November, 1967.

PIERPOINT, WILLIAM, late of 68 Tennyson Street, Elwood, retired general manager, died 15th July, 1974.

TUCKER, WAHNEETAH BLANCHE MARGARET, late of 52 Green Street, Windsor, widow, died 7th August, 1974.

WATSON, JANET MAY, late of Beechworth, pensioner, died 3rd July, 1974.

N. P. BRODY,
Public Trustee.

168 Exhibition Street, Melbourne, 3000, 23rd October, 1974.

NOTICE.

Creditors, next of kin and others having claims against the estate of any of the under-mentioned deceased persons are required to send particulars of their claims to the Public Trustee, 168 Exhibition Street, Melbourne, Vic. 3000, the personal representative, on or before the 6th January, 1975, after which date the Public Trustee may convey or distribute the assets, having regard only to the claims of which the Public Trustee then has notice:—

ARCHER, NORA STEVENSON, formerly of Flat 8, 51 Denham Street, Hawthorn, but late of "Linden House", 3 Albert Street, Blackburn, widow, died 14th May, 1974.

BARNES, BERTHA CHARLOTTE, formerly of 52 Francis Street, Clarence Park, South Australia, but late of Alimar Private Hospital, 34 Scott Street, Essendon, widow, died 15th June, 1974.

BENNETT, LESLIE, late of Dorset Road, Croydon, military pensioner, died 18th October, 1968.

BODEY, HOPE LYLE, formerly of "Lumeah", Bruce Street, West Preston, but late of Greenvale Geriatric Centre, Providence Road, Greenvale, spinster, died 4th August, 1974.

BRACKS, ALEXANDER, late of Flat 2, 10 Kelvin Grove, East Prahran, retired storeman clerk, died 13th August, 1974.

BROWN, VICTORIA ESTHER, late of 173 Bellerine Street, Geelong, widow, died 17th April, 1974.

BRUSH, MARTHA MAY, late of 50 Henry Street, Oakleigh, widow, died 19th July, 1974.

BUTT, RONALD HENRY, late of Bermingham Hotel, Smith Street, Fitzroy, hospital employee, died 17th March, 1974.

CARLTON, GERTRUDE MYRA, late of 7 George Street, Mont Albert, pensioner, died 19th June, 1972.

CLARKE, MURIEL VIOLET MAUDE, late of Dalriada Private Hospital, 21 Railway Parade, Murrumbidgee, widow, died 13th November, 1973.

CLAYTON, MARY VERONICA, late of Flat 22, 3 Surrey Road, South Yarra, widow, died 19th August, 1974.

DALY, DANIEL, late of 64 Wellington Street, Mackay, Queensland, gentleman, died 16th March, 1974.

FILER, WILLIAM EDWARD, also known as William Filer, and William Edwards, formerly of 222 Inkerman Street, St. Kilda, but late of 960 Glenhunted Road, Caulfield South, retired furniture manufacturer, died 8th July, 1974.

HARTSHORN, VIOLET LOUISA, formerly of Station Street, Lower Ferntree Gully, but late of Mont Park, gentlewoman, died 1st May, 1974.

IZZARD, GEORGE, late of Mount Royal, Parkville, T.P.I. pensioner, died 20th July, 1974.

JOEGI, VOLDERMAR, also known as Valdemar Zoegi, late of 37 Foote Street, Albert Park, process worker, died 17th August, 1974.

KEMP, GEORGE ROBERT DANIEL, also known as Daniel Kemp, and George Robert Kemp, late of 508 Barkly Street, West Footscray, retired council employee, died 3rd August, 1974.

KENDALL, GEORGE HENRY, late of Elanora Home & Hospital, 7 Main Street, Brighton Beach, retired gardener, died 2nd July, 1974.

KILEVICS, VILNIS, formerly of 11 Bedford Court, Ringwood East, but late of 3009 Gold Coast Highway, Surfers Paradise, Queensland, carpenter, died 16th July, 1973.

LUND, GEORGE RADSTONE, late of St. Peter's Church Lane, Papworth, Everard, Cambridge, England, storekeeper, died 23rd May, 1973.

MANNING, BERTRAM, late of 2 Loyola Avenue, Brunswick, retired printer, died 23rd August, 1974.

MEAD, CHARLES CLIFFORD, late of 6 Norvel Street, Blackburn, retired clerk, died 8th May, 1974.

MEATES, HAROLD JUSTINIAN, also known as Harold Justin Meates, late of 37 Woolton Avenue, Thornbury, gasfitter, died 7th July, 1974.

MOTHERWELL, CATHERINE MAY, late of 63 Gower Street, Kensington, widow, died 3rd February, 1967.

MCCOOK, WILLIAM ARCHIBALD, formerly of 85 Leila Road, Carnegie, but late of 30 Delta Avenue, Merlynston, P.M.G. linesman, died 16th June, 1974.

McHUGH, FRANK, formerly of 89 Shaftsbury (in the will called Shaftsbury) Street, West Coburg, but late of 9 Devon Avenue, Heathmont, retired postal worker, died 30th June, 1974.

McINTYRE, VIOLET BERTHA, Flat 7, 12 Brennand Street, North Fitzroy, machinist, died 30th August, 1974.

McMAHON, ETHEL MAY, late of 23 Carroll Street, North Melbourne, widow, died 22nd November, 1967.

PIERPOINT, WILLIAM, late of 68 Tennyson Street, Elwood, retired general manager, died 15th July, 1974.

RAMSAY, GERTRUDE MAY, late of 22 John Street, Eltham, widow, died 16th August, 1974.

ROADKNIGHT, EVELYN MERRICK, formerly of 11 Sumner Avenue, Old Colonists' Homes, Rushall Crescent, North Fitzroy, but late of Liscombe House, Leith Park, St. Helena Road, Greensborough, spinster, died 3rd June, 1974.

SAVAGE, MYRTLE GERTRUDE, late of Flat 11, 76 Church Street, Richmond, widow, died 15th July, 1974.

SEARSON, JAMES PATRICK, late of 147 Park Road, Cheltenham, storeman, died 5th August, 1974.

SHERRET, ANNIE HELEN EMSLIE, formerly of 39 Sutherland Street, Coburg West, but late of "Lumeah", 78 Bruce Street, Preston, widow, died 27th August, 1974.

SIELDS, EILEEN DORIS, formerly of 249 Blyth Street, East Brunswick, but late of Ararat, spinster, died 4th May, 1974.

TUCKER, WAHNEETAH BLANCHE MARGARET, late of 52 Green Street, Windsor, widow, died 7th August, 1974.

WATSON, JANET MAY, late of Beechworth, pensioner, died 3rd July, 1974.

N. P. BRODY,
Public Trustee.

Melbourne, 23rd October, 1974.

CONTRACTS ACCEPTED.—(Series 1974-75.)

SOIL CONSERVATION AUTHORITY.

CONTRACT No. 97401.

452. Earthworks—Wilby Almonds Project—L. Johns, Wangaratta, Cat. 12E, \$9.72 per hour; Stand-by Contractor—R. M. & H. J. Rolis, Benalla, Gallion 118, \$10.50 per hour.

CONTRACT No. 97402.

453. Hire of Dozer—Wilby Almonds and Bungeet West Projects—N. Gow, Glenrowan, Michigan 180 with operator, \$16.00 per hour; Stand-by Contractor—K. Lucas Contractors Pty. Ltd., Wangaratta, Cat. D7E 180 h.p. with operator, \$25.00 per hour.

CONTRACT No. 97403.

454. Hire of Scraper—Wilby Almonds and Bungeet West Projects—N. Gow, Glenrowan, Wabco 111A, \$22.00 per hour.

R. A. FITT, Secretary.

NATIONAL PARKS SERVICE.

455. Kinglake National Park—house demolition, \$320.00.—F. Daley, Bundoora.

VICTORIAN RAILWAYS.

77. Removing Departmental Residence No. 4184 from Clunes and re-assembling at Wycheproof, together with outbuilding, for the amount of \$1,940.00 (Contract No.

63914).—M. F. O'Callaghan. 78. Removing Departmental Residence No. 3646 from Willaura and re-assembling at Natimuk, together with outbuilding, for the amount of \$2,340.00 (Contract No. 63974).—M. F. O'Callaghan. 79. Supply and delivery of air compressors, complete with ancillary equipment, at rates (Contract No. 63996).—

Ingersoll-Rand (Australia) Ltd. 80. Supply and delivery and installation of an Automatic Fire Alarm System at the Railway Goods Shed, Dimboola, for the amount of \$1,775.00 (Contract No. 64072).—Wormald Electrics (a division of Wormald International (Aust.) Pty. Ltd.).

C. W. MILLER, Secretary for Railways. 29.10.74.

SCHEDULE No. 1.
POULTRY—MELBOURNE AND METROPOLITAN DISTRICT.

CONTRACT FROM 1ST NOVEMBER, 1974 TO 31ST OCTOBER, 1975.

1974/460.—A. B. Cambridge Poultry Distributors.

582-584 Chapel Street, South Yarra, 3141. Phone : 314 7811.

(Delivery into Institutions.)

Mental Health Authority— Bundoora Repatriation Mental Hospital, Bundoora.
Gresswell Rehabilitation Centre, Mount Park.
Janefield Training Centre, Bundoora.
Kew Children's Cottages, Kew.
Kew Mental Hospital, Kew.
Larundel Mental Hospital, Bundoora.
Malvern Clinic, Malvern.
Mont Park Mental Hospital, Mont Park.
Pleasant View Assessment Centre, Preston.
Royal Park Psychiatric Hospital, Royal Park.
St. Nicholas Hospital, Carlton.
Sunbury Mental Hospital, Sunbury.

Health— Heatherton Sanatorium, Springvale.

Social Welfare— Turana Youth Training Centre, Parkville.
Winlton Girls' Training Centre, Nunawading.
Hillside Boy's Home, Glen Waverley.

Education— Teachers' College Hostels (Metropolitan Area).

NOTE :— Fowls shall be fresh, with all feathers, head, neck, feet and viscera removed and to have been bled.

Item No.	Description.	Unit of Measurement.	Rate.	Name of Contractor.
			\$	
1.	Chickens—Roasting :— Size No. 3 Size No. 4 Size No. 5 Size No. 9	per Kg.	1.13	A. B. Cambridge Poultry Distributors
2.	Fowls—Boiling	per Kg.	0.68	

Approved—R. J. HAMER—Treasurer 15/10/74.

SCHEDULE No. 69 B.
OFFICE MACHINES ETC.

Contracts from 1st September, 1974, to the 31st August, 1975.

1974/456.—Edwards Business Machines Pty. Ltd.

1974/457.—Olympia (Aust.) Pty. Ltd.

1974/458.—Olivetti Australia Pty. Ltd.

1974/459.—Roneo Vickers Pty. Ltd.

" All Items to be Purchased Through Officer in Charge, Stores Branch, Education Department. "

Item No.	Description of Articles.	Unit of Measurement.	Rate.	Name of Contractor.
			\$	
1.	Adding/Listing Machines— Electric, Short Keyboard—" Olivetti " MC 20Q (Capacity 10/11)	Each	88.00	Olivetti Australia Pty. Ltd.
1A	Manual, Short Keyboard	Each	..	No Contract
2	Duplicators— Electric Ink Style—" Roneo Vickers " Model 470 Electric ..	Each	*365.00	Roneo Vickers Pty. Ltd.
3	Electric Spirit Style—" Roneo Vickers " Model 5011 Electric ..	Each	249.00	
	Duplicators, Spirit—Supplies— Spirit Masters Complete, Long Run Black, 100 per Box ..	Per Box	..	Purchase under Items 265 and 266, Schedule No. 69
	Spirit Masters Complete, Long Run Purple, 100 per Box ..	Per Box	..	
4	Spirit for Masters—1 Gallon Container	Gall.	2.23	Edwards Business Machines Pty. Ltd.
5	Typewriters, Electric with Standard Spacing— (a) Fitted with Fabric Ribbon	Each	..	Purchase under Item No. 5 (c) Dual Type
	(b) Fitted with Carbon Ribbon	Each	..	
	(c) Fitted with both Fabric and Carbon Ribbons, Dual Auto Switch—18 in.—Carriage " Olympia " SGE 50 DRD ..	Each	309.90	
	Typewriters, Electric—Supplies	Each	..	Olympia (Aust.) Pty. Ltd. (Contract 1.9.74 to 31.3.75) Purchase under Item Nos. 259 and 260, Schedule No. 69

*Roneo 470 is supplied with an 8 layer silk screen as standard equipment.

Approved—R. J. HAMER—Treasurer—15.10.74.

CONTRACTS ACCEPTED.—(Series 1974-75.)
AMENDMENTS.

Item No.	Unit.	Rate.	Effective From.	Item No.	Unit.	Rate.	Effective From.
PROVISIONS 1974-75. Gazette No. 62—13th June, 1974. Schedule No. 1—Melbourne and Metropolitan District.				GENERAL STORES. Gazette No. 75—31st July, 1974. Schedule No. 19—Construction Materials, Lime, etc.			
		\$				\$	
1	Biscuits :—Dry—Per tin :—			5A	Per tonne	14.00	
	Sao "Arnott" 3-lb. tin .. .	1.64	1.10.74	5B	"	14.75	14.10.74
	Savoy "Brockhoff" 5½-lb. tin .. .	3.18		5C	"	18.25	
	Thin Captain "Arnott" 5½-lb. tin .. .	3.02		5D	Per 50 kg. bag	0.92	
	Thin Captain "Brockhoff" 5½-lb. tin .. .	3.02		6	" 25 kg. "	1.23	
72	Per doz.	6.80	4.11.74	Schedule No. 25—Chemicals, etc.			
177	Maize—per gal.	5.04	21.10.74	17	1-gal. containers per gal. .. .	26.40	1.9.74
	Sunflower—per gal.	5.04		18	5 " " "	25.18	
	Safflower—per gal.	5.26		18	1 " " "	26.82	
185	Per lb.	0.50	11.10.74	5	5 " " "	25.82	
186	"	0.50		Schedule No. 26—Protective Clothing, etc.			
241	"	0.16		1	Each	7.00	14.10.74
242	"	0.16		2	"	7.00	
243	"	0.16		3	"	7.00	
246	"	0.19		4	"	6.20	
247	"	0.20		5	"	6.20	
248	"	0.20		6	"	6.20	
249	"	0.20		7	"	7.95	
250	"	0.14		8	"	7.95	
251	"	0.16		9	"	8.70	
252	"	0.16		10	"	7.95	
254	"	0.20		11	"	5.60	11.10.74
255	"	0.20		12	"	9.15	
256	"	0.14		13	"	5.12	
258	"	0.16		Cancel rate and name of contractor substitute Jones Coats Pty. Ltd. at the following rates :—			
259	"	0.16		15	Each	7.50	14.10.74
260	"	0.16		16	"	7.50	
263	"	0.19		Cancel rate and name of contractor substitute Crown White Coats at the following rate :—			
264	"	0.16		20	Each	4.50	
265	"	0.20		Schedule No. 36—Crockery, Cutlery and Kitchenware.			
269	"	0.16		20	Each	2.98	6.9.74
270	"	0.16		21	"	3.35	
271	"	0.16		22	"	4.25	
272	"	0.16		32	"	2.04	18.10.74
275	"	0.19		33	"	3.15	
277	"	0.16		35	"	4.20	
278	"	0.20		Schedule No. 37—Electrical Goods.			
279	"	0.20		31	Each	32.00	9.9.74
280	"	0.20		32	"	25.30	
281	"	0.20		50	"	77.25	
283	"	0.14	8.10.74	Schedule No. 43—Haberdashery and Needlework Equipment.			
286	"	0.16		36	Per pkt.—5 needles (Size 14) .. .	0.34	20.9.74
287	"	0.16		72	Per pair	1.32	
288	"	0.16		74	"	1.59	11.10.74
291	"	0.19		Schedule No. 46—Hose, Sheeting, etc.			
292	"	0.20		29	Per lb.— $\frac{1}{4}$ "	0.78	16.9.74
293	"	0.20			" $\frac{3}{8}$ "	0.53	
294	"	0.14			" $\frac{1}{2}$ "	0.43	
296	"	0.16			" $\frac{3}{4}$ "	0.40	
297	"	0.16			" $\frac{7}{8}$ "	0.40	
298	"	0.16			" $1\frac{1}{4}$ "	0.42	
299	"	0.16		Schedule No. 48—Iron (Galvanised).			
303	"	0.20		2	"Custom Blue-Orb" E.B.O./0.69 10.5 x 76 :—		14.10.74
304	"	0.20			Orders 450 sq. metres and over—per 10 sq. metres .. .	26.80	
305	"	0.20			Orders below 450 sq. metres—per 10 sq. metres .. .	28.00	
306	"	0.20			"Custom Orb" 0.49 :—		
307	"	0.14			Orders 450 sq. metres and over—per 10 sq. metres .. .	18.90	
310	"	0.16			Orders below 450 sq. metres—per 10 sq. metres .. .	20.10	
311	"	0.16		Schedule No. 57—Nails, Rivets, Screws, etc.			
312	"	0.16		1			3.10.74
313	"	0.16		3			
316	"	0.19		4	List Price No. 29474 BL/V less 15% trade less 3% settlement discount 7 days .. .		
318	"	0.20		5			
319	"	0.20		6			
320	"	0.20		7			
321	"	0.20		23			

AMENDMENTS—continued.

Item No.	Unit.	Rate.	Effective From.
GENERAL STORES—continued.			
Schedule No. 62—Paints and Painters' Sundries.			
		\$	
31	Per 1 gal.	3.75	13.9.74
		4.15	1.10.74
32	Per ½ gal.	2.05	13.9.74
		2.27	1.10.74
33	Per ¼ gal.	1.10	13.9.74
		1.22	1.10.74
34	Per 1 gal.	3.15	13.9.74
		3.50	1.10.74
35	Per ½ gal.	1.72	13.9.74
		1.90	1.10.74
36	Per ¼ gal.	0.92	13.9.74
		1.02	1.10.74
40	Per 1 gal.	4.05	13.9.74
		4.50	1.10.74
41	Per ½ gal.	2.17	13.9.74
		2.40	1.10.74
42	Per ¼ gal.	1.15	13.9.74
		1.28	1.10.74
43	Per 1 gal.	3.80	13.9.74
		4.25	1.10.74
44	Per ½ gal.	2.00	13.9.74
		2.25	1.10.74
45	Per ¼ gal.	1.08	13.9.74
		1.20	1.10.74
52	Per 1 gal.	3.67	13.9.74
		4.10	1.10.74
53	Per ½ gal.	1.95	13.9.74
		2.20	1.10.74
54	Per ¼ gal.	1.05	13.9.74
		1.16	1.10.74
88	Per 1 gal.	3.05	13.9.74
		3.35	1.10.74
89	Per ½ gal.	1.80	13.9.74
		2.00	1.10.74
90	Per ¼ gal.	0.85	13.9.74
		0.95	1.10.74
91	Per 1 gal.	3.05	13.9.74
		3.35	1.10.74
92	Per ½ gal.	1.80	13.9.74
		2.00	1.10.74
93	Per ¼ gal.	0.85	13.9.74
		0.95	1.10.74
94	Per 1 gal.	3.67	13.9.74
		4.10	1.10.74
95	Per ½ gal.	1.95	13.9.74
		2.20	1.10.74
96	Per ¼ gal.	1.05	13.9.74
		1.16	1.10.74
97	Per 1 gal.	3.62	13.9.74
		4.00	1.10.74
98	Per ½ gal.	1.95	13.9.74
		2.18	1.10.74
99	Per ¼ gal.	1.05	13.9.74
		1.16	1.10.74

Schedule No. 64—Cleaning, Polishing and Toilet Requirements, etc.

21	Each	0.49	27.9.74
41	40 gal. drum per gal.	1.28	}
	20 litre drum per 4 litres	1.214	
	1 gal. tin per gal.	1.62	
	1 quart tin per tin	0.63	}
42	40 gal. drum per gal.	1.11	
	20 litre drum per 4 litres	1.118	
	1 gal. tin per gal.	1.47	}
	1 quart tin per tin.	0.59	
42A			
(1)	40 gal. drum per gal.	1.46	
	20 litre drum per 4 litres	1.443	
	1 gal. tin per gal.	1.85	}
(2)	40 gal. drum per gal.	2.25	
	20 litre drum per 4 litres	2.147	
	1 gal. drum per gal.	2.64	}
(3)	40 gal. drum per gal.	2.62	
	20 litre drum per 4 litres	2.482	
	1 gal. drum per gal.	3.01	}
43	1 gal. tin per gal.	2.21	
	5 gal. drum per gal.	2.04	
	1 gal. tin per gal.	2.21	}
44	5 gal. drum per gal.	2.04	
	9.04		
50	Lots 200 ctns. per ctn.	9.04	}
	" 100 " "	9.47	
	" 50 " "	9.70	
	" 10 " "	9.91	}
51	50 pkts. per ctn. per ctn.	10.96	
52	Lots 240 ctns. per ctn.	10.44	
	" 100 " "	10.85	}
	" 50 " "	11.05	
	" 10 " "	11.26	

Item No.	Unit.	Rate.	Effective From.
STATIONERY (GENERAL).			
Gazette No. 97—30th September, 1974.			
Schedule No. 69.			
		\$	
92	Each	1.39	4.10.74

TOOLS (GENERAL).			
Gazette No. 30—13th June, 1974.			
Schedule No. 52.			

3	4-lb.—Each	6.44	}
	44-lb. " "	6.63	
	5-lb. " "	8.29	
147	Each	8.87	}
152	" "	8.87	
154	" "	4.03	
155	" "	4.19	}
156	" "	4.36	
194	Each (straight)	5.80	
	(bent)	5.89	}
195	" —4 prong	8.40	
197	" —4"	3.95	
	" —5"	4.03	}
	" —6"	4.10	
199	Each —heads only 4"	0.65	
	" " " 5"	0.69	}
	" " " 6"	0.73	
	" —handled 4"	1.62	
	" " " 5"	1.67	}
	" " " 6"	1.73	
200	" —6"	2.94	
201	" —8"	5.36	}
204	" "	5.55	
205	" "	4.38	
206	" "	4.86	}
207	" —handled 4-lb.	3.86	
	" " 44-lb.	5.28	
	" " 5-lb.	5.35	}
	" —unhandled 4-lb.	5.60	
	" " 44-lb.	3.77	
	" " 5-lb.	3.84	}
208	" —handled	4.09	
	" —unhandled	6.01	
209	" —handled	4.44	}
	" —unhandled	5.51	
215	" —14 tooth	4.01	
	" —16 tooth	3.40	}
216	" "	3.54	
235	" "	4.99	
278	Each	6.63	}
281	Per lb.—White A	1.35	
	" —Coloured B	0.21	
282	" —White A	0.18	}
	" " "	0.35	
291	Per 5-gal. drum	0.38	
		8.74	13.9.74

JUNIOR SCHOOL REQUISITES.

Gazette No. 97—30th September, 1974.

Schedule No. 1.

10	Each	0.0875	11.10.74
----	------	--------	----------

MOTOR SPIRIT.

Gazette No. 24—27th March, 1974.

Schedule No. 56.

2A	Per gal.	0.4365	}
2B	" "	0.4285	
2C	" "	0.4285	
3A	" "	0.413	}
3B	" —Shell	0.5295	
3C	" —Caltex	0.413	
3D	" "	0.499	}
	" —Shell	0.5295	
	" —Caltex	0.445	
4A	Per gal.	0.445	}
4B	" "	0.5375	
4C	" —Shell	0.445	
4D	" —Caltex	0.5375	}
	" —Shell	0.538	
9	Per ton	55.62	
10	" "	54.42	}
11	Per gal.	0.1845	
12	" "	0.1845	
15	" "	0.2085	}
14	Per ton	53.85	
	" "	58.85	

STATE RIVERS AND WATER SUPPLY COMMISSION.

BY-LAW NO. 5730.—FLOOD PROTECTION CHARGE.—LOCH GARRY FLOOD PROTECTION DISTRICT.

The State Rivers and Water Supply Commission, in pursuance and exercise of the powers conferred by the Water Act, doth hereby make the By-law following:—

1. The following Flood Protection Charge is hereby made under the provisions of the Water Act, and shall be levied upon the occupiers or owners of all lands within the Loch Garry Flood Protection District:—

For the service rendered to such district by the flood protection works constructed for such service—

A Flood Protection Charge of 7·0 cents for each and every hectare of all lands in the Loch Garry Flood Protection District.

Provided that the sum of Two Dollars shall be the minimum charge in respect of any such land or tenement in the said district.

2. Such Flood Protection Charge is made and shall be levied for the year beginning with the 1st day of July, 1974, and ending with the 30th day of June, 1975, and shall be payable on the 1st day of December, 1974, at the office of the State Rivers and Water Supply Commission, at Shepparton.

3. Interest at the rate of eight per cent. per annum will be chargeable on all Flood Protection Charges remaining unpaid after 15th April, 1975.

4. Such person or persons as the State Rivers and Water Supply Commission may from time to time appoint for that purpose shall be and is or are hereby authorized to demand, receive, collect, and recover the said Flood Protection Charges.

The foregoing By-law was made by the State Rivers and Water Supply Commission on the 9th day of September, 1974, and the common seal of the said Commission was hereunto affixed the 1st day of October, 1974, in the presence of—

(SEAL) A. L. TISDALL, Commissioner.
W. E. BROMFIELD, Commissioner.

Approved by the Governor in Council, 22nd October, 1974.—TOM FORRISTAL, Clerk of the Executive Council.

STATE RIVERS AND WATER SUPPLY COMMISSION.

BY-LAW NO. 5728.—FLOOD PROTECTION RATE.—KOO-WEE-RUP FLOOD PROTECTION DISTRICT.

The State Rivers and Water Supply Commission, in pursuance and exercise of the powers conferred by the Water Act, doth hereby make the By-law following:—

1. The following Flood Protection Rates are hereby made under the provisions of the Water Act, and shall be levied upon the occupiers or owners of all lands within the respective divisions of the Koo-wee-rup Flood Protection District for the service rendered to such District by the flood protection works constructed for such services:—

(1) **First Division.**—A Flood Protection Rate of 7·0 cents in the dollar of the rateable value of all lands in the First Division, being the lands included within the red border on the plans of such district signed and sealed by the State Rivers and Water Supply Commission and lodged at the office of the Commission at Melbourne, excepting and excluding all lands in the Second, Third, Fourth and Fifth Divisions as described hereunder.

(2) **Second Division.**—A Flood Protection Rate of 5·25 cents in the dollar of the rateable value of all lands in the Second Division marked on the aforesaid plans in the manner shown opposite the words "Second Division" in the legend thereto.

(3) **Third Division.**—A Flood Protection Rate of 3·5 cents in the dollar of the rateable value of all lands in the Third Division marked on the aforesaid plans in the manner shown opposite the words "Third Division" in the legend thereto.

(4) **Fourth Division.**—A Flood Protection Rate of 1·75 cents in the dollar of the rateable value of all lands in the Fourth Division marked on the aforesaid plans in the manner shown opposite the words "Fourth Division" in the legend thereto.

(5) **Fifth Division.**—No rate is made or shall be levied in respect of the lands marked on the aforesaid plans in the manner shown opposite the words "Fifth Division" in the legend thereto.

Provided that the sum of Two Dollars shall be the minimum amount of rate in respect of any land or tenement liable to be rated in the said district.

2. Such Flood Protection Rates are made and shall be levied for the year beginning with the 1st day of July, 1974, and ending with the 30th day of June, 1975, and shall be payable on the 1st day of December, 1974, at the office of the State Rivers and Water Supply Commission, at Koo-wee-rup.

3. Interest at the rate of eight per cent. per annum will be chargeable on all Flood Protection Rates remaining unpaid after 15th April, 1975.

4. For making and levying such rates the net annual value as set out in the municipal valuation as at 30th June, 1974, shall be deemed and taken to be the rateable value of such lands and tenements.

5. Such person or persons as the State Rivers and Water Supply Commission may from time to time appoint for that purpose shall be, and is, or are, hereby authorized to demand, receive, collect, and recover the said Rate.

The foregoing By-law was made by the State Rivers and Water Supply Commission on the 9th day of September, 1974, and the common seal of the said Commission was hereunto affixed the 1st day of October, 1974, in the presence of—

(SEAL) A. L. TISDALL, Commissioner.
W. E. BROMFIELD, Commissioner.

Approved by the Governor in Council, 22nd October, 1974.—TOM FORRISTAL, Clerk of the Executive Council.

STATE RIVERS AND WATER SUPPLY COMMISSION.

BY-LAW NO. 5729.—FLOOD PROTECTION CHARGE.—KANYAPPELLA FLOOD PROTECTION DISTRICT.

The State Rivers and Water Supply Commission, in pursuance and exercise of the powers conferred by the Water Act, doth hereby make the By-law following:—

1. The following Flood Protection Charges are hereby made under the provisions of the Water Act, and shall be levied upon the occupiers or owners of lands within the Kanyapella Flood Protection District:—

For the service rendered to such district by the flood protection works constructed for such service:—

(1) A Flood Protection Charge of 6·2 cents for each and every hectare of all lands in the **First Flood Protection Division**, comprising all lands within the aforesaid District, excepting and excluding all lands set out and described hereunder comprised within the Third Flood Protection Division.

(2) A Flood Protection Charge of 3·1 cents for each and every hectare of all lands in the **Third Flood Protection Division**, comprising the lands set out hereunder—

PARISH OF KANYAPPELLA.

Allotments 26, 27, 28A, 28B and 28C, of section A; allotments 7, 8A, 8B, 16B, 16C, 16D, 23C, 23D, 24, 25A, 26A, 28A, 29A, 30A, 30B, 31A, 58A, 59A, 59B, 60, 61, 98, 99A, 107, 109, 110, 111A, 111B, 112, 113A, 118A, 118B, 119, 140, 141, 142, 143A, 149, 149A, 149B, 149C, 149D, 149E, 149F, 149G, 150A, 150B, 151, 151A, 151B, 152, 152A, 153, 154, 160, 160B, 160D, 164, 165, 166A and 166B, an area of 10·9 hectares north of allotment 107 (Water Reserve), an area of 2 hectares of Crown lands adjacent to allotment 142 (occupied by P. Pelegrino), an area of 4·9 hectares of Crown lands adjacent to and east of allotment 152A, parts of allotments 31, 32, and 33, containing 41·3 hectares being the holding of T. J. and J. O. Oliver, the north part of allotment 108 containing 4·1 hectares being the holding of C. F. Charlton, the south part of allotment 108 containing 28·7 hectares being the holding of R. B. and R. E. Brown, part of allotment 160A containing 3·2 hectares being the holding of J. W. Phyland, part of allotment 166 containing 53·4 hectares being the holding of H. G. and G. Pettigrove, and parts of allotments 167 and 168 containing 49 hectares being the holding of D. G. M. Christie, all of section B.

PARISH OF WYUNA.

Allotment 4 of section 1; and allotments 1, 1A, 2, 3 and 4 of section 4.

Provided that the sum of Two Dollars shall be the minimum charge in respect of any land or tenement in the said district liable to such charges.

2. Such Flood Protection Charge is made and shall be levied for the year beginning with the 1st day of July, 1974, and ending with the 30th day of June, 1975, and shall be payable on the 1st day of December, 1974, at the office of the State Rivers and Water Supply Commission, at Tongala.

3. Interest at the rate of eight per cent. per annum will be chargeable on all Flood Protection Charges remaining unpaid after 15th April, 1975.

4. Such person or persons as the State Rivers and Water Supply Commission may from time to time appoint for that purpose shall be and is or are hereby authorized to demand, receive, collect, and recover the said charges.

The foregoing By-law was made by the State Rivers and Water Supply Commission on the 9th day of September, 1974, and the common seal of the said Commission was hereunto affixed the 1st day of October, 1974, in the presence of—

(SEAL) A. L. TISDALL, Commissioner.
W. E. BROMFIELD, Commissioner.

Approved by the Governor in Council, 22nd October, 1974.—TOM FORRISTAL, Clerk of the Executive Council.

GLENROWAN WATERWORKS TRUST.

RATING BY-LAW FOR THE YEAR 1975.

THE Glenrowan Waterworks Trust, in pursuance and exercise of the powers conferred by the Water Act, doth hereby make a rate for the supply of water for domestic purposes of Ten cents in the dollar on the annual municipal valuation of lands and tenements liable to be rated within the Glenrowan District.

1. Provided that in no case shall the amount of rate payable per annum in respect of any tenement (other than land on which there is no building), be less than Twenty-seven dollars, and in respect of land on which there is no building less than Fourteen dollars.

2. Such rates are made and shall be levied upon the occupiers or owners of the said lands and tenements for the year commencing the 1st day of January, 1975, and shall be payable on the 31st day of January, 1975, at the office of the said Trust.

3. The maximum quantity of water to be supplied in any one year without further charge to any property rated by the Trust is hereby fixed at a quantity which at a charge of Thirty cents (30c) per One thousand gallons would produce an amount equal to the amount of the rate levied on such property for the said year.

4. The charge for water supplied by measure to any property rated by the Trust in excess of such maximum quantity computed as in the last preceding clause is hereby fixed at Thirty cents (30c) per One thousand gallons.

5. The charge for water supplied by measure to any property not rated by the Trust will be fixed by special agreement with the Trust, provided that in no case shall the amount payable be less than Twenty-seven dollars.

6. The charge for water supplied by measure and by special agreement shall be payable on demand at the office of the said Trust.

Passed this seventh day of October, 1974.

The common seal of the Glenrowan Waterworks Trust was attached hereto in the presence of—

(SEAL) K. L. GRAHAM, Chairman.
R. OATLEY, Commissioner.
E. C. BATES, Secretary.

Approved, 17th October, 1974.—F. J. GRANTER, Minister of Water Supply.

METUNG WATERWORKS TRUST.

RATING BY-LAW No. 13.

THE Metung Waterworks Trust in pursuance and exercise of the powers conferred by the Water Act doth hereby make the following rates for the supply of water for domestic purposes on lands and tenements liable to be rated in the Metung Waterworks Trust District.

On such lands and tenements a rate of five cents in the dollar on the net annual valuation of such properties. Provided that in no case shall the amount of rate payable

per annum in respect of any tenements (other than land on which there is no building) be less than twenty-one dollars and in respect of land on which there is no building less than ten dollars.

Such rates are made and shall be levied upon the occupiers or owners of the said lands and tenements for the year commencing on the 1st day of October, 1974, and shall be payable on the 28th February, 1975, at the office of the Trust. Quarterly instalments shall be due as follows—first instalment within 14 days of posting of rate notice, second instalment by the 31st March, third instalment by the 30th April, fourth instalment by the 31st July.

The maximum quantity of water to be supplied in any one year without further charge to any property rated by the Trust is hereby fixed at the quantity which at the charge of 50 cents per 1,000 gallons would produce an amount equal to the amount of the rate levied on such property for the said year. The charge for water supplied by measure to any property rated by the Trust in excess of such maximum quantity computed as in the last preceding clause is hereby fixed at fifty cents per 1,000 gallons.

The charge for water supplied by measure shall be payable on demand at the office of the Trust.

Passed this 7th day of October, 1974.

(SEAL) R. C. BULL, Chairman.
R. T. WARD, Commissioner.
W. J. HOBSON, Secretary.

Approved, 17th October, 1974.—F. J. GRANTER, Minister of Water Supply.

NHILL WATERWORKS TRUST.

RATING BY-LAW FOR THE YEAR 1975.

THE Nhill Waterworks Trust in pursuance of and in exercise of the powers conferred by the Water Act 1958 and of any and every other power it thereunto enabling doth hereby make a By-Law as follows:—

1. The Trust hereby makes and levies a rate in respect of all the lands and tenements within the Nhill Urban District of Ten and Five Tenths Cents (10.5c) in the Dollar on the net annual value set out in the valuation at present in force of such lands and tenements for the purpose of the municipal rate of the Shire of Lowan which is hereby adopted as the valuation of such lands and tenements respectively.

2. Such rate shall be made and levied upon the occupiers and owners of such lands and tenements for the year ending on the 31st day of December, 1975, and shall be payable on the 1st day of March, 1975, at the office of the Trust.

3. In no case shall the rate payable hereunder in respect of any land on which there is a building be less than Ten Dollars (\$10) and in respect of land on which there is no building be less than Five Dollars (\$5).

4. Such person or persons as the Trust may from time to time appoint for the purposes shall be authorised to demand, receive, collect and recover the rates and charges aforesaid and each of them. And in the absence of such appointment the Secretary of the Trust shall be deemed to have been appointed for the purposes aforesaid and every one of them.

Passed this 1st day of October, 1974.

The common seal of the Nhill Waterworks Trust was hereto affixed this 1st day of October, 1974, in the presence of—

(SEAL) E. M. EDWARDS, Chairman.
R. I. MACAULAY, Commissioner.
I. D. EFFRETT, Secretary.

Approved, 17th October, 1974.—F. J. GRANTER, Minister of Water Supply.

PLENTY-YARRAMBAT WATERWORKS TRUST.

RATING BY-LAW FOR THE YEAR 1974/75.

THE Plenty-Yarrambat Waterworks Trust in pursuance of and in exercise of the powers conferred by the Water Act 1958 and of any and every other power it thereunto enabling doth hereby make a By-Law as follows:—

1. The Trust hereby makes and levies a rate in respect of all the lands and tenements within the Plenty-Yarrambat District of six & one half cents in the dollar on the net annual value set out in the valuation at present in force of such lands and tenements for the purpose of the municipal rates of the Shires of Diamond Valley and Whittlesea which is hereby adopted as the valuation of such lands and tenements respectively. Provided that in no case shall the amount of the rate payable per annum

in respect of any tenement (other than the land on which there is no building) be less than thirteen dollars fifty cents and in respect of any land where there is no building less than four dollars.

2. Such rate shall be made and levied upon the occupiers and owners of such lands and tenements for the year commencing on the 1st day of October, 1974 and shall be due and payable on the 1st day of January, 1975, at the office of the said Trust, 301 Boulevard, Ivanhoe, 3079.

3. When any charge is not paid within six months after it has become payable interest thereon at the rate of eight per centum per annum from the date when such charge became payable until such charge is paid shall be payable.

4. The meter or meters measuring the supply of water to any land or tenement shall be read as near as practicable to twelve months from the date that it was read previously and the quantity of water so measured as having been supplied during the period between any two successive such readings (hereinafter called "the meter year") shall be the basis of the calculating of charges payable under this By-Law provided always that where a meter has been installed on any land or tenement during the course of a meter year the quantity of water measured as having been supplied during the period between the date of such installation and the date of the reading shall be the basis of calculating such charges.

5. Subject as is hereinafter provided in respect of any land or tenement rated by the Trust—

(a) The maximum quantity of water to be supplied in any meter year without charge is hereby fixed as a quantity which if charged at 15.4 cents per kilolitre for any meter year would give an amount equal to the amount of the rate payable in respect of the land or tenement for the financial year in which the said meter year ended.

(b) For all the water supplied in any meter year in excess of the maximum quantity referred to in paragraph (a) of this clause the charge is hereby fixed at 15.4 cents per kilolitre for any meter year.

6. The aforesaid charges shall be payable within fourteen days of demand upon the owner or occupier at the office of the Trust during normal business hours.

7. Where persons liable to pay the rate elect to pay such rate in instalments the first instalment shall be due 14 days after posting of the demand for such rate and the remaining instalments shall be due respectively on 28th February, 31st May, and 31st August in the year 1975.

(SEAL) F. NUSKE, Chairman.
N. H. HEARD, Commissioner.
F. PHILLIPS, Secretary.

Approved, 17th October, 1974.—F. J. GRANTER, Minister of Water Supply.

RIDDELL'S CREEK WATERWORKS TRUST.

RATING BY-LAW FOR 1975.

The Riddell's Creek Waterworks Trust, in pursuance of and in exercise of the powers conferred by the Water Act 1958, and of any and every other power it thereunto enabling, doth hereby make a By-Law as follows:—

1. The Trust hereby makes and levies a rate in respect of all lands and tenements within the Riddell's Creek Urban District, of 4 cents (4c) in the Dollar (\$) on the net annual value set out in the valuations at present in force of such lands and tenements for the purposes of the municipal rate of the Shire of Romsey, which is hereby adopted as the valuation of such lands and tenements respectively.

2. Such rate shall be made and shall be levied upon the occupiers and owners of such lands and tenements for the year commencing on the 1st day of January, 1975, and shall be payable on the 1st day of March, 1975 at the office of the said Trust.

3. In no case shall the rate payable hereunder in respect of any land on which there is a building be less than Twelve Dollars (\$12.00) and in respect of land on which there is no building be less than Twelve Dollars (\$12.00).

Passed this 1st day of October, 1974.

(SEAL) B. HOGAN, Chairman.
UNA I. WRIGHT, Secretary.

Approved, 17th October, 1974.—F. J. GRANTER, Minister of Water Supply.

TRARALGON WATERWORKS TRUST.

RATING BY-LAW 1974/75.

The Traralgon Waterworks Trust, in pursuance and exercise of the powers conferred by the Water Act 1958 and of any and every other power it thereunto enabling doth hereby make a By-law as follows:

1. The Trust hereby makes and levies a rate in respect of all the lands and tenements within the Traralgon Urban District of five-tenths of a cent (0.50 cents) in the dollar on the unimproved capital value set out in the valuation at present in force of such lands and tenements for the purpose of the municipal rate of the City of Traralgon which is hereby adopted as the valuation of such lands and tenements respectively.

2. Such rates shall be made and levied upon the owners or occupiers of such lands and tenements for the year commencing on the first day of October, 1974, and ending on the thirtieth day of September, 1975, and shall be payable on the tenth day of December, 1974, at the office of the said trust.

3. In no case shall the rate payable hereunder in respect of any land on which there is a building be less than twenty dollars (\$20.00) and in respect of land on which there is no building be less than fifteen dollars (\$15.00).

The foregoing By-law was made by the Traralgon Waterworks Trust on the sixteenth day of September, 1974, and the common seal of the said trust was hereunder affixed on the sixteenth day of September, in the presence of—

(SEAL) J. G. McENTEE, Commissioner.
B. A. S. WATKINS, Commissioner.
K. J. SAUNDERS, Secretary.

Approved, 17th October, 1974.—F. J. GRANTER, Minister of Water Supply.

HAMILTON WATERWORKS TRUST.

RATING BY-LAW No. 97, FOR THE YEAR ENDING SEPTEMBER 30, 1975.

The Hamilton Waterworks Trust, the Waterworks District of which Trust has been proclaimed an Urban District for the purpose of the Water Acts—(hereinafter referred to as the Trust) in pursuance and exercise of the powers conferred by the Water Acts doth hereby make this By-Law for such Urban District for determining the rate to be paid in respect of the several lands and tenements to be supplied with water for domestic purposes, and directs as follows:—

1. The said Hamilton Waterworks Trust doth hereby make a rate for the supply of water for domestic purposes of 5.4 cents in the dollar on the annual Municipal Valuation of lands and tenements liable to be rated within the Hamilton Waterworks Urban District. Provided that in no case shall the amount of the rate payable in respect of any land on which there is a building be less than Thirty-one dollars forty cents (\$31.40) and in respect of any land on which there is no building less than Twelve dollars thirty cents (\$12.30).

Such rates are made and shall be levied upon the occupiers or owners of the said lands and tenements for the year commencing on the 1st day of October 1974 and shall be payable on the 10th day of December 1974 at the office of the said Trust.

2. The maximum quantity of water to be supplied in any one year without further charge to any property rated by the Trust is hereby fixed at the quantity which at a charge of Thirty cents (30c) per 1,000 gallons, would produce an amount equal to the amount of the rate levied on such property for the said year.

3. Except where water is supplied by special agreement, and except as provided by By-Law No. 30 of the Trust:—

(a) The charge for water supplied by measure to any property rated by the Trust in excess of such maximum quantity, computed as in the last preceding clause, is hereby fixed at Thirty cents (30c) per 1,000 gallons.

(b) The charge for water supplied by measure to any property not rated by the Trust is hereby fixed at Thirty cents (30c) per 1,000 gallons, and the minimum quantity of water to be charged for in cases where water is so supplied is hereby fixed at 10,000 gallons.

4. The charge for water supplied by measure shall be payable on demand at the office of the Trust.

5. Such person or persons as the Trust may from time to time appoint for the purposes shall be authorized to demand, receive, collect and recover rates and charges aforesaid and each of them. And in the absence of such

appointment the Secretary and/or Rate Collector of the Trust shall be deemed to have been appointed for the purpose aforesaid and every one of them.

Passed the 8th day of August, 1974.

The common seal of the Hamilton Waterworks Trust was hereto affixed this 26th day of September, 1974 in the presence of:—

(SEAL) J. J. SOULSBY, Chairman.
B. G. F. WOODWARD, Commissioner.
T. J. NEVILLE, Secretary.

Approved, 17th October, 1974.—F. J. GRANTER, Minister of Water Supply.

THORNTON WATERWORKS TRUST.
RATING BY-LAW FOR THE YEAR 1975.

The Thornton Waterworks Trust in pursuance of and in exercise of the powers conferred by the *Water Act 1958* and of any and every other power it thereunto enabling hereby make a By-Law as follows:—

1. The Trust hereby makes and levies a rate in respect of all the lands and tenements within the Thornton Urban District of eight and one half cents (8.5) in the dollar on the net annual value set out in the valuation at present in force of such lands and tenements for the purposes of the municipal rate of the Shire of Alexandra which is hereby adopted as the valuation of such lands and tenements respectively.

2. Such rate shall be made and levied upon the occupiers and owners of such lands and tenements for the year commencing on the 1st day of January, 1975 and shall be payable on the 6th day of January, 1975 at the office of the said Trust.

3. In no case shall the rate payable hereunder in respect of any land on which there is a building be less than thirty dollars (\$30) and in respect of land on which there is no building be less than fifteen dollars (\$15).

Passed by the Thornton Waterworks Trust this 9th day of October, 1974.

(SEAL) N. J. COOPER, Chairman.
W. E. ROLLASON, Commissioner.
DONALD O. McLEAN, Secretary.

Approved, 17th October, 1974.—F. J. GRANTER, Minister of Water Supply.

TRENTHAM WATERWORKS TRUST.
RATING BYLAW 1975.

The Trentham Waterworks Trust in pursuance of and in exercise of the powers conferred by the *Water Act 1958* and of any and every other power it thereunto enabling doth hereby make a Bylaw as follows:—

1. The Trust hereby makes and levies a rate in respect of all the lands and tenements within the Trentham Waterworks District of six and a half cents (6.5 cents) in the dollar on the net annual value set out in the valuation at present in force of such lands and tenements for the purposes of the Municipal Rate of the Shire of Kyneton which is hereby adopted as the valuation of such lands and tenements respectively.

2. Such rate shall be made and levied upon the occupiers and owners of such lands and tenements for the year commencing on the 1st day of January, 1975 and shall be payable on the 3rd day of March, 1975 at the Office of the said Trust.

3. In no case shall the rate payable hereunder in respect of any land on which there is a building be less than eleven dollars (\$11.00) and in respect of land on which there is no building be less than six dollars (\$6.00).

Passed this 24th day of September, 1974.

(SEAL) J. G. ROTHE, Chairman.
J. W. L. GROVES, Commissioner.
S. G. PORTER, Secretary.

Approved, 17th October, 1974.—F. J. GRANTER, Minister of Water Supply.

SHIRE OF KOWREE WATERWORKS TRUST.
RATING BY-LAW FOR THE YEAR 1975.

The Shire of Kowree Waterworks Trust in pursuance of and in exercise of the powers conferred by the *Water Act 1958* and of any and every other power it thereunto enabling doth hereby make a By-law as follows—

1. The Trust hereby makes and levies rates in respect of all lands and tenements within the respective Urban Districts of such amount in the dollar on the net annual value set out in the valuation at present in force of such

lands and tenements for the purposes of the municipal rate of the Shire of Kowree which is hereby adopted as the valuation of such lands and tenements respectively, as are set out in the schedule hereto.

2. Such rate shall be made and levied upon the occupiers or owners of such lands and tenements for the year commencing on the first day of January 1975, and shall be payable on the third day of February 1975 at the office of the said Trust.

3. In no case shall the rate payable hereunder in respect of any land on which there is a building be less than the sum set down in the schedule hereto and in respect of land in which there is no building be less than the sum set down in the said schedule.

4. The maximum quantity of water to be supplied in any one year without further charge to any property rated by the Trust is hereby fixed at a quantity which, at a charge as set out for water supplied by measure in the schedule hereto, would produce an amount equal to the amount of rate levied on such property for the said year.

5. The charge for water supplied by measure to any property rated by the Trust in excess of such maximum quantity computed as in the last preceding clause and the charge for water supplied by measure to any property not rated by the Trust is hereby fixed in accordance with the amount set out in the schedule hereto.

SCHEDULE.

	URBAN DISTRICT.			
	Water Rate.			Special Rate.
	Edenhope.	Goroke.	Apsley.	Harrow.
Amount of rate in the \$1 of Municipal Valuation of tenements ..	6c	10c	17.5c	10c
Minimum Amount of Rate per year in respect of tenements (other than lands on which there is no building) ..	\$10	\$9	\$23	\$15
Minimum Amount of Rate per Year in respect of land on which there is no building ..	\$10	\$9	\$9	\$5
Charge per one thousand gallons for water supplied by measure ..	20c	20c	60c	N.A.

Passed this 7th day of October, 1974.

(SEAL) R. L. AMPT, Chairman.
B. D. HAYES, Secretary.

Approved, 17th October, 1974.—F. J. GRANTER, Minister of Water Supply.

OVENS RIVER IMPROVEMENT TRUST.
BY-LAW No. 22.

The Ovens River Improvement Trust, in pursuance and exercise of the power conferred by the *River Improvement Act 1958*, doth hereby make the following By-Law:—

1. The following rate, to be called the Ovens River Improvement District Rate, is hereby made and shall be levied upon the occupiers or owners of all the properties within the Ovens River Improvement District which are rateable to any Municipality:—a rate of one half cent in the Dollar on the Annual Municipal Value of such properties.

Provided that the sum of fifty cents shall be the minimum amount of rate in respect of any property liable to be rated in the said District.

2. Such a rate is made and shall be levied for the year beginning with the 1st day of January, 1975 and ending with the 31st day of December, 1975 and shall be payable on the 6th of January, 1975, at the Office of the Ovens River Improvement Trust at Wangaratta.

3. Such person or persons as the Ovens River Improvement Trust may from time to time appoint for the purpose shall be and is or are hereby authorised to demand, receive, collect and recover the said rate.

The foregoing By-Law was made by the Ovens River Improvement Trust on the 26th day of September, 1974, and the common seal of the said Trust was hereto affixed this 26th day of September, 1974, in the presence of—

(SEAL) A. R. NICOLL, Chairman.
A. E. McCORMACK, Commissioner.
E. F. VAN LEEUWEN, Secretary.

Approved, 17th October, 1974.—F. J. GRANTER, Minister of Water Supply.

ALEXANDRA SEWERAGE AUTHORITY.

RATING BY-LAW FOR THE YEAR 1975.

The Alexandra Sewerage Authority, in pursuance and exercise of the powers conferred by the Sewerage Districts Act, doth hereby make the following By-Laws:—

The following rates are hereby made under the provisions of the Sewerage Districts Act, and shall be levied upon the net annual value of all rateable properties within the Alexandra Sewerage District:—

1. Of any land or tenement within the declared Alexandra Sewerage Area, a sewerage rate of ten and one half cents (10.5) in the Dollar of the net annual value of all rateable "sewered property" within the said District.

2. In no case shall the amount of sewerage rate payable be less than Twenty-six Dollars (\$26) in respect of any rateable sewered property on which there is a building, and Fifteen Dollars (\$15) in respect of which there is no building, or a cistern charge of Twenty-six Dollars (\$26) for the first cistern and Eighteen Dollars (\$18) for each subsequent cistern on non-rateable property.

3. Such rate is made and shall and levied for the year beginning with the 1st day of January, 1975 and ending with the 31st day of December, 1975, and shall be payable on the 7th day of January, 1975, at the office of the Authority, Municipal Office, Perkins Street, Alexandra.

4. For making and levying such rate the valuation for the time being of such lands and tenements for the municipal rate of the municipality in the municipal district of which such lands and tenements are situate shall be deemed and taken to be the valuation of such lands and tenements respectively.

5. Such persons or person as the Alexandra Sewerage Authority may from time to time appoint for that purpose shall be or is or are hereby authorised to demand, receive, collect and recover the said rates and charges.

The resolution for passing the foregoing By-Law was agreed to by the Alexandra Sewerage Authority on the 2nd day of September, 1974, and was confirmed by the said Authority on the 7th day of October, 1974.

The seal of the Alexandra Sewerage Authority was affixed hereto on the 7th day of October, 1974.

(SEAL) B. J. O'BRIEN, Chairman.
H. C. FITZROY, Member.
D. O. McLEAN, Secretary.

Approved, 17th October, 1974.—F. J. GRANTER, Minister of Water Supply.

CITY OF ARARAT WATER SUPPLY DISTRICT.

By-Law No. 85.

Rating By-Law for the Year Ending 30th September, 1975.

The Council of the City of Ararat in pursuance and in exercise of the powers conferred by the Water Act 1958 and of any and every other power it hereunto enabling doth hereby make a By-Law as follows:

1. The Council of the City of Ararat hereby makes and levies a rate in respect of all of the lands and tenements within the City of Ararat Water Supply District of 6.3 cents in the dollar on the Net Annual Value set out in the valuation at present in force of such lands and tenements for the purposes of the municipal rate of the City of Ararat which is hereby adopted as the valuation of such lands and tenements respectively.

2. Such rate shall be made and levied upon the occupiers and owners of such lands and tenements for the year commencing on the First day of October, 1974, and shall be payable on the Tenth day of December, 1974, at the Office of the said Council.

3. In no case shall the rate payable hereunder in respect of any land on which there is a building be less than Twenty dollars and in respect of land on which there is no building be less than Twelve dollars.

4. All water rates levied shall bear interest at the rate of eight per centum per annum from the date when such rates became payable provided that interest shall not be payable in respect of any such rates if paid on or before the 10th day of June, 1975.

Passed this 30th day of September, 1974.

The common seal of the Council of the City of Ararat was hereunto affixed this 30th day of September, 1974, in the presence of:

(SEAL) D. L. MACLENNAN, Mayor.
W. C. HENNING, Councillor.
J. I. GRENFELL, Town Clerk.

Approved, 17th October, 1974.—F. J. GRANTER, Minister of Water Supply.

CITY OF ARARAT WATER SUPPLY DISTRICT.

By-Law No. 86.

The Council of the City of Ararat, in pursuance and in exercise of the powers conferred by the Water Act 1958 and of any and every other power it thereunto enabling doth hereby make a By-Law as follows which shall apply within the City of Ararat Water Supply District.

1. By-Law No. 84 is hereby repealed.

2. The meter or meters measuring the supply of water to any land or tenement shall be read as near as practicable to twelve months from the date of the previous reading of such meter or meters and the quantity of water measured as having been supplied during the period between any two successive such readings (hereinafter called "the meter year") shall be the basis of the calculating of charges payable under this By-Law provided always that where a meter has been installed on any land or tenement during the course of a meter year and the quantity of water measured as having been supplied during the period between the date of such installation and the date of the reading shall be the basis of calculating such charges.

3. Subject as is hereinafter provided in respect of any land or tenement rated by the Council of the City of Ararat within the said City of Ararat Water Supply District:—

(a) The maximum quantity of water to be supplied in any meter year without charge is hereby fixed at a quantity which if charged at Fortyfive cents per thousand gallons or 4.5 kilolitres for any meter year would give an amount equal to the amount of the rate payable in respect of the land or tenement for the financial year in which the said meter year ended.

(b) For all water supplied in any meter year in excess of the maximum quantity referred to in paragraph (a) of this clause the charge is hereby fixed at Fortyfive cents per thousand gallons or 4.5 kilolitres for any meter year.

4. Subject as in hereinafter provided the charge for water supplied by measure to any property not rated by the said Council is hereby fixed at Fortyfive cents per thousand gallons or 4.5 kilolitres.

5. The minimum charge for water supplied by measure to any property not rated by the Council is hereby fixed at Ten Dollars.

6. The aforesaid charges shall be payable within seven days of demand upon the owner or occupier at the office of the Council of the City of Ararat during normal business hours.

7. The provisions of Clauses 3, 4 and 5 of this By-Law shall not apply to any land tenement or property supplied with water by the Council of the City of Ararat under a special Agreement pursuant to Section 215 of the Water Act 1958.

Passed this 30th day of September, 1974.

The common seal of the Council of the City of Ararat was hereunto affixed, this 30th day of September, 1974, in the presence of—

(SEAL) D. L. MACLENNAN, Mayor.
W. C. HENNING, Councillor.
J. I. GRENFELL, Town Clerk.

Approved, 17th October, 1974.—F. J. GRANTER, Minister of Water Supply.

APPOINTMENTS AND RESIGNATIONS

APPOINTMENTS.

His Excellency the Governor of the State of Victoria, by and with the advice of the Executive Council thereof, has, by Orders made on the 22nd day of October, 1974, been pleased to make the under-mentioned appointments, viz.:—

CHIEF SECRETARY'S DEPARTMENT.

Properly Qualified Analyst.

COLLIN ELWYN WOOLCOCK,

pursuant to the provisions of section 80D of the Motor Car Act 1958, to be a Properly Qualified Analyst.

MINISTRY OF HEALTH.

Members of Committees of Management of Hospitals.

EDGAR MAURICE HENDERSON,

to be Government appointee on the Committee of Management of Werribee District Hospital for a further period of three years commencing the 20th November, 1974, pursuant

to the provisions of sub-paragraph (ii) of paragraph (a) of the proviso to sub-section (1) of section 48 of the *Hospitals and Charities Act 1958*;

BENJAMIN ROBERT PAYNE,
to be Government appointee on the Committee of Management of Macarthur and District Memorial Hospital for a period of a further three years commencing the 9th November, 1974, pursuant to the provisions of sub-paragraph (ii) of paragraph (a) of the proviso to sub-section (1) of section 48 of the *Hospitals and Charities Act 1958*; and

LINDSAY PYNOR WHITE, B.Com. (Melb.), F.A.S.A.,
F.C.I.S., F.A.I.M.,

to be Government appointee on the Committee of Management of Prince Henry's Hospital for a period of a further three years commencing the 30th November, 1974, pursuant to the provisions of sub-paragraph (ii) of paragraph (a) of the proviso to sub-section (1) of section 48 of the *Hospitals and Charities Act 1958*.

Hospitals and Charities Commission.

EMANUEL WILDER, M.B., Ch.B., F.R.C.P.A.; F.R.C. Path.,
to be Chairman of the Hospitals and Charities Commission, pursuant to section 9 of the *Hospitals and Charities Act 1958* for the period from 23rd November, 1974 to the 30th June, 1976, both dates inclusive;

ROBERT LEONARD EDWIN THOMAS, B.Com., A.A.S.A.,
F.H.A.,

to be Deputy Chairman of the Hospitals and Charities Commission, pursuant to section 9 of the *Hospitals and Charities Act 1958* for the period from 23rd November, 1974 to the 30th June, 1976, both dates inclusive; and

FRANCIS WILLIAM CREMEAN,

to be Member of the Hospitals and Charities Commission pursuant to section 9 of the *Hospitals and Charities Act 1958* for the period from 23rd November, 1974 to the 30th June, 1976, both dates inclusive.

Mental Health Authority.

JACK LEWIS EVANS, M.B., B.S., D.P.M.,

to be Deputy-Chairman of the Mental Health Authority, and

WILFRED JOHN WOODS, A.A.S.A.,

to be Administrative member of the Mental Health Authority, pursuant to the provisions of section 5 of the *Mental Health Act 1959* for a period of five years commencing the 1st December, 1974.

Member of Food Standards Committee.

SIMON JOSHUA LEACH, B.Sc., Tech. (Manc.) Ph.D.,
D.Sc. (Leeds)

to be Member of Food Standards Committee, pursuant to the provisions of section 228 of the *Health Act 1958* vice Professor F. J. R. Hird, overseas.

LAW DEPARTMENT.

Justices of the Peace.

BRUCE AITKEN, 37 Barry Street, Seaford,
BRIAN FRANCIS CARROLL, Chief Commissioner's Office,
Chief Secretary's Department, Melbourne,
MAXWELL RAYMOND DEAN, 106 Grimshaw Street,
Greensborough,

ALEXANDER COLIN MACKINLAY LAING, 31 Phillips Crescent, Rosanna.

ALAN JOHN MARTIN, Mandurang Road, Spring Gully,
LEO PATRICK MURPHY, Dunnstown,

CLIVE ANTHONY ROGERS, 76 Bellevue Avenue, Rosanna,
and

GEORGE YIANNI, 10 Linda Street, Clayton,

to Keep the Peace in the State of Victoria:

Commissioners for Taking Declarations, &c.

GRAEME FRANKLING ANDERSEN, care of Municipal
Offices, 695 Doncaster Road, Doncaster,

PHILIP JAMES CAIRNS, care of McEwans' Building, 27
Devonshire Road, Sunshine,

RONALD CHARLES HORNE, care of H.B.A., 108 Centre
Road, Chadstone Shopping Centre, Chadstone,

ERIC MAXWELL JENNER,

BRIAN DESMOND VINCENT, care of Housing Commission,
Victoria, 12 Holland Court, Flemington.

COLIN STANLEY McLEAN, Watchem,

DONALD RUPERT MEDSON, care of 3rd Military District
Personnel Depot, Watsonia Barracks, MacLeod,

VERNA EDITH MAY O'BRIEN, care of Sunshine Community
Resource Centre, 41 Dickson Street, Sunshine,

CLIVE LINDLEY PILLEY, care of Lockwood Associates,
209 Hare Street, Echuca.

PETER JAMES STEWART RICHARDSON, care of Department
of Crown Lands and Survey, State Public Offices,
2 Treasury Place, Melbourne,

GEOFFREY D'ARCY SIMS, care of Binder Hamlyn & Co.,
405 Bourke Street, Melbourne,

LAWRENCE FREDERICK VERDUN SYMES, care of Housing
Commission, Victoria, 179 Queen Street, Melbourne, and

DAVID ANTHONY WALKER, care of Personnel Branch,
Public Works Department, 2 Treasury Place, Melbourne,

to be Commissioners for taking Declarations and Affidavits
under the *Evidence Act 1958*.

SOCIAL WELFARE DEPARTMENT.

Honorary Probation Officers.

MARK FRANCIS COGHLAN, Flat 4, 71 Ormond Esplanade,
Elwood,

JAMES MATTHEW CROSTHWAITE, 259 Scotchmer Street,
North Fitzroy,

KATHLEEN JEAN DUNBAR (Mrs.), 13 Clarence Street,
Hamilton,

ANTHONY JAMES HALFPENNY, Wall Street, Alexandra,
MARGARET HARVEY (Mrs.), 19 Johnson Drive, Glen
Waverley,

PATRICIA HOSNA (Mrs.), 85 Fulton Road, Mt. Eliza,
ELSPETH LOUISE KEENAN (Mrs.), 21 Grosvenor Street,
Brighton,

ALISON FRIEDA McLAY (Miss), 7 Rippon Street, Foots-
cray,

ALAN JOSEPH McMAHON (Rev. Fr.), St. Christopher's
Presbytery, 34 Roberts Road, Airport West,

RODNEY DESMOND PRICE, 79 Russell Street, Bendigo,
MATTHEW DENNIS SIMMONS, Unit 7, 86 Hotham Street,
East Melbourne, and

PETER FRANCIS TYDEMAN, Flat 16, 14A Chapel Street,
East St. Kilda,

pursuant to the provisions of section 507 (2) of the *Crimes Act 1958* and section 9 of the *Children's Court Act 1973*,

to be Honorary Probation Officers for all Adult and Children's Courts in Victoria.

DEPARTMENT OF WATER SUPPLY.

Waterworks Trusts Commissioners.

ROBERT STEWART DONALD,
to be a Commissioner of the Coleraine and Casterton
Waterworks Trust to hold such position for a period of
two years from the date hereof, subject to the provisions
of the Water Act;

BRUCE ALEXANDER BURTON,
to be a Commissioner of the Euroa Waterworks Trust, to
hold such position for a period of four years from the date
hereof, subject to the provisions of the Water Act; and

JOHN DESMOND DAVIS,
to be a Commissioner of the Lismore and Derrinallum
Waterworks Trust to hold such position for a period of
four years from the date hereof, subject to the provisions
of the Water Act.

TOM FORRISTAL,

Clerk of the Executive Council.

At the Executive Council Chamber,
Melbourne, 22nd October, 1974.

Vermin and Noxious Weeds Act 1958.

APPOINTMENT.

It is hereby notified that the Public Service Board, in
exercise of its powers, has appointed TREVOR MAGNUS
LAGSTROM, an officer of the Department of Crown Lands
and Survey, as Secretary to the Vermin and Noxious
Weeds Destruction Board, without additional salary.

C. E. MIDDLETON,

Secretary for Lands.

Melbourne, 16th October, 1974.

FORESTS ACT 1958.

FORESTS (PART V.—TIMBER PROMOTION) REGULATIONS 1969.

Pursuant to the provisions of the Forests (Part V.—
Timber Promotion) Regulation 1969 now therefore I, the
Honorable Frederick James Granter, Her Majesty's Minister
of Forests for the State of Victoria, do hereby reappoint—

ALAN JOHN THREADER,

JOHN HILBERT COSSTICK, and

GERALD GRIFFIN,

being persons nominated by the Forests Commission—

THOMAS RICHARD BRABIN,

DANIEL RANDEL DOSSETOR, and

NORMAN ELLIOTT PIZZEY,

being persons nominated by the Victorian Sawmillers
Association; and

ALFRED OSCAR PLATT LAWRENCE,
ROBERT WILLIAM ROY MUNCEY, and
WILLIAM THOMAS KNIGHT,
as members of the Timber Promotion Committee for a
period of two years as from 29th October, 1974. The
said Alfred Oscar Platt Lawrence shall be Chairman of the
Committee.

F. J. GRANTER,
Minister of Forests.
Melbourne, 29th October, 1974.

Liquor Control Act 1968.

APPOINTMENT OF LICENSING INSPECTOR.

In accordance with the authority conferred upon me by
sub-section (1) of Section 22 of the *Liquor Control Act 1968*,
I, Reginald Jackson, Chief Commissioner of Police, hereby
appoint the following Officer of Police as Licensing Inspector
for the Division of the Police District as shown :—

Division Number.	Police District.	Rank and Name.
3	Sunshine	Inspector Allen James Williams (from 14.10.74 to 18.11.74).

R. JACKSON,
Chief Commissioner of Police.

17.10.1974

RESIGNATIONS.

His Excellency the Governor of the State of Victoria,
by and with the advice of the Executive Council thereof,
has, by Orders made on the 22nd day of October, 1974,
accepted the resignations of the persons named hereunder
of the offices mentioned, viz:—

LAW DEPARTMENT.
Justices of the Peace.

BERTRAM CHARLES CARR,
CASPAR JOHN KNEWSTUB, and
GILBERT ERNEST WOLFE,
as Justices of the Peace for the State of Victoria.
Commissioners for Taking Declarations, &c.

LEONARD CHARLES BAUD,
MAXWELL ERIC BLASKETT,
JOHN EDMUND DWYER,
GEORGE ROGER GORDON,
NORMAN MAXWELL HANSEN,
HAROLD LESLIE HOMER, and
VERNON THOMPSON TILLEY,
as Commissioner for taking Declarations and
Affidavits under the *Evidence Act 1958*.

SOCIAL WELFARE DEPARTMENT.
Honorary Probation Officers.

ALBERT EDWARD BENNETT,
VERA BENNETT (Mrs.), and
CLIFFORD WILLIAM ELLEN,
as Honorary Probation Officers pursuant to the
provisions of section 507 (2) of the *Crimes Act 1958*
and section 9 of the *Children's Court Act 1973*
for all Adult and Children's Courts in
Victoria.

TOM FORRISTAL,
Clerk of the Executive Council.
At the Executive Council Chamber,
Melbourne, 22nd October, 1974.

ORDERS IN COUNCIL

TOWN AND COUNTRY PLANNING ACT 1961.

At the Executive Council Chamber, Melbourne, the
twenty-second day of October, 1974.

PRESENT:
His Excellency the Governor of Victoria.
Mr. Byrne | Mr. Meagher
Mr. Scanlan | Mr. Dixon.

**AMENDMENT OF ORDER ESTABLISHING THE LODDON
CAMPASPE REGIONAL PLANNING AUTHORITY.**

Where it is provided by paragraph (c) of sub-section
(1) of section 12 of the *Town and Country Planning Act 1961*,
that the Governor in Council may by Order revoke or
from time to time amend or vary any Order made pursuant
to paragraph (a) of the said sub-section.

And whereas the Governor in Council on the eleventh
day of September, 1973, made an Order pursuant to para-
graph (a) of sub-section (1) of section 12 of the said Act
establishing a Regional Planning Authority to be known as
the Loddon Campaspe Regional Planning Authority for the
purpose of preparing and submitting for approval a plan-
ning scheme or schemes for the area specified in the Order.

Now therefore, His Excellency the Governor of the State
of Victoria, by and with the advice of the Executive Coun-
cil thereof, doth by this Order amend the Order made on
the eleventh day of September, 1973, in the following
manner:—

1. In paragraph 1 for the words "for the area specified
hereunder" there shall be substituted the words "in
respect of any area or areas within the area specified
hereunder".

2. For paragraphs 2 and 3 there shall be substituted the
following paragraphs—

"2. Define the specified area as all that land com-
prising:—

(a) the whole of the municipal districts of the:—

- (i) City of Bendigo;
- (ii) City of Castlemaine;
- (iii) City of Maryborough;
- (iv) Town of St. Arnaud;
- (v) Borough of Eaglehawk;
- (vi) Shire of Bet Bet;
- (vii) Shire of Charlton;
- (viii) Shire of Huntly;
- (ix) Shire of Korong;
- (x) Shire of Marong;
- (xi) Shire of Metcalfe;
- (xii) Shire of Strathfieldsaye;
- (xiii) Shire of Tullaroop;
- (xiv) Shire of Kara Kara; and

(b) the Western Riding of the Shire of Waranga.

3. Specify that the authority shall consist of fifteen
members comprising one councillor appointed by the coun-
cil of each of the municipalities specified hereunder—

- (a) City of Bendigo;
- (b) City of Castlemaine;
- (c) City of Maryborough;
- (d) Town of St. Arnaud;
- (e) Borough of Eaglehawk;
- (f) Shire of Bet Bet;
- (g) Shire of Charlton;
- (h) Shire of Huntly;
- (i) Shire of Korong;
- (j) Shire of Marong;
- (k) Shire of Metcalfe;
- (l) Shire of Strathfieldsaye;
- (m) Shire of Tullaroop;
- (n) Shire of Kara Kara; and
- (o) Shire of Waranga".

And the Honorable Alan John Hunt, Her Majesty's
Minister for Local Government for the State of Victoria,
shall give the necessary directions herein accordingly.

TOM FORRISTAL,
Clerk of the Executive Council.

COUNTRY ROADS BOARD ACT No. 6229.

At the Executive Council Chamber, Melbourne, the
twenty-second day of October, 1974.

PRESENT:
His Excellency the Governor of Victoria.
Mr. Byrne | Mr. Meagher
Mr. Scanlan | Mr. Dixon.

**ORDER APPROVING OF LAND BEING ACQUIRED AND
ROADS, DEVIATIONS OR WIDENINGS BEING MADE
TOGETHER WITH ALL ANCILLARY WORKS RE-
QUIRED TO BE EXECUTED IN CONJUNCTION
THEREWITH.**

His Excellency the Governor of the State of Victoria, by
and with the advice of the Executive Council thereof, being
satisfied that there are funds legally available for acquiring
the land, doth hereby approve the acquiring of the land
described in the schedule hereunder and the making of new
roads and deviations from and widenings of existing roads,
together with all ancillary works required to be executed
in conjunction therewith, referred to in the said schedule.

SCHEDULE.

State Highways.

The land shown hatched on plan numbered G.P.13681
hereunder required for the deviation from the Princes
Highway in the Shire of Orbost and making of the devia-
tion thereon.

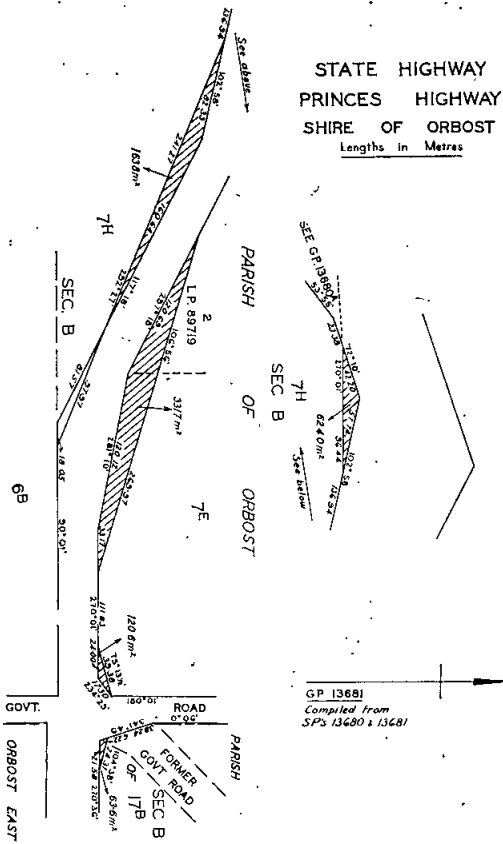

Main Roads.
The land shown hatched on plans numbered G.P.13738 and G.P.13739 hereunder required for the widening of the Healesville—Koo-Wee-Rup Road in the Shire of Healesville and making of the widening thereon.

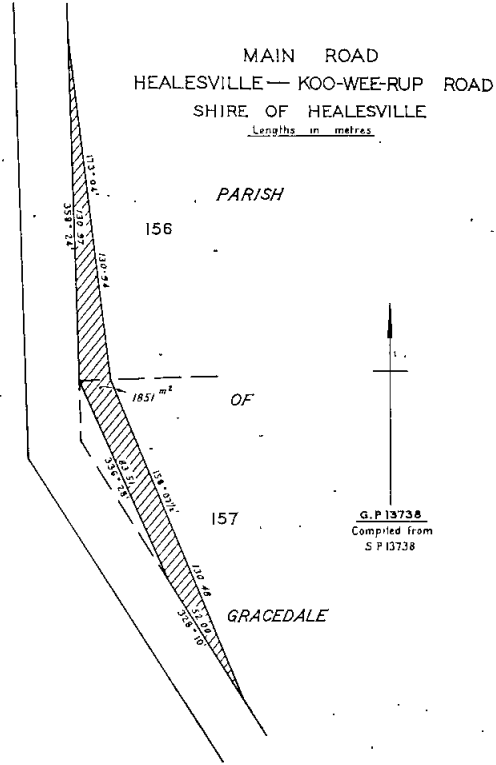

The land shown hatched on plan numbered G.P.13803 hereunder required for the widening of the South Gippsland Highway in the Shire of South Gippsland and making of the widening thereon.

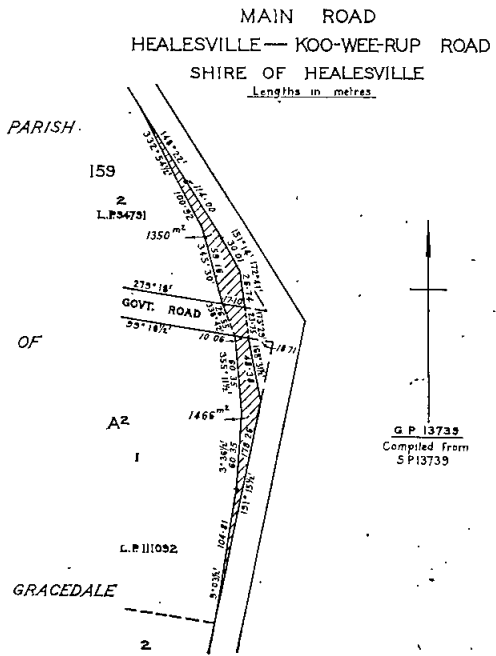
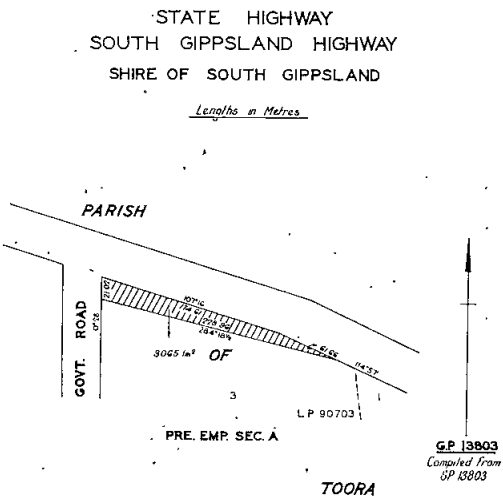

MAIN ROAD
STAWELL - WARRACKNABEAL ROAD
SHIRE OF STAWELL
Lengths in Metres

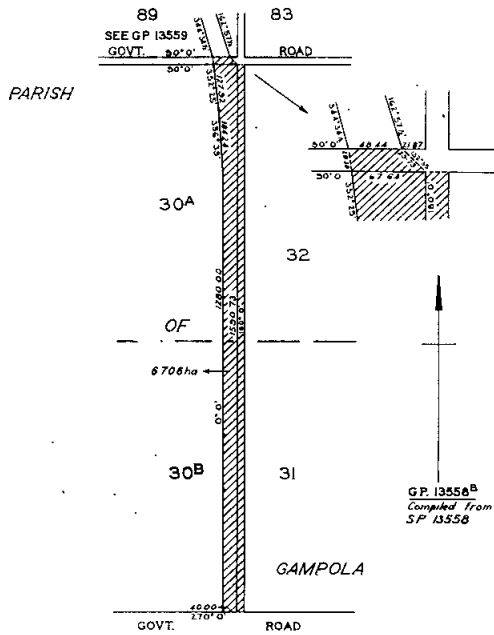

MAIN ROAD
STAWELL - WARRACKNABEAL ROAD
SHIRE OF STAWELL
Lengths in Metres

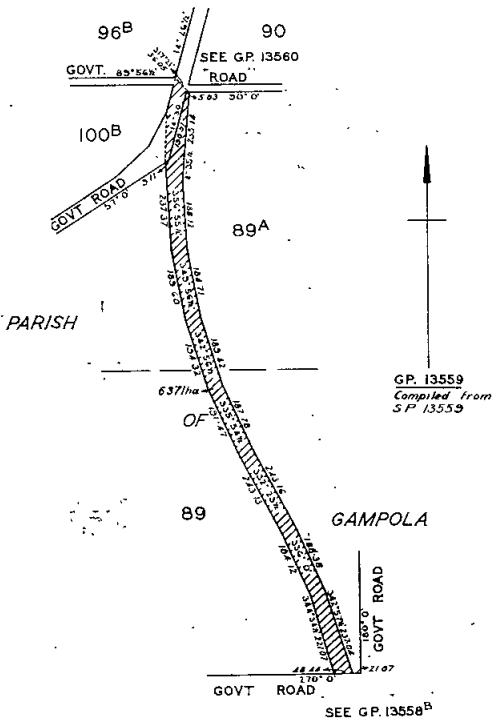

MAIN ROAD
STAWELL - WARRACKNABEAL ROAD
SHIRE OF STAWELL
Lengths in Metres

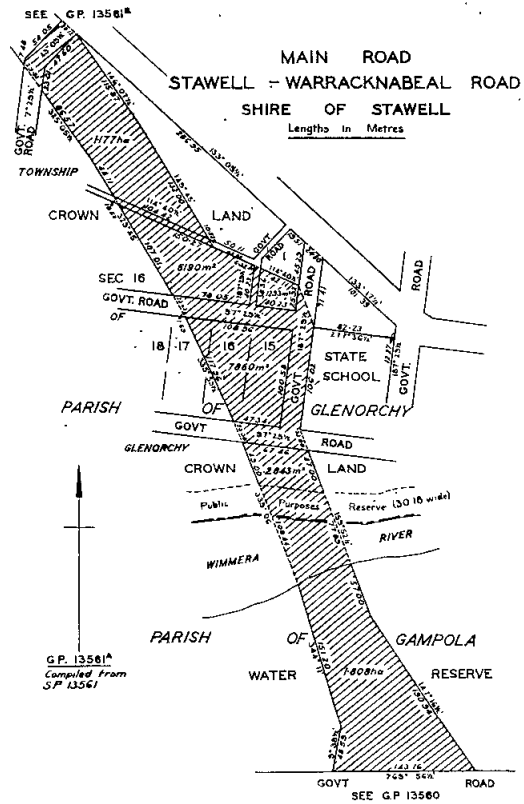
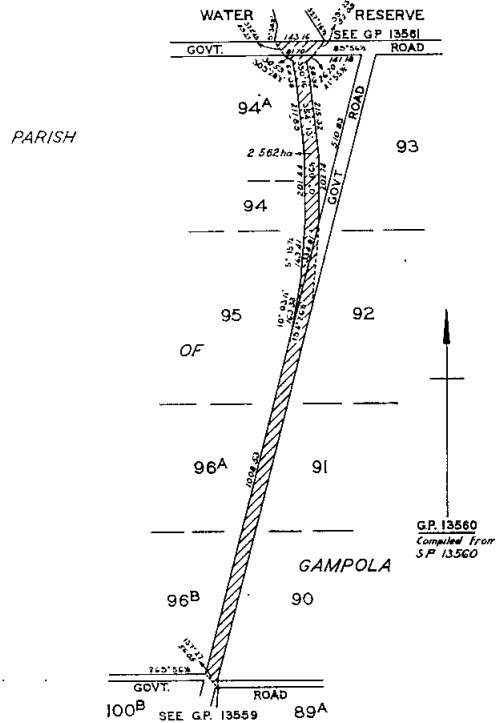

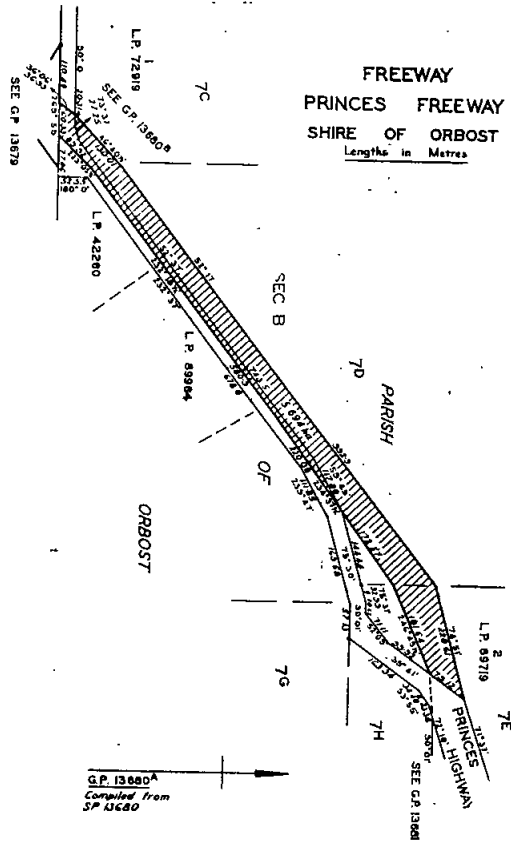
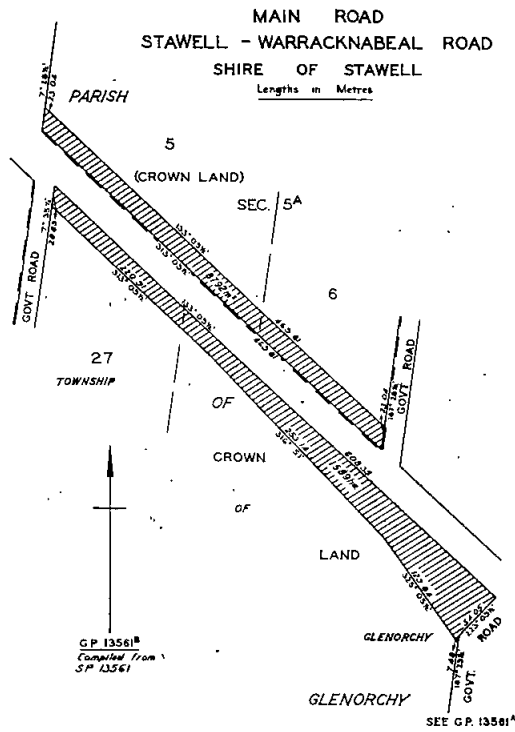

Freeway.

The land shown hatched on plans numbered G.P.13679 and G.P.13680A hereunder required for the making of a new freeway (Princes Freeway) in the Shire of Orbost.

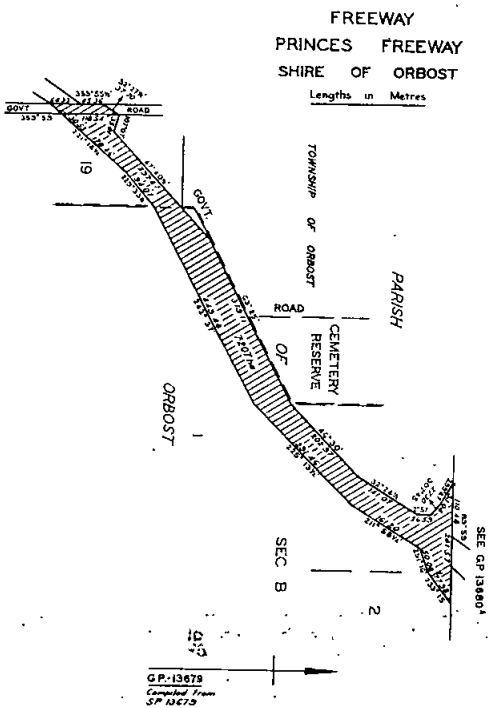

Unclassified Road.

The land shown hatched on plan numbered G.P.13680B hereunder required for the making of a new road in the Shire of Orbost.

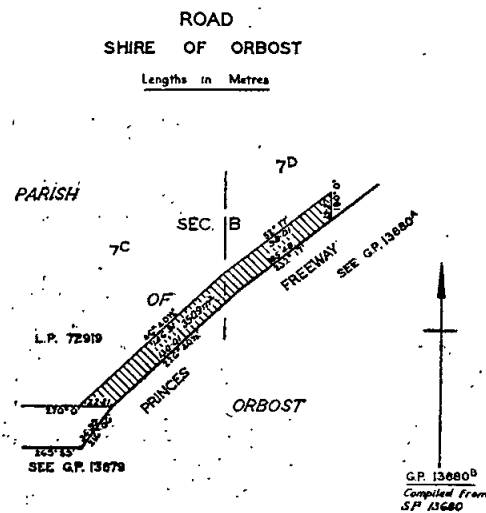

Ancillary Works.

The land shown hatched on plan numbered G.P.13679A hereunder required for ancillary works required to be executed in conjunction with the making of a new freeway in the Shire of Orbost.

**ANCILLARY WORKS
(PRINCES FREEWAY)
SHIRE OF ORBOST**
Lengths in metres.

TOWNSHIP OF ORBOST
PARISH OF ORBOST

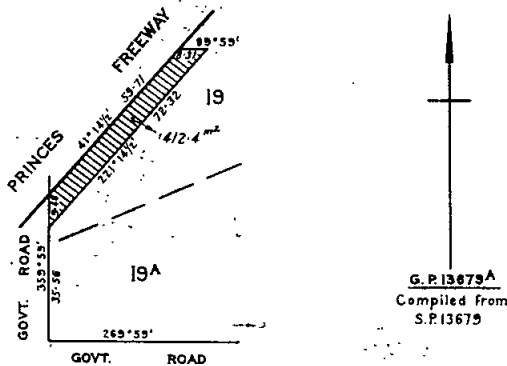

And the Honorable Edward Raymond Meagher, Her Majesty's Minister of Transport for the State of Victoria, shall give the necessary directions herein accordingly.

TOM FORRISTAL,
Clerk of the Executive Council.

Land Act 1958.
DEPARTMENT OF CROWN LANDS AND SURVEY.

At the Executive Council Chamber, Melbourne, the twenty-second day of October, 1974.

PRESENT:
His Excellency the Governor of Victoria.
Mr. Byrne Mr. Meagher
Mr. Scanlan Mr. Dixon.

REVOCATION OF TEMPORARY RESERVATION OF LAND, AS TO PART, BY ORDER IN COUNCIL.

His Excellency the Governor of the State of Victoria, by and with the advice of the Executive Council thereof, in pursuance of the provisions of the Land Act 1958, hereby revokes the temporary reservation of Land by Order in Council hereinafter described:—

MORNINGTON.—The temporary reservation by Order in Council of the 25th May, 1960, of 2433 square metres (2 roods-16 2/10 perches) of land in the Township of Mornington as a site for Municipal Offices and Public Hall, so far only as regards the portion containing 100 square metres, more or less, as defined by description and hatching on plan published in the Government Gazette of the 25th September, 1974, is concerned.—(M.162(?) (Rs.7440).

And the Honorable William Archibald Borthwick, Her Majesty's Minister of Lands for the State of Victoria, shall give the necessary directions herein accordingly.

TOM FORRISTAL,
Clerk of the Executive Council.

HOUSING ACT 1958.

At the Executive Council Chamber, Melbourne, the twenty-second day of October, 1974.

PRESENT:
His Excellency the Governor of Victoria.
Mr. Byrne Mr. Meagher
Mr. Scanlan Mr. Dixon.

CLOSING OF A SECTION OF ROAD.—CITY OF PRAHRAN.

Whereas by virtue and in exercise of the powers contained in the Housing Act 1958 (No. 6275) Housing Commission has recommended to the Governor in Council that the section of road described in the Schedule hereto be closed.

Now therefore, His Excellency the Governor of the State of Victoria in the Commonwealth of Australia, by and with the advice of the Executive Council of the said State, doth in pursuance of the powers conferred by the said Act and upon such recommendation, consent and by this Order hereby close such section of road.

SCHEDULE.

The road delineated and hachured on the plan hereunder.

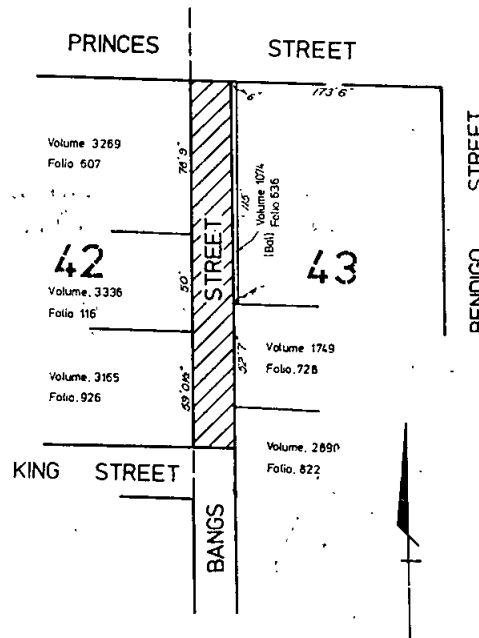

And the Honorable Vance Oakley Dickie, Her Majesty's Minister of Housing for the State of Victoria, shall give the necessary directions herein accordingly.

TOM FORRISTAL,
Clerk of the Executive Council.

ROAD TRAFFIC ACT 1958.

At the Executive Council Chamber, Melbourne, the twenty-second day of October, 1974.

PRESENT:

His Excellency the Governor of Victoria.
 Mr. Byrne Mr. Meagher
 Mr. Scanlan Mr. Dixon.

In pursuance of the powers conferred by the Road Traffic Act 1958, His Excellency the Governor of the State of Victoria, in the Commonwealth of Australia, by and with the advice of the Executive Council of the said State, and at the request, in writing, of the Council of the City of Camberwell, doth by this Order extend the provisions of the said Act to the lands under the control of the City of Camberwell, such lands being those described hereunder:

Rear of Balwyn Road.

Start at the north-west corner of Whitehorse and Balwyn Roads proceed in a north-easterly direction on a bearing of 0 deg. 34 min. for a distance of 125 ft. 0 in.; thence in a westerly direction for a distance of 114 ft. 6 in. as the commencing point.

Proceed in a westerly direction for a distance of 84 ft. 3 1/2 in.; thence in a north-westerly direction on a bearing of 359 deg. 56 min. for a distance of 139 feet; thence in an easterly direction for a distance of 84 ft. 7 1/2 in.; thence in a south-westerly direction on a bearing of 180 deg. 3 1/2 min. for a distance of 139 feet to the commencing point, as shown on Plan "A" hereunder.

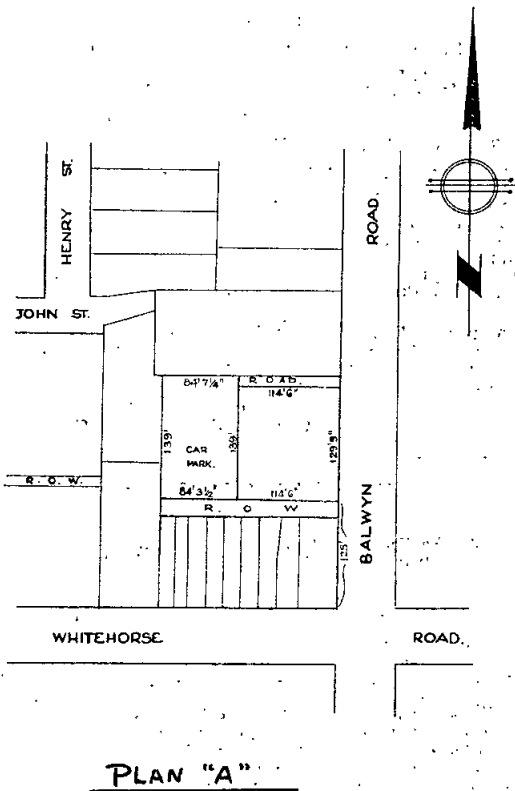

PLAN "A"

Mangan Street.

Start at the north-west corner of Whitehorse Road and Mangan Street, proceed in a northerly direction for a distance of 165 ft. 0 in. as the commencing point.

Proceed in a westerly direction for a distance of 165 ft. 0 in.; thence in a northerly direction for a distance of 66 ft. 0 in.; thence in a easterly direction for a distance of 165 ft. 0 in.; thence in a southerly direction for a distance of 66 ft. 0 in. to the commencing point, as shown on Plan "B" hereunder.

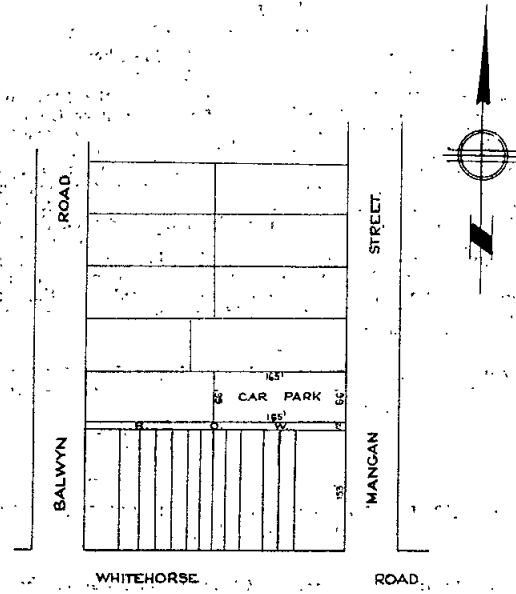

PLAN "B"

And the Honorable John Frederick Rossiter, Her Majesty's Chief Secretary for the State of Victoria, shall give the necessary directions herein accordingly.

TOM FORRISTAL,
 Clerk of the Executive Council.

LOCAL GOVERNMENT DEPARTMENT.

At the Executive Council Chamber, Melbourne, the twenty-second day of October, 1974.

PRESENT:

His Excellency the Governor of Victoria.
 Mr. Byrne Mr. Meagher
 Mr. Scanlan Mr. Dixon.

APPLICATION TO ELECTIONS OF COUNCILLORS FOR THE CITY OF BOX HILL OF REGULATIONS RELATING TO COMPULSORY VOTING.

Whereas it is provided in section 149 of the Local Government Act 1958, that the Governor in Council on the petition of the Council of any municipality, may by Order published in the Government Gazette, apply to elections of councillors for such municipality with any modifications provided for in such Order, all or any of the Regulations relating to compulsory voting made under the said section 149.

Now therefore, His Excellency the Governor of the State of Victoria, by and with the advice of the Executive Council thereof, and in pursuance of a petition of the Council of the City of Box Hill, doth hereby Order that the Regulations relating to the compulsory voting at municipal elections made pursuant to the provisions of the said section 149 shall apply to elections of councillors for the said municipality.

And the Honorable Alan John Hunt, Her Majesty's Minister for Local Government for the State of Victoria, shall give the necessary directions herein accordingly.

TOM FORRISTAL,
 Clerk of the Executive Council.

MELBOURNE AND METROPOLITAN TRAMWAYS ACT
1958 (No. 6311).

At the Executive Council Chamber, Melbourne, the
twenty-second day of October, 1974.

PRESENT:

His Excellency the Governor of Victoria.	
Mr. Byrne	Mr. Meagher
Mr. Scanlan	Mr. Dixon.

Whereas His Excellency the Governor of the State of Victoria, by and with the advice of the Executive Council thereof, has this day consented pursuant to the provisions of section 28 of the *Melbourne and Metropolitan Tramways Act 1958*, to the Melbourne and Metropolitan Tramways Board raising by way of a loan an amount not exceeding Two hundred thousand dollars (\$200,000); And whereas His Excellency the Governor in Council is satisfied that a sufficient proportion of the loan to be so raised will fall due and be repaid in each year during the currency of the proposed loan; Now therefore it is directed, pursuant to the provisions of section 28 (6) of the said Act, that it shall not be necessary to provide a sinking fund in connection with such loan.

And the Honorable Rupert James Hamer, Her Majesty's Treasurer for the State of Victoria, shall give the necessary directions herein accordingly.

TOM FORRISTAL,
Clerk of the Executive Council.

MELBOURNE AND METROPOLITAN TRAMWAYS ACT
1958 (No. 6311).

At the Executive Council Chamber, Melbourne, the
twenty-second day of October, 1974.

PRESENT:

His Excellency the Governor of Victoria.	
Mr. Byrne	Mr. Meagher
Mr. Scanlan	Mr. Dixon.

Whereas His Excellency the Governor of the State of Victoria, by and with the advice of the Executive Council thereof, has this day consented pursuant to the provisions of section 28 of the *Melbourne and Metropolitan Tramways Act 1958*, to the Melbourne and Metropolitan Tramways Board raising by way of a loan an amount not exceeding One million dollars (\$1,000,000); And whereas His Excellency the Governor in Council is satisfied that a sufficient proportion of the loan to be so raised will fall due and be repaid in each year during the currency of the proposed loan; Now therefore it is directed, pursuant to the provisions of section 28 (6) of the said Act, that it shall not be necessary to provide a sinking fund in connection with such loan.

And the Honorable Rupert James Hamer, Her Majesty's Treasurer for the State of Victoria, shall give the necessary directions herein accordingly.

TOM FORRISTAL,
Clerk of the Executive Council.

MELBOURNE UNDERGROUND RAIL LOOP ACT 1970
(No. 8023).

At the Executive Council Chamber, Melbourne, the
twenty-second day of October, 1974.

PRESENT:

His Excellency the Governor of Victoria.	
Mr. Byrne	Mr. Meagher
Mr. Scanlan	Mr. Dixon.

Whereas His Excellency the Governor of the State of Victoria, by and with the advice of the Executive Council thereof has this day consented pursuant to the provisions of the *Melbourne Underground Rail Loop Act 1970* to the Melbourne Underground Rail Loop Authority raising by way of a loan the sum of Two million dollars (\$2,000,000); And whereas His Excellency the Governor in Council is satisfied that a sufficient proportion of the loan to be raised will fall due and be repaid in each year during the currency of the proposed loan; Now therefore it is directed pursuant to the provisions of section 16 (3) of the said Act, that it shall not be necessary to provide a sinking fund in connection with such loan.

And the Honorable Rupert James Hamer, Her Majesty's Treasurer for the State of Victoria, shall give the necessary directions herein accordingly.

TOM FORRISTAL,
Clerk of the Executive Council.

CEMETERIES ACT 1958 (No. 6217), SECTION 36.

At the Executive Council Chamber, Melbourne, the
twenty-second day of October, 1974.

PRESENT:

His Excellency the Governor of Victoria.	
Mr. Byrne	Mr. Meagher
Mr. Scanlan	Mr. Dixon.

Pursuant to section 36 of the *Cemeteries Act 1958*, His Excellency the Governor of the State of Victoria, by and with the advice of the Executive Council of the said State, hereby directs that an amount not exceeding (\$5,000) Five thousand dollars, being part of the balance of funds in the hands of the Trustees of the Boroondara General Cemetery, be expended on the restoration of a portion of the boundary wall.

And the Honorable Alan Henry Scanlan, Her Majesty's Minister of Health for the State of Victoria, shall give the necessary directions herein accordingly.

TOM FORRISTAL,
Clerk of the Executive Council.

ROMSEY WATERWORKS TRUST.

At the Executive Council Chamber, Melbourne, the
twenty-second day of October, 1974.

PRESENT:

His Excellency the Governor of Victoria.	
Mr. Byrne	Mr. Meagher
Mr. Scanlan	Mr. Dixon.

APPROVAL OF PLAN SHOWING SITE OF PIPELINE.

His Excellency the Governor of the State of Victoria, by and with the advice of the Executive Council thereof, doth hereby approve, in accordance with the provisions of the Water Act, the works comprising a pipeline shown on a plan deposited in the office of the State Rivers and Water Supply Commission, Melbourne (Corr. 60/634/104), and of the acquisition of lands necessary for the construction of those works by the Romsey Waterworks Trust.

And the Honorable Frederick James Granter, Her Majesty's Minister of Water supply for the State of Victoria, shall give the necessary directions herein accordingly.

TOM FORRISTAL,
Clerk of the Executive Council.

SUPERANNUATION ACT 1958.

At the Executive Council Chamber, Melbourne,
twenty-second day of October, 1974.

PRESENT:

His Excellency the Governor of Victoria.	
Mr. Byrne	Mr. Meagher
Mr. Scanlan	Mr. Dixon.

Pursuant to the powers conferred by the provisions of paragraph (ja) of subsection (1) of Section 3 of the *Superannuation Act 1958*, His Excellency the Governor of the State of Victoria, by and with the advice of the Executive Council thereof doth by this Order declare that the provisions of the *Superannuation Act* shall apply to Mary Ransome-Smith being an officer of the State College of Victoria at Toorak constituted pursuant to the provisions of the *Education Act 1958*, No. 6240.

And the Honorable Rupert James Hamer, Her Majesty's Treasurer for the State of Victoria, shall give the necessary directions herein accordingly.

TOM FORRISTAL,
Clerk of the Executive Council.

SUPERANNUATION ACT 1958.

At the Executive Council Chamber, Melbourne, the
twenty-second day of October, 1974.

PRESENT:

His Excellency the Governor of Victoria.
Mr. Byrne | Mr. Meagher
Mr. Scanlan | Mr. Dixon.

Pursuant to the powers conferred by the provisions of paragraph (ja) of subsection (1) of Section 3 of the *Superannuation Act 1958*, His Excellency the Governor of the State of Victoria, by and with the advice of the Executive Council thereof doth by this Order declare that the provisions of the *Superannuation Act* shall apply to Kenneth Robert Ray being an officer of the State College of Victoria at Hawthorn constituted pursuant to the provisions of the *Education Act 1958*, No. 6240.

And the Honorable Rupert James Hamer, Her Majesty's Treasurer for the State of Victoria, shall give the necessary directions herein accordingly.

TOM FORRISTAL,
Clerk of the Executive Council.

SUPERANNUATION ACT 1958.

At the Executive Council Chamber, Melbourne, the
twenty-second day of October, 1974.

PRESENT:

His Excellency the Governor of Victoria.
Mr. Byrne | Mr. Meagher
Mr. Scanlan | Mr. Dixon.

Pursuant to the powers conferred by the provisions of paragraph (ja) of subsection (1) of Section 3 of the *Superannuation Act 1958*, His Excellency the Governor of the State of Victoria, by and with the advice of the Executive Council thereof doth by this Order declare that the provisions of the *Superannuation Act* shall apply to Robert Henry Marshall being an officer of the State College of Victoria at Frankston constituted pursuant to the provisions of the *Education Act 1958*, No. 6240.

And the Honorable Rupert James Hamer, Her Majesty's Treasurer for the State of Victoria, shall give the necessary directions herein accordingly.

TOM FORRISTAL,
Clerk of the Executive Council.

SUPERANNUATION ACT 1958.

At the Executive Council Chamber, Melbourne, the
twenty-second day of October, 1974.

PRESENT:

His Excellency the Governor of Victoria.
Mr. Byrne | Mr. Meagher
Mr. Scanlan | Mr. Dixon.

Pursuant to the powers conferred by the provisions of paragraph (ja) of subsection (1) of Section 3 of the *Superannuation Act 1958*, His Excellency the Governor of the State of Victoria, by and with the advice of the Executive Council thereof doth by this Order declare that the provisions of the *Superannuation Act* shall apply to:—
Cole, Gavin Edwin
Crean, David Rutherford
Greenaway, Peter Edward
Rasmussen, Neil Vincent
Robinson, Jennifer Hazell
Wallis, Robert Lindsay
being officers of the State College of Victoria, Rusden, constituted pursuant to the provisions of the *Education Act 1958*, No. 6240.

And the Honorable Rupert James Hamer, Her Majesty's Treasurer for the State of Victoria, shall give the necessary directions herein accordingly.

TOM FORRISTAL,
Clerk of the Executive Council.

SUPERANNUATION ACT 1958.

At the Executive Council Chamber, Melbourne, the
twenty-second day of October, 1974.

PRESENT:

His Excellency the Governor of Victoria.
Mr. Byrne | Mr. Meagher
Mr. Scanlan | Mr. Dixon.

Pursuant to the powers conferred by the provisions of paragraph (ja) of subsection (1) of Section 3 of the *Superannuation Act 1958*, His Excellency the Governor of the State of Victoria, by and with the advice of the Executive Council thereof doth by this Order declare that the provisions of the *Superannuation Act* shall apply to Yvonne Jeanette Thompson being an officer of the State College of Victoria at Melbourne constituted pursuant to the provisions of the *Education Act 1958*, No. 6240.

And the Honorable Rupert James Hamer, Her Majesty's Treasurer for the State of Victoria, shall give the necessary directions herein accordingly.

TOM FORRISTAL,
Clerk of the Executive Council.

LANDS DEPARTMENT NOTICES

APPROACHING LAND SALES.

Sale of Crown Land, in fee-simple, will be held at the under-mentioned places and dates, viz.:—

	No. of Gazette.
Red Cliffs.—Wednesday, 20th November, 1974	100
Swan Hill.—Wednesday, 6th November, 1974	95

COMMITTEE OF MANAGEMENT OF RESERVE.

APPOINTMENT.

Notice is hereby given that, in pursuance of section 221 of the *Land Act 1958*, the following appointment of a Committee of Management of reserved Crown Land has been made by the Minister of Lands:—

THE "COBUNGRA PUBLIC PURPOSES (FOLK MUSEUM) RESERVE".

The Corporation of the Shire of Omeo as the Committee of Management of the land being Crown allotment 1B, section; in the Parish of Cobungra temporarily reserved pursuant to Order in Council dated the 5th September, 1974, as a site for Public Purposes (Folk Museum).—(Corres. No. Rs.9982.)

W. BORTHWICK,
Minister of Lands.

Department of Crown Lands and Survey,
Melbourne, 23rd October, 1974

PROPOSED REVOCATIONS OF TEMPORARY RESERVATIONS OF LANDS BY ORDERS IN COUNCIL.

In pursuance of the provisions of the *Land Act 1958*, notice is hereby given that it is the intention of the Governor in Council to revoke the temporary reservations of lands by Orders in Council hereunder referred to viz.:—

The following Notices were published 1° on the 16th October, 1974, pursuant to Orders of the 8th October, 1974.

LETHBRIDGE.—The temporary reservation by Order in Council of the 8th May, 1973, of 5.236 hectares (12 acres 3 roods 30 perches, more or less) of land in the Township of Lethbridge as a site for Recreation, Convenience and Amusement of the People is about to be revoked.—(L.50(1) (Rs.9737).

MALDON.—The temporary reservation by Order in Council of the 17th June, 1861, of 2023 square metres (2 roods) of land in the Township of Maldon as a site for Powder Magazine is about to be revoked.—(M.449(12) (Rs.9875).

MERBEIN.—The temporary reservation by Order in Council of the 5th September, 1961, of 2175 square metres (2 roods 6 perches) of land in the Parish of Merbein as a site for State School purposes is about to be revoked.—(M.572(*) (Rs.8066).

MIRBOO SOUTH.—The temporary reservation by Order in Council of the 23rd April, 1974, of 110 hectares, more or less, of land in the Parish of Mirboo South as a site for a Public Park is about to be revoked.—(M.517⁽¹⁰⁾) (Rs.9870).

OMEQ.—The temporary reservation by Order in Council of the 4th November, 1889, of certain unappropriated Crown land situate within a distance of 60.35 metres (3 chains) from the banks of the Livingstone Creek for the supply of Gravel and Sand, revoked as to part by various Orders, is about to be revoked so far only as the portion in the Parish of Omeo containing 2.5 hectares, more or less, indicated by hatching on plan hereunder, is concerned.—(O.19⁽¹⁰⁾) (C.86890).

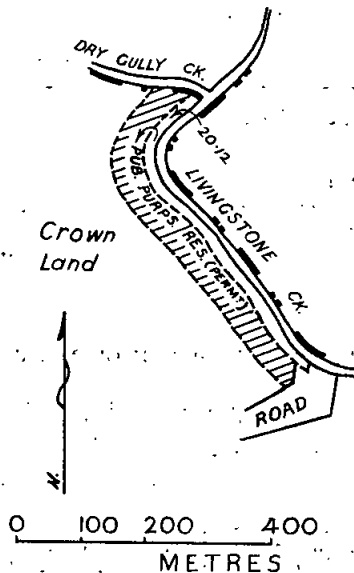

AREA OF HATCHED PORTION
2.5 ha ±

W. BORTHWICK,
Minister of Lands.

PROPOSED REVOCATIONS OF TEMPORARY RESERVATIONS OF LANDS BY ORDERS IN COUNCIL.

In pursuance of the provisions of the Land Act 1958, notice is hereby given that it is the intention of the Governor in Council to revoke the temporary reservations of lands by Orders in Council hereunder referred to viz:—

The following Notices were published 1^o on the 30th October, 1974, pursuant to Orders of the 22nd October, 1974.

WONTHAGGI.—The temporary reservation by Order in Council of the 18th December, 1973, of 3035 square metres of land in the Township of Wonthaggi, as a site for Public purposes (Sewerage Depot) is about to be revoked.—(W.345^(AB)) (Rs.9823).

LILLIMUR.—The temporary reservation by Order in Council of the 19th July, 1960, of 28.73 hectares (71 acres, more or less) of land in the Township of Lillimur, as a site for Water Supply purposes is about to be revoked.—(L.156^(*)) (Rs.2719).

BOROONDARA (HAWTHORN).—The temporary reservation by Order in Council of the 26th January, 1971, of 3642 square metres (3 roods 24 perches) of land in the Parish of Boroondara, as a site for Public purposes (Social Welfare Department purposes) is about to be revoked.—(B.415^(*)) (Rs.9356).

PORTARLINGTON.—The temporary reservation by Order in Council of the 11th April, 1972, of 39.68 hectares (98 acres 9 perches) of land in the Township of Portarlington, as a site for Recreation and Public purposes, is about to be revoked so far only as the portion containing 1417 square metres indicated by hatching on plan hereunder, is concerned.—(P.37^(*)) (Rs.2040).

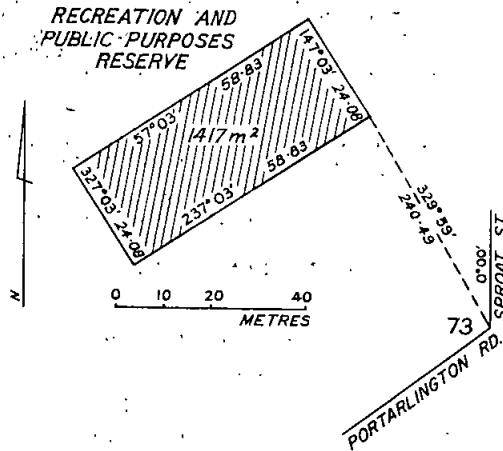

CLEAR LAKE.—The temporary reservation by Order in Council of the 10th October, 1922, of 1.214 hectares (3 acres) of land in the Township of Clear Lake (formerly Township of Jangeowra) as a site for Public Recreation purposes, revoked as to part by Order of the 14th January, 1969, is about to be revoked so far only as the portion containing 55 square metres more or less indicated by hatching on plan hereunder, is concerned.—(C.501⁽¹⁾) (Rs.2630).

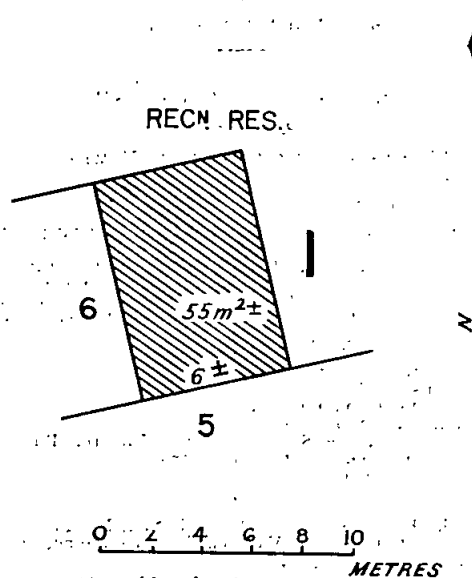

W. BORTHWICK,
Minister of Lands.

Land Act 1958.

LICENCES UNDER THE LAND ACTS DECLARED VOID.

Notice is hereby given that the Licences in the Schedule hereunder have been Declared Void for the reason specified in each case.

District.	Corr. No.	Name of Licensee.	Section of Land Act under which Licensed.	Parish.	Area.	Annual Rental.	Reason.	
Horsham..	5013/138	B. A. McCallum	138	Toolon-grook	Salt licence over White Lake	1500.0.0	20.00	Licence surrendered
Horsham..	5014/138	B. A. McCallum	138	Toolon-grook	Salt licence over Centre Lake	600.0.0	20.00	Licence surrendered
Geelong ..	21/138	C. E. Zanoni	138	Queens-cliff (Tp).	Land nth allot. 3 sec. 3A	0.0.15	2.00	Licence cancelled

Department of Crown Lands and Survey,
Melbourne, 23rd October, 1974.

W. BORTHWICK,
Minister of Lands.

COMMON ABOUT TO BE DIMINISHED.

In pursuance of the provisions contained in the Land Act 1958, notice is hereby given that it is the intention of the Governor in Council to diminish the common herein-after mentioned viz:—

The following Notice was published 1° on the 23rd October, 1974, pursuant to Order of the 15th October, 1974.

The Maldon Shire Common, proclaimed as such by the Governor in Council on the 2nd April, 1889, and altered by Order in Council on the 23rd April, 1912, is about to be diminished by the excision therefrom of the portion in the Township of Maldon containing 1012 square metres, indicated by hatching on plan hereunder.—(Rs.353.)

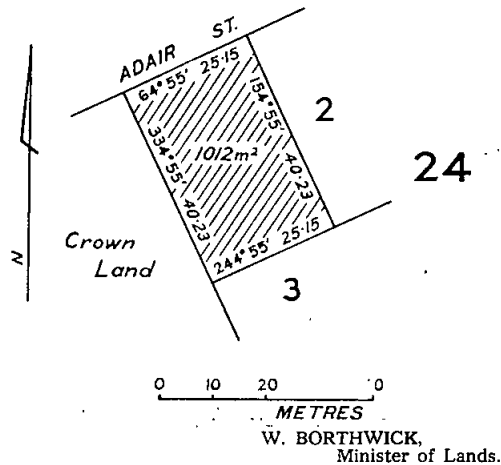

Address tenders to the Minister of Public Works, and endorse the envelope containing the tender "Tender for , closing Tuesday,

Hand delivered tenders to be placed in the Tender Box of the Public Works Department, located on the wall of the centre entrance foyer, Ground Floor, 2 Treasury-place, Melbourne.

No preliminary deposit is required with any tender, but successful tenderer will be required to pay a deposit for any accepted tender of \$10,000 or over.

Wednesday, 6th November, 1974.

Building, Electrical and Mechanical Works.

- BAXTER.—Erection of Art/Craft Room and Library, Pr.S.3023. (W.O., Mornington.)
- CAMPBELLFIELD.—Provision of a General Purpose Room, Art/Craft Room, Library, Staff accommodation improvements and covered play area, Pr.S.143.
- EUROA.—Conversion of Woolclassing Room to Library and construction of Art-Craft Room, H.S. (W.O., Alexandra, Benalla and Shepparton.)
- GLENHUNTLY.—Erection of Library and Staff accommodation improvements, Pr.S.3703.
- MONBULK.—Exterior and interior renovations, Pr.S.3265.
- PARKDALE.—Erection of Science Block, H.S.
- PARKDALE.—Mechanical services—Science Block, H.S.
- PORT FAIRY.—Internal and external repairs and painting, C.S. (W.O., Hamilton and Warrnambool.)
- SHEPPARTON.—Erection of two store rooms, Ambermere Psychiatric Centre. (W.O., Shepparton.)
- SUNVALE.—Erection of Art/Craft Room, Library and Staff and Administration improvements, Pr.S.4818.
- TEMPLESTOWE.—External and internal repairs and painting, H.S.
- TRARALGON.—Internal and external repairs and painting, Pr.S.4699. (W.O., Traralgon.)
- WARRNAMBOOL NORTH.—Administration remodelling and extension, T.S. (W.O., Warrnambool.)
- WARRNAMBOOL NORTH.—Mechanical services, T.S. (W.O., Warrnambool.)

Miscellaneous.

- MELBOURNE.—Supply of one (1) two ton chassis and cabin with container van body, 2 Treasury Place, Public Works Department.

Tuesday, 12th November, 1974.

Building, Electrical and Mechanical Works.

- BALLARAT.—Remodelling of Science Rooms, T.S. (W.O., Ballarat.) (Re-advertised.)
- BALLARAT NORTH.—Additional class-rooms and staff accommodation improvements, T.S. (W.O., Ballarat.) (Re-advertised.) (Amended Specification.)
- COLLINGWOOD.—Internal and external repairs and painting, Pr.S.1895.

TENDERS

PUBLIC WORKS DEPARTMENT

Tenders will be received at Public Works Department, 2 Treasury Place, Melbourne, until TWO p.m. on dates shown and for purposes mentioned hereunder.

Particulars and tender forms available at Contracts Office, Room 27, Ground Floor, No. 2, Treasury Place, and at places indicated in brackets hereunder.

Abbreviations in brackets mean:—W.O.—Inspector of Works Office; P.S.—Police Station; C.S.—Consolidated School; H.E.S.—Higher Elementary School; H.S.—High School; Pr.S.—Primary School; T.S.—Technical School.

Tenders to be submitted on the Department's printed Tender Form and will not be received by telephone. All tenders must be on a "Firm Tender" basis. The lowest or any tender will not necessarily be accepted.

HUNTINGDALE.—Staff accommodation improvements, &c., Pr.S.4716.
 MALVERN.—Mechanical services, Outpatients Clinic, 521 Glenferrie Road.
 SEBASTOPOL.—Electrical services, T.S. (W.O., Ballarat.)
 ST. ALBANS EAST.—External and internal renovations, Pr.S.4741.
 SUNSHINE NORTH.—Internal and external painting and repairs, T.S.
 THOMASTOWN EAST.—Internal and external painting and repairs, Pr.S.4827.
 WATTLE PARK.—Erection of Science Block, H.S.
 WATTLE PARK.—Mechanical services—Science Block, H.S. (Amended Specification.)

Site Works.

ASPENDALE.—Asphalt and concrete pavements, drainage, beautification and associated works, T.S.
 RINGWOOD HEIGHTS.—Asphalt paving, concrete retaining walls, &c., Pr.S.4911.

Miscellaneous.

SOUTH MELBOURNE.—Supply and installation of P.A.B.X. telephone system, Civil Defence, 31 Queens Road.

Furniture and Furnishings.

HAWTHORN.—Supply and fix built in fittings, H.S.
 VARIOUS.—Supply of contract furniture for the period 1st January, 1975, to 31st December, 1975, Schools and other Government Departments. (Investigation & Development Group, Public Works Department, 5 Macarthur Street, Melbourne.)

Tuesday, 19th November, 1974.

Building, Electrical and Mechanical Works.

ALTONA NORTH.—Erection of library complex, T.S. (Re-advertised.) (Amended Specification.)
 CROYDON SOUTH.—Internal and external renovations, Pr.S.4890.
 EAST BRUNSWICK.—Internal and external repairs and painting, Pr.S.3179.
 ELWOOD.—External renovations, H.S. (Re-advertised.)
 HEIDELBERG HEIGHTS.—External renovations, Pr.S.4774.
 JANEFIELD.—Erection of annexe to day rooms in Wards MF. 2, 3 and 4, Training Centre.
 KERANG.—Erection of library complex, H.S. (W.O., Mildura and Swan Hill.)
 KERANG.—Electrical installation, library complex, H.S. (W.O., Swan Hill.)
 KERANG.—Mechanical services, library complex, H.S. (W.O., Mildura and Swan Hill.)
 LORNE.—Internal and external renovations, H.E.S. (W.O., Geelong.)
 LYNDALE.—Erection of Library, H.S. (Re-advertised.) (Amended Specification.)
 LYNDALE.—Electrical services, Library, H.S. (Re-advertised.) (Amended Specification.)
 LYNDALE.—Mechanical services, Library, H.S. (Re-advertised.) (Amended Specification.)
 MENTONE.—Re-sheeting of roof, G.H.S.
 MOORABBIN HEIGHTS.—Internal and external repairs and painting, Pr.S.4837.
 NORTHCOTE.—Mechanical services, T.S. (Re-advertised.) (Amended Specification.)
 OBERON.—Erection of library complex, H.S. (W.O., Geelong.) (Re-advertised.) (Amended Specification.)
 OBERON.—Electrical installation, library complex, H.S. (W.O., Geelong.) (Re-advertised.) (Amended Specification.)
 OBERON.—Heating and hot water service, library complex, H.S. (W.O., Geelong.) (Re-advertised.) (Amended Specification.)
 RESERVOIR EAST.—Staff accommodation improvements, Pr.S.4686.

ST. ALBANS.—External repairs and painting, H.S.
 SWAN HILL.—Erection of library complex, H.S. (W.O., Mildura and Swan Hill.)
 SWAN HILL.—Electrical services, library complex, H.S. (W.O., Mildura and Swan Hill.)
 SWAN HILL.—Mechanical services, library complex, H.S. (W.O., Mildura and Swan Hill.)
 WILLIAMSTOWN.—Internal and external repairs and painting, H.S.
 WARRNAMBOOL NORTH.—Remodelling, plumbing and sheetmetal workshop, T.S. (W.O., Camperdown and Warrnambool.)

Miscellaneous.

PORT MELBOURNE.—Supply of three (3) only portable electric welders, Plant Depot, Salmon Street, Public Works Department.

ROBERTS DUNSTAN,
 Minister for Public Works.

Public Works Department,
 Melbourne, 28th October, 1974.

PUBLIC SERVICE NOTICES

No. 185.

Public Service Act 1958, Section 39.

REGULATIONS.—PART IV.—SALARIES AND INCREMENTS.

The Public Service Board, in pursuance of the powers conferred by the *Public Service Act 1958*, hereby amends its Regulations as shown below :—

FOURTH SCHEDULE.
ADMINISTRATIVE DIVISION.

Amount of Salary Assigned to Offices in Class "A1".

Office.	Yearly Rate of Salary.
	\$
CHIEF SECRETARY'S DEPARTMENT.	
<i>Add—</i> Officer in Charge, Electronic Data Processing Section, State Insurance Offices	15,669

A. J. A. GARDNER, Chairman.
 L. R. BROWN, Secretary.

Office of the Public Service Board,
 Melbourne, 18th October, 1974.

No. 186.

Public Service Act 1958, Section 39.

REGULATIONS.—PART IV.—SALARIES AND INCREMENTS.

The Public Service Board, in pursuance of the powers conferred by the *Public Service Act 1958*, hereby amends its Regulations as shown below :—

FOURTH SCHEDULE.
ADMINISTRATIVE DIVISION.

Amount of Salary Assigned to Offices in Class "A1".

Office.	Yearly Rate of Salary.
	\$
TREASURY.	
<i>Add—</i> Assistant Commissioner, Land Tax, Probate and Gift Duties	15,669

A. J. A. GARDNER, Chairman.
 L. R. BROWN, Secretary.

Office of the Public Service Board,
 Melbourne, 18th October, 1974.

No. 183

Public Service Act 1958, Section 50.

REGULATIONS.—PART IV.—SALARIES AND INCREMENTS.

The Public Service Board, in pursuance of the powers conferred by the Public Service Act 1958, hereby amends its Regulations as shown below :—

FIFTH SCHEDULE.
TEMPORARY EMPLOYEES.
DEPARTMENT OF HEALTH.
MENTAL HYGIENE.

Designations of Positions and Rates of Salaries.

Designation of Position.	Designation Code.	Yearly Rate of Salary.		Salary/Increment Code.
		Minimum.	Maximum.	
		\$	\$	
<i>Delete the existing yearly rates of salary for the undermentioned position and insert the rates shown hereunder in lieu thereof :—</i>				
Fireman	6,141	6,474	AA

This Regulation shall have effect from 13th October, 1974.

A. J. A. GARDNER, Chairman.
L. R. BROWN, Secretary.

Office of the Public Service Board,
Melbourne, 21st October, 1974.

No. 184.

Public Service Act 1958, Section 50.

REGULATIONS.—PART IV.—SALARIES AND INCREMENTS.

The Public Service Board, in pursuance of the powers conferred by the Public Service Act 1958, hereby amends its Regulations as shown below :—

SIXTH SCHEDULE.
TEMPORARY EMPLOYEES.

Designations of Positions and Rates of Salaries.

Department and Designation of Position.	Designation Code.	Yearly Rate of Salary.		Salary/Increment Code.
		Minimum.	Maximum.	
		\$	\$	
<i>Delete the existing yearly rates of salary for the undermentioned positions and insert the rates shown hereunder in lieu thereof :—</i>				
GENERAL.				
Fireman	6,141	6,474	AA
DEPARTMENT OF HEALTH.				
Tuberculosis.	GY	
State Sanatoria.	GY	
Boiler Attendant	6,141	6,474	AA
MINES DEPARTMENT.				
Bulldozer Operator (70-130 brake horsepower)	7,085	7,444	AA
STATE FORESTS, DEPARTMENT.				
Central Workshop.	
Mobile Crane Driver	5,999	6,332	AA

This Regulation shall have effect from 13th October, 1974.

A. J. A. GARDNER, Chairman.
L. R. BROWN, Secretary.

Office of the Public Service Board,
Melbourne, 14th October, 1974.

No. 187.

Public Service Act 1958, Section 50.

REGULATIONS.—PART IV.—SALARIES AND INCREMENTS.

The Public Service Board, in pursuance of the powers conferred by the Public Service Act 1958, hereby amends its Regulations as shown below :—

FIFTH SCHEDULE.
TEMPORARY EMPLOYEES.
DEPARTMENT OF HEALTH.
MENTAL HYGIENE.

Designations of Positions and Rates of Salaries.

Designation of Position.	Designation Code.	Yearly Rate of Salary.		Salary/Increment Code.
		Minimum.	Maximum.	
		\$	\$	
<i>Delete the existing yearly rates of salary for the following position and insert the rates shown hereunder in lieu thereof :—</i>				
Mortuary Attendant	6,498	6,805	AA

This Regulation shall have effect from 20th October, 1974.

A. J. A. GARDNER, Chairman.
L. R. BROWN, Secretary.

Office of the Public Service Board,
Melbourne, 21st October, 1974.

No. 188.

Public Service Act 1958, Section 50.

REGULATIONS.—PART IV.—SALARIES AND INCREMENTS.

The Public Service Board, in pursuance of the powers conferred by the Public Service Act 1958, hereby amends its Regulations as shown below :—

SECOND SCHEDULE.
TECHNICAL AND GENERAL DIVISION.
Grades and Salary Scales.

JUNIOR GRADES (NOT CLASSIFIED IN EIGHTH SCHEDULE).

Delete the existing yearly rates of salary shown for the undermentioned grades and insert the following rates in lieu thereof—

Grade.	Yearly Rate of Salary at Each Age in Years.				
	Under 17.	17.	18.	19.	20.
	\$	\$	\$	\$	\$
J-38	3,225	3,788	4,436	5,061	5,792
J-39	3,296	3,874	4,536	5,175	5,920

SIXTH SCHEDULE.

TEMPORARY EMPLOYEES.

Designations of Positions and Rates of Salaries.

Department and Designation of Position.	Designation Code.	Yearly Rate of Salary.		Salary/Increment Code.
		Minimum.	Maximum.	
		\$	\$	
<i>Delete the existing yearly rates of salary for the following position and insert the rates shown hereunder in lieu thereof :—</i>				
LAW DEPARTMENT.				
Mortuary Attendant, Assistant, Morgue—Adult	6,355	6,663	AA

This Regulation shall have effect from 20th October, 1974.

A. J. A. GARDNER, Chairman.
L. R. BROWN, Secretary.

Office of the Public Service Board,
Melbourne, 18th October, 1974.

PRIVATE ADVERTISEMENTS**CITY OF ALTONA.**

LOAN No. 97.

Notice of Intention to Borrow the Sum of \$100,000 for Permanent Works and Undertakings.

Notice is hereby given that the Council of the City of Altona proposes to borrow the principal sum of one hundred thousand dollars, secured by a charge over the general rates of the municipality, such sum to be raised by the grant of a mortgage in accordance with the provisions of the *Local Government Act 1958*.

1. The maximum rate of interest to be paid is 9.85 per centum per annum.

2. The purposes for which the loan is to be applied are:—

(a) Drainage Works—Altona East	\$63,000
(b) Paw Paw Road Construction	8,000
(c) Paw Paw Road Kerb and Channel	500
(d) Pavilion Extension A. W. Bond Reserve	3,500
(e) Car Parking Facilities—Railway Street North and Galvin Railway Station area	3,000
(f) Kororoit Creek Road Drainage	16,000
(g) Kororoit Creek Road Kerb and Channel	4,000
(h) Construction of En-Tout-Cas Courts, including fencing and drainage, J. K. Grant Reserve	2,000
	\$100,000

3. The period of the loan shall be fifteen years.

4. The moneys borrowed shall be repayable by providing out of the municipal fund 30 equal half yearly instalments of \$6,449.63 each including principal and interest, on the first day of June and the first day of December in each year during the currency of the loan. The first instalment shall be payable on the 1st day of June, 1975.

5. Such moneys shall be repayable at the office of the Commonwealth Savings Bank of Australia, Melbourne, or such other place or places which the bank may from time to time require.

The plans, specifications and estimate of the cost of the proposed works and a statement showing the proposed expenditure of the moneys to be borrowed are open for inspection at the Civic Offices, 115 Civic Parade, Altona.

1542

S. FELL, Town Clerk.

CITY OF BALLAARAT.

LOAN No. 44.

Notice of Intention to Borrow the Sum of \$100,000 for Permanent Works and Undertakings.

Notice is hereby given that the Council of the City of Ballaarat proposes to borrow the principal sum of One Hundred Thousand dollars (\$100,000), secured by a charge over the general rates of the municipality, such sum to be raised by the grant of a mortgage, in accordance with the provisions of the *Local Government Act 1958*.

1. The maximum rate of interest that may be paid is 9.85 per centum per annum.

2. The purpose for which the loan is to be applied is:

Road Construction \$100,000.

3. The period of the loan shall be ten years.

4. The money borrowed shall be repayable by providing out of the municipal fund, twenty half-yearly instalments of \$7,973.31 each, including principal and interest, on the 20th day of June, and the 20th day of December during the currency of the loan. The first instalment shall be payable on the 20th day of June 1975.

Such moneys are to be repayable at the office of the Commonwealth Savings Bank of Australia in Melbourne.

The plans and specifications and the estimate of the cost of the works and a statement showing the proposed expenditure of the moneys to be borrowed, are open for inspection at the Town Hall, Ballaarat.

Dated 25th October, 1974.

1546

F. J. ROGERS, Town Clerk.

CITY OF BALLAARAT.

LOAN No. 45.

Notice of Intention to Borrow the Sum of \$50,000 for Permanent Works and Undertakings.

Notice is hereby given that the Council of the City of Ballaarat proposes to borrow the principal sum of Fifty thousand dollars (\$50,000), secured by a charge over the

general rates of the municipality, such sum to be raised by the grant of a mortgage, in accordance with the provisions of the *Local Government Act 1958*.

1. The maximum rate of interest that may be paid is 9.85 per centum per annum.

2. The purpose for which the loan is to be applied is: Town Hall Redevelopment.

3. The period of the loan shall be twenty years.

4. The money borrowed shall be repayable by providing out of the municipal fund, 40 half-yearly instalments of \$2,884.04 each, including principal and interest, on the 20th day of June, and the 20th day of December, during the currency of the loan. The first instalment shall be payable on the 20th day of June 1975.

Such moneys are to be repayable at the office of the Commonwealth Savings Bank of Australia in Melbourne.

The plans and specifications and the estimate of the cost of the works and a statement showing the proposed expenditure of the moneys to be borrowed, are open for inspection at the Town Hall, Ballaarat.

Dated 25th October, 1974.

1547

F. J. ROGERS, Town Clerk.

CITY OF BALLAARAT.

LOAN No. 43.

Notice of Intention to Borrow the Sum of \$50,000 for Permanent Works and Undertakings.

Notice is hereby given that the Council of the City of Ballaarat proposes to borrow the principal sum of Fifty thousand dollars (\$50,000), secured by a charge over the general rates of the municipality, such sum to be raised by the grant of a mortgage, in accordance with the provisions of the *Local Government Act 1958*.

1. The maximum rate of interest that may be paid is 9.85 per centum per annum.

2. The purpose for which the loan is to be applied is: Drainage Works—\$50,000.

3. The period of the loan shall be ten years.

4. The money borrowed shall be repayable by providing out of the municipal fund, twenty half-yearly instalments of \$3,986.65 each, including principal and interest, on the 20th day of June, and the 20th day of December, during the currency of the loan. The first instalment shall be payable on the 20th day of June, 1975.

Such moneys are to be repayable at the office of the Commonwealth Savings Bank of Australia in Melbourne.

The plans and specifications and the estimate of the cost of the works and a statement showing the proposed expenditure of the moneys to be borrowed, are open for inspection at the Town Hall, Ballaarat.

Dated 25th October, 1974.

1545

F. J. ROGERS, Town Clerk.

CITY OF HEIDELBERG.

LOAN No. 177.

Notice of Intention to Borrow the Sum of \$100,000 for Permanent Works and Undertakings.

Notice is hereby given that the Council of the City of Heidelberg proposes to borrow the principal sum of One hundred thousand dollars (\$100,000) secured by a charge over the general rates of the municipality, such sum to be raised by the grant of a mortgage in accordance with the provisions of the *Local Government Act 1958*.

1. The maximum rate of interest that may be paid is 9.85 per cent. per annum.

2. The purpose for which the loan is to be applied is:—

Construction of Garbage Transfer Station (part cost).

3. The period of the loan shall be Fifteen (15) years.

4. The moneys borrowed shall be repayable by providing out of the municipal fund Thirty half yearly instalments of approximately \$6,449.64 each including principal and interest on the first day of February and the first day of August during the currency of the loan. The first instalment shall be payable on the first day of August, 1975.

5. Such moneys shall be repayable to The Commissioners of The State Savings Bank of Victoria at the office of the said Commissioners, Corner Elizabeth and Bourke Streets, Melbourne.

The plans and specifications and the estimate of the cost of the proposed works and a statement showing the proposed expenditure of the moneys to be borrowed are open for inspection at the office of the Council of the City of Heidelberg at Town Hall, Ivanhoe, Vic. 3079.

Dated 30th October, 1974.

1544

ALAN JONES, Town Clerk.

Town and Country Planning Act 1961 (Twelfth Schedule).
CITY OF KNOX PLANNING SCHEME 1965.

NOTICE THAT A PLANNING SCHEME HAS BEEN PREPARED AND IS AVAILABLE FOR INSPECTION.

Amendment No. 143, 1974.

Notice is hereby given that the Council of the City of Knox in pursuance of its powers under the Town and Country Planning Act 1961, has prepared a Planning Scheme to amend the provisions of the Planning Scheme Ordinance in respect of the Residential A and Residential Medium Zone, and Clause 17 pertaining to subdivisional requirements.

A copy of the Scheme has been deposited at the Office of the City of Knox, Civic Centre, 511 Burwood Highway, Knoxfield, and at the Office of the Town and Country Planning Board, 5th Floor, 235 Queen Street, Melbourne, and will be open for inspection during office hours by any person free of charge.

Any persons affected by the Planning Scheme are required to set forth in writing all objections they may have, addressed to the Town Clerk, City of Knox, Civic Centre, Knoxfield, on or before the 30th day of November 1974, and to state whether they wish to be heard in respect of their objections.

1496

N. G. HAYNES, Town Clerk.

CITY OF MELBOURNE.

By-Law No. 503.

A By-law of the City of Melbourne made under section 12 of the Melbourne Wholesale Fruit and Vegetable Market Act 1968 and numbered 503 to further amend By-law 477.*

In pursuance of the powers conferred by the above-mentioned enactment and of every other Act or power enabling it in that behalf, the Council of the City of Melbourne ORDERS as follows:

1. (1) This By-law may be cited as the *City of Melbourne Wholesale Fruit and Vegetable Market (Amendment) By-law 1974*.

(2) In this By-law, the *City of Melbourne Wholesale Fruit and Vegetable Market By-law 1969*, By-law No. 477, as amended by By-laws Nos. 478, 480, 485, 486, 490, and 496, is referred to as the Principal By-law.

2. Clause 2 of the Principal By-law is amended in sub-clause (1)—

(a) in the definition of "stand"—

- (i) by substituting for the words "a carrier agent or a carrier merchant" the words "or a carrier agent";
- (ii) by substituting for the expression "9 feet 6 inches" the expression "2.896 metres";
- (iii) by substituting for the expression "11 feet" the expression "3.353 metres"; and
- (iv) by substituting for the expression "20 feet" the expression "6.096 metres";

(b) in the definition of "store (type A)"—

- (i) by substituting for the expression "10 feet" the expression "3.048 metres"; and
- (ii) by substituting for the expression "55 feet" the expression "16.764 metres"; and

(c) in the definition of "store (type B)"—

- (i) by substituting for the expression "15 feet" the expression "4.572 metres"; and
- (ii) by substituting for the expression "20 feet" the expression "6.096 metres";

3. Clause 12A of the Principal By-law is amended in sub-clause (2) by substituting for expression "4 a.m." (where twice occurring) the expression "5 a.m."

4. Clause 38 of the Principal By-law is amended—

- (a) in paragraph (a) by substituting for the words "five miles" the words "eight kilometres"; and
- (b) in paragraph (b) by substituting for the words "fifteen miles" the expression "24 kilometres".

5. The First Schedule to the Principal By-law is amended—

- (a) in clause 1 in the definition of "carrier agent", "carrier merchant", and "grower" by repealing the expression "carrier merchant"; and

(b) in clause 2—

- (i) by repealing the expression "carrier merchants from outside that area," (where twice occurring);
- (ii) by repealing the expression "carrier merchants," (wherever occurring);
- (iii) by substituting for the expression "3 a.m." the expression "4.30 a.m.";
- (iv) by substituting for the expression "4 a.m." (wherever occurring) the expression "5 a.m.";
- (v) by substituting for the expression "4.30 a.m." (wherever occurring) the expression "5.30 a.m."; and
- (vi) by substituting for the expression "5 a.m." (wherever occurring) the expression "6 a.m."

6. Schedule 1A to the Principal By-law is amended—

(a) in clause 1 in the definition of "carrier agent", "carrier merchant", and "grower" by repealing the expression "carrier merchant"; and

(b) in clause 2—

- (i) by substituting for the expression "4 a.m." the expression "5 a.m.";
- (ii) by repealing the expression "carrier merchants";
- (iii) by substituting for the expression "50 feet" (where twice occurring) the expression "15 metres"; and
- (iv) by substituting for the expression "16 feet" (where twice occurring) the words "five metres".

7. The Second Schedule to the Principal By-law is amended—

(a) in clause 1 by substituting for the words "carrier agents and carrier merchants" the words "and carrier agents";

(b) in clause 2—

- (i) in the definition of "carrier agent" and "carrier merchant" by substituting for the expression "and 'carrier merchant' each means a person (whether or not a grower)" the words "means a grower";
- (ii) in each of the definitions of "1st right", "2nd right", and "3rd right" by substituting for the words "a carrier agent or a carrier merchant" the words "or a carrier agent";

(c) in clause 8 in sub-clause (2), by repealing the words "or carrier merchants"; and

(d) in Part II by repealing clause 15A.

8. The Third Schedule to the Principal By-law is amended by repealing the words "or a carrier merchant" (where thrice occurring).

9. The Fifth Schedule to the Principal By-law is repealed and the following schedule is substituted for it:

FIFTH SCHEDULE.

[Clause 2 (1)—definitions of "Market Concourse" and "Transport Stand", Clause 9 (2)—Reference to "Cafe", and Clause (2) (a) and (c) (iii) of Schedule 1A—definitions of "Area A1", "Area A2", and "Area B".]

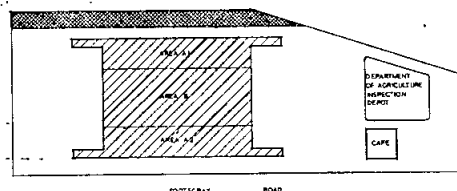

MELBOURNE WHOLESALE FRUIT AND VEGETABLE MARKET

Resolution for passing this By-law agreed to by the Council of the City of Melbourne, the 23rd day of September, 1974, and confirmed the 14th day of October, 1974.

(SEAL)

RONALD WALKER, Lord Mayor.
F. H. ROGAN, Town Clerk.

Approved by the Governor in the Council, the 30th day of October, 1974, so far as the provisions for which approval is required pursuant to the Melbourne Wholesale Fruit and Vegetable Market Act 1968.—TOM FORRISTAL, Clerk of the Executive Council.

*By-law No. 477, as amended by By-laws Nos. 478, 480, 485, 486, 490, and 496.
(74/3634/40)

1530

CITY OF MOE.

ORDER OF COUNCIL THAT ROAD BE DECLARED A PUBLIC HIGHWAY.

PURSUANT to the provisions of Sections 522 and 526 of the Local Government Act 1958, the Council of the City of Moe hereby directs that the land in the Parish of Narracan indicated by hatching endorsed on the diagram hereunder which has been taken, purchased or acquired by it for the deviation of Thompson's Road, shall become a Public Highway on and after the date of publication of this Order in the Government Gazette.

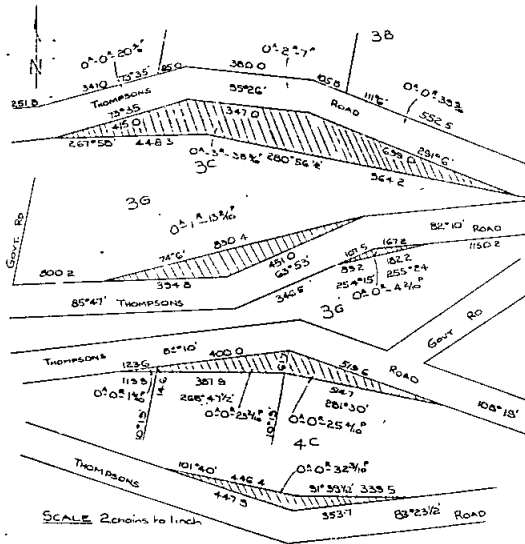

The common seal of the Mayor, Councillors and Citizens of the City of Moe was hereunto affixed this 15th day of October, 1974, in the presence of—

J. CONNAGHAN, Mayor.
 (SEAL) W. BARTHOLOMEUSZ, Councillor.
 R. J. PUGSLEY, Town Clerk.

1543

CITY OF CROYDON.

LOAN No. 129.

Notice of Intention to Borrow the Sum of \$60,000 for Permanent Works and Undertakings.

Notice is hereby given that the Council of the City of Croydon proposes to borrow the principal sum of Sixty thousand dollars (\$60,000) secured by a charge over the general rates of the municipality, such sum to be raised by the grant of a mortgage in accordance with the provisions of the Local Government Act 1958.

- The maximum rate of interest that may be paid is 9.85 per centum per annum.
- The purpose for which the loan is to be applied is:—

(1) Road Reconstruction—Donald Street including outfall drainage to Dorset Road (part)	\$10,000
(2) Road Reconstruction—Jackson Street, east of Windsor Road	\$50,000
	\$60,000
- The period of the loan shall be 10 years.
- The moneys borrowed shall be repayable by twenty half-yearly instalments of approximately \$4,783.98 including principal and interest on the 1st day of January and the 1st day of July during the currency of the loan. The first instalment shall be repayable on the 1st day of July, 1975.
- Such moneys shall be repayable at the Australia and New Zealand Savings Bank Limited, 394-396 Collins Street, Melbourne.

The plans and specifications and the estimate of the cost of the proposed works and a statement showing the proposed expenditure of the moneys to be borrowed are open for inspection at the office of the Council of the City of Croydon at City Offices, Foch Avenue, Croydon.

R. BURTON, Town Clerk.

1501

CITY OF HAWTHORN.

LOAN No. 49.

Notice of Intention to Borrow the Sum of \$130,000 for Permanent Works and Undertakings.

NOTICE is hereby given that the Council of the City of Hawthorn proposes to borrow the sum of One hundred and thirty thousand dollars secured by a charge over the general rates of the municipality such sum to be raised by the grant of a mortgage, in accordance with the provisions of the Local Government Act.

- The amount of the principal moneys which it is proposed to borrow is \$130,000.
- The maximum rate of interest that may be paid is 9.85 per centum per annum.
- The period of the loan shall be fifteen years.
- The moneys borrowed shall be repayable by providing out of the municipal fund 30 half yearly instalments of \$8384.53 each, including principal and interest on the 1st day of August and the 1st day of February during the currency of the loan. The first instalment shall be payable on the 1st day of August, 1975.
- Such moneys shall be repayable at the A.N.Z. Savings Bank Ltd. Melbourne or at the Council's bankers for the time being in Hawthorn.
- The purpose for which the loan is to be applied is the construction of additions to municipal offices and provision of furniture and fittings therein.

The plans and specification and the estimate of the cost of the proposed works and a statement showing the proposed expenditure of the moneys to be borrowed are open for inspection at the Municipal Offices, Town Hall, Hawthorn, during office hours.

Dated this 25th day of October, 1974.

J. R. JOHNSON, Town Clerk.

1499

TOWN OF STAWELL.

BY-LAW No. 67.

Notice is hereby given that the Council of the Town of Stawell has made a By-law for prohibiting the use of motorised vehicles for recreation purposes on certain land.

The resolution for passing the By-law was agreed to by Council on September 11th, 1974 and confirmed by Council on October 16th, 1974.

Copies of the By-law are open for inspection free of charge during office hours at the office of the Council, Main Street, Stawell.

D. H. HUTTON, Town Clerk.

1523

BOROUGH OF SEBASTOPOL.

LOAN No. 9.

Notice of Intention to Borrow the Sum of \$10,000 for Permanent Works and Undertakings.

Notice is hereby given that the Council of the Borough of Sebastopol proposes to borrow the principal sum of Ten Thousand Dollars (\$10,000), secured by a charge over the general rates of the municipality, such sum to be raised by the grant of a mortgage in accordance with the provisions of the Local Government Act 1958.

- The Maximum rate of interest that may be paid is 9.85 per centum per annum.
- The purpose for which the loan is to be applied is:—
Concrete Paving.
- The period of the loan shall be 15 years.
- The money borrowed shall be repayable by providing out of the municipal fund 30 half-yearly instalments of \$644.96 each, including principal and interest, on the 15th day of June and the 15th day of December, during the currency of the loan. The first instalment shall be payable on the 15th day of June, 1975.

Such moneys are to be repayable at the office at the office of the National Bank Savings Bank Limited, 271-285 Collins Street, Melbourne.

The plans and specifications and estimate of the cost of the proposed works and a statement showing the proposed expenditure of the moneys to be borrowed are open for inspection at the office of the Council, Town Hall, Sebastopol.

B. BORCHERS, Acting Town Clerk.

1495

SHIRE OF BALLARAT.

LOAN No. 50.

Notice of Intention to Borrow the Sum of \$50,000 for Permanent Works and Undertakings.

Notice is hereby given that the Council of the Shire of Ballarat proposes to borrow the principal sum of \$50,000 secured by a charge over the general rates of the municipality, such sum to be raised by a grant of a mortgage in accordance with the provisions of the *Local Government Act 1958*.

1. The maximum rate of interest that may be paid is 9.85 per cent. per annum.
2. The purpose for which the loan is to be applied is—
 - (a) Construction of Badminton Stadium, Hollioake Park Sporting Complex, Wendouree.
 - (b) Purchase of land and construction works, Hollioake Park Sporting Complex, Wendouree.
3. The period of the loan shall be twenty (20) years.
4. The moneys borrowed shall be repayable by providing out of the municipal fund forty (40) half-yearly instalments of approximately \$2,884.05 each including principal and interest on the first day of August and the first day of February during the currency of the loan. The first instalment shall be payable on the first day of August 1975.

5. Such moneys shall be repayable to The Commissioners of the State Savings Bank of Victoria at the office of the said Commissioners, Corner Elizabeth and Bourke Streets, Melbourne.

The plans and specifications and the estimate of the cost of the proposed works and a statement showing the proposed expenditure of the moneys to be borrowed are open for inspection at the office of the Council of the Shire of Ballarat, Shire Offices, Gillies Street, Wendouree.
25th October, 1974.

1559 JAMES H. MITCHELL, Shire Secretary.

SHIRE OF BRIGHT.

PROSECUTING OFFICER.

Notice is hereby given that Sergeant Allan Young, No. 10971, has been appointed Prosecuting Officer to the Shire of Bright, in place of Sergeant Leslie Parker, No. 12398.

1500 T. J. RITSON, Shire Secretary.

SHIRE OF BRIGHT.

LOAN No. 56.

Notice of Intention to Borrow the Sum of \$32,000 for Permanent Works and Undertakings.

Notice is hereby given that the Council of the Shire of Bright proposes to borrow the principal sum of \$32,000 secured by a charge over the general rates of the municipality, such sum to be raised by the grant of a mortgage in accordance with the provisions of the *Local Government Act 1958*.

1. The maximum rate of interest that may be paid is 9.85 per cent. per annum.
2. The purpose for which the loan is to be applied is
Construction of Roads \$32,000
3. The period of the loan shall be 20 years.
4. The moneys borrowed shall be repayable by providing out of the municipal fund half-yearly instalments of approximately \$1,845 each including principal and interest on the first day of June and the first day of December during the currency of the loan. The first instalment shall be payable on the first day of June, 1975.

5. Such moneys shall be repayable to The Commissioners of The State Savings Bank of Victoria at the office of the said Commissioners, Corner Elizabeth and Bourke Streets, Melbourne.

The plans and specifications and the estimate of the cost of the proposed works and a statement showing the proposed expenditure of the moneys to be borrowed are open for inspection at the office of the Council of the Shire of Bright, at Ireland Street, Bright.

1594 T. J. RITSON, Shire Secretary.

SHIRE OF DIAMOND VALLEY.

LOAN No. 46.

Notice of Intention to Borrow the Sum of \$200,000 for Permanent Works and Undertakings.

Notice is hereby given that the Council of the Shire of Diamond Valley proposes to borrow the principal sum of \$200,000 secured by a charge over the general rates of the

municipality, such sum to be raised by the grant of a mortgage in accordance with the provisions of the *Local Government Act 1958*.

1. The maximum rate of interest that may be paid is 9.85% per annum.

2. The purposes for which the loan is to be applied are—

Buildings—

Civic Centre sporting complex (pt. prov.)	\$29,500	
Coniston St. tennis pavilion (pt. prov.)	9,000	38,500

Public Works—

Country Roads Board works—Council's proportion (pt. prov.)	48,000	
Private St. construction—Council's proportion (pt. prov.)	50,000	98,000

Traffic control—

Traffic lights Greensborough Rd./Grimshaw St.	15,000	
Traffic lights Plenty Rd./Grimshaw St.	17,000	
Pedestrian lights Main St. Greensborough	6,000	
Pedestrian lights Greenwood Drive	3,500	41,500

Land purchases—

P.O.S. repayments M.M.B.W. (pt. prov.)	22,000	
		\$200,000

3. The period of the loan shall be 15 years.

4. The moneys borrowed shall be repayable by providing out of the municipal fund half-yearly instalments of approximately \$12,899.27 each including principal and interest on the first day of February and the first day of August during the currency of the loan. The first instalment shall be payable on the first day of August, 1975.

5. Such moneys shall be repayable to The Commissioners of the State Savings Bank of Victoria at the office of the said Commissioners, Corner Elizabeth and Bourke Streets, Melbourne.

The plans and specifications and the estimate of the cost of the proposed works and a statement showing the proposed expenditure of the moneys to be borrowed are open for inspection at the office of the Council of the Shire of Diamond Valley, Civic Drive, Greensborough.

1597 W. M. BALKIN, Acting Shire Secretary.

SHIRE OF DONALD.

NOTICE OF CHANGING NAME OF A STREET.

In accordance with the provisions of the *Local Government Act 1958*, the Council of the Shire of Donald hereby gives notice that the said Council has made an order changing the name of the following street.

OLD NAME—WILLOW STREET

NEW NAME—WILLOW COURT

LOCATION—OFF CAMP STREET, DONALD TOWNSHIP.

1548 T. H. BOWLES, Shire Secretary.

SHIRE OF HASTINGS.

LOAN No. 52.

Notice of Intention to Borrow the Sum of \$45,000 for Permanent Works and Undertakings.

Notice is hereby given that the Council of the SHIRE of HASTINGS proposes to borrow the principal sum of FORTY-FIVE THOUSAND DOLLARS, secured by a charge over the general rates of the municipality, such sum to be raised by the grant of a mortgage in accordance with the provisions of the *Local Government Act 1958*.

1. The maximum rate of interest that may be paid is 9.85 per cent. per annum.

2. The purpose for which the loan is to be applied is:
Acquisition of land for Commercial off-street Car Parking.

3. The period of the loan shall be 20 years.

4. The moneys borrowed shall be repayable by providing out of the municipal fund half-yearly instalments of approximately \$2,595.64 each including principal and interest on the first day of June and the first day of December during the currency of the loan. The first instalment shall be payable on the first day of June, 1975.

5. Such moneys shall be repayable to The Commissioners of the State Savings Bank of Victoria at the office of the said Commissioners, corner Elizabeth and Bourke Streets, Melbourne.

The plans and specifications and the estimate of the cost of the proposed works and a statement showing the proposed expenditure of the moneys to be borrowed are open for inspection at the office of the Council of the Shire of Hastings, at Marine Parade, Hastings.

Dated 21st October, 1974.

1497 L. A. WALKER, Shire Secretary.

SHIRE OF HASTINGS.

LOAN No. 53.

Notice of Intention to Borrow the Sum of \$70,000 for Permanent Works and Undertakings.

Notice is hereby given that the Council of the Shire of Hastings proposes to borrow the principal sum of Seventy thousand dollars secured by a charge over the general rates of the municipality, such sum to be raised by the grant of a mortgage in accordance with the provisions of the *Local Government Act 1958*.

1. The maximum rate of interest that may be paid is 9.85 per cent. per annum.

2. The purpose for which the loan is to be applied is

Reconstruction of Grants Road	\$10,000
Balnarring Kindergarten	25,000
Acquisition land off street car park, Hastings	18,500
Acquisition land, parking area, Balnarring	11,250
Acquisition land, public purposes, Bittern	5,250

3. The period of the loan shall be 15 years.

4. The moneys borrowed shall be repayable by providing out of the municipal fund half-yearly instalments of approximately \$4,514.74 each including principal and interest on the first day of June and the first day of December during the currency of the loan. The first instalment shall be payable on the first day of June 1975.

5. Such moneys shall be repayable to Commonwealth Savings Bank of Australia, at their head office, Melbourne, Victoria.

The plans and specifications and the estimate of the cost of the proposed works and a statement showing the proposed expenditure of the moneys to be borrowed are open for inspection at the office of the Council of the Shire of Hastings, at Marine Parade, Hastings.

Dated 21st October, 1974.

1498 L. A. WALKER, Shire Secretary.

SHIRE OF MAFFRA.

LOAN No. 52.

Notice of Intention to Borrow the Sum of \$40,000 for Permanent Works and Undertakings.

Notice is hereby given that the Council of the Shire of Maffra proposes to borrow the sum of Forty Thousand Dollars (\$40,000) secured by a charge over the general rates of the Municipality, such sum to be raised by the grant of a Mortgage in accordance with the provisions of the *Local Government Act 1958*.

1. The maximum rate of interest that may be paid is 9.85 per cent. per annum.

2. The purpose for which the loan is to be applied is: Part cost of the erection of a Basketball Stadium on the Gordon Street Reserve, Heyfield—\$40,000.

3. The period of the loan shall be twenty (20) years.

4. The moneys borrowed, shall be repayable by providing out of the Municipal Fund, forty half yearly instalments of approximately \$2,307.24 each including principal and interest on the first day of January and first day of July, during the currency of the loan. The first instalment shall be repayable on the first day of July, 1975.

5. Such moneys shall be repayable at the C.B.C. Savings Bank Limited, 257 Collins Street, Melbourne.

6. The plans, specifications and estimates of cost of the proposed works and a statement showing the proposed expenditure of the money to be borrowed are open for inspection at the Shire Office, Maffra.

Dated this 17th day of October, 1974.

1525 J. RENNICK, Shire Secretary.

SHIRE OF MARONG.

LOAN No. 28.

Notice of Intention to Borrow the Sum of \$25,000 for Permanent Works and Undertakings.

Notice is hereby given that the Council of the Shire of Marong intends to borrow \$25,000 secured by a charge over the general rates of the Municipality by the grant of a mortgage in accordance with the provisions of the *Local Government Act 1958*.

1. The maximum rate of interest that may be paid is 9.85 per cent. per annum.

2. The purpose for which the loan is to be applied is the part cost of extensions to the Shire Offices.

3. The money borrowed shall be repaid by 40 half yearly instalments of \$1442.02 each, including principal and interest on the 1st day of June and the 1st day of December in each year during the currency of the Loan. The first instalment shall be payable on 1/6/75.

4. Such amounts will be payable at the Australia and New Zealand Savings Bank Ltd. Pall Mall, Bendigo.

The plans and specifications and estimate of the cost of the works and a statement showing the proposed expenditure of the money to be borrowed are open for inspection at the Shire Office, Marong.

1556 J. A. ELVEY, Acting Shire Secretary.

SHIRE OF MILDURA.

LOAN No. 58.

Notice of Intention to Borrow the Sum of \$32,000 for Permanent Works and Undertakings.

Notice is hereby given that the Council of the SHIRE OF MILDURA proposes to borrow the principal sum of Thirty-Two Thousand Dollars (\$32,000), secured by a charge over the General Rates of the Municipality, such sum to be raised by the granting of a mortgage in accordance with the provisions of the *Local Government Act 1958*.

1. The maximum rate of interest that may be paid is 9.85 per centum per annum.

2. The purposes for which the loan is to be applied, is as follows:—

Purchase of Land—	\$32,000
TOTAL:—	\$32,000

3. The period of the loan shall be fifteen years.

4. Monies borrowed shall be repayable by providing out of the Municipal Fund half-yearly instalments of approximately \$2,063.89 each including principal and interest on the first day of June and the first day of December in each year during the currency of the loan. The first instalment shall be payable on the first day of June, 1975.

5. The monies borrowed shall be repayable at the C.B.C. Savings Bank Limited, Melbourne.

The plans and specifications and the estimate of the costs of the proposed works and a statement showing the proposed expenditure of the monies to be borrowed are open for inspection at the office of the Council of the Shire of Mildura, Fifteenth Street, Irymple.

Date: 23rd October, 1974.

1520 DANIEL F. DREW, Shire Secretary.

Town and Country Planning Act 1961 (Twelfth Schedule).

SHIRE OF OTWAY.—OCEAN ROAD PLANNING SCHEME 1955.

NOTICE THAT A PLANNING SCHEME HAS BEEN PREPARED AND IS AVAILABLE FOR INSPECTION.

Amendment No. 11, 1974.

Notice is hereby given that the Council of the Shire of Otway in pursuance of its powers under the *Town and Country Planning Act 1961* has prepared a Planning Scheme within the Parish of Kaanglang, being part of Crown Allotment 29G for the purpose of further regulating, restricting, restraining or prohibiting the use or development of any land or the erection, construction or carrying out of any building or works.

A copy of the Scheme has been deposited at the Shire Offices, Main Street, Beech Forest, at the Shire Offices, Seymour Crescent, Apollo Bay, and at the office of the Town and Country Planning Board, 235 Queen Street, Melbourne, and will be open for inspection during office hours by any person free of charge.

Any persons affected by the Planning Scheme are required to set forth in writing all objections they may have, addressed to the Shire Secretary, Shire of Otway, Beech Forest, on or before 30th November, 1974, and to state whether they wish to be heard in respect of their objections.

1557 T. R. RICHARDSON, Shire Secretary.

Town and Country Planning Act 1961 (Twelfth Schedule).

SHIRE OF OTWAY.—OCEAN ROAD PLANNING SCHEME 1955.

NOTICE THAT A PLANNING SCHEME HAS BEEN PREPARED AND IS AVAILABLE FOR INSPECTION.

Amendment No. 8, 1974.

Notice is hereby given that the Council of the Shire of Otway in pursuance of its powers under the *Town and Country Planning Act 1961* has prepared a Planning

Scheme for that part of the Ocean Road Planning Scheme within the Parish of Krambruk, being Crown Allotment 14, Section 2, for the purpose of further regulating, restricting, restraining or prohibiting the use or development of any land or the erection, construction or carrying out of any building or works and the conservation and enhancement of the character of the area by restricting or regulating the destruction of bushland or trees or other objects.

A copy of the Scheme has been deposited at the Shire Offices, Main Street, Beech Forest, at the Shire Offices, Seymour Crescent, Apollo Bay and at the Office of the Town and Country Planning Board, 235 Queen Street, Melbourne, and will be open for inspection during office hours by any person free of charge.

Any persons affected by the Planning Scheme are required to set forth in writing all objections they may have, addressed to the Shire Secretary, Shire of Otway, Beech Forest on or before the 30th day of November, 1974, and to state whether they wish to be heard in respect of their objection.

1558

T. R. RICHARDSON, Shire Secretary.

SHIRE OF TOWONG.
ROAD DEVIATION ORDER.

Pursuant to the provisions of Sections 522 and 526 of the Local Government Act 1958 the Council of the Shire of Tallangatta doth hereby direct that the land in the Parish of Bullioh shown hatched on the Plans hereunder which has been taken purchased or acquired by it shall be public highways from and after the date of publication of this order in the Government Gazette.

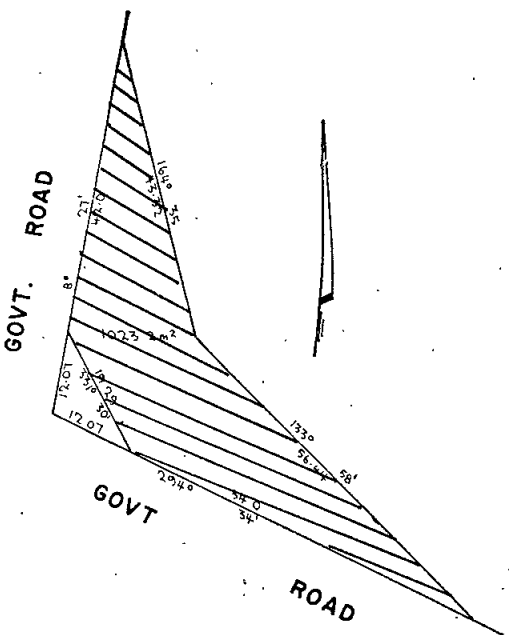
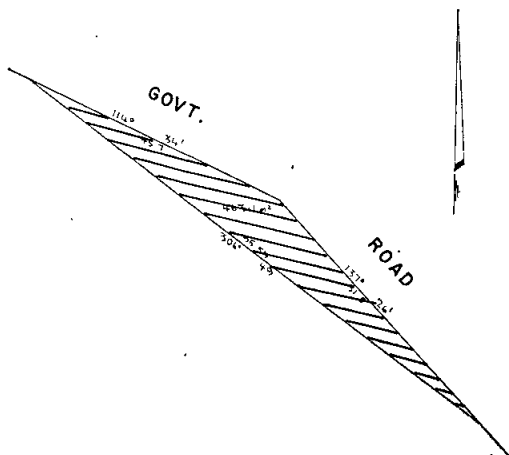

The common seal of the President, Councillors and Ratepayers of the Shire of Tallangatta was hereunto affixed this 23rd day of September, 1974.

(SEAL) D. F. KELLY, President.
LAURIE STEVENSON, Councillor.
I. M. BOWMAN, Secretary.

COUNCIL OF SHIRE OF WARRAGUL.

LOAN No. 97.

Notice of Intention to Borrow.

NOTICE is hereby given that the Council of Shire of Warragul intends to borrow One hundred and eighty five thousand dollars (\$185,000) secured by a charge over the General rates of the municipality by the grant of a Mortgage in accordance with the provisions of the Local Government Acts.

In connection therewith the following information is stated:—

- (a) The amount of the principal moneys which it is proposed to borrow is \$185,000.
- (b) The maximum rate of interest that may be paid is 9.85 per centum per annum.
- (c) The times which the moneys borrowed are to be repayable are the 15th day of June 1975 and the 15th day of December and during the years 1975-1990 inclusive and that the place such moneys shall be repayable is at the Bank of New South Wales Warragul.
- (d) The purpose for which the loan is to be applied is: Decentralized Industry.
- (e) The manner in which the Loan is to be liquidated is by provision out of the Municipal Fund in each half-year during the currency of the Loan of the sum of \$11,931.82 which includes Principal and Interest.

The plans and specifications and estimate of the cost of the works and a statement showing the proposed expenditure of the moneys to be borrowed are open for inspection at the Shire Office.

Dated this 15th day of October, 1974.

1492

D. McADIE, Shire Secretary.

COUNCIL OF SHIRE OF WARRAGUL.

LOAN No. 96.

Notice of Intention to Borrow.

NOTICE is hereby given that the Council of the Shire of Warragul intends to borrow Thirty Thousand Dollars (\$30,000) secured by a charge over the General rates of the municipality by the grant of a Mortgage in accordance with the provisions of the Local Government Acts.

In connection therewith the following information is stated:—

- (a) The amount of the principal moneys which it is proposed to borrow is Thirty Thousand Dollars.
- (b) The maximum rate of interest that may be paid is 9.85 per centum per annum.
- (c) The times which the moneys borrowed are to be repayable are the 15th day of June and the 15th day of December and during the years 1975-1990 inclusive and that the place such moneys shall be repayable is at the Bank of New South Wales Warragul.
- (d) The purpose for which the loan is to be applied is: Decentralized Industry.
- (e) The manner in which the Loan is to be liquidated is by provision out of the Municipal Fund in each half-year during the currency of the Loan of the sum of \$1,934.89 which includes Principal and Interest.

The plans and specifications and estimate of the cost of the works and a statement showing the proposed expenditure of the moneys to be borrowed are open for inspection at the Shire Office.

Dated this 15th day of October, 1974.

1491

D. McADIE, Shire Secretary.

DROUIN SEWERAGE AUTHORITY.

GENERAL NOTICE.

The abovementioned Authority having made provision for carrying off the sewage from each and every property which or any part of which is within the Sewerage Area hereinafter described does HEREBY DECLARE that on and after the first day of November, 1974, each and every property which or any part of which is within the said Sewerage Area shall be deemed to be a sewered property within the meaning of the *Sewerage Districts Act 1958*.

The Sewerage Area hereinbefore referred to shall be known as SEWERAGE AREA No. 15.

The boundaries of said SEWERAGE AREA No. 15 are delineated on plan number B268567 which may be inspected at the office of the Drouin Sewerage Authority.

By order of the said Sewerage Authority,

1494 F. ARMSTRONG, Chairman.
E. J. AUSTIN, Secretary.

FRANKSTON SEWERAGE AUTHORITY.

COMMENCEMENT OF WORKS.

NOTICE is hereby given that the Authority intends constructing sewers generally in the following areas:—

Contract 900/68/L—*Plummer Avenue, Frankston*

Part of the area bounded by Nepean Highway, Menzies Close and Plummer Avenue, Frankston.

Contract 900/134/B—*Part A—Karingal Outfall*

Between Karingal Drive and Woodlea Court via Ashleigh Avenue, Frank Street and Skye Road, Frankston.

Contract 900/134/B—*Parts B and C—Karingal Reticulation*
Part of the section of the Karingal Estate bounded by Skye Road, Frank Street, Wangarra Road, Lindrum Road and Washington Drive, Frankston.

A map defining the areas is available for inspection at the office of the Authority, Civic Centre Annexe, Davey Street, Frankston, during office hours.

G. C. PENTLAND, Secretary.

Civic Centre Annexe, Frankston, 3199. 1493

WARRNAMBOOL SEWERAGE AUTHORITY.

GENERAL NOTICE.

The abovementioned Sewerage Authority, having made sewers for carrying off the sewage from each and every property which, or any part of which abuts on the streets or parts of streets, in which such sewers are laid, and which are included within the Sewerage Area hereinafter described, doth hereby declare that on and after the 1st day of December, 1974, each and every Property which, or any part of which abuts on the said streets or parts of streets shall be deemed to be sewered property within the meaning of the *Sewerage Districts Act 1958*.

The boundaries of the Sewerage Area hereinbefore referred to are:

SEWER AREA No. 96.

That part of the Warrnambool Sewerage District, being part of Crown Allotments 133 and 140, Parish of Wangoom, and bounded by a line which commences at the South West Corner of Declared Sewer Area No. 63, then proceeding in a clockwise direction to the West along the South Building Line of Donovans Road to the point of intersection of the West Building Line of Lot 1 of Crown Allotment 133 produced, then North across Donovans Road, along the said Building Line, then East along the North Boundaries of Lots 1 and 4, Crown Allotment 133a to a point 30 metres West of the West Building Line of Queens Road, North and parallel to the said West Building Line for a distance of 20 metres, then East and parallel to the North boundary lines of Lots 1 and 4 to the East Building Line of Queens Road then North along the said Building Line to the South West Corner of Lot 7, Crown Allotment 140, then proceeding East and North along the South and East Boundary Line of Lot 7 to the North West Corner of Lot 9, Crown Allotment 140, then generally East along the North Boundaries of Lot 9, 10, 11 and 12 Crown Allotment 140, to the West Boundary of Declared Sewer Area No. 63, then South along the said Western Boundary to the starting point.

SEWER AREA No. 97.

That portion of the Warrnambool Sewerage District, being part of Crown Allotment 1 section 65, City of Warrnambool and part of Crown Allotments 83 and 84, Parish of Wangoom and which includes all that land bounded on the East by the East Building Line of Morriss Road, on the South by the Northern Boundary of Sewer Area No. 61 and the Northern and Western Boundary by Sewer Area

No. 64 on the West by the Western Boundary Line of Giffen Street, and on the North by the Southern Boundary of Sewer No. 80.

1519 (SEAL) R. A. MITCHELL, Chairman.
K. L. ARNEL, Secretary.

WESTERNPORT WATERWORKS TRUST.

NOTICE TO OWNERS OF TENEMENTS AND LANDS IN THE UNDERMENTIONED STREETS, IN THE WESTERNPORT WATERWORKS TRUST AREA, AND PRIVATE STREETS, LANES, ALLEYS, AND COURTS OPENING THERETO.

Cowes:

Medina Road from existing main 170 metres.
Settlement Rd. from existing main (lot 77) 80 metres

Corinella:

Smythe St. from existing main—east 70 metres.

Woolamai Waters:

Esplanade from existing main (lot 923) 30 metres.
Esplanade, from existing main (lot 1117) 100 metres.
Surfers Ave., from existing main 30 metres.
Goldensands Rd. from existing main (lot 544) 50 metres.
Esplanade from existing main (lot 1056) 45 metres.
Esplanade from existing main (lot 442) 45 metres.

Newhaven:

Beach Cres. from existing main eastwards 10 metres.

San Remo:

Oceanview Gve. from Coogee Ave. 450 metres.
Boathaven Gve. from Coogee Ave. 240 metres.

The main pipes in the street being laid down, the owners of all tenements situated as above are hereby required on or before the first day of January, 1975, to cause a proper pipe and stop cocks to be laid so as to supply water within such tenements from the main pipes.

STAN A. HARRIS, Trust Secretary.

Trust Office, Cowes, 24th October, 1974. 1524

WESTERNPORT WATERWORKS TRUST.

NOTICE TO OWNERS OF TENEMENTS AND LANDS IN THE UNDERMENTIONED STREETS, IN THE WESTERNPORT WATERWORKS TRUST AREA, AND PRIVATE STREETS, LANES, ALLEYS, AND COURTS OPENING THERETO.

Cowes:

Caroline Ave. from existing main 150 metres.

Woolamai Waters:

Sunnyside Ave. from existing main 190 metres.

The main pipes in the street being laid down, the owners of all tenements situated as above are hereby required on or before the first day of January, 1975, to cause a proper pipe and stop cocks to be laid so as to supply water within such tenements from the main pipes.

STAN A. HARRIS, Trust Secretary.

Trust Office, Cowes, 28th October, 1974. 1614

GEE LONG WATERWORKS AND SEWERAGE TRUST.

The abovementioned Trust having made provision for carrying off the sewage from each and every property which or any part of which is within the sewerage area hereinafter described DOTH HEREBY DECLARE that on or after the first day of November, 1974, each and every property which or any part of which is within the said sewerage area shall be deemed and taken to be sewered property within the meaning of the said *Geelong Waterworks and Sewerage Act 1958*.

SEWERAGE AREA No. 585.

Shire of South Barwon, Parish of Duneed, County of Grant.

Commencement at a point being the south-west corner of allotment No. 13 Stratford Court, Grovedale, which is also on the boundary of Sewerage Area No. 458, thence northerly along the western boundaries of allotments No. 13 to 11 inclusive Stratford Court to the north-west corner of the said allotment No. 11, which is also on the boundary of Sewerage Area No. 458, thence easterly, southerly and westerly following the boundary of Sewerage Area No. 458 and crossing Stratford Court to the point of commencement.

SEWERAGE AREA No. 586.

Shire of Corio, Parish of Moorpanyal, County of Grant.

Commencing at a point being on the north-east corner of the intersection of Rollins Road and Ernest Street, Bell Post Hill, the said point being also on the boundary of

Sewerage Area No. 435, thence northerly along the east side of Rollins Road to the north-west corner of allotment No. 333, which is also on the boundary of Sewerage Area No. 435, thence easterly, southerly, easterly, southerly and westerly following the boundary of Sewerage Area No. 435 to the point of commencement.

SEWERAGE AREA No. 587.

Shire of Bellarine, Parish of Moolap, County of Grant.

Commencing at a point being the south-east corner of the intersection of Helms and Glenburn Streets, Newcomb, the said point being also on the boundary of Sewerage Area No. 449, thence easterly along the south side of Glenburn Street for a distance of 81.86 metres, thence southerly by a line bearing 180 degrees for a distance of 100.57 metres, thence westerly by a line bearing 269 degrees 51 minutes for a distance of 82.03 metres to the east side of Helms Street, thence northerly along the east side of Helms Street to the point of commencement.

SEWERAGE AREA No. 588.

Shire of South Barwon, Parish of Barrarbool, County of Grant.

Commencing at a point being 211.63 metres south from the south-east corner of the intersection of Helms and Lindell Streets, Newcomb, thence easterly by a line bearing 89 degrees 5 minutes for a distance of 77.75 metres, thence southerly by a line bearing 180 degrees for a distance of 52.91 metres, thence westerly by a line bearing 269 degrees 51 minutes for a distance of 97.95 metres and crossing Helms Street to the west side of Helms Street, which is also on the boundary of Sewerage Area No. 331, thence northerly following Sewerage Area No. 331 for a distance of 52.91 metres and crossing Richard Street, thence easterly across Helms Street by a line bearing 89 degrees 5 minutes to the point of commencement.

SEWERAGE AREA No. 589.

Shire of South Barwon, Parish of Barrarbool, County of Grant.

Commencing at a point being 45.7 metres approximately, north from the north-west corner of the intersection of Barrarbool Road and Montague Street, Highton, the said point being also on the boundaries of Sewerage Areas Nos. 223 and 239, thence northerly, easterly, northerly, easterly, southerly, north-westerly, northerly and westerly following the boundaries of Sewerage Areas Nos. 239, 255, 301 and 223 and crossing Montague Street, Duggan Court and Montague Street to the point of commencement.

SEWERAGE AREA No. 590.

Shire of Corio, Parish of Moorpanyal, County of Grant.

Commencing at a point being the south-west corner of allotment No. 277 Braund Avenue, Bell Post Hill, the said point being also on the boundaries of Sewerage Area Nos. 460 and 435, thence northerly following the boundary of Sewerage Area No. 435 and crossing Braund Avenue to the north side of Braund Avenue, thence easterly along the north side of Braund Avenue to the boundary of Sewerage Area No. 427, thence southerly following the boundary of Sewerage Area No. 427 and crossing Braund Avenue to the south-east corner of allotment No. 271 Braund Avenue, thence westerly following the boundaries of Sewerage Areas Nos. 427 and 460 to the point of commencement.

Signed under seal of the Geelong Waterworks and Sewerage Trust this 24th day of October, 1974.

(SEAL) B. C. HENSHAW, Secretary.
1615 R. W. WHITESIDE, Chairman.

NOTICE is hereby given that BP Australia Limited has applied for a lease pursuant to Sections 134 and 135 of the Land Act 1958 for a term of 50 years in respect of Allotment 66d, Section 7, Parish of Cut-paw-paw containing 5.5439 hectares as a site for general industrial purposes. 1526

NOTICE is hereby given that the partnership heretofore subsisting between the undersigned EDWARD ARTHUR COX, GRANVILLE DENNIS HOPKINSON and ALAN ARTHUR HOLBOROW carrying on the business of Builders and Contractors, Alterations and Repairs at 20 Oak Street, Surrey Hills under the name of A.G.E. Building and Renovation has been dissolved by mutual consent as from the 31st day of December 1973. All debts due to and owing by the said late firm will be received and paid by the said partnership.

Dated the 22nd day of October, 1974.

E. A. COX.
1560 G. D. HOPKINSON.
A. A. HOLBOROW.

Grahame Richard John Shaw, John Denton, William Spiers Corker, Barrington Charles Marshall and Andras Kelly formerly conducting the partnership business of Architects, Town Planners and Landscape Architects under the name of Grahame Shaw Denton and Corker at 31 Niagara Lane Melbourne Victoria and Northbourne Avenue Canberra A.C.T. hereby advise the dissolution of that partnership as at the 31st day of August 1974.

Grahame Richard John Shaw will henceforth practise at Northbourne Avenue Canberra A.C.T. and at 552 Lonsdale Street Melbourne under his own name. John Denton, William Spiers Corker, Barrington Charles Marshall and Andras Kelly will henceforth practise under the firm name of Denton Corker Kelly Marshall at 31 Niagara Lane Melbourne and at 16 Richards Street Hackett A.C.T. 1561

NOTICE IS HEREBY GIVEN that the partnership heretofore subsisting between ALEXANDER PERTOUT and FRANCO DE STEFANO of RESTAURANT AND EATING HOUSE under the registered business name of KEYHOLE RESTAURANT on the premises situate at and known as 334-336 Lygon Street, Carlton in the State of Victoria has been dissolved as from the 20th day of October One thousand nine hundred and seventy-four.

All debts due and owing by the business shall be received and paid by the Partnership. 1581

TAKE NOTICE that the partnership heretofore carried on by J. J. RONEC (JORONTEX FABRICS) PROPRIETARY LIMITED, J. J. RONEC (VIC.) PROPRIETARY LIMITED and J. J. RONEC (INTERSTATE) PROPRIETARY LIMITED AS Manufacturers and Distributors of textiles at 86 Flinders Lane, Melbourne was dissolved on the 1st day of September, 1974. J. J. RONEC (JORONTEX FABRICS) PROPRIETARY LIMITED will carry on the business and all debts due to or by the late partnership will be received or paid by it at that address. 1582

TAKE NOTICE that a Partnership being carried on under the firm name Visair and Visair Educational by JOHN STEWART LYONS, COLIN CHARLES GREEN, NORTON HOPE HOBSON and GORDON DAVID LOWING which was constituted by a Partnership Deed dated the 13th December, 1973 has been dissolved in that the said JOHN STEWART LYONS has retired from the said Partnership as from the 11th day of October, 1974. The said COLIN CHARLES GREEN, NORTON HOPE HOBSON and GORDON DAVID LOWING will continue in partnership and continue to trade under the name of Visair and Visair Educational. 1477

NOTICE IS HEREBY GIVEN that the partnership heretofore subsisting between Robert William Heather and Garry Francis Heather, Contractors both of Orbost carrying on a business as Cartage Contractors at Orbost under the style or firm name of R. W. & G. F. Heather has been dissolved from the 31st day of January, 1974.

Dated the 21st day of October, 1974.

R. W. HEATHER.

Messrs. Mosley & Palmer, solicitors, 139 Nicholson Street, Orbost. 1478

NOTICE IS HEREBY GIVEN that the partnership heretofore subsisting between Robert William Heather, Contractor, Martha Faye Heather, Married Woman and Garry Francis Heather, Contractor all of Orbost carrying on a business as Cartage Contractors at Orbost under the style or firm name of R. W., M. F. & G. F. Heather has been dissolved from the 31st day of January, 1974.

Dated the 21st day of October, 1974.

R. W. HEATHER:

Messrs. Mosley & Palmer, solicitors, 139 Nicholson Street, Orbost. 1479

NOTICE IS HEREBY GIVEN that the partnership heretofore subsisting between DAVID WILLIAM TROMANS and PETER CECIL HYDE of Transport Contractors under the name of MALVERN TAXI TRUCK SERVICE at Factory 2, 25 Brunson Street, Bayswater will be dissolved as from the 31st day of October, 1974 by the retirement of the said PETER CECIL HYDE from that partnership, PYRENNE ETHEL TROMANS will on the said date be admitted to partnership with the continuing partner DAVID WILLIAM TROMANS. All debts due and owing by the business shall be received and paid by the said PYRENNE ETHEL TROMANS and DAVID WILLIAM TROMANS who will continue to carry on the said business at the said premises. 1626

Companies Act 1961.

WINIKUR PLUMBING SUPPLIES PTY. LIMITED (IN VOLUNTARY LIQUIDATION).

Notice of Final Meeting.

Notice is hereby given pursuant to Section 272 of the *Companies Act 1961* that a meeting of the members of the abovenamed Company will be held at 3rd Floor, 18 Queen Street, Melbourne, on the 5th day of December, 1974, at 9.30 a.m. for the purpose of having an account laid before the meeting showing the manner in which the winding up has been conducted and the property of the Company disposed of and of hearing any explanations that may be given by the liquidator.

Dated this 22nd day of October, 1974.

1571 D. H. ENGLAND, Liquidator.

DENYS INVESTMENTS PROPRIETARY LIMITED.

Notice is hereby given in pursuance of Section 254 (2) (b) of the *Companies Act 1961*, that an Extraordinary General Meeting of Members of Bramham Proprietary Limited held at 308 Flinders Lane, Melbourne on the twenty seventh of September 1974, the following Special Resolution was passed—

"That the Company be voluntarily wound up."

1572 D. S. BOTTOMLEY, Director.

The *Companies Act 1961*.—In the matter of BOLWELL CARS PTY. LTD.

NOTICE is hereby given that at an Extraordinary General Meeting of the Members of the abovenamed Company held on the 23rd day of October, 1974, it was resolved that the Company be wound up voluntarily, and at a meeting of creditors held on the same day pursuant to Section 260, it was resolved that for such purpose ROBERT EASTAUGH RAMSAY of 296 Little Lonsdale Street, Melbourne, Accountant, be appointed Liquidator.

NOTICE is also given that after twenty one days from this date I shall proceed to distribute the assets. All creditors having any claims against the Company should furnish particulars of same by that date, otherwise I shall proceed to distribute the assets without regard to their claim.

DATED this 28th day of October, 1974.

ROBERT E. RAMSAY, Liquidator.

Kennedy Smail, 296 Little Lonsdale Street, Melbourne.
1573

In the Supreme Court of Victoria.—1974 No. —

In the matter of the *Companies Act 1961*; and in the matter of CONTOUR HOMES PTY. LTD.

NOTICE IS HEREBY GIVEN that a Petition for the winding up of the abovenamed Company by the Supreme Court was on the 22nd day of October 1974 presented by EDRACO (AUSTRALIA) PTY. LTD, SHELSON ROOF TILES, CAMBERWELL POTTERIES ROOFING PTY. LTD., ALEX SERDZEFF and CLIVE CRAVEN SPARKS, and ANTHONY DUNSTAN. AND THAT the said Petition is directed to be heard before the Court sitting at William Street Melbourne at the hour of 10.30 o'clock in the forenoon on the 29th day of November 1974; and any Creditor or Contributory of the said Company desiring to support or oppose the making of an Order on the said Petition may appear at the time of hearing by himself or his Counsel for the purpose; and a copy of the Petition will be furnished to any Creditor or Contributory of the said Company requiring the same by the undersigned on payment of the regulated charge for the same.

The Petitioners' address is:

- 1) Edraco (Australia) Pty. Ltd. of 1123 Whitehorse Road Box Hill.
- 2) Camberwell Potteries Roofing Pty. Ltd. of 134B Burwood Highway Burwood.
- 3) Alex Serdzeff and Clive Craven Sparks both of 257 Princes Highway Dandenong.
- 4) Shelson Roof Tiles of Beaufort Road Croydon.
- 5) A. Dunstan of 26 Blandford Crescent Bayswater.

The Petitioner's Solicitor is Mr. B. F. Williams of the firm of Aughterson Giblett & Williams of 443 Lt. Collins Street Melbourne and 86 Whitehorse Road Ringwood.

BRIAN FRANCIS WILLIAMS.

NOTE: Any person who intends to appear on the hearing of the said Petition must serve on or send by post to the abovenamed Solicitor Notice in writing of his intention so to do. The Notice must state the name and address

of the person, or if a firm, the name and address of the firm, and must be signed by the person or firm, or his or their Solicitor (if any) and must be served, or, if posted must be sent by post in sufficient time to reach the abovenamed not later than four o'clock in the afternoon of the 28th day of November 1974, (the day before the day appointed for the hearing of the Petition or the Friday preceding the day appointed for the hearing of the Petition if such day is Monday or a Tuesday following a public holiday). 1511

Companies Act 1961.

SHANGHAI INVESTMENTS PTY. LIMITED.

NOTICE PURSUANT TO SECTION 254 (2).

At a General Meeting of members of Shanghai Investments Pty. Limited duly convened and held at 95 Queen Street, Melbourne on 22 October, 1974 the following special resolution was duly passed—

That the Company be wound up voluntarily.

Dated this 24th day of October, 1974.

ESMOND J. DOWNEY, liquidator, of Esmond F. Downey & Co., 400 Lonsdale Street, Melbourne. 1528

Companies Act 1961.

J. CARRIGAN PROPRIETARY LIMITED.

NOTICE PURSUANT TO SECTION 254 (2).

At a General Meeting of members of J. Carrigan Proprietary Limited duly convened and held at 95 Queen Street, Melbourne on 22nd October, 1974 the following special resolution was duly passed—

That the Company be wound up voluntarily.

Dated this 24th day of October, 1974.

ESMOND J. DOWNEY, liquidator, of Esmond F. Downey & Co., 400 Lonsdale Street, Melbourne. 1529

The *Companies Act 1961*.—In the matter of DURCO PROPRIETARY LIMITED (in Liquidation).

Notice is hereby given that pursuant to Section 272 of the *Companies Act 1961*, a Final Meeting of the Members of the above Company will be held at the office of H. Guest & Associates Pty. Ltd., 207B Balaclava Road, Caulfield, on Friday the 22nd day of November 1974 at 10.00 a.m.

Business: To receive the Liquidator's Accounts.

Dated this 22nd day of October, 1974.

1538 J. DURLACHER, Liquidator.

BELLAIRE INVESTMENTS PTY. LTD.

At an Extraordinary General Meeting of Shareholders of Bellaire Investments Pty. Ltd. duly convened and held at 367 Victoria Street, Abbotsford, on 25th October, 1974, the following Special Resolution was duly passed—

"That the Company be wound up voluntarily and that J. Muller, Accountant, of 367 Victoria Street, Abbotsford, be appointed Liquidator."

COLEMAN McCLURE & WILBY, 367 Victoria Street, Abbotsford. 1539

CHELTENHAM AMALGAMATED CO-OPERATIVE HOUSING SOCIETY LIMITED (IN LIQUIDATION).

SPECIAL RESOLUTION.

Passed 25th October, 1974.

At a Special General Meeting of the abovenamed Society duly convened and held at the Cheltenham Hall, Corner Nepean Highway and Charman Road, Cheltenham; at 7.30 p.m. on Friday, 25th October, 1974, the subjoined special resolution was duly passed:

"THAT the Society, having successfully completed its objectives 65 months ahead of the notional period be wound up voluntarily and that Ernest Alfred Best Graham of 63 Atherton Road, Oakleigh, be appointed Liquidator for the purpose of the winding-up.

1540 E. A. B. GRAHAM, Liquidator.

Companies Act 1961.—In the matter of IVAN H. SAFFER Pty. LTD., 30 Inkerman Street, St. Kilda, 3182.

NOTICE is hereby given that at an extraordinary Meeting of the Members of the abovenamed Company held on the 24th October, 1974 it was resolved that the Company be wound up voluntarily and at a Meeting of Creditors held on the same day pursuant to Section 260, it was resolved that for such purpose DENNIS JOHN COUGLE of Suite 18, 545 St. Kilda Road, Melbourne, Public Accountant, be appointed Liquidator.

NOTICE is also given that after twenty one days from this date I will proceed to distribute the assets. All creditors having any claims against the Company should furnish particulars of same by that date, otherwise I will proceed to distribute the assets without regard to their claim.

Dated this 24th day of October, 1974.

D. J. COUGLE, Liquidator.

Bent & Cogle, public accountants, suite 18, 545 St. Kilda Road, Melbourne, Vic. 3004. 1541

In the matter of the Companies Act 1961; and in the matter of KATANDRA WEST STORE PTY. LTD.

Notice is hereby given that at a meeting of the members of Katandra West Store Pty. Ltd., on 21st of October, 1974 the following resolution was passed as a Special Resolution:—

That the Company be wound up voluntarily and that Mr. Brendan Kelly, of 56 Stewart Street, Shepparton be and is hereby appointed liquidator for the purpose of such winding up.

1555

BRENDAN P. KELLY, Liquidator.

Companies Act 1961, Section 260 (3).
PERICLES CONSTRUCTIONS PTY. LTD.

NOTICE OF MEETING OF CREDITORS IN CREDITORS' VOLUNTARY WINDING UP.

NOTICE IS HEREBY GIVEN that a Meeting of Creditors of the abovenamed Company in pursuance of Section 260 of the Companies Act 1961 will be held at the office of the Institute of Chartered Accountants, 140 Queen Street, Melbourne on THURSDAY the 14TH day of NOVEMBER, 1974 at 10.30 a.m. for the purposes set out in Sections 260, 261 and 262 of the said Act.

1598

W. E. TURNER, Secretary.

The Companies Act 1961, Section 254.
DARLING RIVER OIL CO. PTY. LIMITED.

SPECIAL RESOLUTION TO WIND UP.

At an Extraordinary General Meeting of the abovenamed Company duly convened and held at 151 Flinders St. Melbourne on the 24th day of October, 1974 the following Resolution was passed as a Special Resolution:

"That the Company be wound up voluntarily."

At the above mentioned meeting Roger Douglas Evans of 351 Collins Street, Melbourne, was appointed Liquidator for the purpose of the winding up.

Notice is also given that after twenty-one days from this date, I shall proceed to distribute the assets. All creditors having any claim against the Company should furnish particulars of same by that date, otherwise I shall proceed to distribute the assets without regard to their Claim.

Dated this 25th day of October, 1974.

1599

ROGER D. EVANS, Liquidator.

The Companies Act 1961, Section 254.
NORTHERN RIVERS OIL CO. PTY. LIMITED.

SPECIAL RESOLUTION TO WIND UP.

At an Extraordinary General Meeting of the abovenamed Company duly convened and held at 151 Flinders St. Melbourne on the 24th day of October, 1974 the following Resolution was passed as a Special Resolution:

"That the Company be wound up voluntarily."

At the above mentioned meeting Roger Douglas Evans of 351 Collins Street, Melbourne, was appointed Liquidator for the purpose of the winding up.

Notice is also given that after twenty-one days from this date, I shall proceed to distribute the assets. All creditors having any claim against the Company should furnish particulars of same by that date, otherwise I shall proceed to distribute the assets without regard to their Claim.

Dated this 25th day of October, 1974.

1600

ROGER D. EVANS, Liquidator.

The Companies Act 1961, Section 254.
WOODSIDE (INTERSTATE) OIL CO. PTY. LIMITED.
SPECIAL RESOLUTION TO WIND UP.

At an Extraordinary General Meeting of the abovenamed Company duly convened and held at 151 Flinders St. Melbourne on the 24th day of October, 1974 the following Resolution was passed as a Special Resolution:

"That the Company be wound up voluntarily."

At the above mentioned meeting Roger Douglas Evans of 351 Collins Street, Melbourne, was appointed Liquidator for the purpose of the winding up.

Notice is also given that after twenty-one days from this date, I shall proceed to distribute the assets. All creditors having any claim against the Company should furnish particulars of same by that date, otherwise I shall proceed to distribute the assets without regard to their Claim.

Dated this 25th day of October, 1974.

1601

ROGER D. EVANS, Liquidator.

THE NORTHERN BOTTLE COMPANY PROPRIETARY LIMITED (IN VOLUNTARY LIQUIDATION).

Notice is hereby given in pursuance to Section 272 (2) of the Companies Act 1961, that the final meeting of members of the abovenamed Company will be held at 10th Floor, 271 William Street, Melbourne at 10.30 a.m. Friday, 29th November, 1974 for the purpose of having an account laid before it showing the manner in which the winding up has been conducted and to hear any explanation that may be given by the Liquidator.

Dated this 28th day of October, 1974.

J. B. HUTCHINS, Liquidator.

Wilson, Bishop, Bowes & Craig, chartered accountants, 271 William Street, Melbourne, 3000. 1610

Companies Act 1961.

G. & S. TAYLOR PROPRIETARY LIMITED (IN VOLUNTARY LIQUIDATION).

NOTICE is hereby given that at an Extraordinary General Meeting of Members of the abovenamed company held on 18th October, 1974, it was resolved that the company be wound up voluntarily and at a meeting of Creditors held on the same day it was resolved that for such purpose Lewis Luckins, Chartered Accountant of 423 Bourke Street, Melbourne, be appointed liquidator.

Notice is also given that after twenty-one days from this date I shall proceed to distribute the assets. All creditors who have any claim against the company should furnish particulars of same by that date, otherwise I shall proceed to distribute the assets without regard to their claim.

Dated this 28th day of October, 1974.

LEWIS LUCKINS, Liquidator.

Lewis Luckins & Co., chartered accountants, 423 Bourke Street, Melbourne, 3000. Telephone 67 6944. 1574

NOTICE OF WINDING UP ORDER.

IN THE MATTER OF Holly Investments Proprietary Limited. Winding up Order made 22nd October, 1974.

Name and address of Liquidator:—Bruce Henry Smith, Suite 801, 343 Little Collins Street, Melbourne.

BLAKE & RIGGALL, solicitors for the petitioner Clarke & Co.

Blake & Riggall, solicitors, 140 William Street, Melbourne. 1575

In the matter of CAPEL COURT NOMINEES LIMITED and in the matter of the Companies Act 1961 NOTICE is hereby given that at a meeting of the members of CAPEL COURT NOMINEES LIMITED on Wednesday 16th October 1974 the following resolution was passed as a special resolution:

"That the company be wound up voluntarily and Mr. Peter William Harvey of Price Waterhouse & Co. be appointed liquidator for the purposes of such winding up."

Dated this 16th day of October, 1974.

P. W. HARVEY, Liquidator.

Price Waterhouse & Co., 447 Collins Street, Melbourne. 1576

In the matter of CAPEL COURT ACCEPTANCE COMPANY LIMITED and in the matter of the Companies Act 1961 NOTICE is hereby given that at a meeting of the members of CAPEL COURT ACCEPTANCE COMPANY LIMITED on Wednesday 16th October, 1974 the following resolution was passed as a special resolution:

"That the company be wound up voluntarily and Mr. Peter William Harvey of Price Waterhouse & Co be appointed liquidator for the purposes of such winding up."

Dated this 16th day of October, 1974.

P. W. HARVEY, Liquidator.

Peter. William Harvey of Price Waterhouse & Co. be 1577

Unclaimed Moneys Act 1962.

Register of Unclaimed Moneys held by the—

Name of Owner on Books and Last Known Address.	Total Amount Due to Owner.	Description of Unclaimed Moneys.	Date when Amount first became Payable.
\$			
THE FEDERAL HOTELS LIMITED.			
Malony, John, C/- Suspense Account, The Federal Hotels Limited, 459 Swanston Street, Melbourne.	36.59	Dividend	7.4.61
Worrall, Robert W. 284 Burwood Road, Burwood	17.27	"	25.11.66
Burgoyne, Robert W., 37 Domain Road, South Yarra	44.37	"	27.10.61
McNeill, Robert, Gardner Road, Rochedale, Qld.	22.19	"	"
Millar, Thomas R., (Estate of), C/- Executors, 22 Medusa Street, Mosman, N.S.W.	133.13	"	"
Murray, John C., Oban, Maxwellton, Qld.	110.48	"	"
Spencer, Gareth J., Flat 3, 10 Stone Street, South Perth, W.A.	25.78	"	"
Bell, Rita J. (Miss) (Address unknown)	83.35	"	23.10.56
Stokes, Z. H. (Address unknown)	10.90	"	"
Reilly, Hugh J., Unit C3, 7 Ocean Avenue, Double Bay, N.S.W.	216.00	Preference Dividend	30.6.70
Abbott, Amy M. M/s, P.O. Box 213, Narooma, N.S.W.	17.10	"	31.12.69
Pascoe, Brenchley J. 31 Saturn Street, Caulfield	90.00	"	30.6.70
Gray, Oliver (estate of) C/- F. M. Williams, Watson & James, 61 Bull Street, Bendigo	21.60	"	30.6.71
Markillie, Richard R. (estate of) C/- The Federal Hotels Ltd. 459 Swanston Street, Melbourne	32.76	"	31.12.71
O'Brien, Eric, Dr. 23 Hazelbank Road, Crows Nest, N.S.W.	90.00	"	30.6.72
Edwards, Esther G. (estate of) C/- Abbott, Tout Green & Wilkinson, 35 Hunter Street, Sydney N.S.W.	18.00	"	31.12.72
O.S.K. Nominees Sdn Berhad Lee Wah Bank Building, Room 207, 2nd Floor Kuala Lumpur, Malaysia.	116.50	Interest on Deposits	30.9.71
Benedikt, Rosa Mrs., 52 St. Frances Street, Melbourne	50.40	"	31.3.72
Turnbull, Christopher S., 3 Sutherland Avenue, Paddington, N.S.W.	225.00	"	"
Donald, Myra M. Mrs., 40 Ryans Road, St. Lucia, Qld.	38.81	"	30.9.72
Hunter, Henry R., 146 Woodland Street, Essendon North	12.60	"	"
Stapleton, Herbert N., 6 Arnham Place, Red Hill, N.S.W.	12.60	"	"
Eardley, Robert P., Faggs Road, Gooburrum, Bundaberg, Qld.	32.00	"	31.10.69
Ither, Pierre J. A., 41 Lyon Street, Carnegie	10.36	"	31.3.72
Brown, Keith C. & Brown, Dorothy E. Mrs., Block 19E P.O., Numurkah	16.00	"	30.6.68
Evans, Vera M. Mrs., 29 Bent Street Caulfield	16.00	"	30.4.62
Frith, Stephen H., (address unknown)	12.00	"	30.4.68
Johnson, Frank G., 7 Queens Road, Hamilton, Qld.	32.00	"	30.4.67
Martin, Barbara M. M/s, 8 Gratton Terrace Wynnum, Qld.	90.00	"	30.4.67
1503			
NATIONAL CONSOLIDATED LIMITED.			
Webster, Frederick (estate of), c/o Wilkinson, Throsby and Edwards, Argyle Street, Moss Vale, N.S.W.	13.50	Dividend	15.11.71
Lynch, Siabhra Gribben (Miss), 62 Upland Road, Kelburn, Wellington, N.Z.	13.77	"	"
Wilderspin, Ivy (Mrs.), 39 Milson Street, South Perth, W.A.	18.00	"	30.3.72
1502			

COMPANIES ACT 1961.

NOTICE is hereby given that a final meeting of Members and Creditors of the below mentioned companies will be held on Monday 25th November, 1974, at the office of Lewis Luckins & Co. 6th Floor, 423 Bourke Street, Melbourne, pursuant to Section 272 of the Companies Act 1961 for the purpose of laying before the meeting an account showing how the winding up has been conducted and how the assets have been disposed of.

J. W. BRENNAN & CO. PTY. LTD. (In Liquidation) to be held at 10 A.M.

OVERSEAS ELECTRICAL PTY. LTD. (In Liquidation) to be held at 10.30 A.M. and also to pass a resolution pursuant to Section 284 (3) of the Companies Act 1961.

CLAYTON HOME FURNISHINGS PTY. LTD. (In Liquidation) to be held at 11 A.M. and also to pass a resolution pursuant to Section 284 (3) of the Companies Act 1961.

Dated this 30th day of October, 1974.

LEWIS LUCKINS, F.C.A., Liquidator.

Lewis Luckins & Co., chartered accountants, 423 Bourke Street, Melbourne, 3000. Telephone 67 6944. 1578

The Companies Act 1961.

GANE & HARRIS PROPRIETARY LIMITED (IN LIQUIDATION).

NOTICE CONVENING FINAL MEETING OF MEMBERS AND CREDITORS PURSUANT TO SECTION 272.

Notice is hereby given pursuant to Section 272 of the Companies Act 1961, that a General Meeting of the members and creditors of the abovenamed company will be held in the offices of Kennedy Small, 296-304 Little Lonsdale Street, Melbourne, on Wednesday the Twenty-

Seventh day of November, 1974, at 10.30 a.m. for the purpose of having an account laid before them showing the manner in which the winding up has been conducted and the property of the company disposed of and of hearing any explanations that may be given by the Liquidator.

Dated this 25th day of October, 1974.

JOHN MARTIN WALSH, Liquidator.

Kennedy Small, 296-304 Little Lonsdale Street, Melbourne, Vic. 3000. 1579

The Companies Act 1961.—In the matter of FRED ADLER & SONS (AUST.) PTY. LTD. (in Liquidation).

A FIRST DIVIDEND is intended to be declared in the above-mentioned matter. Creditors who have not proved their debts by the 14th day of November, 1974 will be excluded from the dividend.

Dated this 24th day of October, 1974.

ROBERT EASTAUGH RAMSAY, Liquidator.

Kennedy Small, 296-304 Little Lonsdale Street, Melbourne, 3000. 1580

The Companies Act 1961.

EASTERN INSTRUMENT & ELECTRONIC SERVICES PTY. LTD. (IN LIQUIDATION).

NOTICE is hereby given that a SECOND and FINAL DIVIDEND is intended to be declared in the above matter. Creditors who have not proved their debts by the 14th day of November, 1974 may be excluded from this dividend.

Dated this 21st day of October, 1974.

G. O. HARRISON, Liquidator.

Hall & Rose, chartered accountants, 395 Collins Street, Melbourne, 3000. 1591

The Companies Act 1961.
STRATH-KNITS PTY. LTD.

PURSUANT TO SECTION 260 OF THE COMPANIES ACT 1961.

Notice is hereby given that a Meeting of Creditors of STRATH-KNITS PTY. LTD. will be held at the Institute of Chartered Accountants, 140 Queen Street, Melbourne on Wednesday, 13th November, 1974 at 10.30 in the forenoon for the purpose of considering the Company's affairs, the Company having convened an Extraordinary General Meeting of its Members to be held on the same day for the purpose of considering and if thought fit, passing a Special Resolution that the Company be wound up voluntarily.

Dated this 24th day of October, 1974.

C. H. STERNFEIN, Director.

Hall & Rose, chartered accountants, 395 Collins Street, Melbourne, Vic., 3000. 1592

Companies Act 1961, Section 254 (2).
TOORAK SWIM POOL PTY. LTD. (IN VOLUNTARY LIQUIDATION).

Notice is hereby given that at an Extraordinary General Meeting of members of the abovenamed Company held on 18th October, 1974, the following Resolution was passed as a Special Resolution:—

"That the company be wound up voluntarily and that Francis Henry Parr of 17 Dorcas Street, South Melbourne, be appointed liquidator for the purposes of such winding up."

Dated this 22nd day of October, 1974.

1593 F. H. PARR, Liquidator.

Companies Act 1961, Section 272.
HAMES & YOUNG PTY. LTD. (IN LIQUIDATION).

NOTICE OF FINAL MEETING OF MEMBERS AND CREDITORS.

Notice is hereby given that the final meeting of members and creditors of the abovenamed Company shall be held on Monday 2nd December, 1974 at 2.00 p.m. at the meeting room of Max Gee & Co., 4 Burwood Highway, Burwood, 3125.

Agenda.

1. Presentation by the Liquidator of an account showing how the winding up has been conducted and the property of the Company has been disposed of, and to give any explanation of the account.

2. The meeting to consider the following resolution:

"That immediately after the dissolution of the Company the Liquidator may destroy the books and papers of the Company pursuant to Section 284 of the Act."

Dated this 24th day of October, 1974.

M. G. GEE, Liquidator.

Max Gee & Co., 325 Warrigal Road, Burwood, Victoria, 3125. Telephone: 288 5109. 1517

Companies Act 1961.—In the matter of APPIN PTY. LTD. (in Voluntary Liquidation).—Members Winding Up, Notice of Final Meeting.

Notice is hereby given pursuant to section 272 of the Companies Act that the final meeting of the members of the abovenamed company will be held on 10th Floor, 44 Market Street, Melbourne, on 25th November 1974 at 9.00 a.m. when I shall lay before the meeting an account of how the winding up has been conducted and the property of the company disposed of.

21st October, 1974.

1490 C. J. WAUGH, Liquidator.

The Companies Act 1961, as amended, Section 254 (2).—PELLEGRINI STATUARY CO. PTY. LIMITED (Members' Voluntary Liquidation).

Notice is hereby given that, at an extraordinary general meeting of the abovementioned company duly convened and held at 543 George Street, Sydney on the 14th October, 1974, the following special resolution was passed: "That the company be wound up voluntarily and that William James Hamilton, C/- Hamilton & Ferrier, Chartered Accountants of 49 York Street, Sydney, be appointed liquidator for the purposes of such winding-up."

1488 M. R. BARBERA, Director.

The Companies Act 1961.—In the matter of MISURACA HOLDINGS PTY. LTD. (in Liquidation).

Notice is hereby given that at an Extraordinary General Meeting of Shareholders of the abovenamed Company held on the 21st day of October, 1974 it was resolved that the

Company be wound up voluntarily and that George Frederick Alfred Farnham of 20 Hastings Square, Warragul, 3820 be and is hereby appointed liquidator for the purpose of such winding up.

Notice is also given that after 21 days from this date, I shall proceed to distribute the assets. All creditors having any claim against the Company should furnish particulars of same by that date, otherwise I shall proceed to distribute the assets, without regard to their claim.

Dated this 21st day of October, 1974.

G. F. A. FARNHAM, 20 Hastings Square, Warragul. 1484

NOTICE OF WINDING UP ORDER.

In the matter of CUSTOM CONTROL COMPANY PTY. LTD.

Winding up Order made the 17th day of October, 1974.

Name and address of Liquidator:—JOHN CHARLES COUZENS 305 Upper Heidelberg Road, IVANHOE.

T. IRLICHY, solicitor for the petitioner. 1485

Companies Act 1961.

CHIC-MAN PTY. LIMITED (IN VOLUNTARY LIQUIDATION).
NOTICE CONVENING FINAL MEETING OF MEMBERS, PURSUANT TO SECTION 272.

NOTICE is hereby given in pursuance of Section 272 of the Companies Act 1961, that a Meeting of the members of the above-named Company will be held on the fourth day of December, 1974 at the office of Messrs. John Rezak and Co., 66-68 Albert Road, South Melbourne at 11.00 a.m. for the purpose of having an account laid before them showing the manner in which the winding up has been conducted and the property of the Company disposed of and of hearing any explanations that may be given by the Liquidator.

Dated this 22nd day of October, 1974.

1486 JOHN REZAK, Liquidator.

In the matter of the Companies Act 1961; and in the matter of SEAL PRESS PTY. LTD. (in Voluntary Liquidation).—Notice of Final Meeting of Members, Pursuant to Section 272.

Notice is hereby given in pursuance of Section 272 of the Companies Act 1961 that a General Meeting of the members of the Company will be held at the office of W. Marshall & Associates, Chartered Accountants of Suite 2, 162 Albert Road, South Melbourne on the 27th day of November, 1974 at 10.30 o'clock in the forenoon for the purpose of having an account laid before it showing the manner in which the winding up has been conducted and the property of the Company disposed of, and hearing any explanation that may be given by the Liquidator.

Dated this 23rd day of October, 1974.

1516 E. S. FIELD, Liquidator.

In the matter of the Companies Act 1961; and in the matter of FAIR BUILDING CO. PROPRIETARY LIMITED (in Voluntary Liquidation).

Notice is hereby given pursuant to s. 272 (2) of the Companies Act 1961 that the final meeting of the company will be held at Suite 4, 556-558 North Road, Ormond, on Wednesday 4th December, 1974, at 12-45 p.m. for the purpose of laying before the meeting the account of the winding up and any explanation thereof.

Dated this 24th day of October, 1974.

FAY N. COUTTS, Liquidator, Suite 4, 556-558 North Road, Ormond. 1518

NOTICE OF WINDING-UP ORDER.

In the matter of WONDER LARDER FOOD SERVICE PTY. LTD.

WINDING-UP ORDER MADE:—The 17th day of October, 1974.

NAME AND ADDRESS OF LIQUIDATOR:—Michael Joseph O'Keefe of 164 High Street, Ashburton.

PIEONE & BORGHESI, solicitors for the petitioner. 1512

NOTICE OF WINDING-UP ORDER.

In the matter of M. F. MASTER FREEZE FREEZERS & FOOD SERVICE PTY. LTD.

WINDING-UP ORDER MADE:—The 17th day of October, 1974.

NAME AND ADDRESS OF LIQUIDATOR:—Michael Joseph O'Keefe of 164 High Street, Ashburton.

PIEONE & BORGHESI, solicitors for petitioner. 1513

The Companies Act 1961.—In the matter of TRIDENT MEAT PACKING CO. PTY. LTD.

NOTICE is hereby given that at a meeting of the members of the abovenamed company held on the 18th day of October, 1974, it was resolved that the company be wound up voluntarily and at a meeting of creditors held on the same day, pursuant to Section 260, it was resolved that for such purpose, Ronald Dennis Widdows, of 703 South Road, Moorabbin, Public Accountant, be appointed Liquidator.

Dated this 23rd day of October, 1974.

R. D. WIDDOWS, public accountant, Office 2, 703 South Road, Moorabbin, Vic. 3189. 1514

Companies Act 1961.—In the matter of YEOVIL PTY. LTD. in Voluntary Liquidation).—Members' Winding Up.—Notice of Final Meeting.

Notice is hereby given pursuant to Section 272 of the Companies Act that the final general meeting of the members of the abovenamed company will be held on 10th Floor, 44 Market Street, Melbourne on 28 November, 1974, at 9.00 a.m. when I shall lay before the meeting an account of how the winding up has been conducted and the property of the company disposed of.

24th October, 1974.

1515

C. J. WAUGH, Liquidator.

J. D. and C. J. LAWSON, TRADING AS "ROMANI CAFE".

NOTICE OF INTENTION TO DECLARE DIVIDEND.

NOTICE is hereby given that a first dividend will be declared on the 29th day of November, 1974.

Proofs of Debt must be lodged with the Trustee by the 25th day of November, 1974.

E. P. TAYLOR, trustee, 67A Church Street, Brighton, 3186, P.O. Box 185, Brighton, 3186. 92 7488. 1489

The Companies Act 1961.—In the matter of The WESTERN IRON FOUNDRY PTY. LIMITED (in Voluntary Liquidation).—Members' Winding Up.

NOTICE is hereby given that at the Extraordinary General Meeting of The Western Iron Foundry Pty. Limited duly convened and held at 1 Nicholson Street, Melbourne in the State of Victoria on the 16th day of September 1974, the following Resolution was proposed and passed as a Special Resolution.

"That the company be wound up voluntarily."

Dated this 17th day of September, 1974.

R. W. BETTS, Liquidator.

Messrs. Coopers & Lybrand, chartered accountants, 461 Bourke Street, Melbourne. 1527

In the matter of the Companies Act 1961; and in the matter of R. G. LONG & CO. PTY. LTD.

Notice is hereby given that at a meeting of the members of R. G. Long & Co. Pty. Ltd. on 25th October, 1974, the following resolution was passed as a Special Resolution:

That the company be wound up voluntarily and that Mr. Robert George Long of Pratt's Road, Junortoun, be and is hereby appointed Liquidator for the purposes of such winding up.

Bendigo, 25th October, 1974.

1613

R. G. LONG, Liquidator.

Companies Act 1961.

O. A. DICKSON PROPRIETARY LIMITED (IN LIQUIDATION).

NOTICE is hereby given, in pursuance of Section 272 of the Companies Act 1961, that a general meeting of the members of the abovenamed company will be held at the offices of Arthur Young & Company, 440 Collins Street, Melbourne on 27th November 1974, at 10.00 a.m. for the purpose of having the liquidator's account laid before them showing the manner in which the winding up has been conducted and the property of the company disposed of and of hearing any explanation that may be given by the liquidator; and also of determining the manner in which the books, accounts and documents of the company and of the liquidator thereof shall be disposed of.

Dated this 25th day of October, 1974.

J. D. SPENCE, Liquidator.

Arthur Young & Company, chartered accountants, 440 Collins Street, Melbourne, 3000. 1633

Companies Act 1961.

CONSOLIDATED THEATRES LIMITED (IN VOLUNTARY LIQUIDATION).

PURSUANT TO SECTION 272 (2).

Notice is hereby given that the Final Meeting of the Members of the above company will be held at the office of Fitzgerald Gunn & Partners, 10th Floor, 470 Collins Street Melbourne on 5 December 1974 at 10 a.m.

The purpose of the meeting is to receive the account of the liquidator showing how the winding up has been conducted and how the property of the company has been disposed of and to give any explanation of this account.

Dated this 28th day of October, 1974.

J. R. BALLANTYNE, liquidator, 470 Collins Street, Melbourne. 1634

The Companies Act 1961.—In the matter of H. J. FELSTEAD PTY. LTD. (in Liquidation).

A FIRST DIVIDEND is intended to be declared in the above-mentioned matter. Creditors who have not proved their debts by the 20th day of November, 1974 will be excluded from the dividend.

Dated this 30th day of October, 1974.

ROBERT EASTAUGH RAMSAY, Liquidator.

Kennedy, Smail, 296 Little Lonsdale Street, Melbourne, 3000. 1635

Companies Act 1961, Section 272 (2).

ALSTERGREN TIMBER INDUSTRIES PTY. LTD.

AMERICAN EASI-BILD PATTERNS PTY. LTD.

CLIMAX MODULAR PTY. LTD.

(ALL IN VOLUNTARY LIQUIDATION).

NOTICE OF FINAL MEETING.

Notice is hereby given that pursuant to Section 272 of the Companies Act 1961, general meetings of the members of the abovenamed companies will be held at Messrs. Peat, Marwick, Mitchell & Co., 12th floor, 447 Collins Street, Melbourne on the 2nd day of December 1974 commencing at 10.00 o'clock in the forenoon.

The purpose of the meetings is to lay accounts before them showing the manner in which the windings ups have been conducted and the property of the companies disposed of and of hearing any explanation that may be given by the liquidator.

Dated this 28th day of October, 1974.

J. M. POULTON and D. A. CRAWFORD,
Joint and Several Liquidators.

Peat, Marwick, Mitchell & Co., 447 Collins Street, Melbourne, 3000. 1636

OSLO HOLDINGS LIMITED (IN LIQUIDATION).

Creditors of the abovenamed company which is being wound-up are required on or before the Twentieth day of November, 1974, to send their names and addresses and particulars of their debts or claims and of any security held by them to the undersigned and, if subsequently required by notice in writing from the liquidator, shall formally prove their debts or claims and establish any title they may have to priority by affidavit as required by any such notice. In default of complying with any such notice they will be excluded from the benefit of any distribution made before such debts or claims are proved or such priority is established and from objecting to any such distribution.

Dated this 18th day of October, 1974.

A. H. BAYLEY, liquidator, 8th Floor, 117 Pitt Street, Sydney, N.S.W. 2000. 1637

Victoria.

Companies Act 1961.

HYDROMECRANE PTY. LIMITED.

NOTICE OF APPOINTMENT OF RECEIVER AND MANAGER.

THE NATIONAL BANK OF AUSTRALASIA LIMITED whose Head Office is situated at 271-285 Collins Street Melbourne in the State of Victoria HEREBY GIVES NOTICE that on the 21st day of October 1974 it appointed ANDREW IAN SINCLAIR of 446 Collins Street Melbourne

in the said State of Victoria Chartered Accountant as Receiver and Manager of the business and property in Victoria and New South Wales of Hydromecrane Pty. Limited under the powers contained in a certain Debenture Charge dated 7th November 1973 and numbered 6045/1 in the register of charges of the Registrar of Companies of the State of South Australia numbered 24605 in the register of charges of the Registrar of Companies in the State of Victoria and numbered 55205 in the register of charges of the Corporate Affairs Commission of the State of New South Wales and given by the said Hydromecrane Pty. Limited to the National Bank of Australasia Limited.

Dated this 21st day of October, 1974.

The National Bank of Australasia Limited,
A. I. SINCLAIR,
Manager for the State of South Australia.

Duesbury & Johnston, chartered accountants, 446 Collins Street, Melbourne, 3000.

In the Supreme Court of Victoria.—No. CO. 8949 of 1974.—
In the matter of the Companies Act 1961; and in the matter of THE WEAVE PTY. LTD.

NOTICE IS HEREBY GIVEN that a Petition for the Winding up of the abovenamed Company by the Supreme Court was on the 16th day of October, 1974 presented by CHARLES PARSONS (VIC.) PTY. LTD.; AND THAT the said Petition is directed to be heard before the court sitting at the 14th Court, Law Courts, William Street, Melbourne on the 29th day of November, 1974 at the hour of 10.30 o'clock in the forenoon; and any creditor or contributory of the said Company desiring to support or oppose the making of an order on the said Petition may appear at the time of hearing by himself or his Counsel for that purpose; and a copy of the Petition will be furnished to any creditor or contributory of the said Company requiring the same by the undersigned on payment of the regulated charge for the same.

THE PETITIONER'S ADDRESS IS 67 Nicholson Street, Brunswick.

THE PETITIONER'S SOLICITORS ARE Messrs. Kirby & Co. of 224 Queen Street, Melbourne.

KIRBY & CO.,
Solicitors for the Petitioner.

NOTE: Any person who intends to appear on the hearing of the said Petition must serve on or send by post to the abovenamed Solicitors, notice in writing of his intention so to do. The notice must state the name and address of the person, or, if a firm, the name and address of the firm and must be signed by the person or firm, or his or their Solicitor (if any) and must be served, or if posted, must be sent by post in sufficient time to reach the abovenamed not later than 4 o'clock in the afternoon of the 28th day of November, 1974. 1487

ALEXANDER REGHENZANI, late of Wandin North, in the State of Victoria, farmer, DECEASED.

Creditors, next of kin and others having claims in respect of the estate of the deceased (who died on the 17th day of August, 1974) are required by the Executors LORNA ALICE REGHENZANI of Wandin North, Widow and RICHARD PATRICK BAYLOR of Healesville, Solicitor to send particulars to them, care of the undersigned, on or before the 10th day of January, 1975 after which date they will distribute the assets having regard only to the claims of which they then have notice.

R. P. BAYLOR & CO., solicitors, Healesville. 1483

WILLIAM SIDNEY AYLING, late of 12 Wedge Street, Hamilton, retired shearing contractor, DECEASED.

Creditors next of kin and others having claims in respect of the estate of the above deceased who died on the 15th day of December 1971 are required by the Executors ELMA GOLDSTEIN MURRAY and ELMA DAWN MURRAY both of 37 Francis Street Hamilton to send particulars thereof to them in care of the undersigned on or before the 3rd day of January 1975 after which date they will distribute the assets having regard only to the claims of which they then have notice.

MELVILLE, ORTON & LEWIS, solicitors, 66 Thompson Street, Hamilton, 3300. 1506

Creditors next of kin and others having claims in respect of the Will of ELLA MAY SEVIOR late of 54 Dover Street Flemington widow who died on the 18th day of September 1974 are requested to send particulars of their claims to the Executors WILLIAM SOUTHWELL MOORE and

REGINALD ARTHUR MOORE care of the undermentioned Solicitor by the 14th day of January 1975 after which date they will distribute the assets having regard only as to the claims of which they then have notice.

JOHN STEWART, of 290 Racecourse Road, Newmarket. 1507

FRANCIS HENRY DYE, late of 87 Clarence Street, Geelong West, retired railway employee, DECEASED.

Creditors, next of kin, and others having claims in respect of the estate of the deceased, who died on the 2nd August 1974, are required by the personal representatives, JAMES DYE, of Inverleigh, Retired Railway Employee, and HENRY CHARLTON FALLAW, of 24 Ryrie Street, Geelong, Solicitor, to send particulars to them, in care of the undermentioned Solicitors, by the 15th day of January 1975, after which date the personal representatives may convey or distribute the assets, having regard only to the claims of which they then have notice.

FALLAW & HENDERSON, solicitors, 24 Ryrie Street, Geelong. 1508

IVY VICTORIA HOLIAN, late of 155 Beavers Road, Northcote, widow, DECEASED, who died on the 19th day of July, 1974.

CREDITORS next of kin and others having claims against the estate of the abovenamed deceased are required by the Executor of her Will THE TRUSTEES EXECUTORS AND AGENCY COMPANY LIMITED of 401 Collins Street, Melbourne to send particulars thereof to the said Company at its said address before the 30th day of December 1974 after which date the Company may distribute the assets of the deceased having regard only to the claims of which notice has then been received.

JOHN DON & EDNEY, solicitors, 24-26 Riddell Parade, Elsternwick. 1509

HOWARD SAMUEL BROWN, late of Gembrook Road, Pakenham, orchardist, DECEASED.

Creditors next of kin and others having claims in respect of the estate of the deceased who died on the Third day of November 1973 are required by BRUCE COX of Gembrook Road Pakenham Medical Practitioner the Executor of the Will of the said deceased to send particulars to him in the care of the undermentioned Solicitors by the Eleventh day of January 1975 after which date the said Executor may convey or distribute the assets having regard only to the claims of which he then has notice.

MACPHERSON & KELLEY, solicitors, 229 Thomas Street, Dandenong. 1510

CREDITORS next of kin and other persons having claims against the estate of RUBENA HAMILTON LOVE late of 33 Moama Road East Malvern Spinster deceased who died on the 23rd day of November 1973 are to send the particulars of their claims to the executors of the Estate in the care of the undermentioned Solicitors by the 17th day of December 1974 after which date the said executors will distribute the assets having regard only to the claims of which they then have notice.

S. W. MISSON & BARTLEY, solicitors, 59 Waverley Road, East Malvern. 1612

Creditors next-of-kin and others having claims in respect of the estate of JOHANNES CORNELIS OOSTERMEYER late of 3 French Street Croydon Bookseller and Publisher deceased who died on 14th April 1973 and Probate of whose Will has been granted to MARIA ANNA OOSTERMEYER of 3 French Street Croydon Widow are required to send particulars of their claims to the Executrix care of the undermentioned Solicitors by the 3rd day of January 1975 after which date she will distribute the assets having regard only to the claims of which she shall then have notice.

J. W. GLOVER & CO., solicitors, 422 Collins Street, Melbourne. 1616

Creditors next-of-kin and others having claims in respect of the estate of ANDREW ZANELLI late of Wellington Road Wandin North Orchardist deceased who died on the 29th day of July 1974 and Probate of whose Will has been granted to NICHOLAS PAUL ZANELLI of 5 Cornish Street Shepparton Retired are required to send particulars of their claims to the said executor care of the undermentioned Solicitors by the 3rd day of January 1975 after which date he will distribute the assets having regard only to the claims of which he then has notice.

J. W. GLOVER & CO., solicitors, 422 Collins Street, Melbourne. 1617

Creditors next-of-kin and others having claims in respect of the estate of IVY MAY MORGAN late of 153 Hutton Street Thornbury Widow deceased who died on the 22nd day of July 1974 and Probate of whose Will has been granted to MARY VIRGINIA ELLIS of 148 Kooyong Road Toorak Solicitor are required to send particulars of their claims to the said Executrix care of the undermentioned Solicitors by the 3rd day of January 1975 after which date she will distribute the assets having regard only to the claims of which she then has notice.

J. W. GLOVER & CO., solicitors, 422 Collins Street, Melbourne. 1618

Creditors next-of-kin and others having claims in respect of the estate of LEWIS HENRY COLLISON late of 9 Crosbie Road Murrumbidgee Real Estate Agent deceased who died on the 11th day of March 1974 and Letters of Administration with the Will annexed of whose Estate have been granted to HEATHER MARLENE MENGLER of 52 Jones Road Dandenong Married Woman are required to send particulars of their claims to the Administratrix care of the undermentioned Solicitors by the 3rd day of January 1975 after which date she will distribute the assets having regard only to the claims of which she then has notice.

J. W. GLOVER & CO., solicitors, 422 Collins Street, Melbourne. 1619

MURIEL VIOLA PATTERSON, late of 11 Seaview Crescent, Black Rock, widow, DECEASED.

Creditors, next of kin and others having claims in respect of the Estate of the deceased who died on the 16th July, 1974 are required by the Trustee LESLIE WASHINGTON PATTERSON of 42 Watahuna Avenue, Hawthorndene in the State of South Australia, Supervisor to send particulars to him care of the under-signed by the 1st January, 1975 after which date the Trustee may convey or distribute the assets having regard only to the claims of which he then has notice.

MESSRS. WHITING & BYRNE, 440 Collins Street, Melbourne. 1620

GIOCONDO ZANATTA, late of Ballarat Mental Hospital, Ballarat, in the State of Victoria, gentleman, DECEASED, intestate.

Creditors, next-of-kin, and others having claims in respect of the estate of the deceased, who died on the 18th November 1973 are required by the Administrator of the estate of the deceased, FRANK JOHN ZANATTA of 58 Phoenix Street Sunshine Clerk to send particulars to him care of the undersigned solicitors by the 30th day of December 1974 after which date the Administrator may convey or distribute the assets, having regard only to the claims of which he then has notice.

FREDERICK OWEN & ASSOCIATES, solicitors, 84 William Street, Melbourne, 3000. 1627

CREDITORS NEXT-OF-KIN AND OTHERS having claims in respect of Estate of MARGARET SIMMONS late of Ashwood Private Hospital High Street Road Ashwood Widow deceased who died on the 24th day of September 1974 are to send particulars of their claims to KEITH ANTHONY GRABAU and JOHN LESLIE EDWARDS care of the undersigned by the 2nd day of January, 1975 after which date they will distribute the assets having regard only to the claims of which they then have notice.

COOK & McCALLUM, solicitors, 422 Collins Street, Melbourne. 1628

CREDITORS next of kin and others having claims in respect of the estate of ELIZABETH MAUDE ROBLEY late of 215 Dandenong Road, Windsor, Widow, deceased, who died on the 2nd April, 1974, are required by the executor ROBERT WINSTON GAYLARD of 51 Queen Street, Melbourne, Solicitor, to send particulars of their claims to him c/- Messrs. Rogers & Gaylard of 51 Queen Street, Melbourne, Solicitors, prior to the 1st January, 1975 after which date the said executor shall distribute the estate having regard only to the claims of which he shall have had notice.

ROGERS & GAYLARD, 51 Queen Street, Melbourne.

1629

RONALD WALTER McCOSKER, late of Flat 2, 444 Dandenong Road, North Caulfield, manufacturer, DECEASED.

CREDITORS next of kin and others having claims in respect of the estate of the deceased who died on 14th March 1974 are required to send particulars of such claims to the Executor William Alfred Bunn care of the under-mentioned Solicitor by 16th January 1975 after

which date the Executor may convey or distribute the assets having regard only to the claims of which he then has notice.

M. JOHN KELLY, solicitor, 422 Collins Street, Melbourne. 1630

CREDITORS next of kin and others having claims against the Estate of MARIE ELLEN BESNARD late of 6 Rhodes Street Springvale in the State of Victoria Widow deceased who died on the 8th day of April 1971 are requested to send particulars of their claims to MARIE JEANNE LAMM of 1 Whitworth Avenue Springvale in the said State Widow care of the below mentioned Solicitors by the 31st day of December 1974 after which date she will distribute the assets having regard only to the claims of which she then has notice.

PURVES & PURVES, solicitors, 121 William Street, Melbourne. 1631

RONALD WALTER McCOSKER, late of Flat 2, 444 Dandenong Road, North Caulfield, manufacturer, DECEASED.

CREDITORS next of kin and others having claims in respect of the estate of the deceased who died on 14th March 1974 are required to send particulars of such claims to the Executor William Alfred Bunn care of the under-mentioned Solicitor by 16th January 1975 after which date the Executor may convey or distribute the assets having regard only to the claims of which he then has notice.

M. JOHN KELLY, solicitor, 422 Collins Street, Melbourne. 1570

CREDITORS next-of-kin and others having claims against the Estate of Thomas Edward Neville Payne late of "Woodburn" Killmore farmer and grazier who died on 20th December 1971 are required by the executors to send particulars of their claims to them in care of the undersigned by 31st December 1974 after which date they will proceed to distribute the estate having regard only to the claims of which they then have notice.

E. L. VAIL & BENJAMIN, solicitors, 480 Bourke Street, Melbourne. 1583

CREDITORS next of kin and others having claims in respect of the estate of JOHN LAWRENCE HENTY HINDSON late of 77 Findlay Street Portland Gentleman deceased (who died on the 30th day of March 1974) are required to send particulars of their claims to THE TRUSTEES EXECUTORS AND AGENCY COMPANY LIMITED and BETH HENTY-ANDERSON at No. 401 Collins Street Melbourne by the 3rd day of January 1975 after which date the executors will distribute the assets having regard only to the claims of which they then have notice.

SEWELL & SEWELL, 454 Collins Street, Melbourne, solicitors. 1584

VERONICA EMILY BATE, late of Flat 9, 7 Waverley Avenue, Ivanhoe, widow, DECEASED.

Creditors and next of kin and others having claims in respect of the estate of the deceased who died on the 25th day of May 1974 are required by the Trustees THE UNION-FIDELITY TRUSTEE COMPANY OF AUSTRALIA LIMITED of 100 Exhibition Street Melbourne to SEND PARTICULARS of their claims to the said Trustees care of the Solicitors below by the 10th day of January 1975 after which date the Trustees may convey or distribute the assets having regard only to the claims of which they shall then have had notice.

DUGDALE DIMMICK & STEVENS, solicitors, 37 Queen Street, Melbourne. 1585

CREDITORS next of kin and others having claims in respect of the Estate of MARY TERESA LARKIN late of 16 Bishop Street Box Hill Married Woman deceased intestate who died on the 2nd day of February 1974 are required to send particulars of their claims to BERNARD JAMES LARKIN of 16 Bishop Street Box Hill Draftsman the Administrator of the Deceased's Estate by the 15th day of January 1975 after which date the Administrator will distribute the assets having regard only to the claims of which he shall have had notice.

HEFFEY & BUTLER, solicitors, 258 Little Bourke Street, Melbourne. 1586

CREDITORS next of kin and others having claims in respect of the Estate of WINIFRED SYBIL DONOHUE late of 10 Baker Street Richmond Pensioner deceased who died on the 6th day of May 1974 are required to send particulars of their claims to STANLEY CHARLES DONOHUE of 10 Baker Street Richmond Pensioner the Executor of the Will of the said Deceased Care of HEFFEY

& BUTLER Solicitors of 258 Little Bourke Street Melbourne prior to the 15th day of January 1975 after which date the said Executor will distribute the assets having regard only to the claims of which he then shall have had notice.

HEFFEY & BUTLER, solicitors, 258 Little Bourke Street, Melbourne. 1587

IAN EDGAR GREENHAM, formerly of 33 William Street, Korumburra, in the State of Victoria, clerk, but late of 19 Cadell Street, Swan Hill, in the said State, invalid pensioner, DECEASED.

Creditors next-of-kin and other persons having CLAIMS against the Estate of the said Deceased who died on the 14th day of July 1974 ARE REQUIRED to send particulars of same to the Executors BASIL FREDERICK GREENHAM and CORAL SHEILA HEIL in care of the undersigned on or before the 2nd day of January 1975 after which date they will distribute the assets having regard only to the claims of which they then have notice.

DELANY & DWYER, barristers and solicitors, 201 Campbell Street, Swan Hill. 1588

Creditors next of kin and others having claims in respect of the estate of IRMA MURIEL CURRY late of 1 Walpole Court Watsonia Married Woman deceased who died on the 10th August 1974 are required by the executor Alfred Horace Jackson to send particulars of their claims to him care of the under mentioned Solicitor by the 31st day of December 1974 after which date he will distribute the assets having regard only to the claims of which he then has notice.

DAVID BULLARD, of 443 Little Bourke Street, Melbourne, solicitor. 1589

In the estate of FREDERICK STEPHENSON, late of 95 Central Road, Blackburn, retired railway employee, DECEASED, intestate.

CREDITORS next of kin and all others having claims against the estate of the abovenamed deceased are hereby required to send particulars in writing of such claims to DORIS MAY STEPHENSON (the administrator of the estate of the said deceased) care of her solicitors at their address set out below on or before the 31st day of December, 1974 after which date she will proceed to distribute the assets of the said deceased having regard only to the claims of which she shall then have had notice.

JOHN MORAN & HAYES, 422 Collins Street, Melbourne, solicitors for the said Doris May Stephenson. 1590

ROBERT WILLIAM BURNES, late of 12 Seventh Street, Eildon, gentleman, DECEASED.

Creditors next of kin and others having claims in respect of the deceased who died on the 27th day of May 1974 are required by his Trustee JACK CHARLES BURNES of Goulburn Valley Highway Thornton Gentleman to SEND PARTICULARS to him care of the undersigned firm of Solicitors by the 10th day of January 1975 after which date the Trustee may convey and distribute the assets having regard to the claims of which they then have notice.

MAL. RYAN, JACKSON & GLEN, of Grant Street, Alexandra, solicitors for the Trustee. 1537

Creditors, next-of-kin and others having claims in respect of the Estate of MAX SALA late of Flat 2, 17 Bowen Street, Hawthorn, Gentleman deceased who died on the Ninth day of July, 1974, are to send the particulars of their claims to THE EQUITY TRUSTEES EXECUTORS AND AGENCY COMPANY LIMITED of 472 Bourke Street, Melbourne, by the First day of January, 1975, after which date it will distribute the assets having regard only to the claims of which it then has notice.

W. H. FLOOD & PERMEZEL, 388 Bourke Street, Melbourne, solicitors for the said company. 1562

CREDITORS next of kin and others having claims in respect of the Estate of CLARENCE WILTON WHITE late of 7 Robinhood Road East Ivanhoe Retired deceased (who died on 4th July, 1974) are required by the Executors Kenneth Clarence White of 7 Robinhood Road East Ivanhoe Commercial Traveller and Phillip Windmiller Ettelson of 100 Queen Street Melbourne Solicitor to send particulars of their claims to them care of the undermentioned Solicitors by 8th February 1975 after which date they will convey or deal with the assets having regard only to the claims of which they then have notice.

UPTON & ETTELSON, solicitors, 100 Queen Street, Melbourne. 1563

TERESA ITALIANO, late of 28 Leveson Street, North Melbourne, widow, DECEASED.

Creditors next-of-kin and others having claims against the estate of the abovenamed deceased who died on the 11th July 1974 are to send particulars of their claims to the Executor Leo Italiano care of the undersigned solicitors by the 2nd day of December 1974 after which date he will distribute the assets of the deceased having regard only to the claims of which he then has notice.

IRVING S. PLOTKIN & CO., solicitors, 388 Bourke Street, Melbourne. 1564

GERALD WILLIAM AUSTIN, formerly of 12A Darling Point Road, Darling Point, near Sydney, in the State of New South Wales, but late of War Veterans' Home, 7 Veterans' Parade, Narrabeen, in the said State, retired grazier, DECEASED.

Creditors, next of kin and others having claims in respect of the estate of the said deceased (who died on the 22nd day of July 1974) are required by THE PERPETUAL EXECUTORS AND TRUSTEES ASSOCIATION OF AUSTRALIA LIMITED of 50 Queen Street, Melbourne, to send particulars of their claims to the said Company by the 1st day of January 1975 after which date it will convey or distribute the assets, having regard only to the claims of which the Company then has notice.

HOME, WILKINSON & LOWRY, solicitors, of 401 Collins Street, Melbourne. 1565

JAMES ALEXANDER GERRARD, late of 2A Cavendish Place, Brighton, company secretary, DECEASED.

Creditors next of kin and others having claims in respect of the estate of the deceased who died on 19th May 1974 are required by the executor Margaret Jean Gerrard of 2A Cavendish Place Brighton to send particulars to her care of the under-mentioned solicitors by the 31st December 1974 after which date the executor may convey or distribute the assets having regard only to the claims of which she then has notice.

HADEN SMITH & FITCHETT, solicitors, 423 Bourke Street, Melbourne. 1566

RICHARD STANLEY PERRY, late of 7 Hastings Avenue, Beaumaris, in the State of Victoria, labourer, DECEASED, intestate.

Creditors, next-of-kin and others, having claims in respect of the estate of the deceased who died on the 27th day of September 1973, are required by the personal representative NATIONAL TRUSTEES EXECUTORS AND AGENCY COMPANY OF AUSTRALASIA LIMITED the registered office of which is at 95 Queen Street, Melbourne, to send particulars to it by the 10th day of January 1975, after which date the said Company may convey or distribute the assets having regard only to the claims of which it then has notice.

CAREY, SCANLAN & BUTCHER, solicitors, 486 Neerim Road, Murrumbidgee. 1567

CREDITORS next of kin and others having claims in respect of the estate of CARMELO GAFFIERO (also known as Charlie or Charles Gaffiero) formerly of 8 St. Leonard Avenue, St. Albans in the State of Victoria, but late of 205 Melville Parade, Como in the State of Western Australia, Auto Mechanic deceased are required by CHARLES WESLEY HAACK the Executor to whom probate of the Will of the said Deceased was granted by the Supreme Court of Victoria on the 28th day of March, 1973 to send particulars in writing of such claims to him care of his undermentioned solicitors before the 21st day of January, 1975 after which date he may convey or distribute the assets of the said deceased having regard only to the claims of which he then has notice.

AKEHURST, FRIEND & HAACK, solicitors, 10 Queen Street, Melbourne, 3000. 1568

MARJORIE HOPE CATO, late of 7 McMaster Court, Toorak, widow, DECEASED.

Creditors next-of-kin and others having claims in respect of the estate of the deceased who died on the Ninth day of June 1974 are required by the personal representatives Maurice Howell Davies and The Trustees Executors and Agency Company Limited c/o 401 Collins Street Melbourne to send particulars to them by the 31st day of December 1974 after which date they will distribute the assets having regard only to the claims of which they then have notice.

E. P. JOHNSON & DAVIES, of 339 Collins Street, Melbourne. 1569

JESSIE EVA MCKAY, late of 22 Wattle Grove, Moreland, married woman, DECEASED.

Creditors next of kin and others having claims in respect of the estate of the abovenamed deceased who died on the Fourteenth day of July 1974 are required by THE TRUSTEES EXECUTORS AND AGENCY COMPANY LIMITED of 401 Collins Street Melbourne the Executor of the Will of the said deceased to send particulars of their claims to the said Company by the Sixth day of January 1975 after which date the said Company will convey or distribute the assets having regard only to the claims of which it then has notice.

RUSSELL, KENNEDY & COOK, solicitors, 257 Collins Street, Melbourne. 1632

CREDITORS next of kin and others having claims in respect of the Estate of NARCISSUS VIOLET LEE late of Flat 2 "Elann" 85 Pleasant Road, Hawthorn in the State of Victoria Widow Deceased who died on the 25th. day of July, 1974 are to send particulars of their claims to THE UNION-FIDELITY TRUSTEE COMPANY OF AUSTRALIA LIMITED of 100 Exhibition Street, Melbourne by the 31st. day of December, 1974 after which date it will distribute the assets having regard only to the claims of which it then has notice.

WILLIAM HARRISON & SON, solicitors, 11 Bank Place, Melbourne. 1596

CREDITORS next of Kin and others having claims in respect of the estate of BRYAN STANLEY LOCKHART late of 1 Iris Road, Glen Iris in the State of Victoria Building Estimator deceased who died on the 4th day of November 1973 are required to send particulars of their claims to the Executors JUDITH CARMEN ELPHICK & BARBARA JEAN LOCKHART C/- Bernard Nolan & Co., Solicitors 380 Bourke Street Melbourne on or before the tenth day of January 1974 after which date they will distribute the assets having regard only to the claims of which they then have notice.

BERNARD NOLAN & CO., solicitors, 4th Floor, 380 Bourke Street, Melbourne. 1602

CREDITORS next-of-kin and others having claims in respect of the estate of YVONNE THERESA BLANCHFIELD late of Flat 1, 42 The Avenue Balaclava in the State of Victoria, Clerk deceased who died on or about the 30th day of August One Thousand Nine Hundred and Seventy Three are to send particulars of their claim to the Executor WILLIAM PARKINSON of 7 Myers Avenue, Glen Waverley in the said State Secretary, care of the undermentioned Solicitors by the 10th day of January, One Thousand Nine Hundred and Seventy Four after which date the Executors will distribute the estate having regard only to the claims of which they then have notice.

BERNARD NOLAN & CO., solicitors, 380 Bourke Street, Melbourne, Vic., 3000. 1603

CREDITORS next-of-kin and others having claims against the Estate of PAULINE CHAPMAN late of 16 Sidwell Avenue, East St. Kilda in the State of Victoria Married Woman deceased who died on the 28th day of December, 1973 are required to send particulars of their claims to the NATIONAL TRUSTEES EXECUTORS AND AGENCY COMPANY OF AUSTRALASIA LIMITED of 95 Queen Street, Melbourne in the said State, one of the executors of the Estate on or before the 7th day of January, 1975 after which date the Executors will distribute the assets of the Estate having regard only to the claims of which they shall then have notice.

SACKVILLE, WILKS & CO., solicitors, of 100 Collins Street, Melbourne. 1604

THOMAS SYDNEY SPINKS, late of 86 Splatt Street, Swan Hill, in the State of Victoria, gentleman, DECEASED.

Creditors next-of-kin and other persons having CLAIMS against the Estate of the said deceased who died on the 22nd day of July 1974 ARE REQUIRED to send particulars of same to the Administratrix EILEEN SPINKS in care of the undersigned on or before the 9th day of January 1975 after which date she will distribute the assets having regard only to the claims of which she then has notice.

DELANY & DWYER, barristers and solicitors, 201 Campbell Street, Swan Hill. 1606

ALL PERSONS having claims against the estate of DAISY MAY FORD late of Elgar Private Hospital, 366 Elgar Road Box Hill in the State of Victoria Widow deceased who died on the 17th day of February 1974 and Letters of Administration with Will annexed of whose estate were granted by the Supreme Court of the said State on the 25th day of October 1974 to THE TRUSTEES

EXECUTORS AND AGENCY COMPANY LIMITED of 401 Collins Street Melbourne in the said State are required to send particulars in writing of such claims to THE TRUSTEES EXECUTORS AND AGENCY COMPANY LIMITED at its abovementioned address on or before the 8th January 1975 after which date THE TRUSTEES EXECUTORS AND AGENCY COMPANY LIMITED will proceed to distribute the assets of DAISY MAY FORD deceased which shall have come to its hands amongst the persons entitled thereto, having regard only to the claims of which it shall then have had notice.

Dated this 28th day of October, 1974.

COOKE & CUSSEN, solicitors, 128 Exhibition Street, Melbourne. 1605

In the will of MAXWELL De MEY WARREN (also known as MAXWELL DEMEY WARREN), late of .65 Coppin Street, East Malvern, in the State of Victoria, retired electrical engineer, DECEASED.

CREDITORS, next of kin, and others having claims in respect of the estate of the deceased who died on the 8th day of July 1974 are required by the Executor THE EQUITY TRUSTEES EXECUTORS AND AGENCY COMPANY LIMITED whose address is 472 Bourke Street, Melbourne to send particulars of their claims to them at the said address by the fourteenth day of January 1975 after which date they will distribute and/or convey the assets amongst the persons entitled thereto having regard only to the claims of which they then have notice.

PETER R. KEMPSON & CO., solicitors, 470 Collins Street, Melbourne, solicitors for the executor. 1608

In the intestate estate of DIANNE PATRICIA JOHNSTON, late of 4 Wingham Court, Frankston, in the State of Victoria, home duties, DECEASED.

CREDITORS, next of kin, and others having claims in respect of the estate of the deceased who died on the 14th day of August 1974 are required by the Administrator WILLIAM ALBERT JOHNSTON whose address is care of Peter R. Kempson & Co., Solicitors, 8th Floor, 470 Collins Street, Melbourne to send particulars of their claims to him at the said address by the fourteenth day of January 1975 after which date he will distribute and/or convey the assets amongst the persons entitled thereto having regard only to the claims of which he then has notice.

PETER R. KEMPSON & CO., solicitors, 470 Collins Street, Melbourne, solicitors for the administrator. 1607

Creditors next of kin and all other persons having claims against the estate of MARGARET MARY GRIFFIN late of 12a/38 Holyrood Road Hampton Teacher who died on the 26th day of April One thousand nine hundred and seventy-four are to send particulars of such claims to NATIONAL TRUSTEES EXECUTORS AND AGENCY COMPANY OF AUSTRALASIA LIMITED of 95 Queen Street Melbourne by the 31st day of December, One thousand nine hundred and seventy-four after which date the Company will distribute the assets having regard only to the claims of which it shall then have notice.

COOKE & CUSSEN, solicitors, 128 Exhibition Street, Melbourne. 1609

CREDITORS next of kin and others having claims in respect of the estate of GRAEME REX McMILLEN late of Flat 5 Number 379 Toorak Road South Yarra representative deceased who died on the 21st day of May 1974 are required to send particulars of their claims to THE TRUSTEES EXECUTORS AND AGENCY COMPANY LIMITED of 401 Collins Street Melbourne by the 8th day of January 1975 after which date it will distribute the assets having regard only to the claims of which it then has notice.

BEACH & THOMSON, solicitors, 472 Bourke Street, Melbourne. 1595

CREDITORS next of kin and others having claims against the Estate of JOSEPH XIBRRAS (also known as JOE XIBERRAS, JOE XIBRRAS and CHARLES XIBRRAS) late of Care of the Ballarat Base Hospital Sturt Street, Ballarat in the State of Victoria Pensioner Deceased (who died on the 17th day of May, 1974) are required to send particulars of their claims to Byrne Jones and Torney of 38 Lydiard Street South, Ballarat in the said State the Solicitors of the Estate of the said deceased by the First day of January One thousand nine hundred and seventy-five after which date the said Solicitors will distribute the assets having regard only to the claims of which it then has notice.

BYRNE, JONES & TORNEY, solicitors, Ballarat. 1536

NITA ALICE DEVINE, late of 51 Tulip Street, Violet Town, widow, DECEASED.

Creditors next-of-kin and others having claims in respect of the estate of the deceased who died on 14th July, 1974 are required by the Executor BRENDAN JOSEPH McGUINNESS of 51 Queen Street, Melbourne to send particulars to him care of the undersigned by 30th December, 1974 after which date the Executor may distribute the assets having regard only to the claims of which he then has notice.

BRENDAN McGUINNESS & CO., solicitors, of 51 Queen Street, Melbourne. 1533

Creditors, Next of Kin and others having claims in respect of the Estate of RICHARD THOMAS PHILLIPS formerly of 25 York Street, Pascoe Vale in the State of Victoria but late of 42 Erasmus Street, Surrey Hills in the said State Retired deceased who died on the 31st day of May 1974 are required by the Executors of the Estate JACOB PHILLIPS of 42 Erasmus Street Surrey Hills aforesaid Retired and LEWIS PHILLIPS of 14 Albert Street, Merlynston aforesaid Retired to send particulars to N. C. Gay & Co., Solicitors of 136 Sydney Road, Brunswick by the 1st day of January 1975 after which date the said Executors may distribute the assets having regard only to claims of which they then have notice.

N. C. GAY & CO., solicitors, 136 Sydney Road, Brunswick. 1552

CREDITORS, next-of-kin and others, having claims in respect of the Estate of VIOLET MURIEL SMITH late of 8 Middle Crescent, North Brighton in the State of Victoria Widow who died on the 2nd September, 1974 are to send particulars of their claims to the Executrix MARGOT BROWNING Married Woman of 24 Swanpool Avenue, Chelsea by the 1st of January 1975 after which date the Executrix will distribute the estate having regard only to the claims of which she then has notice.

SEDDON & WITT, solicitors, 406 Collins Street, Melbourne. 1553

CREDITORS next of kin and others having claims in respect of the estate of RAYMOND CARMODY late of Myola via Toollleen farmer deceased intestate who died on the twenty seventh day of April 1974 are to send particulars of their claims to the NATIONAL TRUSTEES EXECUTORS AND AGENCY COMPANY OF AUSTRALASIA LIMITED of 46 Queen Street Bendigo by the sixth day of January 1975 after which date it will distribute the assets having regard only to the claims of which it then has notice.

WATSON, JAMES & ROGERS, solicitors, 61 Bull Street, Bendigo. 1554

CREDITORS NEXT OF KIN AND OTHERS having claims in respect of the Estate of RICHARD EDWIN MOODY late of Hazelwood North Farmer deceased who died on the 14th June 1974 are to send particulars of their claims to THE UNION-FIDELITY TRUSTEE COMPANY OF AUSTRALIA LIMITED of 100 Exhibition Street Melbourne by the 15th January 1975 after which date it will distribute the assets of the deceased having regard only to the claims of which it then has notice.

BRUCE LITTLETON & HACKFORD, solicitors, Traralgon. 1481

WILLIAM FRANCIS DONNELLY, late of 408 Ascot Street South, Ballarat, labourer, DECEASED, intestate.

Creditors next of kin and others having claims in respect of the estate of the deceased who died on the 8th day of May 1974 are required by the Administratrix LAURIS JEAN DONNELLY of 408 Ascot Street South Ballarat Widow to send particulars of their claims to her care of the undersigned Solicitors by the 6th day of January 1975 after which date the Administratrix may convey or distribute the assets having regard only to the claims of which she then has notice.

D. & A. ARONSON, solicitors, 104 Lydiard Street South, Ballarat. 1535

CREDITORS next of kin and others having claims in respect of the Estate of RICHARD MCKAY late of 144 Dorking Road, Box Hill North Retired Fire Officer deceased who died on 17th April, 1974 are required by MARY GERTRUDE MCKAY of 144 Dorking Road, Box Hill North Widow to send particulars of their claims to her care of the under-mentioned Solicitor by 31st January, 1975 after which date she will distribute the assets having regard only to the claims of which she then has notice.

THOMAS BURKE, solicitor, 152 Wattletree Road, Malvern. 1480

WARREN BARADINE QUINNEY, late of 216 Lyons Street South, Ballarat, motor mechanic, DECEASED, intestate.

Creditors next of kin and others having claims in respect of the estate of the deceased who died on the 22nd day of April 1974 are required by the Administratrix DIANE ELIZABETH QUINNEY of 6 Lightfoot Road Ballarat Widow to send particulars of their claims to her care of the undersigned Solicitors by the 6th day of January 1975 after which date the Administratrix may convey or distribute the assets having regard only to the claims of which she then has notice.

D. & A. ARONSON, solicitors, 104 Lydiard Street South, Ballarat. 1534

WILLIAM KERSHAW, late of 57 Wharf Street, Tuncurry, in the State of New South Wales, invalid pensioner, DECEASED.

Creditors, next of kin and others having claims in respect of the estate of the deceased (who died on the 29th day of June, 1974) are required by the Executor RICHARD PATRICK BAYLOR of Healesville, Solicitor to send particulars to him, care of the undersigned, on or before the 10th day of January, 1975 after which date he will distribute the assets having regard only to the claims of which he then has notice.

R. P. BAYLOR & CO., solicitors, Healesville. 1482

THELMA JOSEPHINE PHILLIPS, late of Flat 1, 49 Clarence Street, Elsternwick, spinster, DECEASED.

Creditors next-of-kin and others having claims in respect of the estate of the deceased who died on 21st July, 1974 are required by the Executor BRENDAN JOSEPH McGUINNESS of 51 Queen Street, Melbourne to send particulars to him care of the undersigned by 30th December, 1974 after which date the Executor may distribute the assets having regard only to the claims of which he then has notice.

BRENDAN McGUINNESS & CO., solicitors, of 51 Queen Street, Melbourne. 1532

In the Supreme Court of the State of Victoria.

SALE BY THE SHERIFF.

ON FRIDAY the 13TH of DECEMBER 1974 at 10.00 a.m. AT THE POLICE STATION ELWOOD (unless process be stayed or satisfied).

ALL the Estate and Interest (if any) of ALICJA WAT, married woman of 35 Mavho Street, Bentleigh as joint proprietor with Leiser Wat of an estate in fee simple in the land described in Certificate of Title Volume 8228 Folio 602 upon which is erected a residential dwelling known as No. 157 Glenhantly Road Elwood.

Registered Caveats Nos. F.215127 and F.267327 affect the said estate and interest.

TERMS—CASH ONLY.

H. BUETTNER, Sheriff's Officer.

30th October, 1974. 1621

In the Supreme Court of the State of Victoria.

SALE BY THE SHERIFF.

ON FRIDAY the 6TH of DECEMBER 1974 at 11.00 a.m. AT THE POLICE STATION RINGWOOD (unless process be stayed or satisfied).

ALL the Estate and Interest (if any) of VIC BIANCO, drainer, of 9 Grant Street, Ringwood as joint proprietor with Vittoria Bianco, married woman of an estate in fee simple in the land described in Certificate of Title Volume 8828 Folio 165 upon which is erected an unfinished double storey brick dwelling situate at Cnr. Oban and Wonga Road, Ringwood.

Registered Mortgage No. F.264057 affects the said estate and interest.

TERMS—CASH ONLY.

H. BUETTNER, Sheriff's Officer.

30th October, 1974. 1622

In the Supreme Court of the State of Victoria.

SALE BY THE SHERIFF.

ON FRIDAY the 6TH of DECEMBER 1974 at 12 noon AT THE POLICE STATION SPRINGVALE (unless process be stayed or satisfied).

ALL the Estate and Interest (if any) of G. GREENDA (shown on Certificate of Title as George Grenda) plumber, of 1 Harbinger Court, Mulgrave, as joint proprietor with Barbara Anne Grenda, married woman, of an estate in fee simple in the land described in Certificate of Title Volume 8851 Folio 829 upon which is erected a double storey brick veneer dwelling known as No. 1 Harbinger Court Mulgrave.

Registered Mortgages Nos. E.3570 and E.173597 and Caveat F.274978 affect the said estate and interest.

TERMS—CASH ONLY.

H. BUETTNER, Sheriff's Officer.

30th October, 1974.

1623

In the Supreme Court of the State of Victoria.

SALE BY THE SHERIFF.

ON FRIDAY the 6TH of DECEMBER 1974 at 12 noon AT THE POST OFFICE METUNG (unless process be stayed or satisfied).

ALL the Estate and Interest (if any) of GRAHAM FREDERICK GADDES and JUNE VERONICA GADDES, both of 3 Corowa Avenue, Lake Illawarra South, New South Wales as joint proprietors of an estate in fee simple in the land described in Certificate of Title Volume 8292 Folio 462 Lot 193 on Plan of Subdivision No. 51820 Parish of Bumberrah. Said land being located in Foreshore Road, 326' 0½" due east of the intersection of Foreshore Road and Boronia Street in the Blue Horizon estate. Said estate is located approx. one mile west of the Township of Metung.

TERMS—CASH ONLY.

Senior Sergeant D. GRIMER, Sheriff's Officer.

30th October, 1974.

1624

In the Supreme Court of the State of Victoria.

SALE BY THE SHERIFF.

ON FRIDAY the 6TH of DECEMBER 1974 at 10.00 a.m. AT THE POLICE STATION BORONIA (unless process be stayed or satisfied).

ALL the Estate and Interest (if any) of DONALD LES WENTMAN as proprietor of an estate in fee simple in the land described in Certificate of Title Volume 8556 Folio 487 upon which is erected a brick dwelling with metal garage known as No. 61 Army Road Boronia.

Registered Mortgages No. C.427869 and E.66683 affect the said estate and interest.

TERMS—CASH ONLY.

H. BUETTNER, Sheriff's Officer.

30th October, 1974.

1625

IMPOUNDINGS

CAMPERDOWN.—Impounded in Council Pound from Princes Highway on 17th October, 1974:—

2 Friesian steers

1 Friesian heifer

1 red heifer

1 Jersey heifer.

If not claimed and expenses paid, will be sold at Camperdown Municipal Saleyards on Tuesday, 12th November, 1974.

1504—\$3.85

L. BREEN,
Poundkeeper.

SHIRE OF HEYTESBURY.

COBDEN.—Impounded in the Cobden Pound from Jancourt East, Timboon-Colac Road.

2 Aberdeen Angus cows

1 Aberdeen Angus heifer, no visible brands or ear marks

If not claimed and expenses paid to be sold by Dennys Lascelles Ltd., at the Camperdown Sale Yards on Tuesday, 12th November, 1974.

1531—\$3.50

J. S. BRADD,
Poundkeeper.

CITY OF ECHUCA.

ECHUCA.—Impounded in Echuca Pound for trespassing 25 kilometres from Echuca, off the Terrick Road.

5 poll Hereford cows

1 horned Hereford cow with 6 calves at foot

If not claimed and expenses paid, to be sold on 20th November, 1974.

1549—\$3.15

B. CLEE,
Poundkeeper.

SHIRE OF KYNETON.

KYNETON.—Impounded in Kyneton Pound on 24th October, 1974, from the Lauriston area.

1 Hereford cross cow, calf at foot

If not claimed and expenses paid, to be sold on the 14th November, 1974.

1551—\$2.80

C. H. RIORDAN,
Poundkeeper.

MARONG.—Impounded in Marong Shire Pound, 10 head of cattle.

1 Guernsey cow

1 Hereford cow

3 Angus cows

1 brindle heifer

3 Angus x Hereford steers

If not claimed and expenses paid, will be sold within 14 days.

1640—\$3.85

H. C. BUTTREY,
Poundkeeper.

CITY OF BERWICK.

NARRE WARREN NORTH.—Impounded in Narre Warren North Pound, from Gardiner Street, Berwick.

1 black and white steer (baldy), 18 months, no visible brand

If not claimed and expenses paid, to be sold at Dandenong Market, Monday, 11th November.

1611—\$3.15

A. DUNCAN,
Poundkeeper.

ORBOST.—Impounded at Orbost.

2 sheep, wethers 2 years old with V out of tops of right ear and side of left ear.

If not claimed and expenses paid, to be sold on or after 15th November, 1974.

1505—\$2.45

R. E. VERNON,
Poundkeeper.

VIOLET TOWN.—Impounded in the Shire of Violet Town Pound.

1 ewe weaner, no visible brand

If not claimed and expenses paid will be sold at 12 noon on 13th November, 1974.

1642—\$2.45

H. G. HARRIS,
Poundkeeper.

SHEPPARTON.—Impounded in the Shire of Shepparton Pound from Doyles Lane.

1 Jersey heifer, 8-10 months, no visible brands

1 Hereford Freisian cross heifer, 8-10 months, chain on neck, no visible brands

If not claimed and expenses paid will be sold 12 noon, 14th November, 1974.

1641—\$3.15

A. MURPHY,
Poundkeeper.

SHIRE OF UPPER YARRA.

YARRA JUNCTION.—Impounded in Yarra Junction Pound.

2 Murray Grey calves

1 Hereford crossbred

If not claimed and expenses paid, to be sold at 12 noon on Saturday, 16th November, 1974.

1550—\$2.80

J. N. EDDY,
Shire Secretary.

Subordinate Legislation Act 1962.

NOTICE OF MAKING OF STATUTORY RULES.

In pursuance of the provisions of the *Subordinate Legislation Act 1962* and the Regulations made thereunder, notice is given of the making of the following statutory rules:—

No.	Explosives Act 1960.	Price.
460/1974.	Classification of Explosives (Amendment No. 3) Order 1974	10c
	<i>Motor Car Act 1958.</i>	
	<i>Recreation Vehicles Act 1973.</i>	
461/1974.	Recreation Vehicles (Third Party Insurance Premiums) Regulations 1974	10c

No.	Motor Car Act 1958.	Price.
462/1974.	Motor Car (Third Party Insurance Premiums) Regulations 1974	10c

Copies of these statutory rules may be purchased at the Sale of Publications Section of the Government Printing Office, located at 7A Parliament Place, Melbourne, 3002. If ordered by mail, remittance should be addressed to "The Government Printer, Box 203, P.O., North Melbourne, 3051", and should include 7c extra for postage. If a credit account is held at this office, no remittance is required with the mail order.

The annual subscription rate for Statutory Rules (including Bound Volumes) is \$28, payable in advance. The subscription year commences on 1st January.

C. H. RIXON,
Government Printer.

STATE ACTS, 1973

Copies of the following Acts of Parliament of Victoria may be obtained at the Government Printing Office, Sale of Publications Branch, off Parliament Place, Melbourne, phone 63 0321, extension 6181, or from any accredited agent, at the price set opposite to each (these prices do not include postage).

The annual subscription for State Acts 1973 et seq. is \$12.50 payable in advance.

Bound Volumes of State Acts are also available on a subscription basis of \$17.50 per annum.

No.		Price.
8385.	The Constitution Act Amendment (Qualifications)	\$0.10
8386.	Hungarian Reformed Church of Australia (Victoria District) Incorporation	\$0.20
8387.	Melbourne Family Care Organization	\$0.10
8388.	Gas and Fuel Corporation (Colonial Gas Holdings Limited)	\$0.10
8389.	Boilers and Pressure Vessels	\$0.10
8390.	State Electricity Commission (Yallourn Council)	\$0.10
8391.	Home Finance (Amendment)	\$0.10
8392.	Zoological Gardens (Amendment)	\$0.10
8393.	Melba Trust Fund	\$0.10
8394.	Hospitals and Charities (Guarantee)	\$0.10
8395.	Water (Amendment)	\$0.15
8396.	Geelong Harbor Trust (Lands)	\$0.10
8397.	Latrobe Valley (Amendment)	\$0.10
8398.	Maryborough Land	\$0.10
8399.	The Constitution Act Amendment (Presiding Officers)	\$0.10
8400.	Constitutional Convention (Alternate Members)	\$0.10
8401.	Ballarat (Sovereign Hill) Land	\$0.15
8402.	Taxation Appeals (Commencement)	\$0.10
8403.	Patriotic Funds (Amendment)	\$0.10
8404.	Abattoir and Meat Inspection	\$0.40
8405.	Valuation of Land (Valuers)	\$0.20
8406.	Egg Industry Stabilization	\$0.40
8407.	Recreation Vehicles	\$0.15
8408.	Motor Car Traders	\$0.50
8409.	Decentralized Industry (Housing)	\$0.15
8410.	Crimes (Amendment)	\$0.10
8411.	Cattle Compensation	\$0.10
8412.	Victorian Inland Meat Authority (Amendment)	\$0.10
8413.	Bendigo Aerodrome	\$0.10
8414.	Ombudsman	\$0.30
8415.	Public Service (Amendment)	\$0.10
8416.	Coal Mines (Pensions Increase)	\$0.10
8417.	Workers Compensation	\$0.10
8418.	Public Records	\$0.20
8419.	Joint Select Committee (Osteopathy, Chiropractic and Naturography)	\$0.10
8420.	Marketing of Primary Products (Citrus Fruit)	\$0.10
8421.	Barley Marketing (Amendment)	\$0.10
8422.	Margarine	\$0.10
8423.	Metric Conversion	\$0.10
8424.	Medical Practitioners (Amendment)	\$0.15
8425.	Crimes (Theft)	\$0.30
8426.	Social Welfare (Amendment)	\$0.20
8427.	Magistrates' Courts (Jurisdiction)	\$0.60
8428.	Victorian Development Corporation	\$0.40
8429.	Motor Accidents	\$0.80
8430.	Motor Car (Amendment)	\$0.15
8431.	Teaching Service	\$0.10
8432.	Lands Compensation	\$0.15
8433.	Police Offences (Publications)	\$0.15

No.	STATE ACTS, 1973—continued.	Price.
8434.	The Constitution Act Amendment (Responsible Ministers)	\$0.10
8435.	Supply (July to October)	\$0.10
8436.	Supply (Supplementary Estimates)	\$0.10
8437.	Joint Select Committee (Meat Industry)	\$0.10
8438.	Joint Select Committee (Road Safety)	\$0.10
8439.	Joint Select Committee (Osteopathy, Chiropractic and Naturography) Amendment	\$0.10
8440.	Public Works Committee	\$0.10
8441.	The Constitution Act Amendment (Qualifications Joint Select Committee)	\$0.10
8442.	Ministry of Consumers Affairs	\$0.10
8443.	Ministry for Planning	\$0.10
8444.	Volunteer Civil Defence Workers Compensation (Amendment)	\$0.10
8445.	Local Government (Rates)	\$0.10
8446.	Hospitals Superannuation (Amendment)	\$0.10
8447.	Public Works Committee (Attendance Fees)	\$0.10
8448.	Unclaimed Moneys	\$0.10
8449.	Appropriation	\$1.90
8450.	Racing (Amendment)	\$0.10
8451.	Ministry for the Arts (Amendment)	\$0.10
8452.	Local Authorities Superannuation (Amendment)	\$0.10
8453.	Sewerage Districts (Amendment)	\$0.10
8454.	Money Lenders (Advertisements)	\$0.15
8455.	Tomato Processing Industry (Uniform Agreement)	\$0.20
8456.	Poisons (Fees)	\$0.10
8457.	Camperdown (Public Park) Land	\$0.10
8458.	Maidstone Land	\$0.10
8459.	Labour and Industry (Amendment)	\$0.10
8460.	Hairdressers Registration (Amendment)	\$0.10
8461.	Land (Metric Conversion)	\$0.30
8462.	Co-operative Housing Societies (Amendment)	\$0.10
8463.	Rosebud Institutions	\$0.10
8464.	Gas and Fuel Corporation (Amalgamations)	\$0.15
8465.	Stamps	\$0.20
8466.	Estate Agents (Fees)	\$0.10
8467.	Auction Sales (Licence Fees)	\$0.10
8468.	Motor Car (Fees)	\$0.10
8469.	Mines (Fees)	\$0.10
8470.	The Constitution Act Amendment (Executive Council)	\$0.10
8471.	State Forests Works and Services	\$0.10
8472.	Entertainments Tax	\$0.10
8473.	State College of Victoria (Staff)	\$0.10
8474.	Decentralized Industry (Land Tax Rebates) Incentive Payments	\$0.10
8475.	Pensions Supplementation	\$0.10
8476.	Metropolitan Fire Brigades (Amendment)	\$0.10
8477.	Children's Court	\$0.60
8478.	Country Fire Authority	\$0.10
8479.	Housing (Commonwealth State Agreement)	\$0.20
8480.	Probate Duty (Amendment)	\$0.15
8481.	Judges Salaries and Allowances	\$0.10
8482.	Pay-roll Tax (Amendment)	\$0.10
8483.	Land Reform	\$0.15
8484.	Flemington Land	\$0.10
8485.	Educational Lands	\$0.10
8486.	Small Claims Tribunals	\$0.20
8487.	Police Regulation (Amendment)	\$0.10
8488.	Consumer Protection	\$0.20
8489.	Country Roads (Amendment)	\$0.10
8490.	Attorney-General and Chief Secretary (Additional Functions)	\$0.10
8491.	Revocation and Excision of Crown Reservations	\$0.15
8492.	Land	\$0.10
8493.	Social Welfare	\$0.40
8494.	Monash University (Amendment)	\$0.15
8495.	Educational Grants	\$0.10
8496.	Victoria Institute of Colleges (Amendment)	\$0.10
8497.	Boilers and Pressure Vessels (Amendment)	\$0.10
8498.	Water Supply Works and Services	\$0.30
8499.	Youth, Sport and Recreation (State School Premises)	\$0.10
8500.	Melbourne Underground Rail Loop (Amendment)	\$0.10
8501.	Health (Special Accommodation Houses)	\$0.10
8502.	St. Kilda (Ormond Restaurant) Land	\$0.10
8503.	Racing (Further Amendment)	\$0.10
8504.	Social Welfare (Financial)	\$0.10
8505.	Education (Handicapped Children)	\$0.15
8506.	Health (Fluoridation)	\$0.10
8507.	Victorian Development Corporation (Amendment)	\$0.10
8508.	Housing (Sale of Land)	\$0.10
8509.	Weights and Measures (Amendment)	\$0.15
8510.	Hospitals and Charities (Amendment)	\$0.10
8511.	Hospitals and Charities (Institutions and Benevolent Societies)	\$0.10

STATE ACTS, 1973—continued.	
No.	Price.
8512. Wheat Industry Stabilization (Amendment)	\$0.15
8513. Audit (Appointment)	\$0.10
8514. Swan Hill (Railways Land)	\$0.10
8515. Water (Further Amendment)	\$0.10
8516. Mines (Amendment)	\$0.15
8517. Public Works and Services	\$0.15
8518. Wodonga Area Land Acquisition	\$0.10
8519. State Savings Bank (Amendment)	\$0.10
8520. Albury-Wodonga Agreement	\$0.40
8521. Melbourne Family Care Organization (Amendment)	\$0.10
8522. Railway Works and Services	\$0.10
8523. Teaching Service (Professional Appointees)	\$0.10
8524. Development Areas	\$0.10
8525. Road Transport	\$0.20
8526. Municipalities Assistance	\$0.10
8527. Land Tax	\$0.20
8528. Abattoirs and Meat Inspection (Commencement)	\$0.10
8529. Local Government (House Builders' Liability)	\$0.30
8530. Parliamentary Salaries and Allowances	\$0.20
8531. Local Government (Subdivision of Land)	\$0.70

C. H. RIXON,
Government Printer.

STATE ACTS, 1974—continued.	
No.	Price.
8557. Local Government (Amendment)	\$0.30
8558. Decentralized Industry (Housing) (Amendment)	\$0.10
8559. Teaching Service (Conditions of Service)	\$0.10
8560. Environment Protection (Amendment)	\$0.10
8561. Motor Car (Further Amendment)	\$0.15
8562. Victorian Civil Ambulance Service	\$0.10
8563. Forests (Wood Pulp Agreement)	\$0.40
8564. Local Government (House Builders Liability Amendment)	\$0.20
8565. Companies (Interstate Corporate Affairs Commission)	\$0.60
8566. Racing (Amendment)	\$0.10
8567. Appropriation (1973-74, No. 2)	\$0.10
8568. Public Servants Ethical Conduct (Joint Select Committee)	\$0.10
8569. Historic Buildings	\$0.30
8570. Appropriation (1973-74, No. 3)	\$0.10
8571. Supply (No. 2, 1974-75)	\$0.10
8572. Victorian Inland Meat Authority	\$0.10
8573. Metropolitan Bridges Highways and Fore-shores	\$0.30

C. H. RIXON,
Government Printer.

STATE ACTS, 1974

Copies of the following Acts of Parliament of Victoria may be obtained at the Government Printing Office, Sale of Publications Branch, off Parliament-place, Melbourne, phone 63 0321, extension 6181, or from any accredited agent, at the price set opposite to each (these prices do not include postage).

The annual subscription for State Acts 1974 is \$15 payable in advance.

Bound Volumes of State Acts are also available on a subscription basis of \$21 per annum.

No.	Price.
8532. Veterinary Research Institute (Consequential Amendment)	\$0.10
8533. Stock (Artificial Breeding) (Amendment)	\$0.10
8534. Carriers and Innkeepers (Licences)	\$0.10
8535. Bittern Land	\$0.10
8536. Labour and Industry	\$0.10
8537. Public Lands and Works (Amendment)	\$0.10
8538. Land Tax (Amendment)	\$0.10
8539. Superannuation (Railway Service)	\$0.10
8540. Consumer Protection (Unordered Goods and Services Amendment)	\$0.10
8541. Morwell and Mirboo Railway Removal	\$0.10
8542. Bread Industry (Amendment)	\$0.10
8543. Co-operative Housing Societies (Amendment)	\$0.10
8544. Lotteries Gaming and Betting (Amendment)	\$0.10
8545. Supply (No. 1, 1974-75)	\$0.15
8546. Melbourne Cricket Club	\$0.15
8547. Home Finance (Amendment)	\$0.10
8548. Swan Hill Pioneer Settlement	\$0.30
8549. Ministry of Transport (Transport Fund)	\$0.10
8550. Youth, Sport and Recreation (Amendment)	\$0.10
8551. Stamps (Bills of Exchange)	\$0.10
8552. Gas and Fuel Corporation (Powers)	\$0.20
8553. Registration of Births Deaths and Marriages	\$0.10
8554. Meat Inspection Services	\$0.10
8555. Sewerage Districts (Interest Subsidies)	\$0.10
8556. Printers and Newspapers (Amendment)	\$0.10

CONTENTS

	PAGE
Acts of Parliament	3805
Acts of Parliament on Sale at the Government Printing Office	3867
Appointments	3833
Contracts	3825
Country Roads Board	3812
Estates of Deceased Persons	3824
Government Notices	3806
Impoundings	3866
Lands	3843
Melbourne and Metropolitan Board of Works—Notice	3824
Mining	3823
Notices to Mariners	3823
Notice of Making of Statutory Rules	3866
Orders in Council—	
Acts—Town and Country Planning; Country Roads; Land; Housing; Road Traffic; Local Government; Melbourne and Metropolitan Tramways; Melbourne Underground Rail Loop; Cemeteries; Water; Superannuation.	3825 et seq
Police Sale	3812
Private Advertisements	3848
Proclamations	3805
Public Holiday—Melbourne Cup Day	3806
Public Service Notices	3846
Resignations	3835
State Rivers and Water Supply Commission	3829
Tenders	3845
Transport Regulation Board—Public Hearings	3807
Waterworks Trusts	3830